

No. 198-2

basic television

by **A. SCHURE**

VOL. 2

**ORGANIZATION OF
THE TV RECEIVER**

THE INTERCARRIER SYSTEM

THE R-F AMPLIFIER

THE OSCILLATOR

THE MIXER

THE I-F AMPLIFIER

THE VIDEO SYSTEM

THE SOUND SYSTEM

SWEEP SYSTEMS

**TV ANTENNAS AND
TRANSMISSION LINES**

a RIDER publication

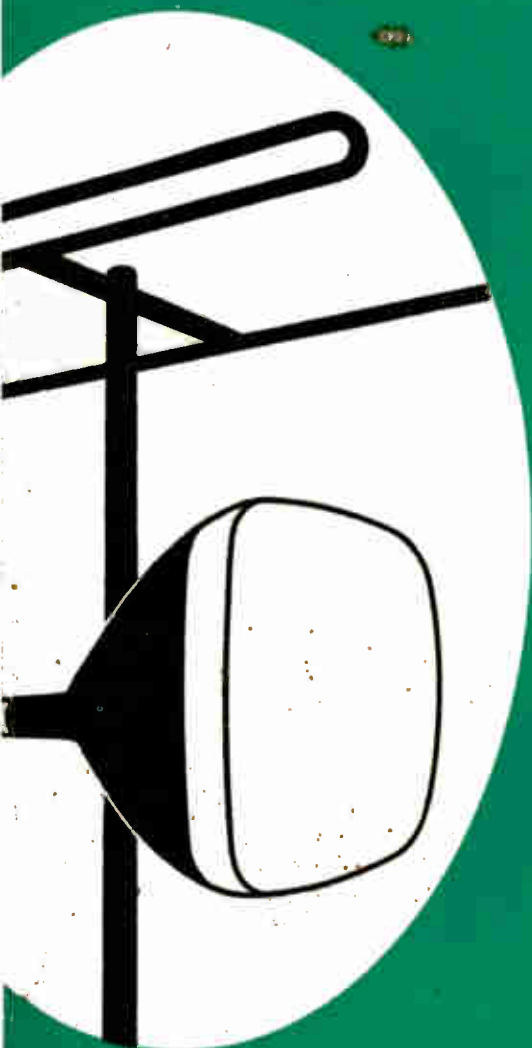

\$2.25

basic television

by Alexander Shure, Ph.D., Ed.D.

VOL. 2



JOHN F. RIDER PUBLISHER, INC.

116 West 14th Street • New York 11, N. Y.

Copyright January 1958 by John F. Rider Publisher, Inc.

All rights reserved. This book or any parts thereof may not be reproduced in any form or in any language without permission of the publisher.

Library of Congress Catalog Card Number 57-13493

Printed in the United States of America

PREFACE

This five-volume course in the fundamental principles of television represents the end product of three years of research and experimentation in teaching methods and presentation at the New York Technical Institute. As a result of this experimentation in correspondence and resident courses approved by the New York State Department of Education, and following the recommendations of advising industrial groups, the highly pictorialized presentation used throughout this book was adopted. An illustration has been provided for each important concept and placed together with the explanatory text on the same page to pinpoint essential material. In addition, review pages spaced throughout each volume summarize the major points already presented.

This combination of the visual approach and idea-per-page technique makes **BASIC TELEVISION** readily understandable with or without an instructor. It is thus suitable for individual or correspondence use as well as for classroom study. Its coverage is complete from the creation of the television image in the studio to its appearance on the receiver screen, and presupposes only a knowledge of basic electronics and radio. Many topics not covered in the more traditional texts are treated here and fully explained for the first time.

The author wishes to acknowledge the assistance of his staff at the New York Technical Institute and that of Mr. Gilbert Gallego in the preparation of some of the illustrations. Special gratitude is due to the staff of John F. Rider Publisher and to Mr. Rider personally for his contributions to both the text and the picturization of this course.

New York, N. Y.
January 1958

ALEXANDER SCHURE

CONTENTS

VOL. II — BASIC TELEVISION

The Television Receiver	1
The Tuner Frequencies	3
Intermediate Frequencies	11
The Tuner I-F Stages	15
The Video Detector	18
Automatic Gain Control	22
The Video Amplifier	24
The Sound Channel	26
Achieving Picture Contrast	29
Review	30
The Synchronizing Circuits	32
The Vertical Sweep Circuits	36
The Horizontal Sweep Circuits	40
Receiver Power Supplies	45
The Split-Sound Receiver	47
UHF Reception	48
Review	50
The Television Antenna	53
Propagation	55
The Radiated Wave	61
The Basic Dipole Antenna	80
Dipole Behavior	67
Review	76
Dipole Antenna Response	82
Antenna Resistance	91
Frequency Response of a Dipole	99
Other Dipole Antennas	103
Review	109
Adding Antenna Elements	111
UHF and VHF Antennas	117
Television Transmission Lines	123
Special Techniques	138
Review	141

THE TELEVISION RECEIVER

The TV Receiver

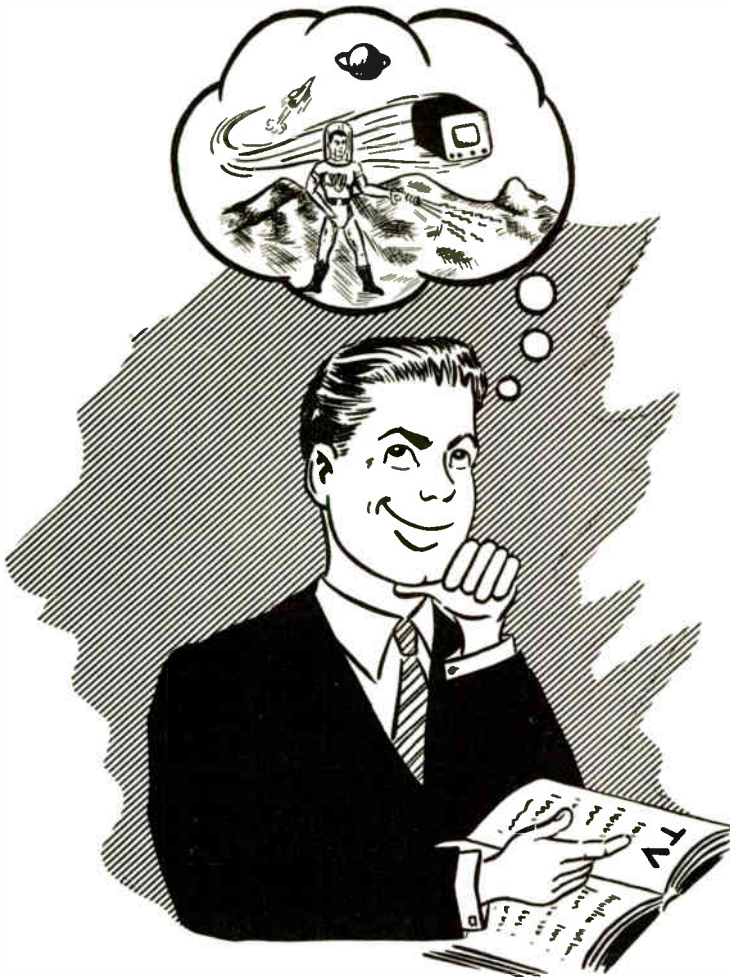

ONCE TV WAS CLASSED WITH SPACE SHIPS

Before World War II, the man in the street thought of television—if he thought about it at all—as a sort of Buck Rogersish device in a class with atomic disintegrators and interplanetary travel. Occasional reports filtering out of experimental laboratories indicated that television was on its way, but details of the new system were hazy and promised to be complicated. When television receivers finally appeared, they were breathtaking—a source of entertainment that rivaled the drawing power of the movies, and the public rushed to buy. Much has happened since then, all of which has led to television becoming a part of our lives.

THE TELEVISION RECEIVER

The TV Receiver (contd.)

The general layout of a television receiver is much like that of the ordinary radio receiver. Both are superheterodynes. Even the circuits in the television receiver with unfamiliar names—e.g., the *video amplifier*, *sync clipper*, and *blocking oscillator*—are not unknown arrangements, even though they have not been part of radio receivers. Television, after all, is a direct descendant of radio, and the two have a distinct family resemblance. Of course, the television receiver is much more elaborate in organization and design than a conventional radio receiver, but all the principles underlying radio receivers known to you will be found applicable to television receivers. In fact, the block diagram organization of the television receiver discussed in this section will be found to be like that of a radio receiver in many respects.

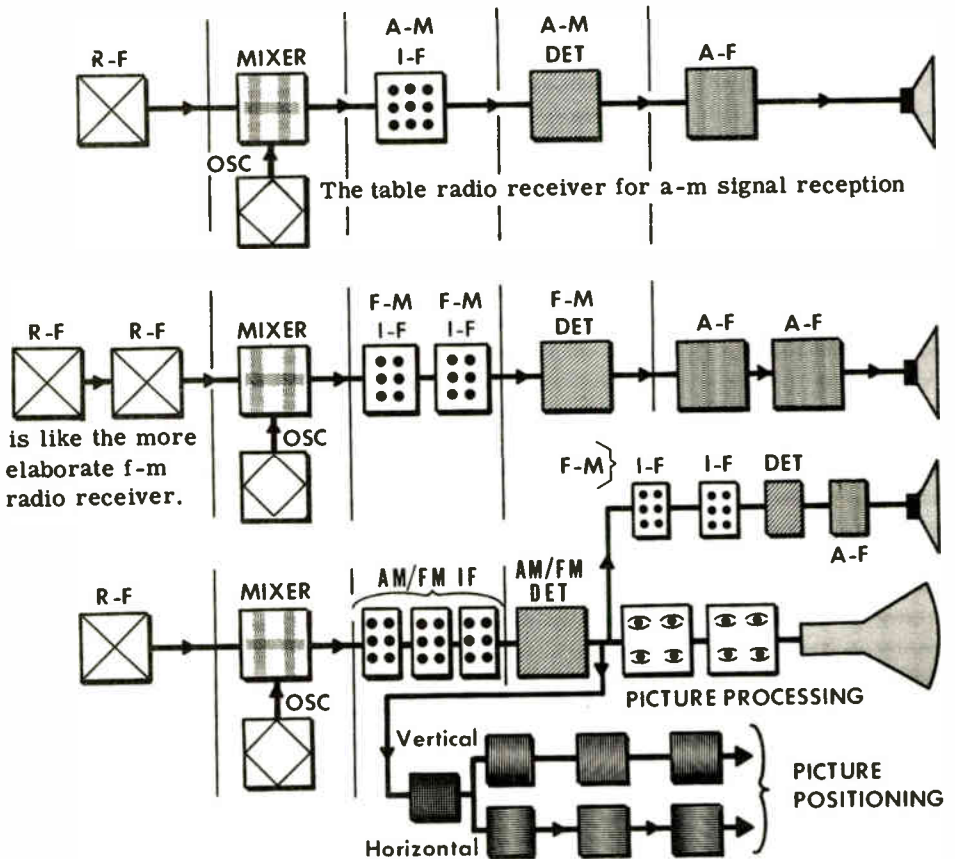

The television receiver has more tubes than either the f-m or a-m radio, since it processes a-m and f-m signals at the same time and also contains tubes that position the picture on the picture tube screen.

THE TUNER FREQUENCIES

The R-F Amplifier

The radio receiver has an antenna to intercept the signal radiated by the transmitter; the television receiver has a device for the same purpose. Television antennas are, however, a broad subject requiring separate treatment. (This is given in the next section.)

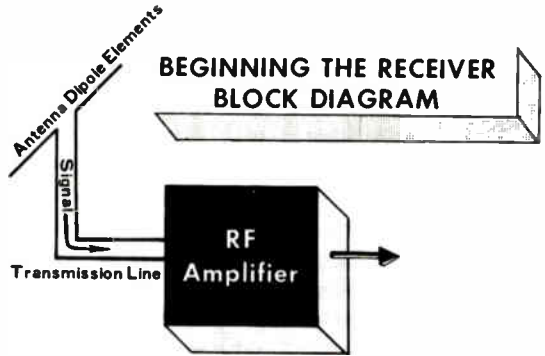

The Function of the R-F Amplifier

The first stage in the superheterodyne radio receiver is generally an r-f amplifier. This is also true of the television receiver. Every such receiver has an r-f amplifier stage. The r-f amplifier in the television receiver performs the same function as it does in the radio receiver. The antenna picks up a variety of television signals from several television transmitters. Usually, the carrier strength is too weak for direct application to the mixer stage. One function of the r-f amplifier is to build up the television carrier.

Amplification, however, is only part of its job. It has another equally important function. The television antenna picks up not only the signal of one transmitter, but also the signals from transmitters operating on adjacent channels. If the signals of more than one station were processed simultaneously in the receiver and displayed on the picture tube, the resulting picture would be hopelessly confusing. The r-f amplifier contains the *tuning* device that helps to select the picture and sound carriers of *just one* channel.

The Amplifier *Selects* and *Builds Up* the Channel Carriers

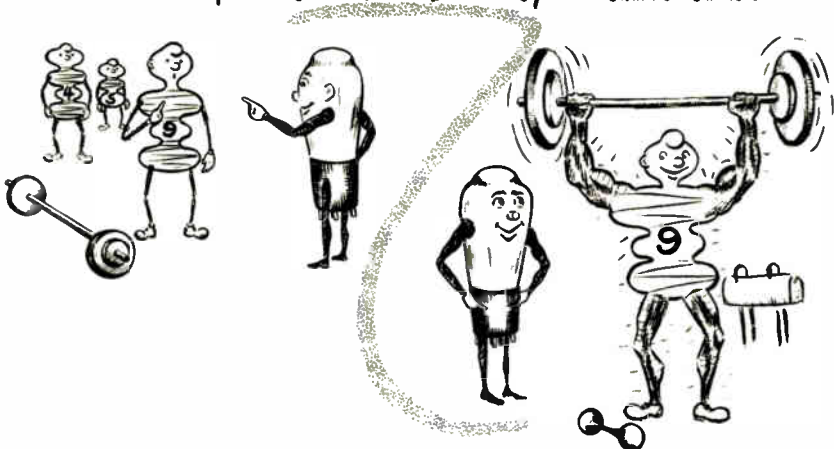

THE TUNER FREQUENCIES

The TV Channel

VHF		UHF		UHF	
Channel	Frequency limits	Channel	Frequency limits	Channel	Frequency limits
2	54-60	35	596-602	73	824-830
3	60-66	36	602-608	74	830-836
4	66-72	37	608-614	75	836-842
5	76-82	38	614-620	76	842-848
6	82-88	39	620-626	77	848-854
7	174-180	40	626-632	78	854-860
8	180-186	41	632-638	79	860-866
9	186-192	42	638-644	80	866-872
10	192-198	43	644-650	81	872-878
11	198-204	44	650-656	82	878-884
12	204-210	45	656-662	83	884-890
13	210-216	46	662-668		
		47	668-674		
		48	674-680		
		49	680-686		
		50	686-692		
		51	692-698		
		52	698-704		
		53	704-710		
		54	710-716		
		55	716-722		
		56	722-728		
		57	728-734		
		58	734-740		
		59	740-746		
		60	746-752		
		61	752-758		
		62	758-764		
		63	764-770		
		64	770-776		
		65	776-782		
		66	782-788		
		67	788-794		
		68	794-800		
		69	800-806		
		70	806-812		
		71	812-818		
		72	818-824		

UHF	
Channel	Frequency limits
14	470-476
15	476-482
16	482-488
17	488-494
18	494-500
19	500-506
20	506-512
21	512-518
22	518-524
23	524-530
24	530-536
25	536-542
26	542-548
27	548-554
28	554-560
29	560-566
30	566-572
31	572-578
32	578-584
33	584-590
34	590-596



List of
Television
Channel
Frequencies

The *station selector* knob of the television receiver is a device that bears numbers indicating the different TV channel positions that are assigned to television stations by the Federal Communications Commission. In New York City, for example, channels 2, 4, 5, 7, 9, 11, and 13 are assigned to different transmitting stations. If the station selector knob on a receiver in that city should be switched to channel 11 for example, the picture viewed would be that of station WPIX, and the music or speech from the speaker would be that broadcast from the WPIX studios.

THE TUNER FREQUENCIES

The 6-mc Channel Bandwidth

A television "channel", containing the video carrier frequency and its associated video information (sidebands), and the audio carrier frequency and its sidebands, is 6 mc wide. This bandwidth is standard in the United States and several other countries. In transmitting video information amplitude modulation is used; for audio, frequency modulation is used. Note that this is *narrow-band* fm with deviation of only plus or minus 25 kilocycles either side of the sound carrier frequency.

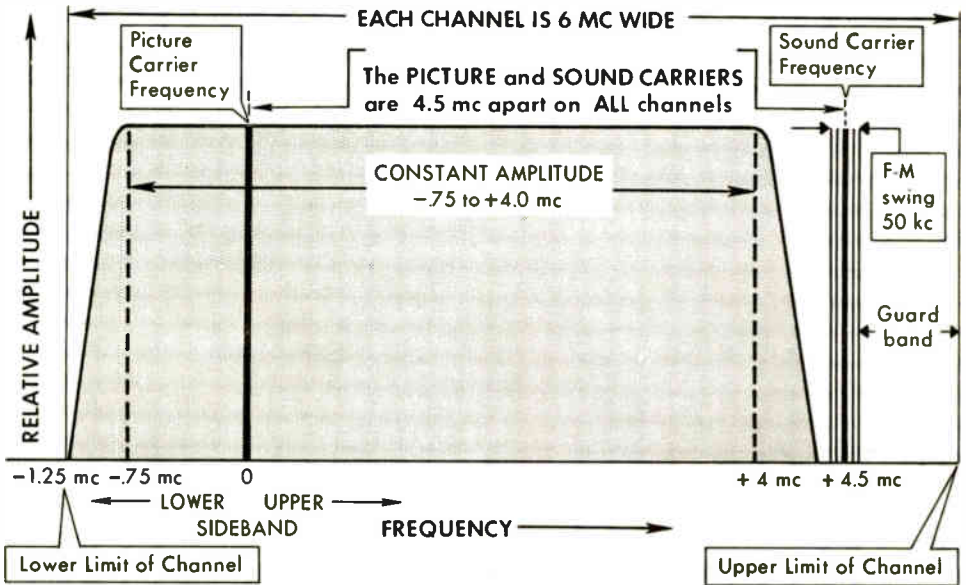

The arch-like curve with its flat top represents the picture (video) signal carrier and its sideband frequencies. If we consider the picture carrier as our reference or zero frequency, the sideband frequencies increase in either direction away from the carrier frequency.

In conventional amplitude modulation both the upper and lower sidebands are transmitted. However, to conserve bandwidth, a system of *vestigial* sideband transmission is used in which a large portion of one sideband is removed or attenuated. (In the United States, it is the lower sideband that is attenuated.) Of the lower sideband frequencies transmitted, from 0 to 0.75 mc are radiated at maximum amplitude, with frequencies from 0.75 mc to 1.25 mc sharply attenuated.

The upper sideband frequencies, starting at the video carrier at 0, extend upwards to approximately 4.5 mc. In this band, frequencies from 0 to about 4 mc are transmitted at maximum amplitude, with frequencies above 4 mc generally transmitted at progressively decreasing amplitude.

THE TUNER FREQUENCIES

The Sound Carrier

As to the radiated f-m sound carrier, frequency space is allocated to permit 100% modulation. This places the low-frequency limit near the high end of the upper sideband of the picture carrier—but still above it. The sound carrier frequency allocated to a television station by the FCC is the resting frequency (unmodulated) of the signal. Frequency modulation applied to this signal “swings” the frequency up and down around the resting frequency. The maximum allowable swing is 25 kc each side of the resting frequency, the remainder of the band being left clear for harmonics and to provide a vacant space between the top of the picture channel and the bottom of the sound channel.

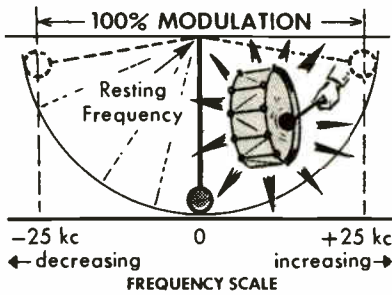

WHEN THE CARRIER IS FREQUENCY MODULATED,

the loudest sound processed in the studio produces an upward swing in frequency to 25 kc higher than the resting frequency and a downward swing to 25 kc lower than the resting frequency.

THIS IS A TOTAL SWING OF 50 KC FOR MAXIMUM LOUDNESS OR 100% MODULATION

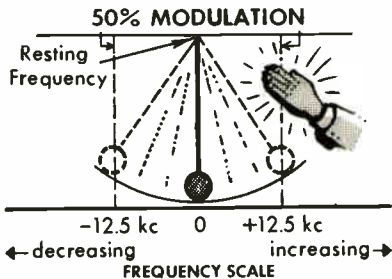

A sound of less than maximum loudness processed in the studio produces an upward swing to less than 25 kc higher than the resting frequency and a downward swing to less than 25 kc lower than the resting frequency, or

A VARIABLE SWING OF LESS THAN 50 KC ACCORDING TO LOUDNESS.

The upper frequency limit of the sound carrier does not mark the end of the television channel band. Beyond it, there is a small “no man’s land” of frequencies known as the *guard band*. This is the space between the upper limit of the sound carrier sidebands of one television channel and the lower limit of the video carrier sideband of the next higher channel. It is used to prevent possible interference due to overmodulation of the f-m sound carrier of a channel interfering with the picture being transmitted on the channel above it.

THE TUNER FREQUENCIES

R-F Amplifier Response

The IDEAL r-f amplifier tuned circuit would allow all frequencies in the 6-mc wide signal to pass equally well and would reject all others.

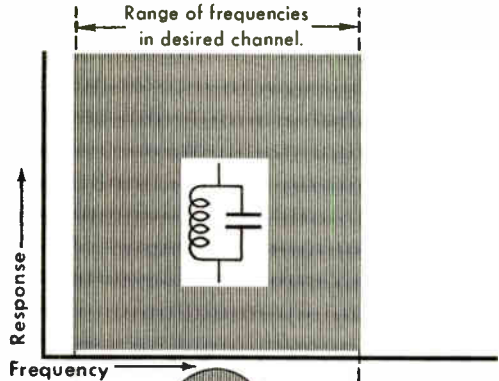

but

a PRACTICAL tuned circuit does not do this. All frequency components are not equally strong at the output.

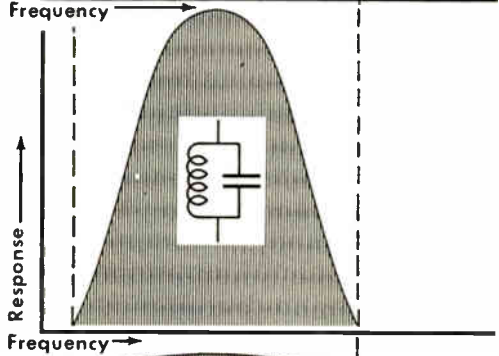

so

the tuned r-f circuit in a TV receiver is designed to accept more frequencies than are desired. The wanted ones are equally strong at the output and the unwanted ones are rejected later.

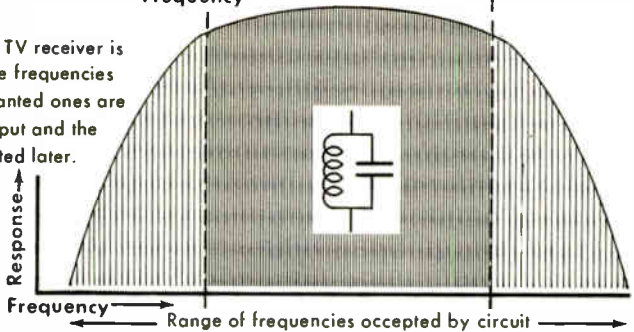

The ideal r-f amplifier in a television receiver would limit response to the 6-mc channel bandwidth of a channel and provide all frequencies within that channel with equal amplification. This does not occur in practice because such amplifiers are very expensive to produce. The usual r-f amplifier passes signals over about a 12-mc frequency band and accepts equally all frequencies about 3 mc each side of the frequency to which the circuit is tuned—that is, a 6 mc band. Further processing in the receiver eliminates the undesired signals passed through the r-f amplifier.

THE TUNER FREQUENCIES

The Mixer and the Oscillator in Radio Receivers

IN A RADIO RECEIVER,

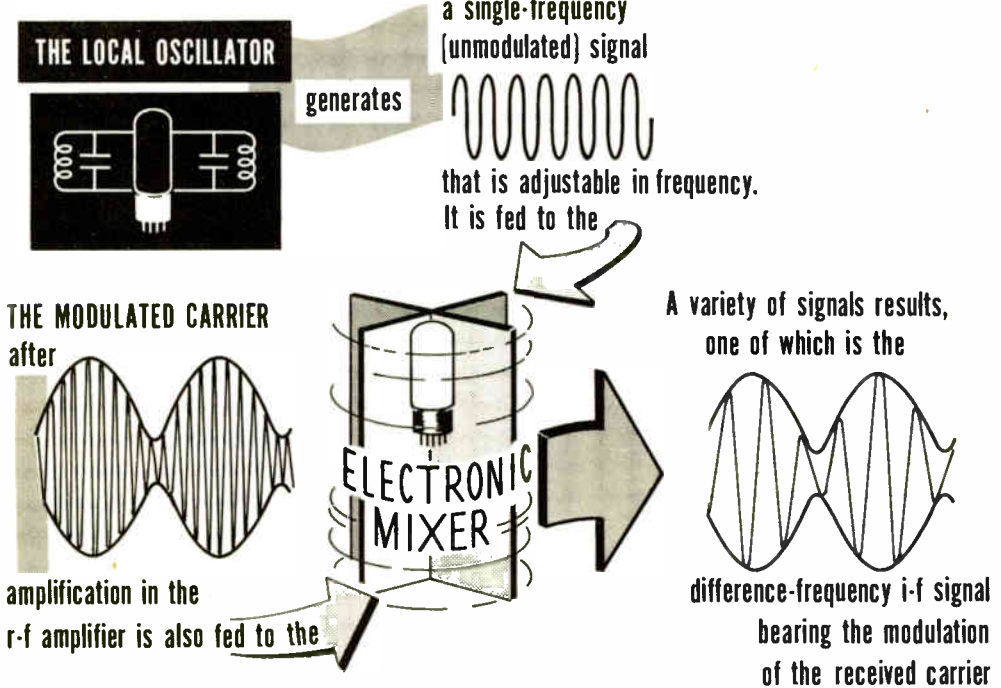

The principle underlying the operation of the superheterodyne receiver is the production within the receiver of a relatively low-frequency counterpart of the incoming carrier signal. This lower-frequency signal is called the intermediate frequency or i-f signal. The foremost advantages gained by this principle are increased sensitivity and selectivity.

Increased sensitivity is obtained as a result of the i-f amplifier processing fixed band of frequencies. The i-f amplifier circuitry can be designed for optimum performance at these frequencies. Excellent selectivity can be attained since the i-f amplifier can be *aligned* for a desired bandwidth.

Two circuits play important parts in the heterodyne principle—the *local oscillator* and the *mixer*. The oscillator generates an unmodulated r-f signal whose frequency can be varied over a wide range to suit the range of carrier frequencies accepted by the receiver. The mixer accepts the amplified version of the carrier from the r-f amplifier and the signal from the local oscillator. It combines or “mixes” these signals and produces a variety of signals in its output. Each bears the modulation of the r-f carrier, but the frequency of one of them is equal to the difference between the r-f carrier and the local oscillator frequency. *This is the i-f signal processed in the receiver.*

THE TUNER FREQUENCIES

The Mixer and the Oscillator in Television Receivers

The mixer and the oscillator in the television receiver function in similar fashion with one major exception. The television transmitter radiates a picture and a sound carrier, therefore *two* signals are processed by the r-f amplifier and *two* signals are fed to the mixer. The local oscillator signal is mixed with these two carrier signals and the mixer stage output contains, among other signals, the two difference-frequency i-f signals used.

In connection with this action, remember that the radiated picture carrier is amplitude modulated, whereas the sound signal is frequency modulated.

IN A TELEVISION RECEIVER, WHEN

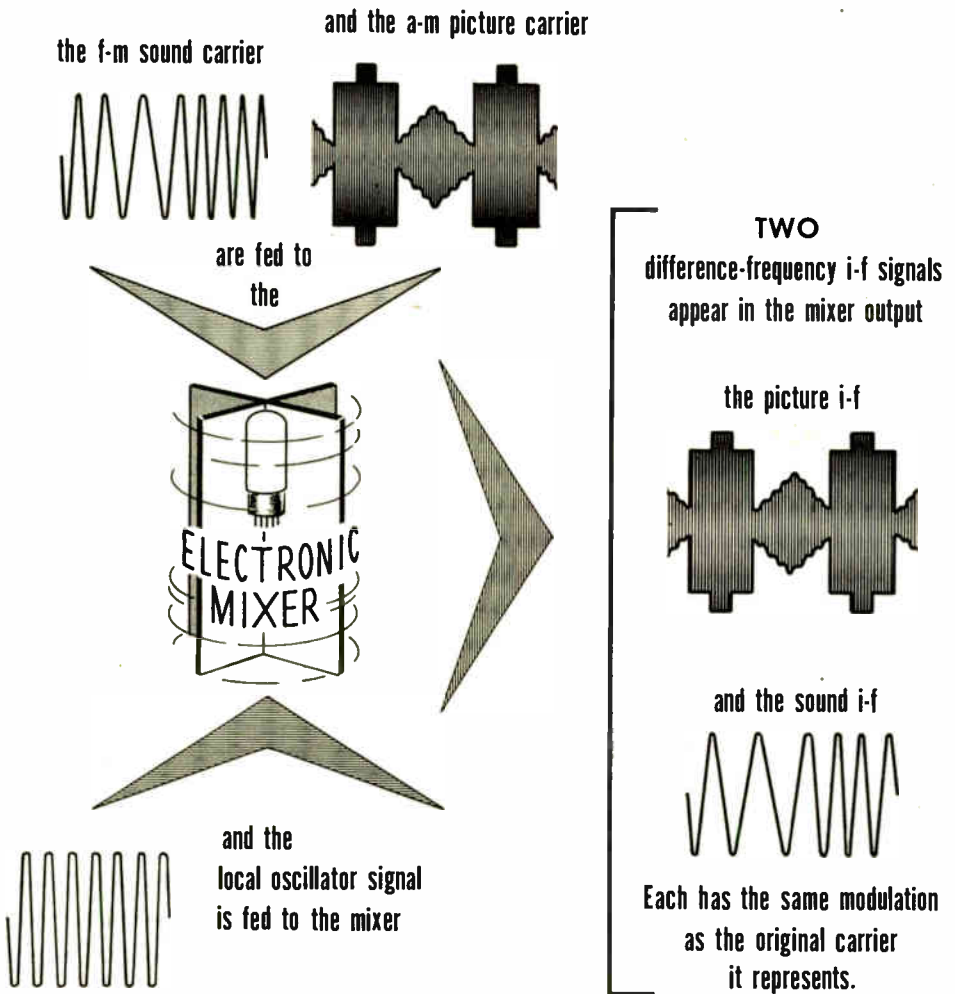

THE TUNER FREQUENCIES

The Frequency of the Local Oscillator

The mixing process in the mixer stage does not depend on the frequency of the signals fed into it. Theoretically, the frequency of the signal generated by the local oscillator can be higher or lower than the r-f picture and sound carriers derived from the r-f amplifier. In either case, two difference-frequency i-f signals (one the equivalent of the received picture carrier and the other the equivalent of the received sound carrier) are produced in the plate circuit of the mixer stage. Both the sound and picture i-f signals contain the original modulation of their carrier waves.

Design of the television receiver is made easier if the local oscillator frequency is higher than the received picture and sound carriers.

More important than the relative position of the local oscillator, with respect to the received carriers, is the precise frequency difference between the local oscillator and the incoming r-f carriers. This frequency difference represents the i-f frequency and must be constant on every TV channel to be received. Since the tuning of the i-f amplifier following the mixer is fixed at intermediate frequency, the frequency separation between the local oscillator and r-f carrier, if more or less than the i-f, will deteriorate picture quality considerably.

Incorrect oscillator output frequency can result from a number of conditions. Slight changes in the values of the oscillator circuit components due to temperature variation can result in incorrect frequency output; changes in temperature as the oscillator is warming up can cause frequency drift. To compensate for these effects, many television receivers are equipped with a *fine tuning control*, located on the panel.

The Fine Tuning Control Compensates For Oscillator Drift

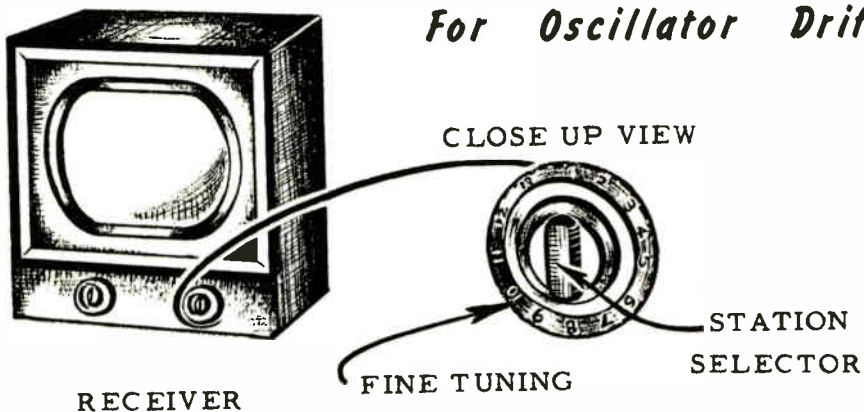

INTERMEDIATE FREQUENCIES

The Picture I-F Signal

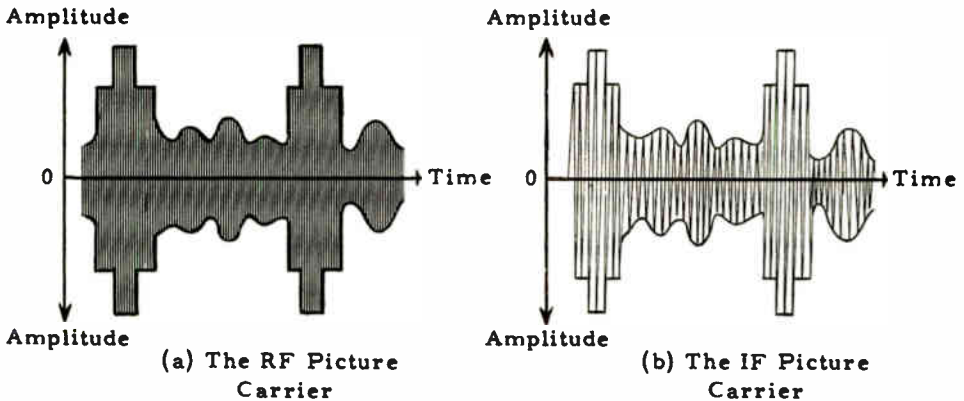
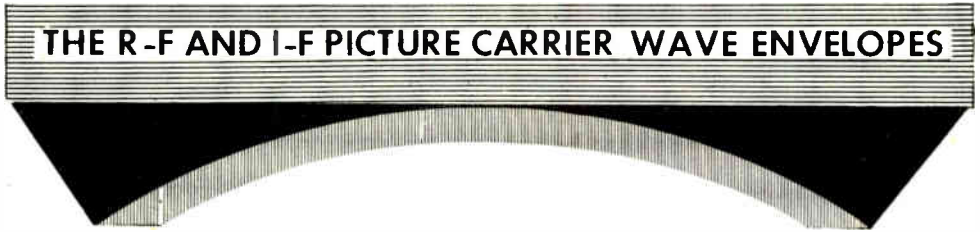

ARE EXACTLY THE SAME AND CONTAIN IDENTICAL PICTURE INFORMATION

The picture (video) i-f output from the mixer carries the same modulation sidebands as the original received r-f picture carrier, consequently it has the same outline or *envelope*. The only basic way in which the i-f and r-f signals differ is in the lower frequency of the i-f as compared to the received picture carrier. The frequency conversion process in the mixer accounts for this. The sideband frequencies, representative of picture information added to the transmitted picture carrier as modulation, exist unchanged in the picture i-f signal. They do not undergo any frequency conversion. Hence we say that the amplitude-modulation components of the transmitted picture carrier are repeated in the picture i-f.

In (A) the r-f carrier is indicated by the line within the envelope. Although the upper and lower envelopes of the i-f (B) are shaped identically with those of (A), the carrier-signal cycles of the i-f are shown farther apart and fewer in number. This is a symbolization that the i-f frequency is lower. Both illustrations, by the way, are exaggerations; the frequencies are much higher than the illustrations indicate.

INTERMEDIATE FREQUENCIES

The Sound I-F Signal

In the same manner as it produces a picture i-f that is the counterpart of the received modulated picture carrier, the mixer also produces a sound i-f signal that is the counterpart of the received frequency-modulated sound carrier. The sound carrier and i-f signals are alike in all respects except for the numerical value of the center or resting frequency.

The sound i-f is really a newly created carrier that is frequency-modulated exactly as the original sound carrier from the transmitter. Thus, if the loudest sound signal processed at the television studio raises and lowers the sound carrier frequency 25 kc in both directions, the sound i-f appears as signals that are 25 kc higher and lower, respectively, than the sound i-f. For instance, if the radiated sound carrier for channel 2 is 59.75 mc and the loudest sound in the studio raises and lowers this carrier or resting frequency by 25 kc, to 59.775 mc and 59.725 mc, respectively, a sound i-f of 21.25 mc would be frequency modulated to 21.275 mc and 21.225 mc.

The symbolization of a frequency-modulated carrier is a series of sine waves non-uniformly distributed along a time axis. Where the cycles are closer together than normal, it indicates an increase in frequency; where the cycles are farther apart than normal, it indicates a decrease in frequency. The so-called normal distribution corresponds to zero modulation or the resting frequency. The fewer cycles per unit length along the time base for zero modulation in the i-f representation, as compared to the r-f representation, indicates that the resting frequency of the i-f signal is lower than the resting frequency of the r-f signal.

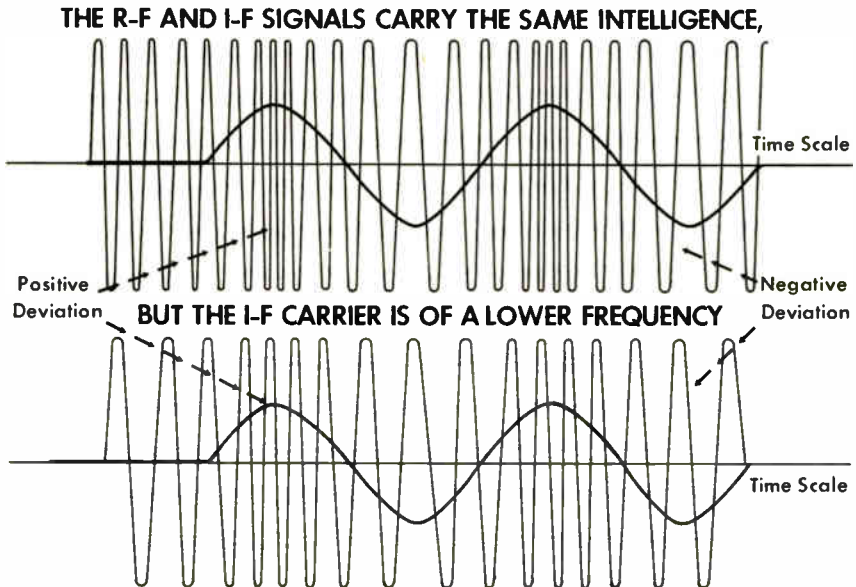

INTERMEDIATE FREQUENCIES

The Frequencies of the Picture and Sound I-F Carriers

Television receivers produced during 1946 and the years following were designed for a picture i-f of 25.75 mc and a sound i-f of 21.25 mc. The past several years of receiver manufacture have witnessed a change in design wherein the picture and sound i-f carrier frequencies were raised to be within the so-called 40-mc range. Specifically, the picture i-f carrier frequency is in the vicinity of 45.75 mc and the sound i-f carrier frequency is in the vicinity of 41.25 mc. Whatever the actual frequencies, the picture and sound i-f frequencies are *always* 4.5 mc apart.

Given any Difference-Frequency I.F.,

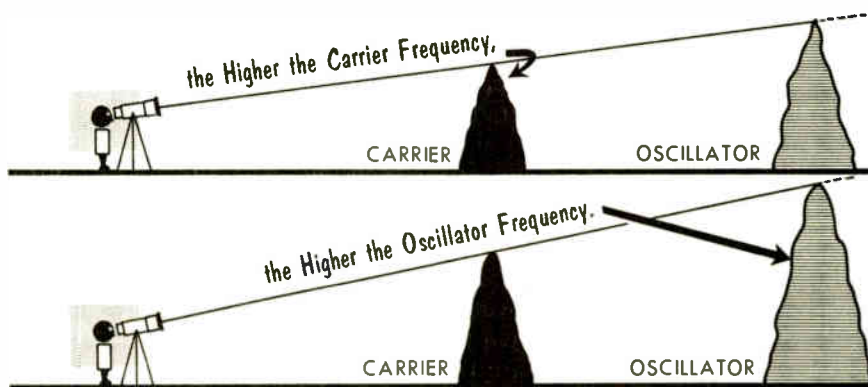

The changeover to the higher intermediate frequencies was made to meet practical needs. The lower i-f's afforded more amplification and greater receiver stability, but the higher i-f's afforded greater freedom from interference such as image frequencies.

Virtually all television receivers function with the local oscillator frequency higher than received picture and sound carriers. For example, let us assume a receiver designed for a 41.25-mc sound i-f and a 45.75-mc picture i-f. Let us assume further that the receiver channel selector is set to channel 7 (174 mc to 180 mc). The picture carrier then is 175.25 mc and the sound carrier frequency is 179.75 mc. To develop a sound i-f of 41.25 mc the local oscillator frequency must be $179.75 + 41.25$ or 221 mc.

By similar reasoning, the 45.75-mc picture i-f carrier is the result of the frequency difference between 221 mc and 175.25 mc, or $221 - 175.25$ mc equals 45.75 mc. For any given difference-frequency i-f, the higher the received carrier the higher must be the local oscillator frequency. Conversely, the lower the received carrier frequency the lower is the local oscillator frequency. The change in frequency of the local oscillator to suit the changes in carrier frequencies is done automatically within the receiver as the station selector is set to the different channels.

INTERMEDIATE FREQUENCIES

The Frequencies of the Picture and Sound I-F (contd.)

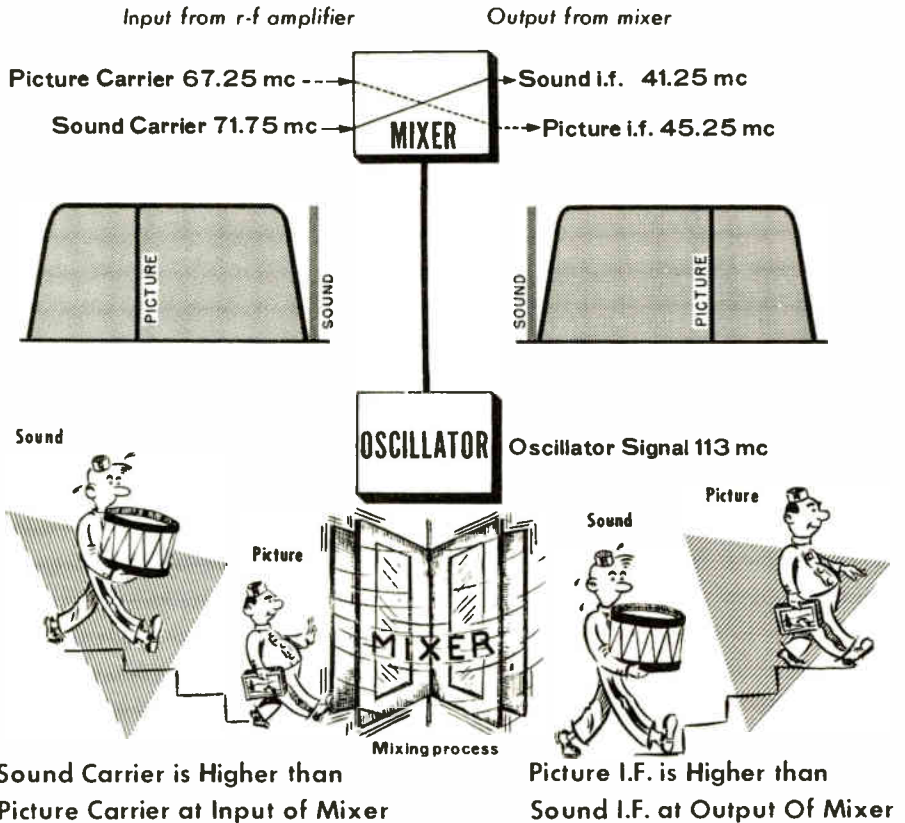

THE TRANSPOSITION OF THE CARRIERS AND I-F'S

The relationship between the radiated picture and sound carriers for every television channel has the sound carrier higher on the frequency scale than the picture carrier. In the case of channel 4, the picture carrier frequency is 67.25 mc whereas the associated sound carrier is 71.75 mc — 4.5 mc higher. This is the frequency relationship when the signal is amplified in the r-f amplifier and when it is fed into the mixer. But after the mixer action the two intermediate-frequency counterparts of the received carriers *change places* frequency-wise. The picture i-f is now 4.5 mc *higher* than the sound i-f. This change in frequency relationship occurs because the oscillator frequency is higher than the two received carriers, hence the difference between the oscillator frequency and the picture carrier ($113 - 67.25 = 45.75$ mc) is greater than between the oscillator frequency and the sound carrier frequency ($113 - 71.75 = 41.25$ mc). All received carriers undergo this transposition of their i-f counterparts.

THE TUNER I-F STAGES

The Front End or Tuner

Having discussed the general functions of the r-f amplifier, mixer, and oscillator, we have in fact examined the organization of the stages that comprise the *front end* of the television receiver. Hence, we can add these stages to the original r-f amplifier block. (The arrows show direction of signal flow.)

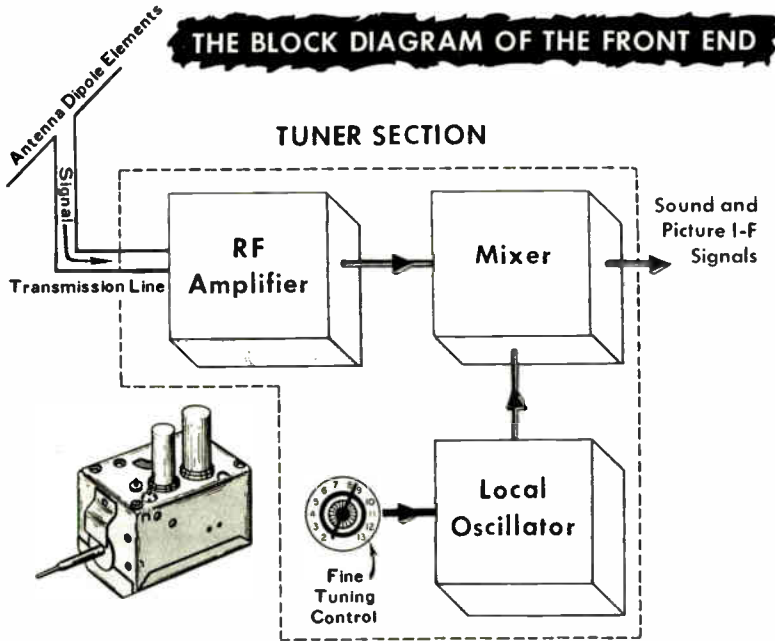

In most current television receivers, the front end is an individual entity. The r-f amplifier, mixer, and oscillator make up a separate group on the main chassis. The front end subchassis is mounted on the chassis slightly apart from the rest of the receiver. The whole section is known as the *receiver front end* or *tuner*. Contained in the tuner are the resonant circuits (coils, capacitors, and resistors) for each of the channels and the means for selecting the circuitry for each channel. The apparent use of two tubes in the illustration of the tuner and the three blocks in the front-end block diagram is not a contradiction; most tuners use a dual-section tube in a single envelope to perform the mixer and oscillator functions. As is shown later in this course, some tuners make use of two stages for the r-f amplifier, and two stages for the mixer-oscillator. Even then, only two tube envelopes are in evidence, because each pair of tube functions is performed by dual tubes in a single envelope.

The tuner shown here is just one example of many physical forms that are to be found in television receivers. It was selected because it typifies the most frequently used variety.

THE TUNER I-F STAGES

I-F Amplifiers in Television Receivers

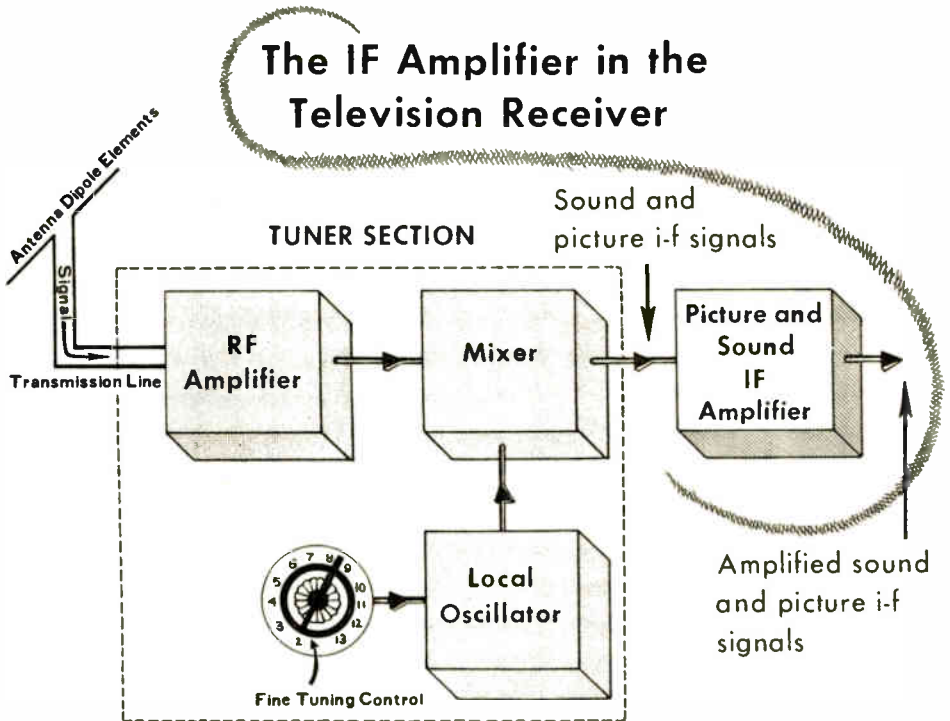

The intermediate-frequency signals derived from the mixer are too weak to be of much use and must be amplified. As has been shown, television receivers differ from conventional radio receivers in that two different i-f signals are delivered by the mixer. Both of them—the picture i-f and the sound i-f signal—are amplified simultaneously in a multistage i-f amplifier. The amplifier circuits tune broadly so as to accommodate the 4.5-mc separation between the picture and sound i-f's and in so doing, the circuits accept the modulation components of both i-f signals. The single i-f amplifier block can represent from 2 to 4 stages of i-f signal amplification.

The picture i-f carrier is amplitude-modulated by the picture information as well as by the control and synchronizing voltages, whereas the sound i-f carrier is frequency-modulated by the accompanying sound. Because the two signals differ in character, they are subject to different forms of processing in the receiver to produce the visible picture on the picture tube screen and the audible sound from the speaker. Unlike the r-f amplifier where the aim is to amplify each frequency component of a signal by a like amount, the dual-signal i-f amplifier is adjusted to *limit* amplification of the lower video modulation frequencies.

THE TUNER I-F STAGES

I-F Amplifiers in Television Receivers (contd.)

As an amplifier of the picture and sound intermediate frequencies, the i-f amplifier system has the additional task of providing more gain for some picture i-f sidebands than for others. In this process an "i-f response curve" is formed that is extremely important in determining the operation and alignment of the television receiver.

To provide equal amplification for the picture i-f and its modulation sidebands, the i-f response curve is shaped so that it slopes downward from maximum amplification 0.75 mc below the picture i-f, shown as zero frequency. At the picture i-f the gain of the i-f amplifier has fallen to approximately 50% of maximum value. From zero frequency the gain continues to fall, effectively reaching zero at 0.75 mc above the picture carrier. Thus, when the responses to the lower sideband -0.75 mc to 0, and the upper sideband 0 to $+0.75$ mc are combined, the lower i-f sideband from 0 to beyond 4 mc is of equal amplitude. This assures equal quality of the low-frequency background and the high-frequency detail.

Another form of frequency correction occurs over the range of the sound i-f band. The amount of amplification provided the f-m sound i-f is only about 10% of the maximum amplitude of the picture i-f. This is done to facilitate the separation between the picture and sound i-f's later in the receiver.

The Response of the picture -sound amplifier is different for picture and sound signals

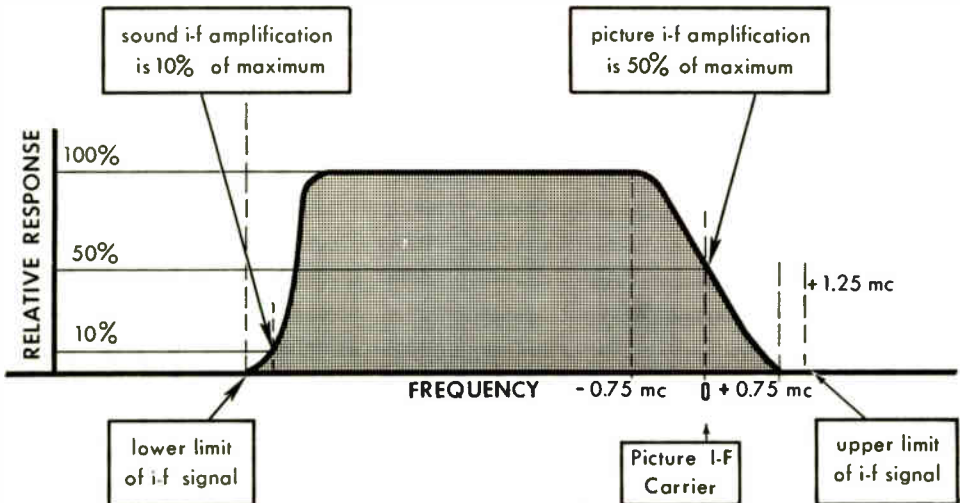

THE VIDEO DETECTOR

The Video Detector

Assuming that the picture and sound i-f signals have been amplified to a usable level (the level required by the video detector) in the picture-sound i-f amplifier, the next step in the evolution of the receiving chain is the addition of the video detector.

The video detector in the television receiver performs the same function as the *second detector* in the conventional superheterodyne radio receiver. It extracts the *intelligence* from the modulated i-f carrier. (This is known as *demodulation* or *detection*. The detector may be a vacuum tube or a crystal diode.)

In the television receiver the video intelligence is the picture information voltage, the blanking pulse voltage, and the synchronizing pulse voltage. As will be explained later, the picture and blanking voltages follow one path to the picture tube, while the synchronizing voltages are channeled to another path where they contribute to achieving synchronization (coincidence) between the motion of the picture-tube electron beam on the picture-tube screen with the movement of the electron beam in the camera tube as it scans the camera tube mosaic at the studio.

The video detector performs still another function in current television receivers. Although explained in detail later in this course, we should mention here that the video detector also behaves as a *mixer*, mixing the two modulated i-f carriers that are fed into it from the picture-sound i-f amplifier. Among the numerous signals resulting from the mixing process is one whose frequency is the difference between the picture i-f and the sound i-f frequencies. Hence, the mixing process in the video detector produces an output signal of 4.5 mc that contains primarily the frequency-modulation characteristics of the sound i-f signal.

ADDING THE VIDEO DETECTOR TO THE INTERCARRIER RECEIVER

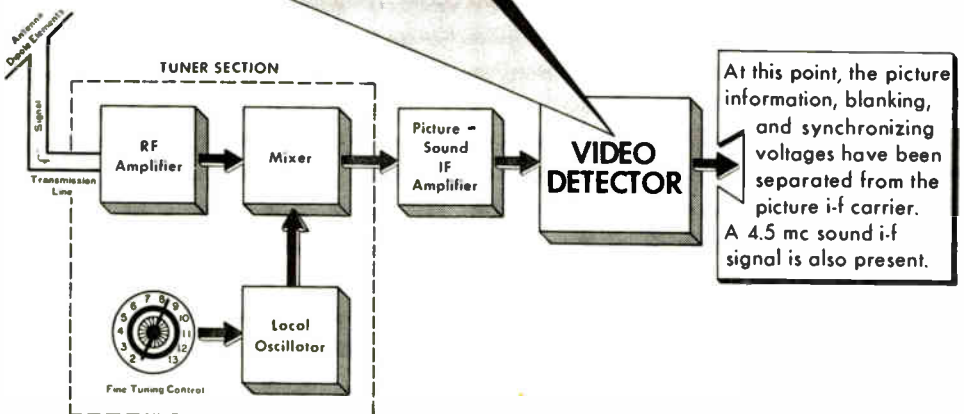

THE VIDEO DETECTOR

The Video Detector as a Picture I-F Signal Demodulator

In the action of demodulation, the video detector translates the instantaneous variations in the peak amplitudes of the picture i-f into a unidirectional voltage of either positive or negative polarity, depending on the kind of circuit used in the detector. In the process of demodulation either the negative or the positive alternations of the input signal are removed. Such behavior is, to all intents and purposes, rectification of the modulated picture i-f signal. Since the sound i-f signal is also present at the input of the video detector, it too is rectified because the video detector cannot distinguish between sound and picture i-f signals.

Assuming one type of video detector, the rectifying action removes the negative alternations of the input signal, whereas the positive alternations cause a composite video output voltage, which although changing in value, remains positive relative to a zero-voltage reference line. This voltage contains all the frequency components originally superimposed on the picture carrier at the transmitter during the process of modulation. These components are the picture information, the blanking pulses and the synchronizing pulses.

A composite video voltage with blanking pulses pointing upwards has been identified as a *positive-going, positive-polarity, or negative-phase* voltage. If this kind of signal voltage is fed to the control grid of the receiver picture tube, the picture will have the appearance of a photographic negative—the light and dark areas will be reversed. This happens because the more positive the instantaneous voltage applied to the control grid of the picture tube, the denser the electron beam and the brighter the spot that it makes on the picture tube screen. To enable such a signal voltage to produce a normal picture on a picture tube screen, it must be applied to the *cathode* of the picture tube.

ONE WAY IN WHICH THE VIDEO DETECTOR WORKS

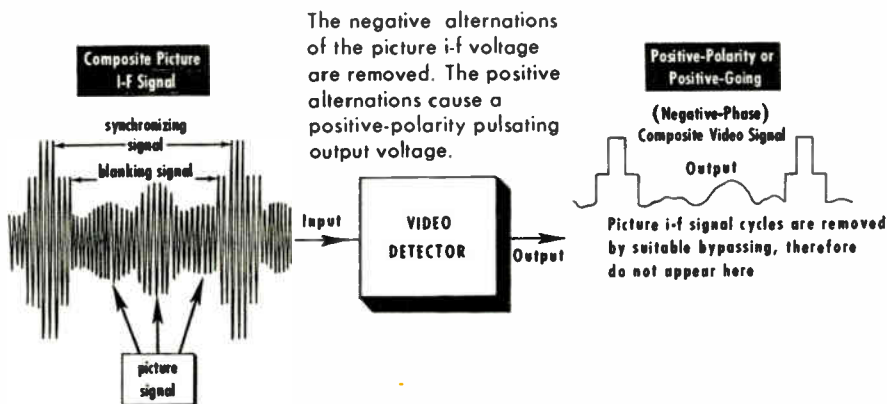

THE VIDEO DETECTOR

The Video Detector as a Picture I-F Signal Demodulator (contd.)



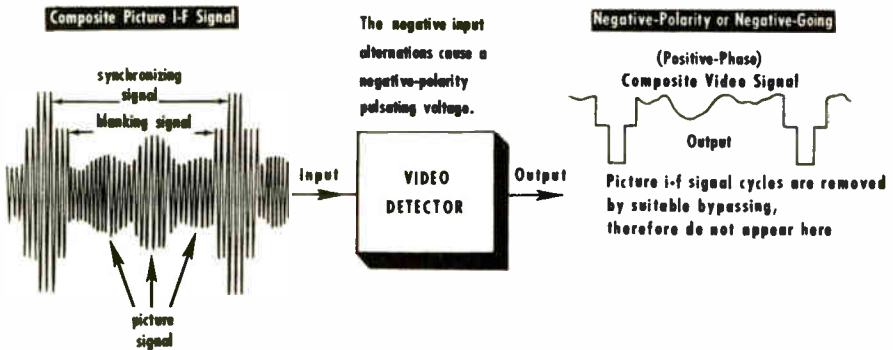

ANOTHER WAY IN WHICH THE VIDEO DETECTOR CAN WORK



If the connections in the video detector are reversed, the positive alterations of the input picture i-f signal voltage are removed, resulting in an output voltage that is negative relative to zero. It is identified as a *negative-polarity* or *positive-phase* video voltage.

If this voltage is applied to the control grid of the television receiver picture tube a proper kind of image results. But if a positive phase voltage is applied to the cathode of the picture tube, a negative image results—the black and white areas are reversed because the more negative the cathode relative to the control grid, the denser the electron beam and the brighter the resultant spot on the screen.

The designer of the receiver has the option of feeding the composite video voltage to either the control grid or to the cathode of the picture tube. Moreover, the opportunity of changing the phase of the composite video voltage exists in the video amplifier stages that follow the video detector. (These stages will be discussed after the intercarrier principle.)

<u>Polarity of Voltage</u>	<u>Phase of Voltage</u>	<u>Applied To</u>	<u>Kind of Image</u>	
<u>Positive</u>	<u>Negative</u>	<u>Control Grid</u>	<u>Reversed</u>	
<u>Positive</u>	<u>Negative</u>	<u>Cathode</u>	<u>Correct</u>	
<u>Negative</u>	<u>Positive</u>	<u>Control Grid</u>	<u>Correct</u>	
<u>Negative</u>	<u>Positive</u>	<u>Cathode</u>	<u>Reversed</u>	

THE VIDEO DETECTOR

The Intercarrier Principle

All current television receivers, as well as most manufactured since 1949, are identified as *intercarrier sound* (simplified to "intercarrier") receivers. This design differs from the *split-sound* type of receiver which is no longer manufactured, although many are still in use. We shall describe split-sound sets briefly after we have completed the description of the intercarrier type.

The basic idea in the intercarrier receiver design is the generation of a low-frequency (4.5-mc) frequency-modulated sound i-f signal within the video detector stage by mixing the picture and sound i-f signals that are supplied to the video detector from the picture-sound i-f amplifier. If, for example, the picture i-f in the picture-sound amplifier is 45.75 mc and the sound i-f is 41.25 mc, the two signals when mixed in the video detector develop a difference-frequency equal to $45.75 - 41.25$ or 4.5 mc. This signal is the intercarrier sound i-f for eventual translation into audible sound. Although it is the result of mixing an amplitude-modulated signal with a frequency-modulated signal, the 4.5-mc i-f voltage is essentially frequency-modulated. This situation stems from the fact that of the two i-f signals fed from the picture-sound i-f amplifier to the video detector, the frequency-modulated sound i-f signal is by far the weaker, and it is a characteristic of the mixing process that the resultant signal bears a preponderance of the modulation characteristics of the weaker of the two signals that are mixed. You will recall the deliberate shaping of the response curve of the picture-sound i-f amplifier to amplify the sound i-f only about 10% of the amount that most of the frequency components of the picture i-f signal were amplified.

Mixing In The Intercarrier Receiver

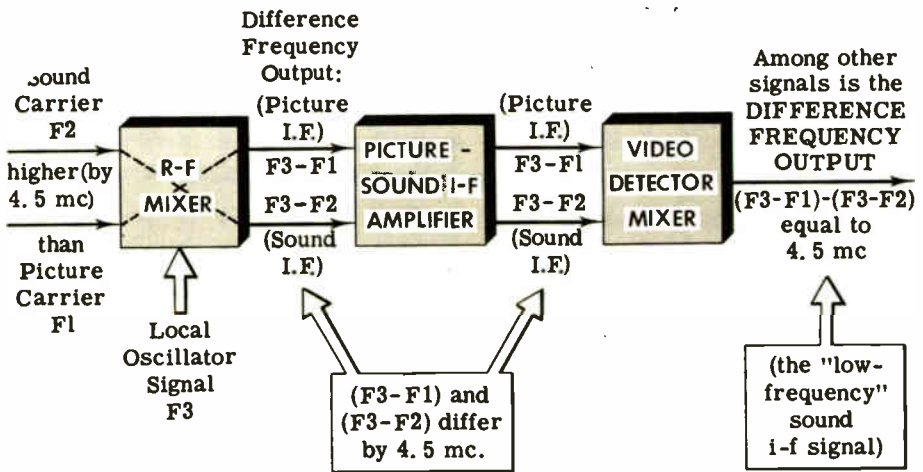

AUTOMATIC GAIN CONTROL

Automatic Gain Control (AGC)

AVC KEEPS THE OUTPUT CONSTANT DESPITE VARIATIONS IN SIGNAL STRENGTH

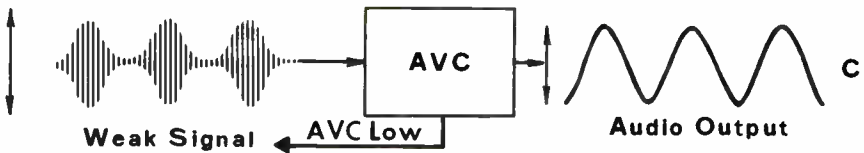
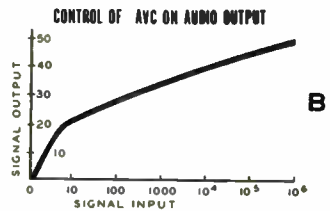
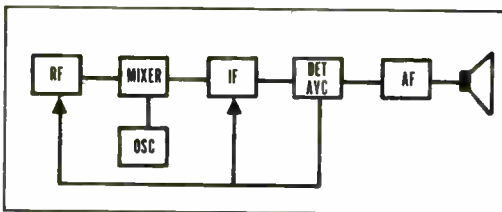
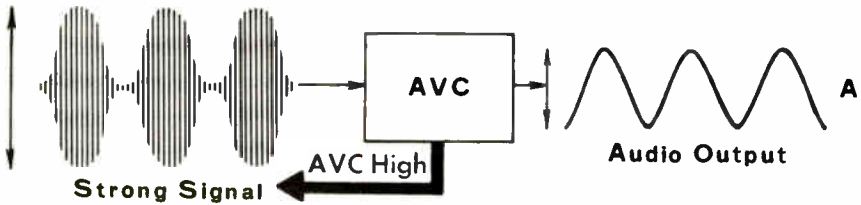

The audio output of the everyday superheterodyne radio receiver is held fairly constant regardless of changes in the strength of the received signal carrier by the use of *avc* (an abbreviation of *automatic volume control*). The *i-f* signal is rectified in the second detector. A portion of the rectified voltage, of negative polarity, is filtered so as to be free of signal fluctuations. It is then applied as a negative d-c control grid bias to the r-f and *i-f* amplifying tubes. The negative bias so developed varies in proportion to the amplitude level of the *i-f* carrier, which is the same as varying in proportion to the received signal carrier. When applied to the controlled amplifying stages, it behaves as an automatically-varying grid bias, increasing and decreasing the amount of amplification available from each stage. As the received signal level increases, the control bias automatically increases, thus reducing the amount of amplifier gain; as the signal level decreases, the amount of control bias decreases, hence the amplification increases. In this way a balance between amplifier gain and signal output from the detector is maintained, resulting in a substantially constant-level audio output.

AUTOMATIC GAIN CONTROL

Automatic Gain Control (contd.)

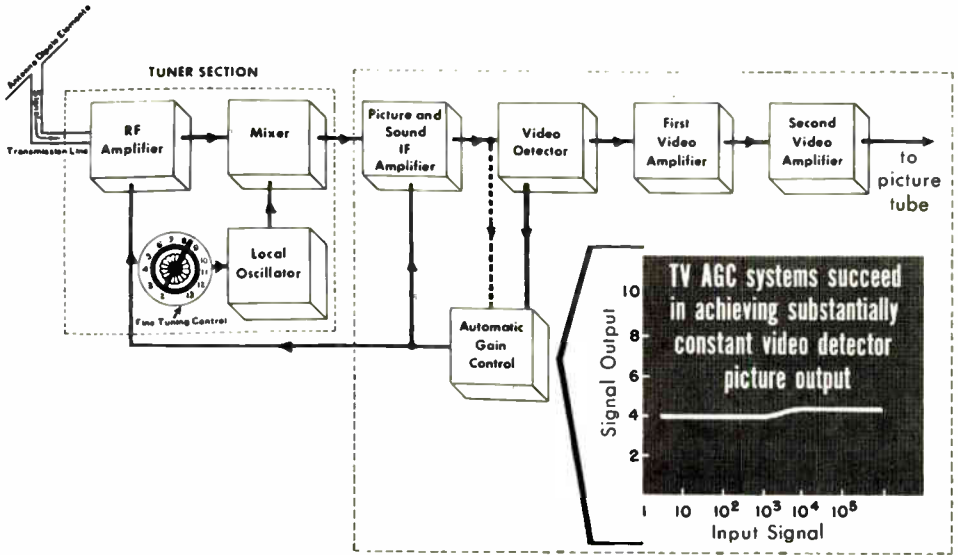

Automatic Gain Control in the Intercarrier Receiver Block Diagram

A similar form of amplification control is used in television receivers except that its purpose is to maintain constant picture signal level at the video detector, regardless of changes in received picture signal strength. Under the circumstances, the signal control system in the television receiver cannot rightfully be called an automatic volume control since it has relatively no effect on the audio output level. Instead it is called agc or automatic *gain* control inasmuch as it automatically varies the gain or the amount of amplification in the r-f and i-f paths of the picture signal.

This control is achieved by applying an automatically varying negative d-c bias voltage (derived by rectification of the picture i-f signal) to the r-f and i-f amplifying tubes. Several different methods of securing this bias voltage are used. Circuit details are given later in this course during the discussion of component organization and function. In the meantime, a simple arrangement is shown above. The automatic gain control block is a single tube acting as a rectifier of the picture i-f signal derived from the picture-sound i-f amplifier. The remainder of the picture i-f signal is fed to the video detector for regular processing.

In basic principle, the agc system in a television receiver is similar to avc systems in radio receivers—it provides a constant-amplitude signal.

THE VIDEO AMPLIFIER

The Intercarrier Video Amplifier

The composite video voltage output of the video detector is not high enough to drive the picture tube directly. It is necessary to use one or two stages of video amplification between the video detector and the picture tube element that receives the composite video signal. In addition to amplifying the video voltage, the blanking voltage and the synchronizing voltage (although the latter serves no function when applied to the picture tube), the video amplifier sometimes amplifies the 4.5-mc frequency-modulated sound i-f signal. Amplification of this signal in the video amplifier affords economies in the number of tubes required in the system that eventually processes the 4.5-mc intercarrier sound signal into audible sound. We shall deal with the sound system separately later; but for the moment let it be said that somewhere along the video amplifier chain the "takeoff" point for the 4.5-mc sound i-f signal is located.

The composite video signal represents a wide band of frequencies substantially everything that makes up the picture carrier sidebands. Certainly the frequencies that correspond to the picture information taken off the camera tube mosaic are vital to the reproduction of the detail in the picture. There are others, as will be discussed later, but dealing with these alone is sufficient to indicate that the video amplifier must pass a certain band of frequencies. If the take-off point for the 4.5-mc sound i-f signal is between the first and second video amplifier stages, the frequency response of the amplifier is from about zero to 4.5 mc up to the sound i-f takeoff point. After that it is limited to around 3.5 mc in order to keep the 4.5 mc sound signal out of the picture tube cathode or control grid circuits. If it reaches these circuits, broad horizontal stripes called *sound bars* appear in the picture.

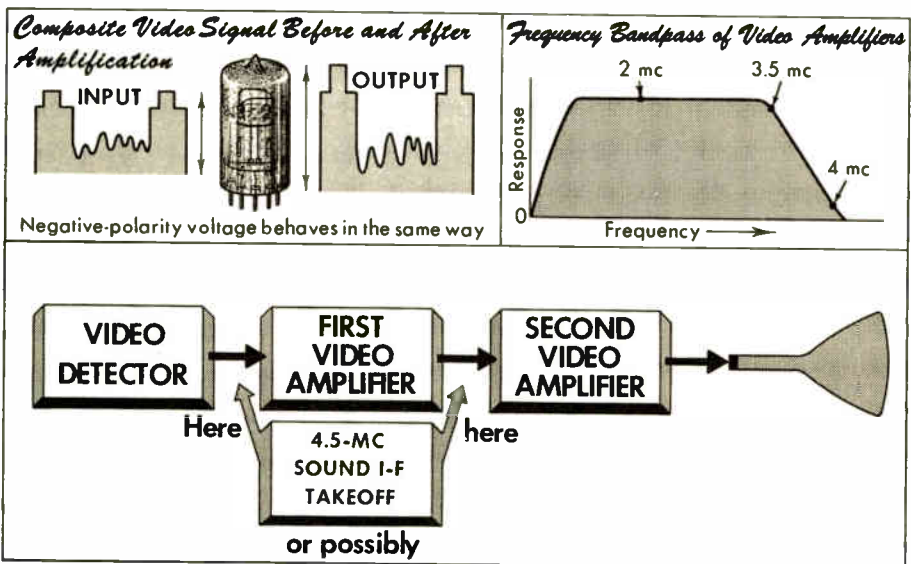

THE VIDEO AMPLIFIER

The Video Amplifier (contd.)

Related to the amplifying function of the video amplifier is the phase of the composite video signal required at the picture tube. The video detector can be arranged to provide a negative phase or a positive phase output signal, whichever may be required. But as was said earlier, the video detector output is too weak to drive the picture tube directly. The video amplifier is therefore responsible not only for raising the level of the video signal, but also for delivering the video voltage in correct phase to the cathode or control grid of the picture tube. These requirements determine whether one or two stages of video amplification are used. In this regard the important point to remember is that a single stage of video amplification inverts the phase of the video signal between input and output.

If a negative phase (positive polarity) signal is delivered by the video detector, the one stage of video amplification will furnish a positive-phase (negative polarity) voltage to the picture tube. If the voltage input to the amplifier is of a negative phase, the output will be of positive phase.

A SINGLE STAGE OF AMPLIFICATION INVERTS THE PHASE

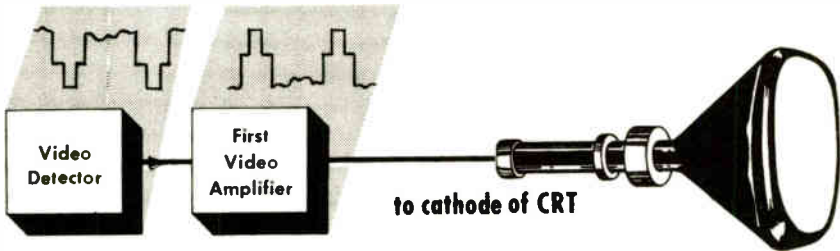

If a two-stage video amplifier is used, the phase of the output voltage is the same as the phase of the input voltage. An amplifier with an even number of stages repeats the phase of the input signal at its output. Each of the amplifying stages inverts the phase in that stage, but the occurrence of two consecutive inversions results in the same phase at the input and output.

TWO STAGES OF AMPLIFICATION REPEAT INPUT PHASE

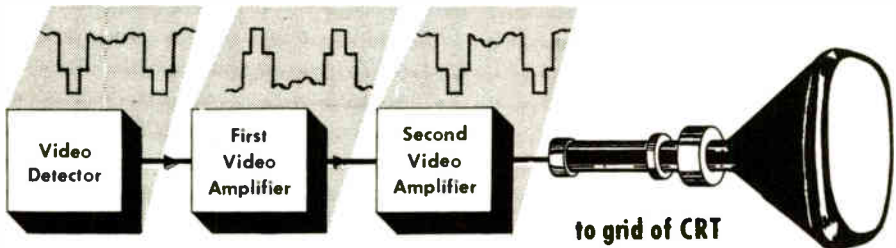

THE SOUND CHANNEL

The FM Sound Channel

The f-m sound channel in the intercarrier television receiver is organized very much like a portion of the everyday f-m radio receiver—the section between the last i-f stage and the loudspeaker. It consists of one or possibly two stages of i-f amplification at a 4.5-mc center frequency; possibly a single limiter stage; an f-m discriminator or ratio detector (whichever is used to translate the changes in signal frequency into audio voltages); one or more stages of audio amplification; and the loudspeaker.

THE BLOCK DIAGRAM OF THE SOUND AND VIDEO SYSTEM IN THE INTERCARRIER RECEIVER

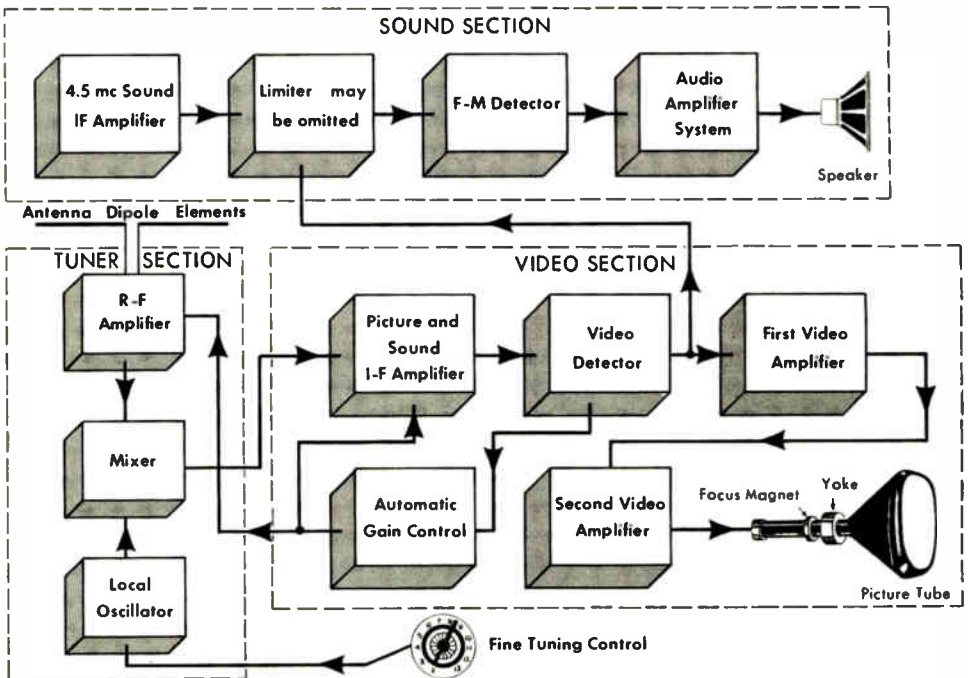

In the television receiver system shown here, the intercarrier f-m sound signal developed in the video detector is passed through one stage of amplification in the video amplifier and then fed to the 4.5-mc intercarrier sound amplifier in the sound channel. In this case a single stage of amplification (in the sound channel) is sufficient because the stage of video amplification aids in building the signal strength to the level required. (In some television receivers the 4.5-mc sound signal takeoff point is immediately after the video detector, as indicated by the dashed line; sometimes it comes directly from the video detector, in which case two stages of 4.5-mc amplification may be used in the sound channel.)

THE SOUND CHANNEL

The Limiter

THE LIMITER IS AN ELECTRONIC GRINDER THAT REMOVES HEIGHT VARIATIONS IN A VOLTAGE WAVE

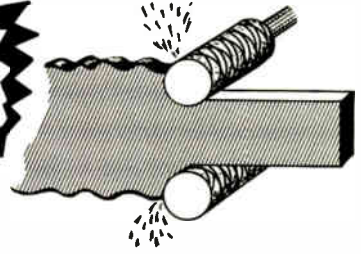

input voltage with noise pulses and varying amplitude

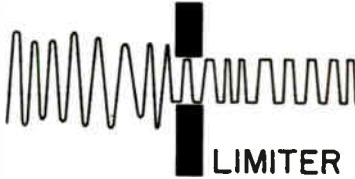

output voltage with noise peaks removed and constant amplitude

LIMITER STAGE

The limiter block following the 4.5-mc amplifier is sometimes omitted from the sound channel when the limiting action is effectively performed by the f-m detector. The action of limiting is really clipping the positive and negative peaks of the f-m sound signal. The normal f-m signal is of constant amplitude, but it is possible that noise signal voltages originating at a variety of sources may find their way into the f-m circuits and will ride on the f-m carrier, thus amplitude-modulating it. The limiter stage removes these noise voltages by limiting the peak amplitude changes of the f-m carrier. Inasmuch as the audio modulation appears as changes in carrier frequency and not as changes in carrier amplitude, reduction of the peak-to-peak amplitude of the carrier does not impair the effectiveness of the frequency-modulated signal.

The F-M Discriminator

The next block in the sound channel chain is the f-m discriminator or f-m detector. Both are translators of variations in frequency into audio voltages.

The audio amplifier follows the detector in the sound channel. Its function is to raise the audio voltage to a usable level. Although we show only a single stage of audio amplification in our typical sound channel, some receivers use two or more stages.

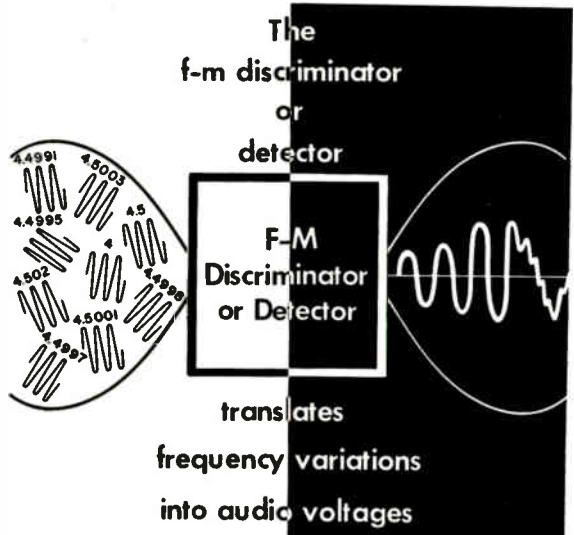

CONTRAST CONTROL

THE BRIGHTNESS CONTROL IN THE RECEIVER BLOCK DIAGRAM

D-C RESTORER

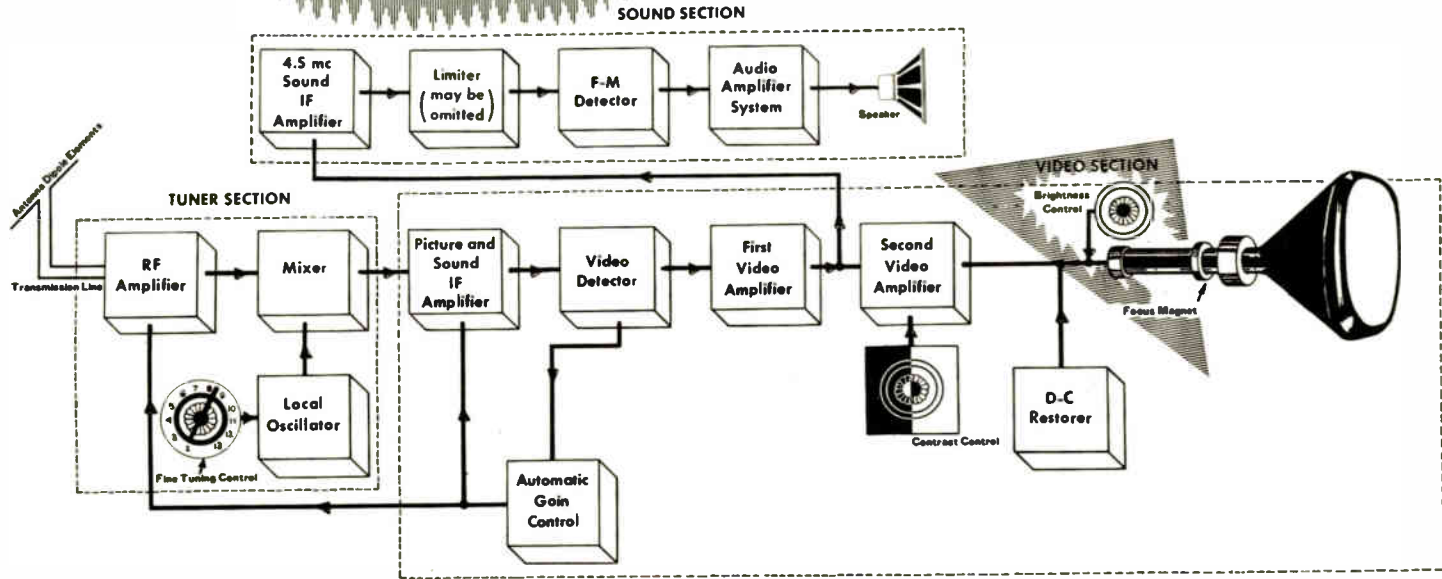

Two variable receiver panel controls and one block complete the picture-information processing channel: the CONTRAST control, the BRIGHTNESS control, and the D-C RESTORER. The d-c restorer is still to be found in many television receivers. although more recent designs have eliminated the need for d-c restoration. The contrast and brightness controls are standard in all television receivers.

ACHIEVING PICTURE CONTRAST

Contrast, Brightness, and D-C Restoration

When the black areas of a reproduced image have the proper blackness and the white areas are really white, it is said the *contrast* is good. The contrast control function in modern receivers is one of amplification control in the video amplifier. Contrast depends on the amplitude of the video or picture-information signal; that is, the difference in video voltage corresponding to black and white. The greater the amplitude of the signal, the greater is the change in voltage between that corresponding to white and that corresponding to black. Early-design television receivers located the contrast control in the circuits that were processing the picture i-f signal. Later designs changed the location to the video amplifier. The actual circuitry of the contrast control is shown and explained later as a part of the circuit discussions.

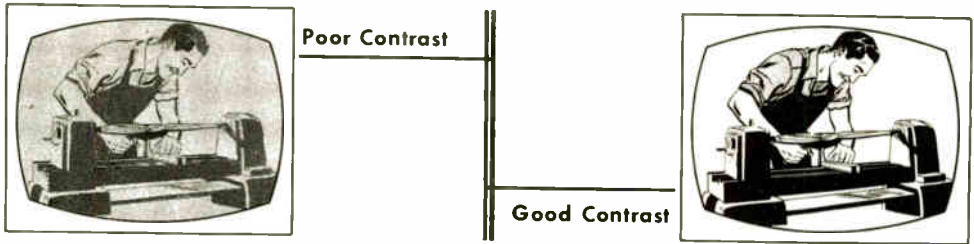

The brightness control is related to contrast control although the two are located in different parts of the video amplifier chain. Every scene that is televised has an average brightness. It is with respect to this average brightness that some parts of the scene are black and others are white with shades of gray in between. If a scene does not have the correct amount of brightness, it appears dark and detail is lost; if the brightness is excessive the image appears washed out and the parts that are supposed to be black take on a grayish appearance. How brightness is controlled is explained later in the course. For the present we can say that the brightness control determines an average voltage level around which the picture voltage varies (in one direction to produce black and in the other direction to produce white in the image.) Adjustment of the contrast and brightness controls is required to produce the most pleasing image on the picture tube screen.

D-C restoration was necessary in the early-design television receivers because the capacitive coupling used between the video detector and the picture tube removed the d-c component of the picture information signal. In the absence of d-c in the video signal fed to the picture tube, control of the brightness of the reproduced image was impossible.

The d-c restorer stage served to put a d-c component back into the video signal. Where used, the d-c restorer is a rectifier that removes a portion of the video signal derived from the video amplifier and inserts it into the picture tube circuit.

REVIEW

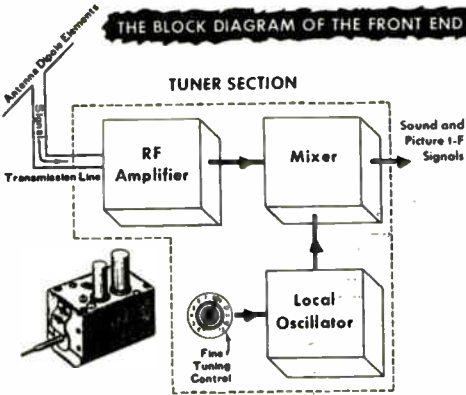

2. *The I-F Amplifier* is used to amplify the weak picture and sound i-f signals from the tuner, thus bringing them up to a usable level for processing in the video detector.

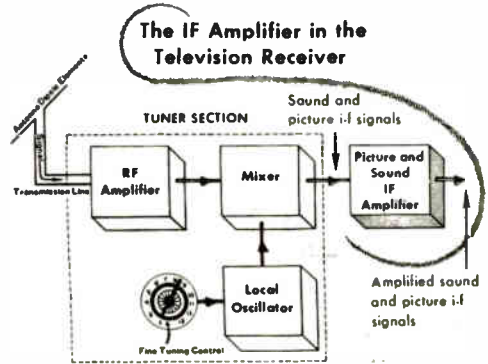

ONE WAY IN WHICH THE VIDEO DETECTOR WORKS

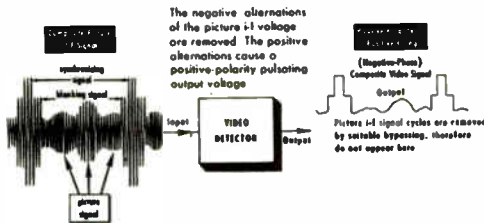

4. *The Intercarrier Principle* is the generation of a low-frequency (4.5-mc) f-m sound signal within the video detector stage, by mixing the picture and sound i-f signals, which have been amplified in the i-f amplifier. 4.5 mc is the difference-frequency equal to the picture i-f carrier minus the sound i-f carrier frequencies.

3. *The Video Detector* extracts the intelligence from (demodulates) the picture i-f signal, thus providing a composite video signal for the video amplifier system. It also functions as a mixer to produce a 4.5-mc sound signal, eventually to be amplified and demodulated in the intercarrier sound stages.

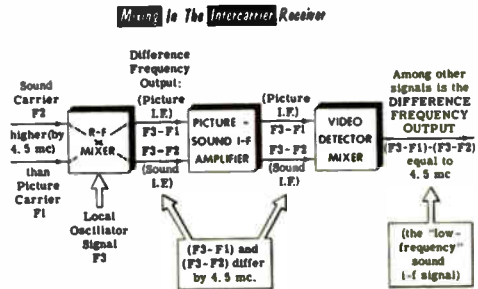

REVIEW

5. *The Automatic Gain Control (AGC) system* maintains a substantially constant video detector picture output by applying an automatically varying negative d-c bias voltage to the r-f and some i-f amplifying tubes. In basic principle, the agc system in a TV receiver is similar to avc systems in radio receivers—it provides a constant-amplitude signal.

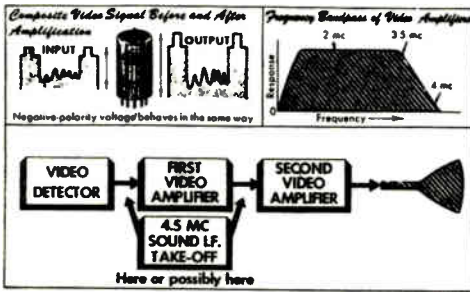

6. *The Video Amplifier* builds up the weak composite video signal from the video detector to a level usable by the picture tube. It is sometimes used to amplify the 4.5-mc sound i-f signal as well.

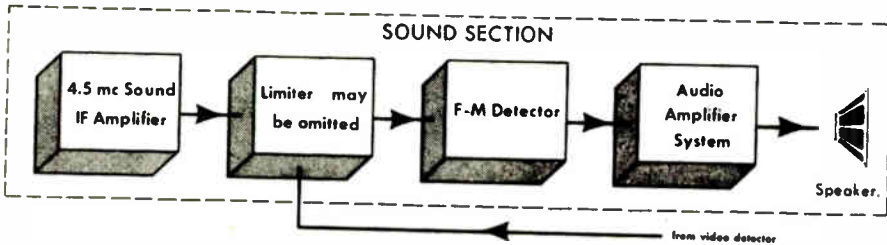

7. *The F-M Sound Channel*, consisting of an i-f amplifier, a limiter (possibly), and an f-m demodulator, amplifies the 4.5-mc f-m sound signal in the i-f amplifier. The limiter removes the noise voltages by limiting the peak amplitude changes of the f-m carrier. The discriminator translates the frequency variations into audio voltages, to be amplified in the audio system.

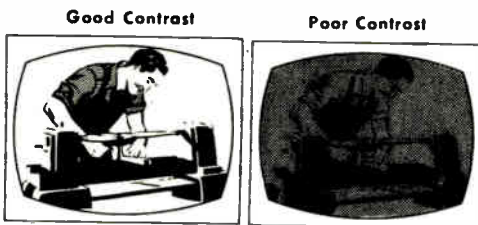

8. *The Contrast and Brightness Controls* are used to produce the most pleasing image on the picture tube screen. The contrast control varies the amplitude of the video signal. The brightness control varies the average illumination level of the screen.

THE SYNCHRONIZING CIRCUITS

The Synchronizing System

End view of the yoke coils.



Downward
Tilt and Spacing
Controlled by
Vertical Sweep Action

They look like this on the CRT

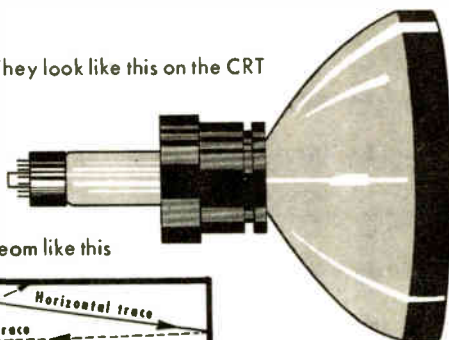

and sweep the beam like this

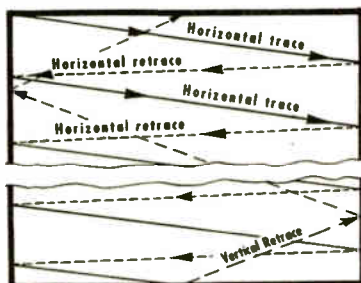

Let us examine what we have discussed so far. The sound and picture processing channels up to the picture tube are complete, and the composite video signal is being fed to the picture tube. However if the beam is to "draw" the picture on the screen, it must sweep both horizontally and vertically across the picture tube screen.

The component responsible for sweeping the electron beam is the deflecting *yoke*, consisting of horizontal and vertical deflecting coils. The yoke fits over the neck of the picture tube, usually as far forward as the flare of the tube permits. Vertical and horizontal deflection current is fed to the yoke, with the vertical-deflecting-coil current causing the electron beam to sweep from the top of the screen to the bottom, and return to the top, 60 times per second. The downward sweep is relatively slow, while the return or *retrace* is considerably faster.

The horizontal-deflecting-coil current causes the electron beam to sweep across the screen from left to right, and return to the left, 15,750 times per second. As with the vertical sweep, the trace is relatively slow, while the right-to-left retrace is considerably faster.

The sweep currents in the horizontal and vertical deflecting coils are produced by special circuits in the receiver called the horizontal and vertical sweep systems. Each system contains an oscillator circuit, the vertical oscillator operating at 60 cycles and the horizontal oscillator operating at the much higher frequency of 15,750 cycles (15.75 kc). In addition, each system contains a power output tube that provides the power necessary for driving the deflecting coils.

THE SYNCHRONIZING CIRCUITS

Synchronization

It is essential that the Transmitter's Camera Tube Scanning Beam

and the Receiver's

Picture Tube

Scanning Beam

move precisely in step



We learned that the scanning beam in the picture tube must move precisely in step with the scanning beam in the camera tube. The sweep oscillators in the receiver develop sweep voltages that can move the receiver picture-tube electron beam at *approximately* the correct rate in each direction. But *approximately* is not good enough! The beams in the receiver picture tube and in the transmitter camera tube must move *exactly* in step. To achieve this, the picture tube beam movement is placed under the control of the transmitting scanning system. The control is maintained by triggering or synchronizing pulses which are received from the transmitter. One is the *horizontal synchronizing* or *sync pulse*; the other is the *vertical sync pulse*. There are also *equalizing pulses*. They are all part of the modulation that is superimposed on the picture carrier at the transmitter and they appear in the signal output of the video detector.

The horizontal sync pulses time the operation of the horizontal sweep oscillator, and keep it on frequency (15,750 cycles). The vertical sync pulses time the operation of the vertical sweep oscillator and keep it on frequency

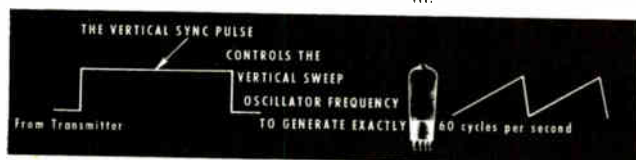
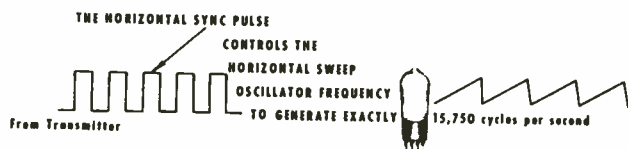

(60 cycles). Most ordinary lighting circuits in the home furnish a 60-cycle voltage, but this frequency may vary, hence it cannot be used as the vertical sweep voltage or for timing purposes, where a high degree of accuracy is required.

THE SYNCHRONIZING CIRCUITS

Synchronizing Pulse Separation

We have established that the synchronizing pulses which control the horizontal and vertical oscillators are part of the modulation that makes up the composite video signal sent to the receiver. These pulses ride on top of blanking pulses. If they are to control the horizontal and vertical sweep oscillators in the receiver, the sync pulses and the blanking pulses as well as the picture information voltages must be separated.

The separation mentioned above is done in the first of the stages which make up the *sync section* of the *beam positioning* portion of the receiver. Different names have been assigned to this stage, as for example *pulse clipper*, *pulse separator*, *sync clipper* and *sync separator*. We shall use the last name mentioned.

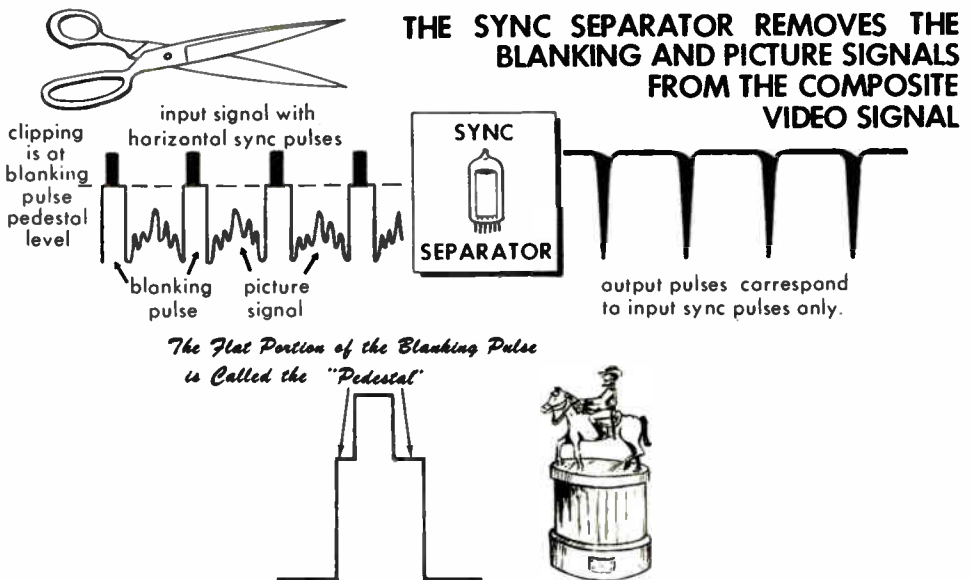

The composite video voltage is derived from the video amplifier after amplification. It is fed into an amplifier which is biased so that only the sync pulses cause plate current to flow. Input signal voltages up to the level of the blanking voltage pedestal have no effect on the plate current. The result is a series of output pulses which correspond to the sync pulses in the input composite video signal. Whatever may be the shape or sequence of the sync pulses that ride on the blanking voltage pedestal, the sync separator output will contain replicas of these pulses. It will be seen later that although three different kinds of pulses—horizontal, vertical, and equalizing—make up the synchronizing group, and they have different shapes relative to their time of duration and the time interval between, all have a time relationship to the horizontal sync pulses.

THE SYNCHRONIZING CIRCUITS

Adding The Sync Separator and Sync Amplifier

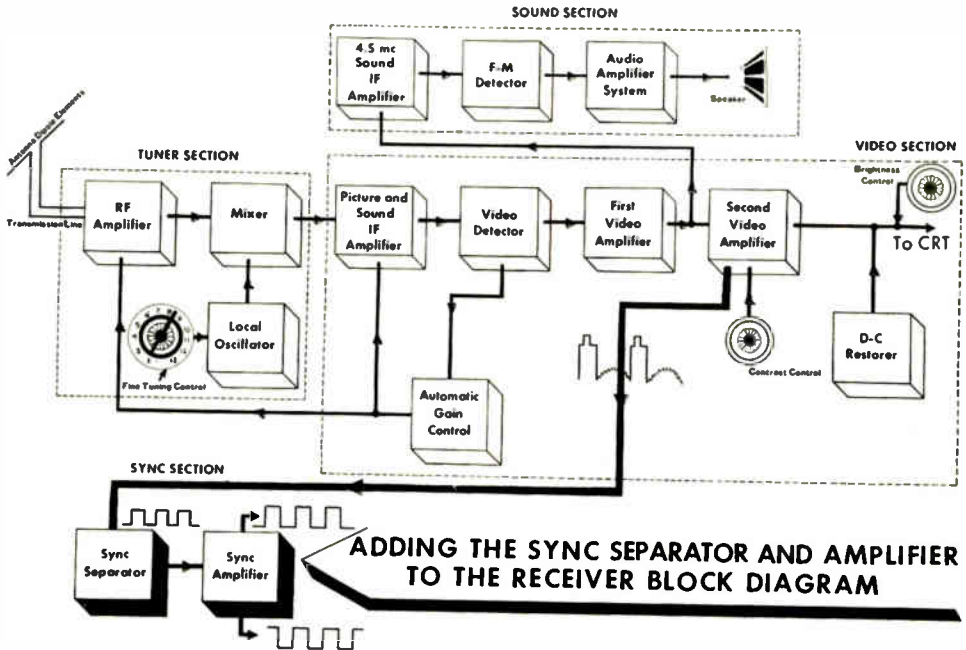

The output pulses available from the sync separator are fed into another amplifier stage (*the sync amplifier*), which performs several functions. It is an amplifier with two output circuits, each of which affords the same signal—amplified versions of the train of pulses fed into it. The reason for the two outputs is to furnish synchronizing signals to two channels, the vertical oscillator path and the horizontal oscillator path. It is very important to bear in mind that there is no distinction between the synchronizing pulses at the output of the sync amplifier. The vertical oscillator path and the horizontal oscillator path receive the same train of pulses from the sync amplifier. Because of the manner in which the two outputs are derived in the sync amplifier, they differ in phase by 180° . That is, one is inverted in polarity relative to the other. Because of this action this stage is often called a *phase splitter*.

The separation of horizontal sync pulses from the vertical and equalizing sync pulses takes place in the two sweep oscillator paths. Here, circuitry made up of resistors and capacitors distinguishes between the higher-frequency (15.750-kc) short-duration horizontal sync pulses and the longer-duration lower-frequency (60-cycle) vertical sync pulses, accepting one and rejecting the other. This makes available only vertical sync pulses to the vertical oscillator and only horizontal sync pulses to the horizontal oscillator.

THE VERTICAL SWEEP CIRCUITS

The Vertical Sweep Circuit

The pulses fed into the vertical oscillator channel from the sync amplifier become vertical sync pulses as the result of the action of the "integrator," a resistor-capacitor combination that lies in the path of the pulses. It is part of the vertical sweep oscillator assembly, although we show it separately for clarity. The "how" of this action is explained later. For the present, suffice it to say that a series of pulses of approximately 15 microseconds duration and occurring 60 times per second issues from the integrator and is applied to the vertical sweep oscillator.

The vertical oscillator frequency must not only be precisely that used at the transmitter for vertical deflection (60 cycles), but also must change in direction and value, instant by instant, in exact synchronization with the vertical sweep voltage active on the camera tube beam. To accomplish the vertical sweep at the constant rate, the waveform of the voltage is like a "sawtooth," in which the long-duration portion (15,500 microseconds) accounts for the downward sweep of the beam from the top of the picture screen to the bottom, and the relatively short duration portion (1,167 microseconds) accounts for the rapid return or *retrace* of the beam from the bottom of the screen to the top. (The full cycle of vertical sweep voltage consumes 16,667 microseconds.) The vertical sync voltage triggers the retrace. It is a recurring reminder to the oscillator to stay on frequency and thereby gives correct vertical positioning of the beam.

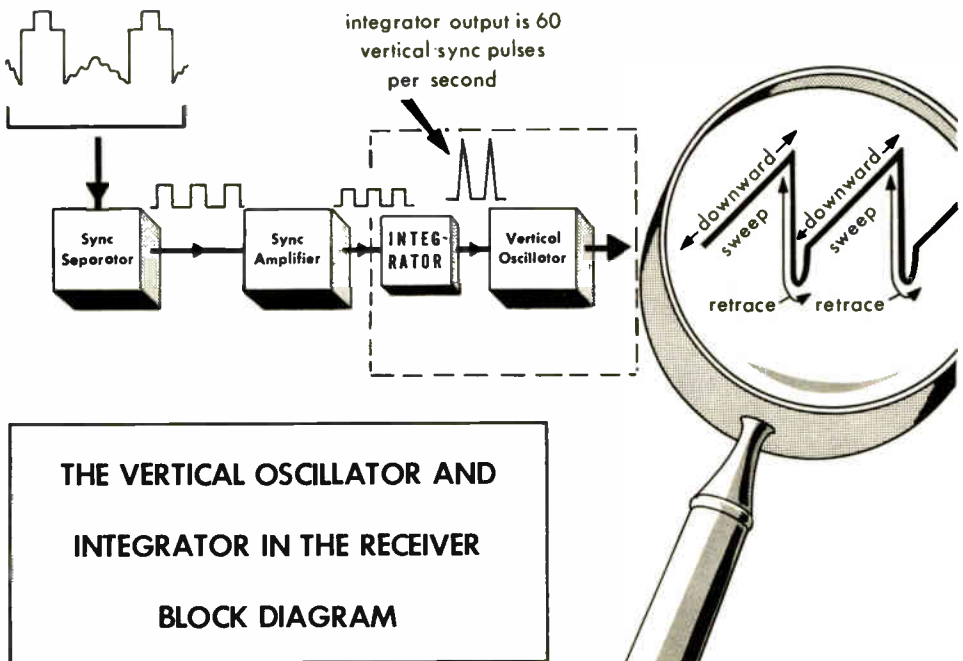

THE VERTICAL SWEEP CIRCUITS

The Vertical Hold and Height Controls

If you have a television receiver at home, you have no doubt experienced pictures that slip upward or downward. The fact that the picture is moving up or down indicates that the vertical oscillator is out of synchronization with the vertical oscillator supplying the vertical sweep signal to the camera tube in the television studio. Most television manufacturers provide an adjustment known as the *vertical hold control* by which the vertical oscillator frequency can be varied until the picture becomes stationary—that is, until it is vertically synced. In some receivers, this control is mounted at the rear of the set, in others it is a front-panel control.

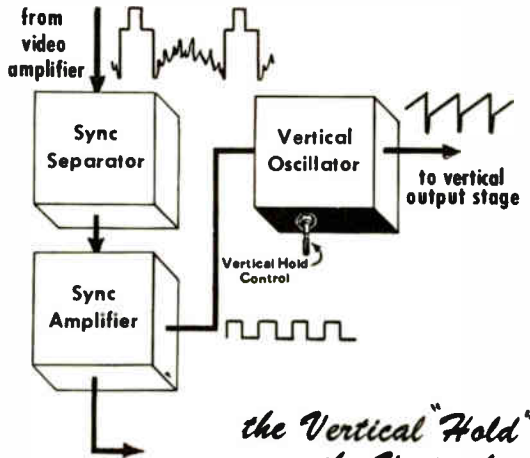

*the Vertical "Hold"
in the Vertical
Oscillator Block*

Every receiver is provided with an adjustment whereby the height of the picture can be changed. It is called the height or *vertical size control*. This adjustment varies the *amplitude* of the voltage output from the vertical oscillator—thus the amount of vertical deflection current in the vertical deflecting coil. Increasing the output increases the height of the picture; decreasing the output reduces the height of the picture.

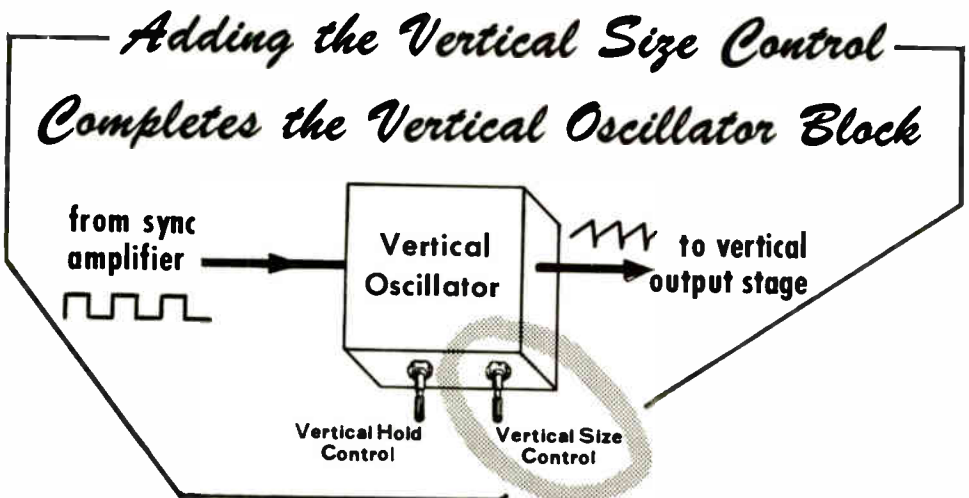

THE VERTICAL SWEEP CIRCUITS

The Vertical Output Stage and Vertical Linearity Control

The output from the vertical oscillator is insufficient to drive the vertical deflection (or deflecting) coils properly. Therefore an amplifying stage (the vertical output tube) is added between the vertical oscillator and the vertical deflection coils. It is primarily an amplifier, but as will be seen, it serves another function as well.

Reference has been made to the need for a constant rate of change in the movement of the electron beam while under the influence of the vertical deflecting force. The amount that the vertical deflecting force depresses the beam as it is describing its horizontal motion is the same for every like interval of time until it reaches the bottom. When this happens adjacent horizontal lines are equidistant. Any condition that prevents this from happening will distort the picture, either compressing it or expanding it vertically. Such a condition may be present in the waveform received from the vertical oscillator. To overcome it, receiver manufacturers provide a linearity control in the vertical output stage that changes the amplifying characteristic of the vertical output tube so that a certain amount of distortion is deliberately introduced. This distortion is somewhat opposite to that present in the sweep input to the vertical output tube. One offsets the other and a substantially distortion-free voltage is delivered to the vertical deflecting coil. The linearity control is variable to permit adjustment.

The Vertical Output Stage with
Linearity Control Follows the
Vertical Oscillator

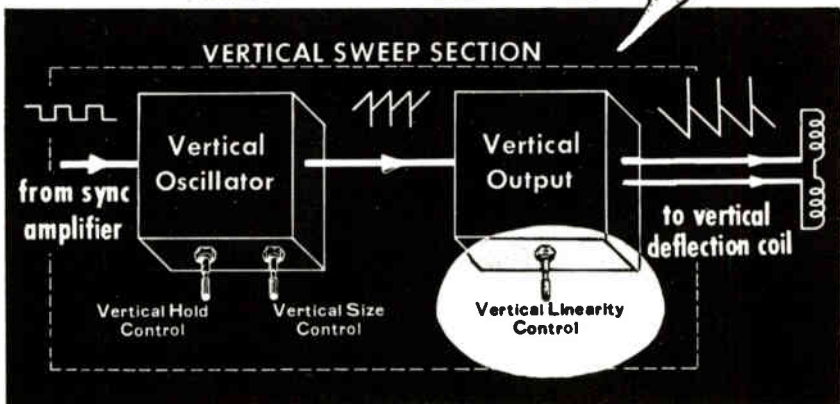

THE ADDITION OF THE VERTICAL OUTPUT STAGE COMPLETES THE VERTICAL SWEEP SECTION

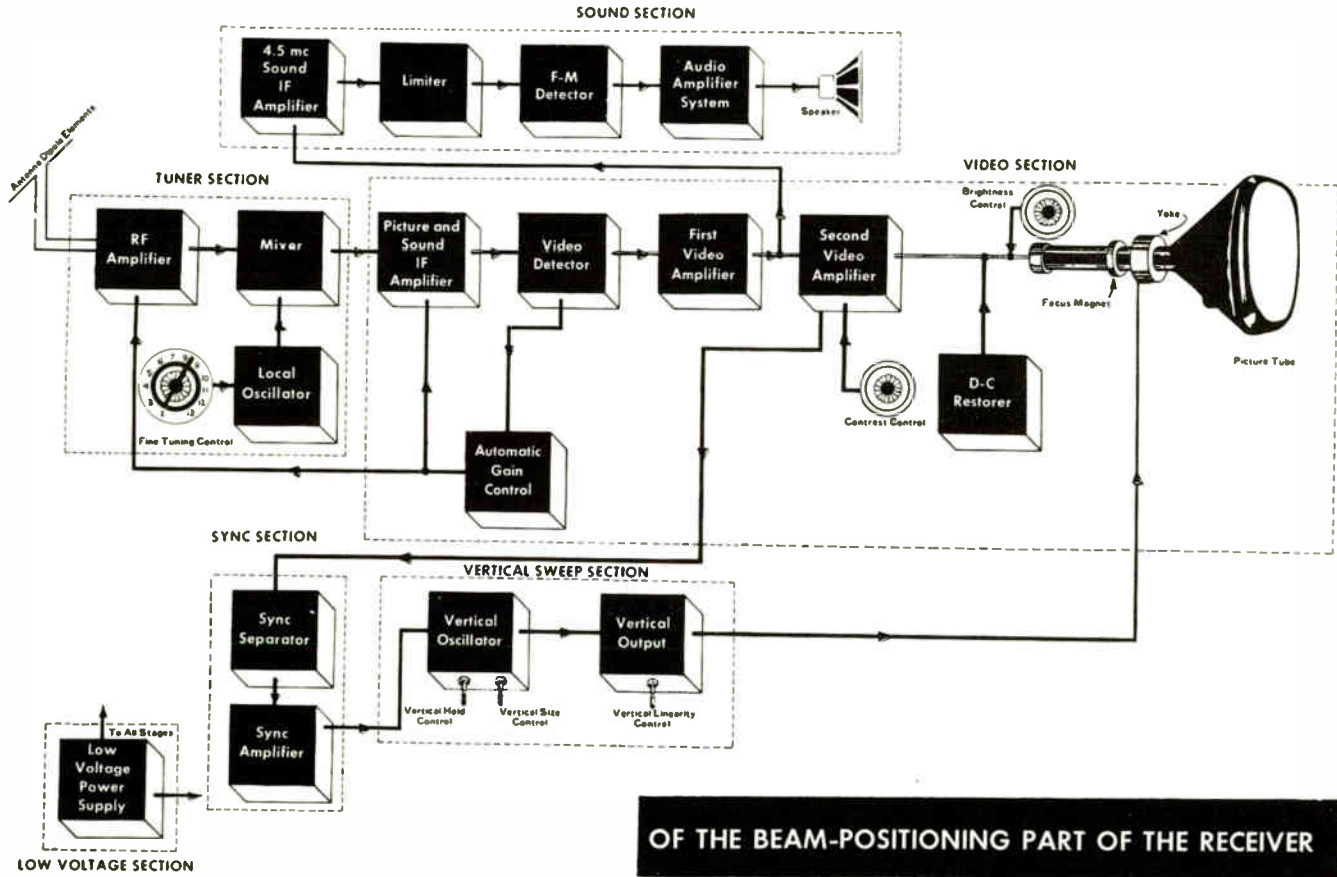

(2-39)

THE VERTICAL SWEEP CIRCUITS

OF THE BEAM-POSITIONING PART OF THE RECEIVER

THE HORIZONTAL SWEEP CIRCUITS

Horizontal Sweep Section and AFC

Now that we have completed our general discussion of the vertical sweep section, we will go back to the sync amplifier and pick up the trail of the composite sync pulses previously indicated as being intended for the horizontal sweep section of the receiver.

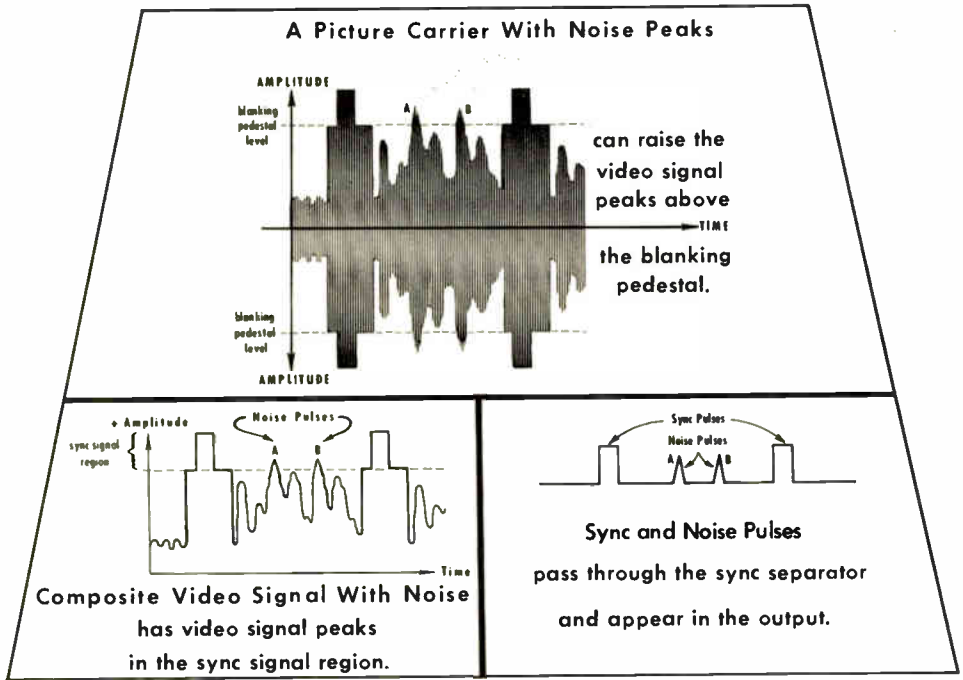

In its general form, the horizontal sweep section follows the pattern of the vertical sweep section. But there are important differences between the two, and because of these we shall find several blocks in the horizontal sweep section that we did not find in the vertical sweep section.

Electrical noise voltages that become part of an amplitude-modulated signal modify the envelope by elevating the peaks. Noise on the picture portion did at one time prove troublesome in television receivers; it caused "tearing" of the picture as well as "jitter."

If we demodulate a picture carrier containing noise of high amplitude we can very easily find noise peaks which extend beyond the blanking voltage pedestal, and are consequently in the sync signal region. When such a signal is fed into a sync separator, that circuit recognizes no difference between the normal sync voltages and noise peaks (shown as A and B in the illustrations). The signal output of the sync separator and that of the of the sync amplifier contain spurious pulses in addition to regular pulses.

THE HORIZONTAL SWEEP CIRCUITS

The Horizontal AFC Circuit

ONE TYPE OF

HORIZONTAL A-F-C CIRCUIT

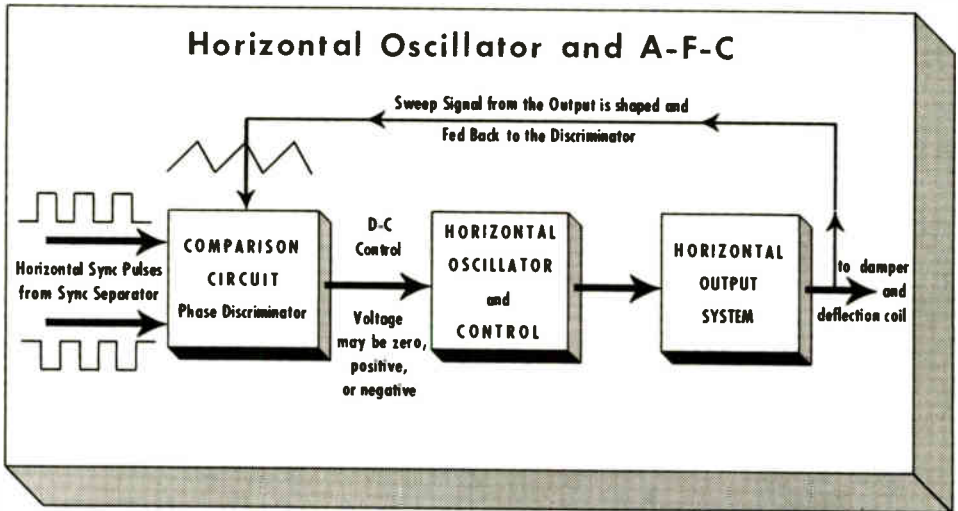

Noise pulses applied to the horizontal oscillator in addition to the horizontal sync pulses could destroy synchronization between the horizontal motion of the electron beams in the picture tube and the camera tube, with consequent horizontal tearing of the picture. In the example shown, four sync pulses (two normal and two spurious) would be experienced in the time interval when only two sync pulses should occur. The result of spurious triggering of the horizontal sweep oscillator raises the frequency of the oscillator output waveform.

Designers of current television receivers have gone a long way toward beating the spurious triggering problem by applying automatic frequency control (afc) to the horizontal sweep section. Several types of horizontal circuits exist, but as far as general organization and function is concerned they are all similar. Here we deal with only one system as typical. Later on, we shall discuss all the popular types. The technique used in the horizontal afc system under consideration is to *compare* the timing of the received horizontal sync pulses with the horizontal sweep voltage that is applied to the horizontal deflecting coils. It should be realized that the horizontal sweep voltage for the horizontal deflecting coil has its origin in the horizontal oscillator. The result of the comparison is the production of a d-c control voltage that is applied to the horizontal oscillator, raising or lowering its frequency to restore horizontal synchronization.

THE HORIZONTAL SWEEP CIRCUITS

Horizontal Output Stage and Hold Control

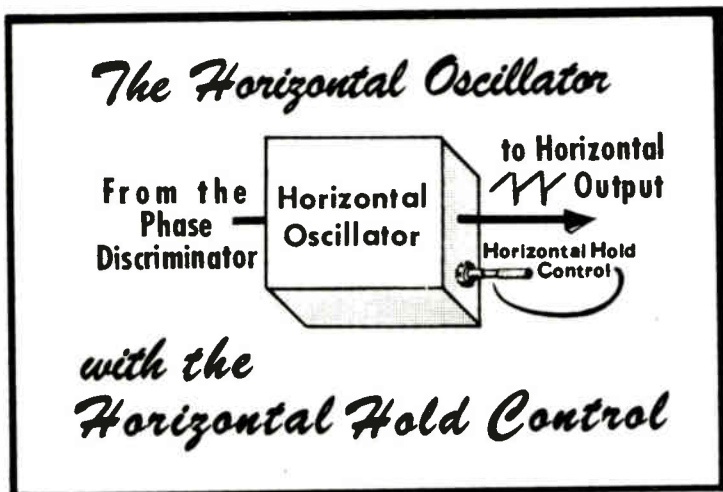

The horizontal sweep voltage to the horizontal deflecting coil has its source in the horizontal oscillator. The oscillator is so designed that its "free-running" output approximates 15,750 cycles, but after afc action it is accurate.

The corrected frequency signal from the horizontal oscillator is fed to the *horizontal output stage*. This stage is primarily a power amplifier intended to raise the horizontal output to a level suitable for further processing. Among these processing operations is the creation of a specially shaped *sawtooth* current required for the horizontal deflecting coil. This occurs in the system associated with the damper tube that follows the output stage. The output stage usually contains a variable control known as the *horizontal drive* that determines the amplitude of the horizontal sweep voltage fed into the output stage. Insufficient "drive" to the horizontal output stage results in insufficient width of the picture on the screen. Another function of the horizontal output stage is to furnish the voltage that eventually is converted to dc by a rectifier and used as high voltage for the picture tube.

Adding the Horizontal Output Stage With the Drive Controls

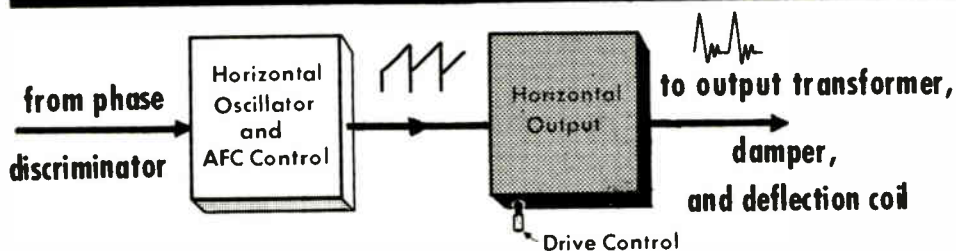

THE HORIZONTAL SWEEP CIRCUITS

Horizontal Output Transformer—Damper—Width—Linearity

The horizontal output tube plate circuit contains a transformer (T), which we show as an entity only because it plays a very important part in the development of the final sweep voltage that is delivered to the horizontal deflecting coil, and to the high voltage delivered to the high-voltage power supply rectifier.

The horizontal output system between the output tube and the horizontal deflection coils is fairly complex. We can only give a brief description of this system here; a more complete discussion appears as part of the discussion on circuitry.

The Complete Horizontal Sweep Section

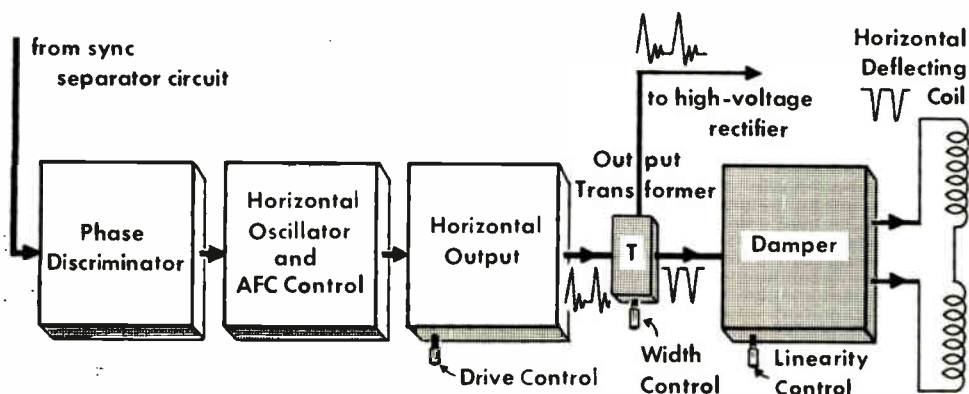

The plate current cutoff behavior of the horizontal output tube is such that when the horizontal sweep voltage is delivered to the horizontal deflecting coil via the horizontal output transformer, relatively high-frequency oscillations appear in the output-transformer deflecting-coil system. As is explained later, these oscillations contribute to the formation of the sawtooth deflection current in the horizontal deflection winding; but to produce it, some of these oscillations must be damped out. During this process, use is made of the damper tube and also of a *linearity* circuit with a variable control. The function of the linearity circuit is to assure horizontal tracing by the electron beam at a constant rate, thus preventing horizontal stretch or compression of the picture.

The output system also contains a *width* control. The width control is related directly to the output transformer and its purpose is to afford a means of increasing or decreasing the horizontal dimension of the image on the picture tube screen. It is to be remembered, however, that inadequate width as well as nonlinearity are related to the drive control which is part of the horizontal output stage.

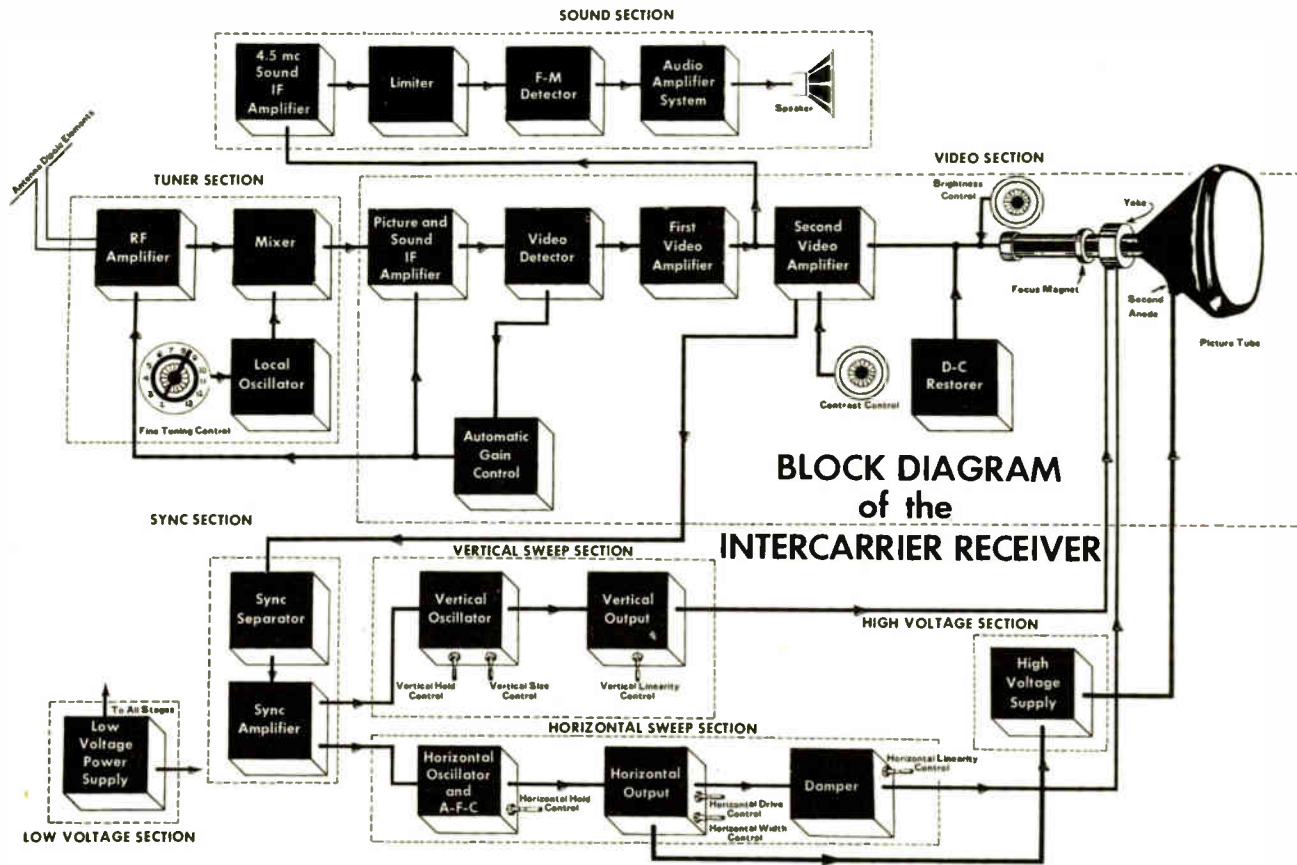

RECEIVER POWER SUPPLIES

High-Voltage Power Supply

The high-voltage power supply in most television receivers resembles the conventional half-wave power supply in most respects. It functions with a 15,750-cycle a-c pulse input voltage of between 10,000 and 20,000 volts. This is a departure from the rectifier arrangement found in most radio equipment, in which the input voltage frequency is usually 60 cycles. The filtering is done by a resistance-capacitance filter, which is adequate because the ripple frequency in the rectified voltage is relatively high. R-F power supplies also have been used in television receivers. They will be discussed separately in connection with the explanation of power-supply circuitry. The rectified d-c output of the high-voltage power supply is applied to the *second anode* or high-voltage anode of the picture tube. Interestingly enough, the output capacitor in the R-C filter of the power supply is often part of the picture tube itself, being formed by the high-voltage Aquadag inner coating and the outer grounded coating of the picture tube envelope.

Low-Voltage Power Supply

All the tubes in the television receiver require a variety of "low" voltages for their operation. The range of voltage values begins at whatever the heater voltage is (usually 6.3 volts ac) and extends upwards to from 200 to perhaps 600 volts dc for screen, plate, voltages and bias voltages. The low-voltage power supply usually is a conventional full-wave vacuum-tube or metallic-rectifier system, although in some instances two rectifier systems may be tied together to function as a single power supply. There are no unusual features associated with these units (but this does not lessen their importance in the overall functioning of the receiver).

The Picture Tube

The picture tube is discussed in detail elsewhere in this course. Hence, for the present, a brief summary of its operation will suffice. The electron beam that produces the image on the screen is generated wholly within the tube and is controlled by a variety of signal and operating voltages that are applied to the tube. The signal voltages derived from the video amplifier *intensity-modulate* the beam, varying its intensity between zero (corresponding to black in the image) and maximum (corresponding to white in the image). The voltages derived from the high-voltage and low-voltage power supplies relate to the development of the beam, and they advance from the cathode to the anodes, and in some cases to the focusing of the beam so that it will produce a sharply defined image on the screen. The deflection coil voltages derived from the horizontal and vertical sweep output systems position the beam on the picture-tube screen so that the location of the elements of the reproduced picture conforms with their location on the camera tube mosaic.

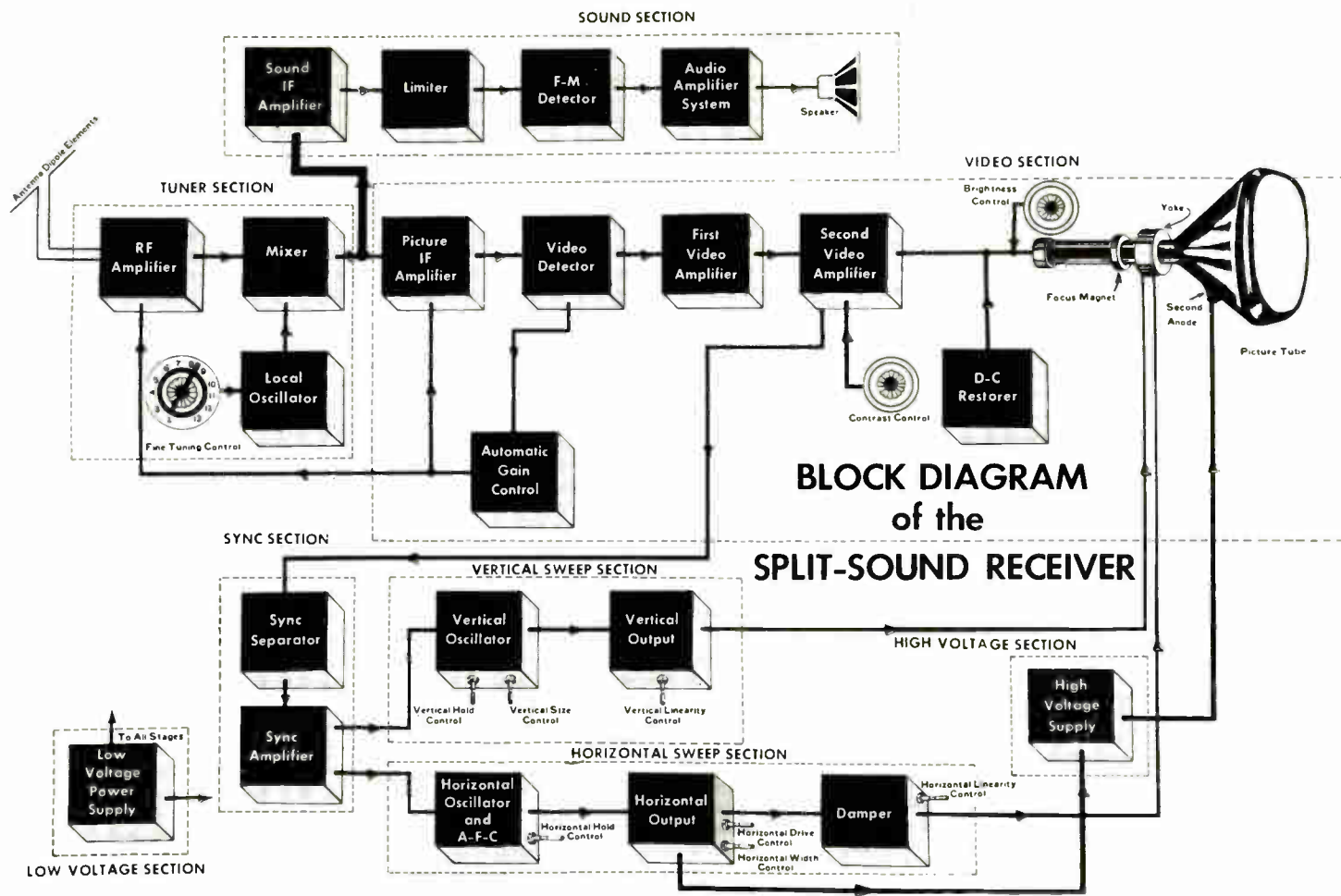

**BLOCK DIAGRAM
of the
SPLIT-SOUND RECEIVER**

THE SPLIT-SOUND TV RECEIVER

The Split-Sound Receiver

Now that we have described the organization of the intercarrier type of television receiver it is time to refer to another type identified as *split-sound*. Although split-sound sets are no longer being manufactured, several million were made, and, doubtless, many are still in use.

The split-sound receiver differs from the intercarrier type in one major respect. The sound i-f signal and the picture i-f signal are fed into separate paths for processing. It is this sound i-f signal that is translated into audio voltages without any further mixing. If, for example the difference-frequency between the received r-f sound carrier and the local oscillator is 21.25 mc at the output of the mixer, the sound i-f amplifier system processes this 21.25-mc signal and the sound demodulator translates it into its audio equivalent. The sound i-f signal takeoff point is located at one of two places; either at the output of the mixer, or after one stage of i-f amplification that is common to both the sound and the picture i-f signals.

In all other respects the split-sound receiver organization is like the intercarrier type. Operating frequencies are the same and destinations of the blanking and synchronizing voltages are alike in both types of receivers. The processing of the sync signal is also the same in both types of receivers, although it might be said that the general run of split-sound receivers utilized more tubes than are usual in the intercarrier type because more single-function types were used.

The vertical and horizontal sweep systems in the split-sound receiver correspond closely to the intercarrier system, although a greater variety of afc circuits are found in intercarrier receivers. The damper, low-voltage, high-voltage and deflection systems are substantially identical in both kinds of receivers. We can summarize by saying that the organization of the split-sound receiver is the same as the intercarrier except for the takeoff point of the sound i-f signal and the operating frequency of the sound i-f amplifier. No split-sound receivers were made with 41-mc i-f systems, whereas in the intercarrier design both 21- and 41-mc i-f systems were used.

It might be well to mention that the demise of the split-sound receiver can be attributed to the economies in design that were effected by the intercarrier approach, as well as by the greater ease of tuning.

Critical tuning was an inherent characteristic of the split-sound receiver because of oscillator drift. Since any change in oscillator frequency produces a change in the sound and picture i-f, it was extremely important that the oscillator frequency be stable. In this respect, the relatively narrow-band sound signal was much more easily lost than the wide-band picture signal. With the intercarrier receiver, the sound signal is locked 4.5 mc away from the picture signal. Oscillator drift causes a decrease in amplitude of the picture and sound signals, but the chance of losing the sound signal entirely has become far less probable.

UHF RECEPTION

UHF Station Reception

Since both uhf and vhf transmitters may serve an area, receiving systems must of necessity be capable of accepting both frequency ranges. Numerous methods have been devised to permit uhf reception using a vhf receiver. Two methods are shown here: in one the vhf tuner in the receiver has been modified so that it can also be used to tune to uhf signals. The second method uses an external uhf tuner or converter that can be connected to the antenna input terminals of the vhf receiver. In converting the uhf signal to a lower frequency, two methods are used: (1) single conversion, where the uhf signal is heterodyned down directly to an intermediate frequency; and (2) double conversion where the uhf signal is heterodyned down to a vhf signal, then down to the intermediate frequency.

Single-Conversion UHF Reception

The uhf tuner is a frequency converter that is part of the uhf-vhf receiver, and consists of a mixer stage and an oscillator. For uhf reception it is switched into the circuit; for vhf reception it is switched out of the circuit. The frequency of the uhf oscillator is such that the difference-frequency picture i-f output from the uhf converter is a modulated 45.75-mc signal, and the sound i-f output from the uhf converter is 41.25 mc. Instead of being fed directly into the receiver i-f amplifier, these two i-f signals are first amplified by the r-f amplifier and mixer stages. These are modified (by appropriate switching) to behave as addition picture-sound i-f amplifiers. The switching system automatically connects while it disables the vhf oscillator. (This is position "13" in the conventional 12-position tuner.)

UHF RECEPTION - SINGLE-CONVERSION METHOD

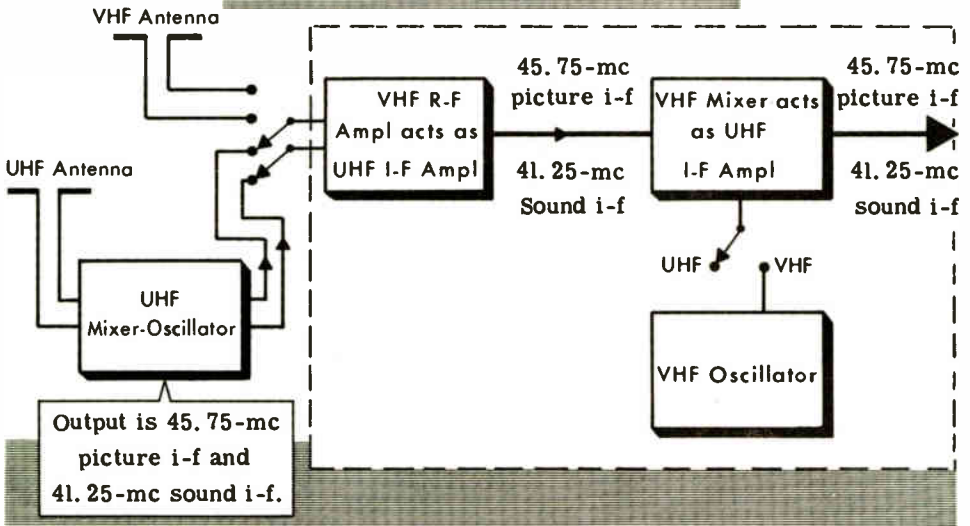

UHF RECEPTION

Double-Conversion UHF Reception

UHF RECEPTION - DOUBLE-CONVERSION METHOD

Assume a UHF Channel 20 signal being received and the VHF Front End set to Channel 6

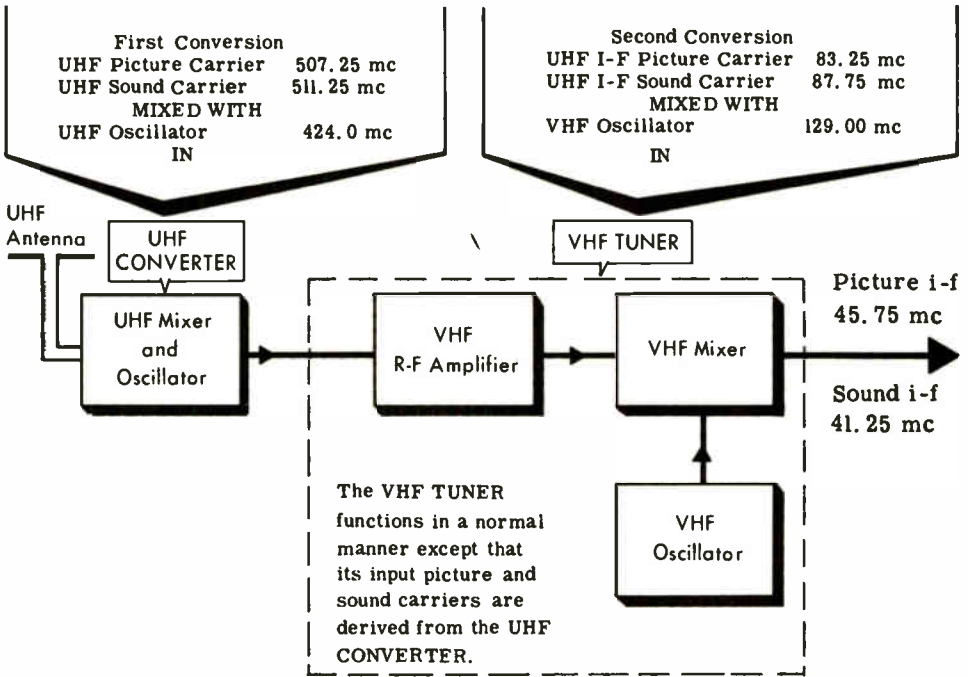

The second method of uhf reception with a vhf television receiver makes use of a uhf converter as an external accessory to the receiver. The converter consists of a uhf mixer and oscillator. It accepts the uhf picture and sound carriers of a given uhf channel and delivers at its output two *difference-frequency* signals that are the equivalent of the uhf picture and sound carriers but are of a lower frequency. By virtue of the design of the uhf oscillator, the output signals from the uhf converter most commonly fall within the frequency band for channels 5 or 6 of the vhf band. Inasmuch as these two vhf channels are never allocated for the same area, one of them is always an unused position on the vhf tuner. The uhf converter output signals are processed by the vhf front-end just as if they were vhf signals received from a vhf transmitter. To position the sound carrier higher in frequency than the picture carrier at the input of the vhf front-end, the uhf oscillator generates a frequency which is lower than the received uhf sound and picture carriers. The numerics shown in the illustration show the double frequency conversion which takes place in the system.

REVIEW

It is essential that the Transmitter's

Camera Tube Scanning Beam

and the Receiver's

Picture Tube

Scanning Beam

move precisely in step

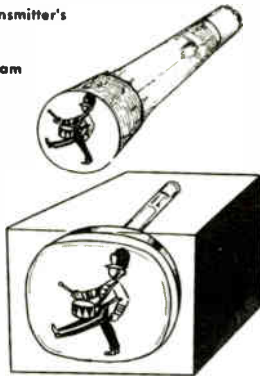

1. *Synchronization* is required to keep the scanning beam in the picture tube precisely in step with the scanning beam in the camera tube. Horizontal sync, vertical sync, and equalizing pulses, which are all a part of the composite video signal, are used for synchronization.

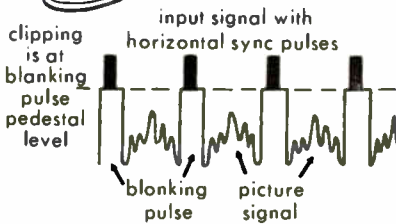

THE SYNC SEPARATOR REMOVES THE BLANKING AND PICTURE SIGNALS FROM THE COMPOSITE VIDEO SIGNAL

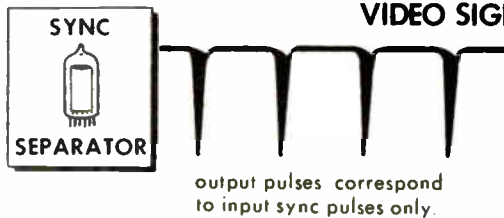

2. *The Sync Separator* removes the horizontal sync pulse (15,750 cycles), the equalizing pulses, and the vertical sync pulses (60 cycles) from the composite video signal.

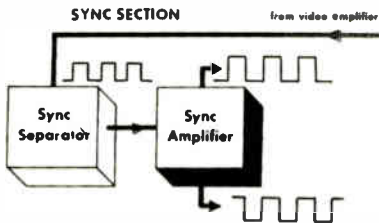

3. *The Sync Amplifier, or phase splitter* amplifies the pulses from the sync separator. The amplified pulse train is made available at two outputs which differ in phase by 180° . This provides two separate paths—one to the horizontal, and one to the vertical sweep oscillator circuits.

4. Except for the 180° phase difference, the pulse trains available at both outputs of the sync amplifier are identical. Separation of horizontal sync, vertical sync and equalizing pulses takes place in the two sweep oscillator paths. Here, resistor and capacitor circuitry distinguishes between the horizontal (15,750-cycle) and vertical (60-cycle) sync pulses, rejecting one and accepting the other. This makes available only vertical sync pulses to the vertical oscillator and only horizontal sync pulses to the horizontal oscillator.

REVIEW

1. *The Vertical Oscillator* generates the 60-cycle vertical sweep voltage whose waveform is shaped like a sawtooth. The 60-cycle vertical sync pulses from the integrator keep the output voltage precisely in step with the vertical sweep voltage active on the camera tube beam.

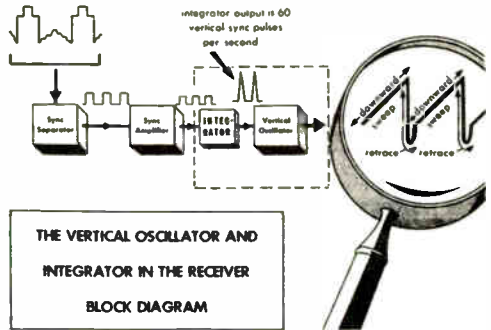

The Vertical Output Stage with Linearity Control Follows the Vertical Oscillator

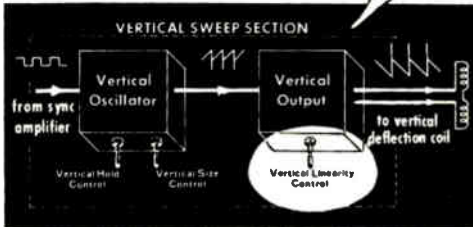

3. *The Horizontal AFC Circuit* compares the timing of the received horizontal sync pulses with the sweep voltage applied to the horizontal deflecting coils to produce a d-c control voltage that is applied to the horizontal oscillator.

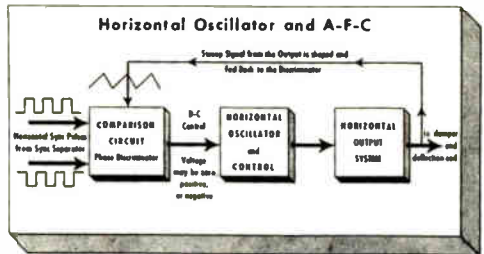

Adding the Horizontal Output Stage With the Drive Controls

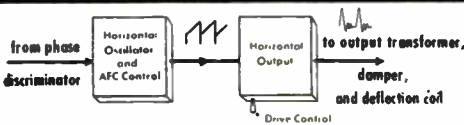

Insufficient drive results in insufficient width of the picture. Among the processing operations is the creation of a specially shaped sawtooth current required for the horizontal deflecting coil. Another function is to furnish the voltage that eventually is converted to dc by a rectifier and used as high voltage for the picture tube.

4. *The Horizontal Output Stage* is primarily a power amplifier which raises the signal from the horizontal oscillator to an output level suitable for further processing. The horizontal drive control determines the amplitude of the horizontal sweep voltage fed into this stage.

REVIEW

The Complete Horizontal Sweep Section

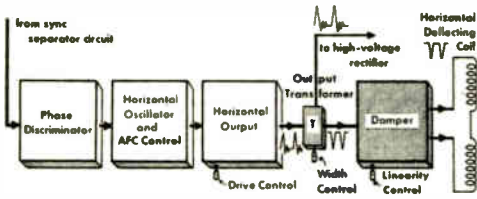

5. *The Horizontal Output Transformer* is in the horizontal output tube plate circuit. In conjunction with the *width control*, *dumper*, and the *linearity* circuit, it develops the final sweep voltage delivered to the horizontal deflecting coil. It also develops the high voltage delivered to the high-voltage power supply rectifier.

6. *The High-Voltage Power Supply* furnishes the high voltage for the high-voltage anode of the picture tube. A 15,750-cycle a-c input voltage of between 10,000 and 20,000 volts supplied by the horizontal output transformer is converted to dc by a half-wave rectifier. This high d-c voltage is filtered by a resistance-capacitance filter before it is fed to the high-voltage anode of the picture tube.

7. In the *Split-Sound Receiver* the sound i-f signal and the picture i-f signal are fed to separate paths for processing.

8. For *Single-Conversion UHF Reception* the uhf signal is heterodyned down directly to an intermediate frequency. The uhf tuner is a frequency converter that is part of the uhf-vhf receiver, and consists of a mixer stage and an oscillator. The switching system automatically connects it while it disables the vhf oscillator.

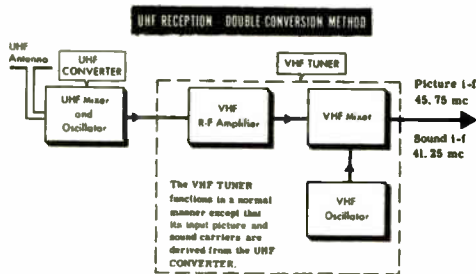
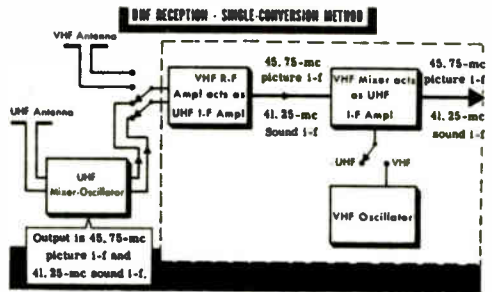

9. For *Double-Conversion UHF Reception* the uhf signal is heterodyned down to a vhf signal, then down to the intermediate frequency. The uhf converter is an external accessory to the receiver. The uhf converter output signals are processed by the vhf front end just as if they were signals received from a vhf transmitter.

THE TELEVISION ANTENNA

The TV Receiver Antenna

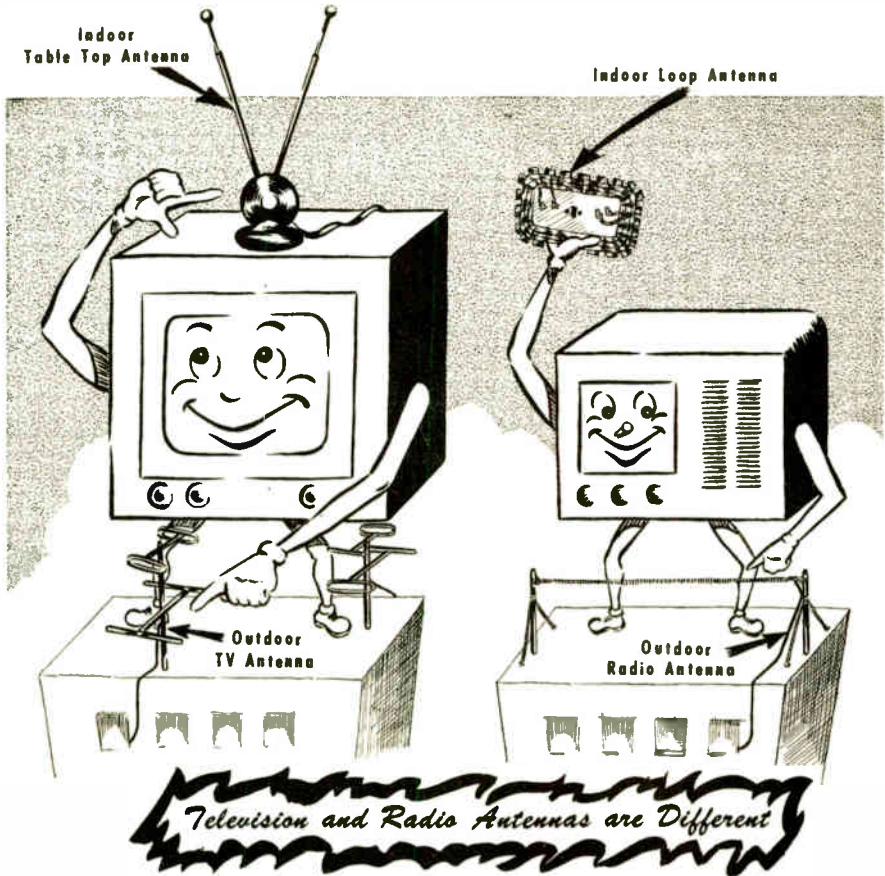

Radio receivers require an antenna to intercept energy radiated from the transmitter. The television receiver needs a similar device. One glance at almost any roof top, however, is enough to establish that the antenna used for television reception differs greatly from the conventional home radio receiving antenna.

An outdoor elevated wire 40 to 60 feet long suspended between two insulators was the standard radio antenna for many years. Today over a hundred million table model radio receivers function with self-contained antennas — a ferrite loopstick, or a loop 6 to 10 inches on a side, made of several turns of wire mounted on a fiber or plastic frame, and housed within the receiver cabinet. Sometimes, in areas close to a transmitter, a small piece of wire is satisfactory antenna for intercepting television signals. This is however, the exception rather than the rule.

THE TELEVISION ANTENNA

The TV Receiver Antenna (contd.)

The directional relationship between the *television* receiving and transmitting antennas is more critical than in home broadcast reception. Moreover, the high-frequency television signals can be blocked off by, or reflected from surfaces or obstacles that might be in their path of advance, just as light rays are blocked by opaque objects or reflected by a shiny surface. This behavior of the radiated television signal dictates the necessity for positioning the television receiving antenna so that it is in the path of the advancing signal. For best reception the receiving antenna should not be hidden from the "line of sight" of the transmitting antenna. When the receiving antenna is "out of sight" of the transmitting antenna, the reception of television signals requires that the receiving antenna be so located as to take advantage of the reflection phenomenon, that is, pick up the "bounce" of the radiated signal from a suitable surface such as an adjacent building, water tower, or gas tank.

Because the frequency of the television signal is high, the physical length of the receiving antenna becomes critical. This is especially so since the receiving antenna is made to behave as a *tuned* signal-pickup device.

The received television signal eventually produces a picture on the picture tube screen. For this picture to have the proper quality, it is necessary that the received signal not be modified or distorted. The first point where changes in signal construction could take place is the antenna. Therefore, it is important that the antenna accept all the frequencies present in the signal. This problem seldom, if ever, arises in broadcast radio reception.

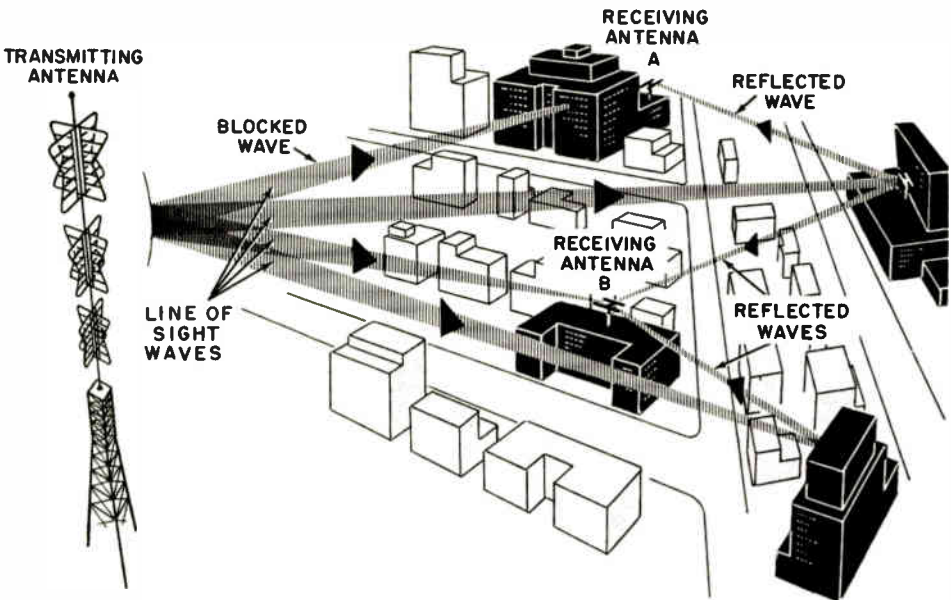

PROPAGATION

Propagation of Television Signals

The word *propagation* refers to the way electromagnetic energy, representative of television signals, travels from the transmitting antenna to the receiver antenna.

The frequency (or wavelength) of a radiated signal determines the path that is effective in causing the signal to reach the receiver. The frequencies used for home television broadcasting begin at about 54 mc and extend upwards to about 890 mc. Within this frequency range are found a number of other communication services, transmitting a-m and f-m radio rather than television signals. They, as well as the television broadcasting stations, make use of the same propagation phenomena.

Television signal radiations can reach a receiver by advancing along one or more of three signal paths. One of these is the *skywave* path. Skywave signals leave the antenna at an angle that directs them upward from the earth. Electromagnetic energy advancing along this path is generally wasted at the present time because there are no television receivers high above the earth and little use is made of skywaves. To minimize the waste of signal energy in this direction, television transmitting antennas are designed to concentrate their radiations in directions towards the earth's surface.

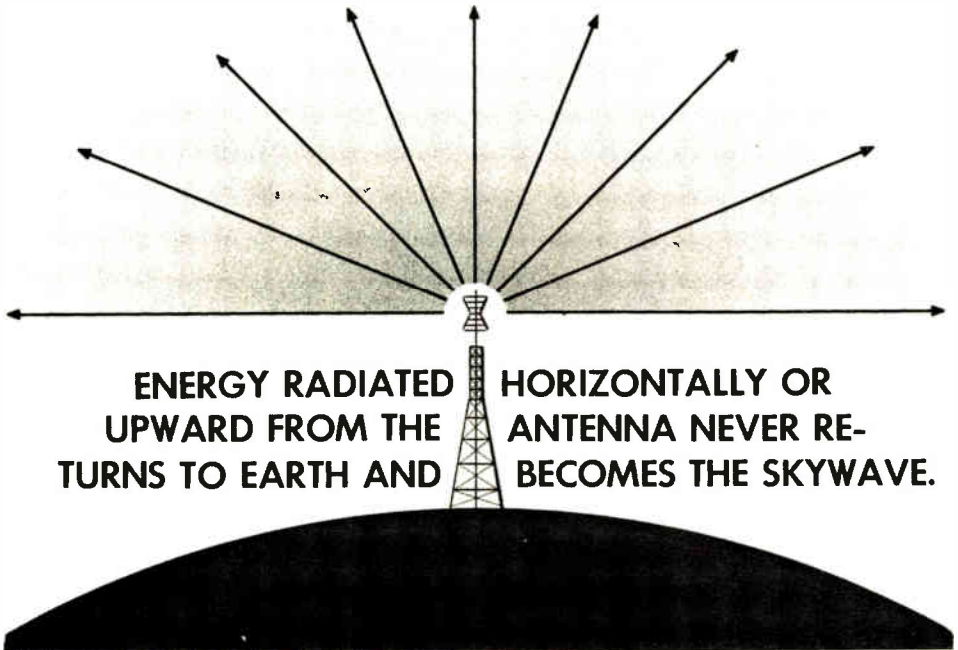

PROPAGATION

The Propagation of Television Signals (contd.)

The second path is the *direct-wave* path. The direct-wave radiations leave the transmitting antenna substantially parallel to the surface of the earth and travel to the receiver in a straight line. It is assumed that this is an unobstructed path free of all intervening obstacles. This is the most useful radiation for television reception, although it does not account for the total signal at the receiver. Also contributing to the received signal is the radiation that follows the *ground-reflected path*.

A portion of the energy released by the transmitting antenna is directed towards the surface of the earth, from which it is reflected, at the same angle at which it struck the earth's surface. The smaller the angle at which the energy from the transmitting antenna strikes the earth or other reflecting surface the more efficient the reflection process (the greater the relative amount of energy that is reflected).

Accompanying the process of reflection is another phenomenon that is important: *flop-over*, or inversion of the signal at the point of reflection. The phase of the signal may be changed almost 180° . For example, a negative-going signal at the instant of arrival at the reflecting surface, can be changed to a positive-going signal after reflection, and vice-versa.

The direct wave signal goes directly to the receiver, whereas the ground-reflected wave reaches it after bouncing off the earth's surface or a rooftop.

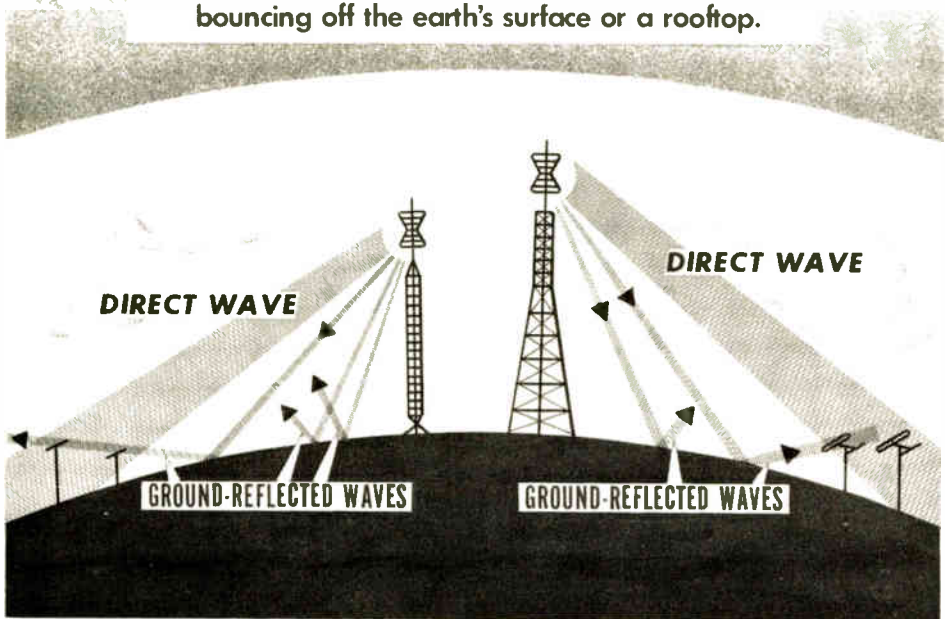

PROPAGATION

The Propagation of Television Signals (contd.)

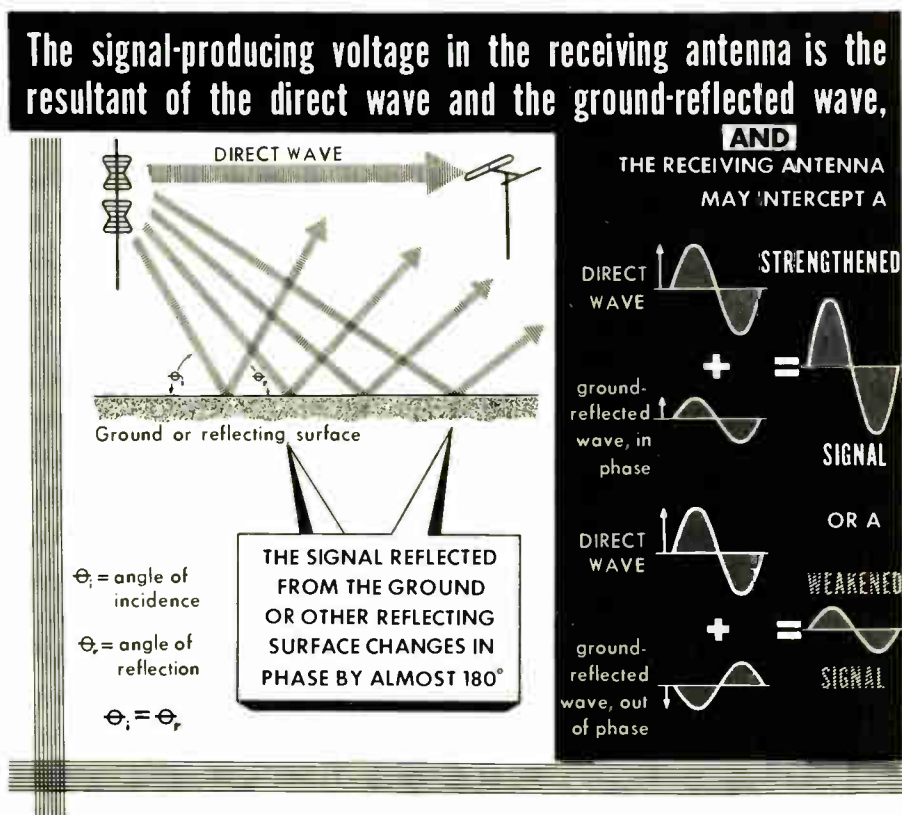

Whether the combination of the direct-wave and ground-reflected signals arriving at the receiving antenna is stronger or weaker than the direct-wave signal alone, depends on whether the two signals aid or oppose each other at the instant of arrival at the receiving antenna. Aiding or bucking is a function of the timing of the two signals that traveled the two paths. The two signals had the same instantaneous phase when they left the transmitting antenna, but if they arrive out of phase at the receiving antenna the resultant or combined signal will be minimum. (Complete cancellation cannot take place.) If the two signals arrive in phase with each other the resultant signal will be a maximum.

The instantaneous phase of the signals that arrive at a receiving antenna after following two signal paths depends on the height of the receiving antenna above the reflecting surface. Interpreting these factors into practice means that increasing the height of a television receiving antenna will not necessarily produce a stronger signal — there will be heights where the signal strength is minimum and others where it is maximum.

PROPAGATION

The Propagation of Television Signals (contd.)

'GROUND REFLECTION' CAN MEAN

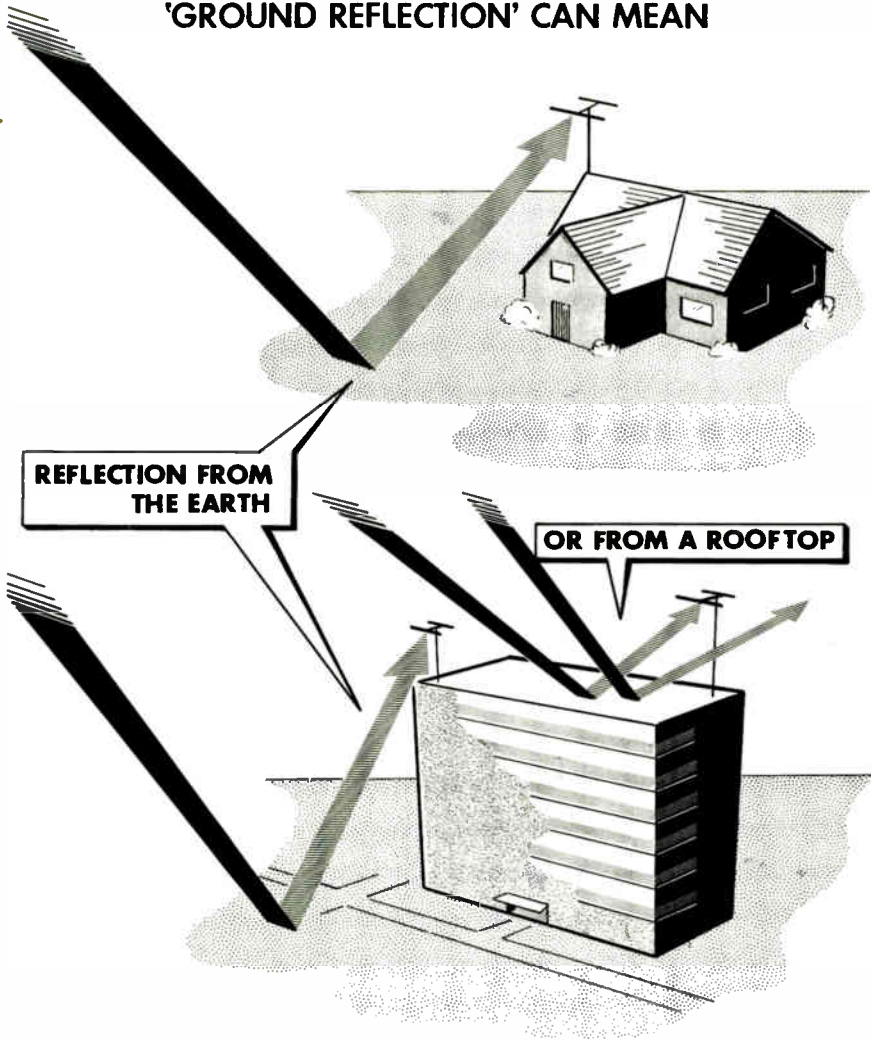

“Ground-reflected path” has several meanings. It can be the path involving reflection from the earth’s surface (the ground itself), or reflection from whatever surface is present below the antenna. An antenna located on a mast mounted above the roof of a private dwelling would, in addition to the direct-ray signal, be subject to a signal reflected from the ground or possibly the roof. An antenna atop an apartment house might receive a reflected signal from the earth or from beneath the tar paper and gravel that is usually used for roofing.

PROPAGATION

Line-of-Sight Transmission

Arrival of the signal energy at the receiving antenna along the direct-wave path is usually referred to as *line-of-sight* propagation. It implies that the maximum distance between transmitter and receiver antennas for useful transmission and reception is determined by the ability to "see" the receiving antenna from the transmitting antenna. The maximum distance that can be "seen" from the television transmitter antenna is called the optical horizon.

An approximation of the useful horizontal range of a television antenna for line-of-sight transmission may be determined from the equation

$$\text{distance in miles} = 1.41 \times \sqrt{\frac{\text{transmitter antenna height (in feet)}}{\text{receiver antenna height (in feet)}}}$$

Assume that the transmitting antenna is located at a height of 900 feet above ground and the receiving antenna is located 50 feet above the ground; what is the maximum useful transmission distance?

$$\begin{aligned} \text{distance} &= 1.41 \times \sqrt{\frac{\text{transmitter antenna height (in feet)}}{\text{receiver antenna height (in feet)}}} \\ &= 1.41 \times \sqrt{\frac{900}{30}} + \sqrt{\frac{50}{7.07}} \\ &= 1.41 \times \sqrt{30} + \sqrt{7.07} = 1.41 \times 37.07 \\ &= 52.3 \text{ miles} \end{aligned}$$

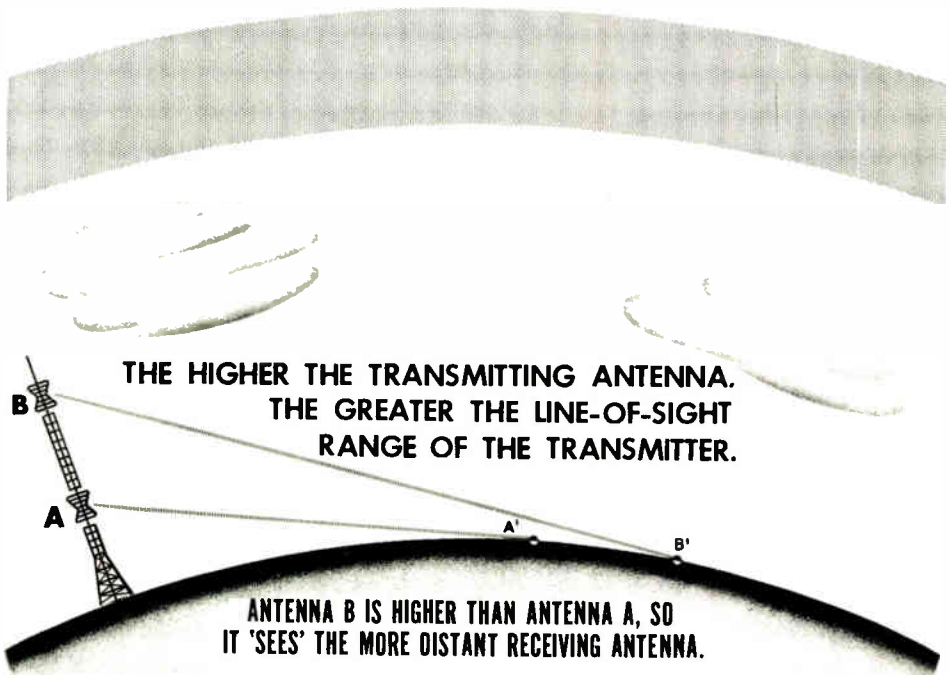

PROPAGATION

Long-Distance Television Reception

On occasion, television reception over many times the normal range is experienced. (This distance may be as great as 500 to 1000 miles, or more.) This is attributed to a phenomenon known as *temperature inversion*. At definite intervals during the year (usually in the spring and fall, sometimes in the summer, and rarely in the winter) layers of hot dry air and cool moist air may exist above the earth. Normally, the higher the altitude, the lower the temperature of the air. But sometimes these conditions are reversed, and a discontinuous change in temperature and humidity prevails in the atmosphere.

When the hot dry air is present above the cool moist air, radio energy entering the region is bent downward because the upper part of the wave (which is in the hot dry air) travels more rapidly than the lower part of the wave (which is in the cool moist air). As a result, radiation that normally would pass over antennas near the ground is bent back to the earth, striking receiving antennas far beyond the optical horizon of the transmitting antenna.

THE EFFECT OF TEMPERATURE INVERSION

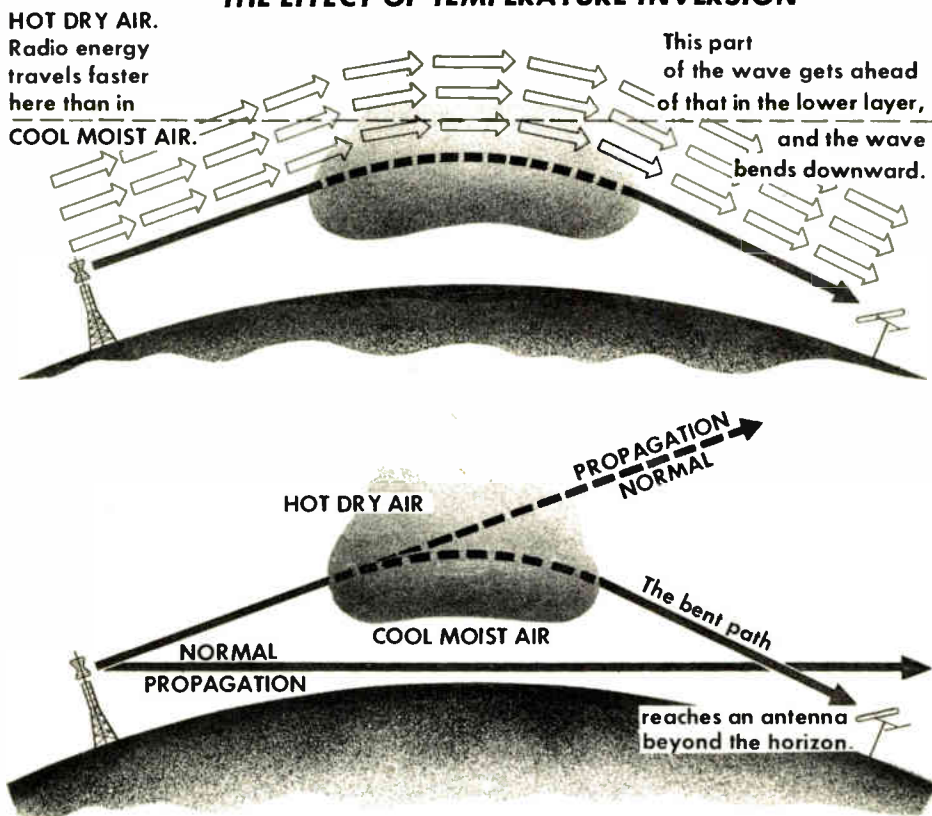

THE RADIATED WAVE

Reflection of Television Waves

The phenomenon of reflection can be a means of receiving a television signal which otherwise would be unavailable because the antenna is located in a "blocked-off" area, as has been illustrated. Reception of reflected signals in a location where direct radiation exists can subject the receiving antenna to two identical signals, one arriving slightly later than the other. The directly received signal will produce a picture on the picture tube screen, and the reflected signal, arriving slightly later, will produce another complete picture displaced to the right of the first. Such secondary signal pictures are called "ghosts" or "lagging ghosts". The existence of line-of-sight conditions is not necessarily productive of "clean" pictures. In areas not too far distant from a television transmitter, a direct-wave signal can find its way into the receiver without benefit of "gain" from a receiver antenna and produce a weak picture on the screen. An identical signal finds its way into the same receiver via the antenna, and produces a second image on the picture tube screen. The signal that enters the receiver without benefit of the antenna system appears ahead (to the left) of the other on the screen because its path into the receiver is the shorter of the two. This signal produces a "leading ghost."

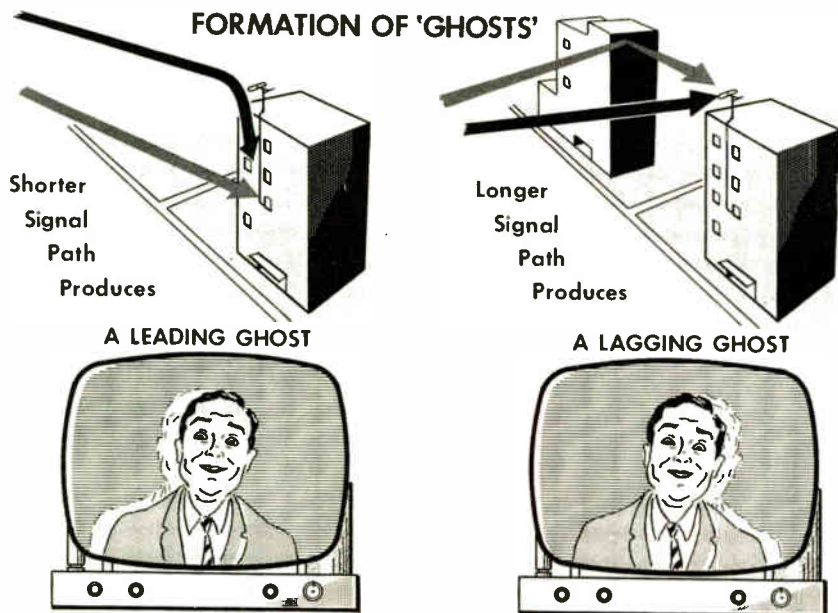

The most logical answer to the reflection problem is to experiment in locating the antenna to minimize these effects, and to select the antenna design that is most directional in its receiving characteristics. Elimination of a leading ghost requires improved shielding of the r-f portion of the receiver, including the small length of transmission line that connects the r-f amplifier of the television receiver to the antenna input terminals.

THE RADIATED WAVE

The Electromagnetic Wave

The energy fed to the transmitting antenna is liberated into space by a process called "radiation." The energy travels in the form of an electromagnetic wave that consists of electric energy corresponding to the voltage distribution on the antenna and magnetic energy corresponding to the current in the antenna. Each of these portions contains half of the radiated energy. Because only the electric part of the wave will be mentioned in our discussion of receiving antennas, we break the wave into its components at this point, rather than considering it as a whole.

THE PHENOMENON OF RADIATION

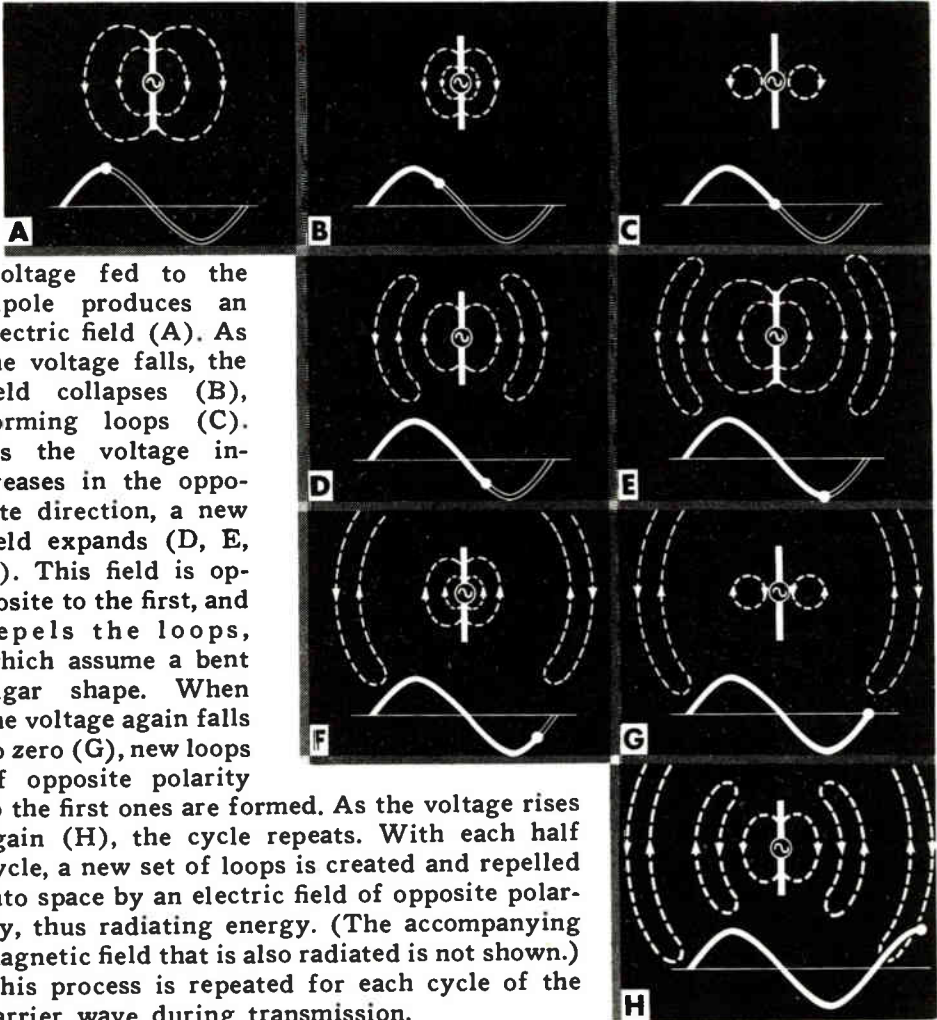

Voltage fed to the dipole produces an electric field (A). As the voltage falls, the field collapses (B), forming loops (C). As the voltage increases in the opposite direction, a new field expands (D, E, F). This field is opposite to the first, and repels the loops, which assume a bent cigar shape. When the voltage again falls to zero (G), new loops of opposite polarity to the first ones are formed. As the voltage rises again (H), the cycle repeats. With each half cycle, a new set of loops is created and repelled into space by an electric field of opposite polarity, thus radiating energy. (The accompanying magnetic field that is also radiated is not shown.) This process is repeated for each cycle of the carrier wave during transmission.

THE RADIATED WAVE

Directional Antennas

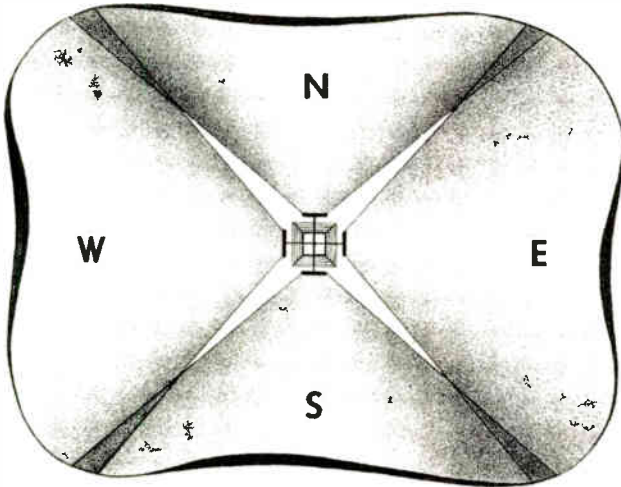

BEAMED ENERGY

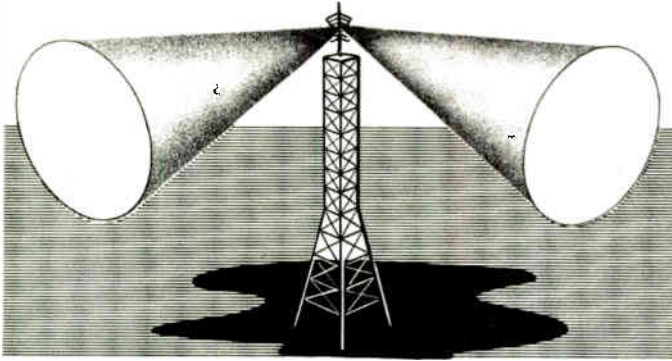

If we assume the transmitting antenna to be a theoretical point source located in space, the liberated energy spreads out from it as an ever-expanding sphere with the energy lying on the surface of the sphere. The sphere of energy expands at the velocity of light (approximately 300,000,000 meters per second), which in round numbers is 186,000 miles per second.

The practical television transmitting antenna is not a point source of radiation. Rather, it is a directional type that concentrates the radiated energy into a beam—somewhat like the beam of a searchlight—so that the signal can be directed as required to serve best the receiver population. The “front” of the beamed energy is the equivalent of a sheet of energy that moves with the speed of light just as in the case of the expanding sphere of energy. By arranging four directional antennas on a tower, one antenna facing north, another south, a third east and a fourth west, beamed radiation can be obtained in all four directions with greatest effectiveness.

THE RADIATED WAVE

The "Field" Concept

Energy is the ability to do work. Unfortunately it cannot readily be pictured. Instead, we use a method of illustration that shows the direction in which electric (or magnetic) energy present in a region will perform work. This is the "field" idea, wherein lines or arrows represent "lines of force" that occupy the region where energy is present. A line of force is an imaginary entity, but it is nevertheless a very convenient way of showing the existence of energy and the direction along which the electric or magnetic energy present in an electromagnetic wave (or field) will do work.

Although we shall deal mainly with the electric energy, that is, with the *electric field* component of the wave, we must nevertheless illustrate it and the magnetic field component at the beginning of the discussion. Both fields are shown by a series of parallel lines positioned at right angles to each other. As a means of identification the electric field lines are called "E" lines, and the magnetic field lines are called "H" lines. Arrowheads on the lines of force indicate the direction in which the fields will do work on free electrons that come within their influence.

If the position of radiating elements is horizontal relative to the earth's surface (assumed to be flat between the transmitter and the receiver) the plane of action of the electric field portion of the radiated signal will likewise be horizontal relative to the earth's surface. The position of the long axis of the antenna rods determines the plane of action of the electric field because the signal voltage fed to the transmitting antenna elements always generates an electric field whose lines run parallel to the long axis of the antenna elements. (This was shown in connection with radiation.)

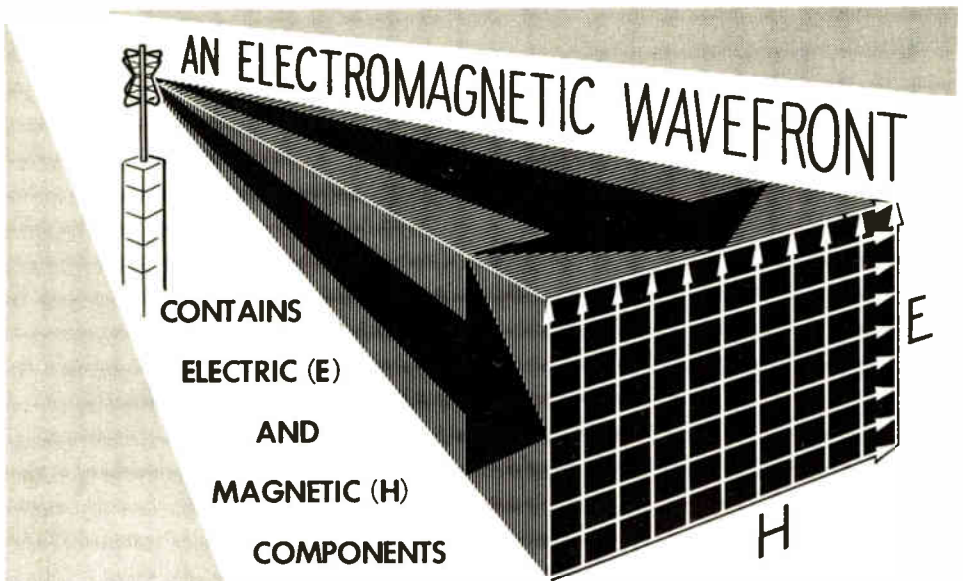

THE RADIATED WAVE

The Field Concept (contd.)

Electric and Magnetic Fields of Horizontally Polarized Antennas

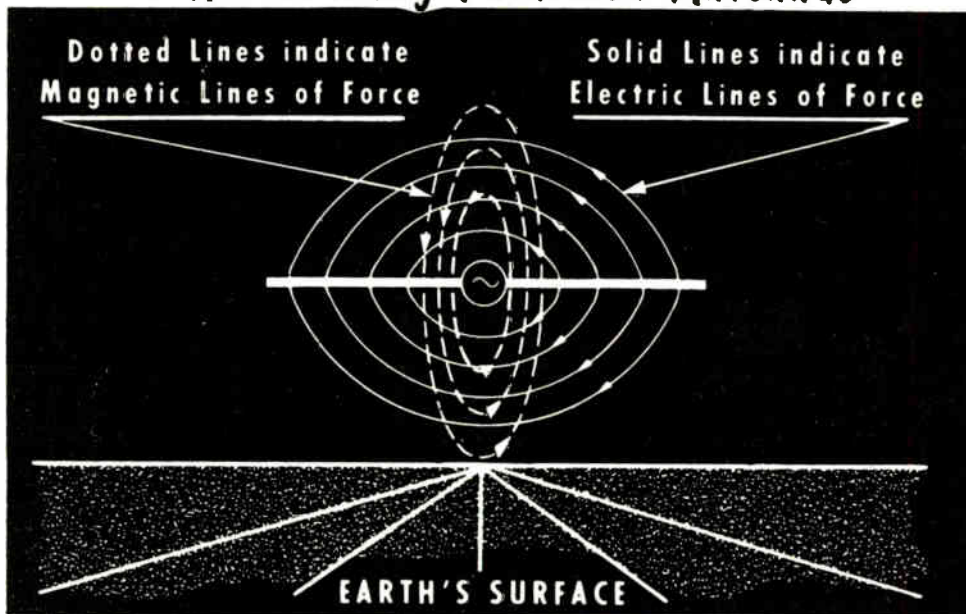

The magnetic energy contained in this radiated wave is shown by magnetic field lines that are positioned at right angles to the electric field lines. This angular relationship stems from the fact that the signal current in the transmitting antenna elements causes magnetic lines of force to surround the antenna conductors. Since the electric field is parallel to the conductors, the magnetic field lines are at right angles to the electric field lines. This relationship repeats itself in the electric and magnetic field components of the radiated wave. The directions in which the electric and magnetic field components of the radiated wave act are at right angles to each other and to the direction in which the wave is propagated. This relationship never changes.

When the transmitting antenna radiates an electromagnetic wave in which the electric field lines are positioned parallel to the earth's surface, the wave or signal is said to be *horizontally polarized*. To receive horizontally polarized signals most effectively the receiving antenna conductors also must be positioned horizontally.

THE RADIATED WAVE

Polarized Radiation

Antenna positioning is important in TV reception

REQUIREMENT #1

If the transmitting antenna is positioned vertically to the earth's surface



The receiving antenna must be positioned vertically to the earth's surface



EARTH'S SURFACE



If the transmitting antenna is positioned parallel to the earth's surface



The receiving antenna must be positioned parallel to the earth's surface



EARTH'S SURFACE

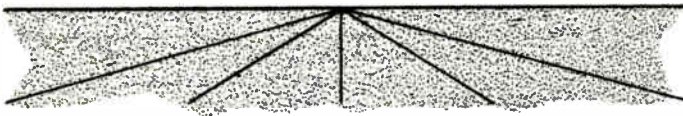

All television receivers used for broadcasting to the public are positioned horizontally relative to the earth's surface.

Television broadcasting in America is never done by transmitting antennas positioned vertically relative to the earth's surface. Transmitting antennas positioned vertically radiate *vertically polarized waves*. The electric field component acts perpendicularly to the earth's surface, and the associated magnetic field energy acts horizontally. The receiving antenna used to intercept vertically polarized radiations must be positioned vertically relative to the earth's surface to make it parallel to the transmitting antenna. Horizontally polarized radiation minimizes pickup of vertically polarized noise voltages generated in the vicinity of receiving antennas. In addition, many of the communication services that function in the frequency vicinity of television stations, or generate harmonics that may fall within the boundaries of the television channels, radiate vertically polarized waves. The use of horizontally polarized antennas minimizes interference from these sources.

THE BASIC DIPOLE ANTENNA

The Simple Dipole TV Antenna

The simplest type of television receiving antenna is the half-wave or half-wavelength dipole. It is the "basic" television antenna from which all other types are derived.

By definition, "a dipole antenna is a symmetrical antenna in which the two ends are at opposite potential relative to the midpoint." The dipole antenna is a metal rod that has a physical length approximating one half-wavelength in free space at the frequency of operation. This frequency is considered to be the resonant frequency of the antenna. The reason for stipulating that the physical length is one half-wavelength at the operating frequency is that a metal rod of this length is the shortest possible conductor that can be made to demonstrate all the characteristics of a resonant (tuned) circuit.

**The Simple Dipole
is a Rod of Continuous Material**

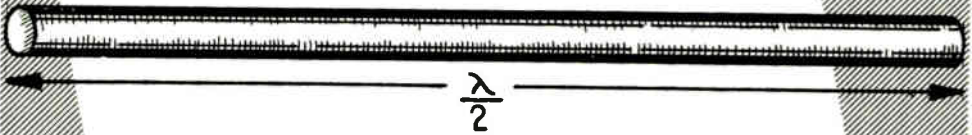

**or
it is Split at the Center**

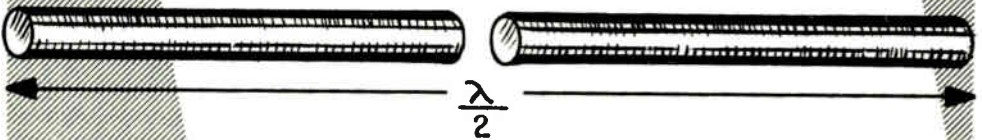

THE BASIC DIPOLE ANTENNA

Finding the Half-Wavelength Dimension

$$\begin{aligned} \text{FREQUENCY} &= 60 \text{ MC} \\ \text{WAVELENGTH} &= ? \\ \\ \text{Wavelength} &= \frac{300,000,000}{\text{Frequency (cycles)}} \\ \text{(meters)} &= \frac{300,000,000}{60,000,000} \\ &= 5 \\ \\ \text{WAVELENGTH} &= 5 \text{ METERS} \end{aligned}$$

The wavelength (λ , lambda) of any signal *in free space* is given by

$$\begin{aligned} \text{wavelength} &= \frac{\text{velocity of electromagnetic propagation (in meters per sec)}}{\text{frequency of signal (in cycles)}} \\ \text{(in meters)} &= \frac{300,000,000}{f \text{ (in cycles)}} \end{aligned}$$

Since most work with television antennas involves frequencies measured in megacycles and antenna lengths measured in feet or inches, it is valuable to convert the fundamental formula given above to a more useful form that permits direct use of these practical values. Substitution of the following equivalents gives us the desired form of the equation:

$$1 \text{ meter} = 39.37 \text{ inches}$$

$$1 \text{ megacycle} = 1,000,000 \text{ cycles}$$

$$\text{Wavelength} = \frac{300,000,000 \times 39.37}{1,000,000 \times f \text{ (in cycles)}} = \frac{300 \times 39.37}{f \text{ (in mc)}} = \frac{11,810}{f \text{ (in mc)}}$$

A half-wavelength is one half of this value or

$$\frac{\lambda}{2} \text{ (in inches)} = \frac{5905}{f \text{ (in mc)}}$$

THE BASIC DIPOLE ANTENNA

The Half-Wavelength Dimension (contd.)

WAVELENGTH = 5 METERS
FREQUENCY = ?

$$\begin{aligned} \text{Frequency (cycles)} &= \frac{300,000,000}{\text{Wavelength (meters)}} \\ &= \frac{300,000,000}{5} \\ &= 60,000,000 \\ \text{FREQUENCY} &= 60,000,000 \text{ CYCLES} \\ &\text{OR } 60 \text{ MC} \end{aligned}$$

If it is desired to find $\lambda/2$ in feet we need only divide by 12:

$$\frac{\lambda}{2} \text{ (in feet)} = \frac{492}{f \text{ (in mc)}}$$

If a particular television signal has a frequency of 60 mc, a half-wavelength in free space is

$$\frac{5905}{60} = 98.4 \text{ inches} \quad \text{or} \quad \frac{492}{60} = 8.2 \text{ feet}$$

Practical antennas made of thin metal rods and used for television reception (or for any other kind of signal) allow electromagnetic energy to move along them at only about 95% of its velocity in free space. Therefore the equation for the wavelength dimension in free space is modified by the multiplying (velocity) factor 0.95, then

$$\begin{aligned} \text{half-wavelength in feet} &= \frac{492 \times 0.95}{f \text{ (mc)}} \quad \text{or} \quad \text{half-wavelength in inches} = \frac{5905 \times 0.95}{f \text{ (mc)}} \\ &= \frac{468}{f \text{ (mc)}} && = \frac{5616}{f \text{ (mc)}} \end{aligned}$$

Using the corrected equation, the half-wavelength antenna dimension for a 60-mc signal becomes 93.5 inches or 7.79 feet.

THE BASIC DIPOLE ANTENNA

Basic Half-Wave Dipole Forms

The basic half-wave dipole antenna appears in two forms; as a continuous rod (shown earlier), and as a rod that is split at the center, that is, consisting of two equal parts, each part being slightly shorter than one quarter-wavelength. The latter type is called the *split* or *center-fed* dipole, the name being derived from the point of connection of the transmission line to the antenna, as will be explained later. The overall physical length of the split-type dipole for any one half-wavelength includes the separation between the inner ends of the two rods, therefore this type has the same dimension for a half-wavelength as the continuous rod. The usual separation between the inner ends of the two portions of the split dipole is approximately 1 to 1.5 inches.

The Center-Fed Split Dipole Antenna

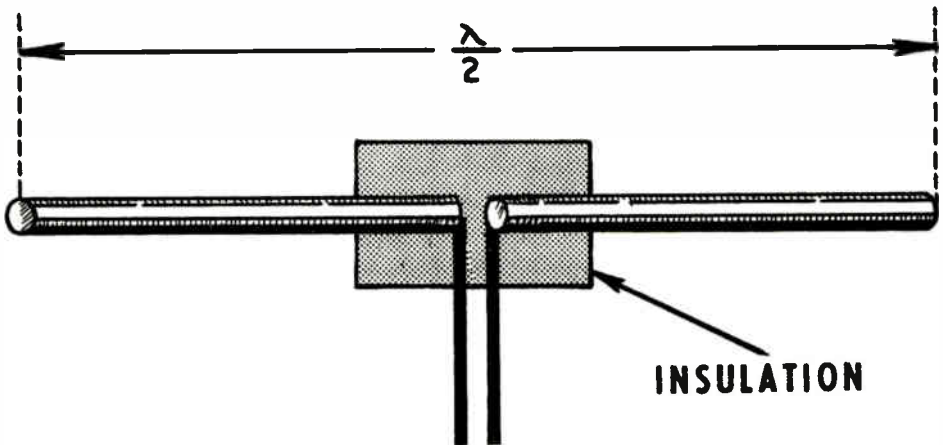

The continuous half-wave dipole and the split half-wave dipole are the equivalent of each other. Both can be used to extract energy from the passing wave and deliver the energy to a receiver via a transmission line. The split dipole antenna is used more often because it is easier to connect to the transmission line. On the other hand, the continuous dipole has applications for which the split dipole is not conveniently suitable. One of these is to extract energy from a passing electromagnetic wave and to re-radiate the energy in a controlled manner to aid the performance of an associated center-fed dipole that is connected to a receiver. This action is explained in detail elsewhere in the course. In the meantime, we shall explain the behavior of the basic half-wave dipole antenna in terms of the split or center-fed rod.

THE BASIC DIPOLE ANTENNA

The Transmission Line

The Transmission Line Feeds Energy

From the Antenna

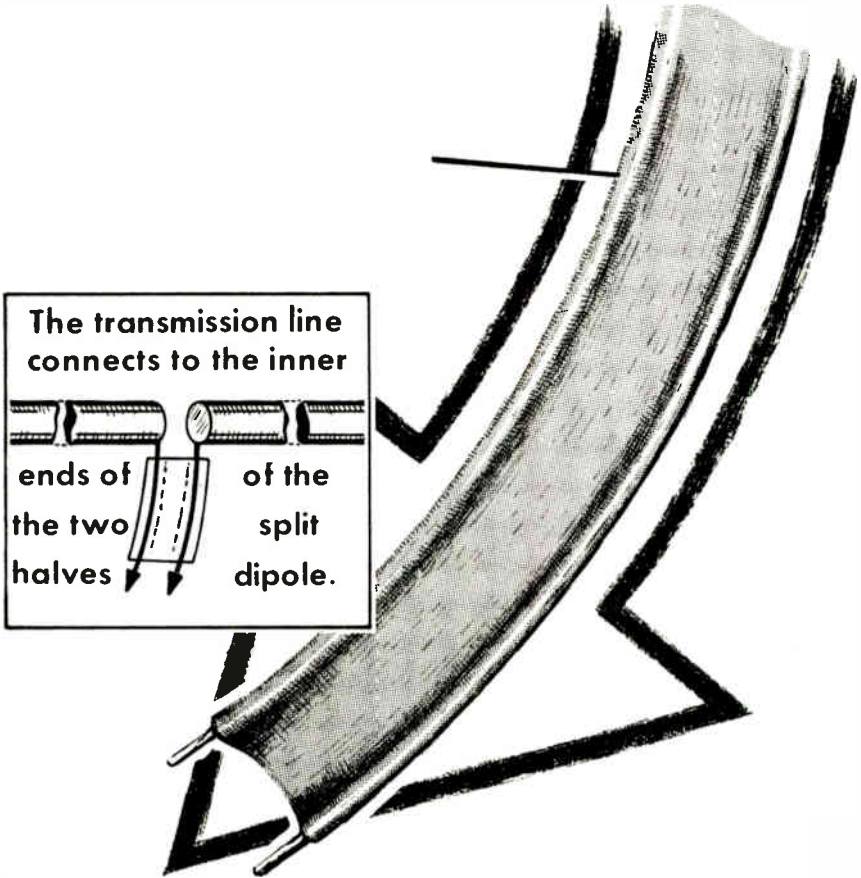

To the Receiver
Antenna Input Terminals

The function of the transmission line is to carry the received signal energy from the antenna to the television receiver. As will be seen later, transmission lines are of many different varieties. Here we show just one kind, but whatever may be the specific type, it is made up of two conductors or leads insulated from each other. The two leads at one end of the transmission line are connected to the dipole antenna, and the two leads at the other end of the line are connected to the antenna terminals of the receiver. The length of the transmission line is such as to conveniently span the distance between the antenna and the receiver, allowing for all mounting requirements.

THE BASIC DIPOLE ANTENNA

The Zero-DB-Gain Rating of the Basic Half-Wave Dipole

The basic half-wavelength dipole—continuous or split at the middle—bears still another identification which is very pertinent. It is called a *zero-db-gain* antenna. This is an artificial term that has become standard and expresses that the portion of energy which such an antenna can capture from a passing electromagnetic wave under standard conditions of use is fixed. Therefore the half-wave dipole can be used as a reference for comparison with the signal-capture capabilities of other type antennas.

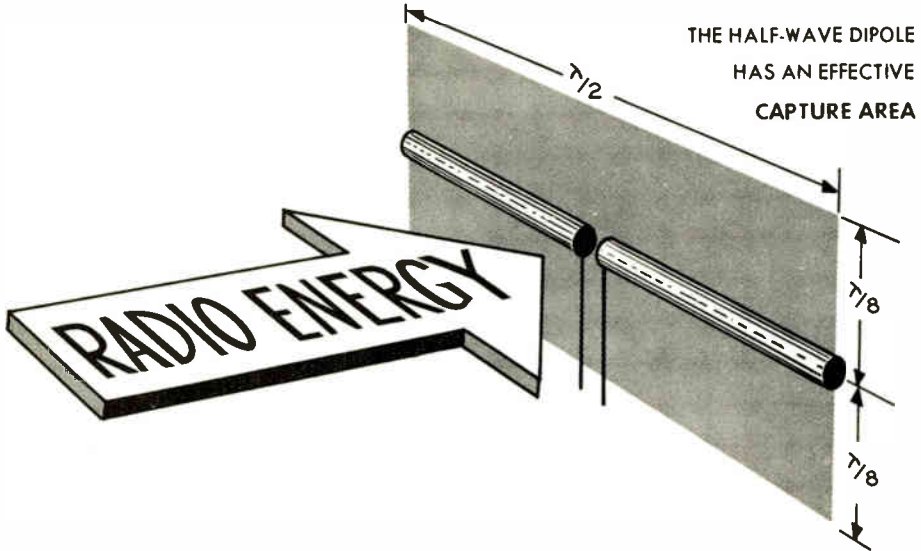

For example, it is assumed on a theoretical basis that the basic half-wave dipole will capture energy from a passing electromagnetic wave over an area that is one half-wavelength along the antenna and $\frac{1}{8}$ -wavelength above and below the antenna. This corresponds to zero-db-gain performance by the antenna. If, by modifying the antenna, it is made capable of capturing more than this normal portion of energy from the wave, the antenna with improved performance is described as having *gain*. Many elaborate antennas are capable of capturing from 2 to 7 times as much energy from a passing electromagnetic wave as the basic half-wave rod. That is, the amount of power extracted from the wave is from 2 to 7 times greater. Such antennas are said to have a *power gain* of from 2 to 7 times over the standard zero-db-gain half-wave dipole. By converting the power gain values to more conveniently usable *db* or *decibel* figures, the antenna with a power gain of 2 times is then described as having a gain of 3 db; the antenna with a power gain of 5 times has a gain of 7 db, and so on.

Comparison of antennas on the basis of gain is commonplace. Of course other bases of comparison are also used, but gain is very important.

THE BASIC DIPOLE ANTENNA

The Zero-DB-Gain Rating of the Basic Half-Wave Dipole (contd.)

THE STANDARD OF COMPARISON
FOR ANTENNA GAIN
IS THE

BASIC DIPOLE



(A ZERO-DB-GAIN ANTENNA)



$$\text{Gain of ANTENNA X (IN DB)} = 10 \log_{10} \frac{P2 \text{ (Power output of antenna X)}}{P1 \text{ (Power output of Basic Dipole)}}$$



DECIBEL TABLE

DB GAIN	POWER RATIO (P2/P1)
1	1.26
2	1.59
3	2.00
4	2.51
5	3.16
6	3.98
7	5.01
8	6.31
9	7.94
10	10.00
15	31.62
20	100.00

THE BASIC DIPOLE ANTENNA

Forms of the Basic Half-Wave Dipole Antenna

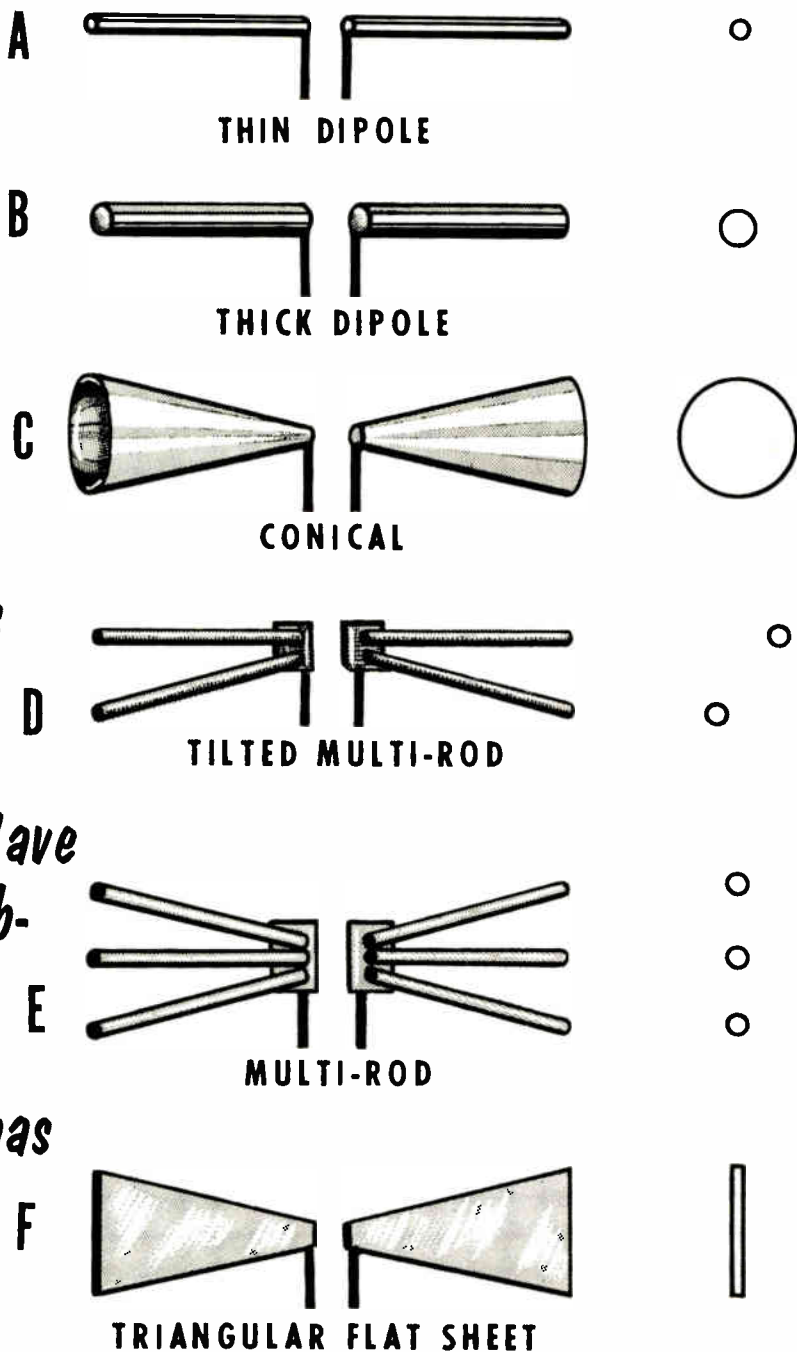

There Are Various Types of Half-Wave Zero-db-Gain Dipole Antennas

THE BASIC DIPOLE ANTENNA

Forms of the Basic Half-Wave Dipole Antenna (contd.)

Basic half-wave dipole antennas are of many physical forms. Each offers something in electrical behavior (characteristics) or physical structure that the other types do not have. All of them are rated at zero-db gain.

Practical antennas in daily use are almost all elaborations of the basic versions, and the study of television antennas must begin with the study of basic forms.

The center-fed half-wave dipole is usually made of a small-diameter ($\frac{1}{4}$ - or $\frac{1}{2}$ -inch) rod (A). Sometimes it is made of tubing of substantially wide diameter, say from 2 to 4 inches (B). Much more popular type of half-wave antennas are variations of the conical form (C). Because the complete cone offers too much physical resistance to wind, its equivalent is created by the use of multiple thin rods that fan outwards from the point of support. Sometimes the rods are all in line and project straight outwards from the point of support (D), and sometimes they are arranged to tilt towards the front (E), forming a horizontally positioned "V" pointing towards the arriving signal. Another basic type is made of flat sheet aluminum of triangular form (F). This is known as the "bat-wing", and is very popular at the ultra-high frequencies (UHF). The end view of each of these basic antennas is shown adjacent to the front or broadside view.

Although the basic half-wave dipole television antennas are shown "split" at the center, these antennas are not restricted to this form. The use of multiple rods to produce the equivalent of the conical form is simply a means of achieving the wide electrical "surface" that the cone presents to an approaching television wave without the disadvantage of the solid surface of the complete cone. The use of three rods instead of two, four, five or six to simulate each quarter-wave section of the cone-shape antenna is a compromise.

Whatever may be the number of thin rods making up each quarter-wave section, they act together as one, and the two halves make up a single *element*. This also is true of the solid-sheet bat-wing when it is simulated by the thin rod bent into a triangle.

Every half-wave dipole antenna displays the properties of resonant circuits, namely inductance, capacitance, and resistance. Resonant circuits tune sharply or broadly, depending on their design, and this action occurs with dipole antennas as well. This is important from the viewpoint of how the antenna will respond to the signals from one or more television stations that serve an area. The thin half-wave dipole antenna (A) tunes much more sharply than the dipole made of a large-diameter rod (B). The conical antenna (C) or its equivalents (D) and (E) will, by virtue of their greater surface, tune as broadly as (B), but also afford other electrical operating conditions that antenna (B) does not offer. The bat-wing (F) also tunes broadly and demonstrates electrical behavior corresponding to that of (C), (D), and (E).

DIPOLE BEHAVIOR

Resonance in a Half-Wave Dipole Antenna

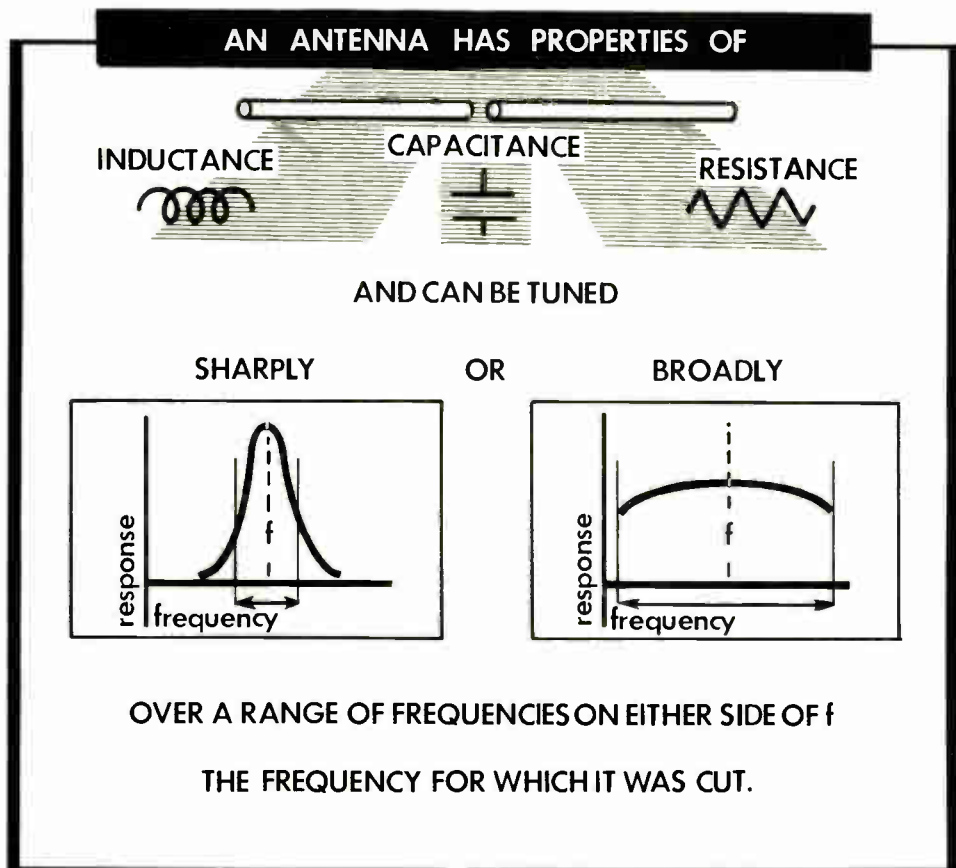

Thus we see that the diameter or surface area of an antenna is an extremely important factor in determining how sharply an antenna tunes. The various configurations shown are all dipole antennas, differing principally in their sharpness of tuning.

This variation in sharpness of tuning makes one type of antenna better suited to the reception of signals from several stations serving an area than another. The more broadly an antenna tunes, the wider is the band of frequencies that it will accept. In addition to frequency response, there exists still another very important consideration. It is referred to as *antenna resistance*. With more details to follow, this operating electrical constant is determined by the current and voltage distribution in the antenna produced by the television signal that the antenna intercepts—that is, the E/I relationship. This electrical constant in turn determines the kind of transmission line that can be used to couple the antenna to the receiver.

DIPOLE BEHAVIOR

Signal Interception by the Basic Dipole Antenna

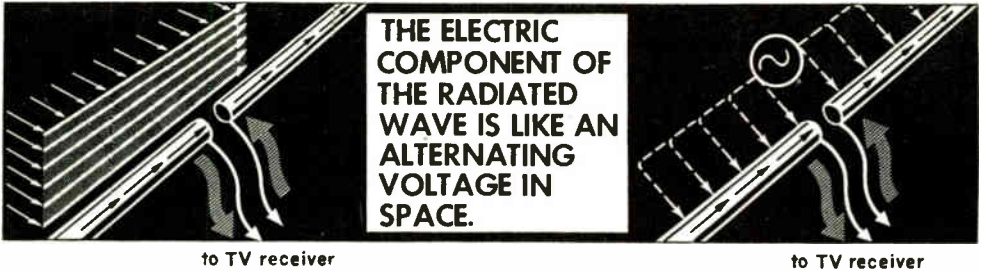

When an electromagnetic wave strikes a half-wave metal rod that is positioned parallel to the electric field lines of the incident wave, the electric energy in the wave induces a difference of potential between points along the surface of the rod.

The action might be visualized in terms of many alternating-voltage sources aiding each other connected across points along the rod. Therefore it is possible to say that the electric field of an electromagnetic wave is the equivalent of an *alternating voltage in space*.

When a voltage is induced along the metal rod, current will flow between the points of different potential along the surface of the rod. This is the signal current. By virtue of the presence of voltage and current in the intercepting antenna, the action is the equivalent of transferring electrical energy from the passing wave to the metal antenna.

For the half-wave rod to extract the greatest amount of electrical power from the passing wave its half-wave dimension must satisfy the frequency of the passing wave. Also, its orientation towards the arriving wavefront must be broadside (parallel). This enables the passing electric field to act "simultaneously" on the full length of the rod.

IF THE HORIZONTAL RECEIVING ANTENNA IS TO PERFORM MOST EFFECTIVELY

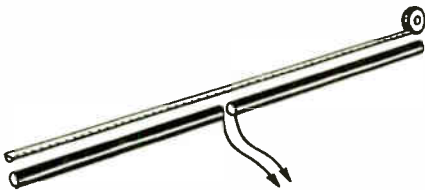

The half-wave dimension should equal the half-wave equivalent of the arriving signal frequency.

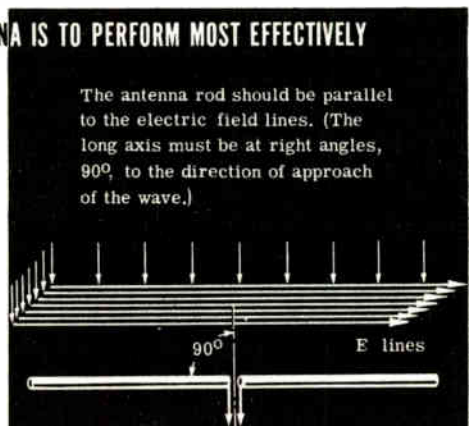

DIPOLE BEHAVIOR

Re-radiation of the Receiving Dipole

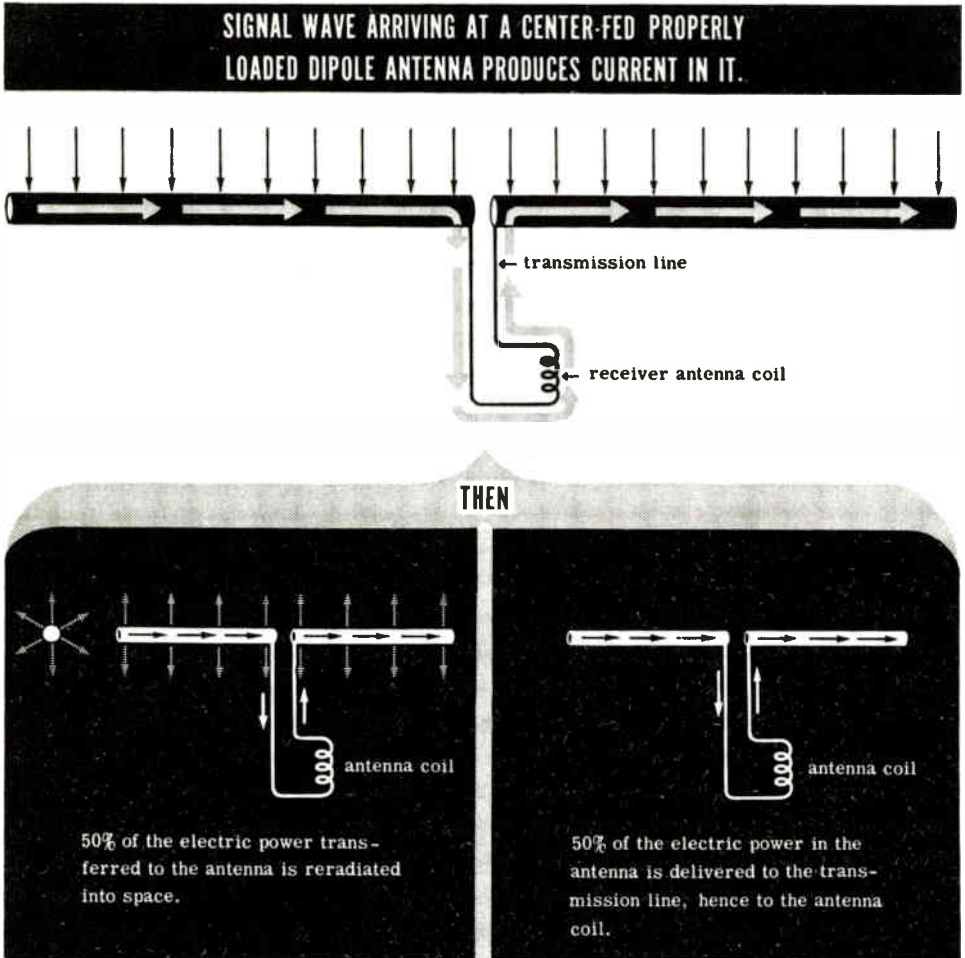

What happens to the electrical energy that is delivered to the receiving antenna? Assume for the moment that the antenna is a split or center-fed dipole with the proper transmission line connected from it to a receiver.

When current flows along the receiving antenna rod, signal energy is delivered to the receiver, but something else also occurs. Current in a transmitting antenna rod results in *radiation*. The same phenomenon occurs in the receiving antenna rod. In other words, the receiving antenna rod not only functions as a means of *extracting* energy from the passing television signal wave, but it also *re-radiates*, or liberates into space, some of the energy that it has extracted from the wave.

DIPOLE BEHAVIOR

Re-radiation From a Continuous Rod

Although the primary function of the antenna is to behave as an intercepting or receiving device, it cannot perform its function without also behaving as a transmitting antenna.

Suppose that the intercepting antenna is a continuous rod instead of a split dipole and there is no transmission line connected to the rod. What happens then?

The movement of electrons along the conductor will make the rod perform as a radiator, just as in the case of the split dipole. However, in the absence of the transmission line connection to the continuous rod, none of the energy transferred to the rod by the passing signal wave is extracted; therefore, the rod *re-radiates virtually all of the energy that it intercepts*. In effect, such a rod takes energy out of a passing signal wave and then sends the energy out into space again, so that its behavior is like that of a transmitting antenna far removed from the actual point of transmission.

This action may appear useless. Actually, it is very important in the operation of the antennas in daily use. It might be well at this time to mention that the signal interception and re-radiation actions of the split and the continuous-rod and half-wave dipole antennas also occur when the element has some other shape—a wide diameter rod, conical (or its equivalent), bat-wing, etc.

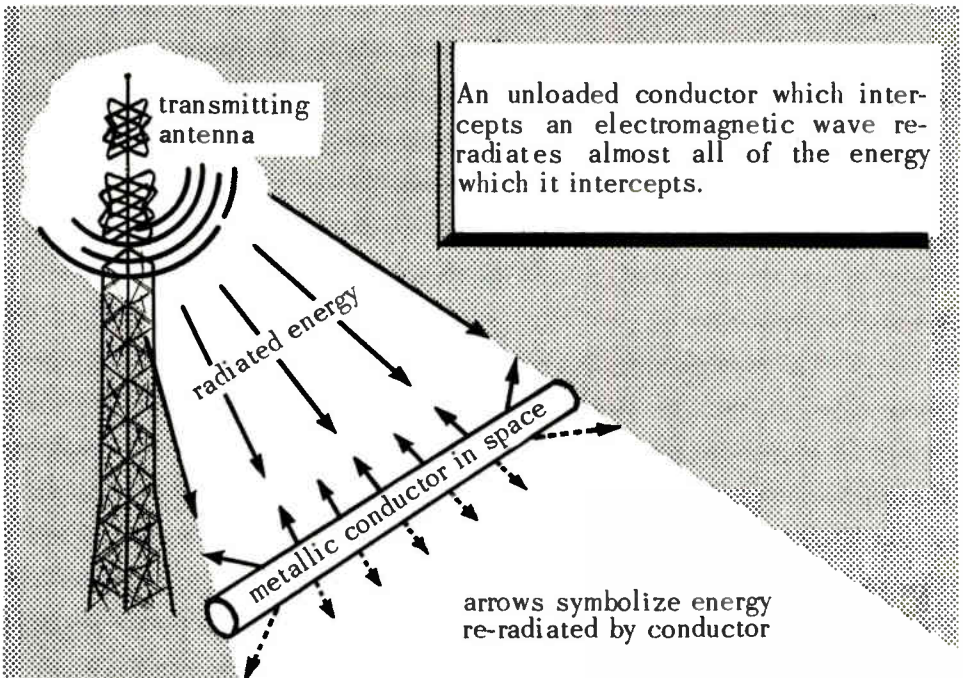

REVIEW

The signal-producing voltage in the receiving antenna is the resultant of the direct wave and the ground-reflected wave.

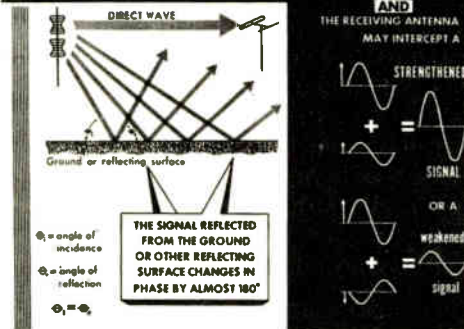

1. *Propagation of Television Signals.* The combination of the direct-wave and ground-reflected signal is stronger or weaker than the direct wave alone, depending on whether or not the two signals aid or oppose each other at the instant of arrival at the receiving antenna.

2. *The Field Concept.* The energy contained in the radiated wave is shown by magnetic field lines positioned at right angles to the electric field lines. The signal is horizontally polarized (i.e., the electric field lines are parallel to the earth's surface).

Electric and Magnetic Fields

of Horizontally Polarized Antennas

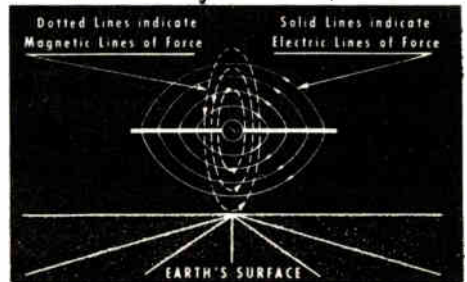

Antenna positioning is important in TV reception

REQUIREMENT #1

If the transmitting antenna is positioned vertically to the earth's surface



The receiving antenna must be positioned vertically to the earth's surface



If the transmitting antenna is positioned parallel to the earth's surface



The receiving antenna must be positioned parallel to the earth's surface



All television receivers used for broadcasting to the public are positioned horizontally relative to the earth's surface.

3. *The Radiated Wave.* All television receivers used for broadcasting to the public are positioned horizontally relative to the earth's surface. Horizontally polarized radiation minimizes pickup from vertically polarized voltages.

4. *The Zero-DB-Gain Rating of the Basic Half-Wave Dipole.* The basic half-wavelength dipole, continuous or split at the middle, is also called a zero-db-gain antenna, which means that the portion of energy that it can capture from an electromagnetic wave is used as a standard of comparison.

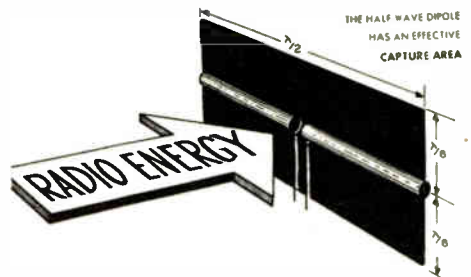

REVIEW

5. *Forms of the Basic Half-Wave Dipole Antenna.* The basic half-wave dipole antenna takes many forms. Each shape has its own physical and electrical characteristics. These antennas are not restricted to the "split-in-the-center" form. Whatever the number of thin rods making up each quarter-wave section, they act together as one, and the two half-sections make up a single dipole element.

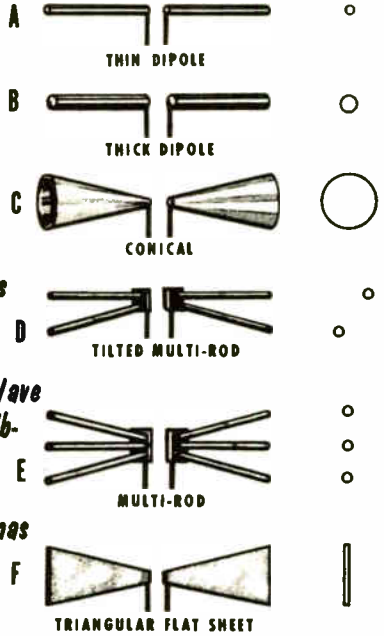

There Are Various Types of Half-Wave Zero-db-Gain Dipole Antennas

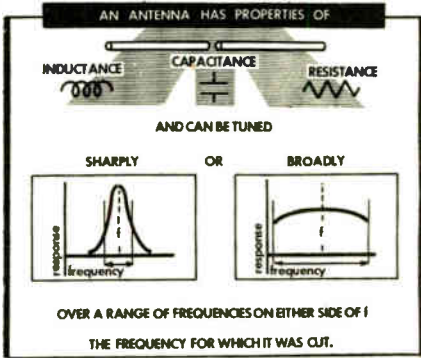

6. *Resonance in a Half-Wave Dipole Antenna.* The diameter or surface area of an antenna is an extremely important factor in determining how sharply an antenna tunes. The various configurations shown are all dipole antennas, differing principally in their sharpness of tuning.

7. *Signal Interception by the Basic Dipole Antenna* is maximum when its half-wave dimension satisfies the frequency of the passing wave, and when it is orientated parallel to the arriving wavefront.

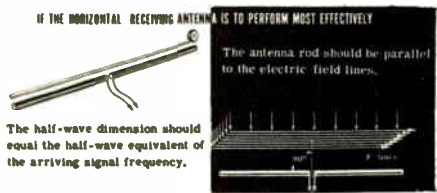

The half-wave dimension should equal the half-wave equivalent of the arriving signal frequency.

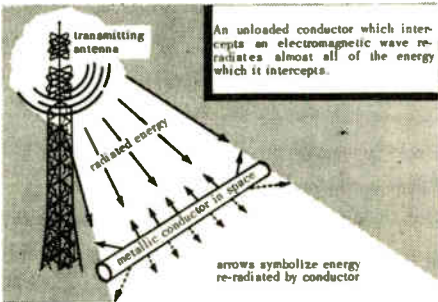

8. *Re-radiation from a Continuous Rod.* When current flows along the receiving antenna rod, signal energy is delivered to the receiver. Current in a receiving antenna rod results in re-radiation of some of the energy extracted from the wave.

DIPOLE ANTENNA RESPONSE

Broadside Positions of the Receiving Dipole

The term *broadside* as used here means *parallel*. For any two surfaces to lie in parallel planes does not require that they be at equal heights. The receiving dipole can be broadside to a radiated wavefront when the transmitting antenna is higher than the receiving dipole, on the same level, or below it. Given any horizontal receiving dipole, the transmitting dipole can also be broadside when it is facing either the front surface or the rear surface of the receiving rod.

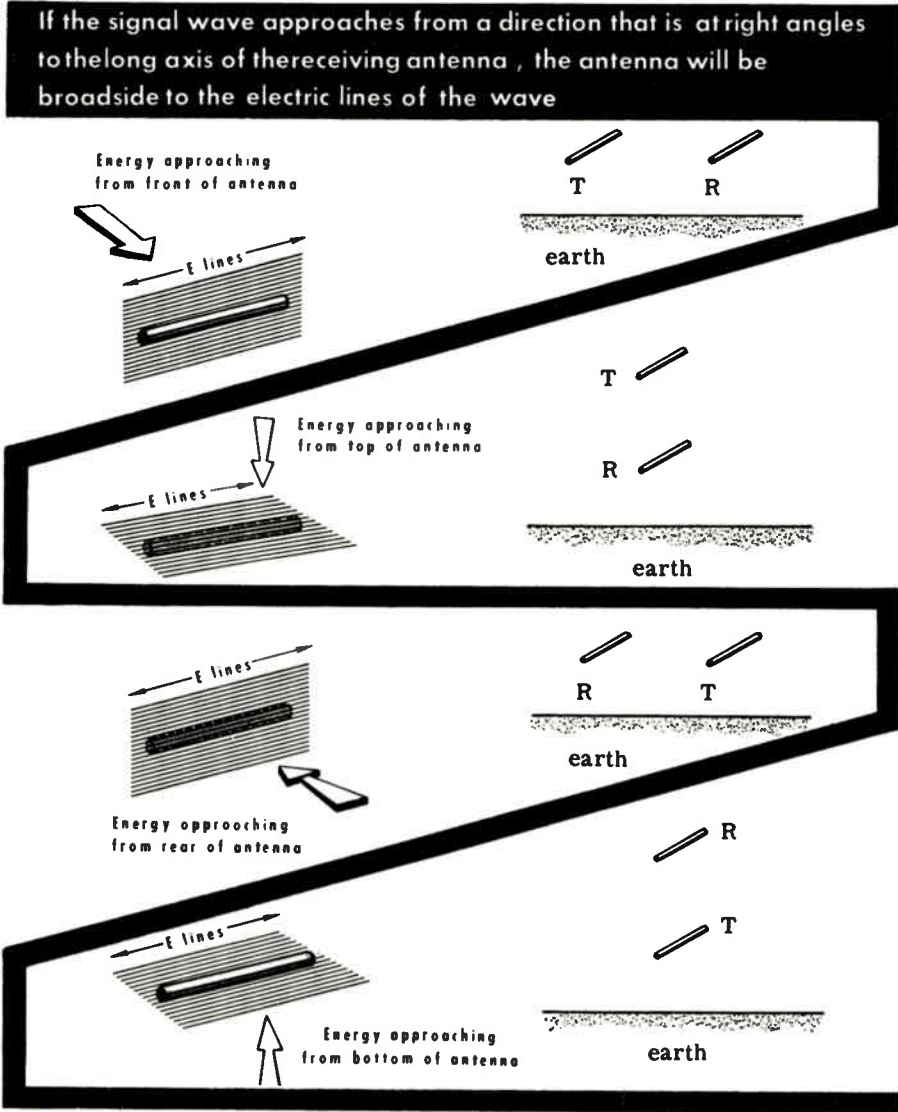

DIPOLE ANTENNA RESPONSE

Directional Response

An extremely important item of television antenna behavior is the manner in which it responds to signals that arrive from different directions. This characteristic is termed the *directional response* of an antenna or its directivity.

Understanding this action makes it possible to "point" the antenna so that best reception of the desired stations (with minimum interference from the undesired stations) results, especially when receiving points are midway between transmitting stations located in different directions relative to the receiving point. Also, it provides one of the reasons why there are different types of antennas. Directional response is very important in areas where signals are received from many angles.

The different

Horizontal Orientations of a receiving antenna

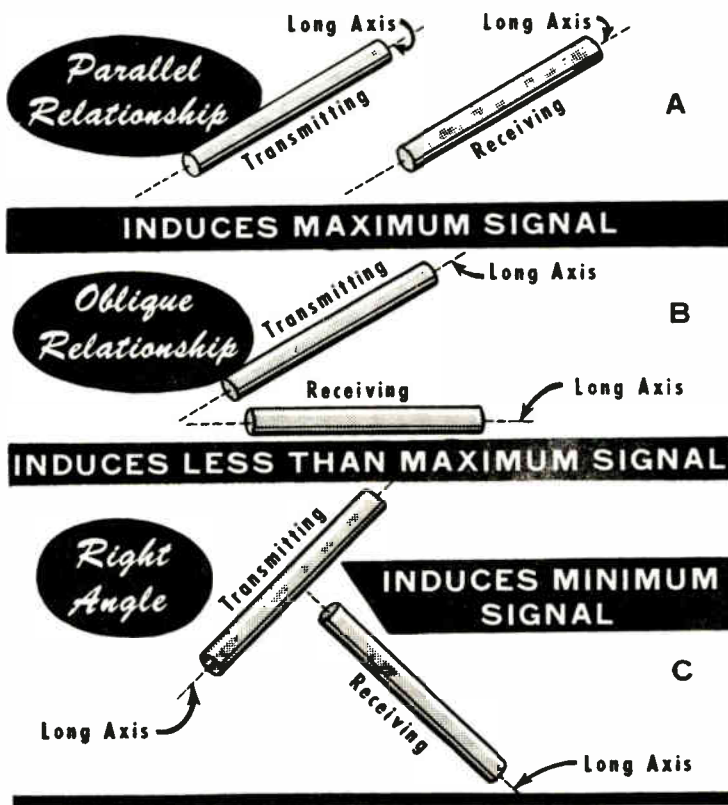

We have said that when the receiving dipole is broadside to the transmitting dipole (which is the same as saying its long axis is parallel to the electric field lines in the approaching television signal wave), maximum signal voltage will be induced in the antenna. What happens if this broadside relationship does not exist?

DIPOLE ANTENNA RESPONSE

Demonstration of Receiving Antenna Dipole Positioning Effects

Let us perform a simple experiment to determine how the signal pickup by a horizontal dipole of correct physical length changes as antenna orientation to an approaching horizontally polarized wave is varied. The demonstration frequency is 600 mc, permitting the use of a small-sized antenna. The experiment is conducted in an area where the signal picked up by the receiving antenna arrives only from the direction of the transmitting antenna. (The ground-reflected signal is neglected.) The transmitting and receiving antennas are at the same height.

The receiving dipole is mounted on a pivot so that it can be revolved through a flat circle of 360°. A scale attached to the antenna upright indicates the angle through which it has been turned relative to its starting position. A suitable rectifier system and an indicating meter connected to the receiving dipole indicate the relative strength of the signal voltage induced in the antenna at each position.

The results of rotation are plotted on the graph. When the two antennas are broadside to each other (positions A-E and E-A), maximum signal voltage is induced in the receiving antenna. In this position the receiving antenna is parallel to the electric field lines of the wave that it intercepts. When the ends of the receiving antenna are pointing straight at the transmitting antenna (positions C-G and G-C), minimum signal voltage is induced in the receiving antenna. (The voltage is never zero because even the tiniest antenna has some cross section, therefore constituting a horizontal surface that can be acted on by the horizontal electric field lines of the approaching wave.)

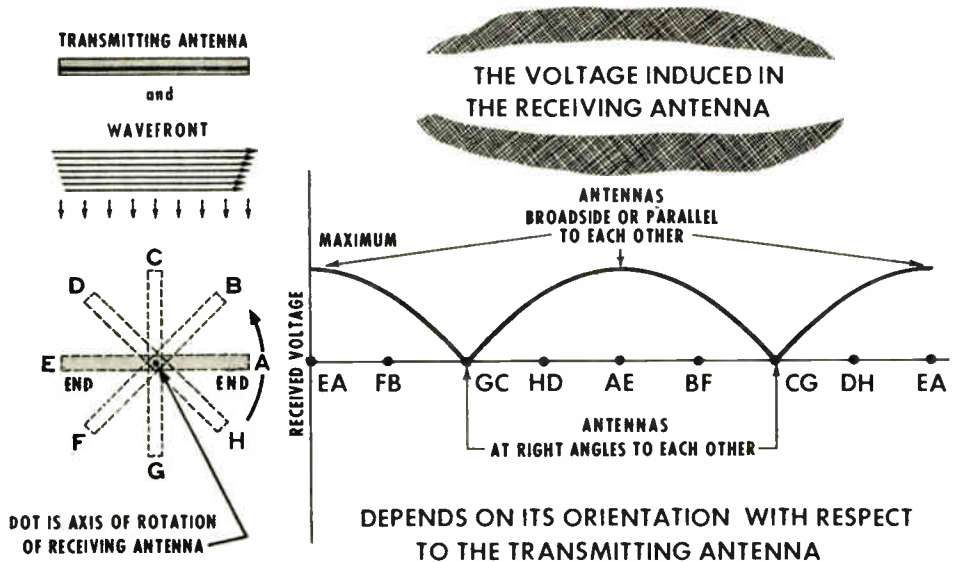

DIPOLE ANTENNA RESPONSE

Dipole Positioning Effects (contd.)

Positioning the receiving antenna between broadside and right angles to the approaching electric field affords different amounts of induced signal voltage. The amount of signal energy contained in the wave that arrives at the receiving antenna always is the same, whereas the amount of signal voltage induced in the receiving antenna differs according to its orientation. Thus, we can attribute the variation in the amount of energy transferred from the wave to the receiving antenna to the behavior of the antenna. How do we explain this? The illustration shows the following:

SOURCE

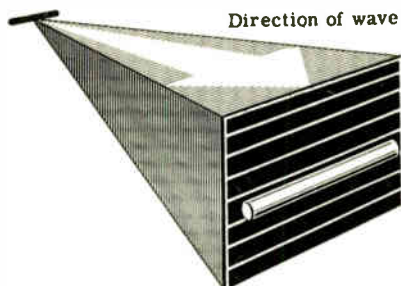

When the receiving dipole is parallel to the approaching wavefront, the electric field "sees" the entire antenna and acts on the entire antenna.—Result is the strongest signal.

SOURCE

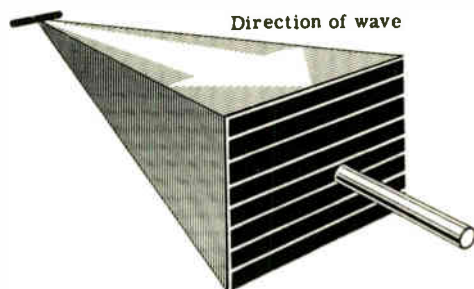

When the receiving dipole is at right angles to the approaching wavefront, the electric field "sees" only a tiny antenna, the cross section of the rod.—Result is theoretically zero signal.

SOURCE

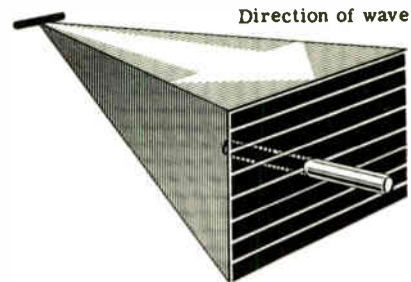

When the receiving dipole is oriented between parallel and right angles to the approaching wavefront, the electric field "sees" only a reduced portion of the rod at any one time.—Result is reduced signal strength.

For intermediate positions of orientation of the receiving antenna, between broadside and right angles, the electric portion of the approaching wave "sees" different amounts of the antenna conductor.

DIPOLE ANTENNA RESPONSE

Directional Response of a Half-Wave Dipole

We have seen that changing the orientation of a horizontal dipole relative to a fixed-position source radiating a horizontally polarized signal changes the amount of signal voltage induced in the antenna. Let us now examine how the same dipole behaves when the horizontally polarized signal approaches from different directions.

To do this we place a half-wave receiving dipole at a fixed point. Attached to it is a suitable rectifier and a meter to indicate the strength of the signal voltage induced in the antenna under different conditions. We arrange to move a transmitter and its antenna in a circle around the fixed receiving dipole. The frequency (600 mc) of the transmitter corresponds to the half-wave dimensions of the receiving and transmitting antennas.

The starting position has the transmitter and receiver dipoles broadside to each other. This point is designated as the 0° (start) and 360° (finish) position. The signal voltage induced in the receiving dipole is measured and noted in conjunction with its angular position, 0° . Then the transmitter is moved through 10° and a second measurement of the signal pickup by the receiving dipole is made and noted.

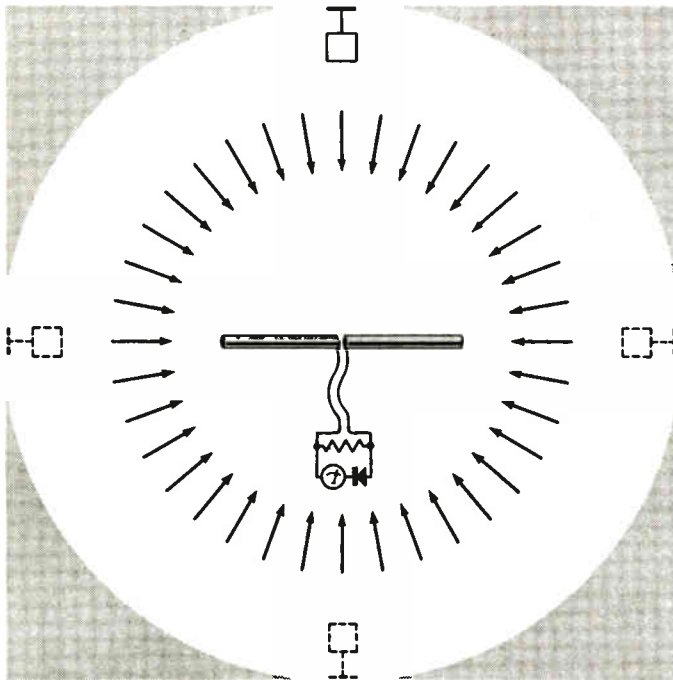

The wavefront of a radiated wave can approach the receiving antenna from a variety of angles

This procedure is repeated every 10° of the circle until the full 360° has been covered. Now we will transfer this information to *polar coordinate* graph paper. This paper is made up of a series of concentric circles, beginning with a dot at the center, and uniformly spaced radii fanning out from the center. Each radius corresponds to a particular angle relative to 0° , and the response, plotted on the radii gives the response pattern.

DIPOLE ANTENNA RESPONSE

Directional Response of a Half-Wave Dipole (contd.)

DATA FOR THE RESPONSE PATTERN

Angle from Broadside (degrees)	Signal Strength Units	Angle from Broadside (degrees)	Signal Strength Units
0	100	190	97
10	97	200	92
20	92	210	83
30	83	220	70
40	70	230	57
50	57	240	42
60	42	250	30
70	30	260	10
80	10	270	1
90	1	280	10
100	10	290	30
110	30	300	70
120	42	310	92
130	57	320	97
140	70	330	100
150	83	340	
160	92	350	
170	97	360	
180	100		

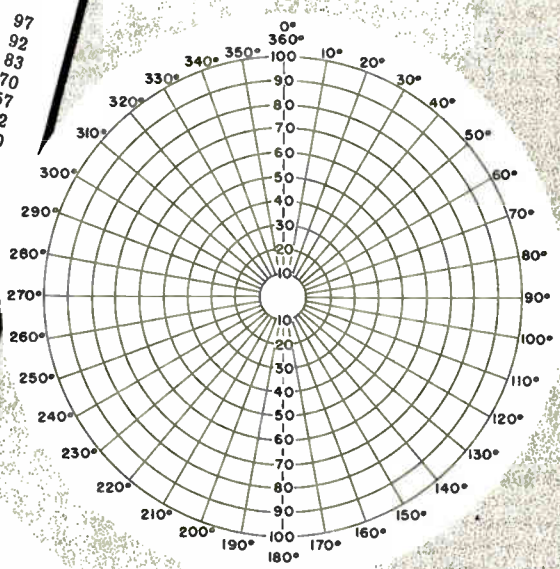

The signal voltage measurements made during the demonstration had a low value of 1 unit and a maximum value of 100 units. We will select the radii at 0° and 180° and use them for the signal response scales. We have 10 uniformly spaced circles intersecting these radii. Each is used to represent a signal voltage level 10 units higher than the preceding one, working outwards from the center, which has a level of 0. The circles joining these points represent voltage levels as shown on the voltage scale. The first (innermost) circle represents 10 units of signal strength; the second one, 20 units; the third one, 30 units, and so on to the outermost circle, which represents 100 units of signal pickup. We draw a short horizontal line through 0 signal level to represent the antenna.

DIPOLE ANTENNA RESPONSE

Directional Response Pattern of a Half-Wave Dipole (contd.)

To transfer the tabulation of signal pickup values to the corresponding points on the polar coordinates, we place a dot at the appropriate level of signal pickup along the radii corresponding to the angular positions of the transmitting antenna where measurements were made. Then we join these points and the result is a *figure 8* pattern.

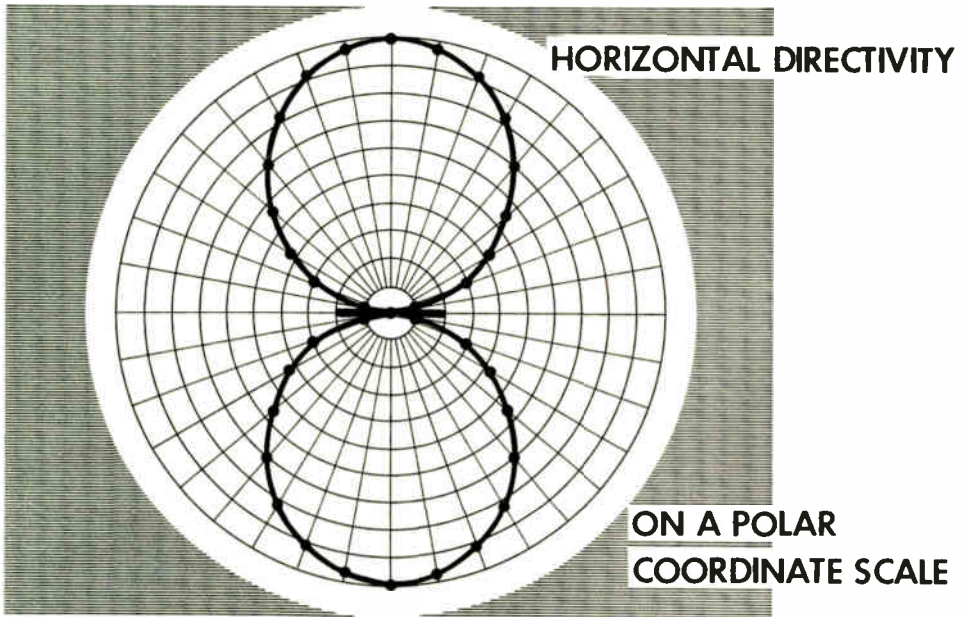

The antenna is seen to be bidirectional; that is, it accepts signals equally well from two directions, the front and the rear. This form of behavior is independent of the transmitter signal output because it is a characteristic of the antenna itself. It does, however, require that the frequency of the signal received be that for which the antenna length equals a half-wavelength. This is the *fundamental* frequency of the antenna. If operation is not on the fundamental frequency the behavior of the antenna no longer is equally bidirectional. It differs substantially as we shall describe later.

The pattern also shows that signals from directions that differ from the broadside positions by equal angular amounts, say 30° and 330° , or 70° and 290° (and are of the correct frequency), will induce like voltages in the receiving antenna, regardless of whether they arrive from the front or from the rear of the antenna. Minimum (theoretically zero) pickup results when the signals arrive from the side of the antenna. This was shown earlier when we rotated the receiving antenna in a flat circle relative to a fixed-position transmitting antenna so that the ends of the receiving antenna were pointing towards the transmitting antenna.

DIPOLE ANTENNA RESPONSE

Directional Response Pattern of a Half-Wave Dipole (contd.)

The response pattern on each side of the antenna is called a *lobe*. Each lobe shows the receptivity of the antenna to signals of the correct frequency originating in directions that are encompassed by the lobe. Each response lobe shows the direction of best and poorest signal pickup by the antenna.

Although it is true that a rotatable antenna can be positioned so as to provide the best signal in the receiver, it is nevertheless valuable to know about antenna directivity. When several stations operating at different frequencies and located in different directions from the receiving site are being received on a single antenna, knowledge concerning the horizontal directivity response makes it easier to position the antenna. The direction of the radiated energy from an undesirable station should be between response lobes or in a direction that minimizes pickup by striking the antenna at a low response point on a lobe.

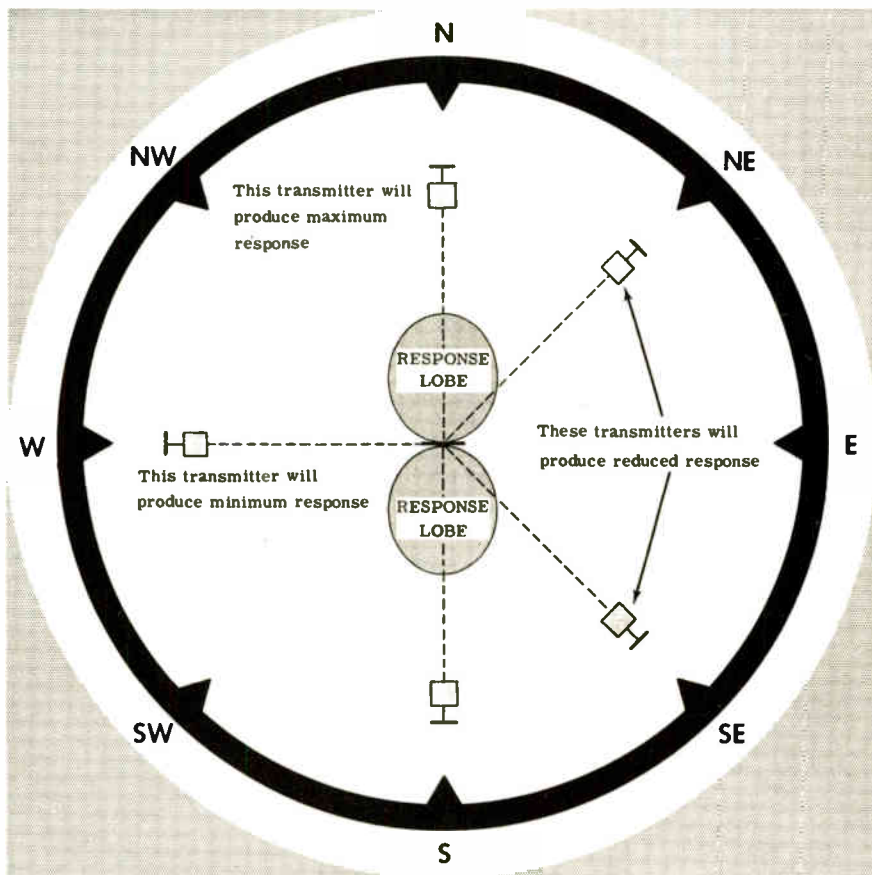

DIPOLE ANTENNA RESPONSE

Directional Response of a Half-Wave Dipole to Nonresonant Frequencies

What happens to the horizontal directional response if an antenna intercepts signals of higher than its resonant frequency? When the frequency of a signal is higher than the resonant frequency of an antenna, the original half-wave antenna length becomes a full-wavelength long relative to the arriving signal. Maximum response is no longer broadside to the front and rear. What was maximum response broadside to the front and rear is now minimum response.

The main signal pickup directions are at four different angles to the long axis of the antenna. To achieve maximum pickup it would be necessary to turn the receiving antenna so that a line drawn through the long axis of any one of the lobes would be at right angles to the wavefront.

The usual method of using television antennas does not involve orientation on the basis of the theoretical response lobes. In most cases the positioning is a practical compromise that affords the best signals from the different TV stations which serve an area. Nevertheless you should be familiar with changes in directional response caused by differences between the frequency of the received signal and the resonant frequency of the half-wave antenna. Suppose the signal frequencies are not whole number multiples of the resonant frequency of the simple half-wave dipole antenna. Assume a signal frequency of 195 mc (channel 10) and a half-wave antenna cut for 79 mc (channel 5), a ratio of about $2\frac{1}{2}:1$ in frequency. The half-wave antenna at resonance (79 mc) is $1\frac{1}{4}$ wavelengths long at 195 mc.

If an antenna is cut to be a half-wavelength at 63 mc (channel 3), it is $1\frac{1}{2}$ wavelengths long at 189 mc (channel 9)—a ratio of three times.

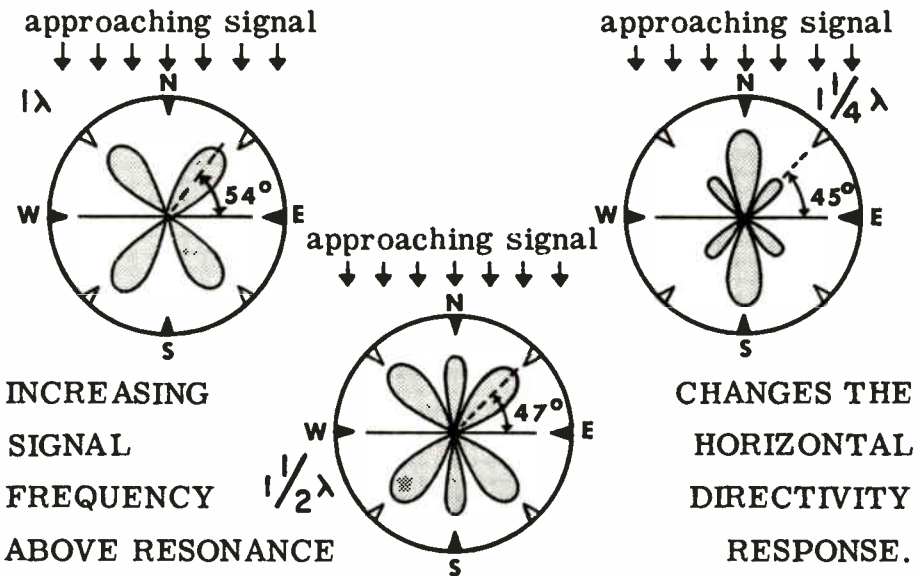

ANTENNA RESISTANCE

Voltage and Current for a Half-Wave Dipole at Resonance

For the sake of explanation, let us assume a radiated signal of a single frequency. When the passing wave induces a voltage (and corresponding current) in a half-wave dipole functioning at the resonant frequency, a special form of voltage and current distribution takes place. This occurs in the continuous-rod half-wave dipole as well as in the split half-wave dipole. The two extreme ends of the half-wave rod assume potentials that are maximum and of opposite polarity, and the voltage decreases to a minimum (not zero) at the center of the rod.

Similarly, the distribution of current caused to flow in the rod by the induced signal voltage is nonuniform. The current is minimum (not zero) at the ends of the rod and is maximum at the center of the rod.

The current and voltage pattern is not influenced by how much signal voltage is induced in the antenna. The passing electromagnetic wave may be strong, from a local station, or weak, from a distant station, thus inducing either a high or a low voltage. In any case, the voltage and current distribution pattern is the same.

The values of voltage and current are not too important from the practical standpoint. What matters more is that for any value of induced voltage there is a finite value of current at every point along the antenna. If we now look at the current and voltage distribution pattern it is evident that some characteristic—inherent in the antenna—is responsible for the amount of current that flows under the influence of the induced voltage. We can regard this as being some form of inherent antenna resistance which we label R_a . It is much greater than conductor resistance, which we neglect.

CURRENT AND VOLTAGE DISTRIBUTION ON A HALF-WAVE DIPOLE

CURRENT IS MAXIMUM AT THE MIDPOINT
OF THE HALF-WAVE ELEMENT

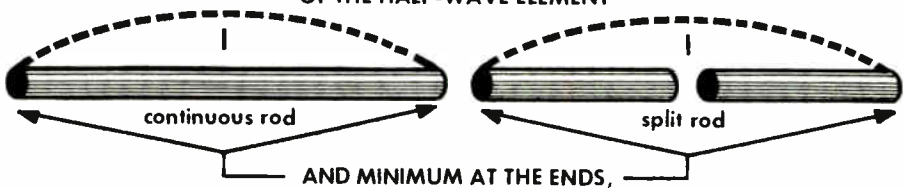

VOLTAGE IS MAXIMUM AT THE ENDS

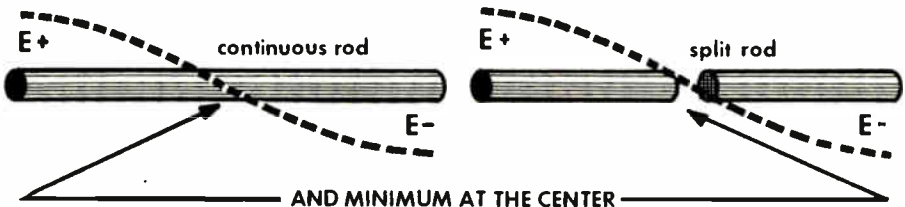

ANTENNA RESISTANCE

Antenna Resistance of Half-Wave Antenna

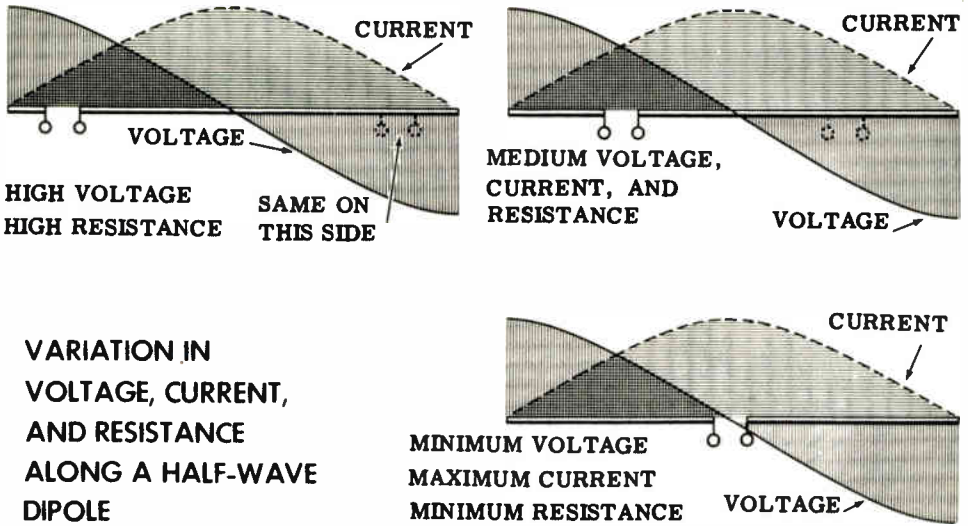

VARIATION IN
VOLTAGE, CURRENT,
AND RESISTANCE
ALONG A HALF-WAVE
DIPOLE

The ratio E/I between the induced voltage and resultant current is, however, not constant along the antenna length. If we view the E/I ratio as being an indicator of antenna resistance (R_a), then

1. the resistance is least at the midpoint of the antenna, as indicated by, the fact that minimum induced voltage results in maximum current;
2. the resistance increases as we move away from the midpoint of the rod, as indicated by the fact that as the voltage increases the resultant current decreases;
3. the resistance increases in similar fashion both sides of the midpoint of the dipole, as indicated by the fact that current changes are similar each side of the dipole midpoint and voltage changes are similar each side of the dipole midpoint;
4. the resistance is greatest at the ends where, although the voltage is maximum, the current is minimum.

Measurement and calculation have shown that the antenna resistance at the midpoint of an infinitely thin, straight half-wave dipole operated at its resonant frequency would be about 72 ohms. The resistance between the ends of such an antenna would be about 2500 ohms. Of these two values it is the center or midpoint resistance that interests us. It is generally considered that any straight, half-wave rod having a diameter up to about $\frac{1}{2}$ inch demonstrates an acceptable approximation of this midpoint resistance of 72 ohms. As shown later, increasing the diameter of the dipole rods or tubes lowers the midpoint resistance substantially.

ANTENNA RESISTANCE

Antenna Resistance of a Nonresonant Half-Wave Antenna

Operation at the fundamental frequency has been discussed. The condition of resonance influences the distribution of the induced voltage and resultant current along the length of the rod and therefore the antenna resistance (R_a) of the antenna. In most instances, television receiving antennas are not resonant to the signals they intercept, and the center impedance is more than 72 ohms. This is not an accident, but rather a deliberate condition created in antenna design to raise the midpoint resistance to satisfy the "generator-to-load" impedance relationship for optimum power transfer. (We will explain this in more detail later.)

THE ANTENNA RESISTANCE OF A HALF-WAVE DIPOLE AT RESONANCE IS LOWEST AT THE CENTER AND INCREASES SYMMETRICALLY ON EACH SIDE OF THE CENTER.

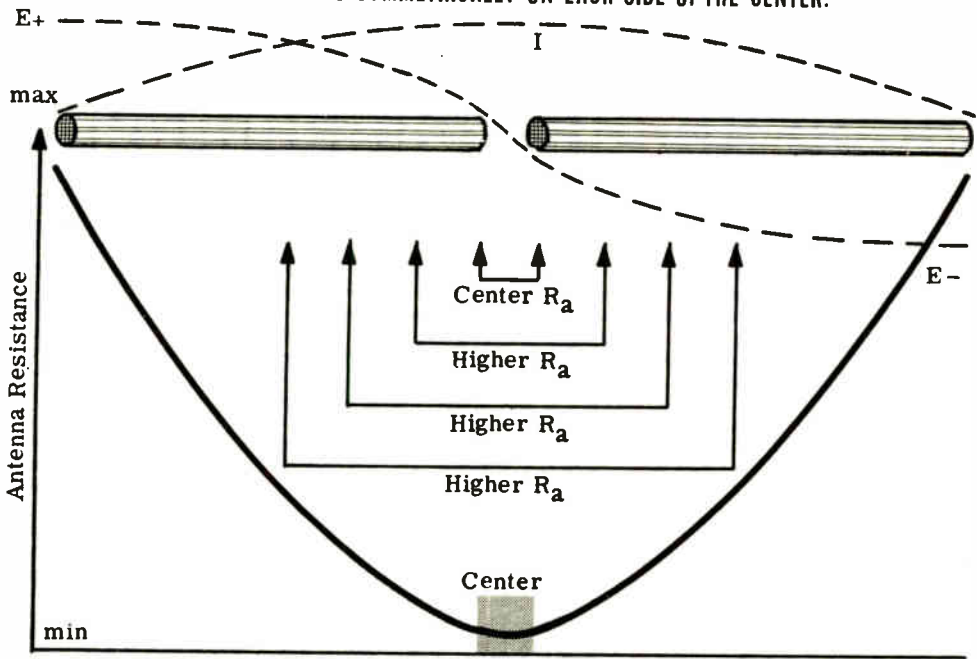

Most modern day television receivers are intended to be used with transmission lines rated at 300 ohms. Therefore, antennas must be arranged to feed signal energy efficiently into a 300-ohm line (load), when intercepting the signals from different television stations. Inasmuch as this value of resistance is obtained only under certain specific conditions, which cannot be realized in practice during multistation reception with a single antenna, we must examine antenna behavior under so-called *nonresonant* conditions.

Television antennas often operate at signal frequencies which differ from that for which the antenna was "cut" to be a half-wavelength long.

ANTENNA RESISTANCE

Antenna Resistance of a Nonresonant Half-Wave Antenna (contd.)

It is easily possible that the received signal frequency is such as to make the half-wavelength dimension of the antenna a fractional or a whole-number multiple relative to the received signal frequency. For instance, if an antenna is a half-wavelength at 63 mc (channel 3), it is $1\frac{1}{2}$ wavelengths long at 189 mc (channel 9), but the same antenna is only a fractional multiple of a half-wavelength for a signal of 85 mc (channel 6). What effect does such operation have on the antenna midpoint resistance? Stated briefly, it raises the antenna resistance at the midpoint. In fact, antenna resistance rises and falls (as the operating frequency relative to the resonant frequency of the antenna changes), but it never falls to the value corresponding to resonant operations at the half-wavelength.

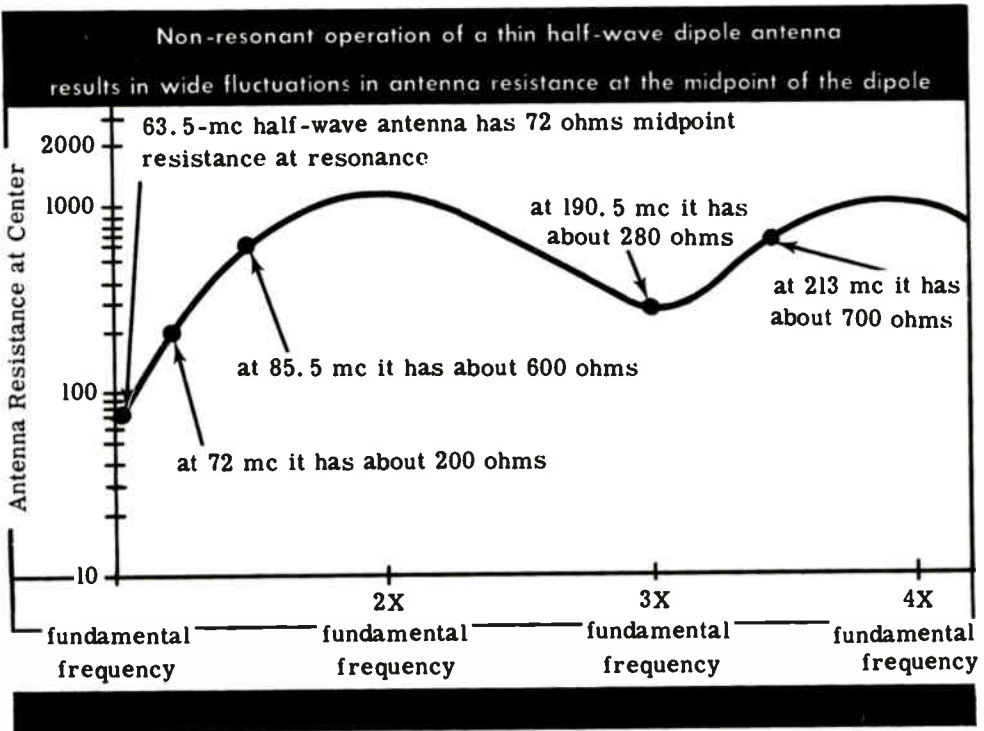

Operation of the simple straight-rod half-wave dipole at some frequency higher than that for which it was cut results in a midpoint resistance higher than at fundamental resonance. Whether the midpoint resistance is very *much* higher or merely higher, depends on the relationship between the antenna length and the arriving signal frequency. Controlling antenna resonance (length) is one means of achieving almost any desired midpoint resistance. Another method is to change the diameter of the antenna conductor or the shape of the antenna.

ANTENNA RESISTANCE

The Antenna Feedpoint or Loadpoint

If we wish to extract energy from the receiving antenna we must connect a *load* to the antenna. Such a load is the transmission line that conducts the energy from the antenna to the antenna-input coil of the receiver. The point along the antenna where the transmission line is connected is called the *feedpoint* or the *loadpoint*.

The word feedpoint arises from the language of transmitting antennas and expresses the place along the antenna where the energy is delivered. The loadpoint is receiving practice language, being the place along the antenna where the signal energy is removed and fed to the receiver. So, feedpoint and loadpoint are one and the same position along the antenna.

In all applications of television receiving half-wave dipoles, the loadpoint is in the vicinity of the midpoint of the antenna. This is so for the continuous-rod dipole and for the split dipole. It affords a balanced antenna structure and also is the most convenient point for attaching the transmission line because the voltage is lowest and the resistance is lowest.

Apropos of the "resistance at the midpoint" of the half-wave dipole, we refer to it as being of a value (say, 72 ohms for the thin-rod half-wave resonant dipole). In practice, this midpoint resistance is considered as being effective over a region of $\frac{1}{2}$ to $\frac{3}{4}$ inch each side of the midpoint of the overall length of the rod. In other words, we assume an acceptable approximation of the rated midpoint resistance (here, 72 ohms) when the transmission line connections to the thin, straight dipole are made at points about $\frac{1}{2}$ to $\frac{3}{4}$ inch each side of the midpoint. This may be considered true for antennas of different conductor thicknesses or shapes and for antennas rated at more or less than 72 ohms midpoint resistance.

THE CENTER OR MIDPOINT of a split dipole



is its **FEED POINT** in all television receiving applications and is the point



where the **TRANSMISSION LINE** is connected.



The midpoint of a continuous half-wave dipole is actually about **1.5 INCHES WIDE**.



A transmission line connection to a continuous rod is not a short circuit because antenna resistance exists between all points along the rod.



ANTENNA RESISTANCE

Power Transfer from a Half-Wave Antenna

Basic electricity teaches that maximum electrical power can be delivered from a generator to a load only when the impedance of the load is equal to the internal impedance of the source (generator). Let us examine this situation from a simple d-c viewpoint, even though in practice we are concerned with alternating voltage and current. The d-c example is applicable to a-c conditions, provided that we consider d-c resistance as being replaced by a-c circuit impedance in the control of current.

Assume that the d-c generator is rated at 100 volts, with an internal d-c resistance of 100 ohms, and is connected to loads of 50 ohms, 100 ohms, and, finally, 150 ohms.

$E = 100$ volts
100 ohms
internal
resistance
of generator

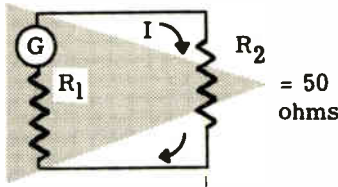

$$I = \frac{E}{R_1 + R_2} = \frac{100}{150} = 0.66 \text{ amp}$$

$$P = I^2 R$$

$$= 0.66^2 \cdot 50 = 0.44 \cdot 50 = 22 \text{ watts}$$

$E = 100$ volts
100 ohms
internal
resistance
of generator

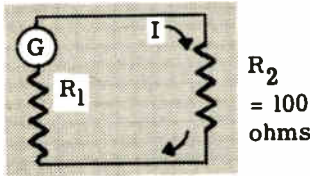

$$I = \frac{E}{R_1 + R_2} = \frac{100}{200} = 0.5 \text{ amp}$$

$$P = I^2 R$$

$$= 0.5^2 \cdot 100 = 0.25 \cdot 100 = 25 \text{ watts}$$

$E = 100$ volts
100 ohms
internal
resistance
of generator

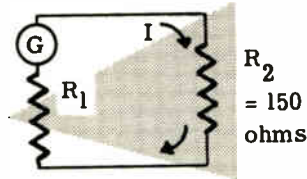

$$I = \frac{E}{R_1 + R_2} = \frac{100}{250} = 0.4 \text{ amp}$$

$$P = I^2 R$$

$$= 0.4^2 \cdot 150 = 0.16 \cdot 150 = 24 \text{ watts}$$

Examining these simple calculations we note two significant facts. Maximum power is delivered to the load only when the load resistance is equal to the internal resistance of the generator. In this case, as much power is delivered to the load as is wasted in the generator. Such operation occurs with the correct resistance (impedance) *matching*. If the load resistance is either greater or smaller than the generator resistance, less than the maximum amount of power that can be delivered to the load is transferred to it. We can relate these findings to a receiving antenna and say that under ideal conditions of matching—that is, when the transmission line impedance (load resistance) equals the midpoint resistance of the antenna—the antenna (generator) will deliver 50% of its energy to the load.

ANTENNA RESISTANCE

Why the Antenna Loadpoint Resistance Is Important

We have explained that maximum power transfer takes place between a generator and its load when the load resistance is equal to the generator resistance. Applying this principle to a television receiving system, the antenna is the generator and the antenna input transformer in the receiver is the load.

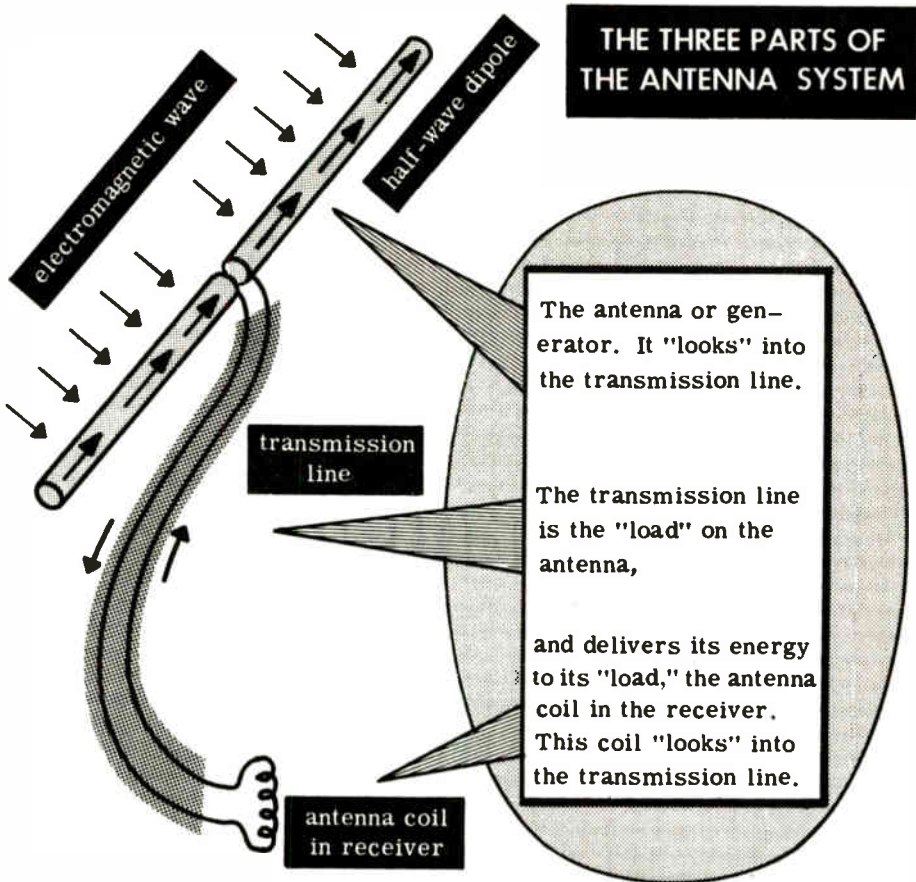

The transmission line impedance, therefore, must satisfy both the antenna loadpoint resistance and the antenna transformer input impedance. Treating each of these individually, the first determining factor for maximum power transfer between the antenna and the transmission line requires that the transmission line impedance equal the antenna loadpoint resistance. Thus the loadpoint resistance of the antenna is one of the determining factors in deciding the impedance of the transmission line. An improper match means a waste of power in the antenna.

ANTENNA RESISTANCE

The Input Impedance of the Antenna Input Transformer

Conditions of impedance match for best transmission of energy from antenna to receiver

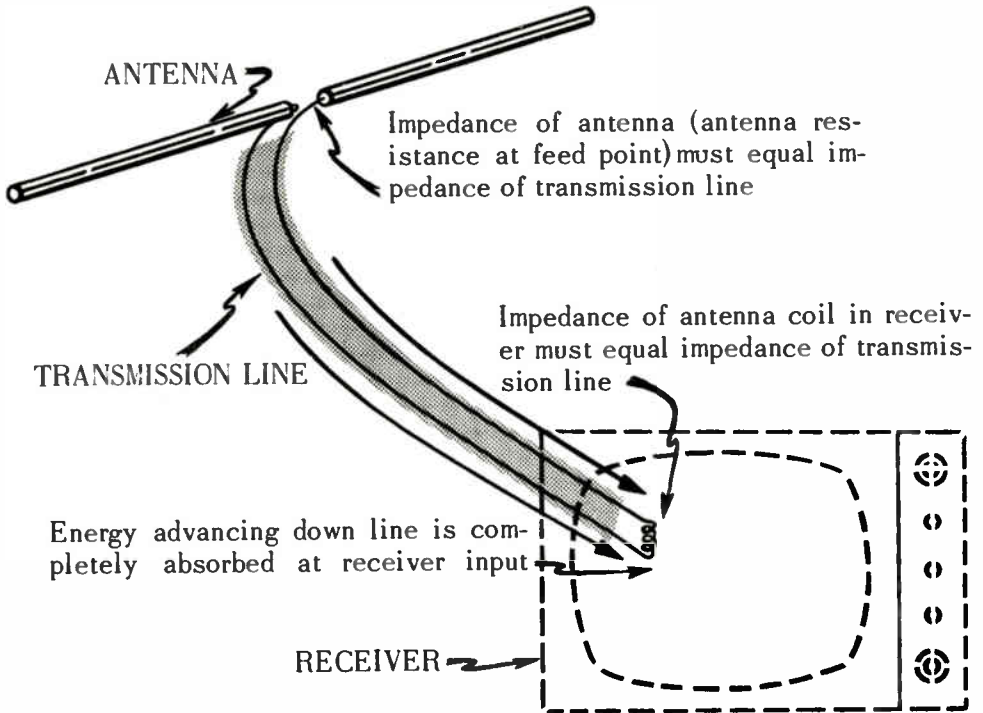

The second determining factor relative to the transmission line impedance is the input impedance of the antenna input transformer. Under ideal conditions this value should equal the loadpoint resistance of the antenna. In that event, the transmission line that matches the antenna loadpoint resistance, automatically matches the antenna input transformer, and maximum signal power is delivered to the receiver.

Appraising the importance of the two determining factors, the input impedance of the antenna input transformer is the more important of the two in deciding the impedance of the transmission line which must be used.

In years past, antenna input transformers in television receivers were rated at 72 ohms, 95 ohms, 150 ohms, and 300 ohms impedance. Therefore, a variety of transmission lines were used to link the antenna with the receiver. Today, the most frequently used type of line is one rated nominally at 300 ohms impedance. Hence, antenna designs are manipulated to make the loadpoint resistance of the antenna approximate 300 ohms.

FREQUENCY RESPONSE OF A DIPOLE

Frequency Response of a Thin Half-Wave Dipole Antenna

The simple thin half-wave dipole (as well as every other type) displays all the properties of a resonant circuit. It has inductance (L), capacitance (C), and resistance (R).

The inductance appears in the antenna element itself, just as it would in any length of conducting material. The capacitance appears between sections of the antenna, between the antenna elements and neighboring structures, and between the antenna elements and ground. The resistance stems from the manner of functioning of the device.

Proper dimensioning of the antenna produces the desired resonant condition. The shape and dipole diameter control the sharp or broad tuning behavior of the antenna.

So far as successful television picture reproduction is concerned, adequate signal strength in an antenna is just one of the requirements. In addition, the response of the antenna must be fairly uniform over the range of signal frequencies present because each frequency component requires equal processing.

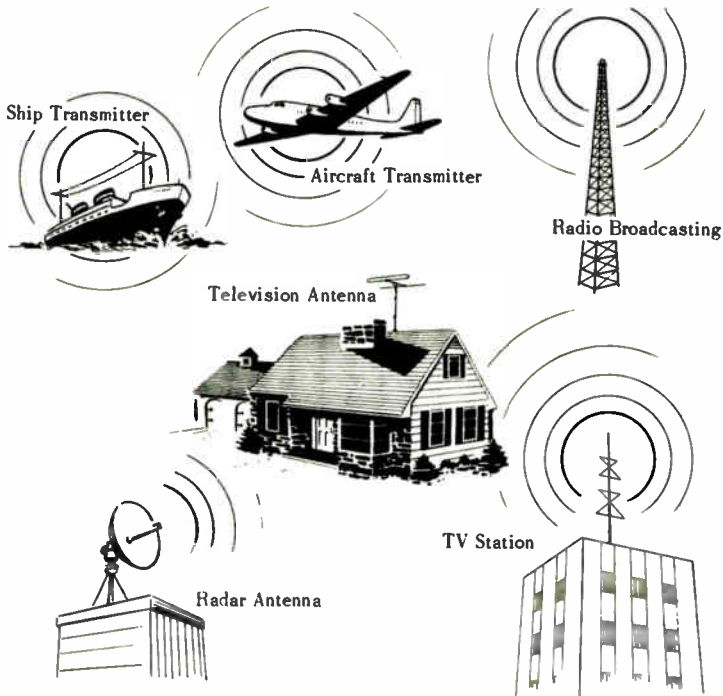

The television antenna receives radiations from all transmitters- and voltages are induced-but most of them are not of usable magnitude

FREQUENCY RESPONSE OF A DIPOLE

Center Frequency

SYMBOLIZATION OF FREQUENCY RESPONSE OF CONVENTIONAL HALF-WAVE DIPOLE RELATIVE TO CENTER FREQUENCY

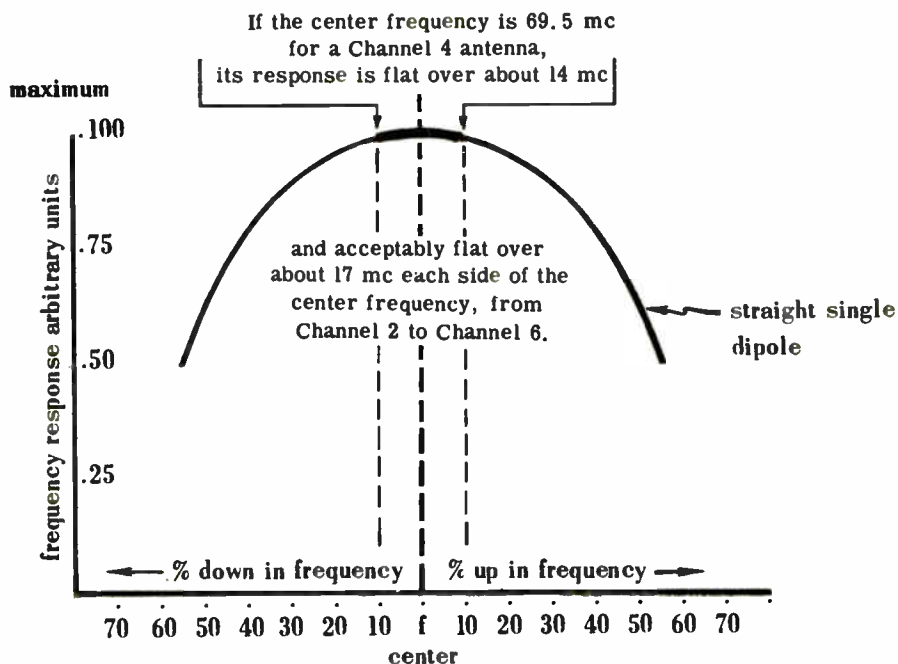

As a tuned circuit, the half-wave dipole responds best to that signal frequency for which it is a half-wavelength long. But even at best, it tunes more broadly than the conventional L-C circuit resonant to the same frequency. When an antenna is cut for a frequency that is at the center of a band of frequencies which it is supposed to cover, the resonant frequency is called the *center* frequency. If a dipole antenna is intended to function on channel 4 only (66–72 mc), it would be cut so that its half-wavelength dimension would correspond to the geometric midfrequency (69.5 mc) of this band. In this way fairly uniform response to the channel signal frequencies (picture and sound) is obtained. The response embraces 14 mc—7 mc each side of the 69.5-mc resonant point—with reduced response at the other frequencies.

It is conceivable that an antenna may be fairly “flat” in its frequency response over a 30- to 40-mc band, but it would still have a *center* frequency because it has a fixed length.

FREQUENCY RESPONSE OF A DIPOLE

Bandwidth of an Antenna

The conventional thin, single half-wavelength dipole affords frequency response over a number of television channels, in addition to the one for which it was cut. But whether or not it is adequate depends on the received signal strength. Given adequate signal strength, the decrease in response over a frequency region each side of the midfrequency may mean very little, in which case even the simplest of antennas may be a four- or five-channel antenna, provided that all other requirements are also satisfied.

For instance, if the center frequency of such an antenna is 195 mc, or the arithmetical center of channel 10, a frequency change of 12.5% is 24.4 mc below 195 mc and 24.4 mc above 195 mc. This places the low limit below the low-frequency limit of channel 7 (54 mc to 60 mc), and the high limit above the high-frequency limit of channel 13 (210 mc to 216 mc). It is therefore reasonable to expect that an antenna which behaves in this manner frequency-wise and which is suitably oriented will handle adequately the signals for stations within the high-frequency band of the vhf group.

Before we can accept such performance capabilities as valid reasons for using this type of antenna for this purpose, it is necessary to consider signal

ANTENNA CUT FOR 195 MC

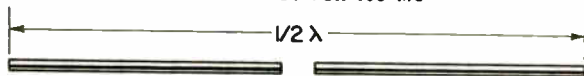

A 12.5% CHANGE EITHER SIDE OF THE CENTER FREQUENCY PROVIDES COVERAGE OF CHANNELS 7 TO 13

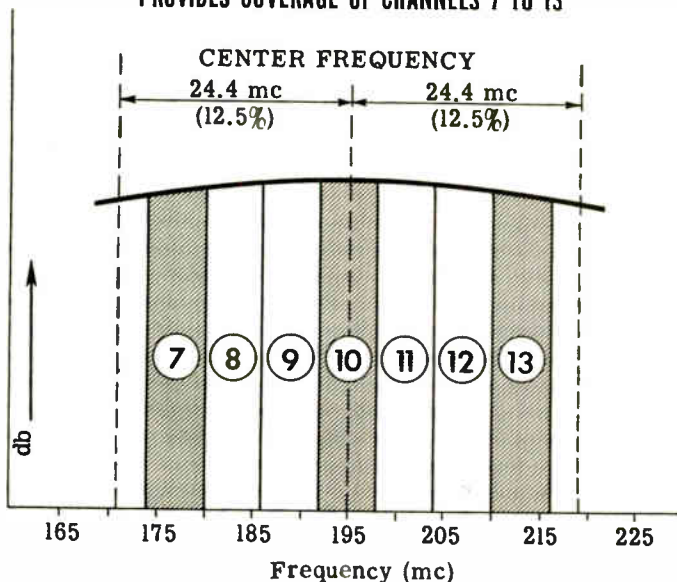

strength at the low-response region and the feedpoint resistance of the dipole. The nominal 72-ohm feedpoint resistance of this type of antenna at resonance makes it difficult to attain a proper match with the receiver antenna input transformer, usually rated at an impedance of 300 ohms. Hence, the general use of antennas of some other type which provide the required frequency response as well as the proper feedpoint resistance for correct matching to the receiver. (Resistance frequently dictates the choice of a design.)

FREQUENCY RESPONSE OF A DIPOLE

Determination of Center Frequency

The determination of the center frequency of a band can be made in two ways. One is the simpler of the two and results in a fair approach to the actual value. Simply, it is the arithmetical mean (average) of the sum of the upper and lower frequency limits of the band involved. For example, the center frequency of the low-frequency band of vhf television channels (54-88 mc) arrived at in this fashion is:

$$\frac{\text{high frequency} + \text{lowest frequency}}{2}$$

$$\frac{54 \text{ mc} + 88 \text{ mc}}{2}$$

$$71 \text{ mc}$$

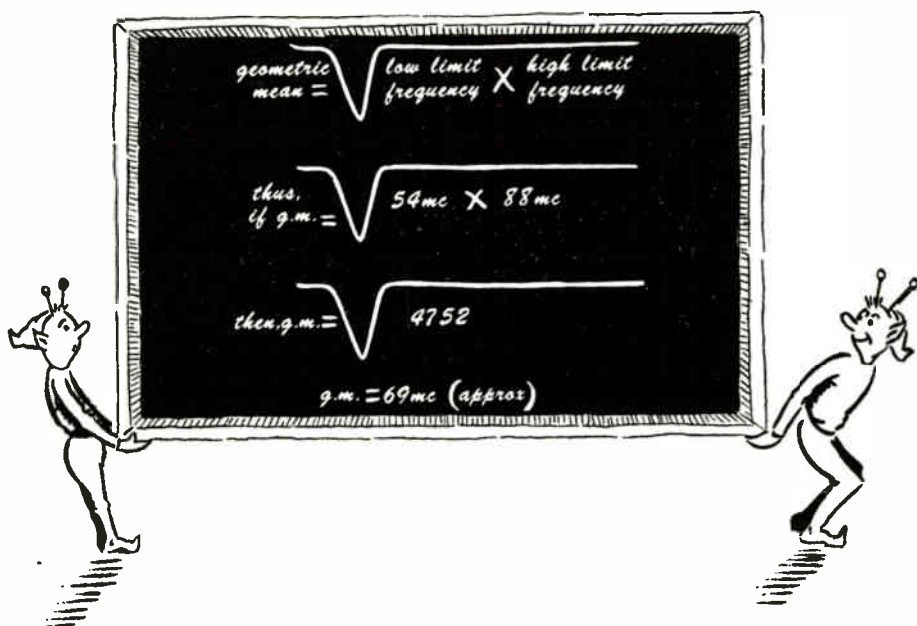

The second method is by determining the *geometric mean*. This is equal to the square root of the product of the low-frequency limit and the high-frequency limit of the band involved. Using the previously mentioned upper and lower frequency limits, the geometric mean frequency is just under 69 mc—in round numbers, 69 mc. For the high-frequency band of the vhf group the arithmetic mean is $(174 + 216) / 2$ or 195 mc. The geometric mean frequency is just under 194 mc.

For general purposes the determination of the center frequency by simple arithmetic means is entirely satisfactory.

OTHER DIPOLE ANTENNAS

Other Zero-DB-Gain Antenna Types and Characteristics

We have said that variations of the single-element, thin-rod half-wave dipole afford a variety of electrical characteristics and behavior that differ from the thin-rod version. The characteristics of interest to us, from the viewpoint of practical application, are antenna feedpoint resistance and frequency response.

Half-wave dipole antennas made of a relatively large-cross-section conductor (2 to perhaps 5 to 6 inches) display some of the characteristics of the thin-cross-section antenna, but exhibit one or more properties that are different. Increasing the cross section of the element shortens the physical length corresponding to a half-wavelength at any frequency. Thus, large-diameter-rod antennas may require velocity correction factors varying between 0.75 and 0.85, rather than 0.95, for rods or tubes up to 0.5 inch in diameter.

There is still another difference. Whereas the thin-rod half-wave dipole has a nominal feedpoint resistance of 72 ohms at resonance, a half-wave dipole made of 2.5- to 5-inch diameter tubing cut for and operated at the same frequency would have a greatly reduced feedpoint resistance—between 35 and 45 ohms. Also, the larger the diameter of the antenna conductor the less drastic the changes in antenna feedpoint resistance as the received signal frequency differs from the antenna resonant frequency.

Accompanying this effect is *flatter* response over a wide frequency range, making the large-cross-section-rod antenna more suitable for the reception of a number of television channels than the small-diameter antenna.

The large-cross-section antenna appears to offer a number of advantages as a receiving dipole. But it has three disadvantages—the low feedpoint resistance, the large wind surface, and the electrical disadvantage which develops at the feedpoint from trying to pass electrical energy from a large cross-section tube to a comparatively thin-wire transmission line. It is like passing water from a large opening into a small one without a funnel.

INCREASING the antenna-conductor diameter

REDUCES the length corresponding to a half

wavelength. For example,

a dipole up to .5 inch in diameter cut for 80 mc would be

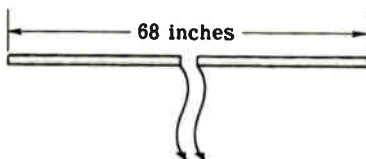

whereas a dipole 2.5 inches in diameter cut for 80 mc would be only

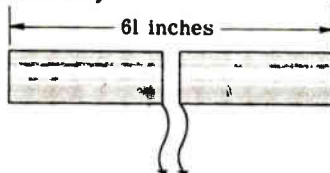

a reduction of more than 10% in length

OTHER DIPOLE ANTENNAS

The Conical Family of Zero-DB-Gain Half-Wave Dipole Antennas

The cone-shaped antenna generally referred to as *biconical* consists of two cone-shaped sections lying along a common axis. It is a fundamental type that is simulated in many ways for use as a practical television receiving antenna. It is the equivalent of a large-cross-section-rod antenna, even though it does not have a uniformly large cross section throughout. In the practical version each section is made up of two or more rods or tubes, usually about 0.5 inch in diameter, fanning outwards from the feedpoint and tilted somewhat towards the approaching wave.

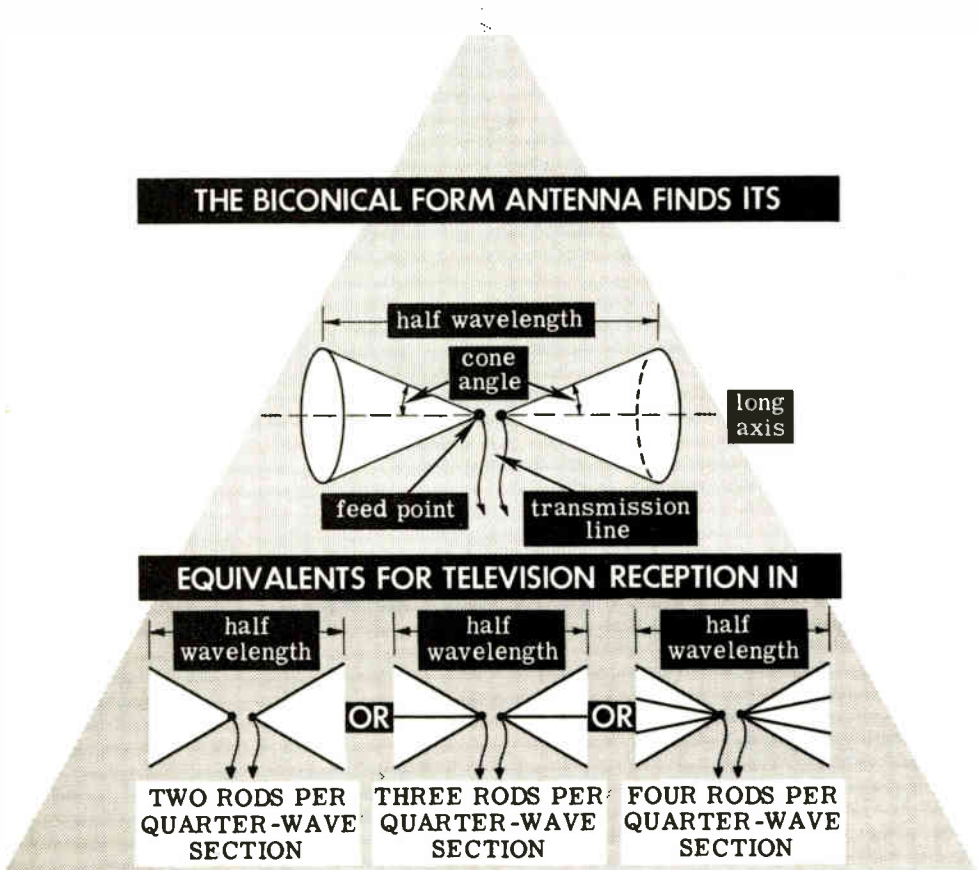

It is unnecessary to analyze each version individually because the general behavior of the conical-shaped equivalents is, in essence, applicable to all variations. All are zero-db gain at resonance. All are single-element antennas with no improvement in the ability to extract energy from a passing wave over that of the simple half-wave dipole. (In this respect we specifically exclude the "V" antenna.)

OTHER DIPOLE ANTENNAS

Conical Antennas (contd.)

The conical form, as depicted by a variety of configurations of multiple rods in each section, is a broadly tuned antenna. Therefore, it is used when reception of several television stations is desired. It can accept all vhf stations, but not both vhf and uhf. The antenna resistance at the feedpoint is a function of the number of rods per section, the angle at which the rods fan outward from the feedpoint, and the degree of tilt in the forward stations, but not both vhf and uhf. The antenna resistance at the feedpoint resistance does not vary as drastically with changes in signal frequency as the thin or even medium-thick straight-rod dipole. This feature, used in a special manner as described later in this lesson, accounts for the popularity of this antenna design.

In this regard, we should mention that different lengths of each section, different numbers of rods per section fanning outward at different angles and with different amounts of tilt, as well as different cross section of the individual rods can be combined in different ways to form antennas with similar electrical characteristics.

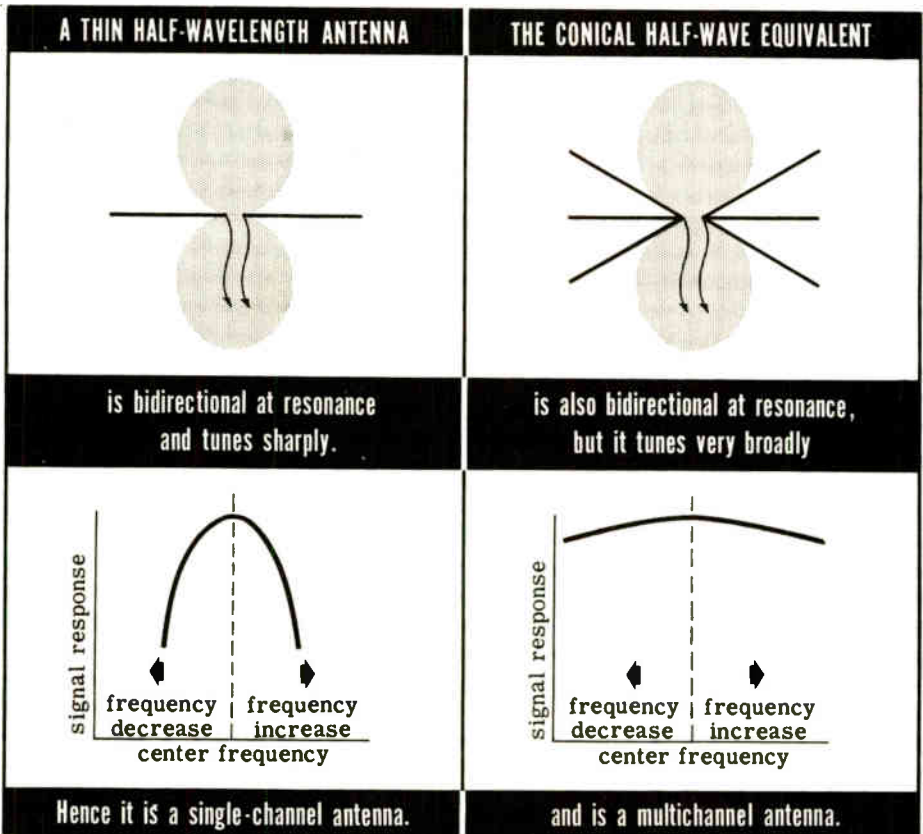

OTHER DIPOLE ANTENNAS

The V Antenna

The V or Vee antenna is a half-wave dipole formed from two medium-thick quarter-wave sections tilted towards each other. Although it is classed a zero-db-gain antenna at the resonant frequency (for which its overall length equals a half-wavelength), certain differences in behavior warrant comment. The V antenna allows reception over a very wide band of television frequencies, oftentimes being used to cover the vhf as well as the uhf stations that serve an area. The V antenna rods are tilted inward between 30° and 40° .

As the frequency of the received signal increases (the corresponding wavelength decreases) the antenna departs from being a half-wavelength structure. Each leg gradually becomes a multiwavelength relative to the frequency of the arriving signal. For instance, an antenna cut for channel 2 (54–60 mc) will accommodate $\frac{3}{4}$ wavelength in each leg at about 180 mc; almost $2\frac{1}{2}$ wavelengths in each leg at 600 mc, and $3\frac{1}{2}$ wavelengths in each leg at about 840 mc. The greater the number of wavelengths accommodated by each leg, the better the antenna performance.

Because of the forward *tilt*, the electric field of a low-frequency signal will not “see” as much of the antenna length as if the two quarter-wave sections were “in line.” Hence, at the low vhf frequencies (perhaps the lowest) the V antenna shows substantially less signal pickup than the conventional straight-rod antenna—actually a little less than the conventional half-wave dipole. But if the frequency of the signal is high (wavelength of the signal is short relative to the wavelength of each leg of the V antenna), the opening between the ends of the V accommodates quite a few half-wavelengths of the approaching wavefront. The currents induced in each leg as the wavefront advances along the antenna aid each other and the antenna shows *gain*. In effect, its signal-extraction capabilities are greatly improved; the response remains bidirectional, but each response lobe becomes narrow. In other words, the antenna as a whole becomes highly directional. This is no problem if all the transmitting antennas serving an area are located in a line intersecting the V.

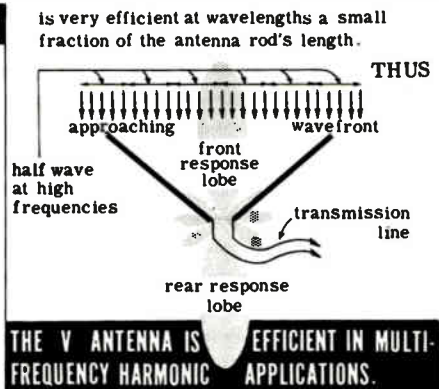
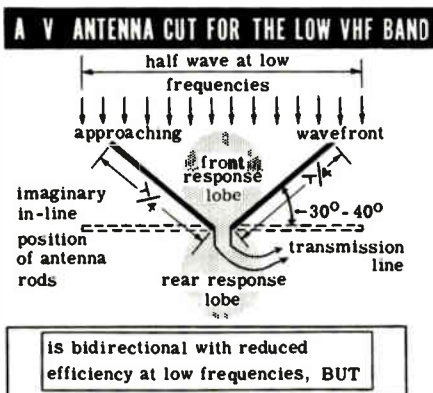

OTHER DIPOLE ANTENNAS

The Bat Wing Antenna

The *bat wing* antenna behaves in a manner similar to the conical group. It is used mostly for the reception of uhf channel television stations as a part of a multielement antenna. Therefore, we shall discuss it when dealing with such wave-intercepting devices.

The Folded Dipole Antenna

THE FOLDED DIPOLE

IS ZERO-DB GAIN,

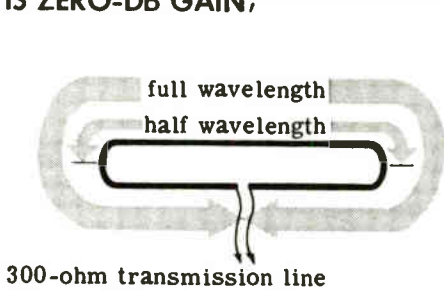

IS BIDIRECTIONAL,

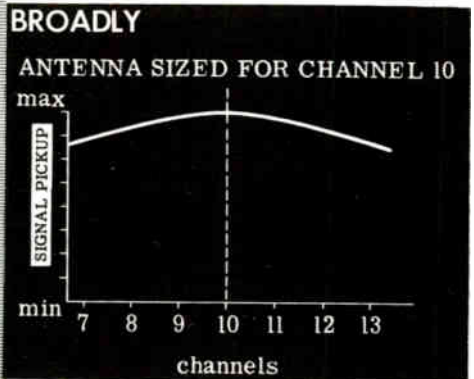
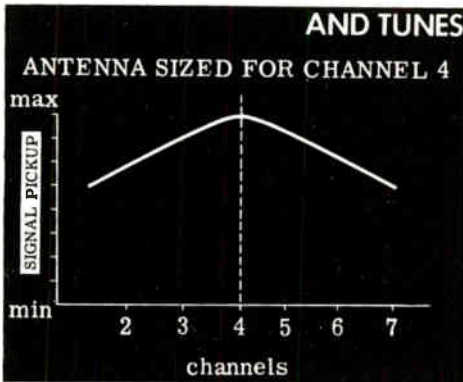
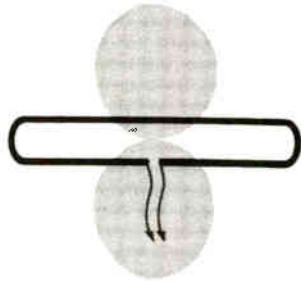

One of the most popular variations of the basic single-element half-wave dipole is the *folded* dipole. It derives its name from its physical structure. It may be viewed as a continuous-rod dipole connected in parallel with a split dipole. The two active parts of the antenna are separated by possibly 5 to 10 times the diameter of the antenna conductors. The overall length of the antenna conductor, inclusive of the separation at the feedpoint, is a full wavelength at the frequency for which the antenna is cut. Since the antenna conductor is folded upon itself, the horizontal length equals a half-wavelength at the resonant frequency. The folded dipole is a zero-db-gain antenna, tunes more broadly than the thin-rod half-wave dipole, and is bidirectional in its horizontal directivity.

OTHER DIPOLE ANTENNAS

The Folded Dipole (contd.)

The principal advantage of a folded dipole is its relatively high feedpoint resistance. When the antenna conductor is of uniform diameter throughout, the feedpoint resistance is 288 ohms at resonance. It is therefore a good match for a 300-ohm transmission line.

IF THE CONTINUOUS ROD HAS TWICE THE
DIAMETER OF THE SPLIT ROD,

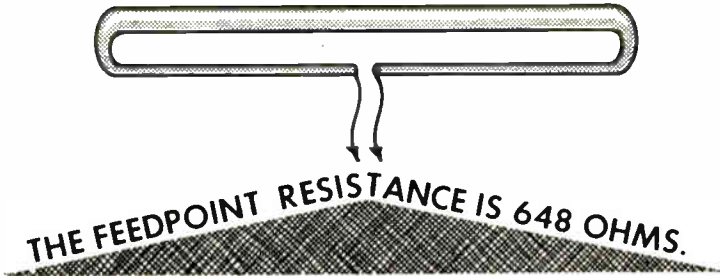

The folded dipole displays a peculiar characteristic when the signal frequency is such that the horizontal length of the antenna equals a full wavelength, or an even multiple of a full wavelength. In these cases the feedpoint resistance falls to a very low value and results in an extremely bad match with a 300-ohm transmission line. For instance, a folded dipole cut for channel 4, or 69 mc, will display a very low feedpoint resistance at 138 mc or 276 mc, and other even-number multiples of 69 mc. Fortunately this is no problem in television reception because a folded dipole cut for the vhf band will not be subject to television signals which will make it operate in this fashion. The same is true for uhf antennas cut for the low end of the uhf band. Moreover, a folded dipole intended for the vhf band is generally not used for the reception of uhf stations. At frequencies other than the above, and when the horizontal length is not an exact wavelength, the feedpoint resistance fluctuates but does not go below the nominal 300 ohms.

Folded dipole made from 300-ohm twin lead

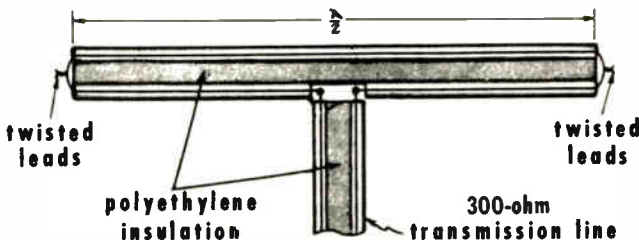

REVIEW

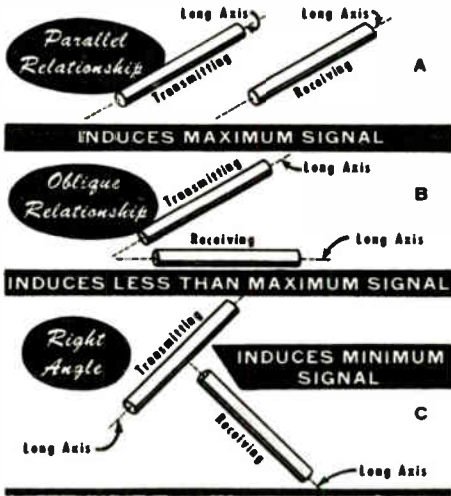

1. **Directional Response.** The manner in which an antenna responds to signals that arrive from different directions is termed its directional response or the directivity. Directional response is very important in areas where signals are received from many different directions.

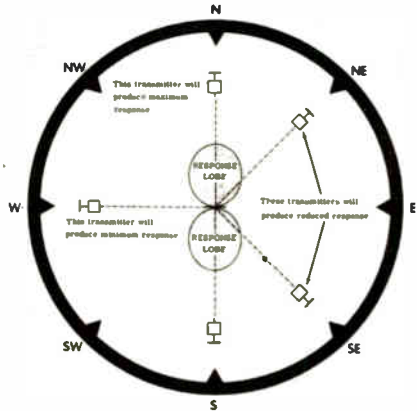

2. **Directional Response Pattern of a Half-Wave Dipole.** The response pattern on each side of the antenna is called a lobe. The direction of the radiated energy from an unwanted station should be between response lobes or striking the antenna at a low response point on the lobe.

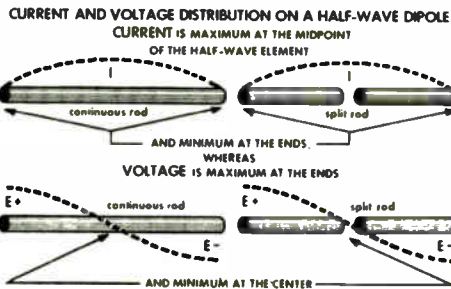

3. **Voltage and Current for a Half-Wave Dipole at Resonance.** When the passing wave induces a voltage and a current in a half-wave dipole functioning at its resonant frequency, a special form of voltage and current distribution takes place.

Conditions of impedance match for best transmission of energy from antenna to receiver

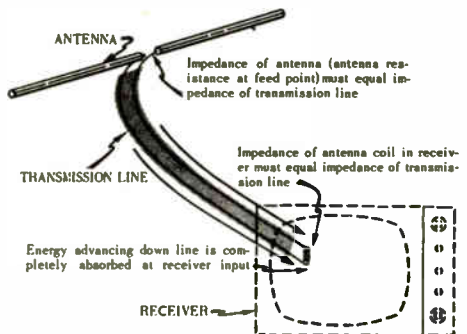

4. **The Input Impedance of the Antenna Input Transformer.** The transmission line impedance must satisfy both the antenna loadpoint resistance and the antenna transformer input impedance. An improper match means a waste of power in the antenna.

REVIEW

ANTENNA CUT FOR 195 MC
A 12.5% CHANGE EITHER SIDE OF THE CENTER FREQUENCY
PROVIDES COVERAGE OF CHANNELS 7 TO 13

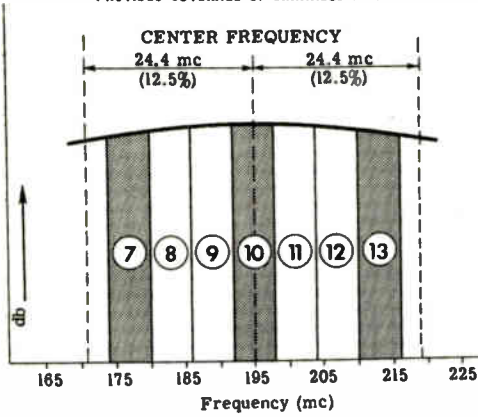

6. *The Conical Family of Half-Wave Dipoles*, generally referred to as biconical, consists of two cone-shaped sections lying along a common axis. It is simulated in many ways for use as a practical television receiving antenna.

5. *Bandwidth of an Antenna*. The conventional thin single half-wave-length dipole affords frequency response over a number of television channels in addition to the one for which it was cut. Whether or not this response is adequate depends on the received signal strength.

THE BICONICAL FORM ANTENNA FINDS ITS

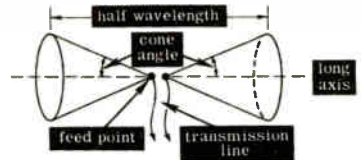

EQUIVALENTS FOR TELEVISION RECEPTION IN

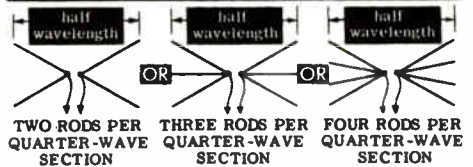

7. *The V or Vee Antenna* is a half-wave dipole formed from two medium-thick quarter-wave sections tilted towards each other. The V antenna allows reception over a very wide band of television frequencies, often-times being used to cover the vhf as well as the uhf stations that serve an area.

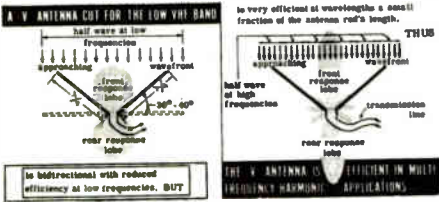

8. *The Folded Dipole Antenna* may be viewed as a continuous-rod dipole connected in parallel with a split dipole. The two active parts of the antenna are separated by possibly 5 to 10 times the diameter of the antenna conductors.

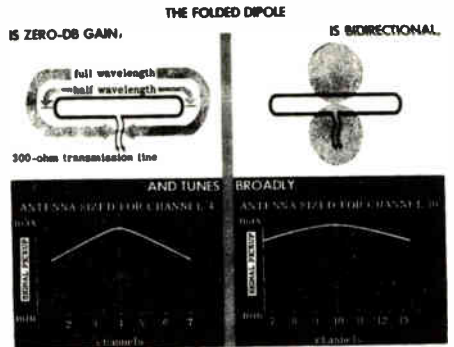

ADDING ANTENNA ELEMENTS

Multiple-Element Antennas

By far the most frequently used television antennas are not simple single-element dipoles or folded dipoles. They are multiple-element antennas, usually consisting of one element that is connected to the receiver, and another element that behaves as a *parasitic* (the meaning of which shall be explained soon). In some installations the antenna is made up of more than two elements. One is connected to the receiver and the remainder contribute to the effectiveness of the system as a single pickup device. The element connected to the receiver can be any one of the numerous varieties we have indicated as being single-element, zero-db-gain half-wave dipoles. The aiding (parasitic) element or elements usually are straight continuous rods, but in some instances, they have the same shape as the element which is connected to the receiver.

The multiple-element antenna generally picks up signals from the front much better than from the rear. It behaves as if it captures more energy from the passing wave that it intercepts than does the single-element dipole. Therefore it has gain. Finally, it tunes more sharply and can thus be made highly selective so that it will respond principally to a single television station.

Based on these capabilities the multiple-element antenna is used when increased signal pickup is desired, when signals arriving from the rear (such as reflections from buildings) are to be minimized, and when maximum signal pickup is desired from a single station.

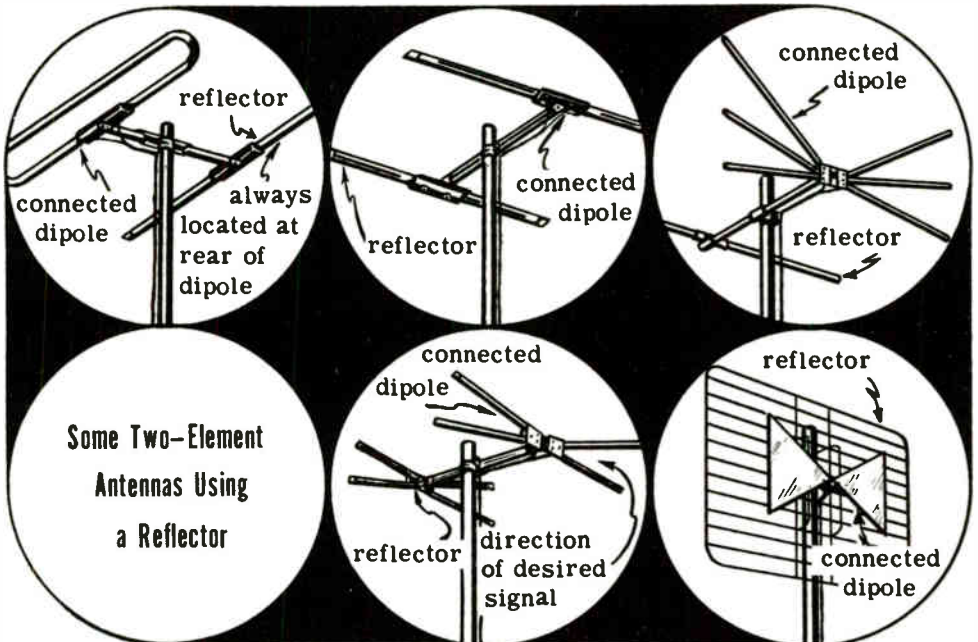

ADDING ANTENNA ELEMENTS

The Operation Of Multiple-Element Antennas

It will be recalled that a receiving antenna connected to a receiver transmits only a portion of the energy that it intercepts to the receiver; the rest is re-radiated. If, however, the dipole is not connected to a receiver or some other load, it re-radiates virtually all of the energy that it captures. If the unconnected rod (*parasitic element*) is cut to be resonant at the received frequency, a 180° phase inversion takes place in the process of re-radiation. (This action is analogous to the reflection of the electromagnetic waves discussed earlier, and an unconnected rod of this kind placed behind the connected element is called a *reflector*.)

Let us examine the action of a dipole-reflector combination on an approaching wavefront. If a wave arrives from the front, part of it is intercepted by the connected dipole, while the rest passes on toward the reflector, which captures additional energy from it. If the reflector is placed a quarter-wavelength behind the connected element, the reflector is excited a quarter-cycle (90°) later than the connected element. The energy is immediately re-radiated with a 180° phase shift, and part of it arrives back at the connected element 90° later. The total of the phase equivalent of the transit times (180°) and the actual phase shift (180°) is equivalent to a full cycle; hence the energy sent back to the connected element from the reflector arrives in phase with the oncoming signal from the front.

A signal that approaches from the back of the combination reaches the connected element 90° after a part of it has been intercepted by the reflector. In this case, the reflector again re-radiates the energy 180° out of phase, and a part of this energy also arrives at the connected element 90° later. The two signals are 180° out of phase at the connected element, hence the re-radiated signal from the reflector cancels part of the signal arriving directly at the connected element. This results in reduced response to signals received from behind.

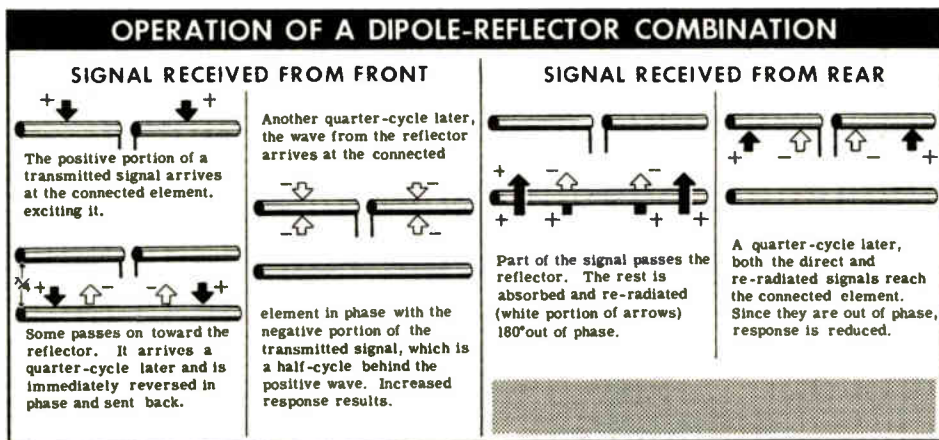

ADDING ANTENNA ELEMENTS

Response of a Dipole-Reflector Combination

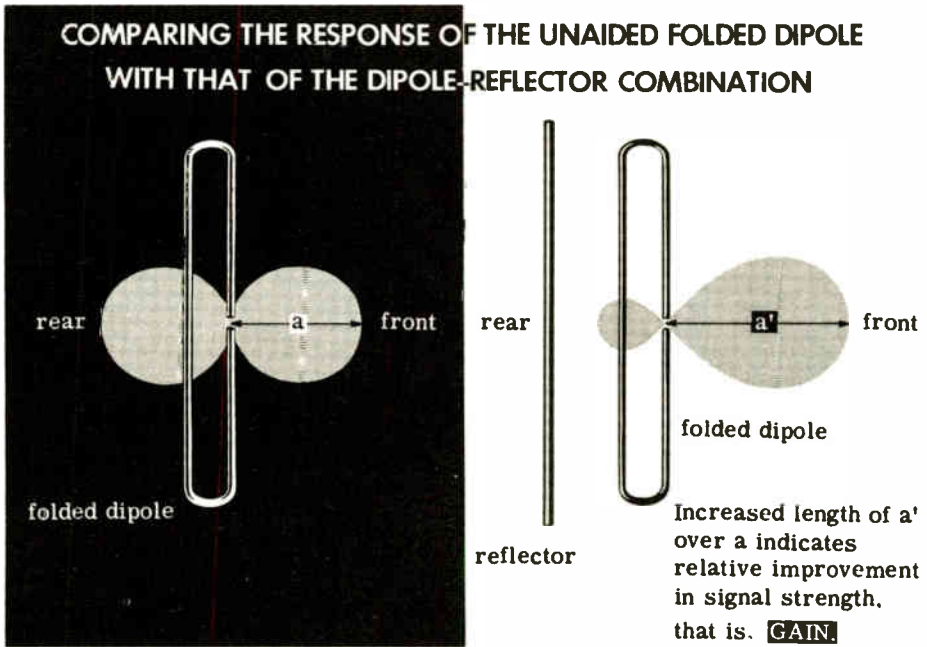

The preceding discussion is greatly simplified. In practice, reflectors are made about 5% longer than the connected element, which results in a phase shift greater than 180° . They are therefore placed closer to the connected element than a quarter-wavelength. In addition, part of the energy intercepted by the connected dipole is re-radiated toward the reflector and returned by it. This energy may not be in phase with the directly received signal and experimentation with reflector length and position is required to get the best compromise result.

It can be seen that the signal available for transfer to the receiver in the connected dipole is more than was actually extracted from the passing wave by that element. The signal intercepted by the reflector makes its contribution by re-radiating some of the energy to the connected element. A dipole-reflector combination will show a *power gain* of about 5 db. This means that the antenna behaves as if the power in the arriving wave had been increased about 3.5 times over that in a single-element half-wave dipole antenna.

The narrower response lobes show the antenna to be more restrictive in its horizontal directivity. Response to signals that approach it from the rear is less than for the conventional single-element dipole. On the other hand, its response is much greater than with the single dipole only, when the signal approaches the antenna from the front.

ADDING ANTENNA ELEMENTS

Other Characteristics of a Dipole-Reflector Combination

The folded-dipole/reflector combination tunes more sharply than the folded dipole alone. (The addition of a reflector will sharpen the tuning of any connected element.) The frequency bandwidth accepted by the antenna remains adequate for reception of either vhf or uhf stations.

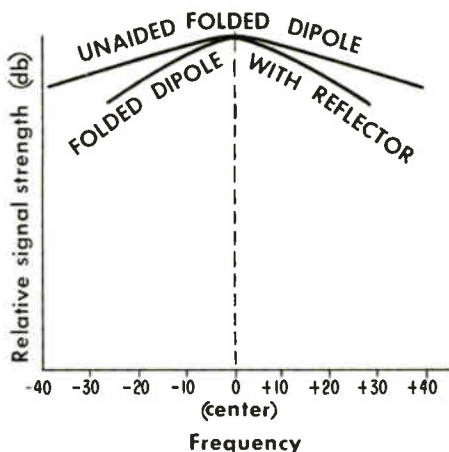

Two other electrical characteristics must be noted. Current in the connected dipole is higher when the reflector is present than when it is absent. This can be interpreted as a decrease in the antenna feed-point resistance. The straight-rod, half-wave dipole-reflector combination will show about 25–30 ohms feedpoint resistance at resonance, contrasted with 72 ohms when the reflector is absent. A folded dipole-reflector combination operated at half-wave resonance will show between 100–110 ohms feedpoint resistance, contrasted with 300 ohms when the reflector is absent. Dipoles of other shapes used with reflectors demonstrate similar reduction in feedpoint resistance. The initial high feedpoint resistance of the folded dipole accounts for its great popularity as the connected element in dipole-reflector type antennas. Operating the antenna off-resonance on the various TV channels raises the feedpoint resistance to a usable value even with the reflector present.

The second significant change in electrical performance brought about by the addition of the reflector is the reduction in the antenna's response bandwidth.

ADDING ANTENNA ELEMENTS

Connected Element with Reflector and Director

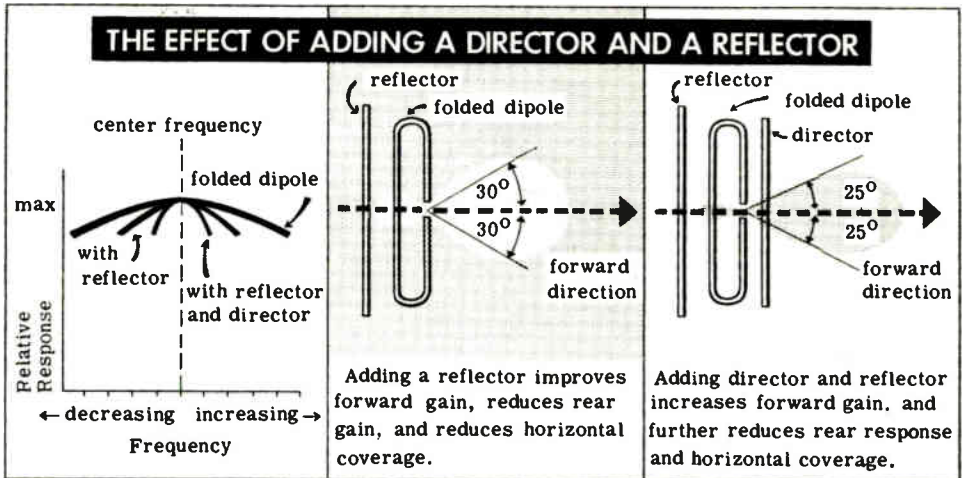

The use of a reflector has been seen to improve forward response and minimize the response from the rear. It is possible to increase forward pickup even more, at the same time sharpening horizontal directivity, and still further reducing the response from the rear. This is done by adding another parasitic element, a *director*. The director is placed in front of the connected element, being separated from it by from 0.1 to 0.2 wavelength for the frequency at which the antenna is sized. The contribution to the antenna behavior by the director is predicated on re-radiation by the director after excitation from the approaching wave. Thus the addition of a properly proportioned director improves the signal pickup of the antenna as a whole. The addition of a director to a connected-element-reflector combination normally sharpens the tuning of the system, limiting the number of channels that can be received with the antenna. However, by departing somewhat from resonating all the antenna elements to the same frequency it is possible, in receiving antennas, to broaden the frequency response and still derive some of the advantages of multiple elements. This is a practical compromise that works.

It must be realized that theoretical considerations do not always result in readily evident improvements in practice. This depends upon the individual set of circumstances. However, that which presents an advantage in theory cannot give poor results in practice, if that which is offered by the theory is what is sought. It might be mentioned that variations in behavior in terms of diameters of elements, as described in connection with an ordinary dipole are also applied, but not too often, to multiple element antennas consisting of connected element, reflector and director. The aim here is to provide the broadest possible frequency response to oncoming signals without sacrificing gain.

ADDING ANTENNA ELEMENTS

The Yagi Antenna

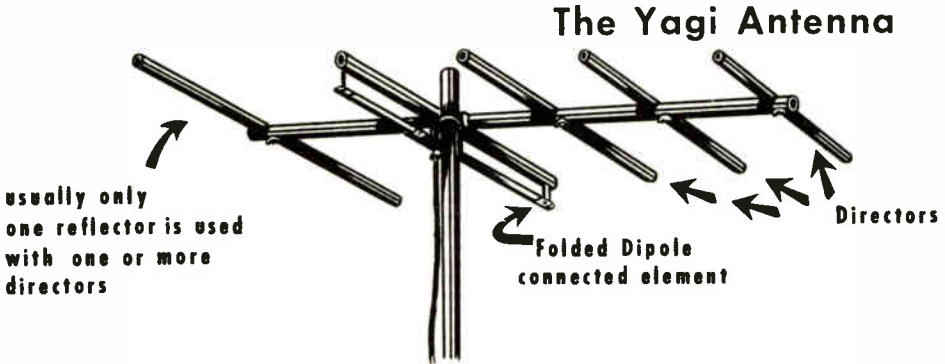

A type of multielement antenna that finds use in many fringe areas has a number of directors, one or more folded-dipole connected elements, and a single reflector. These are called Yagi antennas. The standard Yagi has only one connected element. Because the multiple parasitic elements reduce the feedpoint resistance drastically, the folded-dipole-connected elements are of such design as would result in a very high feedpoint resistance. These would be unlike-diameter conductors, or perhaps three-conductor folded dipoles. The conventional Yagi is intended for single-channel reception because it tunes relatively sharply. The Yagi can demonstrate power gains, depending upon design, of from 9 to 11 db over a conventional half-wave dipole.

Commercial antenna designs have produced *broadband* Yagis which are intended, again depending upon design, to cover from three to perhaps six or seven adjacent television channels. In these compromise designs two differently-sized folded dipoles behave as the connected elements, and the director elements as well as the reflector are adjusted in length so as to function best. They are the result of experimental determination which does not in any way detract from their operating effectiveness.

Broadbanded Yagi

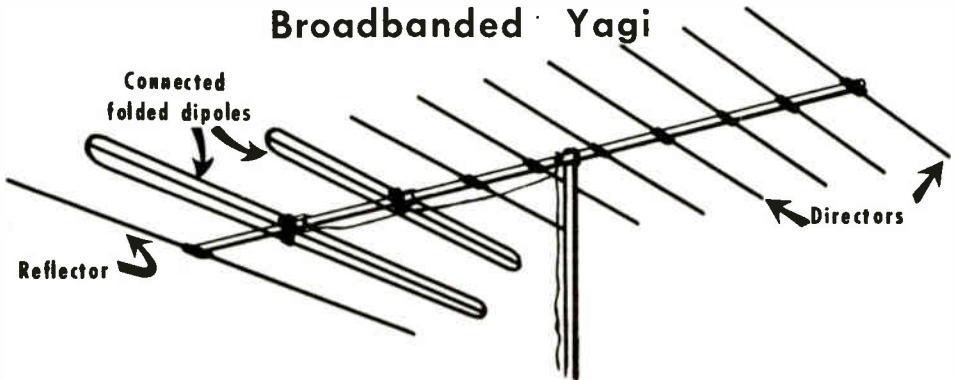

UHF AND VHF ANTENNAS

Antennas for Ultra-High-Frequency (UHF) Reception

THE BILLBOARD ANTENNA

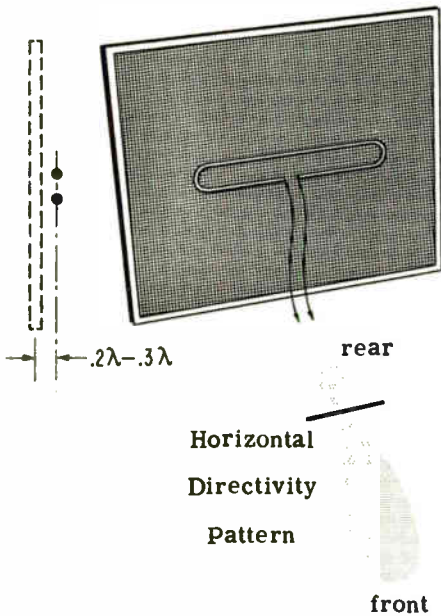

consists of a half-wave dipole mounted in front of a square metal screen that is about half again as long as the connected element. The dipole is mounted about 0.2 or 0.3 wavelength of the selected frequency in front of the screen.

When the connected element is a folded dipole, the feedpoint resistance may vary between 250 and 400 ohms, so that a match to a 300-ohm line is practicable. If the connected element is a conventional dipole, the feedpoint resistance falls to about one quarter of these values.

Antennas designed for the reception of television stations in the uhf band usually are made of the connected element (dipole) and a reflector. In this case, the reflector is somewhat different from that used with vhf antennas. The smaller physical dimensions of the uhf antenna allow the use of wave-reflecting surfaces made of metal, which are very much more effective than the dipole rods of the vhf structures.

The connected elements of the uhf antennas have the same shape as the vhf versions. The dimensional considerations stemming from the frequency-wavelength relationship also are the same, as is the behavior of the connected dipoles when being acted on by the approaching signal wavefront. The points of difference are related to the reflectors used with the uhf dipoles. In the case of the uhf antennas the reflector usually consists of a screen, and increases in effectiveness with increase in overall size. It has a minimum dimension which is determined by the horizontal length of the connected element used with it. Beyond this, its maximum size is a compromise between effective performance and cost. UHF antennas are substantially unidirectional.

UHF AND VHF ANTENNAS

UHF Antennas (contd.)

The *bow-tie* antenna used with a corner reflector is another version that is popular in uhf television areas. In the example shown, the connected dipole is bent into a horizontally positioned V. Its sides then are parallel to the sides of the corner reflector so that maximum energy is returned from the reflector to the dipole. Here too, the larger the reflector (within reason, of course) the more effective its action. By shaping the dipole and the reflector in this manner, wave energy that strikes the reflector bounces off and is intercepted by the connected element. A 90° corner reflector with the bow-tie dipole mounted about 0.3 wavelength (at the chosen frequency) in front of it will provide approximately a 9- to 10-db power gain.

The connected element sometimes is a folded dipole rather than a bow-tie, in which case the feedpoint resistance approximates 250 to 400 ohms, depending upon the condition of resonance. When the connected element is a bow-tie or a large-diameter dipole, the feedpoint resistance is lower. But by operating off-resonance an acceptable match to a 300-ohm transmission line is made. Compromise operation relative to resonance is customary.

The dimensions of the corner reflector are large relative to the half-wavelength dimension of the connected element. Usually, the length of the sides of the reflector approximate several wavelengths at the selected frequency. The horizontal dimension of the reflector sides is perhaps 25 to 100% longer than the horizontal length of the dipole. The antenna is unidirectional, being responsive to the front only.

THE BOW-TIE ANTENNA WITH CORNER REFLECTOR

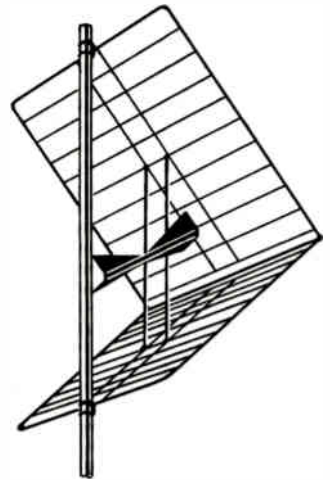
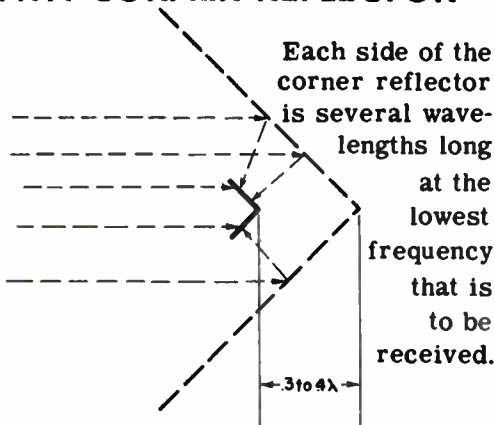

HORIZONTAL DIRECTIVITY PATTERN



UHF AND VHF ANTENNAS

Combination Low- and High-Band VHF Antennas

The division of the vhf channels into the *low-frequency band* (channels 2 through 6 covering 54 to 88 mc) and the *high-frequency band* (channels 7 through 13 covering 174 to 216 mc) has led to the use of various antenna arrangements. In some cases individual antennas are used for each of these bands; in others, a single antenna is designed to be broadband and cover them all. In the case of individual antennas for each band, the installation is relatively simple. The high-band antenna is positioned above the low-band antenna. The vertical separation between the two assemblies usually approximates a half-wavelength corresponding to the geometric mean of the frequencies for which the two antennas were cut. Thus, if the *lo*-band antenna is dimensioned for approximately 69 mc and the *hi*-band antenna is dimensioned for approximately 190 mc, the geometric mean frequency is approximately 115 mc. The vertical separation then would be equal to a half-wavelength corresponding to 115 mc. The points of reference usually are the connecting terminals on the antenna.

Commercially manufactured antennas, which are intended to be used in pairs so as to cover all vhf channels, invariably furnish instructions concerning the vertical separation between the component elements, and these instructions rather than the theoretical considerations should be used. The reason for this is that manufacturers elect their own basis of dimensioning antennas relative to the frequency which may be selected as mid-frequency for the *lo* and *hi* bands.

COMBINATION LOW-BAND AND HIGH-BAND VHF ANTENNA

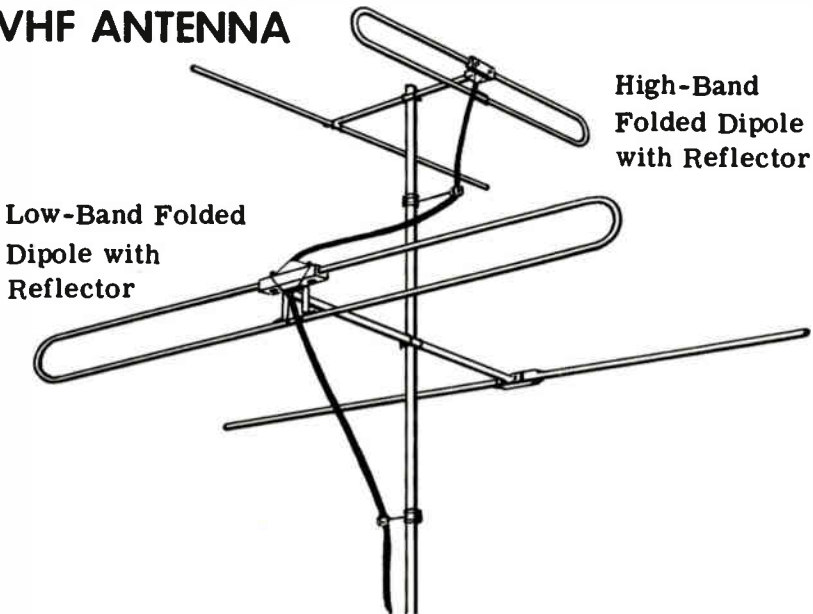

UHF AND VHF ANTENNAS

Combination VHF and UHF Antenna Arrays

ALL-CHANNEL UHF-VHF ANTENNAS

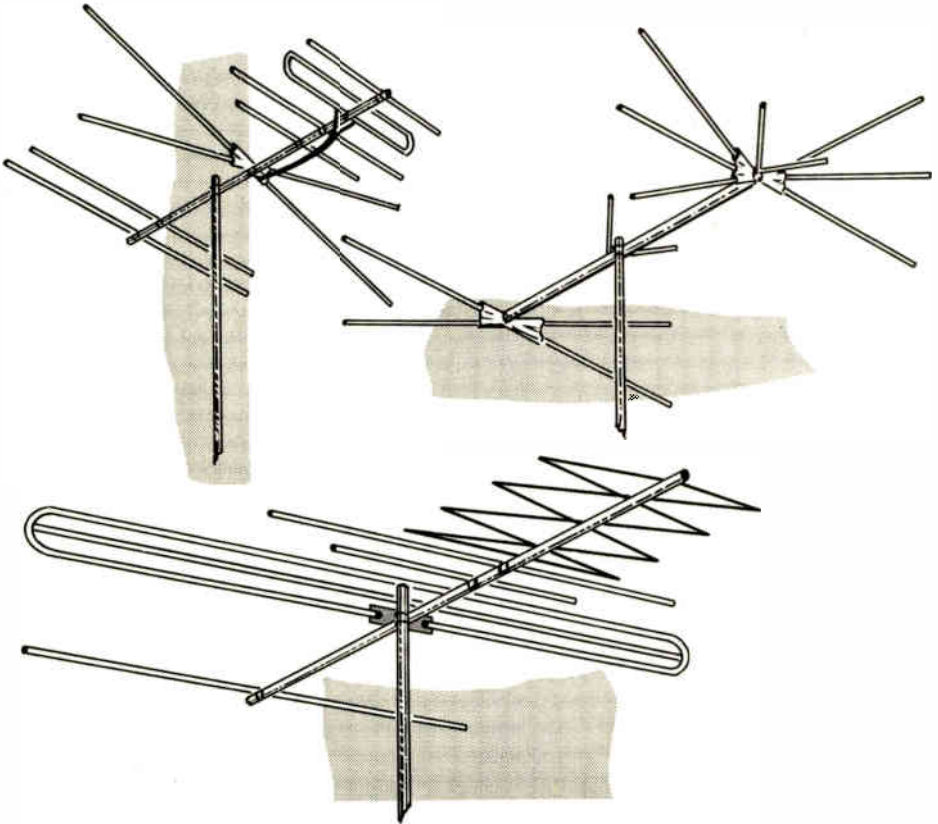

Quite a few receiving locations are served by both vhf and uhf television transmitters. To satisfy this need, antenna manufacturers have produced combinations of vhf and uhf antennas that mount on a single mast and which feed energy to the receiver via a single transmission line. Three examples of quite a few types available are shown here. One of them is a combination of the conical equivalent and the *rhombic* (the rhombic antenna is explained later in this course). The rhombic antenna is used for the uhf channels, whereas the conical equivalent is adjusted for the vhf channels.

The second type consists of a conical equivalent for the vhf channels, which is modified also to behave as a V antenna for the uhf channels. This is done by adding a V element to the conical-equivalent connected dipole, and another V element, which is used as the reflector.

UHF AND VHF ANTENNAS

Combination VHF and UHF Antenna Arrays (contd.)

The third type is a combination of a three-section folded dipole as the connected element for the vhf channels functioning in conjunction with directors and reflector. The three-conductor folded dipole operated at resonance or slightly off resonance affords a high feedpoint resistance, which when paralleled by the feedpoint resistance of the uhf antennas, results in the final value of 300 ohms feedpoint resistance to match a 300-ohm transmission line.

For the uhf channels a specially shaped helix antenna is the pickup device. Strangely enough, antenna manufacturers have conceived many unusual combinations and shapes of antennas which differ from theoretically conceived designs. Many of these are the result of experiments and juggling of constants until a usable antenna is developed. This makes the explanation of the applicable theory quite complex. The objectives are a suitable match to a 300-ohm transmission line and a functioning antenna. Whatever departures from theory must be made to achieve results, are made. As a rule, the vhf-uhf antennas are used in pairs or *bays*, that is, they are *stacked* so as to achieve still greater improvements in signal pickup than are possible from the use of a simple dipole-and-reflector combination. Stacking is explained in connection with transmission lines elsewhere in this course.

UHF-VHF

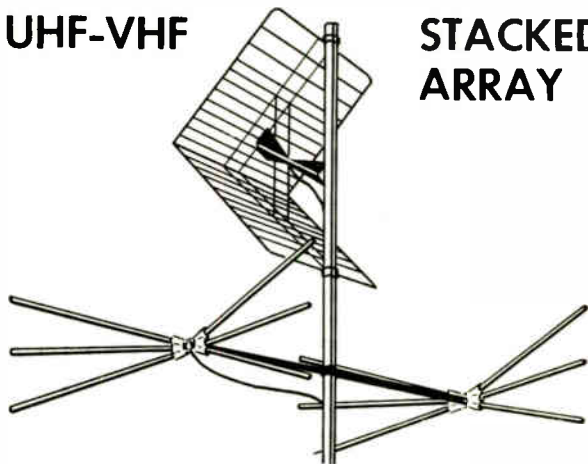

STACKED
ARRAY

There are other varieties in addition to those shown. We cannot overlook the popular and effective simple combination of a conventional conical-equivalent connected-element with reflector, and bow-tie dipole used with a corner reflector, mounted one above the other on a common mast. This arrangement owes much of its popularity to its relatively low cost and its ease of construction and installation.

In fact, the latter version is the more frequent when the directions of approach of the vhf and uhf stations are unlike, and each antenna must be oriented separately. Each antenna is oriented to suit the receiving conditions. This is in contrast to the specially designed single-unit combination uhf and vhf antenna. Most of these require that the direction of approach of the uhf and vhf signals be substantially the same. By virtue of the mechanical arrangement, orientation of the vhf antenna automatically orients the uhf antenna in the same direction.

UHF AND VHF ANTENNAS

The Rhombic Antenna

This is a very efficient antenna of great frequency capabilities. Its original function was as a communication antenna for directional transmission and reception. Although it has been used for television signal receiving on the vhf band, its dimensional requirements for effective operation have restricted its use over the 54-to-216-mc band. But it has found wide application for uhf reception. The high frequencies permit antennas of practical length to be mounted on antenna masts.

In a sense, the rhombic antenna is an extension of the V type. It might be considered as a diamond-shaped affair lying in the horizontal plane, terminated at one end in a resistance of 600–700 ohms and fed at the other end through a 600-ohm line. This feedpoint resistance permits paralleling this antenna with another 600-ohm antenna to produce a required match to both of 300 ohms. If each leg is several wavelengths long at the frequency of operation, and if the angle θ at the apex is 50° – 70° , the antenna will have a power gain of from 8 to perhaps 12 db over the basic dipole. The antenna is substantially unidirectional in the direction of the terminated end, and has a very narrow principal response lobe; therefore, it is highly directional. It is an excellent antenna for operation over a very wide band of frequencies, especially if the leg lengths are several (about 5 or 6) wavelengths long at the lowest frequency of operation.

Its high order of horizontal directivity stems from the development of two principal response lobes in each leg, and from the condition that one lobe in each leg cancels a corresponding lobe in the other leg. This is four lobes pointing in the same direction. These are additive, and result in a single lobe in the forward direction.

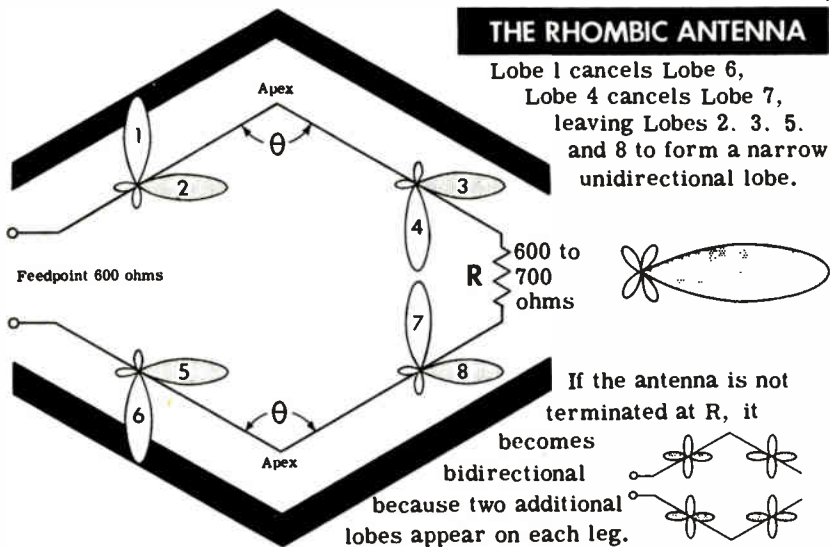

TELEVISION TRANSMISSION LINES

Transmission Lines

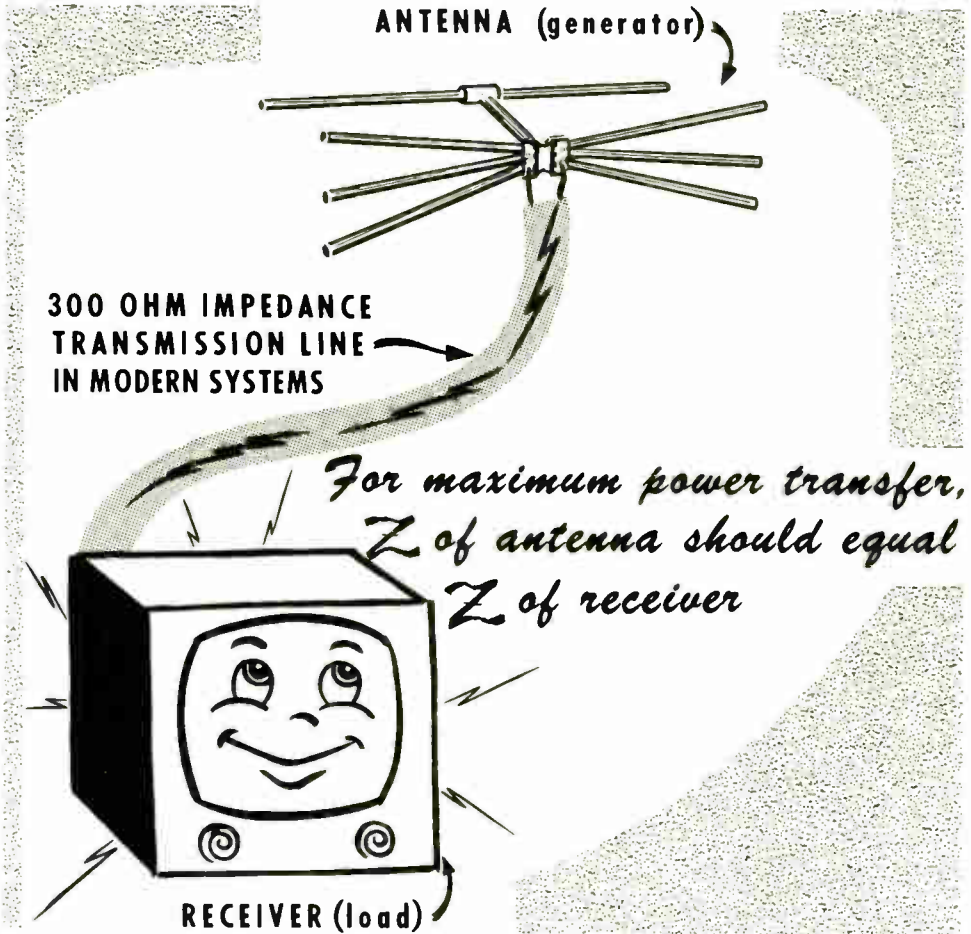

The transmission line is the path over which the signal energy is conducted from the antenna to the television receiver. Its counterpart in the early days of radio broadcast reception was the *lead-in*. But unlike the lead-in wire of old, the television transmission line cannot be just any two wires. On the contrary, it must be selected to electrically “suit” the antenna and receiver constants—specifically, the impedance at each end. We referred to this earlier as matching.

The feedpoint resistance of the antenna also is referred to as *antenna impedance*, with impedance being symbolized by the letter Z . Hence, it is said that the transmission line must match the impedance of the antenna to the input impedance of the receiver. The input impedance of the receiver is the input impedance of its antenna coil.

TELEVISION TRANSMISSION LINES

Transmission-Line Reflection

Among the other desired conditions achieved when a proper impedance match exists between an antenna and a receiver, via a transmission line, is freedom from transmission-line *reflections* that produce transmission-line ghosts. Such ghosts are multiple images on the receiver picture tube screen.

Transmission line mismatch

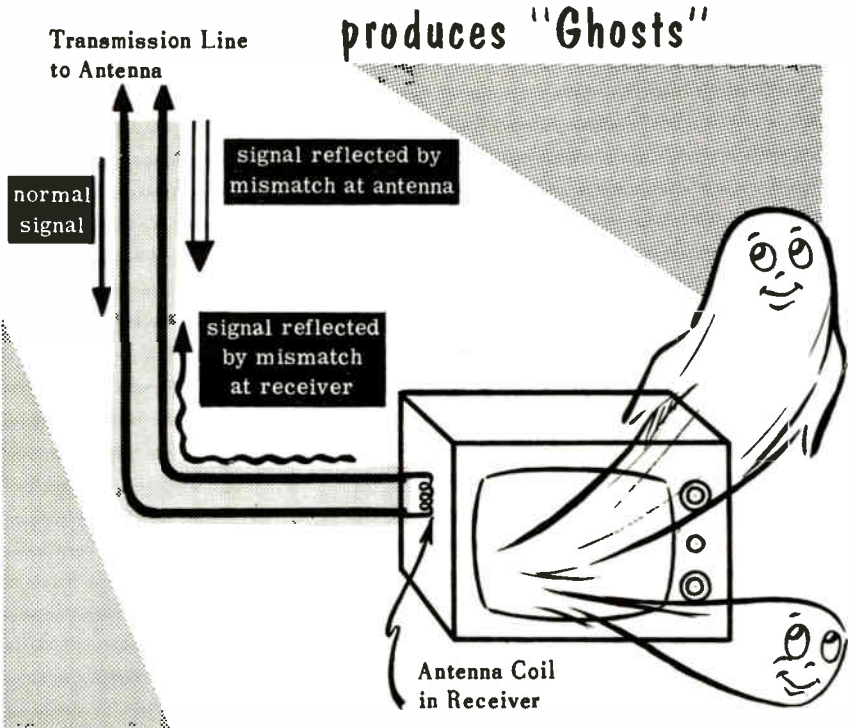

If an impedance mismatch exists between transmission line and antenna input transformer on any channel (or on all channels), all of the signal energy sent down the line is not absorbed by the antenna input coil. Some of it (depending on the amount of mismatch), is sent back up the line towards the antenna. If a mismatch also exists between the transmission line and the antenna, some of the signal energy reflected from the receiver antenna coil is re-reflected at the antenna and sent down the line to the receiver just as if it were a repeat of the original signal. If the transmission line is of substantial length, the re-reflected signal appears as a second image on the picture tube, displaced somewhat to the right. The reflection and re-reflection process can produce several ghost images, depending on how many round trips are made by the reflected signal.

TELEVISION TRANSMISSION LINES

Types of Transmission Lines

Types of transmission lines

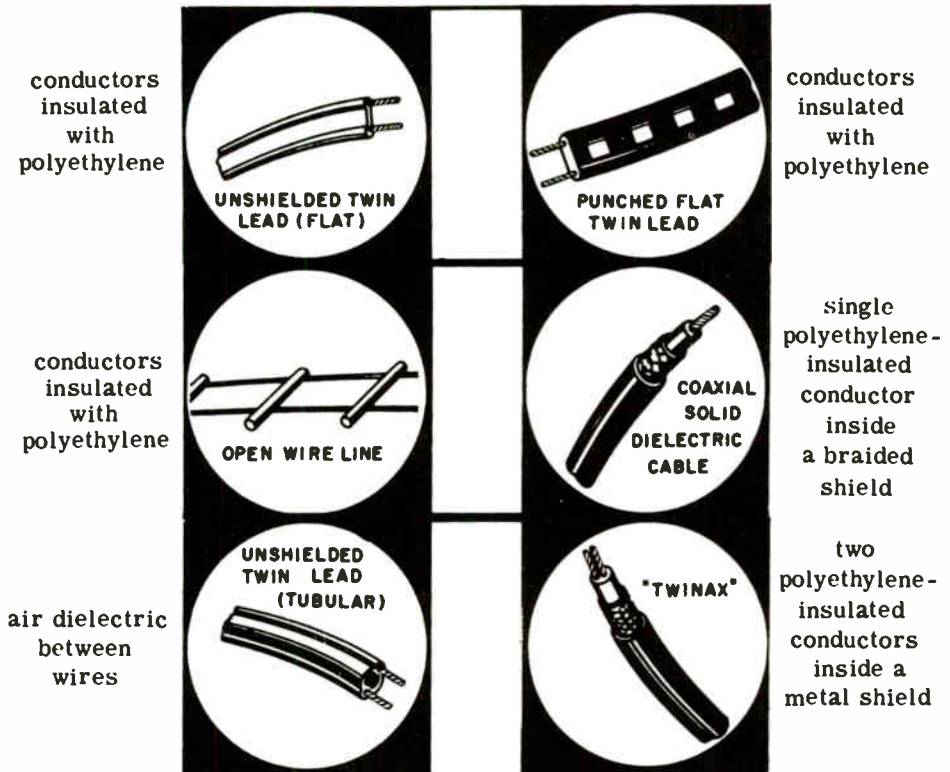

The transmission line used in television receiving systems is a special type of two-conductor cable. It differs from conventional two-wire conductor, such as lamp cord, in many ways. Foremost is the construction; the conductor diameter is constant throughout the length as is the physical separation between the conductors. Also, the material used for keeping the conductors apart and as insulation around the conductors, is *low-loss* material at television frequencies. Although we are concerned with the application of these r-f energy paths to television receiving systems, transmission lines are used over a very wide band of frequencies—far below and above the television broadcasting band.

As to the constructional features, the illustration shows the physical appearance and highlights the constructional details. The types illustrated are those peculiar to television receiving installations. They are only a few of the many varieties that are commercially available for general application as transmission lines in both transmitting and receiving systems.

TELEVISION TRANSMISSION LINES

The Impedance of Transmission Lines

Earlier in this lesson we related the *impedance* of a transmission line to the transfer of energy from an antenna to a receiver. We said that to achieve optimum operation the transmission line must match the feedpoint resistance of the antenna to the impedance of the antenna input transformer.

The impedance (Z) of a transmission line is an abridgement of characteristic impedance (Z_0). It is one of the important electrical constants of a transmission line as well as being a major form of identification relative to application. The impedance rating of the line is the basis of selecting the transmission line which will most suitably link the antenna with the receiver.

Characteristic impedance (Z_0) or simply impedance (Z) is expressed in ohms. In a sense it is comparable to resistance (R) in the conventional d-c circuit or very-low-frequency a-c circuit, although the two are not alike. Circuit resistance (R) expresses the ratio between the voltage E and the current I , or E/I , taking the entire circuit into account. For any given value of d-c voltage E , I is a function of total R . The same is true in a low frequency a-c circuit when the length of the circuit is insignificant relative to a wavelength of the a-c voltage. A wavelength at 60 cycles spans about 3100 miles.

Characteristic impedance similarly expresses the ratio between the voltage E and the current I , or E/I . But instead of dealing with the circuit as a whole, it deals with each point along the transmission line, that is, with instantaneous values of E and I at each point. Also, unlike circuit resistance, which is a function of the conductor material, cross section, and length, Z_0 is a function of the physical construction of the line.

THE CIRCUIT RESISTANCE R

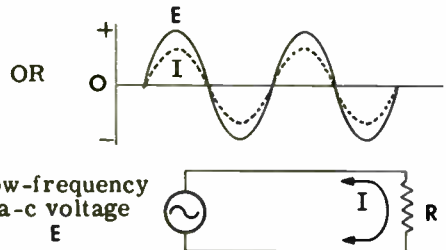
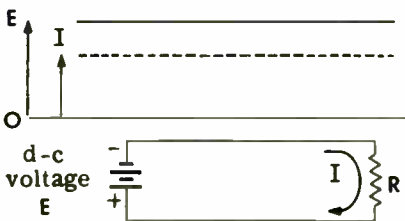

in a d-c circuit or in a low-frequency a-c circuit expresses the ratio between voltage E and current I in the circuit as a whole.

THE CHARACTERISTIC IMPEDANCE Z_0

of a theoretically infinitely long transmission line expresses the ratio between E and I at each point in the circuit, rather than in the circuit as a whole.

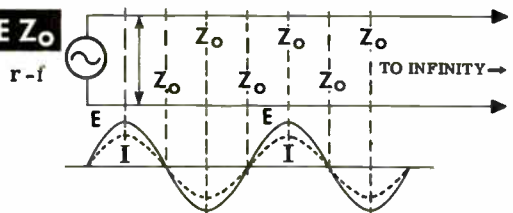

TELEVISION TRANSMISSION LINES

Inductance and Capacitance in Transmission Lines

When a d-c voltage or a low-frequency a-c voltage is applied to a two-conductor cable to which some sort of a load is connected, we concern ourselves mainly with the resistance of the conductors. But when r-f voltage is applied to such a cable we must concern ourselves more with the inductance and capacitance of the cable than with its resistance. Their effects on the current can be very great when the resistance is low. The inductance per foot may be as little as $0.1 \mu\text{h}$ or it may be much more, and the capacitance may be as small as $2 \mu\text{mf}$ per foot. There is of course also resistance in each conductor as well as leakage through the dielectric between the conductors. But for the present we neglect them here.

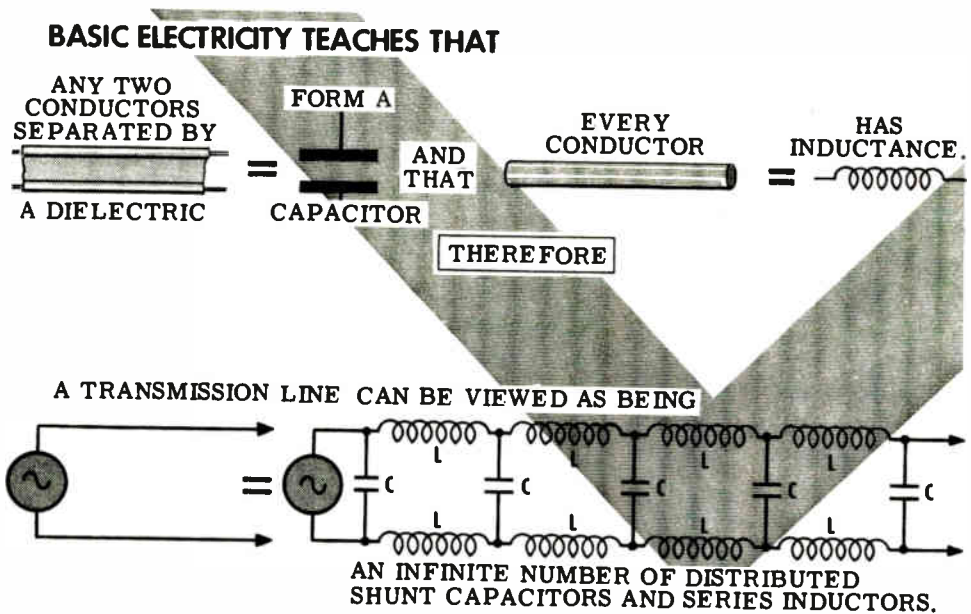

The importance of the inductance and capacitance per section of the line (arbitrarily set here as being 1 foot) arises from the way we look at the behavior of a transmission line. We view it as being made up of a great many sections, each of which presents the same fixed amounts of series inductance (L) and the same fixed amount of shunt capacitance (C). When r-f signal energy is applied at the input end of an infinitely long line, it moves down the line past each section at a fixed velocity determined by the design of the line. At each point in its travel the wave encounters an impedance due to the series L and shunt C , and the resultant current at each point is determined by the impedance existing there. In other words, the current is not governed by the whole circuit resistance. Rather, it is governed only by the impedance at the point where the voltage exists.

TELEVISION TRANSMISSION LINES

Characteristic Impedance

THE INFINITELY LONG TRANSMISSION LINE.

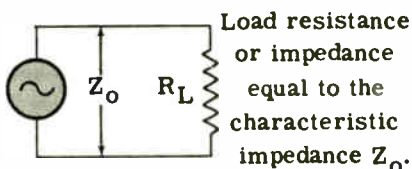
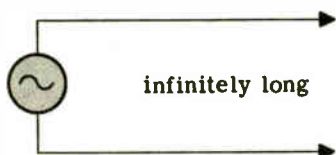

THE PROPERLY TERMINATED LINE OF FINITE LENGTH.

In view of this, the voltage-current ratio is the same everywhere, regardless of the instantaneous value of the voltage. For instance, if the voltage is 1 volt at one point and the current is .0033 ampere at the same point, the ratio $1/.0033$ equals 300 (ohms); if at another point in the same line the voltage is .03 volt and the current is .0001 ampere, the ratio $.03/.0001$ remains 300 (ohms). This ratio is known as the characteristic impedance or, simply the impedance of the line. It is a characteristic of the line construction.

When the characteristic impedance of a transmission line is given, it is assumed that the line is "infinitely" long. The use of an infinitely long transmission line in this discussion is simply a matter of convenience while explaining the action. Obviously a transmission line cannot be endless and still be practical. The conditions which exist with the infinitely long transmission line are achieved by terminating the practical transmission line with a resistance or impedance which is equal to the characteristic impedance of the line. When this is done all the energy sent down the line from the generator is absorbed by the load.

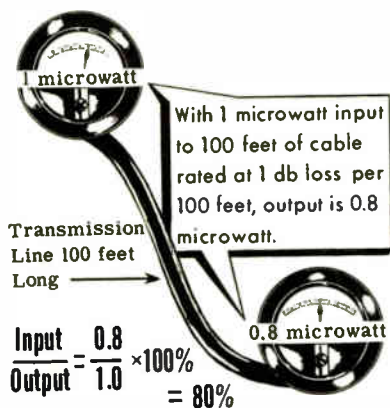

TELEVISION TRANSMISSION LINES

Velocity of Propagation Constant of Transmission Lines

You will recall an earlier statement that electromagnetic energy travels fastest (at the speed of light or roughly 300,000,000 meters per second) in free space and is slowed down in physical paths. It requires the application of a correction factor (0.95) when determining the half-wavelength dimension of a thin-rod dipole as compared to a half-wavelength for the same frequency in free space. The same thing happens in transmission lines. In fact, even to a greater degree.

The velocity of a signal moving along a transmission line relative to its velocity in free space is known as the *velocity of propagation constant*, or simply *propagation constant*. It is symbolized by the letters *VP*. Assuming the velocity in free space to be equal to unity or 1, the propagation constant is a percentage of 1. Thus when the manufacturer of a transmission line rates the line at a VP of 0.82 it means that the signal will travel through it at a velocity equal to 82 percent of its velocity in free space. For some other transmission line design the propagation velocity may be only 66 percent of that in free space. These figures are, of course, only approximations. The VP may vary by two or three percent for lines of the same type produced by different makers. The VP figure is not an indication of quality.

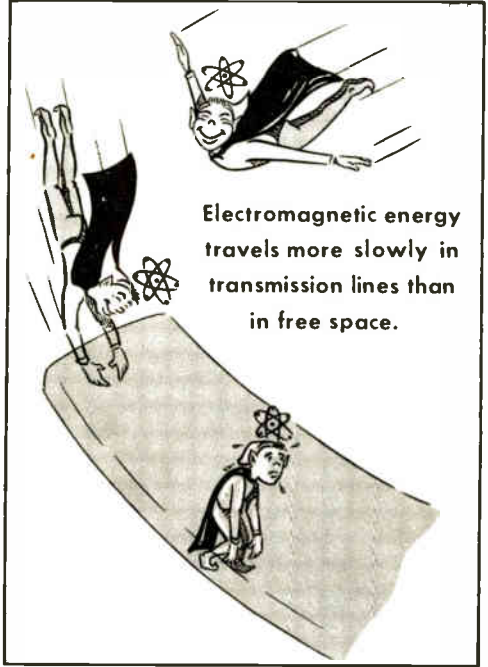

Different kinds of transmission lines bear different propagation-constant ratings. For example, transmission lines spoken of as *open lines*, using air as the dielectric, are rated at a VP of about 0.98. The ribbon type of lead like that which bears the Amphenol trademark Twin-Lead has a VP of 0.83 and the general run of solid dielectric coaxial cables bears a VP of 0.66. Although only three types of transmission lines are shown here, each is representative of a category or type, and therefore can be considered as applying to all versions.

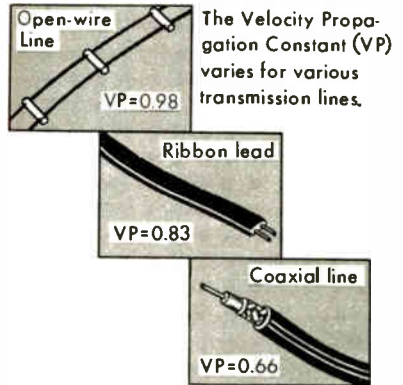

TELEVISION TRANSMISSION LINES

Effect of Velocity of Propagation on Wavelength

It will be remembered that wavelength is a function of frequency when the velocity is constant. If the velocity is changed because the medium through which the wave is moving differs from free space, the wavelength corresponding to a frequency also is changed. For instance, a wavelength corresponding to 85 mc in free space is

$$\begin{array}{l} \text{wavelength} \\ \text{in meters} \end{array} = \frac{300,000,000}{85,000,000} = 3.35 \text{ meters} = 136 \text{ inches}$$

What is the dimension of a wavelength for 85 mc if the energy is being conducted by a transmission line having a propagation constant of 0.83? Having determined the wavelength dimension in free space to be 136 inches, we multiply this figure by 0.83, the propagation constant, and derive the answer— 136×0.83 or about 113 inches. This represents wavelength in this new medium. A half-wavelength then would be $113/2$ or 56.5 inches. If the propagation constant of a medium is 0.66, a wavelength corresponding to 85 mc is 89.7 inches or roughly 90 inches.

THE WAVELENGTH WILL VARY WITH THE PROPAGATION CONSTANT

1 Wavelength of an 85-mc Signal equals

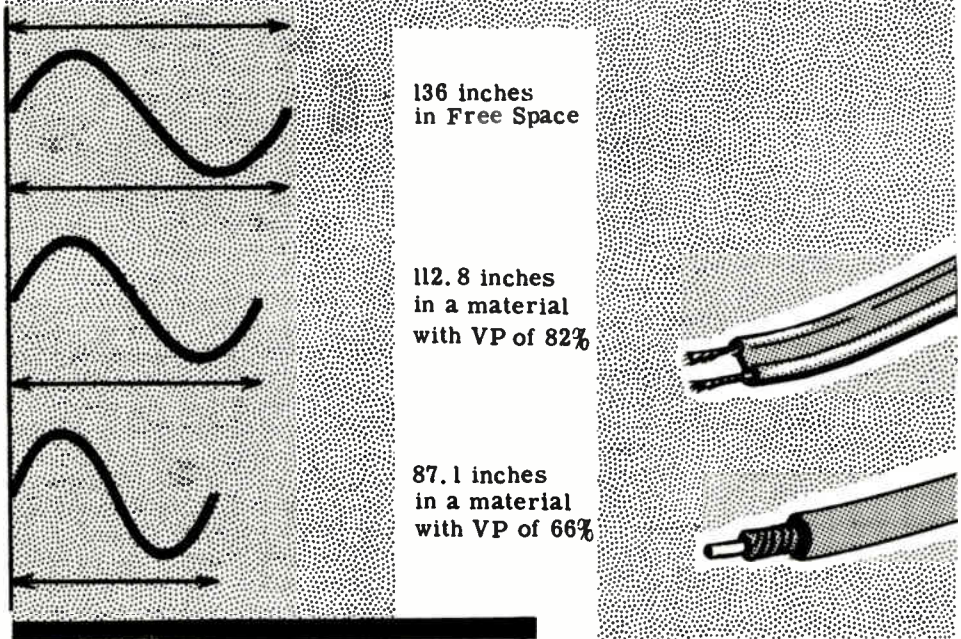

TELEVISION TRANSMISSION LINES

Current and Voltage Distribution in Transmission Lines

WHEN A PROPERLY TERMINATED LINE of any length is subject to a wave of energy, all points along it are subject to all values of voltage and current

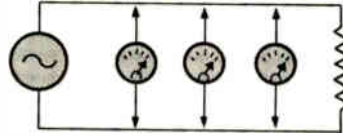
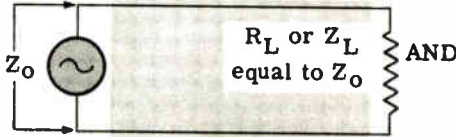

the line behaves as if a constant-amplitude voltage was applied to it.

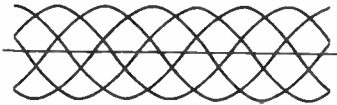

When a transmission line is terminated in a resistance (impedance) equal to its characteristic impedance the energy fed into the line moves from the input to the output, where the energy is absorbed. The input voltage and resultant current pass through cyclic variations between zero and maximum amplitude. The changes occur at every point along the line as the energy advances down the line. Therefore, there are no fixed points along the line at which the voltage or current always are maximum, zero, or any intermediate value between.

A voltmeter connected anywhere along the line will show the same value of voltage; an ammeter inserted anywhere in the line will show the same value of current, ignoring losses. Viewing the voltage and the current as being constant all along a properly terminated transmission line tends to mask a very useful situation. A reversal of phase of 180° occurs every half-wavelength along the line. This condition permits the use of a properly terminated transmission line of suitable length as a means of either changing the phase of the voltage and current by 180° , or tying together two points where the voltage (and current) differ in phase by 180° .

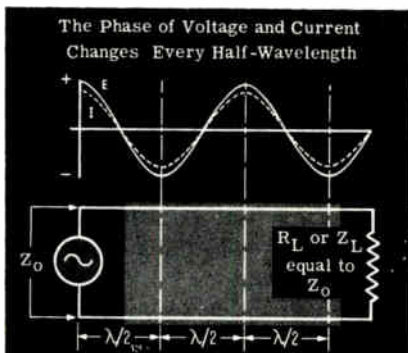

THEREFORE

the phase of the voltage at the input to a half-wavelength line is inverted 180° at the output,

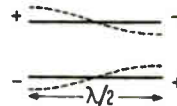

AND

the phase of the input to a full-wave line is duplicated at the output.



TELEVISION TRANSMISSION LINES

Mismatched Lines

Let us now consider the transmission line which is terminated by a resistance which differs substantially from the characteristic impedance of the line. The load resistance may be higher or lower than the characteristic impedance. In either case a mismatch exists. What happens now? The energy sent down the line from the generator (the antenna, for example) is not absorbed; some of it is reflected at the point of mismatch and sent back along the line. The generator continues supplying energy that goes down the line and the mismatch behaves like a generator that sends energy back up the line. Voltage and current move in both directions. The greater the amount of mismatch the greater is the percentage of energy sent down the line which is reflected back along the line.

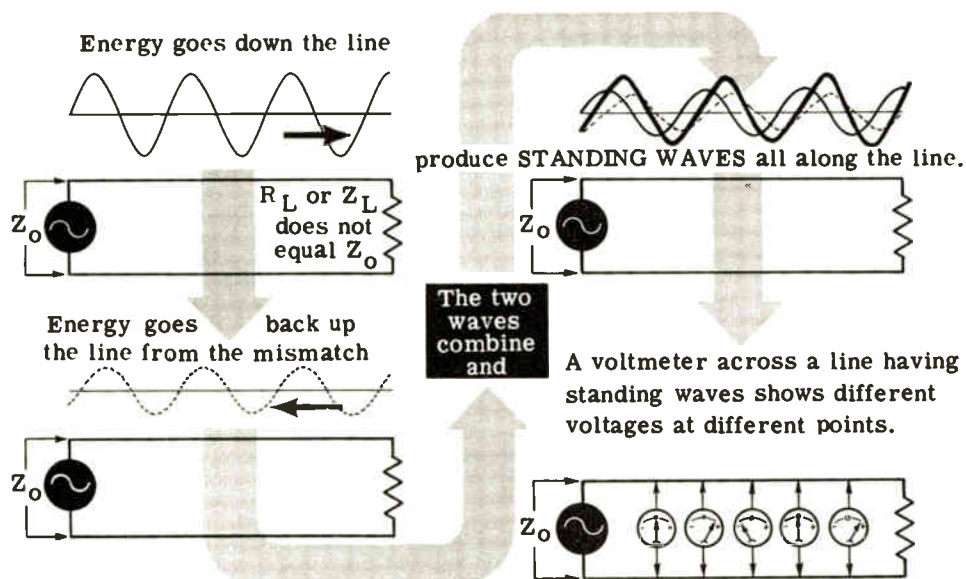

The voltages and resultant currents moving along the line in the two directions combine and produce a new (resultant) pattern of voltage and current all along the line which *remains fixed in position*. They are known as *standing waves* and appear as fixed points of minimum and maximum voltage and current along the line. Let us deal only with the voltage. Corresponding values of voltage would appear a half-wavelength apart relative to the point of mismatch.

As to the practical importance of standing waves on the transmission line between the antenna and the receiver, it means that less than the maximum amount of signal is being delivered to the receiver. Also, it means that the line is sensitive to positioning or handling; motion can result in changes in the appearance of the picture on the picture tube screen.

TELEVISION TRANSMISSION LINES

Open-Circuited Transmission Lines

Let us consider a case of extreme mismatch—the transmission line without a load. Imagine any transmission line open-circuited at the load end. Reflection takes place because of the mismatch, hence standing waves exist on the line. It results in a pattern of voltage and current distribution which leads to special applications.

CHARACTERISTICS OF OPEN-END LINES

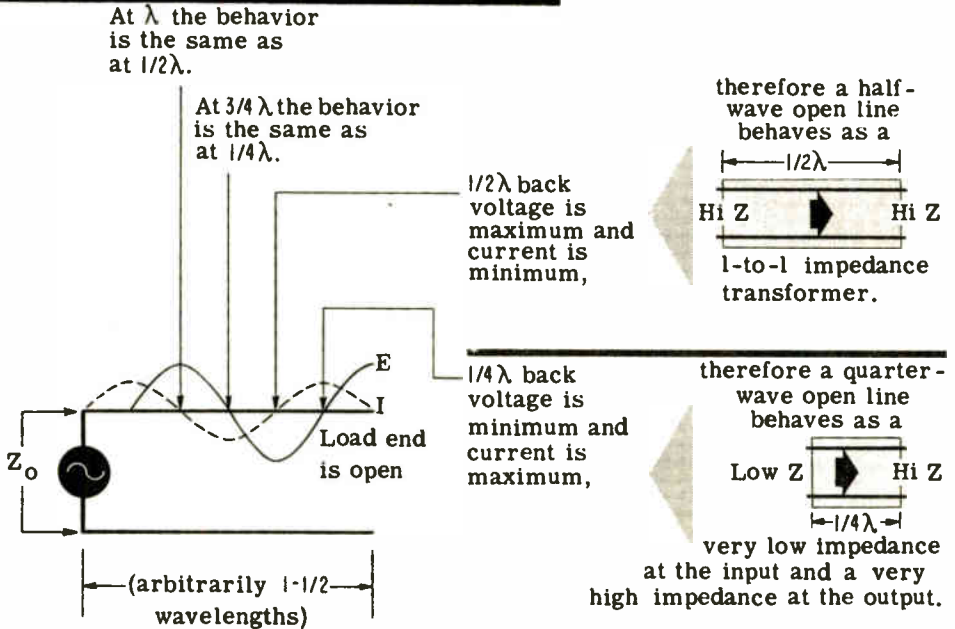

The point of reference for examination is the point of mismatch—the open-circuited end. This is where the reflection originates. Starting at the open end, we say that an open circuit is the equivalent of an infinite impedance or resistance, hence zero current and maximum voltage. One quarter-wavelength back from this point the current is maximum and the voltage is zero. Another way of looking at this is to say that where the voltage is minimum and the current is maximum the transmission line *behaves* as if the impedance is minimum or a short circuit exists. Another quarter-wavelength back along the line we note zero current and maximum voltage; the same conditions as at the open load end. In other words, a half-wave section of open line presents a high impedance at both ends. Moving back another quarter-wavelength, we note maximum current and zero voltage again. Thus the $3/4$ -wavelength line duplicates the conditions of a $1/4$ -wavelength line, and so on. The summary of the behavior is illustrated.

TELEVISION TRANSMISSION LINES

Use of Open-Circuited Transmission Lines

source of signals

connected end

open end

$1/4\lambda$

A quarter-wave line behaves like a

series resonant circuit.

If a quarter-wavelength open line is connected across any source of signals, the source will "see" a very low impedance at the frequency for which the line was dimensioned.

A quarter-wave open line connected to an antenna will "short circuit" the antenna over a narrow band of frequencies around the frequency for which the line was dimensioned.

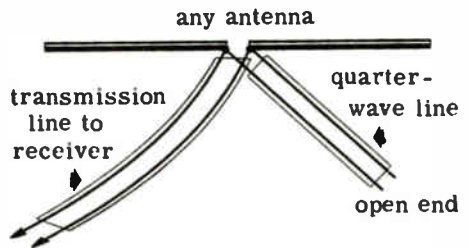

transmission line to antenna

RECEIVER

quarter-wave line

open end

A quarter-wave open line cut for an interfering signal frequency and connected to the antenna terminals of a receiver will act as a short circuit (trap) over a narrow band of frequencies around the interfering frequency.

input

output

A half-wave open line acts a 1-to-1 impedance transformer,

and a half-wave line terminated in a resistance or impedance Z will display the same impedance at the input, accompanied by a 180° phase inversion.



How do we make use of such behavior? If we connect a $1/4$ -wavelength section of an open transmission line across a signal source, the source will "see" very low impedance (a short circuit) at that frequency for which the line is electrically $1/4$ -wavelength long or any *odd multiple* of $1/4$ -wavelength. In this respect it behaves as a series-resonant circuit at resonance.

TELEVISION TRANSMISSION LINES

Use of Open-Circuited Transmission Lines (contd.)

There is still another way of using the $\frac{1}{4}$ -wave open line—as an impedance transformer. The impedance transformer action works in both directions. It would work equally well to match a 300-ohm line to a 72-ohm antenna, or a 72-ohm line to a 300-ohm antenna input transformer.

The half-wave open line is often used as the connecting link between two V antennas positioned in the horizontal plane. The two antennas are separated by a half-wavelength and both behave as connected elements. The approaching wavefront excites the front element and a half cycle later excites the rear element. The lapse in time (half cycle) equals 180° , hence the rear antenna is 180° out of phase with the front antenna. We have said that a half-wave line inverts the voltage by 180° . Therefore the half-wavelength line between the rear and the front antennas shifts the signal voltage by another 180° , making it in phase with the voltage developed in the front antenna.

THE PROBLEM

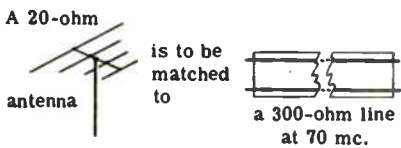

THE SCHEMATIC

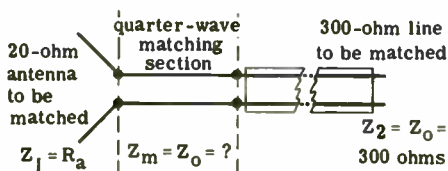

THE EQUATION

$$Z_m = \sqrt{Z_1 \times Z_2}$$

THE SOLUTION

$$Z_m = \sqrt{20 \times 300} = \sqrt{6000} = 78 \text{ ohms}$$

A quarter-wave line with $Z_o = 75$ ohms is satisfactory. The length of the line

$$\text{in inches} = \frac{2952}{70} \times 0.83 = 35 \text{ inches}$$

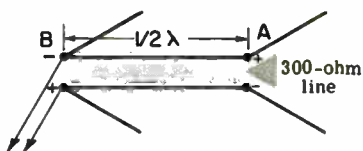
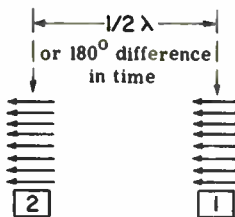

A wave at position 1 excites antenna A and at position 2 excites antenna B (180° later). Therefore, the polarity is reversed at antenna B. A half-wavelength transmission line connected from B to A inverts the voltage from antenna A so that it arrives at B in phase with the voltage generated in it by the passing wave.

TELEVISION TRANSMISSION LINES

Short-Circuited Transmission Lines

At the full-wavelength point, behavior is like that at the half-wavelength point.

a half-wave shorted line behaves as a very low impedance at input

At a half wavelength back from the shorted end, voltage is minimum and current is maximum

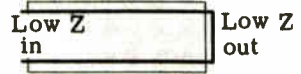

At the three-quarter-wavelength point, behavior is like that at the quarter-wavelength point.

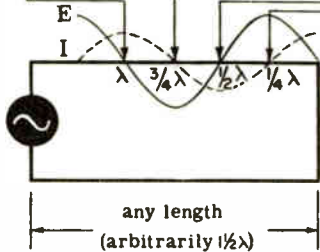

At a quarter-wavelength back from the shorted end, voltage is maximum and current is minimum.

a quarter-wavelength shorted line

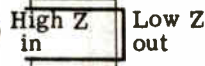

behaves as a very high impedance at the input;

Let us consider another extreme in mismatch—the shorted transmission line. Reflection takes place at the point of mismatch and standing waves appear on the line. The current at the shorted end is maximum and the voltage is minimum—impedance is minimum. Working back from the point of mismatch, the shorted-load end, we note a variety of minimum and maximum impedance points every $\frac{1}{4}$ -wavelength, as summarized in the illustration.

Among many other uses, a shorted $\frac{1}{4}$ -wave line connected across two points where a variety of signals exist will behave as a very low impedance—a virtual short circuit—to all frequencies other than a very narrow band around the one for which it is a $\frac{1}{4}$ -wavelength long. In other words it will select a very narrow band of frequencies and short out the rest. If the shorted line is $\frac{1}{2}$ -wavelength long, it will short circuit a very narrow band of frequencies and pass the rest.

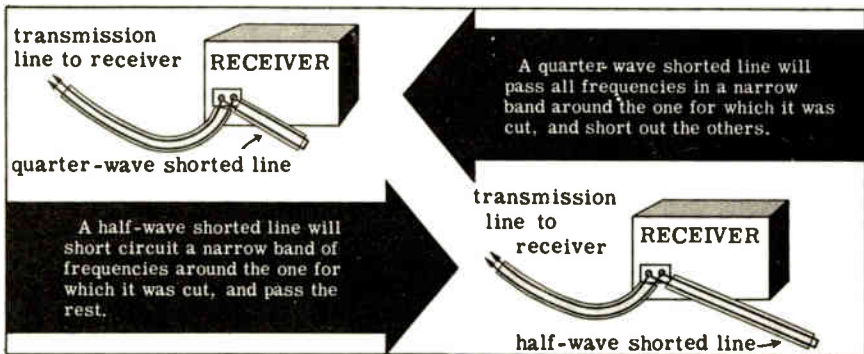

TELEVISION TRANSMISSION LINES

Antennas and 300-Ohm Transmission Lines

It has become standard practice to design television receivers for use with 300-ohm transmission line. To permit the use of these lines antenna manufacturers resort to different means of achieving a suitable approximation of 300 ohms feedpoint resistance. Because of the high signal level which prevails in highly populated areas, feedpoint resistance between 200 and 400 ohms has been found tolerable. The loss in signal strength is not too important in most cases.

A frequent practice followed in antenna design is to operate off-resonance. This does not defeat the fundamental theory as described in these lessons. In fact the reverse is true; it shows the practical application of the change in feedpoint resistance of a dipole antenna cut for a certain frequency as the frequency changes. By making the antenna length somewhat shorter or longer than the half-wave resonant length, the feedpoint resistance is raised so as to become a suitable match for a 300-ohm line. Also, the use of a folded dipole as the connected element is frequent. It is made slightly off-resonant for the connected-element-reflector combination, and when several directors and a reflector are used the folded dipole is designed for feedpoint resistance of two or three times the nominal 300 ohms.

Achieving the Usable Feedpoint Resistance

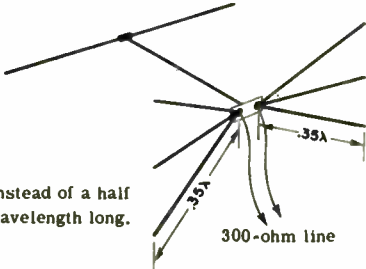
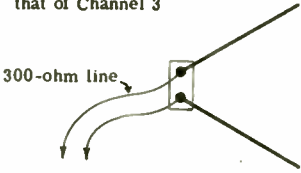
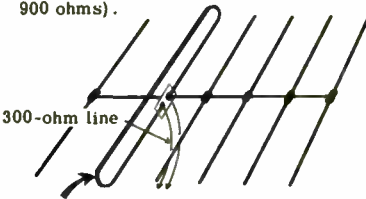
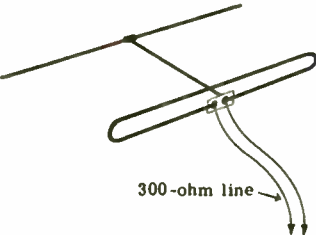
<p>The conical antenna may be 0.7 to 0.75 wavelengths in overall length at its center frequency</p>  <p>instead of a half wavelength long.</p>	<p>The V antenna intended for vhf coverage is cut for a frequency somewhat below that of Channel 4 and above that of Channel 3</p>  <p>and will function over both vhf and uhf channels.</p>
<p>Usually, Yagi antennas are intended for single channels. It has a folded dipole connected element (R_a 600 to 900 ohms).</p>  <p>This element has two rods of unequal diameter or three rods of the same diameter.</p>	<p>The folded-dipole/reflector antenna can be cut slightly longer than a half wavelength at the center frequency.</p> 

SPECIAL TECHNIQUES

Stacked Antennas

It is possible to arrange antennas physically so as to take advantage of the signal distribution along the vertical dimension of the wavefront of an approaching wave and so extract an increased amount of energy. It is done by placing the antennas one above the other, separated by a half-wavelength. Such antennas are stacked vertically. Horizontal stacking also is possible.

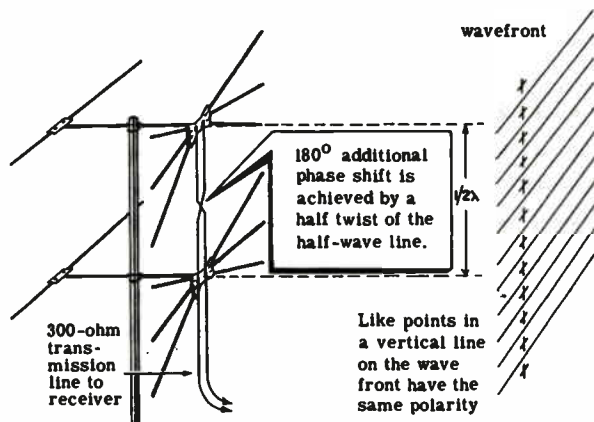

The approaching wavefront strikes both antennas at the same time and induces a like voltage in each of them. The 180° phase shift imparted by the half-wave line is increased to 360° by giving the line a half twist. Currents from the antennas are thus in phase, and maximum signal is delivered via the transmission line to the receiver.

All varieties of dipole antennas can be stacked vertically. But for the sake of simplicity we illustrate the discussion using two conical equivalents with reflectors. The horizontal directional properties of the stacked antenna remain the same as for either one of the antennas alone, the principal advantage of vertical stacking being an approximate two-fold increase in the amount of power extracted from the passing wave. Vertical stacking of two antennas affords a 3-db power gain over one antenna. As a rule, antennas stacked vertically are of an even number such as 2, 4, 6 and so on.

All points in the vertical plane along a wavefront have identical polarity. Hence, each antenna is acted on at the same instant by a voltage of like polarity, and the currents in the two antennas flow in the same direction. In order that the signals in the two antennas be fed to a common transmission line, a half-wave line (of any characteristic impedance) connects the two feedpoints, and the line to the receiver joins the feedpoints of the lower antenna. It will be remembered that a half-wavelength transmission line inverts the polarity of the voltage by 180° between the input and the output. To offset this action and to make the two antennas behave as one relative to signal polarity, the half-wave line connecting the two antenna feedpoints is given a mechanical half twist so that the instantaneous *plus* lead on the top antenna joins the instantaneous *plus* point on the lower antenna. In this way the signals fed to the common transmission line are in phase all the time.

SPECIAL TECHNIQUES

Location of the Transmission Line Takeoff Point

Locating the takeoff point for the main transmission line to the receiver at one of the antenna feedpoints is a compromise based on convenience. It works satisfactorily because of the high antenna resistance at the feedpoints and because some loss of signal can usually be tolerated. Technically speaking, the resistance at the feedpoint under such circumstances is no longer the feedpoint resistance; actually two antenna feedpoint resistances are in parallel and the takeoff resistance now is one-half of what it was when they were unconnected.

Oftentimes the takeoff point for the main transmission line to the receiver is half-way along the transmission-line section that connects the two antennas. In that event, the resistance (impedance) at the takeoff point is equal to half the feedpoint resistance value. Assuming truly 300-ohm antennas, the takeoff point resistance is 150 ohms and would require a transmission line rated at this value. 300-ohm lines have been used in such cases. It is not a good match but it has been found acceptable. In the event that the antenna feedpoint resistance is substantially higher than 300 ohms because of nonresonant operation, the 300-ohm transmission line connected to the takeoff point is entirely satisfactory.

Connection of the transmission line to a stacked array.

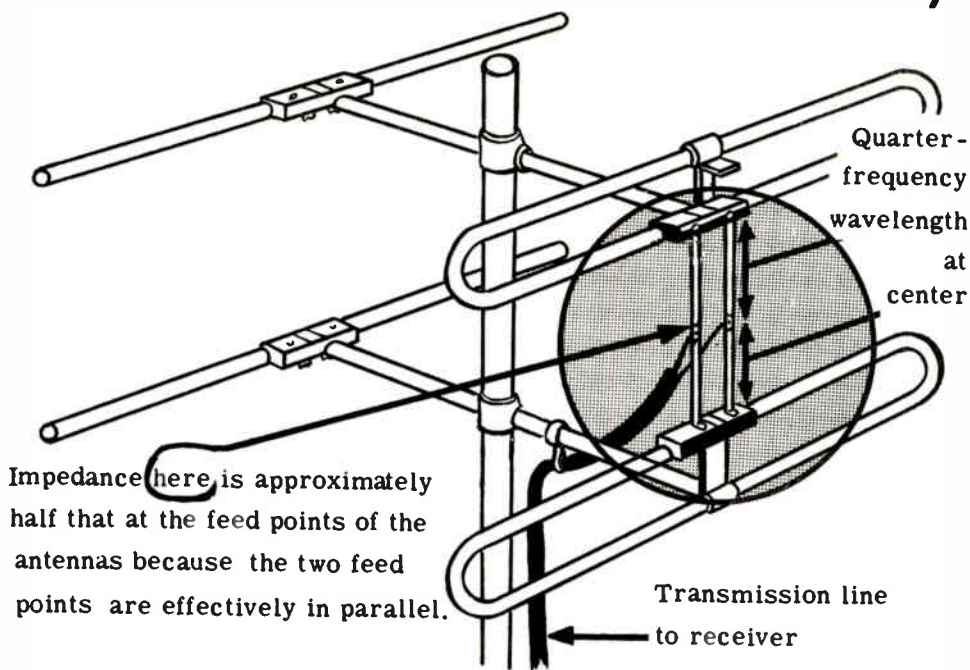

SPECIAL TECHNIQUES

Matching Transformers and Indoor Antennas

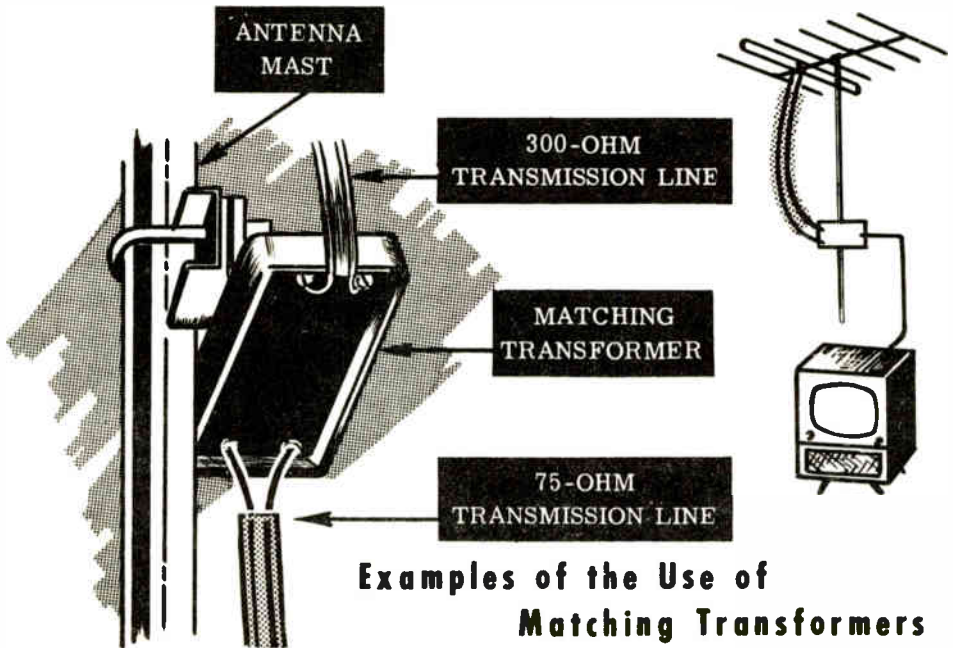

Examples of the Use of Matching Transformers

Many types of antennas are available. The modern installations are designed for 300-ohm transmission lines, but many others in use were designed with feedpoint resistance values which required 72 to 75-ohm lines or 300-ohm lines. To accommodate these different types of antenna designs for receivers rated at 72–75 or 300 ohms input impedance, matching transformers (*baluns*) were conceived. Sometimes they are called elevator transformers. Their function is to match these antenna feedpoint resistance values to the receiver. In essence, matching transformers of this kind are coiled transmission lines which can be connected in parallel or in series as required by the impedance match requirements.

The indoor antenna takes many shapes, most popular of which is the upright V also called *rabbit ears*. The arms are adjustable in length, being adjusted to the best response as seen on the picture tube screen. Although used with a 300-ohm transmission line, it is in the main the equivalent of an ordinary center-fed dipole of adjustable length. Operation off-resonance accounts for whatever feed-point resistance match is made. As a rule, the rabbit ears provides relatively poor performance when compared to conventional antennas. It is used only where an outdoor type cannot be installed.



REVIEW

1. *Response of a Dipole-Reflector Combination.* The signal available for transfer to the receiver in the connected dipole is more than was actually extracted from the passing wave by that element. The signal intercepted by the reflector makes its contribution by re-radiating some of the energy to the connected element.

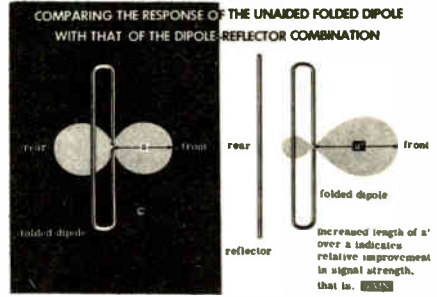

THE BOW-TIE ANTENNA WITH CORNER REFLECTOR

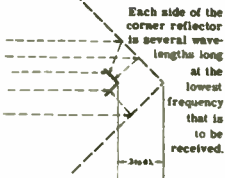

HORIZONTAL DIRECTIVITY PATTERN

2. *UHF Antennas.* In the bow-tie antenna used with a corner reflector, the connected dipole is bent into a horizontally positioned V. Its sides are then parallel to the sides of the corner reflector so that maximum energy is returned from the reflector to the dipole.

3. *Combination Low- and High-Band VHF Antennas.* The high-band antenna is positioned above the low-band antenna. The vertical separation between the two assemblies usually approximates a half-wavelength corresponding to the geometric mean of the frequencies for which the two antennas were cut.

COMBINATION LOW-BAND AND HIGH-BAND VHF ANTENNA

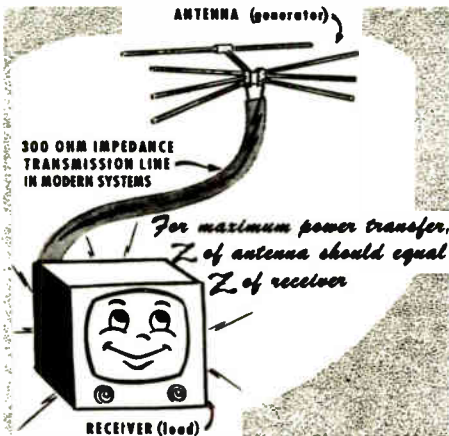
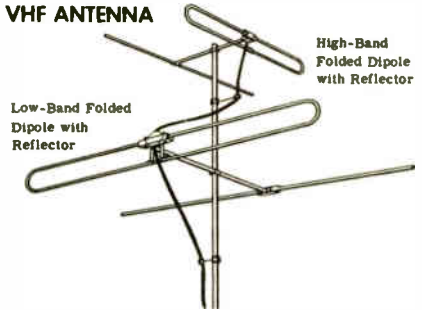

4. *Transmission Lines.* The transmission line is the path over which the signal energy is conducted from the antenna to the receiver. It must be selected to "match" electrically the antenna and the receiver impedances, which are made equal in value.

REVIEW

Types of transmission lines

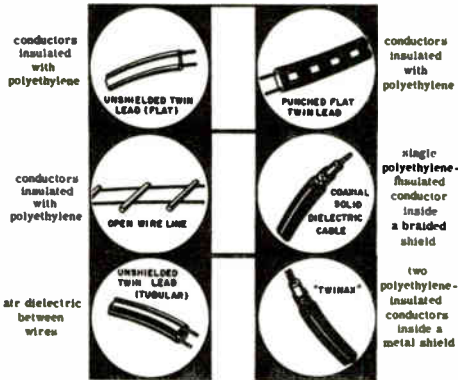

6. *The Velocity of Propagation* of a signal moving along a transmission line relative to its velocity in free space is known as the velocity of propagation constant, or simply propagation constant. Assuming the velocity in free space to be equal to unity, or 1, the propagation constant is some percentage of 1.

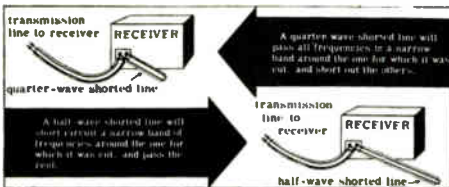

8. *Indoor Antennas.* The most popular indoor antenna is the upright V, also called *rabbit ears*. The arms are adjustable in length, being adjusted to the best response as seen on the picture tube screen. Because of its relatively low gain, it is used only when an outdoor type cannot be installed.

5. *Types of Transmission Lines.* The transmission line used in television receiving systems is a special type of two-conductor cable. The conductor diameter is constant, as in the physical separation between conductors. The dielectric that separates the conductors is low-loss material at television frequencies.

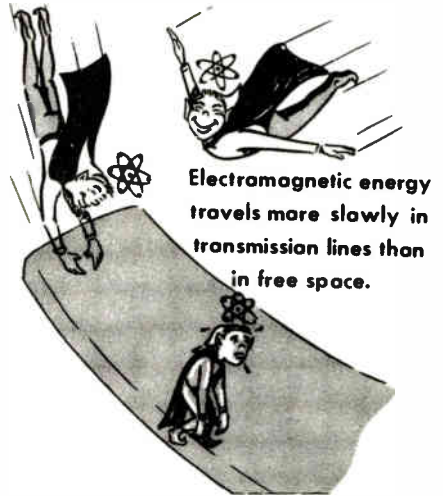

7. *Short-Circuited Transmission Line* $\frac{1}{4}$ -wave long will behave as a virtual short circuit to all frequencies other than a very narrow band around the one for which it was cut. If the shorted line is $\frac{1}{2}$ -wavelength long, it will short circuit a very narrow band of frequencies and pass the rest.

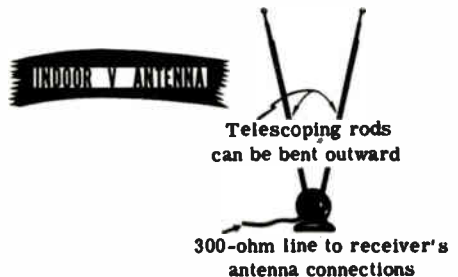

INDEX TO VOL. II

(Note: A cumulative index covering all five volumes in this series will be found at the end of Volume V.)

- AFC, 2-40, 41
- AGC, 2-22, 23
- Amphenol, 2-129
- Antennas:
 - bandwidth, 2-101
 - basic dipole, 2-67-77
 - computations of, 2-68, 69
 - forms of, 2-74, 75
 - resonance in, 2-76
 - signal interception by, 2-77
 - batwing, 2-107
 - biconical, 2-104
 - bow-tie, 2-118
 - broadband yagi, 2-116
 - center frequency, determination of, 2-102
 - combination lo-band and hi-band vhf, 2-119
 - combination vhf and uhf arrays, 2-120, 121
 - conical, 2-105
 - connected element with reflector and director, 2-115
 - continuous rod, re-radiation from, 2-79
 - corner reflector, 2-118
 - corner reflector, equivalent, 2-120
 - dipole:
 - behavior, 2-76-79
 - center frequency, 2-100
 - response, 2-82-90, 99-102
 - broadside positions, 2-82
 - parallel positions, 2-82
 - types of, 2-103-108
 - dipole-reflector combination, 2-113, 114
 - power gain of, 2-113, 114
 - directional response, 2-63, 83
 - directivity, 2-83
 - elements, addition of, 2-113-116
 - feedpoint, 2-95
 - folded dipole, 2-107, 108, 114, 118
 - half-wave dipole:
 - directional response, 2-86-90
 - E and I, at resonance, 2-91
 - nonresonant, resistance of, 2-93, 94
 - power transfer from, 2-96
 - resistance of, 2-92
 - thin, frequency response of, 2-99
 - zero-db rating of, 2-72, 73
 - impedance, 2-123
 - input transformer, 2-98
 - large cross-section, 2-103
 - loadpoint, 2-95
 - loadpoint resistance, 2-97
 - multiple element, 2-111
 - operation of, 2-112
 - parasitic elements, 2-111, 112, 114, 116
 - rabbit ears, 2-140
 - receiving dipole:
 - broadside positions of, 2-82
 - positioning effects, 2-84, 85
 - reflector, 2-112, 115, 117, 120
 - re-radiation:
 - continuous rod, 2-79
 - receiving dipole, 2-78
 - resistance, 2-92-98
 - half-wave, antenna, 2-92
 - nonresonant half-wave antenna, 2-93, 94
 - rhombic, 2-122
 - special techniques, 2-138-140
 - stacked, 2-138
 - TV receiver, general, 2-53, 54
 - uhf, 2-117-122
 - vhf, 2-117-122
 - V, 2-106, 120, 140
 - Yagi, 2-116
- Automatic frequency control, 2-22, 23
- Automatic gain control, 2-22, 23
- Brightness, 2-29
- Characteristic impedance, 2-128
- Contrast, 2-29
- D-C restoration, 2-29
- Deflecting yoke, 2-32
- Delayed avc, 2-22,
- Demodulation, 2-18, 19, 21
- Detector, f-m, 2-27
- Discriminator, f-m, 2-27
- Double-conversion uhf reception, 2-49

INDEX

Electromagnetic wave theory, 2-62

Field concept, 2-64, 65

Fine tuning control, 2-10

Frequency-conversion process, 2-11-14

Ghosts, 2-124

Guard band, 2-6

Horizontal:

afc circuit, 2-40, 41

damper, 2-43

linearity control, 2-43

hold control, 2-42

output stage, 2-42

output transformer, 2-43

sweep circuits, 2-40-43

sweep section, 2-40

width control, 2-43

Impedance mismatch, 2-124

Incorrect oscillator output
frequency, causes of, 2-10

Indoor antennas, 2-140

Infinitely long line, 2-128

Intercarrier principle, 2-21

Intercarrier video amplifier, 2-24, 25

Intermediate frequencies, 2-11-14

Lead-in, 2-123

Limiters, f-m, 2-27

Line-of-sight transmission, 2-59

Local oscillator:

frequency, 2-10

relative position of, 2-10

Long-distance television reception, 2-60

Matching transformers, 2-140

Mixer function, radio receiver, 2-8

Negative-phase voltage, 2-19, 25

Oscillator, function radio receiver, 2-8

Picture i-f:

carriers, frequencies of, 2-13, 14,

16, 17

i-f signal, 2-11

Picture tube, 2-45

Polarized radiation, 2-65, 66

Positive-polarity voltage, 2-19, 25

Power supplies, 2-45

Propagation, 2-55-60

constant, 2-129

Pulse:

clipper, 2-34

separator, 2-34

types, introduction to, 2-33

Radiated wave, 2-61, 66

Reflection of TV waves, 2-61

Resting frequency, 2-6

Review, 2-30, 31, 50, 51, 52, 80, 81,
109, 110, 141, 142

R-F amplifier:

functions of, 2-3

response, 2-7

Sidebands, 2-5, 11

Single-conversion uhf reception, 2-48

Six-mc channel bandwidth, 2-5

Soundbars, 2-24

Sound:

carrier, 2-6

channel. fm. 2-26, 27

i-f carrier, frequencies of, 2-12, 13,
14, 16, 17

Standing waves, 2-132

Station selector, 2-4

Superheterodyne receiver, 2-8

Sync:

amplifier, 2-35

clipper, 2-34

pulse separation, 2-34

separator, 2-34, 35

Synchronization, 2-33

circuits, 2-32-35

Television:

channel, 2-4, 5

receiver:

front end, 2-15

general layout of, 2-1, 2

i-f amplifiers in, 2-16, 17

mixer and oscillator function, 2-9

relation to radio receiver, 2-2

split-sound, 2-47

signals, propagation of, 2-55-58

transmission lines, 2-71, 123-137

INDEX

Transmission lines:

- attenuation, 2-128
- E and I distinction in, 2-131, 132
- impedance, 2-126
- L and C in, 2-127
- open-circuited, 2-134, 135
- reflection, 2-124
- short-circuited, 2-136
- takeoff point, 2-139
- 300-ohm, 2-137

Tuner:

- frequencies, 2-3-10
- i-f stages, 2-15-17

Tuning function, 2-3

UHF reception, 2-48, 49

Vertical:

- height control, 2-37
- hold control, 2-37
- linearity control, 2-38
- output stage, 2-38
- sweep circuits, 2-36-38

VP, 2-129

Vestigial-sideband transmission, 2-5

Video:

- amplifier, 2-24, 25
- detector, 2-18-21

Wavelength, formula for signal in

- free space, 2-68
- sample computation, 2-130



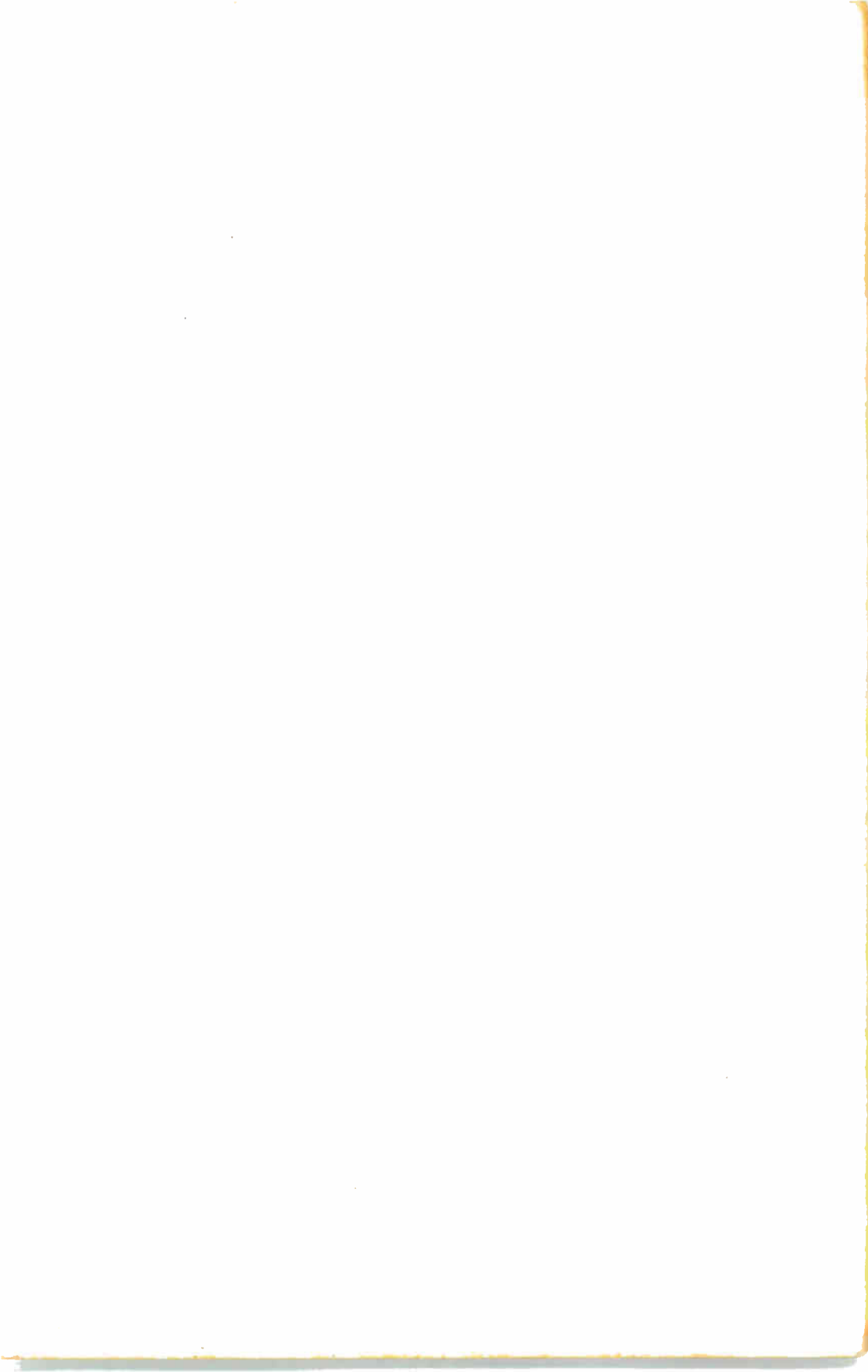

HOW THIS OUTSTANDING COURSE WAS DEVELOPED:

This presentation, dealing with the principles of basic television, is the outgrowth of three years of experimental revision of lessons used in both correspondence and resident study in television courses at New York Technical Institute. These courses, approved by the New York State Department of Education and approved for veteran training, included extensive study of radio and television theory. The examinations and questions submitted by the many thousands of civilian and veteran students who utilized the original instructional material showed the maximum success to be in those areas of the curriculum that were highly pictorialized. The faculty and industrial groups advising the Institute suggested that development of a television theory course, reflecting the most modern visually oriented techniques, would be of great assistance to students and trainees in schools, for industrial training programs, and for home study.

With visualization as one of the aims of the proposed project, the subject matter required to give complete up-to-date coverage of the television field was selected. Technical illustrations and related texts were then prepared and tested upon groups of students to be sure that they were completely understandable to every student. Alternative sketches and subject treatment were devised and re-tested in most areas. The lesson materials that proved most successful from the standpoint of rapid and complete learning on the part of the trainees were selected to form the final completed work.

"Basic Television" consists of five volumes:

Volume 1—The Studio, Development and Transmission of Video and Sound Signals. Volume 2—The Overall View of the Receiver, Antennas and Transmission Lines. Volume 3—Circuitry of Tuners, Conversion, I-F Amplification, Video Detectors and Amplifiers. Volume 4—Circuitry in Synchronization, Vertical and Horizontal Sweep Systems, High-Voltage Power Supply. Volume 5—Picture Tubes, Low-Voltage Power Supplies, Sound Section Circuits, Closed Circuit TV.

JOHN F. RIDER PUBLISHER, INC., 116 West 14th St., N.Y. 11, N.Y.