

ELECTRONIC TECHNOLOGY SERIES

F-M LIMITERS and DETECTORS

a **RIDER** publication

\$.90

F-M
limiters
and
detectors

Edited by

Alexander Schure, Ph. D., Ed. D.

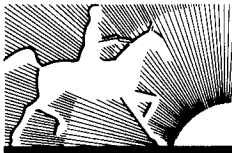

JOHN F. RIDER PUBLISHER, INC.
480 Canal Street • New York 13, N.Y.

Copyright 1955 by

JOHN F. RIDER PUBLISHER, INC.

All rights reserved. This book or parts thereof may
not be reproduced in any form or in any language
without permission of the publisher.

FIRST EDITION

Library of Congress Catalog Card No. 55-9151

Printed in the United States of America

PREFACE

Except for bandwidth and response consideration, f-m and a-m receivers correspond closely in many major circuit details. The point of greatest divergence in principle appears when their respective detector circuits are analyzed; here the concepts, design, and theory differ considerably from each other. Where a-m detectors yield to a simple treatment based upon signal rectification and nonlinear amplification, a discussion of f-m detectors cannot be readily begun without reference to vectorial representation.

Every effort has been made to clarify the logic involved in the vectorial explanation of the discriminator. It is felt that the analysis level is such that it is completely comprehensible to the technician or engineer who wishes to review these fundamental concepts.

A thorough discussion of limiters has also been included since this second point of divergence between a-m and f-m systems warrants completely separate examination.

An entire chapter has been devoted to the operation and adjustment of the gated-beam detector. The 6BN6 limiter-detector circuit is thoroughly described and profusely illustrated to assist the reader in following this radical approach to the problem of eliminating a-m interference and demodulating the f-m carrier with a minimum of tubes and accessory components.

At the time of writing, ratio detectors in new equipment do not depart to any significant extent from the basic circuits presented in this book, and, since this type of detector is still the most popular of all, considerable attention has been given to its theory of operation and optimum adjustment.

Grateful acknowledgement is made to the staff of the New York Technical Institute for its preparation of the manuscript for this booklet.

New York, N. Y.
May, 1955

A. S.

CONTENTS

Chapter	Page
1 Forerunners of Modern F-M Detectors	1
2 F-M Limiters	8
3 The Modern F-M Discriminator	17
4 The Ratio Detector	26
5 The Gated-Beam Tube	33
Index	44

Chapter 1

FORERUNNERS OF MODERN F-M DETECTORS

1. The Function of the F-M Detector

The function of *any* detector in any radio system by which intelligence is to be conveyed is to convert the variations of the instantaneous value of some characteristic of the carrier into corresponding variations in the detector's instantaneous output voltage. An a-m detector first rectifies the received radio wave and then converts the amplitude variations into an audio component capable of being reproduced in the form of sound. A television video detector takes the same approach and produces, as its output, the video and sync pulse frequencies.

The task of an f-m detector is the same as the above except that its instantaneous output voltage must be a function of the instantaneous frequency of the carrier wave. This may be rephrased in this way: The unmodulated carrier must produce a certain fixed d-c voltage (sometimes zero) across the output impedance of the detector; then as frequency modulation begins, the instantaneous output voltage must rise and fall proportionally with the increases and decreases in carrier frequency. Whether an increasing frequency produces a higher voltage across the output impedance or a lower one is relatively immaterial, just as long as proportional variations in output voltage exist as a function of frequency deviations.

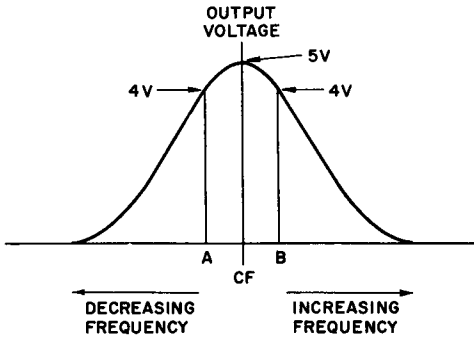

Fig. 1. I-f amplifier response curve.

2. The Slope Detector

One of the earliest attacks on the problem of f-m detection is found in the slope detector.

Consider an ordinary i-f amplifier resonant curve like that shown in Fig. 1. The greatest voltage output from this stage is obtained when the incoming frequency is that of the resonant frequency of the i-f amplifier. This has been assumed to be 5 volts for simplicity. As the frequency of the incoming signal deviates from the resonant value, the output voltage becomes increasingly lower.

If the center vertical line in this figure represents the center frequency (CF) of a received f-m signal, frequency deviations to the left (lower frequencies) *and* frequency deviations to the right (higher frequencies) both give rise to lower voltage output. Thus, the use of the amplifier in this fashion provides no detection because it cannot discriminate between plus and minus frequency deviations. The requirement is that frequencies higher than center value produce larger voltages and those lower than center, produce smaller voltages (or vice versa).

This effect is made possible by detuning the amplifier so that the center or unmodulated carrier frequency appears at about the center of the side slope (Fig. 2).

With no modulation, the carrier generates a 3-volt drop across the output impedance as shown in the figure; as the frequency decreases, the response of the amplifier is not as great and the output voltage goes down to 2 volts. On the upward frequency deviation, the voltage output rises to 4 volts.

This is exactly the result we want, since the voltage variations are quite proportional to the frequency excursions of the carrier

and now may be separated from the carrier by an a-m detector, amplified, and reproduced in the form of sound.

The fidelity of reproduction is determined to a large degree by the linearity of the side slope of the response curve. Only a straight line response provides a strict linear proportionality between the voltage changes and the frequency deviations. This linearity is very difficult to maintain in a practical amplifier over the frequency range required without a considerable sacrifice in gain. For very small frequency excursions, the slope detector, when critically adjusted, is capable of excellent performance; but the moment the deviations swing beyond this small range, distortion begins. The nonlinearity of the curve between the points *a* and *b* and the points *c* and *d* is, of course, responsible for the loss of fidelity.

Fig. 2. Center frequency shifted to slope of response curve.

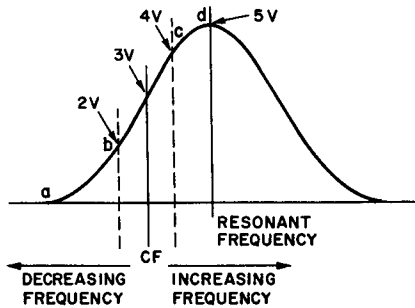

3. Double-Tuned Discriminator

The defects inherent in the slope detector, among other things, probably led to the original design of the double-tuned discriminator shown schematically in Fig. 3.

The resonant circuit comprising $L1-C1$ is broadly tuned to the resting (center) intermediate frequency of the receiver. The broad tuning is necessary to pass the plus and minus frequency deviations which the f-m signal contains. The desired signal voltages are coupled inductively into $L2$ and $L3$. $L2$ is resonated by $C2$ to one frequency and $L3$ by $C3$ to another frequency. One of these frequencies is above the resting frequency and the other below it. To simplify the explanation, assume that the $L2-C2$ combination is tuned to a frequency 75 kc above the center i.f. and that $L3-C3$ is

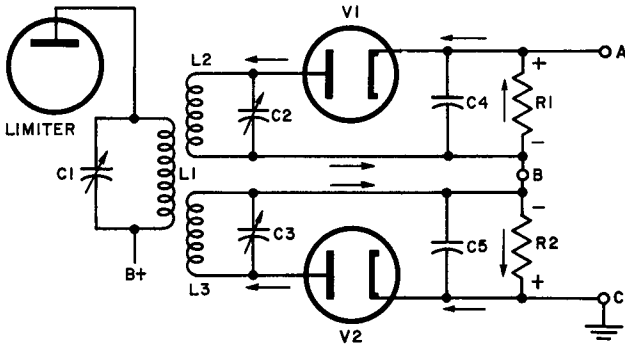

Fig. 3. Schematic of double-tuned discriminator.

resonated to a frequency 75 kc below the center i.f. It makes very little difference which of these frequencies is above and which is below the resting frequency.

If the intermediate frequency is assumed to be 10.7 mc, a signal voltage of this frequency appears across $L1$ and induces a similar voltage across both $L2$ and $L3$. As these tuned circuits ($L2-C2$ and $L3-C3$) are tuned to frequencies other than the center frequency, the voltage appearing in each one is not very large, but is significant nevertheless. As the top of the $L2-C2$ combination goes positive, for example, the plate of $V1$ likewise becomes positive with respect to the cathode and the tube conducts. Were it not for the presence of $C4$, a current which pulsates at the intermediate frequency would flow through $R1$, causing a voltage drop of similar waveform to appear across this resistor. $C4$ removes the a-c component of this voltage by charging up to approximately its peak and by retaining the charge during alternate half-cycles when

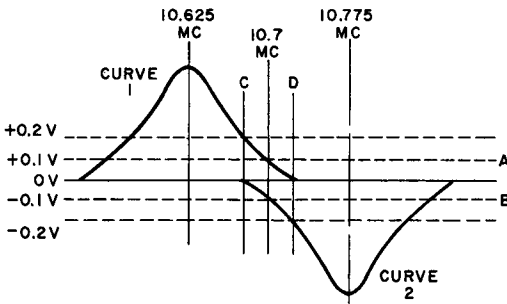

Fig. 4. Double-tuned discriminator response curves.

current does not flow through the detector tube. The arrows on Fig. 3 show the directions of the currents in both diode circuits and the resulting voltage drops across $R1$ and $R2$. It is at once evident that these voltage drops occur in opposite directions so that the algebraic sum is zero insofar as the voltage between terminals A and C is concerned, provided that the magnitudes of the voltages are the same. The numerical examples given in the paragraphs below should help the reader visualize this even more clearly. Thus, the connections and phasing are such that the voltage drops across $R1$ and $R2$, the load resistors, buck each other, the total output voltage between A and C being the algebraic sum of the individual signal drops. Each of the detectors has a standard response curve which peaks at its individual resonant frequency. But when these curves are drawn on a single axis (Fig. 4), one is inverted with respect to the other as a result of circuit arrangement.

When an unmodulated signal is received, it produces a fixed-frequency i-f signal at 10.7 mc. At this frequency, one of the detectors (curve 1) yields an output voltage of $+0.1$ volt while the second detector (curve 2) provides an output voltage of -0.1 volt. These add algebraically to 0 volts total output; a result which is to be desired since there should be no output voltage when no frequency deviation occurs.

Suppose now that the incoming carrier shifts downward in frequency during one half-cycle of modulation to the line C in Fig. 4. At this frequency, the output voltage of the first detector (curve 1) is $+0.2$ volt while the output voltage of the other detector is 0 volts. The total output, then, is $+0.2$ volt at this instant. If the modulation is symmetrical about the i-f center frequency, as it must be during the next half-cycle of audio, the frequency will deviate to the line D at which point the output of the first diode drops to zero while that of the other one (curve 2) rises to -0.2 volt. Again the algebraic sum is -0.2 volt but this time it is in a negative direction.

Referring again to Fig. 3, output terminal A will see a swinging voltage with respect to ground for each audio cycle. As the frequency of the carrier shifts from one side to the other of the center i.f. a demodulated voltage corresponding to the modulation will appear between A and ground; thus, the incoming f-m signal will have been fully detected.

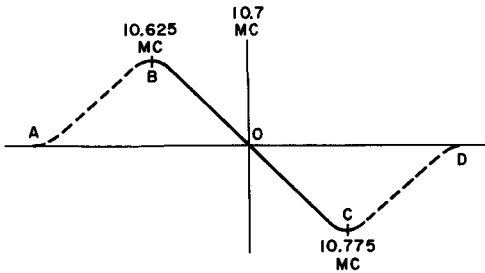

Fig. 5. The discriminator S-curve.

It is inconvenient to analyze the response of a double-tuned discriminator on the basis of two curves as in Fig. 4. Since the portions of the curves between lines C and D may be added algebraically, the resultant single curve given in Fig. 5 may be used to illustrate further discussions of discriminator action.

4. The S-Curve

Figure 5 pictures the curve obtained when curves 1 and 2 of Fig. 4 are combined. Frequency excursions by the incoming i-f signal occur over the range from point B to point C, a range which must find a linear curve if distortion is to be avoided. As the remaining portions of each end of the composite curve (AB and CD) are unused during the detection process, these have been shown in the form of broken lines. The resulting solid line resembles the letter "S" (or a mirror image of it), a curve which is typical of all discriminators now in use, and is referred to as the S-curve.

If the range of frequencies between B and C is too small, deviations of moderate or large extent will spill over to the other sides of the curve and produce severe distortion. To avoid this, discriminators must be designed to have a linear range stretching over approximately 200 kc (± 100 kc around the midfrequency).

5. Review Questions

- (1) Explain the basic differences between, and purposes of an a-m detector and an f-m detector.
- (2) How does the f-m slope detector differ from a normal i-f amplifier?
- (3) Describe the operation of the f-m slope detector.

- (4) What major factor determines the fidelity of reproduction in the slope detector?
- (5) Sketch, from memory, a schematic of an early type of discriminator which uses two secondary windings.
- (6) Explain the action of the circuit you have sketched. Use the response curve for this discriminator in your explanation.
- (7) Explain why a slope detector is unsatisfactory for demodulating strong f-m carriers.
- (8) Why must the primary winding of a discriminator transformer tune broadly? What should its bandpass be?
- (9) What effect would wider than normal frequency swings have upon the output of the double-tuned discriminator?
- (10) What would result if the linear portion of the discriminator S-curve were too short?

Chapter 2

F-M LIMITERS

6. The Need for Amplitude Limiting

If the signal presented to the diode detectors in the double-tuned discriminator had the form shown in Fig. 6 (A), there would be no need for special types of amplifier stages preceding the detector. Actually, however, the incoming signal appears more like that of Fig. 6 (B), the variations in amplitude arising from: (1) noise modulation, (2) signal fading, and (3) variations in wave reflection and absorption from moving objects.

The double-tuned discriminator really consists of two a-m detectors combined in a way which provides for f-m detection as well; but the fact that a-m detectors are present makes the combined system sensitive to both a.m. and f.m. Any attempt to demodulate the signal of Fig. 6 (B) without first removing the amplitude variations would result in an output signal which would contain components other than those superimposed on the carrier at the time of the broadcast. In other words, distortion, or at the very least, extraneous undesirable sounds would be present. To remove this possibility, discriminators are preceded by one or more *limiters*. Simply defined, a limiter is a kind of an electronic "gate" which clips positive and negative carrier peaks down to some predetermined level, thus removing all amplitude variations. The content of a limited signal is, therefore, pure f.m.

7. Limiter Requirements

A theoretically perfect limiting system provides equal output voltages for all values of input voltage. If such a system could be constructed, it would have the characteristic curve shown in Fig. 7 (A), in which the output voltage is always the same regardless of the magnitude of the input signal strength.

Obviously, such a limiter could never be constructed because it is physically impossible to obtain a finite output with no input signal at all. In Fig. 7 (B), a more practical limiter response curve is shown. Here, there is zero signal output for zero input, an ascending curve for small input signals, quick leveling off, (point *a*) and a range (between *a* and *b*) where increasing input voltage does not cause a corresponding increase in output.

The conclusion to be reached from this consideration is simply that the input voltage to a limiter must never be permitted to fall below that value which produces amplitude leveling.

When a limiter circuit as a whole has sufficient input signal to produce constant-amplitude output with input-amplitude variations, it is said to be "saturated." It should be noted that this special use of the term applies to the limiter stage as a whole, and should not be confused with plate saturation in the tube, which may or may not play an important part in the limiting action, depending upon individual design.

If the input signal voltage does fall below limiter saturation, the tube will act as a straightforward amplifier in which amplitude variations are recognized and given weight. This, of course, introduces amplitude modulation into the signal, feeds the same modulation to the f-m detector, and leads to an output which contains both a-m and f-m components. The only insurance against having this condition take place is the proper design of the i-f system, a design which incorporates sufficient i-f amplification to saturate the limiter even when the received signal strength is relatively low.

Fig. 6. Ideal and actual f-m signals.

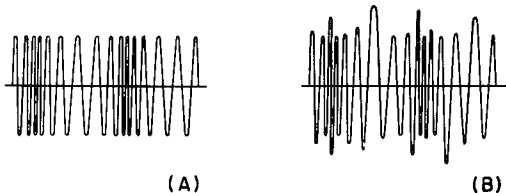

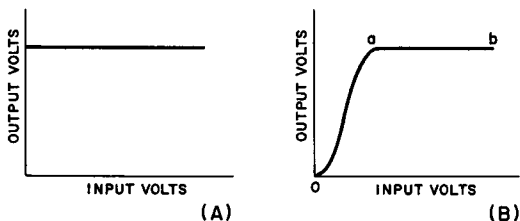

Fig. 7. Ideal and practical limiter responses.

With regard to the limiter itself, it must be designed to saturate very quickly with small magnitudes of input signal.

8. Plate Circuit Limiters

The incidence of limiting may be hastened considerably by reducing the plate and screen voltages of a pentode. A sharp cut-off pentode such as a 6SJ7 or a 6AC7 makes an excellent limiter for both positive and negative amplitude excursions as illustrated in Fig. 8. The input voltage to the limiter comes from the i-f amplifier stage which precedes it. At first glance, the circuit in Fig. 8 appears as a straightforward amplifier until the presence of resistors R_3 and R_4 is noted. These are sufficiently high in value to drop both the screen and plate voltages to the order of 30 volts or less. When this is done, the grid transfer characteristic curve changes from its normal shape to the flattened one pictured in Fig. 8. As illustrated, plate saturation occurs at much lower values of plate

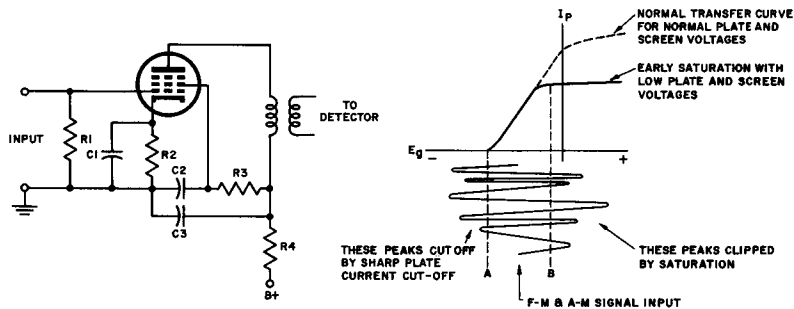

Fig. 8. Plate circuit limiting.

current than previously. This makes it possible for much smaller input voltages to bring out the saturated condition since the linear portion of the transfer curve is much shorter than it is in a normally functioning amplifier.

The net effect of early saturation is this: If the signal swings go further negative than A and more positive than B , all the peaks on the outside of these lines are clipped so that they have absolutely no effect upon the output plate current of the tube. In the negative case, these peaks lie outside the cut-off point of the amplifier and so cannot influence the plate current at all; in the positive case, the input peaks exceed the voltage which produces saturation and, since the maximum plate current has already been attained, it can cause no further change. Hence, the positive and negative clipping action due, on the one hand, to saturation and on the other hand to plate current cutoff results in an output voltage in which all amplitude changes have vanished leaving only f.m.

A plate circuit limiter such as this, although very effective for removing much of the a.m. in the signal, contributes very little to gain of the receiver.

9. Grid Circuit Limiters

By combining grid-circuit limiting with plate-circuit limiting, the plate and screen voltages may be raised somewhat with a consequent elevation of gain without losing limiting performance.

The drawing of Fig. 9 (A) is presented to illustrate a basic grid circuit limiter. In order for this circuit to operate as a grid limiter, the signal must have sufficient amplitude to drive the grid positive so that grid current flows. As the signal drives the grid into the positive region, grid current flow charges capacitor CI to a potential almost equal to that of the peak signal amplitude. The magnitude of the potential on CI is determined by the signal strength (higher positive peaks — more grid current — greater potential) and by the time constant of the combination $RI-CI$. When the signal swing falls, the capacitor discharges through RI and produces a negative voltage which acts as bias for the tube. Since the resistance of RI is much greater than the low cathode-to-grid resistance of the tube when grid current is flowing, most of the input voltage of the positive peak is dropped across the resistor and

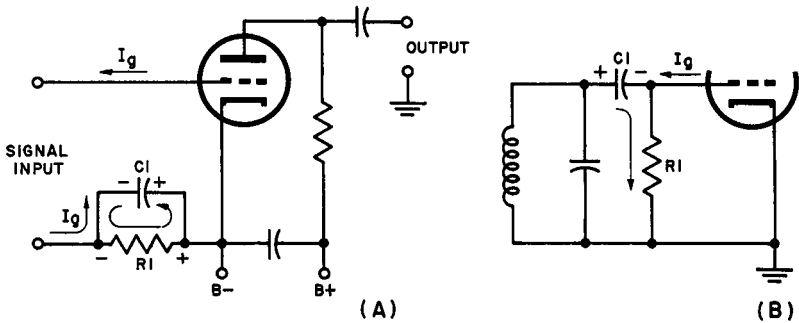

Fig. 9. Basic grid circuit limiter.

only a very small portion of the positive peak is actually applied between grid and ground. Effectively then, the positive peaks are flattened due to the flow of grid current.

An alternate arrangement, which operates in much the same manner, is shown in part (B) of Fig. 9. The shunting effect of the low cathode-to-grid resistance of the tube (when grid current flows on the positive peaks) is responsible for flattening these peaks. Since this arrangement has a greater shunt loading effect on the previous circuits than does the circuit shown in (A), the arrangement in Fig. 9 (A) is more common.

If the time constant of $R1-C1$ is short compared to the *period* of the received signal, the capacitor will discharge to some degree during each negative half-cycle so that its equilibrium voltage will be less than peak signal voltage. If the time constant is too long, limiting action will be impaired.

In practice, the time constant of C and R in the grid circuit of the limiter may range from about 2 microseconds to 20 microseconds. For example, with $C = 100 \mu\mu\text{f}$ and $R = 50\text{k ohms}$, the time constant is:

$$\begin{aligned}
 TC \text{ (sec)} &= R \text{ (meg)} \times C \text{ (}\mu\text{f)} \\
 &= 50,000 \times 10^{-6} \times 100 \times 10^{-6} \\
 &= 5 \times 10^4 \times 10^{-6} \times 10^2 \times 10^{-6} \\
 &= 5 \times 10^{-6} \text{ seconds} \\
 &= 5 \text{ microseconds}
 \end{aligned}$$

The time constant of the $R-C$ combination, if short enough, follows the signal amplitude variations, shifting the operating bias by an amount which partially compensates for the tendency toward

change in input signal strength. A time constant of greater than optimum length, however, does not permit the grid bias to keep pace with the signal variations, thus rendering the limiter ineffective. Likewise, too short a time constant permits the capacitor to discharge all the charge it has taken on during each cycle so that grid bias can not build up.¹

10. Limiting Through Control of Gain

A substantial limiting effect is produced exclusive of cutoff or plate saturation. The gain of the limiter tube depends upon its transconductance, which in turn is affected by the value of bias voltage. Thus, when the strength of the input signal voltage increases, the grid conduction and the bias increases and lowers the gain. The gain reduction opposes the signal-strength increase, tending to keep the signal amplitude in the plate circuit constant.

This factor combines, in varying degrees, according to the nature of the application, with the grid loading, cutoff and plate saturation factors in general to provide the overall limiting characteristic.

11. A Practical Limiter Circuit

The limiter circuit shown in Fig. 10 combines the features of both plate and grid circuit limiting. This arrangement makes possible the use of higher plate and screen voltages, and consequently higher gain, without reducing the efficiency of the limiting action. $C1$ and $R1$ have a time constant of 5 microseconds. This is just about right for effective grid leak limiting as described in a previous paragraph. Resistors $R2$ and $R3$ diminish plate and screen potentials somewhat so that a certain amount of plate limiting occurs as well. Their values, however, need not be as large as they are in a simple plate circuit limiter since both types of limiting are occurring simultaneously. This provides better overall performance both with respect to limiting action and stage gain. $C2$ is a screen

¹ For a further discussion of time constant, see "R-C/R-L Time Constant" by Alexander Schure, published by John F. Rider Publisher, Inc.

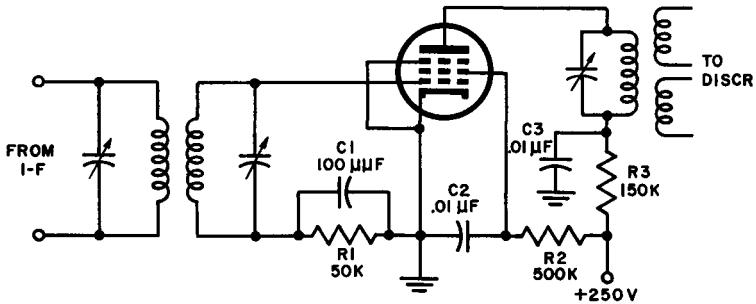

Fig. 10. Plate and grid circuit limiting.

bypass capacitor which maintains the potential of the screen grid constant to prevent its variation with the intermediate-frequency signal. C_3 , together with R_3 , decouples the plate circuit from the power supply so as to prevent undesired feedback which might tend to produce instability. Both input and output tuned circuits are resonant to the intermediate frequency and, as usual, are broadly tuned so that frequency deviations over the limits of the range permitted by the FCC may receive approximately equal amplification.

(Note: In all cases where resonant circuits are shown, such as here or in diagrams to follow, resonant circuits may be tuned by adjustment of powdered iron cores in coils rather than by means of the trimmer capacitors.)

12. The Use of Two-Coupled Limiter

We have seen that the time constant of the R - C network in the grid circuit of the limiter may range over 20 μ sec or more. What value should be used? When the a.m. results from sharp voltage pulses having very short duration (ignition, motor sparking, etc.) a short time constant network is required. Yet if a limiter is designed with a very short time constant, a steady bias is not maintained and gain is reduced. C and R form part of a voltage divider, of which C has a high reactance, reducing the available signal. If this effect is minimized by increasing the time constant, the sharp noise pulses get by the limiter and are heard in the loudspeaker.

Many manufacturers have overcome these mutually contradictory effects by inserting two limiters in cascade between the i-f

output and the discriminator input. The first limiter has a very short time constant ($1.2 \mu\text{sec}$), eliminates sharp noises, has very little gain; the second stage is given a longer time constant, and still helps to limit a.m. consisting of longer duration pulses, and adds considerable gain to the overall performance of the receiver. For example, in one popular commercial limiter system, the time constant of the first limiter is $1.25 \mu\text{sec}$ while that of the second is $20 \mu\text{sec}$. It should be noted that the more limiter stages there are, the more complete the limiting action. At the same time, it must be remembered that a limiter does contribute something to the final gain of the entire receiver, little as it may be, and the use of these stages in cascade does help to raise the signal strength before detection.

13. Limiter Adjustments and Tests

Except for its low gain and limiting effect, the limiter operates like an i-f amplifier. Its input and output circuits are adjusted for resonant peak at the center intermediate frequency.

One of the main features of the limiter circuit is that it provides an indicator voltage for alignment of all sections up to the output circuit of the limiter itself. This indicator voltage is the self-developed bias voltage across $R1$. The stronger the signal reaching the limiter grid, the greater the d-c voltage across $R1$. Thus, in receivers in which all i-f stages are peaked at the same frequency, each such stage is adjusted for peak limiter grid voltage. The adjustments in the i-f stages may be either trimmer capacitors or iron-dust slugs. If the i-f section is stagger-tuned, each stage is adjusted for peak $R1$ d-c voltage at its specified resonant frequency. In all these cases, a steady unmodulated i-f carrier signal injected at the mixer, can be used.

The tuned circuit connected to the limiter grid is also peaked up using the limiter $R1$ voltage as an indicator.

Indication of the limiter grid voltage is obtained by connecting a vtvm between ground and the "hot" side of $R1$. For this purpose, it will be noted that the circuit of Fig. 9 (A) is better than that of Fig. 9 (B) because the "hot" (left) side of $R1$ is effectively at i-f ground potential, (through the low reactance of $C1$ at the intermediate frequency) and the meter will not tend to load the grid circuit. If the circuit is of the type shown in (B) it is desirable to

use an isolating probe, to minimize loading on the limiter grid where the meter must be connected.

If the primary winding of the transformer between the limiter and discriminator is tuned, it is best adjusted with the aid of a voltage indication in the discriminator, as described at the end of Chapter 3.

The limiter *RI* voltage can also be used for adjusting the front end. The r-f amplifier is peaked up with a steady unmodulated signal at proper dial-indicated frequency applied at the antenna. R-f trimmer capacitors are adjusted for peak limiter-grid d-c voltage. The oscillator is adjusted for proper tracking frequencies by feeding in a steady r-f signal of proper dial-indicated frequency and adjusting the trimmer or padder for limiter-grid d-c voltage peak.

14. Review Questions

- (1) What kind of extraneous modulation does noise produce on an f-m carrier? What stage can successfully remove this kind of modulation?
- (2) Explain the operation of an f-m limiter.
- (3) Draw a plate circuit f-m limiting device from memory, and explain its operation.
- (4) What advantages do double (cascade) limiters have over single limiters?
- (5) Sketch the circuit of a limiter using lowered tube voltages and grid-leak bias, showing computations for a time constant of 15 microseconds in the grid circuit of the f-m limiter.
- (6) If a limiter is to be effective against ignition noises, should it have a long or short time constant? About how many microseconds?
- (7) What is the period of a signal wave having a frequency of 100 mc?
- (8) In which form of limiting, grid circuit or plate circuit, does the magnitude of the bias on the limiter depend upon the strength of the signal?
- (9) Which form of limiting depends upon tube saturation?
- (10) In a practical cascaded limiter, what range of time constants might be expected, considering both stages?

Chapter 3

THE MODERN F-M DISCRIMINATOR

15. Circuitry

The double-tuned discriminator discussed in Chapter 1 is effective in performance but rather costly to manufacture and is cumbersome to adjust. The presence of two separately tuned secondary circuits makes alignment more difficult than one might expect because of the interaction between the two resonant circuits.

A modern discriminator circuit which resembles the double-tuned arrangement closely is given in Fig. 11. Originally called the Foster-Seeley discriminator after the two men who developed it, it gained wide popularity immediately after it was introduced because of the comparative ease with which it may be adjusted.

Minor variations of this basic circuit may be found in almost every f-m receiver and television sound system but in every case the operation of the discriminator may be analyzed by the same set of vectors used in the paragraphs which follow. As will be noted from the examination of the schematic of Fig. 11, there is only one secondary tuned circuit. Where, in the double-tuned circuit, the total response was dependent upon the individual differences between two circuits tuned to different frequencies; in this arrangement, the phase differences between the secondary and primary voltages are utilized to affect the diodes in a manner which produces useable output. A complete understanding of what takes place may be had by a step-by-step vector analysis.

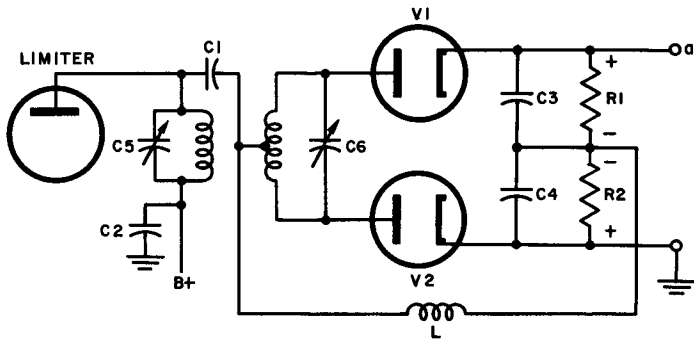

Fig. 11. Foster-Seeley discriminator.

16. Vector Analysis of Discriminator Action

To assist the reader in following the vector development, the steps are numbered in sequence and each step carries a reference to an appropriate figure.

I-F Signal at Center Frequency

(1) (Figure 12A). With the signal unmodulated (or modulated but passing through dead center frequency at the instant of consideration) the voltage E_p developed across the primary winding of the discriminator transformer is taken as a reference voltage and drawn as a horizontal vector pointing toward the right away from the origin.

(2) (Figure 12B). Since the current through any coil lags the voltage across the coil by 90° , the current I_p in the primary winding is shown as a vector which lags the E_p vector by 90° .

(3) (Figure 12C). The primary current I_p induces a voltage in the secondary winding. Since the greatest voltage is generated at the time when the rate of change of current in the primary is greatest — and this occurs when the current wave is passing through the zero axis — the E_s secondary induced voltage vector must be shown displaced from the I_p vector by 90° . This places the E_s vector 180° out-of-phase with the E_p vector.

(4) (Figure 12D). Since this is a perfectly resonant circuit (i-f signal at center frequency) at this instant, the inductive and capacitive reactances cancel each other leaving the series circuit around the tank purely resistive. In a resistive circuit, current is

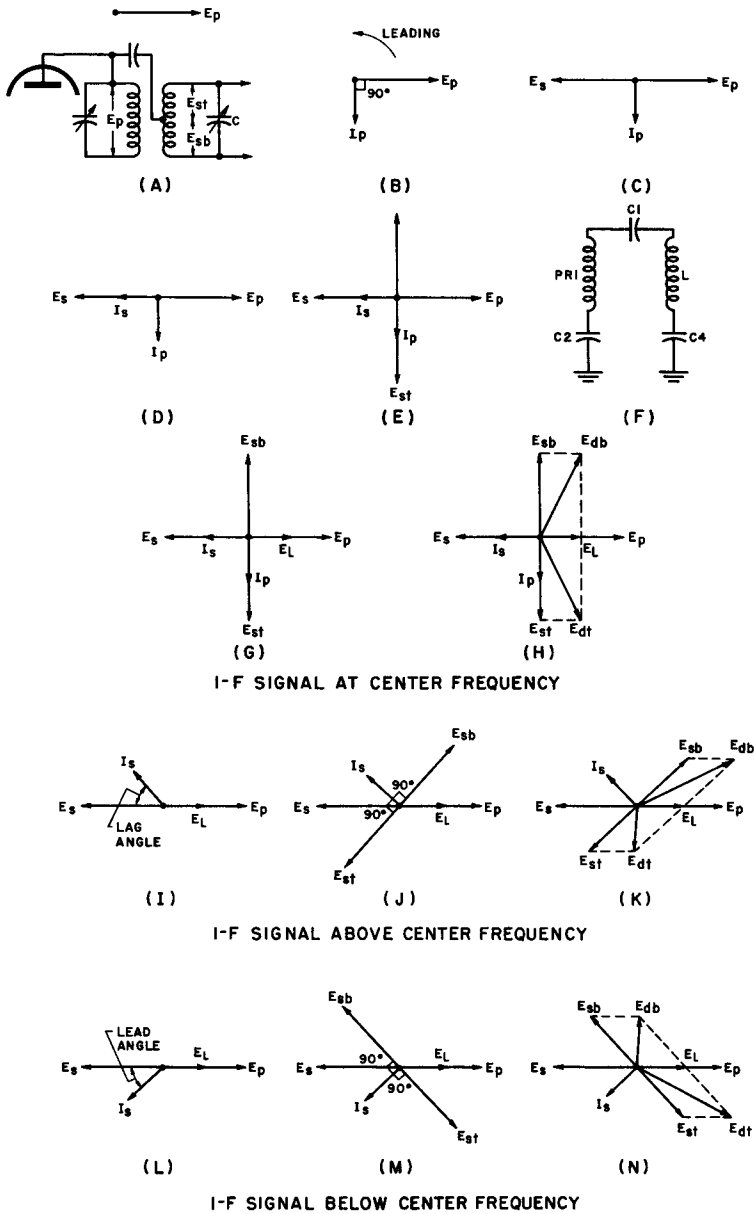

Fig. 12. Vector relations in discriminator.

in phase with driving voltage, hence the series circulating secondary current I_s must be in phase with the secondary induced voltage E_s and is shown as a vector superimposed on E_s .

(5) When, as a result of the induced voltage, a secondary current I_s flows in the split secondary winding, it produces a secondary voltage drop which leads I_s by 90° . This secondary voltage is a reactive voltage drop resulting from the flow of secondary current; it is not to be confused with E_s which is a voltage generated by induction.

(6) (Figure 12E). Since the secondary winding of the transformer is center-tapped, the secondary voltage may be considered as being made up of two separate voltages (E_{st} and E_{sb}) of equal magnitude but opposite in phase with respect to the center. This is a valid consideration because, effectively, the center-tap simply moves the zero reference point from one end of the winding to its middle, thus providing two distinct voltages with reference to this point; E_{sb} which is assumed to be leading E_p by 90° and E_{st} which is shown lagging E_p by 90° . (The symbols "sb" and "st" are used a matter of convenience to represent, respectively, "secondary-bottom half" and "secondary-top half" so that later reference to the transformer secondary halves will be clearer.)

(7) (Figure 12F). Consider now the voltage across the coil L . This coil is effectively in parallel with the primary of the discriminator transformer since the capacitors $C1$, $C2$, and $C4$ which complete the connections for parallelism are so large as to have a negligible reactance at the frequencies used in f.m. Since it is in parallel with the primary, the voltage E_L developed across the coil L is in phase with the primary voltage. (Note: Actually to all intents and purposes, the primary voltage itself may be considered to be applied to the center tap of the secondary directly. Coil L is used to provide a d-c return path, through its low resistance for each diode circuit and for all direct currents through the diodes. The high reactance of this coil prevents the primary voltage from being shorted out but instead offers a load across which the primary signal is developed.)

(8) (Figure 12G). This is the vector picture showing the new voltage E_L superimposed on the primary voltage vector E_p .

(9) (Figure 12H). As mentioned above, coil L is in series with each half of the secondary winding in separate circuits through the two diodes. This may be shown by tracing either circuit; from

the diode plate, through the top half, then through L , up through $R1$, back to the cathode. The identical circuit exists through the lower diode and the lower half of the secondary. In a series circuit like this, the voltages across the two coils must add vectorially. Due to the 90° phase relationship between E_L on the one hand, and E_{st} and E_{sb} on the other, the resultant r-f voltages which drive direct currents through the diodes must form the diagonal of the parallelograms of the vectors. These resultant vectors are labelled E_{dt} (top diode) and E_{db} (bottom diode). The vectors E_{sb} and E_{st} are equal in magnitude because of the symmetry of the coil, so that the driving voltages E_{dt} and E_{db} are also equal. Thus the direct currents in the diodes and the d-c voltage drops across the diode resistors $R1$ and $R2$ are equal. They thus cancel each other, and the output d-c voltage between ground and point a (Fig. 11) is as it should be for center frequency operation; exactly zero.

I-F Signal Above Center Frequency

(10) (Figure 12I). When a signal is higher than the resonant frequency of the series circuit to which it is fed, the series circuit acts *inductively*. This is true because, for the higher frequency, X_L and X_C no longer cancel each other. X_L is larger, and X_C smaller, than at resonance. Thus, X_L predominates and the circuit is said to be inductive. When the circuit was in resonance, the induced secondary series circulating current I_s was in phase with the secondary induced voltage E_s (step 4); now, however, with the circuit predominantly inductive, I_s lags behind E_s .

(11) (Figure 12J). The lag of I_s reflects itself in the changing vector picture by shifting the directions of the E_{st} and E_{sb} vectors to new positions. These voltages (E_{st} and E_{sb}) are produced by an IX_L drop ($I_s \times X_L$ of either half of the secondary) and must therefore always be out-of-phase with the current I_s by 90° . (Review steps 5 and 6).

(12) (Figure 12K). Adding E_L to each of the two secondary voltages (E_{st} and E_{sb}) vectorially, the summed resultants E_{dt} and E_{db} are again obtained. But this time, E_{db} is much greater than E_{dt} so that a larger direct current flows through $R2$ than through $R1$. Thus, a net output voltage (negative in this case) appears across the series load resistors (point a). Again, this is the expected result since the i-f signal is above the center frequency. It is frequency-modulated so that an output voltage must appear if detection is to take place.

I-F Signal Below Center Frequency

(13) The vector diagrams for the condition in which the *i-f* signal is below the center frequency are shown in parts (L), (M) and (N). It must be remembered that the circuit is *capacitive* rather than inductive, and that the current I_s leads the secondary induced voltage E_s . It will be found, as might be expected, that E_{dt} will be greater than E_{db} for this condition. Now, a larger current flows through $R1$ than through $R2$. Again, a net output voltage (positive in this case) appears across the load resistors.

In summary, it may be seen that a voltage will appear across the diode load which will vary in exact accordance with the frequency deviation of the *i-f* signal. The greater the frequency excursion on either side of the mean frequency, the greater will be the magnitude of the voltage developed across the diode load and the louder will be the sound from the speaker of the receiver. (Note: By reversing the winding sense of the transformer, output polarities just the opposite to those indicated above will be produced).

17. A Simplified Discriminator

The original Foster-Seeley discriminator may be modified to omit the return choke L and one of the two diode load bypass capacitors (Fig. 11) without affecting its operation. The modified circuit appears in Fig. 13.

Although at first glance it may appear that an important component, L , cannot be left out without destroying the logic of

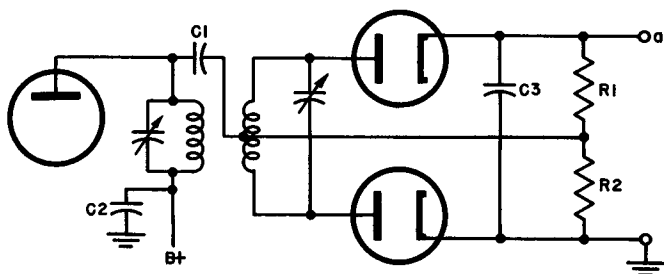

Fig. 13. A simplified discriminator.

the vector picture just drawn, a careful analysis of the circuit discloses that R_2 now takes the place of the coil in developing the voltage we have called E_L .

18. The Need for a New Type of F-M Detector

The Foster-Seeley discriminator, with or without modifications, responds to amplitude modulation as well as frequency modulation; this explains the need for adequate limiting action.

A few simple figures will help to explain why changes in amplitude result in sound output.

Suppose that an unmodulated steady signal at the exact center frequency of the discriminator (21.25 mc for example) appears at the input. Since the signal does not vary in any way, equal voltage drops will appear across the two halves of the load resistor. Assume, for convenience, that the voltage drop across each resistor is 3 volts. The polarity of these voltages is opposite for each resistor so that there is no output. This is normal.

During fm, the frequency of the carrier varies around the center frequency causing a circuit unbalance which might provide a voltage drop of 4 volts across one of the resistors and a drop of 2 volts across the other resulting in a net output of 2 volts applied to the audio amplifiers.

Should the *strength* (or amplitude) of the carrier now change, assuming that it doubles, the voltage drop across each load resistor doubles, becoming 8 volts and 4 volts respectively, or a net audio output voltage of 4 volts results. This change in output voltage occurs because of a change of amplitude, not frequency, hence the discriminator is responsive to a.m.

It should be noted, however, that the ratio between the voltage drops for both cases is the same. That is, when the signal was low in strength, the ratio was 4:2, or 2 and after doubling the strength, the ratio was 8:4, which is still 2.

From these consideration it may be seen that a.m. does cause a change in absolute voltage output but *does not cause a change in the ratio of the two voltages* across the output resistors. An f-m detector which is unresponsive to the difference between these voltages but is sensitive only to the ratio between them would render less critical the need for perfect limiting. This is the ratio detector.

19. Discriminator Alignment and Tests

In alignment of the discriminator, some rather special procedures must be used. Consider the basic circuit of Fig. 11.

(1) Connect the vtvm across $R2$. Feed a signal of exactly the center intermediate frequency into the i-f amplifier.

(2) Adjust $C5$ for peak d-c voltage across $R2$.

(3) Move the vtvm hot lead point a , so it is connected across $R1$ and $R2$ in series. Maintain input signal as before.

(4) If $C6$ is tuned too far in one direction, the d-c voltage indicated by the meter rises positively; if it is tuned too far the other way, the voltage rises negatively. Adjust $C6$ to the condition between these at which the d-c output voltage is exactly zero.

(5) Now if the test signal being fed to the i-f amplifier is changed in frequency, either side of center value within the deviation range, the output d-c voltage will be seen to vary positively and negatively in response, simulating the response of the instantaneous value of audio output voltage to carrier frequency variations.

An alternate method of adjusting $C6$ is to *amplitude modulate* the test signal in the i-f amplifier, then adjust $C6$ until there is *minimum* audio output level from the receiver. This method works because at center frequency, amplitude variations of the input signal cancel out in $R1$ and $R2$ in series. The a-m signal can be obtained through the limiter by keeping the carrier level below the threshold of limiting action, or the signal can be fed into the primary at the limiter plate.

In many receivers, alignment adjustments are made through the use of adjustable iron-dust cores, instead of variable capacitors $C5$ and $C6$; in that case, these capacitors are fixed. Adjustments are made by means of a small screwdriver or an alignment tool, the threaded slugs inside the coils being rotated to provide motion in or out of the coils. This results in a variation of inductance.

20. Review Questions

- (1) Give two disadvantages of the double-tuned f-m discriminator.
- (2) Sketch, from memory, the Foster-Seeley discriminator circuit.
- (3) Describe the operation of the Foster-Seeley discriminator.

(4) Give the exact function of each component in the f-m discriminator drawn in question (2) above.

(5) In Fig. 12G, explain why we may say that the primary of the input transformer and coil L are in parallel.

(6) Why is a series-resonant circuit said to be inductive when the incoming frequency is higher than the resonant frequency of the circuit?

(7) Why is a series-resonant circuit said to be capacitive when the incoming frequency is lower than the resonant frequency of the circuit?

Chapter 4

THE RATIO DETECTOR

21. Principle of Operation

The basic ratio detector is illustrated in Fig. 14. The tuning and coupling of the input transformer is practically the same as in the discriminator discussed previously and, therefore, the i-f voltages applied to the diodes depend upon how much the i-f signal swings from the resonant frequency in each direction. Here the similarity ends.

$V1$, $R1$ and $V2$ form a series circuit which is fed by the secondary winding of the transformer. The two diodes conduct on the same i-f half-cycle because of the inversion of $V1$. When the lower half of the transformer secondary winding is positive, conduction occurs and a voltage drop having the polarity shown appears across $R1$; $C5$ (an electrolytic capacitor) charging to the same voltage. Since $C5$ has a large capacitance, it tends to hold constant the voltage which exists across $R1$. This voltage appears across $R1$ when an intermediate-frequency signal is developed across the primary of the coupling transformer even when no modulation is present. As conduction through the two diodes goes on, a rectified current of intermediate frequency flows through the diodes, through $R1$, and through the resonant circuit containing the transformer secondary and $C6$. As a result of this flow of rectified current, a negative potential develops with respect to ground at the plate of $V1$. Because

can no longer cause an audio voltage to appear because, as we saw in the analysis of the discriminator, this can occur only if the sum voltage is sensitive or responsive to changes in signal amplitude. Therefore, while the ratio of the two individual voltages varies at an audio rate during frequency modulation, their sum is always constant. This explains why, in the ratio detector, the audio output is taken from one of the capacitors ($C4$) whereas in the discriminator the output signal appears across the whole load resistor.

The advantage of the ratio detector may be recognized by examining the typical i-f line-ups found in commercial f-m receivers. For example, in Receiver *A*, which uses a discriminator of the Foster-Seeley type, there are two high-gain i-f stages, one low-gain, short Time Constant limiter for the removal of sharp a-m voltage spikes, and one medium-gain, long Time Constant for output to the discriminator. In receiver *B*, the use of a ratio detector makes it feasible to use one high-gain i-f stage and one medium-gain limiter, thereby eliminating two costly stages.

22. Automatic Volume Control for F-M Receivers

The preceding explanation of the manner in which a-m variations in an f-m signal are largely "ignored" by the ratio detector, mentions that the capacitor $C5$ connected across the output load resistor is quite large and that it is this capacitor which keeps the sum of the voltages across $C3$ and $C4$ (Fig. 14) the same for a given carrier. To perform this job properly, the capacitor must behave like a willing "sponge" which absorbs changes in carrier amplitude without allowing its terminal voltage to change to any significant degree. This idea may be clarified by considering the relationship between capacitor charge, voltage, and capacitance as follows:

$$E = \frac{Q}{C}$$

(E is the voltage which appears across the capacitor of capacitance C when a charge of Q coulombs is fed into it.)

To keep our numbers simple, assume a capacitance of 1 farad and a charge of 1 coulomb. Then the voltage which appears across the capacitor is 1 volt.

$$E = \frac{1}{1} = 1 \text{ volt}$$

Now *add* one coulomb more. This is just what might occur if the carrier strength suddenly rose due to noise or other effects.

$$E = \frac{2}{1} = 2 \text{ volts}$$

For a capacitor of 1 farad, adding one coulomb causes the voltage across the capacitor to double. If, on the other hand, the capacitance is 20 farads, 20 coulombs of charge would be required to raise the terminal potential to 1 volt.

$$E = \frac{20}{20} = 1 \text{ volt}$$

Now *add* one coulomb again.

$$E = \frac{21}{20} = 1.05 \text{ volts}$$

For a capacitor of 20 farads, the addition of one coulomb causes the voltage across the capacitor to rise by a *very small* amount. Compare this with the smaller capacitance. This explains why a larger capacitance permits the carrier amplitude to vary over a considerable range without significant changes in output voltage.

All of the foregoing presupposes that the variations in received carrier intensity occur as short, sharp bursts of energy — the kind of thing that causes crackles and static in a received signal. The large size of *C5* coupled with a reasonably large load resistor *RI* gives the combination a long time constant. Hence the capacitor charges to and maintains the average carrier voltage despite brief discontinuities in the form of noise pulses.

Slow changes in carrier amplitude reflect themselves in a slowly changing potential across the capacitor; a strong signal produces a higher negative voltage with respect to ground than a weak signal at the top of *RI*. This immediately suggests that the d-c potential across *RI* may be used for automatic volume control purposes just as it is in common a-m receivers. Many manufacturers of f-m sets have incorporated this idea in their products by feeding back a portion of this negative voltage to the i-f stages through a standard avc filter for control of gain.

23. Modern Ratio Detectors

As in practically any other kind of circuit, modifications of the basic design of the ratio detector to simplify it, reduce its cost, and

achieve better performance are possible and desirable. Figure 15 illustrates a circuit modification which is in wide use today. Comparing the arrangement with that of Fig. 14, it will be seen that the coupling capacitor $C1$ has been eliminated, the inductor L has been moved so that it is now inductively coupled to both the primary and secondary of the detector input transformer, and the electrical center of the output load resistor has been joined to the junction of bypass capacitors $C3$ and $C4$. The audio output voltage is now taken from the bottom of the coil L , making the circuit much more symmetrical than before.

These circuit changes do not alter the phase relationships established in the previous discussions; the audio output voltage is still a function of the frequency excursions above and below the mean frequency. The advantages attributed to this circuit are: improved symmetry tends to provide an S -curve which is linear over equal distances above and below the mean frequency, and the availability of a voltage which may be used to operate a tuning meter or electron-ray indicator to indicate when tuning is perfect. The indicator takes its voltage from point X , Fig. 15. Analysis shows that the voltage at this point is zero for the center frequency and positive or negative for frequencies off-center so that either the meter or "eye" indicator registers perfect tuning when the voltage at point X is zero.

24. Ratio Detector Alignment and Tests

The ratio detector circuit of Fig. 14 differs from that of the conventional discriminator in that there is no d-c return path for $V1$ individually. $C3$ blocks direct current from the a-f output point (top of $R2$ to $V1$). For this reason, the d-c voltage at this a-f output point is not the same for a given fixed input i-f signal frequency as it would be for the same i-f signal frequency when the i-f signal is rapidly sweeping back and forth. For audio frequency variations, the signal output is a function of the ratio of the $V1$ and $V2$ currents and operation is proper. However, with a test signal set at one frequency, the d-c voltage across $R2$ is only that resulting from the $R2$ as a load resistor for $V2$ only; the capacitors become effectively open circuits. For these reasons, the first technique described for the discriminator (Chapter 3) is not applicable here.

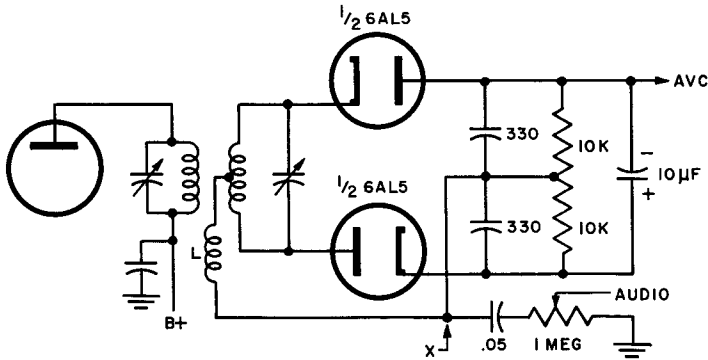

Fig. 15. Modern ratio detector

Accordingly, alignment is accomplished by the amplitude modulation methods, which is the second method described at the end of Chapter 3. With an amplitude modulated input i-f signal, C_6 is adjusted for minimum a-f output level.

Capacitor C_7 is adjusted for peak d-c voltage across R_2 when a steady unmodulated i-f signal of exactly center frequency is applied through the i-f amplifier.

In ratio detector circuits in which there is a d-c return to both diodes, such as that of Fig. 15, the first discriminator method, employing a steady unmodulated carrier at center frequency can be used. However, for this method to work, the $10\text{-}\mu\text{f}$ capacitor must usually be disconnected temporarily until the alignment of the detector is completed. For this reason, and also because the balance between the values of the capacitors may not be the same as the balance between the halves of the load resistor, it is probably better to use the a-m signal method.

25. Review Questions

- (1) If the input to a ratio detector is the mean frequency, unmodulated, what output voltage will appear across R_1 ? Explain, using Fig. 14 as the basic circuit.
- (2) Explain the function of C_1 and C_2 in the circuit above.
- (3) Explain the purpose capacitor C_5 serves in the above circuit.
- (4) To what use may the voltage which appears across R_1 be put? Explain why this use is practical.

- (5) What effect would likely be observed if C_5 were reduced to $.001 \mu\text{F}$? Why?
- (6) Analyze the circuit of Fig. 15 and explain why the voltage at point X is zero when the mean frequency is being received.
- (7) If C_6 in Fig. 14 is adjusted for secondary resonance at the center frequency of the i-f system, what effect would be noticed in the sound output at compared with the condition when C_6 is adjusted off-resonance?
- (8) Answer question (7) once again with reference to C_7 and the primary circuit in this case.
- (9) Why would a symmetrical ratio detector tend to produce a better S-curve?
- (10) Explain why a tuning indicator is an important advantage in an f-m receiver.

Chapter 5

THE GATED-BEAM TUBE

26. Construction

The gated-beam tube (6BN6) is quite revolutionary in design, concept, and approach to the limiting and detecting problem. Its internal construction is shown in Fig. 16 and a top view of the electrodes including the path of the shaped electron stream is given in Fig. 17. Note should be taken of the interconnections between the various elements in the tube to assist the reader in following the electron stream shaping process.

27. Beam Forming Action

Electrons emitted by the cathode pass through the opening in the focusing plate #1 in the form of a tight beam. They enter the highly positive accelerator chamber in which the beam velocity is materially increased. At the same time, the beam shape is maintained by focusing plate #2. Without this second focusing plate, the beam would tend to spread as a result of the positive gradient produced by the potential on the accelerator chamber. On its way through the accelerator chamber, the beam passes through the first control grid (or limiter grid) and the accelerator screen. The function of the first control grid will be discussed later while the func-

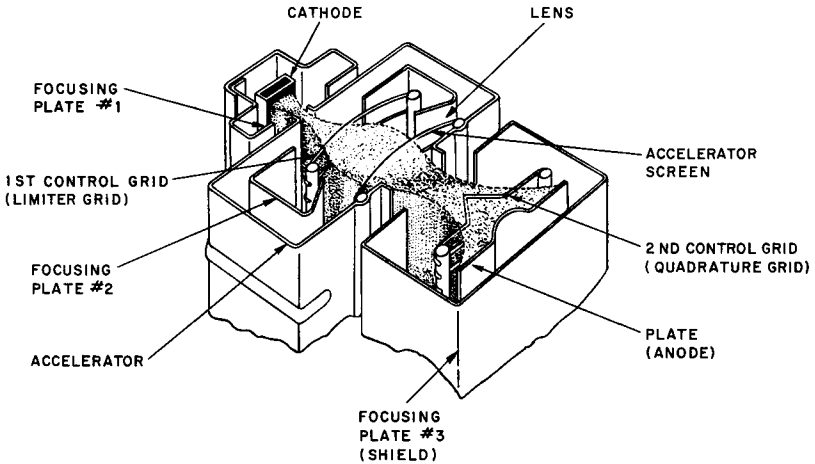

Fig. 16. Internal construction of gated-beam tube (6BN6).

tion of the accelerator screen is evidently the same as that of the accelerator chamber as it is internally connected to the same potential.

As the beam passes through the accelerator window, its velocity is further increased by the highly positive plate gradient while its beam form is maintained by focusing plate #3. Before reaching the plate, however, the beam must first pass the second control grid (quadrature grid). The action of this control grid is discussed under the heading F-M Detector Action in this chapter.

28. Double-Gate Action

In a triode or pentode, when plate current cut-off occurs as a result of a highly negative control grid, cathode current also ceases flowing because the electrons leaving the cathode fall back upon it, making the net current flow equal to zero.

Quite a different action occurs in the gated-beam tube. Should the first control (limiter) grid be given a negative potential greater than cut-off value, electrons still flow back to the power supply via the accelerator assembly so that, although there may be no plate current, cathode current is not greatly affected. In the same fashion, cessation of plate current due to a highly negative

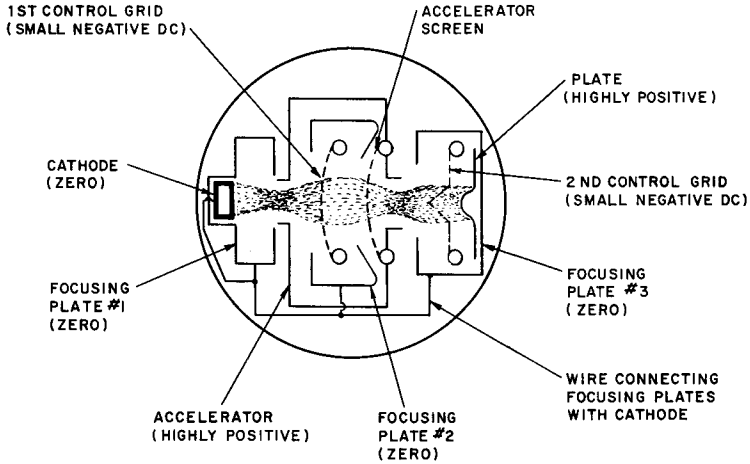

Fig. 17. Top view of the gated-beam tube.

second control grid (quadrature grid) causes the return current to flow through the accelerator assembly again, maintaining the cathode current relatively constant.

The operation of the system may be viewed as a switching action: The electron beam current is switched to the accelerator when either of the two *gates* – the limiter grid or the quadrature grid – is closed and to the plate when both gates are open. All conditions are illustrated in Fig. 18.

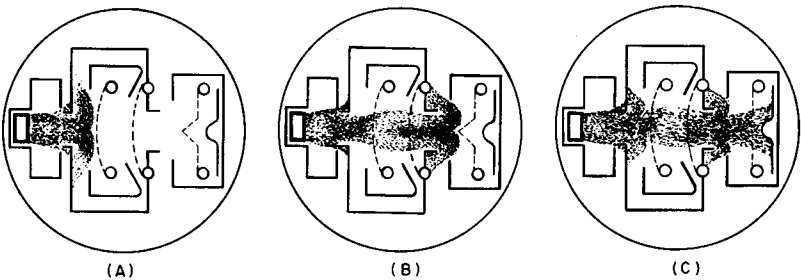

Fig. 18. Gating conditions.

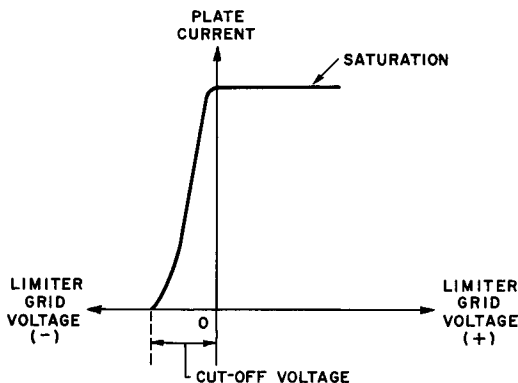

Fig. 19. Limiter grid transfer curve.

29. Limiter Grid Transfer Characteristic

With normal voltage relationships established on the static electrodes as shown in Fig. 17, the limiter grid voltage may be varied while the plate current is recorded to obtain the limiter grid transfer characteristic curve.

Starting with a cut-off potential on this grid, the plate current is, of course, zero but the cathode current may be quite high since the first gate is closed and the beam current has been switched to the accelerator. As the negative bias on the limiter grid is lowered past cut-off, beam current suddenly switches to the plate. This accounts for the extremely sharp rise in plate current given in Fig. 19. Saturation is reached very quickly, the plate current levelling off near zero limiter grid voltage.

As we have seen in the case of standard limiters, the characteristics required of a limiter stage are that the tube cuts-off sharply with relatively small negative grid voltages and that saturation be reached quickly. In the previous circuits, these conditions were achieved by using grid-leak bias and low anode voltages which, it was pointed out, provided limiter action at relatively low gain. Here, however, we have the essential kind of curve needed without the attendant loss of gain common in standard tube limiter circuits.

Figure 20 illustrates the limiting action of the 6BN6 with an applied signal of 4.5 mc, such as one encounters in an intercarrier television receiver, having both amplitude and frequency modulation. Note that the limiter grid is biased near the center of the

linear portion of the curve and that limiting action is good without loss of gain. In most standard circuits using the 6BN6 gated-beam tube, the limiter grid bias is obtained by means of a variable cathode resistor (called a "buzz control"); a potentiometer whose shaft is brought out at the rear apron of sets which use this system. Careful adjustment of this control makes almost perfect limiting possible, thus removing all forms of a.m. including the so-called "intercarrier buzz".

30. The Gated-Beam Tube as an F-M Detector

By connecting the circuit of the 6BN6 as illustrated in Fig. 21, the tube serves as both a limiter and as an f-m detector.

The i-f signal is fed to the primary of transformer *T*, and limiting action occurs as described in the previous paragraphs. A resonant circuit consisting of *C* and *L* (also tuned to the i-f signal frequency) has been connected between the quadrature grid and ground, and an output circuit from the plate of the tube has been added.

Let us see what happens when an i-f signal of center frequency (no fm) is fed to the input transformer. To begin with, it must be assumed that the *L-C* resonant circuit is tuned exactly to the center frequency. When an electron stream modulated or varying at this frequency passes the quadrature grid, sufficient excitation will be supplied to the resonant frequency. Even if the received carrier

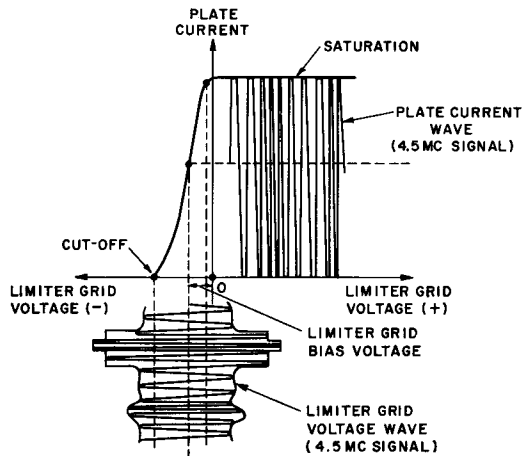

Fig. 20. Illustration of limiting action.

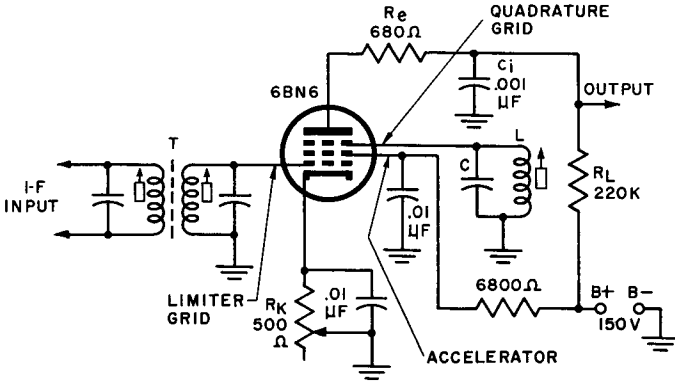

Fig. 21. Basic gated-beam circuit.

frequency is varying, as it would while being deviated by the f-m transmitter, it constantly passes back and forth across the center frequency for each audio cycle so that the L - C circuit receives enough excitation to provide, at the quadrature grid, a relatively uniform set of voltage pulses which appear at the center frequency of the system.

To visualize what happens at the quadrature grid and in the resonant circuit composed of L and C , the changing electric field around the quadrature grid and its effect on the resonant circuit must be considered. Electrons flowing from one element in a tube to another produce electric fields of varying intensities around each of the intermediate elements in the path of the stream. The strength of the field thus produced is a function of the concentration of electrons in that area at that time.

Assume that a relatively large plate current is flowing in the 6BN6 as a result of a sufficiently low bias voltage applied to the first (or limiter) grid. As the concentrated electron stream approaches and reaches the quadrature grid, electrons are driven out of this grid into the resonant circuit, LC . A quadrature grid current, and a voltage across the quadrature tank, result from the charge induced by the moving electrons. This current leads the limiter grid voltage by 90° (as in a capacitor) since, by definition, current is the time rate at which the charge passes a given point.

As soon as the capacitor C has charged to peak voltage, then, the exciting current has dropped to zero and the capacitor can dis-

charge through the inductance L . As it does so, a magnetic field builds up around L as a consequence of the capacitor discharge current, and, as in any oscillating circuit, collapses back through the coil to keep the discharge current flowing in the same direction, thus charging C again but in the opposite direction. C now discharges back through L changing it once more to its original polarity. If nothing else happened, C and L would thus produce a damped oscillatory wave which would gradually decay to zero. But as C recharges in its original polarity — if the resonant circuit is tuned to the same frequency as the varying electron stream in the tube — it will receive a timed pulse of energy causing it to build up once again to peak voltage just as it did before. In this manner, the varying electron stream in the tube by the action of its electric field around the quadrature grid, keeps the L - C circuit oscillating, the voltage pulses appearing at this grid being those of the top of the capacitor C with respect to ground.

Stated once again, an f-m signal applied to the *limiter* grid produces a set of voltage pulses at the quadrature grid which appears and disappears at center i-f frequency and which are 90° out-of-phase with the original, causative f-m voltage pulses. Now it is necessary to examine the combined effect of limiter and quadrature grids with respect to the incoming signal.

Owing to the peak-shearing effect of the limiter grid, the electron beam current between the limiter grid and the quadrature grid varies in the square-wave manner shown in Fig. 22. Like the incoming signal, the wave is frequency modulated and exhibits the familiar "accordion" appearance.

The voltage at the quadrature grid due to the oscillation of the L - C circuit at center frequency would by itself have an effect on

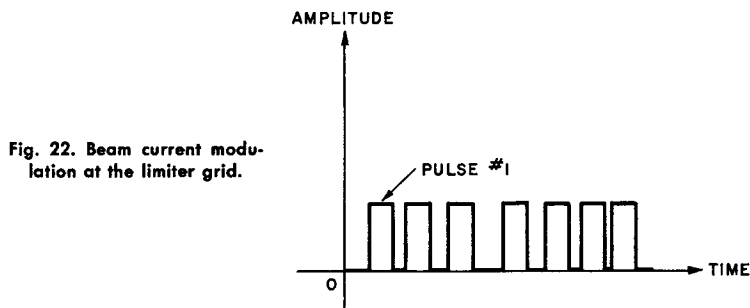

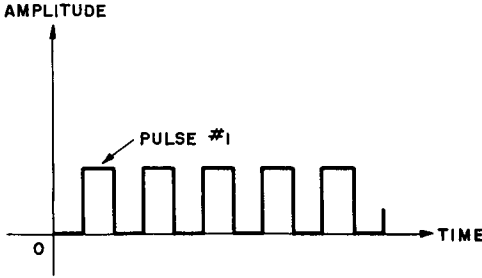

Fig. 23. Beam current modulation at the quadrature grid.

the beam current like that of Fig. 23. It must be remembered that at center frequency, there is a 90° phase difference between the limiter grid pulse and the quadrature grid pulse.

Suppose that an f-m signal at center frequency is received. Pulse #1 at the limiter grid and pulse #1 at the quadrature grid might be represented on a single axis as in Fig. 24.

Remembering that these grids behave as gates, and that plate output can be obtained only when *both* gates are open simultaneously, it is apparent that plate current flows only during the time represented by the shaded portion of the overlapping pulses; the only time when both grids are sufficiently positive to permit passage of the beam to the plate.

At the next instant, there may be a positive frequency deviation, i.e., an increase in frequency. Increasing frequency means a shorter *interval* between pulses. With pulses coming in more quickly than they were at the center frequency (but with the quadrature grid pulses still occurring at the same rate), the limiter pulse will arrive at the quadrature grid *earlier* than it did before to provide a picture like that of Fig. 25.

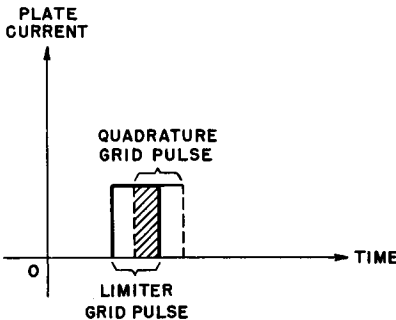
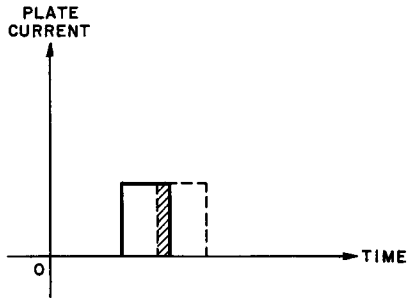

Fig. 24. Both pulses on the same axis.

Fig. 25. F-m signal above resting frequency.



As the illustration indicates, both gates are open together during a shaded interval which is thinner than it was before, indicating that the plate current of the tube is flowing for a shorter time. Similarly, if the incoming signal becomes lower in frequency, the limiter grid pulse arrives at the quadrature grid later than before, thus providing a greater overlap of pulses (see Fig. 26). This means that the plate current flows for a longer time per pulse, or per unit time.

In Fig. 21, no mention was made of the function of capacitor C_i . To appreciate the action of this capacitor, it is necessary to summarize the results obtained in the foregoing discussion. Regardless of the relative occurrence of the gate openings, the plate current magnitude is always the same. The length of time per cycle during which it flows depends entirely upon coincidence of the limiter and quadrature pulses or lack of it; this, in turn, is a function of the frequency of the received signal. A frequency higher than that of the resting frequency results in a short-time flow and a frequency lower than resting yields a plate current flow of longer duration.

Fig. 26. F-m signal below resting frequency.

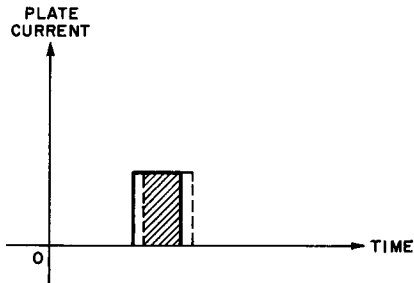

Variations in current time may be translated into proportional variations in output voltage by means of an integrating network as represented by C_i and R_L . Since C_i charges through R_L , it will build up a greater voltage when the current flows for a longer time. This is reflected as a changing voltage across the load resistor, R_L , the audio output voltage. The time constant of $R_L - C_i$ must be large enough to smooth out i-f pulsations but small enough so that that audio modulation frequency signal can be built up across R_L . (Sometimes C_i is omitted, in which case the circuit and tube shunt capacitance provides the filtering or integration required.)

The purpose of R_i (680 ohms in Fig. 21) is to improve the linearity of the audio output signal. If this resistor is not used, output increases somewhat but linearity suffers.

31. Gated-Beam Detector Alignment and Tests

There are only two adjustments for alignment of the gated-beam detector. These are the quadrature circuit $L-C$ and the cathode resistor R_x . The quadrature coil L (or trimmer C) is adjusted by a variable slug to the center intermediate frequency. Cathode resistor R_x is adjusted for best rejection of amplitude modulation. I-f amplifier stages preceding the detector must be aligned with the r-f voltage at the limiter grid as an indicator.

A practical alignment procedure would be as follows:

(1) Apply a steady unmodulated signal at exact intermediate center frequency to the mixer.

(2) By means of a meter equipped with an r-f probe, indicate the r-f voltage between the limiter grid and ground.

(3) Adjust the i-f amplifier circuits preceding for peak r-f voltage at the limiter grid.

(4) Remove the signal generator and connect an antenna to receive an f-m signal. Try to get the f-m signal exactly centered around the resonant frequency of the i-f amplifier, using the r-f voltage at the limiter grid as an indicator.

(5) Using an output (a-c) meter at the loudspeaker circuit, and the ear as indicators, adjust quadrature coil L for maximum a-f output and best a-f quality.

(6) Again apply a signal from a generator to the mixer, this time amplitude modulated; make sure it is at exactly center i-f carrier frequency.

(7) Adjust cathode resistor R_x for a *minimum* a-f output signal at the loudspeaker or in the a-f amplifier.

32. Other Special F-M Detectors

Locked-Oscillator Detector. This circuit, used in early Philco receivers, employs a special pentagrid converter tube (FM-1000) which utilizes the principal of oscillator "lock-in". By this principal, an oscillator is "pulled" in frequency toward the frequency of some strong external signal. If this strong external signal were to vary slightly in frequency, then the oscillator will "lock-in" and follow this signal. A frequency-modulated i-f input signal is applied to the third grid of the converter tube while the cathode and the first two grids of the tube form an oscillator in conjunction with a tuned circuit. Another tuned circuit, coupled back to the oscillator tank is inserted into the plate circuit. This feedback arrangement results in a pulling of the oscillator frequency so that it follows the input f-m signal variations. Plate current in the tube is determined by the amount of oscillator frequency "pull", which in turn is determined by the change in frequency of the incoming f-m signal. Therefore, the average plate current varies in accordance with the audio modulation. The incoming signal strength has no effect on plate current so long as the oscillator operates; thus, the detector does not respond to amplitude modulation.

Fremodyne Detector. In this circuit, a double triode tube is used as a superheterodyne mixer, a super-regenerative i-f amplifier and f-m detector, and a local oscillator. The incoming f-m signal is applied to one triode section along with a local oscillator signal from the other triode section operating as an oscillator. After mixing occurs, the difference frequency signal is reapplied to the first triode section which now operates as a highly sensitive super-regenerative i-f amplifier. By operating this amplifier so that the difference frequency occurs on the slope of the i-f response curve, slope detection of the f-m signal takes place in the same triode section which accomplishes mixing.

33. Review Questions

- (1) Why is the action of a gated-beam tube sometimes described as "switching"?
- (2) Why is the gated-beam tube designed to saturate quickly once plate current has started to flow?
- (3) What makes the resonant circuit connected to the quadrature grid provide pulses of energy to the grid?
- (4) What is the phase relationship between the voltage pulses at the quadrature grid and those at the limiter grid of the gated-beam tube?
- (5) What effect does a positive frequency deviation have upon the length of time during which the double gate is open as compared with the "open time" at the resting frequency?
- (6) Which circuit components change current-flow time to output voltages?

INDEX

- Accelerator chamber, 33
- Accelerator screen, 33
- Accelerator window, 34
- Adjustment, gated-beam system, 42
- Alignment, limiters, 15
- Alignment tool, 24
- Amplitude limiting, need for, 8
- A-M response of simple discriminator, 23
- AVC feedback, 29
- AVC for F-M receivers, 28
- Beam forming action, 33
- Buzz control, 37
- Coincidence of pulses, 41
- Constant sum of voltages in ratio detector, 27
- Construction, gated-beam tube, 33
- Coulomb, 28
- Coupled limiters, 14
- De-coupling filter, 14
- Discriminator alignment, 24
- Discriminator tests, 24
- Discriminator vector analysis, 18
- Distortion in S-curve, 6
- Double gate action, 34
- Double-tuned discriminator, 3
- Electronic gate, 8
- Electron-ray indicator, 30
- Electron stream gates, 35
- Fidelity of reproduction, 3
- Focusing plate, 33
- Foster-Seeley discriminator, 17
- Fremodyne detector, 43
- Function, F-M detector, 1
- Gated-beam system adjustment, 42
- Gated-beam tube construction, 33
- Grid circuit limiters, 11
- Grid current, 11
- Grid transfer characteristic, 10
- Intercarrier Buzz, 37
- Interference, ignition, 14
- Interference, motor sparking, 14
- isolating probe, 16
- Limiter adjustments, 15
- Limiter alignment, 15
- Limiter circuit, 13
- Limiter, definition of, 8
- Limiter requirements, 9
- Limiter response curve, 9
- Limiter saturation, 9, 10, 11
- Limiter, short TC, 15
- Limiter transconductance, 13
- Limiters, plate circuit, 10
- Limiting action, overall, 13
- Locked-oscillator detector, 43
- Long TC limiter, 15
- Modern F-M discriminator, 17
- Modern ratio detectors, 29
- Oscillation, quadrature grid circuit, 38, 39
- Peak clipping, 11
- Period, received signal, 12
- Plate circuit limiters, 10
- Powered iron core tuning, 14
- Quadrature grid, 34
- Quadrature grid circuit oscillation, 38, 39
- Ratio detector, 26
- Ratio detector alignment, 30
- Ratio detector tests, 30
- Received signal period, 12
- S-curve, 6
- Short TC limiter, 15
- Simplified discriminator, 22
- Slope detector, 2
- Special F-M detectors, 43
- Symmetrical ratio detector, 30
- The gated-beam tube, 33
- Time constant, 12
- Transconductance, limiter, 13
- Tuning meter, 30
- Vector analysis, discriminator, 18
- Vectorial addition, 19, 20
- VTVM in alignment, 15