



**NEW
SHORTCUTS
TO TV
SERVICING**

LEONARD C. LANE

\$4.95
(in the U.S.)

VOLUME 2

new
shortcuts
to tv
servicing

LEONARD C. LANE

AUTHOR OF

How to Fix Transistor Radios and Printed Circuits

gersback library inc.
new york 11, n. y.



Copyright © 1958

*Radio-Television Training of America, Inc.,
and Leonard C. Lane*

Revised © 1961

*All rights reserved under Universal
International, and Pan-American
Copyright Conventions.*

Library of Congress Catalog Card No. 61-13970

chapter		page
7	Picture tube and picture tube circuit troubles Types of picture tubes, Picture tube components, Brightness problems, Silvery images, Ion-trap magnet, Corner shadows, Focusing troubles, Deflection yoke defects, Horizontal scanning lines are wavy, Light and dark bars in raster, White vertical lines on left side of screen, Picture non-linearity, Checking picture tube currents, Blooming, Afterglow, Arcing, Picture tube corona, Removing heater-to-cathode and grid-to-cathode shorts, Reactivating cathodes, Retrace blanking, Picture reversal.	2-7
8	High-voltage troubles Sources of high-voltage trouble, Horizontal drive, Significance of bias checks, Oscilloscope check, Checking at plate of horizontal output tube, High-voltage rectifier tube, High-voltage filter, Insufficient high voltage, Blooming, Damping, Light and dark vertical bars, Resistance check of damper, Symptoms of low boost voltage, Yoke trouble, Fuses, Insufficient width, Arcing, Barkhausen oscillation, Poor linearity, Snivets, Foldover, Squeal, Horizontal output transformer.	2-33
9	Deflection troubles Vertical deflection, Integrator troubles, Vertical oscillator, Vertical oscillator troubles, Vertical sync, Multiple pictures, Vertical amplifier defects, Boost voltage effects, Barreling, Buzz, Vertical linearity, Vertical output-tube voltage checks, Poor interlace, Horizontal oscillator, Horizontal afc, Syncroguide troubles, Horizontal sync discriminator, Phase detector troubles, Piecrust, Bending of vertical lines, Differentiator troubles, Horizontal linearity control, Horizontal phasing, Combined oscillator and output circuits.	2-55
10	Sound troubles Video detector operation, Sound takeoff, Sound if stage, Weak sound, Ratio detector, Loss of sound, Hiss, Gated-beam detector, Persistent buzz, Voltage divider, Buzz, Sync buzz due to improper modulation, Hum, Distorted sound, Audio lead dress, Motorboating, Sound and picture weak, Sound missing on some channels, Intermittent sound, Microphonics, Excessive bass response, Noise in sound, Loss of sound due to misalignment, Squealing, Audio output stage, Audio amplifier voltage checks, Scope checks, Audio output transformers, Speaker troubles.	2-79
11	Low voltage troubles Types of power supplies, Transformer type power supply, Testing the power supply, Checking rectifier filament voltage, Checking the primary, On-off switch, Resistance checks, Line-noise filter, Insufficient B-plus voltage, Parallel rectifier tubes, Filters, Half-wave supply, Fusible resistors, Filament surge resistor, Selenium voltage doubler, Input filter capacitor, Power transformer, Line-voltage boost, Series heaters, Special power supply arrangements, Hum, Substituting rectifier tubes.	2-103
12	Miscellaneous troubles Buzz, Capacitors, Dummy tubes, Electrolytics, Flicker, Intermittents, Line-cord check, Loss of high voltage, Making voltage measurements, Peaking coils, Picture spreading, Receiver substitution, Regeneration, Resistors, Ringing, Semiconductor rectifier, Solderless connections, Troubles and servicing techniques cross-reference chart.	2-121
	Index for volumes 1 and 2	2-155

To Mildred

introduction

HERE in the second volume the less delicate circuits are dealt with exclusively. Signal voltages are higher and frequencies are lower. With the exception of the channel selector and contrast and agc, all of the receiver's controls are in these circuits.

While the speaker and the CRT screen are the end result of all the other circuits combined, most customers do not fully appreciate their dependence on the preceding stages. Although the audio circuits of many table radios and TV receivers are designed with a high percentage of distortion tolerance to obtain the maximum volume with the minimum amount of circuitry, it is not possible to do this in most other TV stages. A fraction of a percent of distortion is quite visible to the average viewer and stands out to the discerning.

The ability to apply the principles offered here to the proper situation is something to be developed. Only experience will help decide if a symptom is a design fault or a circuit failure. While it is possible to compensate for faulty components it is always best to find the defective part and replace it. Nevertheless some technicians will consistently bridge an old part with a new part thus introducing the possibility of intermittents. Experience will show this to be an unwise technique. Wherever practical, use parts with the next highest wattage or voltage ratings. Never skimp on replacements as the hardest thing to repair is a ruined reputation. Capacitor voltage ratings must consider the combined ac and dc voltages. Even resistors have a maximum voltage rating although it is seldom mentioned. Ohm's Law will easily determine the safety factor of a circuit's resistors.

While these two volumes are not expected to be utilized for each and every service call, the information contained herein should be indispensable on these bad days if kept handy on a shelf near the bench or in the service vehicle.

LEONARD C. LANE

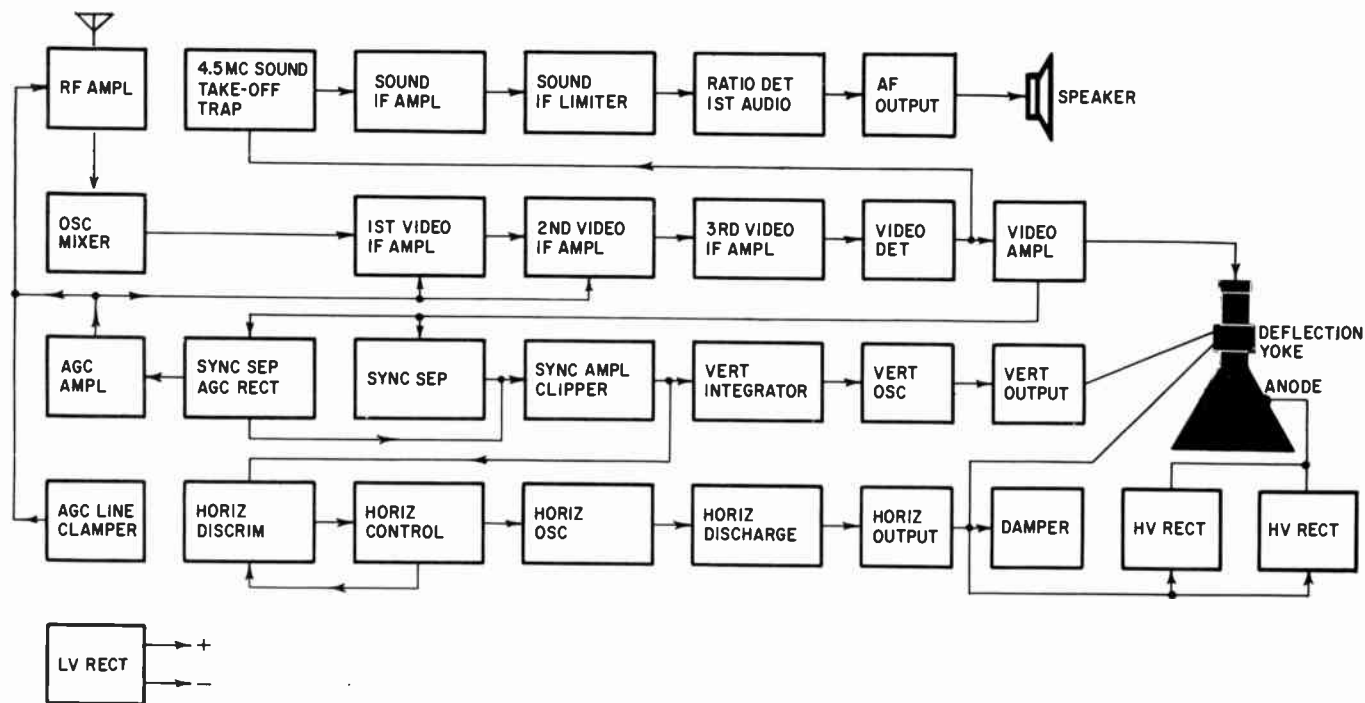

Fig. 701. In this chapter, the CRT and its associated circuits are spotlighted.



picture tube and picture tube circuit troubles

chapter 7

THE picture tube can be considered a receiving depot for a variety of circuits in the television receiver. For example, the input signal, after going through various stages of amplification and detection, is fed either into the cathode or the control grid of the picture tube. At the same time, for its proper operation, the picture tube requires a source of high voltage. In addition, there is also a brightness circuit connected to the picture tube and there may also be a retrace blanking circuit. Trouble in the picture tube can arise because of a defect in the tube itself, or because of complete or partial failure in some circuit connected to the picture tube (Fig. 701).

Around the neck of the tube, we have the deflection yoke, the focus coil (or magnet), a centering magnet and an ion-trap magnet. These components must also be considered when analyzing picture-tube troubles. Sometimes quite dissimilar components can produce troubles that are identical. For example, the setting of the ion-trap magnet is critical. If it should happen to be moved out of position, the result could be loss of the raster or a dim raster with corner shadows. However, loss of raster could also be produced by some trouble in the high-voltage supply, or a result of some physical trouble within the picture tube itself.

It would be useless and time-wasting to replace a picture tube

if all that is required is an adjustment of the ion-trap magnet. At the same time, moving the ion-trap magnet around and misadjusting it when the difficulty lies in the high-voltage supply, can be time-consuming.

Types of picture tubes

Although two tubes may have the same face diameter, it does not follow that these tubes can be used as substitutes for each other. You have about as many differences between picture tubes as you have between smaller size tubes in the TV receiver. There are also differences in gun structure, in focusing techniques, in sweep angle, in length and in high-voltage requirements.

Picture-tube components

The ion-trap magnet, the focusing magnet and the deflection coils (yoke) all depend upon magnetic fields for their action. The yoke is invariably an electromagnet and contains two pairs of coils producing horizontal and vertical deflection of the scanning beam, while the other devices are now mainly of the permanent magnet type.

A centering magnet also sits on the neck of the tube. Each of these magnets has different jobs to perform and various picture-tube troubles can arise if they are not properly positioned on the neck of the tube or if their magnetic fields are permitted to interact with each other.

Physical examination of the picture tube

Turn the receiver on and set the channel selector for a good station. While the set is warming up, look at the rear end of the picture tube. Observe the heater of the tube to see if it is lighting. If not, wiggle the socket gently, to see if the trouble is caused by a poor contact.

If the picture-tube heater still does not light, there are a number of checks you can make to determine if the trouble is inside the tube or outside of it. With the receiver turned off and with the picture-tube socket disconnected, make a resistance measurement between the heater pins. The reading should be fairly low. Use a pin crimping tool or resolder the filament pins. With the ohmmeter test leads again connected, gently tap the neck of the tube. Watch the ohmmeter for any sign of intermittent connection. As a further check, connect the secondary of a filament transformer to the filament pins of the picture tube, with the primary of this filament transformer plugged into the ac power line.

If, however, you do get a resistance reading, or if the heater lights when you use a test transformer but the tube does not light when connected to its socket, the trouble is not in the tube but in the 6.3-volt supply going to the picture-tube heater. Disconnect the socket from the picture tube. Measure the ac voltage across the heater contacts of the socket. The trouble may be due to a loose connection or to a broken wire.

No raster

There are other conditions which can cause loss of the raster. Turn on the receiver and listen carefully, close to the high-voltage cage. Practically all high-voltage supplies in television receivers produce some characteristic noise, even though this may be slight. Hold the tip of an insulated handle screwdriver near the plate cap

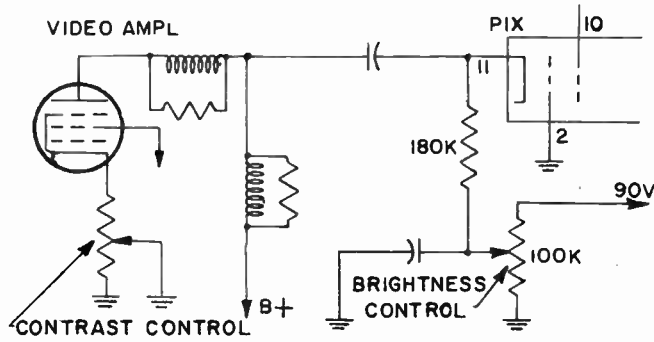

Fig. 702. *Capacitively coupled cathode-driven CRT has brightness control in the cathode.*

of the horizontal output tube (or tubes). Do not ground. A husky arc indicates operation of the horizontal sweep circuit, up to this point. Remove the high-voltage anode connector to the picture tube and spark it to the chassis momentarily. A substantial arc indicates complete functioning of the high-voltage supply.

However, it is entirely possible for the high-voltage supply to be functioning properly and for the raster to be missing. Turn off the receiver and make sure that the picture tube is discharged. Examine the wire going to the high-voltage anode on the picture tube. Sometimes this lead is fastened but not soldered to the button connected to the high-voltage terminal. Check the connection to make sure that it is secure. Solder it, if necessary.

Brightness control

The brightness control, as shown in Figs. 702 and 703, is a definite part of the picture-tube circuit. The brightness control

can be part of the cathode circuit of the picture tube or the control grid. In either case, its job is to put the proper amount of fixed bias on the picture tube. A properly operating brightness control should be able to make the picture tube go from a condition of complete black (no raster) to full brilliance raster.

Check the functioning of the brightness control. Connect a vtvm (set to dc volts) — between control grid and cathode pins of the picture tube socket. The negative test prod of the vtvm should go to the control grid and the positive test lead to the cathode. Set the vtvm to read at least 100 volts. Turn your receiver on and observe the positioning of the meter needle. Vary the brightness control. You should be able to make the meter needle swing between 0 and approximately 50 volts.

Do not assume that it is always possible to check the voltage between cathode and ground or control grid and ground. In some cases, the video amplifier tube is directly coupled to the cathode of the picture tube and as a result the cathode of the picture tube is at approximately the same potential as the plate of the video amplifier. A defect in brightness may be caused by some trouble in the plate circuit of the video amplifier tube.

In Fig. 702 the video amplifier is coupled to the cathode of the picture tube through a capacitor. The brightness control forms a voltage divider from a low-voltage tap in the receiver (usually less than 100 volts). In this particular circuit, the control grid of the picture tube is connected to the chassis. The bias voltage can then be measured, if desired, between the cathode and the chassis.

In Fig. 703 the video amplifier is directly coupled to the cathode of the picture tube. The voltage on the cathode of the picture tube is essentially the same as that on the plate of the video amplifier. In a circuit such as this, the control grid is tied to some positive potential point. For this reason, the bias cannot be measured between cathode and ground or control grid and ground, but must be measured between the two electrodes — between the cathode and the control grid. In either circuit the action of the brightness control is the same and measuring the bias voltage, while rotating the brightness control, will give an indication as to whether the bias circuit is functioning properly.

Brightness problems

Although the brightness circuit, in itself, is quite a simple one, trouble with picture-tube brightness isn't necessarily confined to

the picture tube. When the video amplifier is directly coupled to the picture tube, a defective video amplifier will affect the voltage at the cathode of the picture tube, hence the brightness will be affected.

Other circuits also can reduce or increase brightness: the vertical retrace blanking network; agc; the horizontal sweep circuit

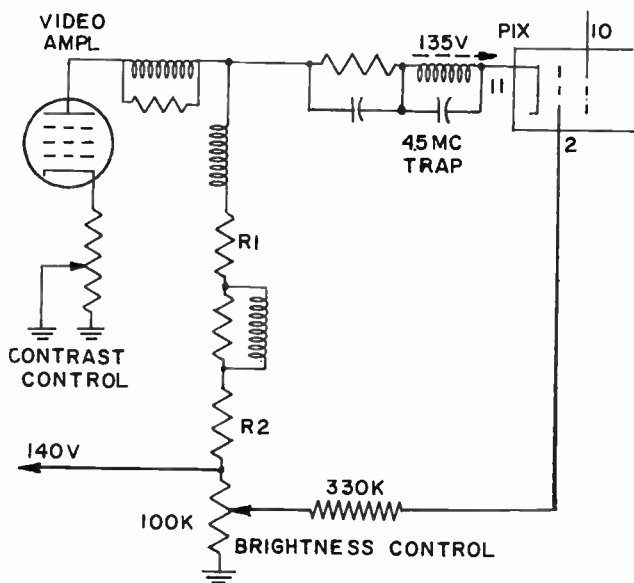

Fig. 703. Direct-coupled cathode-driven CRT has the brightness control in the grid circuit.

(horizontal oscillator and horizontal amplifier tubes); the low-voltage supply, and, in some cases, the audio output tube.

Silvery images

When the images on the screen have a silvery appearance, and the situation cannot be relieved by any adjustment of the brightness and contrast controls, then it is very probable that the picture tube is defective.

Excessive brightness

If the brightness cannot be reduced by any setting of the brightness control, measure the bias voltage on the picture tube while rotating the brightness control, as described earlier. If the bias voltage goes through its normal range, and a visual examination of the picture-tube socket shows it to be in good condition,

then there is a possibility of leakage between the first and second grids in the picture tube. This condition can sometimes be corrected by applying a high-voltage across the pins. Use a substitute picture tube to make sure that the trouble is in the picture tube first.

To burn out a picture tube short, remove the socket. Ground the control grid to the chassis. Momentarily touch the high-voltage lead (disconnect it from the tube) to the cathode of the picture tube. The resulting arc should burn away any material between these two electrodes. *Caution:* This test should be done only if you are clearly convinced that the picture tube is defective. (Also read the section on a safer method for removing internal shorts described later in this chapter.)

With excessive brightness, that can be reduced slightly by the brightness control, it is entirely possible that the high voltage may have increased. This can be due to an improper setting of the horizontal drive control, to a gassy horizontal output tube or high-voltage rectifier. An indication of this trouble can be found by examining the picture. If the width of the picture is decreased, then it is possible that the voltage on the picture tube anode is too high. Verify this by measuring with a high-voltage probe and a vtvm. (Excessive high voltage may not reduce the picture vertically.)

A defective damper tube sometimes causes one side of the picture to be brighter than the other. Substitute a new damper tube.

Where the video amplifier is directly coupled to the cathode of the picture tube, any change in resistance or capacitance values that make the voltage on the cathode of the picture tube abnormal, will reduce the effectiveness of the brightness control. Check the schematic for normal voltage on the cathode and measure the voltage between the cathode and the chassis. If it is lower than that indicated as desirable on the schematic, the trouble is between the video amplifier and the cathode of the picture tube and may be due to some defective component between those two circuits. Sometimes, a defective video amplifier tube will produce this condition.

In Fig. 703, for example, a gassy video amplifier tube means a greater than normal current flow through the tube. This results in a larger voltage drop across R1 and R2, and less voltage at the plate of the video amplifier and the cathode of the picture tube. This upsets the bias on the picture tube, lowering it and

increasing the brightness. The current through the video amplifier can be reduced by adjusting the contrast control. While this may restore picture-tube brightness to its proper level, contrast may be inadequate.

Insufficient brightness

Measure the bias voltage between the control grid and cathode of the picture tube as indicated earlier. If the voltage on the cathode of the picture tube is normal with respect to the chassis, and if the bias voltage varies through its desired range as the brightness control is rotated, then the trouble is either in the picture tube itself or in the high-voltage circuit. Measure the voltage on the high-voltage lead with a high-voltage probe and a vtvm. If all voltages on the picture tube are normal, examine

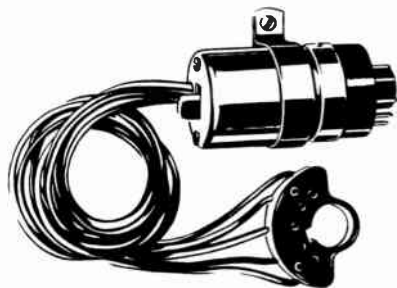

A universal brightener is a handy test gadget. It can isolate heater-to-cathode leakage in series- and parallel-filament chassis as well as indicate weak picture tubes. (Chicago Standard Transformer Corp.)

the setting of the ion trap magnet. It may have been moved out of position. It is also possible that the ion trap magnet has become weak and needs replacement.

Some technicians confuse brightness and contrast. If the picture seems weak and washed out but turning up the brightness control makes the screen brighter (contrast probably will get poorer), then the trouble is due to insufficient signal and not to brightness. If you can get bright, sharp raster lines and if you can control the brilliancy of these lines with the brightness control (from cutoff to very bright), then the trouble is not in the picture tube or the brightness circuit. If, however, the brightness control is in its maximum position (or close to it) and you cannot bring up the brightness of the raster lines, then picture-tube, high-voltage or brightness-circuit trouble is indicated.

Insufficient cathode emission in a picture tube shows itself in

several ways. The picture will seem weak and washed out and the raster will appear dim. Use a picture tube brightener. It takes but a minute to install.

As a final check, use a substitute picture tube. If the test tube functions properly, then the picture tube is defective.

Ion-trap magnet

Most receivers today use a PM magnet ion-trap. Improper positioning of this magnet can result in complete loss of picture, corner shadows and a picture that is out of focus. The sound will not be affected.

An improper setting of the ion-trap magnet is serious since it can result in a defective picture tube. If the magnet is not properly positioned, it can ultimately result in an ion burn, a brownish spot near the center of the picture-tube screen. This brown spot cannot be removed and requires the installation of a new picture tube. When adjusting an ion-trap magnet, keep the brightness turned down and rotate the magnet until you get maximum brightness on the screen. Some picture tubes have a green glow indicator. Set the trap for minimum glow.

Adjust the ion-trap magnet so it is close to the base of the picture tube, if possible. You will sometimes find two settings of the magnet that will give good brightness on the screen. One of these positions will have the magnet close to the focus magnet and the other close to the base of the picture tube. Use the latter position. Sometimes you will find a mark on the magnet to indicate the side which should face the tube. If the magnet does have such a marking, either a circle, a dot or an arrow, then the coding should be toward the picture tube.

The ion-trap magnet should not be checked or moved, except as a last resort. The setting of the magnet is fairly critical. You can get an idea of the strength of the magnet by its position on the neck of the tube during operation. If the ion-trap magnet is too strong, the best position will be fairly close to the socket. If the ion-trap magnet is too weak, you will find that it must be set closer to the focus coil or focus magnet. However, as we mentioned earlier, the best position of the magnet is that which is closest to the base of the tube.

Corner shadows

This trouble is generally due to an improper setting of the ion-trap magnet. Adjust the magnet for maximum brightness on the

screen, but with corner shadows removed. However, corner shadows should not be removed by adjustment of the ion magnet, if this means a reduction of brightness. If the receiver has a centering adjustment, use this to eliminate corner shadows and then adjust the ion-trap magnet until you get maximum brightness on the screen. Also, make sure that the ion-trap magnet is the right type for the particular picture tube being used. Do not try to use a single ion-trap magnet for a tube designed for a double magnet. Nor will a double magnet work well on a tube constructed to use a single magnet.

Corner shadow will exist if the deflection yoke is not right up against the bell of the picture tube. If there is no setting or positioning of the focus coil or deflection yoke which will elim-

Electromagnetic focus coils are found in old receivers. An unrealized advantage with this type of focusing is that any afterglow in the CRT is completely defocused and is not usually noticed.

(Chicago Standard Transformer Corp.)

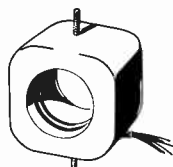

inate corner shadow, try an ion-trap magnet that is slightly stronger. If you can get maximum brightness only by having the ion-trap magnet close to the focus unit, this is an indication that the magnet has lost some of its strength. Do not try using an ion-trap magnet that is too strong for the picture tube. You can recognize an excessively strong magnet by the fact that it needs to be positioned right on the tube base.

Handling ion-trap magnets

Dropping these units or storing them close to heat will cause them to lose their effectiveness. Do not keep these magnets near metal picture tubes and do not keep them in drawers with metal tools.

Focus adjustments

Troubles with the focus adjustment can result in a blurred picture or shadows on the screen. The focus control on the receiver should be able to go through focus. That is, you should be able to rotate the control so that the picture goes into focus at one point during the travel of the control (preferably near the center setting of the focus pot). If the receiver does not have a chassis mounted focus control, you should be able to control focus with the focus magnet.

Although modern receivers use permanent-magnet focusing, you will find some receivers that use electromagnetic focusing or a combination of PM and electromagnetic focusing. On PM units, focus is adjusted by rotating one or more screws. With electromagnetic units, focus is adjusted by adjusting the setting of a potentiometer.

If you find it necessary to move the focus unit on the neck of the picture tube to produce proper focus, you may find that you

Removal of the dried and split rubber flange of the 2nd anode connector can reduce corona discharge problems.

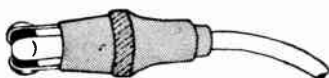

must readjust the ion-trap magnet. Examine the position of the focus unit on the neck of the tube. The focus unit should be centered on the picture tube; that is, every point on the circumference of the neck of the picture tube should be equally distant from the inner ring of the focus unit. The focus unit should be vertical to the neck of the picture tube and should not be tilted.

Fig. 704 shows the circuit of a picture tube using electrostatic focusing. Focusing is by means of an adjustable potentiometer connected to a B-plus point. Focus difficulties with this system can be due either to some defect in the potentiometer (focus control) or to insufficient voltage applied to the focus electrode of the picture tube.

Focusing troubles

The focusing coil or PM unit must be vertical to the neck of the picture tube. A picture that does not have uniform focus — that is, looks blurred along the edges of the screen — can be due to a tilted focus coil. Examine the unit to make sure that it is properly positioned.

If good focus cannot be obtained with any setting of the focus control (electromagnetic units), or if there is poor focus with PM units (for any setting of the slugs in the unit), examine the position of the ion-trap magnet. If this magnet is too close to the focus coil or focus unit, the magnetic fields of the two will interact and poor focus will be the result. Adjust the ion-trap magnet for maximum brightness as described earlier. Then, position the focus magnet and adjust the control or the slugs until the sharpest raster lines are obtained.

Sometimes rotating a focus coil improves focus. This simply indicates that its original positioning was incorrect. It is also possible that the focus magnet is too strong or too weak, or that the adjustment slugs have been turned by a screwdriver-happy customer. When adjusting a PM unit, rotate the slugs with a nonmagnetic material such as brass or plastic.

Do not overlook the fact that faults outside the focusing system can also result in the same trouble. A defect in the high-voltage system can produce defocusing but, generally, this trouble is

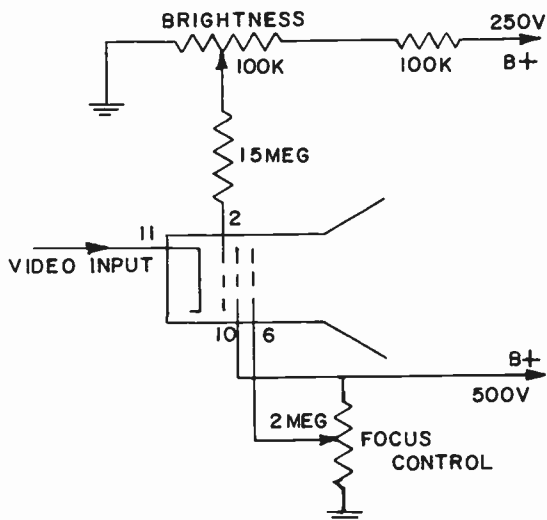

Fig. 704. Electron-beam focus is obtained in this circuit by the electrostatic field created by the difference in potential between the elements connected to pins 6 and 10.

accompanied by other symptoms such as a decrease in brightness or change in width. However, it should not be overlooked as a potential source of trouble. If the picture tube is defective, a condition of poor focus can result. For example, reduced cathode emission (but with high voltage remaining unimpaired) can result in poor focusing.

Deflection yoke

The deflection yoke consists of two pairs of deflection windings, one pair of which is connected in a series-parallel circuit with two resistors. The other has a single capacitor across one of the windings, as shown in Fig. 705. Defects in the deflection yoke can produce a large variety of troubles.

A capacitor is shown across one of the windings in Fig. 705-b. This capacitor is usually about $56\ \mu\text{f}$. Should it become open or have the wrong value, it can produce a ringing effect, resulting in vertical lines on the screen. A defective capacitor or winding

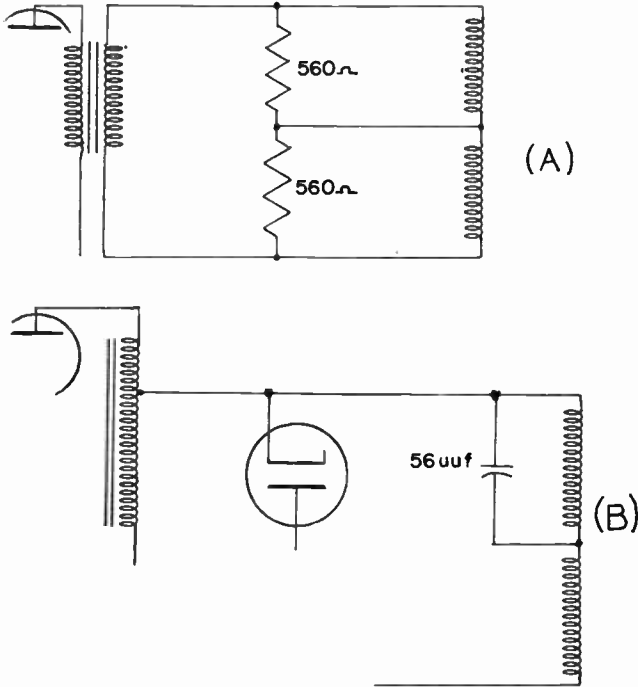

Fig. 705. Typical vertical deflection coil circuit (A) and horizontal deflection coil circuit (B).

can also produce a trapezoidal raster known as keystoneing (Fig. 706). Keystoneing can also be produced by a defect in the vertical winding, or the resistors shunting them, in the horizontal winding or by its shunting capacitor. Defective resistors or windings can also result in horizontal foldover, insufficient height, wavy vertical or horizontal lines in the picture.

Horizontal line across center of screen

Adjust the vertical gain control to maximum. If the result is to increase the thickness of the line but slightly, the trouble is in the vertical deflection system. This could be caused by an open in the vertical deflection coils or the output transformer. These can be checked with an ohmmeter.

The resistance of each vertical deflection coil is less than 50 ohms, 25 ohms being a typical value. Each coil is shunted by a resistor, the most usual value being 560 ohms. When checking resistance, your ohmmeter should read 50 ohms or less. If it shows the value of the shunting resistor (560 ohms), then the coil is open. The leads to the vertical deflection coils are often (but not always) color-coded green and yellow, while the horizontal coils are coded

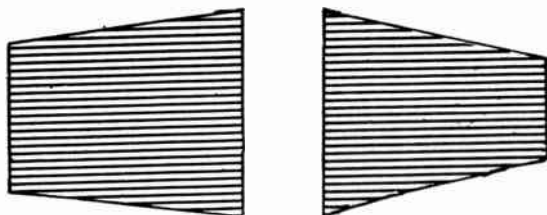

Fig. 706. *Keystoneing could be caused by a short in either of the deflection coils.*

red and black-red or red and blue. You can easily identify the vertical coils by the resistors placed across them. A capacitor (56 μf) is shunted across one half of the horizontal deflection windings.

Frozen yoke

In making a picture-tube replacement, it will be necessary to remove all the components on the neck of the tube, including the yoke. However, the yoke sometimes seems to become permanently fastened to the neck of the tube. Do not break the picture tube in an attempt to remove the yoke since this can be dangerous. To remove the yoke, unsolder the yoke leads and connect them in series. Put approximately 50 volts ac across the windings and wait for several minutes. The yoke will become quite hot and you should be able to slide it off the neck of the tube readily. To facilitate removing the yoke, coat the neck of the picture tube with a lubricant.

The 50 volts for the yoke can be obtained through a stepdown transformer, a variable transformer (such as a Variac) or a fixed resistor. To determine the value of the resistor, measure the dc resistance of the two windings in series and then use a resistor having that value. Use a resistor having a rating of 10 watts or more. If such a resistor is not available, connect two 25-watt electric light bulbs, in series, and then put this combination in series with the yoke windings. If this arrangement does not heat up the

yoke sufficiently, then short the connections across one of the bulbs.

Horizontal scanning lines in raster are wavy

The lines of the raster should be straight across the face of the picture tube. If they evidence a certain amount of waviness, the trouble could be due to an incorrect value of capacitance across

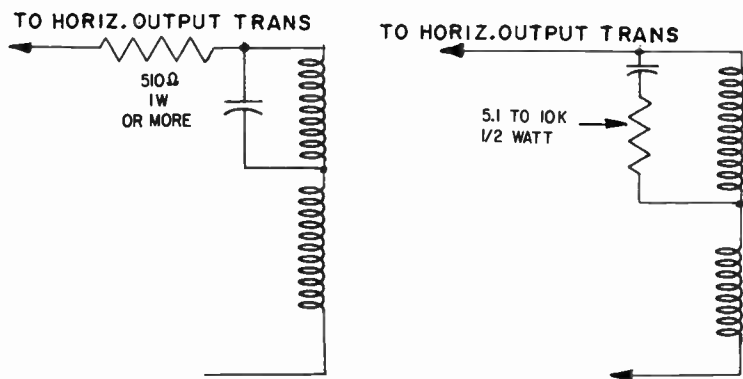

Fig. 707. Putting a resistor in series with the horizontal deflection coils is a simple service change. A resistor can also be placed in series with the capacitor across one half of the winding.

the horizontal deflection coil. Try different values of capacitance (less than 100 μf) and note if the waviness of the lines is reduced.

Light and dark bars in raster

These bars can be due to ringing in the horizontal deflection windings. As a check, insert a 510-ohm resistor (rated at 1 watt, minimum) in series between the damper tube and the horizontal deflection coil, as shown in Fig. 707. Another technique is to put a resistor (value from 5,100 to 10,000 ohms, $\frac{1}{2}$ watt) in series with the capacitor through the yoke winding.

White vertical lines on left side of screen

Make sure that the capacitor is properly placed across the "high" side of the horizontal deflection windings. These lines will appear if the capacitor has been transposed and is across the wrong coil. Also, experiment with different values of capacitance. Try moving the wires going to the picture-tube socket. If they disappear, shift or become weakened, the trouble is due to improper lead dress.

Horizontal reversal of picture

The leads to the horizontal deflection coils have been transposed. Unsolder them and connect them correctly.

Vertical reversal of picture

The leads to the vertical deflection coils have been transposed. Unsolder the leads and connect them correctly.

Yoke is excessively hot

This condition can be produced by a shorted turn in the yoke. This cannot be detected by any resistance check. Generally the condition is indicated by an excessively hot yoke and by some picture keystoneing.

Picture nonlinearity

If the vertical gain control is set to maximum but cannot produce sufficient picture height and the picture is distorted, check the damping resistors across the vertical deflection windings. It will be necessary to disconnect one end of each resistor from the yoke to make a resistance check. A defect in the resistors or in the winding itself can also result in keystoneing.

Horizontal foldover

This can be due to a defect in either one of the horizontal deflection coils. It can also be the result of a higher than normal value of capacitance across the horizontal winding. Try using a smaller capacitor and note its effect on the foldover.

Checking picture-tube currents

To determine if a picture tube is passing current, you can make several checks. The easiest is to disconnect the high-voltage lead and hold it close to the anode cup or receptacle on the picture tube. A steady spark across the space between the two points indicates a current is flowing in the picture-tube circuit. An alternative method is to open the cathode lead to the picture tube and insert a dc meter having 1-ma full-scale deflection. If the meter deflects, current is being passed through the picture tube. The plus terminal of the milliammeter should be connected to the cathode. (Remember, a milliammeter is a current-measuring device and must be placed in series with the circuit or tube whose current is to be measured.)

Blooming

Blooming is a condition in which the picture expands, goes out

of focus and often disappears from the screen as the brightness control is advanced. Most usually, the defect is due to some trouble in the high-voltage supply. However, it can also be produced by trouble in the brightness-control circuit. Check all resistors connected between the brightness control and the picture tube. It is entirely possible that blooming might be caused by a defective picture tube. For example, if the picture tube is gassy or if it has an internal short, a condition of blooming could result.

Other faults leading to blooming, will be discussed in the chapter on the high-voltage power supply (Chapter 8).

Afterglow

A spot of light is sometimes seen on the face of the picture tube after the receiver is turned off. This spot is due to the fact that the hot cathode of the picture tube continues to emit electrons for some time after the removal of filament voltage. High voltage remains on the picture tube because the high-voltage filter capacitor (either a 500- μf unit or the inner and outer coating on the picture tube) takes a long time to discharge. If the spot is a concentrated pinpoint on the face of the screen, it can burn away some of the phosphor material. For complaints of this nature it is only necessary that the customer turn up the brightness control a bit before turning off the receiver. If the spot is fairly large (about the area of a dime), it will do no damage.

The reason for advancing the brightness control is that this action increases the scanning-beam current, thereby discharging the high-voltage capacitor that much more quickly. Also, a slight amount of blooming will cause the spot to become defocused. Some receivers come equipped with a spot killer circuit.

Heater-cathode leakage

Heater-cathode leakage in the picture tube (or in one of the preceding tubes carrying the picture signal) can cause 60-cycle hum modulation of the picture, producing a typical hum bar (horizontal) across the screen. The bar may make the upper or lower portion of the screen dark.

To determine if the leakage is in the picture tube, vary the contrast control. If it has no effect on the hum bar, then the hum modulation exists in the picture tube. Otherwise substitute new tubes (video amplifier, video if amplifiers) one at a time. If you do not have tubes available for substitution, you can ground the cathode of each tube in turn (video amplifier and

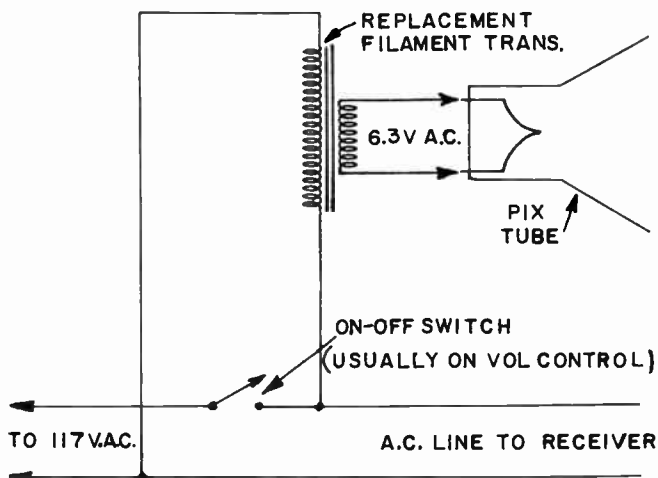

Fig. 708. Connections for adding a filament transformer to isolate the CRT filament.

if's). This test must be done quickly to avoid tube damage. If the hum bar does not disappear, the picture tube is at fault.

If heater-to-cathode leakage does exist in a picture tube and the picture is weak and washed out (due to insufficient cathode emission) try a picture-tube brightener of the isolation type. It may cure both troubles at the same time. If the picture still remains somewhat washed-out, the picture tube should be replaced.

Another cure for heater-cathode leakage in a picture tube is to install a separate filament transformer (Fig. 708). Disconnect the leads going to the heater pins of the tube socket and connect them to the secondary of a filament transformer. The primary of a power transformer must be connected to the ac line coming into the receiver so that the on-off switch opens and closes the circuit to the primary of the new filament transformer.

If the picture-tube heater is part of a series-string arrangement, disconnecting the picture-tube heater leads will open the heater circuit. To restore continuity insert a 10-watt 10-ohm resistor between the heater leads which have been disconnected from the picture tube (Fig. 709).

Arcing

The high-voltage lead going to a metal picture tube is fastened to the rim edge. This must be secure and make good contact. If not, the result will be intermittent flashes in the picture accompanied by a crackling sound.

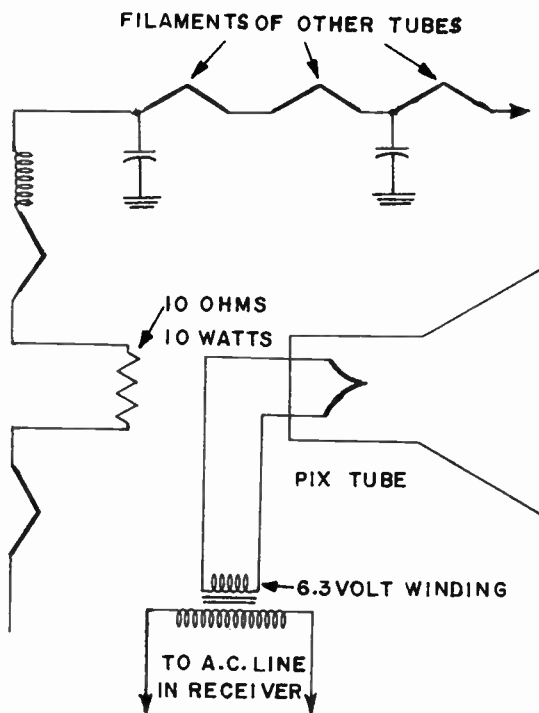

Fig. 709. Additional problems are encountered with series-filament circuits. An isolation brightener is a quick way to test and an easier way to repair.

Barreling

Barreling, as its name implies, causes the raster or picture to push outward, producing a condition that resembles a barrel (Fig. 710). This condition is sometimes produced when vertical or horizontal output transformers are replaced. It is caused by an impedance mismatch between the transformer and the deflection yoke. It can also be the result of poor positioning of anti-pincushioning magnets.

If the output transformer has not been replaced and if the tube has no anti-pincushioning magnets (or if the magnets are properly set), it is possible that a shorted turn in the deflection yoke is causing the condition.

Pincushioning

Pincushioning is a condition in which the sides of the raster or picture are pushed in (Fig. 711). Although the final result is an effect which is opposite to that of barreling, it can be produced

by the same defects — that is, mismatching between vertical or horizontal output transformers and the yoke, shorted turns in the yoke and improper positioning of the anti-pincushioning magnets.

To adjust the anti-pincushioning magnets feed in a signal from a cross-bar generator and adjust the magnets until all lines are straight. If such a generator is not available, reduce the size of the raster with the size controls until the four edges of the raster can be seen. Adjust the magnets until the edges are straight.

Fig. 710. *Barreling is a condition in which the sides of the raster are curved outward.*

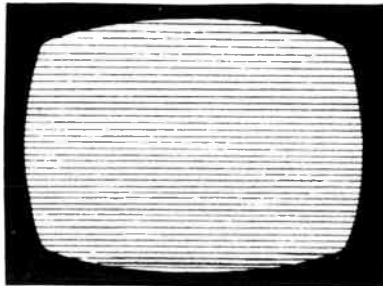

The raster can then be increased in size once again. It may be necessary to readjust the magnets when replacing a picture tube.

Gassy picture tube

A gassy picture tube has excessive beam current. The brightness may be erratic and focus can be poor. A gassy tube may result in a negative picture.

Fig. 711. *Pincushioning is a condition in which the sides of the raster are curved inward.*

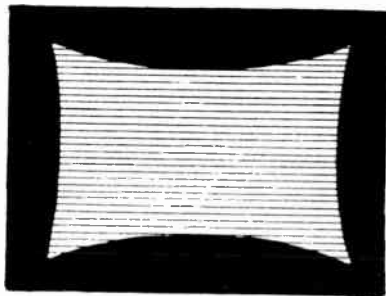

Magnetized picture tube

If the inability to focus is accompanied by a steady bend in the picture, it is possible that the cone of the picture tube (metal picture tube) has become magnetized. Magnetization usually occurs in a small area of the cone. Check for magnetization with

a compass. Make sure the receiver is turned off. Hold the compass in a horizontal position and move it slowly back and forth near the metal portion of the picture tube, gradually covering the entire metal surface area. Any sharp movement of the compass needle indicates a magnetized area.

To demagnetize a metal picture tube use the degaussing coil sometimes required for three-gun, color picture tubes. If such a coil is not available, use any iron-cored coil (such as a filter choke) (Fig. 712). As a precaution, put a 25-watt bulb in series with the coil and connect the combination to the 117-volt ac line. (Note: the filter choke must be an unshielded type.) Now bring the energized choke coil close to the magnetized spot on the picture tube, then move the choke away slowly. Check for completeness of demagnetization with the compass.

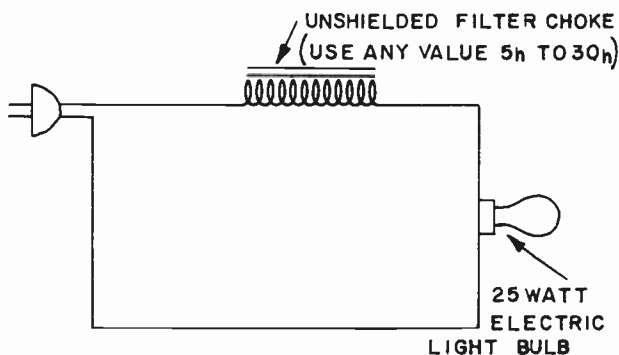

Fig. 712. This simple circuit can be used for demagnetizing the metal cone of a CRT.

Metal tubes in stock should be kept away from PM focus units, PM speakers, ion-trap magnets or other components that have a magnetic field. When the receiver being serviced has the speaker mounted near the picture tube, it may be necessary to relocate the speaker.

Broken or loose picture-tube base

Just because the base of the picture tube is broken or loose does not mean that the picture tube will have to be replaced. If the base is loose, run a thin layer of cement around the edge where the base touches the glass. Masking tape also makes a quick repair.

Buzz

Some glass picture tubes have an outer Aquadag coating. A

pressure contact or clip connects this coating to the chassis. A poor connection between the chassis or ground clip and the Aquadag can result in buzz. To determine if the buzz is due to this, turn the brightness down until the screen is dark. Adjust the contrast control to minimum. Keep the volume control turned up. If the buzz disappears, the trouble is due to poor contact between the Aquadag and ground.

Time-saver

To eliminate any possibility of the picture tube as a source of buzz, disconnect the high-voltage lead or the picture-tube

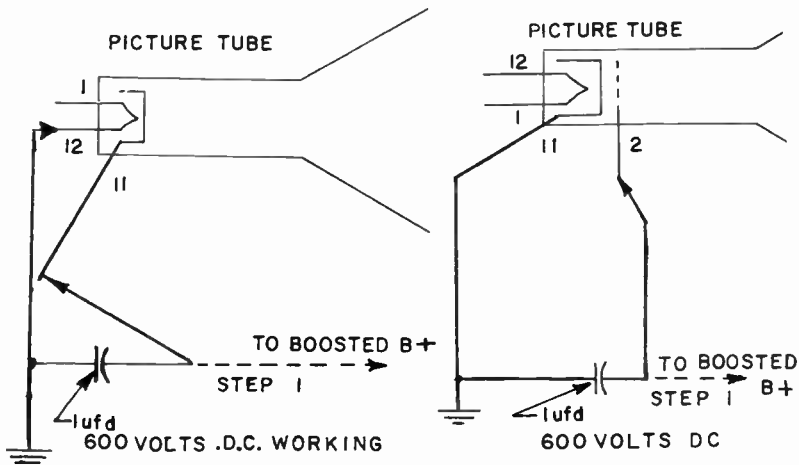

Fig. 713. Techniques for burning out a short between the CRT filament and cathode (left), and grid and cathode.

socket. If the buzz remains, the fault does not exist in the picture tube.

Dark areas at bottom, sides or top of picture

This trouble may be due to improper centering of the picture. Make sure that the deflection yoke is as far forward as it can go, snug against the bell of the picture tube. Turn the receiver on but set the channel selector to an off-channel position. Make sure the raster is perfectly straight and, if not, turn the yoke until it is. Examine the raster scanning lines at each end, center and top to bottom. Adjust the focus unit for sharpest scanning lines over the greatest area of the picture-tube screen. The function of the focus unit is to give sharp scanning lines, not maximum brightness.

Sound normal; picture delayed

It is quite normal for sound to be heard before the picture appears. If, however, it takes some time for the picture to show on the screen, then the trouble may be due to insufficient picture-tube cathode emission. When the picture finally appears, it may not cover the entire screen (some corners will appear pulled in) and picture contrast may be poor. The trouble may be due to inadequate heater voltage at the socket of the picture tube. If voltage is normal (6.3 volts ac), the defect is in the tube. Try a picture-tube brightener or replace the picture tube.

Picture-tube corona

Leakage sometimes takes place between the high-voltage button and the rubber cap surrounding the end of the high-voltage lead. Examine the cap. If it appears to have lines running through it, or if it feels brittle and rough instead of smooth, it is decomposing. When this happens, the rubber loses some of its insulating properties and becomes slightly conductive, providing a leakage path from the high-voltage connector. Trim away the rubber with a razor blade. Wipe the glass area around the high-voltage second anode until it is absolutely clean. It is only necessary to moisten a cloth, sprinkle some household cleanser on it and then scrub the glass area near the second anode. Be sure to rinse and dry the area, after cleaning it.

Heater-to-cathode short

To check for a heater-cathode short, allow the picture tube to remain in an operating condition for at least 10 minutes. Turn the set off, remove the picture-tube socket and then quickly measure (with an ohmmeter) between the cathode pin and either heater pin. A low-resistance reading (it may jump to a high resistance reading as the heater cools) indicates a heater-cathode short. This test must be done quickly before the tube heater has had a chance to cool.

Grid-to-cathode short

This condition results in a picture that is excessively bright. Retrace lines will show while the brightness control will seem not to be functioning. To test for a short between the cathode and control grid, allow the picture tube to operate for at least 10 minutes. Turn the set off and then make an ohmmeter check between cathode and control grid pins. This test must be done quickly before the cathode has had a chance to cool.

Removing internal shorts

If the previous tests show a short between any elements try to clear the short. It is often caused by a bit of material that has become lodged between tube elements. To remove the short, use a $1\ \mu\text{f}$ capacitor rated at 600 working volts dc. Connect one side of the capacitor to the chassis. If the short is between heater and cathode, connect either pin of the picture tube (Fig. 713) to the chassis. Solder a wire to the other side of the $1\ \mu\text{f}$ capacitor. Touch the other end of the wire to the boosted B-plus in the receiver (receiver turned on). This will charge the capacitor. Turn the

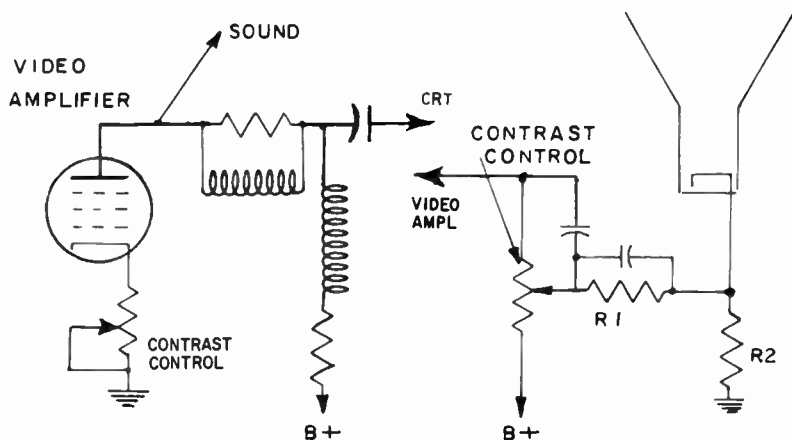

Fig. 714. Although the contrast control is usually found in the cathode circuit of the video amplifier, it has also been used in the CRT input electrode.

set off. Remove the wire from the boosted B-plus point and touch it to the cathode pin of the picture tube. The capacitor will discharge through the material in the tube that is causing the short. Repeat as often as required.

The same technique can be used to remove an internal short between cathode and control grid (Fig. 713).

Contrast-control troubles

Most receivers have the contrast control in the cathode circuit of the video amplifier tube although in a few sets the contrast control is in the plate circuit. However, the contrast control can be located in the cathode circuit of the picture tube. In such cases, the contrast control is part of the load circuit of the video amplifier, and the amount of signal fed into the cathode of the

picture tube depends on the setting of the control. The contrast control and the other components in the circuit can be checked with an ohmmeter.

Note the location of the contrast control shown in Fig. 714 and the effect it can have on receiver symptoms. A defective contrast control in the cathode circuit of the video amplifier can cause loss of picture and sound or weak picture and sound (when the sound takeoff is from the plate circuit of the video amplifier). When the contrast control is placed after the sound takeoff, contrast-control troubles affect only the picture. Once again, intelligent symptom analysis depends upon an examination of the schematic.

Dirty picture tube

The face of the picture tube tends to collect dust and dirt. When the dust layer is uniform, it sometimes has an appearance similar to that produced by a weak, washed-out picture. Make sure that the receiver line cord is disconnected and that the high-voltage filter capacitor (either the tube itself acting as a capacitor or a regular high-voltage filter) is completely discharged. Use moderately warm water. Do not use a soap, household cleanser, abrasive or any substance that could scratch the glass. Use a soft cloth to wipe the face of the tube.

Examine the protective mask or glass in front of the picture tube. Clean, using the same technique as that employed to clean the face of the picture tube. Never use any chemical cleanser on plastic masks. Usually any cleaner used on fine china or glassware is suitable.

Reactivating cathode

If brightness is poor and raster and picture appear dim, it is possible to squeeze some extra life out of the picture tube. This can be done conveniently with a picture-tube brightener. An alternative is to operate the heater with a slightly higher voltage for a short period of time and then to let the heater "cook" for a while. To reactivate a picture-tube cathode, apply the usual 6.3 volts ac for at least 10 minutes so that the heater has a chance to get hot. Now increase this voltage to about 10 volts for 1 minute, then decrease the filament voltage to 7.5 volts for about 2 hours. Never apply a higher than normal heater voltage (10 volts or more) to a cold heater.

The reactivating voltages can be acquired in a number of ways. Connect the picture-tube heater pins to a tube tester and then

apply the necessary heater voltage by rotating the heater voltage-selector switch on the tube tester. Or, use a filament transformer with the primary connected to a variable auto transformer. When using this method, put an ac voltmeter across the secondary to measure the voltage being fed to the picture-tube heater. Some hobby shops sell toy-train transformers having variable outputs

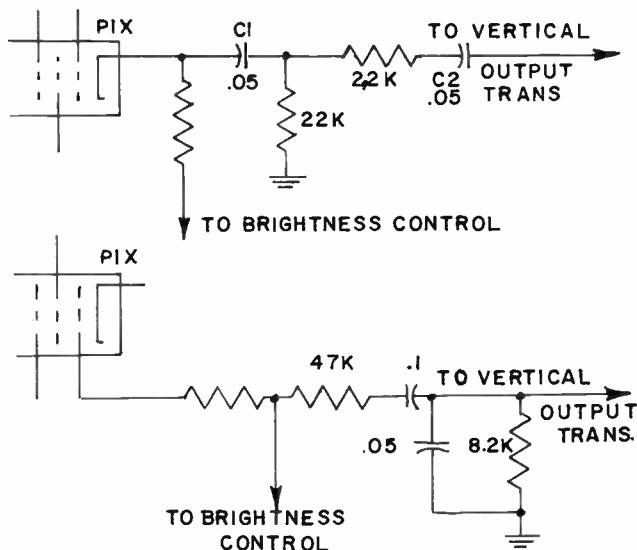

Fig. 715. Retrace blanking circuits can be coupled into the cathode or the grid of the CRT.

ranging from 5 to 10 volts. These can also be used, provided the voltage is monitored with an ac voltmeter.

Vertical retrace blanking

Sets which incorporate a vertical retrace blanking circuit (Fig. 715) should not show vertical retrace lines at the usual brightness-control setting. The presence of retrace lines often indicates an open in the coupling capacitors (C1 and C2) between the vertical output transformer and the cathode or control grid (whichever is the signal electrode) of the picture tube.

Trouble in the retrace blanking network can cause retrace lines to appear bunched together on the screen, looking like a white band. The presence of retrace lines may also be due to an improperly positioned ion trap magnet or to a gassy picture tube.

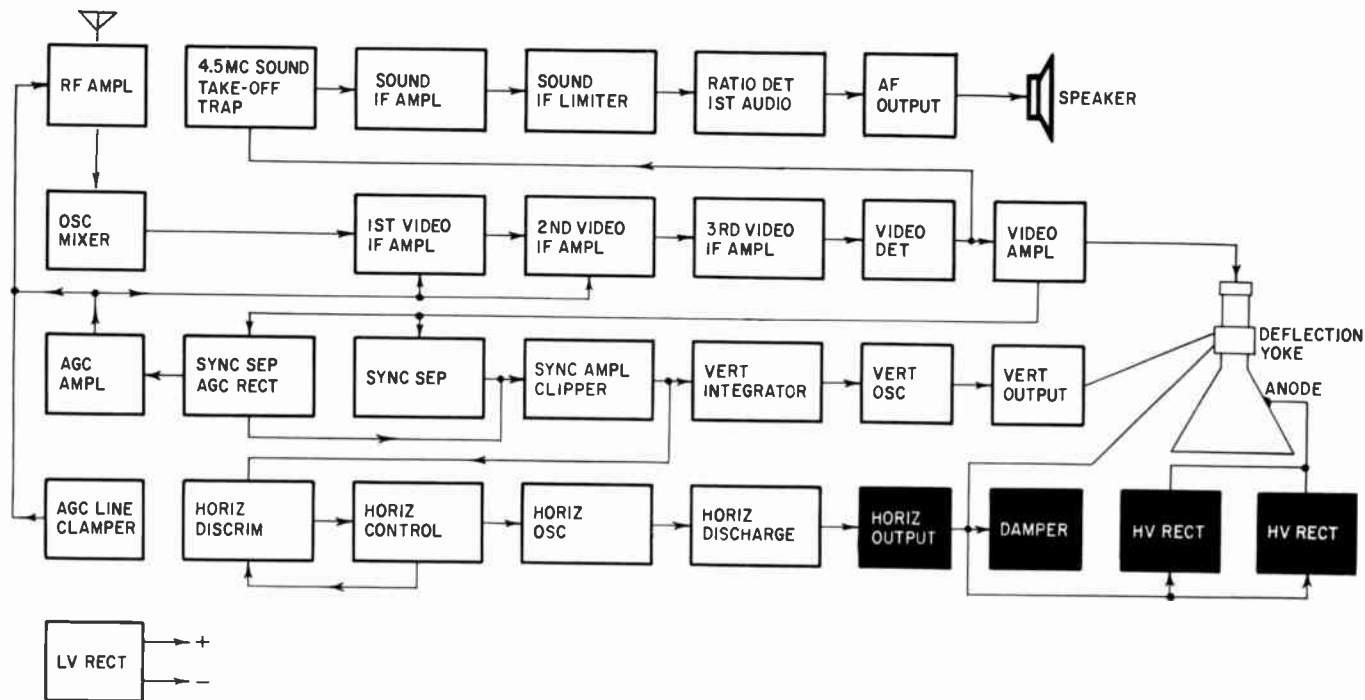

Fig. 801. A number of stages are involved in the production of high voltage.



high-voltage troubles | chapter 8

VOLTAGES present in a television set are often used in a manner that is sometimes confusing but perfectly logical when explained. The positive voltage at one end of a resistor used to develop cathode bias can also be used as a delay voltage on an age tube. A noise voltage is amplified, inverted in phase and then is fed back into the circuit from which it started so that, in effect, it cancels itself. Similarly, the circuits that do the horizontal scanning give us high voltage in addition to scanning action and, as a consequence, these two actions are related to each other in servicing.

The block diagram of the complete television receiver shown in Fig. 801 indicates the relationship of the high-voltage supply to the rest of the receiver. The part of the receiver to be studied now is blocked in black. In Fig. 802 is a block diagram of the high-voltage section showing the circuits that can be involved in high-voltage troubles. Although we show the afc in this diagram, a drift in oscillator frequency will not mean loss of high voltage. For this reason, horizontal afc and horizontal oscillator troubles are covered in the next chapter.

Sources of high-voltage trouble

Loss of high voltage (or insufficient high voltage) can be due to troubles in the horizontal oscillator, horizontal output, damper and high-voltage rectifier circuits. Since loss of high voltage (or

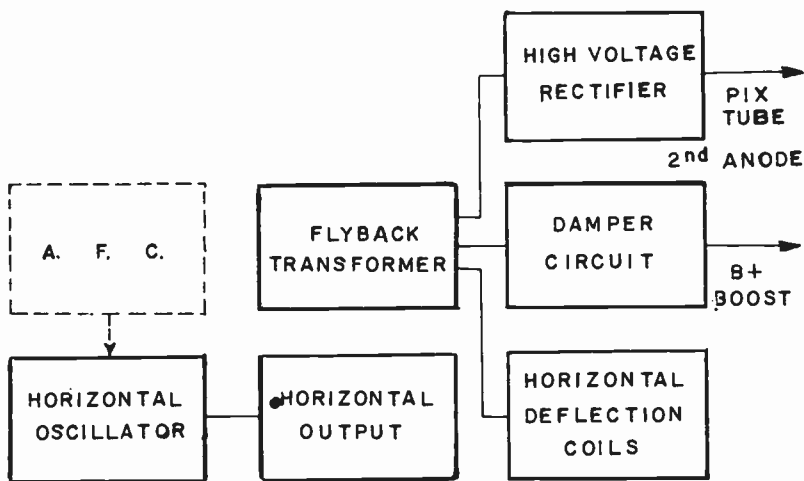

Fig. 802. Block diagram of the stages which can be a source of high-voltage troubles. Although the afc is part of the horizontal oscillator, it usually does not interfere with the generation of high voltage.

insufficient high voltage) causes a condition (no raster) that is also produced by other troubles, it is important at the outset to determine whether the blank screen is actually due to the absence of high voltage. For example, an improperly positioned ion-trap magnet can cause complete disappearance of the raster, but it would not be a good servicing technique to try to adjust the magnet at once. First, determine if high voltage is available or missing. If high voltage is present at the second anode of the picture tube, then this eliminates the sweep section (horizontal oscillator, horizontal output, etc.) as the source of the trouble. The various causes of a blank screen have already been discussed in earlier chapters.

Horizontal output troubles

A common cause of high-voltage failure is a defective horizontal output tube. (see Fig. 803)

Repeated horizontal-output tube failure (requiring frequent replacement of the tube) may be due to operating conditions or components and not to defective tubes.

Picture hook

A heater-cathode short in the horizontal output tube can cause a slight amount of picture hook. An open B-plus capacitor can also cause this trouble.

Horizontal drive

In some receivers the horizontal drive is a small trimmer, as shown in Fig. 803, or a variable pot but in some receivers there is no provision for varying horizontal drive. The purpose of the horizontal drive control is to adjust the amount of signal voltage fed to the control grid of the horizontal output tube. Excessive drive (too much signal output) means excessive pulse currents

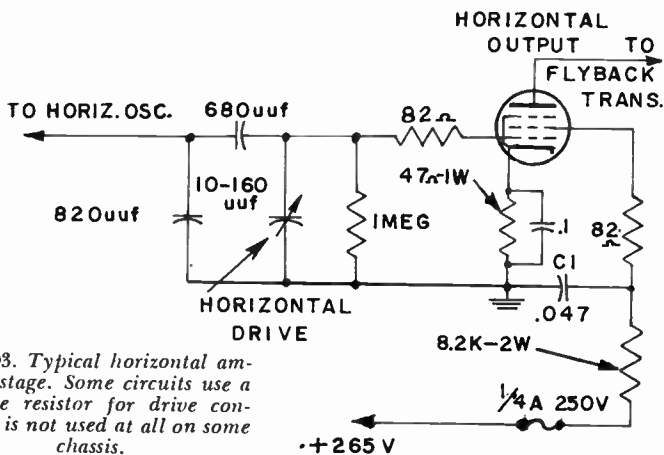

Fig. 803. Typical horizontal amplifier stage. Some circuits use a variable resistor for drive control. It is not used at all on some chassis.

through the tube. The result is poor horizontal linearity, picture stretch (on left side of the screen). Overdrive can also result in a picture that seems squeezed in at the center. There may also be one or more white vertical lines on the screen (overdrive lines).

If the drive control is set so that insufficient excitation (signal voltage) is fed into the control grid of the horizontal output tube, high voltage will be decreased. Since the reduction of drive reduces the grid-leak bias of the tube, the flow of direct current through the tube will be increased. The picture width varies with the amount of drive.

To adjust the horizontal drive, rotate the control until drive lines and nonlinearity occur, then back off the control until the drive lines disappear or the picture becomes linear.

Cathode bias of horizontal output tube

Some horizontal output tubes obtain part of their bias voltage from a cathode resistor (usually 100 ohms or less) connected between the cathode of the tube and chassis. The resistor is not always bypassed by a capacitor. A typical value for this capacitor is 0.1 μ f.

The cathode resistor is generally rated at 2 watts. Never replace this resistor with one having a lower wattage rating (a unit with a higher wattage rating can be substituted). If the resistor gets excessively hot (look for swelling, splitting, smoking), then too much current is flowing through it. Probable cause is under-drive or a gassy horizontal output tube.

Bias for the horizontal output tube may be supplied by the driving signal (from the horizontal oscillator) and by a cathode resistor. A typical value of dc bias between the control grid and cathode of the tube is 35 volts (that is, the control grid is negative 35 volts with respect to the cathode). If the tube has no cathode resistor, the 35 volts of bias is all grid-leak bias and is supplied by the drive signal. If the tube also uses a cathode resistor, cathode bias is approximately 13 volts and grid-leak bias approximately 22 volts.

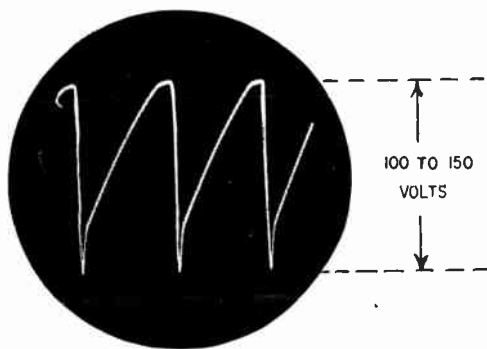

Fig. 804. A 15,750-cycle waveform as seen at the grid of the horizontal amplifier with a scope sweep of 5,250 cycles.

Bias voltages are dc and should be measured with a vtvm. If the horizontal output tube has no cathode resistor, bias can be measured between control grid and ground. If a cathode resistor is part of the circuit, then bias is measured between control grid and cathode.

Significance of bias checks

A bias test of the horizontal output tube supplies useful information. If the horizontal output tube uses a cathode resistor, measure the voltage drop across it. Connect the plus lead of the meter to the cathode and the negative lead to the chassis. If the bias voltage is normal (compare it with that shown on the manufacturer's schematic), then the horizontal output tube, horizontal oscillator and discharge circuits are working. To verify, measure the voltage between the control grid and cathode. Set the vtvm

to read about 50 volts dc, full scale. The control grid has a negative voltage.

In the absence of drive (or insufficient drive), the voltage across the cathode resistor will be above normal. The cathode resistor may be excessively hot and it is possible for it to burn out.

To check the drive voltage, measure the bias voltage across the grid-return resistor of the horizontal output tube (between control grid and chassis). Zero bias voltage indicates lack of drive and that the trouble (no high voltage or insufficient high voltage) exists prior to the horizontal output tube. If the bias is incorrect, adjust the drive control. Also measure the resistor or resistors in the grid circuit of the horizontal output tube.

Oscilloscope check

Connect the vertical input of the scope between the control

Fig. 805. Normal sweep waveform at the plate of the horizontal output tube, seen with the aid of a 100-to-1 capacitive-divider probe. Diagonal line is scope retrace. Peaks are about 6 kv. high.

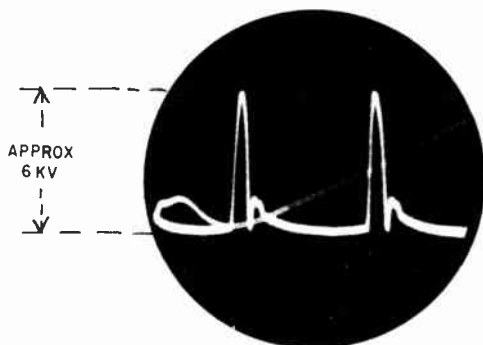

grid of the horizontal tube and ground. Adjust the coarse and fine vernier controls on the scope until you see one or two input signal waveforms on the screen. The waveform will resemble a sawtooth. The peak-to-peak value will vary from one receiver to the next, but will generally be between 100 and 150 volts. (The scope must be calibrated to read this value of peak-to-peak voltage.) The manufacturer's service notes or schematic will indicate the amount of voltage to be expected at this point. If the waveform does not appear, then the trouble is in some circuit preceding the horizontal output tube. A typical waveform at the control grid of the horizontal amplifier tube (as seen on the screen of an oscilloscope) is shown in Fig. 804. A straight line trace is an indication of lack of drive. Either the horizontal oscillator is not working or there is an open coupling capacitor connected to the control grid of the horizontal amplifier tube.

Caution: When making voltage checks with the vtvm or scope on the horizontal output tube, keep the test leads away from the plate cap of the tube. Pulses of 6 kilovolts, peak-to-peak (Fig. 805) are here with 500 to 600 volts dc.

Horizontal output-tube screen circuit

The voltage on the screen is about 135 to 150 volts dc. In some receivers a ¼ amp (250-ma) slow-blow fuse is in the B-plus line going to the screen (and plate of the damper). An open fuse means loss of high voltage. The fuse can open for a number of reasons. C1 (in Fig. 803) can be leaky or shorted. The horizontal output tube can be passing too much current (soft or gassy tube, or improper drive-control adjustment). A heater-to-cathode short in the damper can blow the fuse. Sometimes the fuse will blow if it is replaced by one having a lower current rating. (Do not use

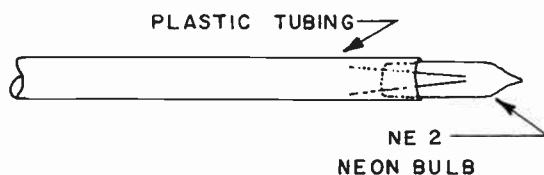

Fig. 806. Neon lamp in plastic holder needs no electrical connection to indicate the presence of horizontal pulses in the output circuit.

a fuse having a higher current rating than the one specified by the manufacturer of the receiver.) Check the bias voltage of the horizontal output tube (between control grid and cathode). If it is lower than normal, excessive current will flow through the tube, blowing the fuse. If bias is normal, then trouble is probably in the damper.

If there is no high voltage and the fuse checks OK, measure the voltage on the screen of the horizontal output tube. If there is no voltage at the screen, turn the receiver off and check all resistors in the screen circuit. These usually have a rating of 1 to 4 watts. Test for resistance and examine physically for tell-tale signs of overheating. Do not replace these resistors with units having a lower wattage rating (resistors of a higher wattage can be substituted).

Note: Not all screen circuits in all television receivers are alike. Some receivers have a horizontal size control as part of the screen circuit. Some sets have a screen bypass connected directly at the screen pin while others have a small resistor (about 100 ohms) connected to it. (Fuse trouble in the damper circuit is described later.)

Checking at plate of horizontal output tube

So far we have concerned ourselves with the cathode, control grid and screen grid of the horizontal output tube. The plate cap of the tube is a good point at which to make checks because it is generally readily accessible.

Manufacturers' schematics usually do not list the voltages on the plate of the horizontal output tube. The dc voltage is between 400 and 500, and the ac pulse voltage in the order of 6 kilovolts. Do not attempt to make direct voltage measurements at the plate of the horizontal output tube. Some technicians arc the plate of the horizontal output tube to judge, from the size of the arc, whether the tube is working properly. A better technique is to bring a small neon lamp (NE-2) close to the plate cap

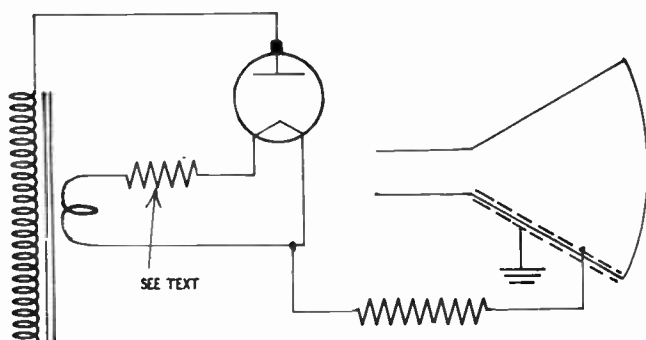

Fig. 807. High-voltage rectifier circuits use various values of series-filament resistance.

and observe whether the bulb lights. As a safety precaution, mount the bulb in the end of a piece of plastic tubing (Fig. 806). No wired connections or ground leads are required.

Using an arc test or a neon-light indicator is satisfactory except that these devices do not tell you how well the tube is working. You can check the pulse voltage at the plate with a 100-to-1 capacitance divider probe and a scope. The scope must be calibrated in terms of peak-to-peak voltage. The advantage of this method is that it enables you to see the waveform and also to measure its actual amplitude.

High-voltage rectifier tube

In all circuits, the top end of the flyback transformer connects to the plate of the high-voltage rectifier tube. Typical high-voltage rectifier circuits are shown in Fig. 807 and Fig. 808.

Most modern receivers use the picture tube as a high-voltage filter capacitor. The glass of the tube is the dielectric while the inner and outer Aquadag coatings form the plates of the capacitor. Because this capacitor can hold its charge for some time, it is always wise, when it is necessary to remove the picture tube, to discharge it. To discharge the picture tube, remove the high-voltage connector from the second-anode terminal. Insert the end of a piece of wire (hold it by the insulation) at the second anode and touch the other end to the chassis. Repeat this several times until you are sure the picture tube is discharged. Some receivers use an additional 500- μf capacitor for high-voltage filtering.

The filament of the high-voltage rectifier is connected to a one- or two-turn coil on the flyback transformer. Sometimes the fila-

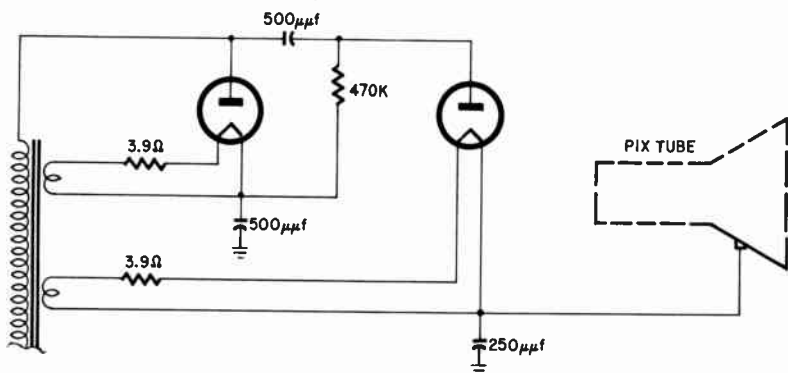

Fig. 808. Voltage-doubler high-voltage rectifier is familiar in many ways.

ment is connected directly to the filament winding, but in many cases you will see a resistor in series with one of the filament leads. Some typical values of resistance you will find are:

0.68 ohm	1.0 ohm	1.8 ohms
3.3 ohms	3.9 ohms	4.7 ohms

In some receivers the connecting lead is a piece of resistance wire.

If the filament resistor opens, there will be a complete loss of high voltage. If it shorts, the rectifier tube will operate but its life will be lessened. If it is necessary to replace a filament resistor, be sure to use the exact value specified in the manufacturer's schematic.

The filament of the high-voltage rectifier consumes very little

power. It is difficult to see if the filament is lit. A dental mirror, with an insulated handle is helpful in this respect.

WARNING: Do not try to measure the voltage across the filament. Although the filament voltage of the rectifier tube is only about 1 volt, the voltage from filament to chassis is measured in many kilovolts.

The picture tube will not light

- (a) if there is no beam current through the picture tube or
- (b) if there is no high voltage.

Disconnect the high-voltage connector but hold it near the second-anode terminal of the picture tube. If it arcs across the small gap, the high voltage is working. Should there be no arc across the gap, bring the high-voltage lead near the chassis. If this produces an arc, then the trouble is in the picture tube (or picture-tube circuit).

If, however, you get no arc when bringing the high-voltage lead near the chassis, the trouble is in the high-voltage supply. Use the neon tester. Try substituting a new high-voltage rectifier tube. Turn the receiver off and disconnect the high-voltage lead. Resistance-check the high-voltage connector going back to the filament pin. Connect one ohmmeter lead to a filament pin (insert the test prod in the tube socket) and the other ohmmeter lead at the opposite end of the high-voltage lead. Flex the lead while observing the ohmmeter. The ohmmeter should read practically zero resistance. If the lead checks OK, insert the ohmmeter leads into the filament pins. You should read the value of the series resistor connected between the flyback and the filament tube socket.

High-voltage filter

A filter resistor (Fig. 808) may be inserted between the filament of the high-voltage rectifier and the second anode of the picture tube. This resistor can have a value from 100K ohms to as high as 1 megohm (or more). There will be no high voltage if the resistor is open. You will get high voltage if the resistor is shorted, but it may be intermittent. (Many television sets omit this resistor.)

If the resistance checks do not reveal the source of the trouble, examine the high-voltage rectifier socket. Sometimes the pins spread, making poor contact between the filament pins of the tube and the socket.

Lift the plate cap off the high-voltage rectifier. Turn the receiver on and bring a neon bulb close to the loose wire. If the bulb does not light, check the horizontal amplifier plate. Make checks at the control grid, cathode and screen grid of the horizontal output tube as outlined earlier. If, however, the neon bulb does light at the plate cap of the high-voltage rectifier (when lifted off the tube), you have an indication of a short in the rectifier circuit. This short can be due to a defective rectifier tube, a gassy picture tube, a shorted high-voltage filter capacitor (when one is used). Disconnect the high-voltage lead from the second anode of the picture tube. If the neon bulb at the plate of the high-voltage rectifier tube (cap connected to the tube) produces a glow, then the trouble lies in the picture tube. Excessive current through the picture tube is overloading the high-voltage circuit. If the neon bulb does not light when this test is made, disconnect the high-voltage filter capacitor (if the set has one) and repeat the test. If this is no help, examine the rectifier socket and any other components (resistors) connected to the filament of the high-voltage rectifier. You may not find a direct short to ground. It doesn't take much of a resistive leak to overload the high-voltage system.

Insufficient high voltage

Arcing tests and neon-bulb tests indicate the presence or absence of voltage but do not reveal the amount of voltage present. For a dc voltage, check anywhere between the filament of the high-voltage rectifier and the second anode of the picture tube. Use a high-voltage probe and vtvm.

Start at the filament (either pin) of the high-voltage rectifier. If the voltage reading as obtained with a high-voltage probe and vtvm is low, replace the rectifier tube and take another measurement. Insufficient emission of a low-voltage rectifier can be a reason.

If rectifier-tube substitution and resistance checks and physical examination reveal nothing wrong in the high-voltage rectifier circuit, check the horizontal sweep circuit as described earlier. With the high-voltage probe connected to the filament of the rectifier tube, adjust the horizontal drive control (if the receiver has one). If varying the setting of the drive control has no effect on the high voltage, then the trouble lies in the horizontal output tube circuit (or it may be caused by a defective horizontal output tube).

Insufficient high voltage can also be due to defects in the damper tube (or circuit), the horizontal output transformer, the horizontal deflection coils or the width control.

A number of symptoms are indicative of insufficient high voltage. Turn the channel selector to an off-channel position and advance the brightness control. If, with the brightness control fully advanced, it is not possible to obtain brilliant lines, there may be insufficient high voltage. Generally, accompanying symptoms will be blooming and a darker picture. Both vertical and horizontal deflection increase as voltage goes down, so you may have trouble maintaining the proper picture size and ratio.

Intermittent flashes in picture

When the Aquadag coating is used as a capacitor (and this technique is widely used), the grounding clip on the outside coating must make good contact with the coating. If the contact is opened, there may be a small reduction in high voltage. If the contact against the coating isn't a good one, there may be intermittent flashing in the picture. Adjust the spring contact so it is firm against the picture tube coating.

Blooming

Blooming is a condition in which the picture expands and goes off the screen when the brightness control is advanced. The picture will go out of focus and may disappear completely. The sound remains normal.

The most usual cause of blooming is weak tubes. Substitute new horizontal output, high-voltage rectifier and damper tubes. Sometimes, a weak low-rectifier tube will produce this trouble. As a quick check remove the audio output tube from its socket (this tube is a fairly heavy load on the low-voltage rectifier). If the amount of blooming decreases, substitute a new low-voltage rectifier tube.

If substitution of the low-voltage rectifier tube does not help, measure the voltage across either filter capacitor of the low-voltage rectifier circuit with a meter set to read dc volts. If this voltage is below normal, check the ac line-voltage input to the receiver. A lower than normal (117 volts rms) line voltage can produce blooming.

A high-resistance leakage to ground in the high-voltage rectifier circuit can cause blooming. If the receiver uses a separate high-voltage filter capacitor, make sure it isn't coated with dust.

If the receiver uses a resistor in the high-voltage rectifier circuit (either a resistor for dropping filament voltage or a high-voltage filter resistor), check these for increased values of resistance.

Faulty lead dress (after servicing) can cause blooming. Move any connecting wires away from the tubes that produce high voltage. Be particularly careful of any wires carrying high voltage (leads to the filament of the high-voltage rectifier or wire going to the second anode of the picture tube). If these wires are too close to ground (chassis), you may get enough leakage right through the insulation to chassis to overload the high-voltage

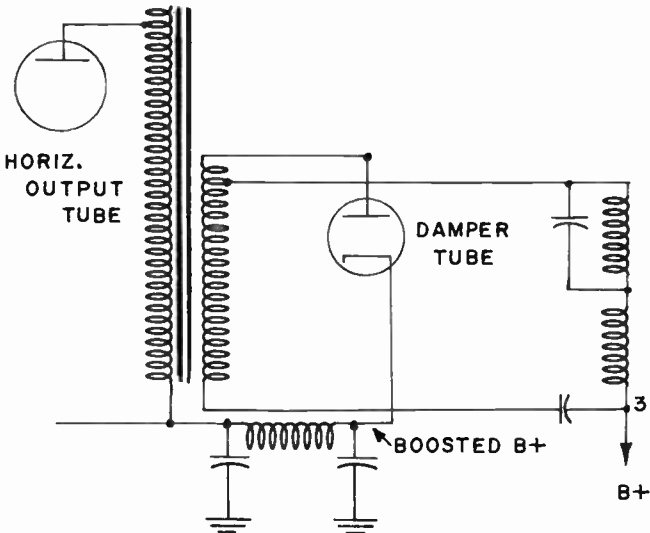

Fig. 809. Basic horizontal output circuit using a transformer with an isolated secondary winding.

system. This leakage may not be visible in the form of corona or arcing.

To determine if a gassy picture tube is the trouble, remove the lead to the second anode of the picture tube and measure the high voltage (with a high-voltage probe and a vtvm). Now connect the high-voltage lead to the picture tube and take a measurement once again with the high-voltage probe. If the high voltage takes a sharp drop, the picture tube may be gassy. With the probe still connected, vary the brightness control. With a very wide variation in high voltage, go from one extreme setting of the control to the other, and if the high voltage seems to be erratic, you have another indication of gas in the picture tube. An internal short

in the picture tube can also produce blooming. To test for and to remove this condition, refer to the chapter on picture tubes.

Damping

If you inserted a resistor in series with one side of the horizontal deflection coils and placed a scope across it, the waveform



Fig. 810. Vertical bars on the raster are due to a defective decoupling network fed by the B-plus boost circuit.

you would see would be a sawtooth. The current flowing through the horizontal deflection coils drops rapidly during retrace time, hence it is possible for a condition of oscillation to be set up. (The inductance of the windings and the capacitance between turns form a resonant circuit.) The purpose of the damper tube is to suppress most of this oscillation or ringing. The horizontal deflection-coil pulse voltage is also rectified by the damper tube. This rectified voltage is filtered and is added to the regular B-plus of the receiver, forming what is known as boosted B-plus.

Fig. 809 is the circuit of a damper using a flyback unit found in older sets. The amount of B-plus boost will vary in different receivers. In some sets (particularly older types) it adds as little as 60 volts to the existing low-voltage B-plus. In more modern sets it may be as high as 300 volts additional. The boosted B-plus is always used to supply plate voltage for the horizontal output tube. However, it is also used in receivers wherever higher B-plus is required. Thus, it may be used to supply the B-plus focus voltage for electrostatically deflected tubes. It may be used on the plate of the horizontal oscillator; as voltage for the agc keyer tube; as plate voltage for the vertical oscillator or amplifier tubes or to a pin of the picture tube (through the brightness control). Thus, defects in the damper tube or its associated components can affect these other circuits, in addition to the high voltage.

Light and dark vertical bars

If the B-plus boost is connected to the vertical output tube, a

defect in the vertical output tube or components connected to it can cause a reduction in the amount of boost voltage available. In Fig. 810 we have a succession of light and dark vertical bars caused by a defective capacitor in the vertical output circuit. The result is a drop in boost voltage, a condition that could cause a

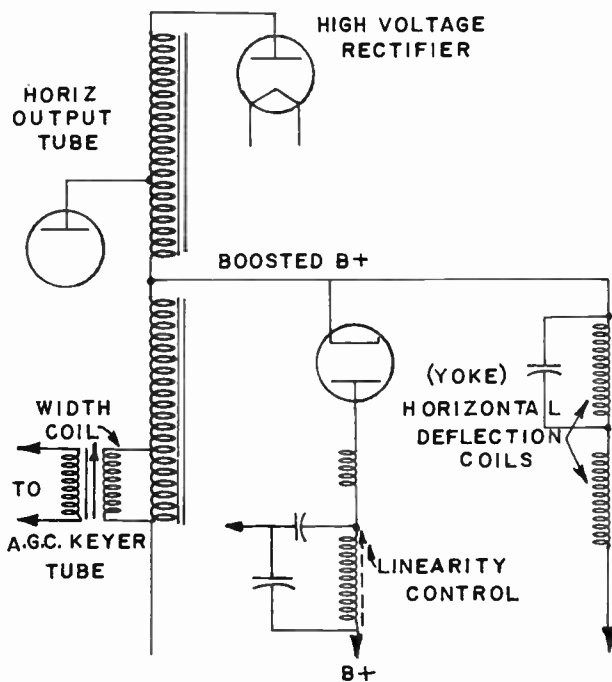

Fig. 811. Basic circuit of autotransformer in horizontal output.

considerable loss of time in hunting through the horizontal amplifier, output and damper tube circuits for the trouble.

Resistance check of damper

With the receiver turned off, make a resistance check (using a vtm) between the plate and the cathode of the damper. If the set is an older type, make sure there is no resistor connected between plate and cathode. If there is, disconnect one side of it. The resistance, as measured between plate and cathode, should be more than 30,000 ohms. Do not perform this test immediately after turning off the receiver. Wait a few minutes and then connect a grounding clip from the plate of the damper to the chassis

and repeat by connecting the grounding clip from cathode of the damper to the chassis. Small voltage charges remain in the damper circuit for some while after the receiver is turned off. These charges, aiding or opposing the ohmmeter battery (depending on how you connect the test leads), will give misleading resistance information.

Boosted dc voltage checks

The boosted B-plus appears at the cathode of the damper and can be measured at this point (Figs. 809, 811, 812). Be sure to

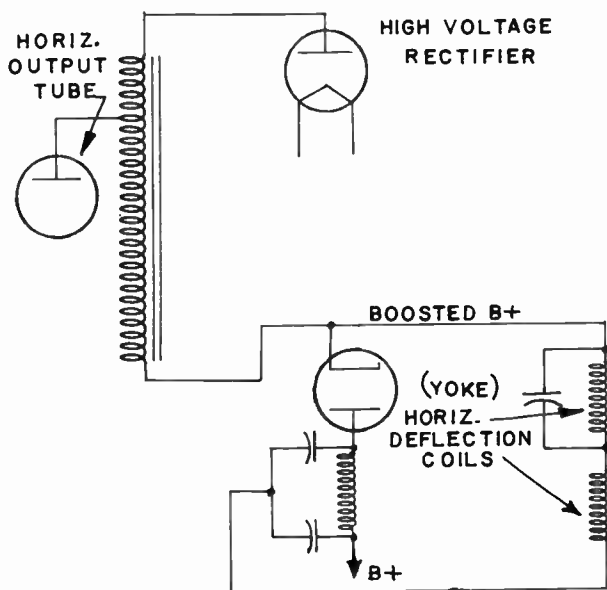

Fig. 812. Basic circuit for direct-drive type of horizontal output components.

select a high enough range. The boosted B-plus should then be compared with the amount of B-plus taken from the cathode of the low-voltage rectifier. If the boost voltage is low, check the horizontal output-tube cathode, control grid and screen grid dc and drive voltages as described earlier.

Symptoms of low boost voltage

The symptoms produced by lowered boost voltage depend on the use to which the boost voltage is put. As indicated earlier, the

boost voltage could be connected to circuits other than the horizontal output tube. Lowered boost can produce insufficient brightness or poor focus. The boost voltage can be lowered, not because of a defect in the boost circuit itself, but because of tubes connected to it. The boost voltage can be reduced by excessive loading (just as any low-voltage supply). For example, if tubes working from boosted B-plus are gassy (thereby drawing more current) or if they are working with reduced bias, the extra load on the boosted B-plus may reduce it. Either substitute new tubes or disconnect the boosted B-plus lead to those tubes while monitoring the voltage. Connect a meter to the boosted B-plus line and note if there is a marked increase in voltage when the lead to a particular tube is removed. If there is, then either the tube is defective or some imperfect component in that tube's circuit is forcing it to draw more current. Insufficient boost voltage can also be caused by a defective horizontal linearity coil or the capacitors connected to it, a defective yoke or flyback transformer.

Warning: Do not remove the voltage to the plate of the horizontal oscillator tube. An inoperative horizontal oscillator means no drive voltage on the horizontal output tube. The rise in current through the horizontal output tube may cause its plate to glow red, possibly damaging the tube and the flyback transformer.

Yoke trouble

A defect in the horizontal deflection windings (shorted turn, open turn) can produce a condition of no high voltage or lowered B-plus boost. If the flyback is the older type as shown in Fig. 809, disconnect the leads going to the yoke. Connect the leads to the horizontal windings of a substitute yoke. The substitute does not have to be mounted on the neck of the picture tube. Now check the boosted B-plus once again. If the boost voltage has increased to normal or shows a substantial rise over earlier measurements, the horizontal yoke coils are defective. Before you replace the yoke, however, unsolder one end of the capacitor shunting the high side of the horizontal deflection windings. If this capacitor is leaky or shorted, it can reduce B-plus boost voltage.

If the flyback is an autotransformer type, disconnect one of the leads going to the horizontal deflection coils. (Do not use a substitute yoke winding.) Take a measurement of the boost voltage. If the boost voltage is higher than normal, then the yoke is defective.

In television sets using a direct-drive type of flyback, disconnect the leads going to the horizontal windings and substitute the horizontal windings of a known good yoke. The substitute yoke need not be mounted on the neck of the picture tube. If the boost voltage returns to normal, the yoke is defective.

Fuses

These are sometimes placed in series with the damper tube and are usually of the slow-blow type. Since the damper tube carries the full plate and screen currents of the horizontal output tube, a fuse in this position will protect the damper tube, the horizontal output tube and the flyback winding. (Not all receivers are protected with fuses.)

An open fuse will mean loss of high voltage, and is due to any condition which could cause a heavier than normal current to flow through the damper or the horizontal output tube. Insufficient bias on the horizontal output tube, loss of drive or a gassy horizontal output tube could cause this trouble.

An open fuse does not always indicate trouble. Sometimes the fuse may open because of a momentary current surge.

There are several ways to determine the reasons for fuse trouble. Measure the flow of direct current by inserting a milliammeter in place of the fuse. The meter should not read much more than 100 ma. Substitute a new horizontal output tube and note its effect on the current reading. If the amount of current is the same, adjust the horizontal linearity control for minimum reading of the meter. Make sure that the horizontal output tube has the correct amount of drive (by measuring horizontal output tube bias as indicated earlier). If the drive is correct and if substitution of the horizontal output tube and adjustment of the linearity control are of no help, try a new damper tube. The trouble may be due to a heater-to-cathode short in the damper. The damper tube may check OK in a tube tester, but a short can develop between heater and cathode when the heater gets hot enough.

Sometimes the only trouble is that the fuse has been replaced with one having a lower rating than required. The manufacturer's schematic will usually indicate the correct size to use.

The boosted B-plus in some receivers is high enough to make leakage a problem. Wires carrying boosted B-plus should not be placed against the metal chassis or any metal components. Enough leakage (not visible or readily detected) can take place to blow the

fuse, yet all components will look satisfactory and check as being good. Finding this sort of leakage can be a very time-consuming job in servicing a TV receiver.

Vertical nonlinearity

If the picture seems compressed at the top, after readjusting height, linearity and centering, the trouble may be due to insufficient boost. If the boost voltage elsewhere checks good, trace the bus from the boost circuit to the vertical oscillator or amplifier.

Insufficient width

Insufficient width can result when the horizontal oscillator plate is tied to the B-boost line and there is a defective component between the oscillator plate and the boost circuit.

Arcing

A sharp crackling or hissing sound is an indication of arcing. It may be difficult to see the arcing, caused by breakdown of air or insulation between the chassis and some high-voltage point. Arcing takes place between the chassis and sharp pointed objects connected to high voltage. It can also be due to poor lead dress. Examine the interior of the high-voltage cage (in a dim light) and look for the arc.

Move high-voltage leads away from metal. If this cannot be done, spray the metal area near the high-voltage lead with acrylic resin spray or anti-corona lacquer. Sometimes wrapping a high-voltage lead with additional insulation material, such as high-voltage electrical tape, is helpful. Make sure all soldered joints are smooth and round and that there are no metallic protrusions. Re-solder all suspected joints.

Rubber insulation is sometimes used on high-voltage wires. The insulation may crack or crumble because of age or heat. Examine high-voltage leads carefully and run fingers along such wires. The insulation should be smooth, and not cracked or split at any point. Do not replace small sections of high-voltage wires (the splice will be a good source of arcing trouble). Replace entire lengths of high-voltage wire at a time.

Excessive dust or dirt can cause arcing. If a separate high-voltage filter capacitor is used (in older receivers), wipe it clean with a cloth. If high-voltage wires must pass through rubber grommets, inspect the grommets carefully to see if they have deteriorated. If they have, replace them.

Arcing in a television receiver can cause a number of conditions often attributed to other circuit faults. Arcing loads the high-voltage supply and can reduce the amount of high voltage available for the picture tube. This means a dark picture. In severe cases, the raster may disappear completely.

Radiation caused by arcing can be picked up by the video if and amplifier tubes, amplified and appear on the screen in the form of flashes. In severe cases, parts of the picture can tear out, and vertical sync may become critical.

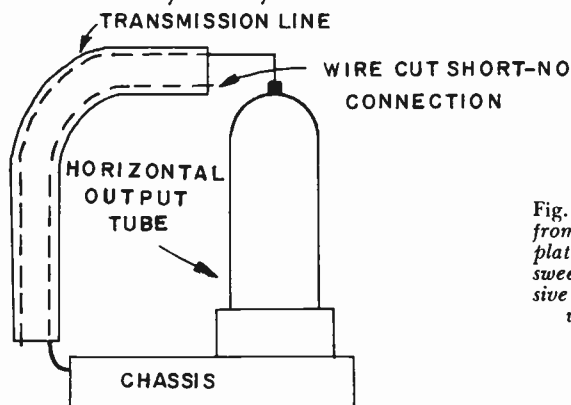

Fig. 813. Adding capacitance from horizontal output tube plate to ground will increase sweep width. For an inexpensive high-voltage capacitor, use 300-ohm twin lead.

Although corona and arcing are somewhat different, they are alike in the symptoms they produce.

The corona ring under the high-voltage socket should be centered under that socket. The socket terminals should be inside the ring, not outside it.

Arcing or corona can occur between terminals of the flyback transformer. This is particularly true in high-humidity areas and in transformers using insulation material having an insufficient high voltage rating. Arcing in a flyback transformer can sometimes be eliminated by spraying anti-corona lacquer on the transformer. When using a spray, do not remove the high-voltage rectifier tube from its socket (or any other tubes) since the spray is an insulating material. Its presence in tube sockets can result in an inoperative receiver or one that works intermittently.

Insufficient width

Insufficient width can be caused by a weak horizontal oscillator, by insufficient drive on the control grid of the horizontal amplifier tube or by excessive high voltage. If the yoke has been replaced make sure that it is as far forward on the picture tube as you can get it. (Do not force the unit since this can cause

mechanical damage.) Try replacing the horizontal amplifier and damper tubes. If the receiver has a width coil, try adjusting it for maximum width. If the agc keyer circuit is not part of the width-coil circuit, disconnect the width coil from the flyback transformer. As a last resort, connect a piece of scrap two-wire line between the plate of the horizontal output tube and the chassis Fig. 813. The two-wire line acts as a capacitor. It reduces the high voltage, permitting greater horizontal deflection. Use as short a piece of transmission line as you can, since the high voltage should be reduced as little as possible.

Excessive brightness on left side of screen

Try replacing the damper tube.

Barkhausen oscillation

These appear as one or more black vertical lines at the left side of the screen. Try adjusting the horizontal drive and horizontal linearity controls to see if the lines can be removed. Make sure that the antenna lead going from the antenna terminal board on the receiver to the front end is dressed away from any high voltage lines. Put a Barkhausen eliminator on the horizontal output tube. (This is a small magnet, similar to an ion trap-magnet). Adjust the magnet until the lines disappear. (Be careful — the plate cap of the horizontal output tube is “hot”).

Poor linearity

Poor linearity can be caused by a defective damper tube. Try adjusting the linearity coil. One or more capacitors may be connected to the linearity coil. Check these for capacitance (in a capacitor checker — also check them for leakage). If you do not have a capacitance and leakage checker, test by substitution.

Snivets

These are black blotches that appear at the right side of screen. They can appear in the raster or in the picture. This is caused by radiation from the high-voltage circuits (more often the horizontal output tube) getting into picture circuits. Try a new horizontal output tube. Sometimes a Barkhausen oscillation eliminator (a small magnet placed over the horizontal output tube) will cure this trouble. Make sure that all high-voltage leads or leads carrying deflection currents are dressed away from video or if amplifier tubes (or picture-tube leads). If the high-voltage supply cage top has been removed, replace it. If the side of the high-voltage cage has been removed, make sure that all self-tapping screws

holding the side are replaced and that they are tight. Improper setting of drive, width and linearity controls can cause this trouble.

Foldover at left side or at right side of picture

Foldover can be caused by practically any defective component in the high-voltage circuit. Try replacing horizontal output and damper tubes. Resistance-check the horizontal deflection windings to see if they correspond to the resistance indicated on the manufacturer's schematic. Check all components connected to the horizontal output tube or to the damper.

Squeal

Sometimes the horizontal output transformer will produce a high-pitched whistle. It has a frequency of 15,750 cycles and is not heard by everyone. It can be very annoying to those whose hearing range extends up into this frequency. It is generally caused by the vibration of some loose part on the flyback transformer. Make sure all parts or screws are tight. Spray the transformer with acrylic resin or anti-corona lacquer. Sometimes a loose lead going to the transformer vibrates.

Horizontal output transformer

Some technicians are rather hasty in replacing the horizontal output transformer when the receiver symptoms indicate a loss of high voltage. Unnecessary replacement of the transformer can be a frustrating and time-consuming experience.

A number of methods have been proposed for checking the horizontal output transformer so that substitution should not be required. Most of these consist of running resonance checks on the transformer — but, unfortunately, these often take as long to do as transformer replacement. Measuring the inductance of the transformer as a check isn't too helpful, nor are resistance tests always satisfactory. A shorted turn, for example, may not be detected by the usual ohmmeter check.

Many technicians arrive at the conclusion that the set has a "defective flyback" through a process of elimination. Consider the flyback as a sort of dividing line or center mark. Preceding the transformer you have the horizontal oscillator and the horizontal output tubes. Following it you have the high-voltage rectifier, the damper and the yoke. To determine the reason for loss of high voltage you can start at the horizontal oscillator and work your way forward to the yoke, or start at the second anode of the picture tube and work your way backward to the horizontal oscillator.

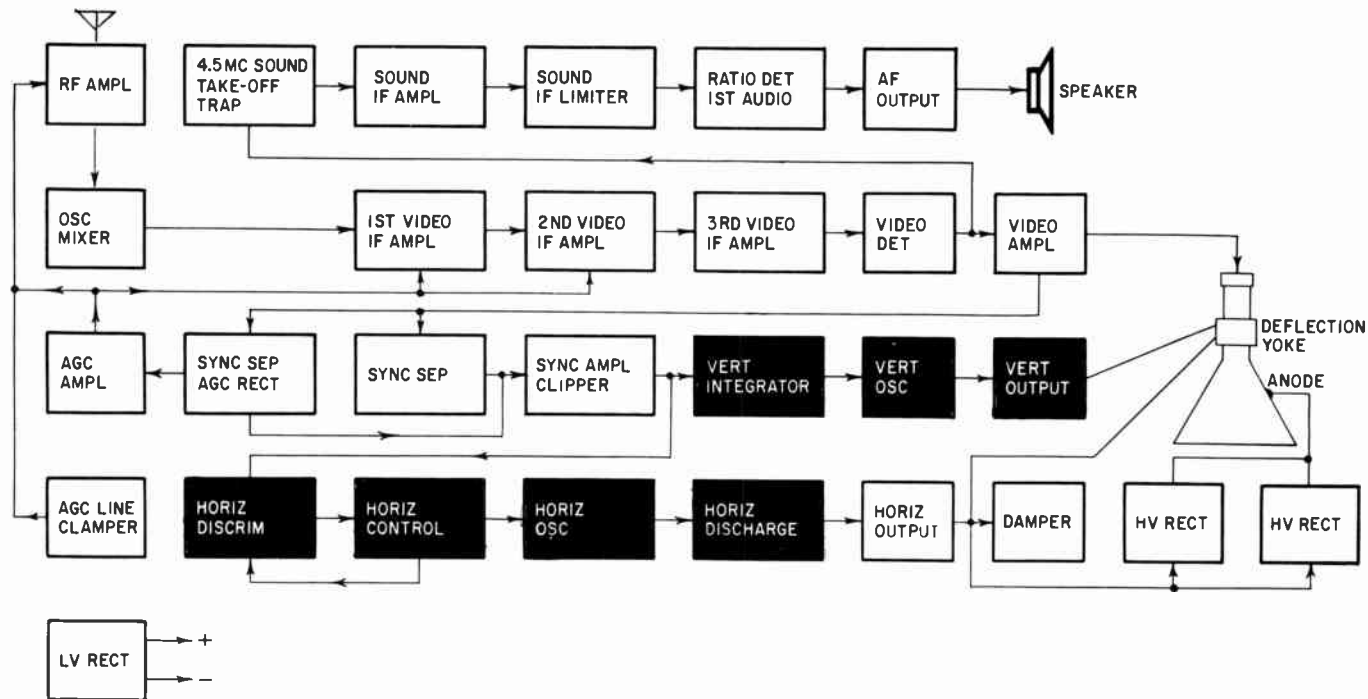

Fig. 901. Many deflection problems are found in the indicated circuits.



deflection troubles

chapter 9

THE scanning beam in the picture tube is deflected both horizontally and vertically. When the circuits function properly, this deflection results in a raster. When the picture-tube scanning beam is modulated — that is, when the intensity of the beam is varied through the injection of a video signal into the cathode or control grid of the picture tube — we have a picture. Deflection in both directions is produced by the yoke around the neck of the picture tube.

The yoke, however, is simply the final component connected to a group of circuits. These are the vertical and horizontal deflection circuits and are marked off in solid areas in the block diagram shown in Fig. 901.

Vertical deflection

At the output of the sync amplifier, you will find two R-C networks. These are filters and are used to separate the low-frequency (60-cycle) pulses and high-frequency (15,750-cycle) pulses. The low-frequency filter, or low-pass filter, is called the integrator. The high-frequency filter, or high-pass filter, is called the differentiator.

Integrator troubles

The integrator, quite often a printed circuit, consists of a group of resistors and capacitors. Two types of integrators are shown in Fig. 902. If the circuit diagram of the receiver shows dash lines around the integrator, this is an indication that the complete unit is a printed circuit.

Troubles in the integrator — changed values of parts, open or shorted resistors or capacitors — can result in poor vertical hold. If a component is open, the picture will roll. An intermittent or changed-value component will cause critical or intermittent vertical hold or poor interlace.

Vertical oscillator

Vertical oscillators used in television receivers are either blocking oscillators or multivibrators. In the blocking oscillator, the

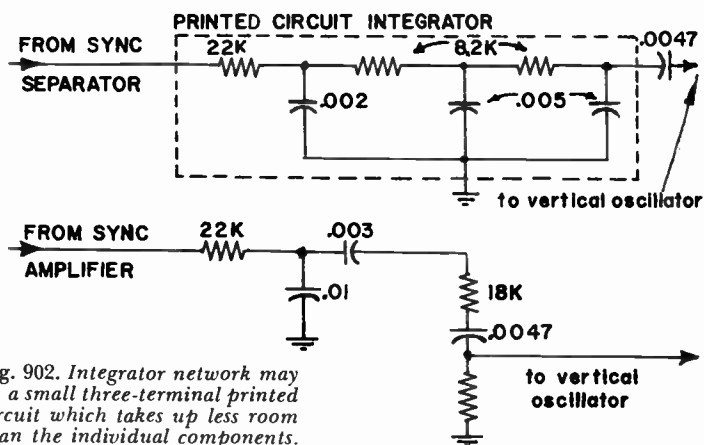

Fig. 902. Integrator network may be a small three-terminal printed circuit which takes up less room than the individual components.

feedback winding can be in the plate circuit or the cathode circuit of the oscillator tube, but in either case the total tube current flows through the feedback winding. Simplified diagrams of these two types are given in Fig. 903.

A multivibrator very closely resembles a resistance-coupled audio amplifier. Feedback can be through a capacitor (from plate to grid) in the plate-coupled multivibrator or through a common cathode resistor (cathode-coupled multivibrator). Fundamental circuits illustrating these two types are shown in Fig. 904.

To see the relationship of the vertical oscillator to the remainder of the vertical sweep circuit, examine the block diagram of Fig. 905.

Vertical oscillator troubles

A large variety of troubles can be caused by defects in the vertical sweep section. These troubles are not confined to the vertical oscillator alone, but may crop up because of tube or component failure or weakness in any one of the sections shown

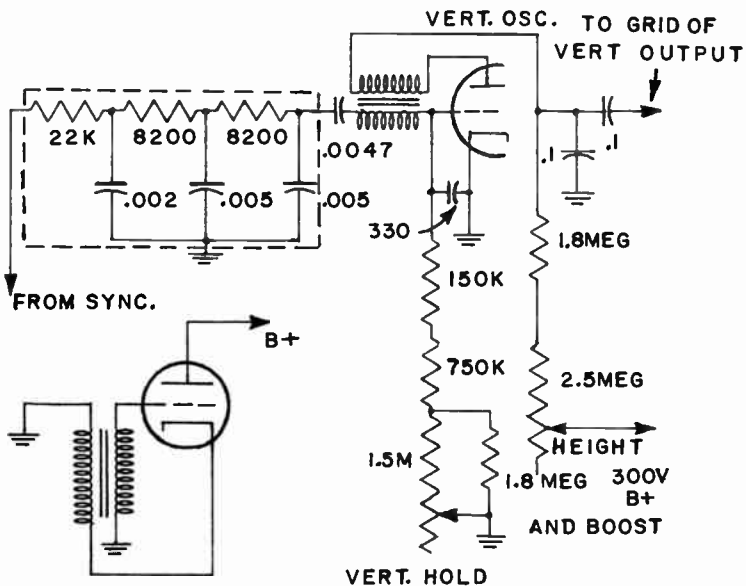

Fig. 903. Blocking-oscillator circuits. Transformer drives grid in both.

in the block diagram of Fig. 905. These can include complete loss of vertical sync (rolling), critical vertical hold, jitter, etc. These troubles will be discussed as we proceed. Remember, however, that symptoms that seem to belong to the vertical sweep circuits are not necessarily caused by troubles in vertical sweep. The vertical sync voltage accompanies the video signal all the way from the antenna input to the vertical sweep section, hence vertical sweep trouble could be caused anywhere along the line from the front end right up to the vertical deflection coils in the yoke.

The first problem then is to divide, mentally, the vertical sweep section from the other circuits passing the vertical pulses. The sync-takeoff point is usually a good center point or dividing line.

To make a start at localizing vertical troubles, rotate the vertical hold control and note its effect on the picture. If the picture can be moved upward and then downward, you have an indication that the vertical oscillator is working normally. If rotation of the vertical hold control can make the pictures move only down or up, but not in both directions, then the fault lies in the vertical oscillator circuit.

After determining that the vertical oscillator is not at fault,

a substantial portion of the television receiver has been eliminated as a possible trouble source. The next step is to learn whether the fault exists somewhere between the sync-takeoff point (usually the video amplifier) and the vertical oscillator. Adjust the vertical hold control so that the horizontal blanking bar appears across the center of the screen. Keep adjusting the vertical hold control to keep the bar centered long enough for observation. Adjust the brightness and contrast controls until the sync and equalizing pulses are visible. If they can be seen, the vertical sync pulses are reaching the picture tube and the trouble exists somewhere between that point and the input to the vertical oscillator.

It is possible, however, to be able to see the sync pulses on the screen and for the trouble to exist prior to the sync takeoff point.

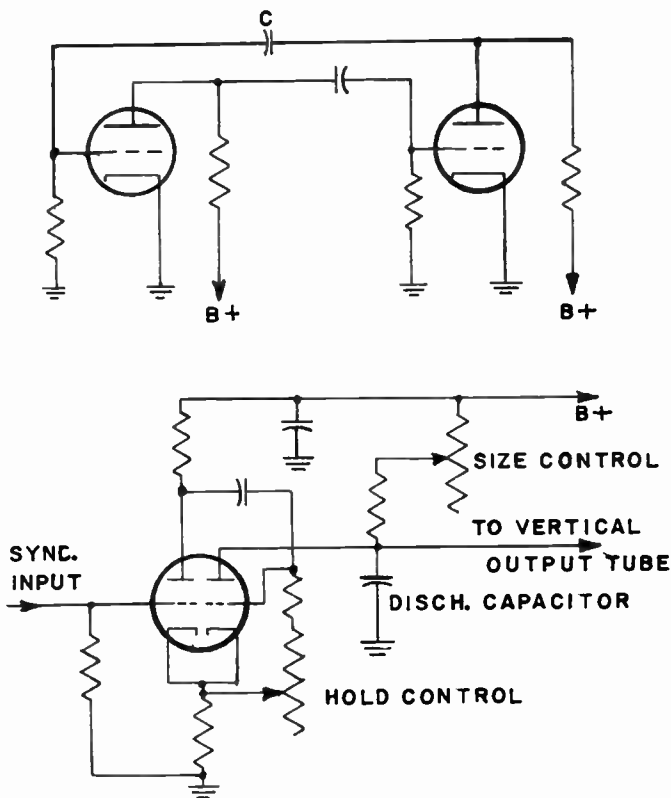

Fig. 904. Plate-coupled and cathode-coupled basic multi-vibrator circuits.

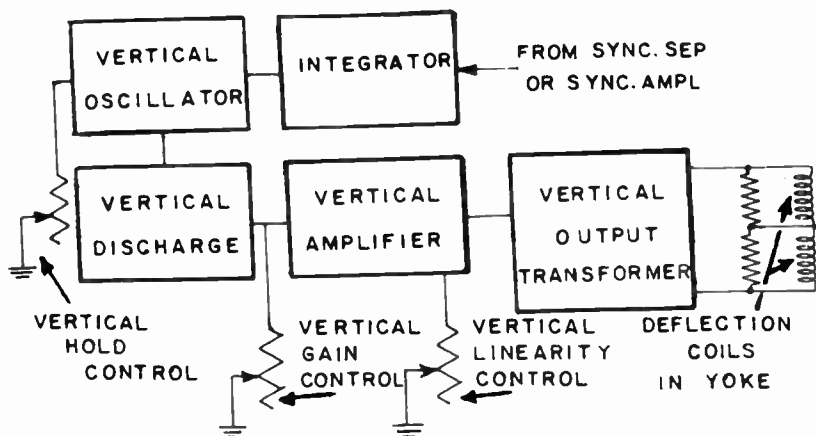

Fig. 905. Vertical sweep block diagram shows locations of controls.

Sync-pulse compression in some earlier stage might result in insufficient amplitude to maintain the vertical oscillator on its frequency. A simple way of checking on this is to turn on a known good receiver, tune to the same channel and observe the blanking bar, comparing it with that shown on the defective receiver.

Perform this check with every receiver you get into the shop, until you become so familiar with the normal appearance of the blanking bar that you will be able to recognize a defective condition immediately.

Remember also that vertical troubles can be due to set design. Not all receivers have the same amount of gain, hence some sets have more margin than others. If the set has amplified the vertical sync pulses sufficiently, the picture will seem to click or snap into place when the vertical hold control is adjusted. You should be able to vary the vertical hold control a small distance on either side of the lock-in point. If the picture does lock in, but only within a very narrow range setting of the vertical hold control, the sync pulses triggering the vertical oscillator do not have sufficient amplitude. Also, be sure to check the vertical hold control when the receiver is switched to a number of different channels.

Unstable vertical sync

Tube trouble in the sync separator, sync amplifier and vertical oscillator circuits is a common cause of unstable vertical sync. The fact that the vertical oscillator locks in temporarily indicates that

the vertical sync pulses are coming through in attenuated form.

If the picture locks in on strong stations, but not on weak ones, there may be agc trouble. To check the agc, tune in a strong signal and note if advancing the agc control produces typical overload symptoms (picture bending or horizontal pulling). Advance the agc control and then back off until overload symptoms disappear.

Examine the vertical blanking bar. If it seems normal (no evidence of sync compression), connect the vertical input terminals of a scope between control grid and ground of the vertical oscillator. Remove the oscillator tube. (In sets using series-string heaters, disconnect the lead going to the plate pin but keep the tube in its socket.) The sync pulse going in to the oscillator grid has a peak-to-peak amplitude of less than 5 volts, and should resemble a sharp spike. If this pulse is present then the instability is in the vertical oscillator circuit. If not, it precedes the vertical oscillator.

Replace the vertical oscillator tube (or reconnect the plate lead). Keep the scope leads connected. Examine the waveform once again. There should be a very definite increase in the pulse amplitude at the grid after the oscillator tube has been replaced. It should range between 12 volts and 100 volts (and more in some receivers). If you do not get a definite increase in pulse amplitude, then trouble in the vertical oscillator is indicated. (Do not change the receiver control settings when doing this test with the tube in and out of its socket.)

If a scope is not readily available, use a vtvm. Set the instrument to read approximately 50 volts dc. The bias voltage should be at least 5 but can be 15 volts or more, negative. Vary the vertical hold control. This changes the resistance in the grid circuit, and the bias should vary as the control is rotated. If it does not, resistance check all resistors connected between control grid and ground. If any resistor is more than 20% away from the values specified in the schematic, replace it.

Since the bias on the oscillator is grid-leak bias, it is possible that the grid capacitor between control grid and ground (or cathode of oscillator tube) is defective.

To determine if unstable vertical sync is caused by trouble prior to the integrator, try rotating the horizontal hold control. If the picture does not tear and remains in horizontal sync over a portion of rotation of the control, then the trouble follows the

sync separator. If the horizontal hold seems critical, the trouble is in circuits common to both pulses. The trouble is in the sync amplifier or some preceding circuit.

Rolling

The vertical hold control is located in either the grid or cathode circuit of the vertical oscillator. A picture will roll if sync pulses do not arrive at the grid of the oscillator, if they arrive in attenuated form, or if they are weakened by some defective component in the vertical oscillator circuit. This trouble can also be caused by a weak vertical oscillator tube. Check for the presence of sync pulses with a scope as described earlier. If sync pulses are present, then the vertical oscillator is operating too far from 60 cycles for the pulses to have any effect — that is, the pulses are unable to lock in the oscillator. Look for changed values of components in the grid circuit of the oscillator.

Rolling can be due to sync compression. Tune to a strong channel and then remove the transmission line leads. Hold them close to the antenna terminal board so that some signal can get through by capacitive coupling. If the picture locks in, sync compression due to overloading is indicated. Try an attenuator pad as described in Chapter 1. Try adjusting the agc control. Further evidence of sync compression is an audio buzz in addition to the rolling. Check through all stages prior to the video detector with a scope and a crystal detector probe.

Multiple pictures

Sometimes two pictures, one above the other and both appearing somewhat squeezed, will show on the screen. Only if the vertical oscillator is running at 30 cycles, will two pictures be seen.

If the picture rolls or if there are multiple pictures (double or triple), examine any components that could cause the frequency of the vertical oscillator to change. Check all resistance and capacitance elements in the grid circuit of the vertical oscillator. If the oscillator has a cathode resistor (multivibrator oscillator) check this as well.

Adjust the vertical hold control to get a single picture (this should be about the center of the vertical hold range). If you can, then the trouble precedes the vertical oscillator. If you cannot, then make the checks indicated in the previous paragraph.

Horizontal line across center of screen

A bright white horizontal line across the center of the screen is a complete loss of vertical sweep. This is not a vertical-sync problem since the vertical oscillator can operate with or without input pulses. Replace the vertical oscillator and vertical output tubes. Determine if the trouble is in the vertical oscillator or vertical output stages by checking the vertical oscillator. Measure the oscillator bias as described earlier. If there is no bias, the oscillator is not working. Check the plate voltage. If it is much lower than normal, the oscillator is not functioning. Examine resistive components in the plate circuit of the oscillator (including the vertical gain or height control).

If the vertical oscillator is working, the trouble may be in the sawtooth-forming network following the oscillator, in the vertical amplifier or in the vertical deflection coils.

Vertical amplifier

The vertical oscillator and vertical amplifier often form a two-tube resistance-coupled amplifier circuit. A typical arrangement is shown in Fig. 906. In this arrangement the vertical output is part of the oscillator circuit since it supplies feedback voltage through a capacitor. Several other representative vertical amplifier circuits are shown in Figs. 907 and 908.

Boost voltage

Either the vertical oscillator, the vertical amplifier or both can operate from the boosted B-plus bus. A decrease in boost voltage can affect vertical oscillator and amplifier operation. However, a defect in the vertical oscillator or amplifier can also lower the boost voltage, so lower than normal voltage at the plate of the vertical oscillator or amplifier does not necessarily mean the fault lies in the boost circuit. Low boost voltage can lead to an inoperative oscillator (no sweep) or a small picture (insufficient sweep). Any component which overloads the boost line can cause lowered B-plus boost voltage as described in the chapter on high voltage. If the audio output tube is connected to the boost voltage, remove it and note if this improves vertical oscillator and amplifier operation. If it does, then some component or tube is overloading the boost line. The circuit of an amplifier using a boost line is shown in Fig. 908.

Time-saver

To determine if the fault is in the oscillator or amplifier cir-

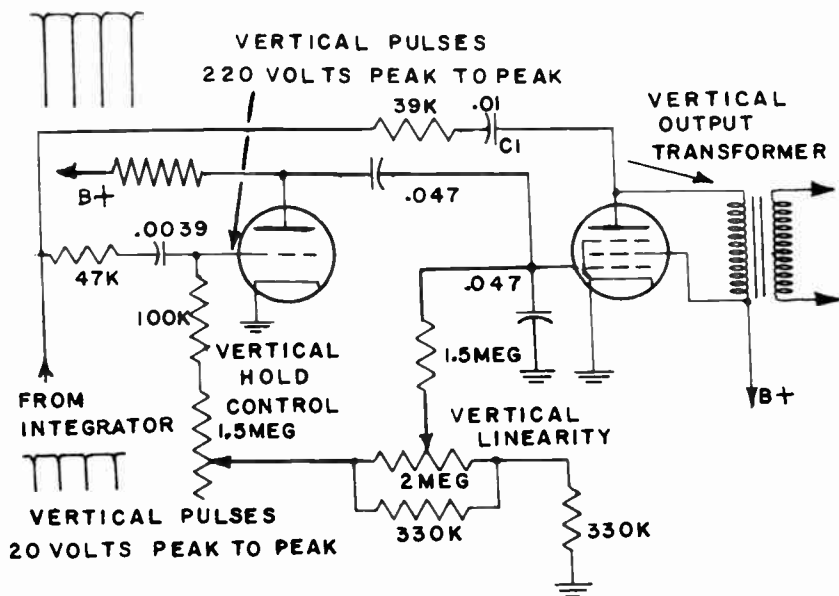

Fig. 906. Vertical amplifier is also part of the oscillator in this typical circuit.

circuits, connect a capacitor (any value from $.05 \mu\text{f}$ to $0.1 \mu\text{f}$) to the center arm of the volume control. Attach a clip lead to the other end of the capacitor. Now connect the clip lead, in turn, to the control grid of the vertical oscillator, the plate and the control grid of the vertical amplifier. In each case you should hear a buzz in the speaker. If, for example, a buzz is heard when testing at the grid of the vertical oscillator, but not at the plate, then the trouble is in the vertical oscillator.

Be sure to use a capacitor that can withstand the B-plus voltage. We do not recommend this check at the plate of the vertical amplifier tube since pulse voltages here can be in the order of 1 kilovolt or more.

A 60 cycle heater voltage can be fed to the vertical amplifier with the clip lead. Some sweep should be seen on the picture tube.

Barreling

This condition, in which the sides of the raster or picture are pushed out, is sometimes caused when vertical output transformers are replaced. It is due to an impedance mismatch between the

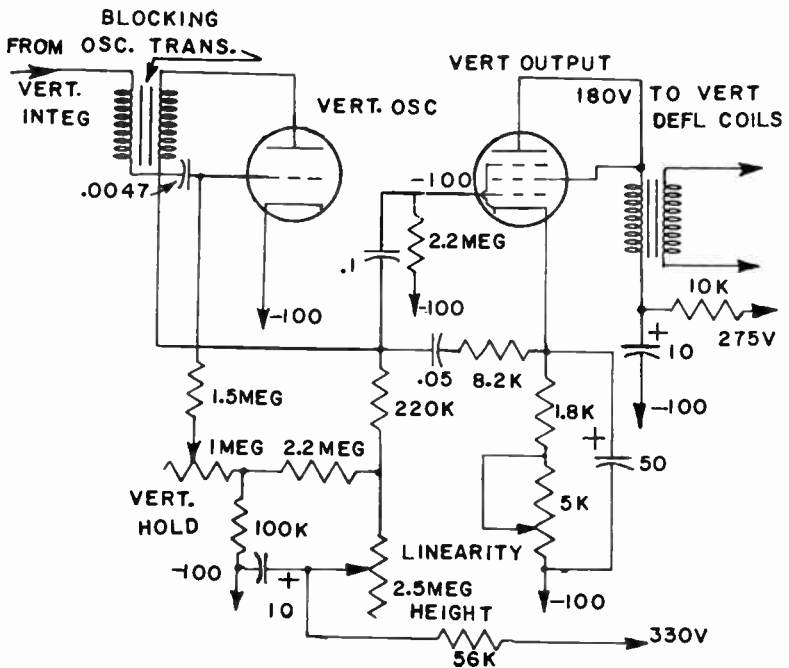

Fig. 907. Typical circuit of blocking oscillator and vertical amplifier.

transformer and the vertical deflection windings. Make sure the correct replacement part is being used.

Buzz

Buzz is sometimes due to trouble in the vertical sweep system. Vary the vertical hold control. If the intensity of the buzz changes, you have an indication of buzz produced by some trouble in the vertical sweep. The buzz can be caused in two ways: (1) by radiation or (2) by feedback of pulses into a common B-plus line. Try shunting filter capacitors in the plate leads of the vertical oscillator and output tubes with additional equivalent units. Try putting a metal shield can over the vertical output transformer (if space permits). If this reduces the buzz, the symptom is produced by radiation. Make sure the shield is grounded. If no shielding is possible, remove the mounting screws and rotate the output transformer to try to minimize the buzz.

Vertical linearity

Poor vertical linearity is often caused by misadjustment of the vertical linearity control. To adjust properly, disable the vertical

sweep by removing the vertical output tube (use a dummy tube — all pins removed except filament pins — in series-string receivers) so that a horizontal line is seen across the screen. Turn the brightness down so the line is barely visible (this is to protect the screen of the picture tube). Adjust the centering control or yoke until the line is across the center of the tube.

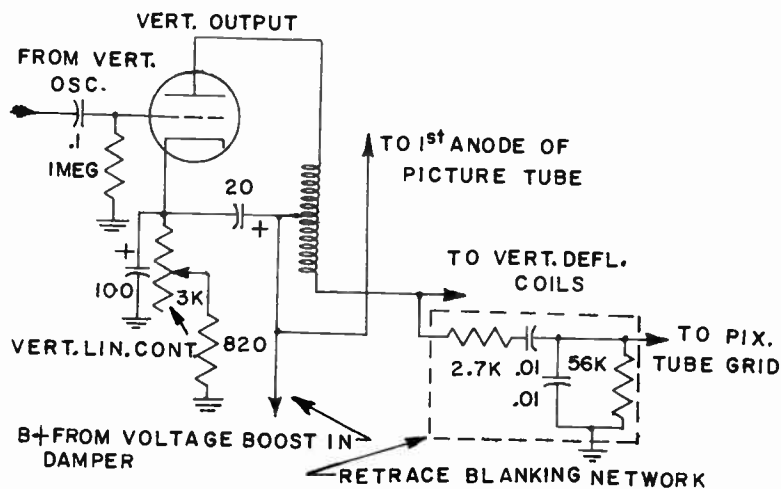

Fig. 908. B-plus boost voltage is often used for increased vertical size.

Replace the vertical output tube and turn the vertical hold control until the picture rolls slowly. The blanking bar should have the same dimensions as the picture moves up or down the screen. If not, adjust the vertical size and linearity controls until it does.

Vertical nonlinearity can be caused by changed values of resistors and capacitors. Check the R-C network in the plate circuit of the vertical oscillator and also the coupling capacitor between the vertical oscillator and amplifier. The vertical linearity control is in the cathode circuit of the vertical amplifier. (Some receivers have two variable vertical linearity controls in series.) Check all resistors (and shunting capacitors) in the cathode circuit of the vertical amplifier tube.

Vertical nonlinearity may show up in a number of ways. If the aspect ratio is poor, the trouble is most generally due to improper setting of the vertical size and linearity controls or to weak tubes. If vertical nonlinearity shows in the form of picture compression including foldover, then the trouble is due to some component. Insufficient height and compression of the top of the pic-

ture can be due to a defect in the vertical output transformer or in the vertical yoke windings. (Refer to the chapter on picture tubes for an analysis of troubles that can occur in the vertical deflection windings.)

Vertical output-tube voltage checks

The vertical oscillator is coupled to the vertical amplifier through a coupling capacitor. An open capacitor can result in a loss of vertical sweep. A leaky capacitor can change the bias on the vertical output tube and will produce vertical nonlinearity. Check with a scope, set at 30 cycles, at the plate of the vertical oscillator and then at the control grid of the vertical output tube. You can quickly determine if the vertical oscillator is working, if the coupling capacitor is good and if the vertical pulses are reaching the control grid of the vertical output tube. The pulse amplitude should be about the same on both sides of the coupling capacitor, or slightly lower on the amplifier side of that capacitor. The peak-to-peak voltage reading will range from about 25 volts to 100, depending upon the way the receiver controls are set and the particular receiver being tested. If the waveshape as seen on your scope is upside down, this is simply an indication of phase inversion in the vertical amplifier of your scope. Fig. 909 shows typical waveforms in the vertical sweep system.

If the vertical output tube has a cathode resistor, read the bias voltage. The voltage at the cathode will range from 15 to 30 volts, and will vary with the linearity control setting. No voltage from the cathode to the chassis indicates that either the tube is not conducting current or the cathode bypass capacitor is shorted. Check plate voltage. A B-plus reading here indicates a good output transformer and probably a defective tube.

When the vertical amplifier tube does not have a cathode resistor, disconnect the lead from the chassis and insert a milliammeter. For repeated tests of this sort an adaptor for measuring current can be made to plug in between the tube and the socket. Make sure that the milliammeter can read the full amount of current to be passed by the tube. The normal amount of current can be found in a tube manual.

Vertical output tubes work with high pulse voltages on the plate. A direct check at this point can possibly damage a scope. Use a capacitance type voltage divider when examining plate waveforms.¹

¹ See "PROBES" Gernsback Library #54.

Vertical foldover

Foldover is shown by a bending over of the top or the bottom portions of the picture. Foldover across the top portion can be caused by an improperly adjusted vertical linearity control. Check the voltage from cathode to ground of the vertical output tube as indicated in the previous paragraphs. Foldover can also be caused by a defective vertical output transformer, yoke, or a defective coupling capacitor between vertical oscillator and amplifier. Check as described earlier.

Insufficient height

Make certain that both the linearity and vertical gain controls are properly adjusted. Try substituting new vertical oscillator and vertical amplifier tubes. Check the cathode-to-ground voltage of the vertical amplifier. If this bias is excessive, gain will be reduced and vertical deflection will be insufficient. If the vertical output tube is a pentode, check the screen voltage. If the vertical output tube is tied to the boost B-plus, check to make sure that the boost voltage is normal.

Insufficient height can also be caused by inadequate B-plus voltage. (Sound may be normal.) Try a new low-voltage rectifier tube. Check the line voltage. It shouldn't be much below 117 volts rms. The receiver could be tied to a line that is being overloaded by a refrigerator, toaster, electric heater, etc.

Check the waveforms and voltages on the oscillator and amplifier stages as mentioned earlier.

Poor interlace

Poor interlace results in a loss of picture quality. It is often due to the setting of the vertical hold control. To check, turn the receiver to an off channel and examine the raster scanning lines. The lines should be equally spaced and of equal intensity. If the lines seem paired (unequally spaced), a condition of poor interlace exists. With a test pattern tuned in observe the lines in the horizontal wedges going into the bulls-eye. A moiré effect is evidence of poor interlace.

To improve the interlace, turn the receiver to an off-channel position and adjust the brightness and focus controls until you can see the sweep lines clearly and distinctly. With a picture, adjust the vertical hold until the lines are equally spaced. The easiest way to do this is to set the vertical hold until the picture starts rolling upward, and then to back off until the picture locks

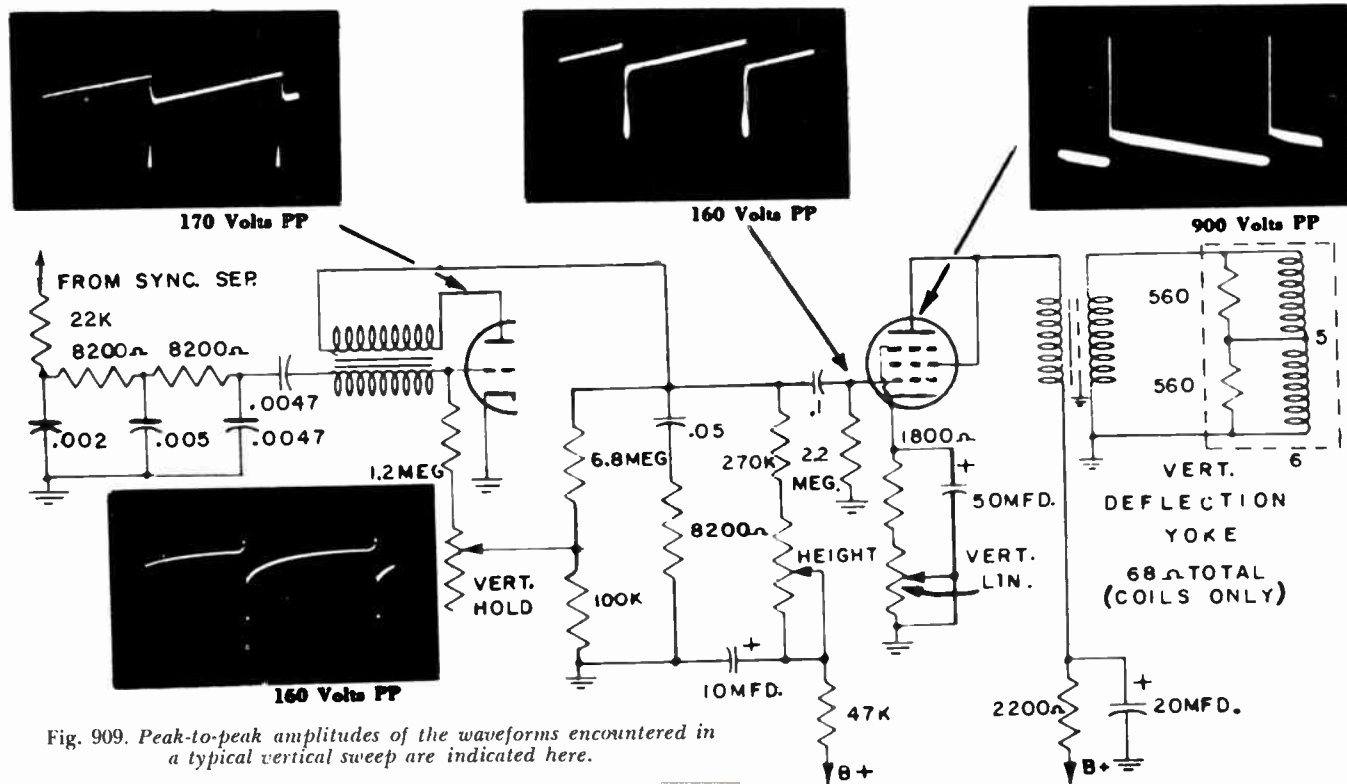

Fig. 909. Peak-to-peak amplitudes of the waveforms encountered in a typical vertical sweep are indicated here.

in. If this does not help, check the components in the vertical integrator at the input to the vertical oscillator.

Horizontal oscillator

Although a number of different oscillator circuits are in use (Hartley, multivibrator, blocking oscillator, etc.), they all perform the same function — oscillation on a frequency of 15,750 cycles. Horizontal oscillator circuits not only differ in design but also in the various ways that are used to keep these oscillator circuits working on their exact frequency. Fig. 910 shows the sections of a horizontal sweep system.

The automatic frequency control keeps the horizontal oscillator working at the exact horizontal oscillator frequency as transmitted by the particular station to which the receiver is tuned. If the afc is defective, the high voltage will not be affected as long as the horizontal oscillator and the remainder of the sweep circuit are functioning properly. Defective afc, however, will result in picture tearing.

Failure of the horizontal oscillator means loss of high voltage. In addition, it is possible for the horizontal output tube to become damaged due to lack of drive. If the plate of the horizontal output tube becomes red, it is an indication of insufficient drive, or it is possible that the horizontal oscillator has stopped working. Check the bias between control grid and cathode of the oscillator tube. Use a vtvm. The amount of bias will vary from one receiver to the next, but should range between 10 and 25 volts. Do not remove the horizontal oscillator tube from the receiver when the receiver is turned on. To do so results in possible damage to the output tube and to the deflection coils.

Horizontal afc

The Synchrolock system has a reactance tube shunted across the grid circuit of a Hartley oscillator. A sync discriminator compares the frequency of the incoming horizontal sync with that of the oscillator in the receiver. A difference in frequency develops a voltage, which is applied to the grid of the horizontal oscillator control tube. The control tube is thus made to behave as a variable reactance (inductive or capacitive). Since it is shunted across the horizontal oscillator input, it serves to bring the oscillator in step with the transmitted horizontal sync pulses.

The Synchroguide and horizontal phase detector are also used

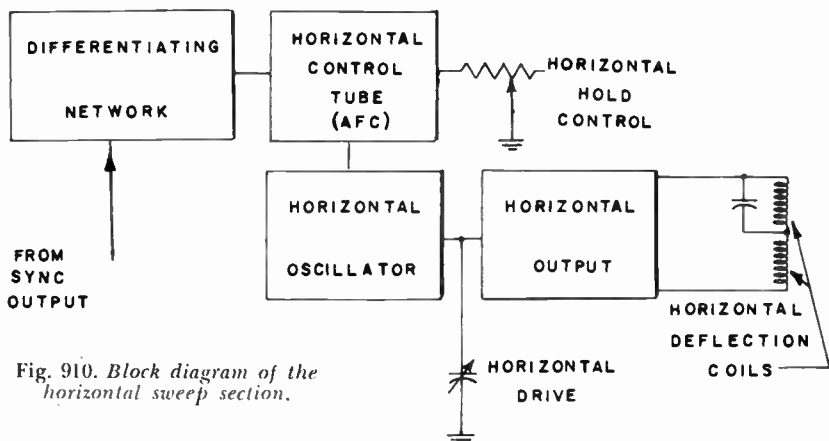

Fig. 910. Block diagram of the horizontal sweep section.

for keeping the horizontal oscillator in step with the transmitted horizontal sync pulses.

A representative Synchroguide circuit is shown in Fig. 911. The horizontal oscillator position (right-hand section of the double triode) is a type of blocking-oscillator. The oscillator transformer is tuned so that the oscillator frequency can be adjusted. The afc portion of the dual triode (this is the left-half of the double triode) develops a correcting voltage whenever the frequency of the horizontal oscillator and the transmitted sync pulses do not agree in frequency or in phase.

The control tube works only when sync pulses drive the grid. The voltage produced across the cathode resistor depends on the phase relationship of oscillator and sync pulses. Any difference in frequency or phase results in the development of a voltage which is fed as a bias to the horizontal oscillator. This bias changes the frequency of the horizontal oscillator so that it keeps in step with the incoming sync pulses.

Two controls may be used to set the horizontal frequency. The tuning slug of the blocking-oscillator transformer is a coarse adjustment that establishes the approximate operating frequency of the oscillator. The other horizontal hold control is a potentiometer in the plate circuit of the afc tube, and is used for fine adjustment.

Many of the parts in this circuit have a very close tolerance. Some of the resistors are 5% tolerance and some of the capacitors are silver mica units. Use exact replacement components only. Watch lead dress. Before removing any part, note its location and the position of the wiring.

Synchroguide troubles

If the picture has poor sync as evidenced by horizontal jitter or piecrust effect, check the resistors and capacitors in the cathode circuit of the afc section of the triode (left-hand side of the triode shown in Fig. 911).

If the sync is poor (that is, if you get horizontal frequency drift), check resistors and capacitors in the grid circuit of the horizontal afc tube. This could also be caused by a defective capacitor connected between the control grid of the oscillator (right-hand section of the triode shown in Fig. 911) and terminal F of the blocking-oscillator transformer.

Some circuit arrangements use two horizontal hold controls (coarse and fine). Make sure that both are set to permit the horizontal oscillator to lock in. Check the horizontal-hold potentiometer itself, and also the two resistors connected on either side of the pot.

Horizontal sync discriminator (phase detector)

Like the Synchrolock and Synchroguide circuits, the phase detector works by developing a bias voltage for the horizontal oscillator when the frequency and phase of the horizontal oscillator are not in agreement with the transmitted sync pulses.

In the circuit shown in Fig. 912, sync pulses are fed into the diode sync discriminator from a sync inverter. The sync inverter is a tube that has a split load — that is, sync signals are taken from the plate and the cathode of the sync inverter tube. Horizontal sync pulses are also fed into the other half of the diode from the width coil on the flyback transformer. (The action of this coil in supplying plate voltage for the agc keyer tube was described in the section on agc.) As long as the frequency and phase of the incoming sync pulses from the sync inverter and those from the width coil are in agreement, there is no output from the diode. However, any frequency or phase difference will develop a voltage across R1. This voltage is filtered by C1, C2 and R2, and is then supplied as a bias voltage to the horizontal oscillator. As the horizontal oscillator comes back into step, the output of the sync discriminator drops to zero.

Phase detector troubles

A double picture is often caused by a defective capacitor (C3) connected between the cathode of the discriminator tube and chassis. A defective phase-detector tube (inoperative or weak) can

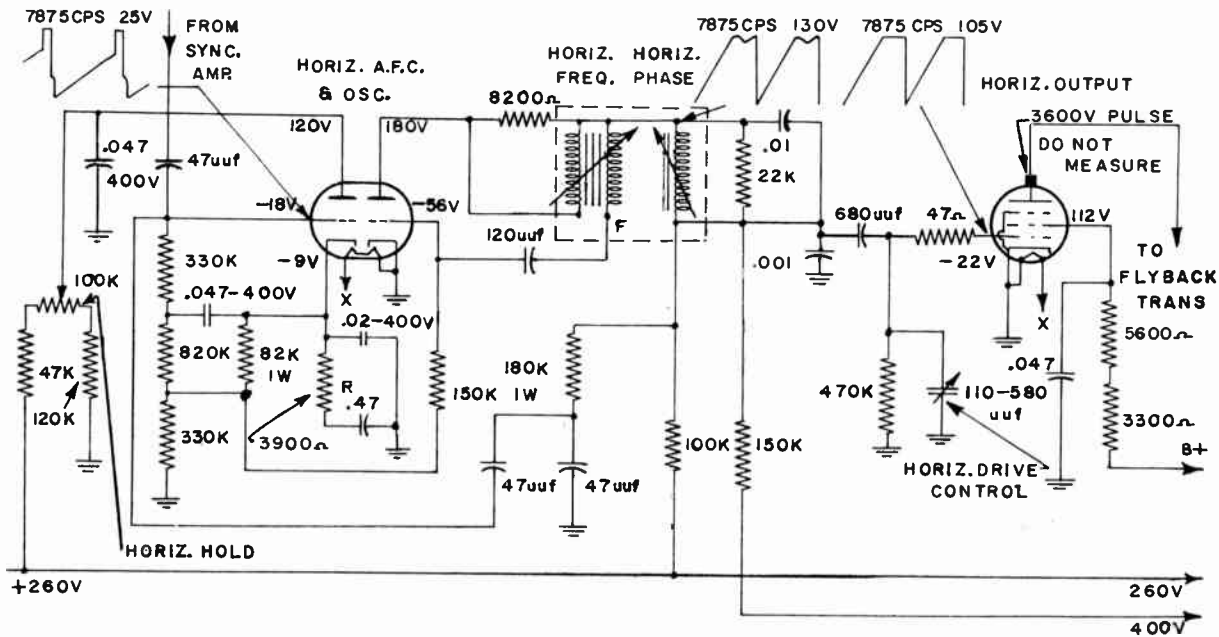

Fig. 911. Synchroguide horizontal oscillator and waveforms generated to drive the horizontal amplifier grid.

result in no sync, poor sync or intermittent sync.

The two 100,000-ohm resistors, R3 and R4, should be as closely matched as possible. The exact value of resistance is not so crucial as the fact that the two resistors should have identical values of resistance. If one of the resistors must be replaced, replace both, using a matched pair.

Picrust

This symptom is so named because the outer edges of the picture resemble the wavy, up and down edges of the outer crust of a

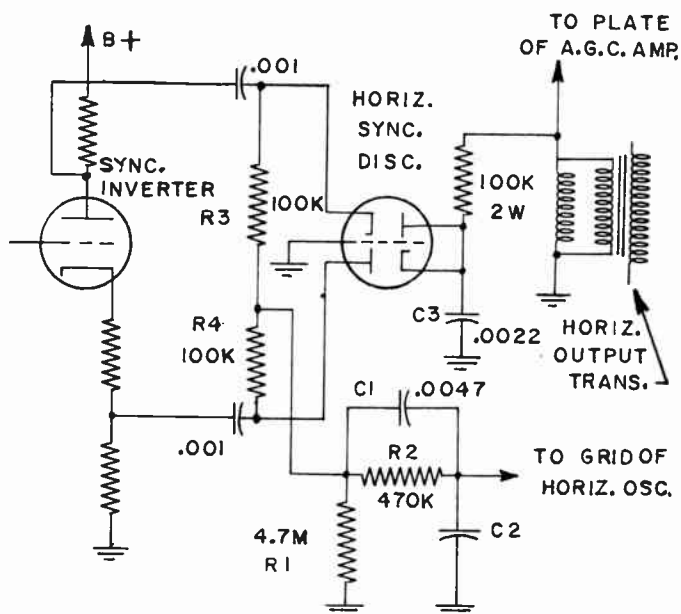

Fig. 912. This phase detector is a simple form of horizontal afc.

pie. This trouble is sometimes caused by defective components associated with the horizontal oscillator – resistors and capacitors in the grid circuit. Sometimes it is caused by a faulty horizontal output tube.

This condition is also the result of breakdown of anti-hunting components associated with the horizontal afc circuit. These are parts that are marked R and C in Fig. 911 and R1, C2 in Fig. 912. The horizontal oscillator is constantly shifting, resulting in a rapid horizontal displacement of the picture. This is a form of horizontal

jitter. When this occurs, check the values of the anti-hunting resistors and capacitors.

Bending of vertical lines

As we explained earlier, this trouble could be due to an improper setting of the agc control. Tube trouble in the horizontal sweep could also produce this symptom. This applies to horizontal

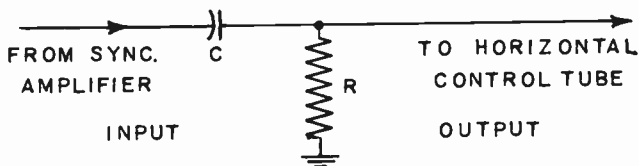

Fig. 913. *The differentiator is a form of high-pass filter.*

oscillator and output tubes and also afc tubes. When the afc is of the phase detector type, remove the diode phase detector from its socket. Adjust the horizontal hold control to get the picture to stay in place momentarily. If the bending has disappeared, the trouble is due to the phase-detector tube or circuit. Another check when removing the phase-detector tube (or reactance tube in the Synchrolock circuit) is to examine the blanking bar. This should be straight. If it is curved, then the bending problem is due to trouble in the horizontal sweep system.

Differentiator troubles

A high-pass filter, (Fig. 913) is connected between the output of the last sync stage and the horizontal control tube. A change in R or C values can cause the setting of the horizontal hold control to become critical. In some cases there will be complete loss of horizontal sync.

Horizontal linearity control

The purpose of the linearity control is to permit a sawtooth current to flow through the horizontal deflection coils. This will produce a linear sweep of the scanning beam across the face of the tube. Nonlinear deflection (sweep) results in cramping of the picture. Whether this takes place at the left of the screen, at center or on the right side depends upon which portion of the sawtooth cur-

rent has been deformed. In some cases the picture may be stretched at one portion and crowded at the other.

Adjust the linearity control to see if the picture can be improved. It may be necessary to readjust the horizontal drive and the width (if the receiver is equipped with such controls). Work back and forth between these controls until picture linearity is good. As a general rule, though, you will find that the horizontal linearity control is not too effective. It can, however, adjust for small amounts of horizontal nonlinearity.

Use the raster to check on linearity. Turn the channel selector to an inactive channel. Increase the brightness until the retrace lines are seen. (Disable the retrace eliminator or blanking network if required.) Adjust the controls until the retrace lines are straight from one side to the other. (Reduce the size of the raster so that you can see all raster edges.)

Horizontal phasing

A vertical black blanking bar will be seen in the picture if the phasing is incorrect. The picture will look as though it had been split in two with a black bar between the two portions. The trouble can be due to a defect in the R-C feedback network between the plate of the horizontal oscillator and the grid of the horizontal control tube. If the receiver has a variable phasing control, try adjusting it so that a single picture locks into place.

Combined oscillator and output circuits

The use of dual triodes or pentodes permits circuits to be combined, particularly when these circuits are associated, such as a vertical oscillator and vertical output. A typical arrangement is shown in Fig. 914. Because the circuit has been simplified, it should be easier to service but, whenever standard circuits change, new complications are always added. Note that the output transformer in Fig. 914 doubles as a combined blocking-oscillator transformer and vertical output transformer. Defects in this unit can mean complete lack of vertical sweep or insufficient vertical gain. Because the transformer is so different, replacement problems may be aggravated. In such circuits there is a greater interaction between the vertical hold, linearity and gain controls than in separate oscillator and amplifier arrangements.

The vertical sync pulses are fed into the screen grid of the tube through a capacitor (C3) and one of the transformer windings. These pulses are also fed through a capacitor (C1) to the cathode-ray-tube grid for blanking purposes. If retrace lines show on the

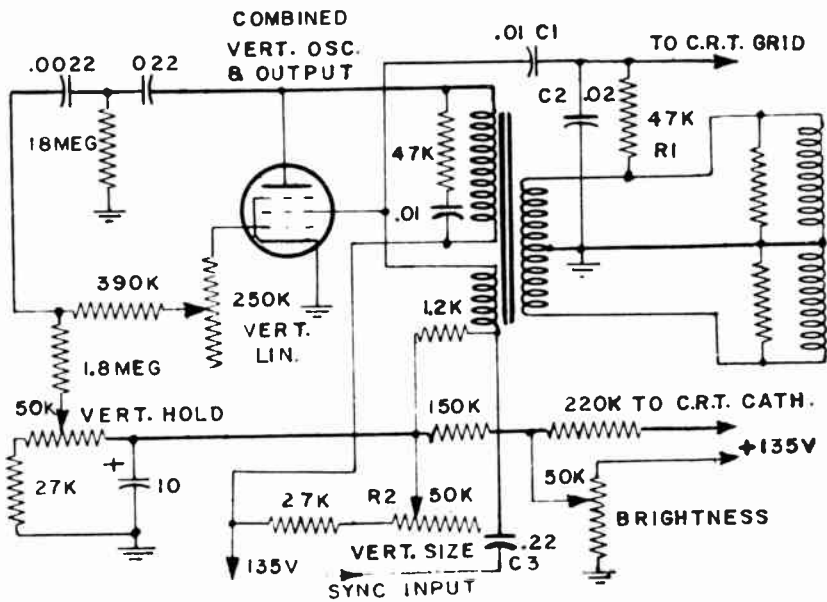

Fig. 914. The vertical amplifier is also the vertical oscillator in this economy circuit.

screen, examine C1, C2 and R1. Vertical size is obtained by varying the voltage on the screen. To check on this control, connect a vtvm to the screen grid (hot lead of vtvm to screen, ground lead to the chassis) and vary the size control. The voltage may vary slightly, but there should be a definite change as the control is turned. To check if all of the series resistors in the screen circuit are working, momentarily lift the tube out of its socket with the vtvm connected as just described. The voltage at the screen should rise to the B-plus voltage (in this case, 135 volts).

A weak vertical output tube in the circuit of Fig. 914 can result in critical vertical hold, jumpy picture or insufficient vertical gain.

You can check the tube for oscillation using the techniques described earlier. If the tube does not oscillate, however, the voltage at the plate will remain the same since there won't be much of a voltage drop across the inductive load in the plate circuit. Check for oscillation. Measure grid voltage with a vtvm. Note that the cathode of the tube is grounded. Loss of bias (that is, failure to oscillate) will mean a very heavy current through the tube with

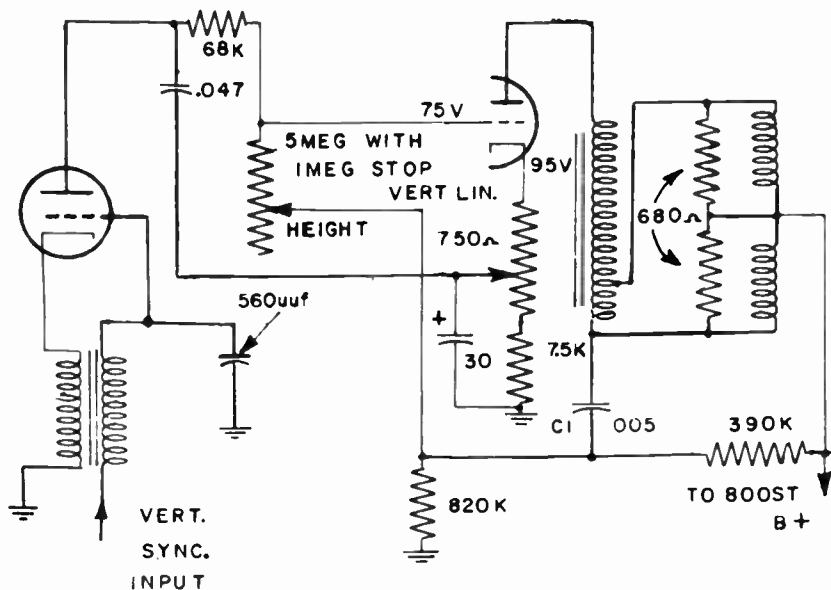

Fig. 915. Direct-coupling the oscillator and autotransformer output increases the circuit efficiency.

possible damage to the tube and (less likely) damage to the output transformer.

Another unusual circuit arrangement is shown in Fig. 915. The vertical oscillator is the familiar blocking oscillator, but it is directly coupled to the grid of the next tube. The cathode of the output tube is above ground. The plate of the output tube is connected to the boosted B-plus line through the output transformer.

An autotransformer is used in the output. The taps on the autotransformer matches the impedance of the vertical deflection coils. Here, as in the case previously described, an exact replacement must be used.

Because of direct coupling, oscillator defects will change amplifier operation. Should the oscillator section stop working, the positive voltage at the control grid of the amplifier section would increase, possibly resulting in the burnout of the tube.

Capacitor C1 in this circuit helps control the amount of negative feedback and in this way determines vertical linearity. If, in substituting a new capacitor, a larger value is used than that shown in the diagram, vertical gain will be reduced. If the value is too small, vertical linearity will suffer.

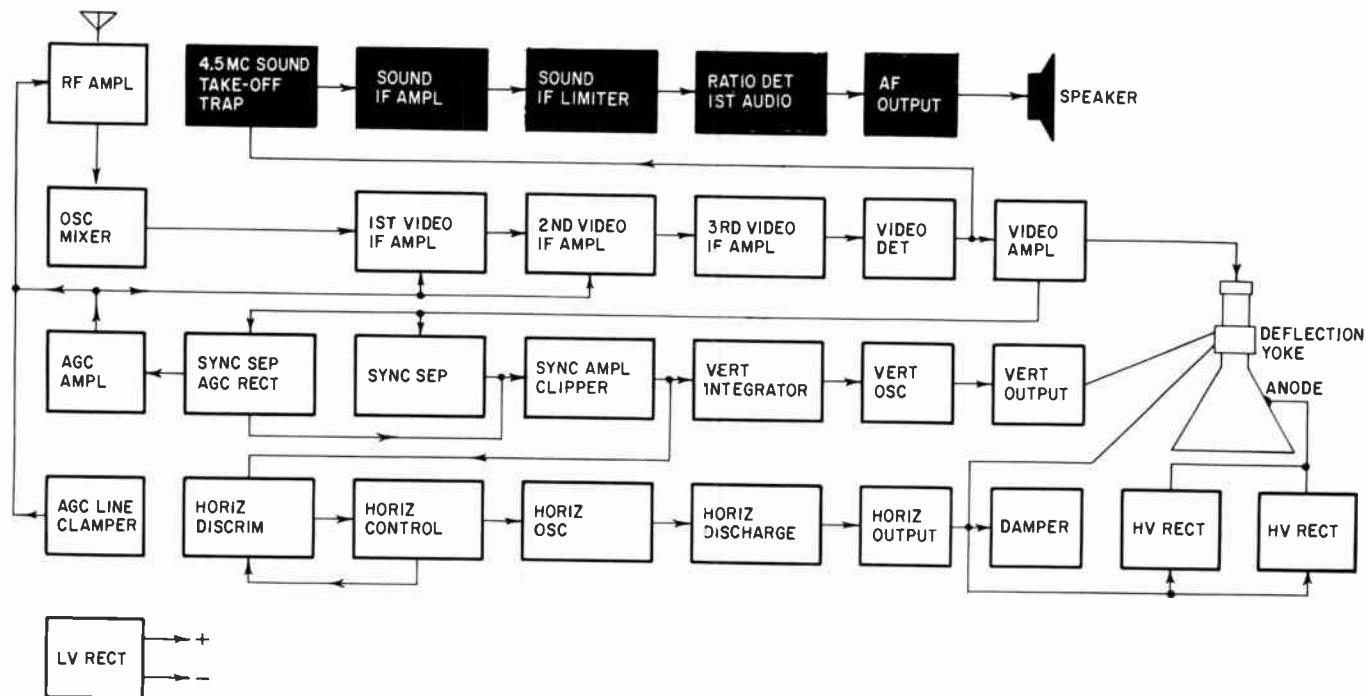

Fig. 1001. The sound circuits follow the video detector.



sound troubles

chapter 10

SYMPTOM analysis in a television receiver is aided by the fact that troubles can make themselves known in two ways—visually and aurally. When we examine a defective television receiver we look at the screen and we listen to the sound—and quite logically we expect both of these to supply us with information.

When reference is made to television receivers with intercarrier type sound, it means that sound and picture travel together at least until the output of the video detector, and quite often right up to the input to the picture tube itself. Consequently, troubles that affect the picture can also affect sound. There can be a great variety of combinations—picture, no sound; sound, no picture; weak picture, good sound; good sound, weak picture, etc.

This makes servicing a bit more complicated. At one time, in television receivers, the sound and picture circuits were separate and distinct. (In split-sound sets, the sound takeoff is right at the output of the front end.) The audio channel can also be tied to the video if through a stacked-tube arrangement, the plate of the audio amplifier might work from the B-plus line, etc. Consequently troubles arise in circuits that you would not even remotely consider as belonging to the sound section and produce trouble in the sound. Similarly, difficulties in the sound circuits can adversely affect other circuits in the receiver.

The block diagram of Fig. 1001 shows that coming out of the video if portion of the receiver we have another intermediate frequency. This is the sound if.

Some differences between these two intermediate frequencies are worth noting. For example, the picture if is amplitude-modulated while the sound if is frequency-modulated.

Video detector operation

One of the functions of the video detector is to rectify or demodulate the picture signal. The video detector, however, also serves as a converter. Disregard for the moment the fact that the picture and sound carriers are traveling together. Imagine the picture if carrier as a local oscillator voltage being injected into the video detector. It will then heterodyne or beat with the sound if. When two signals (in this case picture and sound) heterodyne, a number of other signals are produced. These are known as sum and difference frequencies. They are simply the addition and subtraction of picture and sound frequencies. When one is subtracted from another, the result is the difference frequencies.

Assume that the picture if is 45.75 mc. The sound if would then be 41.25 mc. The difference between these two is 4.5 mc. ($45.75 - 41.25 = 4.5$). Thus, the output of the video detector will supply the picture signal (due to detection or demodulation of the picture if) but there will also be a 4.5-mc signal as a result of the heterodyning action between picture and sound if's. This 4.5-mc sound signal will be FM but it will also have a small amount of amplitude modulation. What we will have, in effect, will be a new if signal (having a center frequency of 4.5 mc). To extract the audio signal, this 4.5-mc if signal will have to be demodulated (or detected) by an FM detector.

Sound takeoff

The sound takeoff in intercarrier receivers can be after the video detector, but often it is taken from the plate of the video amplifier. Fig. 1002 shows two typical sound-takeoff circuits.

The sound takeoff coil performs two jobs. It permits the extraction of the 4.5-mc beat voltage and at the same time it acts to keep the sound out of the picture. Examine the sound takeoff in Fig. 1002-A. The takeoff coil is in series between the plate of the video amplifier tube and the input to the picture tube. The takeoff coil is a parallel-tuned circuit, and has a high impedance at 4.5 mc. The sound takeoff coil will permit the lower frequencies of the video signal (up to 4 mc) to pass through to the picture tube since its impedance at other frequencies will be fairly low.

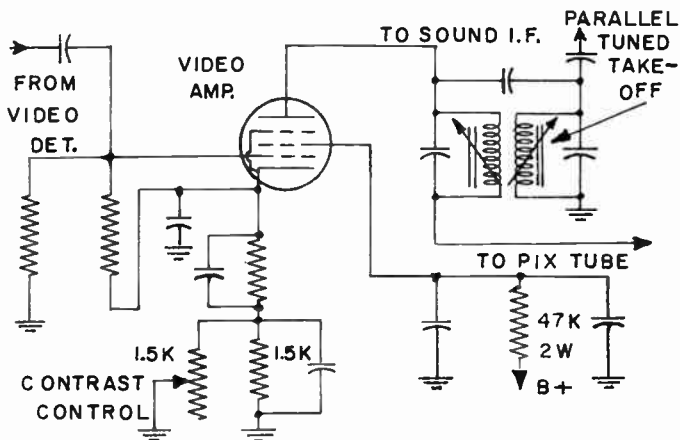

a

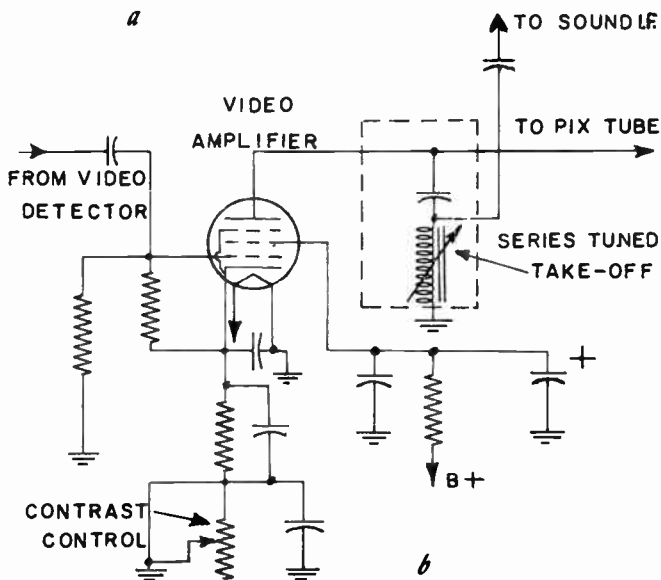

b

Fig. 1002. Sound takeoff transformers may be either series- or parallel-tuned.

Misadjustment of the sound takeoff coil shows itself in two ways. Sound bars get into the picture and sound out of the speaker may be weak. To adjust the takeoff coil without test equipment, set the channel selector to a test pattern if possible, since a steady tone or sound will also be supplied. Adjust the takeoff coil until sound is loudest and bars on the screen have disappeared.

To make a more accurate adjustment, connect a vtvm across the sound detector as shown in Fig. 1003. The takeoff coil should be adjusted for maximum deflection on the meter.

Not all sound takeoff coils are parallel-tuned. Some are series-tuned as shown in Fig. 1002-B. Adjustment is the same as for the parallel-tuned type.

Sound if stage

The sound if is often a single pentode stage, transformer-

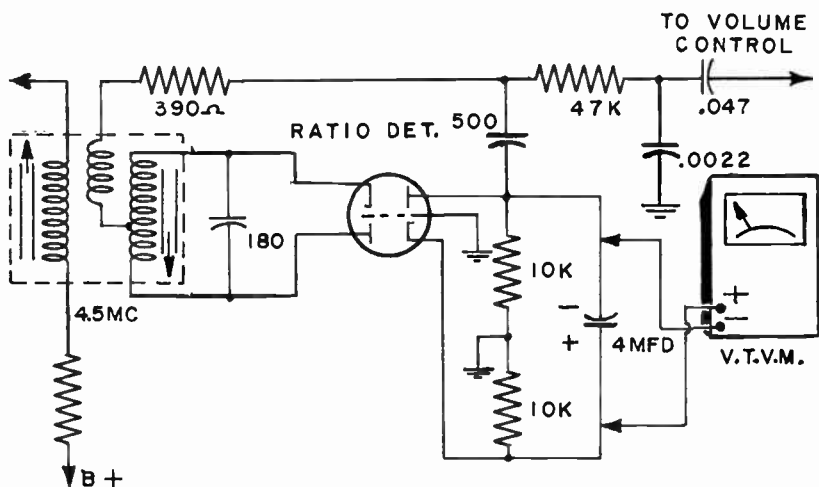

Fig. 1003. Ratio detector circuit. Diodes may be either vacuum-tube or semiconductor types. Vtvm cannot be grounded when measuring across the electrolytic capacitor.

coupled to the ratio detector. Adjustment of the if can be made by tuning for maximum sound. Since this stage is a sound amplifier, troubles here can be anything from complete loss of sound to weak or distorted sound (Fig. 1004).

Weak sound

Low sound volume is often caused by a weak tube. If tube replacement does not help, check voltages at the plate and screen to see if they are near those specified on the manufacturer's schematic. If they are not near normal, check plate and screen components back to the B-plus bus.

Weak or distorted sound may be due to a misaligned sound if

transformer. To adjust, simply tune the primary and secondary for maximum sound output. A station signal can be used for this purpose.

The sound if transformer should tune much more sharply than transformers in the picture if stages. If it tunes very broadly, the transformer or some component shunted across the primary or secondary is defective.

Ratio detector

Most receivers use a ratio detector or a gated-beam detector. Discriminators are usually used only in old television sets (and in high-quality FM receivers). The circuit of a ratio detector is shown in Fig. 1003.

Some ratio detectors are preceded by limiter stages, but most often you will find the sound if feeding directly into the ratio

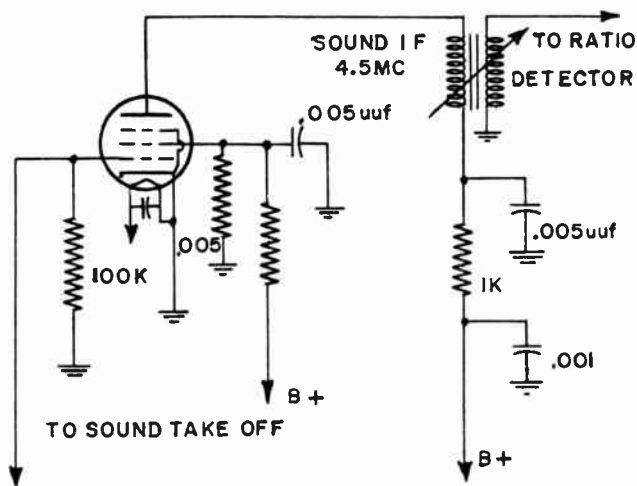

Fig. 1004. A typical sound if stage.

detector. Defects in the ratio detector can result in loss of sound, weak sound, distorted sound, noise (hiss) in the sound.

To determine if trouble exists in the detector circuit, use the volume control as the sound dividing point. Connect an audio signal across the volume control. Attach the hot lead of the test cable to the ungrounded end of the volume control and the ground lead to the chassis. A strong sound signal should come out of the speaker. Vary the volume control. If the sound changes from weak (or completely off) to very strong, the trouble precedes the volume control.

If a check at the volume control indicates that the control and the stages that follow it are in good order, connect a vtvm across the electrolytic of the ratio detector circuit as shown in Fig. 1003. Note that the negative lead of the vtvm is connected to the

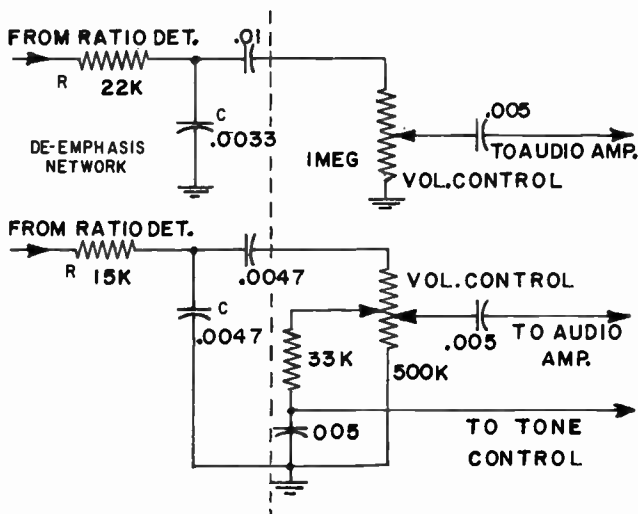

Fig. 1005. De-emphasis networks consist of a series resistor R and shunt capacitor C .

negative terminal of the capacitor. Set the vtvm to read low volts dc and tune in a station. If there is no reading here, the trouble lies in the ratio detector circuit or in some circuit up to and including the sound takeoff coil.

Inject a modulated 4.5-mc signal into the control grid of the sound if tube. Keep the vtvm connected as shown in Fig. 1003. If there is no indication on the meter, the trouble lies between the control grid of the sound if stage and the detector diodes. (*Note:* It is true that television sound is FM and theoretically the system should not respond to an AM signal. However, perfect limiting isn't obtained in a ratio detector, so enough sound signal gets through for test purposes.)

If sound comes through when a test signal is injected at the plate of the sound if amplifier tube, but none when the signal is injected at the control grid, the fault lies in the if tube or components connected to it.

Loss of sound

A complete loss of sound can be caused by loss of screen or

plate voltage of the sound if amplifier tube, by an open in the detector transformer or by an open in the resistors between the control grid of the audio amplifier tube and the secondary of the detector transformer.

Hiss

Representative de-emphasis networks are shown in Fig. 1005. These are simply R-C networks. If a strong hiss is present in the

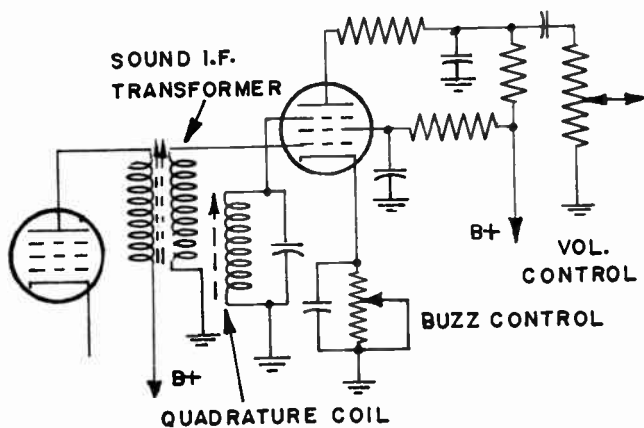

Fig. 1006. Gated-beam detector. Buzz control varies tube bias, resulting in change of buzz level. Tube structure is more complicated than the pentode illustrated here.

sound (all channels), check the values of resistance and capacitance in the de-emphasis circuit to see if they are within 20% of the values indicated on the schematic.

Gated-beam detector

A typical gated-beam detector circuit is shown in Fig. 1006. The tube is called a gated-beam discriminator. The variable resistor in the cathode circuit is a buzz control and should be set for minimum or zero buzz on all channels. The coil connected to the suppressor grid (quadrature grid) is known as a quadrature coil.

The gated-beam detector can be adjusted by using a very weak signal. Insert an attenuator pad between the antenna terminals and the transmission line and set the channel selector on the weakest station. As an alternative, the antenna terminal board can be shunted by a resistor having a low value. Connect a resistance substitution box (or a decade resistor unit) across the

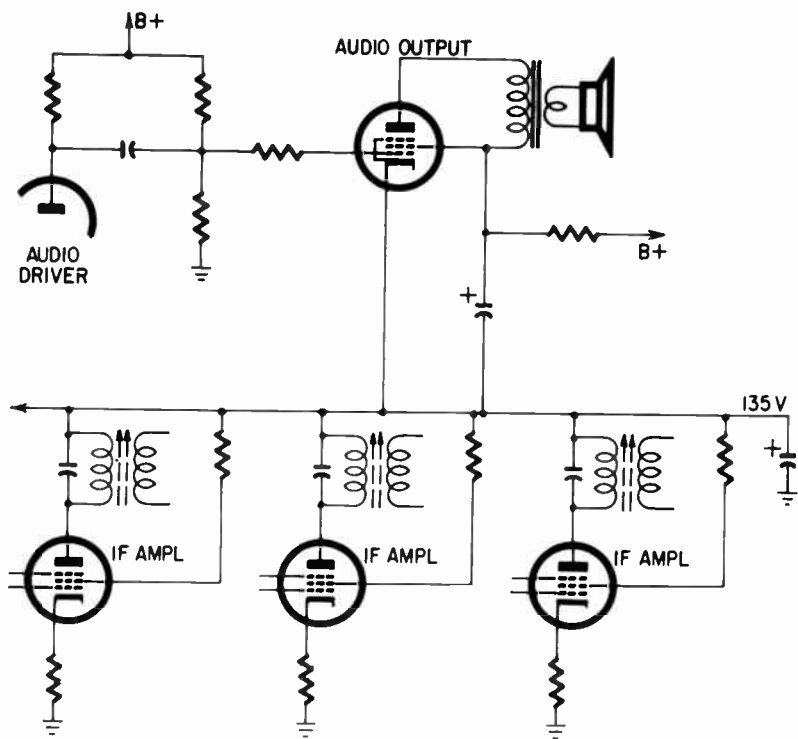

Fig. 1007. *B-plus distribution in circuit using audio output tube as a voltage-dropping resistor.*

antenna terminals but keep the transmission line connected. Set the substitution box for a very weak signal. Do not disable the agc.

Tune in a signal with the fine-tuning control. Sound accompanied by buzz and hiss may be heard. Tune the sound if transformer, the sound takeoff coil, the quadrature coil and the buzz control for the loudest sound with minimum buzz and hiss. After adjusting all the coils and the buzz control, go back over each to see if some improvement can be made.

Persistent buzz

Persistent buzz or hiss that cannot be eliminated despite all efforts when making the adjustments just described may indicate that the front-end tubes, video if's, detector and video amplifier tubes are weak or that the agc needs attention. If the picture seems adequately strong and the contrast control is not too far

advanced, the trouble may be due to defective components in the gated-beam circuit. Try shunting the cathode and screen bypass capacitors with known good units.

Voltage divider

The audio output tube together with other tubes (such as the video if's) sometimes form a voltage-divider combination. In such a circuit arrangement the audio output tubes and the if's act as resistors in series across the B-plus line. The circuit of such an arrangement is shown in Fig. 1007.

Note that the cathode of the audio output tube does not go to ground or chassis. Since the audio and if tubes are in series, the same total current must pass through them. Observe also that the 135-volt B-plus point is not due to a resistive bleeder but is the result of arranging the if tubes and the audio amplifier in series. In circuit connections of this type, measure the B-plus at the cathode of the audio output tube to determine if the circuit is working properly.

If the audio output tube fails, there is loss of picture and sound, as all of the if tubes become inoperative.

The 135-volt bus is often used as the screen-grid voltage supply for other tubes. For example, the screen grid of the horizontal output tube may be connected to it. Should the electrolytic capacitor connected between screen grid and cathode of the sound output become excessively leaky, the potential at the cathode of the audio output tube would rise, effectively raising the bias on the audio output tube cathode, driving it toward cutoff. As the bias increases, the effective voltage between plate and cathode is reduced an equal amount. No damage to the output tube should result.

There are other tubes connected to the 135-volt line, which has now become 240 volts. Excessive current might damage these tubes or produce results which could waste considerable time in useless troubleshooting. If the screen grid of the horizontal output tube has its voltage increased, the high voltage to the picture tube will also rise. As a result, picture size will be reduced. And yet the trouble is in the audio section and has nothing to do with the horizontal sweep.

To check circuits using tubes as voltage dividers, obtain the manufacturer's circuit diagram. Check the bias of the tubes that are connected in this way. Supplement this with screen-grid and plate voltage checks. In a series tube connection, a weak tube can

produce symptoms of trouble much more rapidly than if the tube were operated independently. Do not try to make voltage checks with one of the series tubes out of its socket. Look for electrolytics that have become leaky or shorted. As a quick check, disconnect one side of the suspected electrolytic while making plate, screen or bias measurements. If there is a very noticeable change in voltage, replace the electrolytic.

Buzz

Buzz can be due to misadjusted agc control. Before turning the control, tune in a number of stations and note if it is present on more than one channel. If it is not, it is possible that it is station trouble. Insert an attenuator pad between antenna terminals and the lead-in. If the buzz decreases markedly or disappears completely, then it may be caused by an improper setting of the agc control. Adjust the control for best picture and sound on all channels. Make sure the fine-tuning control is properly set and that the contrast control is positioned for the best picture. Some complaints of buzz are due to the fact the customer does not know how (or does not care to bother) to tune the receiver properly. In some receivers, improper adjustment of the fine-tuning control produces buzz.

Overloading can result in buzz. Since the sound travels through quite a number of tubes (from the front end to the audio amplifier), it may be necessary to check through stages other than the audio if detector and amplifier. Start with the audio output tube and using a vtvm read dc bias volts on all tubes, back to the front end. If the bias is not normal for a particular tube, try a substitute. Make plate and screen voltage checks to determine if B-plus, tube and associated components are what they should be.

Some technicians assume immediately that buzz must be caused by troubles in the audio circuit. This is a mistake. For example, a poor contact between the Aquadag coating of a picture tube and its grounding clip can produce buzz. And, of course, buzz can easily be caused by misaligned video if's. However, before attempting realignment (which may not be necessary) make sure that buzz is not being produced by faults which can be more easily corrected.

Buzz can also be caused by a number of other factors. If the receiver uses a vacuum tube as the video detector, try substituting a new one. An aging crystal diode (used as a video detector) can also be the cause.

Buzz can be a high-voltage problem. The current that flows through the picture tube is an on-off arrangement. The reason a raster is seen at all times is due to persistence of vision. The picture-tube phosphor also glows for a short time after the scanning beam has been cut off. During scanning time, a current flows from the cathode of the picture tube to the screen. During retrace time, the beam (or current flow) is stopped. As the scanning current is switched on and off again, it can induce a voltage into the sound circuits — and this sound will resemble buzz. Remove the high-voltage connector to the second anode of the picture tube. If the buzz stops, it is being caused by picture-tube circuits. You can also check by turning the brightness control so that the raster or picture is cut off, or remove the picture-tube socket. Keep all picture-tube leads away from audio wiring. Make sure the Aquadag coating is securely grounded.

Buzz can be produced by the vertical sweep circuits. Remove the vertical oscillator tube. If the buzz stops, it is being produced by the vertical sweep circuit. Examine wiring to see if any wires are close to audio leads. Buzz can be inserted into the audio section through a common power supply impedance. Both the audio and the vertical sweep work from the same power supply. Consequently, it is possible for some vertical sweep voltage to get into the power supply and from there into the audio. Try adding more filter capacitance (electrolytic) to B-plus lines going to the vertical sweep and to the audio amplifier. Added decoupling filters are helpful. The trouble is sometimes caused by electrolytics in the power supply. This may be accompanied by hum.

Sync buzz due to improper modulation

Sync buzz can be caused by inadequate modulation at the TV station. If the video carrier level is too low with respect to the position of the sound-carrier level, there will be excessive amplitude modulation of the sound. If the picture-signal modulation is properly maintained at the TV station, sync buzz due to this will not be heard.

As a quick check, turn to another active channel. If sync buzz is not heard on other channels, the trouble is not in the receiver.

Hum

It is important that you learn to distinguish between hum and buzz. Buzz sounds rough and raspy; hum is much smoother. Some technicians can identify hum by frequency — that is, whether

it is at the power-line frequency and, therefore, comes from the primary of power transformer or from the heater wiring. In half-wave rectifiers, it can be present in the B-plus output. If the hum is 120 cycles, it invariably comes after the rectifier in full-wave rectifier type power supplies.

The volume control is a handy dividing point when first tracking hum troubles. Adjust the volume control and carefully listen to the hum. If you can change the hum level with the volume control, the trouble is in circuits that precede the control. If rotation of the control has no effect on the hum, then the hum is in circuits following the volume control.

Hum in circuits after volume control

The volume control is in the grid circuit of the audio amplifier tube. If the audio amplifier consists of two tubes, the volume control is in the grid circuit of the first audio amplifier.

If the receiver has a two-tube amplifier, ground the control grid of the audio output tube. If the hum disappears, then the trouble is in the first audio amplifier or components connected to it. Momentarily ground the cathode of the first audio amplifier tube to the chassis. If the hum disappears, the trouble is due to heater-to-cathode leakage. Examine the volume control. Most often, this is a combined on-off switch and volume control. Make sure the power-line leads are dressed away from the wire going to the control grid of the audio amplifier tube.

If the hum cannot be removed except by removing the audio output tube — try an electrolytic capacitor at the B-plus connection of the output transformer. Reduction or elimination of the hum at this point indicates insufficient power supply filtering. Replace or install additional capacitors.

Hum in circuits before volume control

Examine the raster or the picture on the screen. If there is a hum bar (wide dark horizontal bar) on the screen and there is also hum in the sound, the hum is prior to the sound takeoff. If the set has parallel-connected filaments, remove the last video if amplifier tube and examine the raster. If the hum bar remains, the trouble is somewhere between the picture detector and the sound takeoff point. If, however, the hum in the sound and picture disappears when the last video if tube is pulled, then the trouble is in some stage preceding the video detector.

In receivers that have series-connected filaments, use either a dummy tube or remove the plate and screen grid leads from the

last if tube. (WARNING: Do not remove a plate lead with the screen lead connected. This will burn out the screen.)

A sixty-cycle hum can be due to heater-to-cathode leakage in any tube from the front end up to the sound takeoff. Ground each tube cathode and note if the hum symptoms disappear. Do this test quickly so as not to damage the tube. If grounding the cathode of a particular tube causes the hum symptoms to disappear, replace the tube.

Distorted sound

Sound distortion can be so slight that it is annoying (but endurable) or so garbled that speech cannot be understood. First, determine if the problem exists on one or all channels. If sound is bad for one channel only, then it is quite likely that the oscillator slug for that channel needs some retuning. If the sound is distorted for all channels, the difficulty is in the sound section of the receiver.

Locate the defective stage by injecting a signal into the control grid of the audio output tube and work back, stage by stage, to the sound takeoff point. This technique works easily if the distortion is very severe. If the distortion is slight, this method may or may not work.

Measure tube bias, screen-grid and plate voltages. Bias is especially important since a small shift in bias voltage can cause the tube to work in the cutoff or saturation region. Voltage checks often lead to the location of a defective part, such as a resistor or capacitor.

When all voltages check good, it is possible that the sound takeoff coil, the sound if transformer and the ratio detector need some readjustment. Loose slugs in tuned-coil circuits (sound if, ratio detector, etc.) can be the reason for the need for realignment. Hold the screw end of the slug between two fingers and see if you can turn the slug easily. If you can, then the slug is too loose. After realignment, put a dab of coil cement at the point where the slug enters the can. Be careful not to upset the position of the slug when doing this.

Audio lead dress

Some technicians feel that audio lead dress isn't important because of the relatively low frequencies involved. It is true that capacitance between audio leads and chassis is not as important in audio circuits (in television receivers) as, for example, in the front end, but a variety of other troubles can arise if connecting leads are not properly placed.

Running a filament lead close to or parallel to a grid lead can produce 60-cycle hum. Placement of a plate lead near a control grid lead can result in regeneration (unstable audio, whistling, squeals, etc.). If the control grid leads (including the wires going to the volume control) are dressed too closely to vertical sweep circuits, buzz will be heard in the sound. This also applies to sync separator and amplifier leads and wires going into the picture tube socket.

Motorboating

This symptom, as its name implies, produces a sound that will remind you of the noise made by an outboard motor. Look for open electrolytics or filter capacitors that have changed their capacitance (lower values). Check by shunting existing units with capacitors having equal voltage and capacitance ratings. Look especially for filter capacitors that are connected to the B-plus line going to audio circuits.

Sound and picture weak

When sound is weak and the picture seems washed out, look for a trouble that is common to both picture and sound. The low-voltage B-plus supply is such a source and the most common trouble is a weak rectifier. If the low-voltage supply uses two rectifiers, replace both. If the sound and picture are weak on all channels, check the line voltage. Weak picture and sound can be caused by open electrolytics or filter units which have changed their capacitance. This will usually be accompanied by hum in the sound.

Weak picture and sound can be caused by improper agc adjustment or by a weak tube through which both picture and sound will pass (front end, video if's, video detector, video amplifier). Sometimes the trouble will be due to a video if tube that is completely dead but which, through capacitive coupling, will permit some signal to get through. The fact that the filament of a tube lights is no indication that the tube is good.

Sound missing on some channels

If the oscillator slug for a particular channel is not in its proper position, the picture may come through but sound may be missing. Rotate the channel selector to all channels. If the sound is good on all channels except one, then try adjusting the oscillator slug for that channel whose sound is missing.

Intermittent sound

Should frequent adjustment of the volume control be required, or if the sound blasts and then drops to normal, some component is causing a severe change in gain. If the variation is accompanied by changes in picture contrast, the trouble precedes the sound takeoff point and can be caused by trouble from the front end up to that point.

If the picture is good but sound fluctuates, trouble follows the sound takeoff point. This trouble is sometimes caused by the coupling capacitors of the audio tubes. Examine them for loose leads or poorly soldered connections. Tap these capacitors with the rubber end of a pencil while the set is on and note if it has any effect on the sound. Check the grid voltage of the audio tubes to see if capacitor leakage is affecting the bias of those tubes.

Intermittent capacitors and resistors are often difficult to detect. Their appearance may indicate nothing wrong and quite often an inspection would seem to show that they are in good condition. With the set turned on, tug gently on each resistor or capacitor lead (use an insulated tool) to determine if a loose lead is causing the trouble. Try shunting the resistor or capacitor under observation with a known good unit of equivalent value.

This may distort the sound, but keep in mind that we are simply looking for the cause of an intermittent. If shunting a particular component removes the intermittent (even if it distorts the sound), then that component should be replaced.

Intermittents can be caused by items that are difficult to find. A blob of solder may conceal a joint that is really not soldered at all. Wires can be broken or barely touching beneath the insulation. Sometimes sound will not become intermittent until some while after the receiver has been turned on. This indicates that some component is breaking a connection due to expansion. Resistors — especially cathode resistors — are quite often responsible.

Sometimes intermittent sound is produced by nothing more serious than improper seating of tubes. Make sure that each audio tube (if, detector, audio amplifier) is firm in its socket. If tubes are miniatures, examine pins to make sure they are not bent. Don't take for granted that the right tube is in the right socket. Examine tubes with the set turned on and look for telltale signs of internal shorts in the tube (sparking between elements). Such shorts, occurring only after the tube has been on for some time, are not always revealed by tube-tester checks.

Occasionally sound will drift after a set has been in operation for a little time. In severe cases the sound will also become distorted. The trouble may be caused by oscillator drift in the front end. Temperature-compensated components are often used in tuners. Parts replaced with standard components can result in drift. The effect on sound will be much more serious than on the picture because the bandpass of the sound if is much narrower and more critical than that of the picture.

Unless the drift is on all channels, the tuner is not at fault. The trouble may be due to the sound detector tube. A defective tube can detune the secondary of the ratio detector transformer. This will occur only after the tube has been on for some time.

As a last resort, try realignment of the sound takeoff, sound if and ratio detector transformers. Should any of these be sluggish – that is, adjustment of the polyiron slug produces very little change in sound output or quality – examine the coil and any capacitors connected across it.

Microphonics

Microphonics represent a form of sound modulation due to instability of the elements in a vacuum tube. The vibrations of tube elements are too small to be seen – but they can be heard, since even a very tiny change is tremendously amplified.

A microphonic tube produces squealing, howling or whistling. The sound can be intermittent or continuous. It can be produced when the cabinet is touched, when someone walks across the room, or when the volume control is turned up.

Microphonics are caused by vibration. Sponge-rubber padding placed under the set (table model) or rubber cups of the type used for furniture (console models) will help minimize the trouble. Sometimes the speaker is responsible. Remove the speaker and hold it by the metal frame away from the set. If microphonic symptoms diminish or disappear, replace the speaker but insert rubber grommets as spacers between the speaker frame and the cabinet. Try tapping tubes with the rubber end of a pencil to see if you can locate the sensitive tube. Putting a heavy lead shield over a microphonic tube will often eliminate this trouble.

Excessive bass response

In most receivers you will find a capacitor connected between plate and screen grid or plate and cathode of the audio output tube. If the sound seems boomy, check this capacitor. If it is good, replace it with one having a smaller value. This may require

some experimentation. Try a .002- μ f unit rated at 600 volts dc. Also try this if the speaker grille cloth rattles, particularly during a loud sound passage.

Noise in sound

Noise in the sound is not always a defect in the receiver nor is it always a problem that can be cured by the service technician. If the receiver is in a weak-signal area, tubes must operate at maximum gain and agc bias at minimum levels. Under such conditions, there isn't too much that be done about eliminating noise. Test all tubes through which the sound must pass. Reject or substitute any tubes that are weak (not necessarily defective). Adjust the sound take-off transformer so maximum audio signal goes into the first sound. Tune the primary of the ratio detector transformer for maximum sound output. If the cathode resistor of the audio output tube isn't bypassed, try putting a low-voltage high-capacitance electrolytic across it. Adjust the individual oscillator slug in the front end for best sound (without affecting picture strength or quality). Substitute an antenna having higher gain. If this isn't possible, install an indoor antenna but do not remove the connections to the outdoor antenna. Adjust the indoor antenna and experiment by placing it at different locations in the room to see if picture and sound strength can be increased.

Loss of sound due to misalignment

Sometimes, especially in fringe areas, video if's will be aligned for a narrower bandpass to increase picture strength. If the bandpass is made too narrow, it is possible for sound to be lost.

Squealing

Occasionally a receiver will squeal or whistle when the volume control is turned up or when loud audio passages are received. This could be caused by regeneration (positive feedback) in the audio amplifier. Make sure plate and grid leads are away from each other. Wires to the speaker should not be draped near tubes. If the audio section has a decoupling network (resistor and capacitor — usually an electrolytic), try a new electrolytic. If the lead to the volume control is a shielded wire, do not replace it with a wire that is unshielded. Sometimes putting a metal shield over the audio tubes (make sure the shield is grounded) will help. Also, disconnecting the cathode bypass capacitor of the audio tube will help minimize this trouble (it will also reduce the volume slightly).

Fig. 1008. Two-stage audio amplifier with tone-control networks. Signal-injection and signal-tracing test points are indicated.

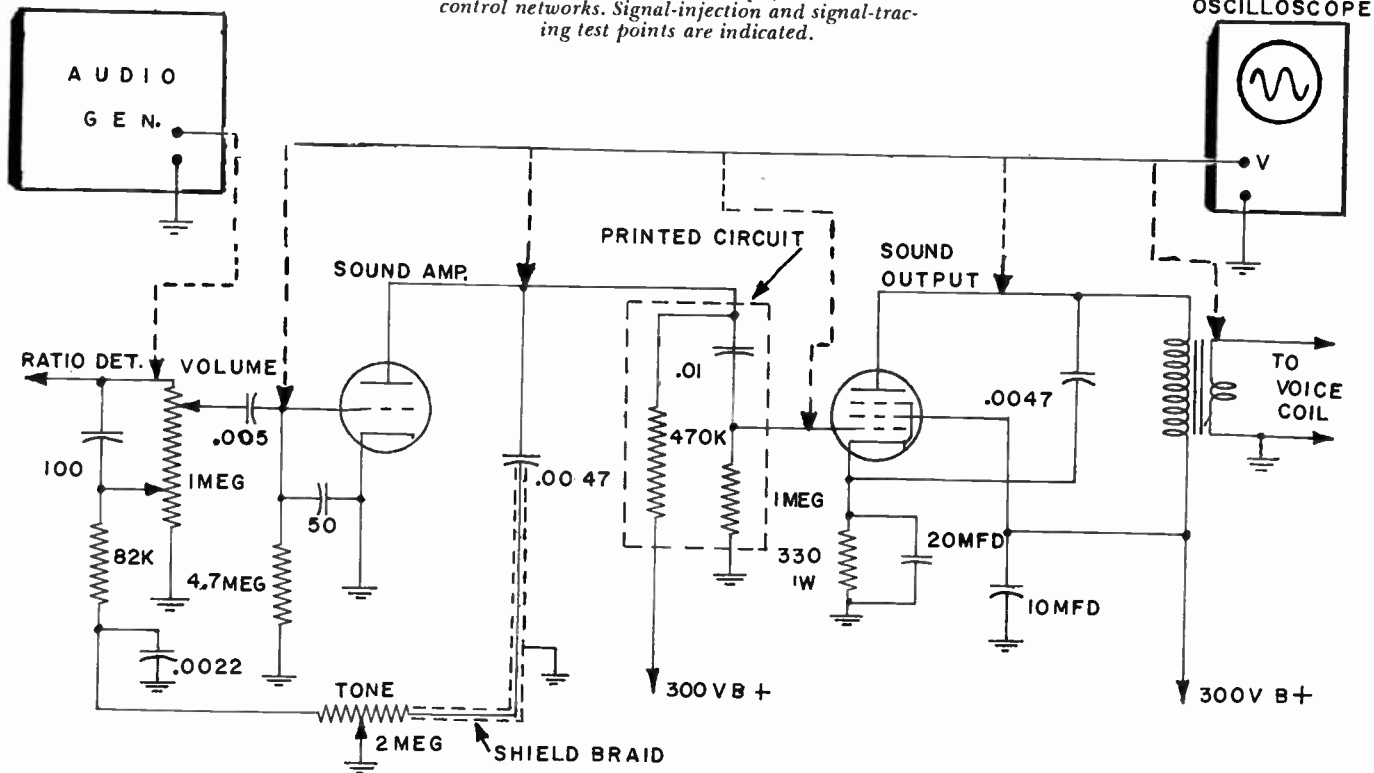

Audio output stage

In some receivers, the output of the sound detector feeds into a single-tube audio amplifier which drives the speaker. More elaborate arrangements are used in other receivers. A two-stage audio amplifier, and quite possibly a tone-control circuit, for example. And some sets use push-pull output.

Fig. 1008 shows a typical two-stage audio amplifier circuit, including a tone control. If the complaint is no sound output, a quick check can be made by injecting a signal at the top end (ungrounded end) of the volume control. Do this by intermittently grounding the top end of the control with a screwdriver — use a capacitor on series heater chassis. (*Be careful*—don't short ac lines connected to the switch control.) This should produce a scratching sound in the output.

Another method is to connect a .01 μf capacitor between the volume control and the ungrounded side of the filament line. Use the filament of the audio tube since this will be a convenient connection. The audio output of a signal generator might be just as convenient.

If this test produces a steady hum or audio tone from the speaker, then the trouble precedes the volume control. It should be possible to increase and decrease the sound level with the volume control.

If there is no sound out of the speaker when injecting a signal at the top end (or hot end) of the volume control, move the test lead over to the control grid of the first audio amplifier. With sound at this point (but no sound when checking at the volume control), then the capacitor between the volume control and the control grid of the audio amplifier tube is open. If injecting a signal at the control grid produces no output, proceed to the plate of that tube.

Use this technique for checking audio amplifier stages. If signal injection into the control grid does not produce sound, but you do get sound when the test lead is connected to the plate, some defective component (or tube) in that circuit is killing the sound.

The "shorting technique" — that is, grounding control grid or plate with a screwdriver — can be used in place of a generated test signal voltage, but it is not recommended (although a number of technicians work this way). Shorting (even if done very quickly) can damage tubes and components and isn't much faster than using a signal generator.

Audio amplifier voltage checks

One of the best checks on the performance of amplifier tubes is to measure the bias across the cathode resistor. If there is no voltage drop across this resistor, the tube isn't conducting. It is shorted or some component is causing the tube circuit to be open. Zero voltage across the cathode resistor could be caused by a shorted cathode bypass capacitor.

To check a doubtful cathode bypass electrolytic, unsolder the lead that goes to the cathode. The ground end of the electrolytic should remain connected. Feed an audio signal from your generator to the volume control. Adjust the volume control for a moderate level of sound. When you have done this, take the free end of the electrolytic lead and touch it to the cathode terminal of the tube. There should be a small, but definite, increase in volume when adding a good capacitor.

The first audio amplifier plate load resistor will have a voltage drop across it if the tube is conducting. Measure the plate voltage (by checking between plate and cathode of the tube). This voltage should be less than the B-plus supply voltage.

The audio output tube will be connected to the primary of the audio output transformer. The plate voltage, the screen voltage and supply voltage are practically identical in the output stage. If the tube has screen voltage but no plate voltage, the primary circuit of the audio output transformer is open.

Scope checks

The scope is excellent for servicing audio amplifier stages. Properly used, it will supply much more information than a vtvm. You can use the scope for troubleshooting, hum checks and gain checks, all at the same time. Connect the audio output of your generator to the hot end of the volume control. Connect the vertical input terminal of the scope to the same point. (Turn on the receiver.) The ground terminal of the generator, the scope and the receiver chassis should all be connected. Now adjust the signal generator and the scope until you see two complete waves on the scope (Fig. 1008).

Connect the scope lead to the control grid of the first audio amplifier. (Do not touch any controls — receiver or instrument.) The waveforms should be practically identical to those first observed. If the waveform disappears (straight line shows on scope) or becomes much weaker, then the coupling capacitor is open or the grid circuit is grounded.

Move the scope lead to the plate of the first amplifier tube. The waveform should be much larger and essentially the same shape as that indicated when the scope was connected to the grid. If the waveform is smaller or if it is severely distorted, then trouble exists in the first audio amplifier. Replace the tube. If this doesn't help, check all components connected to the tube. (This test will also reveal the presence of hum if the complaint is hum in the sound.)

You can also use the scope to check on how well cathode bypass capacitors function. Connect the scope leads across the cathode resistor with the vertical input terminal connected to the cathode of the tube and the ground terminal of the scope connected to

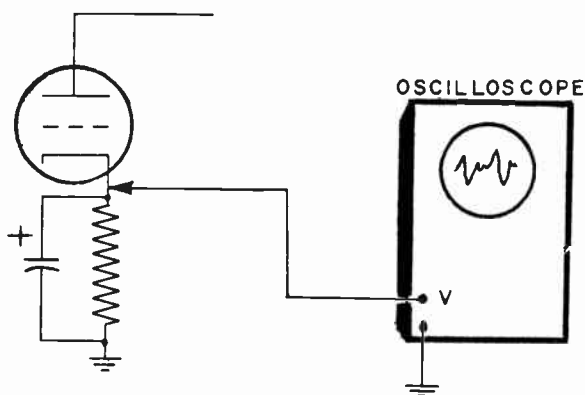

Fig. 1009. Scope connected here will indicate the amount of audio not bypassed.

the chassis (if the cathode resistor is also connected to chassis). (Fig. 1009.) If the electrolytic is working you should see a straight horizontal line on the scope. If you get a wavy line, remove the vertical test lead of the scope and connect it to the chassis also. If a wavy line remains on the scope, the trouble is in the scope and not in the receiver. Keep the scope leads away from any 60-cycle leads (such as the filament lead of the receiver). This can induce a hum voltage into the scope, making tests meaningless.

Audio output transformers

A resistance check across primary and secondary will indicate quickly whether transformer windings have continuity. Average primary resistance is 500 ohms, secondary is a few ohms. It is best to use an identical replacement (or substitute unit recommended

by the manufacturer). Not all audio output transformers are alike. Some are designed to feed a number of speakers, others have tapped secondaries for negative feedback. An incorrect substitute may be too large or too small and may mean drilling mounting holes. In addition, an incorrect replacement may not be satisfactory as far as sound is concerned.

If sound can be heard coming from the output transformer, one of the laminations is probably loose. Remove the metal channel around the transformer and spray the transformer with an acrylic resin or anti-corona lacquer. Wait for the spray to dry, and then test the transformer by tuning in a strong station.

The plate lead of the audio output transformer is sometimes color-coded blue and the B-plus lead is red. As a rule, transposing

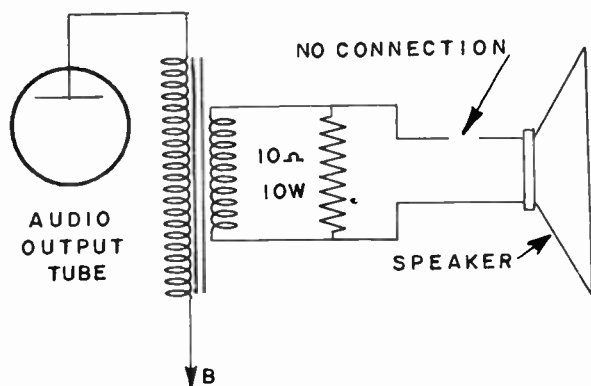

Fig. 1010. With speaker disconnected, it is possible to damage the audio output transformer.

these leads does no harm, except for push-pull types or when the secondary of the transformer is used for negative feedback. If, in replacing a transformer, you get a severe howl or squeal, try transposing a pair of leads.

When servicing, do not remove the speaker from the audio output transformer. If the speaker is disconnected from the secondary of the audio output transformer, the audio output tube will be unloaded and it is possible for it to become damaged. If the sound is annoying when servicing and, for some reason, receiver controls cannot be adjusted to reduce the sound, disconnect one side of the speaker from the output transformer. Across the secondary of the transformer connect a 10-ohm 10-watt resistor (Fig. 1010).

Speaker troubles

A common complaint is that the speaker rattles, particularly on loud passages. Examine the speaker cone for rips or tears. If it has any, put in a new speaker cone or replace the speaker. (If the receiver uses a small, inexpensive speaker — as is often the case — it is probably more economical and quicker to replace the speaker). Do not try patching ripped speaker cones with cellophane tape. As it dries, the tape will become unfastened, producing exasperating rattles every time the cone moves. Rubber cement can be used to hold the edges together and prevent rubbing. A hot soldering iron can readily be used to burn away the rubbing edges, to eliminate the sounds made. When the paper cone warps, the voice coil in the speaker rubs against the magnetic gap material. This is most noticeable when the sound is not very loud. Sometimes a small wad of absorbent cotton or tissue paper can be inserted between the cone and the frame, reducing the distortion sufficiently to make listening enjoyable until a proper replacement can be obtained.

If you get no sound out of the speaker, try pulling the audio output tube out of its socket and then wiggle it so that it makes intermittent contact with the socket. Should there be no sound from the speaker when doing this, turn the receiver off and connect one side of a 1.5-volt battery (either positive or negative terminal) or an ohmmeter to one lead of the secondary winding of the output transformer. Connect a lead to the other terminal of the battery and touch this lead (momentarily) to the other side of the secondary winding. You should hear a click in the speaker. If you do not, the voice coil may be jammed or open. Possibly the magnet of the speaker may be too weak. Connect the voice coil leads of a test speaker to the secondary of the output transformer. If the test speaker operates properly, the receiver speaker needs replacement.

Rattling may be caused by a loose grille cloth. Sometimes one of the screws holding the speaker becomes loose and can produce a distracting rattle.

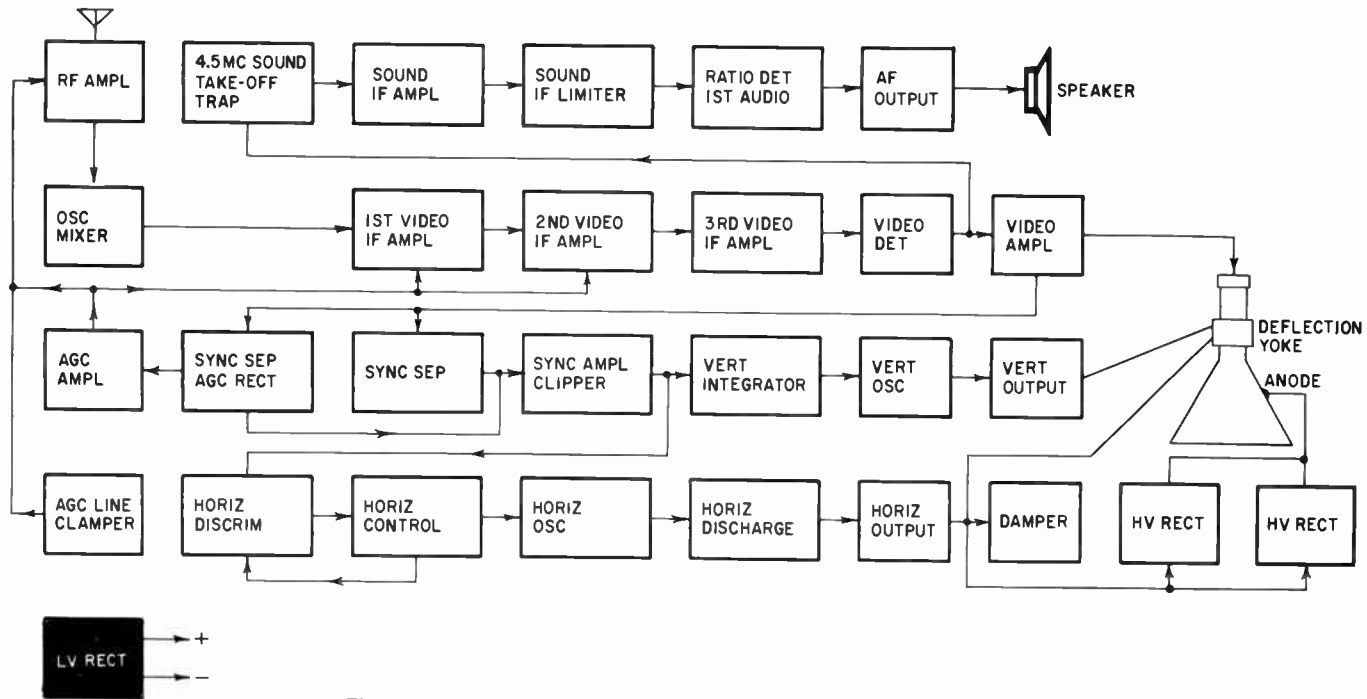

Fig. 1101. The power supply may affect any or all of the receiver sections.



low-voltage troubles

chapter 11

REGARDLESS of its design, the function of every low-voltage supply is to furnish dc screen and plate voltages for almost all of the tubes in the receiver (cathode bias is also part of the low-voltage B-plus distribution system). The amount of B-plus ranges from approximately 150 to 300 volts, depending upon the receiver.

Types of power supplies

All low-voltage power supplies can be divided into two main groups — those that operate from a power transformer and those that work directly from the power line. The receivers that work from the power line are called transformerless. Note that the term ac-dc, as used for radios, does not apply here since transformerless television sets are not intended to operate with dc input.

A clear-cut distinction doesn't always exist between transformer type power supplies and transformerless units, since, in some transformer types, the filaments work from the power line and not from the transformer.

Transformer type power supply

Before we start on this very important section of the TV receiver, examine Fig. 1101. The low-voltage supply is shown as a separate unit with positive and negative leads coming out of it.

To draw all of the connecting lines between the power supply and the receiver would have added unnecessary complications.

A simple diagram of a transformer type supply is shown in Fig. 1102. There are three secondary windings, one for the plates

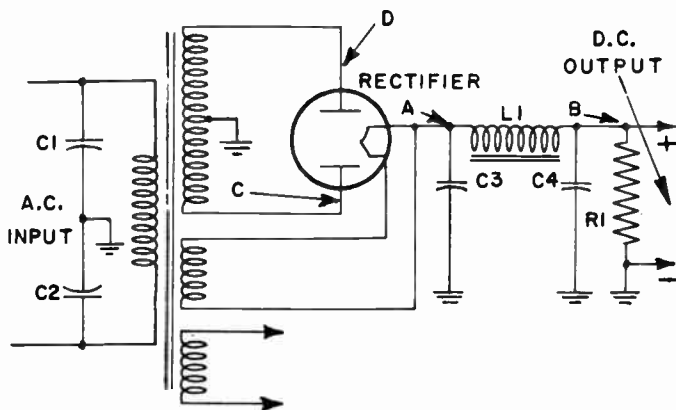

Fig. 1102. A basic full-wave transformer power supply circuit.

of the rectifier tube and two filament windings. One of these windings is for the rectifier while the other supplies filament voltage for the other tubes.

Testing the power supply

A vtvm (or vom) can be used to make checks on the power supply. Every power supply has two kinds of voltage — ac and dc. General servicing technique is to make dc measurements since this will permit you to follow the B-plus line straight through to the various plates and screens in the receiver. This servicing method localizes trouble quickly.

Although the voltage across the filament of the rectifier is ac (low voltage), the emf from filament of the rectifier to the chassis is the maximum low-voltage B-plus you will measure in the receiver.

There will generally be less than 400 volts dc at the filament. If the dc voltage is normal when making this check, voltage troubles follow the rectifier; if not, they precede it. The first check point is shown as A in the diagram of Fig. 1102.

If normal dc voltage appears between the filament of the rectifier and chassis, move to point B. No voltage here means that the filter choke (or resistor, if one is used) is open.

We are not only concerned with a trouble of “no dc voltage”

in the receiver, but also difficulties such as insufficient voltage, hum in the dc, fluctuating dc, dc intermittently on and off, etc.

Checking rectifier filament voltage

A glowing filament, easy to see in most rectifier tubes, indicates that the rectifier is receiving filament voltage. Be careful when trying to measure the filament voltage. Although the filament emf is just a few volts, it is several hundred volts above ground. For safety, remove the rectifier tube and, with the meter set to read low

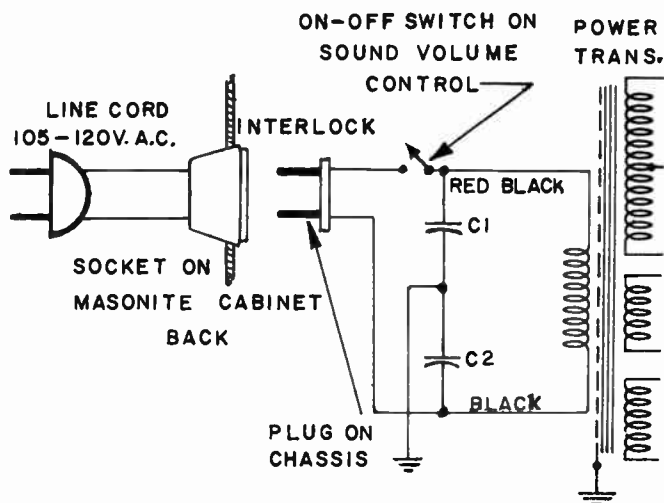

Fig. 1103. Primary circuit of the power transformer can develop faults in many places.

ac volts, place the test prods across the filament pins. After testing, turn the set off. Never plug a rectifier tube into its socket when the set is turned on. Always make sure that the set has been off for at least a few minutes before returning the tube to its socket.

No voltage at rectifier filament

If a test indicates no dc voltage between rectifier filament and chassis, try substituting a new rectifier tube (or check the tube in a tube tester). If the tube is good, the trouble (no dc voltage) is in the transformer or the primary circuit of that transformer.

Set the meter to read ac volts (full-scale reading of not less than 1,000 volts), put the test prods across the plate terminals of the rectifier tube. You can use the socket terminals or else remove

the tube and insert the test prods into the socket (points C and D in Fig. 1102). You should read the full voltage of the secondary winding. If not, remove one of the test prods and connect it to chassis. In this location, the test leads are across one half of the secondary winding — that is, from point C or D to chassis, as shown in Fig. 1102. With no voltage from point C or D to the chassis, and yet the rectifier tube is lit, the trouble is definitely due to an open turn in the high-voltage secondary. Turn the receiver off and make an ohmmeter check of the secondary.

If the rectifier tube does not light, substitute a new tube known to be good. If the new tube does not light, do not make the checks on the high-voltage secondary mentioned in the last paragraph. Measure the rectifier filament voltage. Absence of filament voltage generally indicates a poor connection to the filament or else the trouble is in the primary circuit. An open in the filament winding of the power transformer, although a possibility, is quite unlikely since the secondary is wound with fairly heavy wire.

Checking the primary

If the rectifier tube does not light and there is no ac voltage when measuring at the plates of the rectifier, there is some trouble in the primary circuit.

The primary circuit consists of the following components: primary winding, line filter (shown as C1 and C2 in Fig. 1103), on-off switch, line fuse, line cord and power outlet.

Avoid pulling the chassis if at all possible. Remove the back of the receiver. The line cord is part of the cabinet's back panel

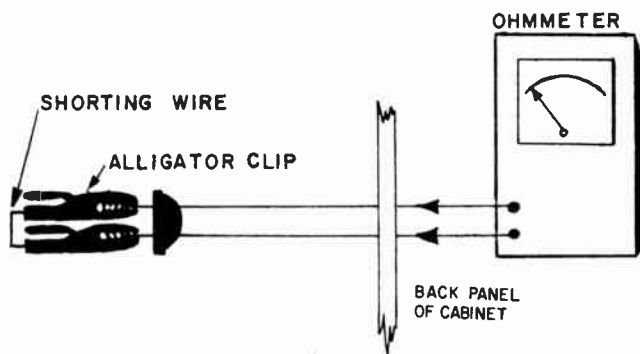

Fig. 1104. Shorting the male-plug end of the line cord simplifies continuity tests of the line cord.

and removing it disconnects the mating male and female connectors (interlock) of the line cord at the receiver. With the line cord plugged into the power outlet, read the ac voltage at the female connector mounted on the back panel. With a line-voltage measurement here, the trouble lies between the male connector mounted at the rear of the receiver and the primary of the power transformer. If there is no line-voltage indication when making this test, the trouble is in the line cord or in the outlet. Examine the male plug of the line cord. The connectors may be spread or broken. Also, try another outlet or line cord. Check the line cord. Short the male-plug ends with a clip lead and then, using an ohmmeter, make a continuity test, as shown in Fig. 1104. If this shows continuity, the trouble is in the power outlet. If you get an infinite-resistance reading, the line cord is defective and needs replacement.

An easy way to check the power outlet is to plug in a lamp. First try the lamp in some other outlet to make sure that it works. Then check the suspected outlet.

On-off switch

If the checks previously described show the presence of ac voltage right up to the back panel of the receiver, replace the back panel but do not fasten it into position. Rotate the on-off switch to the on position. Gently move the back panel a small distance. It is possible that the mating connectors at the back panel are not making good contact. Watch the rectifier tube, or pilot lamp, to see if it lights momentarily. If it does, the trouble is in the female connector. If the connectors are good, check the switch on the volume control.

Resistance checks

Do not assume that the voltage checks must be followed step by step, or only voltage checks should be made. The reason for describing voltage checks in a continuous manner is to indicate the variety of tests which can be made by voltage measurements. A competent service technician, however, will move from voltage to resistance checks and back to voltage tests as the servicing problem requires. And this will also be accompanied by visual inspection. For example, one of the first items to check would be the line fuse. Sometimes this is part of the line plug itself, or it is mounted in or on the receiver chassis. In some sets the fuse is mounted on the rear apron for easy checking and removal.

To check the entire primary circuit (in a receiver using a

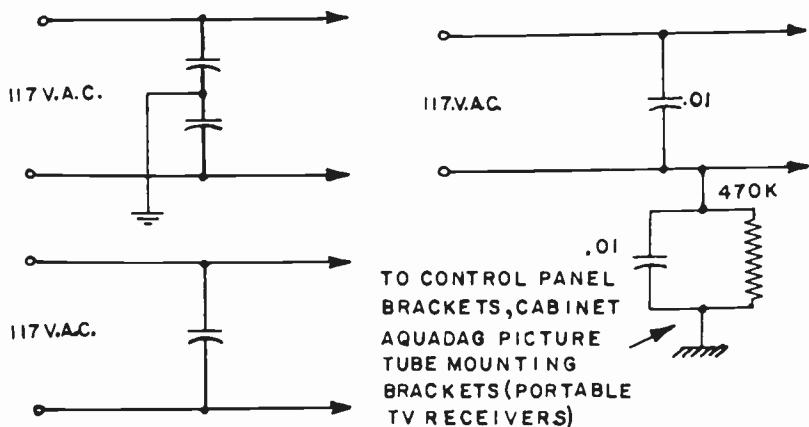

Fig. 1105. In the upper-left circuit, one capacitor is always shorted if chassis has an external ground. The circuit on the right may require line-cord plug reversal for maximum bypassing.

power transformer), set the test meter to read ohms and insert the test leads across the male plug of the line cord. Turn the power switch on and off. With no change of reading on the meter, the trouble is in the primary circuit. Now proceed to pinpoint the difficulty with voltage and resistance checks.

Line-noise filter

Shunted across the primary you will sometimes find one or two capacitors (C1 and C2 in Fig. 1103). These work as a line-noise filter and absorb sudden changes in line voltage caused by noise pulses. For example, line noise could be due to a refrigerator cycling on or off, an oil burner turning on, etc. If the capacitor is open, the only effect would be that the customer might notice a momentary noise out of the speaker. The picture might also slip a frame and then lock into place once again. How serious this is depends entirely on your customer and the number and age of the electrical appliances tied into the same line with the television receiver. If the capacitor is open, little harm will be done. If the capacitor is shorted, the line fuse will blow.

If two capacitors are used, as shown in Fig. 1105, only one of the capacitors will be working. Since one side of the power line is grounded, one of the capacitors will be shorted. The reason for using two capacitors is that no one has any way of knowing just how the plug will be inserted into the power line. Sometimes the capacitor is connected directly across the power line.

Fig. 1105 shows some typical filter arrangements. If the complaint is noise in the receiver, try reversing the line plug. The filter will work only for noise pulses coming through the line. It will not prevent radiated noise voltages from reaching the TV set. It is always best to remove line noise at the offending appliance — prevent it from getting into the line.

Insufficient B-plus voltage

The most usual cause of insufficient B-plus voltage is a rectifier whose emission has decreased. Turn the set off. Allow all tubes to cool. Then substitute a new rectifier tube. Check the power line to make sure that the ac input to the power transformer is adequate. If the line is overloaded, this could cause insufficient B-plus. Many homes today are not adequately wired. The use of

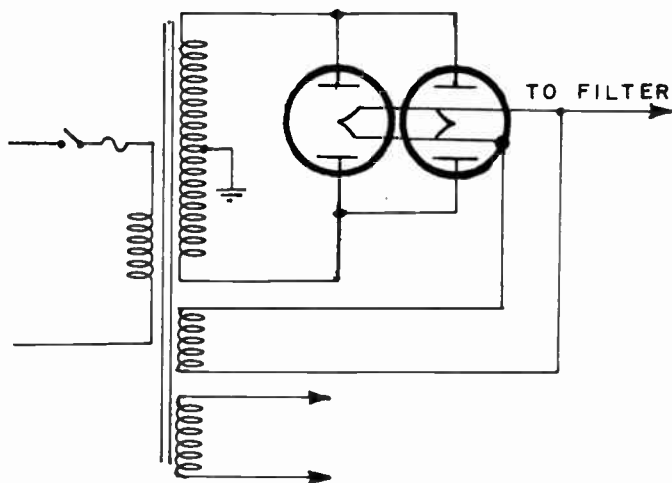

Fig. 1106. Rectifier tubes wired in parallel. If one rectifier tube becomes weak, the other becomes overloaded.

electrical appliances has increased tremendously in the last few years. Insertion of a larger-size fuse does not compensate for lines not designed to carry heavy appliance currents.

If replacement of the rectifier does not help, remove tubes such as the audio power output tube from the receiver. If a voltmeter connected across the output filter capacitor does not show a rise to normal output voltage or higher than normal voltage, it is possible that trouble exists in the power supply. Disconnect the B-plus bus. There should be a definite rise in voltage, as shown on the meter

(still connected). If not, then the trouble exists in the power supply. The cause is most often a leaky or open filter capacitor. Power supply trouble is often accompanied by other symptoms. There may be hum in the sound, picture and sound may be weak or sync may be critical. The raster or picture may be small. Brightness may be low and there may be evidence of blooming.

Parallel rectifier tubes

In some receivers rectifier tubes are connected in parallel as shown in Fig. 1106. Since it is very unlikely that the filament emission of both rectifiers will decrease in an identical manner,

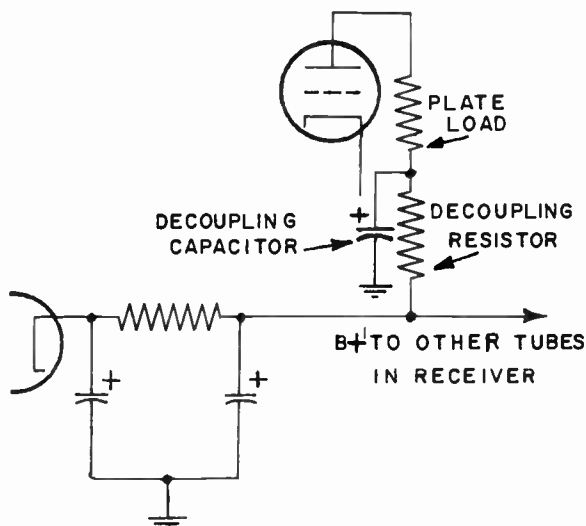

Fig. 1107. Basic decoupling filter network.

a weak rectifier in such an arrangement causes the other rectifier tube to become overloaded. If the receiver has parallel rectifiers and a test shows one of them to be weak, replace both tubes. Never remove one parallel rectifier tube from its socket with the set turned on.

Rectifiers generate considerable amounts of heat. When replacing or adding electrolytics, keep them away from the rectifiers.

Decoupling filters

A decoupling filter consists of a resistor and a capacitor connected in the B-plus line going to a particular tube. The decou-

pling filter is part of the filter system of the power supply itself. The difference between the decoupling components and the filter in the power supply is that the decoupling unit is a filter for a single stage or tube, while the power supply filter is for all tubes. A typical decoupling filter is shown in Fig. 1107. An open decoupling resistor will cut off plate and screen voltage from the tube to which it is connected. The resulting symptoms will depend entirely on the tube to which it is connected. If the decoupling capacitor is shorted, the power supply fuse may blow. If it is excessively leaky, the power supply will be overloaded and the fuse

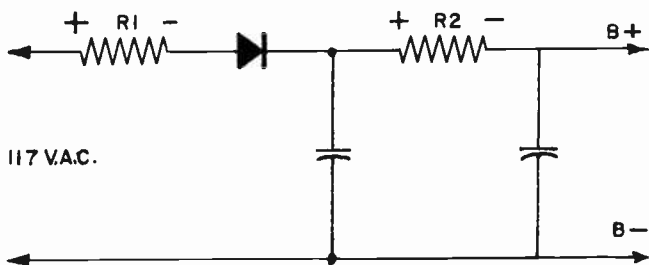

Fig. 1108. Basic half-wave rectifier. R1 is a surge-limiting resistor and R2 is the B-plus filter.

may or may not blow. It is possible for the rectifier filament (or filaments, if two tubes are used) to be damaged. The series filter resistor may become excessively hot.

Half-wave selenium rectifier supply

A typical supply using a single selenium, silicon or germanium rectifier is shown in Fig. 1108. Note that the straight-line portion of the rectifier symbol corresponds to the cathode of the vacuum-tube rectifier. The triangle of the rectifier is the same as the plate of the vacuum-tube rectifier.

The output of a power supply of this type is never more than 150 volts dc without a load. Resistor R1 is a surge resistor while R2 is a filter resistor. Although R1 precedes the rectifier, the voltage drop across it is dc as is the drop across R2. In the absence of dc, check both of these units with a dc voltmeter. The polarity is as indicated in the circuit diagram of Fig. 1108. Alternatively, R1 and R2 can be checked with an ohmmeter (with the receiver turned off).

A defective selenium rectifier is characterized by a bad odor. Test selenium rectifiers the same as crystal detectors — that is,

measure the ratio of forward to back resistance. Connect an ohmmeter and take a resistance reading. Transpose the leads and take another reading. The back resistance should be at least 10 times as much as the forward resistance, preferably more.

Voltage checks can be made in the same manner as described previously for the full-wave vacuum-tube power supply.

When replacing semi-conductor rectifiers, observe proper polarity or the rectifier will be ruined. The positive terminal (corresponding to the cathode of the vacuum tube) will be marked CATH, POS or PLUS. It may have a plus (+) sign or a red dot.

Fusible resistor

A pigtail type fusible resistor is sometimes used as a B-plus voltage and surge fuse. This fuse is sometimes located beneath the chassis, so it may be necessary to pull the receiver to replace it. A typical value is 10 ohms at 5 watts. Replace with an identical type. If a replacement isn't available, insert a 10-ohm 5-watt resistor, but put a fuse of proper current rating in series with the resistor.

Filament surge resistor

Some receivers use a special type of resistor to limit filament current surges. There is a momentary surge of current through tube filaments when the receiver is turned on. Filament resistance varies with temperature. Filament resistance is low when the set is first turned on, but the resistance increases as the tube filaments warm up. The filament current drops to normal as the tubes get hot. To prevent damage to the tubes, a negative-temperature-coefficient resistor is used (in series with the filaments) in some sets. This resistor behaves in a manner that is exactly opposite to that of the tube filaments. Its cold resistance is high but, as current flows through the resistor and it gets warm, its resistance decreases. The approximate cold resistance is almost 1,000 ohms. The hot resistance is less than 100 ohms. Check the efficiency of such a resistor by making an ohmmeter check of it (with the line plug pulled out). Then, turn the receiver on, allow it to operate for about 10 minutes, again pull out the line cord plug and quickly make another resistance check before it cools.

Many receivers use tubes whose filaments are designed to operate with controlled warmup time. You can recognize most of these tubes by the fact that their first number is generally 2, 3, 4 or 5. (There are exceptions to this.) These numbers refer to the heater voltage, but are simply an approximation. Thus,

the 3AL5 has a filament voltage of 3.15. The 5AM8 has a filament voltage of 4.7 volts, etc.

Selenium voltage doubler

A full-wave voltage doubler using selenium rectifiers is shown in Fig. 1109. Note that the surge resistor is rated at 15 watts and that the line fuse is in series with it. The dc output will be approximately 300 volts without a load, dropping to about 250 volts dc in a typical TV receiver. The only difference in the filter circuit is that the input filter capacitors are in series and the electrolytics have a higher voltage rating. Voltage and resistance checks are similar to the other power supplies described in this chapter.

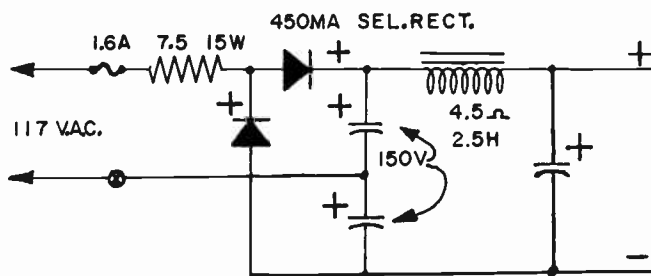

Fig. 1109. Full-wave voltage-doubler supply. Unlike the circuit in Fig. 1112, it is not possible to use an external ground on a chassis having this circuit.

Input filter capacitor

This is probably the most important filter capacitor in the entire receiver. When the set is first turned on, this component demands its charge before any other unit. It is practically a dead short circuit across the rectifier tube until it does begin to charge. Replacement of this filter unit with one having a higher capacitance means a heavier strain on the rectifier tube. If the capacitor is replaced with one of lower value, the result may be lowered B-plus voltage and symptoms such as insufficient brightness, dim picture, blooming, etc. When the plates of the rectifier tube glow red, it is an indication that the input filter capacitor is shorted or extremely leaky.

Filter capacitors (electrolytics) change with age. They are affected by heat and also by not being used. It is helpful, before installing an electrolytic, to re-form it by connecting it across a source of dc. If a test supply with variable dc output is available,

apply about one half the amount of dc the electrolytic will encounter in the receiver – and then (during a period of about 1 hour) gradually bring the dc up full. It is known that most service technicians do not do this, but then again we have no way of knowing how many rectifier tubes have been damaged by not following this procedure.

Power transformer

When a power transformer gets excessively hot, to the point where some of the transformer potting compound becomes very soft or melts, it is an indication of a shorted turn. A resistance

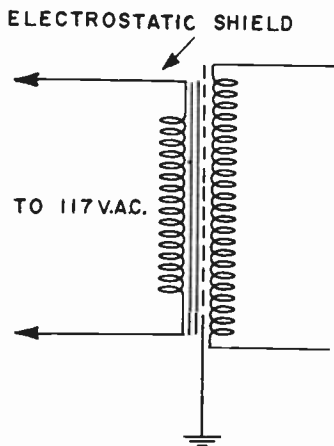

Fig. 1110. Schematic representation of a Faraday electrostatic shield in a transformer. Such a shield may be found in good-quality power and audio transformers.

check isn't of any help, since the shorted turn will not decrease the overall resistance enough to detect it with an ohmmeter.

Some power transformers have a Faraday shield. That is a sheet of copper is placed between the primary and the secondary of the transformer and forms an electrostatic shield. (Fig. 1110.) The shield is connected to a wire which should be grounded to the chassis. Since the transformer works whether the shield is grounded or not, some technicians disregard it. The shield minimizes line-noise voltages getting into the receiver by way of the capacitance between primary and secondary of the power transformer. So don't forget to ground it.

A loose lamination in the power transformer will vibrate at a 60-cycle rate. This causes an annoying buzz. It can be stopped by spraying the laminations with anti-corona lacquer or acrylic resin spray. Make sure all machine screws and nuts are tight. When

substituting a power transformer, replace all mounting screws and make sure that these are as tight as they can be made.

If you need to replace any section of transformer leads, make a good soldered connection and then cover the smooth splice with a section of tubing. Electrical tape is not recommended since this makes a bulky wraparound and eventually becomes dry and falls off or unravels.

When replacing power transformers, an exact replacement is best. It will fit into the available space without drilling new

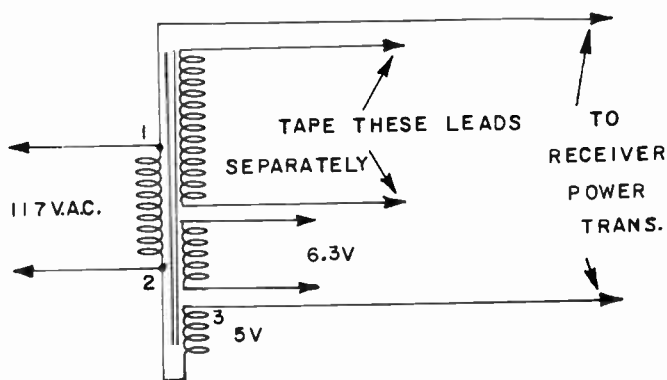

Fig. 1111. Schematic connections for using a spare power transformer to supply a 5-volt ac boost to the power line. Transformers are manufactured just for this purpose. More expensive types are adjustable and may have voltmeters mounted in the same case.

holes in the chassis. When an exact replacement isn't available, make sure that the voltages (low- and high-voltage ac) are identical with that of the original transformer. The transformer must be rated to deliver as much current as the original (or more) but never less.

Line-voltage boost

To get a small boost in low line-voltage areas, use the technique shown in Fig. 1111. Connect the 5-volt filament winding of a spare transformer in series with the primary as shown in the illustration. (A filament transformer can also be used.) This will boost the line voltage input to the television receiver approximately 5 volts (rms). If the connection as shown in Fig. 1111 results in lower voltage instead of higher, transpose the leads of the filament winding of the transformer. Do not exceed the current capacity of the filament winding.

Special transformers are manufactured to do this job with provisions for adjusting the line voltage.

Series heaters

Heaters can be wired in series or in series-parallel. Fig. 1112 shows a power supply circuit using a selenium rectifier voltage doubler. The heaters of all the tubes are series-connected. This means that, if the heater of any one of these tubes should open, none of the tubes would light. An open tube in a parallel-connected arrangement is easy to find. The tube that doesn't light is the defective one. It isn't quite that easy in a series-connected filament circuit.

There are several ways to locate the defective tube. With all tubes in their sockets and with the receiver turned on, set your voltmeter to read not less than 150 volts ac. Connect the voltmeter across the heater pins of each of the tubes. If the meter reads 0 volt ac, the tube is good. The defective tube is the one across whose heater pins line voltage is read.

Another technique for finding the open heater is to make a resistance check. Connect one lead of the ohmmeter to the switch (the receiver plug must be removed from the power outlet). With the other test lead, move from one heater to the next, away from the switch, until an indication of an open circuit is found. In order not to miss any tubes follow them in the order in which they are wired. It is very helpful to have the manufacturer's schematic. In making this check, as long as there is continuity, the tubes are good. At any point in testing that an infinite-resistance reading is noted on the meter, you have located the open. As you move away from the starting point with the test prod, it may be necessary to set the range selector to a higher range.

An open in the heater circuit isn't always caused by a tube. Series dropping resistors are sometimes inserted to permit the application of correct voltage to heaters. Rf chokes are also in series with the heater line. An open choke could keep the heater string from operating. Note in Fig. 1112 that filament bypass capacitors are used. If these should open or be disconnected, the operation of the heater string will not be affected. A shorted capacitor, however, will mean excessive heater voltage on all the tubes between the "hot" side of the power line and the shorted capacitor. This doesn't mean that all of the tube heaters will burn out. Generally, one of the heaters burns up, opening the line and saving the other tubes.

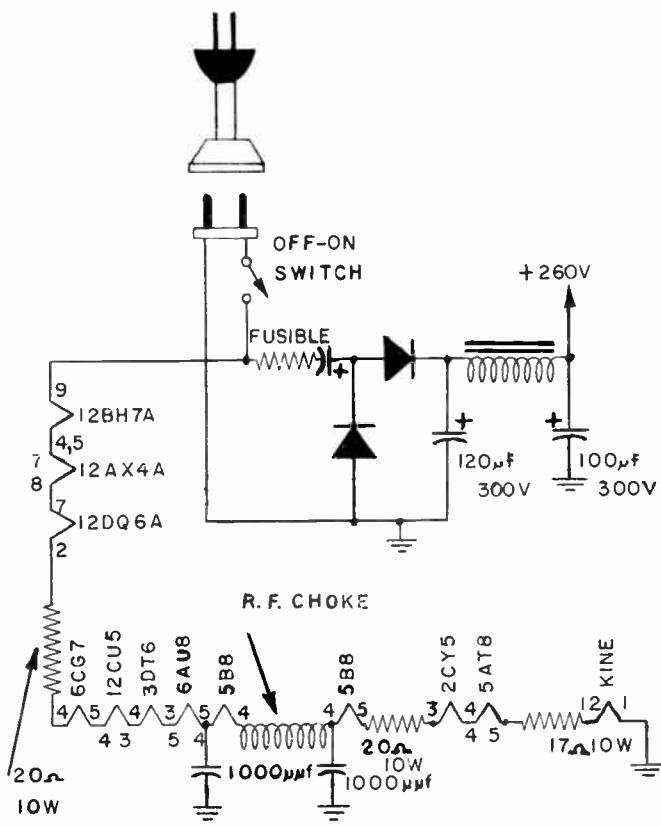

Fig. 1112. Half-wave voltage-doubler supply and series-filament supply circuit is typical for many chassis.

A heater-to-cathode short in any one of the tubes in the series string will have the effect of raising the heater voltage of all tubes that are in series between the "hot" side of the power line and the tube having the short. Here again, the effect will be to raise the voltage on the heaters of the tubes that precede the short. Eventually, one of the heaters will burn out, opening the line and protecting the other tubes.

In earlier chapters the symptoms produced by heater-to-cathode leakage or shorts were discussed. In parallel-connected tubes, the damage is to the defective tube which must be replaced anyway. In series-string receivers, early recognition of a heater-to-cathode short or leakage can probably save one of the other tubes in the series string from damage.

Special power supply arrangements

The circuits that have been studied are typical and will be found in many television receivers. This does not mean, though, that there aren't some exceptions. Consider, for example, the circuit shown in Fig. 1113. Two full-wave rectifiers are used, one supplying less than 200 volts dc while the other rectifier has an output of approximately 300 volts dc. The rectifiers are not in parallel and yet the load imposed on the power supply is divided between the two rectifier tubes. The advantage of this arrangement over that of rectifier tubes in parallel is that you need not replace both rectifiers if one should become weak. The two rectifiers are independent of each other. Also, the need for power consuming voltage dividers is reduced.

Also note the heater arrangements. The total voltage across the filament winding is 12.6. The voltage from either heater lead to chassis is 6.3. All the tubes are connected in parallel, some working off one half the heater winding, and the others working from the other half of the winding.

A receiver of this kind will have two heater buses going to the tubes. A break in the bus will cause half of the tubes to remain unlit but the remainder of the tubes will operate. This can produce some confusion, until you examine the circuit diagram and see how the manufacturer arranged the heater circuit.

Hum

To determine the efficiency of a filter, connect the oscilloscope across the output filter capacitor, the vertical input of the scope going to the B-plus output point of the filter and the ground terminal of the scope connected to the negative terminal of the filter capacitor. Without touching the scope attenuator control, bridge a new filter capacitor across the one in the receiver. If the hum voltage, as shown on the scope, is definitely decreased, the capacitor should be replaced. If the power supply uses selenium rectifiers, a strong hum voltage as shown on the scope can be due to defective rectifiers. The B-plus voltage would be low.

Dark horizontal bar across screen

This can be caused by poor filtering in the low-voltage power supply or heater-to-cathode leakage. If the picture size is not affected and if sound volume is good, check the output filter capacitor. Do this by shunting the existing unit with one that is known to be good. Use a capacitor having a working voltage rating equal to or higher than the one in the receiver.

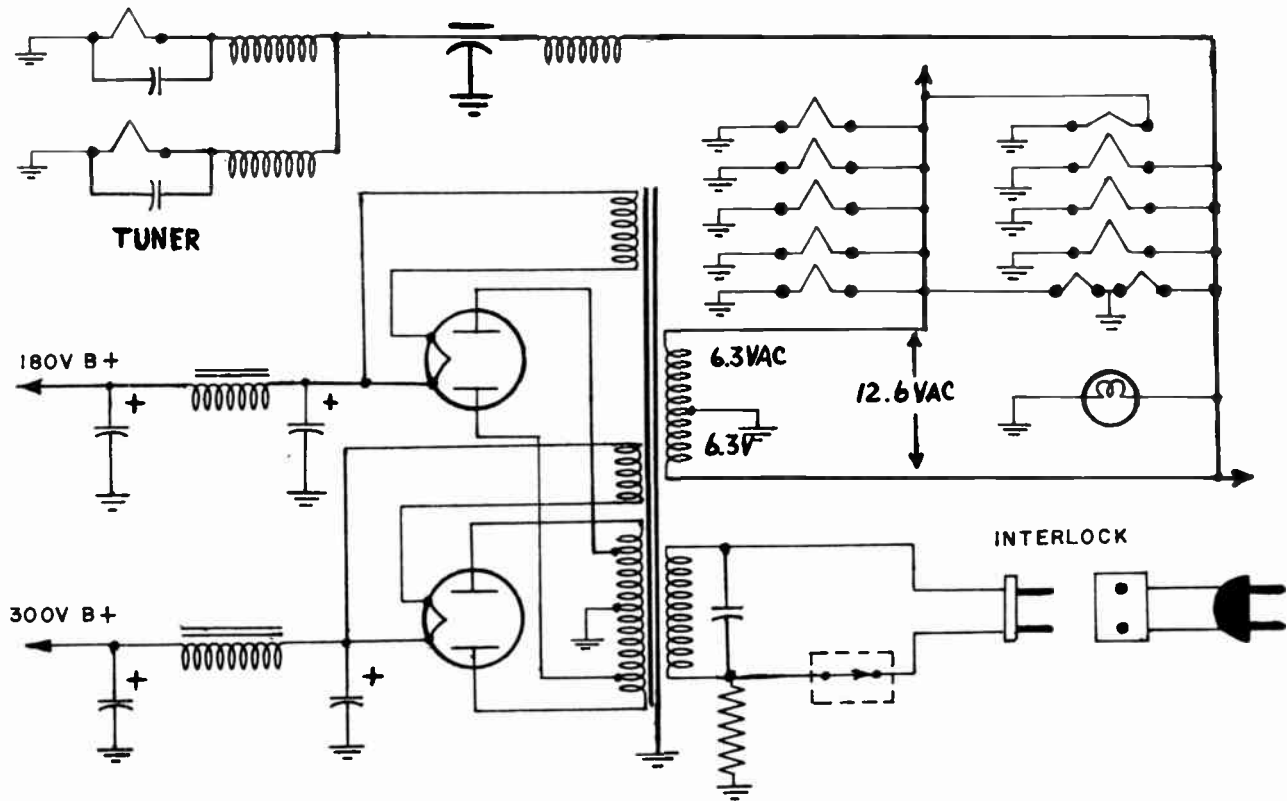
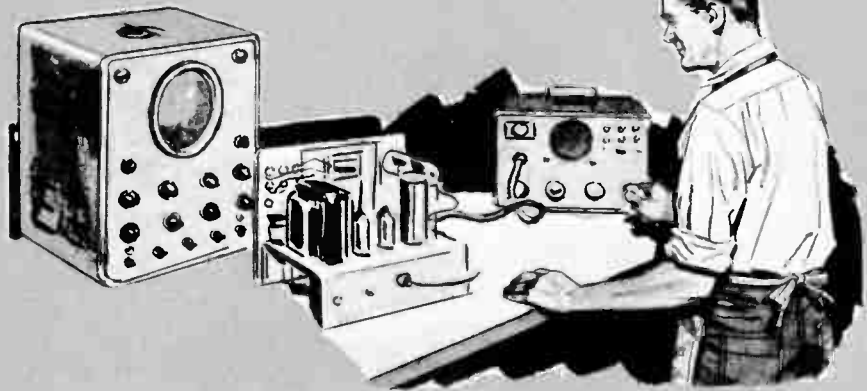

Fig. 1113. Basic schematic for dual-voltage power transformer supply with a typical filament circuit.

If, in addition to the hum bar, picture size is reduced, check the input filter capacitor. If, in shunting either the input or output filter, you note an improvement in receiver operation, be sure to remove the defective filter even though operation is improved when the shunt capacitor is in place.

Substituting rectifier tubes

The fact that two rectifier tubes have exactly the same pin connections does not mean that they can be substituted for each other. Check the tube manual for the output current rating of the rectifier tube. Receiver performance depends upon the current-passing ability of the rectifier tube. If B-plus voltage is lower than normal, sync seems unsteady and picture width or height (or both) is insufficient, check to make sure that the correct rectifier tube is in its socket. Substitute a new rectifier. Also, if pin connections permit, try substituting a rectifier tube having a higher current-passing ability. If you note a blue glow in the rectifier tube, replace it. This indicates the presence of air in the tube which will lead to erratic receiver performance.



miscellaneous troubles

chapter 12

BUZZ is often heard in the sound output due to coupling between the vertical sweep system and the audio circuits. To be certain that buzz is getting into the audio section from the vertical sweep, vary the vertical hold control. If this changes the pitch of the buzz, then you can be sure that the trouble is interaction between vertical sweep and audio circuits.

If the audio output tube is metal, scrape some of the paint from the tube and then run a wire (holding it tightly against the scraped portion) to the chassis. If the buzz disappears, the shield pin connection to the tube is open. Replace the tube.

Mostly the audio tubes are glass. Put a metal shield over each tube in turn, and note if there is any improvement. The shield must make good contact with chassis to be effective.

Buzz can sometimes be minimized or eliminated by very careful realignment of the ratio detector transformer. Also check the agc voltage to make sure that agc-controlled tubes are not being overloaded. Buzz can also originate in the video amplifier stage. To check, rotate the contrast control. If the pitch of the buzz changes, the trouble is in the video amplifier.

Buzz can be caused by defects in the high-voltage supply. Remove the picture-tube socket. If the buzz disappears, the trouble exists in the high-voltage supply.

Capacitors

Capacitors can often be checked without removing them completely from the TV receiver. For example, consider the screen bypass capacitor shown in Fig. 1201. The usual connection is between the screen grid of the tube and chassis. Disconnect the ground side of the capacitor and touch it to the cathode. If the tube is an audio amplifier and if this action cuts off the sound, then the capacitor is leaky or shorted and should be replaced.

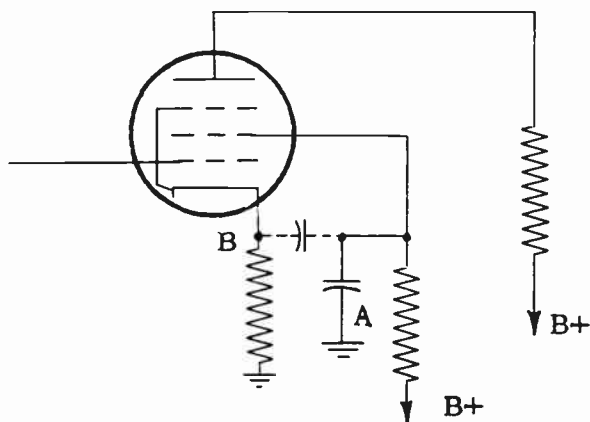

Fig. 1201. Dotted line shows connections for one technique of testing for capacitor leakage without test equipment.

When checking screen bypasses, always examine the screen dropping resistor. If it seems charred or is excessively warm or smokes, then there is little doubt that the screen bypass is excessively leaky.

Coupling capacitors can be checked by measuring the dc voltage on the "cold" side of the capacitor (Fig. 1202). A neon bulb connected in place of the grid leak is also a fairly sensitive device for checking leakage. (Fig. 1203).

A plate bypass is generally connected between the plate of the audio output tube and chassis. A leaky capacitor in this position can result in a burned-out audio output transformer primary winding.

When servicing, keep a lookout for any capacitor that seems obviously defective. If a capacitor seems warm to the touch after the set has been in operation for a little while, replace it. Look for capacitors that have melted wax around the ends. When checking the leads of a capacitor, do two things. Pull the lead horizontally

and then turn it. If either action shows a loose lead, replace the capacitor. Do this test gently.

Dummy tubes

In series-string filaments, the removal of a single tube will cut off all or a large number of tubes (depending on how the series string is wired). This can be a decided inconvenience if you wish

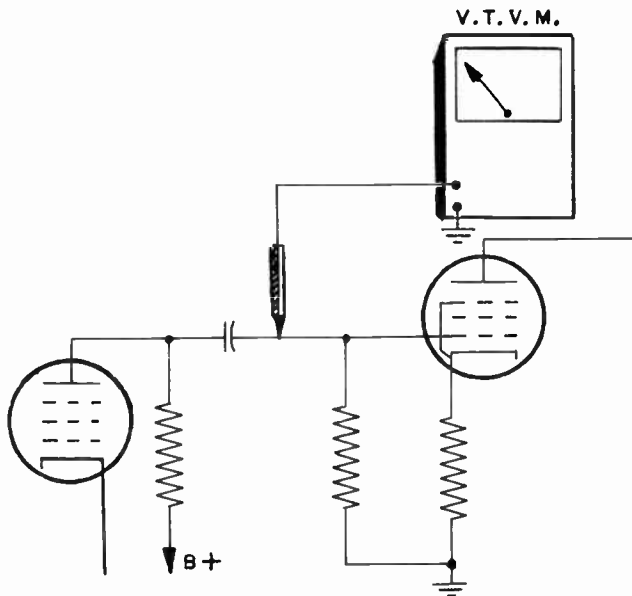

Fig. 1202. *Vtvm will indicate a positive voltage at the grid if the capacitor is leaky or tube is defective.*

to pull a tube and yet have the remainder of the tubes in operation.

One trick to use is to save series-string tubes which would normally be discarded (provided their filaments are intact). Clip off all leads to the tube, except the filament pins. Paste a label on the tube identifying it as a dummy.

Electrolytics

A common technique if filter capacitors are suspected (as they would be in the case of hum or lower than normal B-plus) is to shunt the filter capacitor in the receiver with another electrolytic.

An uncharged electrolytic puts a very heavy drain on the rectifier tube, and the larger the capacitance of the electrolytic the

greater is the chance of damage to the rectifier. This is particularly true if the electrolytic being shunted is the one immediately following the rectifier. To protect the tube and yet be able to perform the test, put a resistor in series with the test electrolytic. The value of this resistor isn't critical, any unit between 5,000 and 10,000 ohms being satisfactory. (Fig. 1204). Use a resistor having a rating of 1 watt or more. After the set has been turned on for a few seconds put a shorting wire across the resistor.

Instead of scrounging for an electrolytic when you need one

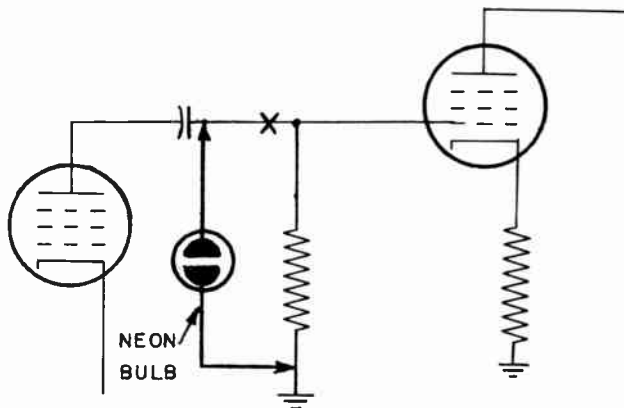

Fig. 1203. Neon tester will indicate leakage if more than 60 volts is at the tube plate.

for test, put one in a small box, with the resistor, and bring the leads from the two to a pair of terminals at the top. An ordinary single-pole single-throw toggle switch can be mounted to short the resistor. The test unit is ideal for shunting cathode resistors as a test unit (if you are looking for extra gain out of a tube), or use it as a capacitive short from grid to ground to kill the signal input to a particular tube.

Flicker

Flicker commonly appears in receivers not equipped with fast-acting agc. However, there can be other causes. Connect an ac voltmeter across the ac line going into the receiver. Set the range control on the meter to read 150 volts rms. If the meter needle jumps at the same time that the picture does, the trouble comes from the power line.

Flicker can be caused by a tube or an improperly soldered wire that makes contact intermittently. If walking across the room or

tapping the side of the receiver produces flicker, the trouble is caused by a poor connection. It may be necessary to pull the receiver and to prod all wires in picture signal circuits. Leads from capacitors or resistors are particularly susceptible to this trouble. Tap those components while watching the picture.

A poor antenna installation will cause flicker, particularly if the antenna or the two-wire transmission line moves around in the wind. The transmission line must be secure all the way from

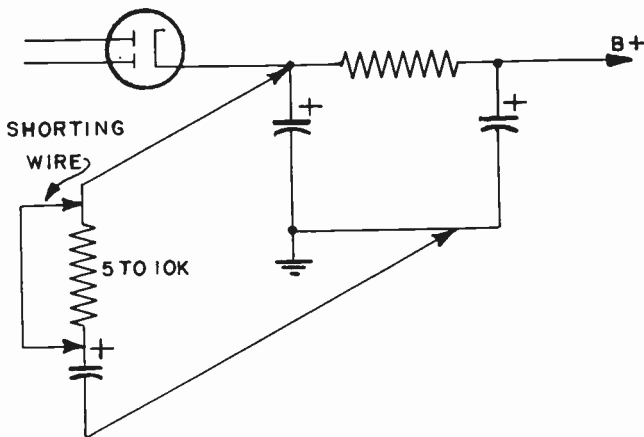

Fig. 1204. Technique for limiting current surge when shunting a suspected electrolytic capacitor.

the antenna itself right down to the antenna terminal board on the receiver. If the transmission line isn't secure, inspect the antenna at the points where the transmission line is connected. Constant movement of the transmission line will break one or more strands of wire. If so, the transmission line should be cut and reconnected to the antenna.

This trouble can also be caused by tubes that have become weak. The gain of a weak tube may vary considerably and, if there is more than one weak tube in the circuits that handle the video signal, the result can be serious variations in overall gain. This is especially true in sets that are more than a few years old and have a history of very few or no tube replacements. In such sets, replacement of just a single tube is often a temporary cure only. In these cases it is best to recommend all new tubes in picture handling circuits.

Intermittents

Intermittents in a TV receiver can be extremely exasperating



Fig. 1205. A shorted turn in a horizontal output transformer lowers the Q of the inductance, which is indicated by the frequency-generating circuits in testers of this type. It is often necessary to unsolder terminal connections and remove the high-voltage rectifier tube from its socket as even the shorted loop of the filament winding can give a REPLACE indication. (Electronic Instrument Co.)

since they sometimes refuse to appear when you are looking for them. An intermittent is due to some component breaking down occasionally. To hasten the process and accelerate the breakdown, remove the audio power output (not possible in all sets). Removal of the tube will reduce the load on the power supply, causing the voltage to rise. This will hasten the breakdown to the point where it may become constant. Another method is to increase the line voltage 5 to 10 volts above normal.

TV sets can be affected by climatic conditions. If servicing in an area noted for high humidity or in a section close to salt water, remember that it is possible for insulation around wiring to absorb water. Usually, this does no harm. But in a high-voltage circuit, any water absorption by the insulation (especially if the water contains salt) can result in a high-voltage intermittent. If the fuse in the high-voltage supply blows without apparent cause, try replacing high-voltage wiring with wire carrying heavier insulation.

Line-cord check

A short in the television receiver can overload the power supply. This, in turn, puts a heavier drain on the power transformer. Since all power for the receiver (in a transformer-operated set)

must come to the receiver via the line cord, an overload condition can sometimes be detected by feeling the line cord. This is particularly true if the transformer has a shorted turn. Generally, the fuse in the primary will blow, but sometimes an overrated fuse is used.

Loss of high voltage

With complete loss of high voltage, let the receiver operate for a short time. Turn the set off and touch the flyback transformer. If, during the short period of operation, the transformer has become warm (or hot), then it may have a shorted turn. At the same time, touch the horizontal output tube. If the horizontal output tube has also become very hot, then it is possible that the shorted turn is in that part of the transformer between the plate tap (horizontal output tube) and the plate of the rectifier. If the receiver has been turned on for any length of time with this defect, it is extremely probable that the horizontal output tube will have to be replaced (Fig. 1205).

Making voltage measurements

The voltages measured in a television receiver will not be in agreement with those indicated on a schematic unless made in the same way as those performed by the manufacturer. In some instances, voltages are measured with the antenna removed and, to make sure that no signal comes in, the antenna terminals are shorted. Quite often the manufacturer will specify the position of the various controls — for example, contrast, fine tuning, channel selector, horizontal drive, etc.

Note the distinction between dc voltage measurements and peak-to-peak voltage measurements. Waveform checks are often done with the receiver tuned to the strongest channel. Some manufacturers specify the amount of signal voltage to be observed at the plate of the video amplifier tube or at the input to the picture tube.

It will be to your advantage to read the instruction notes on voltage measurements before you start working on a chassis. Failure to do so can lead to unusual readings or voltage readings which can be misinterpreted.

Nearly all schematics specify that the voltage on the plate of the horizontal output tube is not to be measured. However, you can make this measurement by using a high-voltage dc probe (Fig. 1206). To make sure that no rf pulses interfere with the measurement, connect a capacitor (0.1 μ f at 600 volts) across the input

terminals of the vtvm. This will bypass rf but not dc. Remember, however, that the amount of dc voltage as measured is reduced by the action of the divider probe. Multiply the reading on the vtvm by the multiplying factor of the probe to get the correct dc voltage at the plate of the horizontal output tube.

Peaking coils

Peaking coils are often wound on, and connected in shunt with, resistors whose value of dc resistance is much higher than that of

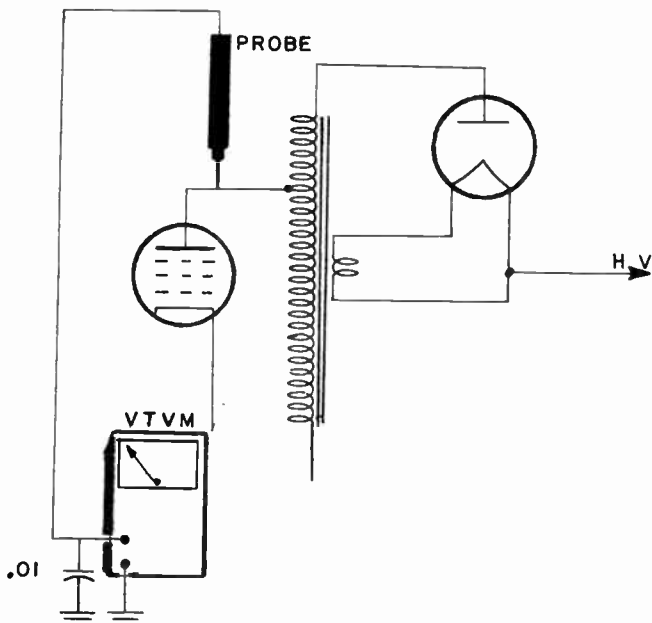

Fig. 1206. The vtvm must be bypassed to eliminate ac on the probe. This measurement can be done but it is not recommended. A neon test lamp will usually give satisfactory results here.

the coil itself. In a typical case, the value of the resistor could be about 5,100 ohms compared with about 10 ohms of the peaking coil itself. If the peaking coil is in series between the plate of the video amplifier and the B-plus line, practically all of the tube's plate current will flow through the coil, instead of the resistor. Peaking coils are subject to opens and also to shorted turns but, because of the shunt arrangement, the plate is still tied to the B-plus line through the resistor. Should the coil open, a resistance check will immediately indicate the value of the shunt-

ing resistor. If, however, the coil has a shorted turn, an ohm-meter check is useless. The symptoms of a shorted turn are smear, poor picture with bad definition. Service this with a scope check at the plate of the video amplifier or else by substitution of a new peaking coil.

Picture spreading

Vertical nonlinearity, as indicated by the picture stretching across the top of the picture, is sometimes due to the vertical output tube. Substitute a new tube. It is often quite helpful to make several substitutions to find the particular tube that will cure

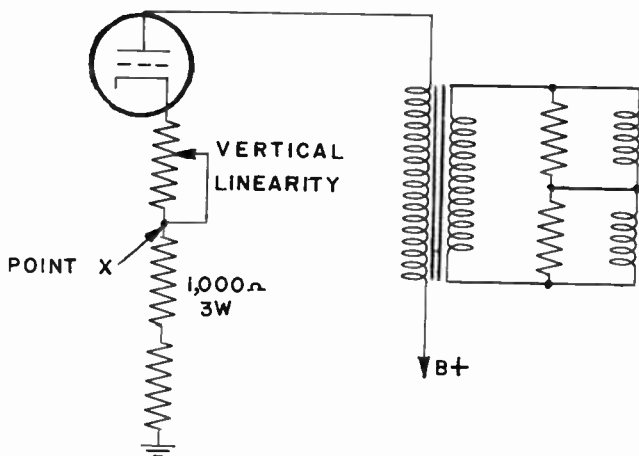

Fig. 1207. An additional or increased value of resistance added to the linearity control circuit will often improve picture linearity at the top of the raster.

the trouble. (We have assumed that adjustment of the vertical linearity control has not eliminated or minimized the condition.)

Stretching can also be caused by a defective vertical output transformer or by a transformer which has been used as an incorrect replacement.

Note the setting of the vertical linearity control. When at its maximum-resistance position, try inserting a 1,000-ohm 3-watt resistor in series with it. Open the cathode circuit at point X in the diagram of Fig. 1207. After making the change, readjust the vertical linearity control and note if there is any improvement. If not, modify the plate circuit by adding a .01- μ f capacitor in series with a 100,000-ohm resistor as shown in Fig. 1208.

Sometimes, a condition exactly opposite that which has just been described will take place. That is, the picture will seem com-

pressed at the top. Try adjusting the vertical linearity control. If this does not help, connect a resistor decade box in series with the control grid of the vertical output tube (Fig. 1209). Try different values of resistance until you find the minimum resistance which will cure the trouble.

Receiver substitution

Service technicians will often obtain (in trade) a receiver which can be put into good working order but which (possibly because

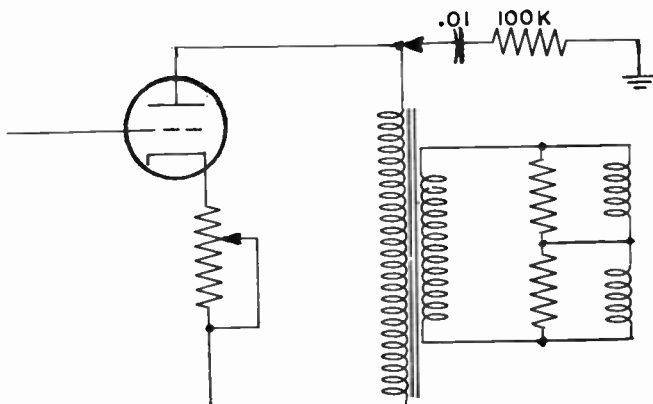

Fig. 1208. The R-C network added to the tube plate circuit will affect linearity.

of small screen size) is no longer a receiver that can be offered for sale. Such a receiver can be made to serve as a useful test instrument.

Consider, for example, a receiver that has picture but no sound. A wire can be run from the volume control (center arm) of the defective receiver directly to the same point on the test receiver. If sound comes through on the test set, then you are sure that the trouble exists between the volume control and the speaker of the defective receiver. This is shown in Fig. 1210.

If sound is not restored, run a connecting link between the sound takeoff point in the defective set and a similar point in the test receiver (Fig. 1211). If sound comes through then you know that the trouble in the defective receiver lies between the sound takeoff coil and the volume control. Thus, in just two steps, you can analyze and localize troubles in the entire sound section of a defective set.

Note: In all of these tests the chassis of the test set should be

connected to the chassis of the receiver. Before connecting the chassis, make sure that both are at ground potential.

A television set used as a test receiver can be made more versatile by putting a front panel on it and mounting terminals on the front panel for various voltages. The test set could supply low-voltage B-plus. This could help localize hum. By substituting a known hum-free B-plus voltage for the B-plus bus in the defective receiver, it could soon be determined if the hum came from the low-voltage power supply. Similarly, terminals on the front panel of the test set for 6.3 volts ac, for vertical and horizontal sync pulses, high voltage and video signal would be convenient. The

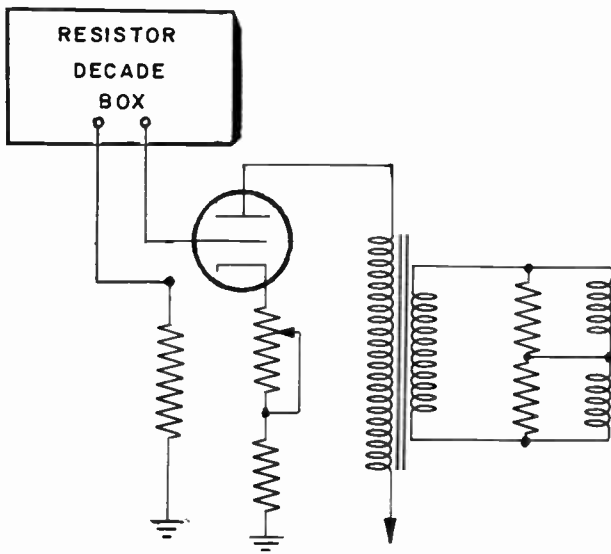

Fig. 1209. Decade box or high resistance potentiometer is adjusted until compression of picture is eliminated.

presence of a picture on the face of the picture tube of the test set would indicate that the test set was in good working order.

Regeneration

Regeneration, or positive feedback, always increases the gain of a circuit. At the same time the bandwidth is reduced. This is of particular importance in video if circuits where correct band-pass is important in order not to lose picture quality.

You can easily calculate the gain of a video if amplifier. The voltage developed across the video detector diode load resistor

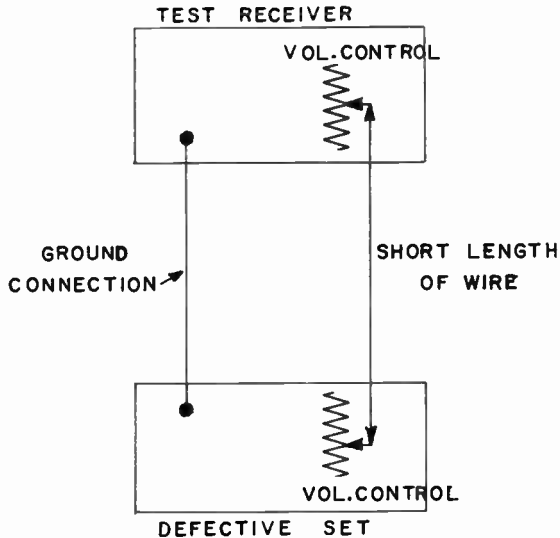

Fig. 1210. *Emergency connections for substituting a good receiver amplifier for a suspected one. This technique is dangerous with transformerless chassis.*

is generally at least 1 volt, usually more. The output of a front end may be in the order of $100 \mu\text{v}$. Since 1 volt is equal to 1,000,000 μv , divide this figure by $100 \mu\text{v}$ to get the gain of the video if stages ($1,000,000/100$ equals 10,000). This means that the overall gain of the video if is 10,000 times. However, in the presence of regeneration, this amount of gain is multiplied by many times. Positive feedback can increase the gain to the point where the signal across the video detector diode load is 20 volts or more. Thus, one of the indications of regeneration is excessive signal voltage across the detector load.

There are other confirming symptoms. The picture may become negative. Loss of low-frequency components (because of the narrower bandpass) will result in smear. If the feedback is strong enough, one of the if tubes will oscillate and, since it will then generate its own signal, it will modulate the existing video signal, producing lines and stripes across the screen.

Since an oscillating stage produces its own signal, find the offending tube by monitoring the video detector diode load (that is, keep the vtvm connected across it) and remove video if tubes one at a time, starting with the tube closest to the detector. When removing a particular tube causes the voltage across the detector load to drop to zero, you have found the troublemaker.

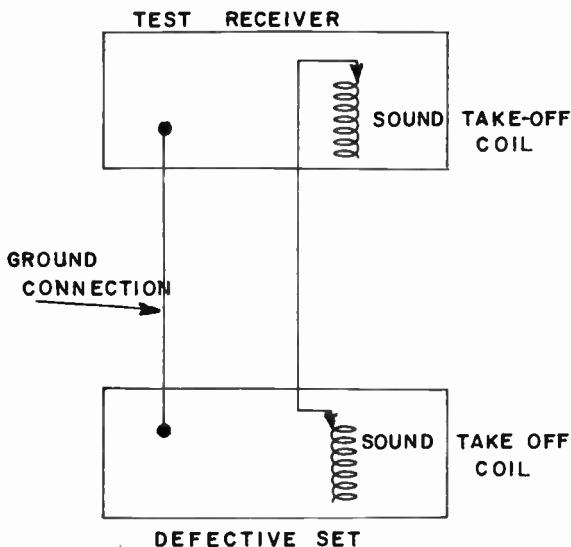

Fig. 1211. A test receiver could be used to analyze a defective chassis thoroughly. Differences between intermediate frequencies of various models might make this impractical for many test benches

Oscillation can sometimes be cured by realignment. If the manufacturer's schematic calls for a shield, make sure that one is supplied and that it is well grounded. Try inserting a 100-ohm resistor in series with the control grid of the tube. Make sure plate and grid leads are well separated.

Resistors

Always replace a resistor with a unit having a wattage rating equal to or higher than the original component. Resistor leads, particularly in high-frequency circuits, should be cut short. Resistors that normally get hot in operation should be kept away from electrolytics or semiconductors.

The most commonly used resistor in television sets is known as the carbon-filament (or composition) type. Take a defective resistor and cut it open with a pair of diagonal cutters. You will see that the resistive element is a very thin tube of carbon material. The carbon is the conductive component. It is surrounded by an insulating type of compound. This compound has a sealing effect on the carbon, giving it some protection against heat and moisture. Resistors are arranged in a scale of preferred values from less than 1 ohm to more than 20 megohms. These resistors are multiples of each other. Thus, for example, a 510-

ohm resistor has its multiple in 51,000 ohms, 510,000 ohms and 5.1 megohms. Composition resistors can be used in any circuit in which low noise is not a requirement.

Resistors will change value when you solder them. To stabilize a resistor — that is, to fix its value of resistance so that it does not change in operation — hold a soldering iron close to the body of the resistor for several minutes. Measure the resistance, repeat the heating operation and then check the resistance again. After several attempts, the value of resistance should be fixed. Composition resistors should not be used, however, in circuits where exceptional stability is required.

Other types of resistors are known as carbon-film resistors (also, boron-carbon resistors and deposited-carbon resistors). The construction of these differs from the composition resistor in that a thin film of carbon is deposited on a ceramic form. The entire unit, as in the case of composition resistors, is covered with an insulating compound. Carbon-film resistors are especially valuable in circuits where low noise is imperative.

Ringings

Ringings is another name for oscillation. Any vacuum-tube television circuit with a coil in the plate circuit is susceptible. The tube can be made to act like an oscillator (even though it is designed to work as an amplifier) under certain conditions. Having an inductive load is one step toward oscillation. A tube having a large interelectrode capacitance is another. If you have both of these (and if the coil in the plate circuit has a reasonably high Q), it is possible for a pulse input (such as provided by a television waveform) to shock-excite the tuned circuit they form.

If the tube is in the video circuit, the oscillations generated by the tube will be amplified and passed on until they reach the picture screen, resulting in wavy lines. To cure this trouble, insert a 100-ohm $\frac{1}{2}$ -watt resistor in series with the grid. Disconnect the wire going into the control grid, solder one end of the resistor to it and the other end of the resistor to the pin on the tube. Another expedient is to shunt the coil in the plate circuit with a resistor.

Insertion of resistance can cause some loss of signal. Hence, if the resistor is to be inserted in the grid circuit, it should have as low a value as possible. If it is to be shunted across the coil in the plate circuit, make the resistance as high a value as possible. The use of a decade resistance box is very helpful since the final value of resistance must be determined experimentally. Connect

the decade box and watch the screen. Advance or adjust the contrast control until the ringing is very noticeable. Then vary the decade box until the correct amount of resistance inserted will eliminate the oscillation. Plate coils will be found in video if stages and as peaking coils in the circuit of the video amplifier.

Semiconductor rectifiers

Because the semiconductor rectifier looks good does not mean that it is. It gets weaker in use, just as a vacuum-tube rectifier

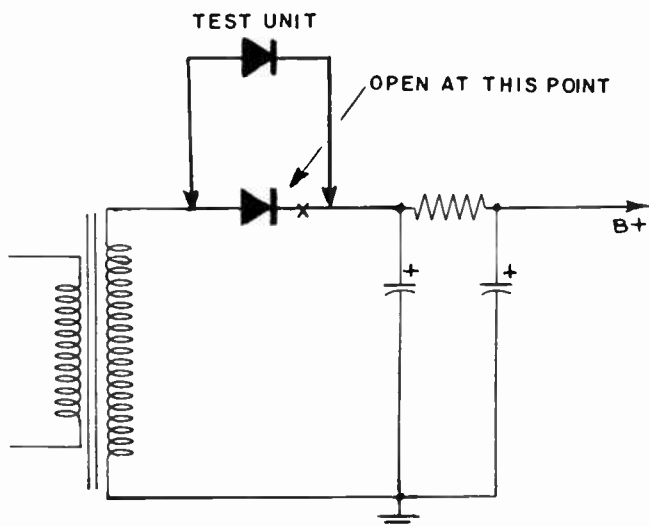

Fig. 1212. *Semiconductor rectifiers are best tested by substitution.*

becomes weak in time. If the picture cannot be made to have sufficient width or height, and if the voltage as measured across the output of the power supply is lower than normal — then the cause can be due to a rectifier that needs replacement.

An ohmmeter check will often reveal a weakened unit, but this test isn't always conclusive since the rectifier isn't being tested under actual working conditions. To check a rectifier, unsolder one lead going into the unit (whichever lead to the rectifier is more conveniently reached). Take a pair of clip leads (refer to Fig. 1212) and attach one pair of clips to a new rectifier. One clip lead end should now go to the disconnected wire in the receiver. The other clip-lead end now goes to the wire that remains connected. Turn on the receiver and note if the picture has increased in size. If it has, the original rectifier is weak.

When making this test, be sure to observe polarity. The chapter on low-voltage power supplies shows how this is done.

If the receiver uses a pair of rectifiers in a doubler circuit, it is best to replace both units. To check, make the test on each rectifier as described in the preceding paragraph. However, if one unit is shown to be weak, it is not necessary to test further since, in any event, it is best to replace both units.

Solderless connections

Some receivers make use of solderless wire-wrap connections. This is done by wrapping approximately a half-dozen turns of wire tightly around a square stud. There is no reason to be disturbed



Fig. 1213. Adapters allow many tests to be made without removing chassis from cabinet.

if you see no signs of a soldered connection. If, however, you must make a new connection, you will have to solder. You will not be able to make a solderless wire-wrap by hand. The wrap that you see in the TV set is done by machine.

Test Adapters

A simple method of obtaining voltage test points is to use a *tube socket test* adapter. The tube is removed from its socket and the test adapter is put in its place. The tube is then seated in the socket on the top of the adapter. The protruding tabs are numbered to facilitate voltage tests. Adapters are made for 7 and 9-pin miniature tubes, octal base tubes (Fig. 1213), and for five types of cathode ray tube bases.

Save time! Use the "quick-check" troubleshooting charts on this and the following pages when you need servicing information in a hurry.

troubles

servicing techniques

Afterglow

Ref. Chapter 7

Bright spot remains on picture tube after set has been turned off and then gradually disappears. Caused by slow cooling of CRT cathode and slow discharge of high-voltage filter capacitor (or picture tube). Spot will do no damage if it covers a wide area. Adjust brightness control so that spot area is maximum after set is turned off.

Airplane flutter and picture flicker

Ref. Chapter 4

Momentary vertical jumping of picture caused by plane passing overhead. Caused by slow-acting agc. Check setting of the agc control. Check components in the agc filter. This condition is sometimes confused with line voltage which fluctuates and produces symptoms which are very similar. Airplane flutter, however, lasts only a very short time while flicker due to changing line voltage usually takes longer.

Antennas

Ref. Chapter 1

Excessive signal can cause bounce and smear. Overloading can result in a negative picture.

Adjacent-channel interference

Refer to Diagonal Lines Across Picture.

Arcing. Crackling sound.

Ozone odor

Ref. Chapter 7

Chapter 8

With receiver on examine interior of high-voltage cage with room lights dim. Look for corona discharge near any high-voltage leads and solder connections where wires pass each other or the chassis. If you hear a hissing sound, examine the flyback transformer from all sides. Arcing between adjacent wire layers in the flyback is sometimes difficult to detect.

Examine the rubber anode cup on the high-voltage lead. If the rubber has deteriorated, cut it away with a knife. Check Aquadag ground. Bending the grounding clip to make good contact. Arcing can occur in connections to the high-voltage rectifier. Spray the socket of the high-voltage rectifier and the anti-corona shield with anti-corona lacquer.

If the arcing is accompanied by momentary loss of the raster, breaks in the raster or dark horizontal lines or areas (momentarily) across the screen, the trouble is due to high voltage dc arcing. Start by checking at the filament pins of the high-voltage rectifier and work out to the second anode of the CRT. Short the receiver's antenna terminals to eliminate outside noise pulses.

See also section entitled Corona.

Audio weak, missing or distorted

Ref. Chapter 2, 10

Barkhausen oscillations

Ref. Chapter 8

Raster and picture are good, but sound level is too low, may be completely absent or cannot be understood. Adjustment of the fine tuning control does not help. For these troubles, refer to the various listings under Sound.

See Black Vertical Line or Lines at Left Side of Screen.

Barreling

Ref. Chapter 7, 9

Bars across the picture

Picture sides are pushed out. Caused when incorrect yoke replacement is made.

Refer to Sound in Picture.

Bending of vertical lines

Ref. Chapter 6, 9

Improper setting of agc control. Defective horizontal oscillator, amplifier or afc tubes or system components.

troubles

Black blotches at right side of screen

Ref. Chapter 8
Chapter 9

Black vertical line (or lines) at left side of screen

Ref. Chapter 8

Blooming

Ref. Chapter 7
Chapter 8

Bright bar across bottom of picture

Buzz

Ref. Chapter 1
Chapter 7
Chapter 9
Chapter 10
Chapter 12

servicing techniques

See Snivets.

Barkhausen oscillation. Replace the horizontal output tube. Use Barkhausen eliminator. Insert 100-ohm resistor in series with horizontal output tube's control grid. Adjust horizontal drive and linearity controls (not all receivers have these controls). Move antenna lead and note its effect. If black line gets weaker, redress antenna lead. The black lines may be due to outside interference.

Picture expands when brightness control is tuned up, goes out of focus and may disappear completely from screen. Trouble is due to poor regulation of the high-voltage supply. Replace high-voltage rectifier, damper and horizontal output tubes. Sometimes blooming is caused by very weak low-voltage rectifier tube.

Check series filament resistor of high-voltage rectifier and a high-voltage filter resistor if used, to make sure that it is value specified by the manufacturer.

If high-voltage leads are too close to the chassis or metal extensions of the chassis, blooming can occur even though there is no arcing or corona.

Caused by trouble in the vertical sweep system. Replace vertical oscillator and output tubes. Look for changed values of grid resistors, sawtooth-forming circuit components. Check the vertical linearity control with an ohmmeter. If linearity control cannot go through its full resistance range, replace it.

Sometimes caused by improper impedance match between transmission line and receiver. Use impedance-matching network. Can also be due to misalignment. Some receivers have a control on the chassis or on the rear apron for minimum buzz. Adjust this control until buzz is weakest.

If buzz increases when contrast control is turned up, condition is due to overloaded video amplifier tube. Try a new tube. Make sure plate and screen tube and bias voltages on video amplifier tube are correct. Try removing cathode bypass capacitor, if video amplifier is so equipped, to see if condition will be helped.

Buzz can be caused by overloading in stages before the video detector that are agc-controlled. Insufficient agc voltage permits gain of tubes to go up, causes one or more tubes to become overloaded. Check agc basis. Reset agc voltage control.

With time, video detector crystals deteriorate and cause a buzz. Substitute a new crystal.

When the sound carrier is too high on the video frequency response curve a strong beat-signal voltage is produced in the video detector and excessive intercarrier signal to the sound if realignment of the video is required.

Buzz can be caused by trouble in sound section. Make sure that ratio-detector transformer is properly adjusted. Check components associated with the ratio detector, especially the electrolytic at the ratio-

Buzz (Continued)

detector output. Shunt the electrolytic with another capacitor of the same rating. If buzz decreases, replace the original unit. Watch polarity. When adjusting the ratio-detector transformer, secondary winding, note the two points of maximum buzz. Set the slug between them at the minimum buzz point.

Ref. Chapter 1
Chapter 7
Chapter 9
Chapter 10
Chapter 12

Sometimes buzz is station trouble. Tune to other stations and note if buzz is present. If buzz is on one station only, wait until scene shifts or program changes. This will generally mean the use of a different camera at the studio. If buzz disappears when this happens, buzz is caused by station trouble.

Buzz can be the result of low screen and plate voltages on all tubes handling the composite video signal. If the buzz is accompanied by hum, check the electrolytics in the low-voltage supply. If the buzz is not accompanied by hum, try substituting a new low-voltage rectifier tube.

Buzz is sometimes due to antenna trouble. Disconnect the antenna and substitute an indoor type. If buzz disappears, try an impedance-matching unit between the transmission line and the receiver. If you do not have a substitute indoor antenna, tune in a station. Listen to the buzz while moving your hand (clenched around the transmission line) along the transmission line near the input to the television set. If buzz gets weaker or disappears, then the trouble is definitely due to an impedance mismatch between transmission line (two-wire line) and receiver. This method will not work with coaxial cable.

If the receiver uses a gated-beam detector, try different values of cathode resistance until buzz is minimum. If the cathode resistor is variable, rotate the control for best results. If buzz becomes minimum when control is at the end of its travel, it may be necessary to add resistance in series. Buzz will also be caused if the cathode bypass capacitor of the gated beam tube is leaky.

Buzz can be caused by high voltage. To check, remove socket to the picture-tube or second-anode lead, whichever is more convenient. If buzz disappears, trouble is caused by the high voltage. Keep high-voltage leads away from audio section. Make sure high-voltage cage is thoroughly grounded. Aquadag on picture tube must make good contact with grounding clips.

Rotate the vertical hold control. If the pitch of the buzz changes when you do this or if you can control the strength of the buzz in this way, then the buzz is caused by the vertical sweep system. (Not 60 cycles, but some high harmonic of it.) Shield all glass audio tubes. If possible, shield the vertical output transformer.

Compression at top of picture
Ref. Chapter 8

Insufficient voltage at amplifier plate. Check B-plus or boost voltage and their decoupling networks.

Contrast, delayed
Ref. Chapter 2

Insufficient cathode emission (weak tube)—any tube from front end up to picture tube. Picture tube may also be at fault.

Corner shadows
Ref. Chapter 7

Improper setting of ion magnet. Improper ion magnet (either too strong or too weak). Deflection yoke must be up against the flare of the picture tube.

Crackling or hissing sound
Ref. Chapter 8

See Arcing.

Crowding of raster lines.
Bunching of raster lines producing a bright horizontal band across screen

Replace the vertical output tube.

Dark and light vertical bars on raster. Horizontal linearity is poor and does not respond to adjustment of linearity control

Replace the damper tube. Check linearity coil and shunting capacitors. Check any resistors connected to plate or cathode of damper tube.

Dark areas at bottom, sides or top of picture
Ref. Chapter 7

Due to improper centering of picture. Adjust picture centering control. Make sure yoke is far forward on neck of picture tube. Check positioning of ion magnet.

Dark horizontal bar across screen
Ref. Chapter 11

A single black band across the screen can be due to a defective half-wave low-voltage supply or tubes in the front end, video if and video amplifier. If hum in the sound is an accompanying symptom, trouble is in the low-voltage power supply. If there is more than one bar, varying from light to dark, trouble may be caused by defect in a full-wave power supply or the vertical sweep. Try replacing the vertical output tube.

Diagonal lines across picture

This is a symptom of adjacent-channel interference and is often the result of trying to tune in a weak station when the adjacent channel is very strong. Adjacent-channel traps in the receiver may need readjustment. (Some receivers do not have adjacent-channel traps.) Careful realignment of video if stages may help.

Differentiator troubles
Ref. Chapter 9

Critical or complete loss of horizontal sync is caused by defective resistor or capacitor of differentiator.

Dim picture
Ref. Chapter 5
Chapter 7

If volume is low and sync is critical, check the low-voltage supply, particularly the rectifiers or tubes.

Trouble can be due to a weak video amplifier tube. Note setting of the contrast control. If it is at its maximum range setting, replace the video amplifier tube. A dim picture does not necessarily indicate contrast troubles. It can be due to some defect in the high voltage supply. Note the setting of the brightness control. If the control is far advanced, trouble is probably in the high-voltage supply. Check ion trap.

A dim picture is sometimes due to nothing more than a dirty screen and safety glass. High voltage causes heavy collection of dirt on picture-tube face. Clean with lukewarm water and soap, but first make absolute sure that picture tube is discharged and that line cord is disconnected from outlet.

**Dim picture
(Continued)**

A dim picture can be caused by a weak picture tube. Try a picture-tube brightener.

If dim picture is accompanied by corner shadow, check the setting of the ion magnet.

**Distorted sound
Ref. Chapter 6
Chapter 10**

Audio output tube is sometimes used as a voltage divider. Check to make sure all voltages are correct. Distorted sound can be caused by misaligned sound if or detector transformers. Incorrect values of bias on any one of the audio tubes or a defective electrolytic capacitor in the ratio-detector circuit or a leaky coupling capacitor in the audio amplifier can result in distortion.

Sound distortion can be due to improper tuning of the front end. If distortion is on one channel only, adjust oscillator slug for that channel. If on all channels, remove antenna leads and note if any improvement. If there is, replace antenna leads and insert impedance-matching device between transmission line and receiver.

**Dots and streaks
in picture
Ref. Chapter 4**

This indicates presence of noise in the picture. Can be due to improper setting of ogc control putting excessive bias on controlled tubes, leading to insufficient gain. Tubes may be weak—substitute front end, video if amplifier, picture detector and video amplifier tubes. Misalignment with excessive bandpass means less gain and also permits more noise to come through. Automobiles, oil-burners, electric signs, even loose or rubbing wires can cause noise in the picture as can a dirty tuner. Use a cleaner lubricant on mechanical contacts.

**Echo effect
Ref. Chapter 5**

Oscillation in the video amplifier. Try new video amplifier tube. Check video amplifier decoupling filter. Remove cathode bypass capacitor of video amplifier tube. Insert a 100-ohm resistor in series with control grid of video amplifier tube. This resistor should be in the signal path between the video detector tube and the video amplifier.

Engraved effect

Replace video amplifier tube. Check peaking coils or replace. Replace video detector.

**Erratic reception
Ref. Chapter 1**

If tuner is separate assembly, make sure that common connection between tuner and receiver is good. Connect by shield braid. Clean-lubricate tuner contacts.

**Excessive bass
response
Ref. Chapter 10**

Capacitor connected across audio output transformer has too much capacitance. Disconnect and note effect. If bass improves, use a smaller value of capacitance.

**Excessive
brightness
Ref. Chapter 7
Chapter 8**

Check brightness control circuit and for leakage between first and second picture-tube grids. Check setting of the horizontal drive control. If one side of the picture is brighter than the other, replace the damper tube. Can be due to defective direct-coupled video amplifier tube.

Check CRT control-grid and cathode voltages.

Check the retroce blanking circuit, if receiver has one. If the retroce-network resistors or capacitors are defective, bias on picture tube will be changed.

There may be an internal short between control grid or cathode and other elements of picture tube.

Excessive contrast
Ref. Chapter 4

Check to see if rf and if amplifier tubes are working at too high gain (caused by insufficient agc voltage). Check the agc network for any components that are shorted or have changed value. Put bias box across agc bus. If normal bias reduces contrast, trouble is definitely in agc. If not, a leaky cathode bypass capacitor of the video amplifier tube can produce this trouble.

Check controls on rear apron of receiver to see if these have been misadjusted by customer.

Locate position of receiver's contrast control. Usually if contrast control, in the cathode of the video amplifier, has no effect, trouble exists in the video amplifier. Turn up the brightness control. If this has an effect on the phase of the picture (changes the picture from positive to negative) or if the brightness control seems to act like a contrast control, then the picture tube is gassy.

Measure the signal voltage across the video detector diode load. If it is normal (less than 5 volts) for typical picture-signal input at the antenna, then trouble follows the video detector. If voltage is unusually high, near 10 volts, then trouble precedes the video detector. Excessive signal voltage across the video detector indicates loss of agc or oscillation in a video if stage. Since the symptom does not include dark lines across the screen, but is simply an overcontrasted picture, rule out oscillation.

Put an attenuator between transmission line and antenna input. If picture contrast improves, fault in agc is indicated.

Flashes across screen when tuner is rotated
Ref. Chapter 1

Noisy tuner. Use a cleaner lubricant.

Flicker
Ref. Chapter 12

Refer to airplane flutter.

Foldover at left or right side of picture
Ref. Chapter 8

Caused by defective components in horizontal sweep circuits. Try new output and damper tubes and all parts connected to horizontal output tube or damper. Resistance-check horizontal deflection windings. Can be caused by open capacitor or capacitors shunting the horizontal linearity coil. Sometimes is produced by weak low-voltage rectifier tube or low line voltage.

Try a new horizontal oscillator tube. Coupling capacitor between horizontal oscillator and horizontal output tubes may be defective. Check peaking resistor and capacitor. Check cathode and screen resistors of horizontal output tube.

Focus, poor
Ref. Chapter 5

See Poor Focus.

Fringe-area problems
Ref. Chapter 1

Weak or snowy picture. Critical sync. These troubles do not arise in the receiver, but are caused by location. Increase antenna height. Use higher-gain antenna and booster. Use "hot" rf and video if tubes. Adjust agc for maximum sensitivity.

Realign video if for narrower bandpass.

Front end, realignment of
Ref. Chapter 1

Symptoms are poor sound or picture. Smear. Buzz cannot be eliminated by any setting of fine-tuning control. Front end needs realignment.

Front end trouble

Ref. Chapter 1
Chapter 6

Trouble in the front end can cause a variety of symptoms. These include loss of picture, sound, smear, jitter, noise, trailing whites, flashes in the picture and erratic reception.

Frozen yoke

Ref. Chapter 7

Deflection yoke cannot be removed from neck of picture tube. Use yoke-removing technique described.

Gassy tubes

Ref. Chapter 2
Chapter 7

Blue glow in tube; whitish deposit near base of tube. Excessive current flow through tube. If tube has a plate load resistor, voltage at the plate will be lower than normal. Gassy tubes can result in hum in the sound or picture. Gassy tubes in picture-handling circuits (such as video if) mean excessive gain with possibility that picture will become negative.

Gassy tubes reduce tube bias by grid-current flow. This counteracts effect of agc. If picture tube or high-voltage rectifier is gassy, blooming will result.

Ghosts

Ref. Chapter 1
Chapter 6

Can be caused by impedance mismatch between transmission line and receiver. Use impedance-matching device. If ghost appears as a reverse, reorient the antenna. Try indoor antenna in parallel with existing antenna. Phasing ghost is caused by defect in phasing network in horizontal afc.

Height, insufficient

Ref. Chapter 9

Adjust vertical linearity and gain controls. Replace vertical oscillator and amplifier tubes. Check B-plus voltages to oscillator and amplifier. Try new low-voltage rectifier tube. Check line voltage. If vertical sweep is tied into the B-plus boost line, check boost voltage. Examine all resistors and capacitors in the vertical sweep circuit. Can be due to defect in yoke or resistors shunting vertical windings. Check for excessive high voltage at CRT.

High voltage, insufficient

Ref. Chapter 8

Substitute new high-voltage rectifier tube, damper, horizontal output tubes. Defective flyback. Check filament resistor of high-voltage rectifier. Resistance-check filter resistor between filament of high-voltage rectifier and input to second anode of picture tube. Check components in horizontal output stage. Make sure horizontal output tube has sufficient drive. Adjust drive control. If drive is insufficient, check horizontal oscillator and resistive and capacitive components between oscillator and output tubes.

Check horizontal screen-grid voltage and bias. If boost voltage is low, high voltage will be affected. Trouble is sometimes caused by overload on high-voltage supply due to gassy picture tube. Disconnect second anode lead and make voltage measurement (by sparking or measurement). It is also possible that the deflection yoke is defective.

His

Ref. Chapter 10

Frying sound, usually associated with high-voltage components. Look for signs of arcing or corona.

Horizontal bending

Ref. Chapter 6

Blending may be due to hum pickup by picture signal. If accompanied by hum in sound, bending is definitely hum pickup.

Bending can be caused by excessive video signal into the picture tube. If video amplifier bias and other dc voltage checks are normal, check setting of the agc control.

Bending is often caused by trouble in the horizontal afc circuit. Quite often, nothing is wrong except misadjustment of the horizontal hold control. If horizontal hold brings picture in, but picture cannot lock

troubles

servicing techniques

Miss (Continued)

into place, trouble is in horizontal afc. Try new horizontal oscillator and afc tubes.

Examine the horizontal blanking and sync pulses by adjusting afc transformer slug. Adjust the brightness control until you see the black edge of the vertical bar. This is the sync pulse. The blanking bar to the left of the pulse should be somewhat lighter. It is possible there is some defect in the differentiator. The condition will then be one of horizontal tearing rather than bending.

Check the components in the horizontal afc. Tolerances of these items tend to be critical.

Horizontal foldover Ref. Chapter 7

The picture can be folded over on the left or right side of the screen. If the foldover is at the left side of the picture, try replacing the damper and the horizontal output tubes. Check the capacitors shunting the horizontal linearity coil. Incorrect yoke replacement (that is, servicing by replacing the deflection yoke) can produce foldover at the left side if there is an impedance mismatch between the yoke and the flyback.

For foldover at right side of picture, check peaking circuit between horizontal oscillator and horizontal amplifier; also coupling capacitor between.

Incorrect bias voltages on the horizontal oscillator and horizontal amplifier tubes can cause foldover.

Changed values of components (resistors and capacitors) in the horizontal oscillator and horizontal output stages can produce horizontal foldover.

Horizontal line across center of screen Ref. Chapter 7 Chapter 9

This trouble is due to complete loss of vertical sweep. Low-voltage and high-voltage supply systems are in working order. Replace vertical oscillator and vertical amplifier tubes. Check oscillator and amplifier tubes. Check oscillator and amplifier voltages. If vertical sweep works from base B-plus, check to see if voltage is correct. Check peaking circuit between vertical oscillator and amplifier. Check vertical frequency (hold) and gain controls. Resistance-check vertical blocking oscillator transformer. Check vertical deflection coils, making certain that leads going to yoke are not broken.

Horizontal linearity control Ref. Chapter 9

Improper setting of this control can result in picture stretch. Also adjust drive and width controls.

Horizontal reversal of picture Ref. Chapter 7

Leads to horizontal deflection coils have been transposed.

Horizontal scanning lines in raster are wavy Ref. Chapter 7

Capacitors across one winding of the horizontal deflection coils is open or the wrong value.

Hum Ref. Chapter 6 Chapter 10 Chapter 11

If hum appears only in audio, the trouble follows the sound takeoff point. If hum appears in picture and sound, it is caused by circuits common to both. A 60-cycle hum is produced by pickup from power transformer, filament bus, heater-to-cathode leakage in a tube or by defective filtering in a half-wave voltage-doubler supply. A 120-cycle hum follows the full-wave rectifier and is usually due to leaky or low-value filter capacitors in the low-voltage power supply.

- Hum (Continued)** Do not confuse hum and buzz. Hum sounds smooth; buzz sounds rough. Buzz can be due to the TV station. Change channels. If buzz disappears, it is caused by the station. If you are not sure whether sound is hum or buzz, remove the vertical oscillator tube. If the symptom remains, it is probably hum.
To reduce hum in the audio, try adding filter capacitors to the B-plus bus going to screens and plates of audio tubes. Make sure hum isn't due to mechanical vibration of loose laminations in receiver power transformer. Keep ac leads on volume control away from control grid leads of audio section. Sometimes reversing the plug to the ac power line helps minimize or eliminate hum.
- Hunting**
Ref. Chapter 9 This condition, sometimes called piecrust effect, is due to fact that horizontal oscillator constantly swings back and forth across its sweep frequency. Check anti-hunting components. See Outer Edges of Picture Are Wavy.
- Insufficient B-plus voltage**
Ref. Chapter 11 Picture may be small horizontally or vertically or both. Sound may be weak. Sync may be critical. Check line voltage. Rectifier tube may be weak. Check semi-conductor rectifier (or rectifiers) by replacement. If accompanied by hum in picture or sound, check electrolytics for leakage.
- Insufficient brightness, small picture, poor focus**
Ref. Chapter 1
Chapter 7 Caused by low line voltage. Some homes are not wired for heavy electrical loads produced by modern appliances.
- Insufficient contrast**
Ref. Chapter 2 Weak pictures on most channels. Often due to weak tubes from front end to picture tube. Insufficient antenna gain or antenna oriented in wrong direction. Improper alignment of video if (bond-poss too wide). Low line voltage. Weak rectifier tube, resulting in lower-than-normal B-plus voltages. Defective video detector tube or crystal. Too low a value of video detector load resistor. Open peaking coil. Overloading of front end and if amplifier tubes caused by excessive ogc voltage. Agc control improperly set. Defective components in ogc filter system. Check bias on picture tube.
- Insufficient height**
Ref. Chapter 9 Replace vertical output tube. Check vertical output tube signal and dc voltages. Vertical gain control may be defective. Lack of height can be due to defective resistors across vertical deflection windings or to shorted turn in the windings. If vertical output tube works from the boost voltage, make sure this voltage is normal.
- Insufficient high voltage**
Ref. Chapter 8 Replace horizontal oscillator, horizontal output, higher voltage rectifier and damper tubes. Check setting of horizontal drive control. Check dc voltages on horizontal output tube. Arcing inside fly-back or in high voltage system. Incorrect value of filament dropping resistor for high voltage rectifier tube.
- Insufficient width**
Ref. Chapter 8 Weak horizontal oscillator tube. Insufficient drive. Excessive high voltage. Yoke not positioned properly. Replace horizontal amplifier and damper tubes. Adjust width coil or width sleeve.
Make sure customer hasn't misadjusted controls on rear apron of receiver. Line voltage may be low. If set is older type with width coil shunted across port of flyback, disconnect the width coil com-

troubles

servicing techniques

- Insufficient width
(Continued)**
- Interlace, poor
Ref. Chapter 9**
- Intermittent
flashes in picture
Ref. Chapter 8**
- Intermittent
picture
Ref. Chapter 2
Chapter 4**
- Intermittent sound
Ref. Chapter 1
Chapter 10**
- Jitter
Ref. Chapter 1
Chapter 4
Chapter 6**
- Lead dress
Ref. Chapter 2
Chapter 6**
- Left side of screen
excessively bright
Ref. Chapter 8**
- Light and dark
vertical bars
Ref. Chapter 7
Chapter 8**
- Linearity, poor
Ref. Chapter 8**
- pletely if it is not part of agc circuit. Condition can be caused by defective resistors or capacitors in horizontal oscillator or amplifier circuits. Insufficient B-plus to horizontal output screen can produce insufficient width. Lowered B-plus boost can also cause this.
- See Poar Interlace.
- Improper contact between spring grounding clip and Aquadag. See also Streaking Across Screen.
- Dirty tuner. Cold solder joints. Loose connections. Can also be caused by filament that shorts to grounded cathode after filament has been operating for a little while. Look for arcing or corona. One or more tubes may not be properly seated in their sockets. Rf or video tubes may not be making good contact (bent pins). Can also be caused by microphonic tube. Check transmission line to see if it is secure and that no strands are broken at the antenna terminal board.
- See Picture and Sound Are Good, Then Become Defective.
- Adjust contrast control. If ineffective, and if jitter appears on single station, trouble may be due to excessive signal, dirty contacts in tuner or unsecured antenna lead-ins. Sometimes caused by microphonic tubes, especially tubes close to picture tube. Try replacing video amplifier. Horizontal instability, due to horizontal afc hunting, can produce jitter. Defective horizontal afc. Can also be caused by improper lead dress. Keep leads carrying pulse voltages (lead to plate cap of high-voltage rectifier and lead to damper tube) away from horizontal oscillator. Jitter is sometimes caused by arcing at corona.
- Improper lead dress can cause snow in picture, bending, interference, regeneration and excessive contrast.
- Replace damper tube.
- Defective capacitor in vertical output circuit causing lower boost B-plus (when boost B-plus is connected to vertical output tube). Defective resistor across vertical deflection coils causing ringing in horizontal coils.
- Replace horizontal oscillator, output and damper tubes. Adjust linearity control. Trouble may show in the form of foldover. For horizontal foldover check settings of drive, width and linearity controls (if set has these). Poor linearity can be due to improper setting of anti-pincushioning magnets.
- For vertical nonlinearity, check vertical linearity and gain controls. Replace vertical oscillator and amplifier tubes. If fed from boost B-plus line, make sure voltage is normal. Check components associated with vertical oscillator and amplifier tubes.
- Also see Trapezoidal Picture, Vertical Foldover.

**Loss of fine
picture detail**
Ref. Chapter 2

Misaligned video if transformers. Impedance mismatch between transmission line and receiver. Weak rf amplifier, if detector and video amplifier tubes. Wrong peaking coils. Excessive capacitance across detector load resistor. Poor lead dress resulting in bypassing of high-frequencies to ground. Excessive agc voltage cutting down on gain of front end and video if tubes. Reset agc control. Improper setting of ion magnet. Improper adjustment of focus control. Insufficient B-plus voltage due to weak rectifier tube or insufficient line voltage. Sound takeoff trap, in series between plate of video amplifier and input to picture tube, may be misadjusted. Picture-tube face may be dirty. Picture-tube emission may be below normal. Try picture-tube brightener. Check for insufficient high voltage.

**Loss of high
voltage**
Ref. Chapter 12

Sound not affected. No raster at any brightness control setting. Check with neon indicator. Replace horizontal oscillator, amplifier, high voltage rectifier and damper tubes. Open filament resistor to high-voltage rectifier. Open high-voltage filter resistor. Defective flyback transformer (shorted turns or internal arcing). Open fuse or linearity coil. Check cathode and screen resistors of horizontal output tube. Incorrect setting of horizontal drive control.

**Loss of picture
and sound**
Ref. Chapter 1

See **No Raster or Sound**.

Microphonics
Ref. Chapter 1
Chapter 2
Chapter 10

Streaks in picture, especially during vibration produced by walking across floor or by passing truck, etc. Loose elements in tubes in front end, video if and video amplifier. Tap tubes gently while watching screen to find defective one.

Motorboating
Ref. Chapter 10

Sounds like motorboat. Check decoupling capacitors and resistors in audio section. Sometimes due to decreased capacitance in low voltage power across the output. Keep plate and control grid leads separated.

Multiple pictures
Ref. Chapter 9

Incorrect operating frequency of the sweep oscillator. Insufficient sync pulse input to oscillator. Can be due to sync separator, sync amplifier or integrator circuits. Overloading in earlier stages (video if) can produce sync pulse compression, resulting in loss of sync. Check hold control. See **Two Pictures, One Above the Other**.

No contrast
Ref. Chapter 4

See **Insufficient Contrast**.

**No picture,
no sound,
raster good**
Ref. Chapter 2
Chapter 4

The presence of a raster indicates that both the low- and high-voltage circuits are working. Trouble exists in some stage that handles both picture and sound. This could be any tube or circuit starting at the antenna input and continuing right up to the sound takeoff point.

No raster or sound
Ref. Chapter 7

Often caused by defective tube. There are a number of tests to make, depending on your personal preference: (1) Try substituting known good tubes in the signal-handling circuits. (2) Inject a modulated signal from a signal generator at the input to the picture tube. If bars show on the screen, work your way back through the video amplifier to the picture detector. A typical test frequency for the video amplifier is 1 megacycle, modulated. Test frequency isn't critical. On the rf side of the video detector, the if frequency, modu-

troubles

servicing techniques

No raster or sound (Continued)

lotted, must be used. Using this technique, work your way back to the antenno input, going from plate to control grid of each tube. At any point where signal on the screen disappears, look for tube or circuit trouble.

Another technique in checking loss of sound and picture is to signal-trace through rf and video if stages. Connect a modulated signal generator across the antenno input terminals and trace the modulated rf signal (about 20 mc or higher) through the rf and video if stages using a crystal probe (demodulator probe) and a scope. Investigate any stage in which signal is lost.

In areas having just one station, no signal or sound may be that the station just isn't on the air.

No picture, raster normal. Sound is good

Good sound indicates that the signal is traveling at least as far as the sound takeoff coil. If the sound takeoff is between the video amplifier and the picture tube, the trouble is in circuits associated with the picture tube. Note that the high voltage and picture tube seems to be working properly because of the presence of the raster. A poor pin connection to the cathode or control grid of the picture tube may be the fault. If the sound takeoff precedes the video amplifier tube, check that tube and all components associated with it. Try injecting a modulated signal into the signal electrode of the picture tube to see if you can get bars across screen. (Use rf generator set at 1 mc and modulation at maximum.)

No raster or sound Ref. Chapter 7

The set is completely inoperative. Check the low-voltage power supply. Make sure that the receiver is plugged into an outlet that is working. Examine the plug. It may be defective. Sometimes the owner of a receiver will remove the back panel and then try to replace it but fail to have the interlock make good contact. Check the line fuse. Put on an ac voltmeter across the primary leads of power transformer and then operate the on-switch to see if you can control the ac input. One open filament in a transformerless chassis will prevent all filaments.

One of the most usual causes of this trouble is a defective rectifier tube (or tubes). If preliminary inspection of the line cord and outlet indicates nothing wrong, see if rectifier needs replacement. Of course, if rectifier lights, then trouble is on secondary side of the power transformer.

Noise Ref. Chapter 1 Chapter 6 Chapter 10

See Flashes Across Screen When Tuner is Rotated. See also TVI.

Nonlinearity, vertical Ref. Chapter 8

See Linearity, Poor.

Outer edges of picture wavy Ref. Chapter 9

Defective horizontal oscillator components. Defective horizontal output tube. Breakdown of anti-hunting components.

Overcontrast Ref. Chapter 6

See Excessive Contrast.

Picture and sound are good, then become defective
Ref. Chapter 1

Picture cannot be tuned in or out.
Ref. Chapter 1

Picture fades in and out
Ref. Chapter 2

Picture hook
Ref. Chapter 8

Picture too strong, then improves
Ref. Chapter 4

Picture jumps out of sync on strong stations
Ref. Chapter 5

Picture oscillation
Ref. Chapter 2

Picture pullout
Ref. Chapter 5

Picture quality, loss of
Ref. Chapter 9
Picture oscillation
Ref. Chapter 2

Poor focus
Ref. Chapter 5
Poor high-frequency response
Ref. Chapter 2

Poor interlace
Ref. Chapter 9
Picture seems blurred — all channels

Picture smear
Ref. Chapter 1
Chapter 5

Picture-tube brightness cannot be varied

Drift of oscillator in front end. Defective oscillator tube. Excessive heating of oscillator tube when covered with a shield. May be caused by loose antenna or loose transmission line.

If condition exists on all channels, finetuning control is defective. If only on one channel, oscillator slug may have broken.

Defective component in agc system. Also check filament bypass capacitors. See also Intermittent Picture.

Heater-to-cathode short in horizontal output tube. Open B-plus boost capacitor.

Slow emission in agc rectifier, agc clamps or keyed agc amplifier tubes. Check by tube substitution.

Caused by sync overload. Reduce value of coupling capacitor between video amplifier and sync input. Reset agc control.

See Lines in Picture Following Small Objects.

Due to defective coupling capacitor between video amplifier and sync separator. Also due to defective video amplifier tube. Can be caused by sync limiting.

See Picture smear Chapter 1.

Check setting of focus. Picture tube may be gassy. Insufficient high voltage can produce this trouble; substitute new horizontal output and oscillator, damper and high-voltage rectifier tubes. Make sure focus magnet is not too far back on the neck of the picture tube. See also Blooming.

See Smear.

Trouble may be in the brightness control circuit or in the picture tube. Measure picture-tube bias while rotating brightness control. If bias varies within normal range, brightness control circuit is good. Repeat bias test with picture-tube socket removed. If bias is good with socket removed, but improper with socket connected, fault lies in the picture tube. Tube may have a heater-to-cathode or cathode-to-control grid short.

troubles

servicing techniques

Raster OK, picture good, no sound, or sound is weak or distorted

Good picture or raster indicates low-voltage supply is working and circuits up to sound takeoff point are good. Loss of sound isn't due to misalignment in video if's since picture comes through satisfactorily. Also sound takeoff coil isn't misaligned since there are no sound bars in picture. If sound is completely lost, touch hot end of volume control with screwdriver or finger. If a hum comes through speaker, trouble is between sound takeoff point and volume control. If no hum comes through, trouble is between volume control and speaker. (1) Click-test by pulling tubes from sockets, starting with audio output and working back to sound if. (2) With signal generator signal inject sound if, sound detector and audio amplifier stages.

If sound is weak or distorted, misalignment of the oscillator slug or the video if's is a possibility. If weak and distorted sound appears on all channels, oscillator slugs are okay and trouble is in the video if's. If distorted or weak sound appears on one channel only, most likely cause is misadjusted oscillator slug for that channel. Weak or distorted sound can also be caused by misaligned radio detector transformer, defective audio tubes or speaker.

See Noise.

Receiver tube noise

Ref. Chapter 1

Resistance measurements

Ref. Chapter 1

Rolling

Ref. Chapter 9

Be careful not to spread socket connections when making resistance checks. Adapter is helpful.

This condition indicates complete or partial loss of vertical sync. Rotate vertical hold control. If you can make picture stop momentarily, or if you can make the picture move up and then down, trouble is due to loss of sync input to the vertical oscillator. Try substitution of sync separator and sync amplifier tubes. If possible to trace pulses up to the output of the last sync amplifier tube, trouble is in the integrator network. Easy check on integrator is to substitute complete new unit of printed-circuit type.

If sync pulses do not appear at input to sync separator, examine blanking bar. Look for evidence of sync compression. If present, overloading in some stage preceding the video amplifier is responsible. Check agc voltage.

Rolling accompanied by hum in the sound or a hum bar on the screen is evidence of heater-to-cathode leakage in tube. If cathode of tube goes to ground through a cathode resistor, momentarily ground cathode to see if hum symptom is removed.

Sides of picture pulled in. Caused by wrong replacement yoke during servicing. Shorted turns or components across yoke windings can result in pincushion effect. Adjust anti-pincushioning magnets.

Pincushioning

Ref. Chapter 7

Poor focus

Ref. Chapter 5

Improperly adjusted slugs in focus magnet. Wrong positioning of focus magnet. Gassy picture tube. Can be due to using wrong ion magnet. Make sure focus magnet is not tilted. Focus magnet may be incorrect for particular picture tube (either too strong or not strong enough).

Misaligned video if.

Poor high-frequency response

Ref. Chapter 2

Poor interlace
Ref. Chapter 9

May be due to nothing more than a wrong setting of the vertical hold control, resulting in poor interlace. A moire effect in the horizontal wedges of the test pattern is a symptom. Defective integrator components can also cause poor interlace.

Troubles may also be due to wrong value of peaking components (between vertical oscillator and amplifier). Keep high-voltage leads away from the vertical oscillator. Sometimes caused by insufficient vertical sync amplification. Try replacing vertical sync, vertical amplifier and video amplifier tubes. If receiver uses a blanking oscillator transformer, connect a capacitor (500 $\mu\mu\text{f}$ or less) between the vertical oscillator grid and chassis.

Raster has rounded corners. Brightness is good

Caused by improper seating of yoke. It should be far forward and snug against picture-tube bell. Check the positioning of the focus and ion magnets. Move the magnet forward to see if this cures the trouble. This difficulty is also due to wrong positioning.

Raster has rounded corners. Brightness is poor

Check the positioning of the focus magnet and the ion magnet. After focus magnet has been properly placed, readjust the magnet slugs to make sure the raster goes through focus.

Raster is dim on one side (left); normal on right side

Check the low-voltage power supply—replace weak rectifiers.

Raster is tilted

Rotate the deflection yoke until the raster reaches its normal position.

Raster is too small

All the edges of the raster can be seen. Make sure that the height and width adjustments are set to produce a raster of normal size. The trouble is often caused by a weak low-voltage rectifier tube (or tubes). Make sure the line voltage is normal. Use line voltage booster transformer and see if picture height and width improves. If raster is too small and cannot be focused properly, picture tube may be gassy. If raster is small and sound volume is reduced, trouble is in the low-voltage power supply.

Silvery images
Ref. Chapter 7

Picture tube is defective.

Single, wide black bar across screen
Ref. Chapter 4

See Hum.

60-cycle hum
Ref. Chapter 2

See Hum.

60-cycle sync buzz
Ref. Chapter 4

See Buzz.

Smear
Ref. Chapter 1

Caused by poor low-frequency response. Poor definition of large objects. Improper alignment of front end or video if. Can be produced by excessive signal strength, by gassy tubes in front end or video if. Peaking in if caused by regeneration can narrow bandpass and result in smear. Check video detector. Can be caused by increased value of video detector load. Video amplifier tube may be gassy. Check voltages at video amplifier. Do not replace peaking coils in video amplifier with incorrect units since smear can be produced in this way. Check resistive and capacitive components in video amplifier.

- Snivets**
Ref. Chapter 8
Chapter 9
- Snow in picture**
Ref. Chapter 1
- Sound in picture**
Ref. Chapter 2
- Sound normal, picture delayed**
Ref. thruout
Chapter 7
- Sound, no picture**
Ref. Chapter 5
- Split picture**
Ref. Chapter 6
- Spooks**
- Squeal**
Ref. Chapter 8
Chapter 10
- Streaks in picture or defective sound**
Ref. Chapter 1
- Sync buzz**
Ref. Chapter 6
Chapter 10
- Trailing reversal (white following black)**
Ref. Chapter 5
- Trailing whites**
Ref. Chapter 1
Chapter 2
- Tube noise**
Ref. Chapter 1
- Black blotches at right side of screen. Caused by radiation from horizontal output tube. Replace tube or put magnet over it. Keep high-voltage leads away from video if.
- Weak picture. Sync is critical. Speckles in picture. See Tube Noise.
- Sometimes caused by improper tuning. Adjust fine tuning control to see if sound bars can be eliminated. If bars appear on one channel only, readjust oscillator slug for that channel. Trouble can be due to microphonic tube (or tubes). Realign the secondary of the sound ratio-detector transformer. Sometimes caused by a misaligned video if transformer or sound traps.
- Remove the audio output tube and note if condition improves. If it does, then trouble is caused by poor regulation of the low-voltage supply. Improve by adding filter capacitance.
- Remove speaker from its mounting (do not disconnect from receiver). Vibration from speaker sometimes causes vibration of tube elements. If sound bars disappear, put rubber grommets between speaker and cabinet or, if possible, locate speaker elsewhere.
- Low emission in picture tube. Weak tubes in horizontal or high-voltage circuits.
- See No Picture, Sound Is Good.
- Gassy sync separator or amplifier tube. Check sync resistors and capacitors.
- See Vertical Line at Left of Raster.
- High-pitched whistle produced by flyback transformer. Tighten assembly screws. Make sure flyback is securely fastened to chassis. Spray flyback with acrylic resin spray.
- Microphonic tubes in the front end can produce this trouble.
- See Buzz.
- See Smear.
- Due to poor low-frequency response. Check alignment. Bandpass of video if amplifier too narrow. See Smear.
- Snowy picture. Substitute local oscillator rf and if amplifier tubes. Check antenna for broken transmission line or impedance mis-match between transmission line and receiver. Look for defect producing loss of gain in rf amplifier or video if amplifier sections. Misaligned video if. Agc voltage too high. Check setting of agc control. A

**Tube noise
(Continued)****Tube troubles
Ref. Chapter 2****TVI (will appear
in picture and/or
sound as buzz,
squealing, whis-
tling, lines on
screen or noise).
Picture may go
out of sync
momentarily**

condition resembling snow in the picture is sometimes caused by arcing or corona.

These include: one or more weak or completely dead, microphonic, noisy or gassy tubes. Heater-to-cathode leakage. Bent tube pins. Shield missing. Wrong tube in socket. When receiver has been in use for long time and has history of few tube replacements, complete substitution of front end, video if, detector and amplifier tubes help considerably.

Antenna transmission line (two-wire line) may be too close to picture-tube high-voltage lead or deflection yoke. Defective horizontal output tube. Horizontal output tube may be oscillating. Put 100-ohm resistor in series with control grid of horizontal output tube. Try adjusting horizontal drive control (if the set has one). Substitute a new damper tube. Make sure high voltage cage is complete (side of cage or top may have been removed for prior servicing) and properly grounded. If moving yoke leads reduces TVI, redress leads or shield them.

Interference may be coming in through power line. Use a line filter. Reverse line plug. Try a different outlet, if possible. If receiver is a portable type, try positioning it elsewhere in room. If interference comes from motors (such as refrigerators, air-conditioning units, power tools, etc.) try grounding the motor frame. Replace motor brushes if worn.

If receiver is in a wooden cabinet, line entire inside of cabinet with metal foil and ground the foil. Be careful not to short any components and do not permit foil near high voltage leads. Try changing unshielded transmission line to coaxial cable. Try rerouting transmission line to a different location. Relocation of antenna sometimes helps.

**Unstable vertical
sync****Ref. Chapter 5
Chapter 6
Chapter 9**

See Rolling.

**Vertical black bar
Ref. Chapter 9**

Caused by incorrect horizontal phasing. Picture looks split in two with black bar in between. Defective R-C feedback network between plate of horizontal oscillator and grid of horizontal control tube. Adjust phasing control.

**Vertical foldover
Ref. Chapter 9**

Check coupling capacitor between vertical oscillator and amplifier stages. Try new vertical output tube. Make sure bias on tube is correct. If not, examine cathode bias resistor and bypass capacitor of vertical output tube.

**Vertical line at
left of raster**

This thin line is generally not noticed since it is usually covered by the mask. However, it may come into view as horizontal sweep becomes weaker. Trouble is due to radiation from damper tube. If set has a width control or width sleeve, adjust to see if you can push line back under mask. Sometimes, adjusting horizontal linearity control will remove the line. Put rf chokes in series with the cathode and plate leads of the damper tube. These can be 10 μ h. Try a new damper tube. Try adding additional capacitance in shunt with linearity control filter capacitors.

troubles

servicing techniques

Vertical lines on screen. These vary in shading

Ref. Chapter 9

Check capacitor (usually 56 $\mu\mu\text{f}$) across one half of horizontal deflection coils.

Vertical reversal of picture

Ref. Chapter 7

Leads to vertical deflection coils have been transposed.

Vertical white line near left side of screen

Caused by improper setting of horizontal drive control (not all sets are so equipped). Results in shorter than normal life of horizontal output tube. Horizontal output transformer becomes excessively warm. Overdrive can affect linearity. If receiver does not have drive control, put small-size capacitor from control grid of horizontal output tube to chassis. Use smallest-size capacitor possible — some experimentation will be needed.

Washed-out picture

Ref. Chapter 4

Excessive agc bias. Weak tubes in front ends, video if, video amplifier.

Whistle, high-pitched

Ref. Chapter 8

See Squeal.

White vertical line

Rotate channel selector. If line disappears, trouble is at the TV station. Trouble can exist in horizontal afc circuit. Substitute a new horizontal control tube. Adjust the afc transformer.

Wiggling in the picture

Ref. Chapter 2

Sound carrier too high on video response curve. Realign video if stages.

This is a cumulative index. It contains listings for volumes 1 and 2.

A

Adapter, Test Point	1-31, 2-136
Adapter, Tube Test	1-31
AFC, Horizontal	2-69
Afterglow	2-15, 2-22
AGC:	
Basic Circuit	1-81
Battery Box	1-84
Bias Supply	1-85, 1-93
Circuit, Delayed	1-82
Circuit, Improved	1-101
Clamp	1-90
Defects	1-92
Delay, for Tuner	1-90
Diode, Separate	1-83
Excessive Bias	1-89
for the Mixer Tube	1-29
Keyed	1-87
R-C Filter	1-101
Tubes, Multipurpose	1-99
Types	1-81
Voltage	1-50, 1-79
Voltage Distribution	1-80
Voltage Substitution	1-84
Winding on Horizontal Output Transformer	1-103
Winding on Width Coil	1-104
Airplane Flutter	1-98
Alignment:	
and AGC	1-86
Fringe Area	1-24
IF	1-42
of Front End	1-20
of Tuner	1-21
Amplifier:	
Audio	2-96
Horizontal	2-44
IF	1-35
Sound IF	2-83
Vertical	2-62
Video	1-107
Anode, 2nd, Connector	2-16
Antenna:	
Attenuator Pads	1-8, 1-9
for Cascode Tuner	1-8
for Pentode Tuner	1-8
One for Two Receivers	1-11
Signal Area, Strong	1-8
Signal Area, Weak	1-8

Antenna (Cont.)

Single Rod Balun	1-25
Test, for Dipole	1-11
Test, for Folded Dipole	1-11
Tips on the	1-10
.....	1-24
Antennas	2-74
Anti-Hunting R-C	2-23
Arcing	1-8, 1-9
Attenuator Pads, Antenna	1-8, 1-9
Audio:	
Amplifier	2-96
Bypass	2-99
Output Transformer	2-99
Tube as a Voltage Divider	1-52, 2-86

B

Balancing Device, Transmission Line	1-16
Balun for Single Rod Antenna	1-25
Bar:	
Black in Picture	1-97
in Picture, Hum	1-72
Signal	1-128, 1-130
Barkhausen Oscillation	1-26, 2-52
Barreling	2-24, 2-63
Bars, Sound	1-26, 1-48, 1-118
Bass Response, Excessive	2-94
Battery Box	1-84
Bend in Picture	1-70
Bias:	
Excessive AGC	1-89
Supply	1-85, 1-93
Black Compression Waveform	1-131
Blanking, Retrace	2-11, 2-31
Blocking Oscillator	2-57
Blooming	2-21, 2-43
Blurred Picture	1-61
Boost, Line Voltage	2-115
Boost Voltage	2-62, 2-65
Boosters	1-17, 2-13
B-Plus Boost Voltage	2-65
B-Plus, Stacked	2-86
Brightner	2-13
Brightness	2-9
Buzz:	
Control	2-85
Cross-Modulation	1-120
Due to Impedance Mismatch	1-13
Sync	1-101, 1-152
Bypass, Filament	1-56

C

Capacitor	2-122
Electrolytic	2-123
Filter	2-113
Leakage	2-122
Limiting Surge in	2-125
Cascade Tuners	1-18
Cathode-Heater Leakage	1-26, 1-38, 1-45, 1-97
Cathode-Heater Leakage, CRT	2-22
Cathode-Heater	
Leakage Repair	2-23, 2-24, 2-27
Cathode-Heater Short	1-38
Chassis, Hot	1-29
Chassis, Removal	1-28
Circuit:	
AGC, Improved	1-101
AGC, Keyed	1-88
Antenna Balun	1-25
Audio Amplifier	2-96
B-plus Distribution	2-86
Basic AGC	1-81
Boost Voltage	2-65
Contrast Control	2-29
Decoupling Filter	2-110
De-Emphasis	2-84
Deflection Coil	2-18
Delayed AGC	1-82
Differentiator	2-74
Direct-Coupled Sweep	2-77
Full-Wave Rectifier	2-104
Full-Wave Voltage-Doubler	2-113
Gated-Beam Detector	2-85
Half-Wave Rectifier	2-111
Half-Wave Voltage-Doubler	2-117
High Voltage	2-32
High-Voltage Doubler	2-40
High-Voltage Rectifier	2-39
Horizontal Amplifier	2-35
Horizontal Output	2-44, 2-46, 2-47
IF Coupling	1-52
Integrator Network	2-56
Line-Noise Filter	2-108
Line-Voltage Boost	2-115
Local Oscillator	1-32
Neutrode Tuner	1-25
Oscillator, Blocking	2-57
Oscillator, Multivibrator	2-58
Parallel Rectifier Tubes	2-109
Peaking Coils in	1-109
Phase Detector	2-73
Power Supply	2-119
Primary	2-105
Ratio Detector	2-82
Rectifier Substitution	2-135
Retrace Blanking	2-31
Sound IF	2-83
Sound Takeoff	1-74, 2-81
Stacked B-Plus	1-53
Step-Wave Filter	1-130
Synchroguide	2-72
Vacuum-Tube Detector	1-64
Vertical Oscillator	2-63
Vertical Oscillator-Amplifier	2-76
Video Detector	1-60
Video Detector Defects	1-75
Video IF	1-42
Circuits, Printed	1-76
Clamp, AGC	1-90
Cleaning Tuner	1-30
Clipper, Sync	1-141
Coil:	
Deflection	2-7
Focus	2-7
Peaking	1-62, 1-113, 2-128
Width, AGC Winding on	1-104
Coils, Peaking, in Circuit	1-109
Color-Burst Signal	1-131
Compression, Sync-Pulse	1-72, 1-139
Connections, Solderless	2-136
Connector, High-Voltage	2-16
Connector, 2nd Anode	2-16
Contrast:	
Control Circuit	2-29

Contrast (Cont.)

Control Troubles	1-113
Delayed	1-45
Excessive	1-97
Insufficient	1-44
Picture, Poor	1-95
Troubles	1-113
Weak	1-44
Corner Shadows	2-7, 2-14
Corona	2-28
Corona Ring	2-51
Coupling, IF Amplifier	1-51
Coupling, Types of IF	1-52
Crimping Tool, Tube-Pin	2-8
Cross-Modulation Buzz	1-120
CRT Heater-Cathode Leakage	2-22
Crystal Diode Performance	1-67
Curve, Response, IF Amplifier	1-43

D

Damping	2-45
Decoupling Filter	1-57, 2-110
De-Emphasis Network	2-84
Deflection:	
Coil	2-7
Coil Circuit	2-19
Coil, Ringing	2-18, 2-20
Horizontal	2-18, 2-33
Vertical	2-55
Yoke	2-7
Delayed AGC	1-90
Delayed Contrast	1-45
Detector:	
Gated-Beam	2-83, 2-85
Phase	2-71
Ratio	2-82
Video	1-59, 2-80
Video, Circuit	1-60
Video, Crystal	1-63
Video, Load Voltage	1-109
Video, Semiconductor	1-63
Video, Vacuum Tube	1-63, 1-70
Waveform, Video	1-71
Differentiator	2-74
Diode:	
Crystal	1-63
Performance	1-67
Semiconductor	1-63, 1-66
Separate AGC	1-83
Symbol, Semiconductor	1-76
Tester	1-100
Vacuum Tube	1-63
Dipole Antenna	1-11
Direct-Coupled Sync Separator	1-150
Dirty Picture Tube	2-31
Discriminator, Sync	2-71
Distance-Local Switch	1-122
Distortion, Sound	2-91
Dots in Picture	1-104
Doubler, Voltage, Full-Wave	2-113
Doubler, Voltage, Half-Wave	2-117
Drive, Horizontal	2-35
Dummy Tube	2-123

E

Electrolytic Capacitors	2-123
Electrostatic Focus	2-17
Electrostatic Shield	2-114

F

Fading Picture	1-54
Faraday Shield	2-114
Filament:	
Bypass	1-56
Series	2-116
Tester, Series	1-37

Filter:	
AGC, R-C	1-101
Circuit, Step Wave	1-130
Decoupling	1-57, 2-110
High-Pass	1-12
High-Voltage	2-41
Input Capacitor	2-113
Line-Noise	2-108
Fine Tuning	1-32
Flashes in Picture	1-29
Flicker	1-98, 2-124
Flutter, Airplane	1-98
Fluyback Tester	2-126
Focus:	
Adjustments	2-15
Coil	2-7
Electrostatic	2-17
Magnet	2-7
Folded Dipole Antenna	1-11
Foldover	2-53, 2-67
Frequency-Burst Signal	1-126, 1-129
Frequency, Sweep	1-131
Fringe:	
Area IF Realignment	1-24
Area Problems	1-23
Area Sync Action	1-24
Lock	1-157
Front End:	
Noisy	1-22
Realignment	1-20
Test Points	1-21
Full-Wave Rectifier	2-104
Fuses	2-49
Fusible Resistor	2-112

G

Gassy Tubes	1-38
Germanium Rectifier	2-111
Ghost Eliminator	1-13
Ghosts Due to Impedance Mismatch	1-13
Ghosts, Lines Similar to	1-55
Gimmick	1-76
Grey Scale	1-130
Grounding, Tuner	1-31

H

Half-Wave Rectifier	2-111
Heat Sink, Semiconductor	1-65
Heater-Cathode:	
Leakage	1-26, 1-38, 1-48, 1-97, 2-22
Leakage Repair	2-23, 2-24, 2-27
Short	1-38
Heaters, Series	2-116
High:	
Frequency Response, Poor	1-49
Pass Filter	1-12
Voltage	2-33, 2-127
Voltage Connector	2-16
Voltage Rectifier	2-39
Hiss	2-85
Hold, Horizontal, Critical	1-96
Hook, Horizontal Picture	1-70
Hook, Picture	2-34
Horizontal:	
AFC	2-69
Amplifier	2-44
Deflection	2-33
Drive	2-35
Hold, Critical	1-96
Linearity Control	2-74
Oscillator	2-69
Oscillator, AFC	2-69
Oscillator, Phase Detector	2-71
Oscillator Sync Discriminator	2-71
Oscillator, Synchroguide	2-69
Oscillator, Synchrolock	2-69
Output Transformer, AGC Winding	1-103
Phasing	2-75
Picture Hook	1-70

Hot Chassis	1-29
Hum	1-116, 2-89, 2-118
Hum Bar in Picture	1-72
Hum in Sync	1-155
Hum, 60-Cycle	1-45

I

IF:	
Alignment	1-24
Amplifier	1-35
Amplifier Coupling	1-51
Amplifier Response Curve	1-43
Amplifier, Sound	2-83
Amplifier Voltages	1-50
Realignment, Fringe Area	1-24
Response Curve	1-153
Transformer, Checking Video	1-56
Transformer, Replacing Video	1-56
Transformer, Video	1-47
Tube Troubles	1-36
Ignition Noise Pick-up	1-12
Ignition Noise Suppressor	1-13
Impedance Match, Transmission Line	1-13
Impedance Matching Device	1-13
Indicator, Neon Lamp	2-38
Integrator Network	2-56
Intercarrier Sound	1-47
Interlace	2-67
Intermittent Picture	1-45
Ion Trap	2-7, 2-14
Isolation Transformer	1-28

J

Jitter	1-20
Jumping Picture	1-104

K

Keyed AGC	1-87
Keyer Tube	1-87
Keyer Voltages	1-105
Keystoning	2-19

L

Lead Dress	1-46, 1-156
Lead-In:	
Impedance Match	1-13
Installation	1-11
Suggestions	1-11
Test for Pipole	1-11
Test for Folded Dipole	1-11
Leakage, Heater-Cathode	1-38, 1-45
Limiting, Capacitor Surge	2-125
Line-Noise Filter	2-108
Line Voltage	1-23
Line Voltage Boost	2-115
Linearity Control, Horizontal	2-74
Linearity, Vertical	2-64
Lines, Similar to Ghosts	1-56
Local-Distance Switch	1-222
Local Oscillator Tube, Replacing	1-18

M

Magnet:	
Centering	2-7
Focus	2-7
Ion Trap	2-7, 2-14
Magnetized Picture Tube	2-25
Matching Device, Impedance	1-13
Matching Stub	1-15
Microphonic Tube	1-26, 1-38

Microphonics	1-19, 2-94
Misalignment	1-42
Mismatch, Impedance, Buzz Due to	1-13
Mismatch, Impedance, Ghosts due to	1-13
Mixer Tube, AGC for	1-29
Modulation, Improper Transmitter	2-89
Motorboating	2-92
Multiple Pictures	2-61

N

Neck Shadow	2-7, 2-14
Negative Picture	1-94
Neon Lamp Indicator	2-38
Neon Tester	2-124
Network, De-Emphasis	2-84
Neutrode Tuner	1-25
Noise Inverter, Sync	1-143
Noise, Receiver Tube	1-22
Noisy Front End	1-22
Noisy Tuners	1-22
Nonlinearity, Picture	2-21
Nonlinearity, Vertical	2-50

O

Oscillation:	
Barkhausen	1-26, 2-52
Picture	1-47
Suppressor	1-120
Video	1-47
Oscillator:	
Blocking	2-57
Horizontal	2-69
Horizontal, AFC	2-69
Horizontal, Phase Detector	2-71
Horizontal, Sync Discriminator	2-71
Horizontal, Synchroguide	2-69
Horizontal, Synchrolock	2-69
Inoperative	1-30
Local	1-32
Multivibrator	2-58
Tube, Local, Replacing	1-18
Vertical	2-56
Output, Video Detector	1-69
Overloaded Picture	1-67
Overloading	1-93
Overpeaking	1-116

P

Pads, Antenna Attenuator	1-8, 1-9
Peak-to-Peak Voltages	1-68
Peaking Coils	1-62, 1-109, 1-113, 2-128
Pentagrid Sync Separator	1-139
Phase Detector	2-71
Phasing Device, Transmission Line	1-16
Phasing, Horizontal	2-75
Picture:	
and Sound, Loss of	1-19
Blurred	1-61
Contrast, Poor	1-95
Detector	1-59
Dots in	1-104
Fades	1-54
Flashes in	1-29
Flicker	1-98
Hook	2-34
Hook, Horizontal	1-70
Hum Bar in	1-72
Intermittent	1-45
Jumping	1-104
Multiple	2-61
Negative	1-94
Nonlinearity	2-21
Oscillation	1-47
Overloaded	1-67
Pullout	1-127
Reversal	2-21

Picture (Cont.)

Smear	1-19, 1-71, 1-114
Sound Bars in	1-118
Stabilizer	1-157
Streaks in	1-104
Tube	2-7
Tube, Corona	2-28
Tube, Dirty	2-30
Tube, Magnetized	2-25
Washed Out	1-95
Wiggling	1-54
Picrust	2-73
Pincushioning	2-24
Poor High-Frequency Response	1-49
Positive Feedback, Video	1-115
Power:	
Supplies	2-103
Supply, Full-Wave	2-104
Tube as a Voltage Divider	1-52, 2-86
Printed Circuits	1-76
Pulse:	
Compression, Sync.	1-38
Voltage, Keyer	1-105
White Reference	1-124, 1-129

R

Raster	2-9
Ratio Detector	2-82
Rattling	2-95, 2-101
R-C Filter, Agc	1-101
Reactivating Cathodes	2-30
Realignment, Fringe-Area IF	1-24
Realignment, IF	1-42
Rectifier:	
Full-Wave Voltage-Doubler	2-113
Germanium	2-111
Half-Wave Voltage-Doubler	2-117
High-Voltage	2-39
Selenium	2-111
Semiconductor	2-111, 2-135
Tube Substitution	2-120
Voltage-Doubler	2-113
Regeneration	2-131
Regeneration, Video	1-48
Resistor:	
Decade Box	2-131
Fusible	2-112
Screen Dropping	1-121
Substitution	2-131
Surge-Limiting	2-111, 2-112
Resistors	2-133
Response:	
Curve, IF	1-153
Curve, IF Amplifier	1-43
High-Frequency, Poor	1-49
Retrace Blanking	2-11, 2-31
Reversal, Picture	2-21
Reversal, Trailing	1-22, 1-43
Ring, Corona	2-51
Ringing	2-134
Ringing, Deflection Coil	2-18, 2-20
Rolling	2-61

S

Scope, Using the	1-136
Screen Dropping Resistor	1-121
Semiconductor:	
Diode	1-66
Diode Performance	1-76
Diode Symbol	1-76
Rectifier	2-111, 2-135
Separator:	
Direct-Coupled Sync	1-150
Pentagrid Sync	1-139
Sync	1-134
Triode Sync	1-137
Series-Filament Tester	1-37
Series Heaters	2-116
Shadow, Neck	2-7, 2-14

Shadows, Corner	2-7, 2-14
Shield:	
Electrostatic	2-114
Faraday	2-114
Tube	1-39
Short, Heater-Cathode	1-38
Shunt, Thermal	1-65
Signal:	
Bar	1-128, 1-130
Color Burst	1-131
Frequency-Burst	1-126, 1-129
Stair-Step	1-129, 1-130
White Reference	1-124, 1-129
Silvery Images	2-11
Slow Warm-up	1-45
Smear, Picture	1-19, 1-71, 1-114
Snivets	2-52
Snow	1-25, 1-27
Snow, Excessive	1-95
Solderless Connections	2-136
Sound:	
and Picture, Loss of	1-19
Bars	1-26, 1-48, 1-118
Distortion	2-91
Excessive Base in	2-94
IF Amplifier	2-83
IF Transformer	1-36
Intercarrier	1-47
Missing	2-92
Modulation, Improper	2-89
Takeoff	2-80
Trap	1-36, 1-49, 1-119
Speaker	2-101
Squeal	2-53
Squealing	2-95
Stabilizer, Picture	2-157
Stair-Step Signal	1-129, 1-130
Step-Wave Filter Circuit	1-130
Streaks in Picture	1-104
Sub, Matching	1-15
Suppressor:	
Ghost	1-13
Ignition Noise	1-13
Oscillation	1-120
Surge Resistor	2-111, 2-112
Sweep:	
Frequency	1-131
Horizontal	2-33
Vertical	2-55
Switch, Local-Distance	1-122
Switch, On-Off	2-107
Symbol, Semiconductor Diode	1-76
Sync:	
Action, Fringe Area	1-24
Buzz	1-101, 1-152
Clipper	1-141
Discriminator	2-71
Hum in	1-155
Noise Inverter	1-143
Pulse Compression	1-72, 1-138
Separator	1-134
Separator, Direct-Coupled	1-150
Separator, Pentagrid	1-139
Separator, Triode	1-137
Takeoff	1-122, 1-134
Vertical	2-59
Voltages	1-135
Waveforms	1-141
Synchroguide	2-69
Synchroguide Waveforms	2-72
Synchrolock	2-69

T

Takeoff, Sound	2-80
Takeoff, Sync	1-122, 1-134
Test Point Adapters	1-31, 2-136
Test Points, Front End	1-21
Test Points, Tuner	1-21
Thermal Shunt	1-65
Trailing Reversal	1-22, 1-43
Trailing Whites	1-43, 1-72

Transformer:	
Audio Output	2-99
Electrostatic Shield	2-114
Horizontal Output	2-53
Isolation	1-28
Power	2-114
Primary Circuit	2-105
Sound IF	1-36
Video IF, Checking	1-56
Video IF, Replacing	1-56
Transmission Line:	
Balancing Device	1-16
Impedance Match	1-13
Installation	1-11
Phasing Device	1-16
Suggestions	1-11
Test for Dipole	1-11
Test for Folded-Dipole	1-11
Types	1-24
Transmitter Modulation, Improper	2-89
Trap, Ion	2-7, 2-14
Trap, Sound	1-36, 1-49, 1-119
Triode Sync Separator	1-137
Tube:	
Dummy	2-123
Keyer	1-87
Microphonic	1-26
Noise	1-25
Noise, Receiver	1-22
Picture	2-7
Pin Crimping Tool	2-8
Pins Bent	1-39
Rectifier	2-110
Rectifier, Substitution	2-120
Removal	1-28
Shield	1-39
Test Adapter	1-31
Troubles, IF	1-36
Tubes:	
Gassy	1-38
Microphonic	1-38
Multipurpose	1-99
Weak	1-38
Tuner:	
AGC Delay	1-90
Cascade	1-18
Cleaning of	1-30
Fine	1-32
Grounding	1-31
Neutrode	1-25
Noisy	1-22
Realignment	1-20
Test Points	1-21
Types	1-33
Twin-Lead	1-24
Twin-Lead (see also Transmission Line)	

V

Vacuum Tube Video Detector	1-70
Vertical:	
Amplifier	2-62
Deflection	2-55
Linearity	2-64
Nonlinearity	2-50
Oscillator	2-56
Sweep Waveforms	2-68
Sync	2-59
Video:	
Amplifier	1-107
Detector	1-59, 1-60, 2-80
Detector, Load Voltage	1-109
Detector, Vacuum Tube	1-70
Detector Waveform	1-71
Fades	1-54
IF Circuit	1-41
IF Transformer	1-47
IF Transformer, Checking	1-56
IF Transformer, Replacing	1-56
Oscillation	1-47
Positive Feedback	1-48
Regeneration	1-48
Smear	1-71

Voltage:	
AGC	1-50, 1-79
AGC Distribution	1-80
AGC Substitution	1-84
B-Plus	2-103
B-Plus Boost	2-65
Bias Supply	1-85
Boost	2-62
Boost, Line	2-115
DC	2-103
Distribution, Video	1-108
Divider	2-87
Divider, Audio Tube as	1-52
Doubler, Full-Wave	2-113
Doubler, Rectifier	2-40, 2-113
IF Amplifier	1-50
Keyer Pulse	1-105
Line	1-23
Measurements	2-127
Peak-to-Peak	1-68
Sync	1-135
Video Detector Load	1-109
VTVM	1-95

W

Warm-up, Slow	1-45
Washed Out Picture	1-95
Waveform:	
Bar Signal	1-28

Waveform (Cont.)

Black-White Compression	1-131
Colorburst Signal	1-131
Frequency-Burst	1-126
Horizontal Drive	2-36
Horizontal Plate	2-37
Stair-Step Signal	1-129
Sync	1-141
Sync Pulse Compression	1-72
Synchronuide	2-72
Vertical Sweep	2-68
Video Detector	1-71
White-Reference Pulse	1-124
Weak Contrast	1-44
Weak Picture	1-44
Weak Tubes	1-38
White Compression Waveform	1-131
White-Reference Pulse	1-124, 1-129
Whites, Trailing	1-43
Width Coil, AGC Winding on	1-104
Width, Insufficient	2-50
Wiggling Picture	1-54

Y

Yoke:	
Deflection	2-7
Frozen	2-19
Troubles	2-48

PRINTED IN THE UNITED STATES OF AMERICA