

radio questions & answers

Prepared

By the Editors of

**RADIO —
ELECTRONICS**
formerly RADIO-CRAFT

PUBLISHED BY
RADCRAFT PUBLICATIONS, INC.
25 west broadway
new york 7, n. y.

C o p y r i g h t , 1 9 4 7
BY HUGO GERNSBACK
All Rights Reserved

First Printing—June, 1947
Second Printing—October, 1947
Third Printing—February, 1949

Printed in United States of America

contents

section 1

Receivers and Tuners 5

section 2

Other R.F. Circuits 16

section 3

Audio Circuits 23

section 4

PA Amplifiers 37

section 5

Power Supplies . . , 44

section 6

Test Instruments 48

section 7

Miscellaneous 58

index 63

(Schematic on page 55, courtesy of Communication Measurements Laboratory)

preface

“WHAT CIRCUIT should I use for a battery-operated audio amplifier?” “For a burglar alarm?” Every day year in and year out since interest in radio began, radio editors’ baskets have been loaded with letters from readers, asking similar answers to their radio problems. As the art advanced and electronic equipment became more complex, the questions kept pace.

This book is a collection of the questions most frequently asked by readers of RADIO-CRAFT magazine, selected with an eye to general interest.

The average questioner usually has a specific problem. He wants a circuit for a certain purpose. It must, if possible, use certain tubes he has on hand. Many of the questions in this book are of this type. The questions selected have specified common tube types to make the answer of general application.

The editors have grouped the questions in different sections for the reader’s convenience. Receivers, tuners and audio amplifiers are the most popular, as expected. Other questions are concerned with fundamentals. A few of these have been included.

For quick reference the book has a complete index, beginning on page 63.

RECEIVERS & TUNERS

? A tuned r.f. stage

I would appreciate a circuit diagram and coil specifications for an efficient r.f. pre-amplifier to be connected to the antenna post of a superheterodyne which at present has no r.f. stage ahead of the converter. The receiver has abundant amplification, and the purpose of the added stage is to eliminate or materially decrease image frequencies.

The preselector stage is to be used in connection with the short-wave band only. Tuning range of single coil 5.5 to 18 mc. Filament and plate currents supplied by the receiver. Tuning condenser capacity 365 μf . Type of 6.3-volt tube is optional.—E. G.

A. An efficient and selective amplifier is shown in Fig. 101. It may be considerably simplified by substituting an r.f. choke for the L2-C2 combination. This will cut sensitivity somewhat, but will also cut out tracking troubles, as you will have only a single tuning condenser. A 6K7 or 6J7 tube may be used. For increased gain a 6SK7 or 6SJ7 can be used (or a 6BA6 miniature tube).

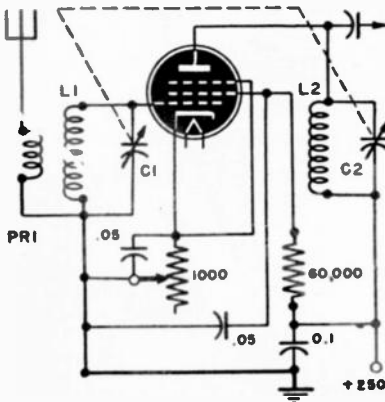

Fig. 101

To cover the required range the coils may be wound with 9 turns of No. 18 wire on $1\frac{1}{2}$ -inch forms. Windings should be spaced to cover $1\frac{1}{4}$ inches. Primary may be 4 to 6 turns of No. 24 to 30 insulated wire wound near the ground end of L1. Output coupling condenser is about 100 μf .

None other than the usual precautions need to be observed in construction. You should be able to obtain excellent reception with the r.f. amplifier shown.

? Superheterodyne receiver

Please publish a diagram of a 4- or 5-tube superheterodyne, using the following tubes (list given).—P.D.S.

A. The diagram printed in Fig. 102 incorporates the tubes you desire. Any standard antenna coil may be used if your tuning condenser has a maximum capacity up to 365 $\mu\mu\text{f}$ or 500 $\mu\mu\text{f}$.

The combination of oscillator coil and oscillator padding and tuning condenser will depend on the items you have available. The intermediate frequency of 456 kc is in turn dependent upon the oscillator frequency, so the oscillator components must be selected with that also in mind.

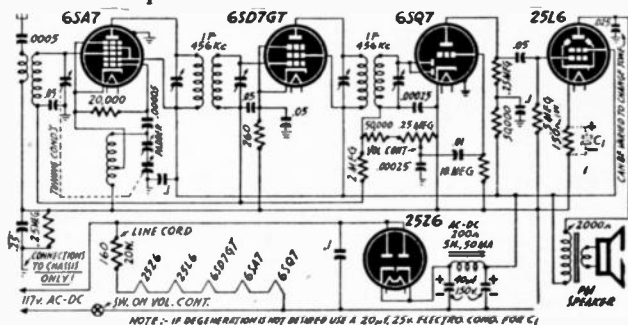

Fig. 102

? 2-tube s.w. receiver

Will you please illustrate a 2-tube receiver using one 1N5 and one 1Q5? A set that will bring in distant stations, with smooth control of regeneration, is required.—A. H.

A. The modified Hartley shown in Fig. 103 will meet your requirements. Ordinary broadcast and short-wave plug-in coils may be used, with the tap made from 10 percent to 25 percent of the way up from the plate end. Experiment to obtain the best point.

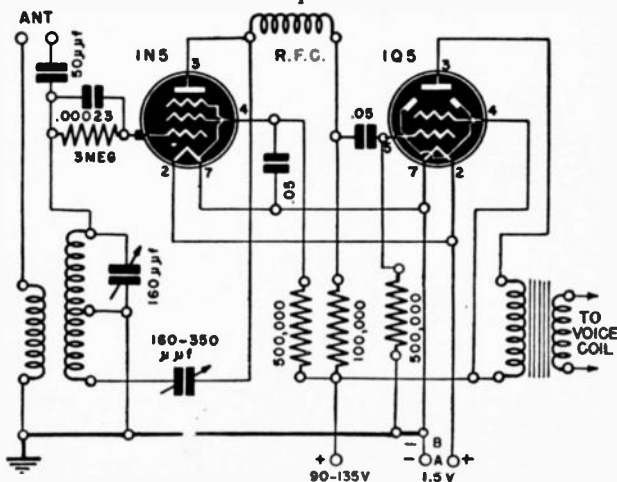

Fig. 103

? Two-in-one receiver

Please furnish a circuit for a radio receiver using only one tube, which can be used with a ground connection only and no aerial. I want to use this as a portable, and would like to have one that would work with 45 volts.—H.H.

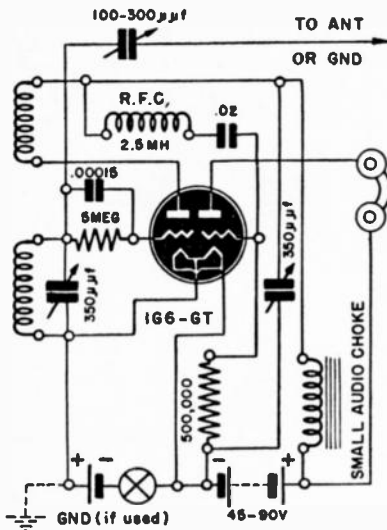

Fig. 104

A. A circuit of the type you require can be made with the 1G6-GT tube shown in Fig. 104. An ordinary 4-prong plug-in coil can be used, or you can wind one experimentally, on a smaller form, if you want a more compact set. Because the set is to be used with low voltage, a small audio choke is used in the detector plate. If more than 40 v is used it may be found better to tap the detector plate off at 45 and use the higher voltage on the audio tube only. Using an aerial and adding a ground will improve the sensitivity of your set, as will connecting the aerial post to any large metal object, such as a bedspring or piece of metal furniture.

? Receiver with 56's

I would like a diagram for a 2-tube receiver using 56's. I have a 180-volt B-eliminator and can supply the 2½-volt filament transformer. I would like to use this with plug-in coils and two condensers, a 30-μf and a 140 μf. I have a 20,000-ohm volume control.—W.A.K.

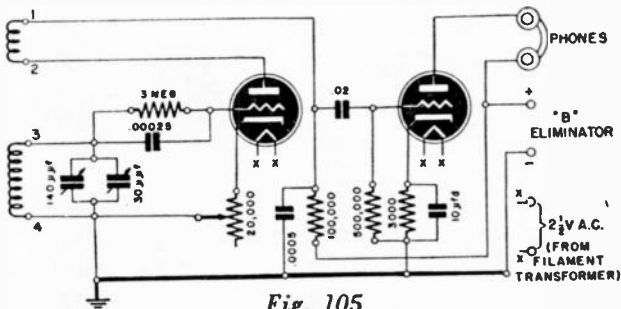

Fig. 105

A. The circuit in Fig. 105 should work well. If your B-eliminator is well filtered you may find it necessary to add a 10,000-ohm resistor between the 100,000-ohm unit in the detector plate circuit and the high-voltage connection, and a large (8 to 20 μf) condenser from the junction of the two resistors to detector cathode or ground. In a regenerative cir-

circuit, there is often a tendency to hum, even using plate supplies that give no trouble in nonregenerative hookups.

Type 27 tubes could be used as well as the 56's, or if a 6-v filament transformer were installed, 76's, 6C5's, 6J5's, or 1-6SN7 would give excellent results.

2-tube regenerator

Please print a diagram of a 2-tube regenerative receiver, using an a.c.-d.c. power supply. I have [a number of tubes, including 35Z5, 50L6, and 12SJ7]. I would like to operate a small PM speaker with this set.—E.A.D.

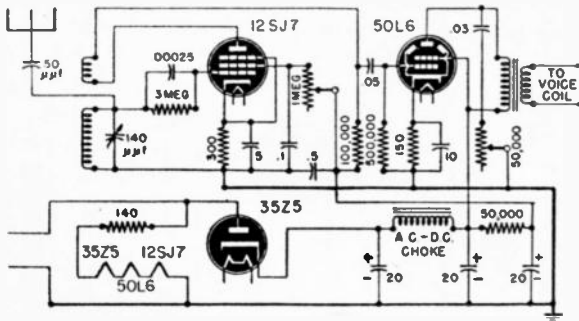

Fig. 106

A. The hookup shown in Fig. 106 will operate a speaker on local station, if a good aerial is used. Coils may be standard broadcast or short-wave plug-ins. The same circuit may be adapted to other types of tubes. For

example, if a 200-ohm line-cord or other filament resistor is used, the line-up might be: 6J7, 25L6 or 43, 25Z5, or 25Z6. Other 6-volt tubes also could be employed.

5-tube t.r.f.

I wish to build a t.r.f. receiver, incorporating an r.f. stage, a detector, a.f., and power output. The final stage should be a 6K6 with tone control.—D. H.

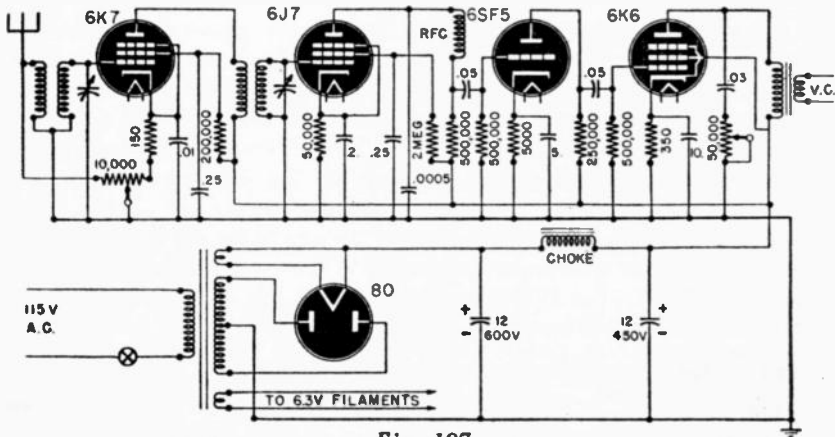

Fig. 107

A. The diagram is shown in Fig. 107. A sensitivity control in the form of a 10,000-ohm potentiometer is used in the first stage. This set, while sufficiently sensitive for most purposes, should give better fidelity than the usual superheterodyne, if built with high-class components.

The two tuning condensers may be ganged for convenience. Separate controls, however, will provide better sensitivity and selectivity.

? 2-tube a.c.-d.c. set

Please print a diagram using a 6C5 and a 12A7 in a circuit with one untuned r.f. stage, detector, and audio amplifier. Plug-in coils are to be used.—P.M.

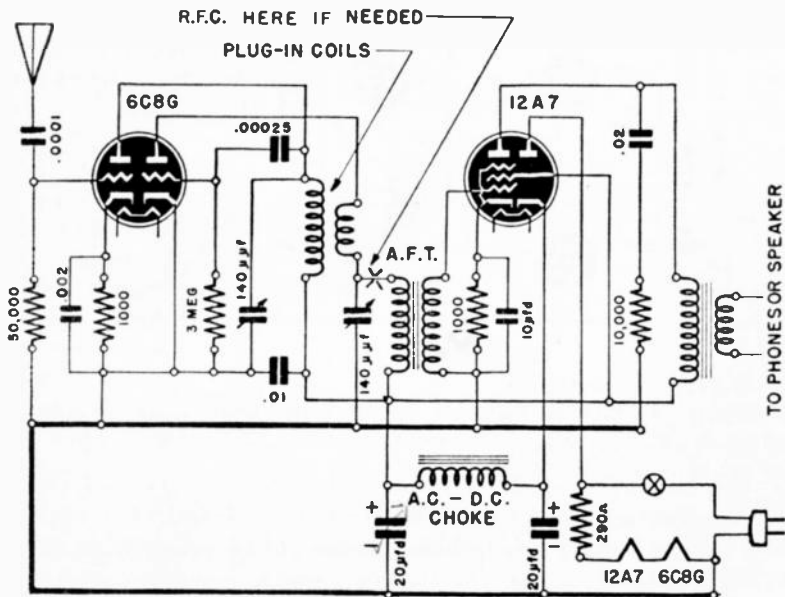

Fig. 108

A. Fig. 108 shows the diagram. As little or no gain can be expected from the untuned radio-frequency stage, a regenerative detector is used. Should the circuit oscillate with the 140- μf regeneration control condenser full out, insert an r.f. choke as indicated. The 10,000-ohm resistor and 0.02- μf condenser in the output circuit are for tone control purposes, and may be varied to suit circuit constants or listeners' tastes.

If phones are used, a 1-1 ratio transformer or an output transformer with a 500-ohm secondary may be employed. If a speaker, an output transformer with secondary suited to the voice coil and a primary impedance of 10,000 to 15,000 ohms is correct. Phones may be damaged by the heavy current if connected in the 12A7 plate circuit.

4-tube t.r.f. receiver

I have a 6U7, a 6P5, a 6F5, and a 12A7. Is it possible to use these in a t.r.f. radio receiver?—D.W.

A. The diagram (Fig. 111) shows a 3-tube t.r.f. receiver with one stage of r.f., a detector with audio amplifier, and a power amplifier stage.

A.v.c. is applied to the first stage. Various coil and tuning condenser combinations may be used to cover the bands you desire.

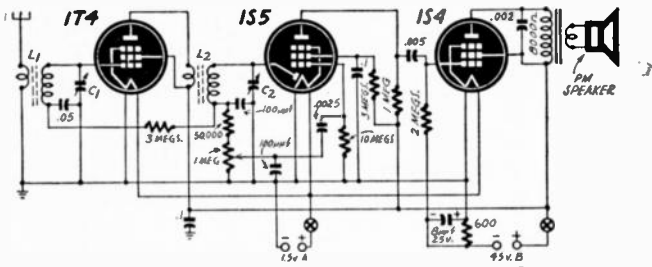

Fig. 111

? 2.5-volt receiver

Please print a diagram of a 5-tube receiver using a 24-A, two 27's, a 45, and an 80. If it cannot be done, please use different tubes. I wish to cover the broadcast band.—E. J. B.

A. The diagram in Fig. 112 uses two 24's, one 27, one 45 and an 80. The transformer system of coupling will help to compensate for the low gain of the 45.

Any standard broadcast coils can be used. The gang condenser should have a capacity between 0.00035 and 0.0005 μ f per section.

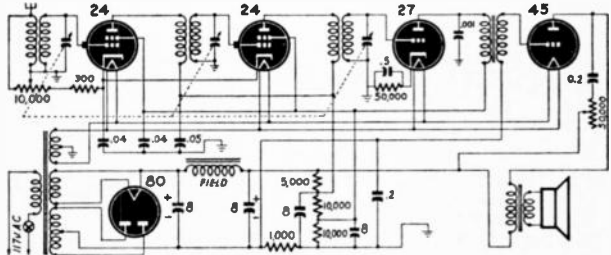

Fig. 112

? 1.5-volt tube set

Show diagram of receiver using the 1.5-volt tubes plus a 25Z5 for a.c.-d.c. supply. Can I eliminate all batteries?—F.R.V.

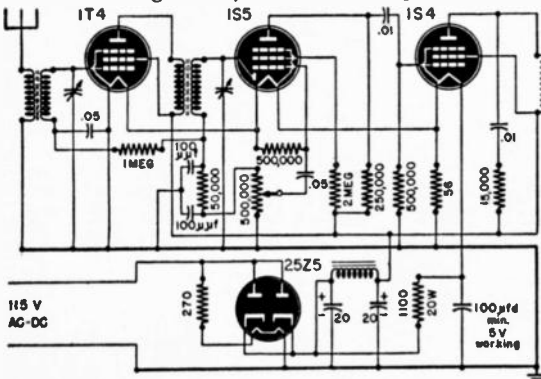

Fig. 113

A. Diagram and all constants are given in Fig. 113. Filament supply is bridged by a condenser of at least 100 μ f. You might parallel several units to obtain a large value, the

working voltage of these condensers being 5 v. The three stages are r.f., detector, and a.f. A.v.c. is applied to the radio-frequency stage.

? A v.h.f. receiver

Kindly publish a diagram of a compact 1¼-meter receiver, with the smallest number of tubes possible—D. J. M.

A. The diagram in Fig. 114 calls for only one tube, and may be hooked up to any amplifier you have—or to your own radio—for its audio amplification.

The coils for 1¼ meters are: L, 2 turns of No. 18, ¼ inch in diameter, spaced to ½-inch length. The antenna coil may be simply a hairpin loop in your half-wave antenna, or you may have your own preferred method of coupling.

V.h.f. coils are preferably wound self-supporting.

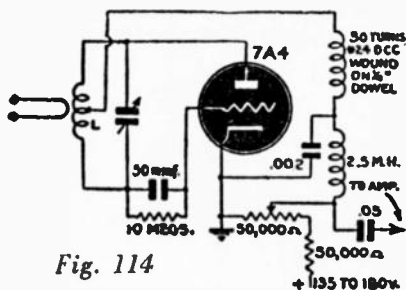

Fig. 114

? Broadcast receiver

Please show a schematic diagram of a broadcast receiver using a 6D6 tuned r.f., 6C6 detector, 6D6 audio (resistance-coupled), and 12A7 output and rectifier, using a line cord resistor.—M. B.

A. The schematic is shown in Fig. 115. Choke may be an ordinary a.c.-d.c. choke or the field of a loudspeaker, if the latter is fairly low in resistance. Check to be sure your line-cord resistor is the right size.

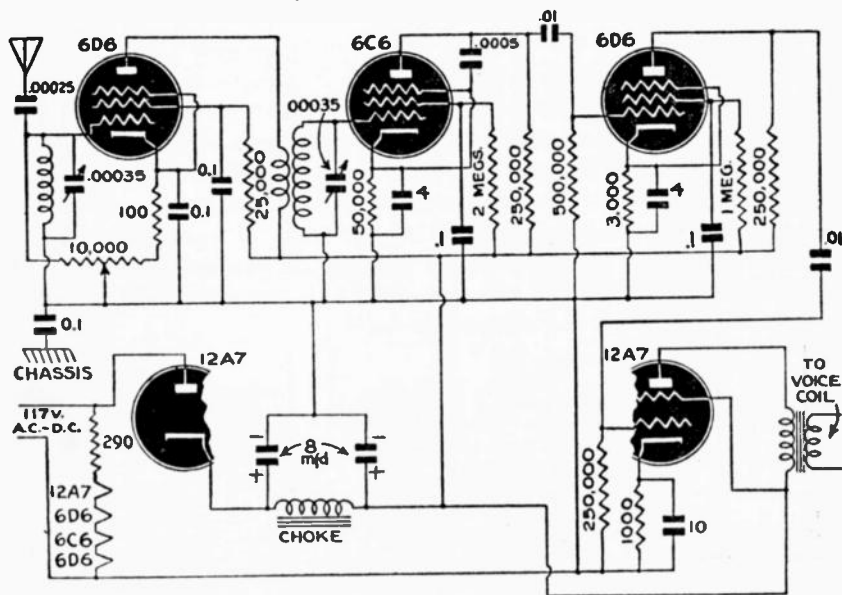

Fig. 115

? 4-tube set

Please give a diagram for a very small 4-tube set, using the miniature-tube types, and working from the line. I have a 50,000-ohm volume control and a 2-gang .00035- μ f variable condenser. Would prefer to have it work with a loop.—J. C. G.

A. The diagram shown in Fig. 116 will work either with phones or a small speaker. A small set of this type is hardly sensitive enough to operate with a loop—better use a flexible throw-antenna of from 20 to 40 feet of insulated flexible aerial wire.

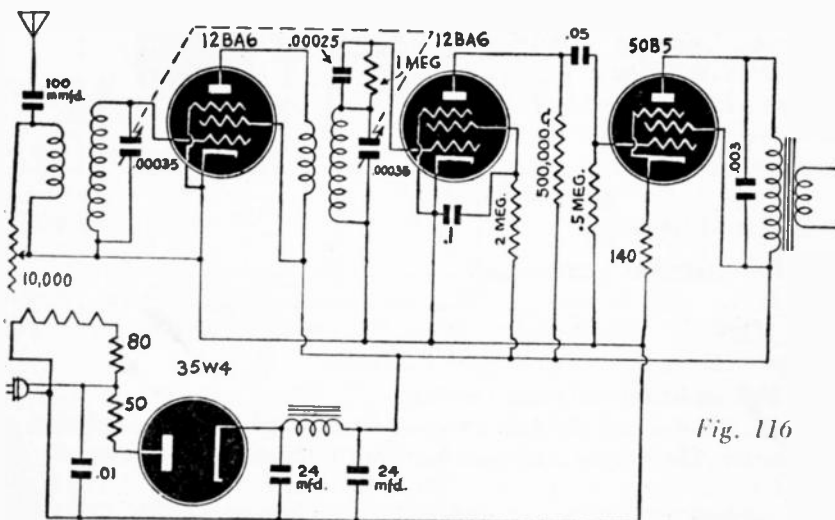
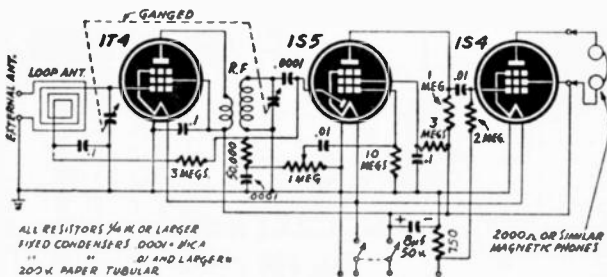

Fig. 116

? Pocket receiver

Can you supply a diagram of a pocket portable receiver using a 1T4, 1S5 and 1S4? I would like to have a loop antenna, and also would like to have the set work on only 10 penlite cells. I want it to work with headphones and to be as compact as possible.—C. B.

A. The receiver diagrammed in Fig. 117 will fill your requirements. It is a t.r.f. hookup. For the B-supply you may use penlite cells or a small 45-v battery. The tuning condensers may be any small type of approximately 350 μ f, to cover the broadcast band.



ALL RESISTORS $\frac{1}{4}$ W. OR LARGER
TUNED CONDENSERS .0001- μ F
" " .01 AND LARGER
200 μ F PAPER TUBULAR

Fig. 117

? Superhet tuner

Please print a diagram, with coil data, of a three-tube superhet tuner using a 6A8, 6K7, and 6Q7. I would like to use plug-in coils with four or five prongs and get full coverage from 500 kc to 25 mc. I want to use 140- μ f tuning condensers with a small bandsread condenser across the oscillator coil. I have a power supply giving 250 volts.—C. V.

A. This diagram (Fig. 120) is designed to meet your needs. The oscillator coil uses a tapped winding, so a 5-prong coil must be used in this circuit. If you desire to use regeneration in the first detector, L3 must be included. This will require a 6-prong form. If this feature is omitted, a four-prong form may be used.

A complete coil table is given. Coils for the lower frequency bands may be close-wound, others should be spaced as stated.

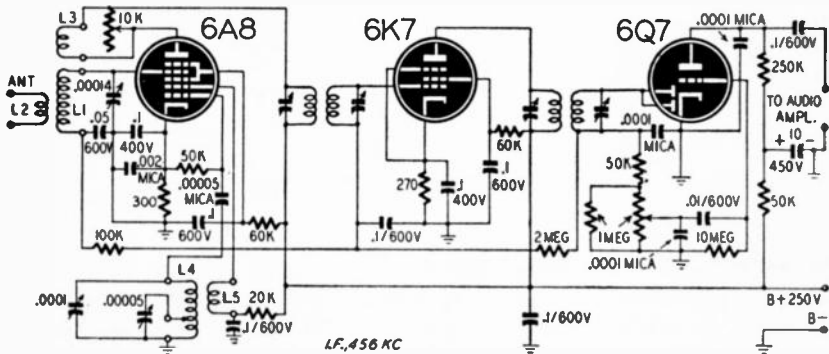

Fig. 120

RANGE	L1		L2		L3		L4		L5		L4 TAP TURNS FROM BOTTOM TO TAP
	TURNS	WIRE SIZE	TURNS	WIRE SIZE	TURNS	WIRE SIZE	TURNS	WIRE SIZE	TURNS	WIRE SIZE	
A— 500 TO 1000 KC 300-600 METERS	195	N° 32 ENAM	40	N° 32 ENAM	40	N° 32 ENAM	127	N° 32 ENAM	33	N° 32 ENAM	TOP
B— 900 TO 1800 KC 160-325 METERS	110	N° 28 ENAM	26	32	26	32	75	28	16	32	TOP
C— 1700 TO 3300 KC 90-170 METERS	60	28	13	22	15	22	56	28	14	22	40
D— 3. TO 6.4 MC 47-100 METERS	33	22	8	22	11	22	30	22	10	22	20
E— 6. TO 12. MC 26-50 METERS	18	22	4	22	8	22	16	22	8	22	7
F— 10. TO 25. MC 14-30 METERS	8.5	18	4	22	6	22	8	18	5	22	3

L3 IS WOUND TO 3/4" DIA. AND PLACED INSIDE NEAR BOTTOM OF L1.
L2 & L5 ARE CLOSEWOUND AND SPACED ABOUT 1/8" FROM BOTTOM OF L1 & L4.
PLUG-IN COIL FORMS 1-1/4" DIA.
L1 & L4 SPACED TO 1-1/2" ON BANDS A, B, C, D, E.
" " " " " 1" ON BAND F.

Section 2

OTHER R. F. CIRCUITS

? Wireless tuner

I would like to have a diagram of a "wireless" push-button tuner to use with my broadcast receiver. I want to operate this device from an a.c.-d.c. power supply so that it may be built as compactly as possible.—E. S. C.

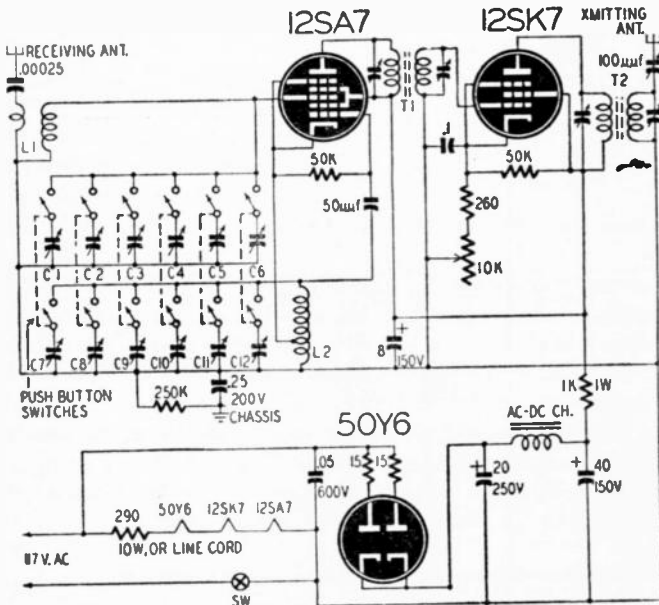

Fig. 201

A. The diagram shown in Fig. 201 should meet your requirements. It is equipped with six push-buttons which will allow you to tune in any one of six pre-selected stations.

T1 and T2 are standard i.f. transformers which may be tuned to frequencies between 550 and 600 kc. It may be necessary to remove several

turns of wire from each of the coils or reduce the size of the i. f. tuning condensers to reach this range with some transformers. When using this tuner to select stations from a remote point, the receiver should be tuned to the same frequency as the i. f. coils.

? Short-wave converter

Please supply a circuit for a short-wave converter to work off the power supply of my receiver and to use ordinary plug-in short-wave coils.—D. M.

A. This converter (See Fig. 202) uses a 6A7 or 6A8 mixer and a 6J5 or similar tube for oscillator. The 140- μf condensers should be mounted on independent shafts and the smaller condensers shunted across them, and ganged. These may be midget types with a maximum capacity of 30 μf or so. Identical coils may be used for the oscillator and aerial circuits, the difference in frequency being compensated for by the variable condensers.

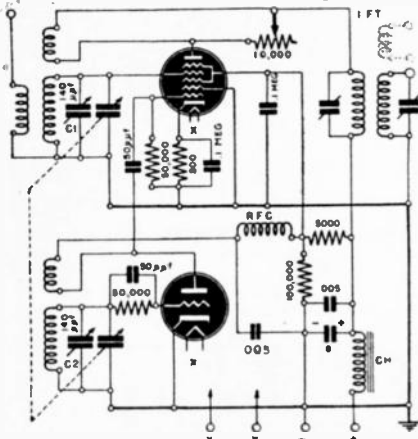

Fig. 202

oscillator coil may be advisable in any case, so the two main dials may read alike.

The output transformer is an ordinary i. f. transformer, but must be tunable to about 600 kc. Several such are listed in the catalogs of various coil companies. It may be connected to the aerial post of the receiver, but if the first tube has a grid cap, a better connection is to remove the original grid lead and connect the output transformer direct to it. Another connection is to tune the output transformer to the i. f. of the receiver, and connect to the grid of the first i. f. tube. The coil shown in dotted lines may be wound with a few turns on the dowel of the transformer and used for a connection to the doublet posts of certain receivers.

? Miniature-tube short-wave converter

Supply a diagram for a short-wave converter using miniature type tubes 1R5, 1T4, 1S5, and 35Z5. Set to have its own power pack and to operate on a.c.-d.c.—W. D.

A. The diagram you ask for is given in Fig. 203. As your choice of tubes is such that it is not clear whether you wish it to work as a radio-frequency converter or to work into the audio end of a receiver, both connections are shown. The switching system permits using the converter,

with either a high- or low-impedance antenna coil, L5 being wound with a small number of turns to couple to low-impedance antenna inputs. Try 20 to 30 turns.

The set is shown with a 25Z5, but can be used with a 35Z5 by making the connection shown in the dotted lines and substituting a 500-ohm line-dropping resistor for the 270-ohm resistor shown in the figure.

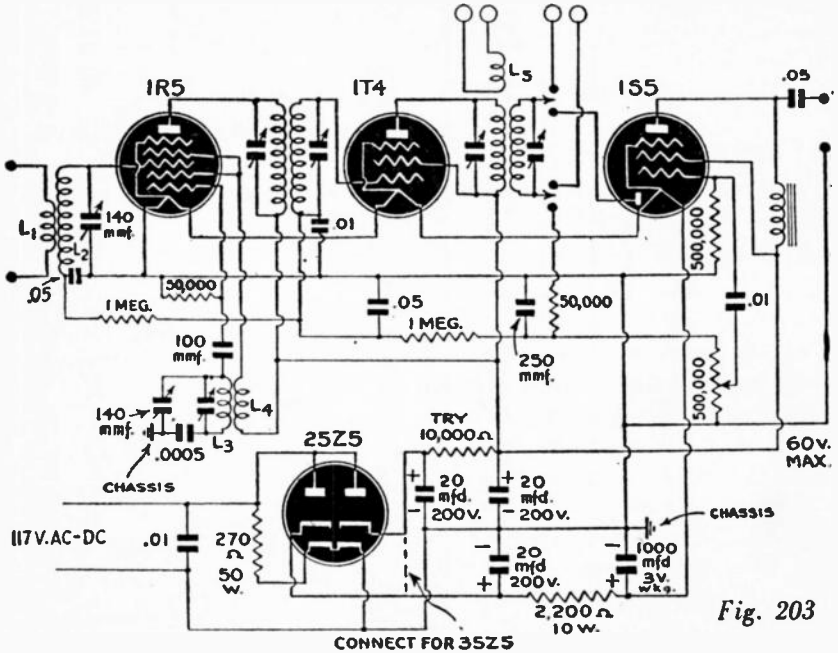

Fig. 203

Any standard set of short-wave superheterodyne coils may be used, or the following scale may be used.

Number of Turns				Spacing
L ₂	L ₁	L ₃	L ₄	L ₁ and L ₃
5	4	4	4	6 per in.
13	7	10	6	10 per in.
27	9	22	8	20 per in.
66	14	56	10	Close

All turns wound on 1½-inch coil forms, with any wire which can be spaced as directed, or with No. 30 throughout if desired. All ticklers close-wound. These four coils should cover the range from about 13 to 200 meters. I.f. is 465 kc.

? V. h. f. converter

Please publish a diagram of a 5 and 10-meter converter using a single 6K8 tube.—I. H. L.

A. Fig. 204 is a converter diagram that covers your requirements. This

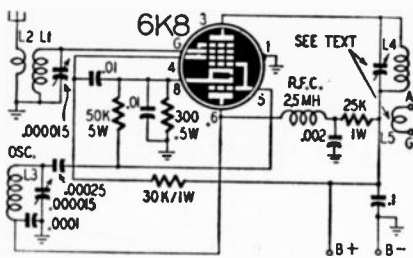

Fig. 204

converter was designed for operation on the 5- and 10-meter bands. Output coil L4 is 34 turns of No. 30 enamel wire wound on an i.f. dowel, with coil L 5, 10 turns, wound over it. The output of the converter is connected to the antenna and ground posts of a receiver tuned to 2,500 kc, which becomes the i.f. Power for the converter may come from receiver.

? Wave trap

Can you give me some information on constructing a wave trap for use with my all-wave receiver?—R. B.

A. The wave trap shown in the diagram (Fig. 205) can be connected in series with the antenna lead to the receiver and tuned to the frequency of the interfering station. It will eliminate any station on that frequency from the receiver input. In order to handle a wide frequency range, several coils will be needed. They can be either of the plug-in type or built onto a switch. In either case, the coil and condenser should preferably be shielded.

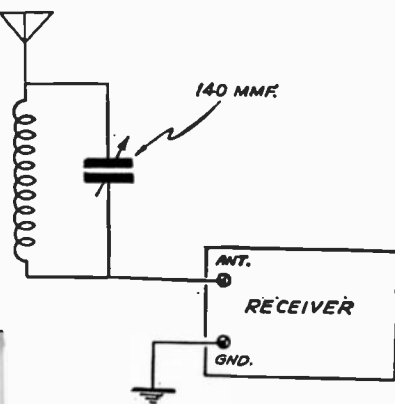

Fig. 205

Band	No. Turns	Wire Size	Coil Form
1,500-3,500 kc	50	No. 14	wound on 1 1/4" diam.
3,500-8,000 kc	35	No. 18	1 1/4" diam, 1" long
7,000-15,000 kc	20	No. 22	1 1/4" diam, 3/4" long

? Fluorescent lamp filter

I desire a diagram of a filter for a 15-w fluorescent lamp to prevent static on the radio.—J.M.D.

A. Three fluorescent filters are shown. Interference from fluorescent lamps occurs in three ways:

1. Radiation direct from the lamp bulb to the antenna system.
2. Radiation from lamp power line to the radio antenna system.
3. Feedback from the lamp unit through the power lines to the radio.

Direct radiation usually does not extend over 10 feet, and it can be eliminated if the radio and the lamp are separated a sufficient distance, or if a grounded metal screen is placed over the lamp, or if the metal parts of the lamp are properly grounded.

Power line radiation and feedback can best be eliminated by means

of filters in the power line, preferably close to the lamp. In your case perhaps there is room for a filter in the base of your lamp.

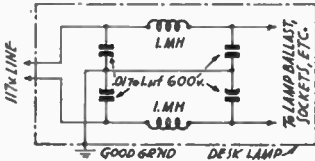
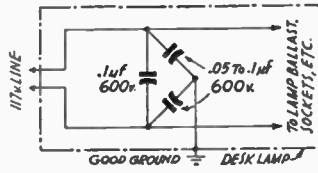
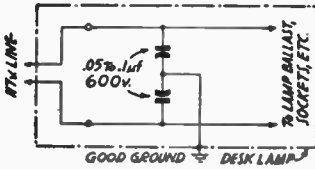

Fig. 206—Top left.

Fig. 207—Directly above.

Fig. 208—Diagram at left.

Occasionally, interference may be due to a defective lamp starter, so it would be well to try a different one if you are not sure of the present one.

Of the diagrams shown, Fig. 206 is the simplest, but will not handle severe interference. Fig. 207 is for intermediate degrees of interference and Fig. 208 is for severe types. The diagrams are self-explanatory, but before installing a filter it is advisable to make certain your interference is not due to direct radiation or starter trouble, mentioned above.

Undoubtedly, you will be able to eliminate your trouble by following one or more of the methods outlined.

❓ Interference elimination

I have a t.r.f. receiver. My problem is interference. I cannot separate many stations received on my set. I do not know how to relieve this condition since, (a) There are no trimmers across variable condensers, (b) There are no slotted end plates on the variable condenser, (c) All tubes are new as well as many parts, (d) The set is completely shielded. What can be done to reduce this interference?—B. W.

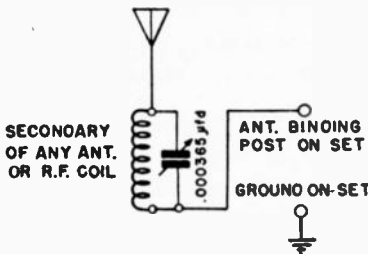

Fig. 209

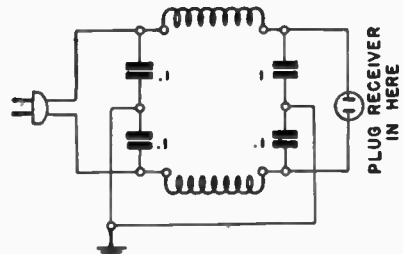

Fig. 210

A. Here are some suggestions which will improve your selectivity and relieve the interference in your receiver.

1. Shunt your variable condensers with $30\text{-}\mu\text{f}$ trimmers. Then

adjust at the high-frequency end of the dial scale when tuned to a weak station in that range of the dial scale.

2. Try a wave trap which should be adjusted to absorb partly or totally the interfering station. Circuit is shown in Fig. 209.

3. Shorten your aerial.

4. Change the direction of your aerial, with the point where lead-in is attached to the flat top facing away from the broadcast station.

5. A line filter helps once in a while. (See Fig. 210.)

? 300-mc transceiver

I would like a diagram of a portable one-meter transceiver, using battery tubes. The range should be about three miles—J. M.

A. Radio transmission is prohibited to the general public without a license. The possession of an amateur radio license permits transmis-

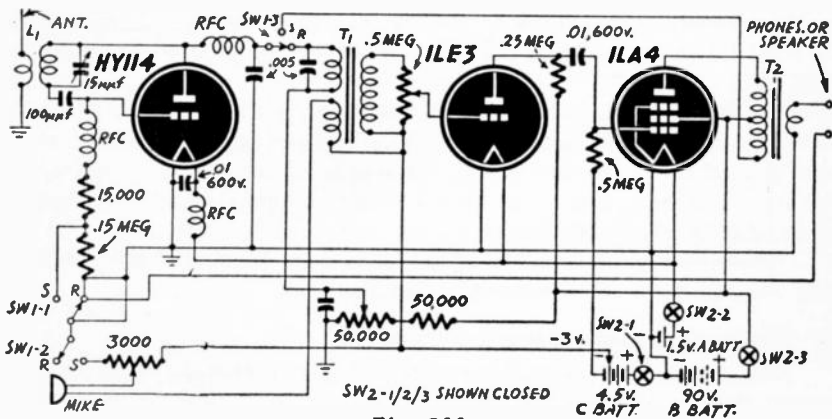

Fig. 211

sion in certain bands, but 300 mc is not included at the present time. The set shown will operate on the $2\frac{1}{2}$ -meter amateur band. See Fig. 211.

In the diagram the HY114 is used both as superregenerative receiver and transmitting oscillator. The antenna coil has one turn of No. 14 wire and the secondary has two turns, each with a diameter of $\frac{1}{4}$ inch. The spacing of the secondary must be determined by experiment, as with Lecher wires, for example.

More than three miles can be covered from a suitably high location with a good antenna. The latter should be about 9 inches long, using the system shown. If a dipole is desired, each half should be 9 inches long.

? Wireless phono

Please print a diagram of a wireless phonograph oscillator that may be modulated with a high-impedance microphone or crystal pickup. I would like to use a 1R5 oscillator and 45Z5 rectifier.—W. L. M.

A. A wireless oscillator is shown in Fig. 212. A high-output phono pickup may be connected directly to the grid circuit of the 1R5. A micro-

phone will require added amplification. A 1S5 microphone amplifier has been added to meet these requirements. Filament voltage for the 1R5 and 1S5 is provided by dropping resistors in the positive high-voltage lead. A 300-ohm resistor is connected across the 1S5 filament to carry the cathode current of the oscillator.

The 1S5 may be eliminated from the circuit by connecting a jumper across A and B and omitting the mike-phono switch.

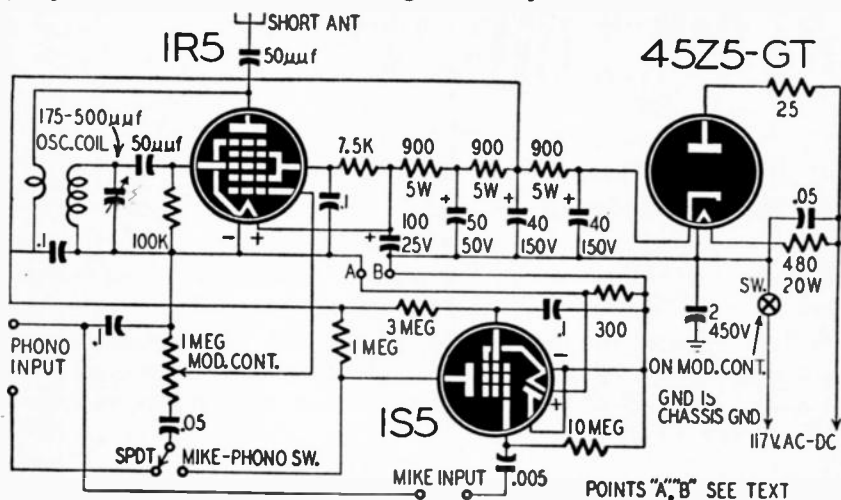

Fig. 212

? Dielectric heater

I would like to have a circuit for an electronic dielectric heater, with about 1-kilowatt power.—L. G. M.

A. A circuit for a heater of approximately 1 kilowatt is shown in Fig. 213. For best results an electric heater must be designed for the given job. Values specified in the circuit are therefore approximate and may be modified to suit the job you have in hand. Power required is usually more than 1 kilowatt, and frequencies 30 mc or higher.

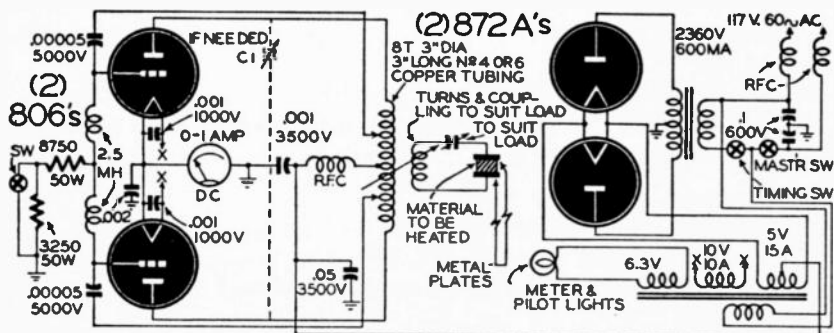

Fig. 213

A. The hookup shown in Fig. 303 is the best fitted to the tubes you have on hand. It uses two 6Q7's as straight triodes, followed by a 6V6. Some experimenting will have to be done with the fixed tone control in the output circuit, as it should be varied to meet your tastes and the characteristics of the apparatus with which it has to work.

The diode plates of the 6Q7's can be left floating, or better, tied to the cathodes. The variable tone control, or treble cut-off circuit, is in the grid circuit of the 6V6, therefore using higher impedances than similar networks in the plate circuit.

Quality will be helped by the use of a large, low-resistance choke. The 100,000-ohm resistor in the first plate lead may also be replaced by a small choke, with some increase in gain.

? 6C6-25A6 amplifier

Please give a diagram of a small amplifier using a 6C6 pentode, a 6C6, triode-connected, a 25A6, and a 25Z5.—S.T.J.

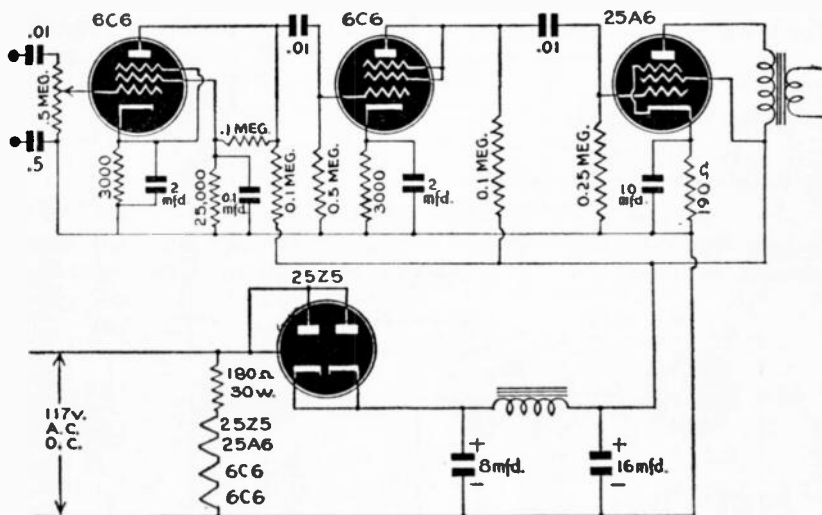

Fig. 304

A. The diagram is shown in Fig. 304. A 76 can be used as the second tube, with a slight loss of gain. A 43 will work as well as the 25A6 in the last stage.

? Low-level pre-amplifier

Please give a diagram of a single-stage pre-amplifier that I can use as an extra channel on my Wilcox-Gay A85-A87. I would like to use this on all positions of the radio-record switch.—D.F.H.

A. This pre-amplifier (Fig. 305) follows the circuit of the microphone amplifier tube already in your set. By attaching the output lead to the

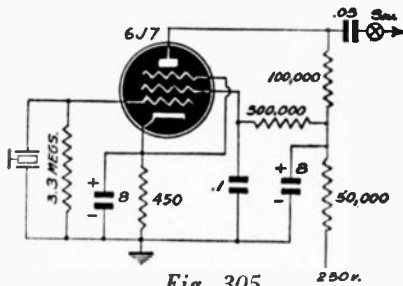

Fig. 305

top or hot end of the volume control, it may be used in practically any receiver. In many sets, it will be sufficient to plug it into the phone input.

All power for the pre-amplifier may be drawn from the receiver, and the ground may be made to the receiver chassis. Shield grid leads and keep them short to minimize hum.

? 2-tube pre-amplifier

Print diagram of a 2 or 3-tube pre-amplifier, using some of the following tubes [list given]. This amplifier should be self-powered. —R.R.Y

A. The tubes shown in the accompanying diagram (Fig. 306) will make the most suitable pre-amplifier. Used with a low-input mike, it will bring up signals sufficiently to feed a medium-sensitivity amplifier;

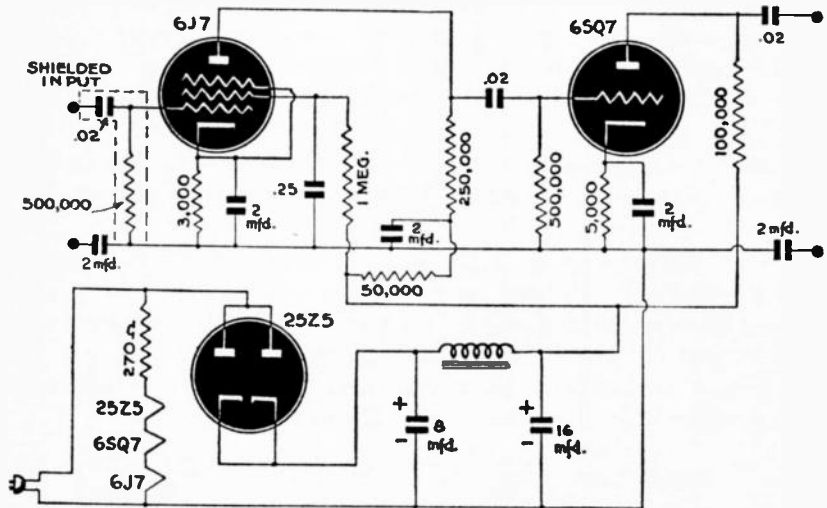

Fig. 306

or used from a phonograph, it will give sufficient gain to make possible the use of a single output stage (of a receiver for example).

? 2-input pre-amplifier

I would like to have a diagram for a pre-amplifier with 2 inputs, so that I can use 2 microphones, or phonograph and microphone, or both together, in connection with an ordinary amplifier.—T.J.R.

A. The 3-tube pre-amplifier shown in Fig. 307 should fill your specifications. The 6F5's will give considerable gain. It will be much

? Guitar amplifier

I would like to build an amplifier for a guitar, using a 6J5, 6SJ7, 39, 78, 42, or 6F6. I have most of the necessary parts for this. Any of these tubes can be used, or others can be obtained.—W.E.P.

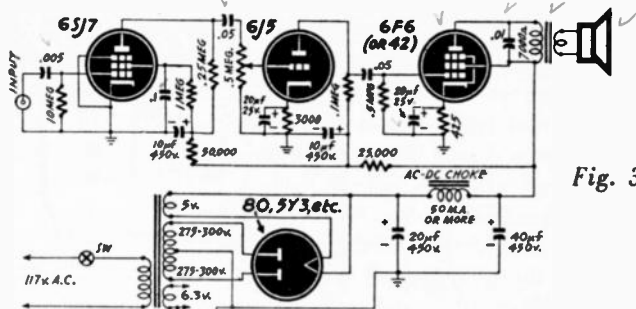

Fig. 309

A. The amplifier shown in Fig. 309 is suitable for a guitar. All parts and values are as marked and none other than the usual precautions should be necessary. The grid bias on the first tube is obtained by means of contact potential, and should be ample for your application.

? A.C. amplifier

Please show a diagram of a small a.c.-operated amplifier that uses as few parts as possible yet will give adequate power for a portable phono.—W.F.

A. The amplifier shown in Fig. 310 is designed to give you the most power with a minimum of parts and reasonably good fidelity. The values of all parts are given on the diagram. Choke should have about 200 ohms resistance. A phono pickup with an output of about 1 volt

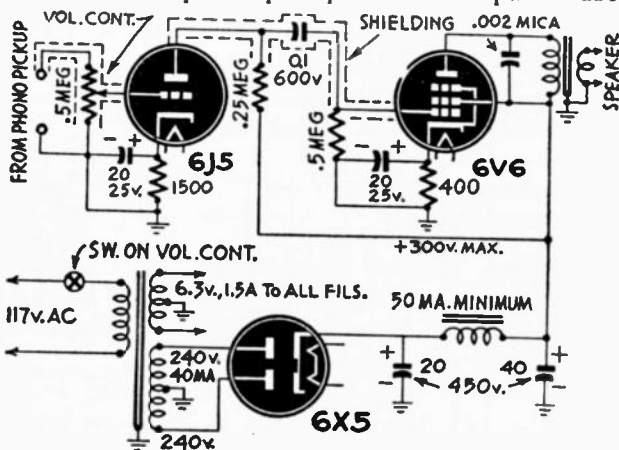

Fig. 310

should drive the amplifier to full power output. Very little shielding should be necessary if the input leads and the 6J5 are kept away from the power and output transformers.

? Magnetic pickup amplifier

I have two old amplifiers, of which the following parts and tubes are good [list given]. Can you show me how to use these to build a fairly good amplifier? I want to use this with a magnetic pickup.—J.F.U.

A. The best amplifier for your apparatus probably will be along the lines of the accompanying diagram Fig 311. With a 400-400-volt winding on your transformer secondary, you should be able to use the 1,800-ohm speaker field as choke and have plenty of voltage on the 2A5's. For a lower transformer voltage, it would be necessary to reverse the position of the chokes, then add a bleeder to draw sufficient current for proper magnetization of the speaker field.

Since you have no pickup coupling transformer, use one of your

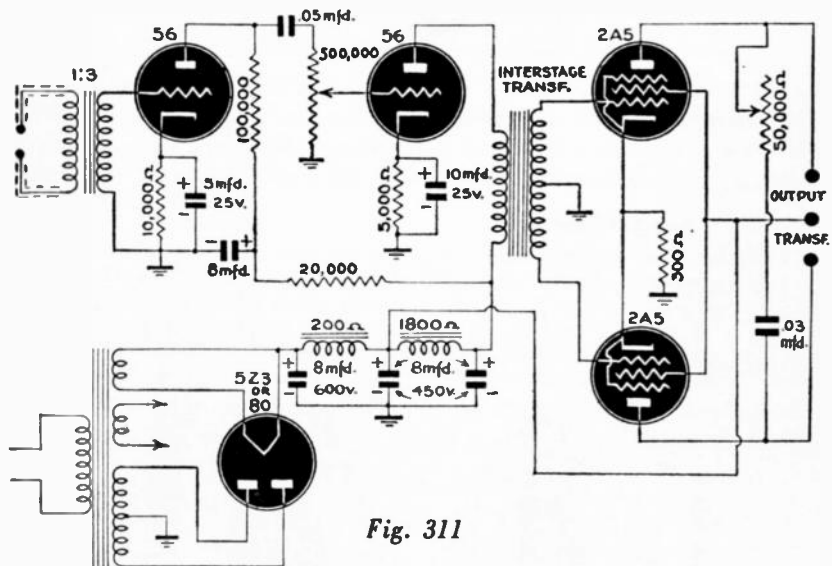

Fig. 311

3-to-1 audio transformers between the pickup and the first grid. A higher ratio would be better. If pickup impedance is below 1,000 ohms, use a matching transformer instead. Shield leads in the pickup circuit.

? Resistance-coupled amplifier

I have an old receiver using two 58's, a 2A5, and an 80. Can I build this into a high-quality resistance-coupled amplifier which could be used for a record player or other purposes?—T.S.

A. An amplifier of good quality can be built with your apparatus. Power will be limited, however, to the amount the single 2A5 can handle without distortion (Fig. 312). A 56 would work well in place of the 58, should one be available. Your own power and output circuit beginning with the grid of the 2A5, can be used without change and you will probably find it advisable to build the amplifier in the old receiver

cabinet, so these parts can be worked into the circuit without disturbing their present wiring.

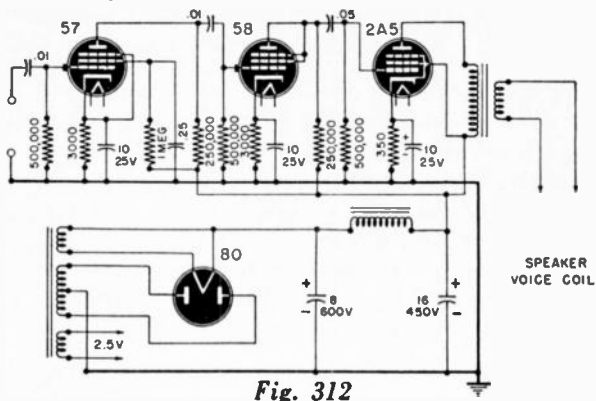

Fig. 312

? Phonograph amplifier

Please show diagram of a small phono amplifier using some of the following tubes 35A5, 35Z3, 7A8, 7B7, 7G6.—W.T.R.

A. Three of these tubes can be made into a satisfactory phonograph amplifier. See Fig. 313.

1st a.f. is a 7B7, output is 35A5, and rectifier 35Z3. If a crystal pickup without volume control is used, omit the 0.05- μ f input condenser and replace the 1-meg resistor in the 7B7 grid circuit with a 500,000-ohm potentiometer.

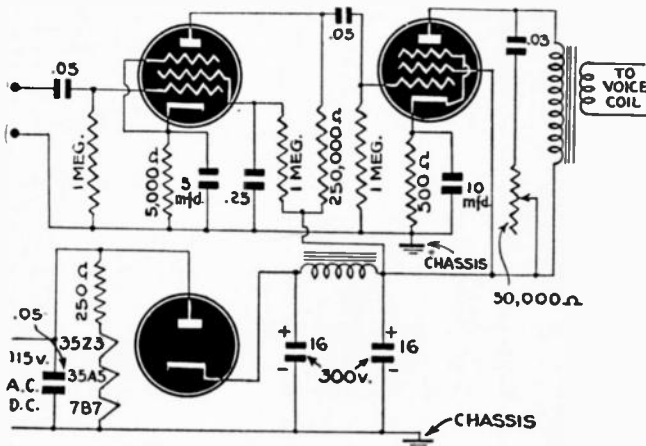

Fig. 313

? Wire-line interphone

Show a diagram for an intercommunicator [to work with wire lines]. I have a 25L6, a 6F5 and a 25Z5. Can these be used? I want an a.c.-d.c. type.—M.E.S.

? Noise silencer

Please print a hookup for a simple noise silencer which can be added to a superheterodyne. The noise is caused by engine ignition.—R.S.

A. The noise silencer shown in Fig. 316 may be used on any set using diode detection. The first tube is V1, the diode section of the detector tube, which may be any of the detector or detector-amplifier tubes. The second tube shown, V2, is a 6H6. The 30 volts used by the silencer tube may be obtained by connecting a 25,000-ohm resistor from the 30-volt point to the screen supply, usually about 100 volts.

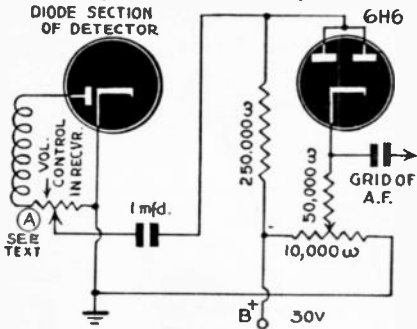

Fig. 316

In sets where there is a path (through resistors) to ground independent of the volume control, the noise silencer diodes can be connected at point A instead of to the arm of the volume control, and the volume control put between the silencer and the first audio grid, with an improvement in noise control.

? Expander-compressor

The a.f. section of my radio uses two 6L6's in cascade, transformer-

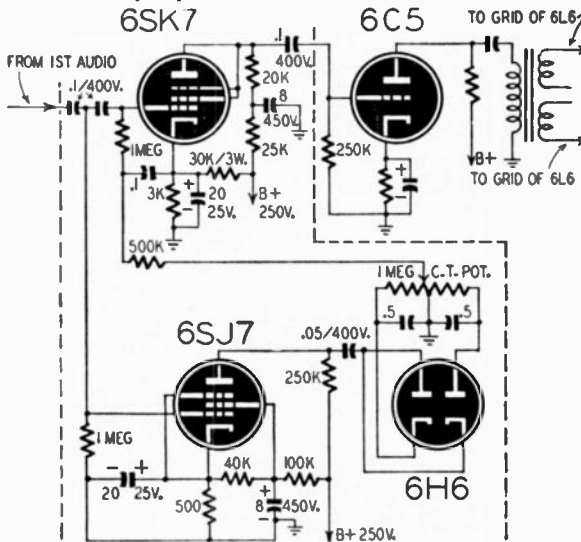

Fig. 317

coupled to push-pull 6L6's. Kindly show me how a simple expander-compressor may be added to the circuit.—J.B.

A. Fig. 317 is a circuit showing how the unit may be added to the

a.f. system in your receiver. A 6SK7 control tube is inserted between the two 6C5's. The output of the first 6C5 is also coupled to the grid circuit of the 6SJ7 expander-amplifier. This tube is coupled to a 6H6 rectifier. The output of the 6H6 appears across a 1-megohm center-tapped potentiometer. One side of the resistor is positive with respect to ground and the other is negative. The position of the slider determines the degree of expansion or compression.

? Volume expander

Please show a diagram of a volume expander using one 6L7 and two 76 tubes. I would like to have it self-powered. I have a 25L6 tube. Could this be used in a transformerless power supply?—J.B.

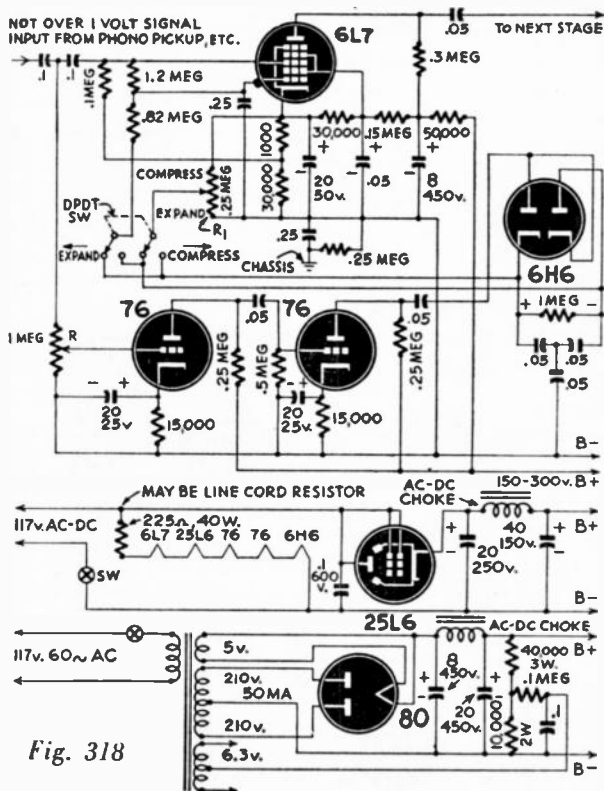

Fig. 318

A. A diagram of a volume expander using one 6L7 and two 76 tubes is given in Fig. 318. Either power-supply may be used, but the transformer type may give you better results.

Connections for volume compression are also included. These may be omitted by leaving out the d.p.d.t. switch and using a fixed resistor at R1. The R1 tap would then be at the "Expand" end. When either expansion or compression is not used, R1 may be used as a stage-gain control. R controls the amount of expansion or compression.

? Volume expander-compressor

Please tell me whether or not my volume expander (diagram included) can be used as a volume compressor for making records. I would like to use it between an amplifier with resistance-coupled 6J7 to 6K6 and a carbon mike. If my expander won't work both ways would you please suggest one that will operate with the amplifier? I would especially like to use the 6H6, which I have.—K.H.

A. It is not hard to make a volume expander act as a compressor. It decreases the grid and suppressor potentials of the amplifier into which it feeds. Reversing the terminals of the 6H6 will cause it to increase the voltages on the grid and suppressor as signals increase. See Fig. 319

A double-pole double-throw switch is used to reverse the connections so that your device will work as an expander in one position and a compressor in the other.

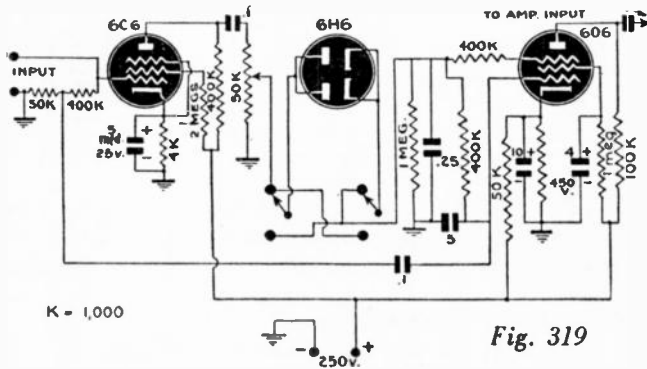

? Reducing amplifier hum

I have an amplifier using a 6J7, 6SJ7, 6C5, and push-pull 2A3 tubes. The 6J7 is used for the microphone while the phonograph is connected to the 6SJ7. Can you tell me how to reduce the hum which results when the mike gain-control is turned up?—J.Q.

A. First make sure you are using shielded cable from the microphone to the amplifier input and that the shield is properly connected to the ground terminal on the amplifier. Second, your grid leads to the first two tubes should be as *short* as possible, and if longer than 1 inch should be *shielded*. Your diagram is technically correct, so these two items should correct your difficulty. Frequently, however, a new 6J7 tube will also eliminate the hum, as many 6J7 tubes, although perfectly satisfactory for other purposes, will prove to have too much hum when used in a high-gain amplifier. A shield cap for the 6J7 may help.

? Push-pull amplifier with tone control

I have a 6V6 audio amplifier which I wish to convert to push-pull.

The first stage at present uses a 6F5. Also, please add an effective form of tone control of simple design (separate bass and treble).—L.D.

A. Tone control is incorporated into the first stage as shown in Fig. 320. The parallel circuit is tuned to a low frequency and as less resistance

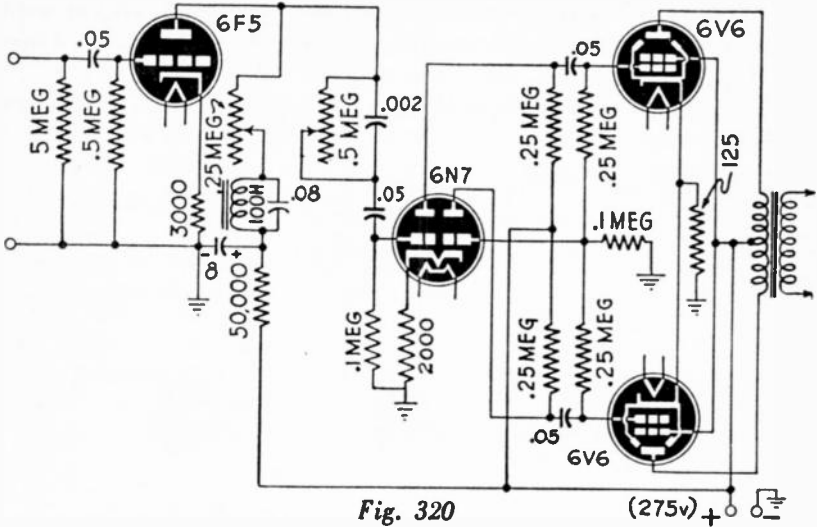

is used, the bass response rises. The 0.002- μ f condenser passes only treble notes when the 0.5 meg potentiometer is at maximum resistance. Decreasing the resistance increases the low-frequency response.

🐨 "Kangaroo" inverter

I wish a diagram for resistance-coupling a single 56, 76, or 6C5 to push-pull 56's, 76's, or 6C5's.—H.S.B.B.

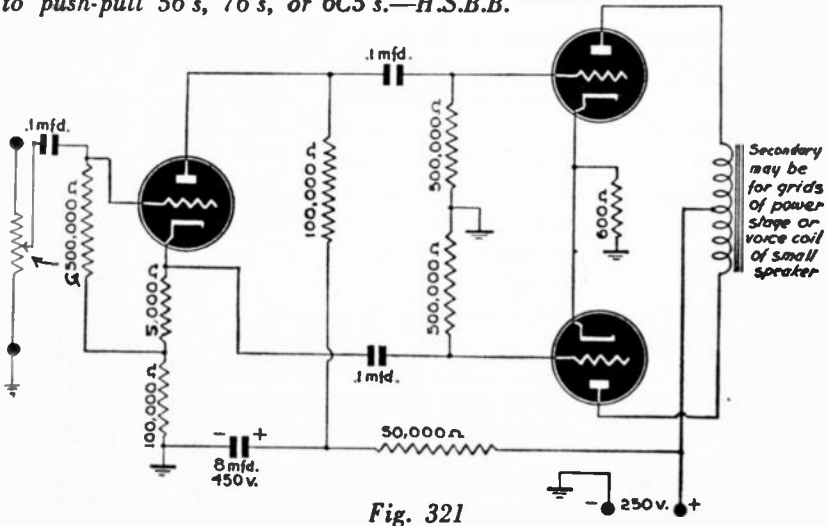

A. Since you did not state what you intend to use this circuit for, we can only suggest the output. See Fig. 321.

The unit itself will have little gain. This is because the inverter stage adds nothing to the signal, due to degeneration; merely splitting it so that the two grids of the next stage will receive impulses equal but 180 degrees out of phase. You can get more gain by adding another tube ahead of your phase inverter.

This circuit came originally from Australia, and is known as the *Kangaroo*.

Amplifiers from old parts

I would appreciate a diagram of an amplifier using old-type 2.5-volt tubes. We have numbers of 26's, 27's, 24's, 56's, 2A5's, and 2A3's.—A.E.F.

A. The amplifier shown in Fig. 322 is for 2A3's but may readily be adapted to 2A5's or 47's by reducing the cathode resistor to about 300 ohms and adding the screen leads. Needless to say, equivalent 6-volt tubes may be used in this circuit. The 56 may also be replaced by a 27, with little difference in results. The center tap resistor in the 2A3 filaments is about 30 ohms.

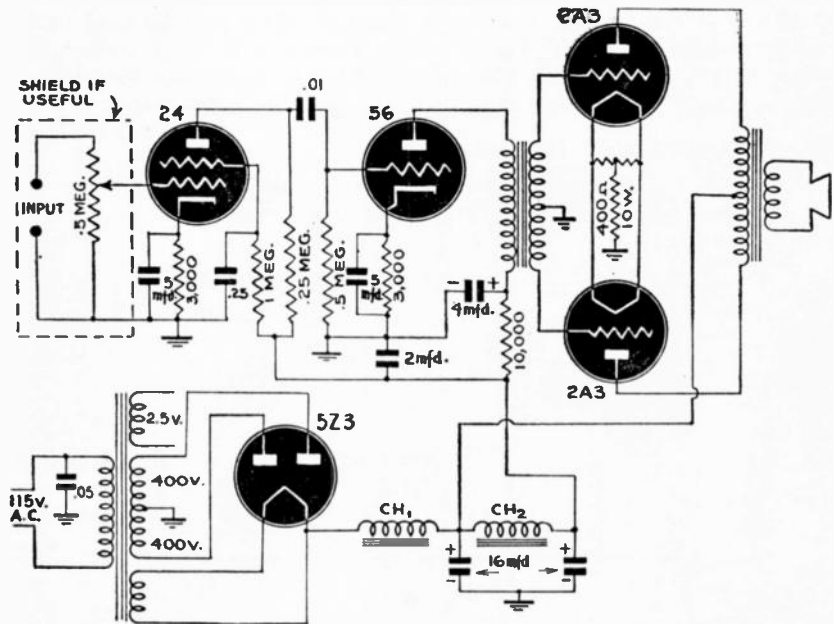

Fig. 322

PA AMPLIFIERS

2-input amplifier

Please print diagram of a high-fidelity amplifier using two 6L6's in the output. I require 2 inputs for crystal microphones and 1 for phonograph.—G.R.C.

The circuit in Fig. 401 will give excellent fidelity, if carefully built from high-grade parts. The 1.5-volt bias cells shown may be ordinary flashlight cells. The large choke should be a low-resistance type with a carrying capacity of at least 150 ma; the other one may be a small a.c.-d.c. type as it carries little current.

Various types of tubes may be used; the 6F5's may be replaced by 6C5's; if the cathode resistor is changed, 6F6's may be used in the output instead of 6L6's. Large power transformers (675 volts c.t.), choke, and a high-quality output transformer (primary 5,000 ohms plate to plate) will greatly improve the quality of reproduction.

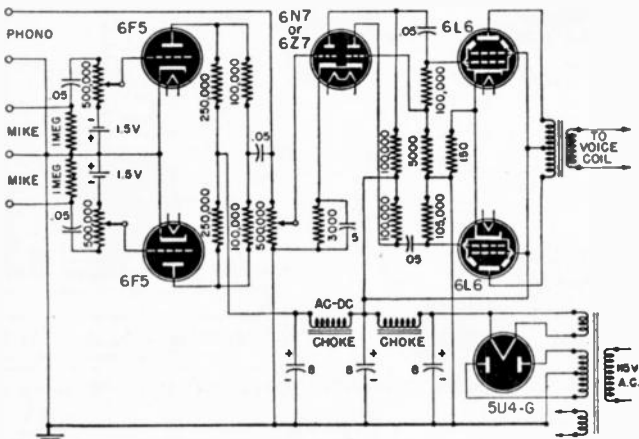
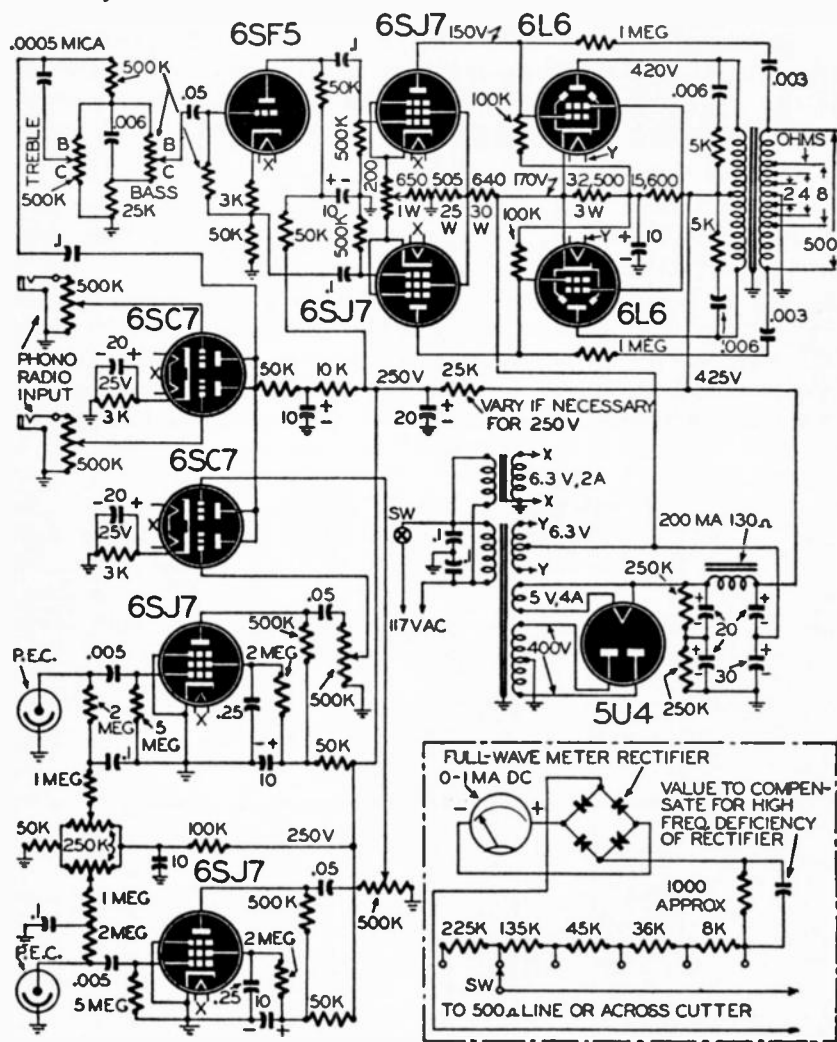

Fig. 401

Direct-coupled amplifier

I want a diagram of a direct-coupled amplifier that would have at least one of the following features: h.f. control, two low-gain input stages, calibrated volume indicator, two photocell inputs if possible.

I have two output transformers for a single 6L6 which I can use in a push-pull output stage. Each of these has a 2, 4, 8, and 500-ohm secondary—W.L.



K=1000; B=BOOST; C=CUT; CONDENSERS: WHOLE NUMBERS=450V. AND DECIMALS=600V.

Fig. 402

A. A circuit is shown in Fig. 402. However, single 6L6 output transformers are not recommended unless you wish each direct-coupled amplifier to function independently. The output transformer should be for 6L6's in push-pull, with a plate-to-plate impedance of 5,000 to 6,600 ohms. You will then be able to obtain 15 watts at low distortion.

A single transformer for each 6L6 would give less than 5 watts each at the equivalent harmonic distortion of a push-pull output transformer.

Values of feedback resistors and condensers may be varied to suit the particular output transformer and speaker you use.

A volume indicator unit is also shown. The resistor values may be used just as given with it, or you may change them to calibrate the meter in whatever units you wish. If you obtain a meter with scales marked in decibels, you may wish to use resistors in line with the scales.

? Small phono amplifier

Please show a circuit for a compact phonograph amplifier. This should use 6SC7, 6V6, and 5W4, and be readily portable, but is to work off the ordinary 115 volt electric lines.—A.M.

A. The diagram in Fig. 403 uses your tubes and combines satisfactory gain with small size. Circuit shown is for input from a crystal pickup. If a magnetic pickup is used, the 2-meg resistor, the 0.5- μ f blocking condenser, and the $\frac{1}{2}$ -meg grid leak may be omitted and the secondary of the pickup transformer connected directly from the grid to ground.

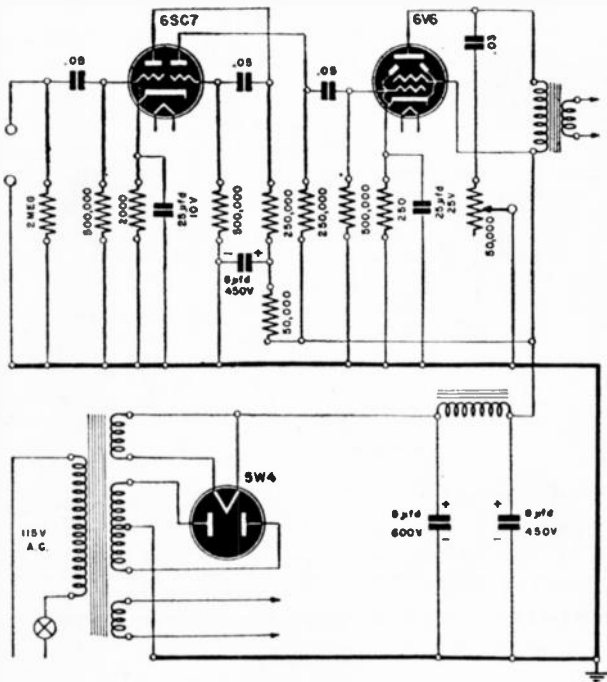

Fig. 403

? 100-watt booster

Show a circuit diagram with all values marked for a 100-watt booster amplifier to be fed with a small amplifier having 2, 4, 8, and 500-ohm outputs, at 15 or 30 watts. I have the following tubes

available: 6J7, 6C5, 6N7, 6L6's, and an 83. Can obtain others if necessary.
 —W.C.J.

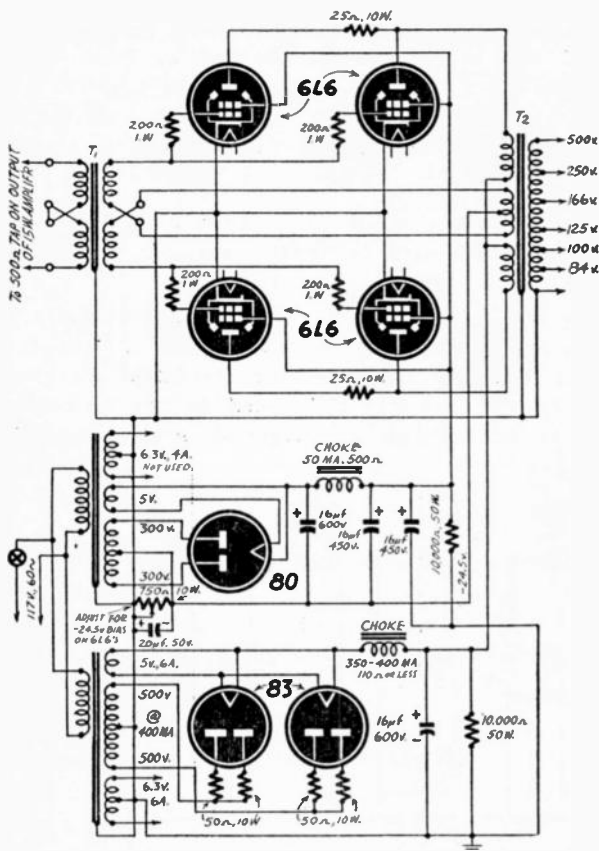

Fig. 404

A. The diagram (Fig. 404) shows a 100-watt amplifier with power supply. If you have a good 15-watt driver, it should give more than ample power for driving the booster. Perhaps you have a power supply, but a good one has been shown so that you may check it. Approximately 400 milliamperes plate current is required by the 6L6's at maximum signal. The grid bias voltage should be adjusted before the plate voltage is applied. In construction you may find that the grid, screen, and plate leads need shielding.

❓ A.C.-D.C. amplifier

I would like to have a diagram of a public address amplifier with push-pull 6L6 or 6V6 tubes with about 12 watts output. Input connections should be provided for crystal mike and phono pickup. The power supply should be designed for operation from either 110-volt a.c. line or a 6-volt storage battery, with a change-over switch.—D.B.S.

A. Fig. 405 is drawn to meet your specification. It uses a 6J7 mike amplifier, 6SC7 phono amplifier-mixer, 6J5 phase inverter, and push-pull 6V6's operated in class AB₁ with 14 watts output.

The power supply is designed to work with a vibrator from a storage battery or from a 110-volt a.c. line. Separate switches are included in the primary power leads to control the input voltage. The power

supply should be mounted on a separate chassis that is equipped with a bottom cover plate.

Shield all grid leads to prevent pickup of vibrator "hash" when using a d.c. power source. The power transformer is designed for

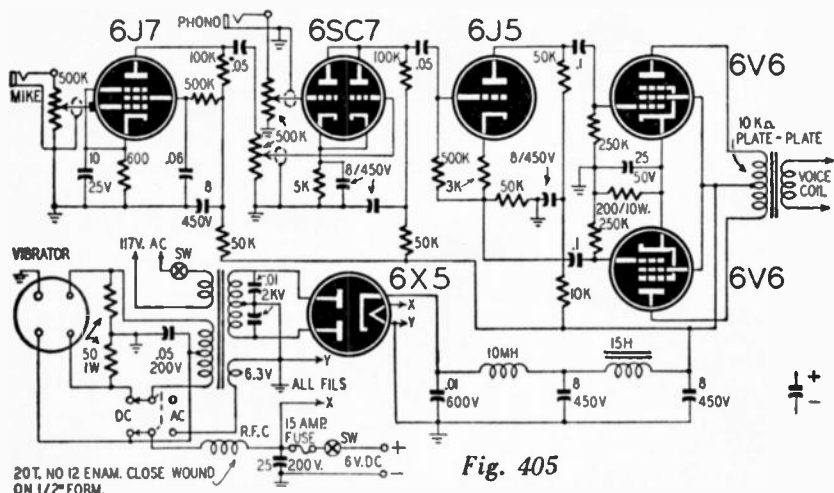

Fig. 405

universal input and its high-voltage secondary should supply 350 volts c.t. at 135 ma. The condensers marked .01 (in the high-voltage secondary) should be varied till the correct size for lowest battery drain and minimum hash is found. Values as low as .002 may suffice.

12-watt amplifier

Please print a diagram of an amplifier that can be used as a PA system with a microphone and phono input. I have a Hammond universal output transformer rated at 30 watts.—L.P.

A. The diagram (Fig. 406) is designed to meet your needs, using your transformer. All resistors, chokes, and condensers are specified. The input to the 6J7 grid will probably need shielding. To place all parts on a small chassis will require more care in shielding and placement.

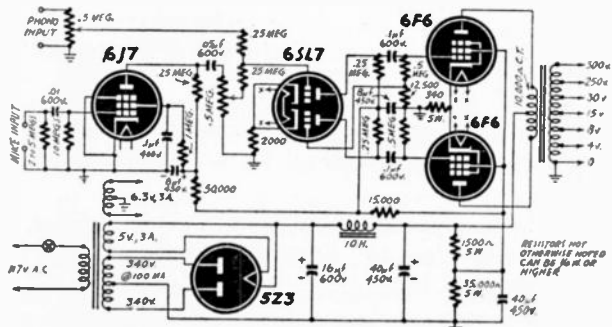

Fig. 406

? 10-watt amplifier

I would like a schematic of an amplifier with 10 watts or more output using a 6N7 as a driver, two 6F6's in push-pull, and an 80 as rectifier.—H.E.S.

A. Since an amplifier with a 6N7 and two 6F6's does not always give enough gain, even for phonographs, we show added to it an input stage, which you may add if you like. With the added tube, the amplifier may be used with microphone as well as with phonograph or radio. (See Fig. 407).

Alternate tubes may be used as 6N7 or 6SC7 for the voltage inverter, and 42's in the output stage. Any good rectifier will work, and the input tube may be a 6C5 or 6J5.

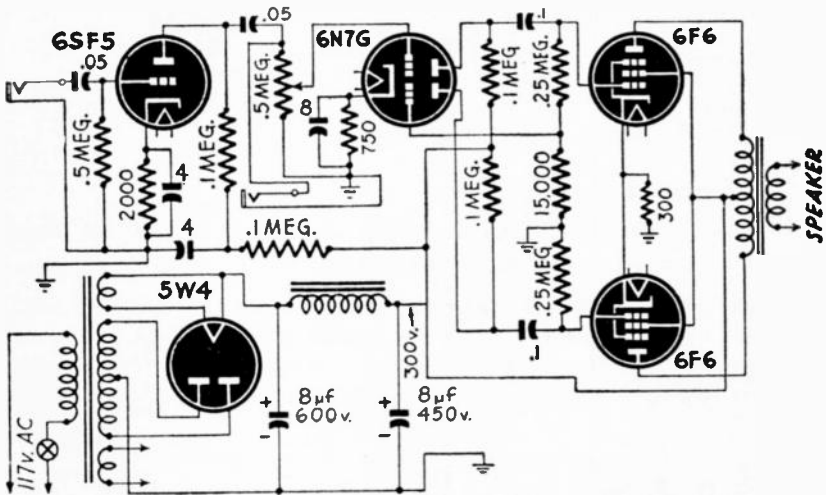

Fig. 407

? A good audio amplifier

Will you please design me a good audio amplifier for phonograph and FM or AM tuner? I have on hand three 6P5's, two 6J5's, and two 6AC5's, all of the glass type.—R.W.J.

A. The schematic (Fig. 408) should give good results. The first tube may prove unnecessary, unless you intend to use the amplifier with a low-gain microphone.

The 6AC5 is an especially interesting audio amplifier, in that the grid is maintained at a positive potential, contrary to general practice. The correct voltage is +13.

Any type of power supply capable of delivering 100 milliamperes or more at 250 volts may be used with this amplifier.

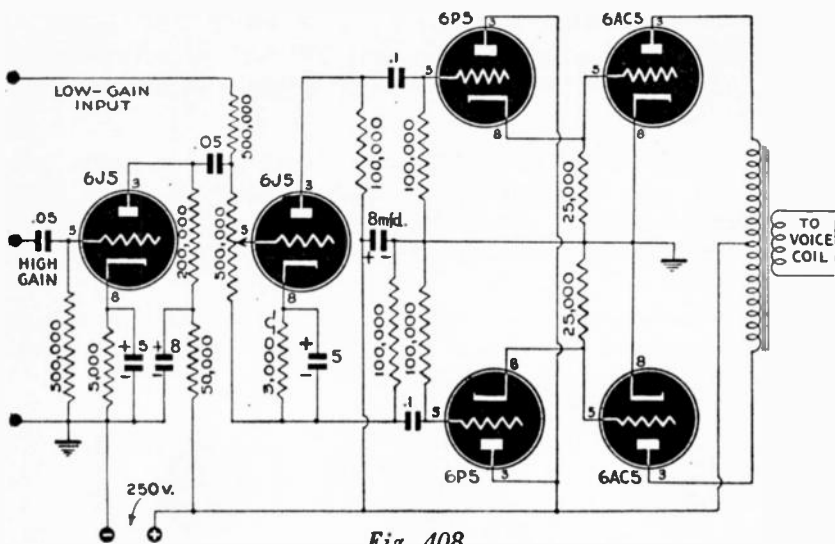

Fig. 408

3-channel audio

I wish to build a 3-stage amplifier utilizing three separate inputs with mixers: phono, guitar, microphone.—M.J.G.

A. Two of the inputs are connected to a 7F7 and the low level input to a 6SQ7 (see Fig. 409). The 6A6 is a phase inverter which is required for push-pull. The bias cells for the input stages may be Mallory cells or small flashlight batteries. Three 50,000-ohm filter resistors are used.

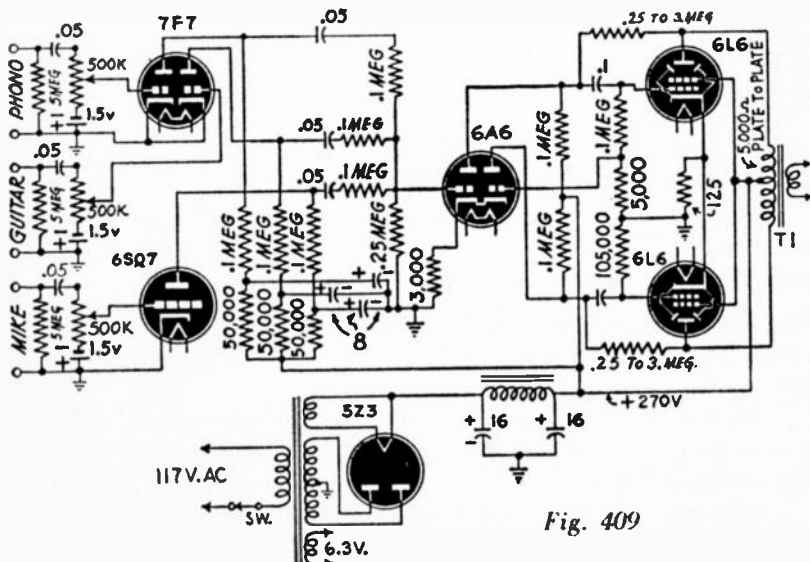

Fig. 409

Section 5

POWER SUPPLIES

? Power converter

I need a 32-volt power pack with which to service 32-volt radios. This power pack must operate from a 110-volt a.c. supply line, and be able to supply from 24 to 40 volts in succeeding steps.—R.G.B.

A. Fig. 501 is a diagram of a 117-volt a.c. to 20-40-volt d.c. converter. Values are given in the diagram. It would be possible to omit the power transformer and apply the 110-volt a.c. directly to all four 83 plates

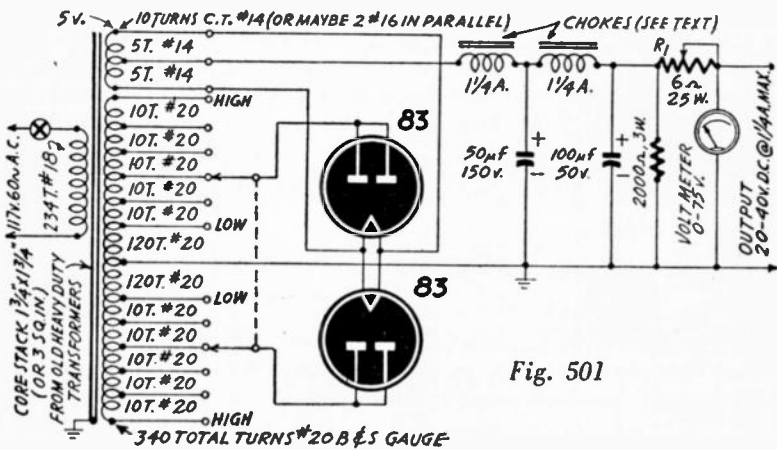

Fig. 501

in parallel, giving half-wave output. Condenser input to the filter would then be needed, giving rise to some objections, such as more filtering needed and exceptionally high accumulated voltage on the filter condensers when no load is on the inverter. If this condition were to remain, there perhaps would be the danger of flashing tubes in the set under test when it is plugged into the converter.

Note that choke input is used. This will give almost uniform voltage output whether you have a light load or close to full load. Another choke and condenser may be added if more filtering is needed.

R1 is not necessary unless fine adjustment of the output is required.

? A.C. power supply for car radio

Please show diagram of a low-voltage power supply suitable for operating a car radio on 110 volt, 60 cycle a.c. circuit.—H.S.

A. The power pack shown in the diagram (Fig. 502) will supply about 100 watts, more than is needed for the common car radio, which draws only about 35 watts.

The transformer secondary should have taps as shown in the diagram.

The selenium disc bridge rectifier is an 18 v, 6-8 amp unit.

The electrolytic condensers are 3,500- μ f, 25-v units. They may be reduced in value if a choke is used, but without a choke hum will occur if they are smaller. By using the high capacity the choke may be omitted, but when using condensers of 500 μ f the choke is necessary.

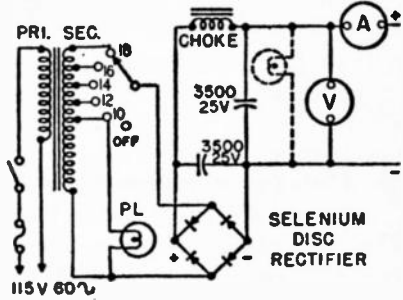

Fig. 502

A heavy-duty changeover switch may be mounted on the panel to get the desired voltage. When heavier current is drawn, the voltage drops, so it is necessary to move the switch to the next higher voltage tap. A 15-v and a 15-amp meter are desirable.

The choke is about 0.002 henry at 8 amp. A pilot lamp (shown in dotted lines) is useful across the output. It prevents voltage from rising to dangerous values if the supply is turned on when there is load.

? Two power supplies

Please publish an a.c.-d.c. power supply for a set with a 25L6 or 43, a 25Z6, 6D6, and 6A7. Please show the value of all parts and resistors. Also please draw an a.c. power supply, using an 80, suitable for a small receiver, test instruments, etc.—R.J.

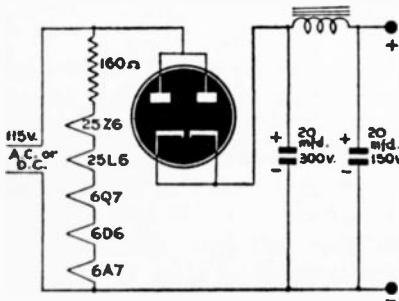

Fig. 503-a

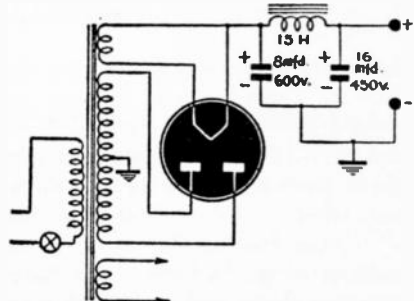

Fig. 503-b

A. The a.c.-d.c. power supply is shown in Fig. 503-a. The tube is the 25Z6 you have on hand.

The a.c. supply in Fig. 503-b may be used with an 80 or similar rectifier. Voltage output will depend on the rating of the transformer used. A bleeder resistor, if available, will improve this unit.

? Portable power supply

I would like a hookup for power supply for a small portable set, using a 117Z6 tube. Filaments can be connected in series.—M.D.

A. The schematic is given in Fig. 504. By using a suitable line-cord or other resistor, it can readily be adapted to almost any type of a.c.-d.c. rectifier tube. The radio with which it is used must be a type with all filaments connected in series and drawing 0.05 amp per tube.

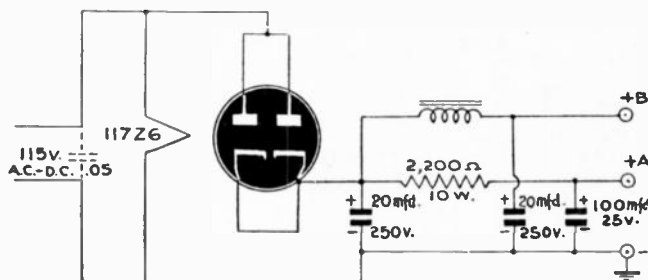

Fig. 504

? Simple B-eliminator

Please show diagram for a simple B-eliminator, with a tap for 6 and also 45 volts.—E.K.

A. Fig. 505 shows the diagram. Since the amount of current required is not stated, the bleeder is supplied with sliders. A high-resistance voltmeter is necessary for proper adjustment. Start with sliders at B—

end. With load connected, connect voltmeter to 6-volt tap and move slider up till meter indicates 6 volts. Repeat procedure with other tap for 45 volts.

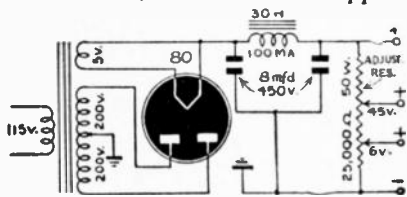

Fig. 505

? Calculating voltage-divider resistances

I have built up a power pack for portables. This calls for a 25,000-ohm, 50-watt voltage divider with a slider.

How may I compute the resistance for each section to such as B—, B + 135 and 250 volts and B + 22 volts?

Or what might I use in place of the divider?—R.T.

A. It is easy to design a voltage divider, if you know Ohm's law, and if you start at the negative end.

The output voltage of your pack and the amount of current needed at each tap must be known or closely estimated. A tube manual will indicate how much current you may expect the tubes to draw, and rectifier output voltage when these currents are drawn may be taken as two-thirds that of the no-load voltage of the pack, for a first rough approximation.

Assuming that the detector will draw about 2.5 ma at about 5 v, and the 2 r.f. tubes and output pentode take 30 ma at 135 v, we start as shown in Fig. 506.

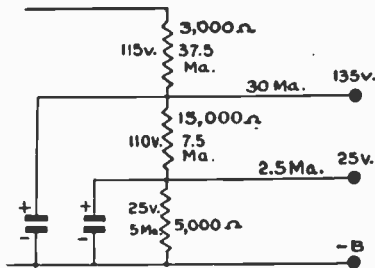

Fig. 506

First we allow a certain amount of bleeder current. If the transformer is large, this may be anything up to 20 ma. A common rule is that the bleeder current should be at least 20 percent of the total drawn. As you have difficulty in obtaining large resistors, we will allow 5 ma. For the first bleeder section, then, we require 5 ma. at roughly 25 v. Ohm's

law tells us that this will require a resistor of 5,000 ohms. The next section takes us up to the 135-volt tap of the bleeder, a difference of 110 v. The current through this section will be the same 5 ma plus the 2.5 ma drawn by the detector, or a total of 7.5 ma. This calls for a resistor of something more than 14,000 ohms. A 15,000-ohm resistor is close to this and is easily obtainable.

The top section of the bleeder must span the distance between the 115-v tap and the 250-v supply, a drop of 115 v. The current through it is 37.5 ma. 37.5 ma at 135 v calls roughly for a 3,000-ohm resistor, by Ohm's law.

Wattages for each of these resistors work out roughly to 4.5, 0.8, and something like 0.1 watt, respectively (115×0.0375 ; 110×0.0075 ; 25×0.005). Practical sizes of resistors are—allowing the usual 100 percent increase—10 watts, 2 watts, and 1 watt. There is little use for a resistor smaller than 1 watt in a bleeder.

If it were desired to put the output pentode on a 180-v tap, it could be easily done. In this case the 135-volt tap might draw approximately 8 ma and the 180-volt tap between 20 and 30, according to the pentode used.

A good size condenser (about $8\mu\text{f}$) between each tap and ground will improve the operation of your set by preventing interstage feedback through the bleeder.

Section 6

TEST INSTRUMENTS

? Neon-bulb oscillator

I wish to make an audio oscillator using a neon bulb. A 25Z5 is to be used as rectifier,—C.H.D.

A. The diagram is shown in Fig. 601. A switching arrangement allows the use of different values of condensers for a wide range. The

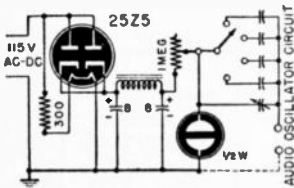

Fig. 601

variable condenser ($500 \mu\text{f}$) allows gradual change and overlapping of ranges. Values of fixed condensers are 250 , $500 \mu\text{f}$; and 0.001 and $0.005 \mu\text{f}$. The 25Z5 is shown as a half-wave rectifier, and provides sufficient voltage to operate the neon bulb. A 300-ohm resistor is used in the filament circuit.

? Electron-coupled crystal oscillator

Please show the circuit of an electron-coupled crystal oscillator which I can use for signal generator calibration, etc. I have a 6.3-volt supply and a B-source of up to 250 volts. —S.G.

A. You will have ample output from a 6F6 crystal oscillator as shown in Fig. 602, LC is tuned to approximately the crystal frequency.

You may find that with a 6F6 tube, it is hard to get the crystal to oscillate, especially if—as is usually the case—a crystal of 455 kc or other intermediate frequency is used. In this case, a condenser between plate and grid is useful. A $10\text{-}\mu\text{f}$ mica condenser or just two pieces of insulated wire twisted together will do.

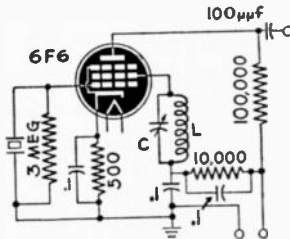

Fig. 602

The output appears in the plate circuit and there will be almost no reaction on the oscillator. You can experiment with the plate and screen-grid voltage required. A lower voltage will heat the crystal less and provide greater stability.

? Saw-tooth sweep

I wish to make a sweep circuit for use as the horizontal sweep of an oscilloscope. Please give me a diagram using an 885 tube—B.W.J.

A. This circuit is given in Fig. 603. A 1-V tube is used as rectifier to provide the high voltage. The several values of condensers are switched in to provide a wide range of frequencies.

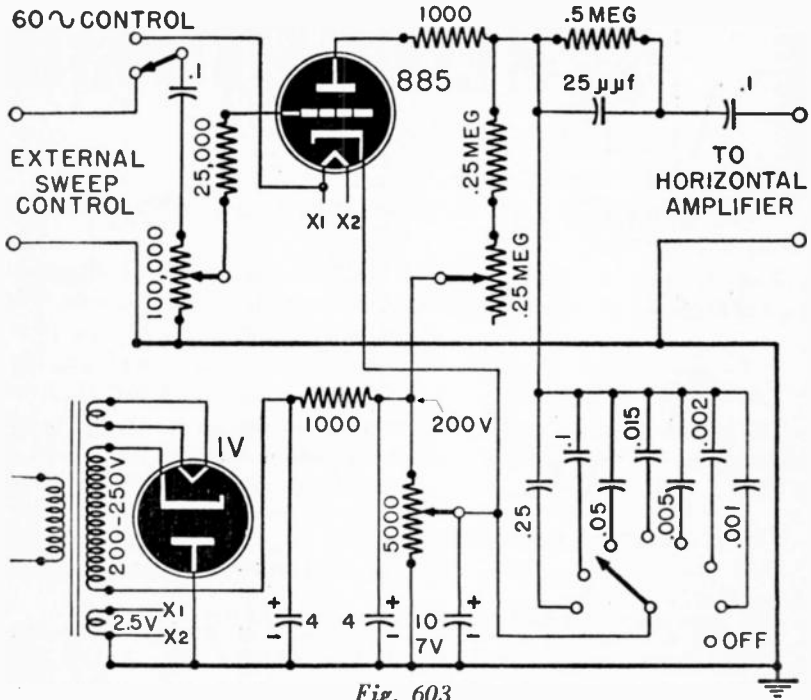

Fig. 603

For external sweep, connection is made at the terminals provided and the switch is set at "off".

A 1 or 2-tube amplifier is necessary to provide a large enough linear sweep. You can follow the diagram of a standard oscilloscope amplifier.

? D.c. condenser tester

I would like to get a circuit for a condenser leakage tester using a 6X5 as a rectifier. The d.c. voltage I want is 50—150—200—400—500. I would also like to be able to check electrolytic condensers on it.—J.F.

A. A small receiver transformer may be used to supply the high voltage required. It should be hooked up in a half-wave circuit, ignoring the center tap. Should the output voltage be too high, it may be reduced by using a resistor in place of the filter choke.

Extreme care should be taken in the wiring of this circuit, and excellent insulating material used throughout. Many of these home made leakage testers fail to work because of other leakage paths through the

device. Using a larger neon lamp sometimes helps in cases like these, but the only correct way is to insure that there is no leakage.

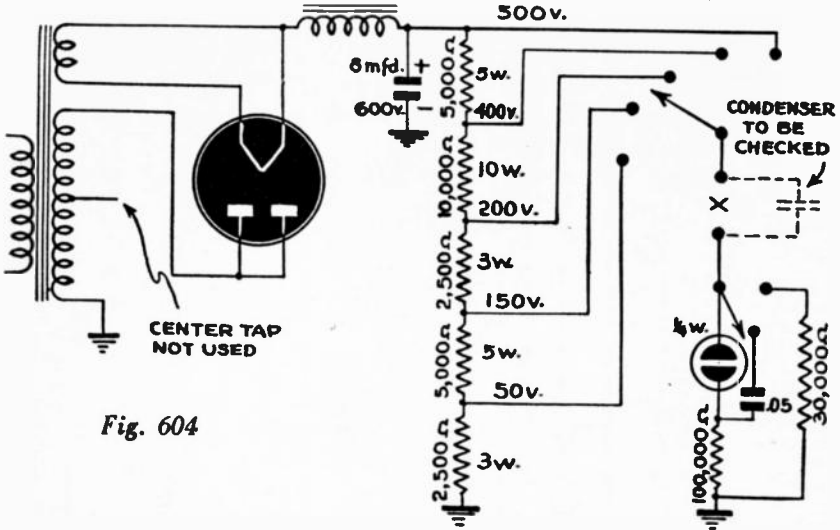

Fig. 604

The switch is connected to the 0.05- μ f condenser to check paper condensers, and to the shunting 30,000-ohm resistor for electrolytics. (See Fig. 604).

? Checker and analyzer

Will you kindly print a diagram of a condenser analyzer and leakage checker?—J.W.

A. The two drawings (Fig. 605 and 606) show an analyzer (capacity and power factor measurer) and a leakage checker. The 12,000-ohm resistor gives the capacity, the 20,000 the power factor. The null indica-

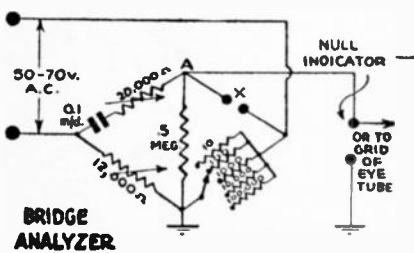

Fig. 605

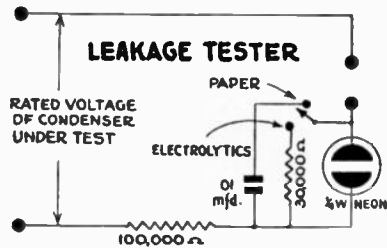

Fig. 606

tor may be a vacuum-tube voltmeter or an electron-ray (6E5) tube. Calibrate with condensers of known capacity.

? Volt-ohmmeter

I would like a diagram of a volt-ohmmeter using a 500-micro-ampere meter I have. Its internal resistance is 62.5 ohms. Voltages re-

quired are 5, 20, 100, 500, and 1,000 d.c. and 8, 32, 160, and 320 a.c. I would like to measure from 1 ohm to 10 megohms.—R.J.B.

A. A diagram is shown in Fig. 607. The resistor for the 8-volt a.c. range will have to be determined by experiment. This is because of the resistance of the rectifier, REC, which may be an ordinary meter rectifier. It will form an appreciable part of the resistance in circuit on the 8-volt scale which should total 14,400 ohms.

To measure higher resistances than can be handled with the

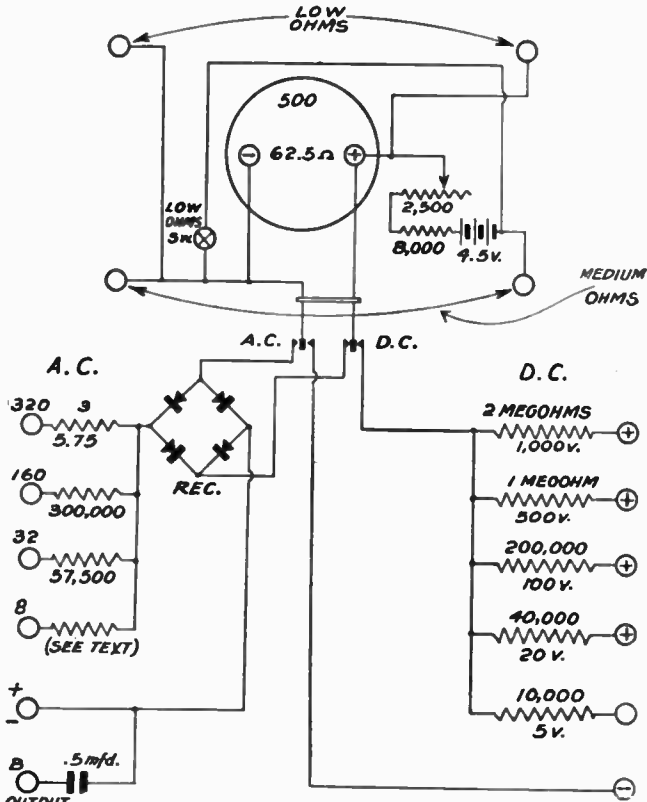

Fig. 607

"medium ohms" scale, a 45-volt battery and a 90,000-ohm resistor in series will multiply your "medium ohms" reading by 10.

The output meter is simply an a.c. meter with a condenser of from 0.5 to 1 μf in series to block out d.c. One of the test prods is inserted in the jack marked "output" and the other in one of the a.c. jacks, according to the strength of the signal. It is wise to start on a fairly high range and to work at all times on the lower part of the scale.

Charts may be made of the readings for the various ohm scales, as attempts to mark the scale will ruin its appearance.

? Volt-ohm milliammeter

I would like to know how to convert my milliammeter into a volt-ohm meter. It has a 1,000-ohms-per-volt movement. I require ranges of 5, 50, 250, and 750 volts d.c. and a.c. I have a small half-wave meter rectifier for the a.c. My meter has an ohms scale, which reads up to 1,000 ohms.—A.K.

A. The schematic is given in Fig. 608. You will find the 5-volt a.c. scale will not be correct, and your resistor will have to be varied from the original value of 4,500 ohms to allow for the resistance of the rec-

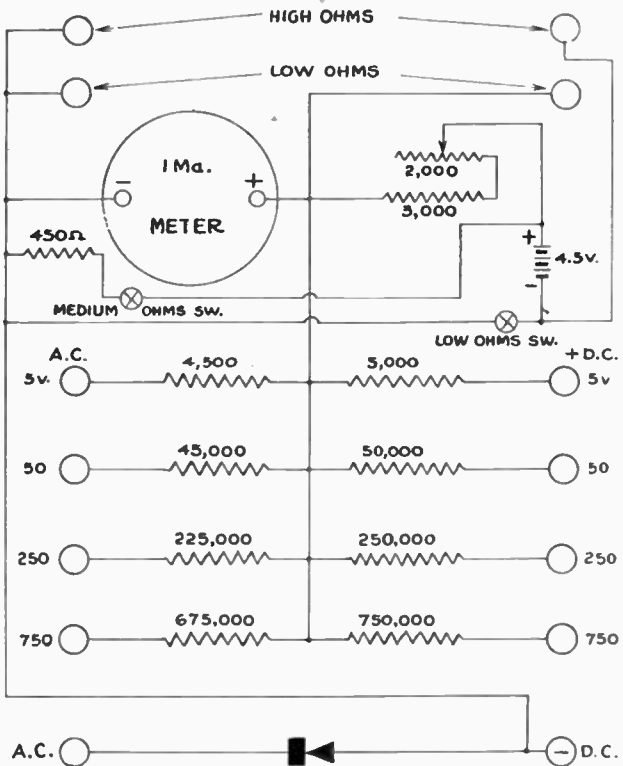

Fig. 608

tifier. This changes with the amount of current through it, making correctness at all points on the scale impossible. Common practice is to adjust it for a correct reading at 2.5 volts. On the higher ranges any error introduced by changing rectifier resistance is too slight to be noticeable.

Although the diagram shows only two ohmmeter ranges, a still higher range may be added by putting a 45-volt battery, a 40,000-ohm fixed, and a 10,000-ohm variable resistor in series with the high-ohms terminal.

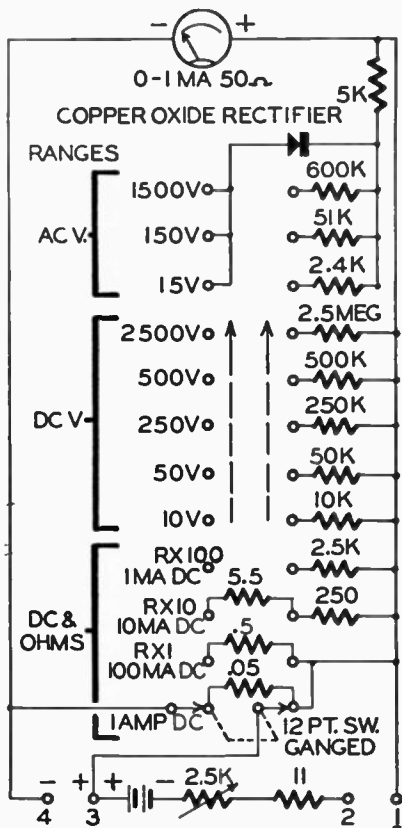

Fig. 611

? A.C.-D.C. multitester

Please publish a diagram for a volt-ohmmeter, a.c. and d.c. to operate with a 0.1 milliammeter, internal resistance 50 ohms.—J.V.

A. A multitester having a.c. and d.c. voltage ranges and d.c. ma as well as ohm ranges is shown in Fig. 611. Terminal 4 is common. For a.c. and d.c. volts, use terminals 3 and 4, with the switch set to the proper ranges. For ohms, terminals 2 and 4 are used. The milliammeter uses terminals 3 and 4 with the same switch ranges as the ohmmeter. As there is a 2,500-ohm resistor in series with the meter in the 1-ma position, another lead, terminal 1, is supplied for that range in applications where the 2.5-v drop across the resistor would throw out calibration.

A.c. voltage ranges are: 15, 150 and 1,500. D.c. voltage ranges are: 10, 50, 250, 500 and 2,500. Current ranges (d.c.) are: 1, 10, 100 ma and 1 amp.

? Conversion of army radar oscilloscope

Recently I purchased a Signal Corps BC-412-A oscilloscope. This scope was used by the Army in radar installations. I would like a diagram showing the changes necessary to convert it for radio servicing.—L.J.L.

A. A diagram is shown in Fig. 612 that will enable you to convert the oscilloscope for radio servicing. The 6L6 pulse and sweep generators and the 6SJ7 spread amplifier are discarded and an 884 gas triode oscillator sweep circuit is added to the circuit. Two controls have been added which permit the operator to make coarse and vernier adjustments on the sweep frequency. Input jacks for external synchronizing voltages and for the horizontal and vertical amplifiers are used for external coupling to the unit.

The parallel vertical amplifier is converted to push-pull for better performance. The vertical sensitivity is approximately 0.045 volt per inch, and the horizontal amplifier has been altered to increase the gain to 0.3 volt per inch.

All leads in the input circuits of the horizontal and vertical amplifiers should be well shielded. Ground the shields of the long leads at several points. Hum and microphonics in the vertical amplifier may be caused by a defective 6AC7.

Extremely high voltages are used in some parts of the circuit and all precautions should be taken to avoid bodily contact with these circuits as this will result in DEATH or SERIOUS INJURY. When working on the unit, all high-voltage condensers should be discharged each time the power is turned off. A well insulated metal screw driver may be used to short the terminals of each of the condensers.

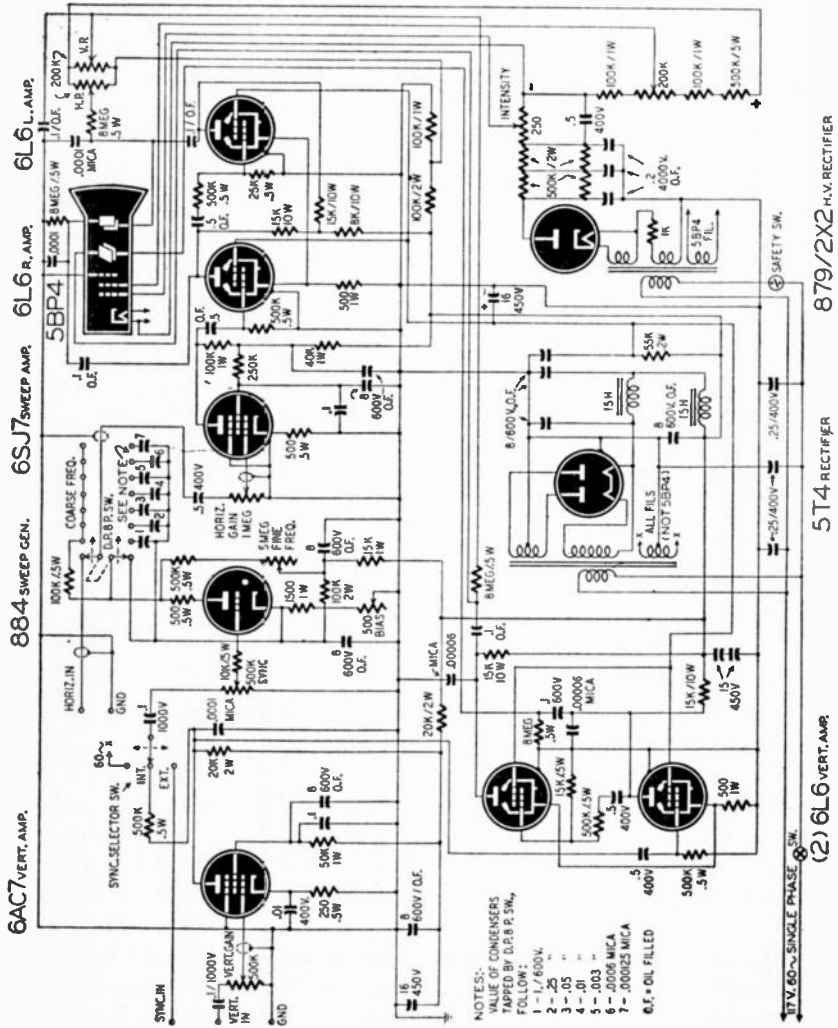

Fig. 612

? Simple tube tester

Please print a diagram of a simple tube tester showing the socket wiring connections for testing all types of tubes.—L.P.

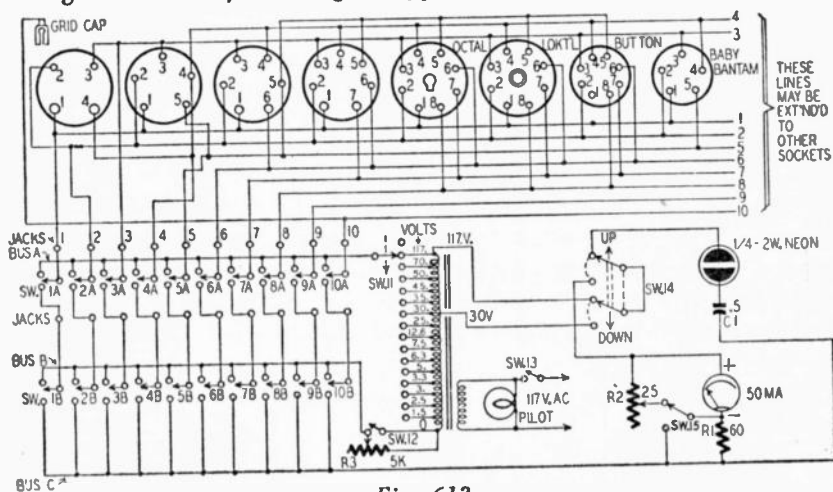

Fig. 613

A. Fig. 613 is a complete diagram of a tube checker showing the connections for all commonly used sockets and for all switches.

To test any tube, you must refer to a tube manual to get the socket connections. Filament voltages are selected by SW 11. Filament voltage is applied by throwing the proper switches to connect the filament leads to busses A and B. If there is a cathode, it is also connected to bus B. For emission tests, all other elements are connected to bus C. In testing full wave rectifier tubes and duo-diodes, each plate is tested in turn by connecting it to bus C. The tube is plugged into the socket last.

The checker is calibrated by testing tubes of known quality and recording the meter readings and setting of R2.

? Wide-band amplifier

I would like to have a diagram of a wide-band amplifier, for use with an oscilloscope, to meet the following specifications:

1. 15 cycles to 2 mc or higher.
 2. Sufficient gain to work with a 5-inch 'scope when a 1.5-volt r.m.s. signal is applied to the input circuit.
 3. A 9002 is to be used in the probe. Please include any special instructions or precautions that may be necessary with this amplifier.
- M.R.

A. A wide-band amplifier circuit is shown in Fig. 614. It will give good results up to 5 mc if care and high-quality parts are used in the construction.

The flatness of the response curve will depend largely upon the

distributed capacity. To keep this factor at a minimum, a few turns may be added or removed from the inductors to obtain the required response.

The amplifier is designed to give full-scale deflection on a 5-inch tube with a 1.5-volt signal applied to the grid of the probe. Sensitivity may be increased up to 20 times by inserting another 6AG7 wide-band amplifier stage between the first 6AG7 and 6J5.

The input lead, blocking condenser, and grid of the 9002 should be spaced as far as possible from the probe shield to prevent excessive stray capacity. A large feed-through insulator through the shield will help in such stray capacity reduction.

Chokes r.f.c. may be from 1 to 2.5 μ h, the latter value being desirable. The resistance of the chokes should be as low as possible to prevent undue reduction of filament voltages. Approximate values of all other inductors are shown. Exact values are determined by distributed and stray capacities and may be adjusted by experiment for flat response.

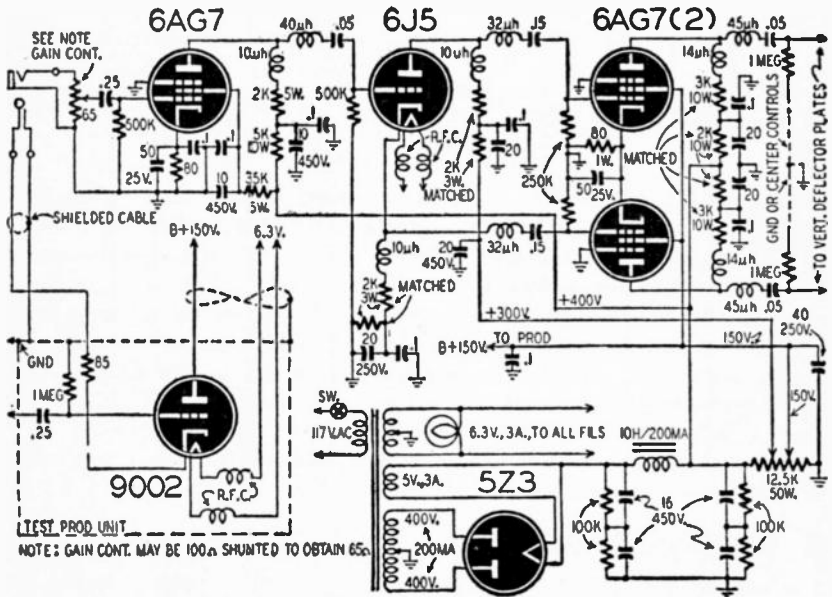

Fig. 614

The strong magnetic fields around the cores of the power transformer and filter choke may induce hum in the grid leads, especially of the first stage. This possibility may be avoided by constructing the power supply on its own separate chassis and placing it at a little distance from the amplifier.

Section 7

MISCELLANEOUS

? Light-beam burglar alarm

Please show diagram of a burglar alarm that operates when a light ray is broken. Alarm should ring a few minutes.—A.S.N.

A. The circuit shown in Fig. 701 should meet your specifications. When the light rays to the CE 1 phototube are interrupted, the bias is removed from the 2051, causing it to conduct current and close

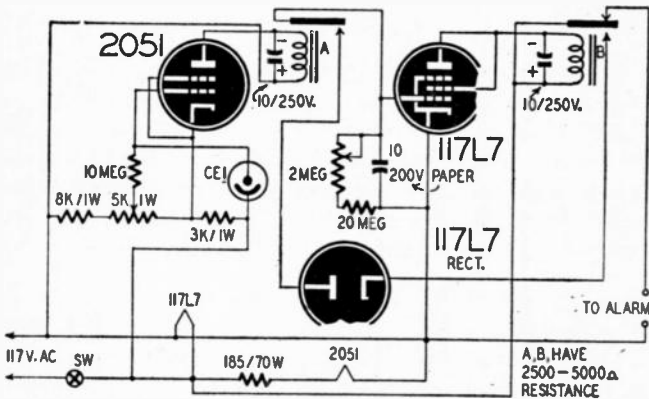

Fig. 701

relay A. This charges the condenser in the grid circuit of the 117L7, biasing it to cut-off and allowing relay B to open, thus closing the alarm circuit. This relay will remain open until the voltage on the condenser has leaked off through the 20-meg resistor. The tube will then again draw current, and the relay will open the alarm circuit. The length of time the alarm rings may be altered by changing the values of the resistors and condenser in the grid of the 117L7.

? Intruder alarm

I have been seeking a diagram of a capacity-operated intruder alarm. This unit is to be operated from 117-volt a.c. lines with low current drain while in operation. It is to be used to protect two windows in our home. Is it possible to place the wires in such manner that the alarm will be set off when anyone approaches from outside the house

to within a few feet of the windows, yet the windows may be approached from the inside without triggering the alarm?—J.O.H.

A. A diagram of a capacity-operated relay is shown in Fig. 702. The tube and relay unit should be placed in a small grounded metal box

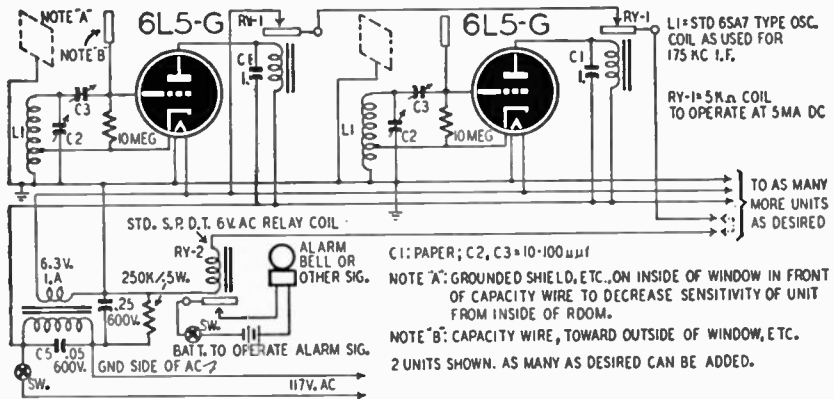

Fig. 702

just inside the windows to avoid using long capacity leads which would present a difficult shielding problem and reduce the sensitivity.

The capacitance wire or screen may be placed toward the outer edge of the window and a grounded shield placed about 6 inches from the wire on the side toward the room. This will reduce the sensitivity from this side. Each location presents its own problem and it will be necessary to do some experimenting for the best results.

? Capacity-operated alarm

Please print a diagram of a burglar alarm using OA4-G gas triodes, in a capacity-operated circuit. The capacity antennas are to be placed at the windows and doors of my home to sound an alarm when anyone approaches from the outside.—J.O.H.

A. Fig. 703 is a diagram of a capacity-operated alarm drawn to your specifications. A capacity wire or screen is placed in the area to be protected. A grounded metal shield or baffle may be mounted about 6 inches from one side to reduce sensitivity from one direction. These tubes have a photoelectric characteristic and should be shielded from light. After relay Ry-1 has been tripped the alarm will ring until SW2 is opened to reset Ry-2. Ry-1 is a 5,000-ohm plate relay and Ry-2 a 6-volt d.c. relay.

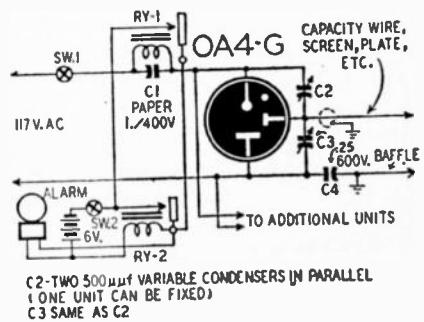

Fig. 703

? Darkroom timer

I would like to have a circuit showing how I may construct a visual and audible timer for use in a darkroom. I have a small a.c. power supply that delivers 240 volts at 40 ma. Can this be used to supply power for the timer?—F.D.

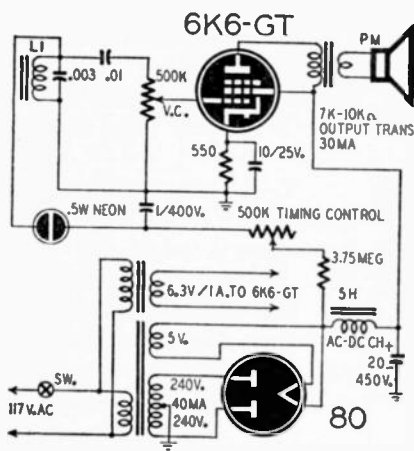

Fig. 704

The tone choke L1 may be any high-impedance a.f. choke or one winding of an old a.f. transformer. If your power transformer does not have a 6.3-volt winding, a small filament transformer should be used.

? Electronic metronome

I would like to see a diagram of an electronic metronome that would be suitable for timing purposes and that could be varied easily in the number of beats per second or minute.—F.B.

A. A diagram shown in Fig. 705 should meet your requirements. It is essentially a multivibrator or relaxation oscillator; the beats may

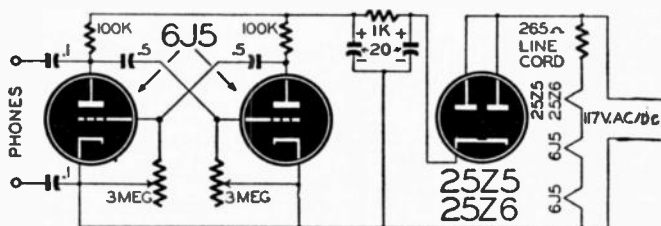

Fig. 705

be made to vary from 20 per minute to above 100 kc per second, depending upon the circuit constants.

It is obvious that if the beat rate is more than a few beats per second, they will appear as one continuous tone, and then the device

may be used as a code practice oscillator by keying the cathode circuit of one of the tubes.

? Color coding

I wish to know the color code for r.f., i.f., and power transformers.
—B.J.H.

A. While these are available in standard texts, and often in manufacturers' handbook, it will be helpful to many to reprint them here. (See Figs. 706 and 707).

There are still old sets in use which follow other codes. Replacement parts for these may follow the original coding. The serviceman is warned to be sure that the coding of a part is standard before taking it

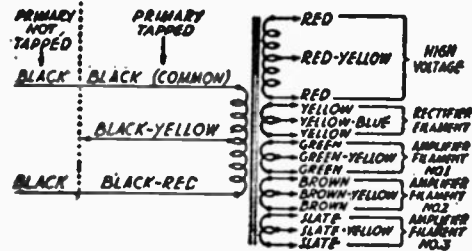

Fig. 706

for granted. Green usually runs to grid and black to ground, when other leads are non standard.

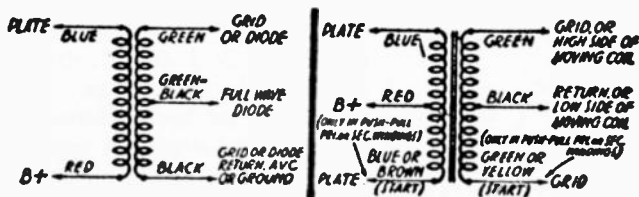

Fig. 707

? Diathermy machines

I have heard that there have been some changes in the regulations regarding the design and frequency of operation of diathermy equipment. What limitations are placed on machines operating on other than assigned frequencies?—E.S.T.

A. Machines operating on other than the assigned bands should be operated in a way that will not cause interference with existing radio services.

The equipment should be provided with a rectified and well-filtered plate supply and efficient line filters. The radiation field from the machine shall not exceed 15 microvolts per meter at a distance greater than 1,000 feet. To reduce sky-wave radiation, all apparatus should be operated as near ground level as possible. Placing equipment away from unshielded light and telephone lines is helpful in this respect.

? Slow-starting motor

I have a small G.E. record player attached to my radio. Before I can play any records I usually have to wait from 10 to 15 minutes for

the turntable to gather sufficient speed. After the turntable comes up to speed reproduction is perfect.—T.J.H.

A. It is most likely that your motor is suffering from lack of lubrication or from stiff or heavy grease. Not having information as to the type of oiling system of your particular changer, our advice is to clean out all present lubricant with kerosene, then to use either vaseline or a light grade of liquid oil, according to whether your player is intended to be used with solid or liquid lubricant. While it is possible there may be some other reason for the particular action of your motor, this is the most likely one.

? A and B battery tester

Please supply diagram of an A- and B-battery tester which can be used for testing radio batteries under load.—E.S.

A. The circuit requested is shown in Fig. 708. The two switches marked SW should be of the instantaneous type and should keep the circuit closed, except when thrown and held over. This will protect the meter.

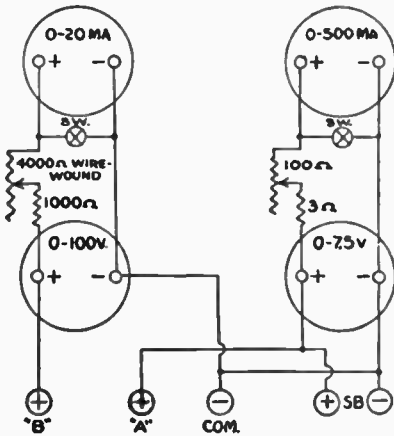

Fig. 708

and should keep the circuit closed, except when thrown and held over. This will protect the meter. The small fixed resistors in series with the variables are for the same purpose, though the wide range in battery voltages makes complete protection impossible. (Fuses might be inserted in series with the meters to protect them.)

An improvement could be made in the B-circuit by using a 2,000-ohm fixed resistor and a 3,000-ohm variable. The only disadvantage of this change is that the amount of current drawn for 22½-volt batteries would be limited, but this is not particularly important if you have very few 22½-volt units to check.

? Electron speeds

Does electromotive force affect the speed of electrons? The speed of electricity is a constant—namely, 186,270 miles per second—but some textbooks use voltage and velocity interchangeably when referring to both electric and electronic actions.—V.J.F.

A. The maximum speed of electricity is in the order of 186,000 miles per second. The electrons you have been reading about have to start from scratch—that is, a standing position in the cathode of a tube—and naturally do not start out at full speed, any more than a locomotive. They speed up according to the voltage which attracts them, so you may read as “. . . accelerated through x volts.”

index...

A.c. - d.c. Multitester.....	54	Expander:	
A.c. Power Supply, Car Radio	45	Compressor	33
Alarm:		Compressor, Volume	34
Capacity-operated	59	Volume	33
Intruder	58	Filter, Fluorescent Lamp	19
Amplifier:		Five-tube t.r.f. Receiver	8
A.c.	28	Fluorescent Lamp Filter	19
A.c. - d.c.	40	Four-tube Receiver	13
All-around	42	Four-tube t.r.f. Receiver	9
Battery (3-tube)	23	Frequency Diathermy Machine	61
Direct-coupled	37	Good Audio Amplifier	38
From Old Parts.....	36	Guitar Amplifier	33
Good Audio	43	Heater, Dielectric	33
Guitar	28	Hum, Reducing Amplifier	34
Low-power	24	Interference Elimination	30
Magnetic Pickup	29	Interphone	31
Phono	39	Interphone, Wire-line	30
Phonograph	30	Intruder Alarm	58
Push-pull (with tone-control)	34	"Kangaroo" Inverter	35
Resistance-coupled	29	Light-beam Burglar Alarm	58
Two-input	37	Low-level Pre-amplifier	35
Wide-band	56	Low-power Amplifier	34
2-tube Midget	23	Magnetic Pick-up Amplifier	29
6C6 - 25A6	25	Metronome Electronic	60
10-watt	42	Microphone Pre-amplifier	37
12-watt	41	Milliammeter, Volt-ohm	53
Analyzer and Checker	50	Miniature-tube s-w Converter	17
Audio (3-channel)	43	Motor, Slow-starting	61
B-Eliminator, Simple	46	Multitester, a.c.-d.c.	64
Battery Amplifier (3-tube)	23	Neon	48
Battery Tester, A and B	63	Noise Silencer	33
Booster, 100-watt	39	Ohmmeter, Volt	50
Broadcast Receiver	12	Old Parts, Amplifier from	36
Burglar Alarm, Light-beam	58	Oscillator:	
Calculating Voltage-divider Resistance	46	Electron-coupled Crystal	48
Camera t.r.f. Receiver	10	Neon-bulb	48
Capacitator	53	Wireless Phono	21
Capacity-operated Alarm	59	Oscilloscope, Conversion of Army	
Car Radio, a.c. Power Supply	45	Radar	64
Checker and Analyzer	50	Permeability Receiver	14
Coding, Color	61	Phono-amplifier	39
Coll Data, Superhet Tuner	15	Phonograph Amplifier	30
Color Coding	61	Pocket Receiver (loop)	13
Condenser Tester	53	Portable Power Supply	46
Condenser Tester, d.c.	49	Power Converter	44
Conversion of Army Radar		Power Supply, Portable	46
Oscilloscope	54	Power Supplies, Two	46
Converter:		Pre-amplifier:	
Miniature-tube s-w	17	Low-level	25
Power	44	Microphone	27
Short-wave	17	Two-input	26
V.h.f.	18	2-tube	26
D.c. Condenser Tester	49	Push-pull Amplifier with Tone control	34
Darkroom Timer	60	Receiver:	
Diathermy Machines	61	Broadcast	13
Dielectric Heater, Electronic	22	Superheterodyne	6
Direct-coupled Amplifier	37	Superhet (tuner)	14
Electron-coupled Crystal Oscillator	48	Superheterodyne (tuner)	15
Electron Speeds	63	Two-in-one	7
Electronic Metronome	60	Two-tube a.w.	6

2-tube a.c.-d.c.	9	Transceiver, 300 mc	21
3-tube t.r.f.	10	T.r.f. Receiver:	
4-tube Broadcast	13	4-tube	9
4-tube t.r.f.	9	5-tube	8
4-tube 1.5 volt	11	5-tube	10
5-tube t.r.f.	8	5-tube, 2.5 volts	11
5 tube t.r.f.	10	3-tube	10
5-tube t.r.f. 2.5 volt	11	Camera	10
Permeability	14	Tube-tester, Simple	56
Pocket (loop)	13	Tuned r.f. Stage	5
V.h.f.	12	Tuner, Superhet	14,15
With 56's	7	Tuner, Wireless	16
Reducing Amplifier Hum	34	Two-in-one Receiver	7
Regenerator:		Two-input Amplifier	37
2-tube	7	Two-input Pre-Amplifier	26
2-tube	9	Two Power Supplies	45
Resistance-coupled Amplifier	29	Two-tube a.c.-d.c. Receiver	9
Saw-tooth Sweep	49	Two-tube Midget Amplifier	23
Short-wave Converter	17	Two-tube Regenerator	8
Silencer, Noise	32	Two-tube s.w. Receiver	6
Simple B-Eliminator	46	V.h.f. Converter	18
Simple Tube Tester	56	V.h.f. Receiver	12
Slow-starting Motor	61	Volt-ohm Milliammeter	52
Speeds, Electron	62	Volt-ohmmeter	50
Superheterodyne Tuner	14	Voltage-divider Resistances,	
Superhet Tuner	15	Calculating	46
Superheterodyne Receiver	6	Volume Expander	33
Sweep, Saw-tooth	49	Volume-Expander-Compressor	34
Tester:		Wave-trap, All-wave	19
A and B Battery	62	Wide-band Amplifier	56
Condenser	53	Wire-line Interphone	20
Three-channel Audio	43	Wireless Phono Oscillator	21
Timer, Darkroom	60	Wireless Tuner	16