

transistors

*their practical
application in
television, radio
and electronics*



PRICE \$1.50



A *Coyne* P U B L I C A T I O N

DISTRIBUTED BY: HOWARD W. SAMS & CO., INC., INDIANAPOLIS 5, IND.

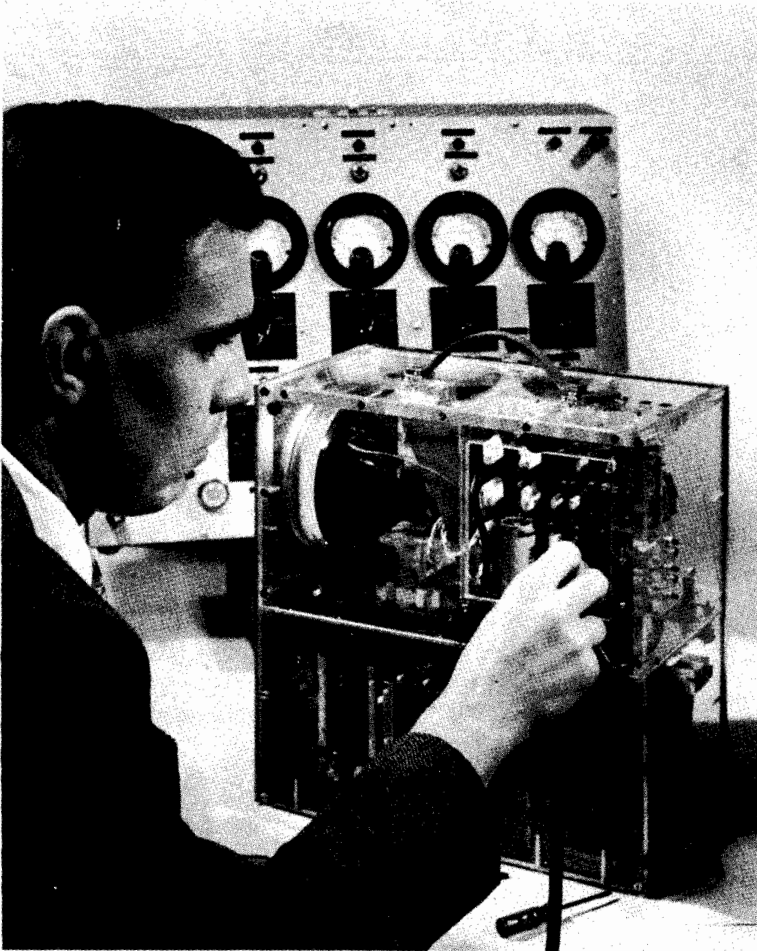

An experimental portable TV Receiver using only one tube - the Picture Tube. This receiver is representative of the type of equipment the serviceman may one day be called on to service and maintain. A knowledge of transistor operation is essential to the proper maintenance of such equipment.

Courtesy - RCA

**TRANSISTORS
AND THEIR
APPLICATIONS
IN
TELEVISION — RADIO
ELECTRONICS**

Copyright—1953 by
COYNE ELECTRICAL SCHOOL
500 South Paulina St.
Chicago, Illinois

All rights reserved. This book or any parts thereof may not be reproduced in any form without written permission of the publishers.

2nd Edition—1954

Printed in the United States of America

**TRANSISTORS AND THEIR
APPLICATIONS
IN
TELEVISION — RADIO
ELECTRONICS**

By

LOUIS E. GARNER, JR.

Published by

**EDUCATIONAL BOOK PUBLISHING DIVISION
COYNE ELECTRICAL SCHOOL
Chicago, Ill.**

ACKNOWLEDGEMENTS

The author and publishers wish to acknowledge the valuable contributions made to this book by the following companies. In the case of photographs, illustrations and direct quotations, further credit will be given in the body of the text.

BELL TELEPHONE LABORATORIES
CHICAGO STANDARD TRANSFORMER CO.
FANSTEEL METALLURGICAL CORPORATION
NATIONAL UNION RADIO CORPORATION
RADIO & TELEVISION NEWS
RADIO RECEPTOR CO., INC.
SYLVANIA ELECTRIC PRODUCTS, INC.
TRANSISTOR PRODUCTS, INC.
CBS-HYTRON
GENERAL ELECTRIC
THE HEATH COMPANY
P. R. MALLORY & CO., INC.
RADIO CORPORATION OF AMERICA
RAYTHEON MANUFACTURING CO.
TEXAS INSTRUMENTS, INC.
RADIO-ELECTRONICS MAGAZINE

FOREWORD

“TRANSISTORS AND THEIR APPLICATIONS” was especially written as a guide and reference volume to provide a PRACTICAL explanation of these “wonder mites,” TRANSISTORS.

The author, Mr. Louis E. Garner Jr. is well qualified to write this book. He has written many articles on the subject of TRANSISTORS that have appeared in America's leading technical magazines. He has been a Technical Consultant for many years for several large Electronics Engineering companies and has written a great deal of material for one of the largest Radio-Television schools in the country.

His earlier background includes work as an Instructor at a Coast Guard Radio Material School, as a Consulting Electrical Engineer, and, during the second World War, work in the Radar Section, Bureau of Ships, and with the Army-Navy Electronics Production Agency.

This practical field experience plus his training at George Washington University and the University of Maryland and his study of the progress in Transistors since their inception qualifies him to explain the many applications of transistors in the radio-television and electronics field.

This book is profusely illustrated with photographs and easy-to-follow schematics. A “how-to-do-it” practical approach was used throughout. Every effort has been made to slant the data toward maximum value to the practicing serviceman, technician, or anyone interested in electronic development.

It is the authors opinion that Transistors will play a most important part in the future of radio-television-electricity and all the phases of electronics. It is therefore paramount that the present day serviceman acquaint himself with—*WHAT TRANSISTORS ARE* and *WHAT THEY CAN DO*. This book will be very helpful in answering these questions.

The COYNE ELECTRICAL SCHOOL wishes to express its thanks to Mr. Garner and the many companies that have contributed material to make the publishing of this reference book possible.

B. W. COOKE, *President*
Coyne Electrical School
Chicago 12, Ill.



TABLE OF CONTENTS

CHAPTER	TITLE AND DESCRIPTION	PAGE
1.	INTRODUCTION—A discussion of transistors and their effect on the Radio-TV and electronics worker. Brief history of the transistor.	11 - 18
2.	UNDERSTANDING TRANSISTOR ACTION—A non-mathematical explanation of how transistors work. Basic types of transistors.	19 - 28
3.	TRANSISTOR CHARACTERISTICS—Physical and electrical properties of transistors. Definitions of terms.	29 - 35
4.	TRANSISTOR AMPLIFIER CIRCUITS—The three basic types of transistor amplifiers, grounded base, grounded emitter, and grounded collector. Gain in transistor circuits. Coupling transistor amplifier stages.	36 - 50
5.	TRANSISTOR OSCILLATOR CIRCUITS—Basic transistor oscillator circuits. "Tickler Feed-back." "Hartley." "Colpitts." Other types.	51 - 57
6.	SPECIAL TRANSISTOR CIRCUITS—D.C. Amplifiers, R.F. Detectors, Clippers, Phase-Inverters, Push-Pull Circuits, Multivibrators, etc.	58 - 68
7.	TRANSISTOR COMPONENTS—Sub-miniature transformers, capacitors, other components. Transistor power supplies.	69 - 77
8.	THE CARE AND SERVICING OF TRANSISTORS—How to avoid damaging transistors. Servicing transistorized equipment. Testing transistors.	78 - 86
9.	PRACTICAL TRANSISTOR CIRCUITS—Experimental circuits with typical parts values. Audio circuits. R.F. circuits. Experimental circuits.	87 - 98
10.	APPENDIX—Reference data. Commercially available transistors and their characteristics.	99 - 103



AN INTRODUCTION TO TRANSISTORS

CHAPTER I

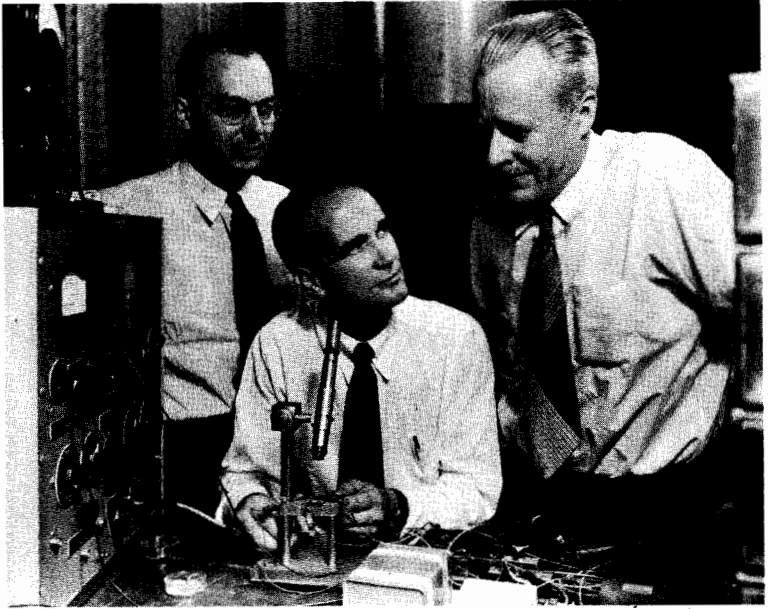

Figure 1. Three of the Bell Telephone Scientists responsible for the invention of the transistor. Seated is Dr. William Shockley, who initiated and directed the Laboratories' transistor research program. Standing are Dr. John Bardeen, left, and Dr. Walter H. Brattain, key scientists in bringing the invention to reality. In this photo, the scientists are shown working with apparatus used in making some of the first investigations leading to the discovery of the transistor.

CREDIT: Courtesy Bell Telephone Laboratories.

Although new inventions are made so rapidly in the electronics field as to be considered almost "every-day" occurrences, few are truly revolutionary in scope. The development of a new vacuum tube, transformer, or capacitor, important as it may be to one branch of the field, generally has little over-all affect on the industry.

But revolutionary inventions are occasionally made . . . one such development was the invention of the triode vacuum tube by DeForest. It is reasonably safe to say that the present-day



Figure 2. An experimental personal-type AM receiver in which transistors are used to permit a better than three-fold reduction in the size and weight of batteries needed to maintain a 100-hour operating life.

The young lady is placing an experimental transistor into its socket.

radio, television and electronics industry has resulted from the applications of this one invention and its modifications.

And the invention of the transistor by Shockley, Bardeen and Brattain of the Bell Telephone Laboratories may be as revolutionary and have as

far-reaching effects as the invention of the triode vacuum tube. For the transistor is capable not only of doing most of the things that vacuum tubes do but can also perform jobs which have heretofore been difficult, if not impossible, for vacuum tubes alone to handle.

The transistor may be used as an oscillator, as an a.c. amplifier, as a d.c. amplifier, as a relay or electronic switch, as a mixer or modulator, and as a detector. It may also be used as an attenuator, for impedance matching, and as an isolation or "buffer" amplifier.

But even with its amazing versatility, the transistor is at one time much smaller, lighter, longer lived, more rugged, fantastically more efficient and potentially less costly than the vacuum tube. And the transistor offers the additional advantage of instant operation . . . no "warm-up" time is required nor is "standby-by" power needed for its operation.

From this it is easy to see that virtually every worker in the electronics field will eventually come into contact with the transistor, even if only indirectly.

The serviceman may expect a gradual introduction of the transistor in equipment he is called on to repair and maintain. Starting with hearing aids, portable record players and radios, electronic megaphones and similar equipment, he may expect to see the transistor eventually used in home broadcast receivers, auto radios, headlight "dimmers", television sets, recorders, and inter-communication equipment.

The ham will find many applications of the transistor in portable and mobile equipment, in small receivers, in transmitters, and in portable test and measuring equipment.



Figure 3. An electronic megaphone in which a transistor operated amplifier is employed. This piece of equipment illustrates one practical application of transistors to commercial equipment.

The electronics engineer will find that he is not only required to design new equipment using transistors but that he will be frequently called on to redesign existing equipment to make use of the advantages offered by transistor operation that is, to "transistorize" vacuum tube equipment.

The experimenter will find the transistor ideally suited to the design of gadgets, electronic toys, and experimental circuits. The fantastically small power requirements of transistor circuits make them ideal for portable equipment, while their light weight and small size suit them for use in remote control circuits.

The radio operator will find that a knowledge of transistor circuitry will be useful in understanding the functioning of transistorized equipment he is called on to operate and to adjust.

And the student will find that an understanding of transistor operation is as important as a knowledge of vacuum tube operation if a well-rounded and up-to-date education in the electronics field is to be acquired.

The military uses of the transistor are obvious, although no details have been officially released at this writing . . . the transistor is potentially suited for use in guided missiles, proximity fuses, portable radio and radar equipment, remote controlled devices, miniature teletype and communication equipment, miniature television "spy" apparatus, radiation detection and measuring instruments, "Secret Agent" radio transmitters and receivers, air-sea rescue radio equipment, compact artillery computers, detonating devices, etc. . . . in short, wherever light weight, small size and economy of operation are desirable in electronic equipment.

Commercially, the transistor promises to revolutionize the design of many types of equipment. Giant electronic "brains" or computers may be reduced to table-top size . . . in fact, miniature all-electronic calculators and adding machines for routine office work may soon become a reality. Hundreds of thousands (if not millions) of transistors may eventually be used in telephone circuits

alone, performing dialing, switching, signaling, routing, relaying, amplifying, and control operations.

But these potential applications of the transistor are but a sample of what the future may bring. It must be remembered that the transistor is a comparatively new invention compared to the vacuum tube, the transistor is but a mere babe-in-arms.

The following chronology, prepared by the Bell Telephone Laboratories, gives a glance backward over the history of transistor development, and illustrates, in concise form, the rapidity with which one transistor development has followed another

JUNE, 1948 -- The point-contact transistor made its first public appearance at the West Street headquarters of Bell Laboratories in New York. It had been demonstrated privately to the military a short time before this announcement to the press.

MARCH, 1950 -- Invention of the photo-transistor by the (Bell Telephone) Laboratories' Dr. J. N. Shive was announced. An entirely new type of "electric eye" -- much smaller and sturdier than present photo-electric cells and possibly cheaper -- it is a transistor controlled by light rather than by electric current.

JULY, 1951 -- The junction transistor, a radically new and in many ways more effective type, invented by Dr. Shockley, was announced. Morgan Sparks built the first of the new type transistors, using crystal processes developed by G.K. Teal and J.B. Little. Among others, R.L. Wallace, Jr., and W.J. Pietenpol worked on their development.

The junction transistor was described as "extremely small, occupying only about 1/400 of a cubic inch" and even less power-consuming than the original point-contact type.

The (Bell Telephone) Laboratories also announced that development work on the point-contact type had resulted in understanding problems involved in reliability and reproductibility, thus bringing regular production nearer.

SEPTEMBER, 1951 -- A transistor symposium held at Murray Hill. Nearly 300 guests attended the sessions; represented were industry, the Army, Navy, Air Force, government agencies and their contractors, and several universities.

OCTOBER, 1951 -- Production of the first transistors begun by the manufacturing department of Western Electric at its Allentown plant.

APRIL, 1952 -- Transistor technology symposium held at Murray Hill and Allentown, Pa. This was concerned with the development of transistors, phototransistors and related semiconductor devices.

JUNE, 1952 -- Sixty-three faculty members, representing 33 universities, colleges, and institutions of technology attended the first transistor school, sponsored by the Laboratories (Bell Telephone) and held at Murray Hill, N.J. The school was designed to facilitate the introduction of transistor physics into university courses.

AUGUST, 1952 -- First announcement of a "tetrode" transistor, invented at Bell Laboratories by R.L. Wallace, Jr. By adding a fourth electrode, Wallace was able to produce a transistor usable at frequencies at least ten times higher than would otherwise be possible.

OCTOBER, 1952 -- The transistor went to work for the first time in the nation's telephone network. Oscillators employing transistor units were installed in dial switching equipment in Englewood, N. J., as part of the customer long distance dialing trial. The first commercial oscillator model was assembled in the (Bell Tele-

phone) Laboratories by F. E. Blount, assisted by D. Houk.

END OF 1952 -- First over-the-counter consumer product to make use of transistors was put on the market by manufacturers of hearing aids.

MARCH, 1953 -- A most important use of the transistor was made public when the (Bell Telephone) Laboratories announced development of the "card translator," which will serve as an automatic routing device for setting up long distance calls across the country. The card translator makes use of both the phototransistor and the current-amplifying transistor.

As for the future of the transistor. . .one engineer has said - "Within a few years. . .five to ten at the most. . .we may expect to see more transistors than vacuum tubes used in new equipment!"

CHAPTER II

Understanding Transistor Action

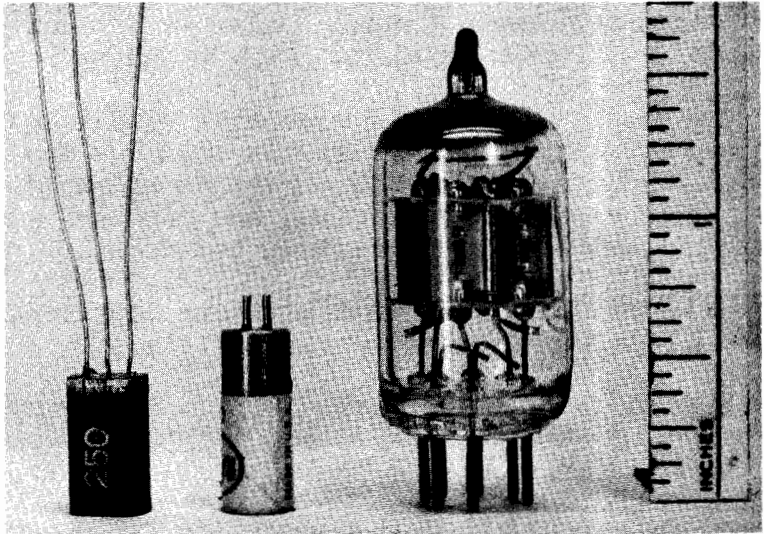

At the left is a junction transistor, with next to it a point-contact transistor. The miniature tube is a 6AL5 twin-diode type.

Transistors, important as they may be, represent only a part of a large group of semi-conductor devices. Included with transistors in this large grouping are the selenium photo-cells used in exposure and light meters, selenium rectifiers used in battery chargers, radio receivers and television sets, the germanium diodes used as video 2nd detectors, as discriminators in FM receivers, as clippers and as limiters, and the silicon diodes used as high frequency mixers in UHF Television front-ends and converters, and in Radar equipment.

The old "crystal" radio receiver, employing a galena crystal and an adjustable "cat's whisker", represents one of the earliest applications of semi-conductor devices to radio.

Transistors, as well as the diodes and other devices mentioned, all depend, for their operation, on the electrical properties of a class of substances known as semi-conductors. A semi-conductor is a substance or material which, under some conditions, acts as a conductor (like copper or aluminum), but which, under other conditions, acts like an insulator (such as glass).

Selenium, silicon and germanium, when combined with certain impurities, are the most popular semi-conductors. There are other materials exhibiting similar properties, but they are not used as extensively as the three mentioned.

Selenium is widely used in power rectifiers and in "self-generating" photocells.

Silicon is used primarily in high frequency "mixer" diodes.

Germanium is used in diodes, transistors, and phototransistors.

Almost all semi-conductors permit electrical current flow to take place easier in one direction than in the other and thus may be used as rectifiers or diodes. In addition, other physical conditions may affect the flow of current -- such conditions include light, heat, and the presence of other electrical fields. It is the last property that makes the transistor possible.

Current flow through a semi-conductor may take place by two different methods, although one generally predominates in a particular case.

Under some conditions, free electrons may be detached from atoms of the material and may travel through the substance much in the same fashion that normal current flow takes place through ordinary conductors.

Those semi-conductors which permit current flow to occur primarily by means of free electrons are called "negative" or "N" type materials. A typical example of an N-type material is pure germanium to which a small amount of arsenic

has been added as an impurity.

On the other hand, should there be few free electrons in the material, the molecular structure of the substance may be such that valence bonds are left unsatisfied, and electrons are actually required by some of the molecules. Under such conditions, the "absence" of an electron in a particular molecule may be considered as a "hole".

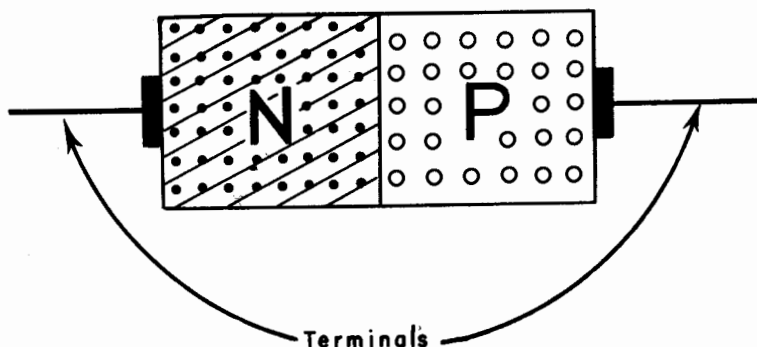

Figure 2-1. Schematic representation of an N-P junction of semi-conductor material. Such a junction is made up of a single piece of material (a single crystal), but with the ends having different electrical characteristics.

The molecule having the "hole" may rob a nearby, electrically neutral, molecule of an electron, leaving the second molecule with a hole. The holes may thus migrate through the material, acting, for practical purposes, like a current flow of positively charged particles.

If the current flow through the material is primarily by means of "holes", then the semi-conductor is called a "positive" or "P" type material. A P-type semi-conductor may be formed by adding a small amount of indium to otherwise pure germanium.

Regardless of whether a particular substance is an N or a P-type material, it must be remembered that "holes" may exist in an N-type or free electrons may exist in a P-type semi-conductor. Both holes and free electrons may also be formed by passing current through the material.

If a junction is made up of an N and a P-type

semi-conductor, as shown in Fig. 2-1, and a d.c. voltage is applied to it, the amount of current flow that can take place will depend on the polarity of the applied potential.

Should the negative terminal of the power source be connected to the N-type material, free electrons will move away from the terminal and toward the junction of the two substances. In a similar fashion, the holes in the P-type material will migrate away from the positive terminal towards the junction, where they can combine with the free electrons of the N-type material.

The junction, under these conditions, permits a free exchange of positive and negative charges (holes and electrons), and a comparatively large current flow may take place. We can say that the junction offers low resistance to current flow, or that it acts like a good conductor.

Should the positive terminal of the voltage source be connected to the N-type material, the free electrons will move toward this terminal and away from the junction. Similarly, the holes in the P-type material will move away from the junction and toward the negative terminal of the power source. Thus, with the d.c. supply voltage reversed, few electrons and holes are present at the junction.

Under these conditions, the previous exchange of positive and negative charges is quite difficult and very little current flow past the junction can take place. . . . the junction now offers a high resistance to current flow and acts somewhat like an insulator.

Since a junction of the type described offers low resistance to current flow in one direction, and high resistance to current flow in the opposite direction, it may be used as a rectifier or as a diode.

Let us now consider the action when two junctions of the type described above are provided. This may be accomplished by using three layers of semi-conductor material, with the center layer of the opposite type from the two outer layers.

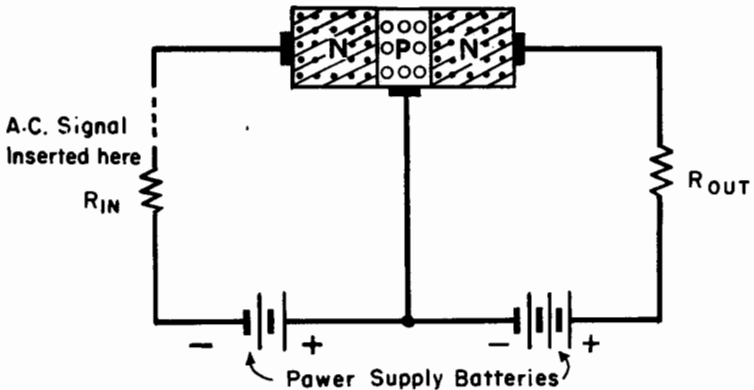

Figure 2-2. Schematic representation of an NPN junction transistor, showing power supply connections and input and output load resistors.

If the outer layers are N-type material and the inner layer is a P-type material, then the unit is called an NPN junction transistor. Such a transistor is represented in Fig. 2-2.

On the other hand, should the outer layers be P-type material and the inner layer an N-type semi-conductor, a PNP junction transistor results.

Referring to Fig. 2-2, let us assume that a voltage source is connected to "bias" the left-hand junction in its low resistance direction. A good current flow will result, limited primarily by series resistor R_{IN} , and producing an excess of electrons in the center material.

If the other junction is now biased in its "reverse", or high resistance, direction, current flow can only take place through this junction because of the excess of electrons in the center material.

Now, if the current flow through the left-hand junction is varied, the number of excess electrons in the center material will be changed, and similar variations will occur in the "reverse" current flow through the right-hand junction.

In practice, a change in the current flow in the left-hand junction is produced by adding a small a.c. signal in series with the d.c. "bias" current.

In many cases, the currents in the two circuits may be on the same order of magnitude. However, an appreciable power gain may be realized between the input and output circuits because of the difference in impedances.

With the circuit arrangement shown in Fig. 2-2, the left-hand terminal of the transistor is called the "emitter". The center section is called the "base", and the right-hand terminal is the "collector".

Since the base-emitter circuit is biased in its forward, or low resistance direction, it forms a low-impedance circuit. The collector (output) circuit, biased in its "reverse" or high-resistance direction, forms a high-impedance circuit. It is this difference between output and input impedances that permits gain to be obtained and the transistor to be used as an amplifier. . . . even though the emitter and collector currents may be nearly the same.

In the PNP junction transistor, power supply voltage polarities are reversed and the major conduction is by holes instead of electrons. Otherwise, the operation of the two transistors is similar.

The part which is to be the emitter is treated during manufacture to perform this function best, while the part designated for the collector has been prepared especially for such service.

The structure of the two types of junction transistors is shown in principle in Fig. 2-3. Opposite sides of a single piece of crystal are of the compositions which are to act as emitter and collector. In between is a section, possibly one-thousandth of an inch thick, which will act as the base.

The usual symbol for the junction transistor is shown at C. The base is represented by a straight line, with emitter and collector represented by lines at angles to the base. The slanting line for the emitter is marked with a small arrowhead, which generally points towards the base in the case of PNP transistors, and away from the base

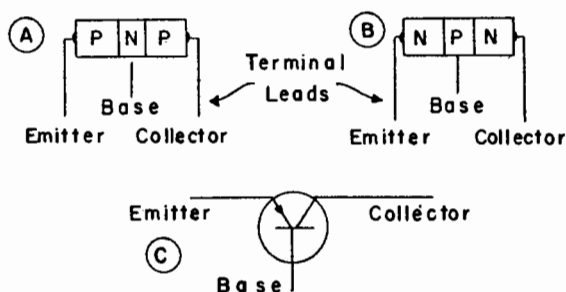

Figure 2-3. Element arrangements for junction transistors, and the symbol for this general type.

in the case of NPN junction transistors. However, there is some tendency to use the same symbol for both types of transistors. . . . where there is any doubt about the type of transistor indicated on a schematic diagram, manufacturer's type numbers should be checked.

There is a second method of transistor construction, resulting in a unit called a "point-contact" transistor. This method of construction is illustrated, in principle, in Fig. 2-4.

In the point-contact transistor, the internal connections to emitter and collector are made through the ends of very small wires in contact with the surface of the crystal at points very close together. As actually constructed the crystal of the point-contact transistor may be only about $1/20$ inch in diameter (or square), and about $1/50$ inch thick. Contacts of the two wires on the crystal surface are separated by only a few thousandths of an inch.

The design represented at A of Fig. 2-4 employs an N-type crystal; the main body of the crystal being of such material. During manufacture there is a forming process which produces at each contact position a small area of P-type material. Therefore, the contact points for emitter and collector actually connect to P-type material, between which is the N-type body of the crystal. This makes the N-type point-contact transistor equivalent in operation and in other

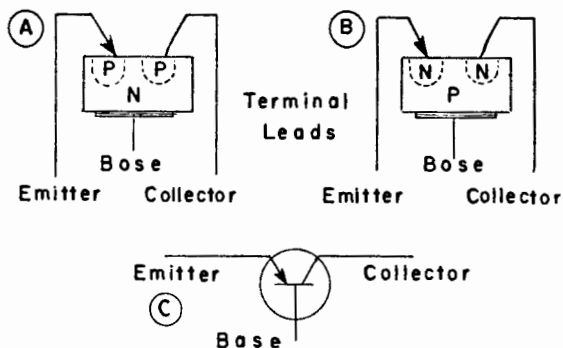

Figure 2-4. Construction and element arrangement for point-contact transistors, and the usual symbol.

respects to the PNP junction type. . . .that is, emitter and collector leads go to P-type material, while the base lead goes to N-type material.

In diagram B (Fig. 2-4) the body of the crystal is P-type material. There are small areas of N-type material formed at the emitter and collector contact points, giving a point-contact transistor that is equivalent, in many respects, to the NPN junction transistor.

The construction of a point-contact transistor is clearly illustrated in the model shown in Fig. 2-5. The small cube represents the piece of semi-conductor material.

Tetrode point-contact transistors are essentially similar to the triode types just discussed, except that an additional "point-contact" or cat's-whisker is provided.

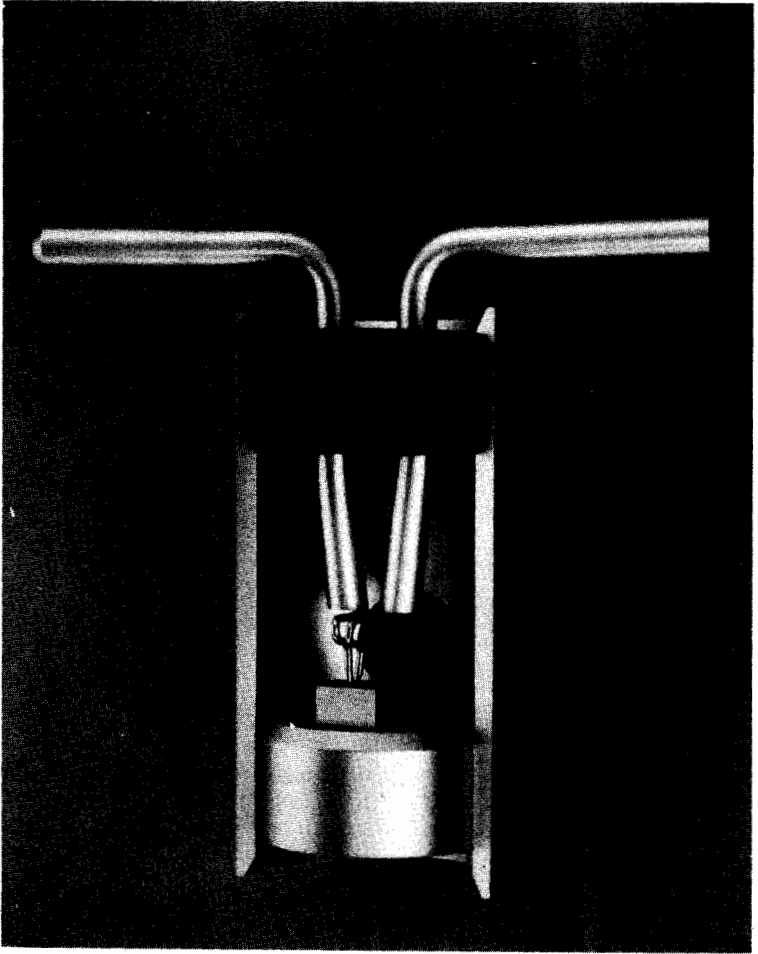

Figure 2-5. Photograph of a model showing the construction of a point-contact transistor. The two "cat-whiskers" and the small cube of semi-conductor material are clearly visible. The "hole" in the front of the cartridge is provided so that the point-contacts may be adjusted during manufacture.

CREDIT: Courtesy Bell Telephone Laboratories.

COMPARISON OF TRANSISTORS AND VACUUM TUBES

Criteria	Transistors	Tube
Gain/Stage	0-40 db	0-40 db
Noise Figure at 1000 c p s, BW = 1 c p s	10-50 db	0-30 db
Freq. Limit as an Amplifier	0-30 mc	0-60 k mc
Freq. Limit as an Oscillator	300 mc	0-60 k mc
Output Power (Po)	0-200 mw †	0-kilowatts
Class A Efficiency	Point Contact 35% Junction 35-49%	35%
Class B Efficiency	>80%	79%
Class C Efficiency	99%	85%
Oscillator Efficiency	>70%	60-70%
Total Power Required	Point Contact 4-50 mw Junction 1-100 μ w	50 mw to 2 w
Physical Volume	0.0005-0.02 in. ³	0.125-1.0 in. ³
Temperature Limitations	-60°C to 80°C	-60°C to 200°C
Shock Limitations	20,000 to 30,000 G	750 G
Life	> 70,000 hours	0-5,000 hours

† Laboratory experiments have indicated that transistors designed with 200 watt ratings are possible.

CHAPTER III

Transistor Characteristics

The electrical ratings of transistors are generally given in terms of a few basic characteristics. Since these characteristics are, for the most part, different from those used to describe vacuum tubes or other electronic components, it is important that the electronic technician, student, and serviceman become familiar with them.

TRANSISTOR TYPES: As we have seen, transistors can be divided into two general types, according to the method of construction employed . . . point-contact and junction. In addition, both basic types can be further sub-divided.

Point-contact transistors can be classed as having either a P-Type or an N-Type base. A further sub-division into triodes and tetrodes is also possible.

Junction transistors may be classified as PNP or NPN.

Still further classifications may be introduced as additional transistor types are produced. For example, a number of manufacturers are developing multi-purpose transistors, high power transistors, and other special types.

At present, there is considerable variation in terminal lead connections between transistors supplied by different manufacturers. However, there is a definite tendency toward standardization and, in the future, we may expect most transistors to have similar lead connections. The presently accepted "standard" is illustrated in Fig. 3-1.

However, even if the lead connections are known, special care should be exercised to check the transistor types used whenever assembling new circuits or repairing transistorized equipment. The application of improper power supply voltage polarities, even if only momentarily, may easily ruin a transistor.

PHYSICAL CHARACTERISTICS: All commercially available transistors are physically quite small, with over-all dimensions, exclusive

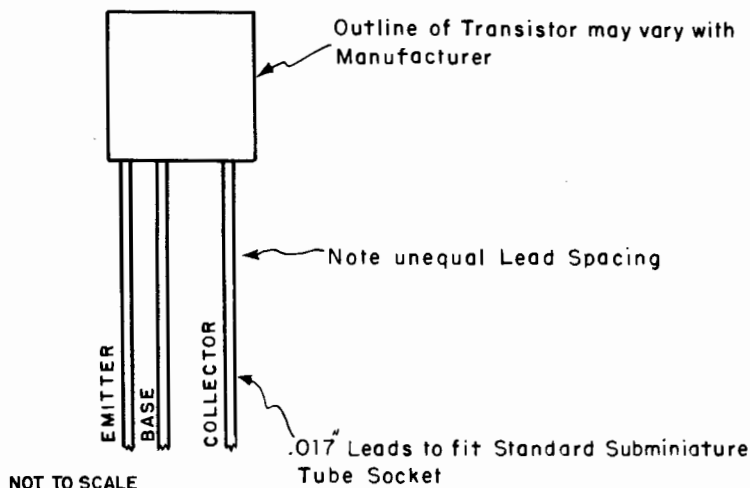

Figure 3-1. The presently accepted "standard" for lead connections of triode transistors. The pin size and spacing is chosen so as to permit the use of a standard 5- or 7-pin "in line" subminiature tube socket. Some manufacturers supply their transistors with long leads to permit the units to be wired directly into a circuit . . . these leads are cut short where a socket is employed.

of leads, seldom exceeding a fraction of an inch. Their weight, too, is generally minute, usually but a tiny part of an ounce.

The semi-conductor crystal itself may be molded in plastic or glass, or both, for protection and mechanical stability. There may be an outer case or shell of metal. Some manufacturers also offer hermetically sealed units, in which the transistor crystal is sealed in a vacuum. . . . such units offer superior stability under some operating conditions.

Both ambient temperature and humidity conditions may affect transistor operation. At this writing, no manufacturer recommends operation of their units above 100°C , and many specify a maximum ambient temperature of 40 or 50°C .

As far as moisture is concerned, this problem is only important if the transistors used are not hermetically sealed, and if the humidity, under operating conditions, is likely to be high. In such cases, special care must often be taken, when designing the transistorized equipment, to insure a reasonably well sealed case.

ELECTRICAL CHARACTERISTICS: Manufacturers of transistors generally tabulate the electrical specifications of their units in three ways, as follows: (1) **MAXIMUM RATINGS**, (2) **TYPICAL OPERATING CHARACTERISTICS**, also called **AVERAGE CHARACTERISTICS**, and as (3) **CHARACTERISTIC CURVES** (or **CHARTS**).

The Maximum Ratings are those that must not be exceeded when operating the units. These values are especially important to the experimenter, to the electronics engineer, and to any worker designing or assembling new circuits in which transistors are employed.

In most cases, the Maximum Ratings will include the Maximum Collector Voltage, Maximum Collector Current, Maximum Emitter Current, and Maximum Collector Dissipation. In the case of point-contact transistors, the Maximum Peak Inverse Emitter Voltage may also be included. Voltages are generally given with respect to the base, with the values indicated in volts. Currents are given in milliamperes or microamperes, and the power dissipation values are given in watts or milliwatts, at a specific ambient temperature.

The Typical Operating Characteristics are given to serve as a guide to the engineer or designer building new equipment, or to the serviceman or technician called on to service transistorized apparatus. These values may vary widely, depending on the "operating conditions" chosen by a particular manufacturer as typical.

From a practical viewpoint, the Typical Operating Conditions need not be followed exactly in designing transistor circuits, provided the Maximum Ratings are not exceeded.

Under Typical Operating Characteristics will generally be listed such values as Collector Voltage, Emitter Current, Current Amplification Factor, Cut-off Current, Power Gain, Input Impedance (or Resistance), Output Impedance, Output Capacitance, Noise Factor, Frequency Cut-Off, Power Output, and Distortion. Several additional values may be given by some manufacturers, including Base Resistance, Output Admittance, and other characteristics, but the values listed above are the most common.

The Collector Voltage and Emitter Current are given in volts and milliamperes (or microamperes), respectively. These values establish the basic conditions under which the other characteristics have the indicated numerical values.

In addition, it is generally customary to indicate the circuit arrangement used to obtain the values given in the manufacturer's technical data sheet. Many of the values listed, especially those for Power Gain, Input and Output Impedance, Power Output and Output Capacitance, may have quite different values with other circuit arrangements.

If not otherwise stated, the Typical Operating Characteristics given by a manufacturer generally apply where the Grounded Base (or Common Base) circuit is employed (refer to the description of basic transistor circuits in Chapter IV).

The Greek letter alpha (α) is used to indicate the Current Amplification Factor of a transistor. The alpha of junction transistors cannot be above 1.0, but values appreciably above 1 may be obtained with point-contact transistors.

Alpha is related to the gain that can be obtained from a transistor and is defined as "the ratio of the change in collector current for a specific change in emitter current at a constant collector potential."

The Cut-Off Current is the collector current drawn under conditions of zero base current, with a d.c. voltage applied between emitter and collector. Its value is generally listed only for junction transistors. The Cut-Off Current usually has a value of from 5 to 25 microamperes, al-

though it may be higher or lower with individual units.

(NOTE: In some instances, a manufacturer may specify the Cut-Off Current as the collector current drawn under conditions of zero emitter current. This definition applies when the Grounded Base circuit is employed, and is most often used when referring to point-contact transistors.)

Both the Power Gain and the Noise Factor are given in decibels (db).

Internal noise, in transistors, is caused primarily by the molecular agitation resulting from the movement of holes and electrons through the material of the semi-conductor.

Although the Noise Factor for junction transistors is generally lower than that for point-contact transistors, it is higher than that for vacuum tubes giving comparable gain. In the case of junction transistors, the Noise Factor may vary appreciably with the collector voltage used (and hence the operating point), with a low collector voltage generally giving minimum noise.

The Input and Output Impedances are particularly important when coupling two or more stages, when using the transistor to drive other equipment, or when connecting a signal source to the input of a transistor. Both values will vary widely with the circuit arrangement employed, but in most cases the input impedance will have a low to medium value while the output impedance will be high. These values are specified in ohms.

The Output Capacitance is given in micro-micro-farads (mmf). Typical values are generally appreciably less than 100 mmf. This characteristic is of special importance when using the transistor in wide-band or high frequency circuits.

The Frequency Cut-Off (or Cut-Off Frequency, as it is often called) is generally taken as the frequency where the value of alpha is 3 db down from its low frequency value (usually 1000 cps or less).

As operating frequency is increased, the gain of transistor circuits decreases because of two actions in the transistor itself. The first is the time required for electrons to move through the crystal material and for holes to shift from place to place. Both of these movements are much slower than the movements of electrons through a vacuum tube, with the holes moving even slower than the electrons.

The other factor is the internal capacities between elements of the transistor.

It is possible to reduce the transit time required by electrons and holes in both point-contact and junction transistors. In point-contact transistors this is accomplished by reducing the spacing between contacts. In junction transistors this is accomplished by using smaller dimensions between end contacts and by using a thinner base layer.

Unfortunately, both of these construction changes, although they reduce transit time, also increase the internal capacities of the transistor, increasing the other limiting factor on frequency response.

For practical purposes, junction transistors are generally limited to the audio range of frequencies, although especially selected units may operate satisfactorily at R.F.at least into the AM Broadcast Band.

Point-contact transistors may generally be operated at much higher frequencies, and some units have been used as oscillators at hundreds of megacycles.

Regardless of the type of transistor, however, it is usually possible to operate units satisfactorily at much higher frequencies as oscillators than as amplifiers.

The Power Output obtained from a transistor will depend on the circuit employed, the d.c. operating currents and voltages, the amount of signal drive (in the case of an amplifier), and on the characteristics of the transistor itself. This value is generally given in milliwatts.

The maximum Power Output that can be obtained from a specific transistor is dependent on the Maximum Power Dissipation of the unit and on the efficiency of the circuit employed.

Distortion is expressed as a percentage and is important where the transistor is used in audio circuits. The Distortion obtained in a particular circuit increases as the operating voltages and currents approach the maximum rated values.

In addition to the tabulated numerical values for the transistor characteristics, the majority of transistor manufacturers also supply CHARACTERISTIC CURVES (or CHARTS) as part of the technical data sheets on their units.

These charts are roughly analogous to the Characteristic Curves furnished by vacuum tube manufacturers and serve approximately the same purpose. . . .to assist the electronics engineer or circuit designer in determining the proper operating conditions for a particular circuit.

As in the case of vacuum tube curves, the data supplied must be considered as approximate only, and as typical only of the average characteristics of a particular type of transistor. Individual units may have somewhat different characteristics due to production tolerances.

Typical transistor Characteristic Curves are given in Fig. 3-2.

CHAPTER IV

TRANSISTOR AMPLIFIER CIRCUITS

Similar circuit arrangements are used with both vacuum tube and transistor amplifiers. This similarity applies to the circuit arrangement only, however, and it is incorrect to consider the transistor as a direct substitute for the vacuum tube . . . the differences between the operation of transistors and vacuum tubes are far greater than their similarities.

The transistor is basically a current operated device. Thus, the transistor operates as a current amplifier and prefers a constant current power supply. The vacuum tube, on the other hand, operates as a voltage amplifier and works best with a constant voltage power source.

In addition, most vacuum tube circuits feature both high input and high output impedances. Transistor circuits generally have a low to moderate input and a moderate to high output impedance. In vacuum tube circuits, the input and output signals are generally well isolated, whereas this is often not the case with transistor amplifiers. And, as we discussed in the last Chapter, the transit time required for electrons (and holes) in transistors is considerably longer than the transit time required by electrons in a vacuum tube.

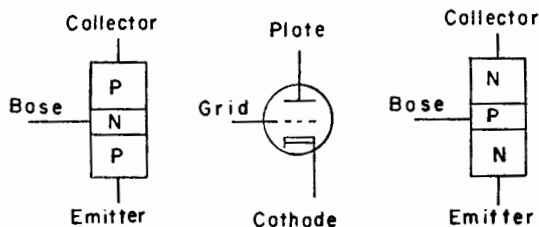

Figure 4-1. This sketch illustrates the three elements of a vacuum tube and the analogous elements of both PNP and NPN transistors.

The similarities in the circuit arrangements of transistor and vacuum tube amplifiers may be most easily observed by considering the various elements of the transistor as analogous, but not equivalent, to corresponding elements in the vacuum tube. These relationships are clearly illustrated in Fig. 4-1.

In the transistor, the collector corresponds to the plate, the base to the grid, and the emitter to the cathode of the vacuum tube.

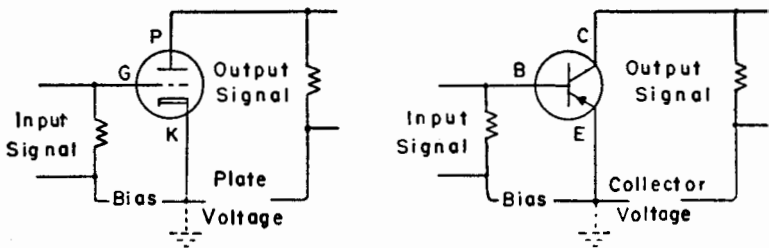

Figure 4-2. Grounded cathode circuit for a vacuum tube (left) and the grounded emitter circuit for a transistor (right). While the plate voltage of the vacuum tube will always be positive with respect to its cathode, the voltage polarities in the transistor circuit will depend on the type of transistor used.

There are three basic vacuum tube amplifier circuits, each of which is identified by the grounded or common element. They are the grounded cathode, the grounded grid, and the grounded plate (or cathode follower) amplifiers. Transistor amplifiers are identified in a similar fashion as grounded emitter, grounded base and grounded collector amplifiers. Let us discuss each of these three basic types.

THE GROUNDED EMITTER AMPLIFIER: The grounded cathode triode tube circuit is shown at the left in Fig. 4-2. The input signal is applied between the grid and cathode, while the output signal appears between plate and cathode. Average grid potential is determined by a grid biasing voltage, and average plate potential with reference to the cathode is fixed by a d.c. plate voltage. The cathode is thus common to both the input and output signals, and may be grounded.

The equivalent transistor amplifier is shown at the right (Fig. 4-2). Input is applied between

base and emitter. Average d.c. base potential, with reference to the emitter, is determined by the bias voltage. However, it is the bias current that determines the mode of operation of the circuit.

The output signal is taken from between the collector and emitter, with average collector potential fixed by the d.c. collector voltage. In many cases, the actual collector voltage has very little effect in determining collector current, as this is primarily a function of the bias current.

When a signal is applied to the input, the bias current varies about its average value, and corresponding variations, though of much greater amplitude, take place in the collector circuit. This results in an amplified version of the input signal appearing across the load impedance.

Although this circuit is termed a grounded emitter amplifier, the emitter need not necessarily be grounded . . . it is simply common to both the input and output circuits.

Note that the polarity of the d.c. power supply voltage is not indicated in Fig. 4-2. The proper polarity will depend on the type of transistor used . . . this is illustrated in Fig. 4-5 for the three basic types of amplifier circuits and for different types of transistors.

These polarities are indicated as positive or negative when measured between the indicated transistor element (emitter, base, or collector) and the grounded element.

"Polarities of the output elements, whether collector or emitter, always are as shown, with reference to the grounded or common element. However, polarities of the input elements may be occasionally reversed in practice. This may occur when the biasing voltage, at the element itself, is 0.2 volt or less. In a few instances, gain may be increased or distortion lessened by using a 'reversed' bias polarity.

"Along the upper row of diagrams (Fig. 4-5) are shown the correct polarities for NPN junction type transistors or for point-contact types with P-type base material. The collector-emitter

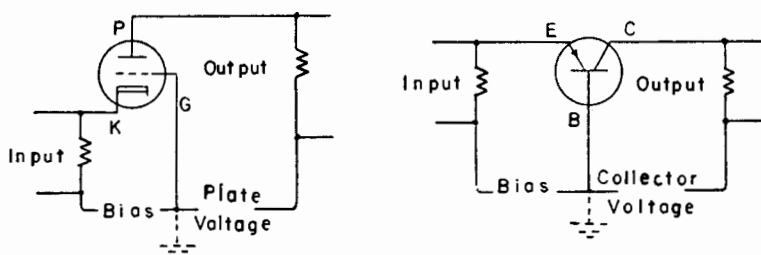

Figure 4-3. Grounded grid triode tube connections (left) and grounded base connections for a transistor (right). Note that these circuits are analogous, but not equivalent.

polarities are similar to those encountered in vacuum tube circuits. Thus, just as the plate of a vacuum tube is positive with respect to its cathode, so is the collector of an NPN transistor positive with respect to its emitter.

"The lower row of diagrams shows relative polarities for PNP junction transistors or for point-contact units with N-type material in the base. Note that these polarities are exactly the opposite of those shown in the top row."

It is extremely important that the proper d.c. polarities always be observed when working with transistor circuits. While the application of a negative voltage on the plate of a vacuum tube, for example, may not injure the tube, the application of improper voltages to a transistor will ruin it almost instantly.

Electron current flow, in transistor circuits, is exactly like that in any electrical circuit. The movement of electrons is from the point of highest negative potential through the circuit elements to those points of less negative (or more positive) potential.

In the grounded emitter circuit, the collector emitter circuit current flow may be on the order of a few milliamperes, while the base-emitter circuit current may be from less than 10 to several hundred microamperes.

The grounded emitter circuit features a low to moderate input impedance and a moderate output impedance. With typical junction transistors, the input impedance may be from 300 to 1500

ohms, and the output impedance may be on the same order or somewhat higher.

Although not quite as stable as the grounded base amplifier, the grounded emitter circuit offers the highest gain of the three basic transistor amplifier circuit arrangements.

Phase reversal occurs in a grounded emitter stage. Thus, if a positive-going signal pulse is applied to the input, a negative-going signal pulse will be obtained in the output circuit.

THE GROUNDED BASE AMPLIFIER: A popular triode vacuum tube amplifier circuit is the grounded grid amplifier, shown in simplified schematic form in the diagram to the left in Fig. 4-3. The input signal is applied between the cathode and grid, by way of ground, with bias voltage applied between cathode and ground . . . this is equivalent, of course, to applying the bias between grid and cathode. Output is obtained between the plate and grid, again by way of ground. Average plate potential is determined by the d.c. plate voltage.

The analogous transistor circuit, the grounded base amplifier, is shown to the right in Fig. 4-3. The input signal is applied between the emitter, corresponding to the tube's cathode, and the base, comparable to the tube's grid. Average emitter potential, with reference to the base, is determined by a bias voltage in the input circuit. The output is taken between the collector and base, with the d.c. collector voltage obtained from a separate power source.

As in the case of the grounded emitter circuit, the base of a grounded base amplifier need not be connected to the circuit ground, as long as it is common to both input and output circuits.

The input impedance of a grounded base amplifier is very low, generally quite a bit less than 100 ohms.* The output impedance, on the other hand, is fairly high. But even with these differences in input and output impedances, the d.c. in the emitter and collector circuits may be on the same order of magnitude.

*For junction transistors . . . point contact units have an input impedance of between 100 and 1000 ohms.

In operation, an a.c. signal applied to the emitter-base circuit results in current variations in this circuit. These current changes, in turn, result in corresponding impedance variations in the collector circuit, so that an amplified signal appears across the collector load. Thus, although signal amplification is possible in a grounded base circuit, and a definite power gain may be obtained, this gain is due almost entirely to the differences between the input and output impedances of the transistor. The actual current amplification, in a grounded base circuit, is always less than 1.*

The d.c. polarities for the grounded base amplifier are shown in the middle pair of schematics in Fig. 4-5. Again, different polarities are employed for different types of transistors.

Phase reversal does not take place in a grounded base amplifier.

Quite stable, the grounded base circuit provides a moderate power gain and is very popular for some applications. It is more generally used with point-contact than with junction transistors, however.

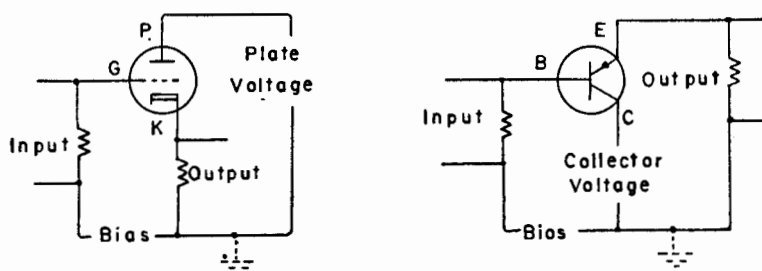

Figure 4-4. Grounded plate (cathode follower) circuit for a triode vacuum tube (left) and the grounded collector circuit for a transistor (right). Both circuits are used primarily for impedance matching.

THE GROUNDED COLLECTOR AMPLIFIER:
The grounded plate vacuum tube amplifier is more popularly known as a cathode follower. The basic circuit is shown to the left in Fig. 4-4, while the equivalent (or, rather, analogous) transistor circuit is shown to the right in the same illustration.

*For junction transistors.

In the vacuum tube version of the circuit, the input signal is applied between grid and the grounded plate circuit, with the output signal obtained across a load impedance placed between the cathode and ground. Thus, it is the plate that is common to both input and output circuits.

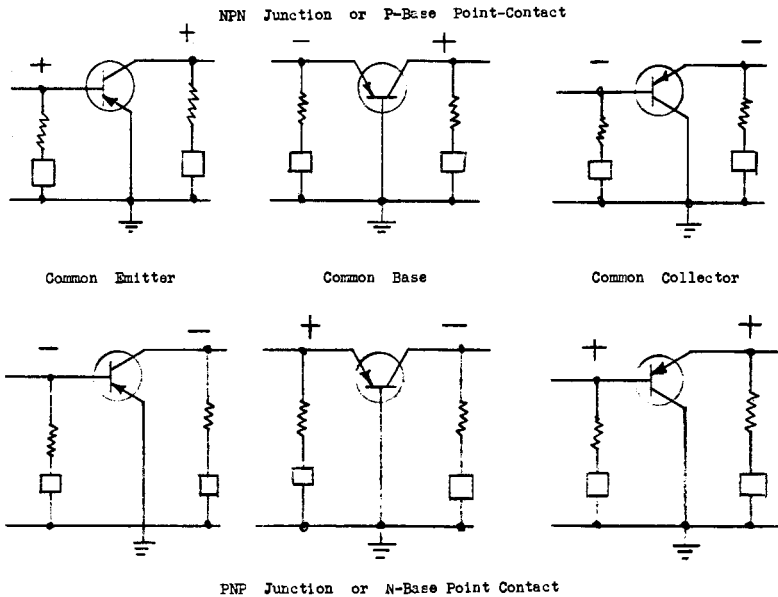

Figure 4-5. Transistor element d.c. polarities with reference to common or grounded element. Note that different polarities are encountered with different types of transistors.

In the grounded collector amplifier, the input signal is applied between base and the grounded side of the collector circuit, with the output obtained across a load impedance placed between emitter and ground. The collector then becomes common to both input and output circuits.

As in the other transistor circuits, bias current and collector voltage are supplied by d.c. sources. D.C. voltage polarities in the grounded collector circuit are shown in the last pair of schematics in Fig. 4-5.

The grounded collector circuit differs from the other basic transistor amplifiers in that the impedance may be relatively high . . . sometimes even approaching, in value, the input impedance of a vacuum tube amplifier. The input imped-

ance is very dependent on load impedance, however.

Since the output impedance of this circuit is moderate to low, it may be used as an impedance matching device, if desired, and, in this respect, apes its vacuum tube cousin, the cathode follower.

A large current amplification and a definite power gain may be obtained with the grounded collector amplifier. The power gain obtained, unfortunately, is less than that obtained with the grounded emitter and grounded base circuits. The voltage gain of the grounded collector circuit cannot exceed 1 . . . thus, the circuit is of little value as a voltage amplifier.

Phase reversal does not take place in the grounded collector stage. The input and output signals therefore have the same phase relationships.

The grounded collector amplifier has one feature that is unique . . . it may serve as a bilateral or "two-way" amplifier under some conditions. The connections of the input and output circuits may be interchanged, permitting a signal to be amplified in either the forward or the inverse direction."

GAIN IN TRANSISTOR CIRCUITS

Gains of transistor circuits usually are specified in decibels of power, instead of as multiplications of voltage, as is more common with vacuum tube circuits (except power output stages).

Fig. 4-6 shows, in graphical form, the relationship between power gain in decibels (db) and gain as an actual ratio between output and input powers. Power in milliwatts is indicated on the chart, although any other common unit of power may be used. Milliwatts are indicated simply because power outputs and permissible power dissipation in transistor circuits are usually measured in these units.

Assuming that there is a reasonably good match between the source and the transistor input im-

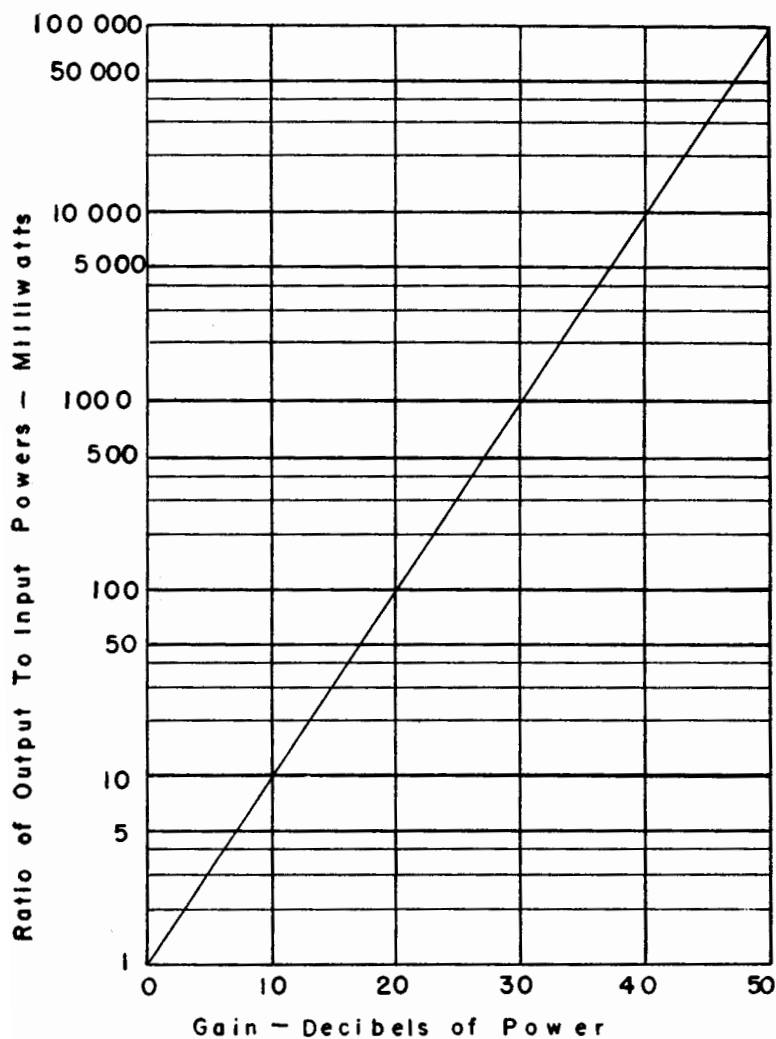

Figure 4-6. Graph showing the relations between gains measured in decibels of power and in ratios of output to input milliwatts. This chart may also be used to compare db gain for other power units.

pedance, and that the input signal current remains constant, the input power of a transistor stage is directly proportional to its input impedance. Comparatively little power will be needed at the input when the input impedance is small.

Similarly, if the output signal current is constant, output power will be directly proportional to output impedance, with a high output impedance giving a comparatively high output power for any given signal current. Thus, as in the case of the grounded base amplifier, where input and output currents may be on the same order of magnitude, the ratio of gain is equal to the ratio of output to input impedances.

On the other hand, with input and output signal currents which are not alike, the input and output powers are proportional to the squares of the currents, as well as being directly proportional to the impedances.

Actual power gains depend not only on the characteristic impedances of the transistor, but, to a great extent, on how well these impedances are matched by the source and the load, on the type of circuit employed, and on the relative potentials at the high-side input and output elements with respect to the common or grounded element. Gain which may be realized in practice is a matter of correct circuit design.

Generally speaking, junction transistors are capable of giving more power gain than point-contact types, when both types are used in similar circuits. However, gain does depend on the basic circuit employed and, as we have seen, the grounded collector circuit provides considerably less gain than either the grounded base or grounded emitter circuits.

There are so many variables that it is difficult to give specific values as representative of typical power gains. However, a figure of 40 db represents an average gain for a number of well designed circuits using junction transistors in the grounded emitter arrangement, while about 25 db might be obtained using typical point contact units. Grounded collector circuits give a

power gain on the order of 15 db, while grounded base circuits give a gain somewhat less than, but approaching, the gain of the grounded emitter circuits.

COUPLING TRANSISTOR AMPLIFIERS

For maximum transfer of signal power from a source to a load the impedances of source and load must be equal. There is a rapid decrease of power transfer as the load impedance is made less than the source impedance, and a less rapid decrease as the impedance of the load is made greater than that of the source.

In a single amplifier stage there are two sources and two loads requiring matching of impedances. There is first the signal source connected to the transistor input, and for which the input impedance of the transistor stage forms the load. The transistor itself is the second source, at its output terminals. For maximum output from the transistor, the impedance of the load connected across its output terminals must approach or equal its own internal impedance.

As we have seen, the input and output impedances of transistors depend on the type of transistor employed on the operating conditions, and on the circuit arrangement used. However, the input impedances of transistor stages are likely to be moderate to small, while the output impedances are likely to be large... this brings up special problems when coupling transistor stages.

Probably the simplest means of coupling two transistor stages is to employ an impedance matching transformer between the two stages. Such a circuit is illustrated in Fig. 4-7. In this circuit, two junction transistor amplifier stages are transformer coupled and are used to drive a beam-power output tube. The grounded emitter circuit arrangement is employed.

In order to match the high output impedance of the first transistor stage to the low input im-

pedance of the second transistor, a step-down turns ratio is used in the interstage coupling transformer.

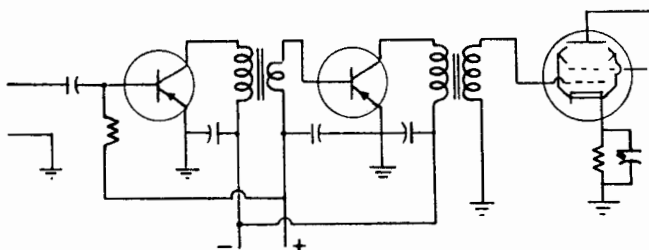

Figure 4-7. This simplified schematic illustrates the use of transformer coupling between transistor amplifier stages. The first coupling transformer has a stepdown turns ratio for matching the high output impedance of the first stage to the low input impedance of the second stage. Grounded emitter circuits are used. The two-stage transistor amplifier is used to drive a beam-power output vacuum tube.

Resistance-capacity and impedance coupling may be used between transistor stages on occasion. Typical circuit arrangements are given in Fig. 4-8. With such circuits, it is assumed that the capacitance of blocking capacitor C_b is large (in audio circuits, on the order of several microfarads) so that its reactance will be small at the signal frequencies used. Thus, as far as the signal is concerned, there is a direct connection between the the output of one stage and the input of

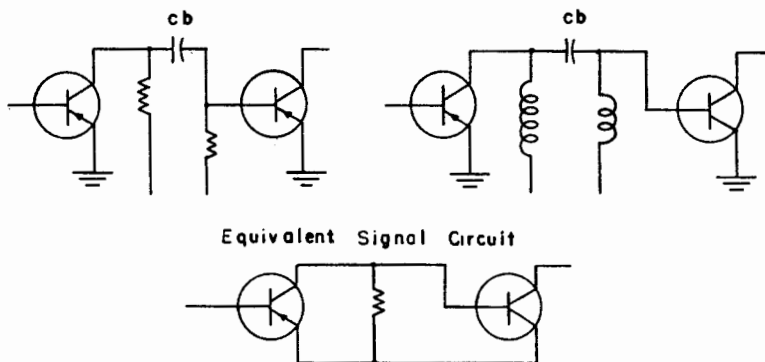

Figure 4-8. Resistance-capacity and impedance coupling techniques, as applied to transistor amplifiers, are illustrated in this sketch. If C_b is large and offers a low reactance at the signal frequencies, the Equivalent Signal Circuit shown applies. Since no special provision is made for matching the input and output impedances of the coupled stages, the efficiency of such circuits is low.

the following stage, as shown by the Equivalent Signal Circuit.

This means that the output impedance of one stage and the input impedance of the next stage are essentially in parallel, giving a total impedance which is less than the smaller value. Because of the differences in the internal impedances of the transistors, a match is impossible, and maximum power transfer between stages cannot occur.

This means that the gain of a resistance-capacity coupled multi-stage transistor amplifier will be considerably less than that obtained with transformer coupling. In some instances, a three or four stage R-C coupled amplifier will be required to give the same gain as obtained with a two stage transformer coupled circuit.

Because there is less difference between the input and output impedances, the grounded emitter arrangement is most often used where R-C or impedance coupling is necessary.

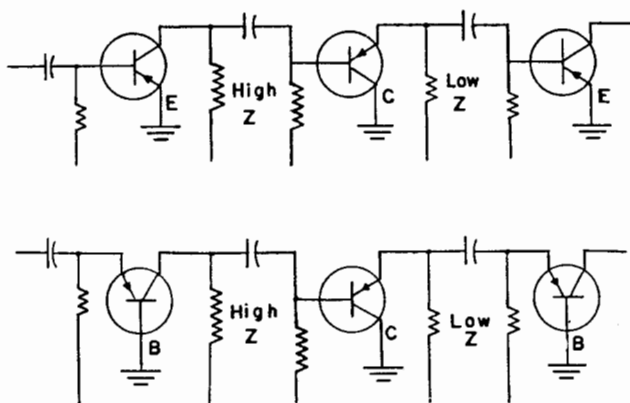

Figure 4-9. Impedances may be matched fairly well by using a grounded collector circuit between two transistor circuits of other types. The grounded collector circuit has a high input and moderate to low output impedance.

There is a method of obtaining a reasonably good impedance match between transistor stages, while retaining the advantages of R-C coupling . . . a grounded collector stage may be used as an impedance matching device between other

amplifier stages. This circuit arrangement is illustrated in Fig. 4-9. In the upper diagram a grounded collector circuit is between two grounded emitter circuits. In the lower diagram there is shown a grounded collector circuit between two grounded base amplifiers.

In either case, the grounded collector circuit serves to match the high output impedance of one stage to the low input impedance of the following stage.

GENERAL CONSIDERATIONS

Transistor amplifier circuits may be used quite successfully at audio frequencies. At R.F., however, special consideration must be given to the high internal capacities and comparatively long transit time of transistors. Careful circuit design is necessary, and considerably less gain is generally obtained than at audio frequencies.

Where the desired power output is greater than that which can be obtained from a single transistor, push-pull and parallel push-pull circuit arrangements may be employed. . . we will discuss such circuits in a later chapter. If even higher power outputs are required, the transistor amplifier may be used to drive a vacuum tube stage . . . see Fig. 4-7.

Where distortion and noise must be kept to low values, it is often desirable to adjust each amplifier stage individually for optimum operation . . . or, where economically feasible, to provide additional stages and to operate each transistor at well within its maximum ratings.

Generally speaking, the grounded emitter and grounded base circuits are used where signal amplification is desirable, the grounded emitter circuit being the more popular where junction transistors are used, and the grounded base the more widely used where point-contact transistors are employed. The grounded collector circuit is used primarily for impedance matching.

Regardless of the type of circuit employed, the terminology refers only to a circuit type . . . not necessarily to the element connected to circuit ground. Thus, with the grounded emitter circuit, the emitter is simply common to both the input and output signal circuits. It need not necessarily be connected to ground.

CHAPTER V

Transistor Oscillator Circuits

An oscillator, basically, is but an amplifier to which a circuit has been added to provide positive (in-phase) feedback between the input and output circuits. It is only natural, therefore, to find that the characteristics of transistor amplifier circuits must be considered when designing transistor oscillators.

In a transistor oscillator, it is necessary that the feed-back circuit chosen serve a multiple function -- (a) it must provide an in-phase feedback signal; (b) it must feed back sufficient signal to overcome circuit losses and thus to start and sustain oscillation; (c) it must serve to match the high output to the low input impedance of the transistor; and (d) in some cases it must select the type of feed-back signal and thus determine the frequency of operation.

Where the oscillator frequency is important, inductance-capacity or resistance-capacity tuned circuits may be included in the feed-back circuit. Piezoelectric (quartz) crystals may be used instead of conventional tuned circuits if unusually stable operation is required.

There are a large number of possible transistor oscillator circuits, depending on the type of transistor used, the basic circuit configuration employed (whether grounded base or grounded emitter), and the means provided to select and feed back energy between the output and input circuits. We will describe a number of the more popular circuit arrangements in this Chapter.

Remember, however, that the circuits to be shown and described do not represent all the possible oscillators, but only a representative grouping.

"Tickler Feedback" Oscillators: A transformer, T, provides the necessary coupling between the transistor's input and output circuits to start

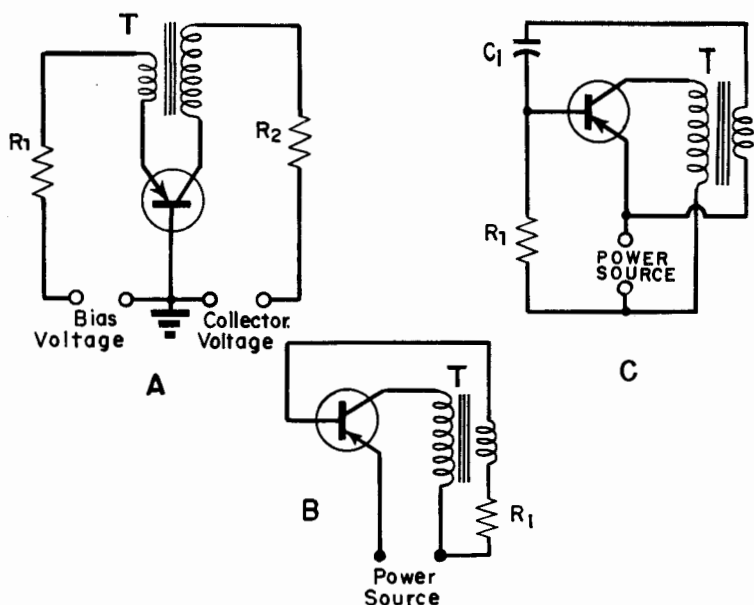

Figure 5-1. Three basic "tickler feedback" transistor oscillator circuits. The grounded base circuit is shown at A; grounded emitter circuits are shown at B and C. Power supply voltage polarities are not shown, as these will depend on the type of transistor employed.

and maintain oscillation in the circuits shown in Fig. 5-1. Ideally, the transformer should have a turns ratio to match the high output impedance to the low input impedance.

A grounded base circuit arrangement is shown at A and a grounded emitter circuit at B. The circuit shown C is a modification of circuit B and is often used where "blocking oscillator" action is desired. In the grounded base circuit, R_1 limits emitter current while R_2 limits collector current. In the grounded emitter circuit, R_1 limits both base and collector current.

Bias and collector voltage polarities are not shown, as these will vary with the type of transistor used . . . refer to the preceding Chapter.

The frequency of operation as well as the signal waveform obtained will vary with the type of transformer used, although, in some cases, it is possible to tune the circuit by connecting a ca-

capacitor across the primary or secondary (or both) windings of the transformer.

When the circuit shown at C is employed, and the transformer chosen to supply sufficient feedback energy to cause blocking, the frequency of operation is determined primarily by the time constant of the R_1 - C_1 combination.

"Hartley" and "Colpitts" Oscillators: A vacuum tube Hartley oscillator utilizes a tapped inductance coil to provide the necessary feedback energy to sustain oscillation. A Colpitts oscillator operates in a similar fashion, except that a "tapped" condenser (really two condensers in series) is employed in place of the tapped inductance.

Analogous transistor circuits are shown in Fig. 5-2. A tapped coil or "Hartley" oscillator is shown at A, while "tapped condenser" or "Colpitts" oscillator circuits are shown at B and C. The circuits at A and B use the grounded emitter arrangement, while the grounded base circuit is shown at C.

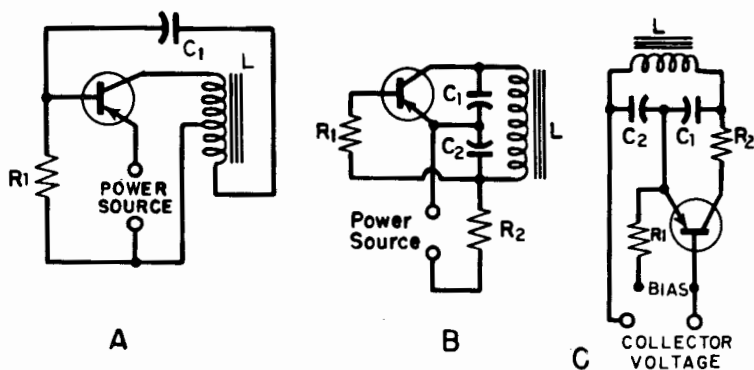

Figure 5-2. Three additional transistor oscillator circuits. The circuit shown at A is somewhat analogous to a vacuum tube "Hartley" oscillator, while those shown at B and C are similar to the vacuum tube "Colpitts" oscillator. Grounded emitter circuits are used at A and B, and a grounded base circuit at C.

The operation of the "Hartley" transistor oscillator is similar to that of the transformer coupled oscillator circuits previously described, except that a tapped coil rather than separate

windings is used to provide the necessary feedback energy. The value of R_1 determines both base and collector currents.

The ideal coil to use in this circuit is one with the tap adjusted to provide the desired high-to-low impedance match between collector and base circuits. However, oscillation is possible even if this match is not obtained, although the signal obtained may not be a sine-wave. It is sometimes even possible to use a center-tapped coil for L .

The "Colpitts" circuits shown at B and C depend on the ratio of two capacitive reactances to establish the necessary impedance match between input and output circuits. In both cases, a "tapped condenser" consisting of C_1 and C_2 in series is employed. In practice C_2 has approximately ten times the capacity of C_1 (or, $C_2 = 10C_1$). The frequency of operation is determined primarily by the tuned circuit made up of L , C_1 and C_2 .

In the circuit shown at B, collector current depends on the electrical sizes of both R_1 and R_2 . In most instances R_1 will be larger than R_2 , but the exact ratio will depend on the circuit operation desired.

Sine-wave operation is possible if R_1 and R_2 are carefully chosen. In addition, these resistors serve to give a form of d.c. stabilization and thus permit quite stable operation.

In the circuit shown at C, emitter current depends on the value of R_1 and collector current on the value of R_2 . A tapped power source may be substituted for individual power supplies in this circuit, if desired.

A Crystal-Controlled Oscillator: Many transistor oscillator circuits may be adapted to crystal control if necessary to obtain exceptional frequency stability. One such circuit, especially suited to junction transistors, is shown in Fig. 5-3. Another circuit, suitable for use with some types of point-contact transistors, is shown at C in Fig. 5-4.

Special Common Base Circuits: The circuits

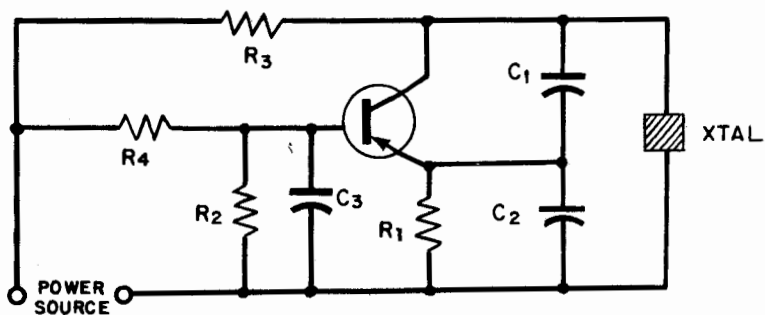
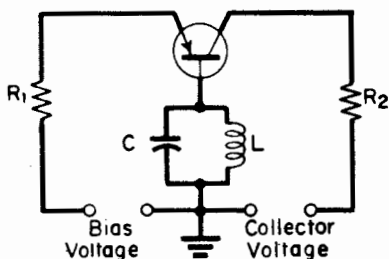
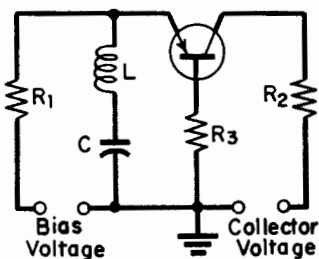

Figure 5-3. One of several possible crystal-controlled oscillator circuits for junction transistors. Note that only a single power source is required for this circuit.



A



B

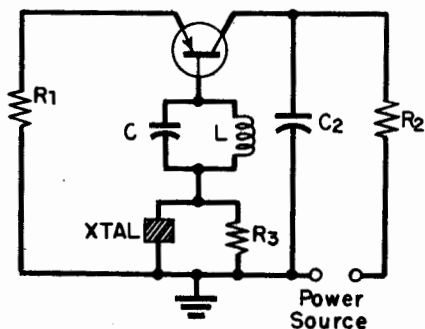

C

Figure 5-4. Three common base oscillator circuits which are suitable for use with point-contact transistors only. The circuit shown at C is crystal-controlled.

shown in Fig. 5-4 can be used where the alpha (current amplification factor) of the transistor employed is greater than 1.0, and hence are suitable for point-contact transistors.

The feed-back necessary to start and sustain oscillation is obtained by means of the high impedance in the common base circuit. Signal voltages developed across this impedance by collector-base signal currents are thus common to the emitter-base circuit. R_1 and R_2 are current limiting resistors, with R_1 being effective in the emitter circuit, and R_2 controlling collector current.

With a common base circuit, oscillation can be initiated and maintained in three ways: (a) By using a high impedance in the common base circuit; (b) By using a low impedance in the emitter circuit; (c) By using a low impedance in the collector circuit.

In operation, the high impedance in the base circuit of circuit A consists of the tuned circuit made up of L and C. In circuit B of Fig. 5-4, oscillation depends on the low impedance of the series circuit (L-C) between the emitter and ground. Resistor R_3 is included to supplement the internal base resistance of the transistor and thus to help maintain oscillation. If the transistor has a high internal base resistance, oscillation may be possible without R_3 .

Circuit C is quite similar to circuit A in operation, except that the frequency is controlled primarily by the piezoelectric crystal (XTAL).

Blocking Oscillator Circuits: Either of the circuits shown at C in Fig. 5-1 or at A in Fig. 5-2 may be used as "blocking" oscillators by a proper choice of R_1 , C_1 , and the transformer (or coil). As blocking oscillators, these circuits can supply fairly sharp pulsed signals over wide repetition rates.

When the circuits are adjusted as blocking oscillators, the frequency of operation is determined primarily by the time constant of the R_1 - C_1 combination. Pulse width is determined

by the characteristics of the transformer (or coil) used.

Blocking oscillator action is generally obtained when the coupling between base and collector circuits is such as to provide a large amount of feedback energy. The condenser, C_1 , then charges rapidly through the transistor and discharges slowly through R_1 . During the discharge of the condenser, little or no collector current can flow.

Average collector current thus depends on the size of R_1 , so that it is often necessary to take over-all circuit operation as well as frequency into account when choosing a particular R_1 - C_1 combination. Several different R_1 - C_1 combinations may result in the same frequency of operation, but only a few of these values may give the desired circuit stability and economy of operation needed for a specific application.

In many instances it is quite difficult to calculate the values of R_1 and C_1 in advance and it is more practicable to determine their sizes experimentally.

CHAPTER VI

Special Transistor Circuits

Transistor circuit applications are by no means limited to their use as simple oscillators and amplifiers. These semi-conductor devices may serve equally well as detectors, as clippers, as multivibrators or as phase inverters. Within their frequency and power limitations, they may, in fact, perform almost any of the basic jobs normally handled by vacuum tubes.

The electronics engineer, serviceman, student, experimenter or ham may often find it necessary to use or to work with these more specialized circuits, either alone or in combination with more

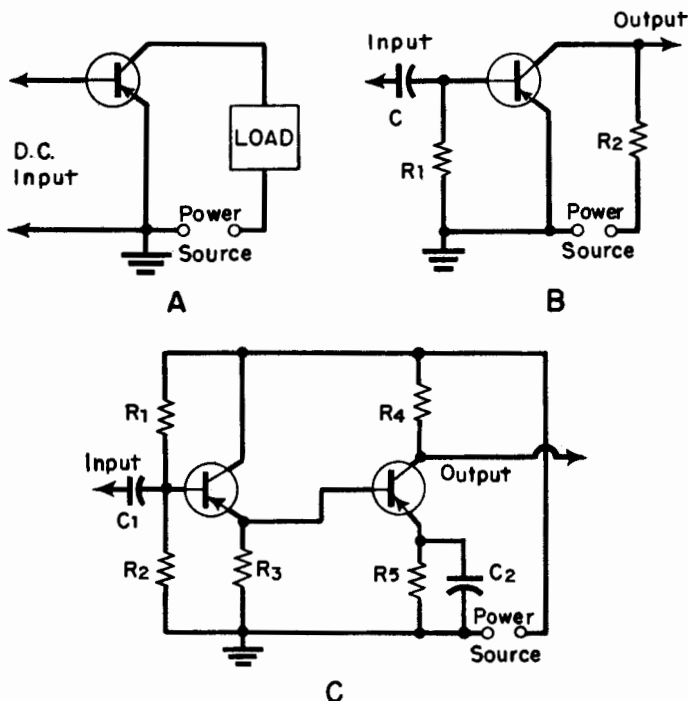

Figure 6-1. Three useful transistor circuits. A d.c. amplifier is shown at A; an R.F. detector or Sine-wave Clipper at B; and a two-stage direct-coupled amplifier at C.

conventional amplifier and oscillator arrangements. A brief review of these circuits should, therefore, prove helpful to almost any worker in the electronics field.

A.D.C. Amplifier: A junction transistor, used in the grounded emitter circuit, may serve as a direct current amplifier. The basic circuit arrangement is shown at A in Fig. 6-1.

In operation, a small direct current applied to the base-emitter circuit can control a much larger current in the collector-emitter circuit. In practice, current amplifications of ten or twelve to one are comparatively easy to achieve with standard commercial transistors. A base-emitter current of 100 microamperes may result in a current through the load of 1 milliampere or more.

The load need not necessarily be a resistor, choke or similar impedance but may well be a relay, meter, small motor or any similar electrical device. It is therefore possible to use a transistor in this circuit to increase the effective sensitivity of a relay or meter by a factor of 10:1 or better.

Applied d.c. control voltage and power source polarities will depend on the type of transistor used and on the action desired.

An R.F. Detector: The input circuit of a transistor amplifier, when the transistor is operated without external bias current, acts like a simple crystal diode. Thus, it will serve to rectify an applied a.c. voltage or to "detect" an amplitude-modulated R.F. signal. A suitable circuit is shown at B in Fig. 6-1.

In operation, the detection action is like that obtained with any diode, whether a vacuum tube or a semi-conductor device. Since the diode permits current to flow easier in one direction than in the other, either the positive or the negative going "half" of the applied signal will be removed by simple rectification, and a pulsating direct current flow will occur through the diodein this case, the base-emitter circuit of

the transistor. The peak value of this pulsating direct current will vary in accordance with the modulation of the original R.F. signal.

The rectified R.F. signal thus contains both an a.c. component (the audio modulation) and a d.c. component (its average value). The d.c. component serves to "bias" the transistor and permits the a.c. component to be amplified, appearing as an audio signal voltage across the collector load impedance. Although there may be R.F. pulsations present in the original detected signal, these are generally "lost" due to the high internal capacities and poor high frequency response of the transistor. If this does not occur, however, and R.F. pulsations are still present in the collector circuit, they may be removed by adding a small R.F. by-pass capacitor between the collector terminal and ground.

This basic circuit thus performs two functions simultaneously. . . it detects an applied R.F. signal and then amplifies the resulting audio signal.

A Sine-Wave Clipper: The R.F. Detector circuit just described (B in Fig. 6-1) may also be used as a sine-wave clipper.

In operation, when a pure sine-wave signal of sufficient amplitude is applied to its input, the "diode action" of the base-emitter circuit removes either the positive or the negative peaks whether the positive or the negative peaks are removed, in a particular case, will depend on the type of transistor used.

The opposite peaks are limited by the voltage drop across the collector load resistor. . . that is, when collector current reaches the point where the entire supply voltage is dropped across the collector load, no further increase is possible, even though the applied signal may continue to rise in amplitude.

Thus, the net result is that both "halves" of the applied signal are clipped. With proper design, this circuit is capable of supplying good quality rectangular waves when driven with a sine-wave of sufficient amplitude. If the applied sine-wave

is not of sufficient amplitude to limit collector current, then only one-half of the signal will be clipped and a rounded, rather than a rectangular, output signal will be obtained.

Since the transistor also serves to amplify the applied signal, this clipper circuit is unique in that the output signal, though "clipped", may be of greater amplitude than the applied sine-wave.

A Direct-Coupled Amplifier: If the amplitudes and polarities of all d.c. voltages and currents are taken into account, and proper component values are selected, it is entirely practicable to direct-couple transistor amplifier circuits. One possible arrangement is shown at C in Fig. 6-1.

In this circuit a common collector stage is direct-coupled to a grounded emitter amplifier. Note, too, that the circuit arrangement permits the use of a single power source.

In operation, the voltage divider made up of R_1 and R_2 provides a source of "bias" current for the common emitter stage. R_3 serves as the load impedance for this stage.

Resistor R_4 serves as the load resistor for the grounded emitter stage and the output signal is developed across this component. Bias current, in the second stage, is obtained by direct-coupling its base to the emitter of the preceding stage, and providing R_5 , by-passed by C_2 , to limit this current to the proper value.

Phase-Inverter Circuits: For the most part, transistor phase-inverter circuits are analogous to their vacuum tube counter-parts. Two popular types are illustrated in Fig. 6-2.

A transformer is used in the circuit shown at A. In order to operate the circuit with a single power source, "bias" current is provided by a voltage divider consisting of R_1 and R_2 .

The circuit shown at B in Fig. 6-2 is an adaptation of the well known "split-load" vacuum tube phase-inverter circuit. Load impedances are placed in both the collector (R_3) and emitter (R_4) circuits simultaneously. Bias current is supplied by the R_1 - R_2 voltage divider.

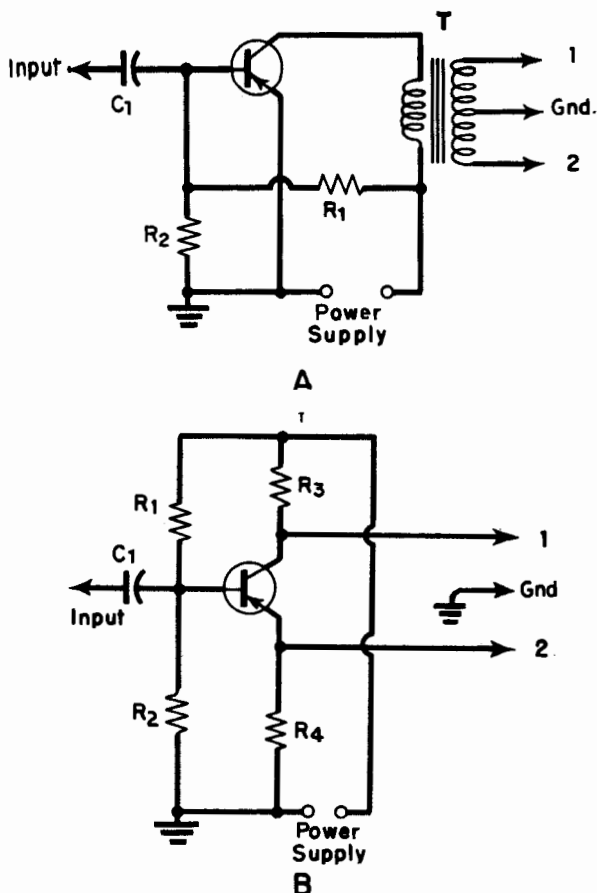

Figure 6-2. Transistor phase-inverter circuits. Note that only a single power source is required for either circuit.

Although the two load impedances, R_3 and R_4 , are generally the same size, this circuit does not supply a perfectly balanced output. . . .that is, the amplitude of the signal at "1" is not exactly the same as the amplitude at "2". However, the balance is close enough for most practical work . . .and especially if the circuit is used to drive a fairly linear amplifier.

Push-Pull Amplifier Circuits: Whenever a circuit designer requires a signal amplitude or power output greater than can be obtained from a single transistor, he generally uses two or more transistors in a push-pull arrangement. Three suitable circuits are shown in Fig. 6-3.

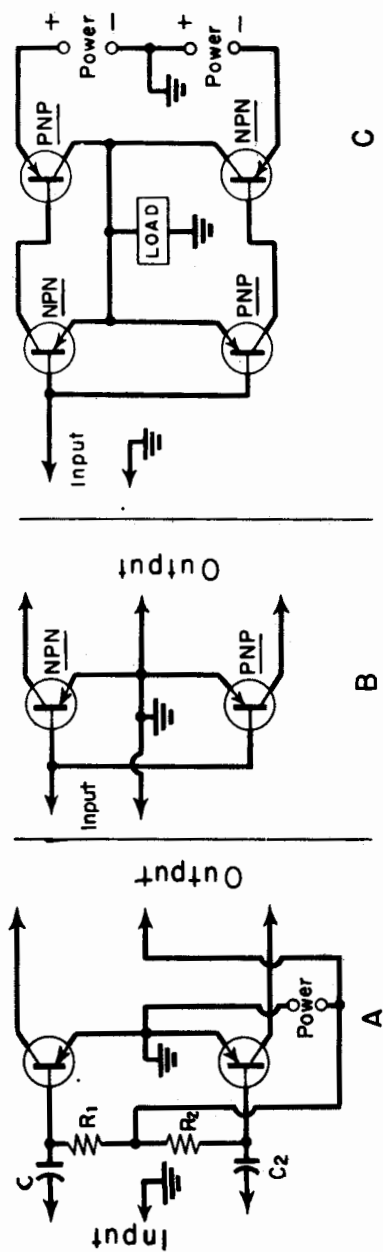

Figure 6-3. Push-pull transistor circuits. The circuits shown at B and C require but a single-ended input signal. The circuit shown at C can drive a low impedance load directly.

A "standard" push-pull circuit arrangement is shown at A. With this circuit, both transistors may be of the same type and a balanced input signal is required. A single power source is needed. The output load will generally be a center-tapped transformer coupled to some other device. . .such as a loud-speaker voice coil.

The push-pull circuit arrangements shown at B and C offer the advantage of requiring a single-ended input signal. . .it is not necessary to use a phase-inverter ahead of these circuits as is the case with the circuit shown at A. However, for these two circuits to operate properly, it is necessary that different type transistors be employed, as shown in the diagrams. Appropriate power supply polarity connections must also be made, of course, so that either two power supplies or a tapped power source is needed.

The circuit shown at C offers the additional advantage of being capable of driving a low impedance load directly.

Both of these circuits operate by virtue of the opposite polarity of the transfer characteristics of different type transistors. Thus, the output signals obtained from the two transistors are 180° out-of-phase even though the same input signal is supplied to both. This characteristic is known as the complementary-symmetry prin-

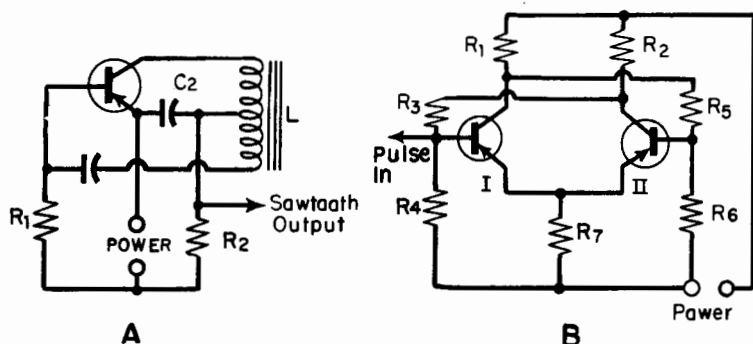

Figure 6-4. The transistor circuit shown at A can supply linear saw-tooth signals. A transistorized "flip-flop" circuit is shown at B.

ciple.

A Saw-Tooth Oscillator: The linear saw-tooth type of signal used as a sweep in oscilloscopes and television receivers may be obtained in various ways from transistor circuits. One simple arrangement is shown at A in Fig. 6-4.

In operation, sufficient feed-back signal is supplied by tapped coil, L, to operate the circuit as a blocking oscillator. During the period when the transistor is blocked, condenser C_2 charges slowly through R_2 . The condenser is then discharged rapidly by the pulse of collector current during the short "unblocked" period.

In order to insure a linear output signal, the time constant of the R_2 - C_2 circuit is made long compared to the repetition time of the oscillator.

A "Flip-Flop" Circuit: The transistor circuit shown at B in Fig. 6-4 has two stable conditions. It may be transferred from one condition to the other by the application of a pulse signal of the proper polarity to the appropriate base. A single power source is required.

In operation, one or the other of the two transistors will start conducting first. Let us say, for purposes of illustration, that transistor II starts first. If this is the case, the collector-emitter impedance of the transistor is very low, and the potential at the juncture of R_2 and R_3 is virtually the same as at the top of R_7 .

This means that little or no bias current can flow in the base-emitter circuit of transistor I so that its collector-emitter circuit remains in a non-conducting (or high-impedance) condition. With the collector-emitter circuit of transistor I offering a high-impedance, there is virtually no voltage drop across R_1 , and the potential at the juncture of R_1 and R_5 is sufficient to maintain a bias current flow in transistor II. . . . and this transistor stays in its low-impedance conducting condition.

Suppose, now, that a signal pulse of the correct polarity and of sufficient amplitude to start transistor I conducting is applied to its base. Transistor I will then change from acting as a high-

impedance to acting as a low-impedance, and there will be an appreciable voltage drop across R_1 . This means that there is no longer sufficient potential applied through R_5 to keep the base-emitter bias current of transistor II flowing, and this transistor changes rapidly from a conducting to a nonconducting condition.

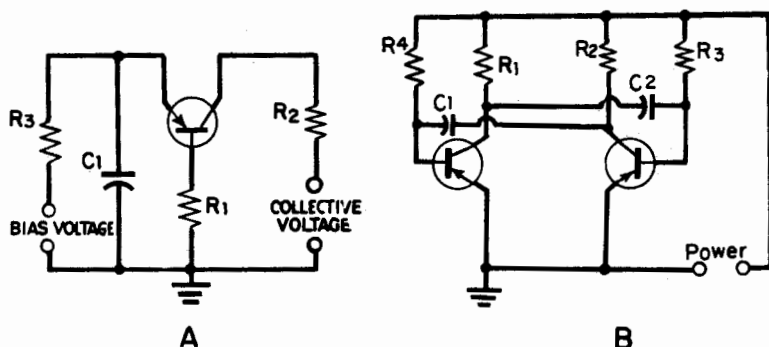

Figure 6-5. Transistor multivibrator circuits. The one shown at A may be used with point-contact transistors; the one shown at B is suitable for use with junction transistors.

Once this action has taken place, the circuit remains stable (but now transistor I is conducting) until a pulse of the opposite polarity is applied to the base of transistor I. . . . in such a case the circuit returns to its original condition.

Since this circuit has two stable conditions, it is useful in switching and in counting operations. It is seldom used alone, however, but, more often, in conjunction with other circuits.

Multivibrator Circuits: Two transistorized multivibrator circuits are illustrated in Fig. 6-5. The circuit shown at A uses a single transistor and requires a minimum of components. However, since this circuit depends, for its operation, on the coupling obtained through the common base impedance, R_1 , the transistor used must have an alpha greater than 1.0. . . . therefore, this circuit is primarily of value when used with point-contact transistors.

The multivibrator circuit shown at B is analogous to a conventional vacuum tube plate-coupled

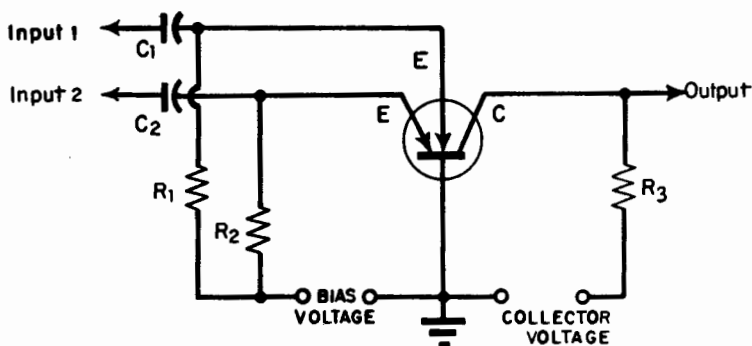

Figure 6-6. A mixer or modulator circuit suitable for use with a point-contact tetrode transistor. The tetrode transistor has two emitter terminals.

CREDIT: Circuit Courtesy SYLVANIA.

circuit. It consists, essentially, of two grounded emitter amplifier stages with resistance-capacity coupling between the input and output circuits. A single power source is required. Junction transistors will work well in this circuit.

A Tetrode Mixer Circuit: The circuit shown in Fig. 6-6 will serve well as a modulator or mixer and is designed to utilize a tetrode point-contact transistor. Note that the common base circuit is employed.

In operation, signals are fed simultaneously to the two emitter contacts, with the combined signal being obtained across the collector load impedance.

Other Circuits: The specialized transistor circuits described in this Chapter do not, by any means, represent all possibilities. Rather, they serve as illustrations of what can be done with transistors and how transistor circuits may be devised to accomplish jobs performed, in the past, by vacuum tube circuits alone.

As new transistor types are produced and as new applications are found for these components, additional specialized circuits will undoubtedly be developed, as well as new combinations of the tried and proven circuit arrangements.

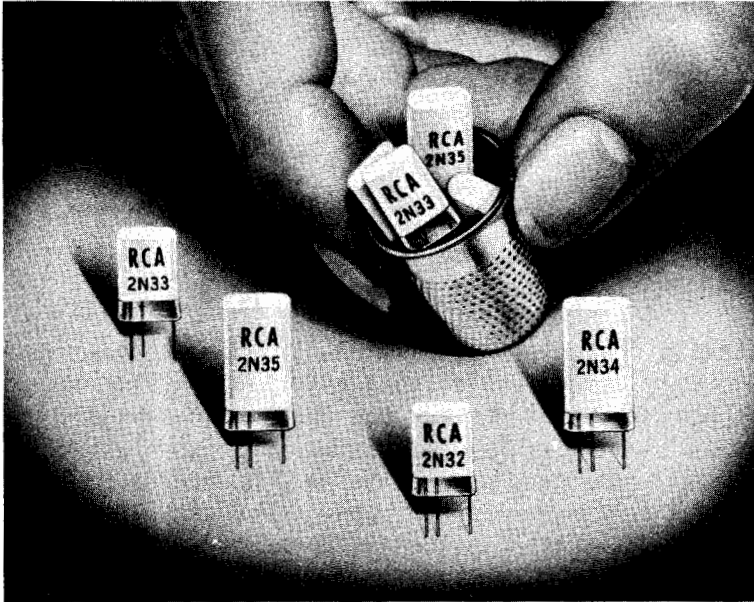

Figure 7-1. Commerically available transistors are so small that several may be easily contained within a standard sized thimble.

CREDIT: Courtesy RCA.

CHAPTER VII

Transistor Components

Most commercially available transistors are so small physically that several may be easily fitted into a standard sized thimble. See Fig. 7-1. Their small size ideally suits them to the construction of sub-miniature radio and electronic equipment. However, since the transistors themselves represent only a part of any practical electrical circuit, it is not surprising to find that a number of manufacturers are producing comparatively sized transformers, capacitors and other small components for use in transistor circuits.

Not all sub-miniature components are designed exclusively for transistor use, of course. For example, sub-miniature "in-line" tube sockets are made by the majority of socket manufacturers. Although designed originally for vacuum tubes, they are suitable for use with all transistors in which the standard lead connections are employed . . . see Chapter III. As can be seen in Fig. 7-2, these sockets are not appreciably larger than the transistor itself and, even with the transistor inserted, may be easily "lost" in the palm of the hand.

Sub-miniature carbon potentiometers, used as volume and tone controls, have also been made for vacuum tube circuits, and especially for use in hearing aids. These controls, in the proper resistance values, are quite suitable for use in transistor circuits. The small size of these commercially available potentiometers is apparent from the over-all dimensions of a typical control - exclusive of terminal leads, but including the knob, one unit measures less than $3/4$ " in diameter by approximately $5/16$ " thick, and weighs less than $1/4$ ounce!

TRANSFORMERS: The amount of iron needed in the core of a transformer is dependent upon several design factors. However, two of the most

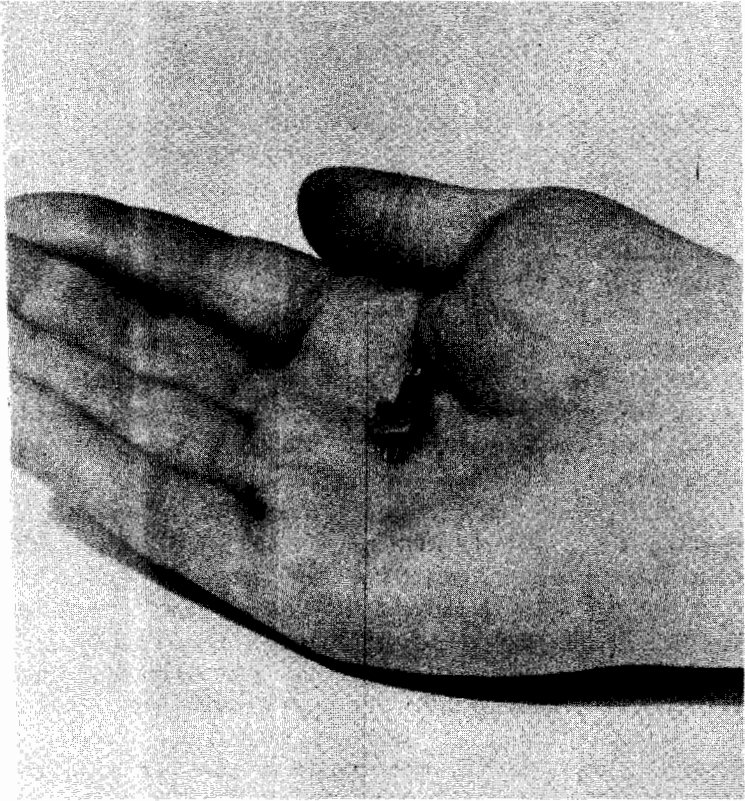

Figure 7-2. A standard "in-line" sub-miniature tube socket may be used for all transistors employing the standard lead connections. This photo shows the small size of the socket and transistor . . . the transistor shown is a point-contact unit.

CREDIT: Courtesy General Electric.

important are the amount of direct current flowing in the transformer's winding (in its intended use) and the power to be handled by the unit. As we have seen, both factors are quite small in transistor circuits. It is possible, therefore, to build extremely tiny iron-core "transistor" transformers.

One such unit is shown in Fig. 7-3, where it is compared in size with a standard miniature

transformer. Over-all dimensions of the transistor transformer are approximately $3/8'' \times 3/8'' \times 3/8''$, while the weight is approximately $1/10$ of an ounce. The power handling capacity of such units is on the order of 1 milliwatt or less.

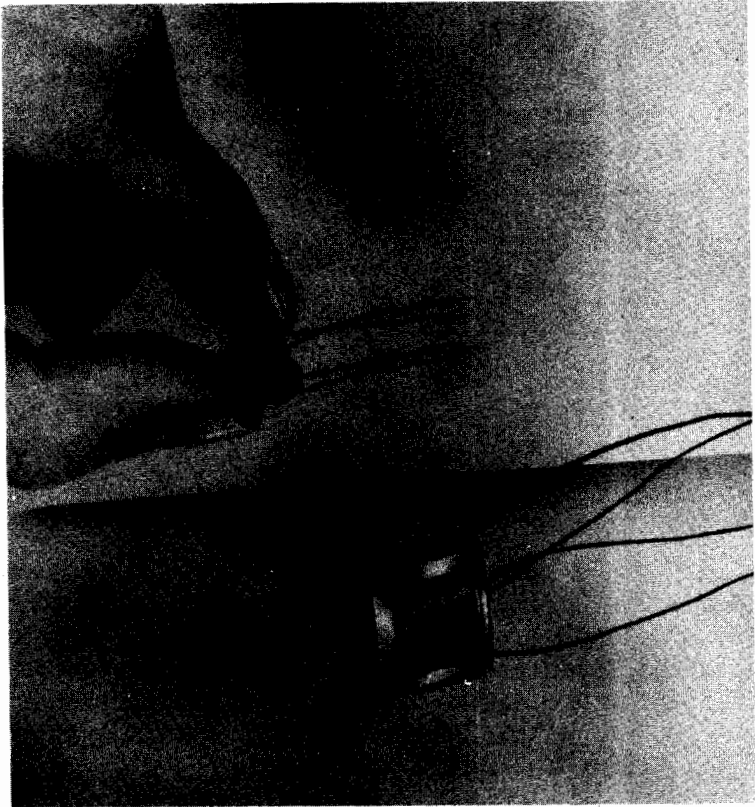

Figure 7-3. A transistor transformer is compared to a conventional "miniature" transformer in this photo. As may be readily observed, the transistor transformer is much smaller than the conventional unit.

CAPACITORS: Because of the low-impedances encountered in transistor circuits, large value by-pass and coupling capacitors are virtually a necessity. Fortunately the low d.c. voltages normally employed in transistorized equipment make it quite feasible to use low working voltage units, and several manufacturers have designed small electrolytic condensers having fairly large capacities.

One commercial unit measures only a little more than $1/8'' \times 3/4''$ over-all, exclusive of leads, yet is rated at 2 mfd at 6 v. d. c.

Another type of small capacitor that is becoming increasingly popular are the extremely small tantalum "electrolytics". These capacitors consist of a porous tantalum anode permanently sealed into a small container, with a silver cathode and the electrolyte. In some commercial units, the silver cathode also serves as a case and as a container for the electrolyte.

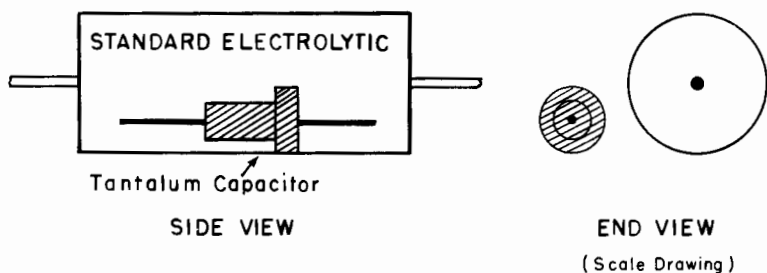

Figure 7-4. A miniature tantalum capacitor is compared to a conventional standard sized electrolytic condenser in this scale drawing. Tantalum capacitors are widely used in subminiature equipment employing transistors.

The small size of these units is illustrated graphically in Fig. 7-4, where a typical commercial tantalum capacitor is compared with a standard sized electrolytic condenser. Over-all dimensions, exclusive of leads, are approximately $5/16'' \times 31/64''$. . . the capacitor occupies less than $1/10$ of a cubic inch!

Electrically, most tantalum capacitors are superior to conventional electrolytics. For example, the manufacturer of the capacitor described offers these units over the range from $1/5$ mfd. to 30 mfd., with d.c. working voltages from 125 to 6 v.d.c. The maximum d.c. leakage of the higher voltage capacitors, even in high tolerance grades, does not exceed 6.0 microamperes, while the low voltage units have a maximum leakage of 2.0 microamperes, or less. The normal operating temperature range of tantalum capacitors is exceptionally good . . . from -55°C to 85°C at rated working voltages, with

operation as high as 100°C possible if the working voltage is derated 15%.

Small paper, ceramic, and mica condensers may also be encountered in transistorized equipment. Except for their physical size and working voltages, they are generally similar to the more familiar units employed in conventional electronic equipment.

TRANSISTOR POWER SUPPLIES

The truly minute power requirements of transistor circuits make it economically practicable to operate transistorized equipment with batteries, even where the equipment may be subject to almost continuous use. Either conventional zinc-carbon or the newer mercury batteries may be found in use in such equipment.

Zinc-carbon batteries are quite familiar to the electronics technician, being used in portable radio receivers, in flashlights, in "breadboard" experimental circuits, in ohmmeters, in hearing aids, and in many other types of equipment.

In transistor circuits, the lower voltage zinc-carbon batteries, such as pen-light cells, flashlight cells, and bias batteries, may be used both as bias and collector voltage power sources. The medium voltage "B" batteries, supplying from 15 to 30 volts, may be used as collector voltage sources. Small Hearing Aid Type "B" batteries will more often be used in sub-miniature equipment, or where intermittent operation is anticipated. The higher voltage "B" batteries may be used most often in circuits employing point-contact or special power transistors.

The mercury cell, though more costly than similar zinc-carbon batteries, offers several advantages over them in many applications. Mercury cells are generally more stable and more rugged, both mechanically and electrically, than their zinc-carbon counterparts. They have a much longer shelf life and a greater capacity than similar sized zinc-carbon batteries and thus

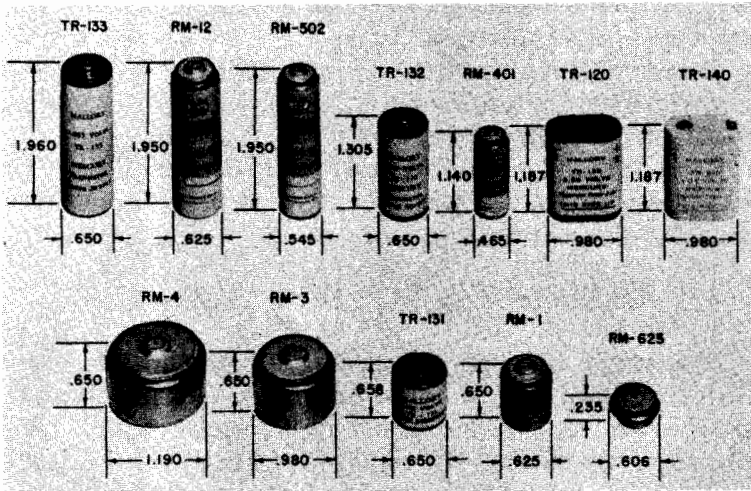

Figure 7-5. A number of commercially available mercury batteries. Several of these are designed specifically for use as transistor power supplies. The dimensions shown are in inches.

CREDIT: Courtesy P. R. Mallory & Co.

are exceptionally well-suited to the design of sub-miniature equipment. Because of this, mercury cells will undoubtedly find wide application in transistorized equipment.

Unfortunately, the average electronics technician, unless he has worked with modern hearing aids, sub-miniature equipment, or a few specialized types of military equipment, may never have encountered mercury cells in his work and, therefore, may be unfamiliar with them. A number of typical mercury cells and batteries are shown in Fig. 7-5. Several of these have been designed specifically to serve as transistor power supplies.

Mercury cells produce electrical energy by an electrochemical reaction between zinc and mercuric oxide, with a potassium hydroxide solution used as the electrolyte. The anode may be a pressed pellet of amalgamated zinc powder or a winding of thin corrugated zinc strip. The cathode consists of mercuric oxide to which a small amount of micronized graphite has been added. The case of mercury cells is generally

of steel. Due to the high stability of the chemicals used in mercury cells and the inactive case material, there is virtually no internal cell reaction until electrical energy is drawn from them.

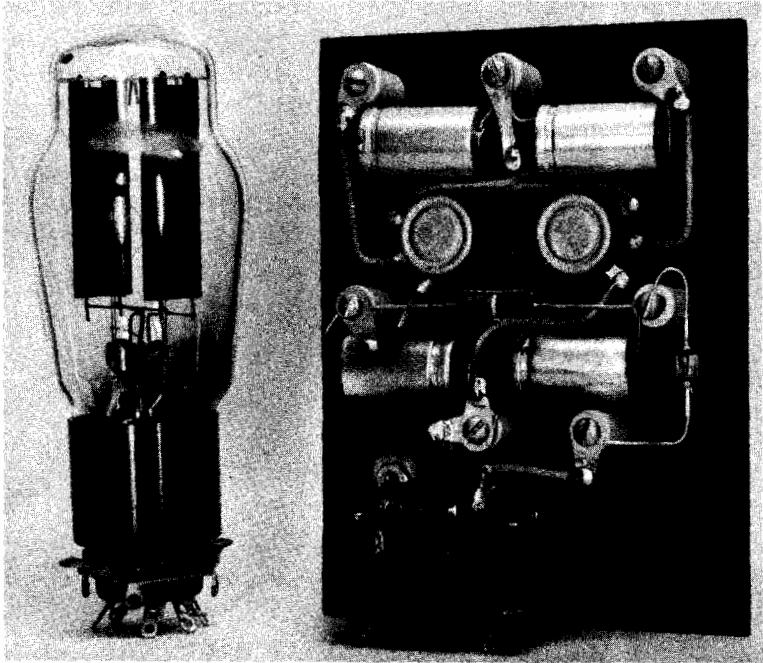

Figure 7-6. A 5U4-G power rectifier tube (left) is compared to a complete A.C. - operated d.c. power supply for transistors.

A.C. POWER SUPPLIES: A.C.-operated d.c. power sources designed to supply transistor circuits are generally as much smaller than their vacuum tube counterparts as transistors are when compared to tubes. This fact is visibly demonstrated in Fig. 7-6, where a vacuum tube rectifier, of the type used in public address amplifiers and television receivers, is compared to a complete d.c. power supply designed for experimental transistor amplifier circuits.

At the top of the transistor power supply, near the output terminals, are two by-pass condensers for the input and output circuits of the amplifier with which the power supply is used. Immedi-

ately below are two potentiometers used for adjusting bias and collector voltage . . . or the voltage to the "high-side" output elements of the amplifier. Near the center of the unit are the filter capacitors and filter resistor and at the lower left is the power transformer. At the right, opposite one of the filter capacitors, is the "power rectifier," which is a high-back-voltage type of germanium crystal diode . . . it is interesting to compare the size of this "power rectifier" with the 5U4-G vacuum tube shown, for both units occupy comparable positions in their respective circuits.

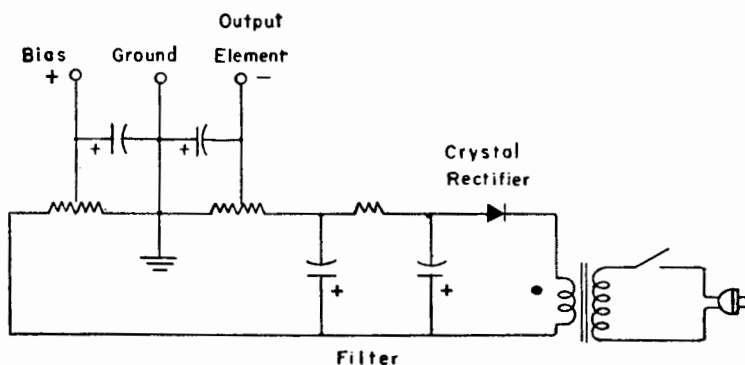

Figure 7-7. The schematic diagram of the transistor d.c. power supply shown in Figure 7-6.

The circuit for this power supply is shown in Fig. 7-7. The rectifier is connected to provide, at the bias terminal, a positive potential with respect to circuit ground, and, at the output terminal, a negative voltage with respect to ground. The electrolytic by-pass and filter condensers used must be connected to suit circuit polarities . . . thus, were the d.c. output voltage polarities to be reversed, it would be necessary to reverse the connections to all capacitors (and to the rectifier). Such a change might be made in the circuit if it were to be used with different type transistors.

Power supplies designed to operate vacuum

tube circuits are generally built to supply a constant output voltage so that variations in signal currents in the connected circuits will not cause excessive changes of plate, screen and grid bias voltages. Similar supplies are sometimes used with transistor circuits, where provision is made for current limiting resistors in the individual stages.

However, with many circuit applications of transistors (especially point-contact units) the applied potentials are of such polarity as might cause excessive current through the low impedance side, were these supply potentials to remain constant regardless of current. That is, the transistor acts like a rectifier to which voltage is applied in the forward or low-resistance direction, and possible destruction may occur due to excessive current . . . unless the supply voltage drops with increasing current drain.

This condition requires that the d.c. power supply used be designed to furnish a nearly constant, or, at least, a limited, current. This is accomplished, in practical circuits, by making d.c. resistances in the power supply and other series resistances much greater than element resistances in the transistor itself. Thus, should the current drain tend to become excessive, sufficient voltage drop will occur across the various series resistances to effectively limit the voltage applied to the transistor, and hence the current through it.

CHAPTER VIII

The Care and Servicing of Transistors

Transistors, although generally more rugged mechanically than vacuum tubes, are still comparatively easy to damage by improper treatment or electrical overload. Many of the earlier transistor experimenters have learned this the hard way, at the cost of one or more expensive transistors.

While the technician who has acquired considerable experience working with transistors may take many liberties in using them, knowing, almost subconsciously, how to avoid damage, the beginner, be he engineer or student, technician, ham or serviceman, will find it worthwhile to keep certain general precautions in mind at all times. A number of these are listed below:

a. Do not overheat transistors or their leads . . . excessive heat may easily cause permanent damage. Where practicable use sockets when building transistorized equipment and do not install the transistors until all wiring is completed and checked. If it is necessary to solder transistors directly into the circuit, however, complete the soldering as quickly as possible. Use a clean, hot, well-tinned iron and good quality solder. Don't cut the transistor leads any shorter than necessary. For maximum protection hold the lead being soldered with a pair of long nose pliers. The pliers should be between the point where heat is applied and the body of the transistor. Used in this fashion, the pliers form a heat "sink", conducting heat away from the transistor itself.

b. Do not exceed the "absolute maximum electrical ratings . . . transistors are generally not under-rated, and the absolute maximum ratings specified by a manufacturer mean exactly that.

While these ratings may sometimes be momentarily exceeded in experimental work without apparent damage to the transistor involved, another unit might be hopelessly damaged by the same overload. There is sufficient variation in transistors that a given overload may not injure one unit, may change the characteristics slightly of another unit, and may completely ruin a third.

If the transistors are to be used in equipment exposed to higher than normal temperatures, it may be necessary to operate them at a fraction of the maximum values . . . such a step will not only permit increased life but also better circuit operation and improved stability.

c. Observe proper power supply polarities . . . this point has been mentioned earlier, but is worth repeating. Reversing the plate voltage polarity of a triode vacuum tube will keep the stage from operating but will generally not injure the tube . . . but reversing the collector voltage polarity of a transistor will often ruin it, instantly and permanently.

Since different types of transistors require different power supply connections, the technician working with these components must always be "on his toes". Whenever there is any question concerning the connections to a particular unit, the manufacturer's specification sheet should be carefully checked . . . before the transistor is installed in the circuit, and before power is applied!

d. Guard against high transient current or voltages . . . this precaution must be observed both when working with new circuits and when testing or servicing old equipment. A damaging transient pulse may be caused in a number of ways . . . by the application of a signal having a sharp leading or trailing edge, by inductive kick-back, by circuit switching, and even by the mere process of turning the equipment "on" or "off."

When working with new equipment or circuits,

carefully study the schematic for transient possibilities before making final connections. If possible, use a variable voltage power supply and increase the operating voltages slowly from zero to the desired operating values.

When working with built-up and tested equipment, do not insert into or remove transistors from their sockets with the power "on". If the circuit application requires an interchange of transistors with the power on, provision should be made for making the base connection first. And avoid all test techniques or methods that might result in sharp voltage transients in the equipment.

TESTING TRANSISTORS

The serviceman will have to rely on some of the following techniques for checking transistors.

In some cases, it is possible to tell that a transistor is defective from the circuit operation obtained. For example, if the collector current runs very high in a particular circuit using the grounded emitter arrangement, and changes in base current seem to have little or no effect on it, there is a good possibility that the transistor is defective.

Another technique some technicians use is to consider the transistor as equivalent, as far as d.c. resistances are concerned, to two diodes connected "back-to-back". An ohmmeter is then used to check "forward" and inverse resistance between base and emitter, and between base and collector. In each case there should be an appreciable difference between the "forward" and the inverse resistance measurements . . . just as is the case with conventional crystal diodes.

If the two resistance measurements are similar in either (or both) case, there is a good chance that the transistor is defective.

Still another technique, perhaps the most effective of all, is the old "stand-by" of substitution . . . that is, trying another transistor of the same

type in the circuit. However, this technique should only be used after the serviceman has assured himself that there are no other circuit defects . . . especially those that might damage a transistor.

The experimenter will find a variation of this last technique useful, especially where he uses a limited number of transistor types. A simple amplifier circuit may be permanently wired, with terminal connections for checking d.c. currents and voltages, and the input and output a.c. signals. A socket is provided for the transistor.

To check a transistor, it is inserted in the socket, instrument connections are made, and power is applied. Operating currents are checked and compared to "average" values as specified by the transistor manufacturer. Finally, an a.c. signal is applied to the input and stage gain checked. If the d.c. values are not too far off, and if reasonable signal gain is obtained, the transistor may be considered "good" . . . at least for most practical work.

Where the circuit in which the transistor is to be used is especially critical, the only real test is to actually try the transistor and to check operation.

SERVICING TRANSISTORIZED EQUIPMENT

The serviceman need not anticipate special difficulties when he is eventually called on to repair transistor operated equipment. In general, he will find that the techniques he has used in the past may be applied, with but little modification, to the servicing of such equipment.

Transistorized equipment should normally require less servicing than equipment in which vacuum tubes are used . . . assuming that good design practices have been followed by the manufacturer and that good quality parts are used, and, of course, that the equipment has not been deliberately mistreated. There are several reasons for this.

First, transistors themselves should have a

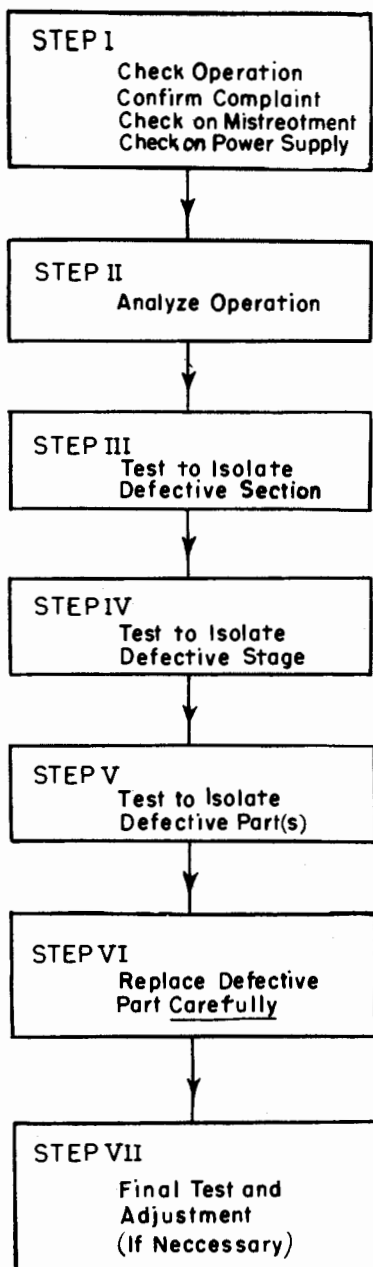

Figure 8-1. A block diagram illustrating the steps to be followed when servicing transistorized equipment. The same steps are followed, generally, when servicing all types of electronic equipment.

much longer life than vacuum tubes. In some types of equipment, in fact, the transistors used should last as long as the normal service life of the equipment itself.

Secondly, very little heat is generated in completely transistorized equipment . . . this means lower operating temperatures with correspondingly longer life for electrolytic condensers, insulation, resistors, batteries, and similar electrical components.

And, finally, transistorized equipment generally operates with much lower d.c. potentials than are found in vacuum tube circuits. This means that less strain will be placed on insulation and components with reduced chances of voltage breakdown.

The basic servicing procedure applicable to all types of electronic equipment, whether transistorized or not, is shown in block diagram form in Fig. 8-1. In following this general procedure, the serviceman, at all times, should keep in mind the general precautions outlined in the first section of this Chapter, and should exercise special care in every step where physical work with the equipment is involved. Let us review, briefly, the various steps in the servicing procedure.

STEP I: When the equipment is first brought to the serviceman for repair, he should check its operation and confirm, for himself, the complaint. He should also check on the possibility of mistreatment - for example, if a transistorized hearing aid were left in a closed car on a hot summer day for any period of time, the temperatures encountered could very easily change the characteristics of the transistors . . . perhaps even ruining them completely.

In addition, since batteries are used in many types of transistorized equipment, he should check the power supply at this point . . . particularly if the complaint is "dead" or "fails to operate".

STEP II. From the nature of the complaint and from his knowledge of transistor circuit operation, the serviceman should next apply reasoning to the problem. He should briefly review, mentally, the defects that might cause the complaint encountered and where in the circuit the defect is likely to be located. This same reasoning procedure should be reapplied at each step in the servicing procedure as new information is acquired.

Where the serviceman has worked with similar equipment in the past, he may be able to determine the defect at this point, perhaps by making one or two simple confirming tests. He can then go directly to the "heart" of the trouble, skipping all intermediate steps.

STEPS III, IV, V: The serviceman should next apply conventional servicing techniques, choosing those techniques best suited to the equipment being serviced and to the nature of the complaint. Signal Tracing, Signal Injection, Parts Substitutions, Resistance Tests, Voltage Measurements, and similar test methods may all be employed. The defective section is generally isolated first, then the stage, and finally the defective part itself.

When carrying out tests, care must be taken that no test method is employed which may cause damaging voltage or current transients. For this reason, Circuit Disturbance tests should generally be avoided, and Parts Substitutions should not be made with the power "on".

STEP VI: When replacing the defective part (or parts) the serviceman must be especially careful not to overheat transistors or their leads. He should also make sure that proper connections are made for all "polarized" components . . . he may sometimes find, for example, that the positive lead of electrolytic condensers is grounded.

STEP VII: Once the defect is repaired, the serviceman should carefully recheck the operation of the equipment and make any final adjustments (or alignment) that may be necessary.

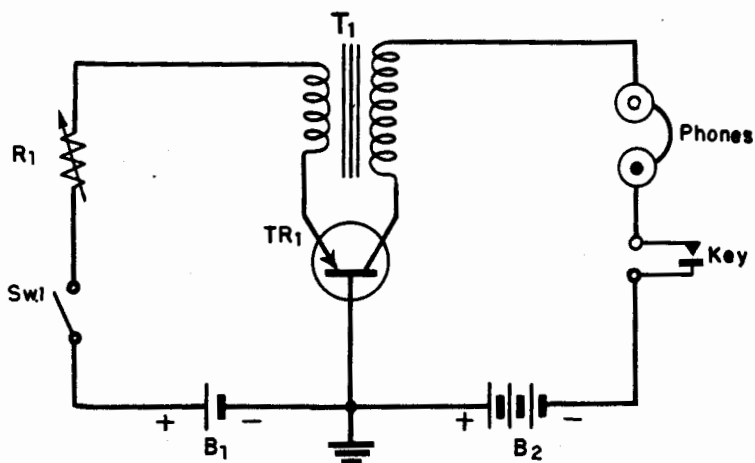

Figure 9-1. A transistor code practice oscillator. Parts values are as follows:

- TR₁ - RAYTHEON type CK722 PNP junction transistor.
- T₁ - Audio interstage transformer, 3:1 turns ratio.
- R₁ - 15K rheostat . . . adjust for optimum operation.
- Sw₁ - SPST "Off-On" Switch.
- B₁ - 1.5 volt bias battery.
- B₂ - 3 to 15 volt collector voltage battery.
- PHONES - 2000 ohm headset.

CREDIT: Circuit Courtesy RADIO & TELEVISION NEWS.
Adapted from "A Transistor Code Practice Oscillator".

CHAPTER IX

Practical Transistor Circuits

The experimenter, student, ham, and practical engineer will often find that considerable time can be saved when designing and wiring experimental circuits if typical component parts values can be obtained. In order to help these workers, a number of characteristic circuits illustrating practical applications of transistors will be shown and described in this chapter.

These circuits have been obtained from a number of sources and may not, in every case, represent optimum final design. The reader should, therefore, use the suggested circuits as a guide only, making any experimental modifications as may be necessary to suit special conditions or his own individual requirements. However, if the reader has not previously worked with transistors, he should exercise special care when wiring, testing, or operating any of the circuits shown. A review of the suggestions given in the preceding Chapter may be found helpful.

For convenience in listing, the various circuits have been divided into three groupings:- AUDIO CIRCUITS, R.F. CIRCUITS, and GENERAL EXPERIMENTAL CIRCUITS.

AUDIO CIRCUITS

A Code Practice Oscillator: A grounded base arrangement is used in the transistor audio oscillator shown in Fig. 9-1. This oscillator may be easily assembled by a skilled technician in a few hours time. The circuit is non-critical and may be adapted not only for use as a code practice oscillator, but as a general-purpose audio signal source.

To adjust the completed oscillator for operation, first set R_1 for maximum resistance. Next, close the "OFF-ON" switch and hold the key

down, listening to the earphones. Gradually reduce the resistance of R_1 until the desired operation is obtained. The size of this resistor will effect both tone and power output. However, do not use values below 2000 ohms for R_1 normal operating values should be in the range from 2500 to 12,000 ohms.

If oscillation does not occur, try reversing the connections to either the primary or the secondary windings of T_1 . Since this transformer serves to feed back the electrical energy needed to start and maintain oscillation, it is extremely important that the lead connections be such that an in-phase feed-back signal is obtained.

The size (voltage) of B_2 is not too important, and satisfactory operation of this circuit has been obtained with from 3 to 15 volts collector voltage. However, the value of R_1 is less critical, and better stability and greater power output are obtained with the higher voltages.

In some cases, this oscillator will supply sufficient power to operate a small loudspeaker. Simply connect the primary winding of a standard audio output transformer in place of the magnetic headset. The secondary winding is connected to the voice coil of a PM loudspeaker . . . any size speaker may be used, but best results are obtained with a 6 or 8 inch speaker, or larger.

A Phonograph Amplifier: The circuit shown in Fig. 9-2 gives a moderately good signal-to-noise ratio and is suitable for use in a small record player. A 10" or 12" PM loudspeaker should be used.

As can be easily seen by reference to the schematic diagram, this circuit uses a single pre-amplifier stage, transformer coupled to a push-pull output stage. Grounded emitter circuit arrangements are used throughout. Transformer T_1 is used primarily for phase inversion and hence its characteristics are not too critical.

Once the circuit is completed and tested, bias control R_3 should be adjusted for optimum operation . . . that is, for maximum power output

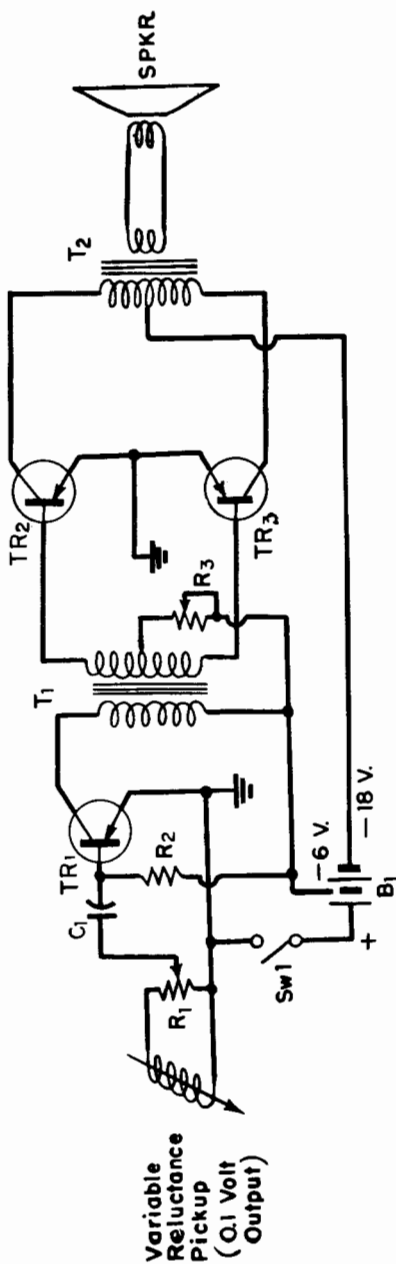

Figure 9-2. A transistor-operated phonograph amplifier. Parts values are as follows:

- TR₁ - CBS-HYTRON type 2N36 PNP junction transistor.
- TR₂, TR₃ - CBS-HYTRON type 2N37 PNP junction transistors.
- R₁ - VOLUME control, 10K.
- R₂ - 100K resistor.
- R₃ - Output bias control, 25K.
- C₁ - 1 mfd.
- T₁ - Interstage Transformer; 3:2 turn ratio.
- T₂ - Output transformer; 4000 ohms to speaker voice coil.
- Sw1 - SPST "Off-On" Switch.
- B₁ - Tapped battery . . . or separate batteries providing 6 and 18 volts.

consistent with low distortion, low noise, and reasonable current drain.

A Transistor Hearing Aid: The transistorized hearing aid circuit given in Fig. 9-3 may be assembled as quite a small unit if the recommended components are used and if care is taken in layout and wiring. As with any multi-stage audio amplifier, the layout chosen should be as "clean" and open as practicable, with ample separation between the input and output leads of individual stages as well as of the amplifier as a whole.

Small rheostats should be used in place of R_1 , R_2 and R_3 during the preliminary assembly of the circuit. These rheostats should then be adjusted for optimum operation with the battery voltage used. That is, to give the best compromise between low background noise, maximum gain, and minimum distortion. Once the values of R_1 , R_2 and R_3 are determined in this fashion, fixed resistors may be installed.

Either tantalum capacitors or sub-miniature electrolytics should be used for the interstage coupling condensers, C_1 , C_2 and C_3 . For long battery life, a mercury cell is the best choice for B_1 , although conventional zinc-carbon batteries will give satisfactory results.

If desired, a high impedance (2000 ohm) magnetic earset may be substituted for the PHONE specified, and T_4 omitted. Simply connect the high impedance phones in place of the primary winding of T_4 .

R. F. CIRCUITS

A Crystal-Controlled Transistor Transmitter: The oscillator circuit shown in Fig. 9-4 uses a point-contact transistor in a grounded base arrangement. 'Phone operation is obtained by modulating the collector current, using a carbon microphone. This circuit is suitable for communication only over very short distances.

Inductance coil L_1 is made up by winding approximately 16 turns of # 24 wire on a $3/8$ " diameter form. The antenna is inductively cou-

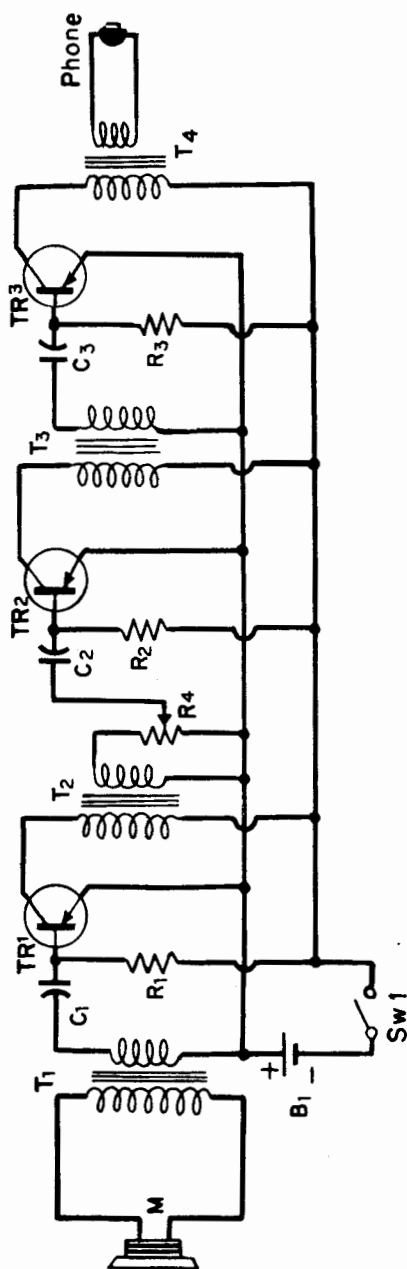

Figure 9-3. A transistorized hearing aid circuit. Parts values are as follows:

TR₁ - RAYTHEON type CK718 PNP junction transistors.

TR₂ - RAYTHEON type CK718 or CK721 PNP junction transistors.

TR₃ - STANCOR type UM1112 transistor transformer.

T₁ - STANCOR type UM1111 transistor transformer.

T₂ - STANCOR type UM1111 transistor transformer.

T₃ - STANCOR type UM1111 transistor transformer.

T₄ - STANCOR type UM1111 transistor transformer.

R₁, R₂ - 10K-15K resistors*.

R₃ - 50K-100K resistor*.

R₄ - VOLUME control - 4K-6K.

C₁, C₂, C₃ - Large interstage coupling capacitors - 2-5 mfd.

M - High impedance microphone (crystal or dynamic).

B₁ - Power supply battery . . . 1.5 to 6.3 volts.

SW₁ - SPST "Off-On" switch.

PHONE - Low impedance hearing aid type earphone.

*These resistor values will vary with battery voltage and transistors used. Choose

pled to this coil through a few turns wound on the same form. The amount of coupling to employ as well as the exact number of turns to use for the antenna winding may be best determined experimentally after the circuit is wired.

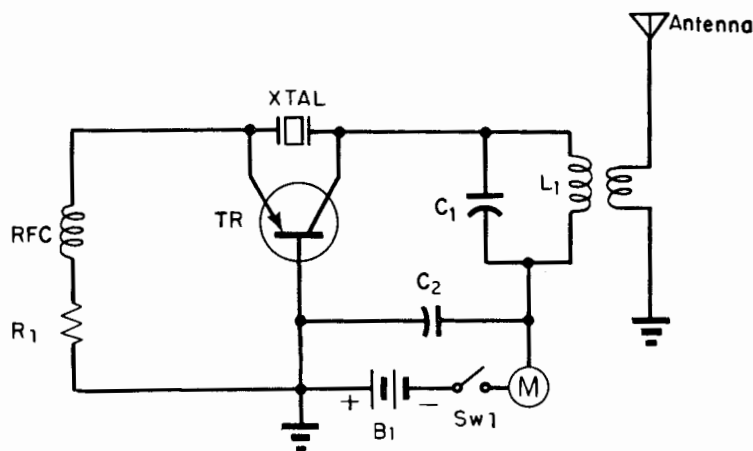

Figure 9-4. A crystal-controlled transistor transmitter. Parts values are as follows:

- XTAL - 7 Mc crystal.
- TR₁ - CBS-HYTRON type PT-2A or PT-2S point-contact transistors.
- RFC - Small radio frequency choke.
- R₁ - 1K carbon resistor.
- C₁ - 220 mfd.
- C₂ - .001 mfd.
- L₁ - Approx. 16 turns # 24 wire on 3/8" D. form.
- M - Carbon microphone.
- Sw₁ - SPST "Off-On" switch.
- B₁ - 12 volt battery.

CREDIT: Circuit Courtesy CBS-HYTRON

A 50-Mc Oscillator: A specially designed and selected point-contact transistor is used for the oscillator circuit given in Fig. 9-5. The power output obtained from this circuit, though quite small (approximately 1 milliwatt), is ample for many types of experimental work.

A Broadcast-Band Radio Receiver: The radio receiver circuit shown in Fig. 9-6 requires a good antenna and ground for best performance. Two transistors are used, with the grounded emitter circuit arrangement being employed in

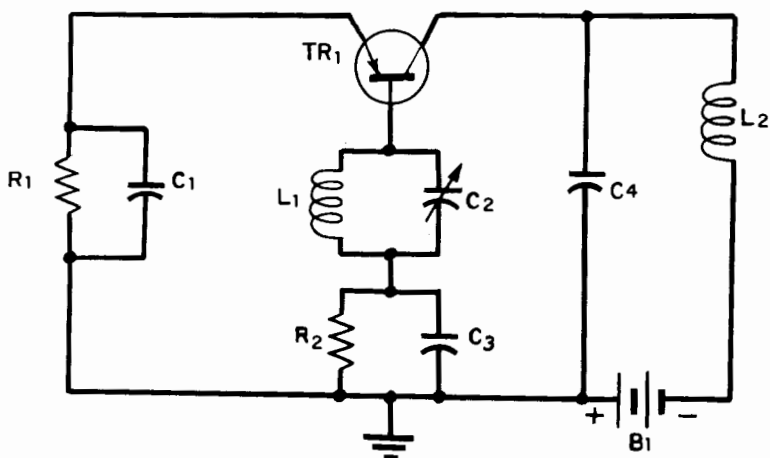

Figure 9-5. A 50-mc transistor oscillator circuit. Parts values are given below:

- TR₁ - RCA type 2N33 point-contact transistor.
- L₁ - 0.46 microhenry inductance.
- L₂ - 1 millihenry R.F. choke.
- C₁ - 1 mmf ceramic condenser.
- C₂ - 4-30 mmf adjustable ceramic condenser.
- C₃ - 270 mmf mica condenser.
- C₄ - 470 mmf mica condenser.
- R₁ - 5100 ohm, 1/2 watt, carbon resistor.
- R₂ - 1K, 1/2 watt, carbon resistor.
- B₁ - Power supply battery . . . not over 8 volts.

CREDIT: Circuit courtesy RCA.

both cases. TR₁ serves as a detector-amplifier, with its output audio signal, appearing across VOLUME control R₁, coupled through C₅ to the input of TR₂ which, in turn, operates as a conventional amplifier stage. In order to obtain reasonable selectivity in the broadcast band (550 to 1500 Kc), two tuned circuits are employed.

When assembling the circuit, a standard broadcast band antenna transformer may be used for T₁. The detector transformer, T₂, is made up by using a second antenna transformer and removing the primary (antenna) winding. The wire from this winding is then used to rewind about 60 turns closely coupled to the tuning coil. This new winding then becomes the "secondary", which is connected to TR₁. The parts layout chosen should permit mutual coupling between T₁ and

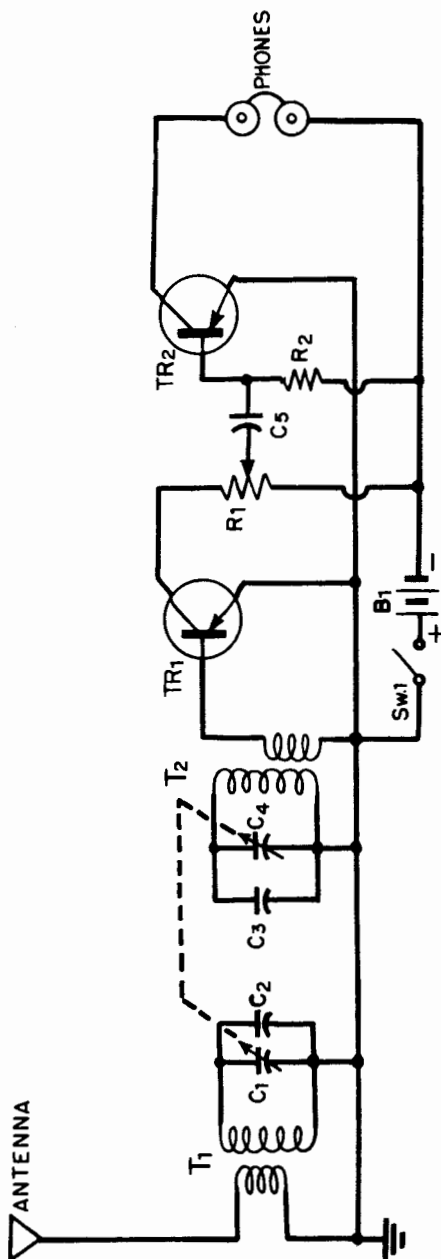

Figure 9-6. A simple broadcast band receiver using two transistors. Parts value are listed below.

TR₁, TR₂ - CBS-HYTRON type 2N38 PNP junction transistors.

T₁ - Standard broadcast band antenna transformer.

T₂ - Modified antenna transformer (see text).

C₁, C₄ - 2-gang, 365 mmf broadcast band variable condenser.

C₂, C₃ - trimmers . . . part of 2-gang condenser.

C₅ - 8 mfd, 25 v. electrolytic condenser.

R₁ - VOLUME control, 25K.

R₂ - 300K, 1/2 w. carbon resistor.

SW₁ - SPST "Off-On" Switch; may be on R₁.

B₁ - 3 volt battery (two pen-light cells in series may be used).

PHONES - 2000 ohm magnetic headset.

CREDIT: Circuit Courtesy CBS-HYTRON.

T_2 , and this coupling should be adjusted for maximum gain consistent with good selectivity.

High impedance magnetic headphones may be connected directly into the collector circuit of TR_2 , as shown. If low impedance phones or a loudspeaker are to be used, however, a small impedance matching transformer must be employed. If crystal headphones are to be used, a 2K to 5K resistor should be connected in the collector circuit of TR_2 , and a .05 mfd coupling condenser used between the headphones and the collector terminal.

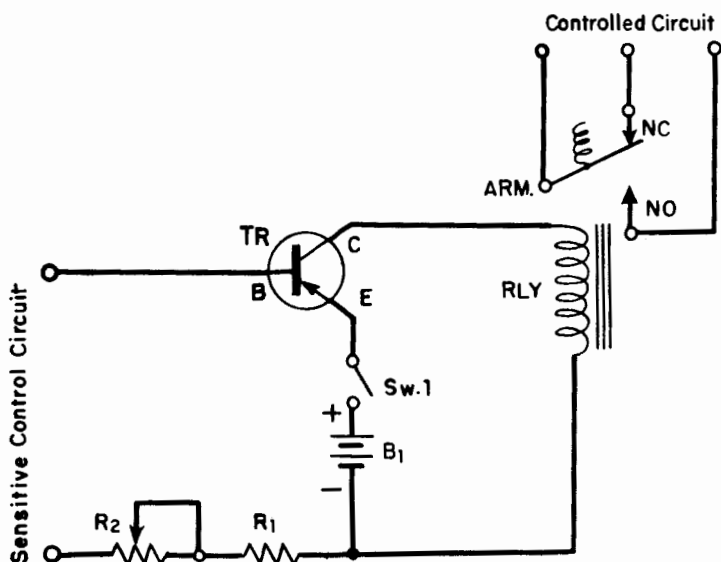

Figure 9-7. A sensitive Relay Circuit. Parts values are as follows:

- TR - RAYTHEON type CK722 PNP junction transistor.
- RLY - High resistance relay, such as ADVANCE type 850 or 1200; Should not require more than 5 ma for coil operation; choose coil resistance to suit battery used.
- B₁ - Battery . . . from 6.3 to 15 volts.
- SW₁ - SPST "Off-On" Switch.
- R₁ - Base current limiting resistor; determine value by Ohm's law for battery voltage used.
- R₂ - 250 K rheostat (SENSITIVITY adjustment).

GENERAL EXPERIMENTAL CIRCUITS

An Ultra-Sensitive Relay Circuit: A direct-coupled common emitter transistor amplifier stage may be used to increase the sensitivity of

a relay by a factor of 10 or 12 to one, using the circuit arrangement shown in Fig. 9-7. Thus, if the relay used normally requires 2 milliamperes coil current to operate, a current flow of only 200 microamperes in the control (base) circuit will permit operation.

The relay chosen should not require a coil current of more than 5 milliamperes, so as not to exceed the maximum collector current rating of the transistor. Battery B_1 should supply sufficient voltage to easily drive the necessary current through the resistance of the relay's coil . . . however, under no conditions should more than 20 volts be used.

Resistor R_1 is a current limiting resistor used to prevent excessive currents through the transistor elements. Its size will vary with the battery voltage used. In general, the resistance value chosen should not permit a current flow of greater than 5 ma. through any of the transistor's elements, even with R_2 turned to minimum resistance (0).

To operate the circuit, close Sw_1 . With R_2 set to its maximum resistance, short the "control circuit" terminals together. Now, gradually reduce the value of R_2 until positive relay closure is obtained. This setting is satisfactory where the "control circuit" has little or no resistance . . . if appreciable resistance is likely to be present in the control circuit, a lower value setting of R_2 may be employed.

The final sensitivity of the completed instrument will vary considerably with the basic relay employed and, to a lesser extent, with the individual transistor used and the battery voltage.

A Photo-Cell Relay Circuit: The Photo-Cell relay circuit shown in Fig. 9-8 represents an adaptation of the Sensitive Relay Circuit given in Fig. 9-7. The operation of the two circuits is almost identical, except that a "self-generating" selenium photo-cell has been substituted for a d.c. voltage source in the base-emitter circuit of the transistor.

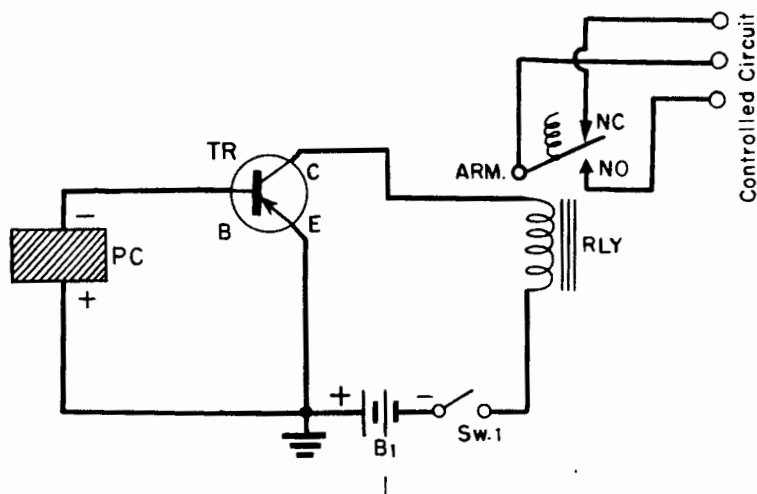

Figure 9-8. A transistorized photo-cell relay. Circuit values as follows:

- TR - RAYTHEON type CK722 PNP junction transistor.
- RLY - Sensitive Relay - ADVANCE type 1200 - choose coil resistance to suit battery voltage used.
- B₁ - Battery - 6.3 to 15 volts.
- Sw₁ - SPST "Off-On" Switch.
- P-C - Barrier type selenium photo-cell.

CREDIT: Basic Circuit Courtesy Radio & Television News.
Adapted from "Transistor-Operated Photocell Relay".

The selenium photo-cell (P-C) used is the same type unit that is employed in photographer's exposure meters. A suitable unit may often be salvaged from a second hand exposure or light meter . . . or purchased from one of the large mail order radio supply houses.

In operation, light striking the photo-cell generates a small d.c. voltage, permitting current flow through the base-emitter circuit of the transistor. This current flow, in turn, permits a correspondingly greater collector current flow, operating the relay. With most photo-cell units, a reasonably strong light source is needed.

As in the preceding circuit, the relay chosen should not require more than a few milliamperes for operation . . . best results are obtained where less than one milliamperes is required. Battery voltage should be suited to relay coil resistance but, again, should not exceed 20 volts.

A Sine-Wave Clipper: When driven with sine-wave signals of sufficient amplitude, the circuit shown in Fig. 9-9 is capable of delivering good quality rectangular waves over the audio band. The output signals obtained are satisfactory for

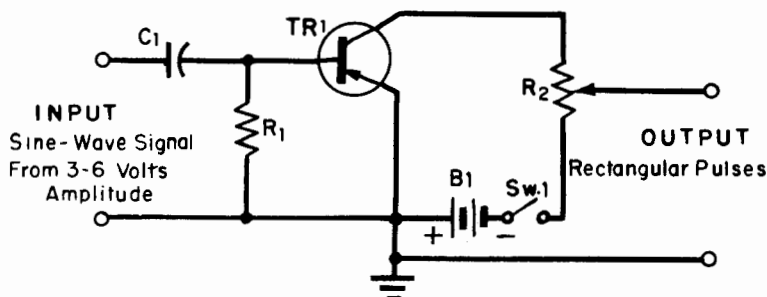

Figure 9-9. A Sine-Wave Clipper using a single transistor. Parts values are as follows:

- TR₁ - RAYTHEON type CK722 PNP junction transistor.
- C₁ - .5 mfd, 200 volt paper tubular condenser.
- R₁ - 18K, 1/2 w. carbon resistor.
- R₂ - 10K pot., OUTPUT LEVEL control.
- Sw₁ - SPST "Off-On" Switch, may be on OUTPUT control.
- B₁ - 15 volt battery.

CREDIT: Circuit Courtesy RADIO & TELEVISION NEWS.
Adapted from "A Transistor Sine-Wave Clipper".

square-wave testing of pre-amps, wide-band amplifiers, filters, and similar audio circuits.

Battery voltage is not critical, but the peak amplitude of the output signal obtained will vary directly with the battery voltage used, assuming that ample signal drive is supplied in every case. If an adjustable output level is not needed, R₂ may be replaced by a fixed resistor, and the output obtained directly from the collector terminal.

In operation, the output signal should be checked with an oscilloscope as the applied sine-wave signal is gradually increased in amplitude. If insufficient drive is supplied, a rounded, rather than a "flat", output pulse will be obtained. If too much drive is used, the output signal will be distorted, and the transistor itself may be overloaded.

TRANSISTORIZED WRIST-RADIO



The transistor wrist-watch receiver is a regenerative, capacitance-tuned set.

TECHNICAL details on the transistorized wrist radio have been released by the Signal Corps. The radio was built to demonstrate the feasibility of constructing a small radio receiver with transistors. The reduced power requirements of transistors as compared to vacuum tubes made it possible to use a very small battery which is included in the wrist case.

The receiver (see photo) uses three transistors; one as a regenerative r. f. stage and two as audio amplifiers. A point-contact transistor (type 1729) is used in the regenerative stage. Regeneration is controlled by varying the coupling between the two coils. A miniature capacitor is used for tuning. The audio is amplified by two p-n-p junction transistors (type TA-153). A bead diode (type 1764) is used as a detector and another one is used as a d.c. return. (Information on the exact commercial equivalents of the transistors and diodes was not available but we understand that the 1729 is similar to the 2N25, the TA-153 is similar to the 2N34, and the diodes (1764's) are roughly equivalent to 1N84's.)

The power supply is a 6.5-volt battery (1/2 x 5/8 inch) consisting of five 1.3-volt RM-412 mercury cells. Battery drain is about 20 milliwatts and battery life about 10 hours. Although in strong

-signal areas no antenna is needed, usually a 1-foot wire should be used. The 2,000-ohm earphone is a small Telex hearing-aid type. The transistors can be replaced without making any circuit adjustments.

The receiver tunes from 1000 to 1600 kc; it has sharp selectivity, and a sensitivity of 50 microvolts. A number of New York stations (35 miles from Fort Monmouth) can be heard quite satisfactorily. When the receiver is in the vicinity of radiators, such as telephones, the reception is improved to the extent that signals from the set can be heard 30 feet from the earphone.

With the addition of a signal audio stage and an output transformer, a loudspeaker could be used. Two stages of audio were needed to compensate for the elimination of the antenna. In metropolitan areas the coils alone will pick up sufficient signal. In the wrist version, the antenna can be built into the strap.

When the receiver is held near the body both the tuning and regeneration are affected by body capacitance. The regeneration should be checked for each tuning adjustment. Regeneration can be more easily controlled electronically than by moving a coil. One method is to insert a small 2,000-ohm potentiometer in series with the collector coil. Another is to use a trimmer capacitor for feedback from collector to emitter. In this case, the collector coil can be replaced with a resistor.

The selection of a power source was primarily determined by the point-contact transistor which operated best with 6 volts. Junction transistors, however, can be satisfactorily operated from a 1-1/2-volt source. With minor modifications, the power requirements can be reduced by a factor of 2.5; and by replacing the point-contact transistor in the regenerative stage with a junction type the requirements can be reduced considerably more.

The publishers thank Radio-Electronics Magazine for information on this transistorized wrist-radio.

CHAPTER X

Appendix

A. Transistor Amplifier Characteristics:

GROUNDING BASE AMPLIFIER:

Input Impedance: Very low.
 Output Impedance: High.
 Power Gain: Moderate to high.
 Current Amplification: Less than 1.0.*
 Frequency Response: Poor.
 Output Signal Phase: In phase with input.

GROUNDING COLLECTOR AMPLIFIER:

Input Impedance: High, but depends on load.
 Output Impedance: Moderate to low.
 Power Gain: Low.
 Current Amplification: Large.
 Frequency Response: Good.
 Output Signal Phase: In phase with input.

GROUNDING EMITTER AMPLIFIER:

Input Impedance: Moderate.
 Output Impedance: Moderate to high.
 Power Gain: High.
 Current Amplification: Large.
 Frequency Response: Moderate.
 Output Signal Phase: Phase reversal occurs.

B. New Transistor Types: - Transistor manufacturers are constantly carrying out development work on new type units. As new types are developed and announced, the electronics technician should obtain technical data and information on them, thus keeping abreast of the field. Some of the types now in the developmental stage are listed below:

PHOTOTRANSISTORS: Although a few phototransistors are currently on the commercial

* For junction transistors

market, new types are being developed. The basic phototransistor may be either a junction or a point-contact unit. They operate somewhat similarly to conventional transistors except that they are basically diode units, with the presence of light energy taking the place of the emitter. . . . thus, light striking the sensitive surface increases the number of electrons and holes, decreasing the resistance of the unit.

ANALOG TRANSISTOR: A theoretical type utilizing a special construction. If production proves practical, this unit should have characteristics similar to those of a vacuum tube.

TETRODE JUNCTION TRANSISTOR: A special junction transistor with improved high frequency response. This is accomplished by reducing the thickness of the center layer of material and adding a fourth electrode lead. The added lead is on the base, directly opposite the normal base connection. A comparatively high bias is applied to this connection, with respect to the regular base lead. The net result is to reduce the conducting area of the base, reducing the effective inter-terminal capacities.

POWER TRANSISTORS: Several manufacturers are developing diffused junction power transistors with increased power handling capacities. Some experimental types are able to handle more than a watt of audio power.

P-N "HOOK" TRANSISTOR: A special type junction transistor employing three junctions (such as a PNP transistor). Theoretically, these transistors may have an alpha greater than 1.0, and may thus provide exceptionally high current gains.

MULTI-PURPOSE TRANSISTORS: Multi-purpose transistors, analogous to multi-purpose tubes, may eventually be introduced. One possible type would combine a PNP and a NPN junction transistor into a single unit, for application in a push-pull stages using the complementary symmetry principle.

C. Commercially available Transistors:--Some of the transistors commercially available at this writing are listed below. Part of the data listed is tentative, however, and revised information is released from time to time. In addition, transistor types, like tube types, may become obsolete as new and improved transistors are introduced. Therefore, the engineer or technician working with transistor circuits should always obtain the latest available technical data directly from the manufacturer.

In the listing below, the following symbols will be used to identify the transistor types: J - junction transistor, with the type given in brackets (PNP), PC - point-contact transistor, PT - phototransistor, TPC - tetrode point-contact transistor.

MANUFACTURER: Transistor Products

TYPE NUMBERS:	2A	2B	2C	2D	2E	2F	2G	
TRANSISTOR TYPES:	PC	PC	PC	PC	PC	PC	PC	
MAXIMUM RATINGS:								
Power Dissipation:	120	120	100	100	100	120	120	MW.
Collector Voltage:	-50	-50	-50	-50	-50	-100	-100	Volts
Collector Current:	-8	-8	-8	-8	-8	-40	-40	Ma.
TYPE NUMBERS:	X-4		X-22		X-23		X-25	
TRANSISTOR TYPES:	PT		J (NPN)		J (NPN)		PT	
MAXIMUM RATINGS:								
Power Dissipation:	--		50		50		--	MW.
Collector Voltage:	--		40		40		--	Volts
Collector Current:	--		5		5		--	Ma.

Note: Type X-4 is a PN junction phototransistor designed for use as a light detector; Type X-25 is an NPN junction phototransistor with a power output of approximately 60 MW.

MANUFACTURER: General Electric

TYPE NUMBERS:	G11	G11A	2N43	2N44	2N45
TRANSISTOR TYPES:	PC	PC	J (PNP)	J (PNP)	J (PNP)
MAXIMUM RATINGS:					
Power Dissipation:	100	100	150	150	150 MW.
Collector Voltage:	-30	-30	-45	-45	-45 Volts
Collector Current:	-7	-7	-10	-10	-10 Ma.

MANUFACTURER: National Union

TYPE NUMBERS:	T18A	T18B	2N39	2N40	2N42
TRANSISTOR TYPES:	PC	PC	J (PNP)	J (PNP)	J (PNP)
MAXIMUM RATINGS:					
Power Dissipation:	120	120	50	50	50 MW
Collector Voltage:	-50	-50	-30	-30	-30 Volts
Collector Current:	-20	-20	-5	-5	-5 Ma.

MANUFACTURER: CBS-HYTRON

TYPE NUMBERS:	PT-2A	PT-2S	2N36	2N37	2N38
TRANSISTOR TYPES:	PC	PC	J (PNP)	J (PNP)	J (PNP)
MAXIMUM RATINGS:					
Power Dissipation:	100	100	50	50	50 MW.
Collector Voltage:	-40	-40	-20	-20	-20 Volts.
Collector Current:	-10	-10	-8	-8	-8 Ma.

MANUFACTURER: Raytheon

TYPE NUMBERS:	CK716	CK718*	CK721	CK722
TRANSISTOR TYPES:	PC	J (PNP)	J (PNP)	J (PNP)
MAXIMUM RATINGS:				
Power Dissipation:	100	-	30	30 MW.
Collector Voltage:	-40	-	-20	-20 Volts
Collector Current:	-4	-	-5	-5 Ma.

*Type CK718 is similar to type CK721, except that it has passed a special noise test. Generally available direct to manufacturers only.

MANUFACTURER: Sylvania Electric Products

TYPE NUMBERS:	2N32	2N34	3N21	
TRANSISTOR TYPES:	PC	J (PNP)	TPC	
MAXIMUM RATINGS:				
Power Dissipation:	50	50	100	MW.
Collector Voltage:	-40	-25	-60	Volts
Collector Current:	-8	-8	---	Ma.

MANUFACTURER: Radio Corporation of America

TYPE NUMBERS:	2N32	2N33	2N34	2N35
TRANSISTOR TYPES:	PC	PC	J (PNP)	J (NPN)
MAXIMUM RATINGS:				
Power Dissipation:	50	30	50	50 MW.
Collector Voltage:	-40	-8.5	-25	25 Volts
Collector Current:	-8	-7	-8	8 Ma.

MANUFACTURER: Radio Receptor Co.

TYPE NUMBERS:	RR14	RR20	RR21	
TRANSISTOR TYPES:	J (PNP)	J (PNP)	J (PNP)	
MAXIMUM RATINGS:				
Power Dissipation:	50	50	50	MW.
Collector Voltage:	-25	-25	-25	Volts
Collector Current:	-5	-5	-5	Ma.

MANUFACTURER: Texas Instruments

TYPE NUMBERS:	100 (100A)	101 (101A)	200	201
TRANSISTOR TYPES:	PC	PC	J (NPN)	J (NPN)
MAXIMUM RATINGS:				
Power Dissipation:	120	120	50	50 MW.
Collector Voltage:	-100	-30	30	30 Volts
Collector Current:	-15	-25	5	5 Ma.



I N D E X

A		Continued	
Alpha, definition	32	Circuits,	
Action, of	19	multivibrator	66
Advantages, of junction type		diagram for	66
transistors	26	oscillator	51-57
transistors	13	photo cell relay	96-97
Amplifiers,		sine wave clipper	98
circuits	36-51	push-pull amplifier	62
grounded emitter type	37	diagram for	63
grounded base type	40	phase inverter	61
grounded collector	41	diagram for	62
coupling transistor	46	sensitive relay	95
multi-stage transistor	48	special common base	54
direct coupled type	61	diagram for	55
diagram	58	special transistor	58-69
Push-Pull circuit	62	tetrode mixer	67
diagram	63	diagram for	67
Phono	88	Clipper, sine wave	60
diagram	89	Coil, Hartley	54
B		Comparison, elements of vacuum	
Base,	27	tubes and transistors	36
Battery vs. Transistor	12	Components	69-77
experimental type receiver		Connections, terminal leads	29
using transistor	12	Construction, point contact types	24
Batteries, mercury	74	methods of	23, 30
photo of	74	Collector,	23, 27
Bias	26	Coupling, means of	46
		use of transistors for	47
C		Current flow, methods	20
Capacitors,	71	Cut off current,	32-33
diagram	72	frequency	33
tantalum	72	Curves, characteristics	35
Capacitance, output	33	Current flow, electron in	
Capacity, resistance	47	transistor circuits	39
Cell, mercury	73	D	
Charges, positive & negative	25	Detector, R-F type	59
Charts, characteristic curves	35	diagram for	58
comparison transistors &		E-F-G	
vacuum tubes	28	Element, polarities	42
Characteristics,	29-35	Emitter, explanation of term	27
analog transistors	100	Emitter	23
commercially available	101	Frequency, cut off	33
grounded base amplifier	99	Free exchange, explanation	22
grounded collector amplifier	99	Graph, relation between gains	44
grounded emitter amplifier	99	Gain, transistors circuits	43
multi-purpose transistor	100	Grid, average potential	37
photo transistors	99	Gain, power	33
P-N hook transistors	100	H	
power	100	Hearing aid, batteries for	73, 90
Chronology,	16-18	diagram for	91
Circuits,	36-51	"Hole", explanation of	21
amplifier	36	I-J-K-L	
analogous transistor	40	Impedance,	33
audio	87	matching	48
blocking oscillator	56		
diagram for	52		
d-c amplifier	58		
diagram for	58		
electron flow in	39		
flip-flop	65		
diagram for	64		

