

**AUDELS**

**RADIOMANS**

**GUIDE**

*Covering*

**R A D I O**

**T E L E V I S I O N**

**I N D U S T R I A L**

**E L E C T R O N I C S**

**P U B L I C A D D R E S S**

**S Y S T E M S**

*by*

**E. P. Anderson**

**AUDELS**  
**RADIOMANS**  
**GUIDE**

COVERING  
**THEORY**  
**CONSTRUCTION**  
AND  
**SERVICING**  
INCLUDING  
**TELEVISION**  
**ELECTRONICS**

*By*  
**EDWIN P. ANDERSON**



**THEO. AUDEL & CO., PUBLISHERS**  
**49 WEST 23<sup>RD</sup> STREET., NEW YORK 10, N.Y.**

AUDELS RADIOMANS GUIDE

COPYRIGHT

1939, 1940, 1942, 1944, 1948, 1952

THEO. AUDEL & CO.

NEW YORK

*All Rights Reserved*

Printed in the United States

# FOREWORD

THIS BOOK, the author believes, will be of the utmost service, not only to the student and radio-electrician, but to anyone who wishes to be informed on this important field of science.

Radio equipment cannot be serviced or maintained by any predetermined set of rules or formulae, but it is necessary rather to understand the principles of electricity, radio and sound.

The main object throughout has been to present as briefly and clearly as possible a progressively arranged treatise with special emphasis on the fundamentals of radio, upon which all knowledge necessarily rests.

In view of the importance of radio in the field of air and marine transportation, several chapters dealing with marine and aircraft communications as well as the principles of the automatic alarm and the radio compass have been included.

It is hoped that the numerous illustrative examples which are introduced throughout the book, may in conjunction with the data supplied, suggest proper treatment of practical problems in design of radio apparatus.

EDWIN P. ANDERSON.

# LIST OF CHAPTERS

---

<i>Chapter</i>	<i>Pages</i>
1 Radio Principles.....	3- 8
2 Physics of Sound.....	9- 22
3 Radio Fundamentals and Ohm's Law.....	23- 58
4 Review Questions and Answers.....	59- 84
5 Radio Batteries.....	85-108
6 Electrical Measuring Instruments.....	109-144
7 Power Supply Units.....	145-164
8 Resistors, Inductors and Condensers.....	165-184
9 Transformers.....	185-198
10 Broadcasting Stations.....	199-214
11 Principles of Radio Telephony.....	215-220
12 Vacuum Tubes.....	221-250
13 Radio Receivers.....	251-296
14 Radio Circuit Diagrams.....	297-320
15 Radio Receiver Construction.....	321-328
16 Control Systems.....	329-358
17 Loud Speakers.....	359-374
18 Antenna Systems.....	375-394
19 Automobile Antennas.....	395-402
20 Phonograph Pick-Ups.....	403-416
21 Public Address Systems.....	417-454
22 Aircraft Radio.....	455-480

**DIODE**  
(2 ELEMENT TUBE)

**TRIODE**  
(3 ELEMENT TUBE)

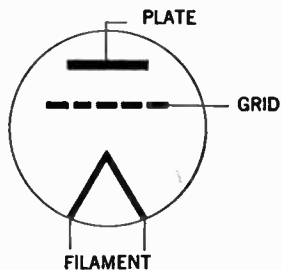
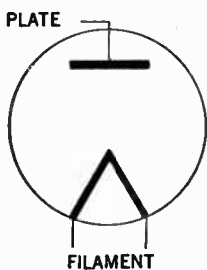
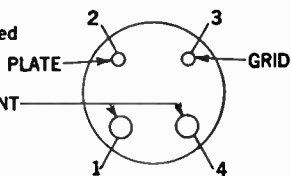
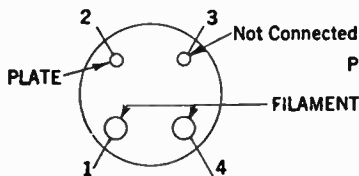
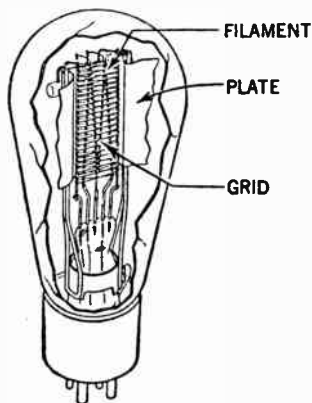
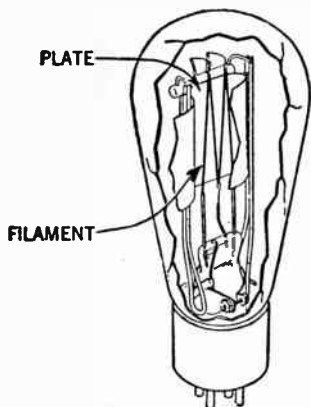

**Views of two and three element vacuum tubes showing arrangement of prongs and wiring symbols (For details see chapter 12)**

WDYN FM7 Stations 89.7

WSMC Ed. College 90.7

WDEF Chattanooga 92.3

WDOD - '91 96.5

WCLF Cleveland 100.7

WRIP Rossville 105.5

~~WLOM~~ Chattanooga 106.5

WKES Chatt. Keswick 88.9

WSIM Red Bank 94.3

Blue Ridge Ga 109.2 ?

WMBW 88.9 Moody Bible Inst.

Atlanta 96.5

WQXI 94.5

WVEE Marietta Ga. 102 KC.

WTPK Blue Ridge Ga. 104.2 11

<i>Chapter</i>		<i>Pages</i>
23	Marine Radio Equipment.....	481-494
24	The Radio Compass.....	495-508
25	Radio Beacons.....	509-518
26	Automatic Radio Alarm.....	519-534
27	Short Wave Receiver Principles.....	535-554
28	Coil Calculations.....	555-560
29	Frequency Modulation.....	561-574
30	Radio Testing.....	575-638
31	Cathode Ray Oscillographs.....	639-660
32	Radio Trouble Pointers.....	661-692
33	Television Antennas.....	693-728
34	T.V. Controls; Test Patterns and Adjustments	729-750
35	T.V. Broadcasting.....	751-770
36	T.V. Receiver Circuit Fundamentals.....	771-776
37	T.V. Circuit Description.....	777-806
38	T.V. Picture Tubes.....	807-826
39	T.V. Trouble Shooting.....	827-840
40	Photo-electric Cells.....	841-862
41	Phototube Amplifiers.....	863-872
42	Phototube Relays.....	873-896
43	Application of Electronic Devices.....	897-964
44	Radar Fundamentals.....	965-1,008
45	Underwriter's Standards.....	1,009-1,028
46	Radio Data.....	1,029-1,040



*Any one, and more especially the attentive student, can with the least trouble avail himself of the subject matter contained in this work by doing as indicated in the following old English couplet quoted by Chas. Reade.*

***“For index-reading turns no student pale,  
Yet takes the eel of science by the tail.”***

# INDEX

## For Quick Reference in Answering Your Question or Problem

### A

- "A" Batteries..... 87  
Abbreviations..... 1,036  
A.C.-D.C. light quantity-metering  
circuit diagrams..... 928  
power supply..... 145  
A.C. high speed photo-electric  
relay..... 907  
illumination ratio measurement,  
circuit diagram..... 930  
light balance indicator, circuit  
diagram..... 923  
quantity metering, circuit  
diagram..... 921  
theory..... 922  
operated, two stage, photo-electric  
relay circuit diagram..... 912, 913, 915  
parallel circuits..... 47  
series circuits..... 42-46  
Acoustics..... 440  
Aerials..... 375  
protector..... 383  
wave-lengths..... 378, 379  
Aircraft, radio..... 455-480  
altitude calculations..... 478  
beacon diagram..... 457  
beacon operation..... 456  
compass assembly diagram..... 464  
diagram of blind landing..... 475  
indicating instruments..... 470  
instrument panel arrangement..... 472  
landing beam advantages..... 474  
landing beam receiver diagram..... 473  
loop antenna control unit..... 466  
position finder..... 467  
radio compass position finder..... 463  
radio compass navigation..... 462  
sonic altimeter diagram..... 479  
sonic altimeter principles..... 476, 477  
visual landing aid..... 468  
Air type condensers..... 177, 180  
Alignment procedure..... 580  
Alternating current..... 42-54  
effective values..... 294  
meters..... 130-137  
root-mean square value..... 293  
Altimeters..... 476  
Ammeters..... 118  
hot wire type..... 71, 130  
how to connect..... 118, 131  
Ampere..... 32, 1,038  
definition of..... 1,038  
hour, definition of..... 1,039  
per second..... 32  
turns..... 191  
Amplification factor..... 59  
Amplification of voltage..... 170  
Amplifiers..... 259, 427  
audio (See Audio Frequency  
Amplifier)  
circuit, speech..... 199  
coupling, impedance type..... 263, 283  
coupling, resistance type..... 262, 282  
dynamic..... 66  
intermediate frequency..... 280  
"motor-boating" of..... 287-289  
operation characteristics class "B"  
circuit..... 261  
push pull type..... 265  
radio frequency..... 262  
ratings..... 428, 430  
various types..... 259, 260  
Analyzers..... 578, 579  
commercial types..... 587-638  
how to use..... 576-638  
Angstrom unit..... 658  
Anode..... 59  
Antenna..... 375-394  
apartment house type..... 390, 391  
automobile..... 395-402  
broadcasting..... 200, 201  
cage type..... 389  
chart, frequency modulation..... 562  
circuits, frequency modulation 565-570  
doublet type..... 382  
erection..... 376, 377  
fan type..... 390  
frequency..... 68, 378  
ground..... 69, 385, 386  
installation..... 376, 377  
insulators..... 380, 381  
lead-in..... 381-385  
lightning arrester..... 384, 385  
loop type aircraft..... 465  
modulation..... 203  
natural frequency and wave-  
lengths..... 378

# Ready Reference Index

Antenna—continued	
radiation formula.....	1,034
shipboard.....	492
spacing.....	382, 393
television type.....	693-728
theory of tuning.....	377
transformer.....	384
variometer tuned aerial.....	378
wave-length.....	378, 392
wire size.....	380
Arrester, lightning.....	384, 385
Atoms.....	23
Attenuation.....	60
Audio frequency amplifiers.....	282-285
transformer.....	60
waves.....	60
waves, length of.....	60
Audio transformer testing.....	692
Autodyne reception.....	60
Automatic frequency control.....	329
frequency discriminator.....	329, 331
tone control.....	357
volume, control.....	60
Automatic radio alarm.....	519-534
basic elements.....	521
characteristics.....	519, 520
false alarms.....	524
log entries.....	531
maintenance and repairs at sea.....	531
operating instructions.....	529
operations of warning lights.....	530
selector unit.....	524
sensitivity control adjustments.....	529
testing.....	533
typical installation.....	528
warning apparatus.....	522
wiring diagrams.....	518, 526
Automobile antennas.....	395-402
di-pole type.....	399, 400
folding top type.....	397
lead-in.....	400
metallic screen.....	396
method of installation.....	396
plate type.....	399
roof type.....	396
triangular types.....	401
under-car types.....	398
V-types.....	402
Automobile ignition system diagrams.....	672
radio diagrams.....	302
Automobile radio interference.....	671, 708
by-pass condenser.....	673
cable bonding.....	674
distributor suppressor.....	673
generator condenser.....	673

Automobile interference—continued	
grounding of engine.....	675
high tension lead shielding.....	673
noisy operation, causes of.....	676
weak pick-up, causes of.....	676

## B

Baffle board.....	10, 372
Baffle, definition of.....	61
loud speakers.....	371
Batteries.....	85-108
charging "B".....	105-107
charging from 32 volts.....	104
charging from 110-220 volts.....	103
charging methods.....	96-107
charging set-up.....	100
classification.....	85
connection of.....	108
current drain.....	88
determination of polarity.....	103
hydrometer readings.....	91
specific gravity.....	91
testing.....	87
"B" batteries.....	87, 90
"B" power supply.....	61
Beacons, radio.....	456, 509-518
Beam current.....	654
voltage.....	654
Bellini, radio compass.....	503, 504
Bleeder resistors.....	158
Blue sensitive phototube.....	854
Brass.....	18
Broadcasting.....	61
Broadcasting stations.....	199-214
antenna.....	200, 201
band spread.....	553
diagram.....	208
power supply.....	208
principles.....	201, 202
rectifiers.....	208
speech input equipment.....	200
Bridge, Wheatstone.....	140
Brilliance, relative.....	658
Burgess selenium type cell.....	848
By-pass, condenser.....	62

## C

"C" battery.....	87
"C" power supply.....	62
Cable extension tuning system.....	338

# Ready Reference Index

- Cage type antenna..... 389  
Calculation of frequency modulation antennas..... 574  
Calculations, transformers..... 188-192  
Calorie..... 1,039  
Camera, television type..... 763  
Candle power distribution..... 655  
Capacitance, direct..... 65  
    formula..... 555  
    inter-electrode..... 71, 242  
Capacitive reactance formula..... 1,033  
Capacity, coupling..... 62  
    how to measure..... 582  
    operated, relay circuits..... 945-949  
    resistance chart..... 584  
Carbon, microphone..... 62  
Carrier, frequency..... 62  
    suppression..... 62  
    wave..... 62, 63  
Cathode, definition of..... 63  
    voltage..... 593  
Cathode ray oscillograph..... 639-660  
    application of..... 639, 653  
    connection diagrams..... 645, 647  
    fundamental parts..... 643, 644  
    various types..... 643-650  
Cathode ray tube..... 639  
    beam current..... 654  
    beam voltage..... 654  
    candle power distribution..... 655  
    definitions..... 654-660  
    defocus..... 655  
    electro-static deflection sensitivity..... 685  
    spot size..... 684  
Charging "A" batteries..... 101  
Charging methods of battery..... 95-107  
Chart, watt, resistance-voltage..... 184  
Choke coil..... 204, 545, 546  
Circuit diagrams..... 297-320  
    automobile radio..... 302, 304, 306  
    ..... 307, 312  
Code colors..... 182  
    Morse..... 1,040  
Coaxial cable..... 700  
Coefficient of coupling..... 174  
Coil design calculation..... 555  
    formulas..... 556-559  
    length..... 557  
    plug-in type..... 560  
    single layer..... 557  
    various types..... 558  
Commercial analyzers..... 587-638  
Comparison of various photo-tubes..... 850, 851  
Compass, radio..... 495-508  
Compensating unit, voltage type..... 691  
Condensers..... 176-182  
    air type..... 177-181  
    blocking..... 284  
    by-pass type..... 62  
    commercial types..... 181  
    connections..... 177, 178  
    electrolytic..... 177  
    examples on..... 182  
    ganged..... 181  
    grid type..... 69  
    mica..... 177  
    plates..... 178, 179  
    shape of rotor plates..... 180  
    straight line capacity..... 178  
    vernier..... 179  
Conductors..... 28  
Conduit wiring..... 448  
Connection diagrams..... 297-320  
Connection of meters..... 109-144  
Converter..... 64  
Copper losses..... 195  
    wire table..... 198  
Cord resistors..... 156  
Core type transformers..... 193  
Cross bearings, diagram..... 507  
Cross modulation..... 64  
Coulomb, definition of..... 1,038  
    formula for..... 32  
Counterpoise ground..... 387  
Coupling co-efficient..... 174, 185  
    definition of..... 64  
    degree of..... 174  
    direct..... 65  
Crystal mounting..... 212  
    natural quartz..... 211  
    oscillator circuit..... 214  
    pick-ups..... 409  
Current amplification..... 64  
    formula for..... 170  
    measurements..... 109-144  
    pulsating type..... 77  
Cycle, definition of..... 64
- ## D
- Damped waves..... 64  
D'Arsonval galvanometer..... 111, 112  
D. C. high speed photo-electric relay cabinet..... 935  
    circuit diagram..... 936  
    light-intensity indicator, circuit diagram..... 916

# Ready Reference Index

D. C. high speed relay—continued	
light variation indicator, circuit diagram	919
matching measurement indicator, circuit diagram	926
voltage, circuit diagram	932
Decibel	429-431
Detection	65
linear	72
power	76
Detector	65, 271
diode	271-275
diode characteristics	273
grid bias	271, 276
grid leak	277
Diagnometer	615
Diagrams (Receivers)	297-320
vector	167, 168
Di-pole antennas, frequency modulation	571-574
Direct current	66
instruments	116
power supply	152
Direction of current flow	29
Discriminator circuit, frequency modulation	570
Distortion	66
Diode	65, 233
Dividers of voltage	154
Doublet, antenna	382
Double modulation	66
Dry cell	90, 92
Dynamic amplifier	66
speaker	362
Dynamotor	218

## E

Ear, internal structure of	21
Edison effect	226
Eddy current loss	195
Efficiency	196
Electric current	28, 29
instruments	109
lamp, resistance of	144
pressure	30, 31
tuning (See Push Button Tuning)	
Electrical conductors	28
insulators	28
Electrical effects	963
Electro-chemical, current measurements	114

Electrodes	29
Electro-dynamometer	135
Electro-magnetic field	4
Electromotive force	31
Electron control	29, 233
direction of	29, 240
emission	67
gun	640, 808
ray indicator tube	286
theory	23-33
Electronic devices, applications of	897-964
Electronic Television (See Television)	
Electrons	25, 26
Elimination of modulation hum	683
E.M.F.	174
Emission characteristics	67
Energy, source	199
Exponential horns	360, 431
External leakage mitigation	917

## F

Fading	684
definition of	67
Farad, definition of	1,038
Facsimile transmission, definition of	67
Fidelity	67, 690
Filament	68, 231
power consumption	143
supply	154
Filter chokes	150
choke-input	150
condensers	150
function of	68
scratch	413
systems	150
Fluorescent patterns	641
Flux	188
density	188
Formulas	1,032-1,034
Frequency	188
definition of	68
resonance	168
v.s. wave-length	539-542
Frequency modulation	560-574
antennas	572
block diagram	564
discriminator circuit	570
distance covered by transmitter	562
fundamental principles	561
intermediate frequency amplifier	565

# Ready Reference Index

Frequency modulation—continued	
limiter circuits.....	567-569
stage.....	566
tubes.....	568
station call letters.....	562
location chart.....	562
wave lengths.....	561
Frequency of sound waves.....	563
Full wave rectifier.....	148, 156

## G

Gain.....	429
decibels.....	429
Galvanometers.....	109-113
D'Arsonval.....	111
coil.....	112
coil deflection.....	113
construction principles.....	110
examples on.....	41
reading method.....	113
tangent.....	109-111
Ganged type condensers.....	177
Garage door opener.....	939
Gas phototube.....	845, 882
Gas tube switch.....	943
Gaseous type characteristics.....	847
Generator.....	31
Good-Bad scale.....	618, 626
Gram-calorie.....	1,039
Grid bias, calculation of.....	291
detectors.....	271, 276
definition.....	289
example on.....	54, 55
resistors.....	290
resistor value.....	290
using speaker field.....	291
Grid condenser.....	69
current measurement.....	592
definition of.....	69
leak detectors.....	277
resistance.....	55, 56
test.....	592
voltage measurement.....	589
Grid controlled glow discharge tube.....	908
Ground (antenna system).....	385, 386
wire.....	70

## H

Half-wave rectifiers.....	148, 156
Hand-capacity effect.....	830
Harmonic waves.....	70, 271, 544
Hartley type oscillator.....	206
Heater.....	70
voltage.....	588
Heaviside layer.....	5, 547
Heising modulation method.....	205
High frequency reception.....	538
Helium atom.....	25
Henry, definition of.....	1,038
Heterodyne reception.....	70
High fidelity, definition of.....	690
Homodyne reception.....	70
Horns, exponential.....	360, 431
Horse power, definition of.....	1,038
Hot-wire ammeter.....	71
instrument, construction of.....	132
Hydrogen atom.....	24
Hydrometer.....	91
Hysteresis loss.....	195

## I

Iconoscope.....	760
Ignitron, mercury rectifier.....	884
tube.....	884
Impedance coupling.....	263, 283
formula.....	46
triangle.....	44
Inductance formulas.....	555
mutual.....	172
Induction type loud speaker.....	71, 365
Inductive measurements.....	585
reactance formula.....	42, 1,033
Instruments 109-144 (See also pages 607-692)	
hot wire type.....	130-132
musical.....	18
scales.....	118, 133
Insulation, transformers.....	194
Insulators.....	28
antenna.....	380
Interference.....	71, 662
how to eliminate.....	663-677
in automobile radio.....	671-677
suppressors.....	665
Interlaced scanning.....	753

# Ready Reference Index

Intermediate frequency	71, 565
amplifiers	280, 281
Intermodulation	72
International Morse code	1,040
standard units	1,038, 1,039
Interrupted, continuous waves	72
Inter-stage coupling, examples on	52
Ion, definition of	72
Iron losses	195

## J

Joule, definition of	1,038
----------------------	-------

## K

Kennelly-Heaviside layer	5, 547
Kilo-cycles	72, 176, 537
lines	188
Kilo-cycle conversion tables	539-542
watt	37, 1,038
Kinescope	763
Kinetic theory	28
Kolster, radio compass	500

## L

Landing beam, receiver diagram	473
Lead-in	72
antennas	381
lead of current	166
Lenses, condensing type	951
objective type	951
Light beam	844
sensitive metals	841
Light, velocity of	536
Lightning arrester	384, 385
Limiter circuits, frequency modulation	567-569
stage, frequency modulation	566
Loading coil	73
Logarithm, definition of	429
Loss	429
Loud speakers	359-374
balanced armature unit	363, 366
baffle	371-374
baffle length calculation	373
baffle purpose	373

Loud speakers—continued	
condenser type	63, 370
conical horn	360
connection diagrams	364-371
coupling system	364, 365
diaphragm	359
dynamic type	362
efficiency	359
electro-static type	368, 369
exponential horn	360
field coil	362, 363
horn shapes	360
induction type	71, 365
magnetic type	73, 361
metal strip type	368
moving coil type	75
speaker parts	359
Piezo-electric type	370
public address system	417-454
resonant frequency	374
voice coil	363
Luminescence	657

## M

Magnetizing current	192
Magnetic field	4
flux	173
leakage	195
Marine radio equipment	481-494
equipment required	483
forms of signalling wave	486
high powered transmitters	486
low powered transmitters	486
power equipment	493
ship antenna	492
typical receiver	493
typical transmitters	487-493
Marker beacon, receiver	460
Master oscillator	73
Matter, structure of	23
Measurements, examples on	141-144
Medium wave coils	560
Meg	1,032
Mega-cycle	73, 537
Mercury vapor, rectifier	208
Meter	1,037
construction	117
definition of	1,037
range	122
Meters, series resistance	123
connection of	118-136
current consumption	132

# Ready Reference Index

Mica type condensers.....	177
Micro-ammeter.....	844
Micro-farad.....	1,039
Micro-micro-farad.....	1,039
Micro-henries.....	175, 1,039
Microphones.....	437-440
carbon type.....	437
definition of.....	74
Milli-ammeter.....	134
Milli-henry.....	1,039
Mixer tube.....	74
Modulation.....	203
antenna.....	203
double.....	66
grid.....	203
Heising's method.....	205
plate.....	205
Modulator circuit.....	199
Molecules.....	23
Monochromatic sensitivity.....	74
Morse code.....	1,040
Motor speed, phonograph.....	410
Motor-generator interference.....	667
Moving armature, speaker.....	74
Mu-factor.....	75
Musical sound.....	15
Mutual inductance.....	172
example on.....	175
Mystery control system.....	346
stepper assembly.....	353
tuning circuit.....	352
volume control assembly.....	354

## N

Natural frequency.....	68
wave-lengths formulas.....	556
Neutron.....	24
Neon sign.....	671
interference elimination.....	669
Noise, suppression.....	661-686
(See also Radio Interference)	

## O

Ohm.....	32
definition of.....	1,037
Ohm's law.....	33, 1,032
A.C. circuits.....	46
parallel circuits.....	34, 38
series circuits.....	33

Ohmmeters.....	139, 596
Oscillator.....	622, 631
characteristics.....	207
circuit.....	199, 204
crystal.....	211
definition of.....	75
master.....	73
tracking condenser.....	581
Oscillatory circuit.....	75, 415
Over-heating of power transformer.....	679
Output meters.....	581, 594
test.....	593

## P

Pattern distortion.....	658
Parallel circuits.....	35, 39
connection of condensers.....	176
Plate current.....	590
voltage.....	589
Pentagrid converter tube.....	281
Pentode tube.....	75
Petoscope.....	849-957
circuit diagram.....	952, 956
special applications.....	955
Philco mystery control.....	346
testing instruments.....	631
Phonograph pick-ups.....	403-416
connections.....	412, 413
cross-section of pick-up.....	407
crystal.....	408
high impedance.....	412
impedance values.....	407
oil damped.....	408
operation principles.....	404
motor speed.....	410
motor governor.....	411
oscillator diagrams.....	414-416
Piezo-electric.....	408
parts of rubber damped pick-up.....	406
reproduction of scratch.....	413
rubber damped.....	404
scratch filter.....	413
speed adjustment of turntable.....	410
Phosphor.....	659, 819
Photo-conductive tubes.....	844
electric cell.....	841-862
electric relay, circuit diagrams.....	873-896
emissive tubes.....	844
sensitive materials.....	842, 843
voltaic cells.....	849
voltaic tubes.....	844



# Ready Reference Index

- Phototube, amplifiers..... 863-872  
A.C. operated, reverse circuit..... 866  
battery operated, forward circuit..... 865  
reverse circuit..... 865  
condenser coupled..... 868, 869  
direct current..... 867  
forward circuit..... 866  
grid resistor function..... 867  
multistage..... 868  
one-stage..... 864  
resistance coupled..... 869  
transformer coupled..... 868  
Phototube, cascade connection of..... 875  
cesium-oxide..... 852  
characteristics..... 966  
chassis..... 876  
circuit closing type..... 873  
diagrams..... 864-962  
opening relays..... 873  
circuits, miscellaneous..... 958-962  
communication type..... 874  
construction..... 845  
current carrying capacity..... 874  
definition of..... 76  
dimensions..... 846  
filters..... 852-858  
gas ratio..... 847  
glow discharge tube..... 879  
high speed light relay..... 876  
mounting..... 876  
operation..... 876  
plate characteristics of vacuum  
type..... 917, 920, 927  
potentiometer..... 876  
relay, amplifier tube..... 876  
relays..... 873-896  
sensitivity..... 66  
terminals..... 876  
thyatron electronic relay..... 879  
tube..... 879-881, 887-896  
construction..... 887-889  
transformer..... 876  
vacuum type..... 845, 846  
Plotron tube..... 883  
Plug-in coils..... 560  
Polarity determination..... 103  
Positrons..... 23-26  
Potential difference..... 31  
Power..... 36  
amplification..... 76  
factor..... 44, 137  
measurement..... 136  
transformer, over-heating..... 679  
unit..... 94  
Power supply units..... 145-164  
calculations..... 158-164  
Power supply units—continued  
complete..... 151, 154  
cord resistors..... 156  
diagrams..... 148, 150, 161  
filament arrangement..... 153  
resistors..... 157  
Power transformer..... 185-198  
Primary of transformer..... 185  
Protons..... 24  
Public address systems..... 417-454  
acoustic considerations..... 440  
amplifier diagram..... 419, 427  
amplifier ratings..... 428  
amplifier unit..... 426  
amplifying equipment..... 424  
causes of low volume..... 446  
decibel..... 429  
Public address system effect of faulty  
tubes..... 447  
how to place speakers..... 443-446  
location of apparatus..... 434  
loud speakers..... 431-434  
loud speaker connections..... 682  
low field excitation..... 447  
low line voltage..... 446  
low speaker field voltage..... 446  
method of installing outlets..... 435  
microphones..... 437-440  
music reproducing system..... 418  
open coils in speakers..... 446  
operation theory..... 419  
over-loaded speakers..... 447  
poor sound quality..... 447  
program sound system cabinet..... 422  
rules for antenna wiring..... 420  
schematic layout..... 420  
sound absorbing materials..... 442  
typical transmitter..... 421  
unresponsive microphones..... 447  
wiring of equipment..... 449  
communication equipment..... 450  
conduits..... 448  
receiver units..... 448  
Push button tuning systems..... 337  
condenser control..... 345  
mechanical accessories..... 344  
motor operated condenser type..... 338  
motor tuning..... 342  
pre-set switch selected condenser  
type..... 340

# Ready Reference Index

## R

- Radar fundamentals..... 965-1,008  
Radial distance covered by F.M. .... 562  
Radiation interference..... 662-677  
Radio alarm on ships..... 519  
Radio beacons..... 509  
  Classes A, B, C..... 511, 512  
  code machine..... 515  
  compass..... 495  
  equipment..... 512  
  power and range..... 511  
  power supply..... 515  
  synchronizer..... 514, 516  
  time schedules of signals..... 511  
  transmitter..... 513  
  warning device..... 517  
Radio compass..... 495-508  
  Bellini type..... 503  
  Bellini type, diagram..... 504  
  chart..... 505  
  cross bearing diagram..... 507  
  example on cross bearings..... 506  
  Kolster compass..... 508  
  Kolster type, diagram..... 500, 501  
  loop antenna..... 495  
  navigation..... 462  
  operating principle..... 495  
  shipboard installation..... 498  
Radio communication..... 6  
  diagrams..... 298-320  
  equipment, marine..... 481  
  frequency..... 77  
  amplifier, Impedance coupled..... 262  
    transformer coupled..... 264  
    various circuits..... 263, 264  
  amplification vs. selectivity..... 266  
  choke..... 545, 546  
  conversion..... 270, 271  
  transformer calculation..... 558  
fundamentals and Ohm's law..... 23-58  
interference..... 662-677  
  fading, causes of..... 684  
  modulation hum..... 683  
  sound distortion..... 683  
  receiver, definition of..... 77  
  shipboard type..... 493  
Radio transmission..... 78  
  telephone..... 215-220  
    control unit..... 218  
    laws..... 217  
    marine radio..... 218  
    power unit..... 218  
  testing..... 575-638  
Range of F.M. receiver..... 563  
Ratio of turns..... 191  
Reactance..... 42  
Readrite, testing instruments..... 626-629  
Receivers..... 251-296  
  alignment..... 580  
  automobile..... 302  
  circuit diagrams..... 297-320  
  control device..... 941-944  
  construction..... 321-328  
  drilling large holes..... 326  
  drilling layout..... 325  
    final development of chassis..... 325  
    guiding principles..... 328  
    how to bend the metal..... 323  
    layout of work..... 324  
    soldering..... 327  
    tapping of holes..... 326  
    tools required..... 321  
    wiring..... 327  
  fidelity..... 257  
  fidelity characteristics..... 258  
  performance characteristics..... 251  
  regenerative..... 267  
  selectivity..... 253  
    characteristics..... 254  
    measurements..... 253  
  sensitivity..... 254  
  super-heterodyne..... 255, 298-320  
  super-infra regenerative..... 251  
  super-regenerative..... 251, 545  
Rectifiers, definition..... 78  
  connections of..... 148  
  full-wave..... 68  
  half-wave..... 70  
  system..... 209  
  tubes..... 149  
  (See also Vacuum Tubes)  
  tube installation..... 210  
  units..... 94, 154  
Reconnection of transformer..... 678  
Reeds..... 18  
Reflex circuits..... 78, 279  
Relative actinic energy..... 659  
  luminous energy..... 659  
  radiant energy..... 658  
Remote control system..... 346-355  
Reproducing system..... 418  
Regeneration..... 78, 267  
Regenerative receiver..... 546  
Resistance, capacitance in series..... 167  
  arrangement..... 125  
  capacity chart..... 584  
  code..... 183  
  combinations..... 33, 35  
  coupling..... 262, 282

# Ready Reference Index

Resistance, capacitance—continued	
formulas.....	35, 1,032
formula application.....	36
inductance, capacity in series.....	166
inductance in series.....	167
measurements.....	137-144
parallel connection of.....	35
series connection of.....	33
unit.....	32, 1,037
voltage, watt chart.....	184
Resistors, calculations.....	155
classes in use.....	687
code colors.....	182
for power supply.....	157
inductors and condensers.....	165-176
Resonance.....	7, 48
formulas.....	168
frequency.....	79, 168
frequency and wave-length.....	175
frequency formulas.....	49, 555
Rheostat.....	79
R.M.A. code colors for resistors.....	183
television standards.....	758
R.M.S. (root mean square).....	293

## S

Scale deflection.....	129, 142
Scanning.....	752
head.....	818
Scratch.....	413
filter.....	413
filter connection.....	413, 680
Screen fluorescence.....	656
grid, function of.....	79
Screens.....	641, 763
Secondary emission.....	79
of transformer.....	185
Selectivity, definition of.....	79
of tuned circuits.....	165
Selenium cell.....	848
Self-induction.....	172
Sensitivity control.....	350
definition of.....	79
Series circuits.....	33
connection of condensers.....	176, 177
Shell type transformers.....	194
Ship antenna.....	492
Short wave antennas.....	572, 693-728
band spread coils.....	558, 689
chart time difference.....	551
circuit diagrams.....	545, 546

Short wave antennas—continued	
coils, assembly of.....	560
coil calculations.....	555-560
coil switching.....	689
communication.....	535
distance reception.....	548, 549
frequency spread.....	553
frequency vs. wave-length.....	539-542
ground wave.....	546
hand-capacity.....	538
megacycle.....	537
plug in coils.....	560
receivers.....	535
receiver operation.....	535-554
reception.....	535
regenerative receiver.....	546
seasonal changes, effect of.....	550
skipping.....	547, 550
sky wave.....	546
super-regenerative receiver.....	545
tickling coil.....	543, 546
time chart.....	551
tuning.....	543
ultra high frequencies.....	535
wave propagation.....	547
wiring of.....	538
Shunts.....	131
Signal desired.....	171
generators.....	622, 630
Smoothing filters.....	152
Sound.....	9
amplitude.....	14
baffle board.....	10, 372
characteristics of.....	13
cycles.....	18
generation of.....	10
measurement of.....	429
on film, circuit diagram.....	931
orchestra.....	18
oscillation.....	10
physics of.....	9-22
pitch, definition of.....	14
pitch, ratio.....	16
quality of.....	17
reference level.....	430
reflection of.....	13
tone, definition of.....	16
wave length.....	19
Spark plug suppressors.....	674
Specific gravity.....	91
Spectral characteristics.....	852-858
Spectrum.....	727
Speech.....	20
input equipment.....	200
Spot diameter.....	654
Standard for radio receivers.....	1,009-1,028

# Ready Reference Index

Step-down transformers.....	186
Stopping condenser.....	81
Strain insulators.....	381
Substances, positive and negative.....	26
Supply systems A.C.....	145
Super-heterodyne.....	255, 298-320
definition of.....	81
Super-regenerative receiver.....	545
Supreme testing instruments.....	607-623
Symbols.....	1,030, 1,031

## T

Tangent galvanometer.....	109
Telegraph transmitter, radio.....	484
Telephone, broadcasting.....	215
radio.....	215
receiver.....	81
Television.....	693-840
antennas.....	693-728
aspect ratio.....	736
Television.....	693-840
antenna calculation.....	701
audio defects.....	830
broadcasting.....	751-770
broadcasting practices.....	767
camera tubes.....	760-767
circuit diagram.....	838, 839
composite signal standards.....	758
controls.....	727-750
deflection yoke adjustment.....	750
dual switch operation.....	731
electron gun.....	808
focus coil adjustment.....	749
frequency bands.....	755
fringe area reception.....	722
halation.....	814
iconoscope camera.....	763
ion trap adjustment.....	749
picture scanning.....	811-814
picture tubes.....	807-826
picture tubes, handling of.....	825
picture tube assembly.....	747
picture tube, data chart.....	818
picture tube replacement.....	824
raster defects.....	829
receiver circuit description.....	777-806
receiver circuit fundamentals.....	771-776
scanning method.....	752
service adjustment controls.....	739
signal components.....	757
signal reflection.....	697
signal standards.....	740
signal transmission.....	895

Television—continued	
sweep and sync defects.....	829
test patterns.....	736-732
transcontinental systems.....	696
transmission lines.....	699
trouble shooting.....	827-840
tuning procedure.....	735
wave length.....	701
yagi antenna.....	727
Temperature effects.....	964
Testing.....	575-638
alignment procedure.....	580
analyzers, various.....	598-602
audio transformer.....	692
cathode voltage.....	593
commercial analyzers.....	587-638
diagnometer.....	615
electrical tests.....	578
equipment.....	587-638
grid current.....	592
grid tests.....	592
grid voltage.....	588
heater voltage.....	588
instruments.....	587
ohmmeter.....	596
out-put test.....	593
plate current.....	590
plate voltage.....	589
point to point tester.....	627
precautions to observe.....	578, 579
resistance capacity chart.....	584
selection of instrument scales.....	579
signal generator.....	622
testing a triode.....	580
Thermal agitation.....	28
Thermo-coupled ammeter.....	82
Thermo-couple instruments.....	132
Thermionic, definition of.....	82
vacuum tube.....	82
Thyratron, electron tube oscillogram.....	896
resistance welds.....	893
tube.....	879-881
welder control panel.....	894
welding application.....	890-896
circuits.....	890, 892
contactor.....	891
Time chart.....	551
Transconductance.....	83
Transformers.....	185-198
ampere turns.....	191
audio.....	194
auto.....	197
calculations.....	188-192
connections.....	147, 148
copper wire table.....	198

# Ready Reference Index

<b>Transformers—continued</b>	
core type.....	193
coupling co-efficient.....	185
definitions.....	185
diagram.....	146
efficiency.....	196
function of.....	186
insulation.....	194
losses.....	195
magnetic leakage.....	195
magnetizing current.....	192
power.....	194
ratio of turns.....	191
reconnection.....	677
schematic diagram.....	186
shell type.....	193, 194
theory.....	187
tuned type.....	83
wire size.....	193, 197
<b>Transmitter, public address system.</b>	421
radio telephony.....	218
<b>Tube chart.....</b>	591
checker.....	602
tester.....	618
<b>Turns, how to find.....</b>	557, 559
per volt chart.....	190
<b>Turntable motor.....</b>	411
speed.....	410
<b>Tuning.....</b>	7
antenna.....	377
definition of.....	83
fork.....	7
indication.....	285
indicator circuits.....	287
<b>Tuned circuits.....</b>	165-172
radio frequency circuit.....	278
theory of.....	165-172

## U

<b>Ultra short waves.....</b>	535
<b>Underwriter's standards.....</b>	1,009-1,028
<b>Units.....</b>	1,037-1,039

## V

<b>Vacuum, contact tube switch.....</b>	885
definition of.....	84
phototube.....	845

<b>Vacuum tubes.....</b>	221-250
assembly of.....	221
cathode construction.....	231
directly heated.....	231
function of.....	230
heater insulator.....	231
indirectly heated.....	231
sleeving.....	231
chart.....	623
cross modulation.....	250
definition of.....	230
diodes.....	228, 233
diode characteristics.....	239
diodes, construction of.....	233
duplex, diode, pentode.....	249
Edison effect.....	226
electron emission.....	226
electron movement.....	230
emission current.....	238
fundamentals.....	230
filament.....	228
transformer.....	232
wire.....	231
glass.....	221, 222
grid function.....	240
internal structure of.....	222, 223
materials used.....	224
multi-purpose tubes.....	248-250
operation of.....	225
oscillator.....	205
pentagrid converter.....	249
pentode.....	245
suppressor grid.....	245
various uses.....	245
plate.....	228, 245
purpose of.....	223, 224
saturation current.....	238
secondary emission.....	227
screen grid.....	229
sharp cut off types.....	250
space charge.....	227
suppressor grid.....	229
tetrodes.....	242
screen function.....	243
triodes.....	228, 239
grid action.....	241
inter-electrode capacitance.....	242
variable Mu-type.....	250
volt-meter.....	633
Vector diagrams.....	43-54, 167, 168
Velocity of light.....	536
Visibility curve.....	853
Visual landing aid for aircraft.....	468
Voltage.....	33, 34
amplification formula.....	170
compensating unit.....	691

# Ready Reference Index

Voltage—continued	
dividers	154
double circuits	161
formula for	33, 34
multiplier chart	119
regulation	149
regulation diagram	147
resistance-watt, chart	184
Volt, definition of	1,038
ammeter	119, 124, 125, 134
Voltmeter	115
Volt-ammeter, resistance arrangement	125
Voltmeters	120
how to connect	118, 123
vacuum tube	84, 633
Volt-milliammeter-ohmmeter	128





















## W

Warning lights, on ships	527
Watt, definition of	1,038
example	37
formula for	36
resistance, voltage chart	184
Wattmeters	136
formulas	137
how to connect	136
Waves, continuous type	63
length	5, 175, 176
waveband-switching	689

Wave-lengths, aerials	378
formula	556, 1,034
motion	6
ripples	4
vs. frequency	539-542
Weston, photronic cell	859-862
diagram of connections	901
effect of external resistance on	
current output	860
internal resistance of cell	861
illumination control	902
diagram	903
relay	903
unit	901
internal resistance of	861
light collector	901
operation	902-906
"turn off" relay	902
"turn on" relay	902
source	900
meters	114, 127, 128, 139
relay cabinet	903, 904
calibration	901
sensitrol relay	901
series and parallel operation of	861
smoke control	898
testing instruments	587-607
Wheatstone bridge	140
Window strip	384, 385
Wireless, remote control system	346
portable control box	347
Wire-size, antenna	380
table	198















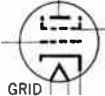





# Radio Symbols

The following symbols have been adopted as standard by engineers and manufacturers, and should be used in making circuit diagrams—also for reference in reading diagrams.

 ANTENNA	 GROUND	 RECTIFIER TUBE (Half - Wave)
 LOOP ANTENNA	 INDUCTOR	 RESISTOR
 AMMETER	 INDUCTOR (Adjustable)	 RESISTOR (Adjustable)
 BATTERY (The negative is indicated by the heavy line)	 INDUCTOR (Variable)	 RESISTOR (Variable)
 CONDENSER	 JACK	 SPARK GAP (Rotary)
 CRYSTAL DETECTOR	 PHOTOELECTRIC CELL	 SPARK GAP (Plain)
 GALVANOMETER	 RECTIFIER TUBE (Full - Wave)	 SPARK GAP (Quenched)

# Radio Symbols

In addition to symbols, given below, abbreviations are used for shortening descriptions. Abbreviations and formulas most commonly used are given on the following pages.

 <p>TELEPHONE RECEIVER</p>	 <p>WIRES CROSS (Not joined)</p>	 <p>SCREEN GRID (With directly heated cathode)</p>
 <p>THERMO ELEMENT</p>	 <p>SWITCH (Single pole)</p>	 <p>SCREEN GRID (With indirectly heated cathode)</p>
 <p>TRANSFORMER (Air core)</p>	 <p>RELAY</p>	 <p>PENTODE (With directly heated cathode)</p>
 <p>TRANSFORMER (Iron core)</p>	 <p>DIODE</p>	 <p>DUPLEX DIODE PENTODE</p>
 <p>TRANSFORMER (Fixed Tap)</p>	 <p>TRIODE (With directly heated cathode)</p>	 <p>PENTAGRID CONVERTER</p>
 <p>VOLTMETER</p>	 <p>TRIODE (With indirectly heated cathode)</p>	 <p>PENTAGRID MIXER</p>
 <p>WIRES JOINED</p>	 <p>TETRODE (With directly heated cathode)</p>	 <p>ELECTRON-RAY TUBE</p>



**RADIO  
SECTION**

## CHAPTER 1

# Radio Principles

Dr. Albert Einstein discards the theory of the ether usually presented by writers in an attempt to explain radio transmission. Dr. Einstein derides radio's ethereal medium as fiction, calling it a makeshift fabricated to explain something for which scientists have not had the correct explanation. Einstein believes it is *an electro-magnetic phenomenon*; so did Charles Proteus Steinmetz.

Shortly before his death Steinmetz said: "*There are no ether waves.*" He explained that radio and light waves are merely properties of an alternating electro-magnetic field of force which extends through space. Scientists, he contended, need no idea of ether. They can think better in the terms of electro-magnetic waves.

If a coil of insulated wire surround a piece of soft iron and a direct current be sent through the coil, it is called an electro-magnet. The space around the coil is the magnetic field. When the current is increased the magnetic field increases. When the current is decreased the breadth of the field is reduced. If the current be reversed, the field is reversed. When an alternating current is sent through the coil the magnetic field alternates. The field becomes a periodic phenomenon or a wave, described by Steinmetz as "an alternating magnetic field wave."

Steinmetz, like Einstein, pointed out that the conception of the ether is one of those hypotheses made in an attempt to explain some scientific difficulty. He declared that the more study is applied to the ether theory

the more unreasonable and untenable it becomes. He held it to be merely conservatism or lack of courage which has kept science from abandoning the ethereal hypothesis.

Steinmetz called attention to the fact that belief in an ether is in contradiction to the relativity theory of Einstein, since this theory holds that there is no absolute position or motion, but that all positions and motions are relative and equivalent. Thus, if science agreed that the theory of relativity is correct the ether theory must be abandoned.

No space will be wasted here in talking about ether waves. The space surrounding a wire that carries an electric current *is an electro-magnetic field, that is, a combination of a magnetic field and an electrostatic field.*

If the current and voltage alternate, the electro-magnetic field alternates; that is, it is a periodic field or an electro-magnetic wave. Thus, the broadcast listener who wants to forget the ether can think of the aerial wire at the transmitter, setting up electro-magnetic waves in a field of electric force, which now, the theories contend, fills all space and therefore every receiving wire is within the field. This field, however, is supposed to be in a state of rest until the broadcast transmitter causes it to vibrate.

The action of the transmitter is like tapping a mold of jello. Waves pass through it, and so radio waves are produced in the electro-magnetic field.

The transmitter taps the hypothetical medium, causing it to vibrate. The receiving set is designed to detect the vibrations and so intelligence is carried from one point to another.

It is well known that a stone thrown into a pond **causes ripples or waves on the surface of the water, which move away**

---

**NOTE.**—*As stated by Dr. Lee de Forest:* Radio is simply a cause and an effect. The *cause* is the radio transmitter. It makes an electro-magnetic splash that sets up radio waves. These waves travel through space in all directions. The *effect* is the setting up of delicate currents in the aerial or loop. These delicate currents are detected and converted into audible sounds by means of the radio receiving set. Imagine a boy operating a paddle at one end of a pond of still water. Ripples are set up in the water. They travel farther and farther away from the paddle, getting weaker as they move along until they reach a piece of wood which bobs up and down as it rides the waves. Put a bell on the piece of wood, in order that it will ring with the action of the waves, this illustrates the mechanical parallel of radio communication.

from the point of disturbance in concentric circles of ever increasing diameters until they reach the shore. The number of waves breaking on the shore in one second is called the *frequency* of the wave motion, and the distance between them measured from crest to crest, is the *wave length*.

The waves are strongest at the point of disturbance and gradually become weaker as they travel away from that point, as shown in figs. 1 and 2. If the distance be sufficiently great they will become so weak as to be invisible.

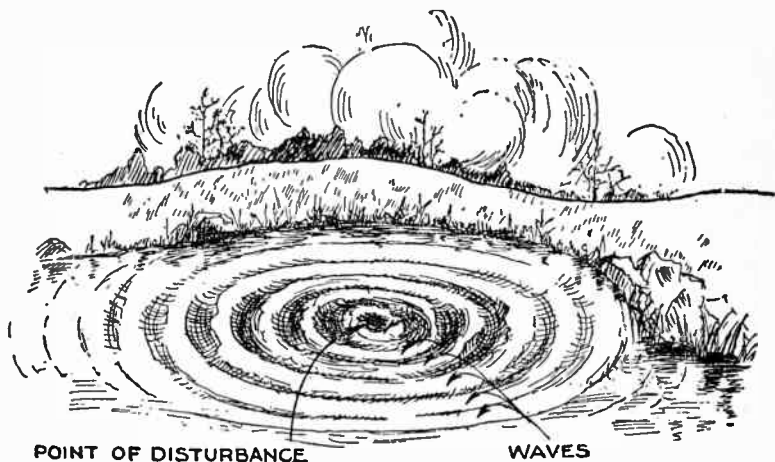

FIG. 1.—Effect of throwing stone in still water; production of waves which radiate or travel from the point where stone enters the water, or “point of disturbance.”

**NOTE.**—According to Marconi radio waves go to outer space. In his inaugural address at the second meeting of the Italian Society for the Advancement of Science Sept. 11, 1930, Sen. Guglielmo Marconi expressed belief that radio waves may travel long distances, even millions of miles, beyond the earth's atmospheric layer. He said that he did not see any reason why, as some scientists maintain, waves produced on the earth should not travel such a distance, since light and heat waves reach the earth from the sun, penetrating the atmospheric layer. He referred to observations of such scientists as Stormer and Pedersen and commented that the former had said that electrified particles derived from the sun and under the magnetic influence of the earth acted as a reflector of electric waves from the earth after they had passed the so called Kenelly-Heaviside layer.

Radio communication as has been explained is a form of wave motion which occurs in an electro-magnetic field, these waves acting in a similar manner to water waves.

In radio communication it is first necessary to create electro-magnetic waves in varying groups and of varying strength, and second to intercept them with apparatus capable of changing them to sound waves.

To create the waves it is necessary to have two surfaces separated by a distance of from ten to several hundred feet and to create between them an electrical pressure which changes its direction (first toward one surface then toward the other) hundreds of thousands of times a second.

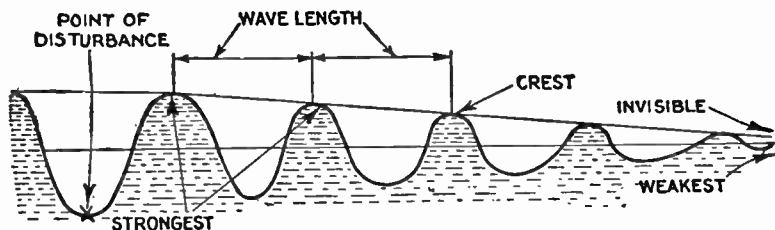

FIG. 2 — Sectional view of waves produced by throwing stone in still water, illustrating crest of wave, wave length and gradual weakening of the waves as they travel from the point of disturbance.

It is the common practice to use the ground for one surface and provide another surface by erecting a structure composed of one or more wires, insulated from the earth and suspended many feet above it.

Between these, by means of suitable transmitting equipment an electrical pressure is produced of from one to twenty volts which starts waves radiating out in all directions. These pressure waves are, however, only part of a radio wave. From any wire in which current is flowing are radiated electro-magnetic waves and radio waves are made up then, of both electro-magnetic and pressure electrostatic waves.

Comparing these waves to the action of hurling a rock into a pool of water, the amperes of electric current put into the antenna correspond to the size of the rock, while the volts of electrical pressure are equivalent to the force with which the rock is hurled. The larger the rock and the

greater the force behind it, the bigger the splash and consequent waves. The more amperes of current flowing in the antenna circuit and the greater the pressure (volts) between antenna and ground, the stronger the waves radiated. These radio waves have similar characteristics to another class of waves—sound waves.

When the note C is struck on the piano (as in fig. 3 ) the sound waves vibrate 256 times per second and either a C tuning fork or a wire tuned to C and in the immediate vicinity will vibrate 256 times per second also. The two wires are said to be in resonance.

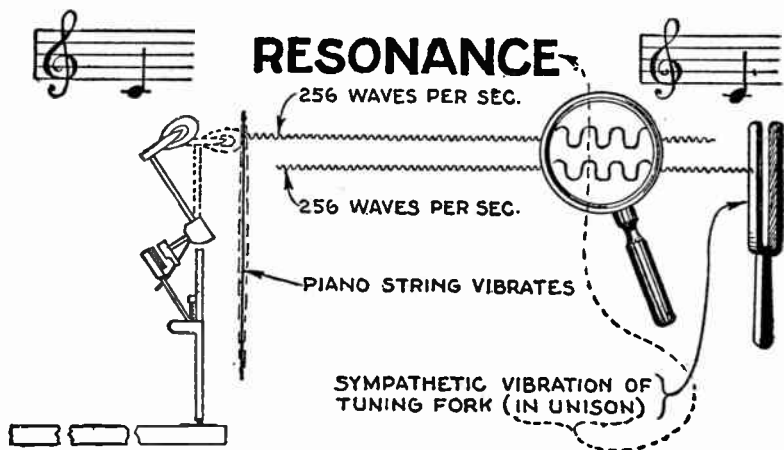
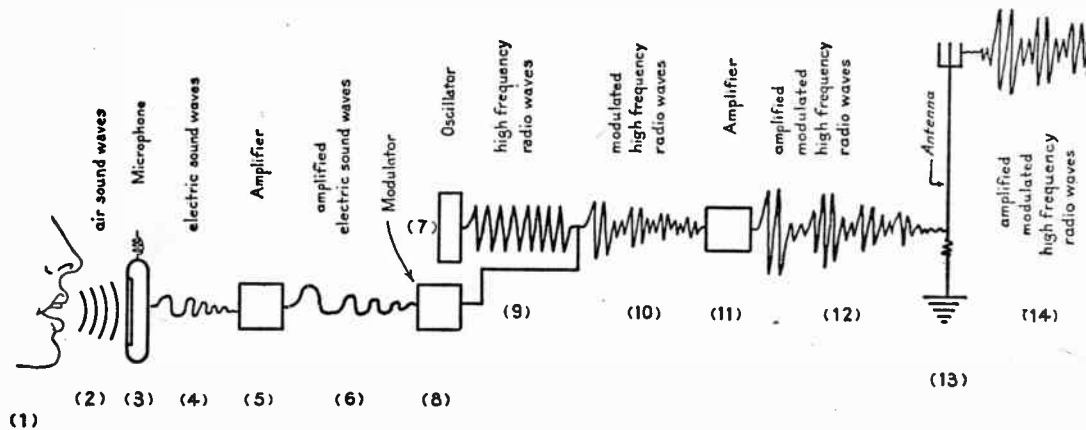

FIG. 3.—Sympathetic vibration of tuning fork with struck piano string when tuned to same pitch, illustrating the wave theory of radio.

The waves radiated by a radio transmitter always have a definite number per second and in order to hear a station, the receiving equipment must be put in resonance with the waves radiated by the transmitter. This operation is known as tuning.

# BROADCASTING PRINCIPLES



Vibration of vocal cords of speaker (1) producing sound, causes air to vibrate in front of mouth (2) which in turn causes the thin diaphragm of microphone (3) to vibrate. The microphone changes the mechanical vibrations to varied electric currents (4); an amplifier (5) amplifies these currents as at (6). An oscillator, or radio wave producing, device (7), in the meantime, produces radio waves (9) for broadcasting. A modulator (8) modulates or changes these radio waves to travel as sound waves. The varied currents (6) enter the modulator (8) and cause the radio waves (9) to flow out as at (10), conforming to the electric sound waves. An amplifier (11) amplifies the modulated radio waves, to give them more power, as at (12); these waves enter the antenna (13) and travel out into space as at (14)—going in all directions ready to be picked up by receiving antennas.

CHAPTER 2

# Physics of Sound

**Production of Sound.**—When air is set in vibration by any means, sound is produced provided that the frequency of vibration is such that it is audible. If a violin string in tension be plucked, as in fig. 1, it springs back into position, but due



FIG. 1.—Sound produced by vibration of violin string.



to its weight and speed, it goes beyond its normal position, oscillates back and forth through its normal position, and gradually comes to rest. These vibrations produce sound.

As the string moves forward it pushes air before it and compresses it, also air rushes in to fill the space left behind the moving string. In this way the air is set into vibration. Since air is an elastic medium, the disturbed portion transmits its motion to the surrounding air so that the disturbance is propagated in all directions from the source of disturbance.

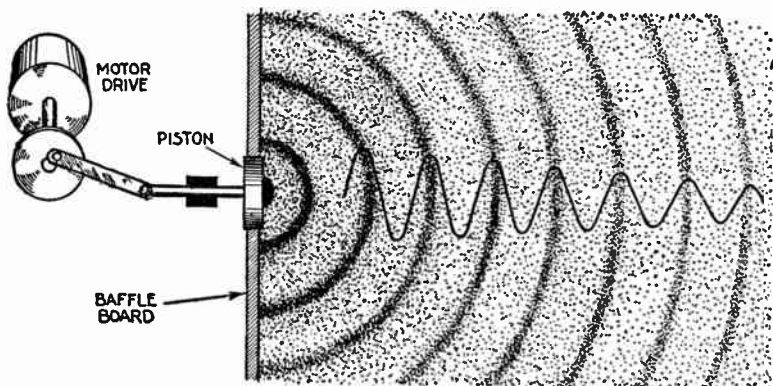

FIG. 2.—Generation of sound waves by the rapid oscillation of a light piston. *As the piston oscillates* the air in front of the piston is compressed when it is driven forward, and the surrounding air expands to fill up the space left by the retreating piston when it is drawn back. Thus a series of compressions and rarefactions (expansion) of the air is the result as the piston is driven back and forth. Due to the elasticity of air, these areas of compression and rarefaction do not remain stationary but move outward in all directions, as shown.

If the string be connected in some way to a diaphragm such as the stretched drum head of a banjo, the motion is transmitted to the drum. The drum, having a large area exposed to the air, sets a greater volume of air in motion and a much louder sound is produced.

If a light piston several inches in diameter, surrounded by a suitable baffle board several feet across, be set in rapid oscillating motion (vibration), as in fig. 2, by some external means, sound is produced.

**Propagation of Sound.**—If the atmospheric pressure could be measured at many points along a line in the direction in which the sound is moving, it would be found that the pressure along the line at any one instant varied in a manner similar to that shown by the wavy line of fig. 2.

To illustrate if extremely sensitive pressure gauges could be set up at several points in the direction in which the sound is moving it would be found that the pressure varied as indicated in fig. 3.

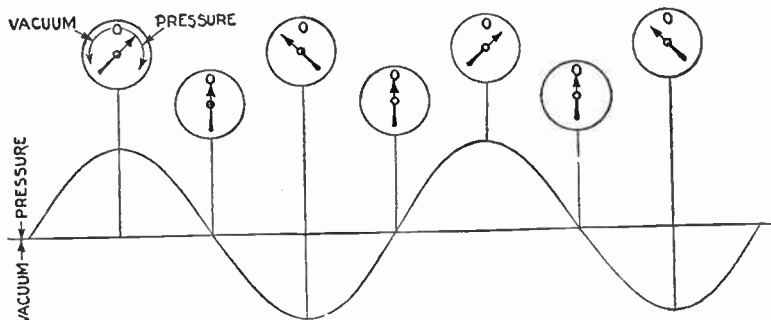

FIG. 3.—Diagram illustrating pressure variations due to sound waves. *It should be noted* that the type gauges shown, register pressure *above* atmospheric when the pointer moves to the right of the vertical, and *vacuum* or pressure *below* atmospheric when it moves to the left of the vertical.

Again, if a pressure gauge be set up at one point and the eye could follow the rapid vibrations of the points it would be found that the pressure varied at regular intervals and in equal amounts above and below the average atmospheric pressure. The eye, of course, cannot see such rapid vibrations, but it *can* see wave motion in water, however, which is very similar to sound waves with the exception that water waves travel on a plane surface, while sound waves travel in all directions.

In the case of water as a medium for wave propagation, if a pebble be dropped into a still pool, as in fig. 4,— and starting at the point where the pebble is dropped, waves will travel outward in concentric circles, becoming lower and lower as they get farther from the starting point, until they are so

small as not to be perceptible, or until they strike some obstructing object.



FIG. 4.—Effect of throwing a stone into still water; it produces waves which travel outwardly in expanding, concentric circles from the point where the stone enters the water or *point of disturbance*.

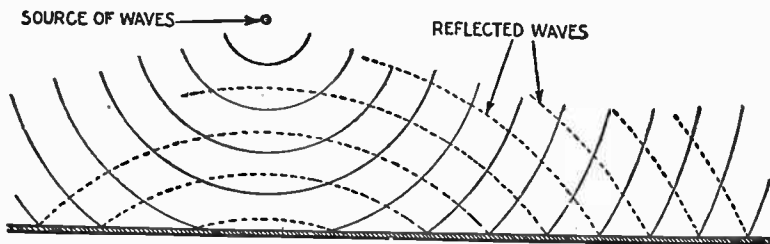

FIG. 5.—Reflection of waves from a plane surface.

If the pond be small it will be noticed that the waves which strike the shore will be reflected back. If the waves strike a shore that is parallel with the waves, they will be reflected back in expanding circles, as in fig. 5.

If the waves strike a hollow or concave shore line as in fig. 6 the reflected waves will tend to converge (focus) to a point.

Comparing water and air as media for wave propagation, water waves travel in *expanding circles* and air waves in *expanding spheres*.

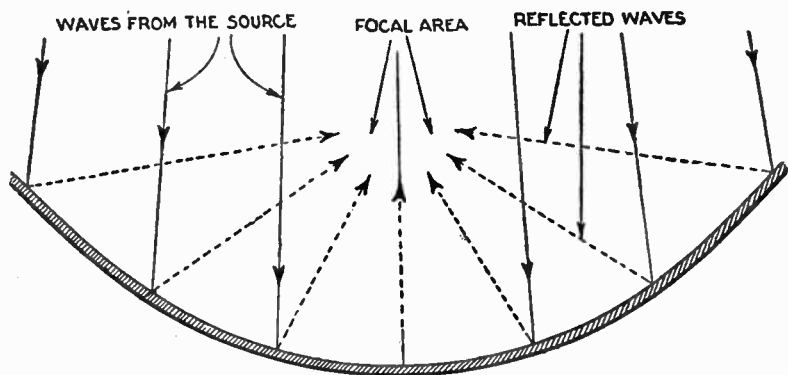

FIG. 6.—Reflection of waves from a curved surface. The solid lines show the direction of the original waves and the dotted lines show the direction and focusing of the reflected waves. Focusing of waves results in their reinforcement, which may cause them to build up to considerable proportion at one point.

Sound waves are reflected in a manner similar to water waves, causing echo and reverberation. If the sound waves focus at a point, loud and dead spots are produced.

Wave motion has certain definite characteristics and these characteristics determine:

1. Loudness;
2. Pitch;
3. Tone.

**Loudness.**—By definition, loudness is *relatively high intensity of sound*. Loudness (or amplitude) is determined by the amount of difference in pressure between the maximum compression and the maximum rarefaction. This corresponds in water waves to the vertical height of the crest above the trough of the wave. Loudness is illustrated in fig. 7.

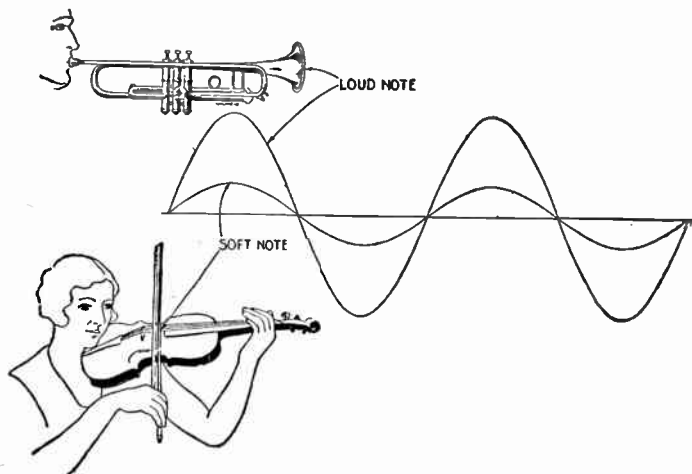

FIG. 7.—Properties of wave motion illustrating what causes loudness of tone.

**Pitch or Frequency.**—*Any one of a series of variations, starting at one condition and returning once to the same condition is called a cycle.* Observe some point on the surface of the water in which waves exist and it will be noticed that at this point the water will rise and fall at regular intervals. At the time at which the wave is at its maximum height the water begins to drop, and continues until a trough is formed, when it rises again to its maximum height. Accordingly, all the variations of height which one point on the surface of the water goes through in the formation of a wave, is a *cycle* of wave motion.

The number of cycles a wave goes through in a definite interval of time is called the frequency. Therefore the number of times

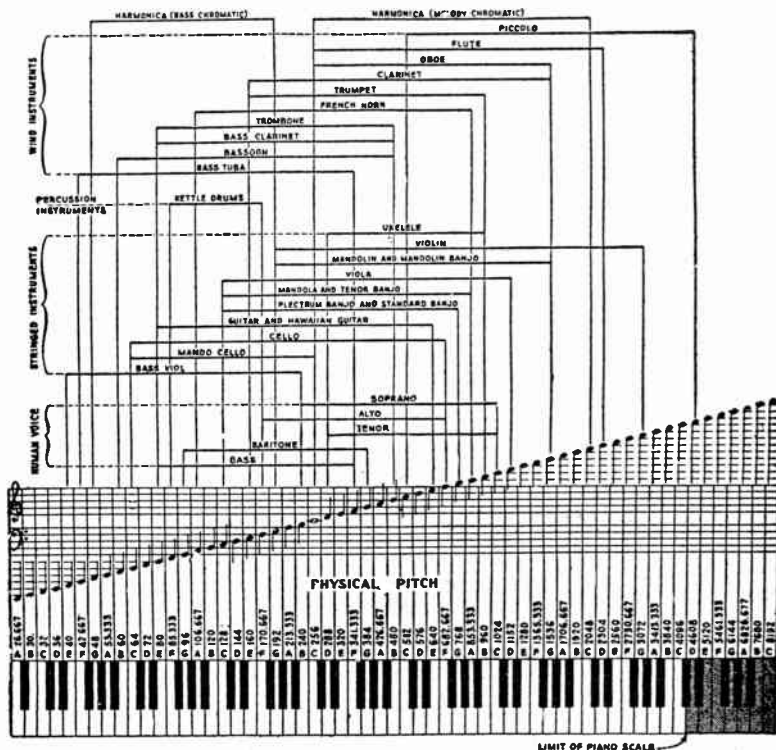

FIG. 8.—Musical pitch chart for piano, voice and various instruments. This chart represents the relation between the musical scale and the piano keyboard, giving the frequency of each note in terms of complete vibrations, or cycles, according to the standard used in scientific work such as the scientific scale based on middle C at a frequency of 256 cycles. The piano keyboard covers nearly the entire range of musical notes and extends from 26.667 cycles to 4,096 cycles. The piccolo reaches two notes beyond the highest note of the piano. The extreme organ range, not shown on the chart, is from 16 cycles to 16,384 cycles, scientific or physical pitch, as it is usually called. Music seldom utilizes the full keyboard of the piano, the extremely high notes and extremely low notes being seldom used. Therefore a reproducing device which reproduces all frequencies from 50 to 4,000 cycles would be satisfactory in reproducing musical notes.

the water rises or falls, at any point in one minute would be called the frequency of the waves per minute, expressed as the *number of cycles per minute*.

In sound, the number of waves per minute is large, and it is more convenient to speak of the frequency of sound waves as the number of waves per second, or, more commonly, as the number of cycles per second. Thus, a sound which is produced by 256 waves a second is called a sound of a frequency of 256 cycles.

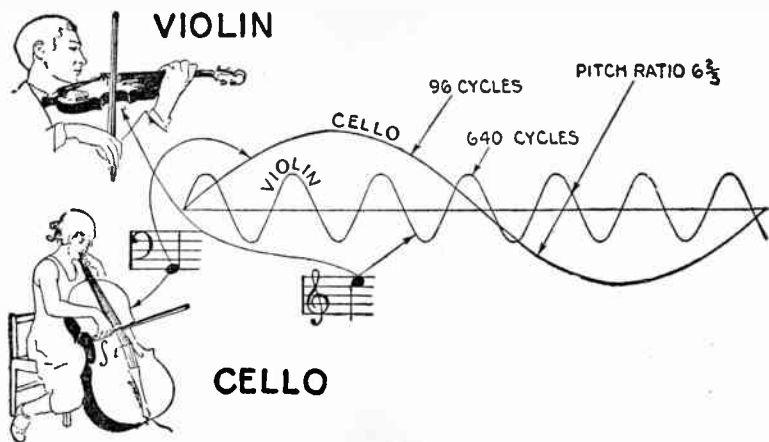

FIG. 9.—Properties of wave motion illustrating *pitch*.

When speaking of sound, cycles always mean cycles per second.

Considered from the standpoint of traveling waves, frequency is determined by the number of complete waves passing a certain point in one second, and this, of course, is equal to the number of vibrations per second generated at the source.

Fig. 8 is a chart showing pitch frequencies corresponding to the various keys of the piano and range of the human voice and various instruments.

**Tone.**—By definition tone is *sound in relation to volume, quality, duration and pitch*; specifically, in acoustics, a sound

that may be employed in music, having a definite pitch and due to vibration of a sounding body; opposed to sound as mere noise.

By common usage in music, tone generally means the *timbre* or *quality of sound*.

A pure note of a given pitch always sounds the same, and the frequency of this note is termed its *fundamental* or *pitch frequency*. However, notes of the same pitch from two different kinds of instruments do not give the same sound impression. This difference is due to the presence of *overtones*, sometimes called *harmonics*.

Consider again the case of a taut string which is plucked to set it in vibration.

If the string be plucked at its exact center, it will vibrate as a whole and give a very nearly pure note; but if it be plucked at some other point, say one-third of the length from one end, it will vibrate as three parts as well as a whole, and a change of tone will be noticed. If the string be plucked indiscriminately, various tones will be heard, all of the same pitch.

Hollow cavities built into the bodies of the various musical instruments give them their characteristic tones, because the air chambers, called resonance chambers, strengthen overtones of certain frequencies and give a very pronounced tone to the instruments.

Other instruments have built into them means of suppressing certain overtones, which help to give them their characteristic sounds. The frequency of an overtone is always some multiple of the pitch frequency; that is, the second overtone has twice the frequency of the pitch note, and the third overtone, three times the frequency, etc.

Overtones of twenty times the frequency of the pitch note are present in the sounds of some musical instruments, but overtones of this order are important only when the pitch note is low, because the frequency of the twentieth overtone of even a moderately high note would be beyond the ability of the human ear to detect.



Overtone give character and brilliance to music, and their presence in reproduced sound is necessary if naturalness is to be attained.

The combined result of all the partial or overtones gives the quality or timbre of the tone, that is the peculiar characteristic sound as of a voice or instrument. A great variety of tone is found in the orchestra as exemplified by the strings, wood wind, brass and reed choirs. See figs. 10 to 13

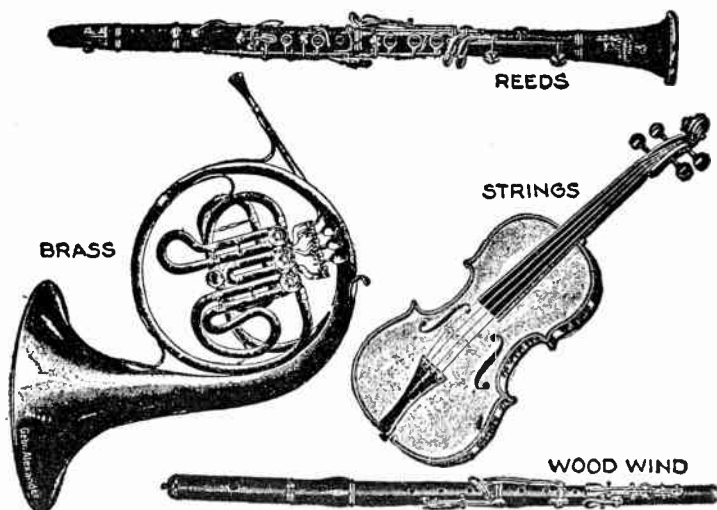

FIG. 10 to 13.—Familiar instruments of the orchestra illustrating the great variety of tone produced by the various "choirs" to which these instruments belong. It is because of this great variety of tone that the orchestra is the finest medium for musical expression. *It should be noted* that even the best organs represent a very poor attempt to imitate the orchestra—it cannot be done. Such impossible instruments as the cornet, saxophone, etc. are not employed in any legitimate orchestra.

A reproducing device which reproduces frequencies from 50 to 6,000 cycles will cover very well all the notes and overtones necessary for naturalness and distinctiveness.

In singing, the range of notes covered is approximately from 64 to 1,200 cycles, extreme limits, but this range cannot be covered by one person's

voice. The frequency of 1,200 cycles does not represent the highest frequency used in singing, because overtones of several times the frequency of the note are always present in the human voice. The presence of the overtones gives the pleasing quality to songs. This quality of the singing voice is called *timbre*. The timbre of the voice transmits the emotions of joy, sadness, etc., from the performer to the audience, and therefore is very important in the enjoyment of vocal music.

**Wave Length.**—By definition the wave length (of a water wave for instance) is *the distance between the crest of one wave and the crest of the next wave*. This distance remains the same as long as the wave continues, even though the wave becomes so small as to be hardly perceptible.

*Frequency in wave motion is related to wave length.*

All waves produced do not have the same wave length. A small pebble dropped into a pond will produce a wave of short length, but a large stone will produce a wave of correspondingly longer length. In sound the wave length is dependent upon the frequency of the source. Similarly, in sound the wave length of a sound wave is *the distance between the point of maximum compression of one wave to the point of maximum compression of the next wave*.

Sound travels at different speeds in different substances, thus it travels at a much higher speed in water and steel than in air.

---

NOTE.—*Voicing* is the art of obtaining a particular quality of tone in an organ pipe and of procuring uniform strength and quality throughout the entire stop. Voicing is one of the most delicate and artistic parts of the organ builder's art, and it is seldom, if ever, that a voicer is good at both flue and reed voicing.

NOTE.—*Percussion instruments* such as drums and the various accessory traps produce the greatest pressures that are used in music. Although the fundamental frequency of the notes which they emit is fairly low, the notes are particularly rich in tones of higher frequency, which may extend as high as 10,000 cycles. Although these higher tones die out rather rapidly, they are essential to good definition.

NOTE.—*The organ, piano and harp* have the greatest compass and cover a frequency range from about 16 to 4,000 cycles. All three of these instruments are characterized by a rather prominent first overtone, so that their effective range extends as high as 8,000 or 9,000 cycles.

NOTE.—*According to Prout* "the *cornet* is a vulgar instrument whereas the *trumpet* is a noble instrument." The only excuse for a cornet is that it is easier to play than a trumpet. Non-musical instruments, such as the cornet and saxophone, if they must be heard, should be confined to 2nd and 3rd rate taxi-dance halls in order that cultured and discriminating ears may not be profaned.

In the latter medium it travels about 1,100 ft. per second. An illustration of the fact that time is required for sound to travel from one place to another is shown by a steam whistle at a distance of several hundred yards. If it be observed when blown, it will be noticed that the "steam"\* can be seen coming from the whistle a considerable length of time before the sound of the whistle is heard. Sounds of all frequencies, or pitches, travel at the same speed. The speed at which sound travels divided by the frequency gives the wave length of the sound wave.

A knowledge of wave length is necessary for the proper construction and location of baffle boards and horns in theatres.

**Speech.**—The sounds of speech are divided into two classes, vowels and consonants. The vowel sounds are used in the pronunciation of the letters *a, e, i, o, u*, and sometimes *y*, in the formation of words.

These letters are also used in combination to indicate other vowel sounds. The pitch frequencies of the vowel sounds in male voices range from 110 cycles to 140 cycles. For female voices the range is from 230 to 270 cycles. The characteristic frequencies, or overtones of the vowel sounds, however, reach frequencies of 3,300 cycles. So important are these overtones that the pitch frequency can be entirely eliminated without noticeably changing the sound sensation produced on the human ear. The full range of frequencies used in vowel sounds is from 110 cycles to 4,800 cycles.

The pitch frequency of the vowel sounds are produced when air is blown through the vocal cords.

The vocal cords are two muscular ledges in the air passage of the throat. When these muscles are taut there is a narrow slit between them, which sets the air passing through into oscillation. The sound produced by the vocal cords is changed by the cavities of the mouth.

The shapes of the cavities continuously change as a person speaks, making it possible for him to produce a wide variety of sounds, all of very nearly the same pitch frequency.

---

\*NOTE.—*The white cloud* seen issuing from a steam whistle usually called "steam," is not steam but a fog of minute liquid particles produced by *condensation*. The term is misused above simply for convenience. Steam is invisible.

Consonant sounds are usually produced without the aid of the vocal cords.

Most of these sounds are produced by the lips and teeth, as in the pronunciation of *th*, *s*, and *f*. The range of frequencies covered by consonant sounds is from 200 to 8,000 cycles, but most consonant sounds have frequencies of less than 6,000 cycles.

**Hearing.**—The actual mechanism of hearing is not very well understood, but certain facts regarding the ability of the ear to register sounds of various frequencies has been determined very accurately.

The range of frequencies which the average person can hear is from about 20 cycles to 17,000 cycles, but a comparatively large amount of sound energy is required before the ear can detect sound of extremely low or extremely high frequencies.

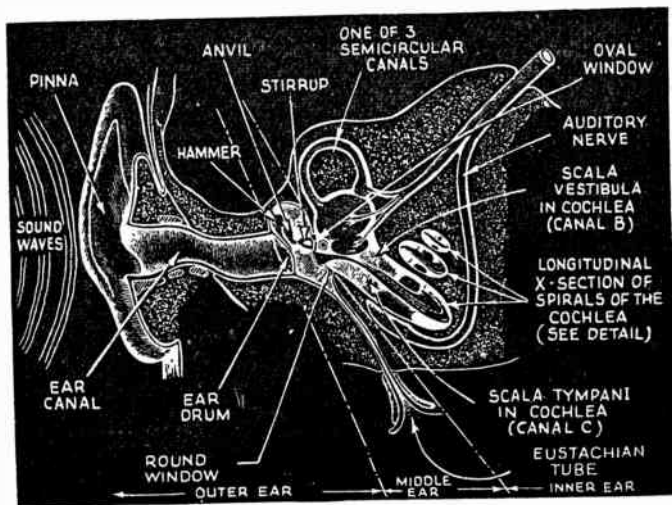

FIG. 14.—Internal Structure of the Human Ear.

The ear is most sensitive to frequencies between 500 cycles and 7,000 cycles; also, the ear is most sensitive to changes of pitch and changes of intensity of sound in this same band of frequencies.

---

NOTE.—*Woman's speech* in general is more difficult to interpret than man's. This may be due in part to the fact that woman's speech has only one half as many tones as man's, so that the membrane of hearing is not disturbed in as many places. It may be inferred therefore that the nerve fibres do not carry as much data to the brain for interpretation. The greatest differences occur in the case of the more difficult consonant sounds. In woman's speech these sounds are not only fainter but require a higher frequency range for interpretation. A range of from 3,000 to 6,000 cycles for man's voice corresponds roughly to a range of from 5,000 to 8,000 cycles for woman's voice. Since the ear is less sensitive in the latter range and the sounds are initially fainter, their difficulty of interpretation is greater.

NOTE.—When sounds containing a number of tones are increased in loudness, the lower tones in the sound deafen the auditor to the higher tones. This deafening or masking effect becomes very marked when the sound pressure of the lower tones is greater than twenty sensation units. In the case of speech, this effect impairs the interpretation of the higher pitched sounds. The best loudness for the interpretation of speech corresponds to a sound pressure between 0 and 20 sensation units. If the sound pressure be less than this, the fainter sounds are inaudible. If the sound pressure be greater, the masking effects impair the interpretation of these sounds.

## CHAPTER 3

# Radio Fundamentals and Ohm's Law

**The Structure of Matter.**—It is now a well known fact that all matter is made up of submicroscopic particles. These particles which are the smallest into which matter can be subdivided and still retain the properties of the original substance, are called *molecules*.

Molecules of different substances vary greatly in complexity, ranging from extreme simplicity in some substances to very great complexity in others. All molecules, however, may be broken up into simpler constituents called atoms, of which there are more than ninety distinct kinds known, each representing one of the chemical elements from which all matter is constructed.

Only a few elements, however, appear in the molecules of any one of even the most complex substances. An element, then is a fundamental substance composed of only one kind of atom. In some elements, the molecules are composed of single atoms; in other elements, two or more like atoms are associated together to form the molecule. Of the more common elements are hydrogen, oxygen, nitrogen, carbon, iron, copper, etc.

Carrying the analysis still further, atoms are well known to have complex structures. In accordance to the most widely accepted modern physical picture of the atom, it corresponds roughly to a miniature of our solar system. Corresponding to the sun in the solar system is the nucleus of the atom which, in general, is a very small, compact structure composed of a combination of extremely minute particles called *protons*, *neutrons*, *positrons* and *electrons*.

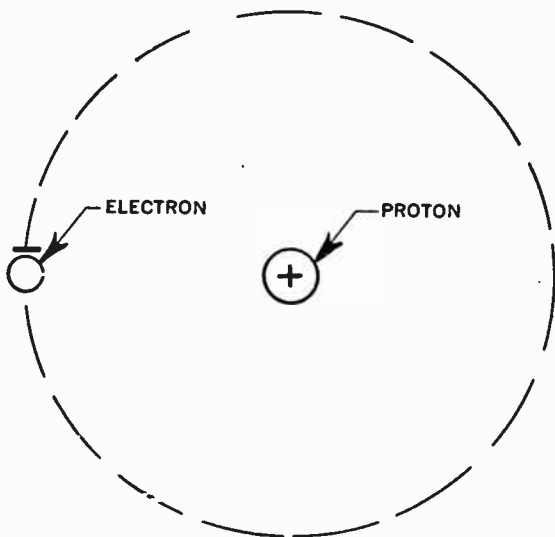

FIG. 1.—Structure and electronic orbit of the hydrogen atom.

The *proton*, whose mass may be taken as the unit of atomic weight has a positive charge equal in magnitude, but opposite in sign, to that of the electron. Its mass is very large compared with that of the electron or of the positron.

The *neutron* has very nearly the same mass as the proton, but is uncharged. The *positron* may be regarded as the ultimate

unit of positive charge just as the electron is the ultimate unit of negative charge. The positron has the same magnitude of charge as the electron and very nearly the same mass. Practically all the mass of the atom is associated with the small, dense nucleus. Revolving about the nucleus in orbits at relatively large distances from it, are one or more electrons.

The simplest of all atoms is that of hydrogen, whose nucleus consists of a single proton with a single electron revolving about it. The two charges revolve about each other in space much like a whirling dumbbell, except that there is no rigid connection between them. See fig. 1.

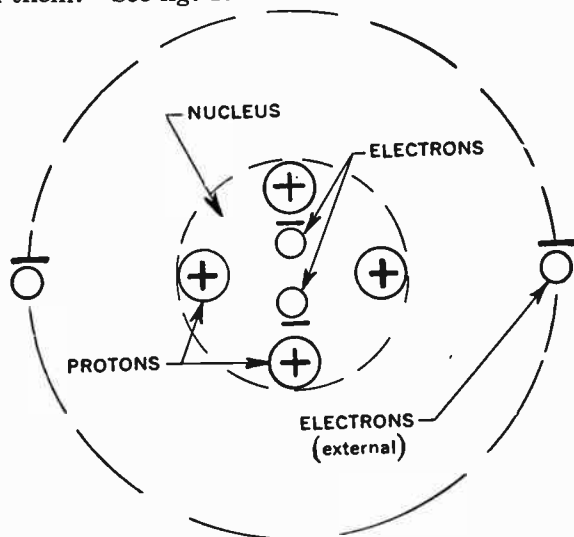

FIG. 2.—Structure and electronic orbit of a neutral helium atom.

The next atom in simplicity is that of helium, whose nucleus consists of four protons and two electrons bound together in a compact central core of great electrical stability. Revolving about this compact nucleus are two electrons. See fig. 2.



Atoms of other elements become increasingly more complex by the successive addition of one electron to those revolving about the nuclei, and with the progressive addition of protons, neutrons, positrons and electrons to the nuclei. In every case the normal atom has an exactly equal number of positive and negative elementary charges, so that the atom as a whole is neutral; that is, it behaves toward electrified bodies at some distance from it as though it had no charge at all.

**Positively and Negatively Charged Substances.**—With reference to the picture of the neutral atom, it will be easy to understand what takes place when a substance is electrically charged.

Assume that by some means one of the external electrons of the neutral helium atom is removed as shown in fig. 3, the result will be an unsatisfied atom in so far as the balance

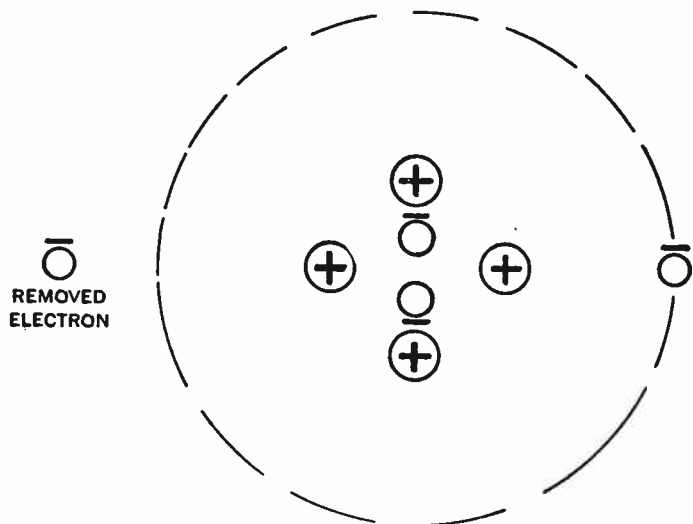

FIG. 3.—Structure and electronic orbit of a positive helium atom.

between the positive and the negative charges are concerned.

The excess of one proton in the nucleus gives the atom a positive charge, and if the previously removed electron is permitted to return to the atom, it will again become neutral as in fig. 2.

A positively charged body therefore is one which has been deprived of some of its electrons, whereas a negatively charged body is one which has a surplus (acquired more than its normal number) of electrons.

In its unbalanced state the atom will tend to attract any free electrons that may be in the vicinity. This is exactly what takes place when a stick of sealing wax or amber is rubbed with

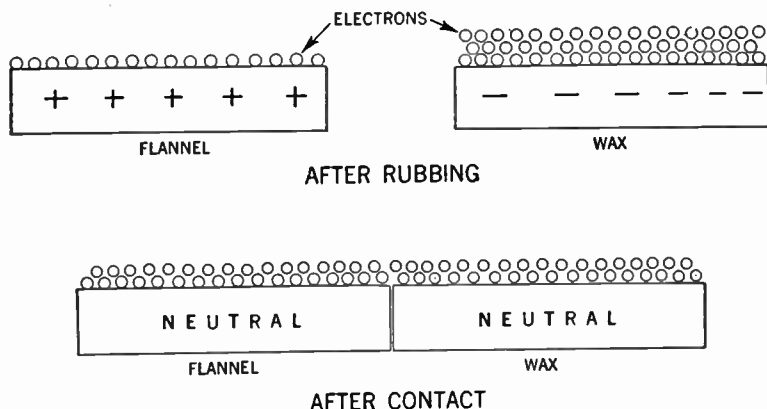

FIG. 4.—Illustrating how the rubbing process removes electrons from the flannel, and the re-distribution of electrons after contact of the two bodies.

a piece of flannel. The wax becomes negatively charged and the flannel positively charged.

During the rubbing process, the friction rubs off some of the electrons from the atoms composing the flannel and leaves them on the surface of the wax. Since the surface atoms or molecules of the flannel are left deficient in electrons and the surface

atoms of the wax with a surplus, if the wax and the flannel are left together after being rubbed, there will be a readjustment of electrons, the excess on the wax returning to the deficient atoms of the flannel, as shown in fig. 4.

Most of the electrons in the universe exist as component parts of atoms as described, but it is possible for an electron to exist in the free state apart from the atom temporarily at least. Free electrons exist to some extent in gases, in liquids and in solids, but are much more plentiful in some substances than in others.

**Conductors and Insulators of Electricity.**—In metals for example, enormous quantities of free electrons exist while such substances as glass and rubber contain only small amounts.

It is the presence of free electrons in substances that enables us to account for the conduction of electricity. The more free electrons a substance contains, the better conductor of electricity is it, and it is on account of the great numbers of free electrons in metals, that metals are good conductors of electricity. Again, substances such as glass, rubber, mica, etc., with their comparatively few free electrons are poor conductors of electricity—good insulators.

**Flow of Electric Current.**—These free electrons are in a state of continual rapid motion, or thermal agitation. The situation is analogous to that in a gas where it is known that the molecules, according to the kinetic theory, are in a state of rapid motion with a random distribution of velocity.

If it were possible at a given instant to examine the individual molecules or electrons, it would be found that their velocities vary enormously and is a function of the temperature. The higher the temperature of a substance the higher the velocity of the atoms and electrons.

Now if by some means, the random motion of the molecules or electrons in a conductor be controlled and be made to flow in one direction, there results what is called a flow of electric current. Such means of controlling or directing the electron motion is provided by an electric battery or a generator. See fig. 5.

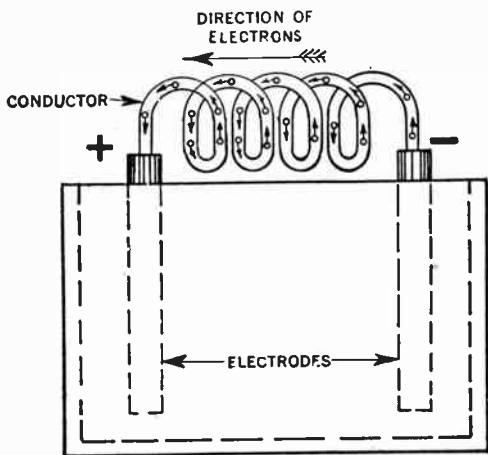

FIG. 5.—Illustrating the movement of electrons from the negative to the positive terminal of a battery. In practice it is customary to think of an electric current as flowing from the positive to the negative. The reason for this contradiction is due to the fact that the early electrical experimenters assumed the direction of current to be from the positive to the negative, which is now known to be opposite as far as analyzing a circuit is concerned. It causes considerable misunderstanding to those not duly informed.

**Resistance to the Movement of Electrons.**—The progressive motion of electrons in a conductor are retarded by the collisions of the atoms of the substance, and it is this hindrance to their movement which constitutes the electrical resistance in a conductor.

This resistance varies in different metals, and also with the temperature of the conductor. When the temperature increases, the higher will be the velocity of the atoms and electrons, which in turn causes more frequent collisions and as a result, there is a greater hindrance to their progress.

The frequency of collisions between the atoms and electrons is also increased when a greater number of electrons are present. It is on account of this fact that the heating in a current carrying conductor increases with the size of the current.

**Electric Pressure.**—It has been previously mentioned that the directed motion of free electrons in a conductor constitutes an electric current. To understand how a flow of current may be established, it is well to consider the analogy of, for example, a water pump in a hydraulic system. See fig. 6.

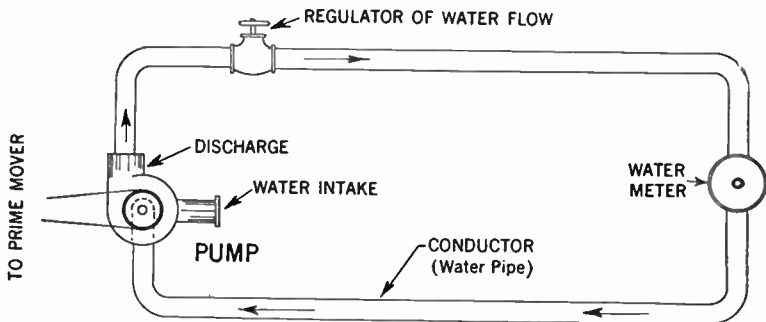

FIG. 6.—Water is forced through the conductor by means of the pump action causing a pressure difference between the conductor terminals.

In this case, by virtue of the pump piston the water enters the pump at the intake end at low pressure and leaves the discharge end at high pressure. The difference in pressure at the two ends of the pump causes water to flow through the pipe.

The action of the electrical system is similar. In any electrical circuit a generator or battery may be used to supply an electromotive force in a similar manner as the pump in the hydraulic system supplies mechanical force. Here the positive and the negative binding posts of the generator correspond to the discharge and the intake end of pump respectively. See fig. 7.

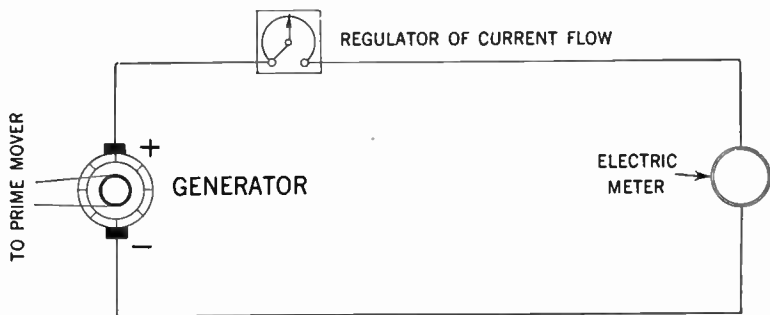

FIG. 7.—Note the similarity to the hydraulic circuit.

Similarly in case of the generator it is said that the pressure is higher at the positive end and lower at the negative, corresponding to the discharge and intake ends of the pump in the hydraulic system.

It is this difference in pressure between the generator terminals which causes an electric current to flow in the circuit, in much the same way as the water is forced through a pipe in the hydraulic system.

Electrical pressure variously called "difference in potential" and "electromotive force" is measured in terms of a unit called the volt.

**Electric Current.**—Again using the circuit (water pipes) in the hydraulic system, the rate at which water is flowing through the pipe may be measured in gallons per second. Similarly in the electric circuit the amount of current flowing is measured in a unit called “coulomb” which expresses the rate of flow.

When the current in a circuit flows at the rate of one coulomb per second the name of one ampere is used. This term facilitates the expression of current flow in that it makes it unnecessary to say “per second” each time, as second is already a part of the unit “*ampere*.”

Thus one coulomb per second is one ampere, and ten coulombs per second is ten amperes, etc.

The relation between coulombs and amperes may be expressed as follows:

$$I = \frac{Q}{t} \text{ or } Q = I \times t$$

where  $I$  is the current in amperes;  $Q$  is the amount of electricity in coulombs; and  $t$  is the time of flow in seconds.

Thus for example if a battery sends a current of 5 amperes through a circuit for one hour, the number of coulombs of electricity that will flow through the circuit will be  $5 \times 60 \times 60 = 18,000$  coulombs.

**Resistance to Current Flow.**—All conductors of electricity oppose the flow of current through them, *i.e.*, they have electrical resistance. The unit of resistance is called the ohm. A conductor may be said to have one ohm's resistance if the ratio of the electrical pressure in volts to the current flowing through it, is unity.

Thus, for example, if the current flowing through a circuit is found to be 10 amperes, and the electrical pressure 10 volts the resistance of the circuit will be  $\frac{10}{10} = 1$  ohm.

**Ohm's Law.**—When considering the flow of electrons in a conductor it is evident that the greater the e.m.f. (electromotive force) is, the more electrons will flow in the circuit, and also the greater the resistance of a conductor, the less number of electrons will flow through.

It has been found that there is a definite mathematical relationship between the e.m.f. applied to a circuit having a definite resistance, and the current flow. This relationship is known as the *ohm's law*. This law states that the current flowing through a resistance under a given e.m.f. is inversely proportional to the resistance and directly proportional to the voltage. Thus  $I = \frac{E}{R}$  in which  $I$ , is the current in amperes;  $E$ , the e.m.f. in volts and  $R$ , the resistance in ohms.

**Series Circuits.**—If there be several resistances in series, as shown in fig. 8, the equation becomes

$$I = \frac{E}{R_1 + R_2 + R_3} \text{ or } E = I (R_1 + R_2 + R_3)$$

$$\text{or } E = I \times R_1 + I \times R_2 + I \times R_3$$

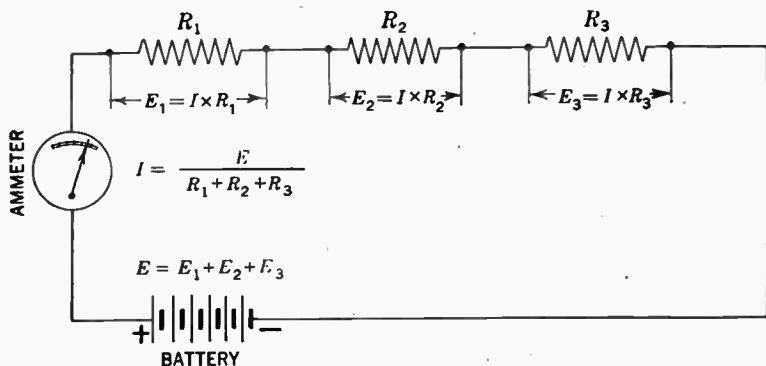

FIG. 8.—Simple circuit with three resistances connected in series.



The sum of the difference of potential across the various parts of the circuit is equal to the total voltage impressed on the circuit. Thus,  $E = E_1 + E_2 + E_3$ .

In a circuit as shown in fig. 8, the current  $I$ , is the same in each part of the circuit, but the voltage across each resistance depends directly upon the size of that resistance.

**Example:**—What voltage must be furnished by the battery in fig. 8, in order to force 0.25 ampere through the circuit if  $R_1$ ,  $R_2$  and  $R_3$  are 5, 15 and 20 ohms respectively?

The total resistance  $R = 5 + 15 + 20 = 40$  ohms. The total voltage is  $40 \times 0.25 = 10$  volts.

The voltage required for each part may be conveniently used as a check. Thus

$$E_1 = 0.25 \times 5 = 1.25 \text{ volts}$$

$$E_2 = 0.25 \times 15 = 3.75 \text{ volts}$$

$$E_3 = 0.25 \times 20 = 5 \text{ volts.}$$

Hence  $1.25 + 3.75 + 5 = 10$  volts, as before.

**Parallel Circuits.**—In parallel circuits, see fig. 9, the voltage across the various resistances is the same and the current flowing through each resistance varies inversely with the value of it. The sum of all the currents, however, is equal to the main current leaving the battery. Thus

$$E = I_1 \times R_1 = I_2 \times R_2 = I_3 \times R_3$$

and

$$I = I_1 + I_2 + I_3$$

When Ohm's law is applied to the individual resistances, the following is obtained:

$$I_1 = \frac{E}{R_1}, I_2 = \frac{E}{R_2}, \text{ and } I_3 = \frac{E}{R_3}$$

Hence  $I = \frac{E}{R_1} + \frac{E}{R_2} + \frac{E}{R_3}$  or  $I = E \left( \frac{1}{R_1} + \frac{1}{R_2} + \frac{1}{R_3} \right)$ ;

and since  $\frac{E}{I} = R$ , the equivalent resistances of the several re-

sistances connected in parallel is  $\frac{1}{R} = \frac{1}{R_1} + \frac{1}{R_2} + \frac{1}{R_3}$

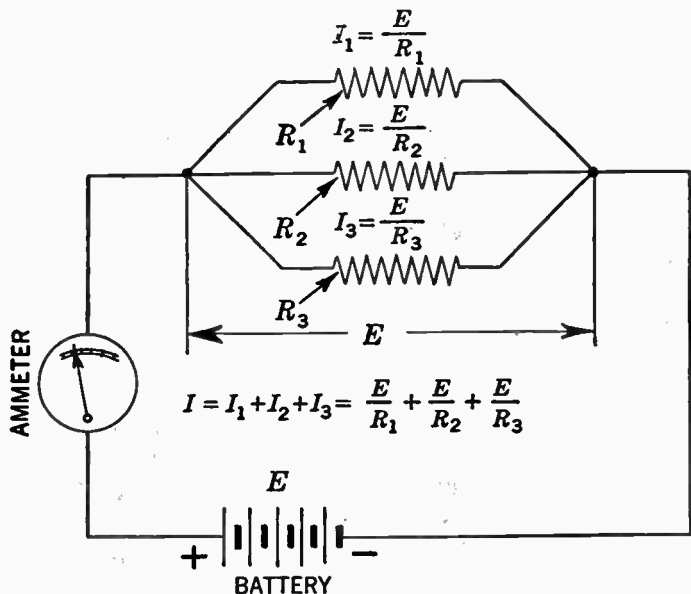

FIG. 9.—Simple circuit with three resistances connected in parallel.

**Example:**—If the resistances in previous example be connected in parallel as shown in fig. 9, what will be the total current and the current flowing through each resistance if the voltage remains unchanged or 10 volts?

The total resistance ( $R$ ) for the combination will be found as follows:

$$\frac{1}{R} = \frac{1}{5} + \frac{1}{15} + \frac{1}{20} = \frac{19}{60} \quad \text{Then } R = \frac{60}{19} = 3.16 \text{ ohm.}$$

$$\text{The total current} = \frac{10}{3.16} = 3.17 \text{ amperes.}$$

$$\text{The current in the 5 ohms resistance is } \frac{10}{5} = 2 \text{ amperes.}$$

$$\text{" " " " 15 " " " } \frac{10}{15} = 0.67 \text{ "}$$

$$\text{" " " " 20 " " " } \frac{10}{20} = 0.5 \text{ "}$$

The current through each resistance may conveniently be added as a check. Thus  $2 + 0.67 + 0.5 = 3.17$  amperes as before.

**Power in Electrical Circuits.**—As previously stated, the electrons in their movement through a circuit do not have a clear path, but are in constant collision with atoms of the metals causing the metal to heat up. The heat so developed, varies with the number of collision and increases with the increase in current flow, due to a higher potential. It has been found that this developed heat or power loss varies directly as the resistance and as the square of the current, which relation may be written

$$W = I^2 \times R = \frac{E^2}{R} = E \times I$$

in which  $W$  is the power in watts;  $E$ ,  $I$  and  $R$  being the voltage current and resistances of the circuit. Thus to determine the power consumed in a device, multiply the voltage across it by the current flowing through it.

**Example:**—If certain heating elements take 25 amperes at a potential of 110 volt, what is the power consumption?

The power is  $W = 25 \times 110 = 2,750$  watts =  $2\frac{3}{4}$  k.w.

As the watt is a small unit of electrical power, the kilowatt (k.w.) which is a unit 1,000 times larger is more convenient, when it is desired to express larger amounts of power.

Therefore to change watts to kilowatts divide by 1,000 and to change kilowatts to watts multiply by 1,000.

One horse power (H.P.) is = 746 watts:

Thus one kilowatt is  $= \frac{1,000}{746}$  or 1.34 horse power.

To obtain the horse power consumption in the above heating elements  $H.P. = \frac{2,750}{746} = 3.7$  horse power.

**Example.**—A certain carbon resistor is marked 1 watt and has 3 code colors as follows: yellow body, black tip and orange colored dot. What is the maximum current that may safely be sent through it?

**Solution.**—In this case it is first necessary to find the resistance value in ohms. With reference to page 182 the Radio Manufacturer's Association's Code colors indicate that the resistor has a resistance of 40,000 ohms, which may be checked as follows: yellow body means (4); black tip means (0) and orange dot means (00) or 40,000. Now the value of power dissipation in watts is equal to  $(I^2R)$  from which it follows that

$$1 = I^2 \times 40,000 \text{ or } I^2 = \frac{1}{40,000} \text{ hence}$$

$$I = \frac{1}{200} \text{ amperes or 5 milli-amperes.}$$

With an increase in current above the derived value, the heating of the resistor may become excessive and may even damage or change the accuracy of the resistance in question.

**SERIES PARALLEL CIRCUITS.**

The solution of circuit shown on opposite page is in reality very simple if it be kept in mind that any number of resistances connected in series may be replaced by a single resistor with a value equal to the arithmetical sum of the individual resistors, or that any number of resistors in parallel can be replaced by an equivalent whose value is equal to the reciprocal of the sum of the reciprocals of the individual units.

Circuit A-1 consists of resistors  $R_a$  and  $R_b$  in series, and the two also in parallel with  $R_d$ . This group is connected in series with  $R_c$  and the whole combination is again connected in parallel with  $R_f$ .

The simplest way to solve a resistance combination of this type is to remember the foregoing and to go through the problem step by step, combining each series and each parallel group and to replace them with their equivalent resistance.

Hence, to solve this circuit first replace  $R_a$  and  $R_b$  by their equivalent  $R_g$ .

The next step is to combine  $R_g$  and  $R_d$  replacing them by their equivalent  $R_h$ . By replacing  $R_c$  and  $R_h$  by their equivalent  $R_j$ , the original circuit now being reduced to the form as shown in fig. A-4.

In the manner similar to that already described  $R_j$  and  $R_f$  in parallel is replaced by a resistance  $R_k$  obtaining the result as shown in fig. A-5. Finally as a result of these calculations a resistance is obtained having the same current limiting-effect as that shown in fig. A-1.

A-1

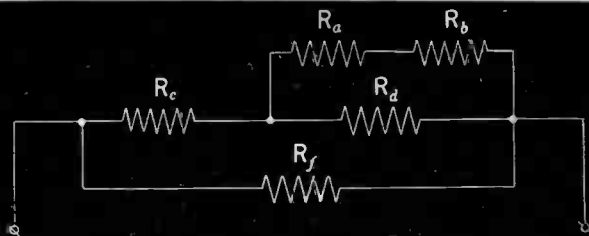

A-2

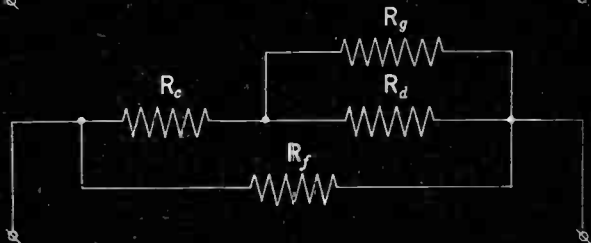

A-3

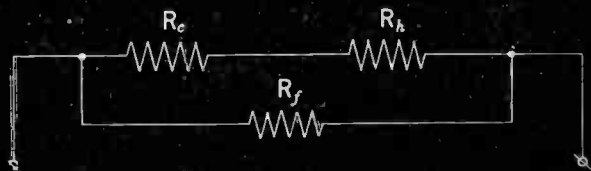

A-4

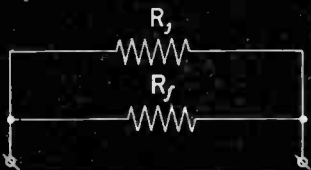

A-5

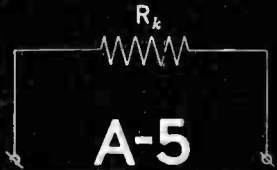

Method illustrating how a series parallel resistance combination of type shown in A-1 may be reduced to the simple form of that shown in fig. A-5.

**Example.**—Assume a battery consisting of two dry cells connected in series, and that each cell has an E.M.F. of 1.5 volts and an internal resistance of 0.3 ohms. In this arrangement the battery then has a total E.M.F. of 3 volts and an internal resistance of 0.6 ohms. If a current of 6 amperes is required through a circuit of 0.2 ohms resistance, how many batteries should be used and how should they be arranged?

**Solution.**—With one battery the current according to Ohm's law will be

$$I = \frac{3}{0.2+0.6} = 3.75 \text{ amperes}$$

This is not sufficient current, and if two batteries be connected in series, we obtain

$$I = \frac{6}{0.2+1.2} = 4.28 \text{ amperes}$$

This current is still too small and represents an increase in current of only about 14% although the voltage has been doubled; if, however, the two batteries be arranged in parallel, the current will be

$$I = \frac{3}{\frac{0.2+0.6}{2}} = 6 \text{ amperes}$$

**Example.**—In a certain galvanometer, the maximum deflection is obtained when the current is 40 milliampere. If the internal resistance is 15 ohms, what is the greatest voltage the instrument can be used to measure? If it is necessary to use the instrument for voltages up to 10 volts, what value of series resistance will be required?

**Solution.**—By application of Ohm's law, the largest possible voltage that can be measured is given by the products of the largest current that can be sent through it (0.04 amperes) and the value of the internal resistance (15 ohms). Thus it may be written:  $0.04 \times 15 = 0.6$  volts.

In order to measure larger voltages, however, it is necessary to insert a resistance in series with the instrument, after which the voltage to be measured is applied across the combination.

The additional voltage is now dissipated in the series resistance, and only the smaller voltage is applied to the galvanometer itself.

Since the same current obviously must flow in both the instrument and the series resistance, write as follows:

$$\frac{\text{Max. volt. drop across galvanometer}}{\text{Max. volt. drop across combination}} = \frac{\text{Galvanometer res.}}{\text{Galvanometer res.} + \text{ser. res.}}$$

In this equation the only unknown factor is the series resistance, hence by substituting known values, the following is obtained:

$$\frac{0.6}{10} = \frac{15}{15 + R_s}$$

where  $R_s$  denotes the unknown series resistance. Therefore,

$$150 = 0.6 (15 + R_s) \text{ or } R_s = 235 \text{ ohms}$$

which is the value of the series resistance to be inserted in series with the galvanometer to give full scale deflection at a potential of 10 volts.



**Alternating Current Series Circuits.** (Inductive Reactance.)  
 —In direct current circuits the current is exactly defined by the mathematical relations between voltage and resistance, whereas in the alternating current circuits this exact relationship no longer exists. For example in the case of direct current, the current through a piece of wire will be the same if the wire be coiled together or uncoiled. In the case of an alternating current the current will be less when the wire is in coiled than in straight form.

This is due to the inductive reactance ( $X_L$ ) of the wire and is written

$$X_L = 2 \times \pi \times f \times L$$

in which  $X_L$  is the inductive reactance in ohms,  $f$ , the frequency of the alternating current source and  $L$  the co-efficient of self-induction in henrys.

**Capacitive Reactance.**—If a direct current be connected across a condenser there will be no current flow, but if the condenser be connected across an alternating current source of high frequency the current will pass through. This is due to the capacitive reactance ( $X_c$ ) of the condenser and is written

$$X_c = \frac{1}{2 \times \pi \times f \times C}$$

in which  $X_c$  is the capacitive reactance in ohms,  $f$ , the frequency of the alternating current source, and  $C$ , the capacity of the circuit in farads.

**Resistance and Inductance in Series.**—When a circuit instead of containing resistance only or inductance only, contains both resistance and inductance as in the case of a coil, it is convenient to consider it as a resistance ( $R$ ) connected in series with a pure inductive reactance ( $X_L$ ). See fig. 10.

In this case it is necessary not only to know how to calculate inductive reactance but also how to combine  $R$  and  $X_L$ . (See impedance triangle fig. 11.)

The combined effect of total amount of resistance and inductive reactance in the circuit is called the impedance ( $Z$ ). The mathematical relation between the impedance, the inductive reactance and the resistance is written

$$Z^2 = X_L^2 + R^2 \text{ or } Z = \sqrt{X_L^2 + R^2}$$

and since

$$X_L = 2 \times \pi \times f \times L$$

as previously shown, the equation may also be written

$$Z = \sqrt{(2 \times \pi \times f \times L)^2 + R^2}$$

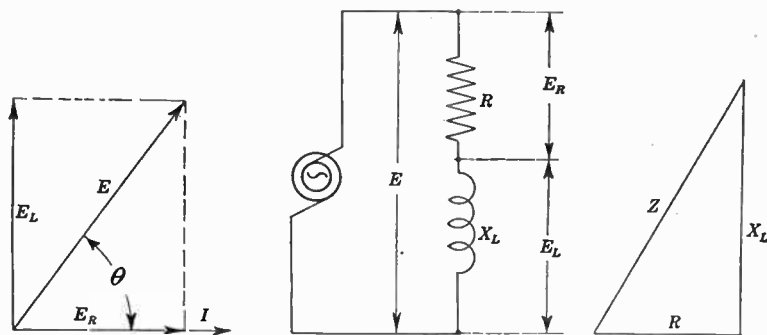

FIG. 10.—Combination of resistance ( $R$ ) and inductive reactance ( $X_L$ ).

**Example:**—A coil connected as shown in fig. 10 contains 5 ohms resistance and 0.04 henry inductance. The voltage and frequency of the source is 100 and 60 respectively.

Find (a) the impedance of the coil; (b) the current through the coil; (c) the voltage drop across the inductance; (d) the voltage drop across the resistance; (e) the power loss; (f) the power factor.

$$X_L = 2 \times \pi \times f \times L = 2 \times 3.14 \times 60 \times 0.04 = 15 \text{ ohms.}$$

$$(a) \quad Z = \sqrt{5^2 + 15^2} = \sqrt{250} = 15.8 \text{ ohms}$$

$$(b) \quad I = \frac{E}{Z} = \frac{100}{\sqrt{5^2 + 15^2}} = 6.3 \text{ amperes}$$

$$(c) \quad E_L = I \times X_L = 6.3 \times 15 = 94.5 \text{ volts}$$

$$(d) \quad E_R = I \times R = 6.3 \times 5 = 31.5 \text{ volts}$$

$$(e) \quad W = I^2 \times R = 6.3 \times 6.3 \times 5 = 198.45 \text{ watts}$$

$$(f) \quad \text{Cos}\theta = \frac{R}{Z} = \frac{5}{15.8} = 0.316 \text{ or } 32\% \text{ approximately}$$

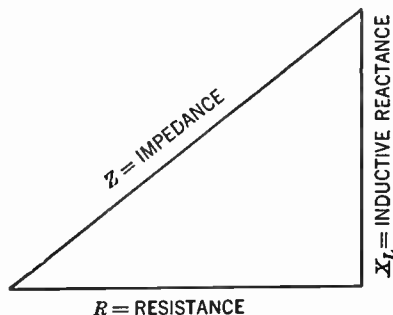

FIG. 11.—Illustrates vector relation between the inductive reactance and the resistance. To obtain the impedance: Resistance  $R$  (in ohms) is laid off horizontally; the inductive reactance  $X_L$  (also in ohms) is laid off to form the perpendicular. Measure the hypotenuse (in the same scale) which gives the impedance of the circuit in ohms. This triangle is variously referred to as the impedance triangle, vector diagram or impedance calculator.

**Resistance and Capacitance in Series.**—If a capacitance be connected in series with a resistance as shown in fig. 12 the impedance may be written  $Z = \sqrt{R^2 + X_c^2}$  and since

$$X_c = \frac{1}{2 \times \pi \times f \times C}$$

it follows that

$$Z = \sqrt{R^2 + \left( \frac{1}{2 \times \pi \times f \times C} \right)^2}$$

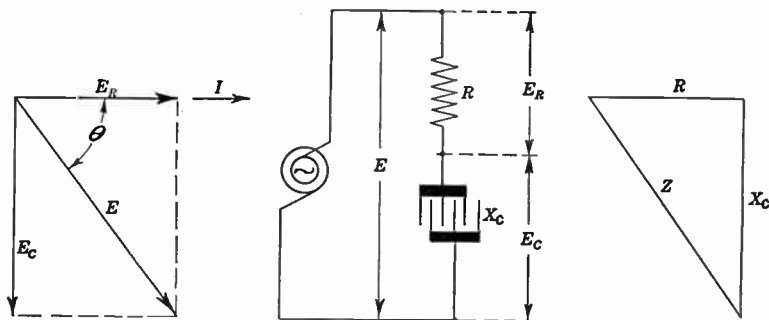

FIG. 12.—Combination of resistance ( $R$ ) and capacitive reactance ( $X_c$ ).

**Example:**—An alternating current circuit, connected as shown in fig. 12 contains 10 ohms resistance in series with a capacitance of 40 microfarads. The voltage and frequency of the source is 120 and 60 respectively.

Find (a) the current in the circuit; (b) the voltage drop across the resistance; (c) the voltage drop across the capacitance; (d) the power factor; (e) the power loss.

$$X_c = \frac{1}{2 \pi \times f \times C} = \frac{1}{2 \times 3.14 \times 60 \times 0.00004} = 66.3 \text{ ohms}$$

$$Z = \sqrt{10^2 + 66.3^2} = 67 \text{ ohms}$$

$$(a) \quad I = \frac{E}{Z} = \frac{120}{67} = 1.8 \text{ amperes}$$

$$(b) \quad E_R = I \times R = 1.8 \times 10 = 18 \text{ volts}$$

$$(c) \quad E_c = I \times X_c = 1.8 \times 66.3 = 119.3 \text{ volts}$$

$$(d) \quad \cos \theta = \frac{R}{Z} = \frac{10}{67} = 0.149 \text{ or } 14.9\%$$

$$(e) \quad W = E \times I \times \cos \theta = 120 \times 1.8 \times 0.149 = 32.18 \text{ watts}$$

**Resistance Inductance and Capacitance in Series.**—In a circuit which contains resistance ( $R$ ) inductance ( $X_L$ ) and capacitance ( $X_c$ ) the reactance ( $X$ ) is equal to the arithmetical difference between the inductive reactance ( $X_L$ ) and the capacitive reactance ( $X_c$ ) which may be written thus

$$X = X_L - X_c,$$

but as previously shown

$$Z = \sqrt{R^2 + X^2} = \sqrt{R^2 + (X_L - X_c)^2}$$

but since

$$X_L = 2 \times \pi \times f \times L \text{ and } X_c = \frac{1}{2 \times \pi \times f \times C}$$

it follows that

$$Z = \sqrt{R^2 + \left( 2 \times \pi \times f \times L - \frac{1}{2 \times \pi \times f \times C} \right)^2} \text{ ohms}$$

also the current flowing in this circuit

$$I = \frac{E}{\sqrt{R^2 + \left( 2 \times \pi \times f \times L - \frac{1}{2 \times \pi \times f \times C} \right)^2}}$$

The equations just derived are of the utmost importance in all alternating current calculations and are generally referred to as *the Ohm's law* for alternating current.

**Alternating Current Parallel Circuits.**—In the previous analysis of direct current parallel circuits, it was found that across each branch of the parallel circuit the voltage was equal, and that the current in each branch varied inversely as the resistance of that branch. The arithmetical sum of the current in each branch circuit was also equal to the main current.

When considering a parallel circuit as shown in fig. 13 through which an alternating current flows, the voltage across each branch (as in the case of the d.c. circuit) is equal.

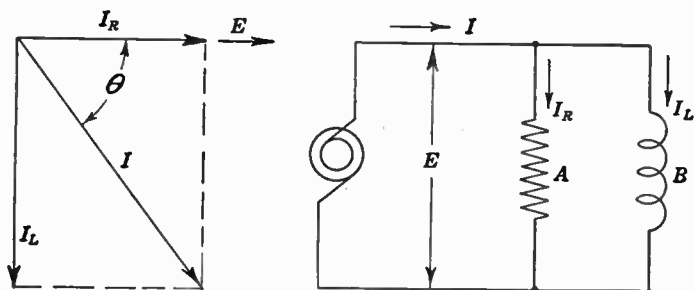

FIG. 13.—Parallel connection of resistance ( $R$ ) and inductive reactance ( $X_L$ ).

The total current, however, can not be obtained (as in direct current circuits) by arithmetical addition of the branch circuit currents, but each branch circuit current must be added vectorially which can best be shown by the following example:

A parallel connection consists of two branches A and B. See fig. 13. A, has a resistance of 40 ohms and B, has an inductive reactance of 30 ohms. If the impressed voltage is 120, determine: (a) the current through branch A; (b) the current through branch B; (c) the line current; (d) the power factor of the circuit.

$$(a) \quad I_R = \frac{120}{40} = 3 \text{ amperes}$$

$$(b) \quad I_L = \frac{120}{30} = 4 \text{ amperes}$$

$$(c) \quad I = \sqrt{3^2 + 4^2} = \sqrt{25} = 5 \text{ amperes}$$

$$(d) \quad \cos \theta = \frac{3}{5} = 0.6 \text{ (or power factor = 60 per cent)}$$

**Resonance.**—When in a series circuit the inductive reactance becomes equal to the capacitive reactance, the circuit is said to be in *resonance*. The only opposition to the current flow then is the ohmic resistance ( $R$ ).

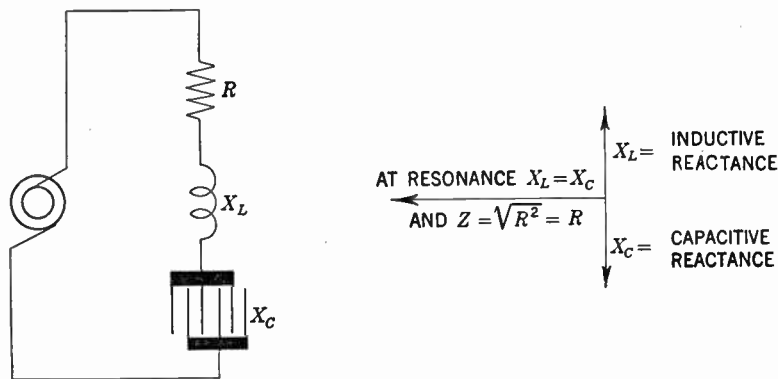

FIG. 14.—Illustrates connection diagram and resonance effect in a series circuit.

Referring to fig. 14 this condition may be written  $X_L = X_c$  but since  $X_L = 2 \times \pi \times f \times L$  and

$$X_c = \frac{1}{2 \times \pi \times f \times C}$$

it follows that

$$2 \times \pi \times f \times L = \frac{1}{2 \times \pi \times f \times C}.$$

If it be desired to find the resonant frequency ( $f$ ) for the circuit, the equation may be written

$$f^2 = \frac{1}{4\pi^2 LC}; f = \frac{1}{2\pi\sqrt{L \times C}}$$

This equation is of importance in all kinds of radio work and is used exclusively in calculations for wavemeters, filters, circuit tuning, etc. If  $C$ , be expressed in microfarads and  $L$ , in microhenries the equation may be written

$$f = \frac{159,000}{\sqrt{C(\text{microfarads}) \times L(\text{microhenries})}}$$

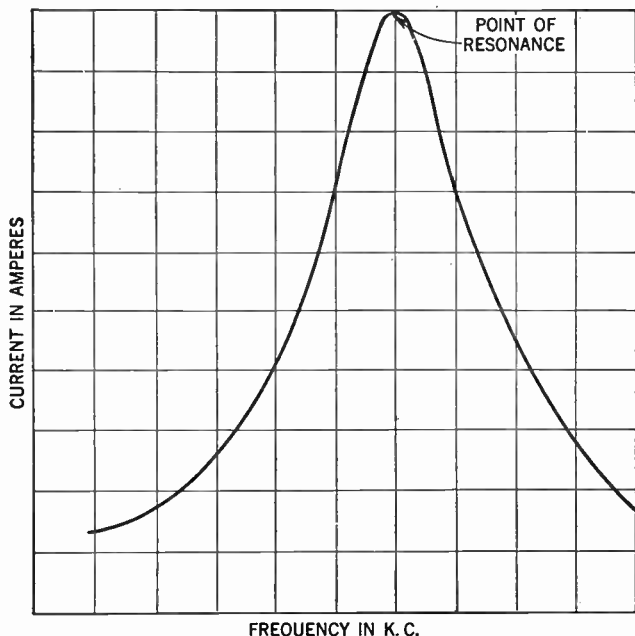
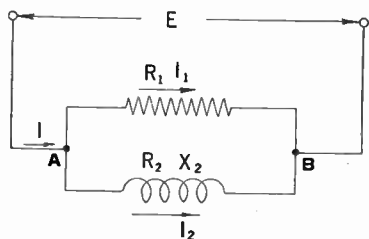

FIG. 15.—Illustrating how the current varies for increasing frequency in a resonance circuit.



**Example.**—Considering the circuit shown in fig. 16A-1 in which a resistance of  $R_1$  ohms is connected in parallel with an inductive coil whose resistance is  $R_2$  ohms and whose reactance is  $X_2$  ohms at the working frequency. If  $R_1 = 15$  ohms,  $R_2 = 12$  ohms and  $X_2 = 16$  ohms what will be the impedance of the circuit between A and B?

**Solution.**—The simplest way to find the impedance is to determine the total current taken when a particular voltage is applied to the ends, the impedance then being given by dividing the voltage by the current obtained. Since the circuit is a parallel one, 10 volts will be applied to each branch, and the voltage vector is thus first drawn as the reference vector, preferably in the horizontal position as shown by  $O-E$  in fig. 16A-2.



A-1

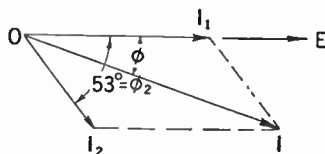

A-2

FIG. 16.—Resistance and inductive reactance in parallel combination.

The current  $I_1$  in the upper branch of the circuit will be calculated from Ohm's law, being  $I_1 = \frac{E}{R} = \frac{10}{15} = 0.667$  amperes, and this is exactly in phase with the voltage. The corresponding current vector  $O-I_1$ , is thus drawn over the top of the voltage vector as shown, and its length could conveniently be made 6.67 inches. The lower branch has an impedance of

$$Z_2 = \sqrt{R_2^2 + X_2^2} = \sqrt{12^2 + 16^2} = 20 \text{ ohms,}$$

and the current in it is therefore

$$I_2 = \frac{E}{Z_2} = \frac{10}{20} = 0.5 \text{ amperes}$$

but as this is an inductive branch the current lags to some extent behind the voltage.

If  $\phi_2$  is the angle of lag  $\cos \phi_2 = \frac{R_2}{Z_2} = \frac{12}{20} = 0.6$  and from a table of cosines, it is found that  $\phi_2 = 53^\circ$  approx. Thus in a vector diagram of fig. 16A-2 the current vector  $O-I_2$  is drawn at an angle of  $53^\circ$  to the voltage vector  $O-E$ , to the right since the current lags by this angle. Using the same scale, its length would be made 5 inches. The total current is then found by completing the parallelogram and measuring the length of the diagonal  $O-I$ . This will be found to be approximately 10.5 inches corresponding to a current of 1.05 amperes, and then the impedance of the whole circuit is  $Z = \frac{E}{I} = \frac{10}{1.05} = 9.52$  ohms. The combined current  $I$  lags behind the applied voltage by the angle  $\phi$  which if measured off by a protractor will be found to be  $22.9^\circ$ .

The circuit values just being arrived at by a combined measurement and calculation method may of course be calculated directly. If this be done, the procedure will be as follows:

(1) current through the upper branch, being  $I_1 = \frac{10}{15}$  or 0.667 amperes

(2) current through the lower branch,  $I_2 = \frac{10}{\sqrt{12^2 + 16^2}} = \frac{10}{20}$  or 0.5 amperes

(3)  $\cos \theta_2 = \frac{12}{20} = 0.6$  and the angle of lag between voltage and  $I_2$  is  $53^\circ$  as before.

(4) Total current  $I = \sqrt{(I_1 + I_2 \times \cos 53^\circ)^2 + (I_2 \times \sin 53^\circ)^2}$  and after substituting numerical values

$$I = \sqrt{(0.667 + 0.5 \times 0.6)^2 + (0.5 \times 0.8)^2}$$

from which  $I = 1.05$  amperes approximately.

Angle of lag between voltage and  $I$  is similarly found, thus

$$\cos \theta = \frac{I_1 + I_2 \times \cos 53^\circ}{1.05} = \frac{0.967}{1.05} = 0.92$$

and  $\theta = 22.9^\circ$  approximately.

In a similar manner most alternating current problems of like nature may readily be solved. The important thing to remember is that currents and potentials must be computed geometrically and not arithmetically as each value is represented by a vector of definite size and direction.

**Application to an Inter-stage Coupling.**—In a low frequency amplifier where resistance, capacitance or choke capacity coupling is employed between the tubes, it is necessary to guard against excessive drop of voltage across the coupling condenser at the lowest frequency and the determination of the fraction of the total available voltage passed on to the grid of the second tube is a matter which is easily analyzed by the aid of vectors, which also give the phase angle of this voltage.

Fig. 17 (a) depicts an ordinary resistance capacity coupling. Assuming that the alternating component of the voltage developed across the anode resistance is  $E$  volts, this potential difference is set up between the ends of the coupling circuit  $CR$  as shown. Suppose that the grid leak  $R$  has a resistance of 0.5 megohms, and that the capacity of the coupling condenser is 0.01 microfarad. Assuming that 50 cycles per second represent the lowest frequency to be dealt with, the reactance of the condenser at this frequency is  $\frac{1}{2\pi f c} = \frac{10^6}{2\pi 50 \times 0.01} = 318,000$  ohms or 0.318 megohms.

Now since  $R$  and  $C$  are in series, there is only one current and so the current vector of fig. 17 (b) is drawn in position first, this being denoted by  $O-I$  of arbitrary length.

In the circuit diagram the voltage required to drive the current through the condenser is denoted by  $E_c$  and through the grid leak by  $E_g$ . What is required to find is the ratio of  $E_g$  to  $E_c$ .

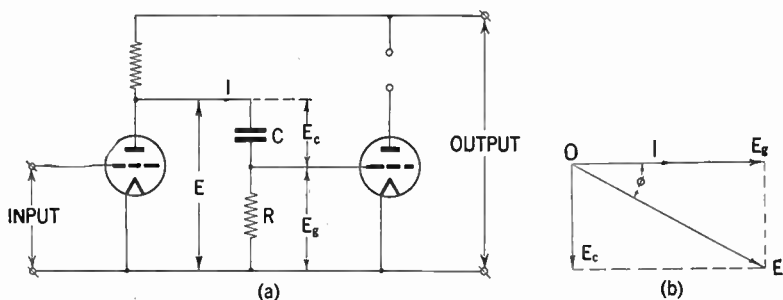

FIG. 17.—Showing interstage coupling and efficiency components with vector diagram.

By Ohm's law  $E_g = IR$  volts in phase with  $I$ . Its numerical value cannot be found yet because  $I$  is not known, but the vector  $O-E_g$  can be drawn parallel to  $O-I$  and its length made proportional to the resistance  $R$ . Since  $R$  is 0.5 mehogms  $O-E_g$  could conveniently be made 5 inches long.

The current taken by the condenser leads the voltage across it by a quarter of a cycle, and the voltage  $E_c$  will therefore lag behind the current by this amount. Hence the vector  $O-E_c$  is drawn at right angles to  $O-I$  in the position shown in fig. 17 (b) and its length is made proportional to the reactance of the condenser to the same scale as  $O-E_g$ .

Since the condenser reactance at 50 cycles is 0.318 megohm,  $O-E_c$  will have to be 3.18 inches using the same scale as before. Now the total voltage  $E$ , across the coupling circuit must be equal to the vector sum of  $E_c$  and  $E_g$ . If the rectangle

$OE$ ,  $EE_0$  be completed as shown  $OE$  will represent the total available voltage to the same scale.

The length of  $OE$  will clearly be

$$\sqrt{OE_0^2 + OE_c^2} = \sqrt{5^2 + 3.18^2} = 5.92 \text{ inches.}$$

Thus the ratio of  $E_0$  to  $E$ , is  $\frac{5}{5.92} = 0.844$  so that 84.4% of the available signal voltage is passed to the succeeding tube at 50 cycles, which represents quite a high efficiency.

Incidentally the actual value of the voltage  $E$  would be  $0.592 I \times 10^{-6}$  volts so that the impedance of the coupling circuit is  $0.592 \times 10^{-6}$  ohms or 0.592 megohms. It can be shown that the efficiency of the coupling is equal to its power factor.

**Example.**—*In a certain two tube receiver the negative grid bias is obtained by means of insertion of a 600 ohms resistor between the high potential and low potential leads. With a tube of 6,500 ohms a.c. resistance, the grid bias is 7 volt negative. With another tube of 8,000 ohms a.c. resistance it is only 4.5 volt negative. If the H.P. supply is 120 volts, what is the steady anode current in each case?*

**Solution.**—When filament current is provided by a battery it is customary to measure the grid bias voltage from the negative end of the filament, which is thus assumed to have zero potential. Fig. 18 shows the essential of the grid biasing arrangement adopted, in which the steady part of the anode current, provided by the H.P. battery flows through the biasing resistance of 600 ohms, while the speech component follows the low impedance path of the shunting condenser. The filament end of the resistance  $F$ , has evidently a more positive potential than the grid end  $G$ , which is connected directly to the negative end of the battery.  $G$ , is thus biased negatively with regard to  $F$ , and since this last has zero potential,  $G$  may be properly regarded as being so many volts negative with respect to  $F$ .

By Ohm's law the steady current  $I$ , in amperes, is given by the quotient  $\frac{E}{R}$  where  $E$  is the potential drop or bias voltage and  $R$  the resistance in ohms. In the case of the first tube, therefore,

$$I = \frac{7}{600} = 0.0117 \text{ amperes} = 11.7 \text{ milliamperes}$$

with the second tube

$$I = \frac{4.5}{600} = 0.0075 \text{ amperes} = 7.5 \text{ milliamperes}$$

In neither case has the *a.c.* anode resistance anything to do with the problem.

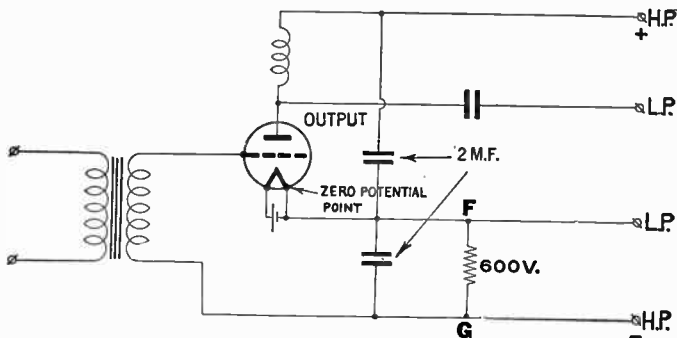

FIG. 18.—Schematic arrangement of components.

**Problem.**—In order to measure the resistance of a grid leak, a 200-volt meter of 980 ohms per volt resistance is employed in conjunction with a dry battery. The direct voltage reading of the battery is 144 volts, but if the grid leak be included in the circuit, the reading drops to 24 volts. What is the value of the leak?

**Solution.**—This is quite a good method of ascertaining the approximate value of the grid leak or similar large resistance if

a reliable high resistance voltmeter be available. The meter resistance in ohms per volt is usually quoted by the manufacturer, but if not, it can readily be calculated by the simple expedient of measuring the current taken by it in order to produce a given deflection and applying ohms law.

In this case, since the meter is scaled for 200 volts, its resistance will be  $200 \times 980$  or 196,000 ohms. First let us denote the unknown value of the grid leak by ( $R$ ) ohms. Then, when the voltmeter is connected to a battery through  $R$ , the circuit will appear as shown in fig. 19. Now since the battery resistance

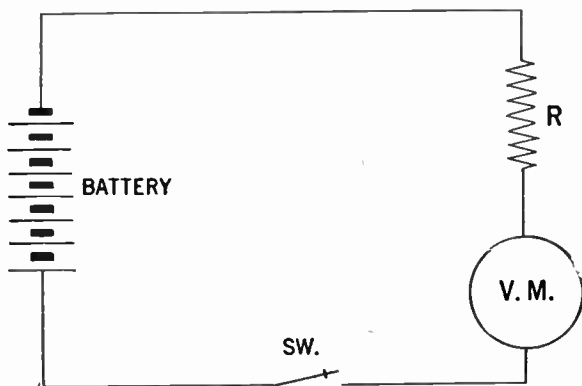

FIG. 19.—Circuit arrangement for approximate determination of grid leak values.

may be assumed negligible in comparison with the other resistance in the circuit, we may regard the voltage drop of the battery when measured directly by the meter as equivalent to the *e.m.f.* in the circuit illustrated. The current flowing will therefore be:

$$I = \frac{E}{\text{total res.}} = \frac{144}{196,000 + R} \text{ amperes}$$

Now it is known that this current flowing through the volt-meter causes it to register a deflection of 24 volts, which is the  $IR$  drop across its terminals, but this  $IR$  drop is also given by the product of the current flowing and the meter resistance, so it may be written:

$$\left(\frac{144}{196,000 + R}\right)196,000 = 24$$

Solving this equation for  $R$ , we may write

$$24(196,000 + R) = 144 \times 196,000$$

from which follows that

$$\begin{aligned} 24R &= 120 \times 196,000 \text{ or} \\ R &= 980,000 \text{ ohms} \end{aligned}$$

**Example.**—Assuming that the galvanometer on page 40 is to be used as an ammeter reading currents up to 2 amperes, how should it be connected?

**Solution.**—Without any changes the instrument is a direct reading milli-ammeter with full scale reading when 40 milli-amperes passes through it. To measure higher currents, this extra current is simply passed through a resistance inserted in parallel with the meter. This resistance must be of such value that when 2 amperes flows in the main circuit, only 0.04 amperes flows through the galvanometer. If  $R_g$ ,  $I_g$ ,  $R_s$ ,  $I_s$  represent the resistance and current in the galvanometer and parallel resistance respectively, then, since the potential drop across both the galvanometer and the parallel resistance are the same, it is obtained as follows:

$R_g \times I_g = R_s \times I_s$ , and since  $R_s$  is the only unknown, by substitution

$$R_s = \frac{R_g \times I_g}{I_s} = \frac{15 \times 0.04}{2 - 0.04} \text{ or } 0.306 \text{ ohms,}$$



which is the value of the resistance to be shunted across the instrument to enable measurements of currents up to 2 amperes.

**Example.**—*What is the maximum direct current that may be sent through a 50,000 ohms resistance rated at 20 watts, without over-heating?*

**Solution.**—The power loss in watts when a direct current of  $I$  amperes passes through a resistance of  $R$ , ohms is given by the formula  $I^2R$ , with regard to the above example in which  $R$  is 50,000 ohms and the power loss is 20 watts, it follows that

$$20 = I^2 \times 50,000 \text{ or } I^2 = \frac{1}{2,500}$$

hence

$$I = \frac{1}{50} \text{ ampere or } 20 \text{ milli-amperes.}$$

**Example.**—*If in an alternating current circuit the following readings are obtained, watts 10, current 125 MA, and voltage 100, what is the power factor and the angle between the current and voltage?*

**Solution.**—In an alternating current of pure sine wave form the power in watts will be equal to voltage times current times  $\cos \theta$  or in equation form  $W = E \times I \times \cos \theta$  in which

$W$  is the power in watts,  $E$  the pressure in volts.

$I$  the current in amperes and  $\theta$  the angle of lag or lead between the current and voltage, or in the above example

$$10 = 100 \times 0.125 \times \cos \theta$$

from which  $\cos \theta = \frac{10}{12.5} = 0.8$  from this it follows that the angle between the current and the voltage is  $60^\circ$ .

CHAPTER 4

# **Review**

## **Questions and Answers**

**What is meant by an "A" power supply?**

Ans. A power supply device providing heating current for the cathode of a vacuum tube.

**What is an alternating current?**

Ans. A current, the direction of which reverses at regularly recurring intervals, the algebraic average value being zero.

**What is meant by amplification factor?**

Ans. A measure of the effectiveness of the grid voltage relative to that of the plate voltage in affecting the plate current.

**Describe an amplifier.**

Ans. A device for increasing the amplitude of electric current, voltage or power, through the control by the input power of a larger amount of power supplied by a local source to the output circuit.

**What is an anode?**

Ans. An electrode to which an electron stream flows.

**What is an antenna?**

Ans. A conductor or a system of conductors for radiating or receiving radio waves.

**What is meant by the term atmospherics?**

Ans. Strays produced by atmospheric conditions.

**Describe what is meant by attenuation.**

Ans. The reduction in power of a wave or a current with increasing distance from the source of transmission.

**What is the approximate length of audio frequency waves?**

Ans. A frequency corresponding to a normally audible sound wave. The upper limit ordinarily lies between 10,000 and 20,000 cycles per second.

**What is an audio frequency transformer?**

Ans. A transformer for use with audio frequency currents.

**What is meant by autodyne reception?**

Ans. A system of heterodyne reception through the use of a device which is both an oscillator and a detector.

**Describe an automatic volume control device.**

Ans. A self-acting device which maintains the output constant within relatively narrow limits while the input voltage varies over a wide range.

**What is meant by a "B" power supply?**

Ans. A power supply connected in the plate circuit of a vacuum tube.

**Describe and give the function of a "Baffle."**

Ans. A partition which may be used with an acoustic radiator to impede circulation between front and back.

**Describe a band-pass filter.**

Ans. A filter designed to pass currents of frequencies within a continuous band limited by an upper and a lower critical or cut-off frequency and substantially reduce the amplitude of currents of all frequencies outside of that band.

**What is meant by the term "Beat"?**

Ans. A complete cycle of pulsations in the phenomenon of beating.

**What is meant by beat-frequency?**

Ans. The number of beats per second. This frequency is equal to the difference between the frequencies of the combining waves.

**What is meant by the term beating?**

Ans. A phenomenon in which two or more periodic quantities of different frequencies react to produce a resultant having pulsations of amplitude.

**What is meant by broadcasting?**

Ans. Radio transmission intended for general reception.

**Describe a by-pass condenser.**

Ans. A condenser used to provide an alternating current path of comparatively low impedance around some circuit element.

**What is meant by a "C" power supply?**

Ans. A power supply device connected in the circuit between the cathode and grid of a vacuum tube so as to apply a grid bias.

**What is meant by a capacity coupling?**

Ans. The association of one circuit with another by means of capacity common or mutual to both.

**Describe a carbon microphone.**

Ans. A microphone which depends for its operation upon the variation in resistance of carbon contacts.

**Describe the meaning of the term carrier.**

Ans. A term broadly used to designate carrier wave, carrier current or carrier voltage.

**What is meant by carrier frequency?**

Ans. The frequency of a carrier wave.

**What is meant by carrier-suppression?**

Ans. That method of operation in which the carrier wave is not transmitted.

**What is a carrier wave?**

Ans. A wave which is modulated by a signal and which enables the signal to be transmitted through a specific physical system.

**What is a cathode?**

Ans. The electrode from which the electron stream flows.

**Describe and give the function of a choke coil.**

Ans. An inductor inserted in a circuit to offer relatively large impedance to alternating current.

**Describe a condenser loud speaker.**

Ans. A loud speaker in which the mechanical forces result from electrostatic reactions.

**Describe a condenser microphone.**

Ans. A microphone which depends for its operation upon variations in capacitance.

**What is meant by continuous waves?**

Ans. Continuous waves are waves in which successive cycles are identical under steady state conditions.

**Define the meaning of Conversion transconductance.**

Ans. The ratio of the magnitude of a single beat-frequency component ( $f_1 + f_2$ ) or ( $f_1 - f_2$ ) of the output current to the magnitude of the input voltage of frequency  $f_1$  under the conditions that all direct voltages and the magnitude of the second input

alternating voltage  $f_2$  must remain constant. As most precisely used, it refers to an infinitesimal magnitude of the voltage of frequency  $f_1$ .

**Describe a converter generally as applied to super-heterodyne receivers.**

Ans. A converter is a vacuum tube which performs simultaneously the functions of oscillation and mixing (first detection) in a radio receiver.

**What is meant by coupling?**

Ans. The association of two circuits in such a way that energy may be transferred from one to the other.

**What is meant by cross modulation?**

Ans. A type of intermodulation due to modulation of the carrier of the desired signal in a radio apparatus by an undesired signal.

**What is meant by current amplification?**

Ans. The ratio of the alternating current produced in the output circuit of an amplifier to the alternating current supplied to the input circuit for specific circuit conditions.

**What is a cycle?**

Ans. One complete set of the recurrent values of periodic phenomenon.

**What are damped waves?**

Ans. Waves of which the amplitude of successive cycles at the source, progressively diminishes.

**What is a decibel?**

Ans. The common transmission unit of the decimal system, equal to 1/10 bel.

$$1 \text{ bel} = 2 \log_{10} \frac{E_1}{E_2} = 2 \log_{10} \frac{I_1}{I_2}$$

**What is meant by detection?**

Ans. Any process of operation on a modulated signal wave to obtain the signal imparted to it in the modulation process.

**What is a detector?**

Ans. A device which is used for operation on a signal wave to obtain the signal imparted to it in the modulation process.

**Describe a diode vacuum tube.**

Ans. A type of thermionic tube containing two electrodes which passes current wholly or predominantly in one direction.

**What is meant by direct capacitance (C) between two conductors?**

Ans. The ratio of the charge produced on one conductor by the voltage between it and the other conductor divided by this voltage, all other conductors in the neighborhood being at the potential of the first conductor.

**What is meant by direct coupling?**

Ans. The association of two circuits by having an inductor, a condenser, or a resistor common to both circuits.



**What is a direct current?**

Ans. An unidirectional current. As ordinarily used, the term designates a practically non-pulsating current.

**Describe what is meant by distortion.**

Ans. A change in wave form occurring in a transducer or transmission medium when the output wave form is not a faithful reproduction of the input wave form.

**What is meant by double modulation?**

Ans. The process of modulation in which a carrier wave of one frequency is first modulated by the signal wave and is then made to modulate a second carrier wave of another frequency.

**Describe an R.C.A. dynamic amplifier.**

Ans. This is a variable gain audio amplifier, the gain of which is proportional to the average intensity of the audio signal. Such an amplifier compensates for the contraction of volume range required because of recording or transmission line limitations.

**What is meant by the dynamic sensitivity of a phototube?**

Ans. The alternating-current response of a phototube to a pulsating light flux at specified values of mean light flux, frequency of pulsation, degree of pulsation, and steady tube voltage.

**What is an electro-acoustic transducer?**

Ans. A transducer which is actuated by power from an electrical system and supplies power to an acoustic system or vice versa.

**Describe what is meant by electron emission.**

Ans. The liberation of electrons from an electrode into the surrounding space. In a vacuum tube it is the rate at which the electrons are emitted from a cathode. This is ordinarily measured as the current carried by the electrons under the influence of a voltage sufficient to draw away all the electrons.

**What is an electron tube?**

Ans. A vacuum tube evacuated to such a degree that its electrical characteristics are due essentially to electron emission.

**What is meant by emission characteristics?**

Ans. A graph plotted between a factor controlling the emission (such as the temperature voltage or current of the cathode) as abscissas, and the emission from the cathode as ordinates.

**What is meant by facsimile transmission?**

Ans. The electrical transmission of a copy or reproduction of a picture, drawing or document. This is also called picture transmission.

**What is fading?**

Ans. The variation of the signal intensity received at a given location from a radio transmitting station as a result of changes occurring in the transmission path.

**What is meant by fidelity?**

Ans. The degree to which a system, or a portion of a system, accurately reproduces at its output the signal which is impressed upon it.

**What is a filament?**

Ans. A cathode in which the heat is supplied by current passing through the cathode.

**Generally define and give the function of a filter.**

Ans. A selective circuit network, designed to pass currents within a continuous band or bands of frequencies or direct current, and substantially reduce the amplitude of currents of undesired frequencies.

**What is meant by the term frequency?**

Ans. The number of cycles per second.

**Describe a full-wave rectifier.**

Ans. A double element rectifier arranged so that current is allowed to pass in the same direction to the load circuit during each half cycle of the alternating current supply, one element functioning during one-half cycle and the other during the next half cycle, and so on.

**What is meant by fundamental frequency?**

Ans. The lowest component frequency of a periodic wave or quantity.

**What is meant by fundamental or natural frequency of an antenna?**

Ans. The lowest resonant frequency of an antenna; without added inductance or capacity.

**What is a gas phototube?**

**Ans.** A type of phototube in which a quantity of gas has been introduced usually for the purpose of increasing its sensitivity.

**What is a grid?**

**Ans.** An electrode having openings through which electrons or ions may pass.

**What is meant by grid bias?**

**Ans.** The direct component of the grid voltage.

**What is a grid condenser?**

**Ans.** A series condenser in the grid or control circuit of a vacuum tube.

**What is a grid leak?**

**Ans.** A resistor in a grid circuit, through which the grid current flows, to affect or determine a grid bias.

**What is meant by the grid-plate transconductance?**

**Ans.** The name for the plate current to grid voltage transconductance. This has also been called mutual conductance.

**Describe a ground system of an antenna.**

**Ans.** That portion of the antenna system below the antenna loading devices or generating apparatus most closely associated with the ground and including the ground itself.

**What is a ground wire?**

Ans. A conductive connection to the earth.

**Describe a half-wave rectifier.**

Ans. A rectifier which changes alternating current into pulsating current, utilizing only one-half of each cycle.

**What is meant by a harmonic?**

Ans. A component of a periodic quantity having a frequency which is an integral multiple of the fundamental frequency. For example, a component the frequency of which is twice the fundamental frequency is called the second harmonic.

**Describe a heater.**

Ans. An electrical heating element for supplying heat to an indirectly heated cathode.

**Describe heterodyne reception.**

Ans. The process of receiving radio waves by combining in a detector a received voltage with a locally generated alternating voltage. The frequency of the locally generated voltage is commonly different from that of the received voltage. Heterodyne reception is sometimes called beat reception.

**What is meant by homodyne reception?**

Ans. A system of reception by the aid of a locally generated voltage of carrier frequency. Homodyne reception is sometimes called zero-beat reception.

**Describe an expansion type hot-wire ammeter.**

Ans. An ammeter dependent for its indications on a change in dimensions of an element which is heated by the current to be measured.

**What is meant by an indirectly heated cathode?**

Ans. A cathode of a thermionic tube in which heat is supplied from a source other than the cathode itself.

**Describe an induction loud speaker.**

Ans. It is a moving coil loud speaker in which the current which reacts with the polarizing field is induced in the moving member.

**What is meant by inductive coupling?**

Ans. The association of one circuit with another by means of inductance common or mutual to both.

**What is meant by interelectrode capacitance?**

Ans. The direct capacitance between two electrodes.

**Describe what is meant by interference.**

Ans. Disturbance of reception due to strays, undesired signals, or other causes; also that which produces the disturbance.

**What is meant by intermediate frequency in superheterodyne reception?**

Ans. A frequency between that of the carrier and the signal, which results from the combination of the carrier frequency and the locally generated frequency.

**What is meant by intermodulation?**

Ans. The production in a non-linear circuit element, of frequencies corresponding to the sums and differences of the fundamentals and harmonics of two or more frequencies which are transmitted to that element.

**Describe what is meant by interrupted continuous waves.**

Ans. These are waves obtained by interruption at audio frequency in a substantially periodic manner of otherwise continuous waves.

**What constitutes an ion?**

Ans. It is an atom or molecule having an electrical charge either positive or negative.

**What does the term "kilocycle" stand for?**

Ans. When used as a unit of frequency, it is one-thousand cycles per second.

**Describe a lead-in.**

Ans. That portion of an antenna system which completes the electrical connection between the elevated outdoor portion and the instruments or disconnecting switches inside the building.

**What is meant by linear detection?**

Ans. That form of detection in which the audio output voltage under consideration is substantially proportional to the modulation envelope throughout the useful range of the detecting device.

**Describe and give the function of a loading coil.**

Ans. An inductor inserted in a circuit to increase its inductance but not to provide coupling with any other circuit.

**What is generally meant by a loud speaker?**

Ans. A telephone receiver or apparatus designed to radiate acoustic power into a room or open air.

**What is meant by a magnetic loud speaker?**

Ans. One in which the mechanical forces result from magnetic reactions.

**What is a magnetic microphone?**

Ans. A microphone whose electrical output results from the motion of a coil or conductor in a magnetic field.

**Describe a master oscillator.**

Ans. An oscillator of comparatively low power so arranged as to establish the carrier frequency of the output of an amplifier.

**How many cycles per second is one megacycle?**

Ans. When used as a unit of frequency, it is one million cycles per second.

**Describe a mercury-vapor rectifier.**

Ans. A mercury-vapor rectifier is a two electrode, vacuum-tube rectifier which contains a small amount of mercury. During operation, the mercury is vaporized. A characteristic of mercury-vapor rectifiers is the low voltage drop in the tube.



**Describe a microphone.**

Ans. A microphone is an electro-acoustic transducer actuated by power in an acoustic system and delivering power to an electric system, the wave form in the electric system corresponding to the wave form in the acoustic system. This is also called a telephone transmitter.

**What is generally understood by a "Mixer tube" in super-heterodyne receivers?**

Ans. A mixer tube is one in which a locally generated frequency is combined with the carrier signal frequency to obtain a desired beat frequency.

**What is a modulated wave?**

Ans. A wave of which either the amplitude, frequency or phase is varied in accordance with a signal.

**Describe what is meant by modulation.**

Ans. Modulation is the process in which the amplitude, frequency or phase of a wave is varied in accordance with a signal, or the result of that process.

**Describe what is meant by monochromatic sensitivity.**

Ans. The response of a phototube to light of a given color, or narrow frequency range.

**What is a moving-armature speaker?**

Ans. A magnetic speaker whose operation involves the vibration of a portion of the ferromagnetic circuit. This is sometimes called an electromagnetic or a magnetic speaker.

**Describe a moving coil loud speaker.**

Ans. A moving coil loud speaker is a magnetic loud speaker in which the mechanical forces are developed by the interaction of currents in a conductor and the polarizing field in which it is located. This is sometimes called an electro-dynamic or a dynamic loud speaker.

**What is meant by Mu-factor?**

Ans. A measure of the relative effect of the voltages on two electrodes upon the current in the circuit of any specified electrode. It is the ratio of the change in one electrode voltage to a change in the other electrode voltage, under the condition that a specified current remains unchanged.

**What is an oscillator?**

Ans. A non-rotating device for producing alternating current, the output frequency of which is determined by the characteristics of the device.

**Describe an oscillatory circuit.**

Ans. A circuit containing inductance and capacitance, such that a voltage impulse will produce a current which periodically reverses.

**Describe a pentode tube.**

Ans. A type of thermionic tube containing a plate, a cathode, and three additional electrodes. Ordinarily the three additional electrodes are of the nature of grids.

**What is meant by percentage modulation?**

Ans. The ratio of half the difference between the maximum and minimum amplitudes of a modulated wave to the average amplitude, expressed in per cent.

**Describe a phonograph pickup.**

Ans. An electro-mechanical transducer actuated by a phonograph record and delivering power to an electrical system, the wave form in the electrical system corresponding to the wave form in the phonograph record.

**What is a phototube?**

Ans. A vacuum tube in which electron emission is produced by the illumination of an electrode. This has also been called photoelectric tube.

**What is meant by the plate in a vacuum tube?**

Ans. A common name for the principal anode.

**Describe what is meant by power amplification of an amplifier.**

Ans. The ratio of the alternating current power produced in the output circuit to the alternating current power supplied to the input circuit.

**What is meant by power detection?**

Ans. That form of detection in which the power output of the detecting device is used to supply a substantial amount of power directly to a device such as a loud speaker or recorder.

**Describe what is meant by pulsating current.**

Ans. A periodic current, that is, current passing through successive cycles, the algebraic average value of which is not zero. A pulsating current is equivalent to the sum of an alternating and a direct current.

**What is a push-pull microphone?**

Ans. One which makes use of two functioning elements 180 degrees out of phase.

**Define the term radio-channel.**

Ans. A band of frequencies or wave-lengths of a width sufficient to permit of its use for radio communication. The width of a channel depends upon the type of transmission.

**What is a radio compass?**

Ans. A direction finder used for navigational purposes.

**Describe what is meant by radio frequency.**

Ans. A frequency higher than those corresponding to normally audible sound waves.

**What is a radio-frequency transformer?**

Ans. A transformer for use with radio-frequency currents.

**What is a radio receiver?**

Ans. A device for converting radio waves into perceptible signals.

**Describe what is meant by radio transmission.**

Ans. The transmission of signals by means of radiated electro-magnetic waves originating in a constructed circuit.

**What is a radio transmitter?**

Ans. A device for producing radio-frequency power, with means for producing a signal.

**Describe a rectifier.**

Ans. A device having an asymmetrical conduction characteristic which is used for the conversion of an alternating current into a pulsating current. Such devices include vacuum-tube rectifiers, gas rectifiers, oxide rectifiers, electrolytic rectifiers, etc.

**What is meant by a Reflex circuit arrangement?**

Ans. A circuit arrangement in which the signal is amplified, both before and after detection, in the same amplifier tube or tubes.

**Describe what is meant by regeneration.**

Ans. The process by which a part of the output power of an amplifying device reacts upon the input circuit in such a manner as to reinforce the initial power, thereby increasing the amplification. This is sometimes called "feedback" or "reaction"

**What is a resistance coupling?**

Ans. The association of one circuit with another by means of resistance common to both.

**What is meant by the term “resonance frequency” of a reactive circuit?**

Ans. The frequency at which the supply current and supply voltage of the circuit are in phase.

**Describe a rheostat.**

Ans. A resistor which is provided with means for readily adjusting its resistance.

**What is the function of the screen grid in a vacuum tube?**

Ans. A screen grid is a grid placed between a control grid and an anode, and maintained at a fixed positive potential, for the purpose of reducing the electrostatic influence of the anode in the space between the screen grid and the cathode.

**What is secondary emission?**

Ans. Electron emission under the influence of electron or ion bombardment.

**What is meant by the term selectivity?**

Ans. The degree to which a radio receiver is capable of differentiating between signals of different carrier frequencies.

**What is meant by sensitivity?**

Ans. The degree to which a radio receiver responds to signals of the frequency to which it is tuned.

**Describe sensitivity as applied to the photo-electric tube.**

Ans. The electrical current response of a phototube with no impedance in its external circuit, to a specified amount and kind

of light. It is usually expressed in terms of the current for a given radiant flux, or for a given luminous flux. In general the sensitivity depends upon the tube voltage, flux intensity, and spectral distribution of the flux.

**What is meant by the term “service band”?**

Ans. A band of frequencies allocated to a given class of radio communication service.

**What is meant by the term “side band”?**

Ans. The bands of frequencies, one on either side of the carrier frequency, produced by the process of modulation.

**What is a signal?**

Ans. The intelligence, message or effect conveyed in communication.

**Describe what is meant by single-side band transmission.**

Ans. That method of operation in which one side band is transmitted, and the other side band is suppressed. The carrier wave may be either transmitted or suppressed.

**What is static?**

Ans. Strays produced by atmospheric conditions.

**What is meant by the static sensitivity of a phototube?**

Ans. The direct current response of a phototube to a light flux of specified value.

**Describe a stopping condenser.**

Ans. A condenser used to introduce a comparatively high impedance in some branch of a circuit for the purpose of limiting the flow of low-frequency alternating current or direct current without materially affecting the flow of high frequency alternating current.

**What is meant by the term “strays”?**

Ans. Electromagnetic disturbances in radio reception other than those produced by radio transmitting systems.

**Describe superheterodyne reception.**

Ans. Superheterodyne reception is a method of reception in which the received voltage is combined with the voltage from a local oscillator and converted into voltage of an intermediate frequency which is usually amplified and then detected to reproduce the original signal wave. This is sometimes called double detection or supersonic reception.

**What is meant by the term “swinging”?**

Ans. The momentary variation in frequency of a received wave.

**Describe a telephone receiver.**

Ans. An electro-acoustic transducer actuated by power from an electrical system and supplying power to an acoustic system, the wave form in the acoustic system corresponding to the wave form in the electrical system.



**What is television?**

Ans. The electrical transmission of a succession of images and their reception in such a way as to give a substantially continuous reproduction of the object or scene before the eye of a distant observer.

**Describe a tetrode vacuum tube.**

Ans. A type of thermionic tube containing a plate, a cathode, and two additional electrodes. Ordinarily the two additional electrodes are of the nature of grids.

**What is meant by the term thermionic?**

Ans. It is a term relating to electron emission under the influence of heat.

**Describe what is meant by thermionic emission.**

Ans. Electron or ion emission under the influence of heat.

**Describe a thermionic vacuum tube.**

Ans. An electron tube in which the electron emission is produced by the heating of an electrode.

**How does a thermo-couple ammeter operate?**

Ans. An ammeter dependent for its indications on the change in thermo-electro-motive force set up in a thermo-electric couple, which is heated by the current to be measured.

**What is meant by the term "total emission"?**

Ans. The value of the current carried by electrons emitted from a cathode under the influence of a voltage such as will draw away all the electrons emitted.

**What is meant by transconductance?**

Ans. The ratio of the change in the current in the circuit of an electrode to the change in the voltage on another electrode, under the condition that all other voltages remain unchanged.

**Describe a transducer.**

Ans. A device actuated by power from one system and supplying power to another system. These systems may be electrical, mechanical or acoustic.

**What is a transmission unit?**

Ans. A unit expressing the logarithmic ratios of powers, voltages, or currents in a transmission system.

**Describe a triode vacuum tube.**

Ans. A type of thermionic tube containing an anode, a cathode, and a third electrode, in which the current flowing between the anode and the cathode may be controlled by the voltage between the third electrode and the cathode.

**Describe a tuned transformer.**

Ans. A transformer whose associated circuit elements are adjusted as a whole to be resonant at the frequency of the alternating current supplied to the primary, thereby causing the secondary voltage to build up to higher values than would otherwise be obtained.

**What is tuning?**

Ans. The adjustment of a circuit or system to secure optimum performance in relation to a frequency; commonly, the adjustment of a circuit or circuits to resonance.

**What constitutes a vacuum?**

Ans. Vacuum is absolutely nothing, if we can conceive of such a thing. The degree of vacuum is measured in microns, one micron represents one-millionth part of the usual atmospheric pressure which is approximately 14.7 pounds per square inch. Thus a perfect vacuum would be zero microns; such a state is however only a theoretical ideal that can never be realized even with the most perfect laboratory technique.

**Describe a vacuum phototube.**

Ans. A type of phototube which is evacuated to such a degree that the residual gas plays a negligible part in its operation.

**What is a vacuum tube?**

Ans. A device consisting of a number of electrodes contained within an evacuated enclosure.

**What is a vacuum tube transmitter?**

Ans. A radio transmitter in which vacuum tubes are utilized to convert the applied electric power into radio-frequency power.

**Describe a vacuum tube volt-meter.**

Ans. A device utilizing the characteristics of a vacuum tube for measuring alternating voltages.

**Define voltage amplification.**

Ans. The ratio of the alternating voltage produced at the output terminals of an amplifier to the alternating voltage impressed at the input terminals.

## CHAPTER 5

# Radio Batteries

There may be confusion in the minds of some as to batteries so a classification of types and functions will be helpful, particularly to the novice.

Radio batteries may be classified according to the three elements of the vacuum tube which they serve, as

“A” battery

“B” battery

“C” battery

The three elements of the common vacuum tube, filament, plate and grid are often designated by the letters A, B and C.

The order in which the letters are assigned corresponds to the historical development of the tube.

The heated filament is comparatively an old device and the battery which lights it is known as the *filament battery* or “A” battery.

The plate was the second element to be invented and any battery used in the plate circuit is a “B” battery.

A later invention is the grid and the battery in the grid circuit is termed a “C” battery.

The B battery, connected in the plate circuit, maintains the plate at proper pressure and supplies the energy which operates the head phones or loud speaker.

The length of the period of satisfactory results, however, depends upon the quality of the battery. No battery can give out more than is put into it. That is why extreme care should be taken in the selection of B batteries, in order to secure the best results possible from radio. All B batteries of standard makes when fresh will measure up to the required voltage and give equal results at the start, but the initial voltage does not indicate the length of its useful life, which in a 45 volt battery ends after it drops below 34 volts.

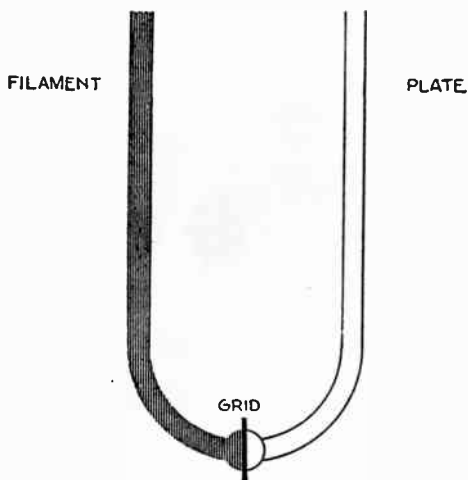

FIG. 1.—Hydrostatic analogy illustrating function of the grid. Consider a U tube at the bottom center of which is placed a pet cock and in one side of which with the pet cock closed is placed a quantity of mercury. If this pet cock be opened wide, the mercury will immediately seek its own level, that is, the same amount of mercury by weight will flow up into the other side of the U tube, and after oscillating for a few moments in an attempt to seek a level, it will come to rest. In the case of the vacuum tube, the flow of this mercury which is the electron flow from the filament is controlled by means of the grid which is the pet cock at the bottom of the U tube, to the plate which is the other side of the U tube.

**NOTE.**—The discriminating radio set purchaser is primarily interested in tone quality that is, the undistorted reproduction of the voice or instrumental music. Many factors govern tone quality. The care used in the adjustment of the transmitting apparatus at the broadcast station and the scientific placement of the pick up microphone, as related to the acoustical properties in the studio have a direct bearing on the tone quality of the broadcast program. The engineering design of the receiving set, together with the care used in its construction, are factors of considerable importance. The proper selection of the parts entering into the set; the scientific balance between the related parts are equally important.

### **A Battery.**

This battery performs one specific function, that of heating the filament in the vacuum tube. If, for any reason this A battery be low in voltage, there will be a consequent low rate of electron emissions and the receiving set will not operate satisfactorily.

### **B Battery.**

This battery performs two specific functions in a receiving set. It insures a positive pressure on the plate of the tube to which the negative electrons which are emitted from the filament may flow and improves the quality of reception.

### **C Battery.**

This battery functions as a governor on the grid or control device to retard or accelerate the flow of electrons from the filament to the plate. By so doing, the C battery permits a correct volume of electrons to flow from filament to plate thus controlling the plate current which flows from plate to filament and allows the tube to be operated on the straight portion of the curve which insures quality reception.

**Testing Radio Batteries.**—Much of the service life of dry cell B batteries in radio receiving sets depends on the conditions of use together with the type and number of tubes.

The term *service hours* is the total time that a battery will deliver the necessary current before it must be discarded from the set as being no longer useful. High service hours are, therefore, necessary for economical operation.

Service hour tests are made by discharging batteries under

various conditions, usually through a constant resistance or at a constant current rate. The latter test is made by maintaining a constant current in the battery by means of an adjustable resistance. This type of test can be either continuous or intermittent with periods of rest between discharges.

The intermittent test represents the service of a battery under usual broadcast listening use.

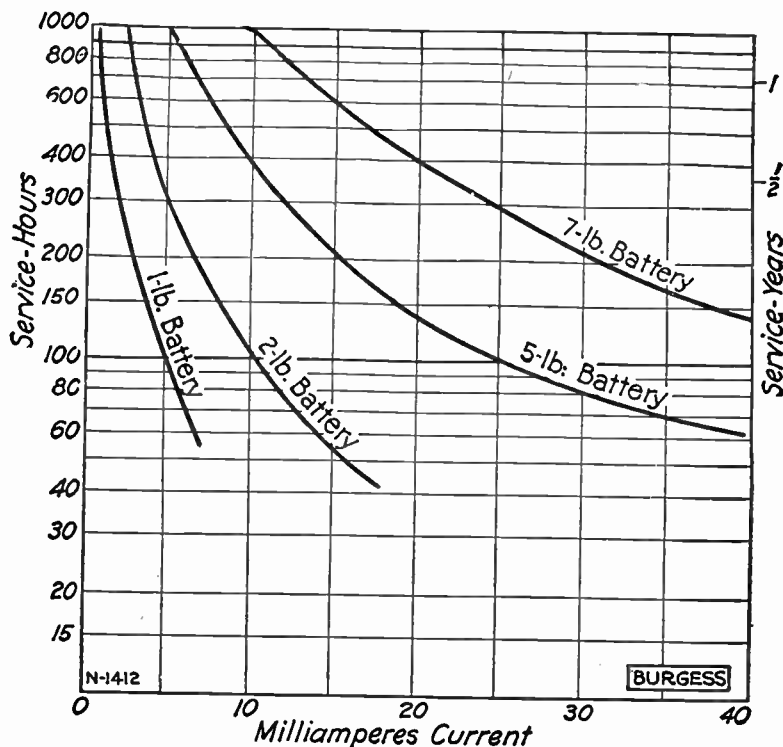

FIG. 2.—Diagram of service hours at various currents from tests made on Burgess dry batteries. Discharge based on intermittent service of 2 hours per day to an end voltage of 17 volts for a 22½ volt battery.

To determine the expected service hours of a B battery, it is only necessary to determine the average current drain on the battery and then pick off the service hours from curves fig. 2. In a receiving set however, it is almost impossible to estimate the plate current accurately as it is affected by the various constants of the receiving set itself. The only correct way to determine this current is by measuring it with a milli-ammeter, and this method is recommended not only to determine the battery drain but as a means of checking the installation in the receiving set and of adjusting the various tube voltages.

The milli-ammeter offers a convenient method of testing the plate and grid battery conditions as well as checking the current drain of the set. When strong signals are received with the set, there should not be a fluctuation of the milli-ammeter pointer. A noticeable fluctuation indicates

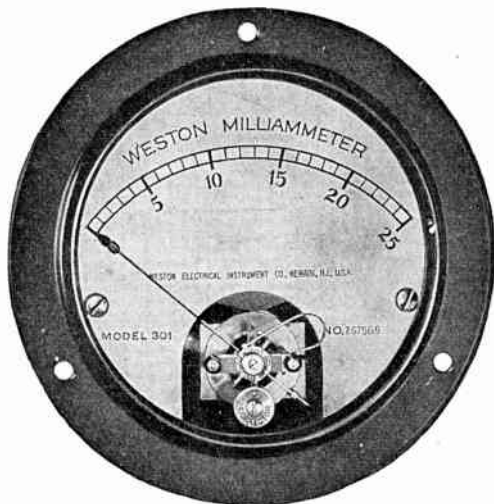

FIG. 3.—Weston plate or grid milli-ammeter for measuring the plate current of vacuum tubes. It will give a deflection for steady or pulsating direct current and will indicate the average value of a pulsating current. Superimposed upon the steady plate current is the current due to the modulation which is an alternating current and will cause the total plate current to be a pulsating current varying at the same frequency as the modulation current. The milli-ammeter will again indicate the average value of this current and if the tube be working at a point where it rectifies, this average value will not be the same as the value of the unmodulated steady plate current and therefore fluctuate with the modulation. For perfect reproduction, amplifying tubes should not rectify and no variation in the indication of the milli-ammeter should occur. In practice however, on account of the properties of vacuum tubes, some rectification will result, but by properly adjusting the grid bias, a minimum fluctuation in the plate current may be obtained consistent with good quality and volume.



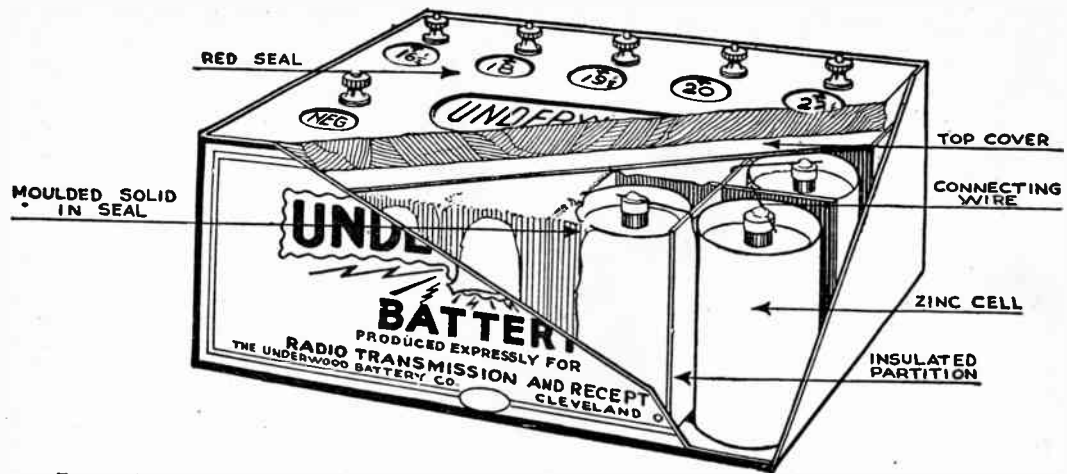

FIG. 4.—Sectional view of Underwood dry B battery showing placement of cells, taps, etc.

improper B or C battery voltages or both. When the C battery voltage is too low there will be a fluctuation of the needle toward zero with strong signals.

In case the milli-ammeter hand vary up the scale, too low a B battery voltage is indicated. Erratic fluctuations indicate too low B and C battery voltages.

The current at the installation of new batteries with a high voltage will be higher than the average current. Experience shows that the average current is about 15% lower than the initial current.

For example if the initial current be 20 milli-amperes, the average can be estimated as being 17 milli-amperes. This figure then, is used to determine the approximate service hours from the curves, fig. 2.

Either a hydrometer or a volt meter or both together may be used to test storage batteries. The hydrometer gives an indication of the specific gravity or unit weight of the acid solution in the battery. The specific gravity gives a good indication of the charge in the battery.

### Specific Gravity

(Table refers to Westinghouse Batteries)

Type of Battery	At Full Charge	At Discharge
All BRO and OB Batteries.....	1.285	1.100
24-RG-2 Battery.....	1.225	1.160
22-LG-2.....	1.240	1.165

The following instructions are given by Westinghouse for hydrometer and volt meter tests:

**A Batteries.**—A hydrometer reading of 1.285\* indicates a fully charged battery; 1.100 indicates a discharged battery.

**B Batteries.**—Small special B battery hydrometers are now obtainable and their use is entirely satisfactory. B batteries are charged and discharged at the gravities given in the accompanying specific gravity table. Do not take a hydrometer reading immediately after adding distilled water to the battery. Such a reading would be incorrect as the water will float on the acid solution. No accurate reading can be obtained until charging has mixed the water with the acid. The hydrometer reading will be a correct indication of the battery charge so long as none of the acid is spilled and occasional overcharges are given. Be sure to replace the acid in the same cell it was taken from for test.

\*NOTE.—Occasionally during the life of a battery, a cell may read as low as 1.260 instead of 1.285. No harm will be done if the cell do not continue to decrease in gravity. Different gravities are used to obtain different results. Where a compact battery is desired acid space is limited and a high gravity solution (that is one having a high percentage of sulphuric acid) must be used to obtain the required capacity. Where there is plenty of space and the current requirements are moderate a lower gravity acid is used.

The table on page 91 gives the specific gravity of different types of batteries at charge and discharge.

Never add acid or any other substance or solution to the battery, except distilled water. Recharge batteries as soon as they have reached the discharge points given previously. Do not allow batteries to stand in a discharged condition. About every fourth charge the batteries should

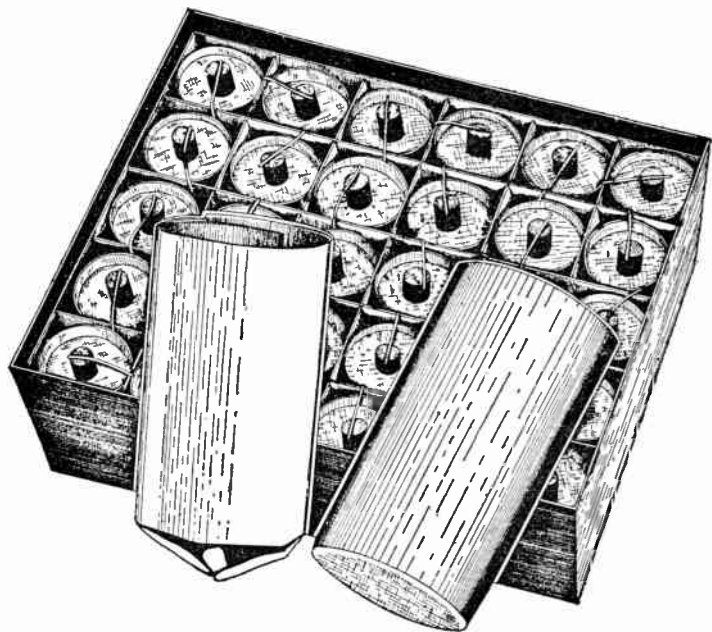

FIG. 5.—Klearstone dry battery with top removed showing what the inside of a 45 volt B battery looks like. The illustration also shows at the right the one piece seamless zinc cup, and at the left the paper insulator and filter which fits inside it.

be given an overcharge by leaving them on for two or three hours longer than necessary. This will insure keeping the plates in such condition as will enable them to give a maximum of capacity.

If only alternating current be available, a rectifier of some kind to change the alternating current into direct current for charging the battery must be used.

**Volt meter Test.**—The individual cells of any radio battery may be tested by means of a volt meter having a scale reading from 0 to 3.

**A Batteries.**—The cells are discharged when the voltage drops to 1.8 while the battery is being used at a normal rate. The cells are fully charged when the voltage averages from 2.4 to 2.6 for a period of several hours while the battery is on the charging line at the finish charge rate.

**B Batteries.**—The B batteries should be immediately recharged when

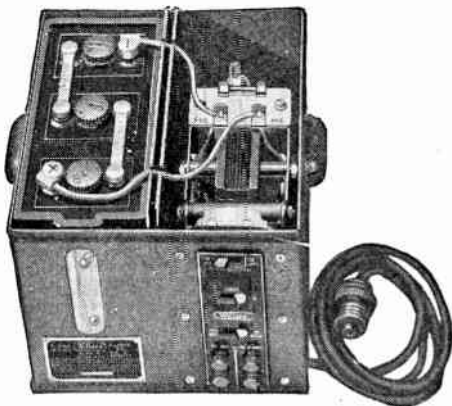
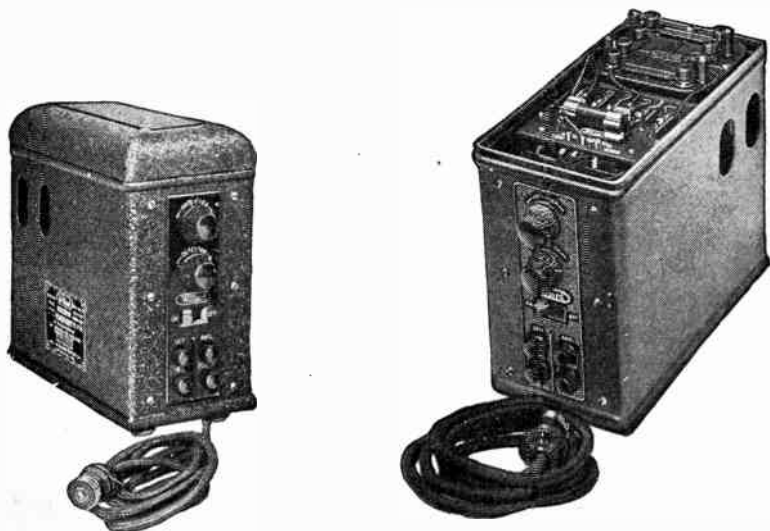

FIG. 6.—Willard A power unit and B battery charger. *It is* a combined trickle charger and conventional radio battery charger with a two ampere rate available. This two ampere rate is held in reserve until such time as it is necessary to compensate for any excessive use of the receiving set. The battery has visible gravity balls and whenever it is found that the green ball shows a tendency to sink, the high charge rate should be resorted to until the battery again comes back to a normal condition. The balance of the time, of course, the unit will be used as a straight trickle charger. A double partition is placed between the battery and charger compartments. The charger is of the bulb type.

any cell in the battery has dropped below 2 volts. The cells should be kept on the charging line until the voltage of the cells averages from 2.4 to 2.6 for a period of several hours. Note carefully that voltage readings to determine discharge should be taken while the batteries are being used with the radio set at a normal rate of discharge. Also note that voltage taken to indicate a charged condition is taken while the battery is on the charging line either at its normal rate of charge or at the finish rate if such be recommended.

A 6 volt battery is not charged when it reads 6 volts and a 24 volt battery is not charged when it reads 24 volts. A cell in good condition will show 2.1 volts in a few minutes after being put on the charging line and some cells may show an even higher voltage. Thus a 3 cell battery would show over 6 volts and a 12 cell battery would show over 24 volts within a few minutes after being placed on charge. A 6 volt battery should not be taken off the charging line until it shows about 7.5 volts and a 12 cell battery should be charged until it shows about 30 volts. If a 6 volt battery be taken off the line at a voltage of 7.5 volts and allowed to stand idle for several



FIGS. 7 and 8.— Willard B power unit. The rectifying units consist of 4 jars containing the electrodes. The rectifier is not the conventional lead aluminum type but has one aluminum and one special electrode in each of the four jars. This special electrode material prevents delay before going into action that is found where the aluminum lead type of rectifier is used. Variable voltage taps for the detector and amplifier allow close regulation and insure maximum results from the receiving set. There is a fixed resistance inside of the power unit, held in fuse clips that looks very similar to a cartridge fuse. This, however, is a special resistor and should not be replaced.

hours it will show a reading of about 6.3 volts, this is not due to any loss of charge or any trouble in the cell, but to the escape of gas from the cell and is a normal process. The voltage of the cell will then gradually decrease from 2.1 to 1.8 as the battery is discharged through use.

It is necessary to watch the voltage on B batteries more closely than on the A batteries.

The amount that the voltage of a cell drops depends upon the quantity of current flowing and the resistance of the circuit through which it flows. The amount of current drawn from a B battery is small and not enough in itself to produce much of a voltage drop. The drop in voltage is due rather to the exhaustion of the plate than to the current flow. The result is that a cell that reads 2 volts to-day may read only 1 volt to-morrow due to the absolute exhaustion of the plates.

The voltage of individual cells of the battery should be tested at frequent

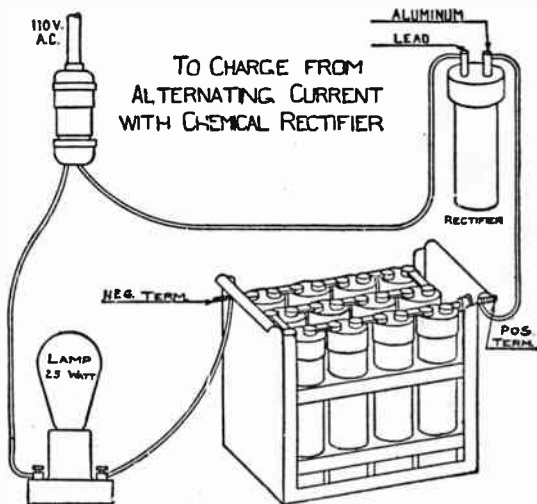
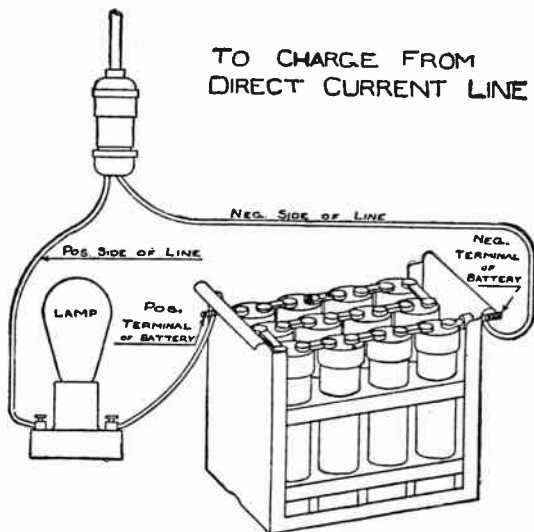

FIG. 9.—Diagram showing method of charging Universal battery from alternating current with Universal chemical rectifier; connect B battery chemical rectifier and lamp as shown. The rectifier must be properly prepared for service by being filled with the chemical solution before connecting. From 110 volt lines, one or two 24 volt batteries can be charged from one lamp by connecting the batteries in series (positive of one to the negative of the next). Use only a 25 watt lamp. For 24 volts this gives a charging rate of .083 ampere; for 48 volts it gives a charging rate of .05 ampere.

intervals and the battery recharged if one or more cells be much lower than the rest. In using a volt meter care must be taken to procure an accurate instrument.

**Charging Radio Storage Batteries.**—A battery is not 100% efficient, and so in charging it is necessary to put about one quarter more current into the battery than is taken out.



**FIG. 10.**—Diagram showing method of charging Universal battery from direct current line. Connect B battery and lamp to the line as shown. The lamp will burn with less than normal brilliancy when properly connected. If the lamp burn brighter than usual, turn the battery around. From 32 volt farm lighting plants only one 24 volt B battery can be charged from one lamp. 48 volt B batteries must be charged half (12 cells) at a time. Use either a 10 watt or a 20 watt 32 volt lamp. A 10 watt lamp charges at .1 ampere; 20 watt lamp charges at .2 ampere. From 110 volt power lines, one, two or three 24 volt batteries can be charged from one lamp by connecting them in series (positive of one battery to the negative of the next). For one battery, 24 volts, use a 25 watt lamp. For two batteries, 48 volts, use a 40 watt lamp. For three batteries, 72 volts, use a 60 watt lamp. The charging rate in each case will be about .2 ampere. "A" radio or automobile batteries can also be charged from direct current lines which include many small town and all farm lighting plants of 32, 65 and 110 volts. The same "hook up" is used as on the B battery except more and larger wattage lamps are used. The number and size of lamps depends on voltage of plant and size of battery.

For instance if 80 ampere hours be taken from an 80 ampere hour battery it will require 100 ampere hours to charge it fully. To do this it will take fifty hours charging, if the charger have a capacity of 2 amperes or 20 hours charging with a 5 ampere charger.

If in doubt as to the kind of current furnished, consult the electric light company. Batteries can be charged only with direct current. If the supply be direct current, only a rheostat, resistance, or lamp bank will be needed to limit the charging current to the rates given herein. Note that a finish charge rate is shown for some batteries.

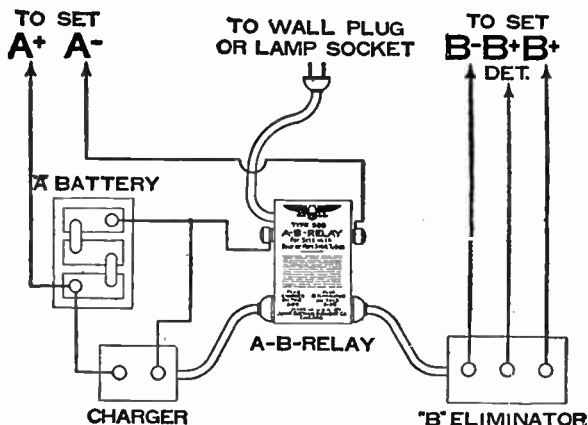

FIG. 11 —Globe Jewell A-B-relay. This relay is a magnetically operated switch so arranged that when the filament switch of the radio receiver is off, the trickle charger or A power is operating to charge the battery. When filament switch is on, the B eliminator is automatically turned on and the trickle charger or A power is cut off. The use of this relay permits control of A power or charger and battery and eliminator by means of one switch regularly provided on the receiver and commonly known as the filament switch. It can be used in connection with any receiver having four or more 5 volt tubes. When used in connection with receivers having ten 201A tubes the total drop through the relay is only .3 volts which is considerably less than the difference between the battery and the tube voltage. If a standard charger be used, which charges at a relatively high rate, or more than 1 ampere, it can be left plugged into the relay only until the battery is fully charged. It should then be disconnected from the relay in order not to overcharge the battery. The relay will then serve to turn the B eliminator on and off.

It is necessary to reduce the charging rate in some batteries to avoid overheating them at the end of the charge. Charging the batteries at higher rates than given is harmful to the plates and shortens the life of the battery.



The temperature of the battery must not be allowed to rise over 100° F., and if more than the slightest degree of warmth be perceptible to the hand the charge rate should be reduced or discontinued for a while.

Overcharging has a tendency to dislodge the active material from the plates. Before charging the battery add sufficient distilled water to cover the plates and separators but do not fill so that the solution touches the inside of the cover.

Vent plugs must be unscrewed if the charging rate be at all high, but may be allowed to sit loosely in the vent. See that holes in vent plugs are open.



FIG. 12.—Vesta dry rectifier socket power "A" unit trickle charger. This unit is built in glass for clear visibility of all that is going on inside the unit and with the dry rectifier. This trickle charger operates through the medium of discs of two dissimilar metals, the elements being aluminum and copper sulphate. This construction gives contact at three points maintained under a central spring pressure to obtain efficient contact and eliminate heat. The low charging rate is .5 and the high rate 1 1/4 amperes. Uses the full wave for rectification. This unit, which included battery of either 4 or 6 volt sizes, has a built in visible hydrometer. An automatic relay is provided. This relay disconnects the charging current from the battery when set is turned on and if used with a B socket power unit not equipped with a relay, automatically connects the B when set is turned on.

A and B radio batteries can be charged in the home with any one of the many chargers on the market as

- 1, Bulb type rectifiers, such as Silver Beauty, Eagle Unitron, Tungar, Rectigon;
2. Chemical rectifiers such as Balkite, Universal;

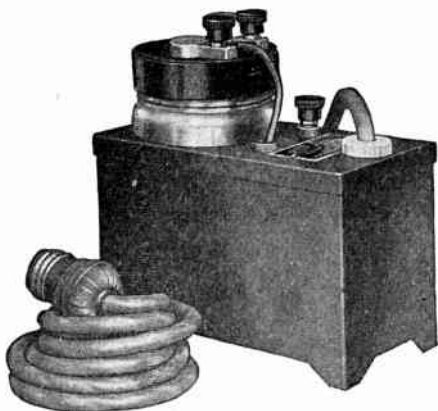

FIG. 13.—Globe Silite trickle charger. This charger uses the new metallic glass element, silite, adapted to storage batteries preferably not over 60 ampere hour capacity. This combination will meet the requirements up to six or eight tube sets which are not used on an average of more than four hours a day. Charges at .6 to .75 ampere rate and may be used with either 4 or 6 volt batteries.

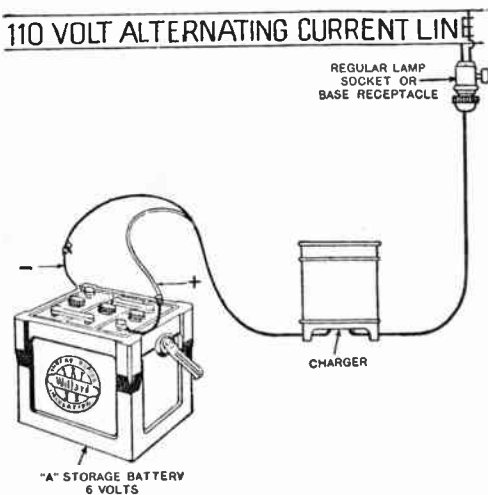
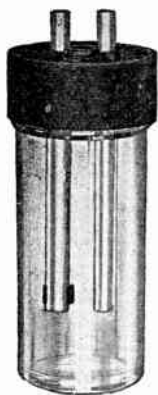

FIG. 14.—Diagram showing method of charging A batteries with Willard charger from 110 volt *a.c.* line.



3. Resistance type from direct current only (rheostat or bank of lamps).

The charging equipment as specified in 1 and 2 is to be used where alternating current only is available. Batteries can be charged only from direct current, and if only alternating current be available then a rectifier of some type must be used to change the alternating current to direct current. If direct current be available a resistance type 3, is necessary to reduce the charging rate to that given on the name plate of battery. These various methods of charging are shown in the accompanying illustrations.

FIG. 15.—Universal chemical rectifier for charging B batteries from 110 volt alternating current line. When attached to any electric light circuit B batteries may be charged.

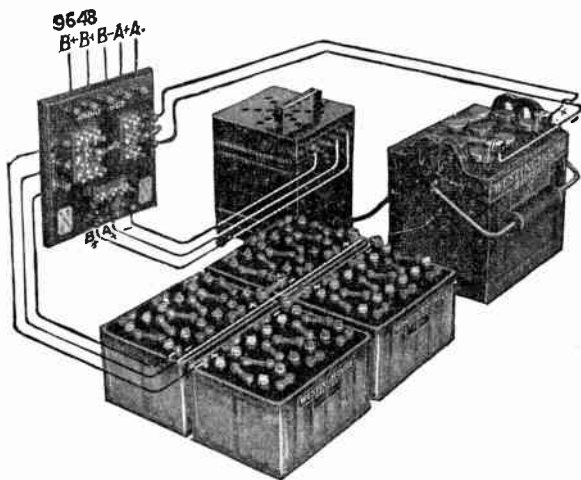

FIG. 16.—Set up of batteries, switches and Westinghouse charging apparatus for charging A and B batteries.

**Charging A Batteries.**—When the gravity of an A battery is shown to be low it should be placed on charge. There are many chargers on the market that are suitable for charging the A battery and the instructions for the use of this charger should be followed very closely. In every case the leads will be marked as to their polarity and the greatest care should be taken to be sure that the positive lead of the charger goes to the positive pole on the battery and the negative of the charger to the negative of the battery. Turn on the charger and if it

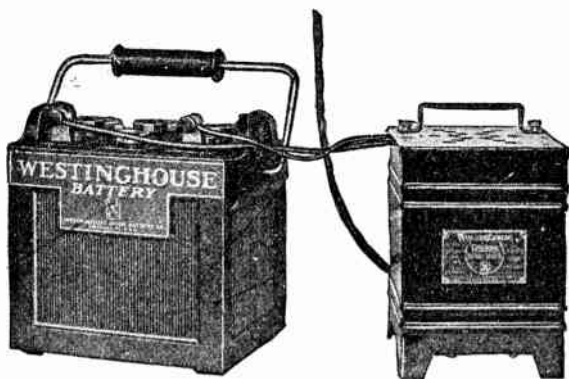

FIG. 17.—Set up showing connections for charging a 6 volt A battery from 110 volt alternating current house lighting circuit using Westinghouse Rectigon charger.

have a meter on it showing charge or discharge be sure that the battery is charging. If the charger do not have a meter, it is a good policy to note any change in gravity of the electrolyte by the use of a hydrometer.

If the gravity start to rise, it indicates that the battery is charging. Charge until all cells gas freely and until the gravity stops rising. This is found by taking a hydrometer reading. After two hours take another reading and if the gravity has risen, keep on charging. Continue to take readings at intervals until the gravity does not show an increase, then the

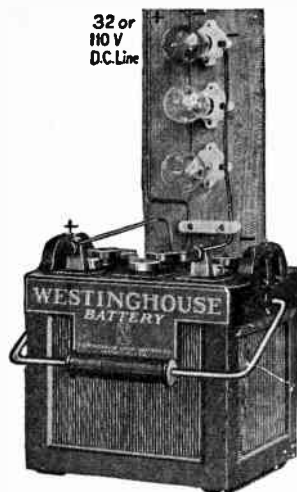

FIG. 18.—Set up showing connections for charging a 6 volt A battery from a 32 or 110 volt direct current line by means of a lamp bank. Adding lamps to the bank will increase the charge rate. Using lamps of larger wattage will also increase the charge rate.

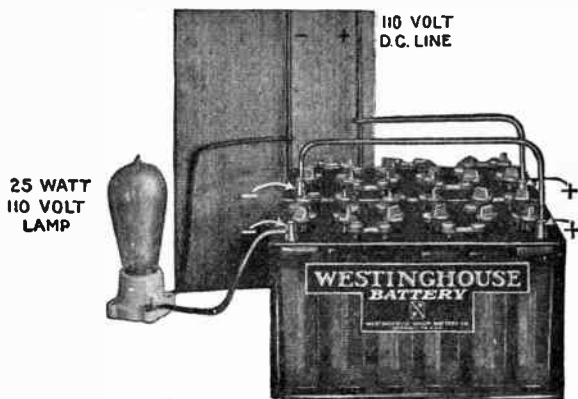

FIG. 19.—Set up showing connections for charging 2 B batteries in series from a 110 volt direct current line. The lamp is shown in the negative lead but may be connected in either lead. Not over 3 batteries may be charged in series from a 110 volt line.

battery is fully charged. The charging leads should be disconnected immediately after the rectifier is shut off, unless a trickle charger is being used.

Before recharging the A battery, its leads to the receiving set should be removed, otherwise the vacuum tubes are liable to be damaged.

In case direct current be the source of power, a rectifier is not required and the battery may be recharged directly from the line by the use of a lamp bank; that is, a series parallel of lamps in series with the battery as in fig. 20. It is important when charging from direct current that the

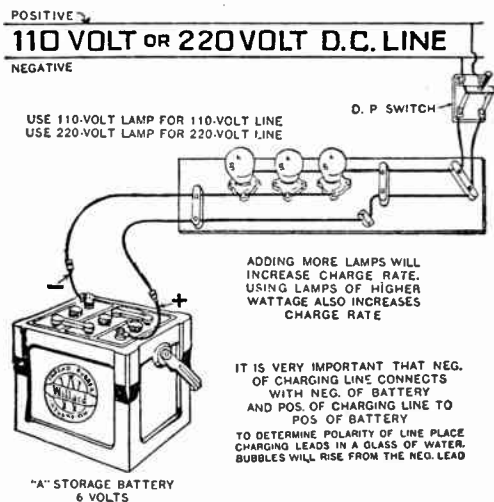

FIG. 20.—Diagram showing method of charging A battery through a lamp bank on 110 or 220 volt d.c. line.

correct polarity of the line be obtained. This may be secured by placing the leads in a glass of water. Bubbles will arise from the negative lead. If bubbles arise from both leads, that having the greater number is the negative lead. It is well after the polarity is found to use some distinguishing mark for future reference.

If the source of current be 32 volt direct current, the more efficient way to charge an A battery from the standpoint of current consumption is to charge it from the lighting plant while the 32 volt battery is being charged as in fig. 21.

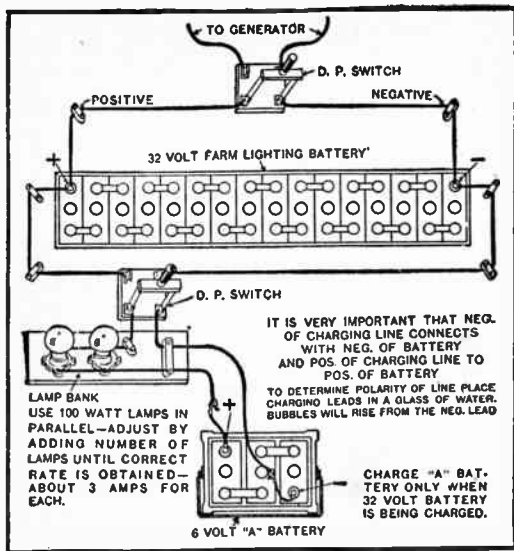
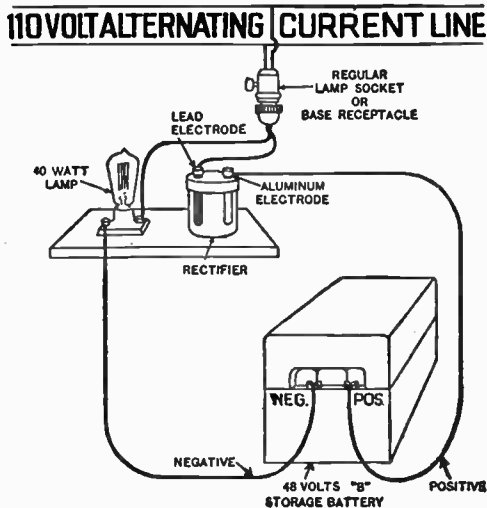

FIG. 21.—Diagram showing method of charging A battery from 32 volt farm lighting plant.

FIG. 22.—Diagram showing method of charging B battery using Willard rectifier.



Where the current source is 110 or 220 volt direct current it is more efficient from a standpoint of current consumption to charge A batteries from a motor dynamo than by a lamp bank.

In most cases however, a motor dynamo of the 110 or 220 d.c. type is not available, and in such cases it will be necessary to use the lamp bank charging method as shown in fig. 20.

## 110 VOLT ALTERNATING CURRENT LINE

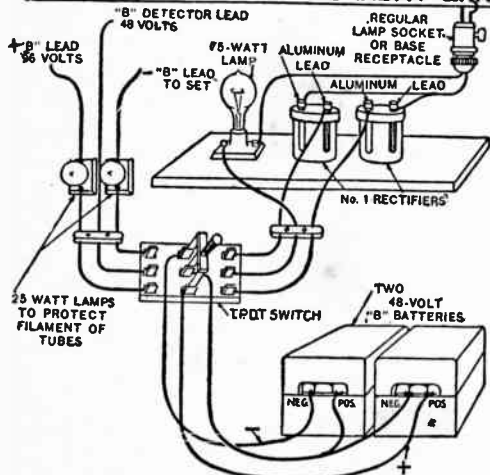

FIG. 23.—Diagram showing charging switch circuit for two 48 volt units.

## 110 VOLT ALTERNATING CURRENT LINE

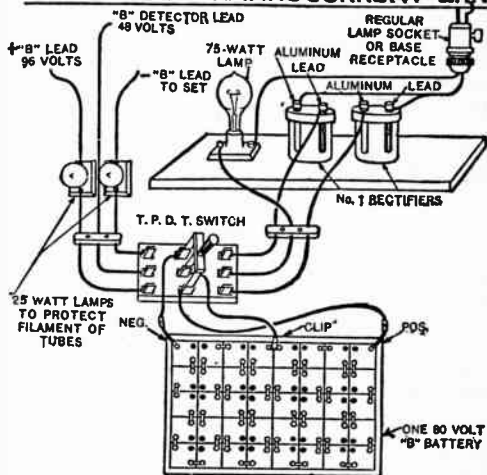

FIG. 24.—Diagram showing charging switch circuit for one 80 volt unit using Willard rectifiers.

**Charging B Batteries.**— fig. 24. shows how batteries may be charged from 110 volts alternating current by the use of the Willard colloid rectifier. Place this rectifier in series with a 110 volt lamp as shown in the diagram, being sure that the positive pole of the battery goes to the aluminum of the rectifier which is plainly marked on the rectifier and battery. As in recharging an A battery, the B battery leads to the receiving set should first be removed.



It is possible to charge only 48 volts of B battery with one rectifier in series at one time from a 110 volt line. The 80 volt battery must be charged in two sections of 40 volts each. If it be desired to charge two 48 volt units or one 80 volt battery at the same time, use the scheme of connection shown in fig. 23.— or fig. 24. If three 48 volt units are to be charged at the same time use either fig. 22 — for one of the units and fig. 23 — for the other two, or three separate hookups as shown in fig. 22.

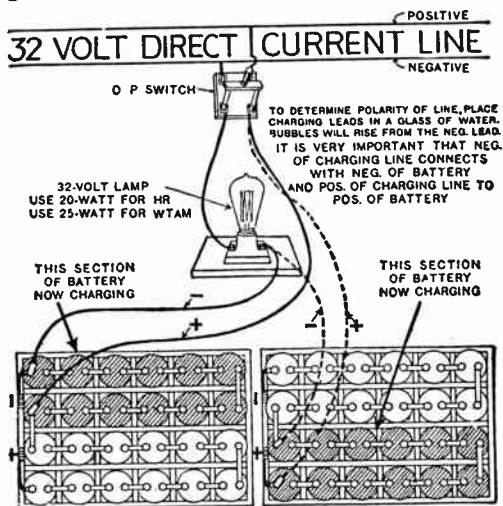

FIG. 25.—Diagram showing method of charging 48 volt B battery from 32 volt d.c. line.

In cases where it is necessary to use two or more colloid rectifiers in series on a 220 volt a.c. circuit, first place one rectifier on line until lamp is dimmed, then replace this with the other rectifier until lamp is dimmed. Then put both rectifiers on the line. In using a switch in the circuit to charge two 48 volt units from 110 volt a.c. line, the detector tap should be changed to 48 volts for charging as shown in FIG. 23.

When charging has been completed the detector tap may then be shifted

back to the voltage demanded by the individual set if it do not happen to be 48 volts. When 110 volts *d.c.* is the source of power, the rectifier is not required and all that is necessary is to use a 40 watt 110 volt lamp in series with the battery and the line, being sure that the correct polarity is obtained as previously described.

In case of 32 volt *d.c.* such as the farm lighting plant, etc. one 20 to 24 volt section of B battery may be recharged at one time. This is accomplished by the use of a 32 volt 20 watt lamp in series with each 20 to 24 volts of battery, being sure that the correct polarity of the line is first obtained.

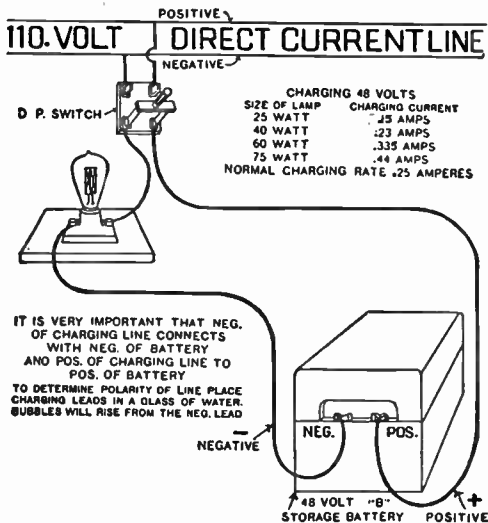

FIG 26.—Diagram showing method of charging 24 volt B battery from 110 volt *d.c.* lines.

For charging Willard battery type HR-155 from 110 volt *d.c.* line connect as in FIG 26.— inserting a 32 volt 25 watt lamp in place of the 115 volt lamp as indicated. For charging HR-155 from a 110 volt *a.c.* line, hook up as shown in FIG 24.

**Battery Hook Ups.**—By using different combinations any desired voltage may be obtained. It is important to have the

correct polarity of A and B batteries when connecting them to the radio set. There should be no difficulty as the terminals are plainly marked.

To obtain different voltages, the following combinations may be used: Two 48 volt units in series giving 96 volts; one 48 volt unit and one 80 volt unit in series giving 128 volts; three 48 volt units in series giving 144 volts, or two 80 volt units in series giving 160 volts.

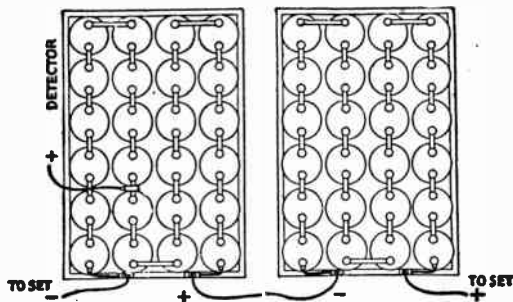

FIG. 27.—Diagram showing two 48 volt B batteries connected in series making 96 volts.

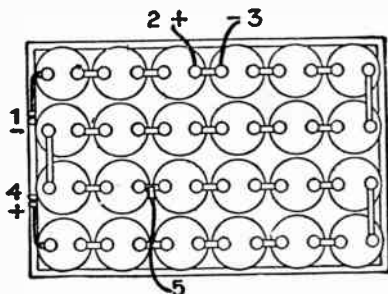

FIG. 28.—Diagram showing C battery as part of a regular B battery and this is recommended where a radio set is so wired that the negative A and negative B battery leads are connected together; 1, negative C tap; 2, positive C tap; 3, negative B tap; 4, positive B tap; 5, detector tap at 22 volts. For proper operation as a C battery the negative B lead is extended to any number of cells which are to be used as a C battery. In this particular diagram, 6 volts or 3 cells are utilized. However, this hook up should not be used where the negative B battery lead goes to the positive A.

## CHAPTER 6

# Electrical Measuring Instruments

**Galvanometers.**—Instruments designed for measuring small amounts of electricity may be called galvanometers, although a galvanometer is generally employed as an electro-dynamic instrument used to indicate current.

There are numerous kinds of galvanometers designed to meet various requirements such as the *astatic*, *tangent*, *differential*, *ballistic* and *D'Arsonval types*, which according to their design may have either a movable magnet and stationary coil or a stationary magnet and movable coil. The above types may be designed with a short or long coil, and the indications or deflections are given in several ways, depending upon the various uses.

**The Tangent Galvanometer.**—In the tangent galvanometer the sensitivity is directly proportional to the number of turns in the coil, and inversely proportional to its diameter. The strength of the current may be calculated in c.g.s. units when the dimension of the instrument is known, by the use of the following formula:

$$I = \frac{r \times H}{2\pi} \times \text{tg } \theta$$

in which  $H$  is the galvanometer constant representing the horizontal force of the earth's magnetism for the place where the galvanometer is used;  $r$ , the radius of the coil in centimeter;  $\theta$ , the angle of the needle deflection in degrees; and  $I$ , the current in c.g.s. units.

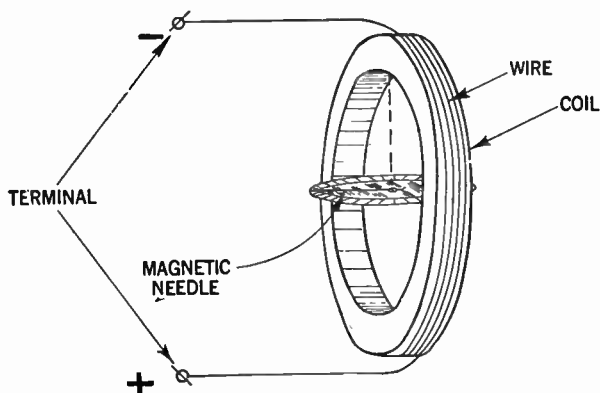

FIG. 1—The tangent galvanometer consists essentially of a short magnetic needle suspended at the center of a coil of large diameter and small cross-section. In practice the diameter of the coil is approximately 17 times the length of the needle. If the instrument be so placed, that when there is no current in the coil, the suspended magnet lies in the plane of the coil, that is, if the plane of the coil be set in the magnetic meridian, then the current passing through the coil is proportional to the tangent of the angle by which the magnet is deflected from the plan of the coil or zero position, hence the name: "Tangent galvanometer."

When the tangent galvanometer has more than one turn the factor  $2\pi$  should be multiplied by the number of turns ( $N$ ) on the coil.

**Example.**—Find the current in a tangent galvanometer having a coil of 25 centimeter radius, when the needle deflects an angle of 10 degrees. Assume  $H = 0.2066$

**Solution.**— $I = \frac{r \times H}{2\pi} \times \text{tg } \theta = \frac{25 \times 0.2066}{2 \times 3.1416} \times 0.1763$  from which

$I = 0.145$  c.g.s. units or 1.45 amperes.

If it be desired to determine the tangent galvanometer constant for a certain location, the current through the galvanometer may be measured by inserting an instrument of known accuracy in the circuit.

With the circuit of known value the galvanometer constant can be computed from the following formula as follows:

$$H = \frac{2 \times \pi \times I}{r \times \text{tg } \theta}$$

This type of galvanometer however, has a number of disadvantages of which the following are the most prominent.

1. The coil being much larger than the needle, and hence far away from it, reduces to a considerable extent its sensitiveness.
2. The readings are effected by an external magnetic field which may exist in the neighborhood of the instrument.
3. Accuracy of readings may be lessened by changes in the earth's magnetic field, which changes may be of considerable proportions especially during magnetic storms.

**D'Arsonval Galvanometer.**—In this type of galvanometer the aforementioned disadvantages are largely eliminated.

The principal design is shown in figs. 2 and 3. In this instrument the indicating needle is attached to a coil of wire, through which the current flows, and inside of which is an iron core.

The coil is free to turn with the core which is held in place with a pin, and suspended between the poles of a horseshoe magnet. When the current to be measured flows through the coil, a magnetic field is set up in and around it, causing the coil to turn.

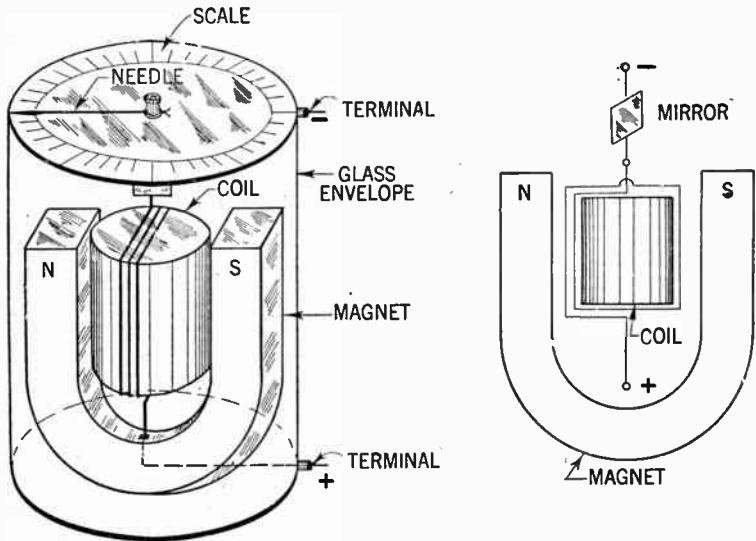

**FIGS. 2 and 3—Drawing showing essential features of construction and principle of operation of D'Arsonval type galvanometer.**

This rotating tendency is prevented by the twisting of the wire which suspends the loop. By planning the weight of the wire used, the number of turns in the coil and the amount of resistance used, this galvanometer can be used for determining small amounts of currents. It is on this principle that many commercial types of current measuring devices is based.

The readings of the galvanometer may be facilitated by means of a mirror which is usually attached to the coil in such

a way that a beam of light from a light source directed to the coil by a lense system, will be reflected back on to a semi-circular graduated scale placed at a suitable distance from the mirror as shown in fig. 4.

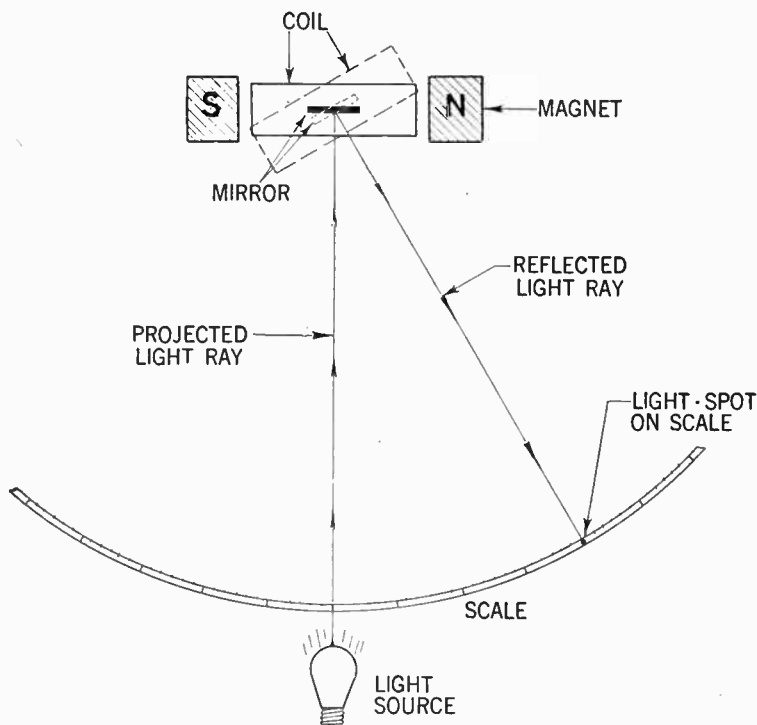

FIG. 4—Arrangement to obtain enlarged view of mirror movement.

In this way a small deflection of the coil and mirror will produce an enlarged amplification of the beam of light on the scale, which reading may be accurately accomplished by means of a telescope.



**Electrochemical Current Measurements.**—Another method of current determination is by utilizing the amount of the chemical decomposition the current causes in passing through the electrolyte in a cell.



FIG. 4a—Weston model 440 movable coil galvanometer.

If a constant current of ( $I$ ) amperes is passed through the electrolyte during ( $t$ ) seconds, the weight increase on the cathode in milligram ( $M$ ) is direct proportional to the amount

of current multiplied by the electrochemical equivalent of the metal ( $C$ ) and the time of current flow.

$$M = C \times I \times t$$

For  $I = 1$  ampere and  $t = 1$  second;  $M = C$ .

Among the various apparatus based on the electrochemical effect of an electric current are:

**The weight voltmeter**

**The gas voltmeter.**

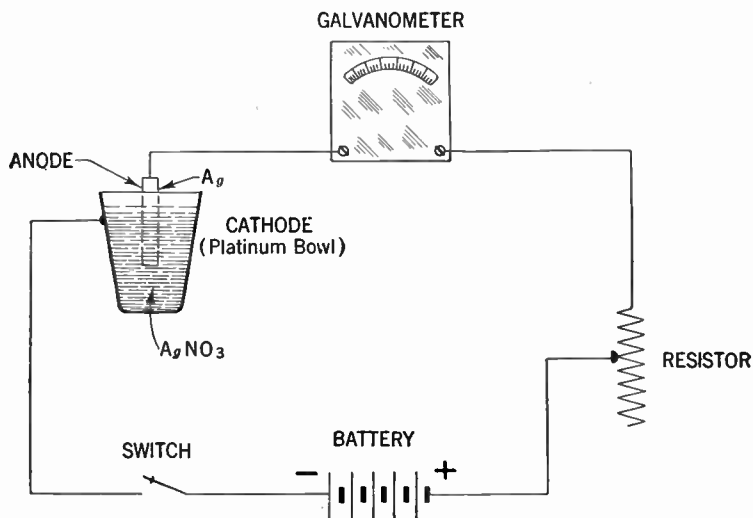

FIG. 5—Diagram of connection to obtain current strength by use of a silver-voltmeter. *Example:* What is the current strength in amperes when after 20 minutes the silver deposit on the cathode is found to be 1.34 gram.

$$\text{Solution: } M = C \times I \times t \text{ or } I = \frac{M}{Ct} = \frac{1.340}{1.118 \times 20 \times 60} = 1 \text{ ampere}$$

A typical silver voltameter is depicted in fig. 5 and functions principally as follows: The cathode on which the silver is de-

posited consists of a platinum bowl not less than 10 centimeters in diameter and from 4 to 5 centimeters in depth.

The anode consists of a disc or plate of pure silver, some 30 square centimeters in area and 2 to 3 centimeters in thickness, which is horizontally supported in the electrolyte near the top by a silver rod riveted through its center.

To prevent the disintegrated silver which is formed on the anode falling upon the cathode, the anode should be wrapped around with pure filter paper, secured at the back by suitable folding.

The liquid consists of a neutral solution of pure silver nitrate ( $Ag NO_3$ ) containing approximately 15 parts by weight of the nitrate to 85 parts of water.

**Direct Current Meters.**—Most electrical measuring devices are fundamentally current measuring devices, being either voltmeters, milliammeters or microammeters.

**Construction.**—Such a meter consists of a horseshoe magnet between the two poles of which is suspended an armature to which is attached a pointer and a spring arrangement to hold the pointer to its zero position when no current is being passed through the meter coil.

**How the Current is Measured.**—When a current be passed through the armature coil, it becomes an electromagnet, with two poles of opposite polarity, and the reaction between the energized coil and the permanent magnet causes the coil to rotate on its axis so as to facilitate the attraction of the unlike poles and the repulsion of the like poles of the two magnets.

The amount of movement is determined by the balance attained between the resiliency of the spring mechanism and the strength of the magnetic field set up around the coil, and since the strength of the magnetic field set up around the coil is

determined by the amount of current flowing through it, the movement may be calibrated in unit of currents, or in any other unit such as volts, ohms or microfarads, all of which possess a definite relationship to the unit of current.

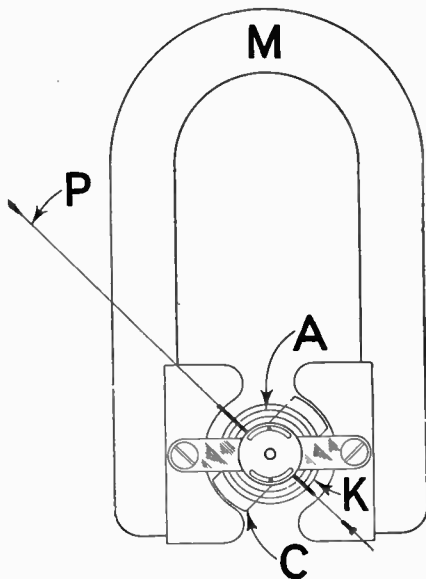
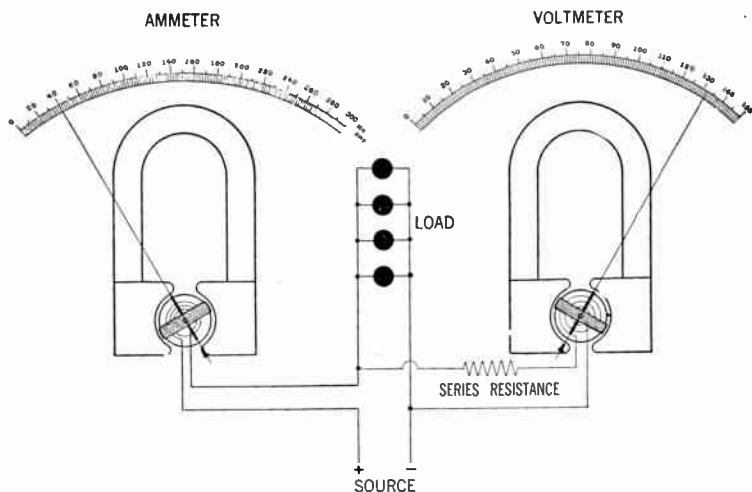

FIG. 6—The essential parts of the instrument are: *A*, spiral spring; *C*, coil; *K*, soft iron core; *M*, permanent magnet and *P*, pointer. Current passing through the coil causes the moving system to turn against the restraining force due to the influence of the permanent magnet.

**Connection of Meters.**—A meter calibrated for current measurement in terms of amperes or fraction thereof, usually has a comparatively low resistance and is connected in *series* with the circuit in which the current is to be measured, whereas a potential pressure measuring meter or voltmeter is of comparatively high resistance and is connected *across* the circuit, across which a potential pressure is to be measured.

**Direct Current Ammeters.**—The ammeter as already described, is an instrument of low resistance, and is *always connected in series with the current it is desired to measure*. It is for this reason that the series resistance usually found in voltmeters are omitted.



**FIG. 7—**Indicating method of connecting for determination of current flow and pressure in a circuit.

Ammeters are employed for current measurement in all branches of electrical work and may be designed for measurement of from a few milliamperes up to thousands of amperes.

A milli-ammeter therefore is an ammeter which measures divisions of currents in  $\frac{1}{1,000}$  of an ampere, whereas an ammeter employed in measurements of larger amounts of current measures amperes in units of 1 to 100 or more.

**Using a Milliammeter as a Voltmeter.**—As previously pointed out the only difference between a voltmeter and a milliammeter is that a voltmeter has a high resistance connected in series with the moving coil.

Hence by connecting accurately fixed resistances in series with the milliammeter, it is possible to make a very useful voltmeter that may be employed to read filament voltages, plate voltages, *C* voltages, the output voltage of *B*-power units, etc.

Of course it is self evident that the accuracy of such a converted meter depends upon the accuracy of the milliammeter, and the fixed resistance used.

The table shown gives the value of resistances required with different milliammeters to read voltages from 1 to 1,000 volts.

VOLTAGE MULTIPLIER FOR MILLIAMMETERS

Milli-Amperes	1,000 Ohms	10,000 Ohms	100,000 Ohms	1,000,000 Ohms
1.	1. volt	10 volts	100 volts	1000 volts
1.5	1.5 "	15 "	150 "	
2.	2. "	20 "	200 "	
3.	3. "	30 "	300 "	
5.	5. "	50 "		
8.	8. "			
10.	10 "			

**Example.**—If a 5 milliampere meter is to be employed to read voltages up to 50 volts, what resistance should be used?

**Solution.**—From table, the resistance required is 10,000 ohms. According to Ohm's law,  $E = IR$  or  $R = \frac{E}{I} = \frac{50}{0.005}$  from which  $R = 10,000$  as already obtained from table.

Likewise, if a 1-milliampere meter is to be used to read voltages up to 1,000 volts, then a 1-megohm resistance is placed in series with it.

If the values of resistance required to read voltages is not found in the table, the resistance may be obtained by calculation in the same manner as that already shown.

Resistors with a wattage rating of one watt will be satisfactory for all those values given in the table, however, it is advisable to use resistors with a rating of approximately 5 watts so that there will be little possibility of the value of the resistance changing due to the heating effect ( $I^2R$ ).

Also, resistors with a 5 watts rating operating considerably below their rated dissipation, will be likely to hold their calibration a longer time than resistors of lower wattage.

**The Direct Current Voltmeter.**—Since the current through a meter is proportional to the voltage impressed at its terminal, any ammeter as previously described may be used as a voltmeter.

In this case however, a resistor of high value must be connected in series with the movable coil, because if an ammeter were connected directly across the line, it would immediately burn out due to the low resistance in its coil.

The high fixed resistance connected in series with the moving coil is considered as part of the meter.

Assume that the moving coil milliammeter, as used in the previous example, is to be utilized for a voltage measurement of 110 volts at full scale deflection, the allowable current drain to be 1 milliampere, what will be the value of the series resistance?

It is evident that the resistance unit must be of such a value that when the voltage across the terminal is 110 volts, exactly 1 milliampere will flow through the resistance and meter coil at full scale deflection of the pointer.

By Ohm's law is obtained:

$$R = \frac{110}{0.001} = 110,000 \text{ ohms}$$

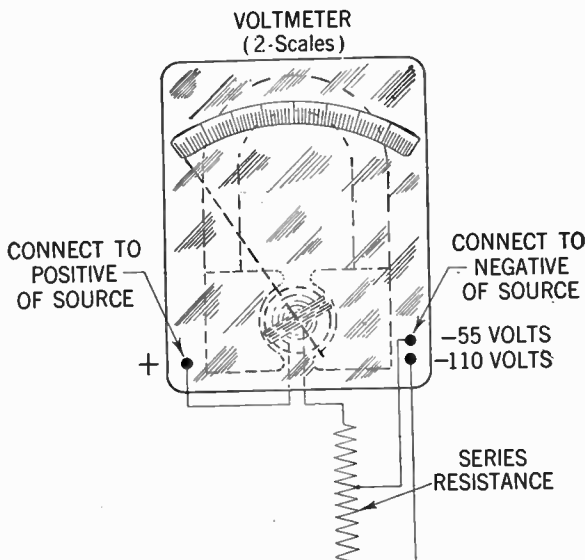

FIG. 8—Connection of multiplier resistance to 2-range voltmeter.

As the moving coil resistance is very small compared with the series resistance, it may readily be omitted for most practical problems.

The series resistance or *multiplier resistance* may be tapped at various places to obtain more than one voltage range, and is usually placed inside the voltmeter case and connected in series with the coil. See fig. 8.



If the voltmeter with the 110,000 ohms series resistance be tapped at its center, the voltage range for the same current drain would be  $E = 0.001 \times 55,000 = 55$  volts.

In order to obtain proper needle deflection the binding posts of the meters are marked + (plus) and - (minus). The post marked + should always be connected to the positive of the line and either of the other binding posts to the negative side.

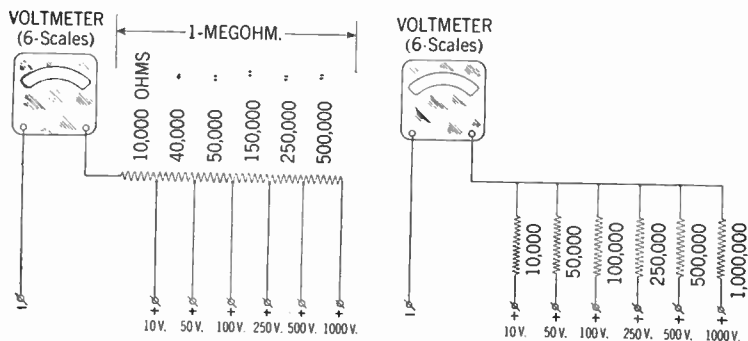

**FIGS. 9 and 10—Two methods of connecting multipliers to a voltmeter. In fig. 9, one resistor is tapped at the various points to obtain the proper multiplier values for each scale as shown. This arrangement obviously is economical in that only one resistor need be used. However, the disadvantage being that if an opening occur for example to the left of the 10 volt tap, the voltmeter will be rendered useless until the fault is being repaired, whereas if an opening occur within a resistance when connected as shown in fig. 10, only that particular scale will be effected.**

**How to Arrange Resistors for a Multi-Range Voltmeter.**—Resistors for multi-range voltmeters may be arranged in various ways as shown in figs. 9 and 10. Each resistor will give a certain definite voltage drop, and should be of the so-called precision type, unaffected by nominal temperature changes.

Voltmeters suitable for radio work usually have a resistance of 1,000 ohms per volt.

Inspecting the resistance arrangement in fig. 10 it is found that when using the 0-100 volt the circuit resistance is 100,000 ohms and when using the 0-250 volt scale, 250,000 ohms, etc.

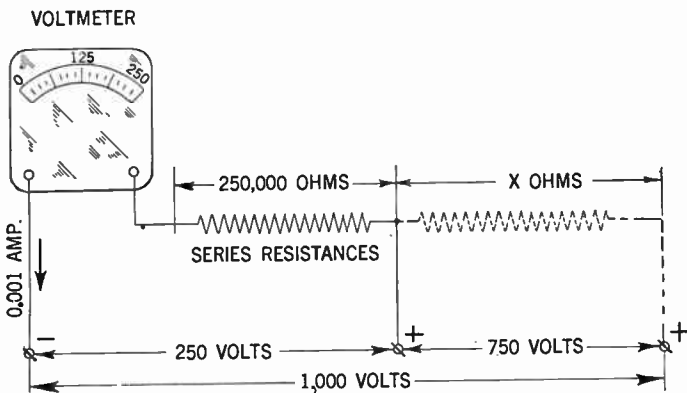

FIG. 11—Illustrating how to increase voltmeter range by adding series resistance.

To compute the resistance to be inserted to obtain a certain voltage range, no difficult mathematical formulas need to be employed.

According to Ohm's law  $E = I \times R$ ; hence to obtain a voltage drop of 100 volts for example, with a current drain of 1 milli-ampere, a resistance of  $\frac{100}{0.001}$  or 100,000 ohms should be inserted.

**Example.**—Assume that the voltmeter shown in fig. 11 which has a range of 250 volts and a resistance of 250,000 ohms must be changed so as to enable it to be used on 1,000 volts, what value must a resistance connected in series with the existing multiplier have?

**Solution.**—The multiplying factor  $= \frac{1000}{250} = 4$   
 using Ohm's law  $E = IR$ ;  $1,000 = 0.001 (250,000 + X)$   
 or  $1,000 = 250 + 0.001X$ ; from which  $X = \frac{750}{0.001} = 750,000$  ohms.

The resistor to be inserted should have a value of 750,000 ohms and each reading taken after insertion of this new resistance should be multiplied by 4 to obtain the true voltage.

**A Combination Volt-Ammeter.**—Since the construction of a voltmeter and ammeter is the same, the difference being that in an ammeter resistors are placed parallel to the moving coil, while in the voltmeter resistors are placed in series with the moving coil, it is possible that by employing a proper switching arrangement, to use a single instrument for measurement of both volts and currents. A typical arrangement of this kind is shown in fig. 12 and 12a.

Other meters of this type may have in addition to the voltage and current scale, a resistance or ohmmeter scale, which makes it convenient to check the value of a certain resistor. It is to be observed that an ohmmeter is simply a low current *d.c.* voltmeter, provided with a source of voltage usually consisting of dry cells, which are connected in series with the unknown resistance.

An instrument of this sort is shown in fig. 13 and it may readily be seen that the instrument is rather complicated with its various scales, switches and terminals.

When using this type of instrument great care should be observed so as to minimize contact resistance. Hence the ordinary selector switches should be substituted for toggle switches if possible.

Before the use of a multi-purpose meter a precautionary examination should be taken to make sure that the respective

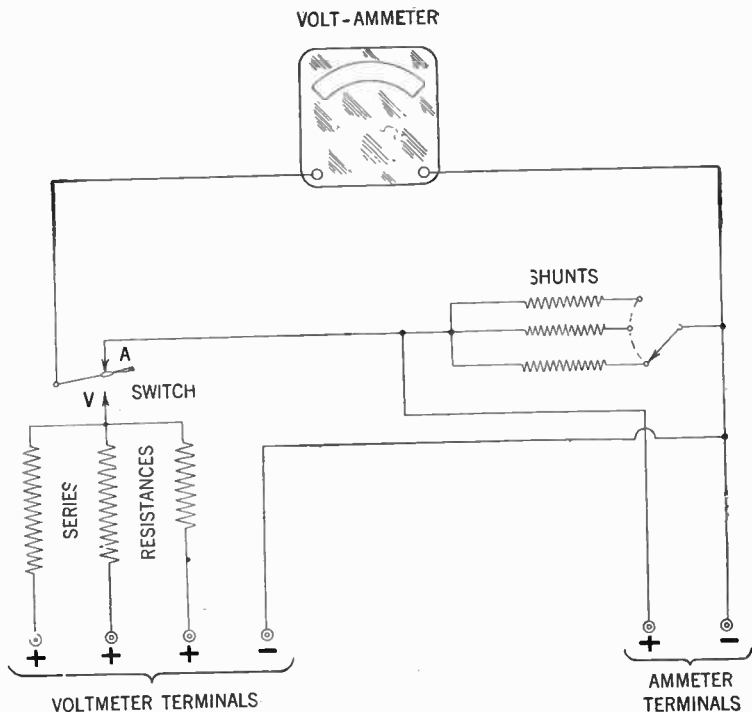

**FIG. 12**—Schematic or simplified diagram showing principal method of circuit hook-up and switching arrangement when using a volt-ammeter instrument. *Current measurement:* When it be desired to employ the meter for current measurement, the current voltage selector switch is closed towards A, after the proper shunt has been selected. *Voltage measurement:* For voltage measurement the meter is connected across the load after selection of proper resistor, and the current voltage selector switch is closed towards V.

controls are properly adjusted, to prevent the instrument from serious damage.

When measuring unknown values of currents, it is an excellent idea to begin with the highest range, and thus identify the proper range for most accurate measurement.

When using the instrument as an ohmmeter the instrument should never be connected across a circuit in which current is flowing, i.e. the receiver power should be turned off when resistance measurements are obtained.

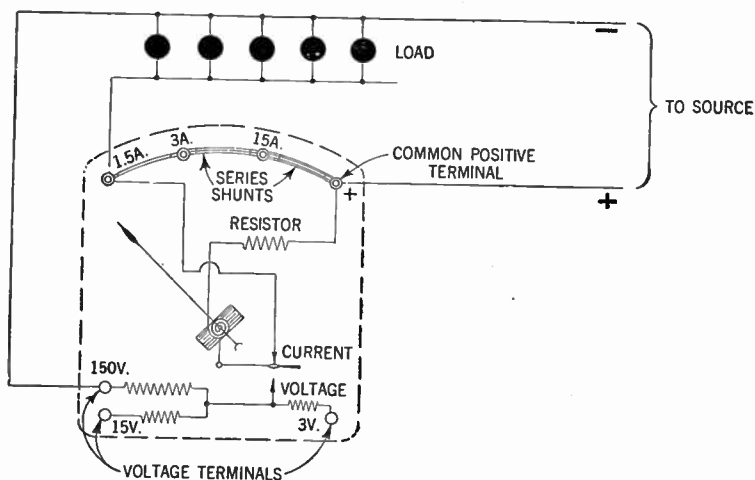

FIG. 12a—Outline of principal construction details of a combination volt-ammeter.

**Shunts and Their Use.**—All ammeters for use in direct current measurements may be designated to pass a similar amount of amperes, although the actual amount of current in the circuit may differ greatly.

The main difference between the various ammeters is in the type of shunts employed. The function of a shunt is to pass a certain definite amount of the circuit current through the meter.

If the full amount of current were allowed to pass through the ammeter, the ammeter coil would of necessity have to be of heavier wire and thereby increase the size and cost, and also cut down the sensitivity of the entire moving element.

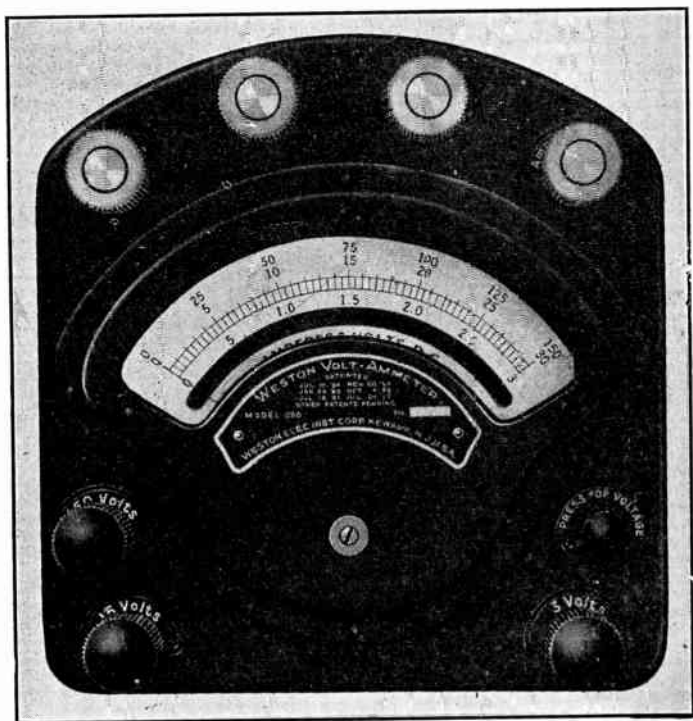

FIG. 12b—Front view of typical combination type volt-ammeter.  
(Courtesy Weston Electrical Instrument Corp.)

A shunt will carry a certain ratio of the total current depending upon the ratio of its resistance to the resistance of the ammeter coil; this makes it possible to use the same sensitive ammeter for different current carrying ranges by merely shunting or by-passing a portion of the current.

The size of the shunts required are designed from a knowledge of the proportional current to be measured, and of the existing resistance of the ammeter coil.

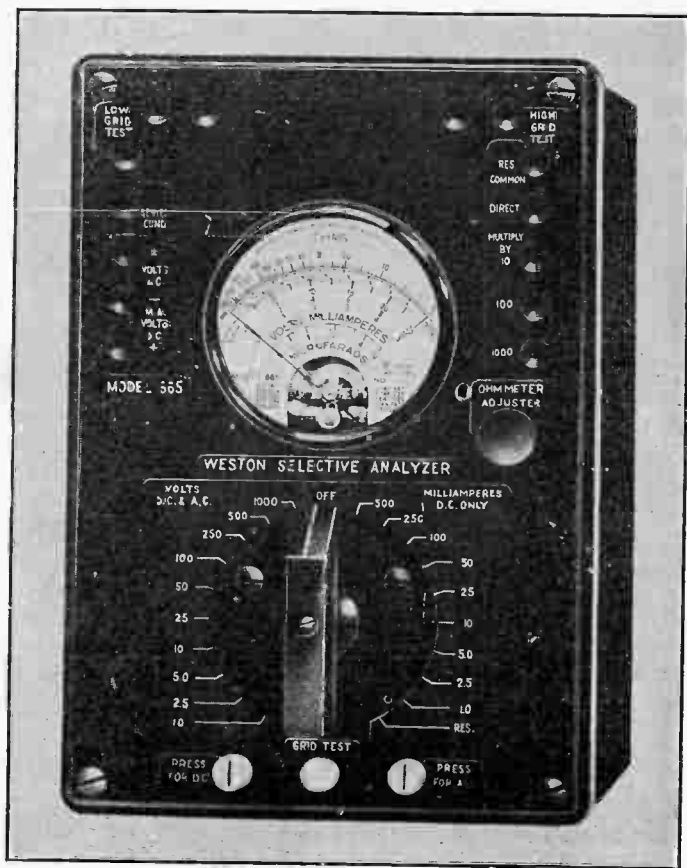

FIG. 13—Typical volt-milliamp-ohmmeter. (Courtesy Weston Electrical Instrument Corp.)

**Example.**—If a milli-ammeter giving full scale deflection on 500 milliamperes  $\left(\frac{500}{1,000}\right)$  of an ampere is required to be changed so

as to enable the measurement of currents up to 5 amperes, what size of shunt should be used?

**Solution.**—The increase in current for full scale deflection is then  $\frac{5}{\frac{1}{2}}$  or 10 times; hence each scale reading would have to be multiplied by 10 for each actual current indication.

The resistance therefore, of the coil and shunt combined, in order to permit 10 times the current to flow through, would have to be such that the coil would carry  $\frac{1}{10}$  of the current and the shunt the remaining  $\frac{9}{10}$  of the total current. By formula: The shunt resistance is equal to the meter resistance divided by the multiplication factor less one or  $R = \frac{r}{n-1}$  in which:

$R$  is the resistance of the shunt;

$n$  is the multiplication factor or the number indicating how many times the meter range is to be extended or multiplied;

$r$  is the internal resistance of the meter.

From the above it follows that the shunt resistance would have to be  $\frac{1}{10}$  of the coil resistance.

If the meter coil has a resistance of  $\frac{2}{10}$  of an ohm the shunt resistance would have to be

$$R = \frac{0.2}{10-1} = \frac{2}{90} \text{ or } 0.0022 \text{ ohms approximately.}$$

Hence a shunt having a resistance of 0.0022 ohms must be connected across the meter. This resistance should be of a size sufficient to carry the current without overheating.



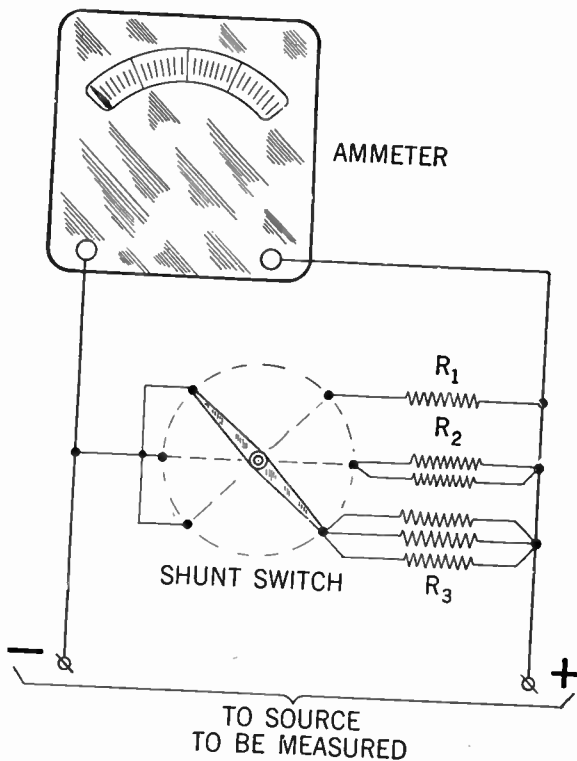
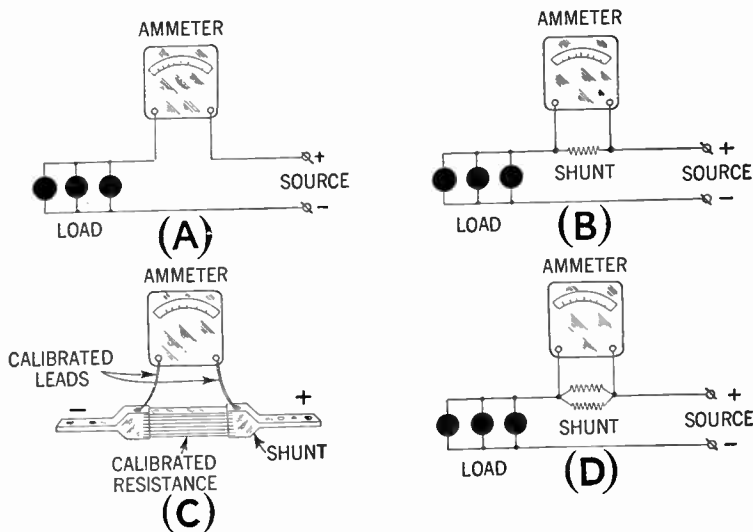

FIG. 14—Arrangement in which shunts  $R_1$ ,  $R_2$  and  $R_3$  may be utilized for various size current measurements. In the case where the meter has only one scale, current indication shown on meter should be multiplied by the value of the multiplication factor given for each shunt.

**Hot Wire Instruments.**—The action of this meter depends upon the heating of a conductor by the current flowing through it, causing an expansion which in turn sets in motion an index needle or pointer, the movements of which by calibration are made to correspond to the amount of the actuating currents.



**FIG. 15**—Various ammeter connections and method of showing connections. As connected in (A) it is obvious the ammeter coil must carry the total current in the circuit. If this current is greater than the meter coil is permitted to carry, then part of the current should be allowed to pass through the shunt as shown in (B), (C) or (D). A shunt as shown at (C) consists of one or more sheets of a special alloy, fitted at each end into grooves of two copper blocks, which are provided with means for connecting the shunt into the circuit with the main conductor and with the meter.

This type of meter is frequently employed in radio work on account of its ability to measure either direct or alternating current.

The principal defects of this type however, are:

1. Scale divisions will not be uniformly spaced, since the heating effect and movement of the pointer depends upon the square of the current ( $I^2R$ ) flowing through it.

2. They are somewhat erratic in the readings near the zero point.

3. They are sluggish in operation and their readings are effected by changes in room temperature.

4. The actuating wire has a tendency to expand when not in use, hence it is necessary to set the pointer back to zero before sending a current through it.

5. They are uneconomical, i.e. the current consumption is considerably in excess of that in other types.

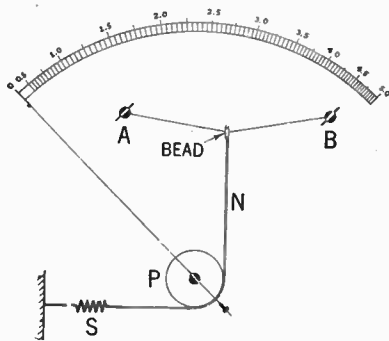
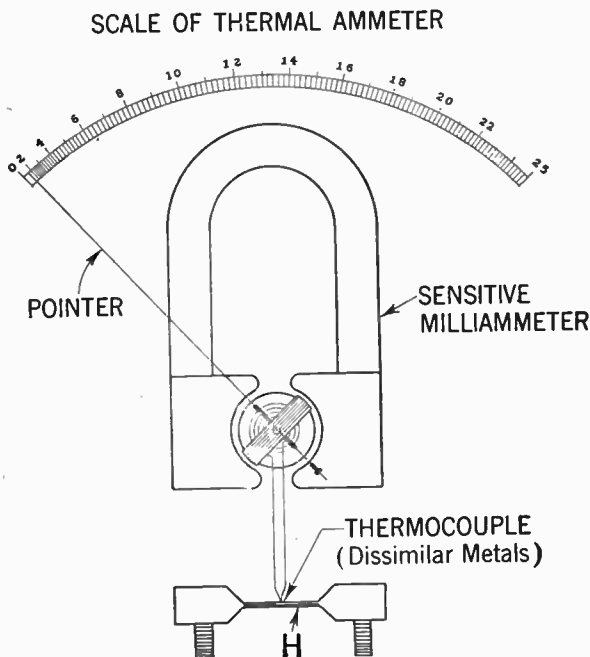

FIG. 16—Simplified diagram illustrating the construction of a hot wire instrument. *N*, represents a silk thread connected to spring *S*, wound around pulley *P*, and attached to a bead threaded on wire *AB*. Wire *AB*, made of platinum alloy, is connected in the circuit whose current is to be measured. This wire lengthens, due to the heating effect ( $I^2R$ ) when a current flows through it. The slack is taken up by spring *S*, causing pulley to turn and move the pointer over the scale.

**Thermocouple Instruments.**—In this type of instrument the direct or alternating current to be measured is sent through heater (*H*) fig. 17, which heats the junction of two dissimilar metals.

When two dissimilar metals are joined together and their junction heated, a voltage is generated which is proportional to the temperature difference between the heated junction and the open end of the thermocouple.

A sensitive milliammeter is connected to the open ends and is generally calibrated to indicate the current through the heater. For measurements of very small values, the heater and the thermocouple are enclosed in an evacuated glass bulb to prevent oxidation.



**FIG. 17**—Schematic thermocouple arrangement and connection to sensitive milliammeter. *Note:* Unequal division of instrument scale.

This vacuum tube thermocouple is usually mounted under the sub-base of the meter. The thermocouple instrument may be used on either alternating or direct current and is extensively used in radio and general high frequency work.

An instrument of this type however has certain disadvantages compared with various other instruments, as follows:

1. The motion of the pointer along the scale will increase approximately in proportion to the square of the *r.f.* current sent through the thermocouple. Hence the instrument scale will not have equal divisions.

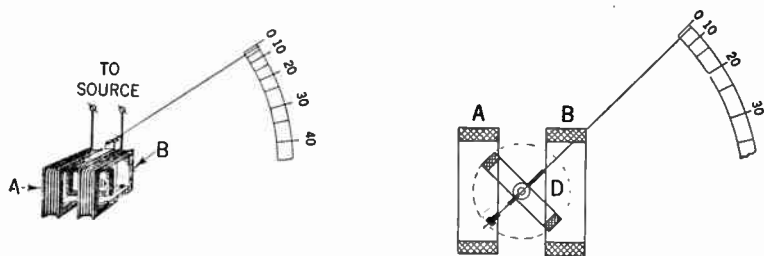

**FIG. 17a—**Weston Model 622 Thermo A.C.-D.C. Milliammeter.

2. The thermocouple is sensitive to overloads and may burn out if excessive amounts of current be sent through it, in which case the thermocouple will have to be replaced and the instrument recalibrated.

**Electrodynamometer Type Instrument.**—This type of instrument can be employed on either alternating or direct current.

Figs. 18 and 19 show a typical instrument which consists of two stationary coils (*A*) and (*B*) and a movable coil (*D*) to which the indicating pointer is attached. The three coils are connected in series through the two spiral springs, which also hold the movable coil in position as indicated.



FIGS. 18 and 19—Principal construction method of an electro-dynamometer type of instrument.

When a current is sent through the coils, coil (*D*) tends to turn in a clockwise direction because its flux tends to line up with the flux of coils (*A*) and (*B*).

If a current be sent through the coils in the reverse direction, the torque developed remains the same, hence the instrument can be used on alternating as well as on direct current.

However, the scale as shown cannot be graded uniformly as in the moving coil type, because the torque developed varies as the square of the current ( $I^2$ ), similarly to that of the direct current motor.

One of the detrimental factors in this type of instrument is that the current requirement is approximately 5 times that of a movable iron type instrument. Hence it is somewhat sluggish, and on account of the large current consumption uneconomical.

**The Wattmeter.**—In direct current circuits the product of voltage and current is a measurement of the amount of power dissipated in the circuit in question and is measured in watts.

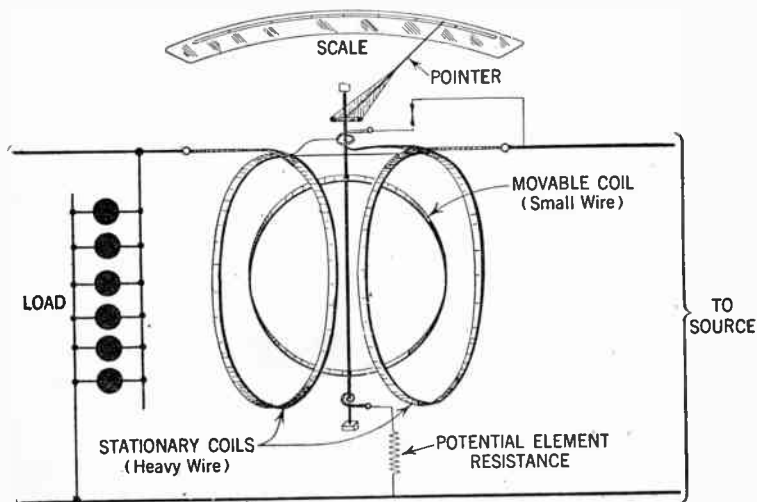

FIG. 20—Construction method of an electro-dynamometer as arranged to read watts.

The number of watts dissipated may be obtained by measuring the voltage across and the current through the circuit.

Thus in a circuit through which a current of 2 amperes flow at a pressure of 110 volts, the power in watts ( $W$ ) will equal  $2 \times 110$  or 220 watts or  $W = I \times E = 2 \times 110 = 220$  watts.

If in an alternating current circuit it be desired to measure the power, this relationship holds true only when the connected load consists of pure ohmic resistance; and when the circuit in addition to the ohmic resistance also contains inductive or

capacitive resistance, the power in watts will be equal to  $E \times I \times \cos \theta$  or  $W = E \times I \times \cos \theta$  in which

$W$  is the power in watts

$E$ , the pressure in volts

$I$ , the current in ampere and  $\theta$  the angle of lag or lead between the current and voltage.

A meter used for the purpose of obtaining the power consumption in an electric circuit is called wattmeter or dynamometer.

The wattmeter may be employed to record directly either the *a.c.* or *d.c.* power at any instant, giving the three values as indicated by the aforementioned formulas.

A typical instrument is shown in fig. 20. Its operation depends on reaction between the coils when current is passed through them. Two coils are fixed and the other is movable.

The fixed coils are composed of a number of turns of heavy wire and fastened to a vertical support and is surrounded by a movable coil composed of a few turns of very fine wire.

In the operation of a wattmeter, when current is passed through the coils, the movable coil is deflected against one of the stop pins, then the torsion head is turned to oppose the movement until the deflection has been overcome and the coil brought back to its original position.

When connecting the meter, care should be taken to prevent damage, i.e. the heavy wire coil (current element) should be connected in series with the load and the small wire and coil, potential element, should be connected across the load to be measured.

**Resistance Measurement.—(Ammeter-Voltmeter Method).**  
—This is one of the simplest methods of measuring resistance, and is convenient because of the fact that the instruments used consist of only an ammeter, voltmeter, battery and switch,



the connection of which is shown in fig. 21. In making the test the ammeter and voltmeter readings are taken simultaneously and the unknown resistance calculated from Ohm's law.

$$I = \frac{E}{R} \text{ or } R = \frac{E}{I}$$

**Example.**—If in fig. 21 the readings obtained are 150 volts and 4 amperes, how many ohms is the unknown resistance?

$$R = \frac{E}{I} = \frac{150}{4} = 37.5 \text{ ohms}$$

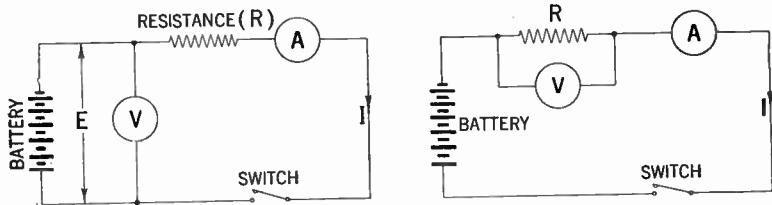

FIGS. 21 and 22—Illustrating two methods of connections to obtain resistance values.

**Ohmmeter Method.**—By using the ohmmeter previously described the value of an unknown resistance may be read directly on the instrument scale without calculation. This type of instrument is shown in fig. 24 and its circuit in fig. 23. On an instrument of this type resistance values up to 300 megohms may readily be obtained.

**Wheatstone Bridge Method.**—The Wheatstone bridge, fig. 25 consists of several resistances so arranged that an unknown resistance may be calculated in terms of known resistances

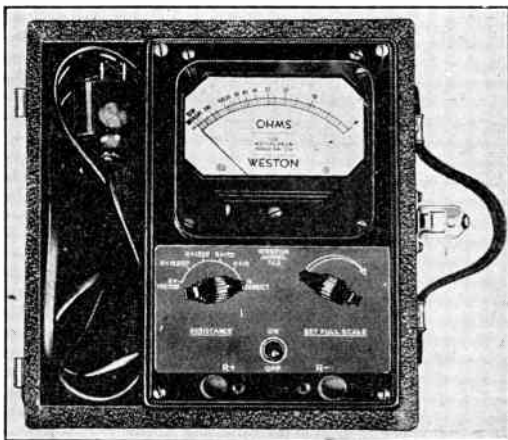
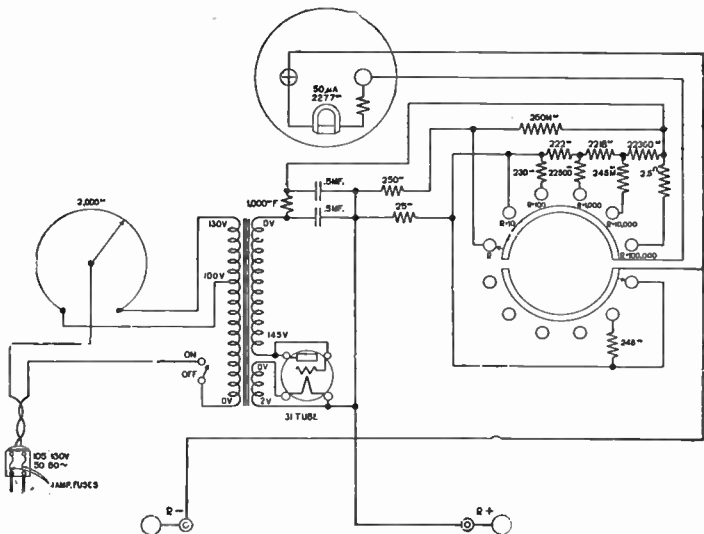

**FIGS. 23 and 24**—Schematic circuit arrangement and front view of typical ohmmeter.

The so called "Wheatstone" bridge was invented by Christie, and improperly credited to Wheatstone, who simply applied Christie's invention to the measurement of resistances.

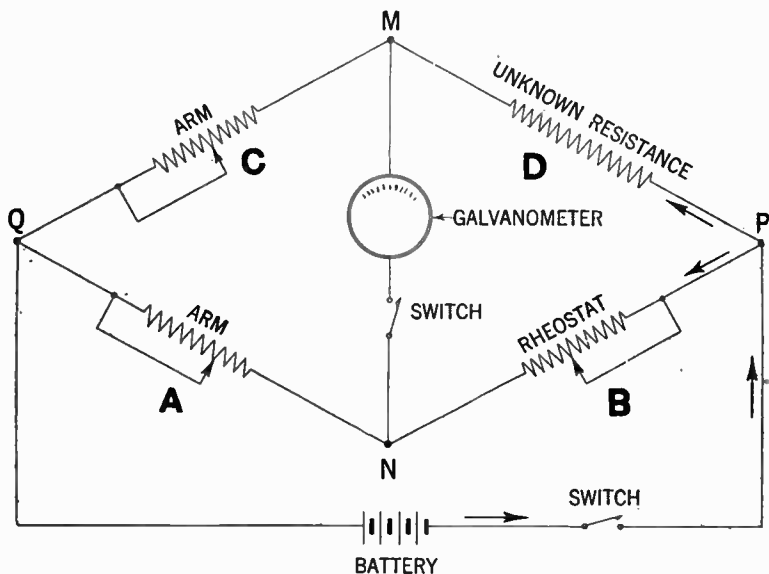

FIG. 25—Schematic diagram of Wheatstone bridge showing resistances and method of connecting galvanometer, battery and unknown resistance.

As shown in fig. 25 the circuit of a constant battery is made to branch at *P*, into two parts, which re-unit at *Q*, so that part of the current flows through the point *M*, the other part through the point *N*. The four conductors, *A*, *B*, *C*, *D*, are spoken of as the arms of the balance or bridge.

It is by the proportion existing between the resistances of these arms that the resistance of one of them can be calculated when the resistances of the other three are known.

When the current which starts from the battery arrives at  $P$ , the pressure will have fallen to a certain value. The pressure in the upper branch falls again to  $M$ , and continues to fall to  $Q$ . The pressure of the lower branch falls to  $N$ , and again falls till it reaches the value at  $Q$ .

Now if  $N$ , be the same proportionate distance along the resistances between  $P$  and  $Q$ , as  $M$ , is along the resistances of the upper line between  $P$  and  $Q$ , the pressure will have fallen at  $N$ , to the same value as it has fallen to at  $M$ ; or, in other words, if the ratio of the resistance  $C$ , to the resistance  $D$ , be equal to the ratio between the resistance  $A$ , and the resistance  $B$ , then  $M$  and  $N$ , will be at equal pressures. To find out if this condition obtain, a sensitive galvanometer is placed in a branch wire between  $M$  and  $N$ , which will show no deflection when  $M$  and  $N$ , are at equal pressure or when the four resistances of the arms "balance" one another by being in proportion, thus:

$$A:C = B:D \dots \dots \dots (1)$$

If then, the value of  $A$ ,  $B$ , and  $C$ , be known,  $D$ , can be calculated. The proportion (1) is reduced to the following equation before substituting.

$$D = \frac{BC}{A}$$

For instance, if  $A$  and  $C$ , be, as in fig. 25, 10 ohms and 100 ohms respectively, and  $B$  be 15 ohms,  $D$  will be

$$(15 \times 100) \div 10 = 150 \text{ ohms.}$$

**Example.**—*It is desired to use a milli-ammeter whose maximum reading is 5 M.A. to measure current up to 100 M.A. If the meter resistance is 50 ohms, what value of external resistance will it be necessary to use, and how should it be connected?*

**Solution.**—At full scale deflection the meter passes 5 M.A. or 0.005 amperes, hence the voltage drop across the instrument at maximum deflection will be  $IR$  or  $0.005 \times 50$  volts, i.e. 0.25 volts. Now, since the meter can take no more current without danger, it follows that the extra current must be shunted away from the instrument through a resistance placed in parallel with it.

In this case, it is desired to pass 100 M.A. through the combination of meter and resistance in parallel so that at the same time the meter will show its full scale reading. Since it does this at 5 M.A. the balance of 95 M.A. must obviously be passed through the parallel resistance.

Now the potential drop across the meter was previously found to be 0.25 volts and this must also be the drop across the resistance since they are both in parallel. There is then a means of finding the value of the resistance, since from Ohm's law—

$$R = \frac{E}{I} \text{ its value is thus } \frac{0.25}{0.095} = 2.63 \text{ ohms.}$$

**Example.**—*What resistance should be placed in parallel with a milliammeter of 5 ohms resistance in order that the total resistance of the combination may be 0.5 ohm?*

**Solution.**—If  $X$  denote the value of the required resistance, by the known formula for resistance in parallel the following may be obtained:

$$\frac{1}{X} + \frac{1}{5} = \frac{1}{0.5} \text{ that is } \frac{1}{X} + 0.2 = 2$$

hence  $\frac{1}{X} = 1.8$  or  $X = \frac{1}{1.8} = 0.555$  ohms (approximately).

**Example.**—*A 2-volt battery is used to supply filament current to a multiple receiver. An ammeter is inserted in one of the battery*

leads and shows that a current of 0.8 ampere is being taken. What is the total resistance of the filament circuit?

**Solution.**—According to Ohm's law, it is known that  $I = \frac{E}{R}$  for any circuit in which direct current flows through a resistance. The current  $I$ , is measured in amperes, and the resistance  $R$ , in ohms. Since  $E = 2$  volts and  $I = 0.8$  amperes, therefore

$$R = \frac{E}{I} = \frac{2}{0.8} = 2.5 \text{ ohms.}$$

**Example.**—After the battery in the previous example had been fully charged, it was noted that the current reading had increased to 1 ampere. What difference does this indicate in (a) the circuit resistance; (b) the E.M.F. of the battery?

**Solution.**—Of course the fact of the increased current is due solely to the greater E.M.F. of the battery, the circuit resistance being entirely independent of this and remaining quite unchanged. The new E.M.F. is obtained by the formula  $E = IR$  in this case  $1 \times 2.5$  or 2.5 volts. This condition is of course only temporary and after a very little time, the battery E.M.F. will have fallen to its normal working value of 2 volts.

**Example.**—What power is consumed by the filaments when the E.M.F. of a battery is 2 volts and the filament current is 0.8 amperes?

**Solution.**—In d.c. circuits, the power consumed in any resistance when measured in watts is given by the product of the number of amperes passing through the resistance and the number of volts across it or  $W = I \times E$  here  $I = 0.8$  and  $E = 2.0$  hence the power consumed  $W = 2 \times 0.8 = 1.6$  watts.

**Example.**—An electric lamp is marked 40 watt, 220 volt. What current will it take from a 220 volt d.c. source and what resistance will it have at that voltage? What further specification

would be required before employing such a lamp in a *d.c.* current receiver?

**Solution.**—It is now fairly common in *d.c.* sets to employ electric light “bulbs” to obtain the necessary voltage drop suitable for the filament supply. Unfortunately, however, the question of selection is complicated by the fact that when so used, the full voltage supply is not effective across the lamp. The result is that a considerably smaller current may flow than would be the case if the lamp was used simply for its normal lighting purpose.

The present example refers to the current and resistance of the lamps at 220 volts; there is therefore no question of employing it as a “voltage reducer.” The fundamental formulæ relating the power taken by a given resistance to the *d.c.* voltage across is  $W = \frac{E^2}{R}$  where  $W$  is in watts and  $E$  and  $R$  in volts and ohms respectively. For the lamp in question,  $W = 40$  and  $E = 220$ , therefore it may be written—

$$R = \frac{E^2}{W} \text{ or } R = \frac{220^2}{40} = 1,210 \text{ ohms}$$

The current taken by the lamp obviously is  $\frac{220}{1210} = 0.182$  amps.

Before the lamp could be employed as a voltage reducing resistance for a *d.c.* receiver it is first necessary to know the voltage and current necessary to operate the tube filaments—usually connected in series. The actual voltage across the lamp would be the difference between the filament voltage and that of the supply. Finally, it is required to know the current actually taken by the lamp at this reduced voltage. If this current were approximately the same as that taken by the filaments, the lamp would be suitable; otherwise another type would have to be employed.

## CHAPTER 7

# Power Supply Units

Receiver power supplies generally may be classified as follows:

1. The *a.c.* supply group which operate from alternating current only.
2. The *d.c.* supply group which operate from direct current only.
3. The *a.c.* and *d.c.* supply group which furnish power to "A" and "B" batteries from either alternating or direct current.

**A.C. Supply Systems.**—The power supply in this group generally consist of a power transformer, rectifier tubes and filter units which consist of capacity condensers and choke coils.

**The Power Transformer.**—The purpose of the power transformer is to supply a high voltage to the rectifier tube for rectification of the *a.c.* current and to supply the filament or heaters with the required current and voltage.

Power transformers generally contain a primary winding and several secondary windings, on a laminated steel core. That part of the secondary winding which furnishes power to the rectifier tube contains more turns than the winding which is used for heater or filament supply.

The method of using only one transformer for the various requirements, makes a compact arrangement, facilitates the



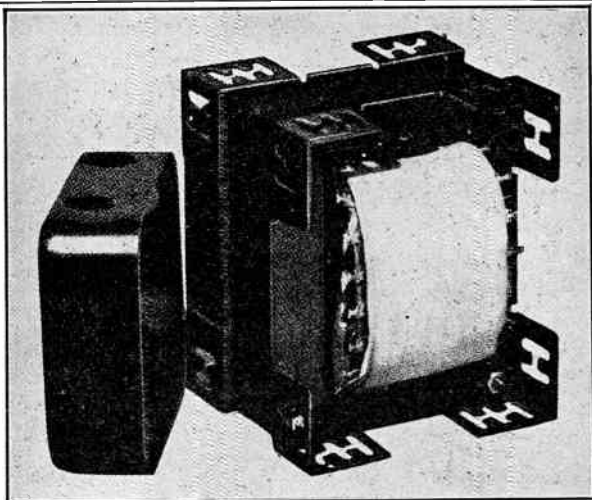

FIG. 1—Exterior view of typical power transformer.

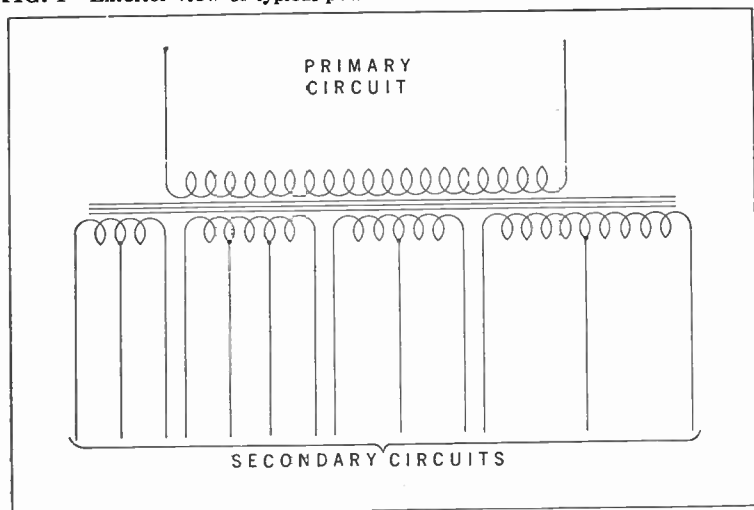

FIG. 2—Conventional diagrammatical representation of power transformer for 5 to 9 tube sets.

assembly and reduces the cost. A power transformer of the type described is shown in fig. 1, and a typical circuit diagram showing the connection of the several windings is shown in fig. 2.

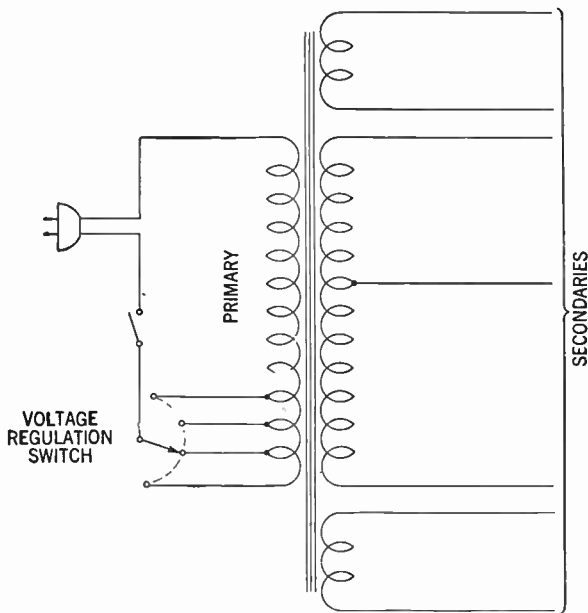
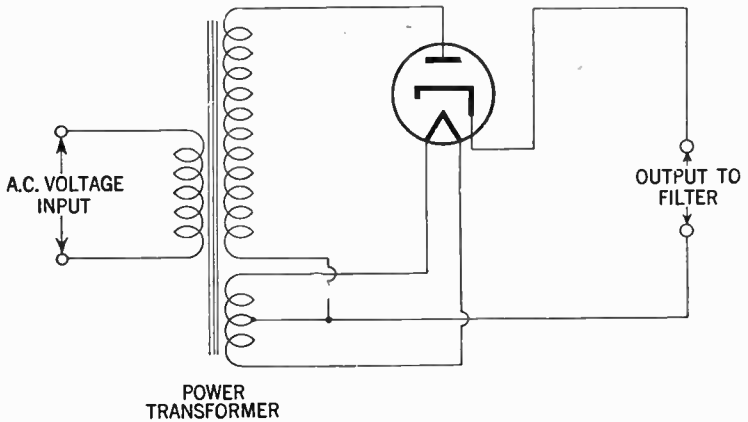

FIG. 3--Power transformer circuit showing voltage regulation switch.

The power transformer should be of ample size to supply the power required in each specific case without over-heating, i.e., the iron and copper should be dimensioned so that the secondary voltage will remain practically constant even in the case of slight variations in primary power supply.

(For further treatment of transformers see transformer chapter.)



**FIG. 4—**Illustrates connection and rectifier tube to obtain half-wave rectification.

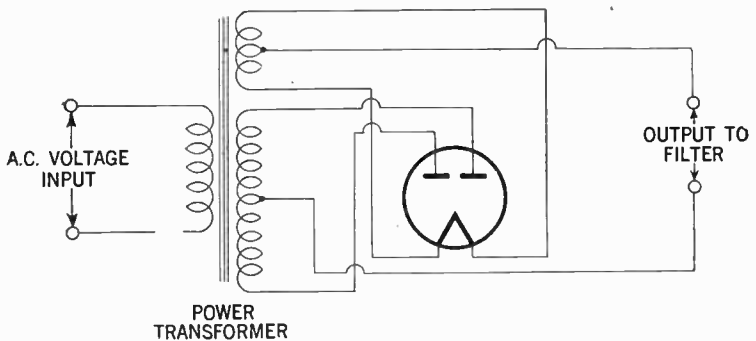

**FIG. 5—**Illustrates connection and rectifier tube to obtain full-wave rectification.

**Method of Line Voltage Regulation.**—In certain locations where comparatively large fluctuation in voltage is experienced, due to variation in the load requirements, the reception may be improved by providing a primary voltage regulating switch as shown in fig. 3. The voltage regulation switch is set for a higher voltage value during the time of the day when the line voltage is low, and put back to its original position when the supply voltage again becomes normal.

**Rectifier Tubes.**—The rectifier tubes are generally divided into two classes namely the half-wave and the full-wave. In modern *a.c.* systems however, the latter is most commonly employed. In half-wave rectifiers only one half of the current wave is utilized as shown in the diagram fig. 4 whereas in the full-wave rectifiers both halves of the waves are utilized. See fig. 5.

It is also possible to connect two half-way rectifier tubes in such a way as to obtain full-way rectification.

As the full-wave rectifier produces twice as many impulses, it is considerably easier to filter into the desired smooth direct current. It is obvious also that because of twice the number of pulsations during a certain time, that the current obtained in this latter system will be twice as great.

There are two general types of rectifier tubes in use. (1) The high vacuum type, in which the conduction is purely by means of the electronic stream from the cathode to the plate and (2) those in which a small quantity of mercury has been introduced after the tube has been evacuated. In the latter type, part of the mercury vaporizes when the cathode reaches its operating temperature and during the part of the cycle in which the rectifier is passing current the mercury vapor is broken down into positive and negative ions. Due to the fact that the positive ions decreases the normal resistance of the plate-cathode circuit

the voltage drop in this type is less than in the high vacuum types.

As a result of this lower voltage drop the power loss ( $I^2R$ ) is lower, and the efficiency of the mercury vacuum rectifier is higher than in the high vacuum type.

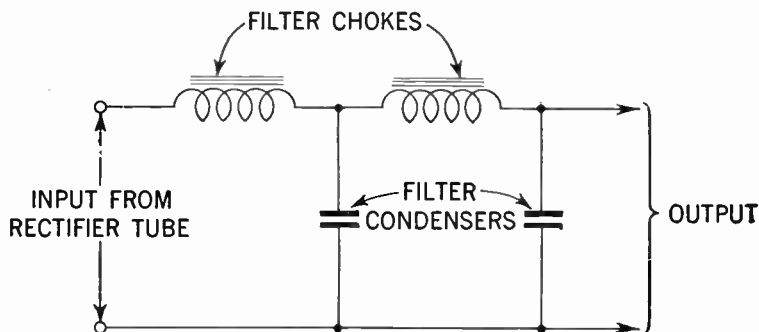

FIG. 6—Choke-input filter.

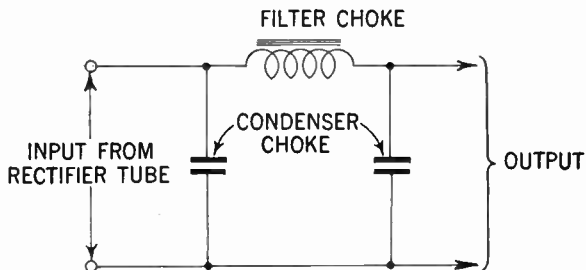

FIG. 7--Condenser-input filter.

**Filter Systems.**—The function of the filter system aside from that of preventing feed-backs into the receiver, is to smooth out the remaining ripples or pulsations in the voltage received from the rectifier.

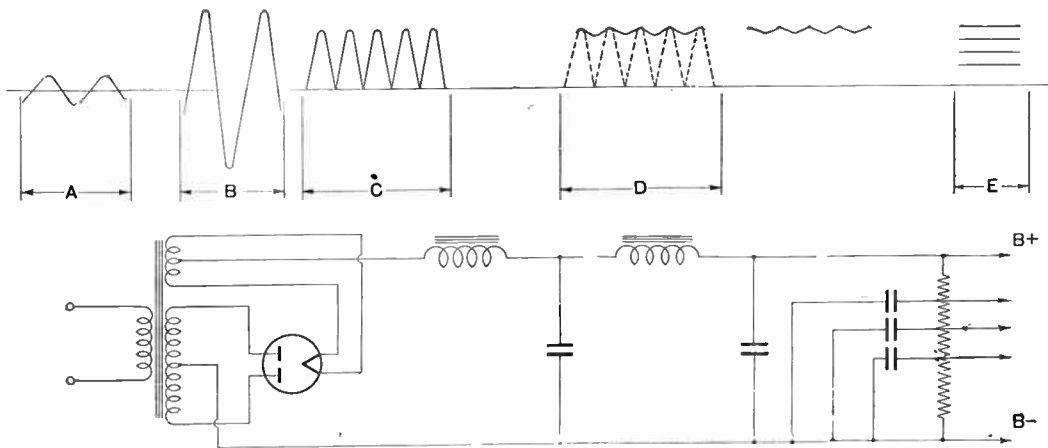

FIG. 8—Illustrates a “B” power supply unit of the full-wave type. The choke-input filter section is connected to the conventional voltage divider supplying plate voltages to the various tubes in the power supply unit. For example: “A” represents current supplied from power line; “B” high voltage current supplied to rectifier tube; “C” rectified unfiltered current as obtained from rectifier; “D” current as obtained from choke-input filter; “E” ripples direct current furnished to plates.

Smoothing filters are generally classified as choke-input or condenser-input according to whether a choke or a condenser is placed next to the rectifier output. Figs. 6 and 7 respectively show a choke-input and condenser-input filter.

If a condenser-input type be used consideration must be given to the instantaneous peak value of the *a.c.* input voltage. This peak voltage is  $\sqrt{2}$  times the root mean square (R.M.S.) value as obtained by an *a.c.* voltmeter. Hence, filter condensers especially the input condenser should be of a rating high enough to withstand the instantaneous peak voltage if breakdown is to be avoided.

When the choke-input type is used, the available *d.c.* output voltage will be somewhat less than with the condenser-input type for a given *a.c.* plate voltage; however, in this latter type improved regulation together with lower peak current will be obtained.

**D.C. Supply Systems.**—Although alternating current is most commonly used in radio receiving sets, there are certain localities in which direct current is furnished, and hence the radio receiving sets in those localities must be designed for operation on *d.c.* current power supply.

It is obvious since the *d.c.* current is practically ripless, that no rectifier unit is necessary. All that is required is a filter system which serves to smooth out the slight remaining "ripples" due to the commutator (brush contact) action on the direct current generator.

The filament supply usually about 6 volts is obtained from the power voltage through a resistor or speaker field of a value to give the necessary voltage drop. See fig. 9.

The filaments may be arranged either in series or parallel. The disadvantage in both cases is a considerable amount of power dissipation in the form of heat, although the power loss is much less when the series arrangement is used.

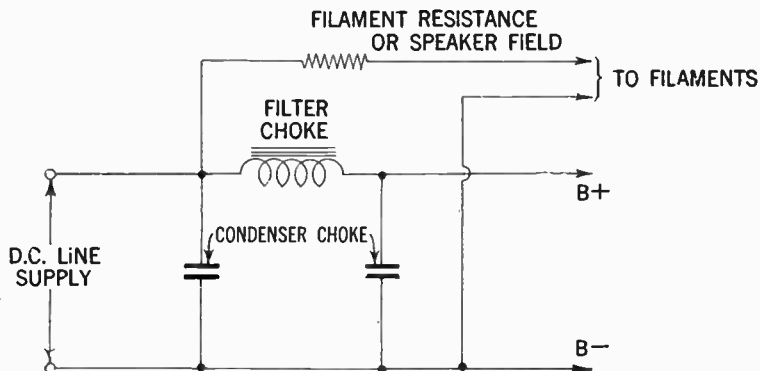

FIG. 9—Conventional filter system used on D.C. receivers.

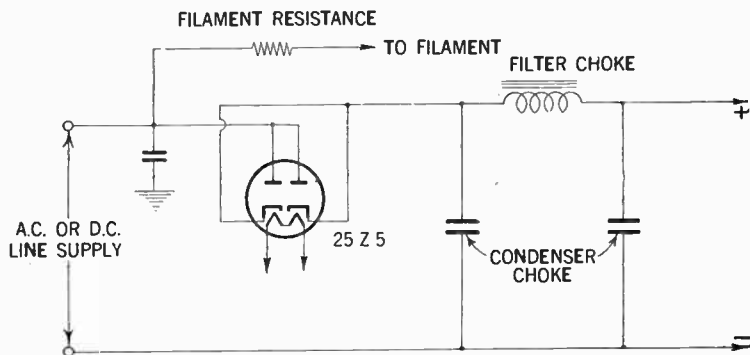

FIG. 10—Full wave rectifier tube circuit used for A.C.-D.C. receivers.



**A.C. and D.C. Supply Systems.**—When the power supply is alternately *a.c.* or *d.c.* the filament supply is connected through a series resistor as shown in fig. 10. This resistor must be of such value as to give the proper voltage drop. The disadvantage with this arrangement is the same as that of the straight *d.c.* supply system, in that a considerable amount of heat ( $I^2R$ ) is dissipated in the filament resistor. The plate voltage is usually supplied by utilizing a full wave rectifier tube as shown in fig. 10.

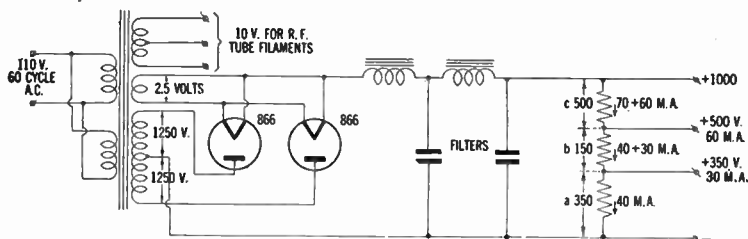

FIG. 11—Full wave rectifier circuit with conventional filters and voltage divider.

**Voltage Dividers.**—The function of a voltage divider is to supply the various plate voltages required by the various tubes employed in the receiver.

The principal method in each system is to lower the voltage by means of one or more resistors inserted in the circuit. When one resistor is utilized the resistor is tapped at suitable intervals, as shown in fig. 11.

In order to facilitate the calculation of the resistance required between the taps, the voltage divider should be laid off in sections as shown.

**Example.**—Assume that the power supply unit shown in fig. 11 has 1,000 volts across its output terminal and that the required plate voltages and currents are as follows:

1. 350 volts at 30 m.a. for the oscillator
2. 500 volts at 60 m.a. for the buffer-doubler
3. 1,000 volts for the final amplifier.

**Solution.**—By using Ohm's law the resistance of (a) or the 350 volt sections will be  $\frac{350}{0.04}$  or 8,750 ohms.

The resistance of section (b) or the 150 volt section will be  $\frac{150}{0.07}$  or 2,150 ohms approx.

The resistance required for section (c) will be  $\frac{500}{0.13}$  or 3,850 ohms.

The current in this last section becomes 60 m.a. in addition to the 70 m.a. already flowing in sections (a) and (b) or  $0.06 + 0.07 = 0.13$  amps.

The total resistance of the divider will therefore be  $8,750 + 2,150 + 3,850 = 14,750$  ohms, which is safely below the value necessary to maintain constant output voltage when the tubes are not drawing current from the power supply.

The power loss may be calculated by multiplying the voltage drop across each resistance by the current flowing through it.

Accordingly the power dissipated

in section (a)  $350 \times 0.04 = 14$  watts

in section (b)  $150 \times 0.07 = 10.5$  watts

in section (c)  $500 \times 0.13 = 65.0$  watts

It is evident from the above that this method of providing operating voltage is uneconomical.

The power calculation should be done for both no-load and full-load conditions, and a resistor selected which should have a rating well above that of the higher of the two values.

In some cases it is desired to have the bleeder resistance total to a pre-determined value—for example, if the bleeder in the above problem is to total 20,000 ohms instead of the calculated value of 14,750 ohms, the same method of calculation may be followed, but different value of idle current should be tried until the correct one is found.

The method outlined may be extended to any number of taps, and is equally applicable to calculation of voltage dividers for radio receivers.

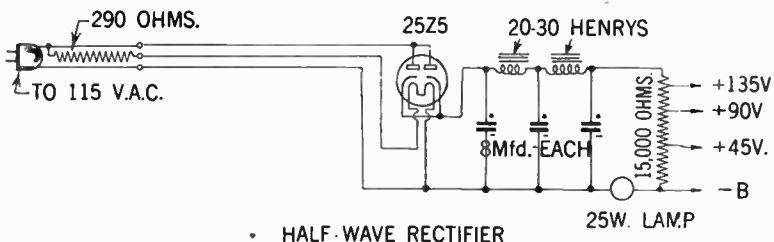
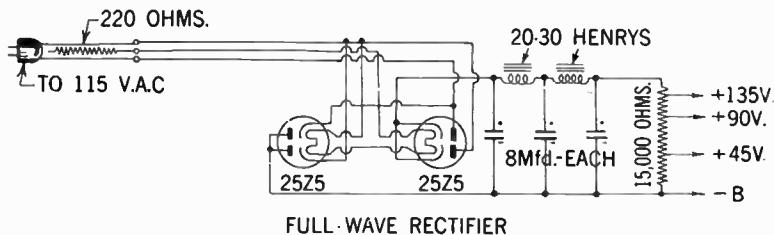

FIGS. 12 and 13—Illustrates two transformerless power supplies, for full-wave and half-wave rectification respectively. Here a line cord resistor is utilized to drop the line voltage to that necessary for the filaments of 25Z5 tubes. The third element in the line cord resistor brings the full line voltage for the plate of the tubes.

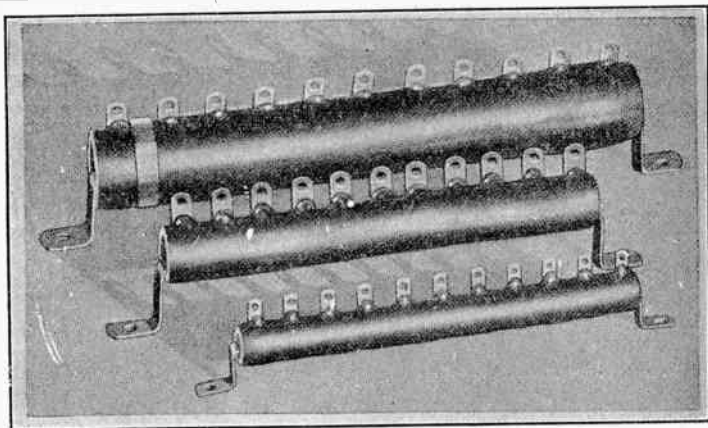

FIG. 14—Typical receiver power supply resistors.

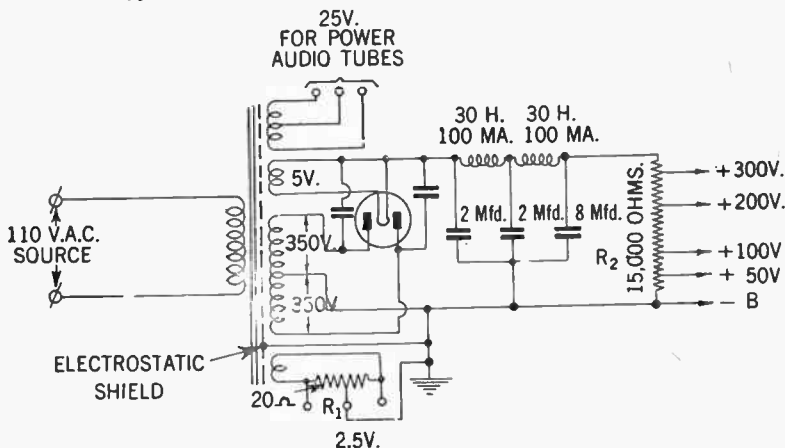

FIG. 15—Here the power transformer is used to step up the 110 volt alternating current to 350 volts on each side of the centre-top. This type of power supply will ordinarily be satisfactory for an ordinary armature receiver as well as an audio amplifier using a 47 or a pair of 45's in push-pull. The 2 m.f.d. condensers and the 30 henry chokes reduces the ripple to satisfactory proportion. Resistor  $R_1$  is centre tapped with a value of 20 ohms.  $R_2$  is the voltage divider for obtaining the different voltages from the power supply.

**Bleeder Resistors and Their Use.**—It is common practice to connect a bleeder resistor across a power supply to obtain a more stable output—to improve voltage regulation. However, this is often accomplished without any fundamental knowledge of how a bleeder resistor actually works, and how its exact size may be calculated.

Voltage regulation may generally be defined as the change in potential with a change in the load or current consumed.

This is an important consideration in power supply for radio receiving and transmitting circuits because the current may change with signal intensity, modulation, keying, line voltage fluctuation, etc. and it is highly desirable and often imperative that the voltage remains constant.

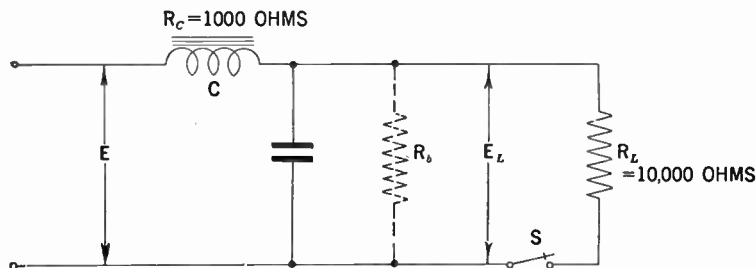

FIG. 16—Showing application of bleeder resistor across power supply.

A problem of this kind may best be studied by considering the arbitrary condition existing in the circuit shown in fig. 16 illustrating a simple filter system of a power supply.

In this circuit  $E$ , is a source of constant voltage. Choke  $C$ , has a resistance of 1,000 ohms.  $E_L$  is the potential supplied to the load  $R_L$ , which may be the plate circuit of a transmitter or receiver. Switch  $S$ , applies or removes the load.

It is assumed that the load is such that it requires 100 *m.a.* at 1,000 volts for the most efficient operation which according to Ohm's law gives  $R_L$  a resistance of 10,000 ohms.  $R_b$  is a 10,000 ohms bleeder resistor which at first, is not connected.

If  $R_L$  draws a current of 100 *m.a.* the drop through the choke  $C$ , will be 100 volts, and  $E$ , therefore must be 1,100 volts in order that  $E_L$  the load voltage shall provide the 1,000 volt potential.

However, with the switch open, the no load voltage  $E_L$ , will be the same as  $E$ , or 1,100 volts. When switch  $S$ , is closed this 1,100 volt potential will be momentarily applied to the load which will drop almost immediately to the required potential of 1,000 volts.

In other words, the change in voltage with the change in load has been a drop from 1,100 volts to 1,000 volts or a voltage regulation of 100 volts.

Assuming that  $R_b$  is also connected in the circuit, it is evident that as  $R_b$  also draws current that the drop through  $R_c$  will be increased. Hence if  $E_L$  is to be maintained at 1,000 volts, the source voltage will also have to be increased.

With  $E_L$  at 1,000 volts,  $R_L$  and  $R_b$  10,000 ohms each, the current drain through the circuit will be 200 *m.a.* and the drop across  $C$ , 200 volts, therefore the voltage at  $E$ , will have to be raised to 1,200 volts.

It is evident that the no load voltage (switch  $S$ , being open) will no longer be the total voltage at  $E$ , but instead the voltage drop across  $R_b$ , this may be easily calculated by using Ohm's law.

The bleeder current through  $R_b$  will be  $\frac{E}{R_c + R_b}$  or 0.109 amperes; the voltage drop across  $R_b$  (or the no load voltage) will be  $I \times R_b = 0.109 \times 10,000$  or 1,090 volts. The no load voltage being 1,000 volts, hence, the change due to regulation will be 90

volts or an improvement of 10 volts over conditions when the bleeder is not employed.

**With Resistor in Parallel.**—In the above example the power supply was so designed that the correct load voltage was obtained when the bleeder was in the circuit. Very often the bleeder is added merely as an afterthought in hope that the regulation secured will compensate the loss in voltage.

With reference to the diagram, the bleeder resistor is connected without boosting the voltage (1,100) at  $E$ .

If considering resistors  $R_L$  and  $R_b$  in parallel, their combined resistance is 5,000 ohms. This plus  $R_c$  gives a total effective resistance of 6,000 ohms, and a total current of 184 *m.a.* The drop across  $R_c$  will be 184 volts, and the load voltage  $E_L$  will be  $E$  minus this value (1,100–184) or 916 volts. The no load voltage will be of course exactly 1,000 and the regulation therefore 84 volts.

This is better than the 100 volt regulations obtained when the bleeder is not employed, but the operating voltage has dropped to 916 volts.

**Summary of Improvement in Regulation.**—Summing up it will be observed that the improvement in regulation with the utilization of a bleeder resistor is not as much as might be assumed. While the conditions in the above problem have been arbitrarily assumed, similar arithmetic treatment will apply to actual cases.

It is evident that the lower the value of the bleeder resistor, the greater the regulating effect, but at the same time the supply voltage must be increased.

The bleeder is essentially a wasteful proposition and particularly so when its value is made sufficiently low to secure any real measure of regulatory effect. However, a bleeder of even

high value, say 100,000 ohms, will be effective in preventing excessively high potentials under no-load conditions which might damage rectifying tubes and filter condensers.

Voltage regulation is best secured through the design of generous size transformer windings, low resistance chokes and mercury-vapor rectifying tubes.

**Voltage Doubler Circuits.**—By means of this type of circuit it is possible to obtain twice the *a.c.* input voltage without the conventional transformer.

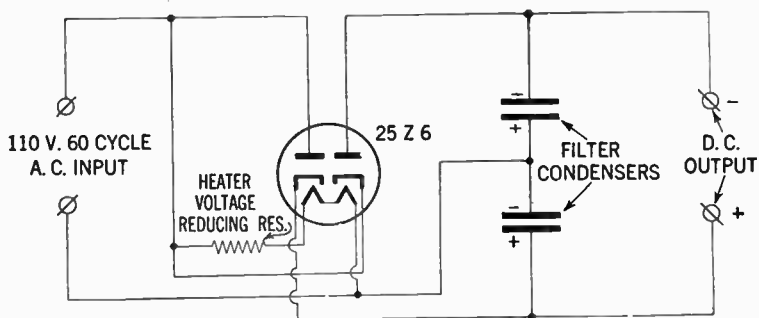

FIG. 17—Voltage doubler circuit utilizing a full-wave rectifier tube.

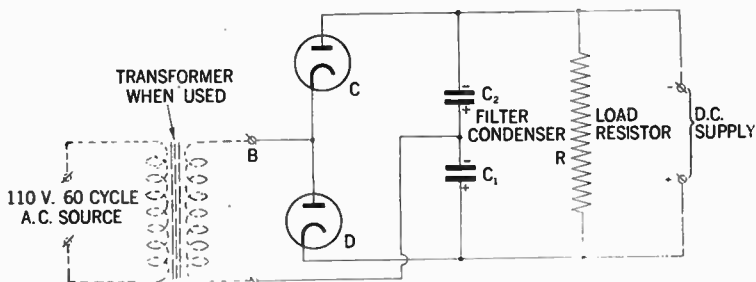

FIG. 18—Voltage doubler circuit utilizing two half-wave rectifier tubes.



The circuit shown in fig. 18 represents a typical voltage doubler without a transformer although a transformer may be used if the voltage requirements thereby will be facilitated.

The action that takes place within this circuit is briefly as follows: With reference to fig. 18 it may be observed that during that one half of the cycle when  $B$ , is positive with respect to  $A$ , rectifier  $D$ , is conducting and the condenser  $C_1$  is being charged. The two condensers are connected in series with respect to the load resistor  $R$ , which results in doubling of the voltage appearing across this resistor.

**Example.**—*A five tube receiver using a 2 volt filament supply battery, takes 1.2 amperes of filament current. What is the total power expended in heating the filaments? If a 40 ohms potentiometer were placed across the battery terminals, what would be the increase in the power consumed?*

**Solution.**—Since direct currents are being dealt with, the power in watts is given by the product of the voltage and the current in amperes. Thus the power is  $2 \times 1.2 = 2.4$  watts. The current taken by the potentiometer is easily found by Ohm's law. This gives  $I(\text{amperes}) = \frac{E}{R} = \frac{2}{40}$  or 0.05 ampere. As before, the power taken is equal to the product of the voltage and this current or  $2 \times 0.05 = 0.1$  watt. A quicker method is to make use of the formula,  $\text{power} = \frac{E^2}{R}$  watts or in this case  $\frac{4}{40} = 0.1$  watt as before.

**Example.**—*The current for a multi-tube receiver is furnished by means of a "B" battery having a potential of 120 volts. If a milliammeter placed in the negative lead indicates that a steady current of 8 m.a. (milliampere) is passing, what is the d.c. resistance of the circuit?*

**Solution.**—The comparatively small current flow in the “B” circuit of a receiver is conveniently measured in milliamperes  $\frac{1}{1,000}$  of an ampere. When, however, a calculation is to be made, it is better to express it into fundamental units of current—the ampere.

When applying Ohm’s law it is always advisable to express the quantities dealt with in terms of the fundamental units—*amperes, volts* and *ohms*, since the formula  $E = I \times R$  holds true for these denominations.

In the example, therefore, it is required to express the current in ampere or 0.008 amperes. The resistance of the circuit may now easily be found by applying Ohm’s law—

$$R = \frac{E}{I} = \frac{120}{0.008} = \frac{120,000}{8} \text{ or } 15,000 \text{ ohms}$$

**Example.**—*What amount of power is dissipated in the circuit of the previous example?*

**Solution.**—The power in watts in any *d.c.* circuit is obtained by multiplying the current through the circuit by the potential across it, or written  $W = E \times I$ . When substituting the values of current and potential in the above equation we obtain very simply  $W = 120 \times 0.008 = 0.96$  watts.

**Problem.**—*A certain receiver consumes 46 m.a. at 250 volts, the current being supplied through a smoothing choke of 25 henry. If the actual d.c. output from the eliminator is 270 volts, what is the resistance of the choke? The high frequency and detector tubes are supplied with 8 m.a. through a special smoothing choke of 200 henry and 3,000 ohms. What is the voltage drop in the choke?*

**Solution.**—This problem offers a simple exercise in voltage drop calculation. The voltage supplied to the *H.P.* terminal of the receiver is 250 volts while the actual eliminator voltage is 270. The difference in 20 volts represents the (*IR*) drop across the choke, the symbol *R*, of course, referring to the resistance and not the inductance of the coil, the latter of which exercises no effect whatever upon the direct current. Of this *IR* product the current value  $\bar{i}$  is known to be 0.046 amperes, thus according to Ohm's law, it may be written

$$20 = I \times R = 0.046 \times R \text{ from which follows}$$

$$R = \frac{20}{0.046} = 435\Omega$$

The (*IR*) voltage drop across the special choke is similarly found. Here  $I \times R = 0.008 \times 3,000 = 24$  volts. Such a slight voltage drop is of course immaterial in the case of tubes in the position as specified.

## CHAPTER 8

# Resistors, Inductors and Condensers

**The Tuned Circuit.**—In the chapter dealing with radio fundamentals, it has been demonstrated that the flow of electrons through a wire constitutes an electric current.

The law governing this flow of current under various conditions, as well as the conditions necessary for the introduction of resonance in an *a.c.* circuit has also been briefly outlined.

**Selectivity of Tuned Circuits.**—In order to understand the selectivity of the tuned circuit and the factors governing this important phenomenon, the behavior of a simple circuit as shown in fig. 1, will be considered.

Here the applied *a.c.* voltage ( $E$ ) forces a current of ( $I$ ) amperes (r.m.s. value) through the loop of the circuit. The circuit itself opposes or impedes the flow of current and this opposition is known as *impedance*.

Now the circuit under consideration comprises the three quantities resistance  $R$ , (ohms) inductance  $L$ , (henries) and capacity  $C$ , (Farads) and the total opposition is due to all three.

That part of the impedance due to coil inductance is referred to as inductive reactance and is given in ohms by the expression  $2\pi fL$  where  $f$  is the frequency. Similarly the condenser possesses a reactance of  $\frac{1}{2\pi fC}$  ohms capacitive reactance.

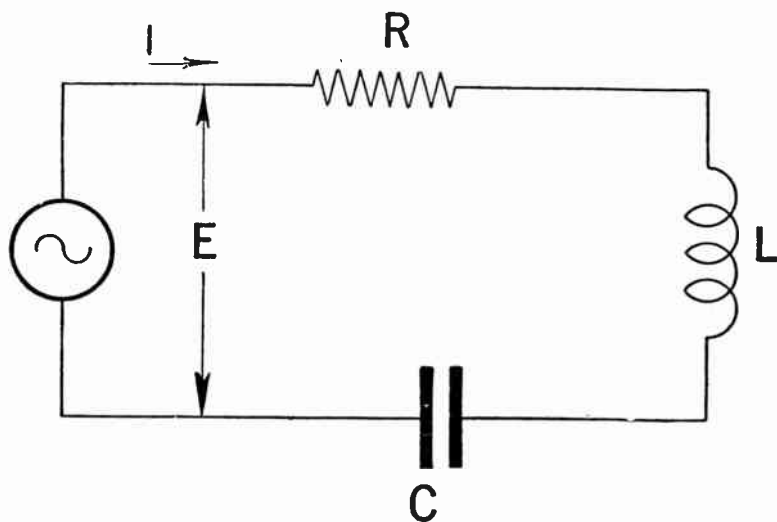

FIG. 1—Circuit containing resistance, inductance and capacity connected in series.

It is a well known fact that the *a.c.* voltage required to force a current through an inductive reactance is a quarter of a cycle in advance of the current, whereas for a condenser the applied voltage lags by a quarter of a cycle behind the resulting current.

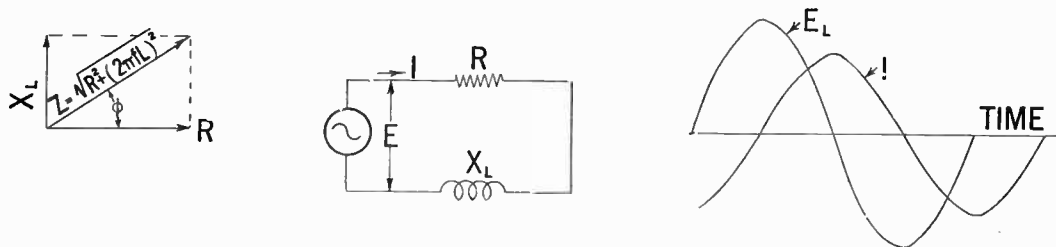

FIG. 2—Voltage and current vectors for a circuit containing resistance and inductance in series.

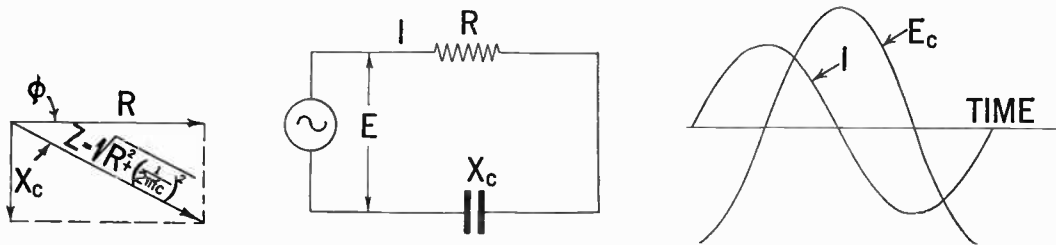

FIG. 3—Voltage and current vectors for a circuit containing resistance and capacity in series.

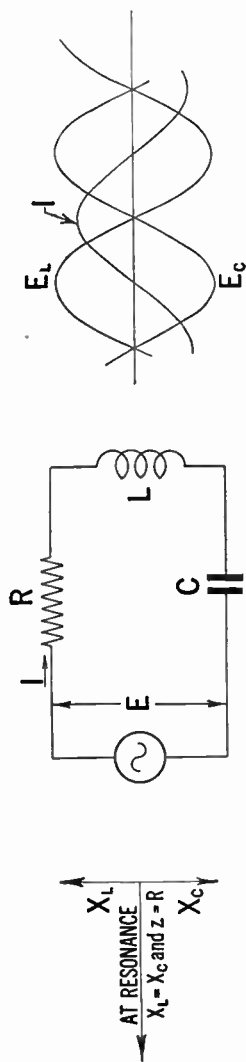

FIG. 4—Resonance conditions in a series circuit.

**Circuit Resonance.**—Consequently the closed loop, where the same current flows throughout, the component voltage absorbed in overcoming the inductive and capacitive reactance are in opposition—when one is positive and the other negative at all times.

Thus the voltage absorbed by the two reactances in series is the difference of the individual voltage. From this it follows that the inductive and capacitive reactances tend to neutralize each other's effects and the resultant reactance of the circuit is given by  $2\pi fL - \frac{1}{2\pi fC}$  ohms.

It is evident from the above that the inductive reactances increase as the frequency is raised, whereas the capacitive reactance decreases. Thus there must be one particular frequency at which the two become equal and neutralize each other completely as far as their influence of the current is concerned. When this happens the circuit is tuned to resonance with the applied frequency, and the formulae for the resonant frequency is derived by equating the inductive and capacitive reactances namely  $2\pi fL = \frac{1}{2\pi fC}$  from which  $f = \frac{1}{2\pi\sqrt{L \times C}}$  cycles per second.

It follows that at resonant frequency the resultant reactance of the circuit is zero, so that only the resistance remains to oppose the flow of current and hence ohms law may be applied,  $I = \frac{E}{R}$  amperes.

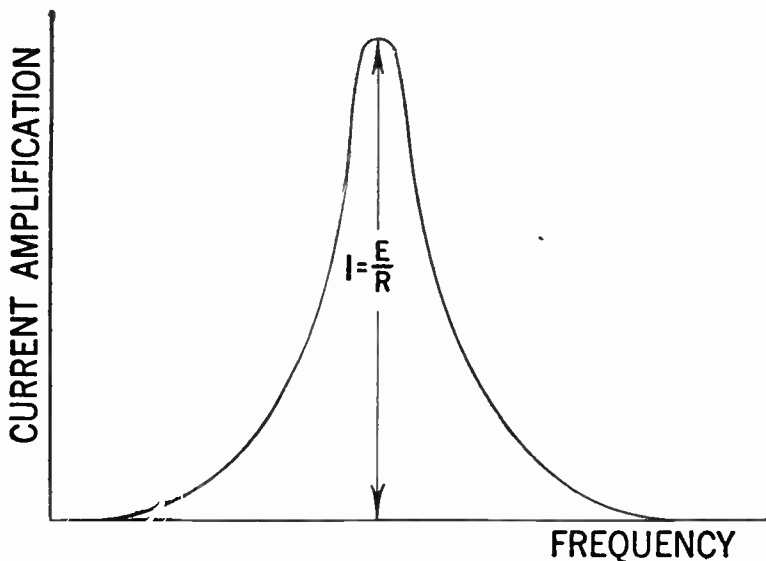

FIG. 5.—Typical current resonance characteristic.

At any frequency different from the resonant value the inductive and capacitive reactances become unequal and their resultant is no longer zero so that the current now experiences an additional opposition which increases as the frequency departs from the resonant value in either direction, the current being reduced as a consequence.



Obviously then the current is greatest at the resonant frequency, its value being  $\frac{E}{R}$  amperes.

The formula for the current at any frequency is

$$I = \frac{E}{\sqrt{R^2 + \left(2 \times \pi \times f \times L - \frac{1}{2 \times \pi \times f \times C}\right)^2}} \text{ amperes.}$$

If a curve be plotted of current against the frequency the familiar resonance curve depicted in fig. 5 will be obtained, the maximum height being  $\frac{E}{R}$  ampere, now in receiving circuits the current is of little significance compared to the voltage built up across it.

**Voltage Amplification.**—The voltage across the condenser is  $I \times \frac{1}{2\pi f C}$  and since at resonance  $\frac{1}{2\pi f C} = 2\pi f L$  it follows that the voltage developed across the tuned circuit is  $I(2\pi f L)$  volts. From Ohm's law the applied voltage is  $IR$  and so the ratio of the developed voltage and the applied voltage is  $\frac{2\pi f L}{R}$ . This is a very important number and is known as the *voltage amplification* of the tuned circuit.

At resonance  $2\pi f = \frac{1}{\sqrt{LC}}$  and so the previous expression for voltage amplification may be re-written in the form

$$E_a = \frac{1}{R} \sqrt{\frac{L}{C}}$$

It now remains to be shown that the selectivity of the tuned circuit is directly proportional to the voltage amplification. This may best be accomplished with a graphic illustration.

In the first place, consider a circuit of fixed inductance and capacity and assume that a number of resonance curves be plotted each for a different resistance value.

With reference to fig. 6, it may be observed that the peak of the curves all appear at the same frequency and it will further be noted that their various heights are inversely proportional to their respective resistance.

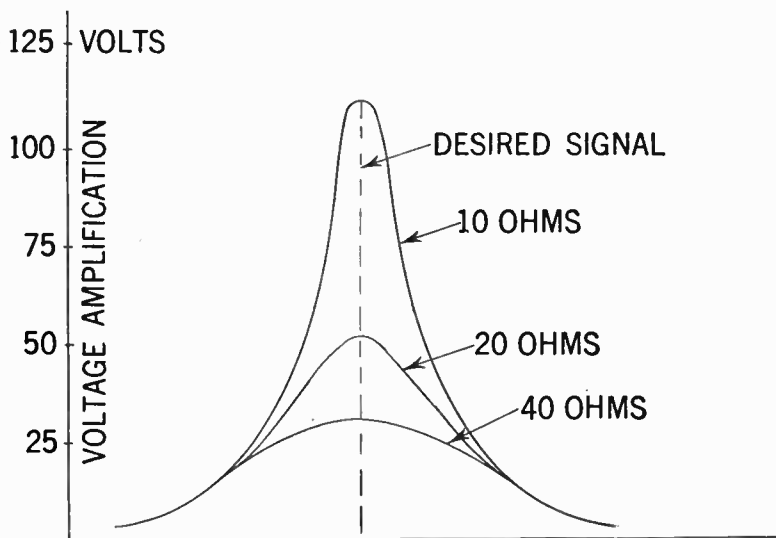

FIG. 6—Typical voltage resonance characteristics indicating the effect of varying the effective resistance.

It is important to note that all the resonance curves have approximately the same width near the base, so that by decreasing the resistance the strength of the desired signal increases at the resonant frequency without appreciably strengthening any signals whose frequency differ moderately from the resonant value.

This the degree of selectivity is approximately proportional to the height of the resonant curve and so inversely proportional to the resistance, like the amplification factor.

**Mutual- and Self-induction.**—Without a knowledge of the fundamental principles of mutual induction, it is difficult to comprehend the theory of coil coupling.

By definition, *mutual induction* is the electro-magnetic property of two circuits or two parts of a single circuit, by virtue of which a changing current in one causes an electromotive force to be induced in the other.

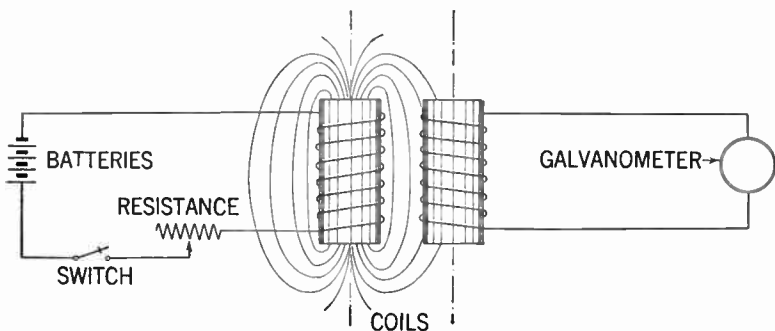

**FIG. 7**—Diagram showing the action of mutual induction between two coils; the one including a source of electrical energy and a switch, the other a current measuring instrument but having no source of electrical energy. During the increase or decrease in strength of current as on closing the switch the current is induced in the secondary circuit. This secondary current is flowing in a direction opposite to that of the primary current.

Similarly it can be said that mutual induction is an electro-magnetic property of two circuits so situated with respect to each other that a current in one sets up a magnetic field which is linked with the latter, that is to say, a property of two circuits which are magnetically coupled together.

It is a fundamental principle that when a magnetic flux linked with a circuit is changing, an electromotive force is induced in the circuit, its magnitude being proportional to the rate of change.

When the magnetic flux linked with a circuit is produced by a current in the circuit itself, then, if the current is varied, the flux will vary also and an E.M.F. is induced in the circuit proportional to the change in current.

This property in a single circuit is called *self-induction*. If, however, there be two circuits magnetically coupled together as explained above, a variation in the current in the one will cause a variation of the magnetic flux through the turns of the other, and an E.M.F. proportional to the *rate of change* of current in the first will cause an E.M.F. to be generated in the other. This property is referred to as *mutual induction*.

The first circuit in which the current is varied, is called the *primary* and the second in which the induced E.M.F. is considered, is called the *secondary* circuit.

As in the case of self-induction, the practical unit in which mutual induction is expressed numerically is the *henry*. *The mutual inductance or co-efficient of mutual inductance between two circuits is said to be one henry if one volt is induced in the secondary circuit, when the current in the primary is changing at the rate of one ampere per second.*

The mutual inductance in henries is usually denoted by the symbol  $M$ , and the induced E.M.F. in volts in one circuit is equal to the product of  $M$ , and the rate of change of current in amperes per second in the other.

The mutual inductance  $M$ , is the same whichever of the two circuits is taken as the primary.

**Degree of Coupling.**—As an example, consider two coils whose self inductances are  $L_1$  and  $L_2$  henries respectively placed in close proximity to each other as shown in fig. 8. When a current is passed through  $L_1$  a magnetic field is established and some of the magnetic loops are linked with the second coil  $L_2$ .

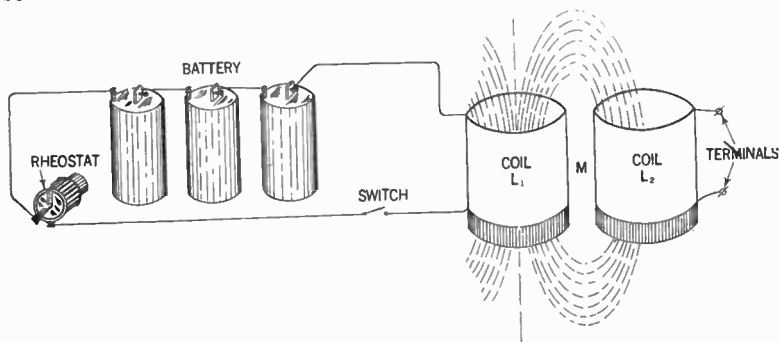

FIG. 8—Illustrating the degree of coupling of two coils.

Let  $M$  be the mutual inductance in henries between the coils. Now if the current in  $L_1$  is varied by changing the rheostat setting the flux linked with  $L_2$  will be varied in proportion and an E.M.F. will be induced in  $L_2$ . The value of this secondary induced E.M.F. is equal to  $M \times$  (rate of change of primary current). The degree of magnetic coupling obviously depends upon the proximity and relative positions of the two coils and is expressed numerically as the ratio of the mutual inductance to the square root of the product of the individual self inductances. This is called the co-efficient of coupling and is given

$$\text{by } K = \frac{M}{\sqrt{L_1 \times L_2}}.$$

This number cannot exceed unity, and in practice never reaches unity. Coils are said to be tightly coupled when they

are brought close together to give a relative high value of  $M$  and  $K$  and vice versa. The tightest coupling is obtained when two coils are wound on the same form (as for example in a transformer) or with the wires wound side by side, but even in this case the co-efficient is less than unity.

**Example.**—*The mutual inductance of two coils  $L_1$  and  $L_2$  is 160 micro-henries. If their self-inductances are  $L_1=150$  and  $L_2=275$  micro-henries respectively, what is the value of the co-efficient of coupling in the system?*

**Solution.**—Since the co-efficient of coupling is expressed by the relation  $K = \frac{M}{\sqrt{L_1 \times L_2}}$  by substituting

$$K = \frac{160}{\sqrt{150 \times 275}} = \frac{160}{203} \text{ or } 79\% \text{ approximately}$$

It should be observed that since in problems of this kind only a ratio between the mutual induction and self-inductances are required the values may be expressed in henries, milli-henries or micro-henries.

**Example.**—*Determine the resonance frequency and wave-length of a circuit containing a coil of 500 micro-henries inductance and a condenser of 0.005 micro-farads capacitance.*

**Solution.**—The frequency of resonance may be determined from the following formula:

$$f = \frac{1}{2\pi\sqrt{LC}} \text{ by substituting } L, \text{ and } C \text{ in henries and}$$

farads respectively, the following is obtained:

$$f = \frac{1}{2\pi\sqrt{5 \times 10^{-4} \times 5 \times 10^{-9}}} = 100,700 \text{ cycles per second or}$$

100.7 kilocycles.

In a similar manner the wave-length in meters may be obtained from the formula for natural wave-length  $L = 1,885 \sqrt{L \times C}$ . Where  $L$  and  $C$  are expressed in micro-henries and microfarads, and  $L$ , is the wave-length in meters. By inserting the above values  $L = 1,885 \sqrt{500 \times 0.005}$  or 2979 meters approximately.

## CONDENSERS

**Condensers in Series and Parallel.**—When condensers are connected in series or parallel, the effect is just opposite to that of connecting resistances and inductances in series or parallel. A simple method, therefore and one which is easy to remember is as follows: Capacities connected in series should be added in similar manner as that of resistances connected in parallel, and capacities connected in parallel should be added similarly as that of resistances connected in series. Thus, the total capacitance of two or more condensers connected in series may be written:

$$\frac{1}{C} = \frac{1}{C_1} + \frac{1}{C_2} + \frac{1}{C_3} \text{ etc. or}$$

$$C = \frac{1}{\frac{1}{C_1} + \frac{1}{C_2} + \frac{1}{C_3}}$$

Where  $C$  is the combined capacitance and  $C_1$ ,  $C_2$  and  $C_3$  are the individual capacities.

Where two or more condensers are connected in parallel the total capacitance  $C = C_1 + C_2 + C_3$ , etc. In this formula  $C_1$ ,  $C_2$  and  $C_3$  represent the individual capacities.

## SERIES CONNECTIONS

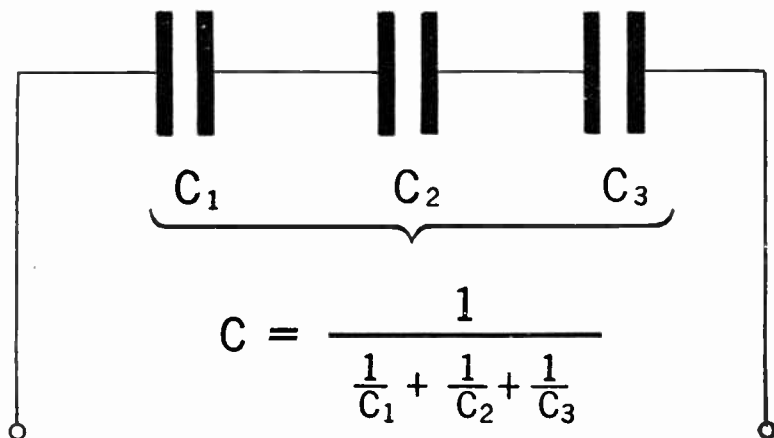

FIG. 9—Mathematical relation between the total capacitance and the individual capacities when connected in series combination.

**Type of Condensers.**—Condensers for radio application may be classified according to their construction as:

1. Mica and paper type
2. Electrolytic type
3. Ganged or air type.

Their capacity may be either *fixed* or *variable*.

As the two first classes utilized in radio circuits do not vary appreciably from those employed in other electrical systems, we shall here deal only with the *ganged condenser* type used in tuning of radio circuits.

This type of condenser generally consists of two parallel connected sets of plates of which one is stationary and the other movable.



## PARALLEL CONNECTIONS

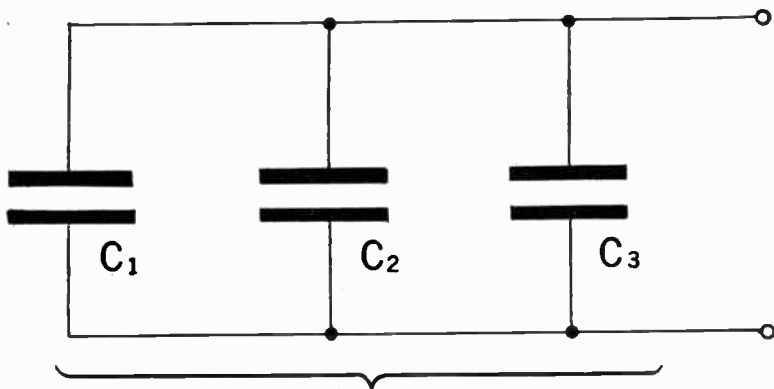

$$C = C_1 + C_2 + C_3$$

FIG. 10—Illustrating condenser connection and mathematical relation between the total capacitance and the individual capacities when connected in parallel combination.

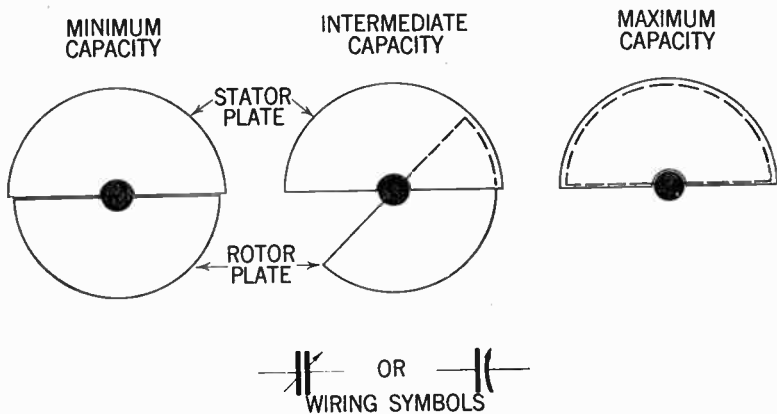

FIG. 11—Arrangement of straight line capacity condensers for various capacities.

The movable plates are made to intermesh (without touching) with those of the stationary plates, and the maximum capacity is obtained when the full areas of the two sets of plates are exposed to each other, and for various other positions some intermediate value of capacitance exists.

The ganged type of condenser is usually made of brass or aluminum sheets. Commercial types are stamped in a die press and will hence be very exact in shape and size.

Condensers of this kind are usually rated by the total number of plates in the combination; that is, a condenser having 8 plates in the rotor and 9 plates in the stator would be rated as a seventeen plate condenser.

When it is found necessary to accomplish very small changes in capacity, the condensers sometimes are provided with one additional plate, which may be separately rotated, and when so used are called *vernier condensers*.

Commercial types are made with various standard capacitance values, and the relation between the number of plates and their maximum capacity in microfarads is approximately as follows:

<i>No. of plates</i>	<i>Max. Capacity in microfarads</i>
11	0.00025
13	0.00025
17	0.00035
21	0.000365
23	0.0005

**Straight Line Capacity Condensers.**—Condenser plates of this type are semi-circular in shape, and the change in capacity is accomplished by rotation as previously discussed. However,

due to the geometrical form of the plates, the *capacity* will vary in direct *proportion* to the angle of rotation, i.e. if a change in capacity of 0.0001 *Mfd.* be made by changing the rotor setting from 15 to 20 degrees, a similar change in capacity will be made by changing the setting from 35 to 40 degrees.

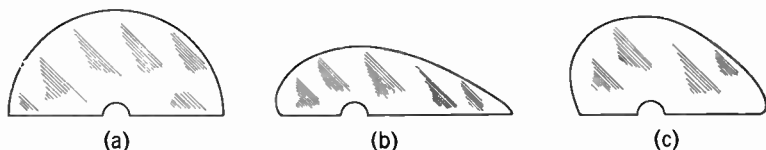
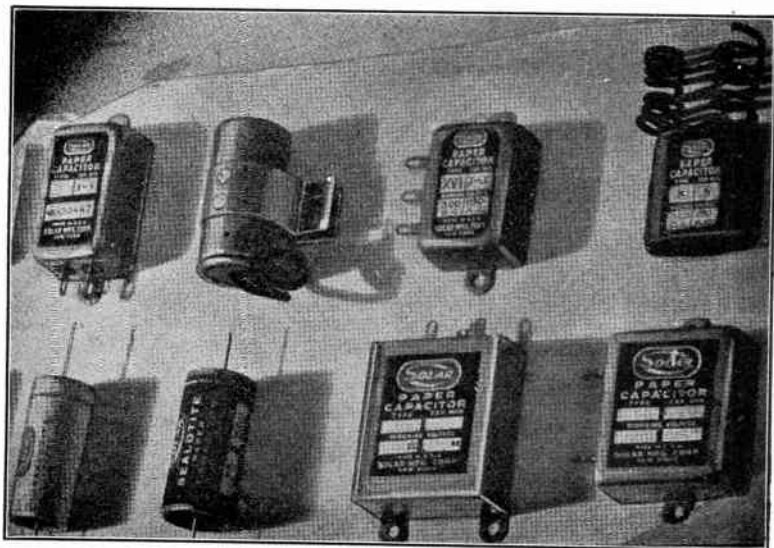
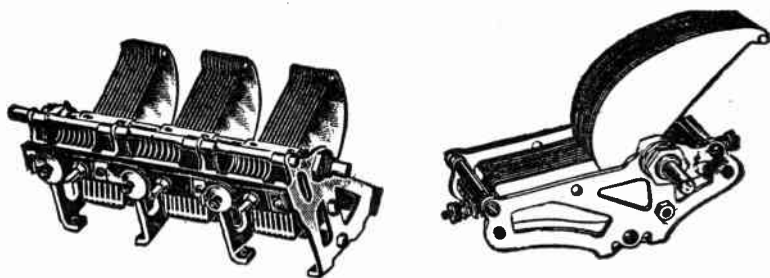

FIG. 12—Shape of rotor plates in various type air condensers. Figs. *a*, *b*, and *c* represent straight line capacity, straight line frequency and straight line wave—length respectively.

**Straight Line Frequency Condensers.**—In modern condensers, however, for convenience in tuning, the condensers are made with logarithmic plates, i.e. the shape of the plates are such that a linear relationship exists between the *rotor setting in degrees* and the *frequency* in the circuit.

The advantage of this arrangement is obvious since the primary employment of the gauged type condenser in oscillatory circuits is for adjustment of frequencies.

The frequency of such a circuit varies inversely as the square root of the capacity, and the wave-length varies directly as the square root of the capacity, hence it is evident that in order to obtain a direct relationship between the rotor setting in degrees and the frequency in the circuit, the rotor plates must therefore possess an exponential characteristic.



**FIGS. 13 to 22**—Various types of condensers used in radio work.

**Example:** A condenser of 0.0002 Mfd. is connected in series with one of 0.002 Mfd. What is the value of the resulting capacitances and what would be the capacity if they had been connected in parallel?

**Solution.**—If  $C$  denotes the resultant capacity of the two capacities in series, then according to the aforementioned formula:

$$\frac{1}{C} = \frac{1}{0.0002} + \frac{1}{0.002} \text{ or}$$

$$\frac{1}{C} = 5,000 + 500 = 5,500 \text{ from which follows that—}$$

$$C = \frac{1}{5,500} \text{ or } 0.00018 \text{ Mfd. (approximately)}$$

If connected in parallel the total capacitance is simply the sum of individual capacities or  $0.002 + 0.0002$  which adds up to 0.0022 Mfd.

**Code colors for indication of resistor values.**—The Standard Radio Manufacturers' Association Code (R.M.A. color code) for resistor values is as follows: With reference to fig. 23 the resistor has 3 colors; a *body color*, a *tip color* and a *central dot color*. The dot color indicates the number of zeros or ciphers to be added to the numerals of the other two colors; and the color of the body is taken first; for instance, if the body color be blue, which means 6, and the tip color be red, which means 2, and the dot is orange, which means 3 ciphers (000), the resistance of the resistor is 62000 or 62,000 ohms. The color values are as follows:

Color	Body and tip numerals	Dot ciphers
Black.....	0.....	—
Brown.....	1.....	0
Red.....	2.....	00
Orange.....	3.....	000
Yellow.....	4.....	0000
Green.....	5.....	00000
Blue.....	6.....	000000
Violet.....	7.....	0000000
Gray.....	8.....	00000000
White.....	9.....	000000000

If no difference in colors are visible, the colors are assumed to be the same and their values are accordingly. For instance, an all brown resistor would be 1, 1, 0; or 110 ohms.

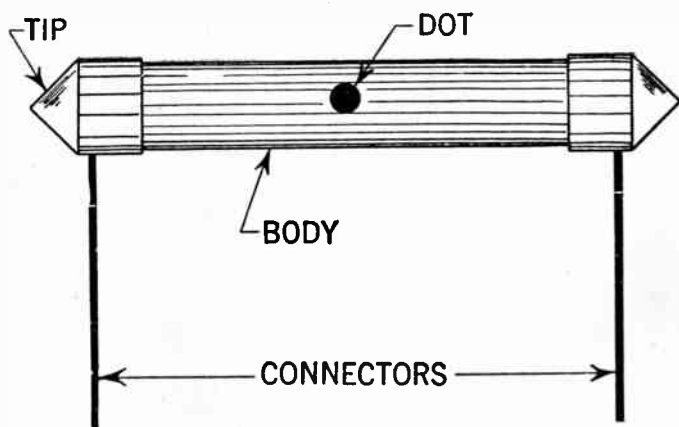

FIG. 23—Illustrating Standard Radio Manufacturer's Association (R.M.A.) color code for carbon resistance.

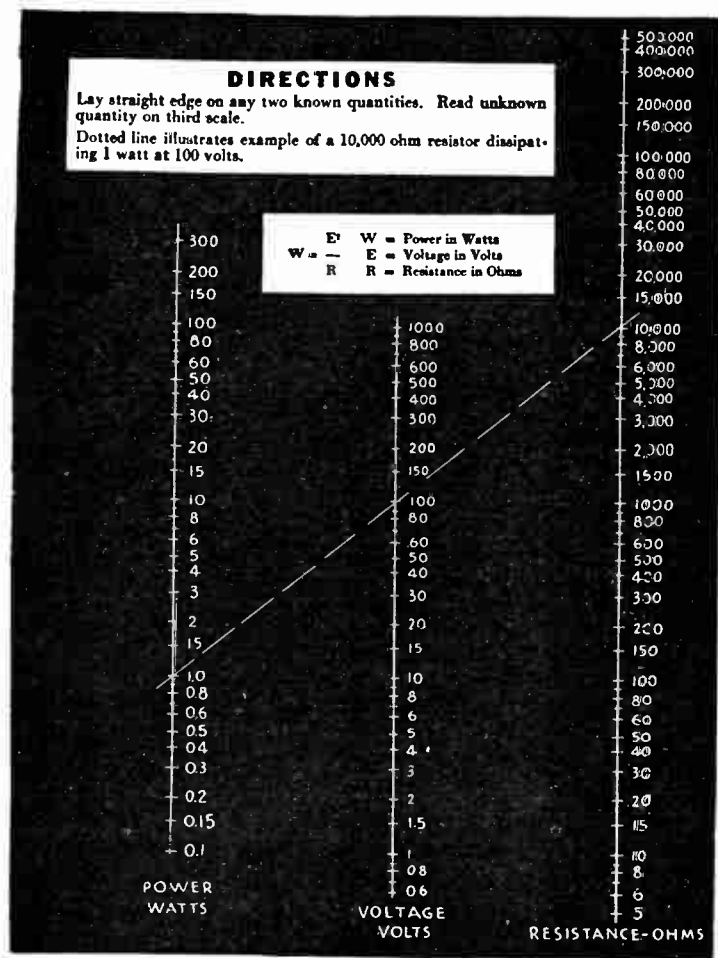

FIG. 24—Convenient table giving the scalar relation between resistance ( $R$ ), voltage ( $E$ ) and power ( $W$ ). With the chart and a straight edge any of the above quantities can be determined if the other two are known.

## CHAPTER 9

# Transformers

The alternating current transformer represents an example of the practical utilization of mutual inductance. By definition a transformer is a form of stationary induction apparatus in which the primary and secondary coils or windings are ordinarily insulated from one another, their relative position being fixed. In the case of low frequency and power transformers, the primary and secondary windings are wound on a common iron

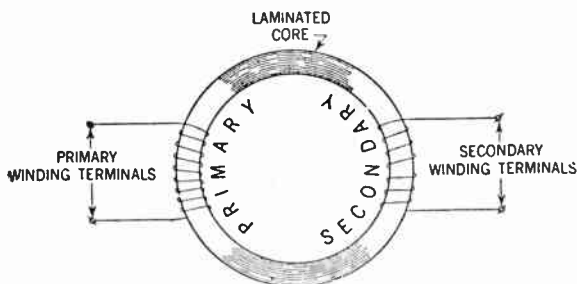

FIG. 1—A transformer in its simplest form consists of two separate and distinct coils of insulated wire wound around the laminated iron core, as shown in the above representation.

core as shown schematically in fig. 1. In this case, the co-efficient of coupling approaches 100%, but for radio frequency transformers the windings are usually carried on a non-magnetic form and are hence said to be *air cored*.



**Transformer Function.**—A transformer does not generate power, its purpose being merely to change the power from one voltage to another. Generally when used in connection with transformation of large amounts of power, from one voltage to another, a transformer utilized to raise the received voltage is called a *step-up transformer*, and when used to lower the voltage, a *step-down transformer*.

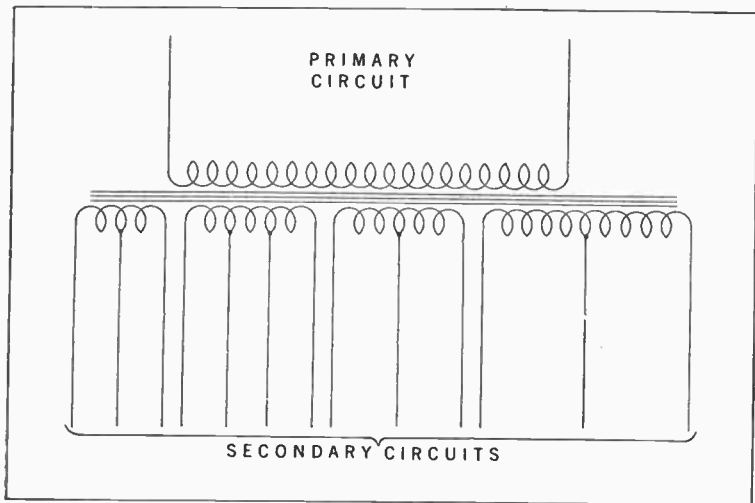

FIG. 2—Typical schematic diagram of power transformer used in radio work.

In radio service, a power transformer is used to supply a high voltage to the rectifier tube for rectification of the alternating current, (furnished through the wire cord leading from the wall outlet to the transformer) and also to supply the filament or heaters with the required voltage and current. For this purpose, the transformer is usually equipped with a single primary winding and several secondary windings as shown in fig. 2.

**Transformer Theory.**—A transformer is said to be loaded when a current is flowing in the secondary coil. When the secondary circuit is open and an alternating current from the power line flows through the primary coil, it causes an alternating magnetic flux to flow in the core.

This magnetic flux rapidly rising, falling and changing direction with the impressed frequency, cuts both primary and secondary coils and induces a voltage in each.

The voltage produced in the primary coil is opposite in direction and nearly equal to the voltage in the power line. The voltage of the secondary coil is proportional to the number of turns of the wire in the primary and secondary coils.

The choking effect produced within the highly inductive primary coil, allows only a small current to flow continually through it. This small current, proportional to the difference between the power line voltage and the voltage or counter electromotive force of the primary coil, keeps the core magnetized and maintains the voltage in the coils.

When the secondary circuit is closed a current flows through it. This secondary current is opposite to the primary current and its magnetizing action in the core opposes and neutralizes to a certain extent the primary flux and reduces the choking effect or counter electromotive force. In the primary coil when this happens more current rushes into the primary coil from the power line and balances the de-magnetizing action of the secondary current.

In this way the transformer is made automatic and maintains its core flux practically constant regardless of the load on the secondary. The variation of the load through the primary varies directly with the load on the secondary.

**Relation of Voltage in Primary and Secondary Coils.**—The induced electromotive force in a transformer coil is due to the three factors: flux, frequency and the number of turns.

Assuming a sine wave current, the fundamental equation used in transformer design is as follows:

$$E = \frac{4.44 \times f \times \phi \times N}{10^8} \dots \dots \dots (1)$$

where  $f$  = frequency in cycles per second

$\phi$  = maximum flux on the sine wave

$N$  = number of turns in the respective coils.

The voltages in the secondary and primary coils are proportional to their respective turns as both have the same frequency and are cut by the same flux. It has also been found that—

$$\phi = B \times A \dots \dots \dots (2)$$

where  $B$  = maximum flux density in lines per square inch.

$A$  = cross section area in square inches.

If  $B \times A$  be substituted for  $\phi$  in equation (1) then

$$E = \frac{4.44 \times B \times N \times f \times A}{10^8} \text{ volts} \dots \dots \dots (3)$$

This formula may be used in transformer calculations as shown in the following example.

**Example.**—*In designing a special 60 cycle step-down transformer a core of 2 sq. ins. cross section was chosen. Using a flux density of 65 kilolines per square inch of the core area, what will be the voltage of primary and secondary winding if the turns are 320 and 80 respectively?*

**Solution.**—

$$E_1 = \frac{4.44 \times 65,000 \times 320 \times 60 \times 2}{10^8} = 110.8 \text{ volts}$$

$$E_2 = \frac{4.44 \times 65,000 \times 80 \times 60 \times 2}{10^8} = 27.7 \text{ volts}$$

Another handy formula for small power transformers is obtained by solving equation (3) with respect to turns per volt.

$$\frac{N}{E} = \frac{10^8}{4.44 B \times f \times A} \dots\dots\dots (4)$$

A useful transformer design chart based on this equation is shown in fig. 3 in which the left column represents the flux density ( $B$ ), the centre column the core area ( $A$ ) and the right column the turns per volt.

Using the data given in the previous example with respect to the primary winding, it may readily be found that if a straight line is drawn through the chart at 65 kilolines per square inch, and 2 square inches area, the line will intersect the right column at approximately 2.9 turns per volt, which is equal to  $\frac{320}{110.8}$  being the primary number of turns divided by the primary voltage.

It is customary to change the turns per volt to an even number so that the proper center taps may easily be made.

Due to the previously described automatic action of the transformer which causes the core flux to remain constant regardless of load, the primary and secondary induced voltages remains practically constant, hence:

$$\frac{E_1}{E_2} = \frac{N_1}{N_2} \dots\dots\dots (5)$$

Where  $E_1$  = voltage of primary coil

$E_2$  = voltage of secondary coil

$N_1$  = number of turns in primary coil

$N_2$  = number of turns in secondary coil.

It follows from the above that if  $N_1$  and  $N_2$  are the number of turns in primary and secondary coils respectively, and if a

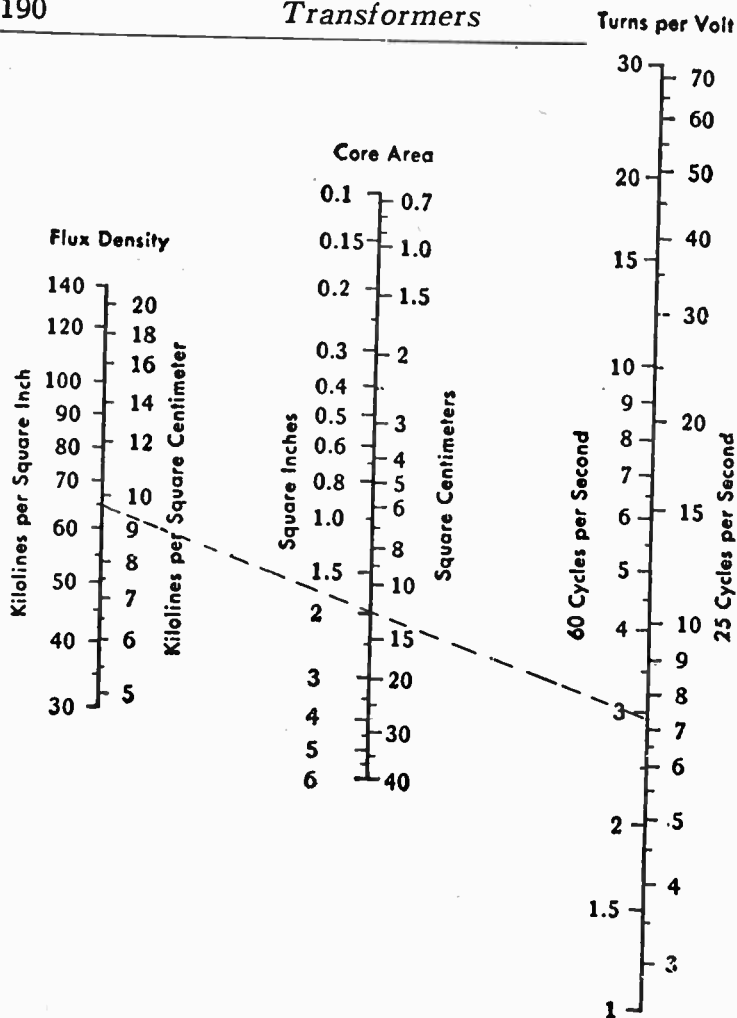

FIG. 3—Turns per volt chart. When it is desired to use flux density in kilolines per square centimeter as well as the core area in square centimeters respectively, the data supplied at the left and center columns of chart should be used.

voltage  $E_1$  is impressed on the end of the primary coil, the secondary voltage is given by the following relationship

$$E_2 = \frac{E_1 \times N_2}{N_1} \dots \dots \dots (6)$$

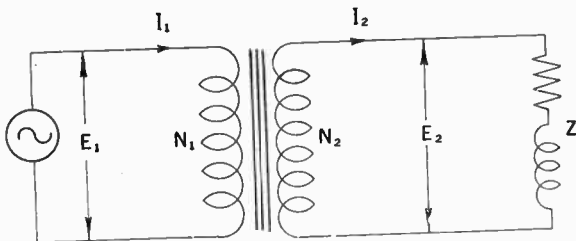

FIG. 4.—Simple diagrammatical representation of typical transformer.

**Example.**—*What will be the ratio of the primary and secondary turns in a power transformer having 110 volts impressed upon the primary coil when 660 volts is required across the plates of the rectifier tubes?*

**Solution.**—

$$\frac{E_1}{E_2} = \frac{N_1}{N_2} \text{ or } \frac{110}{660} = \frac{N_1}{N_2} = \frac{1}{6}$$

That is the secondary coil should have six times as many turns as that of the primary coil.

**Ampere Turns.**—When a load of impedance  $Z$ , of some form is connected across the secondary coil of a transformer as shown in fig. 4, a current flows in the secondary winding and this in turn reacts back on the primary winding through the medium of the mutual induction. Therefore, the current taken by the primary winding will depend upon not only the impedance of

the secondary winding itself, but also on the amount of current flowing in the secondary, although there is no direct electrical connection between the windings.

The extra current taken by the primary winding of a transformer when a current is allowed to flow in the secondary is exactly proportional to the secondary current and these two currents have equal and opposite magnetic effects on the core, the extra primary ampere turns just opposing the secondary ampere turns, so that apart from the initial magnetizing current  $I_1 \times N_1 = I_2 \times N_2 \dots \dots \dots (7)$

**Example.**—*If in a certain step-up transformer, the turns of the primary and secondary windings are 40 and 400 respectively, what will be the current ratio?*

**Solution.**—Inserting the values in equation (7) the following is obtained:

$$\frac{40}{400} = \frac{I_2}{I_1} \text{ or the current ratio} = \frac{1}{10}$$

from which it follows that the current in the primary winding is ten times larger than the current in the secondary winding or  $I_1 = 10I_2$ .

This is just the reverse compared with the relationship for the electromotive force, therefore a transformer which steps the voltage up will step the current down in the same ratio and vice versa.

Consequently the products of primary volts and amperes is approximately equal to the products of the secondary volts and amperes for iron cored transformers, but these conditions do not hold true for *r.f.* transformers where the coupling co-efficient is considerably less than unity.

**Types of Transformers.**—The two transformer types usually found in radio work are:

1. Core type
2. Shell type.

The core types shown in figs. 5 and 6 may have either a closed or open magnetic circuit, and are thus referred to as the *closed core type* and the *open core type*.

The open core type consists primarily of two windings, wound on a straight piece of laminated iron. This type of construction is very economical, but on account of very large leakage losses (its magnetic path being completed mainly through the surrounding air) it is used very sparingly in the radio field.

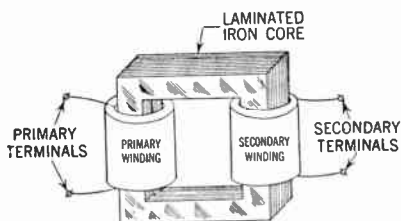

**CLOSED CORE TYPE**

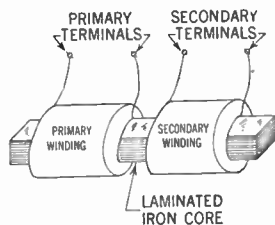

**OPEN CORE TYPE**

**FIGS. 5 and 6**—Closed and open core-type transformers respectively.

In the closed core type the windings are generally placed opposite each other as shown in fig. 5. the sides supporting the windings are referred to as the "core legs."

The coils generally consist of closely wound cotton insulated copper wire, dimensioned so as not to cause excessive heating, i.e. the wire should be of sufficient size to carry the load of the transformer without *over-heating*.



**Insulation.**—In transformers of higher voltage each layer of the winding is usually separated from the next by a thin insulating paper, in order that the effective voltage between each layer may not break down the insulation, causing a short circuit between the wires.

The best possible economy is secured when the winding encloses a maximum of core area with a minimum of wire, and when in addition the magnetic path is the shortest possible. A method widely adopted in small transformer design is the use of a single winding form, all secondaries and primary being placed on one leg of the core.

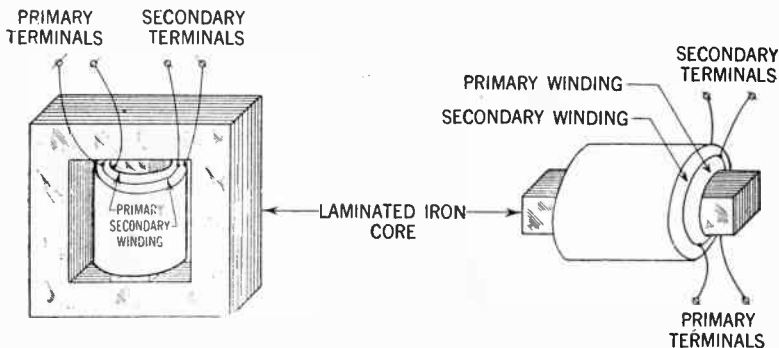

FIGS. 7 and 8—Shell and open core type transformers having the primary and the secondary winding placed directly on top of each other.

**Shell Type Transformers.**—Referring to fig. 7, this type has a completely closed core with a centre and two outside legs, forming two outside parallel paths for the magnetic lines of force.

On account of the above mentioned feature, this type has a very low magnetic leakage, and is hence most commonly used for power and audio transformers in the radio field.

As shown in fig. 7, the windings are placed directly over each other on the centre leg, thereby providing for an economical and compact design.

**Transformer Losses.**—All of the energy drawn from the power line by a transformer is not transformed. The various losses incurred in the transformation process are known as *hysteresis loss, eddy current loss, iron loss, copper loss, magnetic leakage loss, etc.*

**The hysteresis loss** is energy spent in overcoming the friction between the molecules of iron as they move backward and forward with the change of direction of flux; this is theoretical as some believe it is the natural resistance of the metal to the flow of flux and that the molecules of iron do not move backward or forward.

**The eddy current loss** is the energy spent in the heating action of the induced currents in the iron core by the varying flux. Voltages are induced in the core by the alternating flux and these voltages produce eddy currents.

**Iron losses** are practically constant with or without load and are manifested by heating. The energy loss in overcoming the ohmic resistance of both coils of the transformer when current flows through them ( $I^2R$ ) is known as the copper losses.

**Copper losses** vary directly with the square of the current due to the load of the transformer. The total copper loss in the transformer is ( $I_1^2 \times R_1$ ) of the primary, plus ( $I_2^2 \times R_2$ ) of the secondary.

**Magnetic leakage** is another loss. When the magnetic line of force flows through the core some of them do not interlink both

coils, thus causing an inductive resistance or counter electromotive force in the primary coil, which is not transmitted to the secondary coil and therefore causes a loss of voltage analogous to the ohmic resistance loss of the primary winding.

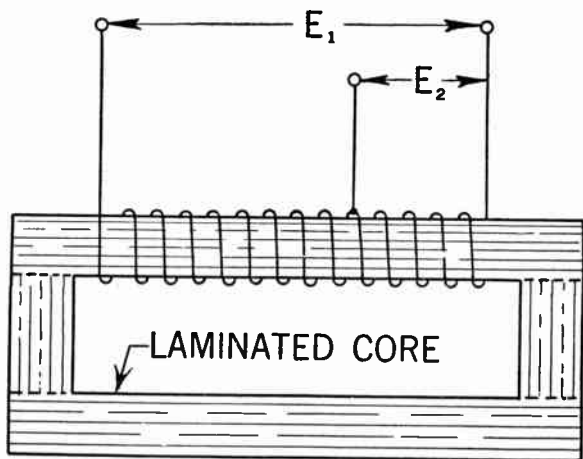

FIG. 9—Typical schematical representation of an auto-transformer in which  $E_1$  is the primary and  $E_2$  the secondary voltage.

**Transformer Efficiency.**—On account of the relatively small power involved in radio transformation, there is no urgent need for high efficiency. Generally an 80% efficient transformer which takes 75 watts to supply 60 watts is satisfactory.

The efficiency of a transformer may be written in the form of an equation as follows:

$$\text{Efficiency} = \frac{\text{output of secondary}}{\text{output of secondary} + \text{transformer losses}}$$

when the iron loss is small the transformer has a high efficiency on light loads. When the iron loss is equal to the copper loss the

transformer has a high efficiency on full load or overload.

The efficiency of a transformer may also be written:

$$\frac{\text{output in watts of secondary}}{\text{input in watts of primary}}$$

**Auto-transformers.**—The auto-transformer is commonly used in audio frequency amplifier couplings, and in connection with battery chargers, bell ringing transformers, etc.

Principally the auto-transformer consists of one coil tapped at certain points, dividing it into parts, any part of which can be used as primary or secondary. The ratio depends upon the number of turns in each part.

On account of its simplicity this form of transformer is economical to build, but is hazardous on high voltage and should be used only for small ratios of transformation. The transformation at low ratios is accomplished partly by transformer action; however, at higher transformation ratios more and more of the power is transformed by regular transformer action and less by direct conduction.

**Wire Size.**—After the current in each winding has been obtained the wire size is determined by the number of circular mils per ampere. Generally it is considered safe to use 1,000 circular mils per ampere for transformers of less than 50 watts, and 1,500 circular mils per ampere for larger transformers.

The design, repair and service of radio and electrical apparatus will be greatly facilitated by utilizing the copper wire table shown on the following page. The reader is, therefore, advised to familiarize himself with this time saving wire table, as it is an easy matter by means of it to find the relation between a certain wire gauge and its diameter in mils, area in circular mils, the number of turns per linear inch, resistance in ohms per 1,000 feet of length, etc.

# COPPER WIRE TABLE

Gauge No. B. & S.	Diam. in Mils <sup>1</sup>	Circular Mil Area	Turns per Linear Inch <sup>2</sup>				Turns per Square Inch <sup>2</sup>			Feet per Lb.		Oms per 1000 ft. 85° C.	Current Carrying Capacity at 1600 C.M. per Amp. <sup>3</sup>	Diam. in mm.	Nearest British S.W.G. No.	
			Enamel	S.C.C.	D.S.C. or S.C.C.	D.C.C.	S.C.C.	Enamel S.C.C.	D.C.C.	Bare	D.C.C.					
1	280.3	82690	—	—	—	—	—	—	—	—	3.947	—	.1264	55.7	7.348	1
2	257.6	66370	—	—	—	—	—	—	—	—	4.977	—	.1593	44.1	6.544	3
3	229.4	52640	—	—	—	—	—	—	—	—	6.276	—	.2009	35.0	5.827	4
4	204.3	41740	—	—	—	—	—	—	—	—	7.914	—	.2533	27.7	5.189	5
5	181.9	33100	—	—	—	—	—	—	—	—	9.980	—	.3195	22.0	4.621	7
6	162.0	26250	—	—	—	—	—	—	—	—	12.58	—	.4028	17.5	4.115	8
7	144.3	20820	—	—	—	—	—	—	—	—	15.87	—	.5080	13.8	3.665	9
8	128.5	18510	7.6	—	7.4	7.1	—	—	—	—	20.01	19.6	.6405	11.0	3.264	10
9	114.4	13090	8.8	—	8.2	7.8	—	—	—	—	25.23	24.6	.8077	8.7	2.906	11
10	101.9	10380	9.8	—	9.3	8.9	87.5	84.8	80.0	—	31.62	30.9	1.018	6.9	2.588	12
11	90.74	8234	10.7	—	10.3	9.8	110	105	97.5	—	40.12	38.8	1.284	5.5	2.305	13
12	80.81	6530	12.0	—	11.5	10.9	136	131	121	—	50.59	48.9	1.619	4.4	2.033	14
13	71.96	5178	13.5	—	12.8	12.0	170	162	150	—	63.80	61.5	2.042	3.5	1.828	15
14	64.08	4107	15.0	—	14.2	13.8	211	198	183	—	80.44	77.3	2.575	2.7	1.628	16
15	57.07	3257	16.8	—	15.8	14.7	262	250	223	—	101.4	97.3	3.247	2.2	1.450	17
16	50.82	2583	18.9	18.9	17.9	16.4	321	306	271	127.9	119	119	4.094	1.7	1.291	18
17	45.26	2048	21.2	21.2	19.9	18.1	397	372	329	161.3	150	150	5.163	1.3	1.150	18
18	40.30	1624	23.6	23.6	22.0	19.8	493	454	399	203.4	188	188	6.510	1.1	1.024	19
19	35.89	1288	26.4	26.4	24.4	21.8	592	553	479	256.5	237	237	8.210	.86	.9116	20
20	31.96	1022	29.4	29.4	27.0	23.8	775	725	625	323.4	298	298	10.35	.68	.8118	21
21	28.46	810.1	33.1	32.7	29.8	26.0	940	895	754	407.8	370	370	13.05	.54	.7230	22
22	25.35	642.4	37.0	36.5	34.1	30.0	1150	1070	910	514.2	461	461	16.46	.43	.6438	23
23	22.57	509.5	41.3	40.6	37.6	31.6	1400	1300	1080	648.4	584	584	20.76	.34	.5733	24
24	20.10	404.0	46.3	35.3	41.5	35.6	1700	1570	1280	817.7	745	745	26.17	.27	.5106	25
25	17.90	320.4	51.7	50.4	45.6	38.6	2080	1910	1510	1031	903	903	38.00	.21	.4547	26
26	15.94	254.1	58.0	55.6	50.2	41.8	2500	2300	1750	1300	1118	1118	41.62	.17	.4049	27
27	14.20	201.6	64.9	61.5	55.0	45.0	3030	2780	2020	1639	1422	1422	52.48	.13	.3606	29
28	12.64	159.8	72.7	68.6	60.2	48.5	3670	3350	2310	2067	1789	1789	66.17	.11	.3211	30
29	11.26	126.7	81.6	74.8	65.4	51.8	4300	3900	2700	2607	2207	2207	83.44	.084	.2859	31
30	10.03	100.5	90.5	83.3	71.5	55.5	5040	4660	3020	3287	2534	2534	105.2	.07	.2546	33
31	8.928	79.70	101.	92.0	77.5	59.2	5920	5280	—	4145	2768	2768	132.7	.053	.2268	34
32	7.950	63.21	113.	101.	83.6	62.6	7060	6260	—	5227	3137	3137	167.3	.042	.2019	36
33	7.080	50.13	127.	110.	90.3	66.3	8120	7360	—	6591	4697	4697	211.0	.033	.1798	37
34	6.305	39.75	143.	120.	97.0	70.0	9600	8310	—	8310	6168	6168	266.0	.026	.1601	38
35	5.615	31.52	158.	132.	104.	73.5	10900	8700	—	10480	6737	6737	335.0	.021	.1426	38-39
36	5.000	25.00	175.	143.	111.	77.0	12200	10700	—	13210	7877	7877	423.0	.017	.1270	39-40
37	4.453	19.83	198.	154.	118.	80.3	—	—	—	16660	9369	9369	533.4	.013	.1131	41
38	3.965	15.72	224.	168.	126.	83.6	—	—	—	21010	10666	10666	672.6	.010	.1007	42
39	3.531	12.47	248.	181.	133.	86.6	—	—	—	26500	11907	11907	848.1	.008	.0897	43
40	3.145	9.88	282.	194.	140.	89.7	—	—	—	33410	14222	14222	1089	.006	.0799	44

<sup>1</sup> A mil is 1/1000 (one thousandth) of an inch.

<sup>2</sup> The figures given are approximate only, since the thickness of the insulation varies with different manufacturers.

<sup>3</sup> The current-carrying capacity at 1000 C.M. per ampere is equal to the circular-mil area (Column 3) divided by 1000.

CHAPTER 10

# Broadcasting Stations

## (Transmitting Apparatus)

The essential elements of a small transmitting station are as follows:

1. **Source of Energy.**—(Such as a storage battery, *a.c.* or *d.c.* supply, diesel engine or any other source from which energy might be obtained.)

2. **Microphone Circuit.**

3. **Speech Amplifier Circuit.**—(This is actually one stage of audio amplification.)

4. **Modulator Circuit.**—(The function of the modulator tubes is to force the amplitudes to vary in size according to the characteristics of the audio-frequencies.)

5. **Oscillator Circuit.**—(The function of which is to convert the available energy into the desired form of high frequency current.)

6. **Antenna.**—(From which radio waves emanate. The height of radio transmitting antennas employed vary, and may reach up to 400 feet, as in case of antennas employed by large commercial broadcasting stations.)

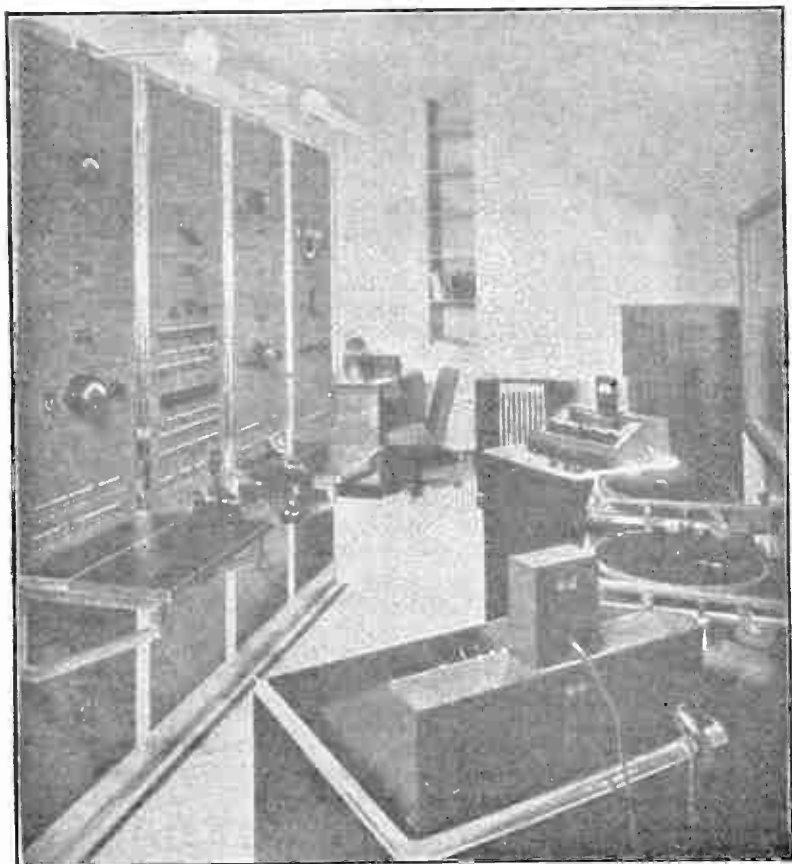

**FIG. 1**—Radio broadcasting station showing speech input equipment and control switchboard. (Courtesy Western Electric Co.)

**General Principles.**—With reference to fig. 3, broadcasting of radio entertainment or programs received by means of radio receivers are generated by various sound waves and generally

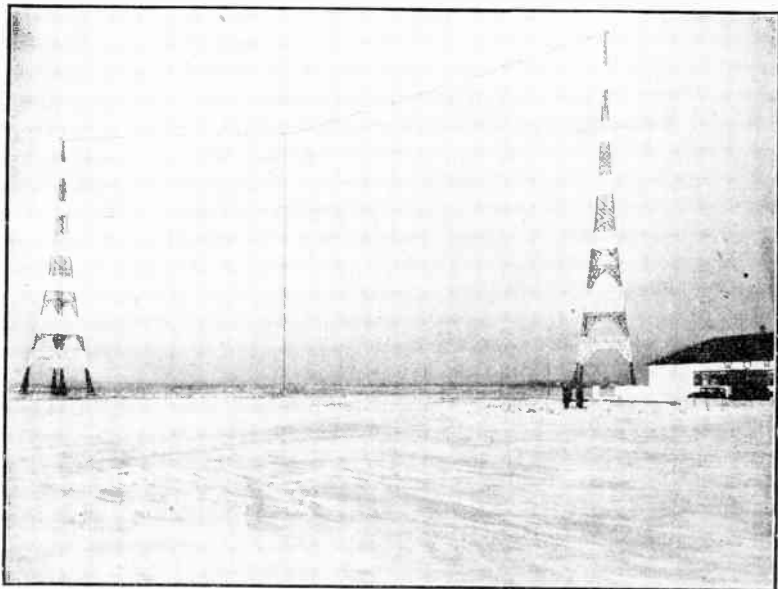

FIG. 2—General view of antenna system of a large transmitting station showing two steel towers each 385 feet high and the transmitter house off to one side. (Courtesy Western Electric Co.)

proceed through the broadcasting equipment in the following manner:

The speaker (1) for example, produces sound which causes air to vibrate in front of the mouth (2) which in turn causes the diaphragm of the microphone (3) to vibrate. The microphone changes the mechanical vibrations into varied electric currents (4); an amplifier (5) amplifies this current as at (6).



## BROADCASTING PRINCIPLES

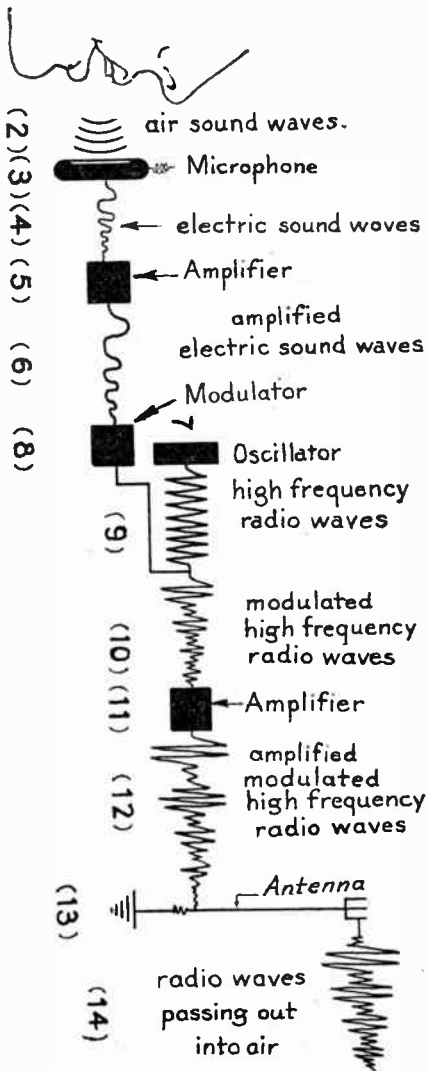

(1) FIG. 3—Schematic illustration of broadcasting principles.

An oscillator or high frequency producing device (7) in the meantime produces radio waves (9) for broadcasting. A modulator (8) modulates or changes these radio waves to travel as sound waves.

The varied currents (6) enter the modulator (8) and cause the radio waves (9) to float out as at (10) conforming to the electric sound waves. An amplifier (11) amplifies the modulated radiowaves as at (12) which enter the antenna (13) and emanates as radio waves into space at (14) to be picked up by receiving antennas.

**Modulation.**—From the foregoing it is obvious that the fundamental principles of broadcasting are essentially those of radio transmission, with the addition of means for combining the speech or music vibrations into regular radio waves.

The process of varying the amplitude of the various radiated waves is known as modulation, of which there are several possible forms, such as:

1. Antenna modulation
2. Grid modulation
3. Plate modulation, etc.

**Antenna Modulation.**—In this method the desired result is obtained by accomplishing changes in the antenna impedance, such as that shown in fig. 4. However, this system is unsatisfactory and hence is not used in practical radio transmission systems.

**Grid Modulation.**—This system is unsuitable for high power transmitters on account of the fact that with a high power output of the oscillator, it is difficult to vary the grid voltage sufficiently to affect modulation, but is employed sometimes in small radio telephone units.

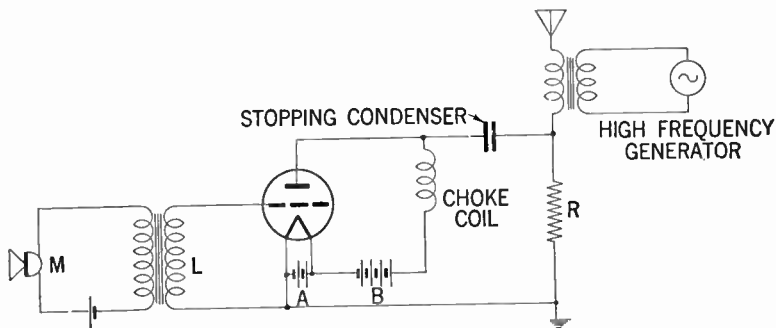

**FIG. 4—Antenna modulation system.** The functioning of this system is substantially as follows: When the diaphragm associated with the microphone (*M*) is set in motion by a sound wave, there will be induced a potential corresponding to the sound pattern in coil *L*, which in turn causes the grid potential and the internal plate resistance of the tube to fluctuate accordingly. As a consequence of this change, the equivalent resistance of the antenna circuit denoted by resistance (*R*) will also be varied according to the pattern of the sound wave actuating the diaphragm, finally causing a change in the radio frequency current sent out by the antenna.

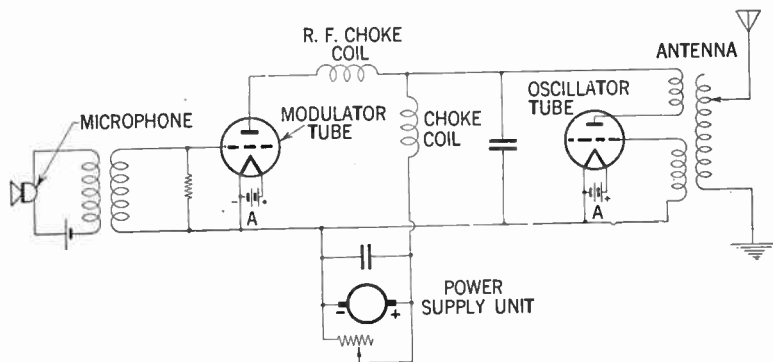

**FIG. 5—Circuit diagram showing essential elements for accomplishing plate modulation.** In practical installations two or more stages of power amplification is usually interconnected between the microphone circuit and the modulation tube.

**Plate Modulation.**—Modulation by this system, sometimes known as the *Heising modulation method* is accomplished by varying the power input of the plate of the oscillator. (See fig. 5.) On account of the fact that this system has been found much more efficient than others, it is extensively employed in high power stations.

From a study of fig. 5, it will be seen that the plate potential of both the oscillator and the modulator tube is supplied from a common source through a choke coil which has such a large inductance that neither the radio nor the audio frequency current can pass through it.

The *RF* choke coil in the plate circuit of the modulator tube now prevents the modulator tube from operating as a by-pass for *RF* currents, but permits *AF* currents to flow through the circuit.

When talking into the microphone the grid potential of the modulator is varied, and hence also the modulator plate current, and the amplitude of the radio frequency oscillations varies accordingly.

To obtain the best possible results, it is desirable that for speech or music of considerable intensity, the amplitude of the *RF* oscillations shall have maximum variation from zero to double the amplitude corresponding to no speech.

**How a Vacuum Tube Oscillator Works.**—A vacuum tube may be used as a generator of high frequency voltage and when so used, it is called an oscillator.

When the vacuum tube is used as an oscillator the *A*, *B* and *C* batteries form the source of energy and the tube is connected to the oscillatory circuit so that there is a coupling between the grid circuit and the oscillator circuit, and also between the plate and the oscillatory circuit as shown in fig. 6.

The operation is fundamentally as follows: With switch  $S$  open and  $S'$  closed, the  $B$  battery sends out a steady current through the choke coil and the internal plate circuit.

Condenser  $C$  prevents this *d.c.* current flowing through coil  $L$ , when  $S$  is closed, thus preventing discharge of the  $B$  battery through coil  $L$ , and also making the reactances of the circuit  $LC$  to radio frequency current low.

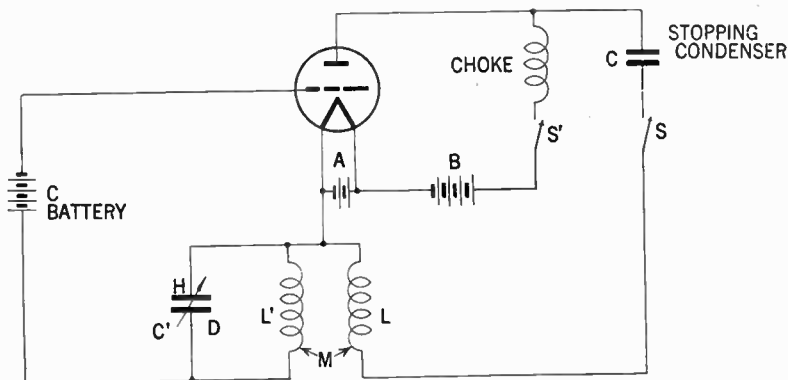

FIG. 6—Modified Hartely type oscillator circuit.

When  $S$  is closed a surge in current takes place via condenser  $C$  and coil  $L$ , which is absorbed from the internal plate circuit. Since the choke maintains the battery current steady, the variable current through coil  $L$  induces a voltage in coil  $L'$ .

Assuming the induced voltage is such as to cause a surge of current down through coil  $L'$ , the condenser  $C'$  would be charged with the plate  $D$ , positive. The voltage across this condenser would then be in opposition to the original grid bias, and would consequently make the grid less negative than before.

This decrease in negative grid voltage would effect an increase in the internal plate current.

Because of the choke coil in the battery circuit, the increased current must flow down through coil  $L$ , and up through the condenser  $C$ , which in turn would induce a voltage in the coil  $L'$ , causing a surge of current up through this coil and charging the condenser  $C'$  with the plate  $H$ , positive.

Now, the voltage across the condenser  $C'$  aids the original grid bias and results in an increased negative grid voltage and therefore the current from plate to the filament is decreased again, with the resulting surge of current down through  $C$ , and up through  $L$ , which induces a voltage in  $L'$  and so the cycle is repeated indefinitely.

**Oscillating Plate Current Characteristics.**—On account of the amplifying action of the vacuum tube, the alternating voltage across the grid condenser  $C'$  (fig. 6), during a given cycle would result in an increased alternating voltage across the coil  $L$ , in the plate circuit, and consequently with sufficient close coupling between  $L$  and  $L'$ , the voltage induced in coil  $L'$ , would be greater than that which previously existed across the condenser  $C'$ .

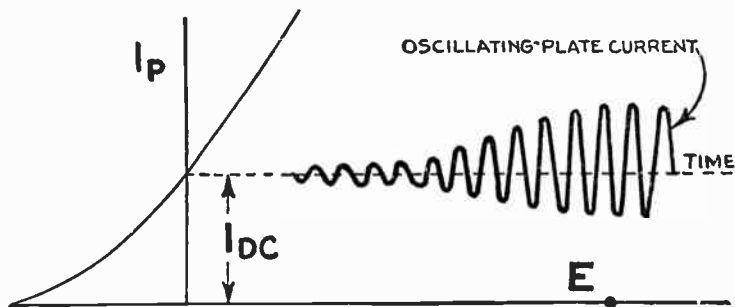

FIG. 7—Oscillating plate current characteristics.

For this reason the amplitude of each cycle would be greater than that of the preceding cycle, and the oscillations of the plate current would continue to increase until the instantaneous values of the plate current varied between some maximum or some minimum determined by the coupling and the circuit constants. The form of this oscillating plate current is shown in fig. 7.

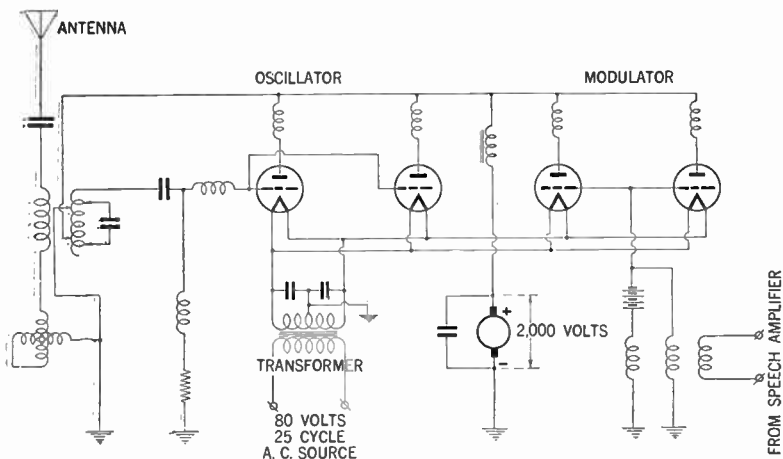

FIG. 8—Simplified schematic circuit diagram of a broadcasting station.

**Power Supply.**—Generally high power radio broadcasting stations receive alternating current of low voltage. This current is stepped up or transformed to high voltage, and then rectified by special designed vacuum tubes, known as *mercury-vapor rectifiers*.

These tubes when used in connection with large capacity stations, are of considerable size and may be mounted and interconnected, as shown in figs. 10 and 9.

The mercury vapor rectifier tubes are designed for use in high voltage devices and will supply high voltage *d.c.* power at uniform voltage, which in some instances may reach up to 20,000 volts.

Other large water-cooled vacuum tubes are connected as oscillators producing the high frequency carrier current.

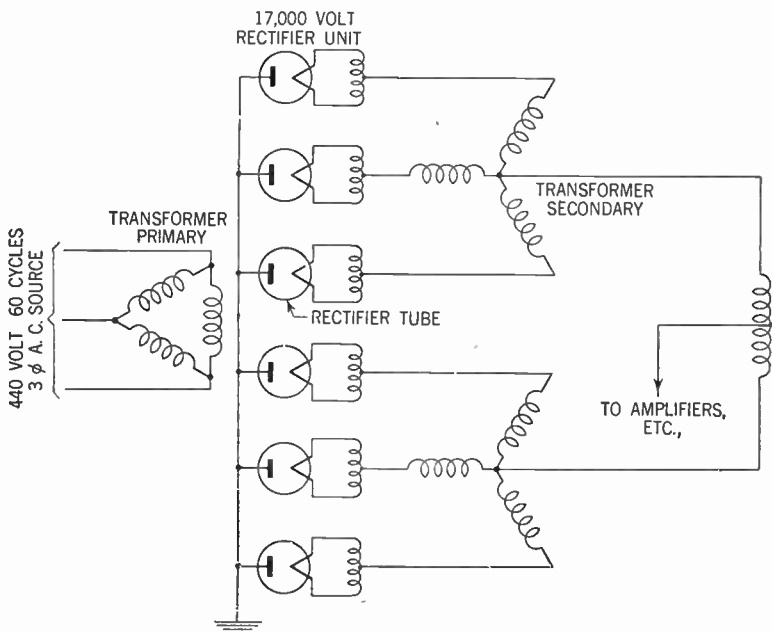
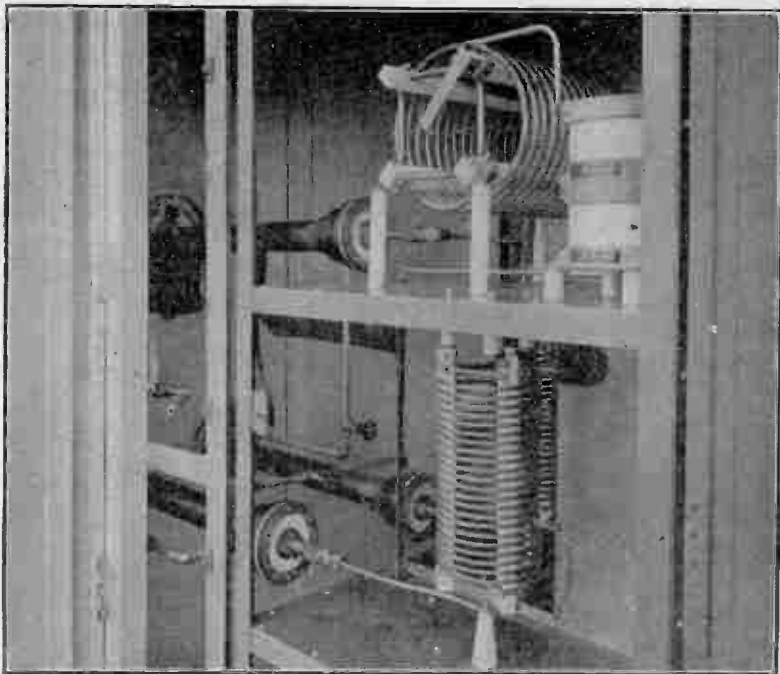

FIG. 9—Showing the incoming line of 3-phase alternating current. When properly rectified this system provides a smoother *d.c.* current than that obtained by single phase rectification. The rectifiers deliver an output direct current of 17,000 volts.





**FIG. 10—View of 17,000 volt rectifier tube unit installation. (Courtesy Western Electric Co.)**



**FIG. 11**—Interior view of coupling house showing details of network through which the concentric transmission line branches three ways—each branch feeding a separate antenna.

**How Crystal Oscillators Work.**—The operation of crystal controlled oscillators depends upon the so called Piezo-electric effect in quartz crystal.

Among the many uses of crystals in radio oscillator circuits is that of a master oscillator or primary frequency standard, controlling the frequency of radio transmitting stations output, as standard for instrument manufacturers, etc.

The natural crystal of quartz is in the shape as shown in fig. 12. The axis parallel to the lengthwise natural edges is called the

optic axis, and the axis perpendicular to the natural edges is called the electrical axis. There is also a third axis perpendicular to the other two which in the figure is designated as the *B* axis.

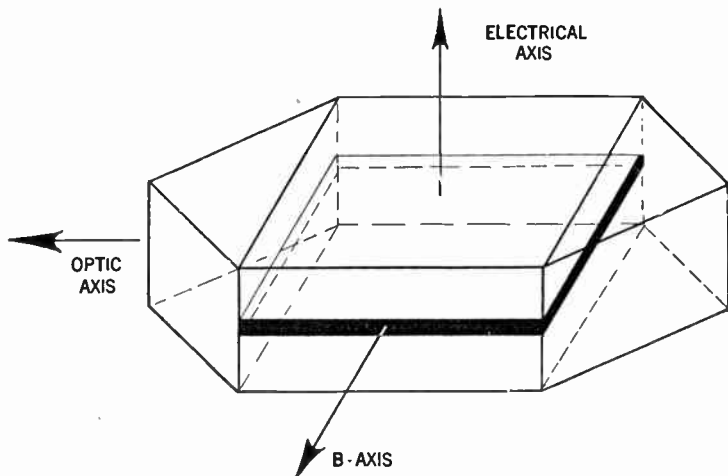

FIG. 12—Natural quartz crystal.

Considering a crystal shown in fig. 12 with the black volume removed and mounted as shown in fig. 13 it has been found that this slab if subjected to an electric pressure of proper sign along its electric axis, the crystal expands along this axis and contracts along the *B* axis. The reversal of the electrical pressure causes a reversal of these expansions and contractions.

It has also been found that when subjected to mechanical pressure tending to contract it along the *B* axis and expand it along the electrical axis, an electromotive force is developed in the crystal along its electrical axis. The electromotive force so developed is opposite in sign to the external electric force which would have produced a corresponding expansion and contraction of the crystal. Hence if an alternating electromotive force

is impressed across the crystal as shown in fig. 14 the crystal will expand and contract along its vertical axis and at the same time contract and expand along its horizontal axis.

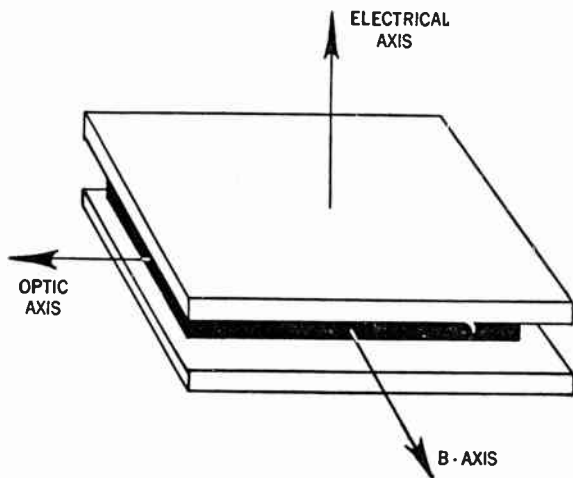

FIG. 13—Mounting of the crystal.

It is a well known fact that a body capable of mechanical vibrations, has a certain natural frequency of vibration, and so the crystal in this instance has a certain natural frequency of expansion and contraction along the vertical axis and some other natural frequency along its horizontal axis, and each one of these frequencies depends upon the actual dimensions of the crystal itself.

The thicker the crystal be cut the lower the frequency to which it will vibrate. From the above it will be readily understood that the manner of cutting crystal is of paramount importance, not only in regard to its thickness, but also to its optical axis.

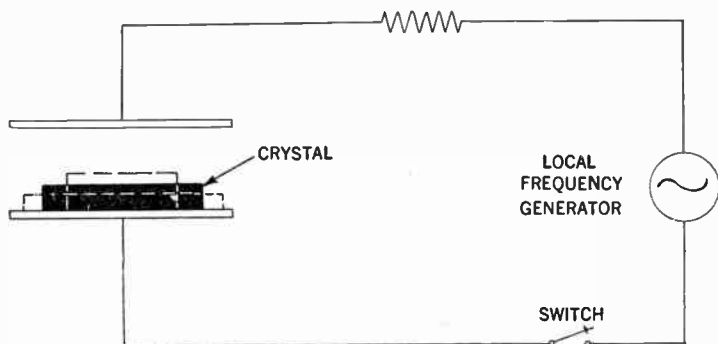

FIG. 14—Illustrating the action of crystal when an electro-motive force is applied.

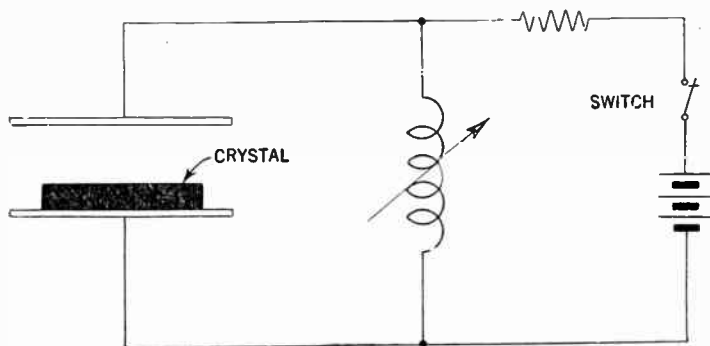

FIG. 15—Crystal oscillator circuit. When a crystal is connected as shown, and the switch be closed for a short period, the condenser formed between the plates of the crystal mounting will be charged, thus subjecting the crystal to an electrical strain, which causes the crystal to expand along the vertical axis and contract along the horizontal axis. When the switch is opened, the electrical strain on the crystal will be relieved and so will tend to return to its previous form, on account of its mechanical properties. However, the crystal will vibrate at one of its own natural frequencies during a short period. The particular one of the two frequencies is dependent upon the constant of the circuit and may be adjusted from one to the other by adjusting the inductance.

## CHAPTER 11

# Principles of Radio Telephony

Radio telephony may be defined as the transmission to a distance of speech, music and other sounds through space without wire, by means of electro-magnetic waves.

In the standard system of radio telephony continuous waves are used of much higher frequency than those of audible sounds. The amplitude of those waves is modulated by the connection of a microphone in the transmitting circuit.

Receiving apparatus are similar to those employed in radio telegraphy and are designed so that the head set or loud-speaker responds to the modulated waves and reproduces the sound as originally sent in through the transmitter.

As radio telephony is principally a combination of the principles of vacuum tube transmitters and wire telephony, there is actually no real boundary line between commercial concerns engaged in telephone broadcasting and telephone companies, hence radio companies are using telephone lines for long distance relaying and telephone companies have installed broadcasting stations.

A most useful service of the radio telephony is by means of communication between ships at sea and between ships and shore. On large passenger lines, commercial telephone stations are now in operation, and telephone extension service may also be had from numerous harbor tugs, pilot boats and private yachts.

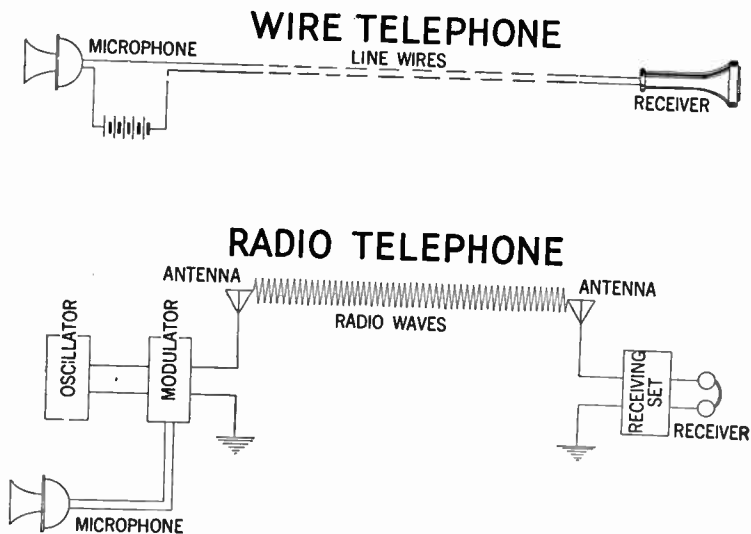

FIG. 1—Diagrammatic representation illustrating similarity between wire and radio telephone.

It is thus possible for the personnel of the above to communicate with their offices or homes when within range of a coastal harbor radio telephone station. At present radio telephone service is available to boats in the areas served by the shore stations at Boston, New York, Miami, Seattle, San Francisco, Los Angeles and Norfolk.

In this connection it may be mentioned, that the regulation of the Federal Communication & Commission permits the operation of *low power* radio telephone equipment on boats, not compulsorily equipped by persons holding a radio telephone third

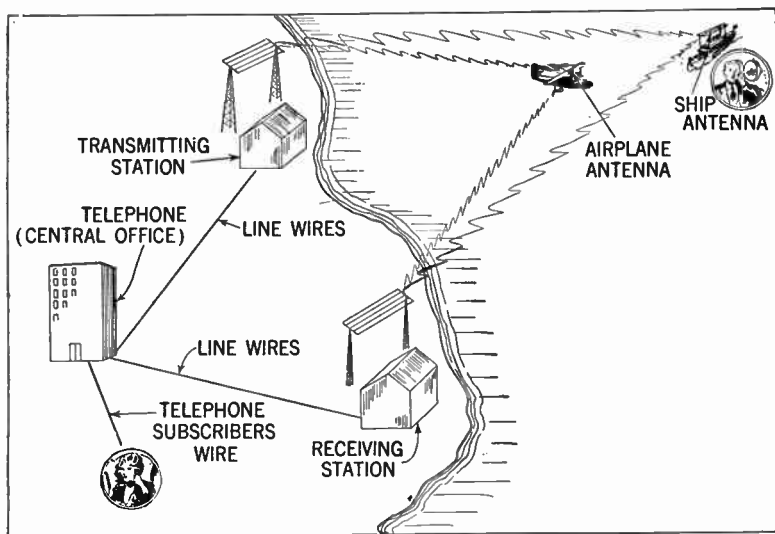

FIG. 2—Schematic diagram showing voice communication between *ship or aircraft and shore*, by means of radio telephony.

class operator's license. The Captain or a member of the crew may obtain this license by passing an examination prescribed by the F.C.C. requiring only knowledge of the radio laws and regulations applicable to this service, and familiarity with the method of operation of this type of equipment. A knowledge of the radio telegraph code is not required.



A typical marine radio telephone set of type shown in fig. 3 consists of the following:

1. Radio receiver
2. Radio transmitter
3. Selector set which operated on tone signals from the output of the receiver
4. Control unit equipped with handset receiver
5. Power unit consisting of two dynamotors.

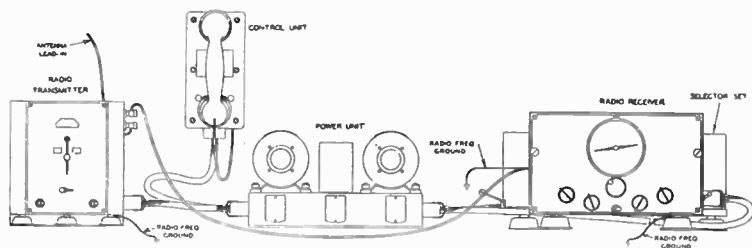
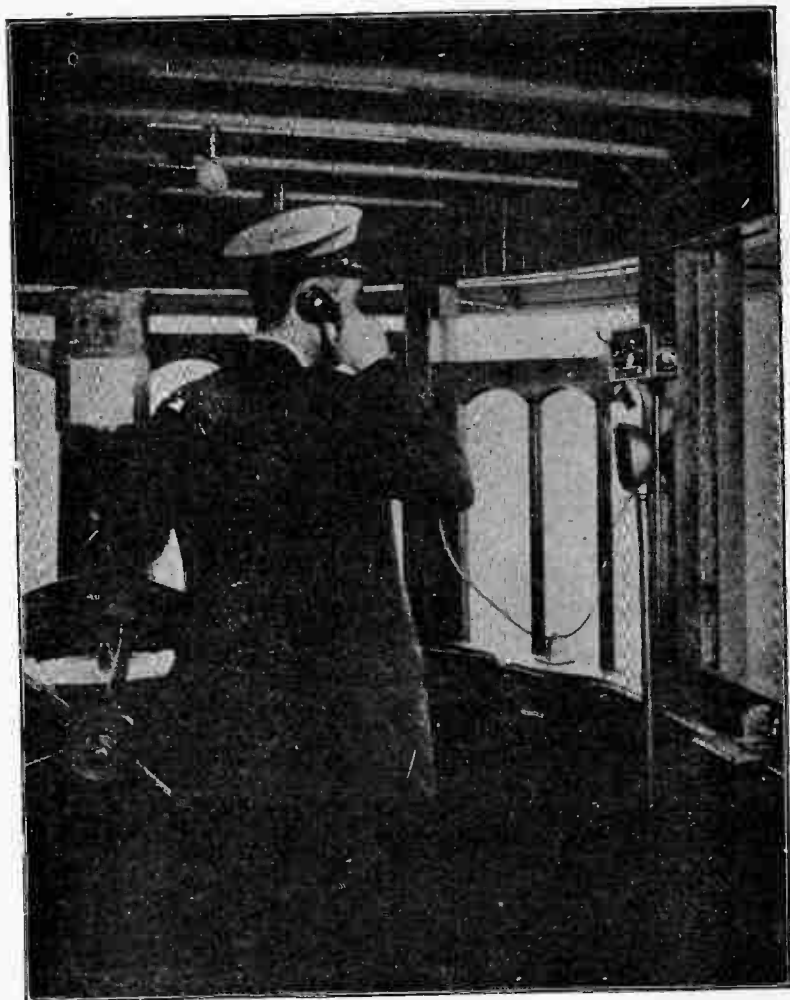

FIG. 3—Marine Radio Telephone equipment. (Courtesy Western Electric Co.)

One of the dynamotors is to supply power to the radio transmitter while the other provides for the receiver. Both dynamotors operate from a 12 volt storage battery. A 110 volt generator can be used if this source of power is available.

The one disadvantage with radio-telephony is that the message may be intercepted by outsiders. However, this lack of secrecy has been successfully attacked by various scientists and may eventually be put to use by commercial firms handling the messages.



**FIG. 4—Marine Radio Telephone Control equipment within easy reach of the pilot. (Courtesy Western Electric Co.)**

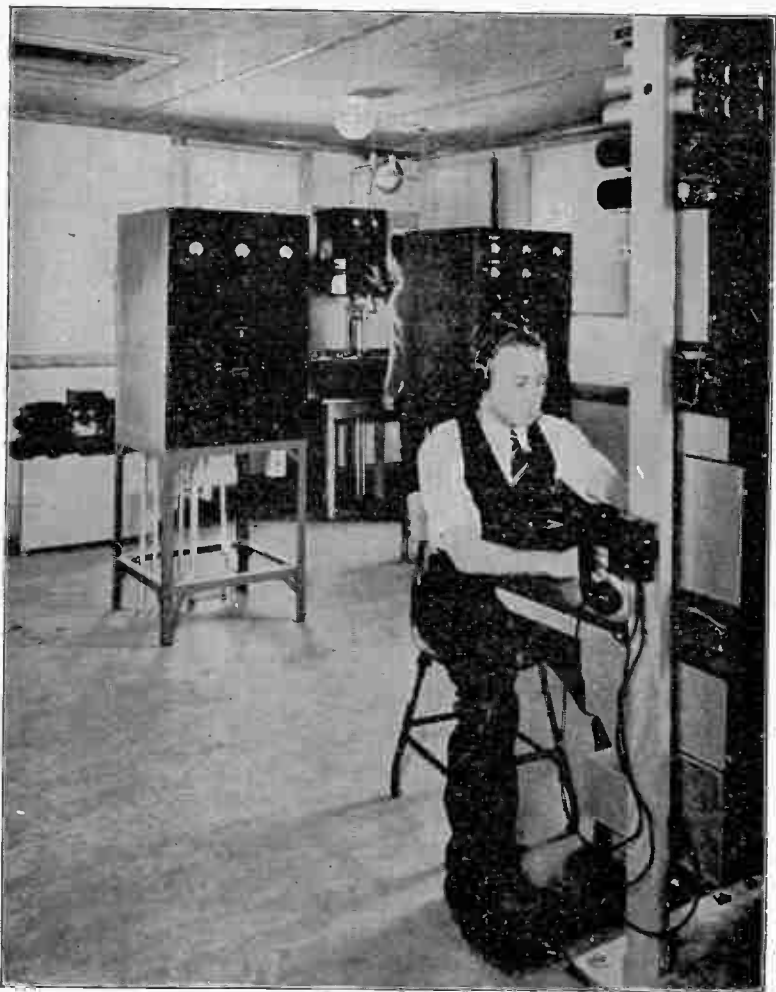

**FIG. 5—Interior view of typical marine radio telephone station. (Courtesy Western Electric Co.)**

## CHAPTER 12

# Vacuum Tubes

**Vacuum Tubes.**—A vacuum radio tube in its simplest form is somewhat similar to an electric light bulb, but contains a number of metallic elements for various purposes for use in conjunction with radio transmission and reception. The parts of a typical vacuum tube is shown below.

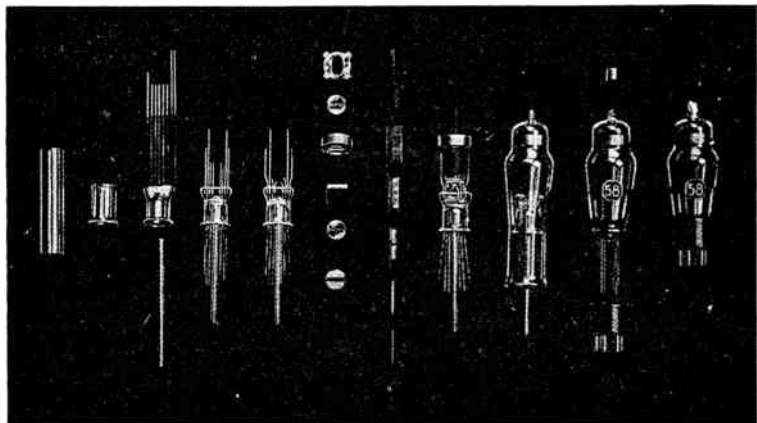

FIG. 1.—Parts and assembly of a typical glass radio tube. The filament, grid screen and plate are sealed in the tube, from which the air has been removed. (Courtesy R.C.A. Mfg. Co.)

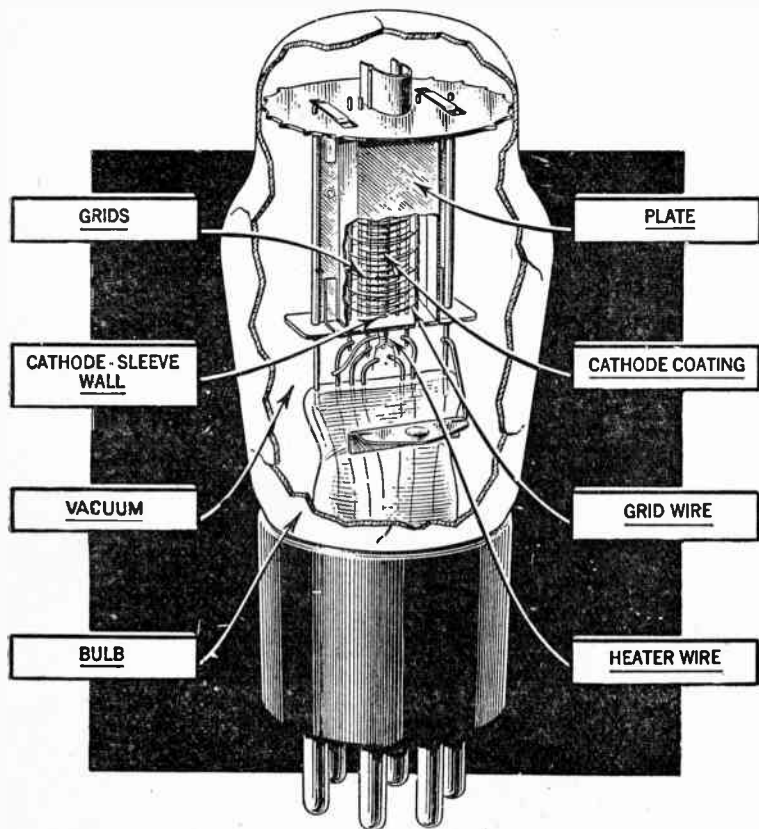

FIG. 2.—Internal structure of a glass radio tube. There is at present a great number of tubes utilized for various requirements. In radio applications they are used for amplifying radio waves; for converting radio waves to sound waves; for converting alternating current to direct current, etc. (Courtesy R.C.A. Mfg. Co.)

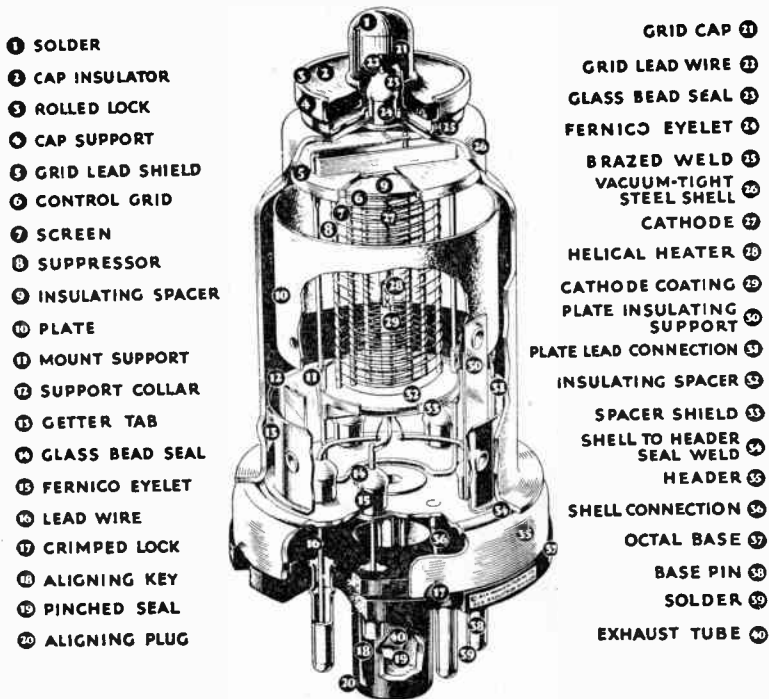

FIG. 3.—Inside view of a metal radio tube. The inside parts are similar to those of a glass radio tube. The housing of the parts consists of metal, which has certain advantages to that of the glass in required electrical shielding. These types of tubes generally are smaller and have a central guide pin projecting from the base for easy insertion in the sockets, and are therefore not as a rule interchangeable with glass tubes. (Courtesy R.C.A. Mfg. Co.)

**Purpose of Vacuum Tubes.**—The general purpose of a vacuum tube is to detect and amplify radio waves; for changing alternating current into direct current; for producing oscilla-

tions or rapid electrical pulsations; for changing an electric current of one degree of pulsation to those of another, and for innumerable other purposes.

**Materials Used in Vacuum Tubes.**—The materials used for housing the elements of a vacuum tube may be glass or metal—sometimes a combination of the two. The essential difference between metal and glass tubes is that the metal tubes as a rule are smaller, and have a central guide pin for insertion in the sockets and hence they are not readily interchangeable with one another.

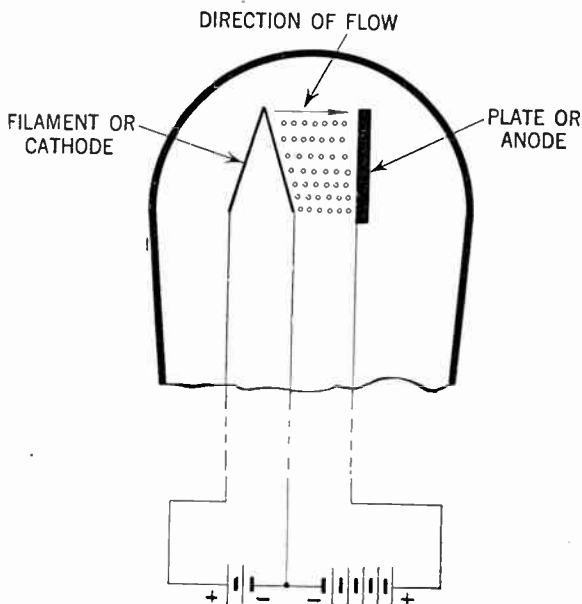

FIG. 4.—Illustrating the flow of electrons in a vacuum tube.

**Principles of Operation of Vacuum Tubes.**—In any electronic tube, thinny electrical charges called electrons jump from a heated metallic surface, in a vacuum, to another metallic surface and cause current to flow between the two when connected together as shown in fig. 4. This current flow is always *one-directional* in that it will flow in *one direction only*—never in the reverse.

To produce such a flow of electrons, which constitutes an electric current the following fundamental requirements must be obtained:

1. There must be a continuous source of supply for the *cathode* which produces the current flow.
2. It must be maintained at the high temperature necessary for the dissipation of electrons from it.
3. To produce this continuous flow of electrons a force must be supplied to transfer them through space.

Now, as the electrons consist of infinitely small negative charges of electricity, it is evident that they are attracted to a positively charged body and repulsed by a similarly or negatively charged substance. (See page 27.)

Hence if a second *element* (anode) be added within the vacuum enclosure and in addition be maintained at a positive potential with respect to the cathode, it will in accordance with the above reasoning, attract the negatively charged electrons to it and at a rate which is dependent upon the rate at which they are supplied by the cathode.

In its simplest form therefore a vacuum tube consists of two electrodes—a *cathode* and an *anode* (sometimes referred to as filament and plate), the former emitting or discharging the electrons and the latter acting as a collector of electrons. When this condition exists the vacuum tube is called a *diode* or *two-electrode* vacuum tube.



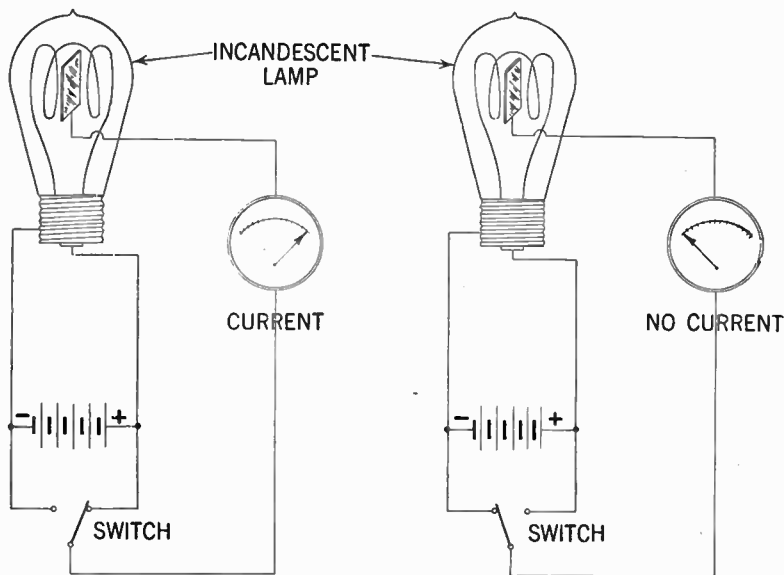

FIG. 5.—Shows how a current will be registered by the galvanometer when the switch is connected to make the insulated plate positive. The current flow, however, will cease when the plate is made negative—the switch connects the insulated plate with the negative terminal of the filament.

**Electron Emission.**—The phenomenon that electrons can be made to leave a conductor when properly stimulated to do so as in the case of a radio vacuum tube, is called *thermonic electron emission*, sometimes called only electron emission.

The electron emission also known as the *Edison effect* was found by the famous inventor in his early experiments with the incandescent lamp sometime before 1890.

Edison observed that when a metal plate was sealed inside a lamp bulb so that it was between and separated the two sides

of the carbon filament, but was entirely insulated electrically from the filament, that an electric current flowed through a galvanometer when connected between the *outside* terminal of the metal plate and the *positive* terminal of the filament.

When on the other hand, the connection was reversed, and the galvanometer connected between the negative terminal of the filament and the outside terminal of the plate, the current flow stopped.

Although this phenomena was known at this early date, its availability could not be utilized, due to the absence of the *vacuum tube*. It was only after discovery of the vacuum tube by Prof. J. A. Fleming and Dr. De Forest that this perhaps greatest invention in the twentieth century could be made serviceable.

The flow of current can be amplified by small voltage changes, the control of all changes is very marked and instantaneous in action—there being no lagging, also the electricity utilized or generated can be almost limitless in their number of pulsations.

This current flow or movement of electrons may be accelerated by increasing the temperature of the conductor. Once free, most of the emitted electrons, in a vacuum tube make their way to the plate, but others return to the cathode, repelled by the cloud of negative electrons immediately surrounding the cathode. This cloud of electrons surrounding the emitting cathode is known as the *space charge*.

A few of the electrons that reach the plate may have sufficient velocity to dislodge one or more electrons already on the plate. The dislodging of those electrons from the plate by other fast moving electrons are called *secondary emission*.

When this occurs there is actually a simultaneous electron flow in two directions.

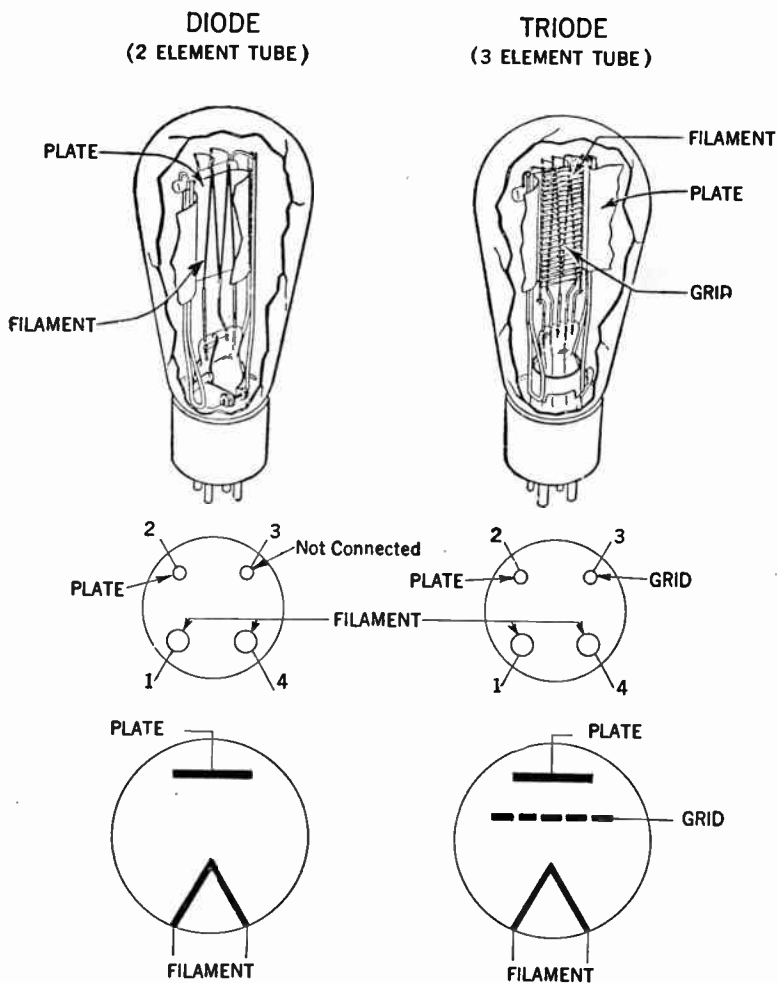

FIG. 6.—Views of two and three element vacuum tubes showing arrangement of prongs and wiring symbols.

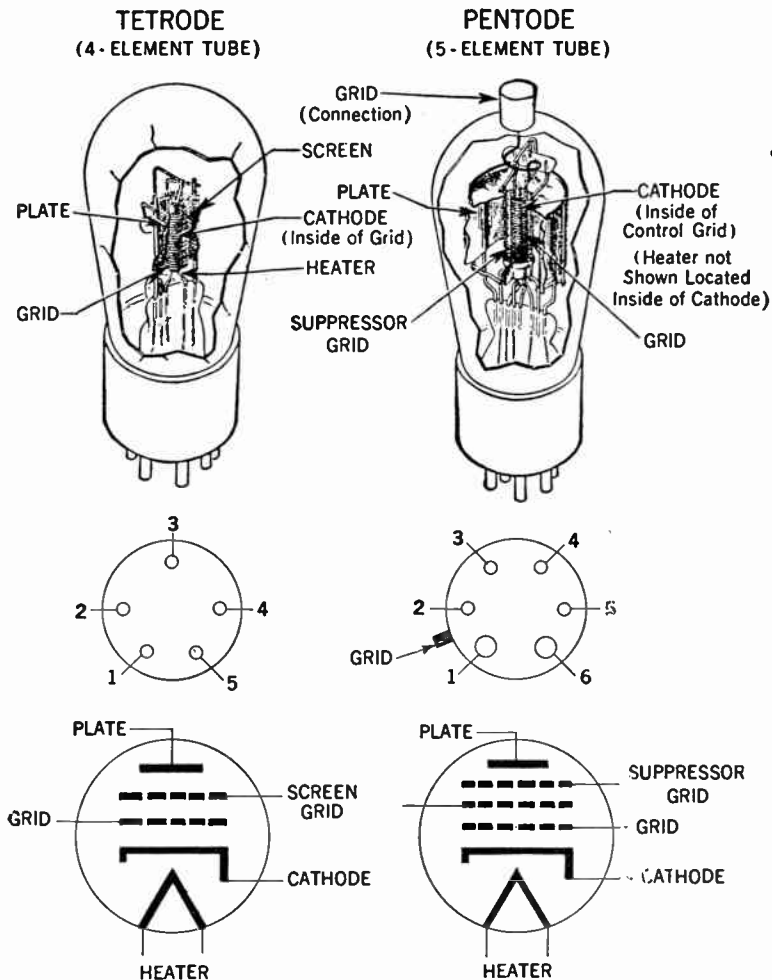

FIG. 7.—Views of four and five element vacuum tubes, showing arrangement of prongs and wiring symbols.

**Vacuum Tube Fundamentals.**—By definition a vacuum tube consists of a cathode, which supplies electrons and one or more additional electrodes whose function it is to control and collect these electrons, mounted in an evacuated envelope. This envelope may consist of a glass bulb or it may be the more compact and efficient metal shell.

The outstanding properties of the vacuum tube lie in its ability to control almost instantly the motion of millions of electrons supplied by the cathode. On account of its almost instantaneous action the vacuum tube can operate very efficiently and accurately at electrical frequencies far above those obtainable with rotating machinery.

As previously stated the electronic movement may be accelerated by the supply of additional energy in form of heat. When the temperature of a metal becomes hot enough to glow, the agitation of the electrons becomes sufficiently great to enable a certain amount of them to break away from the metal, it is this action which is utilized in the radio tube to produce the necessary electron supply.

**The Function of the Cathode.**—A cathode is that part of a vacuum tube which supplied electrons which are essential for its operation. All cathodes in vacuum tubes are universally heated by electricity. The method of heating the cathode may be used to distinguish between the different forms.

The simplest form of a cathode is in the form of a wire or ribbon, heated directly by the passage of current through it as in (b) and (c) fig. 8. Radio tubes having such filaments for cathodes are sometimes referred to as *filamentary tubes*

to distinguish them from tubes having indirectly heated cathodes.

A common arrangement of an indirectly heated cathode is shown in fig. 8 (a). Here the cathode consists of a metallic cylindrical sleeve, usually of nickel, coated with a mixture of barium and strontium oxides. This oxide coating is used on

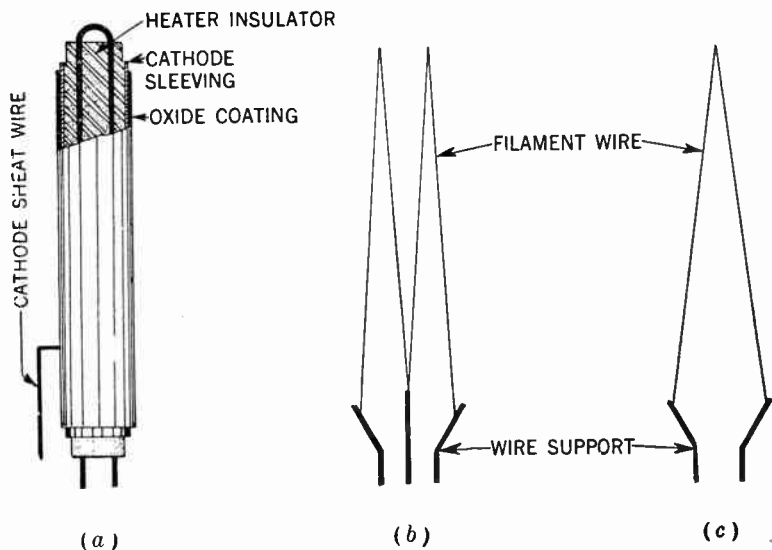

FIG. 8.—Schematic diagram of directly and indirectly heated cathodes.

account of their property to greatly increase the electron emission at a given temperature.

A lead wire from the cathode sheath is carried out to an external tube terminal in order that the cathode may be maintained at any desired potential.

The heater wire consists usually of tungsten and may be in the form of a spiral or as in the illustration, in the form of a hairpin threaded through parallel tubular holes in a ceramic insulator. Tubes having cathodes of this type are referred to as **heater type tubes**.

The heaters may be operated on either direct or alternating current. The one disadvantage of using alternating current

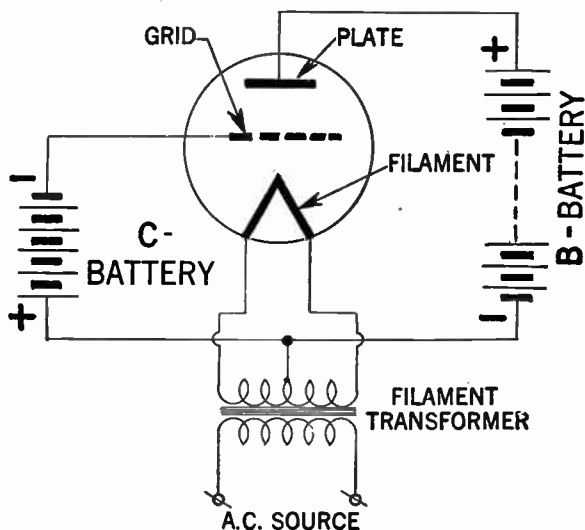

FIG. 9.—Diagram of connection to a triode employing a filament transformer.

for the filament of tubes used in audio-frequency circuits, is that it introduces objectionable hum in the output.

This hum may be lessened by connecting the plate and the grid circuits to the midpoint of the secondary of the trans-

former, as shown in fig. 9. Generally, however, it is not possible to use alternating current in the filament of tubes used in the early stages of high-gain amplifiers.

**Classification of Tubes.**—Tubes are usually classified according to the number of electrodes present, so for example a two-element tube is called a *diode*; a three-element tube a *triode*, and so on to tetrodes and pentodes. A pentode therefore is a tube having five elements. See pages 228 and 229.

Tubes may also be classified according to whether there be high vacuum, gas or an element which vaporizes in the bulb.

**Diodes.**—From the foregoing it is evident that electrons are of no value in a tube unless they can be controlled or made to work according to a pre-determined schedule. The very simplest form of tube consists of two electrodes—a cathode and a plate, and is most often referred to as a *diode*, which is the family name for two-electrode tubes.

In common with all tubes, the electrodes are enclosed in an evacuated envelope with the necessary connection projecting out through airtight seals. The air is removed from the envelope to allow free movement of the electrons and to prevent injury to the emitting surface of the cathode. If the cathode be heated, electrons leave the cathode surface and form an invisible cloud in the space around it. Any positive electric potential within the evacuated envelope will offer a strong attraction to the electrons.

In a diode, the positive potential is applied to the second electrode, known as the anode, or plate. The potential is supplied by a suitable electrical source connected between the



plate terminal and a cathode terminal. See fig. 10. Under the influence of the positive plate potential, electrons flow from the cathode to the plate and return through the external plate-battery circuit to the cathode, thus completing the circuit. This flow of electrons is known as the plate current and may be measured by a sensitive current indicator.

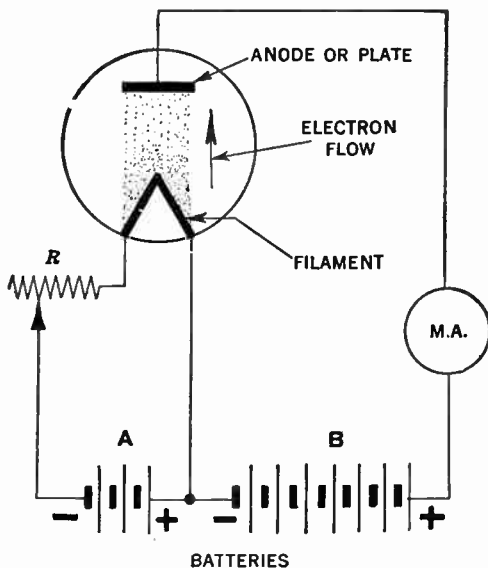

FIG. 10.—Connection diagram for a two electrode tube.

**The Diode as a Rectifier.**—It is obvious that under no conditions can the current flow from the plate to the cathode, i.e., the tube is as far as the direction of the current is concerned a one-way proposition. Increasing the positive potential will

of course increase the flow of electrons from cathode to plate and consequently increase the current flow in the plate circuit, but if the plate is made negative instead of positive it will repel the electrons and no current will flow.

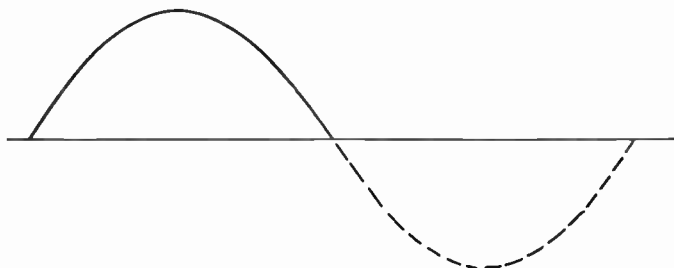
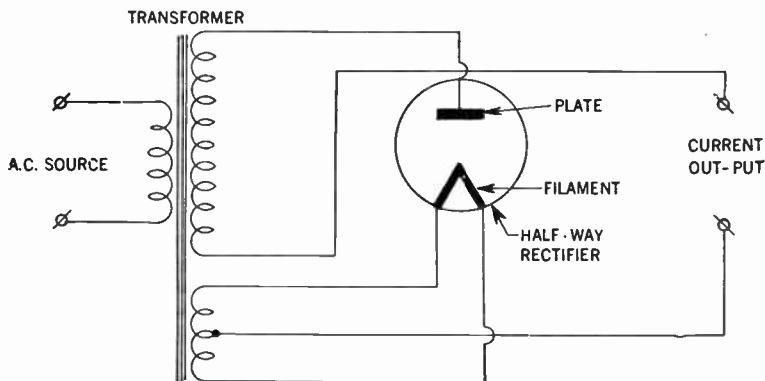

FIG. 11.—Connection diagram of the half-wave rectifier. The rectified current is depicted on the upper half of the wave diagram.

The diode therefore acts as an *electrical valve* that will permit current to flow in one direction, but not in the other. It is

this characteristic of the diode that has been utilized as a means of converting or rectifying an alternating current into a direct current.

The diode is therefore commonly used as a signal rectifier or detector in a radio receiver, and as a power rectifier in the unit employed to change the *a.c. house current* into a direct current for the operation of home receivers or transmitters.

Diode rectifiers may have one plate and one cathode and are as such called *half-wave rectifiers*, (See fig. 11) since as stated the current can flow only during one-half of the alternating current cycle.

**Full Wave Rectifier.**—If two plates and one or more cathodes are used in the same tube, current may be obtained during both halves of the alternating current cycle as shown in fig. 12. The tube is then called a *full wave rectifier*. If as in the diagram shown the rectifier tube be connected to a power transformer, the primary of which is connected to a 110 volt a.c. source, then the disposition of the voltage developed in the secondary of the transformer winding will be such that the center tap will be at zero voltage with respect to terminals 1 and 2, and during the period terminal 1 is positive, terminal 2 will be negative.

Therefore plate  $P_1$  will draw current while plate  $P_2$  is idle and vice versa. In this manner both the positive and the negative half of the alternating current cycle are utilized and the resultant output current consists of a series of unidirectional pulses with no spacing between them as shown in the lower part of fig. 12. These unidirectional pulses may be further smothered by insertion of filters consisting of inductive and capacitive

reactances interconnected to the output terminals of the rectifying system.

**Space Charge Effect.**—Not all of the electrons emitted by the cathode reach the plate. Some return to the cathode while

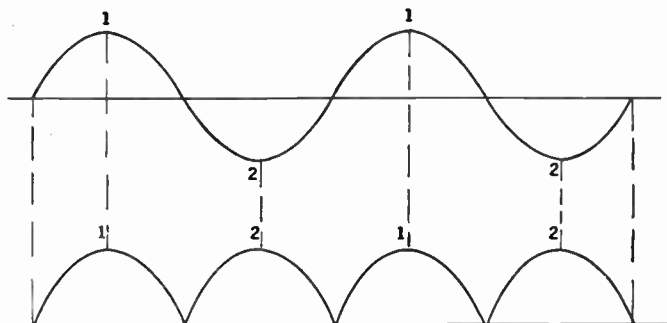
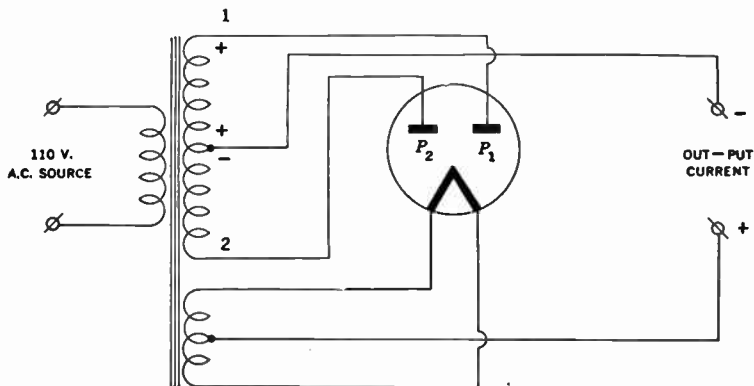

FIG. 12.—Connection diagram and depiction of the action of a full-wave rectifier tube.

others remain in the space between the cathode and plate for a brief period to form an effect known as *space-charge*. This charge has a repelling action on other electrons which leave the cathode surface and impedes their passage to the plate. The extent of this action and the amount of space-charge depend on the cathode temperature and the plate potential.

**Plate voltage vs. Plate current relationship of a diode.**—The higher the plate potential, the less is the tendency for electrons to remain in the space-charge region and repel others. This effect may be noted by applying increasingly higher plate voltages to a tube operating at a fixed heater or filament voltage. Under these conditions, the maximum number of available electrons is fixed, but increasingly higher plate voltages will as previously stated succeed in attracting a greater proportion of the free electrons.

Beyond a certain plate voltage, however, additional plate voltage has little effect in increasing the plate current. The reason is that all of the electrons emitted by the cathode are already being drawn to the plate. This maximum current is called *saturation current*, and because it is an indication of the total number of electrons emitted, it is also known as the *emission current*. See fig. 13.

Tubes are sometimes tested by measurement of their emission current. However, in this test it is generally not feasible to measure the full value of emission because this value would be sufficiently large to cause change in the tube's characteristics, or to damage the tube. For that reason, the test value of current in an emission test is less than the full emission current. However, this test value is larger than the maximum value which will be required from the cathode in the use of the tube.

The emission test, therefore, indicates whether the tube's cathode can supply a sufficiently large number of electrons for satisfactory operation of the tube.

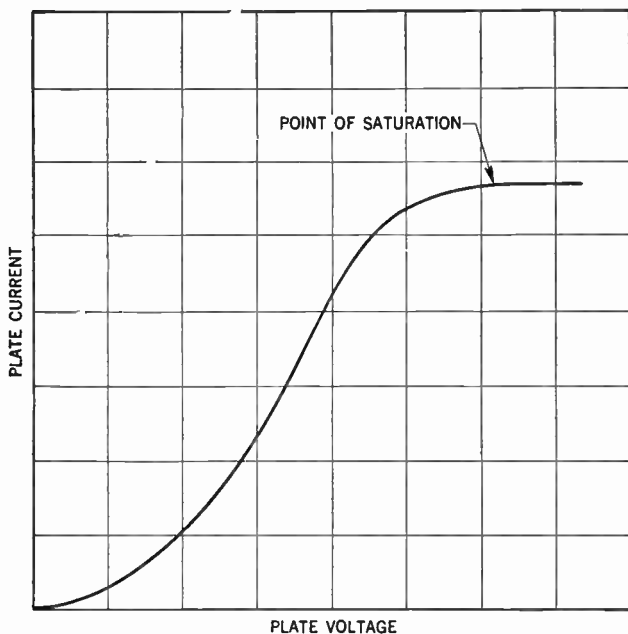

FIG. 13.—Characteristic curve of a diode.

**Triodes.**—The triode or three electrode tube is principally a two-electrode tube in which a third electrode, called the *grid*, is placed between the plate and the cathode. See fig. 14.

The grid consists usually of a mesh of fine wire extending the full length of the cathode. The spaces between the turns of

the wire constituting the grid are comparatively large, so as not to impair the passage of the electrons from the cathode to the plate.

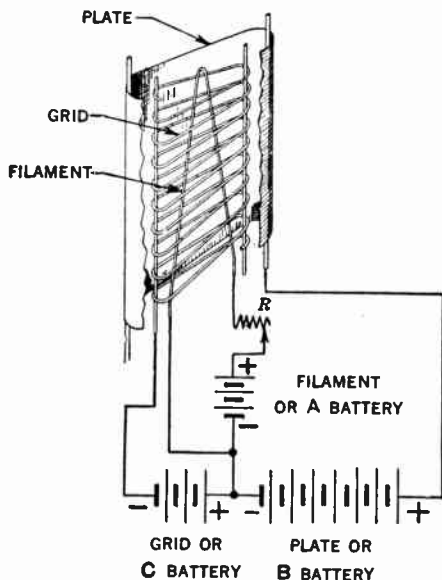

FIG. 14.—Schematic diagram showing triode connection to battery.

**Grid Function.**—The function of the grid is to control the plate current. By maintaining the grid at a negative potential, it will repel electrons and will in part, but not altogether, neutralize the positive or attractive force exerted upon them by the positive plate. Hence, a stream of electrons will flow from the grid to the plate, although smaller than it would be if the negative grid had not been present. Now if the grid is made less negative, it follows that its repelling effect will be reduced and

consequently a larger current will flow through it to the plate.

Similarly if the grid be again made more negative its repelling force will increase and the current to the plate will correspondingly decrease. See fig. 15.

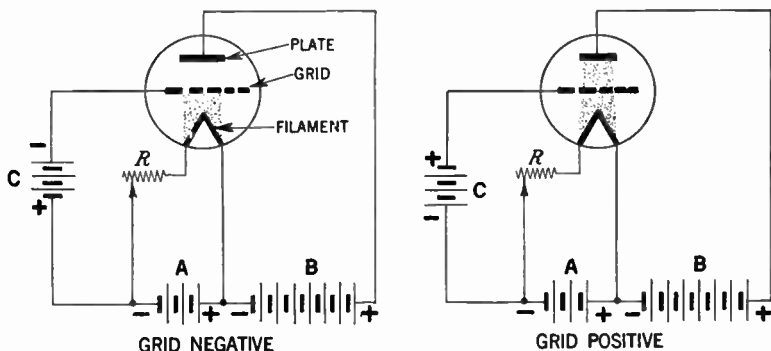

FIG. 15.—Illustrating the action of a grid in a triode vacuum tube.

From the above, it follows that when the potential of the grid be varied in accordance with some desired signal, the plate current will vary in a corresponding manner. Because the grid is assumed at all times to be at negative potential with respect to the cathode, it is evident that it can not collect electrons and so a small amount of energy will be sufficient to vary its potential in accordance with the input signal.

**Capacitance Effect.**—In a triode the grid plate and cathode form what is called an electro-static system, i.e., each electrode acts as a plate of a small condenser. The capacitances are those



existing between grid and plate, plate and cathode, and grid and cathode. See fig. 16.

These capacitances are usually referred to as "Inter-electrode Capacitances." In this connection it may be mentioned that the capacitance between the grid and plate is of the utmost importance, because of the fact that in high-gain radio-fre-

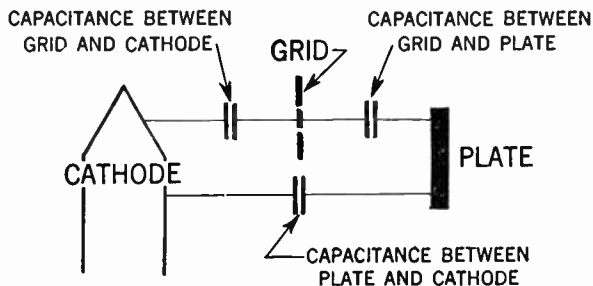

FIG. 16.—Diagram showing inter-electrode capacitances in a triode.

quency amplifier circuits, this capacitance may act to produce undesired coupling between the *input circuit*, the circuit between the grid and cathode, and the *output circuit*, the circuit between the plate and the cathode. The effect of this coupling may cause instability and unsatisfactory performance in the amplifier.

**Tetrodes.**—The undesirable capacitance between the grid and the plate in the triode can be decreased by inserting an additional electrode or *screen* between the grid and the plate as shown in fig. 17. With the addition of this fourth electrode the tube is accordingly referred to as a *tetrode*.

**The Screen Function.**—The position of the screen between the grid and the plate gives it the function of an electrostatic shield between them, thus reducing the capacitance between the two.

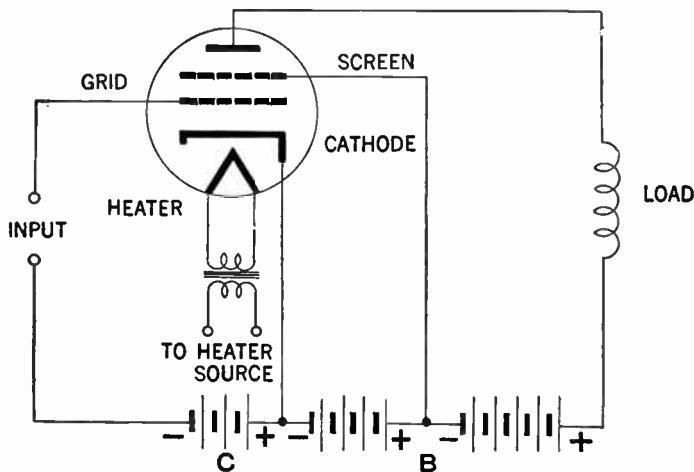

FIG. 17.—Connection of electrodes of a screen grid tube.

The effectiveness of this shielding action is further increased by inserting a by-pass condenser between the screen and the cathode. Therefore, by means of this screen and by-pass condenser, the grid to plate capacitance is very small.

The screen has another desirable effect in that it makes plate current almost independent of plate voltage over a certain range. The screen is operated at a positive voltage and therefore, attracts electrons from the cathode, but because of the comparatively large space between wires of the screen, most of the electrons drawn to the screen pass through it to the plate.

Hence, the screen supplies an electrostatic force pulling electrons from the cathode to the plate.

At the same time the screen shields the electrons between cathode and screen from the plate so that the plate exerts very little electrostatic force on electrons near the cathode. Therefore, plate current in a screen grid tube depends to a great degree on the screen voltage and very little on the plate voltage. This holds true only as long as the plate voltage is higher than the screen voltage.

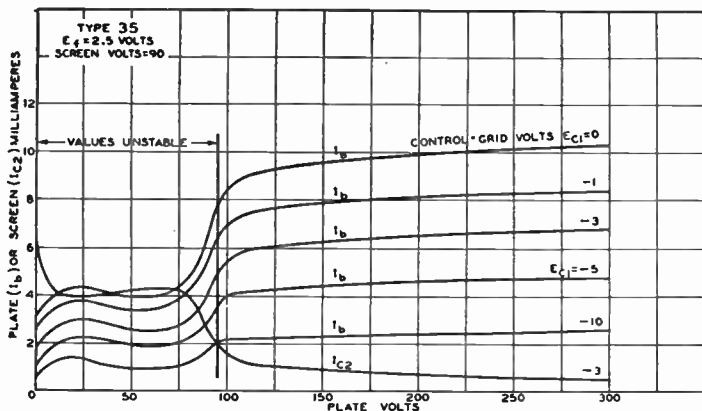

FIG. 18.—Average plate characteristics of a screen grid amplifier tube.

The fact that plate current in a screen grid tube is largely independent of plate voltage makes it possible to obtain much higher amplification with a tetrode than with a triode. The low grid to plate capacitance makes it possible to obtain this high amplification without plate-to-grid feed-back and resultant instability.

**Pentodes.**—It has previously been shown that when electrons strike the plate they may if moving at sufficient speed dislodge other electrons. This in the two and three electrode types does not cause any trouble since no other positive electrode than the plate is present to attract them.

These vagrant electrons therefore are eventually drawn back to the plate.

Emission from the plate caused by bombardment of the plate by electrons from the cathode is referred to as *Secondary Emission* on account of its effect being secondary to the original cathode emission.

In the case of the previously discussed screen grid or tetrode tube, the proximity of the positive screen to the plate offers a strong attraction to these secondary electrons, and more markedly so if the plate voltage be lower than the screen voltage. This results in lowering of the plate current and limits the permissible plate swing for tetrodes.

To overcome the effects of secondary emission a third grid, called the *suppressor grid* is inserted between the screen and plate. This grid, being connected directly to the cathode, repels the relatively low-velocity secondary electrons back to the plate without obstructing to any appreciable extent the regular plate-current flow. Larger undistorted outputs therefore can be secured from the *pentode* than from the *tetrode*.

Pentode-type screen-grid tubes are used as *radio-frequency voltage amplifiers*, and in addition can be used as *audio-frequency voltage amplifiers* to give high voltage gain per stage, since the pentode resembles the tetrode in having a high amplification

factor. Pentode tubes also are suitable as audio-frequency power amplifiers, having greater plate efficiency than triodes and requiring less grid swing for maximum output. The latter quality can be indicated in another way by saying that the *power sensitivity*—ratio of power output to grid swing causing it, is higher. In audio power pentodes, the function of the screen grid is chiefly that of accelerating the electron flow rather than shielding, so that the grid often is called the *accelerator grid*. In radio frequency voltage amplifiers the suppressor grid, in eliminating the secondary emission, makes it possible to operate the tube with the plate voltage as low as the screen voltage, which cannot be done with tetrodes.

As audio-frequency power amplifier pentodes have inherently greater distortion (principally odd-harmonic distortion) than triodes. The output rating usually is based on a total distortion of 10%.

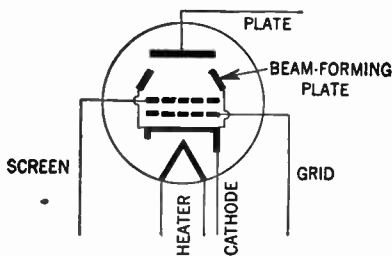

FIG. 19.—Conventional representation of beam power tube.

**The Beam Power Tube.**—In this tube a different method is used for suppressing secondary emission. The tube (See figs. 19 and 20) contains four electrodes, a cathode, grid, screen and plate respectively. The spacing between the electrodes is such

that secondary emission from the plate is suppressed without the suppressor found in the pentode.

Due to this method of spacing the electrodes, electrons travelling to the plate slow down, when the plate voltage is low, the velocity being almost zero in a certain region between the screen and the plate. In this region the electrons form a stationary cloud—a space-charge. The effect of this space-charge is to repel secondary electrons emitted from the plate, and thus cause them to return to the plate, hence causing the suppression of *secondary emission*.

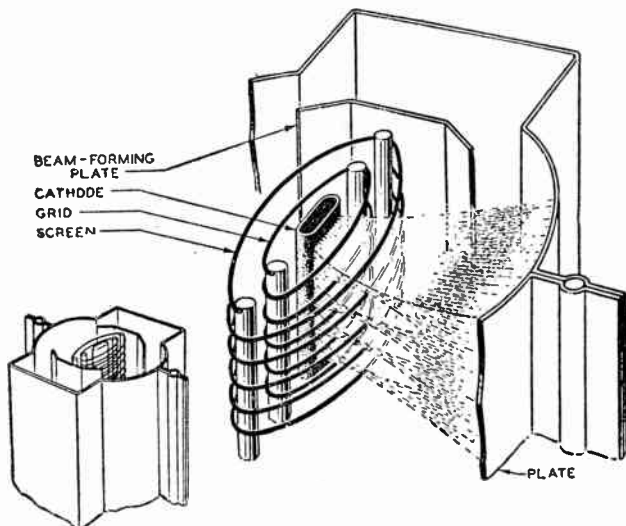

FIG. 23.—Internal structure of beam power tube. (Courtesy R.C.A. Mfg., Inc.)

An added advantage of the beam power tube is the low current drawn by the screen. The screen and the grid consists of spiral wires wound in such a way so that each turn of the screen is

shaded from the cathode by a grid turn. On account of this alignment the screen and grid causes the electrons to travel in sheets between the turn of the screen so that very few of them flow to the screen. Because of the effective suppressor action provided by space charge and because of the low current drawn from the screen, the beam power tube has the advantage of high power output, high sensitivity and efficiency.

**Multi-Purpose Tubes.**—During the early stages of tube development and application, tubes were essentially of the so-called general purpose type, that is a *triode* was used as a radio-frequency amplifier, an intermediate frequency amplifier, an audio frequency amplifier, an oscillator or as a detector.

It is obvious that with this diversity of applications, this one type did not meet all requirements to the best advantage.

At present a great multiplicity of tube types have been developed to do special work in radio circuits. Among the simplest and most important in radio receiver circuits are the full-wave rectifiers, containing two separate diodes of the power type in one bulb, and twin-triodes consisting of two triodes in one bulb for class B audio amplification.

To add the functions of diode detection and automatic volume control to that of amplification, a number of types are made in which two small diode plates are placed near the cathode, but not in the amplifier-portion structure. These types are known as *duplex-diode triodes*, or *duplex-diode pentodes*, depending upon the type of amplifier section incorporated.

Another type is the *pentagrid converter*, a special tube working as both oscillator and first detector in superheterodyne re-

ceivers. There are five grids between cathode and plate in the pentagrid converter; the two inner grids serve as control grid and plate of a small oscillator triode, while the fourth grid is the detector control grid. The third and fifth grids are connected together to form a screen grid which shields the detector control grid from all other tube elements. The pentagrid converter eliminates the need for special coupling between the oscillator and detector circuits.

The conventional diagram representation of these tubes are depicted in figs. 21 to 23. Another type of tube consists of a triode and pentode in one bulb, for use in cases where the oscillator and first detector are preferably separately coupled;

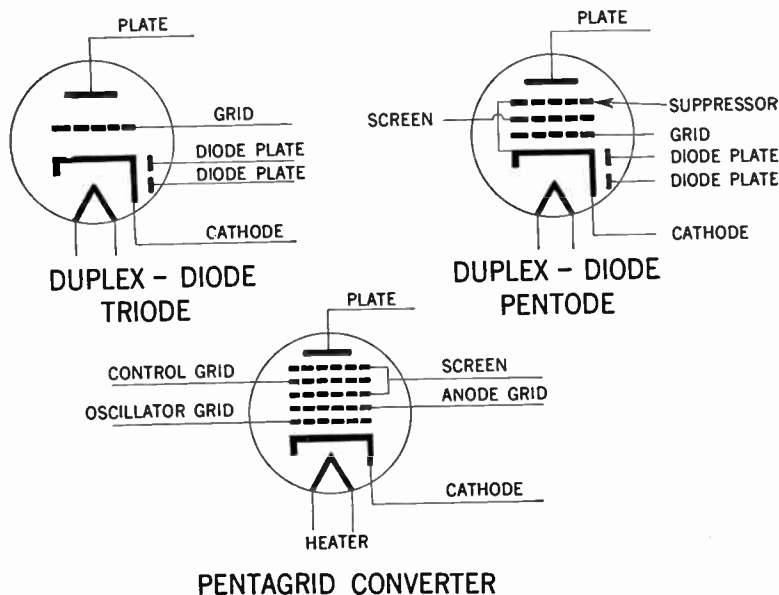

FIGS. 21 to 23.—Schematic representation of multi-purpose tubes.



while still another type is a pentode with a separate grid for connection to an external oscillator circuit. This "injection" grid provides a means for introducing the oscillator voltage into the detector circuit by electronic means.

Receiving screen-grid tetrodes and screen-grid pentodes for radio-frequency voltage amplification are made in two types, known as *sharp cut-off* and *variable-mu* or super-control types. In the sharp-cut off type the amplification factor is practically constant regardless of grid bias, while in the variable-mu type the amplification factor decreases as the negative bias is increased. The purpose of this design is to permit the tube to handle large signal voltages without distortion in circuits in which grid-bias control is used to vary the amplification, and to reduce interference from stations on frequencies near that of the desired station by preventing cross-modulation. Cross-modulation is modulation of the desired signal by an undesired one, and is practically the same thing as detection. The variable-mu type of tube is a poor detector in circuits for r.f. amplification, hence cross-modulation is reduced by its use.

## CHAPTER 13

# Radio Receivers

Generally any electrical circuit used in connection with radio reception is a radio receiving circuit.

The basic receiving circuits are as follows:

1. Regenerative
2. Tuned radio frequency regenerative
3. Super-heterodyne
4. Super-regenerative
5. Super-infra regenerative

The two last circuits are classified as short wave receivers.

**General Receiver Performance Characteristics.**—The receiver performance may be divided into three groups namely:

1. Selectivity
2. Sensitivity
3. Fidelity and stability

The three groups are inter-dependent with selectivity the most important factor.

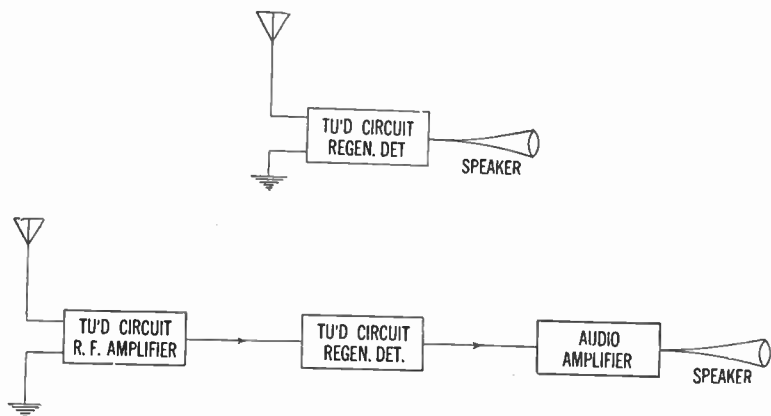

FIGS. 1 and 2—Block diagrams showing essential units of a regenerative and a tuned radio frequency regenerative circuit respectively.

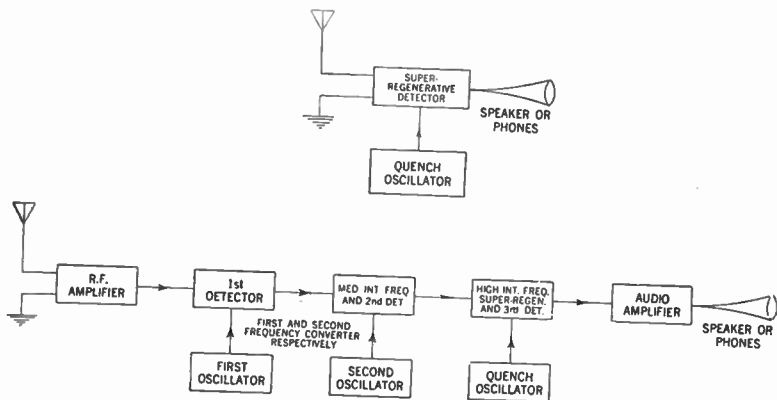

FIGS. 3 and 4—Block diagrams showing essential units of a super-regenerative and a super-infra regenerative circuit respectively.

By definition, *selectivity* of a receiver is its ability to discriminate between signals of various frequencies. The *sensitivity* of a receiver is the minimum radio frequency voltage input required to give a certain specified output. The *fidelity* is that proportionate response through the audio frequency range, required for a given type of receiver.

A receiver's *stability* is identified by its ability to maintain its output constant over a period of time with constant *signal* input.

**Receiver Selectivity.**—As aforementioned the selectivity is that characteristic which makes it possible to determine how well a set will tune out one signal and tune in another.

**Measurements of Selectivity.**—The selectivity is determined with the aid of a radio frequency oscillator by means of which it is possible to impress known *r.f.* potential on the input of a radio receiver.

There are various methods of carrying out this test, although the one generally used is to impress a small potential on the input of the set and note the output, and then to vary gradually the frequency of the *r.f.* oscillator, and at the same time adjust the potential supplied to the receiver so as to maintain the same output.

In this manner a set of figures will be obtained, indicating how the output of the set falls off at either side of the frequency to which it is tuned. Generally it is true that the more rapidly it falls off the better is the selectivity of the receiver.

However, as previously noted, the receiver's selectivity is closely allied with its fidelity, for generally if making the selectivity too great, the side-bands are suppressed and the high frequencies are partially suppressed. A typical selectivity curve is shown in fig. 5.

Such curves may be made up at various points throughout the broadcast band, and the variations in a receiver's selectivity thereby determined.

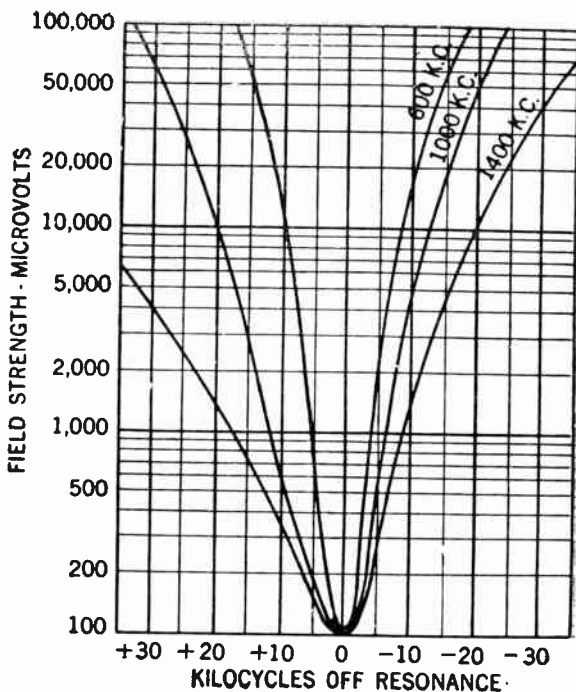
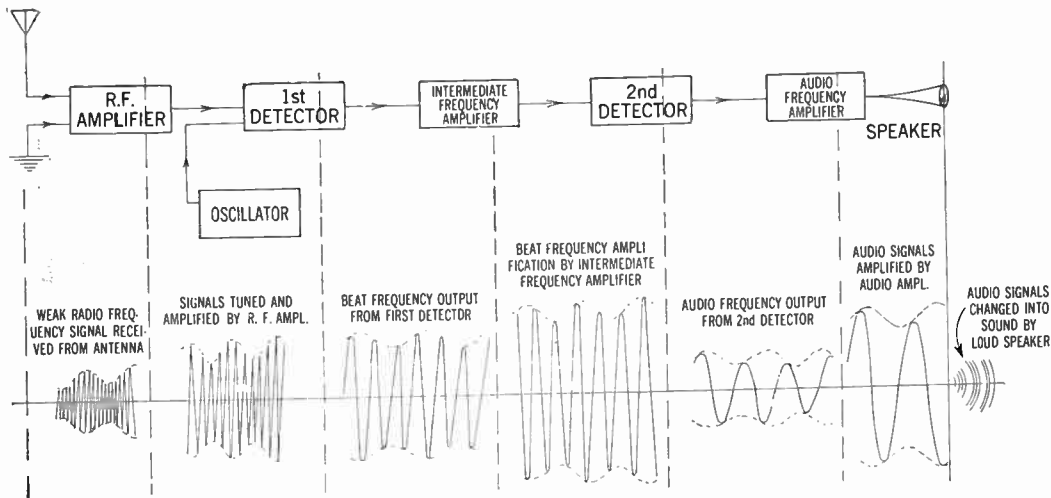

FIG. 5—A typical radio receiver selectivity curve.

**Receiver Sensitivity.**—The sensitivity of a receiver is not simply a matter of amplification, but is fundamentally limited by what is known as “the noise level” in that only signals that are audible above the prevailing noise background at the output are useful.



**FIG. 6—**Combination diagram showing arrangement of the different units of a typical super-heterodyne receiver with wave chart indicating how the radio signals are modified by each unit, that is, how the inaudible signals first picked up by the antenna undergo successive changes en route to the loud speaker.

In order to obtain a common basis facilitating the study and measurement of this characteristic, the term "noise equivalent" is used, which simply means the effective sensitivity of a receiver in terms of its own noise level.

**Measurements of Sensitivity.**—In connection with sensitivity measurements, a certain receiver is often expressed as having a sensitivity of so many micro-volts per meter. Just what this expression implies may best be conveyed by a description of what the term means.

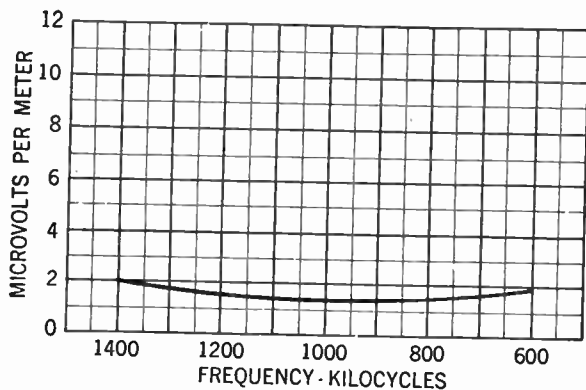

FIG. 7—Typical radio receiver, sensitivity characteristics.

The sensitivity measurements are generally accomplished in the following manner: The receiver is set up and a resistor is connected across the *a.f.* output of the set. The resistor should be of such value so as to give maximum power output per volt on the grid of the power tube. In most cases the resistor will have a value equal to twice the plate resistance of the output tube, which may easily be obtained from the tube performance chart.

The next procedure is to apply to an artificial antenna a known *r.f.* voltage modulated 30% at 400 cycles and to increase the *r.f.* input voltage until 50 milli-watts of audio-frequency power is developed across the output resistance.

The magnitude of the input *r.f.* voltage required to produce this output by dividing by the effective height of the artificial antenna, which is usually four meters is then determined.

Thus, finally the micro-volts per meter input required to produce the standard output of 50 milli-watts is obtained.

If it be assumed that the described method is utilized in determining the sensitivity of a certain receiver, it is simply necessary to give the micro-volts per meter input for standard output in order to define completely the sensitivity of the receiver in question.

It can therefore be said for example, that a certain receiver has a sensitivity of 10 micro-volts per meter. This means that if a 30% modulated *r.f.* signal is impressed across the input, then 50 milli-watts of power will be developed in the output at 400 cycles.

With the constant improvement in *r.f.* amplifier circuits, receiving sets at present are much more sensitive and it is not uncommon to find receivers having a sensitivity in the order of 3 to 5 micro-volts per meter or higher.

**Fidelity.**—Fidelity is the term being used to indicate the accuracy of reproduction, at the output of a radio receiver, of the modulation impressed on the *r.f.* signal applied to the input of the set under test.

This is generally determined by setting up the receiver to be tested and impressing on its input an *r.f.* signal modulated at 30%, the input signal having a value such that the normal output is obtained.



Next the frequency of the modulating signal is varied (the modulation being held constant) over the entire audio frequency band and the output power at each frequency is noted.

From the data so obtained, a curve can be charted showing how the audio-frequency output power from the set varies with the frequency applied.

Such curves are run at various radio frequencies for example at 600, 1000 and 1500 *k.c.* in the broadcast band, so that the variation of fidelity can be determined.

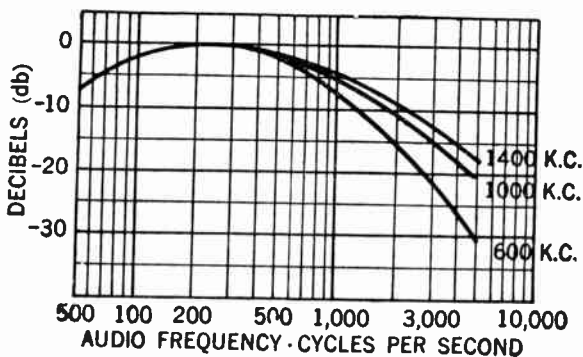

FIG. 8—Typical radio receiver, fidelity characteristics.

In this manner it is possible to obtain information regarding the characteristics of the *r.f.* amplifier system. It is obvious that if the system tunes too sharply at some point in the broadcast band, the side-bands will be suppressed partially and this will show up on the curve which is plotted as a falling off in response at the higher audio frequencies.

When making a test of this type, it is essential that the source of the audio frequency voltage used to modulate the *r.f.* input signal be quite pure (free from harmonics). Generally the total harmonic output from the audio frequency oscillator should not be allowed to exceed 5%.

**Amplifier Classification.**—There are four recognized classes of amplifier service. This classification depends primarily on the fraction of the input cycle during which the plate current is expected to flow under rated full-load conditions.

The term cut-off bias used in the following definitions is the value of grid bias at which plate current is of some very small value.

**Class "A" Amplifiers.**—A class A amplifier is one in which the grid bias and alternating grid voltages are such that the plate current in a specific tube flows at all times.

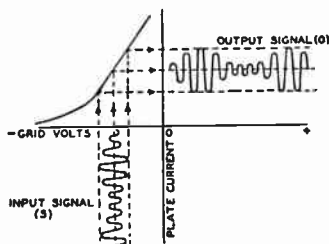

FIG. 9—A graphic illustration of method of amplification showing, by means of grid-voltage vs. plate-current characteristics, the effect of an input signal "S" applied to the grid of the tube. "O" is the resulting amplified plate-current variation.

*Class A amplifiers of the voltage type* find their application in reproducing grid voltage variations across an impedance or a resistance in the plate circuit. These variations are essentially of the same form as the input signal voltage impressed on the grid, but of increased amplitude. See fig. 9. This is accomplished by operating the tube at a suitable grid bias so that the applied grid-input voltage produces plate-current variations proportional to the plate swings. Since the voltage variation obtained in the plate circuit is much larger than that required to swing the grid amplification of the signal is obtained.

*Class A amplifiers of the power type* find their chief application as output amplifiers in audio systems, operating loud speakers in radio receivers and public address systems, where relatively large amounts of power are required.

For above applications, large output power is of much greater importance than high voltage amplification. Therefore gain possibilities are sacrificed in the design of power tubes to obtain this greater power handling capability.

**Class "AB" Amplifiers.**—A class AB amplifier is an amplifier in which the grid bias and alternating grid voltages are such that plate current in a specific tube flows for appreciable more than one-half but less than the entire cycle.

**Class "B" Amplifiers.**—A class B amplifier is an amplifier in which the grid bias is approximately equal to the cut-off value so that the plate current is approximately equal to zero when no exciting grid voltage is applied, and so that the plate current in a specific tube flows for approximately one-half of each cycle when an alternating grid voltage is applied.

*Class B amplifiers of the power type* employs two tubes connected in push-pull, so biased that the plate current is almost zero when no signal voltage is applied to the grids (see figs. 10 and 11). Because of this low value of no signal plate current, class B amplification has the same advantage as class AB, in that large power out-put can be obtained without excessive plate dissipation. The difference between class B and class AB is that, in class B, plate current is cut off for a larger portion of the negative grid swing.

**Class C Amplifiers.**—A class C amplifier is an amplifier in which the grid bias is appreciably greater than the cut-off value so that the plate current in each tube is zero when no alternating

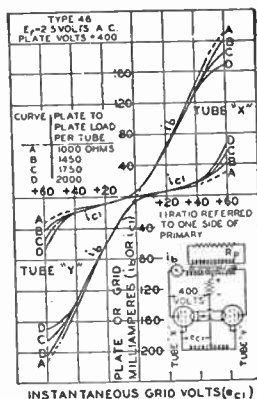

FIG. 10—Illustrates operation of tubes in class "B" circuit.

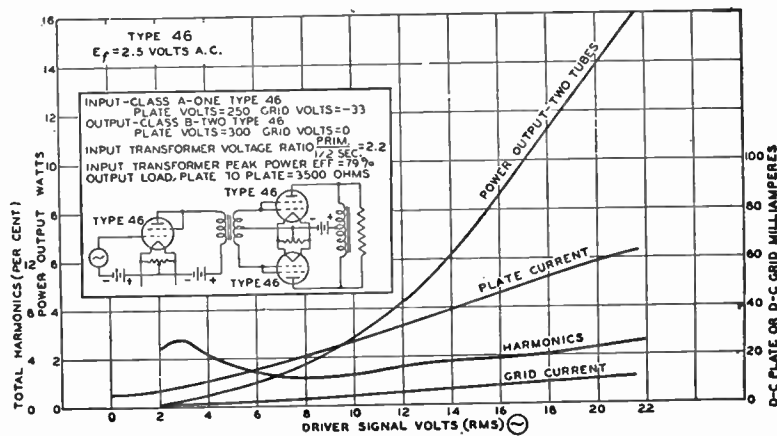

FIG. 11—Illustrates typical class "B" characteristics. An amplifier of this type generates considerable second and other harmonics. The efficiency of an amplifier of this type is higher than the previously discussed class A amplifier.

grid voltage is applied, and so that plate current flows in a tube for appreciably less than one-half of each cycle when an alternating grid voltage is applied.

**Radio Frequency Amplifiers.**—Radio frequency amplification is utilized to increase the volume of the weak radio frequency signals received from the antenna, and occurs before the radio frequency signals arrive at the detector circuit of the receiver

There are three general methods for coupling the tube of one stage of radio frequency amplification to the next stage namely:

1. Resistance coupled
2. Impedance coupled
3. Transformer coupled.

**Resistance-coupled Radio Frequency Amplifier.**—In this type of amplifier (see fig. 12) a high resistance is being utilized for the interstage coupling.

The advantage with this type when used as an audio amplifier is that on account of its simplicity it is economical to build, in addition, the amplification can be made very uniform over a rather wide frequency range. It is these characteristics which have made it useful in television devices.

The function of the blocking condenser is to prevent the plate potential of one stage being impressed on the grid of the next stage.

These blocking condensers, being series condensers, would trap electrons between the grid and the adjacent condenser plate, were it not for the high resistance leakage path provided for their return to the filament circuit.

**Impedance Coupled Amplifiers.**—The method of connection for inductive coupling (also known as choke coil coupling), is shown in fig. 13. The impedances  $X_1$  and  $X_2$  are in the form of auto-transformers;  $R_1$  and  $R_2$  are grid leaks ranging in value of between one-quarter and one-half megohms;  $C_1$  and  $C_2$  are the usual blocking condensers of about one microfarad capacity each.

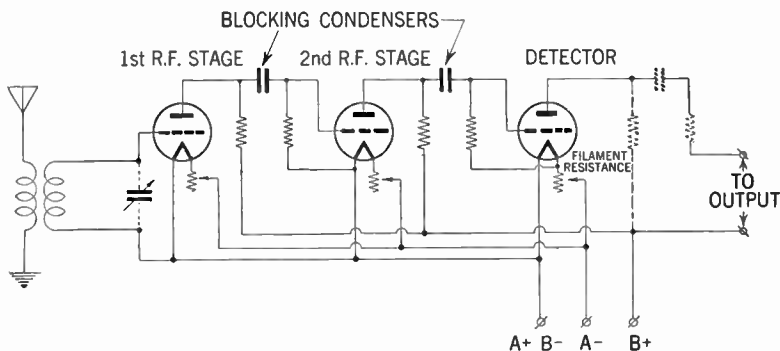

FIG. 12—Typical two stage resistance coupled radio frequency amplifier.

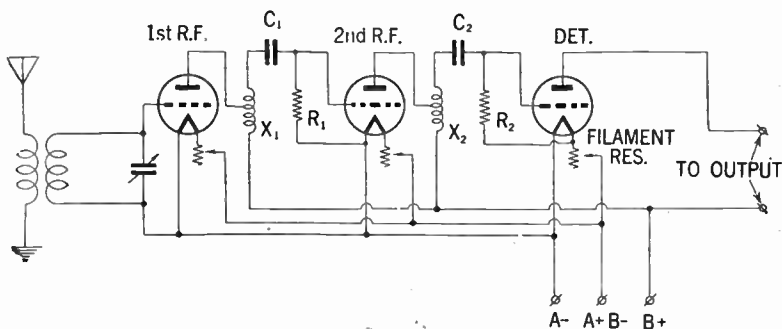

FIG. 13—Two stage impedance coupled radio frequency amplifier.

**Transformer Coupled Amplifiers.**—In this method the air-core transformers with a one to one transformer ratio, are most commonly used.

However, on very long wavelengths it has been found advantageous to use step-up ratio transformers, by having a greater number of secondary than primary turns.

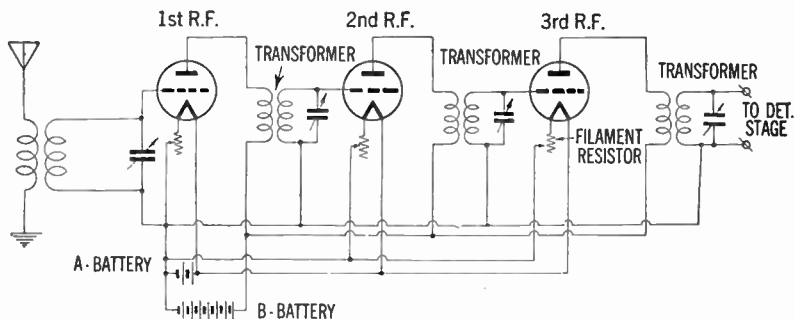

FIG. 14—Three stage radio frequency amplifier circuit.

In the transformer coupled circuit shown in fig. 14, the filaments are connected in parallel across the common "A" battery with a variable rheostat to adjust the filament current. A "B" battery is used to supply all the plate potentials, and a "C" battery (when necessary) to supply all grid biases.

**Push-pull Amplifiers.**—This type of amplifier is frequently used in receiving sets for supplying more power to the loud speaker than is ordinarily obtainable from one or two stage audio amplifiers.

Another advantage with this type of amplifier is that it eliminates any distortion which may exist in ordinary amplifiers due to the non-linear characteristics of the tube.

It will be found by observing circuit, fig. 15, that this is a balanced circuit, i.e. the cathode returns are made to the mid-point of the input and output devices.

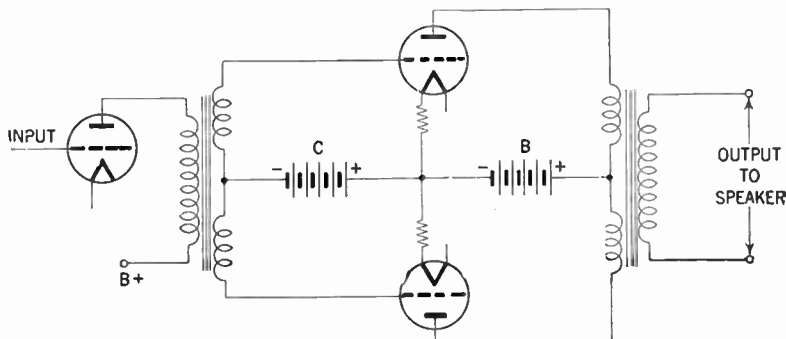

FIG. 15—Push-pull amplifier circuit. This type of amplification requires two identical tubes in each stage. The grids of the tubes are not connected together, as in the case of parallel operation, but are connected to opposite ends of a mid-tapped transformer secondary. The mid tap is used as a common connection for making connection to the negative bias voltage of the grids.

An *a.c.* current flowing through the primary winding of the input transformer will cause an *a.c.* potential to be induced in the secondary, since the ends of the winding will be at exactly opposite voltage with respect to the cathode connection. Hence it will be found that the grid of one tube is swung positive at the same instant that the grid of the other will be negative. From this it follows that the plate current in one tube is increasing, while the plate current of the other tube is decreasing. It is from this characteristic that the name "*push-pull*" has been derived.

Although ordinary amplifier tubes can be utilized in this type of amplifier, it is often desirable to use special power tubes which give a high amplification factor.



**How Selectivity of a Receiver Is Affected by the Number of Radio Frequency Stages.**—As previously explained the selectivity of a receiver is defined as its ability to discriminate between signals of various frequencies. However, this ability among other factors is affected by the number of stages of which the receiver is composed as well as the selectivity of each individual stage.

The influence of the number of stages upon the selectivity may best be understood by referring to fig. 16 which represents the selectivity characteristics of several radio frequency stages.

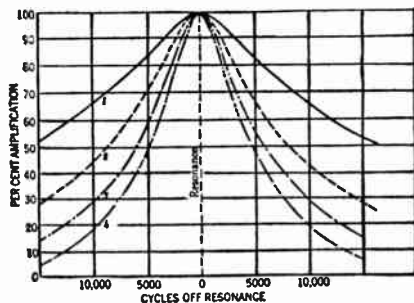

**FIG. 16**—Illustrates how the several stages of *r.f.* amplification increases the selectivity of a receiver by reducing the strength of undesired signals.

Curve 1 represents the selectivity of one single *r.f.* stage. At a point 5,000 cycles of resonance the circuit gives 84% of amplification at resonance and at 10,000 cycles off resonance the amplification has dropped to only 66% of the resonance amplification.

Assuming that instead of having only one *r.f.* stage that other stages be added having exactly the same characteristics as that of the first, the selective action as that represented by curve 2, will be obtained.

If now at a certain point off resonance, the first stage reduced the amplification factor to 84% then the second stage would reduce the amplification to 84% of what came through the first stage.

With reference to the chart at a point 5,000 cycles off resonance, the four stages would introduce a final amplification of only 49% of the resonant frequency.

Analyzing the result further, at a point 5,000 cycles off resonance the first stage is 84%; that of the second stage  $84 \times 84$  or 70%; that of the third stage  $84 \times 84 \times 84$  or 59%, and finally the amplification of the fourth stage  $84 \times 84 \times 84 \times 84$  or only a little better than 49%.

However, since a radio signal includes modulation frequencies up to 5,000 cycles off resonance, it is evident that a radio frequency amplifier having four stages would cause considerable side band suppression with consequent signal distortion.

**Regenerative Circuits and Control Methods.**—The term regenerative is applied to any detector circuit in which a coupling is provided between the plate and oscillatory grid circuit. The tube performs simultaneously the function of a detector and an oscillator.

A typical regenerative circuit is shown in fig. 17. The various methods for control of regeneration in receivers are known as potentiometers, ticklers, reversed capacity, etc. Figs. 18 and 19 shows two ways in which regeneration may be controlled by means of a screen grid detector. In fig. 18 the regeneration control is a variable condenser having a maximum capacity of 100 or 150  $\mu\mu fd$ . It acts as a variable by-pass between the low-potential end of the tickler coil and the cathode of the tube. If the by-pass capacity is too small the tube will not oscillate, while increasing the capacity will cause oscillations to start at a certain critical value of capacity.

This method of regeneration control is very smooth in operation, causes relatively little detuning of the received signal and, since the voltage on the screen-grid of the tube is fixed, permits the detector to be worked at its most sensitive point.

The sensitivity of a screen-grid detector depends a great deal upon maintaining the screen-grid voltage in the vicinity of 30 volts.

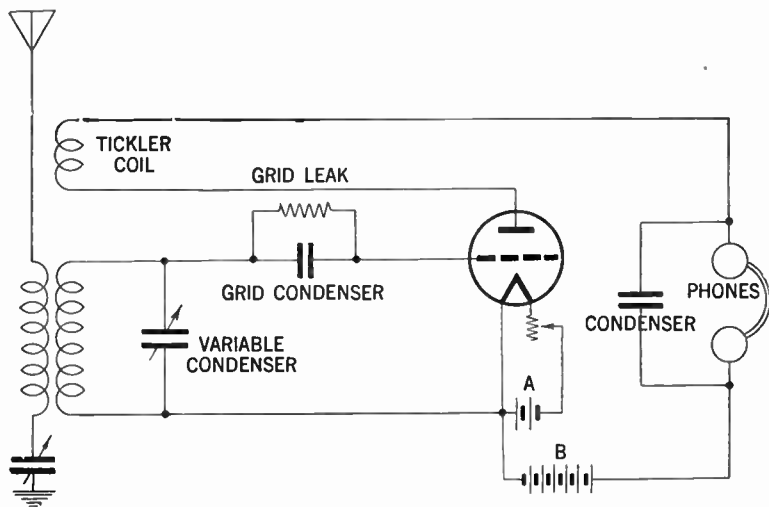
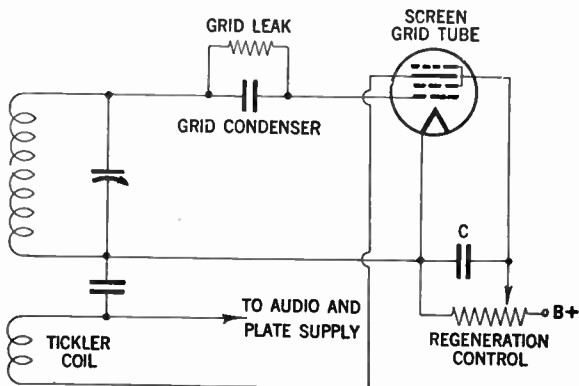
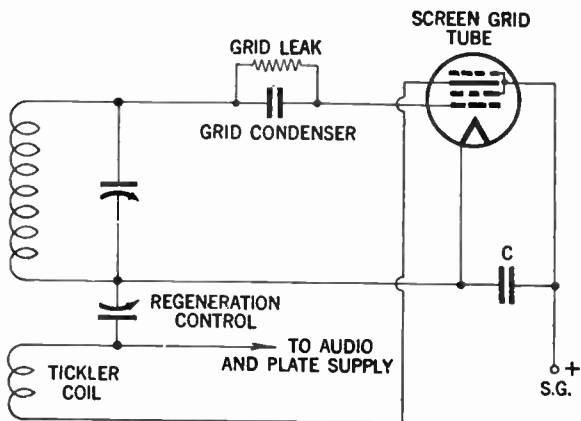

FIG. 17—Regenerative circuit. The scheme of combining a detector circuit with a separate oscillator circuit is called *heterodyning* and oscillators built exclusively for this purpose are called *heterodynes*. A circuit such as this is known as a *regenerative circuit*, and this term is applied to any detector circuit in which a coupling is provided between the plate and the oscillatory grid circuit.

In fig. 19 regeneration is controlled by varying the mutual conductance of the detector tube through varying its screen-grid voltage. The regeneration control is usually a voltage



FIGS. 18 and 19—Showing two methods for control of regeneration in radio receivers.

divider—or so-called “potentiometer”—with a total resistance of 50,000 ohms or more. This circuit causes more detuning of the signal than that in fig. 18 and the resistor is likely to cause some noise unless by-passed by a large capacity (about  $1\mu fd.$ ) at *C*. In fig. 18 condenser *C* may be  $.5\mu fd.$  or larger. With circuit, fig. 19, it is necessary to adjust the number of turns on the tickler coil to make the tube just start oscillating with about 30 volts on the screen grid if maximum sensitivity is desired.

Both the methods shown in figs. 18 and 19 may be applied to three-electrode detectors, although these tubes have been largely superseded as detectors by the more sensitive screen grid tubes. To use the method shown in fig. 19, the regeneration control resistor should be placed in series with the plate of the tube and it need not be used as a voltage-divider, but simply as a series variable resistor. It can also be used as a series resistor when controlling a screen-grid tube. Another type of regeneration control, more suitable for lower radio frequencies, uses a variable resistance across the feed-back portion of the *r.f.* circuit.

**Conversion of a High Radio Frequency to a Low Radio Frequency.**—This method is based on the simple electrical principle that when the energy of two different frequencies is combined in a suitable detector, there is produced a third frequency (termed the beat note or intermediate frequency) which is equal to the difference between the two first frequencies.

Thus if an amplifier is designed for 130 kilocycles and it is desired to receive a broadcast signal of 1,500 *k.c.* all that is needed, is to supply a locally-generated frequency either 130 *k.c.* higher or 130 *k.c.* lower than the received broadcast signal of 1,500 *k.c.*

The combination of the received broadcast signal and the locally-generated signal gives the beat note or intermediate frequency equal to the difference between them or 130 *k.c.*

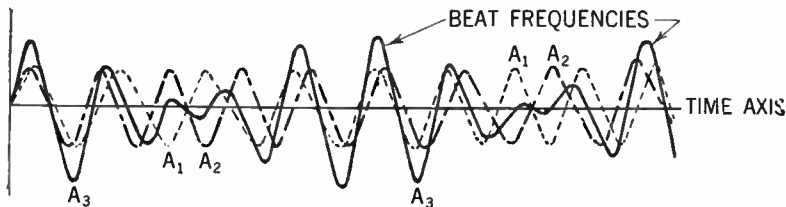

FIG. 20—Illustrates how beat frequencies are generated. With reference to curve  $A_1$  and  $A_2$ , it may readily be observed how the frequencies are alternately in and out of phase with each other. The frequency with which these component curves are in phase with each other is equal to the difference between the frequencies of the two component currents, i.e. the frequency  $f_1$  minus frequency  $f_2$  equals frequency  $f_3$ . When the two frequencies  $f_1$  and  $f_2$  are the same, they are said to be adjusted to zero beat.

**Detection.**—It has been previously explained that *r.f.* amplification in a receiving set takes place before the radio signals arrival to the detector circuit. The function of the detector is to de-modulate the *r.f.* wave before it reaches the *audio* stage.

In the receiver it is desired to reproduce the original *a.f.* modulating wave, from the modulated *r.f.* wave, i.e. it is desired to de-modulate the *r.f.* wave.

The stage in the receiver in which this function is performed is often called the **demodulator** or **detector stage**. There are three detector circuits in general use, namely:

1. The diode detector
2. The grid-bias detector
3. The grid-leak detector.

A typical diode detector circuit is shown in fig. 21.

The action of this circuit when a modulated *r.f.* wave is applied is illustrated by fig. 22. The *r.f.* voltage applied to the circuit is shown in light line, the output voltage across the condenser *C* is shown in heavy line. Between points *a* and *b* on the first positive half-cycle of the applied *r.f.* voltage, the condenser *C* charges up to the peak value of the *r.f.* voltage.

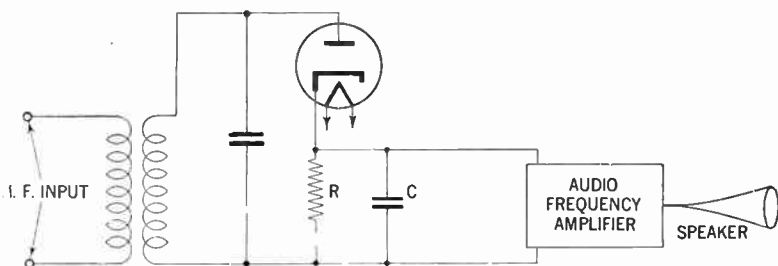

FIG. 21—Diode detector circuit.

Then as the applied *r.f.* voltage falls away from its peak value, the condenser holds the cathode at a potential more positive than the voltage applied to the anode. The condenser thus temporarily cuts off current through the diode. While the diode current is cut off, the condenser discharges from *b* to *c*, through the diode load resistor *R*. When the *r.f.* voltage on the anode rises high enough to exceed the potential at which the condenser holds the cathode, current flows again and the condenser charges up to the peak value of the second positive half-cycle at *d*. In this way, the voltage across the condenser follows the peak value of the applied *r.f.* voltage and thus reproduces the *a.f.* modulation.

The curve for voltage across the condenser, as shown in fig. 22 is somewhat jagged. However, this jaggedness, which represents an *r.f.* component in the voltage across the condenser, is exaggerated in the illustration. In an actual circuit the *r.f.* component of the voltage across the condenser is negligible. Hence, when the voltage across the condenser is amplified, the output of the amplifier reproduces the speech or music originating at the transmitting station.

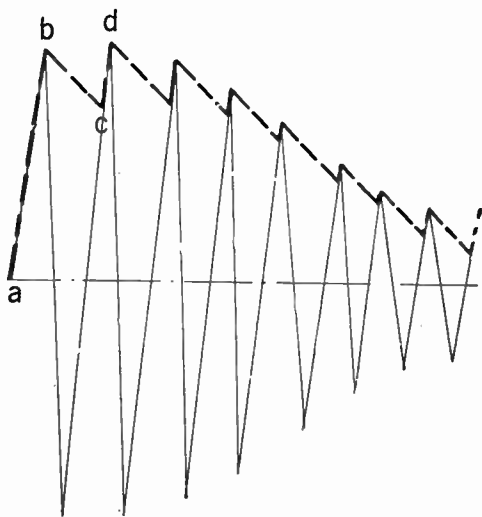

FIG. 22—Diode detector characteristics.

The diode method of detection has the advantage over other methods that it produces less distortion. The reason is that its dynamic characteristic can be made more linear than that of other detectors. It has the disadvantages that it does not amplify the signal, and that it draws current from the input circuit and therefore reduces the selectivity of the input circuit. However,



because the diode method of detection produces less distortion and because it permits the use of simple *a.v.c.* circuits without the necessity for an additional voltage supply, the diode method of detection is most widely used in broadcast receivers.

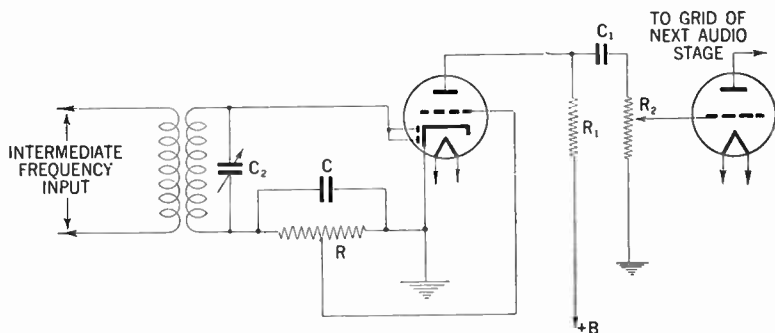

FIG. 23—Diode-biased detector circuit.

Another diode detector circuit, called a diode-biased circuit, is shown in fig. 23. In this circuit, the triode grid is connected directly to a tap on the diode load resistor. When an *r.f.* signal voltage is applied to the diode, the *d.c.* voltage at the tap supplies bias to the triode grid. When the *r.f.* signal is modulated, the *a.f.* voltage at the tap is applied to the grid and is amplified by the triode. The advantage of this circuit over the self biased arrangement shown in fig. 24 is that the diode-biased circuit does not employ a condenser between the grid and the diode load resistor, and consequently does not produce as much distortion of a signal having a high percentage of modulation.

However, there are restrictions on the use of the diode-biased circuit. Because the bias voltage on the triode depends on the average amplitude of the *r.f.* voltage applied to the diode, the

average amplitude of the voltage applied to the diode should be constant for all values of signal strength at the antenna. Otherwise there will be different values of bias on the triode grid for different signal strengths and the triode will produce distortion.

This restriction means, in practice, that the receiver should have a separate-channel automatic volume control system. With such an *a.v.c.* system, the average amplitude of the signal voltage applied to the diode can be held within very close limits for all values of signal strength at the antenna.

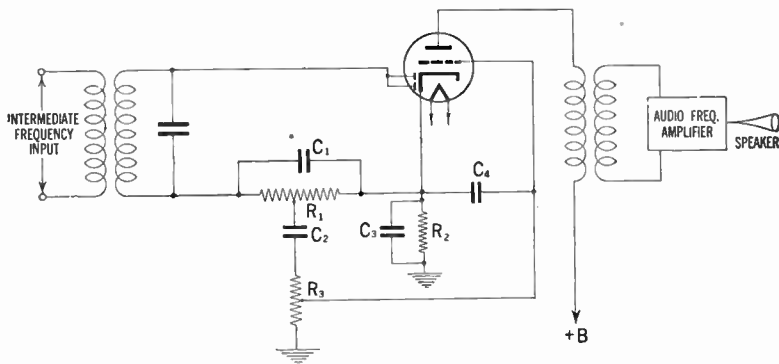

**FIG. 24**—A typical diode-detector circuit using a duplex-diode tube is shown above. In this circuit  $R_1$  is the diode load resistor. A portion of the *a.f.* voltage developed across this resistor is applied to the triode grid through the volume control  $R_3$ . In a typical circuit, resistor  $R_1$  may be tapped so that five-sixths of the total *a.f.* voltage across  $R_1$  is applied to the volume control. This tapped connection reduces the voltage output of the detector circuit, but also reduces audio distortion and improves the *r.f.* filtering. *D.c.* bias voltage for the triode section is provided by the cathode-bias resistor  $R_2$  and the audio by-pass condenser  $C_3$ . The function of condenser  $C_2$  is to block the *d.c.* bias voltage of the cathode from the grid. The function of condenser  $C_4$  is to by-pass any *r.f.* voltage on the grid to cathode. A duplex-diode pentode may also be used in this circuit. With a pentode, the *a.f.* output should be resistance-coupled rather than transformer-coupled.

The tube used in a diode-biased circuit should be one which operates at a fairly large value of bias voltage. The variations in bias voltage are then a small percentage of the total bias and hence produce small distortion. Tubes taking a fairly large bias voltage are types such as the 6R7 or 85 having a medium- $\mu$  triode.

Tube types having a high- $\mu$  triode or a pentode should not be used in a diode biased circuit. Since there is no bias applied to the diode-biased triode when no *r.f.* voltage is applied to the diode, sufficient resistance should be included in the plate circuit of the triode to limit its zero-bias plate current to a safe value.

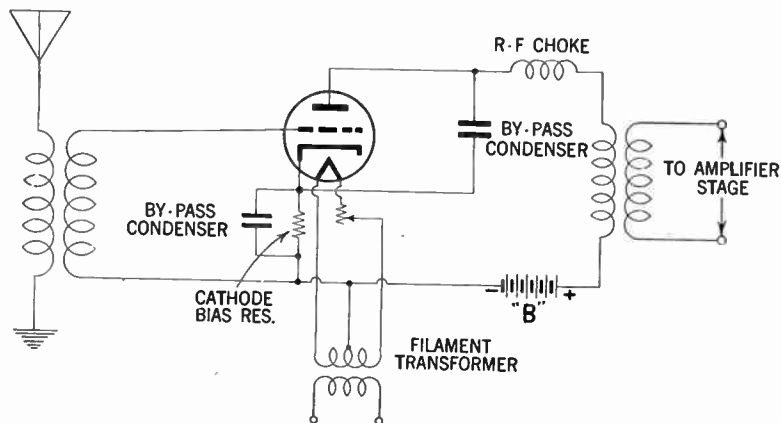

FIG. 25—Grid-biased detector circuit.

A grid-bias detector circuit is shown in fig. 25. In this circuit, the grid is biased almost to cut-off, i.e. operated so that the plate current with zero signal is practically zero. The bias voltage can be obtained from a cathode-bias resistor, a "C" battery, or a bleeder tap. Because of the high negative bias, only the positive half cycles of the *r.f.* signal are amplified by the tube. The signal is therefore detected in the plate circuit.

The advantages of this method of detection are that it amplifies the signal, besides detecting it, and that it does not draw current from the input circuit and therefore does not lower the selectivity of the input circuit.

The grid-leak and condenser method, shown in fig. 26 is somewhat more sensitive than the grid bias method and gives its best results on weak signals. In this circuit, there is no negative *d.c.* bias voltage applied to the grid. Hence, on the positive half-cycles of the *r.f.* signal, current flows from grid to cathode. The grid and cathode thus act as a diode detector, with the grid-leak resistor as the diode load resistor and the grid condenser as the *r.f.* by-pass condenser.

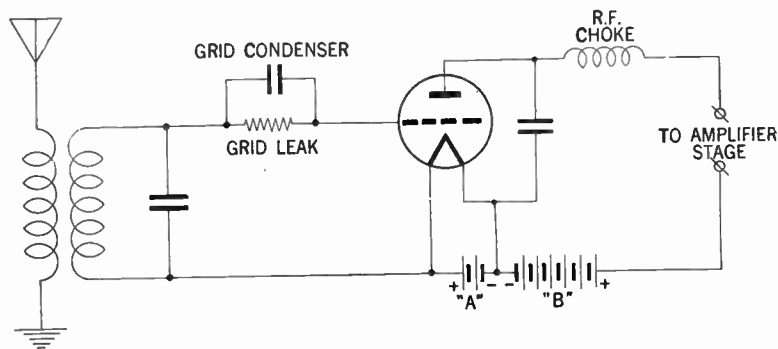

FIG. 26—Detector circuit grid-leak and condenser method.

The voltage across the condenser then reproduces the *a.f.* modulation in the same manner as has been explained for the diode detector. This voltage appears between the grid and cathode and is therefore amplified in the plate circuit. The output voltage thus reproduces the original *a.f.* signal.

In this detector circuit, the use of a high resistance grid leak increases selectivity and sensitivity. However, improved *a.f.* response and stability are obtained with lower values of grid-leak resistance. This detector circuit has the advantage that it amplifies the signal, but has the disadvantage that it draws current from the input circuit and therefore lowers the selectivity of the input circuit.

**Tuned Radio Frequency Circuits.**—The word *tuned* in this connection simply means that the circuit is brought into resonance with the desired signal. A tuned *r.f.* circuit is one in which

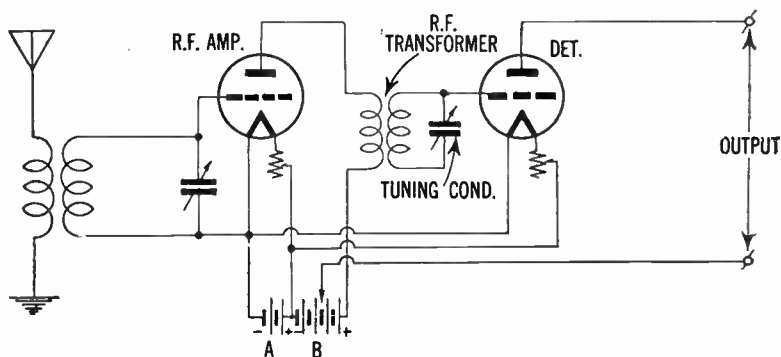

FIG. 27—Diagram illustrating principle of tuned radio frequency. The usual method of tuning is by means of a variable condenser in parallel with the secondary of the radio frequency transformer. A potentiometer is used to control oscillations, as the greatest amplification is obtained when the circuits are operated just at the point before self oscillation starts.

the radio frequency amplifier circuits may be tuned to the desired wave lengths by adjusting the inductance or the capacity or both, although the usual method of tuning is by means of a variable condenser in parallel with the secondary of the radio frequency transformer. (For theory of tuning see page 165.)

**Reflex Circuits.**—The reflex circuit principle is only one of several circuits developed, whose aim it was to extract the maximum use of a tube or a group of tubes, i.e. to reduce the number of tubes required in a multi-stage receiver.

The use of this circuit, however, with the versatility and relative inexpensiveness of the modern vacuum tube has become largely obsolete except in locations where space and weight of a receiver is at a premium—for example, in connection with portables, airplane, and automobile receivers.

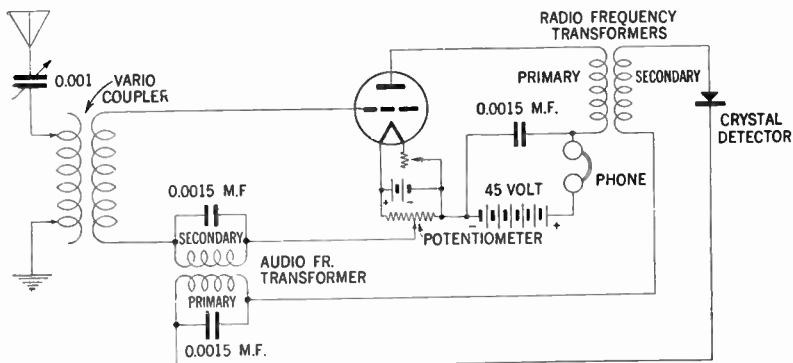

FIG. 28—Diagram showing typical reflex circuit.

In this circuit the vacuum tubes are made to perform the double duties of both radio and audio frequency amplifiers.

The incoming radio frequency signal is amplified at radio frequency, rectified by a detector, and then amplified at audio frequency using the same tube, or if so desired the circuit values can be chosen so that the stage can function as a radio frequency and intermediate frequency amplifier.

It can readily be understood that to construct a stage which will first amplify the signal at the *i.f.* and then further amplify the signal after it has been rectified and converted into an audio

frequency, requires a very careful choice of circuit constants, because not only must the circuit elements give the proper load at both audio and intermediate frequencies but filters must also be inserted to separate the frequencies so as to prevent feedback. A typical reflex circuit using one tube and a crystal detector is shown in fig. 28.

**Intermediate Frequency Amplifiers.**—The function of the intermediate frequency amplifier in a super-heterodyne receiver is to convert the *r.f.* signal to an intermediate frequency.

To obtain this change in frequency, a frequency-converting device consisting of an oscillator and a frequency mixer is commonly employed.

In a circuit of this type two potentials of different frequency namely the radio frequency voltage and the potential generated by the oscillator are applied to the input of the frequency mixer.

The aforementioned potentials beat, or heterodyne with the mixer tube to produce a plate current having in addition to the frequencies of the input potential, numerous sum and difference frequencies.

Generally the output circuit of the mixer stage is provided with a tuned circuit adjusted to select only one beat frequency—that frequency which is equal to the difference between the impressed signal frequency and the oscillator frequency.

It is this selected output frequency which is known as the *intermediate frequency* or in abbreviated form *i.f.*

The output frequency of the mixer tube is kept constant for all signal frequency values by tuning the oscillator to the proper frequency. Methods of frequency conversion for super-heterodyne receivers are as follows:

The first method widely employed before the availability of tubes especially designed for this purpose utilizes as mixer tube either a triode, a tetrode or a pentode. In this method the oscillator and signal potential are applied to the same grid. The coupling between the oscillator and mixer circuits is obtained by means of inductance or capacitance.

A second method employs a tube which is especially designed for this type of service and is known as the *pentagrid converter* tube.

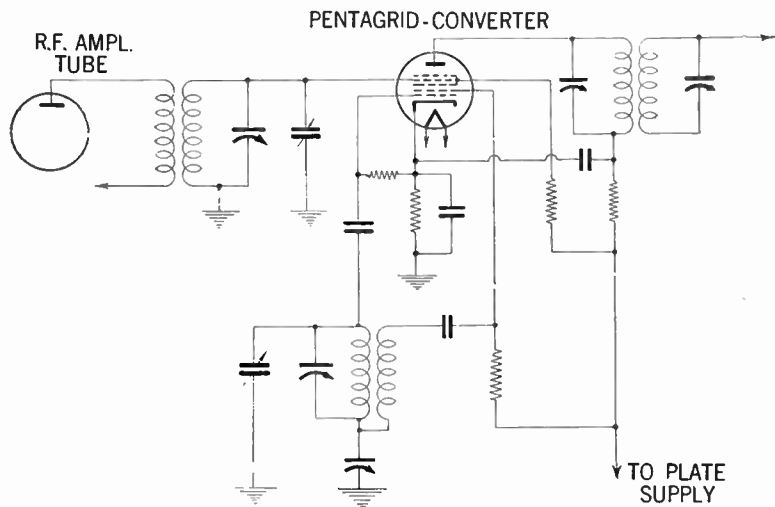

FIG. 29—Pentagrid converter tube employed as an oscillator mixer in a super-heterodyne receiver circuit.

In this tube the oscillator and frequency mixer are combined, and the coupling between the oscillator and mixer circuit is obtained by means of the electron stream within the tube. For the arrangement of elements in a pentagrid converter see page 249.



A third method employs a tube designed for short-wave reception, and is identified as the pentagrid mixer. It has two independent control grids, and is used with a separate oscillator tube.

In this tube the *r.f.* signal potential is applied to one of the control grids and oscillator potential to the other.

**Audio Frequency Amplifiers.**—An audio frequency amplifier is employed to increase the volume of the signals after leaving the detector tube, but before the signal is passed into the loud speaker.

There are three general methods of audio amplifier couplings whereby the tube of one stage of audio frequency amplifier may be connected to the following stage, identified as:

1. Resistance coupled
2. Impedance coupled
3. Transformer coupled.

**Resistance Coupled Audio Frequency Amplifier.**—Here, as in previously discussed *r.f.a.* a resistance is employed in the inter-stage coupling, as shown in fig. 30.

The function of the blocking condenser *C*, is that of insulating the grid of the tube from the high positive potential of the plate supply. In order to prevent the grid from the tendency of accumulating a negative charge, a high resistance leakage path is introduced through grid *R*<sub>2</sub>, the size of which depends upon the value of the grid to filament resistance of the tube.

When a signal potential is received from the detector, a current is generated through coupling resistor *R*<sub>1</sub>, in the plate circuit of the primary tube, these voltage variations lowered by the blocking condenser *C*, are impressed upon the input circuit

of the second tube. Finally the grid voltage variations applied to the secondary tube causes corresponding variations of the plate potentials which are impressed on the input circuit of the final stage.

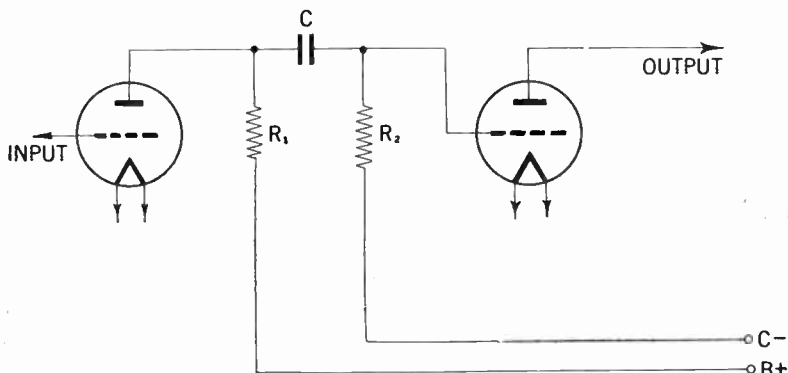

FIG. 30—Interstage coupling in a *resistance coupled* audio frequency amplifier.

Resistance coupling of the audio-frequency stages offer the advantages of good response at low audio frequencies. However, this increases the possibility of trouble from a common plate voltage supply. This is on account of the fact that the bypass condensers are ineffective at very low audio-frequencies and hence the common voltage supply acts as coupling between the stages. This gives rise to oscillations which are known as motor-boating and may be prevented as suggested on page 288.

**Impedance Coupled Audio Amplifiers.**—The impedance coupled audio amplifier is similar to the resistance coupled amplifier just described except that in place of the resistance an inductance consisting of a coil of wire wound on a laminated steel core, is utilized.

This type of coupling is also known as choke coil coupling or choke coil amplification. The voltage amplification obtained in this type is, as in the case of the resistance coupled amplifier, due to the amplification of the tube employed.

The effect of the blocking condenser is similar as that described for the resistance coupled amplifier.

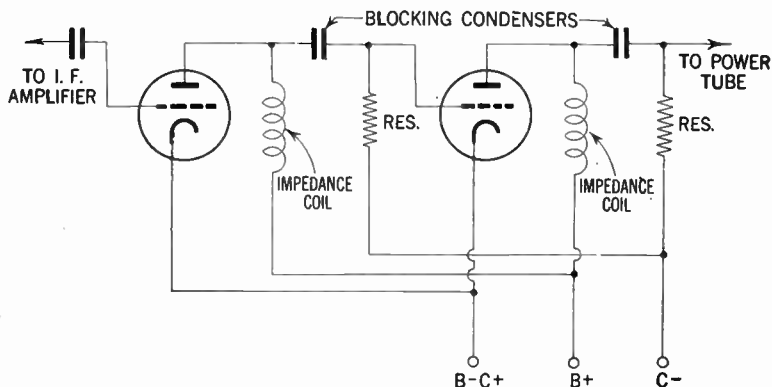

FIG. 31—Inter-stage coupling in an impedance coupled *audio frequency* amplifier.

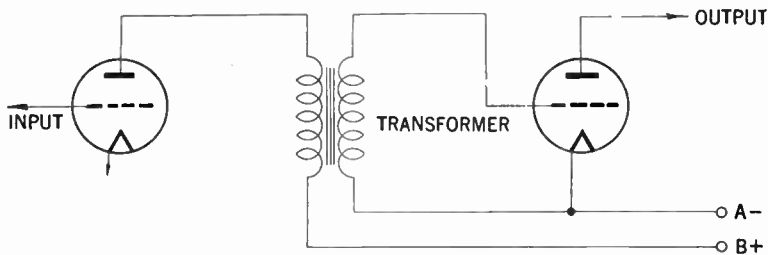

FIG. 32—Method of inter-stage connection of *transformer coupled* audio frequency amplifier.

**Transformer Coupled Audio Amplifier.**—In the transformer amplifier shown in fig. 32, the coupling is made by means of a transformer consisting of two windings—one primary and one secondary.

This type of coupling used extensively in early radio receivers has now largely disappeared on account of a number of disadvantages as compared with previous mentioned types.

The voltage gain received in this type is largely defeated due to the fact that it is not linear for all frequencies.

The frequency distortion is caused largely by the distributed capacity existing between the windings of the transformer.

An additional form of distortion known as harmonic distortion is caused by saturation of the iron core in the transformer.

**Tuning Indication.**—Tuning indication in modern receivers is usually accomplished by the employment of an electronic device identified as the electron-ray tube.

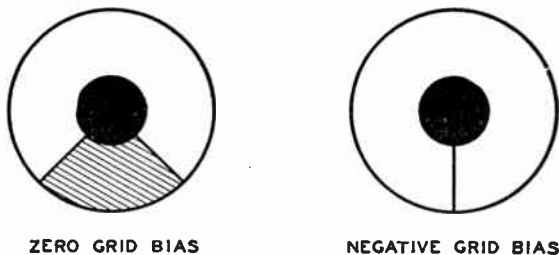

FIG. 33—Electron pattern on the 6E5 target for various grid bias.

The choice between the two types known as the 6E5 and 6G5 for a receiver depends largely on the receiver's automatic volume control characteristics. The 6E5 for example has a sharp cut-off triode which closes the shadow angle on a comparatively

small value of *a.v.c.* potential, whereas the 6G5 has a remote cut-off triode which closes the shadow angle on a larger value of *a.v.c.* potential.

In both types the triode is mounted in an evacuated glass enclosure with a fluorescent target in a dome as shown in fig. 34. The target is operated at a positive potential and hence attracts electrons from the cathode.

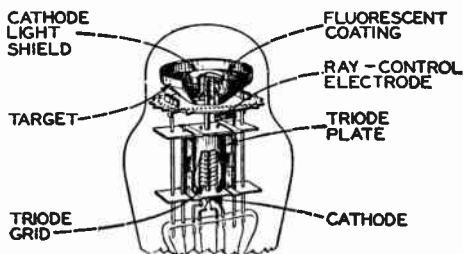

FIG. 34—Internal construction of electron ray indicator tube. (Courtesy R.C.A. Mfg. Co. Inc.)

When the electrons strike the target they produce a glow in the fluorescent coating on the target, which appears as a ring of light when the electrons are flowing over the whole circumference.

The extent of this glow pattern depends upon the grid voltage of the tube, and hence will give an indication on the amount of departure from the condition of resonance or sharpness of tuning.

The tubes may be connected for indicator service as depicted in figs. 35 and 36.

When the receiver reaches a condition of resonance during tuning, the automatic control voltage is at maximum, and since this maximum voltage is applied to the grid of the triode, it acts

to decrease the triode plate current, and decrease the shadow angle to a minimum, which gives an indication that the set is tuned exactly on the desired station.

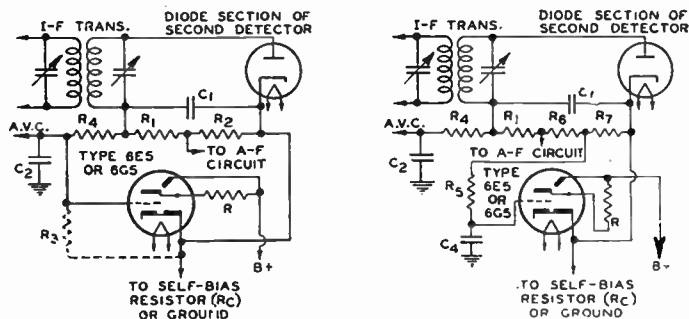

FIGS. 35 and 36—Typical tuning indicator circuits. When the strongest carrier received produces sufficient *a.v.c.* voltage to exceed the cut-off bias value of 8 volts, the shadow area of fluorescent target will overlap. In order to overcome this effect resistor  $R_3$  should be connected, as shown, between the triode unit grid and cathode in order to reduce the control voltage. The value of this resistance may best be determined by applying a strong signal and then adjust  $R_3$  until the shadow angle is nearly zero. (Courtesy R.C.A. Inc.)

$R = \begin{cases} 1.0 \text{ megohm for } B+ = 250 \text{ volts} \\ 0.5 \text{ megohm for } B+ = 100 \text{ volts} \end{cases}$   
 $R_1 = 0.05 \text{ megohm rf (filter)}$   
 $R_2 = 0.2 \text{ megohm}$   
 $R_3 = \text{determined by test}$   
 $R_4 = \text{a.v.c. filter resistor}$

$R_5 = R_4$   
 $R_6 + R_7 = 0.2 \text{ megohm}$   
 $C_1 = 100 \text{ to } 200 \mu\text{f}$   
 $C_2 = \text{A.v.c. filter condenscr}$   
 $C_3 = 0.05 \text{ to } 1.0 \mu\text{f}$   
 $C_4 = C_2$

**“Motor Boating” of Amplifiers.**—Generally this term is derived from the erratic action of a receiving set in giving out a “put-put” sound somewhat resembling that of a motor used in propelling a boat. This is usually caused by inter-action coupling between stages, due to common coupling in the plate-supply unit.

To remedy this situation a circuit known as an "anti-motor-boating" has been found to give good results.

To add a circuit of this kind to any existing receiver it is simply necessary to connect the resistance  $R$ , in series with the lead connecting between the  $B+$  detector terminal on the receiver and the  $B+$  terminal on the detector terminal on the power unit.

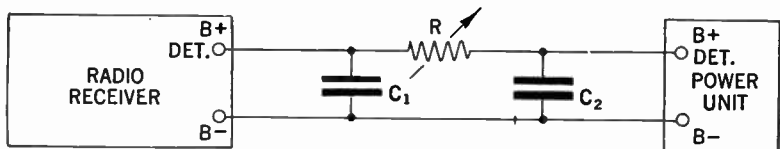

FIG. 37—A method whereby "motor boating" may be eliminated, by means of condensers and resistor connected between the receiver and "B" power supply unit as shown.

Condensers  $C_1$  and  $C_2$  each having a value of 2.0 mfd. are connected between the  $B+$  and  $B-$  as illustrated. It is preferable to locate the resistance at a point close to the receiver rather than near the power unit.

The value of the resistance depends to some extent upon the characteristics of the receiver and the power unit. In some amplifiers a value of 10,000 ohms have been found to be satisfactory whereas in others a resistance of 50,000 to 100,000 ohms has been required to prevent "motor-boating" although in most cases a resistance of 50,000 ohms has been found satisfactory.

A non-motor boating resistance coupled amplifier using two type 6J7 tubes with a voltage gain of 9,000, using circuit values as indicated, is shown in fig. 38.

**Various Methods of Obtaining Grid Bias.**—The grid bias may generally be defined as the direct potential applied to the grid of a vacuum tube, to influence its operation by making it negative with respect to the filament or the cathode.

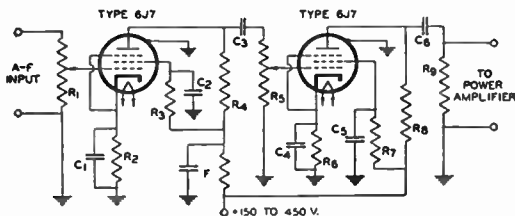

$C_1, C_4 = 8 \mu\text{f}$ , LOW VOLTAGE  
 $C_2, C_5 = 0.06 \mu\text{f}$ , VOLTAGE RATING AS HIGH AS VOLTAGE SUPPLY  
 $C_3, C_6 = 0.006 \mu\text{f}$ , VOLTAGE RATING AS HIGH AS VOLTAGE SUPPLY  
 $R_1 =$  VOLUME-CONTROL POTENTIOMETER  
 $R_2, R_6 = 600$  OHMS, 0.1 WATT  
 $R_3, R_7, R_9 = 500,000$  OHMS, 0.5 WATT  
 $R_4, R_8 = 100,000$  OHMS, 0.1 WATT  
 $R_5 = 500,000$ -OHM VOLUME-CONTROL POTENTIOMETER GANGED WITH  $R_1$   
 $F =$  DECOUPLING FILTER

**FIG. 38**—Schematic circuit diagram of “Non-motor boating” resistance coupled amplifier. (Courtesy R.C.A. Mfg. Co. Inc.)

Among the numerous methods of obtaining bias voltage for amplifier tubes, the simplest and most direct way is to connect the “C” battery in series with the grid return of each tube.

However, because of a rather popular aversion to the use of batteries, to mention nothing of its cost, this classical scheme is ruled out. The next method in order of simplicity is the use of a self-bias resistor, properly by-passed, as shown in fig. 39. This method is familiar to all set builders and experimenters, and therefore requires little comment. The only disadvantage is the high cost of resistors and by-pass condensers, especially when there are numerous tubes in the set.



A number of other bias circuits are available which have the advantages of simplicity, low cost and reliability. These schemes make use of the fact that the total  $B$  drain of the set returns to the power transformer through the minus  $B$ , lead of the set. Fig. 40 shows one of the circuits. A single tapped resistor is used to obtain the  $C$ , bias voltages for all the tubes. When using this circuit, the cathodes of all tubes are grounded.

Experimenters and set builders will appreciate how much this means in cleaning up the wiring around a tube socket.

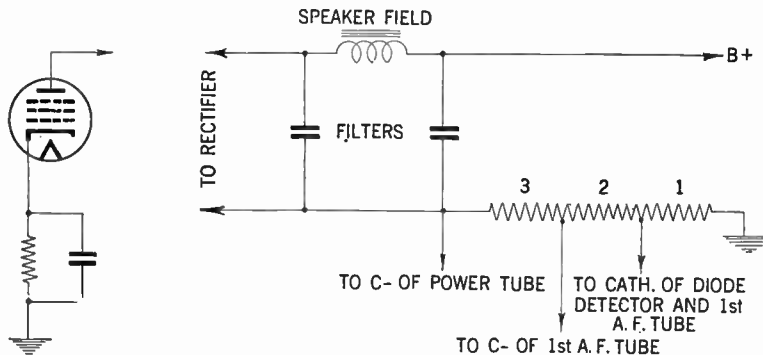

FIG. 39—Showing how grid bias may be obtained by the use of self biased bypassed resistor.

FIG. 40—Illustrating a simple and convenient grid bias scheme.

**Finding Resistor's Value.**—The proper value of this resistor is easy to determine. With reference to fig. 40 add up the plate and screen currents of all the tubes in the set (this value can be obtained from a tube chart) and divide the total into the value of grid bias of the output tube.

For example, if the sum of all the plate and screen currents is, say, 70 milliamperes (0.07 ampere); the grid bias of the output tube is, say 12.5 volts. The value of the entire resistor is then 12.5 divided by 0.07 or approximately 180 ohms. This resistor is divided into three parts: Part 1, is simply the value of the bias on the *r.f.* and *i.f.* tubes divided by 0.07; part 2, is the value of the bias on the first audio tube divided by 0.07, etc.

If trouble be encountered with this calculation, then find the value of the entire resistor and determine the position of the taps by trial and error; the same answer will be obtained either way.

**Using Speaker Field.**—Another convenient bias circuit is to make use of the voltage drop across the speaker field when it is connected in the negative leg of the filter. This circuit is shown in fig. 41. In this circuit, all cathodes are connected directly to chassis. The proper position of the taps is best calculated, because  $R$  should be about 0.5 megohm and accurate readings cannot be obtained on ordinary volt-meters with such high resistors in the circuit.

In a typical case,  $E$  is 100 volts.  $R_1$  is 3 times 500,000 divided by 100, or 15,000 ohms.  $R_2$  is 1.2 times 500,000 divided by 100 or 6,000 ohms; in a similar manner  $R_1$  plus  $R_2$  plus  $R_3$  is determined.

In circuit fig. 43 is another typical device which is used with much success. In this circuit, the *a.v.c.* resistors are used to form a voltage divider with another resistor  $R_3$ . The theory of the circuit is as follows: A bias voltage  $E$ , is developed across resistor  $R_4$  in a manner similar to that described for circuit fig. 1. This voltage is impressed across  $R_1$ ,  $R_2$  and  $R_3$  in series. It is the fraction of  $E$ , that is developed across  $R_1$  plus  $R_2$  that supplies bias for the *r-f* and *i-f* tubes. The entire voltage  $E$

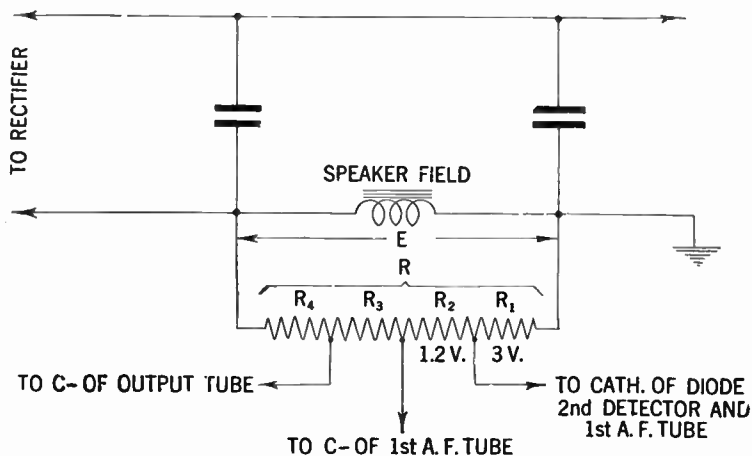
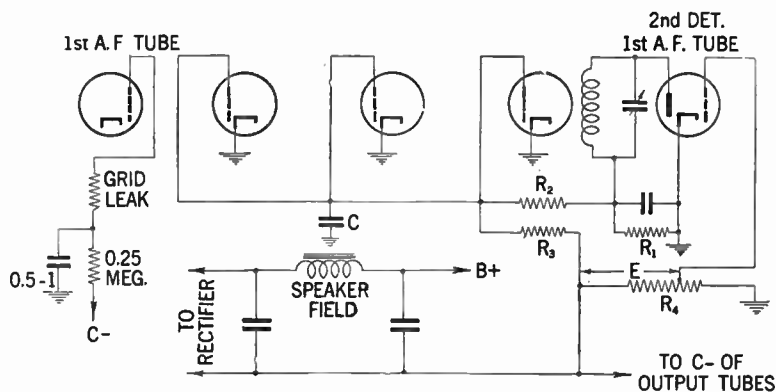

FIG. 41—Method of obtaining grid bias by utilizing voltage drop across speaker field coil.



FIGS. 42 and 43—Grid bias method when receiver is equipped with automatic volume control.

supplies bias for the output tube; the first *a-f* tube obtains bias from a tap on  $R_4$ . The merit of this circuit lies in the fact that any hum on  $R_4$  is filtered from the grids of *r-f* and *i-f* tubes by the *a.v.c.* condenser  $C$ , which is normally in the circuit.

The circuits shown here are fundamental types and there are many deviations from them. This circuit is relatively new and is being adopted by an increasing number of manufacturers for reasons of economy.

Only one precaution need be taken. Should hum develop, simply insert a decoupling resistor in the grid lead of the first audio tube, as shown in fig. 42.

***R.M.S.* (Root mean-square) and Peak Voltage Relations in an Alternating Current.**—In order that a clear conception may be had regarding the exact meaning of the above terms, the definitions are as follows:

1. **The *R.M.S.* (Root mean-square) Value** sometimes identified as effective voltage is that part of an alternating current which has the same heating effect as a direct current of the same potential, and it is for this reason that the *r.m.s.* value of an alternating voltage is termed the effective value.

2. **The Peak Value** of an alternating voltage is the maximum value to which the voltage rises during any part of the cycle. The shape of ordinary *a.c.* voltages are such that the potential is proportional to the sine of an angle, hence the often heard expression of the term "sine curve" shown in fig. 44.

When the voltage has such a form the peak voltage is equal to the  $\sqrt{2}$  times the *r.m.s.* value or if the peak voltage is known divide this voltage by the  $\sqrt{2}$  to obtain the *r.m.s.* or effective value.

**Example.**—*What is the effective or (r.m.s.) value of an oscillating grid voltage whose peak values are 7 and 22 volts negative, and what is the grid bias?*

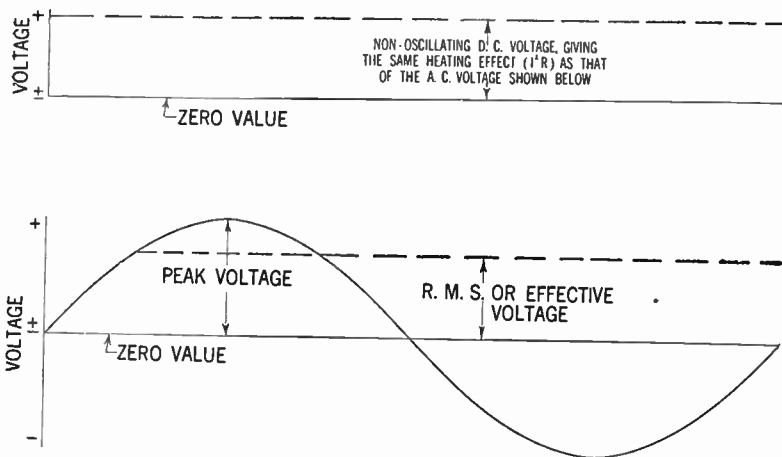

FIG. 44—Illustrating comparative values of *r.m.s.* and peak voltage in an alternating current.

**Solution.**—Since the extreme values of voltage variation are  $-7$  and  $-22$  volts, the total amount of grid “swing” will be their difference or 15 volts, while the amplitude of an oscillation will be half of this or 7.5 volts. Now the *r.m.s.* value is always  $\frac{1}{1.41}$  or 0.707 of the corresponding amplitude; hence the

*r.m.s.* value of the grid voltage oscillations will be  $0.707 \times 7.5 = 5.3$  volts approximately. The grid bias point or mean potential of the grid will obviously lie half-way between the extreme peaks of potential attained in the cycle; it will therefore be  $\frac{1}{2}(7+22)$  or 14.5 volts negative.

**Example.**—*If a 2 volt battery supplies 0.85 watt to a filament circuit, what is the current drain?*

**Solution.**—For the solution of this problem, it is necessary to re-write the equation  $W = I \times E$  in the equivalent form  $I = \frac{W}{E}$  in which as usual  $E$  and  $I$  are in volts and amperes, while  $W$  is expressed in watts. In the above example therefore—

$$I = \frac{0.85}{2} = 0.425 \text{ ampere}$$

**Example.**—*It is desired to use 75% of the possible voltage amplification of a triode in a resistance coupled audio frequency stage. If the  $\mu$  and a.c. resistance of the tube are 22 and 18,000  $\Omega$  with 100 volts on the plate, what resistance load is necessary in the anode circuit?*

**Solution.**—For the purpose of this question, ignore entirely the frequency distortion which is inevitably introduced into the resistance capacity audio frequency coupling, by reason of the inter-electrode capacitance of the tube, and the coupling condenser, and assume simply that amplification is uniform over all frequencies. As a working approximation over a wide frequency band, the actual voltage amplification obtained from a single stage is given by the well known formula:

$$\text{stage gain} = \frac{\mu \times R}{R + R_o}$$

where  $\mu$  and  $R_0$  are the amplification factor and anode *a.c.* resistance of the tube, and  $R$ , is the external load in the anode circuit. In this case, the voltage gain over the stage is 75% of  $\mu$ .

$$\text{Hence, } \frac{\mu \times R}{R + R_0} = \mu \frac{75}{100}$$

equating and substituting, it follows that,

$$\frac{R}{R + 18,000} = \frac{75}{100} \text{ or } R = 54,000 \text{ ohms.}$$

**Example.**—*If the anode resistance in the preceding example is connected directly to the output of an eliminator supplying current at 300 volts, what is the average current taken by the audio frequency tube?*

**Solution.**—Since the anode voltage of the audio frequency tube is specified as 100 volts, the voltage drop across the anode resistance will be the difference between 300 and 100 or 200 volts. The average current passing will therefore be—

$$I = \frac{E}{R} = \frac{200}{54,000} \text{ or } 3.7 \text{ M.A.}$$

## CHAPTER 14

## Radio Circuit Diagrams

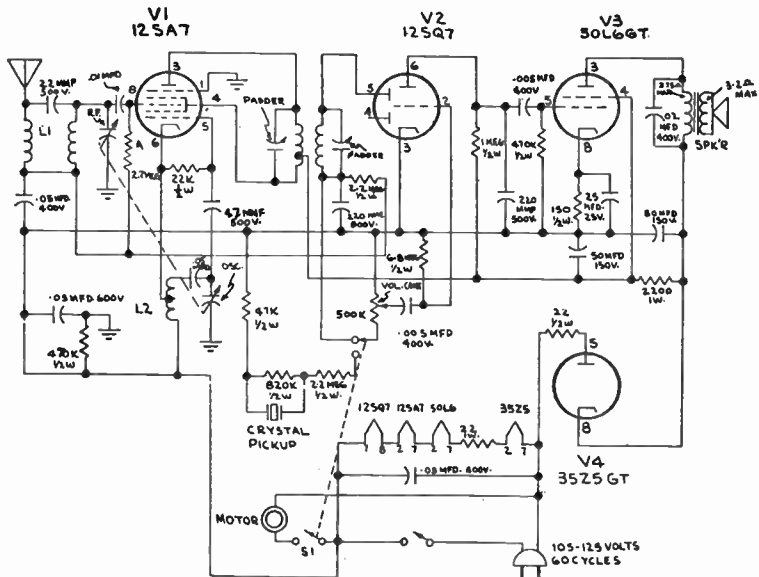

FIG.1—Schematic wiring diagram of General Electric Model 4S3A1 radio phonograph combination. Alignment procedure: 1. Turn S1 to radio and volume to maximum. Connect an output meter across the speaker voice coil. Connect signal generator ground to B—through a .1 mfd. condenser, and the high side to pin 8 of the 12SA7 tube through .03 mfd. Tune signal generator to 445 kc. and tune T1 trimmers for maximum output reading. 2. Remove signal generator connection to pin 8, unsolder antenna and attach generator to L1 through 25 mmfd. Turn tuning condenser of set fully open. Set signal generator to 1620 kc. Tune oscillator trimmer on tuning gang for maximum reading; set R.F. trimmer for maximum output reading. Use only enough signal generator output to obtain a reading on the output meter.



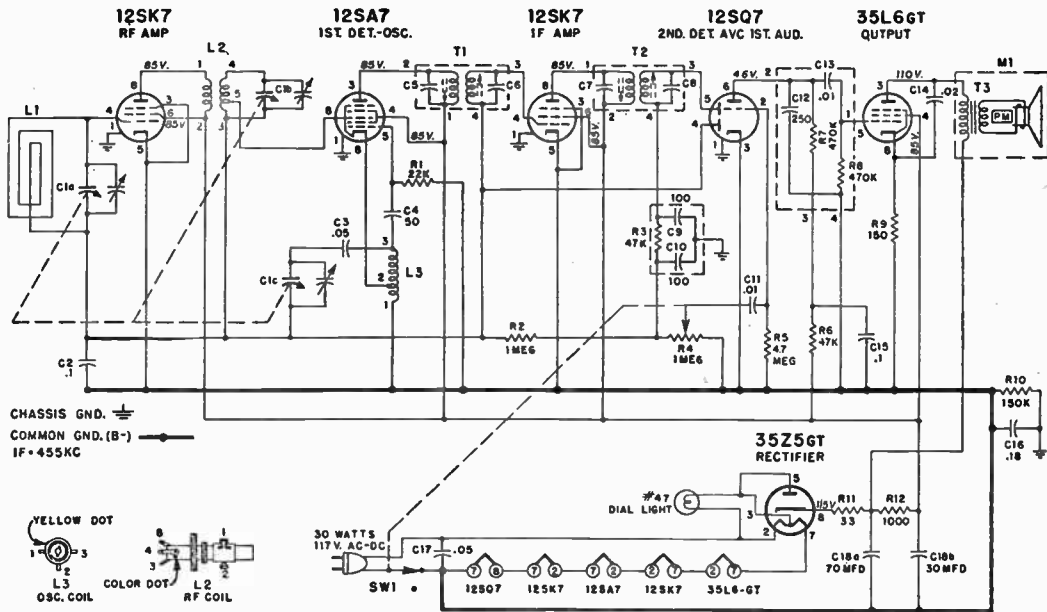

FIG. 2—Schematic wiring diagram of Admiral Models 6A21, 6A22 and 6A23 radio receiver. Alignment procedure: 1. Turn receiver volume control on full. 2. Use an isolation transformer if available otherwise connect a .1 mfd. condenser in series with low side of signal generator and connect to B-terminal of on-off switch. 3. Connect output meter across speaker voice coil. 4. Use lowest output setting of signal generator capable of producing adequate output meter indication. 5. Repeat adjustments to insure good results. 6. Use a non-metallic alignment tool for *i.f.* transformers.

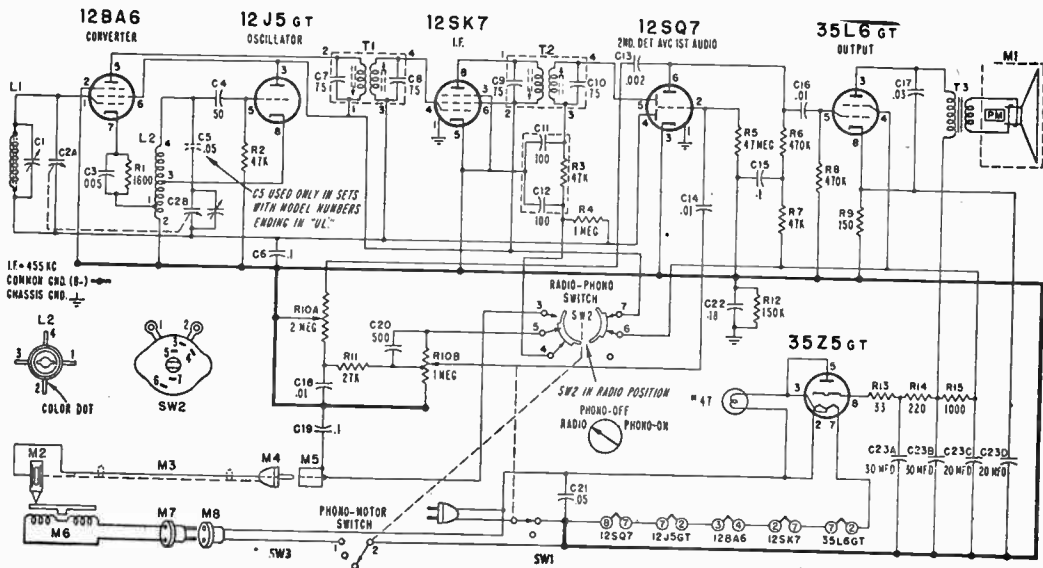

FIG. 3—Schematic wiring diagram of Admiral Model 6S11 and 6S12 radio phonograph combination.

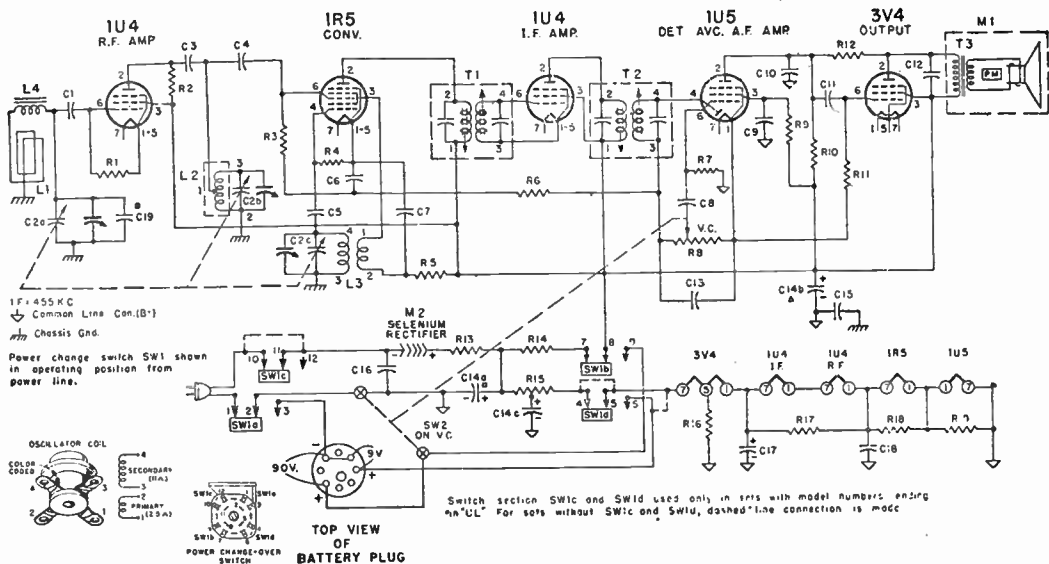

FIG. 4—Circuit diagram of Admiral Model 6Y18 and CY19 radio receiver. This circuit is designed for alternate operation on battery or power line. The electrical characteristics of the battery packs provide for equal life for both the "A" and "B" sections. The "A" section may give satisfactory performance as low as 6.6 volts, the "B" section as low as 60 volts.





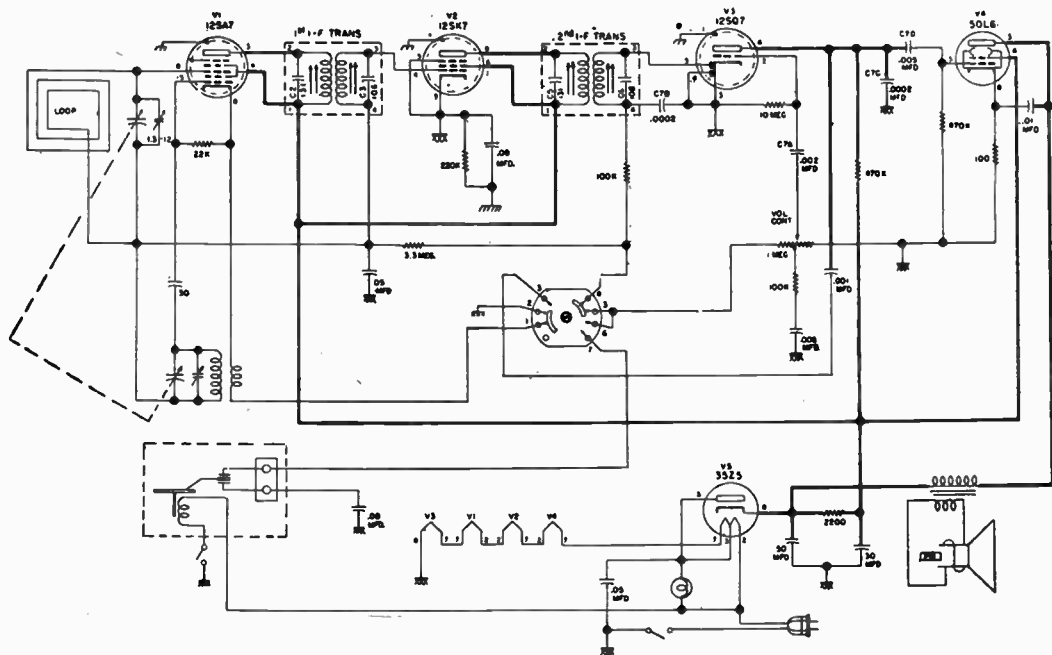

FIG. 7—Circuit diagram of Crosley Model 10-145 M radio-phonograph combination. All capacitance values shown, are in *mmf.* unless otherwise noted.

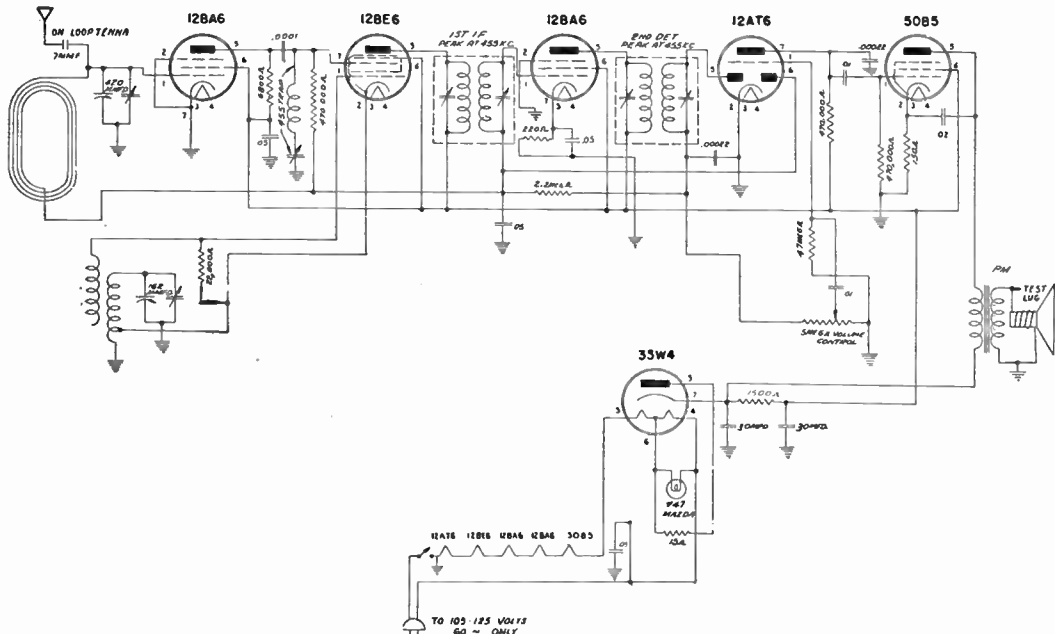

FIG. 8—Circuit diagram of DeWald Model D-616 radio receiver. To calibrate receiver connect the output of signal generator to the flexible antenna lead attached to the loop antenna. Connect the low side of signal generator through a .1 *mf*d. condenser to receiver chassis. Tighten the wave trap condenser. Adjust signal generator to 455 kc. and adjust both *i.f.* transformers for maximum signal. Re-peak the wave trap condenser for minimum capacity. Set signal generator at 1800 kc. Peak oscillator section of receiver condenser for maximum signal. Next set signal generator at 1500 kc. Tune in this signal.





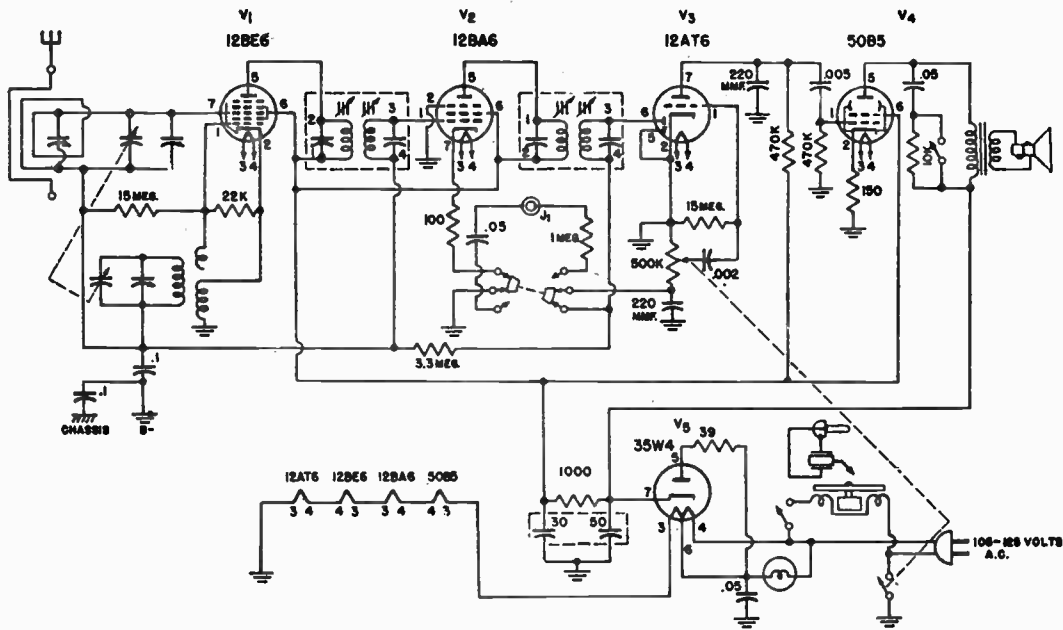

FIG. 10—Schematic circuit diagram of Emerson Model 579 and 596 combination radio and phonograph receiver. *I.f.* peaked at 455 kc. Voltage rating 105 to 125 volts a.c.

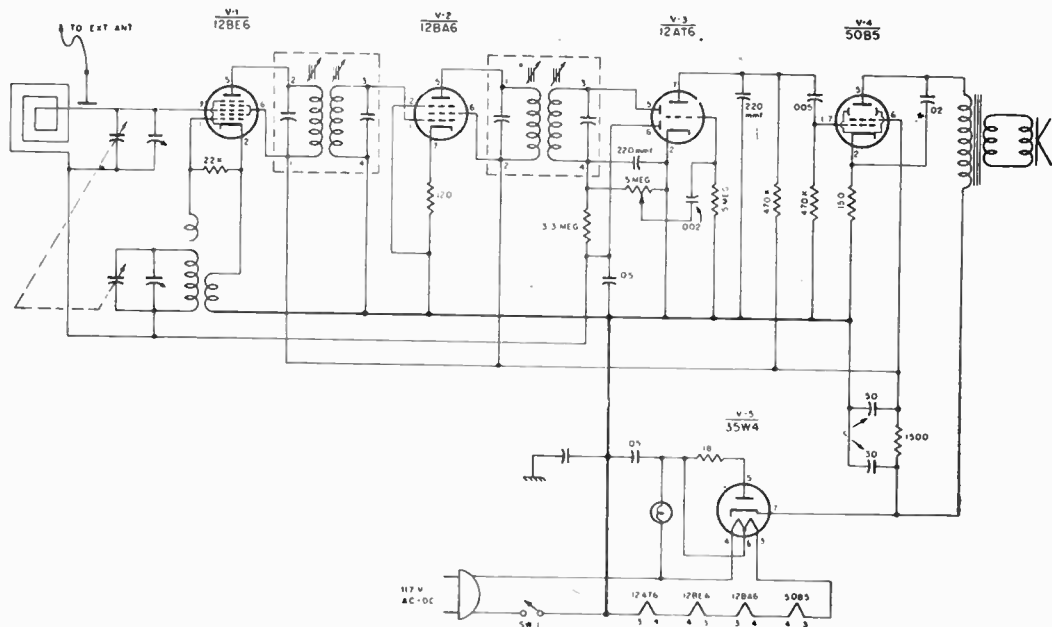

FIG. 11—Circuit diagram of Emerson Model 652 and 653 radio receiver. *f.f.* 455 kc. Voltage rating 117 volts a.c. or d.c.

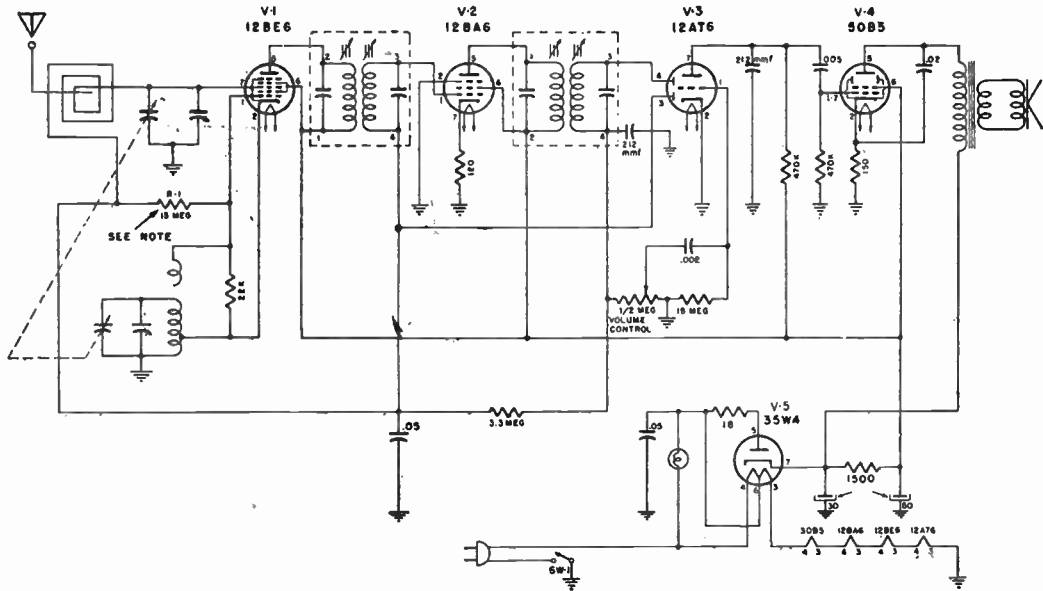

FIG. 12—Circuit diagram of Emerson Model 642 radio receiver. *I.f.* 455 kc. Voltage rating 117 volts a.c. or d.c.

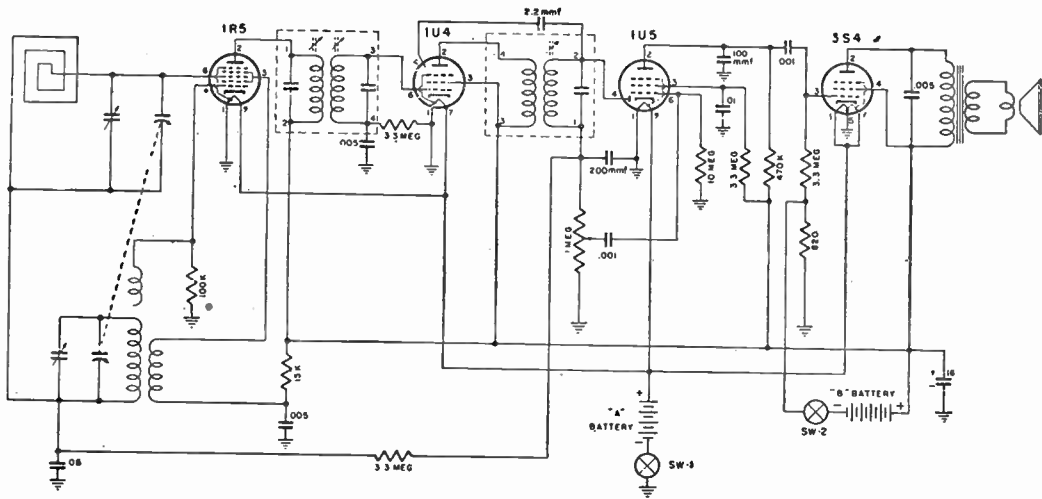

FIG. 13—Schematic circuit diagram of Emerson Model 645 radio receiver. *I.f.* 455 *k.c.* This receiver is battery operated. "B" battery 67.5 volts. "A" battery 15 volts.

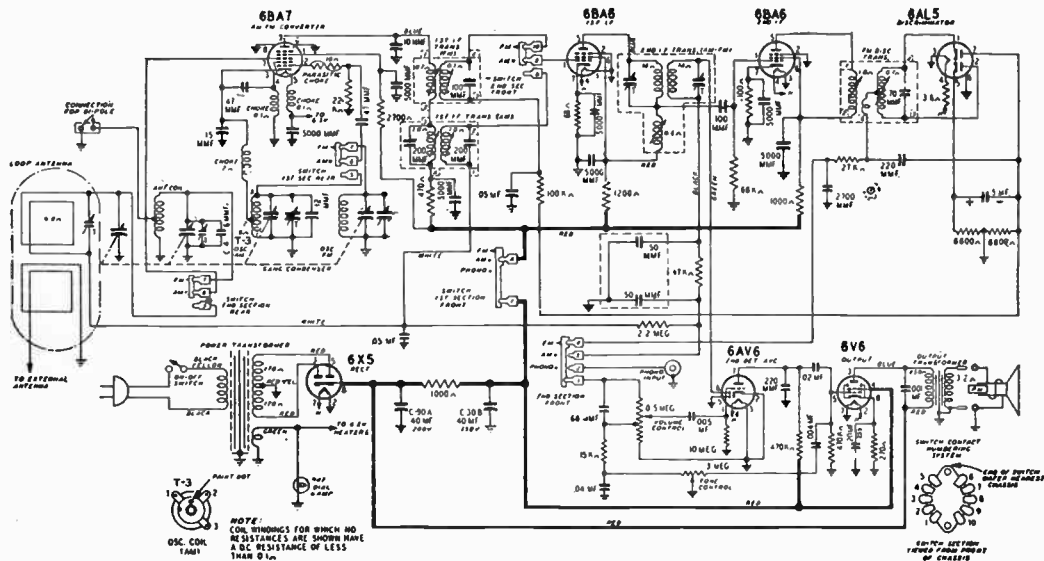

FIG. 14—Circuit diagram of Gamble-Skogmo, Coronado Model 94RA1-43-8510B and 8511B radio receiver. This is an A.M.-F.M. radio phonograph combination. Frequency ranges, broadcast 540-1600 kc.; frequency modulation 88 to 108 mc. Intermediate frequency, A.M. 455 kc.; F.M. 10.7 mc.

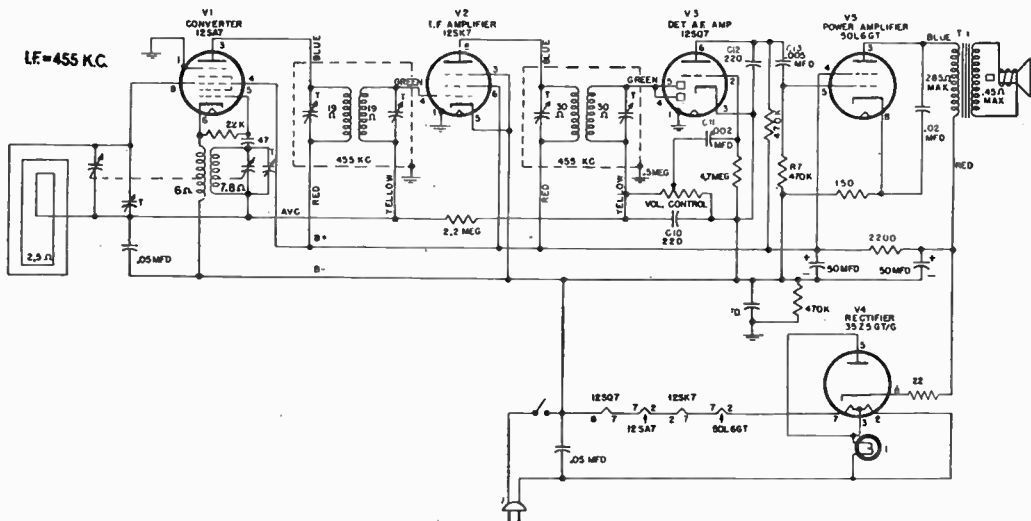

FIG. 15—Circuit diagram of General Electric Model 135 and 136 radio receiver. Values of all capacitors are in *mmf.* unless otherwise noted. The receiver operates from the conventional 115 volts *a.c.* or *d.c.* power circuit.

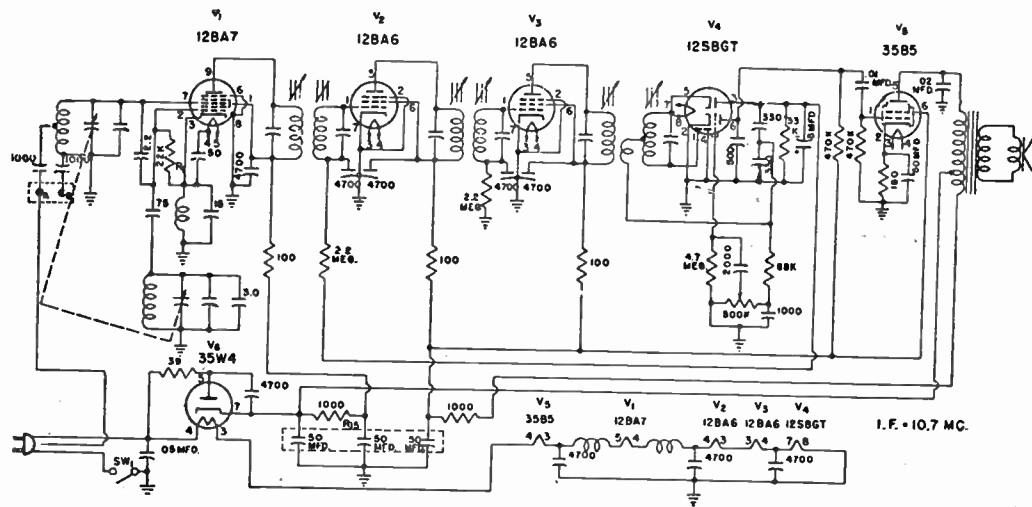

FIG. 16—Schematic circuit diagram of Emerson Model 602 single band F.M. super heterodyne radio receiver. The receiver is provided with an internal power line antenna for F.M. reception in relatively strong signal areas. The line cord should be completely uncoiled for effective operation of this antenna. An external dipole antenna is recommended for maximum F.M. operation. To connect the dipole, remove the wire from the screw terminal at the rear of the chassis marked "A" and connect the dipole leads to "A" and "G".

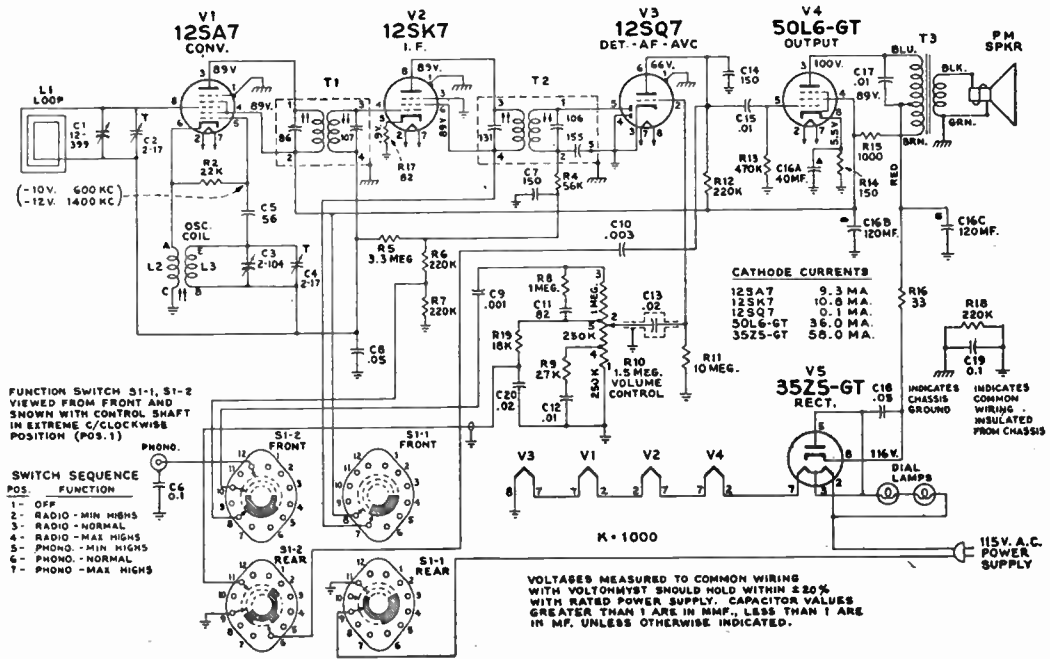

FIG. 17—Schematic circuit diagram of RCA Victor Model 9X571 and 9X572 radio phonograph combination. Tuning range 540 to 1600 kc. Intermediate frequency 455 kc.



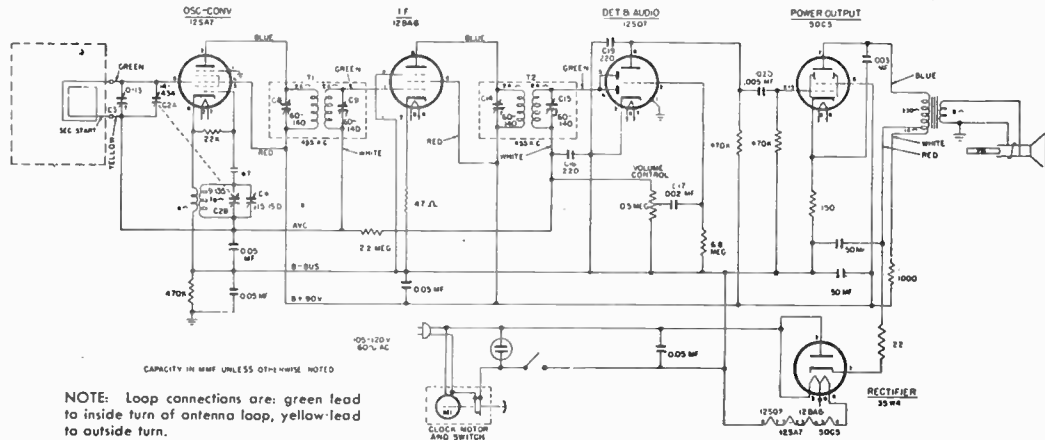

FIG. 18—Schematic diagram of General Electric Model 509 and 530. Since this model is provided with an electric clock the power for its proper operation must be 105 to 120 volts, 60 cycles a.c. For alignment of the oscillator and antenna trimmers, the input signal should be inductively coupled to the radio loop antenna L1, by connecting a four-turn, six-inch diameter loop of bell wire across the signal generator output terminals, and then locating the loop to face the radio antenna  $\pm 70$  about one foot away.

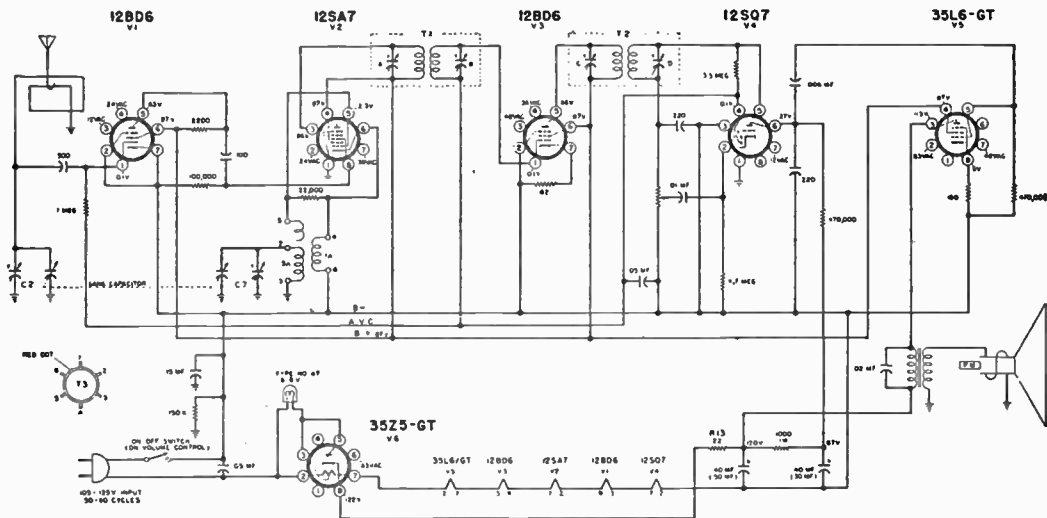

FIG. 19—Schematic circuit diagram of Wards Airline Model 84BR-1517A, 1518A radio receiver. Alignment procedure: The signal source must be an accurately calibrated signal generator capable of supplying r.f. signals, modulated 30% with a 400 cycle audio signal. A 400 cycle source is necessary for the audio measurement. All measurements are based on an output of 50 milliwatts. This may be measured by disconnecting the speaker voice coil and substituting a 3.2 ohms, 5 watt resistor across the secondary winding of the output transformer. A reading of .4 volts across this resistor will be equivalent to a 50 milliwatt output with the speaker connected. Variations of plus or minus 25% are usually permissible. Volume control at maximum for all adjustments.

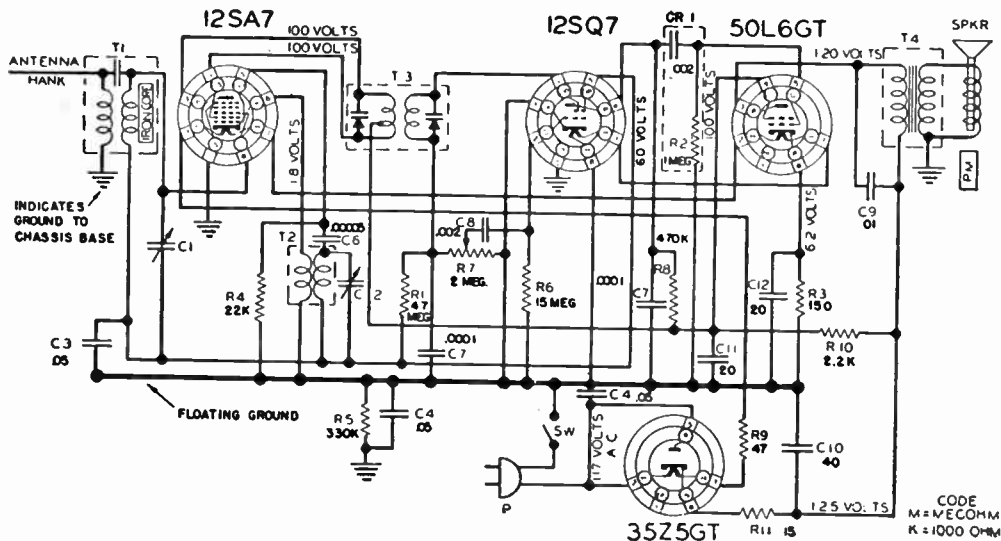
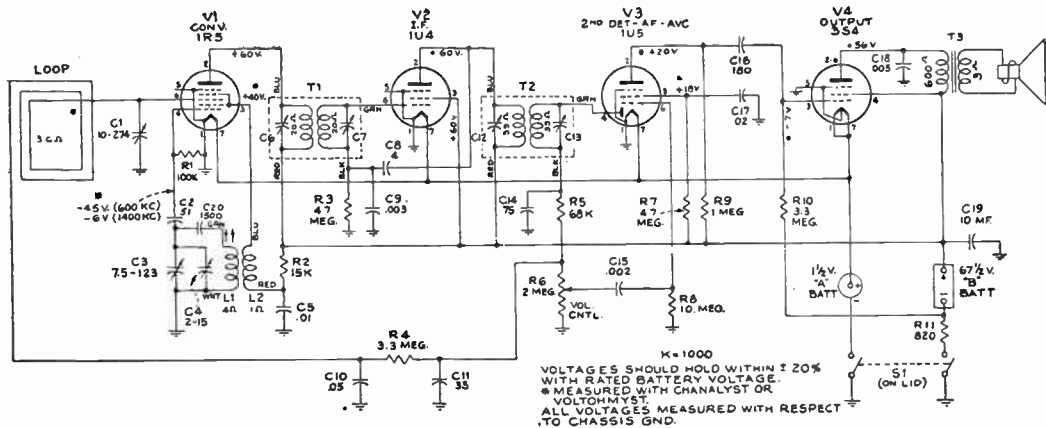

FIG. 20—Circuit diagram of Arvin Model 341T, 4 tube a.c.-d.c. radio receiver. Alignment procedure: Since the antenna section of the variable has no trimmer, the rotor of the variable should be rocked back and forth on both sides of the 1400 kc. while adjusting the trimmer for maximum output. Check sensitivity at 600 kc. If weak, adjust antenna section plates for maximum output at 600 kc. Tracking of the condenser at points other than 1400 kc. is accomplished by bending the outside plates on the variable condenser rotor, which are cut for this purpose. When bending plates to track the condenser at any given frequency, keep in mind the fact that this will affect the tracking at all frequencies below the point where the plates are bent. A tuning wand is very helpful in checking the tracking of this condenser, to indicate whether more or less capacity is needed.



**FIG. 21—Schematic circuit diagram of RCA Victor Models 8B41, 8B42 and 8B43 battery type radio receiver. Alignment procedure: Connect output meter from top lug of TB5 (plate of 3S4) to ground. Turn volume control to maximum position: For alignment operations connect the low side of the test oscillator to the receiver chassis, and keep the oscillator output as low as possible to avoid *a.v.c.* action. It is necessary to use an alignment shield during oscillator alignment.**

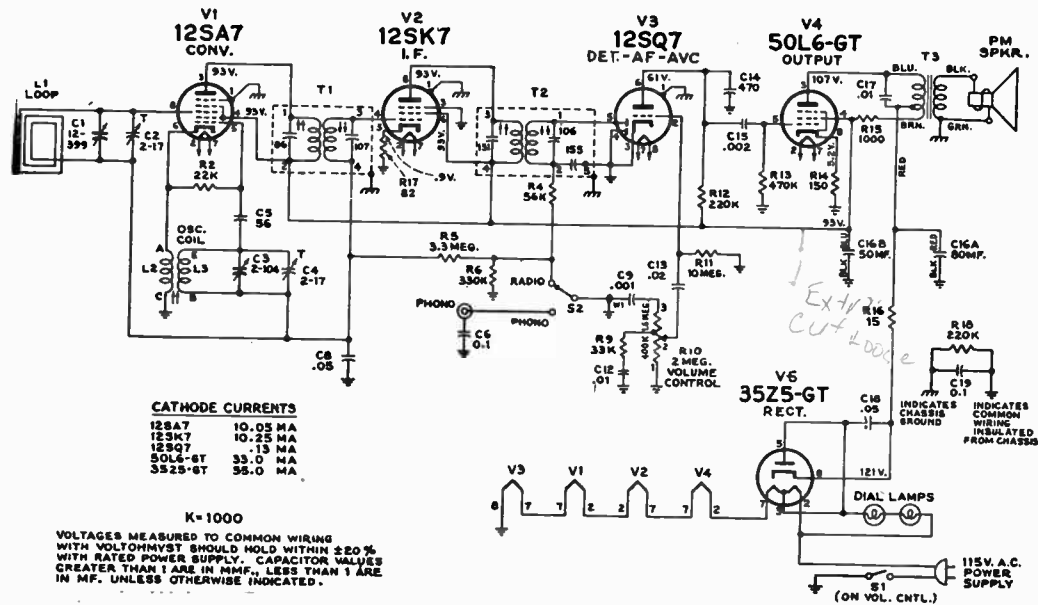

FIG. 22—Schematic circuit diagram of RCA Victor Model 9X561 and 9X562 a.c.-d.c. radio receiver. For all alignment operations, connect the low side of the test oscillator to the receiver chassis, and keep the oscillator output as low as possible to avoid a.v.c. action. On a.c. operation an isolation transformer (115/115v) may be necessary for the receiver if test oscillator be also a.c. operated.

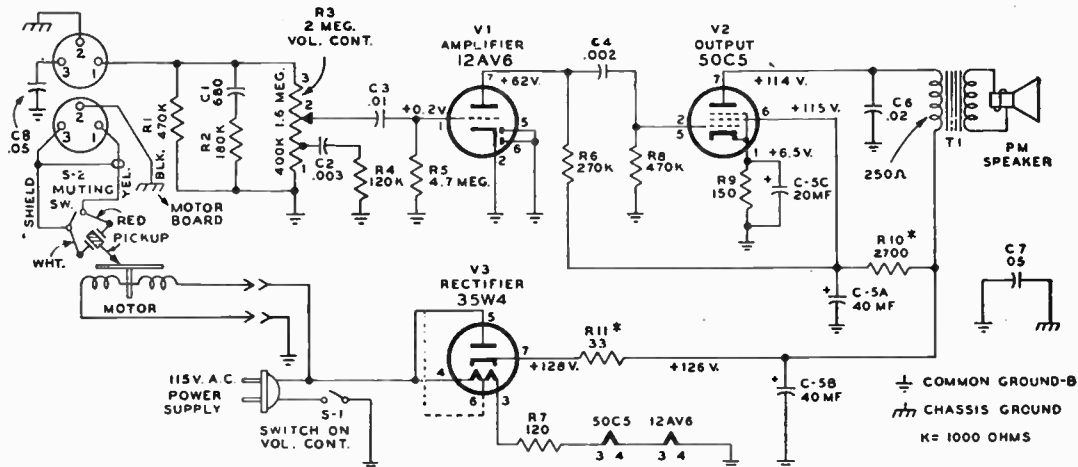

FIG. 23—Schematic circuit diagram of RCA Victor 45 r.p.m. automatic record player Model 9EY3, 9EY35 and 9EY36.

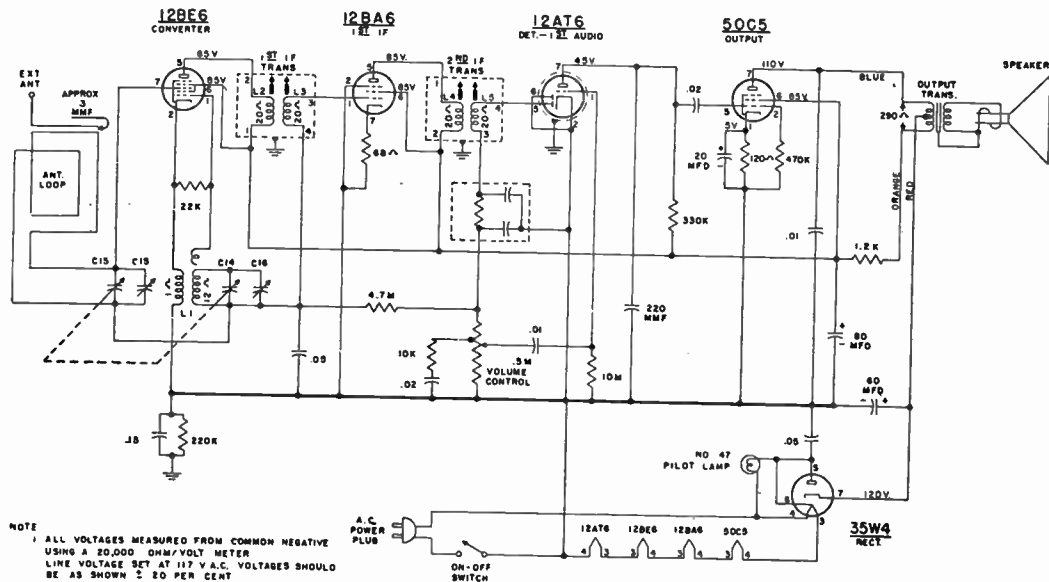

FIG. 24—Schematic circuit diagram of Westinghouse Electric Model H300T5 and H301T5 radio receiver. When aligning the receiver it is recommended that the chassis be isolated from the power line by means of an isolation transformer. Make certain that the dial pointer is correctly positioned with respect to the dial scale. When the gang is completely closed, the pointer should be over the small bump near the left end of the dial background. While making alignment adjustments, keep the volume control set for maximum output and the signal generator output attenuated to avoid *a.v.c.* action.

## CHAPTER 15

# Receiver Construction

**Tools.**—It cannot be denied that a commercial factory built receiver from the standpoint of appearance can be made much neater than most amateur built sets. This is due in most cases to the lack of necessary tools for handling the modern type of construction, found in ready built sets.

It is undoubtedly true that with a few well-chosen tools, an otherwise time consuming piece of work may be turned out neat appearing, satisfactory and reliable from every point of view.

Within certain limits it is true that the greater the variety of tools the better the job will be done, and it is also true that a great many difficult pieces of equipment have been built by only a minimum number of hand tools.

A list of tools commonly required by the amateur are as follows:

- 1 Hacksaw (12 in. blades).
- 1 Pr. slip-joint pliers (6 in.).
- 1 Pr. longnose pliers (6 in.).
- 1 Pr. diagonal cutting pliers (6 in.).
- 1 Ball pein hammer (1 lb. head).
- 1 Bench vise (4 in. jaws).



- 1 Round bastard file (coarse,  $\frac{1}{2}$  in. or more diam.).
- 1 Flat file (12 in. very coarse for fast cutting).
- 1 Taper reamer (1 in.) for brace.
- 1 Taper reamer ( $\frac{1}{2}$  in.) for brace.
- 1 Center punch.
- 1 Electric soldering iron (100 watts, small pointed tip).
- 1 Heavy knife
- 1 Circle cutter (adjustable) for brace.
- 1 Screw driver bit for brace.
- 1 Countersink for brace.
- 1 Carpenter's ratchet brace.
- 1 Hand drill (2 speed).
- 1 Yardstick or other straight edge.
- 1 Carpenter's plane (8 to 12 in.).
- 1 Combination square (12 in.).
- 1 Pr. wing dividers (8 in.).
- 1 Long shank screw driver with screw holding clip ( $\frac{1}{4}$  in blade).
- 1 Screw driver (6 in. to 7 in.  $\frac{1}{4}$  in. blade).
- 1 Screw driver (4 in. to 5 in.  $\frac{1}{8}$  in. blade).
- 1 Scratch awl or ice pick.
- 1 Cold chisel ( $\frac{1}{2}$  in.).
- 1 Wood chisel ( $\frac{1}{2}$  in.).
- 1 Pr. tin shears (10 in.).
- 1 Set small stamped steel open end wrenches.
- Several small "C" clamps.
- Drills; particularly  $\frac{3}{8}$  in.,  $\frac{1}{4}$  in.,  $\frac{3}{16}$  in. and Nos. 13, 21, 28, 29, 33, 42 and 50.
- Solder (rosin core).
- 1 Combination oil stone for sharpening tools
- Sandpaper and emery cloth (several grades).
- Steel wool.
- Soldering paste (non-corroding).

**Method of Bending and Cutting Sheet Metal.**—The cutting of sheet metal is generally performed with a hacksaw, following a marked outline on the panel to be cut, after which the rough edge is trimmed down to measurement with a suitable file.

A dependable steel square should be used in marking out the various lines to be cut, otherwise the assembly will be out of alignment when put together.

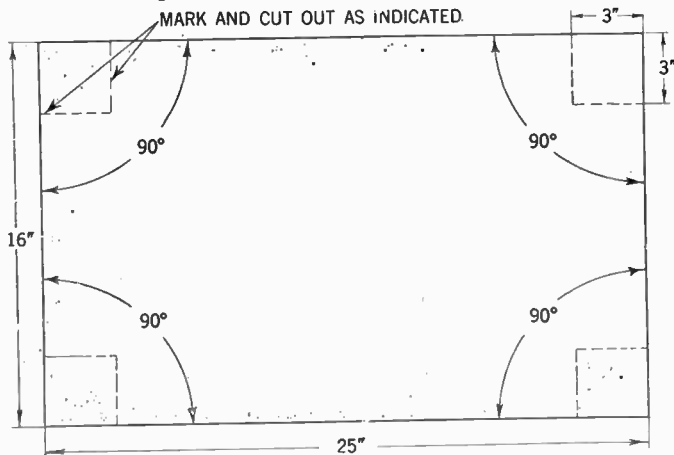

FIG. 1—Showing method of laying out metal to be developed into a radio receiver chassis. The dimensions shown are typical only, and should not be considered as standard for any particular job.

As a final finishing of the edges it is recommended that a long piece of emery cloth or sandpaper be placed on a flat surface, on which the edge of the metal be run back and forth.

In bending a piece of metal the sheet may be scratched as deeply as permissible (without weakening the strength of the piece) after which it is put in a vise and bent to the desired form. Sometimes a pair of iron bars or angles of the same length or longer than the width of the sheet, will facilitate the bending process.

**Laying Out the Apparatus.**—A general practice of good workmanship is to lay out the component parts, on a sheet of heavy paper upon which the exact outline of the panel or chassis has been made. The parts are generally moved around until a satisfactory arrangement has been obtained. The centers and size of the various holes are then laid out on the paper, after which the

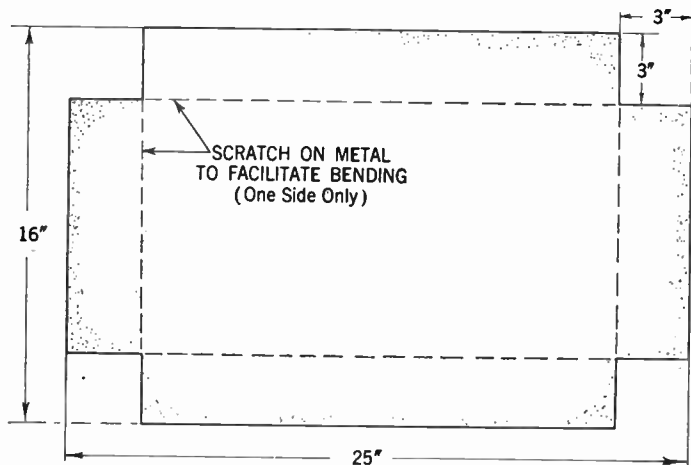

FIG. 2—After corners has been removed and the drilling and cutting completed, the projecting sides of the metal is bent down 90° to form the chassis as shown in fig. 4.

paper is transferred to the panel and properly fastened by gummed paper or adhesive tape. Only after this has been done may the center of the holes be punched through the paper. This general procedure has been found to save a great many valuable panels, and is in the long run, a method of time and money saving.

When measurements are made it is well to observe with great care that the necessary accuracy be obtained, otherwise

unnecessary filing and trimming will be required which may finally make an unsatisfactory assembly.

Generally it can be said that holes larger than  $\frac{1}{8}$  or  $\frac{3}{16}$  in. should be drilled with a small drill and then enlarged successively until the wanted size is obtained.

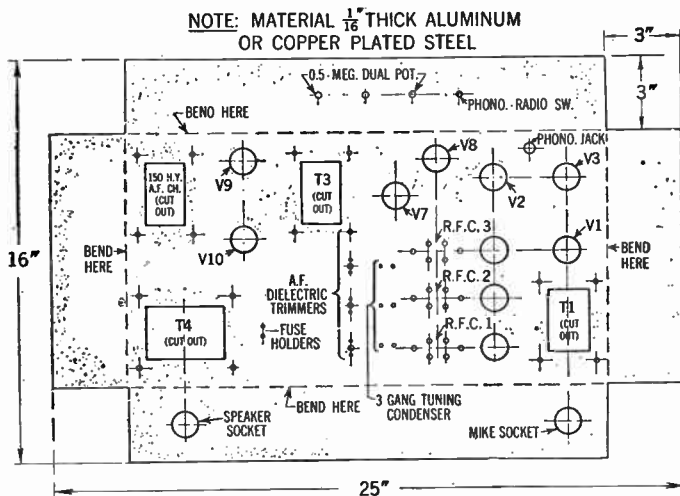

FIG. 3—Example of a typical chassis size and drilling layout, showing location of parts.

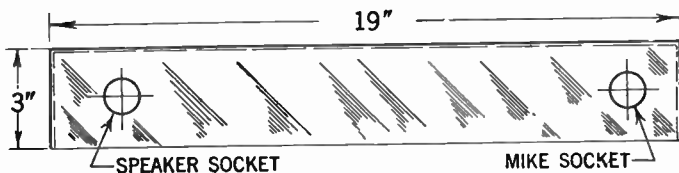

FIG. 4—Side view of final development of chassis.

For holes larger than  $\frac{1}{4}$  in. a taper reamer should be used if possible. When holes of 1 in. diameter or larger are to be drilled, a hole cutter sometimes identified as a fly-cutter is necessary. If such a tool is not available, it may be cut out by drilling a series of small holes as close together as possible, as shown in fig. 5.

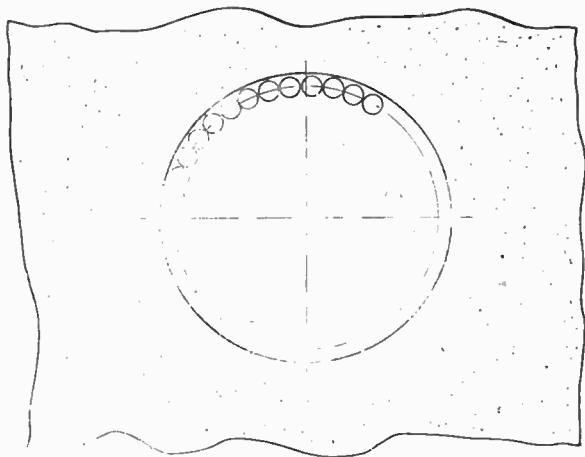

FIG. 5—Method of drilling large diameter holes. After drilling is being completed the remaining corners are removed by a round file of suitable size.

**Tapping of Holes.**—After the holes are drilled to measurement and before they are tapped, it is well to refer to the table showing the tap sizes to be used for the various standard sizes of machine screws.

Certain metals, notably aluminum, are difficult to tap, hence care should be observed not to break the tap and as a precaution the tap should be kept at right angle to the metal surface, and reversed whenever necessary, and machine oil should always be used.

**Soldering.**—Before proceeding to the actual construction it may be well to observe the importance of soldering.

In soldering it is important that the solder and the joint be kept at similar and sufficient temperatures. A good soldering joint is made when the heat applied to the solder is sufficient to melt the solder when it comes into contact with the wire forming the joint. Soldering paste of the non-corroding type is recommended, and should be used sparingly, because of the fact that an excessive amount of solder will spread over the adjacent wire insulation causing leakages and breakdowns.

Finally the tip of the soldering iron should be kept at the correct temperature as well as clean and well heated.

**Wiring.**—The importance of wiring in radio receiver construction should not be underestimated. The old geometrical axiom that a straight line is the shortest distance between two points should not be taken **too seriously** when wiring a radio receiver, if a satisfactory performance is to be expected.

Although there are no specific rules guiding the performance of this task, many skillful constructors wire a receiver in the following order:

1. In case of *a.c.* supply all filaments or heater connections are wired with a pair of twisted wires. They should be placed wherever possible in the angles formed by the top of the chassis separately away from the other circuits.

2. All grid and plate connections are run as directly and with as short leads as possible from the tube socket or cap to the indicated terminal (preferably to the condenser in a tuned circuit) but should be spaced from or run at right angles to other circuit elements.

3. The plate and grid return circuit with their various filter elements are placed in a neat orderly way in place.

**Guiding Principles.**—Whenever possible, a single common ground point should be used for each stage. By-pass condensers should be placed as close to the socket terminal or by-passed element as possible. Choke coils should be placed so that their fields do not mutually interact, and as much spacing between the parts in adjacent stages should be provided as the construction permits.

When ordinary push-back wire is used for plate and grid connection in short-wave receivers, it should be kept away from the chassis or other parts, since the insulation at high frequency is apt to cause leakage. Spaghetti or varnished cambric insulation is generally satisfactory at ordinary radio frequencies.

**Important Information.**—The one important factor to keep in mind when wiring a receiver is that damaging reactions between the stages due to stray coupling between the various circuit elements should be avoided, hence too much dependency should not be placed on ordinary forms of insulation, in keeping the elusive high frequency current in boundaries geometrically formed by the wire.

Also the resistance introduced by one single improperly soldered connection may ruin the performance of an otherwise perfect receiver.

## CHAPTER 16

# Control Systems

## AUTOMATIC FREQUENCY CONTROL (A. F. C.)

In the early kinds of radio sets the receiver control had to be operated manually by the turning of one or more volume control knobs. In modern receivers however, automatic frequency control has been incorporated to make this constant manipulation of the volume control knobs unnecessary.

The action of the automatic frequency control circuits in superheterodyne receivers is such that any mis-tuning by the listener or any frequency drift in the set after it has been properly tuned is automatically corrected by the incoming signal itself.

The requirement for an automatic frequency control circuit are:

1. A *d.c.* detector operated through an *i.f.* frequency discriminator network, and
2. An oscillator frequency control circuit.

**How the Discriminator-Detector Circuit Works.**—The discriminator-detector network as the name implies, discriminates between applied intermediate frequencies which are too low



and those which are too high, and produces a corresponding direct current or voltage whose polarity depends upon the direction of frequency departure from a prescribed intermediate frequency. This *d.c.* voltage is applied to a control element which in turn causes a shift in frequency of the local oscillator such as to bring the *i.f.* signal to very nearly the correct inter-

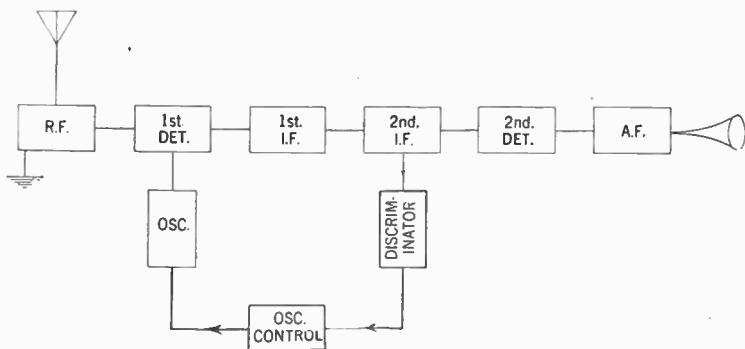

FIG. 1—Conventional block diagram of an automatic radio frequency control circuit.

mediate frequency. Since production of the *d.c.* voltage is due to departure from the resonant or center frequency of the *i.f.* system, obviously the correction cannot be strictly complete; but in the system described a correction ratio of more than 100 to 1 is feasible.

In other words, when the dial of the receiver is mis-tuned 100 *k.c.* for the received signal, the automatic correction may be made to bring the actual *i.f.* signal frequency to only 100 cycles off resonance in the *i.f.* system. Of course that is easily sufficient.

**The Frequency Discriminator.**—A method for obtaining differential *d.c.* potentials (or currents) whose magnitude and polarity are determined by the amount and the sign, respectively, of the difference between an applied frequency and the true intermediate frequency is described herewith. Side circuits tuned above and below the center frequency are not used.

The action depends upon the fact that a  $90^\circ$  phase difference exists between the primary and secondary potentials of a double-tuned, loosely-coupled transformer when the resonant frequency is applied and that this phase angle varies as the applied frequency varies. Thus if the primary and secondary voltages are added vectorially, the absolute magnitude of the resultant vector will be greater on one side of resonance than on the other.

The vector sum of the primary and secondary voltages may be physically realized by connecting the two parallel tuned, coupled circuits in tandem, applying the input potentials to one circuit and taking the output across both circuits in series. In this manner, an action similar to that of a side circuit is produced even though the primary and secondary are both tuned to the center frequency.

The potentials at either end of a secondary winding with respect to a center tap on that winding are  $180^\circ$  out of phase. Therefore, if the center tap, rather than one end, of the secondary is connected to the primary, two potentials may be realized, one maximizing above and one maximizing below the center frequency. See fig. 2.

If a transformer is connected in this manner and the resonant frequency is applied to the primary the two resulting output potentials will be equal in magnitude. If these are then applied to two separate, like detectors and the resulting *d.c.* voltages are added in opposition, the sum will be equal to zero. If, however,

the applied frequency departs from resonance, the sum of their outputs will be some real value whose polarity will depend upon the sign of the frequency departure.

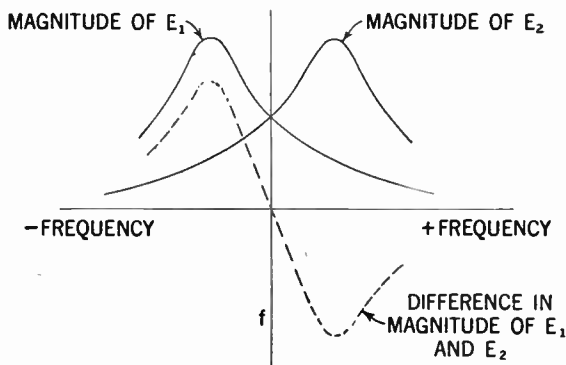
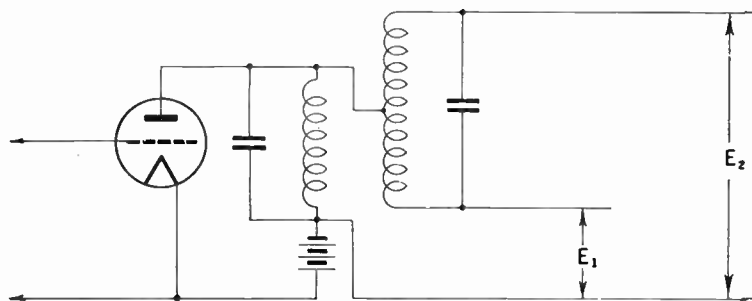

FIG. 2—Diagram and plotted curves illustrating how the potentials at either end of secondary are  $180^\circ$  out of phase.

Referring to fig. 3, the action is as follows: If the resonant or center frequency is applied to the grid of the amplifier tube,

equal amplified voltages will exist between the point *A* and ground and between the point *B* and ground. These are rectified by the diodes and direct currents will flow in the resistors  $R_1$  and  $R_2$  in opposite directions with respect to ground. Thus, the net *d.c.* potential produced by the two  $IR$  drops between *E*, and ground is equal to zero. If, however, the applied frequency departs from resonance the potentials across the diodes will be unequal in magnitude, unequal  $IR$  drops will be produced in the two resistors and a *d.c.* potential will exist between *E* and ground, the polarity of which will depend upon the sign of the frequency departure.

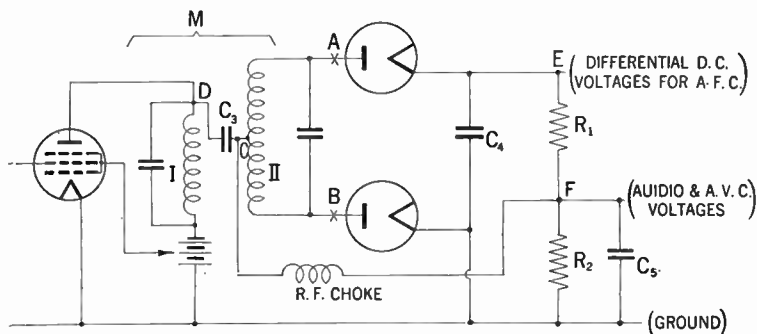

FIG. 3—Automatic radio frequency control detector diagram.

If a carrier at the resonant frequency with normal intensity modulation, but without frequency modulation, is applied to the system, the *a.f.* as well as the *d.c.* voltages across  $R_1$  and  $R_2$  will be equal and opposed. Therefore at resonance there will be no *a.f.* potentials between *E* and ground, and as far as audio components are concerned, the system acts exactly as though point *E*, were grounded with the outputs of the two diodes acting in parallel. Actually if  $C_4$  is sufficiently large to have

negligible reactance at the lowest modulating frequency, this is the case. Then the point  $F$ , becomes a potent source of audio voltages to supply the *a.f.* amplifier system and no other audio detector is necessary.

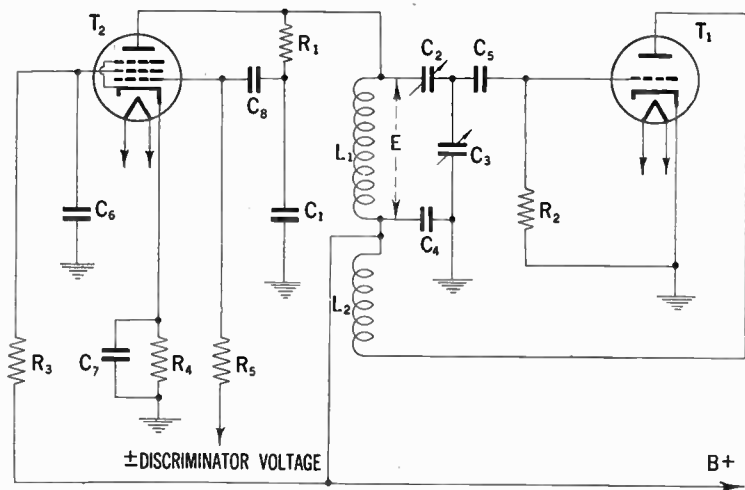

FIG. 4—Typical control circuit diagram.

It can be seen that the *d.c.* potential between ground and the point  $F$ , will have the proper polarity to be used for *avc* action, and that this potential will bear the same ratio to the developed audio voltages as is found in the conventional diode detector *avc* system. The fact that it maximizes at one side of resonance is of no significance if automatic frequency control is used. When the *afc* is cut out of circuit (manually) point  $E$ , is grounded. This causes the *d.c.* potential at  $F$ , to maximize on resonance.

**The Control Circuit.**—A circuit which will convert *d.c.* discriminator voltages into changes in oscillator frequency is shown in fig. 4. In this figure  $T_1$  is the oscillator tube and  $T_2$  the control tube. The combination of  $R_1$  and  $C_1$  connected across the oscillator tank circuit produces a voltage on the grid of the control tube  $90^\circ$  out of phase with that existing across the tank circuit. Variations in grid bias of the control tube (obtained from the discriminator) vary the plate current of that tube. This plate current is  $90^\circ$  out of phase with the tank circuit voltage and therefore the control tube acts like a reactance in shunt to the tank circuit. The magnitude of the reactance and therefore the oscillatory frequency are varied by the control tube grid bias.

With the circuit shown in fig. 4 the control tube is equivalent to an inductance in parallel with the tuned circuit. An increase in mutual conductance of the control tube produces a decrease in the magnitude of this equivalent inductance and consequently an increase in the oscillator frequency.

**Control Tube.**—The amount of control is proportional to  $G_m$ , but is also affected by the control grid voltage for this  $G_m$ , since a high value of bias permits  $R_1$  or  $C_1$  to be smaller for a given oscillatory voltage. Consequently maximum control is proportional to the product of  $G_m$  and  $E_c$ . Sensitivity of control is however, another important requirement, since it is desired that the frequency change be as large as possible for a given change in bias. This means the control tube should be of the short cut-off type. Further requirements are high  $r_p$ , linear change of  $G_m$  with bias, and for economy, low plate and screen currents.

All of these requirements are best met by the short cut-off, *r.f.* pentodes such as 57, 77, 6C6 and 6J7. By proper choice of  $R_1$  and  $C_1$  the maximum amount of frequency correction can be adjusted to suit required conditions.

The frequency control readily obtainable by this circuit is of the order of 9.5% of the oscillator frequency in the broadcast band and 1.5% in the region of 10 megacycles.

In a receiver it has been found that a discriminator sensitivity of 100 volts per *k.c.* and a control sensitivity of 7 *k.c.* per volt can be easily obtained, so that an overall control ratio of 700 to 1 results. A tuning misadjustment of 7 *k.c.* will therefore result in only a 10 cycle shift of the intermediate frequency.

The use of *afc* on the short-wave bands has the very much needed advantage of making the tuning operation easier. The tuning control has to be moved only until the frequency is close enough to resonance that the discriminator will develop sufficient voltage to bias the control tube the amount required for the departure from resonance. Short-wave stations are thus spread out on the dial, making them easier to locate and easier to hold.

In the broadcast band this characteristic would have the disadvantage that the receiver would appear to laymen to be broad in tuning in comparison with receivers without *afc*. This apparent disadvantage can be eliminated by combining the *afc* switch with the tuning mechanism so that the *afc* automatically becomes inoperative during the tuning operation.

## **PUSH BUTTON TUNING SYSTEMS**

**Push-Button Station Selectors.**—Push button station selectors is primarily an arrangement whereby the process of tuning has been greatly simplified. It is thus possible by means of a mechanical arrangement to choose a selected number of stations each one of which may be tuned in by the method of some control to a pre-determined position.

It is only recently however, that these systems have achieved the measure of popularity that it undoubtedly deserves, and this is probably because of the technical difficulties involved in producing a receiver which has the same capabilities as any ordinary set—the problem being not only to incorporate this additional device, but of maintaining it consistently in operation.

These early difficulties, however, have been largely overcome, primarily by the employment of apparatus of a higher standard of quality than was previously possible, and also due to a better understanding of the problems involved.

**Various Systems in Use.**—There are many push-button tuning systems in use as well as many different methods of control. Perhaps most common, however, is that of a series of push buttons (one for each station) located on the receiver itself, although sometimes these buttons may be duplicated, one set being mounted on the receiver, and the other at the end of an extension cable of suitable length.



**Typical Extension Cable System.**—A typical system of this kind is incorporated in the current line of General Electric receivers.

In this system remote tuning and volume control is accomplished by extending the push-button tuning circuits by means of a cable to the remote control box.

Changes in the volume level are effected through the use of a motor on the volume control shaft as shown in fig. 5. A reversible motor is employed and controlled by two switches on the remote control box.

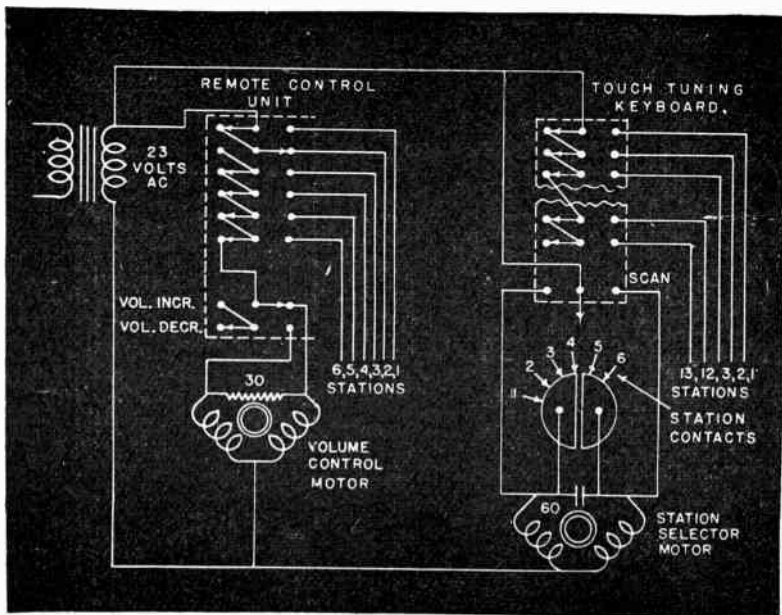

**FIG. 5**—Schematic wiring diagram of a General Electric push button remote control system.

The station selector consists of the usual electric motor mechanism with a split stator winding. On account of the split stator winding arrangement, the device is *homing*, i.e., goes directly to the selected station.

The capacity of the remote tuning system makes thirteen stations available at the remote control box. The arrangement is such that when the button is depressed for any one of the thirteen stations, the power is automatically turned on to the set.

The remote control keys are non-latching in order to avoid any interference with the buttons on the receiver. At present only six of the stations have been extended for the remote control, which is attached to the set by means of a plug on the rear of the set.

To avoid the possibility of keeping the tuning motor running, by pressing two buttons simultaneously, single pole-double throw switches are utilized at both the receiver as well as at the remote control station.

The power to the volume control motor is supplied from the same transformer which supplies the tuning motor.

It is possible to change the volume of the receiver only after the station button at the remote control station has been released on account of the interlocking feature.

Finally a scan switch for rapid manual tuning from one of the bands to another is provided on the receiver. This switch is of the double throw type, normally open, which permits directive operation of the motor.

Again, instead of the usual push-button system a similar effect may be obtained by a mechanism similar to that of the well-known automatic telephone, and as a matter of fact it is perfectly possible to utilize standard telephone parts in the design of such a tuning control system.

Another remote control system in which the previously discussed control cable is being eliminated, and in which the tuning is accomplished by means of tuning pulses oscillations emanating from a dial, is described on page 346.

**How the System Works.**—Electrically these various systems divide themselves into two main classes, namely:

1. Those in which a large number of pre-set switch selected condensers are used.

2. Those in which an ordinary variable condenser is provided for tuning but can be remotely controlled by means of an electric motor.

Considering the former the basis for a tuned circuit is given in fig. 6.

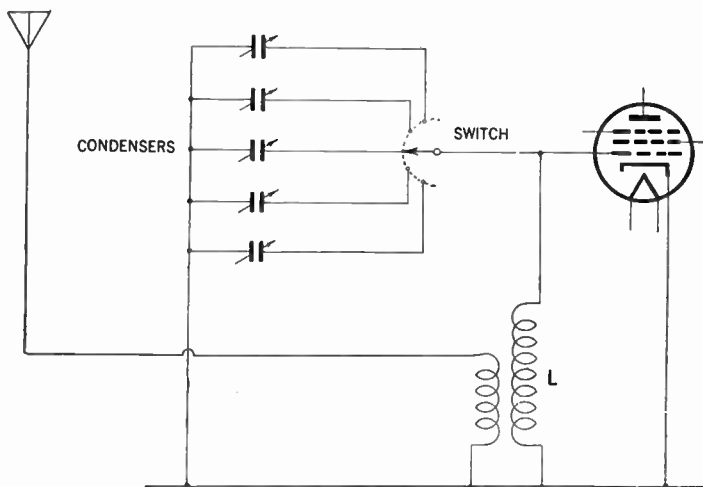

**FIG. 6**—Schematic diagram showing general principles of simple tuning circuits. In this system a separate pre-set condenser is provided for each station and selected by a switch, as shown.

It may be observed that instead of a variable condenser for tuning the coil  $L$ , a number of pre-set condensers are provided and the one desired can be selected by means of the switch shown.

It is obvious that each tuned circuit in the receiver must be provided with a similar bank of condensers and switches. With the system under discussion, the switch is set to the first position, and one station is tuned in on the opposite condensers; the switch is then set to the next position and another station is tuned in and so on.

For every station required, it is necessary to provide an extra condenser and switch contact for each tuned circuit.

This particular system has been commonly employed in the past in simple types of receivers. The system has a great merit especially where only two or three stations are required on account of its simplicity.

It is obvious, however, that if a dozen or more stations are required, it begins to be complicated by virtue of the large number of condensers required. There is also a further drawback when it is applied to a selective receiver such as a super-heterodyne, and this drawback is that it may not prove stable enough for satisfactory operation.

Where the circuits are flatly tuned as in the case of the local station receiver, small changes in tuning capacities and the input capacities of tubes have very little effect upon the performance of the receiver, but where the set is selective, then these changes do command quite a large effect.

In a super-heterodyne the oscillator is the critical circuit, and it is common experience with ordinary receivers that the tuning drift somewhat, for perhaps a quarter of an hour or so after switching on.

Where systems of this kind are used, therefore, great care must be taken to maintain stability, and the oscillator circuit must itself be designed to this end.

In addition, the layout of components must be carefully chosen so that their temperature remains as nearly as possible constant and the condensers themselves often have to be of special types, with unusually high stability of capacity.

**Motor Tuning.**—In this type of remote control tuning systems, the use of a standard type receiver with a gang condenser is utilized.

For the purpose of control the tuning condensers are driven through a chain of gears from a small electric motor of the

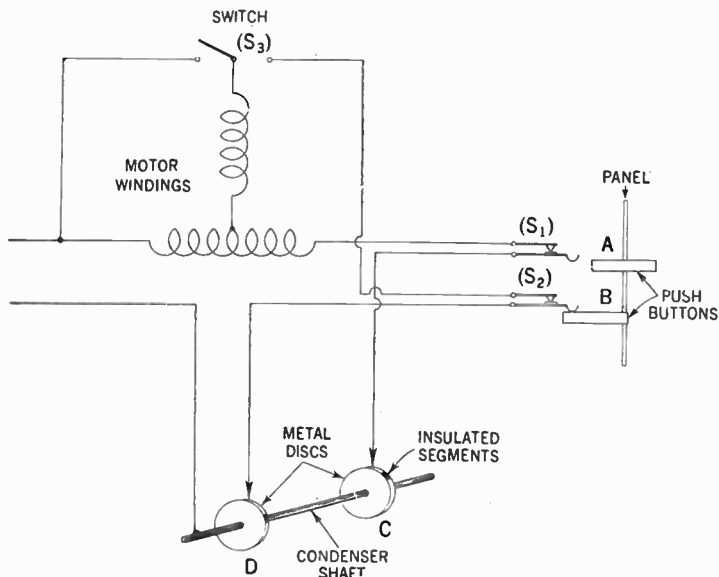

**FIG. 7**—Diagram illustrating a typical push button control system. The tuning condenser is driven by an electric motor which is controlled by press buttons.

reversible type. This motor usually operates from a 24 volt supply and the method of operation may readily be understood with reference to fig. 7 but there will be one disc for every station required and at the remote control there will be one push button for every disc.

It will be noted that of the two push buttons shown, *A* will be out while *B* is pushed in, so that the contacts of  $S_2$  are closed. The circuit is then completed through the ring *D*, and the motor revolves turning the variable condenser and also the disc *D*.

When the insulated segment comes opposite the contact the circuit is broken and the motor stops. The receiver is then tuned to the desired station, for the initial set-up, the discs have been so aligned on the condenser shaft that the insulated segments in every case correspond to the condenser position for the wanted station.

This is a comparatively easy matter and it could for example be imagined that each disc is being held on by its own set screw to the shaft.

To set up any one disc for a particular station, one would tune in that station manually in the usual manner and then twist the disc so that the insulated segment comes opposite the contact and then tighten up the set screw.

It will be seen that upon pressing a button the condenser may start moving away from the desired station instead of towards it. When this happens the condenser goes on moving to minimum or maximum as the case may be, and then trips the automatic reversing switch  $S_3$  and comes back to the desired station.

With some of the latest systems this reversing switch is unnecessary, for means are included to insure that the motor always start off with the correct direction of rotation.

It is clear, however, that a system of the kind under discussion would by itself hardly be satisfactory since it would not

be possible to guarantee sufficiently accurate tuning for a selective receiver. It is, therefore, that this system is almost invariably associated with an *A.F.C.* system which most usually takes the form as shown on page 334. Such *A.F.C.* circuits properly arranged, will give very good control and take out quite large changes in tuning of the medium and long-wave bands, but in general they are not directly applicable to short-wave reception although naturally they can be employed in a double super-heterodyne.

The disadvantage of *A.F.C.* is that it increases the cost of the receiver, because it increases the number of tubes, and the initial adjustments of the circuit involved is fairly critical. It is therefore generally only found in the more expensive types of receivers. In the less expensive sets it is less often included and a good performance is then secured by paying great attention to stability.

**Mechanical Accessories.**—It is not within the scope of this discussion to go deeply into mechanics of the actual control circuits because they vary so widely and generally do not effect the principles of operation.

The use of systems which may be known variably as push-button or dial tuning is not confined to remote control, and in some cases these controls are mounted instead of on the ordinary tuning dial, on the receiver itself.

They are then often very much simpler and one arrangement consists merely of mounting a telephone type of disc with the usual finger holes on the shaft of the gang condenser.

Again in another system the condenser shaft carries a number of heart-shaped discs, one for each station. One operating key is provided for each disc, and its pressure moves the cams around in the manner shown in fig. 8.

Still another system has a series of control bars mounted on the condenser shaft. One such bar with its actuating lever is shown in fig. 9.

The lever presses against the rounded portion of the bar and so rotates the condenser shaft, until it reaches the flat part.

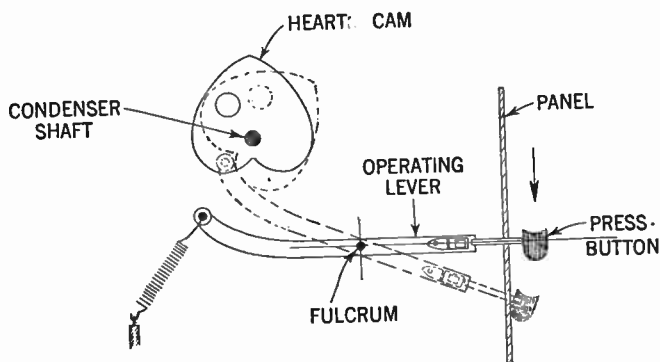

FIG. 8—Principles of control in which the tuning condenser is rotated by the pressure of a lever against a heart cam.

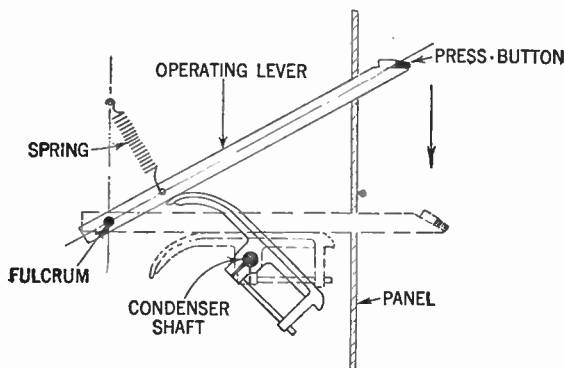

FIG. 9—Method of condenser control by lever system. When pressing the lever it contacts the rounded portion of control bar and so turns the condenser until the flat position is parallel with the lever.



## WIRELESS CONTROL SYSTEM

**Wireless Remote Control Device.**—By utilizing a device recently developed by the Philco Radio & Television Corp., it is possible to operate a radio receiver by means of remote control.

The control box popularly known as the "Mystery Control" is portable, and the desired station may be dialed in a manner similar to that of a dial-type telephone, except that no connected wires are necessary.

With reference to fig. 11, showing the control box, the tube and coils form an oscillator which can be preset to 355, 367, 375, 383, or 395 kilocycles.

The dial mechanism is technically called the "Pulsar unit" since it keys or pulses the output of the oscillator.

Since the control box is battery operated, the device is easily turned on while selecting a station or changing the volume. This means that the battery drain is practically nil.

When the dial is operated, the filament circuit to the tube is closed by means of the lower switch arm and the continuous contact bar.

According to *Radio Today*, the device works principally as follows:

**The Pulses Tune Radip.**—The pulses are caused by making and breaking the plate battery circuit. As the dial mechanism turns, the plate circuit is opened and closed as the switch-arm touches the equally spaced contacts. Each station has a certain definite number of contacts that must be made. Corresponding to the station to be dialed, from 4 to 11 pulses are transmitted by the device. Two pulses increase the volume of the set, while 3 pulses decrease the volume. During the volume changes, a thumb-lever is held down which causes a continuous signal to

be emitted. This lever is released when the volume reaches the proper value.

The signal from the control box is transmitted to a loop or secondary coil in the radio set by induction. The remote control

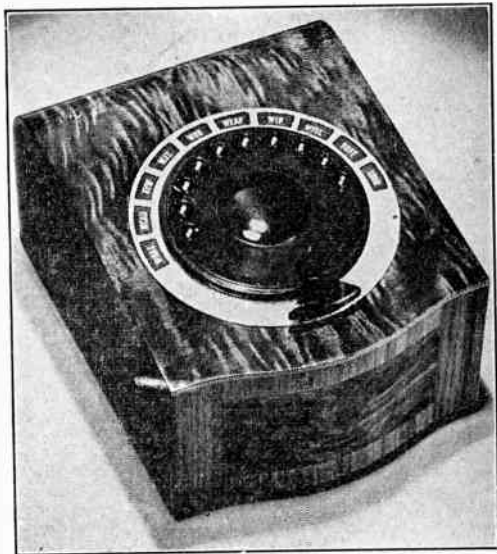
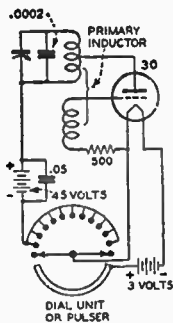

**FIGS. 10 and 11**—Fig. 10 shows circuit diagram of the portable control box. Impulses sent out from the box are picked up by the five tube unit (fig. 12) and amplified to the proper degree to actuate the tuning mechanism shown in fig. 13. All control boxes are adjusted to use one of the five frequencies specified above.

box fig. 11 has a tuned coil (oscillator coil) which acts as a primary to induce a signal in the secondary. The coil in the control box can be likened to the primary of an induction coil. When a current flows in the primary, a current is induced in the secondary. The dimensions of both coils are made as large as possible so as to effect a maximum transfer of energy.

In the mystery control it is desired to transfer energy over a distance approaching 75 feet while avoiding any form of wire connection. It is also desired to limit the maximum operating range of the device as sharply as possible. For numerous reasons, electro-magnetic induction (rather than radiation) seems to be the most suitable means for the purpose.

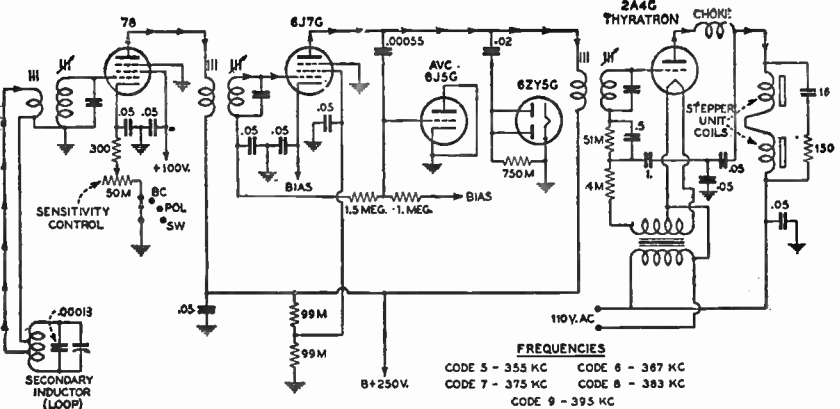

FIG. 12—Five tube stepper unit inter-connected with the high frequency part of the receiver shown in fig. 13. As previously described the receivers are equipped for five different control frequencies with range from 350 to 400 k.c. The purpose of the different control frequencies is to prevent interaction between two similarly equipped receivers which may be located on the same floor or are exceptionally close together. When several such receivers are to be located close together it will be necessary to utilize different control frequencies to avoid interaction between the receivers. In order to prevent interaction between receivers, there should be a difference of 20 k.c. between their control frequencies. If three receivers are to be operated at the same time and are closely situated, it will be advisable to adjust the control frequency of the first to 355 k.c., the second set to 375 k.c. and the third to 395 k.c., etc.

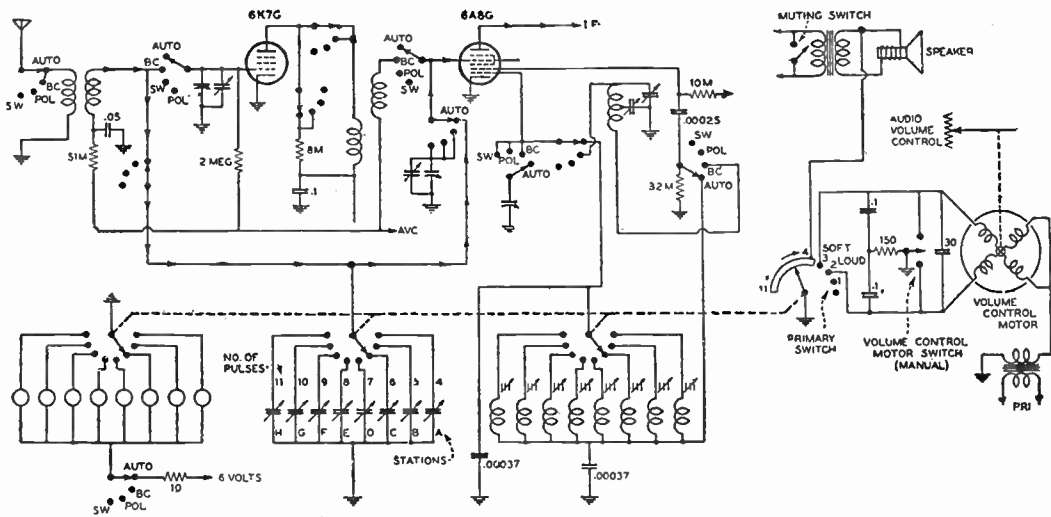

FIG. 13—Circuit diagram of high frequency part of broadcast receiver which is manipulated from a remote point by the control box. The stepper unit, fig. 12, energized by the thyatron tube switches to the desired station. Volume is also controlled remotely by means of a small motor attached to the volume control.

**The Pulse Amplifier.**—Because the pulses sent out from the primary (remote box) unit are rather feeble at the radio set, it is necessary to tune the remote oscillator to the frequency of the secondary coil and amplifier. As the range of the remote control device may be 75 feet under normal conditions, a variable frequency in both the oscillator and amplifier is provided so that no interference will be produced on neighboring mystery control sets. A choice of 5 frequencies from 355 to 395 *k.c.* is provided to eliminate the possibility of two or more sets interfering with one another.

The signals picked up by the loop are coupled to a tuned grid coil by a low-impedance link circuit. From the grid coil, the signals go through two stages of amplification to the grid of a 2A4G thyratron tube. The output from the thyratron tube is fed into the relays which in turn control the stepper unit and station selecting switch.

**The Sensitivity Control.**—In the control (pulse) amplifier circuit there is a sensitivity control which is employed for the purpose of adapting the set to the particular location where it is used. This control is in the cathode of the type 78 first amplifier tube.

The setting of this sensitivity control is of tremendous importance to the mystery control operation. The normal range of mystery control is within a circle of the receiver with a radius of about 25 feet. It is important to remember that mystery control operates in a circle around the receiver cabinet. To get the most from mystery control it is therefore advisable to place the cabinet as close to the center of the "operating circle" as possible.

If the receiver be located against the front wall of a home only half of the effective operating area is within the house. The remainder is outside the walls. There is a distinct advantage

in operating the control amplifier sensitivity control at the lowest possible setting.

Extra sensitivity in the control frequency amplifier is provided so as to permit operation in the presence of inductive shields such as steel girders, metal lath construction and large bodies of metal, furnaces, boilers, stoves, refrigerators, chandeliers, or any similar metallic objects.

The sensitivity of the control frequency amplifier is variable to fit a large range of operating conditions. Normally, sufficient precautions are taken in the amplifier and remote control circuits to greatly reduce the possibility of electrical interference. The control amplifiers are very much less subject to interference than an ordinary radio receiving system. It requires an extreme and unusual type of interference to interfere with the operation of mystery control. There is no possibility of interference affecting mystery control receivers if the sensitivity control is kept down to the first half of its total movement. This illustrates the importance of setting the sensitivity control to the minimum position possible.

In some installations, however, owing to the presence of large metal objects around or near the receiver chassis of the mystery control cabinet, it will be necessary to increase the sensitivity of the control frequency amplifiers owing to the absorption of the metal surfaces.

When this occurs, it will very likely be found that the same metal objects are shielding the receiver from excess static which would normally interfere with the mystery control circuits in a high setting of the sensitivity control. Therefore, when it is necessary to increase the setting of the sensitivity control in order to get operation of mystery control, it will likely be found that interference is not present and that a higher setting of the control is possible.

In all installations be careful to set the sensitivity control at the lowest possible position and to locate the receiver away from metal objects which would absorb the induction field of mystery control.

The 6ZY5G and 6J5G tubes act as a noise gate to exclude unwanted interference which might control the stepper assembly. This noise gate makes the amplifier respond only to pulses having a time interval equal to that of the pulser mechanism. Thus pulses of random timing do not operate the set.

The operation of the thyratron tube is entirely different from any tube so far encountered by the radio serviceman. It is a gas-filled tube which can handle large plate currents—in other words, large amounts of power. Before getting into the operation of the stepper relay unit for station selection, the *r.f.* circuits of the receiver should be examined. The wave-switch selects any one of three wave-bands or automatic tuning (mystery control operation).

**The Tuning Circuits.**—To illustrate the automatic operation, the wave switch has been drawn in that position. The wave switch sections disconnect the *r.f.* amplifier from the circuit and transfer the antenna coil to the grid of the converter tube. Also, the antenna coil is connected to the station selector switch which selects the proper trimmer condenser for any one station. The gange condenser is cut out of the circuit for remote operation.

The oscillator coil system is completely cut out of the circuit and trimmer type inductances with iron-core tuning are connected by the station selector switch.

A third rotary switch turns on the proper station indicator lamp. The assembly for the station selecting circuits is located beneath the chassis and is driven by the stepper assembly.

There are three groups of contacts operated by the switch. One group switches in the oscillator coils, the second group switches in the antenna padding condensers and the third group of switches, lights the pilot lamps indicating the station dialed.

Excessive friction in this switch would cause improper action of the stepper assembly. It should be adjusted so that when the relays have selected the station dialed, the contact arm is squarely on the contact. The tension of the contact arm is regulated by the setting of the hub on the switch shaft. The long wiper contacts exert a firm pressure on the contacts which may be increased or decreased by adjusting the location of the hub.

The position of the contact arm is determined by the set screws which hold the driver arm on its shaft. This is located above the chassis but beneath the stepper assembly. If the contact arms do not come to rest on the contacts it may be necessary to loosen the set screws on the switch shaft and re-locate the position of the driver arm so that the contacts are made correctly.

Excessive tension in the switch would act as a load on the relays and might result in chattering on one of the stations, part way up, and then failing to reach the station dialed.

**The Stepper Assembly.**—The stepper assembly which operates the station selecting switch is operated by the thyatron tube referred to previously. The coils which operates this assembly as shown as the plate load of the thyatron in fig. 12.

When the thyatron tube lights, the holding relay closes and the stepping relay pushes a ratchet as many times as there are pulses sent out by the pulser in the mystery control box. There is a primary and a secondary ratchet. The stepper relay operates the primary ratchet which is connected to the primary switch. This switch controls the volume control motor and



shorts the voice coil to ground in the station selecting positions.

A muting switch, which connects the plates of the output tubes together, is closed during the station selecting operation. The set, of course, is playing during changes in volume but it is muted as the secondary ratchet returns to its home position, and climbs to the station dialed.

This means that whenever any of the eight stations are dialed the set is muted as the secondary ratchet switch turns the "station tuning" switch contacts.

Failure of the primary switch to return home or the secondary ratchet arm to return home, failure of the receiver to mute during dialing would indicate trouble in the stepper assembly, and would make it necessary to return it to the manufacturer for replacement. Dialing of an incorrect station, the skipping of stations or the galloping past of stations also indicates trouble in the stepper assembly.

**The Volume Control Assembly.**—The volume control and the on-off switch are motor driven. The motor has an automatic clutch which releases and drops back as soon as the volume control is released by the stepper primary switch. This prevents "over-shooting" when changing volume and immediately stops the gear train which drives the volume control when the volume control lever is released on the mystery control box. There is also a clutch in the volume control itself, so that the mechanism will not jam if the volume control lever is held down after the set is shut off.

The primary switch is a single pole, double throw switch which connects the desired winding in the volume control motor to increase or decrease volume, as shown in fig. 13. In parallel with this switch there is a single pole, double throw switch connected to the manual volume control. This switch is mounted directly beneath the receiver dial bezel.

The pilot lamp cable is close to this switch. If any of the pilot lamp wires become tangled with the switch they might cause the motor to continue running and might possibly cut through the insulation of the pilot lamp lead, causing the lamp to stay lit. It is important when the chassis has been removed, to check the location of the pilot lamp wiring cable to make certain that it is entirely clear of the volume control motor switch.

**Method of Inter-station Noise Elimination in Automatic Control Systems.**—In modern super-heterodyne receivers the potential amplification is very high, hence the tuning problem would be very difficult if an automatic volume control were not included in the receiver.

It is however a well known fact that all *a.v.c.* systems are designed to regulate the gain of the receiver only while a signal is being received; therefore between stations the sensitivity rises to a maximum.

This means, of course, a great increase in the background noise between stations and unless there be a noise suppression auxiliary provided in the receiver to limit this audible noise it often becomes objectionable, especially in locations where there is a large amount of man-made static.

Several schemes have been advanced to solve the interstation noise problem in the *a.v.c.* equipped receiver. Perhaps the simplest one is to provide an adjustable bias on the *i.f.* tube (in addition to the *a.v.c.*) so that the receiver's maximum sensitivity may be manually decreased below the noise level. This undoubtedly settles the noise problem, but it may, through excessive adjustment, reduce the receiver's sensitivity to such an extent that weak stations, which might otherwise be received fairly well, will be skipped by unnoticed. Then, too, if this manual sensitivity control has to be continually retarded and

advanced in an effort to locate weak stations, it loses much of its effectiveness as far as noise is concerned.

Another idea for checking inter-station noise and one which has found greater favor among set designers and experimenters than that outlined previously, is the utilization of a vacuum tube as a carrier controlled relay to block the audio amplifier when no signal is being received. This system is very efficient as a noise suppressor.

It is fully automatic in action once the circuit has been properly adjusted. However, while some radio men have successfully installed it in existing receivers, it is generally most effective when included in the original design of the set since it is quite critical in its voltage requirements.

In analyzing the nature of this between-station noise, it has been found that most of it occurs in the high audio frequency spectrum; thus, if the high frequency response of the receiver is checked by a tone control, the intensity of the noise will be greatly reduced. However, the degree of high note suppression needed to limit inter-station noise is much greater than can be tolerated where good fidelity of tone is desired from a local station.

For this reason on the usual radio which is equipped with a manual tone control, it is necessary to adjust the control frequently to meet existing conditions. By adding a tube to the diode detector circuit as shown in fig. 14 this tone control action may be effected automatically in the *a.v.c.* equipped receiver. It is an idea that has been successfully used for noise suppression purposes in several of the larger super-heterodynes, and due to its simplicity it can be easily adapted to any receiver using *a.v.c.* A worthy feature of the system is that it will decrease noise without reducing the overall sensitivity.

This automatic tone control must operate in conjunction with a diode type detector. The left half of the accompanying

diagram shows the fundamental diode second detector and *a.v.c.* rectifier circuit found in the majority of modern superheterodynes. Although the tube shown is a 6H6, it may also be the diode portion of a diode-triode or diode-pentode tube; and in some older model receivers, it may even be a triode connected as a diode.

If the associated parts of the detector circuit consisting of resistors  $R_1$ ,  $R_2$  and  $R_3$  and condensers  $C_1$  be arranged as shown,

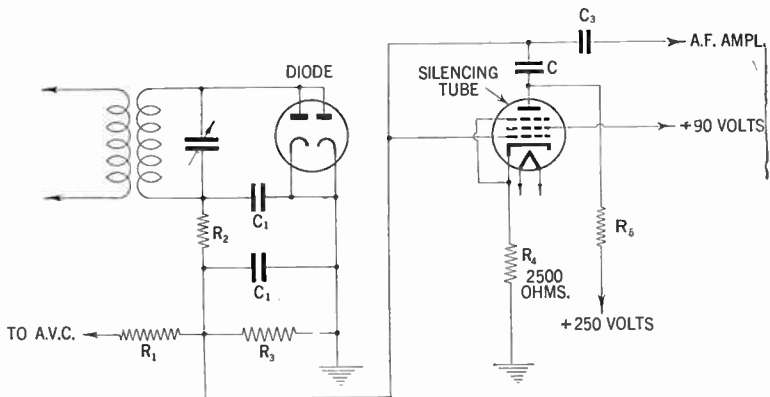

FIG. 14—Automatic tone control circuit.

they need not be disturbed when adding the tone control tube to the receiver. However, if  $R_3$  is a volume control potentiometer, it must be removed and used instead in the grid circuit of the first audio tube to control the input to the grid of this tube. The original fixed resistor in the audio grid circuit may then be shifted to the  $R_3$  position if it be .25 to .5 megohms in value.

In some sets,  $R_2$  may be replaced by an *r.f.* choke or it may be omitted altogether without affecting the performance of the circuit. The experimenter may also find that some receivers

divide the functions of *a.v.c.* and detection, using separate diode sections or tubes for each purpose. In this case, connect the tone control tube to the detector diode circuit and disregard the separate *a.v.c.* system.

The circuit that is to be added to the receiver is shown in the right half of the diagram. The tube may be any sharp cut-off type, either tetrode or pentode, such as the 24, 36, 57, 77, 6C6 or 6J7. Experiment has shown that all of these types work equally well. The choice, therefore, will depend mainly upon the filament voltage available. The tone control tube and associated parts should be mounted as close to the diode detector as possible. Resistor  $R_4$  is non-critical in value, a good compromise being 2,500 ohms.  $R_5$  should not exceed 100,000 ohms regardless of the plate supply voltage.

The audio coupling condenser  $C_3$  is probably already in the receiver and need not be changed. The rating of condenser  $C$  will have to be determined by experiment and values from .0001 to .001 (mica dielectric) should be tried. The final choice will depend upon the maximum degree of high note suppression that can be tolerated when the set is tuned to an extremely weak station. If distortion be encountered on some of the medium powered stations, the screen voltage should be slightly lowered.

## CHAPTER 17

# Loud Speakers

The function of a loud speaker is to convert the amplified audio frequency currents into sound waves. In order to accomplish this the loud speaker must be designed in such a way that it will cause the varying electric currents to set in vibration a diaphragm similar to that used in a telephone receiver, only larger.

The vibration of the diaphragm in turn sets the surrounding air molecules into motion. The vibration of this comparatively large volume of air produces the sound, which the ear receives and the brain sometimes appreciates.

The efficiency of a loud speaker is defined as the ratio of the useful acoustical power radiated, to the electrified power supplied to the load and is very low even in the most carefully designed.

The most efficient type in common use in sound picture work has an efficiency of only about 30%.

**Speaker Parts.**—Generally loud speakers consist of two main parts:

1. That part of a loud speaker which changes the varying currents of the audio frequency amplifier into mechanical vibrations, which is called variously *the driving unit or motor*.

2. The other part is that which acts in conjunction with the driving unit to produce the vibration of the air molecules, and consists of a surface of various geometrical designs such as a *conical* or *flat shaped horns*.

The horn has been known and widely used for centuries for increasing the radiation from a sound source. Although it is not within the province of this chapter to enter into a discussion of

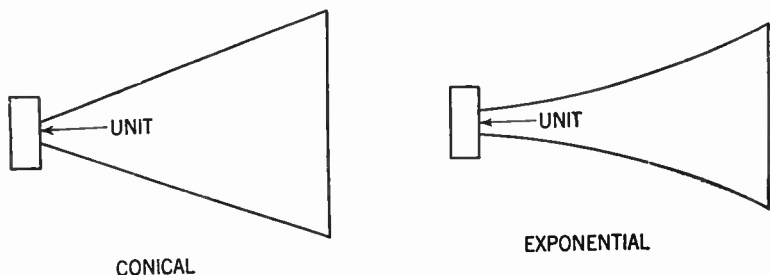

FIGS. 1 and 2—Conical and exponential horn forms.

horn design, it may be well to mention that the horns most commonly used for sound reproduction are the *conical* and the *exponential* types.

Figs. 1 and 2 show the two forms of horns most commonly in use.

The *conical* horn may be defined as one in which the cross-sectional area of the horn varies in direct proportion to its length, whereas in the exponential form the area of the horn varies as an exponent of its length.

**Classification of Speakers.**—Loud speakers may be divided into the following general classes, depending upon the principle involved in operation of the driving unit, namely:

1. Magnetic
2. Dynamic, variously called electro-dynamic
3. Balanced armature
4. Induction
5. Metal strip
6. Electro-static, variously called condenser speaker
7. Piezo-electric, variously called crystal speaker.

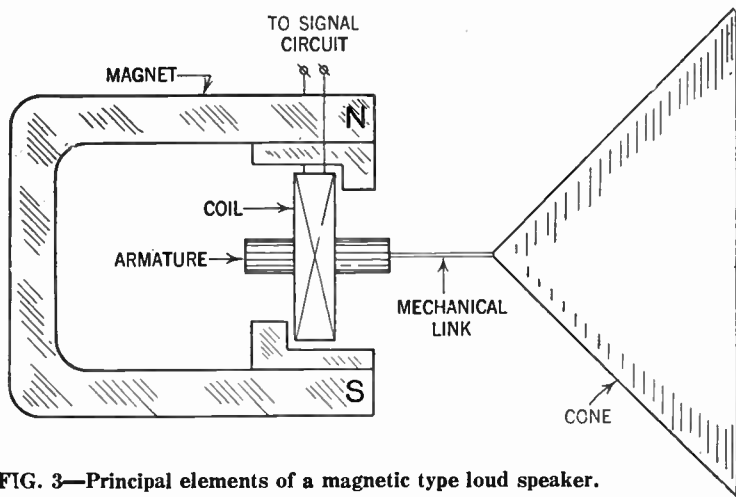

FIG. 3—Principal elements of a magnetic type loud speaker.

**Magnetic Speakers.**—In this type the moving iron driving type is employed. The principle of operation is based on the varying of the magnetic polarity of the armature. These variations are caused by the electrical impulses flowing through the coil winding which encircles the armature.



The movement to the armature is effected by the induced magnetism, causing it to oscillate between the two poles of the permanent magnet.

**Dynamic Speakers.**—A speaker of this type illustrated in figs. 4 and 5 consists principally of the following parts: 1, field coil; 2, voice coil; 3, cone.

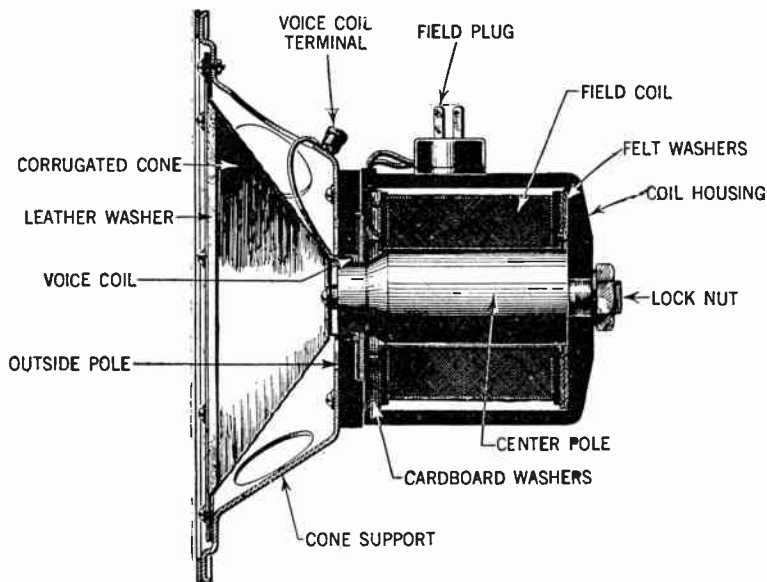

FIG. 4—Cross-section view of a dynamic type loud speaker with a moving coil driving a cone type diaphragm. Details of the various units are here clearly represented.

The field coil is connected to a *d.c.* source, effecting a strong magnetic field across an air gap in which the voice coil is inserted. The signal current from the output terminal of the receiver, flowing through the voice or moving coil placed around the

middle pole of a three pole magnet, causes the voice coil to oscillate corresponding to the oscillations of the signal current.

The diaphragm being mechanically connected with the voice coil oscillates in a similar manner.

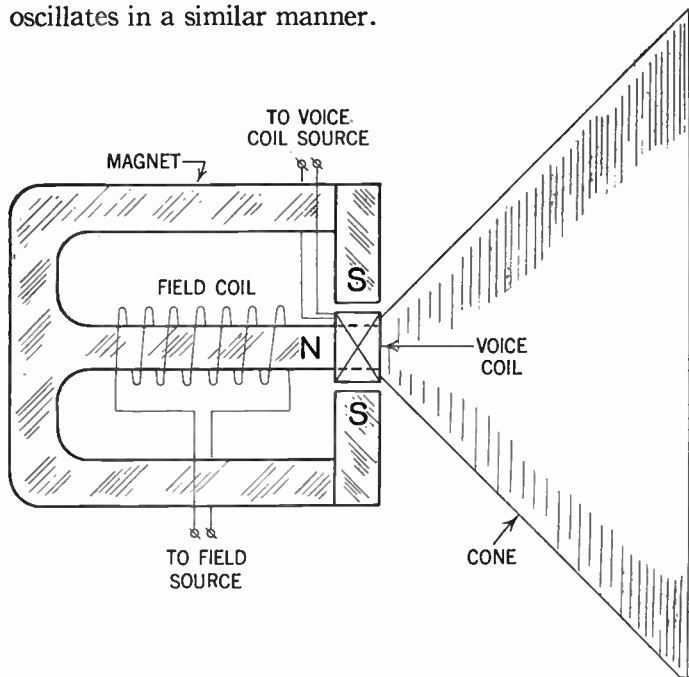

FIG. 5—Simplified diagram of dynamic speaker units shown in fig. 4.

**Balanced Armature Speaker.**—In this type of speaker the armature (as the name implies) is balanced between the two poles of a permanent magnet as shown in fig. 8. The armature is provided with a coil through which the signal current flows as indicated, so that the reaction between the magnetic field due to this current and that due to the permanent magnet causes the armature to oscillate about its pivot.

These movements are communicated to the diaphragm by means of the link connection in a similar manner as in the dynamic speaker previously described.

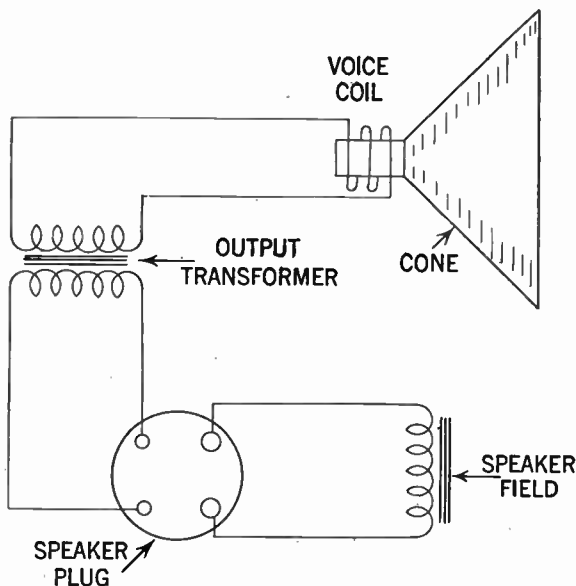

FIG. 6—When the dynamic speakers as in some commercial sets are connected by means of plug and cable to the chassis, the connections may be as shown in fig. 6 or 7; generally however, there is no set rule for these connections. The output transformer may be mounted on the receiver chassis or on the speaker frame. Again, the output tubes may be connected in parallel or in push-pull. Therefore, the connections shown are typical only and may not be considered as standard, but in each case the makers diagram should be carefully checked and followed.

The principal features in this construction is a complete elimination of chattering on loud signals, usually encountered in the magnetic type. However, one of its limitations is that for

a good sensitivity the air gap between the armature and the pole pieces must of necessity be made very small to reduce the reluctance and so as to obtain a strong magnetic field. This is objectional since when receiving low notes the movement of the armature may be so great as to strike the pole pieces, emitting a rattling sound.

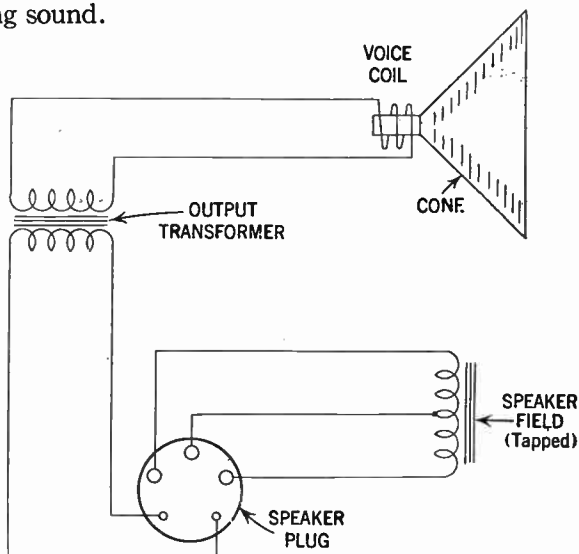
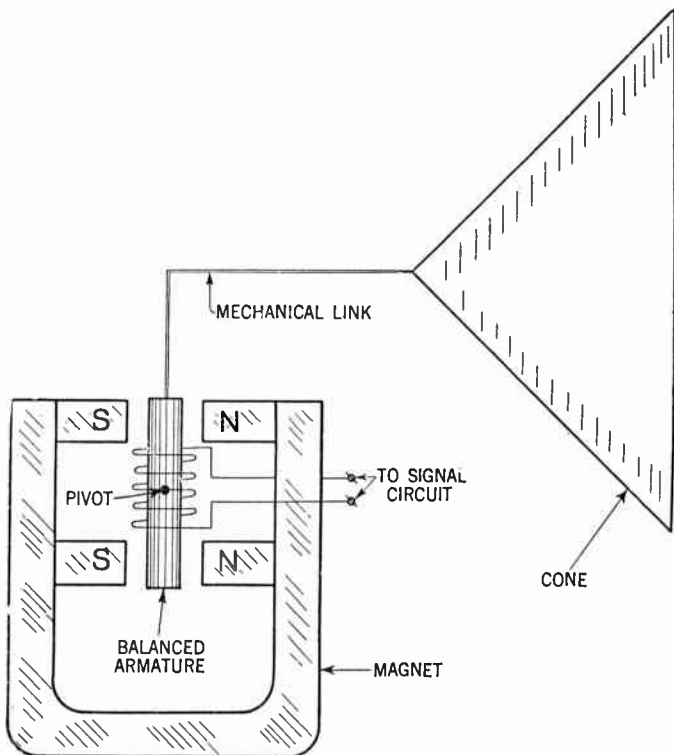

FIG. 7.—Schematic diagram of connections to speaker by means of plug-cable arrangement.

When the air gap is made larger, eliminating this rattling, the field strength decreases with a proportional loss in sensitivity.

**Induction Type Speakers.**—The name induction speaker is derived from the fact that the motion of the driving unit is obtained from a magnetic induction similar to that of the well known A.C. induction motor, where a rotor revolves under the influence of a changing magnetic field.



**FIG. 8—Balanced armature type speaker.** *In construction* the balanced pivoted armature is a soft iron bar forming a core of a coil of several thousand turns of fine wire supplied with audio frequency current. *In operation* when a signal current flows through the coil, a magnetic field is produced, which magnetizes the soft iron armature. The poles react on the poles of the permanent magnet and attraction between the unlike poles and repulsion between the like poles take place. With the polarities shown, the top end of the armature would move to the left and the bottom end to the right when the signal current flows through the coil in the corresponding direction. The amount of pull or movement is proportional to the current flowing through the coil, so the armature moves in accordance with the variations in the current.

As shown in fig. 9, the diaphragm is placed between two sets of concentric coils. Direct current is applied to the two sets of coils in opposite directions, causing a radial field.

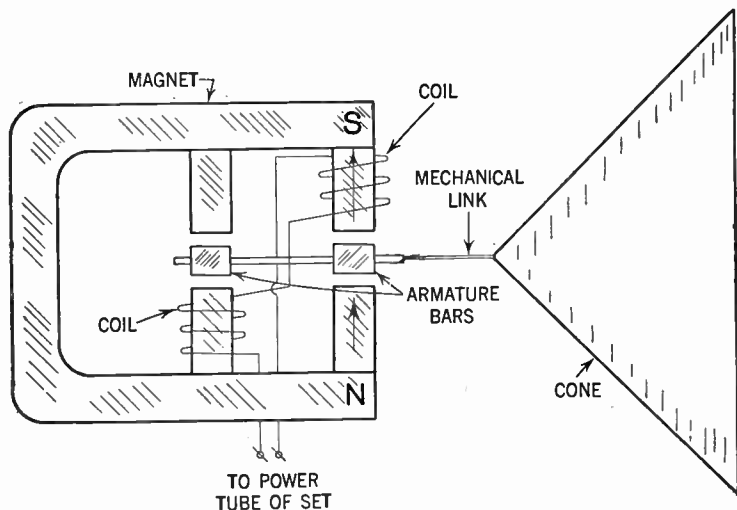

FIG. 9—View showing various units and connections for an induction type loud speaker.

The signal current is also passed through the coils which causes the steady field due to the direct current to vary and which in turn induces eddy currents in the diaphragm.

Since the eddy currents give polarity to the faces of the diaphragm these poles react with the poles of the coils, thus causing vibration of the diaphragm and resulting sound waves.

The utilization of strong permanent magnets makes for a low-priced and simple unit, and since there is very little possibility of objectionable hum being introduced when used in connection with battery operated receivers, it is particularly adaptable for automobile radio use.

**Metal Strip Types.**—In this type a metal strip is suspended between the poles of a permanent or electro-magnet. The signal current passes through this strip (see fig. 10) establishing a magnetic field around it which reacts with the field, due to the permanent magnet, which acts to displace the metal strip in accordance with the variations in the signal currents.

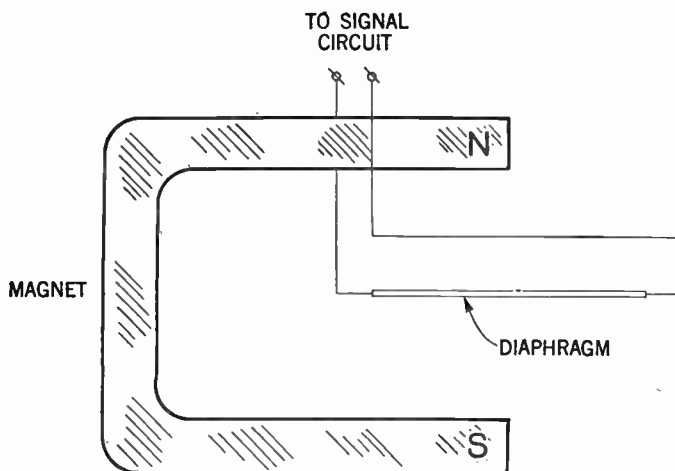
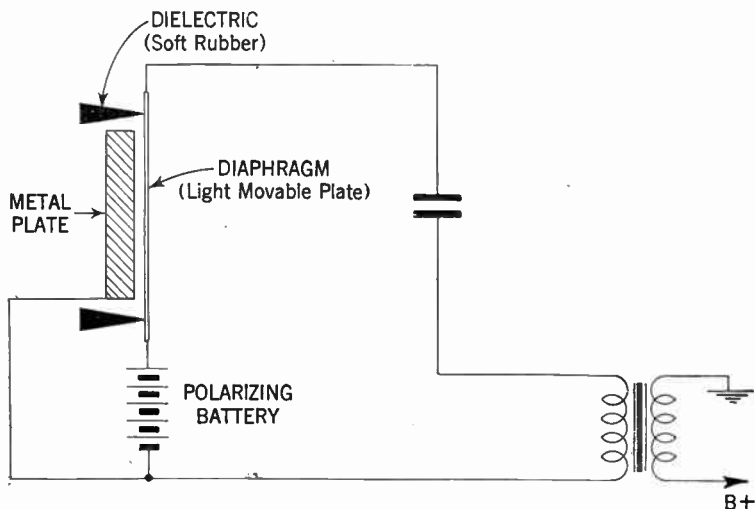

FIG. 10—Principal element of metal strip speaker. A megaphone is usually associated with this type of speaker.

The metal strip is in this case the diaphragm and obviously need not be of magnetic metal.

**Electro-Static Types.**—This type variously called a condenser speaker consists essentially of three parts, namely: two plates of which one is stationary and the other free to vibrate, in addition to the dielectric, assembled as shown in figs. 11 and 12.

It operates on the well known principle of electrostatic attraction and repulsion, in that two bodies of similar charges of electricity repel each other, whereas two opposite charges attract each other.



**FIG. 11**—Electrostatic speaker showing circuit connections. In construction, the metal plate is made rigid. The diaphragm consists of a thin layer of metal sprayed on the rubber dielectric.

When a polarizing voltage is applied to the plates a steady electric field is built up; superimposed upon this is the audio-frequency alternating electrostatic field. This, according to the foregoing, causes an attraction and repulsion between the two plates, producing in the free plate oscillations corresponding to the audio-frequency impulses.

The back or stationary plate in the commercial types of condenser speakers consist usually of stiff metal such as copper, iron or aluminum. The back plate is usually perforated with



slots in order to prevent compression of air between the two plates.

To obtain a large force on the movable plate the dielectric must be very thin and flexible and must have the largest possible dielectric constant, in addition to a high break-down voltage.

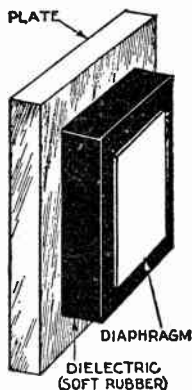
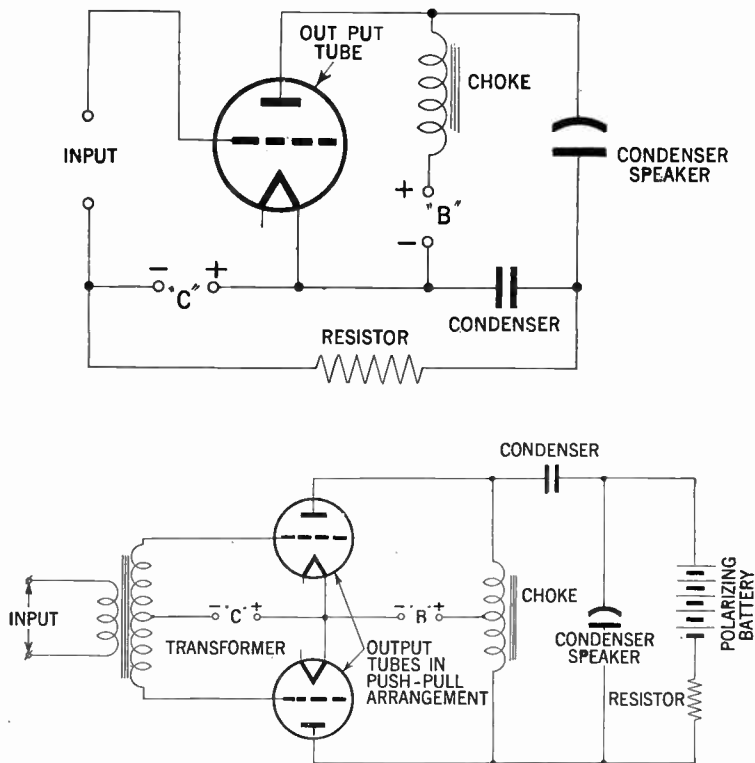

FIG. 12—Elements of an electrostatic speaker. It consists essentially of a form of condenser, hence the name as it is often called a condenser speaker.

**Piezo-Electric Speakers.**—This type of speaker (often referred to as *crystal speaker*) depends for its operation on the property of a crystal of expanding and contracting in accordance with the electrical strain to which it is subjected (for full information on this subject, see page 211).

The crystal speakers are often used in connection with high-frequency reproduction, its use up to the present, however, has been limited to small units. As a speaker of this type is inherently a rectifier, it is obvious that there is no need for any separate output transformer or frequency filtering network.



FIGS. 13 and 14—Showing two circuit arrangements for connections of a condenser type speaker to the power amplifier stage of the receiver.

**Loudspeaker Baffle.**—In a loudspeaker such as that shown in fig. 4 the material constituting the cone is driven forward and backward in the manner of a piston by the action of the impressed audio frequency signal. This constant movement displaces a certain amount of air, and it is this displaced air which generates sound that is perceived by the ear.

The air pushed back in the forward motion must go somewhere, and as a partial vacuum is created in the back as the cone moves forward, the displaced air in the front encounters very little resistance and hence flows rapidly to fill the vacuum created by the forward thrust of the cone.

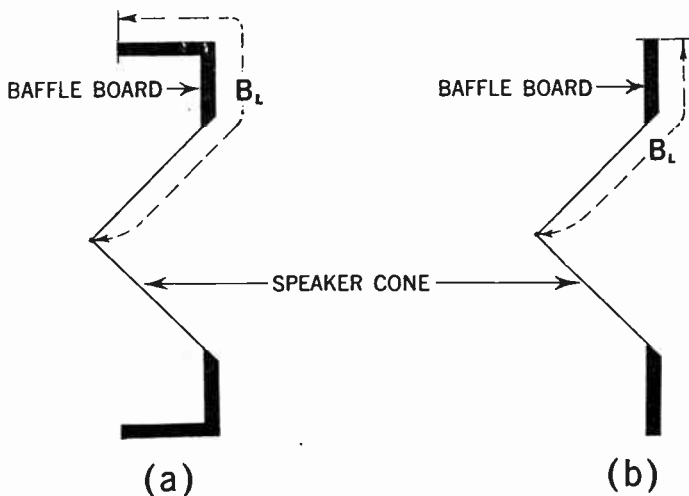

FIG. 15—Various speaker baffles; *a*, and *b*, indicates box and flat baffle types respectively. Dotted lines indicate length of baffle board in each type.

If these air movements were allowed to neutralize each other completely, there would be no air movements and hence no sound waves would be created. The method used to delay these rapid movements is to increase the path of air travel by means of a *baffle board* surrounding the cone as shown in fig. 15.

The amplitude of air movement in a speaker however, is relatively low and therefore theoretically at least sound waves are produced only in the air very close to the moving cone. This is true for low, but not for high frequencies.

Thus in practice an un baffled speaker will reproduce high tones, but will lack almost entirely all low tones due to the neutralization already described.

**Baffle Purpose.**—The purpose of the *baffle* is to delay the meeting of the air creating the sound waves, by an artificial lengthening of the path of its travel.

The baffle, can be anything that will lengthen the airpath from cone center back, to cone center rear.

In practical speakers the baffle is made up of some acoustically suitable material, such as soft wood, thick felt, Celotex, etc.

**Calculation of Baffle Length.**—By recalling that the speed of sound is 1130 feet per second in air, it is possible to calculate the minimum baffle length for a certain frequency.

If  $B_L$  denotes the baffle length in feet, and  $f$  the frequency of the sound wave, then

$$B_L = \frac{1}{4} \times \frac{1130}{f} = \frac{282.5}{f} \dots \dots \dots (1)$$

or expressed in a non-mathematical form, the baffle length in feet is equal to one quarter the wave-length of the note to be reproduced.

**Example.**—Assuming 40 cycles as the lowest tone to be reproduced by a speaker, what is the minimum baffle length required:

**Solution.**—Substituting the numerical values in equation (1) we obtain:

$$B_L = \frac{282.5}{40} \text{ or } 7 \text{ feet (approximately)}$$

In a similar manner the following baffle lengths for low frequency cut-offs below which a loud speaker will not reproduce is as follows:

<i>Lowest frequency to be reproduced.</i>	<i>Baffle length from cone center in feet.</i>
100	2.825
60	4.708
40	7.006
30	9.417
20	14.125

As the tones corresponding to the lowest frequency of various instruments are approximately 20 cycles per second, it follows that for their reproduction baffles of considerable length must be created.

**Example.**—*A loud speaker whose inductance is 1.15 henries is coupled to a power tube through a condenser of 2 micro-farads capacity. To what frequency will the combination be resonant?*

**Solution.**—In this example it is only necessary to find the resonant frequency of a series tuning circuit. When in such a circuit the inductance  $L$ , and capacity  $C$ , are both expressed in the fundamental units of henries and farads, then the resonant frequency in cycles per second is given by the expression

$$f = \frac{1}{2\pi\sqrt{L \times C}}$$

In the present example however, the condenser is of 2 micro-farads capacity, hence it is necessary to convert this unit into the terms of farads before substitution into the above formula.

Inserting values, it is found—

$$f = \frac{1}{2\pi\sqrt{1.15 \times 2 \times 10^{-6}}} = \frac{1,000}{2\pi\sqrt{2.3}} = 105 \text{ cycles per second.}$$

## CHAPTER 18

# Antenna Systems

**General Terms.**—The term “Aerial” generally is applied to that portion of the antenna which is elevated or the flat top portion and the term “lead in” applies to the connection between the aerial and the receiver. The antenna constitutes the combination of the *aerial* and the *lead in*.

By definition an aerial is a conductor or a system of conductors suspended in the air and insulated at the ends for receiving or transmitting radio waves.

Aerials may be classified: 1. According to the number of wires as single or multi-wires, and 2, according to their geometrical design or shape as:

- |                            |                                  |
|----------------------------|----------------------------------|
| <i>a.</i> Inverted L type. | <i>f.</i> Loop (Solenoid spiral, |
| <i>b.</i> Tee (T)          | pancake).                        |
| <i>c.</i> Cage.            | <i>g.</i> Doublet.               |
| <i>d.</i> Fan.             | <i>h.</i> V-doublet.             |
| <i>e.</i> Umbrella.        | <i>i.</i> Spider-web.            |

etc.

**Broadcast Band Receiving Antennas.**—The simplest type of aerial for general broadcast reception especially in rural districts where man-made static is negligible, is the inverted L type shown in figs. 1 and 2.

Ordinarily the antenna will be erected either on the roof of a building or suspended between that roof and a pole, as shown in fig. 2, which consists of a single wire inverted L antenna suspended from the house proper to the garage roof, by means of a pole. The purpose of the pole being to elevate the aerial wire.

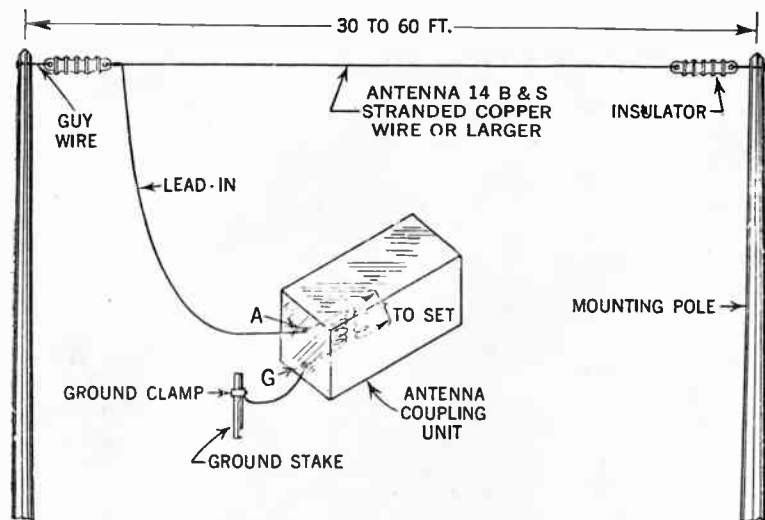

FIG. 1—Outside inverted L-type antenna, with connected lead-in wire.

When erecting an antenna it is of the utmost importance that the horizontal part be removed as far as possible from such objects as trees, walls, chimneys, gutters, telephone and power wires, both to avoid induction from them which may make objectionable noises in the receiving telephone as well as the receiver, and to *avoid injury*.

There has occurred many serious accidents due to ignorance and carelessness in erecting radio antennas too close to high voltage power lines.

**How an Antenna Works.**—Before a discussion of the relative merits of each type of aerial, it is necessary to have a clear conception of how the various aerials receive the radio frequency currents emitted from the broadcasting stations.

In order that an aerial may receive maximum energy from the space in which it is suspended, it is necessary that the aerial be tuned to the broadcasting station, i.e. be resonant at the same frequency.

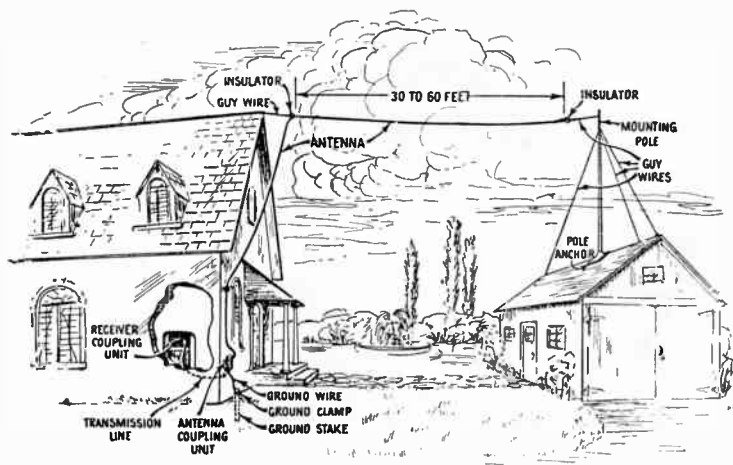

FIG. 2—Typical single-wire antenna installation. (Courtesy R.C.A. Mfg. Co.)

**Theory of Tuning.**—In an aerial circuit the high frequency potential developed by the incoming waves from the transmitting station causes an *a.c. current* to flow in the aerial.

The frequency of such a current is the same as that in the transmitting aerial. The magnitude of the current ( $I_a$ ) through the aerial depends upon the value of the induced voltage ( $E_a$ )



and the effective aerial impedance ( $Z_a$ ), the relations of which according to Ohm's law may be written  $I_a = \frac{E_a}{Z_a}$  ampere.

By varying the impedance ( $Z_a$ ) of the aerial circuit until it becomes in resonance with the frequency of the induced voltage a comparatively large current may be obtained.

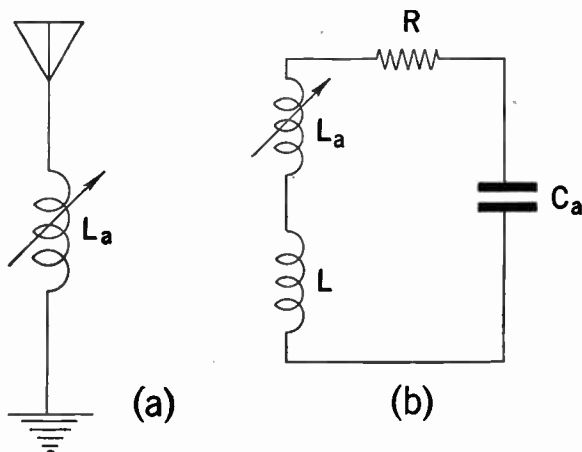

FIG. 3—(a) indicates variometer tuned aerial circuit; (b) indicates equivalent closed aerial circuit.

When the circuit is in resonance the inductive and capacitive reactance will be equal and the impedance of the aerial becomes equal to the effective resistance ( $R$ ).

**Natural Frequency and Wave-length of Aerials.**—The wave-length to which an aerial may be tuned is called its *natural wave-length* or *frequency*. The frequency corresponding to the *natural frequency* ( $f$ ) of an aerial may be derived by remember-

ing that the conditions for resonance is that the inductive reactance ( $2\pi fLa$ ) must equal the capacitive reactance  $\frac{1}{2\pi fCa}$  or  $2\pi fLa = \frac{1}{2\pi fCa}$  from which

$$f = \frac{1}{2\pi\sqrt{La \times Ca}} \text{ cycles per second} \dots (1)$$

In the above equation  $La$  and  $Ca$  are given in henries and farads respectively.

In a similar manner if ( $La$ ) represent the inductance and ( $Ca$ ) the capacity in micro-henries and microfarads respectively, then the natural wave-length

$$\lambda = 1,885\sqrt{La \times Ca} \text{ meters} \dots (2)$$

It is obvious that both the inductance and the capacity depends upon the length and shape of the aerial.

For the inverted "L" type shown on page 377 each of those quantities are more or less proportional to the total length of the aerial wire as measured from the remote end to the ground connection.

That this is true must be self-evident as it has previously been shown that the natural wave-length is proportional to  $\sqrt{La \times Ca}$ . Now then, in order to be able to tune a receiving aerial circuit over a fairly wide range of wave-lengths, a tuning arrangement for varying this product of inductance and capacity is all that is necessary.

**How the Wave-Length of an Aerial May Be Increased.**—It has been found convenient to include an inductance in the down lead wire to the receiver for the purpose of passing the received signal voltage to the set. Sometimes this added inductance coil is connected directly to the set and at other times it is coupled magnetically to the tuned circuit.

When in the closed circuit type, a coil of inductance  $L$  micro-henries is connected in the down-lead of an aerial whose inductance is  $La$  micro-henries, the new wave-length is being given by

$\lambda = 1,885 \sqrt{(L + La) Ca}$  meters, that is assuming that the coil itself has no capacity. Again the corresponding frequency to which the aerial circuit is now tuned is given by

$$f = \frac{1}{2\pi \sqrt{(L + La)C_a}} \text{ cycles per second.}$$

The units in this case being henries and farads.

**Aerial Wire (Size and Material).**—In order that the resistance of the antenna be as low as possible No 14 or 12 B & S stranded copper wire is most generally used.

This wire has a high factor of conductivity, is mechanically strong and can easily be soldered. Antenna wire of this type, of suitable length, is nowadays carried as standard, and can be obtained at any hardware store.

**The Importance of Insulators.**—One important factor when erecting an antenna is to obtain good insulators and use a sufficient number of them.

Approved wire insulators are usually made of Pyrex glass, porcelain, etc. and are made with a hole or eye at each end to facilitate the fastening of the wires.

Fig. 4 shows a ribbed constructed insulator, the purpose of the ribbons being to increase the leakage path and to increase the insulating property of the insulator.

If small insulators are employed, it is necessary to connect two or more in series with short pieces of wire to increase their insulating property. It is obvious that insulators should *not* be inserted in the aerial at random, and should not be used for

example, to connect several pieces of aerial wire to obtain the required length of aerial.

As pointed out in the beginning of this chapter, an aerial has only one insulator at each end, except in case of doublet aerials (which actually consist of two separate aerials) in which case three or four insulators are used. See fig. 5.

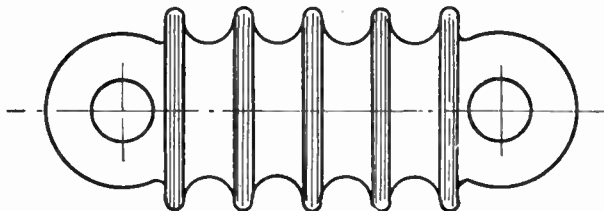

STRAIN INSULATOR

**FIG. 4**—The ribbed construction serves to mitigate leakage of the weak signal energy received by the antenna. This leakage may assume considerable proportions especially during wet weather, hence the necessity of providing good antenna insulators.

**Lead-In Conductors.**—Lead-in conductors should be kept away from the house and should not approach the side of the house closer than six inches.

This is accomplished by insulator supports as shown in fig. 6. The insulator support should be properly fastened by means of wooden screws or brackets. Lead-in conductors should be of stranded copper wire, not smaller than No. 14 B & S gauge.

As in the case of the aerial the lead-in conductors should be kept away from obstructions such as trees, walls, chimneys, gutters, telephone and power wiring. It should also be noted that the lead-in conductor should be of one continuous piece with the aerial.

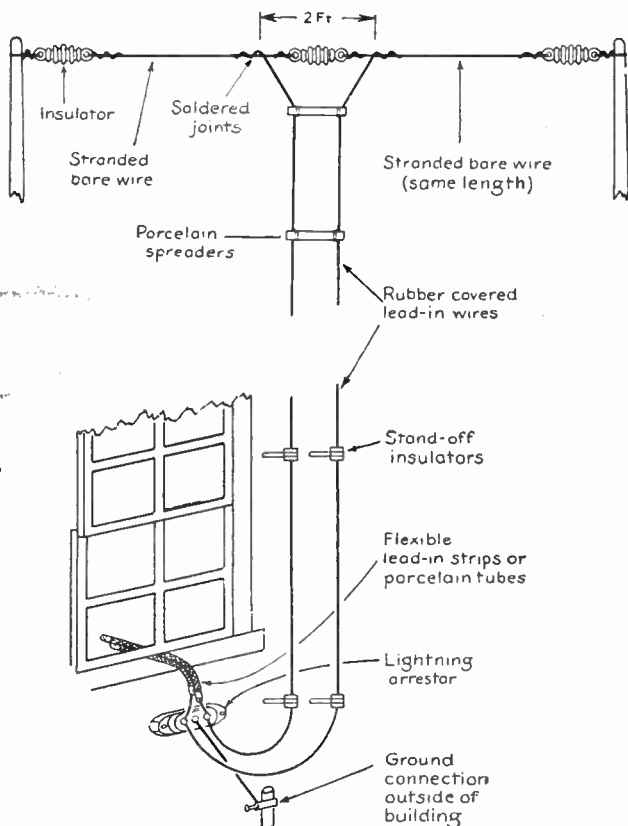

**FIG. 5**—Double antenna may be of the tuned or untuned type. The tuned type have definite aerial lengths (the horizontal portions) for respective wavelengths or frequencies, and the untuned have not; the untuned are, therefore, suitable for a wide range of short-wave frequencies. The lead-in wires, or transmission lines, pick up more noise or interference on short waves than they do on long waves; therefore transposed or closely parallel lead-in wires are used. The drawing shows a typical short wave reception antenna

In entering the building two methods are commonly employed. 1, Entering the conductor through the lower part of a window adjacent to the receiver by means of flat flexible insulated strips, or 2, entering the conductor through a special conduit or porcelain lead-in insulator very similar to that employed in electrical wiring.

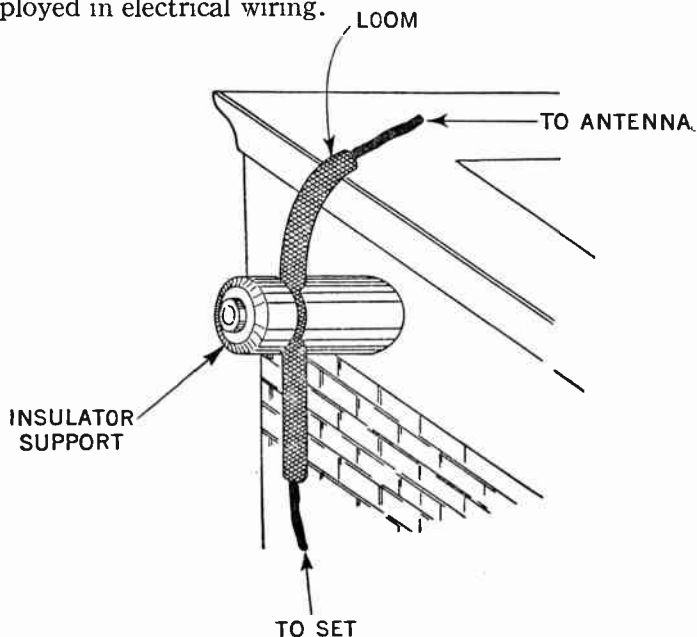
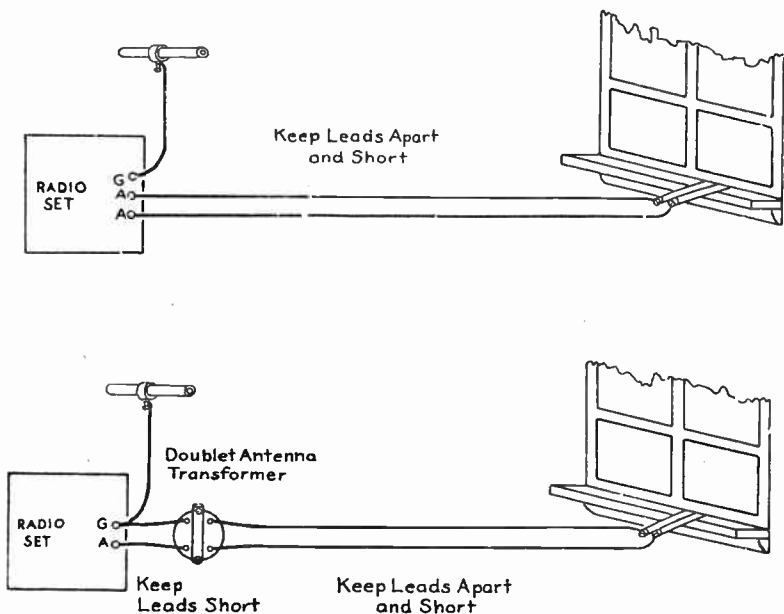

FIG. 6—Demonstrating how a short section of loom is inserted to protect the aerial at the point where the line is supported by a nail-on knob. The loom eliminates swinging and forcing of too sharp a bend in the wire.

When installing the conduit, precautions should be taken that the conductor is sloped outward as shown in fig. 8, this to prevent rain or moisture following the lead-in conductor to enter the building.

**Lightning Arresters.**—The function of the lightning arrester is to prevent sudden voltage surges originating in the aerial (as during a thunderstorm) entering the receiver. Essentially the lightning arrester is a device which provides a very small air gap between the aerial and the ground and through which sudden voltage gradients may escape to ground. See fig. 9.

The rules of the Board of Fire Underwriters require an approved form of lightning arrester. The lightning arrester



**FIG. 7—**Showing method of carrying antenna leads through the windows—using either porcelain tubes or flexible lead-in strips. Upper figure shows connections where antenna transformer is embodied in the radio receiver, and the lower, where it is connected outside. Transmission lines must be well insulated and stand off from the walls, as well as kept away from wires, drain pipes and other metallic surfaces and conductors.

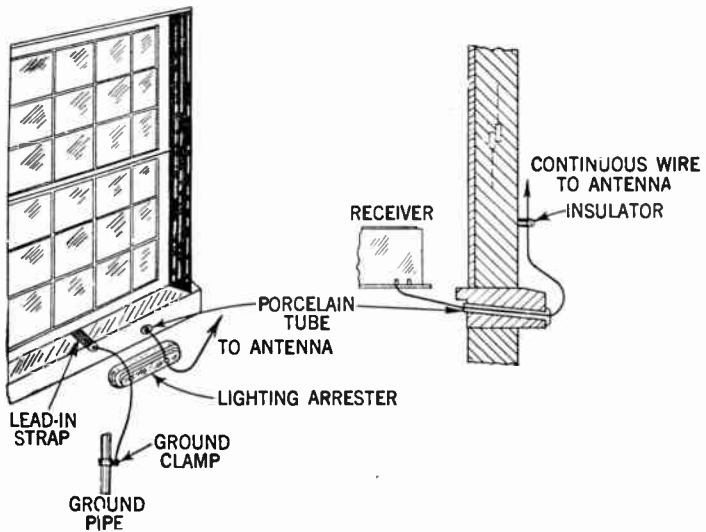

FIG. 8—Conventional method of installing inverted L-antenna lead-ins.

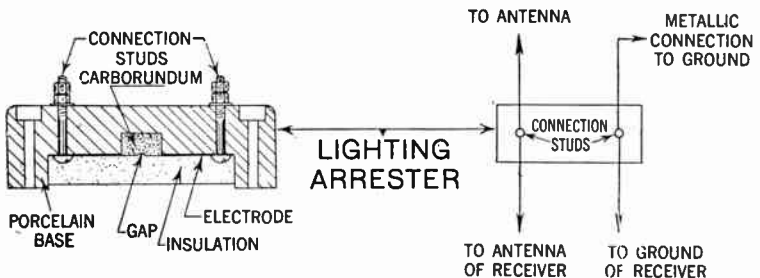

FIG. 9—Lightning arrester detail and diagram of connection.



should be designed to operate at a voltage of 500 volts or less, and should be properly connected and located either inside the building at some point between the entrance and the set which is convenient to ground, or outside the building as near as possible the point of entrance.

Particular precaution should be taken that the lightning arrester be not placed in the proximity of easily ignitable material, or where exposed to inflammable gases or dust, or flying of combustible substances.

**Grounding Conductor.**—Since it is necessary that the grounding conductor be of low resistance, it should be of the same size as the lead-in conductor and should in no case be smaller than No. 14 B & S gauge.

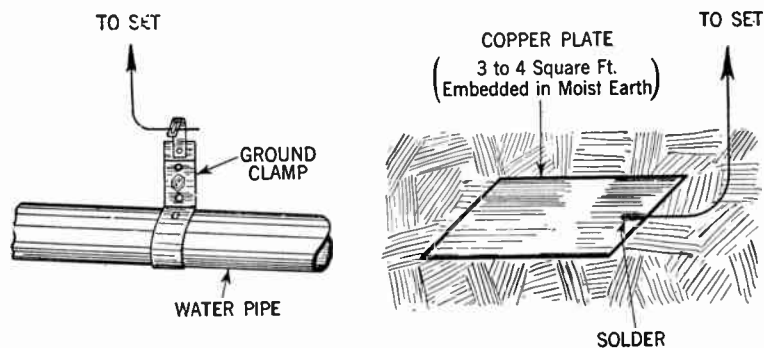

FIGS. 10 and 11—Two methods of ground connection.

Care should be taken to make this connection as short and straight as possible to the nearest water pipe where a good metallic connection should be made. A suitable metal ground clamp designed especially for this purpose can be obtained in any hardware store.

Where a water pipe is not convenient for use as a ground connection, other permissible grounds are grounded steel frames of buildings or other grounded metal work in the building.

When an artificial ground connection has to be made, a large copper plate or a bucket buried in a well or in moist earth may be employed. Under no condition should *gas pipes* be used for ground connection.

In case of exposure to mechanical injury, the ground conductor should be adequately protected.

**Counterpoise Ground.**—In locations where a satisfactory ground cannot readily be secured because of dry soil, a *counterpoise* is used. This consists essentially of a second aerial suspended on supports preferably one foot above the ground and insulated from the latter. See figs. 12 and 13.

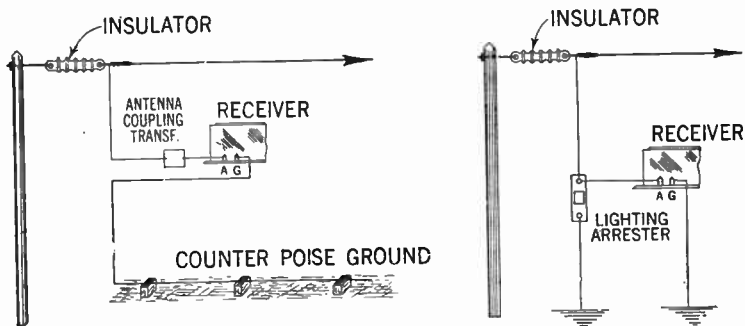

FIG. 12—Counterpoise and connection. Theoretically the counterpoise forms one plate of a condenser of which the main aerial is the other plate.

FIG. 13—Method of connecting lightning arrester to the aerial.

The counterpoise should run parallel with and preferably underneath the main aerial, though if necessary it may be offset to one side.

The action of the counterpoise over the ground is exactly as that of a condenser; in fact it is a *large condenser* conforming to all of the laws pertaining to condensers. In the case of aircraft or automobiles, the body (being metallically bonded together) to which the grounding conductor is connected, acts as a counterpoise.

**Various Types of Antennas.**—Among the various types of antennas enumerated in the beginning of this chapter, it should be observed that each geometrical form has particular characteristics desirable for the particular operating conditions as shown in figs. 14 to 19.

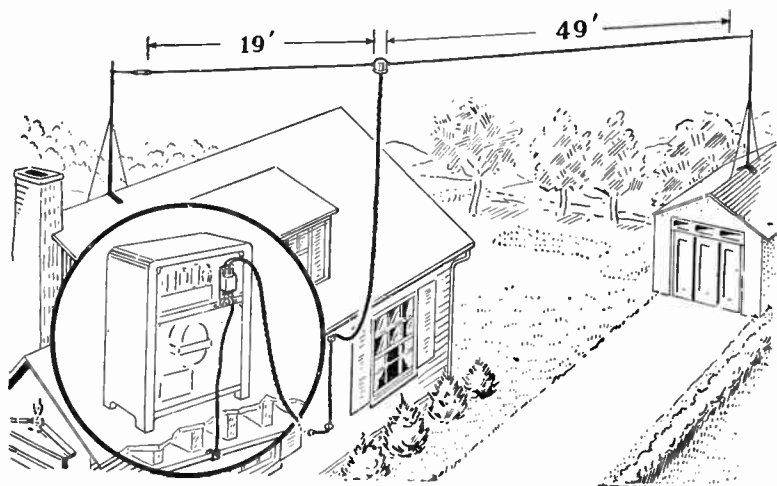

FIG. 14—Illustrating how a doublet receiving antenna may be erected. This antenna consists of a special doublet, a transposed transmission line, and antenna junction box and a receiver coupling unit. An antenna of this type is an efficient pick-up medium giving high signal strength over a wide frequency range.

The doublet antenna shown in fig. 14 has been found to be highly efficient for short wave reception, and should for best results, have a length of  $\frac{1}{4}$  of the desired wave-length. A close approximation of the total length for the two dipoles of the doublet may be obtained by dividing 492,000 by the desired frequency in kilocycles. The lead-in conductors (or transmission line) are

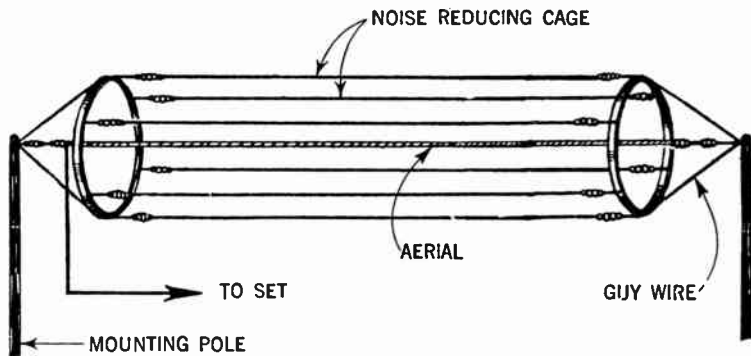

FIG. 15—Cage antenna. A type frequently used at transmitting stations.

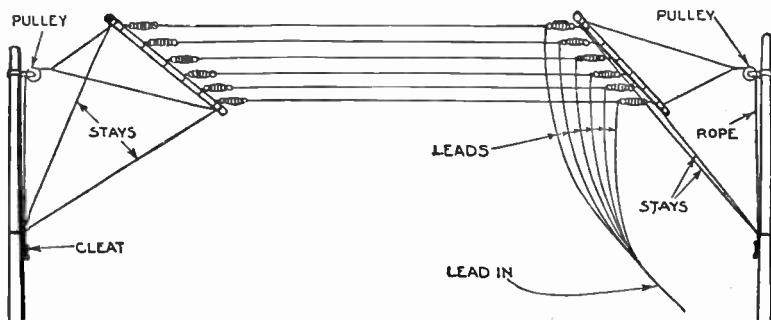

FIG. 16—Multi-wire inverted L (flat top) outside aerial. Where the distance between supports is limited, the necessary length of aerial may be obtained by running two or more lengths of wire parallel as shown.

transposed at intervals as shown in fig. 14. This method is employed in order to eliminate the pick up of man-made static or local interference.

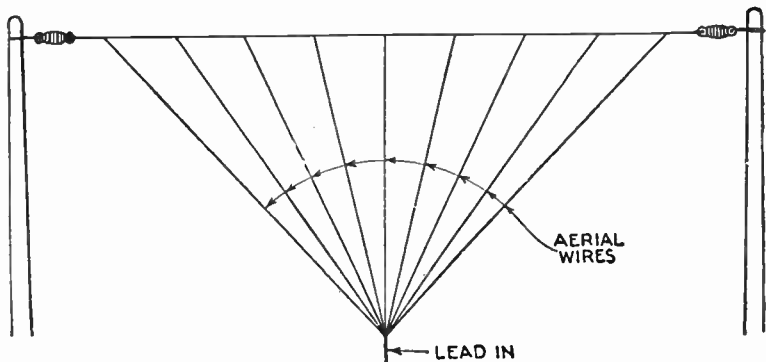

FIG. 17—Fan aerial.

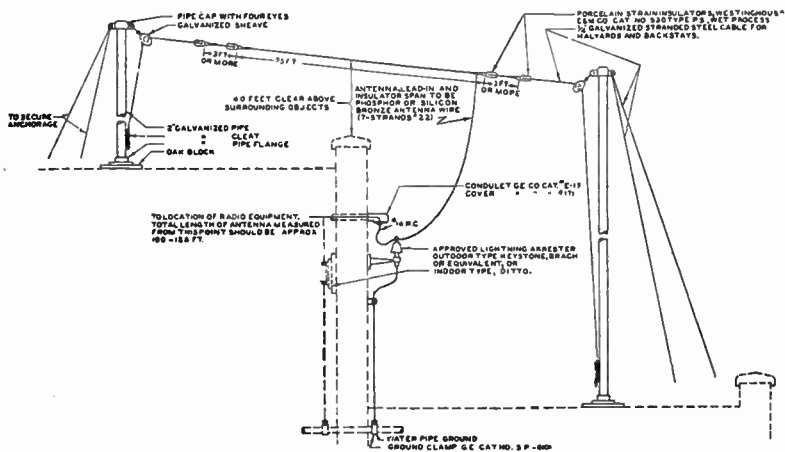
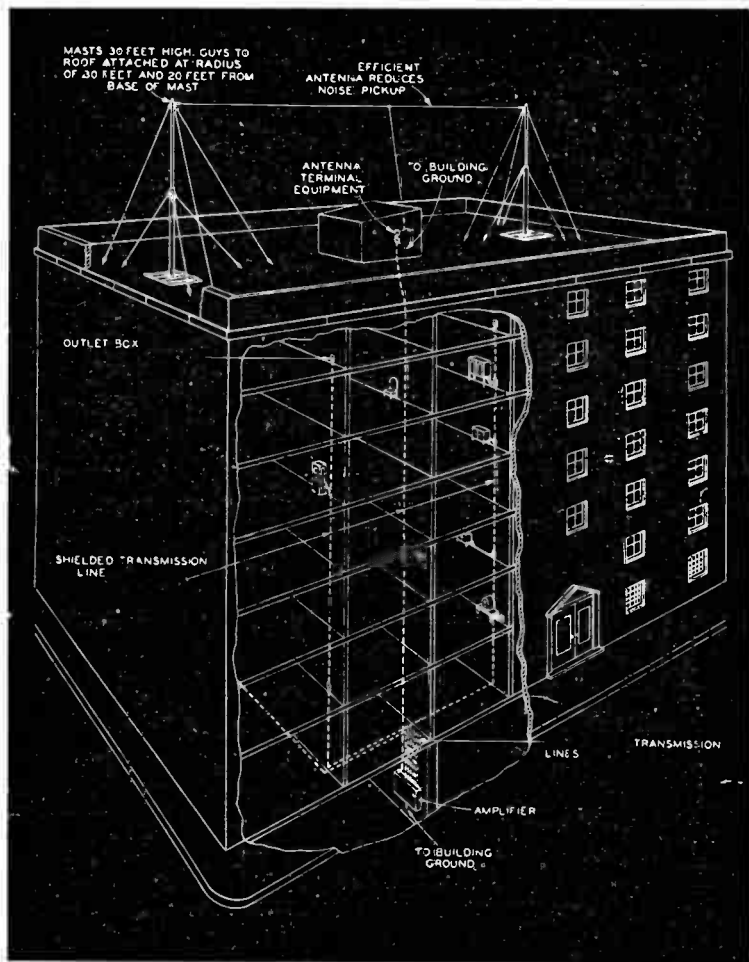

FIG. 18—Substantial antenna construction suitable for apartment house, school or hotel.



**FIG. 19—**Antenna installation for apartment house or hotel. To avoid duplicate and inefficient antenna installations where many radio sets are located in one building, a single, properly installed antenna is most suitable.

**Example.**—*What is the natural wave-length of an aerial the inductance of which is 10 microhenries and the capacity 0.00025 microfarads? If a tuning inductance of 150 microhenries be placed in series with it, what is the resonant wave-length?*

**Solution.**—The formula for the natural wave-length of a series resonant circuit is  $\lambda = 1,885\sqrt{LC}$  in which  $\lambda$  is in meters,  $L$  and  $C$  are the inductance and capacity of the circuit expressed in microhenries and microfarads respectively. In the present example

$\lambda = 1,885\sqrt{10 \times 0.00025} = 1,885 \times 0.05$  or 94 meters approximately.

With the addition of the tuning inductance of 150 microhenries the total inductance becomes 160 microhenries. The resonant wave-length is now  $\lambda = 1,885\sqrt{160 \times 0.00025} = 1,885 \times 0.2 = 377$  meters.

**Example.**—*Assuming that the total inductance of the aerial circuit in the preceding problem is concentrated in the tuning coil, what parallel capacity is required to tune to 500 meters?*

**Solution.**—Let  $C$  represent the extra capacity required since this is placed across the tuning inductance, it may be considered to be in parallel with the existing natural capacity of the aerial, so that the total capacity across the tuning circuit is  $(C + 0.00025)$  Mfd. The required wave-length is given as 500 meters. Applying the same formula as before, the following is obtained:

$$1,885\sqrt{160(C + 0.00025)} = 500, \text{ that is}$$

$$3.77\sqrt{160(C + 0.00025)} = 1; \text{ squaring both sides of the equation,}$$

$$14.2129 \times 160(C + 0.00025) = 1$$

$$\text{therefore } C + 0.00025 = 0.00044$$

$$\text{and } C = 0.00019 \text{ mfd.}$$

**Example.**—Assume in an aerial with the constant as given, that it is required to tune it over a band of wave-lengths varying from 250 meters and upward by means of a coil and a parallel condenser of the variable type, having a maximum capacity of 0.0005 microfarads and a minimum capacity of 0.00003 microfarad, what value of coil induction should be used?

**Solution.**—In substituting the known values in equation (2) the following is obtained:

$$250 = 1,885 \sqrt{(L+10) (0.00003 + 0.0002)}$$

from which  $L = 66.4$  micro-henries.

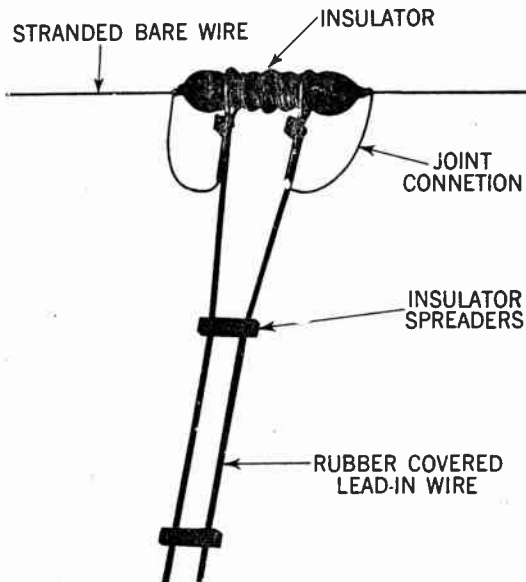

FIG. 20—Illustrating good spacing arrangement for doublet type antenna.



Using a coil with this value of inductance the aerial circuit tunes to 250 meters with the condenser set to its minimum value.

If now the condenser be set to its maximum value of 0.0005 *M.f.* the maximum wave-length of the tuning range is obtained by equation

$$\lambda = 1,885 \sqrt{(66.4 + 10) (0.0005 + 0.0002)} = 436 \text{ meters.}$$

## CHAPTER 19

# Automobile Antennas

Automobile antennas are generally divided into two classes according to their location as:

1. Roof or top antennas
2. Under-car antennas.

Probably the most popular antenna in closed car construction is the roof or top type. The majority of recent built automobiles of the closed body type are already equipped with such antennas installed at the factory, and a lead-in brought down one of the corner posts.

In many of the earlier models of the closed body types, a piece of metallic screen is employed for top material support. This metallic screen may readily be utilized as an antenna, provided that the screen is insulated from the metallic frame of the car.

In order to use an ungrounded support screen, one corner only of the head-lining need be removed. A shielded lead-in (see fig. 1) should first be soldered to the screen and then carried down the front pillar post, nearest to the receiver.

The shield covering should be soldered or bonded to the car frame prior to replacement of the head lining.

The determination of the existence of electrical contacts between the screen and the body proper may readily be found by

an electrical test, without removing any portion of the top fabric. An authorized dealer should be consulted as to the proper procedure of making this test.

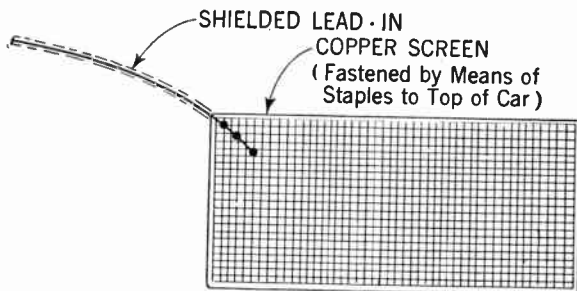

**FIG. 1**—A roof type antenna of this type consists of two copper screens fastened to cardboards and insulated from contact with car body.

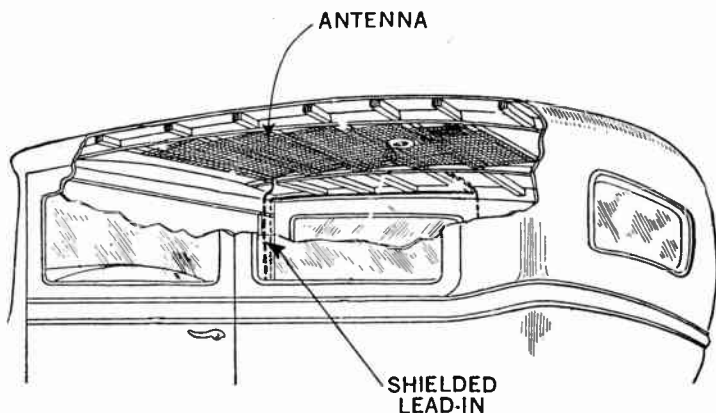

**FIG. 2**—Illustrating location of roof type antenna.

If it be found that the top support screen is grounded or if no screen be present, it will be necessary to remove the entire

head-lining as shown in fig. 2. In the former case the screen may be insulated by removal of a strip several inches from all edges, as well as from the dome light fixture.

Subsequent shifting of the screen may be eliminated by tacking the screen to one of the ribs and by lacing the sides with a cord. If there be no support screen present, a copper screen as shown in fig. 1, having an area of at least ten square feet, should be inserted.

It should be located as far in the rear as possible, and particular precaution should be observed against possible metallic connection to the grounded frame of the car. After the antenna is properly inserted the lead-in wire may then be attached as described and the head-lining replaced.

**Folding Top Antennas.**—In touring cars, roadsters, convertible coupes and convertible sedans, where folding top construction is employed, the wire screen previously described cannot readily be utilized on account of its being not sufficiently flexible to permit the folding of the top.

A flexible wire antenna consisting of approximately 75 feet of No. 18 rubber covered stranded wire is often employed. To install this type of antenna proceed as follows: First remove the tacks that hold the top material to the front bow over the windshield and lay the top back. This operation will expose the cloth pads (quarter deck pads) on each side of the top bows. It is to these pads that the antenna should be fastened.

Start near the windshield and run the wire the entire length of the quarter deck; the wire should be secured with individual knots, approximately 6 inches apart. Run the wire back and forth on the quarter deck until eight rows spaced about one inch apart has been completed and fastened. The wire is then tacked across the roof on one of the roof bows, where a similar operation is repeated on the opposite quarter deck.

The lead-in wire of heavy weather-proof construction is connected to the antenna at the rear of the top where it will not interfere with operation of the folding of the top. This type of antenna is recommended only when the top is used at least half of the time or more. In cases where the top is folded back more than half of the time, a running board antenna may be installed with a provision of switching from the running board to the wire antenna when the top is used. This method is resorted to on account of insufficient pick-up when the top is down.

**Under-Car Antennas.**—As all late cars of the closed type have an all steel roof, it is obviously impossible to include a roof antenna since such a unit would be useless. When in this type of car no provision is made, one of the two general types described may be employed, as follows:

1. Running board type
2. V-type antenna.

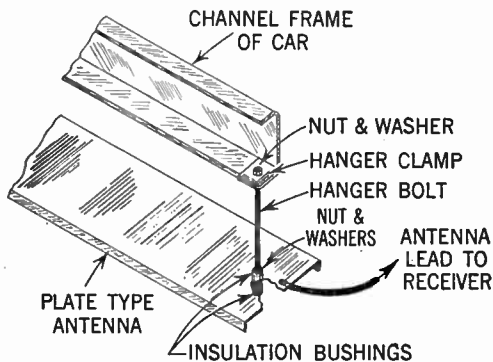

FIG. 3—Showing method of fastening plate-type antenna to channel frame of car.

The running board antenna may be of either the plate type or of the so-called di-pole or hairpin type, shown in figs. 3, 4 and 5 respectively.

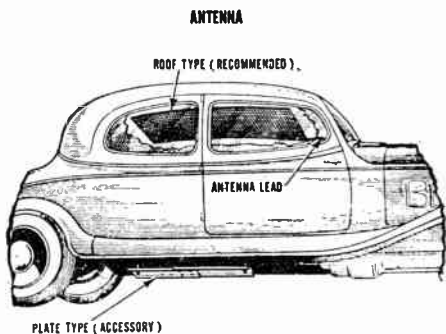

FIG. 4—Showing approximate location of roof-type antenna and plate-type running board antenna.

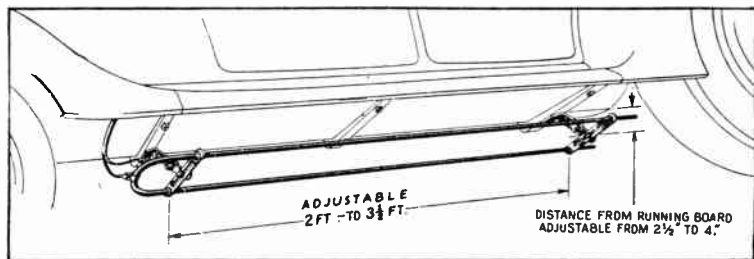

FIG. 5—Di-pole antenna and method of assembly.

**Plate Type Antenna.**—This unit should be clamped to the frame of the chassis as far to the rear as possible. It is adjustable in length and may be mounted either lengthwise or crosswise of the chassis—position to be selected with due regard to precaution of overcrowding.

The plate must be mounted as close to the ground as practical consideration will permit. It is also important to avoid any position in which the plate will impede the free motion of the chassis and parts such as springs, drive shaft or axles to prevent impairment of service; also in order to prevent damage when the car is run alongside a low curb it should be set back approximately 2 inches from the outside edge of the running board.

As this type of antenna is invariably subjected to hazards such as ice, snow, water and wind, it should be anchored to the car as strongly as possible. The fact that the antenna insulators often are wet should be taken into account, i.e. the insulators should be made as long as possible to prevent leakage.

In some cases this type of antenna is made in two parts; one for each running board, in which case they should be properly connected at the rear.

**Di-Pole or Hairpin Type.**—The position, mounting, accessories, as well as the antenna are shown in fig. 5. Decreasing the distance from the antenna to the ground will increase signal strength, but precautions previously described pertaining to the plate type antenna should be observed.

To facilitate the mounting of the antenna two universal type brackets are used for attachment to the running board, by means of the screws normally used on the car. The distance from the road may be adjusted by the brackets to insure necessary road clearance.

**Lead-In.**—The lead-in wire to provide the connections between the car antennas and the receiver should be shielded and as short as possible without putting undue strain on any parts.

If no opening be provided in the car, the lead-in should be brought into the driving compartment through a half inch hole

drilled in the toe-board. It is obvious that in the case where the receiver is located at one side of the car, the antenna lead-in should be brought in at that same side, to make a shorter connection.

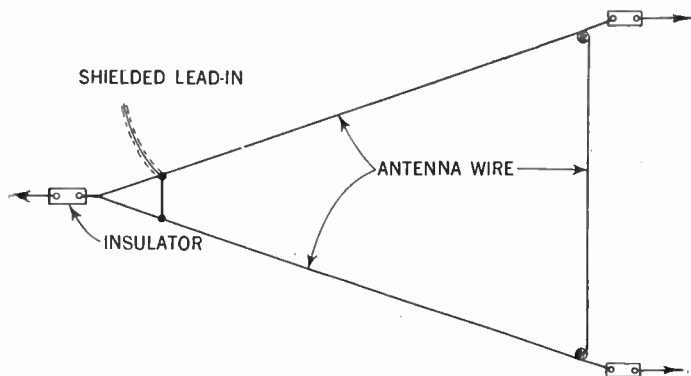

FIG. 6—Method of assembling a triangular wire type antenna.

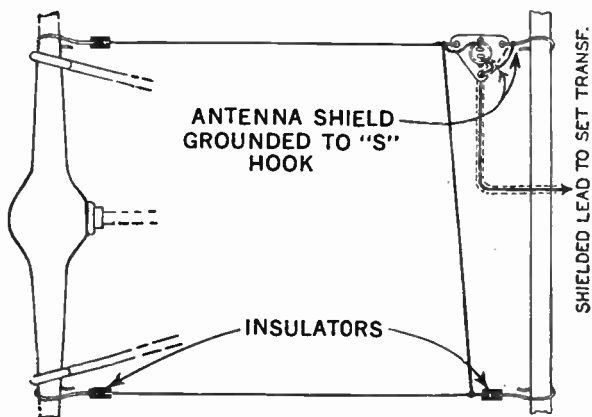

FIG. 7—Method of installing a square type under-car antenna.



**The V-Type Antenna.**—This type of antenna consists essentially of heavy insulated wire which is connected between the transmission housing and each rear spring; with strongly insulated supporters for attachment. The shielded lead-in is connected to the center of the wire near the transmission housing insulator.

Another type of antenna somewhat more efficient is the so-called triangular type shown in fig. 6. Here the wire is brought out to form a triangle. The front part is supported and fastened in the same manner as the V-type, and the back to the rear axle.

Another type of antenna is depicted in fig. 7, consisting of two under-car antennas inter-connected as illustrated.

**(For Information on Automobile Radio Troubles see pages 703 to 709.)**

## CHAPTER 20

# Phonograph Pick-ups

By definition a phonograph pick-up is a device which converts the vibrations of a phonograph needle in traversing a phonograph record into audio frequency currents for reproduction through a radio receiver. See fig. 1.

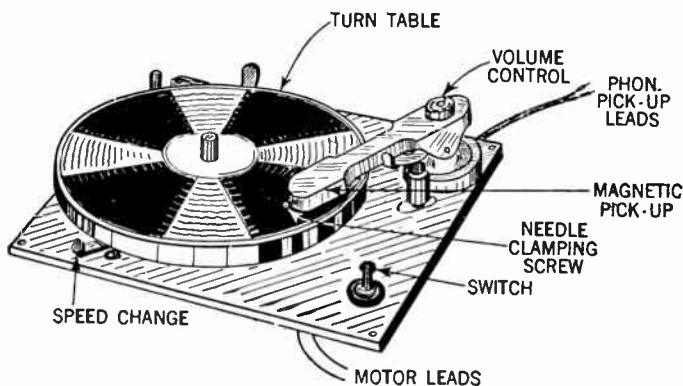

FIG. 1—Modern phonograph pick-up unit.

Phonograph pick-up operating on various well known principles have been developed, such as the condenser type, carbon resistance, magnetic or crystal type.

The pick-ups at present are found almost exclusively to be of either the magnetic or the crystal type. Magnetic pick-ups are divided into two classes depending on the method of damping employed, namely:

1. Rubber damped
2. Oil damped.

Conventional types of rubber damped magnetic pick-ups are shown in figs. 2 and 4.

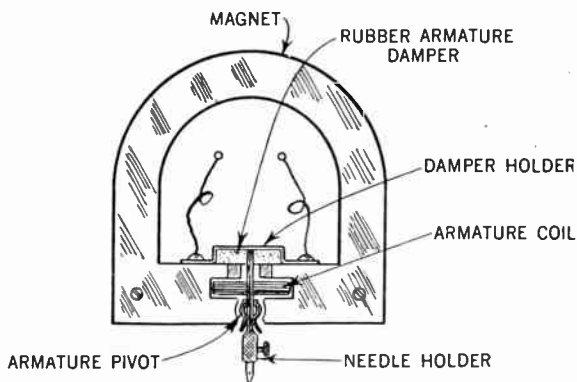

**FIG. 2—Principal parts of a rubber damped magnetic pick-up.**

The operation principles are as follows: The movement of the needle and hence the armature to which the needle is attached is accomplished by the ripples inscribed in the record which rotates at a constant speed.

The coil of wire wound on the armature is made to intercept the magnetic lines of force flowing from the North to the South pole of a strong permanent magnet.

At any instant that the coil cuts the lines of force between the two poles, a voltage is induced within the coil, the value of which is regulated by the amplitude of the vibration. The two

terminals of the coil are brought out to the input terminals of the audio amplifier which amplifies the audio-frequency voltage variations sufficiently to load speaker volume.

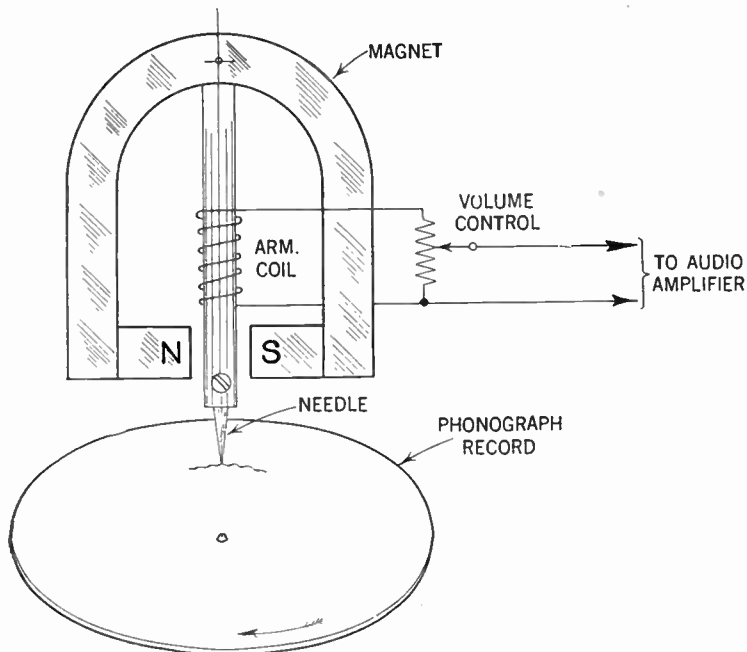

FIG. 3—Simplified layout of a phonograph pick-up.

One detrimental factor with the average pick-up unit, regardless of principle or type, is the weight of the moving parts. The mass of the usual iron armature for example, causes it to have a resonance in the audible range which reveals itself to the ear as a snarly sound in the middle range, and its inertia, coupled with the type and amount of damping necessary, very often curtails the brilliance of reproduction, which is largely bound up with responsiveness to transients.

In order to counteract the weight of the pick-up head and so mitigate the aforementioned undesirable qualities, a counterbalance arm is usually resorted to, although it is not desirable to completely balance the weight of the pick-up because some weight must act on the needle in order to keep it from jumping out of the groove, especially when low frequency notes are being reproduced.

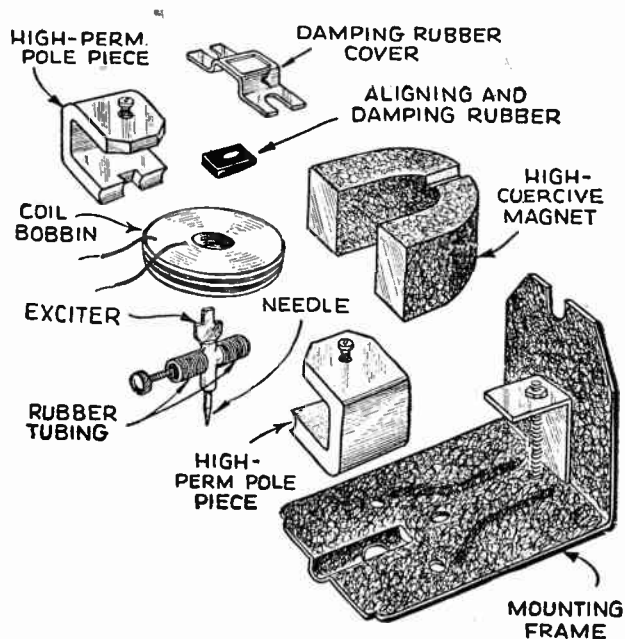

FIG. 4—Parts of modern rubber damped pick-up.

Therefore, it is important that records should be made of hard materials, and at the same time possess abrasive qualities sufficient to grind the needle point at the beginning of its travel in order to reduce the pressure of the needle.

**Impedance Values.**—Magnetic pick-ups are made in all impedance values, the average being around 20,000 ohms. This allows direct feeding of the output into the grid circuit of an amplifier stage without the interposition of any matching transformer.

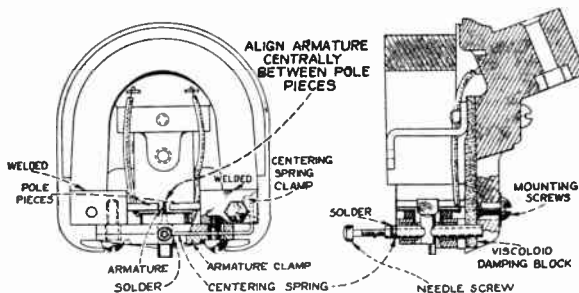

FIG. 5—Front view and section of phonograph pick-up. (Courtesy General Electric Co.)

However, where quality is of the utmost importance, as for example in broadcasting and recording studios, where long cables are commonly employed, 200 to 500 ohms being practical averages.

These lower values are much less affected by long connections in regards to hum pick-up or loss of high frequencies, due to the distributed capacity of the cables and of the armature coil winding itself.

When as in some commercial sets low impedance values are used, a step-up transformer must be resorted to in order to obtain satisfactory operation.

**The Oil-damped Magnetic Pick-up.**—This type of pick-up is more complicated in construction and hence more expensive than the rubber damped type. However on account of its superior frequency response characteristics, it is frequently employed in sound picture reproduction as well as in high grade sound amplifier systems.

In this type the horse shoe magnet is enclosed in a case, and surrounded by oil (which takes the place of rubber in the rubber-damped type pick-up) damping the action of the armature.

**The Crystal, Variously Called Piezo-Electric Pick-up.**—The action of this device, which on account of certain favorable qualities has found an increased use, depends upon the property of a Rochelle salt crystal in converting mechanical motion into electrical voltage. In practice this is accomplished by placing two small crystal slabs together which results in what is known as a bi-morph crystal element. This crystal element is then mounted between two small discs of sponge rubber in a bakelite housing, and a light aluminum rocker arm with rubber pivoted bearings (substantially the same as that employed in magnetic units) is used to communicate the motion of the needle to one end of the crystal.

The "fish tail" of the rocker arm employs a forklike notch in the extreme end to which the crystal is clamped. On account of the fact that this armature is much lighter than the iron ones used in the magnetic pick-ups, they require less damping in addition to the attractive properties of the voltage generating element itself.

The impedance in this unit is very high and the element is inherently capacitive—which two features call for a somewhat different technique in the proper operation of the pick-up.

Good results are being obtained with a volume control of 0.5 megohm. All leads should be well shielded.

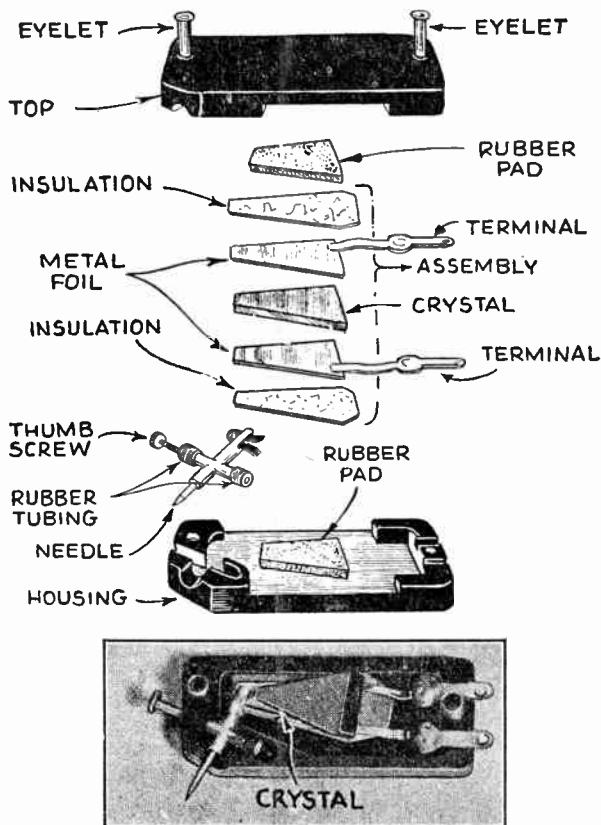

FIG. 6—Parts and assembly of crystal pick-up.



One of the most unfavorable points in the employment of a pick-up of this type is the extreme fragility of the pick-up itself, another being the variations of output with the temperatures in excess of 100° Fahr.

Additional points to be considered when selecting a pick-up unit, regardless of specific types, are solidity of carrying arm construction and freedom of movement of the horizontal and vertical bearings.

The pick-up should be so constructed that not more than three ounces of needle pressure will be used on the record.

**Phonograph Motors.**—An important part of the phonograph mechanism is that of the motor, its function being to produce the revolving motion to the phonographic disc.

The speed of the record should be as nearly constant as possible. The usual speed of the phonograph disc record being 78 *r.p.m.* At 78 *r.p.m.* a 10 inch record plays for 2½ minutes, while the 12 inch record plays for 4 minutes. Again a 16 inch record (employed in sound picture work) revolving at 33⅓ *r.p.m.* plays for approximately 14 minutes.

Motors of the *a.c.* current type are most generally of the induction or synchronous type, its speed being controlled by a governor, as shown in fig. 7. In later type motors a stroboscope disc is employed which makes closed speed adjustment very easy.

If a stroboscope disc is not available the following method may be employed for correct speed adjustments:

1. Place a record on the turntable and insert a small piece of paper under the edge of the record to serve as an indicator.

2. Play the record in the normal manner and count the number of revolutions made by the turntable in one minute. The speed should be 78 revolutions per minute.

3. Turning the speed regulating screw clockwise allows the motor to run faster, and counter-clockwise slower.

Adjust by trial until the speed is as exactly as possible 78 *r.p.m.* as determined from a full minute count.

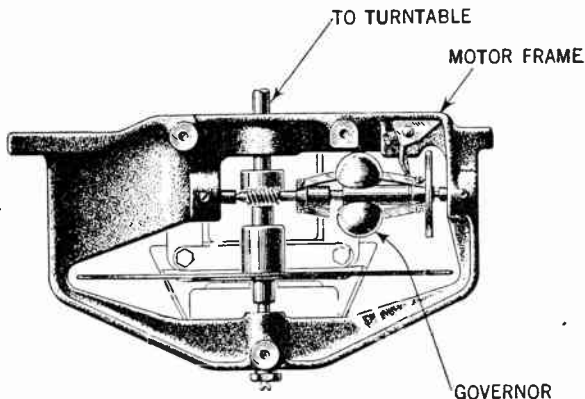

FIG. 7—Motor frame, motor and governor in modern electric phonograph.

The speed of disc should be checked about every two months. Variation in speed will cause distortion.

The governors are generally designed to maintain a constant speed of the motor within a range of sudden voltage changes of 20 volts, if the parts be properly adjusted. Therefore any adjustment made on the motor, including lubrication, will have a certain effect on the speed, which should be checked as previously described.

**Phonograph Pick-Up Connection.**—When a phonograph of the high impedance type pick-up is employed in connection with the radio receiver, it may be connected in one of several ways as shown in figs. 8 to 10.

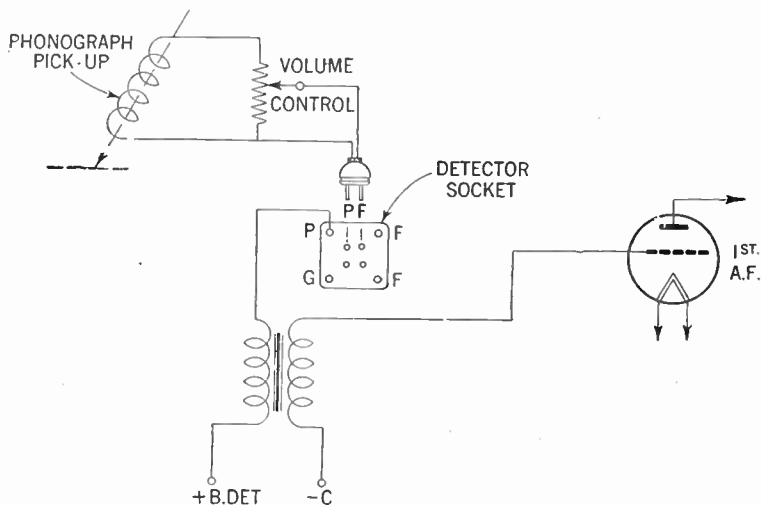

FIG. 8—Method of connecting phonograph pick-up when unit be provided with an adapter for plugging into the detector tube socket. When plugged in the pick-up will be connected to the input of the audio amplifier.

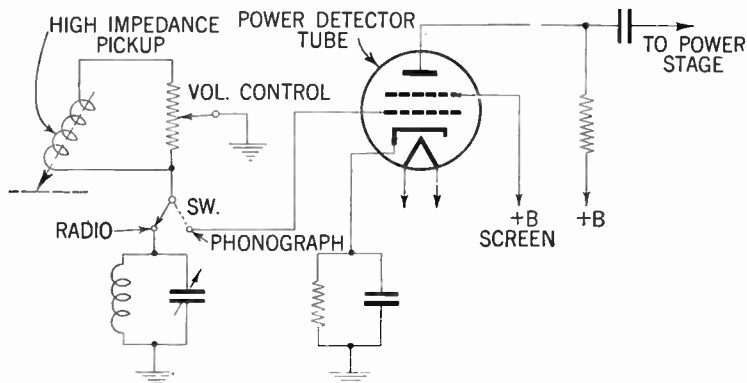

FIG. 9—Conventional method for connection of radio high impedance pick-up.

In more expensive radio phonograph units a so called scratch filter consisting of a combination of inductance and capacity is employed to eliminate or suppress the scratch or hiss caused by the friction of the needle on the record.

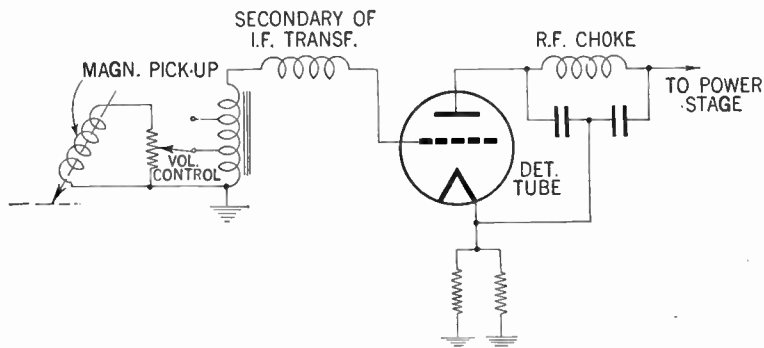

FIG. 10—Method of radio phonograph pick-up connection.

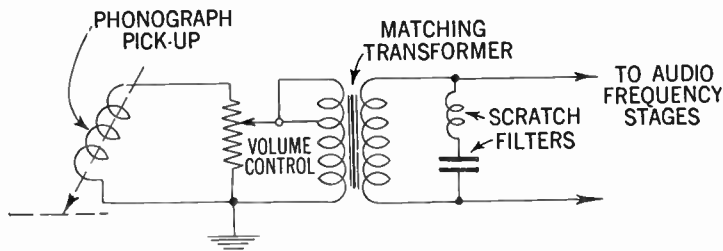
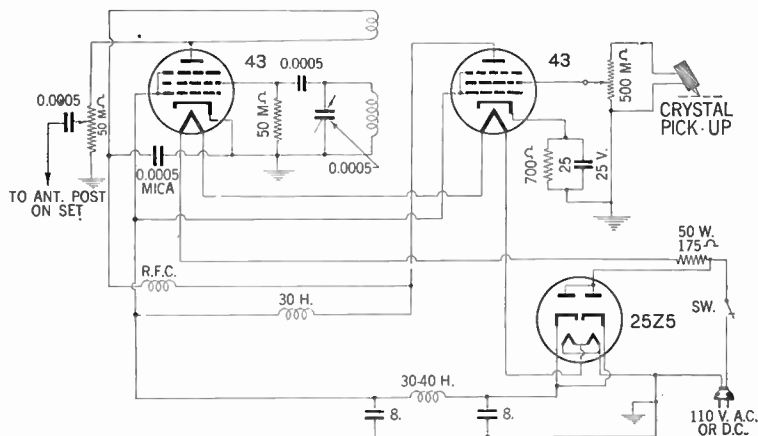

FIG. 11—Method of connection for a needle scratch filter.

The loudspeaker reproduction of scratch is due to the fact that the sides of the wavy grooves in a phonographic record are seldom cut clean or smooth. The almost microscopic rough edges will to some extent, affect the motion of the needle and are responsible for the above described defect. A scratch filter as commonly used, is shown in fig. 11.

The simplest method of record reproduction is to employ an oscillator unit shown in fig. 12. This oscillator in effect is a miniature broadcasting station and the radio is turned to it exactly as to any other station. The oscillator and its connection is clearly indicated in fig. 12 and no changes whatsoever need be made in the receiver.



**FIG. 12**—A portable A.C.-D.C. phonograph oscillator, which may be worked through existing radio receiver. In this phonograph the record reproduction is introduced by means of a miniature carrier wave generated by a local oscillator which is plate-modulated by a single audio power stage into whose grid the output of the pickup can be connected with a minimum of trouble and equipment. In effect this is nothing but a small broadcasting station to which the radio set is tuned, and the carrier pickup is either by conductive or inductive transformers to the sets antenna lead and the set operated in the usual manner.

The frequency of the oscillator may be varied so as to select a channel that is clear of broadcasting.

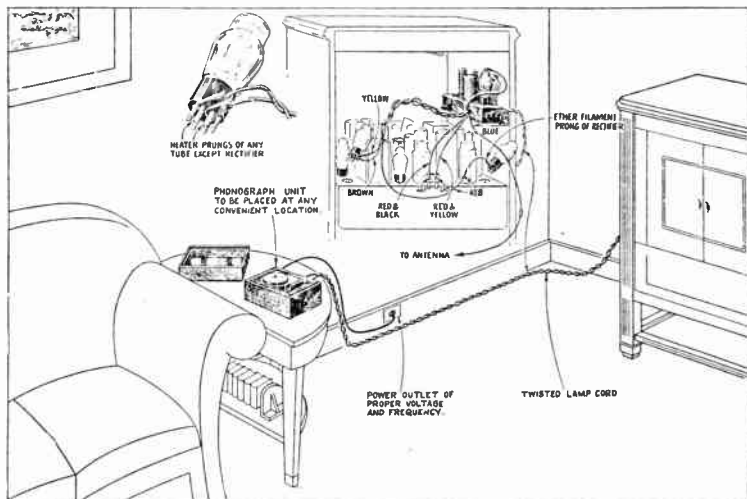

FIG. 13—Diagram of connection when oscillator-phonograph units are employed in connection with receiver for music reproduction.

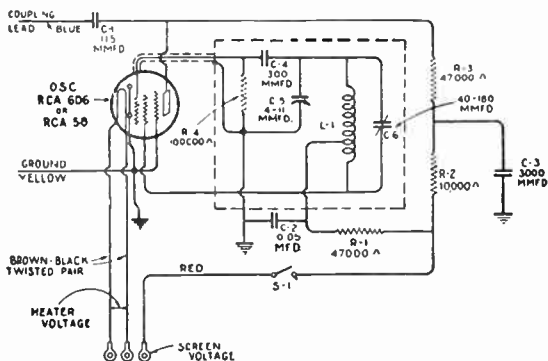

FIG. 14—Schematic circuit diagram of typical oscillator unit.

A schematic diagram of a simple phonograph oscillator which will give high quality performance is shown in fig. 15, when used either with a *crystal phone pick-up* or a *crystal microphone*. The output is sufficient to operate a radio receiver located 50 to 75 feet away.

The oscillator portion utilizes the control grid, screen grid, and plate of a 12SK7 tube. The audio modulating voltage is impressed on the suppressor grid, and the per cent modulation may be varied by adjusting  $R_3$ , which controls the cathode potential of the tube.

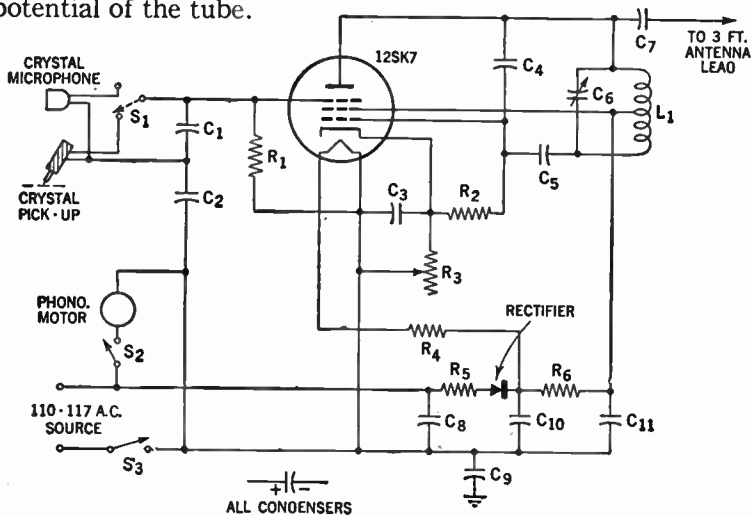

FIG. 15—Schematic diagram of phonograph oscillator, operative for either voice or recordings. The components employed are as follows:

$R_1$ —4.7 megohm,  $\frac{1}{2}$  w. res.

$R_2$ —47,000 ohm,  $\frac{1}{2}$  w. res.

$R_3$ —10,000 ohm rheostat (adjust.

for % of modulation)

$R_4$ —740 ohm, 20 w. res.

$R_5$ —22 ohm,  $\frac{1}{2}$  w. res.

$R_6$ —7000 ohm, 1 w. res.

$C_1$ —500  $\mu$ f.d. mica cond.

$C_2, C_8, C_9$ —.05  $\mu$ f.d., 400 v. cond.

$C_3$ —10  $\mu$ f.d., 25 v. dry elec. cond.

$C_4, C_7$ —25  $\mu$ f.d. mica cond.

$C_5$ —250  $\mu$ f.d. mica cond.

$C_6$ —20-160  $\mu$ f.d. var. cond.

$C_{10}, C_{11}$ —40  $\mu$ f.d., 150 v. elec. cond.

$S_{10}, C_{11}$ —S.p.d.t. sw.

$S_2, S_3$ —S.p.s.t. sw.

$L_1$ —Broadcast ant. coil c.t. (1000 to 1700 kc.)

Rect.—200 ma. selenium rectifier (or two 100 ma. rect. in parallel)

1—12SK7 tube

## CHAPTER 21

# Public Address Systems

By definition a public address system consists of a sound amplifier system supplying sound programs from *radio*, *phonograph* or *microphones* to one or more *loud speakers*.

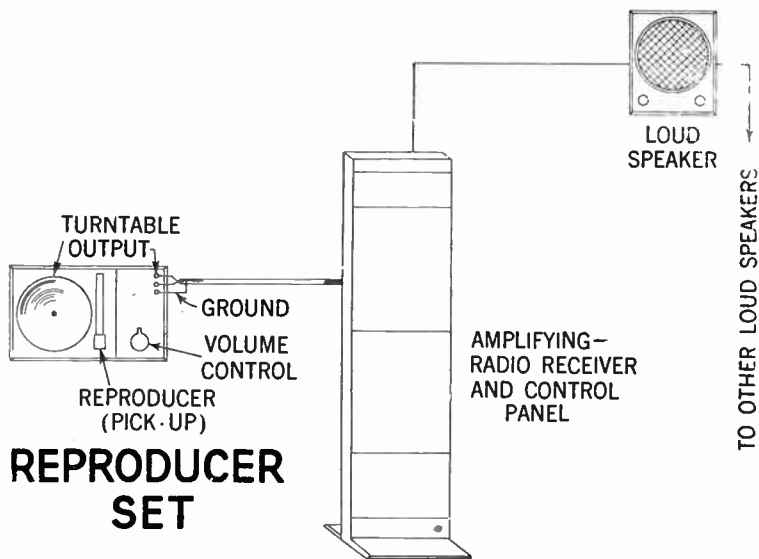

FIG. 1—Schematic view of a music reproducing and program distributing system.



A public address system may be designed to amplify sound in one single place such as in an *auditorium* or in a number of rooms such as in *hotels* or *hospitals*.

In order that the reader may obtain a clear conception of the various units comprising the system, the following definitions are given:

**Music Reproducing System.**—It may be defined as an assembly of apparatus consisting of a reproducer set (program source), the necessary amplifying and control equipment and one or more loud speakers. A music reproducing and program distribution system is shown in fig. 1.

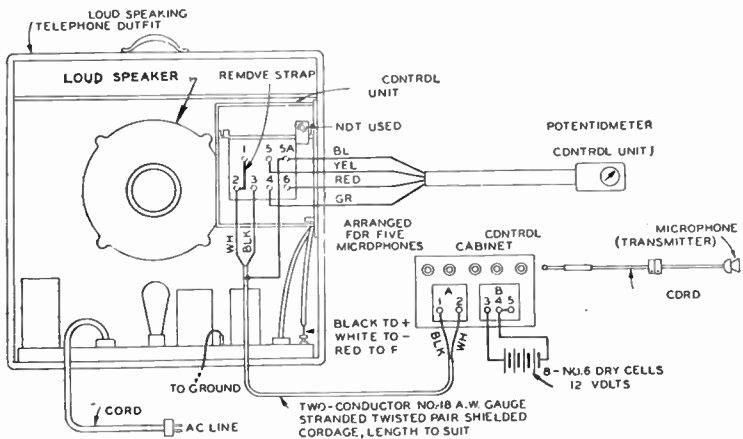

FIG. 2--A small portable announcing system.

**Announcing System.**—It may be defined as an assembly of apparatus comprising one or more announcer's microphones. The necessary amplifying and control equipment, and one or more loud speakers. A system of this type is illustrated in figs. 2 and 3.

**Program Distribution System.**—A system which provides facilities for the distribution of programs from a radio receiver in conjunction with a public address system, announcing system, or music reproducing system to one or more loud speaking telephones.

**Operation Theory.**—The aforementioned apparatus operates as follows: A microphone (which may be of various shapes and designs as shown in figs. 18 to 23 connected into an electric circuit, is placed in such a manner that the sound directed into it will be reinforced.

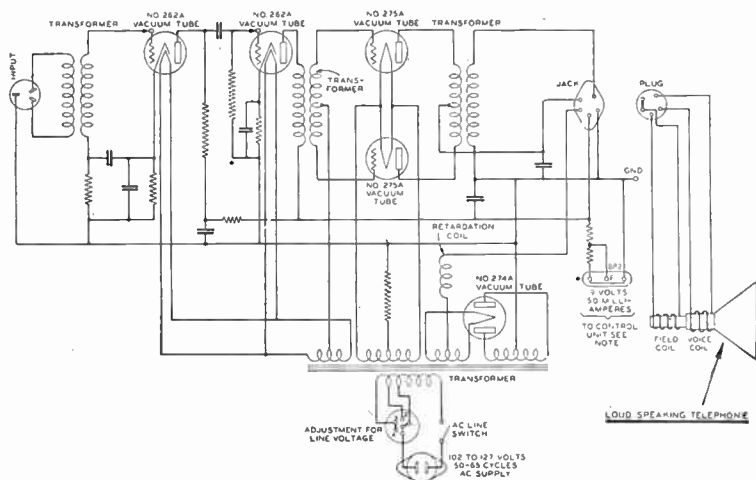
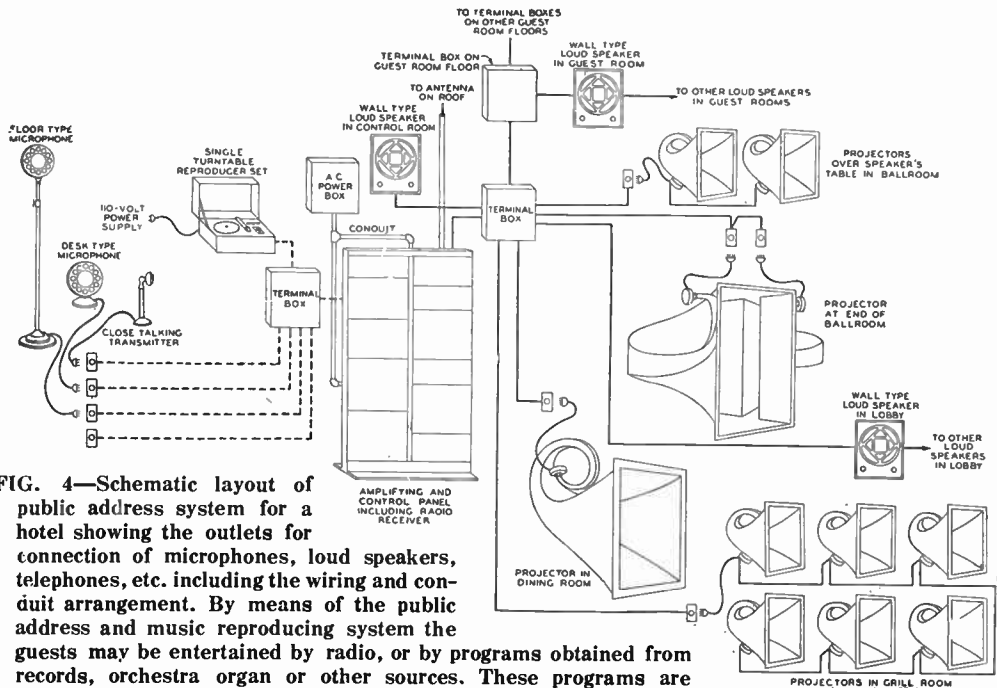

FIG. 3—Schematic diagram of amplifier shown in fig. 2.

The sound waves or vibrations register on the diaphragm of the microphone causing corresponding fluctuations in the electric current. This electrical energy is conducted by wires to control panels which regulate the energy fed into the amplifying



**FIG. 4—Schematic layout of public address system for a hotel showing the outlets for connection of microphones, loud speakers, telephones, etc. including the wiring and conduit arrangement. By means of the public address and music reproducing system the guests may be entertained by radio, or by programs obtained from records, orchestra organ or other sources. These programs are amplified and distributed to the various guest rooms, dining rooms, grill, ballrooms as well as in foyers, lobbies and reception rooms. The ballroom is equipped for the reinforcement of speakers voices at banquets and similar functions.**

equipment, where it is amplified to a level millions of times greater than the original energy put into the microphone. It is obvious that when reproducers or radio receivers are used as program sources, this apparatus may be connected directly into the amplifying equipment.

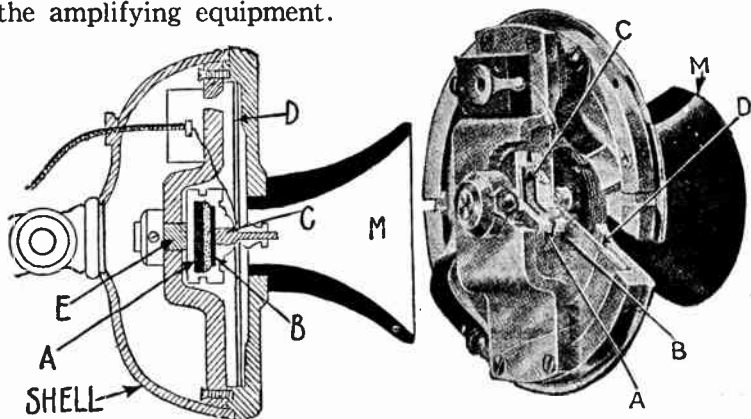

FIG. 5—Typical transmitter. The parts are: A, fixed carbon disc attached to the bridge at E; B, movable carbon disc attached to the center of the aluminum diaphragm D, at C; M, hard rubber mouth piece. The shell is for protection and for mounting the transmitter to a stand or bracket.

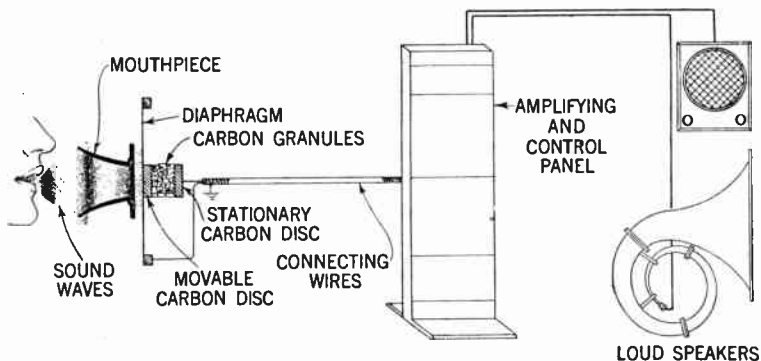
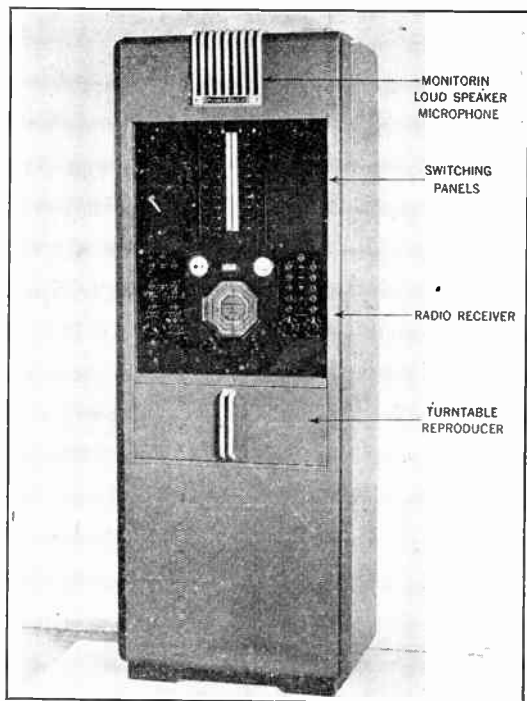

FIG. 6—Illustrating principal parts of a public address system.

The so amplified energy passes on to loud speakers which re-converts it into sound, which is hence distributed over the desired area.



**FIG. 7**—In appearance and design, the new program sound system shows marked improvement over previous types. All the central control equipment is contained in an attractive modern cabinet, including amplifiers, retracting electric phonograph and the monitor loud speaker microphone which operates through a grille at the top. A high fidelity multirange radio receiver with automatic volume control and all necessary switches and extension controls are conveniently located on a bright black panel which makes a pleasing contrast to the aluminum gray finish of the cabinet and its chromium trimmings. (Courtesy Western Electric Co.)

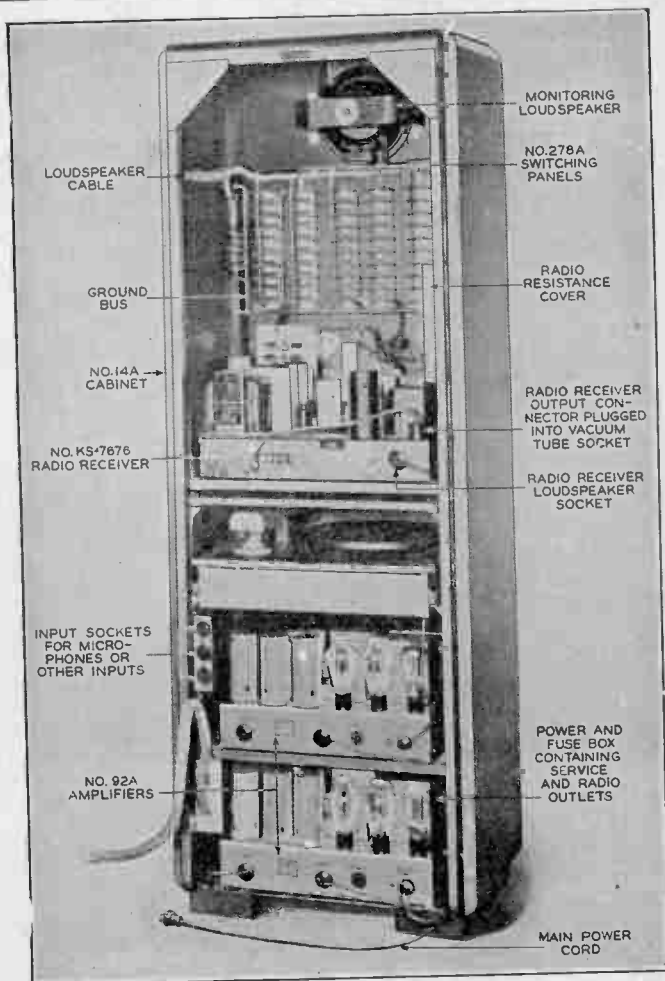
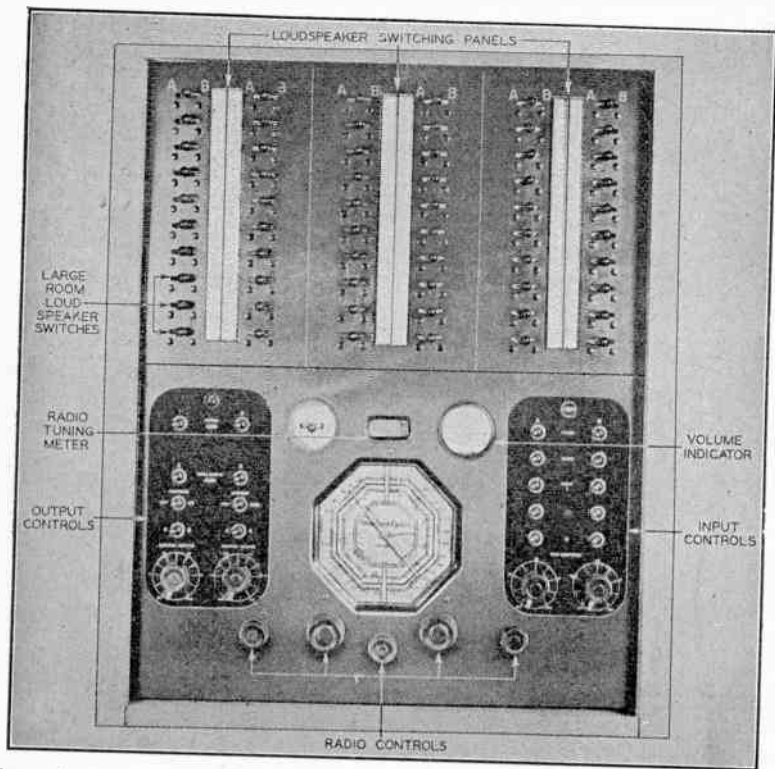

FIG. 8—Rear view of control equipment cabinet shown in fig. 7. Note: The electric phonograph unit is retractable and may be moved back and forth in drawer fashion to facilitate loading and unloading of records. (Courtesy Western Electric Co.)

**Amplifying and Control Equipment.**—Audio-amplifiers used in a P.A. system may be either large or small depending upon the size and the use of the system of which it forms a part.



**FIG. 9**—Detail of radio receiver and switching panels shown in fig. 7. Note: Card rack for identification of speakers location. (Courtesy Western Electric Co.)

Equipment for small size systems is usually designed and assembled with particular attention to facilitate transportation, and is hence assembled in a small portable carrying case,

and is suitable for small music reproducing and announcing systems.

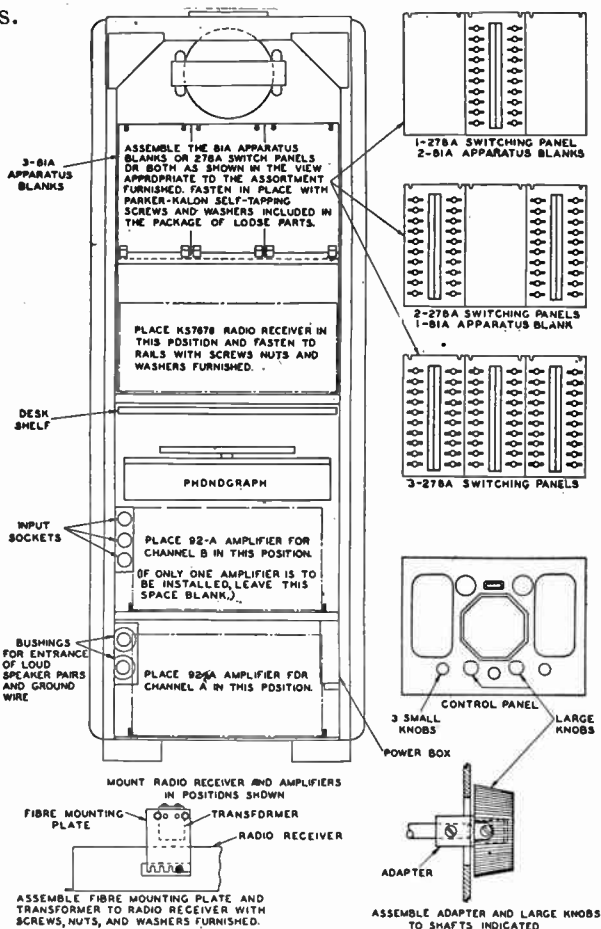

### ASSEMBLY OF SYSTEM

FIG. 10—Rear view of control equipment cabinet, showing assembly instructions and detail of switching panels. (Courtesy Western Electric Co.)



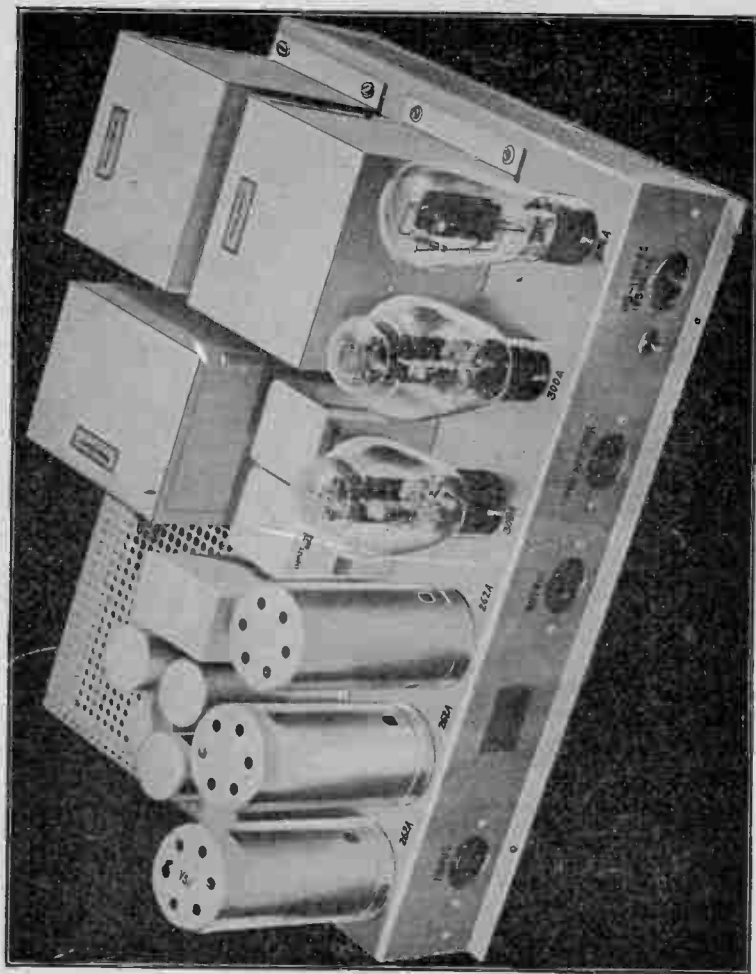

FIG. 11—Detail of amplifier unit shown in lower part of control equipment panel fig. 8. Note: When a two program system is desired, two similar amplifiers are used, as illustrated in fig. 8. (Courtesy Western Electric Co.)

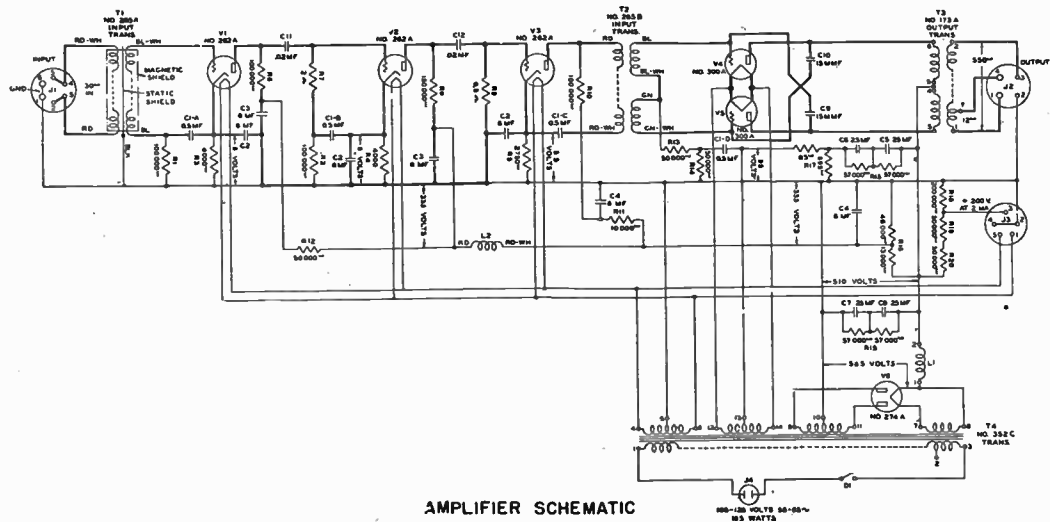

FIG. 12—Schematic wiring diagram of amplifier unit shown in fig. 11. (Courtesy Western Electric Co.)

Again the larger equipments are normally assembled in the *switchboard* manner on metal panels, mounted on angle irons or pipes, and supported securely from movement in either horizontal or vertical direction. These types are used whenever the small equipment just described is insufficient. A typical panel of a public address system of modern type is shown in figs. 7 and 8 with assembly details and amplifier unit shown in figs. 9 to 11.

The power output of an amplifier depends upon the number of loud speakers and input units employed, which in turn depends on the area served and such factors as cubical contents of rooms (if for indoor service) acoustical conditions, etc.

The amplifier schematic diagram for a P.A. system is shown in fig. 12. This amplifier has a power output rating of 20 watts, the input impedance (impedance amplifier is designed to work from) is 30 ohms, output impedance (impedance the amplifier is designed to work into) is 350 ohms. Tubes employed are three 262A—two 300A and one 274A as shown in diagram. Connections to the amplifier are made by plugs to facilitate the operation.

**Amplifier Ratings.**—The ultimate function of an amplifier is to enlarge the sound volume received from the microphone to a level which makes it possible to be heard over a large area.

Amplifiers in public address systems are rated according to the number of watts output delivered without distortion. The output depends upon the design and the size of the amplifier in question.

The amount of this output specifies what volume of sound will be received and hence the area that can be covered.

Before amplification of an amplifier can be measured, however, it is necessary to select some suitable unit of measurement. When, as stated, the output is measured in watts, it would be

most convenient to measure the input in the same unit. This, however, cannot be readily done on account of the fact that the ear responds to different sound energies in an exponential way. From this it follows that the gain of an amplifier must be expressed in the same manner, i.e. by the use of logarithms.\*

**The Decibel.**—The sound volume is measured by means of a unit named *decibel* (db.) which is the unit of sound transmission, and is defined as the smallest difference in loudness or intensity perceptible to the human ear. It is this unit which is used in sound calculations for comparison between power output and input values. Before a comparison can be made, however, it is necessary that the input and output power be expressed in the same units; for example, in kilowatts (kw), watts (w) or milliwatts (mw).

Now, if for example  $P_1$  and  $P_2$  be taken to represent power output and power input respectively and  $N$ , the number of decibels denoting their ratio, then the expressed units may be written thus:

$$N_{db} = 10 \log_{.10} \frac{P_1}{P_2} \dots \dots \dots (1)$$

This formula is correct at all times for rating of amplifiers. The ratio is termed a **gain** when  $P_1$  is greater than  $P_2$  and a **loss** when  $P_1$  is smaller than  $P_2$ .

The unit decibel can also be used for comparison of the two currents or the two voltages. Before such a comparison be made however, it is necessary first to translate the values into equivalent power ratios. As the power expressed in watts is  $I^2R$  or  $\frac{E^2}{R}$  these values may be substituted for  $P_1$  and  $P_2$  in equation

---

\*The logarithm of a number is the power to which 10 must be raised to equal the number in question. For example,  $\log_{} 100 = 2$  because  $10^2 = 100$ . Similarly  $\log_{} 867 = 2.9380$  because  $10^{2.9380} = 867$ , etc.

$$(1) \text{ or } N_{db} = 10 \log_{.10} \frac{I_1^2 R_1}{I_2^2 R_2} = 20 \log_{.10} \frac{I_1 \sqrt{R_1}}{I_2 \sqrt{R_2}} \dots\dots\dots (2)$$

Similarly

$$N_{db} = 20 \log_{.10} \frac{E_1 \div \sqrt{R_1}}{E_2 \div \sqrt{R_2}} \dots\dots\dots (3)$$

**Example.**—*What gain in decibels will be received if the voltage of an amplifier rises to 5 times the normal level at a certain frequency?*

**Solution.**—

$$N = 20 \log_{.10} 5 = 20 \times 0.699 = 14 \text{ decibels (Approx.)}$$

**Reference Level.**—It is important to note that the decibel is not a power unit such as the watt or kilowatt but is strictly speaking, a co-operative unit in that it always expresses the comparison of a ratio between two powers.

In order to make such a comparison, a definite reference level or value has been set for various sound producing devices. This level for example for telephone work is set at 10 milliwatts (0.001 watts) which is the output of a standard transmitter used by telephone engineers, whereas for radio work the reference level has been set at 6 milliwatts (0.006 watts).

By using 6 milliwatts as reference level, amplifiers may be rated at a sound energy level of a certain number of decibels.

The convenience of such a reference may best be illustrated by the following example:

*Assuming an amplifier delivers 6 watts output, what is its output level in decibels?*

$$N_{db} = 10 \log_{.10} \frac{6}{0.006} = 10 \times 3 \text{ or } 30 \text{ decibels}$$

If the output be doubled the ear will notice an increase in volume which will not be twice as great but will increase in logarithm manner,

$$N_{db} = 10 \log. \frac{12}{0.006} = 10 \times 3.3 = 33 \text{ decibels}$$

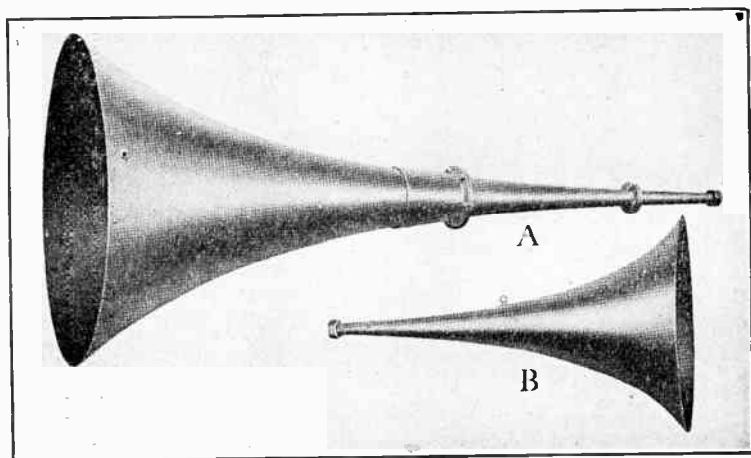
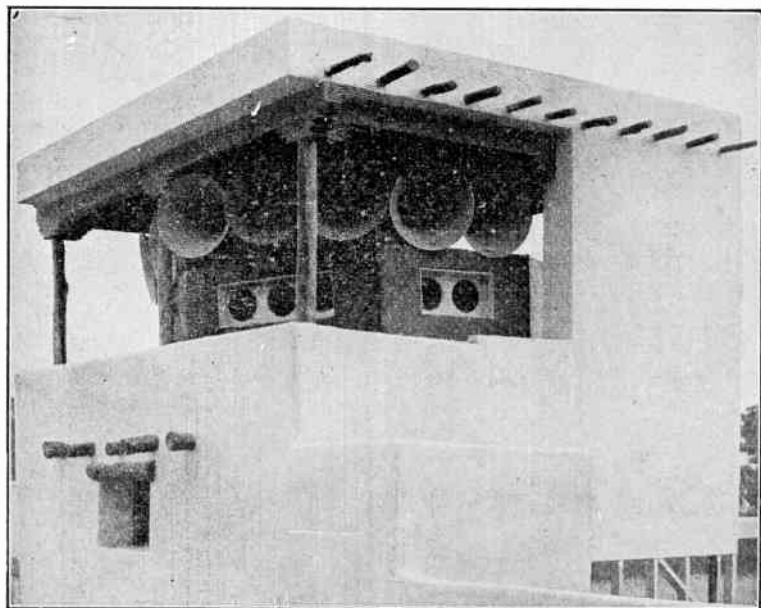

FIG. 13—Typical exponential loud speaker horns.

**Loud speakers for Public Address System.**—The determination of loud speakers to be employed depends on individual service requirement. For example, the straight horns Type A and B shown in figs. 13 are largely used for outdoor installations where it is desired to cover a broad area such as a race track, football field or similar locations. Several such straight horns are sometimes grouped together, as shown in fig. 14.

Because of space requirements the straight exponential horns are not usually employed in indoor installations.

The so called folded horns have been designed for this purpose. In this type the effective length is attained while the actual length has been materially decreased.



**FIG. 14—**Grouping of horns when used for outdoor installation.

When folded horns are employed in very large indoor systems, or in outdoor installations where the power requirements are large, the horns may be equipped with throat sections which will facilitate the attachment of a number of receiver units into one horn. See fig. 15.

In smaller indoor installations such as schools, hospitals, apartment houses, suites or offices, the direct radiator type shown in fig. 16 is largely employed. The loud speakers may be

incorporated in the building design and mounted preferably flush with the wall.

In buildings already completed the loud speakers may be hung on the wall or placed on a suitable piece of furniture which will harmonize with the surroundings.

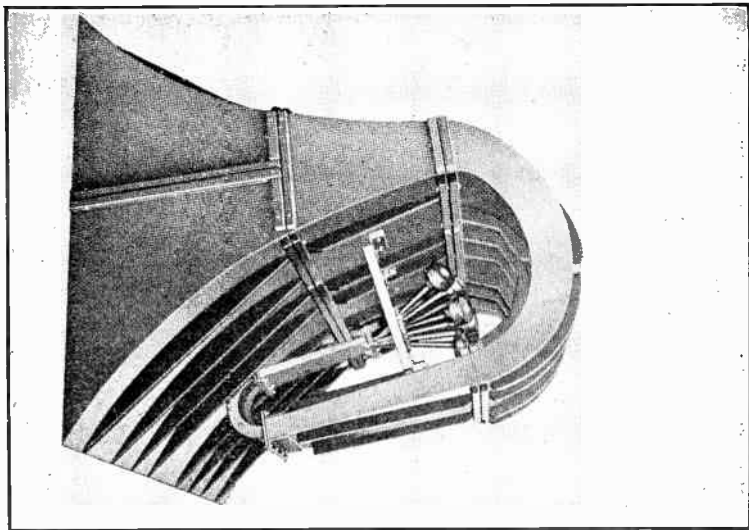

FIG. 15—Cluster of horns for indoor public address system.

Special selectors as well as volume controls may be incorporated to choose programs from any number of radio broadcasting stations when the system is equipped with the radio receiving apparatus required for such reception.

In hospitals and sanatoriums individual head sets or pillow type speakers are often utilized so that patients or guests who listen to programs will not disturb others in doing so.



**Apparatus and Their Location.**—Whenever possible the logical relationship between the various units comprising the P.A. system should be preserved. Locations giving the best results should always be used. Loud speakers should be placed as closely as possible to the program source and so that the sound be directed from it.

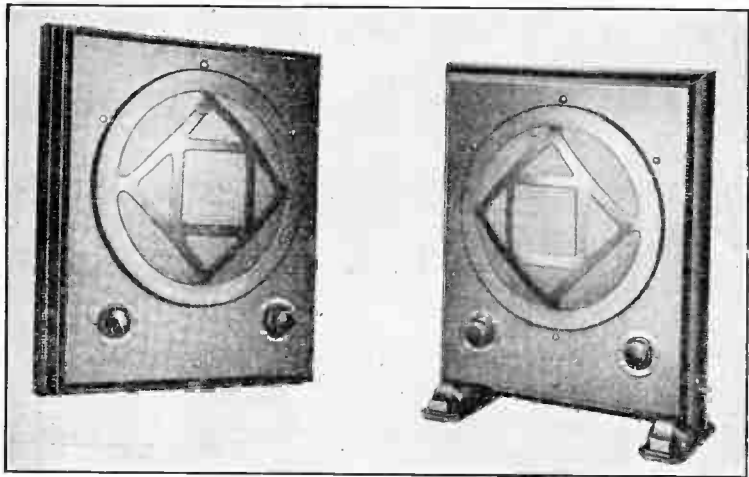

**FIG. 16**—Direct radiator type speaker suitable for indoor installation.

If the system be utilized entirely for music distribution from a reproducer set or a radio set, the location of loud speakers is important only from the standpoint of distribution, as long as care is exercised to guard against acoustic feed-back from the loud speaking telephones to the radio set.

In auditoriums and other buildings provided with a stage or raised platform, horn type loud speakers should be located above the stage in the center of the proscenium arch, mounted so that they are not directed at the microphones on the stage platform.

In buildings already erected, it may not be practicable to install loud speakers behind a grille in the arch. Then the preferable location is outside the arch in the center of the ceiling. When the loud speakers are suspended from the ceiling, the gondola which houses them, or the mouths of the loud speakers themselves should be covered with decorative grille work to harmonize with the architecture. If the ceiling be not more than 15 or 20 feet above the stage platform the horns may be suspended from trusses or other framework so that the tops of the loud speakers will be only a few feet from the ceiling.

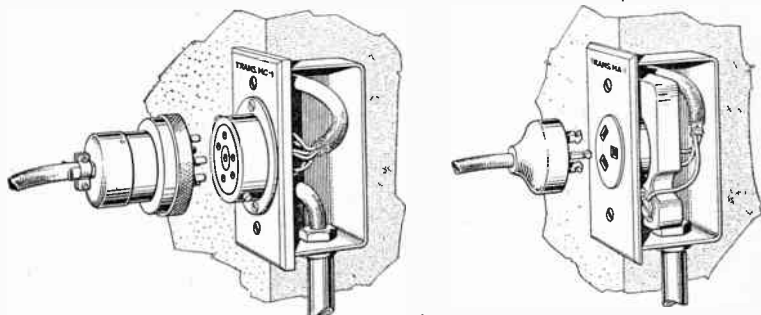

FIG. 17—Method of installing outlets for condenser and carbon microphones.

When simultaneous distribution to a number of committee or similar rooms be desired, individual small, horn type loud speakers with volume control units are preferred. With this equipment, the sound may be regulated to suit the size of each room. Loud speakers should be located at either end, in the corners or in the center of the room, to give equal distribution.

For outdoor use, such as at race tracks, football fields or airports, loud speakers should be of the horn type and in sufficient numbers and of adequate capacity to cover the prescribed area. Horns should be located above the heads of the audience and pointed slightly downward.

The number of microphone outlets provided on a stage or other platform is dependent upon the size of the stage and the kind of programs to be given. Normally, it is advisable to install at least three; one on each side of the stage and one in the center. If more are desired, they should be placed in the most convenient locations. The method of installation is illustrated in fig. 17.

In announcing systems, installed in a hotel, or in a hospital, a close talking microphone is used with flush or surface mounted wall type loud speakers. The microphone may be installed in a telephone booth adjacent to the telephone exchange. Thus the transmitter is shielded from sound radiating from loud speakers and at the same time is conveniently located for use by the telephone switchboard operator. If a telephone booth be not used, the microphone may be located in any convenient place where there will be no interference from the loud speakers.

In indoor installations, available space determines the location of amplifying and control equipments. They should be located in any room which is free from dampness or moisture. For use in outdoor installations they should be located in a room set aside for the purpose in which they are fully protected from the weather. This room may be located under a grandstand or in any other convenient place where wires or cable for the necessary power circuits can be brought in.

The operator in charge of the control equipment should be provided with a monitoring loud speaker to keep him informed of the progress of the programs. For obvious reasons, only authorized persons should have access to the room in which control and amplifying equipments are located.

When a motor generator set be used for supplying power to the amplifiers, it should not be placed in the same room with the amplifying equipment unless there be an intervening space of at least 30 feet. Unless there be this space, the electrical field set

up by the motor generator may be picked up on the input leads to the amplifiers and cause noise in the circuits.

Storage and dry batteries may be placed adjacent to the amplifying equipment or in any other convenient place. When a reproducer set and radio receiver form part of the equipment, they generally are installed in the control room. In auditoriums, they may be placed on or adjacent to the stage. In the latter location, control is provided easily.

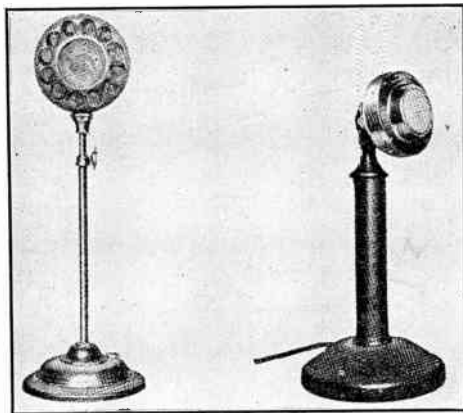

FIGS. 18 and 19—Carbon type desk and close talking type microphone.

**Microphones.**—Microphones used in a public address system may be as follows:

- (a) Carbon type.
- (b) Condenser type.
- (c) Moving coil type.

Carbon type microphones (see figs. 18 and 19) are used exclusively for announcing purposes. This microphone has a mounting similar to the well known desk telephone, except that the receiver and the switch hook is omitted.

When this type is used, it is usually placed upon a small desk or a pedestal where the user speaks into it similarly as he would into an ordinary telephone, holding it in his hand if desired.

Usually the microphones utilized for speech only are designed with a higher sensitivity, but smaller frequency range than types intended to cover ranges of both speech and music combined. The usual type of carbon microphone requires a power source of 12 volts direct current to energize the carbon buttons, with a current drain of approximately 50 M.A. for each microphone.

The condenser transmitter has a vacuum tube amplifier associated with it and requires plate filament power supply for the operation of the vacuum tubes.

A potential of 200 volts direct current usually obtained from dry cell batteries is required for a transmitter polarizing potential and for the plate circuit of the vacuum tubes.

The filaments of the vacuum tubes operate usually on a 6 volt direct current obtained from a storage battery.

The condenser and moving coil microphones are designed usually for use in studios and other locations where musical and other programs originate and where the very best acoustic pick-up characteristics are desired. For these purposes they give better performance than the carbon type.

A typical moving coil microphone of Western Electric manufacture is illustrated in fig. 20. Its basic simplicity is responsible for several distinct advantages. The fact that a permanent magnet of cobalt steel is used to provide the magnetic field in which the moving coil vibrates, obviates the necessity for supplying polarizing energy to the microphone.

A moving coil microphone being a low impedance device is less subject to disturbance from other circuits in the neighborhood than other microphones and may be used with complete satisfaction at a considerable distance from its amplifier.

It is obvious that since no amplifying equipment need be directly associated with it, much of the care formerly required in handling of microphones is unnecessary.

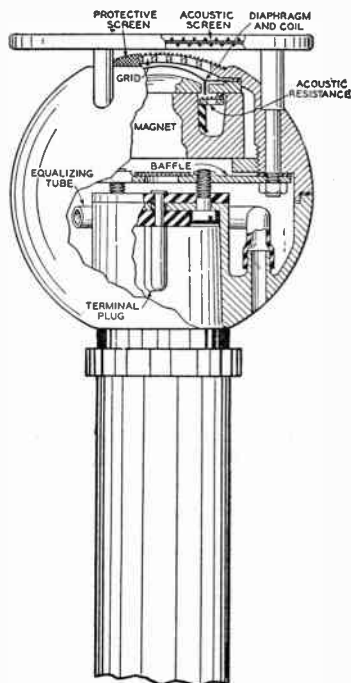
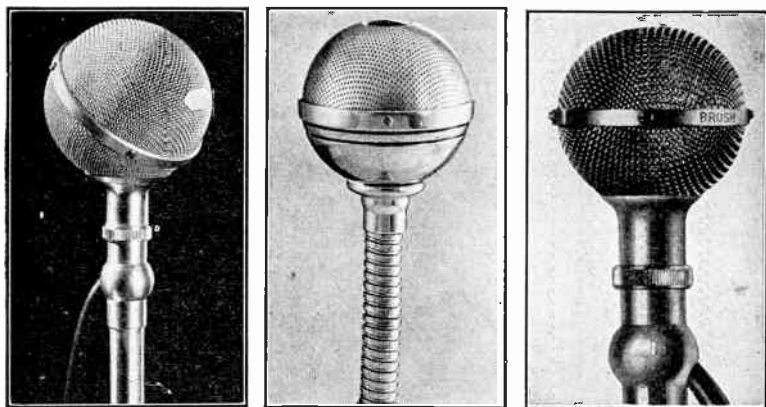

FIG. 20—Simplified cross-sectional view of a non-directional moving coil microphone.

Factors such as changes in temperature, humidity and barometric pressure which have long constituted obstacles in the consistent operation of microphones have no unfavorable effect on the performance of the moving coil microphone.

All microphones are usually furnished with a suitable length of cord and connecting plugs so that they may be connected in circuit by plugging into conveniently placed outlets.



**FIGS. 21 to 23**—Various sound cell type microphones, for use in public address systems. (Courtesy The Brush Development Co.)

**Acoustic Consideration in Public Address Systems.**—It is a well known fact that acoustic conditions exert a considerable influence on the reception of amplified sound. To obtain the most satisfactory result from a P.A. system, it is therefore necessary to understand the principles of acoustics and be accordingly guided when making installations.

There is for example a large difference in materials of which walls are constructed, and even when the two rooms are of the same size and shape a considerable difference may be encountered in tone, volume and clarity.

When surfaces or furnishings are made of hard smooth material such as plaster, brick, concrete, polished wood or glass, only part of the sound which reaches the listener's ear emanates

from the original sound source, part of it comes by way of *reflection*. A full realization of the importance of sound reflection in buildings may be had when it is considered that an ordinary plaster wall is a better reflector of sound of certain frequencies used in speech and music than a good mirror is of light.

Sounds may be repeated and become unduly prolonged, one sound or syllable overlapping the beginning of the next, the result being a noisy, indistinct effect frequently multiplying into a continuous roar called *reverberation*.

When instead of multiple reflections, there is one predominating reflection, sounds being definitely repeated at a definite interval, there is an echo instead of reverberation; however, very frequently both reverberation and a distinct echo are simultaneously present.

Resonance occurs when a thin hard surface such as a wooden panel vibrates freely as a diaphragm at its own natural frequency, hence in the vicinity of a resonant area, tones which are unduly emphasized will sound louder than other tones.

Some porous and soft surfaced materials, such as special acoustic plasters, cloth curtains and felt are relatively poor reflectors of sound because they dissipate a portion of the sound which strikes them. This gives rise to a third effect which is known as *absorption*.

The combination of these three effects namely, *reflection*, *resonance* and *absorption* give rise to the complete phenomena of frequency selection and wave interference responsible for the difference in the volume of quality of sound, heard so often in different parts of a building.



**Pointers in Construction of Walls, Floors and Ceilings and the Use of Sound Absorbing Materials.**—From the foregoing it is evident that excessive reverberation can be largely overcome by covering some wall surfaces with soft porous sound absorbing material such as velour or upholstery fabric. It is on account of this property that velour or monk's cloth is used extensively in broadcasting studios.

If sound be undirected, the absorbent effect is practically independent of the location of the absorbent material with respect to the sound source. Again if sound be directed, the absorbent material as a general rule should be located in the area over which the sound is directed. Frequently the desired effect can be obtained by the use of carpets.

The amount of absorbent materials to be used and the area to be covered may best be determined by tests.

Certain wall surfaces, especially those broken up by pilasters, cornices, coffers, etc. will diffuse the sound and thus eliminate distinct echoes, and if those surfaces are absorbing, they will also help to dampen the sound waves.

It is a known fact that the presence of an audience aids greatly in decreasing reverberation, but at the same time increases the amount of sound absorption, and also increases the noise level in the room so that a greater acoustic power output is required of the loud speakers than would be necessary for the same space if no audience were present. Hence acoustic conditions may be best determined when an average fixed audience be present and the furnishings be all in place.

If sound absorbing materials have been utilized in the construction of a building, then excessive reverberation of voice or

musical instruments can be eliminated only by the employment of acoustic treatment.

The proper location of loud speakers of a P.A. system in, for example, a large reverberant room may be assisted to some

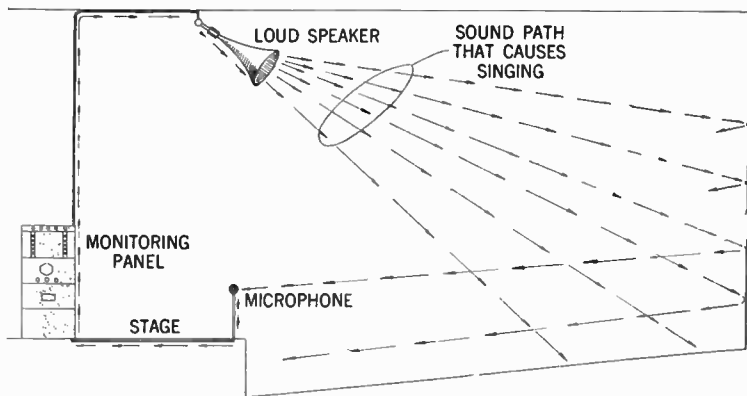
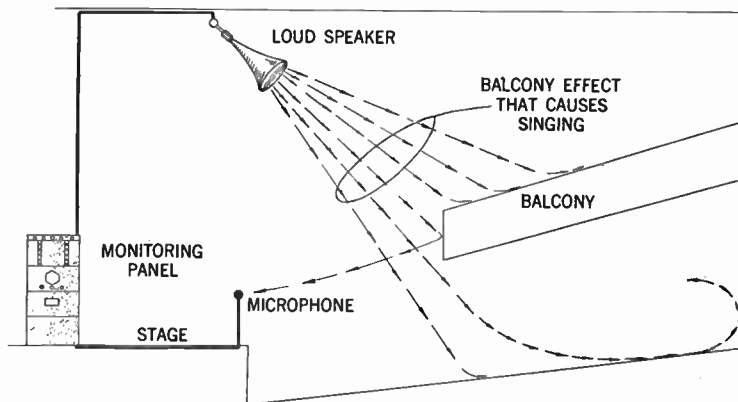

**FIG. 24**—When the horns are placed in front of the microphone as shown, the sounds will travel from the horns to the flat wall surface and then be reflected back, so that the reduced volume will be picked up by the microphone and passed through the amplifying equipment out through the horns again; i.e. a circuit is built partly of sound waves and partly of electrical waves, and in the electrical path a great deal of amplification is obtained. This circuit continues to build itself up until it develops a “sing” or “howl”. The point where the equipment starts to sing is called the “singing point” and is the measure of the maximum amount of amplification which can be used under these conditions.

extent in overcoming the unpleasant results which are encountered with the unaided voice or unaided musical instruments.

Utilization of a P.A. system will permit the speaker to talk in a lower and more natural tone of voice and yet reach each one of his audience. It is evident that if a number of loud speakers

are used, each assigned to a small part of the total area, the acoustic level of each individual loud speaker may be considerably lower than would be the case if only one was operated.



**FIG. 25**—By reference to fig. 24, it will be noted that placing the horn in the most advantageous position is a rather difficult task. It is nearly impossible to place the horns so that they will not have a direct throw at the edge of the balcony. This sound path is much shorter than that shown in fig. 24. Therefore if the horns are placed so that a direct path or short sound wave circuit be built up around the microphone, it will be necessary to reduce the gain of the amplifying equipment. Under the circumstances, the longer the soundpath, the greater the gain on the horns without the tendency to sing. This will explain the need of draping the walls for an inside installation. For that same reason it is also advisable to drape the outside of the buildings, bill boards, etc. on outside installations as well. It is evident that in an outside installation, consideration must be given to weather conditions to determine in so far as possible, which direction the wind may be blowing during the operation of the speakers. In addition, it is also advisable to determine as nearly as possible, the amount of outside noise sources that must be taken into account, such as trains, airplanes, heavy trucks, automobile horns, etc. Therefore arrange to place the horns as closely as possible to the group that emanates the greatest amount of noise. In this manner the greatest number of persons will be able to hear the system.

In case of excessive reverberation the following acoustic treatment is recommended:

1. Care should be taken to point loud speakers away from the microphone because of the fact that when projected sounds reach the microphone in sufficient strength, it will be reinforced again. This will give rise to a factor commonly known as "singing".



FIG. 26—Illustrating adjustable response type microphone. To increase pitch, push button upward; to lower pitch push button down. This adjustment according to the manufacturer will automatically take place without introducing any peaks or undesirable effects. (Courtesy The Amperite Co.)

The loud speakers will if properly directed overcome poor local acoustics, i.e., improve areas where local conditions for hearing are poor.

2. Where, as in auditoriums, it is desired to use sound reinforcement equipment, it will be desirable to use drapes or other

suitable acoustic treatment on the stage to make it relatively non-reflecting or acoustically "dead". This will aid materially in reducing the amount of sound reflected back into the microphone by adjacent surfaces and therefore, permits the use of much higher amplifications without the production of the "singing" effect already described.

3. Local sounding devices such as soundboards and the like are unnecessary when a properly designed P.A. system is used. It may introduce annoying acoustic conditions.

## PUBLIC ADDRESS SYSTEM, MAINTENANCE POINTERS

**Causes of Low Volume.**—Low volume may be caused by one or a combination of the following:

1. *Low Line Voltage.*—This is generally common in rural communities and especially at the tail end of long transmission lines with insufficient capacity of conductors and transforming equipment. Low-tube voltage results in reduced output.

2. *Low Speaker Field Voltage.*—If the field of the speakers are improperly excited, there will be a considerable loss in volume.

3. *Open Coils in Speakers.*—The opening of a voice or field coil will result in a reduced volume especially where a series-parallel voice coil arrangement is used. In this type of connection, two or more speakers will be out of service in each case depending on the particular wiring arrangement used.

4. *Faults in Tubes.*—When weak or faulty tubes are suspected, check by analyzer to determine if the plate current consumption be of proper value. When push-pull stages are employed, both tubes should have approximately equal plate current drain.

5. *Unresponsive Microphone.*—This may be due to moisture, large temperature changes, careless handling, or packing of carbon granules. A weak microphone battery will cause a reduced current through the microphone buttons, and hence reduce the output from the microphone to the amplifiers.

**Poor Sound Quality.**—This may be caused by one or a combination of the following factors:

1. *Weak Tubes.* See 4, on *Low Volume*.

2. *Overloaded Speakers.*—When volume of speaker is run too high it will cause a chattering and distorted sound. The size of the speaker should in each case conform with the power requirements.

3. *Singing of Speakers.*—Cause and remedy for singing, see page 443.

4. *Faulty Microphones.*—See 5, on *Low Volume*, this chapter. In addition, try phonograph reproducer in phonograph input taps if this provision is made and note result.

5. *Field Excitation too Low.*—If the field has improper excitation, the frequency response of the speaker will naturally be poor. This is because of sluggishness of the speaker unit to lower impulses. This voltage should be checked and compared to that specified by the manufacturer.

**No Sound.**—When no sound is received, check for trouble among the following items:

1. A transformer or resistance coil may have become opened or short-circuited. Check for proper voltage across each suspected faulty device.

2. Check tubes. A burnt out tube (except where tubes are connected in push-pull or parallel) will interrupt the current flow.

3. *Microphone Troubles.*—See (5) *Low Volume*, this chapter.

**Wiring of Conduits.**—Since the energy in the microphone circuits is at a level considerably below that required in loud speaker circuits, these circuits must be run in separate conduits.

If this be not done, the difference in gain between these circuits, due to the amplifiers, will cause electrical interference and may result in a singing noise in the output of the loud speakers.

Wiring for the observer's communication system should also be run in a conduit separate from these circuits, unless this wiring be shielded. If shielded it may be run in the same conduit as that of the loud speakers, but should under no circumstances be run in the same conduit as the microphone circuits.

All microphone circuit wiring from the loud speakers and observer's communication circuit wiring should be terminated in separate terminal boxes. The circuits for microphones are usually run so that when copper shielded wire is used, the copper shield is used as the ground side of the circuit.

**Wiring of Receiver Units.**—In the voice circuits of receiver units, No. 14 B & S gauge twisted pair rubber covered wire generally is used. The size of the wire, however, depends

upon the length of the run from the amplifier to the receiver units, the type and number of unit used, and also by the requirements of each individual unit for the operation condition presented.

The wire used must be in twisted pairs in order to provide a balanced circuit. When receiver units which require a direct current circuit for energizing the field coil are used, the wire for the power circuit may be either in a twisted pair or parallel laid.

When an alternating current power circuit is used to supply a rectifier located at the receiver then the power line should consist of a twisted pair. No. 14 B & S wire is generally used for this circuit, but the size depends again upon the length of run and number and type of receiver units.

It should also be observed that receiver circuits of the low impedance type which are used on relatively long runs, will necessitate the installation of wires of larger carrying capacity.

**Wiring of Amplifying and Control Equipment.**—The amplifiers and control equipment are generally mounted on steel racks and are provided with marked terminals to facilitate the making of proper connections.

When connecting the amplifiers and control equipment, it is generally desirable to use shielded wire to prevent against possible feed-back between circuits of different levels. An illustration of public address system wiring is shown in fig. 8.

When making power connections to the amplifiers (110-volt, 60 cycle A.C.) it is desirable that the power leads be run in conduit from the power source to the amplifiers. Wire used for this purpose should be rubber covered. It is also important that all power circuits be properly fused to protect the equipment.



**Wiring of Communication Equipment.**—The wires which should be used for connecting the various observer's communication stations to the control room proper is the same as that used in ordinary telephone work. The size of this wire may be No. 19 or 20 B & S or larger.

**Rules for Antenna Wiring.**—The antenna shall be erected on suitable supports for roof mounting. The horizontal distance between the supports should be 75 to 150 feet, so that an antenna of that length may be stretched between them, at a height of 25 feet from the top of the roof and remote from any metal structure rising above the level of the roof.

The antenna shall be of No. 14 gauge stranded copper wire, and shall be provided with suitable insulators. The lead in wire from the antenna shall be No. 14 gauge rubber covered. This wire shall be run to an antenna terminating panel located on the roof and an antenna transmission line shall be run from this panel to the control room in a half inch conduit and shall be terminated at the receiver panel. The lead in wire shall be brought in through the roof in an approved weather proof fitting.

The ground wire shall be run from the control room to the water pipe and shall be fastened to the pipe by an approved clamp.

An approved lightning arrester shall be installed on the outside of the building clear of all woodwork within three feet of the point where the wires enter the building.

All wiring shall be made to conform with the Underwriter's requirements.

**Example.**—*If by means of an input potentiometer the power output of a certain amplifier can be varied between 0.1 watt and 10 watts. What is the power range in decibels?*

**Solution.**—The decibel system of expressing the difference between two power levels is now coming into everyday use, and to-day it is quite common to express in decibels the range in values which a receiver can handle. It is important to note that the decibel is not a physical unit such as the “watt” or “volt” but it might rather be called a comparative unit in that it always expresses the comparison between the physical quantities. The units compared are usually those of power; thus, in comparing one amount of power with another on a decibel basis, we may refer either to the ratio between them or else to the difference between them in relation to one of the powers.

The point to note is that a given amount of power is not expressible in decibels; it is only when there is a comparison stated or implied, that recourse is made to this unit. The decibel number is thus equivalent to a ratio between two powers, the nature of the equivalent being more precisely defined as follows:

The difference between two power levels expressed in decibels is equal to ten times the common logarithm of the ratio between the two powers. Now if  $P_1$  and  $P_2$  be taken to represent two power values, then the difference  $D$ , decibels in their power level is given by equation (1) page 429 or—

$$D = 10 \log_{.10} \frac{P_1}{P_2} \dots \dots \dots (4)$$

In the present example the ratio between the two powers representing the extremes of the range is  $\frac{10}{0.1}$  or 100, the common log. of which is 2. Accordingly the difference between the

two power levels is  $10 \times 2$  or 20 decibels which thus expresses the power range. Note that a power amplifier varying in output from say 3 to 300 watts would have exactly the same decibel range.

**Example.**—*A transformer coupled stage of audio frequency amplification incorporates a device for tone control by the use of which the effective amplification of the stage may be varied between three times and 0.15 times the amplification of the tube. What is the amplification range of the tone control in decibels?*

**Solution.**—Perhaps the simplest way of looking at the decibel is to regard it as the unit in terms of which the difference between two power levels may be measured. Taking the symbols  $P_1$  and  $P_2$  to represent two power values, then the difference  $D$ , decibels, in their power levels is given by—

$$D = 10 (\log. P_1 - \log. P_2) \dots \dots \dots (5)$$

$$\text{or } 10 \log. \frac{P_1}{P_2} \dots \dots \dots (6)$$

The difference in power levels thus depend upon the ratio between the two powers. Since the decibel is defined in terms of a ratio between powers, care must be taken in applying it to measure ratios between other quantities such as currents and voltage. Where it is desired to express a ratio between voltages and decibels, first translate the voltage ratio in equivalent power ratio. This can be done by making a convention, viz: that the two voltages are arranged to operate across the same resistance  $R$  ohms, so that the resulting power dissipation may be compared.

Thus, if the difference between  $E_1$  and  $E_2$  volts is to be expressed in decibels, the two powers are then  $E_1^2$  and  $E_2^2$  volts and the power ratio is  $\frac{E_1^2}{E_2^2}$ .

Now substitute this for the ratio  $\frac{P_1}{P_2}$  in equation (6) obtaining:

$$D = 10 \log. \frac{E_1^2}{E_2^2} \text{ i.e. } D = 20 \log. \frac{E_1}{E_2} \dots \dots \dots (7)$$

In the example, voltage amplification is dealt with, which of course is quite a different matter from power amplification. Equation (7) will therefore apply,

$E_1$  being  $3 \times M$  while  $E_2$  is  $0.15 \times M$ ;

$$\frac{E_1}{E_2} \text{ is thus } \frac{3}{0.15} = 20$$

Whence,  $D = 20 \log. 20 = 20 \times 1.301 = 26.02$  decibels.

**Example.**—*A loud speaker whose inductance is 1.15 henries is coupled to a power tube through a condenser of 2 mfds. To what frequency will the combination be resonant?*

**Solution.**—This is obviously a simple exercise in finding the resonant frequency of a series tuning circuit and the only point calling for any remarks lies in the treatment of the units involved. When the inductance  $L$ , and the capacity  $C$ , of a series circuit are both expressed in fundamental units, for example, henries and farads, the resonant frequency in cycles per second is given by the well known formula

$$f = \frac{1}{2\pi\sqrt{L.C}}$$

In the present example, the condenser is of 2 microfarads capacity, therefore this must be expressed in terms of farads before applying the formula: evidently it is  $2 \times 10^{-6}$  farads. Substituting numerical values in the formula, the following is obtained:

$$f = \frac{1}{2\pi \times \sqrt{1.15 \times 2 \times 10^{-6}}}$$

which gives  $f = 105$  cycles.

**Example.**—*An alternating current of amplitude 10 milliamperes and frequency 750 cycles, passes through a resistance of 50,000 ohms. What amount of power is dissipated in the resistance? What power would be dissipated if the frequency were increased to 1,000 cycles?*

**Solution.**—It is first necessary to obtain the root mean square (*r.m.s.*) value of the current, which is 0.707 times the amplitude or in this case 7.07 *m.a.*

It is a sound rule in working out electrical problems to express the quantities in fundamental units. In this case, express the (*r.m.s.*) values in amperes, i.e. 0.00707 amperes. Now if an (*r.m.s.*) current of  $I$  amperes flow through a resistance of  $R$  ohms the power dissipated is given by  $I^2R$  watts. Hence,

$$\text{power (W)} = (0.00707)^2 \times 50,000 = 2.5 \text{ watts}$$

## CHAPTER 22

# Aircraft Radio

It is undoubtedly true that without the aid of radio, aerial navigation would not have advanced to the stage where giant airliners arrive and depart keeping time schedules unheard of only a few years ago.

As a matter of fact the airplane is rapidly closing in on such proven means of transport as trains, ships and buses in regards to exact time schedules in all sorts of weather.

It is a recognized fact that the actual value of aircraft radio installations depends entirely upon radio facilities provided on the ground. Hence aircraft radio aids may be roughly divided into two classes, namely:

1. Equipment located on ground
2. Equipment located in the aircraft.

Radio aids to aerial navigation maintained by the Bureau of Air Commerce are of the following three types:

1. Communication stations broadcasting weather information, also available for radio telephony.
2. Radio range stations, radio beacons which work the airway routes by signals which are particularly valuable when clouds, fog, haze or smoke obscure landmarks or lights which would serve as guide in clear weather.
3. Radio marker stations which indicate the locations of strategic points on airway routes and are frequently established at important intermediate landing fields.

Point to point radio is part of the ground communication system. Each airway in the United States has a weather reporting service consisting of Weather Bureau and Bureau of Air Commerce observation station, together with a communication network for collecting and discriminating these reports which on some airways consists of teletypewriter circuits and on others of point to point radio stations.

**How the Airway Radio Beacon Operates.**—With reference to fig. 1, the directional radio range station operates principally as follows: When the pilot is flying by radio guidance, he listens for the Morse Code letters "A" dot dash and "N" dash dot. If the two letters are heard in equal volume, they blend together into a continuous monotone, which is the signal to the pilot that he is on the **true course**. If he moves to one side of the course he hears the letter "A" predominantly, if to the other side he hears the letter "N".

By knowing the orientation of the off-course signals, or determining it by reference to his air navigation map, he changes his direction to get back to the line of flight where the previously described "**on course**" is heard.

For station identification the directional signals are punctured at intervals of about 30 seconds by another **Morse code combination** distinctive for each radio range. This identification signal is usually transmitted twice, first into the "N" quadrants and then into the "A" quadrants.

Flying on course, the pilot hears the two transmissions of the identifying signal with equal intensity. As he moves away from the course one of them begins to fade into the background until finally only one is heard. This provides another guide for quadrant identification.

If the pilot moves into the "N" quadrant, say, the "N" signal predominates as the "A" fades out, and in addition the

first of the two station identifying signals becomes more prominent—both indicating to the pilot that he is off course in an “N” quadrant. This system of landing aid is known as the *aural radio range* as compared with the *visual radio range* described on page 468.

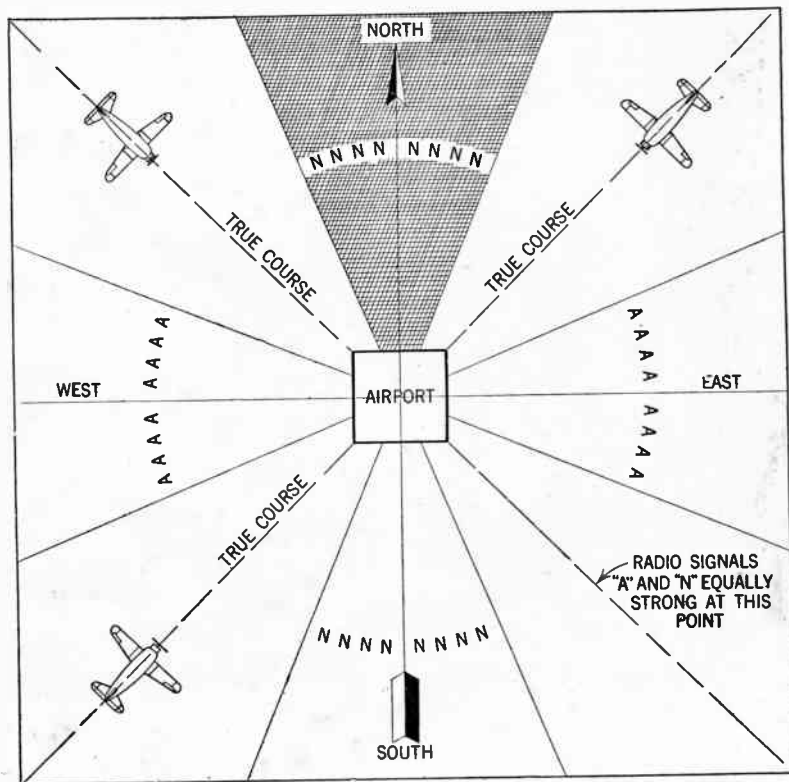

FIG. 1—Schematic diagram illustrating aircraft landing aid by means of radio beacon.

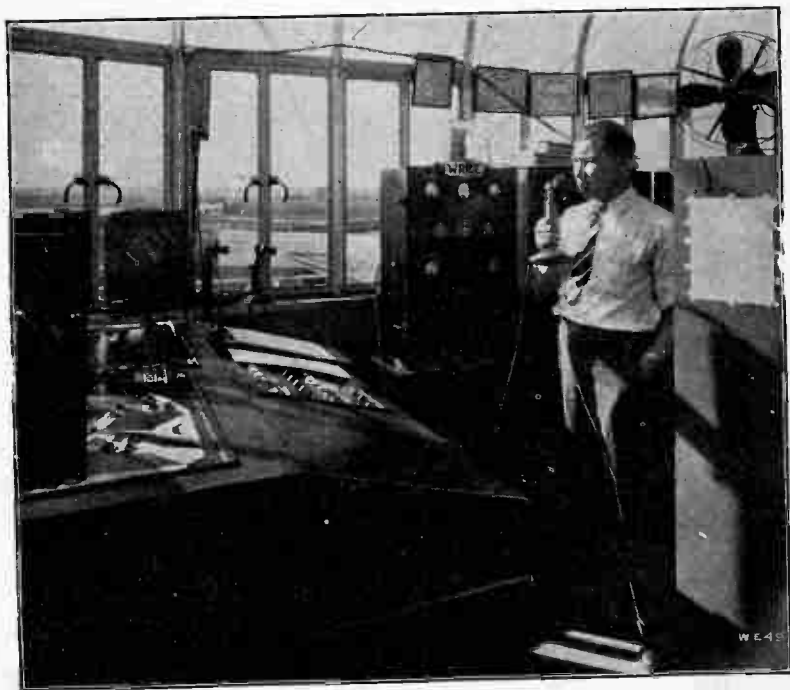



FIG. 2—Illustrating aircraft radio receiver. The pilot receives code and messages through head phones which are interconnected to receiver as shown. (Courtesy Western Electric Co.)

**Radio Marker Stations.**—Radio markers indicate the location of definite points on airway routes, and are in operation at a number of important intermediate landing fields. A marker

station's signal consists of dot and dash combinations identifying the station which may be heard for a distance of from 5 to 7 miles.



**FIG. 3—**Interior view of traffic control tower of modern airport. Dispatcher is directing the landing and take-off of aircraft by radio. The cabinet at the dispatcher's right is the airport's transmitter which puts his voice on the air. Other cabinets contain air line receivers, each one responding to the frequencies allotted to the respective lines. One receiver is utilized for reception of calls from itinerant flyers. On the desk are the loudspeakers working with the receivers and controls for lighting at the field, etc. (Courtesy Western Electric Co. Inc.)

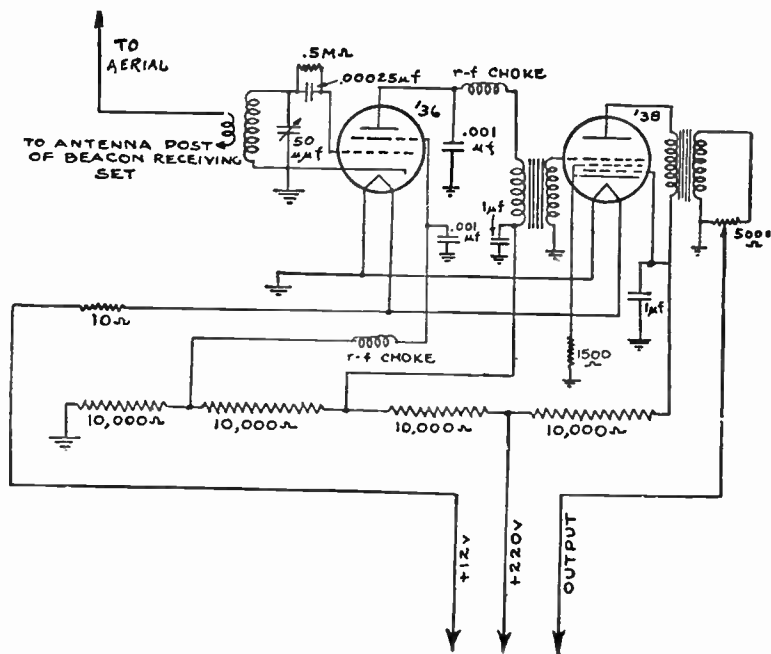

FIG. 4—Schematic circuit diagram of marker beacon receiver set for operation on 10,000 k.c.

They are transmitted on the frequency of the adjacent radio range station. Since the power and range are limited, the pilot flying in or above the clouds and hearing these signals knows that he is close to the transmitter and can determine his approximate position by reference to the location of the station as shown on his air navigation map.

All three types of radio facilities, *radio communication stations*, *radio range stations* and *radio marker stations* are used by the airman in a radio-directed flight. Keeping on his course by following the radio range signals, he listens to the periodic broadcasts of weather information and from time to time checks his progress and position by reference to the signals of the marker stations. He may also call a radio communications station or an intermediate field for additional weather information.

**Radio Compass Navigation.**—The radio compass may be utilized in two different ways. (1), To obtain the direction of a transmitting station, and (2), to obtain position by means of radio bearings from two or more stations.

When it is desired to obtain the direction, the pilot merely turns on the radio compass receiver and moves the station selector to the frequency of the station he desires to pick up.

This may be a commercial broadcasting station, a Department of Commerce radio range station or any other type of transmitting station that sends out signals either continuously or at frequent intervals, and within the receiving range of the compass.

He tunes on this station until the maximum volume is received and from that time on he merely watches a needle on his instrument board which is pointed vertically at zero. If the plane veers off to either side, the needle will move accordingly and hence provide a warning that the plane is deviating from its course. Therefore, the aviator's only duty is to fly the plane in such a direction that the needle constantly points to zero. His course will lead directly to the radio station and from there he points himself to the landing field.

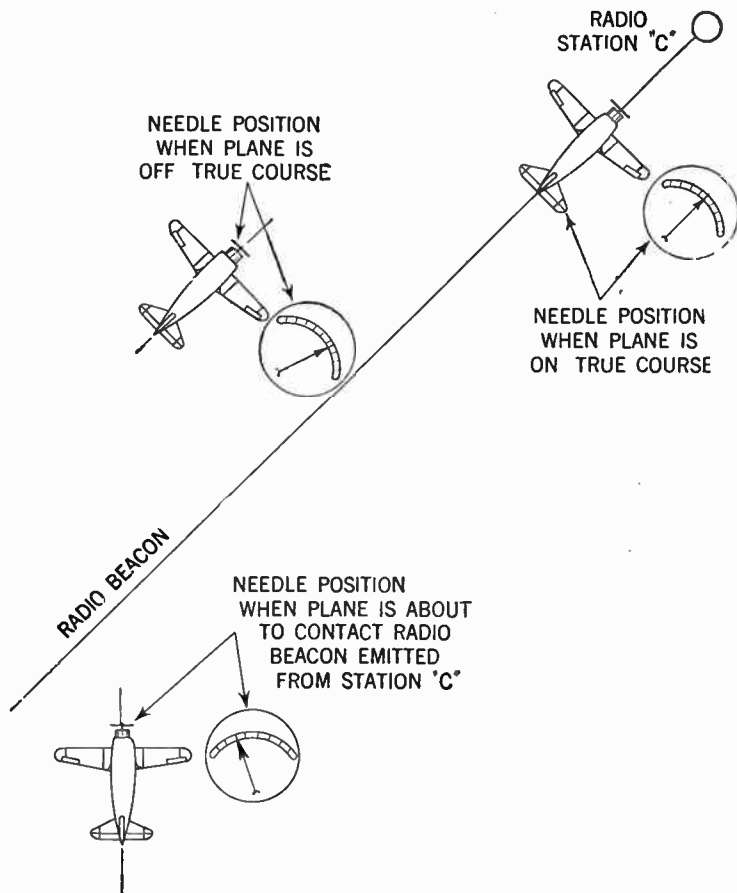

FIG. 5—Simplified representation of needle deflection vs. flight direction with respect to the location of radio transmitting station.

**The Radio Compass as a Position Finder.**—When it be desired to establish the position, the pilot establishes the direction toward a radio station as previously described, or by rotating the loop antenna obtains a bearing from his magnetic compass and draws a line on his navigation chart to indicate this.

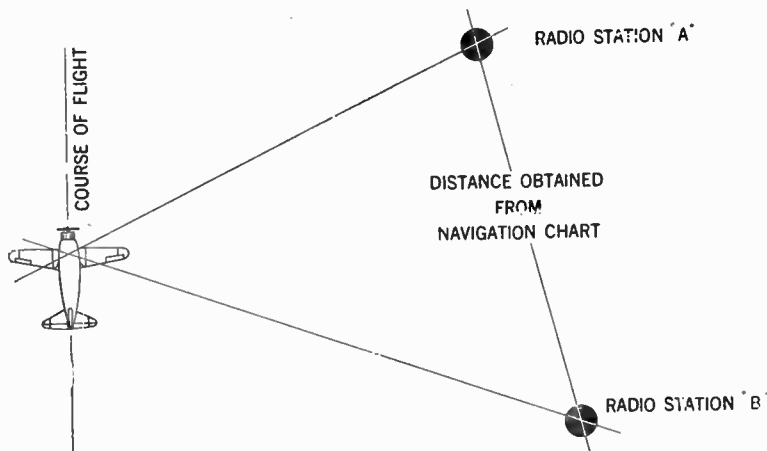

FIG. 6—Illustrating method of determining position by means of radio compass. As the surrounding territory shown on air navigation chart is laid out in scale, it follows that the intersection of the two lines gives the approximate location of the aircraft. It is evident that the accuracy of position so obtained will depend on such factors as: flying speed; angle and distance between aircraft and stations; accuracy of instruments; skill of navigator, etc.

When he takes a bearing on another station and draws the corresponding line on his chart, the airplane's position is at the intersection of the two lines. The utilization along the airways of the radio compass, in conjunction with the radio beacon stations greatly simplifies the problem of orientation.

For example, if the pilot is off the radio beacon course and wants to get back to it, the radio compass is of assistance. It also simplifies the process of proceeding to the landing field when the pilot has reached the radio range station.

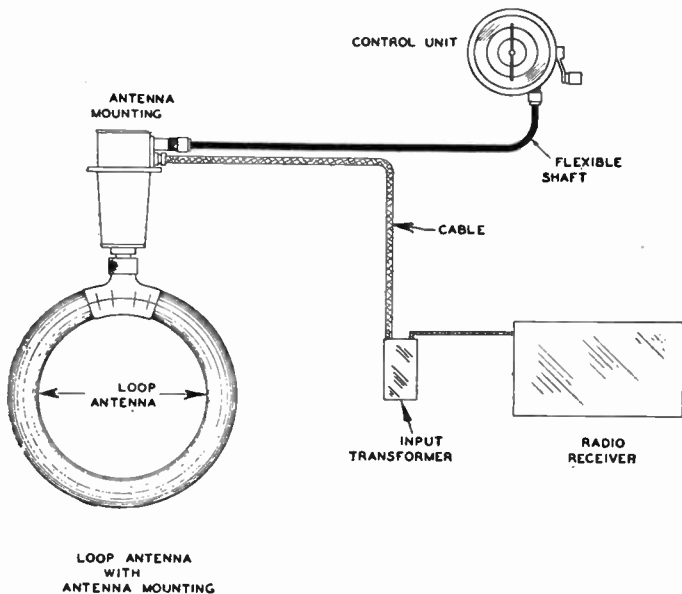

FIG. 7—Radio compass attachment assembly diagram. (Courtesy Western Electric Co. Inc.)

Since it may be used in conjunction with any radio station within its receiving range, the radio compass is an aid for off-airway flying—for flights by various commercial operators and private flyers when these follow routes which are not marked by Federal Air Navigation Aids.

**Commercial Radio Compass.**—Among the several commercial radio compasses at present available, the compass shown in fig. 7 consists of the following units: A loop antenna with attachments; a control unit from which the loop antenna is controlled

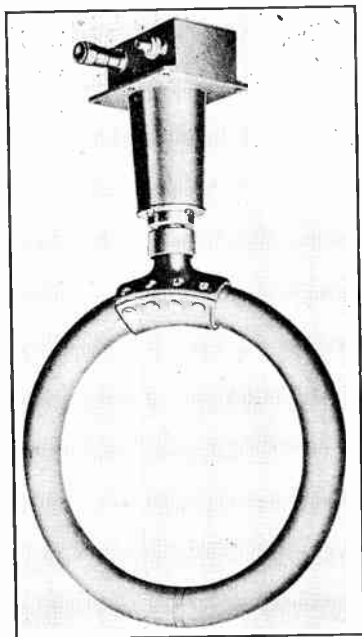

FIG. 8—Aircraft loop-antenna. (Courtesy Western Electric Co. Inc.)

by means of a flexible shaft; an input transformer connected between the radio receiver and the loop antenna and which facilitates the timing and permits the separation of the loop antenna and the receiver of a distance of up to 25 feet.

This system of coupling the loop to the radio receiver offers a great advantage to transport air lines. Because of the unique



coupling arrangement two or more receivers may be tracked into the same loop and the transmission line between the loop and the receiver switched by means of a plug and jack relay or ordinary toggle switches.

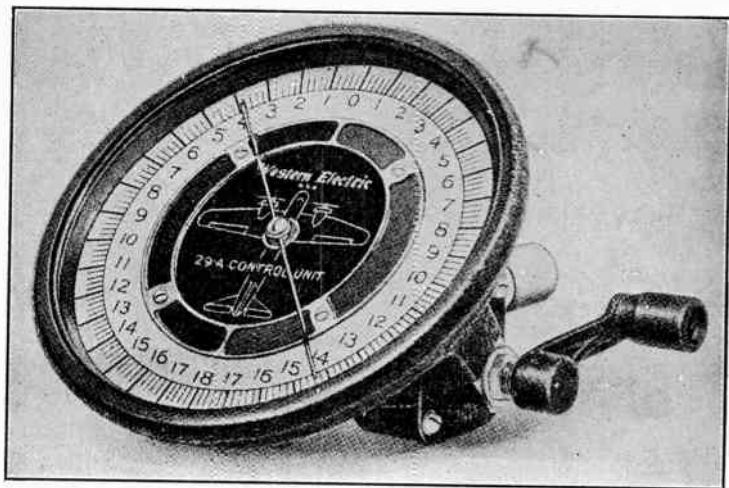

FIG. 9—Aircraft loop-antenna control unit. (Courtesy Western Electric Co., Inc.)

The fact that one loop may be used with either beacon receiver is of great value and this is only possible because of the coupling system employed in the radio compass attachment.

The radio compass loop is surrounded by an electrostatic shield which enables the pilot to fly through atmospheric disturbances such as rain, snow, sleet or dust static which ordinarily paralyzes his receiver when used with a simple wire antenna.

The gear ratio between the control unit and the loop as shown in fig. 7 is 264 to 1, which permits extremely accurate adjustment of the loop. The position of the loop is indicated

on the face of the control unit by the position of the needle and by means of a removable cord it is possible for the user to correctly calibrate the control unit for his particular plane.

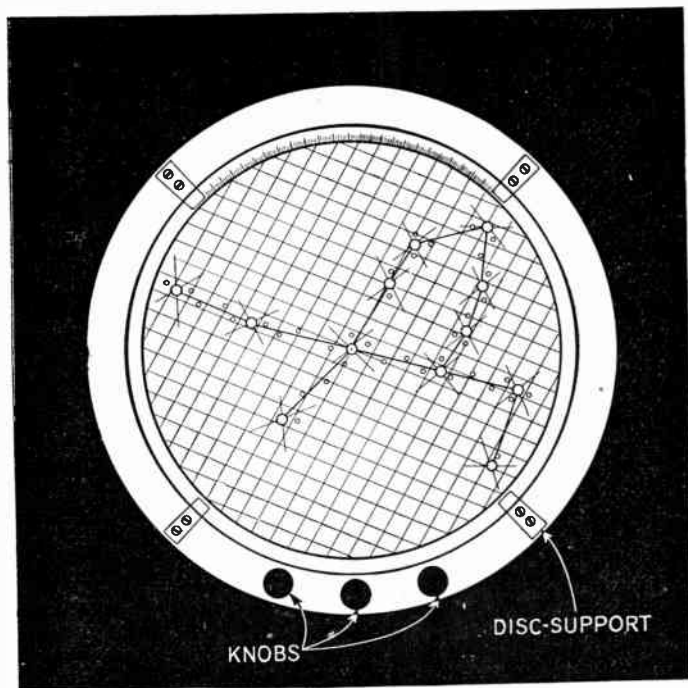

FIG. 10—Aircraft position finder, facilitating orientation when used in conjunction with the radio compass.

**Aircraft Position Finder.**—An aircraft position finder to be used in conjunction with the radio direction finder has recently been put on the market by the Air-Track Mfg. Corp., Inc.

This instrument shown in fig. 10 consists of a circular metal frame  $8\frac{1}{2}$  ins. in diameter containing three movable transparent

discs. The top disc is removable and contains an airway map, accurately scaled down from a full size map by photographic process, showing all radio range stations within an area 520 miles in diameter. The entire airway system in the United States is covered by 16 such discs, allowing ample overlap.

The other two discs are marked with parallel lines, scaled 10 miles apart. The discs are rotated by three knobs through gears cut in the circumference of the discs. The frame is graduated in 360°.

In operation, the map is first oriented to the compass course being flown. Radio bearings on two stations are then obtained, and transferred to the instrument by setting the two discs with parallel lines to show the bearings in degrees. Position of the airplane is then given by the intersection of the lines passing through the selected radio stations.

When using the instrument for off-airway flying, a special blank matt disc is provided. On this the radio range stations may be traced in pencil from Bureau of Air Commerce radio facilities maps. The matt disc is sufficiently transparent, and can be used repeatedly after erasures.

**Visual Radio System Landing Aid.\***—To land an aircraft safely at an air field completely blanketed by fog, it is necessary for the pilot first to find the vicinity of the air field and second to reach a suitable point of landing.

Radio range beacon system previously described and now in operation on the civil airways in the United States, renders the solution to the first part an accomplished fact.

Here the pilot following the beacon signals as described is guided directly over the beacon stations which ordinarily are

---

\*The system briefly described is developed by the U. S. Department of Commerce, Bureau of Standards. Other systems of commercial application of instrument landing aid in this country are: The Air-Track, Bendix and I. I. & T. Lorenz.

located within a few miles of the airport, and thereby learns the exact position with respect to the airport.

The second part of the problem requires information on the position of the landing aircraft in three dimensions. Lateral and longitudinal guidance are required to determine the direction of landing and the boundaries of the landing field, while vertical guidance is necessary for the determination of altitude and of the freedom of the landing path from obstacles. In the system of radio landing aids three elements are utilized to give the necessary guidance in three dimensions.

The runway localizing beacon gives indications of the lateral position of the aircraft with respect to the airport and permits keeping the aircraft directed to and over the desired landing runway. A 200 watt transmitting set of the visual beacon type, operating in the beacon range of frequencies (200 to 400 kc.) and feeding two small, multi-turn loop transmitting antennas, is employed.

One of the beacon courses produced is oriented to coincide with the desired landing direction, depending on the wind conditions. On the aircraft the receiving set normally used by air transport operators for the reception of radio range-beacon signals and airways weather broadcasts is employed for receiving the runway-beacon signals. This set is supplemented by a reed converted to convert the beacon signals to pointer type course indications, and also by an automatic volume control unit whose function is to relieve the pilot of the burden of continuously adjusting the sensitivity of the receiving set as the distance between the aircraft and the ground station changes.

The course indicator consists of the vertical pointer of a combined instrument shown in fig. 12. This pointer is pivoted about its lower end and swings left or right of a vertical index line depending upon whether the aircraft is on one side or the other of the runway course.

A reversing switch is provided so that the deflection of the pointer and the direction of deviation of the aircraft coincide whether the aircraft is flying *away from* or *toward* the beacon.

Vertical guidance of the aircraft is given by a horizontally polarized ultra-high frequency landing beam directed at a small angle above the horizontal and used in such a way as to provide a very convenient gliding path for the landing aircraft. The frequency of operation is 90,800 kilocycles (3.3 meters).

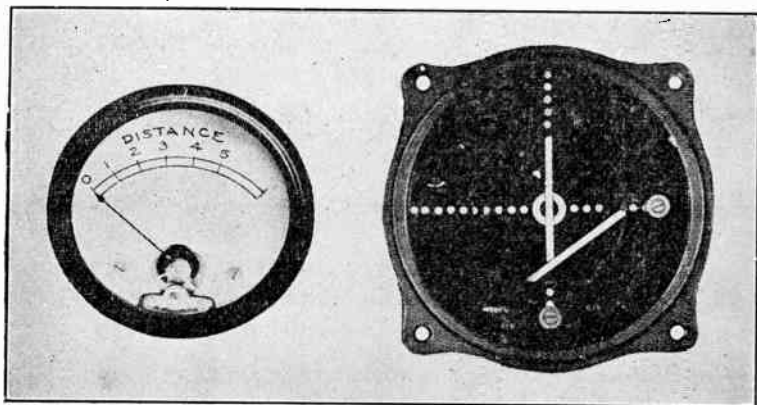

FIGS. 11 and 12—Indicating instrument on the aircraft for utilizing the radio system of landing aids.

On the aircraft a simple ultra-high-frequency receiver is used, fed by a transmission line from a horizontal half-wave receiving antenna which is located in the wing slightly ahead of the leading edge. The rectified output from this receiving set operates the horizontal pointer of the combined instrument shown in fig. 12. The receiver sensitivity is so adjusted that the line of constant received signal below the inclined axis of the beam, corresponding to half-scale deflection of the horizontal

pointer, marks out a landing path which is suitable for the aircraft and airport considered.

The horizontal index line across the face of the combined instrument represents the point of half scale deflection and corresponds to the proper landing path. The horizontal pointer represents the position of the aircraft relative to this path. A rise of this pointer above the horizontal index line indicates that the aircraft is above the proper landing path, while the reverse is true if the pointer falls below the index line.

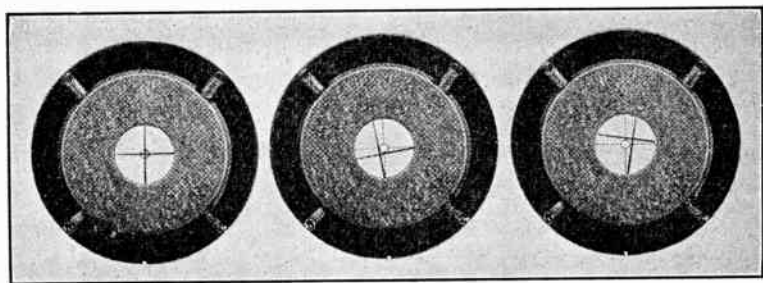

**FIG. 13**—Typical course indications with combined instrument. The positions of the aircraft as indicated on the instrument; 1, on proper spatial landing path; 2, to the left of desired landing direction and too low; 3, to the right of desired landing direction and too high.

Consideration of the operation of the combined instrument will show that the point of intersection of the two pointers represents the position of the aircraft relative to the desired landing runway and the proper landing path. Fig. 13 shows three typical readings on the combined instrument. The co-ordination of the two sets of course indications into a single reading is of utmost importance to the pilot, relieving him of the need for considerable mental effort. Deviations from both courses may be corrected simultaneously.

By keeping the pointers crossed over the small central circle

on the instrument face, a suitable spatial landing path is followed down to the point of landing. Longitudinal position of the aircraft as it approaches the airport is given by the combination of a distance indicator on the aircraft with the aural signals received from two marker beacons.

The distance indicator, see fig. 11 consists simply of a direct current milliammeter connected in the plate supply to the radio frequency amplifying tubes of the beacon receiving set.

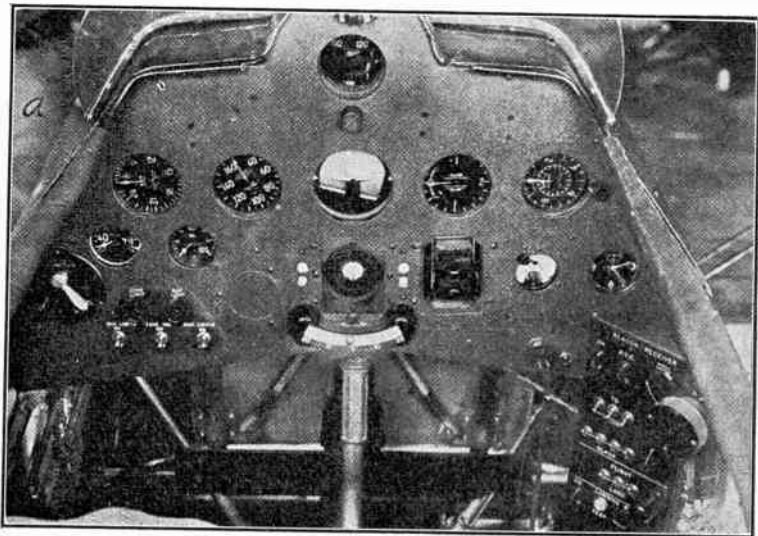

**FIG. 14**—Typical aircraft instrument panel arrangement. This layout is based on the principle of having as nearly as possible all the direction indicating instruments in a vertical row and all the instruments giving altitude in a horizontal row. In accordance with this arrangement the combined instrument (because of its vertical pointer) is placed in a vertical row with the gyroscopic compass at the top and the magnetic compass at the bottom. The horizontal row contains from left to right: The tachometer; the air speed indicator; the gyroscopic artificial horizon; the rate of climb indicator, and the barometric altimeter.

Since the automatic volume control operates to increase the negative biasing voltage on the grids of these tubes with increasing input voltages to the receiving set, the plate current is approximately inversely proportional to the field intensity of the runway beacon. The instrument may therefore be calibrated

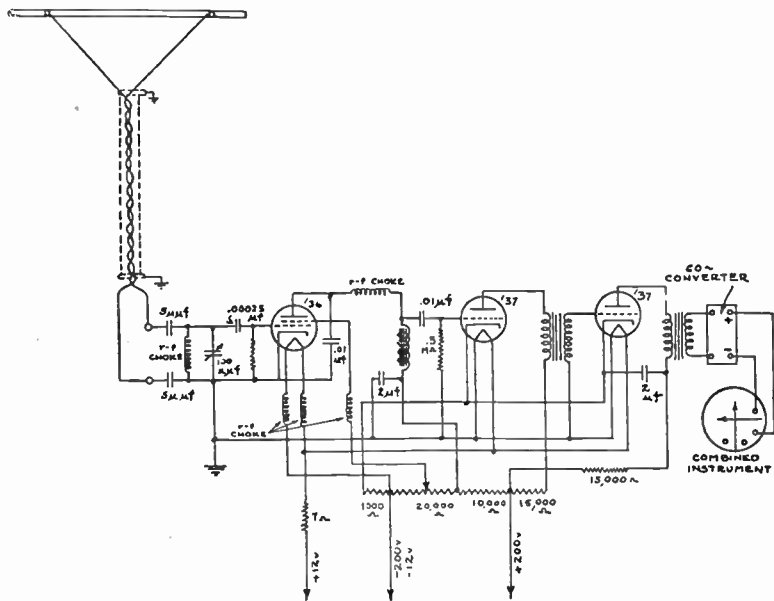

FIG. 15—Schematic circuit diagram of landing beam receiving set. The set comprises a detector and two stages of audio frequency amplification. The detector is untuned, a simple high-pass filter being interposed between the detector input circuit and the transmission line feeding it in order to minimize interference from service operation on lower frequencies. The output from the receiving set passes through a mechanical filter tuned to the modulation frequency at the transmitter (60 cycles) which provides further freedom from interfering signals. Adjustment of the sensitivity of the set is obtained by means of a variable condenser shunting the input to the detector grid.



in miles from the beacon (say, 0 to 5 miles). The distance indication secured is approximate only, but is sufficiently accurate for all necessary maneuvers of the landing aircraft at distances from the airport of the order of 1 to 5 miles.

Absolute indication of the longitudinal position of the aircraft when near the airport is given by aural signals from two low port marker beacon transmitters. One marker beacon is located about 2,000 feet from the approach end of the airport while the other marker defines the boundary or edge of the landing field.

Different modulation frequencies are employed for the two marker beacons to facilitate ready identification of the one being passed over; the marker beacon at the field boundary having a modulation of about 250 cycles and the approach marker beacon a modulation of 1,250 cycles.

The marker beacon transmitting antennas provide for great flexibility of operation; any portion of the landing field boundaries and approaches may be defined, and any radio frequency may be used in the range of from 200 to 20,000 kilocycles.

**Advantages of the Landing Beam.**—The advantages of the landing beam are as follows:

1. The landing path may be so directed that a landing aircraft following the glide path is automatically kept above obstruction without requiring exact knowledge of the territory over which he is passing.

2. The average landing path may be made to suit the particular airport merely by adjusting the power of the landing beam transmitter. Each individual aircraft may follow a path departing considerably from the average landing path and more closely suiting its flying characteristics simply by an adjustment of the sensitivity of the landing beam receiving set.

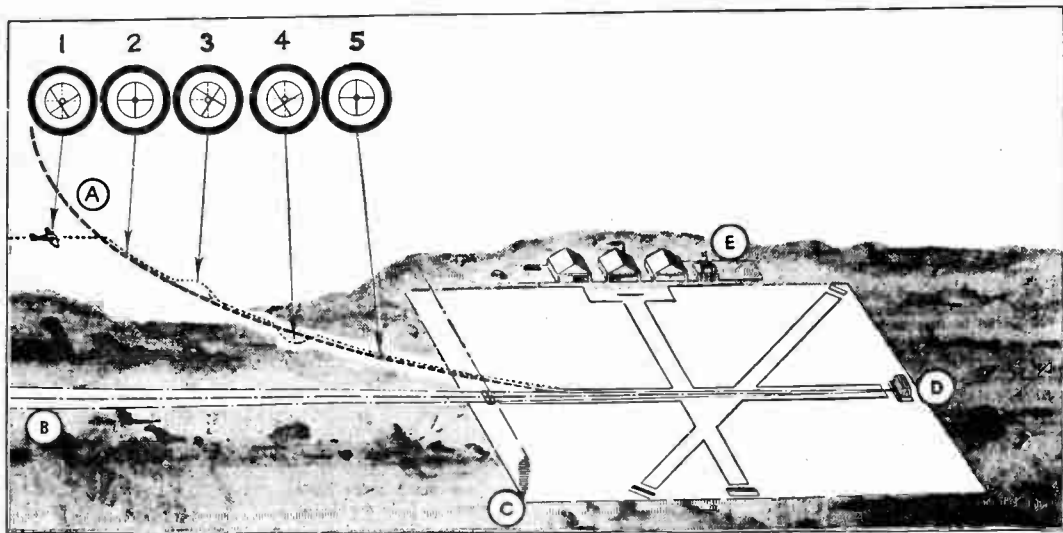

FIG. 16—Depicting the principle of blind landings with the aid of the bent radio beam. The bent beam (shown dotted) gives the pilot approaching the landing field a definite gliding path to follow. Encircled letters indicate: *A*, glide path; *B*, runway localizer beam; *C*, marker beacon at end of runway or edge of field gives pilot audible signals as he flies through it; *D*, airport beam transmitter; *E*, airport control tower containing monitor unit indicating operation of landing system and apparatus for two-way voice communication with pilot. The position of the aircraft as indicated on the combined instrument are: 1, to the left of gliding path and too low; 2, on the left of gliding path and too high; 3, to the right of gliding path and too high; 4, on course and on gliding path, etc.

The power adjustment at a given airport to secure a suitable average landing path and the sensitive adjustment on each aircraft to depart by a desired amount from the average path once made, are permanently fixed. A given aircraft then follows an optimum landing path at all airports equipped with landing beams.

3. The shape of the landing path is such that the aircraft maintains safe flying speed in following the landing path indications up to the point of receiving the boundary marker beacon signals. Thus the aircraft engine is kept at a safe operating speed during all maneuvers outside the airport boundaries.

4. The landing glide may begin at any desired altitude within a rather wide range. Beginning the use of the landing beam does not, therefore, involve accurate location of any point at specific distance from the airport, but comes automatically so long as the pilot is following the runway beacon course in the correct direction and at an altitude within the prescribed limits.

**Sonic Altimeter Principles.**—On account of the fact that aircraft must fly near ground for a considerable time in connection with take-off and landing, it is obviously necessary that for safety of these operations some means be provided to guide the operator to instantly and automatically give his correct altitude above the ground.

Under ordinary circumstances it may seem that the visual judgment of distance by a skilled operator would eliminate this problem, however, sometimes visual observations are impossible on account of darkness, fog or a heavy storm, hence some instruments for measuring height above ground is needed.

Various barometric altimeters it seems could be utilized for this service, but only if the existing barometric pressure and the

local elevation above the sea level are known. Another detrimental factor is that the ordinary barometric altimeter whose hand makes one revolution for 10,000 feet altitude, will not have sufficient sensitivity to be of service in a landing operation, for example, under any circumstances.

Parallel with the constantly improving design in aircraft and various instruments for their safe operation, a great number of devices for measurement of altitude has been developed.

**General Principles.**—Such devices, generally called altimeters or Sonic altimeters, depend on their functioning upon the reflection of either an electromagnetic or sound wave from the ground surface.

Various experimenters have been able to produce practical instruments using sound waves, but there is presently no record of similar successful efforts with any other schemes.

The Sonic altimeter has three essential parts:

1. An emitter which sends out a brief sound signal at controlled intervals.
2. A receiver which detects the echo of the signal when it returns from the earth, and
3. A chronoscope which measures the time interval between signal and echo.

Since the velocity of sound in air is substantially constant, the chronoscope is ordinarily calibrated directly in altitude for some average set of conditions.

**General Requirements.**—With reference to figs. 17 and 18, the essential geometrical features and design of the Sonic altimeter principles will be obtained.

The sound source or emitter  $E$ , sends out a sound signal which strikes the ground, reflects upwards again and is picked up by a receiver at  $R$ .

The apparatus is completed by a chronometer which measures the time interval between the signal and its echo, which is a function of the airplane speed, the speed of the sound and the altitude.

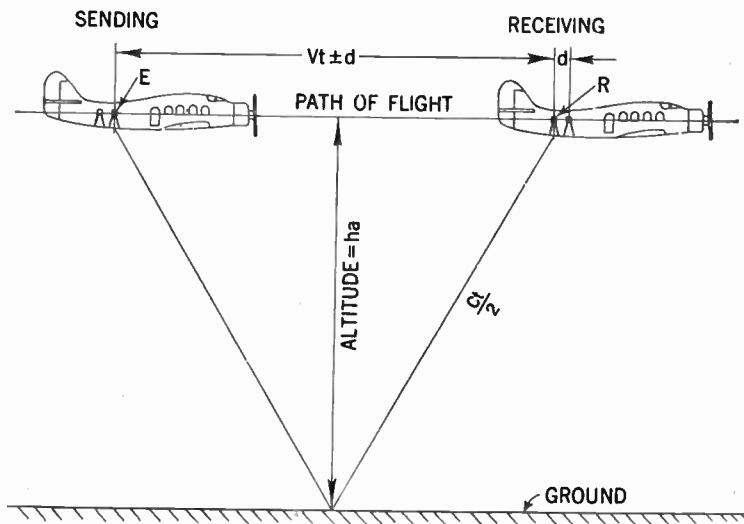

FIG. 17—Conventional geometrical representation for calculation of actual altitude of airplane.

Various manufacturers of altimeter instruments differ only in the means used for carrying out the previously mentioned functions.

With reference to fig. 17, observing the horizontal movement of the plane during the time of signal emittance and receipt of

echo, the actual altitude derived from the triangle will be obtained as follows:

$$ha = \frac{ct}{2} \sqrt{1 - \left( \frac{V \pm \frac{d}{t}}{C} \right)^2} \text{ in which}$$

$c$  = velocity of sound

$V$  = airspeed of plane

$t$  = time interval between sending and receiving

$ha$  = actual altitude.

On account of the fact that the speed of sound is almost constant (being 1,090 ft. per second in air) and the airplane speed has a small effect under ordinary conditions, the echo time is almost proportional to the altitude of plane.

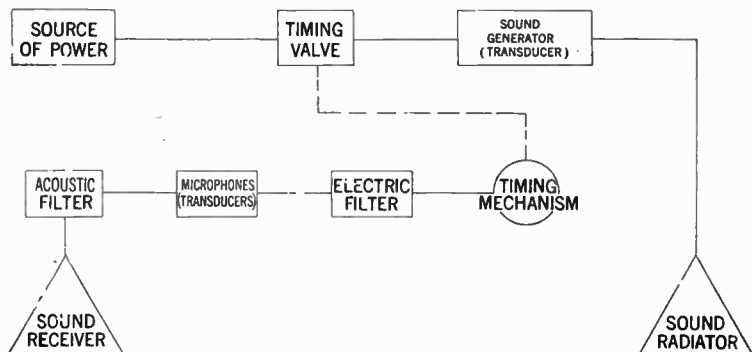

FIG. 18—Diagram showing co-ordination of apparatus usually employed in Sonic airplane altimeters.

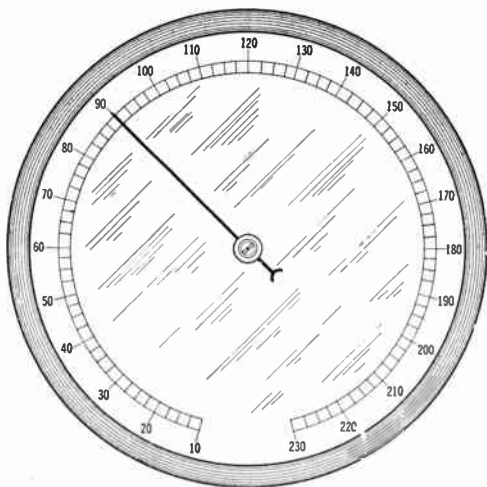

FIG. 19—Typical altitude indicator which may be read directly in feet or meters or with a conventional multiplier, the indicator being located on the airplane instrument board.

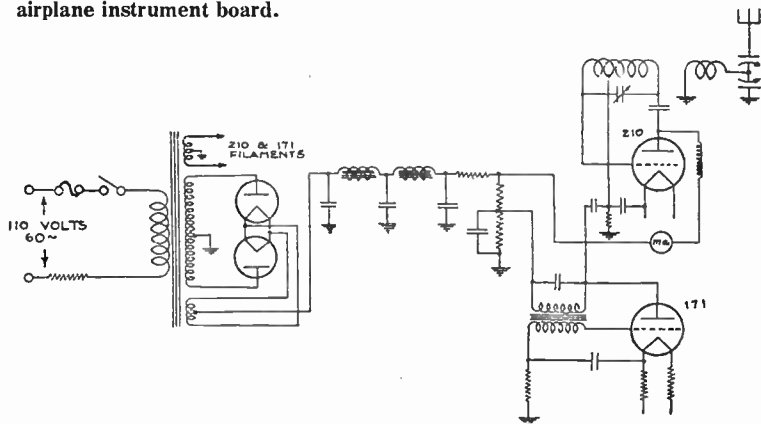
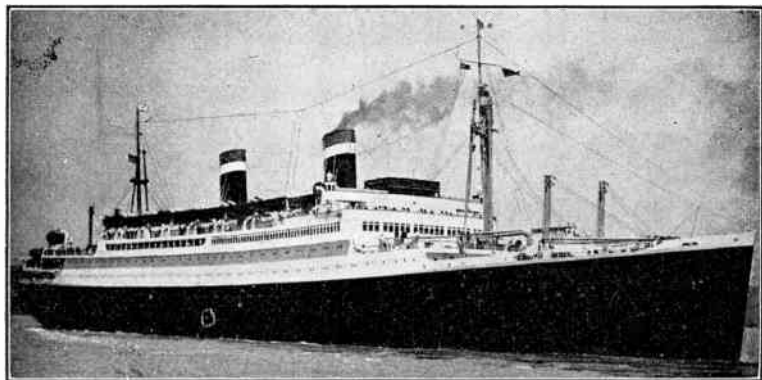

FIG. 20—Schematic circuit diagram of marker beacon transmitter set. The transmitter is enclosed in a weatherproof box and is completely shielded to prevent direct radiation.

## CHAPTER 23

# Marine Radio Equipment

The Federal Communications Commission, by virtue of authority granted to it by the Communications Act of 1934, has promulgated various specifications and regulations applicable to ship-board radio installations. Most of these regulations are found in its General Orders and its rules and regulations.



**FIG. 1**—Photographic view of S.S. Manhattan. View of radio room and equipment shown in fig. 2.

The International Convention for the Safety of Life at Sea, held in London in 1929, adopted a number of new and important regulations effecting radio in commercial marine service.

The United States Senate ratified the Convention on June 19, 1936 and this ratification was deposited with the British



Government on August 7, 1936. On November 7, 1936, the provisions of the Convention became effective for vessels of United States registry.

The radio provision of the Convention apply to all ships of *international voyages*, except vessels of less than 1,600 tons gross.

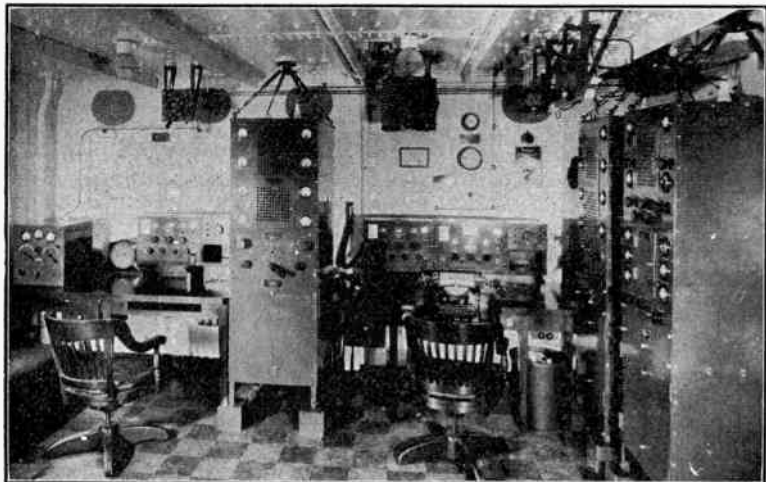

**FIG. 2**—Illustrates equipment in radio room on board S.S. Manhattan.  
(Courtesy Mackay Radio & Telegraph Co.)

A cargo ship is “any ship not being a passenger ship” and a passenger ship is defined as any ship which carries more than 12 passengers. Any person carried on a ship, other than its officers, and the crew actually required to man and operate it; persons employed to carry on the business of the ship and persons who have been rescued from shipwreck, distress or similar situations, are deemed passengers.

**Radio Equipment Required.**—The Safety Convention made the following requirements as to the radio equipment:

1. A main radio radio-telegraph transmitter with a normal range of at least 100 nautical miles to operate on 375 to 500 *k.c.* and at least one working frequency in the band 350-485 *k.c.* with **A-2** (modulated) emission, or **B** (spark) emission if the transmitter was installed prior to January 1, 1930.

2. An emergency transmitter similar to the main transmitter except that a normal range of at least 80 nautical miles is required.

3. A main radio receiver, 350 to 515 *k.c.* and 100 to 200 *k.c.* for reception of **A-1** (continuous) waves, **A-2** (modulated) waves and **B** (spark or damped) waves.

4. An emergency receiver, 350 to 515 *k.c.* with provision for using a crystal rectifier (detector).

5. For emergency operation, a source of power supply independent of the ship's main power supply, with capacity for six hours of operation.

The emergency transmitter and receiver are not required if the main transmitter and receiver also comply with all the requirements for the emergency equipment.

An independent communication system between the radio room and the bridge, emergency lights, seconds-hand clock, spare parts, and tools constitute other equipment required by the Safety Convention.

Passenger vessels of 5,000 tons gross and upwards are required to be equipped with an approved radio direction finder (radio compass). Also where the number of life boats carried exceed thirteen, one is required to be a motor boat fitted with an approved radio-telegraph installation.

If the number of life boats exceed nineteen, two of them must be motor boats each equipped with an approved radio telegraph installation.

The life boat radio equipment must comply with the F.C.C. specifications which calls for **A-2** emission on 500 *k.c.* with a

minimum of 75 watts plate input to the stage supplying power to the antenna. The antenna must be an inverted "L" or "T" and not less than twenty feet above the water line, with a maximum practicable length.

The life boat receiver must cover the band 350 to 550 *k.c.* with reception of **A-1**, **A-2** and **B** waves. A suitable storage battery in the life boat to provide continuous operation for at least six hours is required.

The rules for cargo vessels are in general similar to those outlined above for passenger vessels with the following exceptions: A direction finder is not required. The use of an approved *automatic alarm* (see page 519) is permitted on cargo vessels, provided at least an 8-hour watch per day in the aggregate is maintained by a qualified radio operator. The automatic alarm is required to be in operation whenever the operator is not on watch while the ship is being navigated outside a harbor or port, including periods when the direction finder is in use. A separate emergency transmitter and receiver are not required on cargo vessels, provided the main installation complies with all the provisions affecting the emergency installation.

Where a main transmitter on a cargo vessel is thus affected, this is sometimes accomplished by providing a storage-battery, emergency-power supply to operate the transmitter at 50 watts output. The main receiver normally uses storage batteries for filament supply and dry batteries for plate supply, and if also arranged for crystal-detector reception, will comply with the requirements for the emergency receiver, provided six hours reserve battery capacity is available.

**Marine Radio Telegraph Transmitters.**—The intermediate frequency band of 375 to 500 *k.c.* (800-600 meters) is of very great importance for radio communication in maritime mobile service.

Due to the various specifications and regulations applicable to ship, which of necessity must be international in scope, it is true that practically all of the approx. 15,000 vessels throughout the world which are equipped with radio apparatus are capable of communicating in the intermediate band.

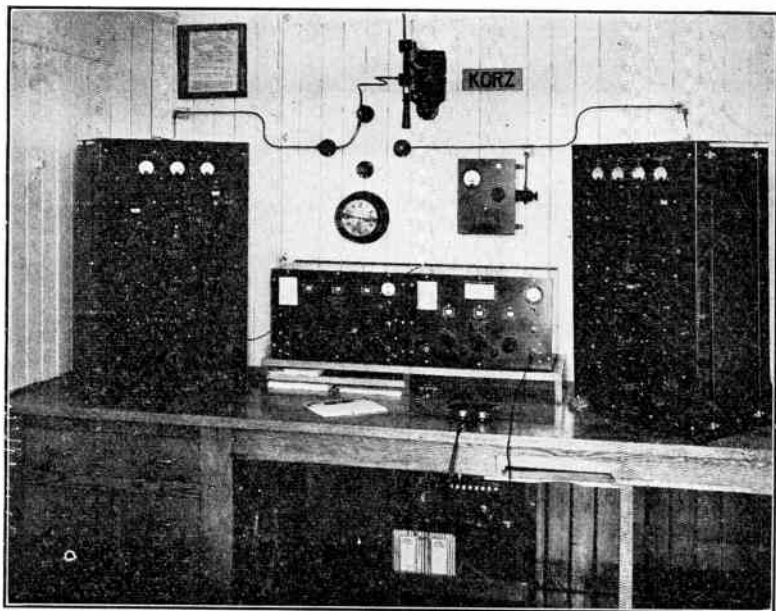

FIG. 3—Typical shipboard radio equipment installation.

Note: Radio compass switch and frequency meter. The output of radio telegraph transmitter's IF-HF is 100 watts. In case of failure in the ship's normal power supply, the emergency equipment provided will automatically go into operation. (Courtesy Mackay Radio & Telegraph Co.)

The 500 *k.c.* (600 meters) is used universally for distress calls while the 375 *k.c.* channel at the other end of the band is employed when a vessel transmits to shore radio compass stations for radio bearings.

Frequencies between 375 and 500 *k.c.* are used for message traffic between ships and shore and from ship to ship.

**Low-powered Transmitters.**—Shipboard transmitters of late design make use of closed oscillator or tank circuits, loosely coupled to the antenna.

Such circuit arrangements when properly designed are effective and find considerable application for low-powered transmitters.

**High or Medium Power Transmitters.**—In this type the master-oscillator power-amplifier type of circuit offers several advantages. The output frequency is determined in the master-oscillator circuit, which in turn supplies grid excitation to the power amplifiers.

Improved overall efficiency is obtained, compared to simple oscillator tank circuits, because it is not necessary for circuit stability to maintain such a large amount of circulating energy in the power amplifier tank circuit. Care must be taken however, to minimize harmonic radiation when the power amplifier tubes are operated at high efficiency.

**Forms of Signalling Waves.**—Two forms of signalling are desirable in an intermediate frequency shipboard transmitter. Continuous waves (**A-1**) are necessary for transmission with the minimum amount of interference to other stations and to permit highly selective receivers to be used. Modulated wave signalling (**A-2**) is also required for use in distress, for calling purposes, and other cases when it is desired to make contact with another station as quickly as possible.

Automatic break-in operation is of value so that transmission and reception can be carried out on the same antenna and to enable the local receiver to be effective instantly whenever the transmitting key is open.

**Typical Marine Radio Telegraph Transmitters.**—The radio telegraph transmitter shown in fig. 4 combines the intermediate and short wave band transmitting unit into one set; one panel, one set of vacuum tubes and one set of power machinery for both transmitting units.

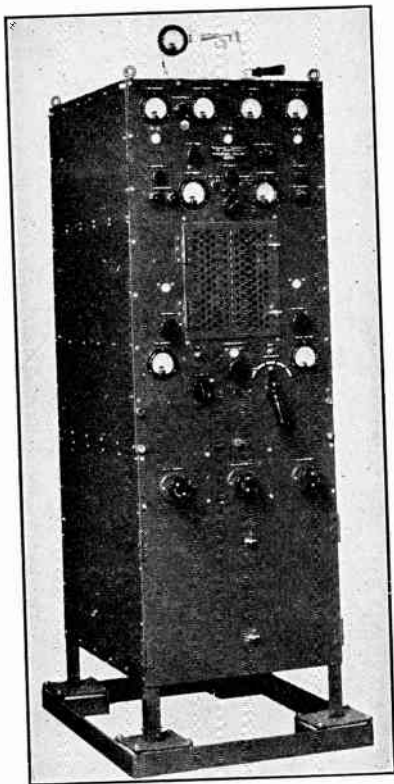

**FIG. 4**—This transmitter operates in the marine wavelength bands between 375 and 500 kilocycles (600-800 meters) and 5,500 to 17,000 kilocycles (17-54 meters). The band from 375 to 500 kilocycles is the one generally

The transmitter is contained in a metal framework which is enclosed by metal sides and doors. In the lower portion are located the high voltage transformer, rectifier and filter system while the upper portion houses the radio frequency and control circuits. The entire transmitter is mounted on a protective cushion support at the bottom and is supported at the top by coil springs fastened to the overhead as shown in fig. 2. This minimizes the effects of ship's vibration on the internal apparatus.

The transmitter uses a Master oscillator—power amplifier type of circuit employing one air-cooled vacuum tube in the oscillator circuit and one air-cooled tube in the amplifier circuit. The construction of the transmitter is such that the same vacuum tubes are used in either the short wave or intermediate wave ranges. A suitable transfer switch is provided which allows quick transfer from one operating range to the other. In general, the inductances and condensers for the short wave portion of the transmitter are mounted immediately behind the front panel, while the larger coils and fixed condensers employed in the intermediate wave range are mounted in the rear portions of the

---

**FIG. 4—Text continued.**

used for short and medium distance communication, radio compass bearings, distress purposes, etc. and complies with the laws governing radio installations on board ship. The band between 5,500 and 17,000 kilocycles is used for long distance communication and is commonly known as the short wave band. Transmissions on this band have the peculiar property of carrying extremely long distances with comparatively low expenditures of power. Many thousands of miles can be covered and communication maintained with this country from almost any part of the world under normal conditions with this type transmitter. The complete transmitting equipment consists of the following: Radio telegraph transmitter; two radio motor generator sets; two magnetic starters and one for each radio motor-generator, transmitting and mercury vapor rectifier tubes, including hand key and spare parts. (Courtesy Mackay Radio & Telegraph Co.)

unit. The perforated door on the front of the panel provides access to the two vacuum tubes. The doors at the bottom provide access to the rectifier and filter systems. When operated in the intermediate frequency band, five predetermined waves are quickly obtainable by manipulating the "wave changer" switch and the antenna tuning control.

Operating controls and indicating meters are all conveniently located on the front panel. These include controls for effecting wave changes, antenna tuning, filament and plate voltage control, *CW* and *ICW* operation, etc. and various meters.

Operation on the short wave bands is simple, any one of the six marine bands being available by means of tap and selector switches and variable controls. Shifting from intermediate to short wave operation is accomplished by means of the "*IF-HF*" switch and the antenna change switch. A short wave wavemeter is incorporated in the transmitter which enables the operator to tune to the exact wavelength desired. The marine operating frequencies between 5,500 and 17,000 kilocycles (17-54 meters) can be easily changed to meet the requirements of the time of day or range of communication desired.

Safety-door interlock switches on the tube compartment door and base section doors remove all high voltages if the doors be opened while the set is in operation, thus providing safety to operating personnel. The lower portion of the transmitter contains a step-up transformer, two rectifier tubes, and associated control circuits. The step-up transformer boosts the low voltage 360 cycles *a.c.* from the motor generator to approximately 2,000 volts, which in turn is converted into *d.c.* by means of the two rectifier tubes and filter circuits. By means of the *CW-ICW* switch either pure *d.c.* is delivered to the plate of the transmitting tubes for *CW* (continuous wave) operation or 720 cycle pulsating current for *ICW* (interrupted continuous wave) operation.



The power input to the transmitter is furnished by two motor generator sets which operate from the ship's power supply to

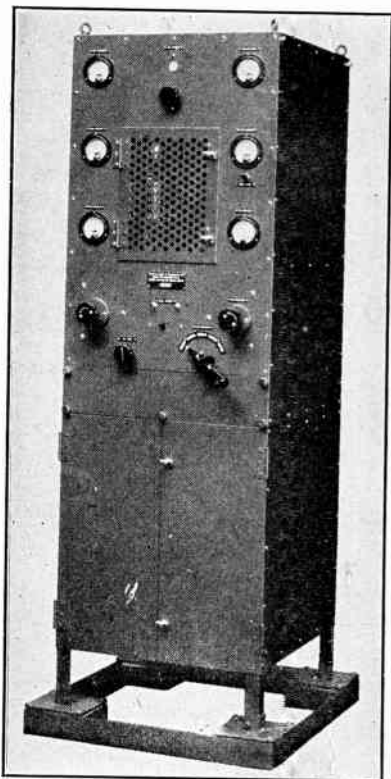

**FIG. 5**—Transmitter designed to operate in the intermediate frequency range of 375 to 500 *k.c.* (600-800 meters) and its operation on both continuous wave (CW) and interrupted continuous wave (ICW) are provided for. The complete transmitting equipment consists of: radio telegraph transmitter; radio motor-generator set; magnetic starter for motor-generator with push button station; the various transmitting and rectifier tubes, including hand key and necessary spare parts. (Courtesy Mackay Radio & Telegraph Co.)

generate the necessary voltages for supplying the filament and plate power to the transmitter.

Another type of shipboard radio telegraph transmitter is shown in fig. 5. This transmitter is commonly used on ships whose type of service or trade route require communication at medium distances. It operates in the intermediate frequency range of 375 to 500 *k.c.* (600-800 meters) and will deliver 500 watts into the average ship's antenna. Both continuous wave (*CW*) and interrupted continuous waves (*ICW*) are provided for.

The various units composing the transmitter is housed in metal framework and completely enclosed with metal panels. The lower part of the transmitter contains the rectifier and filter circuit, while the upper section houses the transmitting tubes and radio frequency apparatus.

The methods of mounting is similar to that of the previously described unit namely, protective cushion supports to mitigate vibration effects. The top of the cabinet is supported by coil springs fastened to the overhead in similar manner as shown in fig. 2.

The transmitter uses a master oscillator-power amplifier type of circuit employing one air-cooled tube in the oscillator circuit and one air-cooled tube in the amplifier circuit. Through operation of the wave changer switch any one of five pre-determined frequencies may be secured.

Resonating the antenna by manipulation of the antenna tuning control, completes the adjustment necessary in effecting a change in wavelength. Operating controls and indicating meters are conveniently located on the front panel, including controls for wave changing, antenna tuning, filament and plate voltage control, *CW* and *ICW* operation, and meters for indicating the line, filament and plate voltages, and grid, plate and antenna currents.

A perforated door in the center of the front panel allows access to the vacuum tubes and also provides an outlet for the cooling stream of air forced through the transmitter by a blower located in the base.

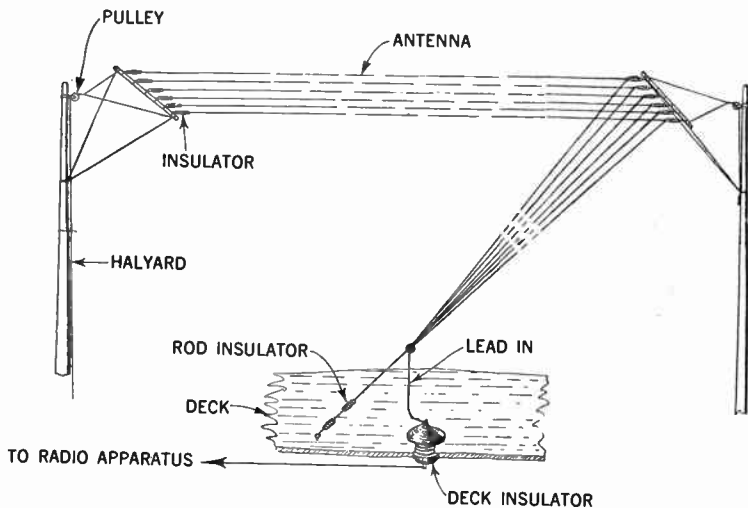

**FIG. 6**—Ship antenna of the flat-top inverted "L" type, showing conventional method of lead-in and deck-insulator details.

The doors to the lower section provide access to the rectifier and filter apparatus, and plate and filament transformers. All external connections except the antenna are made to the terminal board mounted in this section. The receiver break-in lead is also brought into this section by a shielded conductor and connected to the keying relay.

Safety-door interlock switches in the tube compartment door and the base section doors remove all high voltages if the doors be opened while the set is in operation, thus providing safety to

operating personnel. Other safety devices guard the circuits from the danger of overloading and thus make the transmitter as near "fool-proof" as possible.

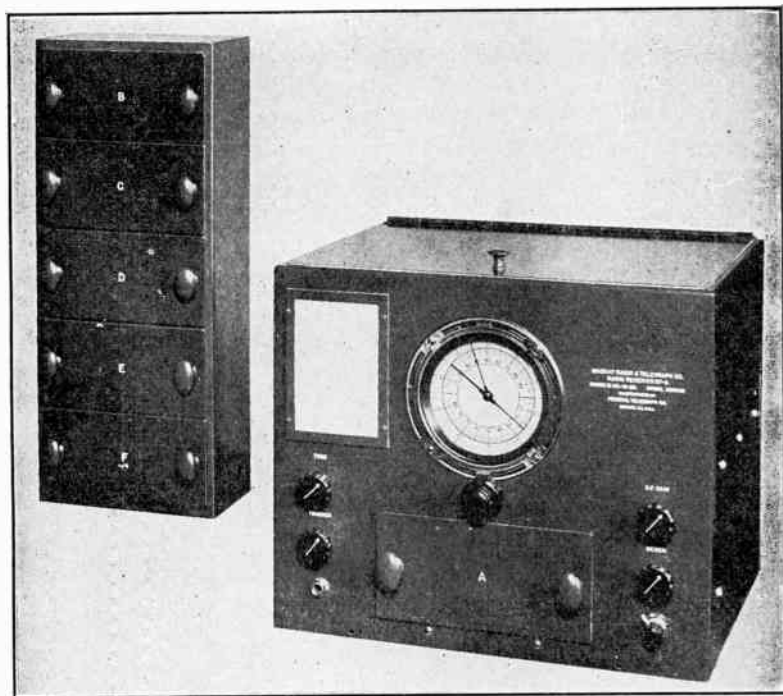

FIG. 7—All wave marine radio receiver. With coils and coil rack. (Courtesy Mackay Radio & Telegraph Co.)

**Power Equipment.**—The radio motor generator usually consists of a single unit, two ball-bearing machine with the motor operating from the *d.c.* ship's mains, arranged through slip rings on the motor to provide 60 cycle *a.c.* power for lighting the

filaments of the transmitting and rectifying tubes, and generator to supply 1,500 watts of 360 cycle *a.c.* power for application to a transformer in the lower section of the transmitting where it is stepped up to approximately 2,000 volts.

The rectifier and filter apparatus then converts this power into pure *d.c.* for *CW* operation or 720 cycles pulsating current *ICW* operation. This allows the use of low voltage generating equipment, thus reducing the hazards existing with high voltage *d.c.* generators. It also allows the use of low voltage wiring between the motor generator and the transmitter unit.

A magnetic starter of the time limit type is furnished, which is controlled by a push button station located at the operating position, within convenient reach of the operator.

## CHAPTER 24

# The Radio Compass

and

## Principle of Operation

The radio compass is an instrument for observing by means of radio, the direction of a station emitting radio signals; briefly, in aerial and marine navigation, it is an instrument for taking radio bearings.

**Operating Principles.**—Since the radio compass is built around the *loop antenna* it is necessary to understand its principles of operation before undertaking a study of the other units.

The radio compass utilizes the directional receiving properties of the coil, which consists essentially of several turns of wire wound into a large coil. This coil will receive the radio signals with maximum intensity when the plane in which the coil is wound is in the line of the direction to the transmitting station. See fig. 1.

As may be observed from the diagram, the minimum is well defined, and the maximum is not, hence it is evident that the strength of the signal varies rapidly with the movement of the coil near minimum, but very slowly with the movement near the maximum.

It is for this reason that the minimum is utilized in observing bearings. If it were not for this, there would be great advantages in taking bearings on the maximum, on account of greater audibility and thus diminishing the interference effect.

The coil or loop antenna part of the compass operates on the principle that the amount of electromotive force induced in a vertical loop of wire by an arriving electromotive wave, depends on the angle between the plan of the loop and the wave front.

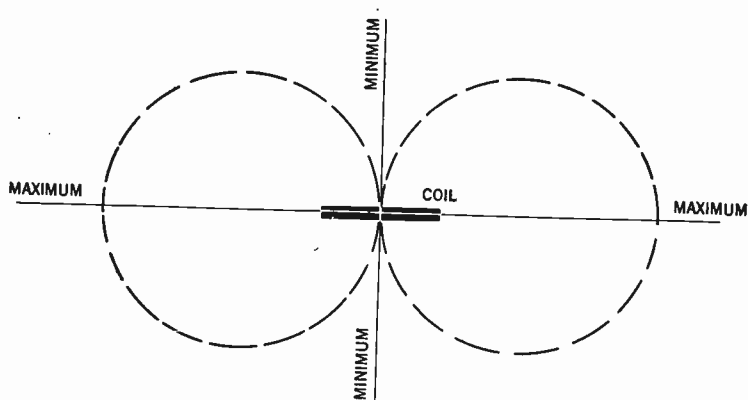

FIG. 1—Illustrating directional effect of radio waves on the loop-antenna part of the radio compass.

In a rotatable coil of practical size the voltage induced by radio signal is very small. Hence for use of such small coil for radio compass purposes, it is necessary to generate a great amplification, and it was the utilization of the multistage vacuum tube amplifier which made the instrument usable for marine and aerial navigation.

As previously asserted, the radio compass utilizes the directional receiving properties of the coil type of the antenna. To

further facilitate the understanding of the instrument, an analysis of the behavior from the point of view of the magnetic field is as follows:

It is a well known fact that the radio waves emanate from the transmitting stations in all directions, very much the same as water waves on the surface of a quiet pond when a stone is dropped in. The length of a radio wave is the distance between successive crests of the wave; the number of crests passing a given point per second is the frequency, and the product of the wave length and frequency gives the velocity of the radio wave. The product of these two factors (wave length and frequency) is always about 300,000,000 meters (186,300 miles) per second. Radio waves are accompanied by a magnetic force which is horizontal and at right angles to the direction in which the waves are traveling.

As a radio wave passes a given point the magnetic force, or field strength, varies from moment to moment from a maximum in one direction through zero to a maximum in the other direction. At a given point the cycle from maximum in one direction back to maximum in the same direction is performed in a very small fractional part of a second. For a wave length of 300 meters this cycle is performed in one-millionth of a second.

If a coil of wire is held in a fixed position, such that the lines of magnetic force thread or pass through the coil and are not parallel to it, while the magnetic field varies in intensity, as is the case with that accompanying the radio wave, an electromotive force or voltage will be induced in the coil.

Since the magnetic force is horizontal and may be thought of as forming circles around the transmitting source, the compass coil when turned with its plane parallel to the direction of the



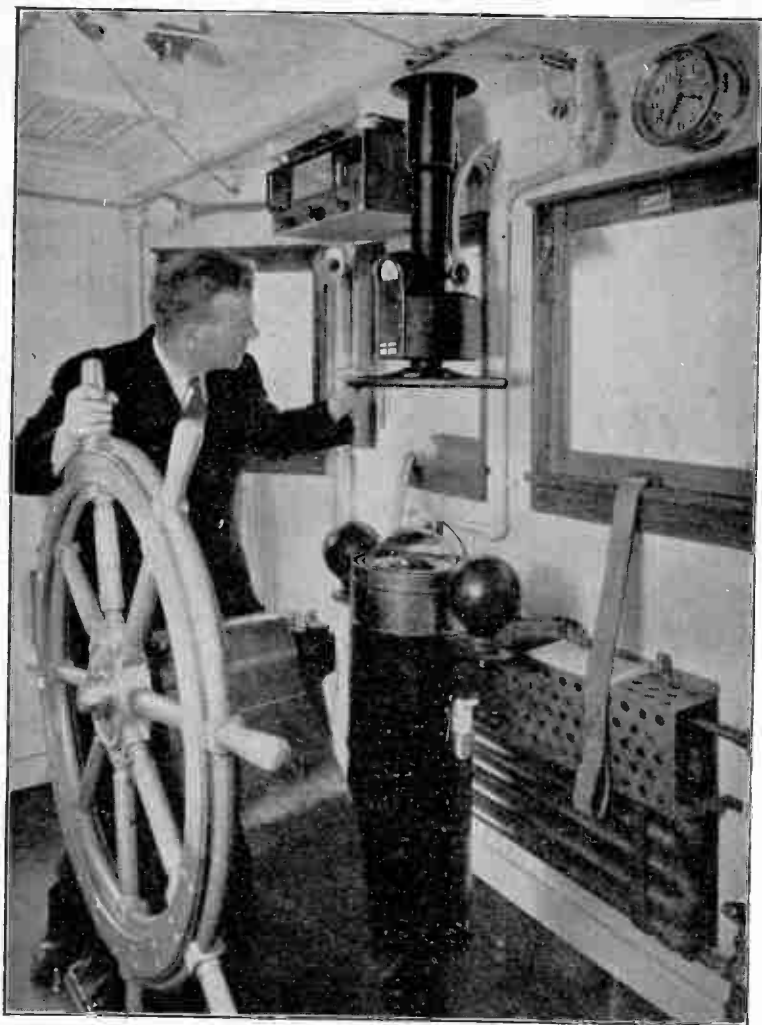

FIG. 2—Typical Marine radio compass installation. (Courtesy Western Electric Co.)

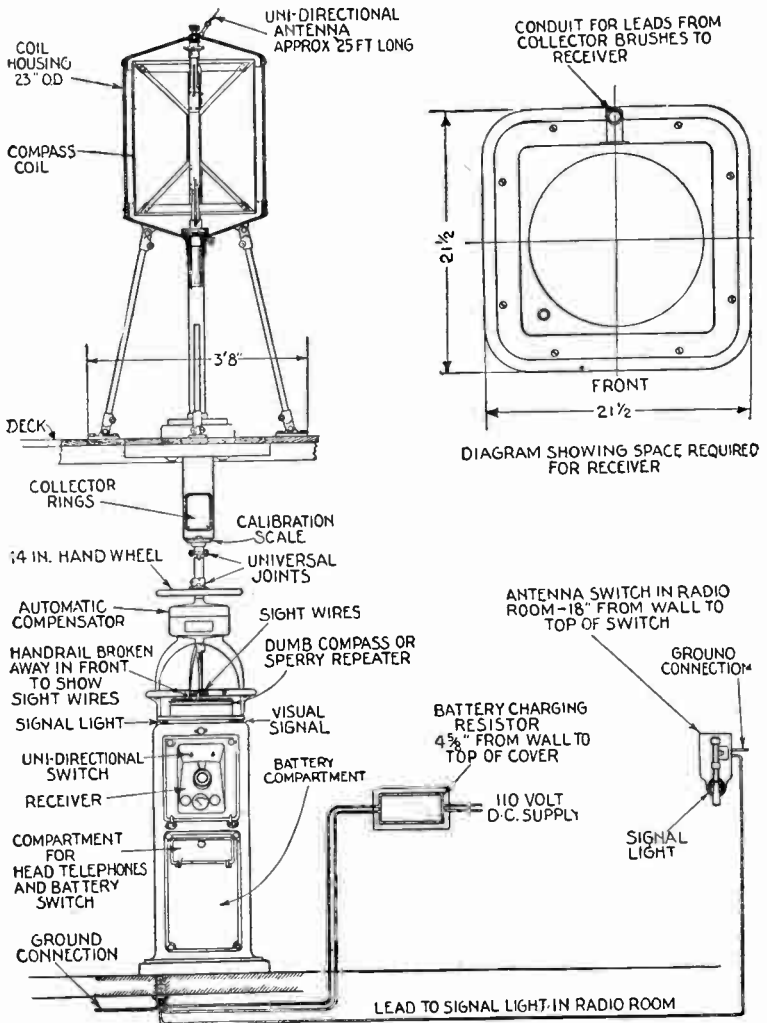

FIG. 3—Kolster radio compass installation.

transmitting station is threaded by the maximum number of magnetic lines of force, and the signal heard in the telephone receivers is a maximum. When the plane of the coil is turned at right angles to the direction of the transmitting station, no magnetic lines of force thread through the coil, and therefore no voltage and no current are induced in the coil and no signal will be heard in the telephone receivers.

**The Marine Radio Compass.**—A radio compass frequently found on board ships of U. S. registry was developed by F. A. Kolster and is manufactured by the Federal Telegraph Co., named variously **The Kolster Radio Direction Finder** or **The Kolster Radio Compass**.

Other radio Direction Finders have been developed by the Radio-Marine Corporation of America, the Marconi Wireless Telegraph Co., etc.

By means of this device, radio bearings can be taken in dense fog, snow storms and over distances greatly beyond the horizon with an accuracy equal to that obtained with visible sight, thus eliminating one of the greatest hazards to marine navigation.

The modern method of obtaining radio compass bearings on shipboard requires the installation of radio beacons on light vessels and light houses in the vicinity of harbor entrances and other places dangerous to navigation, the exact locations of which are shown on all sailing charts.

**Operation of Unit.**—With reference to the electrical circuit fig. 4, the theory and operation of the unit as developed by the U. S. Bureau of Standards is as follows:

The variable condenser  $C_1$  together with coil  $L_1$  form the main receiving circuit which is tuned to the signaling wave length.

Connected across the condenser  $C_1$  either directly or through the potential transformer  $P$ , is the vacuum tube amplifying and detecting apparatus.

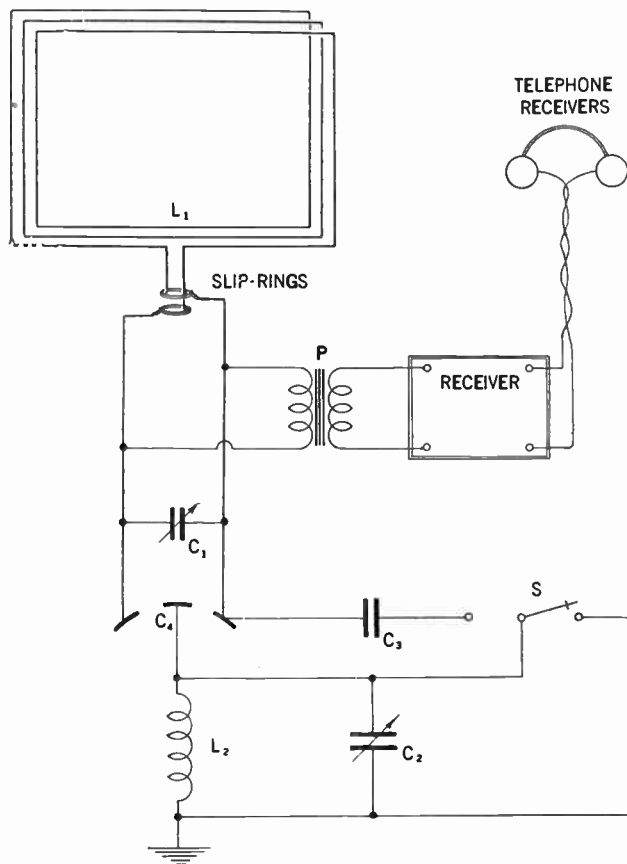

FIG. 4—Circuit of Kolster radio direction finder.

As developed by the U. S. Bureau of Standards this receiver consists of a three-stage radio-frequency amplifier, a detector and a two-stage audio frequency amplifier made up as a unit with a minimum number of operating adjustments. However, the receiver may be of any standard design.

The telephone receivers are located at a distance from the magnetic compass to avoid any effect upon the compass due to the magnets within the telephone receivers.

The auxiliary circuits of the direction finder are controlled by switch *S*. With the switch closed to the right, the middle plates of the double condenser  $C_4$  are directly grounded.

The double condenser is utilized to bring about electrical symmetry of the coil system with respect to the earth. In other words by adjusting the middle plates of the condenser  $C_4$ , to the right or left the earth connection is brought to the electrical midpoint of the coil system, and the signal received in telephones, results only from the energy directly received in coil  $L_1$ .

With the switch closed to the left a small condenser  $C_3$  is connected across half of the double condenser  $C_4$ , and the inductance  $L_2$  and tuning condenser  $C_2$  are inserted in the ground lead.

Under these conditions the coil system is no longer electrically symmetrical with respect to earth, and received energy enters the coil circuit  $L_1C_1$  indirectly through the tuned ground circuit, of which the capacity of the complete coil system to earth forms a part.

By proper adjustment, a complete uni-directional effect can be obtained.

In the practical operation of the direction finder, all tuning adjustments remain set for the wave length of the signaling station. Switch *S* is closed to the right when observing the line

of direction of a given signaling station and to the left when it is desired to determine the sense of direction.

In other words, to determine the line of direction of a station, the coil system which is directly grounded at its electrical midpoint by throwing switch  $S$ , to the right, is rotated to the position of critical silence at which time the plane of the coil is normal to the direction of the approach of the signaling wave.

To determine the sense of direction of the station, switch  $S$  is closed to the left and the coil rotated to the position of maximum signal intensity at which time the plane of the coil is in direction of approach of the signaling wave and pointed toward the signaling station as indicated by an index pointer for that purpose.

**Bellini Radio Compass.**—Another type of radio compass known as the Bellini direction finder, is shown in fig. 5.

The frame consists of the loop  $L$  and condenser  $C_1$  and  $C_2$ . The vertical antenna consists of the grounded center of the loop and the two condensers  $C_1$  and  $C_2$  which are grounded through the tuning condenser  $C_3$ .

**Operation.**—To obtain a bearing the switch  $S$  is closed and the loop tuned to the incoming signals. The false vertical effect of the loop is practically eliminated by grounding the center point of the loop through the variable resistor  $R$ . The sharpening effect of the minimum due to the elimination of the remaining vertical effect is accomplished by varying condensers  $C_1$  and  $C_2$ .

To obtain the sense of true direction, the switch is opened and the vertical antenna tuned by means of condenser  $C_3$ , by varying the resistance  $R$ , it is possible to obtain the conventional heart-shaped diagram.

Dependable bearings can be obtained only by precise adjustments of condenser  $C_1$  and  $C_2$ . The presence of tube damping across the loop is detrimental in that it limits the range and selectivity of the set.

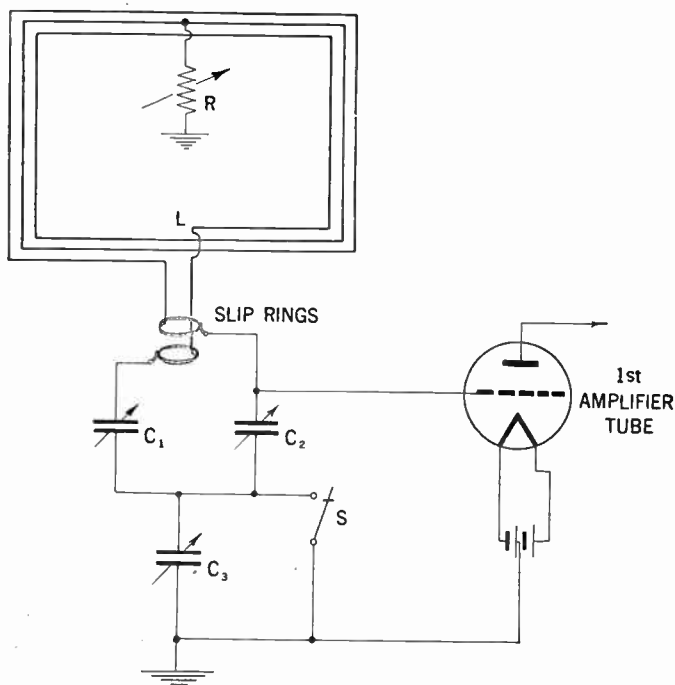

FIG. 5—Circuit of Bellini Radio direction finder.

The frame supporting the loop is square in shape, each side being approximately 32 inches long and ten turns are wound for a wave length of 300 to 1100 meters.

The energy from the frame to the amplifier is transferred similarly to the previously discussed Kolster type direction finder by means of slip rings.

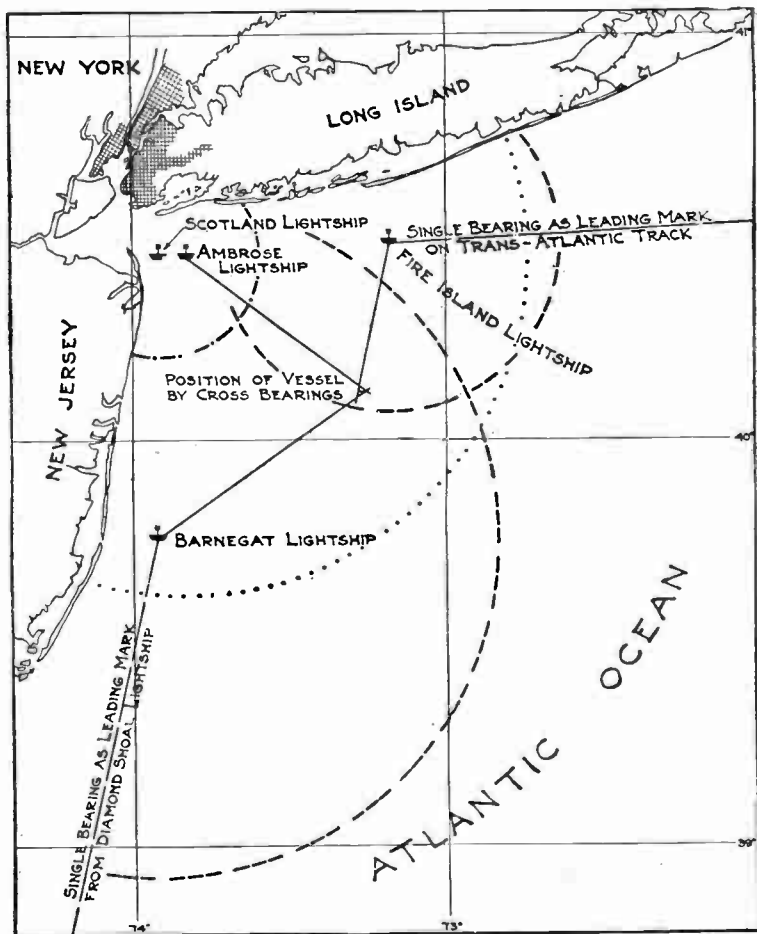

FIG. 6—Illustrating the use of radio beacons in navigation. When approaching New York, the location of four radio beacons as shown, makes it possible to obtain radio bearings, and thus at any instant the position of the vessel will be obtained. The arcs of circles indicate the characteristics of the radio beacons, and the radius shown is approximately half the ordinary range.



A typical shipboard compass installation is shown in fig. 2. When the coil is rotated by means of the hand wheel, the characteristic signal from the signaling station will be heard in the telephone with varying degrees of sharpness until the plane of the coil is at right angle to the direction of the incoming waves at which point the signaling fades out completely.

The position of silence is very sharp and hence indicates with great accuracy the line of direction of the incoming waves.

By means of cross bearings as indicated in chart, fig. 6, on two or more stations or by several bearings on a single station with the distances logged between bearings, the position of the vessel can be determined by simple triangulation with an accuracy equal to sight bearings on visible fixed objects.

**Example on Cross Bearings Obtained by Radio Compass from Two Adjacent Radio Beacons.**—With reference to fig. 7 showing two beacon transmitters  $T_1$  and  $T_2$ , the bearings on ship  $S$  may be computed by the navigator who reads the ship's head and corrects for deviation and variation as follows:

- |   |   |            |                          |                |
|---|---|------------|--------------------------|----------------|
| 1. Ship's head as read by the magnetic compass              | = | $45^\circ$ | =                        | $45^\circ$     |
| Variation obtained from chart                               |   | =          | $10^\circ E = +10^\circ$ |                |
| Deviation obtained from correction table                    |   | =          | $2^\circ E = + 2^\circ$  |                |
| True ship's head relative to true North                     |   |            |                          | = $57^\circ$   |
| 2. Radio beacon $T_1$ as read on radio compass              | = |            |                          | $272^\circ$    |
| Correction from $QE^*$ curve for $92^\circ$                 | = | -          |                          | $1.^\circ 5$   |
| Radio bearing on $T_1$ relative to ship's fore and aft line | = |            |                          | $270.^\circ 5$ |

Thus, bearing on  $T_1$  relative to true north = true ship's head + corrected radio bearing =  $57^\circ + 270.^\circ 5 = 327.^\circ 5$ . This gives position line  $T_1 O Y$  from radio beacon  $T_1$ .

\* $QE$ —Quadrantal error calibration curve. A curve representing the deflection of radio bearings due to the unequal distribution of metal on the ship.

3. Radio beacon  $T_2$  as read on radio compass =  $223.^\circ 5$   
 Correction from  $QE$  curve for  $223^\circ$  = +  $9.5$   
 Radio bearings on  $T_2$  relative to ship's fore  
 and aft line =  $233^\circ$

Thus the bearings on  $T_2$  relative to true north = True ship's head and corrected radio bearings =  $57^\circ + 233^\circ = 290^\circ$ . This gives position line  $T_2OX$  from radio beacon  $T_2$ , and the intersection of the two lines at  $O$  is the ship's position.

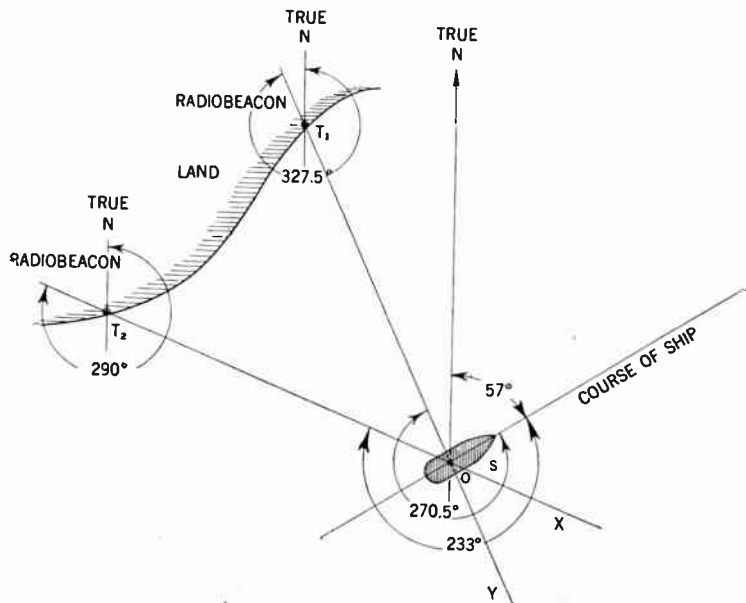
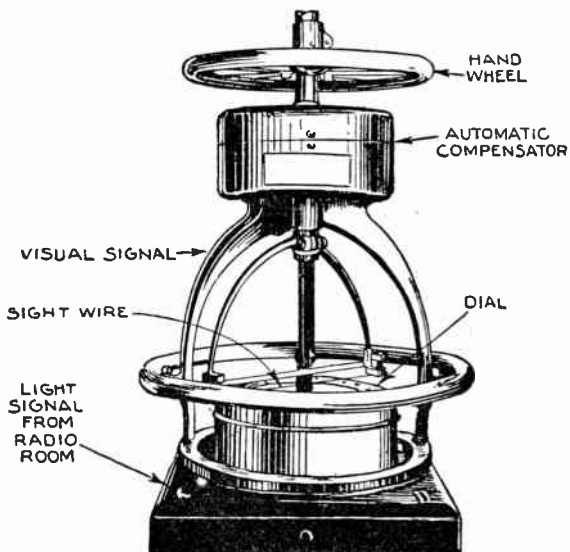

FIG. 7—Diagram illustrating method of computing ship's location by means of radio direction finder. In this illustration the following assumptions should be noted.

1. That the radio bearings are taken very rapidly, so that the distance covered by the ship between observations are negligible.
2. That the distances between the ship and the radio beacons are less than 100 miles and hence no convergency has been considered.



**FIG. 8—Kolster compass and compensator arrangement.**

## CHAPTER 25

# Radio Beacons<sup>\*</sup>

Radio beacons as pertaining to marine radio navigation, are simply *radio stations* installed at lighthouses, on light-ships, or at other points shown on charts for the radial dispatch of radio signals for the guidance of ships.

By means of the radio compass, (see page 500) it is hence possible for the ship navigator to ascertain his position at any time when within receiving distance of the radio beacon.

As the radio compass aboard ships are usually designed to enable the operator to take radio bearings without outside assistance, the general problem and practice in navigation becomes very much the same when using radio bearings as they are with visual bearings on lighthouses and other known objects.

The practical difference between the two being that with the availability of the radio beacon much greater distances can be covered under all conditions of visibility.

As previously asserted, the radio beacons are located at definite points clearly marked on the chart, and send out signals in all directions similar to that of light beams sent out by the lighthouse.

---

\*The radio beacons in the United States are erected and maintained by the U. S. Department of Commerce, Lighthouse Service as a part of its system of aids for the navigation of ships.

Another similarity is that as the light beams may be distinguished from one another by definite characteristics, so has each radio beacon a definite signal.

**Location Methods.**—The common method of ascertaining the location of a ship equipped with radio compass is by means of cross bearings using two or more radio beams as shown in fig. 1 or by visual and radio bearings in combination.

Of course the usual principles apply, as to employing stations which will give good intersections, and as to allowing for the

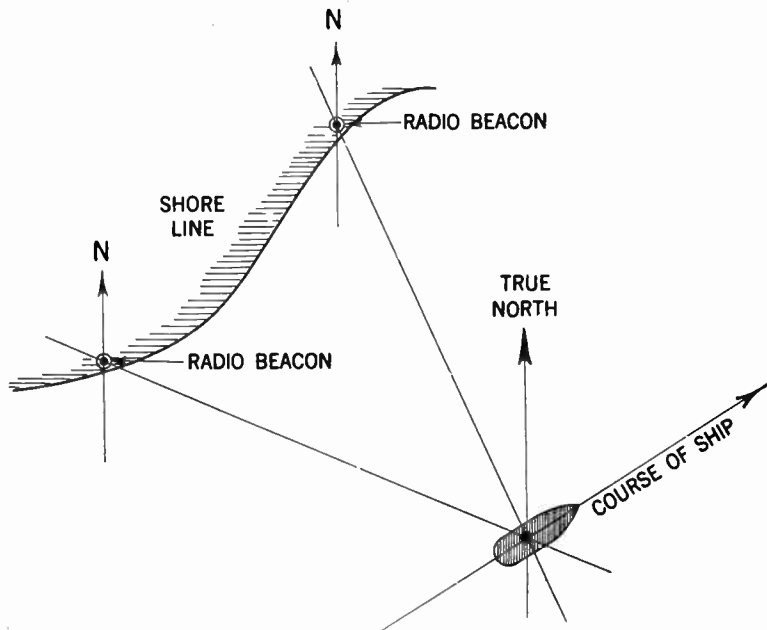

FIG. 1—Illustrating method of ascertaining location of ship, by means of radio compass aboard ship and shore radio beacons.

distance run between the times of taking bearings if the interval is appreciable. A typical example on how to obtain radio bearings is shown on page 506.

The ship's location may also be established by bearings on a single radio beacon using the customary method of taking two or more bearings at sufficiently different azimuths, and plotting these in combination with the distance and course run between bearings.

Indirect use of radio bearings in navigation is also possible. For example a vessel equipped with a radio compass and knowing its own position will be able to assist other vessels by means of radio bearings. Thus, where a vessel seeking another in distress is unable to locate it because of inaccurate reported position, neither having a radio compass, a third vessel so equipped will be able to guide the rescuing vessel by the utilization of radio bearings.

**Time Schedules for Sending of Radio Beacon Signals.**—Generally radio beacon signals when operating are sent for one minute out of each three minutes. Subject to this they are operated continuously during fog and low visibility, and they are also transmitted on regular time schedules regardless of fog.

**Power and Range of Radio Beacon Signals.**—The distance of availability of ranges, considered desirable for radio beacons vary greatly with the purpose of the respective stations. In this country the stations are divided into three general classes:

**Class A**, primary station, with power approximately 500 watts, with a range of 200 to 300 miles.

**Class B**, intermediate power 100 to 200 watts, with a range of 100 to 150 miles.

**Class C**, low power 5 to 50 watts with a range of 10 to 50 miles.

However, the actual range at which signals can be picked up and bearings taken, may under favorable conditions exceed the aforementioned distances.

Although it is possible with present day equipment to greatly exceed these distances, the practical limitations are:

1. The power required may cause a considerable amount of interference.

2. A small error in the direction of a bearing is much magnified in a derived position at a great distance.

3. The possible deviation of radio bearings, particularly as regards the various types of transmission, has not been fully investigated at great distances.

It is at present, considering the above, much more important to develop accurate and dependable direction finding apparatus on ships to be used for distances of 200 miles, than to seek for the possibility of bearings at greater distances.

**Radio Beacon Equipment.**—As the location of radio beacons in the United States in nearly all instances has been established at existing light stations, and as the space required for the transmitting apparatus is comparatively small, they are usually housed within the light emitting station, and generally no additional buildings are necessary.

The equipment of a radio beacon station comprises the following:

1. Radio transmitter
2. Automatic code machine
3. Power supply equipment consisting of a generator, a battery or both
4. Antenna
5. Synchronizing clock

6. Radio receiver
7. Automatic warning devices.

On account of the importance of continuity of service, all apparatus as far as practicable, are installed in duplicate, with means for switching from one transmitter, generator or code machine to another in case of trouble.

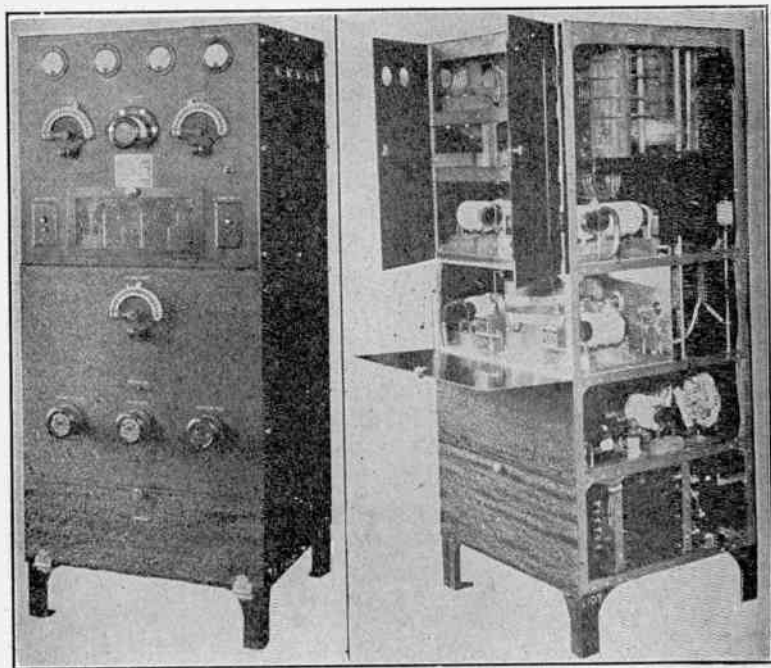
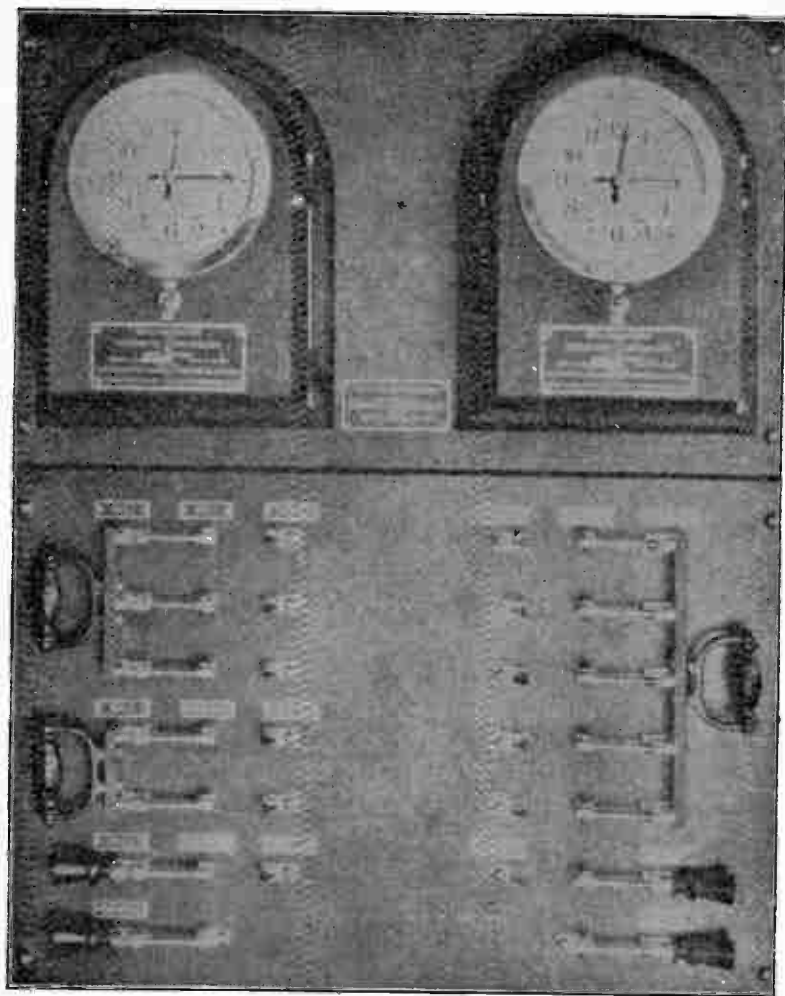

FIG. 2—Standard 200 Watts Marine Radiobeacon transmitter.

**Transmitter.**—Transmitters of late design are generally of the so-called master-oscillator power-amplifier type, usually employing a  $7\frac{1}{2}$  watt tube as master oscillator, following with





**FIG. 3—Radiobeacon Synchronizer, complete with Switchboard, Installation in duplicate.**

one or more 50 watt and 250 watt tubes as intermediate and final power amplifiers.

The plate supply is usually obtained from a 110 volt, 60 cycle, alternating current source through suitable tube rectifying circuits, employing rectifiers of the mercury-vapor type. The filament current in nearly all cases is supplied by a separate motor generator or rotary converter to secure better voltage regulation, and is usually 60 cycle *a.c.* current to obtain uniform filament evaporation.

**Code Machine.**—The code machine is entirely automatic in its operation and provides for the sending of the station characteristics.

The code is formed by a series of combination of short and long segments of a revolving code wheel, making short or long contacts as the wheel is revolved to produce dots and dashes. This wheel is revolved by an electric motor through suitable reduction gears which also drive a contacting cam designed to open or close the circuit, so that any desired combination of "on" or "off" operating intervals may be obtained.

**Power Supply.**—The location of radio beacons usually is a determining factor as to power supply to be used, and commercial current is employed when available. However, when location prohibits the use of commercial current, internal combustion or steam engines with electric generators are provided.

In case of power failure a duplicate source of supply is utilized to provide against possible interruption of service.

On practically all ship stations as well as on land stations where the storage of gasoline utilized in prime movers for generating equipment would constitute a fire hazard, storage batteries are used as a source of power.

**Synchronizer for Radio Beacons.**—This apparatus has been designed to automatically control the sending intervals of a radio beacon, and to synchronize the sending intervals of several stations in a group so that they will not overlap.

The actual work of synchronizing is accomplished through control of the “on” and “off” periods of the transmitter by accurate clocks. Two types of clocks are used to accomplish this, the larger number being of the marine escapement type which are serviceable alike at ship and shore stations. Pendulum clocks are also used at a considerable number of land stations. Both types of control clocks are equipped to close an electric contact at the beginning of each minute. This contact is in series with the windings of an electric solenoid or a similar device, which when the contact is closed advances the drum, carrying the other and larger electrical contacts one step at a time.

This multicontact drum, called a synchronizer or secondary clock, is also divided into minutes, or spaces corresponding to minutes, and makes one complete revolution in an hour. It is this drum that provides that the radio beacon signal shall be emitted for exactly one minute and be silent for two minutes. It is also feasible to select any other “on” and “off” arrangement so long as the changes occur at even-minute intervals. Incidentally, this multi-contact drum which is advanced at minute intervals by an accurate clock, provides a ready means of closing and opening other circuits in addition to those controlling the “on” and “off” minute periods, thus furnishing the means by which any radio beacon station can be made fully automatic.

For example, one contact can start a gasoline driven electric generator, another contact can place the transmitter in operation, while another controls the duration of the characteristic signal period, the operation for 15 minutes in each hour.

Although the control clocks are accurate and sturdy, it is necessary to provide for correction and adjustment against a standard time signal. An attempt to permanently fix the electrical contacting mechanism to the clock time train and depend on regulating the clock to correct for accumulated errors, was found to require too frequent adjustment of the clock.

Instead of this, the contactor itself in the clock is made adjustable, so that the instant of contact can be advanced or retarded manually as necessary to allow for accumulated clock error. This adjustment is made by a suitable device without opening the clock. This provides a ready means whereby the attendant at the radio beacon station can listen in on the other radio beacon stations in the synchronized group and correct at once for any errors. This is done twice a day. For this purpose one station in each group is taken as a master station, to which the clocks at the other stations are adjusted. The clock at the master station is adjusted twice a month from the standard time signals.

**Warning Device.**—Automatic operation of radio beacons is at present being provided in many locations.

In order to insure operation without the constant attendance of the keeper, a positive warning device has been developed whose function it is to notify the keeper in case of failure of any part of the radio-beacon system.

The function of the radio-beacon transmitter system is to induce an *r.f.* current in the antenna, and the warning device being actuated by the antenna current, automatically sounds a warning, in case the antenna current for some reason is being interrupted.

The device operated by sounding a gong or horn whenever the aforementioned antenna current (radio signals) stops for a longer period than two minutes, this being the normal silent period.

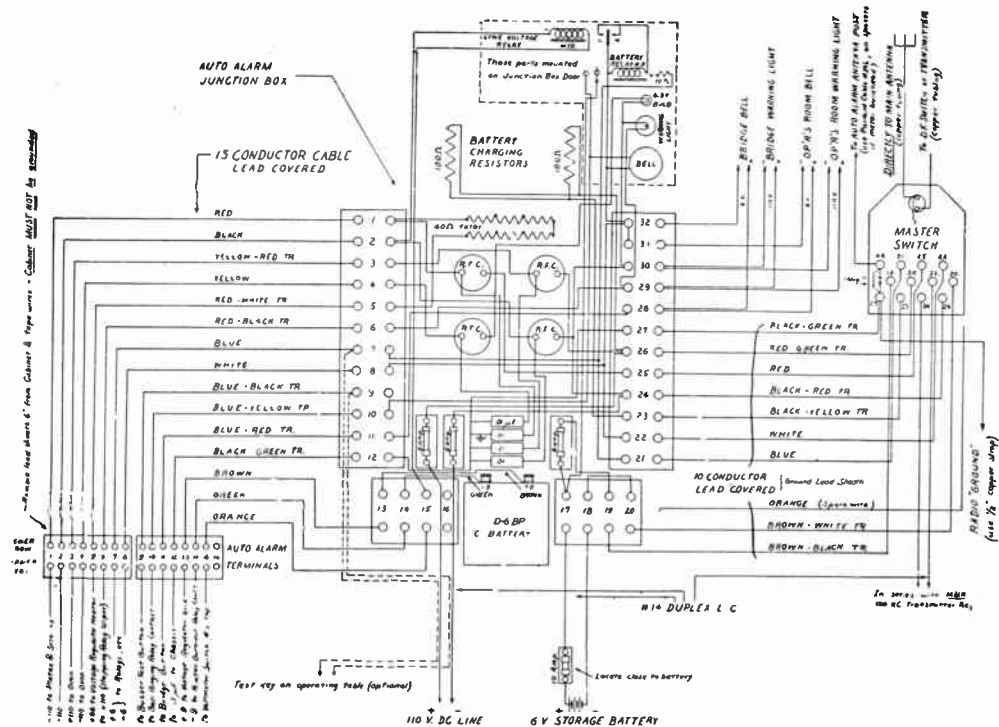

**FIG. 4—External Wiring Diagram of AR-8600 auto alarm unit, shown on page 521.**

## CHAPTER 26

# Automatic Radio Alarm

An automatic alarm is a device used to enable a ship in distress to summon aid at any time by radio from a nearby vessel, and especially during those periods when the radio operator on the nearby vessel might not be "on watch."

Special regulations governing this distress signal and the number of operators which their installation shall release are now in force.

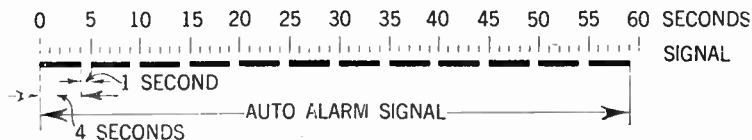

FIG. 1—Standard auto alarm signal.

The function of this distress signal is to actuate an automatic receiving device on the vessel in the vicinity of the ship in distress and by means of bells or other signal producing apparatus, call attention to the fact that a distress call is being transmitted.

This special distress signal only supplements and does not supersede the conventional SOS call, and is known as the *automatic alarm signal* and the special receiving apparatus is called the *auto alarm*.

**Auto Alarm Signal Characteristics.**—The auto alarm signal is transmitted by the ship in distress just prior to sending the normal SOS signal. This signal consists of a series of dashes and spaces, each dash having a duration of four seconds and each space between dashes a duration of one second. Twelve such dashes and spaces can be transmitted during one minute. (See fig. 1)

The auto alarm is designed to operate bells after a certain number of consecutive dashes and spaces are being correctly received.

**Foreign Practice as Compared with F.C.C. Requirements.**—Foreign practice sometimes require the arrangement of bells to ring when three consecutive dashes and spaces pass through the receiver, whereas the U. S. Federal Communication Commission (F.C.C.) requirements are based on ringing of the bells after four consecutive dashes and spaces are correctly received.

It is obvious that the four-dash cycle considerably minimizes the possibility of false alarm, since the chances are quite remote for accidental combination of signals to repeat themselves four times to imitate the alarm signal. In this connection it may be mentioned that the current designs of American auto alarms may be easily arranged to accept either the three or four dash cycle and in any case no International operating difficulties occur since the vessels in distress always send twelve or more dashes.

A single master switch to place the auto alarm in service is required which must be so arranged that power cannot be applied to the alarm circuits unless the main antenna is connected

to the alarm receiver and having an interlocking feature to prevent the ship transmitter from being keyed unless the auto alarm receiver is turned off.

**Basic Elements of the Automatic Radio Alarm.\***—The complete radio alarm consists of two main parts namely the radio receiver and the selector unit.

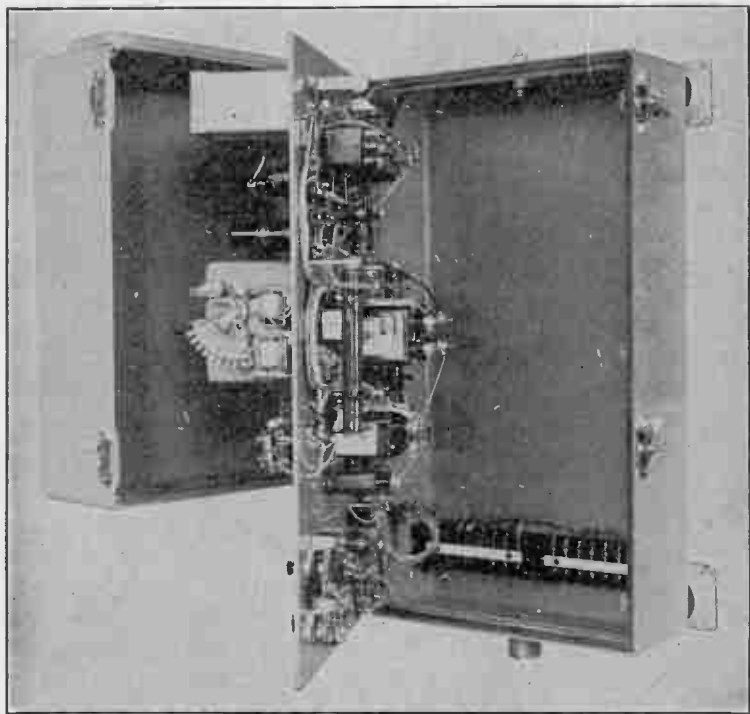

**FIG. 2—Type AR-8600 auto alarm with cover and panel open.**

\*An auto alarm designed by the Radio Marine Corp. of America and generally referred to as the Model AR-8600 is described on the following pages.



The radio receiver forming a part of the alarm must be designed to possess uniform sensitivity over a frequency range from 487.5 to 512.5 *k.c.* The normal distress frequency is 500 *k.c.* but provision must be made for the auto alarm receiver to accept signals outside this exact frequency, thereby permitting some variation in the adjustment of the radio transmitter on the vessel in distress.

The band width of the alarm receiver must also be fixed as an integral part of the design, and not be adjustable by the operator.

**Warning Apparatus.**—Since it is necessary that the auto alarm when connected in the circuit to operate unattended for several hours, some means must be devised to indicate when operation is not normal.

During abnormal atmospheric conditions for example, prolonged static of high level may tend to “hold over” some of the relays in the selector unit. Hence it is necessary to arrange for a warning light or its equivalent to indicate to the bridge that the radio operator is required to readjust the sensitivity control.

At other times vacuum tubes in the alarm may burn out, and when this occurs, a “no current” relay is utilized to energize warning bells located on the bridge. Failure of the source of energy which rings the bells is shown by a continuous burning of warning light placed alongside the bells, in a position where they must be observed.

After the radio signal passes through the receiver it controls the selector mechanism. To allow for reasonable variations in timing of the alarm signal the selector must be designed to accept dashes having a duration of 3.5 to 4.5 seconds and spaces of from 0.1 to 1.5 seconds. The question of operation through interfering signals in the 487.5 to 512.5 *k.c.* band as well as the possibility of false alarm must also be considered when determining the selector timing tolerances.

It is necessary also that the alarm function through a reasonable amount of interference on the same wave length as the distress signals. This interference may produce two effects on the

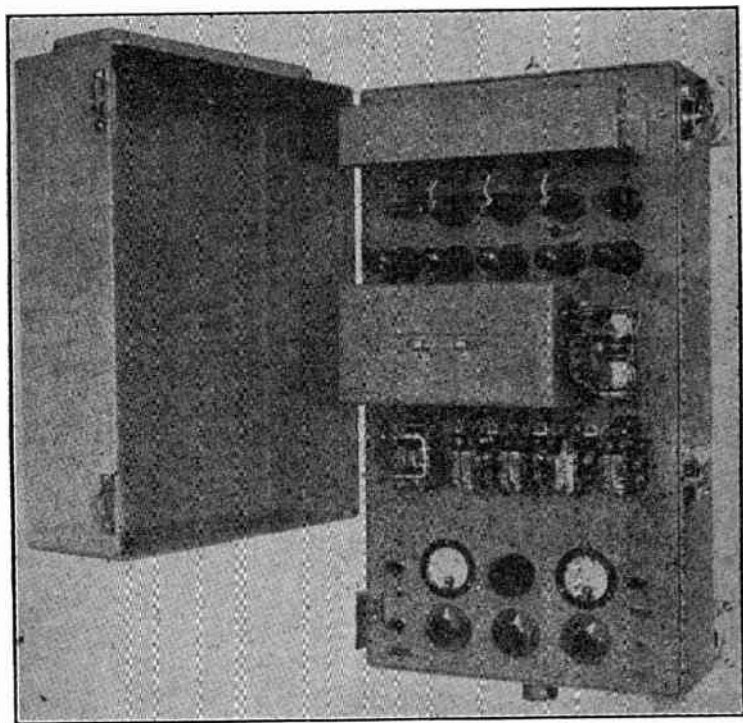

**FIG. 3—Type AR-8600 auto alarm with panel closed and cover open.**

selector, one of which is to prolong the normal four-second alarm signal in case the interference appears at just the correct time to add to the desired signal, the second effect of interference is to "fill in" the normal one second spaces.

If the spaces are completely filled in at the correct time the selector functions to reject the signals and it will do the same if interference unduly prolongs the desired dashes.

**False Alarms.**—The false alarm possibility is determined by a combination of three main factors, namely:

1. Accidental combinations of signals or noise equivalent to the alarm signal.
2. Timing tolerances of the selector.
3. The number of dashes and spaces which are selected to ring the bells.

**The Selector Unit.**—Under normal conditions, 16 hours per day or approximately 5,800 hours per year of operation is necessary, hence the selector unit to be most reliable should have as few moving parts as possible.

As previously mentioned the Standard automatic alarm signal is composed of 12 dashes and spaces, but the alarm bells are to be actuated after the receipt of four dashes with tolerances of 3.5 to 4.5 seconds and spaces with tolerances of 0.1 to 1.5 seconds.

Thus if the space between the first and second dashes is completely filled with interference, the alarm would be actuated at the end of the sixth dash. If interference prolongs the length of any dash beyond 4.5 seconds, or completely fills in the space between dashes, the mechanism used for selection would be restored to normal. Thus, of the 12 dashes comprising the signal, four consecutive dashes having a space at the beginning and ending of the group, as well as between dashes, must be received before the alarm bells will ring.

The obvious advantage of a 12 dash signal is that it permits more chances of the alarm being actuated under severe conditions of interference both from the standpoint of prolonging the dashes and filling in the spaces.

The aforementioned dash and space tolerances seemingly impose difficult terms for the selector response. For example, four dashes and the intervening three spaces might vary in total elapsed time between 14.3 and 22.5 seconds.

Obviously the selector must check individual dashes and spaces since any attempt to use the sum would result in the false alarm probability being greatly increased.

The schematic circuits of the receiver and selector units are shown in fig. 4.

Elapsed time of signal duration is measured by *RC* circuits connected in the grid circuit of individual selector tubes.

The principle utilized is the familiar one of current decay in a series *RC* circuit.

With reference to fig. 4 warning relay No. 8 being connected in series with the tube heaters across the ship's 110 volt line, will cause the alarm bell to ring when any one of the tube heaters burn out, or when voltage failure occurs.

Warning relay No. 9 is connected across the storage battery through a series resistor. Failure of the battery supply will allow relay No. 9 to de-energize and turn on the warning lights at each bell location point. Warning of power failure is therefore obtained except for simultaneous failure of both the 110 volt ship line supply and the storage battery.

The following is a summary of warnings indicating various conditions when using auto alarm apparatus heretofore described:

1. *Bells ringing* may be caused by:
  - a. Receipt of auto alarm signal.
  - b. Receipt of a false auto alarm signal caused by a fortuitous combination of static and keyed interference.
  - c. Loss of ship's line voltage.
  - d. Tube heater burn-out.

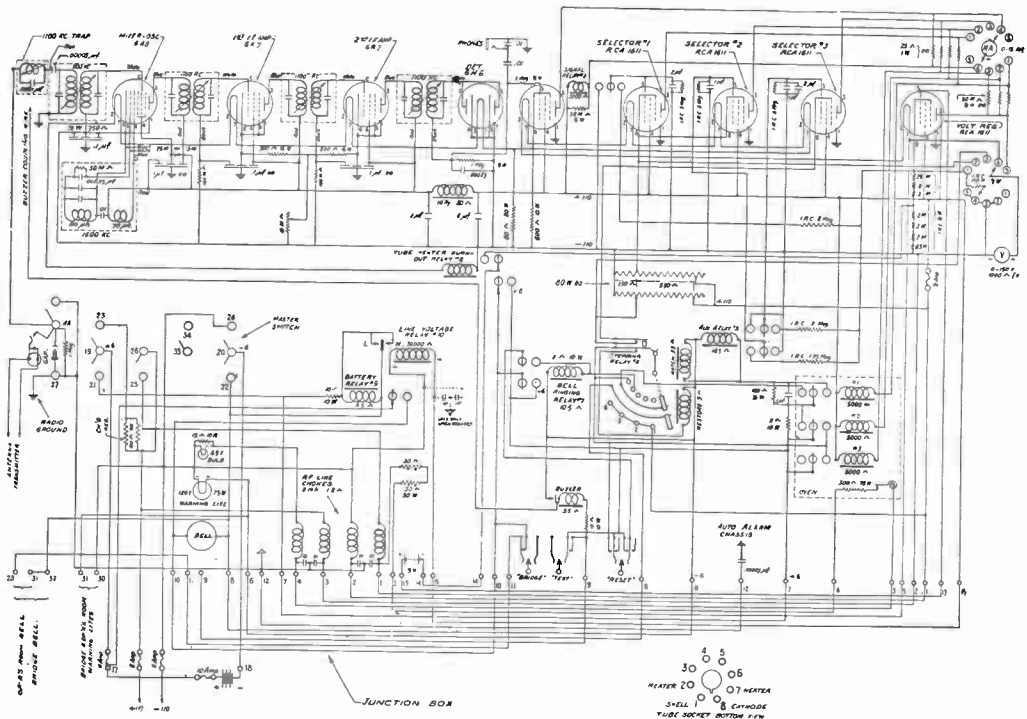

FIG. 4—Complete schematic circuit diagram of AR-8600 auto alarm unit.

2. *Warning lights burning continuously* are caused by:
- Receipt of a continuous signal from a transmitter whose key is being held down for a period considerably greater than 4.5 seconds.
  - Sensitivity control set too high for the prevailing noise level.
  - Loss of 6 volt battery supply.

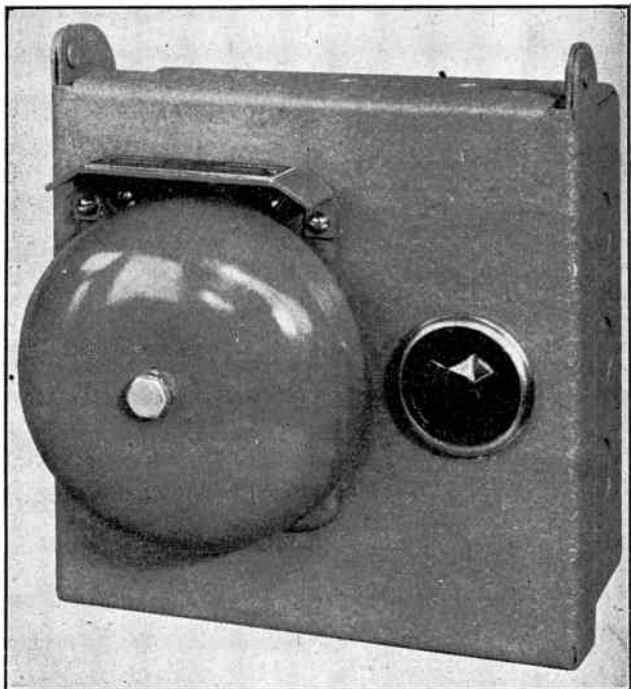
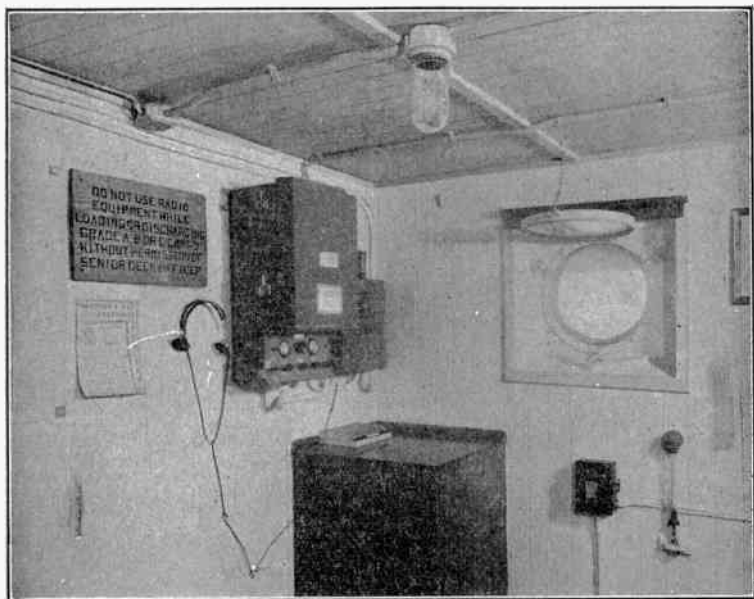

FIG. 5—View of warning light and bell located on bridge of ship.

3. *Warning lights burning intermittently* are caused by:
- Occasional long bursts of static.
  - Transmitter testing using dashes slightly longer than 3.5 seconds.
  - Heavy 500 *k.c.* interference caused by several telegraph transmitters transmitting at the same time.



**FIG. 6—**Typical shipboard installation showing location of auto alarm unit and associated equipment.

Warnings as under 3, are to be expected and indicate that the auto alarm is functioning correctly. Warnings as under 1 and 2, should be investigated as to their cause.

The following gives a summary as to procedure to be followed

in order to properly operate and maintain the auto alarm as given on the instructions accompanying the equipment.

#### ADJUSTMENTS TO BE MADE BY RADIO OPERATOR BEFORE GOING OFF WATCH

On the front cover of the auto alarm there will be found printed instructions which read as follows:

##### IMPORTANT INSTRUCTIONS

**"TO TEST ALARM:** Close master switch. Set sensitivity control to approximately 40. Using radio room clock transmit alarm signal with test push button on auto alarm. Bells will ring after four correct dashes and spaces. See instruction book for further details."

**"TO ADJUST SENSITIVITY CONTROL:** Set scale at 0. Set current switch at 4. Meter will read about 7.5 M.A. Turn sensitivity control to right until average meter reading due to noise, static, etc., is about 1 M.A. less than maximum value. Listen with phones. Incoming signals will cause signal relay to chatter slightly and meter reading to fall toward zero. If sensitivity is set too high for prevailing noise level, warning lights will indicate need for lower setting. Do not set sensitivity control lower than necessary as weak distress calls may not be received."

When testing the auto alarm with the test buzzer and push button the operator should observe that the milliammeter reading falls to zero or nearly so each time the test button is depressed. Close this button quickly several times and observe that the radio relay, whose armature click may be heard, follows the keying speed. Each time a correct four second dash and space are sent with the test buzzer, it may be observed that the stepping relay advances one position. If there is considerable radio interference or static during the time the alarm is being tested, it will be observed that the restore coil on the stepping relay is also energized, thereby preventing the stepping relay from advancing further. This condition will occur during testing whenever static or interference completely fills the spaces between dashes so that the normal auto alarm signal is distorted. The position of the sensitivity control, during the test of the auto alarm, may be used as an approximate check on the sensitivity of the receiver and the correct performance of all tubes. If it is found necessary to advance the sensitivity control beyond approximately 40 to 50 on the scale, it may be inferred that one of the tubes in the radio receiver part of the circuit is defective. After a little experience with the alarm, using the headphones plugged into the jack and by observing the operation of the radio relay on incoming signals, the operator may reach an approximate determination as to whether or not the receiver sensitivity is normal. In other words on the average shipboard antenna it should not be necessary to advance the sensitivity control to the extreme right in order to make the radio relay operate with the average incoming signal.

##### SENSITIVITY CONTROL ADJUSTMENT

A clear understanding of the results to be expected from various settings of the sensitivity control is necessary in order to adjust this control to the optimum or most favorable position. For example if the sensitivity control is turned to the extreme right (100 on the dial) or nearly so, it may be found that the average noise level and static will cause the radio relay to hold over for long periods of time, or to chatter or vibrate steadily. When this occurs the adjustment is not a favorable one, for not only will the warning light be illuminated frequently whenever static or noise persists for 3.5 seconds or more, but also a real alarm signal will be more apt to have its dashes prolonged and its spaces filled in, with such an adjustment. On the other hand if the sensitivity control is adjusted too far to the left, that is toward zero on the scale, then only very strong signals will operate the auto alarm, and a distress call from a distant ship might be missed. The optimum adjustment will be found to be that which gives a reading on the milliammeter (with no incoming signals) which is approximately one milliamperes *less than* the reading



obtained when the volume control is at zero. With such an optimum adjustment the radio relay may close occasionally from short bursts of static or from ordinary code signals. The operator should keep in mind that if the sensitivity control is set too high the radio relay will vibrate constantly, which is an undesirable adjustment. The officers on the bridge will have instructions to summon the radio operator whenever the warning light on the bridge is illuminated for periods of five minutes or more. When the sensitivity is set at 100 or maximum, a signal strength of approximately 200 microvolts will operate the auto alarm. At a dial setting of 50 (midscale) a signal of approximately 1000 microvolts is required. At 0 setting of the sensitivity control a signal strength of 20,000 microvolts is required.

#### FAULTS WHICH WILL CAUSE SOUNDING OF THE AUDIBLE ALARM

1—False alarm. Accidental combination of static or other interference may occasionally cause the stepping relay to advance to its fourth position, which will lock in the bell ringing relay and cause the bells to ring continuously. Bells will stop when reset push button is depressed on auto alarm panel.

2—Filament burnout. If any one of the vacuum tube filaments (heaters) should burn out, or if one of the 30 ohm series filament resistors in the junction box should burn out, the *filament burnout relay* on the auto alarm panel will have its coil de-energized, which will close the back contacts, and cause the bells to ring. Bells can only be stopped from ringing by replacing the defective tube, or resistor or by opening the master switch.

3—Low or high line supply voltage. If the 110 volt shipboard supply is reduced below normal or increased above 120 volts, the *line voltage relay* in the junction box will operate, which will short out the coil on the six volt relay, causing the bells to ring. The bells will continue ringing until line voltage is restored to normal or until master switch is opened.

4—If the six volt battery approaches discharge and its voltage falls below about 4.5 volts, the back contacts will close on the *six volt relay*, causing the bells to ring continuously until a suitably charged battery is placed in circuit or until the master switch is opened.

5—If the one-half ampere fuse on the auto alarm panel or any of the fuses in the junction box should be blown, the bells will ring continuously until the fault is corrected or unless the master switch is opened. The one-half ampere fuse will blow in case of tube shorts or condenser breakdown in the receiver-selector unit.

#### OPERATION OF WARNING LIGHTS

The purpose of the warning lights as explained previously is to provide a visual indication whenever prolonged static or other interference holds the radio relay open. After 3.5 seconds the stepping relay will advance one position and remain there as long as the interference is continuous. An auxiliary set of contacts on the stepping relay will close a circuit to the three warning lights to indicate this condition. The remedy is to readjust the sensitivity control to a slightly lower setting so that the stepping relay drops back to its normal or zero position.

#### PROCEDURE TO BE FOLLOWED WHEN ALARM BELLS RING

1—If alarm bells ring momentarily, then stop ringing, and repeat this cycle frequently, the difficulty is most likely due to low, high or variable line voltage. Go to the radio room, open the door of the junction box and observe the line voltage relay contacts. Also measure the line voltage by placing the voltmeter switch in position five on the auto alarm panel. If the voltage is much below 100 volts, it will be observed that the line voltage relay "left" contact is closed, causing the bells to ring. Higher than normal line voltage will cause the "right" contact to make on the relay, also ringing the bells. This condition of low, variable, or high line voltage should be brought to the attention of the proper ship's officer.

2—Alarm bells ringing continuously. Go to the radio room and depress the reset button on the auto alarm. If this stops the bells from ringing a pair of phones should be immediately plugged into the phone jack to determine if an alarm signal has been transmitted by a vessel in

distress. If the bells do not stop ringing when the reset button is depressed the fault may be low line voltage, high line voltage, low six volt battery supply, filament burnout, or blown fuses. Filament burnout may be immediately determined by placing the voltmeter switch in position four, where a reading of 100 volts or more will be obtained instead of the normal reading of approximately 60 volts. A blown one-half ampere plate fuse or 110 volt line fuse may be quickly determined by observing if any reading is obtained on the voltmeter with the switch in position five. No reading will be obtained if these fuses are blown. If the six volt battery is low this should be checked with the three scale voltmeter carried in the radio room as a part of standard safety of life at sea equipment.

3—When troubles which cause the bells to ring continuously cannot be located quickly, it is desirable to disconnect the bridge bell and operator's bell temporarily to avoid undue annoyance to the ship's personnel. This may be done by removing the lead (blue with red tracer) which will be found on terminal 28 on the vertical right hand terminal block of the junction box. After the trouble has been corrected the operator should make certain that the lead to terminal 28 is firmly reconnected, and he should make a test with the bridge and the operator's room to insure that the bells are again functioning normally.

#### LOG ENTRIES

The following instructions with regard to log entries should be carefully observed as they are required by the Federal Communications Commission.

1—While the ship is at sea the auto alarm shall be tested by means of the testing device supplied, at least once every 24 hours, the timing of the dashes to be made by reference to the sweep seconds hand of the station's clock. Bridge bell and warning light and operator's room bell and light must show correct operation when this test is made. A statement that the foregoing has been fulfilled must be inserted in the ship's official deck log and the radio log daily.

2—If the warning light is illuminated for a continuous period of five minutes or more, the operator shall record in the radio log the time when he was called by the bridge, the time when he goes to the radio room to investigate the difficulty, the reason for the warning lights burning, and a statement as to the adjustments found necessary to restore normal operation.

3—If the bells ring, the operator should record in the radio log the time of the occurrence and the time when he arrives at the radio room to investigate the reason for the bells ringing. A record should also be made in the log to explain what caused the bells to ring, such as actual alarm, false alarm, filament burnout, low line voltage, low battery voltage, blown fuses, etc.

4—Vacuum tube and battery information to be entered in log. Each vacuum tube initially supplied in the auto alarm is dated at the time of installation. If any tube becomes defective the operator should remove the tube and make an entry in the log to indicate the date the tube was removed and replaced and the tube socket from which it was taken. The defective tube should not be destroyed, but should be returned to the radio company responsible for the maintenance of the auto alarm. The new tube which is used to replace the defective tube should be dated by the operator. This may be done by scratching the date on the metal shell of the tube with the point of a knife or other sharp tool.

The 9 volt "C" battery (type D6BP) mounted in the junction box is provided with a label to record the date when installed, and also the date when it should be replaced. If for any reason the operator finds it necessary to replace the "C" battery with his spare "C" battery, he should enter this fact in the log, recording when the old "C" battery was taken out, when the new one was replaced and on the label of the new battery he should write the date when installed. The "C" battery should be replaced when it falls below 8.5 volts.

#### GENERAL MAINTENANCE AND REPAIRS AT SEA

If normal operation of the auto alarm cannot be obtained, the radio operator should proceed as follows:

**IMPORTANT:** Do not remove relay cover or oven cover on the auto alarm panel or work with tools around any of the parts unless the master switch is in the "off" position.

1—Check with three range radio room voltmeter to determine if the 110 volt line voltage and six volt battery power exists across the appropriate input terminals in the junction box. If correct readings are obtained make similar measurements across the proper terminals of the receiver-selector unit. Refer to T-351.

2—Make certain that all leads on the junction box terminals from number 1 to 32 inclusive are tight and making good connections.

3—Relay contacts should be checked and cleaned, if necessary, to insure proper contact. To clean contacts use the special burnishing tool which is furnished, taking care not to remove too much contact material with the burnisher.

4—If defective tubes are suspected, they should be replaced *one at a time*, starting with the 6-A-8 tube, always returning good tubes to the same socket from which they were removed. This will avoid confusion in locating a defective tube. Type 1611 tubes may be checked for emission by placing them successively in the second socket from the left in the lower row of tubes. This is the radio relay tube socket and the plate current of this tube may be read by the milliammeter with the switch in position number four. Normal tubes with 100 volts line should show a plate current with no incoming signal of approximately 7 milliamperes or more. When checking tubes all tube sockets must be filled, otherwise bells will ring.

5—Each selector circuit may be checked by sending a test signal through the auto alarm and successively placing the "current" switch in position 1, 2 and 3. In position 1 after a long dash a current of approximately 8 to 10 milliamperes will be obtained. In position 2 after a long dash a similar value will be obtained. To check selector number 3 place the switch in position 3, send a 4 second dash with the test buzzer and then observe after about 5 seconds that the meter reads momentarily a value of approximately 6 milliamperes. The third selector tube shuts off its own plate current after it checks a space and for this reason only a momentary meter reading will be obtained.

6—It is possible to check various voltages in the junction box and on the various component units back of the auto alarm panel by referring to diagram T-351, and by using the three range voltmeter which is carried in the radio room. Such a voltage analysis will enable the operator to determine if open circuits or poor connections exist in various parts of the circuits.

7—The switch contacts on the master switch should be checked occasionally to insure that they are making good connection, removing any corrosion or oxidation which may have taken place.

8—Normal operation of the oven heater will be indicated by intermittent operation of the small pilot light mounted on the back of the junction box cover. This pilot light is provided to enable the radio operator to determine that the oven circuit is operating normally whether or not the auto alarm is on watch.

9—If for any reason the auto alarm 6 volt battery becomes discharged the operator should substitute one of the radio room 6 volt storage batteries temporarily. The auto alarm battery should then be placed on charge from the standard radio room "A" battery charger. The operator should determine why the auto alarm battery became discharged. The auto alarm master switch is arranged to place the 6 volt battery on charge at a rate of approximately 2 amperes whenever the master switch is in the "off" position. This charging rate is sufficient to keep the alarm battery fully charged if the alarm is "on watch" for a period of 18 hours daily. In other words 6 hours charging in each 24 hours will keep the battery in good condition. If either or both battery charging resistors at the top of the junction box should become defective, standard 110 volt 100 watt lamps may be used as a substitute.

10—When replacing the 9 volt "C" battery, make certain that the green lead connects to the negative terminal and the brown lead to the positive terminal. No current is taken by the "C" battery, therefore if early "C" battery replacement is necessary look for shorts or leakage. A voltmeter connected in series with one of the "C" battery leads should show no reading for normal operation.

11—If plate current is obtained through each selector relay as explained under "5" above and the stepping relay does not operate, inspect the contacts on the selector relay in the oven.

Remove oven cover screws and carefully withdraw the oven cover *straight out* to prevent breakage of the thermometer. Relay contacts may now be examined and cleaned if necessary.

12—Note that the 6 volt storage battery has two fuses in the positive side of the circuit, a 6 ampere glass fuse in the junction box and also an external 10 ampere fuse installed near the battery. Short circuits in the 6 volt circuits in the auto alarm or junction box will normally cause the 6 ampere glass fuse to blow. Short circuits in the wiring to the warning bells will cause blowing of the external 10 ampere fuse. This arrangement allows the warning bells to ring when the 6 ampere fuse is blown. Both fuses should be inspected in case of trouble. Always use the specified ratings when replacing fuses.

13—The line voltage relay will also cause the bells to ring if the polarity of the 110 volt ship-board line is reversed. The voltmeter on the receiver-selector unit in switch position 5 will also indicate this condition by reading in the reverse direction.

#### TYPICAL READINGS OF CURRENT AND VOLTAGE FOR NORMAL AUTO ALARM OPERATION

The following readings are based on an average line voltage of 100 volts. Higher line voltages will give slightly higher readings.

##### CURRENT SWITCH

Position 1—First selector relay closes at approximately 4 M.A.

Position 2—Second selector relay closes at approximately 6.5 M.A.

Position 3—Third selector relay closes momentarily at approximately 6.5 M.A.

Position 4—Signal relay plate current is 7.5 M.A. with no incoming signal. With signals, lower values, down to zero, will be obtained.

Position 5—Not used.

##### VOLTMETER SWITCH

Position 1—Grid charging voltage 52 volts.

Position 2—Grid bias on selector tubes 1 and 2, 29 volts.

Position 3—Grid bias on third selector tube, 29 volts.

Position 4—Heater voltage 60 volts.

Position 5—Reads ship's line voltage.

When going off watch the operator should always leave the "current" switch in position 1 and the "voltage" switch in position 5. If the current switch is left in position 4 the milliammeter will follow all incoming signals, causing unnecessary wear and tear on the instrument.

#### TESTING AUTO ALARM UNDER SEVERE STATIC CONDITIONS

Occasionally when static is very severe the sensitivity control cannot be advanced far enough to permit the test buzzer to actuate the receiver without causing the radio relay to "block" from the static. To test the alarm under these conditions place a temporary short circuit between the AA terminal and ground terminal on the master switch. After the test the short circuit should be removed and the sensitivity control adjusted to optimum for the prevailing noise level.

#### UNDERSTANDING SELECTOR ACTION BY OBSERVING RELAYS

1—Transmit "V"s or other code signals with test buzzer. Radio relay will follow keying and milliammeter in position 4 will show a lower reading each time buzzer is operated. No other relays will operate.

2—Transmit one four second dash. Radio relay will operate instantly and after 3.5 seconds number 1 selector relay in oven will close, auxiliary relay will close, "notch" coil will be energized and stepping relay will advance one position. This checks if dash is long enough.

3—Transmit one dash of 5 seconds or more. Same action as under "2" above will take place and in addition number two selector relay in oven will close and "restore" coil on stepping relay will be energized. When long dash is broken stepping relay will return to zero or normal position. This checks overlong dashes.

4—Transmit one four second dash to advance stepping relay one position and then break this dash. After approximately 5 seconds "restore" coil will click and stepping relay will return to zero. This checks spaces.

5—Transmit four correct 4 second dashes separated by 1 second spaces and watch the stepping relay move up with each dash, finally causing the bell ringing relay to lock in when the fourth dash is broken. Note that each dash, including the fourth dash must be followed by a space to lock in the bell ringing relay. If the fourth dash (or any other dash) is too long the restore coil is energized on the stepping relay

#### PREVENTING OVERCHARGE OF 6 VOLT BATTERY

When the ship is in port or drydock or if the auto alarm is in use for only a few hours each day, the 6 volt storage battery may become overcharged. To avoid this use one charging resistor if the alarm is in use only a short time daily. In port or in drydock remove both charging resistors by unscrewing from sockets.

## CHAPTER 27

# Short Wave Receiver Principles

As short waves permit the reception at much greater distances than that with longer waves, regularly employed by commercial broadcasting stations, it has become the practice to transmit important programs simultaneously on both long and short waves.

Generally a radio program received at a frequency at or above 1,500 *k.c.* is classed as *short wave reception*, and the simultaneous transmitting and receiving of radio waves at or above 1,500 *k.c.* is classed as *short wave communication*.

Short wave communication at present is carried on at wavelengths down to 5 meters or 60 megacycles (60,000,000 cycles per second) although it is now becoming apparent that in the near future the *ultra short wave* range of from 5 down to 1 meter, 60 to 300 megacycles will be considered as familiar and useful territory.

However, as the radio tube design is so closely associated with the utilization of *ultra high frequencies* it is apparent that the exploration of the frequency band of between 60 to 300 megacycles will have to wait for the research laboratories, who in this case must lead the way for successful operation.

The problems introduced in the design of equipment by the attempt to raise the limitations of high frequencies of the order mentioned above can best be appreciated by speaking in terms of wave-lengths.

The wave-length determines directly in the same units the approximate maximum physical size which the equipment to produce that frequency may attain. This results from the fact that the greatest speed at which energy may be sent along an electrical circuit is the same as that of the electro-magnetic energy in space—the velocity of light or approximately 300,000,000 meters\* per second.

In practical circuits, however, due to the fact that inductance and capacitance lowers the speed of electrical energy, this speed is never reached.

From this it follows that the circuits then must be smaller in extent than the wave-lengths and the tubes themselves will be very small in physical size.

**Wave Length and Frequency.**—Since as stated the electro-magnetic energy and flux lines move with the velocity of light of approximately 186,300 miles or 300,000,000 meters per second, the distance between two successive maxima of electric strain directed in the same direction, or as usually expressed,

$$\text{Wave length (in meters)} = \frac{300,000,000}{\text{Frequency (in cycles per second)}} \quad (1)$$

$$\text{or Frequency (in cycles per second)} = \frac{300,000,000}{\text{Wave length (in meters)}} \quad (2)$$

From the formula it is apparent that the shorter the wave length the higher is the frequency.

---

\*A unit of length in the metric system: It represents approx. a ten-millionth part of a quadrant of the earth's meridian measured from the equator to the pole through Paris; one hundred centimeters or 39.37 inches.

For example, if the wave length be one meter (which is not at present a practical wave length) the corresponding frequency is 300,000,000 cycles, 300,000 kilo-cycles (*k.c.*) or 300 megacycles per second.

In general usage, however, "per second" is usually omitted, it being generally understood that so many kilocycles (*k.c.*) or so many megacycles always include the prefix per second.

**Example.**—*What are the frequencies for wave lengths of 5, 25 and 100 meters?*

**Solution.**—Substituting 5 in formula (2)

$$\text{Frequency} = \frac{300,000,000}{5} = 60,000,000 \text{ cycles}$$

60,000 kilocycles or 60 megacycles.

Similarly substituting 25 and 100 in formula (2), 12 and 3 megacycles respectively are obtained.

In order to facilitate the transformation of wave length in meters to frequency in kilocycles or vice versa, a table supplied by the courtesy of the Bureau of Standards is found on pages 539 to 542.

This table is based on the factor 299,820 meaning that the value of the aforementioned speed of light instead of being 300,000 kilometers per second is more closely 299,820 kilometers per second.

The odd and even columns in this table are related to each other; that is the first column is related to the second, the third column to the fourth and so on. Fundamentally the numbers in the odd columns first, third, fifth, etc. refer to wave-lengths in meters. These columns are continuous numerically from 10 to 10,000 meters.

It is obvious from the previous discussion that the frequency corresponding to 10 meters is equivalent to a frequency of



29,982 kilocycles and that the frequency corresponding to 10,000 meters is equivalent to 29.982 kilocycles.

The table is also reversible. The designations for frequency in kilocycles (*kc*) and wave length (*m*) are placed at the top of each column.

From this table it is also possible to determine frequencies and wave-lengths above or below the values included. Thus the frequency corresponding to 5 meters may be determined by selecting the number 50 in the first column and reading it as 5. The answer is 59,960 kilocycles or 59.96 megacycles. In the same manner for 2.5 meters one would select the number 250 in the first column and read it as 2.5. The answer in this case is 119,900 *k.c.* or 119.9 megacycles.

In all cases it is merely a matter of shifting the decimal point to its correct place.

**High Frequency Reception.**—Due to inductance and capacitance effects between coils and wires, the requirements of receivers for short waves are different, from that of ordinary receivers. This is on account of the high frequencies associated with short waves.

In a short wave receiver all wires from grids and plates of tubes should be kept short and well separated. It has been found to be good practice to utilize buss bars in the wiring, as well as metal panels, well grounded—this in order to mitigate the ever present hand-capacity when tuning.

Most short wave set designers do not fully appreciate the fact that the entire success of their receivers depend upon how smoothly and easily they can control regenerative action of the detector tube.

Hence the control of regeneration in the detector stage is an important factor for successful short wave reception.

Relations of natural wavelength in meters (*m*) to frequency in kilocycles (*k.c.*). (Tables are reversible.)—(continued)

<i>m.</i>	<i>k.c.</i>	<i>m.</i>	<i>k.c.</i>	<i>m.</i>	<i>k.c.</i>	<i>m.</i>	<i>k.c.</i>	<i>m.</i>	<i>k.c.</i>
10	29,982	510	587.9	1,010	296.9	1,510	198.6	2,010	149.2
20	14,991	520	576.6	1,020	293.9	1,520	197.2	2,020	148.4
30	9,994	530	565.7	1,030	291.1	1,530	196.0	2,030	147.7
40	7,496	540	555.2	1,040	288.3	1,540	194.7	2,040	147.0
50	5,996	550	545.1	1,050	285.5	1,550	193.4	2,050	146.3
60	4,997	560	535.4	1,060	282.8	1,560	192.2	2,060	145.5
70	4,283	570	526.0	1,070	280.2	1,570	191.0	2,070	144.8
80	3,748	580	516.9	1,080	277.6	1,580	189.8	2,080	144.1
90	3,331	590	508.2	1,090	275.1	1,590	188.6	2,090	143.5
100	2,998	600	499.7	1,100	272.6	1,600	187.4	2,100	142.8
110	2,726	610	491.5	1,110	270.1	1,610	186.2	2,110	142.1
120	2,499	620	483.6	1,120	267.7	1,620	185.1	2,120	141.4
130	2,306	630	475.9	1,130	265.3	1,630	183.9	2,130	140.8
140	2,142	640	468.5	1,140	263.0	1,640	182.8	2,140	140.1
150	1,999	650	461.3	1,150	260.7	1,650	181.7	2,150	139.5
160	1,874	660	454.3	1,160	258.5	1,660	180.6	2,160	138.8
170	1,764	670	447.5	1,170	256.3	1,670	179.5	2,170	138.1
180	1,666	680	440.9	1,180	254.1	1,680	178.5	2,180	137.5
190	1,578	690	434.5	1,190	252.0	1,690	177.4	2,190	136.9
200	1,499	700	428.3	1,200	249.9	1,700	176.4	2,200	136.3
210	1,428	710	422.3	1,210	247.8	1,710	175.3	2,210	135.7
220	1,363	720	416.4	1,220	245.8	1,720	174.3	2,220	135.1
230	1,304	730	410.7	1,230	243.8	1,730	173.3	2,230	134.4
240	1,249	740	405.2	1,240	241.8	1,740	172.3	2,240	133.8
250	1,199	750	399.8	1,250	239.9	1,750	171.3	2,250	133.3
260	1,153	760	394.5	1,260	238.0	1,760	170.4	2,260	132.7
270	1,110	770	389.4	1,270	236.1	1,770	169.4	2,270	132.1
280	1,071	780	384.4	1,280	234.2	1,780	168.4	2,280	131.5
290	1,034	790	379.5	1,290	232.4	1,790	167.5	2,290	130.9
300	999.4	800	374.8	1,300	230.6	1,800	166.6	2,300	130.4
310	967.2	810	370.2	1,310	228.9	1,810	165.6	2,310	129.8
320	936.9	820	365.6	1,320	227.1	1,820	164.7	2,320	129.2
330	908.6	830	361.2	1,330	225.4	1,830	163.8	2,330	128.7
340	881.8	840	356.9	1,340	223.7	1,840	162.9	2,340	128.1
350	856.6	850	352.7	1,350	222.1	1,850	162.1	2,350	127.6
360	832.8	860	348.6	1,360	220.4	1,860	161.2	2,360	127.0
370	810.3	870	344.6	1,370	218.8	1,870	160.3	2,370	126.5
380	789.0	880	340.7	1,380	217.3	1,880	159.5	2,380	126.0
390	768.8	890	336.9	1,390	215.7	1,890	158.6	2,390	125.4
400	749.6	900	333.1	1,400	214.2	1,900	157.8	2,400	124.9
410	731.3	910	329.5	1,410	212.6	1,910	157.0	2,410	124.4
420	713.9	920	325.9	1,420	211.1	1,920	156.2	2,420	123.9
430	697.3	930	322.4	1,430	209.7	1,930	155.3	2,430	123.4
440	681.4	940	319.0	1,440	208.2	1,940	154.5	2,440	122.9
450	666.3	950	315.6	1,450	206.8	1,950	153.8	2,450	122.4
460	651.8	960	312.3	1,460	205.4	1,960	153.0	2,460	121.9
470	637.9	970	309.1	1,470	204.0	1,970	152.2	2,470	121.4
480	624.6	980	303.9	1,480	202.6	1,980	151.4	2,480	120.9
490	611.9	990	302.8	1,490	201.2	1,990	150.7	2,490	120.4
500	599.6	1,000	299.8	1,500	199.9	2,000	149.9	2,500	119.9

Relations of natural wavelength in meters (*m*) to frequency in kilocycles (*k.c.*). (Tables are reversible.)—(continued)

<i>m.</i>	<i>kc.</i>	<i>m.</i>	<i>kc.</i>	<i>m.</i>	<i>kc.</i>	<i>m.</i>	<i>kc.</i>	<i>m.</i>	<i>kc.</i>
2,510	119.5	3,010	99.61	3,510	85.42	4,010	74.77	4,510	66.48
2,520	119.0	3,020	99.28	3,520	85.18	4,020	74.58	4,520	66.33
2,530	118.5	3,030	98.95	3,530	84.94	4,030	74.40	4,530	66.19
2,540	118.0	3,040	98.62	3,540	84.70	4,040	74.21	4,540	66.04
2,550	117.6	3,050	98.30	3,550	94.46	4,050	74.03	4,550	65.89
2,560	117.1	3,060	97.98	3,560	84.22	4,060	73.85	4,560	65.75
2,570	116.7	3,070	97.66	3,570	83.98	4,070	73.67	4,570	65.61
2,580	116.2	3,080	97.34	3,580	83.75	4,080	73.49	4,580	65.46
2,590	115.8	3,090	97.03	3,590	83.52	4,090	73.31	4,590	65.32
2,600	115.3	3,100	96.72	3,600	83.28	4,100	73.13	4,600	65.18
2,610	114.9	3,110	96.41	3,610	83.05	4,110	72.95	4,610	65.04
2,620	114.4	3,120	96.10	3,620	82.82	4,120	72.77	4,620	64.90
2,630	114.0	3,130	95.79	3,630	82.60	4,130	72.60	4,630	64.76
2,640	113.6	3,140	95.48	3,640	82.37	4,140	72.42	4,640	64.62
2,650	113.1	3,150	95.18	3,650	82.14	4,150	72.25	4,650	64.48
2,660	112.7	3,160	94.88	3,660	81.92	4,160	72.07	4,660	64.34
2,670	112.3	3,170	94.58	3,670	81.70	4,170	71.90	4,670	64.20
2,680	111.9	3,180	94.28	3,680	81.47	4,180	71.73	4,680	64.06
2,690	111.5	3,190	93.99	3,690	81.25	4,190	71.56	4,690	63.93
2,700	111.0	3,200	93.69	3,700	81.03	4,200	71.39	4,700	63.79
2,710	110.6	3,210	93.40	3,710	80.81	4,210	71.22	4,710	63.66
2,720	110.2	3,220	93.11	3,720	80.60	4,220	71.05	4,720	63.52
2,730	109.8	3,230	92.82	3,730	80.38	4,230	70.88	4,730	63.39
2,740	109.4	3,240	92.54	3,740	80.17	4,240	70.71	4,740	63.25
2,750	109.0	3,250	92.25	3,750	79.95	4,250	70.55	4,750	63.12
2,760	108.6	3,260	91.97	3,760	79.74	4,260	70.38	4,760	62.99
2,770	108.2	3,270	91.69	3,770	79.53	4,270	70.22	4,770	62.86
2,780	107.8	3,280	91.41	3,780	79.32	4,280	70.05	4,780	62.72
2,790	107.5	3,290	91.13	3,790	79.11	4,290	69.89	4,790	62.59
2,800	107.1	3,300	90.86	3,800	78.90	4,300	69.73	4,800	62.46
2,810	106.7	3,310	90.58	3,810	78.69	4,310	69.56	4,810	62.33
2,820	106.3	3,320	90.31	3,820	78.49	4,320	69.40	4,820	62.20
2,830	105.9	3,330	90.04	3,830	78.28	4,330	69.24	4,830	62.07
2,840	105.6	3,340	89.77	3,840	78.08	4,340	69.08	4,840	61.95
2,850	105.2	3,350	89.50	3,850	77.88	4,350	68.92	4,850	61.82
2,860	104.8	3,360	89.23	3,860	77.67	4,360	68.77	4,860	61.69
2,870	104.5	3,370	88.97	3,870	77.47	4,370	68.61	4,870	61.56
2,880	104.1	3,380	88.70	3,880	77.27	4,380	68.45	4,880	61.44
2,890	103.7	3,390	88.44	3,890	77.07	4,390	68.30	4,890	61.31
2,900	103.4	3,400	88.18	3,900	76.88	4,400	68.14	4,900	61.19
2,910	103.0	3,410	87.92	3,910	76.68	4,410	67.99	4,910	61.06
2,920	102.7	3,420	87.67	3,920	76.48	4,420	67.83	4,920	60.94
2,930	102.3	3,430	87.41	3,930	76.29	4,430	67.68	4,930	60.82
2,940	102.0	3,440	87.16	3,940	76.10	4,440	67.53	4,940	60.69
2,950	101.6	3,450	86.90	3,950	75.90	4,450	67.38	4,950	60.57
2,960	101.3	3,460	86.65	3,960	75.71	4,460	67.22	4,960	60.45
2,970	100.9	3,470	86.40	3,970	75.52	4,470	67.07	4,970	60.33
2,980	100.6	3,480	86.16	3,980	75.33	4,480	66.92	4,980	60.20
2,990	100.3	3,490	85.91	3,990	75.14	4,490	66.78	4,990	60.08
3,000	99.94	3,500	85.66	4,000	74.96	4,500	66.63	5,000	59.96

Relations of natural wavelength in meters (*m*) to frequency in kilocycles (*k.c.*). (Tables are reversible.)—(continued)

<i>m.</i>	<i>kc.</i>	<i>m.</i>	<i>kc.</i>	<i>m.</i>	<i>kc.</i>	<i>m.</i>	<i>kc.</i>	<i>m.</i>	<i>kc.</i>
5,010	59.84	5,510	54.41	6,010	49.89	6,510	46.06	7,010	42.77
5,020	59.73	5,520	54.32	6,020	49.80	6,520	45.98	7,020	42.71
5,030	59.61	5,530	54.22	6,030	49.72	6,530	45.91	7,030	42.65
5,040	59.49	5,540	54.12	6,050	49.64	6,540	45.84	7,040	42.59
5,050	59.37	5,550	54.02	6,050	49.56	6,550	45.77	7,050	42.53
5,060	59.25	5,560	53.92	6,060	49.48	6,560	45.70	7,060	42.47
5,070	59.13	5,570	53.83	6,070	49.39	6,570	45.63	7,070	42.41
5,080	59.02	5,580	53.73	6,080	49.31	6,580	45.57	7,080	42.35
5,090	58.90	5,590	53.64	6,090	49.23	6,590	45.50	7,090	42.29
5,100	58.79	5,600	53.54	6,100	49.15	6,600	45.43	7,100	42.23
5,110	58.67	5,610	53.44	6,110	49.07	6,610	45.36	7,110	42.17
5,120	58.56	5,620	53.35	6,120	48.99	6,620	45.29	7,120	42.11
5,130	58.44	5,630	53.25	6,130	48.91	6,630	45.22	7,130	42.05
5,140	58.33	5,640	53.16	6,140	48.83	6,640	45.15	7,140	41.99
5,150	58.22	5,650	53.07	6,150	48.75	6,650	45.09	7,150	41.93
5,160	58.10	5,660	52.97	6,160	48.67	6,660	45.02	7,160	41.87
5,170	57.99	5,670	52.88	6,170	48.59	6,670	44.95	7,170	41.82
5,180	57.88	5,680	52.79	6,180	48.51	6,680	44.88	7,180	41.76
5,190	57.77	5,690	52.69	6,190	48.44	6,690	44.82	7,190	41.70
5,200	57.66	5,700	52.60	6,200	48.36	6,700	44.75	7,200	41.64
5,210	57.55	5,710	52.51	6,210	48.28	6,710	44.68	7,210	41.58
5,220	57.44	5,720	52.42	6,220	48.20	6,720	44.62	7,220	41.53
5,230	57.33	5,730	52.32	6,230	48.13	6,730	44.55	7,230	41.47
5,240	57.22	5,740	52.23	6,240	48.05	6,740	44.48	7,240	41.41
5,250	57.11	5,750	52.14	6,250	47.97	6,750	44.42	7,250	41.35
5,260	57.00	5,760	52.05	6,260	47.89	6,760	44.35	7,260	41.30
5,270	56.89	5,770	51.96	6,270	47.82	6,770	44.29	7,270	41.24
5,280	56.78	5,780	51.87	6,280	47.74	6,780	44.22	7,280	41.18
5,290	56.68	5,790	51.78	6,290	47.67	6,790	44.16	7,290	41.13
5,300	56.57	5,800	51.69	6,300	47.59	6,800	44.09	7,300	41.07
5,310	56.46	5,810	51.60	6,310	47.52	6,810	44.03	7,310	41.02
5,320	56.36	5,820	51.52	6,320	47.44	6,820	43.96	7,320	40.96
5,330	56.25	5,830	51.43	6,330	47.36	6,830	43.90	7,330	40.90
5,340	56.15	5,840	51.34	6,340	47.29	6,840	43.83	7,340	40.85
5,350	56.04	5,850	51.25	6,350	47.22	6,850	43.77	7,350	40.79
5,360	55.94	5,860	51.16	6,360	47.14	6,860	43.71	7,360	40.74
5,370	55.83	5,870	51.08	6,370	47.07	6,870	43.64	7,370	40.68
5,380	55.73	5,880	50.99	6,380	46.99	6,880	43.58	7,380	40.63
5,390	55.63	5,890	50.90	6,390	46.92	6,890	43.52	7,390	40.57
5,400	55.52	5,900	50.82	6,400	46.85	6,900	43.45	7,400	40.52
5,410	55.42	5,910	50.73	6,410	46.77	6,910	43.39	7,410	40.46
5,420	55.32	5,920	50.65	6,420	46.70	6,920	43.33	7,420	40.41
5,430	55.22	5,930	50.56	6,430	46.63	6,930	43.26	7,430	40.35
5,440	55.11	5,940	50.47	6,440	46.56	6,940	43.20	7,440	40.30
5,450	55.01	5,950	50.39	6,450	46.48	6,950	43.14	7,450	40.24
5,460	54.91	5,960	50.31	6,460	46.41	6,960	43.08	7,460	40.19
5,470	54.81	5,970	50.22	6,470	46.34	6,970	43.02	7,470	40.14
5,480	54.71	5,980	50.14	6,480	46.27	6,980	42.95	7,480	40.08
5,490	54.61	5,990	50.05	6,490	46.20	6,990	42.89	7,490	40.03
5,500	54.51	6,000	49.97	6,500	46.13	7,000	42.83	7,500	39.98

Relations of natural wavelength in meters (*m*) to frequency in kilocycles (*k.c.*). (Tables are reversible.)

<i>m.</i>	<i>kc.</i>	<i>m.</i>	<i>kc.</i>	<i>m.</i>	<i>kc.</i>	<i>m.</i>	<i>kc.</i>	<i>m.</i>	<i>kc.</i>
7,510	39.92	8,010	37.43	8,510	35.23	9,010	33.28	9,510	31.53
7,520	39.87	8,020	37.38	8,520	35.19	9,020	33.24	9,520	31.49
7,530	39.82	8,030	37.34	8,530	35.15	9,030	33.20	9,530	31.46
7,540	39.76	8,040	37.29	8,540	35.11	9,040	33.17	9,540	31.43
7,550	39.71	8,050	37.24	8,550	35.07	9,050	33.13	9,550	31.39
7,560	39.66	8,060	37.20	8,560	35.03	9,060	33.09	9,560	31.36
7,570	39.61	8,070	37.15	8,570	34.98	9,070	33.06	9,570	31.33
7,580	39.55	8,080	37.11	8,580	34.94	9,080	33.02	9,580	31.30
7,590	39.50	8,090	37.06	8,590	34.90	9,090	32.98	9,590	31.26
7,600	39.45	8,100	37.01	8,600	34.86	9,100	32.95	9,600	31.23
7,610	39.40	8,110	36.97	8,610	34.82	9,110	32.91	9,610	31.20
7,620	39.35	8,120	36.92	8,620	34.78	9,120	32.88	9,620	31.17
7,630	39.29	8,130	36.88	8,630	34.74	9,130	32.84	9,630	31.13
7,640	39.24	8,140	36.84	8,640	34.70	9,140	32.80	9,640	31.10
7,650	39.19	8,150	36.79	8,650	34.66	9,150	32.77	9,650	31.07
7,660	39.14	8,160	36.74	8,660	34.62	9,160	32.73	9,660	31.04
7,670	39.09	8,170	36.70	8,670	34.58	9,170	32.70	9,670	31.01
7,680	39.04	8,180	36.65	8,680	34.54	9,180	32.66	9,680	30.97
7,690	38.99	8,190	36.61	8,690	34.50	9,190	32.62	9,690	30.94
7,700	38.94	8,200	36.56	8,700	34.46	9,200	32.59	9,700	30.91
7,710	38.89	8,210	36.52	8,710	34.42	9,210	32.55	9,710	30.88
7,720	38.84	8,220	36.47	8,720	34.38	9,220	32.52	9,720	30.85
7,730	38.79	8,230	36.43	8,730	34.34	9,230	32.48	9,730	30.81
7,740	38.74	8,240	36.39	8,740	34.30	9,240	32.45	9,740	30.78
7,750	38.69	8,250	36.34	8,750	34.27	9,250	32.41	9,750	30.75
7,760	38.64	8,260	36.30	8,760	34.23	9,260	32.38	9,760	30.72
7,770	38.59	8,270	36.25	8,770	34.19	9,270	32.34	9,770	30.69
7,780	38.54	8,280	36.21	8,780	34.15	9,280	32.31	9,780	30.66
7,790	38.49	8,290	36.17	8,790	34.11	9,290	32.27	9,790	30.63
7,800	38.44	8,300	36.12	8,800	34.07	9,300	32.24	9,800	30.59
7,810	38.39	8,310	36.08	8,810	34.03	9,310	32.20	9,810	30.56
7,820	38.34	8,320	36.04	8,820	33.99	9,320	32.17	9,820	30.53
7,830	38.29	8,330	35.99	8,830	33.95	9,330	32.14	9,830	30.50
7,840	38.24	8,340	35.95	8,840	33.92	9,340	32.10	9,840	30.47
7,850	38.19	8,350	35.91	8,850	33.88	9,350	32.07	9,850	30.44
7,860	38.14	8,360	35.86	8,860	33.84	9,360	32.03	9,860	30.41
7,870	38.10	8,370	35.82	8,870	33.80	9,370	32.00	9,870	30.38
7,880	38.05	8,380	35.78	8,880	33.76	9,380	31.96	9,880	30.35
7,890	38.00	8,390	35.74	8,890	33.73	9,390	31.93	9,890	30.32
7,900	37.95	8,400	35.69	8,900	33.69	9,400	31.90	9,900	30.28
7,910	37.90	8,410	35.65	8,910	33.65	9,410	31.86	9,910	30.25
7,920	37.86	8,420	35.61	8,920	33.61	9,420	31.83	9,920	30.22
7,930	37.81	8,430	35.57	8,930	33.57	9,430	31.79	9,930	30.19
7,940	37.76	8,440	35.52	8,940	33.54	9,440	31.76	9,940	30.16
7,950	37.71	8,450	35.48	8,950	33.50	9,450	31.73	9,950	30.13
7,960	37.67	8,460	35.44	8,960	33.46	9,460	31.69	9,960	30.10
7,970	37.62	8,470	35.40	8,970	33.42	9,470	31.66	9,970	30.07
7,980	37.57	8,480	35.36	8,980	33.39	9,480	31.63	9,980	30.04
7,990	37.52	8,490	35.31	8,990	33.35	9,490	31.59	9,990	30.01
8,000	37.48	8,500	35.27	9,000	33.31	9,500	31.56	10,000	29.98

Among the various methods in use, one is to use a variable condenser from one side of the tickler coil to ground as shown in fig. 2 and also have a variable resistor to vary the plate voltage applied to the plate of the detector tube.

In case when a transformer stage is used following the detector it is often found that the placing of a fixed condenser across the primary of the transformer or from the plate side of the transformer to the ground will greatly assist in stabilizing the circuit and facilitate regeneration control.

In case where two audio stages are employed, the common audio howl may be eliminated by the connection of a small 100,000 ohms resistor across the secondary of the first audio transformer.

When the short wave receiver is operated from *a.c.* current, the line power supply should be well filtered. Transformer, inductors and condensers should have a static shield.

As the short wave receivers are very sensitive in tuning, vernier dials should be employed.

**Types of Short Wave Receivers.**—Generally short wave receivers are governed by the same construction principles as that associated with ordinary broadcast band receivers previously discussed.

Referring to figs. 1 to 4, Chapter 13, a short wave receiver may consist of various arrangements from a simple single tube regenerative detector circuit to an elaborate super-infra regenerative type.

**Short Wave Tuning.**—One of the first things to be experienced by the short wave beginner, is the picking up of broadcast stations which cannot be located on available charts showing channel assignments.

What actually occurs is that the harmonics of stations operating in the regular broadcast band is received. Each harmonic has a definite wave, just as much so as the broadcast stations' fundamental carrier wave. A harmonic must have exactly twice, three times, five times, nine times, etc., the frequency of the fundamental (corresponding respectively to  $1/2$ ,  $1/3$ ,  $1/5$ ,  $1/9$  and so on) wave length. Many of these harmonics can be heard on any short wave receiver.

When one of them is picked up and the station identified, it is only a matter of division to determine the exact wave to which the receiver is tuned. By checking a number of these harmonics, with the known short wave stations, it is a simple matter to draw up a calibration curve for each coil of any short wave set.

**Simple Short-wave Receiver.**—A simple single tube super-regenerative receiver circuit is shown in fig. 1. To those familiar with the Armstrong super-regenerative arrangement, the diagram will more or less explain itself. It will be noted that one of the chief drawbacks with this circuit is the poor selectivity, which together with the enormous *r.f.* amplifying properties, make this disadvantage even more serious.

In order to overcome this short-coming, a form of pre-selector circuit is employed which is coupled to the grid circuit by a small capacity condenser; it is advantageous for this to be variable.

This may sound rather unreasonable for short-wave reception where all possible losses should be avoided, but in practice it makes little difference to a super-regenerative receiver, where the sensitivity is very high.

All of the tuned circuits and associated parts including the tube which is of the screen-grid type are completely screened—on top as well. This is very important if the selectivity gained by additional tuned circuits is to be realized, since a super-regenerative receiver will pick up on the coils and wiring to a

surprising extent, even though screened all around, and an aerial often makes little or no difference to the rectified output.

In order to avoid extra coil changing, the aerial coil can be tapped to cover the required wave-length bands, while the grid coil can be interchangeable; or two of the common dual-range short-wave coils can be utilized. Efficiency of coils is not so very important. Coils wound on any old forms will give satisfactory results

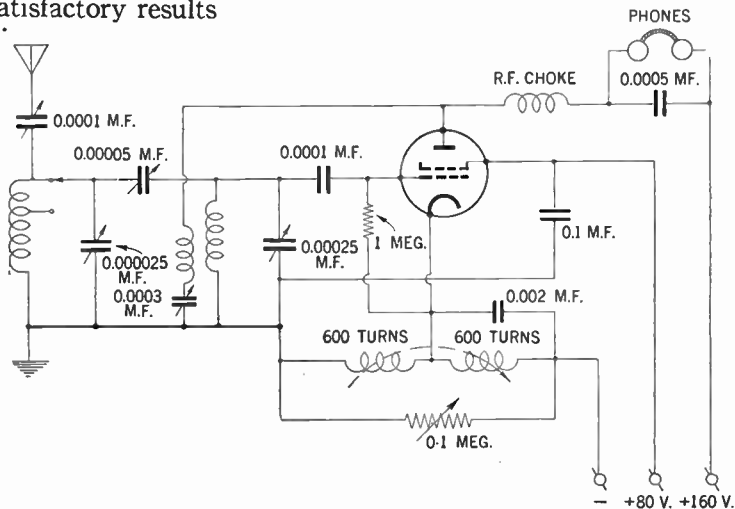

FIG. 1—Schematic diagram of a single tube super-regenerative short-wave receiver.

It must be clearly understood that a receiver of this type requires considerable practice and patience before the best results can be obtained.

The strength of the quencher oscillations (controlled by the variable resistance) has an important bearing on the performance of the receiver, and the best strength can only be found by trial, and may vary with different wave-lengths.



For those who want to get the utmost out of a single tube, there is nothing to compare with the super-regenerative circuit, and with improved selectivity, it bids fair to rival many of the smaller superheterodyne arrangements.

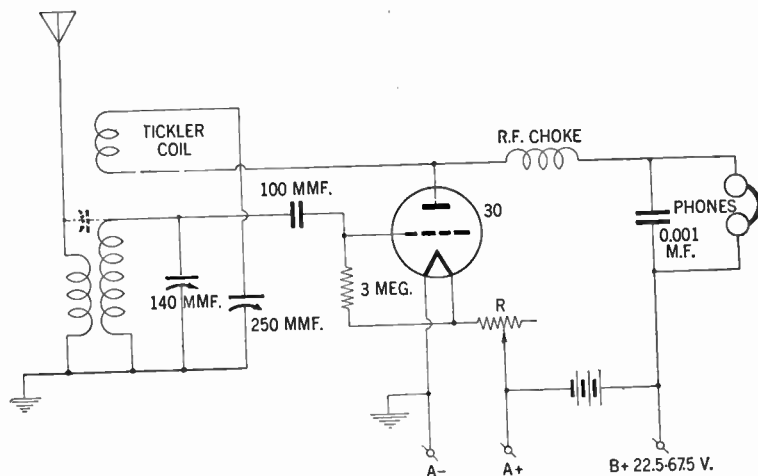

FIG. 2—Schematic diagram of a single tube regenerative detector short-wave receiver. For best results the choke (*r.f.c.*) should be carefully chosen for use at high frequencies, with its natural resonant period in the lower frequency and below 1,500 *k.c.*

**Distance Ranges of Various Wave-lengths.**—All radio wave transmission takes place by the propagation of a **Ground-Wave** along the ground, or a **Sky-Wave** reflected or refracted from the Kennelly-Heaviside layer, or by both means.

Radio waves are subject to absorption both in the ground and in the ionized upper atmosphere. Ground-wave absorption generally increases with the frequency and is reasonably constant with time over a given path at a given frequency; it varies for earth of different conductivities and dielectric constants.

Sky-wave absorption, however, is not constant with time frequency and path; it appears to be maximum in the broadcast band (550-1,500 kilocycles) decreasing with change in frequency in either direction.

During the day-time this absorption of the sky-wave is so great that there is practically no sky-wave, from frequencies, somewhat below and above the broadcast band, the specific limits however vary with the seasons. Therefore sky-wave propagation in the day time is only noticeable in the lower and higher frequency ranges. In the night, however, sky-wave propagation takes place on all waves except extremely high frequencies.

**Other Influences Affecting Sky-Wave Propagation.**—Sky-wave propagation is also materially influenced by condition and changes in ionization of the Kennelly-Heaviside layer.

Daily variation of daylight and darkness in the path of the waves (see charts, pages 548 and 549) and also factors such as latitude, season of the year, magnetic and solar disturbances have been found to influence this ionization.

**Long-Distance Reception.**—High-frequency reception at great distances is due entirely to the sky-wave. However, above a certain frequency which may be as low as 4,000 kilocycles as shown on chart, page 548, no appreciable portion of the sky-wave radiation is reflected back from the Kennelly-Heaviside layer in a certain zone surrounding the transmitter.

In the area bounded by the inner edge of this skipped zone, the receiver wave may be composed of both the ground-wave and the sky-wave, the sky-wave being appreciable on frequencies up to about 6,000 kilocycles in the summer and 12,000 kilocycles in the winter. The sky-wave intensity in this area is ordinarily much less at night than in the day. The outer boundary of the skipped zone is commonly referred to as the **Skip-**

# APPROXIMATE DISTANCE RANGES OF RADIO WAVES THROUGHOUT THE FREQUENCY RANGE

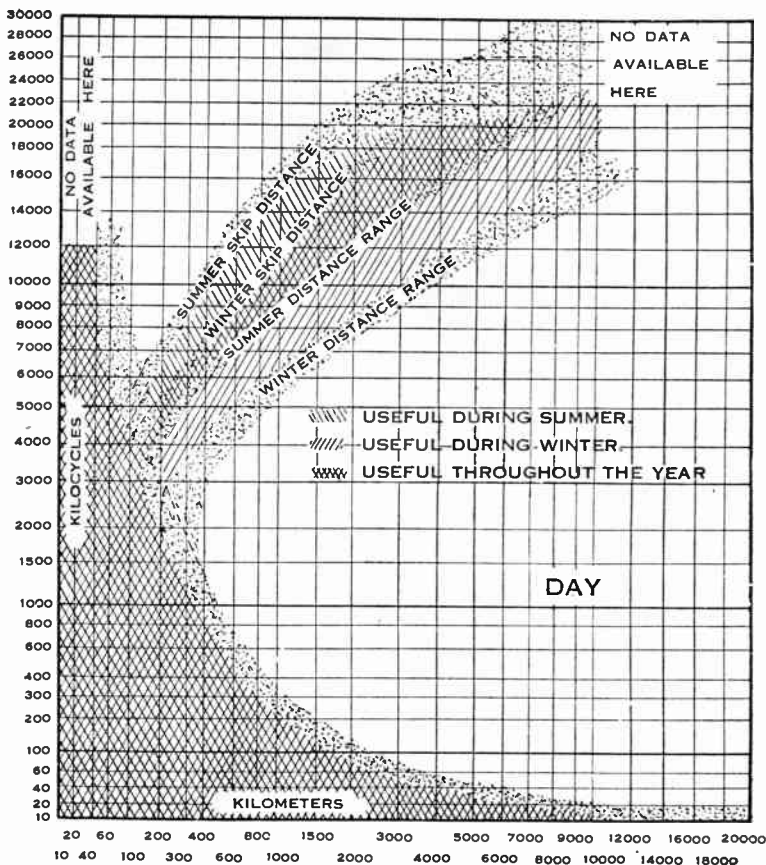

Width of shaded boundaries indicates variations of averages reported by different observers.

The scales of abscissas and ordinates are cubical (i.e., numbers shown are proportional to cube of distance along scale, or, distance along scale is proportional to cube root of numbers). This was chosen because it spaces the data satisfactorily. Obviously a linear scale would crowd the low values too much and a logarithmic scale would crowd the high values too much. The graph shows the limits of distance over which practical communication is

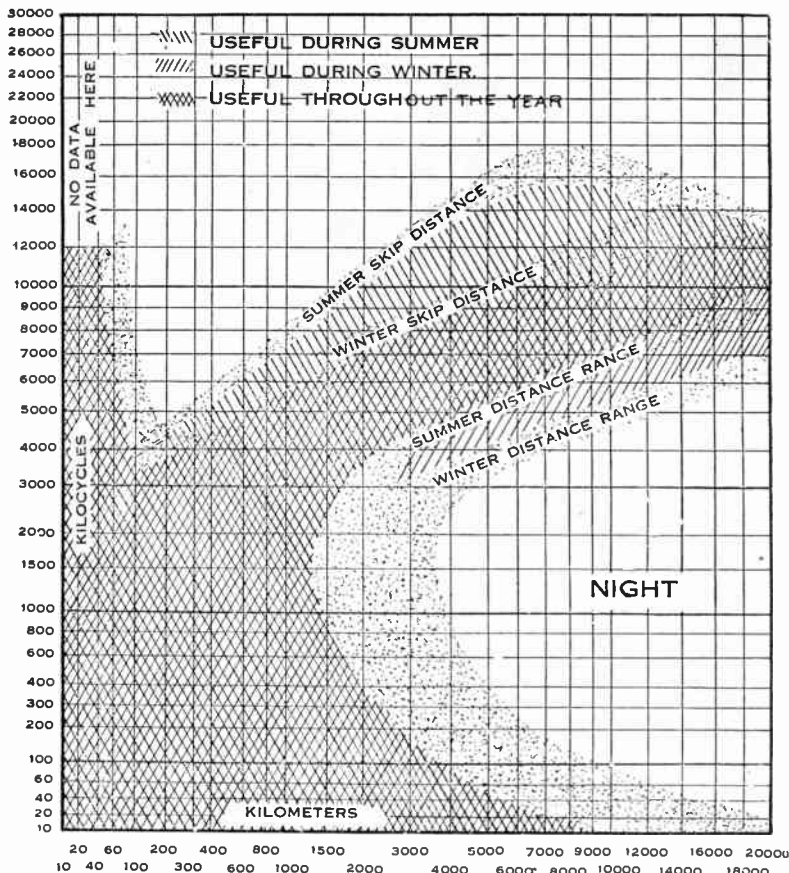

possible. They are based on the lowest field intensity which permits practical reception in the presence of actual background noise. For the broadcasting frequencies this does not mean satisfactory program reception. The limiting field intensity is taken to be 10 micro-volts per meter for frequencies up to 2,000 kilocycles to about 1 micro-volt per meter at 20,000 kilocycles. When atmospheric or other sources of interference are great, for example in the tropics, much larger received field intensities are required and the distance ranges are less.

**distance.** This distance increases with the frequency and varies daily and seasonally. Beyond the skip-distance, the sky-wave radiation is received with useful intensity.

The graphs given on pages 548 and 549 showing the distances for good reception during the day and the night, for summer and winter season as found by test and recorded by the United States Bureau of Standards. The graphs assume the use of about 5 *K.W.* radiated power, and non-directional antennas.

For transmission over a given path, received intensity is proportional to the square root of the radiated power, but there is no simple relation between the range and either radiated power or received field intensity.

**How High Frequency Reception Is Affected by Day, Night and Seasonal Changes.**—Reception on higher frequencies (above 12 megacycles) is generally more satisfactory during the day than at night, on frequencies below 6 megacycles, however, the reverse is usually true.

Except in rare instances, frequencies above 12 megacycles can be heard only when the path between the transmitting station and the receiver lies entirely in daylight. It has also been found that frequencies from 6.5 to 15 megacycles are received best when either the transmitter or receiver lies in darkness, but not both.

The time of the day must also be taken into consideration in high frequency reception. The handy chart shown on page 551 gives the corresponding time in all parts of the globe, and will be of valuable help in determining the time and whether it is day or night at the transmission point.

For example, when it is 8 P.M. in New York and 7 P.M. in Chicago, it is 9 A.M. in Melbourne; 1 A.M. the next day in London and 2 A.M. of the next day in most of Europe. During those hours, of course, the European broadcasting stations are

		YESTERDAY												TODAY													
EAST	180°	FIJI ISLANDS	5	6	7	8	9	10	11	12	1	2	3	4	5	6	7	8	9	10	11	12	1	2	3	4	5
	165°	NEW ZEALAND (Standard Time Ad'd Half Hr)	4	5	6	7	8	9	10	11	12	1	2	3	4	5	6	7	8	9	10	11	12	1	2	3	4
	150°	EASTERN AUSTRALIA	3	4	5	6	7	8	9	10	11	12	1	2	3	4	5	6	7	8	9	10	11	12	1	2	3
	135°	JAPAN	2	3	4	5	6	7	8	9	10	11	12	1	2	3	4	5	6	7	8	9	10	11	12	1	2
	120°	CHINA, WESTERN AUSTRALIA, PHILIPPINE ISLANDS	1	2	3	4	5	6	7	8	9	10	11	12	1	2	3	4	5	6	7	8	9	10	11	12	1
	105°	SIAM, BATAVIA, SINGAPORE	12	1	2	3	4	5	6	7	8	9	10	11	12	1	2	3	4	5	6	7	8	9	10	11	12
	90°	CALCUTTA (Indio Standard Time Subtract Half Hr)	11	12	1	2	3	4	5	6	7	8	9	10	11	12	1	2	3	4	5	6	7	8	9	10	11
	75°		10	11	12	1	2	3	4	5	6	7	8	9	10	11	12	1	2	3	4	5	6	7	8	9	10
	60°	MAURITIUS	9	10	11	12	1	2	3	4	5	6	7	8	9	10	11	12	1	2	3	4	5	6	7	8	9
	45°	ARABIA, MADAGASCAR	8	9	10	11	12	1	2	3	4	5	6	7	8	9	10	11	12	1	2	3	4	5	6	7	8
	30°	EUROPEAN (Eastern Time)	7	8	9	10	11	12	1	2	3	4	5	6	7	8	9	10	11	12	1	2	3	4	5	6	7
	15°	EUROPEAN (Middle Time)	6	7	8	9	10	11	12	1	2	3	4	5	6	7	8	9	10	11	12	1	2	3	4	5	6
	0°	EUROPEAN (Western Time)	5	6	7	8	9	10	11	12	1	2	3	4	5	6	7	8	9	10	11	12	1	2	3	4	5
	15°	ICELAND, CANARY ISLANDS	4	5	6	7	8	9	10	11	12	1	2	3	4	5	6	7	8	9	10	11	12	1	2	3	4
	30°	AZORES	3	4	5	6	7	8	9	10	11	12	1	2	3	4	5	6	7	8	9	10	11	12	1	2	3
	45°	EASTERN BRAZIL	2	3	4	5	6	7	8	9	10	11	12	1	2	3	4	5	6	7	8	9	10	11	12	1	2
	60°	NEW FOUNDLAND	1	2	3	4	5	6	7	8	9	10	11	12	1	2	3	4	5	6	7	8	9	10	11	12	1
	75°	UNITED STATES (Eastern Standard Time)	12	1	2	3	4	5	6	7	8	9	10	11	12	1	2	3	4	5	6	7	8	9	10	11	12
90°	UNITED STATES (Central Standard Time)	11	12	1	2	3	4	5	6	7	8	9	10	11	12	1	2	3	4	5	6	7	8	9	10	11	
105°	UNITED STATES (Mountain Standard Time)	10	11	12	1	2	3	4	5	6	7	8	9	10	11	12	1	2	3	4	5	6	7	8	9	10	
120°	UNITED STATES (Pacific Standard Time)	9	10	11	12	1	2	3	4	5	6	7	8	9	10	11	12	1	2	3	4	5	6	7	8	9	
135°		8	9	10	11	12	1	2	3	4	5	6	7	8	9	10	11	12	1	2	3	4	5	6	7	8	
150°	ALASKA, SOCIETY ISLANDS	7	8	9	10	11	12	1	2	3	4	5	6	7	8	9	10	11	12	1	2	3	4	5	6	7	
165°	HAWAIIAN ISLANDS (Standard Time Subtract Half Hr)	6	7	8	9	10	11	12	1	2	3	4	5	6	7	8	9	10	11	12	1	2	3	4	5	6	
180°	FIJI ISLANDS	5	6	7	8	9	10	11	12	1	2	3	4	5	6	7	8	9	10	11	12	1	2	3	4	5	

### CHART SHOWING CORRESPONDING TIME FOR ALL PARTS OF THE GLOBE

European (Eastern Time) = European part of Russia, Finland, Egypt, South Africa.

European (Middle Time) = Norway, Sweden, Germany, Poland, Czechoslovakia, Austria, Italy, Switzerland.

European (Western Time) = England, France, Holland, Belgium, Spain.

The above chart shows the character of the intervening zones (day or night) to be bridged between the points of transmission and reception, as well as the corresponding time difference between the point of reception and any other part of the World.

*Example on How to Use Chart.*—Assume the radio amateur lives in Chicago. At 5 P.M. he wants to know what time it is in Japan. Follow the 5 opposite central standard time and travel upward until intersection is made with the line “reading” Japan which is 8. Which means 8 o’clock A.M. the next day. The change of date naturally is due to the crossing of the international date line. The black bands on the chart indicates approximately dark hours of the day.

seldom operating. Hence on the American continents, tuning for stations in Europe must be done during the afternoon or early evening. Australian stations, however, will be received in the early morning.

In addition, the season of the year also affects reception. Better reception on the higher frequencies may generally be expected during the summer months and better reception at 6 megacycles and above during the winter months.

Although reception on *higher frequencies* generally is very little affected by atmospheric or static, and good results may be had in mid-summer even during a thunder storm. The same, however, is not true of so-called man-made static, such as trolleys, dial telephones, motors, electric fans, automobiles, airplanes, electrical appliances, flashing signs, oil burners, etc., which create far more interference on high frequencies than they do on ordinary broadcast frequencies.

As an example of the interpretation of the table on effect of time, day and season of the year on high frequency transmission assume that you are in New York and that the time is 1 P.M. mid-summer, and that you tune in a station in Chicago on approximately 15 megacycles (20 meters wave length). Assume now, that this station transmits a continuous program and that your receiver is left tuned in. Several hours later the signal will fluctuate excessively and finally will fade out entirely or become unintelligible. This can be accounted for by the fact that, at mid-summer, the “skip distance” is approxi-

mately 400 miles at noon and increases to 2,500 miles at midnight. Chicago is approximately 600 miles from New York and is one hour later in time; therefore, some few hours after noon, in Chicago, the "skip distance" will have so increased that reliable reception on 15 megacycles cannot be obtained in New York.

It is also well to note that in midwinter, the "skip distance" for 15 megacycles is approximately 900 miles at noon and becomes infinity at midnight—showing that reliable reception could not be effected at this frequency between Chicago and New York; therefore, if you, located in New York, became accustomed during the summer, to receiving a regular 15 megacycle program at noon from Chicago, then as winter came on, the period of time during which reliable communication could be effected, would decrease until at no time could a signal be heard. The reverse would be true the following spring.

**Example.**—*If 10 k.c. be taken as the necessary frequency "spread" of a broadcasting station, how many stations could be operated on wave lengths between—*

a. 100 and 600 meters

b. 3 and 8 meters.

**Solution.**—All that is needed here is to express the various specified wave-lengths as frequencies. The frequency corresponding to a wave-length of  $\lambda$  meters is given by  $\frac{3 \times 10^8}{\lambda}$  cycles per second.

The first band of broadcasting stations will thus have frequencies between 3,000 and 500 k.c. This range occupies a band of 2,500 k.c. so that it would accommodate  $\frac{2,500}{10}$  or 250 stations.



The second group of stations will occupy that part of the frequency "spectrum" between 100,000 and 37,500 *k.c.*, i.e. a band of 62,500 *k.c.* it would thus provide for 6,250 stations. It is interesting to note that the second group could contain 25 times the number of stations in the first, i.e. it has provisions for exactly 6,000 more stations.

This illustrates in a very striking manner the possibilities offered by the short waves in overcoming the congested state of the ether in present day broadcasting. With growing technical advancement the vexed problem of quality and interference may ultimately be solved along these lines.

## CHAPTER 28

# Coil Calculations

**Coil Design Calculations.**—It has been shown on page 49 that any inductance in combination with a certain capacitance will start to resonate (be in resonance with) at a certain definite frequency, which frequency may readily be found by the expression—

$$f = \frac{159,000}{\sqrt{C \times L}} \dots \dots \dots (1)$$

from which

$$C = \frac{(159,000)^2}{f^2 \times L} \dots \dots \dots (2)$$

and

$$L = \frac{(159,000)^2}{f^2 \times C} \dots \dots \dots (3)$$

In a more convenient form for calculation purposes, formulas (2) and (3) may be written—

$$C = \frac{2.528 \times 10^{10}}{f^2 \times L} \dots \dots \dots (4)$$

and

$$L = \frac{2.528 \times 10^{10}}{f^2 \times C} \dots \dots \dots (5)$$

In the preceding formulas ( $f$ ) denotes the frequency in cycles per second, ( $C$ ) the capacitance in micro-farads and ( $L$ ) the inductance in micro-henries.

The formula for the natural wave-length in meters at which resonance takes place as shown on page 379 is—

$$\lambda = 1,885\sqrt{C \times L} \dots \dots \dots (6)$$

in another form the above equation may be written

$$C = \frac{\lambda^2}{3.55 \times 10^6 \times L} \dots \dots \dots (7)$$

and

$$L = \frac{\lambda^2}{3.55 \times 10^6 \times C} \dots \dots \dots (8)$$

$L$  and  $C$  again represents the inductance and capacity of the circuit in micro-henries and micro-farads respectively.

The formula for the inductance of the helical single layer coil is—

$$L = \frac{0.2 \times A^2 \times N^2}{3A + 9B + 10C} \dots \dots \dots (9)$$

Where  $L$  = Inductance in micro-henries

$N$  = Total number of turns

$A$  = Inside diameter of coil in inches

$B$  = Length of winding in inches

$C$  = Radial depth of coil in inches (which value may be omitted for single layer coils)

This formula will be of assistance and is preferred to the cut and try methods which are often found to be of little help when exact values of inductance are required.

Sometimes it may be most convenient to use an existing coil form in which case the diameter is given, the only trouble being then, to determine the number of turns of a certain wire or the length the wire would occupy.

Under those conditions a method which has been found to be most convenient for obtaining the value of  $N$ , is as follows:

1. Determine the size of wire to be used after a careful consideration of current to be carried and the wave bands to be covered.

2. Decide upon the number of turns per inch that will be used. (A consultation of any wire table will give the factors under 1 and 2.)

3. Now express ( $B$ ) as ratio between the total number of turns ( $N$ ) and the number of turns per inch ( $K$ ) or

$$B = \frac{N}{K} \dots \dots \dots (10)$$

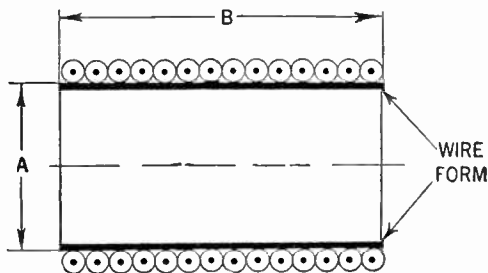

FIG. 1—Cross-section of single layer coil.

**Example.**—*What is resonant frequency of a circuit having an inductance of 200,000 micro-henries with a series condenser of 20 micro-farads?*

**Solution.**—This example provides a simple exercise in using formula (1). With the inductance and capacitance in microhenries and microfarads given, the only unknown is the frequency ( $f$ ) at which the combination will become resonant, thus:

$$f = \frac{159,000}{\sqrt{20 \times 200,000}} = \frac{159}{2} \text{ or } 79.5 \text{ cycles per second.}$$

**Example.**—*What inductance is required in the secondary winding of a radio-frequency transformer, when it is to tune to a wavelength of 600 meters, and the variable condenser is set at its maximum capacitance which is 0.00025 microfarads?*

**Solution.**—From equation (8) page 556 is obtained—

$$L = \frac{600^2}{3.55 \times 10^6 \times 0.00025} = 406 \text{ microhenries}$$

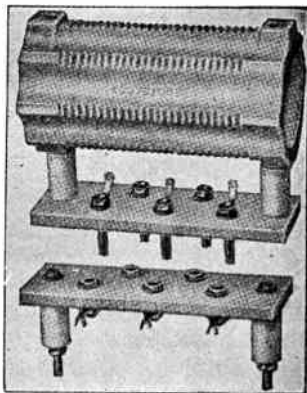
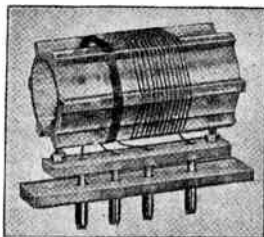
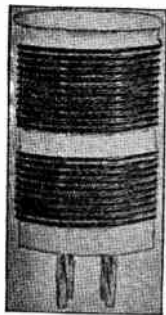

FIGS. 2, 3 and 4—Showing arrangement of typical coils and coil forms.

**Example.**—Assume that a coil is to be wound on a coil form of one inch diameter with a required inductance of 240 micro-henries. The coil is to be employed on a short-wave receiver for reception on 160 meters, and it is hence decided to use No. 32 enamel wire close wound. The wire table gives the number of turns per linear inch as 120. From this data it is required to find the total number of turns ( $N$ ).

**Solution.**—In the present example with reference to equation numbers (9) and (10) the only unknown term is the total number of turns ( $N$ ) of the coil. This problem offers a simple application on the formula for coil design calculations, and it is advisable that before proceeding with our calculations, to put down all the known factors enumerated in the present example, thus:

Diameter of coil ( $A$ ) = 1 inch

Number of turns per linear inch ( $K$ ) = 120

Length of winding ( $B$ ) =  $\frac{N}{K} = \frac{N}{120}$

Inductance of coil in micro-henries ( $L$ ) = 240

Applying the known factors to equations (9) and (10) we obtain—

$$L = 240 = \frac{0.2 \times N^2}{3 + \frac{9N}{120}} = \frac{24N^2}{360 + 9N}$$

which after dividing both sides of the equation by 24 and rearrangement of terms becomes—

$$N^2 - 90N - 3600 = 0$$

$$\text{or } N = 45 \pm \sqrt{45^2 + 3600} = 45 \pm 75$$

from which the positive root equals 120 turns.

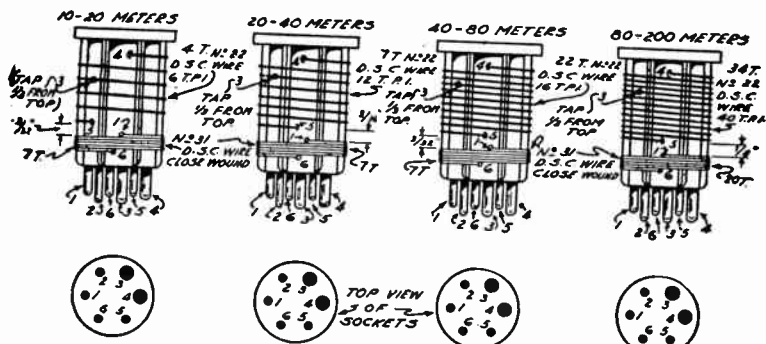

NOTE: 1 = S.G., 2 = P., 3 = H., 4 = H., 5 = K., 6 = C.G. - TUNING CAP. = 150 MMF.

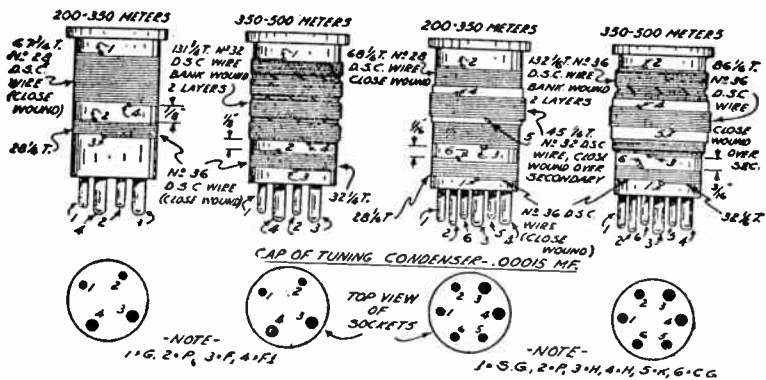

FIGS. 5 to 12—Data for standard short and medium wavebands plug in coils, showing arrangement of windings.

## CHAPTER 29

# Frequency Modulation

## (F.M.)

**Fundamental Principles.**—The method of transmitting speech and music by radio is universally effected by varying the amplitude of the radio waves by the waves of sound which strike the microphone.

By means of another and until quite recently, neglected method, the frequency of radio waves is made to vary while the amplitude remains constant. This is known as *Frequency Modulation*, and is presently employed by numerous transmitting stations operating under the Armstrong patents.

**Wave-Lengths Used.**—Whereas in the regular broadcasting band wave-length of from 500 to 1,500 *k.c.* are employed, a frequency modulated wave takes a part in the frequency spectrum of from 42 to 200 *m.c.* At present regular assignments are from 42 to 50 *m.c.* (Mega-cycles). 34-108

Assuming a maximum frequency deviation for each F.M. station of 200 *k.c.* that is 100 *k.c.* on each side of the carrier, it is evident that one locality would accommodate 8/0.2 or 40 stations. This illustrates the advantage of frequency modulation in opening new and uncrowded channels for broadcasting.



**Distances covered by F.M. transmitters.**—Frequency modulated transmitting stations are designed to cover a number of square miles surrounding the station with a program signal of sufficient strength to cover that area. This service area is determined by the Federal Communication Commission (F.C.C.) and varies from 3,000 square miles up to 20,000 square miles.

Thus, the radial reception limits from the transmitting station are  $\sqrt{\frac{3,000}{\pi}} = 31$  miles, and  $\sqrt{\frac{20,000}{\pi}} = 80$  miles approximately.

**Station Call Letters.**—A new type of station call letters has been originated for frequency modulation which does the two-fold job of telling where the station is on the dial and where the station is located geographically.

The first letter (see dial chart, fig. 1) indicates on which side of the Mississippi River the station is located; W for East and K for West. The two numbers give the station frequency. Since all F.M. stations are within the 42 to 49.9 megacycle

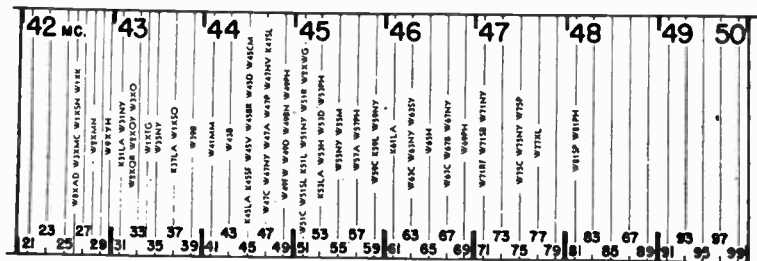

FIG. 1.—Frequency modulation part of the radio spectrum with dial position of stations in operation and under construction. Due to possible changes in frequency assignment, the above chart may not be assumed correct, but serves to illustrate the present location of certain stations. For correct location of your F.M. station consult the Federal Communications Commission or licensed station officials.

band the "40" is common to all stations. Hence, only the unit and decimal part of the frequency are given in the call. Thus "67" means 46.7 megacycles and "99" means 49.9 megacycles. The last letter or letters represent the City where the station is located; "N. Y." stands for New York and "C" for Chicago, etc.

**Comparison of the Two Systems.**—In the conventional system of reception, most interfering noises are amplitude modulated and so receivers designed to receive amplitude modulated signals also receive radio interference.

Frequency modulated signals received on sets designed exclusively for such reception would give greater freedom from interference. This is the most vital point in the system.

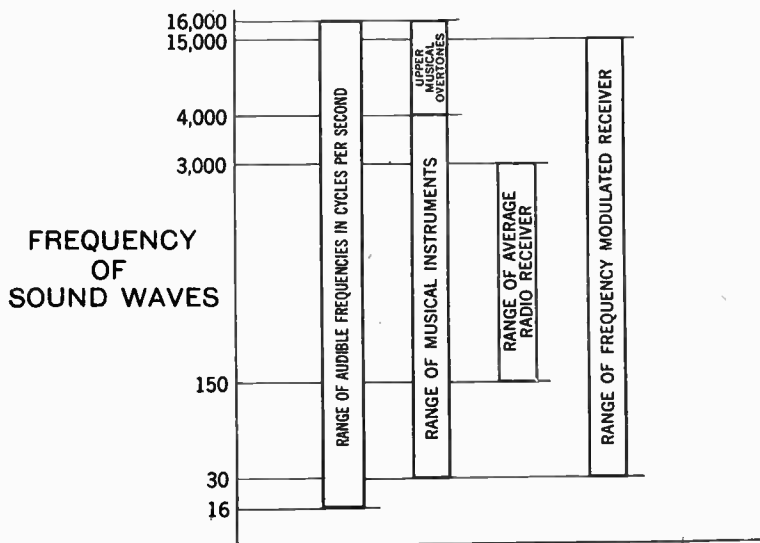
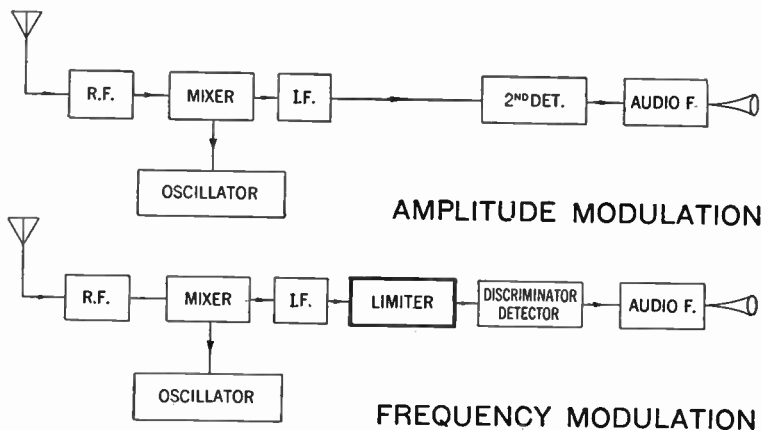

FIG. 2—Diagram illustrating comparative tone coverages of average amplitude modulated and frequency modulated receiver.

The advantages in reception when using frequency modulation are:

1. Freedom from static interference.
2. A greatly extended musical range. (See fig. 2.)

The main difference between the amplitude and frequency modulated receiver is apparent from block diagrams figs. 3 and 4.



FIGS. 3 and 4—Receiver block diagrams showing sequence of amplitude modulated and frequency modulated stages.

With reference to diagrams, both types may have a radio frequency stage, the primary function of which is to provide adequate selectivity and voltage gain.

A converter stage, consisting of a single tube functioning as mixer and oscillator, or two separate tubes performing these functions is common to both circuits.

**The Intermediate Frequency Amplifier.**—Though an intermediate frequency amplifier of one or more stages is also common to both, the intermediate frequency amplifier in a frequency modulated receiver differs from that of an amplitude modulated one by reason of its wide-band characteristics.

In an amplitude modulated receiver the intermediate frequency amplifier is designed to reject a signal more than 10 to 15 *k.c.* from that to which the amplifier is tuned, whereas the intermediate frequency amplifier in a frequency modulated receiver is designed to pass a signal without appreciable attenuation, as much as 100 *k.c.* on either side of the frequency to which the intermediate frequency transformers are aligned.

There are various methods employed to obtain this bandwidth. In some instances, the primary and secondary windings are over-coupled to broaden out the response curve.

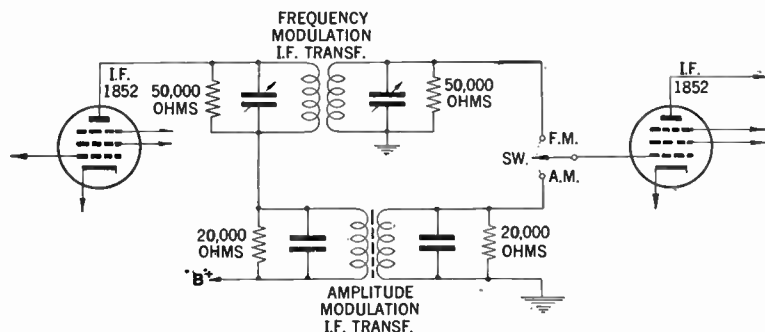

FIG. 5—Illustrates use of resistive loading to broaden response characteristics.

The great majority of frequency modulated receivers, however, employ shunt resistors, to load up either or both of the primary and secondary windings to obtain the required 150 to 200 *k.c.* band-width. In some early receivers as well as several

frequency modulation adapters both primary and secondary of the intermediate frequency transformers are shunted by resistors as indicated by fig. 5.

The values of these shunt resistors varies with each receiver model, and depends upon transformer design and degree of loading required in each case to secure the band-spread. Resistor values from 10,000 to 50,000 ohms are most commonly used for this purpose.

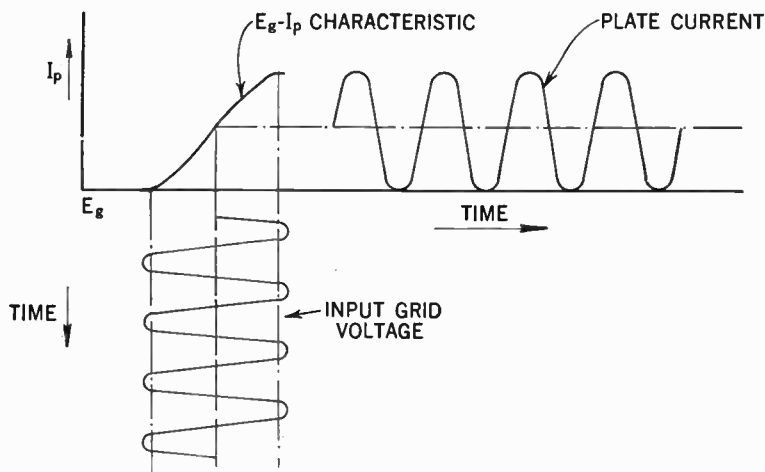

FIG. 6—Shows action of limiter in clipping modulation peaks beyond linear portion of characteristic.

**The Limiter Stage.**—Again referring to our block diagram fig. 4 a limiter stage is shown. This is essentially an intermediate frequency stage, and consists of one or two amplifier tubes so arranged as to deliver constant output regardless of wide variation in signal input.

The tubes employed as limiters are usually of the pentode type, having sharp cut-off characteristics, and operated at

low plate and screen-voltages, so that plate current cut-off occurs with relatively small grid bias or signal input.

Normal signal input will swing the grid voltage considerably above and below the linear portion of the tubes characteristic curve.

Positive peaks beyond the range of the limiter tube will be clipped by grid-bias limiting, whereas negative signal peaks will be clipped due to plate current cut-off. In this manner, variations in signal delivered to the limiter which are greater than the operating limits of the tube are clipped and have no effect on plate current.

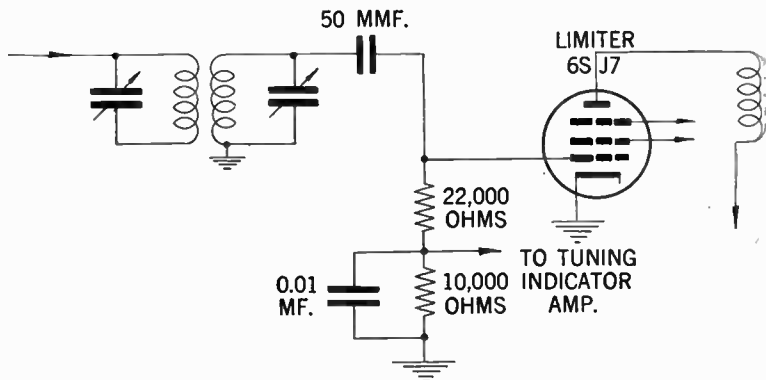

FIG. 7.—Limiter circuit used in certain Stromberg Carlson frequency modulation receivers.

Since static and noise disturbances, primarily produce amplitude changes in the signal, as do tube noises, the clipping of the amplitude changes removes the disturbing effects but leaves the frequency modulated signal unaltered. This action is illustrated in fig. 6.

For complete noise elimination, it is essential that the signal voltage appearing at the limiter grid be sufficiently great to

swing the grid bias to plate current cut-off and saturation points.

Limiter tubes are generally operated at zero bias or with small bias voltage. The limiter circuit shown in fig. 7 is representative of a great many frequency modulation receivers.

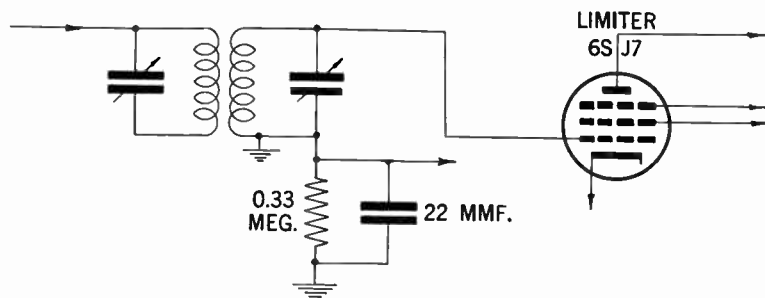

FIG. 8—Limiter circuit employed in certain General Electric frequency modulation receivers.

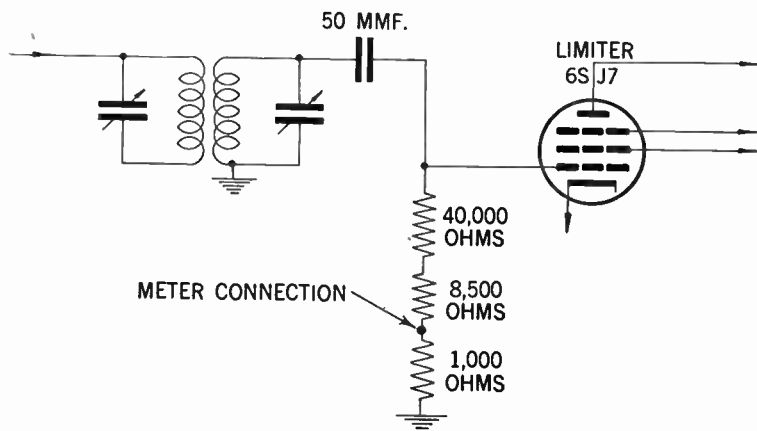

FIG. 9—Limiter circuit used in certain Pilot frequency modulation receivers. Terminal indicates connection for indicating instrument.

Another limiter circuit is shown in fig. 8. In this circuit the load resistance is connected in the secondary return, the tube being supplied with a small initial negative bias.

Circuit fig. 9 shows a low value resistor connected in series with the limiter load resistor so that an indicating meter may be conveniently connected.

Circuit fig. 10 shows how two tubes may be arranged in cascade to operate more efficiently as limiters.

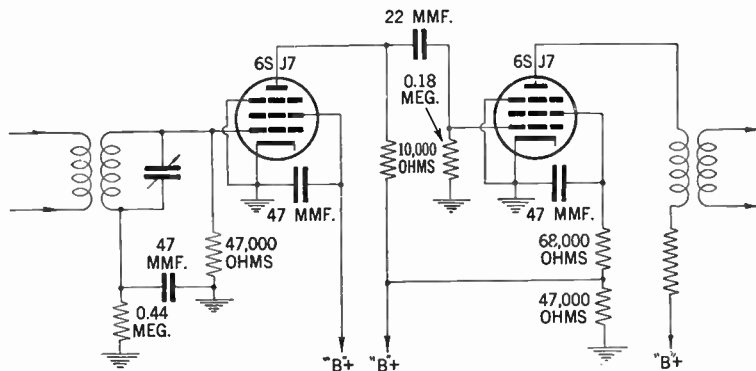

FIG. 10—Double limiter circuit employed in certain General Electric frequency modulation receivers to obtain more effective action.

**The Discriminator.**—The last important point of difference between the amplitude modulated and frequency modulated receiver concerns the second detector or demodulator.

In the frequency modulated receiver, a discriminator detector as shown in fig. 11 is employed. The discriminator consists of a push-pull diode detector in which opposing voltages developed across load resistors are equal and opposite so long as the carrier frequency rest at the intermediate frequency.

The resultant voltage across the two load resistors, from point A, to ground is zero and no audio voltage is developed.



When the signal impressed upon the discriminator transformer is frequency modulated, due to phase changes as a result of both magnetic and capacity coupling, the voltage drops across the load resistors will be unequal as the frequency varies above and below the intermediate frequency with modulation.

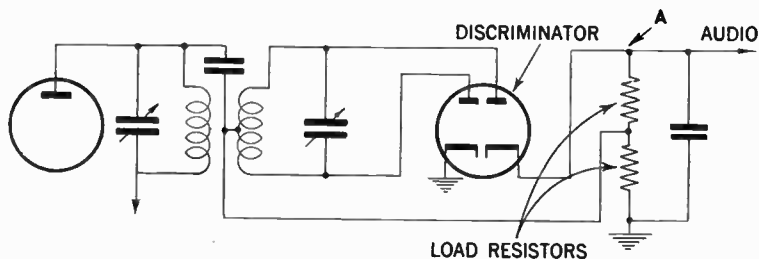

FIG. 11—Typical discriminator circuit. The demodulator of the frequency modulation receiver.

The resultant voltage measured across both diode load resistors will then be equal to the difference between the voltages developed across each, and will vary in polarity from point A, to ground as the modulation swings the frequency higher and lower than the resting or resonant frequency. The degree of modulation or frequency swing, determines the magnitude of the voltage and the number of times per second, or rate at which the intermediate frequency signal swings above and below the resonant frequency, produces the audio signal.

**Need of Antenna for F.M. Receivers.**—Frequency modulated receivers like any other type of receiver will perform better if equipped with a good outdoor antenna. Most F.M. receivers are now equipped with built-in antennas which perform quite

satisfactorily when the receiver is well within the service range of the stations that are to be received.

A special F.M. dipole short wave antenna however, will do much to improve reception if correctly dimensioned and erected. Considering the length of the units we may recall that this depends upon the frequency of operation.

If it be desired to erect an antenna capable of tuning over the entire frequency modulation band, it is best to select a medium frequency and design the antenna for this. In this case an antenna of moderately low "Q" or one that is not critically resonant to any one frequency is recommended.

It has been found that within certain limits the larger the diameter the lower the "Q" of the antenna. A conductor for this purpose should have a diameter of not less than  $\frac{3}{8}$  ins. and be in the form of a tube rather than a solid conductor.

The thickness of the walls of the tubes are not particularly important—the main point is that the rods are of sufficient mechanical strength to support themselves properly, as well as to withstand eventual wind and ice or snow pressure in the particular location in which they are erected.

Tubing of diameters of from one to three ins. may be used although such large diameter is not necessary. Hard drawn tubing of copper, brass or aluminum are satisfactory.

Di-pole antennas are broadly directional on the side and have a sharp minimum reception point on the ends. Theoretically, the pick-up of antennas will be at maximum when the line of the di-poles are at right angles to the line between the receiver and the station.

Reflections and intervening objects occasionally change this and the di-pole should be rotated for maximum signal from the weakest station if this does not interfere with the reception of other F.M. stations.

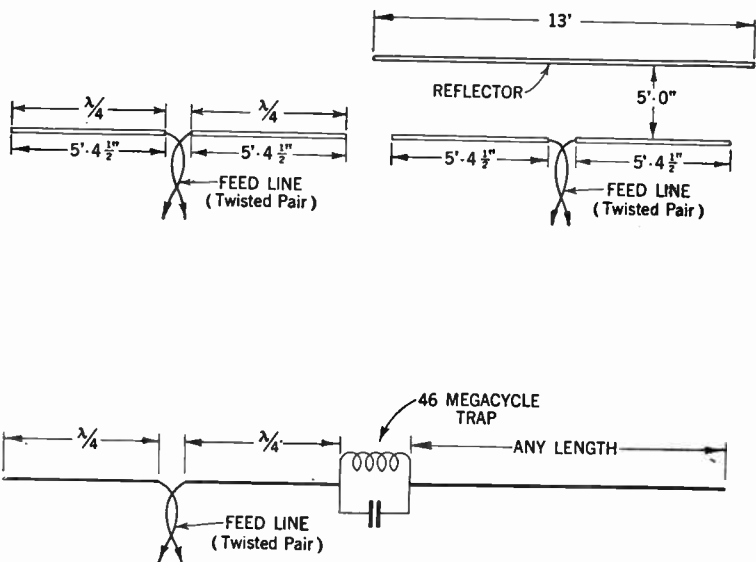

FIGS. 12 to 14—Typical frequency modulation antennas with dimensions for di-pole types. A practical method in erection of antennas of this kind is shown on page 596. Di-pole antennas may be erected either horizontally or vertically. If the transmitting di-pole elements are mounted vertically, the transmissions are said to be vertically polarized. In this event best reception is obtained with a vertical receiving antenna which receives vertically polarized waves best. Likewise, a horizontal antenna producing horizontally polarized waves is best received by a horizontal antenna. Fig. 14 illustrates a combination frequency modulation-amplitude modulation antenna used when it is desired to combine the frequency modulation and regular broadcast band antenna. This can be accomplished in several ways. Some antenna manufacturers are selling units which consist of a long wire section connected to the open end of one di-pole through a wave trap resonated at 46 megacycles. This trap isolates the long antenna section from the ordinary frequency modulation di-pole for the 40 to 50 megacycle range, but permits the full length of the wire to operate on the broadcast band.

Another important consideration when installing an F.M. antenna is to erect the di-pole as high as possible. This is because of the quasi-optic nature of ultra-high frequencies (tendency to follow the line of sight between the transmitter and the receiver). The extra length of transmission line required and possible loss in the two conductor feed-line will be more than compensated for by the greater signal.

A table giving the approximate length of di-pole for various frequencies is given below.

F.M. Band Megacycles	Meters $\lambda$	Meters $\lambda/4$	Length of Di-pole (Single Rod)
40	7.500	1.875	6'- $1\frac{13}{16}$ "
41	7.320	1.830	6'- $\frac{3}{4}$ "
42	7.140	1.780	5'-10 $\frac{5}{8}$ "
43	7.000	1.750	5'- $8\frac{7}{8}$ "
44	6.820	1.705	5'- $7\frac{1}{8}$ "
45	6.667	1.667	5'- $5\frac{3}{4}$ "
46	6.520	1.630	5'- 4"
47	6.400	1.600	5'- $2\frac{3}{4}$ "
48	6.250	1.560	5'- $1\frac{7}{16}$ "
49	6.120	1.530	5'- $\frac{1}{4}$ "
50	6.000	1.500	4'- $11\frac{1}{16}$ "

The method used in calculation of a typical antenna is best understood by considering the following:

**Example.**—*It is desired to calculate the required dimension for a quarter wave di-pole unit antenna capable of tuning to a frequency of 43.5 megacycles.*

**Solution.**—This problem simply involves a calculation of the wave length corresponding to a frequency of 43.5 megacycles. The relations between wave length in meters and frequency is written:

$$\lambda = \frac{3 \times 10^8}{F}$$

Where  $\lambda$  = wave length in meters

$F$  = frequency in cycles per second

Remembering that 43.5 megacycles equals 43,500,000 cycles, a substitution of values gives:

$$\lambda = \frac{300,000,000}{43,500,000} \text{ or } 6.896 \text{ meters}$$

The length of each di-pole unit then is  $6.896/4 = 1.7241$  meters, which translated into inches becomes  $1.7241 \times 39.37 = 67.878$  ins. or 5 ft.  $7\frac{7}{8}$  ins. approximately.

## CHAPTER 30

# Radio Testing

It is of the utmost importance that the serviceman, in order to intelligently cope with the various faults liable to develop in radio sets should be provided with the necessary testing instruments, of which there are a great variety available (some of which have very desirable characteristics).

The selection of instruments described in this chapter however, are by no means essential for intelligent servicing of radio sets.

Testing instruments to be of value to a radio serviceman must have the following features:

1. They should be easily portable.
2. They should be ruggedly constructed so that instruments will not be damaged or their calibration changed in transport.
3. The instruments must be designed to stand considerable overloads without damage, as in service work it is often difficult to estimate the exact magnitude of the measurements being taken.

The following instruments are required to properly service any radio set:

1. A volt-ohm milliammeter for measuring voltage, resistance and current.

2. Analyzer with the necessary selector switches and analyzer cable with adapters.
3. Output meter.
4. All-wave oscillator.
5. Capacity meter.
6. Inductance meter.
7. Tube tester.

This equipment may be supplemented by a cathode-ray oscillograph, a vacuum tube voltmeter, etc., and hence will provide the serviceman with equipment necessary to successfully cope with almost any servicing problem.

**Analyzers and How to Use Them.**—The fundamental purpose of an analyzer is to locate trouble in receivers without undue waste of time and without disturbance to the wiring of the radio set.

A modern analyzer consists of various resistances, capacitances, inductances and meters, which by means of switches are connected to the circuit whose values it is desired to verify, and mounted in a compact cabinet to facilitate transportation.

**Preliminary Pointers.**—However, before analyzing the radio set for trouble, it is well to consider possibilities of trouble in the installation itself. The aerial may be grounded or touching foreign parts; the aerial connection may be corroded; or the lead-in wire itself possibly broken inside its insulation. The lightning arrester may be leaky or short-circuited. A poor ground connection is also a frequent cause of trouble due to interference with reception from outside causes. If, by disconnecting the aerial and ground the noise disappears, the trouble is undoubtedly located outside the set.

If it be evident that the trouble is inside the radio set itself, a careful examination of the wiring connections and interior parts of the set is next in order. The condition of soldered joints should be examined to be sure that there is a good electrical connection.

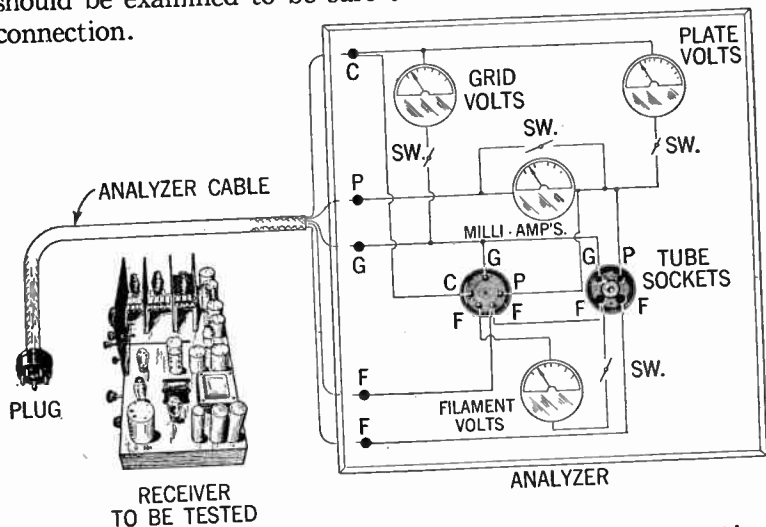

**FIG. 1**—Principal parts of a simple analyzer. The performance of the test is as follows: After a preliminary investigation of possible outside sources of trouble such as faulty or grounded aerials, open soldering joints, broken parts, etc., remove tube to be tested from set to proper socket in analyzer, and insert analyzer plug in place of the tube removed from set. Test the tubes one by one, starting with the antenna stage and proceed until the power amplification stage is reached. This test will indicate the location of troubles in the various circuits or in the tubes as well as in their power supply.

It should be noted that the insulation of the wiring be not cut or frayed where it passes through metal, around the edges of tube socket contacts, etc. The tube socket fingers should be clean and tight. The possibility of variable condenser plates touching should be checked. A visual inspection of this kind may quickly locate the cause of the trouble.



**Electrical Tests.**—The first electrical check on the set should be on the power supply to insure a normal supply of voltage to the various circuits in the radio set.

If the set be a battery operated type, check the condition of the various batteries by making use of the tip jacks on the analyzer and the test leads supplied with it. If the set be supplied with power from an alternating current house lighting circuit, measure the line voltage to be sure that it is correct for the set as indicated on the name plate of the radio set. The various batteries should give approximately their rated voltage readings with the radio set connected and turned on. If the batteries are low they should be re-charged or replaced.

Having checked the source of power to the radio set, the next step is to check the current and voltage supplied to each tube. A suggested method is to check the tubes in the order in which the signal passes through them. That is, start with the antenna stage and end with the power amplifier stage.

After making preliminary tests and a visual inspection and finding everything in good order, the electrical tests should be made. These electrical tests will show the location of troubles in the various circuits, in the tubes and in the power supply to them.

First, place the radio set as near as possible in good operating condition. If battery operated, all batteries should be properly connected. If power operated, connect to the proper power circuit. Turn on the set and make such adjustments as are normally necessary to bring in a good signal.

In general, all electrical tests should be made with the volume control in the maximum volume position, since this position generally gives the optimum distribution of currents and voltages through the various circuits in the radio set. A second set of readings with the volume control in the average working position is often helpful in locating trouble. This second set of

readings is the current and voltage values in the various circuits under average conditions and should compare favorably with the first set. Radical differences should be checked up for a possible source of trouble.

In a battery operated set all batteries should be checked; any which are low in voltage should be replaced before proceeding with a more detailed analysis of the radio set.

**Selection of Voltmeter Scales.**—It is advisable when reading direct current voltages to set the selector switch on the range which will give the smallest deflection of the instrument which can be read satisfactorily. While this may seem to be contrary to general practice, the fact that many modern radio receivers have individual voltage divider networks for each tube, allows the current drawn by the voltmeter to throw the voltage applied to the tube somewhat in error.

It is obvious that a network supplying three milliamperes plate current to a tube will be upset to a considerable extent by connecting a voltmeter to it which requires one milliamperes full scale. Consequently, deflections of less than half scale, as would be obtained on a higher range, will introduce less error than deflections of approximately full scale on a lower range, since the latter require considerably more current from the voltage divider network. When a difference in voltage indicated on the instrument scale exists as the range selection is changed, the indication read on the highest full scale voltage should be taken as the more accurate.

**Selection of Current Scales.**—In reading current always take the reading on the range which will give the largest possible deflection. By doing this the greatest possible accuracy will result.

**Testing a Triode.**—For a complete analysis of a triode for example, it is necessary to measure the following values:

1. Plate voltage
2. Plate current
3. Grid voltage
4. Grid current
5. Filament voltage.

In addition where cathode screen grid or pentode tubes are being tested, it is necessary to measure—

6. Cathode voltage
7. Screen grid voltage.
8. Screen grid current.

A complete outline of the above tests is given on pages 588 to 593

**Test Oscillators and Their Use.**—The fundamental use of a test oscillator is to replace the broadcast signal for test and adjustment of radio receivers. Of special importance to the servicemen are the following uses:

Alignment of *IF*, *RF* and oscillator padding circuits. Checking the condition of tubes. To determine the gain in any part of radio receivers. For testing *a.v.c.* circuits. For checking selectivity.

**Alignment Procedure.**—Unless the manufacturer of the receiver instructs otherwise the following sequence should be followed in the alignment of a radio set:

1. The various tuned circuits of the *IF* amplifier are first aligned properly at the intermediate frequency for which the amplifier was designed.

2. The oscillator tracking condenser should then be adjusted at about 1,400 *k.c.* so that it tracks properly at the high frequency end of the dial. Adjust the padding condenser at about 600 *k.c.* so that it tracks at the low frequency end of the dial.

3. Align the radio frequency, the pre-selector, amplifier or tuned circuit last.

If double spot or image suppression circuit be employed in the receiver, the manufacturer's instructions should be consulted for the proper procedure. Maximum transfer of energy in output is only obtained when every section is synchronized properly.

**Use of Output Meters.**—To determine the condition of tubes feed the signal from the oscillator to the aerial and ground connections of the receiver. Connect an output meter to the radio set; substitute new tubes for those in the radio set, one at a time and if the output meter indicates a greater value when each new tube is placed in the set, the original tube should be replaced.

To determine the gain in any part of the receiver, connect output meter as before and feed signal to aerial connection of radio set. Adjust oscillator to a high output and move the oscillator aerial connection to each succeeding *RF* or *IF* stage, noting the drop in the output voltage as shown on the output meter. Always use the proper frequency and proper scales for the output meter.

To check *a.v.c.* to determine when it is functioning properly, wide changes in the alignment with a large signal voltage will produce no appreciable change in output.

To check selectivity feed a signal of low value to aerial and ground connections, tune oscillator to perfect resonance, move

oscillator signal dial until signal disappears. Note number of kilocycles between resonance and inaudibility.

**Capacity Measurements.**—On account of the fact that capacitors very frequently give rise to trouble in *a.c.* receivers, it is necessary to be able to measure and compare the value received by that as given in the manufacturer's circuit diagram. Hence it is important that the serviceman should understand the theory of capacity values and how they are derived.

The dial of most *a.c.* milliammeters are calibrated to read directly in microfarads (*M.F.*). The capacitive reactance of a condenser in ohms is given by the following formula:

$$X_c = \frac{1,000,000}{2 \times \pi \times f \times C_{m.f.}} \text{ohms} \dots \dots \dots (1)$$

When a 60 cycle current is used ( $f=60$ ) and  $C$  is measured in microfarads, this formula then becomes:

$$C_{m.f.} = \frac{2,650}{X_c} \dots \dots \dots (2)$$

From this last equation it is possible to calibrate an *a.c.* milliammeter to read directly in capacity.

If any other frequency than 60 cycles is used, the result obtained in equation 1 or 2, must be multiplied by the fraction  $\frac{F}{f}$ , where ( $F$ ) is 60 cycles and ( $f$ ) is a cycle of the current being used. For example, if a 50 cycle current be used, then the values of equations 1 or 2 must be multiplied by  $\frac{60}{50}$  or 1.2.

Before using any instruments designed for use on 60 cycles, on any other frequency, one must make sure that the equipment will function at the new frequency.

**How to Make Capacity Measurements When the Capacitor Be Shunted by a Non-Inductive Resistor.**—In *a.c.* receivers it is very frequently desired to obtain the values in microfarads when an ohmic resistor is shunted by a condenser as shown in fig. 2.

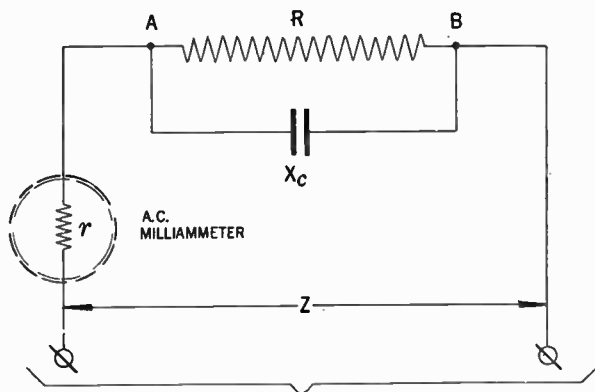

**FIG. 2**—Connection for measurement of capacity when capacitor is shunted by a non-inductive resistor.

The impedance  $Z$ , of the above circuit combination is obtained by the following formula:

$$Z = \sqrt{r^2 + \frac{(R+2r)RX_c^2}{R^2+X_c^2}} \dots \dots \dots (3)$$

in which  $r$  = Resistance of the *a.c.* milliammeter in ohms

$R$  = Resistance of the shunt resistor in ohms

$X_c$  = The reactance of the capacitor to be measured in ohms

$Z$  = The impedance of the circuit combination, in ohms.

The  $X_c$  values as used in formula (3) are the effective resistance values of capacitors given by formula (1).

From the above mathematical relationship, curves may be plotted as shown in chart, fig. 3. In this chart the resistance value from 500 to 5,000 ohms and capacitors from 0.1 to 15 microfarads are covered. The chart is used as follows:

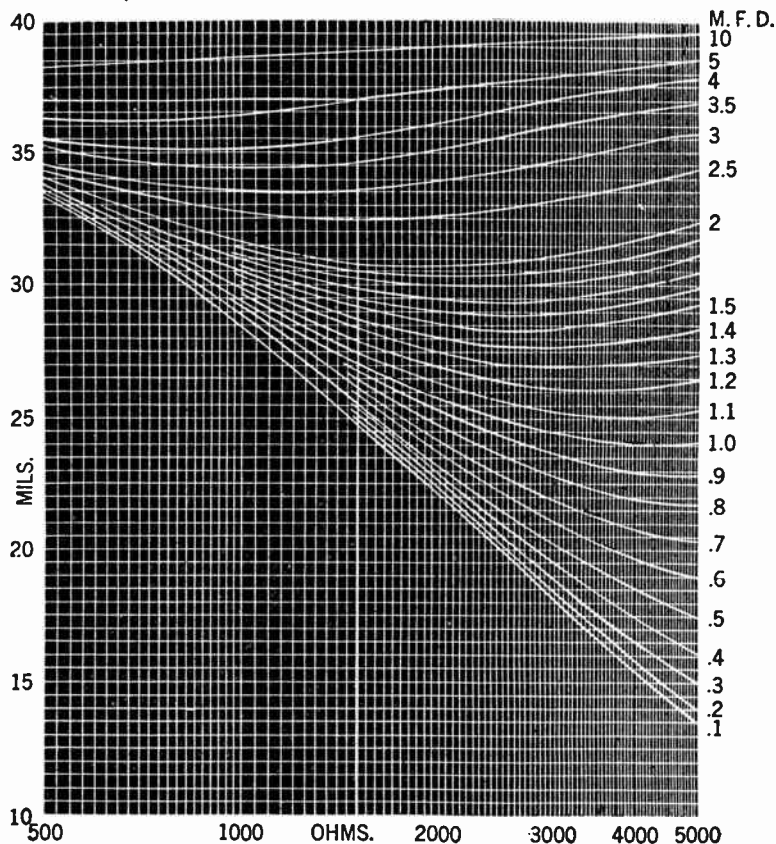

FIG. 3—Parallel resistance-capacity chart. Charts may conveniently be designed to suit individual requirements.

The value of  $r$ , is the resistance of the meter being used.

The value of  $R$  is obtained by an ohmmeter (*d.c.*). The *a.c.* milliammeter reading is obtained by placing it across the points  $A$  and  $B$  of fig. 2 as indicated.

The intersection of the line corresponding to the *a.c.* milliammeter readings and the resistance given by the ohmmeter will intersect on one of the curves and following this curve out, the value of the condenser in microfarad is obtained.

**Example.**—*If the a.c. milliammeter reads 30 M.A., and the resistance (R) is found by the ohmmeter to be 2,500 ohms, what is the value of the condenser?*

**Solution.**—Following the curve fig. 3 at the intersection of the 30 M.A. and the 2,500 ohms line shows the value of  $C$  to be 1.82 microfarads.

**Inductive Measurements.**—Inductance values may be obtained in a manner similar to that already described in capacity measurements. It should however be remembered that inductive reactance is vectorially positive whereas capacitive reactance is negative, and that the larger the value of the inductive reactance the lower will be the reading of the *a.c.* milliammeter. Also the larger the capacitive reactance the higher will be the reading of the *a.c.* milliammeter.

The formula for the inductive reactance ( $X_L$ ) in ohms is:

$$X_L = 2\pi fL \text{ ohms} \dots\dots\dots (4)$$

or if  $f = 60$  cycles, then

$$L = \frac{X_L}{377} \text{ henries} \dots\dots\dots (5)$$



When  $i$  = the *a.c.* current in amperes

$e$  = Impressed *a.c.* voltage

$R$  = Resistance of *a.c.* meter in ohms

$X_L$  = Effective resistance of the inductor in ohms

then the formula for current is as follows:

$$i = \frac{e}{\sqrt{R^2 + X_L^2}} \dots \dots \dots (6)$$

The reading of the *a.c.* milliammeter may conveniently be referred to a chart computed from equation (4) from which the value of the inductance can be found similarly as previously shown.

If 50 cycles is used instead of 60 cycles the results should be multiplied by  $\frac{60}{50}$  or 1.2.

## Commercial Type Analyzers

**Weston Model 665 Selective Analyzer.**—The external view of this instrument is shown in fig. 4. and its internal connection diagram in fig. 5.

The instrument is principally a volt-ohm-milliammeter for both *a.c.* and *d.c.* service.

All voltage ranges are available at the pin jacks, and by means of socket selector units may be had through the plug. They are 0-1/2.5/5/10/25/100/250/500/1,000 volts, either *a.c.* or *d.c.* The individual ranges are selected by means of the large selector switch. A reading cannot be had till either the *d.c.* or *a.c.* push button at the bottom of the panel is pressed. These are locking types and should be returned to their original position after each test is completed.

All current ranges are available at the pin jacks and are also available for current measurements at the socket by means of the socket selector units. These ranges are 0-/2.5/5/10/25/50-/100/250/500 milli-amperes, *d.c.* only.

Resistance measurements may be had with test leads and the various ohmmeter pin jacks, as a point-to-point tester. Also by means of a socket selector unit, resistance measurements may be taken between any two socket prongs or a socket prong and ground.

A very useful feature in this instrument is that it may easily be converted into a complete analyzer by addition of the 666 socket selector shown in fig. 6, thus bringing the tube socket connections to the analyzer circuit.

With reference to the **Tube Base Chart** shown on page 591 the various measurements should be made as follows:

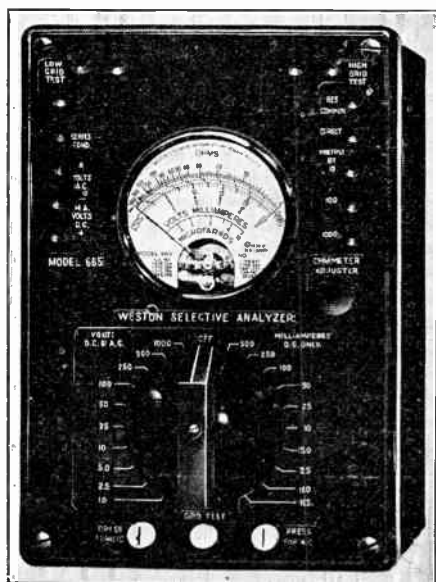

FIG. 4—Front view of Weston Model 665 selective analyzer.

**Heater Voltage.**—This is read between 1 and 4 on 4 prong tubes; 1 and 5 on 5 prong tubes; 1 and 6 on 6 prong tubes, and 1 and 7 on 7 prong tubes. However, it is advisable to check with the tube base chart because no fixed rule for the location of any terminal can be given.

**Plate Voltage.**—The plate is generally terminal No. 2 and for heater type tubes this voltage would be read between plate and cathode and for filament type between plate and negative filament. Since the plate and cathode terminal are not in the same locations for all type tubes, reference to the tube base chart is suggested.

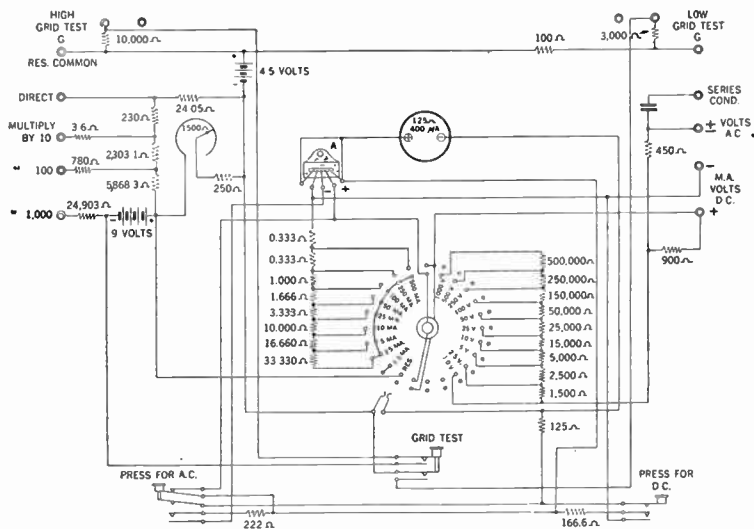

FIG. 5—Internal connection diagram of Weston Model 665 selective analyzer.

**Grid Voltage.**—There are a number of grids such as control, screen, suppressor, anode, etc. For heater type tubes the voltage is measured from the cathode to the desired grid and for filament type tubes from the negative filament to the desired grid. Reference to the tube base chart will give the correct location of the various grids for the tube in question.

Reference should be made to the service manual of the radio set being tested for the determination of the correct values of grid and plate voltage.

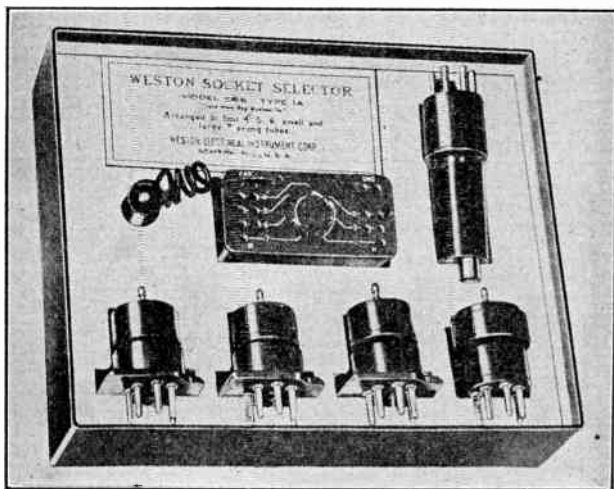

FIG. 6—Socket selector for use with Weston Model 665 analyzer.

**Plate Current.**—A pair of leads are plugged into the M.A. pin jacks on the panel; the other ends of these leads are placed in the two jacks opposite the plate terminal on the socket selector unit. The dial switch is turned to the desired milliamperage range. This will give a plate current reading on the milliammeter. It is necessary to hold down the "Press for D.C." button.

True total current in any lead is read in this way, since the inner jack of each pair functions as a closed circuit jack switch. When a pin tip is plugged into the inner of a pair of jacks, the main circuit is opened between the jacks. The total current,

## TUBE BASE CHART

FOR USE WITH  
THE WESTON METHOD OF SELECTIVE ANALYSIS

Tube	Base	Tube	Base	Tube	Base	Tube	Base	Tube	Base
00A	4-1	27	5-1	47	5-3	71	4-1	98	5-5
01A	4-1	27HM	5-1	48	6-3	71A	4-1	X99	4-1
01AA	4-1	29	6-2	49	5-4	71B	4-1	1A6	6-9
1	4-7	30	4-1	50	4-1	75	6-4	2A3	4-1
IV	4-7	31	4-1	51	5-2	76	5-1	2A3H	4-1
G2	5-5	32	4-2	52	5-3	77	6-1	2A5	6-3
G4	5-5	33	5-3	53	7-4	78	6-1	2A6	6-4
KR1	4-7	34	4-2	55	6-4	79	6-5	2A7	7-2
KR2	4-7	35	5-2	56	5-1	80	4-5	2B6	7-8
KR3	5-3	36	5-2	57	6-1	80M	4-5	2B7	7-3
10	4-1	36A	5-2	57AS	6-1	81	4-6	5Z3	4-5
12A	4-1	37	5-1	58	6-1	81M	4-6	6A4	5-3
10	4-1	37A	5-1	58AS	6-1	82	4-5	6A7	7-2
WX12	4-1	38	5-2	59	7-1	82V	4-5	6B7	7-3
14	5-2	38A	5-2	59B	7-9	83	4-5	6C6	6-1
15	5-2	39	5-2	61	5-2	83V	4-5	6C7	7-10
17	5-1	39A	5-2	64A	5-2	84	5-5	6D6	6-1
18	6-3	40	4-1	65	5-2	84	4-6	6D7	7-2
19	6-6	41	6-3	65A	5-2	85	6-4	6E7	7-2
20	4-1	42	6-3	67	5-1	89	6-1	6F7	7-5
22	4-2	43	6-3	67A	5-1	90	6-2	6Y5	6-10
24	5-2	44	5-2	68	5-2	92	6-2	6Z3	4-7
24A	5-2	45	4-1	68A	5-2	95	6-3	6Z1	5-5
KR25	6-3	46	5-4	69	6-2	96	4-7	6Z5	6-8
26	4-1							12A5	7-6
								14Z3	4-7
								25Z3	4-7
								25Z5	6-7
								182B	4-1
								183	4-1
								213	4-5
								216B	4-6
								482A	4-1
								482B	4-1
								483	4-1
								484	5-1
								485	5-1
								585	4-1
								586	4-1
								864	4-1
								950	5-3
								951	4-2
								AD	4-7
								AF	4-5
								AG	4-5
								LA	5-3
								PZ	5-3
								PZH	6-3

### LOOKING DOWN ON TOP OF SOCKET

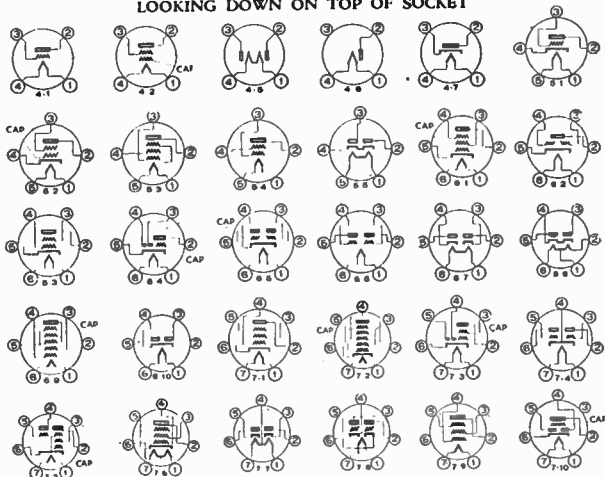

therefore, must flow out through the measuring instrument and back into the other jack. Note that voltage measurements cannot be made in the inner jacks, since the circuit is opened when pin tips are placed in them.

**Grid Current.**—Grid and screen current measurements are made in the same manner as the plate current. All current ranges are available for this purpose. The push button marked "Press for D.C." must be held down for this test. These readings are obtained by placing one end of each of a pair of leads in the "M.A." pin jacks and the other ends in the two pin jacks opposite the terminal of the grid desired.

The plate current of the second plate of rectifier tubes is tested as above. It is advisable to consult the tube base chart for location of the terminals for the various elements.

**Grid Tests.**—Two grid tests are available, one with a low shift of 4.5 volts, the other a high shift of 13.5 volts for power tubes only. A separate set of pin jacks is provided on the panel for each shift.

A pair of short leads is plugged into the panel at the upper corner marked "Grid test" and the other ends plugged into the pin jacks opposite the control grid terminal desired on the selector unit. Be sure lead from "G" pin jack is inserted in the pin jack nearest the tube on selector unit.

Another pair of leads is plugged into the M.A. pin jacks on the panel, the other ends of these leads are placed in the two jacks opposite the plate terminal on the socket selector unit. The dial switch is turned to the desired M.A. range. This will give a plate current reading on the milliammeter. Pressing the "Grid Test" button (located in center of lower edge of panel) will give an increase in the plate current reading.

The grid test reading is an indication of the relative goodness of the tube, and is proportional to the mutual conductance. No values can be given for this reading because of the high plate circuit resistance in many radio sets.

**Cathode Voltage.**—Cathode voltage is measured with reference to the heater. In some sets the cathode is connected directly to the heater, in which case the cathode voltage reading will be zero.

In other sets the cathode is grounded through the grid bias resistor with heater connected to some positive potential, in which case the cathode will read negative with reference to the heater. In most alternating current radio sets the cathode is grounded through the grid bias resistor with the heater grounded, in which case the cathode will read positive with reference to the heater.

**Output Test.**—This test is made exactly like the measurement of *a.c.* voltage, except when *d.c.* is present in the output circuit, then the "Series Condenser" pin jack must be used. All voltage ranges are available for this test. It is necessary to hold down or lock in position the "Press for A.C." push button.

**Weston Model 571 Output Meter.**—The external view of this meter is shown in fig. 7 and its internal connection in fig. 8.

This instrument has a constant resistance of 4,000 ohms on each range, is usually used as a terminating impedance on sound line or receiver output circuits. It can be used, however, on bridging measurements on low impedance lines. It is also valuable as a multi-range *a.c.* volt-meter of wide adaptability.



The 5 voltage ranges are available at pin-jacks and are selected by means of a dial switch. It also has a self-contained condenser for blocking any *d.c.* components. This condenser is connected to a separate pin-jack.

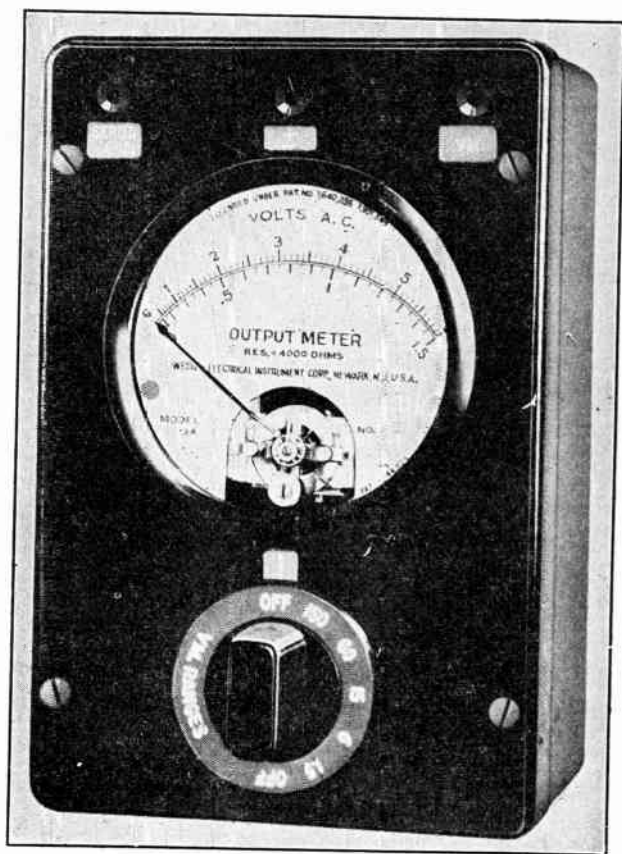

FIG. 7—Panel view of Weston Model 571 output meter.

The voltage ranges are: 0-1.5/6/15/60/150. Test leads and adapter for connection to the plate pin of any output vacuum tube are provided for the meter.

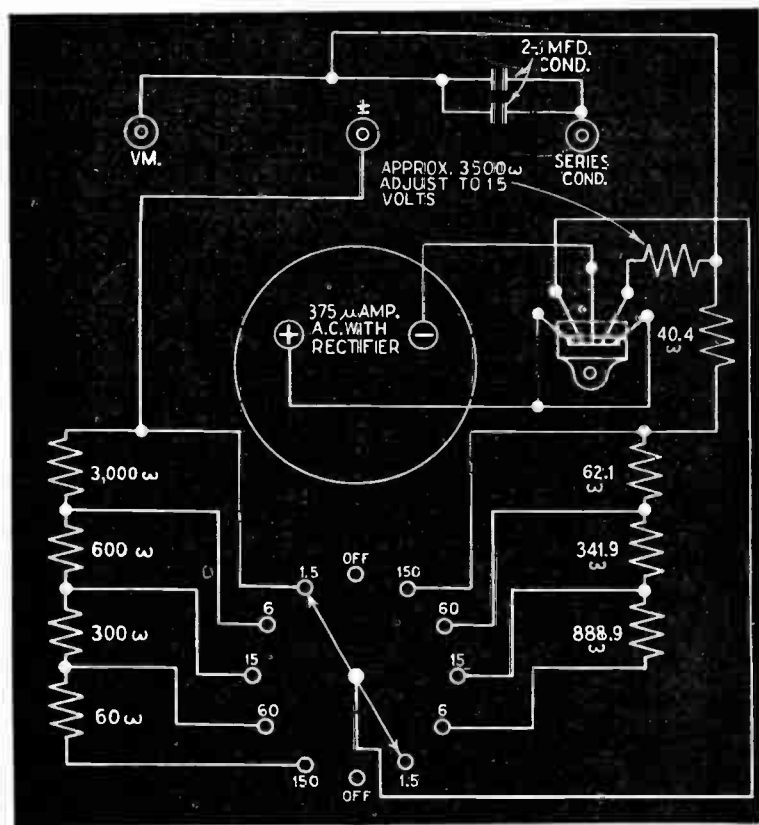
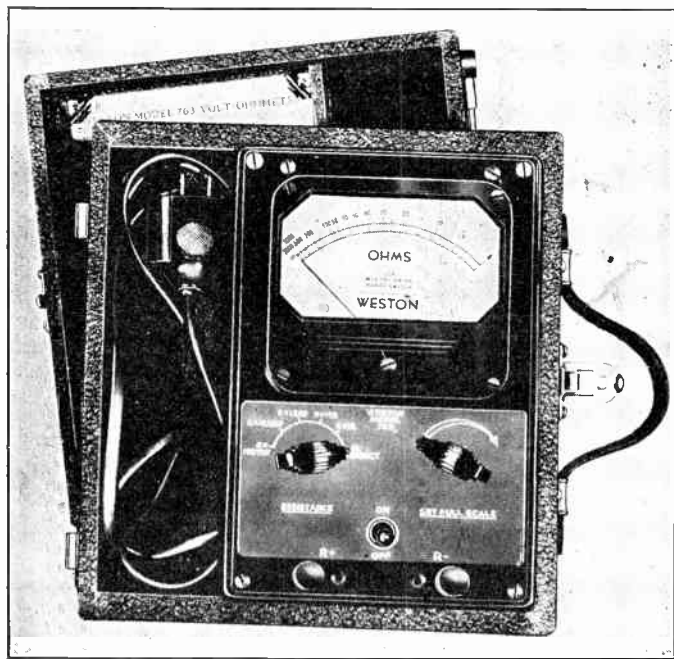

FIG. 8—Schematic wiring diagram of Weston Model 571 output meter.

**Weston Model 763 Ohmmeter.**—Front view and connection diagram of this instrument is shown in figs. 9 and 10 respectively.



**FIG. 9**—Panel view of Weston Model 763 ohmmeter.

With this instrument resistance measurements of from 0.2 ohms to 300 megohms may be made with high accuracy on 6 ranges. It can also be used with good results on the top range as a modified megger in which 125 volts (maximum current 50 microamperes) is available for insulation tests.



**Weston Model 765 Analyzer.**—A front view and internal connection diagram of this instrument is shown in figs. 11 and 12 respectively.

This instrument is claimed to be of very high sensitivity. For



**FIG. 11**—Front view of Weston Model 765 analyzer.





**Weston Model 772 Analyzer.**—This analyzer is designed to make the necessary tests on present day equipment such as commercial radio receivers, transmitters, television receivers,

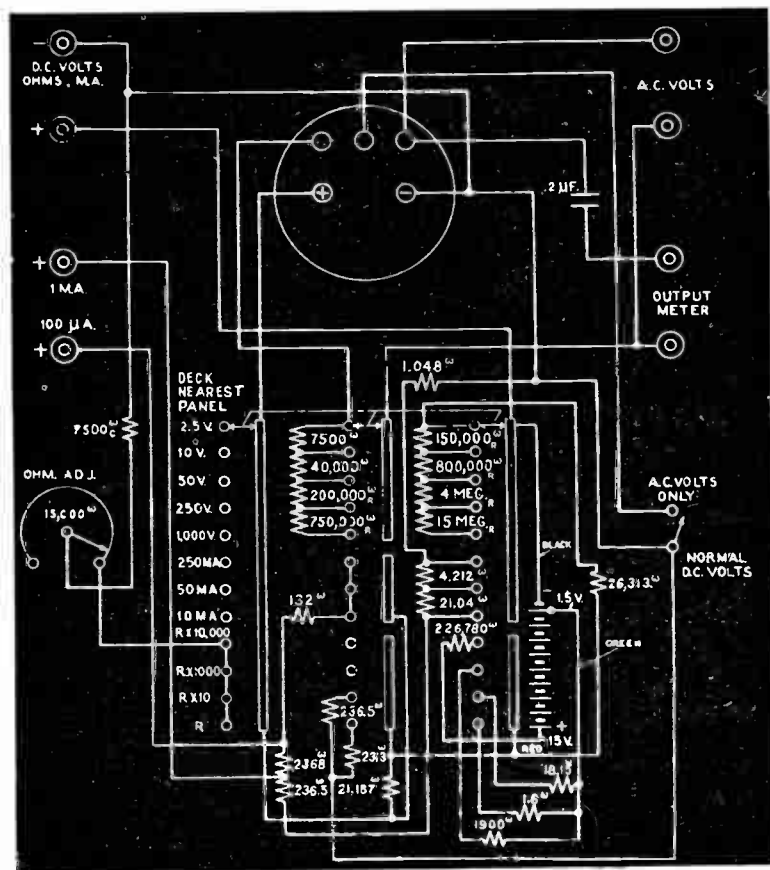

FIG. 14—Wiring diagram of Weston Model 772 analyzer.



public address systems, vacuum tube and cathode ray equipment, etc.

The instrument is illustrated in fig. 13 and its connection diagram in fig. 14.

It has a 20,000 ohms per volt sensitivity on five *d.c.* voltage ranges. *A.c.* readings are made on single arc scale.

The ranges for *d.c.* current measurements are 0-/0.1/10/50/-250 *m.a.*/1*a*/10*a*.

*A.c.* or *d.c.* voltage measurements have the following ranges: 0-2.5/10/50/250/1,000 *v.* Five decibel ranges provide power level measurement from -14 to +54 *db.*

Resistances are measured on the following scales 0-3,000/-30,000/3 Meg./30 Megohms.

The instrument is equipped with pin jacks for mounting model 666 socket selector unit.

**Weston Model 773 Tube Checker.**—This instrument is manufactured both for counter and movable service, as shown in figs. 15 and 17 with a common diagram of connections in fig. 16. It has eight sockets for the various types of tubes, a direct reading "Bad-Good" meter scale, two selector switches, voltage adjustment switch, in addition to position and test switches.

With this instrument a complete analysis of any tube may readily be obtained. Separate electrode switches for grid, plate, screen, suppressor, diode or cathode are provided for emission, short and leakage tests. This point to point testing feature will be recognized as extremely important whenever doubtful tubes are encountered.

A most frequent source of trouble in radio tubes are the defects in circuit continuity of the electrodes and although an over-all efficiency test may at times fail to disclose these defects, a point to point electrode check will nearly always disclose the trouble.



FIG. 15—Front view of counter type Weston Model 773 tube checker.

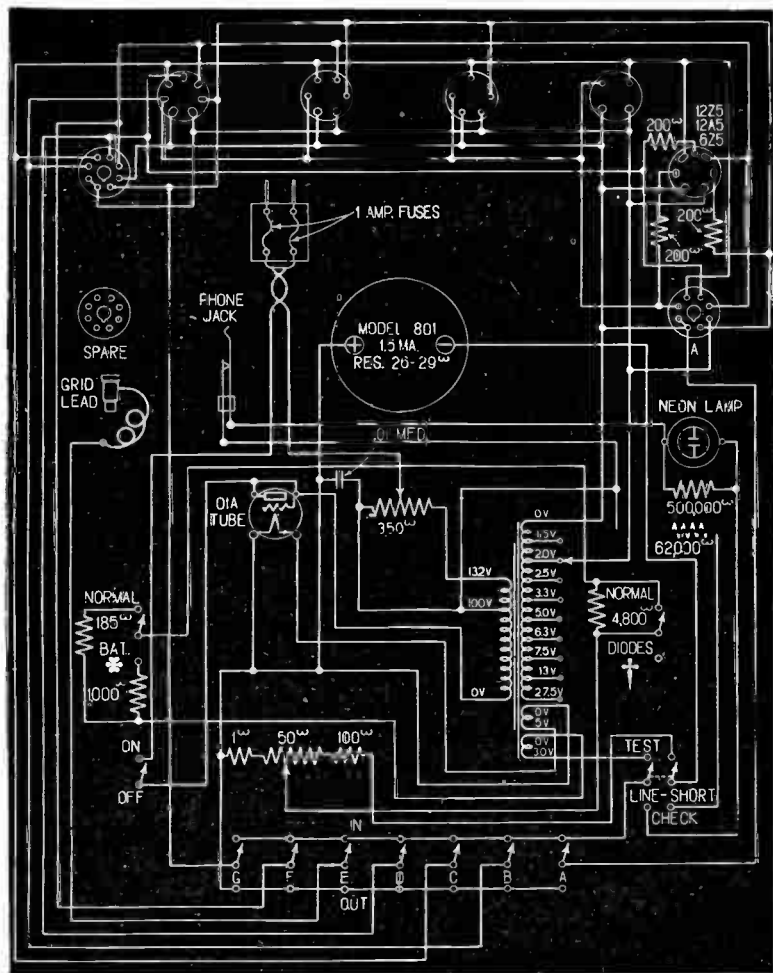

FIG. 16—Diagram of connection for Weston instruments Model 773.



FIG. 17—Panel view of Weston Model 773 movable type tube checker.

Weston Model 655-2 Selective Analyzer.—The internal connection of this instrument is shown in fig. 18.

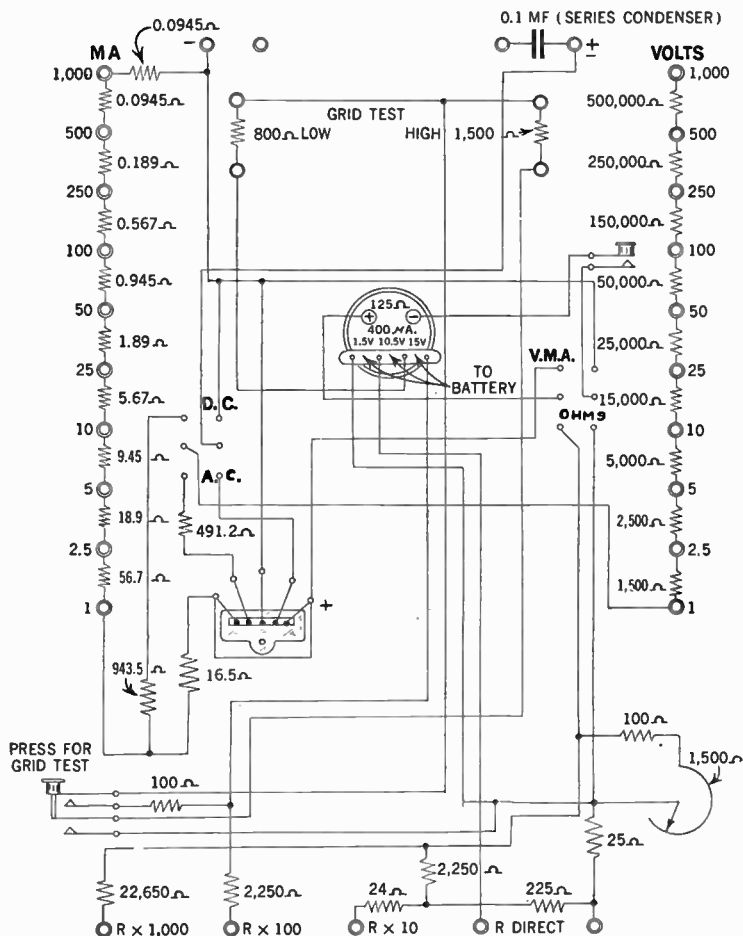

FIG. 18—Connection diagram of Weston Model 665-2 radio set analyzer.

The principal difference between this instrument and the 655 previously described is that the various scales are available by means of pin jacks instead of a rotary switch. The volt meter ranges *a.c.* or *d.c.* are: 0-1/2.5/5/10/25/50/100/250/500/1000 volts. The current ranges *d.c.* only are 0-1/2.5/5/10/25/50/100/250/500/1000 milliamperes.

**Supreme Model 339 Analyzer.**—The panel view and connection diagram of this instrument is shown in figs. 19 and 20 respectively.

It has five sockets for various types of tubes, a sensitive d'Arsonval fan shaped meter, and a rugged 4-gang, 5-position rotary switch for selectivity connecting the meter to any of the following measuring circuits:

- (a) *d.c.* milliammeter—0/5/25/125/250/500 *m.a.*, and 0/1.25 ampere.
- (b) *d.c.* voltmeter—0/2/25/125/250/500/1,250 volts.
- (c) Ohmmeter—0/2,000/20,000/200,000 ohms and 0/2/20 megohms.
- (d) *a.c.* voltmeter—0/5/25/125/250/500/1,250 volts.
- (e) Capacity Meter—0/0.05/0.25/1.25/2.5/5.0/12.5 *mfd.s.* electro-static (paper) and electrolytic.

For current, potential and resistance measurement the meter is "built up" to a resistance value of 300 ohms by means of a multiplier resistor connected in series with the meter, and all shunt and multiplier resistance values are calculated on the basis of a full scale current sensitivity of 1.0 milliamperes and a resistance value of 300 ohms for the meter.

The actual armature resistance of the meter is approximately 115 ohms. The operating procedure for the various measurements is as follows:

1. **Current Measurements.**—When it is desired to obtain current in terms of milliamperes the meter is shunted as shown

in fig. 20. The total shunt value of 75 ohms is determined by the lowest current-measuring range of 5 milliamperes. The meter, with its resistance built up to a value of 300 ohms, requires a potential of 0.3 volt (300 millivolts) to cause a full scale current of 1.0 milliampere to pass through the meter.

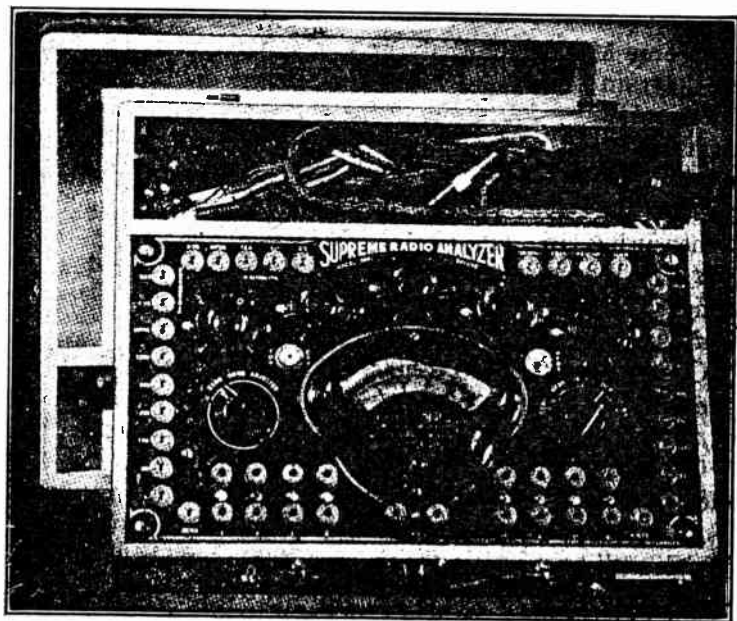

FIG. 19—Front view arrangement of Supreme Model 339 radio set analyzer.

The shunt resistor for the 5 milliampere range, being in parallel with the meter, will have the same 0.3 volt potential difference. Since 1.0 milliampere of the 5 milliampere range will pass through the meter, the shunt resistor will pass the other 4.0 milliamperes and its value is determined by dividing 4.0 milliamperes (0.004 ampere) into 300 millivolts (0.3 volts).

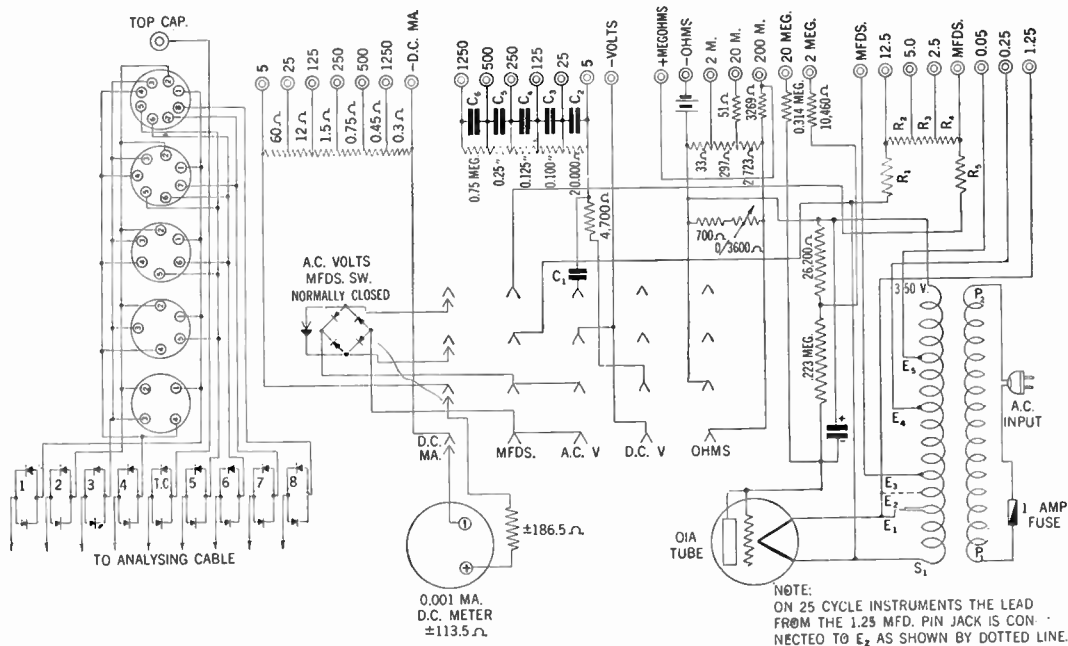

FIG. 20—Wiring arrangement and resistance values in Supreme Model 339 radio set analyzer.



For the current measuring ranges above the 5.0 milliampere range, the 75 ohm shunt resistor is divided into smaller values, thereby forming what is known as a "ring type" shunt, the total "ring" resistance value being 375 ohms.

The resistance values of the 75 ohm shunt resistors are determined by multiplying the total "ring" resistance by the full scale current of the meter, dividing the result by each range value, in turn, from the common terminal, and subtracting the sum of the preceding values from each newly-determined value.

When the "ring" value of 375 ohms is multiplied by the full scale sensitivity value of 0.001 ampere, 0.375 is the result, into which each range value is divided, in turn, for determining the required shunt values. For example, the shunt value for the 1.250 ampere range is determined by dividing 1.250 into 0.375, giving a value of 0.3 ohm for that range.

For the 500 milliampere range, 0.500 ampere is divided into 0.375, giving a value of 0.75 ohm for the 500 milliampere range; but since there already is a value 0.3 ohm for the preceding range, it is necessary to subtract 0.3 ohm from 0.75 ohm, leaving a value of 0.45 ohm for the second section of the shunt.

For the 250 milliampere range, 0.250 ampere is divided into 0.375, giving a value of 1.5 ohms for the 250 milliampere range; but since there already is a value of 0.75 ohm for the two preceding ranges, it is necessary to subtract 0.75 ohm from 1.5 ohms, leaving a value of 0.75 ohm for the third section of the shunt. The shunt sections for the other ranges are determined in a similar manner, and can be checked by Ohm's law.

For example, the shunt value of 0.3 ohm for the 1.250 ampere (1,250-milliampere) range is in parallel with the remaining 374.7 ohms of the "ring" circuit, which when multiplied by the meter current of 0.001 ampere, produces a potential drop of 0.3747 volt. With 0.001 ampere going through the meter, the

remaining value of 1.249 amperes will be going through the 0.3 ohm shunt, producing potential drop of 0.3 times 1.249 or 0.3747 volt. Since the potential drop across both parallel paths is identical by Ohm's law, it is concluded that the calculations are correct. The other ranges may be similarly checked by Ohm's law.

**2. D.C. Potential Measurements.**—When the meter is being used for potential measurements, enough resistance must be connected with it to limit the current to within the full scale sensitivity value of the meter.

The value of the multiplier resistor for the 5-volt range is established by subtracting the meter resistance value of 300 ohms from the 1,000 ohms-per-volt value of 5,000 ohms leaving a multiplier resistance value of 5,000-300 or 4,700 ohms.

For the higher ranges the multiplier resistance values are calculated on this basis of 1,000 ohms per volt.

**3. Resistance Measurements.**—For resistance measurements, the meter is used primarily as a voltmeter, with the current passing through the meter calibrated on an "Ohms" scale instead of being calibrated on a "Volts" scale. In the multi-range ohmmeter circuits of this tester, however, shunts are used to enable the different sensitivities required for each range, and to this extent, the ohmmeter circuits resemble current measuring circuits in which shunts are usually required.

It will be observed from diagram fig. 20, that for the lowest or 2,000 ohm range, the 33 ohm resistor is a shunt resistor, while the 297 ohm and the 2,723 ohm resistors act as multipliers to the meter with its 700/4,300-ohm shunting resistor made up of a fixed 700 ohm resistor and a variable 3,600 ohm rheostat for accommodating battery potential variations.

For the 20,000 ohm range, the 33 ohm and the 297 ohm resistors, totaling 330 ohms, act as a shunting resistor, with the 51 ohm and 2,723 ohm resistors functioning as multipliers. For the 200,000 ohm range, the 33 ohm, 297 ohm and 2,723 ohm resistors act as a shunting resistor, and a 3,269 ohm resistor acts as a multiplier resistor.

**4. A.C. Potential Measurements.**—The *a.c.* potential measuring functions differ from the *d.c.* potential in that the meter is connected to the output terminals of a full-wave instrument rectifier and a capacitor is substituted for the 4,700 ohm multiplier resistor, the capacitor being connected in series with the rectifier input circuit. Each of the multiplier resistors above the 5-volt range is by-passed with a calibration capacitor. The elements involved in the *a.c.* potential measuring functions are indicated in wiring diagram.

**5. Capacity Measurements.**—When the meter is used for capacity measurements, the resistance value of the meter and of the shunt and multiplier resistors associated with the measuring circuit constitutes one leg of an impedance triangle. See fig. 21. The reactance of a capacitor of unknown value, which may be connected into the measuring circuits for the purpose of determining its value, constitutes another leg of the same impedance triangle.

It is obvious that the resistance value of the meter and of its associated shunt and multiplier resistors is a constant value for any particular capacity-measuring range, regardless of the capacitive value of any capacitor which may be connected to that range, and that the capacitive reactance, in every case, is determined by the capacitive value of the capacitor which may be subjected to the measurement; therefore, the capacitive leg of the triangle is the variable element.

It is further obvious that the meter current is related directly to the hypotenuse of the impedance triangle and will not, therefore, have a linear relationship to capacitive values. For example, assume an impedance triangle in which a full-scale meter current corresponds to a certain hypotenuse length, and in which the reactance leg corresponds to a capacitive value of

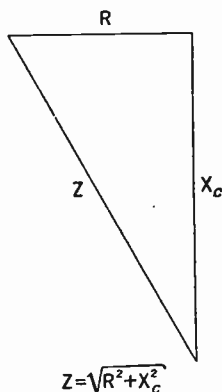

FIG. 21—Arrangement of impedance triangle in capacity measurements.

5.0 microfarads; if we remove the 5.0 mfd. capacitor and put in its place a 2.5 mfd. capacitor, the length of the reactive leg of the triangle will be doubled, but the length of the hypotenuse will not be doubled, and, therefore, the meter current will not be reduced to one-half of its former full scale value. In other words, a linear or evenly-divided scale cannot be used on the basis of fixed resistance values for the meter and its associated shunt and multiplier resistors.

From what has just been explained, it is natural to ask a question as to how capacitive measurements are enabled on an

evenly divided scale in this tester. The answer lies in the fact that, although the meter, shunt and multiplier resistance values constitute a fixed resistive value for each capacity measuring range, a variable resistive value is introduced by the full wave instrument rectifier employed, and shunts and multipliers are employed of such values as will enable the variable element of the rectifier resistance to approximately counter-balance the variable reactive element introduced by the different capacitive values which may be encountered for measurement.

In other words, the divisions of a meter scale would be crowded on the upper end of the scale for capacitive measurements if the rectifier were linear in its characteristics, and the non-linear characteristics of the rectifier would cause the divisions of the meter scale to be crowded on the lower end of the scale, if no capacitive variable elements are introduced into the circuit; but when both variable elements are introduced into the circuit in approximately equal and opposite proportions, the meter scale divisions can be equally separated across the whole scale, or, what amounts to the same thing, the regular evenly-divided scales can be utilized for capacitive measurements.

For the measurement of electrostatic (paper) capacitive values, comparatively high *a.c.* potentials are used, but it is necessary to use comparatively low *a.c.* potential values for the measurement of electrolytic capacitive values, so as not to puncture the electrolytic film around the electrodes. Actually the *a.c.* potential applied to electrolytic capacitors in the 0/1.25/2.5/12.5 mfd. ranges is about 9 volts. The capacity-measuring circuits are shown in the wiring diagram.

**Supreme Model 585 Diagnometer.**—This instrument shown in fig. 22 with the connection diagrams of the tube testing circuit in fig. 23 has the following service facilities. It actually consists of 14 instruments in one compact assembly, for complete circuit and tube checking on all radios, P.A. amplifiers and television sets.

The instrument is a complete point to point set tester, or the "Free Reference" system of analysis direct from tube sockets may be chosen.

The meters provide for the following ranges:

1. Six *d.c.* potential ranges of 0-7/35/140/350/700/1,400 volts.

2. Six *a.c.* potential measuring ranges of 0-7/35/140/350/700/1,400 volts.

3. Seven *d.c.* current measuring ranges of 0-1/7/35/140/350/700/1,400 *m.a.*

A *d.c.* scale 0-14 amp. is provided for checking drain of auto radios and 6 volt mobile sound systems. There are six output meter ranges, ohms 0-200/2,000/20,000/200,000. The first division on the 200 ohm scale is 0.25 ohm. Can be read to 0.05 ohm. Megohmmeter 0-2/20.

The 20 megohm range operating at 450 volts is an excellent electrostatic, and main filter electrolytic condenser breakdown tester.

Decibels—10 to +6/0 to +16/+10 to +26/+20 to +36/+30 to +46 direct reading on the 500 ohm line; zero level 0.006 watts Electrostatic capacity meter 0-.07/0.35/1.4/3.5/7.0/14.0 Mfd.

Electrolytic capacity meter 0-3.5/7.0/14.0 Mfd. Direct meter leakage test for main filter electrolytics on colored "Good-Bad" scale.

Also a sensitive full size neon test for electrolytic condensers.

All meter services and ranges are selected by indicating rotary switches. New "Free Reference" tube for all old and new radio, P.A. and television tubes, except thyratrons and kinescopes.

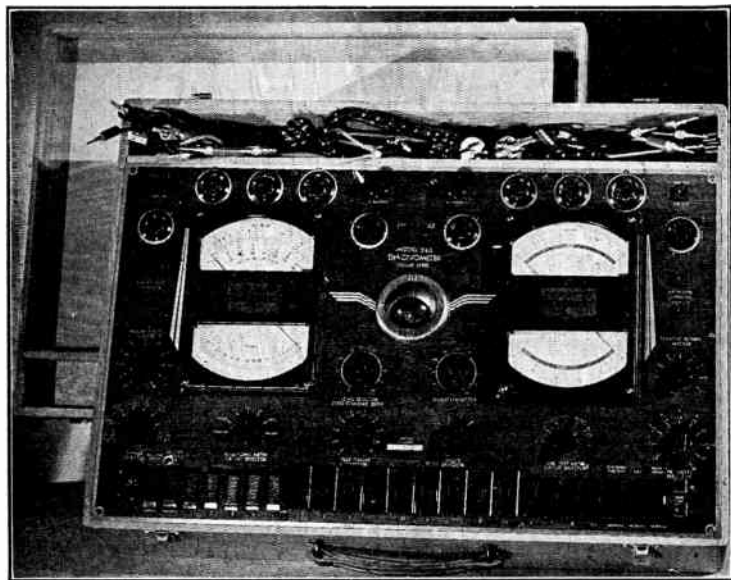

**FIG. 22**—Front view showing arrangement of instruments and switching devices in Supreme Model 585 diognometer.

With this diognometer it is possible to test all multi-purpose tubes section by section, as well as for overall performance, there are 48 possible basic combinations of load and voltage to insure proper and accurate tests of every conceivable type of tube.

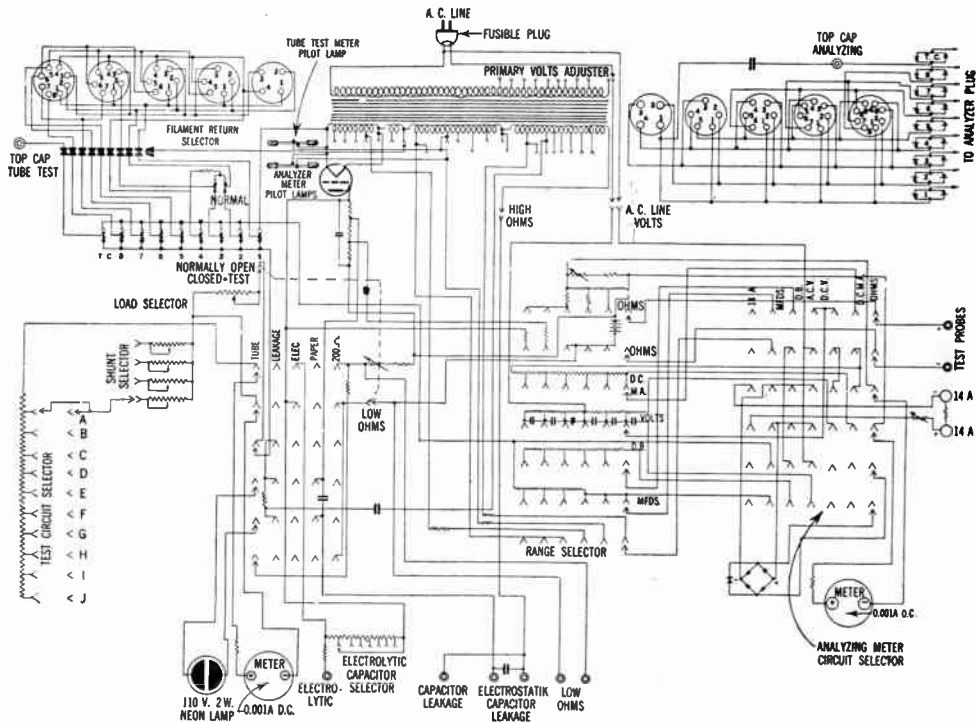
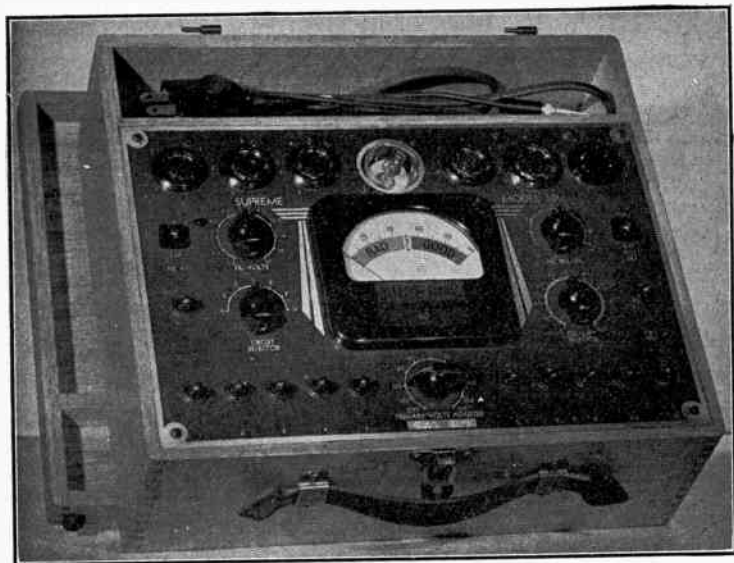

FIG. 23—Internal connection of Supreme Model 585 diagnetometer.



**Supreme Model 501 Tube Tester.**—The panel view of this tester is shown in fig. 24 and illustrates the various controls. The connection diagram is shown in fig. 25. This new improved circuit tests all old and new tubes for radio, public address systems, and television, except thyratrons and kinescopes. It tests all multi-purpose tubes section by section, as well as for overall performance.



**FIG. 24**—Front view of Supreme Model 501 tube tester.

All quality tests are made at full rated load for highest accuracy. Six sockets test all types and combinations of tubes, as both ends of the filament or heater are free, through switches, for instant connection to any pair of tube terminals including the top cap.

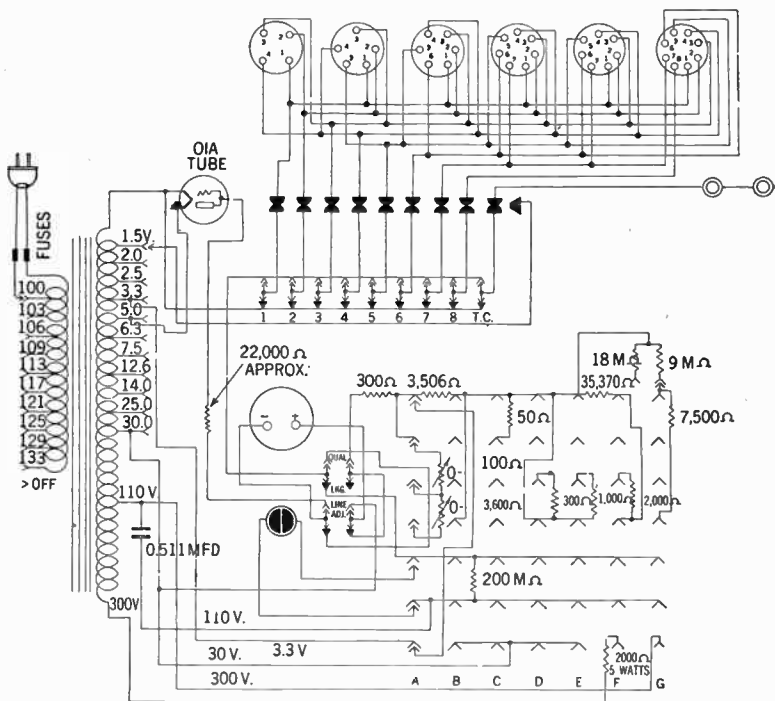

FIG. 25—Schematic wiring diagram of internal connection in Supreme Model 501 tube tester.

**Supreme Model 551 Analyzer.**—The panel view and connection diagram of this instrument are shown in figs. 23 and 24 respectively.

This set analyzer will handle all service and circuit problems of all types of radios, P.A. amplifiers and television sets. It is also as useful in servicing industrial vacuum tubes and photo-cell devices.

It has five sockets for the various types of tubes, and a sensitive 4 in. square meter, with easily readable scale. The various ranges and services are quickly available by means of an indexed rotary switch connecting the meter to any of the following measuring circuits:

- a. *D.c.* volts.....0-7/140/350/1,400
- b. *A.c.* volts.....0-7/140/350/1,400
- c. *D.c.* milliamperes.....0-1/7/35/140
- d. Ohms.....0-200/2,000/20,000

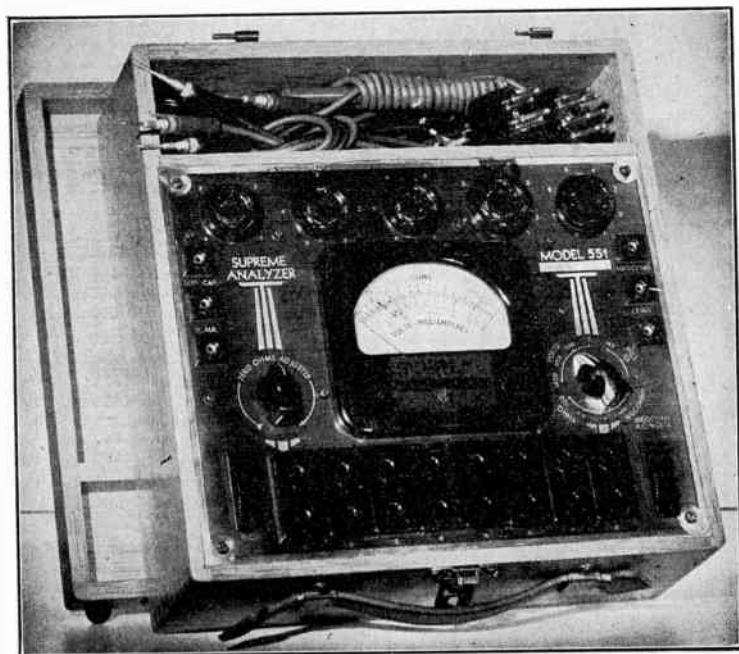

FIG. 26—Exterior view of Supreme Model 551 analyzer.

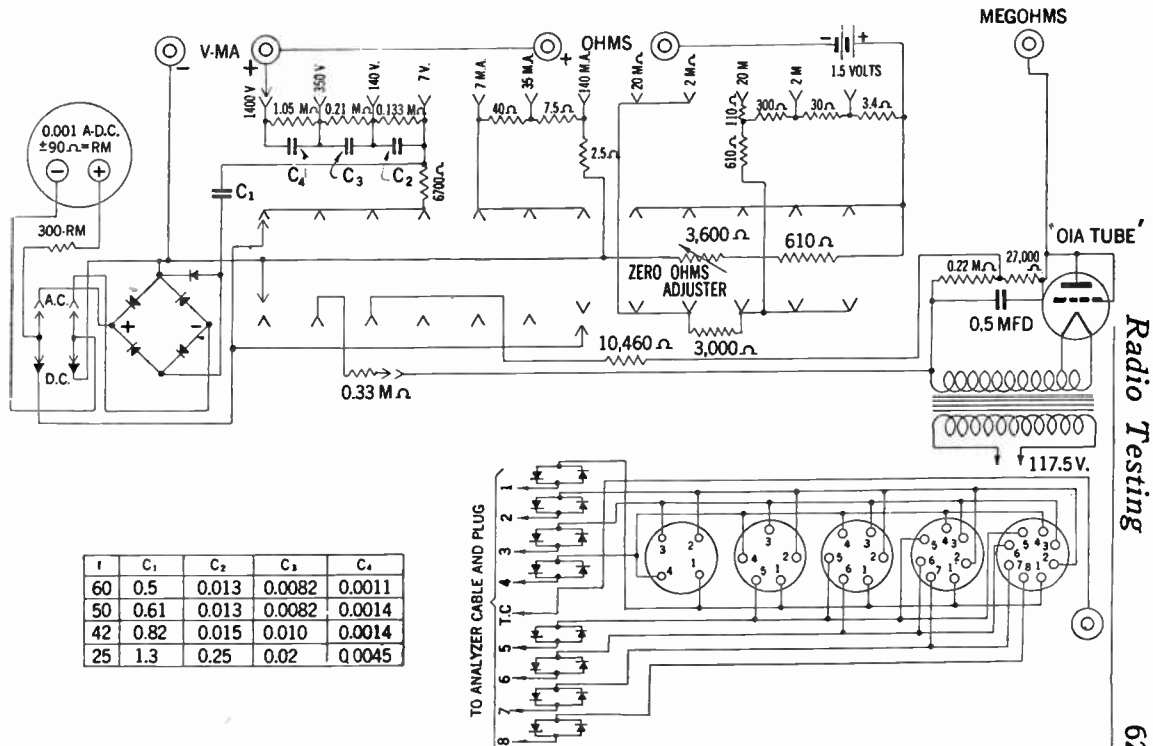

FIG. 27—Wiring diagram of Supreme Model 551 analyzer.

The first scale division of the 0-200 ohm range is 0.1 ohm, and at center scale the resistance reading is 3.5 ohms. This extreme open scale which can easily be read as close as 0.02 ohms is especially valuable when checking the resistance of shorted voice coils, filament windings on transformers, rosin joints, shorted turns in converter armatures, etc.

The megohmmeter has two ranges 0-2/20 megs, which is operated from a self-contained power supply for high resistance and cable leakage testing.

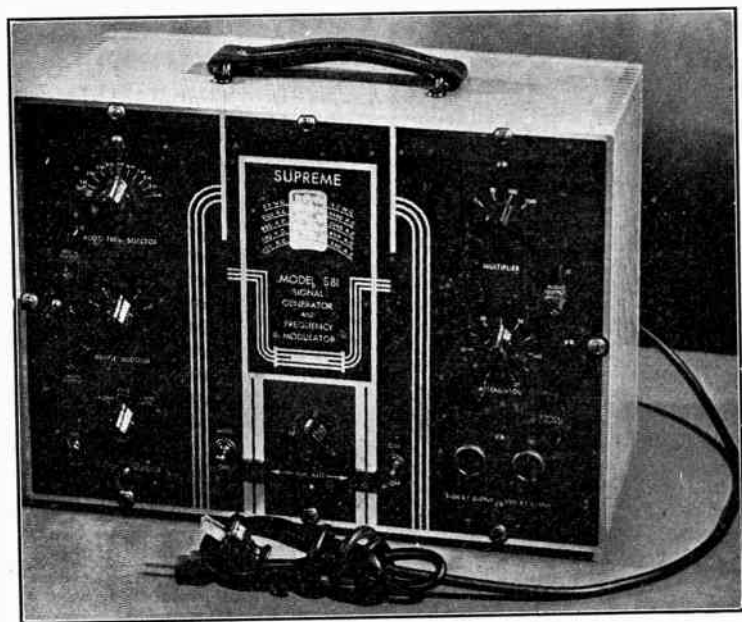

FIG. 28—Panel view of Supreme Model 581 signal generator.

**Supreme Model 581 Signal Generator.**—This all wave *r.f.* oscillator has a range of 130 *k.c.* to 60 *m.c.* on 5 fundamental bands and 3 harmonically related bands.

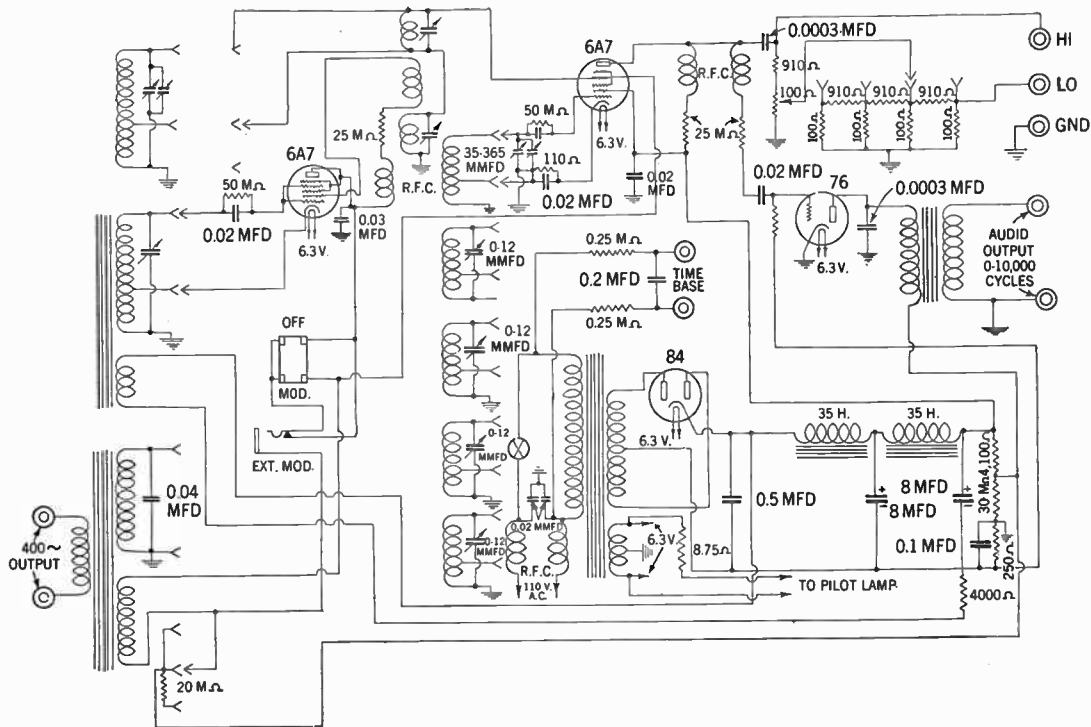

FIG. 29—Circuit diagram of Supreme Model 581 Signal generator.

Other noteworthy features includes a 400 cycle modulating oscillator which modulates the *r.f.* carrier the standard 30%; a beat frequency audio frequency oscillator having a 60/10,000 cycle range with less than 5% harmonic distortion; and an electronic frequency modulator or "Wobbulator."

This model is useful for alignment testing by the output meter (amplitude modulated *r.f.* signal) method or the visual cathode ray tube (frequency modulated *r.f.* signal) method; demodulation and detector testing; checking fidelity and overall response, and gain of audio and P.A. amplifier systems, band pass width; selectivity curves of *i.f.* amplifiers, etc.

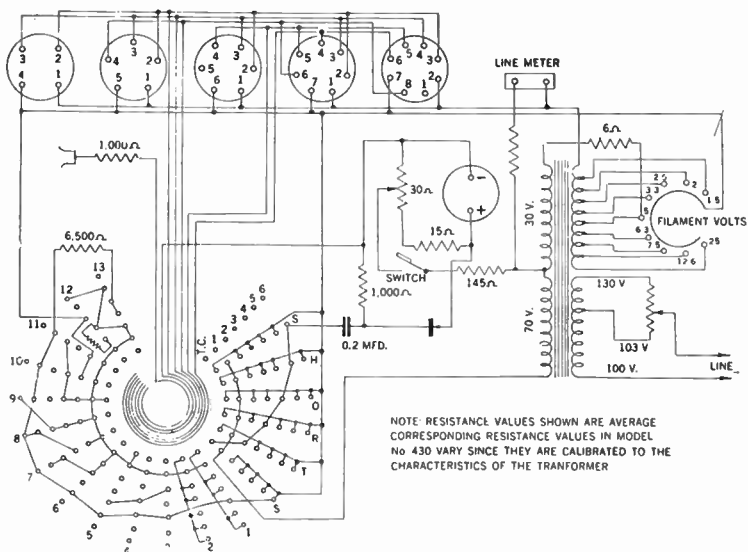

FIG. 30—Internal connection diagram of Readrite Model 430 tube tester.

The whole circuit is very stable, using a modified electron coupled system, which will not drift due to changes in line voltages, ambient temperature or attenuator control operation.

The circuit shown in fig. 29 has incorporated in it two 6A7, one 84 and one 76 tube.

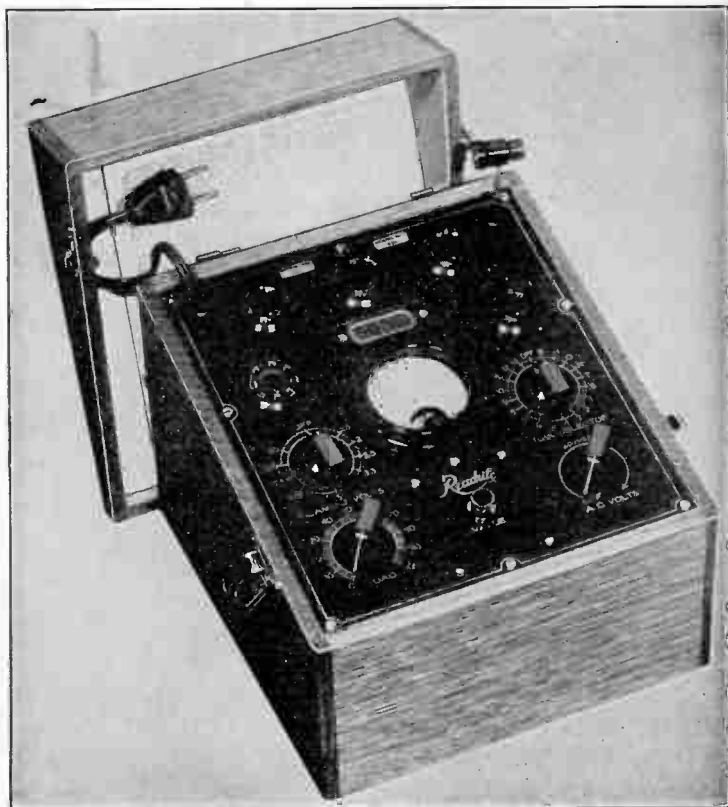

FIG. 31—Front view arrangement of devices in Readrite Model 430 tube tester.



**Readrite Model 430 Tube Tester.**—The wiring diagram and panel view of this type of instrument is shown in figs. 30 and 31 respectively.

This instrument is designed to test both metal and glass types of tubes.

The panel has five sockets and a direct reading "GOOD-BAD" meter scale, two selector switches, one load control knob, one *a.c.* voltage adjustment knob and one push button switch to indicate the condition of the tube under test.

The circuit is designed on the "emission" principle in that the meter indication depends on an emission test of the tube.

Cathode-leakage and short-circuit tests can also be made with this instrument.

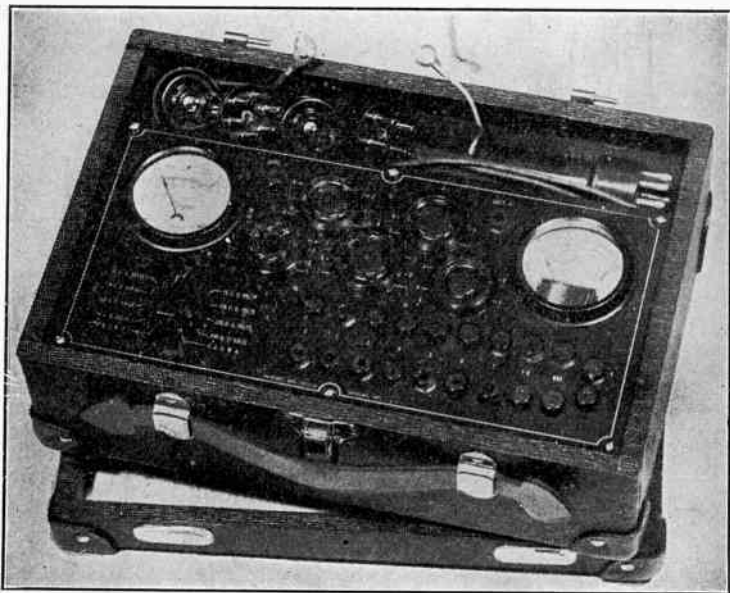

**FIG. 32**—Panel view of Readrite Model 720-A point to point panel.

**Readrite Model 720-A Point-to-Point Tester.**—This tester is equipped to handle both the glass and the glass-metal tubes. It may be used to measure resistance capacity and continuity, as well for voltage checking of any tube circuit.

The point-to-point tests are made through an eight conductor cable, which is plugged into the receiving set socket. Tester socket terminals are arranged according to R.M.A. standards, thereby making it unnecessary to remove chassis from cabinet when localizing faults. Arrangement of the different tube elements does not affect tests.

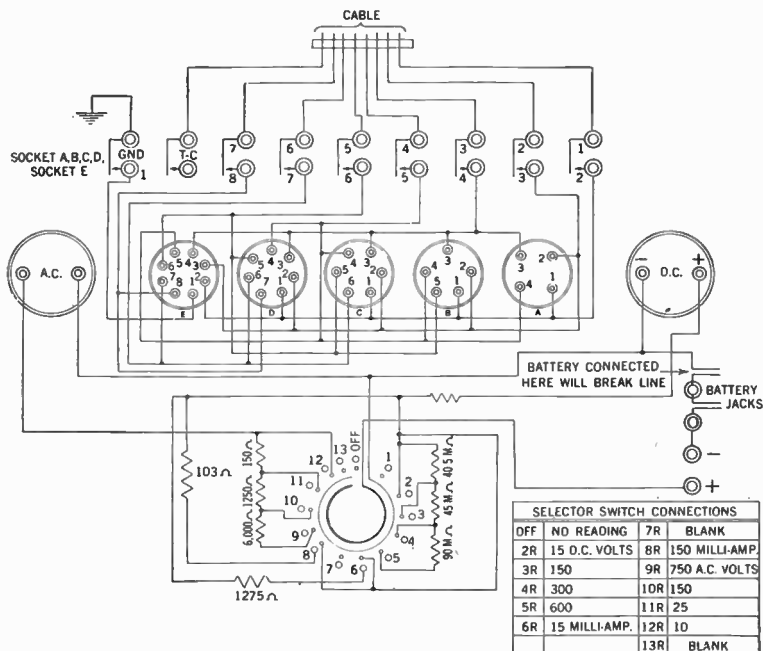

FIG. 33—Connection diagram of Readrite Model 720-A point to point tester.

The tester is equipped with two meters; a *d.c.* meter having scale for reading 15-150-300-600 volts, 15-150 milliamperes and an *a.c.* meter for reading 10-25-150 and 750 volts.

Separate meter ranges made available by connecting a single pair of jacks and using the selector switch. For diagram of connection and panel view, see figs. 33 and 32.

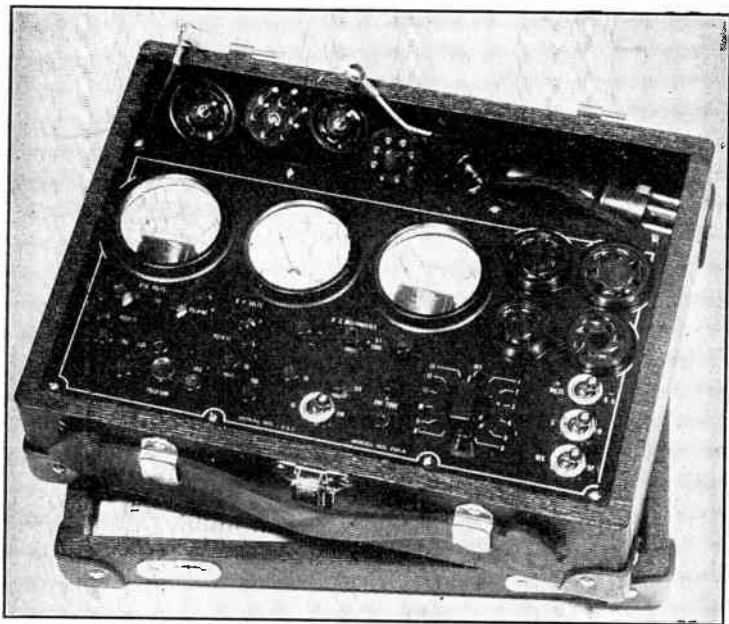
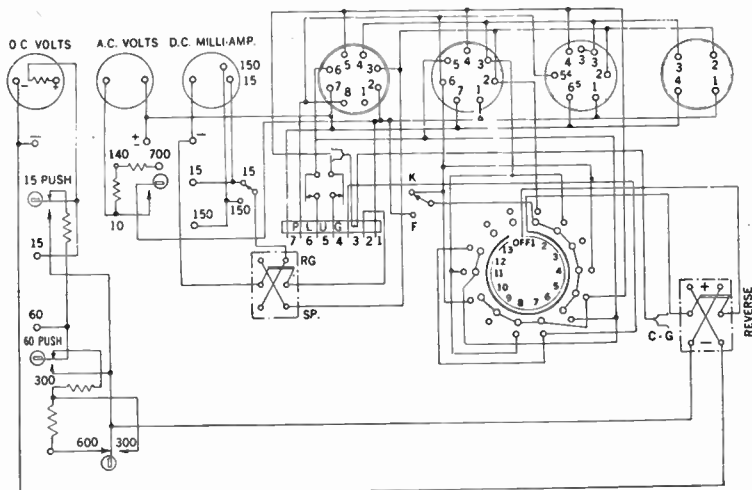

FIG. 34—Front view arrangement of Readrite Model 710-A tester.

**Readrite Model 710-A Tester.**—This instrument is used to test all parts of the tube circuits by plugging directly into the receiving set socket.

It will handle sets equipped with either glass or glass-metal tubes.

There are three meters, a *d.c.* volt-meter which reads 0-20/60/300/600 volts, and has 1,000 ohms resistance per volt, a *d.c.* milli-ammeter scale 0-15/150 and an *a.c.* voltmeter, scale 0-10/140/700.



SELECTOR SWITCH	CONTACTS 7-PRONG SOCKET	SELECTOR SWITCH	CONTACTS 7-PRONG SOCKET
1	2-6	7	4-2
2	3-6	8	4-3
3	C-G-6	9	4-5
4	1-6	10	4-6
5	6-4	11	5-3
6	6-5	12	5-4

FIG. 35—Schematic diagram of connections in Readrite Model 710-A tester.

A special positive contact selector switch connects all *d.c.* circuits to the *d.c.* volt meter. Panel jacks are provided to make individual range connections for the three meters.

The panel view and connection diagram are shown in figs. 34 and 35.

**Philco Model 025 Signal Generator and Radio Tester.**—This instrument consists principally of a volt-ohm-milliammeter for both *a.c.* and *d.c.* service.

The *a.c.* and *d.c.* voltage scales are 0–10/30/100/300/1,000. Current up to 10 amperes may be read directly on the milliammeter by using a special shunt.

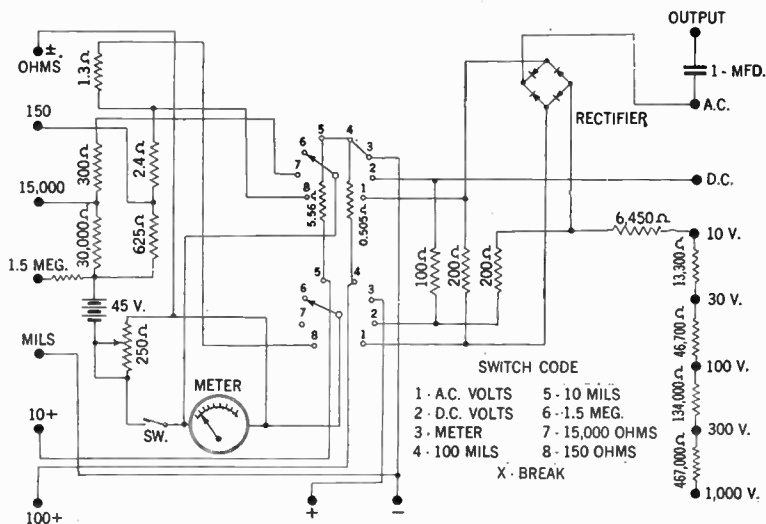

FIG. 36—Wiring diagram of Philco Model 025 radio tester.

The circuit is designed for capacity and resistance measurements which values are recorded on special scales, although in reading capacity (Mfd.) a special calibration chart should be consulted.

For internal connection and exterior views of instrument, see figs. 36 and 37.

**Readrite Model 557 Signal Generator.**—This signal generator is equipped with coil combinations to obtain frequency band as follows:

Coil "A" covers the band from	110 to	295 K.C.
Coil "B" covers the band from	275 to	840 "
Coil "C" covers the band from	820 to	2,800 "
Coil "D" covers the band from	2,500 to	8,500 "
Coil "E" covers the band from	8,000 to	20,500 "

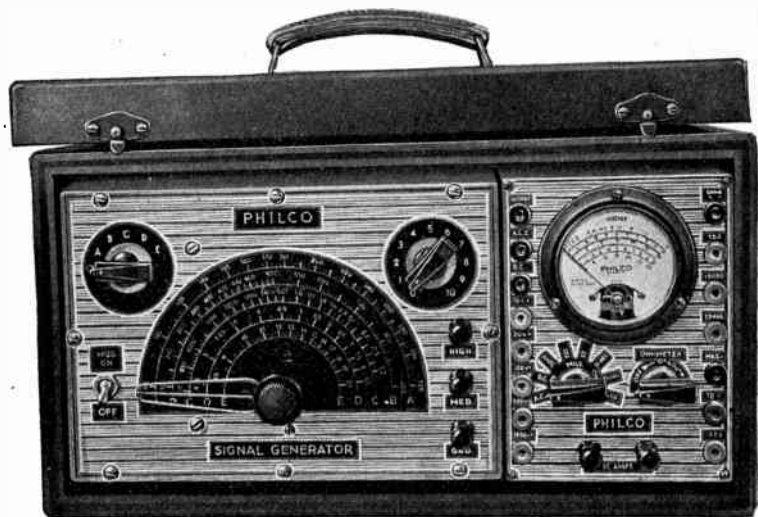

FIG. 37—Panel view of Philco Model 025 Signal generator and radio tester.

The operation of the oscillator is as follows: After determination of the frequency to be covered, select proper plug in the coil as shown under heading "Plug-in Coils"; place coil in 6-hole socket in shield can which is accessible by removing the

nickle cap near the toggle switch marked "On-Off". Connect oscillator and set the attenuator to approximately 75 on the dial, after which the toggle switch marked "MOD-UNMOD" is set to position desired.

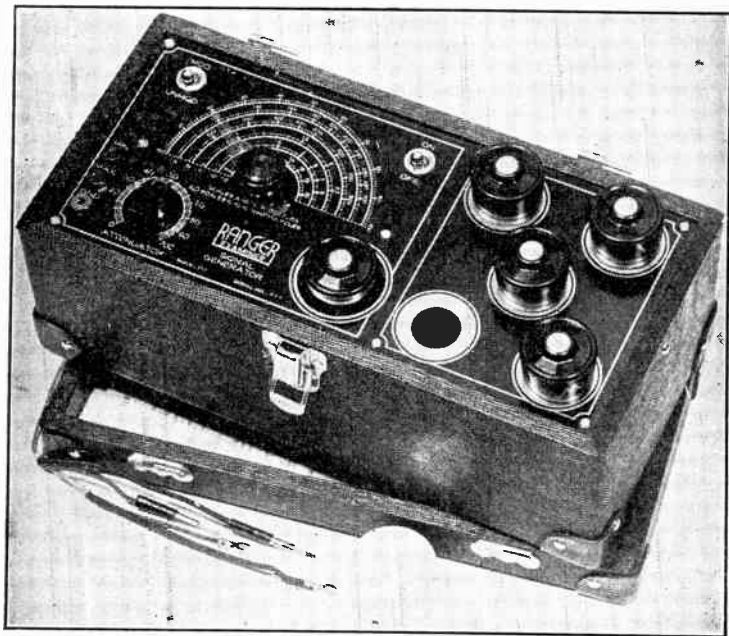

FIG. 38—Panel arrangement of Readrite Model 557 signal generator.

Generally speaking, all oscillator alignments are made with a modulated signal. Consult graph chart for the coil selected. Note dial setting for the frequency desired. Set dial pointer of frequency selector dial to the position as shown on graph. Turn oscillator power on by throwing the OFF-ON switch to the ON position and attenuate the signal to desired level by rotating

the attenuator control so that a minimum signal is reached. If further reduction in signal strength is wanted, use jacks marked Minimum and Ground.

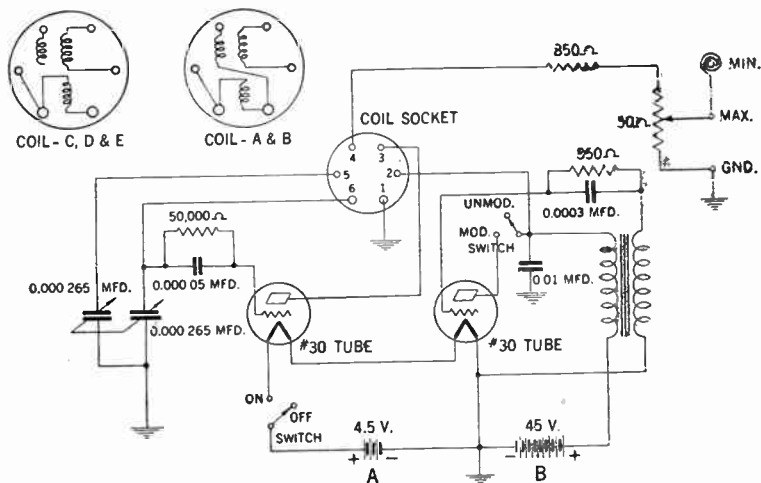

FIG. 39—Wiring diagram and coil arrangement in Readrite Model 557 signal generator.

**Output Meter.**—An output meter should always be connected to the radio output when using a signal generator. In order to avoid serious energy loss the output meter should be connected between the plate of output tube and chassis. If the output meter does not have a condenser there should be a condenser inserted in the output plate lead. This will prevent a burnout of meter. A .5 mfd. 400 volt condenser is suitable.

**Vacuum Tube Voltmeters (General).**—The vacuum tube voltmeter is an instrument used in service work for direct measurement across high impedance circuits, such as in the



measurements of radio-frequency and audio-frequency voltages where the use of power consuming instruments would be unsatisfactory on account of the small current in the circuit.

For example, the impedance of an *r.f.* circuit such as is used in the first and second stage of a receiver may be as high as 2 or 3 megohms when adjusted to resonance with an incoming signal.

To make any measurement of potential across such a circuit it is obvious that a meter having a resistance of 3 to 4 megohms would be required, as a meter having a lower resistance might change the potential condition in the circuit it is desired to measure, too much, and hence make the measurement unsatisfactory.

It has been found that the only connection that could profitably be made across such a circuit without upsetting the circuit potentials would be that of another vacuum tube, the connection being made across the grid and cathode of said tube.

Essentially, the vacuum tube volt meter as the name implies, is nothing more than a vacuum tube connected through a meter in its plate circuit to a suitable power supply.

The grid and the cathode of the tube are connected across the circuit to be measured, the potential of said circuit causing a change in grid voltage on the tube and thus, a resultant change in plate current is indicated on the instrument.

As the vacuum tube is also a rectifier, potentials of any frequency placed across the grid and cathode of the vacuum tube voltmeter will result in a direct current deflection on the instrument in the plate circuit.

It is for this reason that the vacuum tube voltmeter can be used for measuring audio as well as radio frequency potentials provided the circuit is worked out correctly to cover this broad range of frequency.

**Weston Model 669 Vacuum Tube Voltmeter.**—Front view and internal connection of the instrument is shown in figs. 40 and 41 respectively. The principal characteristics of this type of instrument is as follows:

1. It has 6 self-contained ranges controlled by a rotary switch in the lower left hand corner, the full scale readings being 0-1.2/3/6/8/12/16 volts. This meter is different from other multiple range vacuum tube voltmeters in that on all of these ranges only the grid to cathode impedance of the vacuum tube appears across the circuit to be measured.

2. The device operates directly from a 120 volt 60 cycle *a.c.* line, a self-contained transformer and power supply providing the necessary direct current potentials. A neon regulator bulb is used to hold the *d.c.* grid and plate voltages fixed irrespective of variations in line voltage. Up to the present time the problem of eliminating variations in vacuum tube meter readings with line voltage fluctuations has been a serious problem. The use of this regulator bulb has therefore put measurements of this type on a different plane as readings in the vicinity of .2 to 1 volt were practically impossible without having some sort of regulation of supply voltages.

3. Tubes used in the instrument are a type 78 and a type 1V, the former being the measuring tube and the latter the rectifier for the power supply. The 78 tube is mounted with the top projecting through the panel so that direct connection can be made to the grid cap using short leads. In the same way the grid is kept approximately 1 in. from any other metal surface and in this way input capacity is kept at a minimum.

4. A six range scale is provided, all *a.c.* readings being made directly without reference to curves or charts of any kind. The circuit has been worked out so that readings can be taken on 60 cycle lines without visible error, the frequency coverage of the device being from approximately 40 cycles up through receiver



FIG. 40—Panel view of Weston Model 669 vacuum tube voltmeter.

short wave ranges. On very high frequencies such as from 10 to 20 megacycles slight errors will occur due to tube capacity even though this has been kept at a very low value. Such errors, however, are not very great being of approximately the same order as attained on other instruments used in this frequency range.

Among the measurements which can be made on this instrument is analysis of oscillator performance on super-heterodyne receivers, measurements of gain per stage in all types of receivers, checking of resonance, automatic volume control measurements, etc.

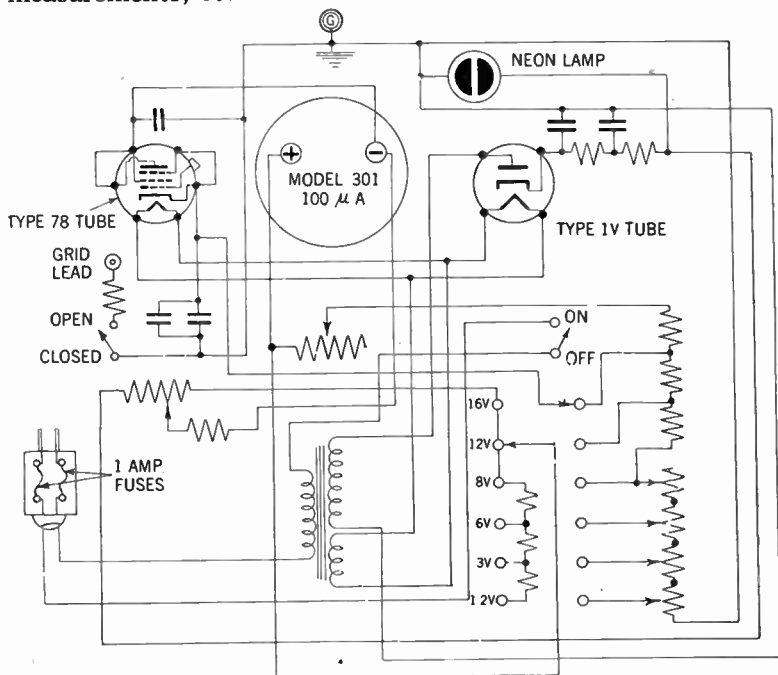
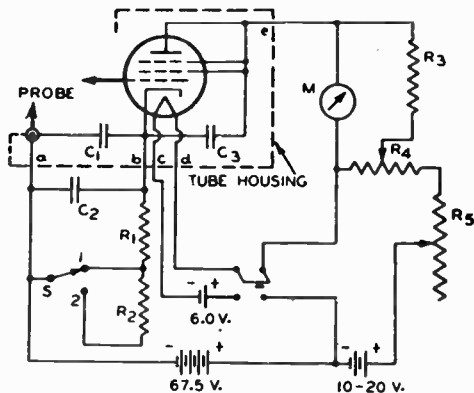

FIG. 41—Schematic wiring diagram of Weston Model 669 vacuum tube voltmeter.

### TYPICAL TUBE-VOLTMETER CIRCUIT SPECIALLY ADAPTED FOR PROBE ARRANGEMENT

TYPE 954 (AS TRIODE)



- $C_1 = 500 \mu\mu\text{f}$  CONDENSER (MICA)  $R_4 = 40000\text{-OHM}$  POTENTIOMETER  
 $C_2 = 16 \mu\text{f}$  COND. FOR CALIBRATION FOR COARSE ADJUSTMENT  
 WITH AND MEASUREMENT OF LOW FREQUENCIES IN BALANCING OUT  
 PLATE CURRENT  
 $C_3 = 500 \mu\mu\text{f}$  CONDENSER (MICA)  $R_5 = 2000\text{-OHM}$  RES. (VARIABLE)  
 $M = \text{MICROAMMETER (50 OHMS APPROX.)}$  { ON POSITION 1 GIVES RANGE  
 OF 2 VOLTS RMS  
 $R_1 = 2000\text{-OHM}$  RES. (WIRE WOUND) { ON POSITION 2 GIVES RANGE  
 OF 14 VOLTS RMS  
 $R_2 = 50000\text{-OHM}$  RES. (WIRE WOUND)  
 $R_3 = 10000\text{-OHM}$  RES. (WIRE WOUND)

NOTE: LEADS b, c, d AND e RETURN INSIDE CABLE. LEAD a IS CONNECTED TO GROUNDED HOUSING.

#### CONSTRUCTION OF PROBE

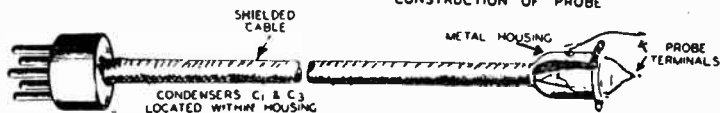

FIG. 42—Vacuum tube voltmeter arrangement in which 954 (on account of its small size) is placed at the point of measurement. In this way long leads and high input capacitances are avoided with the desirable result that measurements can be made at radio frequencies with a minimum effect on the constants of the circuit under measurement. (Courtesy Radio Corp. of America).

## CHAPTER 31

# The Cathode Ray Oscillograph

The cathode ray oscillograph is at present one of the most useful of radio testing devices. Although as yet relatively expensive, its applications are so numerous that it will readily replace a number of measuring instruments of more or less satisfactory characteristics.

A few of the more important applications of the instrument are the study of wave shapes and transients, measurements of modulation and peak voltages, adjustment of radio receivers, comparison of frequencies, the indication of balance in bridge circuits, tracing of vacuum tube characteristics, etc.

One of its chief advantages over other types of instruments is its freedom from inertia, allowing the observation of very rapid changes of current and voltage without appreciable distortion.

**The Cathode Ray Tube.**—Since the cathode ray oscillograph is built around the cathode ray tube, it is necessary to understand the principles of the latter before a study of the instrument itself.

A cathode ray tube, shown schematically in fig. 1 consists fundamentally of the following elements:

1. A glass envelope (*F*) whose purpose it is to maintain a vacuum in the tube.
2. A cathode (*L*) for the production of free electrons.
3. An electrode (*I*) whose purpose it is to accelerate the free electrons.
4. A focusing electrode (*G*) identified as **anode No. 1**, whose purpose it is to concentrate the liberated electrons into a cathode ray or beam.

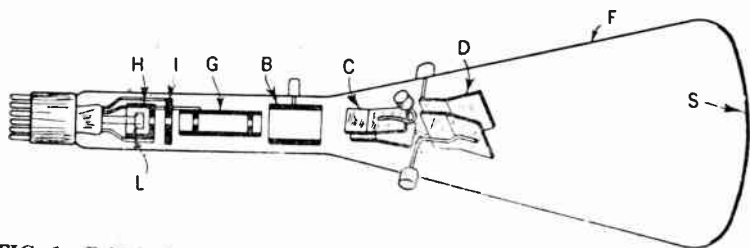
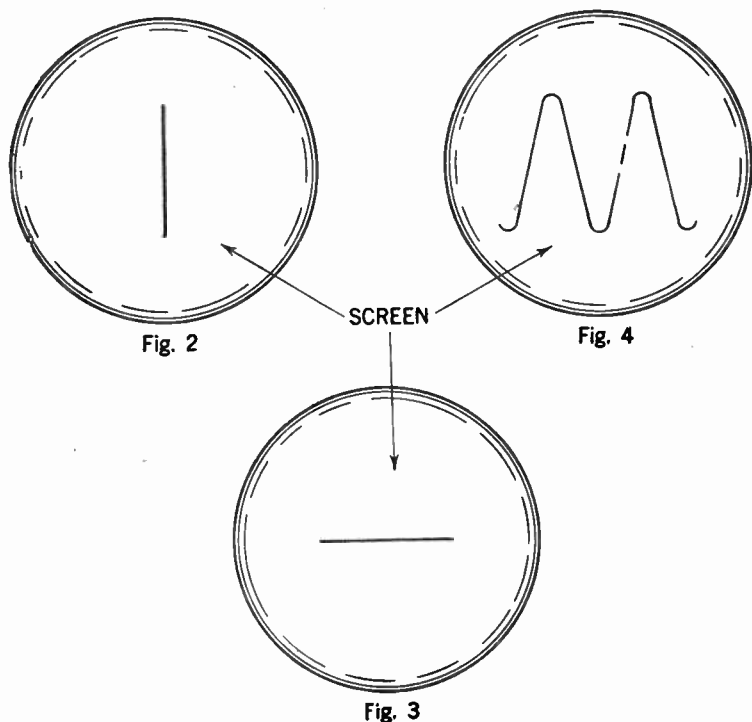

FIG. 1—Principal elements and electrode arrangement in a cathode ray tube of the electro-static deflection type.

5. A high voltage anode (*B*) known as **anode No. 2** for further accelerating the electrons.
  6. A control electrode (*H*) referred to as **grid No. 1** whose purpose it is to control the beam current.
  7. Two sets of electrostatic deflection plates (*C*) and (*D*) for deflection of the electron beam.
  8. The screen (*S*) which is coated on the inner surface of the enlarged end of the bulb with a material which shows a fluorescent glow at the impact point of the electron beam.
- The collective action of electrodes (*L*), (*H*), (*I*), (*G*), and (*B*) are called an "**Electron Gun**" inasmuch as their function is to

generate a beam of electrons and direct it toward the viewing screen (S).

As the electron beam consists of rapidly moving electrons, it constitutes a current having both electromagnetic and electro-



**FIGS. 2, 3 and 4**—Illustrates various fluorescent patterns which the electronic beam traces on the screens of the cathode and ray tube, under various conditions.

static properties. Because no material conductor is required to carry the electrons, the beam has negligible mass and inertia.



It is due to this inertialess characteristic that the electron beam can be deflected easily and rapidly by either electromagnetic or electrostatic fields. In the cathode-ray tube shown in fig. 1 the deflecting force produced by the phenomenon under investigation takes the form of an electrostatic field produced by a potential applied across the deflecting plates *C*. If this be an alternating voltage, the field produced causes the fluorescent spot viewed from the front of screen (*S*) to move up and down.

This movement of the spot traces a vertical line, as in fig. 2. A "time sweep" voltage of suitable wave form is applied across the deflecting plates *D*, causing the beam to move back and forth horizontally, as in fig. 3. The combined deflecting forces of the two fields may be caused to produce a pattern such as that in

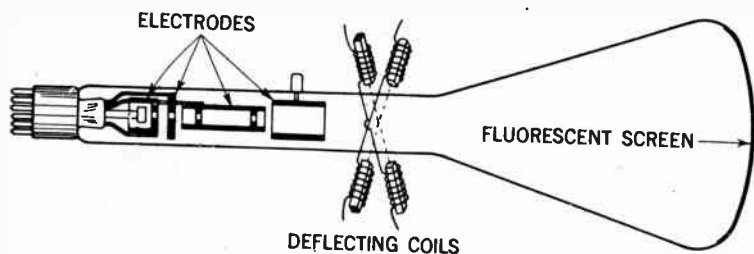
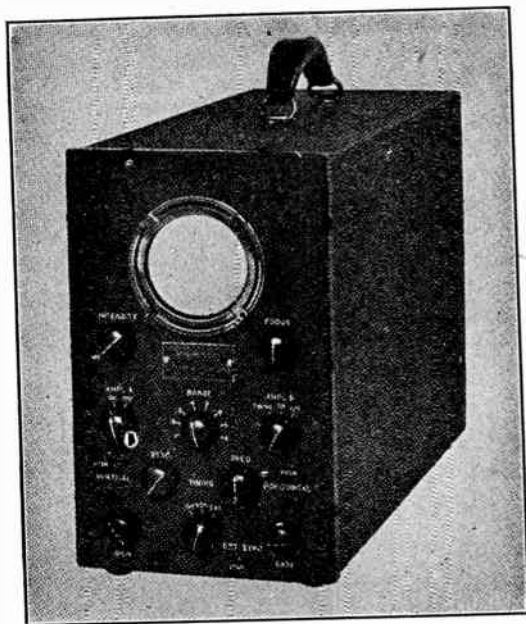

FIG. 5—Principal elements of a cathode ray tube of the electro-magnetic deflection type.

fig. 4. The fluorescent pattern which the electron beam traces on the screen can be distinguished, measured and photographed.

A type of cathode ray tube in which the deflection of the beam both horizontally and vertically is accomplished by means of two electromagnetic fields produced by two deflecting coils schematically depicted in fig. 5. In this case no electrostatic plates are used, otherwise this type of tube functions principally the same as the electrostatic deflection type.

**Parts of R.C.A. Type T.M.V.-122 B Cathode Ray Oscilloscope.**—The fundamental parts of this cathode ray oscilloscope, shown in figs. 6, 7 and 8 are as follows:



**FIG. 6**—Panel view of cathode ray oscilloscope. (Courtesy R.C.A. Inc.)

- (1) The cathode ray tube.
- (2) Signal amplifier for vertical deflection.
- (3) Signal amplifier for horizontal deflection.
- (4) A saw-tooth timing axis oscillator.
- (5) A low voltage full-wave rectifier for amplifier tube supplies.
- (6) A high voltage half-wave rectifier to supply approximately 1,200 volts to the cathode ray tube.

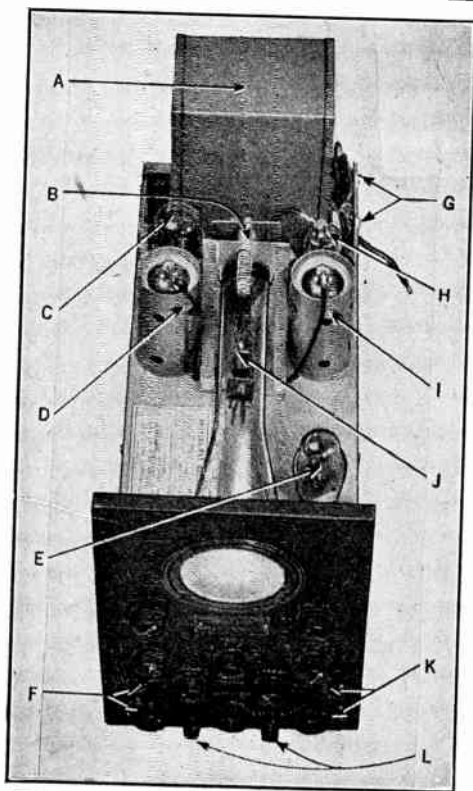

FIG. 7—View of RCA oscilloscope with cover removed. The parts are as follows: *A*, power transformer, supplies power for all tubes and rectifier circuits—oversize to prevent stray magnetic fields; *B*, spring mounted cathode ray tube socket; *C*, low voltage full wave rectifier—supplies amplifier tube; *D*, vertical amplifier, high gain, wide frequency range; *E*, gas triode, “saw-tooth” timing axis oscillator; *F*, input binding post; *G*, vertical and horizontal beam centering adjustment—provide a simple means of centering beam on screen; *H*, high voltage half wave rectifier—supplies 1,200 volts to cathode ray tube; *I*, horizontal amplifier—high gain, wide frequency range; *J*, cathode ray tube—3 in. screen; *K*, binding posts for external horizontal deflecting voltage; *L*, binding posts for external synchronizing voltage.

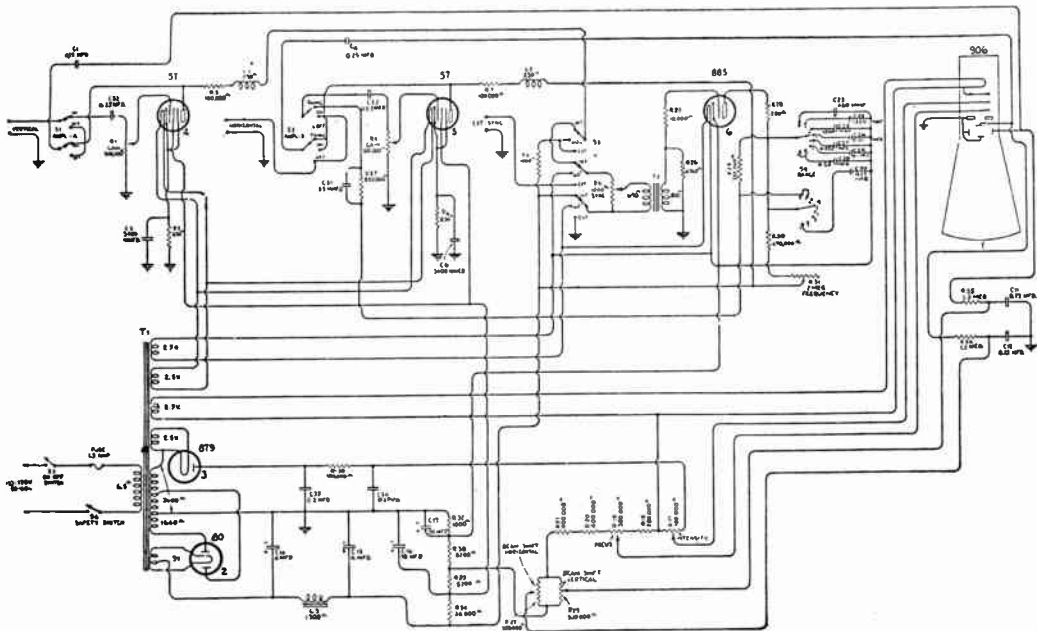

FIG. 8—Schematic connection diagram of R.C.A. type TMV-122B cathode ray oscillograph.

Various designs may vary slightly, although principally the number of elements employed are the same.

In commercial types of cathode ray oscillographs, the deflection of the cathode ray beam is caused by an electrostatic field produced by an impressed alternating current applied across either of two plates (*C*) or (*D*), fig. 1.

Two types of cathode ray tubes commonly employed for radio servicing are 906 or 908. The construction of the two are similar, the only difference being in the screen coating employed.

The use of No. 906 in a typical oscillograph circuit is shown in fig. 9. In this circuit the electrode voltages are obtained from the bleeder circuit connected across the high voltage supply.

Regulation of *spot size* and *intensity* can be accomplished by the variation of No. 2 anode current and voltage. The current to anode No. 2 may be increased by reducing the bias voltage applied to the control electrode (grid No. 1). An increase in the No. 2 anode current increases the size and intensity of the spot. An increase in the voltage applied to anode No. 2 increases the speed of the electrons, which increases spot intensity and decreases spot size.

In applications involving extremely accurate measurements, the No. 2 anode current should be reduced to the minimum value consistent with the desired brilliance of pattern. Where high brightness is an important consideration, the No. 2 anode voltage may be increased to the maximum rated value. This procedure, however, is not always desirable since the greater electron speed causes reduced deflection sensitivity.

The maximum input power to the fluorescent screen should not exceed 10 mw. per sq. cm. except for short-interval operation. The use of screen-input power in excess of this value will adversely affect the fluorescent coating, depending on the mag-

nitude and the duration of the power input. The resultant injury to the screen may be a temporary loss of sensitivity, or a permanent destruction of the active screen material.

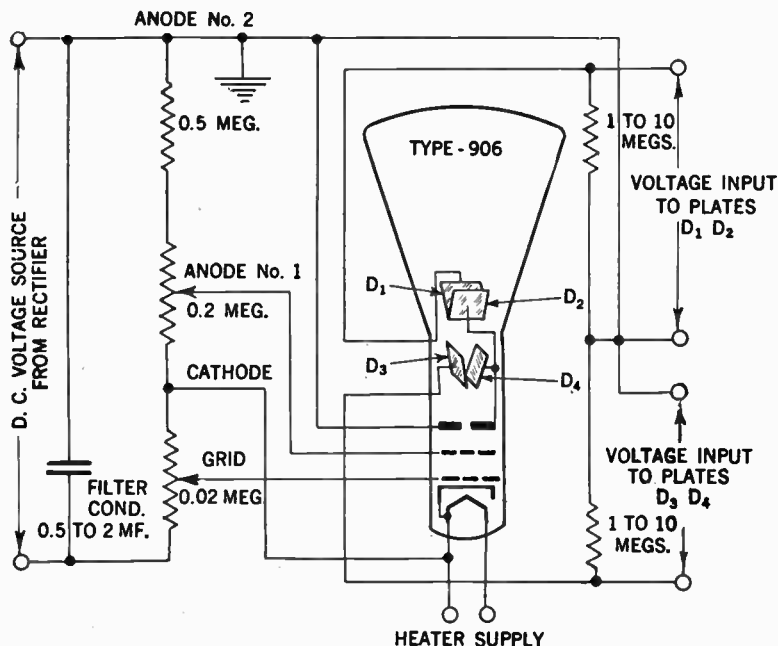

FIG. 9—Schematic diagram of cathode ray tube connection in an oscilloscope.

A high intensity spot should be kept in motion by applying voltage to the deflecting system, in order not to exceed the maximum fluorescent screen input rating. Until this voltage is applied, the fluorescent screen input power should be kept low, either by applying a high negative control-electrode bias or removing the voltage from anode No. 2.

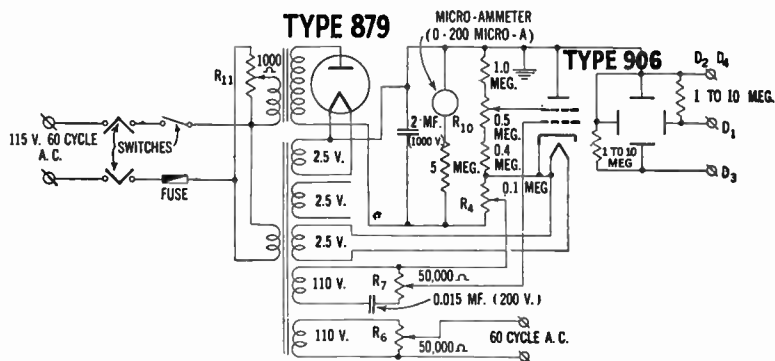

FIG. 10—Typical circuit for cathode ray oscilloscope.

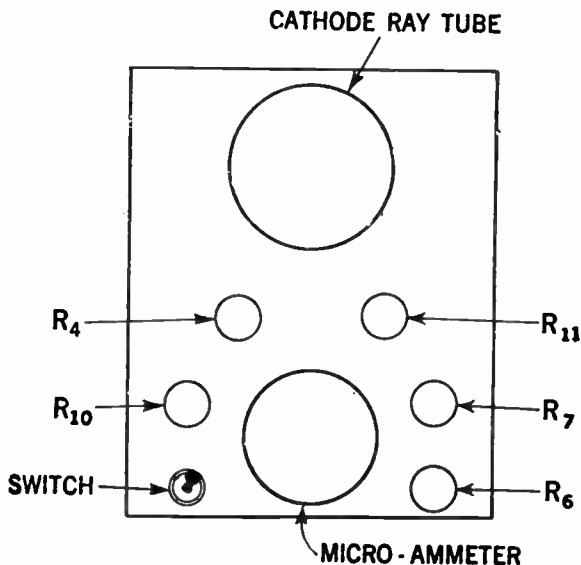

FIG. 11—Front view arrangement of oscilloscope whose circuit is shown in fig. 10.

Time sweep circuits are of various types. The choice of circuit depends upon the type of phenomena under observation as well as upon the type of cathode-ray tube used. For recurrent phenomena, a periodic sweep with a repetition frequency adjustable to a simple multiple relation with the frequency of the phenomena is generally employed. For transient phenomena, a single sweep of the electron beam across the screen is ordinarily desirable; the starting of this sweep essentially coincident with the starting of the transient can be controlled manually, or automatically by electrical circuits, depending upon the application.

**Supreme Model 546 Cathode Ray Oscillograph.**—The front view and connection diagram are shown in figs. 12 and 13 respectively.

All the controls are located on the front panel for instant and convenient use. It has an intensity and focus control, also vertical and horizontal spot centering control. The vertical and horizontal amplifiers are built in, each using a 6C6 tube with graduated gain control.

The input impedance is 500,000 ohms at less than 20 micro-micro-farads input capacitance. Both amplifiers are flat from 15 to 90,000 cycles. The linear saw tooth time base or sweep voltage is developed by an 885 gas triode oscillator which covers a range of from 15 to 30,000 cycles in seven over-lapping steps, which make it possible to observe frequencies of up to approximately 300,000 cycles. A vernier control allows accurate setting of any frequency desired.

Another important feature is the high speed return trace eliminator which takes out the return sweep at high time base frequencies and eliminates distortion when observing high frequency patterns on the cathode ray screen.





FIG. 12—Panel view of Supreme Model 546 cathode ray oscilloscope.

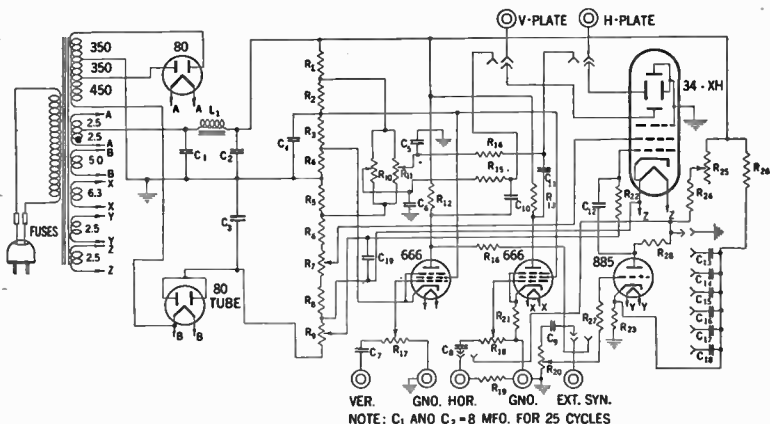

TABLE OF SYMBOLS AND RESISTANCE VALUES

R	OHMS	R	OHMS	R	OHMS	C	MF0S.	C	MFDS.
R - 1	25 M	R - 11	4.0 MEG.	R - 21	1000	C - 1	4.0	C - 11	0.05
R - 2	10 M	R - 12	0.13 "	R - 22	0.5 MEG.	C - 2	4.0	C - 12	50 MMFD.
R - 3	10 M	R - 13	0.10 "	R - 23	1000	C - 3	0.5	C - 13	0.2
R - 4	220	R - 14	1.0 "	R - 24	1.0 MEG.	C - 4	8.0	C - 14	0.04
R - 5	0.25 MEG.	R - 15	0.5 "	R - 25	4.0 MEG.	C - 5	0.05	C - 15	0.01
R - 6	0.75 "	R - 16	1.0 "	R - 26	0.1 MEG.	C - 6	0.05	C - 16	0.0025
R - 7	0.50 "	R - 17	1.0 "	R - 27	0.1 MEG.	C - 7	0.1	C - 17	600 MMFD.
R - 8	0.10 "	R - 18	4.0 "	R - 28	500	C - 8	0.1	C - 18	200 MMFD.
R - 9	0.20 "	R - 19	1.0 "			C - 9	0.05	C - 19	0.5 MFD.
R - 10	4.0 "	R - 20	15 M			C - 10	0.05		

FIG. 13—Schematic wiring diagram of Supreme Model 546 cathode ray oscilloscope.

The operator has a choice of internal or external synchronization, and of either the internal linear sweep or any external sweep.

The rectifier uses two type 80 tubes in a special series circuit. The first one operates a full wave rectifier to supply operating voltages to the two amplifiers and the linear sweep oscillator.

In series with the full wave rectifier is another 80 tube operating as a half-wave rectifier to build up the operating potential to 1,200 volts for the cathode ray tube.

This modern rectifier circuit minimizes the reaction of the amplifiers and 885 gas triode, as adjustments are made about the cathode ray tube and greatly stabilizes their operation.

**Operating Notes on Cathode Ray Tubes.**—The size of cathode ray tubes for oscillograph work may vary for different applications, although the average length will be approximately 12 inches with a screen diameter of between 4 and 5 inches.

The base pins are generally designed to fit standard receiving tube sockets of the five- six- and seven contact type, which may be installed to operate the contacts.

On account of high potential encountered, the socket should be made of good insulating material and should be designed with adequate spacing between the contact springs to prevent voltage breakdown.

A socket designed with insulating baffles between contacts provides an additional factor of safety.

Some types of cathode ray tubes have all leads brought out to their base pins, while in others some of the electrode leads are brought out to caps on the bulb.

When iron or steel material is employed in the case, to minimize the effect of extraneous fields on tube operation, care should be taken that the metal is completely demagnetized.

The heater is usually designed to operate at 2.5 volts. The transformer winding supplying the heater power should be constructed to operate the heater at the rated voltage under average line conditions.

In most circuits where the design is such as to cause a high potential difference between the heater winding and ground, the

heater winding should be adequately insulated to withstand the maximum high voltage that will be applied.

It is very important to note that the high voltage at which the cathode ray tubes are used are dangerous, and hence great care should be observed in the design of the equipment, to guard the operator against coming in contact with these voltages. Some of these precautions are: 1. Enclosure of high potential terminals. 2. The employment of interlock switches to break the primary circuit of the high voltage power supply when access to the apparatus is required.

In most cases it is recommended that the positive high voltage terminals be grounded rather than the cathode terminal, because this method places the cathode and heater at a high negative voltage with respect to the ground, and hence the dangerous voltages can more easily be made inaccessible.

Also in the use of cathode ray tubes, it always should be remembered that high voltages may appear at normally low voltage points in the circuit, due to condenser faults or incorrect circuit connections.

Therefore, before any part of the cathode ray or its associated circuit be touched, the power supply switch should be turned off, and both terminals of any charged condenser should be grounded.

**Additional Applications.**—In addition to the utilizing of the cathode ray tube in the oscillograph, the tube has found a large variety of applications in various fields, a few of which are:

*In the power field.* (a) For voltage and current measurement; (b) study of wave forms; (c) measurement of power; (d) measurements of hysteresis curves.

*In the industrial field.* (a) Study of wave form of spark plug discharge; (b) pressure measurements; (c) gas engine detonation

characteristics; (d) gas engine vibration study; (e) high speed transient phenomena; (f) torsional vibration of axles.

*In the medical field.* (a) The electrocardiograph; (b) study of impulses from the brain.

*In the electronic television field.* As a scanning device in television transmitters and receivers.

**Questions and answers on terms commonly employed in cathode ray tube operation.**

*Is there a difference between apparent line width and the apparent spot size on the luminous screen of a cathode ray tube?*

Yes, the apparent line width can be different from the apparent spot size of the stationary spot because the screen luminescence is dependent upon the duration of excitation.

*What must be noted in the observation of apparent spot size, and apparent spot diameter?*

When the spot size is measured visually or from a photographic record, the resultant spot size is not necessarily the true spot size; therefore, the terms "apparent spot size" and "apparent spot diameter" should be used in such cases.

*What is meant by "Beam current"?*

The current in the electron beam at the screen, usually measured in microamperes.

*Define "Beam voltage".*

The instantaneous voltage of the electron beam at any point; usually referred to as the voltage of the beam at the point of deflection, where the beam voltage is substantially the same as the second anode voltage.

*What is the candlepower distribution characteristics of a cathode ray tube?*

The relation which when plotted is invariably represented by a polar curve illustrating the luminous intensity of a cathode-ray tube in a plane of the tube axis and with the screen at the origin. This characteristic shows how the candlepower of a luminescent screen varies when the screen is viewed at different angles.

*What is meant by the electrostatic, deflection sensitivity of a cathode ray tube?*

The ratio of the distance which the electron beam moves across the screen to the change in potential difference between the deflection plates; this is usually expressed in millimeters\* per volt. The sensitivity varies inversely with the beam voltage at the point of deflection.

*What is meant by the term "Defocus"?*

A term used to describe a spot which is not optimum with respect to shape and size.

*What is meant by the following efficiency terms used in cathode ray tube operation:—(a) Gun current efficiency; (b) Screen actinic efficiency; (c) Screen luminous efficiency; (d) Screen radiant efficiency.*

(a) The ratio of the beam current to the current which leaves the cathode. This ratio, multiplied by 100, gives the gun-current efficiency in per cent.

---

\*One millimeter = 0.03937 inch.

(b) The measure of the ability of a viewing screen to convert the electrical energy of the electron beam to radiation which affects a certain photographic surface. This term should be expressed in microwatts *per watt*, but is often expressed for ease of measurement in terms of actinic power per watt relative to a screen of well-known characteristics.

(c) The measure of the ability of a viewing screen to produce visible radiation from the electrical energy of the electron beam. The efficiency should be measured in lumens per watt. For convenience of measurement, however, it is usually expressed in candlepower per watt, because candlepower is a measure of the luminous flux per unit solid angle in a given direction and can be converted to lumens where the candlepower-distribution characteristic of the screen is known. It is usual practice to measure candlepower in the direction normal to the screen.

(d) The measure of the ability of a viewing screen to produce luminescence from the electrical energy of the electron beam. The efficiency should be expressed in microwatts per watt, but due to the difficulty of making absolute measurements, is more often expressed in radiant energy per watt relative to some screen of well-known characteristics.

*What is meant by Fluorescence of the screen in a cathode ray tube?*

The luminescence emitted by a phosphor during excitation. As applied to a cathode ray tube, this term refers to the radiation emitted by the viewing screen during the period of beam excitation.

*What is meant by the true line width as distinguished from that of the apparent line width of a cathode ray tube?*

The true line width is the width of the moving spot measured at right angles to its direction of motion.

*What is meant by luminescence of the screen in a cathode ray tube?*

The term describing all forms of visible and near-visible radiation which depart widely from the black-body radiation law. It can be divided according to the means of excitation into many classes, such as:

Cando-luminescence—luminescence of incandescent solids

Photo-luminescence—luminescence created by exposure to radiation

Chemi-luminescence—luminescence created by chemical reactions

Electro-luminescence—luminescence given off by ionized gas

Bio-luminescence—luminescence emitted by living organisms

Tribo-luminescence—luminescence created by the disruption of crystals

Crystallo-luminescence—luminescence excited by emissions from radio-active materials

Galvano-luminescence—luminescence phenomena observed at electrodes during some electrolyses

Cathodo-luminescence—luminescence produced by the impact of electrons

etc.

In cathode ray tubes, cathode-luminescence is principally involved; therefore, the luminescence of the screen is that radiation which is produced by the impact of the electron beam.

*What is generally understood by the term luminescent spot on the screen of a cathode ray tube?*

The spot formed on the screen of a cathode ray tube at the impact point of the focused electron beam.



*What is understood by "pattern distortion" on the screen of a cathode ray tube?*

When the electron beam is moved by changing fields, a pattern is formed on the screen; the wave form of the spot movement will be identical with the resultant wave forms of the electrical phenomena producing these fields unless there be pattern distortion present. This distortion takes many forms, such as: amplitude, frequency, phase, brightness, persistence, spot size, etc.

*What is meant by the following characteristics as applied to the cathode ray tube? (a) Persistence; (b) spectral; (c) actinic spectral; (d) visual spectral.*

(a) The relation showing the brilliance of light emitted by a cathode ray tube screen as a function of time after excitation. This characteristic is generally shown in a curve where relative brilliance as the ordinate is plotted on a logarithmic scale against time on a linear scale. *Relative brilliance* is used to denote luminous intensity per unit area evaluated in arbitrary units;

(b) The relation between the radiant energy per element of wave-length and each wave-length of the spectrum. It is generally shown in a curve plotted with relative radiant energy against wave-length in angstroms,\* microns, or millicrons. *Relative radiant energy* is expressed in arbitrary units of radiant energy.

(c) The relation between the energy per element of wave length which affects a certain photographic surface, and each wave length of the spectrum. This is generally shown in a curve

---

\*One Angstrom unit is equal to one ten millionth of a millimeter (0.0000001 m.m.) =  $10^{-10}$  meters.

plotted with relative actinic energy against wave length in angstroms, microns, or millimicrons. *Relative actinic energy* is obtained by multiplying the relative radiant energy values (taken from the screen's spectral characteristic) for each wave length by the relative sensitivity of a given photographic surface at that wave length.

(d) The relation between the luminous energy per element of wave length and each wave length of the spectrum. It is generally shown in a curve plotted with relative microns. *Relative luminous energy* is obtained by multiplying the relative radiant energy values (taken from the screen's spectral characteristic) for each wave length by the relative response of the eye at that wave length.

*What is the purpose in the use of phosphor on the screen of a tube?*

It is used on account of its ability to produce luminescence when actuated by an electron beam.

*What is meant by phosphorescence in a cathode ray tube?*

The luminescence emitted after excitation. As applied to a cathode ray tube, this term refers to the radiation which persists after the electron-beam excitation has ceased.

*What is meant by the following terms: (a) Spot diameter; (b) Spot distortion; (c) Spot size?*

(a) The term used to express the true size of a round spot;

(b) The condition of a spot which is not optimum with regard to shape.

(c) The true dimension or dimensions of the spot. Spot size may be measured under various conditions, and is commonly designated by such names as *spot diameter* or *line width*. When the spot is stationary, its size can be measured in any direction, but is usually determined by its dimensions along the longest and shortest axes.

## CHAPTER 32

# **Radio Trouble Pointers and Interference Suppression**

## **(Questions and Answers)**

It is now generally recognized that successful radio receiver trouble-shooting or radio servicing requires an intimate knowledge of thousands of component parts constituting the receiver.

Years ago, when the best receiver consisted of a condenser, a coil and the catwhisker thrown together in haphazard manner, anybody in possession of a buzzer, a pliers and a screw-driver, could find and eliminate the trouble in short order.

However, since then, radio receivers have gone through an epoch of revolutionary changes—a glance underneath the chassis of a modern receiver for example will illustrate how every fraction of an inch is literally crammed with radio components—which themselves contract in size as time goes on.

There is a bewildering array of colors stamped into the radio parts, and an equal splash of dazzling colors on the connecting wires. In addition, variable condensers, potentiometers, and other moving parts are built in such a manner that it takes special tools and expert handling to adjust or remove them.

Finally, after a look at the dial—the dial mechanism and the various remote control features, it is still more evident that a very fundamental knowledge as well as a thorough understanding is required for servicing the modern radio receiver.

It is self-evident, therefore, that with the increasing refinement and complexity of the receiver, the more susceptible it becomes to various kinds of *interference* and *troubles*, and the more specialized knowledge will be required to eliminate it.

### *Where does radio interference originate?*

There are four broad classifications into which interference normally falls, namely: 1, *that caused by electrical devices*; 2, *by various radio stations or the neighbor's receiver*; 3, *originating in the receiver itself*; 4, *natural static*.

The *first classification* is of interest, particularly to city dwellers where electrical devices are very numerous and their usage condensed. The average city apartment house is a veritable generator of all kinds of so-called man-made radiation interference. The various offending sources to give a few examples are: electric bells and buzzers; elevator motors and contactors; sign flashers; X-ray machines and ultra-violet ray units used by physicians; third rail contacts on elevated structures; overhead wires on trolley lines, etc.

The *second classification* also is more of a problem to city populations than to others. Here, on apartment house roofs for example, several dozens of aerials usually are mounted very close together, with very little thought or method, hence there is bound to be a certain amount of 'inter-play' between the aerials and the set they serve. In addition if some sets are capable of regeneration or circuit oscillation without blocking means, the result will be a constant squeal, sometimes affecting receivers located several blocks distant.

The *third classification* is a problem for the receiver designer, and the serviceman, to be on constant guard against causes of noise. Very often a faulty condenser for example may give rise to an appalling amount of noise. This usually will be blamed on everything, from static to the neighbor's receiver, until found and corrected.

The *fourth classification* deals with natural static, and there is very little anybody can do. It is self-evident that there is no control, or nothing that can be done to prevent it. Although the amount of actual disturbance in this case is less noticeable in locations of strong transmitters and where the serviceable areas are well proportioned, at present at least, there is no remedy for noise for example emanating during a heavy thunderstorm.

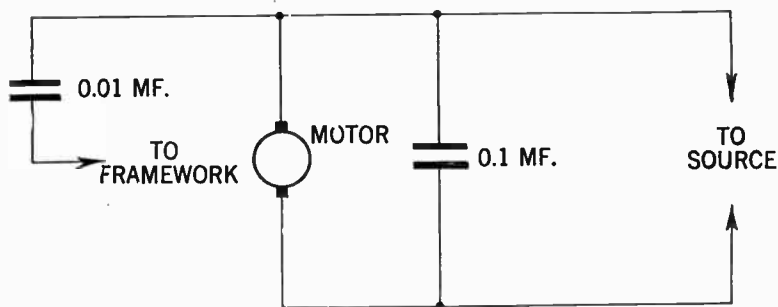

FIG. 1—Schematic diagram showing connection of interference suppressors to a vacuum cleaner.

***How may radiation interference caused by an a.c. vacuum cleaner be eliminated and what are the proper condenser capacity values to be employed?***

Condensers of the values commonly used for interference suppression purposes on fixed electrical machinery are not necessarily suitable for ungrounded appliances such as vacuum

cleaners. A break-down in insulation between the electrical circuits and the metal frame-work of the cleaner might cause an unpleasant (or even dangerous) shock to the operator if the condenser capacity be too high.

Fig. 1 illustrates schematically the connections and values of condenser suppressors generally used on vacuum cleaners or similar portable appliances. It is necessary to observe that the capacity values recommended should not be exceeded, also the voltage rating of the condensers should be the same as that of the voltage employed in operating the appliance in question.

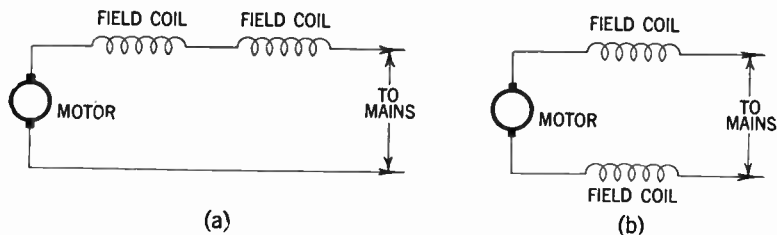

FIG. 2—Diagram indicating how internal connections of a motor may be altered to cause less radiation interference.

***How may field coils, of a small d.c. motor employed to drive a lathe, be rearranged so as to cause less radiation interference?***

Assuming that the motor is series-wound (i.e. the field coils are in series with the armature), it is probable that a simple alteration will reduce the radiation of interference.

Normally the field coils are connected as shown in fig. 2 (a). By rearranging them as shown in (b) with one coil on each side of the brushes, the bad effects on commutator sparking are reduced due to the fact that the coils now act as radio frequency

chokes and prevent interfering impulses generated by the sparks from passing out to the wiring. Rearrangement of the coils in the manner described should have no adverse effect on the operation of the motor.

***Is there a possibility that interference of reception can be caused by a Diesel engine located in the proximity of the receiver?***

Interference from ordinary internal combustion engines originates in the electrical ignition system, which is absent in the Diesel engine, and accordingly a compression ignition engine of this type is totally incapable of causing electrical interference.

***How should interference suppressors (condensers) be connected in order to mitigate leakage in a wiring system?***

From a consideration of fig. 3 (a) it is fairly clear that as one of the main cables is grounded at the power station, full main potential is applied between the condenser and ground. Although the leakage current is largely wattless, it is a source of embarrassment to power station operators and so should be avoided. One of several ways of avoiding appreciable leakage is to use condensers much smaller than the standard value of 2 mfd.

A capacity of 0.01 mfd. is generally recommended and in most cases proves to be effective. Another method of reducing leakage to negligible proportions is to connect the conventional type of suppressor in the manner illustrated in fig. 3 (b). This arrangement is recommended by certain supply companies.



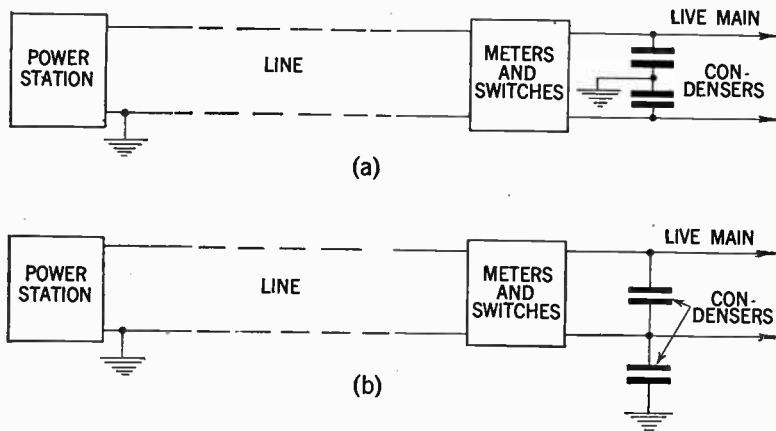

FIG. 3—Outline of connections of interference suppressors, to prevent leakage in an a.c. wiring system.

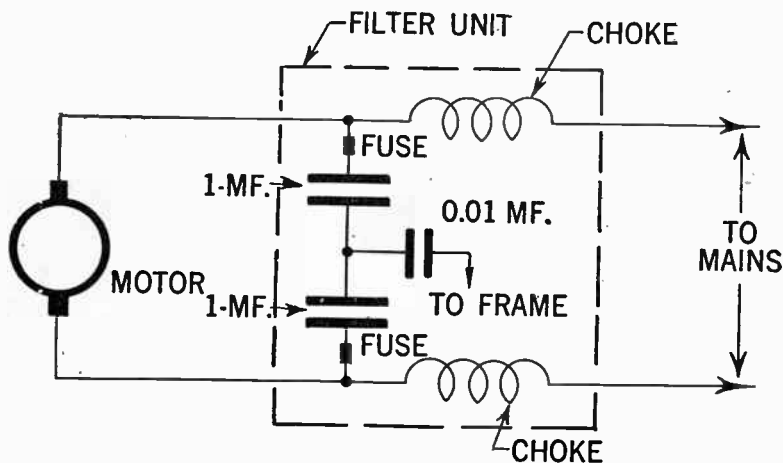

FIG. 4—Arrangement and connection of radiation interference suppressor unit to washing machine.

***It is desired to eliminate the radiation interference caused by a washing machine. How may this be accomplished and what are the component values?***

This trouble will be eliminated by connecting a filter unit as shown in fig. 4. Necessary precautions should be observed that the values of the filter unit does not exceed the values given, also that the voltage and frequency of the source is similar to that of the manufacturers marking on the filter parts.

***How is it possible to locate or to track down suspected sources of man-made static?***

This is usually done by a device known as interference locator, usually a portable receiver with a highly directional antenna or radio frequency pick-up system.

***How may radiation interference emanating from a motor generator set be eliminated?***

Interference of this sort is generally suppressed in the same manner as that of previously described electrical equipment. Referring to fig. 5 employing the same number of condensers as there are incoming and outgoing wires in the system to be filtered. The condensers should not exceed the values given.

***How does radiation interference originate in a switch and how may it be eliminated?***

Radiation interference of this sort is generally due to defective contacts in the switch, causing a spark which may be of short duration and occur only at switching, in which case a short click will be noticed in the receiver. At other times the

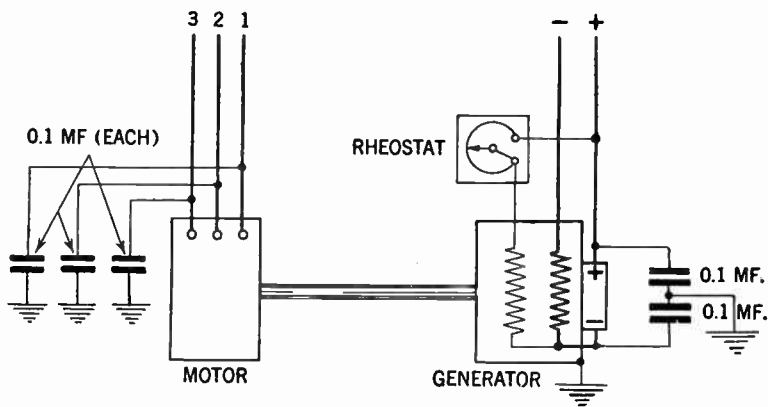

FIG. 5—Interference suppressor arrangement and connection for motor-generator set.

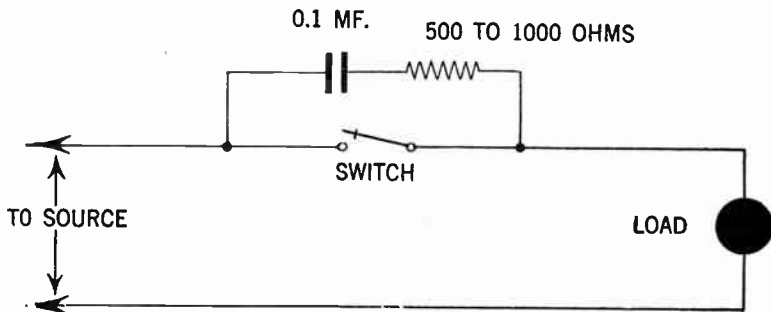

FIG. 6—Method of filter connections across switch.

spark will be observed intermittently causing prolonged scraping or howling. The remedy depends on the extent of damage in the switch. If the switch is relatively inexpensive, a replacement will most likely solve the problem.

However, if the switch be only slightly worn, a thorough cleaning and smoothing of the contact surface will prove to be

helpful. A resistance capacity filter shown in fig. 6 is commonly used as a switch interference eliminator. This filter is connected in parallel with the switch. The proper sizes of resistor and condenser depend on the current drawn by the circuit. In most instances a 500 to 1,000 ohms resistor and a condenser of 0.1 microfarad will be found satisfactory.

***What can be done to eliminate the interference caused by a Neon sign?***

It is a well known fact that Neon signs are notorious offenders in the matter of radio reception disturbance. The flasher device is nothing but a set of switches and hence will be treated similarly to that employed to silence switch disturbances.

Another source of disturbance is arching between connections particularly in the electrode housing, or between cable ends. Again interference may be caused by flickering tubing, overloaded transformers, faulty insulation, corona discharges between tubing and ground, loose connections, ungrounded transformer case, etc.

When reception interference has been found to be caused by the sign, each one of the aforementioned trouble sources should be investigated. As a general rule, however, it has been found that the employment of filters across switch contacts, and also across the primary winding of the transformer, will mitigate the trouble.

It has also been found effective to include a choke properly insulated in between the letters of the sign. Diagrams of connections to effect the above improvements are shown in figs. 8 and 9. When filters are installed, it should be remembered that the designs of components employed must be able to withstand the potentials and the current (in the case of radio frequency chokes) which must flow through them.

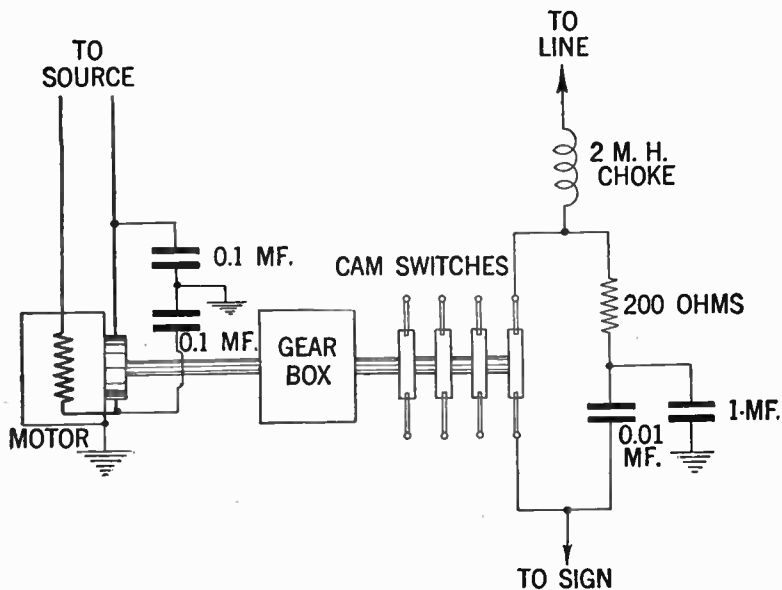
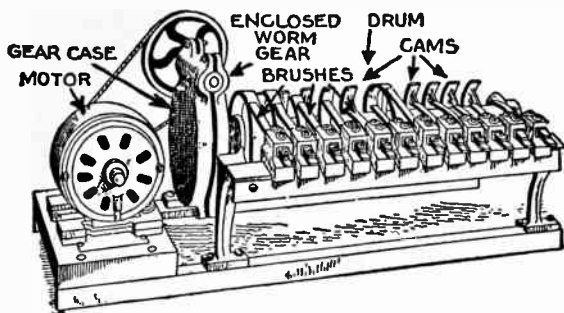

FIGS. 7 and 8—Layout of switch controls and schematic diagram of electrical connections for lightning type sign flasher.

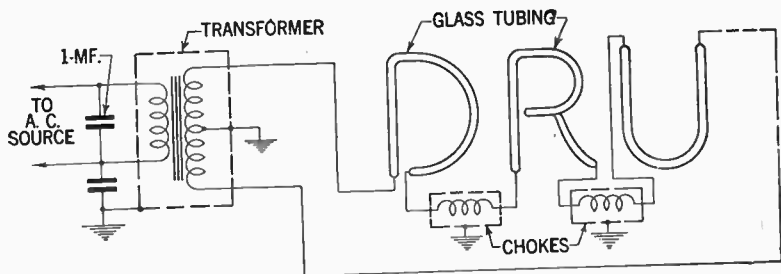

FIG. 9—Typical connection diagram showing interference suppressor arrangement as applied to Neon signs. Chokes, if used, should be of sufficient size to carry the required current without undue heating.

***Where does radiation interference affecting an automobile radio receiver usually originate?***

In the electrical system, and particularly so in the ignition system of which a schematic diagram is shown in fig. 10. The interference originating in the ignition system is usually referred to as *ignition noise interference* and emanates from the electric sparks in various parts of the system, such as in the spark plugs, distributing head, loose contacts in the wiring system, etc.

***What can be done to eliminate radio noise emanating in the electrical system of the automobile?***

There are a number of precautions to be observed in order to be able to successfully cope with this problem and the author believes that the method of *suppression of ignition and generator noise* as described in a bulletin furnished by the General Electric Co. in relation to installation of their popular automobile radio Model N-60, gives a good set of instructions. They are as follows:

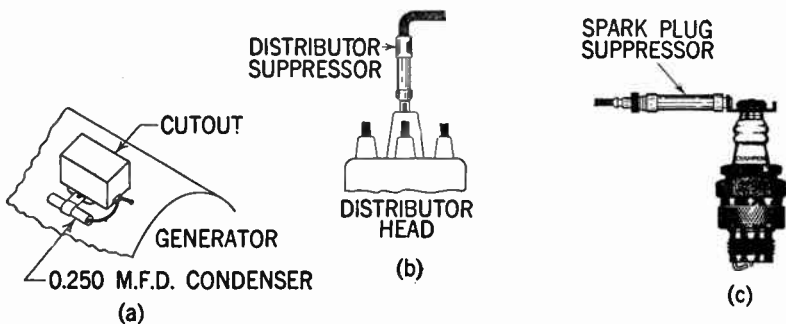
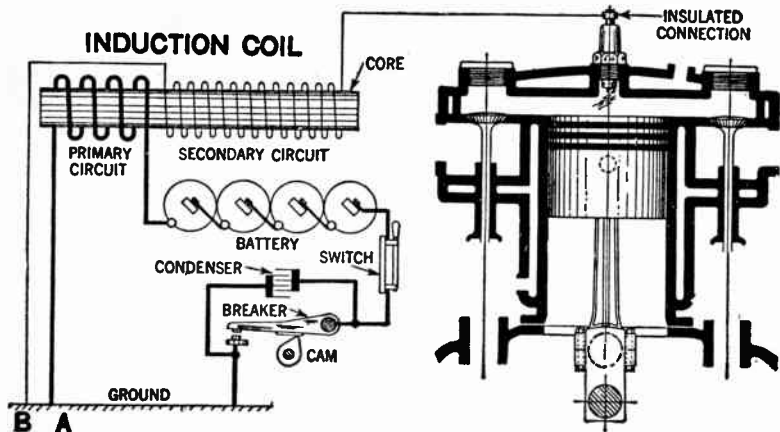

FIG. 10—Fundamental schematic diagram of ignition system of an automobile.

FIG. 11—Method of installing radio interference suppressors in the electrical system of an automobile.

**Distributor Suppressor.**—Remove the high tension lead to the distributor. Insert a distributor suppressor and connect the wire to the other end of the suppressor (see fig. 11b). If this be not practical, cut the high tension lead close to the distributor and use a wood screw end type distributor in this line.

**Generator Condenser.**—The generator condenser is installed at the cut-out as shown in fig. 11 (a). The lead from the condenser goes to the terminal on the cut-out. In some of the new cars the cut-out relay is on the front of the dash or in some other location. It will be most convenient to mount this generator condenser at the relay.

**Withdraw Antenna Cable Plug.**—Turn on the receiver and start the engine. If motor noise be heard, proceed as follows:

**Shielding High Tension Lead.**—In some cars when the coil is mounted on the dash, the high tension lead from the coil to within about 4 ins. of the distributor must be covered with braided shielding and the shield grounded to the motor block or frame.

**By-Pass Condenser.**—Try a .25 or .5 mfd. condenser from the ammeter to ground. Try a condenser from the car fuse to ground, switch to ground, windshield wiper connections and various other 6 volt connections to ground, noting what effect these condensers have on the noise pick-up. Try a .25 or .5 mfd. condenser from the *hot* side of the coil primary to ground. In some cases this condenser may not help. It can be tried out, however, experimentally.



**Spark Plug Suppressors.**—If motor noise persists, spark plug suppressors should be installed. One suppressor is put on each plug as shown in fig. 11 (c). The majority of cars however will not require spark plug suppressors. Care should be taken that a good mechanical and electrical connection be made between the spark plugs, suppressors and plug wires.

Then re-insert antenna cable plug. If motor noise is heard when the antenna cable is reconnected, proceed as follows until the noise is satisfactorily reduced:

**Dome Light Lead.**—To determine the amount of noise due to the dome light lead, disconnect this lead at the ammeter, block, or where it is connected, coil it up, and tuck it as far as possible up in the column at which it comes down. Then, with the engine running, ground the end of this wire. If this be found to reduce the noise noticeably, interference is being radiated by the dome light lead.

Reconnect the dome light lead and try a .25 or .5 mfd. condenser from the connecting point of the lead to ground. If this does not cure the noise, disconnect the lead and encase it in braided copper shield from the point where it leaves the column post to the point of connection. Keep the lead as far away as possible from car ignition wires and ground the shield.

If the noise due to the dome light lead still persists, disconnect this lead and remove it from the front corner post, at which point it is generally run down. Run the lead down one of the side posts in back of the door and direct to the storage battery. If done in this manner this lead should be fused.

**Bonding Cables.**—Try grounding to the dash all cables and tubing which pass through it, such as oil lines, gas lines, etc. By means of a file, contact can be established between any of the lines and the dash, in order to determine whether such a ground will reduce the noise.

To bond the cables to the dash, clean the point of contact, wrap a length of braided shielding around the cable and solder the connection. Then solder the end of the shielding to the dash or ground it under a screw head if one is convenient.

Sufficient play should be left in the bonding shielding so that movement of the cables or tubing will not loosen this shielding from the dash.

**High and Low Tension Leads.**—In some cases, the high and low tension leads between the coil and distributor are run close together. In some cars they are in the same conduit. If this be the case, remove the low tension lead from this conduit. In any event, keep the high and low tension leads as far apart from each other as possible. Shield and ground the shield of the low tension lead, if separating the two leads is not sufficient.

**Steering Column, etc.**—It is possible for the steering column, foot pedals and brake lever to carry interference to the back of the dash at which point it may affect the radio receiver. See if each of these items are well grounded to the frame of the car. By means of a file or a braided shielding jumper, contact can be established between any of these items and the frame in order to determine whether such a ground will reduce the noise. A piece of 1 in. braided shielding should be used if such a ground be necessary and this shielding may be grounded under a screw head, nut or may be soldered in position.

**Grounding Engine and Other Parts.**—The engine must, in every case, be well grounded to the frame of the car. If it be not, use a very heavy braided lead for this purpose, similar to a storage battery ground lead. In like manner it may be necessary to check the grounding of the metal dash, instrument panel, radiator and hood to the frame of the automobile.

**Weak Pick-up.**—Noise, on occasion, may be due to weak pick-up caused by the automobile being in a shielded location or by a faulty antenna system. The action of the automatic volume control, due to the low pick-up, causes the set to operate at its maximum sensitivity, thereby increasing noisy reception, due both to external pick-up and internal conditions.

**Loose Parts in Car**—Noisy operation is also caused in some instances by loose parts in the car body or frame. These loose parts rubbing together affect the grounding and cause noises, due to the rubbing or wiping action. Tightening up the frame and body at all points and in some cases, the use of a copper jumper will eliminate noise of this nature.

*Where does static interference in an automobile receiver originate, and what is usually done to eliminate it?*

This kind of interference is most common in old or worn-out cars and usually originates in wheels and tires, and is identified as *wheel or tire static*. Another source of static interference is badly adjusted break linings, in which case the remedy is obvious. To eliminate wheel and tire static, it is well to have a clear understanding about the cause, as well as how to identify this particular form of interference.

The sounds developed in a receiver from wheel or tire static may be heard as an intermittent rasping or clicking, with the time intervals varying with the speed of the car, or maybe a steady hissing developed after the car reaches a given speed and will change only on the condition to be described.

Wheel and tire static occur only with the car in motion along the road and will occur whether the ignition is turned on or off. It will be most pronounced on asphalt or cement pavement but may be noticed in some cases on brick pavement or on a dry gravel road. To drive off the pavement, should stop the noise.

From the above it is clear that it is the *friction* between the

dry pavement and the rubber tires of the car that generates static electricity which collects on isolated substances in the tires or on the metal wheels which may be electrically isolated from the body of the car by grease and oil. This electricity then discharges to the car body or road bed depending upon the potential developed and the distance to either. Generally the distinguishing symptoms between wheel or tire static is that if on application of the brakes the noise disappears, the noise is attributed to wheel static; if not, to tire static.

When the static interference has been identified as *wheel static*, the most commonly used method of elimination is to make a metallic contact between the movable wheel and the stationary axle end.

This is accomplished by inserting a large coiled spring inside the hub cap so that one end makes good contact against the end of the shaft and the other against the cap.

In case of *tire static* a large percentage of causes has been found due to the use of metallic (zinc oxide) balances used in the bottom of the casing as a valve stem balance. Where this occurs, it may be corrected by removing the casings and buffing out the inside with a wire brush and then wiping the casing thoroughly with benzine and cloth. Vulcanized spots or patches with a metallic glue base will also cause tire static. Sometimes tire static may be reduced to a negligible amount by changing the tires about from wheel to wheel.

***How may a power transformer with a primary rating of 220 volt, 60 cycles and connected as shown in fig 12 (a) be reconnected for temporary use on a 110 volt, 60 cycles supply? An examination shows that the primary winding consists of two bobbins with an accessible junction.***

The transformer should work quite satisfactorily with the primary section connected in parallel as shown in fig. 12 (b).

The secondary winding of the transformer should remain unchanged.

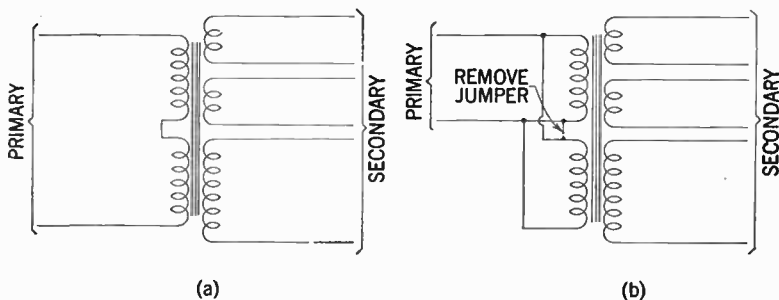

FIG. 12—Before connection to 110 volt source *remove* connection shown with dotted line and connect primary in parallel as shown in (b).

*After design of an a.c. receiver, it is desired to check the various anode voltages. Maximum voltage is in the order of 400 volts, and the only measuring instrument obtainable is a multi-range ammeter of which the highest scale reading is 5 milliamperes.*

Bearing in mind that a voltmeter after all is nothing but a milli-ammeter fitted with a suitable value of series resistance, and then calibrated in volts, voltage readings accurate enough for practical purposes will be obtained by using the milli-ammeter (on the lowest range) in series with a suitable resistance. Ignoring the internal resistance of the instrument, a value of 100,000 ohms will do well and the meter will then measure voltages up to 500. By multiplying the readings in milliamps by 100 the dial indications may be readily converted into voltages; 2 milliamperes will correspond to 200 volts, 3 milliamperes to 300 volts, etc. Of course in this case as always voltage readings will be reasonably accurate only when the value of the external resistance is low compared with that of the meter resistance.

*It is desired to us a standard 60 cycle a.c. receiver on and a.c. system of 25 cycles. Will this be possible and what changes or precautions if any should be taken?*

This problem may be briefly summed up by the fact that almost any *a.c.* set may be made to work satisfactorily on a network of 25 cycles. Of course a specially designed power transformer must be used. This transformer will be somewhat larger than the one used on 60 cycle supply, and hence a slight modification of the original layout may become necessary.

It may also be necessary to change the relative positions of the power transformer and the *a.f.* transformer in order to minimize hum. There is also the question of smoothing. Theoretically, a considerable more generous smoothing system will be required, but in practice the ordinary smoothing circuit may be quite effective; this is because both the loud speaker and the human ear are less sensitive to the lower hum frequency of the 25 cycle supply. It is therefore recommended that additional smoothing condensers and possibly an extra choke should not be added until they are found necessary.

*When operating a receiver of a well-known make, the power transformer becomes exceedingly hot, causing smoking and running of the pitch in fluid form, what may be the cause and how may this trouble be eliminated?*

To correct the trouble a replacement of the power transformer will be necessary. The transformer to be installed should be similar to that originally installed by the manufacturers. However, before connecting it up, a thorough check up of resistance values is recommended.

*It is desired to utilize a scratch filter, suitable for coupling a crystal phonograph pick-up to a high fidelity amplifier. How should the filter be connected, and what are the component values to be employed?*

With reference to fig. 13 giving the schematic arrangement, it should be noted that with the components shown, the resonant period is approximately 4,000 cycles, the amount of attenuation being controlled by the 0.1 megohm variable resistor. If it be desired to shift this period to some other frequency, this will easily be accomplished by changing the value of either the 0.01 m.f. condenser or the 0.2 henry choke.

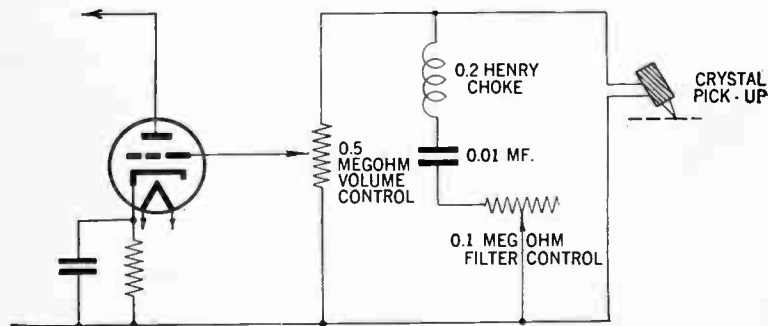

FIG. 13—Method of connection for phonograph pick-up.

*In connection with the instalment of loud-speakers in a public address system, when should the speaker voice coils be connected in series and when should they be connected in parallel?*

From the point of convenience it is preferable to connect the speaker voice coils in parallel. With reference to fig. 14 (a) it

may readily be noted that the wiring will be considerably simplified when several speakers are employed, for example in the parallel system the use of a 3-wire cable in which one side of the voice coil and one side of the field are common may be used. In the series system shown in fig. 14 (b) however, a 4-wire cable is necessary for complete service to every speaker. Again from the point of efficiency the parallel system is superior; a loose connection for instance in any part of the series system will put the combined number of speakers out of service, whereas in the parallel system generally only one speaker will be effected.

*What may cause a receiver to give normal reception for a short period of perhaps five to ten minutes, then suddenly go all "muzzy"?*

There are several possible causes for such trouble—a defective tube; a break in the windings of an audio-frequency inter-stage or output transformer; a faulty power transformer. It is when the receiver reaches a certain temperature while warming up that they become manifest.

*After giving satisfactory performance for some time, a super-heterodyne receiver fails to operate on the medium band of wave-lengths higher than about 400 meters. As the tubes in use are those originally supplied, is it likely that the trouble is due to failing emission?*

It is reasonable to suppose that in the circumstances described, the defect is due to incipient failure of the frequency changer tube. The best course to follow would probably be to replace this tube, but its life may be prolonged a little by increasing the voltage applied to the oscillator anode or by tightening the reaction coupling.



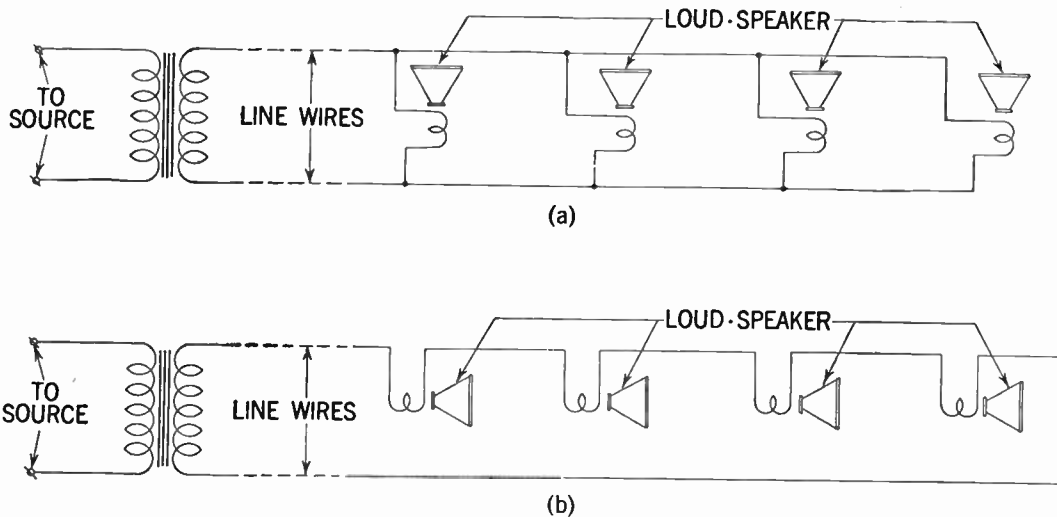

FIG. 14—Schematic diagram of series and parallel connected loudspeakers in a public address system.

*How may modulation hum which is "given a ride" through the r.f. and i.f. circuits of a receiver on the back of any signal that may be passing through them be detected and cured?*

A receiver which emanates hum only when it is tuned to a carrier wave gives the best example of trouble of this kind. This trouble is sometimes due to allowing main leads to run in close proximity to radio and intermediate frequency circuits, in which case the remedy is obvious.

More often, however, the interference enters by way of the main transformer, and nowadays a metal screen between primary and secondary is generally interposed as a barrier. In the absence of such a screen, the simple expedient of connecting a condenser of 0.001 mfd. between one of the main leads and ground is usually effective. The condenser should be rated for working at full supply voltage, and a connection to each main lead should be tried.

*What may cause "distortion of sound"?*

A defect in the loud-speaker—the voice coil may have loosened, or is off center. Lowering the tone volume may show difference in sound; and this localizes the trouble. The power tube or stage may be defective. Tuned circuits may not be properly aligned; in other cases the detector circuit may be overloaded, i.e. the signals are too powerful.

This may be determined by shortening the outside antenna, then noting the results; or the signal input may be lowered by reducing the volume by means of the control if the receiver is so wired that the volume control acts on the radio frequency tubes and not expressly on the audio tubes and stages.

***What may cause "Fading" in a radio receiver?***

Trouble of this sort is most likely to be caused by the following: Leakage within tubes; defective volume control; defective condenser resistor or other parts which changes in value with usage, or by extraneous conditions. The source of trouble is usually best found by an evaluation of circuit components; by means of the usual set analyzer or tube tester. In case replacement is required, care must be observed that correct components are used—otherwise, instead of eliminating the trouble it is likely to be exaggerated.

***How may extensive squeals and pitch interference which changes with tuning, be eliminated in a receiver?***

A type of interference referred to is often encountered in inexpensive receivers and usually appears as an annoying whistle on desired stations that changes in pitch as the receiver is tuned. This is known as image frequency interference and is due to lack of selectivity in the first detector circuit. (Constant pitch whistles are another matter and will be experienced even in high priced receivers.)

Using a shorter antenna will often help matters as it reduces pick up. This in itself has nothing to do with the interference ratio, as it also cuts down the strength of the desired signal. However, to compensate this loss in signal strength the volume control is turned up and this often sharpens the tuning of the first detector circuit.

That other type of interference—the pitch of which varies with tuning, is that of dot and dash code signals. This is due to code stations working close to the intermediate frequency of the receiver. A great many sets have a trap to reduce this type of interference, the adjustment for which appears as a small

screw extending from the rear of the chassis. This screw should be adjusted until the interference is at a minimum. The adjustment can be made without much trouble.

However, in case of attack on the wrong screw, the original position of the slot should be noted, and the screw turned back to its original position, if no improvement is noted.

***Will the all around performance of a receiver used for a year or more be improved by tightening grounds and other connections on the chassis base?***

Yes, the operation of many receivers over one year old can be improved by this simple expedient—which is generally very simple to perform. In every receiver, dozens of by-pass condensers and resistors are grounded to the chassis by means of lugs and nut and bolt connections.

While the leads are soldered to the lugs, the connection between the lug and the chassis becomes oxidized in time, increasing the resistance of the connection to a considerable degree. In effect this places resistors in the receiving circuit where they do not belong with naturally detrimental results.

While the effect of such an added resistor in series with a resistor would ordinarily be negligible, it is another matter in the case of a condenser and the accumulative effect of many such resistors in series with a similar number of condensers may result in lowered sensitivity, instability, alignment shift, etc.

This effect can usually be eliminated by tightening all screws from the top of the chassis. Even when screws are already tight, the slight movement will be sufficient to erase oxidation. Most of the connections are made to the bolts that fasten the socket to the chassis, and it will generally be necessary to remove the tube shields to get at them.

***How may noisy reception originating in the automatic motor driven tuning unit be eliminated?***

The great multiplicity of parts necessarily associated with the tuning device is located immediately within the electric field surrounding the receiver; and as the mechanical connections loosen with usage, microphonic contacts are formed which cause noise.

A loud signal may be sufficient to induce a rasping accompaniment, as well as from any slight movement of the receiver, as might be caused by steps across the floor. In aggravated cases, a hissing scratch, akin to static, will be present at all times.

This difficulty can be removed by *bonding*—making a good electrical connection between the chassis of the receiver and the *floating* parts. Fasten a short length of flexible wire securely under some convenient nut or bolt on the chassis, and touch the free end to various portions of the framework supporting the timing mechanism, at the same time endeavoring to produce the sound by tapping the receiver.

***If the rectifier tube of a receiver has become defective and trouble still exists after changing the tube, what may be the cause?***

A defective electrolytic condenser. The heat, especially in midget type receivers where space is limited and ventilation poor, causes a drying up of the condensers and thereby a lowering of capacity. Voltage measurement of the output of the rectifier tube may show a decreased output, and hence point to condenser trouble.

*If tubes do not light in a series wired receiver, what may be the cause?*

A burned out tube or a loose connection. In a series circuit an open circuit will affect all tubes. In either case the remedy is obvious.

*What important precautions should be observed when replacing parts in a radio receiver?*

It is of extreme importance that they be of the identical types or of the same characteristics throughout, as the parts removed. If components of different values be inserted, they may upset the values of the circuits or cause trouble in other ways. A list of replacement parts for various receivers is usually furnished by the manufacturers of the various sets, and it is these parts that should be used for replacement, to prevent continuation and even exaggeration of the trouble.

*What are the two general classes of resistors used in radio receivers, and where are they used?*

The two types are classified as the wire-wound and the carbon type. Wire wound resistors generally are used where a comparatively large current is required to flow, such as in voltage dividers, and as power tube grid biasing resistors, etc. whereas the carbon resistor is utilized for small currents, i.e. the carbon resistor as a rule has a high resistance, and will usually handle power requirements up to 1 watt. The resistance value of a carbon resistor may be identified by means of special color code markings (see page 182) and the resistance of wire wound resistors are usually plainly marked or tagged on it.

*Is it well to change or remove part of the wiring to eliminate trouble in a radio receiver?*

Only where substitution of wires is absolutely necessary, but the circuit should not be changed. It is evident that if the circuit was incorrect the receiver would never have functioned in the first place. It may generally be assumed that before a receiver leaves the manufacturers test room, the circuit as well as its components are correct. Hence, servicemen should not change circuits on the assumption that they are wrong after the set has been operating properly for some time, but should seek to find the trouble that has occurred and rectify it.

*How many short wave coils be assembled so as to cover a range of short waves as well as medium waves?*

In order to be able to successfully cope with a problem of this sort, the following precaution should be taken: The several coil sections must be reasonably separated from each other, a minimum spacing of one-half in. is recommended. Opinion is divided as to whether to short out the unused sections or to use a change over, but actually neither method is satisfactory by itself. The main difficulty arises from absorption of any particular wave-band from the coil serving the band immediately above it.

Thus in fig. 15 (a) consider the circuit switched from the reception on coils *C* and *D* in series, while coils *A* and *B* are shorted out. Absorption will be found however, at the wavelength corresponding to coil *B*, tuned with its own self capacity since it is actually not short-circuited.

As a rule when it happens to fall within the band covered by coil *C* a dead spot will result. In (b) is shown an arrangement with a change over switch and it will be clear that this trouble

is still present—in fact in an aggravated form. The remedies are to arrange the sections of the coil so that they do not couple to one another, which is not always convenient, or else to arrange to short out the section immediately next to the coil in use, in conjunction with a normal shorting or change over scheme.

Figs. (c) and (d), illustrated the methods likely to be most suitable when critical reaction is being employed.

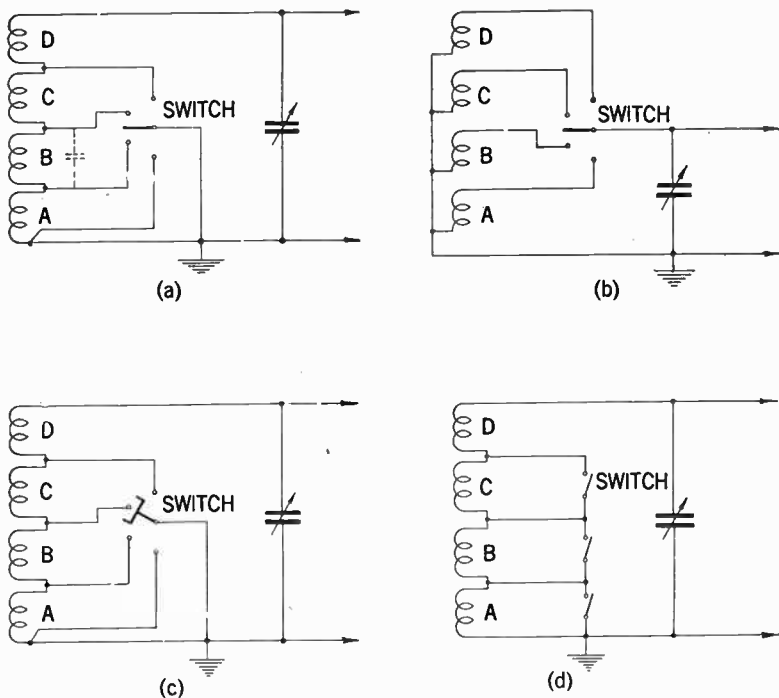

FIG. 15—Various coil switching arrangements for response on short and medium waves.



***What is the simplest way to provide d.c. current necessary for testing of d.c. receivers—i.e. how may a.c. current be rectified to d.c.?***

This problem may best be solved by building a power supply unit as shown in fig. 16. The circuit is largely self-explanatory and with an *a.c.* supply voltage of 110 volts the voltage on the *d.c.* side will be 110 volts as well, provided that the components as shown are used.

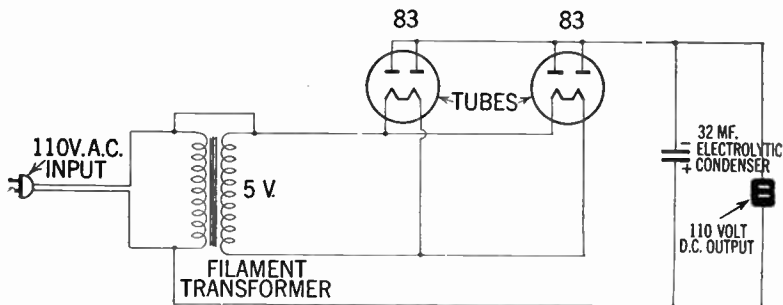

FIG. 16—A simple 110 volt-a.c./110 volt-d.c. rectifier unit.

***What is generally understood by the term high-fidelity as applied to radio amplifiers?***

A set of tentative standards has been set up by the Engineering Department of the Federal Communications Commission for high fidelity transmitting stations. These standards may be applied to audio amplifiers with slight revisions. For example, the total audio distortion shall not exceed 10% at maximum output or 5% at rated output throughout the range of audio frequencies of from 50 to 7,500 cycles. The audio frequency characteristics of the amplifying system measured from the microphone terminals to the speaker voice coil terminal shall be flat within two decibels between 50 and 7,500 cycles.

Hum and other extraneous noises to be at least 60 decibels below peak-power output between 150 and 5,000 cycles, and at least 40 decibels below outside that range.

***What can be done to compensate for voltage fluctuations which at times may amount to 10% or more?***

A simple remedy may be afforded by the addition of a booster transformer shown in fig. 18. This transformer is con-

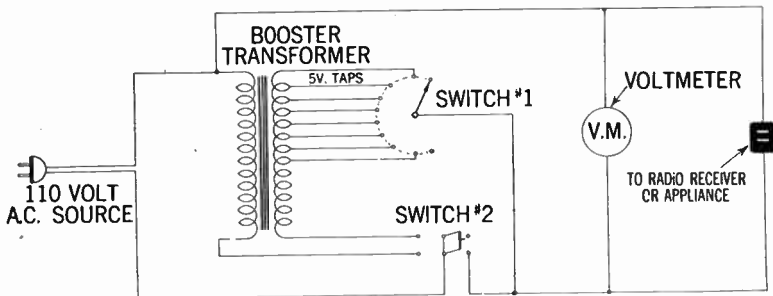

FIG. 17—Schematic diagram of voltage compensating equipment.

nected directly to the line circuit, feeding the individual appliance and thus stepping up the voltage, compensating for the drop. The transformer should have a rating in watts equal to or higher than that of the appliance which it feeds.

The transformer connection scheme is largely self explanatory. For example, switch No. 2 is the "on-off" control for the booster; when it is turned to the left it cuts in the booster and when turned to the right it removes the booster from the line.

As a precautionary measure the volt-meter should always be connected in the circuit when the booster is being used, to

indicate excessive voltage. Switch No. 1 finally controls the amount of booster voltage added to the primary of the transformer.

*It is suspected that a faulty winding in an audio-transformer is the source of a considerable amount of noisy and scratchy reception. What is the simplest way of locating this trouble?*

A means of detecting this trouble may be had by the aid of a simple 4.5 volt dry battery connected to one side of the transformer and a pair of head-phones across the other side as shown in fig. 19.

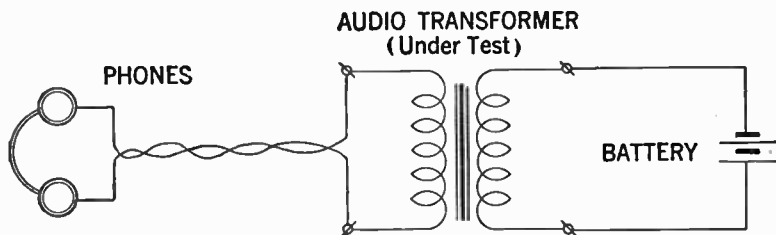

FIG. 18—Method of detecting trouble in audio transformer.

In the case of a defective winding in the transformer, a loud scratch will be heard in a few minutes. For a test of the other winding simply reverse the connections, i.e. connect the battery to the side where the 'phones previously were connected and the 'phones in place of the battery.

**TELEVISION  
SECTION**



## CHAPTER 33

# Television Antennas and Transmission Lines

**General.**—All present day television receivers, irrespective of their location with reference to the transmitting station, require an antenna for their proper functioning.

Television antennas may be classified according to their location as:

1. Built-in antennas.
2. Indoor antennas.
3. Window antennas.
4. Attic antennas.
5. Outdoor antennas.

*Built-in antennas\**, as the name implies, are those which are a component part of the television receiver, and are designed by the set manufacturer to function without the aid of an exterior antenna.

*Indoor type antennas* on the other hand are designed for placement in the immediate vicinity of the receiver, and where the dipoles are usually adjustable both as to length and to V-angle.

---

\*Most television receivers are equipped with built-in antennas connected to antenna terminal screws at the rear of the cabinet. In many locations, however, it will be found that an outdoor antenna will provide better reception. In case an outdoor antenna be used, the built-in antenna has to be disconnected from its terminal screws and the outdoor antenna leads connected in its place.

*Window antennas* are designed for mounting on the window sill and its vicinity, and takes various forms depending upon requirements.

*Attic antennas* are designed for mounting in the attic of small dwellings, from which point they are connected to the receiver in the conventional manner.

*Outdoor antennas* are generally designed for installation on roofs of dwellings and are usually supported by a suitable piece of galvanized iron piping or masts whose dimension depends upon the height of the antenna array.

Television antennas may also be classified with respect to their geometrical structure and number of elements involved, as:

1. Dipole antennas (straight or folded).
2. Conical antennas (double or single).
3. Yagi antennas, etc.

Antennas for television reception are manufactured in a great variety of types as shown in figs. 34 to 46, although for average reception in localities fairly close to the transmitter the half-wave matched dipole type with reflector is most generally employed.

The quality of the picture that is reproduced on the screen of a modern television receiver is dependent upon many factors, some of which are beyond the control of the receiver. The information presented here is intended mainly to assist the service man in determining the factor the antenna plays in the normal reception of television.

The strength of the transmitted picture signal that reaches the receiver is a vitally important factor in determining the quality of the picture that is reproduced on the screen. A very weak signal will produce an unsatisfactory picture. In

locations where the signal is exceedingly weak the picture will display a milky appearance which is usually accompanied by a "speckled" or "snow" effect.

**Television Transmission.**—The very high frequency waves used for the transmission of television picture signals acts quite similar to rays of light, in that they do not bend around corners and are reflected by obstacles in their path.

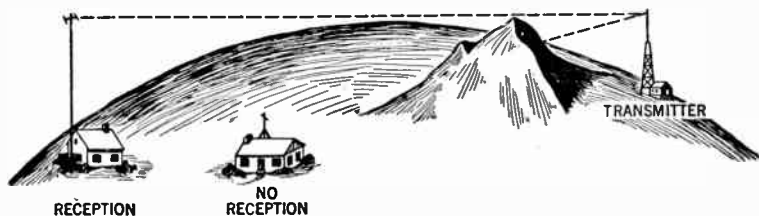

FIG. 1—Illustrating line of sight transmission. Due to the line of sight behavior of television signals, receivers located in obstructed areas will generally not receive television programs unless precautions be taken in the form of special antennas.

It should therefore be appreciated that television waves do not follow the curvature of the earth and reliable reception should only be anticipated in the region determined by the "line of sight\*" to the horizon in all directions from the antenna tower of the transmitting station.

This region is generally designated as the "service area" of the station and includes an area having a radius of 50 miles

\*The line of sight distance as denoted in television literature is the maximum distance which high frequency radio waves will reach without being impeded by the curvature of the earth. It is illustrated in Fig. 1 and is governed by the relationship

$$d = 1.41 (\sqrt{h_t} + \sqrt{h_r})$$

Where  $d$  is the distance between antennas in miles  
 $h_t$  is the transmitting antenna height in feet  
 $h_r$  is the receiving antenna height in feet.



or more, depending upon the relative height of the transmitting and receiving antennas, and the terrain between them.

Since signal strength decreases rapidly when the "line of sight" distance is exceeded, it is not possible to reliably predict conditions which might prevail at greater distances away from the transmitter. The technician who installs the television receiver must always carefully check to determine if signals at a particular location are of satisfactory strength.

The characteristic of high frequency television signals which permit them to be reflected from the walls of nearby buildings or other objects, may under certain conditions, create "multiple transmission paths." This would permit the reflected signal to arrive at the antenna a short interval of time later than the signal travelling in a direct path from the transmitter and the effect produced on the picture of the television receiver consists of a multiple image. These multiple images, known as "echos" or "ghosts" may generally be prevented by careful installation and orientation of the antenna.

**Transcontinental Television Transmission Systems.**—Since television transmission is limited to "the line of sight," an efficient relay system is necessary to link the country into television networks. There are two principal systems presently used for this purpose. They are:

1. The underground coaxial cable system.
2. The micro-wave radio relay system.

The coaxial cable system consists principally of a special type of telephone cable capable of passing a wide range of frequencies without the usual prohibitive losses and distortion. For a successful television transmission over longer distances however,

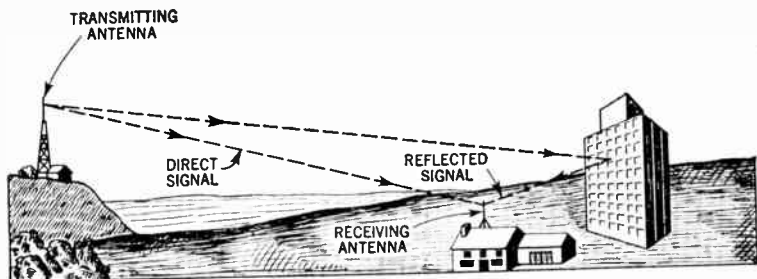

FIG. 2—Showing reflected signal path, causing multiple image or ghost on television receiver screen.

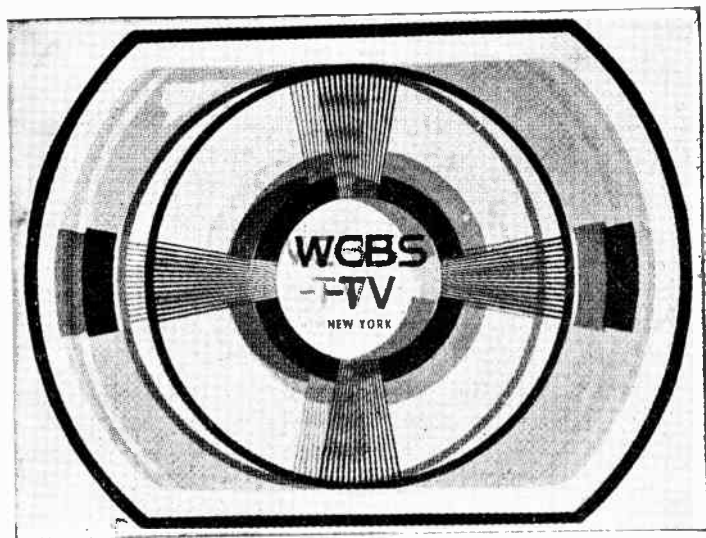

FIG. 3—Typical test pattern showing "ghost signals" due to reflected waves from intervening structures.

in addition to the coaxial cable, special repeater amplifiers (relay stations) are required spaced at an equal distance from one another.

The micro-wave radio relay system of increasing the range of television coverage, on the other hand, consists of a chain of towers located 10 to 25 miles apart. Each tower contains a receiver to pick up the signal from the preceding tower and a transmitter to rebroadcast it to the following tower.

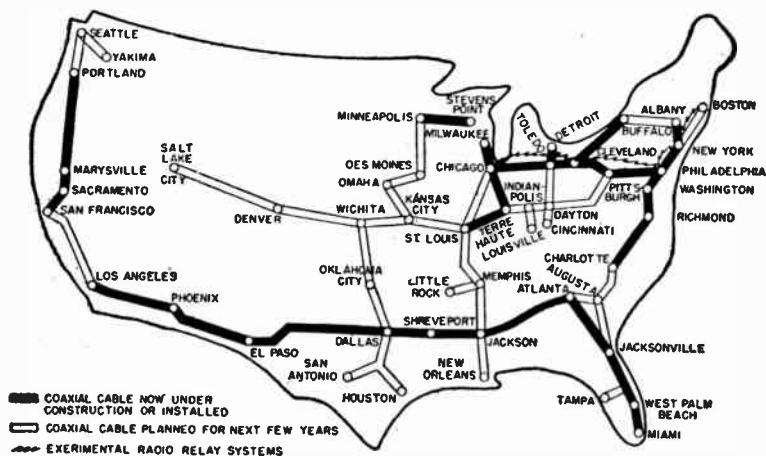

FIG. 4—Showing present status of transcontinental coaxial cable and radio relay system.

**Receiving Antenna Principles.**—For best reception each antenna should be selected with reference to distance and other factors covering the particular installation.

Fundamentally the three elements present in any television antenna installation are:

1. Antenna.

2. Transmission line.
3. Receiver.

The function of the antenna is to pick up the signal transmitted from the station and to transmit the signal to the receiver through the connecting transmission line.

**Transmission Lines.**—There are four general types of transmission lines acting as a transmission link between the antenna and the receiver. They are:

1. The two-wire parallel-conductor type.
2. The coaxial cable type.
3. The twisted pair type.
4. The shielded pair type.

There are several constructional variations in the basic types of transmission lines. Prior to the introduction of the polyethylene dielectric two-wire transmission line, a parallel conductor line in which the two wires (ordinarily No. 12 or No. 14) were supported a fixed distance apart by means of insulating rods called "spacers". The dielectric between the conductors consisted of air.

The modern two-wire transmission line is a parallel conductor line with stranded conductors imbedded in a low-loss insulating material (polyethylene). It has the advantages of low weight, compactness and neat appearance, together with close and uniform spacing. Losses, however, are higher in the solid dielectric than in air, and dirt or moisture on the line tends to change the characteristic impedance. Two-wire transmission lines of this type are available in impedances of 75, 150, and 300 ohms.

The most common type of coaxial transmission line consists of either a solid or stranded wire inner conductor surrounded by

polyethylene dielectric. Copper braid is woven over the dielectric to form the outer conductor, and a waterproof vinyl covering is placed on top of the braid. This cable is made in a number of different diameters. It is moderately flexible, and so is easy to install. Coaxial cable is available in characteristic impedances of 52, 72, or 150 ohms.

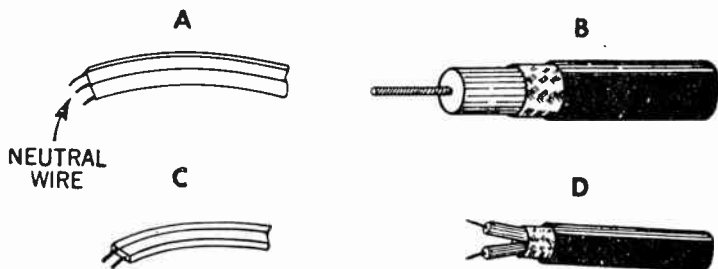

**FIGS. 5 to 8**—Various types of transmission lines. In the illustration A, represents a 300 ohm molded wire line with a third or neutral wire separating the parallel pair. B, coaxial cable with full length polyethylene dielectric. C, typical 300 ohm two wire transmission line. D, shielded parallel twin lead 300 ohm transmission line.

The air insulated coaxial cable transmission lines have lower losses than the solid dielectric type, but are less used because they are expensive and difficult to install as compared with the flexible type. The common type of air insulated coaxial cable uses a solid wire conductor inside a copper tube, with the wire held in the center of the tube by means of special insulating "beads" spaced at regular intervals.

Most television receiver manufacturers have made provision on the 300 ohm input to allow for the direct connection of 72 ohm cable. This is usually accomplished by the employment of a tap connected to unbalance the input circuit when the 72 ohm cable is attached.

**Practical Antenna Calculation.**—For proper antenna design it is necessary to know the length of the electromagnetic waves involved. In order to determine wave lengths, however, it is necessary to know the speed at which electromagnetic waves travel through free space, and the frequency. In speaking of the frequency of electromagnetic waves we merely mean the number of waves passing a given point in one second, expressed in megacycles (millions of cycles).

Since electromagnetic waves of all lengths move at the same speed, the number of waves passing a given point in one second will be small if the waves are long, and large if the waves are short. Thus, 500,000 waves 600 meters in length will pass a given point in one second at a frequency of 500,000 cycles. Similarly, if the waves were only one meter in length 300,000,000 would pass each second, which is a frequency of 300 *mc*.

The actual velocity of electromagnetic waves is for all practical purposes 300,000,000 meters or 984,300,000 feet per second.

Now, if the speed at which the waves travel is equal to  $3 \times 10^8$  meters per second, the distance it will cover in one cycle will be equal to this velocity divided by the frequency in cycles per second, or

$$\lambda = \frac{3 \times 10^8}{f}$$

where “*f*” represents frequency, and the Greek letter *lambda* stands for wave length in meters. Since feet and inches are the measurement used for practical television antennas we obtain:

$$\lambda = \frac{984}{f(mc)} \text{ ft. (approx.)}$$

and

$$\lambda = \frac{11,808}{f(mc)} \text{ ins.}$$

Because the length of each quarter dipole element in inches, is the dimension most frequently required, we obtain:

$$\lambda/4 = \frac{2,952}{f(mc)} \text{ ins.}$$

Due to certain electrical characteristics of the antenna material it has been found that in practice the antenna elements should be somewhat shorter (about 5 per cent) than that given in the foregoing formula. The formula then becomes:

$$\lambda/4 = \frac{2,952 \times 0.95}{f(mc)} = \frac{2,804}{f(mc)} \text{ inches}$$

From this latter formula it is comparatively simple to obtain the antenna dimension for each frequency, by substituting the proper value in megacycles (*mc*).

Dipole antennas that are to be used in outside installations consist usually, of two quarter wavelength sections of 3/8 in. aluminum tubing or rods.

The following example shows the general procedure when it is desired to calculate the exact length in inches, of each element (quarter wavelength) of a simple half-wave dipole antenna.

**Example.**—*It is desired to determine the length of a quarter wave dipole rod suitable for use on channel four, where the frequency according to the table page 755 has an average value of 69 mc. What is the dipole rod length?*

**Solution.**—By employing the foregoing formula a substitution of values gives the quarter wave length in inches as

$$\lambda/4 = \frac{2,804}{69} = 40 \text{ Approx.}$$

By using a similar procedure, it is a comparatively simple matter to calculate antenna dimension for any desired channel or frequency.

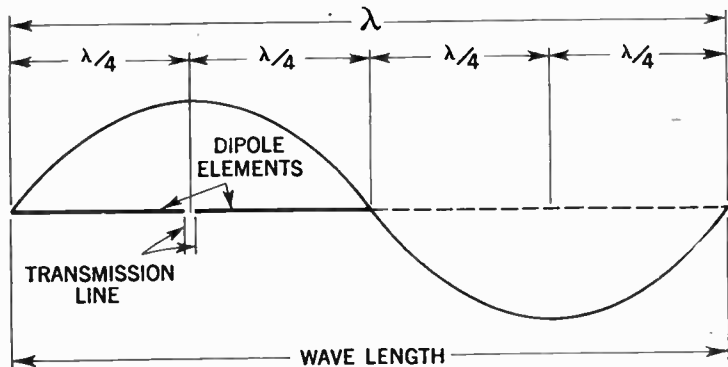

FIG. 9—Showing relations between wavelengths and length of dipole elements used in television antenna construction.

**Dipole Antennas.**—The fundamental form of a dipole antenna consists of two single wires, rods or tubings, whose combined lengths are approximately equal to half the transmitting wavelength. It is from this basic unit various forms of television antennas are constructed. It is also variously known as a half wave dipole, half wave doublet or Hertz antenna.

The complete television receiving antenna normally consists of two half wave dipoles (receiver and reflector) mounted in the form of an H on a substantial supporting mast or pole, strapped at its lower end to the building or roof housing the receiver.

The dipole elements are made of steel, aluminum or copper-alloy tubing and surface treated against corrosion. The receiver dipole is equipped with terminals at its adjacent ends for



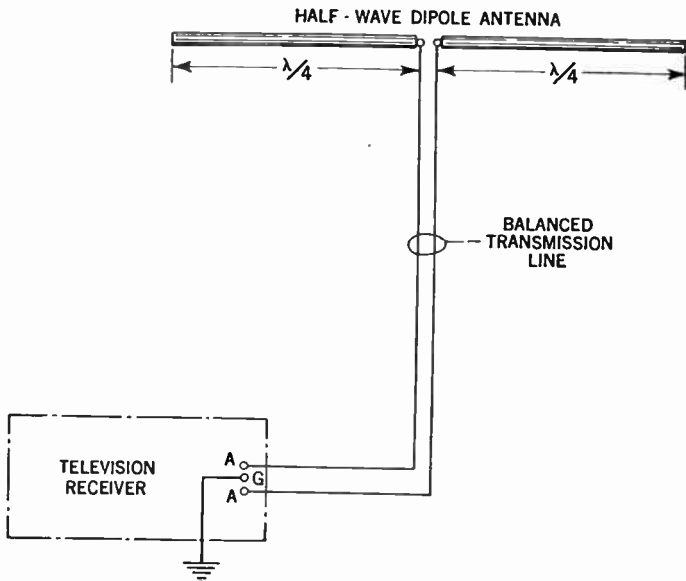

FIG. 10—Showing transmission line connection between a half-wave dipole antenna and television receiver.

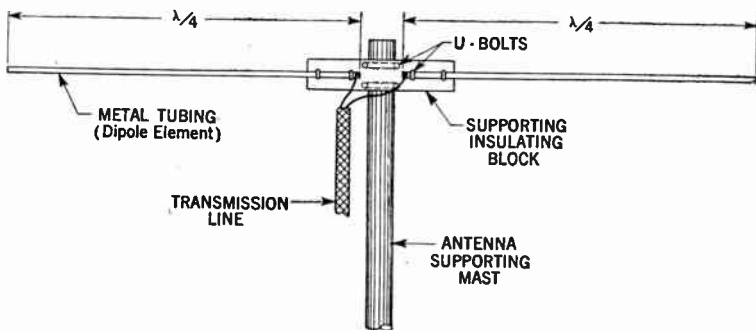
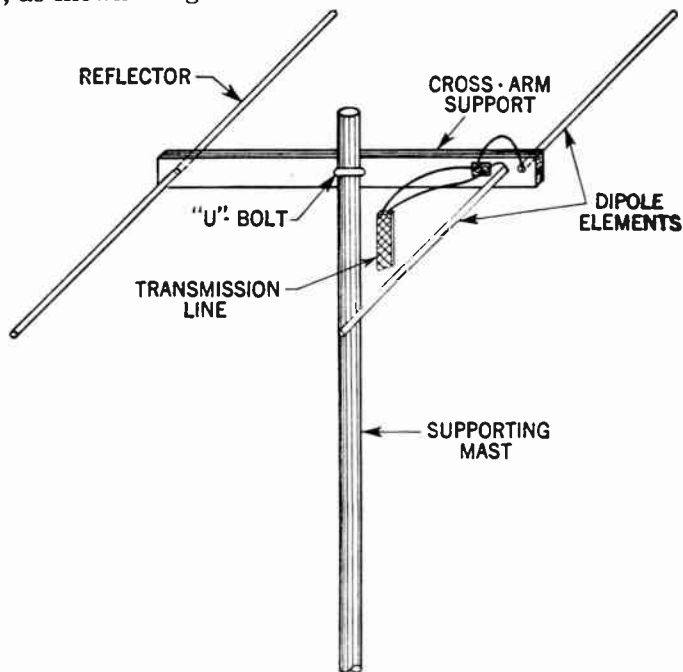

FIG. 11—Illustrating mounting arrangement and connection of half-wave dipole antennas to transmission line.

transmission line connections and must be properly insulated from the mast or supporting structure. The reflector on the other hand, may be joined directly to the antenna cross member, as shown in fig. 12.



**FIG. 12**—Typical mounting arrangement of dipole antenna elements with reflector.

**Folded Dipoles.**—The necessity for separating, insulating and fitting the receiver dipole at its center, however, tends to weaken and complicate the antenna assembly. Because of this, a considerable simplification may be obtained by employing an unbroken member bent and clamped to the supporting

member as shown in fig. 14. A television antenna of this type is known as the *folded dipole type* and is widely used.

The spacing between the folded dipole elements should vary inversely with the frequency, that is, the higher the frequency

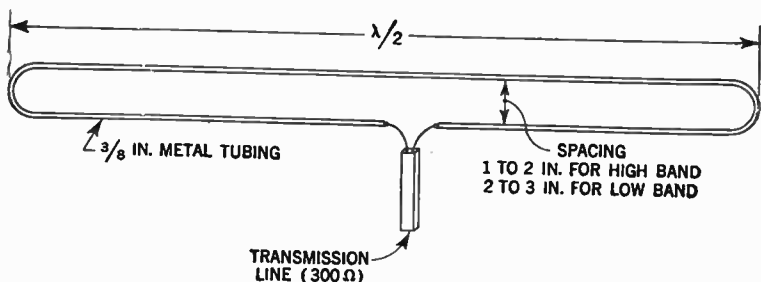

FIG. 13—Dimensional requirements of folded dipole antenna.

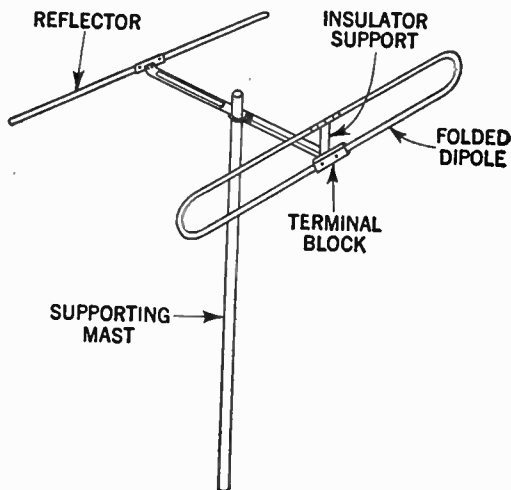
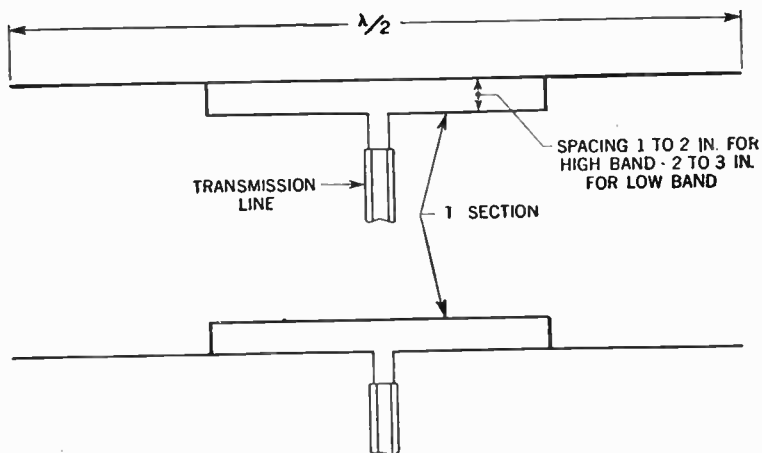

FIG. 14—Showing mounting arrangement of folded dipole antenna with reflector.

the smaller the spacing. The element spacing for the center frequency on the low band is usually 2 to 3 inches, and 1 to 2 inches for the high band.

**T-Matched Dipoles.**—A further combination of the common half-wave dipole and the folded dipole has become known as the T-matched dipole type. With reference to figs. 15 and 16



FIGS. 15 and 16—Showing T-matched dipole antennas. In the illustration both antenna arrangements have identical electrical characteristics.

the assembly is obtained by cutting the ends of a folded dipole and fitting the remaining stub ends to the bottom element, the T-section having a length of two-thirds the length of the dipole.

There are three principal factors to be considered in the design of a dipole antenna for television reception purposes. These are:

1. The length of the dipole shall be suitable for the particular wavelength in use.

2. The polarization of the transmitted waves shall be that for which the dipole is intended.
3. The directional properties of the dipole shall be such as to receive the desired waves effectively, while being unfavorable towards local interference.

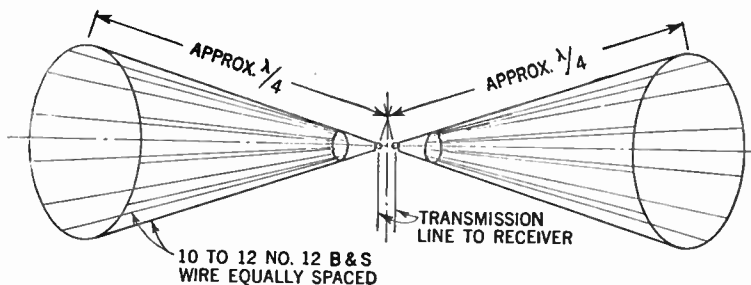

FIG. 17—Construction principles of conical antenna. The characteristics of the conical type are superior to the folded or straight dipole type of antenna from the standpoint of gain and band width. Actually the best arrangement would be the use of solid closed cones made of copper. This arrangement however, is impractical because of its weight which will be considerably increased in locations where the antenna will be exposed to sleet and snow. A satisfactory compromise employs 10 or 12 No. 12 B & S wire rods to take the place of the solid cones.

**Conical Antennas.**—An antenna in which the cross-section of each of the two halves increase smoothly outward from the center is termed a “conical” type. Because of its cone-like design, it will receive a very wide band of frequencies. Since this type of antenna has a large cross-sectional area, the length must be considerably reduced to keep resonance at the same frequency. Mechanically, however, problems arise in its construction, and its mounting on the roof will cause considerable difficulties.

In the case of television reception the first requirement should be extended to include the provision of a flatly tuned antenna system, able to respond fairly evenly over the waveband involved and also pick up the FM sound transmission. This compromise is often assisted by choosing the length of the antenna to resonate at a frequency intermediate between sound and video transmission.

The polarization of the waves to be received may be either vertical or horizontal. An antenna placed in the horizontal plane radiates horizontal polarized signals, whereas, an antenna placed in a vertical plane radiates vertically polarized signals.

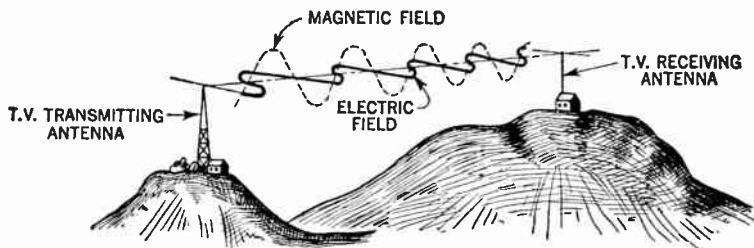

FIG. 18—Showing magnetic and electric field of horizontally polarized wave fronts.

Television transmitting and receiving antennas in the United States use *horizontal polarization* and the receiving antennas are therefore *placed horizontally*.

**Parasitic Elements.**—A parasitic element, as employed in television antennas, is a dipole slightly too long or too short for exact resonance at the desired frequency. It is mounted at some fraction of a wave length before or behind the driven

element. Parasitic elements are not cut at the center and are not connected to the transmission line. The center point of a parasitic element is electrically neutral and can be grounded. This is convenient for lightning protection, as it permits making the entire antenna structure of conductive tubing such as aluminum or stainless steel if desired, and grounding the central supporting mast at the base.

Current induced in a parasitic element by the advancing wave front produces a local field about it which couples it to the driven element by reason of their physical closeness. Spacing and tuning of parasitic elements are adjusted so that current produced in them by the received signal produces fields around them which add up in correct phase to reinforce the field of the received signal itself, in the driven element. For signals from the opposite direction, the action is exactly reversed, and the signal is substantially cancelled in the driven element.

**Director and Reflector Elements.**—A director element is about 4 per cent shorter than the driven element for average element spacing, and is mounted on a horizontal support member of wood or metal which holds all the elements in proper relationship. The spacing between director and driven element can vary from about 0.08 to about 0.15 wavelength in practical antennas. Closer spacing will increase the front-to-back ratio, but makes the array tune more sharply, which is bad where many widely separated television channels must be received on a single antenna. Wider spacing helps broaden the tuning of the array, but lowers the front-to-back ratio. It is possible to use several directors properly tuned and spaced in a line ahead of the driven element, but this complexity and expense is seldom necessary or justified.

A reflector element is about 5 per cent longer than the driven element at usual spacings, and is mounted on the supporting bar behind the driven element, the spacing varying from about 0.10 to 0.25 wavelength. Effects of changing the

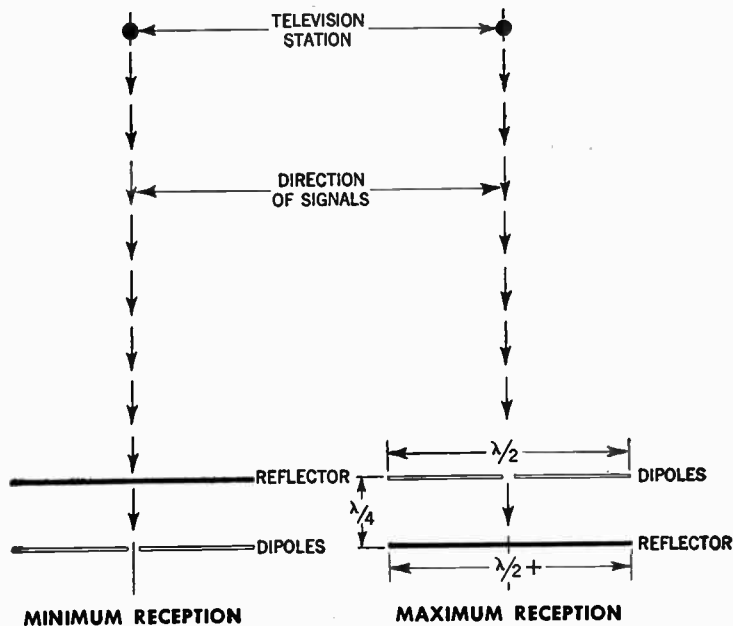

FIGS. 19 and 20—Showing location of reflector element for maximum reception. The antenna elements should always be arranged broadside to the transmitting station, with the reflector approximately one-quarter wave length behind the half-wave dipole.

spacing are quite similar to those produced by similar changes in the director.

The effect of the reflector is critically dependent upon the spacing between reflector and dipole, which as previously noted



should be one-quarter wavelength, when radiation from the reflector should exactly reinforce that from the dipole in a forward direction.

The explanation of this effect is as follows: Radiation from the dipole travels both forward and backward. In the latter direction it reaches the reflector, and induces a current in it. Since the radiation has travelled a quarter wavelength on its way to the reflector, it will reach it 90 degrees lagging in phase relative to that from the dipole where it originated. A current of this phase lag is therefore set up in the reflector, which in turn radiates.

By the time this secondary radiation has returned to the dipole it is a further 90 degrees late in phase, making a total phase lag of 180 degrees, but the oscillations in the dipole will have progressed through a half-cycle during this half-wave time interval, and will be 180 degrees ahead of the initial condition, when the radiation left on its way to the reflector. That is to say, the radiation from the dipole will be a half-cycle ahead of the reference point, while that returning from the reflector will be a half-cycle late, bringing the two to the same point in the period of an oscillation.

Being in identical phase, the radiations from the dipole and reflector reinforce each other in the forward direction, while an extension of the same argument will show that they tend to cancel in the backward direction.

If the current induced into a reflector was as great as that flowing in the dipole, each would produce the same radiated field strength. The forward radiation would therefore be doubled, while that to the rear would be exactly cancelled, giving zero backward radiation.

Since the problem of radiation and absorption by an aerial system are strictly reversible in all ordinary conditions, these directional effects, which are most easily explained when the

antenna is regarded as a transmitter, will be exactly similar when it is used for reception, provided of course that waves arrive in the plane in which dipole and reflector are situated.

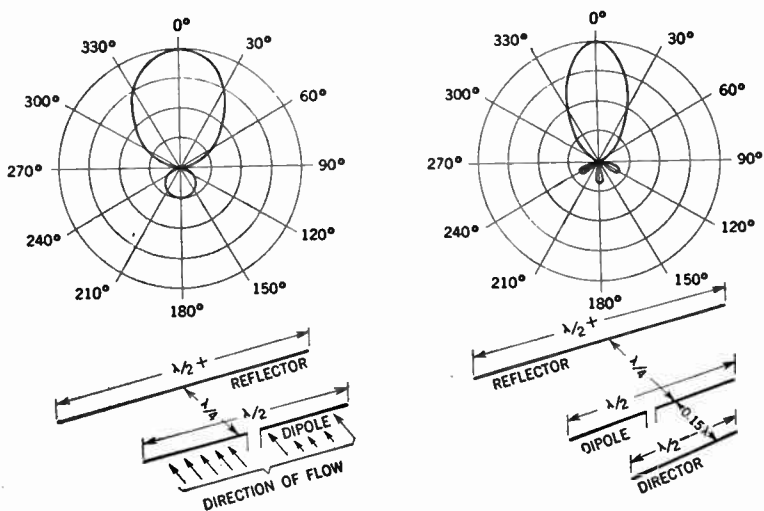

FIGS. 21 to 24—Showing typical response pattern of two and three element antennas, respectively. From the diagrams it may readily be observed that each additional parasitic element increases the directivity and narrowness of the antenna response. An antenna array with three or more elements of the single or stacked type are frequently employed in fringe areas where only one transmitting station is normally receivable.

In practice the resistance of a reflector will never be zero, and while the current in it can be made equal to that of the radiator if both are connected to a feeder, the current in a parasitic reflector must always be less than that in the dipole which gave rise to it. The forward radiation is therefore, never exactly doubled or the backward radiation fully prevented.

**Antenna Directivity Pattern.**—The horizontal antenna dipole is inherently directional, being most effective to signals arriving in the broadside direction and least effective to those arriving from a direction parallel to it. This effect is usually represented in the form of a polar diagram, or directivity pattern, in which the radius of the curve from the center of the antenna elements represent the relative response in any given direction.

The function of an antenna pattern is primarily to enable the service man to evaluate the efficiency of an antenna and assist in the proper orientation of it, on the site of installation.

Plotting an antenna pattern is generally accomplished as follows: A minimum usable value of signal strength is chosen on the basis of what the average television receiver will require for satisfactory reception. Then all the points in the area surrounding the antenna where exactly this value of field strength is found are plotted by bearing from true *North* or some other convenient reference direction, and distance in miles, or some other desired linear unit. With a sufficient number of points plotted, a continuous smoothly curving line is drawn joining them all, and it will be reasonably certain that all the area enclosed by this curve will provide at least the minimum required signal.

In practical service work, directivity patterns are always plotted in terms of voltage gain, as this unit is most convenient to use in connection with the survey meter, which is usually a part of the television service technicians equipment.

Antenna receiving patterns are usually made by rotating the antenna about its vertical axis and plotting values of voltage gain radially outward from the center of each change of angle.

The complexity of an antenna has a direct bearing on its efficiency, as well as its directional effects. Roughly, the

## HOW TO CURE RADIO NOISES

.There's no such thing as a cure-all for radio noises. Each case requires the right type interference filter. And even more so, the right installation.

That is why Aerovox offers a choice of types. The low-priced units (IN-27, IN-28 and IN-29) contain one or more by-pass capacitors. They are adequate in many cases. For the more persistent noise sources, however, such as the latest electric razors and high-speed vacuum cleaners, the more elaborate and costlier units (IN-30 and IN-31) are required. These units incorporate r.f. chokes as well as by-pass capacitors. For severest cases, there is the IN-42.

In installing the Aerovox Interference Filter, these pointers will help:

1. The basic idea is to set up a barrier between noise source and radio set.

2. Sometimes the interference filter can be plugged in between set and line. Usually this does not work because the interference has spread over the house wiring, and that wiring acts as a broadcasting antenna, so the set picks up the noises along with radio programs, out of the air.

3. Insert the interference filter as near as possible to the noise source. Avoid long connecting cords between filter and noise source.

4. Sometimes plugging the interference filter one way or the other makes a noticeable difference.

5. A separate ground connection when units have a ground terminal (IN-28 and IN-31) may make a difference.

6. If noise interference persists, exchange the less expensive type for a costlier type with its better filtering properties.

7. If possible, use the Aerovox Interference Analyzer. In a few minutes it indicates the best solution. Ask your jobber about it.

8. Aerovox Interference Filters are factory-checked for satisfactory operation. Very seldom is such a unit inoperative. Therefore, unsatisfactory operation is due entirely to installation. **DON'T RETURN THE UNIT TO THE FACTORY. RATHER ASK YOUR JOBBER TO HELP YOU WORK OUT YOUR PROBLEM.**

# AEROVOX INTERFERENCE FILTER SELECTOR



**TYPE ANL-37**

Plugs between interfering device and outlet. Selector switch adjusted until noise is eliminated or minimized. Dial indicates which type filter to use. Handsome, sturdy metal cabinet. Compartment contains necessary test leads and attachment plugs and clips. Size  $5\frac{1}{2} \times 5\frac{1}{2} \times 8$  inches.

**TYPE ANL-37**

## AEROVOX Type IN-23 \*



For elimination of interference caused by neon lamps or fractional horsepower motors. Mounting bracket for attaching to neon fixture (one eliminator needed for each fixture) or for attaching to frame of motor.

Flexible leads for connecting across motors such as in hair-driers, fans, mixers, etc. .5-.5 mfd.  $1 \times 2\frac{1}{8}$  in.

**TYPE IN-23**

List Price \$1.05

## AEROVOX Type IN-30



Similar to IN-29 but with additional inductance. Handles more severe interference. Plugs between set and outlet, or preferably between noisy appliance and outlet. Size  $1\frac{1}{8} \times 3$  inches.

**TYPE IN-30**

List Price \$2.50

## AEROVOX Type IN-27



Simple, inexpensive noise filter. Inserted between set and outlet when interference is slight. Also used with appliance causing low-intensity interference.

Keeps troublesome noises out of house wiring and power line. Size  $1\frac{1}{8} \times 1\frac{1}{2}$  inches.

**TYPE IN-27**

List Price \$1.50

## AEROVOX Type IN-31



Plugs in between attachment cord and electric outlet, either of set or preferably at appliance. Additional inductance for better filtering. Works best mounted by bracket directly on interfering

appliance. Size  $1\frac{1}{8} \times 3$  inches.

**TYPE IN-31**

List Price \$3.00



## AEROVOX Type IN-28

Intended for cases where ground is considerable distance from point of application. Most efficient

when mounted directly on interfering device by bracket. Size  $1\frac{1}{8} \times 2$  inches.

**TYPE IN-28**

List Price \$2.00



## AEROVOX Type IN-42

Designed for use in the more serious cases of radio interference from power lines and appliances. Provided with inductance as well as capacitance for thorough filtering action. Plugs into electric outlet. Radio set or interfering device plugs into receptacle of the filter. Recommended for use between interfering device and power line. Size  $2\frac{1}{8} \times 3\frac{3}{8}$ ". Provided with mounting ring. Rated at 6 amps. for 110-220v. A.C..

**TYPE IN-42**

List Price \$7.50

## AEROVOX Type IN-29



Provides additional filtering action over IN-27 and IN-28. Especially effective for local sources of interference of variable character but strong intensity. Very effective for electric razor and other vibrating devices. Plugs between device and line. Size  $1\frac{1}{8} \times 3$  inches.

**TYPE IN-29**

List Price \$1.75

\* For FLUORESCENT LAMP NOISES - IN-23: Connect one interference filter to each offending fluorescent fixture, as shown in diagram below:

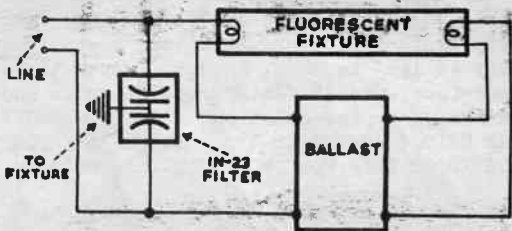

**AEROVOX CORPORATION**

New Bedford, Massachusetts

voltage developed in the antenna is proportional to the combined length of the element multiplied by the field strength of the signal.

This length is measured in units of half-wavelengths. A reduction in the voltage realized at the antenna terminals results from the mutual coupling of the elements.

A comparison of the theoretical efficiency of various types of antennas are as follows:

<i>Elements</i>	<i>Type</i>	<i>Voltage gain</i>
1.....	Simple Dipole.....	1.0 (reference)
2.....	Dipole and Reflector.....	1.6
4.....	2-Bays.....	2.3
6.....	3-Bays.....	2.8
8.....	4-Bays.....	3.2

In the foregoing table, the reference value of 1.0 shown for a simple dipole is the universal standard of comparison. This reference dipole is cut to a half-wavelength for each channel measured.

As previously noted, the voltage developed by a half-wavelength antenna is proportional to the length of the antenna. Therefore for purposes of adding additional elements, multiples of half-wavelengths are used.

The receiving antenna height particularly in fringe areas, is an important factor in its efficiency, or signal capture, as shown in figure 25. The possibility of interference is shown by the irregularity of the curve representing signal on the high channel group. This particular effect, however, is not predictable and can only be determined by proper orientation.

The field pattern (directional response pattern) of a typical dipole antenna is shown in figure 27.

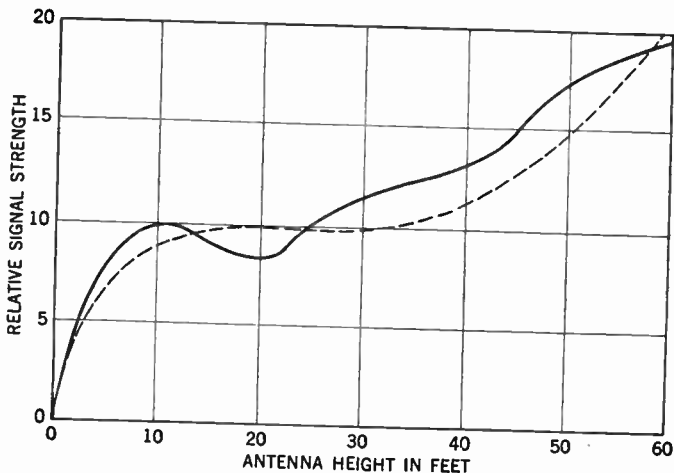
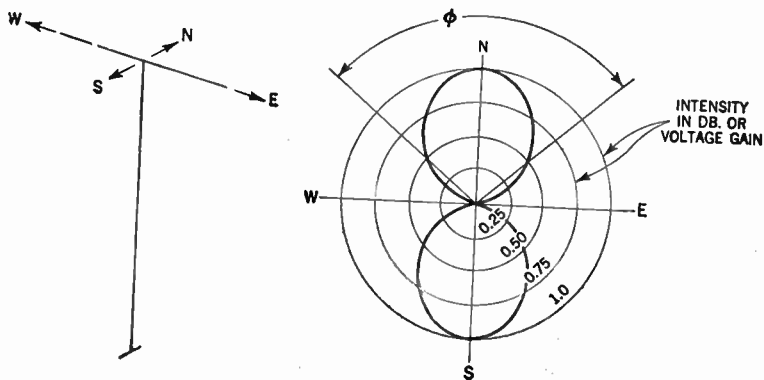

FIG. 25—Showing relative signal strength of antennas per height in feet. The above chart applies to antennas located in fringe areas or at a considerable distance from the transmitting station.



FIGS. 26 and 27—Showing directional response pattern of dipole antenna.

For the sake of simplicity the directions are given as North, South, East and West, in both the schematic antenna and the polar diagram. From this diagram, it will readily be observed that the maximum signal strength will be obtained when the antenna is broadside to the transmitter. Similarly the "signal capture" is not critical over the angle  $\phi$ , which includes the rotation over which the antenna can be rotated before losing more than half of its effectiveness. In the diagram the concentric circles represent the voltage gain, where unity, or 1.0 is taken as reference for all comparisons.

If a reflector be added to dipole, the gain and directional characteristics of the antenna are changed and the polar diagram will take the form as indicated in figure 29. It will be observed from the diagram that the angle  $\phi$ , is still sufficiently wide, generally at least 80 degrees.

So far, an antenna operating only on the channel for which it was designed has been considered. It is the usual practice to use dimensions which give half-wave dipoles in the middle of the low channels. When used on the high channels, a third harmonic will result, giving an antenna pattern shown in figure 31.

A dipole operated in this way will have six lobes, and unless certain dimensions are revised, these lobes are symmetrical, and oriented as indicated. With reference to the field pattern, these lobes are too narrow and are pointing in a different direction, from that previously shown. This will make orientation difficult, or even impossible if the stations on the high and low channels are in the same direction. From this it follows, that no reliable antenna manufacturer would sell an antenna with these characteristics, without showing the relation of the lobes for each frequency:



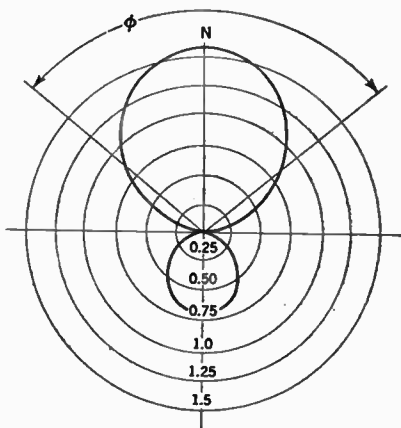
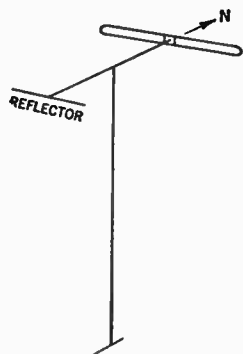

FIGS. 28 and 29—Directional response pattern of folded dipole antenna with reflector.

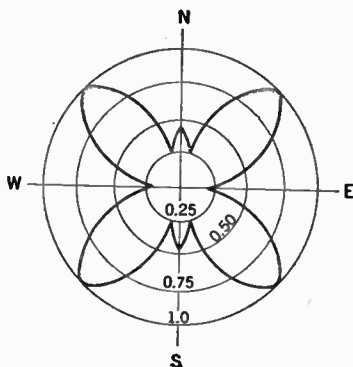
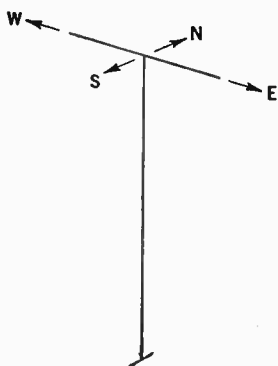

FIGS. 30 and 31—Directional response pattern for dipole antenna showing the necessity for proper dimensioning of antenna elements.

The ratio between maximum and minimum voltage (measured with a voltmeter slid along the line) is called the *voltage standing wave ratio*, abbreviated SWR. It is obtained numeri-

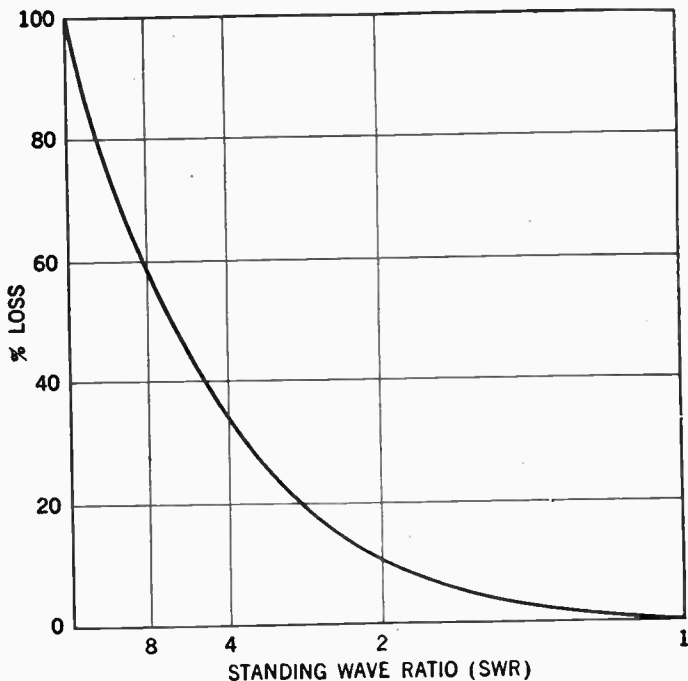

FIG. 32—Characteristic curve showing relation between voltage standing wave ratio and per cent loss due to mismatch in antenna installations.

cally by dividing the maximum by the minimum voltage. Thus maximum and minimum values of 15 and 5 would mean a SWR of 3.

If the SWR be plotted on a logarithmic scale against per cent loss the curve will take the form shown in fig. 32. Here it will be observed that a SWR of two will cause a loss of only 10 per cent, while a SWR of three will cause a loss of 25 per cent.

**Antenna Impedance Matching.**—Impedance matching is a very important factor in antenna installations. When the receiver input matches the impedance of the transmission line, the transmitted signal is completely absorbed and as a result there are no reflections or *standing waves* on the transmission line, and consequently no ghost image. In this connection it should be observed that the antenna impedance is important only from the standpoint of power transfer. It is only when the antenna impedance matches that of the transmission line that maximum power transfer takes place.

A condition which may easily arise is the mismatch of 300 ohms to 72 ohms; this produces a SWR of four and a loss of 37 per cent. This condition will be the result when a 72-ohm antenna is connected to a receiver having a 300-ohm input impedance. Mismatch, and consequent loss of gain also occurs when the antenna and receiver are not connected by transmission cable of proper characteristic impedance.

Impedance matching is most commonly accomplished by the use of the impedance inversion characteristic of a one-quarter wavelength section of cable. This is expressed by the simple relation: Input impedance times the output impedance is equal to the square of the characteristic impedance of the cable used for the one-quarter wave transformer.

That is:

$$(Z_0)^2 = Z_s Z_r$$

Where  $Z_0$  = characteristic impedance

$Z_s$  = input impedance

$Z_r$  = output impedance

To illustrate an impedance matching application of a one-quarter wave linear transformer, when using the 72 ohms antenna connected to a receiver having a 300-ohm input impedance, we obtain:

$$Z_0^2 = 72 \times 300, \text{ from which}$$

$$Z_0 = \sqrt{21,600}, \text{ or}$$

$$Z_0 = 147 \text{ ohms (approx.).}$$

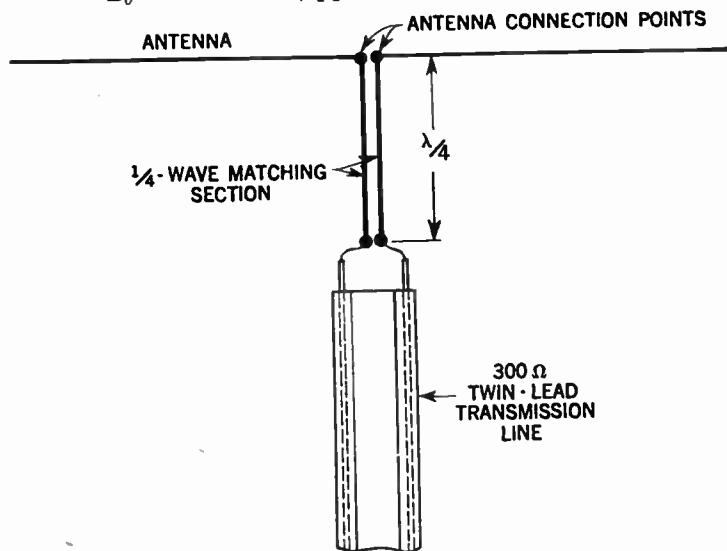

FIG. 33—Illustrating insertion of quarter wave matching section to obtain proper impedance match.

From our calculation it will be observed that one-quarter wave section from a 150-ohm twin conductor line will be very close to a perfect match. This should be spliced in between the end of the 72-ohm line and the receiver input with due attention to good connection.

**Fringe Area Reception.**—By the term *fringe area* is generally understood a receiver location which is considered as outside the normal service area of a transmitting station.

Specifically, a fringe area is considered to be the outlying part of a whole general area reached by the television signals from a given metropolitan center, where signals are so weak so as to require the use of high gain antennas, or masts higher than the standard single length or both.

Television reception in fringe areas is generally dependent upon the following factors:

1. Signal to noise ratio in the area.
2. Gain and directivity of the transmitting antenna.
3. Sensitivity of the receiver.

Factors which contribute adversely to distant reception are:

1. Transmitting stations with power of less than 20 *kw*.
2. Transmitting stations with an antenna of less than 1,000 feet in height.
3. Intervening obstructions between transmitter and receiver such as hills, mountains, forests, etc.

Since the gain and directivity of an antenna depends upon the number of dipole and parasitic elements assembled, a fringe area usually requires a somewhat more complex antenna array than that required in the intermediate service area.

The signal to noise ratio in any fringe area can usually be improved considerably by increasing the height of the receiver antenna and by selecting an antenna with a narrow horizontal and vertical pickup pattern. In some cases an antenna system alone will not suffice and an RF booster (preamplifier) may be required to increase the weak signal to usable value.

**Stacked Arrays.**—It has been found that additional antenna gain may be obtained by stacking the conventional dipole and reflector. This consists in arranging one driven element on top of another at a spacing that will cause the signals to be in phase at the terminals where the transmission line is connected to the antenna system.

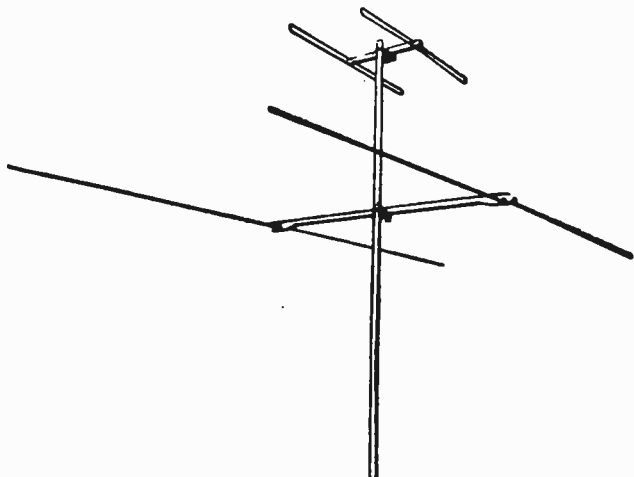
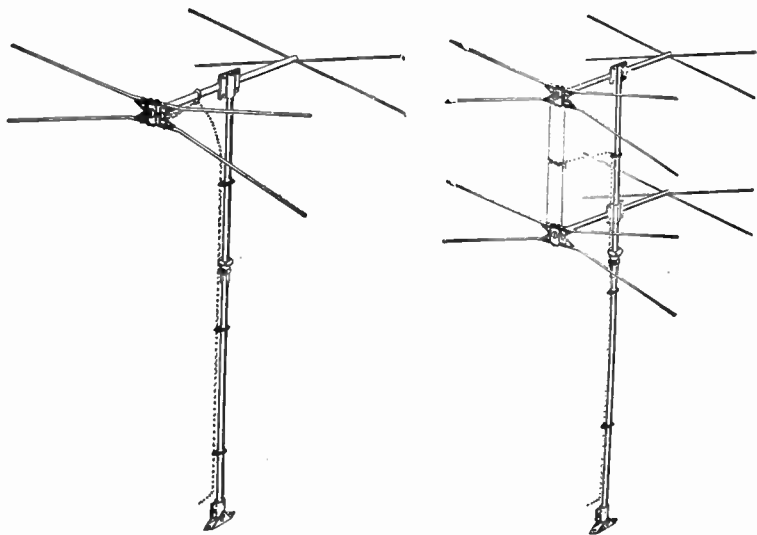

**FIG. 34**—Typical high and low band combination antenna.

There are many types of antennas available for fringe area reception. In general, the stacked dipole and reflector is better than the conical type on the low bands, but it is inferior on the high bands because of the smaller dimensions. It can be made broad-band so that one unit will operate over all the low channels; but for the high channels there must be another set of elements. For this reason, this type is made with two sets of elements, either above each other on the mast, or in line on the same cross-arm. Fig. 34 shows a typical arrangement of this

type, which is generally known in the trade as the high-low combination antenna.

An effective compromise on directivity, gain and band width has been obtained with the introduction of a stacked in-line



FIGS. 35 and 36—Illustrating two types of conical antennas. These antenna arrays are sometimes termed "fan type" antennas.

antenna shown in fig. 41. This antenna combines the added signal on two-stacked folded dipoles and reflectors for a single transmission line

Theoretically, one of the best types of television receiving antennas is the conical type. Because of its cone-like design it will receive a very wide band of frequencies and maintain an almost constant terminal impedance over the entire frequency

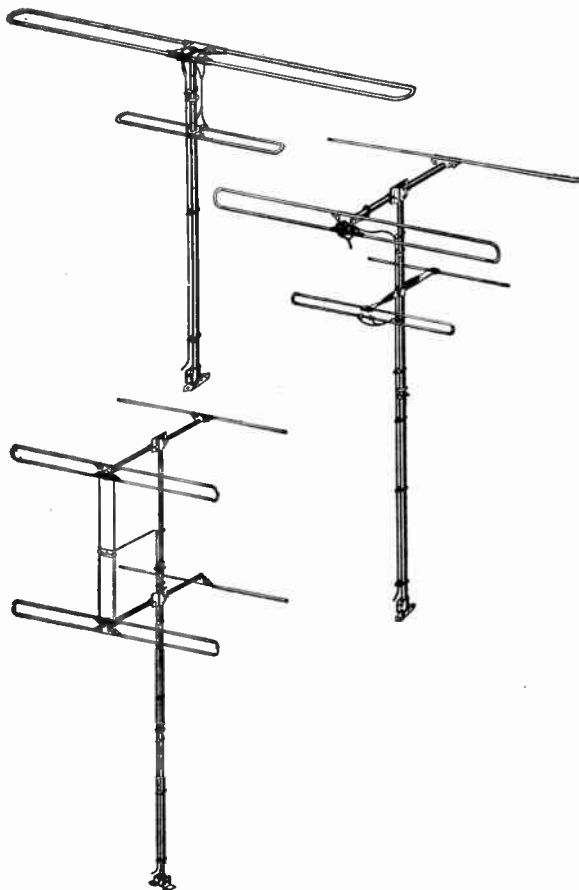

**FIGS. 37 to 39**—Three distinct variations of antennas for fringe area reception. Fig. 37 represents a folded high-low band type; fig. 38, high-low band folded dipole with reflectors; fig. 39, high-gain stacked array.



range it is designed to cover. Two types of stacked conical antennas are shown in figs. 35 and 36.

The Yagi array, fig. 42, is a high-gain antenna. The gain is roughly 2.2 times for one bay and 3.2 times for two bays. It has the disadvantage, however, of being a narrow band antenna, and for full gain a separate array must be used for each channel.



**FIG. 40**—Double folded dipole antenna with reflector. An antenna of this type will give an excellent forward gain and high forward-to-back ratio. The antenna requires only one transmission line to receiver and requires no special matching network to give excellent performance on high and low bands. It is used preferably where transmitting stations are located not too far apart.

The angle of orientation, including the one-half power points is about 40 degrees. It is frequently employed in fringe areas to pick up some station, and for this purpose it is probably the best type available. A typical Yagi type design having two, 4-elements stacked vertically for reception on channel four is shown in fig. 44.

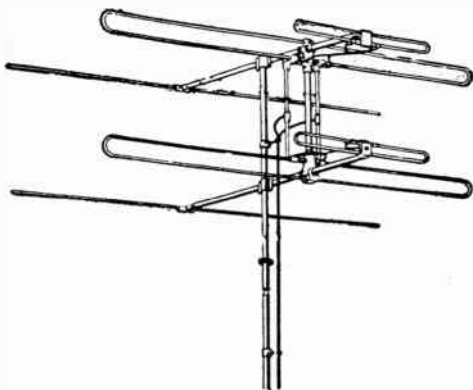
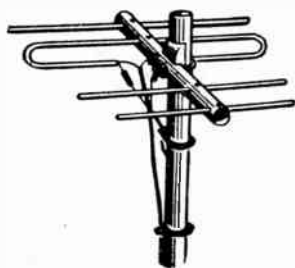
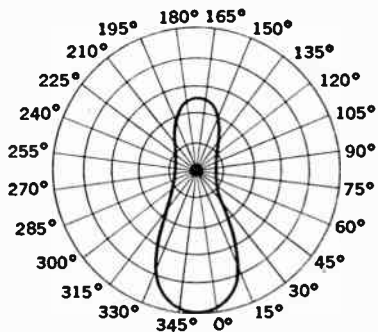

FIG. 41—Typical stacked in line folded dipole antenna array with reflectors.



YAGI ARRAY



DIRECTIVITY PATTERN

FIGS. 42 and 43—Typical Yagi array and associated directivity pattern.

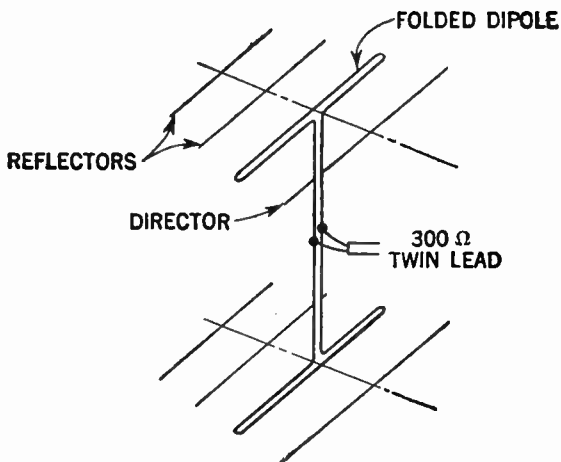

**FIG. 44**—Schematic diagram showing two, 4-element Yagis stacked vertically. This arrangement forms a highly directional and sensitive antenna. One 4-element array is satisfactory in many areas.

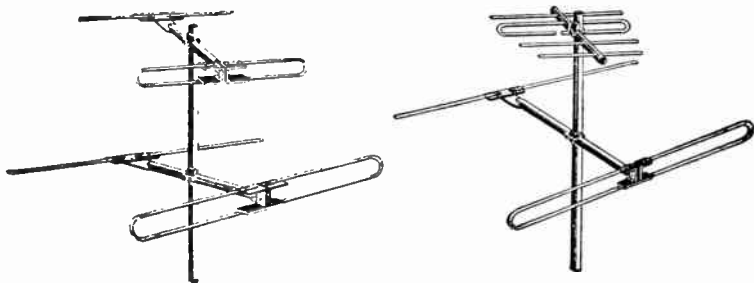

**FIGS. 45 and 46**—Typical folded dipole high and low band antennas. Fig. 46 incorporates in addition to the folded dipole with reflector for the low band, a Yagi array for use on the high band.

## CHAPTER 34

# Television Controls; Test Patterns and Adjustments

In common with the conventional radio receiving set, the television receiver requires certain controls for its proper operation.

The various controls on a television receiver may be divided into two classes, depending upon their frequent need of operation. They are:

1. Operating controls.
2. Preset controls (service adjustment controls).

Operating controls are those which control program selection as well as sound and picture quality and their functions are indicated in figs. 1 and 2.

The preset controls on the other hand, are those which usually require adjustment at the time the receiver is installed, but only rarely need attention thereafter.

Because of this, numerous manufacturers of television receivers have only the *operating controls* located at the front of the cabinet, whereas the *preset* or *service adjustment controls* are usually located at the rear of the chassis.

With reference to fig. 1, the operating controls generally consist of the following:

1. On-off switch and volume control.
2. Channel selector.
3. Fine tuning control.
4. Contrast control.
5. Brightness control.
6. Horizontal hold control.
7. Vertical hold control.

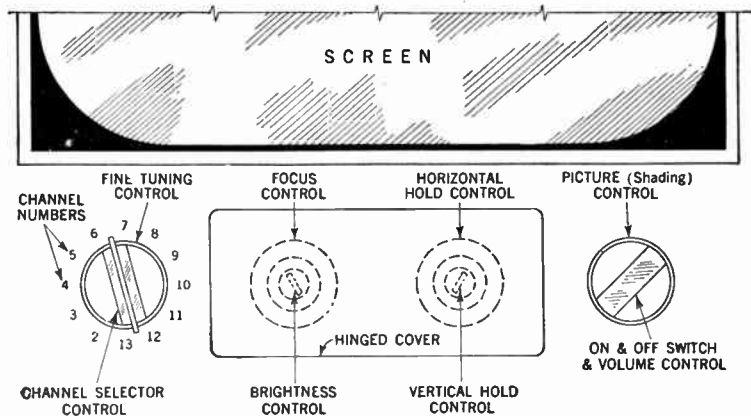

**FIG. 1**—Illustrating operating control location in typical receiver. It should be observed that only two dual operating controls are used in normal tuning of a television station. Behind the hinged cover are located two additional dual controls which may be adjusted under certain conditions to improve reception such as when receiving a weak station or in case of extreme interference.

Depending upon the design of the receiver, only four or five of the foregoing controls need to be operated during normal reception.

**Dual Operation.**—In order to simplify the operation, and to improve the appearance of the cabinet as well, numerous manufacturers arrange the control knobs for dual operation; that

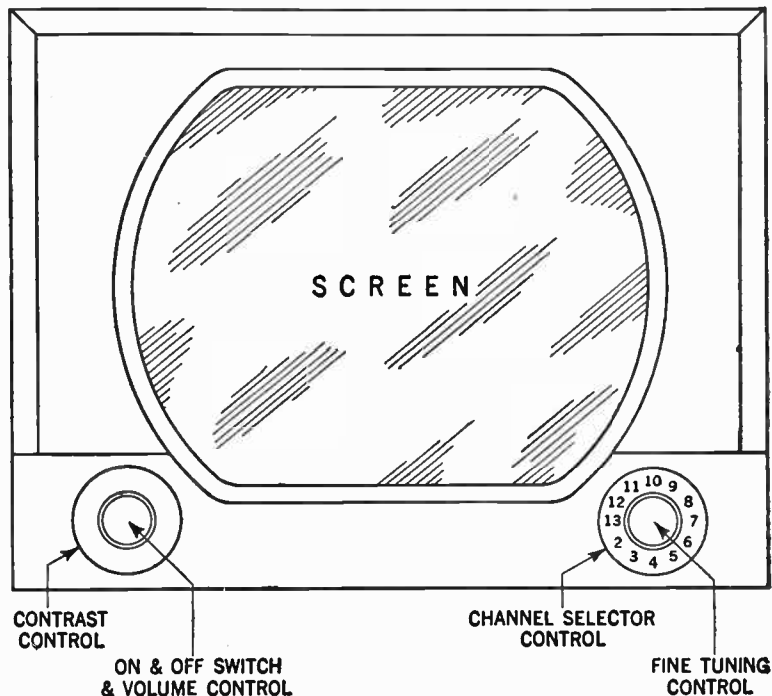

FIG. 2—Showing front view of another typical receiver with operating control location. These are two dual controls, consisting of a small and a large knob each, on the front panel of the receiver.

is, the controls are arranged in pairs of two, consisting of a small inner knob and a larger outer knob. Thus, for example, the *channel selector switch* and the *fine tuning control* are commonly

of the dual type. The *contrast control* and *brightness control* are similarly arranged, as are the *horizontal* and *vertical* hold controls.

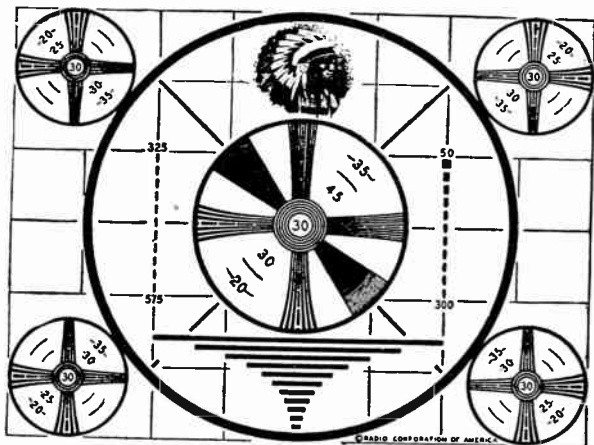

FIG. 3—Showing typical test pattern with receiver functioning normally.

Some manufacturers of television receivers arrange such controls as the *horizontal* and *vertical holds*, in addition to *focus* and *brightness control* underneath a hinged cover, since these usually do not need to be reset each time the receiver is operated, but are properly set at the time of installation. The purpose and function of the operating controls are as follows:

**On-Off Switch and Volume Control.**—The purpose of the on-off switch and volume control is to turn the receiver on and off and to adjust the sound volume to a desired level.

**Channel Selector.**—This consists of a simple selector switch by means of which the correct channel number of the desired

television transmitter may be selected. The channels presently in operation are numbered from 2 to 13.

**Fine Tuning Control.**—This control turns the receiver for best sound and picture. After the proper channel is selected, adjust the fine tuning control to obtain the best picture quality.

**Contrast Control.**—A variation of the amount of background light or *picture shading* is provided by this control. Adjust to receive picture and obtain correct contrast between light and dark shades.

**Brightness Control.**—This control sets the picture brilliance. The brightness control should not be turned past the point at which the picture begins to grow larger, since detail will be lost due to loss of focus.

**Horizontal Hold Control.**—The horizontal hold is an adjustment of the horizontal picture synchronization circuits. Misadjustment of this control will cause the picture to move either right or left or in extreme cases, it will cause black horizontal lines to appear on the screen. This control should be adjusted until the picture appears and there is no horizontal movement.

**Vertical Hold Control.**—When switching from a strong local station to a weak station, it may sometimes be necessary to make adjustment of the vertical hold control. Principally the vertical hold is an adjustment of the vertical synchronization circuits. Misadjustment of this control will cause the picture to move either up or down. The control should be adjusted so that there is no vertical movement of the picture.



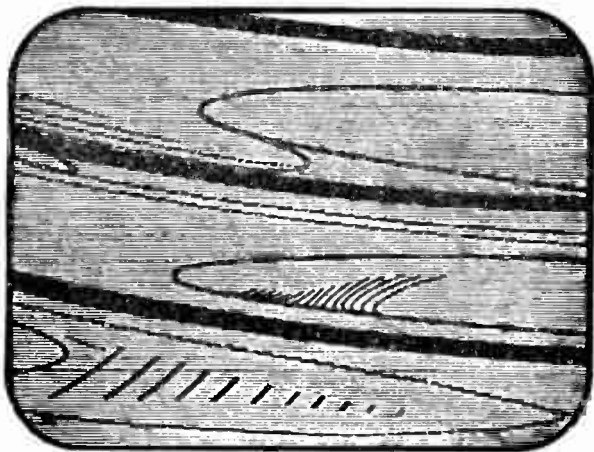

**FIG. 4—**Test pattern showing horizontal movement. To correct, adjust horizontal hold control.

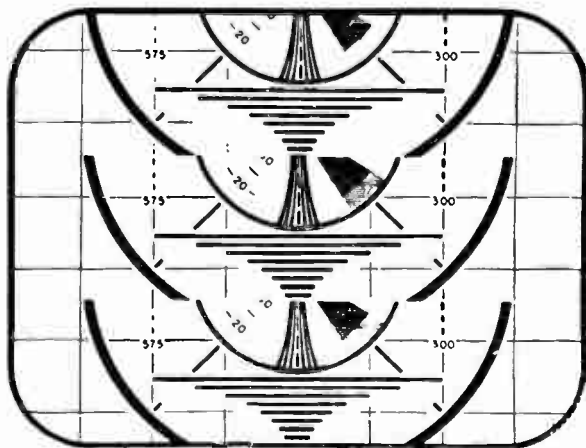

**FIG. 5—**Test pattern showing vertical movement. To correct, adjust vertical hold control.

## **Step by Step Tuning Procedure**

In order to select a particular station and to adjust the various operating controls for correct picture and accompanying aural reception, proceed as follows:

1. Turn volume control about one-half turn clockwise. This supplies power to the receiver. Allow about two minutes for the tubes to reach operating temperature.
2. Turn the channel selector until it points to the number of the desired station channel.
3. Turn the tuning control for best detail of the picture.
4. Adjust contrast control to obtain the proper shading in the picture which means it should have good deep blacks, whites and intermediate shades of gray.
5. Readjust volume for most pleasing reproduction.

After the receiver has been adjusted as indicated, the volume control need only be used to turn *on* or *off* the receiver between the desired programs unless some other station is to be tuned in.

Before commencing the tuning operation, however, it may be well to check to be sure that a television transmitting station actually is on the air at the time it is desired to operate the receiver. Program schedules are usually published in the daily newspapers and many television stations will mail advance copies of their weekly broadcast schedule to set owners upon request.

It should also be noted that during intervals in which stations are only televising their test pattern, the sound will only be a sustained note. This test pattern, fig. 6, and special sound transmission is used by television technicians to adjust certain preset controls at the time of installation.

## The Test Pattern

Prior to a detailed discussion of the operation and functions of the *preset controls*, it will be of assistance to know the part test patterns play in the proper adjustment of the receiver.

The function of any test pattern is to furnish an accurate means of comparing the picture that appears on the picture tube with that actually seen by the television camera. If the two were identical, it would indicate completely perfect transmission of the image through the entire transmitting and receiving system. The extent to which it is approximated gives a measure of the quality of the transmission.

The test patterns, therefore, provide a means for the proper diagnosis and adjustments, which may occur in a television receiver. Test patterns are broadcast regularly by most television stations, and assume several configurations of lines, circles and black bars, as shown in figs. 3 and 6.

Such factors as *picture aspect ratio*, *resolution*, *linearity*, *contrast*, and *brightness* in addition to *focus control* may easily be observed by an analysis of fig. 6.

The *aspect ratio* of a picture determines its proportions. By arbitrary choice the television broadcasting stations have settled on the aspect ratio of 4 to 3; that is, a picture whose width is  $\frac{4}{3}$  as great as its height. Thus, when the aspect ratio of the picture, fig. 6, is correct, the diameter of the large outer white circle (or part of a circle to be exact) is exactly  $\frac{4}{3}$  of the diameter of the large black circle. If this ratio is not maintained, then the aspect ratio of the picture is incorrect and should be adjusted.

By the term *resolution* is meant the extent to which the picture separates the details of the original scenes from one another.

Vertical resolution depends largely on the following:

1. The number of scanning lines employed.

2. Size of the scanning beams in both the camera tube and the picture tube.
3. Sensitivity of the camera tube, and other elements of the transmitting apparatus.

Horizontal resolution on the other hand is not affected to any great extent by the number of scanning lines and by the characteristics of the camera and transmitter.

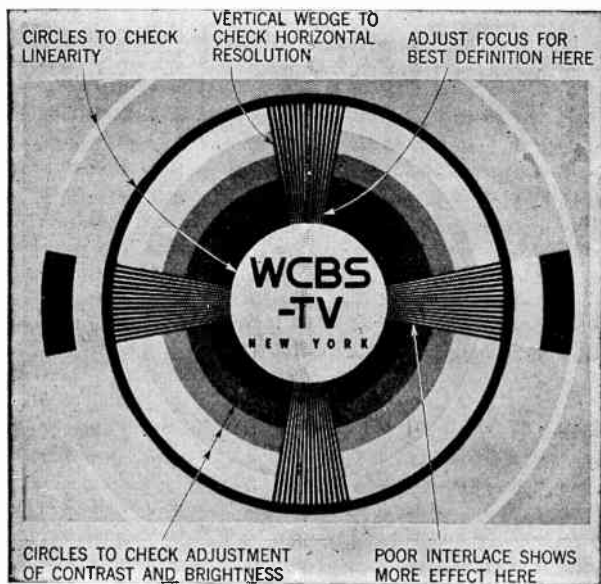

**FIG. 6—**Normal (greatly reduced test pattern) as broadcast by CBS.

A check on the vertical resolution may be made by observing the horizontal wedges of our test pattern, fig. 6. If the lines of the wedges emanating from the central white circle are partially or completely blurred, there is a partial loss of resolution.

In a similar manner the vertical wedges may be used to check horizontal resolution.

*Linearity* refers to the uniformity of distribution of a regular pattern on the picture tube. When the condition of the electron beams on the picture tube are such that the beams do not move at constant speed, the objects in the picture will be distorted in shape, and as a result the picture is said to have poor linearity.

It should be observed that for a completely satisfactory picture, the receiver system should be free from all of the various defects which tend to impair its quality. This includes faulty interlace, improper focus of the beam, 60-cycle power frequency superimposed on deflection voltages, noise and other forms of interference.

*Vertical* and *horizontal linearity* may be checked by observing the large black circle shown on the test pattern. When perfect linearity is present, the circle is geometrically flawless.

*Brightness* and *contrast* must be present in suitable proportions for a pleasing picture. Brightness without adequate contrast actually reduces the clarity of the picture. Contrast depends upon the amount of change of the video voltage applied to the picture tube grid; that is, its peak-to-peak swing. Brightness of the picture depends upon the *d.c.* or average value of the video signal at the picture tube.

*Contrast* and *brightness* correctness may be observed by means of the several concentric circles in the test pattern. These are located between the large black circle and the white circular center area. These are of different shades from light gray to black. When the picture shows tone variations, the brightness and contrast controls are set correctly. If not, they should be adjusted.

Correct *focus control* may be determined by observing the center of the test pattern. When this white circle is perfectly round and sharp, the focus control is properly set. If not, an adjustment should be made.

## Preset or Service Adjustment Controls

These are controls which have been factory adjusted for optimum performance, although it is usually necessary to make some adjustments of these at the time of installation. The service adjustment controls usually consist of the following:

1. Focus control.
2. Vertical size.
3. Vertical linearity.
4. Horizontal size.
5. Horizontal linearity.
6. Horizontal drive.
7. Picture width.
8. Picture height.

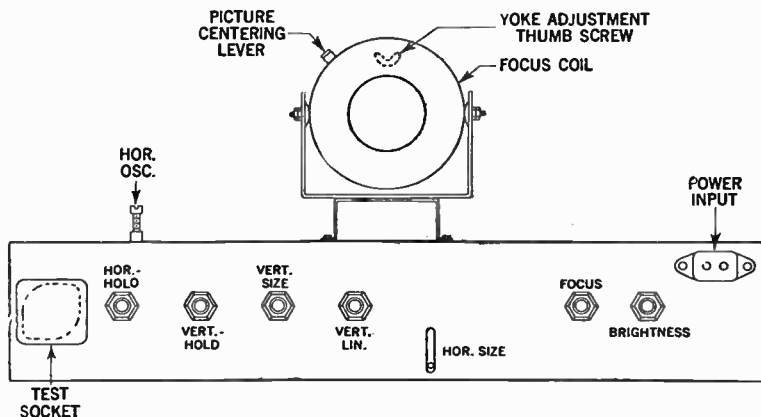

FIG. 7—Showing preset controls for receiver whose operating controls are shown in fig. 2.

Depending upon the design of the receiver some of these controls may be located at the front of the cabinet, whereas others may be located in the rear of the chassis.

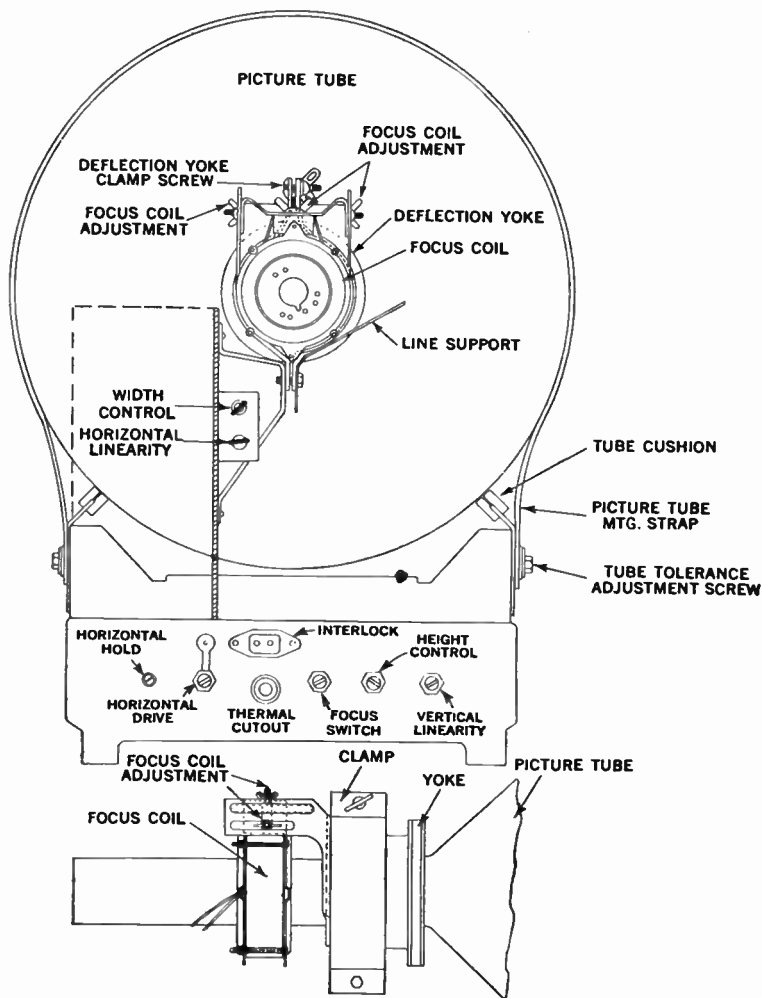
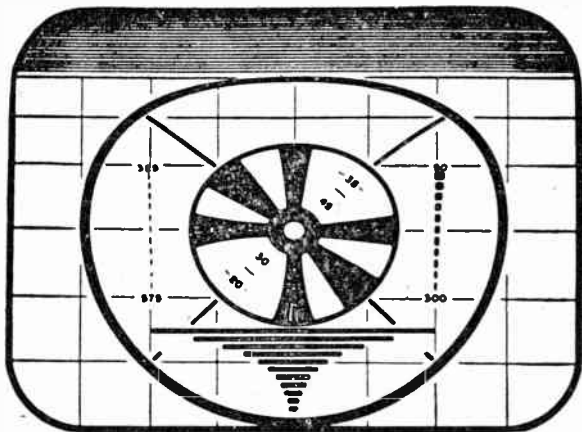

FIG. 8—Showing preset controls for receiver whose operating controls are shown in fig. 1.

**Focus Control.**—This control offers adjustment of the sharpness of detail of the picture. At long intervals the focus control may have to be readjusted for best clarity of the picture. This is done by turning the focus control in either direction until the picture shows best clarity. Observation of the picture slightly right of center when making this adjustment gives the most uniform focus. Tune for clarity of small objects or lettering in the picture.



**FIG. 9**—Test pattern showing vertical distortion. To correct, adjust vertical linearity control.

**Vertical Size and Vertical Linearity Controls.**—These controls should both be adjusted at the same time and preferably while a test pattern is being transmitted. The linearity control affects the upper portion of the picture while the size control affects the lower portion. Adjust both controls simultaneously until the test pattern is symmetrical and fills the entire screen vertically. Readjust the vertical hold control if necessary.



**Horizontal Size Control.**—This control should be adjusted preferably when a test pattern is being transmitted. The size control should be adjusted until the test pattern fills the entire screen horizontally.

**Horizontal Linearity Control.**—This control should be adjusted for best possible horizontal linearity. In the event that proper horizontal linearity cannot be obtained by adjusting this control, then change the setting of the horizontal drive control.

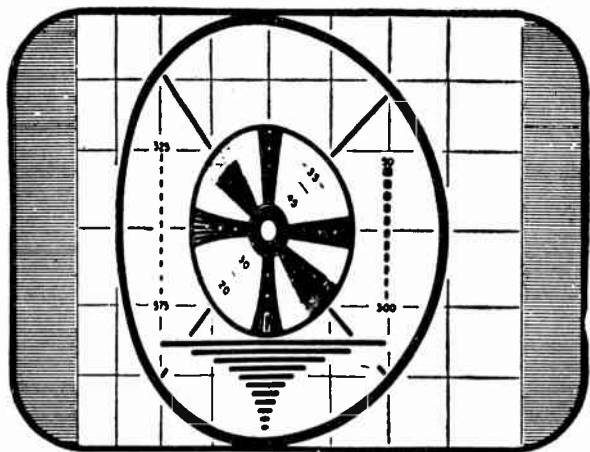

FIG. 10—Test pattern indicating horizontal distortion. To correct, adjust horizontal linearity.

**Horizontal Drive Control.**—The horizontal drive should be set approximately one-third of its total rotation from the counterclockwise end of its rotation. If white vertical bars or black beaded lines appear in the picture, the drive control in either direction should be adjusted to remove these white vertical bars or beaded lines.

**Picture Width Control.**—Control of picture size in the horizontal direction is accomplished by means of the width control. If abnormally low line voltage makes it difficult to obtain sufficient picture width when using the width control, then changing of the horizontal drive control may prove helpful.

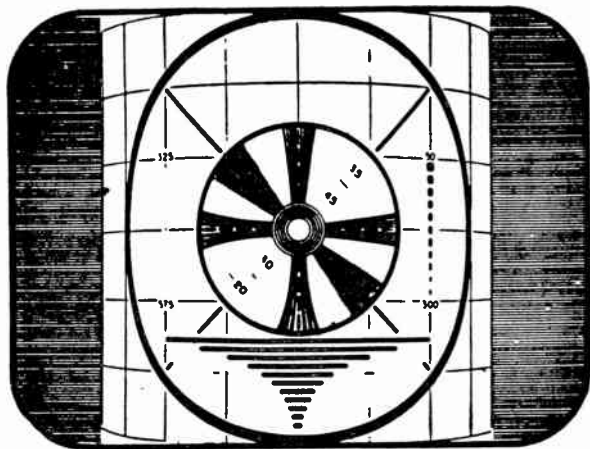

FIG. 11—Test pattern showing picture too narrow. To correct, adjust width control.

**Picture Height Control.**—Control of picture size in the vertical direction is accomplished by means of the height control. Height and width adjustment should be checked for all transmitting stations in order to ascertain that the picture fills the viewing area. It may be necessary to change the setting of the height control after the vertical linearity control is adjusted.

**Straightening Tilted Raster.**—This condition makes the test pattern or picture appear in a slightly tilted position. The remedy consists in a loosening of the deflection yoke locking

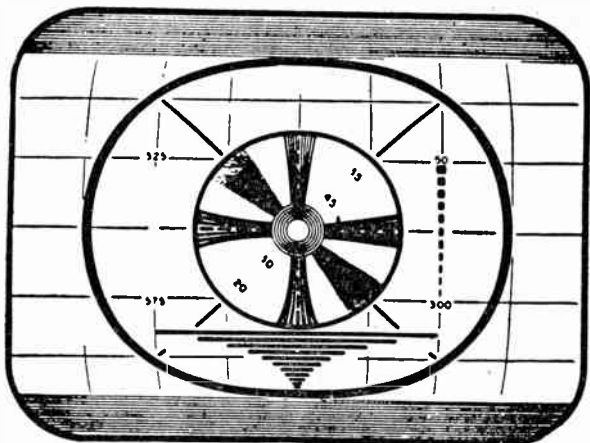

FIG. 12—Test pattern indicating picture too short. To correct, adjust height control.

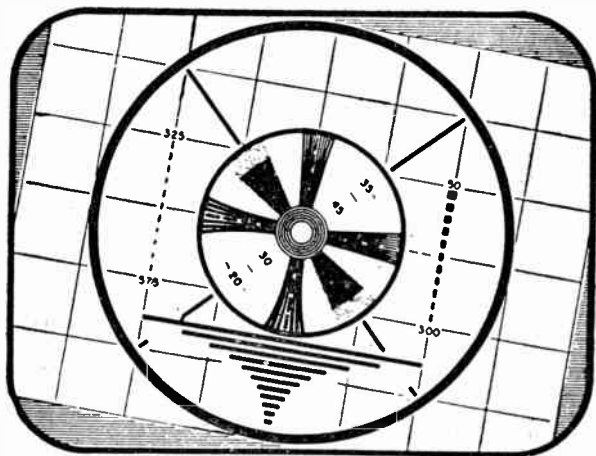
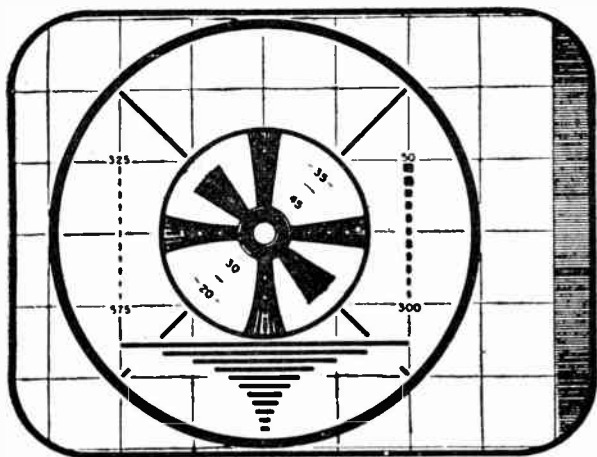

FIG. 13—Test pattern indicating tilted picture. To correct, adjust yoke position.

screw, and in rotating the yoke sufficiently to correct this condition. This locking screw should be retightened after the operation.

**Centering.**—To center the test pattern on the screen, adjust focus coil position. Readjust ion trap for maximum brightness on picture screen. Only in rare cases may it be necessary to rotate the picture tube.



**FIG. 14**—Test pattern indicating picture off-center. To correct, adjust focus coil position.

**Eliminating Semi-circular Shadow.**—This shadow is caused by the electron stream striking the neck of the tube, and it can generally be corrected by applying one or a combination of the following procedures:

1. Make sure that the deflection yoke is positioned as far forward as possible.

2. Reposition the focus coil by readjusting the holding nuts to shift the coil forward.
3. In the event the neck shadow cannot be eliminated by the foregoing procedure raise or lower the entire yoke and focus coil assembly so that focus coil can be repositioned vertically with respect to the tube neck.

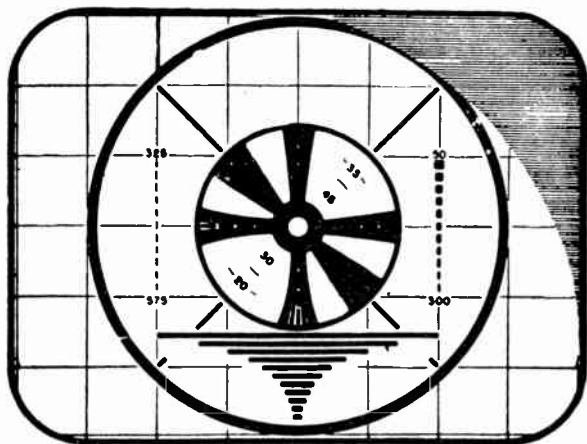

FIG. 15—Test pattern showing semi-circular shadow. For correction, see text.

For complete adjustment of ion trap, focus coil and deflection yoke, see pages following.

## Adjustment of Ion Trap, Focus Coil and Deflection Yoke

Although these components are properly adjusted when the receiver leaves the factory, conditions of rough shipment make it possible for these to become misaligned. The following instructions will enable the service man to bring the parts to their

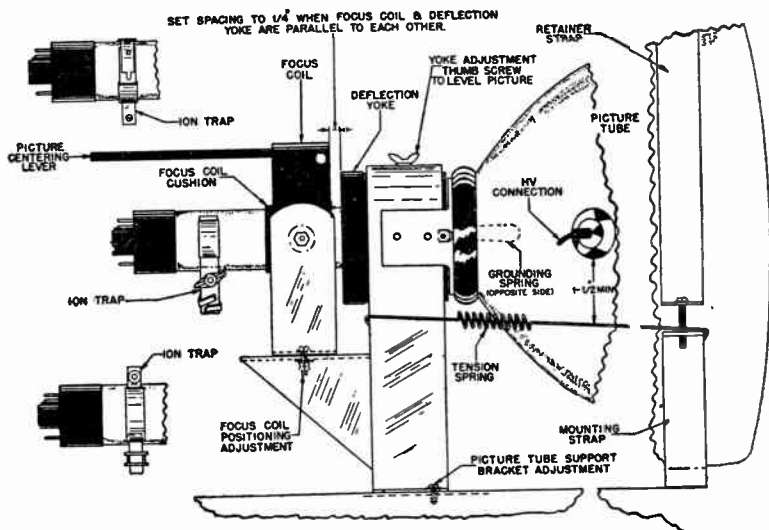
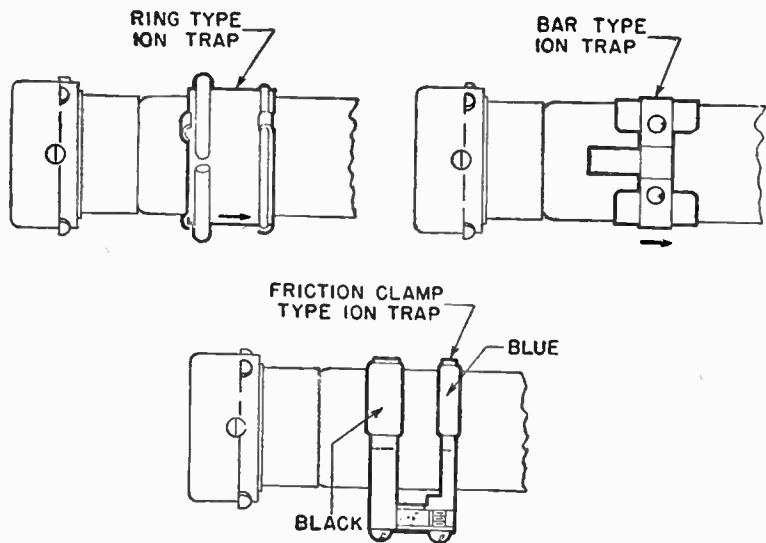

FIG. 16—Showing typical picture tube assembly with location of ion trap, focus coil and deflection yoke.

normal setting. See fig. 16 for adjustment locations. A mirror placed in the front of the receiver will make it possible to watch the picture while the adjustment is being made.

**The Ion Trap Magnet.**—The ion trap consists of a coil or permanent magnet fitted on the neck of the picture tube for the purpose of removing ions from the electron beam. The ions removed are molecules of matter which have been excited by the electron bombardment so as to have a negative charge.



FIGS. 17 to 19—Illustrating various types of ion trap magnets.

If allowed to remain in the electron beam the ions will eventually cause a dark spot in the center of the picture tube face. There are numerous types of ion traps, all differing in appearance but identical in action.

It is of major importance when installing a television receiver to properly adjust the ion trap magnet on the neck of the picture tube, since improper positioning of the magnet may cause areas

of discoloration on the face of the bulb, thus injuring the picture screen.

**Ion Trap Adjustment.**—The ion trap magnet must always be adjusted for maximum picture brightness. With the tube operating and with brightness control adjusted for low intensity, the ion trap magnet is adjusted by moving it forward or backward and at the same time rotating it slightly around the neck of the picture tube until the raster on the screen is brightest.

If, in obtaining the brightest raster the ion trap has to be moved more than one-quarter inch from the internal pole pieces, or if it be pushed against the focus coil, the magnet is probably weak and a new magnet may be required.

As a final check, the ion trap magnet should again be adjusted for maximum raster brilliance, this time with the brightness control set to obtain a raster slightly above average brilliance and with the focus adjusted for a clear line structure to simulate actual operating conditions with a picture.

If the picture tube has been replaced, or the receiver moved to a new location, it is imperative that the brightness control be kept low until after the initial adjustment of the magnet, and also that adjustment of the magnet be made immediately after the receiver is turned on. After the proper adjustment, the ion trap mounting screws should be tightened to prevent shifting.

**Focus Coil Adjustment.\***—If a shadow falls on one corner of the picture or if the picture be not properly centered, adjustment of the focus coil will be necessary. To adjust, turn the focus coil adjustment screw in or out until a position is found where the picture is centered and there is no shadowed corners.

---

\*When carrying out this adjustment, extreme care should be exercised so that no abnormal pressure is exerted on the neck of the picture tube.



In performing the adjustment, the screws should be turned so as to move the focus coil about its vertical and horizontal axis rather than closer to or farther from the face of the picture tube.

It should be observed that the tilt of the focus coil is limited by the clearance to the neck of the picture tube. Therefore, it is important for proper picture centering that the deflection yoke mounting bracket be moved forward until the rubber collar firmly supports the flare of the picture tube. It is also important that the deflection yoke bracket be orientated so that the focus coil will have equal tilt up, down, right or left.

**Deflection Yoke Adjustment.**—This adjustment controls the angle of the picture with respect to the horizontal. If the picture be not squared in the picture mask, loosen the wing nut and move it to the left or right so as to rotate the deflection yoke. The picture will tilt to the left or right with the deflection yoke rotation.

## CHAPTER 35

# Television Broadcasting

**General.**—Broadly speaking, television may be said to be a means of vision obtained of a distant object by means of various devices identified as the *transmitting* and *receiving apparatus*. The problem of television therefore is fundamentally:

1. Converting light signals into electrical signals.
2. Transmitting the signals to a distant station, and
3. Converting the transmitted electrical signals back into light signals.

With reference to figs. 1 and 2 the steps required to pickup transmit and reproduce a television picture are principally as follows:

The video signal (picture signal) released by the *iconoscope*\* camera fig. 1 is a series of electrical charges which represent the light distribution of the object being televised. Light reflected from the face of the object is collected by the lens system and focused on the plate of the television camera tube. This plate is covered with a material, which in effect, forms an innumerable quantity of minute photoelectric cells and is called a *mosaic*. This mosaic is swept or scanned by a thin stream of electrons from the electron gun incorporated in the camera.

\*The name *Iconoscope* relates to a type of television transmitting tube invented by Dr. V. K. Zworykin of the Radio Corporation of America. The word *iconoscope*, taken from the Greek word "*icon*" meaning "image" and "*scope*" meaning observation.

**Scanning Method.**—The scanning in the case of the iconoscope, is accomplished by deflecting the electron beam electromagnetically by means of coils external to the tube. These coils are excited at frequencies which cause the point of impact of the electron beam to move across the mosaic in approximately a horizontal line at a uniform speed, then fly back and scan another line, and so on until the entire mosaic has scanned 525 lines in the desired sequence. This complete scanning is re-

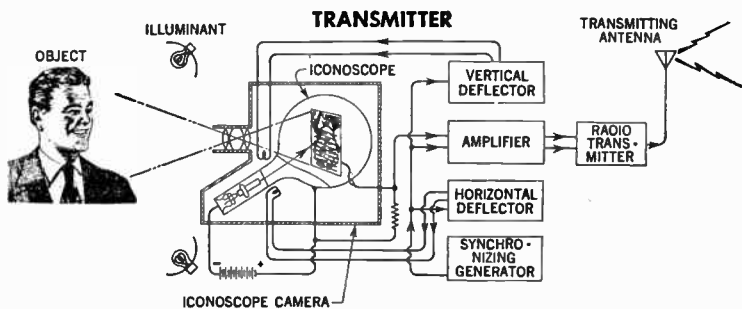

FIG. 1—Schematic diagram of simplified television transmitting system. (Sound portion of system not shown).

peated at the rate of 30 frames per second. Thus, in modern television systems, scanning consists of 525 horizontal lines, which are covered 30 times per second, making a total of  $525 \times 30$  or 15,750 lines scanned per second, and 60 fields (two fields per frame).

When the electron beam falls upon an illuminated portion of the mosaic, current will flow through the output circuit of the iconoscope. When it falls upon a partially illuminated portion a smaller current will flow, and when it falls upon a dark portion very little current will flow.

In this manner, current pulses will be generated which will correspond in time sequence to the light and dark areas of the televised image as they are scanned by the electron beam.

The resulting voltage pulses, termed video signals, are then amplified and combined with special artificially manufactured signals for controlling the timing of the kinescope (receiver picture tube) deflection circuits and for extinguishing (blanking) the kinescope electron beam during the return time. The resulting composite signal is then used to modulate a high frequency transmitter.

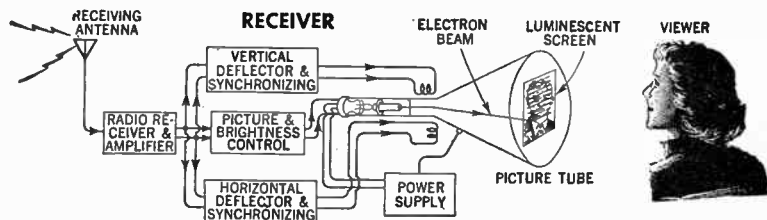

FIG. 2—Schematic diagram of simplified television receiving system. (Sound portion of system not shown).

In the standard interlaced scanning system, scanning of the horizontal lines is not performed in sequence, but the odd-numbered lines are scanned first, that is, 1,3,5, etc. and then the beam returns and scans the even-numbered lines, before the complete scene is scanned. Starting at the upper left extremity of the picture, as in fig. 3 line No. 1 is scanned. Instead of proceeding then, with line No. 2, the scanning spot drops two spaces and No. 2 is omitted. This is because the downward rate has been doubled—60 instead of 30 *c.p.s.* Line No. 3 then comes under scansion, followed by numbers 5,7,9 and every odd numbered line of the picture. Upon reaching the

bottom of the picture, the scanning spot moves again to the top of the picture and begins another scanning field which is displaced from the first by the width of one line so that now lines 2,4,6,8 and all even numbered lines are scanned.

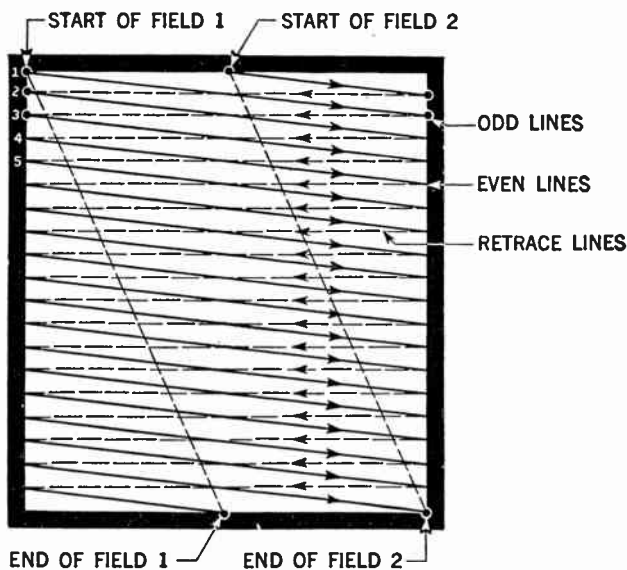

FIG. 3—Scanning raster showing interlaced pattern.

Since each field is completed in one sixtieth second, both fields consume one thirtieth second. Thus, 30 complete pictures are scanned in one second, each having been broken up into two projections as a means of flicker reduction.

Given a line frequency of 15,750 and a picture repetition rate of 30 *c.p.s.* the number of lines per picture is  $15,750/30$  or 525 lines, the number of lines per field being  $262\frac{1}{2}$ .

Approximately 490 of these lines are active, the remainder occurring during the vertical retrace period during which time the viewing tube is blanked out. It is necessary of course, that complete synchronism be maintained between scanning at the transmitter and at the receiver. To effect this, synchronizing pulses are transmitted along with the video signal which locks the receiver oscillators, vertical and horizontal, into step with those at the transmitter.

**Frequency Bands.**—The F.C.C. (*Federal Communications Commission*) has up to the present time assigned two bands for television broadcasting. The frequencies of these bands are considerably higher than frequencies used in ordinary broadcasting. The low band covers frequencies from 54 to 88 mc. and the high band covers a frequency range of from 174 to 216 mc. The lower band consists of five channels as follows:

<i>Channel Number</i>	<i>Frequency (Megacycles)</i>
2.....	54-60
3.....	60-66
4.....	66-72
5.....	76-82
6.....	82-88

The higher band consists of seven channels and each channel has the following frequency allocation:

<i>Channel Number</i>	<i>Frequency (Megacycles)</i>
7.....	174-180
8.....	180-186
9.....	186-192
10.....	192-198
11.....	198-204
12.....	204-210
13.....	210-216

From the foregoing it will be observed that a single television channel is 6 mc. wide, in contrast to the entire commercial broadcast band, which is one mc. wide. Also one broadcast channel is only 10 to 20 *k.c.* wide. The reason for the wide television channel is because of the necessity to transmit video information with clarity and sharpness. It also serves to illustrate that video information must be transmitted on very high frequencies to obtain a satisfactory ratio of carrier frequency to bandwidth.

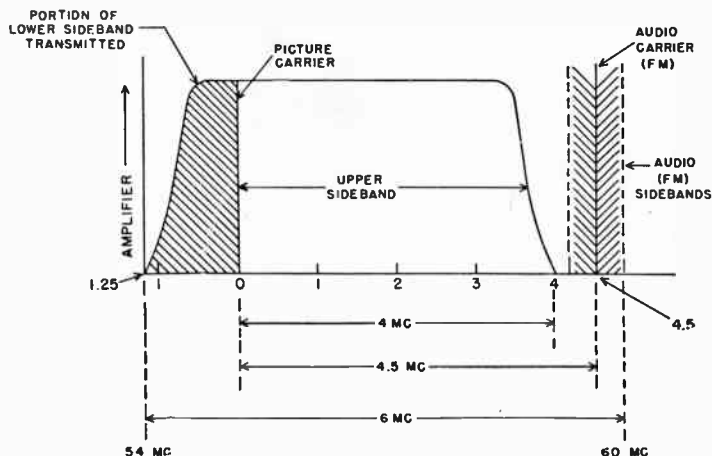

FIG. 4—Showing signal distribution in standard television channel.

**Standard Television Channel.**—A standard television channel is illustrated in fig. 4. As previously noted the bandwidth of each television channel is 6 mc., and both the video and sound signal must be transmitted within this limit. The amplitude-modulated picture signal is always at the low frequency end of each channel allocation and occupies approximately five and three-quarters mc. of the total six mc. bandwidth.

The frequency modulated sound signal is always at the high frequency end of the six mc. bandwidth and covers approximately one-quarter mc. or 25 *kc.*

An unusual feature of the amplitude-modulated picture signal is that the high frequency sideband is four and one-half mc. wide whereas the low frequency sideband is only one and one-quarter mc. wide. This unsymmetrical distribution permits transmission of a better definition picture using only a total bandwidth of six mc.

Such transmission of the picture signal and one sideband, as effected in television practice, is termed *vestigial sideband transmission* wherein the greater portion of the lower sideband is removed by a filter network.

**Television Signal Components.**—For successful transmission, the television signals must be separated into its components. Three types of information are transmitted on the picture carrier. They are:

1. The picture or video signal.
2. The synchronizing pulses (horizontal and vertical).
3. The blanking pulses (horizontal and vertical).

In the foregoing *the picture signal* consists of a progressive series of impulses which convey the light distribution to the scene to be televised.

*The sync signal* consists of a series of rectangular pulses, the function of which is to keep the iconoscope and kinescope (camera and receiver picture tube) locked in synchronism and to prevent the displacement of the pattern on the picture screen.

*The blanking signal* series of rectangular pulses are of longer duration than the sync pulses and as their name implies their function is to block out the fluorescent screen during all retrace intervals, making the retrace line invisible.





Another or fourth group of signals are termed equalizing pulses. These are of shorter duration than are the sync pulses and are transmitted to insure uniform spacing of the interlaced scanning lines, and to prevent loss of synchronism of the horizontal circuits during the retrace intervals between fields and frames.

In the composite standard video signal fig. 5, particular attention is directed to the polarity of transmission. An increase of signal power represents a dark portion of the picture, known as negative polarity of transmission. It is to be noted that the black level represents a portion of the viewing tube screen in which light is absent, that is, the beam has been blanked out. The synchronizing pulses represent a further increase of transmitter radiated power and so a darker spot upon the screen. However, since the beam has been wholly cut off at the black level and the screen is void of light, it cannot be affected by further cutoff and so the sync pulses produce no visible result. Their purpose and effect is evident, however, at the receiver scanning generators which are locked into step by these pulses. It is seen also that the sync pulses alone are not relied upon to blank out the beam during the retrace period. A blanking pulse serves this purpose, the sync pulses being superimposed upon the blanking pulse.

Should one long unbroken pulse be transmitted for vertical synchronization, the horizontal sync pulses during this time would be absent. During that time the horizontal (line frequency) scanning generators at the receivers would lack synchronization and drop out of step. In order that horizontal synchronization be maintained during the vertical retrace period, the vertical sync pulse is broken by serrations. These serrations then maintain horizontal synchronization during the vertical retrace period.

Between blanking (retrace) periods, the picture is being actively scanned. The picture signal is arbitrarily represented in fig. 5 as an irregular line.

All pulse shapes, their relative amplitudes and their duration are standardized. The only variable is the picture signal which varies from line to line as the subject is scanned.

**Signal Standards.**—Certain detailed facts of American standard television composite signals are given herewith. They are:

Channel width.....	6 mc.
Picture aspect ratio.....	4:3
Scanning (interlaced).....	525 lines
Horizontal scanning frequency.....	15,750 <i>c.p.s.</i>
Vertical scanning frequency.....	60 <i>c.p.s.</i>
Frame frequency (picture repetition rate).....	30 <i>c.p.s.</i>

**Camera Tubes.**—The two most widely used camera tubes to-day are the *iconoscope* and the *image orthicon*.

The iconoscope, fig. 6 contains the following essential parts:

1. A photosensitive surface on which the image is focused and which generates the photo-current.
2. An electron gun to direct a narrow beam of electrons at the image surface, and
3. A device to deflect the beam rapidly across the image, causing it to strike each element in an orderly sequence.

The first two of the foregoing are enclosed in an evacuated glass envelope, whereas the third consists of deflection coils and their associated circuits outside the tube. The sawtooth currents, which pass through these coils, are of proper frequencies and amplitudes to cause the electron beam to scan the photosensitive surface upon which the image has been focused, in accordance with the standard interlaced scanning pattern.

*Optical System.*—Light is reflected from the objects in the scene to be televised, picked up by a lens, and projected through the flat front wall of the tube on to the image surface. The image is sharply focused so that light from any one element on the scene falls on only one tiny part of the photosensitive image surface.

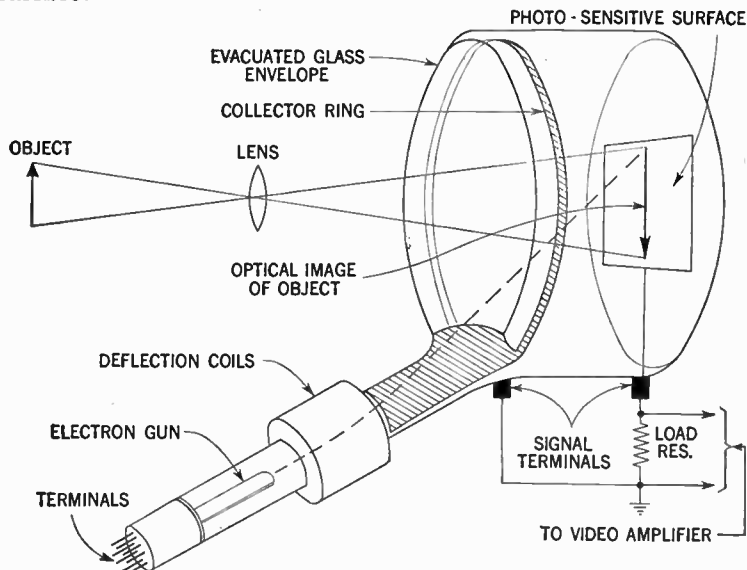

FIG. 6—Showing arrangement of parts of typical iconoscope.

The image surface consists of a thin sheet of mica three and one-half by four and three-quarter inches and approximately 0.001 of an inch in thickness. On the side which faces the lens, the mica strip is covered with myriads of tiny light sensitive globules, each of which forms one plate of a tiny condenser and each insulated from the other. On the other side is a flat conducting plate of collodial graphite which forms the signal plate.

The signal plate is connected to ground through a load resistor outside the tube. The actual signal circuit consists of the image surface, signal plate and collector ring.

*The Mosaic.*—The image surface covered with the photo-sensitive globules is called the *mosaic*. Each globule is made of silver, sensitized with a thin layer of cesium. The globules are not of uniform size, and are not arranged in a regular pattern, but they are so much smaller than the element of the image, that the total sensitive surface of each element is very nearly equal to that of each other element. The largest of the globules is about 0.001 inch in diameter and the scanning beam spot is about 0.008 inch.

Since the scanning beam has a spot size of about 0.008 inch in diameter, a large number of globules are being scanned at one instant. The area covered on the mosaic in any one instant by the scanning beam is called an *element*. The total number of picture elements in a modern television transmitting system is somewhat greater than  $2 \times 10^5$ .

*Operation*—The operation of the iconoscope is fundamentally as follows: An optical image is focused by a lens upon the surface of the mosaic. Under the lighter portions of the image, the individual silver globule photocells emit electrons, while less electrons are emitted by those under the dark or shaded areas. A loss of electrons constitutes a positive charge attained by the individual globule condensers and so is formed an electronic picture, the charge over any portion of the surface varying according to the amount of light present.

Now the electron beam is caused to scan this surface in the familiar way. As the electron beam strikes one of the surface elements, it supplies to it electrons that it had lost by reason of its photo-electric properties, therefore, the beam in effect, discharges the condenser which is formed by the globule, the

mica dielectric and the back coating. In this connection it should be pointed out, that since the lens inverts the image on the mosaic, the scanning process of necessity must start at the bottom of the mosaic.

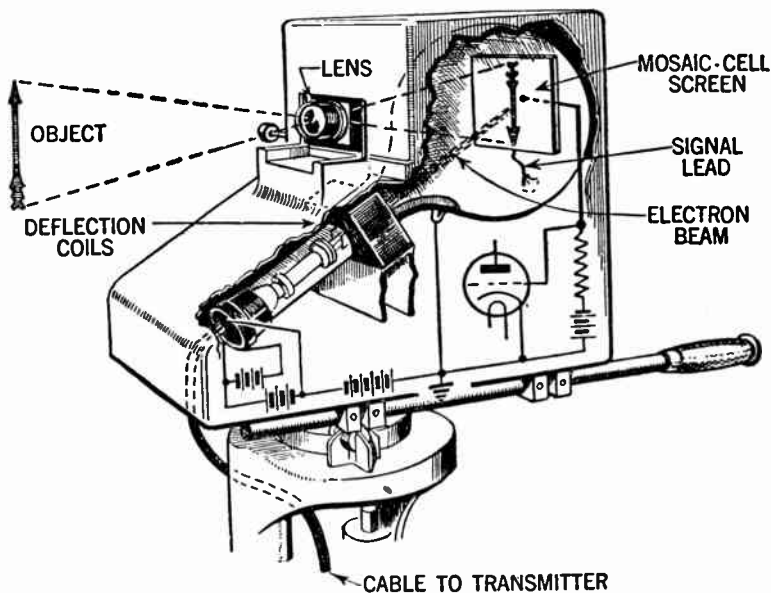

FIG. 7—Illustrating functional components of iconoscope camera. Roughly the camera consists of a lens arrangement similar to that of the ordinary camera which is focused on the scene to be televised. The image is projected upon the screen of the iconoscope which is mounted in the camera as shown.

With reference to fig. 6 it will be observed that the condenser discharge current passes through the tube load resistor, the potential thereby developed being applied to the video amplifier.

This potential is a function of the discharge current which, in turn, is a function of the amount by which the silver globules then under the scanning beam have been made positive by a loss of electrons. Since that is determined by the amount of light from the image at that point, it is evident that as the beam traverses the mosaic, a video signal is produced which represents the highlights and shadows of the televised scene.

The collector ring consists of a platinum band mounted on the inside surface of the iconoscope. Its function is to collect the electrons which leave the mosaic surface, in this manner completing the signal circuit through the load resistor.

**The Image Orthicon**—Because of the generation of a spurious dark spot signal resulting in low sensitivity in addition to the requirement of a high value of illumination, the iconoscope is at a disadvantage where it is necessary to work under a low value of illumination, such as that prevailing in all types of outdoor scenes, as for example, at football, tennis, golf games and the like.

Due to the foregoing deficiencies another type of television camera tube has been developed. This tube is called the *image orthicon*, the principle elements of which are shown in fig. 8.

*Performance.*—The image orthicon is a storage type of camera tube, having a sensitivity of from 100 to 1,000 times that of the iconoscope. It can therefore deliver an entirely satisfactory signal, with negligible noise voltage, from scenes illuminated by very low light levels.

The image orthicon achieves its high sensitivity in three ways. They are:

1. By using a conducting photosensitive surface, instead of an insulated mosaic, thereby increasing the photo emission response.

2. By scanning with a low velocity electron beam, thus eliminating the undesirable effects of secondary emission.
3. By using secondary emission at two different points in the tube so as to provide amplification of the signal by a factor of 100 to 500 without the generation of a corresponding noise voltage.

It has two relatively minor disadvantages, that is, the possible resolution of its picture is slightly less sharp than that of the iconoscope, and in addition it is not as well suited to operation at very high values of illumination.

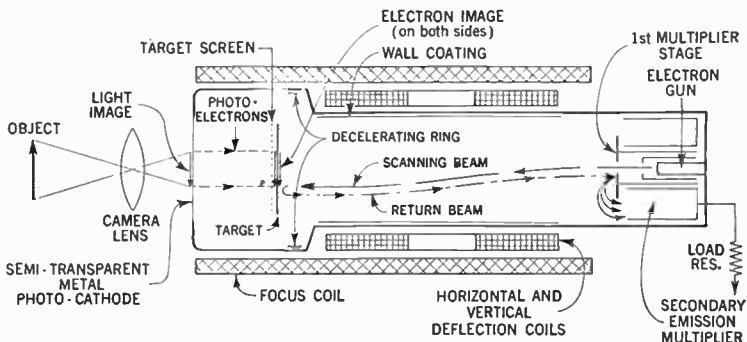

FIG. 8—Showing essential parts of image orthicon and their arrangement.

*Structural Details.*—This type of television camera tube is of a very compact design. It is approximately 15 inches in length, its external diameter being approximately three inches. With reference to fig. 8 the following fundamental differences from the previously discussed iconoscope are:

1. The light image is focused on one side of the photo cathode, while photo emission takes place from its other side.



2. The scanning takes place on a separate plate called the target, *not* on the photo emissive surface.
3. The image modulated current, constituting the video signal, comes from the beam electrons returning from the target toward the cathode from which they came.

One other feature in the illustration, is a focusing coil, wrapped around the entire length of the tube.

*The Photo Cathode.*—By observing the left side of the illustration fig. 8 it will be observed that the image of the scene is focused on a semi-transparent metal photo cathode. This represents an important improvement as compared to the iconoscope. A conducting surface like this has a higher photo sensitivity than an insulated surface, such as the globules of the iconoscope mosaic. Note, too, that the cathode is held at a constant potential of minus 600 volts; this is possible only because the photo electrons have a return path through the external circuit, so they are continuously replaced.

The photo cathode is made of such thin metal that light passes through it readily, as through tracing paper. Photo emission takes place from the back surface of the cathode. The emitted electrons are pulled by the strong electric field existing between the cathode and the target screen by reason of the potential difference of nearly 600 volts between them.

The target screen is made of incredibly fine metal wires, having from 500 to 1,000 meshes per linear inch. Better than 60% of its area is occupied by the holes, so the photo electrons can pass easily through it, and do not cast a "shadow" on the target beyond it.

*Operation.*—The operation of the image orthicon is fundamentally as follows: Light from the televised scene is picked in the conventional way by an optical lens system and focused on the photo sensitive surface behind the face of the tube.

The surface elements emit electrons in direct proportion to the amount of light striking them. These electrons, accelerated by a positive voltage and held on a parallel course by an electromagnetic field, flow from back of the photosensitive surface to a target.

Secondary emission from the target caused by the impact of the electrons, leaves on the target a pattern of varying positive charges, which correspond to the pattern of light from the televised scene.

The rear of the target is scanned by a beam of electrons which are generated by the electron gun in the base of the tube. This beam is modulated, as it scans, by the varying positive charges on the target which are representative of the light pattern of the televised scene.

The returning beam with picture information imposed upon it by the varying losses of electrons left behind in the target, is directed toward the first of a series of dynodes (electron multipliers) near the base of the tube. This multiplying process continues with the strength of the signal increasing at each dynode, until it reaches the signal anode and is conveyed to the external circuit.

**Sound Transmitter.**—The sound transmitter associated with the transmitting system is a conventional frequency modulation system consisting of audio amplifier, frequency modulator, high frequency transmitter and high frequency antenna. Thus, at the transmitting station, there are two transmitters, one for the picture signals, and one for the sound.

**Television Broadcasting Practices.**—In the foregoing overall description of a television system no attention has been given to the apparatus necessary in the broadcasting studios for a suc-

cessful transmission of picture and sound. Most of the apparatus required to produce the conditions described are of necessity extremely complex.

The block diagram of the signal circuits of a typical modern television transmitter is shown in fig. 9. A separate transmitter supplies speech accompanying the scene. A camera selector affords the choice of ten cameras viewing one or more scenes from different vantage points any three of which may be selected simultaneously with control room monitoring of each.

Further selection is made by a channel selector feeding through a fader (volume control) the line amplifier. In addition, provision is made to preview the scene from a given camera prior to switching into the line amplifier.

The line amplifier also serves as a mixer for the injection of synchronization pulses which, along with the picture signal, make up the composite signal of the broadcast. An air monitor shows the picture as it is being transmitted.

The televising of live talent programs presents to the video broadcaster many of the same problems that have confronted the moving picture industry. Rather elaborate backgrounds are frequently necessary and they require the same attention to technical detail and to period authenticity that is evident in well staged plays and in high-grade motion pictures. As the video broadcast must be continuous, unlike the motion picture production which can be interrupted at will, the problems of set lighting and equipment placing require much planning and rehearsal prior to the actual broadcast.

Indoor, as well as outdoor televising usually requires that several cameras be strategically located so as to view the scene from various vantage points without sequential interruption.

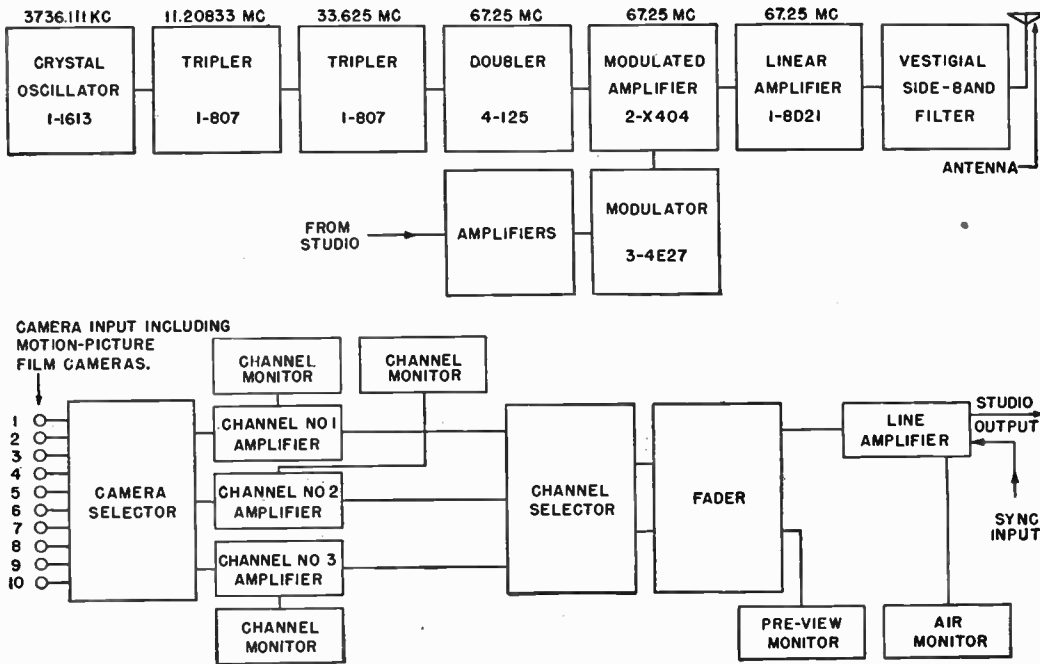

FIG. 9—Illustrating functional block diagram of typical television transmitter.

In addition to the telecasting of live program material, extensive use is made of motion picture film in television programming. For this purpose, special projectors are employed, which by a shutter arrangement, convert the 24 frame per second film projections into 30 frame per second television signals. The film picture is projected directly into the television camera tube, from which the electrical signal is conveyed to the control room over coaxial cable. Sound pickup from the film is in the normal manner.

Since the connection, by coaxial cable, from a remote place to the studio control room equipment is an economic impossibility, small ultra-high frequency radio relay links are employed to relay remote pickups.

The relay equipment is usually contained within a special truck which houses not only the relay transmitter but also complete control and monitoring facilities.

## CHAPTER 36

# Television Receiver Circuit Fundamentals

In the previous chapter a general discussion of the various factors affecting television broadcasting have been made. The function of a television receiver is to extract from space the signal transmitted by the broadcasting station, amplify it and employ it to produce visible pictures and audible sound which in all details conform with the original scene at the broadcasting station.

In the television receiver, therefore, the received signal is amplified and separated into its components. The components are amplified and applied in such a way as to produce variations in the intensity of the electron beam of the picture tube which is similar to a conventional cathode ray tube.

In the receiving picture tube, deflection is accomplished electromagnetically with coils external to the tube. The oscillators which furnish the energy for deflection operate at the same frequencies as the deflection oscillators associated with the transmitting camera tube and are held in synchronism by the transmitting synchronizing pulses.

Thus, the electron beam of the picture tube moves in synchronism with the electron beam of the camera tube, and the variations in brilliancy of illumination at the point of impact on the picture tube screen, correspond to the variations in illumination

of the respective areas of the camera tube mosaic. In this manner, the image on the mosaic in the camera tube is dissected and the information on each element transmitted separately in a manner which permits the television receiver to take these pulses of information and employ them to produce corresponding variations in illumination on the picture tube screen and thus produce a picture of the original scene.

Present television receiver design practice is to use superheterodyne receivers with antenna and *r.f.* circuits which are sufficiently broad in frequency response to accept the entire pass band covered by the two carriers (sound and picture) and their transmitted sidebands. No separation occurs until after the first detector. The output of a single local oscillator is heterodyned with both sound and picture carrier signals to produce signals of two intermediate frequencies.

By having separate picture and sound intermediate frequency amplifying systems, each of which is tuned to the correct intermediate frequency, the television picture and sound signal may be separated. The sound amplifying system from that point on is in most respects similar to that of a conventional radio receiver.

**Block Diagram of Typical Television Receiver.**—In this connection it should be clearly understood that although television receivers may differ considerably as to circuit design (depending upon the manufacture of the particular receiver), they all operate on the same general principles.

In order to simplify the study of television receiver, it is customary to employ so called "*block diagrams*". By means of these, it is possible to separate the complete circuit into its various sections, each of which have been assigned to its particular function in the complete circuit.

Fig. 1 shows a block diagram of a typical television receiver:

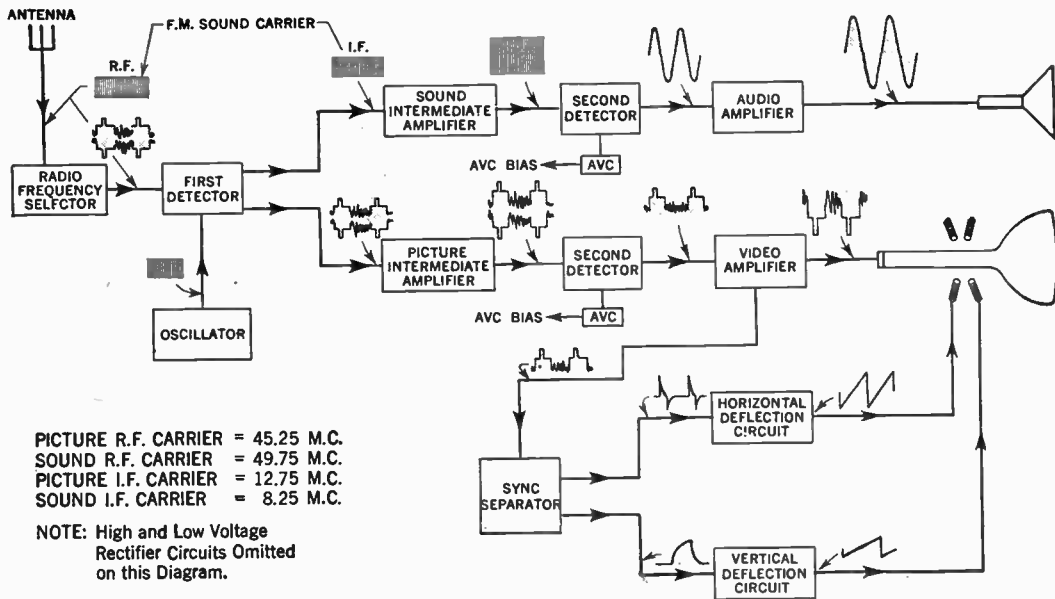

FIG. 1—Block diagram of typical television receiver.



The antenna receives both sound and picture signals. Thus, in a typical transmitter the picture carrier would be 45.25 mc. and the sound carrier 49.75 mc.

The *r.f.* circuits are sufficiently broad to pass both carriers with such portions of their sidebands as are transmitted. These are then passed on to the first detector where they are both heterodyned with a 58 mc. local oscillator signal. This produces two *i.f.* carriers, one at 12.75 mc. modulated with the picture signals, and another at 8.25 mc. modulated with the accompanying sound signals.

The *i.f.* signals with sound modulation are amplified by the sound *i.f.* amplifier, and the *i.f.* signals with picture modulation are amplified by the picture *i.f.* amplifier. In order to prevent cutting of the high frequency side bands in the sound *i.f.* amplifier when the receiver is slightly mistuned, the sound *i.f.* transformers are designed to pass a band up to 100 k.c. wide. As this type of transformer reduces the gain per stage, two sound *i.f.* amplifier stages are used to obtain the necessary amplification. The sound *i.f.* signals are impressed upon the sound second detector and are converted into audio frequencies in the usual manner. These are then amplified and reproduced as sound by a conventional audio amplifier and loudspeaker.

The picture *i.f.* signals are amplified by a picture *i.f.* amplifier system which is tuned to 12.75 mc. and which passes a band of 2.5 mc. to 4 mc. depending upon the quality of the receiver. For vestigial side band transmission within the band widths allocated for television, this will allow modulation frequencies corresponding to video frequencies up to 4.0 mc. An *i.f.* amplifier which will pass a band of this width must necessarily have a low gain per stage and consequently five picture *i.f.*

stages are used in this typical receiver to secure the desired amount of amplification.

The amplified picture *i.f.* is applied to the picture second detector and converted into the television signal represented on page 758. The output of the picture second detector is supplied simultaneously to the picture *a.v.c.* system, to the video amplifier and to the synchronizing separator. The picture *a.v.c.* system utilizes some of the television picture signal to produce a variable *d.c.* voltage which after suitable filtering is applied as negative grid bias to the picture *i.f.* stage to control their gain.

The video amplifier amplifies the *a.c.* portions of the television picture signal and applies them to the grid of the picture tube to control the relative illumination of the elemental areas and to blank the beam during the return periods. A portion of the output of the video amplifier is rectified by a tube called the "*d.c.* restorer" and the *d.c.* voltage thus produced is applied as variable bias voltage to the picture tube grid. This function is usually referred to as the *automatic brightness control* and is necessary when the video amplifier is not a *d.c.* amplifier in order to reproduce correctly the average brightness or illumination of the scene being televised and to secure correct blanking during the return time.

The synchronizing separator incorporates circuits which separate the synchronizing pulses from the remainder of the signal. The horizontal synchronizing pulses are then separated from the vertical synchronizing pulses by suitable circuits and both are then applied to control the timing of the deflection oscillators with which they are associated.



FIG. 2—Illustration showing antenna assembly method. (Courtesy American Phenolic Corporation.)

## CHAPTER 37

# Circuit Description of Typical Television Receiver

The material presented under the foregoing heading has been supplied by the courtesy of *Motorola Inc.*, and while this information has direct reference to their *12T* and *12K* model receivers, it will prove helpful to television students and servicemen in servicing other sets since much of this data is of a general nature.

**Chassis.**—Television chassis fig. 1 contains 19 tubes exclusive of the picture tube. The picture, sound and scanning circuits, together with a selenium rectifier, voltage doubler “B” supply, are contained on a single chassis.

**Tuning Range.**—Channels 2 through 13.

**I.F. Frequency.**—*Channels 2 to 6*; Sound 21.9 mc.; Picture 26.4 mc.; *Channels 7 to 13*; Sound 27.3 mc.; Picture 22.8 mc.

**Antenna Impedance.**—300 ohms.

**Power Supply.**—117 volts, 60 cycles, *a.c.* current only.

**Power Consumption.**—160 watts.

**Audio Output.**—4 watts.

## Chassis Tube Complement

Ref. No.	Tube	Function
V-1	6CB6	<i>r.f.</i> Amplifier
V-2	12AT7	Mixer-Oscillator
V-3	6AU6	1st <i>i.f.</i> Amplifier
V-4	6AU6	2nd <i>i.f.</i> Amplifier
V-5	6AG5	3rd <i>i.f.</i> Amplifier
V-6	6AL5	Video Detector
V-7	6AH6	Video Amplifier
V-8	6AU6	Audio Driver-Limiter
V-9	6AL5	Ratio Detector
V-10	6J5GT	Audio Amplifier
V-11	6V6GT	Audio Output
V-12	6SN7GT	1st and 2nd Clippers
V-13	6J5GT	Vertical Sweep Generator
V-14	25L6GT	Vertical Sweep Output
V-15	6AL5	Phase Detector
V-16	6SN7GT	Horizontal Oscillator
V-17	6BQ6GT	Horizontal Output and High Voltage Generator
V-18	6W4GT	Damping Diode
V-19	1B3GT	High Voltage Rectifier
V-20	12LP4	Picture Tube

**Low Voltage Power Supply.**—The low voltage power supply fig. 2 provides plate voltage for all tubes except the high voltage applied to the second anode of the picture tube. The heater transformers supply heater voltage to all tubes except the *h.v.* rectifier, which is energized by horizontal sweep current.

One low voltage secondary of *T-7*, the step down filament transformer, supplies filament voltage to all tubes except the audio driver-limiter (*V-8*), the vertical output tube (*V-14*), the picture tube (*V-20*), and the horizontal damping diode (*V-18*).

Since the damping diode (*V-18*) develops a high voltage pulse at its cathode, and its cathode is tied to the filament to prevent

breakdown in the tube, it is necessary to provide a separate, low-capacity, well insulated transformer (*T-8*) to heat this filament.

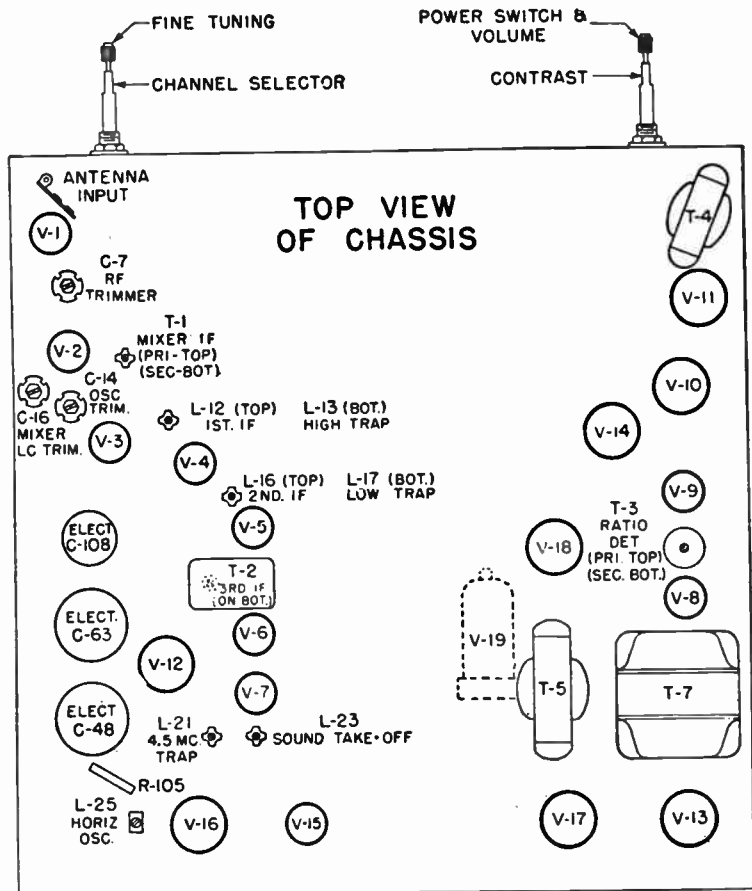

FIG. 1—Top view of typical chassis showing tube and adjustment location.

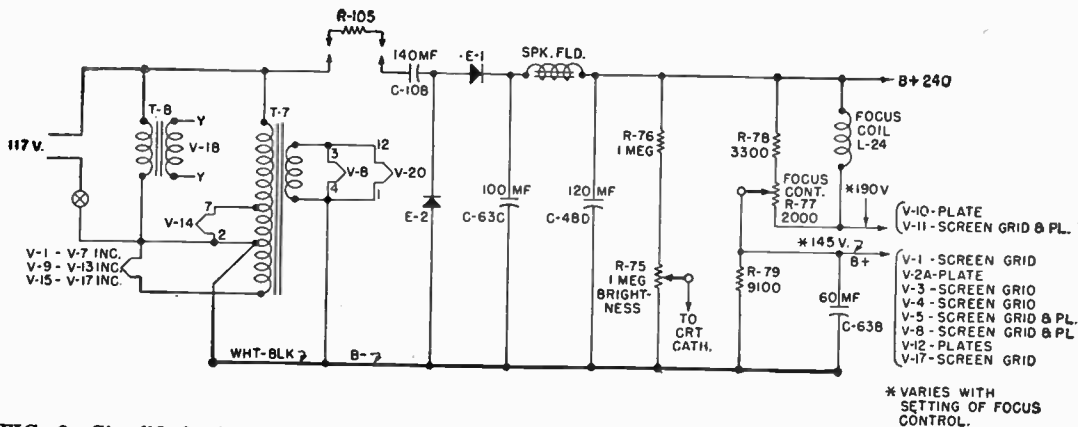

FIG. 2—Simplified schematic of low voltage power supply.

The vertical output tube (*V-14*) requires a 25 volt filament supply, and hence is provided with a separate 25 volt tap on the transformer. *V-8* and *V-20* are supplied by an additional winding, which in sets of late designs, is connected series opposing with the primary to increase the 6.3 volt filament supply voltage slightly to insure that the *r.f.* oscillator will operate on low line voltage.

The "B" + plate supply uses a voltage doubler. *R-105* is a limiting resistor to protect the rectifiers from initial current surges and also serves as a fuse in case of "B" + shorts. When the polarity of the applied 117 volts *a.c.* is such as to make the side of the line connected to *R-105* negative, *E-2* will conduct and charge *C-108* (140 *mf.*) to peak line voltage.

On the next alternation, *E-1* will conduct and the voltage applied to it is now the peak line voltage plus the peak charge stored in *C-108*. This results in a charge of about 260 volts on *C-63C* (100 *mf.*). The speaker field is used as a filter choke. The focus coil and the resistor network, which controls the current through it, act also as a voltage divider to supply plate and screen voltages to several tubes, as shown in fig. 2.

Another voltage divider from "B" + to "B" -, consisting of *R-76* (1 meg.) and the potentiometer, *R-75* (1 meg.) provides a variable bias on the cathode of the picture tube, to serve as a brightness control.

**The R.F. Tuner.**—Fig. 3 is a simplified schematic of the tuner. The antenna input coil, *L-1*, couples the balanced line to the single ended input circuit for the *r.f.* tube, *V-1*. Optimum antenna coupling for all channels is obtained by the coupling coils *L-5A*, *L-5B*, *L-5C*, and the coupling leads on channel positions 8, 10 and 12 of switch wafer *S-1A*. These can be considered the primary of the antenna transformer.



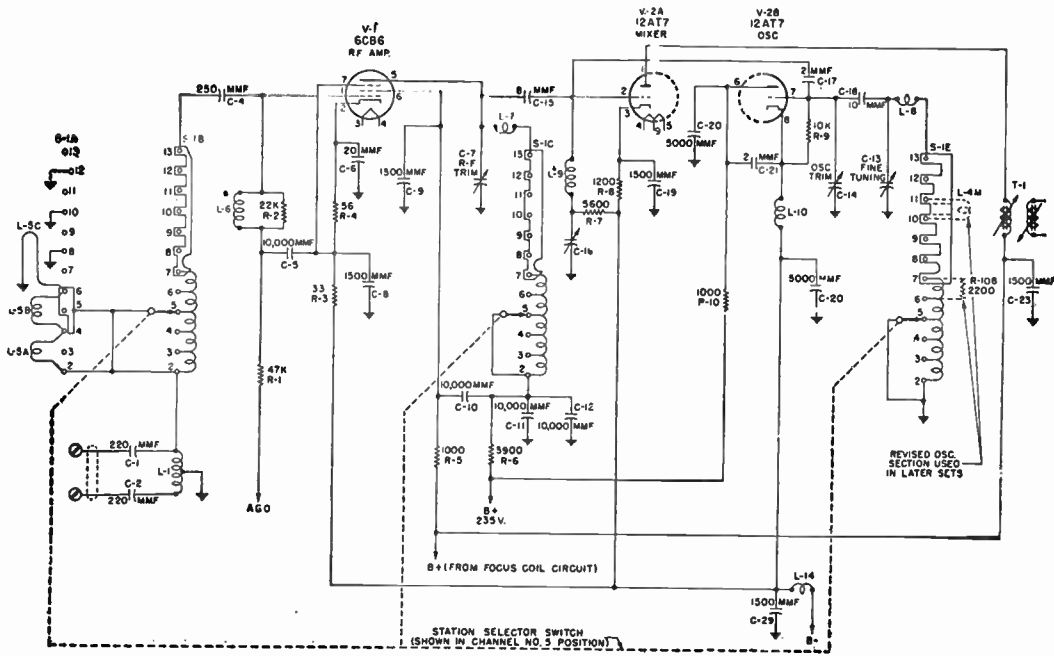

FIG. 3—Simplified schematic of RF tuner.

The secondary, or tuned grid circuit, includes also the continuous, tapped coil mounted on wafer *S-1B* for the low channels (2-6) and the stamped metal plate in series with the coil for the high channels (7-13). The purpose of the antenna coil, coupling leads, and the secondary circuit, is to match the 300 ohm impedance of the transmission line from the antenna to the input impedance of the *r.f.* amplifier grid circuit and to tune this circuit for the channel selected. Referring to fig. 3, it will be seen that the switch in progressing from channel 2 to 13, shorts out the unused portion of the secondary winding or stamped metal plate. The bandwidth of channels 7 through thirteen is about 8 mc. The stamped metal plate is carefully designed so that with this bandwidth no alignment adjustment is needed on the high channels.

**R.F. Amplifier.**—The grid of the *r.f.* amplifier *V-1* (6CB6) is returned to the automatic gain control bus through *L-6* and a bypass capacity (*C-5*). The plate load of this tube consists of another tapped coil for the low channels and a stamped metal plate for the high channels mounted, in this case, on switch wafer *S-1C*. Here again, the switch progressively shorts out the unused sections of the inductance in tuning from channel 2 to 13. In this case, however, a trimmer *C-7* and a choke *L-7* are provided to center the high channel response while the low channel coils may be tuned by expansion or compression.

**The Mixer.**—The mixer uses one-half of *V-2* (12AT7). *C-15* (8 mmf.) couples the *r.f.* amplifier output to the mixer grid. Oscillator injection is accomplished by *C-17* (2 mmf.). *L-9* and *C-17* form a series resonant circuit tuned to the center of the *i.f.* response, to prevent interaction between the *i.f.* and the mixer input.

**The Oscillator.**—The oscillator uses the other half of *V-2* (12AT7) in a Colpitts circuit. Here again, the tuning inductance consists of the tapped coil for the low channels and the stamped metal plate for the high channels mounted on wafer *S-1E*. *L-8* and *C-14* are provided to set the center frequency on the high channels while the low channels are aligned by spreading or compressing the individual coil sections. *C-13* is provided as a fine tuning control for customer use.

The oscillator operates above the *r.f.* on the low channels and below the *r.f.* on the high channels except that in later production the circuit was modified to avoid interference by operating the oscillator on the high side for channels 11, 12 and 13.

**The I.F. Amplifier.**—The *i.f.* amplifier uses two 6AU6 tubes and one 6AG5 tube. Fig. 4 is the schematic of the *i.f.* amplifier. *T-1* couples the mixer plate to the first *i.f.* grid. Coupling between primary and secondary, which are individually slug-tuned, is fixed and is designed for proper bandwidth. The plate choke *L-11*, of the first *i.f.* tube *V-3* (6AU6), is coupled to the grid coil, *L-12*, of the second *i.f.* tube *V-4* (6AU6) through *C-30* (220 mmf.). At *i.f.* frequencies, the impedance of *C-30* is negligible and for all practical purposes, *L-11* and *L-12* can be considered as being in parallel, *L-12* being slug-tuned.

A similar method is used between the second and third *i.f.* tubes. The third *i.f.* plate is coupled to the detector by *T-2*, a unity coupled transformer. The *i.f.* circuits are stagger-tuned for proper bandwidth. *L-13* and *L-17* are separately tuned trap windings on *i.f.* coil forms *L-12* and *L-16*, respectively. Together with *C-31* and *C-38*, they form absorption type trap circuits which steepen the high and low skirts of the *i.f.* response for better picture quality and to stabilize the audio response with intercarrier sound.

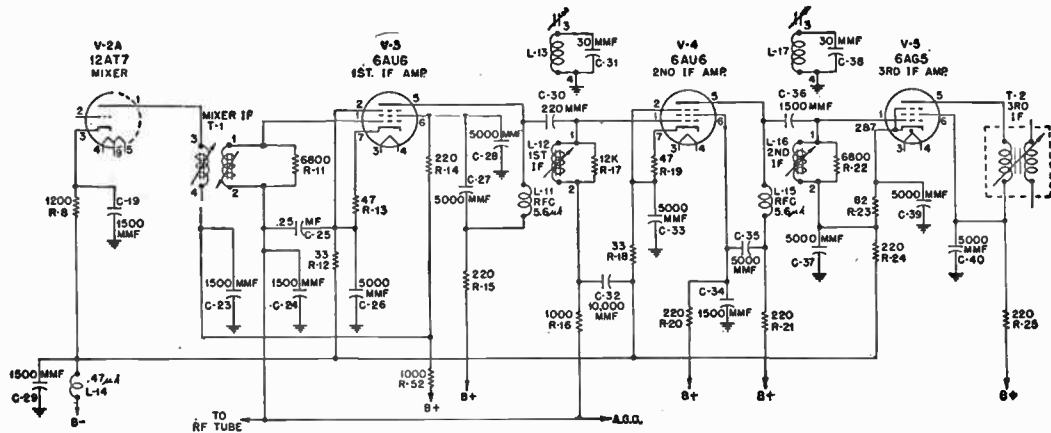

FIG. 4—Simplified schematic of IF amplifier.

Decoupling has been used not only in the plate supply and a.g.c. circuits, but also in the filament circuits to prevent regeneration.

**The Video Detector.**—One-half of V-6 (6AL5) is used as the video detector. Fig. 5 is a schematic of the video detector,

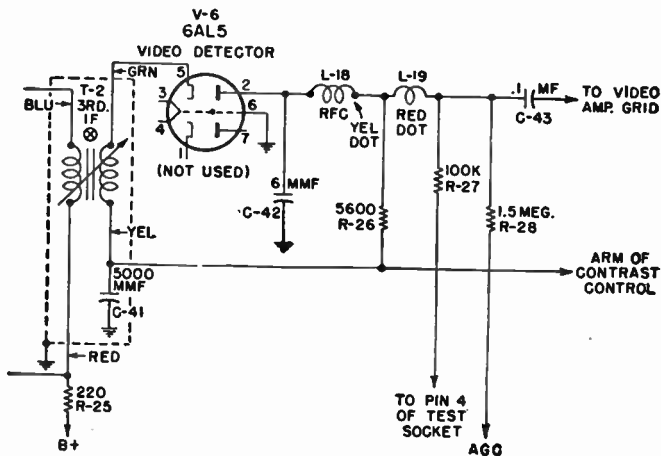

FIG. 5—Simplified schematic of video detector.

Since for noise limiting purposes it is desirable to apply a signal with negative going sync pulses to the grid of the video amplifier, the detector load  $R-26$  (5600) is placed in the plate circuit of the diode.  $L-18$ ,  $L-19$ , and  $C-42$ , form a low pass filter to keep *i.f.* frequencies off the grid of the video amplifier.

Since this chassis operates on the intercarrier sound system, the detector heterodynes the video and sound *i.f.* frequencies, and produces the 4.5 mc. beat frequency which becomes the new audio *i.f.* frequency. The negative *d.c.* voltage developed at the high side of the detector load  $R-26$  (5600) will be a func-

tion of carrier level. This voltage is fed to the a.g.c. bus through *R-28* (1.5 meg.) and controls the gain of the *r.f.* and first and second *i.f.* amplifiers.

**The Video Amplifier.**—The video amplifier *V-7* (6AH6) not only amplifies the video signal but also the 4.5 mc. audio *i.f.* beat. Fig. 6 is a schematic of the video amplifier. In its plate

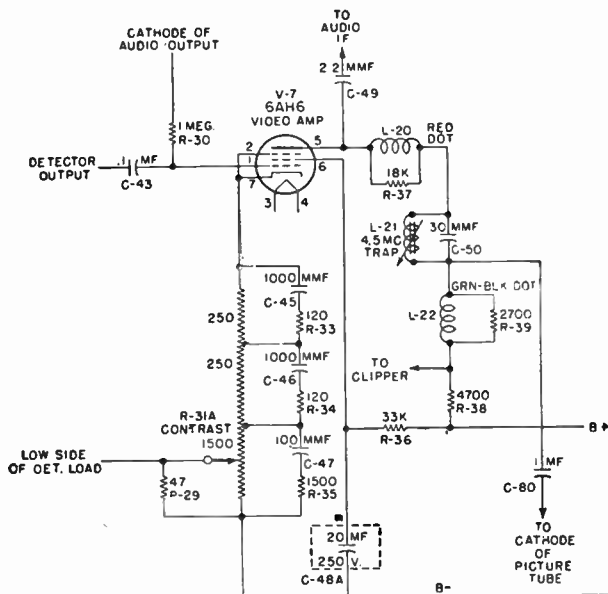

FIG. 6—Simplified schematic of the video amplifier.

circuit, this beat is separated from the video signal and fed to the grid circuit of the audio driver-limiter tube *V-8* (6AU6) by *C-49* (2.2 *mmf.*) and *L-23*, the sound take-off coil. The 4.5 mc. trap, *L-21* and *C-50*, is a parallel resonant circuit which,

when properly tuned, offers a high impedance to this frequency, to prevent its reaching the picture tube.

By applying a negative signal to the grid of the video amplifier, a noise limiting action is achieved because noise pulses of amplitude greater than the sync level will drive the tube to cut off and, therefore, will not be present in the plate circuit. Since a single video amplifier tube is used, the signal at its plate will be positive and, as might be expected, is used to modulate the cathode of the picture tube rather than the grid, because the blanking pulses must cut the picture tube off and the polarity of the video information must be such that dark picture elements result in making the grid more negative with respect to the cathode.

*L-20* and *L-22* are peaking coils to extend the high frequency response of the amplifier. The contrast control, *R-31A*, is placed in the cathode circuit of the video amplifier and controls the bias and, therefore, the gain of this tube. The network of resistors and condensers across taps on the contrast control decreases degeneration at the higher frequencies and, therefore, helps to extend the high frequency response. The composite video signal is fed to the picture tube cathode through coupling condenser *C-80* (.1).

**The Automatic Gain Control (A.G.C.).**—The negative *d.c.* voltage developed across the detector load resistor, *R-26* (5600), is the a.g.c. voltage. It will be noted that the low side of this resistor is connected to the arm of the contrast control potentiometer, *R-31A*. *R-29* (47) is shunted across the arm of the contrast control and B—. In weak signal areas, this arrangement results in delay in the a.g.c. action. For a weak signal, minimum bias is desired on the video amplifier, therefore, the arm of the contrast control will be closest to the cathode end of the potentiometer.

Because *R-29* is then shunted across the entire contrast control, most of the plate current will flow through it and develop a positive voltage of approximately one volt at the arm with respect to *B-*. Since the low side of the detector load is tied to this positive voltage, no a.g.c. voltage will develop until the signal is strong enough to overcome this positive voltage and, therefore, no a.g.c. bias is applied to the controlled tubes under weak signal conditions. In a strong signal area, however, where the arm of the contrast control approaches the *B-* end of the control, *R-29* is shorted out and full a.g.c. voltage is developed.

**The Audio System.**—The audio system employs a driver-limiter, *V-8* (6AU6); a ratio detector *V-9* (6AL5); a first audio amplifier, *V-10* (6J5), and an audio output tube, *V-11* (6V6). Fig. 7 is a schematic of the audio system. The driver-limiter is operated at low plate and screen voltages to act as a partial limiter to minimize any amplitude modulation. A conventional ratio detector and audio amplifier are used.

**The Clipper.**—The clipper uses a 6SN7GT tube. The clipper schematic is shown in fig. 8. The composite video signal with positive going sync is applied through *R-55* (10K) and *C-66* (.005) to the grid of the first clipper from the plate circuit of the video amplifier. Under no signal conditions, the tube is unbiased.

The positive signal, however, will cause the tube to draw grid current and the voltage drop across *R-54* (1 meg.) negative at the grid, will charge *C-66* to such a value that only the most positive part of the signal, which is the sync pulse, will cause plate current to flow. Therefore, the video information and the blanking pulses are clipped off and only the sync pulses,



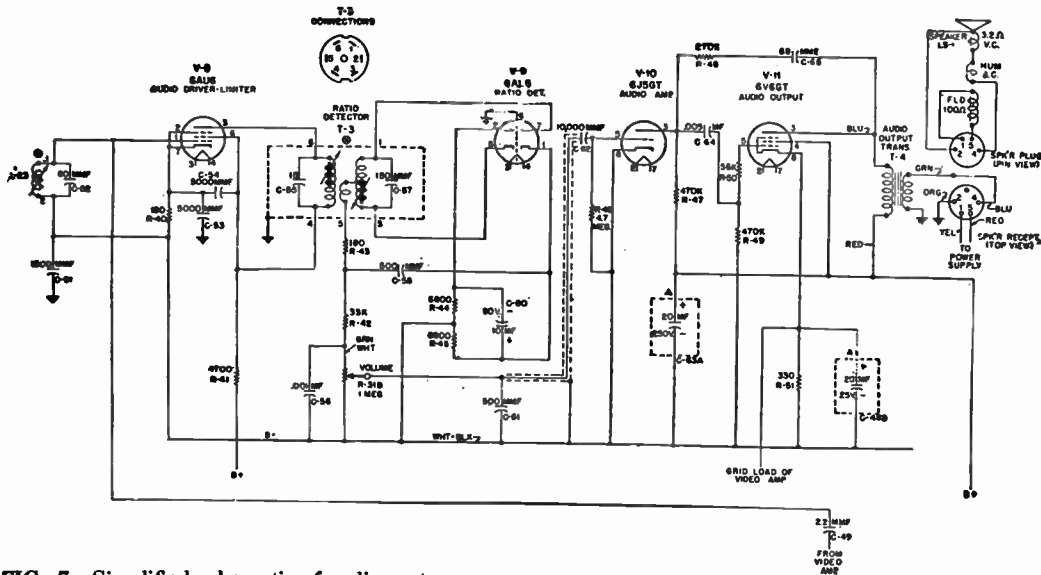

FIG. 7—Simplified schematic of audio system.

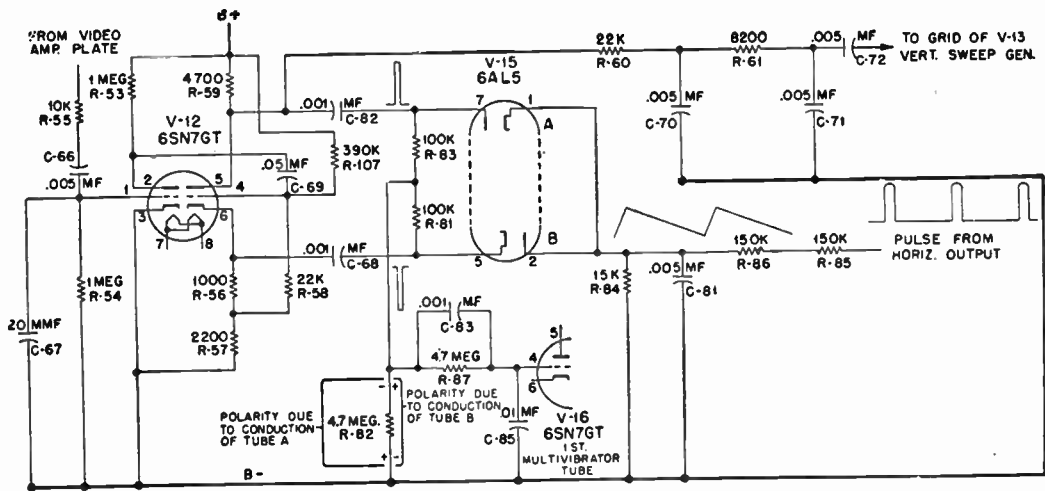

FIG. 8—Simplified schematic of clippers and phase detector.

now negative in polarity, appear in the plate circuit. The second clipper is so biased that the peaks of the sync pulses will drive the tube to cut-off, which results in squared pulses of positive polarity in the plate circuit of this tube. A slight increase in sync pulse amplitude is obtained by a small positive voltage applied to the grid of the second clipper by *R-107* (330K).

**The Vertical Scanning System.**—Fig. 9 is a schematic of the Vertical Scanning System.

The integrating network, shown in fig. 8, composed of *R-60*, *C-70*, *R-61*, and *C-71*, changes the vertical group of sync pulses into a single pulse of suitable amplitude to trigger the vertical oscillator. The vertical oscillator is an asymmetrical multivibrator using two tubes *V-13* (6J5) and *V-14* (25L6). *V-14* also serves as the output tube.

A multivibrator can be considered as a resistance coupled amplifier in which the output of the second tube is coupled back to the input of the first tube. *V-13* is the automatic switch which charges and discharges the sawtooth forming condenser *C-74* (.05), connected in its plate circuit. The circuit components of the multivibrator are chosen so that *V-13's* conductance period is about seven percent of the entire cycle, to insure that retrace time of the scan will have the proper relationship with the trace time.

This circuit is modified from the conventional resistance coupled multivibrator in that the plate of the output stage, which is also the second multivibrator tube, has a fairly large value of inductance, introduced by the output transformer stepping up the yoke inductance. When the tube is cut off, a positive pulse of several hundred volts is developed across this inductance. A portion of this pulse, obtained by means of

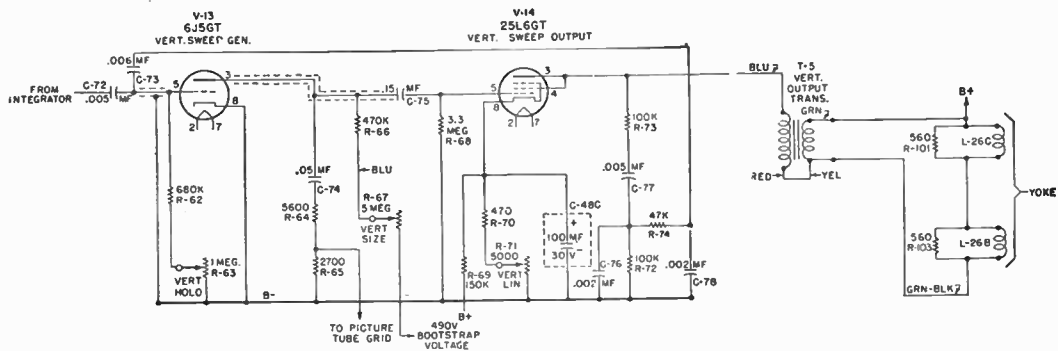

FIG. 9—Simplified schematic of vertical scanning system.

the feedback network, *R-72*, *R-73*, *R-74* and *C-76*, *C-77* and *C-78*, is used to cause the discharge tube *V-13* to go into heavy conduction.

For purposes of explaining the circuit action, assume a time has been reached in the cycle when the trace period is almost completed. During this trace period, *V-13* is cut off and *V-14* is conducting. *C-73* has been discharging through the grid resistors of *V-13*, *R-62* (680K) and *R-63* (the vertical hold control) and resistors *R-74* and *R-72*. This discharge circuit makes the grid end of *R-62* negative and biases the tube beyond cut-off.

When the energy stored in the condenser has decreased sufficiently, the grid of *V-13* reaches the threshold of conductance and the tube begins to draw current. Condenser *C-75*, which has been charged to nearly the B+ voltage, now starts to discharge through *V-13* and *R-68* (3.3 meg.) and this discharge current makes the grid end of *R-68* negative tending to cut off *V-14*, and initiates the retrace. With the sudden change of plate current in *V-14* developed across the plate inductance, a positive pulse is applied to the grid of *V-13* through the feed-back network driving this tube into heavy conduction. *C-74* will then discharge through *V-13*.

The voltage developed at the plate of *V-13* will be the combination sawtooth and pulse voltage shown in fig. 12 (1). The pulse is formed by the peaking resistors *R-64* and *R-65*. When *V-13* goes into conduction, the voltage at the plate of *V-13* drops suddenly to a value determined by the relationship of the plate resistance of *V-13* to the total resistance in the discharge circuit of *C-74*, which consists of *R-64*, *R-65* and the plate resistance of *V-13*.

After this initial instant, the charge on *C-74* decreases, causing the voltage decrease at the plate shown between points

"c" and "d" of fig. 12 (1). When the positive pulse on the grid of *V-13* has decreased to the value where the negative charge on *C-73* becomes operative and cuts off *V-13*, the voltage on the plate of *V-13* and correspondingly on the grid of *V-14*, rises quickly to point "a" on the curve, the start of the trace.

The negative pulse shown between points "b" and "a" of fig. 12 (1) acting on the grid of *V-14*, tends to cut the tube off and raises its plate resistance to the larger value required to dissipate the energy in the plate circuit inductance during the short retrace period.

Since the plate circuit of the vertical output stage *V-14* has inductance, and as the time constant of an inductive circuit decreases with an increase of resistance, just the opposite of an RC circuit, the increase in plate resistance of the tube is used to obtain the short time constant circuit required for proper retrace time.

By returning the grid of the picture tube to the junction of the two peaking resistors, *R-64* and *R-65*, a negative pulse of suitable amplitude to cut the picture tube off during retrace is obtained, resulting in elimination of retrace lines on the screen.

The feedback network to the grid of *V-13* also serves to filter out horizontal pulses which are present in the plate of *V-14* due to coupling in the yoke and which are coupled to the plate through the output transformer. The windings of the vertical output transformer are connected series opposing, which reduces the step-down ratio and, hence, the inductance in the plate of *V-14* in order to shorten the retrace time. The controls found in this circuit are:

1. *The Vertical Hold Control R-63* (1 meg.). This control varies the resistance in the discharge circuit of *C-73* (.006) and, hence, provides a means of varying the frequency of the multivibrator. In practice, this control is adjusted so that the incoming positive sync pulses, which are of constant amplitude, will fire the tube in exact synchronization with the transmitting station's vertical scan.
2. *The Vertical Size Control R-67* (5 meg.). This control varies the charging current into *C-74* (.05) and, hence, the amplitude of the voltage developed across it. Variation of this voltage varies the drive on the grid of *V-14* and controls vertical size.
3. *Vertical Linearity R-71* (5000). This control, by bleeder action through resistor *R-69* (150K) and the output tube's plate current, sets the bias and determines the tube's operating point on its plate current curve. Since this curve is not linear, some distortion can be introduced to counteract any non-linearity in the sawtooth grid voltage.

Since all of these controls are also in the multivibrator circuit and have an effect also on its frequency, there will be some interaction between them. Usually readjustment of size or linearity will require readjustment of the hold control.

**Horizontal Scanning System.**—The horizontal scanning system comprises a phase detector *V-15* (6AL5), and a cathode coupled multivibrator *V-16* (6SN7), the output tube *V-17* (6BQ6) and a damping diode *V-18* (6W4). Fig. 10 is a simplified schematic of this system.

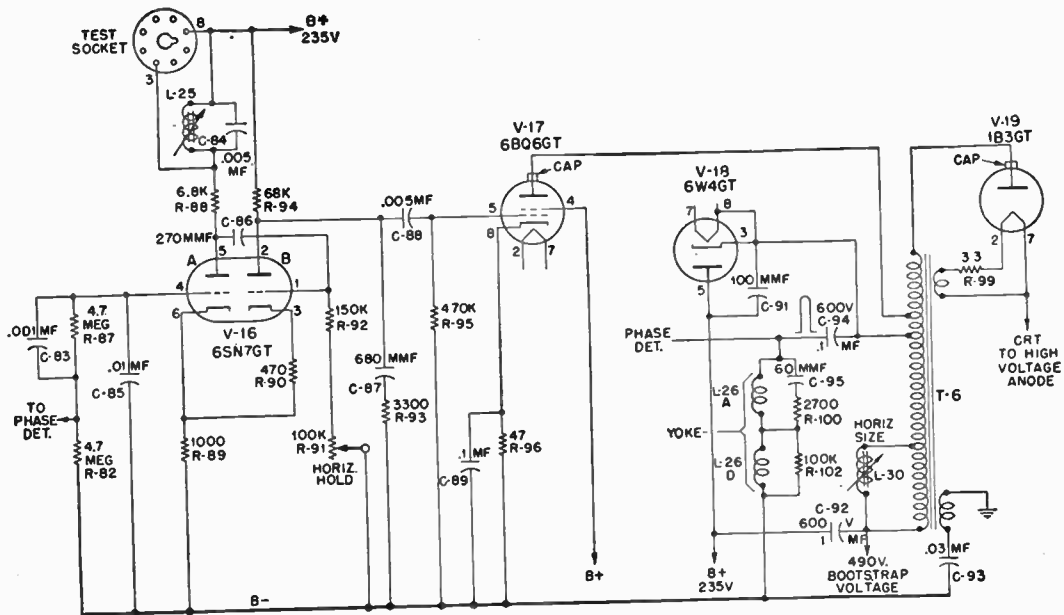

FIG. 10—Simplified schematic of horizontal scanning and high voltage system.



**Horizontal Oscillator.**—In order to see how the phase detector automatically corrects for multivibrator frequency change, it will be necessary to understand how the correction voltage affects the multivibrator. It will be noted that this circuit differs from the vertical multivibrator in that only one coupling condenser is used but that the two tubes have a common cathode resistor. This arrangement is known as a *cathode coupled multivibrator*.

The operation is as follows. Assume that the trace period is almost completed. At this time, tube "A" is conducting, tube "B" is cut off. C-86 is discharging through tube "A", R-92 (150K) and R-91 (the hold control). The discharge current of C-86 is still high enough to keep the grid of tube "B" negative and cut off. Bias is being applied to both tubes by current flow through R-89 (1000) the common cathode resistor.

When the energy stored in C-86 is reduced to the point where its discharge current no longer holds the grid of tube "B" below conductance, tube "B" starts to pass current and this current causes a greater voltage drop across R-89, the common cathode resistor, which increases the bias on tube "A" reducing its plate current.

The resulting increase in voltage at the plate of tube "A" begins to charge C-86 and this charging current applies positive voltage to the grid of tube "B". The resulting heavier conduction of tube "B" develops a pulse of voltage across R-89 which cuts tube "A" off and results in a positive pulse at the plate of tube "A" which throws tube "B" into heavy conduction.

This allows C-87, the saw-forming condenser to discharge through tube "B" and R-93. When C-86 becomes charged the charging current through R-92 and R-91 decreases and the positive voltage on the grid, which has far exceeded the bias developed across R-89, is reduced. This results in reducing

the plate current through tube "B" and, therefore, the bias applied to tube "A" by the voltage drop across *R-89*. Tube "A" starts to conduct and condenser *C-86* starts to discharge, cutting tube "B" off. *C-87* begins to charge, starting the next trace.

*L-25* and *C-84* in the plate circuit of tube "A", form a resonant circuit which is tuned to the horizontal frequency (15,750 cps). The 15,750 cycle sine wave generated by this circuit, if properly phased, will insure that the positive pulse at the plate of tube "A", which throws tube "B" into conduction, will be more frequency stable.

*C-87* and *R-93*, the peaking resistor, will produce the same combination pulse and sawtooth voltage shown in fig. 12 (1). This action was explained in the vertical circuit.

**The Phase Detector.**—The foregoing explanation is based on the assumption that tube "A's" grid is returned to a fixed potential point. It can be seen that if this grid is returned to a point which varies in potential with frequency of the multi-vibrator, it would be possible to make this variation a means of frequency control.

Assume that the grid of "A" in fig. 10 is made more positive. This causes the bias of "B" to increase because of the increased drop across the common cathode resistor *R-89*. Capacitor *C-86* will then discharge for a longer time before "B" conducts, thereby decreasing the frequency of oscillation. If the grid were made more negative, the bias across the common cathode resistor would be less and *C-86* would discharge for less time before "B" started to conduct, thereby increasing the frequency.

Fig. 8 is a simplified schematic of the clipper and phase detector circuits. The phase detector *V-15* (6AL5) is so connected that a comparison of the phase of the incoming sync

## Circuit Description

---

pulses and a sawtooth derived from the horizontal output system is made. A positive sync pulse from the plate of the second clipper *V-12* (6SN7) is fed through *C-82* (.001) to the plate of diode "A" of *V-15*. A negative sync pulse from the cathode of *V-12* is applied through *C-68* (.001) to the cathode of diode "B" of *V-15*.

A sawtooth, derived from the integration of a pulse in the horizontal output circuit, at the yoke, by the integrating network, composed of *R-86* (150K), *R-85* (150K), and *C-81* (.005) is applied to the cathode of diode "A" and the plate of diode "B", which are tied together and returned to B- through *R-84* (15K).

The load for diodes "A" and "B" consists of resistors *R-83* (100K) and *R-81* (100K) whose junction returns to the high side of the grid resistor *R-82* of the first horizontal multivibrator tube *V-16* (6SN7). The voltage applied to the two diodes will be a function of the amplitude of the sawtooth, the amplitude of the sync pulses and the phase relationship between the pulses and the sawtooth.

If the sawtooth, whose phase and frequency are a function of the multivibrator's phase and frequency, is operating in the middle of the lock-in range, the sync pulse will occur in the center of the retrace time. See fig. 11 (1). The sync pulses have an amplitude of from six to eight volts while the sawtooth amplitude is about two volts.

The RC time constant in the pulse input circuit to the diodes is long enough to maintain an average pulse voltage of six to eight volts for two or three horizontal lines, which means that in the "on" frequency condition shown in fig. 11 (1), the diodes conduct only on the pulses and since these are equal in amplitude and develop voltages of opposite polarity across *R-82* in the first multivibrator grid circuit as shown in fig. 8, no control voltage is applied to the grid of *V-16*.

If the oscillator tends to increase in frequency, with respect to the sync pulses, the phase relationship shown in fig. 11 (2) exists at the diodes. The phase of the sawtooth has now shifted

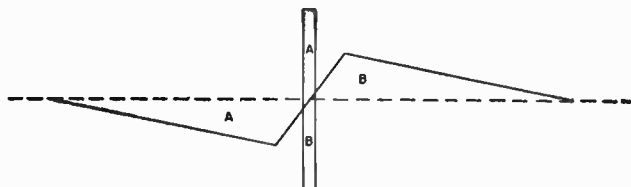

(1) OSCILLATOR ON FREQUENCY

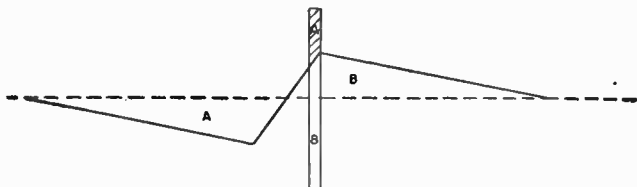

(2) OSCILLATOR HIGH IN FREQUENCY

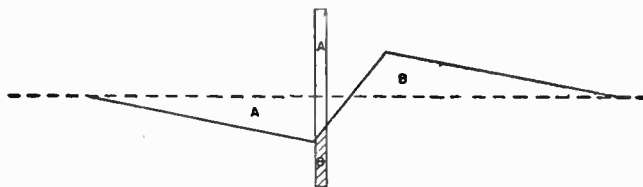

(3) OSCILLATOR LOW IN FREQUENCY

FIG. 11—Wave forms at phase detector.

so that at the same instant that the pulse is applied to the plate of diode "A" the positive saw is also applied to its cathode, so that only the shaded portion of the pulse causes conduction of

diode "A". Diode "B", however, still conducts on the total amplitude of the negative pulse applied to its cathode aided by the positive saw applied to its plate at the same time.

Since current flow through diode "A" makes the grid end of *R-82* negative, with respect to B-, the decreased current flow caused by the sawtooth voltage bucking the pulse voltage at diode "A" results in a more positive voltage across *R-82* applying a more positive voltage to the grid of *V-16* which, as we have seen, results in decreasing the oscillator's frequency.

If the oscillator tends to decrease in frequency, with respect to the sync pulses, the phase relationship shown in fig. 11 (3) exists at the diodes. At the same instant that the negative pulse is applied to the cathode of diode "B", the negative saw is applied to its plate so that only the shaded portion of the pulse causes conduction. Diode "A", however, conducts on the full amplitude of the positive pulse applied to its plate aided by the negative saw applied to its cathode at the same time.

Since current flow through diode "B" makes the grid end of *R-82* positive, with respect to B-, the decreased current through diode "B" results in applying a more negative voltage to the grid of *V-16* which, as we have seen, results in increasing the oscillator frequency. *C-83*, *R-87* and *C-85* provide two time constant filters which are necessary to obtain "fly-wheel" action of this *a.f.c.* sync circuit.

**The Horizontal Output System.**—The combination sawtooth and pulse waveform developed across *C-87* (680) and *R-93* (3300) by the multivibrator circuit, is fed to the grid of the horizontal output tube *V-17* (6BQ6). Fig. 10 is a simplified schematic of the horizontal output system. It will be noted

that in this system an auto-transformer is used. In the horizontal scan it is necessary that retrace be completed in about seven microseconds.

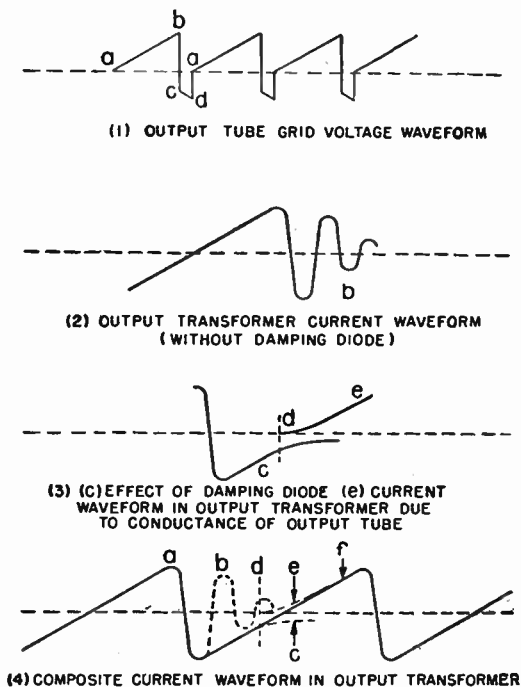

FIG. 12—Wave forms in horizontal scanning system.

In order to accomplish reversal of current in the inductance of the output transformer and the yoke in this short a time, it is necessary to make this circuit resonant at such a frequency that the half cycle time will equal seven microseconds, because

only by shock exciting such a circuit into oscillation will retrace be accomplished in the time allowed. The circuit is made resonant by the inductance of the output transformer and yoke, the distributed capacity and the tube capacity.

Bearing this in mind, the operation can be explained as follows. Referring to fig. 12 (1), assume that the voltage on the grid of the output tube is increasing, point "a". The grid is now being made less negative and the output tube starts to draw current which is supplied from B+ through the damping diode. When point "b" is reached on the grid voltage waveform, the output tube is suddenly cut off because its grid has been made highly negative, (point "c" on the grid voltage waveform).

With the tube cut off, the resonant plate load is undamped and the circuit is shocked into oscillation. The reversal of current through the output inductance produces a positive voltage pulse which makes the cathode of the damping diode (V-18) positive, with respect to its plate; therefore, it cannot conduct. C-91 (100) is placed across the diode to provide a low impedance for the oscillatory current. If the damping diode V-18 were not present, this oscillation would continue and current would flow in the output transformer as shown in fig. 12 (2).

In order to insure a linear trace, however, this oscillation must be stopped and the damping diode serves this purpose. When the current nears its maximum negative value, the polarity and amplitude of the voltage pulse on the damping diode is such that its plate becomes positive, with respect to its cathode, so that the tube conducts heavily and loads the circuit sufficiently to prevent continuation of the oscillation.

The current then follows the decay curve shown at "c" in fig. 12 (3). At the time ["d" in fig. 12 (3)] the voltage at the

grid of the output tube has become less than cut off [point "a" in fig. 12 (1)] and the tube again demands current. The rising current in the tube results in superimposing the waveform "e" of fig. 12 (3) on the current flow already in the output transformer due to the decaying current which resulted from the damped oscillation. Combination of these two currents results in the linear trace current indicated at "f" in fig. 12 (4), which is a composite waveform of the entire action.

During the peak conduction of the damping diode, C-92 (.1) charges and its polarity is such that when the output tube calls for current the charge on the condenser will be in series with the B+ supply so that the voltage at the output tube plate is raised from the 250 volt B+ supply to about 475 volts by this so-called "bootstrap" voltage. When the grid voltage waveform of the output tube again reaches point "b" of fig. 12 (1), the tube is cut off and another cycle starts.

In order to properly match the yoke inductance to the required output inductance for the tube, the yoke is connected to a tap on the winding which effectively makes an auto-transformer of this section. The positive pulse of voltage at this tap is coupled to the yoke through C-94 (.1) and results in a sawtooth of current through the yoke. It will be remembered that a portion of this pulse is also fed to the phase detector for the *a.f.c.* action through R-86 and R-85.

The small additional winding, one terminal of which is connected to chassis while the other terminal is connected to B- through C-93 (.03) is used to cancel the pulse of voltage which is placed on the chassis by induction from the output transformer. By connecting this winding in such a way as to place a pulse of suitable amplitude on the chassis 180 degrees out of phase with the induced voltage, cancellation of the induced voltage will take place.



**High Voltage.**—To take advantage of the large voltage pulse developed across the output inductance by the heavy current flow caused by the retrace oscillation, the plate winding is made the primary of an auto-transformer whose step-up ratio is such as to develop pulses of about 12 *kv.* at its high end. These pulses are rectified by *V-19* (1B3) and the resulting *d.c.* is applied to the second anode of the picture tube. The filament voltage for the 1B3 rectifier is obtained from an additional winding on the output transformer.

**Controls.**—*L-25* is the coil of the sine wave generating circuit in the horizontal multivibrator circuit and should be tuned to 15,750 cycles. *R-91* is the horizontal hold control which can be adjusted for correct frequency operation of the multivibrator. *L-30*, paralleling a small portion of the output choke acts as a size control.

## CHAPTER 38

# Television Picture Tubes

The television picture tube also called *cathode ray tube*, *viewing tube*, *pickup tube*, *receiving tube*, etc. is very similar to the well known test oscilloscope tube employed in all types of electronic testing and research work.

With reference to fig. 1 the principle elements are as follows:

1. A containing envelope of glass for the purpose of maintaining vacuum in the tube.
2. A cathode (indirectly heated) for the production of free electrons.
3. A control grid for controlling the beam current.
4. A focusing electrode identified as the *first anode* for concentrating the electrons into a cathode ray or beam.
5. A high voltage anode referred to as the *second anode* for further acceleration of the electrons.
6. Two sets of electrostatic deflection plates for deflecting the electron beam. These are known as the horizontal and vertical deflection plates.
7. A screen which is coated on the inner surface of the enlarged end of the tube with a material which shows a fluorescent glow at the impact point of the electron beam. This is termed the fluorescent screen.

**The Electron Gun.**—The electrodes consisting of the *cathode*, *control grid*, *first and second anode* are collectively known as the *electron gun*, inasmuch as their function is to generate a beam of electrons and to direct it toward the viewing screen.

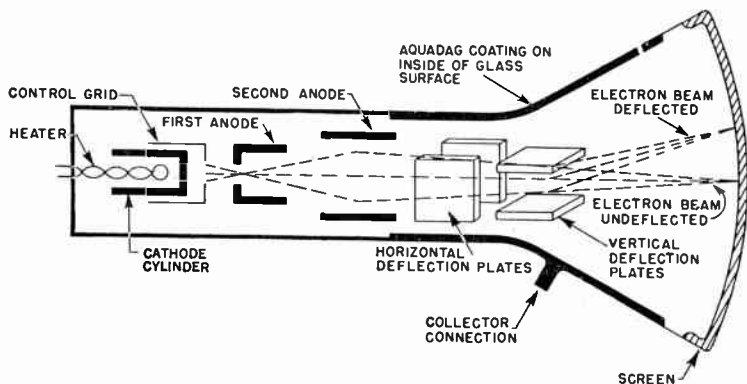

FIG. 1—Showing schematic arrangement of electrodes in a picture tube of the electrostatic deflection type.

**The Electron Beam.**—Since the electron beam consists of rapidly moving electrons, it constitutes a current having both electromagnetic and electrostatic properties. Because no material conductor is required to carry the electrons, the beam has negligible mass and negligible inertia. Due to this inertialess characteristic, the electron beam can be deflected easily and rapidly by either electrostatic or electromagnetic fields.

**Method of Focusing.**—Focusing may be accomplished by either of two methods, namely:

1. By electrostatic means, and
2. By electromagnetic means.

Both methods of focusing will achieve the desired results, that is, a narrow concentrated beam of electrons.

In the picture tube shown in fig. 1 the deflecting force takes the form of an electrostatic field produced by a voltage applied across the deflecting plates.

Another type of picture tube is shown schematically in fig. 2.

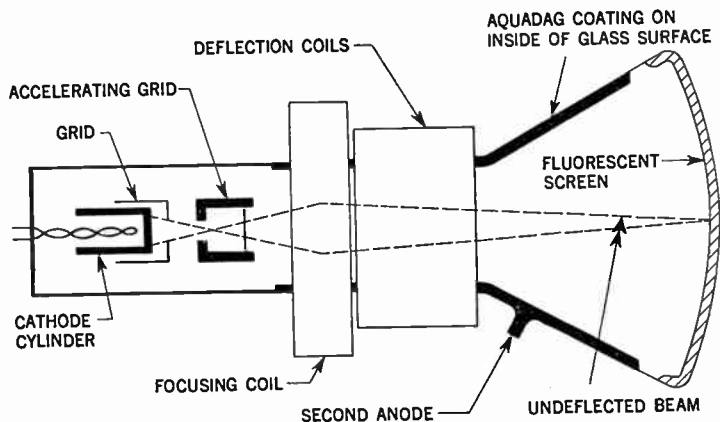
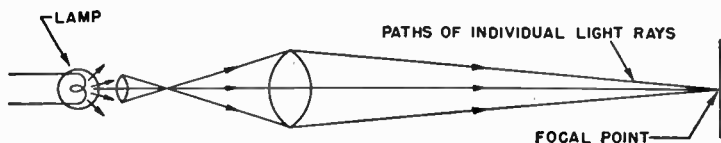

FIG. 2—Schematic arrangement of electrodes in a picture tube of the magnetic deflection type.

In this case no electrostatic deflection plates are used. Here deflection of the electron beam both horizontally and vertically is accomplished by means of two electromagnetic fields, produced by two external pair of coils. This latter type of picture tube is known as the *magnetic deflection type* and is the most common type used for picture tubes.

Also in the magnetically focused picture tube, the first anode is replaced by an accelerating grid which gives the initial acceleration of the beam of electrons.

The second anode of this type of tube is not always a part of the main section of the cylindrical electron gun. Instead it is in the form of a coating on the inner surface of the glass extending from the tube neck up toward the fluorescent screen.



FORMATION OF A FOCUSED LIGHT BEAM BY A GLASS LENS SYSTEM.

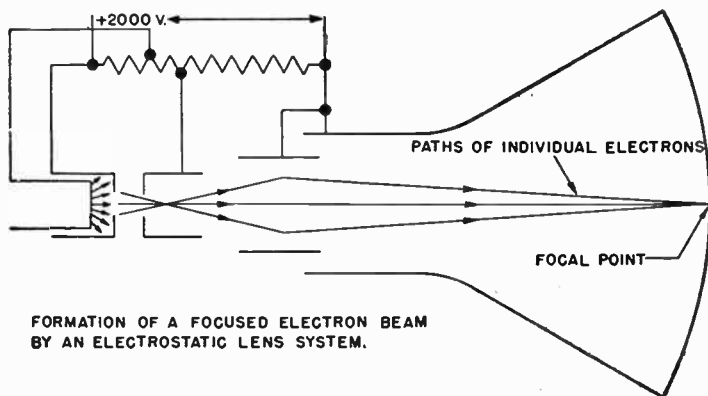

FORMATION OF A FOCUSED ELECTRON BEAM BY AN ELECTROSTATIC LENS SYSTEM.

FIGS. 3 and 4—Illustrating focusing method of a simple lens system as compared to electrostatic focusing. In the familiar glass lens system, the lens may be used to collect a divergent bundle of light rays, converging them to a point and in this manner accomplish the focusing of light. The light lens system may be a simple lens or a compound of several individual elements. An electron lens may be employed to control the many electrons leaving the cathode in exactly the same manner that an optical lens controls the light leaving the lamp. Focusing is accomplished by varying the potentials of the electron lens as illustrated and is due to the electrostatic fields established between successive elements.

In either method of focusing, whether electrostatic or electromagnetic, the amount of focus potential (or current) is varied while observing the fluorescent screen for sharpness of image detail.

**Picture Scanning.**—In scanning, the beam is focused to a spot of small diameter at the fluorescent screen, and it now remains to deflect the beam for scanning in an orderly sequence.

Here again, may be employed either an electrostatic or an electromagnetic method. The former is illustrated in fig. 1, and shows two sets of metallic plates, one set for vertical deflection and one set for horizontal deflection.

Creation of an electrostatic field between any one set of plates will cause the electron stream, which passes between them, to be deflected from its normal path in one direction or the other, depending upon the polarity of potential applied. There is a linear relationship between magnitudes of deflection and applied potential. Therefore, by the application of potential to both vertical and horizontal deflection plates, the electron spot may be caused to move to any desired point on the fluorescent screen. For example, to cause the spot to move upward, the top vertical plate must become positive with respect to the bottom vertical plate.

For downward spot displacement, the polarity is reversed. A similar application to the horizontal plates above will cause either right hand or left hand spot movement and a spot at the upper right hand corner of the screen would indicate equal displacements in both the vertical and the horizontal directions.

Therefore, for scanning, a linear rise of potential is applied to the horizontal plates at a high repetition rate (15,575 cycles in present day standards) while a slow repetition rate is applied to the vertical plates (60 cycles). These scanning potentials are illustrated in fig. 5.

A linear rise of potential causes the beam to be deflected linearly across the screen. After it has traversed the screen, it suddenly returns to the side from whence it started, only to again take up its slower motion in the scanning direction (left to right).

As previously mentioned, a high repetition rate of scanning is applied to the horizontal plates, and a much slower rate to the vertical. Hence, analyzing the spot motion, it is found that

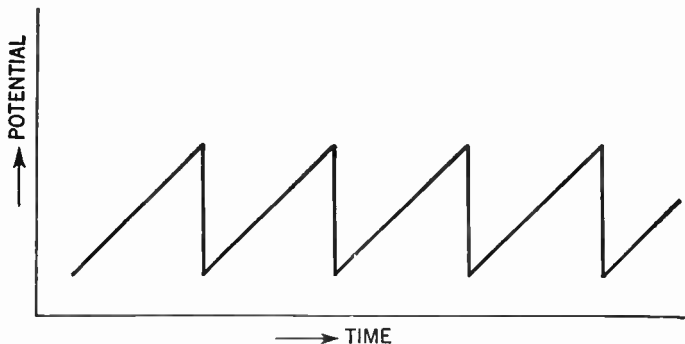

FIG. 5—Showing typical sawtooth scanning potentials.

during the time that it has traveled across the screen, left to right, it has traveled downward by but a very small amount. At the start of the second horizontal cycle, therefore, the slow downward motion has caused the spot to be moved downward in amount equal to the spot size. The second horizontal cycle then carried the spot parallel to and immediately adjacent to the travel of the first cycle. A third cycle finds the downward motion again equal to the spot size and a third scan is completed.

The same general outline may be applied to electromagnetic scanning. In this case, the deflection plates are omitted and a set of deflection coils are placed over the tube neck. There are four coils, that is, two vertical coils (one above and one below the neck of the tube) and two horizontal coils. Instead of a sawtooth of potential, as used with the deflection plates, a sawtooth wave form of current is used which produces a sawtooth of magnetic flux. It has previously been shown that a sawtooth of voltage applied to the deflection coils does not produce a sawtooth of current and that special pulses of voltage must be produced. The complete set of coils, horizontal and vertical, which is placed over the tube for magnetic deflection is known as a *deflection yoke*.

Although it is possible to employ the electrostatic method of deflection in television picture tubes, this is seldom done for several reasons. They are:

1. The deflection potentials necessary in a large tube are very high, requiring large high voltage amplifier tubes.
2. A screen giving green colored light as in oscillograph tubes operating on the electrostatic deflection principle is used for reason of visual efficiency. Television use, however, dictates that a white or blue-white light be used for esthetic reasons and that the decay time of the light be short. Phosphor (screen materials) exhibit the property of remaining lighted for a short time after the electron excitation has passed.
3. Focus of the electron beam is not maintained over the entire screen in an electrostatic type of tube. This would give an image which is "fuzzy" or poorly focused over a portion of its area



For these reasons the television picture tube employs magnetic focusing. Certain electrical properties of the picture tube will now be treated. These being *halation* and the *ion spot*.

**Halation.**—This is the glowing of a phosphor on the fluorescent screen, in a region immediately surrounding the scanning spot. It signifies one undesirable property of the picture tube.

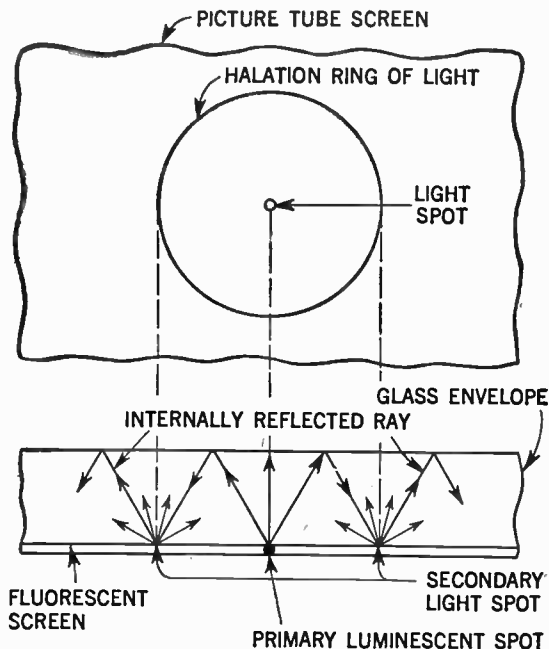

FIG. 6—Showing typical halation effect on picture tube screen.

The face of the tube must have appreciable thickness in order to withstand the atmospheric pressure. A pin point source of light appearing at the inside surface of the face will radiate

light in all directions, being not restricted to the desired direction (straight out from the tube). Such a source is the phosphor being bombarded by a beam of electrons. As illustrated in fig. 6 internal reflections of the light within the glass wall, from surface to surface, give rise to one or more rings of light which surround the original desired point. This effect is known as halation.

**The Ion Spot.**—A second property of the tube is the formation, after some hours of operation of a darkened area near the center of the screen, known as an *ion spot*.

An ion spot is the result of the bombardment of the phosphor by charged particles known as ions. This bombardment results in the deterioration of the phosphor which then produces less light, upon being struck by the electron stream, than does that portion of the surface which has not been so bombarded. The ions travel down the tube in a rather wide angle stream, impinging upon the screen near its center.

There are several methods leading to the elimination of this difficulty, one of which is the use of a completely electrostatic tube which is not troubled with this difficulty. In television practice, two methods used are (1) the use of a bent gun tube and (2), a metallic coating on the inside surface of the phosphor.

The bent gun tube fig. 7 is one whose electron emitting element is not in line with the axis of the tube, that is, its electron stream is directed toward the side of the tube neck. Since the ion stream is not much effected by a magnetic field, a magnet is placed over the neck of the tube which bends the electron stream, directing it axially down the tube in the normal path, allowing the ion stream to continue in its original course. It strikes the side of the tube, where it does no damage.

The metallic coating which is placed upon the inside surface of the phosphor coating accomplishes two advantages. It

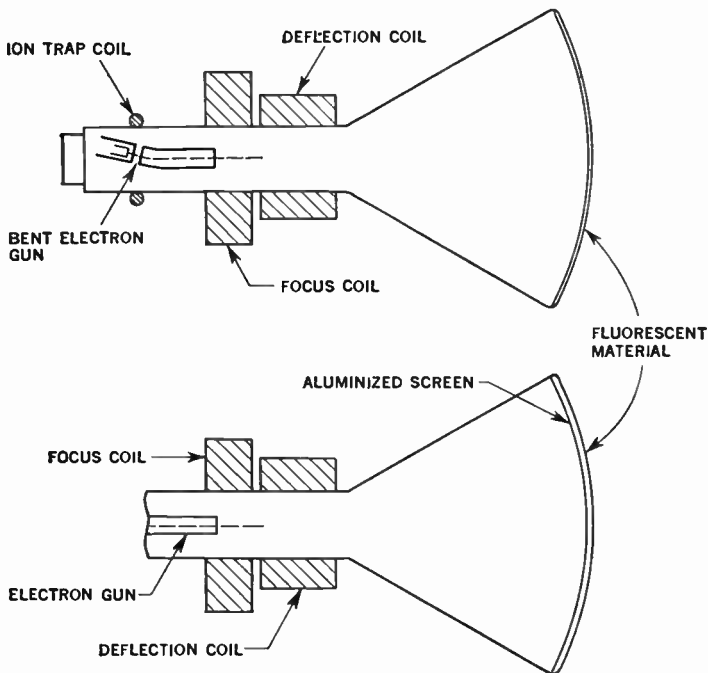

**FIGS. 7 and 8—Methods of ion spot prevention on magnetic deflection type of picture tubes.** In the bent electron gun method, fig. 7, the actual cylindrical elements of the electron gun are mounted at an angle with respect to the tube axis. As the electrons and ions leave the electron gun they come under influence of the magnetic field generated by the external bending or ion trap coils. This magnetic field is of the proper strength and polarity to return the electrons to the center line of the electron tube axis. The ions on the other hand, because of their greater mass cannot be deflected, and therefore strike the collecting walls to be dissipated, thus separating the ions from the electrons. The second method of ion spot prevention as illustrated in fig. 8 consists of a metallic coating of aluminum which because of its thinness is actually an aluminized screen. This aluminized screen will effectively transfer electrons causing them to strike the fluorescent material. The ions, however, having a greater mass will not penetrate the aluminized screen but are dissipated by it and do not reach the fluorescent screen of the picture tube.

increases the light which is emitted from the front of the tube by a considerable amount and it disperses the ions so that they cause no damage to the phosphor. This coating is extremely thin, about the wavelength of light.

**Commercial Picture Tubes.**—These are manufactured in a large variety of shapes and sizes. With the advance of television science the public demand for larger and better pictures has resulted in a great improvement in the size and reliability of picture tubes until at present standard tubes of up to 22 inches in diameter and larger are available.

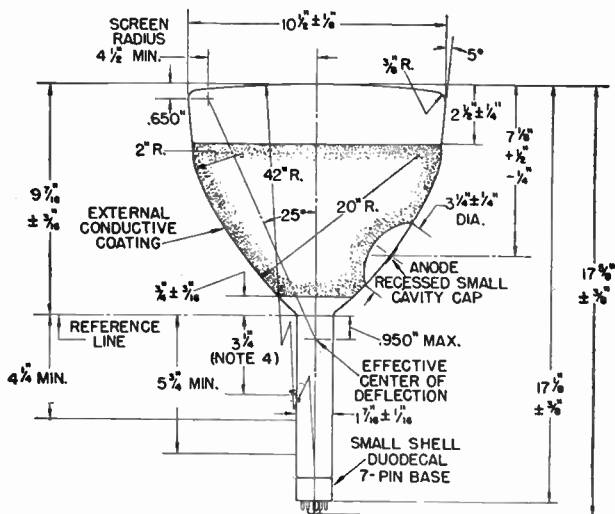

FIG. 9—Outline dimensions of a 10BP4 direct view picture tube.

As previously noted, magnetic deflection is the most common deflection method used, although a few of the smaller size picture tubes employ electrostatic deflection.

A listing of the most common types of commercial picture

tubes and their characteristics is provided by means of picture tube data charts given on pages 820 to 821. From these data charts much useful information in a practical form with reference to operating voltages and general characteristics of the tubes will be obtained. Many of the later manufactured picture tubes have an external conductive coating in addition to the internal second anode coating. In such tubes a high voltage filter capacitor of approximately 500 *mmf.* is formed by the two coatings and the glass which serves as a dielectric. In tubes so equipped the external coating is grounded.

**Using the Data Chart.**—There are several important factors which must be considered by the service technician when using the tube data charts as an index to tube interchangeability. These are as follows:

- a. Tube types with identical bulb outlines present no problem of interchangeability with respect to chassis layout, unless the difference in overall length is so great that the two types in question would not be compatible in the same cabinet design.
- b. When a high focus current tube is replaced for a low focus current tube, it may be necessary to increase the focus current range of the receiver, otherwise, a stronger focus coil must be employed.
- c. It is important that the proper external magnet be used with the ion trap of the tube, particularly when changing from a double to a single magnet. Since these components are relatively inexpensive, it would seem practical to keep them on hand.
- d. If a tube without external coating is replaced for a tube with external coating, a 500 to 1500 *mmf.* capacitor connected between the high voltage output lead and ground will insure proper set operation.

- e. In general there are three types of connectors to the anode of television tubes, the cavity and ball connectors in all glass types, and the clip connector for types with a metal cone envelope. When making tube changes, the appropriate connector must be used.
- f. In practice, the same deflection yoke usually may be employed with all tube types having deflection angles of less than 66 degrees.
- g. Type numbers are assigned to picture tubes and other cathode ray tubes by the *Radio-Television Manufacturers Association*. The first number, made up of one or two digits, represents the largest dimension of the face of the tube to the nearest one-half inch. For round tubes this would be the diameter and for rectangular tubes it would be the diagonal dimension. The letter following the first number is assigned in order of registration and has no significance other than this. The letter *P*, together with the last number designate the type of phosphor used. Thus, the *10BP4* is a 10 inch picture tube with *P4* phosphor. Similarly, the *12AP4* is a 12 inch picture tube with *P4* phosphor.
- h. In some cases an additional letter is added as a suffix to the type number. An example is the type *17BP4A*. The reason for this suffix is that there has been a change in the design of *17BP4*, but not great enough change to justify the use of a new type number. The new tube with the suffix in its type number, will always operate in the same circuit as the original tube, but the old tube may or may not work in all circuits where the new tube is used. In this way it is possible to take advantage of the latest development in picture tube design whenever it may be necessary to replace the old tube

# Television Picture Tube Data Chart (Magnetic deflection and focus)

820

Television Picture Tubes

Type**	Basing	DIMENSIONS (Inches)			Deflection Angle (degrees)	Radius of Face Curvature (Inches)	Envelope	Contact	Ion Trap Magnet	MAX. DESIGN CENTER VALUES		COMPARATIVE OPERATING CONDITIONS**			
		Overall Length	Diameter	Min. Usual Diameter						Anode Volts	Grid No. 2 Volts	Focus* Current (Ma.)	Anode Volts	Mag. Grid No. 1 Cut Off Volts	Grid No. 2 Volts
10BP4 10BP4A*	12D	17 3/8	10 1/2	9	50	42	Glass†	Cavity	Double	12,000	410	132	12,000	33-77	300
10CP4	12D	16 3/8	10 1/2	9	50	42	Glass†	Ball	None	12,000	410	—	12,000	33-77	300
10DP4*,4	12C	17 3/8	10 1/2	9	50	42	Glass	Cavity	None	12,000	410	—	12,000	33-77	300
10EP4	12D	17 3/8	10 1/2	9	50	42	Glass	Ball	Double	12,000	410	132	12,000	33-77	300
10FP4* 10FP4A*,4	12D	17 3/8	10 1/2	9	50	42	Glass†	Cavity	None	12,000	410	115	12,000	33-77	300
10MP4 10MP4A*	12G	17	10 1/2	9 3/8	52	42	Glass†	Cavity	Double	12,000	—	—	12,000	33-77	300
12JP4*	12D	17 1/2	12	11	56	20	Glass	Ball	None	12,000	410	158	12,000	33-77	300
12KP4* 12KP4A*	12D	17 3/8	12 3/8	11 1/4	54	40	Glass†	Cavity	None	12,000	410	140	12,000	33-77	300
12LP4 12LP4A*	12D	18 3/8	12 3/8	11	54	40	Glass†	Cavity	Double	12,000	410	114	12,000	33-77	300
12QP4 12QP4A*	12D	17 1/2	12 3/8	11	55	40	Glass	Ball	Single	12,000	410	148	12,000	33-77	300
12RP4	12D	17 1/2	12	11	56	20	Glass	Ball	Single	12,000	410	148	12,000	33-77	300
12TP4	12D	18 3/8	12 3/8	11	54	40	Glass	Cavity	Double	12,000	410	114	12,000	33-77	300
12UP4 12UP4A* 12UP4B*	12D	18 3/8	12 3/8	11 3/8	54	27	Metal	—	Double Double Single	12,000	410	—	12,000	33-77	300
12VP4 12VP4A*	12G	18	12 3/8	11	55	40	Glass	Cavity	Double	12,000	—	—	12,000	33-77	300
14BP4*,3	12D	16 3/8	9 3/8 x 12 1/2	8 3/8 x 11 1/2	70 diag.	27	Glass†	Cavity	Double	12,000	410	115	12,000	33-77	300
14CP4*,3	12D	16 3/8	9 3/8 x 12 1/2	8 3/8 x 11 1/2	70 diag.	27	Glass†	Cavity	Single	14,000	410	95*	12,000	33-77	300
14DP4*,3	12D	16 3/8	9 3/8 x 12 1/2	8 3/8 x 11 1/2	70 diag.	27	Glass	Cavity	Double	14,000	410	104	12,000	33-77	300
14EP4*,3	12D	16 3/8	9 3/8 x 12 1/2	12 1/2" diag.	70 diag.	27	Glass†	Cavity	Single	14,000	410	110*	12,000	33-77	300
14FP4*,3	12D	16 3/8	9 3/8 x 12 1/2	8 3/8 x 11 1/2	70 diag.	27	Glass	Cavity	Single	14,000	410	115*	12,000	33-77	300
15AP4*	12D	20 1/2	15 1/2	14	57	45	Glass	Ball	None	15,000	410	159	12,000	33-77	300
15CP4	12D	21 1/2	15 1/2	14	57	45	Glass	Cavity	Double	15,000	410	133	12,000	33-77	300
15DP4	12D	20 1/2	15 1/2	14	57	45	Glass	Ball	Single	15,000	410	140	12,000	33-77	300
16AP4 16AP4A*	12D	22 1/2	15 3/8	14 3/8	53	27	Metal	—	Double	14,000	410	89	12,000	33-77	300
16CP4	12D	21 1/2	15 3/8	15	52	56 3/8	Glass	Cavity	Double	15,000	410	110	12,000	33-77	300

# Television Picture Tube Data Chart (Magnetic deflection and focus)

16EP4 16EP4A <sup>a</sup>	12D	19%	15%	14%	60	27	Metal	—	Double	14,000	410	105	12,000	33-77	300
16FP4	12D	20 1/4	16%	15	62	27	Glass	Ball	Single	16,000	410	140	12,000	33-77	300
16GP4 <sup>a</sup>	12D	17%	15%	14%	70	40	Metal	—	Single	14,000	410	100*	12,000	33-77	300
16HP4 16HP4A <sup>a</sup>	12D	21%	15%	14 1/2	60	56%	Glass†	Cavity	Double	14,000	410	110	12,000	33-77	300
16JP4 16JP4A <sup>a</sup>	12D	20%	16%	15	60	27	Glass†	Cavity	Double	14,000	410	120	12,000	33-77	300
16KP4 <sup>a,b</sup>	12D	18%	11 1/2 x 14%	10 1/4 x 13 1/2	70 diag.	27	Glass†	Cavity	Single	16,000	410	97*	12,000	33-77	300
16LP4 16LP4A <sup>a</sup>	12D	22%	15%	14 1/2	52	56%	Glass†	Cavity	Double	14,000	410	110	12,000	33-77	300
16MP4 16MP4A <sup>a</sup>	12D	21%	16%	14%	60	27	Glass†	Cavity	Double	14,000	410	110	12,000	33-77	300
16OP4 <sup>a,b</sup>	12D	19%	11 1/2 x 14%	10 1/4 x 13 1/2	70 diag.	27	Glass	Cavity	Double	16,000	410	125*	12,000	33-77	300
16RP4 <sup>a,b</sup>	12D	18%	11 1/2 x 14%	10 1/4 x 13 1/2	70 diag.	27	Glass†	Cavity	Double	14,000	410	100*	12,000	33-77	300
16SP4 16SP4A <sup>a</sup>	12D	17%	15%	14 1/2	70	56%	Glass†	Cavity	Double	14,000	410	110	12,000	33-77	300
16TP4 <sup>a,b</sup>	12D	18%	11 1/2 x 14%	10 1/4 x 13 1/2	70 diag.	27	Glass†	Cavity	Single	14,000	410	100*	12,000	33-77	300
16UP4 <sup>a,b</sup>	12D	18%	11 1/2 x 14%	10 1/4 x 13 1/2	70 diag.	27	Glass	Cavity	Single	15,000	410	100*	12,000	33-77	300
16VP4 <sup>a</sup>	12D	17%	15%	14 1/2	70	56%	Glass	Cavity	Single	15,000	410	110*	12,000	33-77	300
16WP4 <sup>a</sup> 16WP4A <sup>a</sup>	12D	17%	15%	14 1/2	70	56%	Glass Glasst	Cavity	Double	15,000 16,000	410	110*	12,000	33-77	300
16XP4 <sup>a,b</sup>	12D	18%	11 1/2 x 14%	10 1/4 x 13 1/2	70 diag.	27	Glass	Cavity	Double	15,000	410	100*	12,000	33-77	300
16YP4 <sup>a</sup>	12D	17%	15%	14 1/2	70	56%	Glass†	Cavity	Single	14,000	410	100*	12,000	33-77	300
16ZP4 <sup>a</sup>	12D	22%	15%	14 1/2	52	56%	Glass†	Cavity	Single	14,000	410	110*	12,000	33-77	300
17AP4 <sup>a,b</sup>	12D	18%	12 1/4 x 15%	10 3/4 x 14 1/4	70 diag.	27	Glass	Cavity	Single	16,000	410	100*	12,000	33-77	300
17BP4A <sup>a,b</sup>	12D	19%	16%	14 1/4 x 10 3/4	70 diag.	27	Glass†	Cavity	Single	16,000	410	95*	12,000	33-77	300
19AP4 19AP4A <sup>a</sup> 19AP4B <sup>a,b</sup>	12D	21 1/2	18%	17%	66	28	Metal	—	Single	19,000	410	140	12,000	33-77	300
19DP4 19DP4A <sup>a</sup>	12D	21 1/2	18%	17%	66	60	Glass†	Cavity	Double	19,000	410	140	12,000	33-77	300
19EP4 <sup>a,b</sup>	12D	21%	17 x 13 3/4	12 x 16	70 diag.	27	Glass†	Cavity	Double	19,000	410	140*	12,000	33-77	300
19FP4 <sup>a</sup>	12D	22	18%	17%	66	60	Glass	Cavity	Double	19,000	410	97-126*	12,000	33-77	300
19GP4 <sup>a</sup>	12D	21%	18%	17%	66	60	Glass	Cavity	Single	19,000	410	107-126*	12,000	33-77	300
20BP4	12D	28	20	18%	54	30	Glass	Metal Cap	None	20,000	410	122	12,000	33-77	300
22AP4 22AP4A <sup>a</sup>	12D	22%	21%	20%	70	27	Metal	—	Single	19,000	410	108*	12,000	33-77	300



**Tube specification notes:**

1. All the types listed have heater values of 6.3 volts, 0.6 amps.
2. These types employ electrostatic focus.
3. Types employing gray filter face plate.
4. Type employs metal-backed screen.
5. Rectangular type.
6. Face plate incorporates an anti-reflective feature.

\* Types employ RMA Focus Coil #109 (approx. 470 ohms), all others RMA focus coil #106 (approx. 264 ohms).

a. For replacement see Type 12RP4.

b. For replacement see Type 15DP4.

† Types have external conductive coating.

7. All types employ a white fluorescence material of medium persistence.

\*\* These values are for comparison only and do not imply typical operating conditions.

Data based on latest information from RMA Data Bureau.

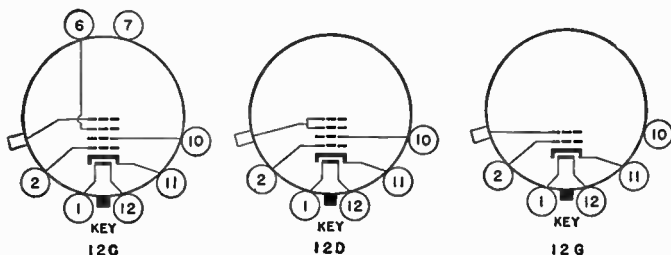

**FIGS. 10 to 12—Base diagram symbols.** By using the picture tube data chart on pages 820 and 821, the proper base connections will be found under the heading of "Basing". Thus, for example, to obtain the correct base connections for the 10BP4 picture tube, a reference to "Basing" on the picture tube data chart shows 12D as the correct base diagram to use. In a similar manner the base connection for any picture tube represented in the chart may readily be found.

## **Replacement of the Picture Tube**

**Chassis Removal.**—Ordinarily the removal of the chassis from the cabinet is accomplished as follows:

1. Remove the control knobs from the front of the cabinet.
2. Remove the wood screws that hold the rear cover to the cabinet, and remove the rear cover.
3. Remove the two wood screws from the block located on the top (inside) of the cabinet, and remove the block.
4. Disconnect the built-in antenna feeder from the antenna terminals.
5. Release the antenna stub from the top of the cabinet by pulling out the thumb-tack.
6. Remove the two screws that secure the antenna assembly to the top of the cabinet.
7. Remove the trimmer assembly and rubber coupling sleeve by carefully pulling the coupling sleeve off the drive shaft.
8. Temporarily tape the drive shaft to the top of the cabinet to avoid breakage.
9. Remove the bracket that clamps the shutter frame to the bottom of the cabinet. This bracket is located near the front (inside) of the cabinet and can be released by removing the screw from the under side of the cabinet.
10. Remove the hex-head chassis bolts from the under side of the cabinet.
11. Remove the chassis by pushing the front of the chassis against the left side of the cabinet, and then easing the chassis out of the cabinet while moving the rear of the chassis gradually toward the right. The chassis must leave the cabinet at an angle so that the shutter mechanism will clear the antenna drive pulleys. This step must be performed cautiously to prevent scratching the plastic front plate.

**Picture Tube Replacement.**—After the chassis has been removed from the cabinet, the picture tube may be replaced as follows:

1. Back off the screen locking the shutter actuating link to the magnifier control shaft.
2. Remove the two self-tapping screws that secure the shutter assembly frame to the chassis.
3. Remove the two self-tapping screws that secure the shutter assembly frame to the brace bars.
4. Remove the wing nut and lock washer from the stud on top of the picture tube strap.
5. Remove the shutter assembly by lifting the bronze strap over the stud and sliding the complete assembly forward.
6. Remove the ion trap magnet and the picture tube socket.
7. Loosen the picture tube cushion screws, the focus coil wing screws, and remove the screw from the picture tube strap.
8. Remove the defective picture tube and insert the replacement through the deflection yoke and focus coil, exercising the caution necessary when handling picture tubes.
9. Replace the screw in the picture tube strap and tighten the strap about the tube just enough to hold the tube in place.
10. Replace the shutter assembly and tighten the self-tapping screws only. Do not tighten the picture tube strap wing nut or the set screws on the magnifier control shaft.
11. Position the picture tube so that the clearance between the tube and the mask is approximately one-thirty-second inch.

## **Handling of Cathode Ray Tubes**

The cathode ray tube bulb (picture tube) due to its large surface area and high vacuum contained within it, is subjected to high air pressure over its entire surface. To understand what takes place when an accidental fracture of the tube takes place, it is only necessary to recall the violent blast which occurs when a small conventional light bulb be imploded. Although the tube face is fairly thick, a fracture of the glass by a blow, or scratch, may cause a sudden collapse, and the force of the implosion, may throw pieces of glass with dangerous violence in every direction.

The following suggestions regarding handling of the picture tube should be put into practice, to avoid damage to the tube or possible personal injury from breakage of it. To prevent injury from picture tube breakage, proceed as follows:

1. Do not unpack the picture tube until ready for use. Exposing it unnecessarily at any time will increase the chances of possible tube damage and injury to personnel.
2. Wear safety goggles when handling the tube and insist upon all persons nearby being similarly equipped with eye protection.
3. Do not allow the metal part of the tube to contact or be brought near any magnetized material. This portion of the tube may become magnetized by such contact, resulting in picture distortion which cannot easily be corrected.
4. Do not handle the picture tube at the bell-shaped glass portion which has been coated with a special insulating material. Finger marks, grease, or other foreign particles may cause high voltage leakage paths under humid conditions.

## **Safety Precautions**

Although every practical safety device possible has been incorporated in television receivers, certain precautionary measures should be observed in their servicing.

It should be clearly understood that servicing of any television receiver, especially when the receiver is on the service bench and possibly with the safety shield removed, offer many shock hazards to the serviceman and work on the receiver should not be attempted by any one who is not familiar with the necessary precautions while working with high voltage circuits and picture tubes.

The following safety regulations should be observed at all times while servicing television receivers.

### **Precautions when Working with High Voltage**

1. Respect high voltage circuits and keep away from them.
2. Do not depend upon interlock switches for protection, always disconnect the power cord if any possible danger exists. Interlock switches are not foolproof.
3. Do not attempt to change tubes or make adjustments in the high voltage circuits when the receiver is turned on.
4. Always use a long-handled well insulated screwdriver to short circuit the large capacitor terminals to ground before working on them.
5. Do not attempt to operate the receiver with the high voltage compartment shield removed.
6. Do not attempt to reach within the cabinet while the interlock switch is closed to effect some minor adjustments.

CHAPTER 39

# Trouble Shooting

In order to facilitate the trouble shooting procedure the following trouble shooting charts are given. The *charts* are subdivided according to the *symptoms* as they affect the *picture* or *sound* so that it is an easy matter to find the symptoms observed on the particular receiver. The *second column* of the charts indicate the part or section to be checked. Circuit components referred to in the text matter are shown on pages 838, and 839.

### Picture Quality Defects\*

<i>Symptom</i>	<i>Check</i>	<i>Refer to</i>
1. No picture, no raster, no sound.	a. Power supply.	
2. No picture, no raster, sound normal.	a. Picture tube. b. High voltage power supply. c. Ion trap.	
3. No picture, no sound, raster normal.	a. <i>r.f.</i> and video <i>i.f.</i> circuit.	See Note 1. (page 832)
4. No picture, raster and sound normal.	a. Video amplifier.	See Note 7. (page 833)
5. Poor focus.	a. Focus coil. b. Focus coil circuit.	See Pages 749 and 750

\*For picture quality defects see also pages 734 to 746.

## Picture Quality Defects—Continued

<i>Symptom</i>	<i>Check</i>	<i>Refer to</i>
6. Poor focus and picture blooming.	a. For gassy picture tube.	See Note 14.
7. Neck shadow.	a. Focus coil adjustment. b. Ion trap adjustment. c. Yoke assembly adjustment.	See Notes 33, 34 and 36.
8. Ghost.	a. Antenna orientation. b. Antenna lead-in.	See Pages 696, 697 and 720.
9. Snow.	a. Antenna installation.	See Ch. 33.
10. Poor detail.	a. <i>r f.</i> and video <i>i f.</i> circuits. b. Picture control circuit.	See Notes. 1 and 4.
11. Insufficient brightness.	a. Ion trap adjustment. b. Picture tube. c. Pix tube anode or bus voltage.	See Note 34.
12. Excessive contrast.	a. Sync. Section.	See Note 30.
13. Excessive contrast with shaky picture.	a. Sync. Section.	See Note 31.
14. Very bright, fuzzy picture.	a. Picture tube circuit.	See Note 16.
15. No picture on one channel.	a. Channel switch.	See Note 6.
16. Distorted picture.	a. Video amplifier.	See Note 7.
17. Smearred picture.	a. Video amplifier.	See Note 10.

## *Raster Defects*

<i>Symptom</i>	<i>Check</i>	<i>Refer to</i>
1. Raster not centered.	a. Focus coil adjustment.	See Note 33.
2. Tilted raster.	a. Focus coil adjustment.	See Note 33.
3. Excessive raster size.	a. Low anode voltage to pix tube.	
4. Raster width too small.	a. Circuit of horizontal sweep output tube. b. Width control shorted or misadjusted.	
5. Raster height too small.	a. Height control circuit. b. Circuit of vertical sweep output tube.	See Note 37.
6. Unsymmetrical, trapezoidal raster.	a. Deflection yoke position.	See Note 35.
7. Barrel distortion.	a. Deflection yoke position.	See Note 35.

## *Sweep and Sync Defects*

<i>Symptom</i>	<i>Check</i>	<i>Refer to</i>
1. No horizontal or vertical sync.	a. Clipper circuit of V10.	See Note 22.
2. Insufficient sweep width.	a. Horizontal sweep circuit.	See Note 18.
3. No raster, one horizontal line.	a. Vertical sweep circuit, b. Vertical deflection yoke.	See Notes 23, and 35.
4. No raster, one vertical line.	a. Horizontal deflection yoke.	See Note 35.
5. Raster not stable.	a. High voltage power supply.	



**Sweep and Sync Defects—Continued**

<i>Symptom</i>	<i>Check</i>	<i>Refer to</i>
6. Poor horizontal linearity.	a. Horizontal sweep circuit. b. Horizontal linearity control.	See Note 19.
7. Poor vertical linearity.	a. Vertical linearity control. b. Vertical sweep circuit.	See Note 25.
8. Picture not centered.	a. Focus coil adjustment. b. Horizontal sweep circuit.	See Note 20.
9. Unstable horizontal sync.	a. Horizontal sweep circuit.	See Note 21.
10. Unstable vertical sync.	a. Vertical sync input.	See Note 27.
11. Reduction of height.	a. Height control. b. Vertical sweep circuit.	See Notes 25, 26 and 28.
12. Small picture.	a. Picture tube circuit.	See Note 16.
13. Retrace lines increasing towards top.	a. Picture tube circuit.	See Note 15.
14. Vertical does not sync.	a. Vertical sweep circuit.	See Note 24.

**Audio Defects**

<i>Symptom</i>	<i>Check</i>	<i>Refer to</i>
1. No sound, picture normal.	a. Audio section.	See Note 38.
2. Hum or buzz.	a. Audio section.	See Note 39.
3. Distortion.	a. Crystal Y1. b. Audio <i>i.f.</i> alignment.	

**Miscellaneous Defects**

<i>Symptom</i>	<i>Check</i>	<i>Refer to</i>
1. Sound bars.	a. Picture tube circuit.	See Note 13.
2. Light and dark vertical bars, poor horizontal linearity.	a. Damper tube.	
3. Two heavy black horizontal bars across screen.	a. Power supply (electrolytic capacitor).	
4. Excessive contrast with bright lines on bottom and top.	a. Sync. section.	See Note 31.
5. Picture distorted and reverse action of picture control.	a. Sync. section.	See Note 32.
6. Picture flutters at 60 cycles rate.	a. Capacitor C251 in video <i>i.f.</i> circuit.	See Note 5.
7. Window shade effect.	a. Picture tube circuit.	See Note 16.
8. Barkhausen oscillation.	a. Drive control R369. b. 19BG6 tube.	
9. "Busy background" on trailing edge.	a. Video amplifier.	See Note 8.
10. Black lines across picture.	a. Video amplifier.	See Note 9.
11. Very bright picture with black lines.	a. Video amplifier.	See Note 11.

## NOTES ON TROUBLE SHOOTING

### (RF and Video IF Circuit)

1. Misalignment of *r.f.*, video *i.f.* stages or sound traps will cause poor picture detail. If some stages are totally detuned, the signal might not get through at all, failing to produce a picture.
2. If the oscillator circuit fails to produce the required frequencies, no *i.f.* signal is formed and no signal will get through: No picture and no sound will be the result. Any defective component in the oscillator circuit may have this effect.
3. Any interruption of the signal path through the *r.f.* and video *i.f.* stages will result in a distorted picture or no picture at all. The location of an open component is easily accomplished by methods used in radio service work.
4. An overloading of the stages will result in loss of picture detail; check picture control circuit.
5. In case the capacitor C251 is short circuited, sound bars will appear in the picture, and trailing white shadows. If this capacitor opens up, the picture will flutter at a 60 cycle rate and at minimum picture control audio motor-boating will start.
6. A defective channel switch will result in intermittent reception of one channel or in extreme cases a channel might be interrupted completely. Clean switch with a cleaning fluid or bend the contacts to increase contact pressure. In some cases it is best to replace head-end unit.

**Video Amplifier**

7. If the path of the signal within the video amplifier is broken, the picture will be distorted or wiped out completely. This may be caused by open chokes, L259, L261, L262 or coupling capacitor C268.
8. Misalignment of the 4.5 mc trap will cause a "busy background" effect on the trailing edge of the picture.
9. If choke L264 or coupling capacitor C275 is open, there will be always enough coupling capacity to carry along at least a fraction of the signal. The resultant picture will have black lines across it.
10. Open or shorted resistances are easily located. Before resistors open up completely, they often show high resistance value. If this happens with the resistors R269 and R272 the effect will be a smeared picture. A high resistance of R273 will cause picture distortion at high values of picture control.
11. A shorted capacitor C275 will have the following effects: The picture is very bright with black lines across it. Brightness control does not reduce the brightness.

**Picture Tube Circuit**

12. A defective picture tube can be the cause of a faint picture, a distorted and unsteady picture or no picture at all.
13. Parts of the electron gun structure might vibrate under the influence of a strong loudspeaker output, resulting in sound bars in the picture.
14. A gassy picture tube will cause a blooming picture which is out of focus.

15. In case the capacitor C279 on the cathode of the picture tube breaks down, a high voltage will be right on the cathode blanking out the picture. If this capacitor opens up, horizontal lines appear on the picture increasing towards the top.
16. A leaking capacitor C278 will cause a small picture with poor brightness and vertical linearity. If the other capacitor C277 becomes defective, the following effects will occur: A shorted capacitor will produce a fuzzy and very bright picture while an open capacitor will produce a bright horizontal area advancing towards the top with increasing brightness control setting ("window shade" effect).

### **Horizontal Sweep Section**

17. No raster on the picture tube indicates a lack of high voltage or horizontal sweep voltage. This may be caused by a defect in the high voltage rectifier circuit, or in the horizontal sweep output circuit, the horizontal oscillator may not be functioning properly or there may be a short in the horizontal deflection circuits.
18. Insufficient sweep width may be caused by defective components in the horizontal deflection circuits. Check the secondary circuits of T351 for defective components. When L353 is shorted or has shorted turns, the picture will be too narrow and L353 will have no or little control on the width.
19. Poor horizontal linearity may be caused by a short in L352 resulting in L352 having no control on the horizontal linearity. High leakage in capacitor C370 will cause poor linearity and also will increase the width.

20. A short in capacitor C377 will change the *d.c.* component through the horizontal deflection coils which will shift the picture horizontally such that it may not be centered with the focus coil setting.
21. Poor horizontal sync with good vertical sync may be caused by a defect in the circuits of V11, or V12 or-B.
22. No vertical or horizontal sync may be caused by defects in the clipper circuits of V10.

### Vertical Sweep Section

23. The vertical sweep generator contains a multivibrator circuit which is made inoperative by the defects of the following capacitors; shorted capacitor C304, C305 or C308. If the capacitor C305 is open, the oscillator is stopped.
24. The frequency of the generator is thrown off by a short circuit of the capacitors C301 and C302 with the effect that the vertical does not sync.
25. The linearity of the vertical sweep is impaired when the electrolytic capacitor C309 loses its capacity to an appreciable extent. If it opens up completely, the height reduces to approx. one-fifth of the normal size.
26. If the paper capacitor C308 develops any leakage, the vertical size is reduced so that the height control R308 does not suffice to obtain the desired height.
27. In case the capacitor C302 has an open circuit, the vertical sync becomes less stable.

28. If the B+ voltages supplied to the circuit is too low, the deflection voltages will not suffice to deflect the beam across the entire surface of the tube.
29. Microphonic tubes might give rise to a very unstable operation, resulting in a jumpy picture.

### **Common Sync Section**

30. A shorted capacitor C354 on pin 1 of V10 tube will produce excessive contrast which cannot be reduced to normal by the picture control. If this capacitor opens up, both horizontal and vertical sync will be inoperative.
31. An open capacitor C353 on the plate (pin 5) of tube V10 will produce a shaky picture with excessive contrast, while an open capacitor on the grid (pin 4) of tube V10 (C351) will produce bright lines on bottom and top together with poor horizontal and vertical sync which is independent of picture control setting.
32. Distorted picture and reverse action of picture control is caused by an open capacitor C261 on the picture control. If C261 is open, increasing picture control will decrease picture control and vice-versa.

### **Focus Coil, Ion Trap and Deflection Yoke**

33. To obtain good focus and centered raster, the focus coil must be carefully positioned as outlined under "Focus Coil Adjustment," page 749. No sharp picture will be possible with an open or shorted coil. A partial short will throw the picture out of focus. Before looking for obscure trouble, be sure to check the focus control circuit for defective components.

34. The correct adjustment of the ion trap will result in maximum brilliance and at the same time will insure long tube life. For adjustment of this trap, see page 749.
35. Any unsymmetry of the deflection yoke will cause picture distortion. A shorted coil or shorted turns will cause barrel distortion and unsymmetric trapezoidal distortion. An open deflection yoke will produce a horizontal or vertical line across the screen. An open horizontal deflection coil produces a vertical line, while an open vertical deflection coil produces a horizontal line. For deflection yoke adjustment, see page 750.
36. The yoke assembly must be pressed against the bell of the picture tube to avoid neck shadow.
37. The correct picture size is obtained by adjusting the width and height control, as outlined under "Preset or Service Adjustment Controls," pages 739 to 746.

### Audio Stages

38. The FM modulated signal can reach the 1st audio tube only when the two *i.f.* transformers are aligned properly. In localizing defective components, follow normal radio trouble shooting procedure.
39. In case of improper alignment especially of discriminator secondary, a buzz or hum is heard when receiving a television station.
40. In case of no sound output the following components should be checked in turn; tubes, output transformer, capacitors and defective speaker.





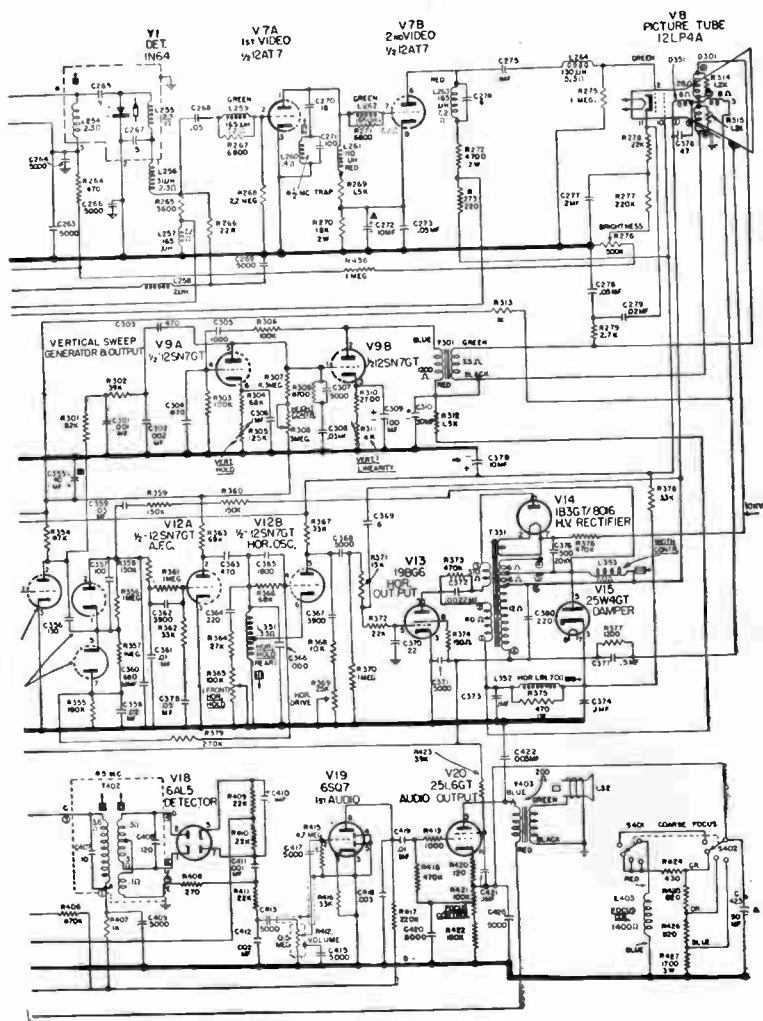

**FIG. 2—**Schematic diagram of *General Electric Model 12T7* television receiver (for continuation of diagram see opposite page).

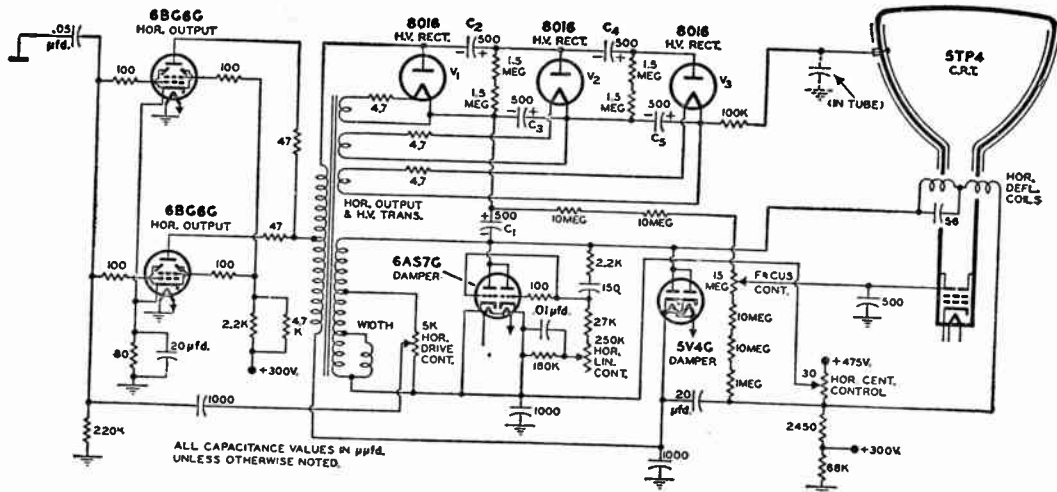

FIG. 3—Circuit diagram of a high voltage flyback power supply unit capable of producing 27 kv. for a projection type picture tube.

**INDUSTRIAL  
ELECTRONICS  
*AND*  
RADAR  
SECTION**



## CHAPTER 40

# Photoelectric Cells

**Light or Photo Sensitive Tubes.**—The fact that certain light sensitive materials emit electrons in vacuum when exposed to a source of light has been known since the time of Hertz, 1887, but the utilization of this phenomena in science and industry in form of the modern photoelectric cell or tube has taken place only during the last eight to ten years.

The modern rugged uniform long-lived phototube has found an extensive use in industry, in fact its employment is limited only by the inventive ability of the user.

Applications in which the phototube is used include photoelectric control, counting, sorting, alarms, the sound-motion-picture industry, illumination control, robot control for ships, etc.

**Light Sensitive Metals.**—It has been found that the light sensitive metal group includes rubidium, lithium, potassium, sodium and caesium. If the surface of a light sensitive metal is exposed to the air atoms at atmospheric pressure or 760 millimeters mercury, the emission of electrons is largely prevented,

but if the metal is put in a vacuum and then exposed to a beam of light the electrons are free to be thrown off the metal into the surrounding space. See figs. 1 and 2.

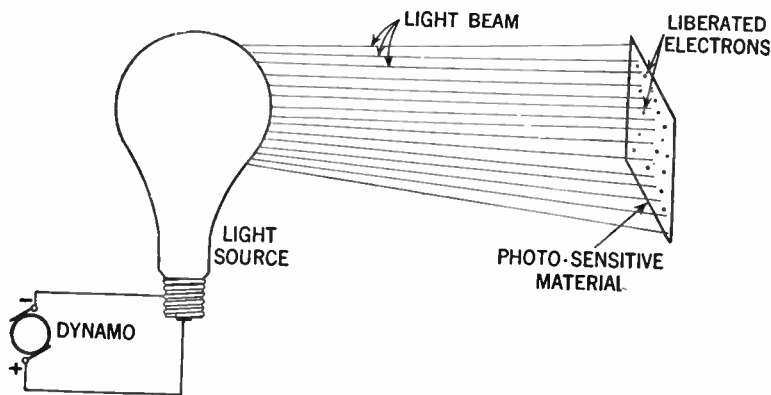

FIG. 1.—Illustrating how a body consisting of photo-sensitive material emits electrons by means of light.

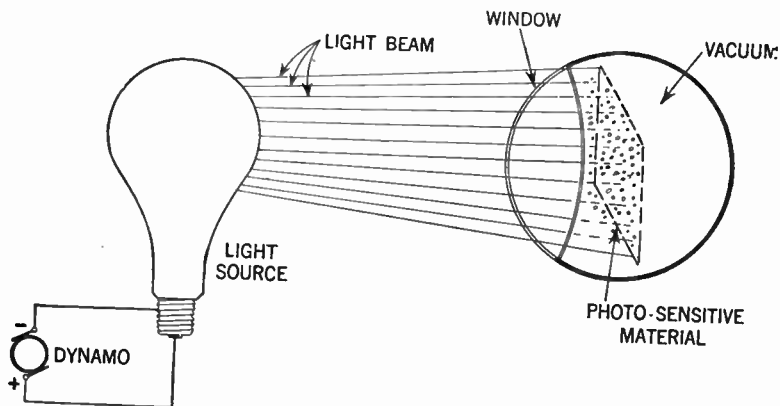

FIG. 2.—The electron emission will be largely increased when the photo-sensitive material is placed in vacuum.

The body which emits or throws off the electrons is called the emitter or cathode, and the body which receives or to which the emitted electrons are attracted is called the anode or plate. It may be mentioned in this connection that the velocity of emission is independent of the temperature of the cathode and is also independent of the intensity of the light with which the cathode is illuminated.

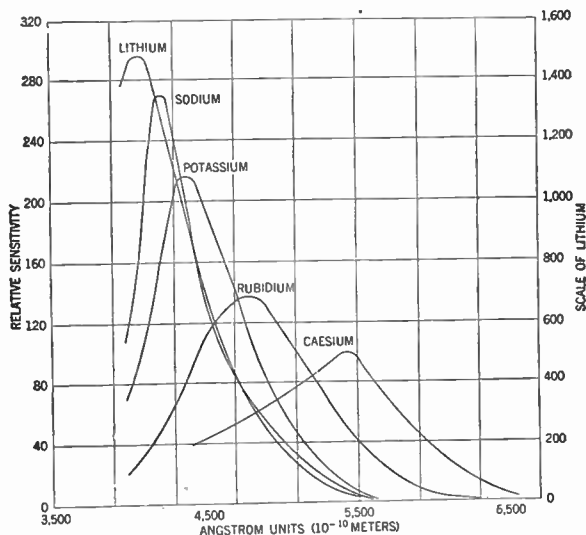

FIG. 3.—Curves showing color sensitivity of various elements.

Therefore, if the intensity of the light is increased, only the number of electrons emitted increases, but their velocity stays the same. The only factor that influences their velocity is the frequency, color or wave length of the light. The higher the light frequency or the nearer the light is toward the ultra-violet end of the spectrum the higher is the speed of the emitted electrons.



It is obvious that when the light source is interrupted the flow of electrons and also the anode current stops.

The sensitivity of phototubes to different light color varies with the type of materials used, but the hydrides and oxides of the metals previously mentioned, have a higher factor of sensitivity than the pure metals themselves, hence are most commonly used.

**Various Types of Phototubes.**—There are at present three general types of photoelectric tubes utilizing light to produce an electric current, known as the *photo-emissive*; *photo-conductive*; and *photo-voltaic*.

**Phototubes of the Emissive Type.**—The photo-emissive tube is essentially a two electrode tube consisting of a semi-cylindrical cathode and a central anode sealed in a glass envelope. The cathode consists of a base metal such as silver with a light sensitive surface, usually caesium oxide, and is the larger element of the two.

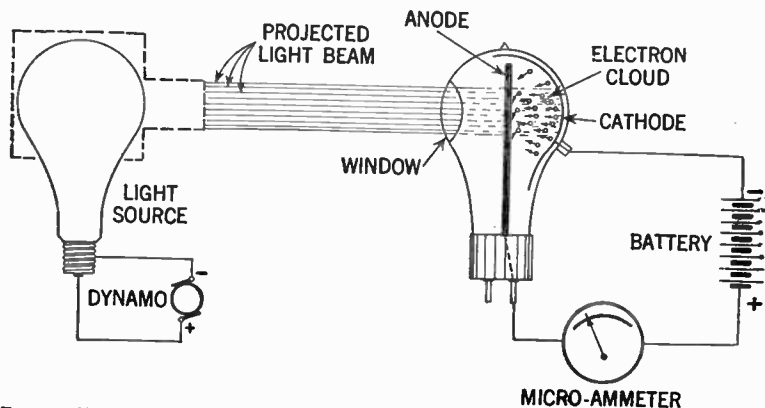

FIG. 4.—Simple phototube circuit. When a strong light beam is projected on the phototube window, the electron emission will be indicated on a sensitive meter.

The anode consists of a straight wire electrode mounted along the axis of the cathode. The action of light upon the cathode results in the emission of electrons from the light sensitive surface, and the electrons which are released by this action are drawn to the anode by virtue of the voltage which is applied between the cathode and the anode. See fig. 4.

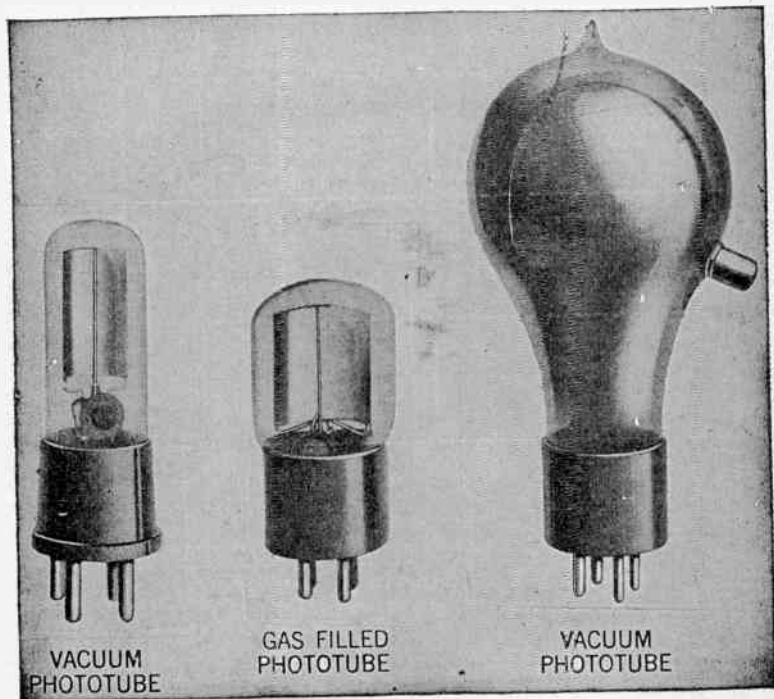

FIG. 5.—Typical phototubes.

These phototubes are made in two different types, namely, vacuum and gas-filled.

The two types are identical as to structure but differ in that

the high vacuum of the vacuum type is replaced with an inert gas of a very low pressure in the gas-filled type. The chief advantage of the vacuum type of phototube is the light-current linear response characteristic; however, the total current consists of only the primary electrons emitted from the light sensitive surface of the cathode.

On account of its *light-current linear response*, the vacuum phototubes are used in measurement and instrument and

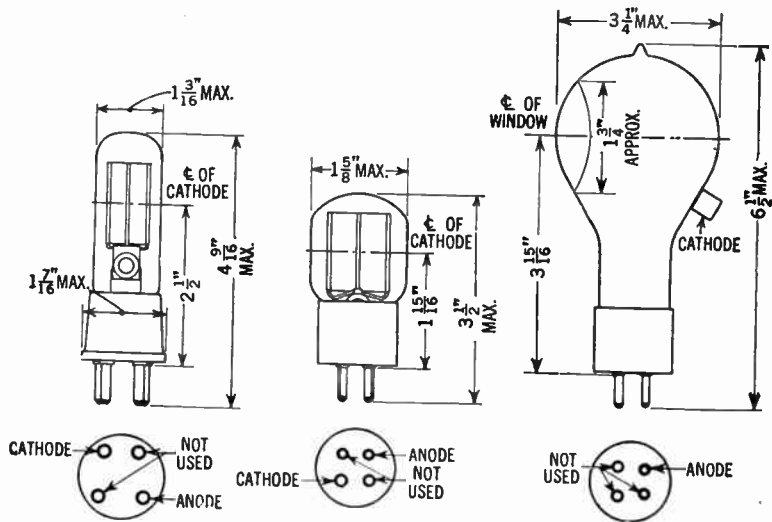

FIG. 6.—External dimension of phototubes shown in fig. 5.

research work where the greatest constancy of characteristics is desired.

In the gas-filled type, greater effective response is obtained due to gas amplification and secondary emission. When the applied voltage is above 25 or 30 volts, the electrons traveling from cathode to anode have sufficient velocity to knock out electrons from gas atoms with which they collide, thus splitting

up the atoms into positive ions and free electrons. The electrons are, of course, attracted to the anode and the positive ions to the cathode, which they may strike sufficiently hard to knock out several "secondary" electrons. Thus these two factors produce an additional current which at higher voltages may be several times the value of the primary electron current.

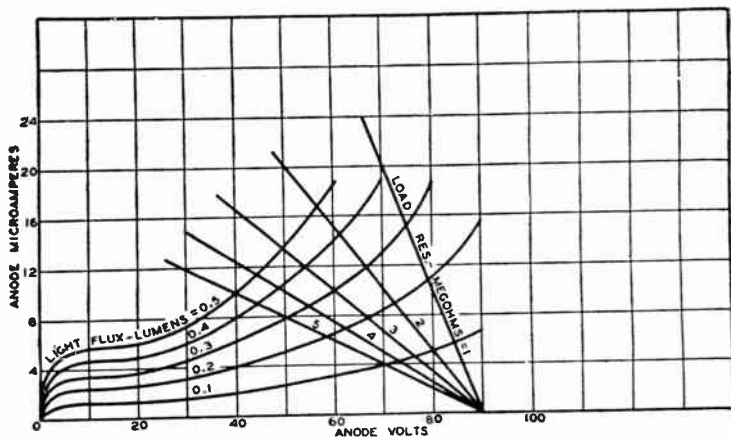

FIG. 7.—Average gaseous type anode characteristics.

The *gas ratio* of a phototube, that is, the ratio of its response at the operating voltage to its response at the voltage where gas amplification begins, for a given illumination, is a measure of the gas and secondary emission amplification. The gas ratio is often taken as the ratio of its response at 90 volts to that at 25 volts with a constant illumination. Care must be taken with gas-filled tubes not to exceed a certain maximum voltage (the value of which depends on the type of tube and the illumination on the tube) or a glow discharge will result which will ruin the sensitive surface. The limits are shown in the accompanying curve of lumens plotted against anode voltage. Anode voltages to the left of this curve are safe values.

**Photo Conductive Tubes.**—The photo conductive tube is a tube which is developed on the characteristics of ohmic resistance changes in certain materials when subjected to the action of light rays.

Selenium, a material discovered by Berzelius in 1817 possesses this peculiar property in that when this substance is illuminated its resistance decreases, permitting the current to increase.

The selenium cell is usually constructed as follows: The selenium surface in the cell is formed entirely in vacuum by a similar process as that of forming the vaporizing metal film in radio tubes. The dry inert gas is admitted during the annealing process. By forming the selenium surface in vacuum, certain defects, such as instability and low efficiency have been largely overcome.

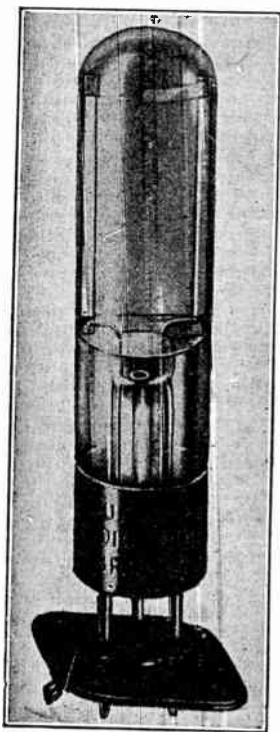

FIG. 8.—The "Burgess" selenium type light sensitive cell.

Several types of selenium tubes of very favorable characteristics are at present in use such as the FJ-31 selenium tube (General Electric Co.), the Burgess Radiovisor Bridge (Burgess Battery Co.), etc. This latest tube is manufactured to operate from 12 to 800 volt with currents from 1 to 250 milliamperes.

**Photo Voltaic Cells.**—In this type the passage of electrons from one surface to another is accelerated by light rays, generating a voltage. This is termed the photo-voltaic effect, and this property is exhibited by certain materials, notably copper oxide, and the cell is often called *the copper oxide photo-voltaic cell*.

One of the advantages of this cell is that since it generates a voltage independently, in most cases an amplifier is not necessary. The cell is able to operate a relay coil directly, but if, however, an amplifier is used, the number of stages required are less than is the case with the photo-emissive type.

## GENERAL COMPARISON OF THE THREE TYPES OF LIGHT RESPONSIVE TUBES

**Photo-Emissive Tubes.**—As a comparison between the three classes of photo-sensitive tubes it can generally be said that photo-emissive tubes have: 1. A high responsivity towards the red end of the spectrum and is therefore suited for operation with the incandescent lamp. 2. High speed—they are practically instantaneous in operation. 3. Relatively high impedance resulting in a high voltage output.

The limitations are: 1. Current generated is low;—maximum output is only about 50 micro-amperes (millionths of an ampere); and they cannot therefore at present operate a relay coil without an amplifier.

**Photo Conductive Tubes.**—The advantages of these types are:

1. They can be operated at low voltage.
2. Some types generate a relatively high current. In some cases the current is sufficiently large to operate a sensitive relay without amplification.
3. They can be made very sensitive towards the infra-red band of the spectral region.

Their limitations are:

1. They are sluggish, *i.e.* have a great time lag.
2. Some types are unstable.
3. They have a rather high temperature coefficient.

**Photo-Voltaic Tubes.**—1. They have the advantage to be able to operate independently without outside source of power and is therefore adaptable in portable use where a normal voltage source is not available.

2. They generate a comparatively high current and can therefore operate a relay coil without an amplifier provided a sufficient change in illumination intensity is available.

3. Several cells can be connected in series or parallel.

4. Its spectral response is similar to that of the human eye.

The limitations of these types are:

1. In respect to operation the time lag is considerable.

2. The output is not readily adaptable for amplification by the usual vacuum tube method.

3. The relays required are rather expensive as they must be designed for a low torque, and therefore has a low contact pressure.

Because of the fact that phototubes are used extensively in various industrial applications and in photometry with the incandescent lamp, whose light is largely towards the red end of the spectrum, the research laboratories have directed their energies towards making the tube of maximum sensitiveness towards the red and infra-red side of the spectrum.

In industrial control applications the gas filled phototube is quite extensively used due to its greater sensitivity, whereas as already described the vacuum tube is frequently used in connection with measurement of intensity of light, etc., because of greater linearity.



## COMPARISON OF PHOTO-ELECTRIC TUBES IN VARIOUS SPECTRAL REGIONS

**Response in the Infra-Red or Heat Wave Region.**—The range of sensitivity of various photo-electric devices extends from 2,000 Angstrom in the ultra-violet region to approximately 20,000 Angstrom in the infra-red or heat wave region. In practice, one need not expect any useful response beyond 12,000 Angstroms in cesium-oxide phototubes. It seems doubtful at present if more than a mere trace of photo-electric effect will ever be experimentally realized for the infra-red region beyond, say, 30,000 Angstroms. Quite possibly dependence will have to be placed on thermal devices such as thermocouples and bolometers for the heat waves.

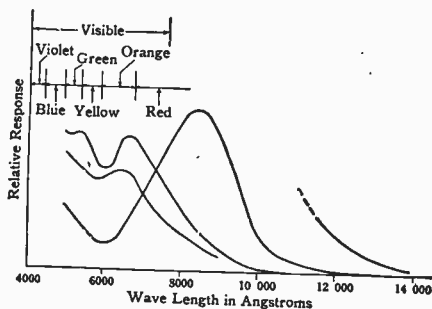

FIG. 9.—Spectral characteristics for various caesium-oxide phototubes, showing their penetration into the infra-red region.

Spectral curves for some experimental cesium-oxide phototubes are given in fig. 9. In the region from 7,000 to 14,000 Angstroms such tubes can be conveniently used to measure or to be actuated by infra-red light. A cesium-oxide tube, together with a visibly opaque, infra-red transmitting filter, such as Corning glass No. 254, Jena glass No. RG-9 or Wratten No. 87, comprises a unit sensitive only to the region just

defined. As tungsten lamps radiate maximum energy in the same region, an efficient system for an invisible burglar alarm is readily suggested.

Both selenium and copper-oxide photocells can be made to have near infra-red response, although generally the selenium cell is more red sensitive as seen in fig. 10, where curves for typical copper-oxide, selenium cells and the human eye are shown together.

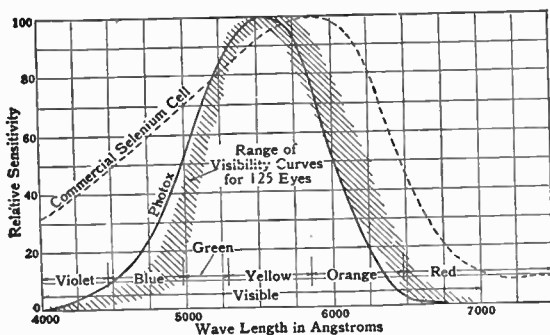

FIG. 10.—Spectral characteristics for selenium and copper oxide cells as compared to the range of sensitivity to that of the human eye.

**Response in the Region of Human Visibility.**—In the visible spectrum it becomes convenient to evaluate light intensities in terms of visibility. Hence it is highly desirable to employ a light-sensitive device whose spectral response closely resembles that of the eye; copper-oxide photocells can be made with natural response amazingly close to the average eye. In general copper-oxide cells tend to be somewhat shy in red response, while selenium cells have excess sensitivity in both red and violet.

However, by the use of a suitable filter, at the expense of sensitivity, the selenium cell can always be made equivalent to the eye. Also it is becoming apparent that the selenium

curve can be shifted by admixture of other elements into the selenium. In any event, for the visible spectrum, the photocell affords the long sought light measuring analogue to the temperature measuring thermocouple.

In devices such as color matchers or color analyzers in which it is necessary to obtain comparable responses in all parts of the visible spectrum, one should have a light sensitive unit at least as responsive to violet as it is to other colors. In fact, since the tungsten lamps, which serve as light sources, are notoriously weak in violet radiation compared to red, it is highly desirable to use a light-sensitive unit more sensitive to violet and blue than to red.

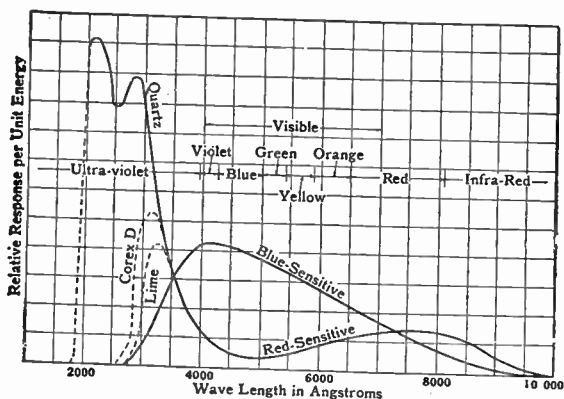

FIG. 11.—Spectral characteristics for two types of caesium-oxide phototubes, illustrating the effect of the envelope on the response.

The normal caesium-oxide tube is relatively weak for blue light, as fig. 11 shows. Fortunately it is possible to modify the manufacturing schedule so as to obtain a blue-sensitive tube that is almost ideal for the application. Superfluous infra-red response can be conveniently removed by means of an infra-red absorbing filter such as Corning Aklo glass.

**Response in the Ultra-Violet Region.**—It is probably a general impression that cesium-oxide cathodes have a sharp maximum of response in the near ultra-violet. This peak, however, is only apparent as is shown in fig. 11. The sharp cut-off on the short waves is caused by the absorption of the glass envelope. Putting the cathode in a Corex D envelope, which is more transparent to ultra-violet, the curve is seen to shift.

If the cathode is mounted in a quartz blank, it appears that the normal or red-sensitive cesium-oxide cathode is super-sensitive to wave lengths at least as short as those transmitted through quartz. Such a tube is doubtless the most sensitive device known for measuring ultra-violet light between 2,000 and 3,000 Angstroms.

When it is desired to measure a limited portion of the ultra-violet spectrum, one is encountered with the embarrassment of choosing proper filters to exclude all radiations not of interest and to transmit these radiations in which interest is centered. For example, if radiations of the erythema region (2,800 to 3,200 Angstroms) are to be measured, a first approximation can be had by using a cesium-oxide cathode in Corex D in addition to a filter such as Corning Red Purple Corex 986. A second approximation results from the addition of a liquid filter consisting of a nickel-sulphate solution.

Ultra-violet response is limited by the combination to the region 2,600 to 3,700 Angstroms, but unfortunately both the Corex 986 and the nickel-sulphate are transparent to infra-red light between 8,000 and 9,000 Angstroms, light to which the cesium-oxide surface is notably sensitive.

One method of obviating this difficulty is illustrated in fig. 12. The continuous curves give the spectral response for a cesium-oxide surface in Corex D, and lime-glass envelopes respectively. The dashed curve represents the difference

between the other two curves. Thus if a cesium-oxide surface in a Corex D envelope is exposed alternately through Corex D and lime-glass filters to general radiation, the variable component of the tube response will be a measure of the intensity in the erythema region. By suitable choice of glass for the envelope and filters, any spectral region can be similarly isolated and measured. The filters can, in practice, be made as alternate sectors of a disc rotated with proper frequency in front of the tube.

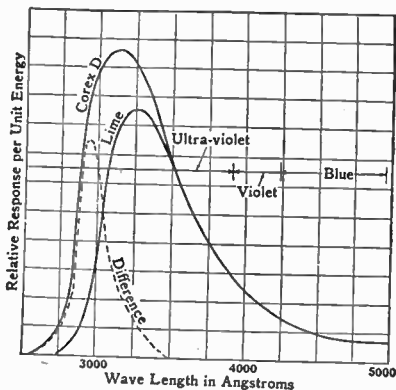

FIG. 12.—Spectral characteristics for a caesium-oxide phototube.

An inherent difficulty of application of this principle, particularly when the energy of the region to be measured is small compared to the total energy of the incident light, is the same as that always encountered in any attempt to detect a small difference between two large quantities. For example, it may be difficult to prevent saturation in the input circuit of an associated amplifier; or in obviating saturation, instability may be introduced. However, the method is feasible and should often prove useful.

Doubtless a better method for measuring isolated regions in the ultra-violet is provided through the use of special ultra-violet phototubes. These tubes consist of pure sputtered films of various metals enclosed in envelopes of Corex glass or quartz. Although their current sensitivity is relatively low, they have the distinct advantage of having their total response confined to quite narrow spectral regions of the ultra-violet, being entirely insensitive to any other light. The long-wave limit is defined by the threshold frequency of the particular metal involved while the short-wave limit is fixed by the absorption characteristics of the envelope.

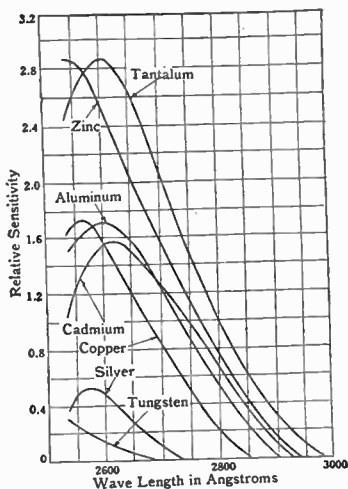

FIG. 13.—Spectral characteristics illustrating the changes in the threshold frequency in the ultra-violet for several metallic cathodes.

Typical spectral curves for such tubes are given in fig. 13. It is apparent that practically any desired region can be isolated by suitable choice of metal and envelope.

The selenium type of photocell exhibits a certain amount of direct response to ultra-violet light, and any type of cell can be made responsive to ultra-violet by use of contiguous fluorescent screens and suitable combinations of filters. Even Roentgen radiations can be conveniently measured by such a combination of fluorescent screen and photocell.

**The Weston Photronic Photoelectric Cell.**—This cell was first introduced in Weston illumination intensity meter in 1930, and has found a wide variety of practical industrial applications.

It consists essentially of a thin metal disc on which there is a film of light-sensitive material. The metal disc forms the positive terminal and a metal collector ring in contact with the light sensitive surface forms the negative terminal.

The cell is contained in a case having a window of glass or quartz depending upon whether the cell is to be used only in the visible or infra-red regions of the spectrum or in the ultra-violet.

It is very compact as there is no separate anode and collector plates or evacuated space as in the usual form of photoelectric cells. A typical photronic photoelectric cell is shown in fig. 14.

The action of the light impinging upon the sensitive surface is entirely electronic, and according to Weston engineers, the tests made indicate that no chemical or physical change takes place during its operation, therefore the life of the cell seems to be unlimited, if operating rules are observed.

The current output varies as usual with the illumination on the cell and also with the external resistance connected to it as shown in chart 15. The output is linear for low resistances;

however, this is not true for higher external circuit resistances, due to the fact that the cell resistances decreases with increasing illumination and current output.

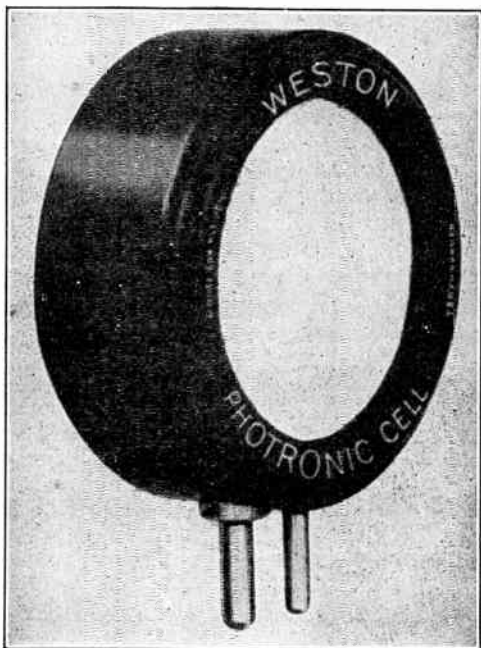

FIG. 14.—A typical "Photronic" photo-electric cell. (Courtesy of Weston Electric Company).

The current output is approximately 1.4 microamperes per foot candle of illumination, or 120 microamperes per lumen. The area of the sensitive surface is 1.8 sq. ins.

An interesting and useful property of this cell is that when connected to low external resistance circuit, it is not necessary to distribute the illumination uniformly over the exposed disc, as the current output per lumen is almost independent of the area of the disc exposed.



For example a lumen of luminous flux concentrated on say a circle of  $\frac{3}{4}$  inch in diameter, will result in approximately the same microampere output as if a lumen were uniformly distributed over the entire area. This may be explained by the fact that the resistance of the unexposed portion is very high compared to that of the exposed portion, so that the shunting effect becomes negligible.

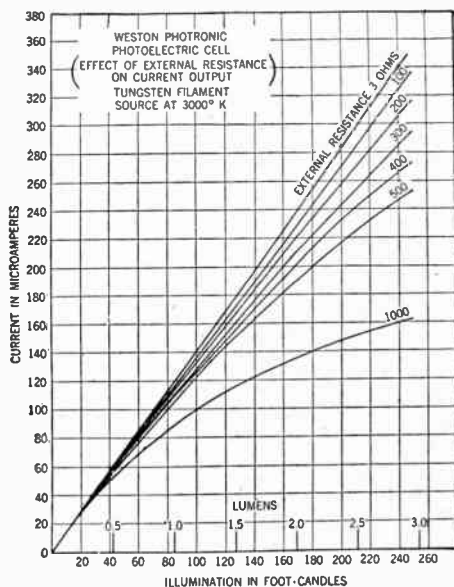

FIG. 15.—Effect of external resistance on current output.

**Series and Parallel Operation.**—The cells may be connected in series or parallel and the effect when so grouped is approximately the same as for the voltaic type cells, remembering, of course, that the resistance is not constant, but is rather a function of both the current output and the intensity of illumination. However, since the cell resistance for low light intensity

is relatively large, there is no practical gain in current output by connecting the cells in series, since each cell adds resistance in approximately the same proportion as it adds e.m.f. When connected in parallel, the combined internal resistance diminishes, resulting in greater current output.

The suitable number of cells to be used in parallel operation for any particular requirement depends upon the intensity of illumination and sensitivity and resistance of the indicating instrument used, and is usually best determined by experiments.

The internal resistance of the cell is not constant, but varies with the illumination of radiant flux, and also upon the leakage current through it. It is of the order of 2,000 to 6,000 ohms decreasing with an increase in illumination and current output. See chart 16.

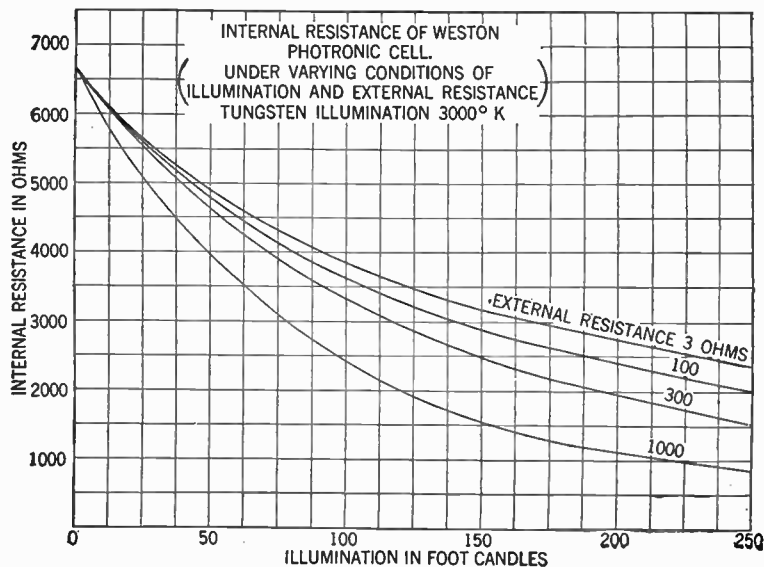

Fig. 16.—Effect of external resistance on internal resistance of the cell.

The frequency response of the cell diminishes with increasing frequencies due largely to the shunting effect of the internal capacitance of the cell, which is about 0.5 microfarad. If the response at 60 cycles is assumed at 100%, that at 120 cycles will be about 58% and at 240 cycles about 30% and finally at 1000 cycles approximately 6.4% and so on as the frequency is increased.

Therefore, this type of cell is not suitable for use in, for example, talking pictures where audio frequencies are employed, or in television work, where similarly high frequencies are encountered.

The speed of response is very rapid, in fact it may be considered as instantaneous. It has been found by tests that the response is sufficiently rapid to record the passage of a rifle bullet through a beam of light incident upon the cell.

When it is desired to amplify the current output, it is recommended to "chop" the illuminating source by a suitable sector disc or by other means, at a frequency of say 60 impulses a second, and then amplify the alternating current derived from the pulsating current output by an audio frequency amplifier.

## CHAPTER 41

# Phototube Amplifiers

**Methods of Current Amplification.**—Since the current generated in most photocells is very low and is usually measured in microamperes, it is evident that for practical operation a way must be found to increase this feeble current, for practical relay operation.

Therefore in order to increase the power output of the photocell a method of amplification very similar to that associated with radio circuits is employed.

The amplifier tubes may be of the high vacuum or of the gaseous type. When the photocell is connected to an amplifier circuit the current can be measured in milliamperes instead of in micro-amperes, as previously, i.e. the current is now one thousand times larger than before.

Two types of photo circuits are shown in figs. 1 and 2. Fig. 1 shows a simple circuit in which the current is measured in micro-amperes and fig. 2 shows an amplifier circuit where the current is measured with a milli-ampmeter.

The amplification can be arranged as required in various ways

so as to give the necessary size of current variation for proper functioning of accessory apparatus.

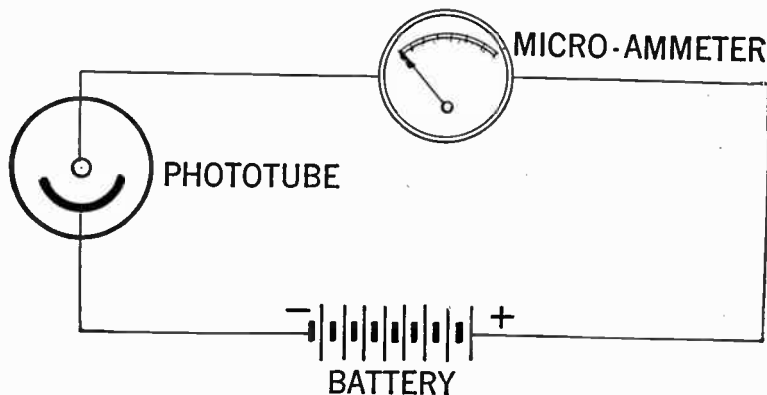

FIG. 1.—Photo-electric cell circuit. When the photocell is connected as shown, the current is too small for practical use.

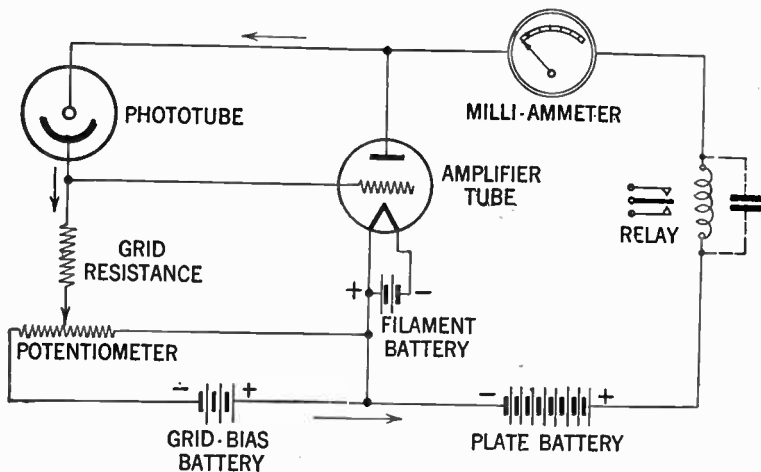

FIG. 2.—Simple battery operated one stage amplifier circuit for use with a photo-electric cell. When the photo-electric cell is connected in this manner the current will operate a sensitive relay.

For example there are single stage amplifiers of type as shown in fig. 2, multi-stage amplifiers, amplifiers designed for direct current operation, and amplifiers for A.C. operation.

The amplifier tubes may be connected to the photocell in such a way so as to increase or decrease the relay or output current when the amount of light on the phototube is varied. Sometimes a circuit connected to increase the output current of the amplifier tube when the light rays on the phototube increases, is called a *forward circuit*, and a circuit connected to decrease the current output of the amplifier tube when the illumination of the phototube increases is called a *reverse circuit*. See figs. 3 and 4.

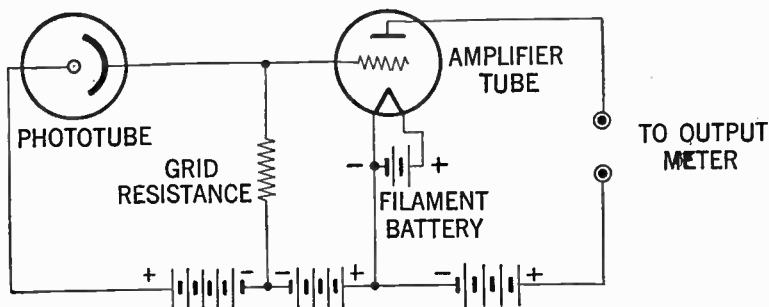

FIG. 3.—Typical battery operated amplifier. *Forward* circuit for phototube operation.

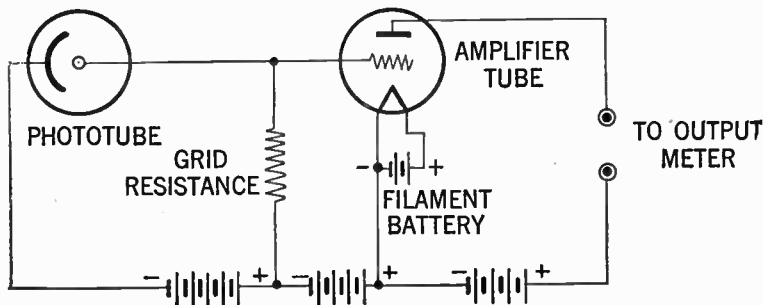

FIG. 4.—Typical battery operated amplifier. *Reverse* circuit for phototube operation.

As seen from the diagrams there is a striking similarity between the two circuits. The forward circuit is more commonly used than the reverse circuit, which is frequently used when the voltage supplied to photocell equipment and the light source is unstable or variable.

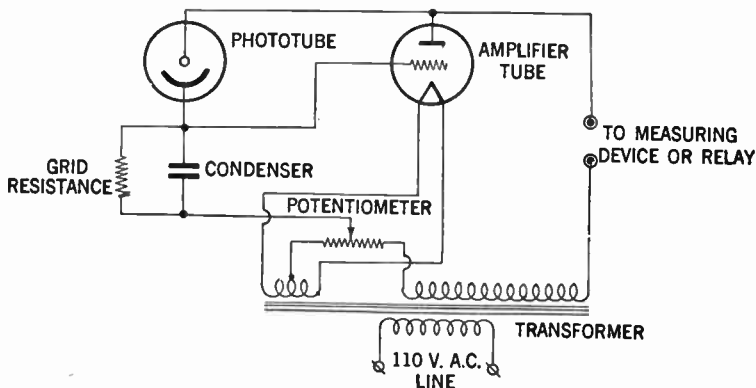

FIG. 5.—Typical A. C. operated amplifier. *Forward* circuit for phototube operation.

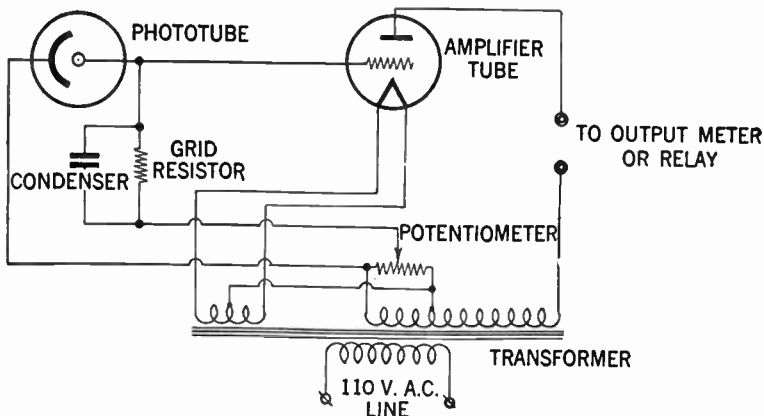

FIG. 6.—Typical A. C. operated amplifier. *Reverse* circuit for phototube operation.

Similarly a forward and reverse circuit may also be operated from an alternating current amplifier. See figs. 5 and 6.

**The Function of Grid Resistors in Amplifier Circuits.**—When comparing the phototube amplifier circuits it may be noted that the grid resistance is common to all circuits. Because of the fact that even when amplified the phototube current is very small, and in order to procure a voltage drop of a size to give the needed change in grid voltage, the grid resistor is necessary, and must be of very high value, usually from 10 to 200 megohms.

It is evident that by increasing the grid resistance we also increase the sensitiveness of the amplifier, but at the same time the amplifier tends to be unstable. Therefore it is considered good practice to compromise between stability and sensitivity, and the grid resistor must obviously be of a size to suit other values of the circuit.

**Type of Current for Phototube Amplifiers.**—1. *Use of Direct Current.* Where very great sensitiveness is required a direct current amplifier is preferred. In this type the output current of the amplifier per unit of illumination on the phototube is direct proportional to the product of sensitivity of the grid resistance and the phototube.

Instead of operating from "A" and "B" batteries it is often preferable to secure the voltage direct from, for example, a 110 V. direct-current source.

One of the disadvantages in this case is that in order to obtain the filament voltage it is necessary to place a certain amount of resistance in the circuit, in which a considerable amount of heat is dissipated, therefore this type is uneconomical.

One other disadvantage is that only a limited potential is available to the amplifier plate circuit.



2. *Use of Alternating Current.*—Because both the phototube and the amplifier tube are half-wave rectifiers, it is possible to operate the amplifier directly on alternating current, and on account of its great flexibility alternating current is most commonly employed in phototube amplifiers for industrial purposes. Direct current is preferred as previously noted where great sensitiveness is desired, for example in measuring laboratories, etc.

**Multi-Stage Amplifiers for Phototubes.**—In general there are three types of multi-stage amplifiers in use with phototubes (although the circuits may be modified to suit individual requirements) classified as: 1. *The transformer-coupled.* 2. *The condenser-coupled.* 3. *The resistance-coupled amplifier.*

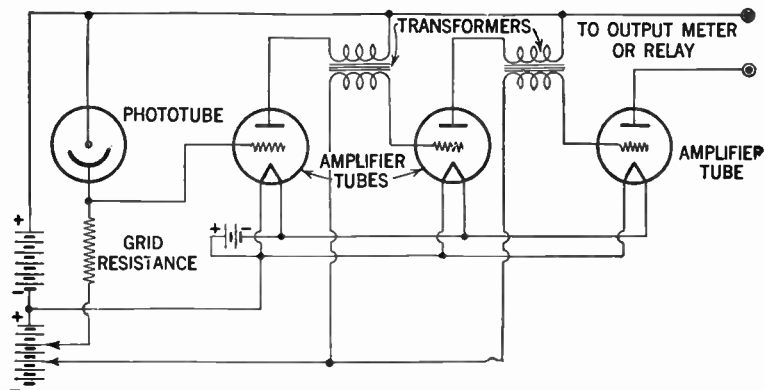

FIG. 7.—Transformer coupled multi-stage amplifier for use with photo-electric tube.

**Transformer Coupled Multi-Stage Amplifier.**—A typical transformer-coupled multi-stage amplifier used with phototubes is shown in fig. 7.

The effect of the transformers is to prevent the plate voltage of one stage from influencing the grid voltage of the successive stages. The amplification factor in this type may be from 20 to 200 per stage, depending on type of tubes used.

**Condenser-Coupled Multi-Stage Amplifier.**—A condenser-coupled amplifier is shown in fig. 8.

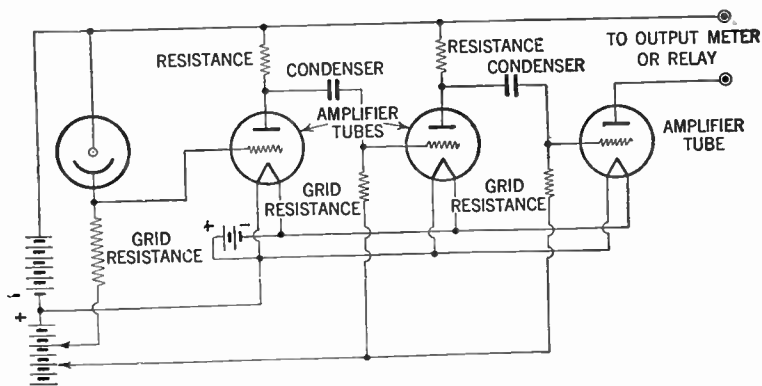

FIG. 8.—Condenser-coupled multistage amplifier for use with photo-electric tube.

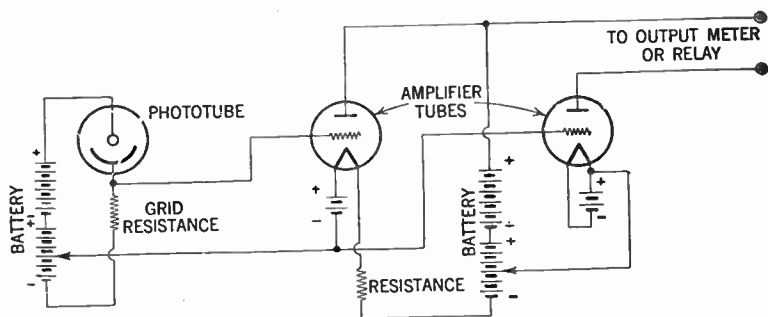

FIG. 9.—Resistance-coupled multistage amplifier for use with photo-electric tube.

Instead of transformers used in the preceding amplifier circuit, between the plate and grid, a condenser is used in this circuit.

This type of connection is commonly employed where it is necessary to amplify very low frequencies.

**Resistance Coupled Multi-Stage Amplifier.**—The type of circuit shown in fig. 9 is often used when it is needed to obtain amplification of ripless D.C. current.

The number of stages, however, are limited on account of amplification of certain variation in first-stage tube characteristics.

**Alternating Current Amplifier for a Vacuum-Type Phototube.**—A typical A.C. multi-stage amplifier for measuring or relay operation is shown in fig. 10 using R.C.A. tubes Nos. 38 and 43 as amplifier tubes and type No. 25Z5 as rectifier tube.

When the vacuum type phototube is connected as shown in solid lines the output current of the 43 is greatest for maximum illumination of the phototube, and with the phototube connected as shown in dotted lines, the output current is greatest for minimum illumination.

In order that best results may be obtained from this circuit, it should be adjusted so that the grid potential of No. 43 stays between zero volts and cut-off bias for all values of illumination on the phototube.

For the connection shown in solid lines, the adjustment can be made as follows: Set  $P_3$  at the positive end of  $R_3$  and  $P_1$  and  $P_2$  at the positive end of  $R_4$ . Then move  $P_1$  towards the negative end of  $R_4$  until the  $IR$  drop across  $R_2$  due to plate current of the 38 brings the 43 to zero grid bias. As the movement of  $P_1$  is started no effect is produced on the output meter read-

ing. When the movement begins to effect the meter reading, the 43 is approximately at zero bias and  $P_1$  has the correct setting.

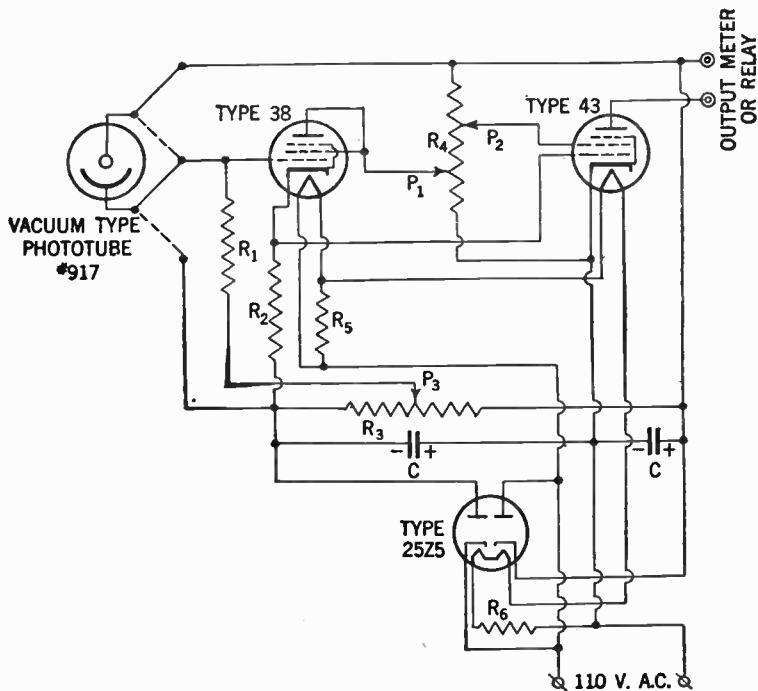

FIG. 10.—Typical amplifier circuit for use with vacuum-type phototube.

$C = 8 \mu f$ ;

Output meter or relay (0-25 MA);

$R_1 = 100$  megohms;

$R_2 = 0.5$  megohm;

$R_3 = 0.1$  to 2.0 megohm;

$R_4 = 0.1$  megohm;

$R_5 = 50$  ohms (1 watt);

$R_6 = 190$  ohms (20 watts).

Then adjust the screen voltage of the 43 by means of  $P_2$  to give the desired maximum value of output current. Next set the illumination of the phototube at zero and move  $P_3$  toward the negative of  $R_3$  until the output current has the desired minimum value.

For the connection shown in dotted lines, a similar procedure may be followed. First, with the illumination of the phototube at zero bring the 43 to zero grid bias and adjust the output current to have the desired maximum value by the same steps as described above. Then with the illumination of the phototube at the maximum value which is to be encountered in practice, adjust  $P_3$  to give the desired minimum value of output current.

## CHAPTER 42

# Phototube Relays

Since as already described the current change accomplished in photoelectric cells is very small, it is necessary to employ an amplifier in order to receive a current of sufficient strength to operate a relay.

When selecting a relay for operation in a photoelectric circuit, it is of course necessary to be informed about the characteristics of the circuit, speed of operation, etc.

It is also important that the relay employed is able to carry the load to be operated across its contacts without damage.

A relay generally is defined as a form of electro-magnet; when a current is passed through the wire surrounding the iron core, this latter becomes magnetized and will close or open a contact placed close to the core.

If the relay is designed to close a circuit, it is often referred to as a "circuit closing relay" or when designed to merely open the circuit as a "circuit opening relay."

With respect to its function a relay may be considered as a form of electrical multiplier in that a weak current in one of the circuits controls a strong current in the other.

The type of relays most commonly used in photoelectric circuits for commercial purposes are usually referred to as the communication type or simply "telephone relays." This type will operate at approximately 5 milliamperes, and the maximum current the spring contacts will carry is about 250 milliampere, i.e. the current flowing in the circuit it is desired to control, should not exceed  $\frac{1}{4}$  of an ampere.

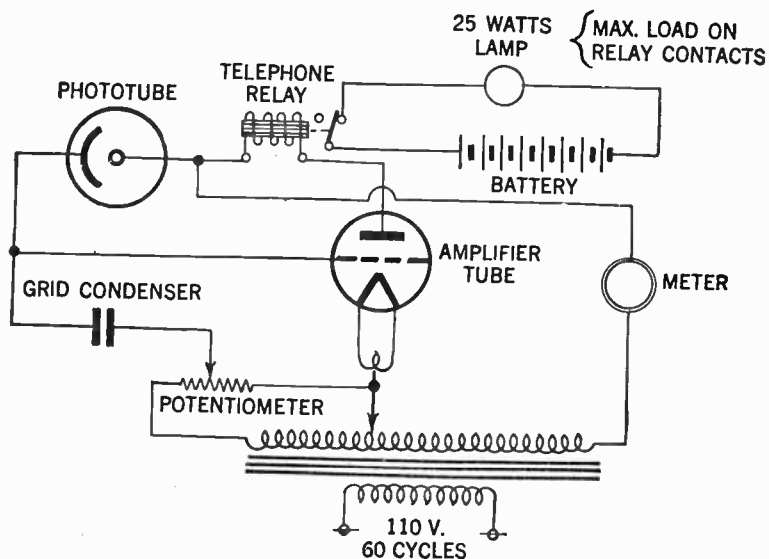

FIG. 1.—Circuit illustrating approximate maximum current to be carried over contacts of a communication type of relay.

In many cases this amount of current is insufficient and the telephone relay is used to energize a larger relay carrying 10 to 15 ampere. The limitation of a telephone type relay and method of connection when an additional relay is used, is shown in figs. 1 and 2.

There is at present a great multiplicity of special purpose relays developed suitable for photoelectric circuits, some of which have very desirable characteristics. Sometimes a combination of a photocell and amplifier is referred to as a light relay, or photomatic light relay. In this type the amount of light on the cell can be varied by inserting plates of various apertures. Other types are known as controlled rectifier relays, photoroller relays, etc.

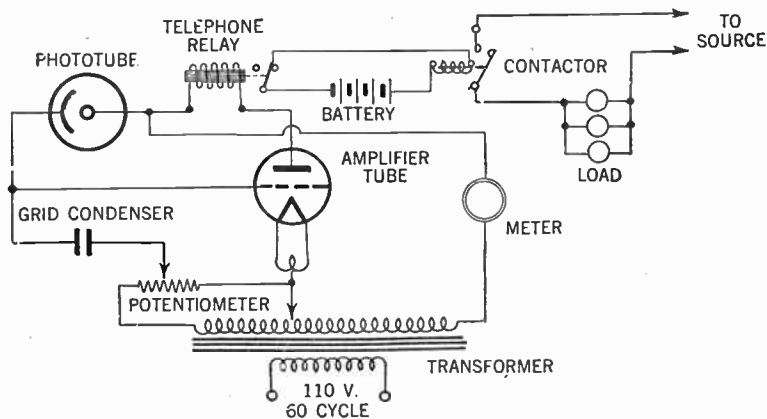

FIG. 2.—Circuit showing typical connection when it is necessary to operate a larger load than is possible when using only a communication type relay.

A relay of the type described in fig. 1 is capable of operating on a few milliamperes output of the amplifier, however, it cannot control any large amount of power directly, nor even the operating coil circuits of medium size contactors or solenoids.



**A High-Speed Light Relay.**—Photographic illustration of a typical and compact photoelectric relay unit is shown in fig. 3 and its circuit diagram in fig. 4.

This relay is able to carry approximately one ampere across its contact tips at 115 volts (non-inductive). It operates with a minimum illumination of 5 foot candles on the phototube and upon a 50% change in light which lasts for not less than 0.066 second when operated from a 60 cycle source, and will operate up to 400 times per minute.

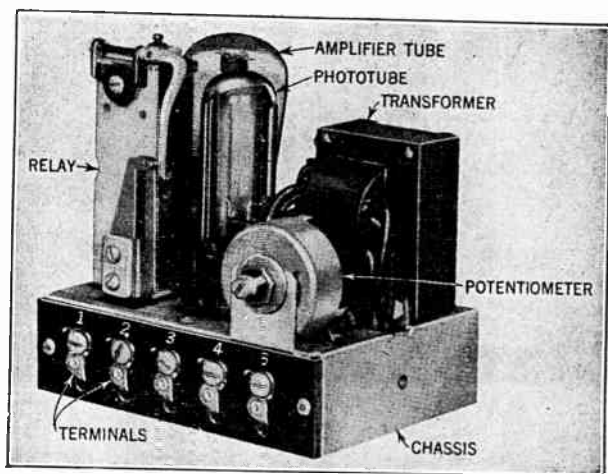

FIGS. 3 and 4.—An A. C. operated photo-electric relay and connection diagram. A relay of this type may be used in automatic weighing processes; in machines for grading ball bearings; for the automatic inspection of vent holes in battery caps, and in many other applications.

The operation of this relay is as follows:

When terminal *A* of the transformer secondary is positive, both the triode amplifier tube and phototube anodes are negative, hence no current flows in either circuit inasmuch as electron tubes are inherently rectifiers.

However, if  $C_1$  be considered to have zero charge the grid of the amplifier tube will be positive when terminal  $A$  is positive and grid current, limited by grid resistor will flow to charge grid capacitor  $C_1$  in the sense indicated on the diagram. Upon reversal of the a.c. voltage, the amplifier tube and photoelectric tube anodes become positive, but the amplifier tube grid is negative by an amount equal to the charge of the capacitor plus the voltage from terminal  $A$  to the slider of the potentiometer and, therefore, no current flows in the amplifier tube anode circuit.

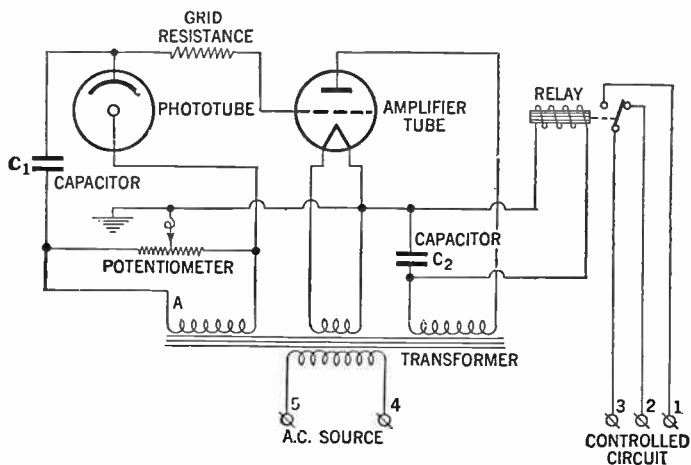

FIG. 4

If there be light on the photo-electric tube, current passes through it to the capacitor in the direction which tends to discharge the capacitor and charge it in the opposite sense. As the voltage across the capacitor decreases and finally reverses, the amplifier tube grid is made less and less negative with respect to the cathode and finally reaches a potential which permits current flow in the anode circuit.

The current of the amplifier tube at first flows largely into the smoothing capacitor  $C_2$  inasmuch as the inductive effect of the magnetic circuit of the sensitive relay tends to maintain zero magnetic flux linkages in the relay coil at the beginning of current flow in the anode circuit. Shortly after anode current of the amplifier tube starts to flow the anode voltage of this tube again reverses and anode current stops.

However, current flows in the local circuit composed of the capacitor  $C_2$ , and the coil of the sensitive relay until the energy stored in that circuit is dissipated in the coil resistance.  $C_2$  is made sufficiently large that it is enabled to maintain continuous current through the coil of the relay between pulses of the amplifier tube anode current before the average value of the current in the relay coil reaches the value necessary to operate the relay.

Hence, the relay has but small tendency to chatter at the critical average current value for pick-up. This complete series of events is repeated each cycle as long as there is light on the photo-electric tube.

With no light on the photo-electric tube, the action during the half-cycle when terminal  $A$  is positive is the same as before. However, in this case, when the a. c. voltage reverses, practically no current flows in the photo-electric tube, and therefore capacitor  $C_1$ , is not discharged but maintains its negative charge and keeps the grid negative throughout the positive half-cycle, thereby prohibiting flow of current in the amplifier tube anode circuit.

Adjustment of the circuit is accomplished by means of the potentiometer, the position of which determines how far capacitor  $C_1$  must be discharged by the photo-electric tube current to permit current to flow in the anode circuit of the amplifier tube.

The average value of anode current of the amplifier tube is therefore determined by 2 factors: (1) The value of light flux impinging upon the photo-electric tube (the magnitude of photo-electric tube current is a function of the magnitude of the light flux); and (2) the potentiometer adjustment.

**The Thyatron Electronic Relay.**—In a number of applications the type of relay previously described works perfectly satisfactory, but frequently applications are encountered in which the speed of response as well as the amount of current required is too great and hence make the described methods unsatisfactory.

In such cases it has been found advantageous to substitute the relay or relays for a grid controlled glow discharge tube, which is also known as the Thyatron tube or the *Thyatron electronic relay*.

These tubes are extensively used in a wide variety of electronic circuits where the grid is used for various control purposes. They may thus be used in a modified form of rectifier circuit to provide power to perform relay operations as well as to secure control of a switching circuit for a definite number of alternating current cycles.

These tubes resemble the conventional three electrode vacuum tubes in construction inasmuch as they contain an anode, a cathode, and a grid, spaced relatively to one another and sealed in an air tight glass or metal container. However, the resemblance ceases here as these tubes are filled with mercury-vapor at a suitably low pressure, and the conduction of current from the cathode to the anode is through a glow or arc-discharge occurring in the gas or vapor. In the conduction of current through a gas or vapor, the electrons ionize the neutral atoms

and thus produce positive ions. These positive ions neutralize the negative space charge caused by the electrons, and thereby permit the passage of large currents with a correspondingly low potential drop across the tube.

The function of the grid is to control the breakdown of the tube, the breakdown being the point at which current is allowed to pass between the anode and cathode. The discharge occurs when the grid is given the proper potential and, after breakdown occurs, the current is conducted between the anode and cathode in the form of a glow or arc-discharge, which is limited mainly by the circuit load conditions.

Once the discharge is started, the tube voltage drop reaches a low and essentially constant value throughout the period of conduction, and the grid is no longer effective in controlling the discharge. Hence, the tube possesses a lock-in characteristic when used with direct current sources.

This is especially desirable in certain applications where the grid is used to block the discharge until some disturbance of very short duration imposes a voltage surge upon the grid which allows the tube to break down. The tube thus affords the highest speed lock-in relay known. The anode potential must then be interrupted to stop the discharge.

The tubes are generally used with alternating current sources where the discharge is periodically extinguished, and the grid control is restored by the reversal of the anode-cathode voltage. Thus grid control is never lost for more than one-half cycle, provided that the frequency is not more than 150 cycles per second.

On alternating current the anode voltage passes through zero during each cycle, thereby giving the grid an opportunity to

—regain control so that the starting potential on the next positive half cycle can be varied. By thus controlling the point on the alternating current wave at which current starts to flow, the average rectified output of the tube may be varied from essentially zero to a maximum value. This control may be effected by either changing the magnitude of the grid potential or its phase with respect to the anode to cathode potential.

## Phototube PJ-23 - - Description and Rating

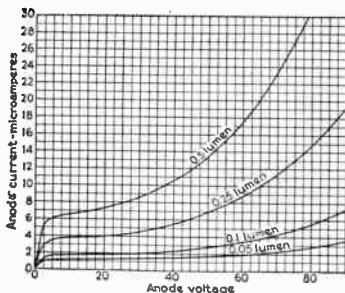

Anode Voltage vs Anode Current  
for Phototube PJ-23

The PJ-23 is a gas-filled phototube designed for general use. The active surface is caesium deposited on oxidized silver. Argon gas is used to produce the ionization, which augments the primary electron emission. This tube is useful in all cases where it is necessary to obtain a greater output than is possible with the vacuum type of phototube.

## TECHNICAL INFORMATION

Number of Electrodes	2
Maximum Anode Voltage, d-c or peak a-c	90
Maximum Anode Current, microamp	20
Average Sensitivity at Anode Voltage of 90, microamp per lumen	50
Interelectrode Capacitance, $\mu\text{f}$	4
Gas Ratio (Ratio of Anode Current at 90 volts to Anode Current at 25 volts) maximum	10
Window Area, square inches	0.9
Maximum Operating Temperature, ambient, deg C	68

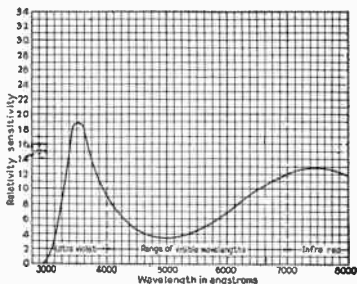

Color Sensitivity Characteristic,  
Constant Energy for Phototube PJ-23

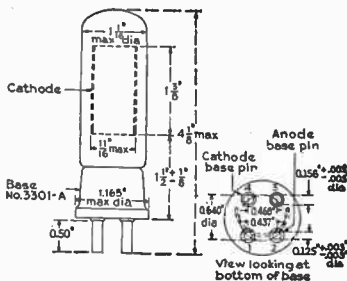

## Pilotron Tube FP-195 - - Description and Rating

The Pilotron FP-195, an improved FP-1 (852), is a three-electrode, high-vacuum tube, designed primarily for use as an oscillator or radio-frequency power amplifier in high-frequency circuits and may be used to replace the FP-1 or 852 types.

The filament, grid, and plate are supported on separate stems with the leads brought out through separate seals, thus assuring high insulation and low interelectrode capacitance.

A 50 per cent larger anode than the FP-1 allows a much increased safety factor in withstanding sudden overloads. To eliminate reverse emission when alternating voltage is used, the anode is made of carbon. Also, it is specially processed and exhausted at extremely high temperature so as to assure freedom from gas.

Another important feature of the FP-195 is the location of the getter in the cathode arm. Former designs have utilized the getter in the anode arm with the assembly attached to the anode support so that at high frequencies both the getter and assembly act as part of the anode. The getter being placed in the cathode arm eliminates the possibility of stray electrons collecting on the getter and causing sufficient heating to gas the tube or puncture the bulb.

These new features are especially important when the tube is used to generate ultrahigh frequencies.

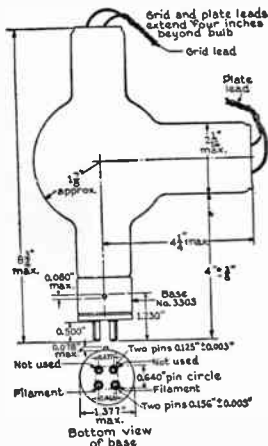

Outline Pilotron Tube FP-195

## MAXIMUM RATINGS AND TYPICAL OPERATING CONDITIONS

Class C, R-f Power Amplifier and Oscillator  
(Key down conditions without modulation)\*

	Typical Operation (Approximate)			Maximum Ratings
Voltage				
Plate (D-c)	2000	2500	3000	3000
Plate (A-c rms)	-	-	-	3000
Grid (D-c)	-200	-350	-500	-
Filament (A-c)	10	10	10	-
Current				
Plate (D-c)	0.150	0.152	0.116	0.150
Grid (D-c)	0.020	0.015	0.015	0.040
R-f Grid	-	-	-	10
Power				
Plate Input	300	330	350	350
Plate Dissipation	110	110	110	125
Output	190	220	240	-

\*Modulation (essentially negative) may be used if the positive peak of the audio-frequency envelope does not exceed 115 per cent of the carrier conditions.

## TECHNICAL INFORMATION

## GENERAL DESIGN

Number of Electrodes	3
Filament Voltage, Volts	10
Filament Current, Amperes	3.25
Average Characteristic Values Calculated at $E_b = 2000$ , $I_b = .050$ , $E_f = 10$ volts	D-c.
Grid Voltage, Volts	-100
Amplification Factor	12
Grid-plate Transconductance, $\mu\text{mhos}$	1200
Approximate Direct Interelectrode Capacitances	
Plate to Grid, $\mu\text{pF}$	2.8
Grid to Filament, $\mu\text{pF}$	2.2
Plate to Filament, $\mu\text{pF}$	1.2
Over-all Dimensions, Inches	
Maximum Length	8-3/4
Maximum Radius	4-1/4
Type of Cooling	Air



## Ignitron Tube FG-235-A - - Description and Rating

Ignitron FG-235-A is a mercury-pool type controlled-rectifier tube designed particularly for high-current, intermittent operation, such as is required in welder-control service. As the tube is water-cooled, it is capable of passing these high instantaneous currents with a relatively high duty factor. The FG-235-A may also be operated continuously as a controlled rectifier at reduced current. Control is maintained by a third electrode or ignitor which initiates the arc at the desired point of each conducting cycle.

## TECHNICAL INFORMATION

## GENERAL DESIGN

Tube Voltage Drop at 300 amperes

Maximum	16
Minimum	8

## MAXIMUM RATINGS

Welder Control Service	Max Peak Anode Voltage, Volts	Maximum Anode Current, Amp	Peak Average	Max Conducting Time per Spot per Tube, Sec
900	750	135		1.50 $\beta$
900	1000	135		1.40
900	3000	95		0.64
900	4000	75		0.25
700	750	135		1.50 $\beta$
700	1250	135		1.33
700	3000	100		0.75
700	4500	70		0.25
360	750	135		1.50 $\beta$
360	1750	135		1.25
360	3000	110		0.97
360	6000	50		0.25

## Rectifier Service

Maximum Peak Voltage, volts	700
Maximum Peak Anode Current, amp	600
Maximum Average Anode Current, amp	100
Maximum Time for Averaging Anode Current, seconds	120
Instantaneous Ignition Current, amperes	
Maximum Required	40
Maximum Allowed	100
Average Ignition Current, amperes	
Maximum Required	0.5
Maximum Allowed	1.0
Maximum Time for Averaging Ignition Current, seconds	10
Instantaneous Ignition Potential, volts	
Maximum Required, Ignitor Positive	250
Maximum Allowed, Ignitor Positive	900
Maximum Allowed, Ignitor Negative	5

Maximum Outlet Water Temperature C 40  
Minimum Flow, gallons per minute 1.5

$\theta$  At any one voltage, straight line interpolation may be used to arrive at other detailed ratings.

$\beta$  At peak currents below 750 amperes, the "Conducting Time per Spot" is limited only by the average current rating and the averaging time of the tube.

$\lambda$  Minimum Off Time Between Spots -- Any period during which a tube has passed the rated "Maximum Conducting Time per Spot" must be followed by sufficient time off, to cause short-time average current to fall below 150 per cent of the rated "Average Anode Current". The time for taking this short-time average is the period during which conduction has taken place, plus the following off period.

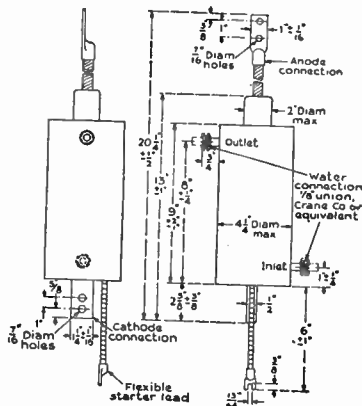
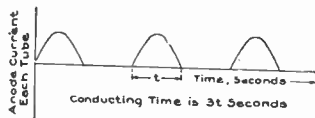

## Metal Vacuum Contact Tube FA-6 -- Description and Rating

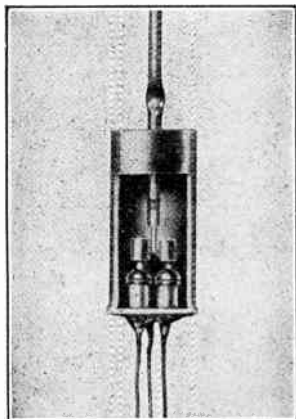

Cut Away View of Vacuum-Contact Tube, Type FA-6

The FA-6 is a vacuum contact tube designed for use as a general-purpose switch. Contacts have a much longer life in vacuum than in air and less pressure is required to close them. Only a few thousandths of an inch movement is required to interrupt the rated current. This small movement and the light construction of the moving parts account for the very small amount of power necessary to operate the device and for the high speed of operation which may be attained.

## TECHNICAL INFORMATION

Circuits	Single-pole Double-throw
Maximum Voltage, d-c	500
Maximum Voltage, a-c	440
Continuous Current, amp	10
Interrupting Rating, Non-inductive	
At 250 v, a-c and 125 v, d-c, amp	10
At 440 v, a-c and 250 v, d-c, amp	7
At 500 volts, d-c, amp	4

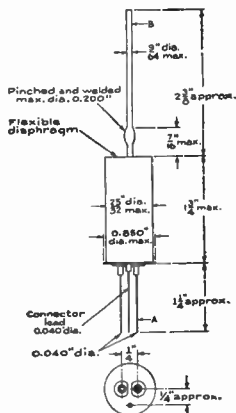

Outline Vacuum Tube FA-6

Force Required to Move Operating Contact from One Stationary Contact to the Other (Initial Tension Neutralized)

Maximum, grams	70
Average, grams	40

Travel of Arm 2-3/8 in. from Diaphragm

Maximum, inch	0.070
Average, inch	0.045

Initial Tension at 2-3/8 in. from Diaphragm

Maximum, grams	50
Minimum	Floating

Maximum Safe Contact Pressure, Measured 2-3/8 in. from Diaphragm, grams

	250
--	-----

A, leads  
B, operating arm } May be cut off as desired

## Vacuum Contact Tube FA-15 - - Description and Rating



Vacuum Contact Tube FA-15

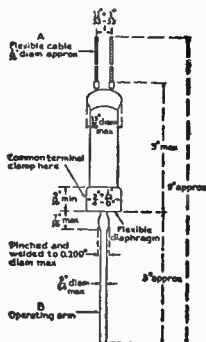

Outline Vacuum Contact Tube FA-15

The FA-15 is a vacuum contact tube for use as a general-purpose switch. This device operates by means of an operating arm which extends through a flexible diaphragm. Glass construction at the contact end permits visibility of the contacts and comparatively high insulation voltage; enclosed construction allows the tube to be mounted in wet or crowded places, or to be immersed in oil. The absence of air in the contact chamber prevents the formation of gaseous arcs and resultant corrosion of the parts. Consequently the contacts last longer than in air; and because they are always clean, less pressure is required to close them. Only a few thousandths of an inch movement is required to interrupt the rated current. This small movement and the light construction of the moving parts account for the very small amount of power necessary to operate the device and for the high speed of operation which may be attained.

## TECHNICAL INFORMATION

Circuits	Single-pole Double-throw
Maximum Voltage, a-c or d-c	3000
Continuous Current, amperes	8
Interrupting Rating, amperes	
At 250 volts a-c and 125 volts d-c	8
At 600 volts a-c and 250 volts d-c	6

## Interrupting Rating, amperes, Cont.

At 500 volts d-c	8
At 1500 volts a-c or d-c	0.5

Force required to move operating contact from one stationary contact to the other

Max including initial tension, grams	75
Max, initial tension neutralized, g	50
Avg, initial tension neutralized, g	30

Maximum safe contact pressure measured at 2 3/8 in. from diaphragm, grams 250

Travel of arm, 2 3/8 in. from diaphragm

Maximum, inch	0.035
Average, inch	0.026

A, Leads } May be cut off  
B, Operating arm } as desired

On inductive loads the surge voltage must be limited to 3000 volts or to the maximum safe voltage for the circuit. This may be done by means of capacity or discharge resistance across the load.

The normal position of the contacts may be either open or closed and must be adjusted externally by the user.

## Thyratron Tube FG-154 - - Description and Rating

The FG-154 is a hot-cathode gas-filled, double-grid Thyratron tube particularly useful in applications where constancy of characteristic is necessary even with large variations in ambient temperature. This tube may be used where the available grid power is small.

## TECHNICAL INFORMATION

## GENERAL DESIGN

Number of Electrodes	4		
Cathode, coated-filament type			
Voltage, volts	5.0		
Current, amperes approx	7.0		
Heating Time, sec typical	10.0		
Tube Voltage Drop, volts			
Maximum	24		
Minimum	10		
Approximate Starting Characteristic, volts			
Anode	Shield Grid	Control Grid	
Voltage	Voltage	Voltage	
60	0	0	
100	0	-3.5	
Deionization Time, microseconds approx	1000		
Ionization Time, microseconds	10		

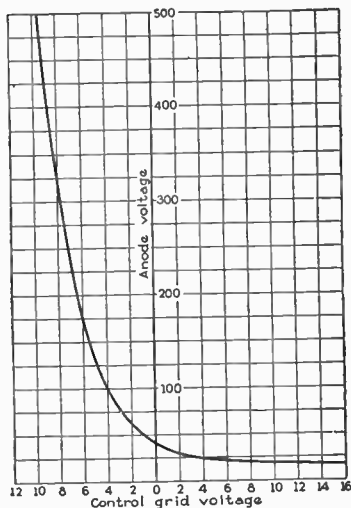

Anode Voltage vs Control-grid Voltage for Thyratron Tube FG-154

## MAXIMUM RATINGS

Maximum Peak Anode Voltage	500
Inverse	500
Forward	500
Maximum Negative Control Grid Voltage	300
Maximum Negative Shield Grid Voltage	0
Maximum Anode Current, amp	
Instantaneous <sup>⊖</sup>	10.0
Average <sup>⊖</sup>	2.5
Surge, for design only	80
Maximum Control Grid Current, amp	
Instantaneous	1.0
Average <sup>⊖</sup>	.25
Maximum Shield Grid Current, amp	
Instantaneous	1.0
Average <sup>⊖</sup>	.25
Temperature Limits, ambient C	-20 to +50

<sup>⊖</sup>When the operating frequency is less than 25 cycles, the maximum instantaneous current rating is reduced to twice the average current rating.

<sup>⊖</sup>Maximum time of averaging current is 15 seconds.

<sup>⊖</sup>It is recommended that the shield grid be connected to the mid-point of the filament through a resistance not greater than 500 ohms.

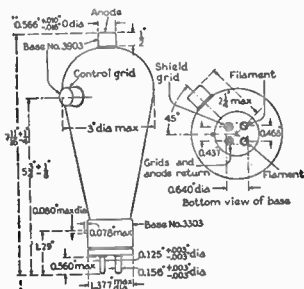

Outline Thyratron Tube FG-154



## Thyratron Tube FG-57 -- Description and Rating

The FG-57 is a Thyratron tube for use in control circuits where it is desired to actuate the tube with a change in negative grid voltage. The tube is suitable, therefore, for relay uses where current flow is desired in the absence of grid excitation. This Thyratron is not satisfactory for inverter operation due to its long deionization time.

## TECHNICAL INFORMATION

Number of Electrodes	3
Cathode	
Volts	5.0
Amperes, approx	4.5
Type	Indirectly Heated
Typical Heating Time, minutes	5
Maximum Peak Anode Voltage	
Inverse	1000
Forward	1000
Maximum Anode Current, amperes	
Instantaneous $\beta$	15
Average	2.5
Surge, for design only	90
Maximum Time of Averaging Anode Current, seconds	15
Maximum Grid Current, amperes	
Instantaneous $\beta$	1.0
Average	.25
Tube Voltage Drop, volts	
Maximum	24
Minimum	10
Approximate Starting Characteristics	
Anode Voltage	Grid Voltage
100	-1.50
1000	-7.0
70	0
Temperature Limits, Cond Mercury C	40 - 80
Deionization Time, microsec, approx	1000
Ionization Time, microsec	10

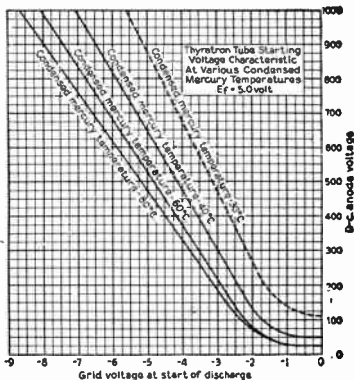

FG-57 Thyratron Tube Starting Voltage Characteristic at Various Condensed Mercury Temperatures

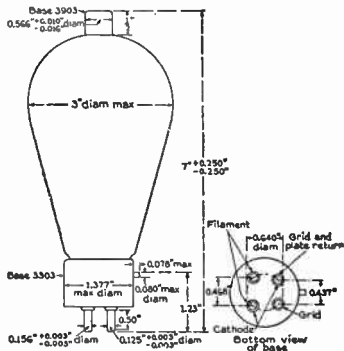

Outline Thyratron FG-57

When the operating frequency is less than 25 cycles, the maximum instantaneous current rating is reduced to twice the average current rating.

**The Thyatron Tube Used as Timer in Low-Speed Welding Application.**—When a resistor-condenser combination is used as a means of measuring short time intervals in electrical circuits, several important difficulties are encountered, one of the most outstanding being that for large power transfer the size of the condenser would be uneconomically large. However, if the condenser be used in the grid circuit of a thyatron, a small condenser can be arranged to charge or discharge during a relatively long interval and therefore exert control over an external load after a predetermined time delay.

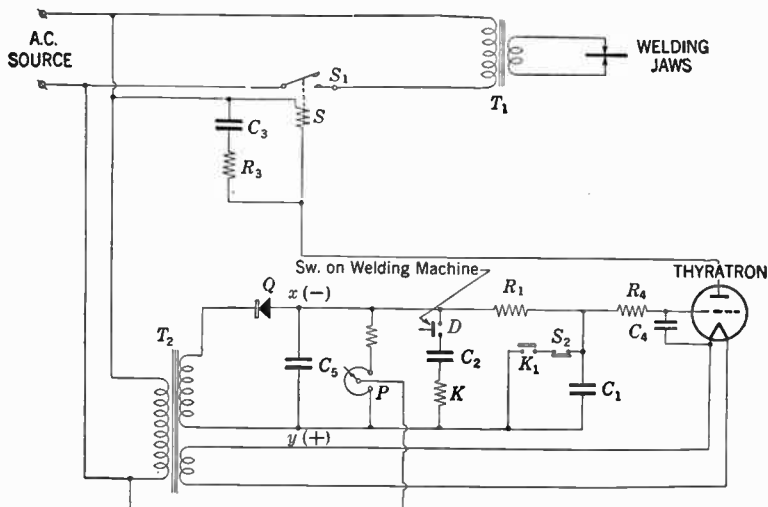

FIG. 5.—Schematic diagram of a low speed welding circuit, with thyatron timer.

Thus, in relatively low-speed spot welding where a contactor provides satisfactory control of the welding current, thyatron timer circuits are being used to determine the duration of the closure of the main contactor. Time intervals adjustable from  $\frac{1}{8}$  to 10 seconds or more can be satisfactorily measured out.

The elementary diagram of such a circuit is given in fig. 5. Here the thyatron performs the double function of a timing device and a rectifier, so that a robust d.c. contactor capable of high speed operation can be used on an a.c. supply.

The welding contactor  $S_1$  has its coil  $S$  energized by half way rectified a.c. current suitably smoothed by parallel condenser  $C_3$ , a resistor  $R_3$  being included to prevent excessive condenser charging currents being used by the thyatron.

In the grid circuit a small rectifier  $Q$ , holds the conductors  $x$  and  $y$  at the potentials indicated, smoothing being effected by condenser  $C_5$ . Prior to the weld being made, the condenser  $C_1$ , is charged up to the potential existing across lines  $x$ - $y$ . The thyatron is therefore held non-conducting owing to the relatively high negative potential between  $x$  and the adjustable potentiometer connection  $P$ , which is tied to the cathode.

$R_4$  is the grid-current limiting resistor, having a sufficiently high value to prevent grid current interfering with the timing circuit.  $C_4$  is the usual surge-suppressing condenser.

Assume now that the electrodes are brought down on the work, the switch  $D$ , on the welding machine closes. Condenser  $C_2$  immediately charges up and momentarily energizes a small relay coil  $K$ . Contacts  $K_1$  of the relay are therefore closed, short-circuiting  $C_1$ . The grid potential is now that of the line  $y$ , and is therefore positive with respect to the cathode by the drop across  $P$ - $y$ . The thyatron arc therefore strikes, energizing the contactor  $S$ . At the instant the main contacts  $S_1$  close thereby starting the welding period proper, an interlock  $S_2$  on the contactor opens, and the condenser  $C_1$  commences to charge up through the resistance  $R_1$ . The grid now falls in potential; a time is reached dependent on the setting of  $P$ , when



it becomes slightly negative with respect to the cathode, and the arc is extinguished. The contactor coil  $S$ , is de-energized and therefore the welding period is terminated.

The duration of each spot weld is determined by the rheostat  $P$ , the value of  $R_1$  or  $C_1$ , and, of course, on the voltage across  $x-y$ . The latter is about 150 volts, so that changes in the control ratio of the thyratron due to temperature variations, etc., do not affect the accuracy of the timing.

Two features of the circuit are that timing period (i.e. the condenser charging period) commences only when the main contacts close, and hence variations in welding heat due to the variable times of closure of the contactor are eliminated; this is of some consequence on a short weld of, say, 8 cycles.

Secondly, a single weld of definite duration is made irrespective of the time of closure of the welding machine switch  $D$ .

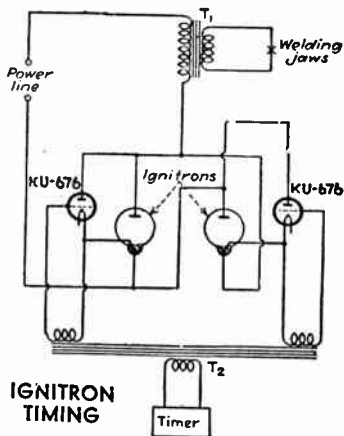
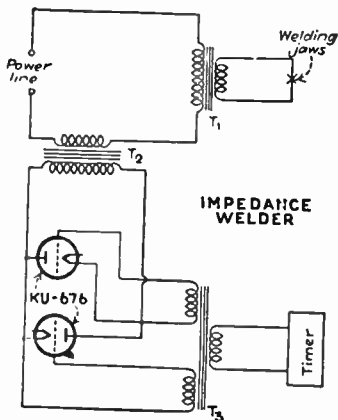

FIGS. 6 and 7.—Illustrates the connection of 2 thyratron tubes in welding applications.

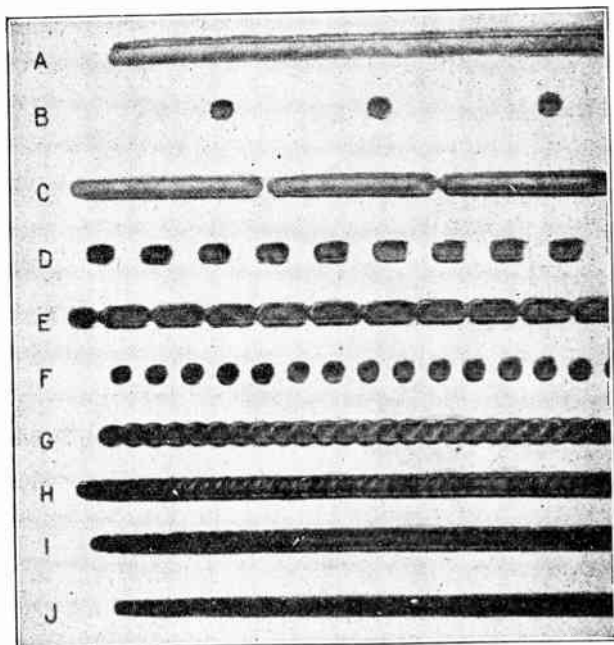
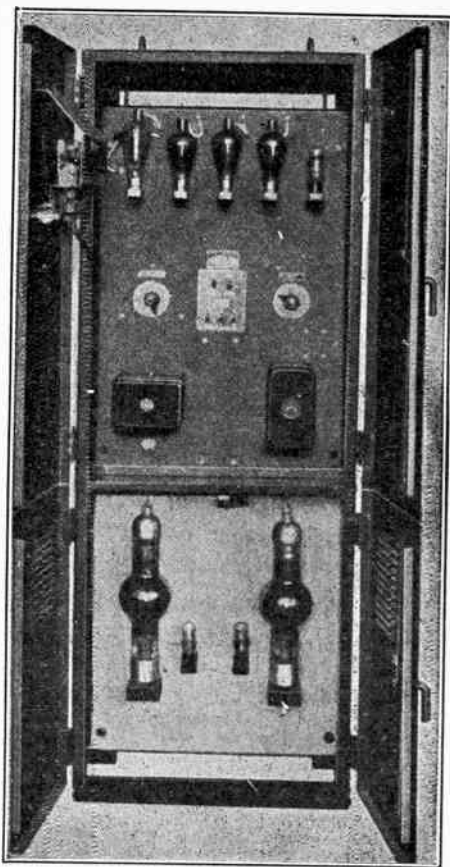

FIG. 8.—Resistance welds made at approximately 7 feet per minute by line welder controlled by a control panel using grid controlled vapor discharge tubes.

- |                                     |                                  |
|-------------------------------------|----------------------------------|
| A. 21 spots per inch                | E. Intermediate speed and ratio  |
| B. Long off period, short on period | F. $1\frac{2}{3}$ spots per inch |
| C. Short off period, long on period | G. 3 spots per inch              |
| D. Intermediate speed and ratio     | H. $4\frac{1}{2}$ spots per inch |
|                                     | I. 6 spots per inch              |
|                                     | J. 14 spots per inch             |



**FIG. 9.**—Front view of control panel for electron tube, spot and line welder (Courtesy General Electric Co.)

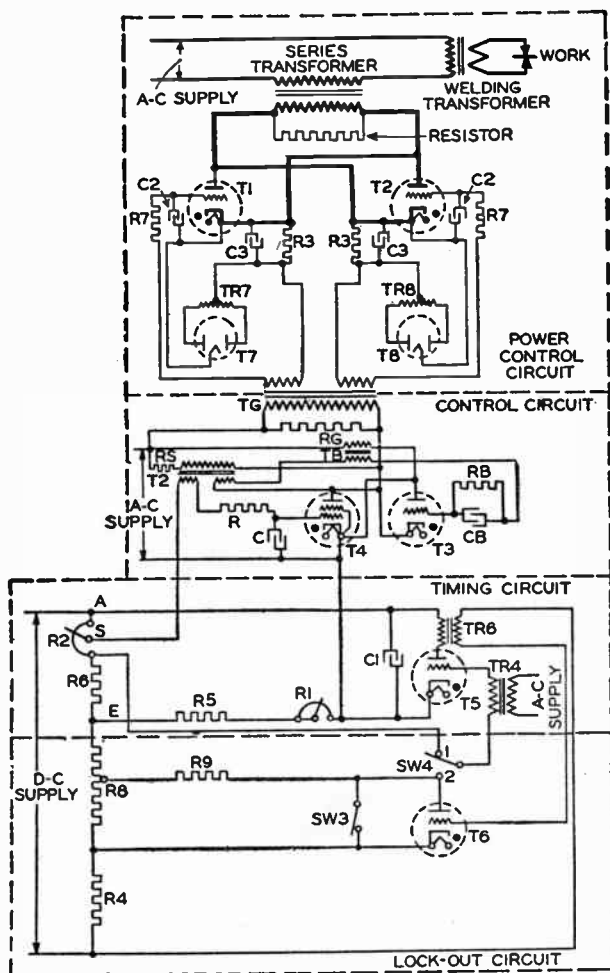

FIG. 10.—Schematic circuit diagram of electron tube welder control panel shown on opposite page.

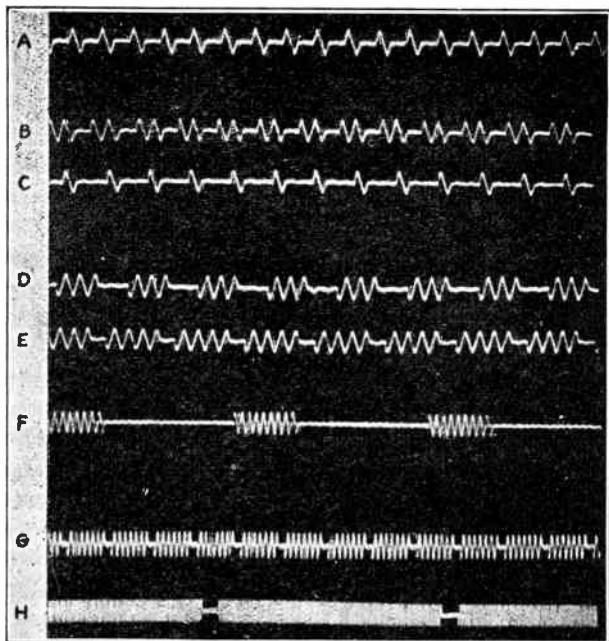

FIG. 11.—Oscillograms showing range of control with electron tube control for resistance welding machines.

A. 1 cycle on, 1 cycle off  
 B. 2 cycles on, 1 cycle off  
 C. 1 cycle on, 2 cycles off  
 D. 3 cycles on, 2 cycles off

E. 4 cycles on, 1 cycle off  
 F. 9 cycles on, 19 cycles off  
 G. 7 cycles on, 1 cycle off  
 H. 97 cycles on, 7 cycles off

## CHAPTER 43

# Application of Electronic Devices

**Instrument and Relays for Use with Weston Photronic Cell.—**When using measuring instruments, galvanometers, or relays in connection with the photronic cell described on page 742 the effect of the resistance of the meter must be considered. In most measurements, it is desirable to have an approximately linear response, that is, when the current produced is directly proportional to the light intensity. To obtain this, it is necessary to use an instrument of relatively low resistance, the value of which in turn depends upon the maximum intensity of the illumination to be measured. For example, if the maximum illumination is say 250 foot-candles, a resistance of 200 ohms or less, will be satisfactory. On the other hand, if the maximum illumination is 5 foot-candles, then an instrument resistance of at least 1000 ohms is necessary to give the linear response required for practical purposes.

Relays usually require high torque to enable them to establish reliable contact, and for this reason their resistances in general are considerably higher than in simple indicating instruments, and as a consequence, the action of a relay may depart considerably from a strictly linear relation, depending upon its resistance.

This of course is not serious but must be considered in the design of the equipment. In fact, an instrument having a definite full scale range in light value, advantage is often taken of the non-linear characteristics of the cell with high external resistance, to increase the sensitivity for relatively low light values within the scale ranges. That is, the change in deflection per unit change in light value is greater in the lower part of the scale than in the upper part.

When using high resistances however, consideration must be given to temperature errors which may occur as a result.

**Smoke Density Control.**—Photoelectric equipment of this nature has been developed to control smoke densities, and to permit consistent adherence to the smoke abatement laws, it also eliminates the fuel waste which is reflected by excessive smoke conditions.

Apparatus of this type work generally as follows: A beam of light is focused through the smoke stack and on to the photoelectric cell. The cell generates electricity in proportion to the amount of light which reaches it. As the smoke passes through the light beam it reduces the intensity of light on the cell, the corresponding loss in the current generated permits a relay located in the boiler room to operate an alarm or suitable colored signal light and warn the fireman of the excessive smoking conditions in the stack. With the knowledge of the amount of smoke in the stack, combined with the data furnished by the boiler control instruments, it enables the operator to adjust the draughts and fuel supply to maintain maximum efficiency in the operation of the boilers at all times.

Continued records of smoke densities in addition to an alarm or light indication, are provided for in a number of systems for smoke control.

Among a great variety of standard smoke control recorders manufactured, the Weston Electrical Instrument Corporation have developed a simple and compact smoke alarm unit shown in fig. 1.

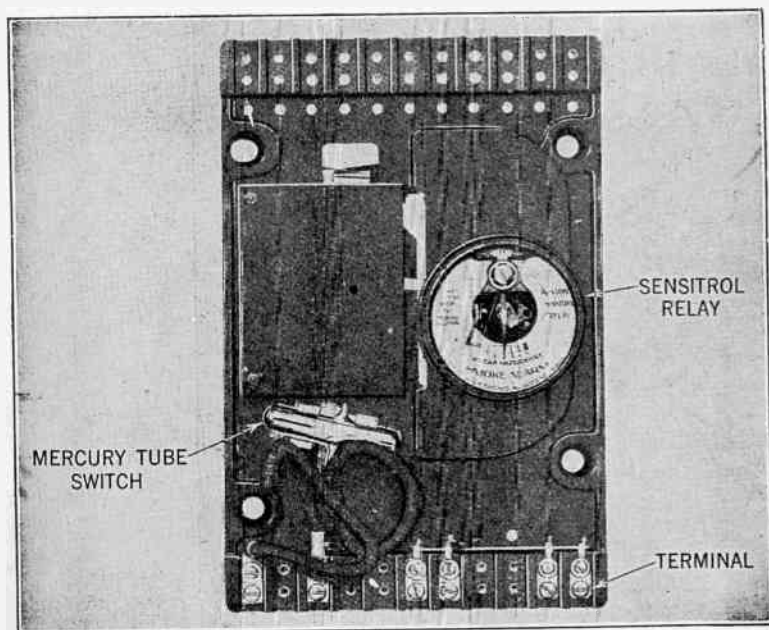
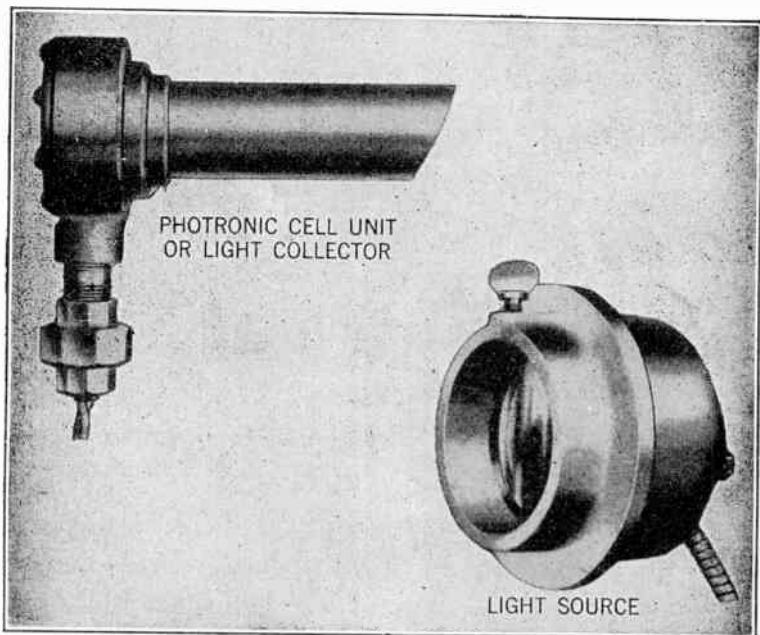

FIG. 1.—Weston Electrical Instrument Corporation's smoke alarm relay unit.

The complete smoke alarm consists of three parts: (1) A light source. (2) A light collector which contains a Weston photronic cell. (3) A relay panel. See fig. 1 to 3. The relay unit may be located at a considerable distance from the photronic cell, the resistance of the leads connecting the relay unit with the cell however, should not exceed 100 ohms.



Fig. 4 illustrates the connections between the various units. For installation of the light source a suitable round hole is cut in smoke stack diametrically opposite the light collector, which is mounted outside of the stack.



FIGS. 2 and 3.—Light collector (cell unit) and light source.

The light source consists of a 6 to 8 volt concentrated filament automobile headlight bulb of 21 to 31 candle power depending on the diameter of the stack. A small 110/6 volt transformer unit and associated rheostat enables the operator to adjust the lamp voltage occasionally to compensate for the accumulation of soot on the lamp and cell windows so that infrequent cleaning periods are necessary.

The relay unit depicted consists of a panel on which are mounted a Weston sensitrol relay, a small a.c. motor and a mercury tube switch.

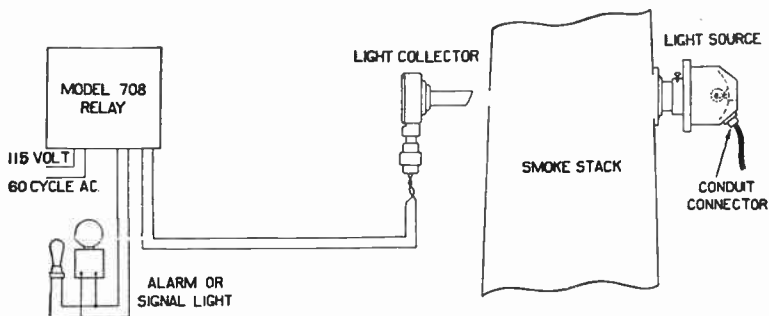

F.G. 4.—Diagram illustrating typical connection of equipment shown in figs. 1 to 3.

Note that the relay is calibrated directly in smoke units, for example: No. 2 on the dial is located at the point of haze or increasing smoke density. The relay may be set or calibrated to operate at this or any other desirable value of density, in which the cycle of operation is as follows: When smoke reduces the intensity of the light beam in the stack, the relay actuates the contact of the a.c. motor which racks the mercury tube completing the circuit to the alarm, notifying the operator about the abnormal condition. The alarm sounds for about 30 seconds, and will continue to sound at this time interval until the operator corrects stack conditions.

The contacts on the relay are automatically reset when smoke ceases to interfere with the light beam.

If a continued record of smoke density is desired, a voltage recorder may be connected with the mercury tube giving a graphic account of the time elements of improper combustion.

**Illumination Control.**—Photoelectric equipment for control of interior or exterior illumination, depending on changes in the intensity of natural light, has to-day almost completely replaced time switches and kindred apparatus.

Application of equipment of this nature range from the illumination of twilight-zone lighting to control of electric signs such as office and show-windows, schools, flood lighting installations, navigation lights, airway and airport lighting, etc.

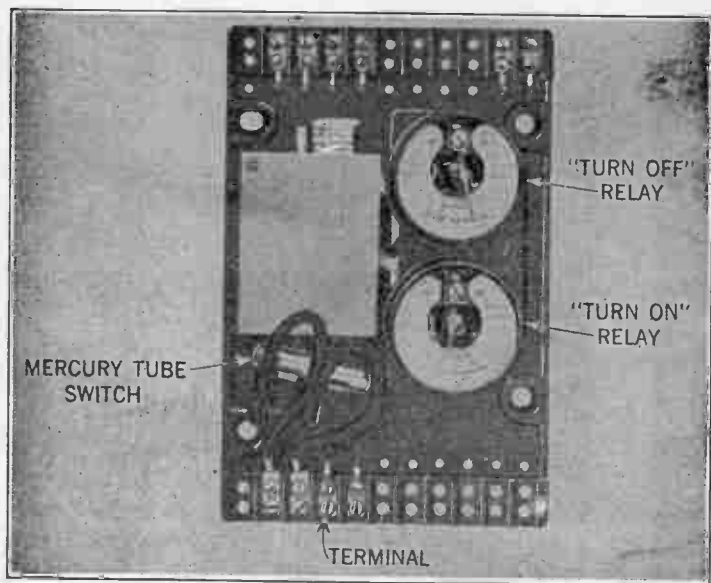

FIG. 5.—Illumination control unit, cover removed.

There is a great variety of standardized units in use for the various illumination controls. A compact and efficient control unit is designed by the Weston Engineers and is depicted in fig. 5.

The light control equipment consists of the light collector and the cabinet on which the instruments are located and interconnected as shown.

The illumination control relays turns lights on and off in accordance with the natural light intensity, so that a pre-determined level of illumination may be maintained. The unit consist of a small panel on which are mounted two Weston sensitrol relays; one for turning on the lights and the other for turning them off.

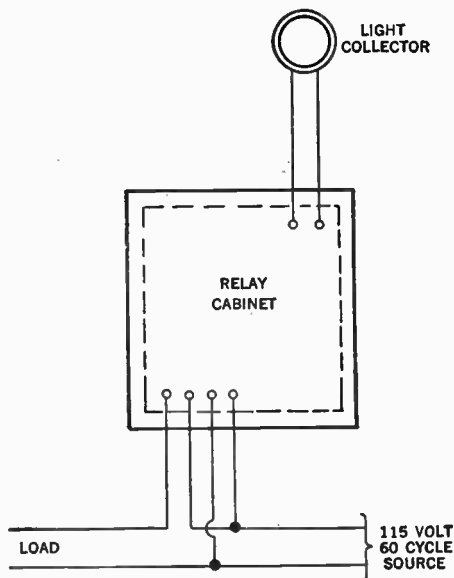

FIG. 6.—Wiring diagram of illumination control unit.

Each relay may be independently adjusted and the value at which it operates may be selected from a calibrated scale.

The design of the relay contact circuits are such as to give a relatively high contact pressure eliminating chattering. The

energy for their operation is obtained from either one of the three interconnected photo-electric cells, shown in fig. 8.

The performance of the unit is dependent upon the positive action of the relays, and in order to fully understand the performance of the "turn on" relay, the operation is as follows:

The relay is a single contact device for closing a primary circuit. The energy delivered to the relay from one of the photoelectric cells is sufficient for their operation and therefore no batteries or auxiliary apparatus are necessary.

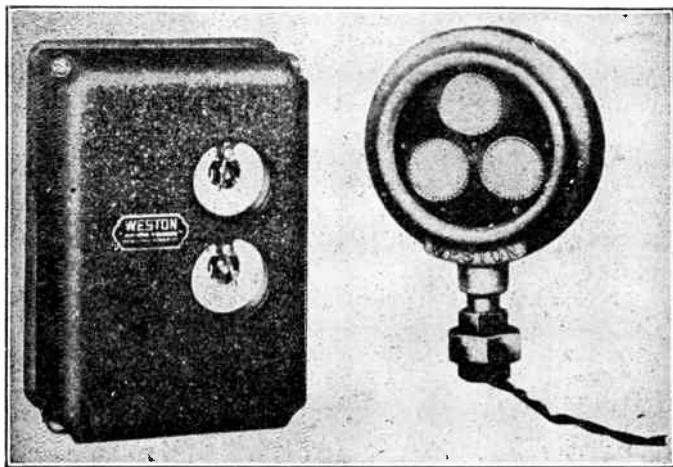

FIGS. 7 and 8.—Illumination control unit (cover attached) and photo-electric light collectors.

In order to make or break a circuit it is necessary to have two contacts, one moveable and the other stationary. The stationary contact in the relay consists of a small permanent magnet, and the moveable contact consists of a magnetic "rider" which is attached to the instrument pointer. Light impinging upon the photoelectric cell generates electric energy in sufficient amount to keep the contacts open.

When the light diminishes, the energy is decreased proportionally until the relay pointer swings the moveable contact into the magnetic field of the permanent magnets stationary contacts. It is then drawn firmly against it, producing a very firm contact pressure and prevents chattering.

The "turn off" relay operates exactly on the same principle, but the action takes place when the natural light intensity is increasing, not diminishing.

When daylight diminishes to a predetermined level, the contacts of the "turn on" relay closes and completes the circuit to a small induction motor, which in turn drives a small cam. This cam rocks a mercury tube switch, completing the lighting circuit. At the same time it locks out and resets the "turn on" relay.

The motor now stops, leaving the light on and releasing the "turn off" relay from its locked out position so that when the light intensity rises to the desired operating value, the lights will be turned off.

This same procedure occurs when the "turn off" relay makes contact. The entire operation is completed in approximately one minute. This operating interval is advantageous as it permits the stabilization of light conditions, thus preventing continuous operation due to shadows falling upon the photoelectric cell.

The above description is common to the illumination control relay units for both interior or exterior operation.

For interior illumination control the relay scales are usually calibrated from 10 to 20 foot-candles "turn on" and 20 to 30 "turn off," although any desired range is supplied. For street lighting or outdoor control the relay is calibrated from 0 to 2 foot-candles, permitting a low operating value of 0.5 foot-candle.

For outdoor mounting the relay unit is encased in a weather-proof housing. The photoelectric cells are also enclosed in a weather-proof light collector.

The installation is simple. It is only necessary to mount the relay panel on a wall or post, set the photoelectric cell and run leads from the relay panel to the connection on the existing switch box. The small induction motor requires approximately two watts for a period of one minute; the energy being obtained from the most convenient 110 volt, 60 cycle source. As no energy is consumed except during the cycles of operation, operating cost is practically negligible.

**Sensitive High Speed A.C. Photo-Electric Relay.**—In applications which require great sensitivity and speed of response a relay of the type shown in fig. 9 may be applied, especially if the device to be operated be a small solenoid or other small magnetic device which may be operated directly from the grid controlled vapor discharge tube in place of the contactor shown, thus saving the time required to operate the magnetic relaying contactor.

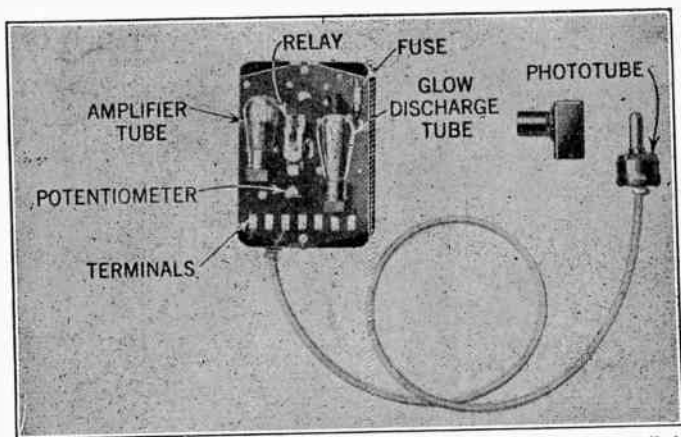

FIG. 9.—A sensitive, high speed A. C. photo-electric relay operating a grid controlled vapor discharge tube.

That is, the relay of fig. 9 employs the photoelectric tube amplifier circuit of fig. 10 to operate a grid controlled vapor discharge tube. Hence, since an arc discharge of a grid controlled vapor discharge tube will establish itself within a few microseconds after its grid receives the tripping impulse, power is applied to the relaying contactor or operating solenoid in minimum time (for an a.c. circuit).



Relays of this type are used in tooth paste tube machines to align properly the end crimp with the printing on the tube, in steel mills to respond to radiant energy from hot bodies, and in slow speed package wrapping machines to insure correct register of the printed matter upon the wrapper to the package.

The circuit of relay, shown in fig. 10 operates as follows:

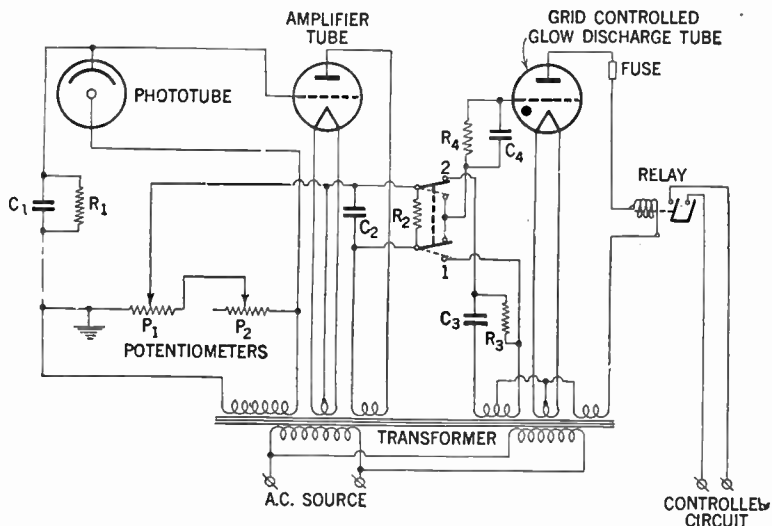

FIG. 10.—Wiring diagram of relay shown in fig. 9.

As before, an increase in light on the photo-electric tube causes an increased average plate current flow through the amplifier tube, but due to the a.c. circuit and to the time constant of the local circuit of  $C_2$  and  $R_2$  (over one-half cycle at 60 cycles) anode current flows through the amplifier tube in quarter-cycle pulses (while the anode voltage of the grid controlled vapor discharge tube is negative) to charge  $C_2$  and so produce a bias voltage in the grid circuit of this latter tube. Inasmuch

as different applications demand that an adjustment be provided so that this tube in one case may be made to conduct upon light increase, and in another may be made to conduct upon light decrease, a change-over switch is provided between the photo-electric tube-amplifier circuit and the circuit of the grid controlled vapor discharge tube to allow the polarity of the tripping voltage introduced into the circuit of the latter tube by the amplifier to be reversed.

With the change-over switch in position 1 and zero current being passed by the amplifier tube, the voltage conditions in the circuit of the grid controlled vapor discharge tube are as shown in fig. 11A i.e., an a.c. grid bias voltage  $180^\circ$  out of phase with the anode voltage is used to charge  $C_4$  through the grid cathode circuit of the grid controlled vapor discharge tube.

The time constant of the local circuit of  $C_4$  and  $R_4$  is less than  $\frac{1}{8}$  cycle at 60 cycles per second, yet is sufficient to carry the grid negative enough before the anode becomes positive so that incidental shifts of anode voltage phase caused by current flow through the contactor coil are insufficient to cause the tube to fire erratically. With the relations of fig. 11A the anode current is zero.

If the amplifier tube is caused to pass more and more current, the conditions of fig. 11B finally obtain; i.e., due to the a.c. bias voltage superimposed on the difference in voltages existing on  $C_4$  and  $C_2$ , the grid of the grid controlled vapor discharge tube is more positive than the critical grid voltage at the beginning of the half-cycle during which the anode of this tube is positive. Hence, full current is passed by the tube.

However, if the change-over switch be thrown to position 2 and there be zero anode current in the amplifier tube, the con-

ditions of fig. 11C obtain; i.e., an a.c. voltage is introduced into the grid circuit of the grid controlled vapor discharge tube from the mid-tap of the bias winding and the junction of  $C_3$  and  $R_3$ , which leads the anode voltage of this latter tube by

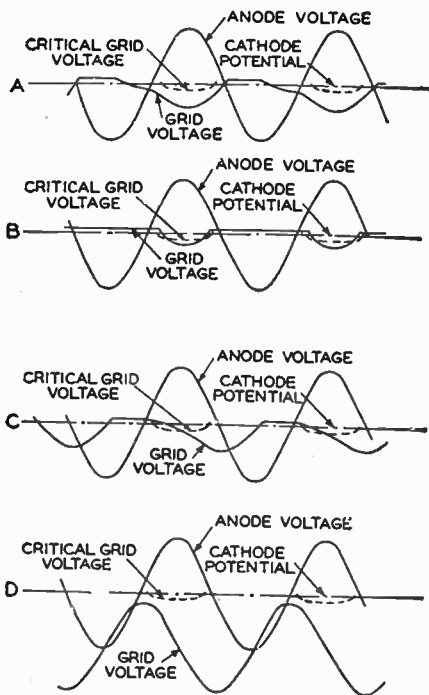

FIG. 11.—Voltage relations of grid controlled vapor discharge tube of the relay shown in fig. 9.

slightly less than  $90^\circ$ . This voltage charges  $C_4$  in a quarter-cycle pulse and holds the grid positive at the beginning of the half-cycle during which the anode is positive. Hence, full current is passed by the grid controlled vapor discharge tube.

If, under the latter conditions the amplifier tube is caused to pass more and more current, the conditions of fig. 11D finally obtain; i.e., the increasing voltage across  $C_2$  shifts the axis of the  $90^\circ$  leading a.c. grid voltage in the negative direction until the critical grid voltage is no longer exceeded, and the grid controlled vapor discharge tube ceases to conduct.

Particular notice should be taken of the care used in the above circuit to provide grid voltages for the vapor discharge tube of the correct phase and ample magnitude such that the tube cannot but pass full or zero anode current—a necessary condition to prevent erratic operation of the device controlled by the tube.

This relay will operate with a minimum illumination on the photo-electric tube of one foot candle and upon a 40% change in illumination at this value, or upon a 10% change in illumination at 10 foot candles, provided these changes last 0.05 second or longer (assuming a 60 cycle source of power). Hence the relay will operate up to 600 times per minute, assuming that the device operated by the grid controlled vapor discharge tube will follow at that speed.

**A Simple Two-Stage A.C. Operated Photo-Amplifier Relay Circuit\*.**—Fig. 12 shows a simple two-stage photo-amplifier relay circuit operating directly on the a.c. line. The simplicity of the circuit is illustrated by the fact that the complete list of circuit parts includes only one voltage divider resistor, one plate load resistor and three condensers. The circuit shown in fig. 12 consists of a high impedance phototube feeding through a voltage amplifier or buffer stage into a power-output stage.

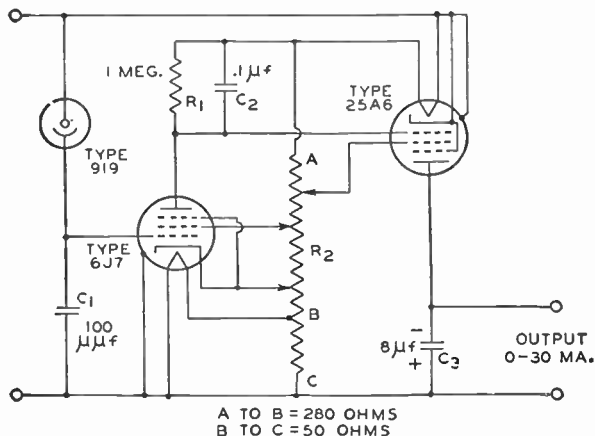

FIG. 12.—A simple two-stage A. C. operated photo-amplifier relay.

The filament voltage of the buffer stage has been lowered to reduce the temperature of and, hence, the electron emission from the grid of the buffer tube.

The plate current of the buffer stage is kept at a minimum in order to reduce the electron bombardment of the gas molecules within the tube and hence, the gas current to the grid.

The bias to the grid of the buffer stage is obtained by means of the rectifying action of the grid itself. This method of obtaining the grid bias keeps the effective bias and, hence, the plate current of the tube constant, regardless of large fluctuations in contact potential between the grid and the cathode.

The impedance of the condenser  $C_1$  acts as a load impedance for the phototube. Condenser  $C_1$  is charged up to a definite negative potential on one-half of the a.c. cycle and is allowed to discharge through the phototube on the other half of the cycle. The amount that it is discharged by the phototube determines the working potential on the grid of the buffer stage. The size of  $C_1$  can be set to any desired value to determine the desired sensitivity range of the relay.

**Quick-Acting A.C. Operated Photo-Amplifier Relay.**—Figs. 13, 14 and 15 show three variations of an a.c. operated photo

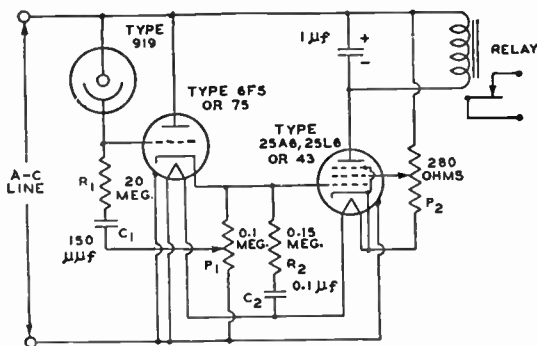

FIG. 13.—A quick-acting A. C. operated photo amplifier relay, functioning in a positive direction on the received light.

relay that will respond to a pulse of light having a duration as short as one-sixtieth of a second, or  $1/120$ th of a second if the pulse is properly phased with the power supply voltage.

The operation of these circuits is essentially as follows: On the negative half of the power supply cycle with no light on the photocell, the cathode of the 6F5 goes negative with respect to the grid, passes current to the grid, and thus during a period of several cycles charges  $C_1$  to a value equal to the peak value of the a.c. voltage applied between the grid and cathode. This voltage added to the instantaneous a.c. voltage applied between the grid and cathode is sufficient to reduce the plate current of the output tube to zero.

When light is received by the phototube, the phototube current has two effects, first, an instantaneous drop appears across the phototube load  $R_1$ , and second, the phototube current into condenser  $C_1$  opposes the current fed into  $C_1$  from the grid of the amplifier.

This action causes the potential across  $C_1$  to balance at some negative value between zero and a value equal to the peak of the a.c. voltage between grid and cathode. The potential across  $C_2$  is fixed in like manner by a balance between the charging grid current and the discharging buffer-tube current.

In figs. 13 and 14 an instantaneous flash of light occurring on the positive half of the cycle will cause an instantaneous drop across  $R_1$ , an instantaneous change in the plate current of the buffer stage, and an instantaneous change in grid voltage of the output tube. In fig. 15 due to the current taken by the buffer stage, there is a rapid loss of potential across  $C_2$ . This loss is slowly restored through  $R_3$  over a period of several cycles. Thus the pulse of output current will have sufficient duration to operate a sluggish mechanical relay, even though the pulse of light be of extremely short duration.

The circuit in fig. 14 is identical to the circuit shown in fig. 13 except that the heater voltages are supplied by suitable transformers. The use of a transformer supply for the heaters eliminates the degeneration or loss of gain that is inherent

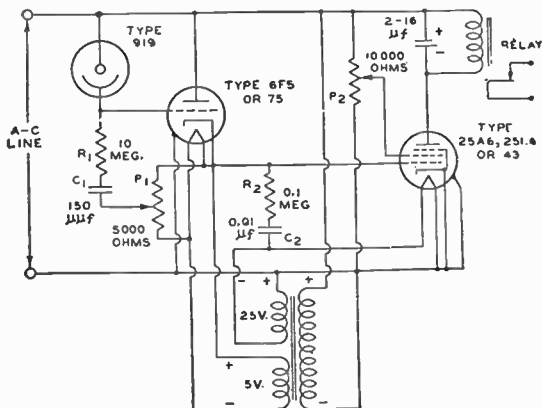

FIG. 14.—A quick-acting non-degenerative A. C. operated photo-amplifier relay, functioning in a positive direction on the received light.

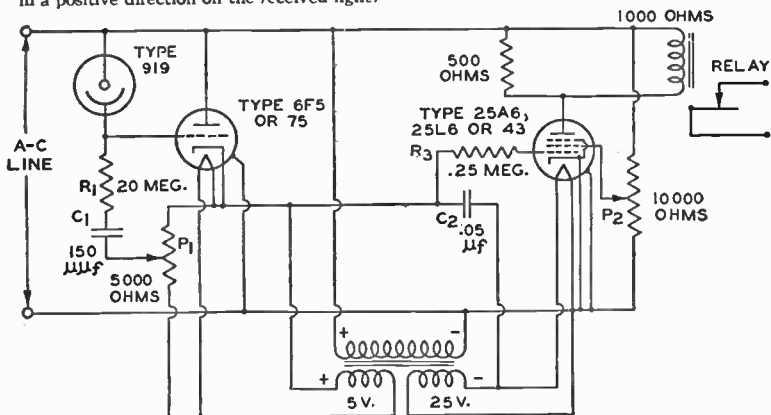

FIG. 15.—A quick-acting slow-releasing A. C. operated amplifier relay, functioning in a positive direction of the received light.



in the circuit shown in fig. 12 due to the fact that the d.c. potential between the lower side of  $C_1$  and the cathode of the buffer tube does not remain constant. In this circuit care should be taken to keep the instantaneous transformer polarities as shown.

These simple photo relays find their application for use in moderately high speed sorters, counters, register controls, shooting galleries, etc.

**A Sensitive Light-Intensity Indicator.**—Fig. 16 shows a sensitive photo-amplifier circuit that can be used for accurately matching the intensities of amounts of light. With this circuit, it is easily possible to indicate light differences or changes which

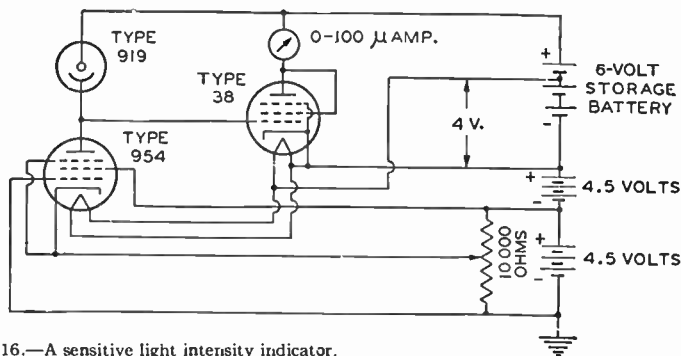

FIG. 16.—A sensitive light intensity indicator.

may amount to small parts of one per cent. In this circuit arrangement, the high-impedance 954 pentode acts as a load impedance for the 919 high-impedance vacuum tube photo-tube. It can be seen by reference to fig. 17 that the potential of the common connection between the 919 and the 954 is determined by the intersection of the 954 and 919 characteristics. It is also evident that a small change of light on the phototube will result in an output of several volts. This output

voltage is applied to the grid of a 38 output tube, the plate current of which is indicated on a 100 microampere meter. Because the phototube with the 954 load has an extremely high output impedance, it is necessary to operate the 38 so that its grid input impedance is extremely high. To reduce the grid emission to a minimum, the voltage to the heaters of the 38 and 954 is reduced to 4 volts. The possibility of emission from the heaters to the grid is eliminated by operating the heaters at a potential positive with respect to the plate of the 954 and the grid of the 38.

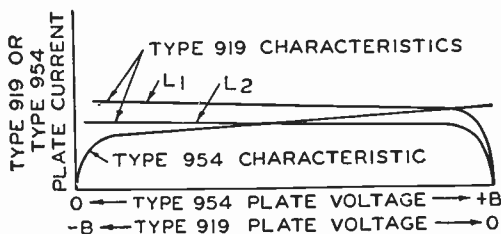

FIG. 17.—Plate characteristics of a vacuum type phototube with a pentode as a plate load.

Gas current to the grid of the 38 is kept at a minimum by keeping the potentials within the 38 low so as to minimize the ionization of any gas that may be in the tube. Because all of the high impedance external connections are made to electrodes brought out from the tops of the tubes, external leakages are reduced to a minimum. External leakage can be greatly reduced by carefully cleaning the tubes and coating them with a non-hygroscopic wax. This can be done by dipping the tubes in hot ceresin wax and holding them under the surface of the wax until the greater part of the moisture on the glass is boiled off. Care should be taken not to scorch the wax. Ceresin wax has long been used by research men for reducing the effects of moisture leakages in high impedance d.c. circuits.

This circuit finds application where it is desirable to indicate very small percentage variations of an amount of light. For instance, it can be used to indicate the absorption of light by a fluid and, consequently, to indicate or control the concentration of certain chemicals in suspension or solution. The use of monochromatic light can be used to advantage when it is desired to isolate a particular constituent. This circuit also finds application in color matchers and in indicating small changes of small amounts of light. For instance when measuring small changes of small amounts of light, it has been demonstrated that a change of light intensity on the order of two-millionths of a lumen is sufficient to swing the output meter over its full scale.

**A Variable-Range, Variable-Sensitivity Light-Variation Indicator.**—It is sometimes desirable to make the sensitivity of the light intensity meter indicator less for small percentage changes of light. The sensitivity can be reduced to any desired degree by varying the plate characteristics of the 954 between those of a pentode and those of a triode. This variation is produced in the arrangement shown in fig. 18 by properly adjusting  $P_2$  and  $P_3$  to control the relative potentials on the control grid and the screen grid.

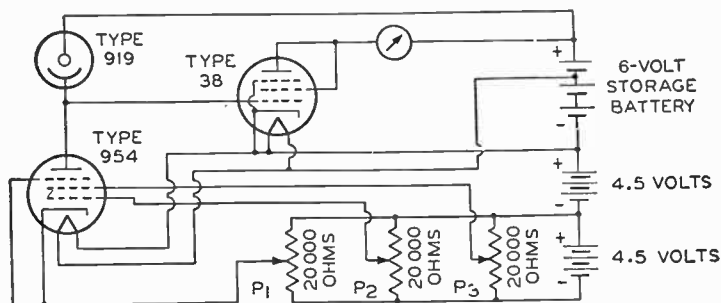

FIG. 18.—A light intensity indicator having a variable range and variable sensitivity.

When the No. 2 grid of the 954 is positive with respect to the cathode, the 954 has a high impedance pentode characteristic. Changing the No. 1 grid bias changes the height of the characteristic as shown in fig. 19 by the curves No. 1 and No. 2. As the potential of the No. 2 grid is made more negative, the characteristic of the 954 changes to that shown by curve No. 3. With zero bias on the No. 1, and the No. 2 grids, the characteristic curve is as shown by curve No. 4.

When a negative bias is placed on the No. 2 grid, the shape of the characteristic is unchanged, but it is shifted along the voltage axis as shown by curve No. 5. If the No. 1 grid is

biased properly, the slope of the characteristic is increased. Curve No. 6 shows the effect of positive bias on the No. 1 grid (bias on the No. 2 grid for this curve is zero). Placing a negative bias on the No. 2 grid shifts this characteristic along the axis as shown by curve No. 7.

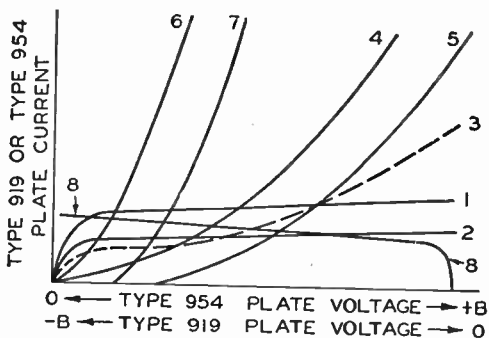

FIG. 19.—Plate characteristics of a vacuum-type phototube with a pentode having a controlled plate impedance as the phototube load.

From this analysis it can be seen that the 954 phototube load can be adjusted to give practically any desired positive impedance load at any desired current and at any desired voltage across the tube. This means that the full scale reading of the output meter can be made to cover a fraction of a per cent light variation, a 100 per cent light variation, or any desired amount of variation between these two extremes. A photo amplifier such as this finds application as a densitometer for use in connection with the analysis of photographically recorded spectra, and for use in connection with a suitable monochrometer or light filter as a means of measuring the absorption lines or the concentration of certain chemicals in solution. These are but two of a large number of possible applications for this type of circuit.

**Photo-Electric Exposure Control.**—Fig. 20 shows a circuit that will act to operate a relay or a solenoid when the phototube has received a certain predetermined amount of light after switch  $S_2$  has been closed. This action is independent of the time over which the light has been received, providing the time is greater than about  $\frac{1}{2}$  a second. In practice the phototube can be arranged to receive the light reflected from or transmitted through a part or the whole of the plate, film, or paper in the camera.

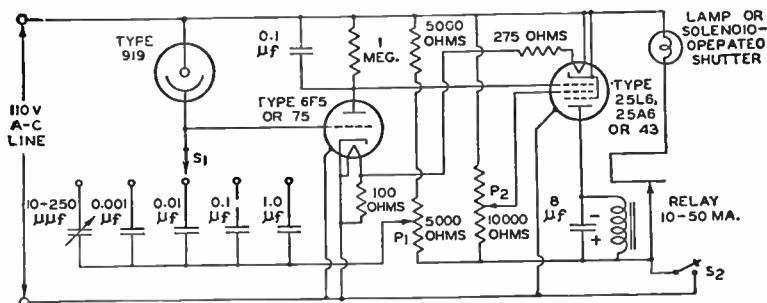

FIG. 20.—A light-quantity metering and control circuit.

When switch  $S_2$  is open the plate and screen voltages to the output tube are zero, and the output relay is de-energized. One side of the a.c. line is applied through one of the timing condensers to the grid, while the cathode is connected to the other side. Due to the rectifying action between the grid and cathode of the buffer the condenser assumes a charge, the direct potential of which reaches a value approaching the peak of the a.c. line voltage. On closing switch  $S_2$  the d.c. voltage or the major portion of this voltage is removed from between the grid and cathode of the buffer stage, thus allowing the above mentioned d.c. potential on the grid to cut off the plate current.

This in turn allows the voltage drop across the plate load of the buffer stage to drop to zero. As this drop across the buffer stage plate load is both signal and bias for the output stage, and as the plate and screen voltages of the output tube are applied by closing switch  $S_2$ , the plate current of the output tube will rise to operate the output relay or solenoid.

This in turn lights the exposure lamp or opens the camera shutter. After the charge across the timing condenser is dissipated through the phototube to a low enough value so that the grid of the buffer stage permits the buffer stage to conduct plate current, a voltage will be developed across the buffer stage plate load resistor of sufficient value to cut off the plate current of the output tube. This action releases the relay or solenoid, and thereby turns off the exposure lamp or closes the camera shutter.

*Theory.*—The current passed by a vacuum tube phototube is directly proportional to the intensity of the light received by the phototube, and is practically independent of the voltage across the tube. The quantity of light received is intensity times time, and is in general a measure of the proper exposure. The quantity of electricity passed by the photocell is proportional to its current times time, hence, the quantity of electricity passed is a measure of the quantity of light received.

As it takes a definite quantity of electricity to discharge a condenser from one potential to another, the size of the condenser and the voltage through which it has to be discharged can be used as a measure of the desired exposure. It should be noted that judgment of the operator is still necessary to determine the setting of  $P_1$ , which compensates for the percentage of light and dark areas in the picture.

This particular circuit finds its application in all types of copy work, and in all types of picture work where time exposures are used. For instance the exposure of zinc plates in newspaper work; the exposure in making microphotographs; in portrait work; in photostat work, in printing, etc. can all be controlled by this device.

**A Sensitive Light-Balance Indicator.**—Where it is desired to indicate accurately the balance between two amounts of light, the circuit shown in fig. 21 is of value. This circuit is capable of indicating a light unbalance of less than  $\frac{1}{4}$  of 1 per cent when the light on the phototubes is as low as 0.0001 lumens; the accuracy of balance is somewhat better with larger amounts of light. All of this is done by using the unregulated a.c. power lines for the power supply.

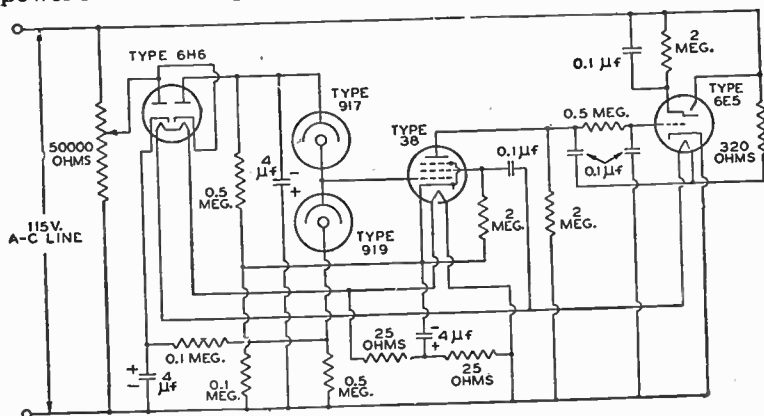

FIG. 21.—A sensitive light-balance indicator.

The circuit uses a 6E5 electron-ray tube as the balance indicator, a 38 as an a.c. operated buffer stage and electrometer, and a 6H6 as a rectifier to supply direct current to the 917 and 919 phototubes.



One phototube acts as the high impedance load for the other, so that relatively high voltage outputs are available, even for very small percentage variations of light.

The high impedance output of the phototube bridge circuit is fed directly to the grid of the 38. Because the cathode of the 919, the anode of the 917 and the grid of the 38 come out of the tops of the tubes, the connecting wires touch nothing but tube caps and the tubes can be coated with a suitable non-hygroscopic wax such as white ceresin wax to reduce to a minimum all external leakages. Low leakage is essential when measuring small amounts of light.

The type 38 acts on the alternating voltage supplied to its plate and screen in such a manner that the average direct potential built up on its plate is negative, and is of such magnitude that it can be used as bias and signal to the grid of the 6E5 indicator tube. As a means of increasing the input resistance of the 38, the heater is operated at reduced voltage, the screen at about 10 volts, and the plate at about 18 volts. To avoid the effects of emission from the heater to the grid, the heater is operated at a potential at all times positive with respect to the control grid.

In actual use a system of mirrors or reflecting surfaces are arranged to take the light from a common source and pass it through or reflect it from the surface of the sample under test.

A calibrated shutter, a pair of rotatable calibrated polarized discs, or a calibrated runway for the light source, can be used to determine accurately the change in balance intensity as various samples are placed between the light source and one of the phototubes.

With a suitable light source having the proper wave-lengths, this device can be used for color matching, turbidity measurements, reflectance measurements, and the absorption analysis of solutions.

It is generally known that all substances in solution have certain spectral absorption lines, and that the measurement of the amount of light of a particular wave-length that is absorbed by a solution, is an indication of the concentration of a particular constituent in the solution.

With a source of monochromatic light of the desired wave-length, the above circuit has been successfully used for accurately determining the sugar concentration in beverages, also the concentration of various syrups and flavorings. This arrangement has also been used commercially for determining the vitamin concentrations of vitamin bearing oils.

**Phototube Circuit for Matching Measurements.**—Matching measurement of photometric qualities such as brightness, color and turbidity, can also be made with high precision by means of circuit fig. 22. In this circuit one vacuum type phototube receives light from the test lamp or test material under observation. The other identical phototube receives light from the standard lamp or standard material.

A small inequality in light falling on the two phototubes causes a comparatively large voltage to be applied to the grid of the amplifier tube. By this means a very slight mis-match between the standard and the unknown can therefore be detected on a meter connected in the plate circuit of the amplifier tube.

Similarly this meter can also be used to obtain quantitative measurements. For example, if the brightness of a lamp is to be measured, the distance from the unknown lamp (or the standard lamp) to its corresponding phototube is varied, until the plate circuit meter indicates equal illumination on the two phototubes.

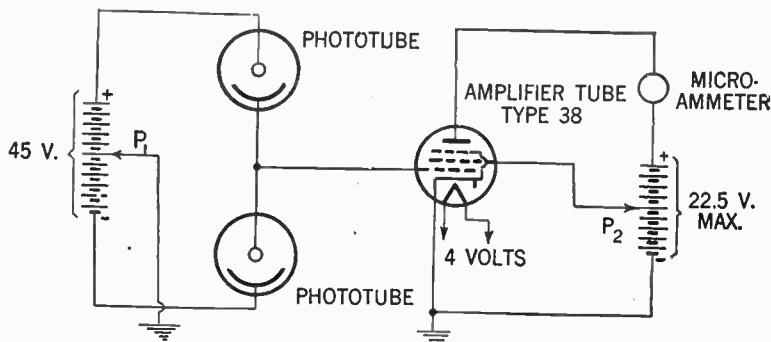

FIG. 22.—Sensitive circuit for matching measurement. Note:  $P_1$  should be set so that with no light on the phototubes, the output-meter reading is approximately mid-scale. Contact  $P_2$  should be set so that the maximum possible output current is limited to 100 microamperes.

The brightness on the unknown lamp can be computed from the inverse square law (see page 14). When other qualities are to be measured, the aperture of a shutter, which controls the amount of light falling on one phototube, is varied until the plate-circuit meter indicates that equal amount of light are falling on both phototubes.

This shutter obviously can be calibrated so that the value under measurement can be read directly from the setting of the shutter aperture.

The theory of this circuit may be considerably simplified if it is considered that one phototube acts as the load of the other as shown in fig. 23. In this figure, one of the phototubes is repre-

sented by the phototube current-voltage characteristics, and on this curve is drawn a reversed phototube current-voltage characteristic as a load line representing the other phototube.

The intersection of the characteristics gives the distribution of voltage across the two phototubes because the two phototubes being in series, must pass the same current.

This intersection is shifted widely by a small change in the light on one phototube. This change is shown by the dotted curves which is the characteristics for one tube under slightly decreased illumination.

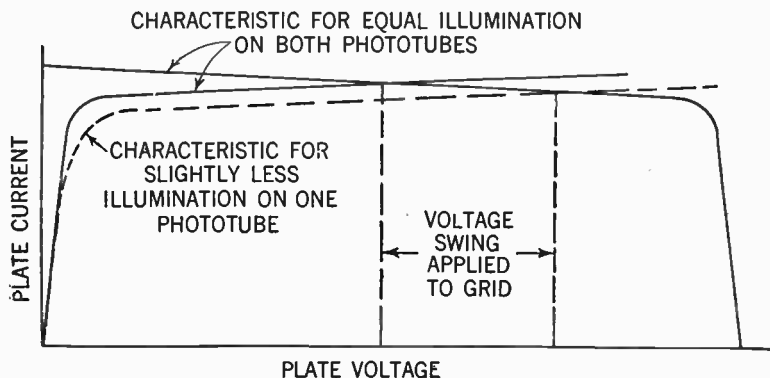

FIG. 23.—Phototube characteristics when connected as shown in fig. 22.

The wide shift means a large voltage swing on the grid of the amplifier tube and consequently, high sensitivity.

**Phototube Circuit for Measuring Low Values of Light.**— Small amounts of lights can also be made with a high degree of accuracy by means of circuit shown in fig. 24.

In this circuit the triode section of the type 85 tube starts to oscillate with  $L_1$  and  $C_1$  as the tank circuit. The oscillations will soon terminate because the grid builds up a negative charge on  $C_2$  and blocks the tube. Oscillations begin again when the grid draws enough positive charge through the vacuum type phototube to unblock the tube.

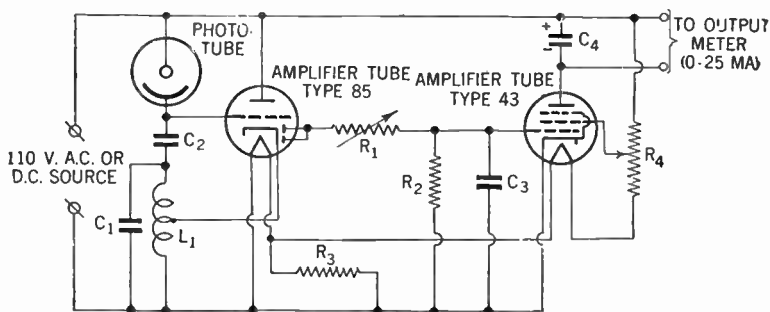

FIG. 24.—Circuit for measurement of small amount of light.

$$C_1 = 20 \text{ to } 150 \mu\mu\text{f}$$

$$C_2 = 50 \mu\mu\text{f}$$

$$C_3 = 0.5 \mu\text{f}$$

$$C_4 = 4 \mu\text{f}$$

$$L_1 = 1 \text{ to } 10 \text{ M H (Mid-tapped)}$$

$$R_1 = 0 \text{ to } 100,000 \text{ ohms (sensitivity control)}$$

$$R_2 = 0.5 \text{ megohm}$$

$$R_3 = 50 \text{ ohms (1 watt)}$$

$$R_4 = 275 \text{ ohms (25 watts)}$$

The same cycle, oscillation followed by cut-off is repeated. The duration of the cut-off period depends on the rate of flow of charge through the phototube, which, in turn, depends on the illumination of the tube.

The output of the 85 triode is, therefore, a series of trains of oscillations and the time trains depends upon the illumination of the phototube.

The diode section of the 85 rectifies these trains of oscillations and feeds a charge into condenser  $C_3$  for each train. The charge on the condenser  $C_3$  leaks off slowly through the high resistance of  $R_2$  so that the net d.c. voltage across  $C_3$  depends on the number of trains per second, which is a measure of illumination of the phototube. This voltage is applied to the grid of the 43 and is amplified to give a meter reading in the plate circuit of the 43. The meter is calibrated in terms of illumination on the phototube.

The high sensitivity of this circuit for the measurement of small amounts of light is due to the fact that it is the duration of the cut-off period which is used to measure the illumination.

Since grid current is small when the tube is cut off, the measurement of small current through the phototube is not disturbed by grid current and as a consequence extremely small amount of light incident on the phototube can be readily measured. The circuit can be adopted to the measurement of different ranges of light intensity by changes in  $R_1$ ,  $R_2$ ,  $C_1$  and  $C_2$ .

Operating power can be obtained directly from a 110 volt line a.c. or d.c. Operation on a.c. gives somewhat less sensitivity than operation on direct current.

**Circuit for Measurement of Illumination Ratios.**—Ratios of illumination can be measured by means of the a.c. operated circuit shown in fig. 25. Condenser  $C_1$  is charged during one half-cycle through one phototube. On the next half-cycle the condenser is charged in the opposite direction through the other phototube.

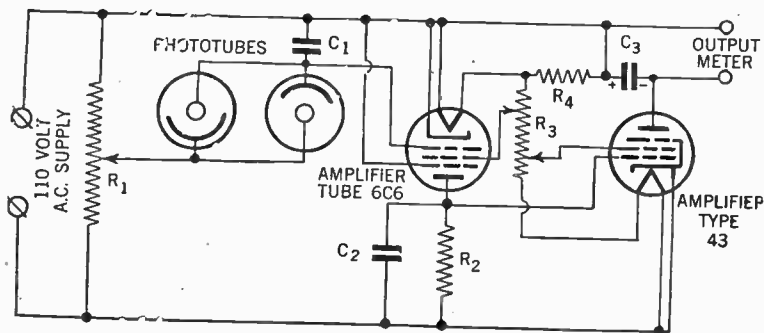

FIG. 25.—Circuit for measurement of light intensity ratios.

$$C_1 = 0.0001 \mu f$$

$$C_2 = 0.25 \mu f$$

$$C_3 = 4 \mu f$$

$$R_1 = 5000 \text{ to } 500,000 \text{ ohms (sensitive control)}$$

$$R_2 = 0.5 \text{ megohm}$$

$$R_3 = 275 \text{ ohms (25 watts)}$$

$$R_4 = 50 \text{ ohms (1 watt)}$$

If now the vacuum type phototubes are equally illuminated they feed equal charges into the condenser and the net d.c. voltage across the condenser is zero.

When, however, the phototubes are *unequally* illuminated there is set up across the condenser, a d.c. voltage whose magnitude is a function of the ratio of illuminations. This condenser voltage amplified by the 6C6 and the 43 is read on the output meter which can be calibrated to show directly the intensity of one source as a multiple or a fraction of that of the other.

**Sound on Film Circuit.**—A typical first stage circuit for a sound-head amplifier is shown in fig. 26. Load resistance values for this service depend on gain and fidelity requirements. Higher values of load resistance give higher gains but with some increase in distortion.

An illustration of a typical relay circuit is given in fig. 27. In this circuit high sensitivity is obtained by the use of a large load resistance.

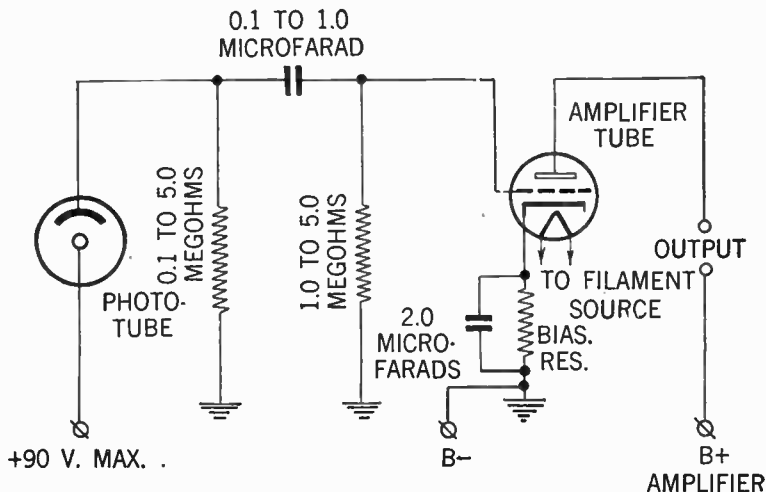

FIG. 26.—Typical circuit employing a gaseous type phototube for sound frequency reproduction.

It should be noted that most amplifier tubes are rated for operation with a grid circuit resistance of less than 1 or 2 megohms. When a higher resistance phototube load is used in the grid circuit of the amplifier tube, it will be necessary to take precautions to prevent the grid of the amplifier tube from building up a high positive potential and thus causing the tube's plate current to become excessive.



Such precautions are: reduction of the plate and screen supply voltages much below the rated values, reduction of the heater or filament voltage, and use of a large resistance in the plate supply lead to limit plate current.

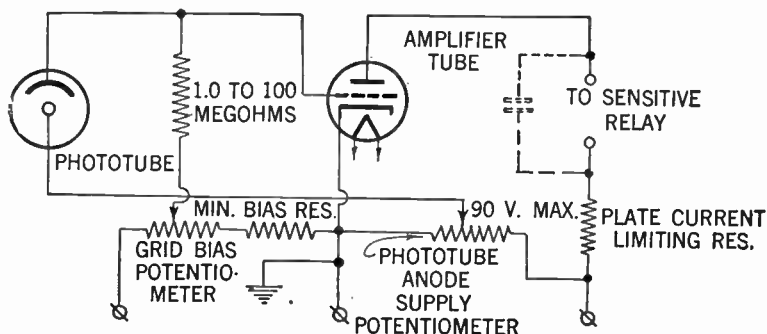

FIG. 27.—Typical relay circuit employing gaseous type phototube.

**High-voltage Circuit Providing Overvoltage Protection of Gaseous Type Phototube.**—In some relay applications, it may be desirable to gain increased sensitivity by the use of a very large supply voltage.

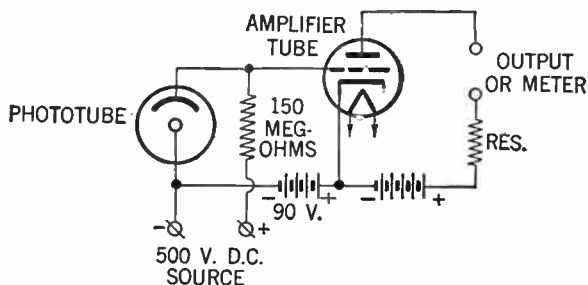

FIG. 28.—Typical high-voltage circuit providing over-voltage protection for phototube.

This can be accomplished by the use of a circuit similar to that shown in fig. 28 in which the voltage across the phototube cannot rise above 90 volts. In this circuit, the amplifier tube must be protected against excessive plate current by following the precautions previously mentioned. These precautions are essential because the resistance of the phototube is very high and is connected in the grid circuit of the amplifier tube.

**Ultra-High Speed D.C. Operated Photo-electric Relay.**—In many modern processes it is required to employ a photo-electric relay which will respond to a light impulse lasting but a few microseconds. For example, many wrappers for packaged articles first have printing applied in a rotary press, then are removed to a machine which cuts the wrapper in register with the printing and applies it to the package.

Here it is necessary for accurate high speed work, for photo-electric control apparatus to provide the synchronizing tie between the cutting knife and the printed matter on the web, because factors such as slip of the web in the machine and variations in stretch of the web preclude successful operation otherwise. Because it is essential that the photo-electric apparatus work on some small part of the printed design which may give but small photo-electric contrast with its background (or on some small mark printed specifically for the purpose) and at the high web speeds possible in modern machines, an extremely sensitive and fast photo-electric device is required.

The type of relay shown in figs. 29 and 30 has been found to be adapted to meet the exacting requirements of this type of service. Its virtues may best be understood, perhaps, from the following description of the operation of its circuit, shown in somewhat simplified form in fig. 31.

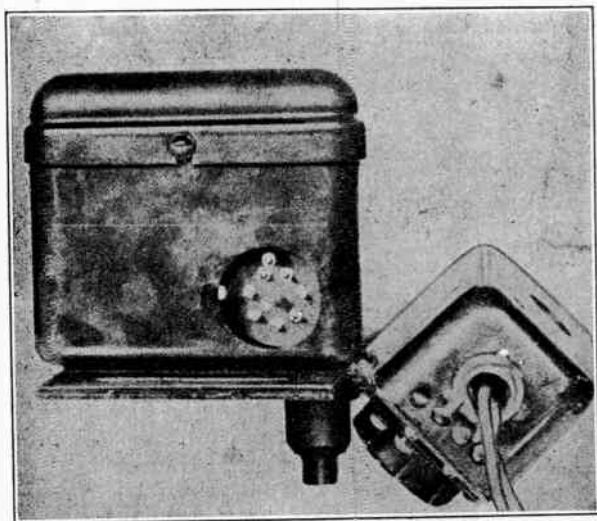

FIG. 29.—Scanning head of ultra high speed D. C. operated photo-electric relay. (Courtesy General Electric Co.).

In order that the tubes may operate at any instant and be as free as possible from the transient voltage disturbances common on industrial power distribution lines, power is usually taken from the a.c. power source used for incandescent lighting, modified in voltage by an electrostatically shielded transformer, rectified and carefully filtered by a full wave rectifier tube and  $\pi$ -filter. The practically pure d.c. voltage thus derived is applied across voltage dividers from which are tapped the voltages required by the various tubes.

Because of the high impedance of the photo-electric tube, and the extreme speed at which this circuit must work, the photo-electric tube and amplifier are placed as close together as possible in a shielded enclosure known as the "scanning head," see fig. 29.

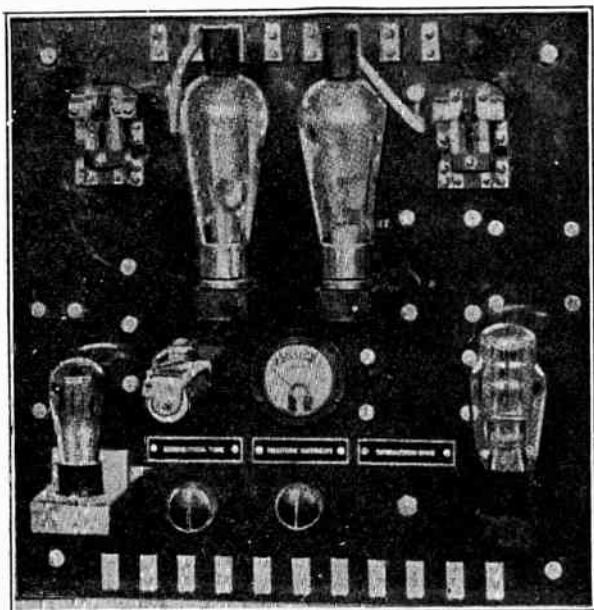

FIG. 30.—Control panel of ultra high speed D. C. operated photo-electric relay. (Courtesy General Electric Co.)

Usually the light source is mounted on the scanning head by a bracket, thus providing a unit which operates from change of reflected light which is relatively free of troubles due to moisture, dirt, electro-static interference, or variations in focus. Sometimes, dependent upon the installation and upon the web material, the light source is mounted on the opposite side of the web from the photo-electric tube housing, thus

providing a unit which operates upon transmitted light, which may allow a larger value of light flux to fall upon the photo-electric tube.

Due to the relatively high level of power output from the scanning head, however, the grid controlled vapor discharge tubes, control contactors, and rectifier may be mounted in a separate enclosure several feet from the scanning head in such a manner as to allow easy access, and in a position free from vibration.

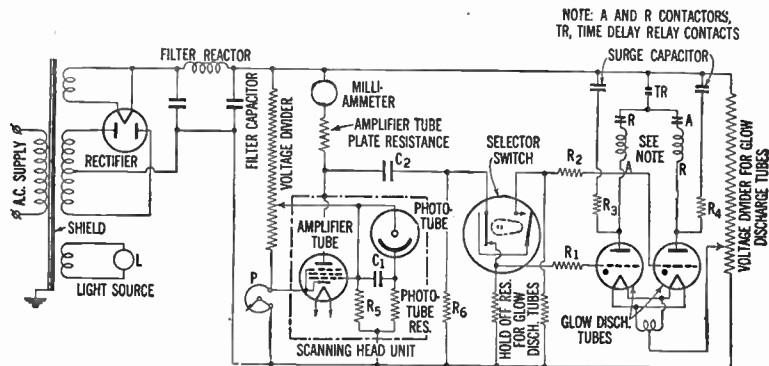

FIG. 31.—Ultra-sensitive high speed D. C. register control using photo-electric tube and grid controlled vapor discharge tubes.

Particular notice should be taken of the method of circuit coupling. Referring to fig. 31 the photo-electric tube-amplifier circuit operates as follows: When there is no change of light on the photo-electric tube, capacitor  $C_1$  assumes the potential existing across the photo-electric tube resistor, there is zero current flow in  $R_3$  and the amplifier tube grid is at ground potential, negative with respect to its cathode. However, upon change of light on the photo-electric tube, since the response of the tube is instantaneous, a new potential value exists across the photo-electric tube resistor.

The voltage across  $C_1$  must finally equal the new voltage across the resistor but, since a capacitor cannot change its charge instantly, the difference between the old and the new voltage existing across the resistor must initially appear across  $R_5$ , changing the grid potential of the amplifier tube by that amount. The grid potential will be carried in a more positive or more negative direction, depending upon whether the capacitor is charged or discharged. Hence, due to the "capacity coupling" effect, the amplifier will respond to rapid changes of light, but not to slow changes.

The pentode is used for the amplifier tube because its plate current is independent, roughly speaking, of the plate voltage value, if that value be kept above a certain minimum. Hence high values of plate resistance may be used and great amplification secured.

The grid controlled vapor discharge tubes are normally biased negatively through hold-off resistors of moderately high value. Their grid circuits are carried through a selector switch and capacity coupled through  $R_6$  and  $C_2$  to the amplifier. Hence, if  $TR$  be closed,  $A$  and  $R$ , be de-energized, one grid controlled vapor discharge tube or the other, according to the position of the selector switch, will be in condition to be rendered conducting by its grid being carried positive by a voltage of correct polarity appearing across  $R_6$  (a circuit of low impedance). The tube, once fired, will remain conducting until  $TR$  is opened, even though the potential across  $R_6$  may have become zero meanwhile, or the selector switch contact opened, carrying the grid negative.  $A$  and  $R$  are the operating coils of contactors which operate to produce the required correction; while  $TR$  opens, then recloses after the desired correction period has passed, rendering the tube non-conducting again and putting it in condition to operate on the next proper impulse.

Relays of the type of fig. 30 will operate on a minimum light change of 0.02 lumen occurring at an average rate of between 2 and 200 lumens per second.

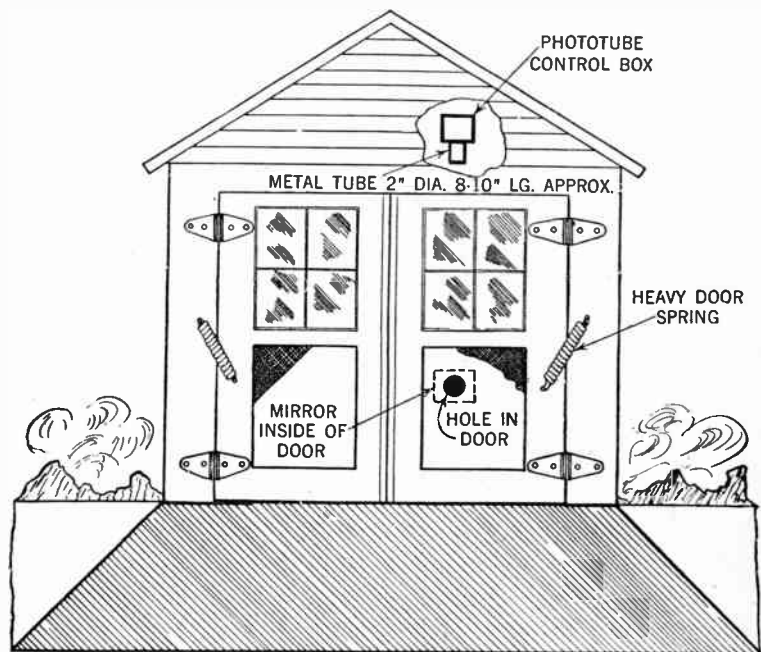

FIG. 32.—Front elevation showing relative approximate location of light admittance opening and relay box.

**Automatic Opening of Garage Doors.**—A practical, inexpensive and reliable device for automatically opening of garage doors by means of directing the headlight beam on a photoelectric tube is shown in figs. 32, 33 and 34.

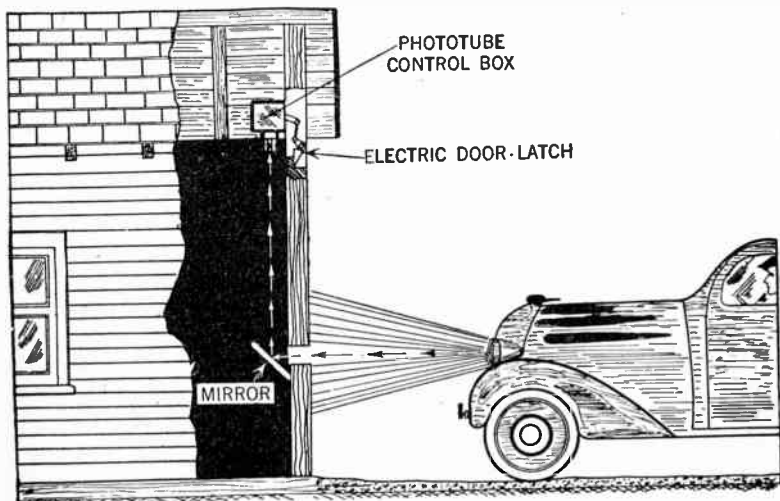

FIG. 33.—View showing arrangement and position of car for automatic opening of garage doors.

Due to the absence of mechanical door actuating or trigger devices the equipment shown is very simple to install and maintain. It consists of two units—an electrically operated door-opener or release associated with the relay cabinet, and a mirror which reflects the light beam to the photo-electric cell.

A circular hole in the door admits the light beam, which is reflected to the light sensitive tube by the mirror which is installed at a  $45^\circ$  angle on the inside of door as depicted.



The door opener (of similar type as is used in apartment house doors) is energized from a bell ringing transformer, which in turn receives current through relay contacts *H*, as shown in diagram fig. 34.

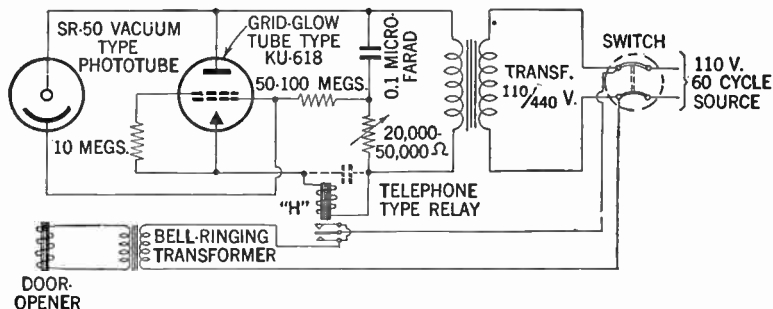

FIG. 34.—Diagram of connections for apparatus suitable to operate garage doors. (Circuit values are approximate only and may be adjusted if required).

When a current impulse is sent through the coil of the door opener it releases the latch, and the doors are opened by action of heavy coil, door springs. The springs should be mounted in such a way so as to exert their full force against the doors, as they are released, and are installed on the outside of doors as shown.

This device is suitable for opening of small and medium sized swing doors only and not for heavy duty doors of roller or folding type. A typical circuit capable of handling currents required for motor operated heavy-duty garage doors, is shown on page 958

When there is no light falling on the photo-electric tube, the grid-glow tube passes no current. As soon as light falls on the phototube a breakdown of ionization of the gas within the grid-glow tube occurs and current passes between the anode and cathode.

Hence this current passes through the relay winding *H* which relay closes its contacts and energizes the bell ringing transformer which operates the coil of the door-opener mechanism.

The relay *H* may be of the D.C. communication or similar type. With some types of relays it may be desirable to shunt the coil winding with a small condenser of 0.1 m.f. or larger to prevent chattering.

The circuit is operated from a regular 60 cycle 110 volt source. The transformer should have a ratio of 110/440 volts, and as the load is very light less than 1 watt, a regular transformer of type used in radio receiving set may be used as long as the voltage ratio is satisfactory.

**Electronic Remote Control Device for Radio Receiver.**—A radio receiver remote control box by means of which a radio can be controlled from any point in the house, has recently been developed by the R.C.A. engineers.

Referring to figs. 35 and 36 the heart of the device consists of a gas discharge tube which is ionized by radio impulses, being created by the simple process of pushing a button of a small box located at the point where the control is desired. This box contains a miniature radio transmitter, the signal of which is sent over the light circuit wires to the receiver. (I.e. with this type of remote control the radio receiver proper is controlled by means of radio waves, which are set in motion by the pushing of a selected button of the control box.)

**How the Control Box Operates.**—The control box shown schematically as in fig. 35 contains a number of push buttons and an oscillator. The box is plugged into a convenient wall outlet of the house lighting circuit. When pressing a button of the control box a radio impulse is generated by the oscillator and instantaneously transmitted over the house lighting circuit to the remotely located receiver, which is put into operation.

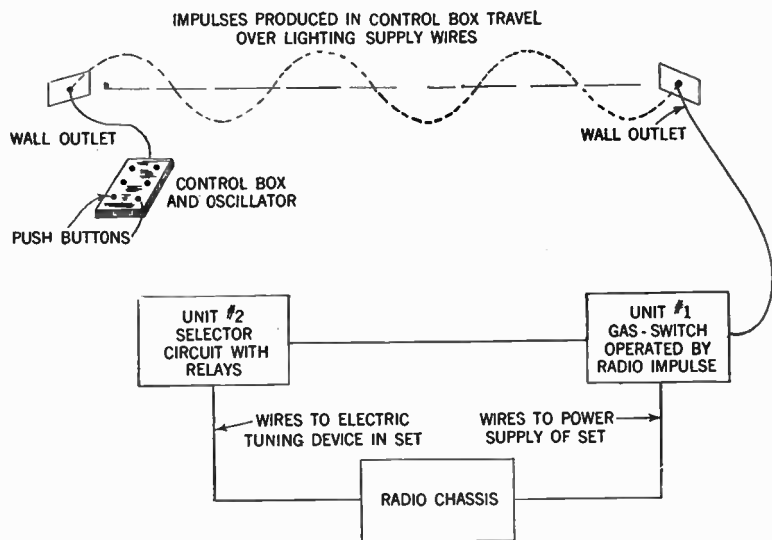

FIG. 35.—Elementary diagram of connection between the principal units used in radio receiver remote control.

If the station so received is not the one desired another button is operated which automatically is atuned to this preferred frequency. If the loud speaker is too high or too low a third button is operated for this adjustment, etc.

**The Gas Discharge Tube Is the Heart of the Device.**—The fundamental principle of this control scheme is the application of the gas tube switch the circuit of which is shown in fig. 36. This tube designated as the WE-313A is connected on one side with a potentiometer formed by condensers  $C_2$  and  $C_3$ .

By varying  $C_3$  the voltage between the electrodes  $A$  and  $B$ , can be adjusted to any desired level. The system operates as follows: It is generally well known that any gas filled tube has a specific breakdown value, which is that voltage at which the tube conducts, and starts a current flow between the electrodes of the tube.

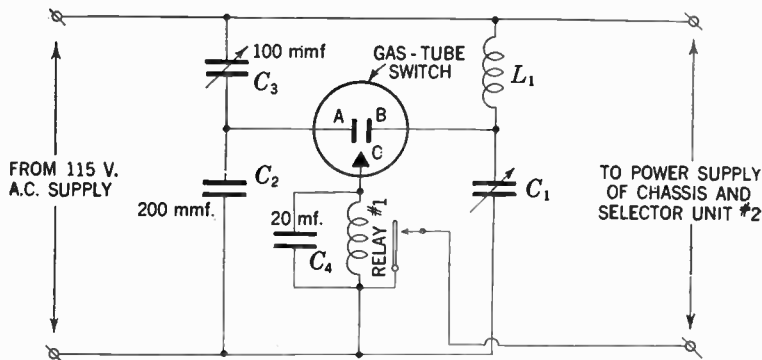

FIG. 36.—Diagram of connection for gas discharge tube, and associated apparatus located in unit No. 1 fig. 35.

The break down value for this particular tube is approximately 70 volts. Now if  $C_3$  be adjusted until only 60 volts exist between points  $A$  and  $B$ , no ionization will take place between those points despite the fact that only 10 volts more are required before the tube will start to conduct, and consequently there will be no current flow through the tube.

With this in mind consider condenser  $C_1$  and the inductive coil  $L_1$ . This condenser and coil are the units of a timed circuit, in this case a circuit tuned to 300 K.C.

The oscillator contained in the previously described control box shown in fig. 35 radiates a radio impulse of 300 K.C. into the power line. Since now  $L_1$  and  $C_1$  are coupled with this line a radio potential will form across  $L_1$ . This additional voltage added to the existing 60 volts already across the gap will start the ionization between electrodes  $A$  and  $B$ , and a current will flow instantaneously. However, this flow is also taking place across  $B$  and  $C$ , and when relay No. 1 closes the circuit, the set as well as the selector unit No. 2 are connected with the power line.

Additional tubes and relays installed in the No. 2 selector unit respond to other signals originating in the oscillator and operate a small electric motor of the type already built into modern electric tuned receivers.

It is by these means that a large number of different radio transmitting stations, together with the off and on switch and the volume control, may be operated. Also since the impulses require only the house lighting circuit as a tie-in between the control box and the radio set with its auxiliaries, it is evident that the radio may be controlled from any place in the house where a wall outlet can be found.

Evidently the above described control units may be assembled together with the set proper, and thus simplify the assembly as a whole.

**Capacity Operated Relay Circuits.**—It is a well known fact that if the grid from any ordinary vacuum tube be entirely disconnected from the outside circuit and the tube be connected as shown in fig. 36, and the base pins be insulated to prevent leakage, the tube will be sensitive to capacity effects, a body, or metal objects placed in proximity of the tube. This phenomenon has been utilized in various ways such as in burglar alarms, show window displays, door openers, counters, signaling systems, etc.

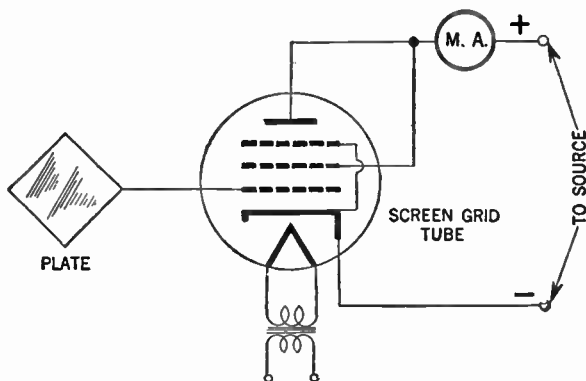

FIG. 36.—Simple circuit for capacity indications.

**Self-Balancing Capacity-Operated Relay.**—When it is desired to operate a relay only on a change of capacity occurring within a period of several seconds, the antenna to ground capacity may drift considerably over long periods of time, due to temperature and humidity changes. A circuit which will automatically re-balance itself after a short period of time to compensate for the slow variations of the antenna to ground capacity within a certain range is shown in fig. 38.

In this circuit operating on the a.c. line, the sensitive element consists of a pentode oscillator, the feed-back of which is determined by the difference in the ratio between the inductance of

the two parts of the oscillator coil  $L_1$  and  $L_2$  and the ratio between  $C_1$  and the antenna-to-ground capacity. Because the cathode of the oscillator is at an  $r$ - $f$  potential, and because the control grid of the output is by-passed for high frequencies

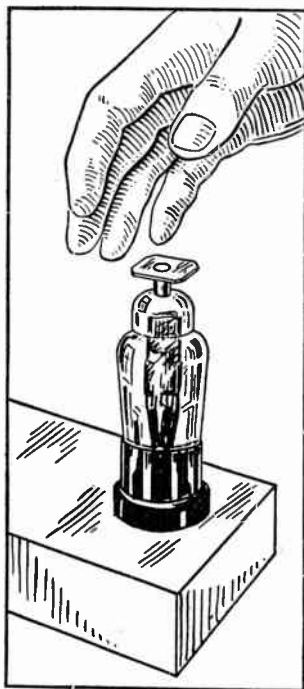

FIG. 37.--If a sensitive current indicator be connected as shown in fig. 36, the meter will show the current change due to the capacity effect, if a hand be placed in proximity to the antenna.

through suitable by-pass condensers to the cathode of the oscillator, a negative d.c. voltage equal to the peak  $r$ - $f$  voltage on the cathode of the  $6J7$  is built up across the grid-leak and condenser of the  $25L6$  due to the rectifying action of the grid. The  $6J7$  oscillator oscillates at high frequency on one-half of the a.c.

cycle and builds up the above mentioned negative charge on the grid of the output tube.

During this time, the output tube has negative plate and screen voltages and so is non-conducting. On the other half of the a.c. cycle, the 6J7 oscillator has negative plate and screen voltages and so ceases oscillating. The negative charge built up on the grid of the output tube does not leak off during this interval and, hence, is effective in controlling the plate current of the output tube during its positive plate-voltage interval.

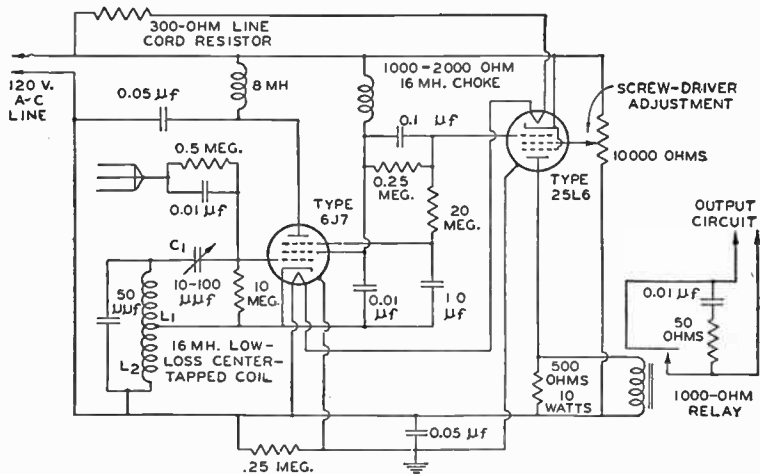

FIG. 38.—Self-balancing capacity-operated relay.

The sensitivity of the unit is an inverse function of the quality of the oscillator coil; that is, the lower the losses in the oscillating circuit, the greater will be the sensitivity. Theoretically, as the oscillator plate impedance approaches infinity and the losses in the antenna and the tuned circuit approach zero, the sensitivity approaches infinity. Sensitivity gained in this manner is much more stable than that gained by regeneration.



The sensitivity of this circuit to small changes in capacity can be increased regeneratively by increasing the resistance of the choke coil feeding the screen of the 6J7. When this resistance is more than about 15,000 ohms, the circuit will become unstable, *i.e.*, the relay will relax.

The increase in sensitivity is caused by the fact that as the intensity of oscillation of the 6J7 increases, its plate and screen currents decrease. This causes the screen voltage and hence, the mutual conductance of the 6J7 to increase; the increase, in turn, helps to increase the intensity of oscillation. Chattering of the relay can be effectively eliminated by the damping resistor placed across the relay coil. If desired, the resistor can be replaced by an electrolytic condenser large enough to keep the relay from chattering. (8 microfarads for most relays.)

The intensity of oscillation is automatically controlled by feeding a negative potential to the No. 3 grid of the 6J7. This potential makes the grid negative with respect to the cathode, reduces the mutual conductance of the tube, and reduces the plate impedance of the tube which is effectively shunted across the lower part of the tuned circuit. Both of these actions tend to reduce the amplitude of oscillation for a given feed-back or to make the oscillator require a greater feed-back for a given intensity of oscillation.

As the negative potential applied to the No. 3 grid of the 6J7 is derived through a time-delay circuit from the grid of the output tube, this grid, as explained above, assumes a direct potential equal to the peak high-frequency voltage appearing across the lower half of the oscillator coil,  $L_2$ . Thus, the intensity of oscillation is maintained substantially constant for wide variations in antenna-to-ground capacity (feed-back).

The above is true for slow capacity variations; however, sudden variations cause the intensity of oscillation to vary rapidly before the corrective voltage can be applied through the condenser-resistor time-delay circuit to the No. 3 grid of the 6J7. Hence, short time capacity variations are effective in operating the relay while long-time variations within limits are automatically compensated for.

**The "Petescope"\* and Principle of Operation.**—In all of the hitherto employed photo cell applications the apparatus have been actuated by either an increase or a decrease in the photo-electric current caused by the actuating light effect. They have, therefore, been responsive to a quantitative charge.

The magnitude of this change is in general closely related to the ratio between the extent of the controlling light effect and the total light flux received by the photo-electric cell.

Obviously for reliable practical results the percentage change in relay current which is due directly to the actuating effect must be substantially greater than that due to all other possible variables.

In commercial applications, it is apparent, from the above, that unless the actuating effect represent a sizeable fraction of the total light, which in the general cases means, unless the actuating effect occupies a substantial portion of the field of view embraced by the photo cell, the system will require a closely adjusted and sensitive relay and commensurate maintenance.

\*The "Petescope." A new principle in photo-electric application, by Alan S. Fitzgerald. *Franklin Inst. Journal*, September, 1936.

The apparatus has been named the "Petescope" in reference to its outstanding quality of actually seeing moving objects. It requires no light source or other external appurtenance, the motion of the object being the primary actuating agent.

It is a feature of a very large majority of photo-electric applications that the object to which they are required to be responsive is, incidentally, a moving object.

In the photo-electric system represented by the "petescope" a degree of sensitivity, far surpassing the hitherto obtained in systems based on purely quantitative action, is achieved by making the system specifically responsive to the motion of the object.

This system is actuated not by the amount of light falling upon the light sensitive element, but instead, in accordance with the first divided function or rate of change in illumination. The apparatus is entirely unresponsive to any steady value of illumination, whether of high or low intensity.

In addition a double optical system is used in conjunction with a pair of photocells connected in a balanced bridge arrangement. As a result of this feature the apparatus can only be actuated by effects tending to unbalance the bridge arrangement, and accordingly the system is entirely unresponsive to fluctuation in the general level of illumination of the field of view.

It responds only to pulsations in the light affecting the two optical systems which have the effect of causing an alternating unbalancing of the bridge. The response is proportional to the rate of change, or the frequency of the unbalancing effect.

The field of view is, therefore, exhibited to the photo-electric elements through special screens or gratings by means of which continuous movement of any object within the field of view causes a fluctuating or alternating component in the photo-electric currents.

Where there are no moving objects no alternating component is present. The movement of the objects creates an alternating component. This represents a qualitative change in conditions which, even though it be of minute amplitude, may be detected with much greater effective sensitivity than merely a quantitative change.

The presence or absence of a characteristic effect can obviously be more readily detected than a difference between the magnitudes of two effects of like nature. Thus a much greater degree of amplification can effectively be employed and exceptional sensitivity to small or distant object is achieved.

Fig. 39 shows the essential elements of the system in a diagrammatical form. A pair of objective lenses  $L_1$  and  $L_2$  embrace an optical field which includes a movable object which is distinguishable by color or shade from its background; such, as for example, an airplane.

Light falling upon the objective lenses is directed through two approximately parallel beams onto the two phototubes  $P_1$  and  $P_2$  shown in the diagram, a pair of condensing lenses  $C_1$  and  $C_2$  serve to concentrate the light onto the photocells. The two objective lenses tend to set up duplicate images of the optical field at their respective focal planes. Approximately at these focal planes are mounted two specially divided screens  $S_1$  and  $S_2$  through which all the lights reaching the photocells have to pass.

The two screens are divided into a number of small portions alternately transparent and opaque. The divisions may be regular or irregular and may be of various shapes or patterns, but both screens are exactly identical in patterns and are of opposite characteristics. That is to say, if any portion of the screen  $S_1$  is opaque the corresponding section of  $S_2$  is transparent; and vice versa.

In other words the two screens have exactly the characteristics of a photographic negative and a transparent positive thereon. The screens may conveniently be found in this manner.

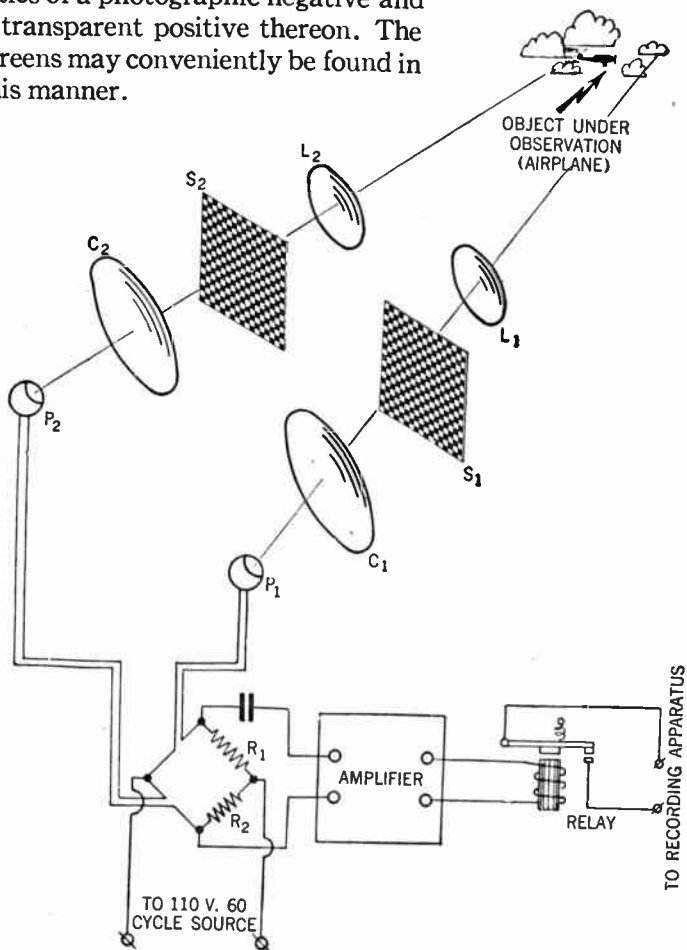

FIG. 39.—The P-tescope and arrangement when an object moving both in the horizontal and the vertical plane is under observation.

In fig. 39 these screens are shown divided regularly, according to a checker-board pattern.

The rectangular divisions are identical in shape and dimensions, but it will be seen that each square which is transparent in  $S_1$ , is opaque in  $S_2$ . Likewise, each square which is opaque in one is transparent in the other.

It will be apparent that, according to this arrangement, duplicate images of the field will be cast on the screens. A ray of light emanating from any given point in the field will be projected to duplicate focal points on the screens.

It is important to note that if the position of the point in the image falls on an opaque section on  $S_1$ , the position of the same point on the image formed on  $S_2$  will lay on a transparent section. Thus the ray of light from the said point will pass through the screen  $S_2$  and will impinge on the photo-sensitive element  $P_2$  whereas the duplicate ray falling on  $S_1$  will be stopped thereby and will not reach  $P_1$ .

It follows therefore that a ray of light emitted by any given point in the field will be transmitted in duplicate as far as screens  $S_1$  and  $S_2$  but therefore only one of the duplicate beams of light will be further transmitted to the photo-sensitive device, the other one being stopped by the screens.

Thus, light from any given point may reach one or the other of the photo-sensitive elements, but not under any circumstances both of them at the same time. Therefore, if an object in the field be mobile, and if it be of such distance from the lenses and of such dimensions that the image thereof, on screens  $S_1$  and  $S_2$  is of the same order of magnitude as the divisions of the screens, or smaller, the image of the object, as the latter moves across the field, will alternately appear on opaque and on transparent divisions on the screens.

When it appears on a transparent portion of  $S_1$  it will stimulate  $P_1$ , but will be on an opaque section of  $S_2$  and will not affect  $P_2$ . Likewise, after it has moved a short distance, it will come onto an opaque area on  $S_1$  and into a transparent portion of  $S_2$  when it will affect the photo-sensitive element of  $P_2$  but not  $P_1$ .

Thus, movement of the object will give rise to alternating stimulation on the photo cells  $P_1$  and  $P_2$ .

The frequency of these alternations will depend on the velocity of the movement, the distance of the object from the lenses, and upon the dimensions of the divisions on the screens  $S_1$  and  $S_2$ .

If on the other hand there be no measurement of any kind occurring in the field, no matter what degree of differing color or shade may be distributed, according to any kind of pattern, in the background and other objects comprising the field, the light reaching the photo-sensitive elements  $P_1$  and  $P_2$  respectively will be substantially equivalent and of steady value. Variations in the intensity of the general illumination of the field will cause like variation in the stimulus of  $P_1$  and  $P_2$ .

The photocells  $P_1$  and  $P_2$  together with two resistors  $R_1$  and  $R_2$  are therefore connected so as to form a balanced bridge circuit as shown in fig. 39.

The amplifier is connected through a coupling condenser, across normally equi-potential points of the bridge.

Thus, only a difference between the amount of light received by the two photocells  $P_1$  and  $P_2$  will unbalance the bridge, and because of the condenser coupling, only a varying out-of-balance voltage will affect the amplifier.

The amplifier, therefore, will not respond to changes in intensity of daylight because this tends to affect both photocells simultaneously. This feature is of importance because under weather conditions involving cloud effects of the cumulus and similar forms, the passage of cloud patches, of the type which

have clearly defined margins, across the place of the sun, may cause the ambient light intensity to undergo a change of several hundred per cent, in a few seconds, representing an appreciable rate of change quite enough to affect, in a substantial degree, a single condenser coupled photocell and sensitive amplifier.

A still more important external condition that must not be overlooked is the possible use of apparatus of this type under artificial illuminations.

The 120 cycle flicker, present in all 60 cycle light sources, while it is not important to the eye, would affect a single condenser connected to the photo-cell and amplifier an extent many times greater than the minimum threshold value of response possible in modern amplifiers.

Both of the above disturbing elements are obviated by the use of bridge connections.

**Special Applications:**—In fig. 39,  $S_1$  and  $S_2$  are shown divided in checker-board pattern. This is an appropriate arrangement for applications associated with aircraft or any purpose in which the movement of the object may take place in any direction.

If, however, the application is such that, due to the essential nature of the case the motion of the object take place, entirely, or principally in one plane only, any other component of the motion being of no significance, it is not necessary to utilize screens  $S_1$  and  $S_2$  divided as previously shown. For example in a system primarily intended to be actuated by objects moving across the field of view in a horizontal plane, screens divided vertically only as shown in fig. 40 may be used.

It is obvious that only the horizontal component of the motion in such an application will be of significance.

The effect of the screen of this form will be that the apparatus will be responsive only to the horizontal component of motion



since only movement in this direction will set up an alternating component in the photo-electric currents. Similarly the axis of screen divisions may be circulated according to any direction if it is desired to provide a system for responding selectively to a given directional component of motion.

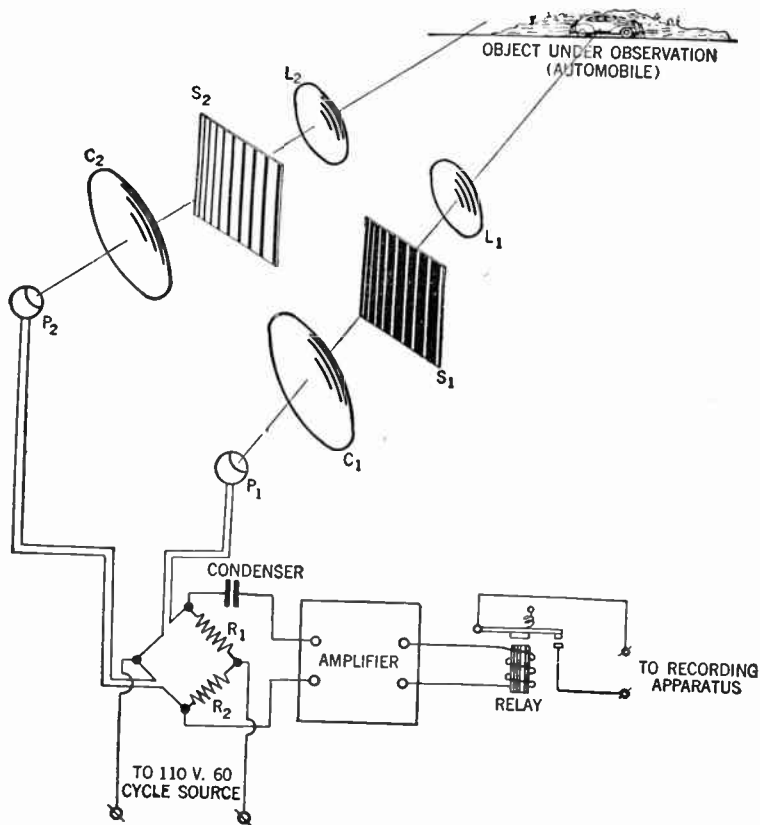

FIG. 40.—The Petescope and arrangement when an object moving in the horizontal plane is under observation.

Where as shown in fig. 40 an automobile is moving along a highway approximately at right angles to the optical axis of the apparatus, the latter being located at a known distance from the highway, the frequency of the signal emitted by the apparatus is a direct function of the speed of the car.

It is possible therefore to check the speed of vehicles on a highway in this manner by means of apparatus mounted on side of the road only, and installed, if desired, at some considerable distance from the highway.

By employing screens as shown in fig. 39 indication of the sense of the motion may be obtained. In fig. 40 the screens have vertical divisions and are thus intended to be actuated by horizontal motion. The vertical divisions are now, however, of uniform width, but are of increasing width from left to right.

Thus if an object traveling at uniform speed moves so that its image traverses the screens from left to right, a signal of decreasing frequency will be obtained. If the object moves in the opposite direction the frequency will increase. Thus, if the signals be transmitted or registered in any suitable manner, an indication or record of the sense of motion of the object may be obtained. For example, if the signal be listened to on a telephone it will have a clearly defined characteristic sound in accordance with the sense of motion. Alternatively the signal may be recorded on an oscillograph or string galvanometer.

As is suggested in fig. 39 *this principle has obvious possibilities in connection with military and naval reconnaissance.*

If the Petescope be properly adjusted and built for maximum sensitivity movements of airplanes can be easily detected at an altitude of 2,000 feet and under favorable weather conditions at altitudes up to 3,000 feet or more.

**Miscellaneous Phototube Circuits.**—The several circuits shown illustrate additional methods of using phototubes. In most cases operating voltages and circuit values are given.

It will, however, often be found that these do not represent the ideal condition for a particular purpose, and therefore the values which produce the best result should be used. In several of the circuits the phototube controls the grid bias of a vacuum amplifier tube, while in other circuits the phototube controls the grid bias of a thyatron.

This latter circuits are particularly useful in that they operate entirely from alternating current and the control current may be relatively large.

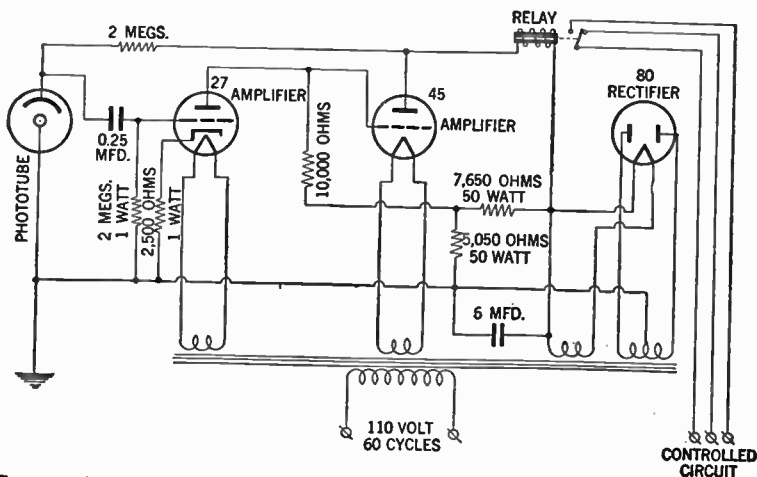

FIG. 41.—Amplifier circuit suitable for control of small motors.

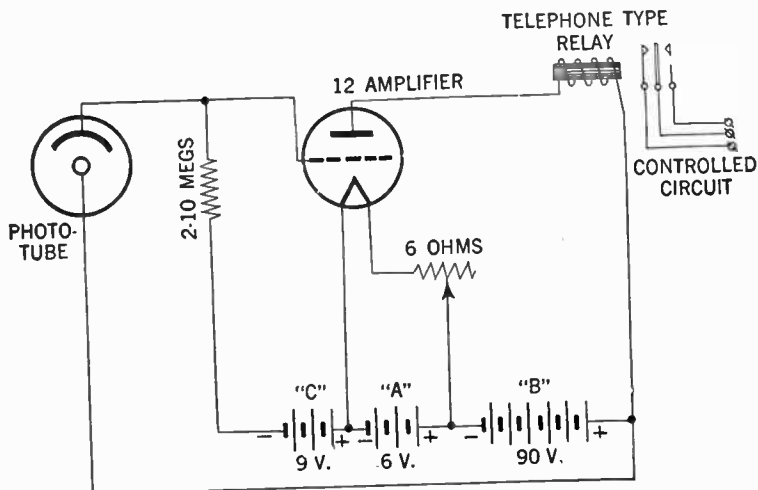

FIG. 42.—Simple battery operated amplifier.

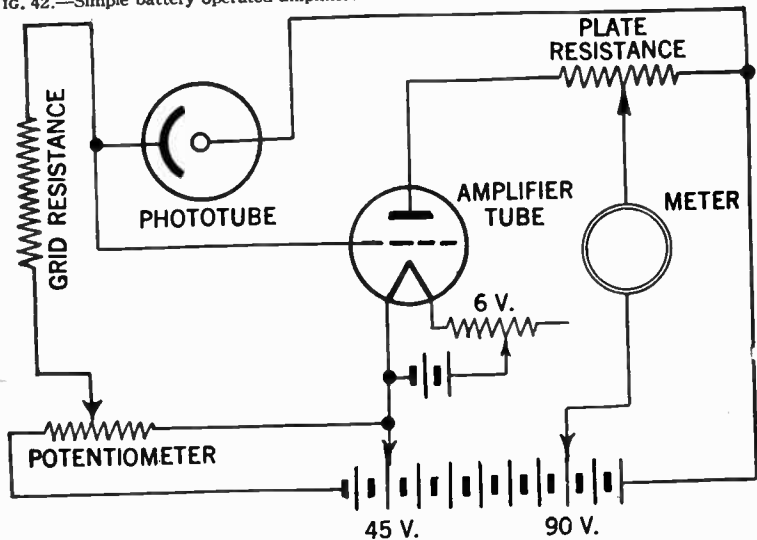

FIG. 43.—Flexible D. C. amplifier with neutralized anode current.

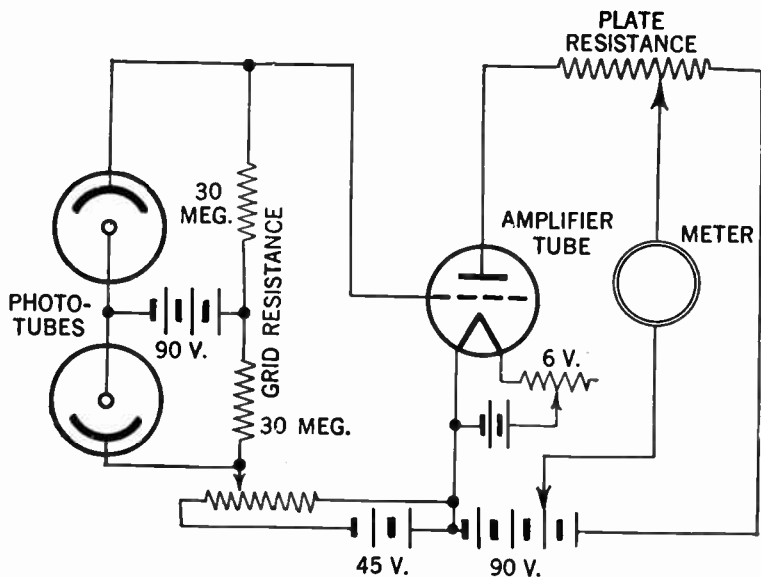

FIG. 44.—Differential D. C. circuit with neutralized anode current.

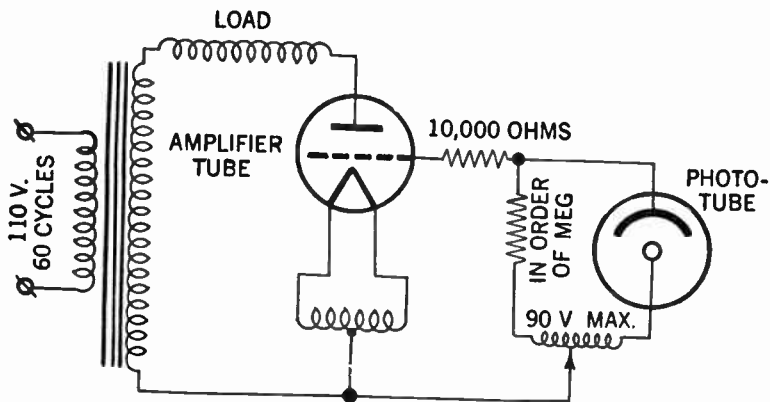

FIG. 45.—Negative control Grid-Glow relay circuit for A. C. operation.

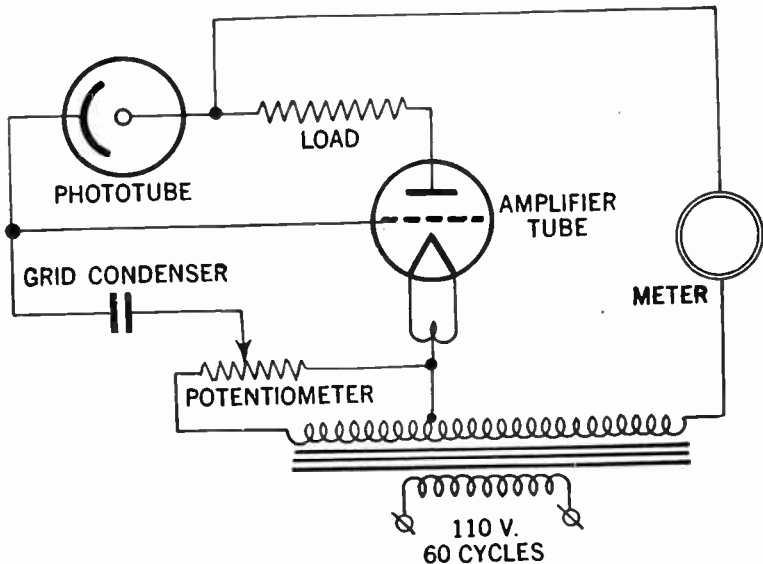

FIG. 46.—Simple amplifier for straight A. C. operation.

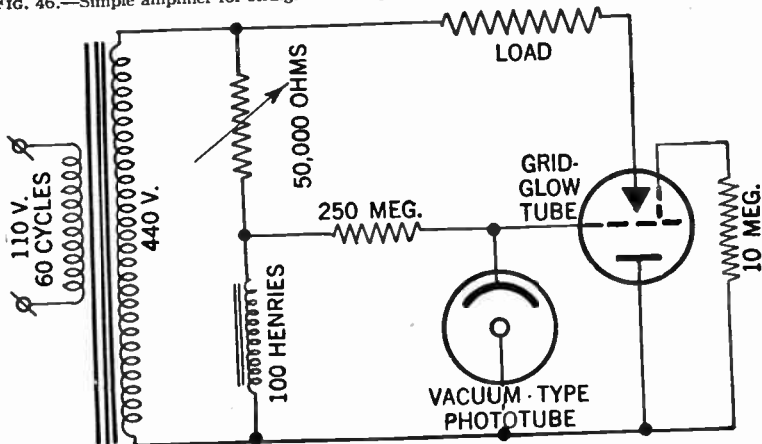

FIG. 47.—Grid-Glow relay circuit A. C. operation.

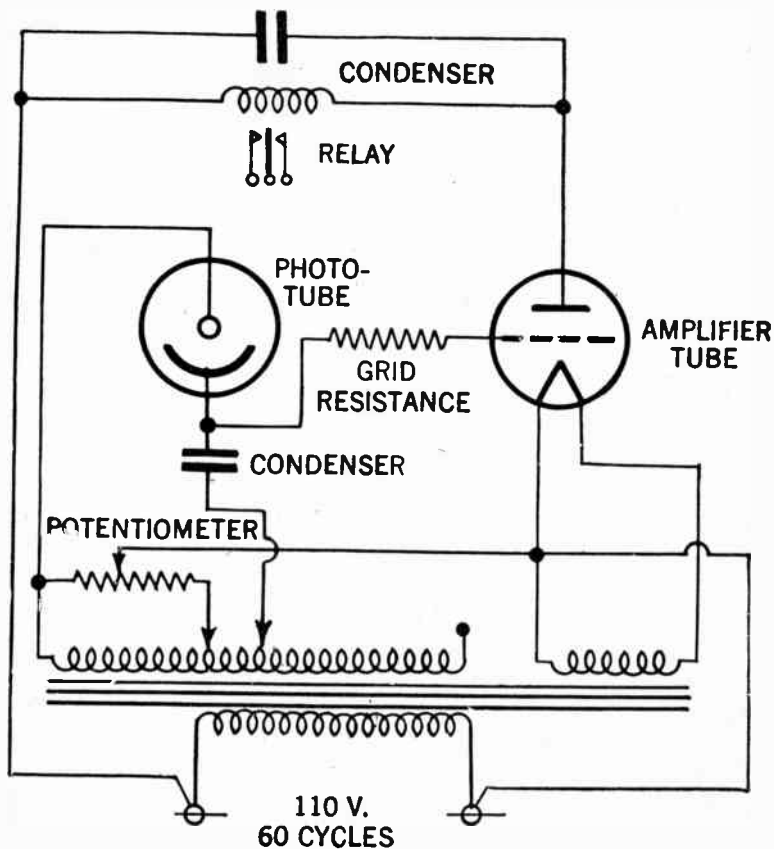

FIG. 48.—Simple amplifier for straight A. C. operation.

**Maintenance and Operation Considerations of Electronic Apparatus.—Installation.**—While generally electronic tubes are manufactured uniformly rugged in mechanical respects, to withstand a moderate amount of vibration, care should be taken to protect them from unnecessary vibration. However, in some cases a certain amount of vibrations cannot be avoided and in such cases it is recommended that the tubes be properly cushioned.

Generally electronic tubes will perform properly in any mounting position although it is recommended that they be installed in a vertical position with the base of the tubes either up or down. In the case of the phototube it is of course imperative that the cathode emitting surface face the light source upon which the function of the tube is dependent.

Usually tubes designed for industrial applications are equipped with rugged bases, made of a high quality moulded insulating material with a high resistance which remains practically constant for temperature changes of up to 70 degrees centigrade, and humidity up to 90 per cent.

**Electrical Effects.**—It is important to minimize the detrimental shunt effect of leakage between electrode connections and capacitance between the leads. Hence the importance of high quality sockets, and properly insulated leads and particularly so the lead which connects the anode or positive voltage supply.

The leads from the phototube to the amplifier should always be as short as possible to minimize capacity loss and pick-up from stray fields, and since the tubes are high resistance devices, it is extremely important that the insulation of associated circuit parts be as high as possible.

Care should be taken to avoid any extraneous or undesired light from reaching the phototube otherwise erratic results may



occur. For both steady and pulsating light the sensitivity of the gas filled type of phototubes within their normal operating range is practically independent of the amount of light. Their sensitivity, however, is effected by the frequency of light modulation.

This is characteristic of gaseous phototubes and is due to the relatively large mass of the positive ions and their correspondingly sluggish motion.

Because there is a time lag between the disruption of a gas atom and the increase in current due to the resultant positive ion, fluctuation in the gas component of current, lag slightly behind fluctuation in the primary photo-emission component.

For high frequency of modulation, this lag tends to smooth out the pulsations in the phototube current, thus decreasing the alternating component of the current and, to some extent, the sensitivity.

For low frequencies, however, the effect is not important and the low-frequency sensitivity is practically equal to the static sensitivity.

**Temperature Effects.**—Most electronic tubes are designed to withstand nominal temperature changes, although the upper temperature limit for proper operation is usually 50 degrees centigrade. This refers to the ambient air temperature or the temperature of the air coming in contact with the tubes. For example, operation of a phototube consistently at too high a temperature may cause a change in the sensitivity of the light sensitive surface due to evaporation of the volatile materials within the tube, causing a consequent decrease in its sensitivity as well as its life.

Generally higher temperatures will slightly decrease the sensitivity of a phototube.

## CHAPTER 44

# Radar Fundamentals

**General.**—By definition the word Radar means radio detecting and ranging, the letters having been taken from the beginning of each word. More precisely radar may be defined as the process of locating the position of an object in space by radio waves.

This relatively new system of radio communication is brought about by the application of the laws of physics, radio principles and optics in harnessing electromagnetic waves for detection and location of an object, fixed or moving, by the aid of the difference in electrical properties from those of the medium adjacent to or surrounding it.

Although radar principles has been known for a great many years, the actual construction of workable radar came about in the early part of World War II as a means of detection and location of enemy aircraft.

**Radar Applications.**—Radars peace time application will undoubtedly be in the field of ship and aircraft navigation. Ships at sea will be able to proceed at full speed regardless of weather, unimpeded by the threat of obstructions, while fog will no longer delay their entrance to harbors.

Aircraft will for the first time have a means of precise navigation independent of atmospheric conditions—particularly desir-

able for trans-oceanic flights. At the same time the hazards for landing in overcast weather will be practically eliminated by radar blind-landing systems, and the utilization of radar in meteorology will vastly increase our knowledge of weather.

These applications of radar are obvious and real, but they give little indication of the full impact of the art. Indirectly the knowledge and techniques gained in the ultra-high frequencies will expand and accelerate developments in the whole field of electronics.

**Radar Development.**—As previously noted, radar was born of war need, and no one man can be given credit as its inventor; it was made workable rather by a number of the world's most outstanding electronic scientists working with unlimited resources—monetary and technical.

Thus it was possible for a group or groups of highly trained scientists to develop, coordinate and finally simplify this highly complicated mechanism in a relatively short time, due to the pressure of war.

In this connection it should be noted that in the early thirties, several scientists were experimenting simultaneously along the road of radio wave echo reflection.

Thus, for example, it is alleged that Sir Robert Watson-Watt of England around 1933, made experiments on position of atmospheric disturbances by means of radio wave deflection. It is further alleged that when during an experiment an aircraft flew overhead Watt found an echo reflected from it, and so the principle of detection and ranging was noted.

**Speed of Sound.**—In order to obtain a clear conception of the principles upon which radar works, it will be helpful to study the well known wave action of sound.

Sound waves travel through the air at approximately 1,100 feet per second. Thus it takes the sound waves  $5,280/1,100$  or 4.8 seconds to travel a distance of one mile. It is for this reason that an appreciable amount of time elapses between the sight of a distant lightning flash and the accompanying thunder, although they occurred simultaneously.

Similarly the report of a gun is heard some time after the actual flash of the weapon, the elapsed time depending upon the distance involved.

Another illustration of the fact that time is required for sound to travel from one place to another may be observed when a steam whistle blows at a distance of several hundred yards. If

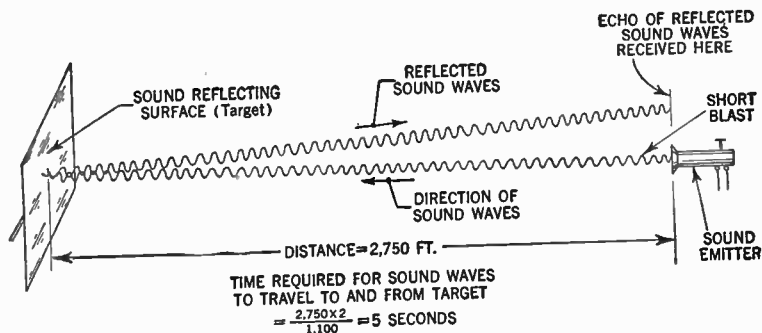

FIG. 1—Diagrammatical representation of distance determination by means of sound echo timing.

it is observed when blown, it will be noticed that the steam can be seen coming from the whistle a considerable length of time before the sound of the whistle is heard.

**Sound Wave Reflection.**—It is a well known fact that sound waves may be reflected back to their original source. The re-

flection of sound waves is called an *echo*, an example of which may be had when shouting or emitting sound towards a cliff or other sound reflecting surface.

One of the simplest kind of blind navigation systems has long been used by pilots of boats operating in the rivers and harbors, where obstacles are detected by the simple expedient of emitting a series of short whistle blasts and then listening for the direction and time interval of echoes.

In this connection it should be observed that whenever an echo or sound wave reflection is involved the sound waves must travel both forth and back to its source, thus for example if a certain sound wave be reflected back in say 2.4 seconds, the reflecting obstacle is located *not* one half of a mile distant, but only one quarter of a mile, since the sound waves have to travel the same distance twice.

**Radar Waves.**—Radio detecting and ranging is made possible by the simple expedient of transmitting radio frequency energy in pulses of high intensity and then to measure the round-trip travel time of the reflected energy with sufficient accuracy to establish the range to the obstacle.

Radio waves travel with the speed of light or 186,000 miles a second; 186 miles per millisecond or 0.186 miles per microsecond. This speed will be equivalent to 982 feet or 327 yards per microsecond.

If it be desired, for example, to find the time interval it takes for a radio wave to be reflected back from a target located one mile distant, it may easily be calculated as follows:

From the foregoing it follows that a radio wave takes  $1/186,000$  or 0.000005375 second to travel one mile, that is 5.375 microseconds. Inasmuch as all radar considerations are based on the round-trip travel time of the reflected energy, we

arrive at an elapsed time of  $2 \times 5.375$  or 10.75 microseconds per loop mile.

If on the other hand it be required to find the round-trip travel time for each 1,000 yards of range, the elapsed time is  $5.375 \times 6,000 / 5,280$  or 6 microseconds approximately.

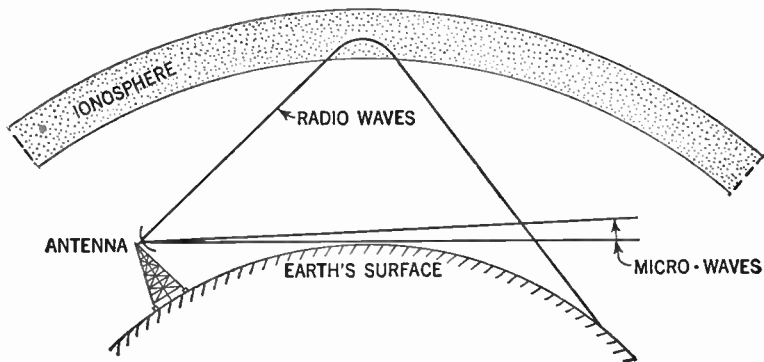

FIG. 2—Schematic representation showing how "long radio waves" such as are employed by radio broadcast transmitters are reflected from the ionosphere back again towards the earth. Microwaves such as are employed in radar sets, on the other hand, travel in a straight path (e.g. the line of sight). This property tends to limit the distance at which a radar equipped ship, for example, may see through fog and darkness 12 to 20 miles due to the curvature of the earth.

In target detection by radar high frequency radio waves are projected into space, in much the same way that a searchlight probes the surrounding darkness.

Some of the energy bounces off the target in its path, but a small portion of the energy returns to the radar base where sensitive receivers pick it up.

The radio waves are created in an electronic generator (transmitter) which produce frequencies of from 200 up to 10,000 megacycles per second (mcps), which frequencies have a wavelength of from  $1\frac{1}{2}$  meters down to 3 centimeter. All radio waves shorter than 30 centimeter are usually called *microwaves*.

These ultra-short or microwaves are a key factor in radar because of the desirability of focusing radar energy into sharp beams, so that the direction as well as the range of the target can be determined. Also for any given antenna size the breadth of the beam produced is proportional to the wavelength employed. Thus in order to limit the physical dimension of the antenna to reasonable dimension microwaves are universally employed in radar technique. The limitation in antenna size is particularly desirable in airborne radar where a large antenna cannot be tolerated for aerodynamic reasons.

Microwaves, like light, are propagated in straight lines, that is, they follow the line of sight and are not reflected from the ionosphere in the manner of longer radio waves such as are employed by radio broadcast transmitters. Because of this, the maximum range of a radar set will be governed by the optical horizon which occurs because of the curvature of the earth.

**Radar Range.**—In modern radar a single antenna is commonly used to do both jobs of sending and receiving. A short burst of energy generated in the transmitter is first sent out from the antenna, then after a fraction of a second the return signal is intercepted by the antenna and fed to the receiver.

The duration of the outgoing burst of energy is measured in microseconds, depending upon the estimated range of targets. Thus, for example, if the shortest range desired is say 327 yards, then the radar beam would travel to and from the target in two microseconds, since radio waves travel at the rate of 327 yards every microsecond. From this it follows that the duration of the outgoing burst of energy must be no more than two microseconds in order not to interfere with the return signal.

The length of time between outgoing signals is determined by the longest range desired. If this be 327,000 yards, for example, the beam would have to travel twice this distance or

654,000 yards to reach the target and return. At 327 yards for every microsecond, it would take the beam 2,000 microseconds or one five-hundredth of a second for the round trip. Therefore, in this particular case the time between the outgoing signals must be no less than five-hundredth of a second; otherwise, the weak returning signal might be lost in the strong transmitting beam.

As an example of the extreme distance of radar, may be mentioned the recently successful experiment in reaching the moon, where the distance involved was approximately 240,000 miles.

**Power Used.**—The outgoing signal consists of a tremendous burst of energy, very often more powerful than the maximum output of the nation's largest radio station. This is necessary because the beam, as soon as it leaves the antenna, is dispersed through hundreds of square miles of space in search of a target.

Only a very small portion of the spreading rays strike the target, and of these a still smaller portion rebound to the receiver. On the return journey also the beam fragment is still further dispersed throughout space, so that by the time the beam reaches the receiver it is literally a mere shadow of its former self.

If, for example, 100,000 watts of short wave energy were projected by a certain directive radar antenna at a target 1,000 feet away, the effective power in the region of the target might be only 0.8 of a watt per square foot.

This tiny fraction of power is still further weakened on its return journey. Assuming that 50 square feet of the target is struck by the beam and reflects it back to the receiver, then the amount of power making the homeward trip is 50 times 0.8 or 40 watts. This fragment is in turn "dispersed" through the



1,000 feet of space, so that by the time it reaches the receiving antenna its power density has been reduced to  $1/150,000$  of a watt per square foot.

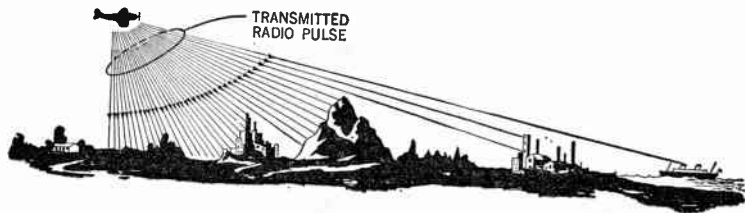

FIG. 3—Illustration showing how radio energy may be radiated from a radar set borne by aircraft. If the radio beam be directed towards the ground at a forward angle, the reflection will be a function of the aspect of the target. The energy which strikes the smooth surface of the water is reflected away from the source and leaves a dark region on the indicator tube. A shore line, buildings and normal incidence on the terrain directly below the aircraft will each provide a strong target echo. A radar beam of uniform intensity directed from the aircraft results in ground illumination and echo response as shown in figs. 3 and 4, respectively. These figures also illustrate how it is possible to correlate a radar picture with a relief map of the area.

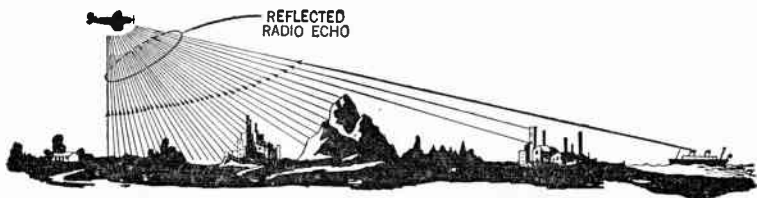

FIG. 4—An exaggerated view showing how the radio energy emitted from a radar antenna is reflected from the target. In reality only a tiny fraction of the radiated energy is reflected back to the receiver in form of an echo.

If the antenna is three square feet in area, then the total power entering the receiver would be three times  $1/150,000$  of a watt, or  $1/50,000$  of a watt. In short, the returning signal is one five-billionth of the original burst of energy. Yet sensitive

receivers pick it up, electronic amplifiers increase its volume and its message is easily read by the radar operator.

**Radar Principles.**—In most radar sets the principles of operation are briefly as follows: The output of the magnetron is delivered to the antenna through the “transmit-receive” (T.R.) tube whose function it is to protect the receiver during transmitter pulses and to close off the path to the magnetron during the receiving time, between pulses.

The returning echo from the “target” is collected by the parabolic reflector, focused on the antenna dipole, and carried through the T.R. tube to the receiver circuits. In the crystal mixer, the returning signal is caused to beat with the output of a klystron local oscillator, the resultant frequency being about 30 MC. This is amplified by a wide band I.F. amplifier, detected and further amplified by the video amplifier, thence applied to the control grid of the cathode ray tube.

In the meantime, the antenna assembly has been rotating continuously and its motion has been transmitted by a very compact and simple Selsyn system to the rotating magnetic deflection coil located around the neck of the cathode ray tube. Impressed across this rotating coil is the sawtooth sweep voltage which provides a linear, radial time axis. Time too, is synchronized with the transmitter, and as both the outgoing pulse and the returning echo travel at the speed of light, this time axis is really a distance measure.

The overall result is that as the radial time (i.e., distance) axis rotates, any returning echo will intensify a portion of this axis as the rotating antenna “beams” on the target. With an ordinary cathode ray screen, the bright flashes of light would

indicate the presence of reflecting objects, but the operator would have to remember where the flashes occurred, obviously an undesirable disadvantage.

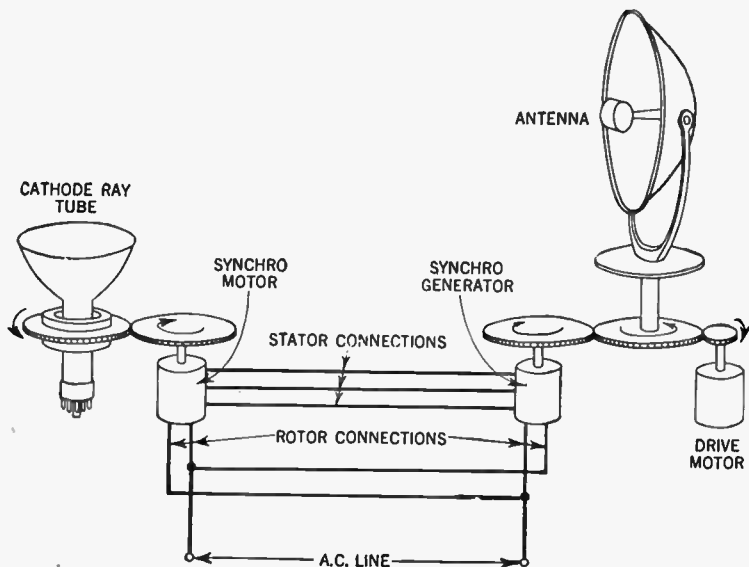
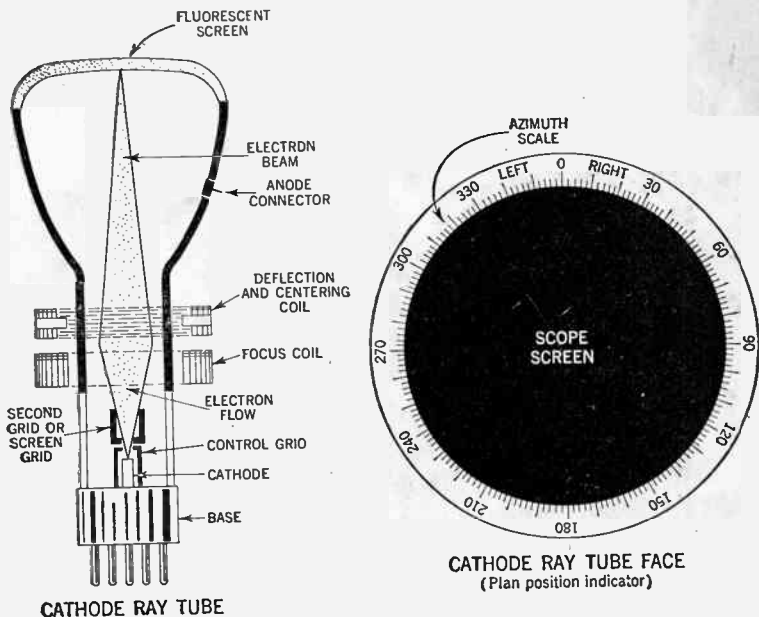

FIG. 5—Illustrating elementary principles of synchro system for turning cathode ray tube deflection coil in accordance with the rotation of the radar antenna. It is in this manner that the deflection coil geared to the motor is made to follow the motion of the antenna. A system of this type depends for its functioning upon the ability of A.C. generators and motors of identical construction to operate in synchronism, that is, the angular motion of each rotor of the interconnected system will always remain the same. In the system shown, corresponding stator and rotor terminals of generator and motor are connected together, and the rotor windings are connected to the A.C. line, causing the motor and generator to rotate in the same direction.

Hence, a long persistence screen is used in which the cathode ray first excites a short persistence phosphor, which in turn causes a second, long persistence phosphor to glow. This glow

persists for a long enough time to "remember" a scene until rekindled by the next rotation of the radial sweep.

Since the resultant illumination is in the form of a plan view of the surrounding area, with the transmitter at the center, the



FIGS. 6 and 7.—Showing essential elements in a typical magnetic type cathode ray tube. The deflection coil is rotated in synchronism with the antenna by means of a synchro system such as that shown in fig. 5.

system is commonly termed "Plan Presentation Indicator" or simply "P.P.I."

For comparison, the actual chart of the area to be scanned is printed beside the radar chart.

## ESSENTIAL PARTS OF A RADAR SYSTEM

Practically every radar set is made up of the following parts or components:

1. Transmitter.
2. A radio frequency oscillator.
3. An antenna with suitable scanning mechanism.
4. A receiver.
5. An indicator.

While the physical form of each of these components may vary widely from one kind of radar set to another, each radar must have this complement in order to function.

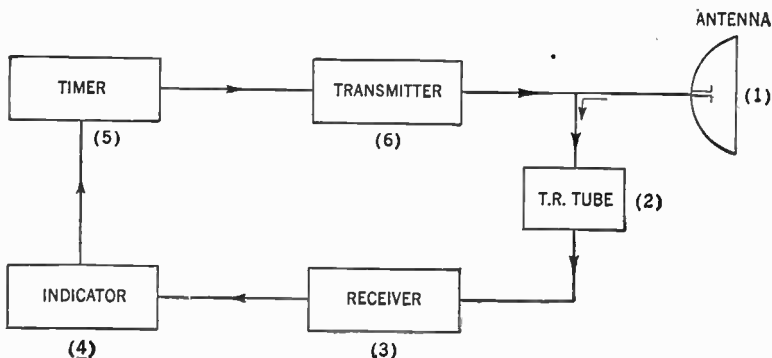

FIG. 8.—Block diagram showing a simple radar set. The function of the various components shown are as follows: (1) The antenna radiates strong bursts of radio energy into space and picks up reflected echo signals. (2) The T.R. (transmitting and receiving) tube automatically disconnects the receiver when the transmitter is operating. (3) The receiver amplifies minute echo signals sufficiently to actuate indicator. (4) The indicator transforms the echo signals in a form best adapted for efficient use of the set, by means of visual display on the cathode ray tube face. (5) The timer is the source of start and stop control pulses for transmitter and indicator. (6) The transmitter is the source of pulses of ultra-high radio energy which are fed to the antenna.

**The Transmitter.**—The transmitter is the source of pulses of ultra-high frequency radio energy which is fed to the antenna. The two principal elements of the transmitting system are the radio frequency oscillator and the source of high voltage pulses, variously called *modulator*, *keyer* or *pulser*.

This modulator or keyer is a device for taking power from the primary power source (which may be the commercial power line, a special engine or motor-driven generator or storage batteries) and forming suitable voltage pulses to drive the radio frequency oscillator in its burst of radio frequency oscillations.

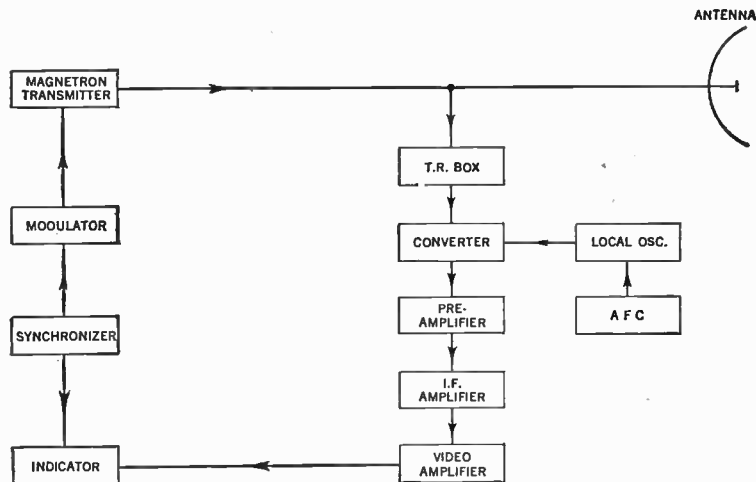

FIG. 9.—Block diagram showing essential circuit components of typical radar set.

These pulses of very high voltage are of the square-topped type of the order of a microsecond in length and spaced of the order of a millisecond apart. These specific values, however, may vary over a considerable range according to the specific purpose of the radar set.

There are generally two basic methods used to form the microsecond pulses:

- (1) By means of short-circuiting or open circuiting a charged artificial transmission line, often called a charged pulse network, and
- (2) By means of creating large voltage surges by driving a magnetic circuit into the region of saturation.

In the case of the first method, the switches used to open or short circuit the charged pulse network have been:

- (a) High voltage vacuum tubes.
- (b) A spark-gap discharge either of the open air or enclosed type, and
- (c) The hydrogen filled thyatron.

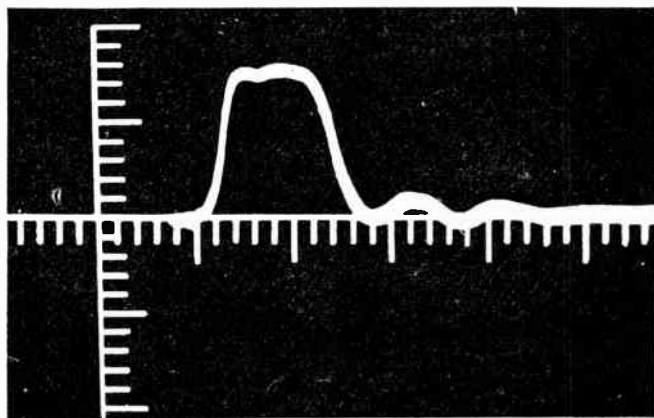

$\frac{3}{8} \mu\text{s}$ , 800 PPS  
 MAG. CURRENT = 4.5 Ma (Average)  
 MAG. CURRENT = 14 AMPS (Peak)  
 RISE TIME = 0.03  $\mu\text{s}$   
 PULSE WIDTH = 0.42  $\mu\text{s}$   
 SCALE = 0.07  $\mu\text{s}/\text{div}$ .

FIG. 10.—Magnetron input current delivered by a hard tube modulator.

All of these systems were applied extensively in radar operating systems, although recent designs favor the use of the thyatron.

During the brief interval of the pulse, powers ranging up to the order of a megawatt may be delivered by the pulser. Since the particular combination of current and voltage put out by the pulser may not be that required by the oscillator it is common to interpose a pulse transformer, the function of which is to step the voltage up or down to the desired level.

In some radar systems, a transmission line is required between the pulser and its associated transmitter, in which case pulse transformers may be required at each end of the line. A typical oscillogram of the magnetron input current as a function of time, delivered by a hard tube modulator used extensively in airborne systems, is shown in fig. 10.

Various forms of more or less conventional triodes found application as transmitting oscillators in the earlier longer wave radars. In this class of tube, time of flight of electron from cathode to plate must be short compared with the signal period, an increasingly serious limitation as the art moved into the microwave range. Velocity modulation tubes avoid this limitation in a sense by making use of the electron stream in flight. A particular form of velocity modulation tube, the cavity magnetron, fig. 11, has virtually monopolized the transmitting oscillator role in the more modern systems. In fact, its adaptation to very high power, very short pulse operation and its very high frequency stability make it ideally suited to this purpose.

In earlier forms, the magnetron was a fixed frequency device but more recently, external means of tuning over a moderate range have been devised and applied in practical design. While



the frequency of the cavity magnetron is largely controlled by its built-in cavity construction it is, of course, necessary to couple the oscillations in the internal cavities with the output

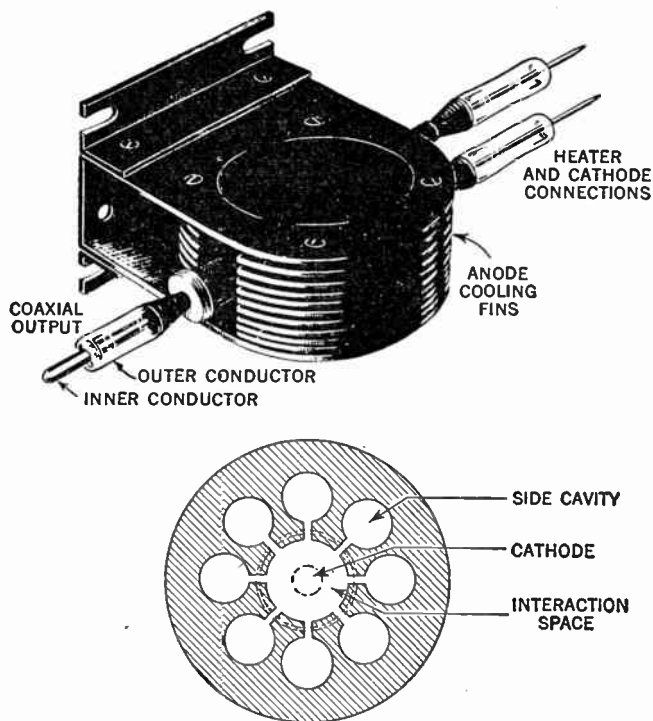

SECTION THROUGH ANODE BLOCK

Fig. 11.—External view of typical 10 c.m. cavity magnetron and cross-section through anode block.

line and the reaction on the magnetron of this coupling imposes a complex problem of system design.

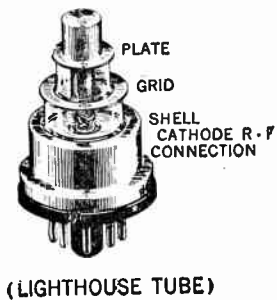
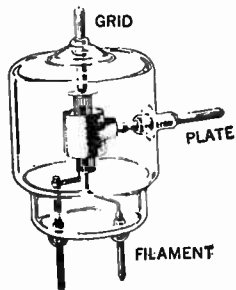
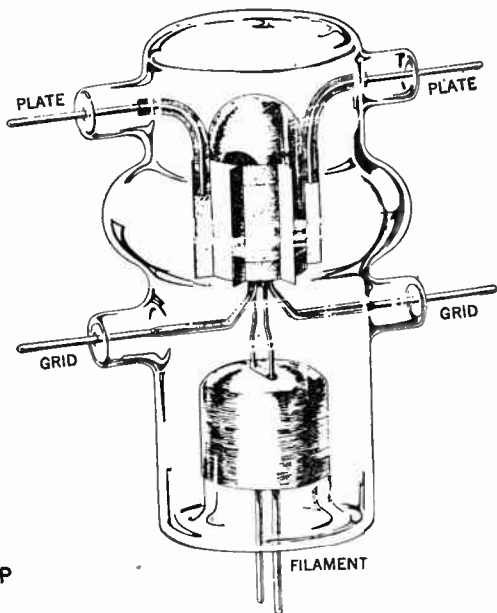
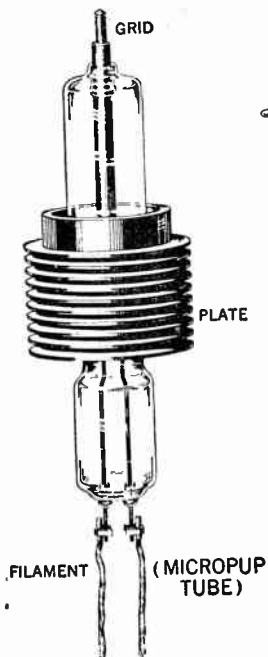

Figs. 12 to 15.—Showing typical radar triode transmitting tubes.

As the antenna scans, the impedance facing the magnetron varies due to varying reflections from discontinuities such as rotary joints in the output line to the antenna. These effective impedance changes, reflected back into the magnetron through its output coupling, tend to modulate or pull the frequency of the magnetron. Maximum power output calls for tight coupling between the magnetron and its antenna system but such tight coupling in turn accentuates this pulling effect. In addition, there is a "long line" effect which causes an impedance irregularity to be more serious the longer the transmission path between it and the magnetron.

Practical system design makes it necessary to take all of these factors into account and to tailor the characteristics of the magnetron to the degree of smoothness and excellence it is practicable to achieve in the radio frequency transmission system.

*Function of the T.R. Tube.*—To enable the same antenna to serve for both transmitting and receiving a T.R. (transmitting and receiving) tube or switch is used. Since the outgoing radar pulses occupies a very small fraction of time, characteristically about one-tenth of one per cent, a switch which would associate the transmitter with the antenna during this brief interval and then disconnect the transmitter and connect the receiver during this relatively long silent interval, was called for. If it be observed that the total cycle was only of the order of a milli-second, it is obvious that a very fast switch was required.

In practical design a gas filled T.R. tube such as shown in fig. 16, is almost universally used for this purpose. This consists generally of a partially evacuated resonant cavity containing a spark gap which breaks down during the transmitting pulse, thus preventing the transmitted power from injuring the sensitive receiver. The tube, however, recovers rapidly

enough to admit echoes from nearby targets, thus achieving the desired minimum range for the system.

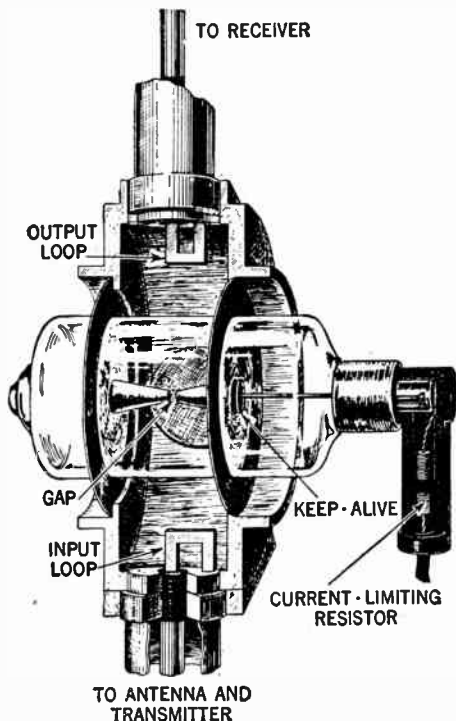

FIG. 16.—View of typical T.R. tube and cavity assembly. A device of this general appearance is typical of those used in the medium power 10 c.m. radar systems employing coaxial lines.

After amplification and detection of the received signal, the resultant video pulses are applied to an indicator which may present information in any of several different ways. Customarily the direction of the target (determined by antenna orientation) and its range (determined by reflection interval, 10.7 microseconds per mile) are shown.

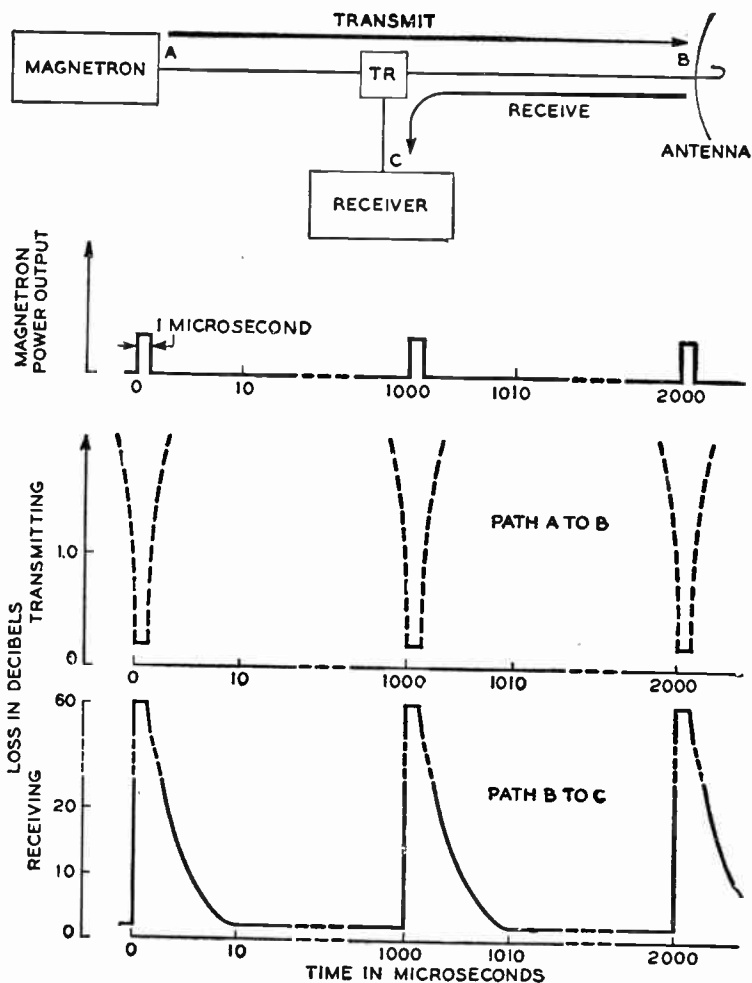

FIG. 17.—Showing transmission characteristics of T.R. tube assembly.

Fig. 17 shows the transmission characteristics of a typical T.R. tube assembly as measured in the transmitting and receiving paths over one complete cycle.

**The Radio Frequency Oscillator.**—The radio frequency oscillator is a vacuum tube of suitable design or a group of such tubes, which will oscillate at the desired radio frequency and give the desired bursts of radio frequency power when connected to the modulator. The development of suitable oscillator tubes has been one of the major achievements of the radar art. It is a relatively simple job to produce a radio frequency oscillator which will give oscillations of any desired frequency, provided one is satisfied with the power of only a few thousandths of a watt.

In the receiving part of a radar circuit this amount of power is adequate. A practical radar transmitter, however, must generate during its momentary burst of oscillations a power which may run into hundreds of kilowatts. Since the oscillator is turned on a small fraction of the time, the average power is usually hundreds of times less than the peak power, but even the average power may run up to the order of one kilowatt. Thus, practical radar equipment requires extremely high frequency oscillators running at powers thousands of times greater than was thought possible a few years ago.

**The Antenna.**—The problem of antenna design is also one of the major problems in radar, incomprehensible as this may seem to the operator of a home radio receiver, who finds a few yards of wire strung up on his roof adequate for this purpose. A suitable radar antenna must have the following characteristics:

- (a) It must be directional, that is, it must concentrate the radio energy into a definitely defined beam, since this is

the method by which the direction to the objects detected is determined.

(b) It must be highly efficient. All of the generated power must go into the beam and none must leak off into "side lobes" in other directions, since such side lobes may often be fatally confusing, and

(c) The radar antenna must be capable of being directed or scanned from one point into space to another, and on ship-board and in aircraft it must frequently be stabilized to take out the motions of the ship or airplane itself.

An antenna must be made directional either by building it up of an array of small antennas or dipoles, suitably spaced and phased to concentrate the energy in one direction, or it may be built on the searchlight principle of spraying the energy into a large parabolic "mirror" which focuses the energy into a beam. In either case, the larger the antenna, the sharper the beam for any given wavelength. Sometimes antennas may be longer in one direction than the other, giving a beam which is sharper in the first direction and thus fanshaped.

The scanning of the portion of space which the radar set is intended to cover must usually be performed by the mechanical movement of the antenna itself. This means that the structure, whatever its size, must swing around or up and down to direct the beam in the necessary direction. In certain cases where one needs to scan only a small sector, techniques have been worked out for rapid electrical scanning not requiring the motions of the whole antenna structure itself. So far, however, there has been no method for extending this rapid electrical scanning to cover more than a relatively small sector. Radars for directing guns which employ accurate and fast data in a small sector are making use, however, of this technique.

To carry the radio frequency energy from the oscillator to the antenna, and the echo from the antenna to the receiver, wires

and co-axial cables are used for ordinary wave lengths. For microwaves however, it is more efficient to use wave guides, which essentially are carefully proportioned hollow pipes—and the transmission system hence is often called “plumbing.”

*Various Antenna Types.*—The radar antenna takes various forms, depending upon the purpose for which the set is designed. Well known forms of directional antennas are:

1. The dipole type, and
2. The parabolic reflector type.

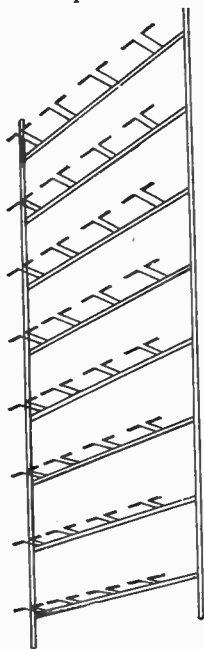

DIPOLE ANTENNA

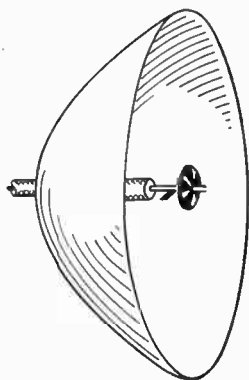

PARABOLIC ANTENNA

FIGS. 18 and 19.—Showing various forms of directional antenna used in radar sets. Fig. 18 shows the arrangement of a typical dipole array. Radar antennas of this type are built both for mobile use and for fixed-station installation, and has a reliable range of approximately 100 miles. Fig. 19 shows the form of the popular parabolic type.



The dipole form consists of a large number of stacked dipoles, having critical spacings with a reflecting screen, resembling a giant bed-spring.

This form of antenna is usually mounted on rotating platform either stationary or on top of a truck.

The parabolic type of radar antenna is of simple design and resembles a searchlight in that it consists of a suitable shaped

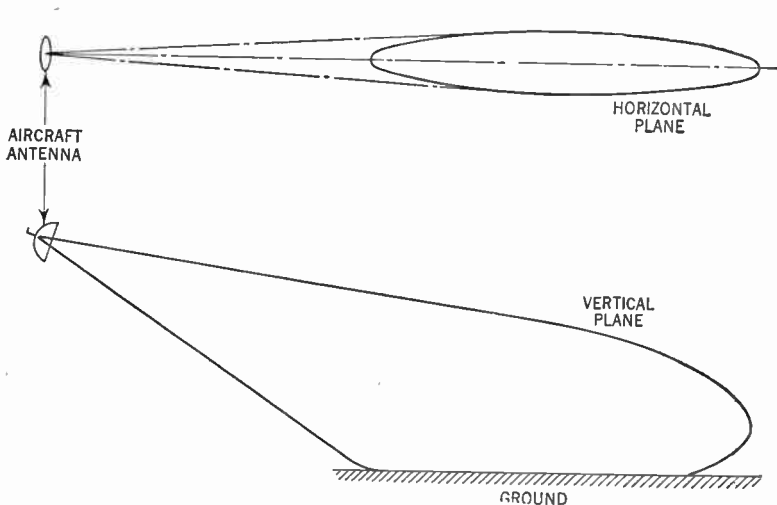

Figs. 20 and 21.—Showing conventional antenna patterns for navigational radar. Note that the beam is narrow in the horizontal plane in order to obtain azimuth accuracy, while in the vertical plane the beam is broadened to sweep a large arc with a corresponding loss in elevation accuracy.

reflector illuminated by one or more sources of electromagnetic energy.

If the reflector be a paraboloid of revolution with the source at its focus, the radiation is of the single lobe or beam variety in which the angular width of the beam is inversely proportional

to the diameter of the reflector and directly proportional to the wavelength of the radiation.

While such a beam antenna has been extensively used, many of the more recent radar systems have demanded more specialized radiation patterns. For example, in airborne search and bombing radars, a fanshaped beam has come to be considered optimum. At any one position, such an antenna illuminates a narrow wedge of the terrain below extending ideally from the point of the terrain vertically beneath the plane out radially to the maximum effective range of the system. The design objective here is to produce as narrow a beam as possible with a vertical pattern such that substantially equal signals are received at all ground ranges. This requires that the effective voltage be approximately proportional to the square of the cosecant of the vertical angle measured downward from the horizon.

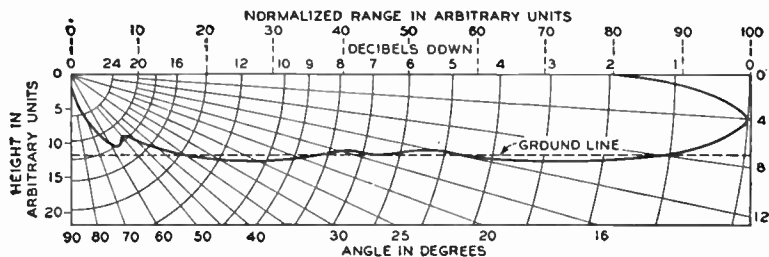

FIG. 22.—Showing vertical antenna pattern used in an airborne radar system.

A more recent study of this problem has indicated that some modification of this cosecant squared formula may be advisable. In any event, the fair approximations to the ideal that it has been possible to achieve in actual design give satisfactorily uniform ground illumination.

Other variations on antenna pattern include beams very much sharper in azimuth than in elevation for airplane search purposes and the reverse for height-finding purposes. One of the latest refinements here is illustrated by a typical vertical antenna pattern of a recent land-based air search antenna, as shown in fig. 23. In this case, in order to get high angle coverage, something approaching the cosecant squared pattern is achieved, the vertical angle being measured upward rather than downward from the horizon.

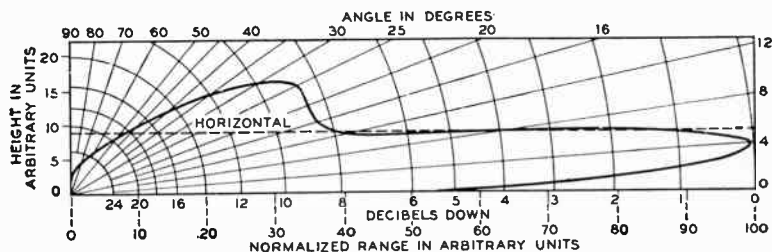

FIG. 23.—Showing vertical antenna pattern in a free space land-based search radar system.

In general, land and ship-mounted radars used to search the horizon for either ships or planes must take account of the fact that the intervening land or water surfaces reflect that part of the radiation directed below the horizon. Combination of the direct and the reflected waves produces a characteristic interference pattern in the vertical plane, greatly extending the range of the radar at certain elevation angles and correspondingly reducing it at intermediate angles. A typical vertical performance or coverage chart of a light early-warning system is shown in fig. 24. In this case, the beam in free space is fan-shaped with a horizontal width of about  $3.5^\circ$ . The horizontal pattern

is not greatly affected by the surface reflection while the vertical pattern shows the very sharp lobes resulting from direct and reflected wave interference.

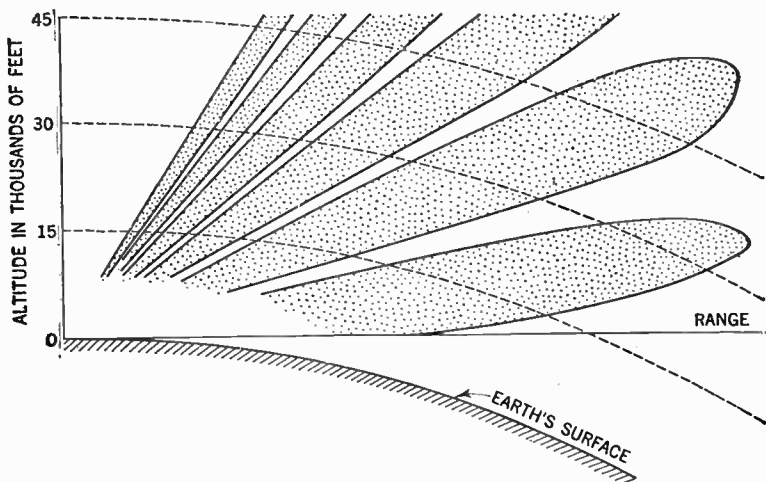

FIG. 24.—Vertical coverage chart of a land-based radar system at a low site overlooking water.

**The Receiver.**—The problem of the receiver for radar is also a complex one. In practically all radars the superheterodyne principle is employed which involves generating at low power a radio frequency fairly close to that received, and “beating” this against the received signals, forming an intermediate frequency which is then amplified many times.

Curiously enough the crystal used as a detector and mixer has again come into its own in microwave receivers.

The peculiar characteristics of pulse signals require that receivers be built with extremely fast response, much faster even than that required in television.

The final stages must prepare the signals for suitable presentation in the indicator. The receiver normally occupies a relatively small box in the complete radar set, and yet this box represents a marvel of engineering ingenuity.

A particularly difficult piece of development is concerned with a part closely connected to the receiver. This is a method of disconnecting the receiver from the antenna during intervals when the transmitter is operating so that the receiver will not be paralyzed or burned out by the stupendous burst of radio frequency energy generated by the transmitter. Within a microsecond after the transmitter has completed its pulse, however, the receiver must be open to receive the relatively weak echo signals; but now the transmitter part of the circuit must be closed off so it will not absorb any of this energy.

The most significant elements of the radar receiver in order in the circuit are:

- (a) The beating oscillator.
- (b) The first detector (converter).
- (c) The intermediate frequency amplifier.
- (d) The second detector.
- (e) The video amplifier.
- (f) The display system.

While each one of the foregoing elements has its own design problems, there are certain broad systems considerations.

For the early long wavelength radars, beating oscillators were of the more or less conventional triode construction and, in fact, one very special triode, the so called lighthouse tube, fig. 15, has been used as a beating oscillator up into the microwave range.

As in the case of transmitting oscillators, velocity modulation has been the key to the design of most of the receiving or beating oscillators used in microwave systems and for the most part, these have been of the single cavity built-in type.

The earlier forms had fixed or manually tuned cavities and beyond this, were tunable within a fairly narrow range by adjustment of the voltage of the repeller electrode. Not only was this voltage adjustment used for narrow range manual tuning of the receiver to its transmitter output, but automatic frequency control circuits employing an intermediate frequency discriminator circuit were devised which regulated the repeller voltage at the proper value for reception of echoes of the transmitted pulse.

These automatic frequency control circuits were not without their difficulties but various improvements were introduced so that those embodied in most recent systems are quite stable and satisfactory.

More recently, however, thermal means of controlling oscillator cavity size has been devised, the heating effect being regulated by a control voltage. Where thermal control of this type is available automatic frequency control may be built around it rather than resorting to repeller voltage control as in earlier systems.

*First Detector (Converter).*—In any radar system the selection of frequency is based among other things on the noise figure available in the receiver. The input circuit of the receiver is the low signal level point of the system and the problem here has been to achieve the greatest possible freedom from noise. The longer wave radar receivers employ a combination of vacuum tube pre-amplifier and detector to achieve the best noise figure.

In general, however, crystal detectors of the fixed cat's whisker-on-silicon type have been almost universally used at wavelengths of about 30 centimeters and less. Fig. 25 shows a comparison between the noise values of the lighthouse tube as an amplifier or detector, and the crystal type detector. A great amount of development work has been done on these

crystals with the result that a uniform product has been achieved within a few db. of the theoretical resistance noise limit. While the crystal is not strictly frequency sensitive, optimum designs for different crystal units for the different frequency bands. Means must be provided in the system to protect the crystal from high voltage overload which would destroy its sensitivity.

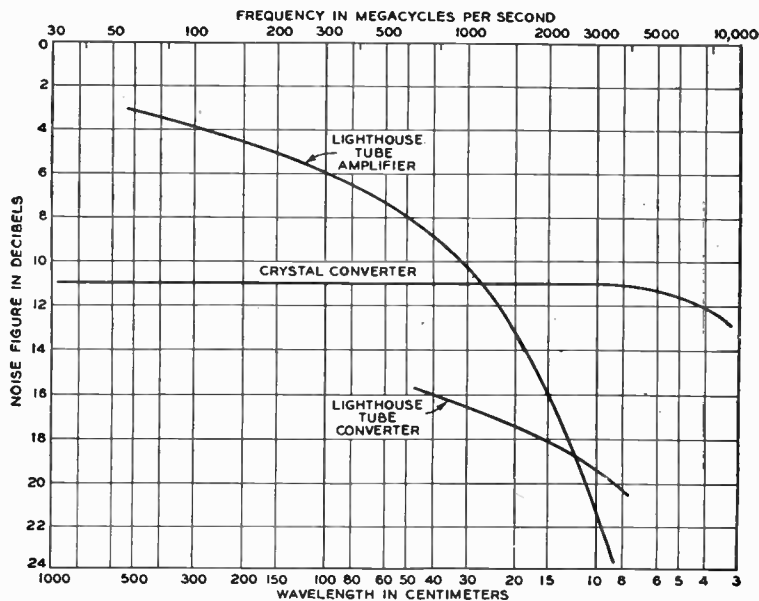

Fig. 25.—Showing effect of wavelength on radar receiver noise.

*Intermediate Frequency Amplification.*—Choice of intermediate frequency rests on a number of factors including signal-to-noise ratio, band width and others. About 90 db. of IF gain

is required with a band width of from one to ten or more megacycles. Since resistance noise (power) is proportional to band width, the early tendency was to make IF amplifiers as narrow as possible consistent with the pulse length to be accommodated.

In more recent systems, there has been a trend toward wider band receivers as a means of sharpening up the picture. While, for example, a one megacycle IF system followed up by a one-half megacycle video system would be expected to give about optimum signal-to-noise ratio for a radar employing a pulse of about one microsecond, it has been found in certain types of display that considerable advantage can be had by widening the band by a factor of as much as five. In such cases, the increased noise is more than offset by the greater sharpness of the signal and by the finer grain structure of the noise.

Actually, most of the IF amplifiers have been designed around a frequency of either 30 or 60 megacycles but it would go beyond the scope of the present chapter to discuss the relative uses and advantages of these two intermediate frequencies.

Great progress has been made in achieving very low noise amplification and in producing the desired gain and gain frequency characteristic with a minimum of tubes and other components.

*Second Detector.*—It is the purpose of the second detector to produce a rectified voltage that is proportional to the amplitude of the IF waves. It is important that this rectified voltage be proportional to the first power of the IF amplitude. One of the simplest types of detector used in radar receivers is the diode type connected in series with a load impedance consisting of resistance and capacitance in parallel.

The diode may be the 6H6 or 6AL5 although many other types have been employed.



*Video Amplifier.*—Following the detector one or more stages of video amplification is employed. The form of the video amplifier depends largely upon the number and location of the indicator tubes. In aircraft radar there may be only a single indicator, in which case the video amplifier will be very simple.

In ground and marine radar, on the other hand, there are usually several indicators remotely located, hence the video amplifier will be more complex. In this case, the video amplifier drives a terminated line at a level of a few volts and individual indicators are driven by video amplifiers bridged across this line.

The simplest and most common form of video amplifiers are the resistance capacitance, coupled type.

*The Cathode Ray Tube.*—The cathode ray tube is a vacuum tube with a rounded flat surface called *screen*. It is made of glass and may be anywhere from 14 to 24 inches in length, with a screen diameter of from 3 to 20 inches. The inner surface of the screen portion of the tube is painted with a fluorescent material.

When energized a current of electrons flows from the negative terminal of the tube past a grid in a straight beam toward the fluorescent screen. When the beam strikes the screen, it excites the fluorescent material producing a spot of light. This spot of light can be put to work in various ways. In several different kinds of radar oscilloscopes the spot can be made to travel back and forth a thousand times a second across the screen by means of a switching device governed by the master timer of the radar set.

The result to the eye is a glowing beam called a *time base* or *sweep*, lying across the center of the screen. This sweep is synchronized with the radar antenna as it scans. Any time pulse echo returning from a target is fed as a positive charge

into the grid between the negative terminal and the screen of the tube. When this occurs, more electrons flow, causing a V-shaped break (called "pip") along the sweep. The position of the pip along the sweep is a measure of distance from the target.

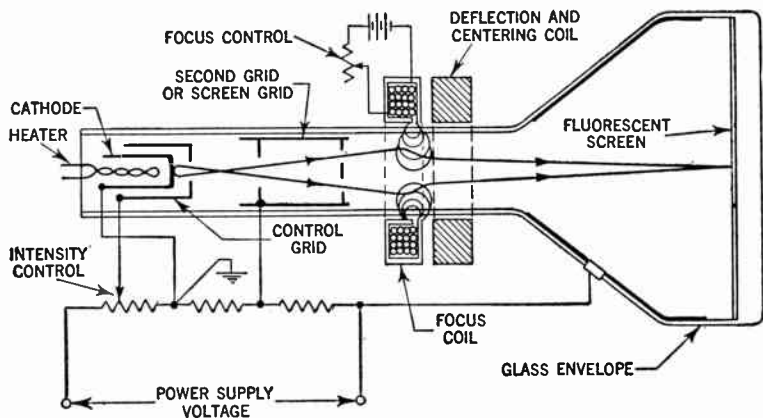

FIG. 26.—Schematic illustration showing arrangement of a magnetic type cathode ray tube. When a cathode ray tube of this type is employed in a radar set it is customary to mount the deflection coil in such a manner that the rotation of the antenna by means of gearings and a synchro system is transferred to the deflection coil. In some radar sets using synchro systems, the synchros are geared to rotate ten times as fast as the antenna system and rotating coil.

Another type of oscilloscope is called the P.P.I. (Plan position indicator). In this type the sweep may be made to travel in a radial streak from the center of the screen to its edge by switching on and off an electromagnet at the rim of the scope. By rotating a magnet around the edge of the tube in exact time with the rotations of the radar antenna, say at 15 times a minute, for example, the sweep can be made to follow the magnet around the screen like the hand of a clock.

In this case, an echo that has returned to the antenna and has been applied as a positive electrical charge to the cathode-ray grid, causes a very bright point of light along the sweep. After the sweep has moved on, the persistence of the fluorescence leaves on the screen a map-like outline of the area scanned by the radar beam.

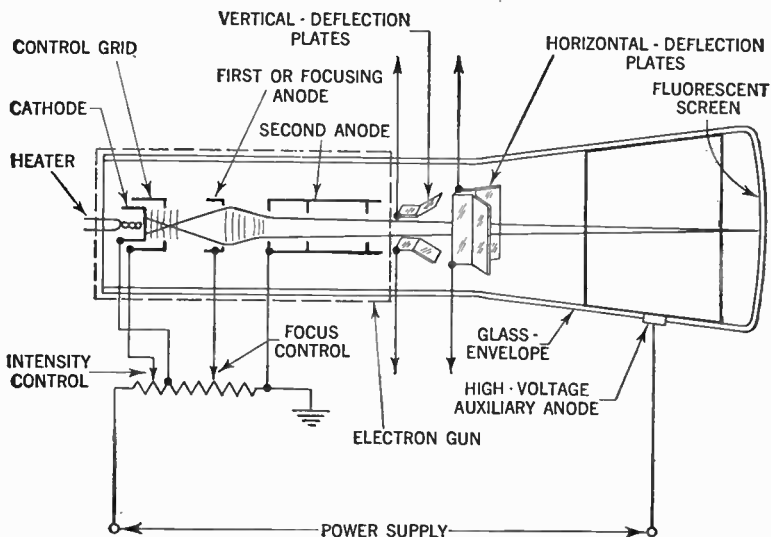

FIG. 27.—Schematic illustration showing arrangement of main components in an electrostatic type cathode ray tube. In a cathode ray tube of this type the electron beam is deflected by the electric field set up by the voltage applied to two pairs of plates located beyond the second anode. These sets of plates are mounted at right angles to one another, the plane of one set being horizontal and the other vertical. When a voltage is applied to one set of plates, the amount of beam deflection towards the plate with the higher positive charge is directly proportional to the difference in charge between the two plates.

By means of calibrations and scales the bright point may be read instantly in terms of *azimuth* (the angle with a fixed point such as true North) or *elevation* (the height above the earth)

and *distance* (the time lapse between pulse and echo, plotted against their known rate of speed and shown on the screen as linear measurement).

These assembled data which together give exact location of a desired target or area, is the ultimate purpose of any radar system and are used for a multitude of purposes.

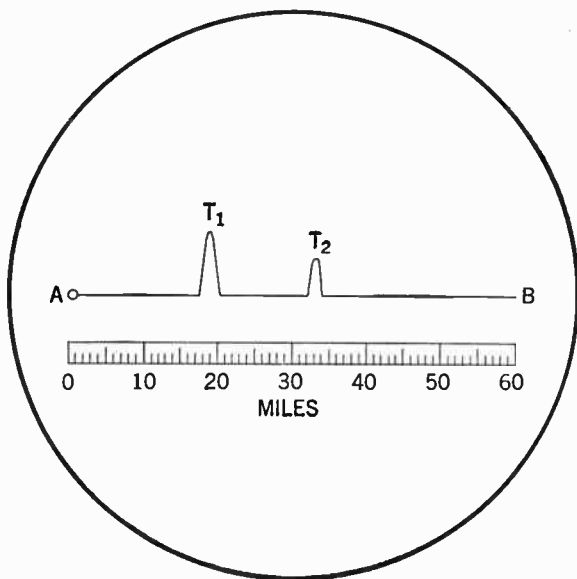

FIG. 28.—Type of echo display observed on the screen of the cathode tube. The fluorescent spot sweeps along the time base  $AB$ , in synchronism with the transmitted pulses. The received echoes from the two targets are seen at a distance from  $A$ , corresponding to the time taken for the pulses to travel to and from targets  $T_1$  and  $T_2$ . The time base can be provided with range scale as indicated.

The type of picture obtained on the screen of the cathode ray tube is illustrated in fig. 28 in which the line  $AB$  represents the time base which is locked to the transmitter in such a way

that the length  $AT$ , represents the time taken by an emitted pulse to arrive back at the receiver after reflection from target  $T_1$ . As we know the velocity of radio waves is substantially 186,000 miles per second, the scale of the time base can be graduated in miles, so that the distance of target  $T_1$  is seen to be about 19 miles.

A second received pulse is seen at  $T_2$  returned from another target at a range of about 33 miles. If one or both of these targets are moving, their changes in position are indicated by the movement of the pulses along the base line of the screen of the cathode ray tube toward or away from point  $A$ .

The amplitude of the pulse on the tube is proportional to the strength of its received signal, so that this naturally increases as the target from which the echo is received approaches the receiver.

When other conditions remain the same the amplitude of the echo is also a measure to some extent of the reflecting properties of the target, for example, its size; and an experienced observer may be able to guess the nature of the target from the echo pulse seen on the tube screen.

This measurement of the distance of the reflecting body responsible for the echo signals must be supplemented by a determination of the direction of arrival of the waves in both horizontal and vertical planes, before the actual position of the reflector in space is completely known. These measurements can be made by the well established methods for observing the bearing or azimuth ( $\phi$  in fig. 29) and the angle of elevation above the horizontal ( $\theta$  in fig. 29).

The first observation can be made by rotating the receiving antenna which may at certain wave lengths be a horizontal dipole, about a vertical axis until the amplitude of the corresponding pulse decreases to zero; it is then known that the bearing is in line with the direction of the dipole. Alternately a pair of

fixed antennas at right angles to one another can be used, connected to the field coils of a radio goniometer in the usual manner of a direction finder. Rotation of the search coil to the signal minimum position again enables the bearing to be determined.

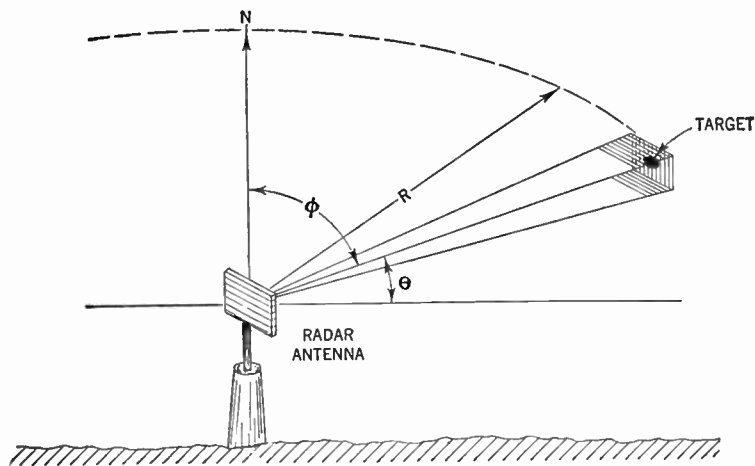
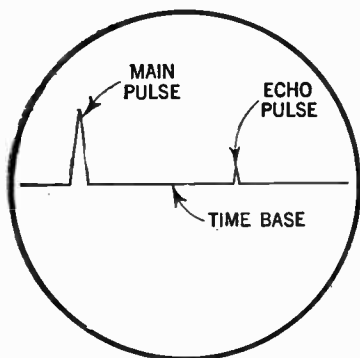
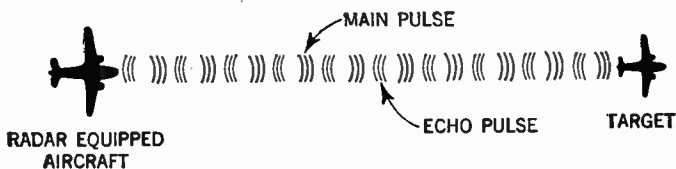

FIG. 29.—The position of the target is defined by its range  $R$ , angle of elevation  $\theta$ , and bearing or azimuth  $\phi$ .

The angle of elevation of the arriving waves can be measured by comparing the amplitudes of the voltage induced in two similar antennas mounted one above the other at a known distance apart, depending upon the wavelength in use and the range of angle elevation it is desired to cover

This technique has been used for many years past by several investigators for measuring the angles of arrival of radio waves over long distance communication paths, and is directly applicable to the problem under discussion.

If the reflecting object be an aircraft then a knowledge of range  $R$  and angle of elevation  $\theta$  enables the altitude of which the craft is flying to be determined. If the object under observation be a ship then the angle of elevation is negligible and the range and bearing determines its position.



**CATHODE RAY TUBE**  
(Position indicator)

FIG. 30.—Showing time difference between transmitted and received signal as it appears on the cathode ray tube screen. Thus, by reading the time scale on the screen the distance to the target may be determined.

When microwave radar technique is employed and with the parabolic antenna trained on the target to give the maximum deflection of the received pulse, the azimuth and elevation can

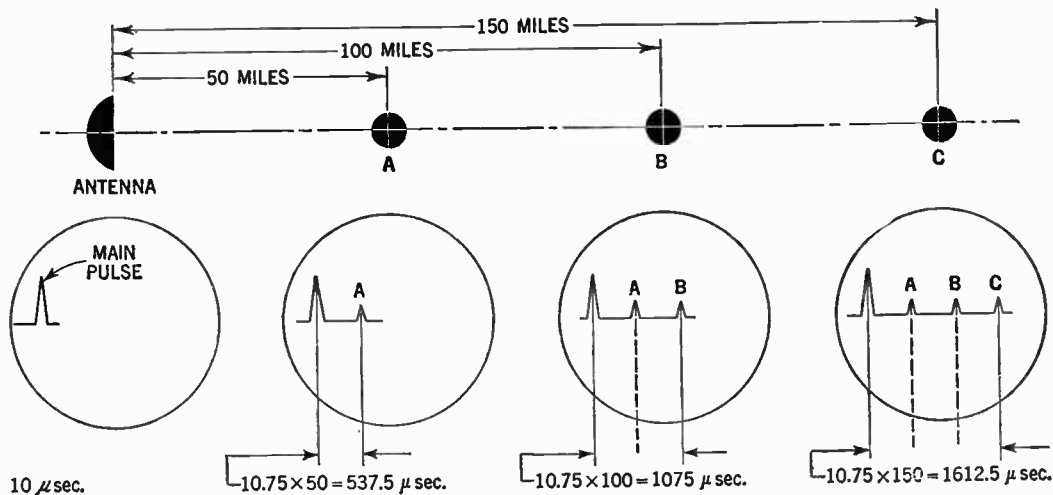

FIG. 31.—Schematic representation of three equally spaced targets and method of distance determination as represented on the scope. Assume the electrical impulse from the timer triggers the transmitter and for a certain period of say 10 microseconds it sends out a strong pulse from the antenna and then is shut off. Since the horizontal trace upon the scope is associated with time and distance, a single target will cause a change on the time base line position only at one point, namely, that which corresponds to the distance of the target from the radar set. In our particular example, the echo from target A will return to the scope 537.5 microseconds after the main pulse, that from target B 1,075 microseconds, and that from target C 1,612.5 microseconds, etc. It should be observed that the total distance of travel for the radio waves are twice the single distance or loop miles in each instance



be read off the horizontal and vertical scales respectively, while the range of the target is observed from the position of the pulse along the time base on the screen of the cathode ray tube.

**Types of Radar Indicators.**—It is the indicator of a radar that presents the information collected in a form best adapted to efficient use of the set. Nearly all radar indicators consist of one or more cathode ray tubes.

The more common type of data presentation are denoted as:

1. Type "A"
2. Type "B" and
3. Type "P".

In the simplest or "A" type of presentation, the electron beam is given a deflection proportional to time in one direction, say horizontally, and proportional to the strength of the echo pulse in the other, say vertically, as indicated in fig. 32.

If no signals be visible, a bright horizontal line (the time base) appears across the tube face, the distance along this line representing time elapse after the outgoing pulse. A returning echo then gives an inverted V-shaped break in the line at this point corresponding to the time it took the echo to return back from the target.

When searching for a target the scanning spot is maintained at constant intensity and is set in uniform motion horizontally across the face of the scope at the instant at which the pulse of energy is radiated by the transmitter.

Upon reaching the extreme right side of the screen the spot is extinguished by grid control in the tube and is returned to the left where it is illuminated again to start another similar cycle.

As previously noted the horizontal distance across the screen from the end of the transmitting pulse to the end of one or

several received pulses, constitutes indication of the distance to the respective reflecting objects.

In the type "B" presentation on the other hand both the azimuth and the range of reflecting objects are presented on the screen of the tube horizontally and vertically, respectively.

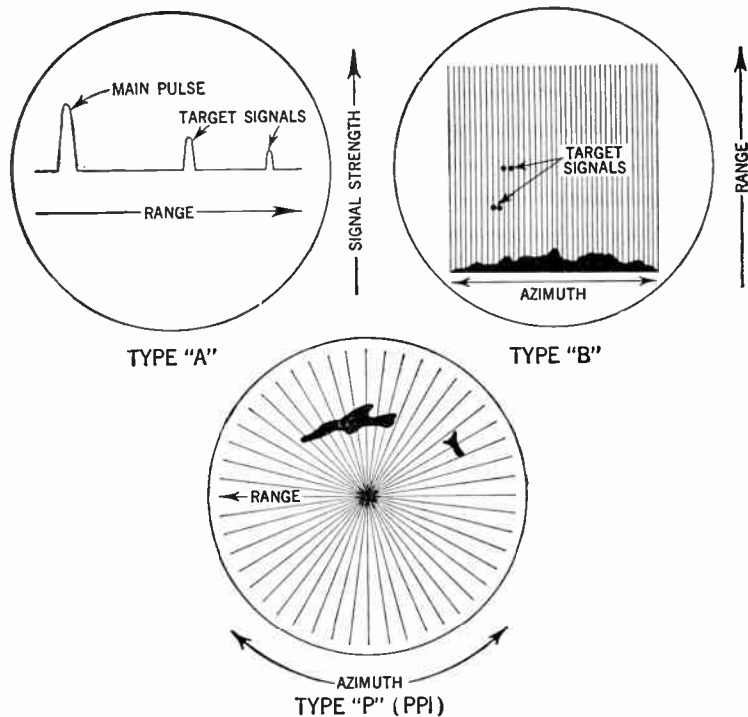

FIGS. 32 to 34.—Types of data presentation. In the "A" type of display the range of the target (usually given in miles) is read horizontally and the signal strength vertically. Type "B" display gives the azimuth (or bearing) of the target horizontally and the range vertically. Here the target signals appears as two dots; left dot gives range and azimuth of target, whereas relative position of right dot gives an approximate indication of elevation. In the type "P" display method, the range of the target is measured radially from the center and the azimuth as a function of the polar angle.

When this method of presentation is employed, a highly directive antenna system is rotated about a vertical axis so that the radiated beam covers a horizontal plane.

Another type of presentation is known as the "P" or *Plan Position Indicator*. This method of presentation (abbreviated P.P.I.) is usually employed where it is required to obtain range and bearing indication, but not elevation indication, concerning objects in or near a horizontal plane centered near the radar station.

In a radar set employing this display method the antenna is rotated uniformly about a vertical axis so that the principal axis of the radiated beam periodically searches all angles in a horizontal plane. A very large number of pulses are transmitted with each revolution of the antenna and as each pulse starts the reflected spot moves outward with uniform speed along radial lines from the center of the screen, thus providing a radial range indication.

When reaching the edge of the screen, the spot or spots return to the center of the tube to begin a similar cycle. The polar angle of the radial line on which the spot appears indicates the azimuth of the antenna beam and hence of the reflecting target. The radial distance of the spot from the center of the screen indicates the range of the target. Targets then appear in the proper direction as well as at the proper relative distances from this origin and the result is a *map* of the territory surrounding the observing radar station displayed on the cathode ray tube.

Since the antenna can usually be rotated only slowly (e.g. from 1 to 30 r.p.m.) and since the light from an ordinary cath-

ode-ray tube fades away almost instantly, one might expect not to see a "map" at all, but only bright flashes at various spots as the antenna revolves. Some way had to be found to make the brightness of these flashes persist for many seconds after they were produced. Special screens were developed which continue to glow for some time after being lighted by a signal. Thus the whole map is displayed at once.

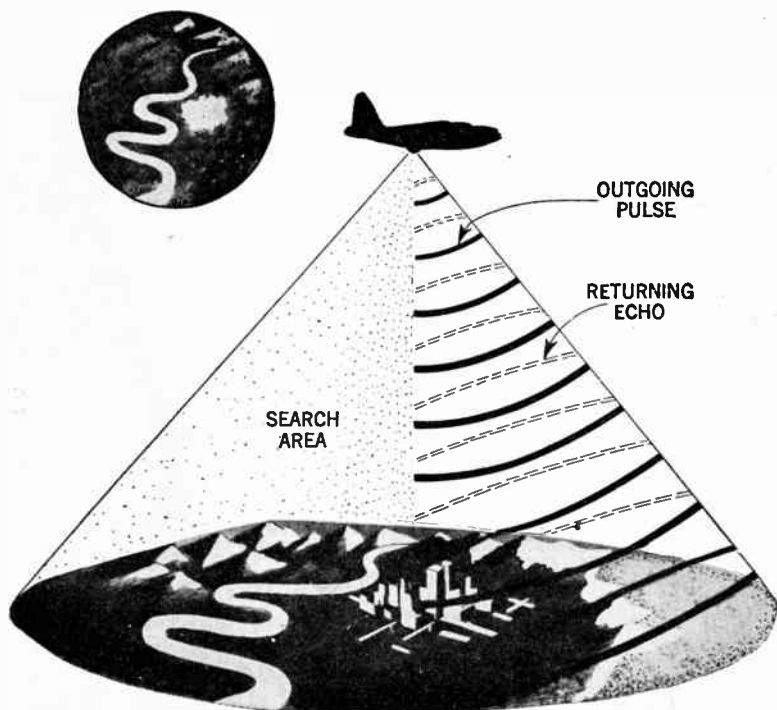

FIG. 35.—Showing how a radar map appears on the cathode ray tube when a certain area is scanned by means of an airborne radar set.

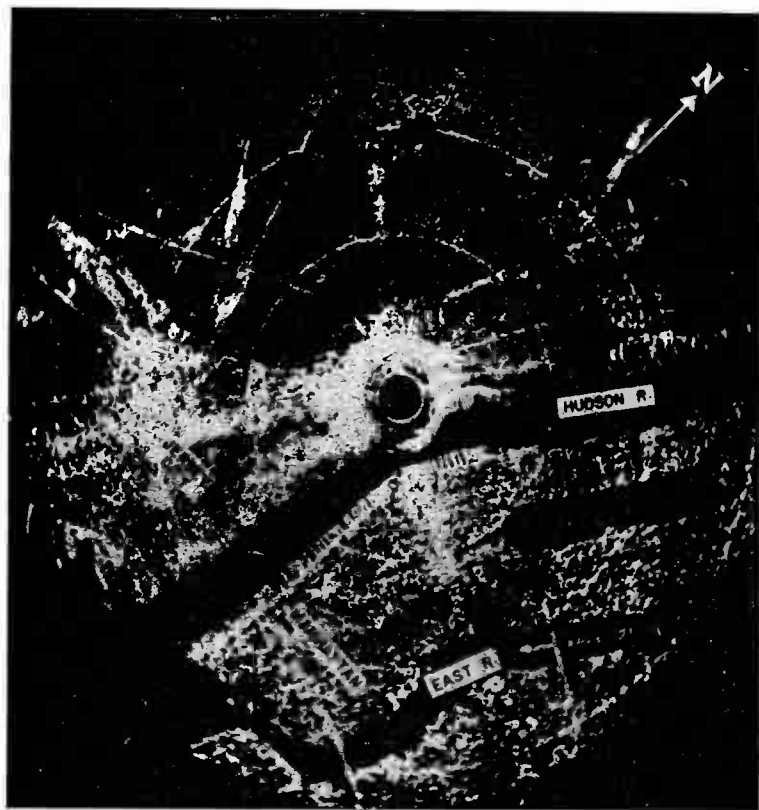

FIG. 36.—Radar map of greater New York. The photograph illustrates the definition obtainable when employing a very narrow beam system. In the photograph the individual docks on the Manhattan water front, the bridges across the East River and the Railroad tracks in Jersey City are clearly distinguishable.

CHAPTER 45

**STANDARD**

**FOR**

**POWER-OPERATED**

**RADIO RECEIVING APPLIANCES**

AMERICAN STANDARD  
Approved March 23, 1938 by the  
AMERICAN STANDARDS ASSOCIATION  
A. S. A. No. C 65—1938



**REQUIREMENTS FOR  
ALTERNATING-CURRENT POWER-OPERATED  
RADIO RECEIVING APPLIANCES**

**Scope**

- 1        These Requirements cover power-operated radio receiving appliances for non-commercial use, designed to be employed on alternating-current interior wiring systems in accordance with the National Electrical Code.
- 2        These Requirements, in so far as they apply, cover features of non-commercial or domestic sound equipment similar to the features of radio appliances mentioned herein.
- 3        Battery chargers, either portable or for permanent installation and not intended for use with radio appliances, are classed as rectifiers and are not covered by these Requirements.
- 4        These Requirements are based upon records of tests and field experience and are subject to revision as further experience and investigation may show to be necessary or desirable.
- 5        Devices or products which comply with these requirements will not necessarily be acceptable if they have other features which, when examined and tested, are found to impair the result contemplated by these Requirements.
- 6        A device or product having materials or forms of construction differing from those detailed in these Requirements may be examined and tested according to the intent of the Requirements, and if found to be substantially equivalent may be given recognition.
- 7        Requirements are shown in bold-faced type and are supplemented by explanatory notes and descriptions of test apparatus and methods in light-faced type.
- 8        If not otherwise specified, voltages referred to are root-mean-square values.

**General**

- 9        A radio appliance shall employ materials throughout which are acceptable for the particular use, and shall be made and finished with the degree of uniformity and grade of workmanship practicable in a well-equipped factory.

- 10 Attachment plugs, circuit-breakers, cords, cutout bases, lamp-holders, receptacles, switches, wires, etc. which are provided as a part of a radio receiving appliance are judged under the Requirements of Underwriters' Laboratories, Inc., for such devices and also with respect to their suitability for the particular application.

### Enclosure

- 11 The enclosing case or cabinet shall enclose all current-carrying parts of a radio appliance except primary leads and secondary terminals which are designed for wiring connections by the user.
- 12 The enclosing case shall be of substantial construction and shall have the necessary mechanical strength to protect the various parts of the appliance against physical injury.
- 13 An enclosing case or cabinet of suitable nonmetallic material is considered to be acceptable; but if such a cabinet is employed, individual units such as inductors and capacitors which are conductively connected to the power-supply circuit shall be enclosed in non-combustible material, except as noted in the following paragraph. Phenolic composition as the enclosure of a capacitor is considered to be non-combustible.
- 14 If an inductor or capacitor is protected by a series resistance of not less than 120,000 ohms, the enclosure of such an individual unit may be omitted. The usual type of variable capacitor with its air dielectric and small amount of combustible material is not required to be enclosed. Motor windings, and other coil windings which are not affected electrically (overloaded) by the failure of other parts are not required to be enclosed individually.
- 15 A metal enclosure shall be enameled or otherwise acceptably protected against corrosion.

### Supply Circuit

- 16 At a point where a flexible cord passes through an opening in a wall, barrier, or enclosing case, there shall be a suitable bushing or the equivalent which shall be substantial, reliably secured in place, and shall have a smoothly rounded surface against which the cord may bear. If a cord lighter than type P-64 is employed, and if the wall or barrier is of metal, and if the construction is such that the cord may be subjected to strain or motion, a non-combustible, moisture-resistant, insulating bushing shall be provided.
- 17 If the flexible cord is connected in the primary circuit, no other flexible cord or wire not connected in the primary circuit shall pass through the bushing or opening.
- 18 If the cord hole is in wood, porcelain, phenolic composition, or other suitable non-conducting material, a smoothly rounded surface is considered to be the equivalent of a bushing.



- 19 Ceramic materials and some molded compositions are considered to be acceptable generally for insulating bushings; and fiber may be employed where it will not be subjected to a temperature higher than 90 C under normal operating conditions and if it is so formed and secured in place that it will not be affected adversely by conditions of ordinary moisture. Separate insulating bushings of wood, rubber, and so-called hot-molded shellac and tar compositions are not considered to be acceptable.
- 20 Strain relief shall be provided so that a mechanical strain on a flexible cord will not be transmitted to terminals, splices, or interior wiring.
- 21 The power-supply cord shall be provided with a knot or equivalent stop which will prevent the cord from being pushed inside the chassis.
- 22 If a knot in a flexible cord serves as strain relief, the surface against which the knot may bear or with which it may come in contact shall be free from projections, sharp edges, burrs, fins, etc., which may cause abrasion of the insulation on the conductors.
- 23 The type of flexible cord required shall depend upon the nature of the device with which it is supplied.
- 24 Material for the mounting of current-carrying parts shall be phenolic composition, cold-molded composition, or the equivalent in electrical properties.
- 25 Hard fiber may be used for insulating bushings, washers, separators, and barriers, but not as the sole support for uninsulated current-carrying parts.
- 26 A control switch, lamp-holder, or attachment-plug receptacle shall be mounted securely and prevented from turning by means other than friction between surfaces. Clips for cartridge fuses shall be mounted securely and prevented from turning by hand.

## Transformers

- 27 A transformer shall be of thoroughly substantial design. The coils shall be wound in a workmanlike manner and impregnated or otherwise enclosed to exclude moisture.
- 28 A transformer which is connected to a power-supply circuit shall be completely and individually housed in non-combustible material. The enclosure shall not be provided with holes or louvres which will allow the circulation of air, except holes for the entrance of wires. The unused portion of any hole in the enclosure for the leads to the transformer shall be not larger than 0.2 sq in. in area; and the total unused portion of two or more holes shall be not larger than 0.35 sq in. in area. Any hole provided in the transformer for lead wires, but not so used, shall be effectively closed with non-combustible material.
- 29 A small amount of phenolic composition, such as a terminal block, will be considered to be acceptable in the enclosure of a transformer under the requirement of the preceding paragraph.

### Capacitors

- 30 A capacitor shall employ such materials and shall be so constructed that it will not constitute an undue fire hazard. It shall not be affected injuriously by the temperature attained by the device under the most severe conditions of normal use. A paper capacitor shall be impregnated or otherwise enclosed to exclude moisture.

### Wiring

- 31 All wires which are accessible when alive shall be insulated, and the insulation shall be suitable for the voltage involved and the temperature attained under any conditions of actual use. Wires of special types shall be made the subject of special investigation with respect to their intended use and shall be judged accordingly.
- 32 The special investigation of wires referred to in the preceding paragraph ordinarily will include a breakdown test involving a potential of three times the maximum voltage to which the wires may be subjected.
- 33 Insulating tubing (frequently referred to as "spaghetti") employed in a radio receiver shall not be readily combustible.
- 34 If the power transformer of a receiver is of the conductively connected (auto-transformer) type, it will be necessary to give consideration to the insulation and arrangement of conductors in the antenna and ground circuits.
- 35 No terminals or other uninsulated current-carrying parts shall come in contact with the enclosing case unless the case is of an acceptable insulating material or unless a permanent secondary connection is made to the case. If there is a permanent secondary connection to a metal case where an auto-transformer is employed, the case (or chassis) and all metal parts conductively connected thereto shall be treated as live parts.
- 36 If permanent secondary leads are supplied, strain relief shall be provided and the cord or cords shall be properly bushed, in accordance with pars. 16-22, where they pass through the wall of the cabinet or enclosing case.

### Accessibility of Live Parts

- 37 Except as provided in the following paragraph, no uninsulated live parts conductively connected to the power-supply circuit shall be exposed to contact.
- 38 An uninsulated live part conductively connected to the power-supply circuit may be exposed to contact provided that (1) there is an impedance of not less than 120,000 ohms between the uninsulated live part and the supply circuit and (2) that there is an impedance of not less than 35,000 ohms between an insulated-type grid cap and the supply circuit.
- 39 Electrical capacity of more than 0.1 microfarad from either side of the line to the chassis, antenna, or ground connection is not considered to be acceptable.

- 40 No uninsulated live parts in a secondary circuit involving a potential higher than 300 volts shall be exposed to contact; and some degree of protection shall be provided for uninsulated live parts involving potentials from 150 to 300 volts if they are so located that they are likely to be touched, particularly during the replacement of tubes.
- 41 For square and circular holes, rectangular slots, and other openings in an enclosing case which do not involve extraordinary shapes, the requirement of pars. 37 and 40 will be considered to be met if any opening has no dimension greater than  $\frac{1}{4}$  in.; and slots not wider than  $\frac{3}{32}$  in. will be disregarded. A larger opening may be considered to be acceptable if the distance between live parts and the opening is not less than three times the smaller dimension of the hole (such as the minor axis of an ellipse or the width of a rectangle). Irregular openings, special shapes, and slots from  $\frac{3}{32}$  in. to  $\frac{1}{4}$  in. in width will be given special consideration, including their accessibility, with respect to the intent of the requirements of pars. 37 and 40.
- 42 Compliance of a radio appliance with the requirement of par. 40 shall be determined under conditions of "normal maximum voltage," as described in par. 73.
- 43 A live part is considered to be exposed to contact if touchable by children or if touchable by adults without meddling.
- 44 A live part is not considered to be exposed to contact if it is located within a suitable enclosure whose cover does not need to be opened or removed in the normal operation or servicing of the device and can be opened or removed only by the use of a tool. Normal servicing of a device includes replacement of tubes and making such adjustments as are provided for the user to effect. Normal servicing does not include replacement of fuses or making repairs.
- 45 A pilot lamp is considered to be a non-serviceable part if it has a life of not less than 5000 hours at its operating voltage.
- 46 Live terminals of a panel or pilot-lamp receptacle shall be protected or fixed so that the possibility of grounding in use or in service is remote.
- 47 A positive interlock switch may be employed to accomplish the required protection of live parts against accidental contact.
- 48 In a power-supply circuit and in a secondary circuit where a potential of more than 300 volts is involved, a guard or barrier of insulating material employed to render live parts inaccessible shall be not less than  $\frac{1}{32}$  in. in thickness. Such protection, except as noted in the following paragraph, is required for speaker-field and audio-transformer windings, including the splices in their wiring if they are not otherwise suitably protected.
- 49 A covering of tough, insulating material not less than  $\frac{1}{64}$  in. in thickness is considered to be acceptable for a primary conductor brought out to an external protected splice.

## Spacings

50 A spacing of not less than  $\frac{1}{2}$  in. over surface or through air shall be maintained between uninsulated live or current-carrying parts of the primary or power-supply circuit and an enclosure of conducting material, except where the location and relative arrangement of the parts are such that permanent separation is assured.

51 A removable metal piece covering a fuse shall be lined with insulating material not less than  $\frac{1}{32}$  in. in thickness, if necessary to prevent contact between uninsulated live parts and non-current-carrying metal parts.

52 If a fuse or fuses are employed in a power-supply circuit, there shall be a spacing through air of not less than  $\frac{1}{8}$  in. between any live metal of a fuse or fuse clip and the chassis or metal in electrical connection with the chassis. This spacing shall be determined with the fuse in any position of contact with both fuse clips.

## Fuses

53 Fuses wherever used shall be devices recognized as suitable for the particular application and shall be housed.

54 A fuse, circuit-breaker, or fusible link employed in a power-supply circuit will not be depended upon to safeguard a radio appliance against excessive heating or overload conditions, although the presence of such protective devices is not undesirable.

## Power Consumption

55 Except as noted in the following paragraph, the current or wattage consumption of a radio appliance shall not exceed the marked input rating by more than five per cent when the device is operated with full load on the secondary output and while connected to a supply circuit of rated frequency and voltage corresponding to the mean of the marked primary voltage rating.

56 The current or wattage consumption of a radio appliance incorporating a Class B amplifier shall not exceed 87 per cent of the marked input rating by more than five per cent when the device is operated under no-load or no-signal conditions and while connected to a supply circuit of rated frequency and voltage corresponding to the mean of the marked primary voltage rating.

57 The requirement of the preceding paragraph is based on a marked current or wattage rating 15 per cent greater than the no-load or no-signal input in order to approximate an average value where input varies considerably with signal strength.

## Temperature

58 Materials employed in the construction of a radio receiving appliance shall not be affected adversely by the temperatures attained under condi-

tions of normal operation, and the temperature attained at any point on the exterior surface of a cabinet or enclosing case of non-combustible material shall be not higher than 90 C.

<sup>79</sup> With reference to the requirement of the preceding paragraph, materials will be considered as being affected adversely if temperatures higher than the following are attained:

- 49 C on conductors having rubber insulation.
  - 90 C on conductors having slow-burning insulation.
  - 90 C on fiber employed as electrical insulation.
  - 90 C on wood.
  - 90 C at any point on the interior surface of a cabinet or enclosing case of combustible material.
  - 105 C at any point on a winding employing impregnated organic insulation or enameled wire.
  - 150 C on phenolic composition employed as electrical insulation.
- The melting point of any sealing compound.

<sup>80</sup> Compliance of a radio appliance with the requirements of pars. 58-59 shall be determined by operating the appliance at full load while connected to a supply circuit whose voltage corresponds to the maximum primary rating of the device, and operation shall be continued until constant temperatures are reached. For a radio appliance incorporating a Class B amplifier, full load is considered to be the condition where the setting of the controls results in a current or wattage input 15 per cent greater than the no-load or no-signal input.

<sup>81</sup> With the receiver connected to a suitable antenna or the equivalent in the intended manner and tuned for the reception of a local broadcasting station, the volume control is to be adjusted so that the required power input results without undue distortion.

<sup>82</sup> If no voltage range is given in the rating of the appliance, maximum rated voltage is considered to be five volts above rated voltage.

<sup>83</sup> If a cabinet or enclosing case is of non-combustible material, temperatures shall be noted at various points on the exterior surface of the device. If a cabinet or enclosing case is of combustible material, temperatures shall be noted at various points within the cabinet and on the interior surface.

<sup>84</sup> The temperatures given in these requirements are based on a room temperature of 24 C. Temperature tests may be made at any room temperature and the variation from 24 C added to or subtracted from the observed temperature readings.

<sup>85</sup> Temperature readings may be obtained by thermocouples, by glass-bulb mercury thermometers, the bulbs of which are brought into good thermal contact with the surface under observation by means of fresh glazier's putty, or by other standard methods; and a temperature shall be considered to be constant when three successive readings, taken at 5-min intervals, indicate no change.

## Dielectric Strength

- 65 The insulation and spacings of a radio appliance, while still heated from the temperature test, shall be capable of withstanding for a period of one minute without breakdown the potentials indicated below:
- 67 (1) If the primary and secondary windings of the power transformer are not conductively connected: a 60-cycle alternating potential of 900 volts applied between any live or current-carrying part of the primary or power-supply circuit and (A) the core of the transformer, (B) non-current-carrying metal parts such as the enclosure or chassis, and (C) any live or current-carrying part of the secondary circuit.
- 68 (2) If the primary and secondary windings of a power transformer are conductively connected: a 60-cycle alternating potential of 900 volts applied between any live or current-carrying part connected to the supply circuit and antenna, ground, or any other user terminals.
- 69 (3) If the primary and secondary windings of the power transformer are conductively connected, but if there is no connection between the chassis and the supply circuit: a 60-cycle alternating potential of 900 volts applied between any live or current-carrying parts conductively connected to the supply circuit and any non-current-carrying metal parts.
- 70 (4) A 60-cycle alternating potential of 900 volts applied across any capacitor connected in the primary circuit and which was not tested under the conditions outlined in the preceding paragraphs.
- 71 (5) A direct-current potential of four times the maximum direct-current plate voltage used on the output tube, applied across any blocking capacitor used for speaker coupling, if the speaker is not supplied as a part of the receiver.
- 72 (6) A potential of three times the "normal maximum voltage," as explained in the following paragraph, applied to all secondary circuits; except that a capacitor may be accepted under the provisions of pars. 83-84.
- 73 "Normal maximum voltage" in a secondary circuit is the potential existing across any insulation when a potential of maximum rated voltage and frequency is applied to the primary connections, and under any condition of removed vacuum tubes, removed plug connectors, or adjustment of user controls, etc. — but not under the condition of a removed part which is permanently wired or fixed, or the adjustment of a primary tap, fuse, or other "non-serviceable" control. Normal maximum voltage is to be measured with a voltmeter or a voltmeter-multiplier combination having a resistance of not less than 300,000 ohms.
- 74 Compliance of a radio appliance with the requirements of pars. 66-70 is to be determined by means of a suitable testing transformer, the output voltage of which can be regulated. Starting at zero, the applied potential is to be increased gradually until the required test value is reached or until breakdown occurs.

- 75 Compliance of a radio appliance with the requirement of par 71 is to be determined by means of any convenient direct-current source of supply, the voltage of which can be regulated. The testing may be done with kenotrons or similar rectifying elements and without filtering. Starting at zero the applied potential is to be increased gradually until the required test value is reached or until breakdown occurs.
- 76 Compliance of a radio appliance with the requirement of par 72 is to be determined by means of the apparatus and according to the method described below.
- 77 Apparatus — The apparatus consists of (1) a voltmeter or voltmeter-multiplier combination having a resistance of not less than 300,000 ohms and (2) any convenient alternating-current source of supply, the frequency of which is not less than three times the rated frequency of the appliance, and the voltage of which can be regulated and can be brought to a value not less than three times the rated voltage of the appliance.
- 78 Method — The primary winding of the power transformer of the radio appliance is to be connected to the alternating-current source of supply which is delivering the frequency of not less than three times that of the rating of the appliance. Starting at zero, the potential is to be increased gradually until the secondary voltage values are three times the normal maximum voltages described in par 73, or until breakdown occurs. The higher test frequency is employed in order to permit the secondary voltage of the transformer to reach the required potential without being limited by the saturation of the iron of the transformer core.
- 79 During the test all lamps and amplifier tubes are to be removed and ballast tubes or other automatic regulating devices are to be rendered inoperative, if necessary to carry out the test. Primary circuit adjustments, if any, are to be in the proper position for the voltage which is to be used as a basis for the test-voltage value. The voice-coil circuit and the frame of the loud speaker are to be electrically connected to the chassis (ground) in order to make certain that the insulation of the output transformer or capacitor and the speaker is stressed.
- 80 As an indication (1) that the test has been made correctly and (2) that the insulation has or has not failed, the high-resistance voltmeter is to be connected across the high-voltage plate-supply circuit. During the test the meter should read three times the voltage existing under the normal maximum voltage condition. Insulation failure will be indicated by a falling off of the meter reading.
- 81 Burnout of a resistor or other conductor is not to be considered as a failure. A resistor may be cooled artificially to prevent burnout, replaced by an equivalent external resistance, or cut out of the circuit — care being taken to prevent any insulation being stressed with a potential higher than the required value.
- 82 Burnout or voltage failure of a rectifier tube is not to be considered as a failure. A high-voltage, separately lighted rectifier tube or tubes may be substituted for the rectifier tube of the appliance and wired to the rectifier socket.

- 83 The testing of an electrolytic capacitor as a part of a radio receiving appliance under the requirements for dielectric strength may be waived if the capacitor is found to comply with the following requirements: the capacitor shall be plainly marked with the manufacturers' name or trademark and the voltage rating; if the voltage rating across the capacitor in the radio appliance exceeds the marked capacitor voltage rating under the conditions of normal maximum voltage as described in par. 73, the capacitor shall be capable of continuous operation under these conditions for a period of not less than 15 min without breakdown; and if any increase of the leakage current is noted, as measured by a suitable milliammeter, two additional samples of the capacitor shall be tested under the same conditions and shall be capable of withstanding the 15-min application of normal maximum voltage without breakdown.
- 84 At the option of the submitter, the testing of a capacitor other than an electrolytic capacitor under the requirements for dielectric strength may be waived and the acceptability of the capacitor for the particular application may be made the subject of special investigation.
- 85 A separable connector, such as in a dynamic-speaker circuit, shall be capable of performing acceptably, without injuriously affecting other parts of the device, when subjected to a test consisting of ten cycles of make and break, in a period of one minute, with full primary input voltage applied to the device.
- 86 A separable connector is considered to be one which is not held in place by a screw, clamp, or the like, and which does not require the use of a tool in order to accomplish the separation.

### Rating

- 87 The electrical rating of a radio appliance shall include the primary voltage, frequency, and input in amperes or watts.
- 88 In the case of a radio appliance incorporating a Class B amplifier, the rated primary input in amperes or watts shall be not less than 115 per cent of the no-load or no-signal input as described in pars. 56-57.

### Marking

- 89 A complete radio appliance shall be plainly marked where it will be readily visible with the name of the manufacturer, a distinctive catalog number or the equivalent, and the electrical rating.
- 90 The distinctive marking of a receiver may be a combination of chassis and cabinet markings.
- 91 An installation diagram or instructions shall accompany a radio appliance if the connections and method of operation are such that there may be any question regarding them.



## REQUIREMENTS FOR DIRECT-CURRENT AND UNIVERSAL POWER-OPERATED RADIO RECEIVING APPLIANCES

### Scope

- 92 These Requirements cover power-operated radio receiving appliances for non-commercial use designed to be employed on direct-current interior wiring systems in accordance with the National Electrical Code, and similar appliances designed for use on both direct- and alternating-current circuits.
- 93 Under this classification are included only those devices which dissipate within themselves all energy (except for speaker connections) taken from the supply circuit.
- 94 These Requirements, in so far as they apply, cover features of non-commercial or domestic sound equipment similar to the features of radio appliances mentioned herein.
- 95 These Requirements are based upon records of tests and field experience and are subject to revision as further experience and investigation may show to be necessary or desirable.
- 96 Devices or products which comply with these Requirements will not necessarily be acceptable if they have other features which, when examined and tested, are found to impair the result contemplated by these Requirements.
- 97 A device or product having materials or forms of construction differing from those detailed in these Requirements may be examined and tested according to the intent of the Requirements, and if found to be substantially equivalent may be given recognition.
- 98 Requirements are shown in bold-faced type and are supplemented by explanatory notes and descriptions of test apparatus and methods in light-faced type.
- 99 If not otherwise specified, voltages referred to are root-mean-square values.

### General

- 100 A radio appliance shall employ materials throughout which are acceptable for the particular use, and shall be made and finished with the degree of uniformity and grade of workmanship practicable in a well-equipped factory.

- 101 Attachment plugs, circuit-breakers, cords, cutout bases, lamp-holders, receptacles, switches, wires, etc., which are provided as a part of a radio receiving appliance are judged under the Requirements of Underwriters' Laboratories, Inc., for such devices and also with respect to their suitability for the particular application.

## Enclosure

- 102 The enclosing case or cabinet shall enclose all current-carrying parts of a radio appliance which are conductively connected to the power-supply circuit, except the supply leads which are connected to the device.
- 103 If a radio appliance is so designed that it is necessary for the user to open the case to replace tubes, batteries, or other renewable parts, or to make adjustments, the arrangement shall be such that uninsulated current-carrying parts conductively connected to the power-supply circuit will be disconnected automatically, covered, or otherwise protected against accidental contact. If a cover-operated switch is used to accomplish this purpose, it shall be of the two-pole type.
- 104 Under certain conditions where the desired result can be accomplished — as, for instance, where a "C" battery is involved — the cover-operated switch referred to in the preceding paragraph may be of the single-pole type.
- 105 A radio appliance may be so designed that tubes can be replaced without opening the enclosure, provided that the current-carrying parts of the tubes are not exposed to contact.
- 106 The enclosing case shall be of substantial construction and shall have the necessary mechanical strength to protect the various parts of the appliance against physical injury.
- 107 An enclosing case or cabinet of suitable non-metallic material is considered to be acceptable; but if such a cabinet is employed, individual units such as inductors and capacitors which are conductively connected to the power-supply circuit shall be enclosed in non-combustible material, except as noted in the following paragraph. Phenolic composition as the enclosure of a capacitor is considered to be non-combustible.
- 108 If an inductor or capacitor is protected by a suitable series resistance, impedance, or equivalent safeguard and if a special investigation cannot be made to show that an undue fire or accident hazard exists, the enclosure of such an individual unit may be omitted. The usual type of variable capacitor with its air dielectric and small amount of combustible material is not required to be enclosed. Motor windings, and other coil windings which are not affected electrically (overloaded) by the failure of other parts are not required to be enclosed individually.
- 109 A metal enclosure shall be enameled or otherwise acceptably protected against corrosion.

**Supply Circuit**

- 110 At a point where a flexible cord passes through an opening in a wall, barrier, or enclosing case, there shall be a suitable bushing or the equivalent which shall be substantial, reliably secured in place, and shall have a smoothly rounded surface against which the cord may bear. If a cord lighter than type P-64 is employed, and if the wall or barrier is of metal, and if the construction is such that the cord may be subjected to strain or motion, a non-combustible, moisture-resistant, insulating bushing shall be provided.
- 111 If the flexible cord is connected in the primary circuit, no other flexible cord or wire not connected in the primary circuit shall pass through the bushing or opening.
- 112 If the cord hole is in wood, porcelain, phenolic composition, or other suitable non-conducting material, a smoothly rounded surface is considered to be the equivalent of a bushing.
- 113 Ceramic materials and some molded compositions are considered to be acceptable generally for insulating bushings; and fiber may be employed where it will not be subjected to a temperature higher than 90 C under normal operating conditions and if it is so formed and secured in place that it will not be affected adversely by conditions of ordinary moisture. Separate insulating bushings of wood, rubber, and so-called hot-molded shellac and tar compositions are not considered to be acceptable.
- 114 Strain relief shall be provided so that a mechanical strain on a flexible cord will not be transmitted to terminals, splices, or interior wiring.
- 115 The power-supply cord shall be provided with a knot or equivalent stop which will prevent the cord from being pushed inside the chassis.
- 116 If a knot in a flexible cord serves as strain relief, the surface against which the knot may bear or with which it may come in contact shall be free from projections, sharp edges, burrs, fins, etc., which may cause abrasion of the insulation on the conductors.
- 117 The type of flexible cord required shall depend upon the nature of the device with which it is supplied.
- 118 Material for the mounting of current-carrying parts shall be phenolic composition, cold-molded composition, or the equivalent in electrical properties.
- 119 The paper insulation on a "C" battery will not be considered to be sufficient as the insulation of the battery. This will generally require the provision of an additional container of moisture-resistant, insulating material for the battery; but wood protected by a suitable insulating paint may be considered to be acceptable as a material on which a "C" battery may be mounted.

- 120 Hard fiber may be used for insulating bushings, washers, separators, and barriers, but not as the sole support for uninsulated current-carrying parts.
- 121 A control switch, lamp-holder, or attachment-plug receptacle shall be mounted securely and prevented from turning by means other than friction between surfaces. Clips for cartridge fuses shall be mounted securely and prevented from turning by hand.

### Capacitors

- 122 A capacitor shall employ such materials and shall be so constructed that it will not constitute an undue fire hazard. It shall not be affected injuriously by the temperature attained by the device under the most severe conditions of normal use. A paper capacitor shall be impregnated or otherwise enclosed to exclude moisture.

### Wiring

- 123 All wires which are accessible when alive shall be insulated, and the insulation shall be suitable for the voltage involved and the temperature attained under any conditions of actual use. Wires of special types shall be made the subject of special investigation with respect to their intended use and shall be judged accordingly.
- 124 The special investigation of wires referred to in the preceding paragraph ordinarily will include a breakdown test involving a potential of three times the maximum voltage to which the wires may be subjected.
- 125 Insulating tubing (frequently referred to as "spaghetti") employed in a radio receiver shall not be readily combustible.
- 126 No terminals or other uninsulated current-carrying parts shall come in contact with the enclosing case, unless the case is of acceptable insulating material.
- 127 Wood protected by a suitable insulating paint may be considered to be acceptable as insulating material with respect to the requirement of the preceding paragraph.

### Accessibility of Live Parts

- 128 Except as provided in the following paragraph, no uninsulated live parts conductively connected to the power-supply circuit shall be exposed to contact.
- 129 An uninsulated live part conductively connected to the power-supply circuit may be exposed to contact provided that (1) there is an impedance of not less than 120,000 ohms between the uninsulated live part and the supply circuit, and (2) that there is an impedance of not less than 35,000 ohms between an insulated-type grid cap and the supply circuit

- 130 Electrical capacity of more than 0.25 microfarad from either side of the line to the chassis, or more than 0.1 microfarad from either side of the line to the antenna and/or ground connection is not considered to be acceptable.
- 131 For square and circular holes, rectangular slots, and other openings in an enclosing case which do not involve extraordinary shapes, the requirement of par. 128 will be considered to be met if any opening has no dimension greater than  $\frac{1}{4}$  in.; and slots not wider than  $\frac{3}{32}$  in. will be disregarded. A larger opening may be considered to be acceptable if the distance between live parts and the opening is not less than three times the smaller dimension of the hole (such as the minor axis of an ellipse or the width of a rectangle). Irregular openings, special shapes, and slots from  $\frac{3}{32}$  in. to  $\frac{1}{4}$  in. in width will be given special consideration, including their accessibility, with respect to the intent of the requirements of pars. 128-129.
- 132 A live part is considered to be exposed to contact if touchable by children or if touchable by adults without meddling.
- 133 A live part is not considered to be exposed to contact if it is located within a suitable enclosure whose cover does not need to be opened or removed in the normal operation or servicing of the device and can be opened or removed only by the use of a tool. Normal servicing of a device includes replacement of tubes and making such adjustments as are provided for the user to effect. Normal servicing does not include replacement of fuses or making repairs.
- 134 A pilot lamp is considered to be a non-serviceable part if it has a life of not less than 5000 hours at its operating voltage.
- 135 Live terminals of a panel or pilot-lamp receptacle shall be protected or fixed so that the possibility of grounding in use or in service is remote.
- 136 A positive interlock switch may be employed to accomplish the required protection of live parts against accidental contact, under the conditions described in pars. 103-104.
- 137 In a power-supply circuit and where parts are electrically connected to a power-supply circuit, a guard or barrier of insulating material employed to render live parts inaccessible shall be not less than  $\frac{1}{32}$  in. in thickness.

### Spacings

- 138 A spacing of not less than  $\frac{1}{2}$  in. over surface or through air shall be maintained between uninsulated, live or current-carrying parts of the power-supply circuit and an enclosure of conducting material, except where the location and relative arrangement of the parts are such that permanent separation is assured.
- 139 A removable metal piece covering a fuse shall be lined with insulating material not less than  $\frac{1}{32}$  in. in thickness, if necessary to prevent contact between uninsulated, live parts and non-current-carrying metal parts.

- 140 If a fuse or fuses are employed in a power-supply circuit, there shall be a spacing through air of not less than  $\frac{1}{8}$  in. between any live metal of a fuse or fuse clip and the chassis or metal in electrical connection with the chassis. This spacing shall be determined with the fuse in any position of contact with both fuse clips.

### Fuses

- 141 Fuses wherever used shall be devices recognized as suitable for the particular application and shall be housed.
- 142 A fuse, circuit-breaker, or fusible link employed in a power-supply circuit will not be depended upon to safeguard a radio appliance against excessive heating or overload conditions, although the presence of such protective devices is not undesirable.

### Tube Sockets

- 143 A tube socket, the tube of which is removable when its circuits are alive, shall be capable of performing acceptably when subjected to 50 cycles of operation (insertion and removal of the tube) making and breaking the circuits in question, with the complete radio appliance connected to a supply circuit of maximum rated voltage.

### Power Consumption

- 144 Except as noted in the following paragraph, the current or wattage consumption of a radio appliance shall not exceed the marked input rating by more than five per cent when the device is operated with full load on the output and while connected to a supply circuit of voltage corresponding to the mean of the marked primary voltage rating.
- 145 The current or wattage consumption of a radio appliance incorporating a Class B amplifier shall not exceed 87 per cent of the marked input rating by more than five per cent when the device is operated under no-load or no-signal conditions and while connected to a supply circuit of voltage corresponding to the mean of the marked primary voltage rating.
- 146 The requirement of the preceding paragraph is based on a marked current or wattage rating 15 per cent greater than the no-load or no-signal input in order to approximate an average value where input varies considerably with signal strength

### Temperature

- 147 Materials employed in the construction of a radio receiving appliance shall not be affected adversely by the temperatures attained under conditions of normal operation, and the temperature attained at any point on the exterior surface of a cabinet or enclosing case of non-combustible material shall be not higher than 90 C.

- 148 With reference to the requirement of the preceding paragraph, materials will be considered as being affected adversely if temperatures higher than the following are attained:

- 49 C on conductors having rubber insulation.
  - 90 C on conductors having slow-burning insulation.
  - 90 C on fiber employed as electrical insulation.
  - 90 C on wood.
  - 90 C at any point on the interior surface of a cabinet or enclosing case of combustible material.
  - 105 C at any point on a winding employing impregnated organic insulation or enameled wire.
  - 150 C on phenolic composition employed as electrical insulation.
- The melting point of any sealing compound.

- 149 Compliance of a receiver with the requirements of par. 147-148 shall be determined by operating the appliance at full load while connected to a supply circuit whose voltage corresponds to the maximum primary rating of the device, and operation shall be continued until constant temperatures are reached. If a Class B amplifier is employed, full load is considered to be the condition where the setting of the controls results in a current or wattage input 15 per cent greater than the no-load or no-signal input.

- 150 With the receiver connected to a suitable antenna or the equivalent in the intended manner and tuned for the reception of a local broadcasting station, the volume control is to be adjusted so that the required power input results without undue distortion.

- 151 If no voltage range is given in the rating of the appliance, maximum rated voltage is considered to be five volts above rated voltage.

- 152 If a cabinet or enclosing case is of noncombustible material, temperatures shall be noted at various points on the exterior surface of the device. If a cabinet or enclosing case is of combustible material, temperatures shall be noted at various points within the cabinet and on the interior surface.

- 153 The temperatures given in these requirements are based on a room temperature of 24 C. Temperature tests may be made at any room temperature and the variation from 24 C added to or subtracted from the observed temperature readings.

- 154 Temperature readings may be obtained by thermocouples, by glass-bulb mercury thermometers, the bulbs of which are brought into good thermal contact with the surface under observation by means of fresh glazier's putty, or by other standard methods; and a temperature shall be considered to be constant when three successive readings, taken at 5-min intervals, indicate no change.

### Dielectric Strength

- 155 The insulation and spacings of a radio appliance, while still heated from the temperature test, shall be capable of withstanding for a period of one minute without breakdown the potentials indicated below:

- 156 (1) A 60-cycle alternating potential of 900 volts applied between any live or current-carrying part conductively connected to the supply circuit and any non-current-carrying metal parts.
- 157 (2) A direct-current potential of four times the maximum direct-current plate voltage used on the output tube, applied across any blocking capacitor used for speaker coupling, if the speaker is not supplied as a part of the receiver.
- 158 (3) A direct-current potential of three times "normal maximum voltage," as explained in the following paragraph, applied to all circuits of the appliance.
- 159 "Normal maximum voltage" is the potential existing across any insulation when a potential of maximum rated voltage is applied to the supply connections, and under any condition of removed vacuum tubes, removed plug connectors, or adjustment of user controls, etc.—but not under the condition of a removed part which is permanently wired or fixed, or the adjustment of a tap, fuse, or other "non-serviceable" control. Normal maximum voltage is to be measured with a voltmeter or a voltmeter-multiplier combination having a resistance of not less than 300,000 ohms.
- 160 Compliance of a radio appliance with the requirement of par. 156 is to be determined by means of a suitable testing transformer, the output voltage of which can be regulated. Starting at zero, the applied potential is to be increased gradually until the required test value is reached or until breakdown occurs. During this test the antenna and ground or loop terminals of the appliance are to be electrically connected to the chassis.
- 161 Compliance of a radio appliance with the requirement of par. 157 is to be determined by means of any convenient direct-current source of supply, the voltage of which can be regulated. The testing may be done with kenotrons or similar rectifying elements and without filtering. Starting at zero, the applied potential is to be increased gradually until the required test value is reached or until breakdown occurs.
- 162 Compliance of a radio appliance with the requirement of par. 158 is to be determined as indicated in the preceding paragraph. Starting at zero, the applied potential is to be increased gradually until the circuit potentials are three times the normal maximum voltages described in par. 159 or until breakdown occurs.
- 163 The appliance is to be connected to the test circuit with correct polarity applied to the supply connections. The test is then to be repeated with reversed polarity.
- 164 During the test all lamps and amplifier tubes are to be removed and ballast tubes or other automatic regulating devices are to be rendered inoperative, if necessary to carry out the test. The voice-coil circuit and the frame of the loud speaker are to be electrically connected to the chassis (ground) in order to make certain that the insulation of the output transformer or capacitor and the speaker is stressed.



- 165 As an indication (1) that the test has been made correctly and (2) that the insulation has or has not failed, a high-resistance voltmeter is to be connected across the plate-supply circuit. During the tests the meter should read three times the voltage existing under the normal maximum voltage condition. Insulation failure will be indicated by a falling off of the meter reading.
- 166 Burnout of a resistor or other conductor is not to be considered as a failure. A resistor may be cooled artificially to prevent burnout, replaced by an equivalent external resistance, or cut out of the circuit—care being taken to prevent any insulation being stressed with a potential higher than the required value.
- 167 At the option of the submitter, the testing of a capacitor under the requirements for dielectric strength may be waived and the acceptability of the capacitor for the particular application may be made the subject of special investigation.
- 168 A separable connector, such as in a dynamic-speaker circuit, shall be capable of performing acceptably, without injuriously affecting other parts of the device, when subjected to a test consisting of ten cycles of make and break, in a period of one minute, with full primary input voltage applied to the device.
- 169 A separable connector is considered to be one which is not held in place by a screw, clamp, or the like, and which does not require the use of a tool in order to accomplish the separation.

### Rating

- 170 The electrical rating of a radio appliance shall include the primary voltage, and input in amperes or watts. The voltage rating shall be not greater than 250 volts.
- 171 In the case of a radio appliance incorporating a class B amplifier, the rated primary input in amperes or watts shall be not less than 115 per cent of the no-load or no-signal input as described in pars. 145-146.

### Marking

- 172 A complete radio appliance shall be plainly marked where it will be readily visible with the name of the manufacturer, a distinctive catalog number or the equivalent, and the electrical rating.
- 173 The distinctive marking of a receiver may be a combination of chassis and cabinet markings.
- 174 An installation diagram or instructions shall accompany a radio appliance if the connections and method of operation are such that there may be any question regarding them.

## CHAPTER 46

# Radio Data

## (Symbols, Abbreviations and Units)



















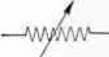

The purpose of symbols and abbreviations is to make it possible to illustrate and describe more briefly and clearly.

A drawing in which every part or piece of apparatus would be repeatedly described, would of necessity, be large and unintelligible; therefore symbols have been devised which represent every part and piece of apparatus and which take up little space. Similarly, where long words or terms are to be used, single letters or shortened words are substituted; these have been adopted as standard and to mean just the things specified.













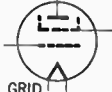







Engineering societies and manufacturers have adopted and authorized their use, and made them the specific way of indicating apparatus, equipment and terms in their fields; it is therefore necessary to become familiar with these in order to have a full understanding of the subject.

Diagrams should be made accordingly and descriptions should be written with the abbreviations; likewise, diagrams can be read only by a knowledge of the symbols; and descriptions understood only by a knowledge of the abbreviations.

On the following pages are given the most important symbols and abbreviations used:

 ANTENNA	 GROUND	 RECTIFIER TUBE (Half - Wave)
 LOOP ANTENNA	 INDUCTOR	 RESISTOR
 AMMETER	 INDUCTOR (Adjustable)	 RESISTOR (Adjustable)
 BATTERY (The negative is indicated by the heavy line)	 INDUCTOR (Variable)	 RESISTOR (Variable)
 CONDENSER	 JACK	 SPARK GAP (Rotary)
 CRYSTAL DETECTOR	 PHOTOELECTRIC CELL	 SPARK GAP (Plain)
 GALVANOMETER	 RECTIFIER TUBE (Full - Wave)	 SPARK GAP (Quenched)

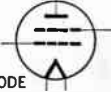
The above symbols have been adopted as standard by engineers and manufacturers, and should be used in making circuit diagrams—also for reference, in reading diagrams.

 <p>TELEPHONE RECEIVER</p>	 <p>WIRES CROSS (Not joined)</p>	 <p>SCREEN GRID (With directly heated cathode)</p>
 <p>THERMO ELEMENT</p>	 <p>SWITCH (Single pole)</p>	 <p>SCREEN GRID (With indirectly heated cathode)</p>
 <p>TRANSFORMER (Air core)</p>	 <p>RELAY</p>	 <p>PENTODE (With directly heated cathode)</p>
 <p>TRANSFORMER (Iron core)</p>	 <p>DIODE</p>	 <p>DUPLEX DIODE PENTODE</p>
 <p>TRANSFORMER (Fixed Tap)</p>	 <p>TRIODE (With directly heated cathode)</p>	 <p>PENTAGRID CONVERTER</p>
 <p>VOLTMETER</p>	 <p>TRIODE (With indirectly heated cathode)</p>	 <p>PENTAGRID MIXER</p>
 <p>WIRES JOINED</p>	 <p>TETRODE (With directly heated cathode)</p>	 <p>ELECTRON-RAY TUBE</p>

In addition to symbols, given above, abbreviations are used for shortening descriptions. Abbreviations and formulas most commonly used are given on the following pages.

**Electrical Prefixes:**

- Kilo Denotes a quantity one thousand times as great as a unit.  
 Milli Denotes a quantity equal to one-thousandth part of a unit.  
 Micro Denotes a quantity equal to one-millionth part of a unit.  
 Meg Denotes a quantity one million times as great; for example,  
 1,000,000 cycles = 1 megacycle, and 1,000,000 ohms = 1 megohm.

**Ohm's Law for direct current**

$$I = \frac{E}{R} \quad R = \frac{E}{I} \quad E = I \times R$$

- where  $I$  = amperes;  
 $E$  = volts;  
 $R$  = resistance.

**Formula for resistances in series**

$$R_{(\text{Total})} = R_1 + R_2 + R_3 \quad \text{etc.}$$

**Formula for resistances in parallel**

$$R_{(\text{Total})} = \frac{1}{\frac{1}{R_1} + \frac{1}{R_2} + \frac{1}{R_3} \quad \text{etc.}}$$

**Determination of frequency of an alternator**

$$\text{Frequency} = \frac{N \times S}{2}$$

- where  $N$  = the number of field poles;  
 $S$  = the speed of the armature in revolutions per second.

**Fundamental frequency formula**

$$f = \frac{1}{2\pi\sqrt{LC}}$$

- where  $f$  = frequency in cycles per second;  
 $L$  = inductance of the circuit in henries;  
 $C$  = capacitance of the circuit in farads.

**Inductive reactance formula**

$$X_L = 2\pi fL$$

where  $X_L$  = inductive reactance;  
 $L$  = inductance in henries.

**Capacitive reactance formula**

$$X_c = \frac{1}{2\pi fC}$$

where  $X_c$  = capacitive reactance;  
 $C$  = capacity in farads.

**Ohm's Law for alternating current**

$$I = \frac{E}{Z} \quad \text{or} \quad I = \frac{E}{\sqrt{R^2 + \left[ (2\pi fL) - \left( \frac{1}{2\pi fC} \right) \right]^2}}$$

where  $I$  = current;  
 $E$  = voltage;  
 $Z$  = impedance (total of all oppositions).

**Condensers connected in parallel**

$$C_{(\text{Total})} = C_1 + C_2 + C_3 \quad \text{etc.}$$

**Condensers connected in series**

$$C_{(\text{Total})} = \frac{1}{\frac{1}{C_1} + \frac{1}{C_2} + \frac{1}{C_3} \text{ etc.}}$$

## Resonance formula

$$2\pi fL = \frac{1}{2\pi fC}$$

where  $2\pi fL$  = inductive reactance;

and  $\frac{1}{2\pi fC}$  = capacitive reactance.

## Wavelength formula

$$(\lambda) \text{ wavelength} = 1884\sqrt{LC}$$

where  $L$  = inductance in microhenries;

and  $C$  = capacity in microfarads.

## Antenna radiation formula

$$W = 1578 \times \frac{h^2}{\lambda^2} \times I^2$$

in which  $W$  = the energy radiated in watts effective;

$h$  = the effective height of the antenna in meters;

$\lambda$  = the wavelength of the antenna in meters;

$I$  = the current in amperes at the base of the antenna or point of maximum current.

## Signs

$\propto$  proportional to; varies as

= equal to

$\times$  multiplied by

+

- minus; subtraction

$\div$  divided by

$\odot$  circle

$\sphericalangle$  angle

$<$  is less than

$\ll$  much less than

$>$  is greater than

$\gg$  much greater than

$\odot$  cycle

## Symbols

$\mu$ = permeability ( $B/H$ )	a-f = audio-frequency
$\pi$ = 3.1416	r-f = radio-frequency
$\rho$ = volume resistivity	e.m.f. = electromotive force
$\tau$ = thickness	m.m.f. = magnetomotive force
$\kappa$ = susceptibility	a-c = alternating current
$\lambda$ = wavelength in meters	d-c = direct current
$\delta$ = logarithmic decrement	$\mu f$ = microfarad
$\epsilon$ = 2.7183 (base of Napierian logarithms)	$\mu\mu f$ = micro-microfarad
$\eta$ = efficiency (per cent)	h = henry
$\theta$ = phase angle (degree or radian)	mh = millihenry
$\phi$ = angle	$\mu h$ = microhenry
$\psi$ = difference in phase	f = frequency
$\omega$ = $2\pi f$ (angular velocity in radians per second);	$M\Omega$ = megohm
$\Phi$ = magnetic flux	rms = root-mean-square
$\Psi$ = electrostatic flux	rpm = revolutions per minute
$\Omega$ = ohm	rps = revolutions per second

## Greek alphabet

Letters	Names	Letters	Names	Letters	Names
A $\alpha$	Alpha	I $\iota$	Iota	P $\rho$	Rho
B $\beta$	Beta	K $\kappa$	Kappa	$\Sigma$ $\sigma$ s	Sigma
$\Gamma$ $\gamma$	Gamma	$\Lambda$ $\lambda$	Lambda	T $\tau$	Tau
$\Delta$ $\delta$	Delta	M $\mu$	Mu	Y $\upsilon$	Upsilon
E $\epsilon$	Epsilon	N $\nu$	Nu	$\Phi$ $\phi$	Phi
Z $\zeta$	Zeta	$\Xi$ $\xi$	Xi	X $\chi$	Chi
H $\eta$	Eta	O $\omicron$	Omicron	$\Psi$ $\psi$	Psi
$\Theta$ $\theta$	Theta	$\Pi$ $\pi$	Pi	$\Omega$ $\omega$	Omega



## Abbreviations

<i>C</i>	capacity (electrostatic capacity)	<i>d</i>	diameter; distance
<i>E</i>	effective electromotive force	<i>f</i>	frequency; cycles per second
<i>I</i>	effective current	<i>g</i>	conductance
<i>K</i>	dielectric constant	<i>h</i>	height
<i>L</i>	inductance	<i>i</i>	instantaneous current
<i>M</i>	mutual inductance	<i>k</i>	coefficient of coupling
<i>N</i>	number of conductors or turns	<i>l</i>	length
<i>Q</i>	quantity of electricity	<i>r</i>	distance from a point (radius)
<i>R</i>	resistance	<i>t</i>	time
<i>T</i>	period, or one complete cycle	<i>v</i>	velocity
<i>W</i>	watts		
<i>X</i>	reactance		
<i>Z</i>	impedance		

## Letter Symbols—Vacuum Tube Notation

Grid potential	-----	$E_g, e_g$
Grid current	-----	$I_g, i_g$
Grid conductance	-----	$g_g$
Grid resistance	-----	$r_g$
Grid bias voltage	-----	$E_b$
Plate potential	-----	$E_p, e_p$
Plate current	-----	$I_b, I_p, i_p$
Plate conductance	-----	$g_p$
Plate resistance	-----	$r_p$
Plate supply voltage	-----	$E_b$
Emission current	-----	$I_s$
Mutual conductance	-----	$g_m$
Amplification factor	-----	$\mu$
Filament terminal voltage	-----	$E_f$
Filament current	-----	$I_f$
Grid-plate capacity	-----	$C_{gp}$
Grid-cathode capacity	-----	$C_{gk}$
Plate-cathode capacity	-----	$C_{pk}$
Grid capacity (input)	-----	$C_g$
Plate capacity (output)	-----	$C_p$

**UNITS.**—Electrical units are based on the **metric system**, which is the name applied to the system of units employed in continental Europe.

The fundamental units in the metric system are the meter, the gram, and the second. The **unit meter** is the length of a certain metal standard *bar* which is preserved at the International Bureau near Paris.

From this unit of length, the units of volume (*liter*) and of mass (*gram*) are derived. The three units—*meter*, *liter* and *gram*—are simply related, thus one cubic decimeter equals one liter and one liter of water weighs one kilogram.

The above units are comparatively familiar to the radio man, as the meter is universally used for the expression of the length of radio waves. The meter is 39.37 inches or 3.281 feet.

Without giving any historical information as to the development of electric and magnetic units, it may be said that those now used are the so-called international electric units. The international units are based on four fundamental units—the *ohm*, *ampere*, *centimeter* and *second*. The first of these is the unit of *resistance*, and is defined in terms of the resistance of a very pure conductor of specified dimensions. The *ampere* is the unit of current and is defined in terms of a chemical effect of electric current, the amount of silver deposited from a certain solution for a current flow for a definite time. The other electric units follow from these in accordance with the principles of electrical science. Some of the units thus defined are given in the following definitions, which are those adopted by international congresses of science and universally used in electrical work:

One **ohm** = the resistance of a column of mercury (at the temperature of melting ice) of a uniform cross section of one square millimeter and a length of 106.30 centimeters.

One **ampere** = the current which when passed through a solution of nitrate of silver in water in accordance with certain specifications, deposits silver at the rate of 0.001118 of a gram per second.

One **volt** = the electromotive force which produces a current of one ampere when steadily applied to a conductor the resistance of which is one ohm.

One **coulomb** = the quantity of electricity transferred by a current of one ampere in one second.

One **farad** = the capacity of a condenser in which a potential difference of one volt causes it to have a charge of one coulomb of electricity.

One **henry** = the inductance in a circuit in which the electromotive force induced is one volt when the inducing current varies at the rate of one ampere per second.

One **watt** = the power expended by a current of one ampere in a resistance of one ohm.

One **joule** = the energy expended in one second by a flow of one ampere in one ohm.

The **watt** and **joule** are not primarily electric units, but they need to be learned in connection with electric units because the energy required or the power expended in electrical processes are among the most important phases of the actions.

The **horse-power** is sometimes used as a unit of power in rating electrical machinery. The **horse-power** is equal to 746 **watts**.

The **gram-calorie** or simply "**calorie**" is the energy required to raise one gram of water one degree centigrade in temperature. One **gram-calorie** is, very nearly, equal to 4.18 **joules**.

Another unit of quantity of electricity, in addition to the **coulomb**, is the "**ampere-hour**" which is the quantity of electricity transferred by a current of one ampere in one hour, and is therefore equal to 3,600 **coulombs**.

The units of capacity actually used in radio work are the **micro-farad** =  $10^{-6}$  **farads** (a millionth of a farad) and the **micro-micro-farad** =  $10^{-12}$  **farads** (a millionth of a micro-farad), since the farad is found to be too large a unit. Another unit sometimes used is the C.G.S. **electro-static** unit of capacity, often called the centimeter of capacity, which is approximately equal to 1.11 **micro-farads**.

The units of inductance commonly used in radio work are the **milli-henry** =  $10^{-3}$  **henry** (a thousandth of a henry) and the **micro-henry** =  $10^{-6}$  **henry** (a millionth of a henry). Another unit sometimes used is the **centimeter of inductance**, which is one one-thousandth of a **micro-henry**.

## INTERNATIONAL MORSE CODE AND CONVENTIONAL SIGNALS

TO BE USED FOR ALL GENERAL PUBLIC SERVICE RADIO COMMUNICATION

1. A dash is equal to three dots.

2. The space between parts of the same letter is equal to one dot.

3. The space between two letters is equal to three dots.

4. The space between two words is equal to five dots.

A	• —
B	• — • • •
C	• — • — •
D	• — • •
E	•
F	• • — • •
G	• — • — •
H	• • • •
I	• •
J	• — • — • —
K	• — • —
L	• — • •
M	• — • —
N	• — •
O	• — • — • —
P	• • — • •
Q	• — • — • —
R	• — • •
S	• • • •
T	• —
U	• • —
V	• • • —
W	• — • —
X	• — • • —
Y	• • — • —
Z	• — • • •
Ä (German)	• • — • —
Å or Å (Spanish-Scandinavian)	• • — • — • —
CH (German-Spanish)	• — • — • —
É (French)	• • — • •
Ñ (Spanish)	• — • — • —
Ö (German)	• — • — • •
Û (German)	• • — • —
1	• — • — • —
2	• • — • — • —
3	• • • — • —
4	• • • • —
5	• • • • •
6	• • • • •
7	• — • • • •
8	• — • — • • •
9	• — • — • — •
0	• — • — • — • —

Period	• • • • •
Semicolon	• — • — • • •
Comma	• — • — • — • —
Colon	• — • — • — • • •
Interrogation	• • — • — • •
Exclamation point	• • — • • — • — • —
Apostrophe	• — • — • — • — •
Hyphen	• • • • • —
Bar indicating fraction	• — • • • •
Parenthesis	• • — • — • — • —
Inverted commas	• — • — • — •
Underline	• • — • — • —
Double dash	• — • • • —
Distress Call	• • • — • — • — • • • • •
Attention call to precede every transmission	• — • — • •
General inquiry call	• — • • • — • — • — • —
From (de)	• • • •
Invitation to transmit (go ahead)	• • — • —
Warning—high power	• — • — • • — • — • —
Question (please repeat after .....)—interrupting long messages	• • — • — • — • — • —
Wait	• — • • •
Break (Bk.) (double dash)	• — • • • —
Understand	• • — • — •
Error	• • • • • • •
Received (O. K.)	• — • • •
Position report <sup>a</sup> (to precede all position messages)	• — • — • — • —
End of each message (cross)	• — • — • — •
Transmission finished (end of work) (conclusion of correspondence)	• • — • — • — • —





















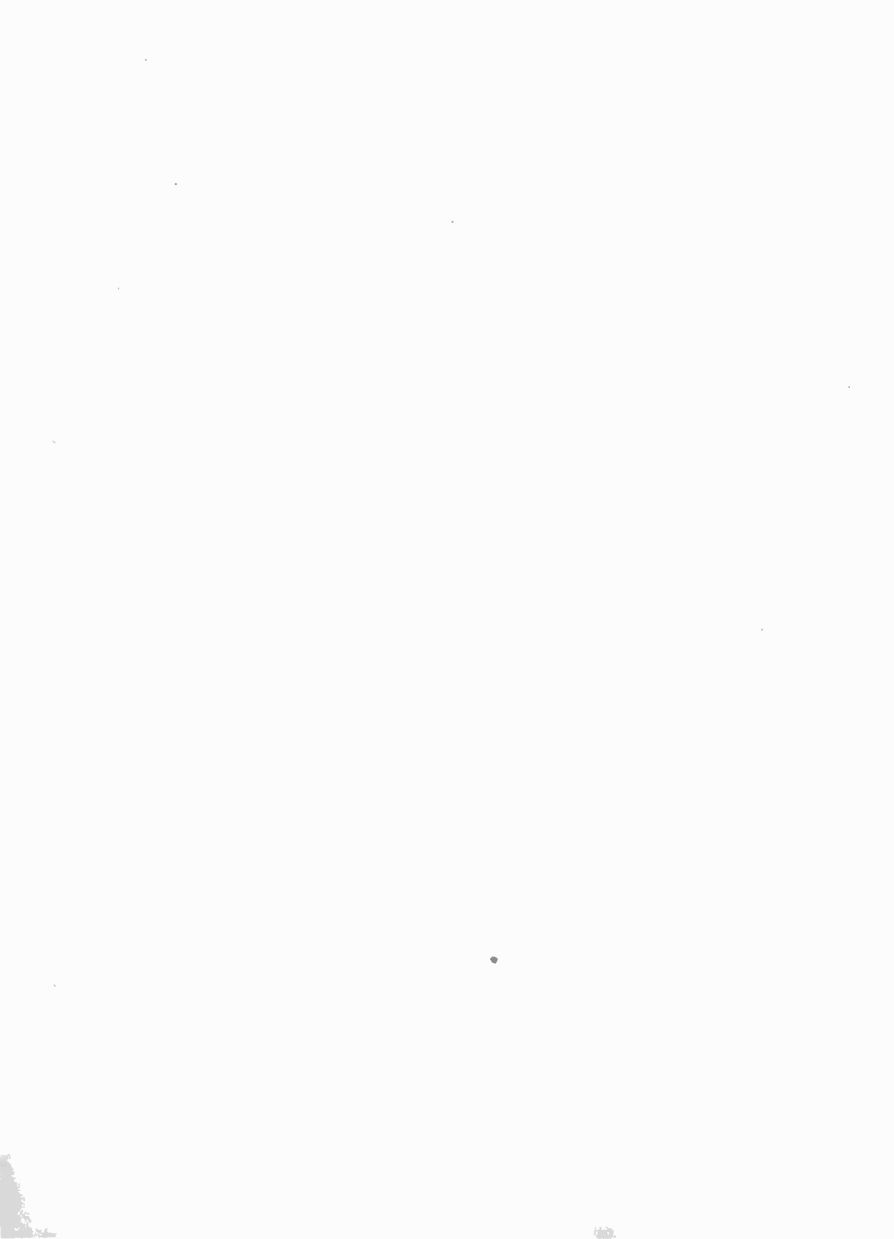

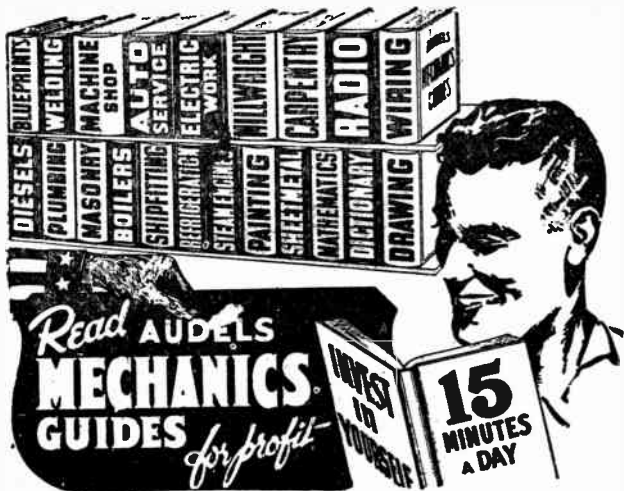

**AUDELS WELDERS GUIDE . . . . . \$1**

A CONCISE, PRACTICAL TEXT ON OPERATION AND MAINTENANCE OF ALL WELDING MACHINES, FOR ALL MECHANICS.

Over 400 pages, fully illustrated, 5 x 6½ x 2, flexible covers.

Covers Electric, Oxy-acetylene, Thermit, Unionmelt Welding for sheet metal, spot and pipe welds, pressure vessels and aluminum, copper, brass, bronze and other metals, airplane work, surface hardening and hard facing, cutting, brazing—eye protection. EVERY WELDER SHOULD OWN THIS GUIDE.

**AUDELS ANSWERS ON BLUE PRINT READING . . . \$2**

COVERS ALL TYPES OF BLUE PRINT READING FOR MECHANICS AND BUILDERS.

376 pages, very fully illustrated, service bound, pocket size.

How to read scales—the standard symbols—detail and assembly prints—the different kinds of working drawings; orthographic, pictorial, descriptive—development by parallel and radial lines, conventional lines, triangulation. Warped and other surfaces—specifications—how to sketch—how to make working drawings—how to make blue prints—short cuts—helps—hints and suggestions.

"The blue print of to-day is the machine of to-morrow." The man who can read blue prints is in line for a better job. This book gives you this secret language, step by step in easy stages.

NO OTHER TRADE BOOK LIKE IT—NEW, COMPLETE.

**AUDELS OIL BURNER GUIDE . . . . . \$1**

A new practical, concise treatise explaining in detail both domestic & industrial oil burners, including electrical hook ups and wiring diagrams.

Over 375 pages, 320 illustrations & diagrams. Flexible binding, pocket size.

Fully covering the Theory, Construction, installation, Operation, Testing, Servicing & Repair of all oil burner equipment. Fully indexed for ready reference.

**Audels REFRIGERATION & Air Conditioning Guide \$4**

4 Books in One; covering basic principles, servicing, operation, repair of:—1. Household Refrigeration. 2. Special Refrigeration Units. 3. Commercial and Industrial Refrigeration. 4. Air Conditioning Systems. A gold mine of essential important facts for Engineers, Servicemen and Users.

A Good Book is a Good Friend! Here you have at your fingers' ends a Complete Library in ONE VOLUME the necessary data you have been looking for on: MODERN UNITS, SYSTEMS & MACHINES, REFRIGERANTS including Freon, Quick Freezing, Lockers, Water Coolers & Air Conditioning Systems.

1280 Pages, 46 Chapters all Fully Illustrated & Indexed for Ready Reference with Answers to Your Questions.



## AUDELS POWER PLANT ENGINEERS GUIDE . . \$4

A COMPLETE STEAM ENGINEERS LIBRARY IN ONE BOOK WITH QUESTIONS & ANSWERS. NEW FROM COVER TO COVER. 1500 Pages, over 1700 clear, expertly drawn illustrations, Graphs and Charts, 1001 FACTS & FIGURES AT YOUR FINGER ENDS. For all Engineers, Firemen, Water Tenders, Oilers, Operators, Repairmen and Applicants for Engineers' License Examinations.

**SPECIAL FEATURES INCLUDE:** Boilers, all types; Boiler and Engine room Physics; Fireman's Guide; Boiler Examination Questions; Boiler Operation; Pulverized Coal Systems; Instant Steam; Boiler Fixtures; Boiler Repairs and Calculations; Boiler Accessories; Feed Pumps; Feed Water Heaters; Economizers; Feed Water Treatment and Deaeration; Injectors; Safety Valve Calculations; Mechanical Stokers; Oil Burners; Condensers; Air Pumps and Air Ejectors; Evaporators; Steam and Hot Water Heating; Pipe Fitting. Steam Engines; Valve gears; Turbines; Compressors; Hoists; Gas and Diesel Engines; Lubricants and Lubrication.

65 Instructive, Interesting Illustrated Chapters — ALL FULLY INDEXED FOR READY REFERENCE.

## AUDELS SHEET METAL WORKERS HANDY BOOK . . . . . \$1

Containing practical inside information, essential and important facts and figures. Easy to understand. Fundamentals of sheet metal layout work. Clearly written in everyday language covering: Aircraft sheet metal work, principles of pattern cutting, sheet metal work layout, development of air conditioning ducts, sheet metal machines, welding sheet metal, boiler plate work, practical drawing, how to read plans, geometrical problems, mensuration. FULLY ILLUSTRATED. READY REFERENCE INDEX. 888 PAGES—HANDY SIZE—FLEXIBLE BINDING

## AUDELS SHEET METAL PATTERN LAYOUTS. \$4

10 Sections, 1100 pages, 350 layouts, 1600 illustrations.  
A PRACTICAL ILLUSTRATED ENCYCLOPEDIA COVERING ALL PHASES OF SHEET METAL WORK INCLUDING PATTERN CUTTING, PATTERN DEVELOPMENT AND SHOP PROCEDURE.

10 Big Sections Covering: Heating & Air Conditioning Duct Patterns—Special Sheet Metal Layouts—Layouts for various sheet metal shapes—Conductors, Leaders and Leader Head Layouts—Gutters and Roof Outlet Layouts—Sheet Metal Roofing Patterns—Skylights and Louvers Pattern Layouts—Cornice Pattern Layouts—Sheet Metal Boat Patterns—Geometrical Problems, Mensuration and Sheet Metal Mathematics.

Developed by experts for Sheet Metal Workers—Layout men—Mechanics and Artisans, Apprentices and Students. A MASTER BOOK FOR ALL THE SHEET METAL TRADES.

## AUDELS MATHEMATICS & CALCULATIONS FOR MECHANICS . . . . . \$2

MATHEMATICS FOR HOME STUDY OR REFERENCE. 700 pages, 650 illustrations, pocket size.

This work has been arranged as a progressive study, starting with the first principles of arithmetic and advancing step by step, through the various phases of mathematics, including the many necessary rules and calculations, for figuring mechanical and electrical engineering problems. Thousands of mathematical calculations and tables, fully indexed for quick use.

Practical mathematics from the beginning. How to figure correctly. New, easy, correct methods covering a complete review of practical arithmetic. Illustrated with examples. Includes mensuration—plane and solid geometry—trigonometry—algebra—calculus—electrical and mechanical shop calculation—practical tests—reference tables and data. How to use the slide rule. A REAL HELP TO ALL MECHANICS.

## AUDELS NEW MACHINISTS & TOOL MAKERS HANDY BOOK . . . . . \$4

COVERS MODERN MACHINE SHOP PRACTICE IN ALL BRANCHES. 6 PRACTICAL BOOKS IN ONE. New from cover to cover. Tells how to set up and operate lathes, screw and milling machines, shapers, drill presses and all other machine tools.

1600 pages, fully illustrated, 6 x 9 1/2 x 2, flexible covers. Indexed. 6 sections, 60 chapters. Easy to read and understand.

A complete instructor and reference book for every machinist, tool maker, engineer, machine operator, mechanical draftsman, metal worker, mechanic and student, covering lathes, screw and milling machines, shapers, drill presses, etc. 6 practical books in 1: Section 1: Modern machine shop practice—2: blue print reading—3: mathematics for machinists—4: shop physics—5: how to use the slide rule. A SHOP COMPANION THAT ANSWERS YOUR QUESTIONS.

## **AUELS AUTO MECHANICS GUIDE . . . . . \$4**

PRACTICAL READY REFERENCE FOR AUTO MECHANICS, SERVICE MEN, TRAINEES & OWNERS Explains theory, construction and servicing of modern motor cars, trucks, buses, and auto type Diesel engines. 1800 pages, fully illustrated. 73 chapters. Indexed.

FEATURES: All parts of an automobile—physics—gas engines—pistons—rings—connecting rods—crank shafts—valves—valve gear—cams—timing—cooling systems—fuel feed systems—mixture—carburetors—automatic choke—superchargers—transmissions—clutches—universals, propeller shafts—differentials—rear axles—running gear—brakes—wheel alignment—knee action—steering gear—tires—lubrication—ignition systems—magneto ignition—spark plugs—ignition coils—distributors—automatic spark control—ignition timing—generators—starters—lighting systems—storage batteries—Diesel engines. Fluid & Hydramatic Drives Fully Explained.

A STANDARD BOOK FOR AUTO MECHANICS AND OPERATORS.

## **AUELS TRUCK & TRACTOR GUIDE . . . . . \$4**

A Shop Companion for Truck Mechanics & Drivers—Shop Foremen—Garagemen—Maintenance Men—Helpers—Owners—Trouble Shooters—Fleet Maintenance Men—Bus Mechanics & Drivers—Farm Tractor Operators & Mechanics—Covering Gas & Diesel Motor Principles—Construction—Operation—Maintenance—Repair—Service Operations—Trouble Shooting—Engine Tune Up—Carburetor Adjusting—Ignition Tuning—Brakes—Service of all Parts—Over 1299 Pages. 78 PRACTICAL FULLY ILLUSTRATED CHAPTERS—INDEXED—1001 FACTS AT YOUR FINGER ENDS.

## **AUELS DIESEL ENGINE MANUAL . . . . . \$2**

A PRACTICAL, CONCISE TREATISE WITH QUESTIONS AND ANSWERS ON THE THEORY, PRACTICAL OPERATION AND MAINTENANCE OF MODERN DIESEL ENGINES.

384 pages, fully illustrated. Explains Diesel principles—starting—starting valves—fuel spray valves—valves—timing—fuel pumps—fuel injection compressors—starting air compressors—scavenging air compressors—pistons and piston rings—cylinders—lubrication—cooling systems—fuel oil—engine indicator—governors—engine reversing—semi-Diesel engines—high speed Diesel engines—answers on operation—calculations, including two-cycle Diesel engines.

THIS BOOK IS OF EXTREME VALUE TO ENGINEERS, OPERATORS, STUDENTS.

## **AUELS MECHANICAL DICTIONARY . . . . . \$4**

A WORD BOOK FOR MECHANICS, COVERING THE MECHANIC ARTS, TRADES AND SCIENCES. A very useful book. If constantly referred to will enable the student to acquire a correct knowledge of the words, terms and phrases in use in mechanical engineering and its various branches. Included are valuable tables, formulas and helps—an encyclopedia as well as a dictionary. 950 Pages.

## **AUELS PUMPS, HYDRAULICS <sup>AIR</sup> COMPRESSORS . . . . . \$4**

A COMPREHENSIVE GUIDE FOR ENGINEERS, OPERATORS, MECHANICS, STUDENTS, WITH QUESTIONS AND ANSWERS.

1658 Pages—3 Books in one—fully illustrated. Practical information covering:

PUMPS: Centrifugal—Rotary—Reciprocating Pumps—Air and Vacuum Chambers—Power & Air Pumps—Jet Condensers—Surface Condensers—calculations. Cooling Ponds—Cooling Towers—Water Supply—Hydraulic Rams—Special Service Pumps—Automotive Fire Pumps—Dredges.

HYDRAULICS: Physics—Drives—Machine Tool Power—Accumulators—Elevators—Airplane Control—Automobile Brakes—Shock Absorbers—Presses—Turbines.

AIR COMPRESSION: Compression—Work—Compressor Classification—Parts, Types—Inter and After Coolers—Regulating Devices—Installation—Lubrication—Operation—Maintenance—Blowers—Superchargers—Pneumatic Hand Tools—A Ready Reference.

## **AUELS MARINE ENGINEERS HANDY BOOK . . . . . \$4**

MODERN, PRACTICAL TREATISE FOR MARINE ENGINEERS (ALL GRADES), FIREMEN, OILERS, MACHINISTS, HELPERS AND STUDENTS, WITH CALCULATIONS AND QUESTIONS AND ANSWERS FOR EXAMINATIONS.

1246 Pages—23 Chapters, logically arranged—fully illustrated and Indexed for Ready Reference.

## **AUELS HOUSE HEATING GUIDE . . . . . \$4**

For Heating, Ventilating and Air Conditioning Engineers, Plumbers, Maintenance Men, Contractors, Building Superintendents and Mechanics seeking practical, authentic information on Heating, Ventilating, Air Conditioning. 1000 Pages—910 Illustrations—57 Chapters explaining the working principles of all Modern House Heating, Ventilation and Air Conditioning systems. Fully illustrated and Indexed. This up-to-date book of reference gives answers to 1001 questions.

## AUDELS ENGINEERS LIBRARY..... 3 Vols. \$9

For all Stationary, Steam, Diesel and Hoisting Engineers, Firemen, Water Tenders, Oilers, Boiler Operators, Repair Men and Applicants for Engineer's and Firemen's License Examinations.

### **VOL. 1.**

Over 1550 pages, over 1700 clear, expertly drawn Illustrations, Graphs and Charts. 1001 FACTS & FIGURES AT YOUR FINGER ENDS. SPECIAL FEATURES INCLUDE: Boilers, all types; Boiler and Engine room Physics; Fireman's Guide; Boiler Examination Questions; Boiler Operation; Pulverized Coal Systems; Feed Water Heaters; Economizers; Feed Water Treatment and Deaeration; Injectors; Safety Valve Calculations; Mechanical Stokers; Oil Burners; Condensers; Air Pumps and Air Ejectors; Evaporators; Steam and Hot Water Heating; Pipe Fitting; Steam Engines; Valve gears; Turbines; Compressors; Hoists; Gas and Diesel Engines; Lubricants and Lubrication. 65 Instructive, Interesting Illustrated Chapters—ALL FULLY INDEXED FOR READY REFERENCE.

### **VOL. 2.**

A quick, simplified, ready reference book, giving complete instruction and practical information on the rules and laws of electricity—maintenance of electrical machinery—A.C. and D.C. motors—armature winding and repair—wiring diagrams—house lighting—power wiring—cable splicing—meters—batteries—transformers—elevators—electric cranes—railways—bells—sign flashers—telephone—ignition—radio principles—refrigeration—air conditioning—oil burners—air compressors—welding, and many modern applications explained so you can understand. 1472 Pages, 2600 Illustrations. THE KEY TO A PRACTICAL UNDERSTANDING OF ELECTRICITY.

### **VOL. 3.**

An aid for Stationary, Steam, Diesel & Hoisting Engineers' Examinations for all grades of Licenses. A concise review explaining in detail the Principles, Facts & Figures of Practical Engineering. Over 500 Pages and 435 Illustrations of Questions & Answers, fully indexed for ready reference. Pocket size.

## AUDELS SHIPFITTERS HANDY BOOK..... \$1

288 PAGES OF INFORMATION, INSTRUCTION, PICTURES AND REFERENCE CHARTS, TOGETHER WITH MANY SHORT CUTS AND TROUBLE SAVERS FOR SHIPFITTERS IN THEIR DAILY ROUTINE. EVERY SHIPFITTER NEEDS THIS BOOK. NO OTHER TRADE BOOK LIKE IT.

## AUDELS AIRCRAFT WORKER..... \$1

A HANDY POCKET BOOK FOR ALL MECHANICS, LEADMEN, LAYOUT MEN, DRAFTSMEN, DESIGNERS, APPRENTICES AND STUDENTS. 240 pages—fully illustrated and indexed. Flexible binding. Answers your daily questions with clear, concise practical information, pointers, facts and figures.

## PAINTING & DECORATING MANUAL..... \$2

FOR PAINTERS, JOURNEYMEN, CONTRACTORS, APPRENTICES & ALL PAINT USERS  
INSIDE TRADE INFORMATION ON outside and inside work—how to mix paints—preparation of surfaces—paper and paper-hanging—wood finishes—tools and their proper use—synthetic paints, where and how to use them—the care of brushes and bristles—color, with color chart—spray painting and equipment—scaffolds—rigging—costs—estimating—better painting methods and a dictionary of trade terms. ANSWERS YOUR QUESTIONS 450 Pages—35 Chapters, Fully Illustrated. A Guide to Easier, Better Painting. MONEY BACK IF NOT O.K.

## AUDELS GARDENERS & GROWERS GUIDES

EXPERT GUIDANCE FOR BETTER FRUIT, FLOWERS, VEGETABLES.

Here is your opportunity to get a vast amount of expert plans—helps—hints—suggestions—secrets—short cuts—discoveries for better results.

4 practical help reference volumes—1700 pages—rich, flexible covers—hundreds of illustrations.

Vol. 1—Working, fertilizing, irrigating, draining the soil—284 pages, fully illustrated.

Vol. 2—Good vegetables and market gardening—243 pages, fully illustrated.

Vol. 3—Fine fruit culture, cash crops—492 pages, fully illustrated.

Vol. 4—Beautiful flowers, successful cultivation, propagation. Over 500 pages, fully illustrated.

EXCEPTIONALLY VALUABLE BOOKS FOR SUCCESSFUL GARDENING FOR PLEASURE OR PROFIT. COMPLETE SET OF 4, \$6. SOLD SEPARATELY, \$1.50 EACH.

## AUDELS QUESTIONS & ANSWERS FOR ENGINEERS AND FIREMANS EXAMINATIONS... \$1

An aid for Stationary, Marine, Diesel & Hoisting Engineers' Examinations for all grades of Licenses. A new concise review explaining in detail the Principles, Facts & Figures of Practical Engineering. Over 500 Pages & 435 illustrations of Questions & Answers, fully indexed for ready reference. Pocket size.

## **□ GUETHS MECHANICAL DRAWING . . . . . \$1**

A CONCISE DRAWING COURSE. 150 pages, 50 plates, size 6 x 9, flexible cover.  
A complete instructor and reference work on: Drawing tools and their use, drafting room and shop practice, laying out sheets and lettering, important rules for working drawings, three views and isometric simple models, joints and carpentry work, machine drawing, projections, sections, intersections, warped surfaces, method of plan of elevation, method of vanishing point, shades and shadows, points, lines and planes, prisms and pyramids, spheres, screw surfaces, shadow perspective. How to use the slide rule.

## **□ ROGERS DRAWING AND DESIGN . . . . . \$2**

MECHANICAL DRAWING SELF TAUGHT.  
506 pages, 600 illustrations (many full page drawings), flat-opening.  
A standard work, with all details so clearly explained that this valuable training is easily obtained without an instructor. Covers terms and definitions, how to use drawing board—instruments, T square, triangles, how to do lettering, shade and section lining, geometrical drawing, development of surfaces and isometric, cabinet and orthographic projections, working drawings, explains how to do tracing and make blue prints, how to read prints, machine design. Reference index, with valuable tables. How to use the slide rule. A STANDARD STUDY TEXT FOR DRAFTING ROOM AND SHOP.

## **□ AUDELS MILLWRIGHTS & MECHANICS GUIDE . \$4**

PRACTICAL LATE INFORMATION ON PLANT INSTALLATION, OPERATION & MAINTENANCE.  
1200 pages, completely illustrated, 5 x 6½ x 2, flexible covers, fully indexed, 1000 facts at your fingertips. For millwrights, mechanics, erecting maintenance men, riggers, shopmen, service men, foremen, inspectors, superintendents.  
Section 1: Mechanical power transmission—2: millwrights and mechanics tools and their use—3: building and construction work—4: plant operation and maintenance—5: installation and maintenance of electrical machinery—6: practical calculation and technical data—how to read blue prints.

## **□ AUDELS CARPENTERS & BUILDERS GUIDES**

A PRACTICAL ILLUSTRATED TRADE ASSISTANT ON MODERN CONSTRUCTION FOR CARPENTERS, JOINERS, BUILDERS, MECHANICS AND ALL WOODWORKERS.  
Explaining in practical, concise language and by illustrations, diagrams, charts, graphs and pictures, principles, advances, short cuts, based on modern practice. How to figure and calculate various jobs.  
Vol. 1—Tools, steel square, saw filing, joinery, furniture—431 pages—1200 illustrations.  
Vol. 2—Builders mathematics, drawing plans, specifications, estimates—455 pages—400 illustrations.  
Vol. 3—House and roof framing, laying out, foundations—255 pages—400 illustrations.  
Vol. 4—Doors, windows, stair building, millwork, painting—448 pages—400 illustrations.  
4 VOLS., 1600 PAGES, 3700 ILLUSTRATIONS, FLEXIBLE COVERS, \$6. EACH VOLUME POCKET SIZE. SOLD SEPARATELY \$1.50 A VOL.

## **□ AUDELS PLUMBERS & STEAMFITTERS GUIDES**

A PRACTICAL ILLUSTRATED TRADE ASSISTANT AND READY REFERENCE FOR MASTER PLUMBERS, JOURNEYMEN AND APPRENTICE STEAM FITTERS, GAS FITTERS AND HELPERS, SHEET METAL WORKERS AND DRAUGHTSMEN, MASTER BUILDERS AND ENGINEERS.  
Explaining in plain language and by clear illustrations, diagrams, charts, graphs and pictures the principles of modern plumbing practice.  
Vol. 1—Mathematics, physics, materials, tools, lead work—374 pages—716 diagrams.  
Vol. 2—Water supply, drainage, rough work, tests—496 pages—6126 diagrams.  
Vol. 3—Pipe fitting, ventilation, gas, steam—400 pages—900 diagrams.  
Vol. 4—Sheet metal work, smithing, brazing, motors.  
4 VOLS.—1670 PAGES—3642 DIAGRAMS—FLEXIBLE COVERS, \$6. EACH VOL. POCKET SIZE. SOLD SEPARATELY \$1.50 A VOL.

## **□ AUDELS MASONS & BUILDERS GUIDES**

A PRACTICAL ILLUSTRATED TRADE ASSISTANT ON MODERN CONSTRUCTION FOR BRICKLAYERS—STONE MASONS—CEMENT WORKERS—PLASTERERS AND TILE SETTERS.  
Explaining in clear language and by well-done illustrations, diagrams, charts, graphs and pictures, principles, advances, short cuts, based on modern practice—including how to figure and calculate various jobs.  
Vol. 1—Brick work, bricklaying, bonding, designs—266 pages.  
Vol. 2—Brick foundations, arches, tile setting, estimating—245 pages.  
Vol. 3—Concrete mixing, placing forms, reinforced stucco—259 pages.  
Vol. 4—Plastering, stone masonry, steel construction, blue prints—345 pages.  
4 VOLS.—1100 PAGES—2067 ILLUSTRATIONS—COMPLETE SET, \$6. EACH VOL. (POCKET SIZE, FLEXIBLE COVER) \$1.50 A VOL.

## AUDELS TELEVISION SERVICE MANUAL . . . \$2

Gives practical information on Installing, Trouble-Shooting & Repairing. This greatly needed fact-finding manual is easy to understand, 384 pages, more than 225 illustrations & diagrams covering operating principles of modern television receivers.

Covers T.V. information at your finger ends. Shows good receiver adjustment and How to get Sharp, Clear Pictures. How to Install Aerials—Avoid Blurs, Smears and How to test. Explains color systems and methods of conversion. 1001 FACTS—18 CHAPTERS.

## AUDELS ELECTRIC MOTOR GUIDE . . . . . \$4

Covers the construction, hook-ups, control, maintenance and trouble shooting of all types of motors including armature winding. Explains entire subject in every detail. A Handy Guide for Electricians and all Electrical Workers.

Over 1000 Pages of Information—31 Instructive, Interesting Chapters—617 Diagrams, hook-ups and drawings. All types of motors fully illustrated and indexed for ready reference.

## AUDELS QUESTIONS & ANSWERS FOR ELECTRICIANS EXAMINATIONS . . . . . \$1

A PRACTICAL BOOK TO HELP YOU PREPARE FOR ALL GRADES OF ELECTRICIANS LICENSE EXAMINATIONS. A Helpful Review of all the fundamental principles underlying each question and answer needed to prepare you to solve any new or similar problem, which while being asked differently still calls for the same answer and knowledge.

Covering the National Electrical Code, Questions and Answers for License Tests; Ohm's Law with applied Examples; Hook-ups for Motors; Lighting and Instruments; 250 Pages. Fully Indexed and Illustrated. Pocket Size. Flexible Covers. A COMPLETE REVIEW FOR ALL ELECTRICAL WORKERS.

## AUDELS WIRING DIAGRAMS FOR LIGHT & POWER . . . . . \$1

Electricians, wiremen, linemen, plant superintendents, construction engineers, electrical contractors and students will find these diagrams a valuable source of practical help.

This book gives the practical man the facts on wiring of electrical apparatus. It explains clearly in simple language how to wire apparatus for practically all fields of electricity. Each diagram is complete and self-explaining—210 pages, illustrated. A PRACTICAL, HANDY BOOK OF HOOK-UPS.

## AUDELS HANDY BOOK OF PRACTICAL ELECTRICITY . . . . . \$4

FOR MAINTENANCE ENGINEERS, ELECTRICIANS AND ALL ELECTRICAL WORKERS.

1340 pages, 2600 illustrations.

A quick, simplified, ready reference book, giving complete instruction and practical information on the rules and laws of electricity—maintenance of electrical machinery—A.C. and D.C. motors—armature winding and repair—wiring diagrams—house lighting—power wiring—cable splicing—meters—batteries—transformers—elevators—electric cranes—railways—bells—sign flashers—telephone—ignition—radio principles—refrigeration—air conditioning—oil burners—air compressors—welding, and many modern applications explained so you can understand.

THE KEY TO A PRACTICAL UNDERSTANDING OF ELECTRICITY.

## AUDELS ELECTRONIC DEVICES . . . . . \$2

TELLS WHAT YOU WANT TO KNOW ABOUT THE ELECTRIC EYE.

Covering photo-electric cells and their applications. Includes easily understood explanations of the workings of the electric eye, amplifiers, anodes, candlepower, color temperature, illumination, frequencies, photo tubes, grid basis, voltage, photo-electric tubes, photocell, vacuum tubes, the oscillator, electron tubes, electrons versus atoms, Ohm's Law, wiring diagrams.

A PRACTICAL BOOK ON ELECTRONICS.

## AUDELS ELECTRICAL POWER CALCULATIONS . \$2

276 TYPICAL PROBLEMS FULLY WORKED OUT.

Gives and explains the mathematical formulae and the fundamental electrical laws for all the everyday, practical problems in electricity—Ohm's and Kirchoff's laws for Direct Current—the generation and application of alternating current—problems in series and parallel circuits—transformers—transmission lines—electrical machinery. Valuable notes on Radio Circuit Calculation.

With 289 Diagrams, and Tables on Conversion, Wire Gauges and Capacities, etc. Other Data; Symbols, Formulae. 420 pages, fully diagrammed. Two parts (A.C.—D.C.). Indexed.  
EVERY ELECTRICAL WORKER & STUDENT NEEDS THIS MODERN "MATHEMATICAL TOOL."

## AUDELS NEW ELECTRIC DICTIONARY . . . . . \$2

FOR EVERY WORKER WHO HAS TO DO WITH ELECTRICITY.

The language of your profession in convenient, alphabetical order so you can instantly locate any word, phrase or term. To be an expert in any line, you must "talk the language." Audels New Electric Dictionary enables you to understand and explain electrical problems so your hearer will thoroughly understand you.

Defines more than 9000 words, terms and phrases in plain and unmistakable language, compiled with the same accuracy and thoroughness that has characterized Audel books for 65 years.

Valuable as an Encyclopedia of Electricity and as a Dictionary.

AN ABSOLUTE NECESSITY TO EVERY ELECTRICAL WORKER AND STUDENT.

## AUDELS NEW RADIOMANS GUIDE . . . . . \$4

A KEY TO THE PRACTICAL UNDERSTANDING OF RADIO. FOR RADIO ENGINEERS, SERVICE-MEN, AMATEURS.

750 pages, 400 illustrations and diagrams. Size 5 x 6 1/2.

Features: Radio fundamentals and Ohm's Law—physics of sound as related to radio science—electrical measuring instruments—power supply units—resistors, indicators and condensers—radio transformers and examples on their designs—broadcasting stations—principles of radio telephony—vacuum tubes—radio receivers—radio circuit diagrams—receiver construction—radio control systems—loud speakers—antenna systems—antenna systems (automobile)—phonograph pickups—public address systems—aircraft radio—marine radio equipment—the radio compass and principle of operation—radio beacons—automatic radio alarms—short wave radio—coil calculations—radio testing—cathode ray oscillographs—static elimination and radio trouble pointers—underwriter's standards—units and tables.  
AUTHENTIC, CLEAR, CONCISE.

## AUDELS NEW ELECTRIC LIBRARY . . \$1.50 a vol.

FOR ENGINEERS, ELECTRICIANS, ALL ELECTRICAL WORKERS, MECHANICS AND STUDENTS. Presenting in simplest, concise form the fundamental principles, rules and applications of applied electricity. Fully illustrated with diagrams & sketches, also calculations & tables for ready reference. Helpful questions and answers. Trial tests for practice, study and review. Design, construction, operation and maintenance of modern electrical machines and appliances. Based on the best knowledge and experience of applied electricity.

- Vol. 1—Principles and rules of electricity, magnetism, armature winding, repairs—700 illustrations—480 pages.
- Vol. 2—Dynamoes, D.C. motors, construction, installation, maintenance, trouble shooting—573 illustrations—418 pages.
- Vol. 3—Electrical testing instruments and tests, storage battery construction and repairs—631 illustrations—472 pages.
- Vol. 4—Alternating current principles and diagrams, power factor, alternators, transformers—801 illustrations—484 pages.
- Vol. 5—A.C. motors, windings, reconnecting, maintenance, converters, switches, fuses, circuit breakers—1489 illustrations—498 pages.
- Vol. 6—Relays, condensers, regulators, rectifiers, meters, switchboards, power station practice—689 illustrations—548 pages.
- Vol. 7—Wiring—house, light and power, circuits, high tension transmission, plans, calculations, code, marine wiring practice—1218 illustrations—728 pages.
- Vol. 8—Railways, signals, elevators, ignition—1078 illustrations—812 pages.
- Vol. 9—Radio, telephone, telegraph, television, motion pictures—793 illustrations—576 pages.
- Vol. 10—Refrigeration, illumination, welding, x-ray, modern electrical appliances, index—1084 illustrations—674 pages.
- Vol. 11—Electric mathematics and calculations—700 pages.
- Vol. 12—Electric dictionary, 9000 words and terms—550 pages.

COMPLETE IN 12 VOLUMES—EACH VOLUME SOLD SEPARATELY AT \$1.50 EACH.

# MAIL ORDER

THEO. AUDEL & CO., 49 W. 23rd St., New York 10, N. Y.

Please mail me for 7 days' free examination the books marked (X) below. I agree to mail \$1 in 7 days on each book or set ordered, and to further mail \$1 a month on each book or set ordered until I have paid purchased price.

If I am not satisfied with Guides I will return them.

<input type="checkbox"/>	Audels OIL BURNER GUIDE	\$1.
<input type="checkbox"/>	Audels REFRIGERATION & Air Conditioning Guide.	4.
<input type="checkbox"/>	Audels POWER PLANT ENGINEERS GUIDE	4.
<input type="checkbox"/>	Audels PUMPS, HYDRAULICS & AIR COMPRESSORS.	4.
<input type="checkbox"/>	Audels WELDERS GUIDE	1.
<input type="checkbox"/>	Audels BLUE PRINT READING	2.
<input type="checkbox"/>	Audels SHEET METAL WORKERS Handy Book	1.
<input type="checkbox"/>	Audels SHEET METAL PATTERN LAYOUTS	1.
<input type="checkbox"/>	Audels AIRCRAFT WORKER	1.
<input type="checkbox"/>	Audels MATHEMATICS and CALCULATIONS.	2.
<input type="checkbox"/>	Audels MACHINISTS & TOOLMAKERS Handy Book	4.
<input type="checkbox"/>	Audels MECHANICAL Dictionary	4.
<input type="checkbox"/>	Audels AUTOMOBILE GUIDE	4.
<input type="checkbox"/>	Audels DIESEL ENGINE MANUAL	2.
<input type="checkbox"/>	Audels MARINE ENGINEERS Handy Book	4.
<input type="checkbox"/>	Audels SHIPFITTERS Handy Book	1.
<input type="checkbox"/>	Gueths MECHANICAL DRAWING COURSE	1.
<input type="checkbox"/>	Rogers DRAWING and DESIGN	2.
<input type="checkbox"/>	Audels MILLWRIGHTS and Mechanics Guide.	4.
<input type="checkbox"/>	Audels CARPENTERS and Builders Guides (4 vols.)	6.
<input type="checkbox"/>	Audels PLUMBERS and Steamfitters Guides (4 vols.)	6.
<input type="checkbox"/>	Audels MASONS and Builders Guides (4 vols.)	6.
<input type="checkbox"/>	Master PAINTER and DECORATOR	2.
<input type="checkbox"/>	Audels GARDENERS & GROWERS GUIDES (4 vols.)	6.
<input type="checkbox"/>	Audels ENGINEERS & FIREMANS EXAMINATIONS	1.
<input type="checkbox"/>	Audels ENGINEERS and Mechanics Guides Nos. 1, 2, 3, 4, 5, 6, 7 and 8 complete	12.
<input type="checkbox"/>	Audels Answers on Practical ENGINEERING	1.
<input type="checkbox"/>	Audels ELECTRICIANS EXAMINATIONS	1.
<input type="checkbox"/>	Audels WIRING DIAGRAMS	1.
<input type="checkbox"/>	Audels Handy Book of PRACTICAL ELECTRICITY	4.
<input type="checkbox"/>	Audels ELECTRICAL POWER CALCULATIONS	2.
<input type="checkbox"/>	Audels ELECTRONIC DEVICES	2.
<input type="checkbox"/>	Audels ELECTRIC Dictionary	2.
<input type="checkbox"/>	Audels RADIOMANS GUIDE	4.
<input type="checkbox"/>	Audels NEW ELECTRIC LIBRARY at \$1.50 a Volume Vols. I, II, III, IV, V, VI, VII, VIII, IX, X, XI, XII.	

RECOMMENDED BY

\_\_\_\_\_

Name \_\_\_\_\_

Address \_\_\_\_\_

Occupation \_\_\_\_\_

Employed by \_\_\_\_\_



## Check NOW!

You Can  
Look Over  
Any Guide  
In Your  
Own Home

—  
Start the  
Easy Pay-  
ments If  
Satisfied

# MAIL THIS TODAY