

the 1930s, the radio became a central part of American life. It was the only mass medium that could reach into the homes of millions of people, and it was used for everything from news and entertainment to education and social reform. The radio was a powerful force for change, and it helped to shape the American identity of the 1930s.

The radio was also a powerful force for social reform. It was used to spread the message of the New Deal, and it helped to bring attention to the plight of the poor and the unemployed. The radio was a powerful tool for social change, and it helped to shape the American identity of the 1930s.

The radio was also a powerful force for education. It was used to spread the message of the New Deal, and it helped to bring attention to the plight of the poor and the unemployed. The radio was a powerful tool for social change, and it helped to shape the American identity of the 1930s.

The radio was also a powerful force for social reform. It was used to spread the message of the New Deal, and it helped to bring attention to the plight of the poor and the unemployed. The radio was a powerful tool for social change, and it helped to shape the American identity of the 1930s.

The radio was also a powerful force for education. It was used to spread the message of the New Deal, and it helped to bring attention to the plight of the poor and the unemployed. The radio was a powerful tool for social change, and it helped to shape the American identity of the 1930s.

The radio was also a powerful force for social reform. It was used to spread the message of the New Deal, and it helped to bring attention to the plight of the poor and the unemployed. The radio was a powerful tool for social change, and it helped to shape the American identity of the 1930s.

The radio was also a powerful force for education. It was used to spread the message of the New Deal, and it helped to bring attention to the plight of the poor and the unemployed. The radio was a powerful tool for social change, and it helped to shape the American identity of the 1930s.

The radio was also a powerful force for social reform. It was used to spread the message of the New Deal, and it helped to bring attention to the plight of the poor and the unemployed. The radio was a powerful tool for social change, and it helped to shape the American identity of the 1930s.

The radio was also a powerful force for education. It was used to spread the message of the New Deal, and it helped to bring attention to the plight of the poor and the unemployed. The radio was a powerful tool for social change, and it helped to shape the American identity of the 1930s.

The radio was also a powerful force for social reform. It was used to spread the message of the New Deal, and it helped to bring attention to the plight of the poor and the unemployed. The radio was a powerful tool for social change, and it helped to shape the American identity of the 1930s.

THE RADIO AMATEUR'S HANDBOOK

By the HEADQUARTERS STAFF
of the
AMERICAN RADIO RELAY LEAGUE
WEST HARTFORD, CONN., U.S.A.



1957

Thirty-fourth Edition

COPYRIGHT 1957 BY
THE AMERICAN RADIO RELAY LEAGUE, INC.

Copyright secured under the Pan-American Convention

International Copyright secured

This work is Publication No. 6 of The Radio Amateur's Library, published by the League. All rights reserved. No part of this work may be reproduced in any form except by written permission of the publisher. All rights of translation are reserved. Printed in U. S. A.

Quedan reservados todos los derechos

Library of Congress Catalog Card Number: 41-3345

Thirty-fourth Edition

\$3.50 in U. S. A. proper
\$4.00 in U. S. Possessions and Canada
\$4.50 elsewhere
Buckram Edition \$6.00 Everywhere

THE RUMFORD PRESS
Concord, New Hampshire, U. S. A.

Foreword

In over thirty years of continuous publication *The Radio Amateur's Handbook* has become as much of an institution as amateur radio itself. Produced by the amateur's own organization, the American Radio Relay League, and written with the needs of the practical amateur constantly in mind, it has earned universal acceptance not only by amateurs but by all segments of the technical radio world. This wide dependence on the *Handbook* is founded on its practical utility, its treatment of radio communication problems in terms of how-to-do-it rather than by abstract discussion.

Virtually continuous modification is a feature of the *Handbook* — always with the objective of presenting the soundest and best aspects of current practice rather than the merely new and novel. Its annual revision, a major task of the headquarters group of the League, is participated in by skilled and experienced amateurs well acquainted with the practical problems in the art.

The *Handbook* is printed in the format of the League's monthly magazine, *QST*. This, together with extensive and useful catalog advertising by manufacturers producing equipment for the radio amateur and industry, makes it possible to distribute for a very modest charge, a work which in volume of subject matter and profusion of illustration surpasses most available radio texts selling for several times its price.

The *Handbook* has long been considered an indispensable part of the amateur's equipment. We earnestly hope that the present edition will succeed in bringing as much assistance and inspiration to amateurs and would-be amateurs as have its predecessors.

A. L. BUDLONG
General Manager, A.R.R.L.

West Hartford, Conn.

CONTENTS

<i>The Amateur's Code</i>	8
<i>Chapter 1—Amateur Radio</i>	9
2—Electrical Laws and Circuits.....	15
3—Vacuum-Tube Principles.....	60
4—Semiconductor Devices.....	80
5—High-Frequency Receivers.....	85
6—High-Frequency Transmitters.....	143
7—Power Supplies.....	215
8—Keying and Break-In.....	237
9—Speech Amplifiers and Modulators.....	247
10—Amplitude Modulation.....	275
11—Frequency and Phase Modulation.....	294
12—Single Side Band.....	300
13—Transmission Lines.....	318
14—Antennas.....	343
15—Wave Propagation.....	376
16—V.H.F. Receivers.....	384
17—V.H.F. Transmitters.....	405
18—V.H.F. Antennas.....	435
19—Mobile and Portable-Emergency Equipment..	447
20—Construction Practices.....	484
21—Measurements.....	493
22—Assembling a Station.....	525
23—BCI and TVI.....	532
24—Operating a Station.....	553
25—Miscellaneous Data.....	568
26—Vacuum Tubes and Semiconductors.....	VI

Catalog Section

Index

THE AMATEUR'S CODE

• ONE •

The Amateur is Gentlemanly . . . He never knowingly uses the air for his own amusement in such a way as to lessen the pleasure of others. He abides by the pledges given by the ARRL in his behalf to the public and the Government.

• TWO •

The Amateur is Loyal . . . He owes his amateur radio to the American Radio Relay League, and he offers it his unswerving loyalty.

• THREE •

The Amateur is Progressive . . . He keeps his station abreast of science. It is built well and efficiently. His operating practice is clean and regular.

• FOUR •

The Amateur is Friendly . . . Slow and patient sending when requested, friendly advice and counsel to the beginner, kindly assistance and cooperation for the broadcast listener; these are marks of the amateur spirit.

• FIVE •

The Amateur is Balanced . . . Radio is his hobby. He never allows it to interfere with any of the duties he owes to his home, his job, his school, or his community.

• SIX •

The Amateur is Patriotic . . . His knowledge and his station are always ready for the service of his country and his community.

— Paul M. Segal

Amateur Radio

Amateur radio is a scientific hobby, a means of gaining personal skill in the fascinating art of electronics and an opportunity to communicate with fellow citizens by private short-wave radio. Scattered over the globe are over 200,000 amateur radio operators who perform a service defined in international law as one of "self-training, intercommunication and technical investigations carried on by . . . duly authorized persons interested in radio technique solely with a personal aim and without pecuniary interest."

From a humble beginning at the turn of the century, amateur radio has grown to become an established institution. Today the American followers of amateur radio number over 150,000, trained communicators from whose ranks will come the professional communications specialists and executives of tomorrow — just as many of today's radio leaders were first attracted to radio by their early interest in amateur radio communication. A powerful and prosperous organization now provides a bond between amateurs and protects their interests; an internationally-respected magazine is published solely for their benefit. The military services seek the cooperation of the amateur in developing communications reserves. Amateur radio supports a manufacturing industry which, by the very demands of amateurs for the latest and best equipment, is always up-to-date in its designs and production techniques — in itself a national asset. Amateurs have won the gratitude of the nation for their heroic performances in times of natural disaster; traditional amateur skills in emergency communication are also the standby system for the nation's civil defense. Amateur radio is, indeed, a magnificently useful institution.

Although as old as the art of radio itself, amateur radio did not always enjoy such prestige. Its first enthusiasts were private citizens of an experimental turn of mind whose imaginations went wild when Marconi first proved that messages actually could be sent by wireless. They set about learning enough about the new scientific marvel to build home-made spark transmitters. By 1912 there were numerous Government and commercial stations, and hundreds of amateurs; regulation was needed, so laws, licenses and wavelength specifications appeared. There was then no amateur organization nor spokesman. The official viewpoint toward amateurs was something like this:

"Amateurs? . . . Oh, yes. . . . Well, stick 'em on 200 meters and below; they'll never get out of their backyards with that."

But as the years rolled on, amateurs found out how, and DX (distance) jumped from local to 500-mile and even occasional 1,000-mile two-way contacts. Because all long-distance messages had to be relayed, relaying developed into a fine art — an ability that was to prove invaluable when the Government suddenly called hundreds of skilled amateurs into war service in 1917. Meanwhile U. S. amateurs began to wonder if there were amateurs in other countries across the seas and if, some day, we might not span the Atlantic on 200 meters.

Most important of all, this period witnessed the birth of the American Radio Relay League, the amateur radio organization whose name was to be virtually synonymous with subsequent amateur progress and short-wave development. Conceived and formed by the famous inventor, the late Hiram Percy Maxim, ARRL was formally launched in early 1914. It had just begun to exert its full force in amateur activities when the United States declared war in 1917, and by that act sounded the knell for amateur radio for the next two and a half years. There were then over 6000 amateurs. Over 4000 of them served in the armed forces during that war.

Today, few amateurs realize that World War I not only marked the close of the first phase of amateur development but came very



HIRAM PERCY MAXIM
President ARRL, 1914-1936

and for all time. The fate of was in the balance in the days following the signing of the Armistice. The Government, having had a taste of supreme authority over communications in wartime, was more than half inclined to keep it. The war had not been ended a month before Congress was considering legislation that would have made it impossible for the amateur radio of old ever to be resumed. ARRL's President Maxim rushed to Washington, pleaded, argued, and the bill was defeated. But there was still no amateur radio; the war ban continued. Repeated representations to Washington met only with silence. The League's offices had been closed for a year and a half, its records stored away. Most of the former amateurs had gone into service; many of them would never come back. Would those returning be interested in such things as amateur radio? Mr. Maxim, determined to find out, called a meeting of the old Board of Directors. The situation was discouraging: amateur radio still banned by law, former members scattered, no organization, no membership, no funds. But those few determined men financed the publication of a notice to all the former amateurs that could be located, hired Kenneth B. Warner as the League's first paid secretary, floated a bond issue among old League members to obtain money for immediate running expenses, bought the magazine *QST* to be the League's official organ, started activities, and dunned officialdom until the wartime ban was lifted and amateur radio resumed again, on October 1, 1919. There was a headlong rush by amateurs to get back on the air. Gangway for King Spark! Manufacturers were hard put to supply radio apparatus fast enough. Each night saw additional dozens of stations crashing out over the air. Interference? It was bedlam!

But it was an era of progress. Wartime needs had stimulated technical development. Vacuum tubes were being used both for receiving and transmitting. Amateurs immediately adapted the new gear to 200-meter work. Ranges promptly increased and it became possible to bridge the continent with but one intermediate relay.

● TRANS-ATLANTICS

As DX became 1000, then 1500 and then 2000 miles, amateurs began to dream of trans-Atlantic work. Could they get across? In December, 1921, ARRL sent abroad an expert amateur, Paul F. Godley, 2ZE, with the best receiving equipment available. Tests were run, and *thirty* American stations were heard in Europe. In 1922 another trans-Atlantic test was carried out and 315 American calls were logged by European amateurs and one French and two British stations were heard on this side.

Everything now was centered on one objective: two-way amateur communication across

the Atlantic! It must be possible — but somehow it couldn't quite be done. More power? Many already were using the legal maximum. Better receivers? They had superheterodynes. Another wave length? What about those undisturbed wave lengths *below* 200 meters? The engineering world thought they were worthless — but they had said that about 200 meters. So, in 1922, tests between Hartford and Boston were made on 130 meters with encouraging results. Early in 1923, ARRL-sponsored tests on wave lengths down to 90 meters were successful. Reports indicated that *as the wave length dropped the results were better*. Excitement began to spread through amateur ranks.

Finally, in November, 1923, after some months of careful preparation, two-way amateur trans-Atlantic communication was accomplished, when Schnell, 1MO, and Reinartz, 1XAM (now W9UZ and K6BJ, respectively) worked for several hours with Deloy, 8AB, in France, with all three stations on 110 meters! Additional stations dropped down to 100 meters and found that they, too, could easily work two-way across the Atlantic. The exodus from the 200-meter region had started. The "short-wave" era had begun!

By 1924 dozens of commercial companies had rushed stations into the 100-meter region. Chaos threatened, until the first of a series of national and international radio conferences partitioned off various bands of frequencies for the different services. Although thought still centered around 100 meters, League officials at the first of these frequency-determining conferences, in 1924, wisely obtained amateur bands not only at 80 meters but at 40, 20, and even 5 meters.

Eighty meters proved so successful that "forty" was given a try, and QSOs with Australia, New Zealand and South Africa soon became commonplace. Then how about 20 meters? This new band revealed entirely unexpected possibilities when 1XAM worked 6TS on the West Coast, direct, at high noon. The dream of amateur radio — daylight DX! — was finally true.

● PUBLIC SERVICE

Amateur radio is a grand and glorious hobby but this fact alone would hardly merit such wholehearted support as is given it by our Government at international conferences. There are other reasons. One of these is a thorough appreciation by the military and civil defense authorities of the value of the amateur as a source of skilled radio personnel in time of war. Another asset is best described as "public service."

About 4000 amateurs had contributed their skill and ability in '17-'18. After the war it was only natural that cordial relations should prevail between the Army and Navy and the amateur. These relations strengthened in the next few years and, in gradual steps, grew into cooperative activities which resulted, in 1925, in

the establishment of the Naval Communications Reserve and the Army-Amateur Radio System (now the Military Affiliate Radio System). In World War II thousands of amateurs in the Naval Reserve were called to active duty, where they served with distinction, while many other thousands served in the Army, Air Forces, Coast Guard and Marine Corps. Altogether, more than 25,000 radio amateurs served in the armed forces of the United States. Other thousands were engaged in vital civilian electronic research, development and manufacturing. They also organized and manned the War Emergency Radio Service, the communications section of OCD.

The "public-service" record of the amateur is a brilliant tribute to his work. These activities can be roughly divided into two classes, expeditions and emergencies. Amateur co-operation with expeditions began in 1923 when a League member, Don Mix, 1TS, of Bristol, Conn. (now assistant technical editor of *QST*), accompanied MacMillan to the Arctic on the schooner *Bowdoin* with an amateur station. Amateurs in Canada and the U.S. provided the home contacts. The success of this venture was so outstanding that other explorers followed suit. During subsequent years a total of perhaps two hundred voyages and expeditions were assisted by amateur radio, the several explorations of the Antarctic being perhaps the best known.

Since 1913 amateur radio has been the principal, and in many cases the only, means of outside communication in several hundred storm, flood and earthquake emergencies in this country. The 1936 and 1937 eastern states floods, the Southern California flood and Long Island-New England hurricane disaster in 1938, the Florida-Gulf Coast hurricanes of 1947, and the 1955 flood disasters called for the amateur's greatest emergency effort. In these disasters and many others—tornadoes, sleet storms, forest fires, blizzards—amateurs played a major rôle in the relief work and earned wide commendation for their resourcefulness in effecting communication where all other means had failed. During 1938 ARRL inaugurated a new emergency-preparedness program, registering personnel and equipment in its Emergency Corps and putting into effect a comprehensive program of coöperation with the Red Cross, and in 1947 a National Emergency Coordinator was appointed to full-time duty at League headquarters.

The amateur's outstanding record of organized preparation for emergency communications and performance under fire has been largely responsible for the decision of the Federal Government to set up special regulations and set aside special frequencies for use by amateurs in providing auxiliary communications for civil defense purposes in the event of war. Under the banner, "Radio Amateur Civil Emergency Service," amateurs are setting up and manning community and area networks integrated with civil defense functions of the municipal governments. Should a war cause the shut-down of routine amateur activi-

ties, the RACES will be immediately available in the national defense, manned by amateurs highly skilled in emergency communication.

● TECHNICAL DEVELOPMENTS

Throughout these many years the amateur was careful not to slight experimental development in the enthusiasm incident to international DX. The experimenter was constantly at work on ever-higher frequencies, devising improved apparatus, and learning how to cram several stations where previously there was room for only one! In particular, the amateur pressed on to the development of the very high frequencies and his experience with five meters is especially representative of his initiative and resourcefulness and his ability to make the most of what is at hand. In 1924, first amateur experiments in the vicinity of 56 Mc. indicated that band to be practically worthless for DX. Nonetheless, great "short-haul" activity eventually came about in the band and new gear was developed to meet its special problems. Beginning in 1934 a series of investigations by the brilliant experimenter, Ross Hull (later *QST*'s editor), developed the theory of v.h.f. wave-bending in the lower atmosphere and led amateurs to the attainment of better distances; while occasional manifestations of ionospheric propagation, with still greater distances, gave the band uniquely erratic performance. By Pearl Harbor thousands of amateurs were spending much of their time on this and the next higher band, many having worked hundreds of stations at distances up to several thousand miles. Transcontinental 6-meter DX is not uncommon; during solar peaks, even the oceans have been bridged! It is a tribute to these indefatigable amateurs that today's concept of v.h.f. propagation was developed largely through amateur research.

The amateur is constantly in the forefront of technical progress. His incessant curiosity, his eagerness to try anything new, are two reasons. Another is that ever-growing amateur radio continually overcrowds its frequency assignments, spurring amateurs to the development and adoption of new techniques to permit the



A corner of the ARRL laboratory.

accommodation of more stations. For examples, amateurs turned from spark to c.w., designed more selective receivers, adopted crystal control and pure d.c. power supplies. From the ARRL's own laboratory in 1932 came James Lamb's "single-signal" super-heterodyne — the world's most advanced high-frequency radiotelegraph receiver — and, in 1936, the "noise-silencer" circuit. Amateurs are now turning to speech "clippers" to reduce bandwidths of 'phone transmissions and "single-sideband suppressed-carrier" systems as well as even more selectivity in receiving equipment for greater efficiency in spectrum use.

During World War II, thousands of skilled amateurs contributed their knowledge to the development of secret radio devices, both in Government and private laboratories. Equally as important, the prewar technical progress by amateurs provided the keystone for the development of modern military communications equipment. Perhaps more important today than individual contributions to the art is the mass coöperation of the amateur body in Government projects such as propagation studies; each participating station is in reality a separate field laboratory from which reports are made for correlation and analysis. An outstanding example is varied amateur participation in several activities of the 1957-1958 International Geophysical Year program. ARRL, with Air Force sponsorship, is conducting an intensive study of v.h.f. propagation phenomena — DX transmissions via little-understood methods such as meteor and auroral reflections, and transequatorial scatter. ARRL-affiliated clubs and groups are setting up precision receiving antennas and apparatus to help track the earth satellite via radio. For volunteer astronomers searching visually for the satellite, other amateurs are manning networks to provide instant radio reports of sightings to a central agency so that an orbit may be computed.

Emergency relief, expedition contact, experimental work and countless instances of other forms of public service — rendered, as they always have been and always will be, without hope or expectation of material reward — made amateur radio an integral part of our peacetime national life. The importance of amateur participation in the armed forces and in other aspects of national defense have emphasized more strongly than ever that amateur radio is vital to our national existence

● THE AMERICAN RADIO RELAY LEAGUE

The ARRL is today not only the spokesman for amateur radio in this country but it is the largest amateur organization in the world. It is strictly of, by and for amateurs, is noncommercial and has no stockholders. The members of the League are the owners of the ARRL and *QST*.



The operating room at WIAW.

The League is pledged to promote interest in two-way amateur communication and experimentation. It is interested in the relaying of messages by amateur radio. It is concerned with the advancement of the radio art. It stands for the maintenance of fraternalism and a high standard of conduct. It represents the amateur in legislative matters.

One of the League's principal purposes is to keep amateur activities so well conducted that the amateur will continue to justify his existence. Amateur radio offers its followers countless pleasures and unending satisfaction. It also calls for the shouldering of responsibilities — the maintenance of high standards, a coöperative loyalty to the traditions of amateur radio, a dedication to its ideals and principles, so that the institution of amateur radio may continue to operate "in the public interest, convenience and necessity."

The operating territory of ARRL is divided into one Canadian and fifteen U. S. divisions. The affairs of the League are managed by a Board of Directors. One director is elected every two years by the membership of each U. S. division, and one by the Canadian membership. These directors then choose the president and vice-president, who are also members of the Board. The secretary and treasurer are also appointed by the Board. The directors, as representatives of the amateurs in their divisions, meet annually to examine current amateur problems and formulate ARRL policies thereon. The directors appoint a general manager to supervise the operations of the League and its headquarters, and to carry out the policies and instructions of the Board.

ARRL owns and publishes the monthly magazine, *QST*. Acting as a bulletin of the League's organized activities, *QST* also serves as a medium for the exchange of ideas and fosters amateur spirit. Its technical articles are renowned. It has grown to be the "amateur's bible," as well as one of the foremost radio magazines in the world. Membership dues include a subscription to *QST*.

ARRL maintains a model headquarters amateur station, known as the Hiram Percy Maxim Memorial Station, in Newington, Conn. Its call is WIAW, the call held by Mr. Maxim until his death and later transferred

to the League station by a special FCC action. Separate transmitters of maximum legal power on each amateur band have permitted the station to be heard regularly all over the world. More important, WIAW transmits on regular schedules bulletins of general interest to amateurs, conducts code practice as a training feature, and engages in two-way work on all popular bands with as many amateurs as time permits.

At the headquarters of the League in West Hartford, Conn., is a well-equipped laboratory to assist staff members in preparation of technical material for *QST* and the *Radio Amateur's Handbook*. Among its other activities, the League maintains a Communications Department concerned with the operating activities of League members. A large field organization is headed by a Section Communications Manager in each of the League's seventy-three sections. There are appointments for qualified members in various fields, as outlined in chapter 24. Special activities and contests promote operating skill. A special section is reserved each month in *QST* for amateur news from every section of the country.

● AMATEUR LICENSING IN THE UNITED STATES

Pursuant to the law, FCC has issued detailed regulations for the amateur service.

A radio amateur is a duly authorized person interested in radio technique solely with a personal aim and without pecuniary interest. Amateur operator licenses are given to U. S. citizens who pass an examination on operation and apparatus and on the provisions of law and regulations affecting amateurs, and who demonstrate ability to send and receive code. There are four available classes of amateur license — Novice, Technician, General (called "Conditional" if exam taken by mail), and Amateur Extra Class. Each has different requirements, the first two being the simplest and consequently conveying limited privileges as to frequencies available. Exams for Novice, Technician and Conditional classes are taken by mail under the supervision of a volunteer examiner. Station licenses are granted only to licensed operators and permit communication between such stations for amateur purposes, i.e., for personal noncommercial aims flowing from an interest in radio technique. An amateur station may not be used for material compensation of any sort nor for broadcasting. Narrow bands of frequencies are allocated exclusively for use by amateur stations. Transmissions may be on any frequency within the assigned bands. All the frequencies may be used for c.w. telegraphy; some are available for radiotelephone, others for special forms of transmission such as teletype, facsimile, amateur television or radio control. The input to the final stage of amateur stations is limited to 1000 watts and on frequencies below 144 Mc. must be adequately-filtered direct current. Emissions must be free from spurious radiations. The licensee must

provide for measurement of the transmitter frequency and establish a procedure for checking it regularly. A complete log of station operation must be maintained, with specified data. The station license also authorizes the holder to operate portable and mobile stations subject to further regulations. All radio licensees are subject to penalties for violation of regulations.

Amateur licenses are issued entirely free of charge. They can be issued only to citizens but that is the only limitation, and they are given without regard to age or physical condition to anyone who successfully completes the examination. When you are able to copy code at the required speed, have studied basic transmitter theory and are familiar with the law and amateur regulations, you are ready to give serious thought to securing the Government amateur licenses which are issued you, after examination by an FCC engineer (or by a volunteer, depending on the license class), through FCC at Washington. A complete up-to-the-minute discussion of license requirements, and study guides for those preparing for the examinations, are to be found in an ARRL publication, *The Radio Amateur's License Manual*, available from the American Radio Relay League, West Hartford 7, Conn., for 50¢, postpaid.

● LEARNING THE CODE

In starting to learn the code, you should consider it simply another means of conveying

A	<u>didah</u>	N	<u>dahdit</u>
B	<u>dahdididit</u>	O	<u>dahdahdah</u>
C	<u>dahdidahdit</u>	P	<u>didahdahdit</u>
D	<u>dahdidit</u>	Q	<u>dahdahdidah</u>
E	<u>dit</u>	R	<u>didahdit</u>
F	<u>dididahdit</u>	S	<u>dididit</u>
G	<u>dahdahdit</u>	T	<u>dah</u>
H	<u>didididit</u>	U	<u>dididah</u>
I	<u>didit</u>	V	<u>didididah</u>
J	<u>didahdahdah</u>	W	<u>didahdah</u>
K	<u>dahdidah</u>	X	<u>dahdididah</u>
L	<u>didahdidit</u>	Y	<u>dahdidahdah</u>
M	<u>dahdah</u>	Z	<u>dahdahdidit</u>
1	<u>didahdahdahdah</u>	6	<u>dahdidididit</u>
2	<u>dididahdahdah</u>	7	<u>dahdahdididit</u>
3	<u>didididahdah</u>	8	<u>dahdahdahdidit</u>
4	<u>dididididah</u>	9	<u>dahdahdahdahdit</u>
5	<u>dididididit</u>	0	<u>dahdahdahdahdah</u>

Period: didahdidahdidah. Comma: dahdahdididahdah. Question mark: dididahdahdidit. Error: dididididididit. Double dash: dahdidididah. Wait: didahdididit. End of message: didahdidahdit. Invitation to transmit: dahdidah. End of work: didididahdidah. Fraction bar: dahdididahdit.

Fig. 1-1 — The Continental (International Morse) code.

information. The spoken word is one method, the printed page another, and typewriting and shorthand are additional examples. Learning the code is as easy — or as difficult — as learning to type.

The important thing in beginning to study code is to think of it as a language of *sound*, never as combinations of dots and dashes. It is easy to “speak” code equivalents by using “dit” and “dah,” so that A would be “didah” (the “i” is dropped in such combinations). The sound “di” should be staccato; a code character such as “5” should sound like a machine-gun burst: didididit! Stress each “dah” equally; they are underlined and italicized in this text because they should be slightly accented and drawn out.

Take a few characters at a time. Learn them thoroughly in *didah* language before going on to new ones. If someone who is familiar with code can be found to “send” to you, either by whistling or by means of a buzzer or code oscillator, enlist his cooperation. Learn the code by *listening* to it. Don’t think about speed to start; the first requirement is to learn the characters to the point where you can recognize each of them without hesitation. Concentrate on any difficult letters. Learning the code is not at all hard; a simple booklet treating the subject in detail is another of the beginner publications available from the League, and is entitled, *Learning the Radiotelegraph Code*, 50¢ postpaid.

● THE AMATEUR BANDS

Amateurs are assigned bands of frequencies at approximate harmonic intervals throughout the spectrum. Like assignments to all services, they are subject to modification to fit the changing picture of world communications needs. Modifications of rules to provide for domestic needs are also occasionally issued by FCC, and in that respect each amateur should keep himself informed by WIAW bulletins, *QST* reports, or by communication with ARRL Hq. concerning a specific point.

In the adjoining table is a summary of the U. S. amateur bands on which operation is permitted as of our press date. Figures are megacycles. A0 means an unmodulated carrier, A1 means c.w. telegraphy, A2 is tone-modulated c.w. telegraphy, A3 is amplitude-modulated phone, A4 is facsimile, A5 is television, n.f.m. designates narrow-band frequency- or phase-modulated radiotelephony, f.m. means frequency modulation, phone (including n.f.m.) or telegraphy, and F1 is frequency-shift keying.

80 meters	3,500-4,000 — A1 3,500-3,800 — F1 3,800-4,000 — A3 and n.f.m.
40 m.	7,000-7,300 — A1 7,000-7,200 — F1 7,200-7,300 — A3 and n.f.m.
20 m.	14,000-14,350 — A1 14,000-14,200 — F1 14,200-14,300 — A3 and n.f.m. 14,300-14,350 — F1
15 m.	21,000-21,450 — A1 21,000-21,250 — F1 21,250-21,450 — A3 and n.f.m.
11 m.	26,960-27,230 — A0, A1, A2, A3, A4, f.m. 28,000-29,700 — A1
10 m.	28,500-29,700 — A3 and n.f.m. 29,000-29,700 — f.m.
6 m.	50-54 — A1, A2, A3, A4, n.f.m. 51-54 — A0 52.5-54 — f.m.
2 m.	144-148 } 220-225 } A0, A1, A2, A3, A4, f.m. 420-450 } A0, A1, A2, A3, A4, A5, f.m. 1,215-1,300 } 2,300-2,450 } 3,300-3,500 } 5,650-5,925 } A0, A1, A2, A3, A4, A5, f.m., pulse 10,000-10,500 } 21,000-22,000 } All above 30,000 }

¹ Input power must not exceed 50 watts.

In addition, A1 and A3 on portions of 1,800-2,000, as follows:

Area	Band, kc.	Power (watts)	
		Day	Night
Minn., Iowa, Wis., Mich., Pa., Md., Del. and states to north	1800-1825	500	200
N.D., S.D., Nebr., Colo., N. Mex., and 1 states west, including Hawaiian Ids.	1900-1925	500*	200*
Okla., Kans., Mo., Ark., Ill., Ind., Ky., Tenn., Ohio, W. Va., Va., N. C., S. C., and Texas (west of 99° W or north of 32° N)	1800-1825	200	50
	1875-1900		

No operation elsewhere.
* Except in state of Washington, 200 watts day, 50 watts night.

Novice licensees may use the following frequencies, transmitters to be crystal-controlled and have a maximum power input of 75 watts.

3,700-3,750	A1	21,100-21,250	A1
7,150-7,200	A1	145-147	A1, A2, A3, f.m.

Technician licensees are permitted all amateur privileges in 50 Mc. and in the bands 220 Mc. and above.

Electrical Laws and Circuits

● ELECTRIC AND MAGNETIC FIELDS

When something occurs at one point in space because something else happened at another point, with no visible means by which the "cause" can be related to the "effect," we say the two events are connected by a **field**. The fields with which we are concerned are the **electric** and **magnetic**, and the combination of the two called the **electromagnetic field**.

A field has two important properties, intensity (magnitude) and direction. The field exerts a **force** on an object immersed in it; this force represents potential (ready-to-be-used) energy, so the **potential** of the field is a measure of the **field intensity**. The **direction** of the field is the direction in which the object on which the force is exerted will tend to move.

An electrically-charged object in an electric field will be acted on by a force that will tend to move it in a direction determined by the direction of the field. Similarly, a magnet in a magnetic field will be subject to a force. Everyone has seen demonstrations of magnetic fields with pocket magnets, so intensity and direction are not hard to grasp.

A "static" field is one that neither moves nor changes in intensity. Such a field can be set up by a stationary electric charge (**electrostatic field**) or by a stationary magnet (**magnetostatic field**). But if either an electric or magnetic field is moving in space or changing in intensity, the motion or change sets up the other kind of field. That is, a changing electric field sets up a magnetic field, and a changing magnetic field generates an electric field. This interrelationship between magnetic and electric fields makes possible such things as the electromagnet and the electric motor. It also makes possible the **electromagnetic waves** by which radio communication is carried on, for such waves are simply traveling fields in which the energy is alternately handed back and forth between the electric and magnetic fields.

Lines of Force

Although no one knows what it is that composes the field itself, it is useful to invent a picture of it that will help in visualizing the forces and the way in which they act.

A field can be pictured as being made up of **lines of force**, or **flux lines**. These are purely imaginary threads that show, by the direction in which they lie, the direction the object on

which the force is exerted will move. The *number* of lines in a chosen cross section of the field is a measure of the *intensity* of the force. The number of lines per square inch, or per square centimeter, is called the **flux density**.

● ELECTRICITY AND THE ELECTRIC CURRENT

Everything physical is built up of atoms, particles so small that they cannot be seen even through the most powerful microscope. But the atom in turn consists of several different kinds of still smaller particles. One is the **electron**, essentially a small particle of electricity. The quantity or **charge** of electricity represented by the electron is, in fact, the smallest quantity of electricity that can exist. The kind of electricity associated with the electron is called **negative**.

An ordinary atom consists of a central core called the **nucleus**, around which one or more electrons circulate somewhat as the earth and other planets circulate around the sun. The nucleus has an electric charge of the kind of electricity called **positive**, the amount of its charge being just exactly equal to the sum of the negative charges on all the electrons associated with that nucleus.

The important fact about these two "opposite" kinds of electricity is that they are strongly attracted to each other. Also, there is a strong force of repulsion between two charges of the *same* kind. The positive nucleus and the negative electrons are attracted to each other, but two electrons will be repelled from each other and so will two nuclei.

While in a normal atom the positive charge on the nucleus is exactly balanced by the negative charges on the electrons, it is possible for an atom to lose one of its electrons. When that happens the atom has a little less negative charge than it should — that is, it has a net positive charge. Such an atom is said to be **ionized**, and in this case the atom is a **positive ion**. If an atom picks up an extra electron, as it sometimes does, it has a net negative charge and is called a **negative ion**. A positive ion will attract any stray electron in the vicinity, including the extra one that may be attached to a nearby negative ion. In this way it is possible for electrons to travel from atom to atom. The movement of ions or electrons constitutes the **electric current**.

The **amplitude** of the current (that is, its intensity or magnitude) is determined by the rate at which electric charge — an accumulation of elec-

trons or ions of the same kind — moves past a point in a circuit. Since the charge on a single electron or ion is extremely small, the number that must move as a group to form even a tiny current is almost inconceivably large.

Conductors and Insulators

Atoms of some materials, notably metals and acids, will give up an electron readily, but atoms of other materials will not part with any of their electrons even when the electric force is extremely strong. Materials in which electrons or ions can be moved with relative ease are called **conductors**, while those that refuse to permit such movement are called **nonconductors** or **insulators**. The following list shows how some common materials divide between the conductor and insulator classifications:

<i>Conductors</i>	<i>Insulators</i>
Metals	Dry Air
Carbon	Wood
Acids	Porcelain
	Textiles
	Glass
	Rubber
	Resins

Electromotive Force

The electric force or potential (called **electromotive force**, and abbreviated **e.m.f.**) that causes current flow may be developed in several ways. The action of certain chemical solutions on dissimilar metals sets up an e.m.f.; such a combination is called a **cell**, and a group of cells forms an **electric battery**. The amount of current that such cells can carry is limited, and in the course of current flow one of the metals is eaten away. The amount of electrical energy that can be taken from a battery consequently is rather small. Where a large amount of energy is needed it is usually furnished by an **electric generator**, which develops its e.m.f. by a combination of magnetic and mechanical means.

In picturing current flow it is natural to think of a single, constant force causing the electrons to move. When this is so, the electrons always move in the same direction through a path or circuit made up of conductors connected together in a continuous chain. Such a current is called a **direct current**, abbreviated **d.c.** It is the type of current furnished by batteries and by certain types of generators. However, it is also possible to have an e.m.f. that periodically reverses. With this kind of e.m.f. the current flows first in one direction through the circuit and then in the other. Such an e.m.f. is called an **alternating e.m.f.**, and the current is called an **alternating current** (abbreviated **a.c.**). The reversals (**alternations**) may occur at any rate from a few per second up to several billion per second. Two reversals make a **cycle**; in one cycle the force acts first in one direction, then in the other, and then returns to the first direction to begin the next cycle. The number of cycles in one second is called the **frequency** of the alternating current.

Direct and Alternating Currents

The difference between direct current and alternating current is shown in Fig. 2-1. In these graphs the horizontal axis measures time, increasing toward the right away from the vertical axis. The vertical axis represents the amplitude or strength of the current, increasing in either the up or down direction away from the horizontal axis. If the graph is *above* the horizontal axis the current is flowing in one direction through the circuit (indicated by the + sign) and if it is *below* the horizontal axis the current is flowing in the reverse direction through the circuit (indicated by the - sign). Fig. 2-1A shows that, if we close the circuit — that is, make the path for the current complete — at the time indicated by X, the current instantly takes the amplitude indicated by the height A. After that, the current continues at the same amplitude as time goes on. This is an ordinary **direct current**.

In Fig. 2-1B, the current starts flowing with the amplitude A at time X, continues at that amplitude until time Y and then instantly ceases. After an interval YZ the current again begins to flow and the same sort of start-and-stop performance is repeated. This is an **intermittent direct current**. We could get it by alternately closing and opening a switch in the circuit. It is a **direct current** because the *direction* of current flow does not change; the graph is always on the + side of the horizontal axis.

In Fig. 2-1C the current starts at zero, increases in amplitude as time goes on until it reaches the amplitude A₁ while flowing in the + direction, then decreases until it drops to zero amplitude once more. At that time (X) the

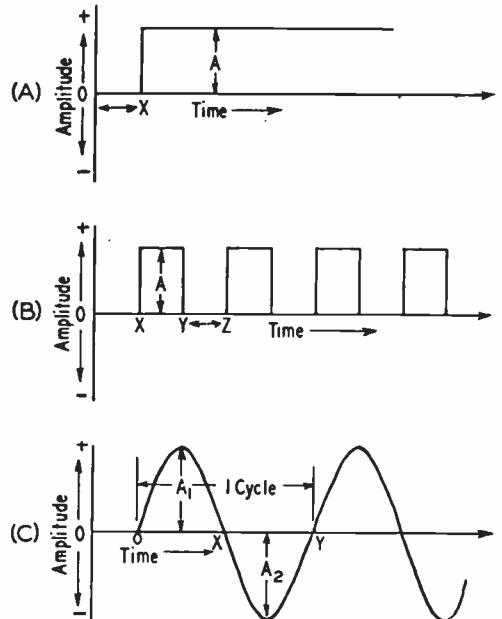

Fig. 2-1 — Three types of current flow. A — direct current; B — intermittent direct current; C — alternating current.

direction of the current flow reverses; this is indicated by the fact that the next part of the graph is below the axis. As time goes on the amplitude increases, with the current now flowing in the - direction, until it reaches amplitude A_2 . Then the amplitude decreases until finally it drops to zero (Y) and the direction reverses once more. This is an *alternating current*.

Waveforms

The type of alternating current shown in Fig. 2-1 is known as a *sine wave*. The variations in many a.c. waves are not so smooth, nor is one half-cycle necessarily just like the preceding one in shape. However, these **complex waves** can be shown to be the sum of two or more sine waves of frequencies that are exact integral (whole-number) multiples of some lower frequency. The lowest frequency is called the **fundamental frequency**, and the higher frequencies (2 times, 3 times the fundamental frequency, and so on) are called **harmonics**.

Fig. 2-2 shows how a fundamental and a second harmonic (twice the fundamental) might add to form a complex wave. Simply by changing the relative amplitudes of the two waves, as well as the times at which they pass through zero amplitude, an infinite number of waveshapes can be constructed from just a fundamental and second harmonic. Waves that are still more complex can be constructed if more harmonics are used.

Electrical Units

The unit of electromotive force is called the **volt**. An ordinary flashlight cell generates an e.m.f. of about 1.5 volts. The e.m.f. commonly supplied for domestic lighting and power is 115 volts, usually a.c. having a frequency of 60 cycles per second. The voltages used in radio receiving and transmitting circuits range from a few volts (usually a.c.) for filament heating to as high as a few thousand d.c. volts for the operation of power tubes.

The flow of electric current is measured in **amperes**. One ampere is equivalent to the movement of many billions of electrons past a point in the circuit in one second. Currents in the neighborhood of an ampere are required for heating the filaments of small power tubes. The *direct* currents used in amateur radio equipment usually are not so large, and it is customary to measure such currents in **milliamperes**. One milliampere is equal to one one-thousandth of an ampere, or 1000 milliamperes equals one ampere.

A "d.c. ampere" is a measure of a *steady* current, but the "a.c. ampere" must measure a current that is continually varying in amplitude and periodically reversing direction. To put the two on the same basis, an a.c. ampere is defined as the amount of current that will cause the same heating effect (see later section) as one ampere of steady direct current. For sine-wave a.c., this **effective** (or **r.m.s.**) value is equal to the *maximum* amplitude (A_1 or A_2 in Fig. 2-1C) multiplied by 0.707. The **instantaneous value** is the value

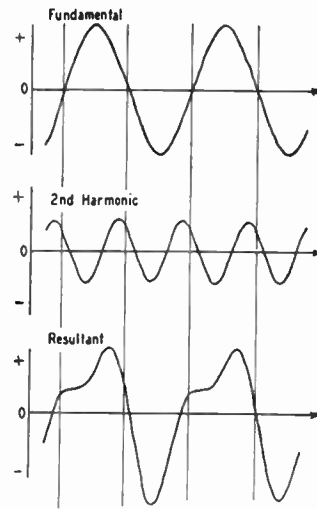

Fig. 2-2 — A complex waveform. A fundamental (top) and second harmonic (center) added together, point by point at each instant, result in the waveform shown at the bottom. When the two components have the same polarity at a selected instant, the resultant is the simple sum of the two. When they have opposite polarities, the resultant is the *difference*: if the negative-polarity component is larger, the resultant is negative at that instant.

that the current (or voltage) has at any selected instant in the cycle.

If all the instantaneous values in a sine wave are averaged over a *half-cycle*, the resulting figure is the **average value**. It is equal to 0.636 times the maximum amplitude. The average value is useful in connection with rectifier systems, as described in a later chapter.

● FREQUENCY AND WAVELENGTH

Frequency Spectrum

Frequencies ranging from about 15 to 15,000 cycles per second are called **audio frequencies**, because the vibrations of air particles that our ears recognize as sounds occur at a similar rate. Audio frequencies (abbreviated **a.f.**) are used to actuate loudspeakers and thus create sound waves.

Frequencies above about 15,000 cycles are called **radio frequencies (r.f.)** because they are useful in radio transmission. Frequencies all the way up to and beyond 10,000,000,000 cycles have been used for radio purposes. At radio frequencies the numbers become so large that it becomes convenient to use a larger unit than the cycle. Two such units are the **kilocycle**, which is equal to 1000 cycles and is abbreviated **kc.**, and the **megacycle**, which is equal to 1,000,000 cycles or 1000 kilocycles and is abbreviated **Mc.**

The various radio frequencies are divided off into classifications for ready identification. These classifications, listed below, constitute the **frequency spectrum** so far as it extends for radio purposes at the present time.

Frequency	Classification	Abbreviation
10 to 30 kc.	Very-low frequencies	v.l.f.
30 to 300 kc.	Low frequencies	l.f.
300 to 3000 kc.	Medium frequencies	m.f.
3 to 30 Mc.	High frequencies	h.f.
30 to 300 Mc.	Very-high frequencies	v.h.f.
300 to 3000 Mc.	Ultrahigh frequencies	u.h.f.
3000 to 30,000 Mc.	Superhigh frequencies	s.h.f.

Wavelength

Radio waves travel at the same speed as light — 300,000,000 meters or about 186,000 miles a second in space. They can be set up by a radio-frequency current flowing in a circuit, because the rapidly-changing current sets up a magnetic field that changes in the same way, and the varying magnetic field in turn sets up a varying electric field. And whenever this happens, the two fields move outward at the speed of light.

Suppose an r.f. current has a frequency of 3,000,000 cycles per second. The fields will go through complete reversals (one cycle) in 1/3,000,000 second. In that same period of time the fields — that is, the wave — will move 300,000,000/3,000,000 meters, or 100 meters. By the time the wave has moved that distance

the next cycle has begun and a new wave has started out. The first wave, in other words, covers a distance of 100 meters before the beginning of the next, and so on. This distance is the **wavelength**.

The longer the time of one cycle — that is, the lower the frequency — the greater the distance occupied by each wave and hence the longer the wavelength. The relationship between wavelength and frequency is shown by the formula

$$\lambda = \frac{300,000}{f}$$

where λ = Wavelength in meters
 f = Frequency in kilocycles

or
$$\lambda = \frac{300}{f}$$

where λ = Wavelength in meters
 f = Frequency in megacycles

Example: The wavelength corresponding to a frequency of 3650 kilocycles is

$$\lambda = \frac{300,000}{3650} = 82.2 \text{ meters}$$

Resistance

Given two conductors of the same size and shape, but of different materials, the amount of current that will flow when a given e.m.f. is applied will be found to vary with what is called the **resistance** of the material. The lower the resistance, the greater the current for a given value of e.m.f.

Resistance is measured in **ohms**. A circuit has a resistance of one ohm when an applied e.m.f. of one volt causes a current of one ampere to flow. The **resistivity** of a material is the resistance, in ohms, of a cube of the material measuring one centimeter on each edge. One of the best conductors is copper, and it is frequently convenient, in making resistance calculations, to compare the resistance of the material under consideration with that of a copper conductor of the same size and shape. Table 2-1 gives the ratio of the resistivity of various conductors to that of copper.

The longer the path through which the current flows the higher the resistance of that conductor. For direct current and low-frequency alternating

currents (up to a few thousand cycles per second) the resistance is *inversely* proportional to the cross-sectional area of the path the current must travel; that is, given two conductors of the same material and having the same length, but differing in cross-sectional area, the one with the larger area will have the lower resistance.

Resistance of Wires

The problem of determining the resistance of a round wire of given diameter and length — or its opposite, finding a suitable size and length of wire to supply a desired amount of resistance — can be easily solved with the help of the copper-wire table given in a later chapter. This table gives the resistance, in ohms per thousand feet, of each standard wire size.

Example: Suppose a resistance of 3.5 ohms is needed and some No. 28 wire is on hand. The wire table in Chapter 20 shows that No. 28 has a resistance of 66.17 ohms per thousand feet. Since the desired resistance is 3.5 ohms, the length of wire required will be

$$\frac{3.5}{66.17} \times 1000 = 52.89 \text{ feet.}$$

Or, suppose that the resistance of the wire in the circuit must not exceed 0.05 ohm and that the length of wire required for making the connections totals 14 feet. Then

$$\frac{14}{1000} \times R = 0.05 \text{ ohm}$$

where R is the maximum allowable resistance in ohms per thousand feet. Rearranging the formula gives

$$R = \frac{0.05 \times 1000}{14} = 3.57 \text{ ohms/1000 ft.}$$

Reference to the wire table shows that No. 15 is the smallest size having a resistance less than this value.

When the wire is not copper, the resistance values given in the wire table should be multi-

TABLE 2-1
Relative Resistivity of Metals

Material	Resistivity Compared to Copper
Aluminum (pure)	1.70
Brass	3.57
Cadmium	5.26
Chromium	1.82
Copper (hard-drawn)	1.12
Copper (annealed)	1.00
Iron (pure)	5.65
Lead	14.3
Nickel	6.25 to 8.33
Phosphor Bronze	2.78
Silver	0.94
Tin	7.70
Zinc	3.54

Types of resistors used in radio equipment. Those in the foreground with wire leads are carbon types, ranging in size from 1/2 watt at the left to 2 watts at the right. The larger resistors use resistance wire wound on ceramic tubes; sizes shown range from 5 watts to 100 watts. Three are of the adjustable type, having a sliding contact on an exposed section of the resistance winding.

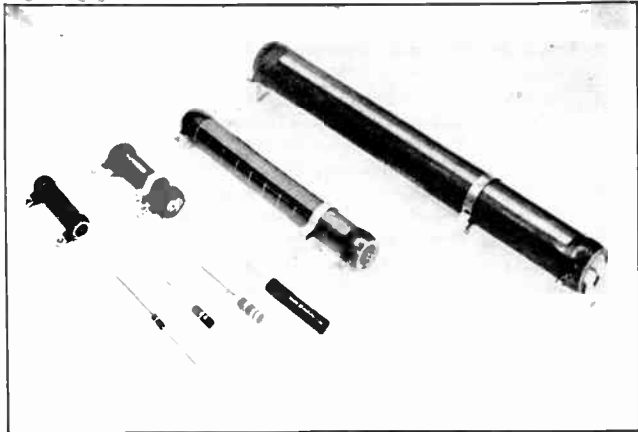

plied by the ratios given in Table 2-1 to obtain the resistance.

Example: If the wire in the first example were iron instead of copper the length required for 3.5 ohms would be

$$\frac{3.5}{66.17 \times 5.65} \times 1000 = 9.35 \text{ feet.}$$

Temperature Effects

The resistance of a conductor changes with its temperature. Although it is seldom necessary to consider temperature in making resistance calculations for amateur work, it is well to know that the resistance of practically all metallic conductors increases with increasing temperature. Carbon, however, acts in the opposite way; its resistance *decreases* when its temperature rises. The temperature effect is important when it is necessary to maintain a constant resistance under all conditions. Special materials that have little or no change in resistance over a wide temperature range are used in that case.

Resistors

A "package" of resistance made up into a single unit is called a resistor. Resistors having the same resistance value may be considerably different in size and construction. The flow of current through resistance causes the conductor to become heated; the higher the resistance and the larger the current, the greater the amount of heat developed. Resistors intended for carrying large currents must be physically large so the heat can be radiated quickly to the surrounding air. If the resistor does not get rid of the heat quickly it may reach a temperature that will cause it to melt or burn.

Skin Effect

The resistance of a conductor is not the same for alternating current as it is for direct current. When the current is alternating there are internal effects that tend to force the current to flow mostly in the outer parts of the conductor. This decreases the effective cross-sectional area of the conductor, with the result that the resistance increases.

For low audio frequencies the increase in resistance is unimportant, but at radio frequencies this *skin effect* is so great that practically all the current flow is confined within a few thousandths of an inch of the conductor surface. The r.f. resistance is consequently many times the d.c. resistance, and increases with increasing frequency. In the r.f. range a conductor of thin tubing will have just as low resistance as a solid conductor of the same diameter, because material not close to the surface carries practically no current.

Conductance

The reciprocal of resistance (that is, 1/R) is called **conductance**. It is usually represented by the symbol *G*. A circuit having large conductance has low resistance, and vice versa. In radio work the term is used chiefly in connection with vacuum-tube characteristics. The unit of conductance is the **mho**. A resistance of one ohm has a conductance of one mho, a resistance of 1000 ohms has a conductance of 0.001 mho, and so on. A unit frequently used in connection with vacuum tubes is the **micromho**, or one-millionth of a mho. It is the conductance of a resistance of one megohm.

● **OHM'S LAW**

The simplest form of electric circuit is a battery with a resistance connected to its terminals, as shown by the symbols in Fig. 2-3. A complete circuit must have an unbroken path so current



Fig. 2-3 — A simple circuit consisting of a battery and resistor.

can flow out of the battery, through the apparatus connected to it, and back into the battery. The circuit is broken, or open, if a connection is removed at any point. A switch is a device for making and breaking connections and thereby closing or opening the circuit, either allowing current to flow or preventing it from flowing.

TABLE 2-II Conversion Factors for Fractional and Multiple Units			
To change from	To	Divide by	Multiply by
Units	Micro-units		1,000,000
	Milli-units	1000	1000
	Kilo-units	1,000,000	
	Mega-units		
Micro-units	Milli-units	1000	
Milli-units	Micro-units	1,000,000	
Milli-units	Micro-units	1000	1000
Kilo-units	Units		1000
Kilo-units	Mega-units	1000	
Mega-units	Units		1,000,000
Mega-units	Kilo-units		1000

The values of current, voltage and resistance in a circuit are by no means independent of each other. The relationship between them is known as **Ohm's Law**. It can be stated as follows: The current flowing in a circuit is directly proportional to the applied e.m.f. and inversely proportional to the resistance. Expressed as an equation, it is

$$I \text{ (amperes)} = \frac{E \text{ (volts)}}{R \text{ (ohms)}}$$

The equation above gives the value of current when the voltage and resistance are known. It may be transposed so that each of the three quantities may be found when the other two are known:

$$E = IR$$

(that is, the voltage acting is equal to the current in amperes multiplied by the resistance in ohms) and

$$R = \frac{E}{I}$$

(or, the resistance of the circuit is equal to the applied voltage divided by the current).

All three forms of the equation are used almost constantly in radio work. It must be remembered that the quantities are in *volts, ohms and amperes*; other units cannot be used in the equations without first being converted. For example, if the current is in milliamperes it must be changed to the equivalent fraction of an ampere before the value can be substituted in the equations.

Table 2-II shows how to convert between the various units in common use. The prefixes attached to the basic-unit name indicate the nature of the unit. These prefixes are:

- micro — one-millionth (abbreviated μ)
- milli — one-thousandth (abbreviated m)
- kilo — one thousand (abbreviated k)
- mega — one million (abbreviated M)

For example, one microvolt is one-millionth of a volt, and one megohm is 1,000,000 ohms. There are therefore 1,000,000 microvolts in one volt, and 0.000001 megohm in one ohm.

The following examples illustrate the use of Ohm's Law:

The current flowing in a resistance of 20,000 ohms is 150 milliamperes. What is the voltage? Since the voltage is to be found, the equation to use is $E = IR$. The current must first be converted from milliamperes to amperes, and reference to the table shows that to do so it is necessary to divide by 1000. Therefore,

$$E = \frac{150}{1000} \times 20,000 = 3000 \text{ volts}$$

When a voltage of 150 is applied to a circuit the current is measured at 2.5 amperes. What is the resistance of the circuit? In this case R is the unknown, so

$$R = \frac{E}{I} = \frac{150}{2.5} = 60 \text{ ohms}$$

No conversion was necessary because the voltage and current were given in volts and amperes.

How much current will flow if 250 volts is applied to a 5000-ohm resistor? Since I is unknown

$$I = \frac{E}{R} = \frac{250}{5000} = 0.05 \text{ ampere}$$

Milliampere units would be more convenient for the current, and $0.05 \text{ amp.} \times 1000 = 50 \text{ milliamperes}$.

SERIES AND PARALLEL RESISTANCES

Very few actual electric circuits are as simple as the illustration in the preceding section. Commonly, resistances are found connected in a

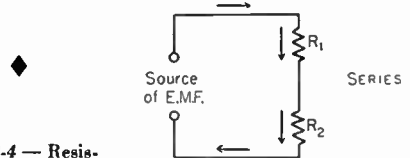
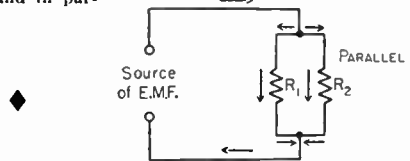

Fig. 2-4 — Resistors connected in series and in parallel.



variety of ways. The two fundamental methods of connecting resistances are shown in Fig. 2-4. In the upper drawing, the current flows from the source of e.m.f. (in the direction shown by the arrow, let us say) down through the first resistance, R_1 , then through the second, R_2 , and then back to the source. These resistors are connected in series. The current everywhere in the circuit has the same value.

In the lower drawing the current flows to the common connection point at the top of the two resistors and then divides, one part of it flowing through R_1 and the other through R_2 . At the lower connection point these two currents again combine; the total is the same as the current that flowed into the upper common connection. In this case the two resistors are connected in parallel.

Resistors in Series

When a circuit has a number of resistances connected in series, the total resistance of the circuit is the sum of the individual resistances. If these are numbered R_1, R_2, R_3 , etc., then R (total) = $R_1 + R_2 + R_3 + R_4 + \dots$ where the dots indicate that as many resistors as necessary may be added.

Example: Suppose that three resistors are connected to a source of e.m.f. as shown in Fig. 2-5. The e.m.f. is 250 volts, R_1 is 5000 ohms, R_2 is 20,000 ohms, and R_3 is 8000 ohms. The total resistance is then

$$R = R_1 + R_2 + R_3 = 5000 + 20,000 + 8000 = 33,000 \text{ ohms}$$

The current flowing in the circuit is then

$$I = \frac{E}{R} = \frac{250}{33,000} = 0.00757 \text{ amp.} = 7.57 \text{ ma.}$$

(We need not carry calculations beyond three significant figures, and often two will suffice because the accuracy of measurements is seldom better than a few per cent.)

Voltage Drop

Ohm's Law applies to *any part* of a circuit as well as to the whole circuit. Although the current is the same in all three of the resistances in the example, the total voltage divides among them. The voltage appearing across each resistor (the **voltage drop**) can be found from Ohm's Law.

Example: If the voltage across R_1 (Fig. 2-5) is called E_1 , that across R_2 is called E_2 , and that across R_3 is called E_3 , then

$$\begin{aligned} E_1 &= IR_1 = 0.00757 \times 5000 = 37.9 \text{ volts} \\ E_2 &= IR_2 = 0.00757 \times 20,000 = 151.4 \text{ volts} \\ E_3 &= IR_3 = 0.00757 \times 8000 = 60.6 \text{ volts} \end{aligned}$$

The applied voltage must equal the sum of the individual voltage drops:

$$E = E_1 + E_2 + E_3 = 37.9 + 151.4 + 60.6 = 249.9 \text{ volts}$$

The answer would have been more nearly exact if the current had been calculated to more decimal places, but as explained above a very high order of accuracy is not necessary.

In problems such as this considerable time and trouble can be saved, when the current is small enough to be expressed in milliamperes, if the

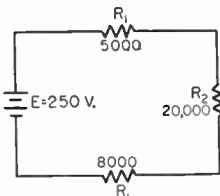

Fig. 2-5 — An example of resistors in series. The solution of the circuit is worked out in the text.

resistance is expressed in kilohms rather than ohms. When resistance in kilohms is substituted directly in Ohm's Law the current will be in milliamperes if the e.m.f. is in volts.

Resistors in Parallel

In a circuit with resistances in parallel, the total resistance is *less* than that of the *lowest* value of resistance present. This is because the

total current is always greater than the current in any individual resistor. The formula for finding the total resistance of resistances in parallel is

$$R = \frac{1}{\frac{1}{R_1} + \frac{1}{R_2} + \frac{1}{R_3} + \frac{1}{R_4} + \dots}$$

where the dots again indicate that any number of resistors can be combined by the same method. For only two resistances in parallel (a very common case) the formula becomes

$$R = \frac{R_1 R_2}{R_1 + R_2}$$

Example: If a 500-ohm resistor is paralleled with one of 1200 ohms, the total resistance is

$$R = \frac{R_1 R_2}{R_1 + R_2} = \frac{500 \times 1200}{500 + 1200} = \frac{600,000}{1700} = 353 \text{ ohms}$$

It is probably easier to solve practical problems by a different method than the "reciprocal of reciprocals" formula. Suppose the three re-

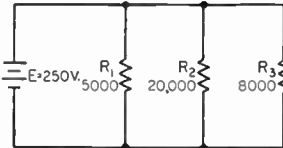

Fig. 2-6 — An example of resistors in parallel. The solution is worked out in the text.

sistors of the previous example are connected in parallel as shown in Fig. 2-6. The same e.m.f., 250 volts, is applied to all three of the resistors. The current in each can be found from Ohm's Law as shown below, I_1 being the current through R_1 , I_2 the current through R_2 and I_3 the current through R_3 .

For convenience, the resistance will be expressed in kilohms so the current will be in milliamperes.

$$I_1 = \frac{E}{R_1} = \frac{250}{5} = 50 \text{ ma.}$$

$$I_2 = \frac{E}{R_2} = \frac{250}{20} = 12.5 \text{ ma.}$$

$$I_3 = \frac{E}{R_3} = \frac{250}{8} = 31.25 \text{ ma.}$$

The total current is

$$I = I_1 + I_2 + I_3 = 50 + 12.5 + 31.25 = 93.75 \text{ ma.}$$

The total resistance of the circuit is therefore

$$R = \frac{E}{I} = \frac{250}{93.75} = 2.66 \text{ kilohms} (= 2660 \text{ ohms})$$

Resistors in Series-Parallel

An actual circuit may have resistances both in parallel and in series. To illustrate, we use the same three resistances again, but now connected as in Fig. 2-7. The method of solving a circuit such as Fig. 2-7 is as follows: Consider R_2 and R_3 in parallel as though they formed a single resistor. Find their equivalent resistance. Then this resistance in series with R_1 forms a simple series circuit, as shown at the right in Fig. 2-7.

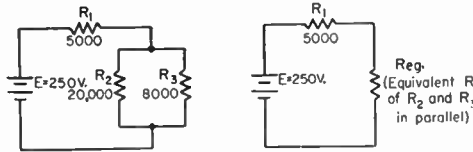

Fig. 2-7 — An example of resistors in series-parallel. The equivalent circuit is at the right. The solution is worked out in the text.

Example: The first step is to find the equivalent resistance of R_2 and R_3 . From the formula for two resistances in parallel,

$$R_{eq} = \frac{R_2 R_3}{R_2 + R_3} = \frac{20 \times 8}{20 + 8} = \frac{160}{28} = 5.71 \text{ kilohms}$$

The total resistance in the circuit is then
 $R = R_1 + R_{eq} = 5 + 5.71 \text{ kilohms} = 10.71 \text{ kilohms}$

The current is

$$I = \frac{E}{R} = \frac{250}{10.71} = 23.4 \text{ ma.}$$

The voltage drops across R_1 and R_{eq} are
 $E_1 = IR_1 = 23.4 \times 5 = 117 \text{ volts}$
 $E_2 = IR_{eq} = 23.4 \times 5.71 = 133 \text{ volts}$
 with sufficient accuracy. These total 250 volts, thus checking the calculations so far, because the sum of the voltage drops must equal the applied voltage. Since E_2 appears across both R_2 and R_3 ,

$$I_2 = \frac{E_2}{R_2} = \frac{133}{20} = 6.75 \text{ ma.}$$

$$I_3 = \frac{E_2}{R_3} = \frac{133}{8} = 16.6 \text{ ma.}$$

where $I_2 =$ Current through R_2
 $I_3 =$ Current through R_3

The total is 23.35 ma., which checks closely enough with 23.4 ma., the current through the whole circuit.

● POWER AND ENERGY

Power — the rate of doing work — is equal to voltage multiplied by current. The unit of electrical power, called the watt, is equal to one volt multiplied by one ampere. The equation for power therefore is

$$P = EI$$

where $P =$ Power in watts

$E =$ E.m.f. in volts

$I =$ Current in amperes

Common fractional and multiple units for power are the milliwatt, one one-thousandth of a watt, and the kilowatt, or one thousand watts.

Example: The plate voltage on a transmitting vacuum tube is 2000 volts and the plate current is 350 milliamperes. (The current must be changed to amperes before substitution in the formula, and so is 0.35 amp.) Then

$$P = EI = 2000 \times 0.35 = 700 \text{ watts}$$

By substituting the Ohm's Law equivalents for E and I , the following formulas are obtained for power:

$$P = \frac{E^2}{R}$$

$$P = I^2 R$$

These formulas are useful in power calculations

when the resistance and either the current or voltage (but not both) are known.

Example: How much power will be used up in a 4000-ohm resistor if the voltage applied to it is 200 volts? From the equation

$$P = \frac{E^2}{R} = \frac{(200)^2}{4000} = \frac{40,000}{4000} = 10 \text{ watts}$$

Or, suppose a current of 20 milliamperes flows through a 300-ohm resistor. Then

$$P = I^2 R = (0.02)^2 \times 300 = 0.0004 \times 300 = 0.12 \text{ watt}$$

Note that the current was changed from milliamperes to amperes before substitution in the formula.

Electrical power in a resistance is turned into heat. The greater the power the more rapidly the heat is generated. Resistors for radio work are made in many sizes, the smallest being rated to "dissipate" (or carry safely) about $\frac{1}{4}$ watt. The largest resistors used in amateur equipment will dissipate about 100 watts.

Generalized Definition of Resistance

Electrical power is not always turned into heat. The power used in running a motor, for example, is converted to mechanical motion. The power supplied to a radio transmitter is largely converted into radio waves. Power applied to a loud-speaker is changed into sound waves. But in every case of this kind the power is completely "used up" — it cannot be recovered. Also, for proper operation of the device the power must be supplied at a definite ratio of voltage to current. Both these features are characteristics of resistance, so it can be said that any device that dissipates power has a definite value of "resistance." This concept of resistance as something that absorbs power at a definite voltage/current ratio is very useful, since it permits substituting a simple resistance for the load or power-consuming part of the device receiving power, often with considerable simplification of calculations. Of course, every electrical device has some resistance of its own in the more narrow sense, so a part of the power supplied to it is dissipated in that resistance and hence appears as heat even though the major part of the power may be converted to another form.

Efficiency

In devices such as motors and vacuum tubes, the object is to obtain power in some other form than heat. Therefore power used in heating is considered to be a loss, because it is not the useful power. The efficiency of a device is the useful power output (in its converted form) divided by the power input to the device. In a vacuum-tube transmitter, for example, the object is to convert power from a d.c. source into a.c. power at some radio frequency. The ratio of the r.f. power output to the d.c. input is the efficiency of the tube. That is,

$$Eff. = \frac{P_o}{P_i}$$

where *Eff.* = Efficiency (as a decimal)

P_o = Power output (watts)

P_i = Power input (watts)

Example: If the d.c. input to the tube is 100 watts and the r.f. power output is 60 watts, the efficiency is

$$\text{Eff.} = \frac{P_o}{P_i} = \frac{60}{100} = 0.6$$

Efficiency is usually expressed as a percentage; that is, it tells what per cent of the input power will be available as useful output. The efficiency in the above example is 60 per cent.

Energy

In residences, the power company's bill is for electric **energy**, not for power. What you pay for is the *work* that electricity does for you, not the *rate* at which that work is done.

Capacitance

Suppose two flat metal plates are placed close to each other (but not touching) as shown in Fig. 2-8. Normally, the plates will be electrically "neutral"; that is, no electrical charge will be evident on either plate.

Now suppose that the plates are connected to a battery through a switch, as shown. At the

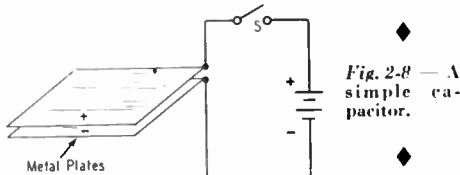

instant the switch is closed, electrons will be attracted from the upper plate to the positive terminal of the battery, and the same number will be repelled into the lower plate from the negative battery terminal. This electron movement will continue until enough electrons move into one plate and out of the other to make the e.m.f. between them the same as the e.m.f. of the battery.

If the switch is opened after the plates have been charged, the top plate is left with a deficiency of electrons and the bottom plate with an excess. In other words, the plates remain charged despite the fact that the battery no longer is connected. However, if a wire is touched between the two plates (**short-circuiting** them) the excess electrons on the bottom plate will flow through the wire to the upper plate, thus restoring electrical neutrality to both plates. The plates have then been **discharged**.

The two plates constitute an electrical **capacitor** or **condenser**, and from the discussion above it should be clear that a capacitor possesses the property of storing electricity. It should also be clear that during the time the electrons are moving—that is, while the capacitor is being charged or discharged—a current is flowing in the circuit even though the circuit is "broken" by the gap between the capacitor plates. However, the current flows only during the time of

Electrical work is equal to power multiplied by time; the common unit is the **watt-hour**, which means that a power of one watt has been used for one hour. That is,

$$W = PT$$

where W = Energy in watt-hours

P = Power in watts

T = Time in hours

Other energy units are the **kilowatt-hour** and the **watt-second**. These units should be self-explanatory.

Energy units are seldom used in amateur practice, but it is obvious that a small amount of power used for a long time can eventually result in a "power" bill that is just as large as though a large amount of power had been used for a very short time.

charge and discharge, and this time is usually very short. There can be no continuous flow of direct current "through" a capacitor.

The charge or quantity of electricity that can be placed on a capacitor is proportional to the applied voltage and to the **capacitance** or **capacity** of the condenser. The larger the plate area and the smaller the spacing between the plates the greater the capacitance. The capacitance also depends upon the kind of insulating material between the plates; it is smallest with air insulation, but substitution of other insulating materials for air may increase the capacitance many times. The ratio of the capacitance with some material other than air between the plates, to the capacitance of the same condenser with air insulation, is called the **specific inductive capacity** or **dielectric constant** of that particular insulating material. The material itself is called a **dielectric**. The dielectric constants of a number of materials commonly used as dielectrics in

TABLE 2-III
Dielectric Constants and Breakdown Voltages

Material	Dielectric Constant	Puncture Voltage*
Air	1.0	19.8-22.8
Alsimag A196	5.7	240
Bakelite (paper-base)	3.8-5.5	650-750
Bakelite (mica-filled)	5-6	475-600
Celluloid	4-16	
Cellulose acetate	6-8	300-1000
Fiber	5-7.5	150-180
Formica	4.6-4.9	450
Glass (window)	7.6-8	200-250
Glass (photographic)	7.5	
Glass (Pyrex)	4.2-4.9	335
Lucite	2.5-3	480-500
Mica	2.5-8	
Mica (clear India)	6.4-7.5	600-1500
Mycalex	7.4	250
Paper	2.0-2.6	1250
Polyethylene	2.3-2.4	1000
Polystyrene	2.4-2.9	500-2500
Porcelain	6.2-7.5	40-100
Rubber (hard)	2-3.5	450
Steatite (low-loss)	4.4	150-315
Wood (dry oak)	2.5-6.8	

* In volts per mil (0.001 inch).

capacitors are given in Table 2-111. If a sheet of photographic glass is substituted for air between the plates of a capacitor, for example, the capacitance will be increased 7.5 times.

Units

The fundamental unit of capacitance is the farad, but this unit is much too large for practical work. Capacitance is usually measured in microfarads (abbreviated $\mu\text{f.}$) or micromicrofarads ($\mu\mu\text{f.}$). The microfarad is one-millionth



Fig. 2-9—A multiple-plate capacitor. Alternate plates are connected together.

of a farad, and the micromicrofarad is one-millionth of a microfarad. Capacitors nearly always have more than two plates, the alternate plates being connected together to form two sets as shown in Fig. 2-9. This makes it possible to attain a fairly large capacitance in a small space, since several plates of smaller individual area can be stacked to form the equivalent of a single large plate of the same total area. Also, all plates, except the two on the ends, are exposed to plates of the other group on both sides, and so are twice as effective in increasing the capacitance.

The formula for calculating capacitance is:

$$C = 0.224 \frac{KA}{d} (n - 1)$$

where C = Capacitance in $\mu\mu\text{f.}$

K = Dielectric constant of material between plates

A = Area of one side of one plate in square inches

d = Separation of plate surfaces in inches

n = Number of plates

If the plates in one group do not have the same area as the plates in the other, use the area of the smaller plates.

Example: A "variable" capacitor has 7 semicircular plates on its rotor, the diameter of the semicircle being 2 inches. The stator has 6 rectangular plates, with a semicircular cut-out to clear the rotor shaft, but otherwise large enough to face the entire area of a rotor plate. The diameter of the cut-out is $\frac{1}{2}$ inch. The distance between the adjacent surfaces of rotor and stator plates is $\frac{1}{8}$ inch. The dielectric is air. What is the capacitance with the plates fully meshed?

In this case, the "effective" area is the area of the rotor plate minus the area of the cut-out in the stator plate. The area of either semicircle is $\frac{\pi r^2}{2}$, where r is the radius. The area of the rotor plate is $\frac{\pi}{2}$, or 1.57 square inches (the radius is 1 inch). The area of the cut-out is $\pi(\frac{1}{4})^2/2 = \pi/32 = 0.10$ square inch, approximately. The "effective" area is therefore $1.57 - 0.10 = 1.47$ square inches. The capacitance is therefore

$$C = 0.224 \frac{KA}{d} (n - 1) = 0.224 \frac{1 \times 1.47}{0.125} (13 - 1)$$

$$= 0.224 \times 11.76 \times 12 = 31.6 \mu\mu\text{f.}$$

(The answer is only approximate, because of the difficulty of accurate measurement, plus a "fringing" effect at the edges of the plates that makes the actual capacitance a little higher.)

The usefulness of a capacitor in electrical circuits lies in the fact that it can be charged with electricity at one time and then discharged at a later time. In other words, it is capable of storing electrical energy that can be released later when it is needed; it is an "electrical reservoir."

Capacitors in Radio

The types of capacitors used in radio work differ considerably in physical size, construction, and capacitance. Some representative types are shown in the photograph. In variable capacitors (almost always constructed with air for the dielectric) one set of plates is made movable with respect to the other set so that the capacitance can be varied. Fixed condensers — that is, having fixed capacitance — also can be made with metal plates and with air as the dielectric, but usually

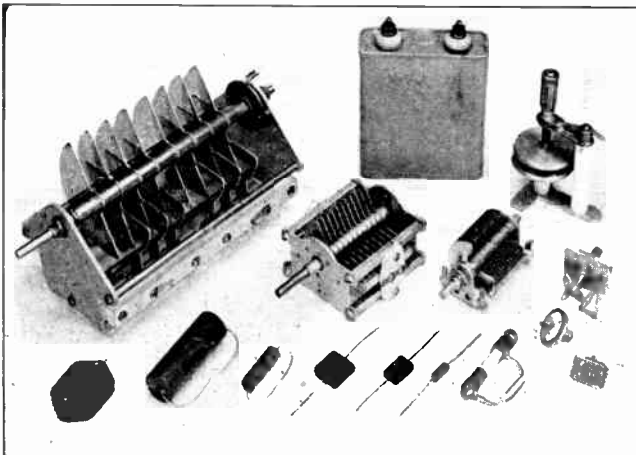

Fixed and variable capacitors. The bottom row includes, left to right, a high-voltage mica fixed capacitor, a tubular electrolytic, tubular paper, two sizes of "postage-stamp" micas, a small ceramic type (temperature compensating), an adjustable capacitor with ceramic insulation (for neutralizing in transmitters), a "button" ceramic capacitor, and an adjustable "padding" capacitor. Four sizes of variable capacitors are shown in the second row. The two-plate capacitor with the micrometer adjustment is used in transmitters. The capacitor enclosed in the metal case is a high-voltage paper type used in power-supply filters.

are constructed from plates of metal foil with a thin solid or liquid dielectric sandwiched in between, so that a relatively large capacitance can be secured in a small unit. The solid dielectrics commonly used are mica, paper and special ceramics. An example of a liquid dielectric is mineral oil. The electrolytic capacitor uses aluminum-foil plates with a semiliquid conducting chemical compound between them; the actual dielectric is a very thin film of insulating material that forms on one set of plates through electrochemical action when a d.c. voltage is applied to the capacitor. The capacitance obtained with a given plate area in an electrolytic capacitor is very large, compared with capacitors having other dielectrics, because the film is so extremely thin — much less than any thickness that is practicable with a solid dielectric.

Voltage Breakdown

When a high voltage is applied to the plates of a capacitor, a considerable force is exerted on the electrons and nuclei of the dielectric. Because the dielectric is an insulator the electrons do not become detached from atoms the way they do in conductors. However, if the force is great enough the dielectric will “break down”; usually it will puncture and may char (if it is solid) and permit current to flow. The **breakdown voltage** depends upon the kind and thickness of the dielectric, as shown in Table 2-III. It is not directly proportional to the thickness; that is, doubling the thickness does not quite double the breakdown voltage. If the dielectric is air or any other gas, breakdown is evidenced by a spark or arc between the plates, but if the voltage is removed the arc ceases and the capacitor is ready for use again. Breakdown will occur at a lower voltage between pointed or sharp-edged surfaces than between rounded and polished surfaces; consequently, the breakdown voltage between metal plates of given spacing in air can be increased by buffing the edges of the plates.

Since the dielectric must be thick to withstand high voltages, and since the thicker the dielectric the smaller the capacitance for a given plate area, a high-voltage capacitor must have more plate area than a low-voltage one of the same capacitance. High-voltage high-capacitance condensers are physically large.

● **CAPACITORS IN SERIES AND PARALLEL**

The terms “parallel” and “series” when used with reference to capacitors have the same circuit meaning as with resistances. When a number of capacitors are connected in parallel, as in Fig. 2-10, the total capacitance of the group is equal to the sum of the individual capacitances, so

$$C \text{ (total)} = C_1 + C_2 + C_3 + C_4 + \dots$$

However, if two or more capacitors are connected in series, as in the second drawing,

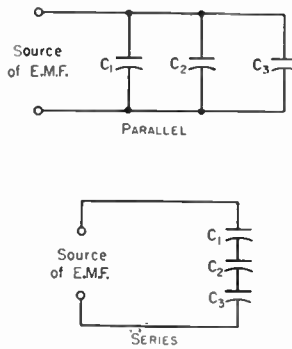

Fig. 2-10 — Capacitors in series and parallel.

the total capacitance is less than that of the smallest capacitor in the group. The rule for finding the capacitance of a number of series-connected capacitors is the same as that for finding the resistance of a number of parallel-connected resistors. That is,

$$C \text{ (total)} = \frac{1}{\frac{1}{C_1} + \frac{1}{C_2} + \frac{1}{C_3} + \frac{1}{C_4} + \dots}$$

and, for only two capacitors in series,

$$C \text{ (total)} = \frac{C_1 C_2}{C_1 + C_2}$$

The same units must be used throughout; that is, all capacitances must be expressed in either $\mu\text{f.}$ or $\mu\mu\text{f.}$; you cannot use both units in the same equation.

Capacitors are connected in parallel to obtain a larger total capacitance than is available in one unit. The largest voltage that can be applied safely to a group of capacitors in parallel is the voltage that can be applied safely to the one having the *lowest* voltage rating.

When capacitors are connected in series, the applied voltage is divided up among them; the situation is much the same as when resistors are in series and there is a voltage drop across each. However, the voltage that appears across each capacitor of a group connected in series is in *inverse* proportion to its capacitance, as compared with the capacitance of the whole group.

Example: Three capacitors having capacitances of 1, 2 and 4 $\mu\text{f.}$, respectively, are con-

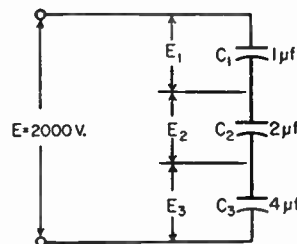

Fig. 2-11 — An example of capacitors connected in series. The solution to this arrangement is worked out in the text.

netted in series as shown in Fig. 2-11. The total capacitance is

$$C = \frac{1}{\frac{1}{C_1} + \frac{1}{C_2} + \frac{1}{C_3}} = \frac{1}{\frac{1}{1} + \frac{1}{2} + \frac{1}{4}} = \frac{1}{\frac{7}{4}} = \frac{4}{7} = 0.571 \mu\text{f.}$$

The voltage across each capacitor is proportional to the total capacitance divided by the capacitance of the condenser in question, so the voltage across C_1 is

$$E_1 = \frac{0.571}{1} \times 2000 = 1142 \text{ volts}$$

Similarly, the voltages across C_2 and C_3 are

$$E_2 = \frac{0.571}{2} \times 2000 = 571 \text{ volts}$$

$$E_3 = \frac{0.571}{4} \times 2000 = 286 \text{ volts}$$

totaling approximately 2000 volts, the applied voltage.

Capacitors are frequently connected in series to enable the group to withstand a larger voltage (at the expense of decreased total capacitance) than any individual condenser is rated to stand. However, as shown by the previous example, the applied voltage does not divide equally among the capacitors (except when all the capacitances are the same) so care must be taken to see that the voltage rating of no capacitor in the group is exceeded.

Inductance

It is possible to show that the flow of current through a conductor is accompanied by magnetic effects; a compass needle brought near the conductor, for example, will be deflected from its normal north-south position. The current, in other words, sets up a magnetic field.

If a wire conductor is formed into a coil, the same current will set up a stronger magnetic field than it will if the wire is straight. Also, if the wire is wound around an iron or steel core the field will be still stronger. The relationship between the strength of the field and the intensity of the current causing it is expressed by the **inductance** of the conductor or coil. If the same current flows through two coils, for example, and it is found that the magnetic field set up by one coil is twice as strong as that set up by the other, the first coil has twice as much inductance as the second. Inductance is a property of the conductor or coil and is determined by its shape and dimensions. The unit of inductance (corresponding to the ohm for resistance and the farad for capacitance) is the **henry**. The general term for a component having inductance as its principal property is **inductor**.

If the current through a conductor or coil is made to vary in intensity, it is found that an

e.m.f. will appear across the terminals of the conductor or coil. This e.m.f. is entirely separate from the e.m.f. that is causing the current to flow. The strength of this **induced e.m.f.** becomes greater, the greater the intensity of the magnetic field and the more rapidly the current (and hence the field) is made to vary. Since the intensity of the magnetic field depends upon the inductance, the induced voltage (for a given current intensity and rate of variation) is proportional to the inductance of the conductor or coil.

The induced e.m.f. (sometimes called **back e.m.f.**) tends to send a current through the circuit in the *opposite* direction to the current that flows because of the external e.m.f. so long as the latter current is *increasing*. However, if the current caused by the applied e.m.f. *decreases*, the induced e.m.f. tends to send current through the circuit in the *same* direction as the current from the applied e.m.f. The effect of inductance, therefore, is to oppose any *change* in the current flowing in the circuit, regardless of the nature of the change. It accomplishes this by storing energy in its magnetic field when the current in the circuit is being increased, and by releasing the stored energy when the current is being decreased.

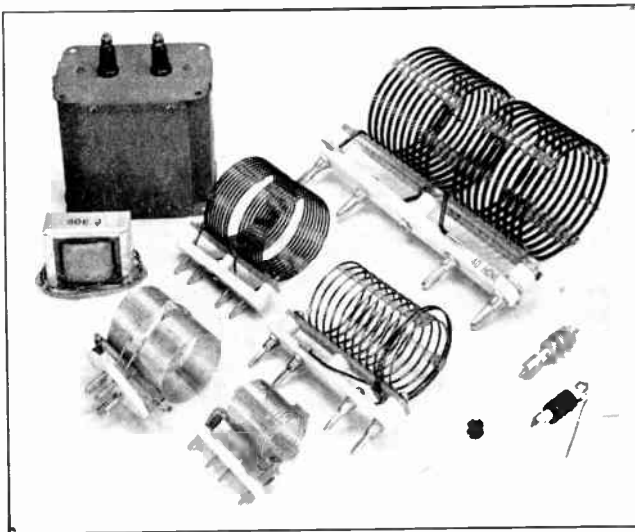

Inductors for power and radio frequencies. The two iron-core coils at the upper left are "chokes" for power-supply filters. The three "pie"-wound coils at the lower right are used as chokes in radio-frequency circuits. The other coils are for r.f. tuned circuits ranging in power from 25 watts to a kilowatt.

The values of inductance used in radio equipment vary over a wide range. Inductance of several henrys is required in power-supply circuits (see chapter on Power Supplies) and to obtain such values of inductance it is necessary to use coils of many turns wound on iron cores. In radio-frequency circuits, the inductance values used will be measured in millihenrys (a millihenry is one one-thousandth of a henry) at low frequencies, and in microhenrys (one one-millionth of a henry) at medium frequencies and higher. Although coils for radio frequencies may be wound on special iron cores (ordinary iron is not suitable) most r.f. coils made and used by amateurs are of the "air-core" type; that is, wound on an insulating support consisting of nonmagnetic material.

Every conductor has inductance, even though the conductor is not formed into a coil. The inductance of a short length of straight wire is small — but it may not be negligible, because if the current through it changes its intensity rapidly enough the induced voltage may be appreciable. This will be the case in even a few inches of wire when an alternating current having a frequency of the order of 100 Mc. or higher is flowing. However, at much lower frequencies the inductance of the same wire could be left out of any calculations because the induced voltage would be negligibly small.

Calculating Inductance

The inductance of air-core coils may be calculated from the formula

$$L (\mu h.) = \frac{0.2 a^2 n^2}{3a + 9b + 10c}$$

- where *L* = Inductance in microhenrys
- a* = Average diameter of coil in inches
- b* = Length of winding in inches
- c* = Radial depth of winding in inches
- n* = Number of turns

The notation is explained in Fig. 2-12. The

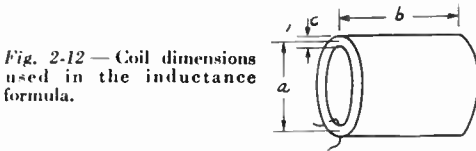

Fig. 2-12 — Coil dimensions used in the inductance formula.

quantity *10c* may be neglected if the coil only has one layer of wire.

Example: Assume a coil having 35 turns of No. 30 d.s.c. wire on a form 1.5 inches in diameter. Consulting the wire table, 35 turns of No. 30 d.s.c. will occupy 0.5 inch. Therefore, *a* = 1.5, *b* = 0.5, *n* = 35, and

$$L = \frac{0.2 \times (1.5)^2 \times (35)^2}{(3 \times 1.5) + (9 \times 0.5)} = 61.25 \mu h.$$

To calculate the number of turns of a single-layer coil for a required value of inductance:

$$N = \sqrt{\frac{3a + 9b}{0.2a^2} \times L}$$

Example: Suppose an inductance of 10 microhenrys is required. The form on which the coil is

to be wound has a diameter of one inch and is long enough to accommodate a coil length of 1 1/4 inches. Then *a* = 1, *b* = 1.25, and *L* = 10. Substituting,

$$N = \sqrt{\frac{(3 \times 1) + (9 \times 1.25)}{0.2 \times 1^2} \times 10}$$

$$= \sqrt{\frac{14.25}{0.2} \times 10} = \sqrt{712.5}$$

$$= 26.6 \text{ turns.}$$

A 27-turn coil would be close enough to the required value of inductance, in practical work. Since the coil will be 1.25 inches long, the number of turns per inch will be 27/1.25 = 21.6. Consulting the wire table, we find that No. 18 enameled wire (or any smaller size) can be used. The proper inductance is obtained by winding the required number of turns on the form and then adjusting the spacing between the turns to make a uniformly-spaced coil 1.25 inches long.

Inductance Charts

Most inductance formulas lose accuracy when applied to small coils (such as are used in v.h.f. work and in low-pass filters built for reducing harmonic interference to television) because the conductor thickness is no longer negligible in comparison with the size of the coil. Fig. 2-13 shows the measured inductance of v.h.f. coils, and may be used as a basis for circuit design. Two curves are given: curve *A* is for coils wound to an inside diameter of 1/2 inch; curve *B* is for coils of 3/4-inch inside diameter. In both curves the wire size is No. 12, winding pitch 8 turns to the inch (1/8 inch center-to-center turn spacing). The inductance values given include leads 1/2 inch long.

The charts of Figs. 2-14 and 2-15 are useful for rapid determination of the inductance of coils of the type commonly used in radio-frequency circuits in the range 3-30 Mc. They are based on the formula above, and are of sufficient accuracy for most practical work. Given the coil length in inches, the curves show the multiplying factor to be applied to the inductance value given in the table below the curve for a coil of the same diameter and number of turns per inch.

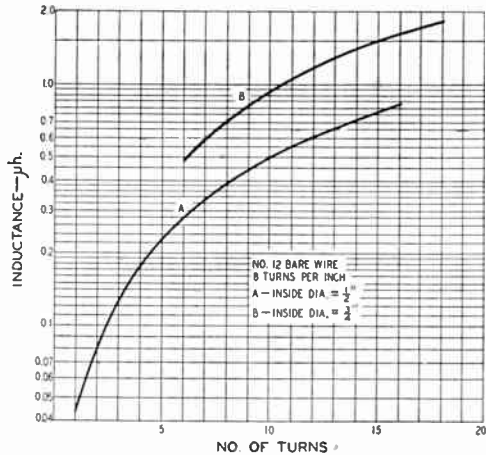

Fig. 2-13 — Measured inductance of coils wound with No. 12 bare wire, 8 turns to the inch. The values include half-inch leads.

Example: A coil 1 inch in diameter is $1\frac{1}{4}$ inches long and has 20 turns. Therefore it has 16 turns per inch, and from the table under Fig. 2-15 it is found that the reference inductance for a coil of this diameter and number of turns per inch is 16.8 μ h. From curve B in the figure the multiplying factor is 0.35, so the inductance is

$$16.8 \times 0.35 = 5.9 \mu\text{h.}$$

The charts also can be used for finding suitable dimensions for a coil having a required value of inductance.

Example: A coil having an inductance of 12 μ h. is required. It is to be wound on a form having a diameter of 1 inch, the length available for the winding being not more than $1\frac{1}{4}$ inches. From Fig. 2-15, the multiplying factor for a 1-inch diameter coil (curve B) having the maximum possible length of $1\frac{1}{4}$ inches is 0.35. Hence the

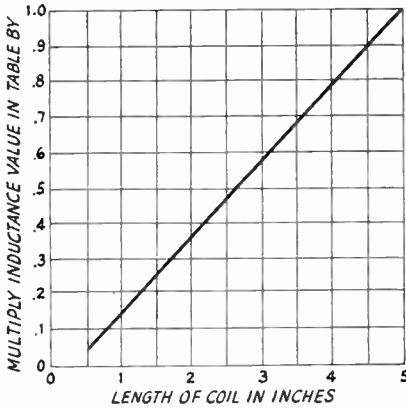

Fig. 2-14 — Factor to be applied to the inductance of coils listed in the table below, for coil lengths up to 5 inches.

Coil diameter, Inches	No. of turns per inch	Inductance in μ h.
$1\frac{1}{4}$	4	2.75
	6	6.3
	8	11.2
	10	17.5
	16	42.5
$1\frac{1}{2}$	4	3.9
	6	8.8
	8	15.6
	10	24.5
	16	63
$1\frac{3}{4}$	4	5.2
	6	11.8
	8	21
	10	33
	16	85
2	4	6.6
	6	15
	8	26.5
	10	42
	16	108
$2\frac{1}{2}$	4	10.2
	6	23
	8	41
	10	64
3	4	14
	6	31.5
	8	56
	10	89

number of turns per inch must be chosen for a reference inductance of at least $12/0.35$, or 34 μ h. From the Table under Fig. 2-15 it is seen that 16 turns per inch (reference inductance 16.8 μ h.) is too small. Using 32 turns per inch, the multiplying factor is $12/68$, or 0.177, and from curve B this corresponds to a coil length of $\frac{3}{4}$ inch. There will be 24 turns in this length, since the winding "pitch" is 32 turns per inch.

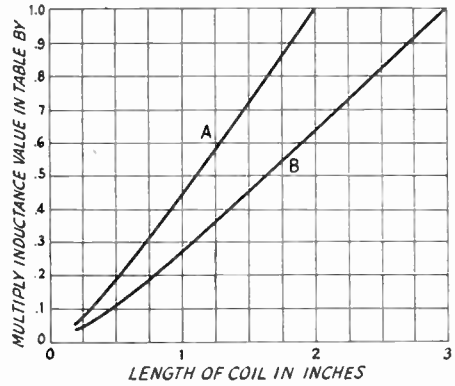

Fig. 2-15 — Factor to be applied to the inductance of coils listed in the table below, as a function of coil length. Use curve A for coils marked A, curve B for coil marked B.

Coil diameter, Inches	No. of turns per inch	Inductance in μ h.
$\frac{1}{2}$ (A)	4	0.18
	6	0.40
	8	0.72
	10	1.12
	16	2.9
	32	12
$\frac{5}{8}$ (A)	4	0.28
	6	0.62
	8	1.1
	10	1.7
	16	4.4
	32	18
$\frac{3}{4}$ (A)	4	0.39
	6	0.87
	8	1.57
	10	2.45
	16	6.4
	32	26
1 (B)	4	1.0
	6	2.3
	8	4.2
	10	6.6
	16	16.8
	32	68

● IRON-CORE COILS

Permeability

Suppose that the coil in Fig. 2-16 is wound on an iron core having a cross-sectional area of 2 square inches. When a certain current is sent through the coil it is found that there are 80,000 lines of force in the core. Since the area is 2 square inches, the flux density is 40,000 lines per square inch. Now suppose that the iron core is removed and the same current is maintained in the coil, and that the flux density without the iron core is found to be 50 lines per square inch. The ratio of the flux density with the given core

material to the flux density (with the same coil and same current) with an air core is called the permeability of the material. In this case the permeability of the iron is $40,000/50 = 800$. The inductance of the coil is increased 800 times by inserting the iron core, therefore.

The permeability of a magnetic material varies with the flux density. At low flux densities (or with an air core) increasing the current through the coil will cause a proportionate increase in flux, but at very high flux densities, increasing the current may cause no appreciable change in the flux. When this is so, the iron is said to be saturated. "Saturation" causes a rapid decrease in permeability, because it decreases the ratio of flux lines to those obtainable with the same current and an air core. Obviously, the inductance of an iron-core inductor is highly dependent upon the current flowing in the coil. In an air-core coil, the inductance is independent of current because air does not "saturate."

In amateur work, iron-core coils such as the one sketched in Fig. 2-16 are used chiefly in power-supply equipment. They usually have direct current flowing through the winding,

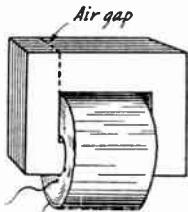

Fig. 2-16 — Typical construction of an iron-core inductor. The small air gap prevents magnetic saturation of the iron and thus maintains the inductance at high currents.

and the variation in inductance with current is usually undesirable. It may be overcome by keeping the flux density below the saturation point of the iron. This is done by cutting the core so that there is a small "air gap," as indicated by the dashed lines. The magnetic "resistance" introduced by such a gap is so large — even though the gap is only a small fraction of an inch — compared with that of the iron that the gap, rather than the iron, controls the flux density. This naturally reduces the inductance compared to what it would be without the air gap, but the inductance is practically constant regardless of the value of the current.

Eddy Currents and Hysteresis

When alternating current flows through a coil wound on an iron core an e.m.f. will be induced, as previously explained, and since iron is a conductor a current will flow in the core. Such currents (called eddy currents) represent a waste of power because they flow through the resistance of the iron and thus cause heating. Eddy-current losses can be reduced by laminating the core; that is, by cutting it into thin strips. These strips or laminations must be insulated from each other by painting them with some insulating material such as varnish or shellac.

There is also another type of energy loss in an iron core: the iron tends to resist any change in its magnetic state, so a rapidly-changing

current such as a.c. is forced continually to supply energy to the iron to overcome this "inertia." Losses of this sort are called hysteresis losses.

Eddy-current and hysteresis losses in iron increase rapidly as the frequency of the alternating current is increased. For this reason, we can use ordinary iron cores only at power and audio frequencies — up to, say, 15,000 cycles. Even so, a very good grade of iron or steel is necessary if the core is to perform well at the higher audio frequencies. Iron cores of this type are completely useless at radio frequencies.

For radio-frequency work, the losses in iron cores can be reduced to a satisfactory figure by grinding the iron into a powder and then mixing it with a "binder" of insulating material in such a way that the individual iron particles are insulated from each other. By this means cores can be made that will function satisfactorily even through the v.h.f. range — that is, at frequencies up to perhaps 100 Mc. Because a large part of the magnetic path is through a nonmagnetic material, the permeability of the iron is low compared with the values obtained at power-supply frequencies. The core is usually in the form of a "slug" or cylinder which fits inside the insulating form on which the coil is wound. Despite the fact that, with this construction, the major portion of the magnetic path for the flux is in the air surrounding the coil, the slug is quite effective in increasing the coil inductance. By pushing the slug in and out of the coil the inductance can be varied over a considerable range.

● INDUCTANCES IN SERIES AND PARALLEL

When two or more inductors are connected in series (Fig. 2-17, left) the total inductance is

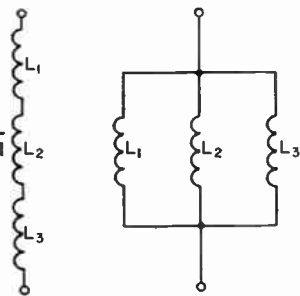

Fig. 2-17 — Inductances in series and parallel.

equal to the sum of the individual inductances, provided the coils are sufficiently separated so that no coil is in the magnetic field of another. That is,

$$L_{\text{total}} = L_1 + L_2 + L_3 + L_4 + \dots$$

If inductors are connected in parallel (Fig. 2-17, right), the total inductance is

$$L_{\text{total}} = \frac{1}{\frac{1}{L_1} + \frac{1}{L_2} + \frac{1}{L_3} + \frac{1}{L_4} + \dots}$$

and for two inductances in parallel,

$$L = \frac{L_1 L_2}{L_1 + L_2}$$

Thus the rules for combining inductances in series and parallel are the same as for resistances, if the coils are far enough apart so that each is unaffected by another's magnetic field. When this is not so the formulas given above cannot be used.

● MUTUAL INDUCTANCE

If two coils are arranged with their axes on the same line, as shown in Fig. 2-18, a current sent through Coil 1 will cause a magnetic field which "cuts" Coil 2. Consequently, an e.m.f. will be induced in Coil 2 whenever the field strength is changing. This induced e.m.f. is similar to the e.m.f. of self-induction, but since it appears in the *second* coil because of current flowing in the *first*, it is a "mutual" effect and results from the **mutual inductance** between the two coils.

If all the flux set up by one coil cuts all the turns of the other coil the mutual inductance has its maximum possible value. If only a small part of the flux set up by one coil cuts the turns of the other the mutual inductance is relatively small. Two coils having mutual inductance are said to be **coupled**.

The ratio of actual mutual inductance to the maximum possible value that could theoretically be obtained with two given coils is called the **coefficient of coupling** between the coils. It is

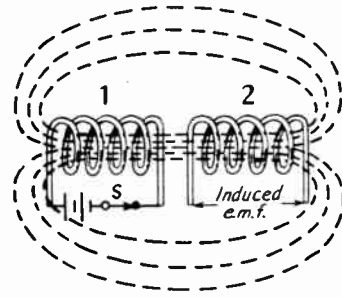

Fig. 2-18 — Mutual inductance. When the switch, *S*, is closed current flows through coil No. 1, setting up a magnetic field that induces an e.m.f. in the turns of coil No. 2.

frequently expressed as a percentage. Coils that have nearly the maximum possible (coefficient = 1 or 100%) mutual inductance are said to be **closely**, or **tightly**, coupled, but if the mutual inductance is relatively small the coils are said to be **loosely** coupled. The degree of coupling depends upon the physical spacing between the coils and how they are placed with respect to each other. Maximum coupling exists when they have a common axis and are as close together as possible (one wound over the other). The coupling is least when the coils are far apart or are placed so their axes are at right angles.

The maximum possible coefficient of coupling is closely approached only when the two coils are wound on a closed iron core. The coefficient with air-core coils may run as high as 0.6 or 0.7 if one coil is wound over the other, but will be much less if the two coils are separated.

Time Constant

Capacitance and Resistance

In Fig. 2-19A a battery having an e.m.f., *E*, a switch, *S*, a resistor, *R*, and capacitor, *C*, are connected in series. Suppose for the moment that *R* is short-circuited and that there is no other resistance in the circuit. If *S* is now closed, condenser *C* will charge *instantly* to the battery voltage; that is, the electrons that constitute the charge redistribute themselves in a time interval so small that it can be considered to be zero. For just this instant, therefore, a very large current flows in the circuit, because all the electricity needed to charge the capacitor has

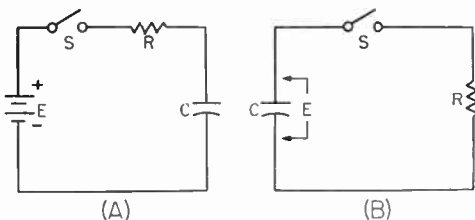

Fig. 2-19 — Schematics illustrating the time constant of an *RC* circuit.

moved from the battery to the capacitor at an extremely high rate.

When the resistance *R* is put into the circuit the capacitor no longer can be charged instantaneously. If the battery e.m.f. is 100 volts, for example, and *R* is 10 ohms, the maximum current that can flow is 10 amperes, and even this much can flow only at the instant the switch is closed. But as soon as *any* current flows, capacitor *C* begins to acquire a charge, which means that the voltage between its plates rises. Since the upper plate (in Fig. 2-19A) will be positive and the lower negative, the voltage on the capacitor tries to send a current through the circuit in the opposite direction to the current from the battery. Immediately after the switch is closed, therefore, the current drops below its initial Ohm's Law value, and as the capacitor continues to acquire charge and its potential or e.m.f. rises, the current becomes smaller and smaller.

The length of time required to complete the charging process depends upon the capacitance and the resistance in the circuit. Theoretically, the charging process is never really finished,

but eventually the charging current drops to a value that is smaller than anything that can be measured. The **time constant** of such a circuit is the length of time, in seconds, required for the voltage across the capacitor to reach 63 per cent of the applied e.m.f. (this figure is chosen for mathematical reasons). The voltage across the capacitor rises logarithmically, as shown by Fig. 2-20.

The formula for time constant is

$$T = CR$$

where T = Time constant in seconds

C = Capacitance in farads

R = Resistance in ohms

If C is in microfarads and R in megohms, the time constant also is in seconds. These units usually are more convenient.

Example: The time constant of a 2- μ f. capacitor and a 250,000-ohm (0.25 megohm) resistor is

$$T = CR = 2 \times 0.25 = 0.5 \text{ second}$$

If the applied e.m.f. is 1000 volts, the voltage across the capacitor plates will be 630 volts at the end of $\frac{1}{2}$ second.

If a charged capacitor is *discharged* through a resistor, as indicated in Fig. 2-19B, the same time constant applies. If there were no resistance, the capacitor would discharge instantly when

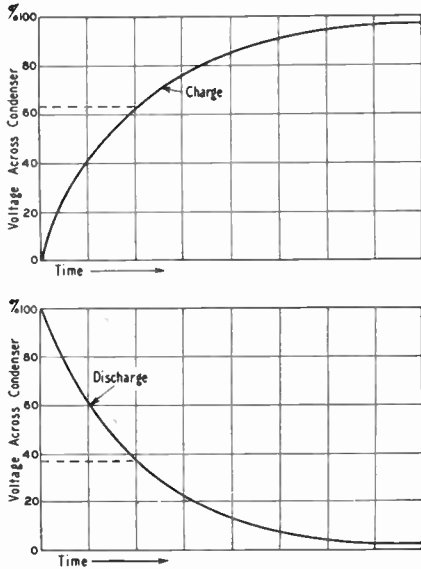

Fig. 2-20 — How the voltage across a capacitor rises, with time, when charged through a resistor. The lower curve shows the way in which the voltage decreases across the capacitor terminals on discharging through the same resistor.

S was closed. However, since R limits the current flow the capacitor voltage cannot instantly go to zero, but it will decrease just as rapidly as the capacitor can rid itself of its charge through R . When the capacitor is discharging through a resistance, the time constant (calculated in the same way as above) is the time, in seconds, that

it takes for the capacitor to *lose* 63 per cent of its voltage; that is, for the voltage to drop to 37 per cent of its initial value.

Example: If the capacitor of the example above is charged to 1000 volts, it will discharge to 370 volts in $\frac{1}{2}$ second through the 250,000-ohm resistor.

Inductance and Resistance

A comparable situation exists when resistance and inductance are in series. In Fig. 2-21, first consider L to have no resistance and also assume that R is zero. Then closing S would tend

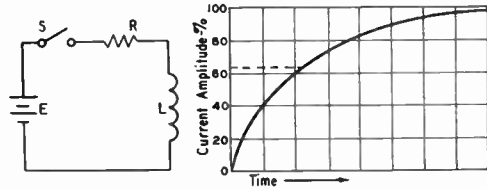

Fig. 2-21 — Time constant of an LR circuit.

to send a current through the circuit. However, the instantaneous transition from no current to a finite value, however small, represents a very rapid *change* in current, and a back e.m.f. is developed by the self-inductance of L that is practically equal and opposite to the applied e.m.f. The result is that the initial current is very small.

The back e.m.f. depends upon the *change* in current and would cease to offer opposition if the current did not continue to increase. With no resistance in the circuit (which would lead to an infinitely-large current, by Ohm's Law) the current would increase forever, always growing just fast enough to keep the e.m.f. of self-induction equal to the applied e.m.f.

When resistance is in series, Ohm's Law sets a limit to the value that the current can reach. In such a circuit the current is small at first, just as in the case without resistance. But as the current grows the voltage drop across R becomes larger. The back e.m.f. generated in L has only to equal the *difference* between E and the drop across R , because that difference is the voltage actually applied to L . This difference becomes smaller as the current approaches the final Ohm's Law value. Theoretically, the back e.m.f. never quite disappears (that is, the current never quite reaches the Ohm's Law value) but practically it becomes unmeasurable after a time. The difference between the actual current and the Ohm's Law value also becomes undetectable. The time constant of an inductive circuit is the time in seconds required for the current to reach 63 per cent of its final value. The formula is

$$T = \frac{L}{R}$$

where T = Time constant in seconds

L = Inductance in henrys

R = Resistance in ohms

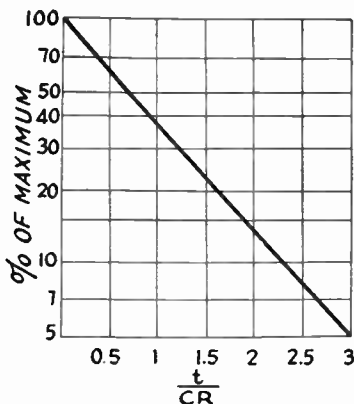

Fig. 2-22 — Voltage across capacitor terminals in a discharging CR circuit, in terms of the initial charged voltage. To obtain time in seconds, multiply the factor t/CR by the time constant of the circuit.

The resistance of the wire in a coil acts as though it were in series with the inductance.

Example: A coil having an inductance of 20 henrys and a resistance of 100 ohms has a time constant of

$$T = \frac{L}{R} = \frac{20}{100} = 0.2 \text{ second}$$

if there is no other resistance in the circuit. If a d.c. e.m.f. of 10 volts is applied to such a coil, the final current, by Ohm's Law, is

$$I = \frac{E}{R} = \frac{10}{100} = 0.1 \text{ amp. or } 100 \text{ ma.}$$

The current would rise from zero to 63 milliamperes in 0.2 second after closing the switch.

An inductor cannot be discharged in the same way as a condenser, because the magnetic field disappears as soon as current flow ceases. Opening S does not leave the inductor "recharged." The energy stored in the magnetic field instantly returns to the circuit when S is opened. The rapid disappearance of the field causes a very large voltage to be induced

in the coil — ordinarily many times larger than the voltage applied, because the induced voltage is proportional to the *speed* with which the field changes. The common result of opening the switch in a circuit such as the one shown is that a spark or arc forms at the switch contacts at the instant of opening. If the inductance is large and the current in the circuit is high, a great deal of energy is released in a very short period of time. It is not at all unusual for the switch contacts to burn or melt under such circumstances.

Time constants play an important part in numerous devices, such as electronic keys, timing and control circuits, and shaping of keying characteristics by vacuum tubes. The time constants of circuits are also important in such applications as automatic gain control and noise limiters. In nearly all such applications a capacitance-resistance (CR) time constant is involved, and it is usually necessary to know the voltage across the capacitor at some time interval larger or smaller than the actual time constant of the circuit as given by the formula above. Fig. 2-22 can be used for the solution of such problems, since the curve gives the voltage across the capacitor, in terms of percentage of the initial charge, for percentages between 5 and 100, at any time after discharge begins.

Example: A 0.01- μ f. capacitor is charged to 150 volts and then allowed to discharge through a 0.1-megohm resistor. How long will it take the voltage to fall to 10 volts? In percentage, $10/150 = 6.7\%$. From the chart, the factor corresponding to 6.7% is 2.7. The time constant of the circuit is equal to $CR = 0.01 \times 0.1 = 0.001$. The time is therefore $2.7 \times 0.001 = 0.0027$ second, or 2.7 milliseconds.

Example: An RC circuit is desired in which the voltage will fall to 50% of the initial value in 1 second. From the chart, $t/CR = 0.7$ at the 50%-voltage point. Therefore $CR = t/0.7 = 1/0.7 = 1.43$. Any combination of resistance and capacitance whose product (R in megohms and C in microfarads) is equal to 1.43 can be used; for example, C could be 1 μ f. and R 1.43 megohms.

Alternating Currents

● PHASE

The term **phase** essentially means "time," or the *time interval* between the instant when one thing occurs and the instant when a second related thing takes place. When a baseball pitcher throws the ball to the catcher there is a definite interval, represented by the time of flight of the ball, between the act of throwing and the act of catching. The throwing and catching are "out of phase" because they do not occur at exactly the same time.

Simply saying that two events are out of phase does not tell us which one occurred first. To give this information, the later event is said to **lag** the earlier, while the one that occurs first is said to **lead**. Thus, throwing the ball "leads" the catch, or the catch "lags" the throw.

In a.c. circuits the current amplitude changes continuously, so the concept of phase or time becomes important. Phase can be measured in

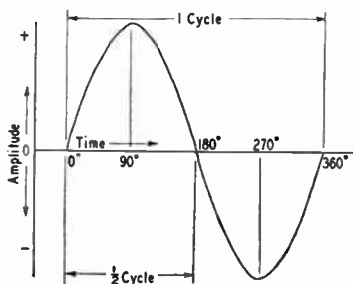

Fig. 2-23 — An a.c. cycle is divided off into 360 degrees that are used as a measure of time or phase.

the ordinary time units, such as the second, but there is a more convenient method: Since each a.c. cycle occupies exactly the same amount of time as every other cycle of the same frequency, we can use the cycle itself as the time unit. Using

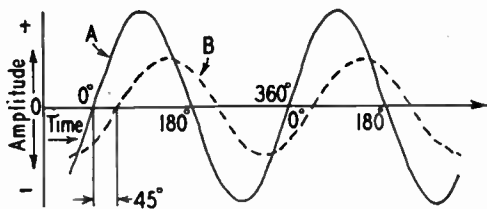

Fig. 2-24 — When two waves of the same frequency start their cycles at slightly different times, the time difference or phase difference is measured in degrees. In this drawing wave *B* starts 45 degrees (one-eighth cycle) later than wave *A*, and so lags 45 degrees behind *A*.

the cycle as the time unit makes the specification or measurement of phase independent of the frequency of the current, so long as only one frequency is under consideration at a time. If there are two or more frequencies, the measurement of phase has to be modified just as the measurements of two lengths must be reconciled if one is given in feet and the other in meters.

The time interval or "phase difference" under consideration usually will be less than one cycle. Phase difference could be measured in decimal parts of a cycle, but it is more convenient to divide the cycle into 360 parts or degrees. A phase degree is therefore $1/360$ of a cycle. The reason for this choice is that with sine-wave alternating current the value of the current at any instant is proportional to the sine of the angle that corresponds to the number of degrees — that is, length of time — from the instant the cycle began. There is no actual "angle" associated with an alternating current. Fig. 2-23 should help make this method of measurement clear.

Measuring Phase

To compare the phase of two currents of the same frequency, we measure between corresponding parts of cycles of the two currents. This is shown in Fig. 2-24. The current labeled *A* leads the one marked *B* by 45 degrees, since *A*'s cycles begin 45 degrees sooner in time. It is equally correct to say that *B* lags *A* by 45 degrees.

Two important special cases are shown in Fig. 2-25. In the upper drawing *B* lags 90 degrees behind *A*; that is, its cycle begins just one-quarter cycle later than that of *A*. When one wave is passing through zero, the other is just at its maximum point.

In the lower drawing *A* and *B* are 180 degrees out of phase. In this case it does not matter which one is to lead or lag. *B* is always positive while *A* is negative, and vice versa. The two waves are thus completely out of phase.

The waves shown in Figs. 2-24 and 2-25 could represent current, voltage, or both. *A* and *B* might be two currents in separate circuits, or *A* might represent voltage while *B* represented

current in the same circuit. If *A* and *B* represent two currents in the same circuit (or two voltages in the same circuit) the total or resultant current (or voltage) also is a sine wave, because adding any number of sine waves of the same frequency always gives a sine wave also of the same frequency.

Phase in Resistive Circuits

When an alternating voltage is applied to a resistance, the current flows exactly in step with the voltage. In other words, the voltage and current are in phase. This is true at any frequency if the resistance is "pure" — that is, is free from the reactive effects discussed in the next section. Practically, it is often difficult to obtain a purely resistive circuit at radio frequencies, because the

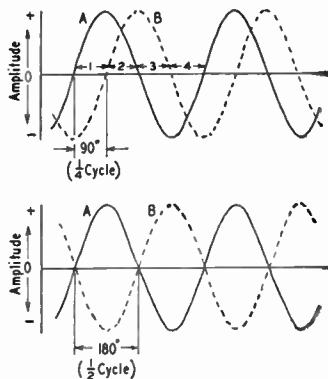

Fig. 2-25 — Two important special cases of phase difference. In the upper drawing, the phase difference between *A* and *B* is 90 degrees; in the lower drawing the phase difference is 180 degrees.

reactive effects become more pronounced as the frequency is increased.

In a purely resistive circuit, or for purely resistive parts of circuits, Ohm's Law is just as valid for a.c. of any frequency as it is for d.c.

REACTANCE

Alternating Current in Capacitance

Suppose a sine-wave a.c. voltage is applied to a capacitor in a circuit containing no resistance, as indicated in Fig. 2-26. In the period *OA*, the applied voltage increases from zero to 38 volts; at the end of this period the capacitor is charged to that voltage. In interval *AB* the voltage increases to 71 volts; that is, 33 volts additional. In this interval a smaller quantity of charge has been added than in *OA*, because the voltage rise during interval *AB* is smaller. Consequently the average current during *AB* is smaller than during *OA*. In the third interval, *BC*, the voltage rises from 71 to 92 volts, an increase of 21 volts. This is less than the voltage increase during *AB*, so the quantity of electricity added is less; in other words, the average current during interval *BC* is still smaller. In the fourth interval, *CD*, the voltage increases only 8 volts; the

charge added is smaller than in any preceding interval and therefore the current also is smaller.

Thus as the instantaneous value of the applied voltage increases the current decreases.

By dividing the first quarter cycle into a very large number of intervals it could be shown that the current charging the capacitor has the shape of a sine wave, just as the applied voltage does. The current is largest at the beginning of the cycle and becomes zero at the maximum value of the voltage (the capacitor cannot be charged to a higher voltage than the maximum applied, so no further current can flow) so there is a phase

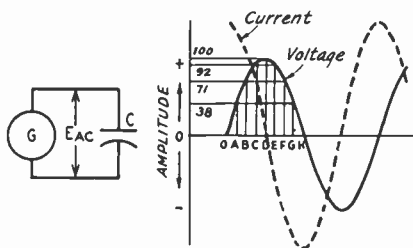

Fig. 2-26 — Voltage and current phase relationships when an alternating voltage is applied to a condenser.

difference of 90 degrees between the voltage and current. During the first quarter cycle of the applied voltage the current is flowing in the normal direction through the circuit, since the capacitor is being charged. Hence the current is positive during this first quarter cycle, as indicated by the dashed line in Fig. 2-26.

In the second quarter cycle — that is, in the time from *D* to *H*, the voltage applied to the capacitor decreases. During this time the capacitor loses the charge it acquired during the first quarter cycle. Applying the same reasoning, it is plain that the current is small in interval *DE* and continues to increase during each succeeding interval. However, the current is flowing *against* the applied voltage because the capacitor is *discharging into the circuit*. Hence the current is *negative* during this quarter cycle.

The third and fourth quarter cycles repeat the events of the first and second, respectively, with this difference — the polarity of the applied voltage has reversed, and the current changes to correspond. In other words, *an alternating current flows "through" a capacitor when an a.c. voltage is applied to it.* (Actually, current never flows "through" a condenser. It flows in the associated circuit because of the alternate charging and discharging of the capacitance.) As shown by Fig. 2-26, the current starts its cycle 90 degrees before the voltage, so the current in a capacitor *leads the applied voltage by 90 degrees.*

Capacitive Reactance

The amount of charge that is alternately stored in and released from the capacitor is proportional to the applied voltage and the capacitance. Consequently, the current in the circuit will be proportional to both these quantities, since current is simply the rate at which charge is moved. The

current also will be proportional to the frequency of the a.c. voltage, because the same charge is being moved back and forth at a rate that is proportional to the number of cycles per second.

The fact that the current is proportional to the applied voltage is important, because it is the same thing that Ohm's Law says about current flow in a resistive circuit. That being the case, there must be something in the capacitor that corresponds in a general way to resistance — something that tends to limit the current that can flow when a given voltage is applied. The "something" clearly must include the effects of capacitance and frequency, since these also affect the amount of current that flows. It is called **reactance**, and its relationship to capacitance and frequency is given by the formula

$$X_C = \frac{1}{2\pi fC}$$

where X_C = Capacitive reactance in ohms
 f = Frequency in cycles per second
 C = Capacitance in farads
 π = 3.14

Reactance and resistance are not the same thing, but because they have a similar current-limiting effect the same unit, the ohm, is used for both. Unlike resistance, reactance does not consume or dissipate power. The energy stored in the capacitor in one quarter of the cycle is simply returned to the circuit in the next.

The fundamental units (cycles per second, farads) are too large for practical use in radio circuits. However, if the capacitance is in microfarads and the frequency is in megacycles, the reactance will come out in ohms in the formula.

Example: The reactance of a capacitor of 470 $\mu\text{f.}$ (0.00047 $\mu\text{f.}$) at a frequency of 7150 kc. (7.15 Mc.) is

$$X = \frac{1}{2\pi fC} = \frac{1}{6.28 \times 7.15 \times 0.00047} = 47.4 \text{ ohms}$$

Inductive Reactance

When an alternating voltage is applied to a circuit containing only inductance, with no resistance, the current always changes just rapidly enough to induce a back e.m.f. that equals and opposes the applied voltage. In Fig. 2-27, the cycle is again divided off into equal intervals. Assuming that the current has a maximum value of 1 ampere, the instantaneous current at the end of each interval will be as shown. The value of the induced voltage is proportional to the *rate at which the current changes*. It is therefore greatest in the intervals *OA* and *GH* and least in the intervals *CD* and *DE*. The induced voltage actually is a sine wave (if the current is a sine wave) as shown by the dashed curve. The *applied* voltage, because it is always equal to and opposed by the induced voltage, is equal to and 180 degrees out of phase with the induced voltage, as shown by the second dashed curve. The result, therefore, is that the current flowing in an inductance is 90 degrees out of phase with the applied voltage, and lags behind the applied

voltage. This is just the opposite of the capacitive case.

Since the value of the induced e.m.f. is proportional to the rate at which the current changes, a small current changing rapidly (that is, at a high frequency) can generate a large back e.m.f.

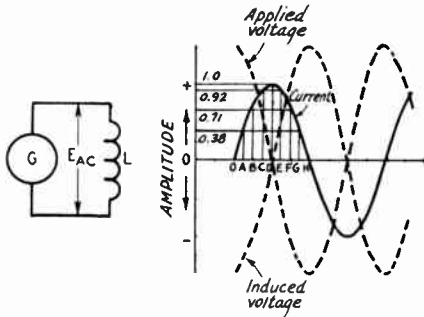

Fig. 2-27 — Phase relationships between voltage and current when an alternating voltage is applied to an inductance.

in a given inductance just as well as a large current changing slowly (low frequency). Consequently, the current that flows through a given inductance will decrease as the frequency is raised, if the applied e.m.f. is held constant. Also, when the applied voltage and frequency are fixed, the value of current required becomes less as the inductance is made larger, because the induced e.m.f. also is proportional to inductance.

When the frequency and inductance are constant but the applied e.m.f. is varied, the necessary rate of current change (to induce the proper back e.m.f.) can be obtained only if the amplitude of the current is directly proportional to the voltage. This is Ohm's Law again, and again the current-limiting effect is similar to, but not identical with, the effect of resistance. It is called **inductive reactance** and, like capacitive reactance, is measured in ohms. There is no energy loss in inductive reactance; the energy is stored in the magnetic field in one quarter cycle and then returned to the circuit in the next.

The formula for inductive reactance is

$$X_L = 2\pi fL$$

- where X_L = Inductive reactance in ohms
- f = Frequency in cycles per second
- L = Inductance in henrys
- $\pi = 3.14$

Example: The reactance of a coil having an inductance of 8 henrys, at a frequency of 120 cycles, is

$$X_L = 2\pi fL = 6.28 \times 120 \times 8 = 6029 \text{ ohms}$$

In radio-frequency circuits the inductance values usually are small and the frequencies are large. If the inductance is expressed in millihenrys and the frequency in kilocycles, the conversion factors for the two units cancel, and the formula for reactance may be used without first converting to fundamental units. Similarly, no conversion is necessary if the inductance is in microhenrys and the frequency is in megacycles.

Example: The reactance of a 15-microhenry coil at a frequency of 14 Mc. is

$$X_L = 2\pi fL = 6.28 \times 14 \times 15 = 1319 \text{ ohms}$$

The resistance of the wire of which the coil is wound has no effect on the reactance, but simply acts as though it were a separate resistor connected in series with the coil.

Ohm's Law for Reactance

Ohm's Law for an a.c. circuit containing *only* reactance is

$$I = \frac{E}{X}$$

$$E = IX$$

$$X = \frac{E}{I}$$

where E = E.m.f. in volts

I = Current in amperes

X = Reactance in ohms

The reactance may be either inductive or capacitive.

Example: If a current of 2 amperes is flowing through the capacitor of the previous example (reactance = 47.4 ohms) at 7150 kc., the voltage drop across the capacitor is

$$E = IX = 2 \times 47.4 = 94.8 \text{ volts}$$

If 400 volts at 120 cycles is applied to the 8-henry inductor of the previous example, the current through the coil will be

$$I = \frac{E}{X} = \frac{400}{6029} = 0.0663 \text{ amp. (66.3 ma.)}$$

When the circuit consists of an inductance in series with a capacitance, the same current flows through both reactances. However, the voltage across the inductor *leads* the current by 90 de-

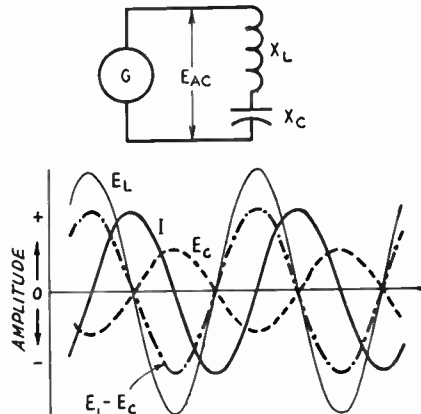

Fig. 2-28 — Current and voltages in a circuit having inductive and capacitive reactances in series.

grees, and the voltage across the capacitor *lags* behind the current by 90 degrees. The voltages therefore are 180 degrees out of phase.

A simple circuit of this type is shown in Fig. 2-28. The same figure also shows the current

reactances calculated from the formulas given above, and thus avoid "decimal-point errors".

Reactive Power

In Fig. 2-28 the voltage drop across the inductor is larger than the voltage applied to the circuit. This might seem to be an impossible condition, but it is not; the explanation is that while energy is being stored in the inductor's magnetic field, energy is being returned to the circuit from the capacitor's electric field, and vice versa. This stored energy is responsible for the fact that the voltages across reactances in series can be larger than the voltage applied to them.

In a resistance the flow of current causes heating and a power loss equal to I^2R . The power in a reactance is equal to I^2X , but is not a "loss"; it is simply power that is transferred back and forth between the field and the circuit but not used up in heating anything. To distinguish this "nondissipated" power from the power which is actually consumed, the unit of reactive power is called the volt-ampere instead of the watt. Reactive power is sometimes called "wattless" power.

● **IMPEDANCE**

The fact that resistance, inductive reactance and capacitive reactance all are measured in ohms does not indicate that they can be combined indiscriminately. Voltage and current are in phase in resistance, but differ in phase by a quarter cycle in reactance. In the simple circuit shown in Fig. 2-30, for example, it is not possible simply to add the resistance and reactance together to obtain a quantity that will indicate the opposition offered by the combination to the flow of current. Inasmuch as both resistance and reactance

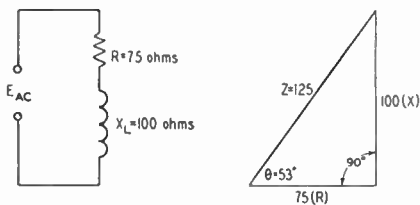

Fig. 2-30 — Resistance and inductive reactance connected in series.

are present, the total effect can obviously be neither wholly one nor the other. In circuits containing both reactance and resistance the opposition effect is called **impedance (Z)**. The unit of impedance is also the ohm.

The term "impedance" also is generalized to include any quantity that can be expressed as a ratio of voltage to current. Pure resistance and pure reactance are both included in "impedance" in this sense. A circuit with resistive impedance is either one with resistance alone or one in which the effects of any reactance present have been eliminated. Similarly, a reactive impedance

is one having reactance only. A **complex impedance** is one in which both resistance and reactance effects are observable.

It can be shown that resistance and reactance can be combined in the same way that a right-angled triangle is constructed, if the resistance is laid off to proper scale as the base of the triangle and the reactance is laid off as the altitude to the same scale. This is also indicated in Fig. 2-30. When this is done the hypotenuse of the triangle represents the impedance of the circuit, to the same scale, and the angle between Z and R (usually called θ and so indicated in the drawing) is equal to the phase angle between the applied e.m.f. and the current. By geometry,

$$Z = \sqrt{R^2 + X^2}$$

In the case shown in the drawing,

$$Z = \sqrt{(75)^2 + (100)^2} = \sqrt{15,625} = 125 \text{ ohms.}$$

The phase angle can be found from simple trigonometry. Its tangent is equal to X/R ; in this case $X/R = 100/75 = 1.33$. From trigonometric tables it can be determined that the angle having a tangent equal to 1.33 is approximately 53 degrees. In ordinary amateur work it is seldom necessary to give much consideration to the phase angle.

A circuit containing resistance and capacitance in series (Fig. 2-31) can be treated in the same way. The difference is that in this case the current

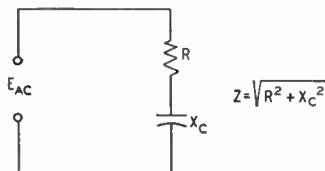

Fig. 2-31 — Resistance and capacitive reactance in series.

leads the applied e.m.f., while in the resistance-inductance case it lags behind the voltage.

If either X or R is small compared with the other (say 1/10 or less) the impedance is very nearly equal to the larger of the two quantities. For example, if $R = 1$ ohm and $X = 10$ ohms,

$$Z = \sqrt{R^2 + X^2} = \sqrt{(1)^2 + (10)^2} = \sqrt{101} = 10.05 \text{ ohms.}$$

Hence if either X or R is at least 10 times as large as the other, the error in assuming that the impedance is equal to the larger of the two will not exceed 1/2 of 1 per cent, which is usually negligible.

Since one of the components of impedance is reactance, and since the reactance of a given coil or capacitor changes with the applied frequency, impedance also changes with frequency. The change in impedance as the frequency is changed may be very slow if the resistance is considerably larger than the reactance. However, if the impedance is mostly reactance a change in frequency will cause the impedance to change practically as rapidly as the reactance itself changes.

Ohm's Law for Impedance

Ohm's Law can be applied to circuits containing impedance just as readily as to circuits having resistance or reactance only. The formulas are

$$I = \frac{E}{Z}$$

$$E = IZ$$

$$Z = \frac{E}{I}$$

where E = E.m.f. in volts
 I = Current in amperes
 Z = Impedance in ohms

Example: Assume that the e.m.f. applied to the circuit of Fig. 2-30 is 250 volts. Then

$$I = \frac{E}{Z} = \frac{250}{125} = 2 \text{ amperes.}$$

The same current is flowing in both R and X_L , and Ohm's Law as applied to either of these quantities says that the voltage drop across R should equal IR and the voltage drop across X_L should equal IX_L . Substituting,

$$E_R = IR = 2 \times 75 = 150 \text{ volts}$$

$$E_{X_L} = IX_L = 2 \times 100 = 200 \text{ volts}$$

The arithmetical sum of these voltages is greater than the applied voltage. However, the *actual* sum of the two when the phase relationship is taken into account is equal to 250 volts r.m.s., as shown by Fig. 2-32, where the instantaneous values are added throughout the cycle. Whenever resistance and reactance are in series, the individual voltage drops always add up, arithmetically, to more than the applied voltage. There is nothing fictitious about these voltage drops; they can be measured readily by suitable instruments. It is simply an illustration of the importance of phase in a.c. circuits.

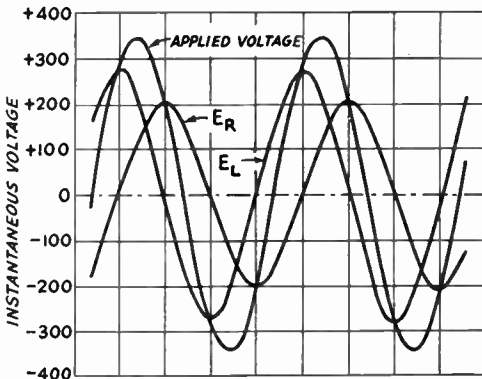

Fig. 2-32 — Voltage drops around the circuit of Fig. 2-30. Because of the phase relationships, the applied voltage is less than the arithmetical sum of the drops across the resistor and inductor.

A more complex series circuit, containing resistance, inductive reactance and capacitive reactance, is shown in Fig. 2-33. In this case it is necessary to take into account the fact that the phase angles between current and voltage differ in all three elements. Since it is a series circuit, the current is the same throughout. Considering first just the inductance and capacitance and neglecting the resistance, the net reactance is

$$X_L - X_C = 150 - 50 = 100 \text{ ohms (inductive)}$$

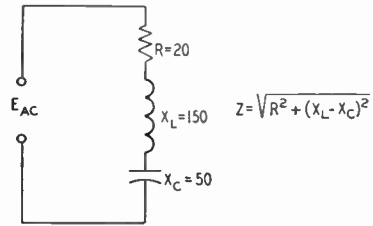

Fig. 2-33 — Resistance, inductive reactance, and capacitive reactance in series.

Thus the impedance of a circuit containing resistance, inductance and capacitance in series is

$$Z = \sqrt{R^2 + (X_L - X_C)^2}$$

Example: In the circuit of Fig. 2-33, the impedance is

$$Z = \sqrt{R^2 + (X_L - X_C)^2}$$

$$= \sqrt{(20)^2 + (150 - 50)^2} = \sqrt{(20)^2 + (100)^2}$$

$$= \sqrt{10,400} = 102 \text{ ohms}$$

The phase angle can be found from X/R , where $X = X_L - X_C$.

Parallel Circuits

Suppose that a resistor, capacitor and coil are connected in parallel as shown in Fig. 2-34 and

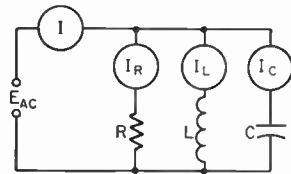

Fig. 2-34 — Resistance, inductance and capacitance in parallel. Instruments connected as shown will read the total current, I , and the individual currents in the three branches of the circuit.

an a.c. voltage is applied to the combination. In any one branch, the current will be unchanged if one or both of the other two branches is disconnected, so long as the applied voltage remains unchanged. Hence the current in each branch can be calculated quite simply by the Ohm's Law formulas given in the preceding sections. The total current, I , is the sum of the currents through all three branches — not the arithmetical sum, but the sum when phase is taken into account.

The currents through the various branches will be as shown in Fig. 2-35, assuming for purposes of illustration that X_L is smaller than X_C and that X_C is smaller than R , thus making I_L larger than I_C , and I_C larger than I_R . The current through C leads the voltage by 90 degrees and the current through L lags the voltage by 90 degrees, so these two currents are 180 degrees out of phase. As shown at E, the total reactive current is the difference between I_C and I_L . This resultant current lags the voltage by 90 degrees, because I_L is larger than I_C . When the reactive current is added to I_R , the total current, I , is as shown at F. It can be seen that I lags the applied

voltage by an angle smaller than 90 degrees and that the total current, while less than the simple arithmetical sum (neglecting phase) of the three branch currents, is larger than the current through R alone.

The impedance looking into the parallel circuit from the source of voltage is equal to the applied voltage divided by the total or line current, I .

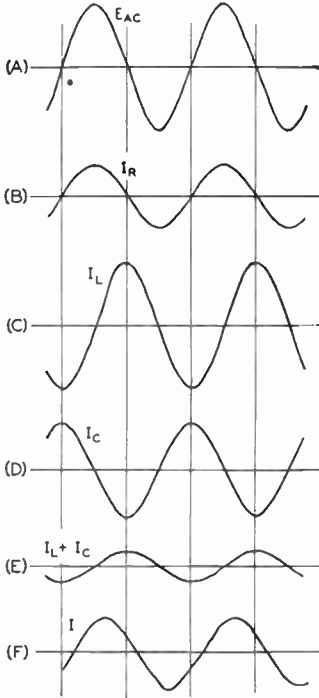

Fig. 2-35—Phase relationships between branch currents and applied voltage for the circuit of Fig. 2-31. The total current through L and C in parallel ($I_L + I_C$) and the total current in the entire circuit (I) also are shown.

In the case illustrated, I is greater than I_R , so the impedance of the circuit is less than the resistance of R . How much less depends upon the net reactive current flowing through L and C in parallel. If X_L and X_C are very nearly equal the net reactive current will be quite small because it is equal to the difference between two nearly equal currents. In such a case the impedance of the circuit will be almost the same as the resistance of R alone. On the other hand, if X_L and X_C are quite different the net reactive current can be relatively large and the total current also will be appreciably larger than I_R . In such a case the circuit impedance will be lower than the resistance of R alone.

Power Factor

In the circuit of Fig. 2-30 an applied e.m.f. of 250 volts results in a current of 2 amperes. If the circuit were purely resistive (containing no reactance) this would mean a power dissipation of $250 \times 2 = 500$ watts. However, the circuit actually consists of resistance and reactance,

and only the resistance consumes power. The power in the resistance is

$$P = I^2R = (2)^2 \times 75 = 300 \text{ watts}$$

The ratio of the power consumed to the apparent power is called the **power factor** of the circuit, and in the case used as an example would be $300/500 = 0.6$. Power factor is frequently expressed as a percentage; in this case, the power factor would be 60 per cent.

“Real” or dissipated power is measured in watts; apparent power, to distinguish it from real power, is measured in volt-amperes (just like the “wattless” power in a reactance). It is simply the product of volts and amperes and has no direct relationship to the power actually used up or dissipated unless the power factor of the circuit is known. The power factor of a purely resistive circuit is 100 per cent or 1, while the power factor of a pure reactance is zero. In this illustration, the reactive power is

$$\begin{aligned} VA \text{ (volt-amperes)} &= I^2X = (2)^2 \times 100 \\ &= 400 \text{ volt-amperes.} \end{aligned}$$

Complex Waves

It was pointed out early in this chapter that a complex wave (a “nonsinusoidal” wave) can be resolved into a fundamental frequency and a series of harmonic frequencies. When such a complex voltage wave is applied to a circuit containing reactance, the current through the circuit will not have the same wave shape as the applied voltage. This is because the reactance of an inductor and capacitor depend upon the applied frequency. For the second-harmonic component of a complex wave, the reactance of the inductor is twice and the reactance of the capacitor one-half their respective values at the fundamental frequency; for the third harmonic the inductor reactance is three times and the capacitor reactance one-third, and so on. Thus the circuit impedance is different for each harmonic component.

Just what happens to the current wave shape depends upon the values of resistance and reactance involved and how the circuit is arranged. In a simple circuit with resistance and inductive reactance in series, the amplitudes of the harmonics will be reduced because the inductive reactance increases in proportion to frequency. When capacitance and resistance are in series, the harmonic current is likely to be accentuated because the capacitive reactance becomes lower as the frequency is raised. When both inductive and capacitive reactance are present the shape of the current wave can be altered in a variety of ways, depending upon the circuit and the “constants,” or the relative values of L , C , and R , selected.

This property of nonuniform behavior with respect to fundamental and harmonics is an extremely useful one. It is the basis of “filtering,” or the suppression of undesired frequencies in favor of a single desired frequency or group of such frequencies.

Transformers

Two coils having mutual inductance constitute a **transformer**. The coil connected to the source of energy is called the **primary** coil, and the other is called the **secondary** coil.

The usefulness of the transformer lies in the fact that electrical energy can be transferred from one circuit to another without direct connection, and in the process can be readily changed from one voltage level to another. Thus, if a device to be operated requires, for example, 115 volts and only a 440-volt source is available, a transformer can be used to change the source voltage to that required. A transformer can be used only with a.c., since no voltage will be induced in the secondary if the magnetic field is not changing. If d.c. is applied to the primary of a transformer, a voltage will be induced in the secondary only at the instant of closing or opening the primary circuit, since it is only at these times that the field is changing.

The Iron-Core Transformer

As shown in Fig. 2-36, the primary and secondary coils of a transformer may be wound on a core

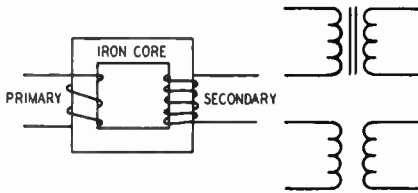

Fig. 2-36 — The transformer. Power is transferred from the primary coil to the secondary by means of the magnetic field. The upper symbol at right indicates an iron-core transformer, the lower one an air-core transformer.

of magnetic material. This increases the inductance of the coils so that a relatively small number of turns may be used to induce a given value of voltage with a small current. A **closed core** (one having a continuous magnetic path) such as that shown in Fig. 2-36 also tends to insure that practically all of the field set up by the current in the primary coil will cut the turns of the secondary coil. However, the core introduces a power loss because of hysteresis and eddy currents so this type of construction is practicable only at power and audio frequencies. The discussion in this section is confined to transformers operating at such frequencies.

Voltage and Turns Ratio

For a given varying magnetic field, the voltage induced in a coil in the field will be proportional to the number of turns on the coil. If the two coils of a transformer are in the same field (which is the case when both are wound on the same closed core) it follows that the induced voltages will be proportional to the number of turns on each coil. In the primary the induced voltage is

practically equal to, and opposes, the applied voltage, as described in the section on inductive reactance. Hence,

$$E_s = \frac{n_s}{n_p} E_p$$

where E_s = Secondary voltage

E_p = Primary applied voltage

n_s = Number of turns on secondary

n_p = Number of turns on primary

The ratio n_s/n_p is called the **turns ratio** of the transformer.

Example: A transformer has a primary of 400 turns and a secondary of 2800 turns, and 115 volts is applied to the primary. The secondary voltage will be

$$E_s = \frac{n_s}{n_p} E_p = \frac{2800}{400} \times 115 = 7 \times 115 = 805 \text{ volts}$$

Also, if 805 volts is applied to the 2800-turn winding (which then becomes the primary) the output voltage from the 400-turn winding will be 115 volts.

Either winding of a transformer can be used as the primary, providing the winding has enough turns (enough inductance) to induce a voltage equal to the applied voltage without requiring an excessive current flow.

Effect of Secondary Current

The current that flows in the primary when no current is taken from the secondary is called the **magnetizing current** of the transformer. In any properly-designed transformer the primary inductance will be so large that the magnetizing current will be quite small. The power consumed by the transformer when the secondary is "open" — that is, not delivering power — is only the amount necessary to supply the losses in the iron core and in the resistance of the wire with which the primary is wound.

When power is taken from the secondary winding, the secondary current sets up a magnetic field that opposes the field set up by the primary current. But if the induced voltage in the primary is to equal the applied voltage, the original field must be maintained. Consequently, the primary must draw enough additional current to set up a field exactly equal and opposite to the field set up by the secondary current.

In practical calculations on transformers it may be assumed that the entire primary current is caused by the secondary "load." This is justifiable because the magnetizing current should be very small in comparison with the primary "load" current at rated power output.

If the magnetic fields set up by the primary and secondary currents are to be equal, the primary current multiplied by the primary turns must equal the secondary current multiplied by the secondary turns. From this it follows that

$$I_p = \frac{n_s}{n_p} I_s$$

where I_p = Primary current

I_s = Secondary current

n_p = Number of turns on primary

n_s = Number of turns on secondary

Example: Suppose that the secondary of the transformer in the previous example is delivering a current of 0.2 ampere to a load. Then the primary current will be

$$I_p = \frac{n_s I_s}{n_p} = \frac{2800}{400} \times 0.2 = 7 \times 0.2 = 1.4 \text{ amp.}$$

Although the secondary voltage is higher than the primary voltage, the secondary current is lower than the primary current, and by the same ratio.

Power Relationships; Efficiency

A transformer cannot create power; it can only transfer it and change the e.m.f. Hence, the power taken from the secondary cannot exceed that taken by the primary from the source of applied e.m.f. There is always some power loss in the resistance of the coils and in the iron core, so in all practical cases the power taken from the source will exceed that taken from the secondary. Thus,

$$P_o = nP_i$$

where P_o = Power output from secondary

P_i = Power input to primary

n = Efficiency factor

The efficiency, n , always is less than 1. It is usually expressed as a percentage; if n is 0.65, for instance, the efficiency is 65 per cent.

Example: A transformer has an efficiency of 85% at its full-load output of 150 watts. The power input to the primary at full secondary load will be

$$P_i = \frac{P_o}{n} = \frac{150}{0.85} = 176.5 \text{ watts}$$

A transformer is usually designed to have its highest efficiency at the power output for which it is rated. The efficiency decreases with either lower or higher outputs. On the other hand, the losses in the transformer are relatively small at low output but increase as more power is taken. The amount of power that the transformer can handle is determined by its own losses, because these heat the wire and core and raise the operating temperature. There is a limit to the temperature rise that can be tolerated, because too-high temperature either will melt the wire or cause the insulation to break down. A transformer always can be operated at reduced output, even though the efficiency is low, because the actual loss also will be low under such conditions.

The full-load efficiency of small power transformers such as are used in radio receivers and transmitters usually lies between about 60 per cent and 90 per cent, depending upon the size and design.

Leakage Reactance

In a practical transformer not all of the magnetic flux is common to both windings, although in well-designed transformers the amount of flux that "cuts" one coil and not the other is only a small percentage of the total flux. This leakage flux causes an e.m.f. of self-induction; conse-

quently, there are small amounts of leakage inductance associated with both windings of the transformer. Leakage inductance acts in exactly the same way as an equivalent amount of ordinary inductance inserted in series with the circuit.

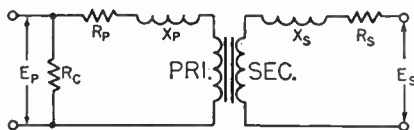

Fig. 2-37 — The equivalent circuit of a transformer includes the effects of leakage inductance and resistance of both primary and secondary windings. The resistance R_c is an equivalent resistance representing the core losses, which are essentially constant for any given applied voltage and frequency. Since these are comparatively small, their effect may be neglected in many approximate calculations.

It has, therefore, a certain reactance, depending upon the amount of leakage inductance and the frequency. This reactance is called leakage reactance.

Current flowing through the leakage reactance causes a voltage drop. This voltage drop increases with increasing current, hence it increases as more power is taken from the secondary. Thus, the greater the secondary current, the smaller the secondary terminal voltage becomes. The resistances of the transformer windings also cause voltage drops when current is flowing; although these voltage drops are not in phase with those caused by leakage reactance, together they result in a lower secondary voltage under load than is indicated by the turns ratio of the transformer.

At power frequencies (60 cycles) the voltage at the secondary, with a reasonably well-designed transformer, should not drop more than about 10 per cent from open-circuit conditions to full load. The drop in voltage may be considerably more than this in a transformer operating at audio frequencies because the leakage reactance increases directly with the frequency.

Impedance Ratio

In an ideal transformer — one without losses or leakage reactance — the following relationship is true:

$$Z_p = Z_o N^2$$

where Z_p = Impedance looking into primary terminals from source of power

Z_o = Impedance of load connected to secondary

N = Turns ratio, primary to secondary

That is, a load of any given impedance connected to the secondary of the transformer will be transformed to a different value "looking into" the primary from the source of power. The impedance transformation is proportional to the square of the primary-to-secondary turns ratio.

Example: A transformer has a primary-to-secondary turns ratio of 0.6 (primary has 6/10 as many turns as the secondary) and a load of 3000 ohms is connected to the secondary. The impedance looking into the primary then will be

$$Z_p = Z_o N^2 = 3000 \times (0.6)^2 = 3000 \times 0.36 = 1080 \text{ ohms}$$

By choosing the proper turns ratio, the impedance of a fixed load can be transformed to any desired value, within practical limits. The transformed or "reflected" impedance has the same phase angle as the actual load impedance; thus if the load is a pure resistance the load presented by the primary to the source of power also will be a pure resistance.

The above relationship may be used in practical work even though it is based on an "ideal" transformer. Aside from the normal design requirements of reasonably low internal losses and low leakage reactance, the only requirement is that the primary have enough inductance to operate with low magnetizing current at the voltage applied to the primary.

The primary impedance of a transformer — as it appears to the source of power — is determined wholly by the load connected to the secondary and by the turns ratio. If the characteristics of the transformer have an appreciable effect on the impedance presented to the power source, the transformer is either poorly designed or is not suited to the voltage and frequency at which it is being used. Most transformers will operate quite well at voltages from slightly above to well below the design figure.

Impedance Matching

Many devices require a specific value of load resistance (or impedance) for optimum operation. The impedance of the actual load that is to dissipate the power may differ widely from this value, so a transformer is used to change the actual load into an impedance of the desired value. This is called **impedance matching**. From the preceding,

$$N = \sqrt{\frac{Z_s}{Z_p}}$$

where N = Required turns ratio, secondary to primary

Z_s = Impedance of load connected to secondary

Z_p = Impedance required

Example: A vacuum-tube a.f. amplifier requires a load of 5000 ohms for optimum performance, and is to be connected to a loud-speaker having an impedance of 10 ohms. The turns ratio, secondary to primary, required in the coupling transformer is

$$N = \sqrt{\frac{Z_s}{Z_p}} = \sqrt{\frac{10}{5000}} = \sqrt{\frac{1}{500}} = \frac{1}{22.4}$$

The primary therefore must have 22.4 times as many turns as the secondary.

Impedance matching means, in general, adjusting the load impedance — by means of a transformer or otherwise — to a desired value. However, there is also another meaning. It is possible to show that any source of power will deliver its maximum possible output when the impedance of the load is equal to the internal impedance of the source. The impedance of the source is said to be "matched" under this condition. The efficiency is only 50 per cent in such

a case; just as much power is used up in the source as is delivered to the load. Because of the poor efficiency, this type of impedance matching is limited to cases where only a small amount of power is available and heating from power loss in the source is not important.

Transformer Construction

Transformers usually are designed so that the magnetic path around the core is as short as possible. A short magnetic path means that the transformer will operate with fewer turns, for a given applied voltage, than if the path were long. It also helps to reduce flux leakage and therefore minimizes leakage reactance. The number of turns required also is inversely proportional to the cross-sectional area of the core.

Two core shapes are in common use, as shown in Fig. 2-38. In the shell type both windings are placed on the inner leg, while in the core type

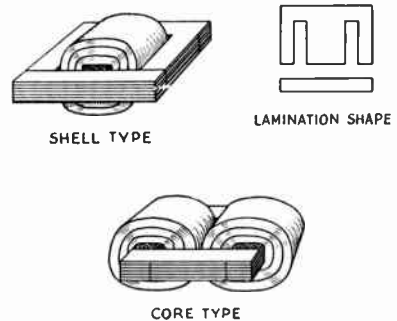

Fig. 2-38 — Two common types of transformer construction. Core pieces are interleaved to provide a continuous magnetic path

the primary and secondary windings may be placed on separate legs, if desired. This is sometimes done when it is necessary to minimize capacitive effects between the primary and secondary, or when one of the windings must operate at very high voltage.

Core material for small transformers is usually silicon steel, called "transformer iron." The core is built up of laminations, insulated from each other (by a thin coating of shellac, for example) to prevent the flow of eddy currents. The laminations are interleaved at the ends to make the magnetic path as continuous as possible and thus reduce flux leakage.

The number of turns required on the primary for a given applied e.m.f. is determined by the size, shape and type of core material used, and the frequency. As a rough indication, windings of small power transformers frequently have about six to eight turns per volt on a core of 1-square-inch cross section and have a magnetic path 10 or 12 inches in length. A longer path or smaller cross section requires more turns per volt, and vice versa.

In most transformers the coils are wound in layers, with a thin sheet of treated-paper insulation between each layer. Thicker insulation is used between coils and between coils and core.

Autotransformers

The transformer principle can be utilized with only one winding instead of two, as shown in Fig. 2-39; the principles just discussed apply equally well. A one-winding transformer is called an **autotransformer**. The current in the common section (A) of the winding is the difference between the line (primary) and the load (secondary) currents, since these currents are out of phase. Hence if the line and load currents are nearly equal the common section of the winding may be wound with comparatively small wire. This will be the case only when the primary (line) and

Fig. 2-39 — The autotransformer is based on the transformer principle, but uses only one winding. The line and load currents (A) flow in opposite directions, so that the resultant current is the difference between them. The voltage across A is proportional to the turns ratio.

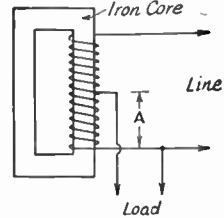

secondary (load) voltages are not very different. The autotransformer is used chiefly for boosting or reducing the power-line voltage by relatively small amounts.

The Decibel

In most radio communication the received signal is converted into sound. This being the case, it is useful to appraise signal strengths in terms of relative loudness as registered by the ear. A peculiarity of the ear is that an increase or decrease in loudness is responsive to the *ratio* of the amounts of power involved, and is practically independent of absolute value of the power. For example, if a person estimates that the signal is "twice as loud" when the transmitter power is increased from 10 watts to 40 watts, he will also estimate that a 400-watt signal is twice as loud as a 100-watt signal. In other words, the human ear has a *logarithmic* response.

This fact is the basis for the use of the relative-power unit called the **decibel**. A change of one decibel (abbreviated **db.**) in the power level is just detectable as a change in loudness under ideal conditions. The number of decibels corresponding with a given power ratio is given by the following formula:

$$Db. = 10 \log \frac{P_2}{P_1}$$

Common logarithms (base 10) are used.

Voltage and Current Ratios

Note that the decibel is based on *power* ratios. Voltage or current ratios can be used, but only when the impedance is the same for both values of voltage, or current. The gain of an amplifier cannot be expressed correctly in db. if it is based on the ratio of the output voltage to the input voltage unless both voltages are measured across the same value of impedance. When the impedance at both points of measurement is the same, the following formula may be used for voltage or current ratios:

$$Db. = 20 \log \frac{V_2}{V_1}$$

or $20 \log \frac{I_2}{I_1}$

Decibel Chart

The two formulas are shown graphically in Fig. 2-40 for ratios from 1 to 10. Gains (increases) expressed in decibels may be added arithmetically; losses (decreases) may be subtracted. A power decrease is indicated by prefixing the decibel figure with a minus sign. Thus +6 db. means that the power has been multiplied by 4, while -6 db. means that the power has been divided by 4.

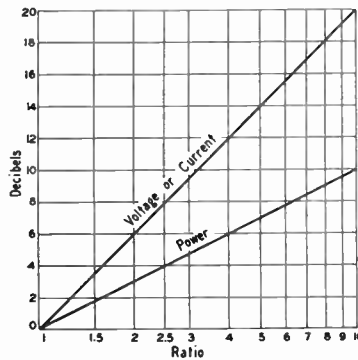

Fig. 2-40 — Decibel chart for power, voltage and current ratios for power ratios of 1:1 to 10:1. In determining decibels for current or voltage ratios the currents (or voltages) being compared must be referred to the same value of impedance.

The chart may be used for other ratios by adding (or subtracting, if a loss) 10 db. each time the ratio scale is multiplied by 10, for power ratios; or by adding (or subtracting) 20 db. each time the scale is multiplied by 10 for voltage or current ratios. For example, a power ratio of 10 is 4 db. (from the chart). A power ratio of 10 times 2.5, or 25, is 14 db. (10 + 4), and a power ratio of 100 times 2.5, or 250, is 24 db. (20 + 4). A voltage or current ratio of 4 is 12 db., a voltage or current ratio of 40 is 32 db. (20 + 12), and a voltage or current ratio of 400 is 52 db. (40 + 12).

Radio-Frequency Circuits

● RESONANCE

Fig. 2-41 shows a resistor, capacitor and inductor connected in series with a source of alternating current, the frequency of which can be varied over a wide range. At some *low* frequency the capacitive reactance will be much larger than the resistance of *R*, and the inductive reactance will be small compared with either the reactance

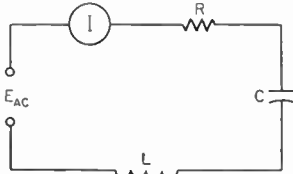

Fig. 2-41 — A series circuit containing *L*, *C* and *R* is “resonant” at the applied frequency when the reactance of *C* is equal to the reactance of *L*.

of *C* or the resistance of *R*. (*R* is assumed to be the same at all frequencies.) On the other hand, at some very *high* frequency the reactance of *C* will be very small and the reactance of *L* will be very large. In either of these cases the current will be small, because the reactance is large at either low or high frequencies.

At some intermediate frequency, the reactances of *C* and *L* will be equal and the voltage drops across the coil and capacitor will be equal and 180 degrees out of phase. Therefore they cancel each other completely and the current flow is determined wholly by the resistance, *R*. At that frequency the current has its largest possible value, assuming the source voltage to be constant regardless of frequency. A series circuit in which the inductive and capacitive reactances are equal is said to be resonant.

Although resonance is possible at any frequency, it finds its most extensive application in radio-frequency circuits. The reactive effects associated with even small inductances and capacitances would place drastic limitations on r.f. circuit operation if it were not possible to “cancel them out” by supplying the right amount of reactance of the opposite kind — in other words, “tuning the circuit to resonance.”

Resonant Frequency

The frequency at which a series circuit is resonant is that for which $X_L = X_C$. Substituting the formulas for inductive and capacitive reactance gives

$$f = \frac{1}{2\pi\sqrt{LC}}$$

where *f* = Frequency in cycles per second

L = Inductance in henrys

C = Capacitance in farads

$\pi = 3.14$

These units are inconveniently large for radio-

frequency circuits. A formula using more appropriate units is

$$f = \frac{10^6}{2\pi\sqrt{LC}}$$

where *f* = Frequency in kilocycles (kc.)

L = Inductance in microhenrys (μ h.)

C = Capacitance in micromicrofarads ($\mu\mu$ f.)

$\pi = 3.14$

Example: The resonant frequency of a series circuit containing a 5- μ h. inductor and a 35- $\mu\mu$ f. capacitor is

$$\begin{aligned} &= \frac{10^6}{2\pi\sqrt{LC}} = \frac{10^6}{6.28 \times \sqrt{5 \times 35}} \\ &= \frac{10^6}{6.28 \times 13.2} = \frac{10^6}{83} = 12,050 \text{ kc.} \end{aligned}$$

The formula for resonant frequency is not affected by the resistance in the circuit.

Resonance Curves

If a plot is drawn of the current flowing in the circuit of Fig. 2-41 as the frequency is varied (the applied voltage being constant) it would look like one of the curves in Fig. 2-42. The shape of the resonance curve at frequencies near resonance is determined by the ratio of reactance to resistance.

If the reactance of either the coil or capacitor is of the same order of magnitude as the resistance, the current decreases rather slowly as the fre-

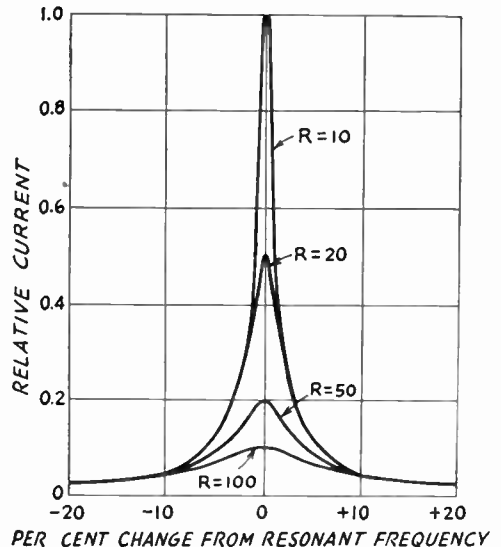

Fig. 2-42 — Current in a series-resonant circuit with various values of series resistance. The values are arbitrary and would not apply to all circuits, but represent a typical case. It is assumed that the reactances (at the resonant frequency) are 1000 ohms (minimum *Q* = 10). Note that at frequencies more than plus or minus ten per cent away from the resonant frequency the current is substantially unaffected by the resistance in the circuit.

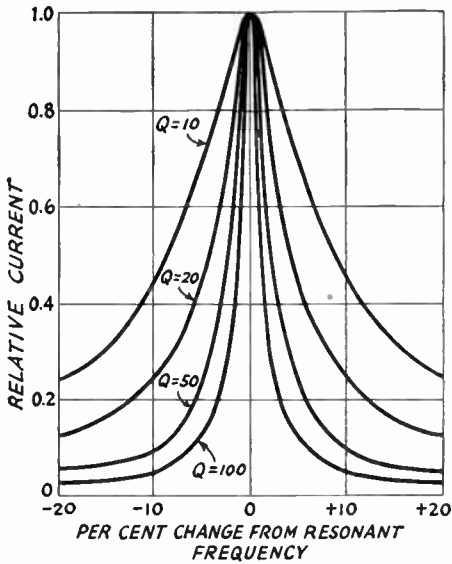

Fig. 2-43 — Current in series-resonant circuits having different *Q*s. In this graph the current at resonance is assumed to be the same in all cases. The lower the *Q*, the more slowly the current decreases as the applied frequency is moved away from resonance.

quency is moved in either direction away from resonance. Such a curve is said to be **broad**. On the other hand, if the reactance is considerably larger than the resistance the current decreases rapidly as the frequency moves away from resonance and the circuit is said to be **sharp**. A sharp circuit will respond a great deal more readily to the resonant frequency than to frequencies quite close to resonance; a broad circuit will respond almost equally well to a group or band of frequencies centering around the resonant frequency.

Both types of resonance curves are useful. A sharp circuit gives good **selectivity** — the ability to respond strongly (in terms of current amplitude) at one desired frequency and discriminate against others. A broad circuit is used when the apparatus must give about the same response over a band of frequencies rather than to a single frequency alone.

Q

Most diagrams of resonant circuits show only inductance and capacitance; no resistance is indicated. Nevertheless, resistance is always present. At frequencies up to perhaps 30 Mc. this resistance is mostly in the wire of the coil. Above this frequency energy loss in the capacitor (principally in the solid dielectric which must be used to form an insulating support for the capacitor plates) becomes appreciable. This energy loss is equivalent to resistance. When maximum sharpness or selectivity is needed the object of design is to reduce the inherent resistance to the lowest possible value.

The value of the reactance of either the inductor or capacitor at the resonant frequency of a series-resonant circuit, divided by the resistance

in the circuit, is called the *Q* (quality factor) of the circuit, or

$$Q = \frac{X}{R}$$

where *Q* = Quality factor

X = Reactance of either coil or condenser, in ohms

R = Resistance in ohms

Example: The inductor and capacitor in a series circuit each have a reactance of 350 ohms at the resonant frequency. The resistance is 5 ohms. Then the *Q* is

$$Q = \frac{X}{R} = \frac{350}{5} = 70$$

The effect of *Q* on the sharpness of resonance of a circuit is shown by the curves of Fig. 2-43. In these curves the frequency change is shown in percentage above and below the resonant frequency. *Q*s of 10, 20, 50 and 100 are shown; these values cover much of the range commonly used in radio work.

Voltage Rise

When a voltage of the resonant frequency is inserted in series in a resonant circuit, the voltage that appears across either the inductor or capacitor is considerably higher than the applied voltage. The current in the circuit is limited only by the resistance and may have a relatively high value; however, the same current flows through the high reactances of the inductor and capacitor and causes large voltage drops. The ratio of the reactive voltage to the applied voltage is equal to the ratio of reactance to resistance. This ratio is the *Q* of the circuit. Therefore, the voltage across either the inductor or capacitor is equal to *Q* times the voltage inserted in series with the circuit.

Example: The inductive reactance of a circuit is 200 ohms, the capacitive reactance is 200 ohms, the resistance 5 ohms, and the applied voltage is 50. The two reactances cancel and there will be but 5 ohms of pure resistance to limit the current flow. Thus the current will be 50/5, or 10 amperes. The voltage developed across either the inductor or the capacitor will be equal to its reactance times the current, or 200 × 10 = 2000 volts. An alternate method: The *Q* of the circuit is *X/R* = 200/5 = 40. The reactive voltage is equal to *Q* times the applied voltage, or 40 × 50 = 2000 volts.

Parallel Resonance

When a variable-frequency source of constant voltage is applied to a parallel circuit of the type shown in Fig. 2-44 there is a resonance effect similar to that in a series circuit. However, in this case the "line" current (measured at the point indicated) is *smallest* at the frequency for which the inductive and capacitive reactances are equal. At that frequency the current through *L* is exactly canceled by the out-of-phase current through *C*, so that only the current taken by *R* flows in the line. At frequencies *below* resonance the current through *L* is larger than that through *C*, because the reactance of *L* is smaller and that of *C* higher at low frequencies; there is only partial cancellation of the two reactive

currents and the line current therefore is larger than the current taken by R alone. At frequencies above resonance the situation is reversed and more current flows through C than through L , so the line current again increases. The current at resonance, being determined wholly by R , will be small if R is large and large if R is small.

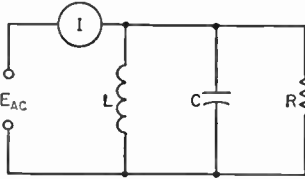

Fig. 2-44 — Circuit illustrating parallel resonance.

The resistance R shown in Fig. 2-44 is not necessarily an actual resistor. In most cases it will be an "equivalent" resistance that represents the energy loss in the circuit. This loss can be inherent in the coil or capacitor, or may represent energy transferred to a load by means of the resonant circuit. (For example, the resonant circuit may be used for transferring power from a vacuum-tube amplifier to an antenna system.)

Parallel and series resonant circuits are quite alike in some respects. For instance, the circuits given at A and B in Fig. 2-45 will behave identically, when an external voltage is applied, if (1) L and C are the same in both cases; and (2) R_p

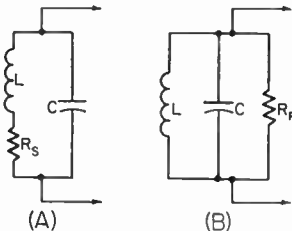

Fig. 2-45 — Series and parallel equivalents when the two circuits are resonant. The series resistor, R_s , in A can be replaced by an equivalent parallel resistor, R_p , in B, and vice versa.

multiplied by R_s equals the square of the reactance (at resonance) of either L or C . When these conditions are met the two circuits will have the same Q s. (These statements are approximate, but are quite accurate if the Q is 10 or more.) The circuit at A is a series circuit if it is viewed from the "inside" — that is, going around the loop formed by L , C and R — so its Q can be found from the ratio of X to R_s .

Thus a circuit like that of Fig. 2-45A has an equivalent parallel impedance (at resonance) equal to R_p , the relationship between R_s and R_p being as explained above. Although R_p is not an actual resistor, to the source of voltage the parallel-resonant circuit "looks like" a pure resistance of that value. It is "pure" resistance because the inductive and capacitive currents are 180 degrees out of phase and are equal; thus there is no reactive current in the line. At the resonant

frequency the parallel impedance of a resonant circuit is

$$Z_r = QX$$

where Z_r = Resistive impedance at resonance
 Q = Quality factor
 X = Reactance (in ohms) of either the inductor or capacitor

Example: The parallel impedance of a circuit having a Q of 50 and having inductive and capacitive reactances of 300 ohms will be

$$Z_r = QX = 50 \times 300 = 15,000 \text{ ohms.}$$

At frequencies off resonance the impedance is no longer purely resistive because the inductive

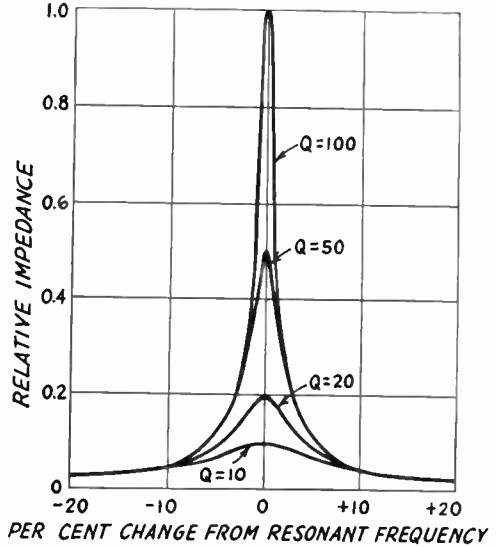

Fig. 2-46 — Relative impedance of parallel-resonant circuits with different Q s. These curves are similar to those in Fig. 2-12 for current in a series-resonant circuit. The effect of Q on impedance is most marked near the resonant frequency.

and capacitive currents are not equal. The off-resonant impedance therefore is complex, and is lower than the resonant impedance for the reasons previously outlined.

The higher the Q of the circuit, the higher the parallel impedance. Curves showing the variation of impedance (with frequency) of a parallel circuit have just the same shape as the curves showing the variation of current with frequency in a series circuit. Fig. 2-46 is a set of such curves.

Parallel Resonance in Low- Q Circuits

The preceding discussion is accurate only for Q s of 10 or more. When the Q is below 10, resonance in a parallel circuit having resistance in series with the coil, as in Fig. 2-45A, is not so easily defined. There is a set of values for L and C that will make the parallel impedance a pure resistance, but with these values the impedance does not have its maximum possible value. Another set of values for L and C will make the parallel impedance a maximum, but this maximum value is not a pure resistance. Either

condition could be called "resonance," so with low-*Q* circuits it is necessary to distinguish between maximum impedance and resistive impedance parallel resonance. The difference between these *L* and *C* values and the equal reactances of a series-resonant circuit is appreciable when the *Q* is in the vicinity of 5, and becomes more marked with still lower *Q* values.

Q of Loaded Circuits

In many applications of resonant circuits the only power lost is that dissipated in the resistance of the circuit itself. At frequencies below 30 Mc. most of this resistance is in the coil. Within limits, increasing the number of turns on the coil increases the reactance faster than it raises the resistance, so coils for circuits in which the *Q* must be high may have reactances of 1000 ohms or more at the frequency under consideration.

However, when the circuit delivers energy to a load (as in the case of the resonant circuits used in transmitters) the energy consumed in the circuit itself is usually negligible compared with that consumed by the load. The equivalent of such a circuit is shown in Fig. 2-47A, where the parallel resistor represents the load to which power is delivered. If the power dissipated in the load is at least ten times as great as the power lost in the inductor and capacitor, the parallel impedance of the resonant circuit itself will be so high compared with the resistance of the load that for all practical purposes the impedance of the combined circuit is equal to the load resistance. Under these conditions the *Q* of a parallel-resonant circuit loaded by a resistive impedance is

$$Q = \frac{R}{X}$$

- where *Q* = Quality factor
- R* = Parallel load resistance (ohms)
- X* = Reactance (ohms) of either the inductor or capacitor

Example: A resistive load of 3000 ohms is connected across a resonant circuit in which the inductive and capacitive reactances are each 250 ohms. The circuit *Q* is then

$$Q = \frac{R}{X} = \frac{3000}{250} = 12$$

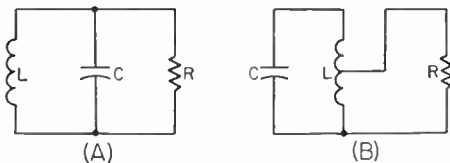

Fig. 2-47 -- The equivalent circuit of a resonant circuit delivering power to a load. The resistor *R* represents the load resistance. At B the load is tapped across part of *L*, which by transformer action is equivalent to using a higher load resistance across the whole circuit.

The "effective" *Q* of a circuit loaded by a parallel resistance becomes higher when the reactances are decreased. A circuit loaded with a relatively low resistance (a few thousand ohms) must have low-reactance elements (large capaci-

tance and small inductance) to have reasonably high *Q*.

Impedance Transformation

An important application of the parallel-resonant circuit is as an impedance-matching device in the output circuit of a vacuum-tube r.f. power amplifier. As described in the chapter on vacuum tubes, there is an optimum value of load resistance for each type of tube and set of operating conditions. However, the resistance of the load to which the tube is to deliver power usually is considerably lower than the value required for proper tube operation. To transform the actual load resistance to the desired value the load may be tapped across part of the coil, as shown in Fig. 2-47B. This is equivalent to connecting a higher value of load resistance across the whole circuit, and is similar in principle to impedance transformation with an iron-core transformer. In high-frequency resonant circuits the impedance ratio does not vary exactly as the square of the turns ratio, because all the magnetic flux lines do not cut every turn of the coil. A desired reflected impedance usually must be obtained by experimental adjustment.

When the load resistance has a very low value (say below 100 ohms) it may be connected in series in the resonant circuit (as in Fig. 2-45A, for example), in which case it is transformed to an equivalent parallel impedance as previously described. If the *Q* is at least 10, the equivalent parallel impedance is

$$Z_r = \frac{X^2}{R}$$

- where *Z_r* = Resistive impedance at resonance
- X* = Reactance (in ohms) of either the coil or condenser
- R* = Load resistance inserted in series

If the *Q* is lower than 10 the reactance will have to be adjusted somewhat, for the reasons given in the discussion of low-*Q* circuits, to obtain a resistive impedance of the desired value.

Reactance Values

The charts of Figs. 2-48 and 2-49 show reactance values of inductances and capacitances in the range commonly used in r.f. tuned circuits for the amateur bands. With the exception of the 3.5-4 Mc. band, limiting values for which are shown on the charts, the change in reactance over a band, for either inductors or capacitors, is small enough so that a single curve gives the reactance with sufficient accuracy for most practical purposes.

L/C Ratio

The formula for resonant frequency of a circuit shows that the same frequency always will be obtained so long as the product of *L* and *C* is constant. Within this limitation, it is evident that *L* can be large and *C* small, *L* small and *C* large, etc. The relation between the two for a fixed frequency is called the *L/C* ratio. A high-*C* circuit

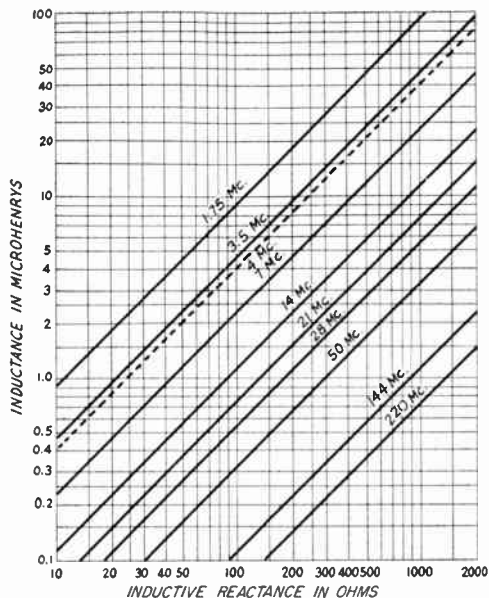

Fig. 2-48 — Reactance chart for inductance values commonly used in amateur bands from 1.75 to 220 Mc.

is one that has more capacitance than “normal” for the frequency; a low-*C* circuit one that has less than normal capacitance. These terms depend to a considerable extent upon the particular application considered, and have no exact numerical meaning.

LC Constants

It is frequently convenient to use the numerical value of the *LC* constant when a number of calcu-

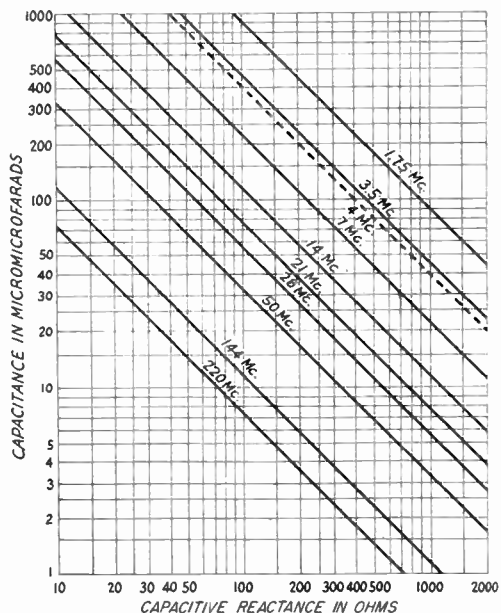

Fig. 2-49 — Reactance chart for capacitance values commonly used in amateur bands from 1.75 to 220 Mc.

lations have to be made involving different *L/C* ratios for the same frequency. The constant for any frequency is given by the following equation:

$$LC = \frac{25,330}{f^2}$$

- where *L* = Inductance in microhenrys (μ h.)
- C* = Capacitance in micromicrofarads ($\mu\mu$ f.)
- f* = Frequency in megacycles

Example: Find the inductance required to resonate at 3650 kc. (3.65 Mc.) with capacitances of 25, 50, 100, and 500 $\mu\mu$ f. The *LC* constant is

$$LC = \frac{25,330}{(3.65)^2} = \frac{25,330}{13.35} = 1900$$

- With 25 $\mu\mu$ f. $L = 1900/C = 1900/25 = 76 \mu$ h.
- 50 $\mu\mu$ f. $L = 1900/C = 1900/50 = 38 \mu$ h.
- 100 $\mu\mu$ f. $L = 1900/C = 1900/100 = 19 \mu$ h.
- 500 $\mu\mu$ f. $L = 1900/C = 1900/500 = 3.8 \mu$ h.

● **COUPLED CIRCUITS**

Energy Transfer and Loading

Two circuits are coupled when energy can be transferred from one to the other. The circuit delivering power is called the **primary** circuit; the one receiving power is called the **secondary** circuit. The power may be practically all dissipated in the secondary circuit itself (this is usually the case in receiver circuits) or the secondary may simply act as a medium through which the power is transferred to a load. In the latter case, the coupled circuits may act as a radio-frequency impedance-matching device. The matching can be accomplished by adjusting the loading on the secondary and by varying the amount of coupling between the primary and secondary.

Coupling by a Common Circuit Element

One method of coupling between two resonant circuits is through a circuit element common to both. The three variations of this type of coupling shown at A, B and C of Fig. 2-50, utilize a common inductance, capacitance and resistance, respectively. Current circulating in one *LC* branch flows through the common element (*L_c*, *C_c* or *R_c*) and the voltage developed across this element causes current to flow in the other *LC* branch.

If both circuits are resonant to the same frequency, as is usually the case, the value of coupling reactance or resistance required for maximum energy transfer is generally quite small compared with the other reactances in the circuits. The common-circuit-element method of coupling is used only occasionally in amateur apparatus.

Capacitive Coupling

In the circuit at D the coupling increases as the capacitance of *C_c*, the “coupling capacitor,” is made greater (reactance of *C_c* is decreased).

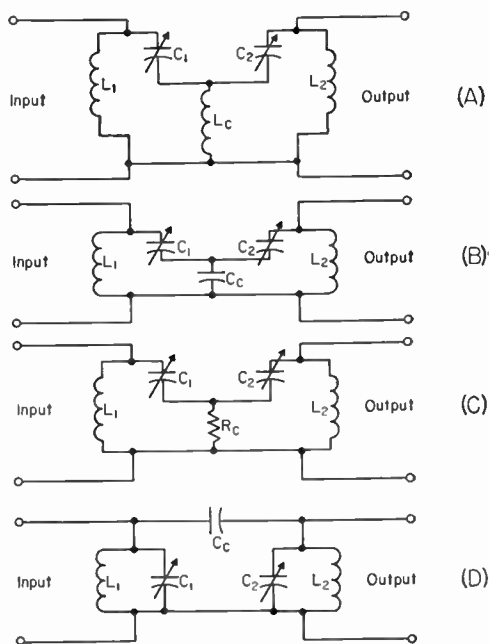

Fig. 2-50 — Four methods of circuit coupling.

When two resonant circuits are coupled by this means, the capacitance required for maximum energy transfer is quite small if the Q of the secondary circuit is at all high. For example, if the parallel impedance of the secondary circuit is 100,000 ohms, a reactance of 10,000 ohms or so in the capacitor will give ample coupling. The corresponding capacitance required is only a few micromicrofarads at high frequencies.

Inductive Coupling

Figs. 2-51 and 2-52 show inductive coupling, or coupling by means of the mutual inductance between two coils. Circuits of this type resemble the

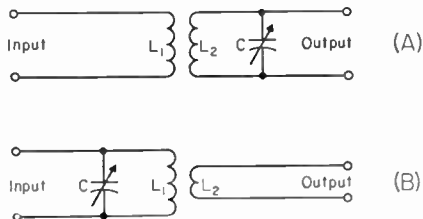

Fig. 2-51 — Single-tuned inductively-coupled circuits.

iron-core transformer, but because only a part of the magnetic flux lines set up by one coil cut the turns of the other coil, the simple relationships between turns ratio, voltage ratio and impedance ratio in the iron-core transformer do not hold.

Two types of inductively-coupled circuits are shown in Fig. 2-51. Only one circuit is resonant. The circuit at A is frequently used in receivers for coupling between amplifier tubes when the tuning of the circuit must be varied to respond to signals of different frequencies. Circuit B is used prin-

cipally in transmitters, for coupling a radio-frequency amplifier to a resistive load.

In these circuits the coupling between the primary and secondary coils usually is "tight" — that is, the coefficient of coupling between the coils is large. With very tight coupling either circuit operates nearly as though the device to which the untuned coil is connected were simply tapped across a corresponding number of turns on the tuned-circuit coil, thus either circuit is approximately equivalent to Fig. 2-47B.

By proper choice of the number of turns on the untuned coil, and by adjustment of the coupling, the parallel impedance of the tuned circuit may be adjusted to the value required for the proper operation of the device to which it is connected. In any case, the maximum energy transfer possible for a given coefficient of coupling is obtained when the reactance of the untuned coil is equal to the resistance of its load.

The Q and parallel impedance of the tuned circuit are reduced by coupling through an untuned coil in much the same way as by the tapping arrangement shown in Fig. 2-47B.

Coupled Resonant Circuits

When the primary and secondary circuits are both tuned, as in Fig. 2-52, the resonance effects

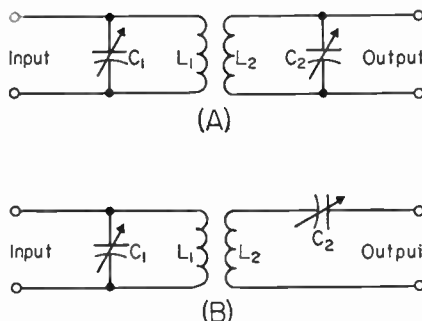

Fig. 2-52 — Inductively-coupled resonant circuits. Circuit A is used for high-resistance loads (reactance of either L_2 or C_2 comparable with the load resistance at the resonant frequency). Circuit B is suitable for low resistance loads where the reactance of either L_2 or C_2 is of the same order as the load resistance.

in both circuits make the operation somewhat more complicated than in the simpler circuits just considered. Imagine first that the two circuits are not coupled and that each is independently tuned to the resonant frequency. The impedance of each will be purely resistive. If the primary circuit is connected to a source of r.f. energy of the resonant frequency and the secondary is then loosely coupled to the primary, a current will flow in the secondary circuit. In flowing through the resistance of the secondary circuit and any load that may be connected to it, the current causes a power loss. This power must come from the energy source through the primary circuit, and manifests itself in the primary as an increase in the equivalent resistance in series with the primary coil. Hence the Q and parallel impedance of the primary circuit are decreased by the

coupled secondary. As the coupling is made greater (without changing the tuning of either circuit) the coupled resistance becomes larger and the parallel impedance of the primary continues to decrease. Also, as the coupling is made tighter the amount of power transferred from the primary to the secondary will increase to a maximum at one value of coupling, called **critical coupling**, but then decreases if the coupling is tightened still more (still without changing the tuning).

Critical coupling is a function of the Q s of the two circuits. A higher coefficient of coupling is required to reach critical coupling when the Q s are low; if the Q s are high, as in receiving applications, a coupling coefficient of a few per cent may give critical coupling.

With loaded circuits such as are used in transmitters the Q may be too low to give the desired power transfer even when the coils are coupled as tightly as the physical construction permits. In such case, increasing the Q of either circuit will be helpful, although it is generally better to increase the Q of the lower- Q circuit rather than the reverse. The Q of the parallel-tuned primary (input) circuit can be increased by decreasing the L/C ratio because, as shown in connection with Fig. 2-47, this circuit is in effect loaded by a parallel resistance (effect of coupled-in resistance). In the parallel-tuned secondary circuit, Fig. 2-52A, the Q can be increased, for a fixed value of load resistance, either by decreasing the L/C ratio or by tapping the load down (see Fig. 2-49). In the series-tuned secondary circuit, Fig. 2-52B, the Q may be increased by increasing the L/C ratio. There will generally be no difficulty in securing sufficient coupling, with practicable coils, if the product of the Q s of the two tuned circuits is 10 or more. A smaller product will suffice if the coil construction permits tight coupling.

Selectivity

In Fig. 2-51 only one circuit is tuned and the selectivity curve will be essentially that of a single resonant circuit. As stated, the effective Q depends upon the resistance connected to the untuned coil.

In Fig. 2-52, the selectivity is the same as that of a single tuned circuit having a Q equal to the product of the Q s of the individual circuits — if the coupling is well below critical (this is not the condition for optimum power transfer discussed immediately above) and both circuits are tuned to resonance. The Q s of the individual circuits are affected by the degree of coupling, because each couples resistance into the other; the tighter the coupling, the lower the individual Q s and therefore the lower the over-all selectivity.

If both circuits are independently tuned to resonance, the over-all selectivity will vary about as shown in Fig. 2-53 as the coupling is varied. With loose coupling, A, the output voltage (across the secondary circuit) is small and the selectivity is high. As the coupling is increased the secondary voltage also increases until critical

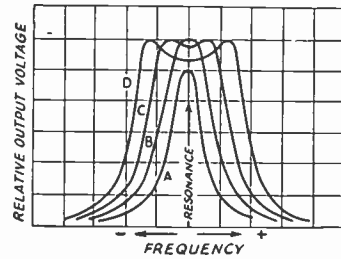

Fig. 2-53 — Showing the effect on the output voltage from the secondary circuit of changing the coefficient of coupling between two resonant circuits independently tuned to the same frequency. The voltage applied to the primary is held constant in amplitude while the frequency is varied, and the output voltage is measured across the secondary.

coupling, B, is reached. At this point the output voltage at the resonant frequency is maximum but the selectivity is lower than with looser coupling. At still tighter coupling, C, the output voltage at the resonant frequency decreases, but as the frequency is varied either side of resonance it is found that there are two “humps” to the curve, one on either side of resonance. With very tight coupling, D, there is a further decrease in the output voltage at resonance and the “humps” are farther away from the resonant frequency. Curves such as those at C and D are called **flat-topped** because the output voltage does not change much over an appreciable band of frequencies.

Note that the off-resonance humps have the same maximum value as the resonant output voltage by the fact that at frequencies off resonance the secondary circuit is reactive and couples reactance as well as resistance into the primary. The coupled resistance decreases off resonance, and each hump represents a new condition of critical coupling at a frequency to which the primary is tuned by the additional coupled-in reactance from the secondary.

Band-Pass Coupling

Over-coupled resonant circuits are useful where substantially uniform output is desired over a continuous band of frequencies, without readjustment of tuning. The width of the flat top of the resonance curve depends on the Q s of the two circuits as well as the tightness of coupling; the frequency separation between the humps will increase, and the curve become more flat-topped, as the Q s are lowered.

Band-pass operation also is secured by tuning the two circuits to slightly different frequencies, which gives a double-humped resonance curve even with loose coupling. This is called **stagger tuning**. However, to secure adequate power transfer over the frequency band it is usually necessary to use tight coupling and experimentally adjust the circuits for the desired performance.

Link Coupling

A modification of inductive coupling, called **link coupling**, is shown in Fig. 2-54. This gives the effect of inductive coupling between two coils

that have no mutual inductance; the link is simply a means for providing the mutual inductance. The total mutual inductance between two coils coupled by a link cannot be made as great as if the coils themselves were coupled. This is because the coefficient of coupling between air-core coils is considerably less than 1, and since there are two coupling points the over-all coupling

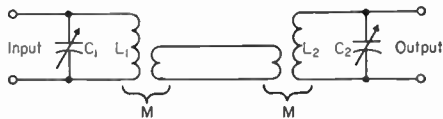

Fig. 2-54 — Link coupling. The mutual inductances at both ends of the link are equivalent to mutual inductance between the tuned circuits, and serve the same purpose.

coefficient is less than for any pair of coils. In practice this need not be disadvantageous because the power transfer can be made great enough by making the tuned circuits sufficiently high-*Q*. Link coupling is convenient when ordinary inductive coupling would be impracticable for constructional reasons.

The link coils usually have a small number of turns compared with the resonant-circuit coils. The number of turns is not greatly important, because the coefficient of coupling is relatively independent of the number of turns on either coil; it is more important that both link coils should have about the same inductance. The length of the link between the coils is not critical if it is very small compared with the wave length, but if the length is more than about one-twentieth of a wave length the link operates more as a transmission line than as a means for providing mutual inductance. In such case it should be treated by the methods described in the chapter on Transmission Lines.

● IMPEDANCE-MATCHING CIRCUITS

The coupling circuits discussed in the preceding section have been based either on inductive coupling or on coupling through a common circuit element between two resonant circuits. These are not the only circuits that may be used for transferring power from one device to another. There is, in fact, a wide variety of such circuits available, all of them being classified generally as impedance-matching networks. Two such net-

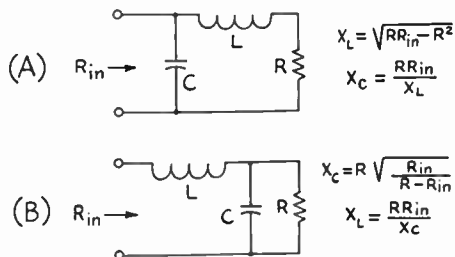

Fig. 2-55 — The *L* network for transforming a desired resistive load, *R*, into a desired value of resistance, *R*_{in}. (A) is for transforming to a higher value of resistance, (B) for transforming to a lower value.

works frequently used in amateur equipment are the *L* network and the pi network, shown in the form commonly used in Figs. 2-55 and 2-56.

The *L* Network

The *L* network is the simplest possible impedance-matching circuit. It closely resembles an ordinary resonant circuit with the load resistance, *R*, Fig. 2-55, either in series or parallel. The arrangement shown in Fig. 2-55A is used when the desired impedance, *R*_{in}, is larger than the actual load resistance, *R*, while Fig. 2-55B is used in the opposite case. The design equations for each case are given in the figure, in terms of the circuit reactances. The reactances may be converted to inductance and capacitance by means of the formulas previously given or taken directly from the charts of Figs. 2-48 and 2-49.

When the impedance transformation ratio is large — that is, one of the two impedances is of the order of 100 times (or more) larger than the other — the operation of the circuit is exactly the same as previously discussed in connection with impedance transformation with a simple *LC* resonant circuit.

The *Q* of an *L* network is found in the same way as for simple resonant circuits. That is, it is equal to *X*_L/*R* or *R*_{in}/*X*_C in Fig. 2-55A, and to *X*_L/*R*_{in} or *R*/*X*_C in Fig. 2-55B. The value of *Q* is determined by the ratio of the impedances to be matched, and cannot be selected independently. In the equations of Fig. 2-55 it is assumed that both *R* and *R*_{in} are pure resistances.

The *Pi* Network

The pi network, shown in Fig. 2-56, offers more flexibility than the *L* since the operating *Q* may

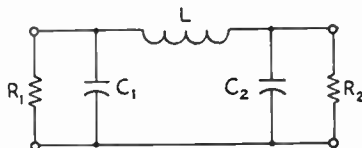

$$X_{C1} = \frac{R_1}{Q}$$

$$X_{C2} = R_2 \sqrt{\frac{R_1/R_2}{Q^2 + 1 - (R_1/R_2)}}$$

$$X_L = \frac{QR_1 + (R_1 R_2 / X_{C2})}{Q^2 + 1}$$

Fig. 2-56 — The pi network, for matching any two values of purely resistive impedances, *R*₁ and *R*₂. In the definition of the *Q* of the network it is assumed that *R*₁ is the higher of the two resistances, and should be so chosen in using the equations.

be chosen practically at will. The only limitation on the circuit values that may be used is that the reactance of the series arm, the inductor *L* in the figure, must not be greater than the square root of the product of the two values of resistive impedance to be matched. As the circuit is applied in amateur equipment, this limiting value of reactance would represent a network with an undesirably low operating *Q*, and the circuit values ordinarily used are well on the safe side of the limiting values.

In its principal application as a "tank" circuit matching a transmission line to a power amplifier tube, the load R_2 will generally have a fairly low value of resistance (up to a few hundred ohms) while R_1 , the required load for the tube, will be of the order of a few thousand ohms. In such a case the Q of the circuit is defined as R_1/X_{C1} , so the choice of a value for the operating Q immediately sets the value of X_{C1} and hence of C_1 . The values of X_{C2} and X_L are then found from the equations given in the figure.

Graphical solutions of these equations for the most important practical cases are given in the chapter on transmitter design in the discussion of plate tank circuits. The L and C values may be calculated from the reactances or read from the charts of Figs. 2-48 and 2-49.

PIEZOELECTRIC CRYSTALS

A number of crystalline substances found in nature have the ability to transform mechanical strain into an electrical charge, and *vice versa*. This property is known as **piezoelectricity**. A small plate or bar cut in the proper way from a quartz crystal and placed between two conducting electrodes will be mechanically strained when the electrodes are connected to a source of voltage. Conversely, if the crystal is squeezed between two electrodes a voltage will be developed between the electrodes.

Piezoelectric crystals can be used to transform mechanical energy into electrical energy, and vice versa. They are used in microphones and phonograph pick-ups, where mechanical vibrations are transformed into alternating voltages of corresponding frequency. They are also used in headsets and loudspeakers, transforming electrical energy into mechanical vibration. Crystals of Rochelle salts are used for these purposes.

Crystal Resonators

Crystalline plates also are mechanical resonators that have natural frequencies of vibration ranging from a few thousand cycles to several megacycles per second. The vibration frequency depends on the kind of crystal, the way the plate is cut from the natural crystal, and on the dimensions of the plate. The thing that makes the **crystal resonator** valuable is that it has extremely high Q , ranging from 5 to 10 times the Q s obtainable with good LC resonant circuits.

Analogies can be drawn between various mechanical properties of the crystal and the electrical characteristics of a tuned circuit. This leads to an "equivalent circuit" for the crystal. The electrical coupling to the crystal is through the electrodes between which it is sandwiched; these electrodes form, with the crystal as the dielectric, a small capacitor like any other capacitor constructed of two plates with a dielectric between. The crystal itself is equivalent to a series-resonant circuit, and together with the capacitance of the electrodes forms the equivalent circuit shown in Fig. 2-57. At frequencies of the order of 450 kc., where crystals are widely used as resonators, the equivalent L may be several

henrys and the equivalent C only a few hundredths of a micromicrofarad. Although the

Fig. 2-57—Equivalent circuit of a crystal resonator. L , C and R are the electrical equivalents of the mechanical properties of the crystal; C_h is the capacitance of the electrodes with the crystal plate between them.

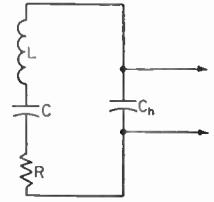

equivalent R is of the order of a few thousand ohms, the reactance at resonance is so high that the Q of the crystal likewise is high.

A circuit of the type shown in Fig. 2-57 has a series-resonant frequency, when viewed from the circuit terminals indicated by the arrowheads, determined by L and C only. At this frequency the circuit impedance is simply equal to R , providing the reactance of C_h is large compared with R (this is generally the case). The circuit also has a parallel-resonant frequency determined by L and the equivalent capacitance of C and C_h in series. Since this equivalent capacitance is smaller than C alone, the parallel-resonant frequency is higher than the series-resonant frequency. The separation between the two resonant frequencies depends on the ratio of C_h to C , and when this ratio is large (as in the case of a crystal resonator, where C_h will be a few $\mu\mu\text{f}$. in the average case) the two frequencies will be quite close together. A separation of a kilocycle or less is typical of a quartz crystal.

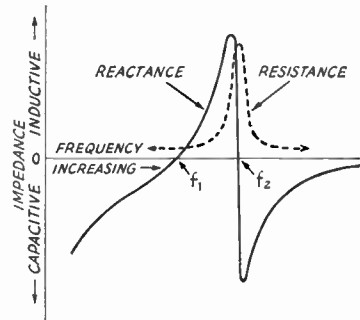

Fig. 2-58—Reactance and resistance vs. frequency of a circuit of the type shown in Fig. 2-57. Actual values of reactance, resistance and the separation between the series- and parallel-resonant frequencies, f_1 and f_2 , respectively, depend on the circuit constants.

Fig. 2-58 shows how the resistance and reactance of such a circuit vary as the applied frequency is varied. The reactance passes through zero at both resonant frequencies, but the resistance rises to a large value at parallel resonance, just as in any tuned circuit.

Quartz crystals may be used either as simple resonators for their selective properties or as the frequency-controlling elements in oscillators as described in later chapters. The series-resonant frequency is the one principally used in the former case, while the more common forms of oscillator circuit use the parallel-resonant frequency.

Practical Circuit Details

● COMBINED A.C. AND D.C.

Most radio circuits are built around vacuum tubes, and it is the nature of these tubes to require direct current (usually at a fairly high voltage) for their operation. They convert the direct current into an alternating current (and sometimes the reverse) at frequencies varying from well down in the audio range to well up in the super-high range. The conversion process almost invariably requires that the direct and alternating currents meet somewhere in the circuit.

In this meeting, the a.c. and d.c. are actually combined into a single current that "pulsates" (at the a.c. frequency) about an average value equal to the direct current. This is shown in Fig. 2-59. It is convenient to consider that the alter-

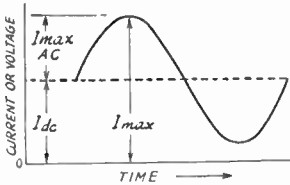

Fig. 2-59 — Pulsating d. c., composed of an alternating current or voltage superimposed on a steady direct current or voltage.

nating current is superimposed on the direct current, so we may look upon the actual current as having two components, one d.c. and the other a.c.

In an alternating current the positive and negative alternations have the same average amplitude, so when the wave is superimposed on a direct current the latter is alternately increased and decreased by the same amount. There is thus no average change in the direct current. If a d.c. instrument is being used to read the current, the reading will be exactly the same whether or not the a.c. is superimposed.

However, there is actually more power in such a combination current than there is in the direct current alone. This is because power varies as the square of the instantaneous value of the current, and when all the instantaneous squared values are averaged over a cycle the total power is greater than the d.c. power alone. If the a.c. is a sine wave having a peak value just equal to the d.c., the power in the circuit is 1.5 times the d.c. power. An instrument whose readings are proportional to power will show such an increase.

Series and Parallel Feed

Fig. 2-60 shows in simplified form how d.c. and a.c. may be combined in a vacuum-tube circuit. In this case, it is assumed that the a.c. is at radio frequency, as suggested by the coil-and-capacitor tuned circuit. It is also assumed that r.f. current can easily flow through the d.c. supply; that is, the impedance of the supply at radio frequencies is so small as to be negligible.

In the circuit at the left, the tube, tuned circuit, and d.c. supply all are connected in series. The

direct current flows through the r.f. coil to get to the tube; the r.f. current generated by the tube flows through the d.c. supply to get to the tuned circuit. This is series feed. It works because the impedance of the d.c. supply at radio frequencies is so low that it does not affect the flow of r.f. current, and because the d.c. resistance of the coil is so low that it does not affect the flow of direct current.

In the circuit at the right the direct current does not flow through the r.f. tuned circuit, but instead goes to the tube through a second coil, RFC (radio-frequency choke). Direct current cannot flow through L because a blocking capacitance, C , is placed in the circuit to prevent it. (Without C , the d.c. supply would be short-circuited by the low resistance of L .) On the other hand, the r.f. current generated by the tube can easily flow through C to the tuned circuit because the capacitance of C is intentionally chosen to have low reactance (compared with the impedance of the tuned circuit) at the radio frequency. The r.f. current cannot flow through the d.c. supply because the inductance of RFC is intentionally made so large that it has a very high reactance at the radio frequency. The resistance of RFC, however, is too low to have an appre-

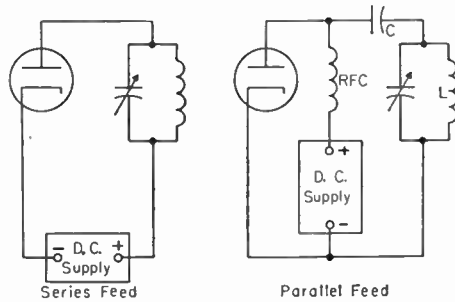

Fig. 2-60 — Illustrating series and parallel feed.

ciable effect on the flow of direct current. The two currents are thus in parallel, hence the name parallel feed.

Either type of feed may be used for both a.f. and r.f. circuits. In parallel feed there is no d.c. voltage on the a.c. circuit, a desirable feature from the viewpoint of safety to the operator, because the voltages applied to tubes — particularly transmitting tubes — are dangerous. On the other hand, it is somewhat difficult to make an r.f. choke work well over a wide range of frequencies. Series feed is often preferred, therefore, because it is relatively easy to keep the impedance between the a.c. circuit and the tube low.

Bypassing

In the series-feed circuit just discussed, it was assumed that the d.c. supply had very low impedance at radio frequencies. This is not likely to be true in a practical power supply, partly

because the normal physical separation between the supply and the r.f. circuit would make it necessary to use rather long connecting wires or leads. At radio frequencies, even a few feet of wire can have fairly large reactance — too large to be considered a really “low-impedance” connection.

An actual circuit would be provided with a **by-pass capacitor**, as shown in Fig. 2-61. Capacitor C is chosen to have low reactance at the operating frequency, and is installed right in the circuit where it can be wired to the other parts with quite short connecting wires. Hence the r.f. current will tend to flow through it rather than through the d.c. supply.

To be effective, the reactance of the by-pass capacitor should not be more than one-tenth of the impedance of the by-passed part of the circuit. Very often the latter impedance is not known, in which case it is desirable to use the largest capacitance in the bypass that circumstances permit. To make doubly sure that r.f. current will not flow through a non-r.f. circuit such as a power supply, an r.f. choke may be connected in the lead to the latter, as shown in Fig. 2-61.

The same type of bypassing is used when audio frequencies are present in addition to r.f. Because the reactance of a capacitor changes with frequency, it is readily possible to choose a capacitance that will represent a very low reactance at

◆
Fig. 2-61 — Typical use of a by-pass capacitor in a series-feed circuit.
◆

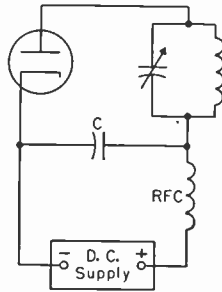

radio frequencies but that will have such high reactance at audio frequencies that it is practically an open circuit. A capacitance of $0.001 \mu\text{f}$. is practically a short circuit for r.f., for example, but is almost an open circuit at audio frequencies. (The actual value of capacitance that is usable will be modified by the impedances concerned.) By-pass capacitors also are used in audio circuits to carry the audio frequencies around a d.c. supply.

Distributed Capacitance and Inductance

In the discussions earlier in this chapter it was assumed that a capacitor has only capacitance and that an inductor has only inductance. Unfortunately, this is not strictly true. There is always a certain amount of inductance in a conductor of any length, and a capacitor is bound to have a little inductance in addition to its intended capacitance. Also, there is always capacitance between two conductors or between

parts of the same conductor, and thus there is appreciable capacitance between the turns of an inductance coil.

This **distributed inductance** in a capacitor and the **distributed capacitance** in an inductor have important practical effects. Actually, every capacitor is a tuned circuit, resonant at the frequency where its capacitance and distributed inductance have the same reactance. The same thing is true of a coil and its distributed capacitance. At frequencies well below these **natural resonances**, the capacitor will act like a normal capacitance and the coil will act like a normal inductance. Near the natural resonant points, the coil and capacitor act like self-tuned circuits. Above resonance, the capacitor acts like an inductor and the inductor acts like a capacitor. Thus there is a limit to the amount of capacitance that can be used at a given frequency. There is a similar limit to the inductance that can be used. At audio frequencies, capacitances measured in microfarads and inductances measured in henrys are practicable. At low and medium radio frequencies, inductances of a few millihenrys and capacitances of a few thousand micromicrofarads are the largest practicable. At high radio frequencies, usable inductance values drop to a few microhenrys and capacitances to a few hundred micromicrofarads.

Distributed capacitance and inductance are important not only in r.f. tuned circuits, but in bypassing and choking as well. It will be appreciated that a by-pass capacitor that actually acts like an inductance, or an r.f. choke that acts like a low-reactance capacitor, cannot work as it is intended they should.

Grounds

Throughout this book there are frequent references to **ground** and **ground potential**. When a connection is said to be “grounded” it does not necessarily mean that it actually goes to earth. What it means is that an actual earth connection to that point in the circuit should not disturb the operation of the circuit in any way. The term also is used to indicate a “common” point in the circuit where power supplies and metallic supports (such as a metal chassis) are electrically tied together. It is general practice, for example, to “ground” the negative terminal of a d.c. power supply, and to “ground” the filament or heater power supplies for vacuum tubes. Since the cathode of a vacuum tube is a junction point for grid and plate voltage supplies, and since the various circuits connected to the tube elements have at least one point connected to cathode, these points also are “returned to ground.” “Ground is therefore a common reference point in the radio circuit. “Ground potential” means that there is no “difference of potential” — that is, no voltage — between the circuit point and the earth.

Single-Ended and Balanced Circuits

With reference to ground, a circuit may be either **single-ended** (unbalanced) or **balanced**.

In a single-ended circuit, one side of the circuit is connected to ground. In a balanced circuit, the electrical midpoint is connected to ground, so that the circuit has two ends each at the same voltage "above" ground.

Typical single-ended and balanced circuits are shown in Fig. 2-62. R.f. circuits are shown in the upper row, while iron-core transformers (such

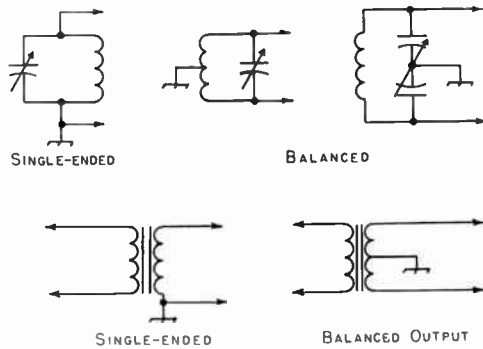

Fig. 2-62 — Single-ended and balanced circuits.

as are used in power-supply and audio circuits) are shown in the lower row. The r.f. circuits may be balanced either by connecting the center of the coil to ground or by using a "balanced" or "split-stator" capacitor and connecting its rotor to ground. In the iron-core transformer, one or both windings may be tapped at the center of the winding to provide the ground connection.

Shielding

Two circuits that are physically near each other usually will be coupled to each other in some degree even though no coupling is intended. The metallic parts of the two circuits form a small capacitance through which energy can be transferred by means of the electric field. Also, the magnetic field about the coil or wiring of one circuit can couple that circuit to a second through the latter's coil and wiring. In many

cases these unwanted couplings must be prevented if the circuits are to work properly.

Capacitive coupling may readily be prevented by enclosing one or both of the circuits in grounded low-resistance metallic containers, called **shields**. The electric field from the circuit components does not penetrate the shield. A metallic plate, called a **baffle shield**, inserted between two components also may suffice to prevent electrostatic coupling between them. It should be large enough to make the components invisible to each other.

Similar metallic shielding is used at radio frequencies to prevent magnetic coupling. The shielding effect increases with frequency and with the conductivity and thickness of the shielding material.

A closed shield is required for good magnetic shielding; in some cases separate shields, one about each coil, may be required. The baffle shield is rather ineffective for magnetic shielding, although it will give partial shielding if placed at right angles to the axes of, and between, the coils to be shielded from each other.

Shielding a coil reduces its inductance, because part of its field is canceled by the shield. Also, there is always a small amount of resistance in the shield, and there is therefore an energy loss. This loss raises the effective resistance of the coil. The decrease in inductance and increase in resistance lower the Q of the coil, but the reduction in inductance and Q will be small if the spacing between the sides of the coil and the shield is at least half the coil diameter, and if the spacing at the ends of the coil is at least equal to the coil diameter. The higher the conductivity of the shield material, the less the effect on the inductance and Q . Copper is the best material, but aluminum is quite satisfactory.

For good magnetic shielding at audio frequencies it is necessary to enclose the coil in a container of high-permeability iron or steel. In this case the shield can be quite close to the coil without harming its performance.

U.H.F. Circuits

● RESONANT LINES

In resonant circuits as employed at the lower frequencies it is possible to consider each of the reactance components as a separate entity. The fact that an inductor has a certain amount of self-capacitance, as well as some resistance, while a capacitor also possesses a small self-inductance, can usually be disregarded.

At the very-high and ultrahigh frequencies it is not readily possible to separate these components. Also, the connecting leads, which at lower frequencies would serve merely to join the capacitor and coil, now may have more inductance than the coil itself. The required inductance coil may be no more than a single turn of wire,

yet even this single turn may have dimensions comparable to a wave length at the operating frequency. Thus the energy in the field surrounding the "coil" may in part be radiated. At a sufficiently high frequency the loss by radiation may represent a major portion of the total energy in the circuit.

For these reasons it is common practice to utilize resonant sections of transmission line as tuned circuits at frequencies above 100 Mc. or so. A quarter-wave-length line, or any odd multiple thereof, shorted at one end and open at the other exhibits large standing waves, as described in the chapter on transmission lines. When a voltage of the frequency at which such a line is resonant is applied to the open end, the re-

sponse is very similar to that of a parallel resonant circuit. The equivalent relationships are shown in Fig. 2-63. At frequencies off resonance the line displays qualities comparable with the

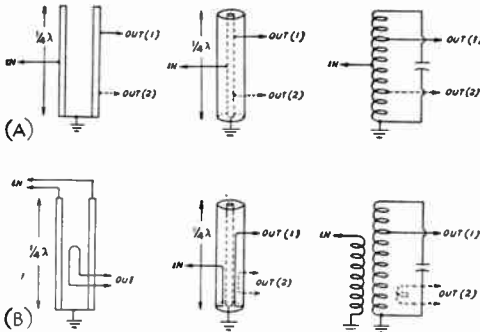

Fig. 2-63 — Equivalent coupling circuits for parallel-line, coaxial-line and conventional resonant circuits.

inductive and capacitive reactances of a conventional tuned circuit, so sections of transmission line can be used in much the same manner as inductors and capacitors.

To minimize radiation less the two conductors of a parallel-conductor line should not be more than about one-tenth wave length apart, the spacing being measured between the conductor axes. On the other hand, the spacing should not be less than about twice the conductor diameter because of "proximity effect," which causes eddy currents and an increase in loss. Above 300 Mc. it is difficult to satisfy both these requirements simultaneously, and the radiation from an open line tends to become excessive, reducing the *Q*. In such case the coaxial type of line is to be preferred, since it is inherently shielded.

Representative methods for adjusting coaxial lines to resonance are shown in Fig. 2-64. At the left, a sliding shorting disk is used to reduce the

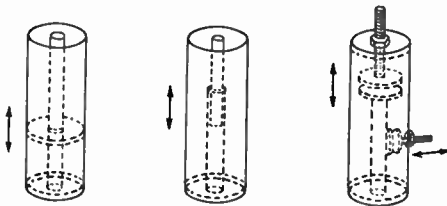

Fig. 2-64 — Methods of tuning coaxial resonant lines.

effective length of the line by altering the position of the short-circuit. In the center, the same effect is accomplished by using a telescoping tube in the end of the inner conductor to vary its length and thereby the effective length of the line. At the right, two possible methods of using parallel-plate capacitors are illustrated. The arrangement with the loading capacitor at the open end of the line has the greatest tuning effect per unit of capacitance; the alternative method, which is equivalent to tapping the condenser down on the line, has less effect on the *Q* of the circuit. Lines with capacitive "loading" of the

sort illustrated will be shorter, physically, than an unloaded line resonant at the same frequency.

Two methods of tuning parallel-conductor lines are shown in Fig. 2-65. The sliding short-circuiting strap can be tightened by means of screws and nuts to make good electrical contact. The parallel-plate capacitor in the second drawing may be placed anywhere along the line, the tuning effect becoming less as the capacitor is located nearer the shorted end of the line. Although a low-capacitance variable capacitor of ordinary construction can be used, the circular-plate type shown is symmet-

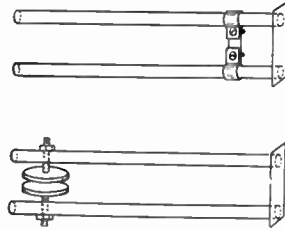

Fig. 2-65 — Methods of tuning parallel-type resonant lines.

rical and thus does not unbalance the line. It also has the further advantage that no insulating material is required.

● WAVE GUIDES

A wave guide is a conducting tube through which energy is transmitted in the form of electromagnetic waves. The tube is not considered as carrying a current in the same sense that the wires of a two-conductor line do, but rather as a *boundary* which confines the waves to the enclosed space. Skin effect prevents any electromagnetic effects from being evident outside the guide. The energy is injected at one end, either through capacitive or inductive coupling or by radiation, and is received at the other end. The wave guide then merely confines the energy of the fields, which are propagated through it to the receiving end by means of reflections against its inner walls.

Analysis of wave-guide operation is based on the assumption that the guide material is a perfect conductor of electricity. Typical distributions of electric and magnetic fields in a rectangular guide are shown in Fig. 2-66. It will be observed that the intensity of the electric field is greatest (as indicated by closer spacing of the lines of force) at the center along the *x* dimension, Fig. 2-66B, diminishing to zero at the end walls. The latter is a necessary condition, since the existence of any electric field parallel to the walls at the surface would cause an infinite current to flow in a perfect conductor. This represents an impossible situation.

Modes of Propagation

Fig. 2-66 represents a relatively simple distribution of the electric and magnetic fields. There is in general an infinite number of ways in which the fields can arrange themselves in a

guide so long as there is no upper limit to the frequency to be transmitted. Each field configuration is called a **mode**. All modes may be separated into two general groups. One group,

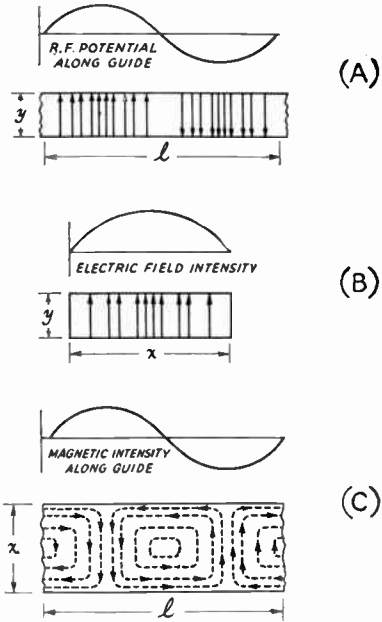

Fig. 2-66 — Field distribution in a rectangular wave guide. The $TE_{1,0}$ mode of propagation is depicted.

designated **TM** (transverse magnetic), has the magnetic field entirely transverse to the direction of propagation, but has a component of electric field in that direction. The other type, designated **TE** (transverse electric) has the electric field entirely transverse, but has a component of magnetic field in the direction of propagation. *TM* waves are sometimes called *E* waves, and *TE* waves are sometimes called *H* waves, but the *TM* and *TE* designations are preferred.

The particular mode of transmission is identified by the group letters followed by two subscript numerals; for example, $TE_{1,0}$, $TM_{1,1}$, etc. The number of possible modes increases with frequency for a given size of guide. There is only one possible mode (called the **dominant mode**) for the lowest frequency that can be transmitted. The dominant mode is the one generally used in practical work.

Wave-Guide Dimensions

In the rectangular guide the critical dimension is *x* in Fig. 2-66; this dimension must be more than one-half wave length at the lowest frequency to be transmitted. In practice, the *y* dimension usually is made about equal to $\frac{1}{2}x$ to avoid the possibility of operation at other than the dominant mode.

Other cross-sectional shapes than the rectangle can be used, the most important being the circular pipe. Much the same considera-

tions apply as in the rectangular case.

Wave-length formulas for rectangular and circular guides are given in the following table, where *x* is the width of a rectangular guide and *r* is the radius of a circular guide. All figures are in terms of the dominant mode.

	Rectangular	Circular
Cut-off wave length.....	2 <i>x</i>	3.41 <i>r</i>
Longest wave length transmitted with little attenuation.....	1.6 <i>x</i>	3.2 <i>r</i>
Shortest wave length before next mode becomes possible.....	1.1 <i>x</i>	2.8 <i>r</i>

Cavity Resonators

Another kind of circuit particularly applicable at wave lengths of the order of centimeters is the **cavity resonator**, which may be looked upon as a section of a wave guide with the dimensions chosen so that waves of a given length can be maintained inside.

Typical shapes used for resonators are the cylinder, the rectangular box and the sphere, as shown in Fig. 2-67. The resonant frequency depends upon the dimensions of the cavity and the mode of oscillation of the waves (compar-

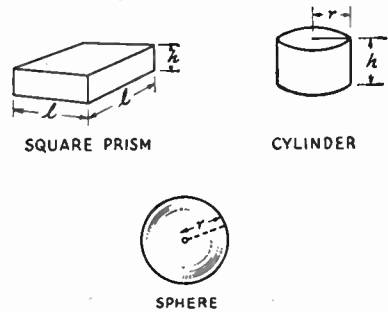

Fig. 2-67 — Forms of cavity resonators.

able to the transmission modes in a wave guide). For the lowest modes the resonant wavelengths are as follows:

Cylinder.....	2.61 <i>r</i>
Square box.....	1.41 <i>l</i>
Sphere.....	2.28 <i>r</i>

The resonant wave lengths of the cylinder and square box are independent of the height when the height is less than a half wave length. In other modes of oscillation the height must be a multiple of a half wave length as measured inside the cavity. A cylindrical cavity can be tuned by a sliding shorting disk when operating in such a mode. Other tuning methods include placing adjustable tuning paddles or "slugs" inside the cavity so that the standing-wave pattern of the electric and magnetic fields can be varied.

A form of cavity resonator in practical use is the re-entrant cylindrical type shown in Fig. 2-68. In construction it resembles a concentric line closed at both ends with capacitive loading at the top, but the actual mode of oscillation may differ considerably from that occurring in

coaxial lines. The resonant frequency of such a cavity depends upon the diameters of the two cylinders and the distance d between the ends of the inner and outer cylinders.

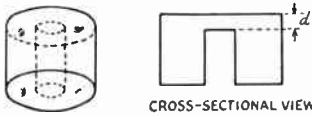

Fig. 2-68 — Re-entrant cylindrical cavity resonator.

Compared with ordinary resonant circuits, cavity resonators have extremely high Q . A value of Q of the order of 1000 or more is readily obtainable, and Q values of several thousand can be secured with good design and construction.

Coupling to Wave Guides and Cavity Resonators

Energy may be introduced into or abstracted from a wave guide or resonator by means of either the electric or magnetic field. The energy transfer frequently is through a coaxial line, two methods for coupling to which are shown in Fig. 2-69. The probe shown at A is simply a short extension of the inner con-

ductor of the coaxial line, so oriented that it is parallel to the electric lines of force. The loop shown at B is arranged so that it encloses some of the magnetic lines of force. The point at which maximum magnetic coupling will be secured depends upon the particular mode of propagation in the guide or cavity; the coupling will be maximum when the coupling device is in the most intense field.

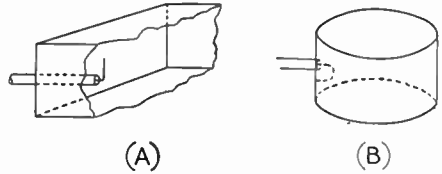

Fig. 2-69 — Coupling to wave guides and resonators.

Coupling can be varied by turning either the probe or loop through a 90-degree angle. When the probe is perpendicular to the electric lines the coupling will be minimum; similarly, when the plane of the loop is parallel to the magnetic lines the coupling will have its least possible value.

Modulation, Heterodyning and Beats

Since one of the most widespread uses of radio frequencies is the transmission of speech and music, it would be very convenient if the audio spectrum to be transmitted could simply be shifted up to some radio frequency, transmitted as radio waves, and shifted back down to the audio spectrum at the receiving point. Suppose the audio signal to be transmitted by radio is a pure 1000-cycle tone, and we wish to transmit it at some frequency around 1 Mc. (1,000,000 cycles). One possible way might be to add 1,000,000 cycles and 1,000 cycles together, thereby obtaining a radio frequency of 1,001,000 cycles. No simple method for doing such a thing directly has ever been devised, although the *effect* is obtained and used in advanced communications techniques.

Actually, when two different frequencies are present simultaneously in an ordinary circuit (specifically, one in which Ohm's Law holds) each behaves as though the other were not there. It is true that the total or resultant voltage (or current) in the circuit will be the sum of the instantaneous values of the two at every instant. This is because there can be only one value of current or voltage at any single point in a circuit at any instant. Fig. 2-70A and B show two such frequencies, and C shows the resultant. The amplitude of the 1,000,000-cycle current is not affected by the presence of the 1000-cycle current, but merely has its axis shifted back and forth at the 1000-cycle rate. An attempt to transmit such a combination as a radio wave would result simply

in the transmission of the 1,000,000-cycle frequency, since the 1000-cycle frequency retains its identity as an audio frequency and hence will not be radiated.

There are devices, however, which make it possible for one frequency to control the amplitude of the other. If, for example, a 1000-cycle tone is used to control a 1-Mc. signal, the maximum r.f. output will be obtained when the 1000-cycle signal is at the peak of one alternation and the minimum will occur at the peak of the next alternation. The process is called **amplitude modulation**, and the effect is shown in Fig. 2-70D. The resultant signal is now entirely at radio frequency, but with its amplitude varying at the modulation rate (1000 cycles). Receiving equipment adjusted to receive the 1,000,000-cycle r.f. signal can reproduce these changes in amplitude, and thus tell what the audio signal is, through a process called **detection** or **demodulation**.

It might be assumed that the only radio frequency present in such a signal is the original 1,000,000 cycles, but such is not the case. It will be found that two new frequencies have appeared. These are the sum (1,000,000 + 1000) and difference (1,000,000 - 1000) frequencies, and hence the radio frequencies appearing in the circuit after modulation are 999,000, 1,000,000 and 1,001,000 cycles.

When an audio frequency is used to control the amplitude of a radio frequency, the process is generally called "amplitude modulation," as

Fig. 2-70 — Amplitude-vs.-time and amplitude-vs.-frequency plots of various signals. (A) $1\frac{1}{2}$ cycles of a 1000-cycle signal. (B) A 1,000,000-cycle signal plotted to the same scale as A. Because there are 1500 cycles during this time, they cannot be shown accurately. (C) The signals of A and B flowing in the same circuit. (D) The signals of A and B combined in a circuit where A can control the amplitude of B. The 1,000,000-cycle signal is *modulated* by the 1000-cycle signal. (E), (F), (G), (H) Amplitude-vs.-frequency plots of the signals in A, B, C and D.

»

mentioned previously, but when a radio frequency modulates another radio frequency it is called **heterodyning**. However, the processes are identical. A general term for the sum and difference frequencies generated during heterodyning or amplitude modulation is “**beat frequencies**,” and a more specific one is **upper side frequency**, for the sum frequency, and **lower side frequency** for the difference frequency.

In the simple example, the modulating signal was assumed to be a pure tone, but the modulating signal can just as well be a *band* of frequencies making up speech or music. In this case, the side frequencies are grouped into what are called the **upper side band** and the **lower side band**. In any case, the frequency that is modulated is called the **carrier frequency**.

In A, B, C and D of Fig. 2-70, the sketches are obtained by plotting amplitude against time. However, it is equally helpful to be able to visualize the spectrum, or what a plot of amplitude vs. frequency looks like, at any given instant of time. E, F, G and H of Fig. 2-70 show the signals of Fig. 2-70A, B, C and D on an amplitude-vs.-

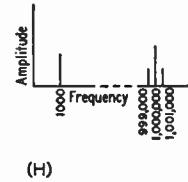
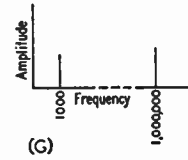
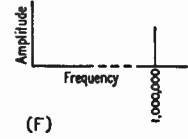
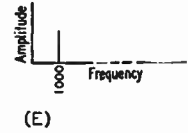
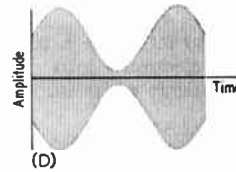
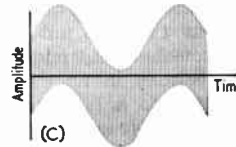
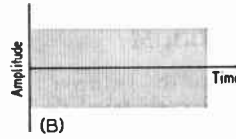
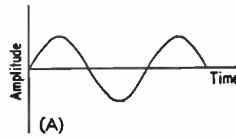

frequency basis. Any one frequency is, of course, represented by a vertical line. Fig. 2-70H shows the side frequencies appearing as a result of the modulation process.

Amplitude modulation (**a.m.**) is not the only possible type nor is it the only one in use. This and other types of modulation are treated in detail in later chapters.

Vacuum-Tube Principles

● CURRENT IN A VACUUM

The outstanding difference between the vacuum tube and most other electrical devices is that the electric current does not flow through a conductor but through empty space—a vacuum. This is only possible when “free” electrons—that is, electrons that are not attached to atoms—are somehow introduced into the vacuum. Free electrons in an evacuated space will be attracted to a positively-charged object within the same space, or will be repelled by a negatively-charged object. The movement of the electrons under the attraction or repulsion of such charged objects constitutes the current in the vacuum.

The most practical way to introduce a sufficiently-large number of electrons into the evacuated space is by **thermionic emission**.

Thermionic Emission

If a thin wire or **filament** is heated to incandescence in a vacuum, electrons near the surface are given enough energy of motion to fly off into the surrounding space. The higher the temperature, the greater the number of electrons **emitted**. A more general name for the filament is **cathode**.

If the cathode is the only thing in the vacuum, most of the emitted electrons stay in its immediate vicinity, forming a “cloud” about the cathode. The reason for this is that the electrons in the space, being negative electricity, form a negative charge (**space charge**) in the region of the cathode. The space charge repels

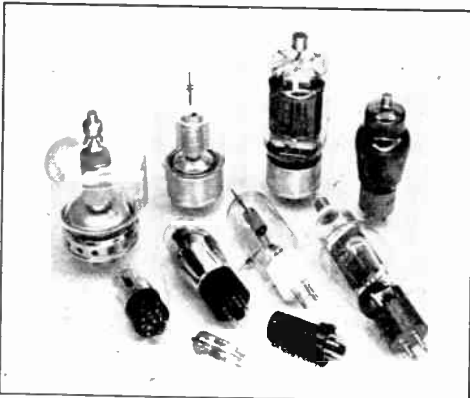

Representative tube types. The miniature, metal-envelope and small glass tubes in the foreground are receiving types. The two tubes with connections at the top of the bulb, lying down, are transmitting triodes of moderate power ratings. Those in the rear are transmitting-type beam tetrodes.

those electrons nearest the cathode, tending to make them fall back on it.

Now suppose a second conductor is introduced into the vacuum, but not connected to anything else inside the tube. If this second conductor is given a positive charge by connecting a source of e.m.f. between it and the

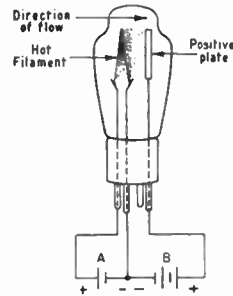

Fig. 3-1—Conduction by thermionic emission in a vacuum tube. One battery is used to heat the filament to a temperature that will cause it to emit electrons. The other battery makes the plate positive with respect to the filament, thereby causing the emitted electrons to be attracted to the plate. Electrons captured by the plate flow back through the battery to the filament.

cathode, as indicated in Fig. 3-1, electrons emitted by the cathode are attracted to the positively-charged conductor. An electric current then flows through the circuit formed by the cathode, the charged conductor, and the source of e.m.f. In Fig. 3-1 this e.m.f. is supplied by a battery (“B” battery); a second battery (“A” battery) is also indicated for heating the cathode or filament to the proper operating temperature.

The positively-charged conductor is usually a metal plate or cylinder (surrounding the cathode) and is called an **anode** or **plate**. Like the other working parts of a tube, it is a **tube element** or **electrode**. The tube shown in Fig. 3-1 is a **two-element** or **two-electrode** tube, one element being the cathode or filament and the other the anode or plate.

Since electrons are negative electricity, they will be attracted to the plate *only* when the plate is positive with respect to the cathode. If the plate is given a negative charge, the electrons will be repelled back to the cathode and no current will flow. The vacuum tube therefore can conduct *only in one direction*.

Cathodes

Before electron emission can occur, the cathode must be heated to a high temperature. However, it is not essential that the heating cur-

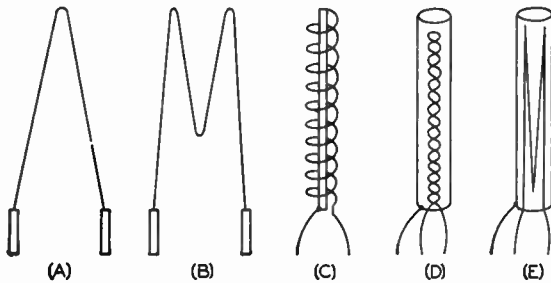

Fig. 3-2 — Types of cathode construction. Directly-heated cathodes or filaments are shown at A, B, and C. The inverted V filament is used in small receiving tubes, the M in both receiving and transmitting tubes. The spiral filament is a transmitting-tube type. The indirectly-heated cathodes at D and E show two types of heater construction, one a twisted loop and the other bunched heater wires. Both types tend to cancel the magnetic fields set up by the current through the heater.

rent flow through the actual material that does the emitting; the filament or heater can be electrically separate from the emitting cathode. Such a cathode is called **indirectly heated**, while an emitting filament is called **directly heated**. Fig. 3-2 shows both types in the forms in which they are commonly used.

Much greater electron emission can be obtained, at relatively low temperatures, by using special cathode materials rather than pure metals. One of these is **thoriated tungsten**, or tungsten in which thorium is dissolved. Still greater efficiency is achieved in the **oxide-coated cathode**, a cathode in which rare-earth oxides form a coating over a metal base.

Although the oxide-coated cathode has much the highest efficiency, it can be used successfully only in tubes that operate at rather low plate voltages. Its use is therefore confined to receiving-type tubes and to the smaller varieties of transmitting tubes. The thoriated filament, on the other hand, will operate well in high-voltage tubes.

Plate Current

If there is only a small positive voltage on the plate, the number of electrons reaching it will be small because the space charge (which is negative) prevents those electrons nearest the cathode from being attracted to the plate. As the plate voltage is increased, the effect of the space charge is increasingly overcome and the number of electrons attracted to the plate becomes larger. That is, the **plate current** increases with increasing plate voltage.

Fig. 3-3 shows a typical plot of plate current vs. plate voltage for a two-element tube or diode. A curve of this type can be obtained with the circuit shown, if the plate voltage is increased in small steps and a current reading taken (by means of the current-indicating instrument—a milliammeter) at each voltage. The plate current is zero with no plate voltage and the curve rises until a **saturation point** is reached. This is where the positive charge on the plate has substantially overcome the space charge and

almost all the electrons are going to the plate. At higher voltages the plate current stays at practically the same value.

The plate voltage multiplied by the plate current is the **power input** to the tube. In a circuit like that of Fig. 3-3 this power is all used in heating the plate. If the power input is large, the plate temperature may rise to a very high value (the plate may become red or even white hot). The heat developed in the plate is radiated to the bulb of the tube, and in turn radiated by the bulb to the surrounding air.

RECTIFICATION

Since current can flow through a tube in only one direction, a diode can be used to change alternating current into direct current. It does this by permitting current to flow when the plate is positive with respect to the cathode, but by shutting off current flow when the plate is negative.

Fig. 3-4 shows a representative circuit. Alternating voltage from the secondary of the transformer, *T*, is applied to the diode tube in series with a load resistor, *R*. The voltage varies as is usual with a.c., but current flows through the tube and *R* only when the plate is positive with respect to the cathode—that is, during the half-cycle when the upper end of the transformer winding is positive. During the negative half-cycle there is simply a gap in the current flow. This **rectified** alternating current therefore is an **intermittent** direct current.

The load resistor, *R*, represents the actual circuit in which the rectified alternating current does work. All tubes work with a load of one type or another; in this respect a tube is much like a generator or transformer. A circuit that did not provide a load for the tube would be like a short-circuit across a transformer; no useful purpose would be accomplished and the only result would be the generation of heat in the transformer. So it is with vacuum tubes; they must cause power to be developed in a load in order to serve a useful purpose. Also, to be **efficient** most of the power must do useful work in the load and not be used in heating the plate of the tube. This means that most of the voltage should appear as a drop across the load rather than as a drop between the plate and cathode.

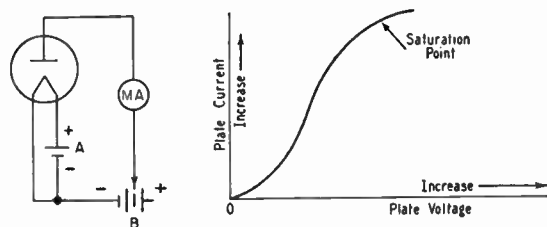

Fig. 3-3 — The diode, or two-element tube, and a typical curve showing how the plate current depends upon the voltage applied to the plate.

With the diode connected as shown in Fig. 3-4, the polarity of the voltage drop across the load is such that the end of the load nearest the cathode is positive. If the connections to the diode elements are reversed, the direction of rectified current flow also will be reversed through the load.

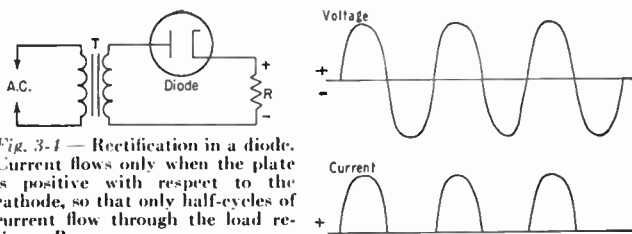

Fig. 3-4 — Rectification in a diode. Current flows only when the plate is positive with respect to the cathode, so that only half-cycles of current flow through the load resistor, R .

Vacuum-Tube Amplifiers

● TRIODES

Grid Control

If a third element — called the control grid, or simply grid — is inserted between the cathode and plate as in Fig. 3-5, it can be used to control the effect of the space charge. If the grid is given a positive voltage with respect to the cathode, the positive charge will tend to neutralize the negative space charge. The

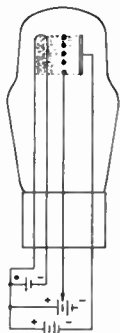

Fig. 3-5 — Construction of an elementary triode vacuum tube, showing the filament, grid (with an end view of the grid wires) and plate. The relative density of the space charge is indicated roughly by the dot density.

result is that, at any selected plate voltage, more electrons will flow to the plate than if the grid were not present. On the other hand, if the grid is made negative with respect to the cathode the negative charge on the grid will *add* to the space charge. This will *reduce* the number of electrons that can reach the plate at any selected plate voltage.

The grid is inserted in the tube to control the space charge and not to attract electrons to itself, so it is made in the form of a wire mesh or spiral. Electrons then can go through the open spaces in the grid to reach the plate.

Characteristic Curves

For any particular tube, the effect of the grid voltage on the plate current can be shown by a set of characteristic curves. A typical set of curves is shown in Fig. 3-6, together with the circuit that is used for getting them. For each value of plate voltage, there is a value of negative grid voltage that will reduce the plate current to zero; that is, there is

a value of negative grid voltage that will cut off the plate current.

The curves could be extended by making the grid voltage positive as well as negative. When the grid is negative, it repels electrons and therefore none of them reaches it; in other words, no current flows in the grid circuit. However, when the grid is positive, it attracts electrons and a current (**grid current**) flows, just as current flows to the positive plate. Whenever there is grid current there is an accompanying power loss in the grid circuit, but so long as the grid is negative no power is used.

It is obvious that the grid can act as a valve to control the flow of plate current. Actually, the grid has a much greater effect on plate current flow than does the plate voltage. A small change in grid voltage is just as effective in bringing about a given change in plate current as is a large change in plate voltage.

The fact that a small voltage acting on the grid is equivalent to a large voltage acting on the plate indicates the possibility of **amplification** with the triode tube. The many uses of the electronic tube nearly all are based upon this amplifying feature. The amplified output is not obtained from the tube itself, but from the source of e.m.f. connected between its plate and cathode. The tube simply *controls* the power from this source, changing it to the desired form.

To utilize the controlled power, a load must be connected in the plate or "output" circuit, just as in the diode case. The load may be

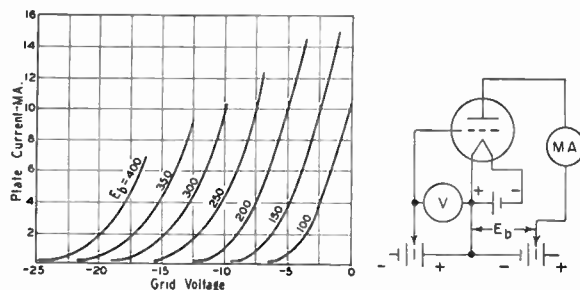

Fig. 3-6 — Grid-voltage-vs.-plate-current curves at various fixed values of plate voltage (E_b) for a typical small triode. Characteristic curves of this type can be taken by varying the battery voltages in the circuit at the right.

either a resistance or an impedance. The term "impedance" is frequently used even when the load is purely resistive.

Tube Characteristics

The physical construction of a triode determines the relative effectiveness of the grid and plate in controlling the plate current. If a very small change in the grid voltage has just as much effect on the plate current as a very large change in plate voltage, the tube is said to have a high **amplification factor**. Amplification factor is commonly designated by the Greek letter μ . An amplification factor of 20, for example, means that if the grid voltage is changed by 1 volt, the effect on the plate current will be the same as when the plate voltage is changed by 20 volts. The amplification factors of triode tubes range from 3 to 100 or so. A **high- μ** tube is one with an amplification factor of perhaps 30 or more; **medium- μ** tubes have amplification factors in the approximate range 8 to 30, and **low- μ** tubes in the range below 7 or 8.

It would be natural to think that a tube that has a large μ would be the best amplifier, but to obtain a high μ it is necessary to construct the grid with many turns of wire per inch, or in the form of a fine mesh. This leaves a relatively small open area for electrons to go through to reach the plate, so it is difficult for the plate to attract large numbers of electrons. Quite a large change in the plate voltage must be made to effect a given change in plate current. This means that the resistance of the plate-cathode path — that is, the **plate resistance** — of the tube is high. Since this resistance acts in series with the load, the amount of current that can be made to flow through the load is relatively small. On the other hand, the plate resistance of a low- μ tube is relatively low.

The best all-around indication of the effectiveness of the tube as an amplifier is its **grid-plate transconductance** — also called **mutual conductance**. This characteristic takes account of both amplification factor and plate resistance, and therefore is a figure of merit for the tube. Transconductance is the change in plate current divided by the change in grid voltage that causes the plate-current change (the plate voltage being fixed at a desired value). Since current divided by voltage is conductance, transconductance is measured in the unit of conductance, the mho. Practical values of transconductance are very small, so the micromho (one-millionth of a mho) is the commonly-used unit. Different types of tubes have transconductances ranging from a few hundred to several thousand. The higher the transconductance the greater the possible amplification.

● AMPLIFICATION

The way in which a tube amplifies is best shown by a type of graph called the **dynamic characteristic**. Such a graph, together with the

circuit used for obtaining it, is shown in Fig. 3-7. The curves are taken with the plate-supply voltage fixed at the desired operating value. The difference between this circuit and the one shown in Fig. 3-6 is that in Fig. 3-7 a load resistance is connected in series with the plate of the tube. Fig. 3-7 thus shows how the plate current will vary, with different grid voltages, *when the plate current is made to flow through a load and thus do useful work.*

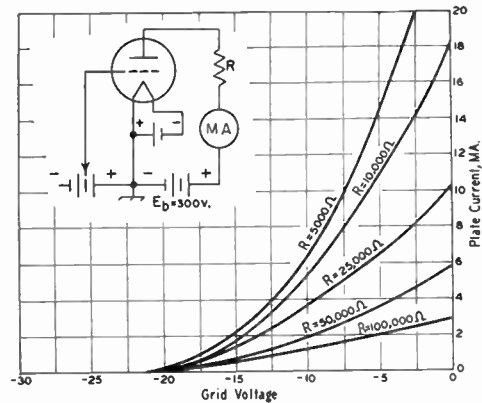

Fig. 3-7 — Dynamic characteristics of a small triode with various load resistances from 5000 to 100,000 ohms.

The several curves in Fig. 3-7 are for various values of load resistance. When the resistance is small (as in the case of the 5000-ohm load) the plate current changes rather rapidly with a given change in grid voltage. If the load resistance is high (as in the 100,000-ohm curve), the change in plate current for the same grid-voltage change is relatively small; also, the curve tends to be straighter.

Fig. 3-8 is the same type of curve, but with the circuit arranged so that a source of alternating voltage (signal) is inserted between the grid and the grid battery ("C" battery). The voltage of the grid battery is fixed at -5 volts, and from the curve it is seen that the plate current at this grid voltage is 2 milliamperes. This current flows when the load resistance is 50,000 ohms, as indicated in the circuit diagram. If there is no a.c. signal in the grid circuit, the voltage drop in the load resistor is $50,000 \times 0.002 = 100$ volts, leaving 200 volts between the plate and cathode.

When a sine-wave signal having a peak value of 2 volts is applied in series with the bias voltage in the grid circuit, the instantaneous voltage at the grid will swing to -3 volts at the instant the signal reaches its positive peak, and to -7 volts at the instant the signal reaches its negative peak. The maximum plate current will occur at the instant the grid voltage is -3 volts. As shown by the graph, it will have a value of 2.65 milliamperes. The minimum plate current occurs at the instant the grid voltage is -7 volts, and has a value of 1.35 ma. At intermediate values of grid voltage, intermediate plate-current values will occur.

The instantaneous voltage between the plate

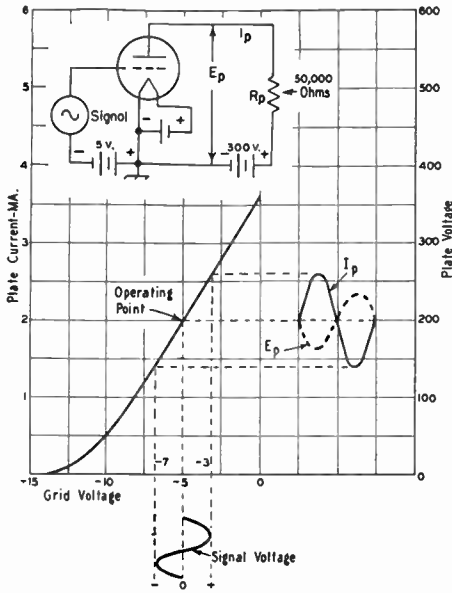

Fig. 3-8 — Amplifier operation. When the plate current varies in response to the signal applied to the grid, a varying voltage drop appears across the load, R_p , as shown by the dashed curve, E_p . I_p is the plate current.

and cathode of the tube also is shown on the graph. When the plate current is maximum, the instantaneous voltage drop in R_p is $50,000 \times 0.00265 = 132.5$ volts; when the plate current is minimum the instantaneous voltage drop in R_p is $50,000 \times 0.00135 = 67.5$ volts. The actual voltage between plate and cathode is the difference between the plate-supply potential, 300 volts, and the voltage drop in the load resistance. The plate-to-cathode voltage is therefore 167.5 volts at maximum plate current and 232.5 volts at minimum plate current.

This varying plate voltage is an a.c. voltage superimposed on the steady plate-cathode potential of 200 volts (as previously determined for no-signal conditions). The peak value of this a.c. output voltage is the difference between either the maximum or minimum plate-cathode voltage and the no-signal value of 200 volts. In the illustration this difference is $232.5 - 200$ or $200 - 167.5$; that is, 32.5 volts in either case. Since the grid signal voltage has a peak value of 2 volts, the voltage-amplification ratio of the amplifier is $32.5/2$ or 16.25. That is, approximately 16 times as much voltage is obtained from the plate circuit as is applied to the grid circuit.

As shown by the drawings in Fig. 3-8, the alternating component of the plate voltage swings in the *negative* direction (with reference to the no-signal value of plate-cathode voltage) when the grid voltage swings in the *positive* direction, and vice versa. This means that the alternating component of plate voltage (that is, the amplified signal) is 180 degrees out of phase with the signal voltage on the grid.

Bias

The fixed negative grid voltage (called *grid bias*) in Fig. 3-8 serves a very useful purpose. One object of the type of amplification shown in this drawing is to obtain, from the plate circuit, an alternating voltage that has the same wave-shape as the signal voltage applied to the grid. To do so, an *operating point* on the *straight* part of the curve must be selected. The curve must be straight in both directions from the operating point at least far enough to accommodate the maximum value of the signal applied to the grid. If the grid signal swings the plate current back and forth over a part of the curve that is not straight, as in Fig. 3-9, the shape of the a.c. wave in the plate circuit will not be the same as the shape of the grid-signal wave. In such a case the output wave shape will be distorted.

A second reason for using negative grid bias is that any signal whose peak positive voltage does not exceed the fixed negative voltage on the grid cannot cause grid current to flow. With no current flow there is no power consumption, so the tube will amplify *without taking any power from the signal source*. (However, if the positive peak of the signal does exceed the negative bias, current will flow in the grid circuit during the time the grid is positive.)

Distortion of the output wave shape that results from working over a part of the curve that is not straight (that is, a *nonlinear* part of the curve) has the effect of transforming a sine-wave grid signal into a more complex waveform. As explained in an earlier chapter, a complex wave can be resolved into a fundamental and a series of harmonics. In other words, distortion from nonlinearity causes the generation of harmonic frequencies — frequencies that are not present in the signal applied to the grid. Harmonic distortion is undesirable in most amplifiers, although

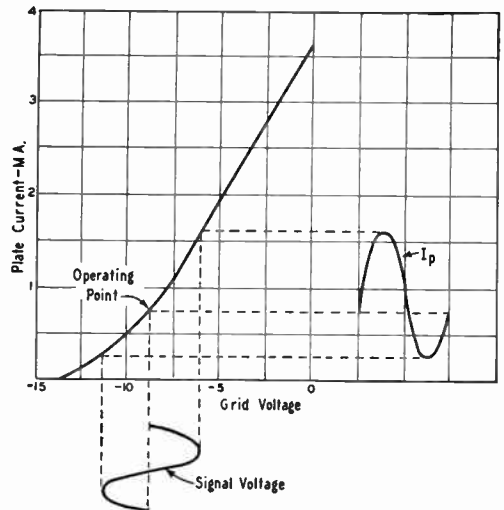

Fig. 3-9 — Harmonic distortion resulting from choice of an operating point on the curved part of the tube characteristic. The lower half-cycle of plate current does not have the same shape as the upper half-cycle.

there are occasions when harmonics are deliberately generated and used.

Amplifier Output Circuits

The useful output of a vacuum-tube amplifier is the *alternating* component of plate current or plate voltage. The d.c. voltage on the plate of the tube is essential for the tube's operation, but it almost invariably would cause difficulties if it were applied, along with the a.c. output voltage, to the load. The output circuits of vacuum tubes are therefore arranged so that the a.c. is transferred to the load but the d.c. is not.

Three types of coupling are in common use at audio frequencies. These are **resistance coupling**, **impedance coupling**, and **transformer coupling**. They are shown in Fig. 3-10. In all three cases the output is shown coupled to the grid circuit of a subsequent amplifier tube, but the same types of circuits can be used to couple to other devices than tubes.

In the resistance-coupled circuit, the a.c. voltage developed across the **plate resistor** R_p (that is, the voltage between the plate and cathode of the tube) is applied to a second resistor, R_g , through a **coupling capacitor**, C_c . The capacitor "blocks off" the d.c. voltage on the plate of the first tube and prevents it from being applied to the grid of tube B . The latter tube has negative grid bias supplied by the battery shown. No current flows in the grid circuit of tube B and there is therefore no d.c. voltage drop in R_g ; in other words, the full voltage of the bias battery is applied to the grid of tube B .

The **grid resistor**, R_g , usually has a rather high value (0.5 to 2 megohms). The reactance of the coupling capacitor, C_c , must be low enough compared with the resistance of R_g so that the a.c. voltage drop in C_c is negligible at the lowest frequency to be amplified. If R_g is at least 0.5 megohm, a 0.1- μ f. capacitor will be amply large for the usual range of audio frequencies.

So far as the alternating component of plate voltage is concerned, it will be realized that if the voltage drop in C_c is negligible then R_p and R_g are effectively in parallel (although they are quite separate so far as d.c. is concerned). The resultant parallel resistance of the two is therefore the actual load resistance for the tube. That is why R_g is made as high in resistance as possible; then it will have the least effect on the load represented by R_p .

The impedance-coupled circuit differs from that using resistance coupling only in the substitution of a high-inductance coil (usually several hundred henrys for audio frequencies) for the plate resistor. The advantage of using an inductance rather than a resistor is that its impedance is high for alternating currents, but its resistance is relatively low for d.c. It thus permits obtaining a high value of load impedance for a.c. without an excessive d.c. voltage drop that would use up a good deal of the voltage from the plate supply.

The transformer-coupled amplifier uses a transformer with its primary connected in the plate

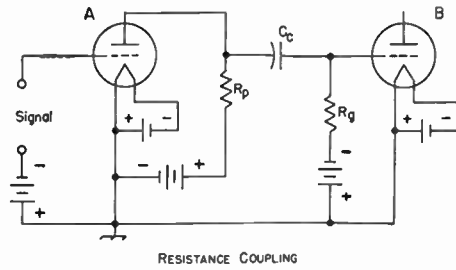

RESISTANCE COUPLING

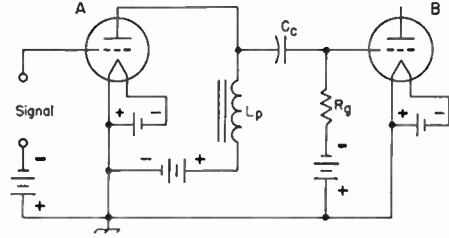

IMPEDANCE COUPLING

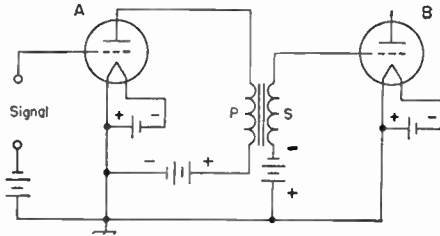

TRANSFORMER COUPLING

Fig. 3-10 — Three basic forms of coupling between vacuum-tube amplifiers.

circuit of the tube and its secondary connected to the load (in the circuit shown, a following amplifier). There is no direct connection between the two windings, so the plate voltage on tube A is isolated from the grid of tube B . The transformer-coupled amplifier has the same advantage as the impedance-coupled circuit with respect to loss of voltage from the plate supply. Also, if the secondary has more turns than the primary, the output voltage will be "stepped up" in proportion to the turns ratio.

Resistance coupling is simple, inexpensive, and will give the same amount of amplification — or **voltage gain** — over a wide range of frequencies; it will give substantially the same amplification at any frequency in the audio range, for example. Impedance coupling will give somewhat more gain, with the same tube and same plate-supply voltage, than resistance coupling. However, it is not quite so good over a wide frequency range; it tends to "peak," or give maximum gain, over a comparatively narrow band of frequencies. With a good transformer the gain of a transformer-coupled amplifier can be kept fairly constant over the audio-frequency range. On the

other hand, transformer coupling in voltage amplifiers (see below) is best suited to triodes having amplification factors of about 20 or less, for the reason that the primary inductance of a practicable transformer cannot be made large enough to work well with a tube having high plate resistance.

An amplifier in which voltage gain is the primary consideration is called a **voltage amplifier**. Maximum voltage gain is secured when the load resistance or impedance is made as high as possible in comparison with the plate resistance of the tube. In such a case, the major portion of the voltage generated will appear across the load and only a relatively small part will be "lost" in the plate resistance.

Voltage amplifiers belong to a group called **Class A amplifiers**. A Class A amplifier is one operated so that the wave shape of the output voltage is the same as that of the signal voltage applied to the grid. If a Class A amplifier is biased so that the grid is always negative, even with the largest signal to be handled by the grid, it is called a **Class A₁ amplifier**. Voltage amplifiers are always Class A₁ amplifiers, and their primary use is in driving a following Class A₁ amplifier.

Power Amplifiers

The end result of any amplification is that the amplified signal does some *work*. For example, an audio-frequency amplifier usually drives a loud-speaker that in turn produces sound waves. The greater the amount of a.f. *power* supplied to the speaker, the louder the sound it will produce.

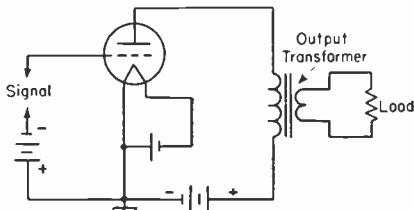

Fig. 3-11 — An elementary power-amplifier circuit in which the power-consuming load is coupled to the plate circuit through an impedance-matching transformer.

Fig. 3-11 shows an elementary **power-amplifier** circuit. It is simply a transformer-coupled amplifier with the load connected to the secondary. Although the load is shown as a resistor, it actually would be some device, such as a loud-speaker, that employs the power usefully. Every power tube requires a specific value of load resistance from plate to cathode, usually some thousands of ohms, for optimum operation. The resistance of the actual load is rarely the right value for "matching" this optimum load resistance, so the transformer turns ratio is chosen to reflect the proper value of resistance into the primary. The turns ratio may be either step-up or step-down, depending on whether the actual load resistance is higher or lower than the load the tube wants.

The **power-amplification ratio** of an amplifier is the ratio of the power output obtained from the plate circuit to the power required from the a.c. signal in the grid circuit. There is no power lost in the grid circuit of a Class A₁ amplifier, so such an amplifier has an infinitely large power-amplification ratio. However, it is quite possible to operate a Class A amplifier in such a way that current flows in its grid circuit during at least part of the cycle. In such a case power is used up in the grid circuit and the power amplification ratio is not infinite. A tube operated in this fashion is known as a **Class A₂ amplifier**. It is necessary to use a power amplifier to drive a Class A₂ amplifier, because a voltage amplifier cannot deliver power without serious distortion of the wave shape.

Another term used in connection with power amplifiers is **power sensitivity**. In the case of a Class A₁ amplifier, it means the ratio of power output to the grid signal voltage that causes it. If grid current flows, the term usually means the ratio of plate power output to grid power input.

The a.c. power that is delivered to a load by an amplifier tube has to be paid for in power taken from the source of plate voltage and current. In fact, there is always more power going into the plate circuit of the tube than is coming out as useful output. The difference between the input and output power is used up in heating the plate of the tube, as explained previously. The ratio of useful power output to d.c. plate input is called the **plate efficiency**. The higher the plate efficiency, the greater the amount of power that can be taken from a tube having a fixed plate-dissipation rating.

Parallel and Push-Pull

When it is necessary to obtain more power output than one tube is capable of giving, two or more similar tubes may be connected in **parallel**. In this case the similar elements in all tubes are connected together. This method is shown in Fig. 3-12 for a transformer-coupled amplifier. The power output is in proportion to the number of tubes used; the grid signal or **exciting voltage** required, however, is the same as for one tube.

If the amplifier operates in such a way as to consume power in the grid circuit, the grid power required is in proportion to the number of tubes used.

An increase in power output also can be secured by connecting two tubes in **push-pull**. In this case the grids and plates of the two tubes are connected to opposite ends of a balanced circuit as shown in Fig. 3-12. At any instant the ends of the secondary winding of the input transformer, T_1 , will be at opposite polarity with respect to the cathode connection, so the grid of one tube is swung positive at the same instant that the grid of the other is swung negative. Hence, in any push-pull-connected amplifier the voltages and currents of one tube are out of phase with those of the other tube.

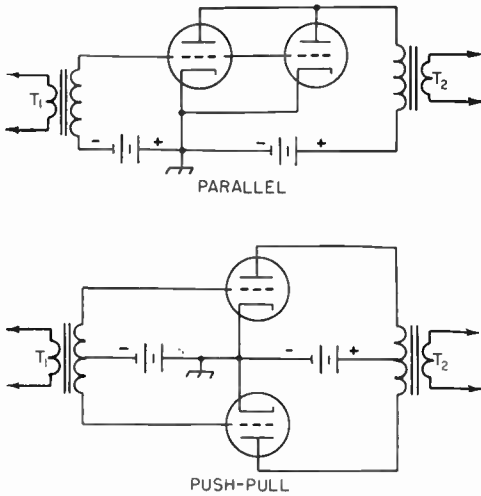

Fig. 3-12 — Parallel and push-pull a.f. amplifier circuits.

In push-pull operation the even-harmonic (second, fourth, etc.) distortion is balanced out in the plate circuit. This means that for the same power output the distortion will be less than with parallel operation.

The exciting voltage measured between the two grids must be twice that required for one tube. If the grids consume power, the driving power for the push-pull amplifier is twice that taken by either tube alone.

Cascade Amplifiers

It is readily possible to take the output of one amplifier and apply it as a signal on the grid of a second amplifier, then take the second amplifier's output and apply it to a third, and so on. Each amplifier is called a **stage**, and stages used successively are said to be in **cascade**.

Class B Amplifiers

Fig. 3-13 shows two tubes connected in a push-pull circuit. If the grid bias is set at the point where (when no signal is applied) the plate current is just cut off, then a signal can cause plate current to flow in either tube *only* when the signal voltage applied to that particular tube is positive with respect to the cathode. Since in the balanced grid circuit the signal voltages on the grids of the two tubes always have opposite polarities, plate current flows only in one tube at a time.

The graphs show the operation of such an amplifier. The plate current of tube B is drawn inverted to show that it flows in the opposite direction, through the primary of the output transformer, to the plate current of tube A. Thus each half of the output-transformer primary works alternately to induce a half-cycle of voltage in the secondary. In the secondary of *T*₂, the original wave form is restored. This type of operation is called **Class B amplification**.

The Class B amplifier has considerably higher plate efficiency than the Class A amplifier. Fur-

thermore, the d.c. plate current of a Class B amplifier is proportional to the signal voltage on the grids, so the power input is small with small signals. The d.c. plate power input to a Class A amplifier is the same whether the signal is large, small, or absent altogether; therefore the maximum d.c. plate input that can be applied to a Class A amplifier is equal to the rated plate dissipation of the tube or tubes. Two tubes in a Class B amplifier can deliver approximately twelve times as much audio power as the same two tubes in a Class A amplifier.

A Class B amplifier usually is operated in such a way as to secure the maximum possible power output. This requires rather large values of plate current, and to obtain them the signal voltage must completely overcome the grid bias during at least part of the cycle, so grid current flows and the grid circuit consumes power. While the power requirements are fairly low (as compared with the power output), the fact that the grids are positive during only *part* of the cycle means that the load on the preceding amplifier or **driver stage** varies in magnitude during the cycle; the effective load resistance is high when the grids are not drawing current and relatively low when they do take current. This must be allowed for when designing the driver.

Certain types of tubes have been designed specifically for Class B service and can be operated without fixed or other form of grid bias (**zero-bias tubes**). The amplification factor is so high that the plate current is small without signal. Because there is no fixed bias, the grids start drawing current immediately whenever a signal is applied, so the grid-current flow is continuous throughout the cycle. This makes the load on the driver much more constant than is the case with tubes of lower μ biased to plate-current cut-off.

Class B amplifiers used at radio frequencies are known as **linear amplifiers** because they are

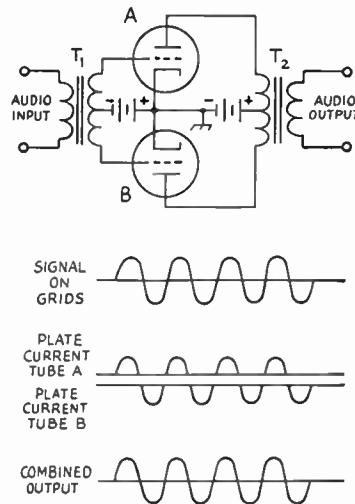

Fig. 3-13 — Class B amplifier operation.

adjusted to operate in such a way that the power output is proportional to the square of the r.f. exciting voltage. This permits amplification of a modulated r.f. signal without distortion. Push-pull is not required in this type of operation; a single tube can be used equally well.

Class AB Amplifiers

A Class AB amplifier is a push-pull amplifier with higher bias than would be normal for pure Class A operation, but less than the cut-off bias required for Class B. At low signal levels the tubes operate practically as Class A amplifiers, and the plate current is the same with or without signal. At higher signal levels, the plate current of one tube is cut off during part of the *negative* cycle of the signal applied to its grid, and the plate current of the other tube rises with the signal. The plate current for the whole amplifier also rises above the no-signal level when a large signal is applied.

In a properly-designed Class AB amplifier the distortion is as low as with a Class A stage, but the efficiency and power output are considerably higher than with pure Class A operation. A Class AB amplifier can be operated either with or without driving the grids into the positive region. A Class AB₁ amplifier is one in which the grids are never positive with respect to the cathode; therefore, no driving power is required — only voltage. A Class AB₂ amplifier is one that has grid-current flow during part of the cycle if the applied signal is large; it takes a small amount of driving power. The Class AB₂ amplifier will deliver somewhat more power (using the same tubes) but the Class AB₁ amplifier avoids the problem of designing a driver that will deliver power, without distortion, into a load of highly-variable resistance.

Operating Angle

Inspection of Fig. 3-13 shows that either of the two tubes actually is working for only half the a.c. cycle and idling during the other half. It is convenient to describe the amount of time during which plate current flows in terms of electrical degrees. In Fig. 3-13 each tube has "180-degree" excitation, a half-cycle being equal to 180 degrees. The number of degrees during which plate current flows is called the **operating angle** of the amplifier. From the descriptions given above, it should be clear that a Class A amplifier has 360-degree excitation, because plate current flows during the whole cycle. In a Class AB amplifier the operating angle is between 180 and 360 degrees (in each tube) depending on the particular operating conditions chosen. The greater the amount of negative grid bias, the smaller the operating angle becomes.

An operating angle of less than 180 degrees leads to a considerable amount of distortion, because there is no way for the tube to reproduce even a half-cycle of the signal on its grid. Using two tubes in push-pull, as in Fig. 3-13, would merely put together two distorted half-cycles. An operating angle of less than 180 degrees

therefore cannot be used if distortionless output is wanted.

Class C Amplifiers

In power amplifiers operating at radio frequencies distortion of the r.f. wave form is relatively unimportant. For reasons described later in this chapter, an r.f. amplifier must be operated with tuned circuits, and the selectivity of such circuits "filters out" the r.f. harmonics resulting from distortion.

A radio-frequency power amplifier therefore can be used with an operating angle of less than 180 degrees. This is called Class C operation. The advantage is that the plate efficiency is increased, because the loss in the plate is proportional, among other things, to the amount of time during which the plate current flows, and this time is reduced by decreasing the operating angle.

Depending on the type of tube, the optimum load resistance for a Class C amplifier ranges from about 1500 to 5000 ohms. It is usually secured by using tuned-circuit arrangements, of the type described in the chapter on circuit fundamentals, to transform the resistance of the actual load to the value required by the tube. The grid is driven well into the positive region, so that grid current flows and power is consumed in the grid circuit. The smaller the operating angle, the greater the driving voltage and the larger the grid driving power required to develop full output in the load resistance. The best compromise between driving power, plate efficiency, and power output usually results when the minimum plate voltage (at the peak of the driving cycle, when the plate current reaches its highest value) is just equal to the peak positive grid voltage. Under these conditions the operating angle is usually between 150 and 180 degrees and the plate efficiency lies in the range of 70 to 80 percent. While higher plate efficiencies are possible, attaining them requires excessive driving power and grid bias, together with higher plate voltage than is "normal" for the particular tube type.

With proper design and adjustment, a Class C amplifier can be made to operate in such a way that the power input and output are proportional to the square of the applied plate voltage. This is an important consideration when the amplifier is to be plate-modulated for radiotelephony, as described in the chapter on amplitude modulation.

● FEEDBACK

It is possible to take a part of the amplified energy in the plate circuit of an amplifier and insert it into the grid circuit. When this is done the amplifier is said to have **feedback**.

If the voltage that is inserted in the grid circuit is 180 degrees out of phase with the signal voltage acting on the grid, the feedback is called **negative**, or **degenerative**. On the other hand, if the voltage is feedback *in* phase with the grid signal, the feedback is called **positive**, or **regenerative**.

Negative Feedback

With negative feedback the voltage that is fed back *opposes* the signal voltage. This decreases the amplitude of the voltage acting between the grid and cathode and thus has the effect of reducing the voltage amplification. That is, a larger exciting voltage is required for obtaining the same output voltage from the plate circuit.

The greater the amount of negative feedback (when properly applied) the more independent the amplification becomes of tube characteristics and circuit conditions. This tends to make the frequency-response characteristic of the amplifier **flat** — that is, the amplification tends to be the same at all frequencies within the range for which the amplifier is designed. Also, any distortion generated in the plate circuit of the tube tends to “buck itself out.” Amplifiers with negative feedback are therefore comparatively free from harmonic distortion. These advantages are worth while if the amplifier otherwise has enough voltage gain for its intended use.

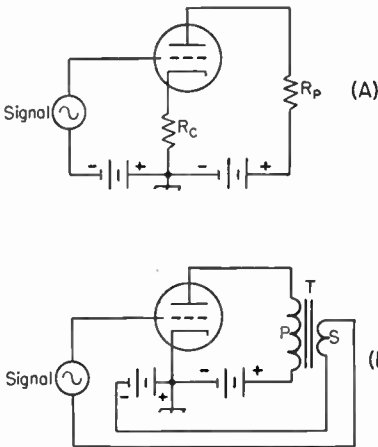

Fig. 3-14 — Simple circuits for producing feedback.

In the circuit shown at A in Fig. 3-14 resistor R_c is in series with the regular plate resistor, R_p , and thus is a part of the load for the tube. Therefore, part of the output voltage will appear across R_c . However, R_c also is connected in series with the *grid* circuit, and so the output voltage that appears across R_c is in series with the signal voltage. The output voltage across R_c opposes the signal voltage, so the actual a.c. voltage between the grid and cathode is equal to the *difference* between the two voltages.

The circuit shown at B in Fig. 3-14 can be used to give either negative or positive feedback. The secondary of a transformer is connected back into the grid circuit to insert a desired amount of feed-back voltage. Reversing the terminals of either transformer winding (but not both simultaneously) will reverse the phase.

Positive Feedback

Positive feedback *increases* the amplification because the feed-back voltage adds to the original

signal voltage and the resulting larger voltage on the grid causes a larger output voltage. The amplification tends to be greatest at one frequency (which depends upon the particular circuit arrangement) and harmonic distortion is increased. If enough energy is fed back, a self-sustaining oscillation — in which energy at essentially one frequency is generated by the tube itself — will be set up. In such case all the signal voltage on the grid can be supplied from the plate circuit; no external signal is needed because any small irregularity in the plate current — and there are always some such irregularities — will be amplified and thus give the oscillation an opportunity to build up. Positive feedback finds a major application in such “oscillators,” and in addition is used for selective amplification at both audio and radio frequencies, the feedback being kept below the value that causes self-oscillation.

● **INTERELECTRODE CAPACITANCES**

Each pair of elements in a tube forms a small capacitor, with each element acting as a capacitor “plate.” There are three such capacitances in a triode — that between the grid and cathode, that between the grid and plate, and that between the plate and cathode. The capacitances are very small — only a few micromicrofarads at most — but they frequently have a very pronounced effect on the operation of an amplifier circuit.

Input Capacitance

It was explained previously that the a.c. grid voltage and a.c. plate voltage of an amplifier having a resistive load are 180 degrees out of phase, using the cathode of the tube as a reference point. However, these two voltages are *in phase* going around the circuit from plate to grid as shown in Fig. 3-15. This means that their sum is acting between the grid and plate; that is, across the grid-plate capacitance of the tube.

As a result, a capacitive current flows around the circuit, its amplitude being directly proportional to the sum of the a.c. grid and plate voltages and to the grid-plate capacitance. The source of grid signal must furnish this amount of current, in addition to the capacitive current that flows in the grid-cathode capacitance. Hence the signal source “sees” an effective capacitance that is larger than the grid-cathode capacitance. This is known as the **Miller Effect**.

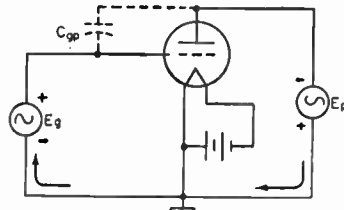

Fig. 3-15 — The a.c. voltage appearing between the grid and plate of the amplifier is the sum of the signal voltage and the output voltage, as shown by this simplified circuit. Instantaneous polarities are indicated.

The greater the voltage amplification the greater the effective input capacitance. The input capacitance of a resistance-coupled amplifier is given by the formula

$$C_{\text{input}} = C_{gk} + C_{gp}(A + 1)$$

where C_{gk} is the grid-to-cathode capacitance, C_{gp} is the grid-to-plate capacitance, and A is the voltage amplification. The input capacitance may be as much as several hundred micromicrofarads when the voltage amplification is large, even though the interelectrode capacitances are quite small.

Output Capacitance

The principal component of the output capacitance of an amplifier is the actual plate-to-cathode capacitance of the tube. The output capacitance usually need not be considered in audio amplifiers, but becomes of importance at radio frequencies.

Tube Capacitance at R.F.

At radio frequencies the reactances of even very small interelectrode capacitances drop to very low values. A resistance-coupled amplifier gives very little amplification at r.f., for example, because the reactances of the interelectrode "capacitors" are so low that they practically short-circuit the input and output circuits and thus the tube is unable to amplify. This is overcome at radio frequencies by using tuned circuits for the grid and plate, making the tube capacitances part of the tuning capacitances. In this way the circuits can have the high resistive impedances necessary for satisfactory amplification.

The grid-plate capacitance is important at radio frequencies because its reactance, relatively low at r.f., offers a path over which energy can be fed back from the plate to the grid. In practically every case the feedback is in the right phase and of sufficient amplitude to cause self-oscillation, so the circuit becomes useless as an amplifier.

Special "neutralizing" circuits can be used to prevent feedback but they are, in general, not too satisfactory when used in radio receivers. They are, however, used in transmitters.

● SCREEN-GRID TUBES

The grid-plate capacitance can be reduced to a negligible value by inserting a second grid between the control grid and the plate, as indicated in Fig. 3-16. The second grid, called the **screen grid**, acts as an electrostatic shield to prevent capacitive coupling between the control grid and plate. It is made in the form of a grid or coarse screen so that electrons can pass through it.

Because of the shielding action of the screen grid, the positively-charged plate cannot attract electrons from the cathode as it does in a triode. In order to get electrons to the plate, it is necessary to apply a positive voltage (with respect to the cathode) to the screen. The screen then attracts electrons much as does the plate in a triode tube. In traveling toward the screen the electrons acquire such velocity that most of them

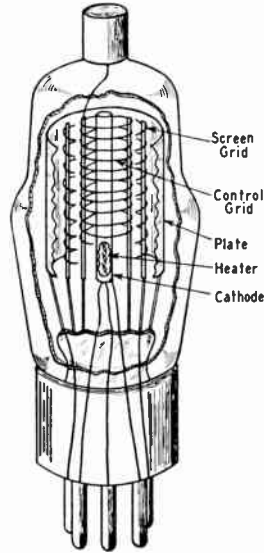

Fig. 3-16 — Representative arrangement of elements in a screen-grid tube, with front part of plate and screen grid cut away. In this drawing the control-grid connection is made through a cap on the top of the tube, thus eliminating the capacitance that would exist between the plate and grid-lead wires if both passed through the base. "Single-ended" tubes that have both leads going through the base use special shielding and construction to eliminate interlead capacitance.

shoot between the screen wires and then are attracted to the plate. A certain proportion do strike the screen, however, with the result that some current also flows in the screen-grid circuit.

To be a good shield, the screen grid must be connected to the cathode through a circuit that has low impedance at the frequency being amplified. A by-pass capacitor from screen grid to cathode, having a reactance of not more than a few hundred ohms, is generally used.

A tube having a cathode, control grid, screen grid and plate (four elements) is called a **tetrode**.

Pentodes

When an electron traveling at appreciable velocity through a tube strikes the plate it dislodges other electrons which "splash" from the plate into the interelement space. This is called **secondary emission**. In a triode the negative grid repels the secondary electrons back into the plate and they cause no disturbance. In the screen-grid tube, however, the positively-charged screen *attracts* the secondary electrons, causing a reverse current to flow between screen and plate.

To overcome the effects of secondary emission, a third grid, called the **suppressor grid**, may be inserted between the screen and plate. This grid acts as a shield between the screen grid and plate so the secondary electrons cannot be attracted by the screen grid. They are hence attracted back to the plate without appreciably obstructing the regular plate-current flow. A five-element tube of this type is called a **pentode**.

Although the screen grid in either the tetrode or pentode greatly reduces the influence of the plate upon plate-current flow, the control grid still can control the plate current in essentially the same way that it does in a triode. Consequently, the grid-plate transconductance (or mutual conductance) of a tetrode or pentode will be of the same order of value as in a triode of cor-

responding structure. On the other hand, since a change in plate voltage has very little effect on the plate-current flow, both the amplification factor and plate resistance of a pentode or tetrode are very high. In small receiving pentodes the amplification factor is of the order of 1000 or higher, while the plate resistance may be from 0.5 to 1 or more megohms. Because of the high plate resistance, the actual voltage amplification possible with a pentode is very much less than the large amplification factor might indicate. A voltage gain in the vicinity of 50 to 200 is typical of a pentode stage.

In practical screen-grid tubes the grid-plate capacitance is only a small fraction of a micro-microfarad. This capacitance is too small to cause an appreciable increase in input capacitance as described in the preceding section, so the input capacitance of a screen-grid tube is simply the sum of its grid-cathode capacitance and control-grid-to-screen capacitance. The output capacitance of a screen-grid tube is equal to the capacitance between the plate and screen.

In addition to their applications as radio-frequency amplifiers, pentodes or tetrodes also are used for audio-frequency power amplification. In tubes designed for this purpose the chief function of the screen is to serve as an accelerator of the electrons, so that large values of plate current can be drawn at relatively low plate voltages. Such tubes have quite high power sensitivity compared with triodes of the same power output, although harmonic distortion is somewhat greater.

Beam Tubes

A **beam tetrode** is a four-element screen-grid tube constructed in such a way that the electrons are formed into concentrated beams on their way to the plate. Additional design features overcome the effects of secondary emission so that a suppressor grid is not needed. The "beam" construction makes it possible to draw large plate currents at relatively low plate voltages, and increases the power sensitivity.

For power amplification at both audio and radio frequencies beam tetrodes have largely supplanted the pentode type because large power outputs can be secured with very small amounts of grid driving power.

Variable- μ Tubes

The mutual conductance of a vacuum tube decreases when its grid bias is made more negative, assuming that the other electrode voltages are held constant. Since the mutual conductance controls the amount of amplification, it is possible to adjust the gain of the amplifier by adjusting the grid bias. This method of gain control is universally used in radio-frequency amplifiers designed for receivers.

The ordinary type of tube has what is known as a **sharp-cutoff** characteristic. The mutual conductance decreases at a uniform rate as the negative bias is increased. The amount of signal voltage that such a tube can handle without causing distortion is not sufficient to take care of

very strong signals. To overcome this, some tubes are made with a **variable- μ** characteristic — that is, the amplification factor decreases with increasing grid bias. The variable- μ tube can handle a much larger signal than the sharp-cutoff type before the signal swings either beyond the zero grid-bias point or the plate-current cutoff point.

● INPUT AND OUTPUT IMPEDANCES

The **input impedance** of a vacuum-tube amplifier is the impedance "seen" by the signal source when connected to the input terminals of the amplifier. In the types of amplifiers previously discussed, the input impedance is the impedance measured between the grid and cathode of the tube with operating voltages applied. At audio frequencies the input impedance of a Class A₁ amplifier is for all practical purposes the input capacitance of the stage. If the tube is driven into the grid-current region there is in addition a resistance component in the input impedance, the resistance having an average value equal to E^2/P , where E is the r.m.s. driving voltage and P is the power in watts consumed in the grid. The resistance usually will vary during the a.c. cycle because grid current may flow only during part of the cycle; also, the grid-voltage/grid-current characteristic is seldom linear.

The **output impedance** of amplifiers of this type consists of the plate resistance of the tube shunted by the output capacitance.

At radio frequencies, when tuned circuits are employed, the input and output impedances are usually pure resistances; any reactive components are "tuned out" in the process of adjusting the circuits to resonance at the operating frequency.

● OTHER TYPES OF AMPLIFIERS

In the amplifier circuits so far discussed, the signal has been applied between the grid and cathode and the amplified output has been taken from the plate-to-cathode circuit. That is, the *cathode* has been the meeting point for the input and output circuits. However, it is possible to use any one of the three principal elements as the common point. This leads to two additional kinds of amplifiers, commonly called the **grounded-grid amplifier** (or **grid-separation** circuit) and the **cathode follower**.

These two circuits are shown in simplified form in Fig. 3-17. In both circuits the resistor R represents the load into which the amplifier works; the actual load may be resistance-capacitance-coupled, transformer-coupled, may be a tuned circuit if the amplifier operates at radio frequencies, and so on. Also, in both circuits the batteries that supply grid bias and plate power are assumed to have such negligible impedance that they do not enter into the operation of the circuits.

Grounded-Grid Amplifier

In the grounded-grid amplifier the input signal is applied between the cathode and grid, and the output is taken between the plate and grid. The

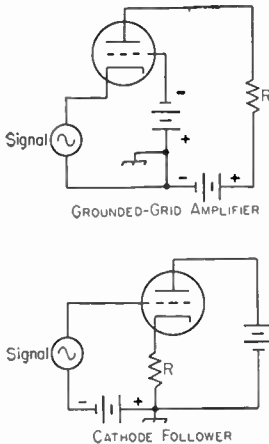

Fig. 3-17 — In the upper circuit, the grid is the junction point between the input and output circuits. In the lower drawing, the plate is the junction. In either case the output is developed in the load resistor, R , and may be coupled to a following amplifier by the usual methods.

grid is thus the common element. The a.c. component of the plate current has to flow through the signal source to reach the cathode. The source of signal is in series with the load through the plate-to-cathode resistance of the tube, so some of the power in the load is supplied by the signal source. In transmitting applications this fed-through power is of the order of 10 per cent of the total power output, using tubes suitable for grounded-grid service.

The input impedance of the grounded-grid amplifier consists of a capacitance in parallel with an equivalent resistance representing the power furnished by the driving source to the grid and to the load. This resistance is of the order of a few hundred ohms. The output impedance, neglecting the interelectrode capacitances, is equal to the plate resistance of the tube. This is the same as in the case of the grounded-cathode amplifier.

The grounded-grid amplifier is widely used at v.h.f. and u.h.f., where the more conventional amplifier circuit fails to work properly. With a triode tube designed for this type of operation, an r.f. amplifier can be built that is free from the type of feedback that causes oscillation. This requires that the grid act as a shield between the cathode and plate, reducing the plate-cathode capacitance to a very low value.

Cathode Follower

The cathode follower uses the plate of the tube as the common element. The input signal is applied between the grid and plate (assuming negligible impedance in the batteries) and the output is taken between cathode and plate. This circuit is degenerative; in fact, all of the output voltage is fed back into the input circuit out of phase with the grid signal. The input signal therefore has to be larger than the output voltage; that is, the cathode follower gives a loss in voltage, although it gives the same power gain as other circuits under equivalent operating conditions.

An important feature of the cathode follower is its low output impedance, which is given by the formula (neglecting interelectrode capacitances)

$$Z_{out} = \frac{r_p}{1 + \mu}$$

where r_p is the tube plate resistance and μ is the amplification factor. Low output impedance is a valuable characteristic in an amplifier designed to cover a wide band of frequencies. In addition, the input capacitance is only a fraction of the grid-to-cathode capacitance of the tube, a feature of further benefit in a wide-band amplifier. The cathode follower is useful as a step-down impedance transformer, since the input impedance is high and the output impedance is low.

CATHODE CIRCUITS AND GRID BIAS

Most of the equipment used by amateurs is powered by the a.c. line. This includes the filaments or heaters of vacuum tubes. Although supplies for the plate (and sometimes the grid) are usually rectified and filtered to give pure d.c. — that is, direct current that is constant and without a superimposed a.c. component — the relatively large currents required by filaments and heaters usually make a rectifier-type d.c. supply impracticable.

Filament Hum

Alternating current is just as good as direct current from the heating standpoint, but some of the a.c. voltage is likely to get on the grid and cause a low-pitched "a.c. hum" to be superimposed on the output.

Hum troubles are worst with directly-heated cathodes or filaments, because with such cathodes there has to be a direct connection between the source of heating power and the rest of the circuit. The hum can be minimized by either of the connections shown in Fig. 3-18. In both cases the grid- and plate-return circuits are connected to the electrical midpoint (center tap) of the filament supply. Thus, so far as the grid and plate are concerned, the voltage and current on one side of the filament are balanced by an equal and opposite voltage and current on the other side. The balance is never quite perfect, however, so filament-type tubes are never completely hum-

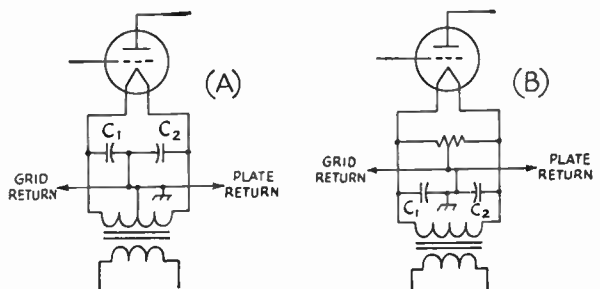

Fig. 3-18 — Filament center-tapping methods for use with directly-heated tubes.

free. For this reason directly-heated filaments are employed for the most part in power tubes, where the amount of hum introduced is extremely small in comparison with the power-output level.

With indirectly-heated cathodes the chief problem is the magnetic field set up by the heater. Occasionally, also, there is leakage between the heater and cathode, allowing a small a.c. voltage to get to the grid. If hum appears, grounding one side of the heater supply usually will help to reduce it, although sometimes better results are obtained if the heater supply is center-tapped and the center-tap grounded, as in Fig. 3-18.

Cathode Bias

In the simplified amplifier circuits discussed in this chapter, grid bias has been supplied by a battery. However, in equipment that operates from the power line cathode bias is very frequently used.

The cathode-bias method uses a resistor (cathode resistor) connected in series with the cathode, as shown at R in Fig. 3-19. The direction of plate-current flow is such that the end of the resistor nearest the cathode is positive. The voltage drop

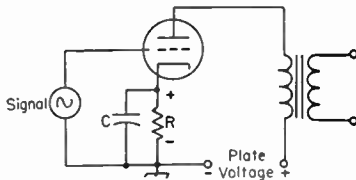

Fig. 3-19—Cathode biasing. R is the cathode resistor and C is the cathode by-pass capacitor.

across R therefore places a *negative* voltage on the grid. This negative bias is obtained from the steady d.c. plate current.

If the alternating component of plate current flows through R when the tube is amplifying, the voltage drop caused by the a.c. will be degenerative (note the similarity between this circuit and that of Fig. 3-14A). To prevent this the resistor is bypassed by a capacitor, C , that has very low reactance compared with the resistance of R . Depending on the type of tube and the particular kind of operation, R may be between about 100 and 3000 ohms. For good bypassing at the low audio frequencies, C should be 10 to 50 microfarads (electrolytic capacitors are used for this purpose). At radio frequencies, capacitances of about 100 $\mu\text{f.}$ to 0.1 $\mu\text{f.}$ are used; the small values are sufficient at very high frequencies and the largest at low and medium frequencies. In the range 3 to 30 megacycles a capacitance of 0.01 $\mu\text{f.}$ is satisfactory.

The value of cathode resistor for an amplifier having negligible d.c. resistance in its plate circuit (transformer or impedance coupled) can easily be calculated from the known operating conditions of the tube. The proper grid bias and plate current always are specified by the manufacturer. Knowing these, the required resistance can be found by applying Ohm's Law.

Example: It is found from tube tables that the tube to be used should have a negative grid bias of 8 volts and that at this bias the plate current will be 12 milliamperes (0.012 amp.). The required cathode resistance is then

$$R = \frac{E}{I} = \frac{8}{0.012} = 667 \text{ ohms.}$$

The nearest standard value, 680 ohms, would be close enough. The power used in the resistor is

$$P = EI = 8 \times 0.012 = 0.096 \text{ watt.}$$

A $\frac{1}{4}$ -watt or $\frac{1}{2}$ -watt resistor would have ample rating.

The current that flows through R is the total cathode current. In an ordinary triode amplifier this is the same as the plate current, but in a screen-grid tube the cathode current is the sum of the plate and screen currents. Hence these two currents must be added when calculating the value of cathode resistor required for a screen-grid tube.

Example: A receiving pentode requires 3 volts negative bias. At this bias and the recommended plate and screen voltages, its plate current is 9 ma. and its screen current is 2 ma. The cathode current is therefore 11 ma. (0.011 amp.). The required resistance is

$$R = \frac{E}{I} = \frac{3}{0.011} = 272 \text{ ohms.}$$

A 270-ohm resistor would be satisfactory. The power in the resistor is

$$P = EI = 3 \times 0.011 = 0.033 \text{ watt.}$$

The cathode-resistor method of biasing is self-regulating, because if the tube characteristics vary slightly from the published values (as they do in practice) the bias will increase if the plate current is slightly high, or decrease if it is slightly low. This tends to hold the plate current at the proper value.

Calculation of the cathode resistor for a resistance-coupled amplifier is ordinarily not practicable by the method described above, because the plate current in such an amplifier is usually much smaller than the rated value given in the tube tables. However, representative data for the tubes commonly used as resistance-coupled amplifiers are given in the chapter on audio amplifiers, including cathode-resistor values.

"Contact Potential" Bias

In the absence of any negative bias voltage on the grid of a tube, some of the electrons in the space charge will have enough velocity to reach the grid. This causes a small current (of the order of microamperes) to flow in the external circuit between the grid and cathode. If the current is made to flow through a high resistance — a megohm or so — the resulting voltage drop in the resistor will give the grid a negative bias of the order of one volt. The bias so obtained is called contact-potential bias.

Contact-potential bias can be used to advantage in circuits operating at low signal levels (less than one volt peak) since it eliminates the cathode-bias resistor and by-pass capacitor. It is principally used in low-level resistance-coupled audio

amplifiers. The bias resistor is connected directly between grid and cathode, and must be isolated from the signal source by a blocking capacitor.

Screen Supply

In practical circuits using tetrodes and pentodes the voltage for the screen frequently is taken from the plate supply through a resistor. A typical circuit for an r.f. amplifier is shown in Fig. 3-20. Resistor R is the screen dropping resistor, and C is the screen by-pass capacitor. In flowing through R , the screen current causes a voltage drop in R that reduces the plate-supply voltage to the proper value for the screen. When the plate-supply voltage and the screen current are known, the value of R can be calculated from Ohm's Law.

Example: An r.f. receiving pentode has a rated screen current of 2 milliamperes (0.002 amp.) at normal operating conditions. The rated screen voltage is 100 volts, and the plate supply gives 250 volts. To put 100 volts on the screen, the drop across R must be equal to the difference between the plate-supply voltage and the screen voltage; that is, $250 - 100 = 150$ volts. Then

$$R = \frac{E}{I} = \frac{150}{0.002} = 75,000 \text{ ohms.}$$

The power to be dissipated in the resistor is

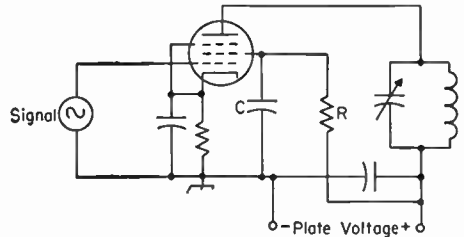

Fig. 3-20 — Screen-voltage supply for a pentode tube through a dropping resistor, R . The screen by-pass capacitor, C , must have low enough reactance to bring the screen to ground potential for the frequency or frequencies being amplified.

$$P = EI = 150 \times 0.002 = 0.3 \text{ watt.}$$

A $\frac{1}{2}$ - or 1-watt resistor would be satisfactory.

The reactance of the screen by-pass capacitor, C , should be low compared with the screen-to-cathode impedance. For radio-frequency applications a capacitance in the vicinity of $0.01 \mu\text{f}$. is amply large.

In some vacuum-tube circuits the screen voltage is obtained from a voltage divider connected across the plate supply. The design of voltage dividers is discussed at length in the chapter on Power Supplies.

Oscillators

It was mentioned earlier in this chapter that if there is enough positive feedback in an amplifier circuit, self-sustaining oscillations will be set up. When an amplifier is arranged so that this condition exists it is called an oscillator.

Oscillations normally take place at only one frequency, and a desired frequency of oscillation can be obtained by using a resonant circuit tuned to that frequency. For example, in Fig. 3-21A the circuit LC is tuned to the desired frequency of oscillation. The cathode of the tube is connected to a tap on coil L and the grid and plate are connected to opposite ends of the tuned circuit. When an r.f. current flows in the tuned circuit there is a voltage drop across L that increases progressively along the turns. Thus the point at which the tap is connected will be at an intermediate potential with respect to the two ends of the coil. The amplified current in the plate circuit, which flows through the bottom section of L , is in phase with the current already flowing in the circuit and thus in the proper relationship for positive feedback.

The amount of feedback depends on the position of the tap. If the tap is too near the grid end the voltage drop between grid and cathode is too small to give enough feedback to sustain oscillation, and if it is too near the plate end the impedance between the cathode and plate is too small to permit good amplification. Maximum feedback usually is obtained when the tap is somewhere near the center of the coil.

The circuit of Fig. 3-21A is parallel-fed, C_b being the blocking capacitor. The value of C_b is not critical so long as its reactance is low (not more than a few hundred ohms) at the operating frequency.

Condenser C_g is the grid capacitor. It and R_g (the grid leak) are used for the purpose of ob-

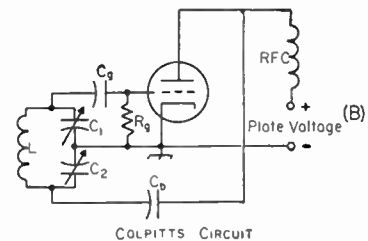
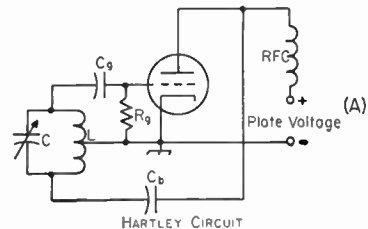

Fig. 3-21 — Basic oscillator circuits. Feed-back voltage is obtained by tapping the grid and cathode across a portion of the tuned circuit. In the Hartley circuit the tap is on the coil, but in the Colpitts circuit the voltage is obtained from the drop across a capacitor.

taining grid bias for the tube. In practically all oscillator circuits the tube generates its own bias. During the part of the cycle when the grid is positive with respect to the cathode, it attracts electrons. These electrons cannot flow through L back to the cathode because C_g "blocks" direct current. They therefore have to flow or "leak" through R_g to cathode, and in doing so cause a voltage drop in R_g that places a negative bias on the grid. The amount of bias so developed is equal to the grid current multiplied by the resistance of R_g (Ohm's Law). The value of grid-leak resistance required depends upon the kind of tube used and the purpose for which the oscillator is intended. Values range all the way from a few thousand to several hundred thousand ohms. The capacitance of C_g should be large enough to have low reactance (a few hundred ohms) at the operating frequency.

The circuit shown at B in Fig. 3-21 uses the voltage drops across two capacitors in series in the tuned circuit to supply the feedback. Other than this, the operation is the same as just described. The feedback can be varied by varying the ratio of the reactances of C_1 and C_2 (that is, by varying the ratio of their capacitances).

Another type of oscillator, called the **tuned-plate tuned-grid circuit**, is shown in Fig. 3-22.

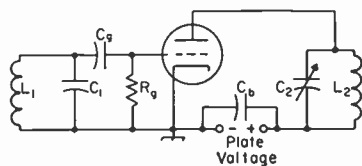

Fig. 3-22 — The tuned-plate tuned-grid oscillator.

Resonant circuits tuned approximately to the same frequency are connected between grid and cathode and between plate and cathode. The two coils, L_1 and L_2 , are not magnetically coupled. The feedback is through the grid-plate capacitance of the tube, and will be in the right phase to be positive when the plate circuit, C_2L_2 , is tuned to a slightly higher frequency than the grid circuit, L_1C_1 . The amount of feedback can be adjusted by varying the tuning of either circuit. The frequency of oscillation is determined by the tuned circuit that has the higher Q . The grid leak and grid capacitor have the same functions as in the other circuits. In this case it is convenient to use series feed for the plate circuit, so C_b is a by-pass capacitor to guide the r.f. current around the plate supply.

There are many oscillator circuits (examples of others will be found in later chapters) but the basic feature of all of them is that there is positive feedback in the proper amplitude to sustain oscillation.

Oscillator Operating Characteristics

When an oscillator is delivering power to a load, the adjustment for proper feedback will depend on how heavily the oscillator is loaded — that is, how much power is being taken from

the circuit. If the feedback is not large enough — **grid excitation** too small — a small increase in load may tend to throw the circuit out of oscillation. On the other hand, too much feedback will make the grid current excessively high, with the result that the power loss in the grid circuit becomes larger than necessary. Since the oscillator itself supplies this grid power, excessive feedback lowers the over-all efficiency because whatever power is used in the grid circuit is not available as useful output.

One of the most important considerations in oscillator design is **frequency stability**. The principal factors that cause a change in frequency are (1) temperature, (2) plate voltage, (3) loading, (4) mechanical variations of circuit elements. Temperature changes will cause vacuum-tube elements to expand or contract slightly, thus causing variations in the interelectrode capacitances. Since these are unavoidably part of the tuned circuit, the frequency will change correspondingly. Temperature changes in the coil or the tuning capacitor will alter the inductance or capacitance slightly, again causing a shift in the resonant frequency. These effects are relatively slow in operation, and the frequency change caused by them is called **drift**.

A change in plate voltage usually will cause the frequency to change a small amount, an effect called **dynamic instability**. Dynamic instability can be reduced by using a tuned circuit of high effective Q . The energy taken from the circuit to supply grid losses, as well as energy supplied to a load, represent an increase in the effective resistance of the tuned circuit and thus lower its Q . For highest stability, therefore, the coupling between the tuned circuit and the tube and load must be kept as loose as possible. Preferably, the oscillator should not be required to deliver power to an external circuit, and a high value of grid leak resistance should be used since this helps to raise the tube grid and plate resistances as seen by the tuned circuit. Loose coupling can be effected in a variety of ways — one, for example, is by "tapping down" on the tank for the connections to the grid and plate. This is done in the "series-tuned" Colpitts circuit widely used in variable-frequency oscillators for amateur transmitters and described in a later chapter. Alternatively, the L/C ratio may be made as small as possible while sustaining stable oscillation (**high C**) with the grid and plate connected to the ends of the circuit as shown in Figs. 3-21 and 3-22. Using relatively high plate voltage and low plate current also is desirable.

In general, dynamic stability will be at maximum when the feedback is adjusted to the least value that permits reliable oscillation. The use of a tube having a high value of transconductance is desirable, since the higher the transconductance the looser the permissible coupling to the tuned circuit and the smaller the feedback required.

Load variations act in much the same way as plate-voltage variations. A temperature change in the load may also result in drift.

Mechanical variations, usually caused by

vibration, cause changes in inductance and/or capacitance that in turn cause the frequency to "wobble" in step with the vibration.

Methods of minimizing frequency variations in oscillators are taken up in detail in later chapters.

Ground Point

In the oscillator circuits shown in Figs. 3-21 and 3-22 the cathode is connected to ground. It is not actually essential that the radio-frequency circuit should be grounded at the cathode; in fact, there are many times when an r.f. ground on some other point in the circuit is desirable. The r.f. ground can be placed at any point so long as proper provisions are made for feeding the supply voltages to the tube elements.

Fig. 3-23 shows the Hartley circuit with the plate end of the circuit grounded. No r.f. choke is needed in the plate circuit because the plate already is at ground potential and there is no r.f. to choke off. All that is necessary is a by-pass capacitor, C_b , across the plate supply. Direct

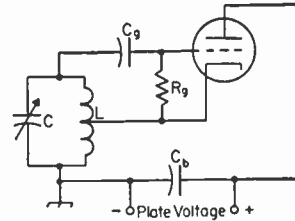

Fig. 3-23 — Showing how the plate may be grounded for r.f. in a typical oscillator circuit (Hartley).

current flows to the cathode through the lower part of the tuned-circuit coil, L . An advantage of such a circuit is that the frame of the tuning capacitor can be grounded.

Tubes having indirectly-heated cathodes are more easily adaptable to circuits grounded at other points than the cathode than are tubes having directly-heated filaments. With the latter tubes special precautions have to be taken to prevent the filament from being bypassed to ground by the capacitance of the filament-heating transformer.

Clipping Circuits

Vacuum tubes are readily adaptable to other types of operation than ordinary amplification (without substantial distortion) and the genera-

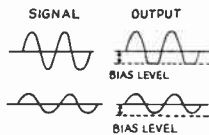
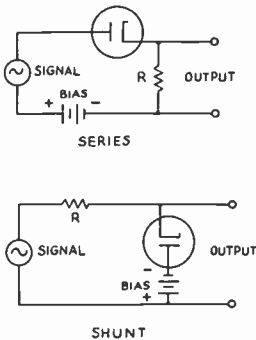

Fig. 3-24 — Series and shunt diode clippers. Typical operation is shown at the right.

tion of single-frequency oscillations. Of particular interest is the clipper or limiter circuit, because of its several applications in receiving and other equipment.

Diode Clipper Circuits

Basic diode clipper circuits are shown in Fig. 3-24. In the series type a positive d.c. bias voltage is applied to the plate of the diode so it is normally conducting. When a signal is applied the current through the diode will change proportionately during the time the signal voltage is positive at the diode plate and for that part of the negative half of the signal during which the instantaneous voltage does not exceed the bias. When the negative signal voltage exceeds the positive bias the resultant voltage at the diode

plate is negative and there is no conduction. Thus part of the negative half cycle is clipped as shown in the drawing at the right. The level at which clipping occurs depends on the bias voltage, and the proportion of signal clipping depends on the signal strength in relation to the bias voltage. If the peak signal voltage is below the bias level there is no clipping and the output wave shape is the same as the input wave shape, as shown in the lower sketch. The output voltage results from the current flow through the load resistor R .

In the shunt-type diode clipper negative bias is applied to the plate so the diode is normally nonconducting. In this case the signal voltage is fed through the series resistor R to the output circuit (which must have high impedance compared with the resistance of R). When the negative half of the signal voltage exceeds the bias voltage the diode conducts, and because of the voltage drop in R when current flows the output voltage is reduced. By proper choice of R in relationship to the load on the output circuit the clipping can be made equivalent to that given by the series circuit. There is no clipping when the peak signal voltage is below the bias level.

Two diode circuits can be combined so that both the negative and positive peaks of the signal are clipped.

Triode Clippers

The circuit shown at A in Fig. 3-25 is capable of clipping both negative and positive signal peaks. On positive peaks its operation is similar to the shunt diode clipper, the clipping taking place when the positive peak of the signal voltage

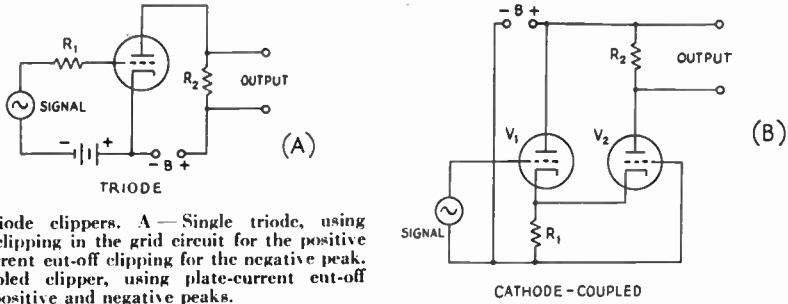

Fig. 3-25 — Triode clippers. A — Single triode, using shunt-type diode clipping in the grid circuit for the positive peak and plate-current cut-off clipping for the negative peak. B — Cathode-coupled clipper, using plate-current cut-off clipping for both positive and negative peaks.

is large enough to drive the grid positive. The positive-clipped signal is amplified by the tube as a resistance-coupled amplifier. Negative peak clipping occurs when the negative peak of the signal voltage exceeds the fixed grid bias and thus cuts off the plate current in the output circuit.

In the cathode-coupled clipper shown at B in Fig. 3-25 V_1 is a cathode follower with its output circuit directly connected to the cathode of V_2 , which is a grounded-grid amplifier. The tubes are biased by the voltage drop across R_1 , which carries the d.c. plate currents of both tubes. When the negative peak of the signal voltage ex-

ceeds the d.c. voltage across R_1 clipping occurs in V_1 , and when the positive peak exceeds the same value of voltage V_2 's plate current is cut off. (The bias developed in R_1 tends to be constant because the plate current of one tube increases when the plate current of the other decreases.) Thus the circuit clips both positive and negative peaks. The clipping is symmetrical, providing the d.c. voltage drop in R_2 is small enough so that the operating conditions of the two tubes are substantially the same. For signal voltages below the clipping level the circuit operates as normal amplifier with low distortion.

U.H.F. and Microwave Tubes

At ultrahigh frequencies, interelectrode capacitances and the inductance of internal leads determine the highest possible frequency to which a vacuum tube can be tuned. The tube usually will not oscillate up to this limit, however, because of dielectric losses, transit time and other effects. In low-frequency operation, the actual time of flight of electrons between the cathode and the anode is negligible in relation to the duration of the cycle. At 1000 kc., for example, transit time of 0.001 microsecond, which is typical of conventional tubes, is only 1/1000 cycle. But at 100 Mc., this same transit time represents 1/10 of a cycle, and a full cycle at 1000 Mc. These limiting factors establish about 3000 Mc. as the upper frequency limit for negative-grid tubes.

With most tubes of conventional design, the upper limit of useful operation is around 150 Mc. For higher frequencies tubes of special construction are required. About the only means available for reducing interelectrode capacitances is to reduce the physical size of the elements, which is practical only in tubes which do not have to handle appreciable power. However, it is possible to reduce the internal lead inductance very materially by minimizing the lead length and by using two or more leads in parallel from an electrode.

In some types the electrodes are provided with up to five separate leads which may be connected in parallel externally. In double-lead types the plate and grid elements are supported by heavy single wires which run entirely through the envelope, providing terminals at either end of the

bulb. With linear tank circuits the leads become a part of the line and have distributed rather than lumped constants.

In "lighthouse" tubes or disk-seal tubes, the plate, grid and cathode are assembled in parallel

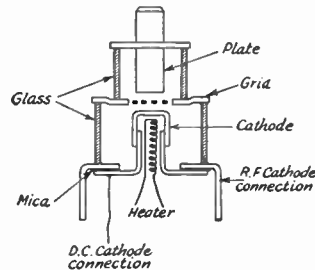

Fig. 3-26 — Sectional view of the "lighthouse" tube's construction. Close electrode spacing reduces transit time while the disk electrode connections reduce lead inductance.

planes, as shown in Fig. 3-26, instead of coaxially. The disk-seal terminals practically eliminate lead inductance.

Velocity Modulation

In conventional tube operation the potential on the grid tends to reduce the electron velocity during the more negative half of the cycle, while on the other half cycle the positive potential on the grid serves to accelerate the electrons. Thus the electrons tend to separate into groups, those leaving the cathode during the negative half-cycle being collectively slowed down, while those

leaving on the positive half are accelerated. After passing into the grid-plate space only a part of the electron stream follows the original form of the oscillation cycle, the remainder traveling to the plate at differing velocities. Since these contribute nothing to the power output at the operating frequency, the efficiency is reduced in direct proportion to the variation in velocity, the output reaching a value of zero when the transit time approaches a half-cycle.

This effect is turned to advantage in **velocity-modulated tubes** in that the input signal voltage on the grid is used to change the velocity of the electrons in a constant-current electron beam, rather than to vary the intensity of a constant-velocity current flow as is the method in ordinary tubes.

The velocity modulation principle may be used in a number of ways, leading to several tube designs. The major tube of this type is the "klystron."

The Klystron

In the **klystron tube** the electrons emitted by the cathode pass through an electric field established by two grids in a cavity resonator called the **buncher**. The high-frequency electric field between the grids is parallel to the electron stream. This field accelerates the electrons at one moment and retards them at another, in accordance with the variations of the r.f. voltage applied. The resulting velocity-modulated beam travels through a field-free "drift space," where the slower-moving electrons are gradually overtaken by the faster ones. The electrons emerging from the pair of grids therefore are separated into groups or "bunched" along the direction of motion. The velocity-modulated electron stream then goes to a **catcher cavity** where it again passes through two parallel grids, and the r.f. current created by the bunching of the elec-

tron beam induces an r.f. voltage between the grids. The catcher cavity is made resonant at the frequency of the velocity-modulated electron beam, so that an oscillating field is set up within it by the passage of the electron bunches through the grid aperture.

If a feed-back loop is provided between the two cavities, as shown in Fig. 3-27, oscillations will occur. The resonant frequency depends on the electrode voltages and on the shape of the cavities, and may be adjusted by varying the supply voltage and altering the dimensions of the cavities. Although the bunched beam current is rich in harmonics the output wave form is remarkably pure because the high *Q* of the catcher cavity suppresses the unwanted harmonics.

Magnetrons

A **magnetron** is fundamentally a diode with cylindrical electrodes placed in a uniform magnetic field, with the lines of magnetic force parallel to the axes of the elements. The simple cylindrical magnetron consists of a cathode surrounded by a concentric cylindrical anode. In the more effi-

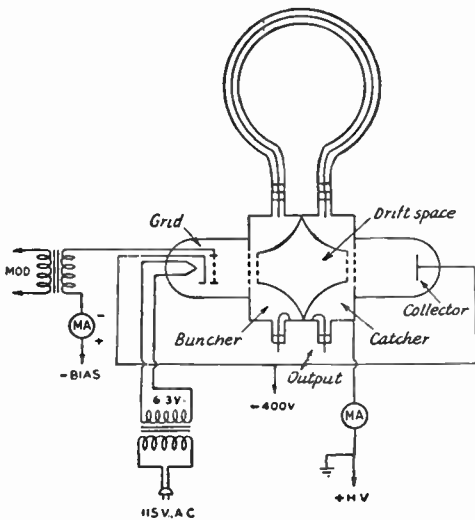

Fig. 3-27 — Circuit diagram of the klystron oscillator, showing the feed-back loop coupling the frequency-controlling cavities.

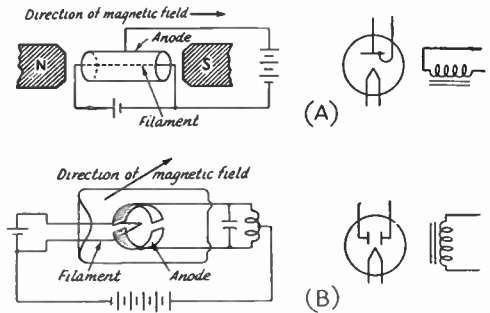

Fig. 3-28 — Conventional magnetrons, with equivalent schematic symbols at the right. A, simple cylindrical magnetron. B, split-anode negative-resistance magnetron.

cient split-anode magnetron the cylinder is divided lengthwise.

Magnetron oscillators are operated in two different ways. Electrically the circuits are similar, the difference being in the relation between electron transit time and the frequency of oscillation.

In the negative-resistance or dynatron type of magnetron oscillator, the element dimensions and anode voltage are such that the transit time is short compared with the period of the oscillation frequency. Electrons emitted from the cathode are driven toward both halves of the anode. If the potentials of the two halves are unequal, the effect of the magnetic field is such that the majority of the electrons travel to the half of the anode that is at the lower potential. That is, a decrease in the potential of either half of the anode results in an increase in the electron current flowing to that half. The magnetron consequently exhibits negative-resistance characteristics. Negative-resistance magnetron oscillators are useful between 100 and 1000 Mc. Under the best operating conditions efficiencies of 20 to 25 per cent may be obtained.

In the transit-time magnetron the frequency is determined primarily by the tube dimensions and by the electric and magnetic field intensities rather than by the tuning of the tank circuits. The intensity of the magnetic field is adjusted so that, under static conditions, electrons leaving the cathode move in curved paths which just fail to reach the anode. All electrons are therefore deflected back to the cathode, and the anode current is zero. An alternating voltage applied between the two halves of the anode will cause the

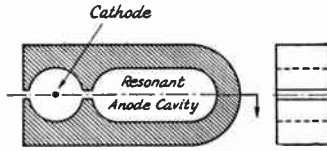

Fig. 3-29 — Split-anode magnetron with integral resonant anode cavity for use at u.h.f.

potentials of these halves to vary about their average positive values. If the period (time required for one cycle) of the alternating voltage is made equal to the time required for an electron to make one complete rotation in the magnetic field, the a.c. component of the anode voltage reverses direction twice with each electron rotation. Some electrons will lose energy to the electric field, with the result that they are unable to reach the cathode and continue to rotate about it. Meanwhile other electrons gain energy from the field and are

returned to the cathode. Since those electrons that lose energy remain in the interelectrode space longer than those that gain energy, the net effect is a transfer of energy from the electrons to the electric field. This energy can be used to sustain oscillations in a resonant transmission line connected between the two halves of the anode.

Split-anode magnetrons for u.h.f. are constructed with a cavity resonator built into the tube structure, as illustrated in Fig. 3-29. The assembly is a solid block of copper which assists in heat dissipation. At extremely high frequencies operation is improved by subdividing the anode structure into 4 to 16 or more segments, the resonant cavities for each anode being coupled to the common cathode region by slots of critical dimensions.

Traveling-Wave Tubes

The efficiency of multisegment magnetrons reaches 65 or 70 per cent. Slotted-anode magnetrons with four segments function up to 30,000 Mc. (1 cm.), delivering up to 100 watts at efficiencies greater than 50 per cent. Using larger multiples of anodes and higher-order modes, performance can be attained at 0.2 cm.

Gains as high as 23 db. over a band width of 800 Mc. at a center frequency of 3600 Mc. have been obtained through the use of a traveling-wave amplifier tube shown schematically in Fig. 3-30. An electromagnetic wave travels down the helix, and an electron beam is shot through the helix parallel to its axis, and in the direction of propagation of the wave. When the electron velocity is about the same as the wave velocity in the absence of the electrons, turning on the electron beam causes a power gain for wave propagation in the direction of the electron motion.

Fig. 3-30 — Schematic drawing of a traveling-wave amplifier tube.

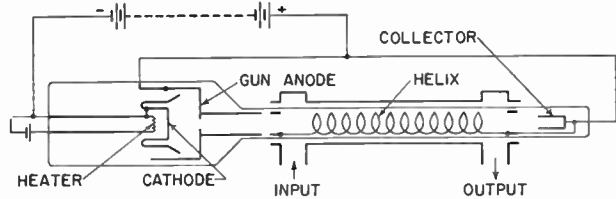

returned to the cathode. Since those electrons that lose energy remain in the interelectrode space longer than those that gain energy, the net effect is a transfer of energy from the electrons to the electric field. This energy can be used to sustain oscillations in a resonant transmission line connected between the two halves of the anode.

Split-anode magnetrons for u.h.f. are constructed with a cavity resonator built into the tube structure, as illustrated in Fig. 3-29. The

“output” are wave-guide sections to which the ends of the helix are coupled. In practice two electromagnetic focusing coils are used, one forming a lens at the electron gun end, and the other a solenoid running the length of the helix.

The outstanding features of the traveling-wave amplifier tube are its great bandwidth and large power gain. However, the efficiency is rather low. Typical power output is of the order of 200 milliwatts.

Semiconductor Devices

Certain materials whose resistivity is not high enough to classify them as good insulators, but is still high compared with the resistivity of common metals, are known as **semiconductors**. These materials, of which germanium and silicon are examples, have an atomic structure that normally is associated with insulators. However, it is possible for free electrons to exist in them and to move through them under the influence of an electric field. It is also possible for some of the atoms to be deficient in an electron, and these electron deficiencies or **holes** can move from atom to atom when urged to do so by an applied electric force. (The movement of a hole is actually the movement of an electron, the electron becoming detached from one atom, making a hole in that atom, in order to move into an existing hole in another atom.)

Electron and Hole Conduction

Material which conducts by virtue of a deficiency in electrons — that is, by **hole conduction** — is called **P-type material**. In **N-type material**, which has an excess of electrons, the conduction is termed “**electronic**.” If a piece of P-type material is joined to a piece of N-type material as at A in Fig. 4-1 and a voltage is applied to the pair as at B, current will flow across the boundary or junction between the two (and also in the external circuit) when the battery has the polarity indicated. Electrons, indicated by the minus symbol, are attracted across the junction from the N material through the P material to the positive terminal of the battery, and holes, indicated by the plus symbol, are attracted in the opposite direction across the junction by the negative potential of the battery. Thus current flows through the circuit by means of electrons moving one way and holes the other.

If the battery polarity is reversed, as at C, the excess electrons in the N material are attracted away from the junction and the holes in the P material are attracted by the negative potential of the battery away from the junction. This leaves the junction region without any current carriers, consequently there is no conduction.

In other words, a junction of P- and N-type materials constitutes a rectifier. It differs from the tube diode rectifier in that there is a measurable, although compara-

tively very small, reverse current, since the operation of the device is not as perfect as assumed in this simplified description.

Electrons and holes do not move as rapidly through the solid materials as electrons do in a vacuum. Also, the holes move more slowly than the electrons. This, together with the fact that the junction forms a capacitor with the two plates separated by practically zero spacing and hence has relatively high capacitance, places a limit on the upper frequency at which semiconductor devices of this construction will operate, as compared with vacuum tubes. Also, the number of excess electrons and holes in the material depends upon temperature, and since the conductivity in turn depends on the number of excess holes and electrons, the device is more temperature sensitive than is a vacuum tube.

Capacitance may be reduced by making the contact area very small. This is done by means of a **point contact**, a tiny P-type region being formed under the contact point during manufacture when N-type material is used for the main body of the device.

SEMICONDUCTOR DIODES

Diodes of the point-contact type are used for many of the same purposes for which tube diodes are used. The construction of such a diode is shown in Fig. 4-2. Germanium and silicon are the most widely used materials, the latter principally in the u.h.f. region.

As compared with the tube diode for r.f. applications, the crystal diode has the advantages of very small size, very low interelectrode capacitance (of the order of 1 $\mu\text{mf.}$ or less) and requires no heater or filament power.

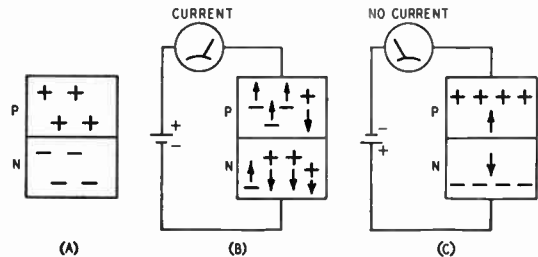

Fig. 4-1 — A P-N junction (A) and its behavior when conducting (B) and nonconducting (C).

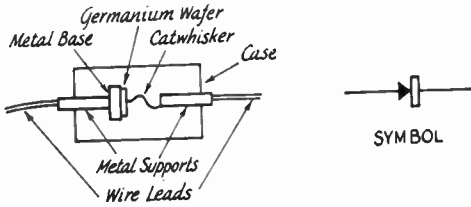

Fig. 4-2 — Construction of a germanium-point-contact diode. In the circuit symbol for a contact rectifier the arrow points in the direction of minimum resistance measured by the conventional method — that is, going from the positive terminal of the voltage source through the rectifier to the negative terminal of the source. The arrow thus corresponds to the plate and the bar to the cathode of a tube diode.

Junction Diodes

Junction-type diodes made of germanium are employed principally as power rectifiers, being useful for applications similar to those in which selenium rectifiers are used. Depending on the design of the particular diode, they are capable of rectifying currents up to several hundred milliamperes. The safe inverse peak voltage of a junction is relatively low, so an appropriate number of rectifiers must be connected in series to operate safely on a given a.c. input voltage.

Ratings

Crystal diodes are rated primarily in terms of maximum safe inverse voltage and maximum average rectified current. Inverse voltage is a voltage applied in the direction opposite to that which causes maximum current flow. The average current is that which would be read by a d.c. meter connected in the current path.

It is also customary to specify standards of performance with respect to forward and back current. A minimum value of forward current is usually specified for one volt applied. The voltage at which the maximum tolerable back current is specified varies with the type of diode.

Characteristic Curves

The germanium crystal diode is characterized by relatively large current flow with small applied voltages in the "forward" direction, and small, although finite, current flow in the reverse or "back" direction for much larger applied voltages. A typical characteristic curve is shown in Fig. 4-3. The dynamic resistance in either the forward or back direction is determined by the change in current that occurs, at any given point on the curve, when the applied voltage is changed by a small amount. The forward resistance shows some variation in the region of very small applied voltages, but the curve is for the most part quite straight, indicating fairly constant dynamic resistance. For small applied voltages, the forward resistance is of the order of 200 ohms in most such diodes. The back resistance shows considerable variation, depending on the particular voltage chosen for the measurement. It may run from a few hundred thousand ohms to over a megohm. In applications such as meter rectifiers for r.f. indicating instruments (r.f. voltmeters, wave-meter indicators, and so on) where the load resistance may be small and the applied voltage of the order of several volts, the resistances vary with the value of the applied voltage and are considerably lower.

Fig. 4-3 — Typical germanium diode characteristic curve. Because the back current is much smaller than the forward current, for much larger applied voltages, a different scale is used for back voltage and current than for forward voltage and current.

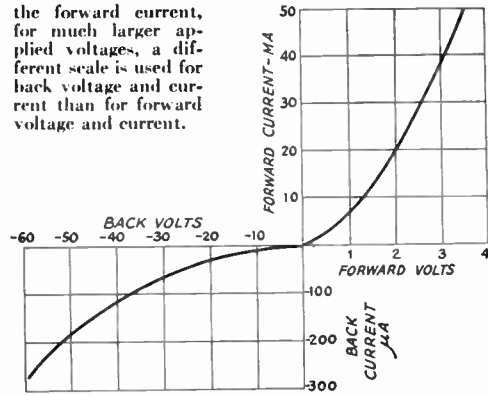

Transistors

Fig. 4-4 shows a "sandwich" made from two layers of P-type semiconductor material with a thin layer of N-type between. There are in effect two P-N junctions back to back. If a

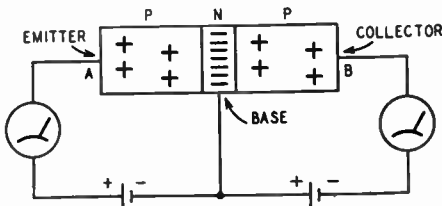

Fig. 4-4 — The basic arrangement of a transistor. This represents a junction-type P-N-P unit.

positive bias is applied to the P-type material at the left as shown, current will flow through the left-hand junction, the holes moving to the right and the electrons from the N-type material moving to the left. Some of the holes moving into the N-type material will combine with the electrons there and be neutralized, but some of them also will travel to the region of the right-hand junction.

If the P-N combination at the right is biased negatively, as shown, there would normally be no current flow in this circuit (see Fig. 4-1C). However, there are now additional holes available at the junction to travel to point B and electrons can travel toward point A, so a current can flow even though this section of the sandwich

considered alone is biased to prevent conduction. Most of the current is between *A* and *B* and does not flow out through the common connection to the N-type material in the sandwich.

A semiconductor combination of this type is called a **transistor**, and the three sections are known as the **emitter, base and collector**, respectively. The amplitude of the collector current depends principally upon the amplitude of the emitter current; that is, the collector current is controlled by the emitter current.

Power Amplification

Because the collector is biased in the back direction the collector-to-base resistance is high. On the other hand, the emitter and collector currents are substantially equal, so the power in the collector circuit is larger than the power in the emitter circuit ($P = I^2 R$, so the powers are proportional to the respective resistances, if the current is the same). In practical transistors emitter resistance is of the order of a few hundred ohms while the collector resistance is hundreds or thousands of times higher, so power gains of 20 to 40 db. or even more are possible.

Types

The transistor may be either of the **point-contact** or **junction** type, as shown in Fig. 4-5. Also, the assembly of P- and N-type materials may be reversed; that is, N-type material may be used instead of P-type for the emitter and collector, and P-type instead of N-type for the base. The type shown in Fig. 4-4 is known as a **P-N-P** transistor, while the opposite is the **N-P-N**.

Point-Contact Transistors

The point-contact transistor, shown at the left in Fig. 4-5, has two "cat whiskers" placed very close together on the surface of a germanium wafer, usually N-type material. Small P-type areas are formed under each point during manufacture. This type of construction results in quite low interelectrode capacitances, with the result that some point-contact transistors have been used at frequencies up to the v.h.f. region.

The point-contact transistor was the first type invented, but is now practically superseded by the junction type. It is difficult to manufacture, since the two contact points must be extremely close together if good characteristics are to be secured, particularly for high-frequency work.

The Junction Transistor

The junction transistor, the essential construction of which is shown at the right in Fig. 4-5, has higher capacitances and higher power-handling capacity than the point-contact type. The "electrode" areas and thickness of the intermediate layer have an important effect on the upper frequency limit. At the present time junction transistors having cut-off frequencies (see next section) up to 20 Mc. or so are available, and the frequency limit is constantly being extended. The types used for audio and low radio frequencies usually have cut-off frequencies ranging from 500 to 1000 kc.

Experimental work now under way with "diffused" junctions indicates that junction-type transistors capable of satisfactory operation in the v.h.f. region are possible. It is to be expected that further development will make the construction of such transistors commercially practicable.

● **TRANSISTOR CHARACTERISTICS**

An important characteristic of a transistor is its **current amplification factor**, usually designated by α . This is the ratio of the change in collector current to a small change in emitter current, and is comparable with the voltage amplification factor (μ) of a vacuum tube. The current amplification factor is almost, but not quite, 1 in a junction transistor. It is larger than 1 in the point-contact type, values in the neighborhood of 2 being typical.

The α **cut-off frequency** is the frequency at which the current amplification drops 3 db. below its low-frequency value. Cut-off frequencies range from 500 kc. to frequencies in the v.h.f. region. The cut-off frequency indicates in a general way the frequency spread over which the

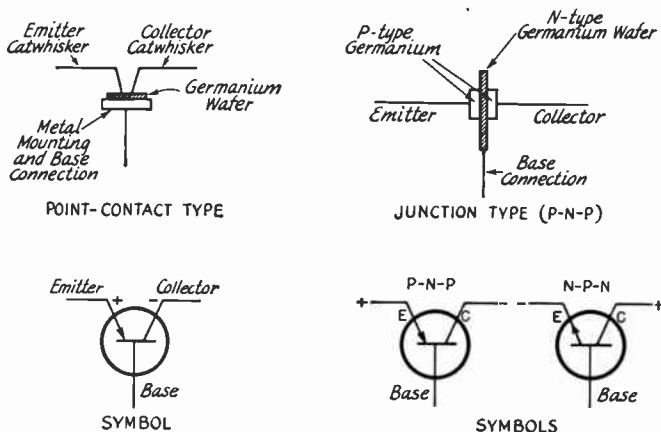

Fig. 4-5 — Point-contact and junction-type transistors with their circuit symbols. The plus and minus signs associated with the symbols indicate polarities of voltages, with respect to the base, to be applied to the elements.

transistor is useful.

Each of the three elements in the transistor has a resistance associated with it, the emitter and collector resistances having been discussed earlier. There is also a certain amount of resistance associated with the base, a value of a few hundred to 1000 ohms being typical of the base resistance.

The values of all three resistances vary with the type of transistor and the operating voltages. The collector resistance, in particular, is sensitive to operating conditions.

Characteristic Curves

The operating characteristics of transistors can be shown by a series of characteristic curves. One such set of curves is shown in Fig. 4-6. It

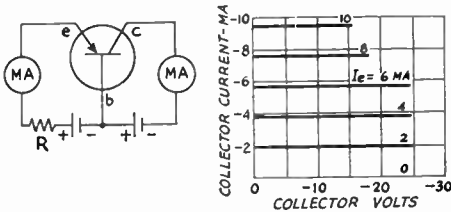

Fig. 4-6—A typical collector-current vs. collector-voltage characteristic of a junction-type transistor, for various emitter-current values. The circuit shows the setup for taking such measurements. Since the emitter resistance is low, a current-limiting resistor, R , is connected in series with the source of current. The emitter current can be set at a desired value by adjustment of this resistance.

shows the collector current vs. collector voltage for a number of fixed values of emitter current. Practically, the collector current depends almost entirely on the emitter current and is independent of the collector voltage. The separation between curves representing equal steps of emitter current is quite uniform, indicating that almost distortionless output can be obtained over the useful operating range of the transistor.

Another type of curve is shown in Fig. 4-7, together with the circuit used for obtaining it. This also shows collector current vs. collector voltage, but for a number of different values of base current. In this case the emitter element is used as the common point in the circuit. The collector current is not independent of collector voltage with this type of connection, indicating that the output resistance of the device is fairly low. The base current also is quite low, which

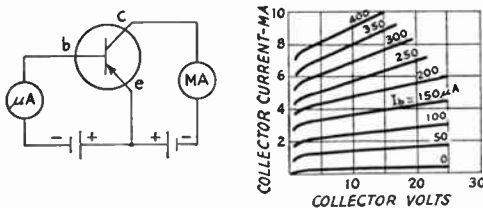

Fig. 4-7—Collector current vs. collector voltage for various values of base current, for a junction-type transistor. The values are determined by means of the circuit shown.

means that the resistance of the base-emitter circuit is moderately high with this method of connection. This may be contrasted with the high values of collector current shown in Fig. 4-6.

Ratings

The principal ratings applied to transistors are maximum collector dissipation, maximum collector voltage, maximum collector current, and maximum emitter current. Except possibly for collector dissipation, the terms are self-explanatory.

The collector dissipation is the power, usually expressed in milliwatts, that can safely be dissipated by the transistor as heat. With some types provision is made for transferring heat rapidly through the container, and such units usually require installation on a heat "sink" or mounting that can absorb heat from the transistor.

The amount of undistorted output power that can be obtained depends on the collector voltage, although the collector current is practically independent of the voltage. Increasing the collector voltage extends the range of linear operation with a given swing in collector current, but cannot be carried beyond the point where either the voltage or dissipation ratings are exceeded.

TRANSISTOR AMPLIFIERS

Amplifier circuits used with transistors fall into one of three types, known as the grounded-base, grounded-emitter, and grounded-collector circuits. These are shown in Fig. 4-8 in elementary form. The three circuits correspond approximately with the grounded-grid, grounded-cathode and cathode-follower circuits, respectively, used with vacuum tubes.

Grounded-Base Circuit

The input circuit of a grounded-base amplifier must be designed for low impedance, since the emitter resistance is of the order of a few hundred ohms. The optimum output load impedance, however, is high, and may range from a few thousand ohms to 100,000 or so, depending upon the requirements.

The resistor R_1 in the grounded-base circuit is used to limit the emitter current to a desired value and thus establish the operating point. It is bypassed by C_1 , the capacitance of which should meet the usual requirements for bypassing. The limiting resistor is necessary in this circuit to prevent damaging the transistor, since without such limiting, relatively large currents will flow with quite small voltages on the emitter.

In this circuit the phase of the output (collector) current is the same as that of the input (emitter) current. The parts of these currents that flow through the base resistance are likewise in phase, so the circuit tends to be regenerative and will oscillate if the current amplification factor is greater than 1. A junction transistor is stable in this circuit since α is less than 1, but a point-contact transistor will oscillate.

Grounded-Emitter Circuit

The grounded-emitter circuit shown in Fig. 4-8 corresponds to the ordinary grounded-cathode vacuum-tube amplifier and is the basic circuit most frequently used. As indicated by the curves of Fig. 4-7, the base current is small and the input impedance is therefore fairly high — several thousand ohms in the average case. The collector resistance is of the same order, or somewhat higher than, the base resistance in this circuit. The grounded-emitter circuit gives the highest power gain of any and, as indicated in Fig. 4-7 by the fact that a base current of a few hundred microamperes results in collector current of several milliamperes, gives a rather large current gain as well.

In the grounded-emitter circuit shown the base bias is obtained through R_2 and only a single current source is needed. R_2 may be of the order of 100,000 ohms.

In this circuit the phase of the output (collector) current is opposite to that of the input (base) current so such feed-back as occurs through the small emitter resistance is negative and the amplifier is stable with either junction or point-contact transistors.

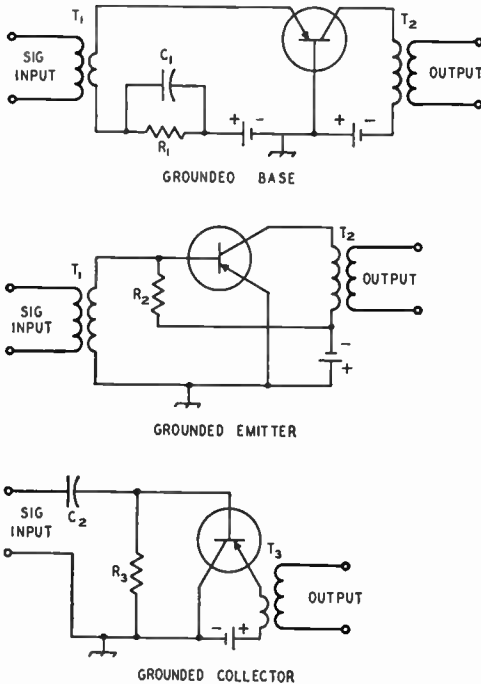

Fig. 4-8 — Basic transistor amplifier circuits. T_1 , T_2 and T_3 are transformers having turns ratios suitable for the impedances involved; these impedances are discussed in the text. Other types of coupling may be substituted.

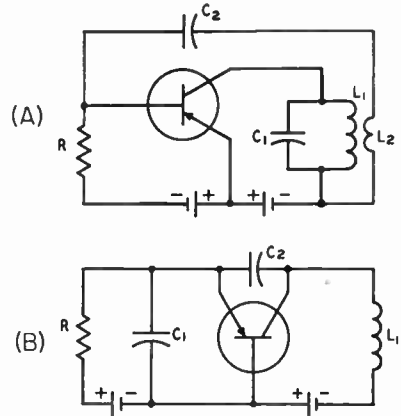

Fig. 4-9 — Transistor oscillator circuits. Component values are discussed in the text.

Grounded-Collector Circuit

Like the cathode follower, the grounded-collector transistor amplifier has high input impedance and low output impedance. The latter is approximately equal to the impedance of the signal input source multiplied by $(1 - \alpha)$. The input resistance depends on the load resistance, being approximately equal to the load resistance divided by $(1 - \alpha)$. The fact that input resistance is directly related to the load resistance is a disadvantage of this type of amplifier if the load is one whose resistance or impedance varies with frequency.

● **TRANSISTOR OSCILLATORS**

Since more power is available from the output circuit than is necessary for its generation in the input circuit, it is possible to use some of the output power to supply the input circuit and thus sustain self-oscillation. Two representative oscillator circuits are shown in Fig. 4-9. The circuit at A uses inductive coupling to supply a feed-back current in the proper phase, the grounded-emitter arrangement being used. The resistor R usually will be in the 50,000–100,000-ohm region. The frequency is determined by L_1C_1 . In order to sustain oscillation, the current fed back through C_2 to the base must be larger than the nonoscillating base current.

The circuit at B uses capacitive voltage division for feed-back with a grounded-base transistor. The resonant frequency is determined by LC_1C_2 . (The battery in the collector circuit is assumed to have negligible impedance.) The ratio of C_1 to C_2 for self-sustaining oscillation depends on the current amplification and must be greater than $(1 - \alpha)/\alpha$, approximately.

High-Frequency Receivers

A good receiver in the amateur station makes the difference between mediocre contacts and solid QSOs, and its importance cannot be over-emphasized. In the uncrowded v.h.f. bands, sensitivity (the ability to bring in weak signals) is the most important factor in a receiver. In the more crowded amateur bands, good sensitivity must be combined with selectivity (the ability to distinguish between signals separated by only a small frequency difference). To receive weak signals, the receiver must furnish enough amplification to amplify the minute signal power delivered by the antenna up to a useful amount of power that will operate a loudspeaker or set of headphones. Before the amplified signal can operate the speaker or phones, it must be converted to audio-frequency power by the process of detection. The sequence of amplification is not too important — some of the amplification can take place (and usually does) before detection, and some can be used after detection.

There are major differences between receivers for phone reception and for code reception. An a.m. phone signal has side bands that make the signal take up about 6 or 8 kc. in the band, and the audio quality of the received signal is impaired if the bandwidth is less than half of this. A code signal occupies only a few hundred cycles at the most, and consequently the bandwidth of a code receiver can be small. A single-side-band phone signal takes up 3 to 4 kc., and the audio quality can be impaired if the bandwidth is much less than 3 kc. although the intelligibility will hold up down to around 2 kc. In any case, if the bandwidth of the receiver is more than nec-

essary, signals adjacent to the desired one can be heard, and the selectivity of the receiver is less than maximum. The detection process delivers directly the audio frequencies present as modulation on an a.m. phone signal. There is no modulation on a code signal, and it is necessary to introduce a second radio frequency, differing from the signal frequency by a suitable audio frequency, into the detector circuit to produce an audible beat. The frequency difference, and hence the beat note, is generally made on the order of 500 to 1000 cycles, since these tones are within the range of optimum response of both the ear and the headset. There is no carrier frequency present in an s.s.b. signal, and this frequency must be furnished at the receiver before the audio can be recovered. The same source that is used in code reception can be utilized for the purpose. If the source of the locally-generated radio frequency is a separate oscillator, the system is known as heterodyne reception; if the detector is made to oscillate and produce the frequency, it is known as an autodyne detector. Modern superheterodyne receivers generally use a separate oscillator (beat oscillator) to supply the locally-generated frequency. Summing up the differences, phone receivers can't use as much selectivity as code receivers, and code and s.s.b. receivers require some kind of locally-generated frequency to give a readable signal. Broadcast receivers can receive only a.m. phone signals because no beat oscillator is included. Communications receivers include beat oscillators and often some means for varying the selectivity. With high selectivity they often have a slow tuning rate.

Receiver Characteristics

Sensitivity

In commercial circles "sensitivity" is defined as the strength of the signal (in microvolts) at the input of the receiver that is required to produce a specified audio power output at the speaker or headphones. This is a satisfactory definition for broadcast and communications receivers operating below about 20 Mc., where atmospheric and man-made electrical noises normally mask any noise generated by the receiver itself.

Another commercial measure of sensitivity defines it as the signal at the input of the receiver required to give an audio output some stated amount (generally 10 db.) above the noise output of the receiver. This is a more useful sensitivity measure for the amateur, since it indicates how well a weak signal will be heard and

is not merely a measure of the over-all amplification of the receiver. However, it is not an absolute method for comparing two receivers, because the bandwidth of the receiver plays a large part in the result.

The random motion of the molecules in the antenna and receiver circuits generates small voltages called thermal-agitation noise voltages. The frequency of this noise is random and the noise exists across the entire radio spectrum. Its amplitude increases with the temperature of the circuits. Only the noise in the antenna and first stage of a receiver is normally significant, since the noise developed in later stages is masked by the amplified noise from the first stage. The only noise that is amplified is that which is accepted by the receiver, so the

noise appearing in the receiver output is less when the bandwidth is reduced. Noise is also generated by the current flow within the first tube itself; this effect can be combined with the thermal noise and called **receiver noise**.

The limit of a receiver's ability to detect weak signals is the thermal noise generated in the input circuit. Even if a perfect noise-free tube were developed and used throughout the receiver, the limit to reception would be the thermal noise. (Atmospheric- and man-made noise is a *practical* limit below 20 Mc.) The degree to which a receiver approaches this ideal is called the **noise figure** of the receiver, and it is expressed as the ratio of noise power at the input of the receiver required to increase the noise output of the receiver 3 db. Since the noise power passed by the receiver is dependent on the bandwidth, the figure shows how far the receiver departs from the ideal. The ratio is generally expressed in db., and runs around 6 to 12 db. for a good receiver, although figures of 2 to 4 db. have been obtained. Comparisons of noise figures can be made by the amateur with simple equipment. (See *QST*, August, 1949, p. 20.)

Selectivity

Selectivity is the ability of a receiver to discriminate against signals of frequencies differing from that of the desired signal. The over-all selectivity will depend upon the selectivity of the individual tuned circuits and the number of such circuits.

The selectivity of a receiver is shown graphically by drawing a curve that gives the ratio of signal strength required at various frequencies off resonance to the signal strength at resonance, to give constant output. A **resonance curve** of this type is shown in Fig. 5-1. The **bandwidth** is the width of the resonance curve (in cycles or kilocycles) of a receiver at a specified ratio; in Fig. 5-1, the bandwidths are indicated for ratios of response of 2 and 10 ("6 db. down" and "20 db. down").

The bandwidth at 6 db. down must be sufficient to pass the signal and its sidebands if faithful reproduction of the signal is desired. However, in the crowded amateur bands, it is generally advisable to sacrifice fidelity for intelligibility. The ability to reject adjacent-channel signals depends upon the **skirt selectivity** of the receiver, which is determined by the bandwidth at high attenuation. In a receiver with good skirt selectivity, the

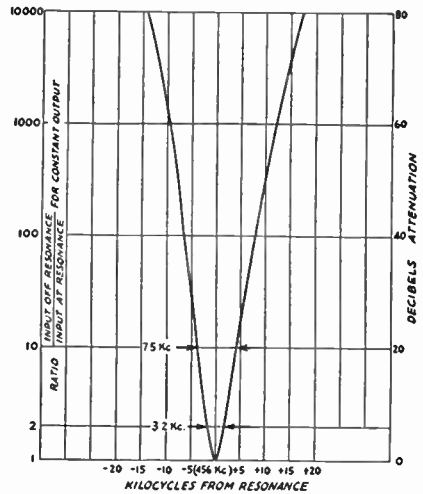

Fig. 5-1 — Typical selectivity curve of a modern superheterodyne receiver. Relative response is plotted against deviations above and below the resonance frequency. The scale at the left is in terms of voltage ratios, the corresponding decibel steps are shown at the right.

ratio of the 6-db. bandwidth to the 60-db. bandwidth will be about 0.25 for code and 0.5 for phone. The minimum usable bandwidth at 6 db. down is about 150 cycles for code reception and about 2000 cycles for phone.

Stability

The stability of a receiver is its ability to "stay put" on a signal under varying conditions of gain-control setting, temperature, supply-voltage changes and mechanical shock and distortion. The term "unstable" is also applied to a receiver that breaks into oscillation or a regenerative condition with some settings of its controls that are not specifically intended to control such a condition.

Fidelity

Fidelity is the relative ability of the receiver to reproduce in its output the modulation carried by the incoming signal. For perfect fidelity, the relative amplitudes of the various components must not be changed by passing through the receiver. However, in amateur communication the important requirement is to transmit intelligence and not "high-fidelity" signals.

Detection and Detectors

Detection is the process of recovering the modulation from a signal (see "Modulation, Heterodyning and Beats"). Any device that is "nonlinear" (i.e., whose output is not *exactly* proportional to its input) will act as a detector. It can be used as a detector if an impedance for the desired modulation frequency is connected in the output circuit.

Detector sensitivity is the ratio of desired

detector output to the input. Detector linearity is a measure of the ability of the detector to reproduce the exact form of the modulation on the incoming signal. The resistance or impedance of the detector is the resistance or impedance it presents to the circuits it is connected to. The input resistance is important in receiver design, since if it is relatively low it means that the detector will consume power,

and this power must be furnished by the preceding stage. The signal-handling capability means the ability to accept signals of a specified amplitude without overloading or distortion.

Diode Detectors

The simplest detector for a.m. is the diode. A galena, silicon or germanium crystal is an imperfect form of diode (a small current can pass in the reverse direction), and the principle of detection in a crystal is similar to that in a vacuum-tube diode.

Circuits for both half-wave and full-wave diodes are given in Fig. 5-2. The simplified half-wave circuit at 5-2A includes the r.f. tuned circuit, L_2C_1 , a coupling coil, L_1 , from which the r.f. energy is fed to L_2C_1 , and the diode, D , with its load resistance, R_1 , and bypass condenser, C_2 . The flow of rectified r.f. current causes a d.c. voltage to develop across the terminals of R_1 . The - and + signs show the polarity of the voltage. The variation in amplitude of the r.f. signal with modulation

causes corresponding variations in the value of the d.c. voltage across R_1 . In audio work the load resistor, R_1 , is usually 0.1 megohm or higher, so that a fairly large voltage will develop from a small rectified-current flow.

The progress of the signal through the detector or rectifier is shown in Fig. 5-3. A typical modulated signal as it exists in the tuned

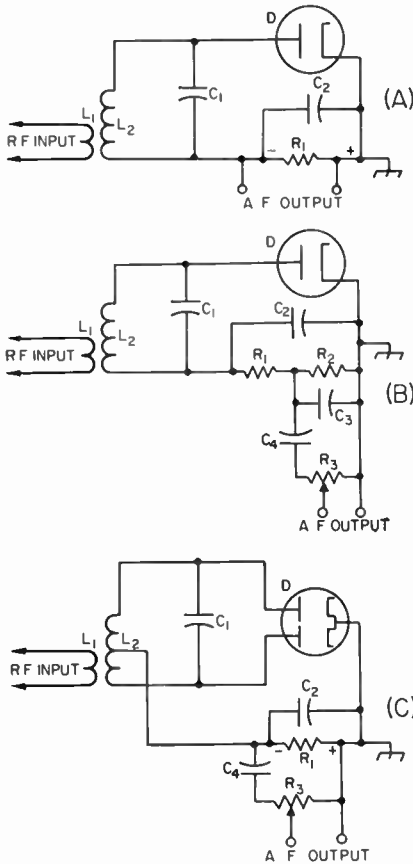

Fig. 5-2 — Simplified and practical diode detector circuits. A, the elementary half-wave diode detector; B, a practical circuit, with r.f. filtering and audio output coupling; C, full-wave diode detector, with output coupling indicated. The circuit, L_2C_1 , is tuned to the signal frequency; typical values for C_2 and R_1 in A and C are 250 $\mu\text{f.}$ and 250,000 ohms, respectively; in B, C_2 and C_3 are 100 $\mu\text{f.}$ each; R_1 , 50,000 ohms; and R_2 , 250,000 ohms. C_1 is 0.1 $\mu\text{f.}$ and R_3 may be 0.5 to 1 megohm.

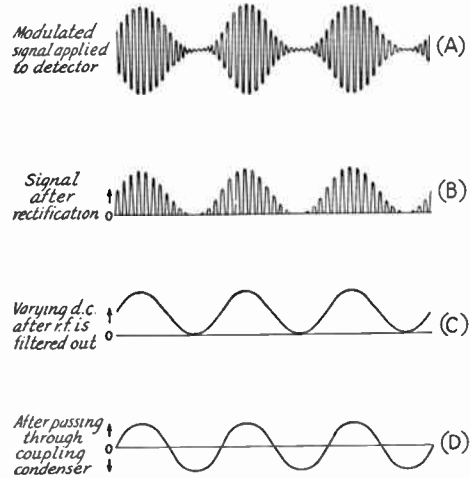

Fig. 5-3 — Diagrams showing the detection process.

circuit is shown at A. When this signal is applied to the rectifier tube, current will flow only during the part of the r.f. cycle when the plate is positive with respect to the cathode, so that the output of the rectifier consists of half-cycles of r.f. These current pulses flow in the load circuit comprised of R_1 and C_2 , the resistance of R_1 and the capacity of C_2 being so proportioned that C_2 charges to the peak value of the rectified voltage on each pulse and retains enough charge between pulses so that the voltage across R_1 is smoothed out, as shown in C. C_2 thus acts as a filter for the radio-frequency component of the output of the rectifier, leaving a d.c. component that varies in the same way as the modulation on the original signal. When this varying d.c. voltage is applied to a following amplifier through a coupling capacitor (C_4 in Fig. 5-2B), only the variations in voltage are transferred, so that the final output signal is a.c., as shown in D.

In the circuit at 5-2B, R_1 and C_2 have been divided for the purpose of providing a more effective filter for r.f. It is important to prevent the appearance of any r.f. voltage in the output of the detector, because it may cause overloading of a succeeding amplifier tube. The audio-frequency variations can be transferred to another circuit through a coupling capacitor, C_4 , to a load resistor, R_3 , which usually is a "potentiometer" so that the audio volume can be adjusted to a desired level.

Coupling to the potentiometer (volume control) through a capacitor also avoids any flow of d.c. through the control. The flow of d.c. through a high-resistance volume control often

tends to make the control noisy (scratchy) after a short while.

The full-wave diode circuit at 5-2C differs in operation from the half-wave circuit only in that both halves of the r.f. cycle are utilized. The full-wave circuit has the advantage that r.f. filtering is easier than in the half-wave circuit. As a result, less attenuation of the higher audio frequencies will be obtained for any given degree of r.f. filtering.

The reactance of C_2 must be small compared to the resistance of R_1 at the radio frequency being rectified, but at audio frequencies must be relatively large compared to R_1 . If the capacity of C_2 is too large, response at the higher audio frequencies will be lowered.

Compared with other detectors, the sensitivity of the diode is low, normally running around 0.8 in audio work. Since the diode consumes power, the Q of the tuned circuit is reduced, bringing about a reduction in selectivity. The loading effect of the diode is close to one-half the load resistance. The detector linearity is good, and the signal-handling capability is high.

Plate Detectors

The plate detector is arranged so that rectification of the r.f. signal takes place in the plate

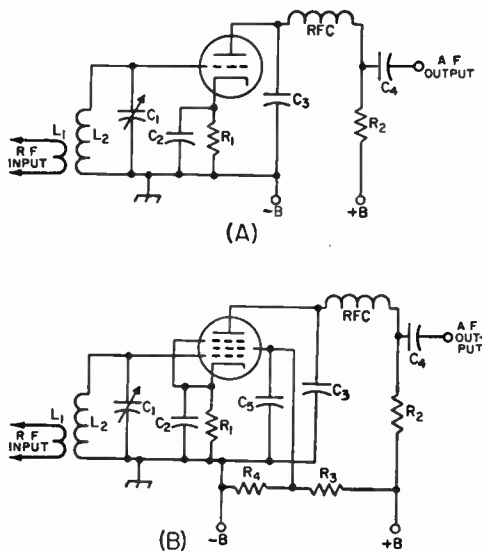

Fig. 5-4—Circuits for plate detection. A, triode; B, pentode. The input circuit, L_1C_1 , is tuned to the signal frequency. Typical values for the other components are:

Component	Circuit A	Circuit B
C_2	0.5 μ f. or larger.	0.5 μ f. or larger.
C_3	0.001 to 0.002 μ f.	250 to 500 μ f.
C_4	0.1 μ f.	0.1 μ f.
C_5		0.5 μ f. or larger.
R_1	25,000 to 150,000 ohms.	10,000 to 20,000 ohms.
R_2	50,000 to 100,000 ohms.	100,000 to 250,000 ohms.
R_3		50,000 ohms.
R_4		20,000 ohms.
RFC	2.5 mh.	2.5 mh.

Plate voltages from 100 to 250 volts may be used. Effective screen voltage in B should be about 30 volts.

circuit of the tube. Sufficient negative bias is applied to the grid to bring the plate current nearly to the cut-off point, so that application of a signal to the grid circuit causes an increase in average plate current. The average plate current follows the changes in signal in a fashion similar to the rectified current in a diode detector.

Circuits for triodes and pentodes are given in Fig. 5-4. C_3 is the plate by-pass capacitor, and, with RFC, prevents r.f. from appearing in the output. The cathode resistor, R_1 , provides the operating grid bias, and C_2 is a bypass for both radio and audio frequencies. R_2 is the plate load resistance and C_4 is the output coupling capacitor. In the pentode circuit at B, R_3 and R_4 form a voltage divider to supply the proper screen potential (about 30 volts), and C_5 is a by-pass capacitor. C_2 and C_5 must have low reactance for both radio and audio frequencies.

In general, transformer coupling from the plate circuit of a plate detector is not satisfactory, because the plate impedance of any tube is very high when the bias is near the plate-current cut-off point. Impedance coupling may be used in place of the resistance coupling shown in Fig. 5-4. Usually 100 henrys or more inductance is required.

The plate detector is more sensitive than the diode because there is some amplifying action in the tube. It will handle large signals, but is not so tolerant in this respect as the diode. Linearity, with the self-biased circuits shown, is good. Up to the overload point the detector takes no power from the tuned circuit, and so does not affect its Q and selectivity.

Infinite-Impedance Detector

The circuit of Fig. 5-5 combines the high signal-handling capabilities of the diode detector with low distortion and, like the plate detector, does not load the tuned circuit it connects to. The circuit resembles that of the plate detector, except that the load resistance, R_1 , is connected between cathode and ground and thus is common to both grid and plate circuits, giving negative feedback for the audio frequencies. The cathode resistor is bypassed for r.f. but not for audio, while the plate circuit is bypassed to

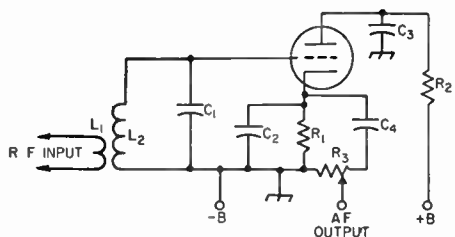

Fig. 5-5—The infinite-impedance detector. The input circuit, L_2C_1 , is tuned to the signal frequency. Typical values for the other components are:

C_2 — 250 μ f.	R_1 — 0.15 megohm.
C_3 — 0.5 μ f.	R_2 — 25,000 ohms.
C_4 — 0.1 μ f.	R_3 — 0.25-megohm volume control.

A tube having a medium amplification factor (about 20) should be used. Plate voltage should be 250 volts.

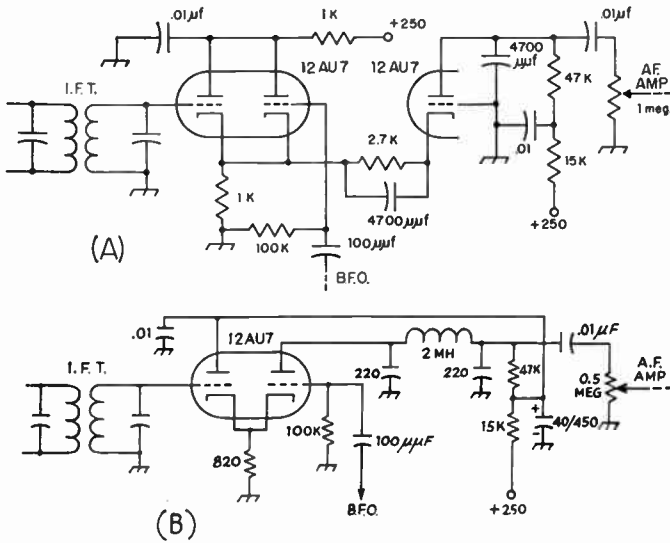

Fig. 5-6—Two versions of the "product detector" circuit. In the circuit in A separate tubes are used for the signal circuit cathode follower, the b.f.o. cathode follower and the mixer tube. In B the mixer and b.f.o. follower are combined in one tube, and a low-pass filter is used in the output.

ground for both audio and radio frequencies. R_2 forms, with C_3 , an RC filter to isolate the plate from the "B" supply. An r.f. filter, consisting of a series r.f. choke and a shunt capacitor, can be connected between the cathode and C_4 to eliminate any r.f. that might otherwise appear in the output.

The plate current is very low at no signal, increasing with signal as in the case of the plate detector. The voltage drop across R_1 consequently increases with signal. Because of this and the large initial drop across R_1 , the grid usually cannot be driven positive by the signal, and no grid current can be drawn.

Product Detector

The product detector circuits of Fig. 5-6 are useful in s.s.b. and code reception because they minimize intermodulation at the detector and don't require a large b.f.o. injection voltage. In Fig. 5-6A, two triodes are used as cathode followers, for the signal and for the b.f.o., working into a common cathode resistor (1000 ohms). The third triode also shares this cathode resistor and consequently the same signals, but it has an audio load in its plate circuit and it operates at a higher grid bias (by virtue of the 2700-ohm resistor in its cathode circuit). The signals and the b.f.o. mix in this third triode. If the b.f.o. is turned off, a modulated signal running through the signal cathode follower should yield little or no audio output from the detector, up to the overload point of the signal cathode follower. Turning on the b.f.o. brings in modulation, because now the detector output is the product of the two signals. The plates of the cathode followers are grounded and filtered for the i.f., and the 4700- μf . capacitor from plate to ground in the output triode furnishes a bypass at the i.f. The b.f.o. voltage should be about 3.5 r.m.s.

The circuit in Fig. 5-6B is a simplification requiring one less triode. Its principle of operation is substantially the same except that the addi-

tional bias for the output tube is derived from rectified b.f.o. voltage across the 100,000-ohm resistor. More elaborate r.f. filtering is shown in the plate of the output tube (2-mh. choke and the 220- μf . capacitors), and the degree of plate filtering in either circuit will depend upon the frequencies involved. At low intermediate frequencies more elaborate filtering is required.

REGENERATIVE DETECTORS

By providing controllable r.f. feedback (regeneration) in a triode or pentode detector circuit, the incoming signal can be amplified many times, thereby greatly increasing the sensitivity of the detector. Regeneration also increases the effective Q of the circuit and thus the selectivity. The grid-leak type of detector is most suitable for the purpose.

The grid-leak detector is a combination diode rectifier and audio-frequency amplifier. In the circuits of Fig. 5-7, the grid corresponds to the diode plate and the rectifying action is exactly the same as in a diode. The d.c. voltage from rectified-current flow through the grid leak, R_1 , biases the grid negatively, and the audio-frequency variations in voltage across R_1 are amplified through the tube as in a normal a.f. amplifier. In the plate circuit, T_1 , L_4 and L_3 are the plate load resistances, C_4 is a by-pass capacitor and RFC an r.f. choke to eliminate r.f. in the output circuit.

A grid-leak detector has considerably greater sensitivity than a diode. The sensitivity is further increased by using a screen-grid tube instead of a triode, as at 5-7 B and C. The operation is equivalent to that of the triode circuit. The screen by-pass capacitor, C_5 , should have low reactance for both radio and audio frequencies. R_2 and R_3 constitute a voltage divider on the plate supply to furnish the proper screen voltage. In both circuits, C_2 must have low r.f. reactance and high a.f. reactance compared to the resistance of R_1 .

Although the regenerative grid-leak detector is more sensitive than any other type, its many disadvantages commend it for use only in the simplest receivers. The linearity is rather poor, and the signal-handling capability is limited. The signal-handling capability can be improved by reducing R_1 to 0.1 megohm, but the sensitivity will be decreased. The degree of antenna coupling is often critical.

The circuits in Fig. 5-7 are regenerative, the feedback being obtained by feeding some signal to the grid back from the plate circuit. The amount of regeneration must be controllable, because maximum regenerative amplification is secured at the critical point where the circuit is just about to oscillate. The critical point in turn depends upon circuit conditions, which may vary with the frequency to which the detector is tuned. In the oscillating condition, a regenerative detector can be detuned slightly from an incoming c.w. signal to give *autolyne* reception.

The circuit of Fig. 5-7A uses a variable bypass capacitor, C_4 , in the plate circuit to control regeneration. When the capacity is small the tube does not regenerate, but as it increases toward maximum its reactance becomes smaller until there is sufficient feedback to cause oscillation. If L_2 and L_3 are wound end-to-end in the same direction, the plate connection is to the outside of the plate or "tickler" coil, L_3 , when the grid connection is to the outside of L_2 .

The circuit of 5-7B is for a pentode tube, regeneration being controlled by adjustment of the screen-grid voltage. The tickler, L_3 , is in the plate circuit. The portion of the control resistor between the rotating contact and ground is bypassed by a large capacitor (0.5 $\mu\text{f.}$ or more) to filter out scratching noise when the arm is rotated. The feedback is adjusted by varying the number of turns on L_3 or the coupling between L_2 and L_3 , until the tube just goes into oscillation at a screen potential of approximately 30 volts.

Circuit C is identical with B in principle of operation. Since the screen and plate are in parallel for r.f. in this circuit, only a small amount of "tickler"—that is, relatively few turns between the cathode tap and ground—is required for oscillation.

Smooth Regeneration Control

The ideal regeneration control would permit the detector to go into and out of oscillation smoothly, would have no effect on the frequency of oscillation, and would give the same value of regeneration regardless of frequency and the loading on the circuit. In practice, the effects of loading, particularly the loading that occurs when the detector circuit is coupled to an antenna, are difficult to overcome. Likewise, the regeneration is usually affected by the frequency to which the grid circuit is tuned.

In all circuits it is best to wind the tickler at the ground or cathode end of the grid coil, and to use as few turns on the tickler as will allow the detector to oscillate easily over the whole

tuning range at the plate (and screen, if a pentode) voltage that gives maximum sensitivity. Should the tube break into oscillation suddenly as the regeneration control is advanced, making a click, it usually indicates that the coupling to the antenna (or r.f. amplifier) is too tight. The wrong value of grid leak plus too-high plate and screen voltage are also frequent causes of lack of smoothness in going into oscillation.

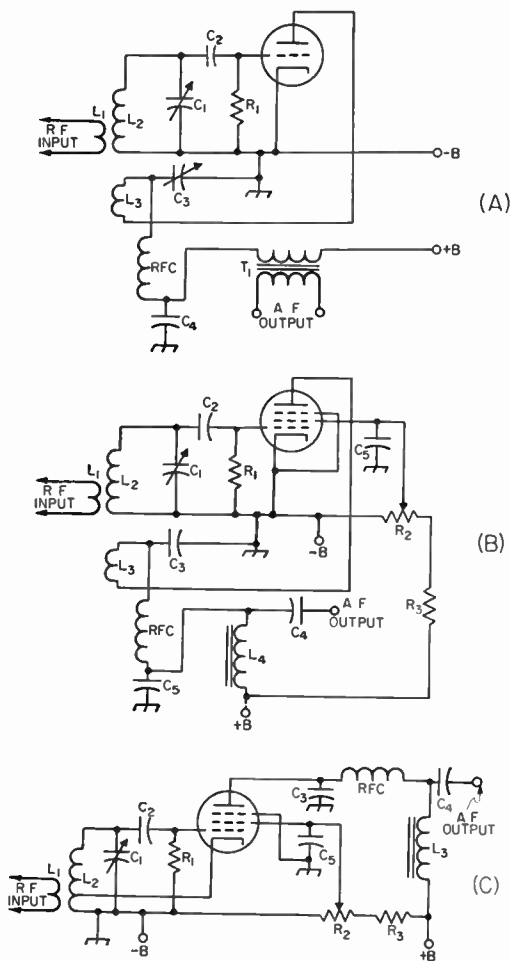

Fig. 5-7—Triode and pentode regenerative detector circuits. The input circuit, L_2C_1 , is tuned to the signal frequency. The grid capacitor, C_2 , should have a value of about 100 $\mu\text{f.}$ in all circuits; the grid leak, R_1 , may range in value from 1 to 5 megohms. The tickler coil, L_3 , ordinarily will have from 10 to 25 per cent of the number of turns on L_2 ; in C, the cathode tap is about 10 per cent of the number of turns on L_2 above ground. Regeneration-control capacitor C_3 in A should have a maximum capacity of 100 $\mu\text{f.}$ or more; by-pass capacitors C_3 in B and C are likewise 100 $\mu\text{f.}$ C_5 is ordinarily 1 $\mu\text{f.}$ or more; R_2 , a 50,000-ohm potentiometer; R_3 , 50,000 to 100,000 ohms. L_4 in B (L_3 in C) is a 500-henry inductance, C_4 is 0.1 $\mu\text{f.}$ in both circuits. T_1 in A is a conventional audio transformer for coupling from the plate of a tube to a following grid. RFC is 2.5 mh. In A, the plate voltage should be about 50 volts for best sensitivity. Pentode circuits require about 30 volts on the screen; plate potential may be 100 to 250 volts.

Antenna Coupling

If the detector is coupled to an antenna, slight changes in the antenna (as when the wire swings in a breeze) affect the frequency of the oscillations generated, and thereby the beat frequency when code signals are being received. The tighter the antenna coupling is made, the greater will be the feedback required or the higher will be the voltage necessary to make the detector oscillate. The antenna coupling should be the maximum that will allow the detector to go into oscillation smoothly with the correct voltages on the tube. If capacity coupling to the grid end of the coil is used, generally only a very small amount of capacity will be needed to couple to the antenna. Increasing the capacity increases the coupling.

At frequencies where the antenna system is resonant the absorption of energy from the oscillating detector circuit will be greater, with the consequence that more regeneration is needed. In extreme cases it may not be possible to make the detector oscillate with normal voltages. The remedy for these "dead spots" is to loosen the antenna coupling to a point that permits normal oscillation and smooth regeneration control.

Body Capacity

A regenerative detector occasionally shows a tendency to change frequency slightly as the hand is moved near the dial. This condition (**body capacity**) can be corrected by better shielding, and sometimes by r.f. filtering of the phone leads. A good, short ground connection and loosening the coupling to the antenna will help.

Hum

Hum at the power-supply frequency, even when using battery plate supply, may result from the use of a.c. on the tube heater. Effects of this type normally are troublesome only when the circuit of Fig. 5-7C is used, and then only at 14 Mc. and higher. Connecting one side of the heater supply to ground, or grounding the center-tap of the heater-transformer winding, will reduce the hum. The heater wiring should be kept as far as possible from the r.f. circuits.

House wiring, if of the "open" type, may cause hum if the detector tube, grid lead, and grid condenser and leak are not shielded. This type of hum is easily recognizable because of its rather high pitch.

Tuning

For c.w. reception, the regeneration control is advanced until the detector breaks into a "hiss," which indicates that the detector is oscillating. Further advancing the regeneration control after the detector starts oscillating will result in a slight decrease in the strength of the hiss, indicating that the sensitivity of the detector is decreasing.

The proper adjustment of the regeneration control for best reception of code signals is where the detector just starts to oscillate. Then

code signals can be tuned in and will give a tone with each signal depending on the setting of the tuning control. As the receiver is tuned through a signal the tone first will be heard as a very high pitch, then will go down through "zero beat" and rise again on the other side, finally disappearing at a very high pitch. This behavior is shown in Fig. 5-8. A low-pitched beat-note cannot be obtained from a strong signal because

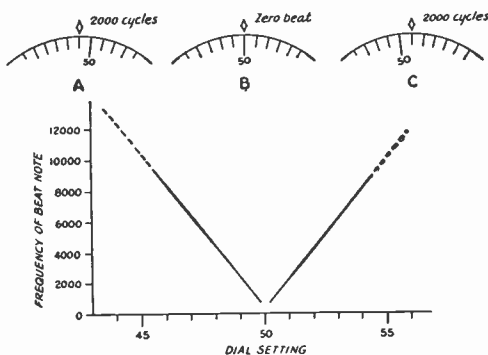

Fig. 5-8—As the tuning dial of a receiver is turned past a code signal, the beat-note varies from a high tone down through "zero beat" (no audible frequency difference) and back up to a high tone, as shown at A, B and C. The curve is a graphical representation of the action. The beat exists past 8000 or 10,000 cycles but usually is not heard because of the limitations of the audio system.

the detector "pulls in" or "blocks"; that is, the signal forces the detector to oscillate at the signal frequency, even though the circuit may not be tuned exactly to the signal. This phenomenon, is also called "locking in"; the more stable of the two frequencies assumes control over the other. It usually can be corrected by advancing the regeneration control until the beat-note is heard again, or by reducing the input signal.

The point just after the detector starts oscillating is the most sensitive condition for code reception. Further advancing the regeneration control makes the receiver less susceptible to blocking by strong signals, but also less sensitive to weak signals.

If the detector is in the oscillating condition and a phone signal is tuned in, a steady audible beat-note will result. While it is possible to listen to phone if the receiver can be tuned to exact zero beat, it is more satisfactory to reduce the regeneration to the point just before the receiver goes into oscillation. This is also the most sensitive operating point.

Single-side-band phone signals can be received with a regenerative detector by advancing the regeneration control to the point used for code reception and tuning carefully across the s.s.b. signal. The tuning will be very critical, however, and the operator must be prepared to just "creep" across the signal. A strong signal will pull the detector and make reception impossible, so either the regeneration must be advanced far enough to prevent this condition, or the signal must be reduced by using loose antenna coupling.

Tuning and Band-Changing Methods

Band-Changing

The resonant circuits that are tuned to the frequency of the incoming signal constitute a special problem in the design of amateur receivers, since the amateur frequency assignments consist of groups or bands of frequencies at widely-spaced intervals. The same coil and tuning capacitor cannot be used for, say, 14 Mc. to 3.5 Mc., because of the impracticable maximum-to-minimum capacity ratio required, and also because the tuning would be excessively critical with such a large frequency range. It is necessary, therefore, to provide a means for changing the circuit constants for various frequency bands. As a matter of convenience the same tuning capacitor usually is retained, but new coils are inserted in the circuit for each band.

One method of changing inductances is to use a switch having an appropriate number of contacts, which connects the desired coil and disconnects the others. The unused coils are sometimes short-circuited by the switch, to avoid the possibility of undesirable self resonances in the unused coils. This is not necessary if the coils are separated from each other by several coil diameters, or are mounted at right angles to each other.

Another method is to use coils wound on forms with contacts (usually pins) that can be plugged in and removed from a socket. These plug-in coils are advantageous when space in a multiband receiver is at a premium. They are also very useful when considerable experimental work is involved, because they are easier to work on than coils clustered around a switch.

Bandspreading

The tuning range of a given coil and variable capacitor will depend upon the inductance of the coil and the change in tuning capacity. For ease of tuning, it is desirable to adjust the tuning range so that practically the whole dial scale is occupied by the band in use. This is called **bandspreading**. Because of the varying widths of the bands, special tuning methods must be devised to give the correct maximum-minimum capacity ratio on each band. Several of these methods are shown in Fig. 5-9.

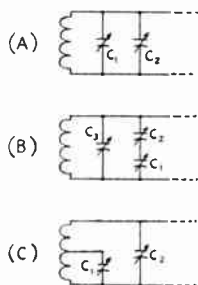

Fig. 5-9 — Essentials of the three basic band-spread tuning systems.

In A, a small bandspread capacitor, C_2 (15- to 25- μf . maximum capacity), is used in par-

allel with a capacitor, C_2 , which is usually large enough (100 to 140 μf .) to cover a 2-to-1 frequency range. The setting of C_2 will determine the minimum capacity of the circuit, and the maximum capacity for bandspread tuning will be the maximum capacity of C_1 plus the setting of C_2 . The inductance of the coil can be adjusted so that the maximum-minimum ratio will give adequate bandspread. It is almost impossible, because of the non-harmonic relation of the various band limits, to get full bandspread on all bands with the same pair of capacitors. C_2 is variously called the **band-setting** or **main-tuning** capacitor. It must be reset each time the band is changed.

The method shown at B makes use of capacitors in series. The tuning capacitor, C_1 , may have a maximum capacity of 100 μf . or more. The minimum capacity is determined principally by the setting of C_3 , which usually has low capacity, and the maximum capacity by the setting of C_2 , which is of the order of 25 to 50 μf . This method is capable of close adjustment to practically any desired degree of bandspread. Either C_2 and C_3 must be adjusted for each band or separate pre-adjusted capacitors must be switched in.

The circuit at C also gives complete spread on each band. C_1 , the bandspread capacitor, may have any convenient value; 50 μf . is satisfactory. C_2 may be used for continuous frequency coverage ("general coverage") and as a band-setting capacitor. The effective maximum-minimum capacitance ratio depends upon C_2 and the point at which C_1 is tapped on the coil. The nearer the tap to the bottom of the coil, the greater the bandspread, and vice versa. For a given coil and tap, the bandspread will be greater if C_2 is set at higher capacitance. C_2 may be connected permanently across the individual inductor and preset, if desired. This requires a separate capacitor for each band, but eliminates the necessity for resetting C_2 each time.

Ganged Tuning

The tuning capacitors of the several r.f. circuits may be coupled together mechanically and operated by a single control. However, this operating convenience involves more complicated construction, both electrically and mechanically. It becomes necessary to make the various circuits **track** — that is, tune to the same frequency at each setting of the tuning control.

True tracking can be obtained only when the inductance, tuning capacitors, and circuit inductances and minimum and maximum capacities are identical in all "ganged" stages. A small trimmer or **padding** capacitor may be connected across the coil, so that variations in minimum capacity can be compensated. The fundamental circuit is shown in Fig. 5-10, where C_1 is the trimmer and C_2 the tuning capacitor. The use of the trimmer necessarily increases the

minimum circuit capacity, but it is a necessity for satisfactory tracking. Midget capacitors having maximum capacities of 15 to 30 $\mu\text{mf.}$ are commonly used.

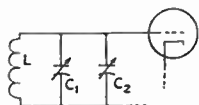

Fig. 5-10 — Showing the use of a trimmer capacitor to set the minimum circuit capacity in order to obtain true tracking for gang-tuning.

The same methods are applied to hand-spread circuits that must be tracked. The circuits are identical with those of Fig. 5-9. If both general-coverage and handspread tuning are to be available, an additional trimmer capacitor must be connected across the coil in each circuit shown. If only amateur-band tuning is desired, however, then C_3 in Fig. 5-9B, and C_2 in Fig. 5-9C, serve as trimmers.

The coil inductance can be adjusted by starting with a larger number of turns than

necessary and removing a turn or fraction of a turn at a time until the circuits track satisfactorily. An alternative method, provided the inductance is reasonably close to the correct value initially, is to make the coil so that the last turn is variable with respect to the whole coil.

Another method for trimming the inductance is to use an adjustable brass (or copper) or powdered-iron core. The brass core acts like a single shorted turn, and the inductance of the coil is decreased as the brass core, or "slug," is moved into the coil. The powdered-iron core has the opposite effect, and *increases* the inductance as it is moved into the coil. The Q of the coil is not affected materially by the use of the brass slug, provided the brass slug has a clean surface or is silverplated. The use of the powdered-iron core will raise the Q of a coil, provided the iron is suitable for the frequency in use. Good powdered-iron cores can be obtained for use up to about 50 Mc.

The Superheterodyne

For many years (until about 1932) practically the only type of receiver to be found in amateur stations consisted of a regenerative detector and one or more stages of audio amplification. Receivers of this type can be made quite sensitive but strong signals block them easily and, in our present crowded bands, they are seldom used except in emergencies. They have been replaced by **superheterodyne** receivers, generally called "superhets."

The Superheterodyne Principle

In a superheterodyne receiver, the frequency of the incoming signal is heterodyned to a new radio frequency, the **intermediate frequency** (abbreviated "i.f."), then amplified, and finally detected. The frequency is changed by modulating the output of a tunable oscillator (the **high-frequency**, or **local**, oscillator) by the incoming signal in a mixer or converter stage (**first detector**) to produce a side frequency equal to the intermediate frequency. The other side frequency is rejected by selective circuits. The audio-frequency signal is obtained at the **second detector**. Code signals are made audible by autodyne or heterodyne reception at the second detector.

As a numerical example, assume that an intermediate frequency of 455 kc. is chosen and that the incoming signal is at 7000 kc. Then the high-frequency oscillator frequency may be set to 7455 kc., in order that one side frequency (7455 minus 7000) will be 455 kc. The high-frequency oscillator could also be set to 6545 kc. and give the same difference frequency. To produce an audible code signal at the second detector of, say, 1000 cycles, the autodyning or heterodyning oscillator would be set to either 454 or 456 kc.

The frequency-conversion process permits

r.f. amplification at a relatively low frequency, the i.f. High selectivity and gain can be obtained at this frequency, and this selectivity and gain are constant. The separate oscillators can be designed for good stability and, since they are working at frequencies considerably removed from the signal frequencies (percentage-wise), they are not normally "pulled" by the incoming signal.

Images

Each h.f. oscillator frequency will cause i.f. response at two signal frequencies, one higher and one lower than the oscillator frequency. If the oscillator is set to 7455 kc. to tune to a 7000-kc. signal, for example, the receiver can respond also to a signal on 7910 kc., which likewise gives a 455-kc. beat. The undesired signal is called the **image**. It can cause unnecessary interference if it isn't eliminated.

The radio-frequency circuits of the receiver (those used before the signal is heterodyned to the i.f.) normally are tuned to the desired signal, so that the selectivity of the circuits reduces or eliminates the response to the image signal. The ratio of the receiver voltage output from the desired signal to that from the image is called the **signal-to-image ratio**, or **image ratio**.

The image ratio depends upon the selectivity of the r.f. tuned circuits preceding the mixer tube. Also, the higher the intermediate frequency, the higher the image ratio, since raising the i.f. increases the frequency separation between the signal and the image and places the latter further away from the resonance peak of the signal-frequency input circuits. Most receiver designs represent a compromise between economy (few r.f. stages) and image rejection (large number of r.f. stages).

Other Spurious Responses

In addition to images, other signals to which the receiver is not ostensibly tuned may be heard. Harmonics of the high-frequency oscillator may beat with signals far removed from the desired frequency to produce output at the intermediate frequency; such spurious responses can be reduced by adequate selectivity before the mixer stage, and by using sufficient shielding to prevent signal pick-up by any means other than the antenna. When a strong signal is received, the harmonics generated by rectification in the second detector may, by stray coupling, be introduced into the r.f. or mixer circuit and converted to the intermediate frequency, to go through the receiver in the same way as an ordinary signal. These "birdies" appear as a heterodyne beat on the desired signal, and are principally bothersome when the frequency of the incoming signal is not greatly different from the intermediate frequency. The cure is proper circuit isolation and shielding.

Harmonics of the beat oscillator also may be converted in similar fashion and amplified through the receiver; these responses can be reduced by shielding the beat oscillator and operating it at a low power level.

The Double Superheterodyne

At high and very-high frequencies it is difficult to secure an adequate image ratio when the intermediate frequency is of the order of 455 kc. To reduce image response the signal frequently is converted first to a rather high (1,500, 5000, or even 10,000 kc.) intermediate frequency, and then — sometimes after further amplification — reconverted to a lower i.f. where higher adjacent-channel selectivity can be obtained. Such a receiver is called a **double superheterodyne**.

● **FREQUENCY CONVERTERS**

A circuit tuned to the intermediate frequency is placed in the plate circuit of the mixer, to offer a high impedance load for the i.f. voltage that is developed. The signal- and oscillator-frequency voltages appearing in the plate circuit are rejected by the selectivity of this circuit. The i.f. tuned circuit should have low impedance for these frequencies, a condition easily met if they do not approach the intermediate frequency.

The **conversion efficiency** of the mixer is the ratio of i.f. output voltage from the plate circuit to r.f. signal voltage applied to the grid. High conversion efficiency is desirable. The mixer tube noise also should be low if a good signal-to-noise ratio is wanted, particularly if the mixer is the first tube in the receiver.

A change in oscillator frequency caused by tuning of the mixer grid circuit is called **pulling**. Pulling should be minimized, because the stability of the whole receiver depends critically upon the stability of the h.f. oscillator. Pulling decreases with separation of the signal and h.f.-oscillator frequencies, being less with high in-

termediate frequencies. Another type of pulling is caused by regulation in the power supply. Strong signals cause the voltage to change, which in turn shifts the oscillator frequency.

Circuits

If the first detector and high-frequency oscillator are separate tubes, the first detector is called a "mixer." If the two are combined in one envelope (as is often done for reasons of economy or efficiency), the first detector is called a "converter." In either case the function is the same.

Typical mixer circuits are shown in Fig. 5-11. The variations are chiefly in the way in which the oscillator voltage is introduced. In 5-11A, a pentode functions as a plate detector; the oscillator voltage is capacity-coupled to the grid of the tube through C_2 . Inductive coupling may be used instead. The conversion gain and input selectivity generally are good, so long as

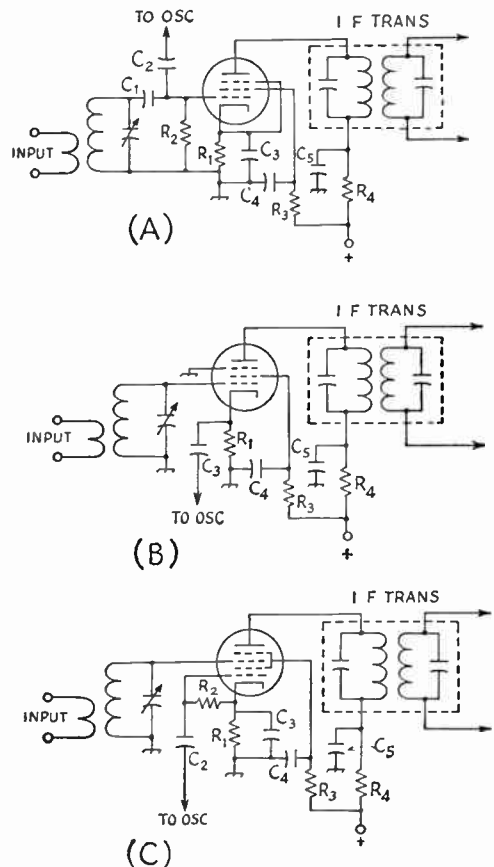

Fig. 5-11 — Typical circuits for separately-excited mixers. Grid injection of a pentode mixer is shown at A, cathode injection at B, and separate excitation of a pentagrid converter is given in C. Typical values for C will be found in Table 5-1 — the values below are for the pentode mixer of A and B.

- C_1 — 10 to 50 μf .
- C_2 — 5 to 10 μf .
- C_3, C_4, C_5 — 0.001 μf .
- R_1 — 6800 ohms.
- R_2 — 1.0 megohm.
- R_3 — 0.47 megohm.
- R_4 — 1500 ohms.

Positive supply voltage can be 250 volts with a 6AC7, 150 with a 6AK5.

the sum of the two voltages (signal and oscillator) impressed on the mixer grid does not exceed the grid bias. It is desirable to make the oscillator voltage as high as possible without exceeding this limitation. The oscillator power required is negligible. If the signal frequency is only 5 or 10 times the i.f., it may be difficult to develop enough oscillator voltage at the grid (because of the selectivity of the tuned input circuit). However, the circuit is a sensitive one and makes a good mixer, particularly with high-transconductance tubes like the 6AC7, 6AK5 or 6U8 (pentode section). A good triode also works well in the circuit, and tubes like the 6J6 (one section), the 12AT7 (one section), and the 6J4 work well. When a triode is used, the signal frequency must be short-circuited in the plate circuit, and this is done by connecting the tuning capacitor of the i.f. transformer directly from plate to cathode.

The circuit in Fig. 5-11B shows cathode injection at the mixer. Operation is similar to the grid-injection case, and the same considerations apply.

It is difficult to avoid "pulling" in a triode or pentode mixer, and a pentagrid mixer tube provides much better isolation. A typical circuit is shown in Fig. 5-11C, and tubes like the 6SA7, 6BA7 or 6BE6 are commonly used. The oscillator voltage is introduced through an "injection" grid. Measurement of the rectified current flowing in R_2 is used as a check for proper oscillator-voltage amplitude. Tuning of the signal-grid circuit can have little effect on the oscillator frequency because the injection grid is isolated from the signal grid by a screen grid that is at r.f. ground potential. The pentagrid mixer is much noisier than a triode or pentode mixer, but its isolating characteristics make it a very useful device.

Many receivers use pentagrid converters, and two typical circuits are shown in Fig. 5-12. The circuit shown in Fig. 5-12A, which is suitable for the 6K8, is for a "triode-hexode" converter. A triode oscillator tube is mounted in the same envelope with a hexode, and the control grid of the oscillator portion is connected internally to an injection grid in the hexode. The isolation between oscillator and converter tube is reasonably good, and very little pulling results, except on signal frequencies that are quite large compared with the i.f.

The pentagrid-converter circuit shown in Fig.

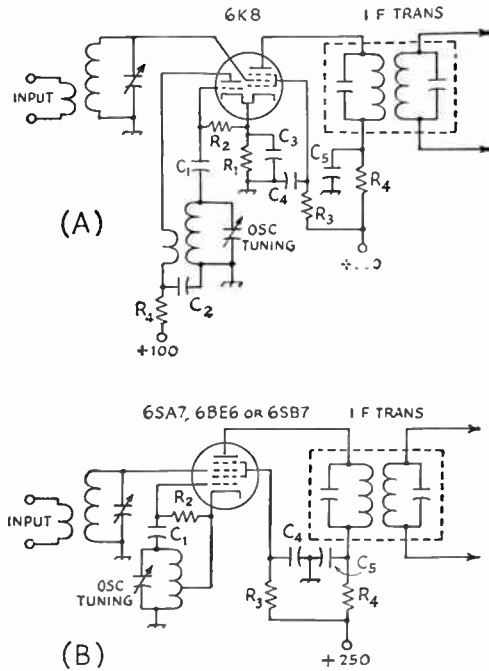

Fig. 5-12 — Typical circuits for triode-hexode (A) and pentagrid (B) converters. Values for R_1 , R_2 and R_3 can be found in Table 5-1; others are given below.

C_1 — 47 μ f. C_3 — 0.01 μ f.
 C_2, C_4, C_5 — 0.001 μ f. R_4 — 1000 ohms.

5-12B can be used with a tube like the 6SA7, 6SB7Y, 6BA7 or 6BE6. Generally the only care necessary is to adjust the feedback of the oscillator circuit to give the proper oscillator r.f. voltage. This condition is checked by measuring the d.c. current flowing in grid resistor R_2 .

A more stable receiver generally results, particularly at the higher frequencies, when separate tubes are used for the mixer and oscillator. Practically the same number of circuit components is required whether or not a combination tube is used, so that there is very little difference to be realized from the cost standpoint.

Typical circuit constants for converter tubes are given in Table 5-1. The grid leak referred to is the oscillator grid leak or injection-grid return, R_2 of Figs. 5-11C and 5-12.

The effectiveness of converter tubes of the type just described becomes less as the signal frequency is increased. Some oscillator voltage will

TABLE 5-1
Circuit and Operating Values for Converter Tubes
 Plate voltage = 250
 Screen voltage = 100, or through specified resistor from 250 volts

Tube	SELF-EXCITED				SEPARATE EXCITATION			
	Cathode Resistor	Screen Resistor	Grid Leak	Grid Current	Cathode Resistor	Screen Resistor	Grid Leak	Grid Current
6BA7 ¹	0	12,000	22,000	0.35 ma.	68	15,000	22,000	0.35 ma.
6BE6 ¹	0	22,000	22,000	0.5	150	22,000	22,000	0.5
6K8 ²	240	27,000	47,000	0.15-0.2	—	—	—	—
6SA7 ² (7Q7) ³	0	18,000	22,000	0.5	150	18,000	22,000	0.5
6SB7Y ²	0	15,000	22,000	0.35	68	15,000	22,000	0.35

¹ Miniature tube ² Octal base, metal. ³ Lock-in base.

be coupled to the signal grid through "space-charge" coupling, an effect that increases with frequency. If there is relatively little frequency difference between oscillator and signal, as for example a 14- or 28-Mc. signal and an i.f. of 455 kc., this voltage can become considerable because the selectivity of the signal circuit will be unable to reject it. If the signal grid is not returned directly to ground, but instead is returned through a resistor or part of an a.v.c. system, considerable bias can be developed which will cut down the gain. For this reason, and to reduce image response, the i.f. following the first converter of a receiver should be not less than 5 or 10 percent of the signal frequency, for best results.

Audio Converters

Converter circuits of the type shown in Fig. 5-12 can be used to advantage in the reception of code and single-side-band suppressed-carrier signals, by introducing the local oscillator on the No. 1 grid, the signal on the No. 3 grid, and working the tube into an audio load. Its operation can be visualized as heterodyning the incoming signal into the audio range. The use of such circuits for audio conversion has been limited to selective i.f. amplifiers operating below 500 kc. and usually below 100 kc. An ordinary a.m. signal cannot be received on such a detector unless the tuning is adjusted to make the local oscillator zero-beat with the incoming carrier.

Since the beat oscillator modulates the electron stream completely, a large beat-oscillator component exists in the plate circuit. To prevent overload of the following audio amplifier stages, an adequate i.f. filter must be used in the output of the converter.

The "product detector" of Fig. 5-6 is also a converter circuit, and the statements above for audio converters apply to the product detector.

THE HIGH-FREQUENCY OSCILLATOR

Stability of the receiver is dependent chiefly upon the stability of the h.f. oscillator, and particular care should be given this part of the receiver. The frequency of oscillation should be insensitive to mechanical shock and changes in voltage and loading. Thermal effects (slow change in frequency because of tube or circuit heating) should be minimized. They can be reduced by using ceramic instead of bakelite insulation in the r.f. circuits, a large cabinet relative to the chassis (to provide for good radiation of developed heat), minimizing the number of high-wattage resistors in the receiver and putting them in the separate power supply, and not mounting the oscillator coils and tuning condenser too close to a tube. Propping up the lid of a receiver will often reduce drift by lowering the terminal temperature of the unit.

Sensitivity to vibration and shock can be minimized by using good mechanical support for coils and tuning capacitors, a heavy chassis, and by not hanging any of the oscillator-circuit components on long leads. Tie-points should be used

to avoid long leads. Stiff *short* leads are excellent because they can't be made to vibrate.

Smooth tuning is a great convenience to the operator, and can be obtained by taking pains with the mounting of the dial and tuning capacitors. They should have good alignment and no back-lash. If the capacitors are mounted off the chassis on posts instead of brackets, it is almost impossible to avoid some back-lash unless the posts have extra-wide bases. The capacitors should be selected with good wiping contacts to the rotor, since with age the rotor

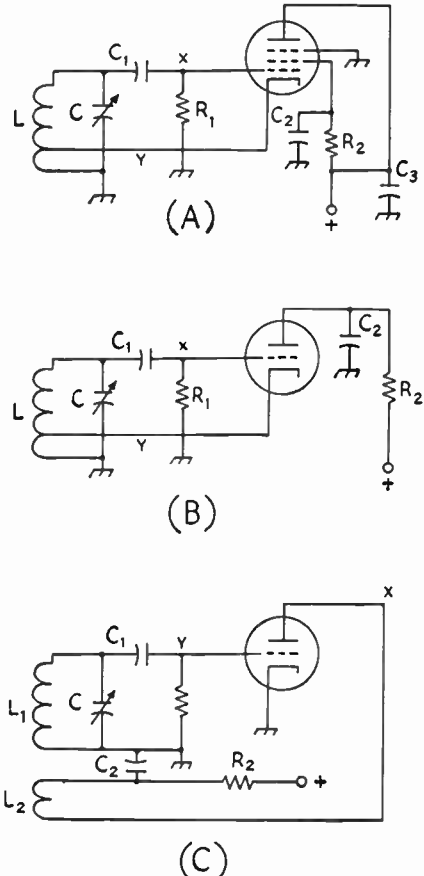

Fig. 5-13 — High-frequency oscillator circuits. A, pentode grounded-plate oscillator; B, triode grounded-plate oscillator; C, triode oscillator with tickler circuit. Coupling to the mixer may be taken from points X and Y. In A and B, coupling from Y will reduce pulling effects, but gives less voltage than from X; this type is best adapted to mixer circuits with small oscillator-voltage requirements. Typical values for components are as follows:

	Circuit A	Circuit B	Circuit C
C_1 —	100 $\mu\text{f.}$	100 $\mu\text{f.}$	100 $\mu\text{f.}$
C_2 —	0.1 $\mu\text{f.}$	0.1 $\mu\text{f.}$	0.1 $\mu\text{f.}$
C_3 —	0.1 $\mu\text{f.}$		
R_1 —	47,000 ohms.	47,000 ohms.	47,000 ohms.
R_2 —	47,000 ohms.	10,000 to 25,000 ohms.	100,000 to 25,000 ohms.

The plate-supply voltage should be 250 volts. In circuits B and C, R_2 is used to drop the supply voltage to 100–150 volts; it may be omitted if voltage is obtained from a voltage divider in the power supply.

contacts can be a source of erratic tuning. All joints in the oscillator tuning circuit should be carefully soldered, because a loose connection or "rosin joint" can develop trouble that is sometimes hard to locate. The chassis and panel materials should be heavy and rigid enough so that pressure on the tuning dial will not cause torsion and a shift in the frequency.

In addition, the oscillator must be capable of furnishing sufficient r.f. voltage and power for the particular mixer circuit chosen, at all frequencies within the range of the receiver, and its harmonic output should be as low as possible to reduce the possibility of spurious responses.

The oscillator plate power should be as low as is consistent with adequate output. Low plate power will reduce tube heating and thereby lower the frequency drift. The oscillator and mixer circuits should be well isolated, preferably by shielding, since coupling other than by the intended means may result in pulling.

If the h.f.-oscillator frequency is affected by changes in plate voltage, a voltage-regulated plate supply (VR tube) can be used.

Circuits

Several oscillator circuits are shown in Fig. 5-13. Circuits A and B will give about the same results, and require only one coil. However, in these two circuits the cathode is above ground potential for r.f., which often is a cause of hum modulation of the oscillator output at 14 Mc. and higher frequencies when a.c.-heated-cathode tubes are used. The circuit of Fig. 5-13C reduces hum because the cathode is grounded. It is simple to adjust, and it is also the best circuit to use with filament-type tubes. With filament-type tubes, the other two circuits would require r.f. chokes to keep the filament above r.f. ground.

Besides the use of a fairly high C/L ratio in the tuned circuit, it is necessary to adjust the feedback to obtain optimum results. Too much feedback may cause "squegging" of the oscillator and the generation of several frequencies simultaneously; too little feedback will cause the output to be low. In the tapped-coil circuits (A, B), the feedback is increased by moving the tap toward the grid end of the coil. In C, feedback is obtained by increasing the number of turns on L_2 or by moving L_2 closer to L_1 .

The Intermediate-Frequency Amplifier

One major advantage of the superhet is that high gain and selectivity can be obtained by using a good i.f. amplifier. This can be a one-stage affair in simple receivers, or two or three stages in the more elaborate sets.

Choice of Frequency

The selection of an intermediate frequency is a compromise between conflicting factors. The lower the i.f. the higher the selectivity and gain, but a low i.f. brings the image nearer the desired signal and hence decreases the image ratio. A low i.f. also increases pulling of the oscillator frequency. On the other hand, a high i.f. is beneficial to both image ratio and pulling, but the gain is lowered and selectivity is harder to obtain by simple means.

An i.f. of the order of 455 kc. gives good selectivity and is satisfactory from the standpoint of image ratio and oscillator pulling at frequencies up to 7 Mc. The image ratio is poor at 14 Mc. when the mixer is connected to the antenna, but adequate when there is a tuned r.f. amplifier between antenna and mixer. At 28 Mc. and on the very high frequencies, the image ratio is very poor unless several r.f. stages are used. Above 14 Mc., pulling is likely to be bad without very loose coupling between mixer and oscillator.

With an i.f. of about 1600 kc., satisfactory image ratios can be secured on 14, 21 and 28 Mc. with one r.f. stage of good design. For frequencies of 28 Mc. and higher, the best solution is to use a double superheterodyne, choosing one high i.f. for image reduction (5 and 10 Mc. are frequently used) and a lower one for gain and selectivity.

In choosing an i.f. it is wise to avoid frequencies on which there is considerable activity by the various radio services, since such signals may be picked up directly on the i.f. wiring. Shifting the i.f. or better shielding are the solutions to this interference problem.

Fidelity; Side-band Cutting

Modulation of a carrier causes the generation of side-band frequencies numerically equal to the carrier frequency plus and minus the highest modulation frequency present. If the receiver is to give a faithful reproduction of modulation that contains, for instance, audio frequencies up to 5000 cycles, it must at least be capable of amplifying equally all frequencies contained in a band extending from 5000 cycles above or below the carrier frequency. In a superheterodyne, where all carrier frequencies are changed to the fixed intermediate frequency, the i.f. amplification must be uniform over a band 5 kc. wide, when the carrier is set at one edge. If the carrier is set in the center, a 10-kc. band is required. The signal-frequency circuits usually do not have enough over-all selectivity to affect materially the "adjacent-channel" selectivity, so that only the i.f.-amplifier selectivity need be considered.

If the selectivity is too great to permit uniform amplification over the band of frequencies occupied by the modulated signal, some of the side bands are "cut." While side-band cutting reduces fidelity, it is frequently preferable to sacrifice naturalness of reproduction in favor of communications effectiveness.

The selectivity of an i.f. amplifier, and hence

the tendency to cut side bands, increases with the number of amplifier stages and also is greater the lower the intermediate frequency. From the standpoint of communication, side-band cutting is never serious with two-stage amplifiers at frequencies as low as 455 kc. A two-stage i.f. amplifier at 85 or 100 kc. will be sharp enough to cut some of the higher-frequency side bands, if good transformers are used. However, the cutting is not at all serious, and the gain in selectivity is worthwhile in crowded amateur bands.

Circuits

I.f. amplifiers usually consist of one or two stages. At 455 kc. two stages generally give all the gain usable, and also give suitable selectivity for phone reception.

A typical circuit arrangement is shown in Fig. 5-14. A second stage would simply duplicate the circuit of the first. The i.f. amplifier practically always uses a remote cut-off pentode-type tube operated as a Class A amplifier. For maximum selectivity, double-tuned transformers are used for interstage coupling, although single-tuned circuits or transformers with untuned primaries can be used for coupling, with a consequent loss in selectivity. All other things being equal, the selectivity of an i.f. amplifier is proportional to the number of tuned circuits in it.

In Fig. 5-14, the gain of the stage is reduced by introducing a negative voltage to the lead marked "AVC" or a positive voltage to R_1 at the point marked "manual gain control." In either case, the voltage increases the bias on the tube and reduces the mutual conductance and hence the gain. When two or more stages are used, these voltages are generally obtained from common sources. The decoupling resistor, R_3 , helps to prevent unwanted interstage coupling. C_2 and R_4 are part of the automatic volume-control circuit (described later); if no a.v.c. is used, the lower end of the i.f.-transformer secondary is connected to chassis.

Tubes for I.F. Amplifiers

Variable- μ (remote cut-off) pentodes are almost invariably used in i.f. amplifier stages, since grid-bias gain control is practically always applied to the i.f. amplifier. Tubes with high plate resistance will have least effect on the selectivity of the amplifier, and those with high mutual conductance will give greatest gain. The choice of i.f. tubes normally has no effect on the

Tube	Plate Volts	Screen Volts	Cathode Resistor	Screen Resistor
6AB7 ^{1*}	300		200 ohms	33,000 ohms
6AC7 ¹	300		160	62,000
6AH6 ²	300	150	160	62,000
6AK5 ²	180	120	200	27,000
6AU6 ²	250	150	68	33,000
6BA6 ^{2*}	250	100	68	33,000
6B116 ²	250	150	100	33,000
6BJ6 ^{2*}	250	100	82	47,000
6J7 ¹	250	100	1200	270,000
6K7 ^{1*}	250	125	240	47,000
6SG7 ^{1*}	250	125	68	27,000
6SJ7 ^{1*}	250	150	200	47,000
6SH7 ¹	250	150	68	39,000
6SJ7 ¹	250	100	820	180,000
6SK7 ^{1*}	250	100	270	56,000

¹ Octal base, metal. ² Miniature tube
* Remote cut-off type.

signal-to-noise ratio, since this is determined by the preceding mixer and r.f. amplifier.

Typical values of cathode and screen resistors for common tubes are given in Table 5-II. The 6K7, 6SK7 and 6BJ6 are recommended for i.f. work because they have desirable remote cut-off characteristics. The indicated screen resistors drop the plate voltage to the correct screen voltage, as R_2 in Fig. 5-14.

When two or more stages are used the high gain may tend to cause instability and oscillation, so that good shielding, bypassing, and careful circuit arrangement to prevent stray coupling between input and output circuits are necessary.

When single-ended tubes are used, the plate and grid leads should be well separated. With these tubes it is advisable to mount the screen bypass capacitor directly on the bottom of the socket, crosswise between the plate and grid pins, to provide additional shielding. If a paper capacitor is used, the outside foil should be grounded to the chassis.

I.F. Transformers

The tuned circuits of i.f. amplifiers are built up as transformer units consisting of a metal shield container in which the coils and tuning capacitors are mounted. Both air-core and powdered iron-core universal-wound coils are used, the latter having somewhat higher Q_s and hence greater selectivity and gain. In universal windings the coil is wound in layers with each turn traversing the length of the coil, back

Fig. 5-14—Typical intermediate-frequency amplifier circuit for a super-heterodyne receiver. Representative values for components are as follows: C_1, C_3, C_4, C_5 — 0.02 μ f. at 455 kc.; 0.01 μ f. at 1600 kc. and higher. C_2 — 0.01 μ f. R_1, R_2 — See Table 5-II. R_3, R_5 — 1500 ohms. R_4 — 0.22 megohm.

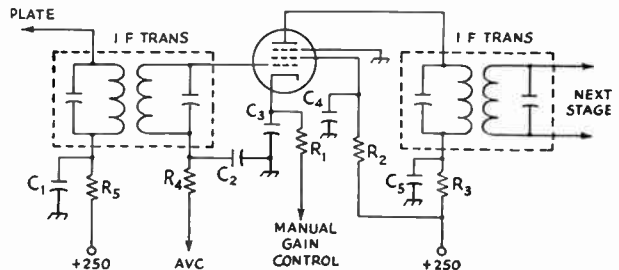

and forth, rather than being wound perpendicular to the axis as in ordinary single-layer coils. In a straight multilayer winding, a fairly large capacitance can exist between layers. Universal winding, with its "criss-crossed" turns, tends to reduce distributed-capacity effects.

For tuning, air-dielectric tuning capacitors are preferable to mica compression types because their capacity is practically unaffected by changes in temperature and humidity. Iron-core transformers may be tuned by varying the inductance (permeability tuning), in which case stability comparable to that of variable air-capacitor tuning can be obtained by use of high-stability fixed mica or ceramic capacitors. Such stability is of great importance, since a circuit whose frequency "drifts" with time eventually will be tuned to a different frequency than the other circuits, thereby reducing the gain and selectivity of the amplifier. Typical i.f.-transformer construction is shown in Fig. 5-15.

The normal interstage i.f. transformer is loosely coupled, to give good selectivity consistent

the over-all selectivity of the transformer.

A method of varying the selectivity is to vary the coupling between primary and secondary, overcoupling being used to broaden the selectivity curve. Special circuits using single tuned circuits, coupled in any of several different ways, are used in some advanced receivers.

Selectivity

The over-all selectivity of the r.f. amplifier will depend on the frequency and the number of stages. The following figures are indicative of the bandwidths to be expected with good-quality transformers in amplifiers so constructed as to keep regeneration at a minimum:

Intermediate Frequency	Bandwidth in Kilocycles		
	6 db. down	20 db. down	40 db. down
One stage, 50 kc. (iron core) . . .	0.8	1.4	2.8
One stage, 455 kc. (air core) . . .	8.7	17.8	32.3
One stage, 455 kc. (iron core) . . .	4.3	10.3	20.4
Two stages, 455 kc. (iron core) . . .	2.9	6.4	10.8
Two stages, 1600 kc.	11.0	16.6	27.4

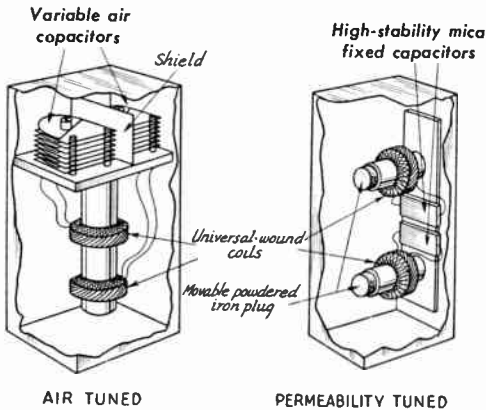

Fig. 5-15 — Representative i.f.-transformer construction. Coils are supported on insulating tubing or (in the air-tuned type) on wax-impregnated wooden dowels. The shield in the air-tuned transformer prevents capacity coupling between the tuning capacitors. In the permeability-tuned transformer the cores consist of finely-divided iron particles supported in an insulating binder, formed into cylindrical "plugs." The tuning capacitance is fixed, and the inductances of the coils are varied by moving the iron plugs in and out.

with adequate gain. A so-called diode transformer is similar, but the coupling is tighter, to give sufficient transfer when working into the finite load presented by a diode detector. Using a diode transformer in place of an interstage transformer would result in loss of selectivity; using an interstage transformer to couple to the diode would result in loss of gain.

Besides the type of i.f. transformer shown in Fig. 5-15, special units to give desired selectivity characteristics are available. For higher-than-ordinary adjacent-channel selectivity triple-tuned transformers, with a third tuned circuit inserted between the input and output windings, are sometimes used. The energy is transferred from the input to the output windings via this tertiary winding, thus adding its selectivity to

THE SECOND DETECTOR AND BEAT OSCILLATOR

Detector Circuits

The second detector of a superheterodyne receiver performs the same function as the detector in the simple receiver, but usually operates at a higher input level because of the relatively great amplification ahead of it. Therefore, the ability to handle large signals without distortion is preferable to high sensitivity. Plate detection is used to some extent, but the diode detector is most popular. It is especially adapted to furnishing automatic gain or volume control. The basic circuits have been described, although in many cases the diode elements are incorporated in a multipurpose tube that contains an amplifier section in addition to the diode.

Audio-converter circuits and product detectors are often used for code or s.s.b. detectors.

The Beat Oscillator

Any standard oscillator circuit may be used for the beat oscillator required for heterodyne reception. Special beat-oscillator transformers are available, usually consisting of a tapped coil with adjustable tuning; these are most conveniently used with the circuits shown in Fig. 5-13A and B, with the output taken from Y. A variable capacitor of about 25- μf . capacitance can be connected between cathode and ground to provide fine adjustment of the frequency. The beat oscillator usually is coupled to the second-detector tuned circuit through a fixed capacitor of a few μf .

The beat oscillator should be well shielded, to prevent coupling to any part of the receiver except the second detector and to prevent its harmonics from getting into the front end and being amplified along with desired signals. The b.f.o. power should be as low as is consistent with sufficient audio-frequency output on the strongest

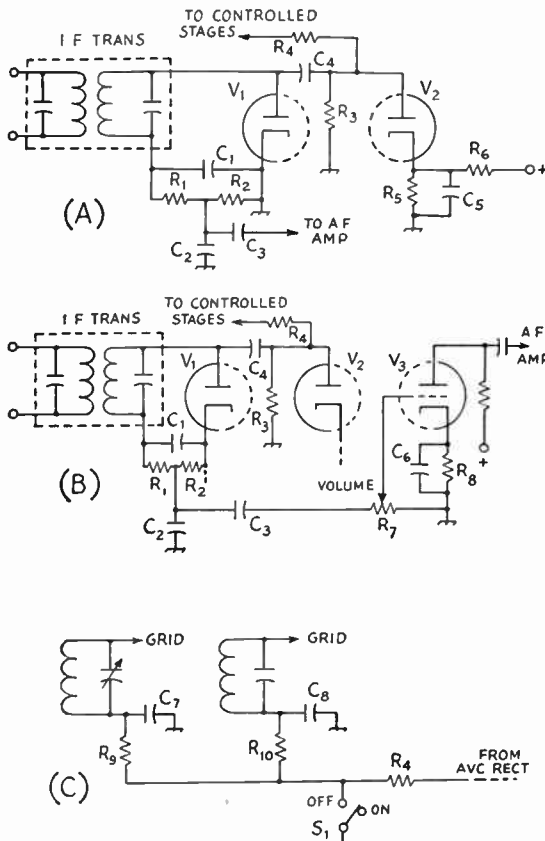

Fig. 5-16 — Delayed automatic volume control circuits using a twin diode (A) and a dual-diode triode. The circuits are essentially the same and differ only in the method of biasing the a.v.c. rectifier. The a.v.c. control voltage is applied to the controlled stages as in (C). For these circuits, typical values are:

C_1, C_2, C_4 — 100 μf .

C_3, C_5, C_7, C_8 — 0.01 μf .

C_6 — 5- μf . electrolytic.

R_1, R_9, R_{10} — 0.1 megohm.

R_2 — 0.27 megohm.

R_3 — 2 megohms.

R_4 — 0.47 megohm.

R_5, R_6 — Voltage divider to give 2 to 10 volts bias at 1 to 2 ma. drain.

R_7 — 0.5-megohm volume control.

R_8 — Correct bias resistor for triode section of dual-diode triode.

signals. However, if the beat-oscillator output is too low, strong signals will not give a proportionately strong audio signal. Contrary to some opinion, a weak b.f.o. is never an advantage.

● AUTOMATIC VOLUME CONTROL

Automatic regulation of the gain of the receiver in inverse proportion to the signal strength is an operating convenience in phone reception, since it tends to keep the output level of the receiver constant regardless of input-signal strength. The average rectified d.c. voltage, developed by the received signal across a resistance in a detector circuit, is used to vary the bias on the r.f. and i.f. amplifier tubes. Since this voltage is proportional to the average amplitude

of the signal, the gain is reduced as the signal strength becomes greater. The control will be more complete and the output more constant as the number of stages to which the a.v.c. bias is applied is increased. Control of at least two stages is advisable.

Circuits

Although some receivers derive the a.v.c. voltage from the diode detector, the usual practice is to use a separate a.v.c. rectifier. Typical circuits are shown in Figs. 5-16A and 5-16B. The two rectifiers can be combined in one tube, as in the 6H16 and 6AL5. In Fig. 5-16A V_1 is the diode detector; the signal is developed across R_1R_2 and coupled to the audio stages through C_3 . C_1, R_1 and C_2 are included for r.f. filtering, to prevent a large r.f. component being coupled to the audio circuits. The a.v.c. rectifier, V_2 , is coupled to the last i.f. transformer through C_4 , and most of the rectified voltage is developed across R_3 . V_2 does not rectify on weak signals, however; the fixed bias at R_5 must be exceeded before rectification can take place. The developed negative a.v.c. bias is fed to the controlled stages through R_4 .

The circuit of Fig. 5-16B is similar, except that a dual-diode triode tube is used. Since this has only one common cathode, the circuitry is slightly different but the principle is the same. The triode stage serves as the first audio stage, and its bias is developed in the cathode circuit across R_8 . This same bias is applied to the a.v.c. rectifier by returning its load resistor, R_3 , to ground. To avoid placing this bias on the detector, V_1 , its load resistor R_1R_2 is returned to cathode, thus avoiding any bias on the detector and permitting it to respond to weak signals.

The developed negative a.v.c. bias is applied to the controlled stages through their grid circuits, as shown in Fig. 5-16C. C_7R_9 and C_8R_{10} serve as filters to avoid common coupling and possible feedback and oscillation. The a.v.c. is disabled by closing switch S_1 .

The a.v.c. rectifier bias in Fig. 5-16B is set by the bias required for proper operation of V_3 . If less bias for the a.v.c. rectifier is required, R_3 can be tapped up on R_8 instead of being returned to chassis ground. In Fig. 5-16A, proper choice of bias at R_5 depends upon the over-all gain of the receiver and the number of controlled stages. In general, the bias at R_5 will be made higher for receivers with more gain and more stages.

Time Constant

The time constant of the resistor-capacitor combinations in the a.v.c. circuit is an important part of the system. It must be high enough so that the modulation on the signal is completely filtered from the d.c. output, leaving only an average d.c. component which follows the rela-

tively slow carrier variations with fading. Audio-frequency variations in the a.v.c. voltage applied to the amplifier grids would reduce the percentage of modulation on the incoming signal. But the time constant must not be too great or the a.v.c. will be unable to follow rapid fading. The capacitance and resistance values indicated in Fig. 5-16 will give a time constant that is satisfactory for average reception.

C.W. and S.S.B.

A.v.c. can be used for c.w. and s.s.b. reception but the circuit is more complicated. The a.v.c. voltage must be derived from a rectifier that is isolated from the beat-frequency oscillator (other-

wise the rectified b.f.o. voltage will reduce the receiver gain even with no signal coming through). This is generally done by using a separate a.v.c. channel connected to an i.f. amplifier stage ahead of the second detector (and b.f.o.). If the selectivity ahead of the a.v.c. rectifier isn't good, strong adjacent signals will develop a.v.c. voltages that will reduce the receiver gain while listening to weak signals. When clear channels are available, however, e.w. and s.s.b. a.v.c. will hold the receiver output constant over a wide range of signal input. A.v.c. systems designed to work on these signals must have fairly long time constants to work satisfactorily, and often a selection of time constants is made available.

Noise Reduction

Types of Noise

In addition to tube and circuit noise, much of the noise interference experienced in reception of high-frequency signals is caused by domestic or industrial electrical equipment and by automobile ignition systems. The interference is of two types in its effects. The first is the "hiss" type, consisting of overlapping pulses similar in nature to the receiver noise. It is largely reduced by high selectivity in the receiver, especially for code reception. The second is the "pistol-shot" or "machine-gun" type, consisting of separated impulses of high amplitude. The "hiss" type of interference usually is caused by commutator sparking in d.c. and series-wound a.c. motors, while the "shot" type results from separated spark discharges (a.c. power leaks, switch and key clicks, ignition sparks, and the like).

The only known approach to reducing tube and circuit noise is through better "front-end" design and through more over-all selectivity.

Impulse Noise

Impulse noise, because of the short duration of the pulses compared with the time between them, must have high amplitude to contain much average energy. Hence, noise of this type strong enough to cause much interference generally has an instantaneous amplitude much higher than that of the signal being received. The general principles of devices intended to reduce such noise is to allow the desired signal to pass through the receiver unaffected, but to make the receiver inoperative for amplitudes greater than that of the signal. The greater the amplitude of the pulse compared with its time of duration, the more successful the noise reduction.

Another approach is to "silence" (render inoperative) the receiver during the short duration time of any individual pulse. The listener will not hear the "hole" because of its short duration, and very effective noise reduction is obtained. Such devices are called "silencers" rather than "limiters."

In passing through selective receiver circuits, the time duration of the impulses is increased, because of the Q of the circuits. Thus the more selectivity ahead of the noise-reducing device, the more difficult it becomes to secure good pulse-type noise suppression.

Audio Limiting

A considerable degree of noise reduction in code reception can be accomplished by amplitude-limiting arrangements applied to the audio-output circuit of a receiver. Such limiters also maintain the signal output nearly constant during fading. These output-limiter systems are simple, and adaptable to most receivers. However, they cannot prevent noise peaks from overloading previous stages.

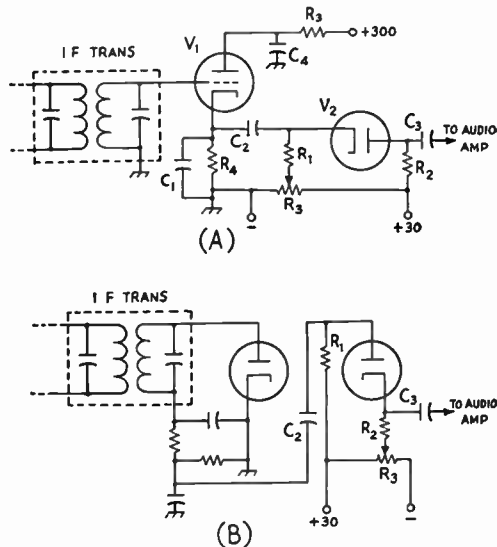

Fig. 5-17—Series-valve noise-limiter circuits. A, as used with an infinite-impedance detector; B, with a diode detector. Typical values for components are as follows:
 R_1 —0.27 megohm. R_4 —20,000 to 47,000 ohms.
 R_2 —47,000 ohms. C_1 —270 μ f.
 R_3, R_5 —10,000 ohms. C_2, C_3, C_4 —0.1 μ f.
 All other diode-circuit constants in B are conventional.

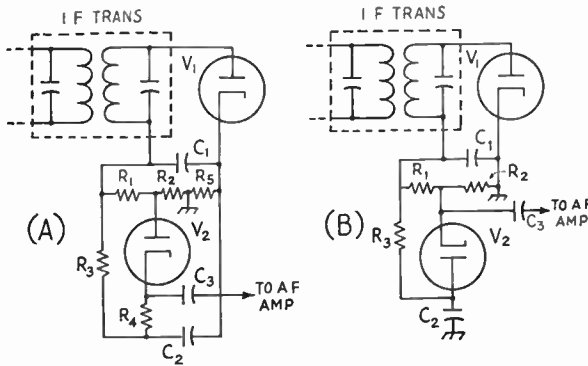

Fig. 5-18 — Self-adjusting series (A) and shunt (B) noise limiters. The functions of V_1 and V_2 can be combined in one tube like the 6H6 or 6AL5.

- C_1 — 100 μf .
- C_2, C_3 — 0.05 μf .
- R_1 — 0.27 meg. in A; 47,000 ohms in B.
- R_2 — 0.27 meg. in A; 0.15 meg. in B.
- R_3 — 1.0 megohm.
- R_4 — 0.82 megohm.
- R_5 — 6800 ohms.

● SECOND-DETECTOR NOISE LIMITER CIRCUITS

The circuit of Fig. 5-17 "chops" noise peaks at the second detector of a superhet receiver by means of a biased diode, which becomes nonconducting above a predetermined signal level. The audio output of the detector must pass through the diode to the grid of the amplifier tube. The diode normally would be nonconducting with the connections shown were it not for the fact that it is given positive bias from a 30-volt source through the adjustable potentiometer, R_3 . Resistors R_1 and R_2 must be fairly large in value to prevent loss of audio signal.

The audio signal from the detector can be considered to modulate the steady diode current, and conduction will take place so long as the diode plate is positive with respect to the cathode. When the signal is sufficiently large to swing the cathode positive with respect to the plate, however, conduction ceases, and that portion of the signal is cut off from the audio amplifier. The point at which cut-off occurs can be selected by adjustment of R_3 . By setting R_3 so that the signal just passes through the "valve," noise pulses higher in amplitude than the signal will be cut off. The circuit of Fig. 5-17A, using an infinite-impedance detector, gives a positive voltage on rectification. When the rectified voltage is negative, as it is from the usual diode detector, the circuit arrangement shown in Fig. 5-17B must be used.

An audio signal of about ten volts is required for good limiting action. The limiter will work on either c.w. or phone signals, but in either case the potentiometer must be set at a point determined by the strength of the incoming signal.

Second-detector noise-limiting circuits that automatically adjust themselves to the received carrier level are shown in Fig. 5-18. In either circuit, V_1 is the usual diode second detector,

R_1R_2 is the diode load resistor, and C_1 is an r.f. bypass. A negative voltage proportional to the carrier level is developed across C_2 , and this voltage cannot change rapidly because R_3 and C_2 are both large. In the circuit at A, diode V_2 acts as a conductor for the audio signal up to the point where its anode is negative with respect to the cathode. Noise peaks that exceed the maximum carrier-modulation level will drive the anode negative instantaneously, and during this time the diode does not conduct. The large time constant of C_2R_3 prevents any rapid change of the reference voltage. In the circuit at B, the diode V_2 is inactive until its cathode voltage exceeds its anode voltage. This condition will obtain under noise peaks and when it does, the diode V_2 short-circuits the signal

and no voltage is passed on to the audio amplifier. Diode rectifiers such as the 6H6 and 6AL5 can be used for these types of noise limiters. Neither circuit is useful for c.w. or s.s.b. reception, but they are both quite effective for a.m. phone work. The series circuit (A) is slightly better than the shunt circuit.

● SIGNAL-STRENGTH AND TUNING INDICATORS

The simplest tuning indicator is a milliammeter connected in the d.c. plate lead of an a.v.c.-controlled r.f. or i.f. stage. Since the plate current is reduced as the a.v.c. voltage becomes higher with a stronger signal, the plate current is a measure of the signal strength. The meter can have a 0-1, 0-2 or 0-5 ma. movement, and it should be shunted by a 25-ohm rheostat which is used to set the no-signal reading to full scale on the meter. If a "forward-reading" meter is desired, the meter can be mounted upside down.

Two other types of indicators are shown in Fig. 5-19. That at A uses an electron-ray, or

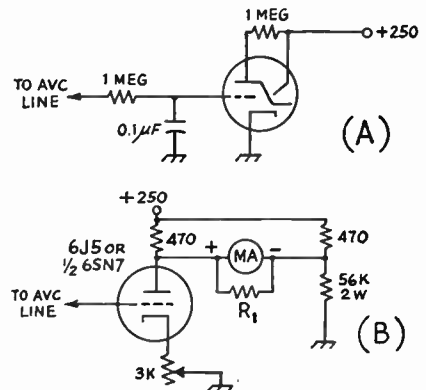

Fig. 5-19 — Tuning-indicator or S-meter circuits for superheterodyne receivers. A, electron-ray indicator; B, bridge circuit for a.v.c.-controlled tube.

MA — 0-1 or 0-2 milliammeter. R_1 — See text.

"tuning eye," tube. The choice of tube type depends upon the voltage available for its grid; where the a.v.c. voltage is large, a remote cut-off type (6G5, 6N5 or 6AD6G) should be used in preference to the sharp cut-off type (6E5).

The system at B uses a milliammeter in a bridge circuit, arranged so that the meter readings increase with the a.v.c. voltage and signal strength. The meter reads approximately in a linear decibel scale and will not be "crowded" at some point.

To adjust the system in Fig. 5-19B, pull the tube out of its socket or otherwise break the cathode circuit so that no plate current flows, and adjust the value of resistor R_1 across the meter until the scale reading is maximum. The value of resistance required will depend on the internal resistance of the meter, and must be determined by trial and error (the current is

approximately 2.5 ma.). Then replace the tube, allow it to warm up, turn the a.v.c. switch to "off" so the grid is shorted to ground, and adjust the 3000-ohm variable resistor for zero meter current. When the a.v.c. is "on," the meter will follow the signal variations up to the point where the voltage is high enough to cut off the meter tube's plate current. This will occur in the neighborhood of 15 volts with a 6J5 or 6SN7GT, and represents a rather high-amplitude signal.

The bridge circuit, while not exactly linear, is quite satisfactory from a practical standpoint. It will handle a signal range of well over 80 db. The meter cannot be "pinned" because the maximum reading occurs when the tube plate current is driven to zero, at which point further increases in a.v.c. bias cause no change.

Improving Receiver Selectivity

● INTERMEDIATE-FREQUENCY AMPLIFIERS

As mentioned earlier in this chapter, one of the big advantages of the superheterodyne receiver is the improved selectivity that is possible. This selectivity is obtained in the i.f. amplifier, where the lower frequency allows more selectivity per stage than at the higher signal frequency. For phone reception, the limit to useful selectivity in the i.f. amplifier is the point where so many of the side bands are cut that intelligibility is lost, although it is possible to remove completely one full set of side bands without impairing the quality at all. Maximum receiver selectivity in phone reception requires good stability in both transmitter and receiver, so that they will both remain "in tune" during the transmission. The limit to useful selectivity in code work is around 100 or 200 *cycles* for hand-key speeds, but this much selectivity requires good stability in both transmitter and receiver, and a slow receiver tuning rate for ease of operation.

Single-Signal Effect

In heterodyne c.w. reception with a superheterodyne receiver, the beat oscillator is set to give a suitable audio-frequency beat note when the incoming signal is converted to the intermediate frequency. For example, the beat oscillator may be set to 456 kc. (the i.f. being 455 kc.) to give a 1000-cycle beat note. Now, if an interfering signal appears at 457 kc., or if the receiver is tuned to heterodyne the incoming signal to 457 kc., it will also be heterodyned by the beat oscillator to produce a 1000-cycle beat. Hence every signal can be tuned in at two places that will give a 1000-cycle beat (or any other low audio frequency). This **audio-frequency image** effect can be reduced if the i.f. selectivity is such that the incoming signal,

when heterodyned to 457 kc., is attenuated to a very low level.

When this is done, tuning through a given signal will show a strong response at the desired beat note on one side of zero beat only, instead of the two beat notes on either side of zero beat characteristic of less-selective reception, hence the name: **single-signal reception**.

The necessary selectivity is not obtained with nonregenerative amplifiers using ordinary tuned circuits unless a low i.f. or a large number of circuits is used.

Regeneration

Regeneration can be used to give a single-signal effect, particularly when the i.f. is 455 kc. or lower. The resonance curve of an i.f. stage at critical regeneration (just below the oscillating point) is extremely sharp, a band width of 1 kc. at 10 times down and 5 kc. at 100 times down being obtainable in one stage. The audio-frequency image of a given signal thus can be reduced by a factor of nearly 100 for a 1000-cycle beat note (image 2000 cycles from resonance).

Regeneration is easily introduced into an i.f. amplifier by providing a small amount of capacity coupling between grid and plate. Bringing a short length of wire, connected to the grid, into the vicinity of the plate lead usually will suffice. The feedback may be controlled by the regular cathode-resistor gain control. When the i.f. is regenerative, it is preferable to operate the tube at reduced gain (high bias) and depend on regeneration to bring up the signal strength. This type of operation prevents overloading and increases selectivity.

The higher selectivity with regeneration reduces the over-all response to noise generated in the earlier stages of the receiver, just as does high selectivity produced by other means, and therefore improves the signal-to-noise ratio. However, the regenerative gain varies with signal

strength, being less on strong signals, and the selectivity varies.

Crystal Filters

Probably the simplest means for obtaining high selectivity is by the use of a piezoelectric quartz crystal as a selective filter in the i.f. amplifier. Compared to a good tuned circuit, the Q of such a crystal is extremely high. The crystal is ground to be resonant at the desired intermediate frequency. It is then used as a selective coupler between i.f. stages.

Fig. 5-20 gives a typical crystal-filter resonance curve. For single-signal reception, the audio-frequency image can be reduced by a factor of 1000 or more. Besides practically eliminating the a.f. image, the high selectivity of the crystal filter provides good discrimination against signals very close to the desired signal

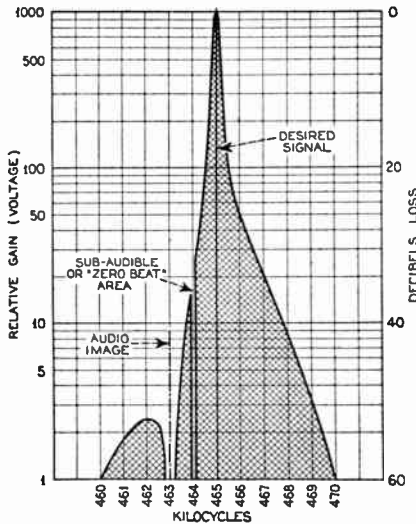

Fig. 5-20 — Graphical representation of single-signal selectivity. The shaded area indicates the over-all bandwidth, or region in which response is obtainable.

and, by reducing the band-width, reduces the response of the receiver to noise.

Crystal-Filter Circuits; Phasing

Two crystal-filter circuits are shown in Fig. 5-21. The circuit at A (or a variation) is found in many of the current communications receivers. The crystal is connected in one side of a bridge circuit, and a "phasing" capacitor, C_1 , is connected in the other. When C_1 is set to balance the crystal-holder capacitance, the resonance curve of the filter is practically symmetrical; the crystal acts as a series-resonant circuit of very high Q and allows signals over a narrow band of frequencies to pass through to the following tube. More or less capacitance at C_1 introduces the "rejection notch" of Fig. 5-20 (at 463 kc. as drawn). The Q of the load circuit for the filter is adjusted by the setting of R_1 , which in turn varies the bandwidth of the filter from "sharp" to a

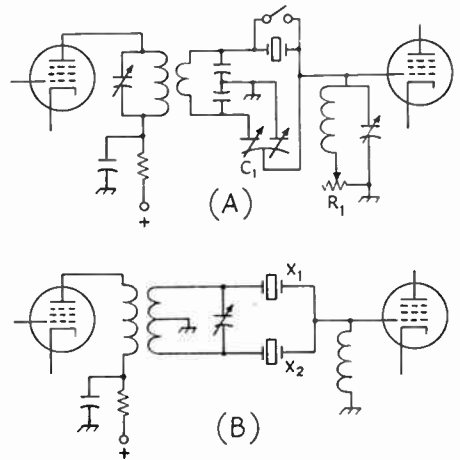

Fig. 5-21 — A variable-selectivity crystal filter (A) and a band-pass crystal filter (B).

bandwidth suitable for phone reception. Since some of the components of this filter are special and not generally available to amateurs, home construction of the filter is usually out of the question.

The "band-pass" crystal filter at D uses two crystals separated slightly in frequency to give a band-pass characteristic to the filter. If the frequencies are removed only a few hundred cycles from each, the characteristic is an excellent one for c.w. reception. With crystals about 2 kc. apart, a good phone characteristic is obtained.

Additional I.F. Selectivity

Many commercial communications receivers do not have sufficient selectivity for amateur use, and their performance can be improved by adding additional selectivity. One popular method is to couple a BC-453 aircraft receiver (war surplus, tuning range 190 to 550 kc.) to the tail end of the 465-ke. i.f. amplifier in the communications receiver and use the resultant output of the BC-153. The aircraft receiver uses an 85-ke. i.f. amplifier that is sharp for voice work —

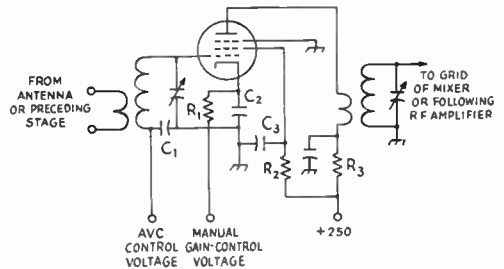

Fig. 5-22 — Typical radio-frequency amplifier circuit for a superheterodyne receiver. Representative values for components are as follows:

- C_1, C_2, C_3, C_4 — 0.01 μ f. below 15 Mc., 0.001 μ f. at 30 Mc.
- R_1, R_2 — See Table 5-II
- R_3 — 1800 ohms.
- R_4 — 0.22 megohm.

6.5 kc. wide at -60 db. — and it helps considerably in separating phone signals and in backing up crystal filters for improved c.w. reception. (See Q87, January, 1948, p. 40.)

If a BC-453 is not available, one can still enjoy the benefits of improved selectivity. It is only necessary to heterodyne to a lower frequency the 465-kc. signal existing in the receiver i.f. amplifier and then rectify it after passing it through the sharp low-frequency amplifier. The Hammarlund Company and the J. W. Miller Company both offer 50-kc. transformers for this application.

QST references on high i.f. selectivity include: McLaughlin, "Selectable Single Sideband," April, 1948; Githens, "Super-Selective C.W. Receiver," Aug., 1948.

● RADIO-FREQUENCY AMPLIFIERS

While selectivity to reduce audio-frequency images can be built into the i.f. amplifier, discrimination against radio-frequency images can only be obtained in circuits ahead of the first detector. These tuned circuits and their associated vacuum tubes are called **radio-frequency amplifiers**. For top performance of a communications receiver on frequencies above 7 Mc., it is mandatory that it have one or two stages of r.f. amplification, for image rejection and improved sensitivity.

Receivers with an i.f. of 455 kc. can be expected to have some r.f. image response at a signal frequency of 14 Mc. and higher if only one stage of r.f. amplification is used. (Regeneration in the r.f. amplifier will reduce image response, but regeneration usually requires frequent readjustment when tuning across a band.) With two stages of r.f. amplification and an i.f. of 455 kc., no images should be apparent at 14 Mc., but they will show up on 28 Mc. and higher. Three stages or more of r.f. amplification, with an i.f. of 455 kc., will reduce the images at 28 Mc., but it really takes four or more stages to do a good job. The better solution at 28 Mc. is to use a "triple-detection" superheterodyne, with one stage of r.f. amplification and a first i.f. of 1600 kc. or higher. A normal receiver with an i.f. of 455 kc. can be converted to a triple superhet by connecting a "converter" (to be described later) ahead of the receiver.

For best selectivity, r.f. amplifiers should use high-Q circuits and tubes with high input and output resistance. Variable- μ pentodes are practically always used, although triodes (neutralized or otherwise connected so that they won't oscillate) are often used on the higher frequencies because they introduce less noise. Pentodes are better where maximum image rejection is desired, because they have less loading effect on the tuned circuits.

● FEEDBACK

Feedback giving rise to regeneration and oscillation can occur in a single stage or it may appear as an over-all feedback through several stages that are on the same frequency. To avoid

feedback in a single stage, the output must be isolated from the input in every way possible, with the vacuum tube furnishing the only coupling between the two circuits. An oscillation can be obtained in an r.f. or i.f. stage if there is any undue capacitive or inductive coupling between output and input circuits, if there is too high an impedance between cathode and ground or screen and ground, or if there is any appreciable impedance through which the grid and plate currents can flow in common. This means good shielding of coils and tuning capacitors in r.f. and i.f. circuits, the use of good by-pass capacitors (mica or ceramic at r.f., paper or ceramic at i.f.), and returning all by-pass capacitors (grid, cathode, plate and screen) for a given stage with short leads to one spot on the chassis. If single-ended tubes are used, the screen or cathode by-pass capacitor should be mounted across the socket, to serve as a shield between grid and plate pins. Less care is required as the frequency is lowered, but in high-impedance circuits, it is sometimes necessary to shield grid and plate leads and to be careful not to run them close together.

To avoid over-all feedback in a multistage amplifier, attention must be paid to avoid running any part of the output circuit back near the input circuit without first filtering it carefully. Since the signal-carrying parts of the circuit (the "hot" grid and plate leads) can't be filtered, the best design for any multistage amplifier is a straight line, to keep the output as far away from the input as possible. For example, an r.f. amplifier might run along a chassis in a straight line, run into a mixer where the frequency is changed, and then the i.f. amplifier could be run back parallel to the r.f. amplifier, provided there was a very large frequency difference between the r.f. and the i.f. amplifiers. However, to avoid any possible coupling, it would be better to run the i.f. amplifier off at right angles to the r.f.-amplifier line, just to be on the safe side. Good shielding is important in preventing over-all oscillation in high-gain-per-stage amplifiers, but it becomes less important when the stage gain drops to a low value. In a high-gain amplifier, the power leads (including the heater circuit) are common to all stages, and they can provide the over-all coupling if they aren't properly filtered. Good bypassing and the use of series isolating resistors will generally eliminate any possibility of coupling through the power leads. R.f. chokes, instead of resistors, are used in the heater leads where necessary.

● CROSS-MODULATION

Since a one- or two-stage r.f. amplifier will have a band width measured in hundreds of kc. at 14 Mc. or higher, strong signals will be amplified through the r.f. amplifier even though it is not tuned exactly to them. If these signals are strong enough, their amplified magnitude may be measurable in volts after passing through several r.f. stages. If an undesired signal is strong enough after amplification in the r.f. stages to

shift the operating point of a tube (by driving the grid into the positive region), the undesired signal will modulate the desired signal. This effect is called **cross-modulation**, and is often encountered in receivers with several r.f. stages working at high gain. It shows up as a superimposed modulation on the signal being listened to, and often the effect is that a signal can be tuned in at several points. It can be reduced or eliminated by greater selectivity in the antenna and r.f. stages (difficult to obtain), the use of variable- μ tubes in the r.f. amplifier, reduced gain in the r.f. amplifier, or reduced antenna input to the receiver. The 6BJ6, 6BA6 and 6DC6 are recommended for r.f. amplifiers where cross-modulation may be a problem.

A receiver designed for minimum cross-modulation will use as little gain as possible ahead of the high-selectivity stages, to hold strong unwanted signals below the overload point.

Gain Control

To avoid cross-modulation and other overload effects in the mixer and r.f. stages, the gain of the r.f. stages is usually made adjustable. This is accomplished by using variable- μ tubes and varying the d.c. grid bias, either in the grid or cathode circuit. If the gain control is automatic, as in the case of a.v.c., the bias is controlled in the grid circuit. Manual control of r.f. gain is generally done in the cathode circuit. A typical r.f. amplifier stage with the two types of gain control is shown in schematic form in Fig. 5-22.

Tracking

In a receiver with no r.f. stage, it is no inconvenience to adjust the high-frequency oscillator and the mixer circuit independently, because the mixer tuning is broad and requires little attention over an amateur band. However, when r.f. stages are added ahead of the mixer, the r.f. stages and mixer will require retuning over an entire amateur band. Hence most receivers with one or more r.f. stages gang all of the tuning controls to give a single-tuning-control receiver. Obviously there must exist a constant difference in frequency (the i.f.) between the oscillator and the mixer/r.f. circuits, and when this condition is achieved the circuits are said to **track**.

In amateur-band receivers, tracking is simplified by choosing a bandspread circuit that gives practically straight-line-frequency tuning (equal frequency change for each dial division), and then adjusting the oscillator and mixer tuned circuits so that both cover the same total number of kilocycles. For example, if the i.f. is 455 kc. and the mixer circuit tunes from 7000 to 7300 kc. between two given points on the

dial, then the oscillator must tune from 7455 to 7755 kc. between the same two dial readings. With the bandspread arrangement of Fig. 5-9A, the tuning will be practically straight-line-frequency if C_2 (bandset) is 4 times or more the maximum capacity of C_1 (bandspread), as is usually the case for strictly amateur-band coverage. C_1 should be of the straight-line-capacity type (semicircular plates).

Squelch Circuits

An audio squelch circuit is one that cuts off the receiver output when no signal is coming through the receiver. It is useful in mobile or net work where the no-signal receiver noise may be as

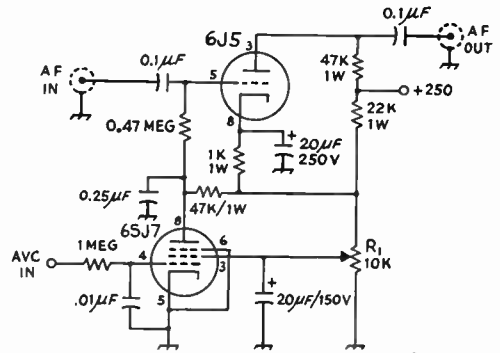

Fig. 5-23 — A practical squelch circuit for cutting off the receiver output when no signal is present.

loud as the signal, causing undue operator fatigue during no-signal periods.

A practical squelch circuit is shown in Fig. 5-23. When the a.v.c. voltage is low or zero, the 6SJ7 draws plate current. Voltage drop across the 47,000-ohm resistor in its plate circuit cuts off the 6J5 and no receiver signal or noise is passed. When the a.v.c. voltage rises to the cut-off value of the 6SJ7, the pentode no longer draws current and the bias on the 6J5 is now only the operating bias, furnished by the 1000-ohm cathode resistor. The triode now functions as an ordinary amplifier and passes signals. By varying the screen voltage on the 6SJ7 through R_1 , the pentode's cut-off bias can be varied, so that the relation between a.v.c. voltage and signal cut-off point of the amplifier is adjustable.

Connections to the receiver consist of two a.f. lines (shielded), the a.v.c. lead, and chassis ground. The squelch circuit is normally inserted between detector output and the audio volume control of the receiver. Since the circuit is used in the low-level audio point, its plate supply must be free from a.c. or objectionable hum will be introduced.

Improving Receiver Sensitivity

The sensitivity (signal-to-noise ratio) of a receiver on the higher frequencies above 20 Mc. is dependent upon the band width of the re-

ceiver and the noise contributed by the "front end" of the receiver. Neglecting the fact that image rejection may be poor, a receiver with no

r.f. stage is generally satisfactory, from a sensitivity point, in the 3.5- and 7-Mc. bands. However, as the frequency is increased and the atmospheric noise becomes less, the advantage of a good "front end" becomes apparent. Hence at 14 Mc. and higher it is worth while to use at least one stage of r.f. amplification ahead of the first detector for best sensitivity as well as image rejection. The multigrid converter tubes have very poor noise figures, and even the best pentodes and triodes are three or four times noisier when used as mixers than they are when used as amplifiers.

If the purpose of an r.f. amplifier is to improve the receiver noise figure at 14 Mc. and higher, a high- g_m pentode or triode should be used. Among the pentodes, the best tubes are the 6AC7, 6AK5 and the 6SG7, in the order named. The 6AK5 takes the lead around 30 Mc. The 6J4, 6J6, 7F8 and triode-connected 6AK5 are the best of the triodes. For best noise figure, the antenna circuit should be coupled a little heavier than optimum. This cannot give best selectivity in the antenna circuit, so it is futile to try to maximize sensitivity *and* selectivity in this circuit.

When a receiver is satisfactory in every respect (stability and selectivity) except sensitivity on 14 through 30 Mc., the best solution for the amateur is to add a **preamplifier**, a stage of r.f. amplification designed expressly to improve the sensitivity. If image rejection is lacking in the receiver, some selectivity should be built into the preamplifier (it is then called a preselector). If, however, the receiver operation is poor on the higher frequencies but is satisfactory on the lower ones, a "converter" is the best solution.

Some commercial receivers that appear to lack sensitivity on the higher frequencies can be improved simply by tighter coupling to the antenna. Since the receiver manufacturer has no way to predict the type of antenna that will be used, he generally designs the input for some compromise value, usually around 300 or 400 ohms in the high-frequency ranges. If your antenna looks like something far different than this, the receiver effectiveness can be improved by proper matching. This can be accomplished by changing the antenna feed line to the right value (as determined from the receiver instruction book) or by using a simple matching device

as described later in this chapter. Overcoupling the input circuit will often improve sensitivity but it will, of course, always reduce the image-rejection contribution of the antenna circuit.

Commercial receivers can also be "hopped up" by substituting a high- g_m tube in the first r.f. stage if one isn't already there. The amateur must be prepared to take the consequences, however, since the stage may oscillate, or not track without some modification. A simpler solution is to add the "hot" r.f. stage ahead of the receiver.

Regeneration

Regeneration in the r.f. stage of a receiver (where only one stage exists) will often improve the sensitivity because the greater gain it provides serves to mask more completely the first-detector noise, and it also provides a measure of automatic matching to the antenna through tighter coupling. However, accurate ganging becomes a problem, because of the increased selectivity of the regenerative r.f. stage, and the receiver almost invariably becomes a two-handed-tuning device. Regeneration should not be overlooked as an expedient, however, and amateurs have used it with considerable success. High- g_m tubes are the best as regenerative amplifiers, and the feedback should not be controlled by changing the operating voltages (which should be the same as for the tube used in a high-gain amplifier) but by changing the loading or the feed-back coupling. This is a tricky process and another reason why regeneration is not too widely used.

Gain Control

In a receiver front end designed for best signal-to-noise ratio, it is advantageous in the reception of weak signals to eliminate the gain control from the first r.f. stage and allow it to run "wide open" all of the time. If the first stage is controlled along with the i.f. (and other r.f. stages, if any), the signal-to-noise ratio of the receiver will suffer. As the gain is reduced, the g_m of the first tube is reduced, and its noise figure becomes higher. A good receiver might well have two gain controls, one for the first radio-frequency stage and another for the i.f. and other r.f. stages.

Extending the Tuning Range

As mentioned earlier, when a receiver doesn't cover a particular frequency range, either in fact or in satisfactory performance, a simple solution is to use a **converter**. A converter is another "front end" for the receiver, and it is made to tune the proper range or to give the necessary performance. It works into the receiver at some frequency between 1.6 and 10 Mc. and thus forms with the receiver a "triple-detection" superhet.

There are several different types of converters in vogue at the present time. The commonest

type, since it is the oldest, uses a regular tunable oscillator, mixer, and r.f. stages as desired, and works into the receiver at a fixed frequency. A second type uses broad-banded r.f. stages in the r.f. and mixer stages of the converter, and only the oscillator is tuned. Since the frequency the converter works into is high (7 Mc. or more), little or no trouble with images is experienced, despite the broad-band r.f. stages. A third type of converter uses broad-banded r.f. and output stages and a fixed-frequency oscillator (self- or crystal-controlled). The tuning is done with

the receiver the converter is connected to. This is an excellent system if the receiver itself is well shielded and has no external pick-up of its own. Many war-surplus receivers fall in this category. A fourth type of converter uses a fixed oscillator with ganged mixer and r.f. stages, and requires two-handed tuning, for the r.f. stages and for the receiver. The r.f. tuning is not critical, however, unless there are many stages.

The broad-banded r.f. stages have the advantage that they can be built with short leads, since no tuning capacitors are required and the unit can be tuned initially by trimming the inductances. They are more prone to cross-modulation than the gang-tuned r.f. stages, however, because of the lack of selectivity. The fourth type of converter is probably the most satisfactory, particularly if a crystal-controlled high-

frequency oscillator is used. It not only has the advantage of the best selectivity and protection against images and cross-modulation, but the crystal gives it a stability unobtainable with self-controlled oscillators. Amateurs who specialize in operation on 28 and 50 Mc. generally use good converters ahead of conventional communication receivers, and it pays off in better performance for the station.

While converters can extend the operating range of an existing receiver, their greatest advantage probably lies in the opportunity they give for getting the best performance on any one band. By selecting the best tubes and techniques for any particular band, the amateur is assured of top receiver performance. With separate converters for each of several bands, changes can be made in any one without disabling or impairing the receiver performance on another band.

Tuning a Receiver

C.W. Reception

For making code signals audible, the beat oscillator should be set to a frequency slightly different from the intermediate frequency. To adjust the beat-oscillator frequency, first tune in a moderately-weak but steady carrier with the beat oscillator turned off. Adjust the receiver tuning for maximum signal strength, as indicated by maximum hiss. Then turn on the beat oscillator and adjust its frequency (leaving the receiver tuning unchanged) to give a suitable beat note. The beat oscillator need not subsequently be touched, except for occasional checking to make certain the frequency has not drifted from the initial setting. The b.f.o. may be set on either the high- or low-frequency side of zero beat.

The best receiver condition for the reception of code signals will have the first r.f. stage running at maximum gain, the following r.f., mixer and i.f. stages operating with just enough gain to maintain the signal-to-noise ratio, and the audio gain set to give comfortable headphone or speaker volume. The audio volume should be controlled by the audio gain control, not the i.f. gain control. Under the above conditions, the selectivity of the receiver is being used to best advantage, and cross-modulation is minimized. It precludes the use of a receiver in which the gain of the first r.f. stage and the i.f. stages are controlled simultaneously.

Tuning with the Crystal Filter

If the receiver is equipped with a crystal filter the tuning instructions in the preceding paragraph still apply, but more care must be used both in the initial adjustment of the beat oscillator and in tuning. The beat oscillator is set as described above, but with the crystal filter set at its sharpest position, if variable selectivity is available. The initial adjustment should be made with the phasing control in an intermediate position. Once adjusted, the beat oscillator should

be left set and the receiver tuned to the other side of zero beat (audio-frequency image) on the same signal to give a beat note of the same tone. This beat will be considerably weaker than the first, and may be "phased out" almost completely by careful adjustment of the phasing control. This is the adjustment for normal operation; it will be found that one side of zero beat has practically disappeared, leaving maximum response on the other.

An interfering signal having a beat note differing from that of the a.f. image can be similarly phased out, provided its frequency is not too near the desired signal.

Depending upon the filter design, maximum selectivity may cause the dots and dashes to lengthen out so that they seem to "run together." It must be emphasized that, to realize the benefits of the crystal filter in reducing interference, it is necessary to do *all* tuning with it in the circuit. Its high selectivity often makes it difficult to find the desired station quickly, if the filter is switched in only at times when interference is present.

Phone Reception

In reception of phone signals, the normal procedure is to set the r.f. and i.f. gain at maximum, switch on the a.v.c., and use the audio gain control for setting the volume. This insures maximum effectiveness of the a.v.c. system in compensating for fading and maintaining constant audio output on either strong or weak signals. On occasion a strong signal close to the frequency of a weaker desired station may take control of the a.v.c., in which case the weaker station may disappear because of the reduced gain. In this case better reception may result if the a.v.c. is switched off, using the manual r.f. gain control to set the gain at a point that prevents "blocking" by the stronger signal.

When receiving an a.m. signal on a frequency within 5 to 20 kc. from a single-side-band signal

it may also be necessary to switch off the a.v.c. and resort to the use of manual gain control, unless the receiver has excellent skirt selectivity. No ordinary a.v.c. circuit can handle the syllabic bursts of energy from the s.s.b. station, but there are special circuits that will.

A crystal filter will help reduce interference in phone reception. Although the high selectivity cuts side-bands and reduces the audio output at the higher audio frequencies, it is possible to use quite high selectivity without destroying intelligibility. As in code reception, it is advisable to do all tuning with the filter in the circuit. Variable-selectivity filters permit a choice of selectivity to suit interference conditions.

An undesired carrier close in frequency to a desired carrier will heterodyne with it to produce a beat note equal to the frequency difference. Such a heterodyne can be reduced by adjustment of the phasing control in the crystal filter.

A tone control often will be of help in reducing the effects of high-pitched heterodynes, side-band splatter and noise, by cutting off the higher audio frequencies. This, like side-band cutting with high selectivity circuits, reduces naturalness.

Spurious Responses

Spurious responses can be recognized without a great deal of difficulty. Often it is possible to

identify an image by the nature of the transmitting station, if the frequency assignments applying to the frequency to which the receiver is tuned are known. However, an image also can be recognized by its behavior with tuning. If the signal causes a heterodyne beat note with the desired signal and is actually on the same frequency, the beat note will not change as the receiver is tuned through the signal; but if the interfering signal is an image, the beat will vary in pitch as the receiver is tuned. The beat oscillator in the receiver must be turned off for this test. Using a crystal filter with the beat oscillator on, an image will peak on the side of zero beat opposite that on which desired signals peak.

Harmonic response can be recognized by the "tuning rate," or movement of the tuning dial required to give a specified change in beat note. Signals getting into the i.f. via high-frequency oscillator harmonics tune more rapidly (less dial movement) through a given change in beat note than do signals received by normal means.

Harmonics of the beat oscillator can be recognized by the tuning rate of the beat-oscillator pitch control. A smaller movement of the control will suffice for a given change in beat note than that necessary with legitimate signals. In poorly-shielded receivers it is often possible to find b.f.o. harmonics below 2 Mc., but they should be very weak at higher frequencies.

Narrow-Band Frequency- and Phase-Modulation Reception

F.M. Reception

In the reception of n.f.m. (narrow-band f.m.) by a normal a.m. receiver, the a.v.c. is switched off and the incoming signal is not tuned "on the nose," as indicated by maximum reading of the S meter, but slightly off to one side or the other. This puts the carrier of the incoming signal on one side or the other of the i.f. selectivity characteristic (see Fig. 5-1). As the frequency of the signal changes back and forth over a small range with modulation, these variations in frequency are translated to variations in amplitude, and the consequent a.m. is detected in the normal manner. The signal is tuned in (on one side or the other of maximum carrier strength) until the audio quality appears to be best. If the audio is too weak, the transmitting operator should be advised to increase his swing slightly, and if the audio quality is bad ("splashy" and with serious distortion on volume peaks) he should be advised to reduce his swing. Cooperation between transmitting and receiving operators is a necessity for best audio quality. The transmitting station should always be advised immediately if at any time his bandwidth exceeds that of an a.m. signal, since this is a violation of FCC regulations, except in those portions of the bands where wide-band f.m. is permitted.

If the receiver has a discriminator or other

detector designed expressly for f.m. reception the signal is *peaked* on the receiver (as indicated by maximum S-meter reading or minimum background noise). There is also a spot on either side of this tuning condition where audio is recovered through slope detection, but the signal will not be as loud and the noise will be higher.

P.M. Reception

Phase-modulated signals can be received the same as n.f.m. signals are, except that the audio output will appear to be lacking in "lows," because of the differences in the deviation-vs.-audio characteristics of the two systems. This can be remedied some by advancing the tone control of the receiver to the point where more nearly normal speech output is obtained.

Narrow p.m. signals can be received on communications receivers by making use of the crystal filter. The crystal filter should be set to the sharpest position and the carrier should be tuned in on the crystal peak, *not* set off to one side. The phasing capacitor should be set not for exact neutralization but to give a rejection notch at a side frequency about 1000 cycles off resonance. There is attenuation of the side bands with such tuning, but it can be made up by additional audio gain. Narrow f.m. signals received through the crystal filter will have a "boomy" characteristic.

Reception of Single-Side-Band Signals

Single-side-band signals are generally transmitted with little or no carrier, and it is necessary to furnish the carrier at the receiver before proper reception can be obtained. Because little or no carrier is transmitted, the a.v.c. in the receiver has nothing that indicates the average signal level, and manual variation of the r.f. gain control is required.

A single-side-band signal can be identified by the absence of a strong carrier and by the severe variation of the S meter at a syllabic rate. When such a signal is encountered, it should first be peaked with the main tuning dial. (This centers the signal in the i.f. pass band.) After this operation, do not touch the main tuning dial. Then set the r.f. gain control at a very low level and switch off the a.v.c. Increase the audio volume control to maximum, and bring up the r.f. gain control until the signal can be heard weakly. Switch on the beat oscillator, and carefully adjust the frequency of the beat oscillator until proper speech is heard. If there is a slight amount of carrier present, it is only necessary to *zero-beat* the beat oscillator with this weak carrier. It will be noticed that with incorrect tuning of an s.s.b. signal, the speech will sound high- or low-pitched or even in-

verted (very garbled), but no trouble will be had in getting the correct setting once a little experience has been obtained. The use of minimum r.f. gain and maximum audio gain will insure that no distortion (overload) occurs in the receiver. It may require a readjustment of your tuning habits to tune the receiver slowly enough during the first few trials.

Once the proper setting of the b.f.o. has been established by the procedure above, all further tuning should be done with the main tuning control. However, it is not unlikely that s.s.b. stations will be encountered that are transmitting the other side band, and to receive them will require shifting the b.f.o. setting to the other side of the receiver i.f. passband. The initial tuning procedure is exactly the same as outlined above, except that you will end up with a considerably different b.f.o. setting. The two b.f.o. settings should be noted for future reference, and all tuning of s.s.b. signals can then be done with the main tuning dial. After a little experience, it becomes a simple matter to determine which way to tune the receiver if the receiver (or transmitter) drifts off to make the received signal sound low- or high-pitched.

Alignment and Servicing of Superheterodyne Receivers

I.F. Alignment

A calibrated signal generator or test oscillator is a useful device for alignment of an i.f. amplifier. Some means for measuring the output of the receiver is required. If the receiver has a tuning meter, its indications will serve. Lacking an S meter, a high-resistance voltmeter or a vacuum-tube voltmeter can be connected across the second-detector load resistor, if the second detector is a diode. Alternatively, if the signal generator is a modulated type, an a.c. voltmeter can be connected across the primary of the transformer feeding the speaker, or from the plate of the last audio amplifier through a 0.1- μ f. blocking capacitor to the receiver chassis. Lacking an a.c. voltmeter, the audio output can be judged by ear, although this method is not as accurate as the others. If the tuning meter is used as an indication, the a.v.c. of the receiver should be turned on, but any other indication requires that it be turned off. Lacking a test oscillator, a steady signal tuned through the input of the receiver (if the job is one of just touching up the i.f. amplifier) will be suitable. However, with no oscillator and tuning an amplifier for the first time, one's only recourse is to try to peak the i.f. transformers on "noise," a difficult task if the transformers are badly off resonance, as they are apt to be. It would be much better to spend a little time and haywire together a simple oscillator for test purposes.

Initial alignment of a new i.f. amplifier is as follows: The test oscillator is set to the correct frequency, and its output is coupled through a condenser to the grid of the last i.f. amplifier tube. The trimmer capacitors of the transformer feeding the second detector are then adjusted for maximum output, as shown by the indicating device being used. The oscillator output lead is then clipped on to the grid of the next-to-the-last i.f. amplifier tube, and the second-from-the-last transformer trimmer adjustments are peaked for maximum output. This process is continued, working back from the second detector, until all of the i.f. transformers have been aligned. It will be necessary to reduce the output of the test oscillator as more of the i.f. amplifier is brought into use. It is desirable in all cases to use the minimum signal that will give useful output readings. The i.f. transformer in the plate circuit of the mixer is aligned with the signal introduced to the grid of the mixer. Since the tuned circuit feeding the mixer grid may have a very low impedance at the i.f., it may be necessary to boost the test generator output or to disconnect the tuned circuit temporarily from the mixer-stage grid.

If the i.f. amplifier has a crystal filter, the filter should first be switched out and the alignment carried out as above, setting the test oscillator as closely as possible to the crystal frequency. When this is completed, the crystal

should be switched in and the oscillator frequency varied back and forth over a small range either side of the crystal frequency to find the exact frequency, as indicated by a sharp rise in output. Leaving the test oscillator set on the crystal peak, the i.f. trimmers should be realigned for maximum output. The necessary readjustment should be small. The oscillator frequency should be checked frequently to make sure it has not drifted from the crystal peak.

A modulated signal is not of much value for aligning a crystal-filter i.f. amplifier, since the high selectivity cuts sidebands and the results may be inaccurate if the audio output is used as the tuning indication. Lacking the a.v.c. tuning meter, the transformers may be conveniently aligned by ear, using a weak unmodulated signal adjusted to the crystal peak. Switch on the beat oscillator, adjust to a suitable tone, and align the i.f. transformers for maximum audio output.

An amplifier that is only slightly out of alignment, as a result of normal drift or aging, can be realigned by using any steady signal, such as a local broadcast station, instead of the test oscillator. One's 100-kc. standard makes an excellent signal source for "touching up" an i.f. amplifier. Allow the receiver to warm up thoroughly, tune in the signal, and trim the i.f. for maximum output.

If you bought your receiver instead of making it, be sure to read the instruction book carefully before attempting to realign the receiver. Most instruction books include alignment details, and any little special tricks that are peculiar to the receiver will also be described in detail.

R.F. Alignment

The objective in aligning the r.f. circuits of a gang-tuned receiver is to secure adequate tracking over each tuning range. The adjustment may be carried out with a test oscillator of suitable frequency range, with harmonics from your 100-kc. standard or other known oscillator, or even on noise or such signals as may be heard. First set the tuning dial at the high-frequency end of the range in use. Then set the test oscillator to the frequency indicated by the receiver dial. The test-oscillator output may be connected to the antenna terminals of the receiver for this test. Adjust the oscillator trimmer capacitor in the receiver to give maximum response on the test-oscillator signal, then reset the receiver dial to the low-frequency end of the range. Set the test-oscillator frequency near the frequency indicated by the receiver dial and tune the test oscillator until its signal is heard in the receiver. If the frequency of the signal as indicated by the test-oscillator calibration is higher than that indicated by the receiver dial, more inductance (or more capacity in the tracking capacitor) is needed in the receiver oscillator circuit; if the frequency is lower, less inductance (less tracking capacity) is required in the receiver oscillator.

Most commercial receivers provide some means for varying the inductance of the coils or the capacity of the tracking capacitor, to permit aligning the receiver tuning with the dial calibration. Set the test oscillator to the frequency indicated by the receiver dial, and then adjust the tracking capacity or inductance of the receiver oscillator coil to obtain maximum response. After making this adjustment, recheck the high-frequency end of the scale as previously described. It may be necessary to go back and forth between the ends of the range several times before the proper combination of inductance and capacity is secured. In many cases, better over-all tracking will result if frequencies near but not actually at the ends of the tuning range are selected, instead of taking the extreme dial settings.

After the oscillator range is properly adjusted, set the receiver and test oscillator to the high-frequency end of the range. Adjust the mixer trimmer capacitor for maximum hiss or signal, then the r.f. trimmers. Reset the tuning dial and test oscillator to the low-frequency end of the range, and repeat; if the circuits are properly designed, no change in trimmer settings should be necessary. If it is necessary to increase the trimmer capacity in any circuit, it indicates that more inductance is needed; conversely, if less capacity resonates the circuit, less inductance is required.

Tracking seldom is perfect throughout a tuning range, so that a check of alignment at intermediate points in the range may show it to be slightly off. Normally the gain variation from this cause will be small, however, and it will suffice to bring the circuits into line at both ends of the range. If most reception is in a particular part of the range, such as an amateur band, the circuits may be aligned for maximum performance in that region, even though the ends of the frequency range as a whole may be slightly out of alignment.

Oscillation in R.F. or I.F. Amplifiers

Oscillation in high-frequency amplifier and mixer circuits shows up as squeals or "birdies" as the tuning is varied, or by complete lack of audible output if the oscillation is strong enough to cause the a.v.c. system to reduce the receiver gain drastically. Oscillation can be caused by poor connections in the common ground circuits. Inadequate or defective by-pass capacitors in cathode, plate and screen-grid circuits also can cause such oscillation. A metal tube with an ungrounded shell may cause trouble. Improper screen-grid voltage, resulting from a shorted or too-low screen-grid series resistor, also may be responsible for such instability.

Oscillation in the i.f. circuits is independent of high-frequency tuning, and is indicated by a continuous squeal that appears when the gain is advanced with the c.w. beat oscillator on. It can result from defects in i.f.-amplifier circuits similar to those above. Inadequate screen or plate by-pass capacitance is a common cause of such oscillation.

Instability

"Birdies" or a mushy hiss occurring with tuning of the high-frequency oscillator may indicate that the oscillator is "squegging" or oscillating simultaneously at high and low frequencies. This may be caused by a defective tube, too-high oscillator plate or screen-grid voltage, excessive feedback, or too-high grid-leak resistance.

A varying beat note in c.w. reception indicates instability in either the h.f. oscillator or beat oscillator, usually the former. The stability of the beat oscillator can be checked by introducing a signal of intermediate frequency (from a test oscillator) into the i.f. amplifier; if the beat note is unstable, the trouble is in the beat oscillator. Poor connections or defective parts are the likely cause. Instability in the high-frequency oscillator may be the result of poor circuit design, loose connections, defective tubes or circuit components, or poor voltage regulation in the oscillator plate- and/or screen-supply circuits. Mixer pulling of the oscillator circuit also will cause the

beat note to "chirp" on strong c.w. signals.

In phone reception with a.v.c., a peculiar type of instability ("motorboating") may appear if the h.f.-oscillator frequency is sensitive to changes in plate voltage. As the a.v.c. voltage rises the currents of the controlled tubes decrease, decreasing the load on the power supply and causing its output voltage to rise. Since this increases the voltage applied to the oscillator, its frequency changes correspondingly, throwing the signal off the peak of the i.f. resonance curve and reducing the a.v.c. voltage, thus tending to restore the original conditions. The process then repeats itself, at a rate determined by the signal strength and the time constant of the power-supply circuits. This effect is most pronounced with high i.f. selectivity, as when a crystal filter is used, and can be cured by making the oscillator insensitive to voltage changes or by regulating the plate-voltage supply. The better receivers use VR-type tubes to stabilize the oscillator voltage — a defective VR tube may be the cause of oscillator instability.

Improving the Performance of Receivers

Frequently amateurs unjustly criticize a receiver's performance when actually part of the trouble lies with the operator, in his lack of knowledge about the receiver's operation or in his inability to recognize a readily-curable fault. The best example of this is a complaint about "lack of selectivity" when the receiver contains an i.f. crystal filter and the operator hasn't bothered to learn how to use it properly. "Lack of sensitivity" may be nothing more than poor alignment of the r.f. and mixer tuning. The cures for these two complaints are obvious, and the details are treated both in this chapter and in the receiver instruction book.

However, many complaints about selectivity, sensitivity, and other points are justified. Inexpensive, and most second-hand, receivers cannot be expected to measure up to the performance standards of some of the current and top-priced receivers. Nevertheless, many amateurs overlook the possibility of improving the performance of these "bargains" (they may or may not be bargains) by a few simple additions or modifications. From time to time articles in *QST* describe improvements for specific receivers, and it may repay the owner of a newly-acquired second-hand receiver to examine past issues and see if an applicable article was published. The annual index in each December issue is a help in this respect.

Where no applicable article can be found, a few general principles can be laid down. If the complaint is the inability to separate stations, better i.f. (and occasionally audio) selectivity is indicated. The subject has been treated earlier in this chapter, and several constructional articles follow. The answer is not to be found in better bandspread tuning of the dial as is sometimes erroneously concluded. However, with the addition of more i.f. selectivity, it may be

found that the receiver's tuning rate (number of kc. tuned per dial revolution) is too high, and consequently the tuning with good i.f. selectivity becomes too critical. If this is the case, a 5-to-1 reduction planetary dial drive mechanism may be added to make the tuning rate more favorable. These drives are sold by the larger supply houses and can usually be added to the receiver if a suitable mounting bracket is made from sheet metal. If there is already some backlash in the dial mechanism, the addition of the planetary drive will magnify its effect, so it is necessary to minimize the backlash before attempting to improve the tuning rate. While this is not possible in all cases, it should be investigated from every angle before giving up. Replacing a small tuning knob with a larger one will add to ease of tuning.

In many of the inexpensive receivers the frequency calibration of the dial is not very accurate. The receiver's usefulness for determining band limits will be greatly improved by the addition of a 100-kc. crystal-controlled frequency standard. These units can be built or purchased complete at very reasonable prices, and no amateur station worthy of the name should be without one.

Some receivers that show a considerable frequency drift as they are warming up can be improved by the simple expedient of furnishing more ventilation, by propping up the lid or by drilling extra ventilation holes. In many cases the warm-up drift can be cut in half.

Receivers that show frequency changes with line-voltage or gain-control variations can be greatly improved by the addition of regulated voltage on the oscillators (high-frequency and h.f.o.) and the screen of the mixer tube. There is usually room in any receiver for the addition of a VR tube of the right rating.

A One-Tube Regenerative Receiver

The receiver shown in Figs. 5-24, 5-26, and 5-27 represents close to the minimum requirements of a useful short-wave receiver. Under suitable conditions, it is capable of receiving signals from many foreign countries. It is a good receiver for the beginner, because it is

While the title indicates that the receiver has one tube, actually it uses two tubes in one envelope — envelope meaning the glass enclosure. The 6U8 is a triode-pentode, and in this receiver the pentode section is used as a regenerative detector and the triode as an audio amplifier.

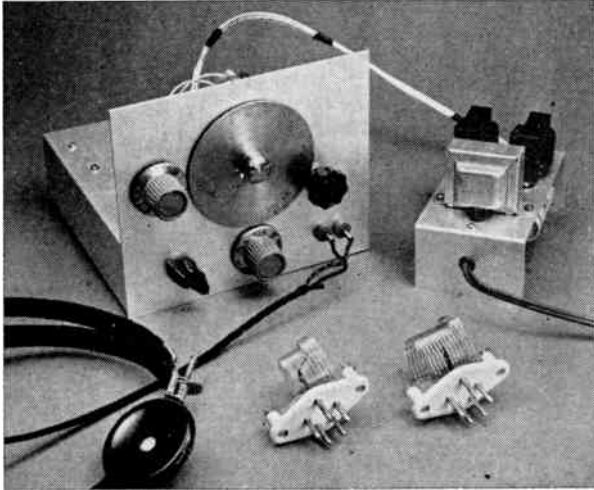

Fig. 5-24 — Front view of the one-tube regenerative receiver and power supply. The control at the upper left is the general-coverage tuning, center is bandspread, lower left the regeneration control, and the bottom center the antenna trimmer.

easy to build and the components are not expensive.

With this receiver it is possible to hear amateur and commercial stations in the 2- to 20-Mc. range. This tuning range will enable the builder to listen to the two low-frequency Novice bands. Also, if one is interested in obtaining code practice, WIAW, the ARRL Hq. station, can be tuned in for its nightly code-practice sessions.

Referring to Fig. 5-25, the antenna coil, L_1 , couples the signal to the detector tuned circuit $L_2C_2C_3$. The capacitor, C_2 , is larger than C_3 and is used as the "bandset" capacitor — once C_2 is set for a particular frequency range, C_3 is used as the "bandspread" tuning control. To facilitate using manufactured coils, the coil L_2 is tapped to obtain a feedback or "tickler" winding. Regeneration in the detector is controlled by changing the screen voltage obtained at the potentiometer R_1 . An r.f. filter, using two capacitors and an r.f. choke, is placed in the plate circuit of the pentode detector to reduce r.f. appearing at the grid of the triode audio amplifier. Still further attenuation of r.f. at the grid is obtained through the use of a series resistor and a shunt capacitor right at the grid of the audio stage. The audio coupling choke, L_3 , is

made from an interstage audio transformer with the two windings connected in series. A high-inductance choke could be used here, but the series-connected transformer is less expensive.

The headphones are connected directly in the plate circuit of the audio stage, and consequently the plate voltage appears at the terminals — you can get an electrical shock here if you aren't careful. Some receivers eliminate this hazard by feeding the plate through an audio choke and

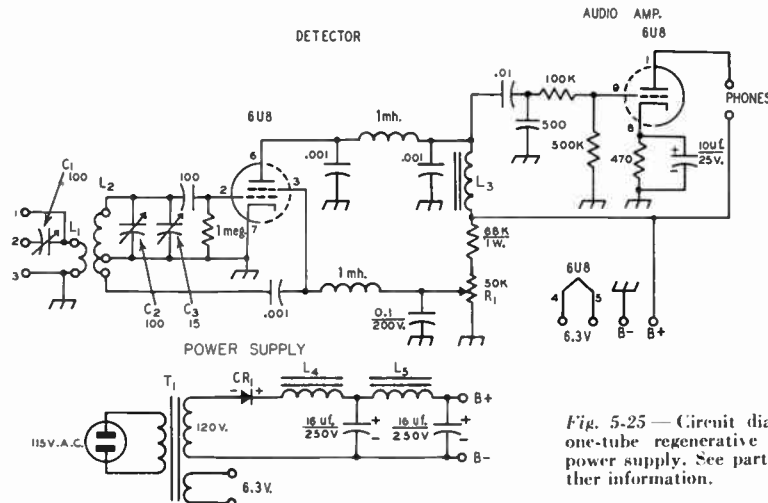

Fig. 5-25 — Circuit diagram of the one-tube regenerative receiver and power supply. See parts list for further information.

Parts List for Regenerative Receiver

- 2 100- μ f. midjet variables (Millen 20100) (C_1, C_2)
- 1 15- μ f. midjet variable (Millen 20015) (C_3)
- 1 100- μ f. mica or ceramic capacitor
- 1 500- μ f. mica or ceramic capacitor
- 3 0.001- μ f. disk ceramic capacitors
- 1 0.01- μ f. disk ceramic capacitor
- 1 0.1- μ f. 200-volt paper capacitor
- 1 10- μ f. 25-volt electrolytic capacitor
- 2 16- μ f. 250-volt electrolytic (or dual 16- μ f.)
- 1 470-ohm $\frac{1}{2}$ -watt carbon resistor
- 1 68,000-ohm 1-watt carbon resistor
- 1 0.1-megohm $\frac{1}{2}$ -watt carbon resistor
- 1 0.5-megohm $\frac{1}{2}$ -watt carbon resistor
- 1 1.0-megohm $\frac{1}{2}$ -watt carbon resistor
- 1 50,000-ohm potentiometer
- 2 1-mh. r.f. chokes (National R-50)
- 80-, 40-, and 20-meter Barker & Williamson Baby Inductors MEL (L_1, L_2)
- 1 interstage transformer (Stancor A-53-C) (L_3)
- 2 4-henry 40-ma. filter chokes (UTC R-55) (L_4, L_5)
- 1 power transformer, 120-volt secondary at 50 ma.; 6.3 volt at 1 amp. (Merit P3045 or P3046)
- 1 dry rectifier, 130 volts, 20 ma. (Federal 1150) (CR_1)
- 1 aluminum chassis, 7" \times 7" \times 2"
- 1 aluminum panel, 7" \times 6"
- 1 piece of aluminum for power-supply chassis, 3" by 10" (the panel and this piece are obtainable at any sheet-metal shop)
- 1 9-pin miniature tube socket, bakelite or mica filled
- 1 5-pin socket for coils L_1 and L_2 , bakelite or isolantite
- 4 3-terminal tie points
- 7 $\frac{3}{4}$ " rubber grommets
- 1 Panel bearing assembly, over-all length 6"
- 1 insulated shaft coupler
- 1 terminal strip, 6 terminals
- 2 pin jacks, insulated type
- Miscellaneous 6-32 machine screws and nuts
- 6 ground lugs
- 25 feet of hook-up wire
- 4 knobs for controls
- 1 6U8 tube
- 1 length of spaghetti wire covering
- Line cord and plug

coupling to the headphones through a capacitor, but in the interest of saving a few dollars this protective feature was not included. Be sure to use "high-impedance" headphones with this receiver — the low-impedance headphones that have been available in surplus will not work well in this particular circuit.

The receiver is built on a 7 \times 7 \times 2-inch aluminum chassis, with the power supply mounted on a separate chassis. In order to minimize hum pickup and vibration from the power transformer, it is not advisable to mount the power

supply on the same chassis as the receiver. An aluminum chassis is easy to work; a $\frac{1}{8}$ - and $\frac{1}{4}$ -inch drill, plus a small rat tail file and hack-saw blade are all the tools needed for the job, although two socket punches will save some work.

The first step is to mount the coil and tube sockets. They are spaced 2 inches from the sides at the center of the chassis. Ground lugs should be mounted under the nuts that hold the tube socket and also under the rear nut holding the coil socket. Next, the panel holes are drilled.

Looking at Fig. 5-24, front, the knob at the lower left is the regeneration control, lower center is the antenna trimmer, and the headphone tips are at the lower right. The knob at the upper left is for the general-coverage capacitor, and the one at the right the band spread tuning. The dial shown in the photograph is the National type K.

After the holes are drilled in the panel, it is held in place against the chassis and the four holes along the bottom are used as a template for the chassis holes. A small right-angle bracket to hold the antenna-trimmer capacitor is made from a piece of aluminum. The hole in the bracket should be large enough to clear the rotor of the capacitor, since both the rotor and stator are insulated from the chassis. The trimmer is mounted to the bracket by screws and the insulated nuts on the capacitor frame. The bracket, tie points, and audio choke L_3 can now be mounted in place.

The two capacitors, C_2 and C_3 , should then be installed on the panel. When the potentiometer R_1 and the pin jacks are mounted in place, they will hold the panel to the chassis. Be sure to insulate the pin jacks from the panel and chassis with fiber washers. The through-shaft bushing is then measured and cut to size, making allowance for the insulated coupler.

If this is your first construction project, see the chapter on Construction Practices for tips on wiring and soldering before starting this job.

It is important that a separate ground lead be connected to the rotors of C_2 and C_3 and the lead brought below the chassis to a common grounding

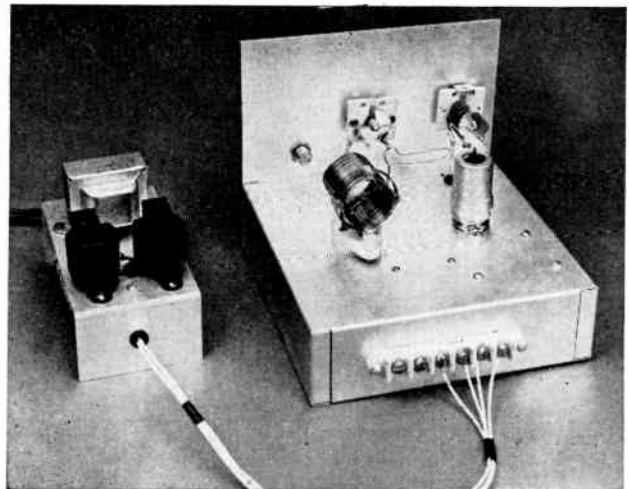

Fig. 5-26 — Rear view of receiver and power supply showing the placement of parts. The variable capacitor on the left is for band-spread and the one on the right for general coverage. The leads from the two capacitors are run through rubber grommets to avoid shorting to the chassis top.

point at the tube socket. This will help make the receiver stable and reduce hand capacity.

There are five leads coming from the interstage transformer: red, blue, black, and two green. The red lead and green lead that are directly opposite each other are connected together. After the leads are soldered and taped, the end of the black lead is also taped. These leads are then rolled up and tucked in the corner of the chassis. The remaining blue and green leads then become those used for wiring the series-connected transformer into the circuit. One is connected to the junction of the 0.01- μ f. disk capacitor and the 1-mh. r.f. choke and the other lead is connected to the B+ voltage terminal.

The Barker & Williamson coils are mounted on five-prong plugs, although only four of the contacts are used. The link mounted at one end of the coil is L_1 and the coil proper is L_2 . To make the tickler tap, a short piece of hook-up wire approximately 3 inches long is soldered to the fifth prong on the plug. The piece of wire is then run through the middle turns of the coil and soldered to the tap point. For the 80-meter coil, the tap is connected to the 8th turn in from the link end. To get the tap wire through the middle turns of the coil, it will be necessary to bend two or three turns of the coil in towards the center of the coil. This will provide sufficient clearance for the tap lead. It is also necessary to bend in the 8th turn to make the tap connection. Be sure that none of the bent turns touches adjacent turns.

For maximum bandwidth on 40 meters, it is necessary to remove nine turns from the 40-meter coil. The turns are taken from the end opposite the link end of the coil. The tickler tap is made on the 4th turn end from the link end.

To bandwidth the 20-meter coil, two turns are removed from the end opposite the link end. The tap is placed on the 4th turn from the link end. In all three coils, the tap lead should be insulated where it passes through the coil turns.

The power-supply components can now be wired. There are two important points that beginners should keep in mind when wiring the

supply. The first is that the electrolytic capacitors should be wired with the leads marked with a minus sign, or negative, connected to the chassis. The plus sign, or positive, connects to the choke leads. Likewise, the selenium rectifier is marked with a plus sign, and this lead is connected to the choke lead. Four leads are brought out from the power supply to connect to the receiver: the two heater leads, the B+ lead, and the B- lead.

When the power supply is wired and the leads connected to the receiver, the unit is ready to test.

If you already have an antenna strung up, connect the end of it to Terminal 2 — the one connected to the rotor of C_1 . If you don't have an antenna, any wire, 20 to 40 feet long or longer, can be strung up. An outside antenna will perform better than one indoors, although you'll hear many signals with just a wire in the room.

Connect your headphones to the tip jacks and plug in the 80-meter coil. Plug the power cord into the 115-volt a.c. line and watch the 6U8 to see if the heater lights up. If it doesn't, turn off the power and check wiring from the power supply to the heater pins on the 6U8 socket.

The receiver will only take a minute to warm up. Turn the regeneration control and, at one point, you should hear a change in the characteristic of the noise. This is the point where the receiver starts to oscillate. Tune the general-coverage capacitor slowly and you should hear signals. Leave the capacitor set at or near one of the signals and then tune the band-spread capacitor. This capacitor gives a slower tuning rate, making it much easier to tune in signals.

With a signal tuned in, rotate the antenna-trimmer control and the signal should get louder at one point. If it doesn't, change the antenna to terminal number 1 and short terminals 2 and 3 together with a short piece of wire. Try the antenna trimmer again, and you should find that the signal will peak up. The regeneration control setting may have to be changed to maintain oscillation.

Locating the amateur Novice bands is simple. Tune the receiver until you find an amateur phone station. The Novice band on both 80 and 40 meters is immediately below the phone bands. To tune lower in frequency than the phone bands, the band-spread capacitor is turned so that the plates mesh more.

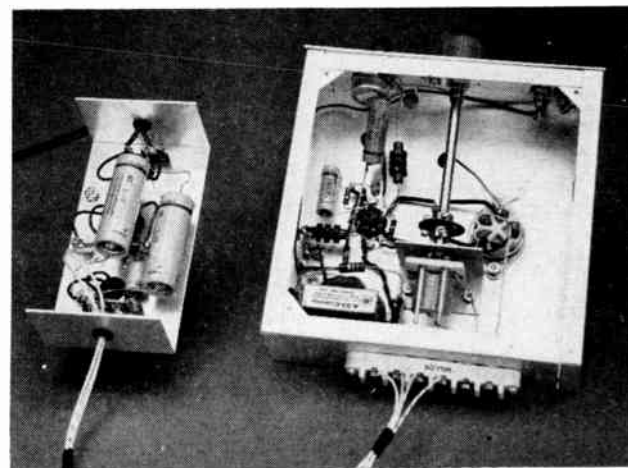

Fig. 5-27 — Bottom view of the two units. At the lower left in the receiver is the interstage transformer L_3 . To the right of L_3 is the antenna-trimmer capacitor mounted on a right-angle bracket. Immediately in front of the bracket is the insulated shaft coupler which connects the through-shaft bushing to the antenna trimmer.

The selenium rectifier in the power supply is visible between the two electrolytic capacitors.

A Two-Band Three-Tube Superheterodyne

The three-tube superheterodyne shown in Figs. 5-28, 5-30 and 5-31 might be called a "minimum" receiver, since it probably represents the minimum in receiving equipment that will give a good account of itself under present band conditions. By using an i.f. of 1700 kc. it is possible to use an oscillator that tunes 5.2 to 5.7 Mc. and provides receiver coverage of the 80- and 40-meter bands without switching. To listen on higher frequencies, a crystal-controlled converter can be used ahead of the set, working into it at 80 meters.

Referring to the circuit in Fig. 5-29, it can be seen that adjustable input coupling is provided (variable coupling between L_1 and L_2). While the signal level can be reduced by detuning the 140- $\mu\mu\text{f}$. ANT capacitor, C_1 , the adjustable coupling is easy to construct and permits reducing the input level without detuning. The high-frequency oscillator output is coupled to the cathode of the pentode mixer, to provide a low-noise mixer and a minimum of "pulling." Changing the setting of the ANT capacitor does not pull the oscillator frequency appreciably unless the mixer input circuit is tuned close to the oscillator frequency,

a condition that is never used. The setting of the ANT capacitor, C_1 , determines whether the set is receiving 80- or 40-meter signals.

The 1700-ke. i.f. transformer (L_5 and L_6 and the associated shunt capacitors) uses two of the compact ferrite broadcast-antenna coils

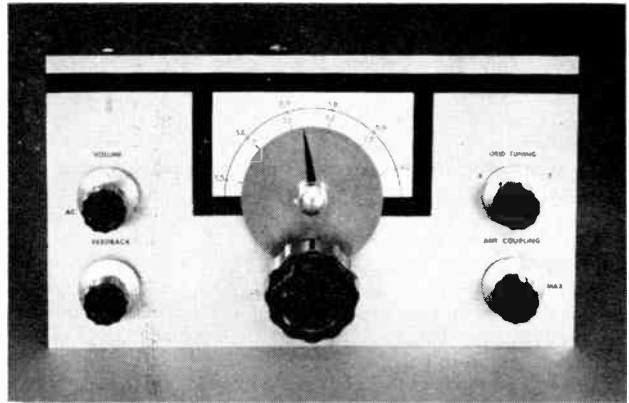

Fig. 5-28 — This two-band superheterodyne receiver uses an autodyne second detector and adjustable antenna coupling. The dial pointer and black trim strips are made of black Scotch Tape. The control marked "Feedback" is the regeneration control.

that have become popular recently. They have the twin virtues of low cost and quite adequate Q for this job. The regenerative detector uses the Colpitts circuit to eliminate the need for

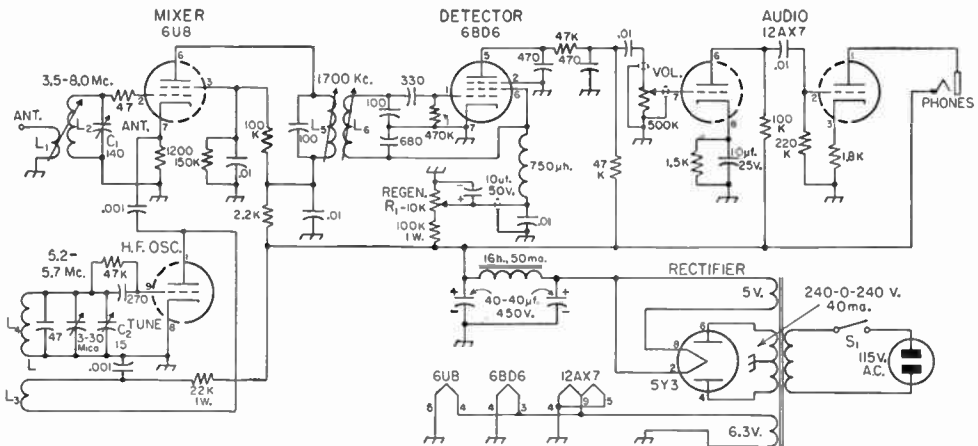

Fig. 5-29 — Schematic diagram of the two-band superheterodyne. All resistors $\frac{1}{2}$ -watt unless specified otherwise. All capacitances in $\mu\mu\text{f}$. unless otherwise noted. All fixed capacitors except two across L_6 , one across L_4 , and the electrolytics (polarity marked) are ceramic. Fixed capacitors across L_4 and L_6 are silver mica.

- C_1 — 140- $\mu\mu\text{f}$. midget variable (Hammarlund HF-140).
- C_2 — 15- $\mu\mu\text{f}$. midget variable (Hammarlund HF-15).
- R_1 — 10,000-ohm 2-watt wire-wound potentiometer (Clarostat A43-10K).
- L_1, L_2, L_3, L_4 — B & W No. 3016 Miniductor, 1-inch diam., 32 turns per inch, No. 22 wire.
 - L_1 — 12 turns.
 - L_2 — 26 turns.
 - L_3 — 8 turns.

- L_4 — 21 turns, separated from L_3 by one (removed) turn.
- Adjacent turns on L_3 and L_4 go to 0.001 μf . and chassis respectively.
- L_5, L_6 — Grayburne Vari-Loopstick. (80 μh ., approx.)
- S_1 — Mounted on 500K volume control.
- Power transformer is Knight (Allied Radio) 62-G-034, filter choke is Knight 62-G-137, filter capacitor is Mallory 2N-537.

tapping the coil or adding a tickler winding. An electrolytic capacitor across the regeneration control eliminates the noise produced by varying the wire-wound potentiometer. With any significant current flowing, a wire-wound potentiometer usually has longer life than does the more common composition control.

The two-stage audio amplifier is conventional, except that a cathode by-pass capacitor is omitted from the second stage because there is already sufficient gain in the amplifier. Switch S_1 is mounted on the audio volume control.

An $8 \times 12 \times 3$ -inch aluminum chassis plus a 7×13 -inch panel provides enough metal for the receiver, with the single exception of the scrap of aluminum needed for the bracket that supports the $15\text{-}\mu\text{f}$. tuning capacitor, C_2 . The panel is held to the chassis by the two shaft bearings and the regeneration-control potentiometer, as can be seen in Fig. 5-31. It will pay off to take a little care in the location of the holes for the National type K dial, in the interests of a smooth-tuning receiver. Build the tuning-capacitor bracket first, then line up the capacitor shaft against the panel to mark the dial bushing hole, and finally locate the drive bushing hole. Replace the small knob that comes with the Type K dial with a larger one, and use a couple of drops of oil to lubricate the drive bushing.

Practically everything else in the receiver can be located from the photographs. The adjustable antenna-coupling coil is mounted on the end of a length of $\frac{1}{4}$ -inch diameter lucite rod by cutting the end of the rod at 45 degrees and cementing a small scrap of polystyrene sheet to this face. The scrap is then filed to fit inside the coil and secured with a few drops of Duco cement. Four small holes are drilled through the rod: two for the coil ends (which also serve as tie points for the flexible antenna and ground leads), one through which the antenna and ground leads are threaded and cemented, and the fourth through which a piece of No. 20 wire is pushed and bent back around the rod. This last

wire serves as a shoulder that bears against a fiber (or metal) washer that in turn bears against a large rubber grommet with a $\frac{1}{4}$ -inch hole, as shown in Fig. 5-32. The other side of the grommet has another washer between it and the panel bushing. The rod is pushed through the bushing, two more washers are added, and then the knob is put on. By pushing the rod out through the panel as the knob is tightened, the rubber grommet is left in compression, and it serves as a simple friction lock for the control.

The two coils L_5 and L_6 are mounted on 1-inch separated centers. The "phones" jack is insulated from the chassis by fiber washers. Plate voltage will appear at this point, so always use an insulated phone plug. Both C_2 and C_1 capacitors are insulated from the chassis — the former by mounting it with short bushings on the mounting bracket, and the latter by fastening it to the chassis with a machine screw through small extruded fiber washers. Clearance holes for leads from both stators and rotors of these capacitors are provided, as can be seen in Figs. 5-30 and 5-31.

To minimize hum, shield the leads to and from the volume control. These pass through a grommet in the chassis and make connection to the chassis only at the 12AX7 chassis. Also shield the lead from the arm of the regeneration control.

Assuming that the wiring is correct, that the tube heaters light when you turn on the set, and that the power supply delivers 250 to 300 volts, the first step is to check the detector. This is conveniently done with the 6U8 out of its socket — then if something is wrong in the "front end" it won't confuse the detector checking. With headphones plugged in and the receiver (less 6U8) warmed up, advancing the volume control should give a hissing sound in the headphones. Advancing the regeneration control (increasing the voltage on the 6BD6 screen) you should find a point where the hiss increases appreciably and perhaps a very slight hum is heard. This is the point where the detector "oscillates" — below this point you won't get a beat note with c.w. signals, and beyond it you will. The detector works — the next step is to get it on 1700 kc. (If it doesn't work,

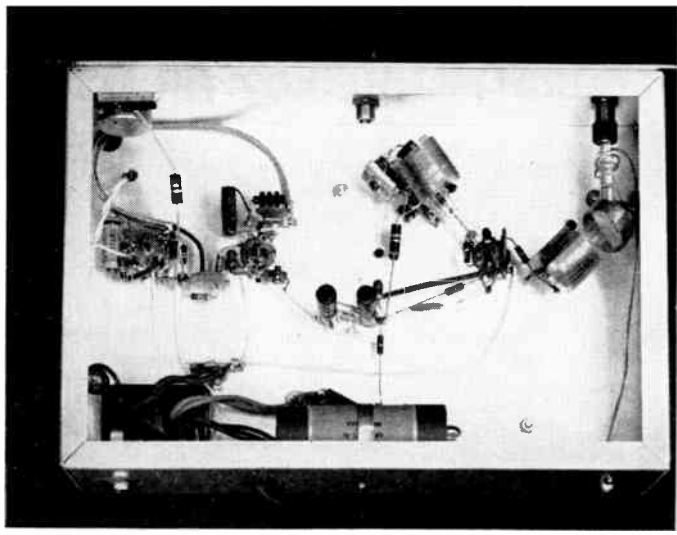

Fig. 5-30 — The miniature tubes, from left to right, are 6U8, 6BD6 (in shield) and 12AX7. The left-hand variable capacitor tunes the mixer input circuit, and the small one in the center tunes the high-frequency oscillator. Note the phono-jack antenna terminal and headphone output jack on the wall of the chassis. The tuning capacitor at rear center is mounted on an aluminum bracket.

◆

Fig. 5-31 — The mixer input and high-frequency oscillator coils are mounted on tie points, as shown here. The antenna coil, L_1 , is mounted on the end of a piece of lucite rod, as shown here and in Fig. 5-32. The leads to it are wrapped several times around the rod, to provide a "pig tail" connection.

◆



check your wiring and the voltages at the 6BD6 and 12AX7 pins.) If you can beg, borrow or steal a test generator, put the detector on 1700 kc. by adjusting the slug in L_6 until the 1700-ke. signal is heard. The test signal need only be loosely coupled to L_6 — a wire placed a foot from the coil and connected to the test generator should suffice. Lacking the test generator, you may be able to use a broadcast receiver by tuning it to around 1245 kc. If the receiver has a 455-ke. i.f., the oscillator will be close to 1700 kc., and if the BC set is placed within a few feet of the receiver under test, there will be enough radiation from the set to act as the test signal. Don't go

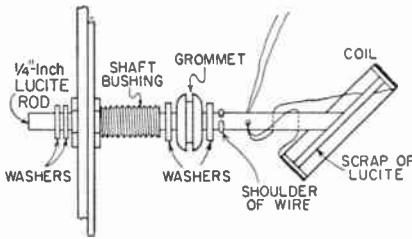

Fig. 5-32 — Details of the adjustable antenna coupling coil. Part of the coil has been cut away to show the support.

by the calibration on the BC receiver; make a new one from known stations.

When the autodyne detector is working satisfactorily and you have acquainted yourself a little with its operation, plug in the 6U8 and let it warm up. Trim L_5 until you find a point where it pulls the detector out of oscillation, and detune it slightly until regeneration starts about 10 or 15 degrees farther along the regeneration control, R_1 , than it did when L_5 was tuned well off the frequency. Check again to make sure that you are still on or close to 1700 kc.

Now connect an antenna (any wire 20 feet long or more) and swing the ANT capacitor, C_1 , across its range. The receiver noise should increase at two points — one near minimum on the capacitor (40 meters) and one around $3/4$ meshed (80 meters). The 3-30- μ mf. compression oscillator trimmer should be set at about $1/2$ turn back from its tightest setting. Leaving the ANT capacitor on 80 or 40 meters, tune around with the TUNE capacitor, C_2 , until you locate some amateur signals. If you lack a frequency standard or the ability to borrow one, you have no alternative but to identify the bands by the limits of phone or c.w. signals in the various subbands.

In any event, once you have found the signals, you can move the bands on the TUNE scale by changing the setting of the mica compression trimmer. However, unless the i.f. is *exactly* on 1700 kc., the 7.0- and 3.6-Mc. points, 7.1 and 3.7 Mc., etc., won't coincide as they do on the homemade scale shown in Fig. 5-28. Observing the error, however, you can bring the i.f. to 1700 kc. easily. The homemade scale is simply a sheet of white paper held down with black Scotch Tape, with a sliver of tape on the dial to serve as a pointer. The pointer laps over the "0" end, and the 0-100 scale of the dial can still be used for logging by referring it to the upper edge of the lower black strip on the right-hand side.

For the reception of c.w. signals, the regeneration control is advanced far enough for the detector to oscillate, as indicated by the sudden increase in hiss. It may be noticed that on strong signals it is impossible to tune in a signal at a low beat note (200 to 300 cycles). This indicates that the signal is too strong and is "pulling" or "blocking" the detector. To overcome this, increase the regeneration control or reduce the antenna coupling. After you have used the receiver for a while, you will get used to the "feel" of it and you will find the settings that work best for various QRM levels.

When receiving a.m. phone, the regeneration control is maintained just below the oscillation point. This is the most sensitive point for phone reception, since the gain of the detector decreases as you back off the regeneration control still more. The selectivity of the receiver for phone reception is not as great as can be expected from a small superheterodyne using several tuned circuits in a 455-ke. i.f. amplifier. However, you can make up a lot of this selectivity by decreasing the antenna coupling and running the detector just under the oscillation point. A strong signal decreases the selectivity of the regenerative detector, hence the need for reducing the signal by decreasing the antenna coupling. S.s.b. phone is received the same as a c.w. signal, by advancing the regeneration control past the oscillation point and tuning carefully about the signal until it becomes intelligible. Overload is again the enemy here, so run the antenna coupling at a value consistent with good signal noise ratio.

A Two-Band Five-Tube Superheterodyne

The five-tube superheterodyne shown in Figs. 5-33, 5-35 and 5-36 is a double-conversion receiver tuning the 3.5- and 7-Mc. amateur bands. It is not difficult to build, and it has stability and selectivity not surpassed by factory-built receivers costing much more.

As can be seen in Fig. 5-34, the circuit diagram, the receiver uses intermediate frequencies of 1700 and 100 kc. The 1700-kc. first i.f. permits using an oscillator that tunes only one range for the two bands. Tuning the oscillator from 5.2 to 5.7 Mc. gives an i.f. of 1700 kc. for the 3.5- to 4.0-Mc. range and the same i.f. for the 6.9- to 7.4-Mc. range. The oscillator components are soldered in place (no switching or plug-in coils) and the dial calibration is made once and can then be relied upon. To change bands, it is only necessary to swing the input capacitor, C_1 , to the 80- or 40-meter band. The 1700-kc. i.f. eliminates any pulling on the oscillator, in either range.

With no r.f. stage, the receiver's signal-to-noise ratio is determined by the mixer. The 6AC7 is the best tube available for the purpose. To minimize spurious responses, two tuned circuits are used in the input between antenna and converter grid. The stator plates of the dual capacitor, C_1 , are shielded from each other, as are the two coils L_2 and L_3 , and the coupling between circuits is obtained by the 0.001- μ f. capacitor.

The 1700-kc. signal from the first converter is converted in the 6K8 second converter to 100 kc. The use of a 1600-kc. crystal for the oscillator at this point permits using an r.f. gain control that has no effect on the frequency. No frequency change with gain-control setting is a desirable characteristic of any good receiver, so the 1600-kc. crystal at \$2.75 is not a luxury. While the 1600-kc. oscillator could be made self-controlled,

it would be almost certain to "pull" with gain-control changes.

Instead of a commercial unit, a homemade 1700-kc. i.f. transformer is used at T_1 . It is made from two "Vari Loopsticks" (high- Q broadcast antennas) shunted by 100- μ f. fixed capacitors. This works well and is cheaper than any commercially-available unit.

The 100-kc. output from the 6K8 is filtered through three tuned circuits and feeds a triode plate detector ($\frac{1}{2}$ 6SN7). This detector is regenerative, but the regeneration is fixed and doesn't have to be bothered with by the operator unless he changes tubes and the new tube has considerably different characteristics. The regeneration in the 100-kc. detector gives the receiver its single-signal c.w. reception characteristic, since there aren't enough tuned circuits to give it otherwise. The b.f.o. uses the other triode in the 6SN7 envelope, and stray coupling is used for the b.f.o. injection. No panel control of b.f.o. pitch is available, because the selectivity is not adjustable and the variable-pitch feature is not essential.

Up to this point the gain of the receiver is not too high, and two stages of audio amplification are used. Omitting the cathode by-pass capacitors still leaves more than enough audio for any pair of high-impedance headphones.

By keeping the signal level low up to and through the selective stages, there is a minimum opportunity for overloading and cross-modulation, and the gain need be kept only high enough to prevent degrading the signal-to-noise ratio. Further, a regenerative stage has a tendency to "flatten out" with strong signals, so the regenerative detector is somewhat protected by holding the gain down. However, the receiver has quite adequate sensitivity — in any normal location

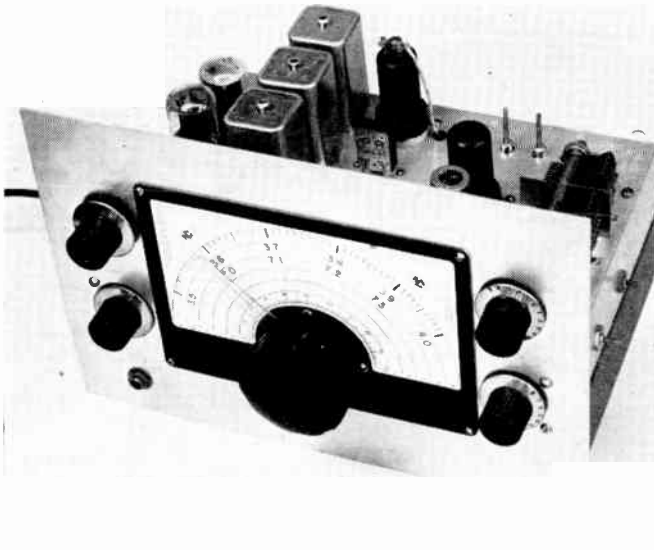

Fig. 5-33 — The five-tube double-conversion superheterodyne tunes the 3.5- and 7-Mc. bands without band-switching. The controls on the left are audio volume (upper) and b.f.o. switch, and those on the right are antenna tuning (upper) and i.f. gain.

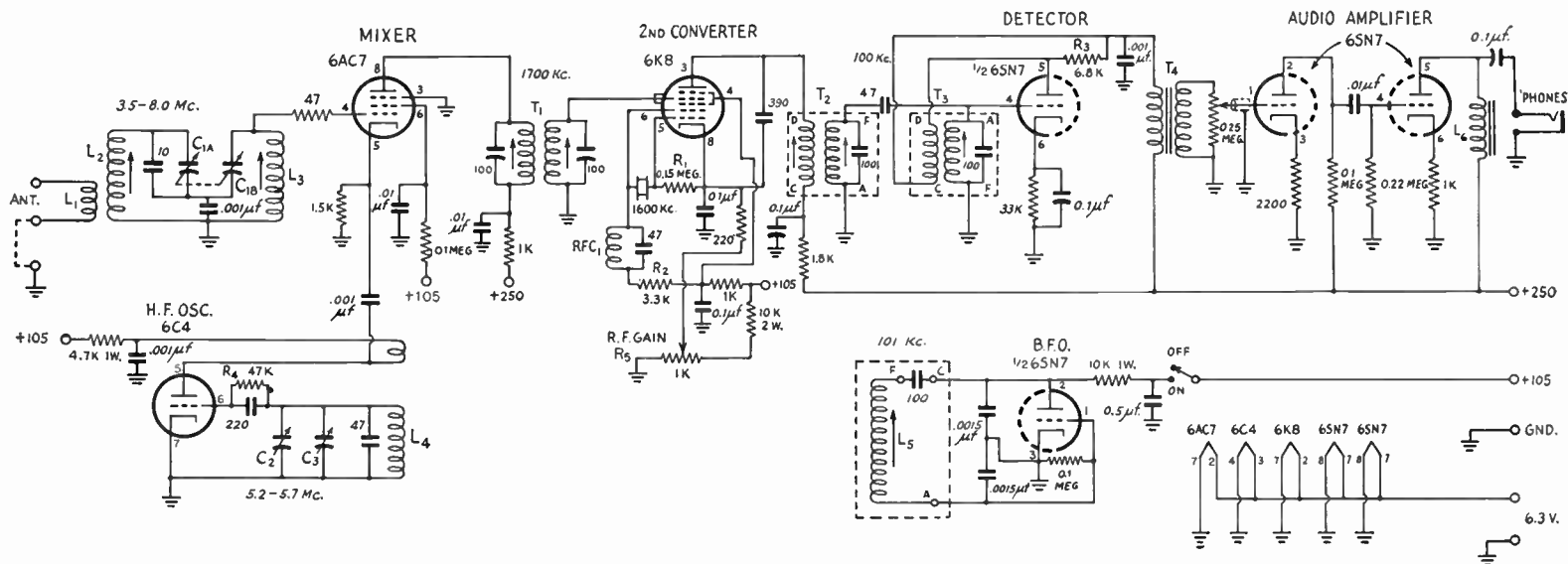

Fig. 5-34—Wiring diagram of the five-tube receiver.

All capacitances in μmf , unless specified otherwise. All resistors $\frac{1}{2}$ -watt unless specified otherwise.

C_1 — 140- μmf , per-section dual variable (Hammarlund MCD-140-M).

C_2 — 35- μmf , midget variable (Hammarlund HF-35).

C_3 — 100- μmf , midget variable (National PSR-100).

R_5 — 1000-ohm wire-wound potentiometer (Mallory A1MP).

L_1 — 8 turns No. 30 d.c.e. close-wound over ground end of L_2 .

L_2, L_3 — 35 turns No. 30 d.c.e. close-wound on National XR-50 slug-tuned form.

L_4 — 23 turns No. 24 bare space-wound 32 turns per inch, $\frac{5}{8}$ -inch

diam. Ticker is $1\frac{3}{4}$ turns spaced 1 turn from L_4 . See text.

(Made from B & W 3008 Miniductor.)

L_5 — 20-mh. (approx.) slug-tuned coil (RCA 205R1).

L_6 — 20 henry, 15 ma. choke (Stancor C1515).

T_1 — 1700-ke. i.f. transformer (made from two Vari Loopsticks shunted by 100- μmf . mica capacitors. See text).

T_2, T_3 — 100-ke. transformers made from TV components (RCA 73576 or Merit TV-162). See text.

T_4 — Small 3:1 audio transformer (Stancor A-63-C).

RFC₁ — 750 μh . (National R-33).

The 1600-ke. crystal is a Peterson Radio type Z-2.

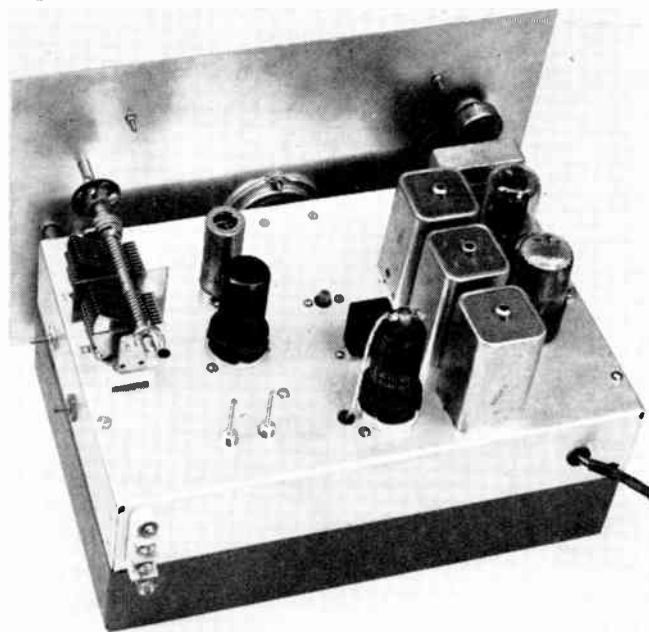

Fig. 5-35 — A top view of the five-tube superheterodyne shows how an aluminum and a steel chassis are combined for greater weight and strength. The 6C4 oscillator and 6AC7 mixer are at the left, and the two 6SN7s are at the extreme right. Note the shield between the stator sections of the capacitor on the left.

and with a fair to good antenna, any signal that can be heard by a large receiver can be heard by this one, except in rare cases where the large receiver's superior selectivity makes the difference.

Construction

The construction of the receiver is unconventional in that two chassis are used, as shown in Figs. 5-33 and 5-35, and the panel is mounted away from the chassis. All of the electrical components are mounted on the aluminum $7 \times 11 \times 2$ -inch chassis, and this sits on an inverted $7 \times 11 \times 2$ -inch steel chassis that serves as a base and bottom cover. The bottom chassis has rubber feet (grommets) at its corners that prevent its slipping on the table. The 8×12 -inch panel is supported away from the aluminum chassis on $\frac{1}{2}$ -inch-long brass collars, secured by suitable washers and 6-32 screws, as shown in Fig. 5-36. The panel is supported by two such collars at each end of the chassis and by two more that make up to two of the mounting screws of the National ACN dial at the center. The two center collars add to the strength of the assembly by furnishing additional support for the panel and dial, and they should not be omitted.

The aluminum chassis is bolted to the steel chassis by two $4\frac{1}{4}$ -inch lengths of $\frac{1}{8}$ -inch diameter brass rod, threaded 6-32 at each end. These rods pass through holes in the top and lip of each chassis. The only holes that are required in the steel chassis are those for the two tie rods, the four holes for the rubber feet, and a $1\frac{1}{4}$ -inch diameter hole to clear the headphone jack.

In the oscillator circuit, the 35- μ f. tuning capacitor, C_2 , is supported by a small aluminum bracket. The correct location of the capacitor

on the bracket can be found after the dial-and-chassis assembly has been completed. It is imperative to the smooth operation of the tuning capacitor that the shaft of the capacitor be correctly aligned with the coupling of the dial.

The 100- μ f. trimmer, C_3 , is mounted under the chassis with its shaft extending through to the top, so that the capacitor is adjustable from above the chassis. Neither C_2 nor C_3 is grounded to the chassis through its mounting — leads from the rotors are grounded to the chassis at one point near the 6AC7 tube socket. The oscillator coil, L_4 , is mounted by its leads on a multiple tie point.

The shield between the input coils, L_2 and L_3 , is made of thin aluminum. It has a notch in the edge that goes against the chassis side, to clear the antenna-coil leads, and it has a hole through it for the lead between the bottoms of L_2 and L_3 . The dual capacitor, C_1 is fastened to the chassis by a single 6-32 screw, and the head of this screw has a copper shield soldered to it for minimizing coupling between C_{1A} and C_{1B} . The shield is easily cut out from copper flashing and soldered to the screw head. The rotor assembly of C_1 must be removed to put the shield in place, but this is just a matter of loosening four screws. Don't touch the stator plates. The screw with the shield on it, which holds C_1 to the chassis, also holds the coil shield in place underneath the chassis.

The 1700-ke. i.f. transformer is made by mounting the two "Loopsticks" 1-inch apart on the chassis, as shown in Figs. 5-33 and 5-35. The 100- μ f. capacitors are mounted on the coils.

The 100-ke. circuits use a TV component, a special Horizontal Oscillator coil. As purchased, they have the soldering lugs and tuning screw out of the top of the can, but they are easily reversed by uncrimping the can and reversing the assembly. Before reassembly, however, there are a few things to be done. The large coil is used for the 100-ke. tuned circuit by connecting a 100-

$\mu\text{f.}$ mica capacitor between Pins A and F and lifting the center-tap from Pin C. Don't break the center-tap — the easiest way is to scrape the two wires first to remove the insulation, flow a drop of solder on the scraped portion, and then cut the two wires away at the pin. The other winding is used as the primary in T_2 and the tickler in T_3 . The primary in T_2 can be tuned from the top, because there is also an iron slug in this smaller coil.

In wiring the set, use tie points liberally so that no components will be floppy. The only shielded wires are the one running from the volume control to Pin 1 of the audio amplifier and the leads from T_3 to Pins 4 and 5 of the detector. The shields are grounded to the chassis at the ends and any other convenient points.

The oscillator coil, L_4 , is made from B & W Miniductor. To separate the two coils of L_4 , push the 3rd or 4th turn from one end of the piece of Miniductor through toward the center of the coil. Snip this wire with a pair of cutters and push the two ends back out. Each end is then peeled around for $\frac{1}{2}$ turn. The two coils are adjusted to the right number of turns by working in from the outside ends.

The rotor of C_1 is connected underneath the chassis to the 0.001- $\mu\text{f.}$ coupling capacitor by running a wire from the front support of the rotor through a $\frac{1}{4}$ -inch clearance hole in the chassis. The 0.001- $\mu\text{f.}$ coupling capacitor and L_2 and L_3 are grounded to the lug under L_2 .

Fig. 5-36 — A bottom view of the five-tube superheterodyne. The audio choke, L_6 , is in the upper right-hand corner, near where the power leads leave the chassis. The 6SN7 socket nearer the panel is the detector-b.f.o. section.

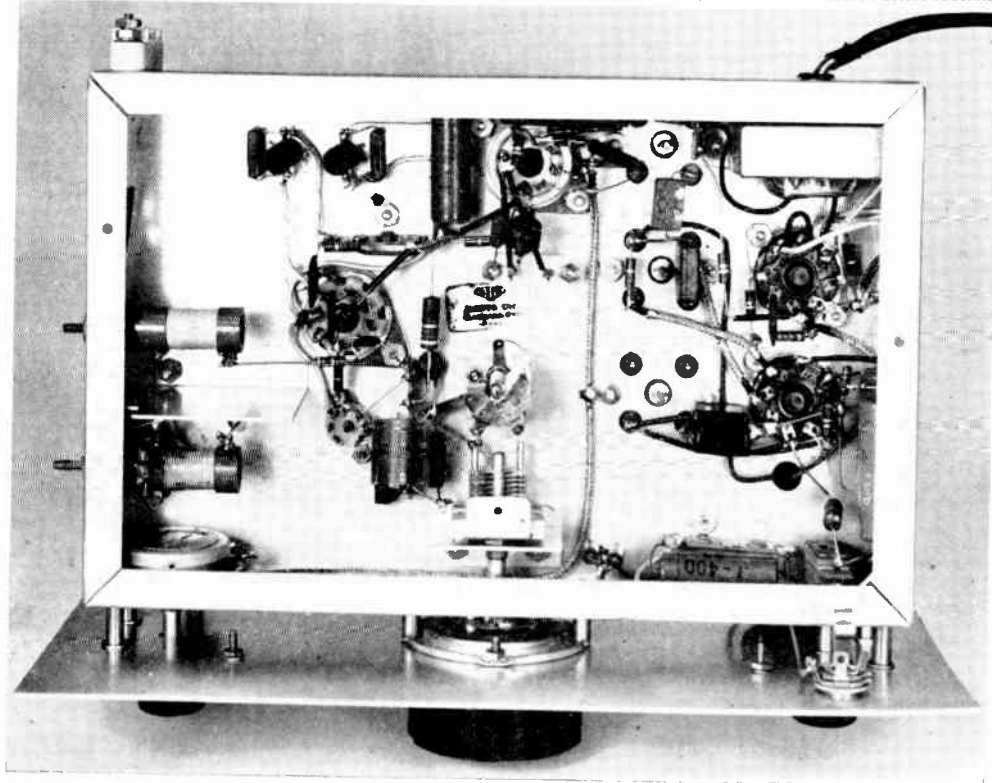

Adjustment

There are two types of adjustment that must be made to get the receiver working: adjusting the circuits to the proper frequencies and adjusting the oscillators and the regenerative detector to the proper amplitudes. To this latter end, leave the cathode end of R_1 disconnected in the original wiring, and lightly solder (so that it can be changed later) the lead from Pin 5 of the detector to Terminal C of T_3 . Resistors R_2 and R_3 may require changing, so don't solder them too well at first.

Connect a power supply to the receiver and see that the tubes light and that the power-supply voltages are approximately correct. The 250 volts can be anything 25 volts either side of 250, and the 105 volts, coming from a VR tube, will be nothing to worry about if the VR tube lights.

Next connect a low-range milliammeter between R_1 and cathode (+ lead to cathode) and apply power again. The grid current should read about 0.05 ma. (50 $\mu\text{a.}$). If it reads much more than this, try a slightly larger resistor at R_2 , or a smaller one if the grid current is too low. Make these adjustments with the rotor arm of the r.f. gain control at the grounded end.

Next check the oscillation of the 6C4 high-frequency oscillator. To do this, connect a 0-10 voltmeter across the 4700-ohm resistor in the plate circuit of the 6C4 (+ terminal to

+ 105 side, - terminal to the 0.001- μ f. capacitor). Observe the voltage reading and then touch your finger to the stator of C_2 or C_3 . If the oscillator is working, the voltmeter reading will increase. If you get no change, it means the oscillator isn't working. With both coils of L_4 wound in the same direction (as they will be

3650 kc., you know that the first 100-kc. harmonic you hear on the high-frequency side will be 3700 kc., and the first one on the low side will be 3600 kc. The second harmonic of the 3650-kc. signal will furnish a check point at 7300 kc. (2×3650), so swinging C_1 to about $\frac{1}{2}$ meshed (where it will peak the 7-Mc. signals) will allow you to locate

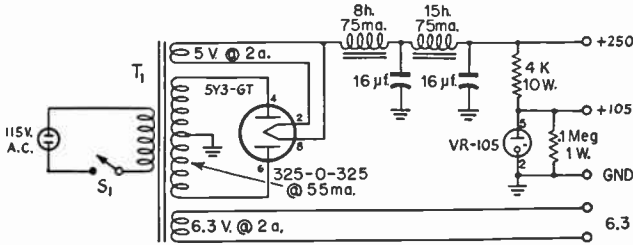

Fig. 5-37 — Suggested circuit diagram for the receiver power supply. T_1 — Stancor PM-8407 or equivalent. S_1 — S.p.s.t. toggle switch.

if Miniductor is used), the stator of the tuning capacitor should be connected to the outer end of the larger coil, and Pin 5 of the 6C4 should be connected to the outside turn of the smaller coil.

If you can borrow a serviceman's test oscillator that will give a modulated signal at 1700 kc., this signal can be introduced at the grid of the 6K8 and the 100-kc. i.f. circuits can be peaked (b.f.o. turned off), listening in the headphones for maximum response. The 1700-kc. signal can then be transferred to the grid of the 6AC7 and the slugs peaked on T_1 . Lacking the signal generator, the alternative is to provide a modulated signal in the 80- or 40-meter band and couple it to the stator of C_{1B} . If the signal is from a crystal oscillator or v.f.o. at 3750 kc. (for example), running from an unfiltered power supply to furnish the modulation, set the tuning dial vertical. If the signal is at 3500 kc., set the tuning capacitor C_2 at almost full capacity. Rock C_3 slowly until the signal is heard. Then peak the 100-kc. transformers T_2 and T_3 , reducing the signal input as necessary to avoid overloading. Next turn on the b.f.o. and adjust the slug in L_5 until a beat note is heard. Then peak the slugs in T_1 .

With the initial tuning of the 100-kc. channel done, the slugs of L_2 and L_3 can be adjusted for maximum signal, with no antenna connected. Set C_1 at almost full capacity, the signal near 3.5 Mc., and adjust the iron slugs for maximum in the headphones. If a v.f.o. or crystal oscillator is furnishing the signal, there will probably be enough pick-up without any apparent coupling, but a short 6-inch wire connected to the antenna terminal may be required to pick up the output from a low-powered signal source.

It is not likely that the 100-kc. circuits will be tuned to the exact frequency that makes the calibrations coincide on 80 and 40 meters. While this isn't necessary, of course, it does make the dial look cleaner. To bring the calibrations into line, beg or borrow a frequency standard that will give signals at 100-kc. intervals. First locate the 4.0- and 7.0-Mc. points on the receiver dial, by referring the harmonics from the 100-kc. standard to the original signal you used for alignment. If, for example, the 80-meter signal you used was at

the 7-Mc. points. Thus you will have 100-kc. intervals on the dial from 3.5 to 4.0 Mc. and from 6.9 to 7.4 Mc., but not necessarily coinciding. To make them coincide, some slight retuning of the 100-kc. transformers is required. If, for example, the 7.0-Mc. point occurs to the right of the 3.6-Mc. point, the 100-kc. amplifier is tuned low, and the slugs should be turned out slightly. A few trials will bring the circuits into place.

Now check the regeneration of the detector by connecting the lead from Pin 5 of the detector to D on T_3 . If a steady beat is heard, indicating that the detector is oscillating, tune both circuits of T_2 and see if they will kill the oscillation. Their action is to load the regenerative detector to where it won't oscillate — if the action persists, try a 4700-ohm resistor at R_3 as a last resort. These circuits should be peaked on a modulated signal, with the b.f.o. turned off.

After the detector has been made regenerative, the calibration can again be checked as in a preceding paragraph, and any minor changes in tuning made as are found necessary. Once the 100-kc. circuits have been aligned they can be left alone, and if the 3.5- and 4.0-Mc. points don't come where you want them on the tuning dial, a slight adjustment of C_3 will correct it.

Connect a 140- μ f. variable in series between antenna and the antenna post. On 80 meters, peak C_1 on a signal and rock the adjustment slug of L_2 . If it tunes fairly sharp, the antenna coupling is not too tight on that band. Swing C_1 out until you are listening on 40 (to a signal) and again rock the slug on L_2 . If it tunes broad, reduce the capacity of the 140- μ f. antenna capacitor until L_2 shows a definite peak. Note the settings of the capacitor for the two bands.

The input capacitor, C_1 , will tune sharply on either band, and it should always be peaked when listening to a weak signal. It can be detuned slightly when receiving abnormally loud signals.

The power-supply requirements for the receiver are slight: about 15 ma. at 250 volts and 25 ma. at 105. A 60-ma. power supply will take care of this and the extra 10-12 ma. for a VR-105. A circuit diagram with suggested values is shown in Fig. 5-37.

A Selective Converter for 80 and 40 Meters

Many inexpensive "communications" receivers are lacking in selectivity and bandspread. The 80- and 40-meter performance of such a receiver can be improved considerably by using ahead of it the converter shown in Figs. 5-38 and 5-40. This converter is not intended to be used ahead of a broadcast receiver except for phone reception, because the BC set has no b.f.o. or manual

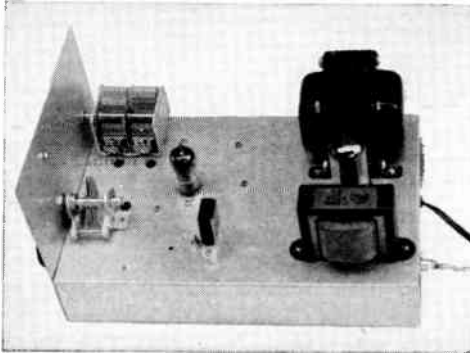

Fig. 5-38 — Used ahead of a small receiver that tunes to 1700 kc., this converter will add tuning ease and selectivity on the 80- and 40-meter bands. The input capacitor is the dual section unit at the upper left-hand corner. The crystal and the tuning slug for L_6 are near the center at the foreground edge.

gain control, and both of these features are necessary for good c.w. reception. The converter can be built for less than \$20, and that cost can be cut appreciably if the power can be "borrowed" from another source.

The converter uses the tuning principle employed in the two-band superheterodynes described earlier in this chapter. A double-tuned in-

put circuit with large capacitors covers both 80 and 40 meters without switching, and the oscillator tunes from 5.2 to 5.7 Mc. Consequently with an i.f. of 1700 kc. the tuning range of the converter is 3.5 to 4.0 Mc. and 6.9 to 7.4 Mc. Which band is being heard will depend upon the setting of the input circuit tuning (C_1 in Fig. 5-39). The converter output is amplified in the receiver, which must of course be set to 1700 kc. To add selectivity, a 1700-ke. quartz crystal is used in series with the output connection. A small power supply is shown with the converter, and some expense can be eliminated if 300 volts d.c. at 15 ma. and 6.3 volts a.c. at 0.45 ampere is available from an existing supply.

Construction

The unit is built on a $7 \times 11 \times 2$ -inch aluminum chassis. The front panel is made from a 6×7 -inch piece of aluminum. The power supply is mounted to the rear of the chassis and the converter components are in the center and front. The layout shown in the bottom view should be followed, at least for the placement of L_1, L_2, L_3 and L_4 .

The input and oscillator coils are made from a single length of B & W Miniductor stock, No. 3016. Count off 31 turns of the coil stock and bend the 32nd turn in toward the axis of the coil. Cut the wire at this point and then unwind the 32nd turn from the support bars. Using a hacksaw blade, carefully cut the polystyrene support bars and separate the 31-turn coil from the original stock. Next, count off 9 turns from the 31-turn coil and cut the wire at the 9th turn. At the cut unwind a half turn from each coil, and also unwind a half turn at the outside ends. This will

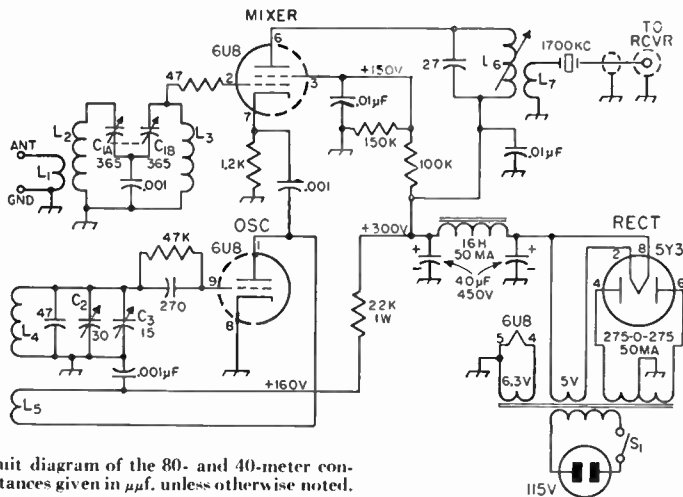

Fig. 5-39 — Circuit diagram of the 80- and 40-meter converter. All capacitances given in μf , unless otherwise noted.

- C_1 — 365- μf . dual variable, t.r.f. type.
- C_2 — 3-30- μf . trimmer.
- C_3 — 15- μf . variable (Bud 1850, Cardwell ZR-15AS, Millen 20015).
- L_1, L_2, L_3, L_4, L_5 — B & W No. 3016 Miniductor, 1-inch diameter, 32 turns per inch, No. 22 wire, cut as below.
- L_1 — 8 turns separated from L_2 by one turn. (see text).

- L_2, L_3 — 19 turns.
- L_4 — 21 turns separated from L_5 by one turn.
- L_5 — 8 turns.
- L_6 — 105-200- μh . slug-tuned coil (North Hills Electric 12011).
- L_7 — See text.
- Crystal — 1700 kc. (E. B. Lewis Co. Type EL-3).

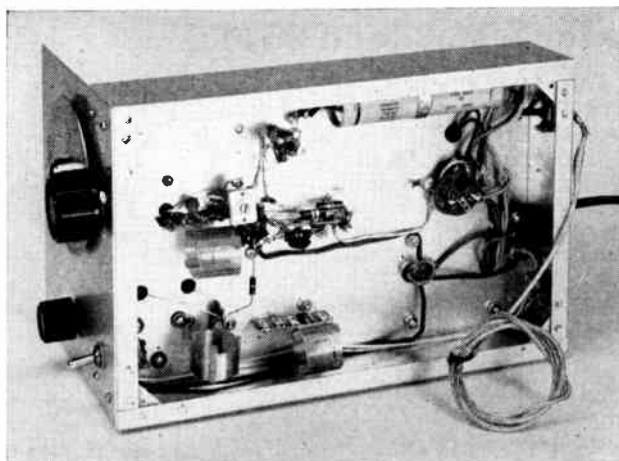

Fig. 5-40 — Bottom view of the converter showing placement of parts. The coil at the lower left is L_3 , and the input coil, L_1L_2 , is just to the right of L_3 . The oscillator coil, L_4L_5 , is at the left near the center. The output coil, L_6 , is near the top center.

leave two coils on the same support bars, with half-turn leads at their ends. One coil has 21 turns and the other has 8 turns, and they are separated by the space of one turn. These coils are L_4 and L_5 .

The input coils L_1 and L_2 are made up in the same manner. Standard bakelite tie points are used to mount the coils. Two 4-terminal tie points are needed for L_1L_2 and L_4L_5 , and a one-terminal unit is required for L_3 . The plate load inductance L_6 is a 105–200 μh . variable-inductance coil (North Hills 1201H). The coupling coil L_7 is 45 turns of No. 32 d.c.c. scramble-wound adjacent to L_6 . If the constructor should have difficulty in obtaining No. 32 wire, any size small enough to allow 45 turns on the coil form can be substituted.

The input capacitor, C_1 , is a 2-gang t.r.f. variable, 365 μmf . per section. As both the stators and rotor must be insulated from the chassis, extruded fiber washers should be used with the screws that hold the unit to the chassis. The panel shaft hole should be made large enough to clear the rotor shaft.

A National type O dial assembly is used to tune C_3 . One word of advice when drilling the holes for the dial assembly: the template furnished with the unit is in error on the 2-inch dimension (it is slightly short) so use a ruler to measure the hole spacing.

In wiring the unit, it is important that the output lead from the crystal socket be run in shielded wire. A phono jack is mounted on the back of the chassis, and a piece of shielded lead connects from the jack to the crystal socket terminal. The leads from the stators of C_1 and C_3 are insulated from the chassis by means of rubber grommets.

Testing and Adjustment

A length of shielded wire is used to connect the converter to the receiver: the inner conductor of the wire is connected to one antenna terminal; the shield is connected to the other terminal and grounded to the receiver chassis. The use of shielded wire helps to prevent pickup of un-

wanted 1700-ke. signals. Turn on the converter and receiver and allow them to warm up. Tune the receiver to the 5.2-Mc. region and listen for the oscillator of the converter. The b.f.o. in the receiver should be turned on. Tune around until the oscillator is heard. Once you spot it, tune C_3 to maximum capacitance and the receiver to as close to 5.2 Mc. as you can. Adjust the oscillator trimmer capacitor, C_2 , until you hear the oscillator signal. Put your receiving antenna on the converter, set the receiver to 1700 kc., and tune the input capacitor, C_1 , to near maximum capacitance. At one point you'll hear the background noise come up. This is the 80-meter tuning. The point near minimum capacitance — where the noise is loudest — is the 40-meter tuning.

With the input tuning set to 80 meters, turn on your transmitter and tune in the signal. By spotting your crystal-controlled frequency you'll have one sure calibration point for the dial. By listening in the evening when the band is crowded you should be able to find the band edges for calibration points. If you have access to a signal generator, it is a simple matter to calibrate the dial.

You'll find by experimenting that there is one point at or near 1700 kc. on your receiver where the background noise is the loudest. Set the receiver to this point and adjust the slug on L_6 for maximum noise or signal. When you have the receiver tuned *exactly* to the frequency of the crystal in the converter, you'll find that you have quite a bit of selectivity. Tune in a c.w. signal and tune slowly through zero beat. You should notice that on one side of zero beat the signal is strong, and on the other side you won't hear the signal or it will be very weak (if it isn't, off-set the b.f.o. a bit). This is known as single-signal c.w. reception, because the "audio image" of the c.w. signal is reduced.

When listening to phone signals, it may be found that the use of the quartz crystal destroys some of the naturalness of the voice signal. If this is the case, the crystal should be unplugged and replaced by a 10- or 20- μmf . capacitor.

Converters for 7, 14, 21 and 28 Mc.

The crystal-controlled converters shown in Figs. 5-41, 5-43 and 5-46 are intended to be used ahead of a receiver or receiving system that will tune 3.5 to 4.0 Mc., except the 28-Mc. converter which requires that the receiver tune 3.5 to 5.2 Mc. if the entire 10-meter band is to be tuned. The 14- and 21-Mc. converters can be used to extend the tuning ranges of the two 80 40-meter receivers described earlier in this chapter. While many crystal-controlled converters use band-pass r.f. circuits that need no tuning other than the initial adjustment, the r.f. circuits of these converters are manually tuned, to give the best selectivity and image rejection. Adjustable antenna coupling is also provided, to facilitate matching to the antenna and also to extend the signal-handling capabilities.

With two exceptions, the circuits for these converters are the same, differing only in the tuning range of the signal circuits and the frequency of the crystal. The exceptions can be found in the 7- and 28-Mc. converters. In the former, the 3400-ke. crystal is fairly close to one limit of the mixer output range, so a trap is included to attenuate the 3400-ke. signal that appears in the mixer output and might tend to overload the following receiver. The other exception can be found in the 28-Mc. unit, where a switch and additional crystal were added to permit covering the 27-Mc. band. It would not be necessary if the following receiver could tune as low as 2.5 Mc., and could be omitted in such a case.

The basic circuit is shown in Fig. 5-42, with the mixer plate-circuit trap (L_6 and 15 $\mu\text{f.}$) in place but not the s.p.d.t. crystal switch for the highest-frequency converter. Following the adjustable coupling between L_1 and L_2 , the signal goes to the 6BJ6 r.f. amplifier and then to a second inductively-coupled circuit and to the grid of the mixer. The mixer is the pentode section of a 6AN8; the crystal oscillator is the triode section of the 6AN8, and part of its output is applied to the mixer cathode via a capacitance divider, C_5C_6 . By using high-frequency crystals that are

now available, no overtone oscillator circuit is required. Since the 1500-ohm cathode resistor of the mixer is the load for the oscillator, the capacitance divider, C_5C_6 , is required to avoid overloading the oscillator and consequent non-oscillation. In the oscillator in the 10/11-meter converter, a single setting of the oscillator coil, L_5 , suffices for the two crystals. In the r.f. stage, provision is included for introducing a.v.c. voltage as well as manually-controlled cathode bias.

Construction

Although these converters are shown as separate units each assembled in a $5 \times 9\frac{1}{2} \times 3$ -inch chassis, they might also be built as one large unit with sub shielding. In the design shown, and it is important in any design, particular attention was paid to see that the chassis grounds for the r.f. stage were all at one point, next to the socket. Since rather large diameter (for receivers) high-Q coils are used, a shield was used between the coils to minimize the chances for stray coupling. The shield straddles the 6BJ6 socket. The tuning capacitors, C_1 and C_3 , are ganged mechanically by a length of $\frac{1}{8}$ -inch diameter rod and two of the Millen M008 miniaturized shaft couplings. The Hammarlund MAPC-B capacitor has a standard $\frac{1}{4}$ -inch shaft at the front and a $\frac{1}{8}$ -inch shaft at the rear. To make room for the shaft couplers, two rotor and two stator plates were removed from each MAPC-35-B 35- $\mu\text{f.}$ variable.

Dimensions for the sub-chassis are shown in Fig. 5-44, as well as the location of most of the holes. Partitions A and B are held to the chassis by 6-32 hardware; partition A has mounting holes for the variable capacitor similar to those in the front view except that the two small holes are on the horizontal center line. Partition A also carries the crystal socket and two clearance holes for the stator and rotor leads from the variable capacitor. Partition B has a clearance hole for the variable capacitor shaft. The dashed hole on the front view is for the crystal switch shaft on the 10-meter converter; this switch mounts on

◆
 Fig. 5-41 — A 7-Mc. crystal-controlled converter. The two shafts extending to the right are (lower) adjustable antenna coupling and (upper) signal-circuit tuning. The crystal holder is the dark object in the center section, just behind the coils.
 ◆

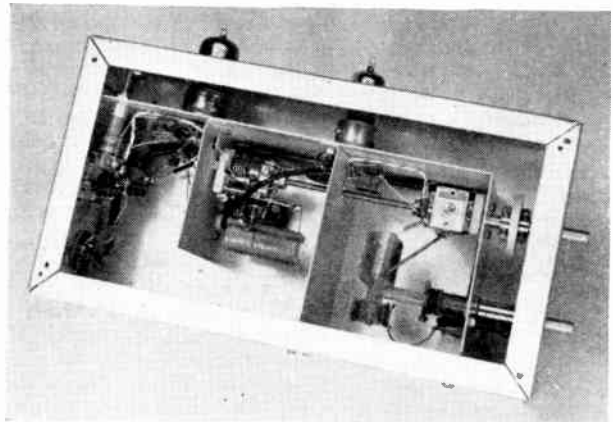

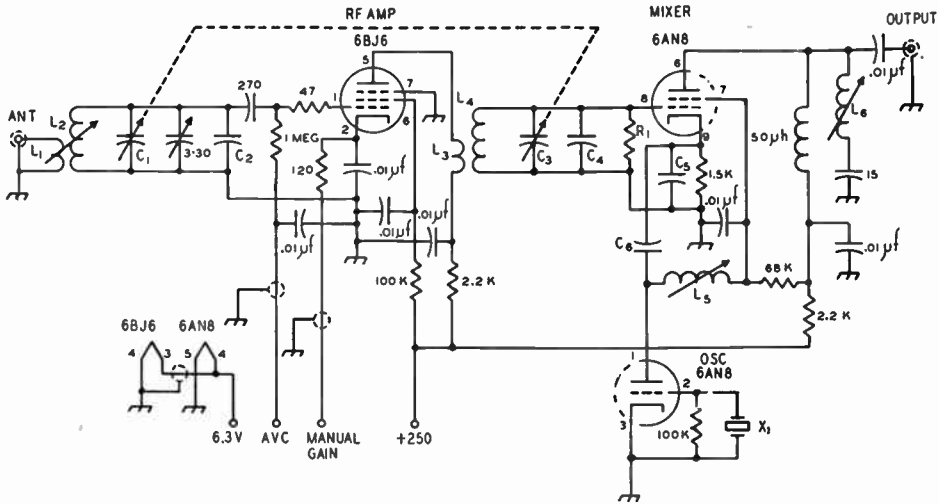

Fig. 5-42 — Schematic diagram of a crystal-controlled converter. The plate trap, L_6 and the 15- μf . capacitor, is used only in the 7-Mc. converter. The 10-meter converter uses two crystals, switched by a s.p.d.t. rotary in the "cold" lead from chassis ground.

All fixed capacitors are ceramic; all resistors are $\frac{1}{2}$ -watt.

C_1 , C_3 — 25- μf . midget variable (Hammarlund MAPC-35-B with 2 rotor and 2 stator plates removed).

L_6 — 105 — 200 μh . (North Hills Electric 120-II).

X_1 — See Table 5-III. (International Crystal, Type FA-9).

partition A and is turned by the Lucite "crankshaft" shown in Fig. 5-43. It is a simple matter to soften a length of $\frac{1}{4}$ -inch diameter Lucite rod by rolling it on a soldering iron. When it is suitably soft, it is then bent and held in position until cool. The insulating crankshaft is used to escape running metal near or through the coil. As mentioned above, it isn't necessary to switch crystals if the tuning range of the receiver following the converter includes 2.5 Mc.

The variable antenna coupling is made by running a piece of $\frac{1}{4}$ -inch Lucite rod through a shaft bushing and using a rubber grommet between fiber washers as a friction lock. A screw through the shaft serves as a stop for the washer on one side of the grommet, and the shaft bearing serves as the stop on the other. Compression is maintained by using a solid shaft coupler on the other side of the bearing. Using a long set-screw on the solid shaft coupler provides an arm that can hit either of two stops (small screws) and thus limit the travel of the coil.

In wiring a converter, shielded wire was used for the heater and d.c. leads that ran past partition A up toward the r.f. stage. The antenna lead is a length of RG-59/U coaxial cable. Input and output connections are brought to phono jacks at the rear of the unit; power and control leads are terminated in a Cinch-Jones P-304-AB plug.

Coils L_2 and L_4 are supported by No. 14 wire leads extending from the tuning capacitors. The B+ end of L_3 is cemented to the ground end of L_4 with Duco or Ambroid cement. This gives an improvement in minimizing spurious responses over that obtainable with mounting L_3 over L_4 , but on the two lower-frequency ranges it requires the use of padding capacitors, C_2 and C_4 , because otherwise the L_3L_4 assembly becomes too long. The 3- to 30- μf . compression capacitor across C_1 is mounted on the leads of the variable capacitor.

Wires from the rotors of C_1 and C_3 are brought to the grounding lugs at the sockets, in keeping with the "single stage ground" policy mentioned earlier. The lead from the stator of C_3 to Pin 8

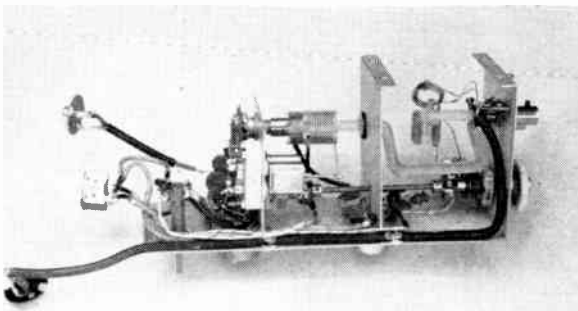

Fig. 5-43 — The 10-11-meter converter removed from its case. The Lucite "crankshaft" for switching crystals can be seen in the right-hand compartment.

TABLE 5-III
Component Values for the Crystal-Controlled Converters

Band	L_1	L_2, L_4	L_3	L_5	C_2	C_4	C_5	C_6	R_1	X_1
7 Mc.	12t ¹	28t ¹	18t ¹	9-16 μ h (120-I) ³	25 μ mf	50 μ mf	1500 μ mf	150 μ mf	47K	3.4 Mc.
14	5t ²	19t ²	15t ¹	3-5 μ h (120-B) ³	15 μ mf	25 μ mf	330 μ mf	33 μ mf	27K	10.5 Mc.
21	12t ¹	17t ²	15t ¹	2-3 μ h (120-A) ³	—	—	330 μ mf	33 μ mf	33K	17.5 Mc.
28	8t ¹	10t ²	10t ¹	2-3 μ h (120-A) ³	—	—	150 μ mf	15 μ mf	18K	11 meters: 23.4 Mc. 10 meters: 24.5 Mc.

¹ 32 t.p.i. No. 24, $\frac{5}{8}$ -inch diam. (B & W 3008).

² 16 t.p.i. No. 18, $\frac{5}{8}$ -inch diam. (B & W 3007)

³ North Hills Electric Co. designation.

of the 6AN8 is brought through a small hole in partition A.

In wiring the oscillator portion of the 6AN8, it is convenient to run a lead from L_5 to Pin 1 of the 6AN8 socket, and then mount C_5 , C_6 and the 1500-ohm cathode resistor on the socket pins and the chassis grounding lug. There are two unused soldering lugs on L_5 , and one of these is used as the junction point for the 68,000-ohm resistor, the 2200-ohm resistor, the 50- μ h. r.f. choke and the .01- μ f. capacitor.

Adjustment

The first step in checking a converter, after the wiring has been checked and a power supply and receiver have been connected, is to check the oscillator and mixer. With only the 6AN8 in its socket, turn on the power and look around the crystal frequency with your receiver to see if the crystal oscillator is working, as indicated by a strong signal. If the oscillator doesn't work, tune L_5 until it does. Then put the receiver in the range 3.5 to 4.0 Mc. and tune C_3 . At some setting you should hear an increase in noise, indicating that the mixer input circuit is tuned to resonance. If the increase in noise is quite sharp, it indicates regeneration in the mixer, and the value of R_1 should be reduced. This mixer-oscillator combination is basically regenerative, and with R_1 re-

moved the mixer will oscillate.

Under normal operation of the mixer and oscillator, the voltage at Pin 7 will run around 50 to 60 volts, and around 3 volts at Pin 9.

When the 7-Mc. converter is being tested, the following receiver can be tuned to 3.4 Mc., where the loud signal from the crystal oscillator will be received. The slug in L_6 is then tuned for minimum signal in the receiver. Don't expect this minimum to be around S_1 or S_2 — it may still be enough to "pin the meter" with the receiver gain wide open.

Leave the ganged capacitors C_1 and C_3 at the setting that gave the noise peak, connect a 2500-ohm wire wound potentiometer in the manual gain circuit to chassis ground, short the AVC connection to chassis, and plug in the 6BJ6. Connect an antenna and, with the gain control at maximum gain (minimum resistance), adjust the compression trimmer across C_1 for maximum noise. The two circuits are now tracking and should tune together over the band. Tuning 3.5 to 4.0 Mc. with the receiver should now bring in signals from the band for which the converter is designed. Loosening the antenna coupling by swinging L_1 away from L_2 should reduce the strength of incoming signals. If it doesn't, or if the sharpness of C_1C_3 tuning changes with the gain-control setting, it indicates that the r.f. stage is regenerative. You shouldn't have any trouble with a regenerative r.f. stage, however, if the stage grounds are brought to one point on the

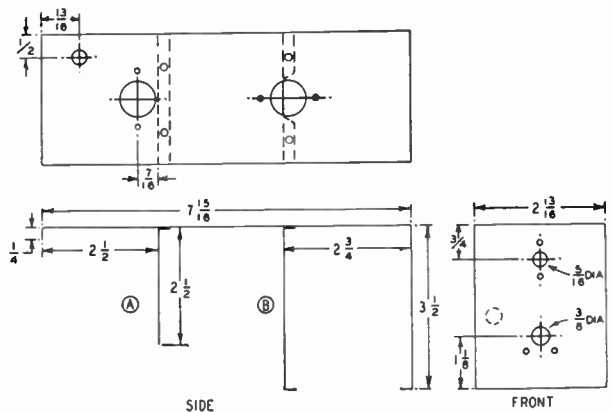

Fig. 5-11 — Details of the sub chassis and partitions. The bottom lips of the front and of piece B rest on $\frac{1}{4}$ -inch bars at the bottom.

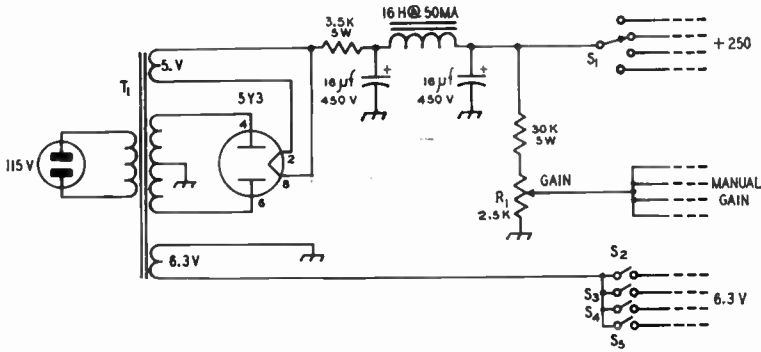

Fig. 5-45 — Schematic of a power supply for the crystal-controlled converters. If the power supply is to be used with only one converter, the switches can be eliminated from the circuit.

R₁ — Wire-wound potentiometer (IRC WK2500).

S₁ — 2-section 4-pole rotary switch. Sections not shown switch antenna inputs and converter outputs through coaxial line. (Centralab PA-2015, one

pole not used).

L₁ — Replacement-type choke (Knight 62 G 137).

T₁ — Replacement-type transformer, 325-0-325 v. (Knight 62 G 042).

chassis, as mentioned earlier.

To get a wide range of gain control from the 2500-ohm gain control, a bleed current of 8 or 9 ma. should pass through it. A typical power supply and gain-control circuit is shown in Fig. 5-45, although this is more elaborate than necessary if only one converter is used. Where only one converter is used, the switches can be eliminated, and a smaller transformer can be used for T₁. They are all included in the unit shown in Fig. 5-46, which was designed to take four converters. In this unit S₁ is a 3-section rotary switch that switches the plate power as shown in Fig. 5-45 in one section, the antenna inputs in the second section, and the converter outputs in the third section. Converters that are to be used during an operating period have their heater power applied through the appropriate toggle switch, S₂ through S₅. It is not necessary to switch the gain control or a.v.c. leads, because only one converter will be working at a time, as selected by S₁. An arrangement like this permits keeping all converters warm during a contest, or the use of only one during casual operation. It also permits the ready comparison of two converters on the same band (if some later developments show up or if

you want to compare different circuits), and if the two crystals are on the same frequency no retuning of the following receiver will be required.

These converters have very low response to the r.f. image frequency, and no trouble with images should be encountered. It is possible that under some circumstances you may hear 80-meter signals when you are using a converter, and this is usually an indication of a poorly-shielded receiver or a faulty installation. The receiver should have no response to 80-meter signals when no antenna is connected to it — if it has, it indicates that better shielding is required — and it should have no response to 80-meter signals when the cable used for connecting the converter to the receiver is connected to the receiver and left open at the converter end. Good shielded wire or coaxial cable (RG-58/U or RG-59/U) should be used between converters and receivers, and a minimum of inner conductor should be exposed at the receiver antenna posts. The outer conductor or shield should connect to the ground terminal at the receiver and to one of the antenna posts, and the inner conductor should connect to the other antenna post.

Fig. 5-46 — Several crystal-controlled converters can be installed on a chassis with a common power supply. Here the 20- and 15-meter converters are shown in place. On the panel, the lower left-hand knob is the common gain control, and the right-hand knob controls the switch that selects the converter to be used. The toggle switches control the heater circuits separately.

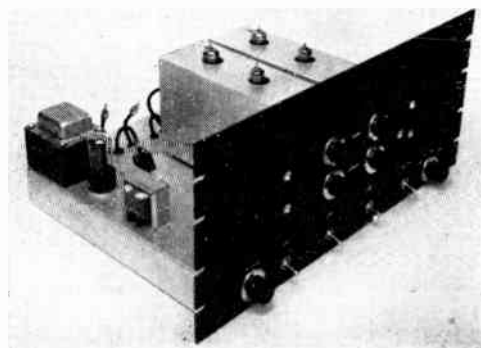

Variable-Coupling Antenna Tuning Unit

A variable-coupling antenna tuning unit connected between antenna and receiver is useful for three reasons. In many instances it will improve reception slightly by providing a better match between antenna and receiver. Where trouble from r.f. images is encountered, as is often the

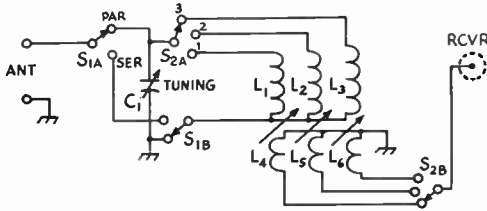

Fig. 5-47 — Schematic of the variable-coupling antenna tuning unit.

C₁ — 140- μ mf. midget variable (Hammarlund HF-110).
S₁, S₂ — 2-pole miniature rotary switch (Centralab PA-2003).

L₁ — 72 turns (2 $\frac{1}{4}$ inches).
L₂, L₄ — 20 turns ($\frac{5}{8}$ inches).
L₃ — 4 turns ($\frac{1}{8}$ inches).
L₅ — 12 turns ($\frac{5}{8}$ inches).
L₆ — 2 turns.

All coils 1-inch diameter 32 turns per inch (B & W 3016).

case on the higher frequencies with simple receivers, an antenna unit will provide additional selectivity. The unit shown on this page improved image rejection 15 db. at 10 Mc. and 12 db. at 25 Mc. in a typical case. The third useful feature of this unit is the variable coupling, which provides an auxiliary gain control that is useful on strong local signals as well as permitting a wide range of matching.

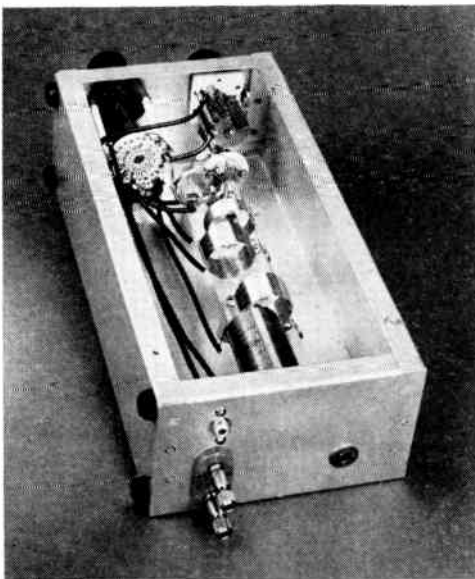

Fig. 5-48 — View inside the case of the antenna tuning unit. The input terminals are a National FWH strip, and the output jack is a shielded phono jack.

As can be seen in Fig. 5-47, the unit provides for series or parallel tuning of the tuned circuit, bandswitching over the range 1.8 to 30 Mc. Band 1 tunes 1.8 to 4.9 Mc., Band 2 covers 4.9 to 13 Mc., and Band 3 tunes 12 to 30 Mc.

The antenna tuning unit is built in a 3 \times 10 \times 5-inch aluminum chassis. To aid in shielding, a side plate for the box is made from a piece of flat aluminum stock. The four operating controls are mounted on one end of the box with the antenna terminal and output jack on the other. Three coils, L₁, L₂ and L₃, are bonded to a lucite bar with Duco cement, and the bar is in turn supported by three ceramic cone insulators. The three coils should be spaced about one coil diameter from each other and from the ends of the box. Three variable coupling links, L₄L₅L₆,



Fig. 5-49 — Front view of the antenna tuner.

are soldered to small machine screws that have been bolted to a length of $\frac{1}{4}$ -inch diameter lucite rod. The rod extends the full length of the box and is supported at the ends by a bushing and a panel bearing. An insulated coupling is used to join the panel bearing shaft and the lucite rod. Connections to the links are made by soldering the leads to the machine screws in the rod. The "panel" end of the box can be finished off with decals indicating the knob functions.

In operation, the tuner is connected between the antenna and the receiver. With some antenna systems the parallel connection will give the better results, while with other antennas and other frequencies the opposite will be true. It is a simple matter to switch between the two conditions and see which gives the sharper peak or louder signals at resonance.

An Antenna-Coupling Unit for Receiving

It will often be found advantageous on the 14- and 28-Mc. bands to tune (or match) the receiving-antenna feed line to the receiver, in order to get the most out of the antenna. One way to do this is to use, in reverse, any of the line-coupling devices advocated for use with a transmitter. Naturally the components can be small, because the power involved is negli-

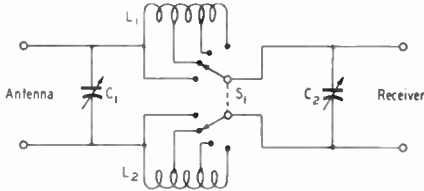

Fig. 5-50 — Circuit diagram of the coupling unit.

- C₁ — 110- μ mf. midget variable (Millen 22140).
- C₂ — 100- μ mf. midget variable (Millen 22100).
- L₁, L₂ — 25 turns No. 26 d.c.c. space-wound to occupy 1 inch on 1-inch diameter form (Millen 45000), tapped at 3, 7, 12 and 18 turns.
- S₁ — 2-circuit 5-position single-section ceramic wafer switch (Mallory 173C).

ble, and small receiving capacitors and coils are quite satisfactory. Some provision for adjustable coupling is recommended, as in the transmitting case, because the signal-to-noise ratio at 14 and 28 Mc. is dependent, to a large extent, on the degree of coupling to the antenna system. The tuning unit can be built on a small chassis located near the receiver, or it can be mounted on the wall and a piece of RG-59/U run from the unit to the receiver input, in the manner of a link line in transmitting practice. For ease in changing bands, the coils can be switched or plugged into a suitable socket. Adjustable coupling not only offers an opportunity to adjust for best signal-to-noise ratio, but the coupling can be decreased when a strong local

signal is on the air, to eliminate "blocking" and cross-modulation effects in the receiver.

One convenient type of antenna-coupling unit for receivers uses the familiar pi-section filter circuit, and can be used to match a wide range of antenna impedances. The diagram of a compact unit of this type is shown in Fig. 5-50. Through proper selection of capacitors and inductances, a match can be obtained over a wide range of values. The device can be placed close to the receiver and left connected all of the time, since it will have little or no effect on the lower frequencies. A short length of 300-ohm Twin-Lead is convenient for connecting the antenna coupler to the receiver.

The antenna coupler is built in a 5 × 7 × 2-inch metal chassis. All of the components except the two coils are mounted on the front and rear faces. The capacitors are mounted off the panel by the spacers furnished with the capacitors, and a clearance hole for the shaft prevents any short-circuit to the panel. The coils, wound on Millen 45000 phenolic forms, are fastened to the chassis with brass screws, and the coils should be wound on the forms as far away as possible from the mounting end. The switch should be wired so that the switching sequence puts in, in each coil, 3 turns, 7 turns, 12 turns, 18 and 25 turns.

The unit is adjusted for maximum signal by switching to different coil positions and adjusting C₁ and C₂. It will not be necessary to retrim the capacitors except when going from one end of a band to the other, and when the unit is not in use, as on 7 and 3.5 Mc., the coils should be set at the minimum number of turns and the capacitors set at minimum. The small reactances remaining have a negligible effect. The coil in the grounded side should be shorted if coaxial-line feed is used.

Fig. 5-51 — A compact coupling network for matching a balanced line to the receiver on 14 and 28 Mc.

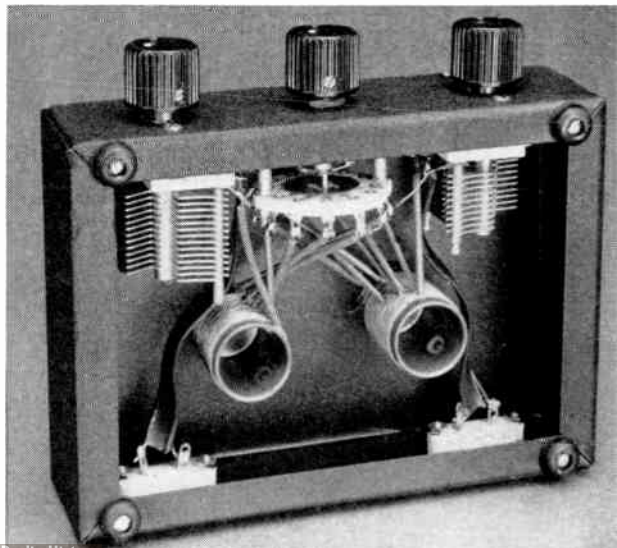

The "Selectoject"

The Selectoject is a receiver adjunct that can be used as a sharp amplifier or as a single-frequency rejection filter. The frequency of operation may be set to any point in the audio range by turning a single knob. The degree of selectivity (or depth of the null) is continuously adjustable and is independent of tuning. In phone work, the rejection notch can be used to reduce or eliminate a heterodyne. In c.w. reception, interfering signals may be rejected or, alternatively, the desired signal may be picked out and amplified. The Selectoject may also be operated as a low-distortion variable-frequency audio oscillator suitable for amplifier frequency-response measurements, modulation tests, and the like, by advancing the "selectivity" control far enough in the selective-amplifier condition. The Selectoject is connected in a receiver between the detector and the first audio stage. Its power requirements are 4 ma. at 150 volts and 6.3 volts at 0.6 ampere. For proper operation, the 150 volts should be obtained from across a VR-150 or from a supply with an output capacity of at least 20 μ f.

The wiring diagram of the Selectoject is shown in Fig. 5-52. Resistors R_2 and R_3 , and R_4 and R_5 , can be within 10 per cent of the nominal value but

they should be as close to each other as possible. An ohmmeter is quite satisfactory for doing the matching. One-watt resistors are used because the larger ratings are usually more stable over a long period of time.

If the station receiver has an "accessory socket" on it, the cable of the Selectoject can be made up to match the connections to the socket, and the numbers will not necessarily match those shown in Fig. 5-52. The lead between the second detector and the receiver gain control should be broken and run in shielded leads to the two pins of the socket corresponding to those on the plug marked "A.F. Input" and "A.F. Output." If the receiver has a VR-150 included in it for voltage stabilization there will be no problem in getting the plate voltage — otherwise a suitable voltage divider should be incorporated in the receiver, with a 20- to 40- μ f. electrolytic capacitor connected from the +150-volt tap to ground.

In operation, overload of the receiver or the Selectoject should be avoided, or all of the possible selectivity may not be realized.

The Selectoject is useful as a means for obtaining much of the performance of a crystal filter from a receiver lacking a filter.

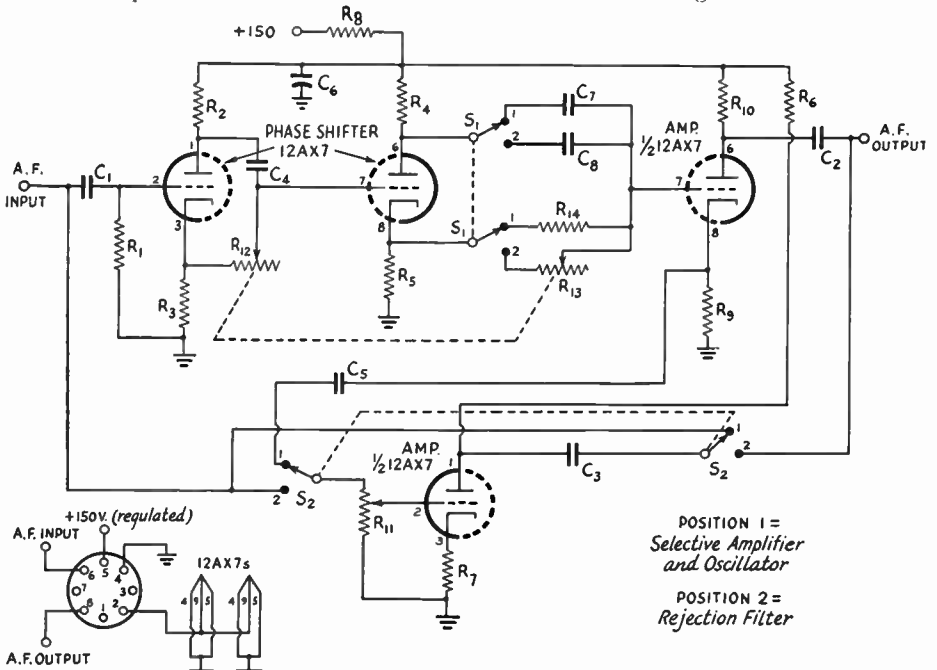

Fig. 5-52 — Complete schematic of Selectoject using 12AX7 tubes.

- C_1 — 0.01- μ f. mica, 400 volts.
- C_2, C_3 — 0.1- μ f. paper, 200 volts.
- C_4, C_8 — 0.002- μ f. paper, 400 volts.
- C_5 — 0.05- μ f. paper, 400 volts.
- C_6 — 16- μ f. 150-volt electrolytic.
- C_7 — 0.0002- μ f. mica.
- R_1 — 1 megohm, $\frac{1}{2}$ watt.
- R_2, R_3 — 1000 ohms, 1 watt, matched as closely as possible (see text).
- R_4, R_5 — 2000 ohms, 1 watt, matched as closely as possible (see text).

- R_6 — 20,000 ohms, $\frac{1}{2}$ watt.
- R_7 — 2000 ohms, $\frac{1}{2}$ watt.
- R_8 — 10,000 ohms, 1 watt.
- R_9 — 6000 ohms, $\frac{1}{2}$ watt.
- R_{10} — 20,000 ohms, $\frac{1}{2}$ watt.
- R_{11} — 0.5-megohm $\frac{1}{2}$ -watt potentiometer (selectivity).
- R_{12}, R_{13} — Ganged 5-megohm potentiometers, standard audio taper (tuning control).
- R_{14} — 0.12 megohm, $\frac{1}{2}$ watt.
- S_1, S_2 — D.p.d.t. toggle (can be ganged).

A Clipper/Filter for C.W. or Phone

The clipper/filter shown in Fig. 5-54 is plugged into the receiver headphone jack and the headphones are plugged into the limiter, with no work required on the receiver. The limiter will cut down serious noise on phone or c.w. signals, it will keep the strength of c.w. signals at a constant level, and it will add selectivity to your receiver for c.w. reception. It will do much to relieve the operating fatigue caused by long hours of listening to static crashes, key clicks encountered on the air and with break-in operation, and the like.

There are times when the best results are secured with the selective audio circuit following the clipper. On other occasions it is better to have the selectivity precede the clipper. Since it is a simple matter to provide a switching arrangement so that either combination, clipper-to-filter or filter-to-clipper, can be used at will, this has been done in the unit described here.

The frequency response of the selective circuit reaches a peak at about 900 cycles and has a null at about 1800 cycles. The peak frequency is determined by the combined values of L_1 , C_1 , and C_2 , while the notch frequency is that of the parallel-resonant circuit L_1C_1 . If different peak and null frequencies are desired the values of C_1 and C_2 can be changed; for raising the notch frequency the capacitance of C_1 should be made smaller; to raise the peak frequency reduce the capacitance at C_2 .

The rotary switch S_1 (Fig. 5-53) is used to

provide different combinations of the clipper and filter. To simplify the wiring diagram the switching circuit is shown separately in the diagram.

The filter-clipper is built on a $5 \times 5\frac{1}{2}$ inch aluminum chassis with a two-inch lip. This is secured to the front panel by the two potentiometers and rotary switch S_1 . A $6 \times 6 \times 6$ -inch steel cabinet encloses the unit. Steel is preferable to aluminum because L_1 is sensitive to stray magnetic fields (which would show up as hum at the output) and the steel cabinet aids in shielding. The aluminum chassis is mounted in a vertical position with the transformers and tubes on one side and rotary switch and small components on the other. One layout precaution should be observed: Place the filter inductor L_1 as far as possible from the power transformer, and mount the two units with their cores at right angles. This will minimize hum pickup by the inductor.

Before mounting L_1 , it will be necessary to remove the mounting frame and the "I" laminations. The frame is removed easily by prying out its two legs and then lifting it from the core. The "I" laminations are in the form of a bar lying across the top of the "E" core.

By mounting the choke with a nonmetallic strap the Q will remain high. Use a strip of heavy cardboard cut to the same width as the core, about $\frac{5}{8}$ inch, as a clamp for mounting the inductor. The cardboard clamp is fastened to the chassis with two $\frac{5}{8}$ -inch square aluminum

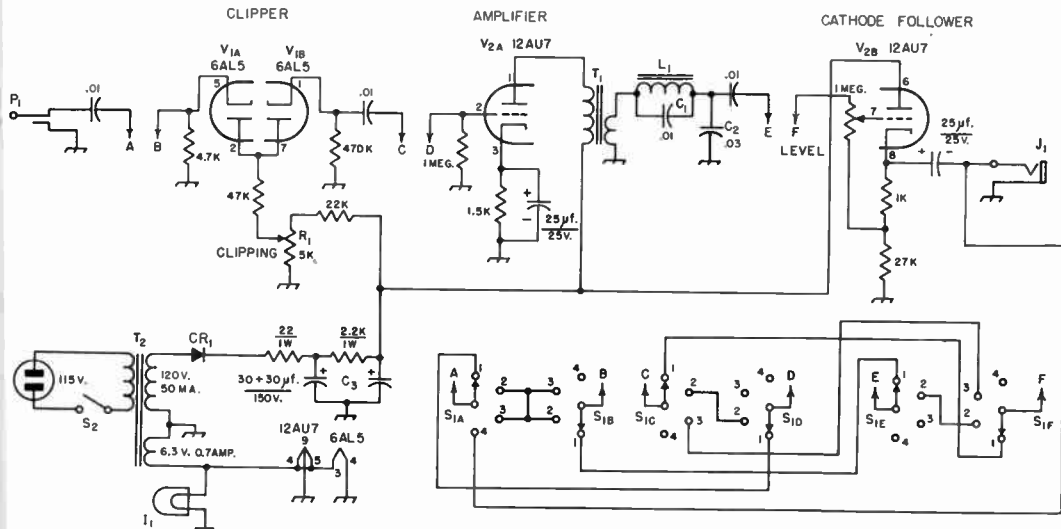

Fig. 5-53—Schematic diagram of the clipper-filter. Switch positions are: 1. Filter-clipper. 2. Clipper-filter. 3. Clipper. 4. Straight through. Resistors are $\frac{1}{2}$ watt unless otherwise specified; capacitances are in μf ; 0.01- μf capacitors not listed below are ceramic.

- C_1 — 0.01 plastic tubular capacitor (Sprague Telecap).
 - C_2 — 0.03 plastic tubular capacitor (Sprague Telecap).
 - C_3 — Dual section 30–30 μf . 150-volt electrolytic (Sprague TVA 2134).
 - CR1 — Selenium rectifier, 50 ma. (Federal 1224).
 - I_1 — 6.3-volt pilot light, 60 ma.
 - J_1 — Open-circuit phone jack.
 - L_1 — Filter choke, 5 h. 65 ma. (Thordarson 20C59).
- Modified; see text.

- P_1 — Phone plug.
- S_1 — 6-pole, 4-position, 3-section rotary switch (Centralab PA-1020).
- S_2 — S.p.s.t. toggle.
- T_1 — Output transformer 7000–10,000-ohm pri., 3.2-ohm sec. (Thordarson 24S52).
- T_2 — Power transformer 120 v. 50 ma.; 6.3 v. 0.7 amp. (Thordarson 26R32).

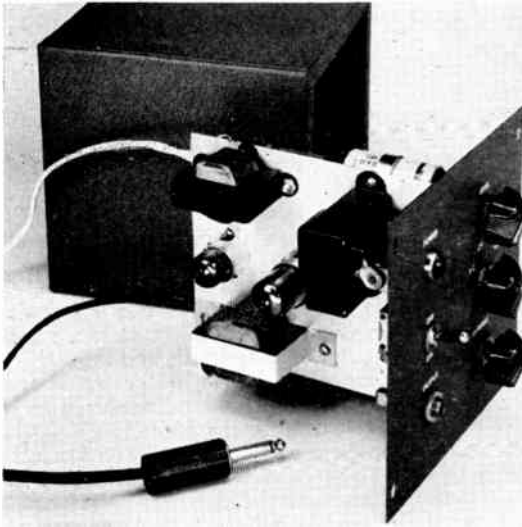

Fig. 5-54—A view of the filter-clipper removed from its case. Plug P_1 is in the foreground. Note the method of mounting choke L_1 , which is placed at right angles to the power transformer T_2 .

washers that can be cut from a piece of scrap. It is very important that the clamp be nonmetallic. If aluminum or other nonmagnetic materials are used the Q will be adversely affected and the selectivity of the filter will suffer.

The switch wiring shown at the bottom of the schematic diagram can be done before mounting S_1 in place. After the switch is mounted the wiring between it and the other components can be completed.

Apply power by closing S_2 , insert plug P_1 in the receiver phone jack and turn switch S_1 to the "out" or straight-through position. Tune the receiver until a c.w. signal is found and adjust the receiver controls for comfortable copying.

Now turn S_1 to the "clipper" position. In order to become familiar with the action of the clipper these steps should be followed: Adjust the "clipping" control so no clipping occurs (maximum positive bias on the diode plates). Set the "level"

control on the unit so that there will be no apparent change in the strength of the c.w. signal when switching from "clipper" to "out" and back to "clipper." Then turn the "clipping" control until the positive bias is low enough to cause limiting to start; the point at which limiting begins can be recognized by the fact that the signal strength begins to decrease. Back off slightly with the "clipping" control so that the signal strength in the phones is just at the original level.

Tuning the receiver without the use of the limiter shows signals of all strengths, some so loud as to be ear-breaking; but switching to "clipper" will make these big ones drop down to the "comfortable" preset level.

It should not take long to become familiar with use of this unit. However, there are many applications for the clipper-filter which can only be discovered by actual use. The "clipper-to-filter" position is best suited where the audio selectivity is required and a high level of ignition noise is encountered. However, where impulse noise is not a factor the "filter-to-clipper" position is best. Because of the saturation characteristic of limiters, a strong signal being received along with a weak one has the tendency to take command, making it impossible to copy the weaker one. By using the selective audio filter first, peaking up a weak desired signal and attenuating strong interfering ones, the desired signal takes command in passing through the limiter, and can be copied over the interference.

In order to peak a desired signal the receiver b.f.o. or tuning control should be adjusted so the pitch of the signal is 900 cycles. Since the selectivity curve is rather sharp, any adjacent undesired signals will fall short of the peak and be attenuated. If the receiver b.f.o. has sufficient range to tune 900 cycles or more on both sides of zero beat, the undesired signal can always be placed on the notch side of the peak.

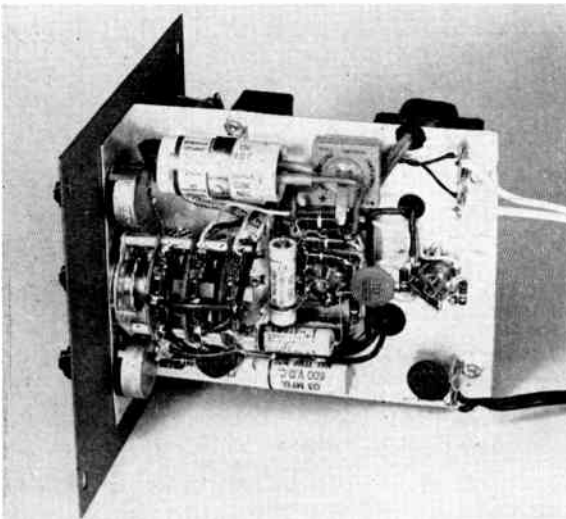

Fig. 5-55—Side view of the unit. Switch S_1 is located at the front center with the filter capacitor C_3 above it. Leads running away from the unit are the a.c. line cord and the cord for plug P_1 .

A Regenerative Preselector for 7 to 30 Mc.

The performance of many receivers begins to drop off at 14 Mc. and higher. The signal-to-noise ratio is reduced, and unless double conversion is used in the receiver there is likely to be increased trouble with r.f. images at the higher frequencies. The preselector shown in Figs. 5-56 and 5-58 can be added ahead of any receiver without making any changes within the receiver, and

through the use of the preselector.

A 6AN8 triode-pentode is used in the preselector, the pentode as a band-switch regenerative r.f. stage and the triode as a cathode follower. The conventional screen-grid neutralizing circuit is used; by upsetting this circuit enough the stage can be made to oscillate. Smooth control of regeneration up to this point is obtained

◆
 Fig. 5-56 — A regenerative preselector for 7 to 30 Mc. This unit can be used ahead of any receiver to add gain and image rejection; its effect will be most marked with receivers that fall off in performance at the higher frequencies. Adjustable antenna coupling is obtained by supporting the antenna coils on an insulated rod that is controlled from the panel.
 ◆

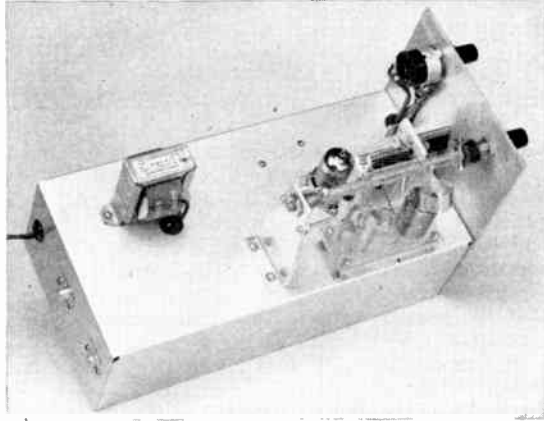

a self-contained power supply eliminates the problem of furnishing heater and plate power. The poorer the receiver is at the higher frequencies, the more it will benefit by the addition of the preselector. A truly good receiver at 28 Mc. would show little or no improvement when the preselector was added, but a mediocre receiver or one without an r.f. stage will be improved greatly

by varying one of the capacitances in the neutralizing circuit. To handle a wide range of antenna impedances, adjustable antenna coupling is included, while cathode bias control of the pentode allows the gain to be reduced if and when it becomes necessary to do so. One position of the bandswitch permits straight-through operation, so the preselector unit can be left connected to

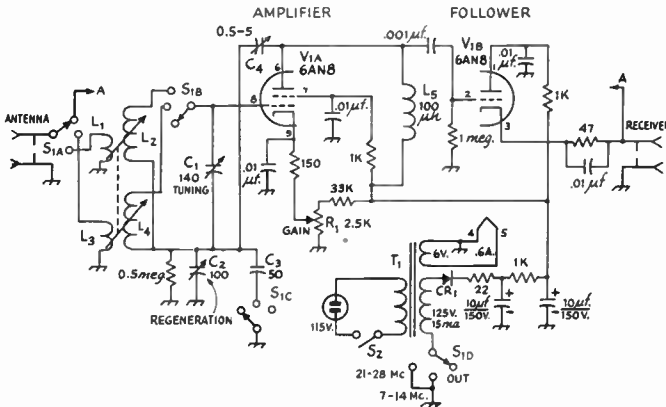

Fig. 5-57 — Schematic diagram of the regenerative preselector. Capacitances are in $\mu\text{f.}$ unless otherwise specified. Resistors are $\frac{1}{2}$ -watt unless otherwise specified.

- C₁ — 140- $\mu\text{f.}$ variable capacitor (Hammarlund IIF-140).
- C₂ — 100- $\mu\text{f.}$ variable capacitor (Hammarlund MAPC-100-B).
- C₃ — 50- $\mu\text{f.}$ mica (see text).
- C₄ — 0.5 to 5- $\mu\text{f.}$ tubular trimmer (Eric 532-08-OR5).
- CR₁ — 50-ma. selenium rectifier (International Rectifier RSO50).
- L₁ through L₄ made of No. 20, $\frac{3}{4}$ inch diam., 16 turns per inch (B & W 3011 Miniductor)
- L₁ — 2 turns.
- L₂ — 5 turns.

- L₃ — 7 turns.
- L₄ — 19 turns.
- L₅ — 100- $\mu\text{h.}$ r.f. choke (National R-33 100 $\mu\text{h.}$)
- R₁ — 2500-ohm potentiometer (Mallory U7).
- S_{1A}, S_{1B} — 1-pole 3-position wafer (Centralab PA-1).
- S_{1C-D} — 2-pole 3-position wafer (Centralab PA-3). See text for switch assembly instructions on indexing head (Centralab PA-301).
- S₂ — S.p.s.t. switch, part of R₁ (Mallory US-26).
- T₁ — 125 volts at 15 ma., 6.3 volts at 0.6 amp. (Stancor PS-8115).

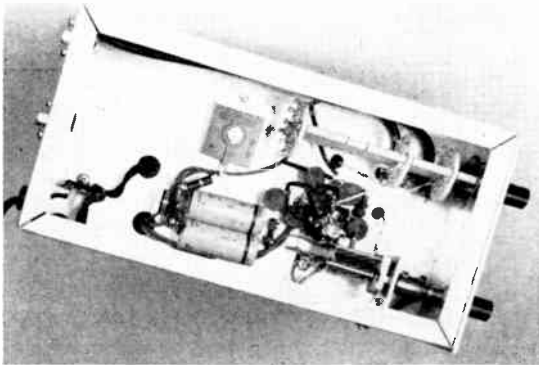

Fig. 5-58—The r.f. components are bunched around the tube socket. Power supply components are supported by screws and tie points.

the receiver even during low-frequency reception.

The preselector is built on a $5 \times 10 \times 3$ -inch chassis (Bud AC-404). A $5 \times 6\frac{1}{2}$ -inch aluminum panel is held to the chassis by the regeneration and bandswitch controls. Coils L_2 and L_4 are supported on a small staging of $1\frac{1}{4} \times 3$ -inch clear plastic. (It can be made from the lid of the box that the Sprague 5GA-S1 .01- μ f. disk ceramic capacitors come in.) All coils can be made from a single length of B&W 3011 Miniductor; L_4 is brought to the proper height by removing turns but retaining the plastic support bars. The coils are cemented to the plastic staging with Duco cement. The links L_1 and L_3 are moved by means of a 6-inch length of $\frac{1}{4}$ -inch diameter lucite rod; the rod is supported at each end by panel bushings, and a friction lock is provided by washers and a rubber grommet. A screw through the lucite shaft and two others in the end bracket provide stops that limit the antenna coil rotation to 45 degrees.

The rotor of C_1 must be insulated from the chassis, and its shaft is extended through the use of an insulated extender shaft (Allied Radio No. 60 H 355). The bandswitch S_1 is made from the specified sections (see Fig. 5-57). The first section is spaced $\frac{3}{4}$ inch from the indexing head, there is 1-inch separation between this and the next section (S_{1B}), and the next section (S_{1C} , S_{1D}) is spaced $2\frac{1}{2}$ inches from S_{1B} .

The regeneration control, C_2 , is mounted on a small aluminum bracket. Its shaft does not have to be insulated from the chassis, so an insulated or solid shaft connector can be used. The small neutralizing capacitor, C_4 , is supported by soldering one lead of it to a stator bar of C_2 and running a wire from the other lead to pin 6 of the tube socket. The rotor and stator connections from C_1 are brought through the chassis deck through small rubber grommets.

Power supply components, resistors and capacitors are supported by suitable lugs and tie points. The selenium rectifier is held by the same screw that secures the link supporting bracket. Phono plugs are used for the input and output jacks.

The leads to R_1 are run up through the deck in shielded wire. Switch S_2 , part of the R_1 assembly, can be connected with ordinary wire.

Adjustment

Assuming that the wiring is correct and that the coils have been constructed properly and cover the required ranges, the only preliminary adjustment is the proper setting of C_4 . Connect an antenna to the input jack and connect the receiver to the output jack through a suitable length of RG-59/U. Turn on the receiver b.f.o. and tune to 28 Mc. with S_1 in the OUT position. Now turn S_1 to the 21- to 28-Mc. range, and set the GAIN and ANTENNA COUPLING controls to maximum (R_1 arm at ground end and L_2 close to L_4). Swing the TUNING capacitor and listen for a loud rough signal which indicates that the preselector is oscillating. If nothing is heard, advance the regeneration control toward the minimum capacitance end and repeat. If no oscillation is heard, it may be necessary to change the setting of C_4 . Once the oscillating condition has been found, set the regeneration control at minimum capacitance and slowly adjust C_4 until the preselector oscillates only when the regeneration control is set at minimum capacitance. You can now swing the receiver to 21 Mc. and peak the preselector tuning capacitor. It will be found that the regeneration capacitance will have to be increased to avoid oscillation.

Check the performance on the lower range by tuning in signals at 14 and 7 Mc. and peaking the preselector. It should be possible to set the regeneration control in these two ranges to give both an oscillating and a non-oscillating condition of the preselector. If it is not possible, a different value may be required at C_3 .

A little experience will be required before you can get the best performance out of the preselector. It will be found, for example, that loosening the antenna coupling when the preselector is close to oscillation will bring it into oscillation, which will then require backing off on the regeneration control. This is perfectly normal. Reducing the tube gain by changing the setting of R_1 will also reduce the regeneration, and the gain control will probably only require touching in the presence of extremely strong signals. Strong signals can also be held down by reducing the antenna coupling, but this will require backing off on the regeneration control.

A Selective I.F. Amplifier for Phone and C.W.

The i.f. amplifier shown in Figs. 5-59 and 5-62 operates at a frequency of 2.215 Mc. High selectivity is obtained through the use of commercially-available band-pass crystal filters that have selectivity characteristics similar to lower-frequency devices. A high-frequency i.f. amplifier of this type retains the advantage of a high-frequency first i.f. (good image rejection), overcomes some of the disadvantages of multiple conversion (spurious signals, cross modulation) and retains the advantages of high adjacent-channel selectivity heretofore obtained only through multiple conversion. An a.v.c. circuit that works well on s.s.b. and c.w. is included, together with an audio limiter for noise reduction.

The i.f. amplifier is designed for both phone and code reception; you can save the price of one filter if you're a phone or code specialist by using just one filter. The broad filter is the first element in the i.f. (following a coupling device), and this is followed by the sharp filter, which can be switched in or out. Following the filters there is a two-stage i.f. amplifier that feeds a product detector for heterodyne reception or a diode detector for a.m. work. The detector output is then amplified after passing through an adjustable clipper circuit. The a.v.c. amplifier is taken off through a separate i.f. amplifier after the first stage because it was found that getting any closer to the detector allows a little b.f.o. voltage to leak into the a.v.c. circuit. A buffer stage is used between the b.f.o. and product detector so that the b.f.o. can be run at low input and consequent low drift.

The broad filter has a band width of 2800 cycles at -6 db. and 9.5 kc. at -60 db., giving it an excellent characteristic for phone work. The sharp filter has a band width of 220 cycles at -6 db. and just over 1 kc. at -60 db., which is about as sharp as can be used for code.

The schematic diagram of the i.f. amplifier up to the audio amplifier is shown in Fig. 5-60. The intent is to take the input signal from the plate circuit of a mixer stage (high impedance) into the broad filter at 4000 ohms. The input tuning coil, L_1 , is adjusted to resonate at 2.215 Mc. with the fixed capacitor C_1 and the capacitance of the length of connecting coaxial line connected to J_1 . Since the impedance of this resonant circuit (in shunt or not with the mixer output circuit, depending upon how you utilize the amplifier) may not be known with decent accuracy, provision for impedance matching is included by using the 3- to 30- μf . adjustable trimmer. To go from 4000 to 300 ohms between the two filters, an L section is used, consisting of the 68- μf . capacitor and the 75- μh . inductor. (The computed value of capacitance is 63 μf ., but 68 μf . is close enough.) To step up the impedance level at the grid of the first i.f. stage, a tapped circuit is used. The capacitance divider uses 150 and 1200 μf . These values are based on a coil Q of 60, the measured Q of the coil specified. The larger capacitor calculates to 1350 μf . but 1200 μf . is close enough. If it is decided to eliminate one crystal filter, or to install it later, you can simply add a jumper where the filter terminals would have been.

It is worthwhile to use as good a first i.f. tube

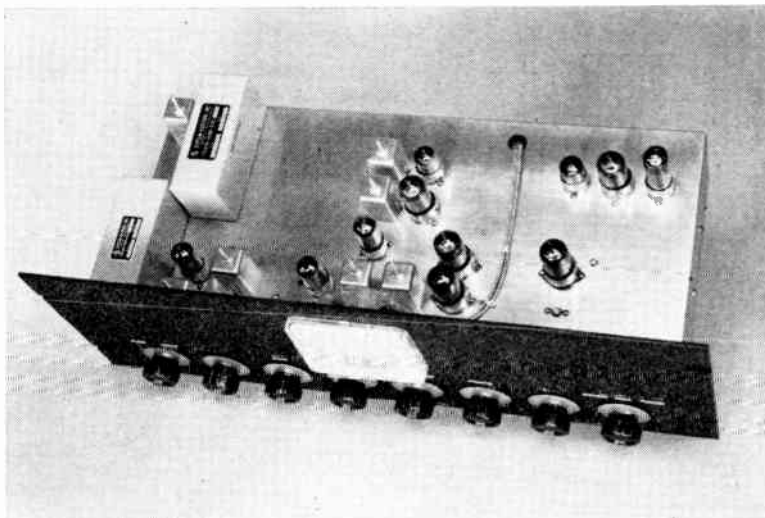

Fig. 5-59 — This i.f. amplifier uses cascaded band-pass crystal filters at 2.2 Mc. The filters are at the left of the chassis. Moving from left to right near the front of the chassis, the tubes are 6AH6 i.f., 6BJ6 i.f., two 12AU7 detector tubes and the 6L8 b.f.o. Moving back from the S meter, the a.v.c.-circuit tubes are 6BJ6 amplifier, 12UA7 and 6AL5. The remaining tubes at the rear right are 6AL5 limiter, 12AU7 audio and 6AR5 audio. The shielded leads on the top of the chassis run to the S meter.

Panel controls, from left to right, are selectivity switch, limiter set, gain control, a.v.c. switch, a.m.-s.s.b. switch, audio volume, b.f.o. pitch, and speaker/headphones switch. The b.f.o. trimmer shaft is in front of the 6L8.

as possible, because if the gain ahead of this stage isn't high enough there can be some degrading of the over-all noise figure. This is the reason a 6AH6 is used in the first i.f. stage instead of a 6BJ6. Since the selectivity has already been determined by the crystal filter(s), there is no need for additional selectivity in the i.f. amplifier, and a single tuned circuit is used for coupling between first and second i.f. stages. The switch that shifts the signal to either of the detectors, S_3 , also switches the b.f.o. on (S_{3D}), selects the output (S_{3C}), and shifts the a.v.c., when on, from the "hang" type for heterodyne reception to the more conventional type for a.m. (S_{3B}).

In the "hang" a.v.c. circuit, an incoming signal will be rectified by V_{4A} and develop a voltage across the 6.8-megohm resistor. This voltage is applied to the grid of V_{4B} . A voltage is also developed across the 470K load resistor of V_{3A} ; this is the voltage used for a.v.c. control. Through V_{5B} , the a.v.c. voltage is used to charge up the 0.05- μ f. capacitor in the a.v.c. line; this can be done quickly because V_{5B} has relatively little

resistance. When the signal is removed, the only discharge path for the 0.05- μ f. capacitor is through V_{4B} . By virtue of the 0.1- μ f. capacitor across the 6.8-megohm load for V_{4A} , V_{4B} will remain at cut-off potential for a noticeable portion of a second, and the a.v.c. will "hang" at a given value until V_{4B} becomes conductive and starts to discharge the 0.05- μ f. capacitor.

In the a.v.c. circuit, switch S_{2B} turns the a.v.c. on or off, S_{2A} opens the S-meter circuit when the a.v.c. isn't used, and S_{2C} takes the cathode return off the gain control so that the S-meter reading isn't affected by the gain setting. The S-meter circuit meters the voltage difference between a reference and the cathode voltage of an a.v.c.-controlled stage. It helps to show which signals are stronger when a.v.c. is being used. If you have a signal generator you can calibrate the meter in db. above some arbitrary level. With the constants shown, the meter has a range of about 90 db. The no-signal point will be lower on a.m. than on s.s.b. by a few divisions, because of contact-potential effect in the hang-a.v.c. circuit.

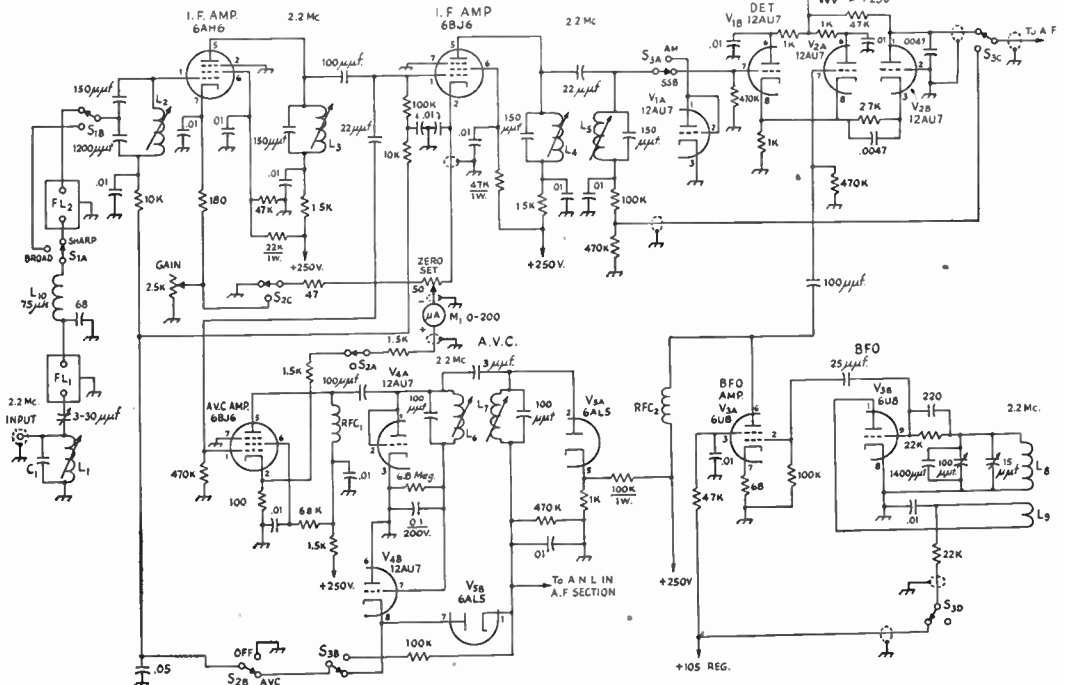

Fig. 5-60 — Schematic diagram of the i.f. amplifier up to and including the detector circuits.

Capacitances in μ f. unless otherwise noted. Resistors are $\frac{1}{2}$ watt unless otherwise noted.

- C₁ — 150 μ f. less the capacitance of the cable connected to J₁. RG-59/U runs 21 μ f. per foot.
- FL₁ — 2.215-Mc. band-pass crystal filter, 2800 cycles wide at -6 db. (Hycon Eastern* Type 22 Model 159-1P1).
- FL₂ — 2.215-Mc. band-pass crystal filter, 220 cycles wide at -6 db. (Hycon Eastern Type 22 Model 159-1Q1).
- J₁ — Phono jack.
- L₁ through L₇ — 36-64- μ h. adjustable coils (North Hills Type 120F coil mounted in North Hills S-120 shield can).

- L₈ — 18 turns No. 20, 16 t.p.i., $\frac{3}{4}$ -inch diam. (B & W 3011 stock).
- L₉ — 9 turns No. 20, 16 t.p.i., $\frac{3}{4}$ -inch diam. (B & W 3011 stock). $\frac{1}{8}$ inch between L₈ and L₉.
- L₁₀ — 75 μ h. National R-33 100- μ h. choke with 20 turns removed.
- M₁ — 0-200 microammeter (Triplett Model 327-PL).
- RFC₁, RFC₂ — National R-30, 2.5-mh. choke.
- S₁ — Two-pole 2-position 2-section rotary switch (Centralab PA-31 sections on PA-301 assembly).
- S₂ — Three-pole 2-position rotary switch (Centralab PA-1007).
- S₃ — Six-pole (5 used) 2-position 2-section rotary switch (Centralab PA-1019). See Fig. 5-61.

* Hycon Eastern, Inc., 75 Cambridge Parkway, Cambridge 42, Mass.

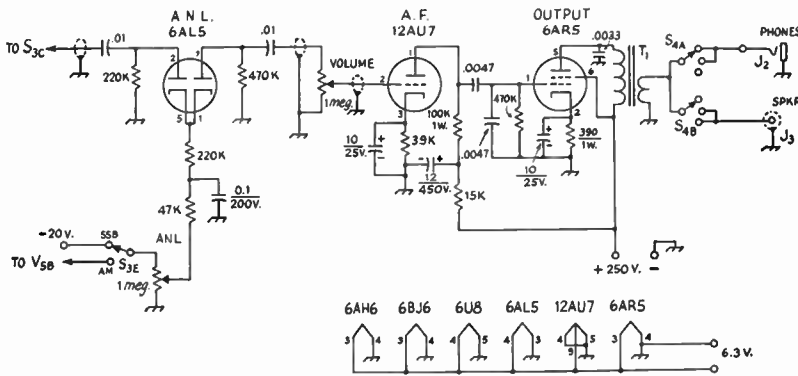

Fig. 5-61 — Schematic diagram of the audio portion of the amplifier.

J₂ — Open-circuit phone jack.

J₃ — Phono jack.

S₃ — See Fig. 3.

S₄ — Two-pole 3-position rotary switch (Centralab PA-1002).

T₁ — 7000-ohms-to-voice-coil output transformer, 4 watts (Stancor A-3822).

Everything in the audio amplifier (Fig. 5-61) section is conventional, with the exception of the three-position switch S₄, which permits feeding output to headphones, loudspeaker or both. This is a convenience when visitors are in the shack. The circuit is shown for low-impedance headphones that work at voice-coil impedance level; a constructor with high-impedance phones might take the headphone output from the plate of the 6AR5 through a 0.05- μ f. capacitor.

Construction

The chassis is an 8 × 17 × 3-inch aluminum one, and the panel is a standard relay rack panel 7 inches high. The panel is held to the chassis by the mounting nuts of the switches and potentiometers; the shaft bushing of the Hammarlund HF-15X b.f.o. capacitor isn't long enough to be used in this way, and consequently a clearance hole is required in the panel large enough to clear the nut that holds the capacitor to the chassis. Fig. 5-62 shows that ceramic switches were used in this unit; there is no need for them, and the captions show phenolic switches specified. Ceramic capacitors can be used for any of the values up to 0.01 μ f., with the exception of those associated with the b.f.o., where silvered mica and air capacitors are recommended. The 150- μ f. capacitors shunting the i.f. coils can be mica, since the circuits aren't sharp enough to justify silvered mica.

Figs. 5-60 and 5-61 show that a number of shielded leads are used, in the audio between tubes and switches and for some of the other leads. Actually, the shielded leads in the audio circuit are pieces of coaxial line; this is done to carry the grounds back to the audio tubes and not depend upon the chassis for a return. In some cases this latter procedure can introduce a.c. hum when one side of the heaters is grounded as in this case. The other shielded wires are included to minimize the chances for feedback and b.f.o. leakage into the "front end." A shield partition masks the input tube and S₁ from the rest of the amplifier; this is done to knock down some slight

b.f.o. energy that otherwise might leak into the grid of the first tube.

Most of the remainder of the unit follows standard practices and requires no elaboration. The b.f.o. coil, L₈ and L₉, is supported by its leads on a long tie point. The 1400- μ f. capacitor shown shunting the 100- μ f. trimmer is made up of two 680- and one 47- μ f. silvered mica capacitors; with tolerances running the way they do you may have to use something other than a 47- μ f. capacitor to bring the b.f.o. close enough to 2.215 Mc. to be set by the Hammarlund MAPC-100 trimmer. The 15- μ f. b.f.o. panel control tunes over more than 8 kc., and some builders might want to pull off a plate or so to bring this range down to about 6 kc., although the tuning rate is quite adequate.

The power-supply requirements are 95 ma. at around 280 volts for the plates, a few ma. at regulated + 105 (from a VR tube), 3¼ amperes at 6.3 volts for the heaters, and - 15 volts at negligible current for one terminal of S_{3E} (Fig. 5-61). The latter voltage can be obtained from the same power transformer through a 1-V rectifier and an RC filter.

Alignment

There is nothing unusual about the alignment of the amplifier. If you have a signal generator (or grid-dip meter) you can use the output to tune the circuits L₂ through L₅ close to 2.215 Mc. This portion of the amplifier is broad, so if you get in the vicinity of 2.215 Mc. you will be able to hear a signal passed through the crystal filters, after which you can again peak the coils. The a.v.c. circuit can be aligned initially by connecting a voltmeter from ground to the cold ends of L₆ and L₇, after which the S meter will serve as an indicator. It will require some further juggling, which will be described later. The b.f.o. is brought into tune with the 100- μ f. trimmer; if you can't hit because the silvered-mica capacitors are at the edges of tolerance you may have to add capacitance or else remove a turn from L₈. If you have a v.t.v.m. and r.f. probe, the

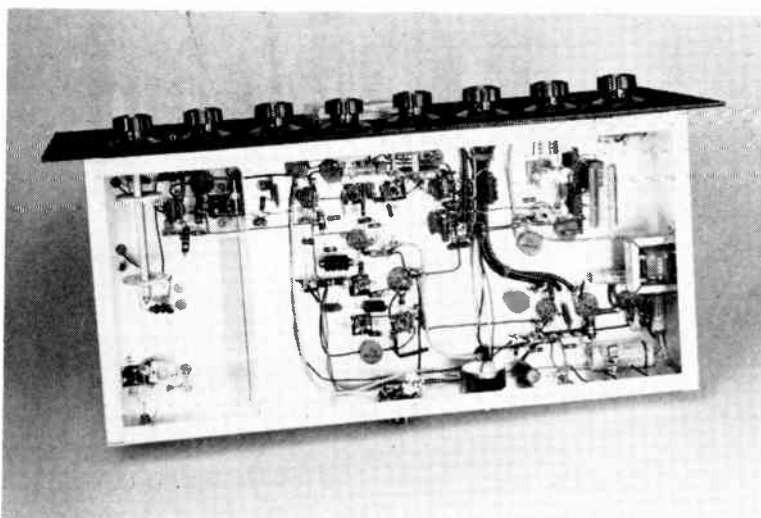

Fig. 5-62 — The audio output transformer is mounted on the side wall of the chassis, and the rear wall of the chassis has the input and output jacks, the power plug and the S-meter zero set. Audio leads between limiter and audio stage and panel controls are carried in small coaxial cable. The shield at the left-hand side of the chassis is held in place by the mounting screws of the shield can.

voltage at the grid of V_{2A} should be adjusted to about 5 volts peak, by changing the value of the 22K resistor between S_{3D} and L_9 .

With a steady signal coming through the amplifier, its amplitude should be adjusted to give about -6 volts at the grid of V_{4B} . You will need a v.t.v.m. for this job. Then measure the voltage at the cathode of V_{5B} and detune L_7 until it gives a reading of about 40 per cent of the other reading, or $2\frac{1}{2}$ volts. Don't try to measure the voltage on the a.v.c. line, because even the high input resistance of the v.t.v.m. (11 megohms) will impair the a.v.c. performance. When you get the a.v.c. completely aligned, as mentioned a little later, L_6 will be peaked for maximum signal through V_{4A} and for something less than this through V_{5A} .

The i.f. should now be in a condition suitable for the reception of signals, but it requires a "front end." The NC-300 can be used, because it has a first i.f. of 2.215 Mc., or you can build or revise a converter for the job. Use a length of RG-59/U to connect from J_1 to the plate of the mixer tube, with a 100- μf . capacitor between plate and inside conductor of the coax to avoid short-circuiting the plate supply in the receiver. If a home-built converter is used, the plate voltage to the mixer can be fed through L_1 , by lifting the bottom of L_1 and feeding the plate voltage to it through a 1000-ohm resistor. Bypass the bottom of L_1 with a 0.01- μf . capacitor to chassis.

Tune around until you find a signal or, better yet, feed in a stable signal from a signal generator or 100-ke. crystal-oscillator harmonic. Peak L_2 for maximum signal; then "rook" L_1 and the 3-to-30- μf . trimmer for maximum signal. If you are using both filters, do these jobs with both filters switched in. You should now be able to

tune around the bands and get accustomed to the i.f. and its operation. You will need a slow tuning rate when the sharp filter is used, because the signals come in and out rather fast with this much selectivity. You also need a slow tuning rate with s.s.b. reception, as any operator knows. You can get a line on the a.v.c. action by tuning in a few code signals. On slow sending around 12 or 15 words a minute the S meter will start to drop back between words, while at speeds of 20 w.p.m. or more the S meter should "hang" steady and only follow fading. If it doesn't hang in long enough, detune L_7 a little.

As you familiarize yourself with the operation of the amplifier, you may notice that the broad filter characteristic isn't as "smooth" as one might expect for a band-pass filter. (If it is, it's just blind luck.) You won't notice this in operating in a ham band; it will show up when you tune slowly through a steady medium-strength signal (as from a 100-ke. calibration oscillator harmonic) with the selectivity in BROAD, the a.v.c. on, S_3 in the a.m. position and with no antenna on the receiver front end. As you tune slowly through the signal, the S meter may rise to a maximum, fall off slightly, rise again and then fall off. The slight falling off at the center may be 5 db. or so; it has no obvious effect on signals, but it indicates that the filter isn't looking into and back to the correct terminations. When the center dip (or dips) is minimized, the terminations will be correct. You do this by tuning to the dip and giving the 3- to 30- μf . capacitor and L_1 both a slight adjustment to make the S meter rise slightly. Now tune across the signal again and see if the dip has been reduced any. By trying this several times you will be able to bring the "ripple" at the top of the pass band of the filter down to a low value.

Conelrad

Effective January 2, 1957, the "Conelrad" rules became part of the amateur regulations. Essentially, compliance with the rules consists of monitoring a broadcast station — standard band, f.m. or TV — either continuously or at intervals not exceeding ten minutes, during periods in which the amateur transmitter is in use. On receipt of a Conelrad Alert all transmitting must cease, except as authorized in 12.193 and 12.194 of the FCC regulations.

The existence of an Alert may be determined as outlined in 12.192(b)(3). Operation during hours when local broadcast stations are not on the air will require tuning through the standard broadcast band to determine if operation appears to be normal. The presence of any U. S. broadcast stations on frequencies other than 640 and 1240 kc. indicates normal operation.

Perhaps the simplest form of compliance is by means of a simple converter working into the i.f. amplifier of the regular station receiver. A typical circuit is shown in Fig. 5-63. The converter can be built in a small metal case and mounted at a convenient spot on the receiver so that S_1 can be closed at regular intervals for checking the

broadcast station. As an alternative, the converter can be mounted out of the way at the rear of the receiver and the switch leads brought out to a convenient spot.

● A "FAIL-PROOF" CONELRAD ALARM

The Conelrad alarm shown in Fig. 5-64 uses a small BC receiver to furnish both audible and visible indications of a Conelrad Alert (the receiver may still be used for normal broadcast reception).

With the receiver tuned to a broadcast carrier and the alarm circuit in operation, a green "safe" light indicates that all is well on the broadcast band. When the broadcast carrier goes off, as it will in a Conelrad Radio Alert, the green light goes out, a red "danger" light comes on, a buzzer sounds, and the 115-volt a.c. line to the transmitter is opened up. In other words, the device puts you off the air! The audible and visible warnings also are given in the event of a component failure in either the control receiver or the alarm. Even the disappearance of the 115-volt supply will not go unnoticed, since in that case the green "safe" light will go out, indicating that the alarm is inoperative.

The alarm requires a minimum of 0.7 volts (negative) from the receiver's a.v.c. circuit for dependable operation. Receivers having one stage of i.f. amplification will develop at least this much a.v.c. voltage when tuned to a signal of reasonable strength. But watch out for the "superhets" that do not have an i.f. stage; they are of little value as a source of control voltage for the alarm. You can usually find out if the receiver has an i.f. stage by looking at the tube list pasted on either the chassis or the inside of the cabinet.

The circuit of the alarm is shown in section B, Fig. 5-64. Section A is a typical a.v.c.-detector-first audio stage of an a.c.-d.c. receiver, and shows how the alarm circuit is tied into a receiver.

Although a 12AV6 is shown as the detector, other tubes may be used in some receivers. However, the basic circuit will be the same or very similar.

Finding the a.v.c. line in the jumble beneath the chassis of the ordinary a.c.-d.c. receiver is not always easy. Here are a few hints:

Using section A, Fig. 5-64, as a guide, locate the detector tube socket. Trace out the leads going to the secondary of the last i.f. transformer, T_1 . This transformer usually will be adjacent to the detector tube. The lower end of the secondary winding will be connected to several different resistors, one of these being the diode-load filter resistor (approximately 50K in most circuits) and another the a.v.c. filter resistor, R_1 . The value of the latter resistor is ordinarily above one megohm. Trace through R_1 in the direction of the arrow (Fig. 5-64), until you locate the fairly high value (0.05 μ f. or so) a.v.c. filter capacitor, C_1 .

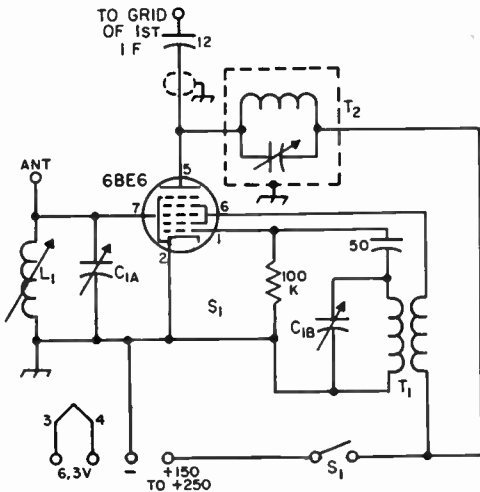

Fig. 5-63 — Converter circuit for monitoring broadcast stations in connection with a communications receiver. Capacitances are in μ f.

C_{1A} , C_{1B} — Two-gang broadcast capacitor, oscillator section according to intermediate frequency to be used.

L_1 — Loop stick.

T_1 — B.c. oscillator transformer (for i.f. to be used).

T_2 — I.f. coil and trimmer. This can be taken from an i.f. transformer, or the transformer can be used intact, the output being taken from the secondary.

Note: If only one broadcast station is to be monitored C_{1A} and C_{1B} can be padding-type capacitors (or a combination of padding and fixed capacitance as required) adjusted for the desired station and intermediate frequencies. Other types of converter tubes may be substituted if desired.

Power for the unit can be taken from the receiver's "accessory" socket.

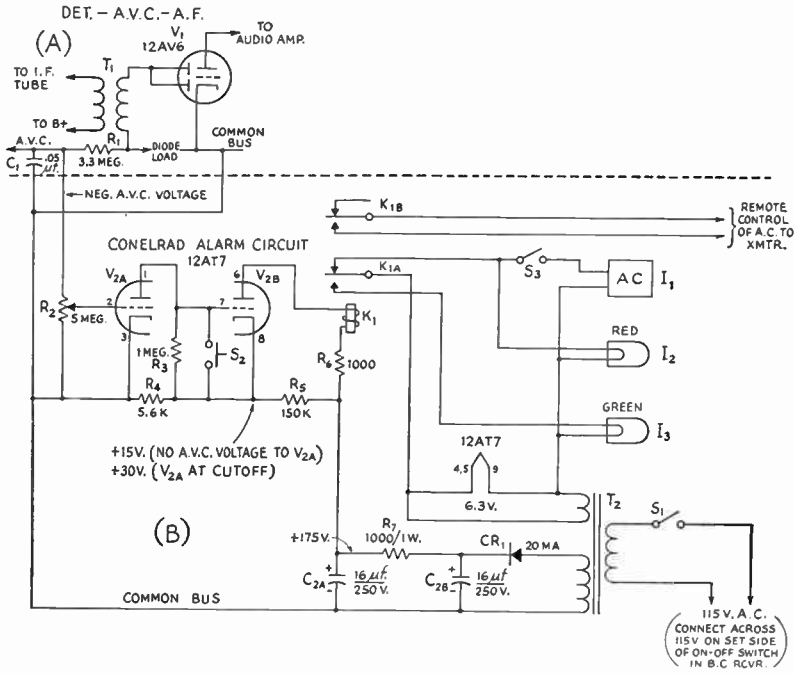

Fig. 5-64 — Circuit of the Conelrad alarm (B) connected to the a.v.c. circuit (A) of a typical a.c.-d.c. broadcast receiver. Resistors are 1/2 watt unless otherwise specified. C₁, R₁ and T₁ in section A are components in the broadcast receiver. I₁ — 6-volt a.c. buzzer (Edwards 725). I₂, I₃ — 6-volt pilot lamp, No. 47. K₁ — D.p.d.t. sensitive relay, 5000-ohm coil, 5-amp. contacts (Potter & Brumfield GB11D). R₂ — 5-megohm potentiometer.

Now you have the a.v.c. line clearly identified and the tap for the alarm circuit may be made.

Notice that the cathode of V₁ and the cold side of C₁ are both returned to a common bus or -B line, not directly to the chassis. Also observe that the return for the alarm circuit is made to the common bus in the receiver, not to the chassis of the set. *Do not ground this lead to the chassis or connect it to any exposed metal parts.* If there is any difficulty in locating the common bus in the vicinity of the detector stage, check back from the negative side of the power-supply filter capacitors, as this point is always attached to the common bus.

The monitor should be built in an insulated box of some kind and not in a metal case. The box can be made of plywood, or a bakelite instrument case (e.g., ICA type 8202). The bakelite case is ideal for the application, but it must be handled with care during construction, to avoid scratching, chipping, or breakage. Be especially careful when drilling large holes such as those used in mounting the pilot-lamp assemblies and switches, because a large drill tends to bind and crack the case.

Testing and Operating

The chances are pretty good that right after the receiver and the monitor have been turned on the red lamp will light and — if you haven't had the foresight to open S₃ to prevent the noise — the buzzer will sound. Tune the receiver to a broadcast station and see if the red light goes out and the green light comes on. If this happens, close S₃ and you're all set for Conelrad compliance. If the "safe" light does not come on, tune around for a signal strong enough to actuate the alarm. Should the signal of greatest apparent strength fail to trigger the monitor, leave the receiver tuned to this signal and then momentarily press S₂. The alarm should now lock on "safe," provided the a.v.c. circuit delivers 0.7 volt or more to V_{2A}.

The only d.c. measurements of any consequence that need be made in checking through the alarm circuit are the output voltage of the power supply and the voltage at the cathode of V_{2B}. The proper voltages at these two points are given on the circuit diagram. If the alarm fails to respond properly, it may be advisable to check the a.v.c. voltage with a v.t.v.m.

High-Frequency Transmitters

The principal requirements to be met in c.w. transmitters for the amateur bands between 1.8 and 30 Mc. are that the frequency must be as stable as good practice permits, the output signal must be free from modulation and that harmonics and other spurious emissions must be eliminated or reduced to the point where they do not cause interference to other stations.

The over-all design depends primarily upon the bands in which operation is desired, and the power output. A simple oscillator with satisfactory frequency stability may be used as a transmitter at the lower frequencies, as indicated in Fig. 6-1A, but the power output obtainable is small. As a general rule, the output of the oscillator is fed into one or more amplifiers to bring the power fed to the antenna up to the desired level, as shown in B.

An amplifier whose output frequency is the same as the input frequency is called a **straight amplifier**. A **buffer amplifier** is the term sometimes applied to an amplifier stage to indicate that its primary purpose is one of isolation, rather than power gain.

Because it becomes increasingly difficult to maintain oscillator frequency stability as the frequency is increased, it is most usual practice in working at the higher frequencies to operate the oscillator at a low frequency and follow it with one or more **frequency multipliers** as required to arrive at the desired output frequency. A frequency multiplier is an amplifier that delivers output at a multiple of the exciting frequency. A **doubler** is a multiplier that gives output at twice the exciting frequency; a **tripler** multiplies the exciting frequency by three, etc. From the viewpoint of any particular stage in a transmitter, the preceding stage is its **driver**.

As a general rule, frequency multipliers should not be used to feed the antenna system directly, but should feed a straight amplifier which, in turn, feeds the antenna system, as shown in Fig. 1-C, D and E. As the diagrams indicate, it is often possible to operate more than one stage from a single power supply.

Good frequency stability is most easily obtained through the use of a **crystal-controlled oscillator**, although a different crystal is needed for each frequency desired (or multiples of that frequency). A **self-controlled oscillator** or **v.f.o.** (variable-frequency oscillator) may be tuned to any frequency with a dial in the manner of a

receiver, but requires great care in design and construction if its stability is to compare with that of a crystal oscillator.

In all types of transmitter stages, screen-grid tubes have the advantage over triodes that they require less driving power. With a lower-power exciter, the problem of harmonic reduction is made easier. Most satisfactory oscillator circuits use a screen-grid tube.

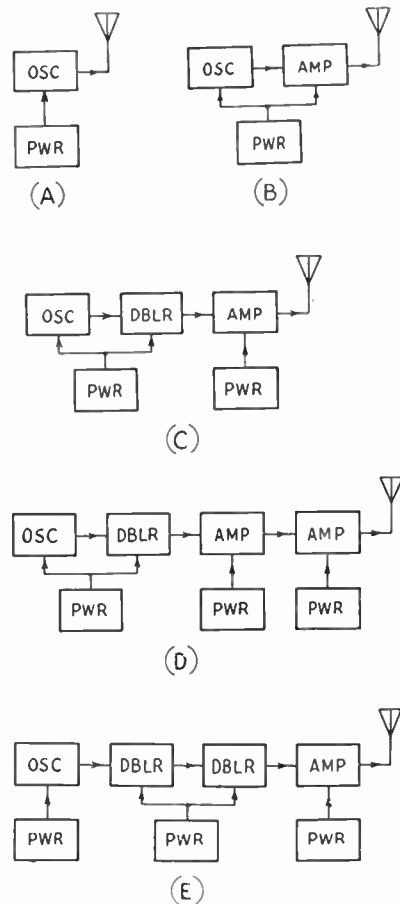

Fig. 6-1 — Block diagrams showing typical combinations of oscillator and amplifiers and power-supply arrangements for transmitters. A wide selection is possible, depending upon the number of bands in which operation is desired and the power output.

Oscillators

● CRYSTAL OSCILLATORS

The frequency of a crystal-controlled oscillator is held constant to a high degree of accuracy by the use of a quartz crystal. The frequency depends almost entirely on the dimensions of the crystal (essentially its thickness); other circuit values have comparatively negligible effect. However, the power obtainable is limited by the heat the crystal will stand without fracturing. The amount of heating is dependent upon the r.f. crystal current which, in turn, is a function of the amount of feedback required to provide proper excitation. Crystal heating short of the danger point results in frequency drift to an extent depending upon the way the crystal is cut. Excitation should always be adjusted to the minimum necessary for proper operation.

Crystal-Oscillator Circuits

The simplest crystal-oscillator circuit is shown in Fig. 6-2A. An equivalent is shown at B. It is a Colpitts circuit (see chapter on vacuum-tube principles) with the tube tapped across part of the tuned circuit. The crystal has been replaced by its equivalent—a series-tuned circuit L_1C_4 . (See chapter on electrical laws and circuits.) C_5 and C_6 are the tube grid-cathode and plate-

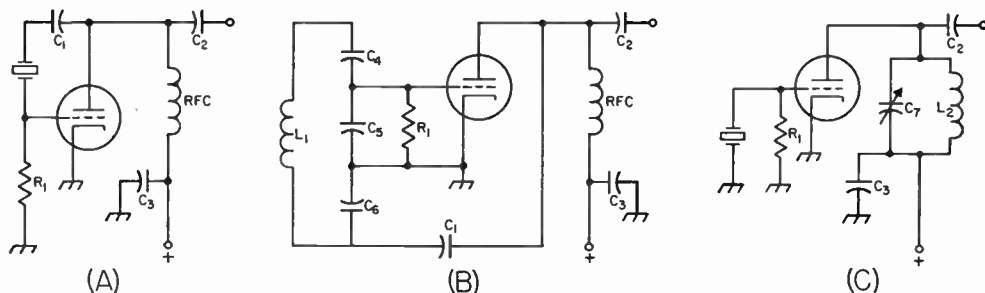

Fig. 6-2 — Simple crystal-oscillator circuits. A — Pierce. B — Equivalent of circuit A. C — Simple triode oscillator. C_1 is a plate blocking capacitor, C_2 an output coupling capacitor, and C_3 a plate bypass. L_1 , C_4 , C_5 and C_6 are discussed in the text. C_7 and L_2 should tune to the crystal fundamental frequency. R_1 is the grid leak.

cathode capacitances, respectively. In best practical form, C_5 or C_6 , or both, would be augmented by external capacitors from grid to cathode and plate to cathode so that feedback could be adjusted properly.

The circuit shown in Fig. 6-2C is the equivalent of the tuned-grid tuned-plate circuit discussed in the chapter on vacuum-tube principles, the crystal replacing the tuned grid circuit.

The most commonly used crystal-oscillator circuits are based on one or the other of these two simple types, and are shown in Fig. 6-3. Although these circuits are somewhat more complicated, they combine the functions of oscillator and amplifier or frequency multiplier in a single tube. In all of these circuits, the screen of a tetrode or pentode is used as the plate in a triode oscillator. Power output is taken from a separate tuned tank

circuit in the actual plate circuit. Although the oscillator itself is not entirely independent of adjustments made in the plate tank circuit when the latter is tuned near the fundamental frequency of the crystal, the effects can be satisfactorily minimized by proper choice of the oscillator tube.

The circuit of Fig. 6-3A is known as the Tritet. The oscillator circuit is that of Fig. 6-2C. Excitation is controlled by adjustment of the tank L_1C_1 , which should have a low L/C ratio, and be tuned considerably to the high-frequency side of the crystal frequency (approximately 5 Mc. for a 3.5-Mc. crystal) to prevent over-excitation and high crystal current. Once the proper adjustment for average crystals has been found, C_1 may be replaced with a fixed capacitor of equal value.

The oscillator circuit of Fig. 3-B is that of Fig. 6-2A. Excitation is controlled by C_9 .

The oscillator of the grid-plate circuit of Fig. 6-3C is the same as that of Fig. 6-3B, except that the ground point has been moved from the cathode to the plate of the oscillator (in other words, to the screen of the tube). Excitation is adjusted by proper proportioning of C_6 and C_7 .

When most types of tubes are used in the circuits of Fig. 6-3, oscillation will stop when the output plate circuit is tuned to the crystal fre-

quency, and it is necessary to operate with the plate tank circuit critically detuned for maximum output with stability. However, when the 6AG7, 5763, or the lower-power 6AH6 is used with proper adjustment of excitation, it is possible to tune to the crystal frequency without stopping oscillation. The plate tuning characteristic should then be similar to Fig. 6-4. These tubes also operate with less crystal current than most other types for a given power output, and less frequency change occurs when the plate circuit is tuned through the crystal frequency (less than 25 cycles at 3.5 Mc.).

Crystal current may be estimated by observing the relative brilliance of a 60-ma. dial lamp connected in series with the crystal. Current should be held to the minimum for satisfactory output by careful adjustment of excitation. With the

operating voltages shown, satisfactory output should be obtained with crystal currents of 40 ma. or less.

In these circuits, output may be obtained at multiples of the crystal frequency by tuning the plate tank circuit to the desired harmonic, the output dropping off, of course, at the higher har-

monics. Especially for harmonic operation, a low-*C* plate tank circuit is desirable.

For best performance with a 6AG7 or 5763, the values given under Fig. 6-3 should be followed closely. (For a discussion of values for other tubes, see *QST* for March, 1950, page 28.)

● VARIABLE-FREQUENCY OSCILLATORS

The frequency of a v.f.o. depends entirely on the values of inductance and capacitance in the circuit. Therefore, it is necessary to take careful steps to minimize changes in these values not under the control of the operator. As examples, even the minute changes of dimensions with temperature, particularly those of the coil, may result in a slow but noticeable change in frequency called drift. The effective input capacitance of the oscillator tube, which must be connected across the circuit, changes with variations in electrode voltages. This, in turn, causes a change in the frequency of the oscillator. To make use of the power from the oscillator, a load, usually in the form of an amplifier, must be coupled to the oscillator, and variations in the load may reflect on the frequency. Very slight mechanical movement of components may result in a shift in frequency, and vibration can cause modulation.

V.F.O. Circuits

Fig. 6-5 shows the most commonly used circuits. They are all designed to minimize the effects mentioned above. All are similar to the crystal oscillators of Fig. 6-3 in that the screen of a tetrode or pentode is used as the oscillator plate. The oscillating circuits in Figs. 6-5A and B are the Hartley type; those in C and D are Colpitts circuits. (See chapter on vacuum-tube principles.) In the circuits of A and C, all of the above-mentioned effects, except changes in inductance, are minimized by the use of a high-*Q* tank circuit obtained through the use of large tank capacitances. Any uncontrolled changes in capacitance thus become a very small percentage of the total circuit capacitance.

In the series-tuned Colpitts circuit of Fig. 6-5D) (sometimes called the Clapp circuit), a high-*Q* circuit is obtained in a different manner. The tube is tapped across only a small portion of the oscillating tank circuit, resulting in very loose coupling between tube and circuit. The taps are provided by a series of three capacitors across the coil. In addition, the tube capacitances are shunted by large capacitors, so the effects of the tube — changes in electrode voltages and loading — are still further reduced. In contrast

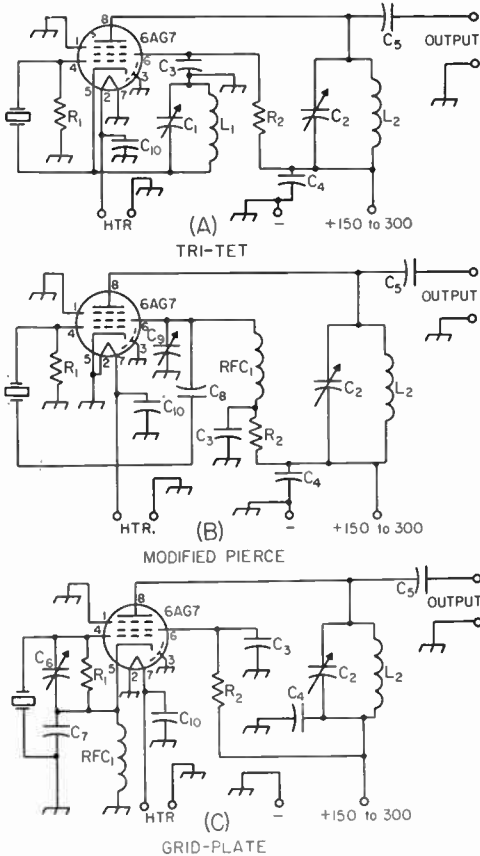

Fig. 6-3 — Commonly-used crystal-controlled oscillator circuits. Values are those recommended for a 6AG7 or 5763 tube. (See reference in text for other tubes.)

- C₁ — Feed-back-control capacitor — 3.5-Mc. crystals — approx. 220- μ mf. mica — 7-Mc. crystals — approx. 150- μ mf. mica.
- C₂ — Output tank capacitor — 100- μ mf. variable for single-band tank; 250- μ mf. variable for two-band tank.
- C₃ — Screen bypass — 0.001- μ f. disk ceramic.
- C₄ — Plate bypass — 0.001- μ f. disk ceramic.
- C₅ — Output coupling capacitor — 50 to 100 μ mf.
- C₆ — Excitation-control capacitor — 30- μ mf. trimmer.
- C₇ — Excitation capacitor — 220- μ mf. mica for 6AG7; 100- μ mf. for 5763.
- C₈ — D.c. blocking capacitor — 0.001- μ f. mica.
- C₉ — Excitation-control capacitor — 220- μ mf. mica.
- C₁₀ — Heater bypass — 0.001- μ f. disk ceramic.
- R₁ — Grid leak — 0.1 megohm, $\frac{1}{2}$ watt.
- R₂ — Screen resistor — 47,000 ohms, 1 watt.
- L₁ — Excitation-control inductance — 3.5-Mc. crystals — approx. 4 μ h.; 7-Mc. crystals — approx. 2 μ h.
- L₂ — Output-circuit coil — single band: — 3.5 Mc. — 17 μ h.; 7 Mc. — 8 μ h.; 14 Mc. — 2.5 μ h.; 28 Mc. — 1 μ h. Two-band operation: 3.5 & 7 Mc. — 7.5 μ h.; 7 & 14 Mc. — 2.5 μ h.
- RFC₁ — 2.5-mh. 50-ma. r.f. choke.

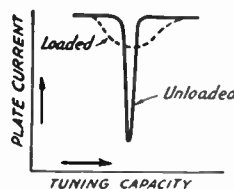

Fig. 6-4 — Plate tuning characteristic of circuits of Fig. 6-3 with preferred types (see text). The plate-current dip at resonance broadens and is less pronounced when the circuit is loaded.

to the preceding circuits, the resulting tank circuit has a high L/C ratio and therefore the tank current is much lower than in the circuits using high- C tanks. As a result, it will usually be found that, other things being equal, drift will be less with the low- C circuit.

For best stability, the ratio of $C_{11} + C_{12}$ to C_{13} or C_{14} (which are usually equal) should be as high as possible without stopping oscillation. The permissible ratio will be higher the higher the Q of the coil and the mutual conductance of the tube. If the circuit does not oscillate over the desired range, a coil of higher Q must be used or the capacitance of C_{13} and C_{14} reduced.

Load Isolation

In spite of the precautions already discussed, the tuning of the output plate circuit will cause a

noticeable change in frequency, particularly in the region around resonance. This effect can be reduced considerably by designing the oscillator for half the desired frequency and doubling frequency in the output circuit.

It is desirable, although not a strict necessity if detuning is recognized and taken into account, to approach as closely as possible the condition where the adjustment of tuning controls in the transmitter, beyond the v.f.o. frequency control, will have negligible effect on the frequency. This can be done by substituting a fixed-tuned circuit in the output of the oscillator, and adding isolating stages whose tuning is fixed between the oscillator and the first tunable amplifier stage in the transmitter. Fig. 6-6 shows such an arrangement that gives good isolation. In the first stage, a 6C4 is connected as a cathode follower. This

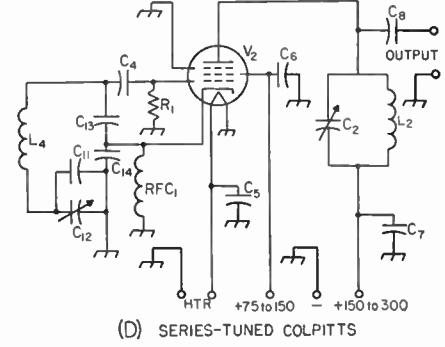
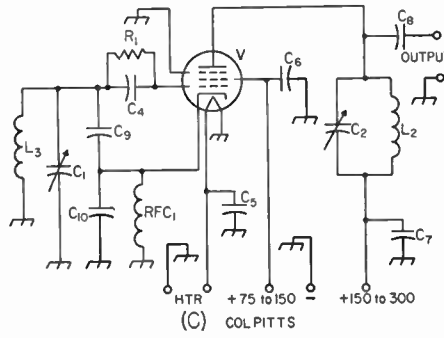
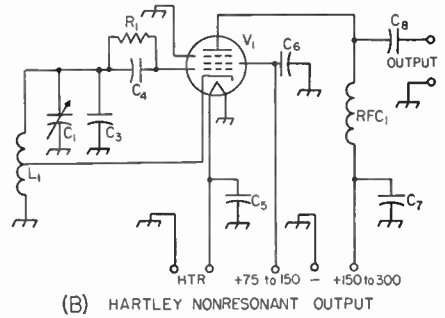
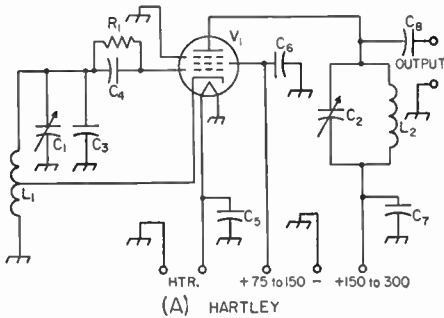

Fig. 6-5—V.f.o. circuits. Approximate values for 3.5 Mc. are given below. For 1.75 Mc., all tank-circuit values of capacitance and inductance, all tuning capacitances and C_{13} and C_{14} should be doubled; for 7 Mc., they should be cut in half.

- C₁—Oscillator bandspread tuning capacitor—150- μ f. variable.
- C₂—Output-circuit tank capacitor—100- μ f.
- C₃—Oscillator tank capacitor—500- μ f. zero-temperature-coefficient mica.
- C₄—Grid coupling capacitor—100- μ f. zero-temperature-coefficient mica.
- C₅—Heater bypass—0.001- μ f. disk ceramic.
- C₆—Screen bypass—0.001- μ f. disk ceramic.
- C₇—Plate bypass—0.001- μ f. disk ceramic.
- C₈—Output coupling capacitor—50 to 100- μ f. mica.
- C₉—Oscillator tank capacitor—680- μ f. zero-temperature-coefficient mica.
- C₁₀—Oscillator tank capacitor—0.0022- μ f. zero-temperature-coefficient mica.

- C₁₁—Oscillator bandspread padder—50- μ f. variable air.
- C₁₂—Oscillator bandspread tuning capacitor—25- μ f. variable.
- C₁₃, C₁₄—Tube-coupling capacitor—0.001- μ f. zero-temperature-coefficient mica.
- R₁—47,000 ohms, $\frac{1}{2}$ watt.
- L₁—Oscillator tank coil—4.3 μ h., tapped about one-third-way from grounded end.
- L₂—Output-circuit tank coil—22 μ h.
- L₃—Oscillator tank coil—4.3 μ h.
- L₄—Oscillator tank coil—33 μ h. (B & W JEL-80).
- RFC₁—2.5-mh. 50-ma. r.f. choke.
- V₁—6AG7, 5763 or 6AH6 preferred; other types usable.
- V₂—6AG7, 5763 or 6AH6 required for feed-back capacitances shown.

drives a 5763 buffer amplifier whose input circuit is fixed-tuned to the approximate band of the v.f.o. output. For best isolation, it is important that the 6C4 does not draw grid current. The output of the v.f.o., or the cathode resistor of the 6C4 should be adjusted until the voltage across the cathode resistor of the 6C4 (as measured with a high-resistance d.c. voltmeter with an r.f. choke in the positive lead) is the same with or without excitation from the v.f.o. L_1 should be adjusted for most constant output from the 5763 over the band.

Chirp

In all of the circuits shown there will be some change of frequency with changes in screen and plate voltages, and the use of regulated voltages for both usually is necessary. One of the most serious results of voltage instability occurs if the oscillator is keyed, as it often is for break-in operation. Although voltage regulation will supply a steady voltage from the power supply and therefore is still desirable, it cannot alter the fact that the voltage on the tube must rise from zero when the key is open, to full voltage when the key is closed, and must fall back again to zero when the key is opened. The result is a chirp each time the key is opened or closed, unless the time constant in the keying circuit is reduced to the point where the chirp takes place so rapidly that the receiving operator's ear cannot detect it. Unfortunately, as explained in the chapter on keying, a certain minimum time constant is necessary if key clicks are to be minimized. Therefore it is evident that the measures necessary for the reduction of chirp and clicks are in opposition, and a compromise is necessary. For best keying characteristics, the oscillator should be allowed to run continuously while a subsequent amplifier is keyed. However, a keyed amplifier represents a widely variable load and unless sufficient isolation is provided between the oscillator and the keyed amplifier, the keying characteristics may be little better than when the oscillator itself is keyed. (See keying chapter for other methods of break-in keying.)

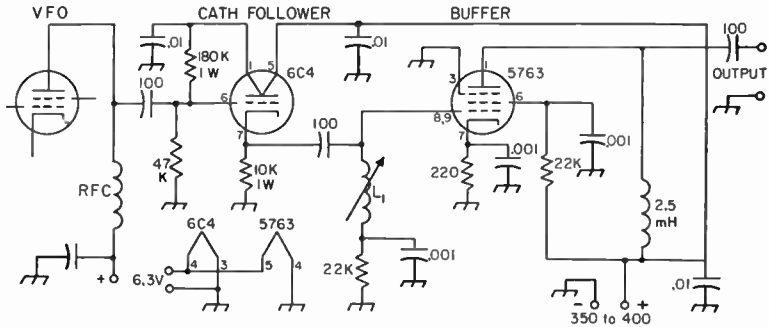

Fig. 6-6 — Circuit of an isolating amplifier for use between v.f.o. and first tunable stage. All capacitances below 0.001 μ f. are in μ f. All resistors are $\frac{1}{2}$ watt. L_1 , for the 3.5-Mc. band, consists of 93 turns No. 36 enam., 17/32 inch long, $\frac{1}{2}$ inch diameter, close-wound on National XR-50 iron-slug form. Inductance 69 to 134 μ h. All capacitors are disk ceramic.

Therefore it is evident that the measures necessary for the reduction of chirp and clicks are in opposition, and a compromise is necessary. For best keying characteristics, the oscillator should be allowed to run continuously while a subsequent amplifier is keyed. However, a keyed amplifier represents a widely variable load and unless sufficient isolation is provided between the oscillator and the keyed amplifier, the keying characteristics may be little better than when the oscillator itself is keyed. (See keying chapter for other methods of break-in keying.)

Frequency Drift

Frequency drift is further reduced most easily by limiting the power input as much as possible and by mounting the components of the tuned circuit in a separate shielded compartment, so that they will be isolated from the direct heat from tubes and resistors. The shielding also will

eliminate changes in frequency caused by movement of nearby objects, such as the operator's hand when tuning the v.f.o. The circuit of Fig. 6-5D lends itself well to this arrangement, since relatively long leads between the tube and the tank circuit have negligible effect on frequency because of the large shunting capacitances. The grid, cathode and ground leads to the tube can be bunched in a cable up to several feet long.

Variable capacitors should have ceramic insulation, good bearing contacts and should preferably be of the double-bearing type, and fixed capacitors should have zero temperature coefficient. The tube socket also should have ceramic insulation and special attention should be paid to the selection of the coil in the oscillating section.

Oscillator Coils

The Q of the tank coil used in the oscillating portion of any of the circuits under discussion should be as high as circumstances (usually space) permit, since the losses, and therefore the heating, will be less. With recommended care in regard to other factors mentioned previously, most of the drift will originate in the coil. The coil should be well spaced from shielding and other large metal surfaces, and be of a type that radiates heat well, such as a commercial air-

wound type, or should be wound tightly on a threaded ceramic form so that the dimensions will not change readily with temperature. The wire with which the coil is wound should be as large as practicable, especially in the high- C circuits.

Mechanical Vibration

To eliminate mechanical vibration, components should be mounted securely. Particularly in the circuit of Fig. 6-5D, the capacitor should preferably have small, thick plates and the coil braced, if necessary, to prevent the slightest mechanical movement. Wire connections between tank-circuit components should be as short as possible and flexible wire will have less tendency to vibrate than solid wire. It is advisable to cushion the entire oscillator unit by mounting on sponge rubber or other shock mounting.

Tuning Characteristic

If the circuit is oscillating, touching the grid of the tube or any part of the circuit connected to it will show a change in plate current. In tuning the plate output circuit without load, the plate current will be relatively high until it is tuned near resonance where the plate current will dip to a low value, as illustrated in Fig. 6-1. When the output circuit is loaded, the dip should still be found, but broader and much less pronounced as indicated by the dashed line. The circuit should not be loaded beyond the point where the dip is still recognizable.

Checking V.F.O. Stability

A v.f.o. should be checked thoroughly before it is placed in regular operation on the air. Since succeeding amplifier stages may affect the signal characteristics, final tests should be made with the complete transmitter in operation. Almost any v.f.o. will show signals of good quality and stability when it is running free and not connected to a load. A well-isolated monitor is a necessity. Perhaps the most convenient, as well as one of the most satisfactory, well-shielded monitoring arrangements is a receiver combined with a crystal oscillator, as shown in Fig. 6-7. (See "Crystal Oscillators," this chapter.) The crystal frequency should lie in the band of the lowest frequency to be checked and in the frequency range where its harmonics will fall in the higher-frequency bands. The receiver b.f.o. is turned off and the v.f.o. signal is tuned to beat with the signal from the crystal oscillator instead. In this way any receiver instability caused by overloading of the input circuits, which may result in "pulling" of the h.f. oscillator in the receiver, or by a change in line voltage to the receiver when the transmitter is keyed, will not

affect the reliability of the check. Most crystals have a sufficiently-low temperature coefficient to give a check on drift as well as on chirp and signal quality if they are not overloaded.

Harmonics of the crystal may be used to beat with the transmitter signal when monitoring at the higher frequencies. Since any chirp at the lower frequencies will be magnified at the higher frequencies, accurate checking can best be done by monitoring at a harmonic.

The distance between the crystal oscillator and receiver should be adjusted to give a good beat between the crystal oscillator and the transmitter signal. When using harmonics of the crystal oscillator, it may be necessary to attach a piece

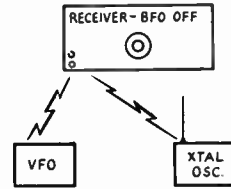

Fig. 6-7—Setup for checking v.f.o. stability. The receiver should be tuned preferably to a harmonic of the v.f.o. frequency. The crystal oscillator may operate somewhere in the band in which the v.f.o. is operating. The receiver b.f.o. should be turned off.

of wire to the oscillator as an antenna to give sufficient signal in the receiver. Checks may show that the stability is sufficiently good to permit oscillator keying at the lower frequencies, where break-in operation is of greater value, but that chirp becomes objectionable at the higher frequencies. If further improvement does not seem possible, it would be logical in this case to use oscillator keying at the lower frequencies and amplifier keying at the higher frequencies.

R.F. Power-Amplifier Tanks and Coupling

R.f. power amplifiers used in amateur transmitters usually are operated under Class C conditions (see chapter on vacuum-tube fundamentals). Fig. 6-10 shows a screen-grid tube with the required tuned tank in its plate circuit. Equivalent cathode connections for a filament-type tube are shown in Fig. 6-8. It is assumed that the tube is being properly driven and that the various electrode voltages are appropriate for Class C operation.

● **PLATE TANK Q**

The main objective, of course, is to deliver as much fundamental power as possible into a load, R , without exceeding the tube ratings. The load resistance R may be in the form of a transmission line to an antenna, or the grid circuit of another amplifier. A further objective is to minimize the harmonic energy (always generated by a Class C amplifier) fed into the load circuit. In attaining these objectives, the Q of the tank circuit is of importance. When a load is coupled inductively, as in Fig. 6-10, the Q of the tank circuit will have an effect on the coefficient of coupling nec-

essary for proper loading of the amplifier. In respect to all of these factors, a tank Q of 10 to 20 is usually considered optimum. A much lower Q will result in less efficient operation of the amplifier tube, greater harmonic output, and greater difficulty in coupling inductively to a load. A much higher Q will result in higher tank current with increased loss in the tank coil.

The Q is determined (see chapter on electrical laws and circuits) by the L/C ratio and the load resistance at which the tube is operated. The tube load resistance is related, in approximation, to



Fig. 6-8 — Filament center-tap connections to be substituted in place of cathode connections shown in diagrams when filament-type tubes are substituted. T_1 is the filament transformer. Filament by-passes, C_1 , should be 0.001- μ f. disk ceramic capacitors. If a self-biasing (cathode) resistor is used, it should be placed between the center tap and ground.

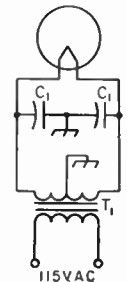

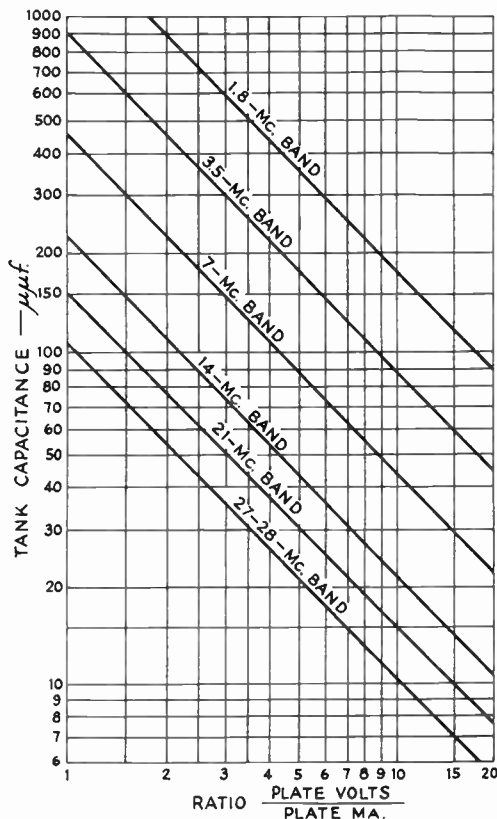

Fig. 6-9 — Chart showing plate tank capacitance required for a Q of 10. To use the chart, divide the tube plate voltage by the plate current in milliamperes. Select the vertical line corresponding to the answer obtained. Follow this vertical line to the diagonal line for the band in question, and thence horizontally to the left to read the capacitance. For a given ratio of plate-voltage/plate current, doubling the capacitance shown doubles the Q etc. When a split-stator capacitor is used in a balanced circuit, the capacitance of each section may be one half of the value given by the chart.

the ratio of the d.c. plate voltage to d.c. plate current at which the tube is operated.

The amount of C that will give a Q of 10 or various ratios is shown in Fig. 6-9. For a given plate-voltage/plate-current ratio, the Q will vary directly as the tank capacitance, twice the capacitance doubles the Q etc. For the same Q , the capacitance of each section of a split-stator capacitor in a balanced circuit should be half the value shown.

These values of capacitance include the output capacitance (plate-cathode) of the amplifier tube, the input capacitance (grid-cathode) of a following amplifier tube if it is coupled capacitively, and all other stray capacitances. At the higher plate-voltage/plate-current ratios, the chart may show values of capacitance, for the higher frequencies, smaller than those attainable in practice. In such a case, a tank Q higher than 10 is unavoidable.

In low-power exciter stages, where capacitive coupling is used, very low- Q circuits, tuned only by the tube and stray circuit capacitances are

sometimes used for the purpose of "broadbanding" to avoid the necessity for retuning a stage across a band. Higher-order harmonics generated in such a stage can usually be satisfactorily attenuated in the tank circuit of the final output amplifier.

● INDUCTIVE-LINK COUPLING

Coupling to Flat Coaxial Lines

When the load R in Fig. 6-10A is located for convenience at some distance from the amplifier, or when maximum harmonic reduction is desired, it is advisable to feed the power to the load through a low-impedance coaxial cable. The shielded construction of the cable prevents radiation and makes it possible to install the line in any convenient manner without danger of unwanted coupling to other circuits.

If the line is more than a small fraction of a wave length long, the load resistance at its output end should be adjusted, by a matching circuit if necessary, to match the impedance of the cable. This reduces losses in the cable and makes the coupling adjustments at the transmitter independent of the cable length. Matching circuits for use between the cable and another transmission line are discussed in the chapter on transmission lines, while the matching adjustments when the load is the grid circuit of a following amplifier are described elsewhere in this chapter.

Assuming that the cable is properly terminated, proper loading of the amplifier will be assured, using the circuit of Fig. 6-11C, if

- 1) The plate tank circuit has reasonably high value of Q . A value of 10 is usually sufficient.
- 2) The inductance of the pick-up or link coil is close to the optimum value for the frequency and type of line used. The optimum coil is one whose self-inductance is such that its reactance at the operating frequency is equal to the charac-

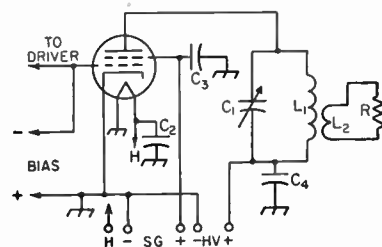

Fig. 6-10 — Inductive-link output coupling circuits. C_1 — Plate tank capacitor — see text and Fig. 6-9 for capacitance, Fig. 6-33 for voltage rating.

C_2 — Heater bypass — 0.001- μ f. disk ceramic.

C_3 — Screen bypass — voltage rating depends on method of screen supply. See section on screen considerations. Voltage rating same as plate voltage will be safe under any condition.

C_4 — Plate bypass — 0.001- μ f. disk ceramic or mica. Voltage rating same as C_1 , plus safety factor.

L_1 — To resonate at operating frequency with C_1 . See LC chart in miscellaneous-data chapter and inductance formula in electrical-laws chapter, or use ARRL *Lightning Calculator*.

L_2 — Reactance equal to line impedance. See reactance chart and inductance formula in electrical-laws chapter, or use ARRL *Lightning Calculator*.

R — Representing load.

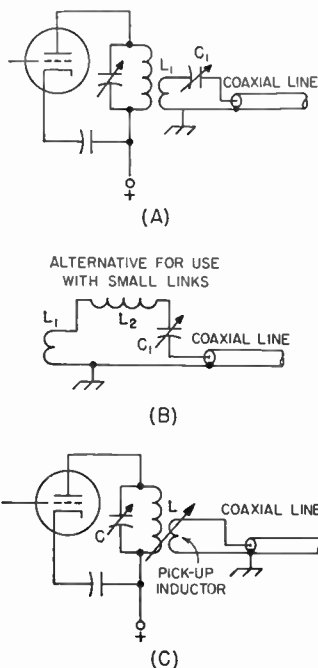

Fig. 6-11 — With flat transmission lines power transfer is obtained with looser coupling if the line input is tuned to resonance. C_1 and L_1 should resonate at the operating frequency. See table for maximum usable value of C_1 . If circuit does not resonate with maximum C_1 or less, inductance of L_1 must be increased, or added in series at L_2 .

teristic impedance, Z_0 , of the line.

3) It is possible to make the coupling between the tank and pick-up coils very tight.

The second in this list is often hard to meet. Few manufactured link coils have adequate inductance even for coupling to a 50-ohm line at low frequencies.

If the line is operating with a low s.w.r., the system shown in Fig. 6-11C will require tight coupling between the two coils. Since the secondary (pick-up coil) circuit is not resonant, the leakage reactance of the pick-up coil will cause some detuning of the amplifier tank circuit. This detuning effect increases with increasing coupling, but is usually not serious. However, the amplifier tuning must be adjusted to resonance, as indicated by the plate-current dip, each time the coupling is changed.

Capacitance in $\mu\mu\text{f}$. Required for Coupling to Flat Coaxial Lines with Tuned Coupling Circuit

Frequency Band	Characteristic Impedance of Line	
	52 ohms ¹	75 ohms ¹
Mc.		
1.8	900	600
3.5	150	300
7	230	150
14	115	75
28	60	40

¹ Capacitance values are maximum usable.

Note: Inductance in circuit must be adjusted to resonate at operating frequency.

Tuned Coupling

The design difficulties of using "untuned" pick-up coils, mentioned above, can be avoided by using a coupling circuit tuned to the operating frequency. This contributes additional selectivity as well, and hence aids in the suppression of spurious radiations.

If the line is flat the input impedance will be essentially resistive and equal to the Z_0 of the line. With coaxial cable, a circuit of reasonable Q can be obtained with practicable values of inductance and capacitance connected in series with the line's input terminals. Suitable circuits are given in Fig. 6-11 at A and B. The Q of the coupling circuit often may be as low as 2, without running into difficulty in getting adequate coupling to a tank circuit of proper design. Larger values of Q can be used and will result in increased ease of coupling, but as the Q is increased the frequency range over which the circuit will operate without readjustment becomes smaller. It is usually good practice, therefore, to use a coupling-circuit Q just low enough to permit operation, over as much of a band as is normally used for a particular type of communication, without requiring retuning.

Capacitance values for a Q of 2 and line impedances of 52 and 75 ohms are given in the accompanying table. These are the *maximum* values that should be used. The inductance in the circuit should be adjusted to give resonance at the operating frequency. If the link coil used for a particular band does not have enough inductance to resonate, the additional inductance may be connected in series as shown in Fig. 6-11B.

Characteristics

In practice, the amount of inductance in the circuit should be chosen so that, with somewhat loose coupling between L_1 and the amplifier tank coil, the amplifier plate current will increase when the variable capacitor, C_1 , is tuned through the value of capacitance given by the table. The coupling between the two coils should then be increased until the amplifier loads normally, without changing the setting of C_1 . If the transmission line is flat over the entire frequency band under consideration, it should not be necessary to readjust C_1 when changing frequency, if the values given in the table are used. However, it is unlikely that the line actually will be flat over such a range, so some readjustment of C_1 may be needed to compensate for changes in the input impedance of the line. If the input impedance variations are not large, C_1 may be used as a loading control, no changes in the coupling between L_1 and the tank coil being necessary.

The degree of coupling between L_1 and the amplifier tank coil will depend on the coupling-circuit Q . With a Q of 2, the coupling should be tight — comparable with the coupling that is typical of "fixed-link" manufactured coils. With a swinging link it may be necessary to increase the Q of the coupling circuit in order to get sufficient power transfer. This can be done by increasing the L/C ratio.

PI-SECTION OUTPUT TANK

A pi-section tank circuit may also be used in coupling to an antenna or transmission line, as shown in Fig. 6-12. The values of capacitance for C_1 and C_2 , and inductance for L_1 for any values of tube load resistance and output load resistance may be calculated by the following procedure:

R_1 = Plate load resistance.

R_2 = Output load resistance (resonant or matched antenna system — nonreactive).

R_X = Imaginary common resistance (used only for calculation purposes).

Q_1 = Tank Q .

Q_2 = Output-section Q (not significant here except for calculation purposes).

X_{C1} = Reactance of C_1 in ohms.

X_{L1} = Reactance of L_1 (= $X_{LA} + X_{LB}$ for calculation purposes).

X_{C2} = Reactance of C_2 in ohms.

Formulas

$$(1) R_1 = \frac{\text{Plate volts} \times 500}{\text{Plate ma.}}$$

(2) Q_1 = Values between 10 and 20 should be used.

$$(3) X_{LA} = \frac{R_1}{Q_1}$$

$$(4) X_{C1} = \frac{R_1}{Q_1}$$

$$(5) R_X = \frac{R_1}{Q_1^2 + 1}$$

$$(6) Q_2 = \sqrt{\frac{R_2}{R_X} - 1}$$

$$(7) X_{LB} = Q_2 \times R_X$$

$$(8) X_{L1} = X_{LA} + X_{LB}$$

$$(9) X_{C2} = \frac{R_2}{Q_2}$$

$$(10) C_1 \mu\text{f.} = \frac{159,000}{(f_{\text{Mc.}})(X_{C1})}$$

$$(11) L_1 \mu\text{h.} = \frac{0.159 X_{L1}}{f_{\text{Mc.}}}$$

$$(12) C_2 \mu\text{f.} = \frac{159,000}{(f_{\text{Mc.}})(X_{C2})}$$

Example:

An amplifier tube is to be operated at 1000 volts, 200 ma. It is to work into a matched antenna system fed with 50-ohm coax cable. A tank Q of 15 is chosen.

$$(1) R_1 = \frac{1000 \times 500}{200} = 2500 \text{ ohms.}$$

$$(2) Q_1 = 15, \text{ as chosen.}$$

$$(3) X_{LA} = \frac{2500}{15} = 167 \text{ ohms.}$$

$$(4) X_{C1} = \frac{2500}{15} = 167 \text{ ohms.}$$

$$(5) R_X = \frac{2500}{15^2 + 1} = \frac{2500}{226} = 11 \text{ ohms.}$$

$$(6) Q_2 = \sqrt{\frac{50}{11} - 1} = \sqrt{4.55 - 1} = \sqrt{3.55} = 1.89$$

$$(7) X_{LB} = 1.89 \times 11 = 20.1 \text{ ohms.}$$

$$(8) X_{L1} = 167 + 20.1 = 187.4 \text{ ohms.}$$

$$(9) X_{C2} = \frac{50}{1.89} = 26.4 \text{ ohms.}$$

$$(10) C_1 \mu\text{f.} = \frac{159,000}{3.5 \times 167} = 270 \mu\text{f. for 3.5 Mc.}$$

$$(11) L_1 \mu\text{h.} = \frac{0.159 \times 187.4}{3.5} = 8.5 \mu\text{h. for 3.5 Mc.}$$

$$(12) C_2 \mu\text{f.} = \frac{159,000}{3.5 \times 26.4} = 1720 \mu\text{f. for 3.5 Mc.}$$

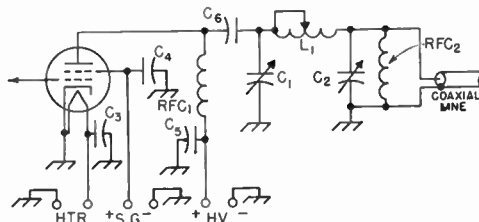

Fig. 6-12 — Pi-section output tank circuit.

C_1 — Input capacitor. See text or Fig. 6-13 for reactance. Voltage rating should be equal to d.c. plate voltage for c.w.; double this value for plate modulation.

C_2 — Output capacitor. See text or Fig. 6-15 for reactance. See text for voltage rating.

C_3 — Heater bypass — 0.001- $\mu\text{f.}$ disk ceramic.

C_4 — Screen bypass. See Fig. 6-10.

C_5 — Plate bypass. See Fig. 6-10.

C_6 — Plate blocking capacitor — 0.001- $\mu\text{f.}$ disk ceramic or mica. Voltage rating same as C_1 .

L_1 — See text or Fig. 6-14 for reactance.

RFC_1 — See later section on r.f. chokes.

RFC_2 — 2.5-mh. receiving type (essential to reduce peak voltage across both input and output capacitors).

For the higher-frequency bands under the same conditions of tube load resistance, tank Q and output load resistance, divide the values obtained in (10), (11) and (12) as follows:

7 Mc., divide by 2; 14 Mc., divide by 4; 21 Mc., divide by 6; 28 Mc., divide by 8. For 1.75 Mc., multiply by 2.

Values of reactance for C_1 , L_1 and C_2 may be taken directly from the charts of Figs. 6-13, 6-14 and 6-15 if the output load resistance is 52 or 72 ohms. It should be borne in mind that these values apply only where the output load is resistive, i.e., where the antenna and line have been matched.

Output-Capacitor Ratings

The voltage rating of the output capacitor will depend upon the s.w.r. If the load is resistive, receiving-type air capacitors should be adequate for amplifier input powers up to 1 kw. with plate modulation when feeding 52- or 72-ohm loads. In obtaining the larger capacitances required for the lower frequencies, it is common practice to switch fixed capacitors in parallel with the variable air capacitor. While the voltage

PI-NETWORK DESIGN CHARTS FOR FEEDING 52- OR 72-OHM COAXIAL TRANSMISSION LINES

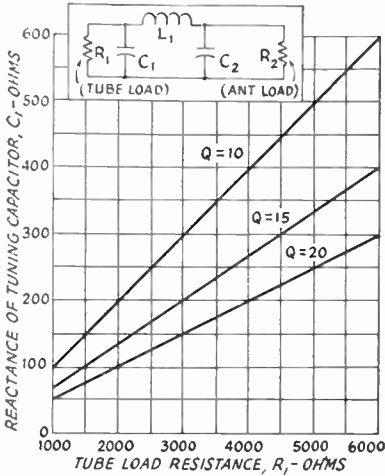

Fig. 6-13 — Reactance of input capacitor, C_1 , as a function of tube load resistance, R_1 , for pi networks.

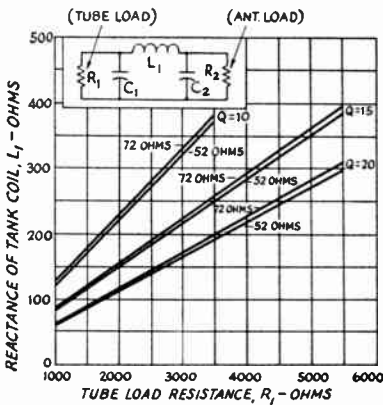

Fig. 6-14 — Reactance of tank coil, L_1 , as a function of load resistance, R_1 , for pi networks.

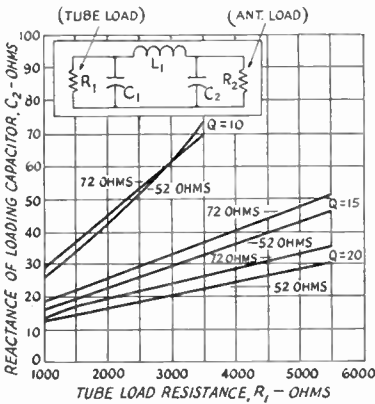

Fig. 6-15 — Reactance of loading capacitor, C_2 , as a function of tube load resistance, R_1 , for pi networks.

rating of a mica or ceramic capacitor may not be exceeded in a particular case, capacitors of these types are limited in current-carrying capacity. The type of capacitor to be selected depends upon the frequency as well as the amplifier power. Postage-stamp silver-mica capacitors should be adequate for amplifier inputs over the range from about 70 watts at 28 Mc. to 400 watts at 14 Mc. and lower. The larger mica capacitors (CM-45 case) having voltage ratings of 1200 and 2500 volts are usually satisfactory for inputs varying from about 350 watts at 28 Mc. to 1 kw. at 14 Mc. and lower. Because of these current limitations, particularly at the higher frequencies, it is advisable to use as large an air capacitor as practicable, using the micas only at the lower frequencies. Broadcast-receiver replacement-type capacitors can be obtained very reasonably. They are available in triple units totaling about 1100 $\mu\text{f.}$, or dual units totaling about 900 $\mu\text{f.}$ Their insulation should be sufficient for inputs of 500 watts or more. Air capacitors have the additional advantage that they are seldom permanently damaged by a voltage break-down.

Neutralizing with Pi Network

Screen-grid amplifier using a pi-network output circuit may be neutralized by the system shown in Figs. 6-25B and C.

● **MULTIBAND TANK CIRCUITS**

Multiband tank circuits provide a convenient means of covering several bands without the need for changing coils. Tuners of this type consist essentially of two tank circuits, tuned simultaneously with a single control. In a tuner designed to cover 80 through 10 meters, each circuit has a sufficiently large capacitance variation to assure an approximately 2-to-1 frequency range. Thus, one circuit is designed so that it covers 3.5 through 7.3 Mc., while the other covers 14 through 29.7 Mc.

A single-ended, or unbalanced, circuit of this type is shown in Fig. 6-16A. In principle, the reactance of the high-frequency coil, L_2 , is small enough at the lower frequencies so that it can be largely neglected, and C_1 and C_2 are in parallel across L_1 . Then the circuit for low frequencies becomes that shown in Fig. 6-16B. At the high frequencies, the reactance of L_1 is high, so that it may be considered simply as a choke shunting C_1 . The high-frequency circuit is essentially that of Fig. 6-16C, L_2 being tuned by C_1 and C_2 in series.

In practice, the effect of one circuit on the other cannot be neglected entirely. L_2 tends to increase the effective capacitance of C_2 , while L_1 tends to decrease the effective capacitance of C_1 . This effect, however, is relatively small. Each circuit must cover somewhat more than a 2-to-1 frequency range to permit staggering the two ranges sufficiently to avoid simultaneous responses to a frequency in the low-frequency range, and one of its harmonics lying in the range of the high-frequency circuit.

Fig. 6-16 — Multiband tuner circuits. In the unbalanced circuit of A, C_1 and C_2 are sections of a single split-stator capacitor. In the balanced circuit of D, the two split-stator capacitors are ganged to a single control with an insulated shaft coupling between the two. In D, the two sections of L_2 are wound on the same form, with the inner ends connected to C_2 . In A, each section of the capacitor should have a voltage rating the same as Fig. 6-34A. In D, C_1 should have a rating the same as Fig. 6-34H (or Fig. 6-34E if the feed system corresponds). C_2 may have the rating of Fig. 6-34E so long as the rotor is not grounded or bypassed to ground.

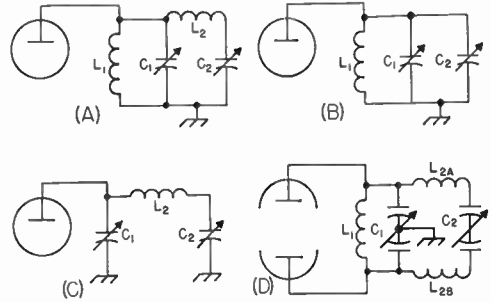

In any circuit covering a frequency range as great as 2 to 1 by capacitance alone, the circuit Q must vary rather widely. If the circuit is designed for a Q of 12 at 80, the Q will be 6 at 40, 24 at 20, 18 at 15, and 12 at 10 meters. The increase in tank current as a result of the increase in Q toward the low-frequency end of the high-frequency range may make it necessary to design the high-frequency coil with care to minimize loss in this portion of the tuning range. It is

generally found desirable to provide separate output coupling coils for each circuit.

Fig. 6-16D shows a similar tank for balanced circuits. The same principles apply.

Series or parallel feed may be used with either balanced or unbalanced circuits. In the balanced circuit of Fig. 6-16D, the series feed point would be at the center of L_1 , with an r.f. choke in series.

(For further discussion see *QST*, July, 1954.)

R.F. Amplifier-Tube Operating Conditions

In addition to proper tank and output-coupling circuits discussed in the preceding sections, an r.f. amplifier must be provided with suitable electrode voltages and an r.f. driving or excitation voltage (see vacuum-tube chapter).

All r. f. amplifier tubes require a voltage to operate the filament or heater (a.c. is usually permissible), and a positive d.c. voltage between the plate and filament or cathode (plate voltage). Most tubes also require a negative d.c. voltage (biasing voltage) between control grid (Grid No. 1) and filament or cathode. Screen-grid tubes require in addition a positive voltage (screen voltage or Grid No. 2 voltage) between screen and filament or cathode.

Biasing and plate voltages may be fed to the tube either in series with or in parallel with the associated r.f. tank circuit as discussed in the chapter on electrical laws and circuits.

It is important to remember that true plate, screen or biasing voltage is the voltage between the particular electrode and filament or cathode. Only when the cathode is directly grounded to the chassis may the electrode-to-chassis voltage be taken as the true voltage.

The required r.f. driving voltage is applied between grid and cathode.

Power Input and Plate Dissipation

Plate power input is the d.c. power input to the plate circuit (d.c. plate voltage \times d.c. plate current). Screen power input likewise is the d.c. screen voltage \times the d.c. screen current.

Plate dissipation is the difference between the r.f. power delivered by the tube to its loaded plate tank circuit and the d.c. plate power input. The screen, on the other hand, does not deliver any output power, and therefore its dissipation is the same as the screen power input.

● TRANSMITTING-TUBE RATINGS

Tube manufacturers specify the maximum values that should be applied to the tubes they produce. They also publish sets of typical operating values that should result in good efficiency and normal tube life.

Maximum values for all of the most popular transmitting tubes will be found in the tables of transmitting tubes in the last chapter. Also included are as many sets of typical operating values as space permits. However, it is recommended that the amateur secure a transmitting-tube manual from the manufacturer of the tube or tubes he plans to use.

CCS and ICAS Ratings

The same transmitting tube may have different ratings depending upon the manner in which the tube is to be operated, and the service in which it is to be used. These different ratings are based primarily upon the heat that the tube can safely dissipate. Some types of operation, such as with grid or screen modulation, are less efficient than others, meaning that the tube must dissipate more heat. Other types of operation, such as c.w. or single-side-band phone are intermittent in nature, resulting in less average heating than in other modes where there is a continuous power input to the tube during transmissions. There are also different ratings for tubes used in transmitters that are in almost constant use (CCS — Continuous Commercial Service), and for tubes that are to be used in transmitters that average only a few hours of daily operation (ICAS — Intermittent Commercial and Amateur Service). The latter are the ratings used by amateurs who wish to obtain maximum output with reasonable tube life.

Maximum Ratings

Maximum ratings, where they differ from the values given under typical operating values, are not normally of significance to the amateur except in special applications. No single maximum value should be used unless all other ratings can simultaneously be held within the maximum values. As an example, a tube may have a maximum plate-voltage rating of 2000, a maximum plate-current rating of 300 ma., and a maximum plate-power-input rating of 400 watts. Therefore, if the maximum plate voltage of 2000 is used, the plate current should be limited to 200 ma. (instead of 300 ma.) to stay within the maximum power-input rating of 400 watts.

● SOURCES OF ELECTRODE VOLTAGES

Filament or Heater Voltage

The filament voltage for the indirectly-heated cathode-type tubes found in low-power classifications may vary 10 per cent above or below rating without seriously reducing the life of the tube. But the voltage of the higher-power filament-type tubes should be held closely between the rated voltage as a minimum and 5 per cent above rating as a maximum. Make sure that the plate power drawn from the power line does not cause a drop in filament voltage below the proper value when plate power is applied.

Thoriated-type filaments lose emission when the tube is overloaded appreciably. If the overload has not been too prolonged, emission sometimes may be restored by operating the filament at rated voltage with all other voltages removed for a period of 10 minutes, or at 20 per cent above rated voltage for a few minutes.

Plate Voltage

D.c. plate voltage for the operation of r.f. amplifiers is most often obtained from a transformer-rectifier-filter system (see power-supply chapter) designed to deliver the required plate voltage at the required current. However, batteries or other d.c.-generating devices are sometimes used in certain types of operation (see portable-mobile chapter).

Bias and Tube Protection

Several methods of obtaining bias are shown in Fig. 6-17. In A, bias is obtained by the voltage drop across a resistor in the grid d.c. return circuit when rectified grid current flows. The proper value of resistance may be determined by dividing the required biasing voltage by the d.c. grid current at which the tube will be operated. Then, so long as the r.f. driving voltage is adjusted so that the d.c. grid current is the recommended value, the biasing voltage will be the proper value. The tube is biased only when excitation is applied, since the voltage drop across the resistor depends upon grid-current flow. When excitation is removed, the bias falls to zero. At zero bias most tubes draw power far in excess of the plate-dissipation rating. So it is

advisable to make provision for protecting the tube when excitation fails by accident, or by intent as it does when a preceding stage in a c.w. transmitter is keyed.

If the maximum c.w. ratings shown in the tube tables are to be used, the input should be cut to zero when the key is open. Aside from this, it is not necessary that plate current be cut off completely but only to the point where the rated dissipation is not exceeded. In this case plate-modulated phone ratings should be used for c.w. operation, however.

With triodes this protection can be supplied by obtaining all bias from a source of fixed voltage, as shown in Fig. 6-17B. It is preferable, however, to use only sufficient fixed bias to protect the tube and obtain the balance needed for operating bias from a grid leak, as in C. The grid-leak resistance is calculated as above, except that the fixed voltage is subtracted first.

Fixed bias may be obtained from dry batteries or from a power pack (see power-supply chapter). If dry batteries are used, they should be checked periodically, since even though they may show normal voltage, they eventually develop a high internal resistance. Grid-current flow through this battery resistance may increase the bias considerably above that anticipated. The life of batteries in bias service will be approximately the same as though they were subject to a drain equal to the grid current, despite the fact that the grid-current flow is in such a direction as to charge the battery, rather than to discharge it.

In Fig. 6-17F, bias is obtained from the voltage drop across a resistor in the cathode (or filament center-tap) lead. Protective bias is obtained by the voltage drop across R_5 as a result of plate (and screen) current flow. Since plate current must flow to obtain a voltage drop across the resistor, it is obvious that cut-off protective bias cannot be obtained. When excitation is applied, plate (and screen) current increases and the grid current also contributes to the drop across R_5 , thereby increasing the bias to the operating value. Since the voltage between plate and cathode is reduced by the amount of the voltage drop across R_5 , the over-all supply voltage must be the sum of the plate and operating-bias voltages. For this reason, the use of cathode bias usually is limited to low-voltage tubes when the extra voltage is not difficult to obtain.

The resistance of the cathode biasing resistor R_5 should be adjusted to the value which will give the correct operating bias voltage with rated grid, plate and screen currents flowing with the amplifier loaded to rated input. When excitation is removed, the input to most types of tubes will fall to a value that will prevent damage to the tube, at least for the period of time required to remove plate voltage. A disadvantage of this biasing system is that the cathode r.f. connection to ground depends upon a by-pass capacitor. From the consideration of v.h.f. harmonics and stability with high-perveance tubes, it is preferable to make the cathode-to-ground impedance as close to zero as possible.

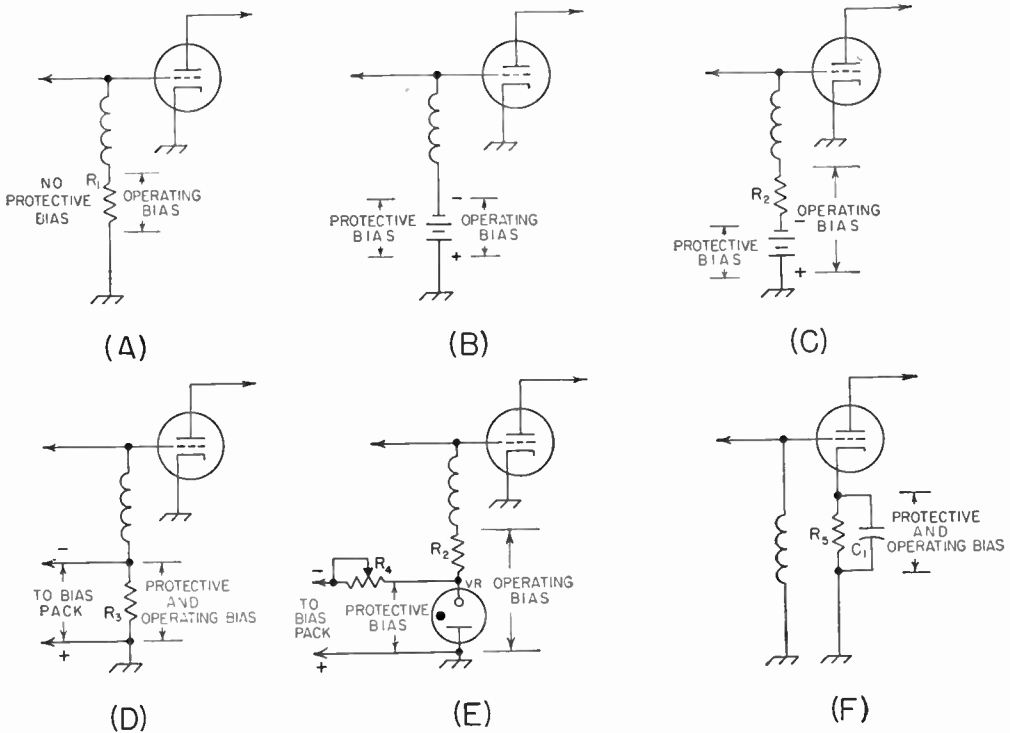

Fig. 6-17 — Various systems for obtaining protective and operating bias for r.f. amplifiers. A — Grid-leak. B — Battery. C — Combination battery and grid leak. D — Grid leak and adjusted-voltage bias pack. E — Combination grid leak and voltage-regulated pack. F — Cathode bias.

Screen Voltage

For c.w. operation, and under certain conditions of phone operation (see amplitude-modulation chapter), the screen may be operated from a power supply of the same type used for plate supply, except that voltage and current ratings should be appropriate for screen requirements. The screen may also be operated through a series resistor or voltage-divider (see power-supply chapter) from a source of higher voltage, such as the plate-voltage supply, thus making a separate supply for the screen unnecessary. Certain precautions are necessary, depending upon the method used.

It should be kept in mind that screen current varies widely with both excitation and loading. If the screen is operated from a fixed-voltage source, the tube should never be operated without plate voltage and load, otherwise the screen may be damaged within a short time. Supplying the screen through a series dropping resistor from a higher-voltage source, such as the plate supply, affords a measure of protection, since the resistor causes the screen voltage to drop as the current increases, thereby limiting the power drawn by the screen. However, with a resistor, the screen voltage may vary considerably with excitation, making it necessary to check the voltage at the screen terminal under actual operating conditions to make sure that the screen voltage is normal. Reducing excitation will cause the screen current to drop, increasing the voltage;

increasing excitation will have the opposite effect. These changes are in addition to those caused by changes in bias and plate loading, so if a screen-grid tube is operated from a series resistor or a voltage divider, its voltage should be checked as one of the final adjustments after excitation and loading have been set.

An approximate value of resistance for the screen-voltage dropping resistor may be obtained by dividing the voltage drop required from the supply voltage (difference between the supply voltage and rated screen voltage) by the rated screen current in decimal parts of an ampere. Some further adjustment may be necessary, as mentioned above, so an adjustable resistor with a total resistance above that calculated should be provided.

Protecting Screen-Grid Tubes

Screen-grid tubes cannot be cut off with bias unless the screen is operated from a fixed-voltage supply. In this case the cut-off bias is approximately the screen voltage divided by the amplification factor of the screen. This figure is not always shown in tube-data sheets, but cut-off voltage may be determined from an inspection of tube curves, or by experiment.

When the screen is supplied from a series dropping resistor, the tube can be protected by the use of a screen-clamper tube, as shown in Fig. 6-18. The grid-leak bias of the amplifier tube with excitation is applied also to the grid of the

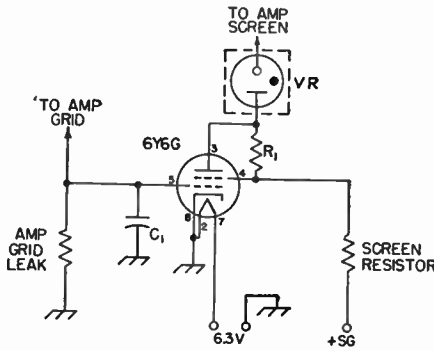

Fig. 6-18 — Screen clamber circuit for protecting screen-grid power tubes. The VR tube is needed only for complete cut-off.
 C₁ — 0.001- μ f. disk ceramic. R₁ — 100 ohms.

clamber tube. This is usually sufficient to cut off the clamber tube. However, when excitation is removed, the clamber-tube bias falls to zero and it draws enough current through the screen dropping resistor usually to limit the input to the amplifier to a safe value. If complete screen-voltage cut-off is desired, a VR tube may be inserted in the screen lead as shown. The VR-tube voltage rating should be high enough so that it will extinguish when excitation to the amplifier is removed.

● FEEDING EXCITATION TO THE GRID

The required r.f. driving voltage is supplied by an oscillator generating a voltage at the desired frequency, either directly or through intermediate amplifiers or frequency multipliers.

As explained in the chapter on vacuum-tube fundamentals, the grid of an amplifier operating under Class C conditions must have an exciting voltage whose peak value exceeds the negative biasing voltage over a portion of the excitation cycle. During this portion of the cycle, current will flow in the grid-cathode circuit as it does in a diode circuit when the plate of the diode is positive in respect to the cathode. This requires that the r.f. driver supply power. The power required to develop the required peak driving voltage across the grid-cathode impedance of the amplifier is the r.f. driving power.

The tube tables give approximate figures for the grid driving power required for each tube under various operating conditions. These figures, however, do not include circuit losses. In general, the driver stage for any Class C amplifier should be capable of supplying at least three times the driving power shown for typical operating conditions at frequencies up to 30 Mc., and from three to ten times at higher frequencies.

Since the d.c. grid current relative to the biasing voltage is related to the peak driving voltage, the d.c. grid current is commonly used as a convenient indicator of driving conditions. A driver adjustment that results in rated d.c.

grid current when the d.c. bias is at its rated value, indicates proper excitation to the amplifier when it is fully loaded.

In coupling the grid input circuit of an amplifier to the output circuit of a driving stage the objective is to load the driver plate circuit so that the desired amplifier grid excitation is obtained without exceeding the plate-input ratings of the driver tube.

Driving Impedance

The grid-current flow that results when the grid is driven positive in respect to the cathode over a portion of the excitation cycle represents an average resistance across which the exciting voltage must be developed by the driver. In other words, this is the load resistance into which the driver plate circuit must be coupled. The approximate grid input resistance is given by:

$$\text{Input impedance (ohms)} = \frac{\text{driving power (watts)}}{\text{d.c. grid current (ma.)}^2} \times 622 \times 10^3.$$

For normal operation, the values of driving power and grid current may be taken from the tube tables.

Since the grid input resistance is a matter of a few thousand ohms, an impedance step-down is necessary if the grid is to be fed from a low-impedance transmission line. This can be done by the use of a tank as an impedance-transforming device in the grid circuit of the amplifier as shown in Fig. 6-19. This coupling system may be considered either as simply a means of obtaining mutual inductance between the two tank coils, or as a low-impedance transmission line. If the line is longer than a small fraction of a wave length, and if a s.w.r. bridge is available, the line is more easily handled by adjusting it as a matched transmission line.

Inductive Link Coupling with Flat Line

In adjusting this type of line, the object is to make the s.w.r. on the line as low as possible over as wide a band of frequencies as possible so that power can be transferred over this range without retuning. It is assumed that the output coupling considerations discussed earlier have been observed in connection with the driver plate circuit. So far as the amplifier grid circuit is concerned, the controlling factors are the Q of the tuned grid circuit, L₂C₂, (see Fig. 6-20) the inductance of the coupling coil, L₄, and the degree of coupling between L₂ and L₄. Variable coupling between the coils is convenient, but not strictly necessary if one or both of the other factors can be varied. An s.w.r. indicator (shown as "SWR" in the drawing) is essential. An indicator such as the "Micromatch" (a commercially available instrument) may be connected as shown and the adjustments made under actual operating conditions; that is, with full power applied to the amplifier grid.

Assuming that the coupling is adjustable, start with a trial position of L₄ with respect to L₂, and adjust C₂ for the lowest s.w.r. Then

change the coupling slightly and repeat. Continue until the s.w.r. is as low as possible; if the circuit constants are in the right region it should not be difficult to get the s.w.r. down to 1 to 1. The Q of the tuned grid circuit should be designed to be at least 10, and if it is not possible to get a very low s.w.r. with such a grid circuit the probable reason is that L_4 is too small. Maximum coupling, for a given degree of physical coupling, will occur when the inductance of L_4 is such that its reactance at the operating frequency is equal to the characteristic impedance of the link line. The reactance can be calculated as described in the chapter on electrical fundamentals if the inductance is known; the inductance can either be calculated from the formula in the same chapter or measured as described in the chapter on measurements.

Once the s.w.r. has been brought down to 1 to 1, the frequency should be shifted over the band so that the variation in s.w.r. can be observed, without changing C_2 or the coupling between L_2 and L_4 . If the s.w.r. rises rapidly on either side of the original frequency the circuit can be made "flatter" by reducing the Q of the tuned grid circuit. This may be done by decreasing C_2 and correspondingly increasing L_2 to maintain resonance, and by tightening the coupling between L_2 and L_4 , going through the same adjustment process again. It is possible to set up the system so that the s.w.r. will not exceed 1.5 to 1 over, for example, the entire 7-Mc. band and proportionately on other bands. Under these circumstances a single setting will serve for work anywhere in the band, with essentially constant power transfer from the line to the power-amplifier grids.

If the coupling between L_2 and L_4 is not adjustable the same result may be secured by varying the L/C ratio of the tuned grid circuit — that is, by varying its Q . If any difficulty is encountered it can be overcome by changing the number of turns in L_4 until a match is secured. The two

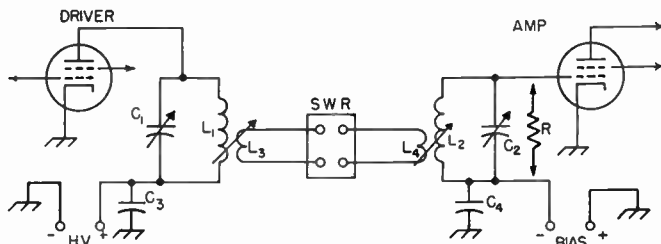

Fig. 6-19 — Coupling excitation to the grid of an r.f. power amplifier by means of a low-impedance coaxial line.

- C_1, C_3, L_1, L_3 — See corresponding components in Fig. 6-10.
- C_2 — Amplifier grid tank capacitor — see text and Fig. 6-20 for capacitance, Fig. 6-34 for voltage rating.
- C_4 — 0.001- μ f. disk ceramic.
- L_2 — To resonate at operating frequency with C_2 . See LC chart in miscellaneous-data chapter and inductance formula in electrical-laws chapter, or use ARRL *Lightning Calculator*.
- L_4 — Reactance equal to line impedance — see reactance chart and inductance formula in electrical-laws chapter, or use ARRL *Lightning Calculator*.

R is used to simulate grid impedance of the amplifier when a low-power s.w.r. indicator, such as a resistance bridge, is used. See formula in text for calculating value. Standing-wave indicator SWR is inserted in line only while line is made flat.

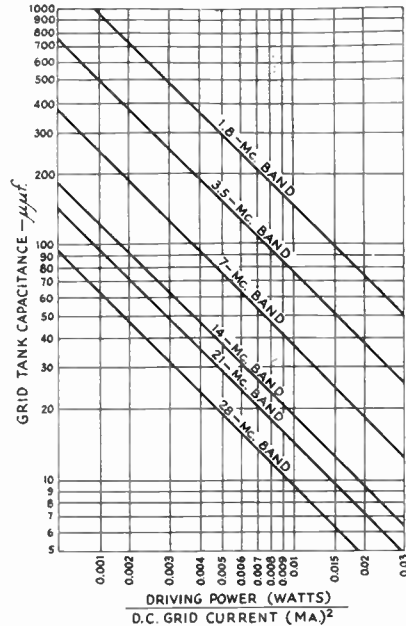

Fig. 6-20 — Chart showing required grid tank capacitance for a Q of 12. To use, divide the driving power in watts by the square of the d.c. grid current in milliamperes and proceed as described under Fig. 6-9. Driving power and grid current may be taken from the tube tables. When a split-stator capacitor is used in a balanced grid circuit, the capacitance of each section may be half that shown by the chart.

coils should be tightly coupled.

When a resistance-bridge type s.w.r. indicator (see measuring-equipment chapter) is used it is not possible to put the full power through the line when making adjustments. In such case the operating conditions in the amplifier grid circuit can be simulated by using a carbon resistor ($\frac{1}{2}$ or 1 watt size) of the same value as the calculated amplifier grid impedance, connected as indicated by the arrows in Fig. 6-19. In this case the amplifier tube must be operated "cold" — without filament or heater power. The adjustment process is the same as described above, but with the driver power reduced to a value suitable for operating the s.w.r. bridge.

When the grid coupling system has been adjusted so that the s.w.r. is close to 1 to 1 over the desired frequency range, it is certain that the power put into the link line will be delivered to the grid circuit. Coupling will be facilitated if the line is tuned as described under the earlier section on output coupling systems.

Link Feed with Unmatched Line

When the system is to be treated without regard to transmission-line effects, the link line must not offer appreciable reactance at the operating frequency. Any appreciable reactance will in effect reduce the coupling, making it impossible to transfer sufficient power from the driver to the amplifier grid circuit. Coaxial cables especially have considerable capacitance for even short lengths and it may be more desirable to use a spaced line, such as Twin-Lead, if the radiation can be tolerated.

The reactance of the line can be nullified only by making the link resonant. This may require changing the number of turns in the link coils, the length of the line, or the insertion of a tuning capacitance. Since the s.w.r. on the link line may be quite high, the line losses increase because of the greater current, the voltage increase may be sufficient to cause a breakdown in the insulation of the cable and the added tuned circuit makes adjustment more critical with relatively small changes in frequency.

These troubles may not be encountered if the link line is kept very short for the highest frequency. A length of 5 feet or more may be tolerable at 3.5 Mc., but a length of a foot at 28 Mc. may be enough to cause serious effects on the functioning of the system.

Adjusting the coupling in such a system must necessarily be largely a matter of cut and try. If the line is short enough so as to have negligible reactance, the coupling between the two tank circuits will increase within limits by adding turns to the link coils, or by coupling the link coils more tightly, if possible, to the tank coils. If it is impossible to change either of these, a variable capacitor in series with or in parallel with the link coil at the driver end of the line, depending upon which connection is the most effective.

If coaxial line is used, the capacitor should be connected in series with the inner conductor. If the line is long enough to have appreciable reactance, the variable capacitor is used to resonate the entire link circuit.

As mentioned previously, the size of the link coils and the length of the line, as well as the size of the capacitor, will affect the resonant frequency and it may take an adjustment of all three before the capacitor will show a pronounced effect on the coupling.

When the system has been made resonant, coupling may be adjusted by varying the link capacitor.

Simple Capacitive Interstage Coupling

The capacitive system of Fig. 6-21A is the simplest of all coupling systems. (See Fig. 6-8 for filament-type tubes.) In this circuit, the plate tank circuit of the driver, C_1L_1 , serves also as the grid tank of the amplifier. Although it is used more frequently than any other system, it is less flexible and has certain limitations that must be taken into consideration.

The two stages cannot be separated physically any appreciable distance without involving loss in transferred power, radiation from the coupling lead and the danger of feedback from this lead. Since both the output capacitance of the driver tube and the input capacitance of the amplifier are across the single circuit, it is sometimes difficult to obtain a tank circuit with a sufficiently low Q to provide an efficient circuit at the higher frequencies. The coupling can be

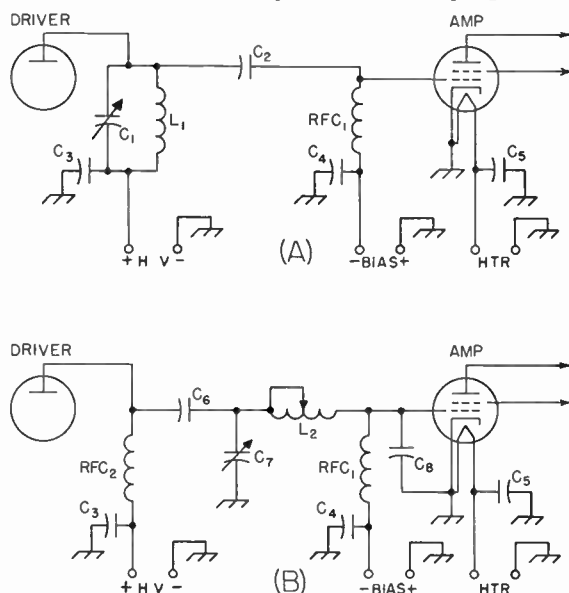

Fig. 6-21 — Capacitive-coupled amplifiers. A — Simple capacitive coupling. B — Pi-section coupling.

- C₁ — Driver plate tank capacitor — see text and Fig. 6-9 for capacitance, Fig. 6-33 for voltage rating.
- C₂ — Coupling capacitor — 50 to 150 μf . mica, as necessary for desired coupling. Voltage rating sum of driver plate and amplifier biasing voltages, plus safety factor.
- C₃ — Driver plate by-pass capacitor — 0.001- μf . disk ceramic or mica. Voltage rating same as plate voltage.
- C₄ — Grid by-pass — 0.001- μf . disk ceramic.
- C₅ — Heater by-pass — 0.001- μf . disk ceramic.
- C₆ — Driver plate blocking capacitor — 0.001- μf . disk ceramic or mica. Voltage rating same as C₂.
- C₇ — Pi-section input capacitor — see text referring to Fig. 6-12 for capacitance. Voltage rating — see Fig. 6-33A.
- C₈ — Pi-section output capacitor — 100- μf . mica. Voltage rating same as driver plate voltage plus safety factor.
- L₁ — To resonate at operating frequency with C₁. See *LC* chart in miscellaneous-data chapter and inductance formula in electrical-laws chapter, or use ARRL *Lightning Calculator*.
- L₂ — Pi-section inductor — See Fig. 6-12. Approx. same as L₁.
- RFC₁ — Grid r.f. choke — 2.5-mh.
- RFC₂ — Driver plate r.f. choke — 2.5 mh.

varied by altering the capacitance of the coupling capacitor, C_2 , but no impedance transforming is possible. The driver load impedance is the sum of the amplifier grid resistance and the reactance of the coupling capacitor in series, the coupling capacitor serving simply as a series reactor. Driver load resistance increases with a decrease in the capacitance of the coupling capacitor.

When the amplifier grid impedance is lower than the optimum load resistance for the driver, a transforming action is possible by tapping the grid down on the tank coil, but this is not recommended because it invariably causes an increase in v.h.f. harmonics and sometimes sets up a parasitic circuit.

So far as coupling is concerned, the Q of the circuit is of little significance. However, the other considerations discussed earlier in connection with tank-circuit Q should be observed.

Pi-Section Tank as Interstage Coupler

A pi-section tank circuit, as shown in Fig. 6-21B, may be used as a coupling device between screen-grid amplifier stages. The circuit is actually a capacitive coupling arrangement with the grid of the amplifier tapped down on the circuit by means of a capacitive divider. In contrast to the tapped-coil method mentioned previously, this system will be very effective in reducing v.h.f. harmonics, because the output capacitor, C_3 , provides a direct capacitive shunt for harmonics across the amplifier grid circuit.

To be most effective in reducing v.h.f. harmonics, C_3 should be a mica capacitor connected directly across the tube-socket terminals. Tapping down on the circuit in this manner also helps to stabilize the amplifier at the operating frequency because of the grid-circuit loading provided by C_3 . For the purposes both of stability and harmonic reduction, experience has shown that a value of 100 $\mu\mu\text{f}$. for C_3 usually is sufficient. In general, C_7 and L_2 should have values approximating the capacitance and inductance used in a conventional tank circuit. A reduction in the inductance of L_2 results in an increase in coupling because C_7 must be increased to retune the circuit to resonance. This changes the ratio of C_7 to C_3 and has the effect of moving the grid tap up on the circuit. Since the coupling to the grid is comparatively loose under any condition, it may be found that it is impossible to utilize the full power capability of the driver stage. If sufficient excitation cannot be obtained, it may be necessary to raise the plate voltage of the driver, if this is permissible. Otherwise a larger driver tube may be required. As shown in Fig. 6-21B, parallel driver plate feed and amplifier grid feed are necessary.

● STABILIZING AMPLIFIERS

External Coupling

A straight amplifier operates with its input and output circuits tuned to the same frequency. Therefore, unless the coupling between these two

circuits is brought to the necessary minimum, the amplifier will oscillate as a tuned-plate tuned-grid circuit. Care should be used in arranging components and wiring of the two circuits so that there will be negligible opportunity for coupling external to the tube itself. Complete shielding between input and output circuits usually is required. All r.f. leads should be kept as short as possible and particular attention should be paid to the r.f. return paths from plate and grid tank circuits to cathode. In general, the best arrangement is one in which the cathode (or filament center tap) connection to ground, and the plate tank circuit are on the same side of the chassis or other shielding. Then the "hot" lead from the grid tank (or driver plate tank) should be brought to the socket through a hole in the shielding. Then when the grid tank capacitor or bypass is grounded, a return path through the hole to cathode will be encouraged, since transmission-line characteristics are simulated.

A check on external coupling between input and output circuits can be made with a sensitive indicating device, such as the one diagrammed in Fig. 6-22. The amplifier tube is removed from its socket and if the plate terminal is

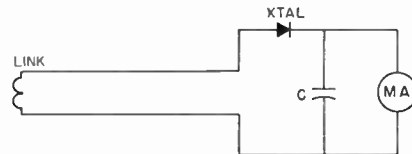

Fig. 6-22 — Circuit of sensitive neutralizing indicator. *Ktal* is a 1N31 crystal detector, *MA* a 0-1 direct-current milliammeter and *C* a 0.001- μf . mica by-pass capacitor.

at the socket, it should be disconnected. With the driver stage running and tuned to resonance, the indicator should be coupled to the output tank coil and the output tank capacitor tuned for any indication of r.f. feedthrough. Experiment with shielding and rearrangement of parts will show whether the isolation can be improved.

Screen-Grid Neutralizing Circuits

The plate-grid capacitance of screen-grid tubes is reduced to a fraction of a micro-microfarad by the interposed grounded screen. Nevertheless, the power sensitivity of these tubes is so great that only a very small amount of feed-back is necessary to start oscillation. To assure a stable amplifier, it is usually necessary to load the grid circuit, or to use a neutralizing circuit. A neutralizing circuit is one external to the tube that balances the voltage fed back through the grid-plate capacitance, by another voltage of opposite phase.

Fig. 6-23A shows how a screen-grid amplifier may be neutralized by the use of an inductive link line coupling the input and output tank circuits in proper phase. The two coils must be properly polarized. If the initial connection proves to be incorrect, connections to one of the link coils should be reversed. Neutralizing is adjusted by changing the distance between the link coils and the tank coils. In the case of ca-

capacitive coupling between stages, one of the link coils will be coupled to the plate tank coil of the driver stage.

A capacitive neutralizing system for screen-grid tubes is shown in Fig. 6-23B. C_2 is the neutralizing capacitor. The capacitance should be chosen so that at some adjustment of C_2 ,

$$\frac{C_2}{C_1} = \frac{\text{Tube grid-plate capacitance (or } C_{gp})}{\text{Tube input capacitance (or } C_{ix})}$$

The tube interelectrode capacitances C_{gp} and C_{ix} are given in the tube tables in the last chapter. The grid-cathode capacitance must include all strays directly across the tube capacitance, including the capacitance of the tuning-capacitor stator to ground. This may amount to 5 to 20 μf . In the case of capacitance coupling, as shown in Fig. 6-23C, the output capacitance of the driver tube must be added to the grid-cathode capacitance of the amplifier in arriving at the value of C_2 . If C_2 works out to an impractically large or small value, C_1 can be changed to compensate by using combinations of fixed mica capacitors in parallel.

Neutralizing Adjustment

The procedure in neutralizing is essentially the same for all types of tubes and circuits. The filament of the amplifier tube should be lighted and excitation from the preceding stage fed to the grid circuit. There should be no plate voltage applied to the amplifier.

The immediate objective of the neutralizing process is reducing to a minimum the r.f. driver voltage fed from the input of the amplifier to its output circuit through the grid-plate capacitance of the tube. This is done by adjusting carefully, bit by bit, the neutralizing capacitor or link coils until an r.f. indicator in the output circuit reads minimum.

The device shown in Fig. 6-22 makes a sensitive neutralizing indicator. The link should be coupled to the output tank coil at the low-potential or "ground" point. Care should be taken to make sure that the coupling is loose enough at all times to prevent burning out the meter or the rectifier. The plate tank capacitor should be readjusted for maximum reading after each change in neutralizing.

A simple indicator is a flashlight bulb (the lower the power the more sensitive) connected at the center of a turn or two of wire coupled to the tank coil at the low-potential point. However, its sensitivity is poor compared with the milliammeter-rectifier.

The grid-current meter may also be used as a neutralizing indicator. If the amplifier is not neutralized, there will be a large dip in grid current as the plate-tank tuning passes through resonance. This dip reduces as neutralization is approached until at exact neutralization all change in grid current should disappear.

When neutralizing an amplifier of medium or high power, it may not be possible to bring the reading of the rectifier indicator down to zero, but a minimum point in the adjustment of the

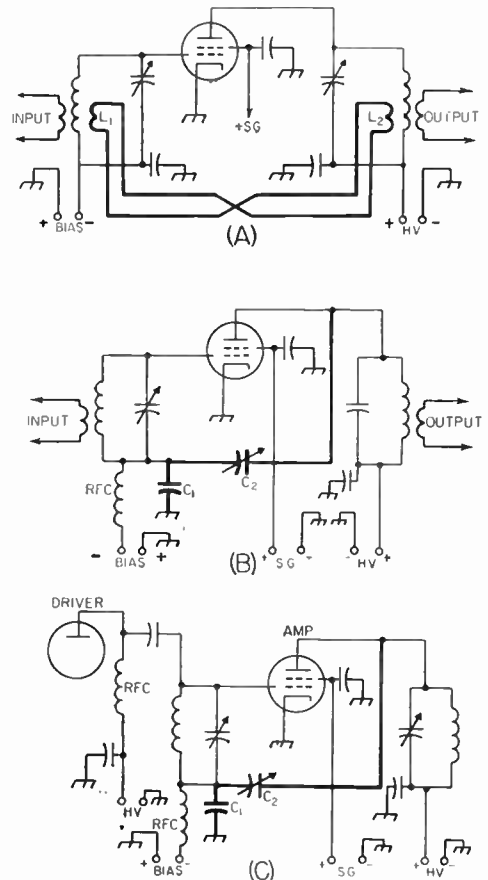

Fig. 6-23 — Screen-grid neutralizing circuits. A — Inductive neutralizing. B-C — Capacitive neutralizing. C_1 — Grid by-pass capacitor — approx. 0.001- μf . mica. Voltage rating same as biasing voltage in B, same as driver plate voltage in C. C_2 — Neutralizing capacitor — approx. 2 to 10 μf . — see text. Voltage rating same as amplifier plate voltage for c.w., twice this value for plate modulation. L_1, L_2 — Neutralizing link — usually a turn or two will be sufficient.

neutralizing control should be found where higher readings are obtained on either side.

Grid Loading

The use of a neutralizing circuit may often be avoided by loading the grid circuit if the driving stage has some power capability to spare. Loading by tapping the grid down on the grid tank coil (or the plate tank coil of the driver in the case of capacitive coupling), or by a resistor from grid to cathode is effective in stabilizing an amplifier, but either device may increase v.h.f. harmonics. The best loading system is the use of a pi-section filter, as shown in Fig. 6-21B. This circuit places a capacitance directly between grid and cathode. This not only provides the desirable loading, but also a very effective capacitive short for v.h.f. harmonics. A 100- μf . mica capacitor for C_8 , wired directly between tube terminals will usually provide sufficient loading to stabilize the amplifier.

V.H.F. Parasitic Oscillation

Parasitic oscillation in the v.h.f. range will take place in almost every r.f. power amplifier. To test for v.h.f. parasitic oscillation, the grid tank coil (or driver tank coil in the case of capacitive coupling) should be short-circuited with a clip lead. This is to prevent any possible t.g.t.p. oscillation at the operating frequency which might lead to confusion in identifying the parasitic. Any fixed bias should be replaced with a grid leak of 10,000 to 20,000 ohms. All load on the output of the amplifier should be disconnected. Plate and screen voltages should be reduced to the point where the rated dissipation is not exceeded. If a Variac is not available, voltage may be reduced by a 115-volt lamp in series with the primary of the plate transformer.

With power applied only to the amplifier under test, a search should be made by adjusting the input capacitor to several settings, including minimum and maximum, and turning the plate capacitor through its range for each of the grid-capacitor settings. Any grid current, or any dip or flicker in plate current at any point, indicates oscillation. This can be confirmed by an indicating absorption wave meter tuned to the frequency of the parasitic and held close to the plate lead of the tube.

The heavy lines of Fig. 6-24A show the usual parasitic tank circuit, which resonates, in most cases, between 150 and 200 Mc. For each type of tetrode, there is a region, usually above the parasitic frequency, in which the tube will be self-neutralized. By adding the right amount of inductance to the parasitic circuit, its resonant frequency can be brought down to the frequency at which the tube is self-neutralized. However, the resonant frequency should not be brought down so low that it falls close to TV Channel 6 (88 Mc.). From the consideration of TVI, the circuit may be loaded down to a frequency not lower than 100 Mc. If the self-neutralizing frequency is below 100 Mc., the circuit should be loaded down to somewhere between 100 and 120 Mc. with inductance. Then the parasitic can be suppressed

by loading with resistance, as shown in Fig. 6-24. A coil of 4 or 5 turns, $\frac{1}{4}$ inch in diameter, is a good starting size. With the tank capacitor turned to maximum capacitance, the circuit should be checked with a g.d.o. to make sure the resonance is above 100 Mc. Then, with the shortest possible leads, a noninductive 100-ohm 1-watt resistor should be connected across the entire coil. The amplifier should be tuned up to its highest-frequency band and operated at low voltage. The tap should be moved a little at a time to find the minimum number of turns required to suppress the parasitic. Then voltage should be increased until the resistor begins to feel warm after several minutes of operation, and the power input noted. This input should be compared with the normal input and the power rating of the resistor increased by this proportion; i.e., if the power is half normal, the wattage rating should be doubled. This increase is best made by connecting 1-watt carbon resistors in parallel to give a resultant of about 100 ohms. As power input is increased, the parasitic may start up again, so power should be applied only momentarily until it is made certain that the parasitic is still suppressed. If the parasitic starts up again when voltage is raised, the tap must be moved to include more turns. So long as the parasitic is suppressed, the resistors will heat up only from the operating-frequency current.

Since the resistor can be placed across only that portion of the parasitic circuit represented by L_p , the latter should form as large a portion of the circuit as possible. Therefore, the tank and bypass capacitors should have the lowest possible inductance and the leads shown in heavy lines should be as short as possible and of the heaviest practical conductor. This will permit L_p to be of maximum size without tuning the circuit below the 100-Mc. limit.

Another arrangement that has been used successfully is shown in Fig. 6-24C. A small turn or two is inserted in place of L_p and this is coupled to a circuit tuned to the parasitic frequency and loaded with resistance. The heavy-line circuit should first be checked with a g.d.o. Then the loaded circuit should be tuned to the same frequency and coupled in to the point where the parasitic ceases. The two coils can be wound on the same form and the coupling varied by sliding one of them. Slight retuning of the loaded circuit may be required after coupling. Start out with low power as before, until the parasitic is suppressed. Since the loaded circuit in this case carries much less operating-frequency current, a single 100-ohm 1-watt resistor will often be sufficient and a 30- μ mf. mica trimmer should serve as the tuning capacitor, C_p .

Low-Frequency Parasitic Oscillation

The screening of most transmitting screen-grid tubes is sufficient to prevent low-frequency parasitic oscillation caused by resonant circuits set up by r.f. chokes in grid and plate circuits. Should this type of oscillation (usually between 1200 and 200 kc.) occur, see section under triode amplifiers.

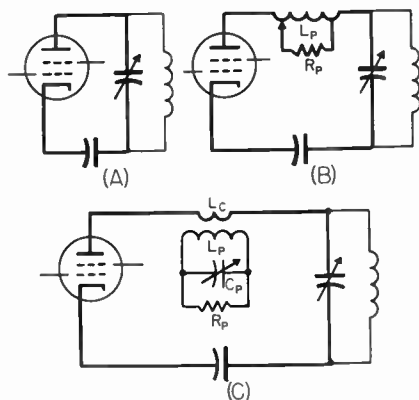

Fig. 6-24 — A — Usual parasitic circuit. B — Resistive loading of parasitic circuit. C — Inductive coupling of loading resistance into parasitic circuit.

● PARALLEL-TUBE AMPLIFIERS

The circuits for parallel-tube amplifiers are the same as for a single tube, similar terminals of the tubes being connected together. The grid impedance of two tubes in parallel is half that of a single tube. This means that twice the grid tank capacitance shown in Fig. 6-20 should be used for the same Q .

The plate load resistance is halved so that the plate tank capacitance for a single tube (Fig. 6-10) also should be doubled. The total grid current will be doubled, so to maintain the same grid bias, the grid-leak resistance should be half that used for a single tube. The required driving power is doubled. The capacitance of a neutralizing capacitor, if used, should be doubled and the value of the screen dropping resistor should be cut in half.

In treating parasitic oscillation, it may be necessary to use a choke in each plate lead, rather than one in the common lead. Input and output capacitances are doubled, which may be a factor in obtaining efficient operation at higher frequencies.

● PUSH-PULL AMPLIFIERS

Circuits for push-pull amplifiers are shown in Fig. 6-25. With this arrangement both grid-input impedance and optimum plate load resistance are doubled. For the same Q , each section of the split-stator tank capacitor should have half the capacitance for a single tube drawing the same total plate current and having the same grid impedance shown by Figs. 6-9 and 6-20. This means that the total tank-circuit capacitance is one-quarter that for a single tube and that the inductances of the tank coils must be quadrupled to resonate at the same frequency. Other values remain the same, except that the total grid, screen and plate currents will be twice the values for a single tube and the stage will require twice the driving power.

In Fig. 6-25A, inductive link coupling is shown. The neutralizing circuit is shown in heavy lines and may not be necessary. Fig. 6-25B shows capacitive coupling to the grids. The driver in this case must be provided with a balanced output circuit. To maintain balanced excitation, it may be necessary to place C_{13} , shown in dashed lines,

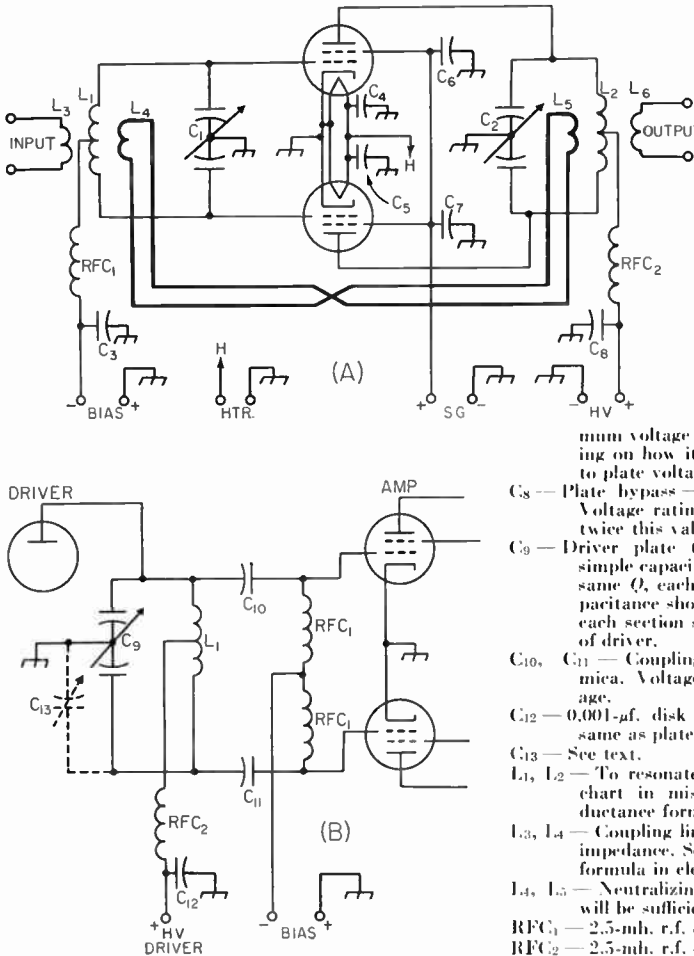

Fig. 6-25 — Push-pull screen-grid amplifier circuits.

- A — Inductive-link coupling. B — Capacitive coupling.
- C_1 — Split-stator grid tank capacitor — see text and Fig. 6-20 for capacitance, Fig. 6-34 for voltage rating.
- C_2 — Split-stator plate tank capacitor — see text and Fig. 6-10 for capacitance, Fig. 6-33 for voltage rating.
- C_3 — Grid by-pass capacitor — 0.001- μ f. disk ceramic.
- C_4, C_5 — Filament by-pass — 0.001- μ f. disk ceramic.
- C_6, C_7 — Screen by-pass — 0.001- μ f. disk ceramic or mica. Voltage rating depends on maximum voltage to which screen may soar, depending on how it is supplied. Voltage rating equal to plate voltage will be safe in any case.
- C_8 — Plate by-pass — 0.001- μ f. disk ceramic or mica. Voltage rating same as plate voltage for c.w.; twice this value for plate modulation.
- C_9 — Driver plate tank capacitor — see section on simple capacitive coupling with single tube. For same Q , each section should have half the capacitance shown in Fig. 6-10. Voltage rating of each section should be twice d.c. plate voltage of driver.
- C_{10}, C_{11} — Coupling capacitor — 50- to 150- μ f. mica. Voltage rating twice driver plate voltage.
- C_{12} — 0.001- μ f. disk ceramic or mica. Voltage rating same as plate voltage.
- C_{13} — See text.
- L_1, L_2 — To resonate at operating frequency. See LC chart in miscellaneous-data chapter and inductance formula in electrical-laws chapter.
- L_3, L_4 — Coupling links — reactance equal to feed-line impedance. See reactance chart and inductance formula in electrical-laws chapter.
- L_4, L_5 — Neutralizing links — usually a turn or two will be sufficient.
- RFC_1 — 2.5-mh. r.f. choke to carry grid current.
- RFC_2 — 2.5-mh. r.f. choke to carry plate current.

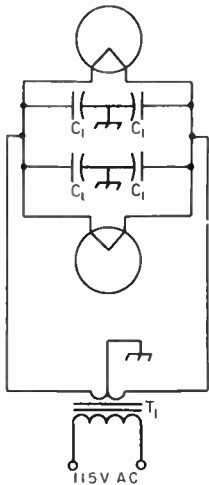

Fig. 6-26 — Connections for tubes in push-pull when filament types are used. The by-pass capacitors, C_1 , should be 0.001- μ f. disk ceramic, one placed close to each filament terminal. T_1 is the filament transformer.

across the lower portion of the circuit to balance the driver-tube output capacitance across the upper half. The remainder of circuit B is the same as A. If a neutralizing link is needed, it should be coupled at the center of the driver plate tank coil.

It is advisable to use separate screen and heater by-pass capacitors, especially when TVI is a factor. Fig. 6-26 shows equivalent "cathode" connections to be substituted when filament-type tubes are used. Also, individual v.h.f. parasitic chokes will be necessary.

Balance in Push-Pull Amplifiers

Proper push-pull operation requires an accurate balance between the two sides of the circuit. Otherwise the dissipation will not be distributed evenly between the two tubes, one being overloaded if an attempt is made to operate the amplifier at full rating. Unbalance is indicated when the grid and/or plate currents are not equal and, if serious, is accompanied by a visible difference in the color of the tube plates. If interchanging the tubes does not change the unbalance, the circuit is not symmetrical electrically.

If the coil center-tap in split-stator tank circuits is insufficiently well-isolated from ground, the balance will depend upon the accuracy of capacitive balance in the tank capacitor, the length of leads connecting the tubes to the capacitor (including the return lead from rotor to filament) and the settings of the neutralizing capacitors. Unbalance in the plate circuit will seldom influence the balance in the grid circuit, but the opposite may not be true. Lengthening one or the other of the leads between the tubes and the tank capacitor will alter the balance, particularly in the plate circuit. In extremes it may be necessary to place a trimmer across one section of the split-stator capacitor. Small differences often may be taken care of by a readjustment of the neutralizing capacitors, possibly to slightly unequal settings. Otherwise, the neutralizing capacitors are adjusted together, keeping the capacitances as equal as possible at each step.

● TRIODE AMPLIFIERS

Circuits for triode amplifiers are shown in Fig. 6-28. Neglecting references to the screen, all of the foregoing information applies equally well to triodes. All triode straight amplifiers must be neutralized, as Fig. 6-28 indicates. From the tube tables, it will be seen that triodes require considerably more driving power than screen-grid tubes. However, they also have less power sensitivity, so that greater feedback can be tolerated without the danger of instability.

Low-Frequency Parasitic Oscillation

When r.f. chokes are used in both grid and plate circuits of a triode amplifier, the split-stator tank capacitors combine with the r.f. chokes to form a low-frequency parasitic circuit, unless the amplifier circuit is arranged to prevent it. In the circuit of Fig. 6-28B, the amplifier grid is series fed and the driver plate is parallel fed. For low frequencies, the r.f. choke in the driver plate circuit is shorted to ground through the tank coil. In Figs. 6-28C and D, a resistor is substituted for the grid r.f. choke. This resistance should be at least 100 ohms. If any grid-leak resistance is used for biasing, it should be substituted for the 100-ohm resistor.

Triode Amplifiers with Pi-Network Output

Pi-network output tanks, designed as described earlier for screen-grid tubes, may also be used with triodes. However, in this case, a balanced input circuit must be provided for neutralizing. Fig. 6-27A shows the circuit when inductive-link input coupling is used, while B shows the circuit to be used when the amplifier

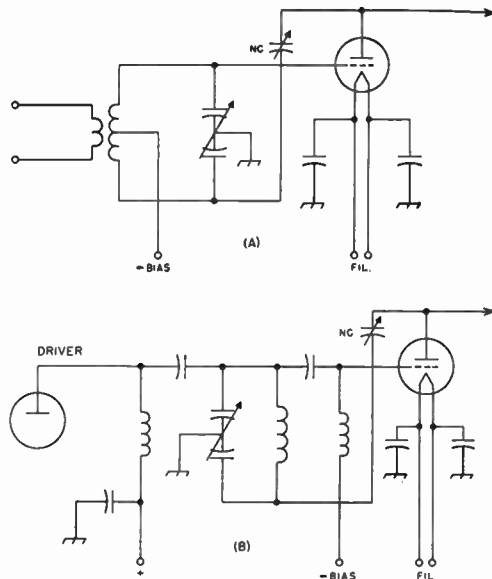

Fig. 6-27 — When a pi-network output circuit is used with a triode, a balanced grid circuit must be provided for neutralizing. A — Inductive-link input. B — Capacitive input coupling.

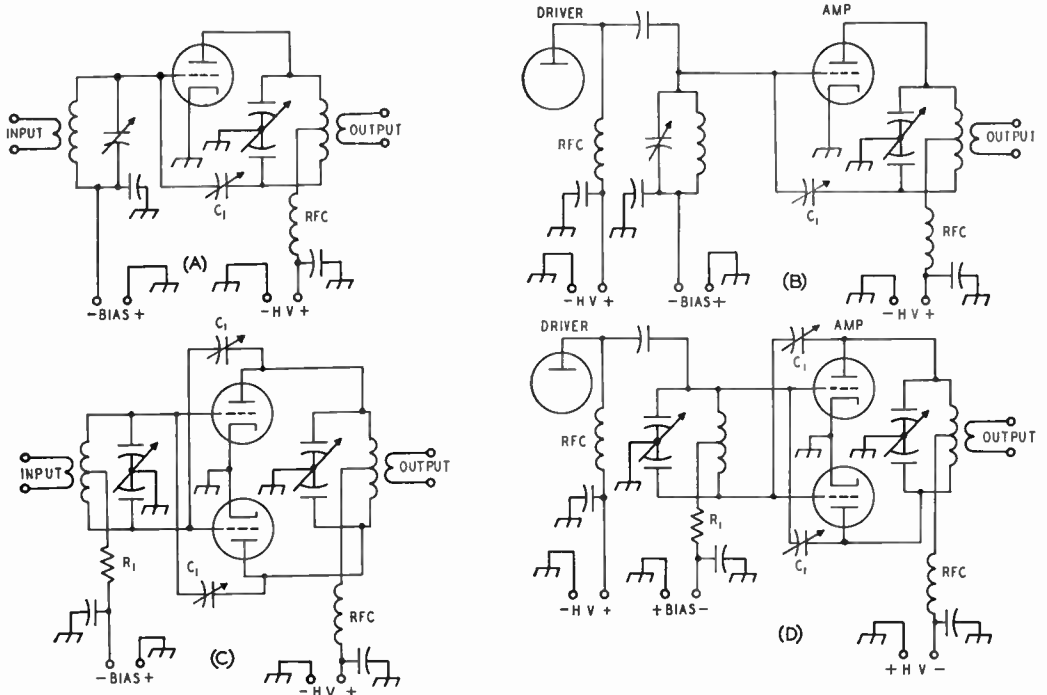

Fig. 6-28 — Triode amplifier circuits. A — Link coupling, single tube. B — Capacitive coupling, single tube. C — Link coupling, push-pull. D — Capacitive coupling, push-pull. Aside from the neutralizing circuits, which are mandatory with triodes, the circuits are the same as for screen-grid tubes, and should have the same values throughout. The neutralizing capacitor, C_1 , should have a capacitance somewhat greater than the grid-plate capacitance of the tube. Voltage rating should be twice the d.c. plate voltage for c.w., or four times for plate modulation, plus safety factor. The resistance R_1 should be at least 100 ohms and it may consist of part or preferably all of the grid leak. For other component values, see similar screen-grid diagrams.

is coupled capacitively to the driver. Pi-network circuits cannot be used in both input and output circuits, since no means is provided for neutralizing.

FREQUENCY MULTIPLIERS

Single-Tube Multiplier

Output at a multiple of the frequency at which it is being driven may be obtained from an amplifier stage if the output circuit is tuned to a harmonic of the exciting frequency instead of to the fundamental. Thus, when the frequency at the grid is 3.5 Mc., output at 7 Mc., 10.5 Mc., 14 Mc., etc., may be obtained by tuning the plate tank circuit to one of these frequencies. The circuit otherwise remains the same as that for a straight amplifier, although some of the values and operating conditions may require change for maximum multiplier efficiency.

Efficiency in a single- or parallel-tube multiplier comparable with the efficiency obtainable when operating the same tube as a straight amplifier involves decreasing the operating angle in proportion to the increase in the order of frequency multiplication. Obtaining output comparable with that possible from the same tube as a straight amplifier involves greatly increasing the plate voltage. A practical limit

as to efficiency and output within normal tube ratings is reached when the multiplier is operated at maximum permissible plate voltage and maximum permissible grid current. The plate current should be reduced as necessary to limit the dissipation to the rated value by increasing the bias. High efficiency in multipliers is not often required in practice, since the purpose is usually served if the frequency multiplication is obtained without an appreciable gain in power in the stage.

Multiplications of four or five sometimes are used to reach the bands above 28 Mc. from a lower-frequency crystal, but in the majority of lower-frequency transmitters, multiplication in a single stage is limited to a factor of two or three, because of the rapid decline in practically obtainable efficiency as the multiplication factor is increased. Screen-grid tubes make the best frequency multipliers because their high power-sensitivity makes them easier to drive properly than triodes.

Since the input and output circuits are not tuned close to the same frequency, neutralization usually will not be required. Instances may be encountered with tubes of high transconductance, however, when a doubler will oscillate in t.g.t.p. fashion, requiring neutralization. The link neutralizing system of Fig. 6-25A is convenient in such a contingency.

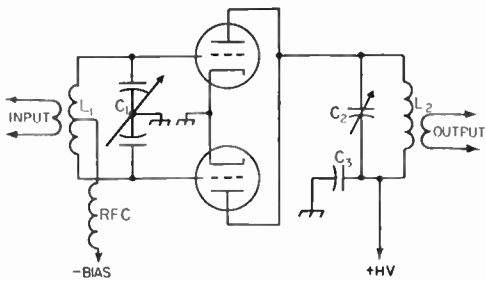

Fig. 6-29 — Circuit of a push-push frequency multiplier for even harmonics.

C_1L_1 and C_2L_2 — See text.

C_3 — Plate bypass — 0.001- μ f. disk ceramic or mica. Voltage rating equal to plate voltage plus safety factor.

RFC — 2.5-mh. r.f. choke.

Push-Push Multipliers

A two-tube circuit which works well at even harmonics, but not at the fundamental or odd harmonics, is shown in Fig. 6-29. It is known as the **push-push** circuit. The grids are connected in push-pull while the plates are connected in parallel. The efficiency of a doubler using this circuit may approach that of a straight amplifier, because there is a plate-current pulse for each cycle of the output frequency.

This arrangement has an advantage in some applications. If the heater of one tube is turned off, its grid-plate capacitance, being the same as that of the remaining tube, serves to neutralize the circuit. Thus provision is made for either straight amplification at the fundamental with a single tube, or doubling frequency with two tubes as desired.

The grid tank circuit is tuned to the frequency of the driving stage and should have the same constants as the grid tank circuit of a push-pull amplifier (see Fig. 6-25). The plate tank circuit is tuned to an even multiple of the exciting frequency, and should have the same values as a straight amplifier for the harmonic frequency (see Fig. 6-10), bearing in mind that the total plate current of both tubes determines the C to be used.

Push-Pull Multiplier

A single- or parallel-tube multiplier will deliver output at either even or odd multiples of the exciting frequency. A push-pull multiplier does not work satisfactorily at even multiples because even harmonics are largely canceled in the output. On the other hand, amplifiers of this type work well as triplers or at other odd harmonics. The operating requirements are similar to those for single-tube multipliers, the plate tank circuit being tuned, of course, to the desired odd harmonic frequency.

METERING

Fig. 6-30 shows how a voltmeter and milliammeter should be connected to read various voltages and currents. Voltmeters are seldom installed permanently, since their principal use is in preliminary checking. Also, milliammeters are not normally installed permanently in all of the positions shown. Those most often used are the ones reading grid current and plate current, or grid current and cathode current.

Milliammeters come in various current ranges. Current values to be expected can be taken from the tube tables and the meter ranges selected accordingly. To take care of normal overloads and pointer swing, a meter having a current range of about twice the normal current to be expected should be selected.

Meter Installation

Grid-current meters connected as shown in Fig. 6-30 and meters connected in the cathode circuit need no special precautions in mounting on the transmitter panel so far as safety is concerned. However, milliammeters having zero-adjusting screws on the face of the meter should be recessed behind the panel so that accidental

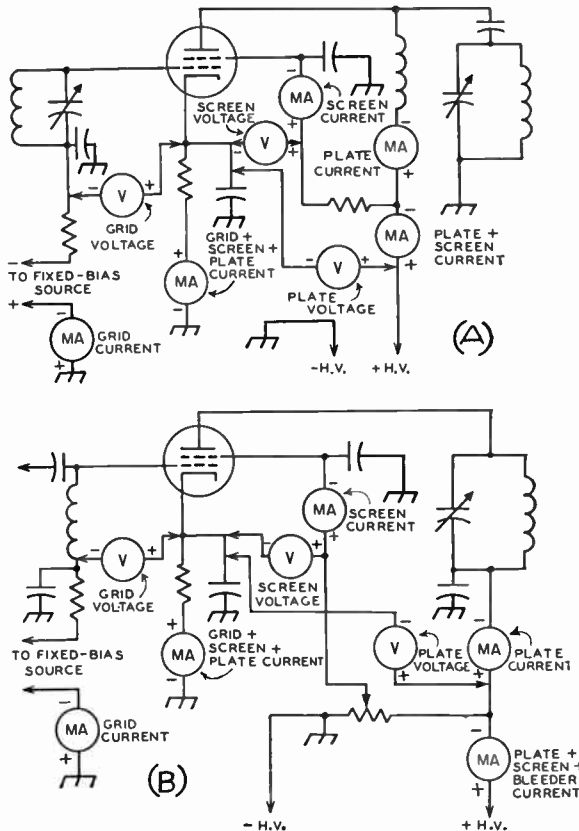

Fig. 6-30 — Diagrams showing placement of voltmeter and milliammeter to obtain desired measurements. A — Series grid feed, parallel plate feed and series screen voltage-dropping resistor. B — Parallel grid feed, series plate feed and screen voltage divider.

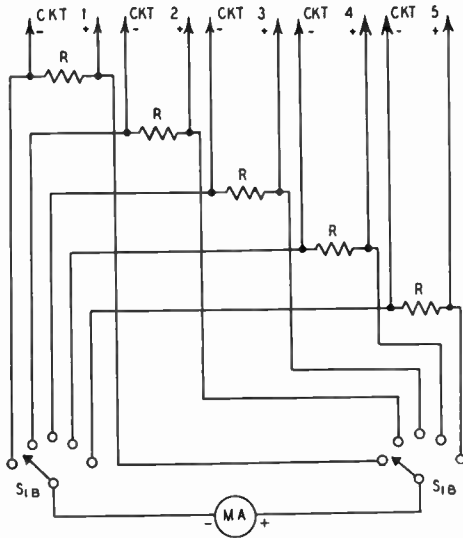

Fig. 6-31 — Switching a single milliammeter. The resistors, R , should be 10 to 20 times the internal resistance of the meter: 17 ohms will usually be satisfactory. S_1 is a 2-section rotary switch. Its insulation should be ceramic for high voltages, and an insulating coupling should always be used between shaft and control.

contact with the adjusting screw is not possible, if the meter is connected in any of the other positions shown in Fig. 6-30. The meter can be mounted on a small subpanel attached to the front panel with long screws and spacers. The meter opening should be covered with glass or celluloid. Illuminated meters make reading easier. Reference should also be made to the TVI chapter of this Handbook in regard to wiring and shielding of meters to suppress TVI.

Meter Switching

Milliammeters are expensive items and therefore it is seldom feasible to provide even grid-current and plate-current meters for all stages. The exciter stages in a multistage transmitter often do not require metering after initial adjustments. It is common practice to provide a meter-switching system by which a single milliammeter may be switched to read currents in as many circuits as desired. Such a meter-switching circuit is shown in Fig. 6-31. The resistors, R , are connected in the various circuits in place of the milliammeters shown in Fig. 6-30. Since the resistance of R is several times the internal resistance of the milliammeter, it will have no practical effect upon the reading of the meter.

When the meter must read currents of widely differing values, a meter with a range sufficiently low to accommodate the lowest values of current to be measured may be selected. In the circuits in which the current will be above the scale of the meter, the resistance of R can be adjusted to a lower value which will give the meter reading a multiplying factor. (See chapter on measurements.) Care should be taken to observe proper polarity in making the connections between the resistors and the switch.

● AMPLIFIER ADJUSTMENT

Earlier sections in this chapter have dealt with the design and adjustment of input (grid) and output (plate) coupling systems, the stabilization of amplifiers, and the methods of obtaining the required electrode voltages. Reference to these sections should be made as necessary in following a procedure of amplifier adjustment.

The objective in the adjustment of an intermediate amplifier stage is to secure adequate excitation to the following stage. In the case of the output or final amplifier, the objective is to obtain maximum power output to the antenna. In both cases, the adjustment must be consistent with the tube ratings as to voltage, current and dissipation ratings.

Adequate drive to a following amplifier is normally indicated when rated grid current in the following stage is obtained with the stage operating at rated bias, the stage loaded to rated plate current, and the driver stage tuned to resonance. In a final amplifier, maximum output is normally indicated when the output coupling is adjusted so that the amplifier tube draws rated plate current when it is tuned to resonance.

Resonance in the plate circuit is normally indicated by the dip in plate-current reading as the plate tank capacitor is tuned through its range. When the stage is unloaded, or lightly loaded, this dip in plate current will be quite pronounced. As the loading is increased, the dip will become less noticeable. See Fig. 6-4. However, in the case of a screen-grid tube whose screen is fed through a series resistor, maximum output may not be simultaneous with the dip in plate current. The reason for this is that the screen current varies widely as the plate circuit is tuned through resonance. This variation in screen current causes a corresponding variation in the voltage drop across the screen resistor. In this case, maximum output may occur at an adjustment that results in an optimum combination of screen voltage and nearness to resonance. This effect will seldom be observed when the screen is operated from a fixed-voltage source.

The first step in the adjustment of an amplifier is to stabilize it, both at the operating frequency by neutralizing it if necessary, and at parasitic frequencies by introducing suppression circuits.

If "flat" transmission-line coupling is used, the output end of the line should be matched, as described in this chapter for the case where the amplifier is to feed the grid of a following stage, or in the transmission-line chapter if the amplifier is to feed an antenna system. After proper match has been obtained, all adjustments in coupling should be made at the *input* end of the line.

Until preliminary adjustments of excitation have been made, the amplifier should be operated with filament voltage on and fixed bias, if it is required, but screen and plate voltages off. With the exciter coupled to the amplifier, the coupling to the driver should be adjusted until the amplifier draws rated grid current, or somewhat above

the rated value. Then a load (the antenna grid of the following stage, or a dummy load—see Fig. 6-32) should be coupled to the amplifier.

With screen and plate voltages (preferably reduced) applied, the plate tank capacitor should be adjusted to resonance as indicated by a dip in plate current. Then, with full screen and plate voltages applied, the coupling to the load should be adjusted until the amplifier draws rated plate current. Changing the coupling to the load will usually detune the tank circuit, so that it will be necessary to readjust for resonance each time a change in coupling is made. An amplifier should not be operated with its plate circuit off resonance for any except the briefest necessary time, since the plate dissipation increases greatly when the plate circuit is not at resonance. Also, a screen-grid tube should not be operated without normal load for any appreciable length of time, since the screen dissipation increases.

It is normal for the grid current to decrease when plate voltage is applied, and to decrease again as the amplifier is loaded more heavily. As the grid current falls off, the coupling to the driver should be increased to maintain the grid current at its rated value.

MEASURING POWER OUTPUT

The power output of any transmitter stage can be checked with reasonable accuracy by simply coupling an ordinary lamp to the output tank circuit and comparing its brilliance with that of another lamp of the same size operating from a.c. Since it is difficult to judge power accurately when the lamp is over or under normal brilliance, the lamp selected should have a wattage rating as close as possible to that expected from the amplifier. Flashlight bulbs can be used for low power. At frequencies above 7 Mc. sufficient coupling usually is obtained by connecting the lamp in series with a few turns of wire that can be slipped over or inside the tank coil, as shown in Fig. 6-32A. But at 3.5 and 7 Mc., it is usually necessary to tap the bulb directly across a portion of the tank coil, as shown at B. **WARNING!** Turn off the high voltage when tapping a series-fed tank circuit. The coupling should be adjusted until the plate current at resonance is the rated loaded value for the tube. A more accurate dummy load is described in *QST* for March, 1951.

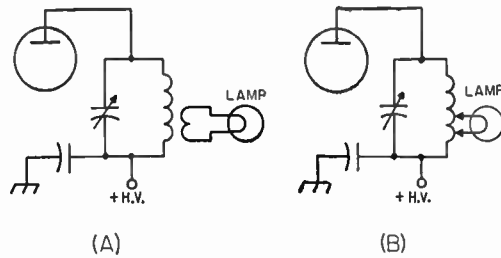

Fig. 6-32—Using a lamp bulb for an approximate check on the output of an oscillator or amplifier, always turn off the power before changing the tap.

COMPONENT RATINGS AND INSTALLATION

Plate Tank-Capacitor Voltage

In selecting a tank capacitor with a spacing between plates sufficient to prevent voltage breakdown, the peak r.f. voltage across a tank circuit under load, but without modulation, may be taken conservatively as equal to the d.c. plate voltage. If the d.c. plate voltage also appears across the tank capacitor, this must be added to the peak r.f. voltage, making the total peak voltage twice the d.c. plate voltage. If the amplifier is to be plate-modulated, this last value must be doubled to make it four times the d.c. plate voltage, because both d.c. and r.f. voltages double with 100-per-cent plate modulation. At the higher plate voltages, it is desirable to choose a tank circuit in which

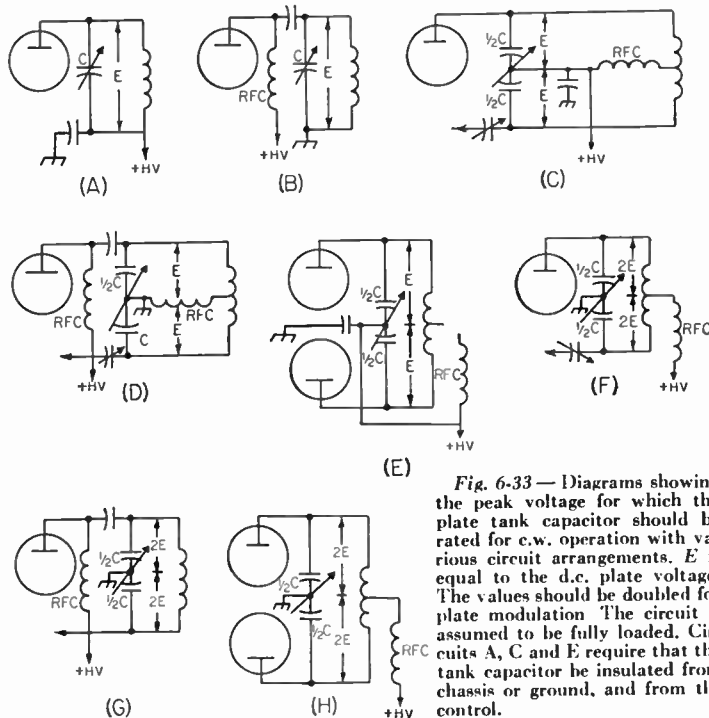

Fig. 6-33—Diagrams showing the peak voltage for which the plate tank capacitor should be rated for c.w. operation with various circuit arrangements. E is equal to the d.c. plate voltage. The values should be doubled for plate modulation. The circuit is assumed to be fully loaded. Circuits A, C and E require that the tank capacitor be insulated from chassis or ground, and from the control.

the d.c. and modulation voltages do not appear across the tank capacitor, to permit the use of a smaller capacitor with less plate spacing. Fig. 6-33 shows the peak voltage, in terms of d.c. plate voltage, to be expected across the tank capacitor in various circuit arrangements. These peak-voltage values are given assuming that the amplifier is loaded to rated plate current. Without load, the peak r.f. voltage will run much higher.

The plate spacing to be used for a given peak voltage will depend upon the design of the variable capacitor, influencing factors being the mechanical construction of the unit, the insulation used and its placement in respect to intense fields, and the capacitor plate shape and degree of polish. Capacitor manufacturers usually rate their products in terms of the peak voltage between plates. Typical plate spacings are shown in the following table.

Typical Tank-Capacitor Plate Spacings					
Spacing (In.)	Peak Voltage	Spacing (In.)	Peak Voltage	Spacing (In.)	Peak Voltage
0.015	1000	0.07	3000	0.175	7000
0.02	1200	0.08	3500	0.25	9000
0.03	1500	0.125	4500	0.35	11000
0.05	2000	0.15	6000	0.5	13000

Plate tank capacitors should be mounted as close to the tube as temperature considerations will permit to make possible the shortest capacitive path from plate to cathode. Especially at the higher frequencies where minimum circuit capacitance becomes important, the capacitor should be mounted with its stator plates well spaced from the chassis or other shielding. In circuits where the rotor must be insulated from ground, the capacitor should be mounted on ceramic insulators of size commensurate with the plate voltage involved and — most important of all, from the viewpoint of safety to the operator — a well-insulated coupling should be used between the capacitor shaft and the dial. *The section of the shaft attached to the dial should be well grounded.* This can be done conveniently through the use of panel shaft-bearing units.

Grid Tank Capacitors

In the circuit of Fig. 6-34, the grid tank capacitor should have a voltage rating approximately equal to the biasing voltage plus 20 per cent of the plate voltage. In the balanced circuit of B, the voltage rating of *each section* of the capacitor should be this same value.

The grid tank capacitor is preferably mounted with shielding between it and the tube socket for isolation purposes. It should, however, be mounted close to the socket so that a short lead can be passed through a hole to the socket. The rotor ground lead or by-pass lead should be run directly to the nearest point on the chassis or other shielding. In the circuit of Fig. 6-34A, the same insulating precautions mentioned in connection with the plate tank capacitor should be used.

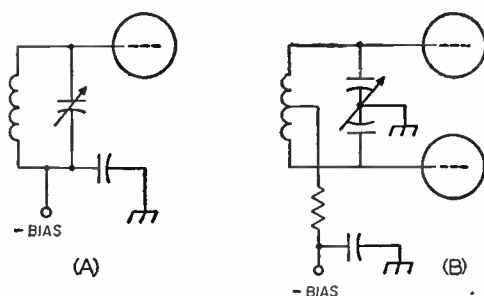

Fig. 6-34 — The voltage rating of the grid tank capacitor in A should be equal to the biasing voltage plus about 20 per cent of the plate voltage.

Plate Tank Coils

The inductance of a manufactured coil usually is based upon the highest plate-voltage/plate-current ratio likely to be used at the maximum power level for which the coil is designed. Therefore in the majority of cases, the capacitance shown by Figs. 6-9 and 6-20 will be greater than that for which the coil is designed and turns must be removed if a Q of 10 or more is needed. At 28 Mc., and sometimes 14 Mc., the value of capacitance shown by the chart for a high plate-voltage/plate-current ratio may be lower than that attainable in practice with the components available. The design of manufactured coils usually takes this into consideration also and it may be found that values of capacitance greater than those shown (if stray capacitance is included) are required to tune these coils to the band.

Manufactured coils are rated according to the plate-power input to the tube or tubes when the stage is loaded. Since the circulating tank current is much greater when the amplifier is unloaded, care should be taken to operate the amplifier conservatively when unloaded to prevent damage to the coil as a result of excessive heating.

Tank coils should be mounted at least their diameter away from shielding to prevent a marked loss in Q . Except perhaps at 28 Mc., it is not important that the coil be mounted quite close to the tank capacitor. Leads up to 6 or 8 inches are permissible. It is more important to keep the tank capacitor as well as other components out of the immediate field of the coil. For this reason, it is preferable to mount the coil so that its axis is parallel to the capacitor shaft, either alongside the capacitor or above it.

There are many factors that must be taken into consideration in determining the size of wire that should be used in winding a tank coil. The considerations of form factor and wire size that will produce a coil of minimum loss are often of less importance in practice than the coil size that will fit into available space or that will handle the required power without excessive heating. This is particularly true in the case of screen-grid tubes where the relatively small driving power required can be easily obtained even if the losses in the driver are quite high. It may be considered preferable to take the power loss if the physical

size of the exciter can be kept down by making the coils small.

The accompanying table shows typical conductor sizes that are usually found to be adequate for various power levels. For powers under 25 watts, the minimum wire sizes shown are largely a matter of obtaining a coil of reasonable *Q*. So far as the power is concerned, smaller wire could be used.

Space-winding the turns invariably will result in a coil of higher *Q*, especially at frequencies above 7 Mc., and a form factor in which the turns spacing results in a coil length between 1 and 2 times the diameter is usually considered satisfactory. Space winding is especially desirable at the higher power levels because the heat developed is dissipated more readily. The power lost in a tank coil that develops appreciable heat at the higher-power levels does not usually represent a serious loss percentage-wise. A more serious consequence, especially at the higher frequencies, is that coils of the popular "air-wound" type supported on plastic strips may deform. In this case, it may be necessary to use wire (or copper tubing) of sufficient size to make the coil self-supporting. Coils wound on tubular forms of ceramic or mica-filled bakelite will also stand higher temperatures.

voltages, disk ceramics with higher-voltage ratings, or capacitors of the TV "doorknob" type are recommended. Voltage ratings of by-pass capacitors should be similar to those for blocking capacitors.

R. F. Chokes

The characteristics of any r.f. choke will vary with frequency, from characteristics resembling those of a parallel-resonant circuit, of high impedance, to those of a series-resonant circuit, where the impedance is lowest. In between these extremes, the choke will show varying amounts of inductive or capacitive reactance.

In series-feed circuits, these characteristics are of relatively small importance because, in a correctly-operating circuit, the r.f. voltage across the choke is negligible. In a parallel-feed circuit, however, the choke is shunted across the tank circuit, and is subject to the full tank r.f. voltage. If the choke does not present a sufficiently high impedance, enough power will be absorbed by the choke to cause it to burn out. With chokes of the usual type, wound with small wire for compactness, a relatively small amount of power loss in the choke will cause excessive heating.

To avoid this, the choke must have a sufficiently high reactance to be effective at the lowest frequency, and yet have no series resonances near the higher-frequency bands. This is not difficult to accomplish for a frequency range of 2 to 1 or less. But the design of a choke that meets requirements over a range as wide as 3.5 to 30 Mc. at the higher voltages is quite critical.

Universal pie-wound chokes of the "receiver" type (2.5 mh., 125 ma.) are usually satisfactory if the plate voltage does not exceed 750. For higher voltages, a single-layer solenoid-type choke of correct design has been found satisfactory. The National type R-175A is a representative manufactured type. An example of a satisfactory home-made choke for voltages up to at least 3000 consists of 112 turns of No. 26 wire, spaced to a length of $3\frac{7}{8}$ inches on a 1-inch ceramic form (Centralab stand-off insulator, type X3022H). A ceramic form is advisable from the consideration of temperature. This choke has only one series resonance (near 24 Mc.), and exhibits an equivalent parallel resistance of 0.25 megohm or more in all of the amateur bands from 80 through 10.

Since the characteristics of a choke will be affected by any metal in its field, it should be checked when mounted in the position in which it is to be used, or in a temporary set-up simulating the same conditions. The plate end of the choke should not be connected, but the power-supply end should be connected directly, or by-passed, to the chassis. The g.d.o. should be coupled as close to the ground end of the choke as possible. Series resonances, indicating the frequencies of greatest loss, should be checked with the choke short-circuited with a short piece of wire. Parallel resonances, indicating frequencies of least loss are checked with the short removed.

(For further discussion, see *QST*, May, 1954.)

Wire Sizes for Transmitting Coils

Power Input (Watts)	Band (Mc.)	Wire Size
1000	28-21	6
	14-7	8
	3.5-1.8	10
500	28-21	8
	14-7	12
	3.5-1.8	14
150	28-21	12
	14-7	14
	3.5-1.8	18
75	28-21	14
	14-7	18
	3.5-1.8	22
25 or less*	28-21	18
	14-7	24
	3.5-1.8	28

* Wire size limited principally by consideration of *Q*.

Plate-Blocking and By-Pass Capacitors

Plate-blocking capacitors should have low inductance; therefore capacitors of the mica or ceramic type are preferred. For frequencies between 3.5 and 30 Mc., a capacitance of 0.001 is commonly used. The voltage rating should be 25 to 50% above the plate-supply voltage (twice this rating for plate modulation).

Small disk ceramic capacitors (approximately $\frac{1}{4}$ inch in diameter) are to be preferred as by-pass capacitors, since when they are applied correctly (see TVI chapter), they are series resonant in the TV range and therefore are an important measure in filtering power-supply leads. Capacitors of this type are rated at 600 to 1000 volts. At higher

A One-Tube Two-Band Transmitter for the Novice

Figs. 6-35, 6-36, and 6-37 show the details of a low-power crystal-oscillator transmitter covering the 3.5- and 7-Mc. bands. It is complete with power supply, and an output circuit that will feed directly into a simple antenna without the need for an antenna tuner. The circuit diagram appears in Fig. 6-36. A 6AG7 pentode is used in an oscillator of the grid-plate type. The output circuit, consisting of C_{10} , C_{11} and L_1 , is in the form of a pi-section network that will couple into a wire of random length. The circuit is keyed in the cathode circuit.

J_1 is an octal tube socket that is used as a combination crystal socket and key jack. R_1 is the grid leak, C_1 and C_2 are excitation-control capacitors. RFC_1 is necessary to prevent short-circuiting C_2 for r.f. when the key is closed. R_2 is the screen voltage-dropping resistor that reduces the voltage to the screen. RFC_2 is the plate feed choke. Plate current is measured by the milliammeter, MA_1 . C_7 is the plate blocking capacitor, and C_3 , C_5 and C_6 are by-pass capacitors.

The power supply is a simple one delivering about 350 volts. The smoothing filter, consisting of C_8 , C_9 and the 8-h. 40-ma. choke, is of the capacitive-input type. R_3 is the bleeder resistor. S_1 turns the power supply on and off.

Construction

The parts are assembled on a $7 \times 12 \times 3$ -inch aluminum chassis. In the placement of parts, the power-supply section is kept in a line at the back of the chassis. The r.f. components are mounted toward the front of the chassis. As can be seen in the photographs, there are three octal sockets — one for the 5Y3GT rectifier, one for the 6AG7 oscillator, and the third which is used as a crystal socket and key jack.

With the exception of the three sockets and

the meter, all the mounting holes can be made with an ordinary hand drill. For the socket holes, one can purchase, or borrow, a socket punch. The meter hole can be started with the socket punch and then enlarged with a half-round or rattail file. The variable capacitors are mounted directly against the under side of the chassis. In placing them, be sure that their shafts extend far enough out from the front of the chassis to accommodate the tuning knobs. These capacitors are of the broadcast-receiver replacement type, and can be purchased locally, or from one of the large mail-order houses. They are usually listed as single-gang midget t.r.f. capacitors and have a maximum capacitance of more than 300 $\mu\mu\text{f}$.

The power transformer is mounted in such a manner that the high-voltage leads and the 5-volt rectifier leads are brought out at a point closest to the 5Y3GT rectifier socket. A three-terminal tie point is mounted close to the transformer 115-volt leads to furnish terminals for the power switch and transformer leads. After the sockets, a.c. switch, meter, and feed-through bushings for holding L_1 are all mounted in place, the wiring can be started.

Wiring

Connect the two 115-volt transformer primary leads (black), each to one of the tie points. Then also connect one of the power-cord wires to one of these tie points, and one terminal of the power switch, S_1 , to the other. Connect the remaining side of S_1 , and the remaining power-cord wire to the third tie point. Fasten one of the 6.3-volt transformer leads (green) to a soldering lug under the tie-point mounting screw. The remaining 6.3-volt transformer wire (green) is connected to Pin 7 on the 6AG7 socket.

For the high-voltage wiring, the center-tap

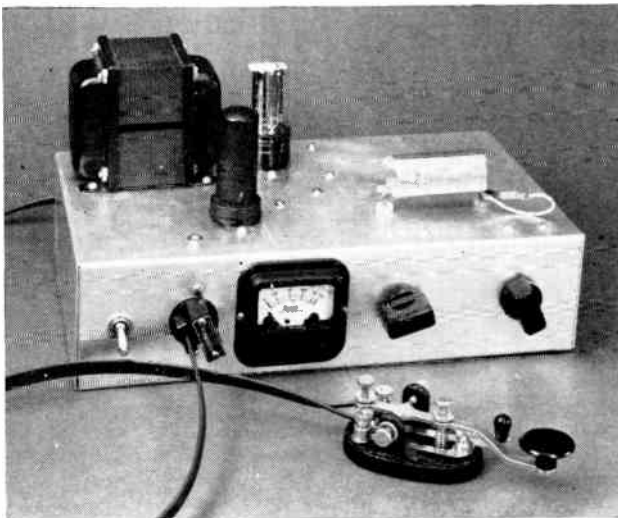
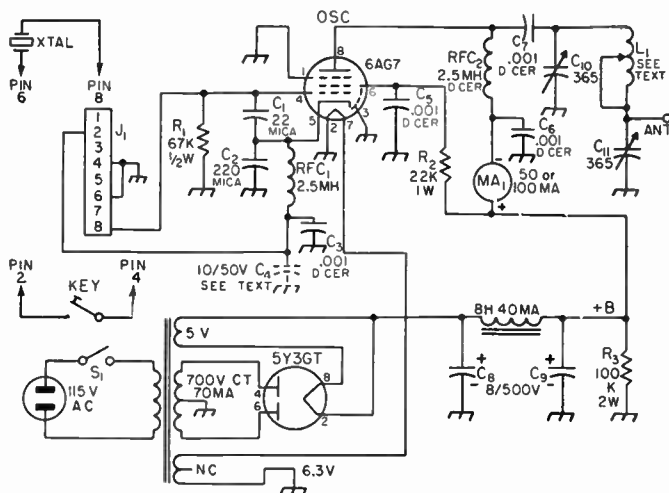

Fig. 6-35 — Top view of the Novice 2-band transmitter. L_1 at the top right-hand side is shown with the clip in the 80-meter position. It is clipped to the feed-through bushing. The lead to the key is a short piece of 300-ohm Twin-Lead which is terminated in a Millen 300-ohm plug. This type of plug is the correct size for octal socket Pins 2 and 1.

Fig. 6-36 — Circuit diagram of the beginner's transmitter.



wire of the high-voltage secondary (red and yellow) is connected to ground, one of the high-voltage leads (red) is connected to Pin 4 of the 5Y3GT socket, while the other red lead goes to Pin 6. One of the 5-volt rectifier-filament leads (yellow) is connected to Pin 8 of the 5Y3GT socket, and the other yellow lead is run to Pin 2. Also connected to Pin 2 of the 5Y3GT socket is a lead from the choke, and the lead marked + from C_8 . The other side of C_8 , or the *negative* side, is grounded. The remaining lead of the choke, the *plus* side of C_9 , and a lead from R_3 , are all run to a terminal on a tie point. The *negative* side of C_9 and the other lead from R_3 are grounded. This completes the power-supply wiring.

Pins 1, 2, and 3 of the 6AG7 socket are connected together with a bare wire and the wire run to ground. Also, one side of C_2 must be grounded, so it can be connected to one of these pins. The other side of C_2 is run to Pin 5. A lead to RFC_1 is also connected to Pin 5. One side of C_1 , one side of R_1 , and a lead to Pin 8 of J_1 are all soldered to Pin 4 of the 6AG7 socket. The other side of R_1 is grounded, while the remaining side of C_1 goes to Pin 5. Pins 4 and 6 of the crystal socket are also grounded. The remaining side of RFC_1 is connected to Pin 2 of J_1 . Also connected to Pin 2 is one side of C_3 . The other side of C_3 is grounded.

The screen resistor, R_2 , is connected between the B+ (+ terminal of C_9) terminal and Pin 6 of the 6AG7 socket. Also connected to Pin 6 is one side of C_5 . The other side of C_5 is grounded. A lead is connected between the B+ terminal and the + side of the meter. The other terminal of the meter is connected to one side of RFC_2 . Also connected to this point on RFC_2 is one side of C_6 , the other side of C_6 being grounded. The remaining side of RFC_2 is connected to Pin 8 of the 6AG7 socket and C_7 is connected between this side of RFC_2 and the stator section of C_{10} is also connected to the nearest of the two feed-through bushings holding L_1 . The stator of C_{11} is connected to the other feed-through bushing, and a lead is run from this bushing to the trans-

mitter output terminal mounted on the back side of the chassis. This should complete all wiring below the chassis.

Coil

As shown in the parts list, L_1 is a Barker & Williamson stock No. 3016 coil with 13 turns removed from each end. For 40-meter operation, it is necessary to short out a large part of the coil. This is accomplished by use of a short clip lead. One end of the lead is connected along with one end of L_1 to the output bushing (the one connected to C_{11}). The other end of L_1 is soldered to the input bushing. To operate on 40 meters, it is necessary to attach the clip to the 30th turn of L_1 , from the input side. In order not to short out the 29th and 31st turns, they can be bent in toward the axis of the coil.

Testing

An 80-meter crystal between 3700 and 3750 kc. will be needed for 80-meter operation. For 40-meter work, one between 3588 and 3598 kc. will be required. (The crystal frequency is doubled for 7-Mc. operation.)

In tuning up on 80 meters, insert the crystal in Pins 6 and 8 of the octal socket. The key leads are inserted in Pins 2 and 4. A 115-volt 10- or 15-watt light bulb will serve as an artificial load for testing purposes. Connect the bulb to the output of the rig by soldering a piece of wire to the center terminal in the base of the bulb, and one to the screw shell portion. One of the wires is then connected to the output terminal of the transmitter and the other to the chassis. The 115-volt a.c. switch is turned on and the tubes allowed a minute or so to warm up. After the rig has been on for a minute, close the key. Tune the station receiver to the crystal frequency and the transmitter's signal should be heard. The input capacitor, C_{10} , is slowly tuned through its range. Two things should happen — the dummy load lamp should light and the meter should show a dip, or lower reading, at the point where the bulb lights. Also, the signal should be louder at this point. Now

tune the output capacitor, C_{11} , across its range and the bulb should brighten at one point, and the signal get louder in the receiver. Also, the meter should show a greater reading than before. Switching back and forth between the two capacitors, always tune for maximum brilliance in the bulb.

Antenna

An antenna may now be substituted for the lamp. The type of output circuit used in the rig will load with almost any length of wire. However, it will load with a 30-foot length of wire on both 80 and 40 meters a great deal easier than with some lengths. One end of the wire should be connected to the output terminal and the other end suspended on an insulator attached to a cord or rope slung from the highest available support. (See the antenna chapter for methods of bringing the wire in to the transmitter.)

Output Indicator

The transmitter *can* be tuned up by the meter, but sometimes a beginner may become confused trying to interpret the readings he gets. A simple device to show that the antenna is taking power consists of two pieces of wire, about two feet long, and a 2-volt 0.06-ampere flashlight bulb, either No. 48 or 49. The bulb is connected between the two pieces of wire, one lead to the tip of the bulb base and the other lead to the shell of the base, making a four-foot length of wire with the bulb in the center. One end of this wire is connected to the output terminal, while the other end is clipped on the antenna, three or four feet up. Scrape the wire at this point if it is insulated. When the transmitter is turned on and the capacitors are tuned, a point will be reached in the tuning where the bulb will glow, or light up. Tune the capacitors for maximum brilliance in the bulb; this is an indication that maximum power is going into the antenna.

Forty-meter tune-up procedure is the same as

Shopping List for Novice Transmitter

- 22- μ f. mica capacitor.
- 220- μ f. mica capacitor.
- 4 0.001- μ f. disk ceramic capacitors.
- 2 8- μ f. 500-volt midget electrolytic capacitors.
- 67,000-ohm resistor, $\frac{1}{2}$ watt.
- 22,000-ohm resistor, 1 watt.
- 0.1-megohm resistor, 2 watts.
- 2 2 $\frac{1}{2}$ -mh. r.f. chokes (National R1008 or Millen 34102).
- 2 variable capacitors (midget type r.f. one-gang broadcast receiver replacement).
- 70 turns of No. 24 wire, 1-inch diam., 2 $\frac{1}{4}$ inches long (B & W 3016 with 13 turns removed from each end).
- 8-h. 40-ma. filter choke (Thorndarson T200'52).
- Power transformer: 350-0-350 volts r.m.s., 70 ma.; 5 v., 2 amp.; 6.3 v., 2 $\frac{1}{2}$ amp. (Thorndarson TS-21R02).
- 3 octal sockets.
- Single-pole single-throw toggle switch.
- 2 feed-through insulators (National TPB).
- Tip jack (Amphenol type 7818).
- 2 three-point terminal strips.
- 0-50 or 0-100 d.c. milliammeter (Shurite).
- Aluminum chassis 3 by 7 by 12 inches.
- 6 feet of hook-up wire.
- 6A17 tube.
- 5Y3 tube.
- 6 solder lugs.
- 18 6-32 \times $\frac{1}{2}$ -inch nuts, bolts, and washers.
- Two tuning knobs to fit $\frac{1}{4}$ -inch shaft.
- Crystal.

for 80 with the exception of using the correct crystal, and shorting out the section of L_1 . Remember to listen on the receiver when tuning up the transmitter on 40 or 80. When tuning up on 40, the signal should be definitely louder on 40 than on 80 meters, and vice versa for 80-meter tune-up.

When the oscillator is fully loaded and tuned to resonance, the plate current should run between 20 and 30 ma., representing a power input of 7 to 10 watts.

(This unit originally described in the November, 1953, issue of *QST*.)

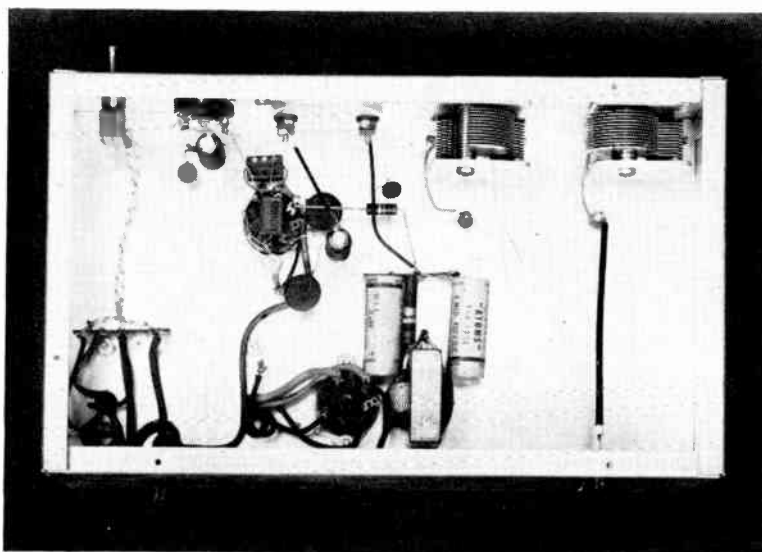

Fig. 6-37 — Bottom view of the Novice one-tube transmitter showing the wiring of parts. The power supply components are mounted along the back side while the r.f. section runs along the front. The output lead from the feed-through bushing is clearly visible on the right-hand side. The only openings at the back are the output terminal and the 115-volt a.c. leads.

A Single-Tube 75-Watt Novice Transmitter

Figs. 6-38 through 6-42 show a 75-watt c.w. transmitter using a 6146 in a crystal oscillator. The power supply uses an ordinary replacement-type transformer in a bridge circuit. In the circuit diagram, Fig. 6-40, the transformer rating is 360 volts each side of center tap, but the supply will deliver 500 volts at 140 ma. For tune-up purposes, the output of the power supply can be switched from high to low voltage. The low potential output is 280 volts.

In order to limit the input to 75 watts, the screen voltage is held to 125 volts by R_1R_2 . With the supply output switched to low voltage, the screen drops to 80 volts for tune-up purposes.

The crystal current is monitored by a 2-volt 60-ma. bulb connected between the crystal and chassis ground. The bulb also serves as a fuse, in the event the crystal current should accidentally rise above a safe value.

To avoid coil changing, a portion of the plate coil is shorted out for 40-meter operation.

Construction

The transmitter is built on an $11 \times 7 \times 3$ -inch aluminum chassis and the 6146 and r.f. components above deck are shielded by a $6 \times 6 \times 6$ -inch aluminum box.

The power transformer, T_2 , and rectifiers are mounted on the chassis top at one end. The other power supply components, T_1 , L_4 , the 8- μ f. electrolytic capacitors and the 20,000-ohm 10-watt resistors, are mounted below deck.

The 6146 socket is mounted $1\frac{1}{2}$ inches in from the front of the chassis and $4\frac{1}{2}$ inches from the end. Two 1-inch isolantite standoffs are used to support L_2L_3 , and they are mounted $2\frac{1}{4}$ inches apart. The rear one is $2\frac{1}{8}$ inches from the chassis

back and 2 inches from the right-hand end.

A row of $\frac{1}{4}$ -inch holes is drilled near the bottom on both sides of the cover box to permit ventilation. Several $\frac{1}{4}$ -inch holes are also made in the box top directly over the 6146.

Wiring

The power supply is wired first. The center taps of T_1 and the high-voltage winding of T_2 are connected together and soldered to the low-voltage terminal of S_3 . A lead is connected from one of the 5Y3GT filament terminals to the high-voltage terminal on S_3 . One lead from L_4 is connected to the arm of S_3 .

Next, the below-chassis portion wiring of the r.f. section is completed. No socket should be used for the 2-volt 60-ma. dial lamp in series with the crystal. A $\frac{5}{8}$ -inch rubber grommet is used to hold the dial lamp in place. Connections are made to the lamp by soldering leads to the base point and to the metal shell. The lead from the shell connects to the chassis.

Standard coil stock (B & W 3900, 2-inch diam., 8 turns per inch, No. 14 wire) is used for L_2L_3 . A total of 38 turns is cut from the original stock. At one end of the piece, a single turn is unwound from the support bars. From this end, count up $7\frac{1}{2}$ turns and cut the seventh turn. The cut should be made at the support bar opposite the bar from which the first lead extends. The leads from the cut point are separated from the side support bars and brought around to the same bar as the first lead. At the other end of the coil, which will be the top, a lead is unwound from the support bars and extended from the bar opposite the one with the three leads. This coil is shown in one of the photographs.

◆
◆
Fig. 6-38 — Pictured is the completed 6146 rig. The plate-current indicator lamp is to the left of the tuning knob. In areas where TVI is likely to be a problem, a metal bottom plate should be used on the chassis in addition to the $6 \times 6 \times 6$ aluminum box shown.



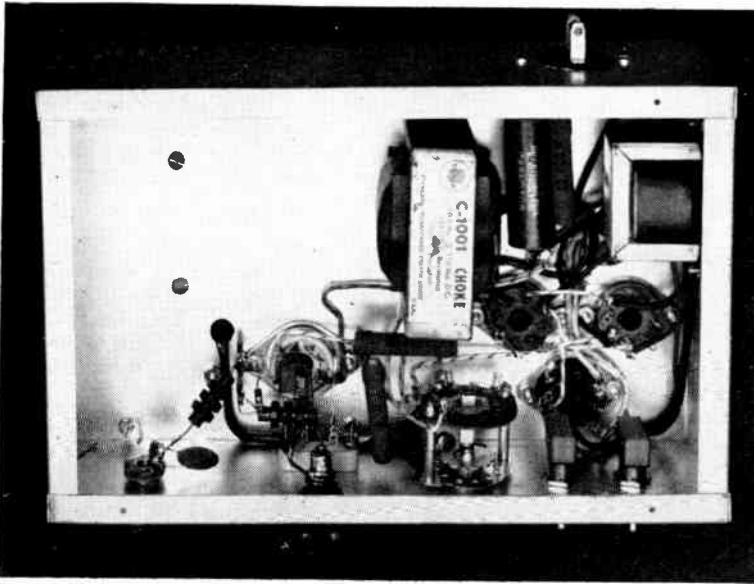

Fig. 6-39 — Bottom view of the one-tube transmitter. The 6.3-volt filament transformer is mounted on the side of the chassis at the upper right-hand corner. To the left of the transformer is one of the 8- μ f. electrolytics; the other electrolytic is not visible, being mounted behind the power-supply choke coil.

Counting from the top, the 15th and 17th turns are bent in, allowing access to the 16th turn. This is for the 40-meter tap. A four-inch length of wire can be soldered to this point. The other end

should be connected to the switch terminal on S_4 . The coil is supported on the isolantite standoffs by two soldering lugs. The small ends of the lugs are first bent around the bottom turn. Before

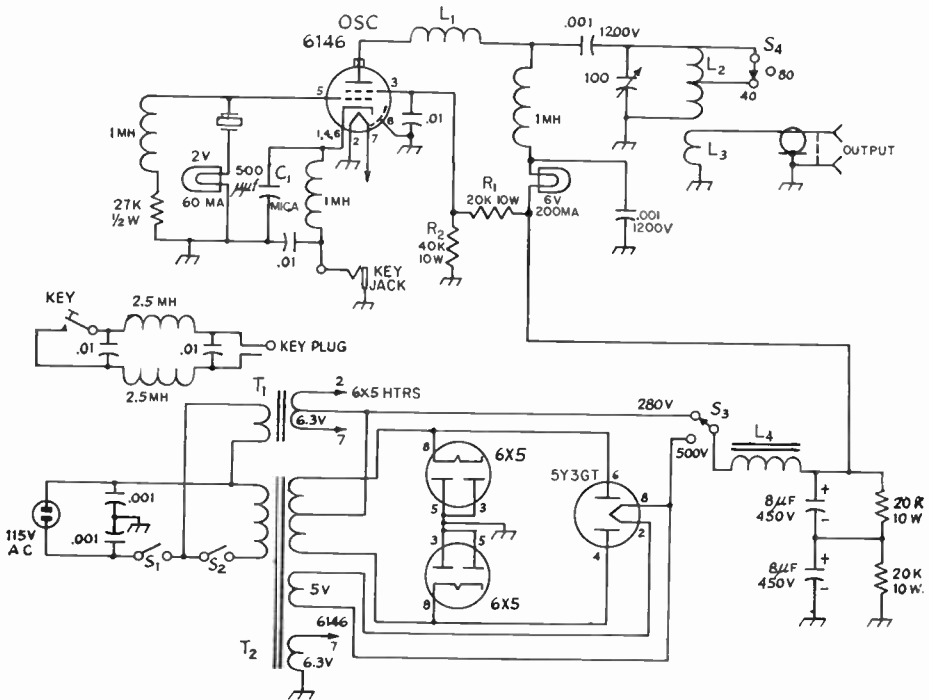

Fig. 6-10 — Circuit diagram of the 6146 o-oscillator.

- L_1 — 1.8 μ h. (Ohmite Z-114) choke.
- L_2, L_3 — See text and photograph.
- L_4 — 10.5 henrys, 110 ma., 225 ohms.
- S_3 — 1-pole 6-position (2 used) wafer switch, non-shorting (Centralab 1101).
- S_4 — 1-pole 6-position (2 used) steatite wafer switch, nonshorting (Centralab 2501).

- T_1 — Filament transformer, 6.3 volt, 1.2 amperes.
- T_2 — Power transformer, 360-0-360 volts, 120 ma., 6.3 volts 3.5 amperes, 5 volts 3 amperes (Stancor PC8110).

Unless otherwise specified, all capacitor values are given in microfarads. Fixed capacitors except 8- μ f. electrolytics and C_1 are disk ceramic.

soldering them in place, the large holes in the lugs should be located over the holes in the stand-offs for proper alignment.

A coax receptacle is mounted on the back of the shield box and positioned so that the terminal is opposite the ungrounded end of link L_3 . The switch and capacitor can be mounted in the box first and then wired. However, it will probably be easier for the beginner to wire all the components first, and then mount them in the box. Three holes are needed in the front of the shield box. The capacitor and switch holes are $1\frac{1}{2}$ inches from the side of the box and $2\frac{1}{4}$ and $4\frac{1}{2}$ inches from the bottom, respectively. The hole for the $\frac{5}{8}$ -inch grommet is 2 inches to the left of the capacitor hole. With the holes cut in the box, it is easy to fit the box over the wired parts.

When mounting the glass bulb of the plate circuit 6-volt dial lamp in its grommet, be careful that none of the metal parts of the bulb base come in contact with the metal of the box. If the builder desires, a 200- or 250-ma. milliammeter can be substituted for the bulb.

Testing the Transmitter

The r.f. chokes and capacitors at the key comprise a click filter, which should be connected directly at the key terminals (not the plug).

For testing purposes, a dummy antenna should be connected to the output terminal. Use a 40- or 60-watt electric lamp for the dummy load. The key plug is inserted in its jack and the key is left open. With the 115-volt line connected to the rig, S_1 is turned on and the 6X5 filaments are allowed to warm up for a minute or so. Then S_2 is turned on and the 5Y3GT allowed to warm up for another few minutes. The power supply is switched to the low-voltage output. The key is

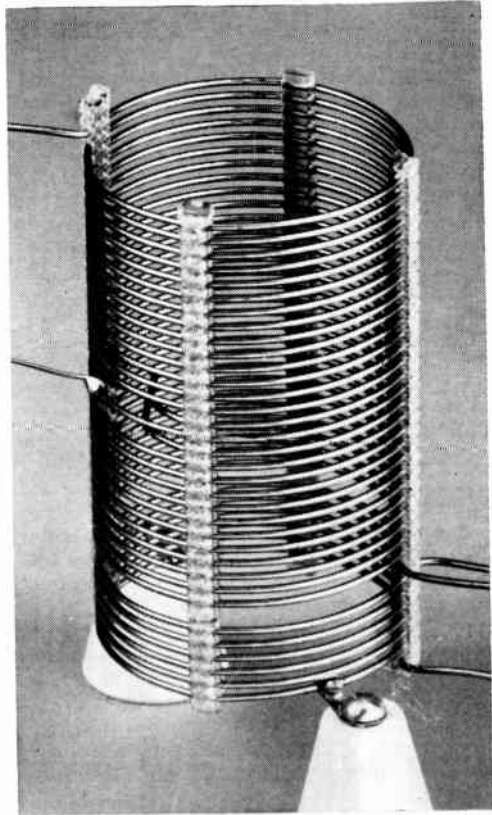

Fig. 6-11 — Close-up view of the coil construction.

then closed and the plate capacitor tuned for resonance as indicated by minimum brilliance in the plate dial lamp. The dummy lamp should also light up at this point.

For 40-meter operation, a 40-meter crystal should be inserted in the crystal socket and S_4 switched to short out the unused portion of the plate coil. Tune-up procedure is the same as on 80 meters.

(From *QST*, Aug., 1955.)

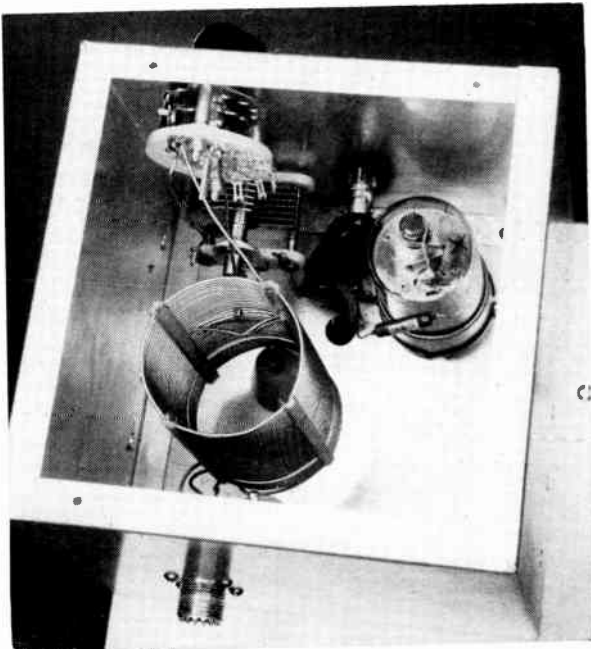

Fig. 6-12 — Looking down into the oscillator compartment.

75 Watts on Four Bands

Fig. 6-41 shows the circuit of a simple band-switching transmitter that can be operated at inputs up to 75 watts on the 80-, 40-, 20- and 15-meter bands. A 6AG7 grid-plate crystal oscillator drives a pair of 6L6GBs. Either 80- or 40-meter crystals may be used for 40-meter output, and 40-meter crystals will supply adequate drive to the amplifier on the 20- and 15-meter bands.

The pi network in the output of the amplifier is designed to feed a 50- or 70-ohm load. C_5 is a triple-gang BC-type variable (ICA 531, Miller 2113, Philmore 9047 or similar), having a capacitance of 365 μmf . or more per section. The sections are wired in parallel. L_3 and L_4 are v.h.f. parasitic suppressors. Each consists of 6½ turns of No. 18 wire wound around a 10-ohm 1-watt carbon resistor across which the coil is connected.

A single milliammeter, M_1 , may be switched to read either amplifier grid current or amplifier cathode current. A combination of series resistor R_3 and shunt resistors R_1 and R_2 provides full-scale meter readings of 20 ma. for grid current and 300 ma. for cathode current.

A power supply is included, and ample space remains on the chassis for adding a modulator. The power supply as described should be adequate for powering the modulator in addition to the transmitter. If c.w. operating only is contemplated, a similar transformer and choke having current ratings of 200 ma. may be substituted.

Construction

Most of the constructional details are apparent in the photographs. A 12 × 17 × 3-inch alumi-

num chassis surmounted by a 12 × 7 × 6-inch aluminum box (Premier AC-1276) is used as a shielding enclosure. Two octal tube sockets, placed between S_1 and the 6AG7 socket, are used as crystal sockets. Each will accommodate two FT-243 crystal holders. On each socket, Pins 1 and 3 should be wired together and grounded to the chassis. Pins 5 and 7 should each be connected to a terminal on S_1 . The crystals should be plugged in between Pins 3 and 5 and between Pins 1 and 7.

The shaft of C_2 must be insulated from the chassis. This is done by drilling a clearance hole for the shaft, and using insulating washers both inside and outside the chassis.

Coil dimensions are given in the table. Taps are most easily made by bending in toward the center of the coil one or two turns on either side of the turn to which the tap is to be soldered. Make sure that no turns are shorted by the solder.

Adjustment

The amplifier must be neutralized first. For this it is necessary to disconnect the high-voltage line to the amplifier plates and screens at the point marked "X" in the diagram. With a 7-Mc. crystal plugged into the crystal socket, power turned on and the key closed, turn S_2 to the 21-Mc. position, and adjust C_2 for maximum grid current to the amplifier. The meter should read half scale or more. Listen to the signal on a receiver and adjust C_1 for best keying characteristics.

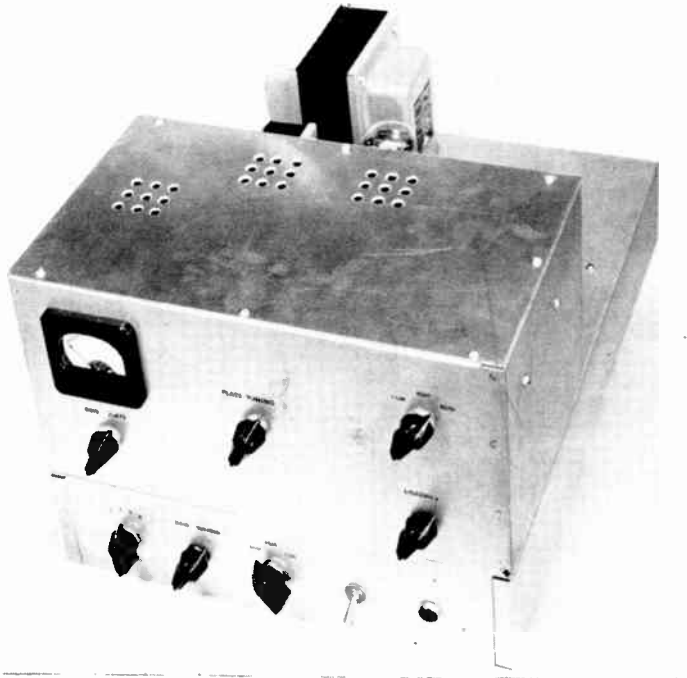

Fig. 6-43 — A 75-watt 4-band transmitter. The shafts of S_4 (below the meter) and C_3 (see Fig. 6-15) are placed symmetrically. S_3 , C_5 and I_1 are centered on the same vertical line, as are the meter, S_1 and S_1 at the opposite end. C_4 is at the center of the panel, with S_2 directly below. C_2 and S_5 are spaced evenly on either side of S_2 . A series of ¼-inch ventilating holes is drilled in the box cover, above each of the tubes, and along the back of the box, toward the bottom. The power transformer, filter choke and rectifier tube are grouped in the left rear corner of the chassis.

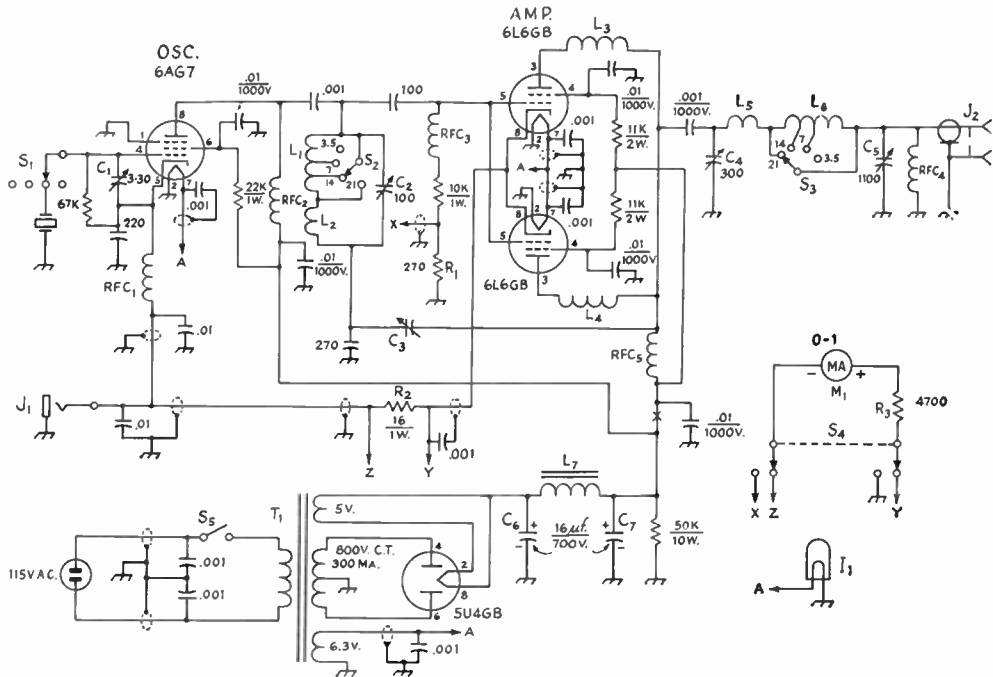
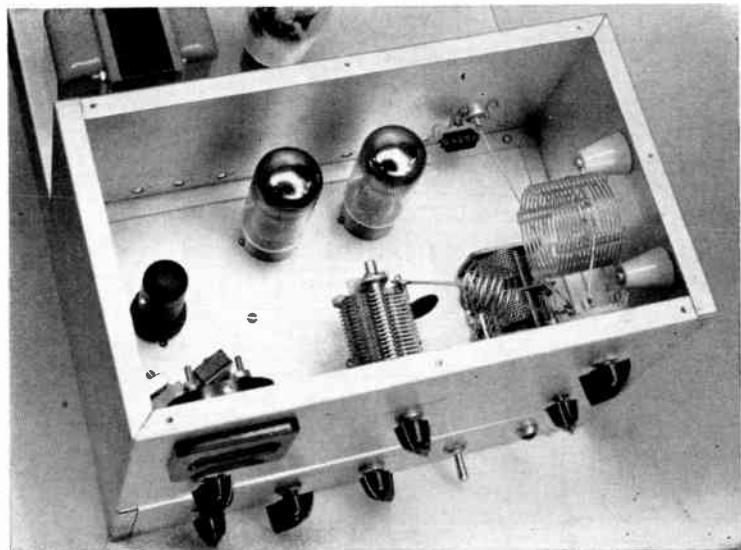

Fig. 6-44 — Circuit of the 75-watt 4-band transmitter. All capacitances less than 0.001 μf . are in μf . All 0.001- and 0.01- μf . capacitors are disk ceramic. Capacitors marked with polarity are electrolytic. Other fixed capacitors should be mica. All resistors are $\frac{1}{2}$ watt unless otherwise specified. Amplifier screen resistors are each two 22K 1-watt resistors in parallel.

- C₁ — 30- μf . mica trimmer.
- C₂ — 100- μf . midget variable (Bud MC-1885).
- C₃ — 15- μf . air trimmer (Johnson 15M11).
- C₄ — 300- μf . variable (Bud MC-1860).
- C₅ — 3-gang BC variable (see text).
- I₁ — 6-volt dial lamp.
- J₁ — Open-circuit key jack.
- J₂ — Coaxial receptacle (SO-239).
- L₁ — L₆ — See text and table.
- L₇ — 10-h. 200-ma. filter choke (Triad C16-A).

- M₁ — 0-1 d.c. milliammeter (Triplett 227-T).
- RFC₁, RFC₂, RFC₃ — 750 μh . (National R-33).
- RFC₄ — 2.5 mh. (National R-50).
- RFC₅ — 2.5 mh. (National R-300).
- S₁ — 1-pole 6-position rotary (Centralab 1101).
- S₂, S₃ — 1-pole 6-position rotary (Centralab 2501).
- S₄ — 2-pole 2-position rotary (Centralab 1172).
- S₅ — S.p.s.t. toggle switch.
- T₁ — 800 volts c.t., 300 ma.; 5 volts, 3 amps.; 6.3 volts, 4 amps. (Triad R24-A).

Fig. 6-45 — I_6 is mounted on the right-hand end of the box by soldering lugs to the end turn and fastening the lugs to 1-inch cone insulators which are centered 2 inches down from the top. I_5 is soldered directly between the 21-Mc. switch terminal and the stator terminal of C₄. C₅ is fastened directly to the chassis, with its shaft 2 inches from the right-hand end. S₄ is placed symmetrically at the opposite end of the panel.



Now turn S_3 to the 21-Mc. position and turn C_4 through its range. At some point there should be a kick in the grid-current reading. Adjust C_3 to the point where this kick is reduced to a minimum. Once this adjustment has been made, it should require no further attention.

Now turn off the power supply, and reconnect the high voltage to the amplifier. Connect a 60-watt lamp across J_2 . Set C_5 at maximum capacitance, turn S_4 to read cathode current, turn on the power and close the key. Adjust C_4 for a dip in cathode current (resonance). Then reduce the capacitance of C_5 a little at a time, resetting C_4 each time for resonance. As these adjustments are continued alternately, the current at the dip will increase and the dip will become less pronounced (see Fig. 6-4). Simultaneously, the load lamp should increase in brilliance. Continue these adjustments until the highest reading is obtained with C_4 adjusted to resonance. However, do not allow the current at this point to rise above about 230 ma.

The transmitter can be tested on the other bands in a similar manner, first tuning C_2 for maximum grid current, and then adjusting the output circuit. Be sure that the switches are

	Turns	Wire Size	Diam. In.	Lgth. In.	Tap Turns*	Approx. $L_{\mu h}$	B & W No.
L_1	36	24	1	1 $\frac{3}{8}$	22, 32	19	3016
L_2	5	20	$\frac{3}{4}$	$\frac{5}{16}$	—	0.5	3011
L_3	6	14	1	1 $\frac{1}{4}$	—	0.5	—
L_4	14	16	1	1 $\frac{3}{8}$	7 $\frac{1}{2}$, 11	8.5	3907-1

* From 3.5-Mc. end of coil.

turned to the proper band, and that the proper crystal is in use.

A simple antenna system for multiband operation is the parallel-dipole system described in *QST* for July, 1956. Other types of antennas may be fed through an antenna coupler. Adjustment when feeding an antenna is similar to that described for the dummy load. An output indicator is described in *QST* for September, 1956.

With the power supply shown, the output voltage with the amplifier fully loaded should be about 400. The amplifier screen voltage should be approximately 200. Under fully-loaded conditions, maximum output should be obtained with a grid current of about 6 ma. If the grid current exceeds this value, it can be reduced by slightly detuning C_2 .

(Originally described in *QST*, Jan., 1957.)

Fig. 6-16—Bottom view showing the arrangement of components underneath the chassis. C_3 is mounted by soldering its stator rods to insulated contacts on a terminal strip. L_1 is cemented to a 1-inch cone insulator. L_2 is soldered between the rotor terminal of C_2 and the 21-Mc. contact on S_2 . C_2 must be insulated from the chassis as described in the text. The crystal sockets are to the rear of S_1 . Shielded wire is used as indicated in Fig. 6-11. Not shown in this view are C_5 and C_7 , which are mounted between terminal strips farther to the rear, and J_1 which is set in the rear edge of the chassis.

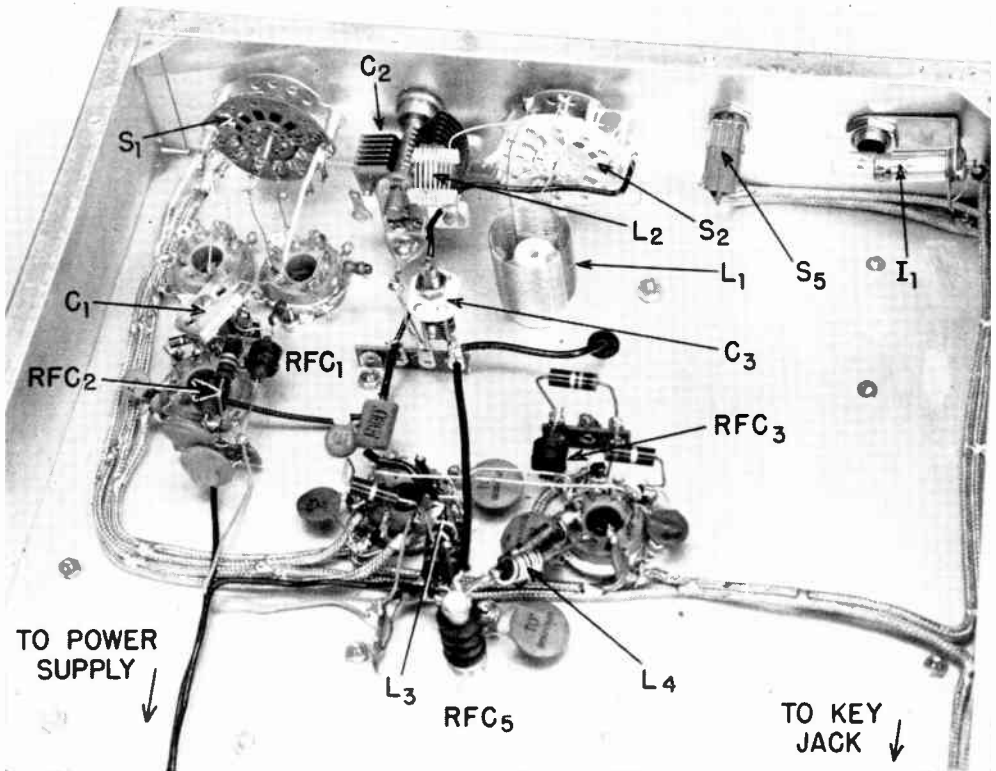

A 7-Band 90-Watt Transmitter

Figs. 6-47 through 6-53 show photographs and circuit diagrams of a 90-watt bandswitching transmitter covering all bands from 160 (if a 160-meter oscillator is provided, of course) through 10 meters. The r.f. circuit is shown in Fig. 6-48. A string of four multiplier stages drives a 6146 final amplifier. A well-screened tube (6AK6) is used in the first stage, whose output is in the 80-meter band, so that the stage will be stable when driven by an oscillator operating in the same band. For simplicity, triodes (6C4s) are used in the remaining multiplier stages. The third stage of this section operates either as a doubler to 14 Mc., or as a tripler to 21 Mc., the change being made as the band switch opens or closes a short across a portion of the tank inductor. Tuning adjustments are simplified by ganging the tuning capacitors of all four multiplier stages to a single control. The 80-meter tank circuit, $C_{1A}-L_1$, is designed to cover only the required tuning range — 3500 to 4000 kc. However, when the band switch is turned to the 7-Mc. and higher-frequency positions, the 47- μ mf. capacitor across the input of the first 6C4 adds enough capacitance to shift the tank circuit's lowest frequency to about 3350 kc. so that the harmonics will include the 11-meter band. This is permissible, of course, since the frequencies at the high end of the 80-meter band are not needed for multiplying into the other bands.

A pi-section tank circuit is used in the output of the 6146. It is designed to work into low-impedance coaxial cable. In order to obtain better operation on 10 meters, and to cover 160 meters, the tank inductor, L_6 , is broken up into three sections. L_{6A} is the only inductance in the circuit when operating on 10 meters, the roller contact on L_{6B} being run all the way to one end to short L_{6B} out. In its last position, S_{2B} opens the short across L_{6C} , adding its inductance for 160 meters.

L_5 is a v.h.f. parasitic suppressor. L_7 and C_3 comprise a series-resonant circuit that may be adjusted to attenuate TVI in the most susceptible channel. RFC_2 provides a d.c. short across C_7 so that the latter need have only

approximately half the voltage rating that might otherwise be required.

The milliammeter, MA , may be switched to read total exciter plate current, amplifier grid current, or amplifier cathode current. R_3 and R_4 are shunts that multiply the meter reading by 10 when reading exciter current, and by 20 when reading amplifier cathode current.

Construction

The shielding enclosure is made up of two $8 \times 17 \times 3$ -inch aluminum chassis, fastened together with top surfaces one against the other. At the right-hand end, the chassis tops are cut away to provide an opening 7 inches deep by 8 inches wide. Into this opening the "dish" of Fig. 6-50 is fastened to provide a well for the final-amplifier components. A series of $\frac{1}{4}$ -inch ventilating holes should be drilled in the bottom of the well, and in both top and bottom covers in the area above and below the 6146.

The components should be mounted so that the six control knobs on the panel come at the same level, using spacers under the components where necessary to accomplish this. The three controls at the left, and the three at the right are grouped with equal spacing. The meter is mounted at the center line, and the tuning chart is centered over the exciter tuning control. A combination of gears (see Fig. 6-51), operating from the shaft of the rotary inductor, was used to drive a surplus turns-counter dial, but the Groth (R. W. Groth Mfg. Co., 10009 Franklin Ave., Franklin Pk., Ill.) counter should be equally compact.

In the exciter section, the four tube sockets are lined up between the tuning-capacitor gang and the band switch. The 6AK6 is toward the front, with the 6C4 multipliers following in logical sequence to the rear.

The capacitor gang, C_1 , is made up of two Hammarlund HFD-100 dual units whose shafts are joined with a Millen 39003 rigid brass coupling. Since the tail shaft of the Hammarlund unit is rather short, it may be necessary to grind down the front end of the Millen coupling almost to the set-screw hole to allow the set screw to

Fig. 6-47 — Controls, from left to right, are for band switch, exciter tuning, meter switch, pi-section tank capacitor, rotary inductor and turns counter, and output-capacitor switch. The panel is 7 by 19 inches. The top cover (a chassis bottom cover) is in place in this view.



bear on the tail shaft.

The capacitor sections must be modified as follows: C_{1A} —remove the last 5 rotor plates; C_{1B} —remove the first 9 rotor plates; C_{1C} —remove all rotor plates except the first four, and remove the fourth stator plate; C_{1D} —remove all rotor plates except the last four.

After the modification is complete, test each section to make sure that no plates are shorting. Use an ohmmeter, or use a lamp in series with the a.c. line.

The band switch, S_1 , is made up of Centralab Switchkit parts. The index assembly is type

P-123; the ceramic wafers are type X. For short leads, the wafers are spaced out so as to come approximately half-way between the tube sockets. Vertically-mounted r.f. chokes are used, since they occupy a minimum of chassis space. L_1 is wound on a Millen 45000 form, 1 inch in diameter. It is mounted to the left of C_{1A} , and can be seen in the bottom-view photograph. The other multiplier coils are supported by their leads, soldered to the capacitor terminals. The tap lead on L_3 should be a piece of wire about 3 inches long. The length of this tap is adjusted later for tracking over the 21-Mc. band.

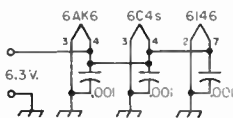
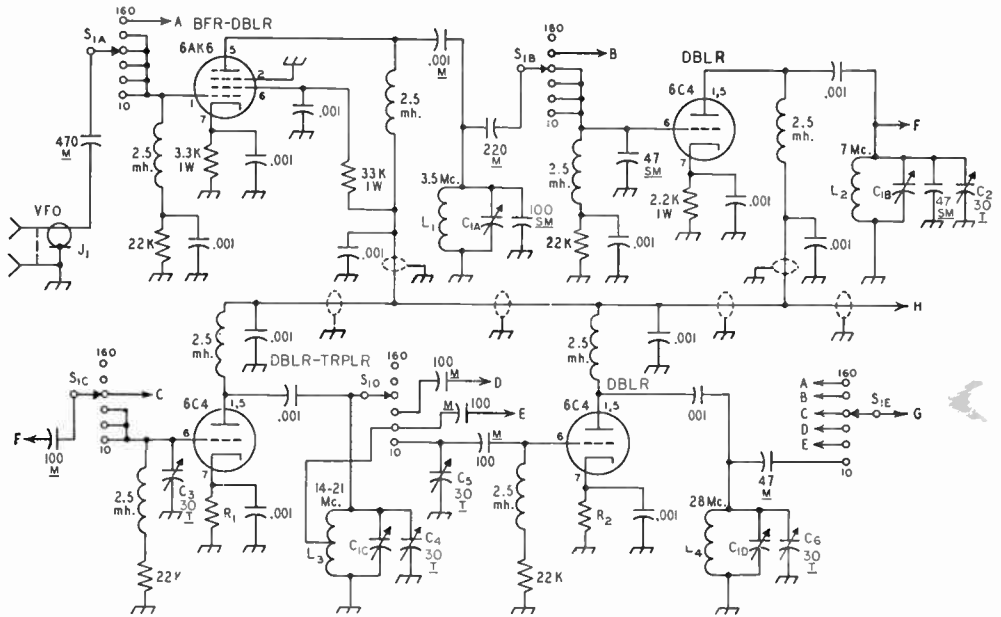

AMPLIFIER

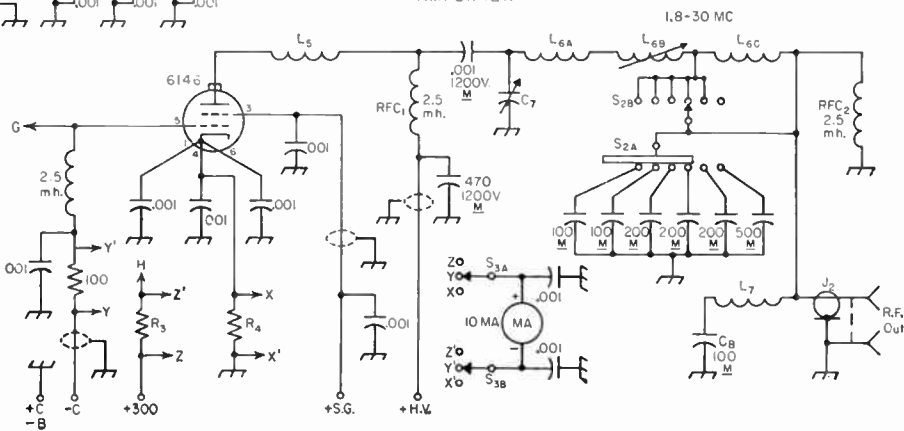

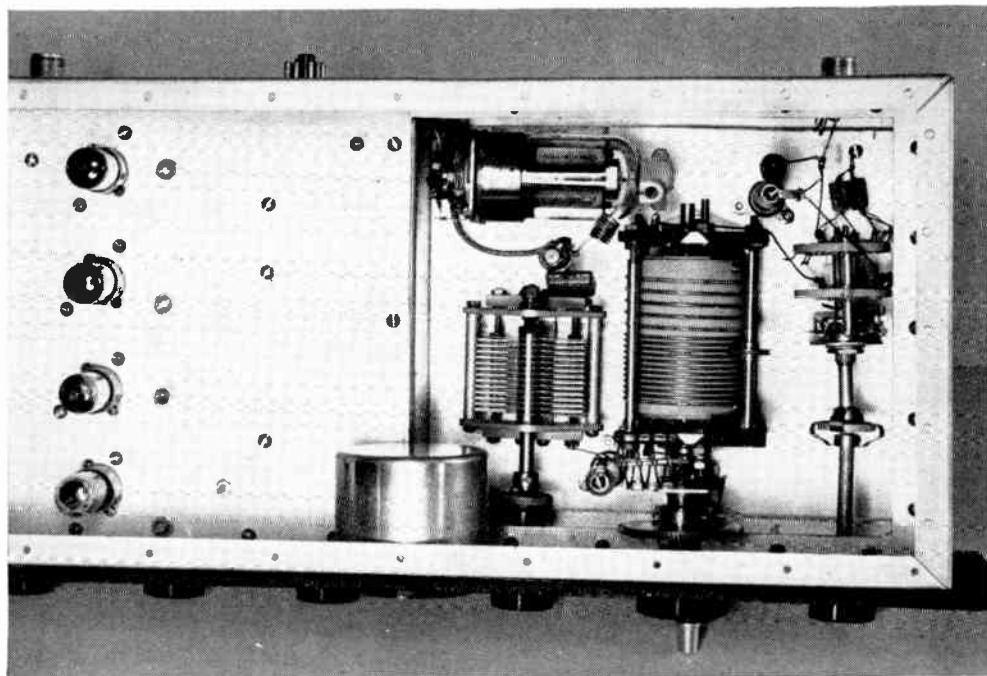

Fig. 6-49 — Top view of the amplifier compartment, showing the pi-section tank capacitor, the rotary inductor with separate 10-meter coil, and the output capacitor switch. The 160-meter loading coil, removed for this picture, normally is mounted between the stand-off insulator off the right rear corner of the rotary inductor and the rear rotary-inductor terminal. Exciter tubes are to the left.

The mica trimmer capacitors are mounted in such positions that they can be adjusted through holes drilled in the chassis and in the bottom cover.

The socket for the 6146 is mounted near the inside wall of the well by means of an L bracket attached to the rear wall of the chassis. Holes are drilled in the wall of the well for wires connecting to the socket terminals. Since working space is limited, all necessary bypassing and other wiring at the 6146 socket should be done before the socket is mounted.

The output capacitor switch is assembled on a Centralab P-121 index head.

The rear of the meter is shielded with an ICA type 1540 shield can cut down to a depth of 2 inches. Shielded leads are brought out through

notches in the wall of the can, close to the panel. The meter shunts, R_3 and R_4 , are wound with copper wire as described in the measurements chapter. R_3 should be adjusted to increase the full-scale reading to 100 ma., and R_4 to increase the range to 200 ma.

Following standard practice (see chapter on BCI and TVI) all d.c. and filament wiring is done with shielded wire.

The diagram of a suitable power supply is shown in Fig. 6-52. A pair of voltage-regulator tubes regulates the voltage drop across the 4000-ohm, 25-watt series resistor that drops the voltage to 300 for the exciter. The 6AQ5 is a screen clamper which, in combination with the 22 volts of battery bias, keeps the input to the 6146 at zero when excitation is removed.

←

Fig. 6-48 — Wiring diagram of the 7-band 90-watt transmitter. All resistors $\frac{1}{2}$ watt unless otherwise specified. Capacitor values below 0.001 $\mu\text{f.}$ are in $\mu\text{mfd.}$ M = mica, SM = silver mica, T = mica trimmer. All other fixed capacitors are disk ceramic.

C_{1A} — Approx. 65 $\mu\text{mfd.}$ (see text).

C_{1B} — Approx. 35 $\mu\text{mfd.}$ (see text).

C_{1C}, C_{1D} — Approx. 25 $\mu\text{mfd.}$ (see text).

C_7 — 300- $\mu\text{mfd.}$, 0.026-inch plate spacing (National TMS-300).

R_1 — Two 1700-ohm 1-watt resistors in parallel.

R_2 — 1700- and 3300-ohm 1-watt resistors in parallel.

R_3, R_4 — Meter shunts (see text).

L_1 — 12 $\mu\text{h.}$ — 21 turns No. 22 d.c.c., 1 inch diam., close-wound.

L_2 — 4.2 $\mu\text{h.}$ — 17 turns, $\frac{3}{4}$ inch diam., 17/32 inch long (B & W 3012 Miniductor).

L_3 — 1.8 $\mu\text{h.}$ — 12 turns, $\frac{3}{4}$ inch diam., $\frac{3}{4}$ inch long,

tapped 6 $\frac{1}{2}$ turns from ground end (B & W 3011 Miniductor).

L_4 — 0.1 $\mu\text{h.}$ — 7 turns, $\frac{1}{2}$ inch diam., $\frac{3}{16}$ inch long (B & W 3003 Miniductor).

L_5 — 8 turns No. 18, $\frac{1}{2}$ inch diam., $\frac{3}{8}$ inch long.

L_{6A} — 0.3 $\mu\text{h.}$ — 4 turns, $\frac{3}{4}$ inch diam., 1 inch long (B & W 3009 Miniductor).

L_{6B} — 10- $\mu\text{h.}$ variable (Johnson 229-201).

L_{6C} — 11 $\mu\text{h.}$ — 18 turns No. 16, 2 inches diam., 1 $\frac{3}{4}$ inches long (B & W 3907 inductor).

L_7 — See text.

J_1, J_2 — Coax connector.

MA — 3-inch, 10-ma. meter.

S_1 — Ceramic rotary switch, 5 sections, 6 positions (see text).

S_{2A} — Centralab PIS section (see text).

S_{2B} — Centralab X section (see text).

S_3 — Bakelite rotary.

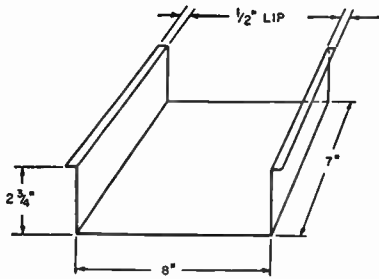

Fig. 6-50 — The "dish" for the final amplifier. It is bent from aluminum sheet.

Adjustment

Until the exciter has been tuned up, screen and high-voltage lines should be disconnected from the transmitter, and the 6AQ5 clamp tube should be removed from its socket. The meter switch should be turned to its grid-current position, and the 6I46 heater turned on.

If an oscillator with 160-meter output is available, turn the band switch to the 160-meter position, and adjust the coupling to the oscillator until the meter reads a grid current of 3 ma.

Then with an oscillator delivering output on either 160 or 80 meters, turn the band switch to the 80-meter position, and adjust C_1 for maximum grid current. This should be at least 3 ma. If it is less, try readjusting the coupling to the oscillator. If a v.f.o. is used, the multiplier should be checked at both 3500 and 1000 kc. to make sure that it is covering the proper frequency range. It may be necessary to spread out the last few turns on L_1 to get the circuit to hit both ends of the band. If the output from the v.f.o. is reasonably constant, the grid current should remain essentially constant over the band.

With the 80-meter stage working properly, the switch should be turned to the 40-meter position. Set the v.f.o. to 3500 kc., and adjust C_1 for maximum grid-current reading. If there is no indica-

tion of drive to the amplifier, it may be necessary to adjust the 7-Mc. trimmer, C_2 , a little bit at a time, retuning C_1 , until an indication of output is obtained. As an aid, the meter, when switched to read exciter plate current, should show a slight dip when C_2 is tuned through resonance. When an indication of grid current is obtained, tune C_1 for peak drive, and then readjust C_2 to increase the peak. The correct adjustment is the one where no readjustment of either C_1 or C_2 will increase the drive. Now tune the oscillator to 3750 kc. (half this frequency, of course, if the oscillator output is in the 160-meter band) and retune C_1 . The drive to the 6I46 should remain essentially unchanged.

Now tune the oscillator back to 3500 kc. and retune C_1 for maximum drive. Leave the oscillator and C_1 at this point, and turn the band switch to 14 Mc. Adjust first C_4 , and then C_3 for maximum grid current. It may take a little juggling back and forth between these two before a maximum reading is obtained. The meter, when turned to read exciter current should show a dip when C_4 is tuned through resonance.

Leaving all tuning adjustments fixed, turn the switch to the 21-Mc. position. Adjust C_4 carefully, and note whether an increase or a decrease in capacitance causes an increase in drive to the 6I46. If it is an increase, lengthen the tap wire slightly. Then turn the switch back to 14 Mc. and readjust C_4 for maximum drive. Then switch back to 21 Mc. and check carefully again. By adjusting the length of the tap wire carefully, it should be possible to arrive at a condition where maximum drive is obtained at both 14 and 21 Mc. at the same setting of C_4 . Remember, after each adjustment of the tap length, first go back to 14 Mc. and retune, then switch to 21 Mc.

Adjustment for 28 Mc. is similar to that for 14 Mc., although it will be more critical. Careful adjustment of C_5 and C_6 will be necessary for maximum drive. The 11-meter band is covered by tuning C_1 to resonance with the switch in the 28-Mc. position. The various circuits should be checked with an absorption wavemeter to make sure that they are tuning to the right multiple.

When the above adjustments for the low-frequency ends of the various bands have been completed as described, it should be found that the output will be essentially the same at any point within any selected band. Although such accuracy in lining up is not necessary, it should be possible to resonate C_1 for maximum drive at 7000 kc. and then, without retuning, switch to 14, 21 and 28 Mc. and find that the stages are delivering maximum drive. As mentioned previously, a different frequency range is used for 80 meters, so it is always necessary to retune C_1 when changing to this band.

The harmonic trap, L_7-C_8 , is adjusted to resonate at the frequency of the TV channel most susceptible to TVI, with the coax-connector terminals shorted. The frequency should be checked with a grid-dip meter. As an example, 3 turns of No. 18, 1/4 inch diameter for L_7 and 100 $\mu\text{f.}$ for C_8 resonates in Channel 6, by proper

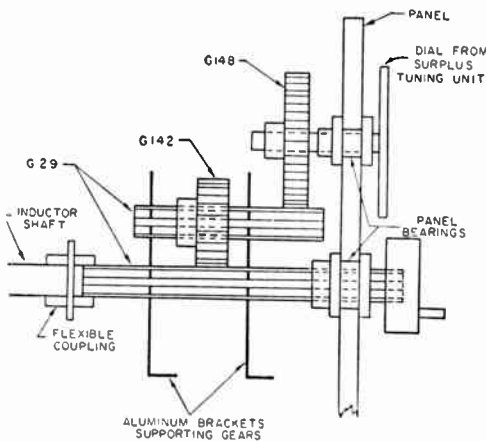

Fig. 6-51 — Sketch of drive and indicator for the final-tank variable inductor. The gears are standard Boston Gear Works items.

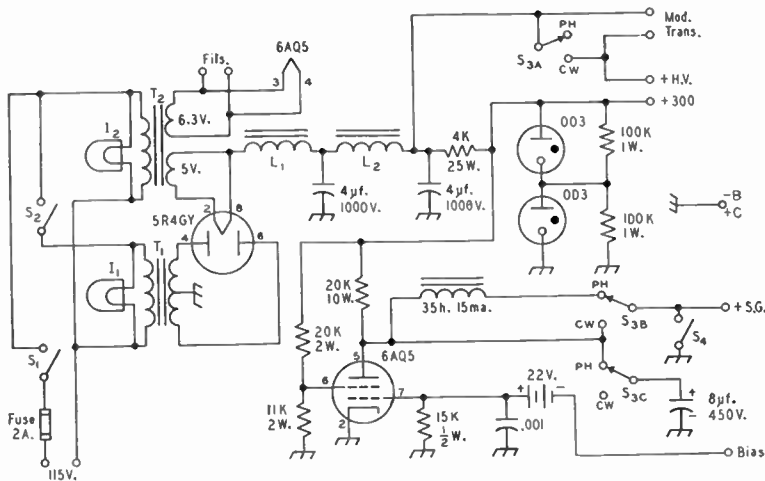

Fig. 6-52 — Power-supply and clamp-tube circuit.

- L₁ — Swinging choke, 5-25 h., 20-200 ma. (Triad C-31A).
- L₂ — Smoothing choke, 10 h., 200 ma. (Triad C-16A).
- S₃ — 3-pole 2-position rotary ceramic switch (Centralab 2507).

- I₁, I₂ — 115-volt pilot lamp.
- T₁ — Plate transformer: 750 volts d.c., 225 ma. (Merit P-3159).
- T₂ — Filament transformer: 5 volts, 3 amp.; 6.3 volts, 6 amp. (Stancor P-5009).

adjustment of the turns spacing of L₇.

The 80-meter band is tuned with all of L_{6B} in the circuit, 40 is tuned with about 12 turns in the circuit, 20 meters with about 7 turns, and 15 meters with about 5 turns. For 10 meters, L_{6B} is shorted out entirely by running the contactor all the way to the end of the coil. In each case,

the inductor is set, and the circuit resonated by means of C₇. Then the loading is adjusted by S₂, re-resonating with C₇ for each position of S₂. The output circuit is designed to couple into a matched low-impedance line feeding an antenna tuner or coax-fed antenna.

(Originally described in *QST* for May, 1955.)

Fig. 6-53 — Bottom view of the exciter section, showing the meter switch, tuning-capacitor gang and the band switch. The r.f. choke near top center is the amplifier grid choke. Ventilating holes in the bottom of the amplifier "dish" are duplicated in the bottom plate which was removed for this picture.

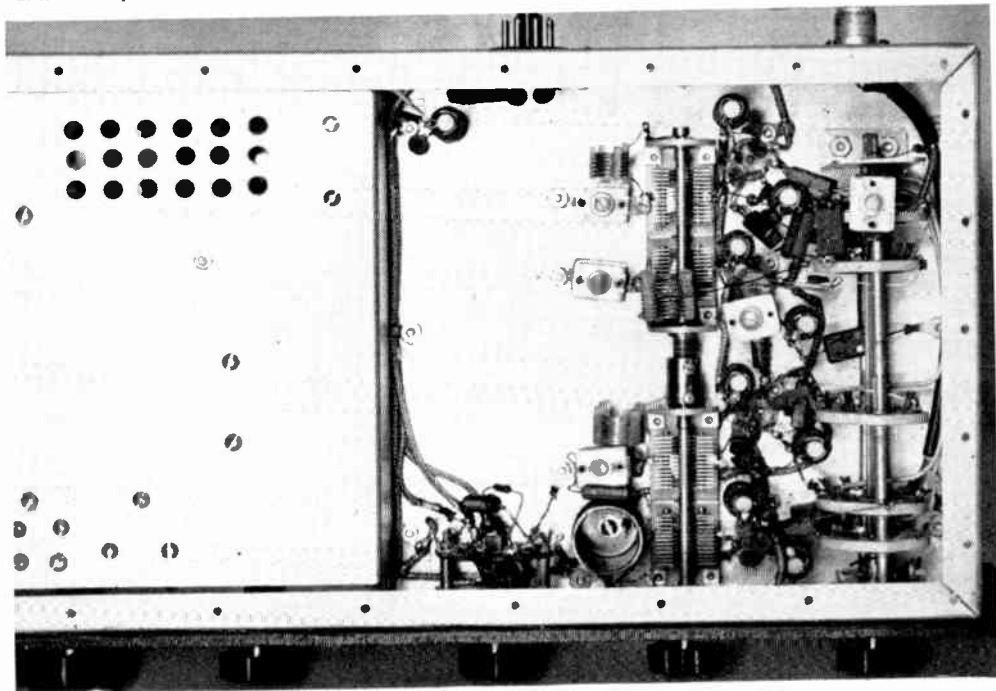

75 to 300 Watts with V.F.O. Control

Figs. 6-54 through 6-62 show circuits and constructional details of a v.f.o. band-switching transmitter that covers all bands from 80 through 10 meters. Depending on the plate voltage used, the final may be operated efficiently at inputs from 75 to 300 watts. A differential break-in keying system is included.

The circuit of the r.f. section is shown in Fig. 6-56. The v.f.o. follows the series-tuned Colpitts, or Clapp, circuit. It is remotely tuned through a length of coax cable to minimize frequency drift. Output from the oscillator is in the 80-meter band. A switch, S_1 , changes the frequency range. One range covers approximately 3.5 to 3.75 Mc. This range is used to cover the c.w. portion of the 80-meter band, and to drive multipliers covering the higher-frequency bands. The second range is from 3.75 to 4 Mc., and is used only for covering the 80-meter phone band.

Good isolation between the v.f.o. and following stages is provided by a 6C4 cathode follower and a 6AK6 buffer.

The output of the buffer may be switched (S_{2A}) to drive either the 5763 driver stage or a series of three multiplier stages using 6C4s, and covering the 7-, 14-, and 21-Mc. bands. The 5763 is used as a doubler from 14 to 28 Mc. for output on 10 meters. Band-pass couplers are used between stages in the multiplier section. After initial adjustment, no tuning of these stages is required. A multiband tuner in the output of the 5763 covers all bands by adjustment of its tuning capacitor, C_{14} . Excitation to the final amplifier may be controlled by R_1 which varies the 5763 screen voltage.

A 4-65A is used in the final amplifier. Its characteristics are such that it operates efficiently over a wide range of plate voltages, extending from 600 to 2000 volts. By proper choice of tank capacitor, a Novice may limit the input to 75 watts by using low plate voltage, and later increase the power input up to 300 watts by raising plate voltage. A pi network is used in the output of the final stage. It is designed to work into a low-impedance coax line. C_{15} is the input capacitor. L_{14} is a variable inductor, used for all bands except the 10-meter band. On 28 Mc., L_{14} is shorted out by running the shorting contact to the end of the coil, and L_{13} alone supplies the necessary inductance. The output capacitance is furnished by a group of fixed mica capacitors that may be connected in parallel according to the need for each band, or operating condition, by S_3 . L_{15} and C_{16} form a series-resonant circuit that may be adjusted to resonate at the frequency of the television channel most likely to be interfered with in a given locality. It consists of a 100- μf . mica capacitor in series with a few turns of wire.

Keying

The v.f.o. and the 5763 stage are keyed. A 6W6GT clamper, and a 0B2 voltage-regulator tube (the latter used here as an electronic switch) hold the input to the 4-65A to a low level during keying intervals. The other unkeyed stages are protected by cathode bias.

A differential keyer provides clean amplifier keying with all the conveniences of oscillator keying for break-in work. The circuit consists of a 12AU7 twin-triode vacuum-tube switch for

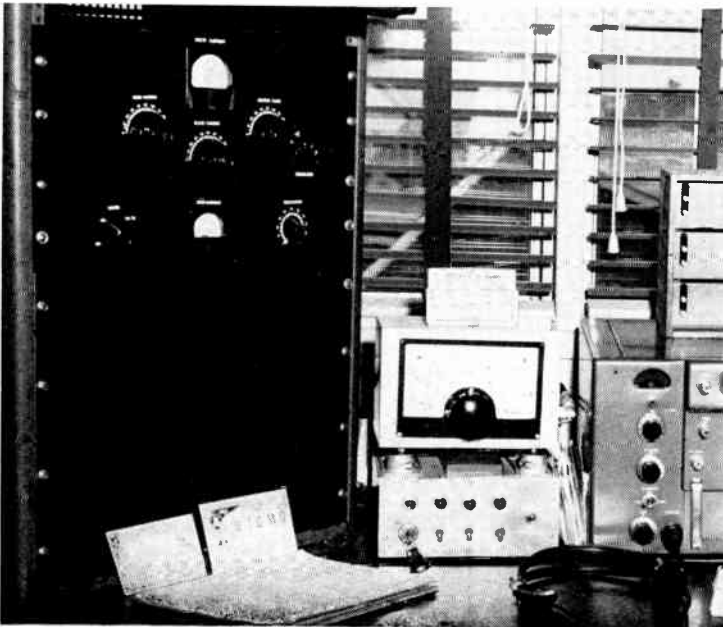

Fig. 6-54—The 4-65A transmitter of W8ETU in a rack cabinet with remote v.f.o. and control unit to the right. Along the bottom of the main panel are the bandswitch, the grid meter and the excitation control. Above are the controls for the multiband tuner, the plate tank capacitor, the rotary inductor, and the output-capacitor switch. The plate milliammeter is at the top.

turning the v.f.o. on and off as the key is operated, a 6BL7GT twin-triode vacuum-tube keyer in the cathode of the 5763, and a simple power supply to provide biasing voltages for the system. The a.c. voltage for the selenium rectifier is supplied by a small 6-volt filament transformer, operating in reverse from the 6-volt transformer that supplies filament voltage for the 4-65A, 6W6GT and 6BL7GT. The primary, used here as a secondary, delivers 115 volts r.m.s.

When the key is open, a blocking voltage is applied to the grid of the v.f.o. tube so that it will not draw plate current. The 6BL7GT is also biased to cut-off so that it will not pass the 5763 cathode current. When the key is closed, blocking bias is removed first from the v.f.o., and then, an instant later, from the keyer tube. Although the v.f.o. may chirp when it is turned on, the chirp does not appear on the output signal because of the delay in the keying of the 5763 by the keyer tube.

The reverse action takes place when the key is opened. The amplifier is turned off first, and

then the v.f.o., masking any oscillator chirp. The values of R_3 , R_4 and C_{17} determine the keying characteristic of the 5763. With a fixed value for C_{17} , R_3 controls the make characteristic, and R_4 the break characteristic. Increasing resistance softens the keying. The interval between oscillator and amplifier keying is controlled by R_2 . The farther that the tap is advanced toward the ground end, the faster the oscillator will turn off after the key is opened. However, if it is advanced too far, the break keying characteristic may be clipped because the oscillator is turned off too quickly.

Separate milliammeters are used in the grid and plate circuits of the final amplifier. This is the only metering required.

Construction

The r.f. section of the transmitter is assembled on a $13 \times 17 \times 3$ -inch aluminum chassis fitted with a $10\frac{1}{2} \times 19$ -inch rack panel. The amplifier is enclosed in a box constructed of angle stock and aluminum sheet. Perforated sheet will pro-

Fig. 6-55 — Top view of W8ETU's transmitter. At the right, from left to right, progressing toward the bottom are the 12AU7, the 6C4 cathode follower and the 6AH6, the 40-meter 6C4 and the 80-meter 6AK6, the 15- and 20-meter 6C4s, the 6BL7GT, and the 5763. The 6W6GT clamper tube is at the upper left. The multiband tuner for the 5763 is enclosed in the box fastened against the final-amplifier enclosure. The tank capacitor is placed so that its shaft is central on the panel, and the rotary inductor is located so that its control and the control for the multiband tuner are symmetrical in respect to the tank-capacitor control. The turns counter for the rotary inductor is geared to the coil drive shaft. S_3 and the mica output capacitors are off the left rear corner of the inductor. The v.h.f. series-resonated circuit is mounted against the rear wall, adjacent to the output connect.

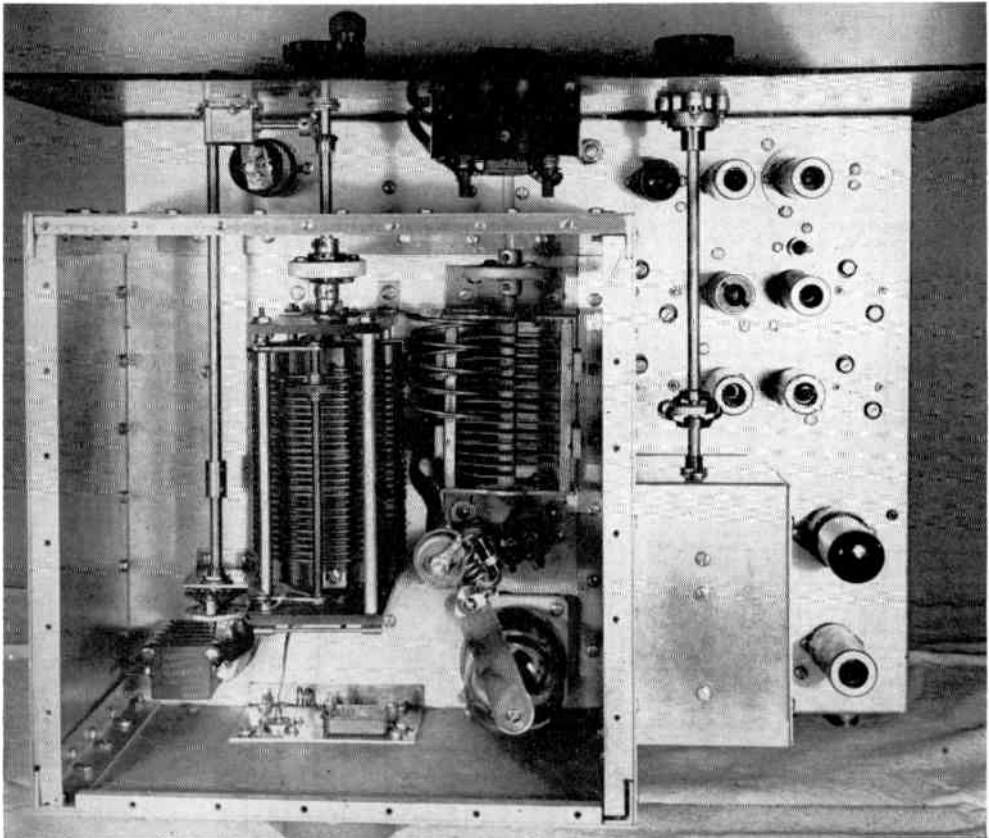

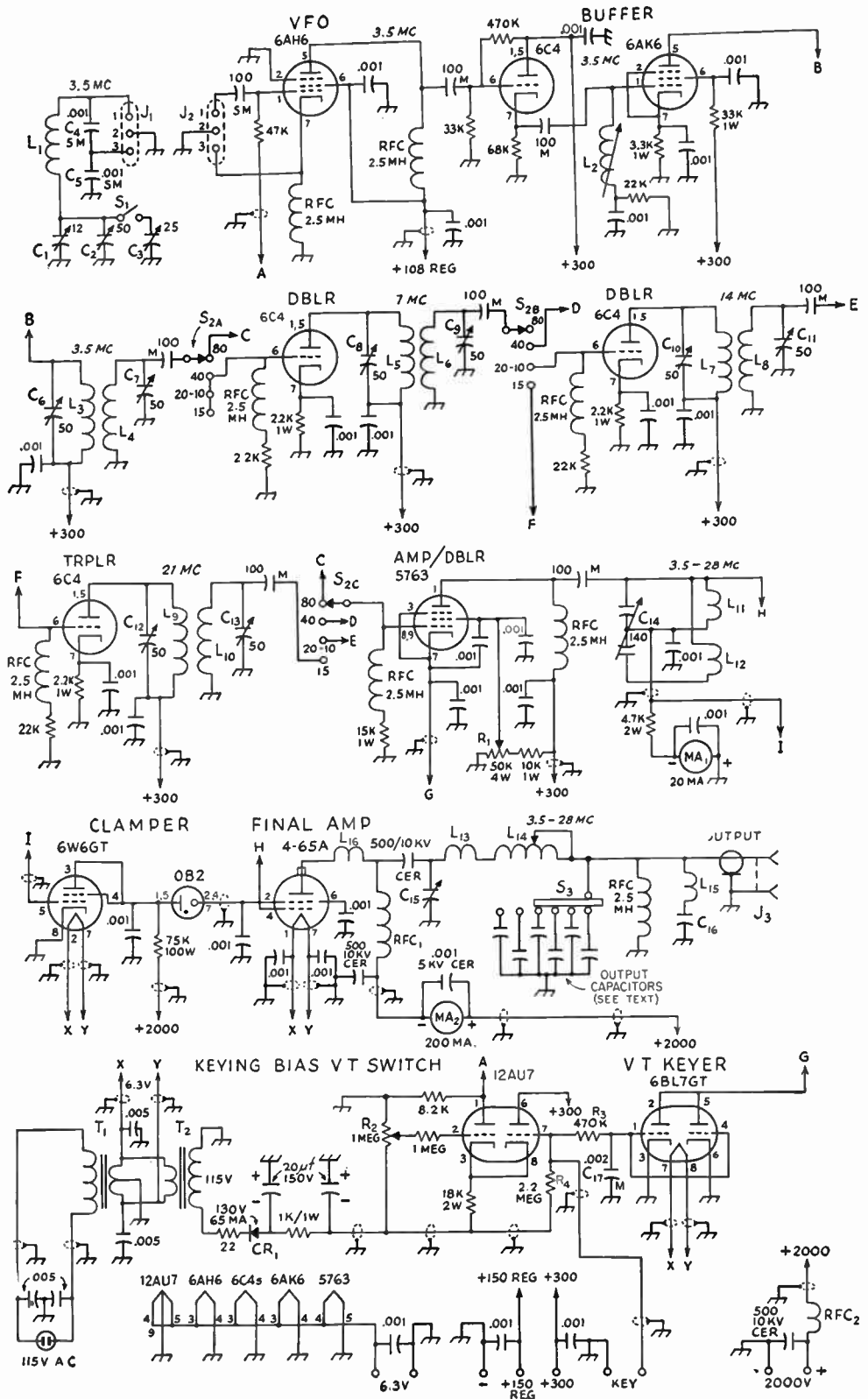

Fig. 6-56 — All capacitances less than 0.001 μf . are in μf . All 0.001- and 0.005- μf . capacitors are disk ceramic. M — Mica, SM — Silver mica, CER — Ceramic. See text and Table II for output capacitors.

- C₁ — Midget variable.
- C₂, C₃, C₆, C₇, C₈, C₉, C₁₀, C₁₁, C₁₂, C₁₃ — Air trimmer.
- C₁₄ — Midget dual variable, 110 μf . per section.
- C₁₅ — See text and Table II.
- C₁₆ — 100- μf . mica (Sprague 9FM or similar).
- L₁ — 50 turns No. 14, 2 inches diam., 5 inches long B & W 3907-1 coil stock).
- L₂ — 90 turns No. 30 enam., on $\frac{1}{2}$ -inch iron-slug form.
- L₃—L₁₀ — See Table 6-I.
- L₁₁ — 22 turns No. 18 enam., 1 inch diam., close-wound.
- L₁₂ — 8 turns No. 18 enam., 1 inch diam., 1 inch long.
- L₁₃ — 4 turns No. 14, 2 inches diam., 2 $\frac{1}{2}$ inches long.
- L₁₄ — Rotary inductor, 25 μh . (Johnson 229-203).
- L₁₅ — See text.
- L₁₆ — Parasitic suppressor — Approx. 5 turns No. 16, $\frac{3}{8}$ inch diam., $\frac{1}{2}$ inch long, shunted by loading resistor (see section on parasitic suppression).
- CR₁ — Selenium rectifier.
- J₁, J₂ — Amphenol 83-22R connector.
- J₃ — Amphenol 83-1R coax connector.
- MA₁ — 2-inch square meter.
- MA₂ — 3-inch square meter.
- RFC₁ — National R-15A.
- RFC₂ — 7 μh . (Ohmite Z-50).
- S₁ — S.p.s.t. toggle.
- S₂ — Ceramic rotary switch; 3 sections, 1 circuit per section, 1 position (Centralab 2514).
- S₃ — Progressively-shorting switch, 10 positions (Centralab P-121 index head with type PLS wafer).
- T₁ — 6.3-volt 6 amp. filament transformer.
- T₂ — 6.3-volt 1.2-amp. filament transformer.

TABLE 6-I

Band-pass Coupler Data

Coil	Band	Turns	Wire	Spacing	B & W No.
L ₃	80	41	30 enam.	$\frac{1}{8}$ "	
L ₄	80	37	30 enam.		
L ₅	40	21	30 enam.	7/16"	
L ₆	40	16	26 enam.		
L ₇	20	15	24 tinned	9/16"	3012
L ₈	20	10	24 tinned		
L ₉	15	9	24 tinned	$\frac{1}{4}$ "	3012
L ₁₀	15	6	24 tinned		

TABLE 6-II

Approximate Pi-Section Values for Resistive 50- or 70-ohm Loads (80-meter band)

Input		Tank Q	C ₁₅		L ₁₃ + L ₁₄ μh^2	Output μf^2
Volts	Ma.		μf^2	Volts		
600	140	10	200	600	12	1000
600	125 ¹	10	200	600	12	1000
1000	150	11	150	1000	17	1000
1500	150	10	100	1500	23	500
2000	150	14	100	2000	23	700

¹ Suggested for Novice operation.
² One half this value for 10 meters, one quarter for 20 meters, one sixth for 15 meters, and one eighth for 30 meters.

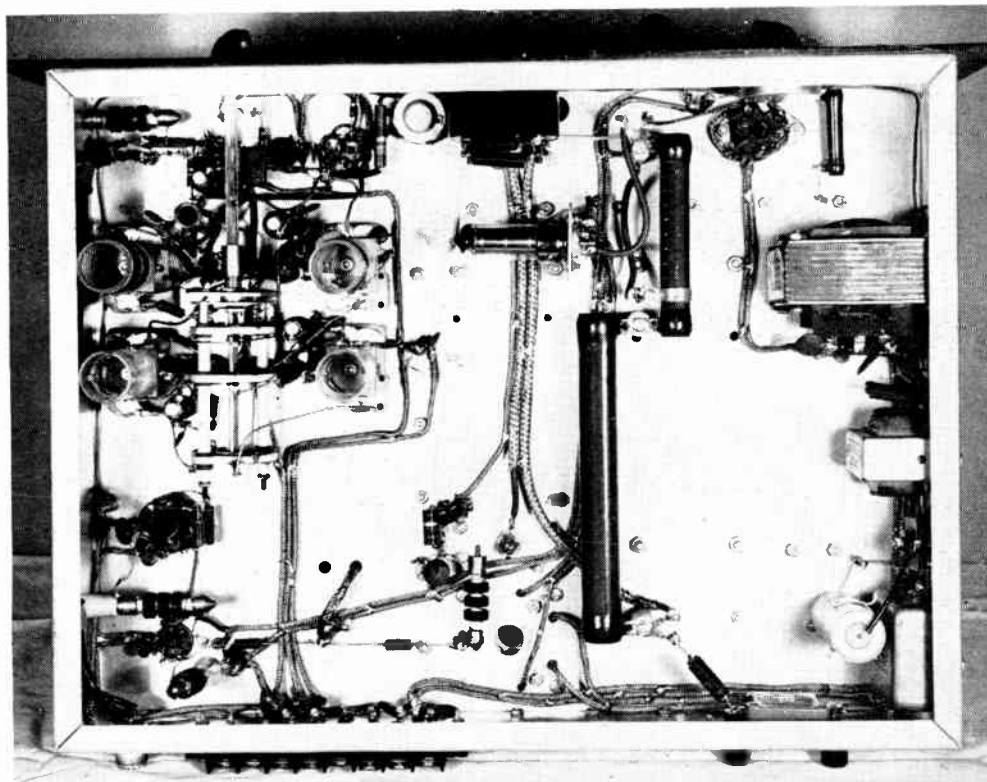

Fig. 6-57 — Bottom view of the main chassis showing the grouping of the bandpass couplers around the bandswitch in the upper left-hand corner. R₂, the bias-adjusting potentiometer for the v.t. switch circuit, is to the left of the grid-current milliammeter, top center. The OB2 in the 4-65A screen circuit is mounted on a bracket below the meter. Filament and bias transformers are to the right. All power wiring is done with shielded wire.

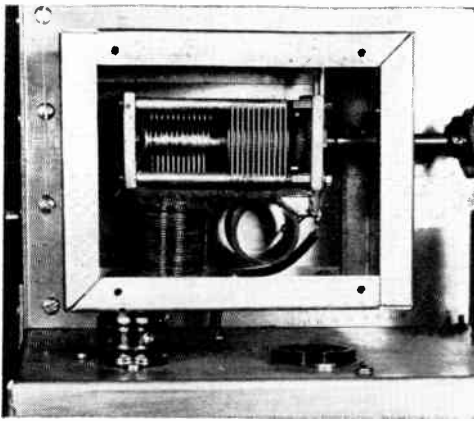

Fig. 6-58 — The multiband tuner used between the driver and final amplifier is housed in a 3 × 4 × 5-inch box fastened to the side wall of the amplifier enclosure. The 5763 and 6BL7 have been removed in this view.

vide better ventilation. The dimensions of the enclosure are approximately 10 inches square by 7 inches high, but may be varied somewhat to accommodate the components selected.

The multiband tuner in the output of the 5763 is built into a 3 × 4 × 5-inch aluminum box (see detail photograph of Fig. 6-58) attached to the amplifier enclosure. A vernier mechanism, such as the National AN or AVD, or a type AM dial, is recommended. The components are laid out so that, on the panel, the control for the multiband tuner is balanced by the control of the variable inductor, with the control for the input capacitor, C_{15} , central. A turns counter is geared to the shaft of the rotary inductor. (A control with a built-in turns counter, such

as the Groth — R. W. Groth Mfg. Co., 10009 Franklin Ave., Franklin Pk., Ill., may be substituted.) In Fig. 6-55, the 4-65A is in the lower right-hand corner of the amplifier enclosure, with the plate r.f. choke between it and the rear of C_{15} . The mica output capacitors are stacked in the opposite corner, close to the selector switch, S_3 . L_{15} and C_{16} are against the rear wall, close to the coax output connector.

Underneath the chassis, the band switch is placed so as to allow room between it and the end of the chassis for the 6AK6 and the 20-meter 6C4 and their bandpass couplers. The 40-meter and 15-meter 6C4s, and their couplers are similarly placed on the other side of the switch. L_2 and the 6AH6 v.f.o. tube are forward from the

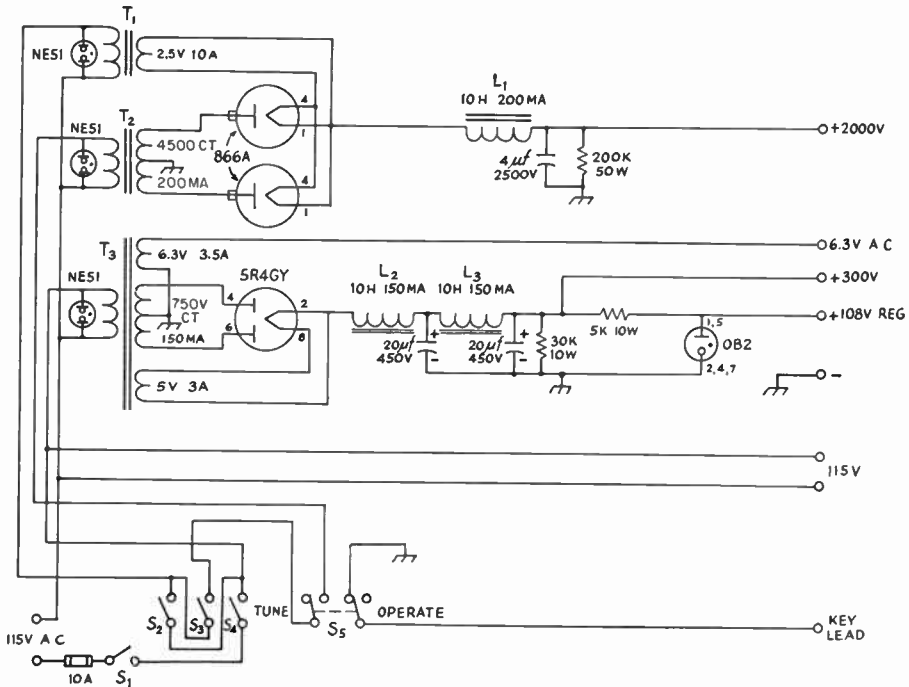

Fig. 6-59 — Power-supply circuit for the 4-65A transmitter. S_1 is an automobile ignition switch, controlling all primary power. S_4 turns on line voltage to the transmitter filament transformers and also turns on the low-voltage supply. S_2 turns on the 866 rectifier filaments, and S_3 controls the high-voltage transformer.

6AK6. The cathode follower is in front of the 40-meter 6C4, with the 12AU7 to the left in Fig. 6-55. In this view, the 5763 is in the rear left-hand corner, with the 6BL7GT keyer tube in front. The 6W6GT clamper tube is between the amplifier enclosure and the panel, near the inductor turns counter. The OB2 VR tube is placed underneath the chassis, on a bracket to the rear of the grid milliammeter. The excitation control, R_1 , is placed so as to balance the control for the band switch on the panel. T_1 , T_2 , the selenium rectifier, and the components for the keyer bias-supply filter are assembled against the right-hand end wall of the chassis in Fig. 6-57.

All power wiring is done with shielded wire, by-passed as described in the chapter on BCI and TVI.

Band-Pass Couplers

The band-pass couplers shown were constructed using the air tuning capacitors and mountings from discarded i.f. transformers. The arrangement shown in the detail photograph of Fig. 6-60 may be duplicated closely using a polystyrene-strip base and midjet air trimmers. The coil forms shown are polystyrene, 1 inch in diameter and $1\frac{1}{2}$ inches long, but Millen type 45000 may be substituted. A hole is drilled through the bottom of the form so that it can be mounted on a spacer or bracket between the two capacitors.

Winding dimensions are shown in Table 6-1. The primary windings of the 80- and 40-meter coils are wound at the bottom ends of the forms, and cemented in place with coil dope. After the dope has dried, the rest of the coil form should be sprinkled with talcum powder, and a layer of cellophane tape wound around it, with the adhesive side out. On the sticky side, the secondary turns should be wound firmly, but not so tightly that the winding cannot be slid along the form for adjustment. The ends of the secondary winding are held in place with coil dope applied carefully so that the secondary does not become cemented to the form so that it cannot be moved. The ends of the windings should now be soldered to the capacitor terminals, completing the assembly.

The 20- and 15-meter couplers are made from Barker and Williamson inductors, lengths of which are slid inside the coil forms. The forms should first be slit with a fine saw to permit the ends of the windings to come out radially. The primary windings should be inserted in the form first, and the secondaries slid in and out as needed for adjustment.

V.F.O. Construction

The remote tuned circuit for the v.f.o. is assembled in a $5 \times 6 \times 9$ -inch aluminum box. The National ACN dial is centered on one of the covers. The inductor is cemented to a strip of polystyrene, and the strip is supported on sections of polystyrene rod that have been tapped for machine screws at each end. Air trimmers

C_2 and C_3 are mounted on a panel so that they may be adjusted with a screwdriver through holes in the end of the box. The frequency-range switch, S_1 , and the coax output connector, J_1 , are mounted at this end.

The box is fitted with shock mountings attached to a base made of two $7 \times 9 \times 2$ -inch chassis, bottom to bottom, and fitted with an aluminum panel. The base is used as a control box, and contains the switches and indicator lamps shown in the power-supply diagram of Fig. 6-59. The main power switch is an automobile ignition switch. With the key removed, the transmitter cannot be turned on. A terminal strip at the rear provides connections to power supply and transmitter. A length of RG-22 U two-conductor cable is used between the output connector of the tuning unit, and the input connector at the transmitter.

Fig. 6-59 shows the circuit of the power supply used with the transmitter. It was assembled on a $13 \times 17 \times 3$ -inch steel chassis.

Pi-Section Values

Table 6-II shows approximate values for maximum rated plate current for c.w. operation at plate voltages ranging from 600 to 2000 volts on 80-meters. The 600-volt, 125-ma. rating provides 75 watts input for Novice operation. To maintain the same values of Q at the higher frequencies, the values of capacitance and inductance shown in the table should be cut in half each time frequency is doubled ($\frac{1}{2}$ for 40, $\frac{1}{4}$ for 20, $\frac{1}{6}$ for 15 and $\frac{1}{8}$ for 10). On 28 Mc., and possibly on 21 Mc., minimum circuit capacitance may make it impossible to reduce the Q

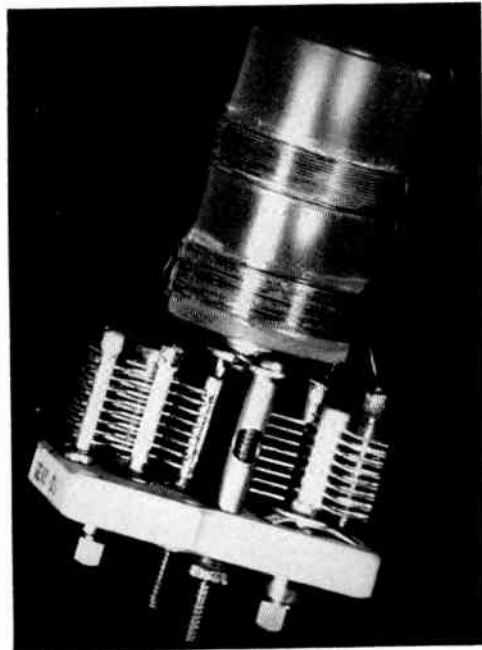

Fig. 6-60—This photograph shows the method of assembling the band-pass couplers as described in the text.

to the values indicated by the table. This will mean that less inductance and greater output capacitance will be required.

If 80-meter operation over the complete range of inputs shown in Table 6-II is desired, the input capacitor C_{15} must have a voltage rating for the highest voltage (2000 volts) and sufficient capacitance for the lowest voltage (200 $\mu\text{f.}$). (Johnson 250F20 has suitable dimensions.) Otherwise, a capacitor of voltage and capacitance ratings shown in the table may be used.

The output capacitance selector switch, S_3 , has 10 contacts. The output capacitance required over the voltage range of 600 to 2000 volts for all bands will be satisfactorily approximated if 50- $\mu\text{f.}$ capacitors are connected to each of the first six positions, 100- $\mu\text{f.}$ units to the next two positions, and 250- $\mu\text{f.}$ units to the last two positions. It should be possible to compensate for minor departures from the needed values by readjustment of the other two elements, C_{15} and L_{14} . To take care of operation at maximum power input, the output capacitors should be mica units rated at 2500 volts, such as Sprague type 9FM.

Tuning Up

After all wiring is checked, the oscillator tube and cathode follower are plugged into their sockets, and the exciter power turned on. If all is well, the signal will be heard in a receiver, in the vicinity of the 80-meter band. Next, S_1 is opened, C_1 set at minimum capacitance, and C_2 adjusted until the signal is heard slightly above 4 Mc. When C_1 is set at maximum capacitance,

the signal should be found in the vicinity of 3.75 Mc. S_1 should now be closed, and C_3 adjusted until the signal is heard at slightly below 3.5 Mc. Some slight pruning of the tuned circuits may be necessary, but it should be possible to get the oscillator to operate from below 3.5 Mc. to over 4.0 Mc., with a slight overlap around 3.75 Mc.

Now the band-pass couplers can be tuned. Set the bandswitch in the 80-meter position, the excitation control at zero, and plug in the rest of the tubes in the exciter section. Temporarily ground the cathode of the 5763, and connect a high-resistance voltmeter across the 5763 grid-leak resistor. All band-pass-coupler secondary windings should be pulled as far away from the primaries as possible. The v.f.o. is now set at 3.75 Mc., and C_6 and C_7 tuned for maximum indication on the voltmeter. The secondary winding, L_4 , should now be moved toward L_3 , until the spacing is that given in the coil table. This spacing should be set very carefully in all cases, since a small deviation will result in a change in the band-pass characteristic. It is also to be noted that the coupler tuning capacitors are to be adjusted only when the windings are at the maximum spacing.

Next, move the high-resistance voltmeter to read the drop across the 6AK6 grid-leak resistor and set the v.f.o. frequency at 4 Mc. Now adjust L_2 for maximum grid voltage, and swing the v.f.o. through its entire range. If the grid voltage increases when the frequency is lowered, decrease the inductance of L_2 . Correct adjustment of L_2 will result in nearly constant drive to the 6AK6 throughout the entire v.f.o. range.

The rest of the band-pass couplers can now

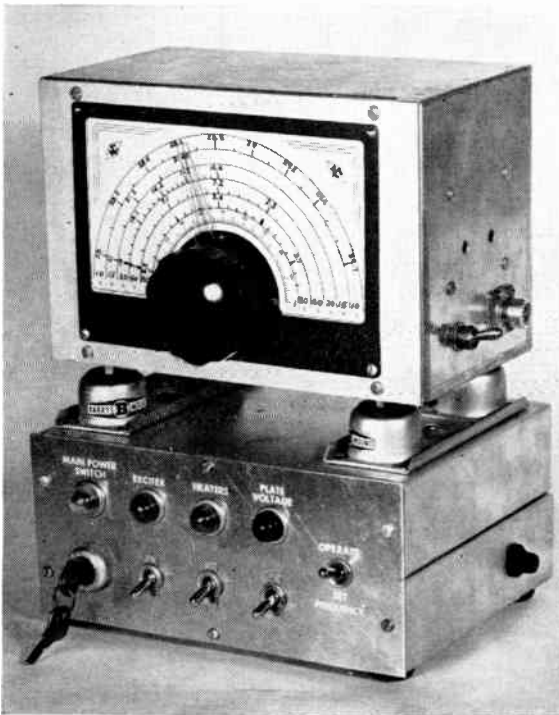

Fig. 6-61 — The v.f.o. remote tuning unit and control box. The tuning unit is enclosed in a 5 × 6 × 9-inch aluminum box mounted on shock absorbers. The control-unit enclosure is made up of two 7 × 9 × 2-inch aluminum chassis, bottom to bottom. The range-control switch and remote cable connector are mounted on one end of the tuning unit. A fuse holder projects from the end of the control unit.

be adjusted, following the procedure described above for the 3.5-Mc. coupler, and with the voltmeter once again reading driver grid voltage. The 40-meter coupler should be adjusted with the v.f.o. set at 3.6 Mc., the 20-meter coupler should be adjusted at 3.6 Mc., and the 15-meter coupler at 3.55 Mc. It should be possible to tune through any of the bands with less than ten per cent variation in drive to the 5763.

The Multiband Tuner

The multiband tuner can now be checked, with the 4-65A in its socket, and heater voltage applied. It is suggested that a grid-dipper be used to ascertain that the grid circuit is tuning to the proper frequency and not to a harmonic. Grid tuning-dial settings should be logged for future reference, and note taken if two bands resonate at the same dial setting. If, for example, the 80- and 20-meter resonance points occur at or near the same dial setting, pruning of one of the coils will be necessary. For best separation between the two frequency ranges, the low-frequency inductor, L_{11} , should be adjusted so that 7300 kc. comes close to the minimum capacitance of C_{14} , and the high-frequency inductor, L_{12} , adjusted so that 14 Mc. comes close to maximum capacitance. The dial settings in this unit were 95, 23, 82, 15, and 5, respectively for the 80-, 40-, 20-, 15-, and 10-meter bands.

Adjustment of the keyer can now be made after removing the ground from the 5763 cathode. R_2 is advanced toward its positive end (ground) until the voltage at Pin 1 of the 12AU7 is - 15 volts. The keying characteristic can be adjusted

to individual taste later by adjusting the value of C_{17} .

Pi-Tank Adjustment

The final amplifier is best tested at reduced plate voltage. Either a 50-ohm dummy load or an antenna known to present a resistive load of 50 ohms should be used for initial tune-up. Adjustment of the excitation control, R_1 , will provide the correct grid current of 15 ma. to the final. With the bandswitch set in its 80-meter position, and the grid tank resonated, the plate tank capacitor, C_{15} , should be set at about 90 per cent of its maximum value, and the rotary inductor set at near-maximum inductance. A grid-dipper could be used here to establish a near-resonance point. The plate voltage should be applied, and C_{15} quickly tuned for a plate-current dip. If an appreciable change in capacitance is necessary to establish resonance, a new setting of the variable inductor should be tried, until the plate circuit resonates at 3.5 Mc. with almost all of the capacitance of C_{15} in the circuit. Full plate voltage can now be applied, and loading adjusted for a plate current of 150 ma. Now is a good time to check the 4-65A screen voltage, which should be 250 volts.

Adjusting the final amplifier on the other bands is carried on in much the same manner, setting the final tank capacitor to approximately the correct value (see Table 6-11), adjusting the rotary inductor for resonance with a grid dipper, and finally resonating the circuit with power on. All settings should be logged for future reference.

(From *QST*, October, 1955.)

Fig. 6-62 — Rear view of the tuning unit showing the mounting of the inductor on polystyrene sheet and rods and the arrangement of other components. Ceramic trimmers, mounted on the insulating panel at the left, were later replaced with air trimmers (C_2 and C_3).



A 500-Watt Multiband V.F.O. Transmitter

Figs. 6-63 through 6-71 show the circuit and other details of a 500-watt transmitter with v.f.o. frequency control, capable of operation in any band from 3.5 to 28 Mc. It is completely shielded and all tuning adjustments, including band changing, may be done with the panel controls.

As the circuit of Fig. 6-66 shows, the v.f.o. uses a 5763 in a Clapp circuit operating over a range of 3370 to 4000 kc., split into three bandspread ranges, tuned by C_1 which is fitted with a calibrated dial. These ranges, selected by proper setting of C_2 , are 3500 to 3750 kc., 3370 to 3405 kc. (for 11-meter operation) and 3750 to 4000 kc. for 75-meter phone work.

The oscillator circuit is followed by two isolating stages. The first is a 6C4 connected as a cathode follower, which is very effective in reducing reaction on the oscillator by subsequent stages. Since the output of the cathode follower is quite small, it is followed by a 5763 in an amplifier fixed-tuned in the 3.5-Mc. region.

Frequency multiplying to reach the higher-frequency bands is done in the next two stages, the first using a 5763, while the second employs the larger 6146 to drive the final amplifier. These two stages are tuned with multiband tuners — circuits which have a tuning range that includes all necessary bands. Thus no switching or plug-in coils are needed. Neither of these two stages is operated as a straight amplifier, except on 80 meters. Frequency is doubled in the 6146 stage for output on 40, 20 and 10 meters, and tripled for

output on 15 meters. The 5763 stage is operated at 3.5 Mc. for 80- and 40-meter output, doubles to 7 Mc. for 20- and 15-meter output, and quadruples to 14 Mc. for 10-meter output. Excitation to the final is adjusted by the potentiometer in the screen circuit of this stage.

The 813 in the final amplifier also uses a multiband tuner to cover all bands. This stage is always operated as a straight amplifier and a neutralizing circuit is provided. The only switching necessary is in the output link circuit in changing between high- and low-frequency bands. Loading is adjusted by C_{10} .

V_8 and V_9 are used in a differential break-in keying system which automatically turns the v.f.o. on before the 5763 cathode is closed by the keyer tube V_9 , and turns the v.f.o. off after the 5763 cathode circuit has been opened. This prevents any chirp in the oscillator from appearing on the output signal of the transmitter.

A 50-ma. meter may be switched to read plate current in the exciter stages, grid current in the driver and final-amplifier stages, or screen current to the 813. The $\frac{1}{2}$ -ohm resistor in the 6146 high-voltage lead multiplies the meter-scale reading by three, while the 1-ohm shunt in the 813 screen lead increases the full-scale reading to 100 ma. A separate 500-ma. meter is used to check plate current to the 813.

The two-circuit rotary switch, S_1 , is used to bias the screens of the 6146 and 813 negative while tuning up the preceding stages and setting

Fig. 6-63 — The standard-rack panel is $12\frac{1}{4}$ inches high. Controls (National HRS) along the bottom, centers spaced at intervals of $2\frac{1}{8}$ inches either side of center, are, left to right, for C_1 , S_2 , C_3 , C_2 , S_1 (Centralab 1405), S_2 and C_{10} . Power toggles are below at the center, spaced 1 inch apart. The calibrated v.f.o. dial (National SCN) for C_1 is at the center, with the excitation control to the left, and the dial for C_9 to the right (both National type AM). National CFA chart frames outline the rectangular openings for the recessed meters, 50-ma. to the left, 500-ma. to the right. The shielding enclosure is built up using aluminum angle, perforated sheet (also used for the bottom plate), and sheet-metal screws.

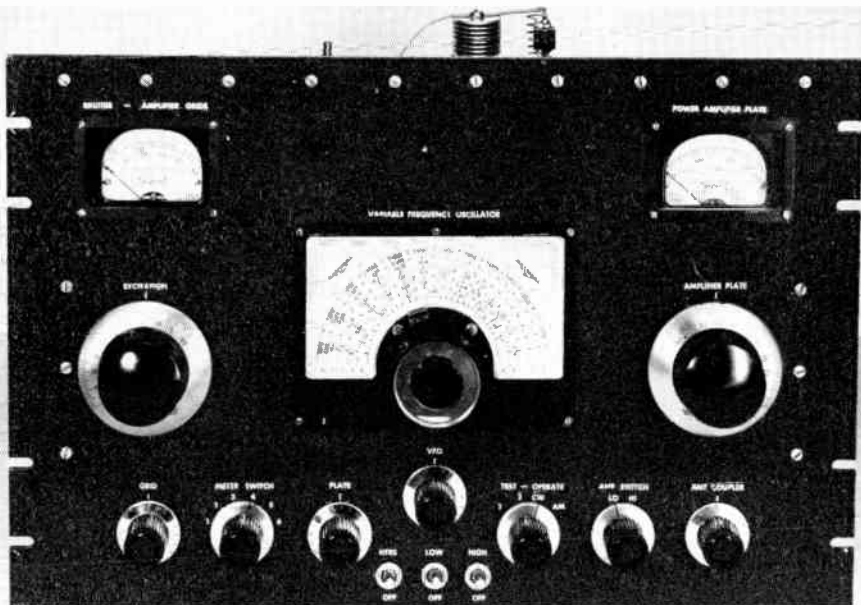
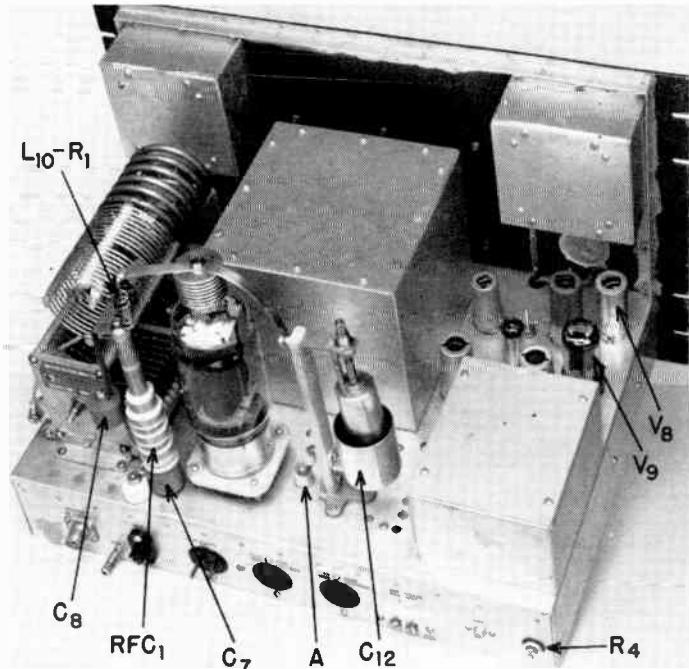

Fig. 6-64 — The components are assembled on a 17 × 12 × 3-inch aluminum chassis. The meters are housed in 4 × 4 × 2-inch boxes, the v.f.o. enclosure is 6 × 6 × 6 while the box enclosing L_3 and L_4 , to the right, measures 3 × 4 × 5 inches. The National R-175A r.f. choke is threaded into C_7 (Sprague 20DK-T5). C_8 (also Sprague 20DK-T5) is mounted on a metal bracket fastened to a stator terminal of C_9 . C_2 (a Johnson N-250) connects to C_{13} via feed-through A . V.h.f. parasitic choke L_{10} consists of 6 turns No. 16, $\frac{3}{4}$ inch diameter, $1\frac{1}{4}$ inches long. R_1 is made up of five 470-ohm 1-watt carbon resistors in parallel. It is connected across 3 turns of L_{10} . The 813 socket is mounted on $\frac{1}{2}$ -inch pillars over a $2\frac{1}{4}$ -inch hole in the chassis. Along the rear apron are J_2 , + h.v. (Millen 37001) and ground terminals, a.c. power-input connector, two a.c. outlets, low-voltage input terminals, key connector, and R_4 .



the v.f.o. to frequency. In the first position, both screens are biased; in the second position, only the 813 screen is biased, while positive voltage is applied to the screen of the 6146 so that this stage may be tuned up. In the third and fourth positions, positive voltage is applied to both screens, but in the last position it is applied to the 813 screen through an audio choke so that the stage may be screen-plate modulated.

Two bias rectifiers are included to supply fixed bias to the 6146 and 813, so that the plate currents will be cut off during keying intervals. Negative blocking voltage is also provided for the keying system. Both rectifiers operate from a single 6.3-volt filament transformer connected in reverse. The bias transformer T_2 is operated from the 6.3-volt winding of the filament transformer T_1 .

Two a.c. outlets are provided for connecting the primaries of external high- and low-voltage

supplies into the control circuit consisting of three toggle switches. B_1 is a ventilating blower that operates when the filament switch is closed.

It is highly important that the v.f.o. box make good contact with the chassis; otherwise the v.f.o. may be adversely affected by feedback from the adjacent final tank when working on 80 meters. Mounting screws spaced an inch around the bottom lip of the box, and correspondingly in the top cover, should eliminate this completely.

L_1 (35 μ h.) is a B&W 80-BCL coil with the link and base removed. L_2 is described over Fig. 6-71. L_3 (2.6 μ h.) is 31 turns of B&W 3003 Miniductor, while L_4 (5.3 μ h.) is 30 turns of 3011. L_5 (1.5 μ h.) consists of 11 turns of No. 16, $\frac{3}{4}$ -inch diameter, $1\frac{3}{16}$ inch long. L_6 (8.9 μ h.) has $20\frac{1}{2}$ turns of B&W 3015 Miniductor. L_9 (1.6 μ h.) has 6 turns of $\frac{1}{4}$ -inch copper tubing, $2\frac{1}{4}$ inches inside diameter, $2\frac{3}{4}$ inches long.

L_7 (4.8 μ h.) and L_8 (4.2 μ h.) are made from

Fig. 6-65 — The v.f.o. box is placed with its front wall $1\frac{3}{8}$ inches back of the panel, central on the chassis. L_1 is mounted on 2-inch cones to center it in the box. The shaft of C_1 (Cardwell PL-6001 minus last rotor plate) is central on the box front, at a height to match that of C_3 . C_2 (Cardwell PL-6002) is mounted, between C_1 and the coil, shaft downward, to engage the right-angle drive below. C_3 (Cardwell PL-6009) is similarly mounted, to the left of C_2 . Grouped to the left are L_4 , L_2 , and L_3 in front, with L_5 and L_1 to the rear, and L_2 in the center. Feed-throughs in the bottom of the coil box to the rear connect L_3 and L_4 to C_3 below. The ventilating holes are over the 6146. C_9 (Johnson 2001D35) is placed with its shaft $2\frac{1}{4}$ inches from the end of the chassis, and its rear end plate $1\frac{1}{2}$ inches in from the back edge. The three feed-throughs to the left connect L_3 to S_2 . This photograph was made before the installation of C_{12} , the R-175A choke, V_8 and V_9 .

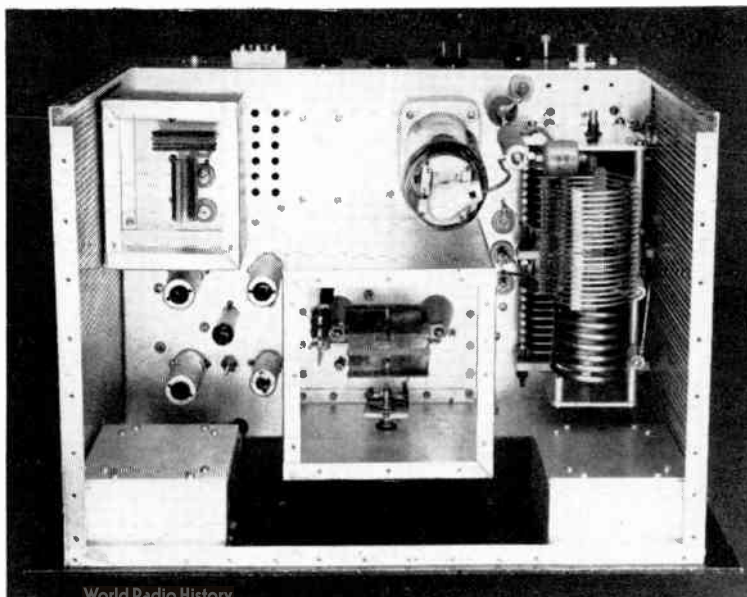

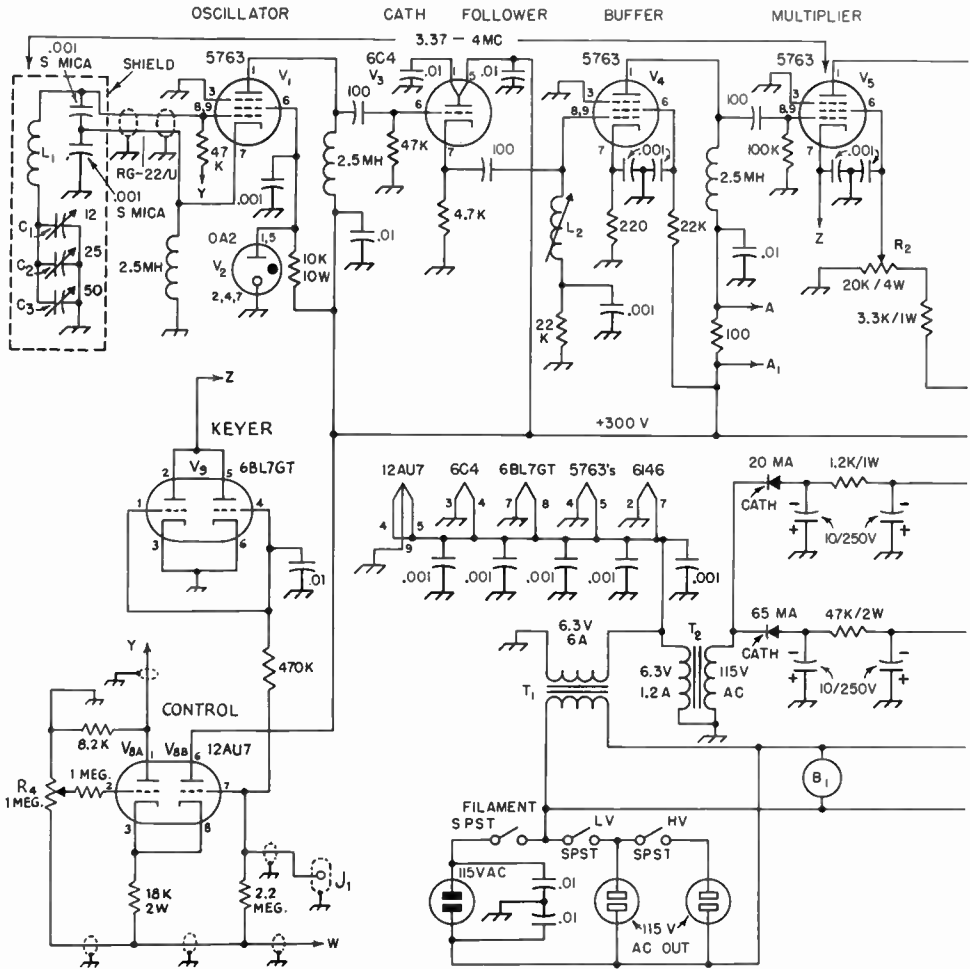
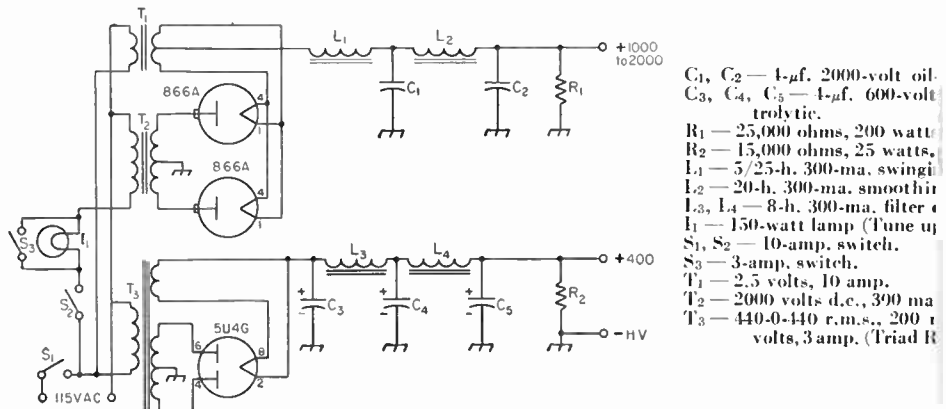
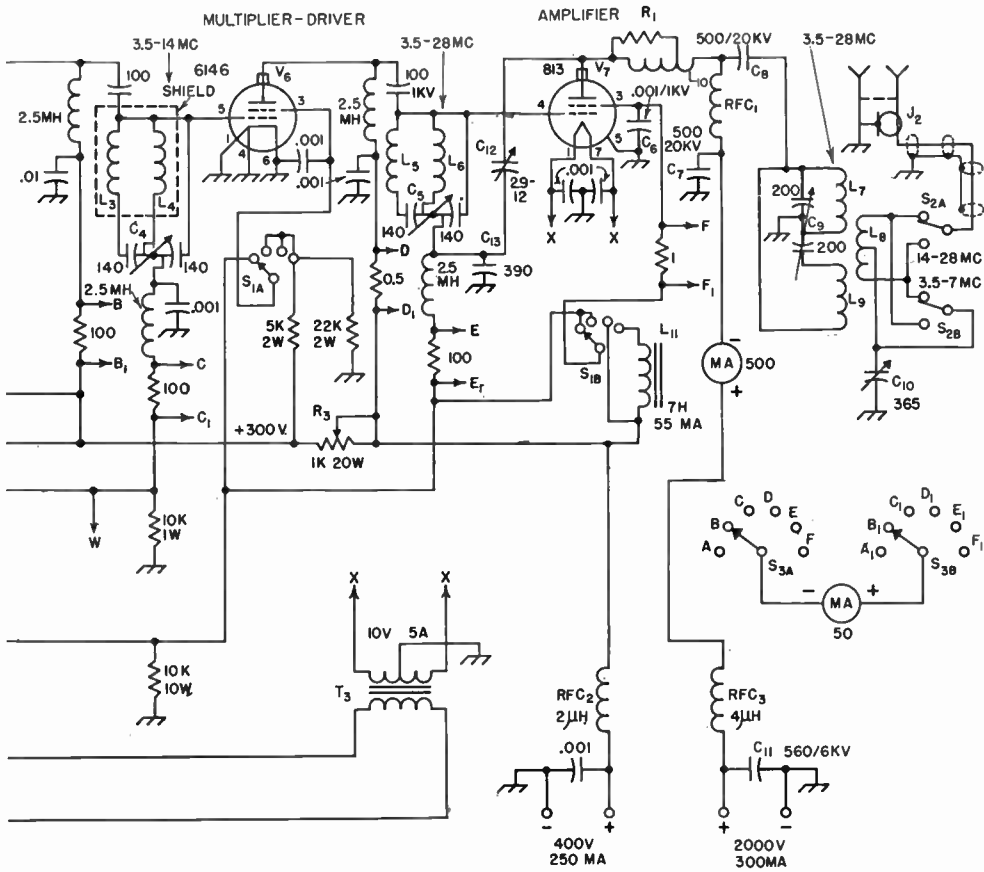

Fig. 6-66 — All capacitances less than 0.001 μ f. are in μ f. All unmarked by-passes are disk ceramic. All 10 fixed capacitors are mica. All resistors are $\frac{1}{2}$ watt unless otherwise specified. RFC₂ and RFC₃ are National C₁ is Sprague DD60-561. Rectifiers are selenium. R₂ is the excitation control. R₃ is the oscillator-lag adjust B₁ is the ventilating-fan motor.



- C₁, C₂ — 4- μ f. 2000-volt oil.
- C₃, C₄, C₅ — 4- μ f. 600-volt electrolytic.
- R₁ — 25,000 ohms, 200 watt
- R₂ — 15,000 ohms, 25 watts,
- L₁ — 5/25-h. 300-ma. swing in
- L₂ — 20-h. 300-ma. smooth in
- L₃, L₄ — 8-h. 300-ma. filter
- I₁ — 150-watt lamp (Tune up
- S₁, S₂ — 10-amp. switch.
- S₃ — 3-amp. switch.
- T₁ — 2.5 volts, 10 amp.
- T₂ — 2000 volts d.c., 390 ma
- T₃ — 440-0-440 r.m.s., 200 r

Fig. 6-67 — Circuit of a suitable power supply for the 813 transmitter.



B&W 3905-1 strip coil as follows: Unwind one full turn from one end. Then count off $9\frac{1}{4}$ turns, clip the wire without breaking the support bars. Bend the last quarter turn out. This portion is L_7 . Remove the next $\frac{3}{4}$ turn to make a $\frac{1}{4}$ -inch space between L_7 and L_8 . Count off 10 turns more, cut the remainder of the coil stock off. Unwind the last turn on L_8 . Tap L_8 at the 8th turn from L_7 .

Adjustment

The diagram of a suitable power supply is shown in Fig. 6-67. The low voltage supply should deliver a full 400 volts under load, and R_3 should be adjusted eventually so that the voltage to V_1 , V_3 , V_4 and V_5 is 300 under load.

The v.f.o. tuning ranges should be adjusted first. Set S_1 to the first position. Adjust R_2 to zero and turn on the filaments and low-voltage supply. Set C_1 at 95 degrees on the dial (near minimum capacitance). Set C_2 accurately at midscale. Listening on a calibrated receiver, adjust C_3 until the v.f.o. signal is heard at 3750 kc. Tune the receiver to 3500 kc., turn C_1 toward maximum capacitance until the v.f.o. signal is heard. This should be close to the lower end of the dial. By carefully bending the rearmost stator plate of C_1 backward, it should be possible to adjust the range of 3500 to 3750 kc. so that it covers from 5 to 95 degrees on the dial. Some slight readjustment

of C_3 may be necessary during the plate-bending process to keep the band centered on the dial.

Now set C_1 at about 15 degrees. Set the receiver at 3750 kc. and reduce the capacitance of C_2 until the v.f.o. signal is heard. Then tuning the receiver to 4000 kc., the v.f.o. signal should be heard when its dial is set at about 85 degrees. Mark this setting of C_2 accurately. If it is desired to center the 11-meter band on the dial, set C_1 at midscale. Increase the capacitance of C_2 until the v.f.o. signal is heard at 3387 kc. Mark this setting of C_2 also accurately.

When the v.f.o. frequency ranges have been set, tune the v.f.o. to 3.6 Mc. and adjust the slug of L_2 for a maximum voltage reading across the 22K grid leak of V_4 . A high-resistance voltmeter should read about - 25 volts.

Readjust C_2 to midscale and turn the meter switch to read 6146 grid current, and turn up the

Tuning Chart for the 813 Transmitter

Output Band (Mc.)	C_4		C_5		C_9 Dial ²
	Dial ¹	Band (Mc.)	Dial ¹	Band (Mc.)	
3.5	8.8	3.5	6.1	3.5	77
7	8.8	3.5	0.5	7	9
14	1.5	7	9.5	14	82
21	1.5	7	3.7	21	26
27-28	4.7	14	1.8	28	7

¹ 10-division dial - 10 max. capacitance.

² 100-division dial - 100 max. capacitance.

excitation control to give a reading of 2 or 3 ma. Resonate the output tank circuit of the 5763 frequency multiplier at 80 meters (near maximum capacitance) as indicated by maximum 6146 grid current. Turn S_1 to the second position so that screen voltage is applied to the 6146 but not to the 813. Turn the meter switch to read 6146 plate current and resonate the 6146 output tank circuit as indicated by the plate current dip near maximum capacitance. Turning the meter switch to read 813 grid current, adjust the excitation control to give a reading of about 25 ma.

Before applying power to the 813, the neutralizing should be adjusted as described in an earlier section of this chapter. After neutralization, reduced plate voltage should be applied. Plate voltage can be reduced by inserting a 150-watt lamp in series with the high-voltage-transformer primary. A 300-watt lamp connected across the output connector can be used as a dummy load for testing. Make sure that S_2 is turned to the low-frequency position. This position is used for 3.5- and 7-Mc. operation. The other position is used for 14, 21 and 28 Mc. Turn S_1 to the third position to apply screen voltage to the 813, apply plate voltage and resonate the output tank circuit (near maximum capacitance) as indicated by a dip in plate current. Full plate voltage may now be applied and C_{10} adjusted to give proper loading (220 ma. maximum). Adjust the excitation control to give an 813 grid current of 15 to 20 ma. Tuning up on the other bands is done in a similar manner, by adjusting the tuners in each circuit to the correct band to obtain the desired multiplication. The tuning chart shows the approximate dial setting for each band, but each should be checked with an absorption wave meter and the setting logged for future reference. The voltage-current chart shows typical values to be expected. The output circuit is designed for a 50- or 70-ohm resistive load. For other loads, a link-coupled antenna tuner (see transmission-line chapter) should be used.

In the keyer circuit, turning R_4 toward ground causes the oscillator to cut off more quickly after the key has been opened.

(Originally described in *QST* for January,

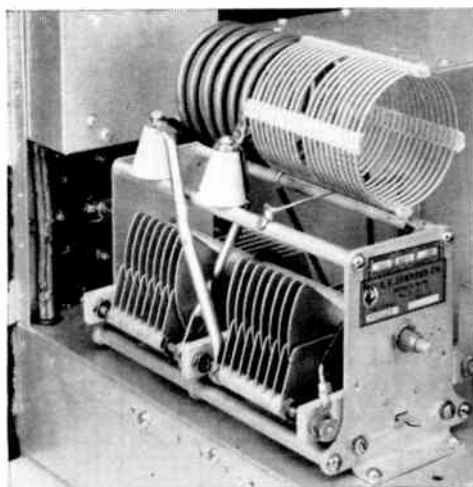

Fig. 6-68 — Close-up showing method of mounting L_7 , L_8 and L_9 . The stator rods of C_9 are tapped 6-32 for threaded studs by which the 1-inch cone insulators are attached. The bracket attaching C_8 to the stator of C_9 is at the lower right.

1954; with modifications in the issues for June, 1954, June and October, 1956).

Voltage-Current Chart for the 813 Transmitter

Tube	Band (Mc.)	Grid 1 (volts)	Grid 1 (ma.)	Grid 2 (volts)	Grid 2 (ma.)	Cathode (volts)	Plate (volts)	Plate (ma.)
V_1	3.5	-16	—	150	—	0.6	300	—
V_3	3.5	—	—	—	—	39	300	—
V_4	3.5	-18	—	190	—	9	300	35
V_5	3.5	-64	—	115	—	27.5	300	5.5
V_5	7	-61	—	115	—	27.5	300	5.5
V_5	14	-58	—	170	—	34	300	8.5
V_6	3.5	-75	*	170	—	—	100	55
V_6	7	-76	*	170	—	—	100	63
V_6	14	-80	*	185	—	—	100	87
V_6	21	-80	*	195	—	—	100	90
V_6	28	-75	*	175	—	—	100	105
V_7	3.5	-165	17	400	40	—	2000	220
V_7	7	-185	18	400	40	—	2000	220
V_7	14	-190	19	400	35	—	2000	220
V_7	21	-190	20	400	35	—	2000	220
V_7	28	-190	19	400	40	—	2000	220

* Approximately 2 ma. Depends on setting of excitation control.

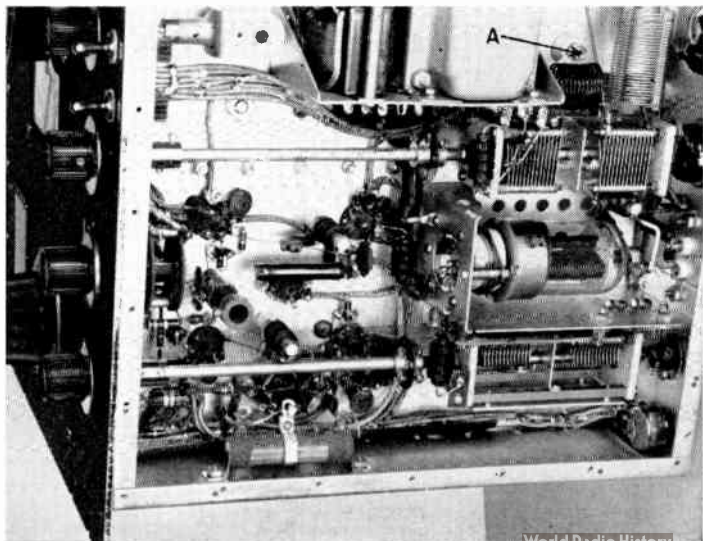

Fig. 6-69 — Detail view of the exciter section. The neutralizing lead from C_{12} comes through the chassis at feed-through A . R_4 in the keyer circuit is in the lower right corner. R_3 is near the lower left corner. Leads to the 6146 socket pass through a large clearance hole in the bracket.

Fig. 6-70 — The chart frame, the panel and the aluminum box are held together, as shown in A, by the hardware supplied with the CFA. B shows a meter (Triplet Model 327-T), its insulated mounting ring, and the rear cover of the box. The meter assembly is slipped into the metal box after the latter has been attached to the rear of the panel. Shielded meter leads enter the bottom of the box through a rubber grommet. The shield braid should be bonded to the outside of the aluminum case at the point of entry.

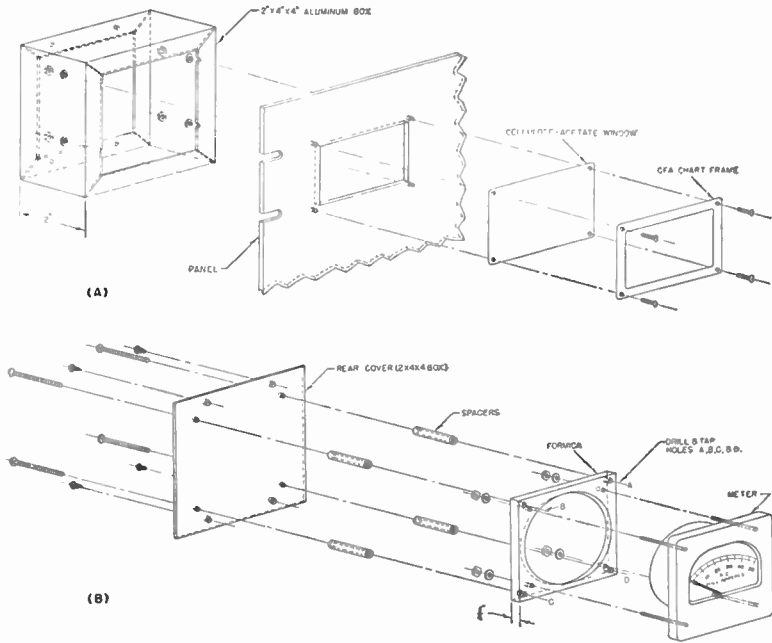
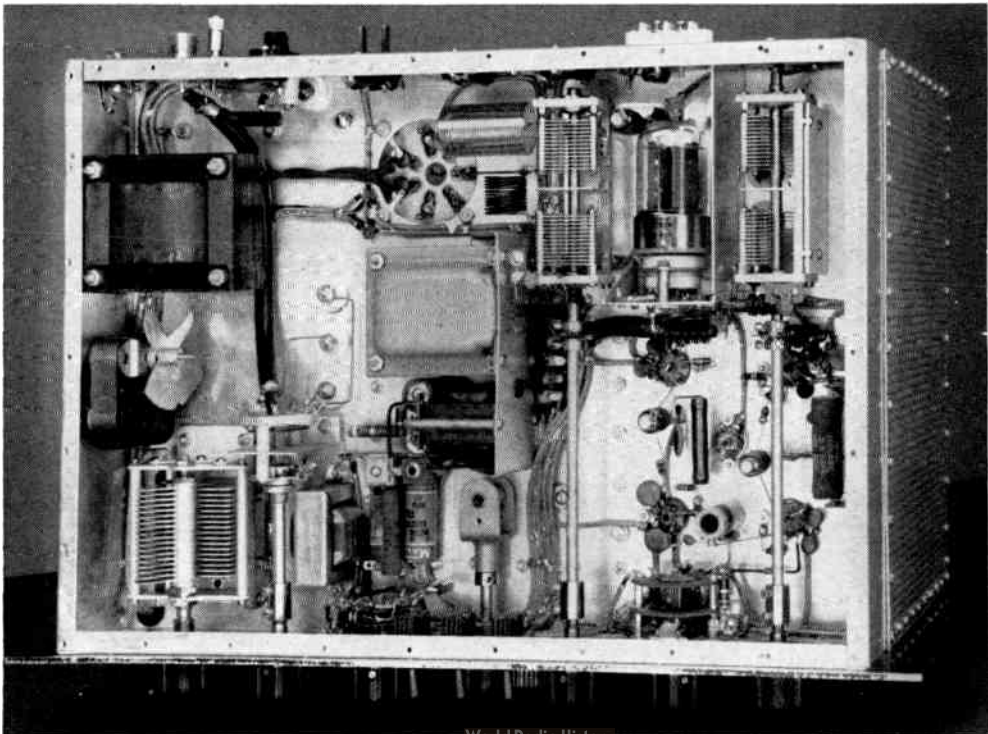

Fig. 6-71 — The panel drops $\frac{3}{16}$ inch below the bottom edge of the chassis. The National RAD right-angle drive for C_2 is at the center. The other controls along the bottom are placed $1\frac{1}{2}$ inches up from the bottom edge of the chassis, and the corresponding components mounted so that their shafts line up with the controls. Panel bushings should be provided for the shafts of C_{10} (Cardwell PL-7006), and the right-angle drive; panel-bearing shaft units for C_4 and C_5 (Cardwell PL-6013), and S_2 (Centralab RR wafer on P-121 index assembly). The 6146 is mounted on a $5 \times 2\frac{1}{4}$ -inch bracket between C_4 and C_5 , whose shafts are fitted with insulating couplings. C_5 is mounted on spacers, while C_4 is mounted on its side on a bracket. T_1 (Triad F-18A) and T_2 (Triad F-14X) are mounted on another bracket at the center. L_5 and L_6 , at right angles, are soldered between the terminals of C_5 and Pin 4 of the 813 socket, seen through the $2\frac{1}{4}$ -inch hole in the chassis. C_{10} and S_2 are mounted on small brackets. T_3 (Triad F-23U) and the blower (available from Allied Radio, Chicago, No. 72P715) are to the left. The screwdriver-slotted shaft of C_3 may be seen between the shaft of C_5 and the shielded power wires to the left. All power wiring is done with shielded wire (Belden 8656, Birmbach 1820, or shielded ignition wire for the 2000-volt line; Belden 8885 for the rest). L_2 , behind S_3 (Centralab 1411), is a National XR-50 slug-tuned form close-wound with 93 turns No. 36 enameled wire.



A Remotely-Tuned V.F.O.

The v.f.o. shown in Figs. 6-72 through 6-76 is a series-tuned Colpitts (Clapp) circuit built in two sections. The large compartment contains only the tuned circuit (Fig. 6-73A), while the other contains the 5763 tube and a pair of OB2 voltage regulators (Fig. 6-73B). The two are connected with a piece of double-conductor coaxial cable that may be of any length up to 40 feet or so. The advantages of such a system are, first, that the tuned circuit is well removed from heat-generating equipment, including the oscillator tube itself, and second, that it forms a convenient means of remote frequency control. While this arrangement was designed primarily as a driver for a frequency-multiplier unit, in many cases the existing crystal-oscillator tube of a transmitter can be substituted for the second section of Fig. 6-73B, if the tube is a 6AG7 or 5763. If the grid-plate crystal-oscillator circuit is in use in the transmitter, it should be possible to feed the tuned circuit directly through the 2-conductor cable to grid, cathode and ground without modifying the crystal oscillator circuit in any way. RG-22/U shielded twin conductor is recommended for the connecting cable.

The oscillator operates in the 3.5-Mc. region and the bandspread tuning system, consisting of C_1 , C_2 and C_3 , is designed to cover the desired frequency ranges in three steps, when C_1 and C_2 are altered as described under Fig. 6-73. With one setting of C_2 , the tuning capacitor C_1 spreads the range of 3500 to 3750 kc. out over 95 per cent of the National ACN dial. Since this fundamental range covers the most-used 80-meter c.w. frequencies, and harmonics of this range cover all of the higher-frequency bands, excepting only

the 11-meter band, this range will usually suffice for 90 per cent of all operating. By shifting the setting of C_2 , the range of 3750 to 4000 kc. is spread out over about 75 per cent of the dial. The 11-meter band is provided for by a third setting of C_2 .

Tuned-Circuit Unit

The tuned circuit is housed in a $5 \times 6 \times 9$ -inch aluminum box. An enclosure of this size is needed not only to provide mounting for an adequate dial, but also to permit spacing the coil well away from the sides of the box so that its Q will not be drastically reduced by the shielding in its field.

The dial is first mounted centrally on one of the 5×9 -inch sides of the box. The tuning capacitor, C_1 , is then coupled to the dial and the mounting step at the rear of the capacitor is supported against the bottom of the box with a heavy metal spacer cut to fit. The band-set capacitor, C_2 , is shaft-hole mounted 1 inch in from the left side and bottom of the box. This necessitates drilling the shaft hole through the edge of the dial frame. C_3 is soldered directly across the terminals of C_2 . The knob is a National HRS-5.

The B & W coil is removed from its mounting by first drilling out the rivets in the plug-in base, leaving the metal angle pieces at each end attached to the coil, and unsoldering the leads from the pins. The link winding is carefully removed by snipping the turns and prying the spacing blocks loose with a knife. One turn is removed from the coil itself. The coil is then mounted on National GS-1 pillar insulators so that it will be centrally located in the box in both directions.

The three-contact jack for the remote-tuning

Fig. 6-72 — The remotely-tuned v.f.o. The large box contains the tuned circuit, the smaller one the oscillator and voltage-regulator tubes. The two terminals on the smaller box are for output and key connections. The power connector is at the end opposite the cable connection.

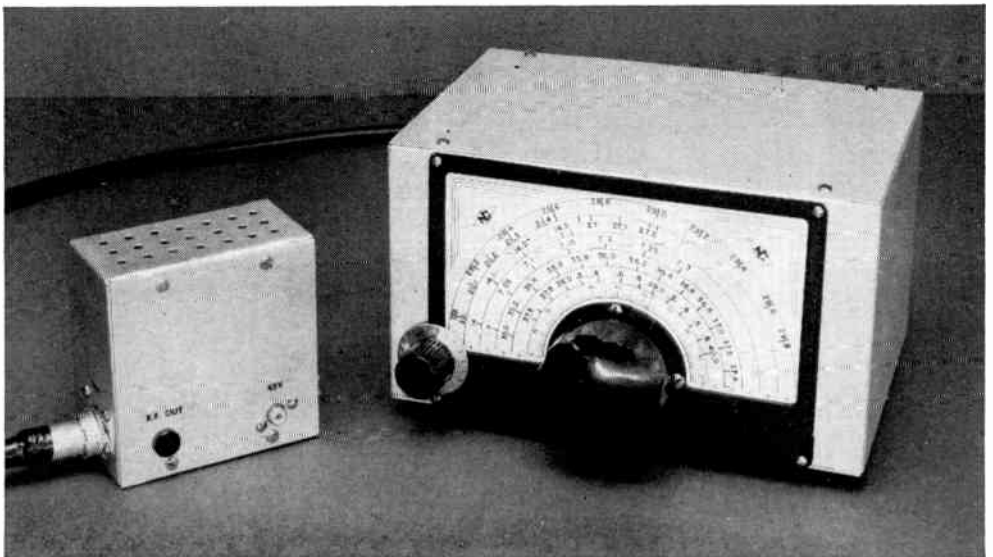

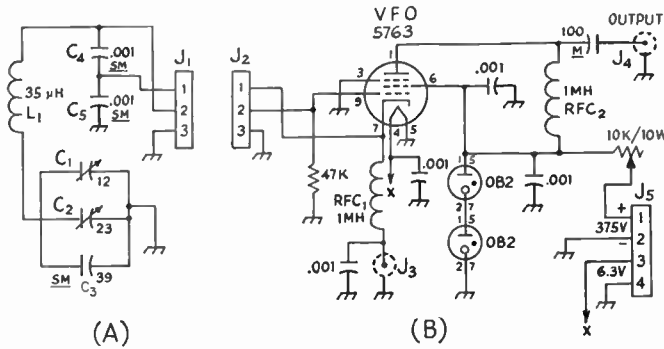

Fig. 6-73 — Circuit of the remotely-tuned v.f.o. All capacitances less than 0.001 μf . are in μf . All 0.001- μf . capacitors are disk ceramic. M — Mica. SM — Silver mica. All resistors are $\frac{1}{2}$ watt unless otherwise specified.

- C₁ — Hammarlund HF-15, rear stator plate removed, rear rotor plate bent; see text.
- C₂ — Hammarlund HF-35, last stator and last two rotor plates removed.
- R₁ — Adjustable slider.
- L₁ — 35 μh . — 39 turns No. 18, $1\frac{1}{8}$ inches long, $1\frac{1}{2}$ inches diam. (B & W JEL-80, 1 turn and link removed).
- J₁, J₂ — 3-contact female jack (Amphenol 78-PCG3F).
- J₃ — Key jack — phono input jack.
- J₄ — Insulated phone-tip jack.
- J₅ — 4-contact male connector (C-J P-304-AB).
- RFC₁, RFC₂ — National R-50.

NOTE: RG-22 U remote cable is terminated at each end with Amphenol 91-MPM-36 male connector to fit J₁ and J₂.

cable is set in the back of the box, and C₄ and C₅ are soldered to its terminals.

Tube Unit

The photographs show the essential details of the assembly of the tube unit. The enclosure is a standard 2 × 2 × 4-inch aluminum box. The three tubes are mounted on a shelf spaced $1\frac{1}{2}$ inches from the top of the box. This dimension is critical if the tubes are to be removed without difficulty. The keying and output jacks are mounted

in one of the covers, below the shelf level, and the power connector is mounted at one end and the jack for the coax cable at the other. The adjustable resistor is mounted on top of the shelf, alongside the tubes, on the same side of the box as the keying and output jacks. This makes it possible to remove the tubes and adjust the slider by removing the blank cover of the box. The resistor is supported between two small angle pieces

joined with a piece of threaded rod (or a long 6-32 screw) through the resistor form.

All wiring, with the exception of the connections to the keying and output jacks and the cable connector, can be done before the shelf is placed in the box. This includes connections to the power connector which mounts from the inside. In the bottom view of Fig. 6-76, the plate choke, RFC₂ is to the lower left, soldered between Pin 6 of the 5763 socket and Pin 5 of the socket of the first OB2 regulator. The cathode choke, RFC₁, is above, with one end fastened to Pin 7 of the 5763 socket, while the other end is left free until the cover plate carrying the key jack is ready to be put in place. A 0.001- μf . capacitor is soldered directly across J₃. Leads of proper length are made for the jacks and cable connector, and these connections can be made after the shelf has been put in place, and just before the cover is put on. Care should be used in placing the tubes in their sockets, since there is little height to spare. If necessary, the tips of the tubes can be run up through the ventilating holes in the top of the box to allow the pins to clear the sockets.

Power Supply

Any power supply delivering between 300 and 400 volts at 50 ma. or more may be used to operate this v.f.o.

Fig. 6-74 — Interior of the tuned-circuit box. C₄ and C₅ are to the rear. C₃ is soldered across C₂ to the left in front.

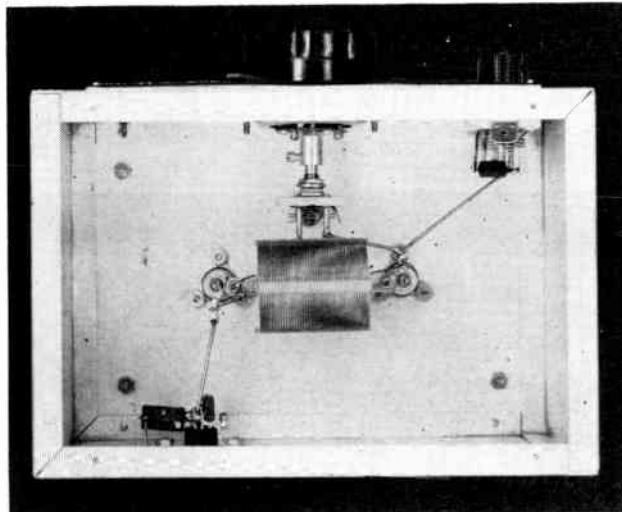

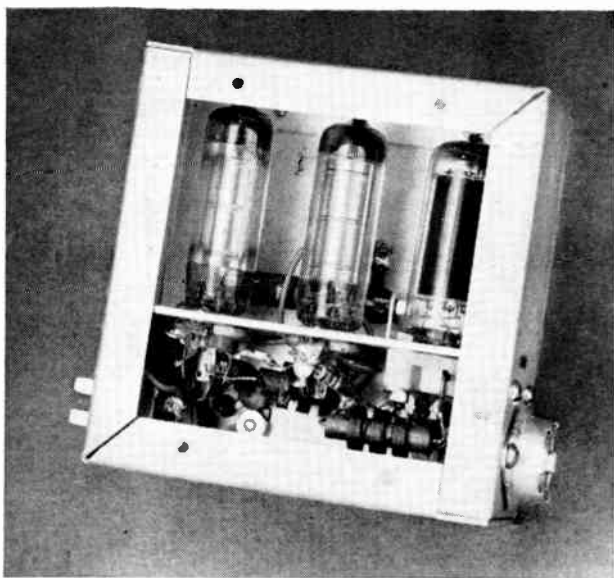

◆
 Fig. 6-75 — The completed tube section with the tubes in place. Ventilation holes are drilled in the top of the box and in the plate covering the free side.
 ◆

Adjustment

Adjustment of the frequency range for maximum bandspread is quite simple. Set C_1 to a dial reading of 5. Then adjust C_2 until the oscillator signal is heard on the receiver at 3500 kc. Set the receiver to 3750 kc. and adjust C_1 until the signal is heard. If this occurs with the dial set at less than 100, carefully bend the rearmost rotor plate of C_1 away from the adjacent stator plate, making sure that the plates do not touch and short the capacitor in any position of the rotor. Turn C_1 again to a dial reading of 5, reset C_2 for 3500 kc., and check again for the point where C_1 tunes to 3750 kc. By proper adjustment of the rotor plate on C_1 , the 3500-to-3750-kc. range can be made to cover the entire dial, or as much of it as desired.

Phone Band

After this initial range has been set, tune the receiver to 3875 kc. Set C_1 to midscale and adjust C_2 until the v.f.o. signal is heard. Then the range of 3750 to 4000 kc. should be approximately centered on the dial with a coverage of about 75 divisions. The range can be shifted one way or the other by simply shifting C_2 slightly.

11-Meter Band

If it is desired to center the 11-meter band on the dial, set C_1 to midscale, set the receiver to 3387 kc. and adjust C_2 until the v.f.o. is heard. All three settings of C_2 should be plainly marked so that they can be returned to when desired.

The cathode current may vary from about 28 ma. with both C_1 and C_2 set at maximum capacitance to 37 ma. with both at minimum.

In using the v.f.o., the tube unit should be placed close to the stage to be driven and fastened securely to the chassis. A short lead should be used to connect the output terminal to the grid of the stage to be driven. If the driven stage has a grid capacitor, the 100- $\mu\mu\text{f}$. mica capacitor shown connected between the output terminal and the plate choke RFC_2 should be omitted. If more than adequate drive is obtained, the screen of the oscillator tube can be connected to the junction between the two VR tubes, rather than to the end of the adjustable resistor as shown in Fig. 6-73. This unit is not a power device, and adequate gain in the way of a crystal-oscillator tube or other buffer amplifier should be provided.

(Originally described in *QST*, Jan. 1953.)

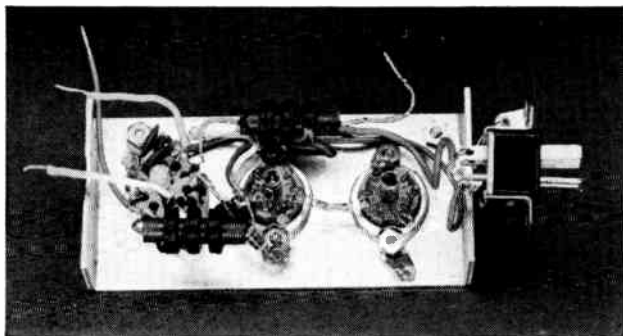

◆
 Fig. 6-76 — Bottom view of the tube-unit shelf. RFC_1 is above, RFC_2 below. A 0.001- μf . capacitor is soldered to J_3 on the cover plate. The two leads going to the left solder to the cable connector. The one to the left above goes to J_4 , the lead to the right to J_3 .
 ◆

A Single 6146 Amplifier

The photographs of Fig. 6-77, 6-79 and 6-80 show views of an amplifier using a single 6146. It is actually a revision of the 75-watt Novice oscillator transmitter described in an earlier section. The circuit is shown in Fig. 6-78. The input circuit is a conventional parallel-tuned tank with link coupling. However, the inductor is made up in two sections to avoid the inefficiencies of shorting turns on a single large coil in switching to the higher frequencies. A separate link coil is used with each of the two grid coils.

A pi-section tank circuit is used in the output. The amplifier is keyed in the cathode circuit. The single milliammeter may be switched to read either grid current or cathode current. The 150-ohm series resistor and the 22-ohm parallel resistor form a meter shunt that increases the full-scale reading to 250 ma. when checking cathode current.

Construction

The layout of components is shown in the

photographs. In the box, the tube socket should be placed far enough back on the chassis so that the tube will clear the meter. C_7 is placed to the rear to space it about an inch from the tube. It is mounted on an aluminum bracket so as to bring its shaft up to the proper level. A panel bearing is coupled to the shaft.

RFC_3 , C_8 and C_9 are mounted on an insulated terminal strip to the left of the tube socket (Fig. 6-79). The flexible plate lead to the 6146 is connected to RFC_3 and C_8 at this strip. The v.h.f. parasitic suppressor L_5 is connected between this lead and the plate connector.

To the rear of the tube socket is another strip with two insulated terminals. A piece of No. 16 wire about 2 inches long is soldered vertically to each of the insulated terminals. Then a piece of "spaghetti" is slid over each of the wires. The capacitance between these wires provides the capacitance shown in Fig. 6-78 as C_3 .

If this is a modification of the oscillator transmitter (Fig. 6-38), the crystal socket may be used as the input connector J_1 , as shown in Fig.

Fig. 6-77 — The base for the 6146 amplifier is a $11 \times 7 \times 3$ -inch aluminum chassis. A $6 \times 6 \times 6$ -inch aluminum box encloses the amplifier tube and its output circuit. S_2 is to the right of the meter. Below, from left to right, are controls for S_1 , C_7 and C_4 . On the chassis, from left to right, are the power-supply switches (see Fig. 6-10), J_1 (see text) and J_2 , and controls for C_1 and S_1 . Ventilation holes are drilled in the cover in the area above the tube, and along the sides of the box, near the bottom. The power supply is a duplicate of the one shown in Fig. 6-38.



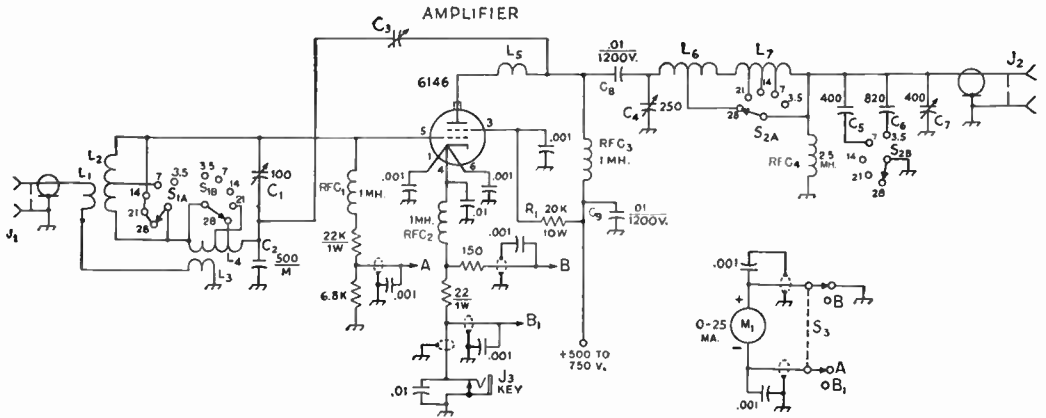

Fig. 6-78 — Circuit of the 6116 band-switching amplifier. All capacitances less than 0.001 $\mu\text{f.}$ are in $\mu\text{f.}$ All unmarked bypasses are disk ceramic. All resistors are $\frac{1}{2}$ watt unless otherwise specified. Filament and meter wiring should be shielded as indicated.

- C₁ — 100- $\mu\text{f.}$ variable (Hammarlund MC-100-S).
 - C₂ — 470- $\mu\text{f.}$ mica.
 - C₃ — Neutralizing capacitor (see text).
 - C₄ — 250- $\mu\text{f.}$ variable (Hammarlund MC-250-S).
 - C₅ — 400- $\mu\text{f.}$ tub. ceramic (Centralab D6-401).
 - C₆ — 820- $\mu\text{f.}$ tub. ceramic (Centralab D6-821).
 - C₇ — 400- $\mu\text{f.}$ variable capacitor (broadcast replacement type).
 - C₈ — C₉ — Disk ceramic.
 - 1 — See text.
 - J₂ — Coaxial receptacle (SO-239).
 - J₃ — Close-circuit key jack.
 - L₁-L₇ — See coil data opposite.
 - M₁ — 0-25-ma. d.c. milliammeter, 2½-inch square (Shurite).
 - RFC₁, RFC₄ — 1- or 2.5-mh. (National R-50).
 - RFC₂, RFC₃ — 1- or 2.5-mh. (National R-100).
 - S₁, S₂ — Double-pole 6-position rotary switch (Centralab PA-2003).
- See Fig. 6-40 for suitable power supply.

COIL DATA

The coils L₁L₂ are made from a single length of B & W Miniductor stock. Unwind 8 turns from the support bars and using side cutters, snip off the projecting bars. Snip the unwound piece of wire off about one inch from the coil stock. Next count off 13 turns and bend the 13th turn in toward the axis of the coil and cut the wire at this point. At the cut, unwind ½ turn from each coil. This leaves two coils on the same support bars. Unwind ½ turn at the end of the large coil. The 12-turn coil is L₁ and the 42-turn coil is L₂. Similar procedure is followed in making L₃L₄.

- L₁ — 12 turns of No. 24, 1-inch diam, 32 turns per inch (B & W 3016).
- L₂ — 42 turns of No. 24, 1-inch diam., 32 turns per inch (B & W 3016).
40-meter tap is made at 25th turn counting from junction of L₂L₄.
- L₃ — 4 turns of No. 20, ½-inch diam., 16 turns per inch (B & W 3007).
- L₄ — 13 turns of No. 20, ½-inch diam., 16 turns per inch (B & W 3007).
20-meter tap is made at junction of L₂L₄.
15-meter tap is made 7½ turns from junction of L₂L₄.
10-meter tap is made 4½ turns from junction of L₂L₄.
- L₅ — 4 turns of No. 14, ¼-inch diam., turns spaced wire diam.
- L₆ — 5½ turns of No. 12, 1-inch diam., turns spaced so that coil is 1-inch long.
10-meter tap is made 1½ turns from junction of L₆L₇.
- L₇ — 17½ turns of No. 16, 2-inch diam., 10 turns per inch (B & W 3907-1).
15-meter tap is made 2 turns from junction of L₆L₇.
20-meter tap is made 5 turns from junction of L₆L₇.
40-meter tap is made 9 turns from junction of L₆L₇.

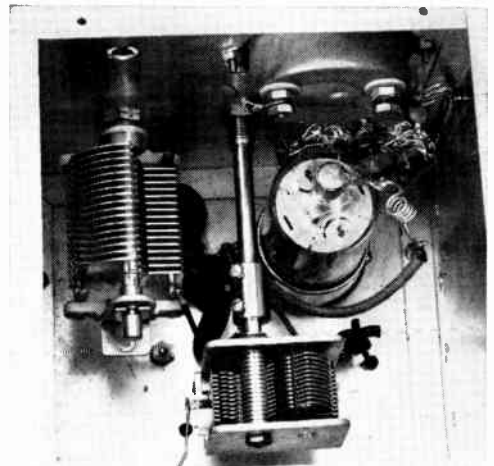

Fig. 6-79A — Looking into the amplifier box before mounting the output coils and hand-switch. The meter switch is between the 6116 and the panel. The output capacitor is mounted on a bracket and is turned by the extension shaft. Twisted wires to the right of the loading capacitor form the neutralizing capacitor.

Fig. 6-79B -- This view shows the arrangement of components in the box. L_7 is supported by two lugs soldered to the end turn and fastened to 1-inch cone insulators centered $1\frac{3}{4}$ inches down from the top of the box. L_6 is supported at right angles to L_7 by soldering its top end to the inner end of L_7 . The twisted insulated wires forming C_3 appear immediately in front of C_7 near the center.

»

6-77. Otherwise, a coaxial receptacle similar to J_2 may be mounted at the rear.

Adjustment

The amplifier requires a driver delivering at least 2 watts. The usual v.f.o. will not drive it without an intermediate amplifier, such as a 6AQ5. However, most crystal oscillators operating at 300 volts should be adequate.

The first step in the adjustment is to neutralize the amplifier. The high-voltage line to the plate and screen should be disconnected temporarily at the point marked *X* in Fig. 6-78. The exciter should be tuned up on the highest-frequency band available.

With the heater voltage only applied to the 6146, excitation should be applied, and C_1 adjusted to give maximum grid current. Then, with S_2 set to the same band as the grid circuit, and C_7 set at maximum capacitance, C_4 should be turned through its range. Unless the amplifier is neutralized, there should be a kick in the grid current at some point within the range of C_4 . When this point has been found, the two insulated wires representing C_3 should be twisted together a bit at a time until the grid-current kick is brought to a minimum.

The high-voltage connection to the plate and screen may now be replaced. A 60-watt lamp may be connected across J_2 to serve as a dummy load during testing. With power and excitation applied, and C_7 at maximum capacitance, adjust C_4 for a dip in cathode current. Then reduce C_7 a little at a time, each time readjusting C_4 for the dip in cathode current. As C_7 is reduced, the dip in cathode current should become less pronounced and the load lamp should increase in brilliance. Continue these alternate adjustments until the cathode current at the point of dip is maximum, but do not allow it to exceed 150 ma.

The output circuit is designed to feed 50- or 70-ohm matched antenna systems. For other antenna systems, an antenna tuner should be used between the amplifier and the antenna. With an antenna replacing the dummy load, the adjustment procedure should be similar.

(Originally described in *QST*, August, 1956.)

»

Fig. 6-80 — The grid tank coils L_2 and L_4 are supported on soldering-lug strips to the rear of S_1 and C_1 . Power-supply filter components are grouped in the lower right-hand corner.

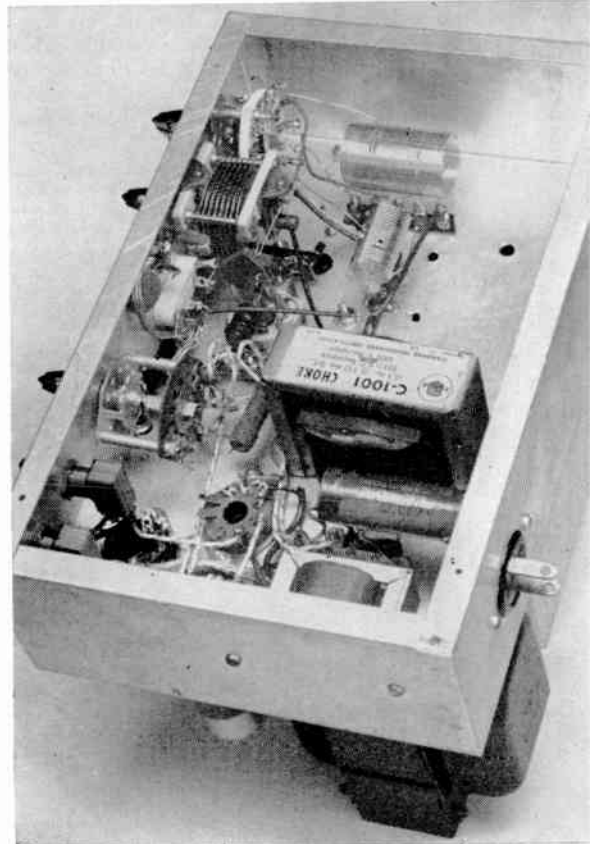
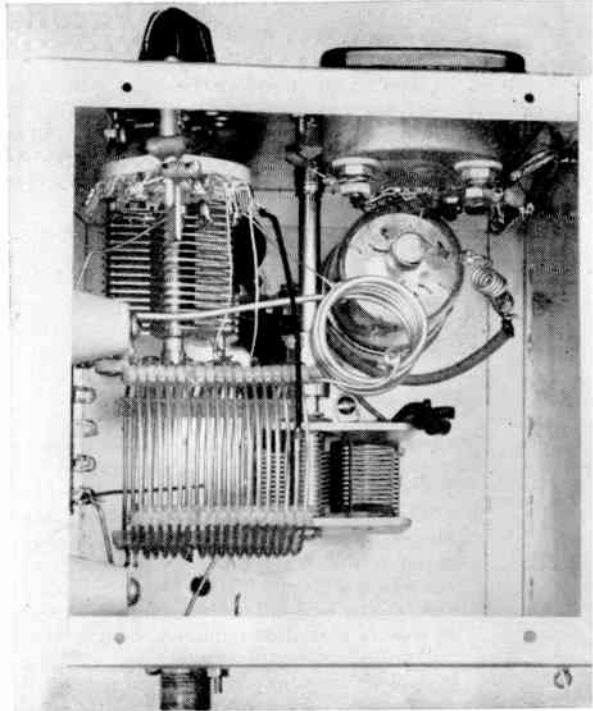

A Parallel 807 Amplifier

The amplifier shown in Figs. 6-81 through 6-84 was designed to cover all bands from 3.5 to 30 Mc. It can be operated at an input of 150 watts on c.w., or 120 watts on phone. However, it will operate efficiently at 75 watts input for Novice use.

A pair of 807s in parallel is shown in the circuit diagram of Fig. 6-83. A pair of 1625s may be substituted if a 12.6-volt filament transformer is provided. The amplifier is capacitively coupled to the driver through the 100- μmf . mica capacitor, C_1 . L_1 and L_2 are small inductors which, in conjunction with R_2 and R_3 in the screen leads, are used for the suppression of v.h.f. parasitics.

A combination of battery and grid-leak bias is used. Since the screens are operated from a low-voltage source, the fixed bias provided by the battery will cut the input to the 807s to zero when excitation is removed, as in keying preceding stages for c.w. operation. When the screens are supplied through a dropping resistor from the plate supply, as required for plate-screen modulation, the battery will hold the input to a safe level in case of excitation failure, although the input will not be reduced to zero.

A pi-section tank circuit is used in the output, and parallel plate feed is therefore necessary. Either a rotary inductor from a surplus BC-375-E antenna-tuning unit or a Johnson type 229-201 inductor may be used as the variable inductor, L_4 . L_3 is a separate inductor for 10-meter operation. This coil will not be needed if the Johnson variable inductor is used, or if the surplus induc-

tor is used and 10-meter operation is not required.

The required output capacitance is furnished by a combination of a variable capacitor, C_5 , and several fixed capacitors that may be switched in parallel with the variable. A total of about 2000 μmf . should be provided. For a continuous range of capacitance, each of the fixed capacitors should have a capacitance not greater than the maximum of the variable. As an example, a 500- μmf . variable and three 500- μmf . fixed capacitors may be used. A 250- μmf . variable, on the other hand, will require seven 250- μmf . fixed capacitors and a switch to accommodate them.

C_6 may be useful in localities where TVI is bothersome on one particular v.h.f. channel. In this case, the capacitor can be series-resonated to the particular channel by adjusting its lead length (represented by L_5). It should be connected directly across the output coax connector.

Plate and grid milliammeters are not included in the unit, but are mounted externally on another panel to keep them out of r.f. fields. J_2 is provided for plugging in a cord from the grid milliammeter while checking grid current. The plate meter is wired in permanently through terminals at the rear of the chassis. If desired, the jack can be omitted and the grid milliammeter wired in permanently, also.

Construction

An inverted $10 \times 17 \times 4$ -inch aluminum chassis is used as a shielding enclosure for the amplifier. A standard bottom cover is used as the

Fig. 6-81 — Top view of K4CDO's parallel 807 amplifier. The variable output capacitor is at the upper left with the fixed mica capacitors and switch in the corner. The variable input capacitor is to the right of the variable inductor. The r.f. choke and by-pass fastened to the rear wall of the chassis are in the plate circuit. The biasing battery can be seen in the compartment to the right which also houses the input-circuit components.

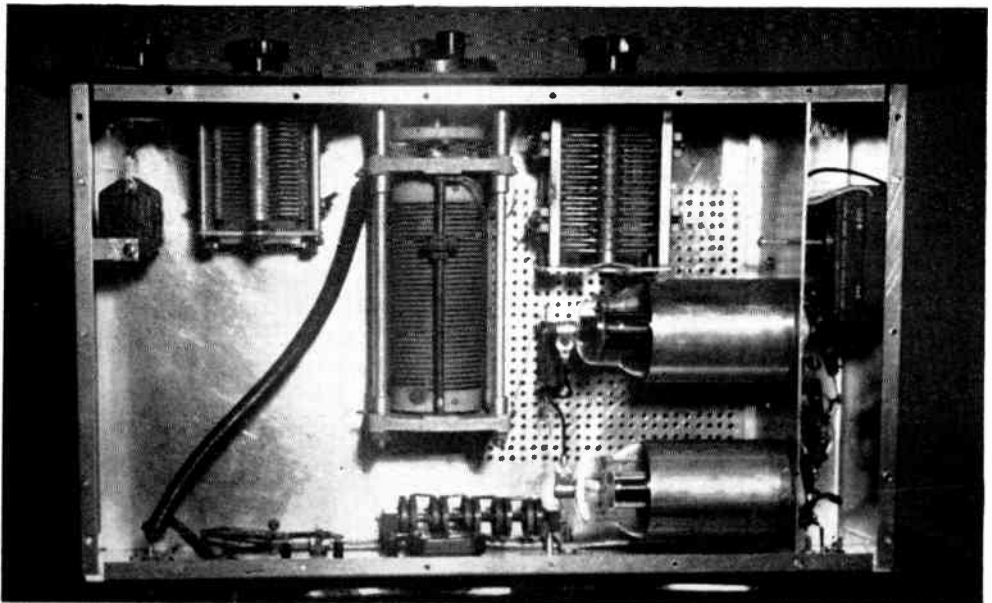

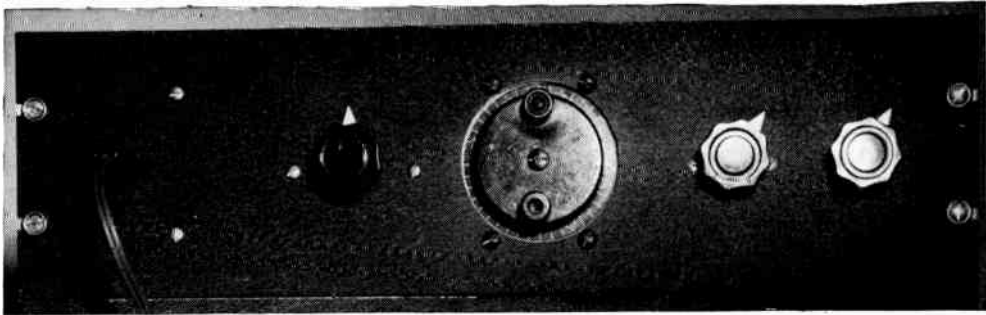

Fig. 6-82 — Panel view of the 150-watt amplifier showing the grid-meter jack, and controls for the pi-section input capacitor, variable inductor, variable output capacitor and fixed-capacitor switch.

top cover. The chassis and the cover are perforated in the area near the tubes to provide ventilation. Holes in addition to those provided are drilled in the cover and along the lips of the chassis so that the cover may be secured tightly to the chassis with No. 6 sheet-metal screws. The chassis is centered behind a standard 5¼-inch aluminum rack panel.

The 807s are mounted horizontally from a partition spanning the chassis. This partition is made from a piece of aluminum cut 43⅝ inches wide by 10 inches long. Half-inch lips are bent over at the front end and along the bottom edge for fastening it with machine screws to the front wall and bottom of the chassis. The partition is spaced 2 inches from the end of the chassis. The tubes are provided with aluminum shield cans, and the sockets placed sufficiently far to the rear to leave space for the input capacitor, C_4 .

Most of the assembly and wiring to the sockets can be done before the partition is fastened permanently in place. Pins 4 and 5 of each socket should be grounded right at the socket. The No. 2

pins are joined by the two resistors R_2 and R_3 in series. RFC_1 is a National R-100S, or similar model, with an insulating mounting. It is placed centrally between the two sockets and between the partition and the end of the chassis. It is eventually fastened against the bottom of the chassis. However, until the assembly is ready to be fastened in place, it is suspended by its leads. The two parasitic suppressor chokes, L_1 and L_2 , are connected between the No. 3 pins on the sockets and the top of RFC_1 . If C_1 is used, it should be connected between the top of the r.f. choke and the excitation input connector, J_1 . Otherwise, a short piece of wire should be substituted. The grid leak, R_1 , is mounted between the bottom end of RFC_1 and an insulated tie point, and the grid by-pass, C_2 , is connected between the bottom end of the choke and a ground on the partition. The negative terminal of the biasing battery is also connected to this tie point, while the positive terminal goes to J_2 .

Three shielded and by-passed leads are prepared as described in the chapter on TVI and

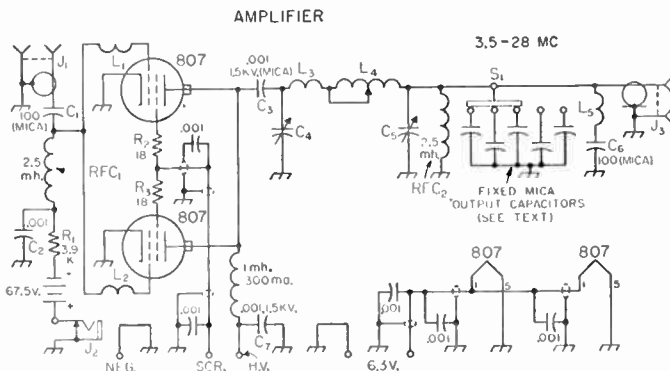

Fig. 6-83 — Circuit of the parallel 807 amplifier.

- C_1 — Not needed if driver has output coupling capacitor.
- C_4 — 250- μ mf. 1200-volt variable (National TMS-250 or TMS-300, Bud CE-2007 or similar. 0.03-inch plate spacing). See text.
- C_5 — 250 μ mf. or larger. See text. For low-impedance output, providing spacing adequate. (Johnson 140R12, Bud MC-1860, MC-909 or MC-910, Hammarlund RMC-325-S, MC-250-M or MC-325-M).
- L_1, L_2 — 22 turns No. 30 enam., ¼-inch diam., 7/16 inch long.

- L_3 — 3 turns No. 10, ¼-inch diam., ¼ inch long (see text).
- L_4 — Rotary inductor — 15 μ h. (see text).
- L_5 — See text.
- J_1 — RCA-type shielded phono jack.
- J_2 — Closed-circuit phone jack.
- J_3 — Coax connector.
- S_1 — Progressively-shorting rotary switch (Centralab P-121 index head, P1S wafer).

All capacitances less than 0.001 μ f. are given in μ mf. All fixed capacitors disk ceramic unless otherwise specified. All resistors ½ watt unless otherwise indicated.

BC1. One lead is connected to the junction of R_2 and R_3 . The other two leads are fastened to the No. 1 pins of the sockets. After the partition has been fastened in place, the lead from the junction of the resistors should be connected to the screen-voltage input terminal. The other two leads both are run together to the ungrounded heater input terminal. The shields of these three leads are grounded at both ends, to each other, and to the chassis at several points.

The plate blocking capacitor, C_3 , is mounted with one of its terminals central in respect to the two 807 plate caps to permit plate leads of equal length. The 1-mh. 300-ma. parallel-fed plate choke is mounted off the rear wall of the chassis, with its cold end close to the high-voltage input terminal. The plate bypass, C_7 , is fastened against the rear wall of the chassis, and is connected between the cold end of the r.f. choke and the high-voltage input terminal with the shortest possible leads.

The variable inductor cannot be mounted centrally in the chassis without interfering with the removal of the 807s. It is placed an inch or so away from the plate caps of the tubes, and the input and variable output capacitors are spaced symmetrically on either side. The fixed capacitors in parallel with C_5 are stacked up and fastened to a grounding bracket attached to the left-hand end of the chassis. The front terminals of these capacitors are connected to the terminals of S_1 mounted immediately in front.

Adjustment

The values of input and output capacitance and the value of the inductance to be used in the pi network will depend upon the voltage and current at which the amplifier is operated. For full input on e.w., a voltage of 750 at 200 ma. is required for the plates, and 250 volts at 12 ma. for the screen grids. In this case, screen voltage is best obtained from the exciter plate supply. For full input on phone, a supply delivering 600 volts at 200 ma. is needed, and 275 volts at 13 ma. for the screens. For phone work, the screen voltage should be taken from the plate supply through a 25,000-ohm 20-watt resistor.

For Novice operation, the amplifier can be operated, for instance, at 500 volts, 150 ma.

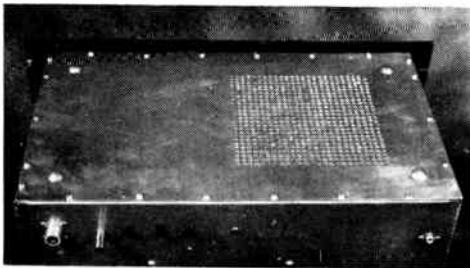

Fig. 6-81—The amplifier is enclosed in an inverted aluminum chassis in which the bottom plate serves as the top cover. Along the rear edge are the output coax connector, ground post, tip jacks for heater, screen and plate voltages, and r.f. input jack.

OUTPUT-CIRCUIT VALUES						
Band (Mc.)	3.5	3.5	7	14	21	28
750 volts, 100 ma. (3750 ohms)						
C_{IN} (uuf.)	150	230 ¹	75	38	25	20
C_{OUT} (uuf.)	910	1700	450	225	150	110
L (uh.)	14.8	10.0	7.4	3.7	2.5	1.8
750 volts, 200 ma. (1875 ohms)						
C_{IN} (uuf.)	300	250 ²	150	75	50	37
C_{OUT} (uuf.)	1570	1160	785	390	260	195
L (uh.)	7.9	9.3	4.0	2.0	1.3	1.0
500 volts, 150 ma. (1666 ohms)						
C_{IN} (uuf.)	340	250 ³	170	85	55	40
C_{OUT} (uuf.)	1680	1100	810	420	280	210
L (uh.)	7.1	9.3	3.5	1.8	1.2	0.9
600 volts, 200 ma. (1500 ohms)						
C_{IN} (uuf.)	380	250 ⁴	190	95	63	47
C_{OUT} (uuf.)	1820	1000	910	455	300	227
L (uh.)	6.4	9.3	3.2	1.6	1.1	0.8
¹ $Q = 19$ ² $Q = 10$ ³ $Q = 9$ ⁴ $Q = 8$ All others $Q = 12$						

with both tubes in use, or at 750 volts, 100 ma. with one of the tubes removed.

An accompanying table shows the values of input and output capacitance and the inductance required for a tank-circuit Q of 12 and 50-ohm output under the four operating conditions described above. The Johnson inductor does not have sufficient inductance for a Q of 12 under the 750-volt 100-ma. condition. In this case, with maximum inductance in use, the Q will run around 17 or 18. Also, the values of input capacitance shown in the table include tube output capacitance and other stray capacitances, so that input capacitances of less than about 50 μ uf. will probably be unattainable. Where the table shows less than 50 μ uf. input capacitance, C_4 should be operated as close to minimum capacitance as practicable.

An exciter should be connected to J_1 , and the coupling adjusted to give about 7 ma. of grid current. With a 50-ohm load connected, the input and output capacitances should be set as closely as possible to the values indicated in the table, and the variable inductor should be adjusted for resonance as indicated by the customary dip in plate current. Decreasing the output capacitance or the inductance while maintaining resonance with the input capacitor should increase loading.

(From *QST*, August, 1955.)

A Single 813 Amplifier

Figs. 6-85 through 6-89 illustrate a multiband single-tube r.f. amplifier using an 813. The circuit diagram is shown in Fig. 6-87. The bands, 3.5 through 28 Mc., are changed in the grid circuit by switching coils. A 100- μf . capacitor, C_1 , is added to the capacitance of the grid tuning ca-

value when excitation is removed, or if stages ahead of the 813 are keyed.

Separate meters are provided for reading grid and plate current. A voltmeter is included to permit a continuous check on filament voltage. Filament transformers are mounted in the unit,

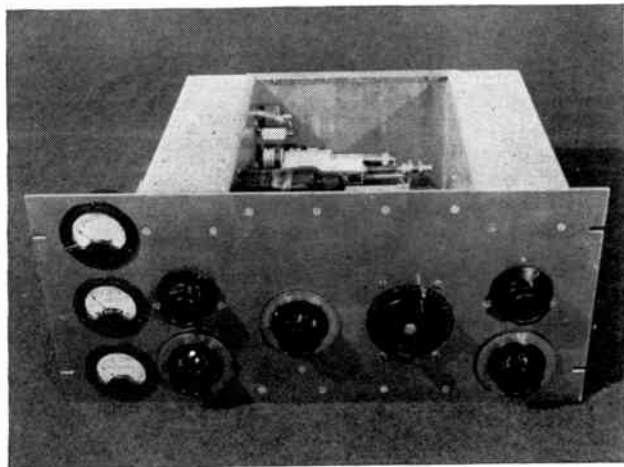

Fig. 6-85—A multiband band-switching 813 amplifier with a shielding enclosure made up of standard chassis and bottom plates. To the right of the meters are the controls for S_1 (above) and C_2 . At the center are the controls for C_{13} and L_{13} . To the right are controls for S_2 (above) and C_{14} . (Designed by W6KEV.)

pacitor, C_2 , when the bandswitch, S_1 , is in the 80-meter position.

A pi-section tank is used in the plate circuit. C_{13} is the input capacitor. The output capacitance is made up of a group of four 375- μf . variable capacitors, C_{14} , ganged to a single control shaft, plus a 0.001- μf . fixed capacitor, C_{15} . The three positions of S_2 provide a means of changing the maximum capacitance in the circuit over a wide range, for matching various load resistances. The variable inductor, L_{13} , is a rotary coil taken from a surplus BC-375. However, the B & W type 3852 rotary coil has sufficient inductance (15 μh .) to be used as a substitute, although the coil requires somewhat greater space. L_{12} is a separate coil for 10 meters, L_{13} being turned so that it is shorted out on this band.

L_{11} and R_2 constitute a v.h.f. parasitic suppressor. The amplifier is neutralized by the capacitive-bridge method, C_6 being the neutralizing capacitor. A 6Y6G clamper tube is used in the screen circuit to reduce the input to the 813 to a safe

and all power leads are bypassed for v.h.f. as they enter the shielding enclosure. Meters are also similarly bypassed.

Construction

The construction of a shielding enclosure for the amplifier is simplified by the use of standard aluminum chassis and chassis bottom plates. Two 8 x 12 x 3-inch chassis, with their tops toward the inside, are used as the sides. They are fastened to the 8 $\frac{3}{4}$ -inch relay-rack panel with the 8-inch sides against the panel. The one at the left is placed with its outer edge 3 $\frac{3}{4}$ inches from the end of the panel, while the one at the right is positioned with its outer edge 1 $\frac{1}{8}$ inches from the right-hand end of the panel. This leaves an open space of 8 $\frac{1}{8}$ inches between the two chassis.

Fig. 6-86—End view of the 813 amplifier, showing the grid-circuit assembly and filament transformers.

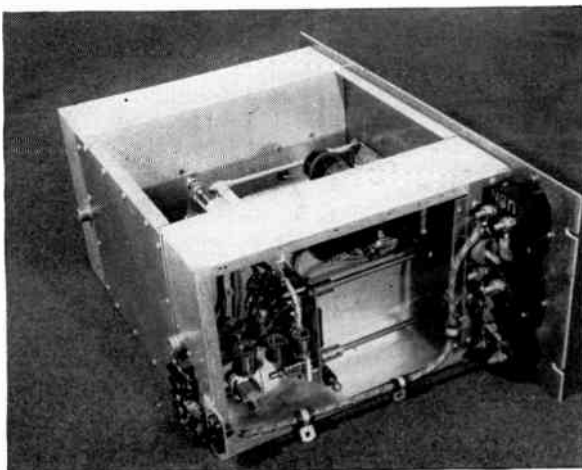

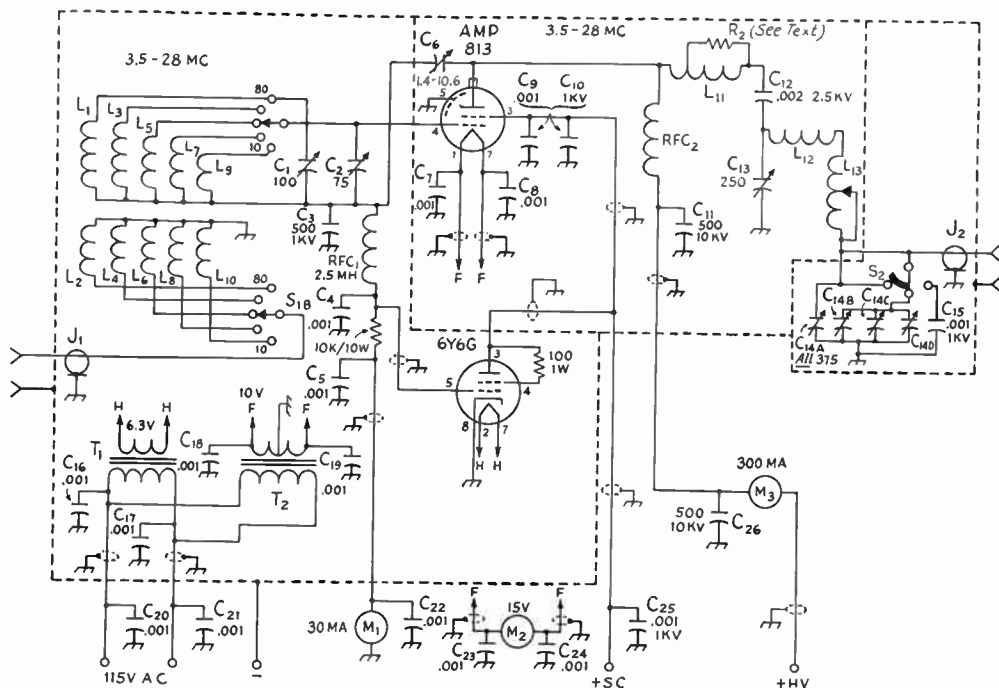

Fig. 6-87 — Circuit of the 813 amplifier. All capacitances below 0.001 $\mu\text{f.}$ are in $\mu\mu\text{f.}$

- C₁ — Air trimmer.
 C₂ — 0.025-inch plate spacing.
 C₃, C₁₂, C₁₅ — Mica.
 C₄, C₅, C₇, C₈, C₉, C₁₀, C₁₁, C₁₆, C₁₇, C₁₈, C₁₉, C₂₀, C₂₁, C₂₂, C₂₃, C₂₄, C₂₅, C₂₆ — Ceramic.
 C₆ — Neutralizing capacitor (Johnson N-250, 0.25-inch spacing).
 C₁₃ — 0.070-inch plate spacing.
 C₁₄ — Four-section variable gang, 374 $\mu\text{f.}$ per section, 0.025-inch plate spacing.
 R₂ — Five 680-ohm 1-watt carbon resistors in parallel, tapped across 3 turns of L₁₁.
 L₁ — 32 turns No. 24 enam., close-wound, $\frac{3}{4}$ -inch diam.
 L₂ — 3 turns No. 20 enam., close-wound, $\frac{3}{4}$ -inch diam.
 L₃ — 20 turns No. 20 enam., close-wound, $\frac{3}{4}$ -inch diam.
 L₄ — 3 turns No. 22 hook-up wire over cold end of L₃.
 L₅ — 14 turns No. 20 enam., close-wound, $\frac{5}{8}$ -inch diam.
 L₆ — 2 turns No. 22 hook-up wire over cold end of L₅.
 L₇ — 10 turns No. 18 enam., $\frac{5}{8}$ -inch long, $\frac{5}{8}$ -inch diam.
 L₈ — 2 turns No. 22 hook-up wire over cold end of L₇.

- L₉ — 8 turns No. 18 enam., $\frac{5}{8}$ -inch long, $\frac{5}{8}$ -inch diam.
 L₁₀ — 2 turns No. 22 hook-up wire over cold end of L₉.
 L₁₁ — Parasitic suppressor — 5 $\frac{1}{2}$ turns No. 14, $\frac{1}{4}$ -inch diam.
 L₁₂ — 3 turns No. 10, $\frac{3}{4}$ inch long, $\frac{3}{4}$ -inch diam.
 L₁₃ — Variable inductor from BC-375 (25 $\mu\text{h.}$ max.),¹ $\frac{1}{4}$ -inch diam.
 J₁, J₂ — Coax connector.
 M₁, M₃ — D.c. milliammeter, 2-inch.
 M₂ — A.c. voltmeter, 2-inch.
 RFC₁ — 125 ma.
 RFC₂ — National R-175A.
 S₁ — 2-circuit 5-position ceramic rotary switch (Centralab RR wafer).
 S₂ — 3-position progressively-shortening ceramic rotary switch (Centralab P1S wafer).
 T₁ — Filament transformer: 6.3 volts, 1.2 amp.
 T₂ — Filament transformer: 10 volts, 5 amp.

¹ The B & W type 3852 or Johnson type 220-202 rotary coil (15 $\mu\text{h.}$) has sufficient inductance to be used as a substitute, although it requires somewhat more space.

The bottom, top and rear are closed with aluminum plates that may be cut from chassis bottom plates if no other material is available. However, from the consideration of ventilation, perforated aluminum sheet is preferable. If solid sheet is used, top, bottom and back should be drilled with several holes not larger than $\frac{1}{4}$ inch in diameter, particularly in the areas in the vicinity of the 813 tube. Cracks in the shielding, where the top and bottom covers meet the rear cover and panel, are avoided by the use of strips of aluminum angle attached to the panel and rear cover. The shielding is completed by bottom covers to fit the two chassis.

The output capacitors and the switch, S₂, are enclosed in the chassis to the right. The chassis at the left contains the grid coils, the bandswitch, S₁, and the two filament transformers, T₁ and T₂.

Most of the remaining components are mounted in the main compartment at the center. The rotary inductor, L₁₃, and the pi-network input capacitor, C₁₃, are fastened to the panel. The latter is mounted on ceramic pillars. The only ground connection is at the rear of the capacitor, where the metal end plate is connected to the adjacent chassis with the shortest possible lead. This eliminates multiple paths to ground. Insulated flexible couplings are used between the shafts of the capacitor and coil and their panel controls.

As shown in the bottom view of Fig. 6-88, the 813 is mounted toward the rear, and near the bottom of the right-hand chassis. The socket is supported on metal pillars to space it $\frac{1}{2}$ inch from the chassis, and is so oriented that the filament will lie in a vertical plane. Grid, screen and filament wires are run through holes to the grid-

◆

Fig. 6-88 — In this view, the 813 amplifier has been turned upside down to show the horizontally-mounted 813, and C_{13} . The rotary inductor, L_{13} , is partially hidden. Also shown in the shielding compartment at the left is the ganged variable, C_{14} . A suitable substitute is a 2- or 3-gang broadcast t.r.f. capacitor with more fixed capacitors at S2.

◆

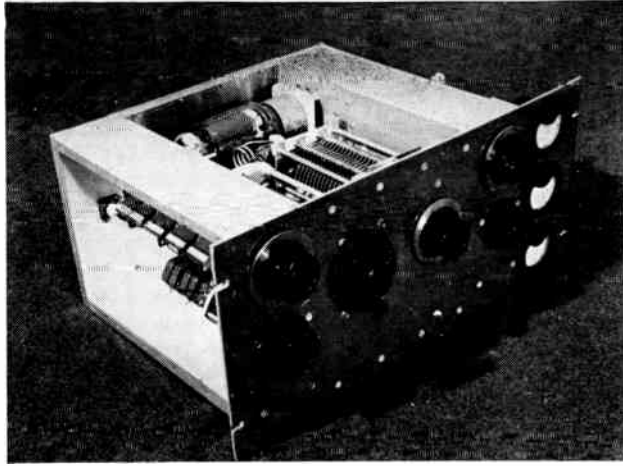

circuit compartment. Filament and screen bypass capacitors are grounded immediately on the socket side of the enclosure.

The plate r.f. choke, RFC_2 , and the neutralizing capacitor, C_6 , are mounted above the 813, as shown in the top view of Fig. 6-89. The plate by-pass, C_{11} , is mounted close to the base of the choke. The placement of the 6Y6G clamper is also shown. The socket is submounted with its terminals inside the grid-circuit compartment.

The three meters are mounted on the panel, one above the other, in the space to the left. All power wiring is done with shielded wire, and input and output connections are brought to coaxial fittings at the rear of the two chassis.

The plate spacing of the pi-section input capacitor, C_{13} , should be adequate for a plate voltage of about 2000 for c.w. operation, or about 1000 volts with plate modulation, provided that the amplifier is fully loaded. Provision should be made for reducing voltage during preliminary tune-up. A 2.5-mh. r.f. choke (not shown in the circuit diagram) connected across C_{14A} is a precaution worth adding, since this, in effect, removes the d.c. plate voltage from across both input and output capacitors, thereby decreasing

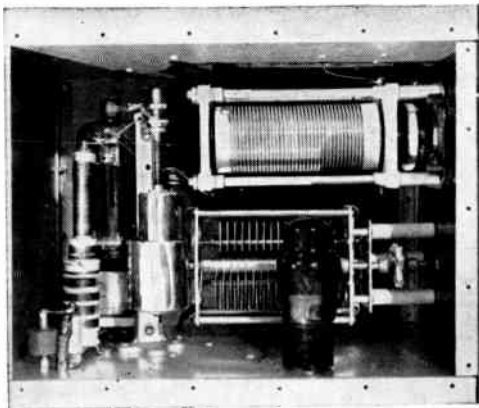

Fig. 6-89 — Looking down into the main compartment of the 813 amplifier, showing the placement of the pi-section components, neutralizing capacitor, plate r.f. choke, and the 6Y6 clamper tube.

any tendency for the capacitors to arc over at maximum voltage.

The circuit of the high-voltage-supply circuit shown in Fig. 6-59 should be suitable for this amplifier. The screen should be supplied through an external series resistor. The resistor should have a total resistance of 50,000 ohms (150 watts) and be equipped with an adjustable slider so that it can be set to give a screen voltage of 350 or 400 under actual operating conditions.

Adjustment

The amplifier is neutralized by applying excitation, but no screen or plate voltage, and then adjusting the neutralizing capacitor, C_6 , until the kick in grid current, as the plate circuit is tuned through resonance, is brought to a minimum. Later, when plate voltage and load are applied, the adjustment should be touched up so that the grid-current peak and the plate-current dip occur at the same setting of C_{13} .

Assuming that the amplifier will be loaded to the maximum rated plate current (200 ma.), the approximate capacitance for the pi-section input capacitor, C_{13} , for a Q of 12 will depend on the plate voltage. When the 813 is operated at 1000 volts, this capacitance should be approximately 200 $\mu\text{f.}$ for 80, 100 $\mu\text{f.}$ for 40, 50 $\mu\text{f.}$ for 20, 37 $\mu\text{f.}$ for 15, and 25 $\mu\text{f.}$ for 10. For 1500 volts, the approximate capacitances should be 140 $\mu\text{f.}$ for 80, 70 $\mu\text{f.}$ for 40, 35 $\mu\text{f.}$ for 20, 25 $\mu\text{f.}$ for 15, and 18 $\mu\text{f.}$ for 10. For 2000 volts, the input capacitance should be 100 $\mu\text{f.}$ for 80, 50 $\mu\text{f.}$ for 40, 25 $\mu\text{f.}$ for 20, 19 $\mu\text{f.}$ for 15, and 13 $\mu\text{f.}$ for 10. In case the B & W coil is used, the maximum inductance should be used on 80 meters for plate voltages in excess of 1000, and the circuit should be resonated with the capacitor, C_{13} , alone. Since the capacitances listed above include tube and other stray capacitances, amounting to at least 25 $\mu\text{f.}$, C_{13} should be set at or near minimum for the higher frequencies, and the coil adjusted for resonance.

The output capacitance should be adjusted for proper loading. Variation of the output capacitance will require readjustment of C_{13} , or L_{13} . (Originally described in *QST*, Nov., 1954.)

4-250-A's in a 1-Kw. Final

The amplifier shown in the accompanying photographs uses two 4-250As in parallel and covers 3.5 to 28 Mc. with complete band-switching. The output circuit is a pi network designed for working into reasonably well-matched 52- to 75-ohm coaxial lines. The amplifier can handle a kilowatt input in Class C operation on either phone or c.w. without pushing the tubes to their limits. It can also be operated as a linear amplifier for single side band.

The various components are mounted on a $17 \times 13 \times 4$ -inch aluminum chassis attached to a standard 19-inch relay rack panel $15\frac{3}{4}$ -inches high. The above-chassis section is enclosed in a $11\frac{1}{2}$ -inch high shield made from $\frac{1}{16}$ -inch sheet aluminum. An aluminum bottom plate completes the below-chassis shielding. Enclosing the amplifier in this way, plus the use of shielded wire and filters in the supply leads, takes care of the harmonic TVI question.

The 4-250As are cooled by forcing air into the chassis and thence up past the tubes by means of a 21 cu. ft. per minute blower. The air is exhausted through two 3-inch diameter circular openings over the tubes in the top cover. To maintain the shielding intact, these are covered with perforated aluminum.

A Barker and Williamson Model 850 band-switching pi-tank inductor is used in the output circuit. It is tuned by a vacuum variable ca-

pacitor operated through the counter dial (Groth TC-3) shown in the panel view.

Circuit Details

The circuit, Fig. 6-91, is electrically the more-or-less standard arrangement of a parallel-tuned grid circuit and a pi-network output circuit. The amplifier is neutralized by the capacitive bridge method. A filament transformer is included, but all other voltages come from external supplies.

The grid input circuit of the amplifier uses a slightly modified B&W turret assembly. The grid coils are tuned by a $75\text{-}\mu\text{f.}$ variable. The 20-, 15-, and 10-meter coils each must have a few turns removed for proper grid tuning on these bands.

The circuit includes a 2000-ohm grid leak and has provisions for external bias, which should be used in combination with the leak. The by-pass capacitors on the screen leads all carry a rating of 1600 volts. This rating is necessary to avoid capacitor breakdowns when operating the amplifier screens at their rated voltages for AB_1 operation, and also with plate-modulated Class C operation where the 600-volt rating of the smaller ceramic capacitors would be exceeded on modulation peaks. All of the 0.001- and 0.003- $\mu\text{f.}$ capacitors are the disk type, and aside from the screen by-passes are used mainly for filtering TV harmonics from the supply leads.

The by-pass capacitors in the high-voltage lead

Fig. 6-90 — A 1-kw. final using a pair of 4-250-A's in parallel.

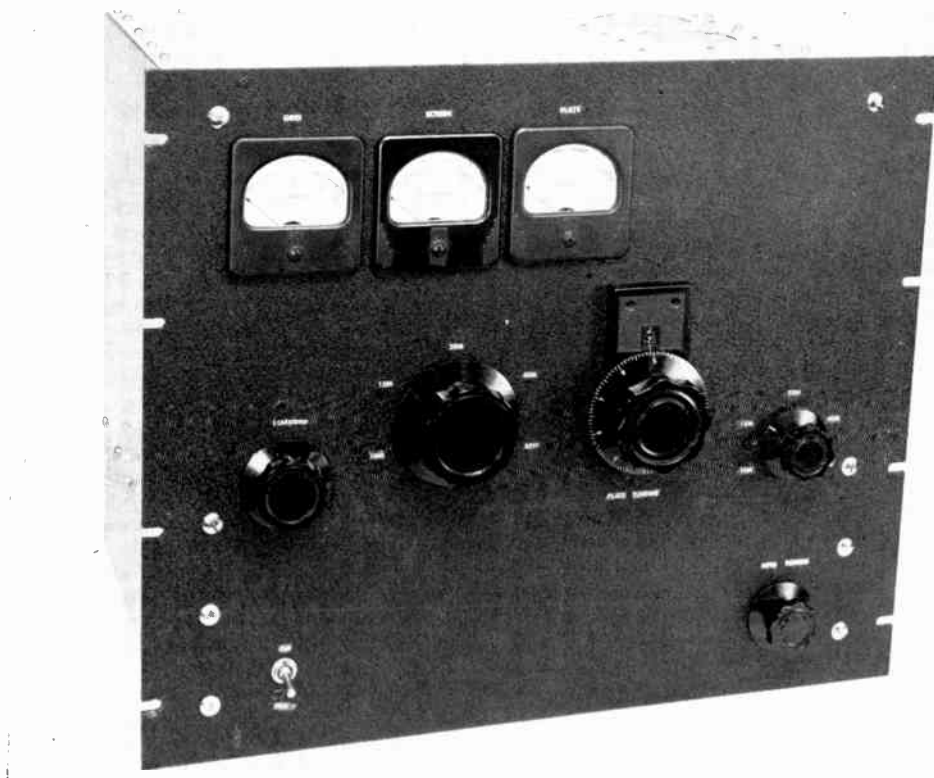

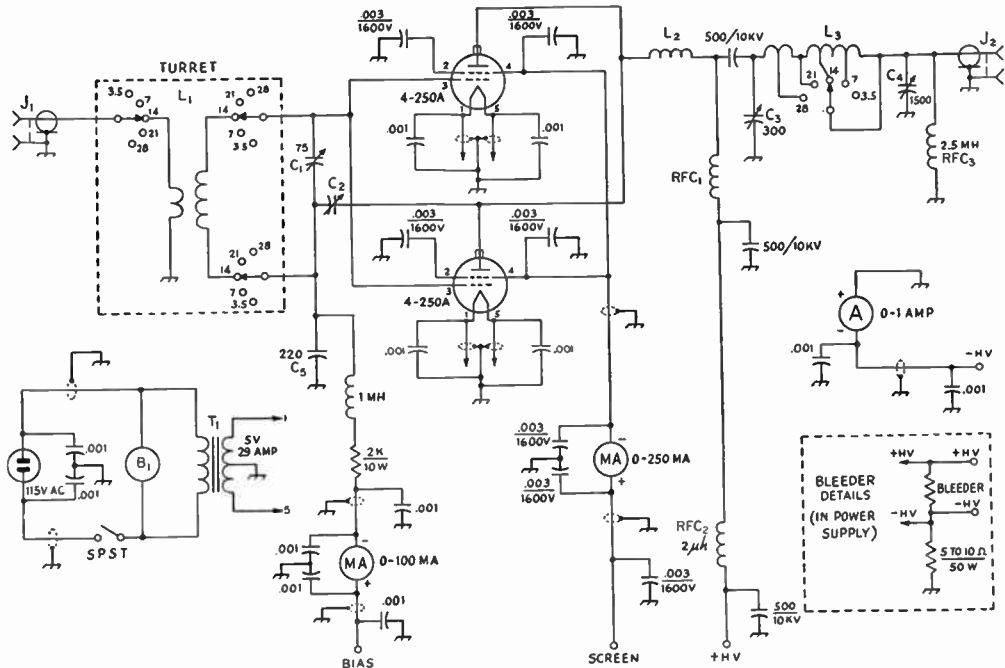

Fig. 6-91 — Circuit diagram of the 4-250A amplifier.
 B₁ — Blower-motor assembly, 21 c.f.m. (Ripley model 8133).
 C₁ — 75- μ f. variable, receiving spacing (Millen 19075).
 C₂ — 7- μ f. neutralizing capacitor (Cardwell type ADN).
 C₃ — 300- μ f. vacuum variable (Jennings type UCS).
 C₄ — 1500- μ f. variable (Cardwell type 8013).
 C₅ — 220- μ f. mica or NP0 ceramic.
 J₁, J₂ — Coax receptacle, chassis mounting.
 L₁ — Turret assembly (B&W BTEL with 14-, 21-, and 28-Mc. coils modified by removing turns).
 3.5 Mc.: 39 turns No. 22, 1 $\frac{1}{4}$ inches diam., 1 $\frac{3}{8}$ inches long, link 3 turns No. 18.
 7 Mc.: 20 turns No. 20, 1 $\frac{1}{4}$ inches diam., 1 $\frac{3}{8}$ inches long, link 3 turns No. 18.

14 Mc.: 8 turns No. 18, 1 $\frac{1}{4}$ inches diam., $\frac{3}{4}$ inch long, link 2 turns No. 18.
 21 Mc.: 4 turns No. 16, 1 $\frac{1}{4}$ inches diam., $\frac{1}{2}$ inch long, link 1 turn No. 18.
 28 Mc.: 2 $\frac{1}{2}$ turns No. 16, 1 $\frac{1}{4}$ inches diam., $\frac{1}{2}$ inch long, link 1 turn No. 18.
 L₂ — V.h.f. parasitic suppressor, 4 turns No. 12, $\frac{1}{4}$ inch dia., turns spaced wire diameter.
 L₃ — Pi-tank inductor (B&W Model 850). Inductances as follows: 3.5 Mc., 13.5 μ h.; 7 Mc., 6.5 μ h.; 14 Mc. 1.75 μ h.; 21 Mc., 1 μ h.; 28 Mc., 0.8 μ h.
 RFC₁ — National type R175A r.f. choke.
 RFC₂ — 2- μ h. 500-ma. r.f. choke (National type R-60).
 RFC₃ — 2.5-mh. r.f. choke.
 T₁ — Filament transformer, 5 volts, 29 amp. (Thordarson T-21F07-A).

are the TV high-voltage ceramic type, as is also the blocking capacitor in the tank circuit. The loading capacitor, C₄, in the output circuit of the amplifier is a variable having enough range (1500 μ f. total capacitance) to give adequate loading on 80 through 10 meters when working into a 52- or 75-ohm resistive load.

Plate current is metered by a 0-1 ammeter shunted across a resistor in the negative high-voltage lead. As shown in Fig. 6-91, this resistor is incorporated in the power supply, not in the amplifier unit. A 50-watt rating represents an ample safety factor, since the power dissipated would not exceed a few watts should the ammeter open up.

Separate milliammeters are provided for the grid and screen circuits. The screen meter is quite essential since the screen current, and hence screen dissipation, is very sensitive to grid driving voltage and plate tuning.

Layout Details

Fig. 6-92 is a view looking into the amplifier with the top cover removed. The variable capaci-

tor at the right is the output loading control, C₄. To the left of C₄ is the Model 850 inductor unit. Immediately to the rear (below, in the photograph) of the inductor is the output lead, connected to a coaxial receptacle mounted on the rear cover. The vacuum variable, C₃, is mounted between the inductor and the 4-250As. It is supported by an aluminum bracket 6 inches high and 4 inches wide. The neutralizing capacitor C₂ is between the 4-250As and the front panel.

The grid turret and tuning capacitor are mounted underneath the chassis to take advantage of the shielding afforded thereby. To fit under the chassis the turret is mounted with the switch shaft vertical, necessitating a right-angle drive to the panel control. The shaft approaches the panel at an angle, so a flexible coupling of the ball type (Millen 39001) is used between the shaft and panel bearing.

The meters are in a separate enclosure measuring 11 \times 3 \times 3-inches. It is mounted to the front of the box by countersunk flat-head screws. The top lips of the meter box are drilled to take sheet-metal screws when the lid is in place.

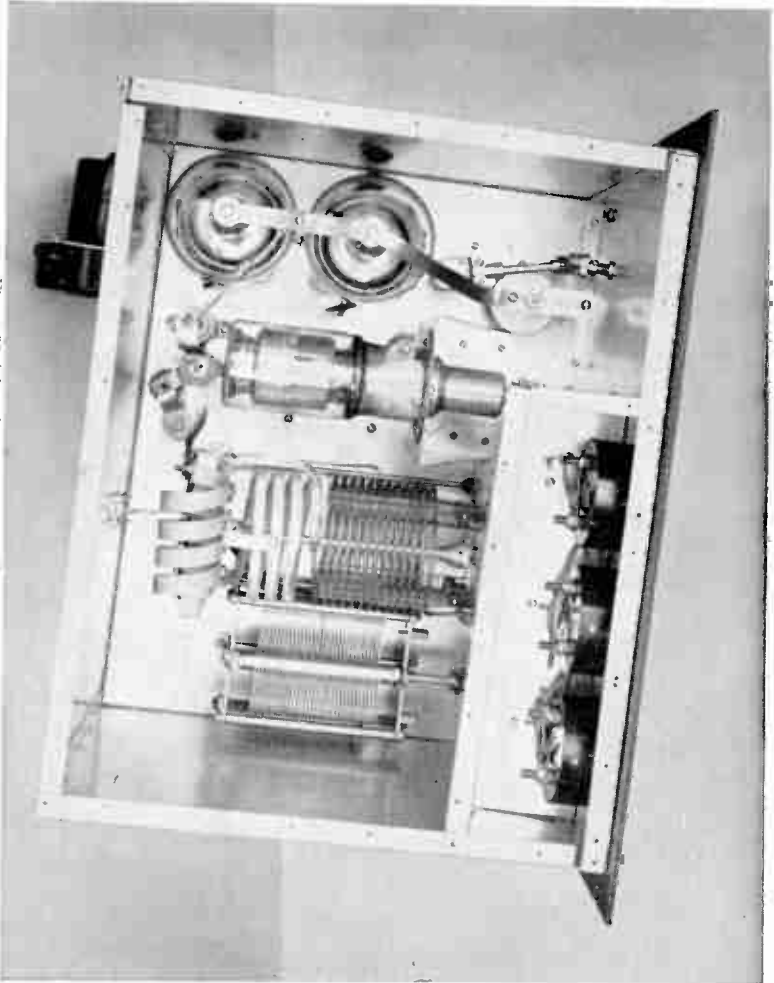

Fig. 6-93 (in low)

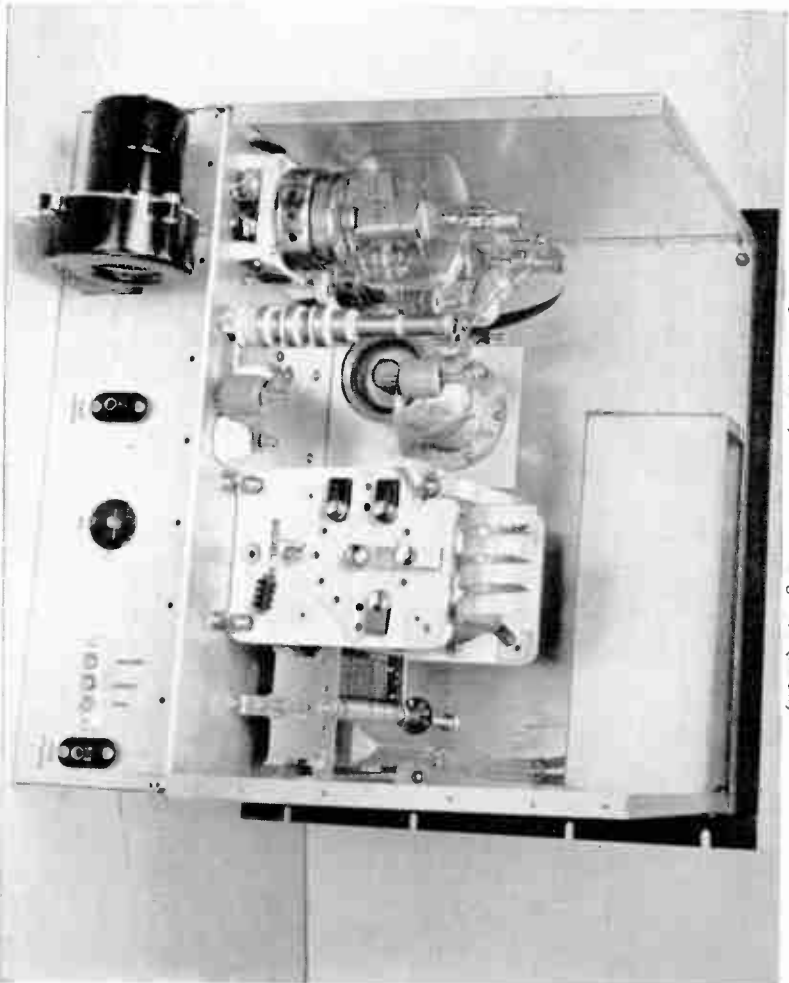

Fig. 6-92 (above)

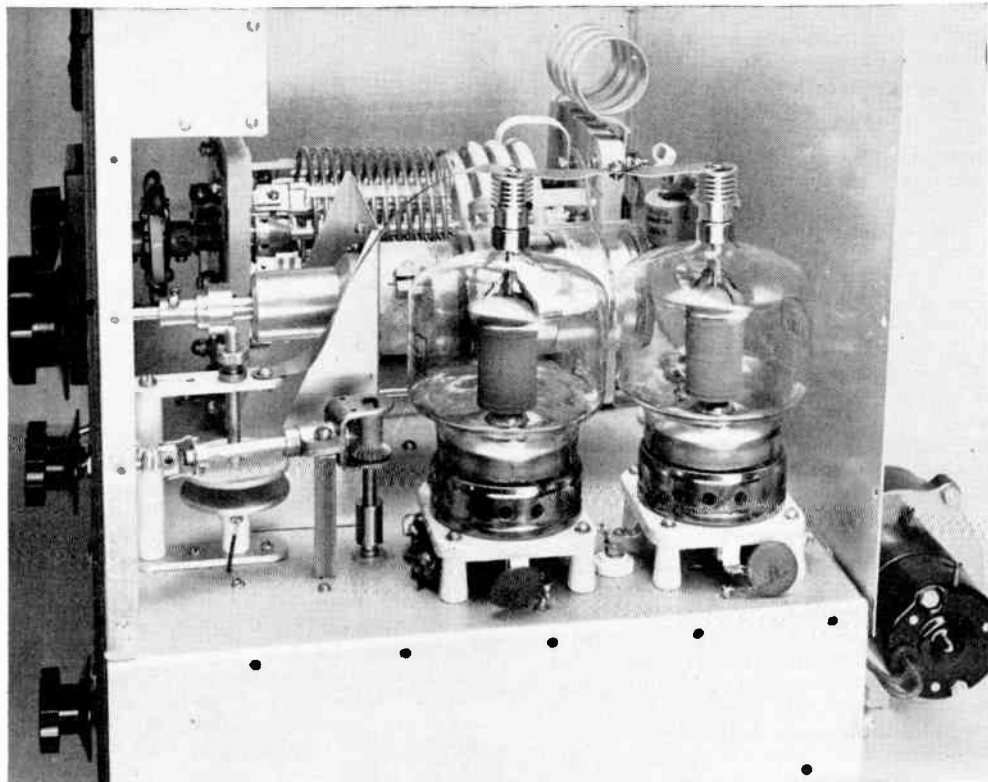

Fig. 6-94

Connections to the tube plates and neutralizing capacitor are made from flexible brass strip $\frac{1}{2}$ inch wide. A piece of $\frac{3}{4}$ -inch wide brass strip is used for the connection between the stator terminal of the vacuum variable and the tank inductor. The blocking capacitor is mounted on this strip.

Fig. 6-93 shows the amplifier with the top and back panels removed. The blower assembly is mounted on the rear chassis wall. To the right of the motor is the high-voltage terminal, the 115-volt connector, the grid and screen terminals, and the high-voltage negative connector. Leads from these last three terminals run below chassis in shielded wire and then up to the meter box. These leads are visible in front of the loading capacitor. Belden 8885 shielded wire is used for the leads. The inner conductor is bypassed to the shield braid at each end. The 2.5-mh. "safety" choke, RFC_3 , shunting the output end of the pi network is mounted on the back of the tank coil between the output lead and chassis ground.

The isolantite feed-through insulator to the left of the inductor is used to bring the high voltage through the chassis. Adjacent to it is the bypass at the bottom of the plate choke, RFC_1 .

Mounting details of the right-angle drive assembly for switching the grid circuit are clearly visible in Fig. 6-94. A $\frac{1}{2}$ -inch square rod $2\frac{3}{4}$ inches long is drilled and tapped at both ends to support the drive.

The sockets for the 4-250As are mounted on one-inch isolantite pillars. The screen and filament terminals are bypassed directly at the socket terminals. The grid terminals on the sockets face each other, and a small feedthrough is used to bring the grid lead up through the chassis.

Fig. 6-95 is a bottom view of the amplifier and Fig. 6-96 is a close-up view of the grid circuit. A short length of RF-58/U is used to connect J_1 on the rear chassis wall to the link terminals on the turret assembly. The high-voltage lead is filtered by the 500- μmf . ceramic bypass and RFC_2 . These two components are visible on the inside of the rear wall above the blower assembly. Two-terminal tie-points are used for the a.c. connections to the filament transformer and blower motor. Shielded leads are used between the tie-points and the 115-volt connector.

Fig. 6-96 shows the grid-circuit wiring in a bit more detail, particularly the grid choke, grid resistor and C_5 clustered just above the tuning capacitor. The modifications to the 10- and 15-meter coils also are somewhat more easily seen in this photograph.

Adjustment and Operating Data

The amplifier should be neutralized with the plate and screen supply leads disconnected and the bandswitch set to 28 Mc. An indicating wave meter should be coupled to the tank circuit and drive applied to the amplifier. Resonate the grid

and plate tanks and adjust the neutralizing capacitor for minimum r.f. in the tank circuit as indicated by the wave meter. The same neutralizing adjustment should hold for all bands. Don't attempt to neutralize with the plate and screen supply leads connected — i.e., with a complete circuit for d.c. — because even with the power turned off this permits electrons to flow from the cathode to the plate and screen, and r.f. will be present that cannot be neutralized out.

The parasitic choke will, in general, resonate the plate lead in one of the low v.h.f. TV channels, and will tend to increase harmonic output in that channel. Measure the resonant frequency of the plate lead at L_2 with a grid-dip meter, and if it is in one of the channels received in your locality, either pull the turns apart, or squeeze them together to move the frequency to an unused channel. Any frequency from 70 to 100 Mc. should be satisfactory.

Power Supply

For 1 kw. input, a plate voltage of at least 2000 is required. Screen voltage is obtained preferably from a separate 400-volt supply. For Class C operation, an external bias supply regulated by a VR-150, plus a grid leak of 2000 ohms is recommended. With this combination the grid current should be 25 ma. Screen current should be about 60 ma. with the amplifier fully loaded.

Some sort of r.f. output indicator, such as a

Fig. 6-95

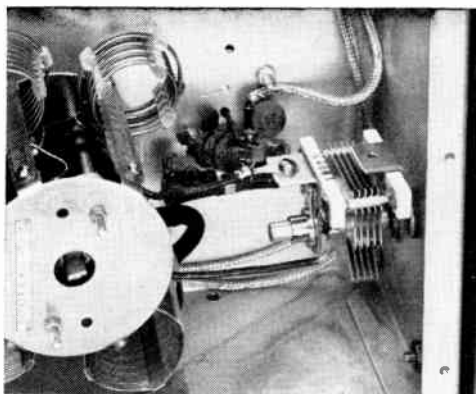
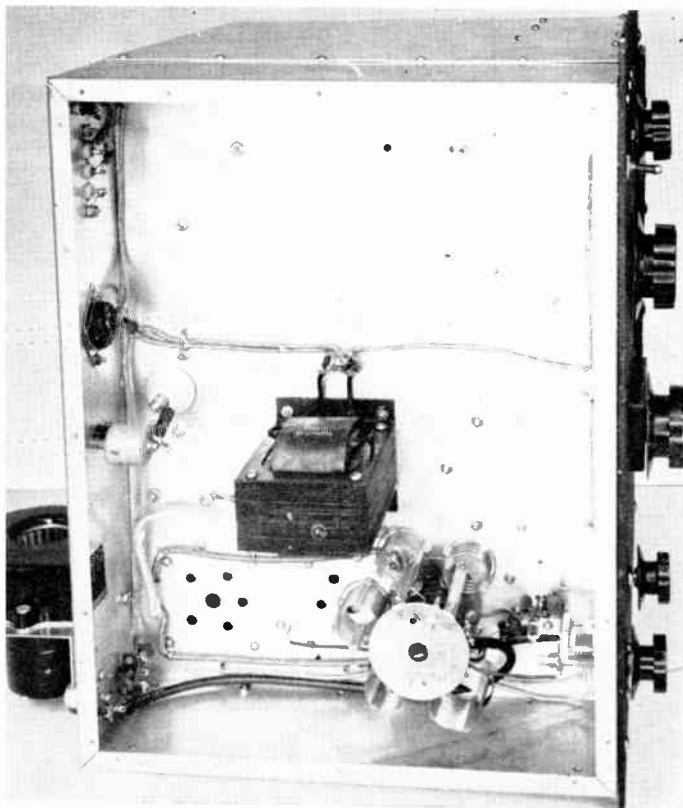

Fig. 6-96

crystal-rectifier voltmeter or r.f. ammeter in the feed line, should be used in tuning. It is preferable to do the preliminary tuning with the plate voltage applied to the tubes but with the screen voltage at zero. Zero screen voltage, provided the d.c. screen circuit is complete, will give enough output for tuning adjustments. C_2 and C_4 are adjusted to give maximum output, and the screen voltage is then increased until the amplifier is running at the desired input. C_3 is of course tuned for the plate-current dip so that the amplifier tank is kept tuned to resonance.

The fixed values of inductance available in the B&W unit preclude the possibility of matching over a wide range of impedances. The circuit can handle an s.w.r. in the coax line of about 2 to 1, but with higher s.w.r. values it may not be possible to get the desired loading. Also, although the construction is such that the amplifier is "clean" insofar as direct radiation and leakage of harmonics in the TV bands are concerned, a good low-pass filter will be required in most installations. A low s.w.r. in the coax line is definitely a requirement if excessive build-up of currents or voltages in the filter is to be avoided. If the line cannot be matched at the antenna, an auxiliary antenna coupler will have to be used.

For plate modulation a choke coil may be connected in the d.c. screen lead so the screen voltage will follow the audio variations in plate voltage. The choke should have an inductance of about 10 henrys, and must be capable of carrying 125 ma. d.c. For Class AB₁ operation on single side band the circuit may be left intact, the only requirement being to supply the proper operating voltages from suitably well-regulated supplies. If the amplifier is to be operated in AB₂ on s.s.b. the grid-leak resistor should be shorted out; also, suitable loading should be applied to the grid tank to maintain good regulation of the r.f. driving voltage.

(From *QST*, June, 1956.)

Power Supplies

Essentially pure direct-current plate supply is required to prevent serious hum in the output of receivers, speech amplifiers, modulators and transmitters. In the case of transmitters, d.c. plate supply is also dictated by government regulation.

The filaments of tubes in a transmitter or modulator usually may be operated from a.c. However, the filament power for tubes in a receiver (excepting power audio tubes), or those in a speech amplifier may be a.c. only if the tubes are of the indirectly-heated-cathode type, if hum is to be avoided.

Wherever commercial a.c. lines are available, high-voltage d.c. plate supply is most cheaply and conveniently obtained by the use of a transformer-rectifier-filter system. An example of such a system is shown in Fig. 7-1.

In this circuit, the plate transformer, T_1 , steps up the a.c. line voltage to the required high voltage. The a.c. is changed to pulsating d.c. by the rectifiers, V_1 and V_2 . Pulsations in the d.c. appearing at the output of the rectifier (points A and B) are smoothed out by the filter composed of L_1 and C_1 . R_1 is a bleeder resistor. Its chief function is to discharge C_1 as a safety measure, after the supply is turned off. By proper selection of value, R_1

also helps to minimize changes in output voltage with changes in the amount of current drawn from the supply. T_2 is a step-down transformer to provide filament voltage for the rectifier tubes. It must have sufficient insulation between the

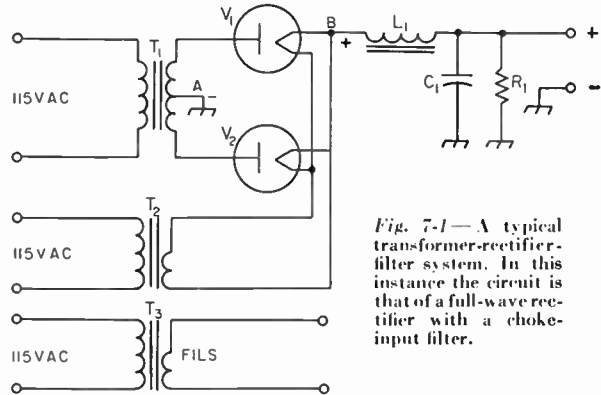

Fig. 7-1—A typical transformer-rectifier-filter system. In this instance the circuit is that of a full-wave rectifier with a choke-input filter.

filament winding and the core and primary winding to withstand the peak value of the rectified voltage. T_3 is a similar transformer to supply the filaments or heaters of the tubes in the equipment operating from the supply. Frequently, these three transformers are combined in a single unit having a single 115-volt primary winding and the required three secondary windings on one core.

Rectifier Circuits

Half-Wave Rectifier

Fig. 7-2 shows three rectifier circuits covering most of the common applications in amateur equipment. Fig. 7-2A is the circuit of a half-wave rectifier. During that half of the a.c. cycle when the rectifier plate is positive with respect to the cathode (or filament), current will flow through the rectifier and load. But during the other half of the cycle, when the plate is negative with respect to the cathode, no current can flow. The shape of the output wave is shown in (A) at the right. It shows that the current always flows in the same direction but that the flow of current is not continuous and is pulsating in amplitude.

The average output voltage—the voltage read by the usual d.c. voltmeter—with this circuit is 0.15 times the r.m.s. value of the a.c. voltage delivered by the transformer secondary. Because the frequency of the pulses in the output wave is relatively low (one pulsation per cycle), considerable filtering is required to

provide adequately smooth d.c. output, and for this reason this circuit is usually limited to applications where the current involved is small, such as in supplies for cathode-ray tubes and for protective bias in a transmitter.

Another disadvantage of the half-wave rectifier circuit is that the transformer must have a considerably higher primary volt-ampere rating (approximately 40 per cent greater), for the same d.c. power output, than in other rectifier circuits.

Full-Wave Center-Tap Rectifier

The most universally-used rectifier circuit is shown in Fig. 7-2B. Being essentially an arrangement in which the outputs of two half-wave rectifiers are combined, it makes use of both halves of the a.c. cycle. A transformer with a center-tapped secondary is required with the circuit. When the plate of V_1 is positive, current flows through the load to the center tap. Current cannot flow through V_2 because at this

instant its cathode (or filament) is positive in respect to its plate. When the polarity reverses, V_2 conducts and current again flows through the load to the center-tap, this time through V_2 .

The average output voltage is 0.45 times the r.m.s. voltage of the entire transformer-secondary, or 0.9 times the voltage across half of the transformer secondary. For the same total secondary voltage, the average output voltage is the same as that delivered with a half-wave rectifier. However, as can be seen from the sketches of the output wave form in (B) to the right, the frequency of the output pulses is twice that of the half-wave rectifier. Therefore much less filtering is required. Since the rectifiers work alternately, each handles half of the average load current. Therefore the load-current rating of each rectifier need be only half the total load current drawn from the supply.

Two separate transformers, with their primaries connected in parallel and secondaries connected in series (with the proper polarity) may be used in this circuit. However, if this substitution is made, the primary volt-ampere rating must be reduced to about 40 per cent less than twice the rating of one transformer.

Full-Wave Bridge Rectifier

Another full-wave rectifier circuit is shown in Fig. 7-2C. In this arrangement, two rectifiers operate in series on each half of the cycle, one rectifier being in the lead to the load, the other being in the return lead. Over that portion of the cycle when the upper end of the transformer secondary is positive with respect to the other end, current flows through V_1 , through the load and thence through V_2 . During this period current cannot flow through rectifier V_4 because its plate is negative with respect to its cathode (or filament). Over the other half of the cycle, current flows through V_3 , through the load and thence through V_4 . Three filament transformers

Cold-Cathode Rectifiers

Tube rectifiers fall into three general classifications as to type. The cold-cathode type is a diode which requires no cathode heating. Certain types will handle up to 350 ma. at 200 volts d.c. output. The internal drop in most types lies between 60 and 90 volts. Rectifiers of this kind are

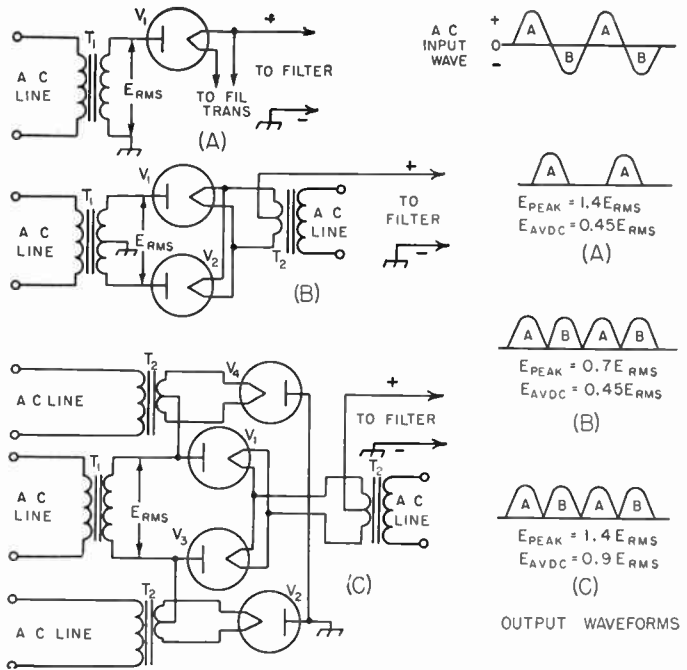

Fig. 7-2—Fundamental vacuum-tube rectifier circuits. A—Half-wave. B—Full-wave. C—Full-wave bridge. A.c. input and pulsating-d.c. output wave forms are shown at the right. Output-voltage values indicated do not include rectifier drops. Other types of rectifiers may be substituted.

are needed — one for V_1 and V_3 and one each for V_2 and V_4 . The output wave shape (C), to the right, is the same as that from the simple center-tap rectifier circuit. The output voltage obtainable with this circuit is 0.9 times the r.m.s. voltage delivered by the transformer secondary. For the same total transformer-secondary voltage, the average output voltage when using the bridge rectifier will be twice that obtainable with the center-tap rectifier circuit. However, when comparing rectifier circuits for use with the same transformer, it should be remembered that the power which a given transformer will handle remains the same regardless of the rectifier circuit used. If the output voltage is doubled by substituting the bridge circuit for the center-tap rectifier circuit, only half the rated load current can be taken from the transformer without exceeding its normal rating. Each rectifier in a bridge circuit should have a minimum load-current rating of one half the total load current to be drawn from the supply.

Rectifiers

produced in both half-wave (single-diode) and full-wave (double-diode) types.

High-Vacuum Rectifiers

High-vacuum rectifiers depend entirely upon the thermionic emission from a heated filament and are characterized by a relatively high

internal resistance. For this reason, their application usually is limited to low power, although there are a few types designed for medium and high power in cases where the relatively high internal voltage drop may be tolerated. This high internal resistance makes them less susceptible to damage from temporary overload and they are free from the bothersome electrical noise sometimes associated with other types of rectifiers.

Some rectifiers of the high-vacuum full-wave type in the so-called receiver-tube class will handle up to 250 ma. at 400 to 500 volts d.c. output. Those in the higher-power class can be used to handle up to 500 ma. at 2000 volts d.c. in full-wave circuits. Most low-power high-vacuum rectifiers are produced in the full-wave type, while those for greater power are invariably of the half-wave type, two tubes being required for a full-wave rectifier circuit. A few of the lower-voltage types have indirectly heated cathodes, but are limited in heater-to-cathode voltage rating.

Mercury-Vapor Rectifiers

The voltage drop through a mercury-vapor rectifier is practically constant at approximately 15 volts regardless of the load current. For high power they have the advantage of cheapness. Rectifiers of this type, however, have a tendency toward a type of oscillation which produces noise in nearby receivers, sometimes difficult to eliminate. R.f. filtering in the primary circuit and at the rectifier plates as well as shielding may be required. As with high-vacuum rectifiers, full-wave types are available in the lower-power ratings only. For higher power, two tubes are required in a full-wave circuit.

Selenium Rectifiers

Selenium rectifiers are available which make it possible to design a power supply capable of delivering up to 400 or 450 volts, 200 ma. These units have the advantages of compactness, low internal voltage drop (about 5 volts), and the fact that no filament transformer is needed. However, to limit the charging current with capacitive input, a resistance of 5 to 50 ohms should be used in series with the rectifier (see table at the end of this chapter). They may be substituted in any of the basic circuits shown in Fig. 7-2, the terminal marked "+" or "cathode" corresponding to the filament in these circuits. Circuits in which the selenium rectifier is particularly adaptable are shown later in Figs. 7-23 through 7-25. Since they develop little heat if operated within their ratings, they are especially suitable for use in equipment requiring minimum temperature variation.

Rectifier Ratings

Vacuum-tube rectifiers are subject to limitations as to breakdown voltage and current-handling capability. Some types are rated in terms of the maximum r.m.s. voltage which should be applied to the rectifier plate. This is sometimes dependent on whether a choke- or capacitive-input filter is used. Others, particularly mercury-

vapor types, are rated according to maximum inverse peak voltage — the peak voltage between plate and cathode while the tube is not conducting. In the circuits of Fig. 7-2, the inverse peak voltage across each rectifier is 1.4 times the r.m.s. value of the voltage delivered by the entire transformer secondary.

All rectifier tubes are rated also as to maximum d.c. load current and many, in addition, carry peak-current ratings, all of which should be carefully observed to assure normal tube life. With a capacitive-input filter, the peak current may run several times the d.c. current, while with a choke-input filter the peak value may not run more than twice the d.c. load current.

Operation of Rectifiers

In operating rectifiers requiring filament or cathode heating, care should be taken to provide the correct filament voltage at the tube terminals. Low filament voltage can cause excessive voltage drop in high-vacuum rectifiers and a considerable reduction in the inverse peak-voltage rating of a mercury-vapor tube. Filament connections to the rectifier socket should be firmly soldered, particularly in the case of the larger mercury-vapor tubes whose filaments operate at low voltage and high current. The socket should be selected with care, not only as to contact surface but also as to insulation, since the filament usually is at full output voltage to ground. Bakelite sockets will serve at voltages up to 500 or so, but ceramic sockets, well spaced from the chassis, always should be used at the higher voltages. Special filament transformers with high-voltage insulation between primary and secondary are required for rectifiers operating at potentials in excess of 1000 volts inverse peak.

The rectifier tubes should be placed in the equipment with adequate space surrounding them to provide for ventilation. When mercury-vapor tubes are first placed in service, and each time after the mercury has been disturbed, as by removal from the socket to a horizontal position, they should be run with filament voltage only for 30 minutes before applying high voltage. After

Fig. 7-3 — Connecting mercury-vapor rectifiers in parallel for heavier currents. R_1 and R_2 should have the same value, between 50 and 100 ohms, and corresponding filament terminals should be connected together.

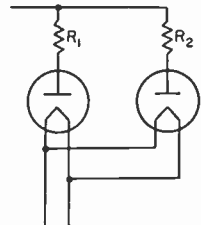

that, a delay of 30 seconds is recommended each time the filament is turned on.

Rectifiers may be connected in parallel for current higher than the rated current of a single unit. This includes the use of the sections of a double diode for this purpose. With mercury-vapor types, equalizing resistors of 50 to 100 ohms should be connected in series with each plate, as shown in Fig. 7-3, to help maintain an equal division of current between the two rectifiers.

Filters

The pulsating d.c. waves from the rectifiers shown in Fig. 7-2 are not sufficiently constant in amplitude to prevent hum corresponding to the pulsations. Filters consisting of capacitances and inductances are required between the rectifier and the load to smooth out the pulsations to an essentially constant d.c. voltage. Also, upon the design of the filter depends to a large extent the *voltage regulation* of the power supply and the maximum load current that can be drawn from the supply without exceeding the peak-current rating of the rectifier.

Power-supply filters fall into two classifications, depending upon whether the first filter element following the rectifier is a capacitor or a choke. Capacitive-input filters are characterized by relatively high output voltage in respect to the transformer voltage, but poor voltage regulation. Choke-input filters result in much better regulation, when properly designed, but the output voltage is less than would be obtained with a capacitive-input filter from the same transformer.

Voltage Regulation

The output voltage of a power supply always decreases as more current is drawn, not only because of increased voltage drops in the transformer, filter chokes and the rectifier (if high-vacuum rectifiers are used) but also because the output voltage at light loads tends to soar to the peak value of the transformer voltage as a result of charging the first capacitor. By proper filter design the latter effect can be eliminated. The change in output voltage with load is called *voltage regulation* and is expressed as a percentage.

$$\text{Per cent regulation} = \frac{100 (E_1 - E_2)}{E_2}$$

Example: No-load voltage = $E_1 = 1550$ volts.

Full-load voltage = $E_2 = 1230$ volts.

$$\begin{aligned} \text{Percentage regulation} &= \frac{100 (1550 - 1230)}{1230} \\ &= \frac{32,000}{1230} = 26 \text{ per cent.} \end{aligned}$$

Regulation may be as great as 100% or more with a capacitive-input filter, but by proper design can be held to 20% or less with a choke-input filter.

Good regulation is desirable if the load current varies during operation, as in a keyed stage or a Class B modulator, because a large change in voltage may increase the tendency toward key clicks in the former case or distortion in the latter. On the other hand, a steady load, such as is represented by a receiver, speech amplifier or unkeyed stages in a transmitter, does not require good regulation so long as the proper voltage is obtained under load conditions. Another consideration that makes good voltage regulation desirable is that the filter capacitors must have a voltage rating safe for the highest value to which the voltage will soar when the external load is removed.

When essentially constant voltage, regardless

of current variation is required (for stabilizing an oscillator, for example), special voltage-regulating circuits described elsewhere in this chapter are used.

Load Resistance

In discussing the performance of power-supply filters, it is sometimes convenient to express the load connected to the output terminals of the supply in terms of resistance. The load resistance is equal to the output voltage divided by the total current drawn, including the current drawn by the bleeder resistor.

Input Resistance

The sum of the transformer impedance and the rectifier resistance is called the input resistance. The approximate transformer impedance is given by

$$Z_{TR} = N^2 R_{PRI} + R_{SEC}$$

where N is the transformer turns ratio, primary to secondary (primary to $\frac{1}{2}$ secondary in the case of a full-wave rectifier), and R_{PRI} and R_{SEC} are the primary and secondary resistances respectively. R_{SEC} will be the resistance of half of the secondary in the case of a full-wave circuit.

Bleeder

A bleeder resistor is a resistance connected across the output terminals of the power supply (see Fig. 7-1). Its functions are to discharge the filter capacitors as a safety measure when the power is turned off and to improve voltage regulation by providing a minimum load resistance. When voltage regulation is not of importance, the resistance may be as high as 100 ohms per volt. The resistance value to be used for voltage-regulating purposes is discussed in later sections. From the consideration of safety, the power rating of the resistor should be as conservative as possible, since a burned-out bleeder resistor is more dangerous than none at all!

Ripple Frequency and Voltage

The pulsations in the output of the rectifier can be considered to be the resultant of an alternating current superimposed upon a steady direct current. From this viewpoint, the filter may be considered to consist of shunting capacitors which short-circuit the a.c. component while not interfering with the flow of the d.c. component, and series chokes which pass d.c. readily but which impede the flow of the a.c. component.

The alternating component is called the ripple. The effectiveness of the filter can be expressed in terms of per cent ripple, which is the ratio of the r.m.s. value of the ripple to the d.c. value in terms of percentage. For c.w. transmitters, the output ripple from the power supply should not exceed 5 per cent. The ripple in the output of supplies for voice transmitters should not exceed 1 per cent. Class B modulators require a ripple reduction to about 0.25%, while v.f.o.'s, high-

gain speech amplifiers, and receivers may require a reduction in ripple to 0.01%.

Ripple frequency is the frequency of the pulsations in the rectifier output wave — the number of pulsations per second. The frequency of the ripple with half-wave rectifiers is the same as the frequency of the line supply — 60 cycles with 60-cycle supply. Since the output pulses are doubled with a full-wave rectifier, the ripple frequency is doubled — to 120 cycles with 60-cycle supply.

The amount of filtering (values of inductance and capacitance) required to give adequate smoothing depends upon the ripple frequency, more filtering being required as the ripple frequency is lowered.

● CAPACITIVE-INPUT FILTERS

Capacitive-input filter systems are shown in Fig. 7-4. Disregarding voltage drops in the chokes, all have the same characteristics except

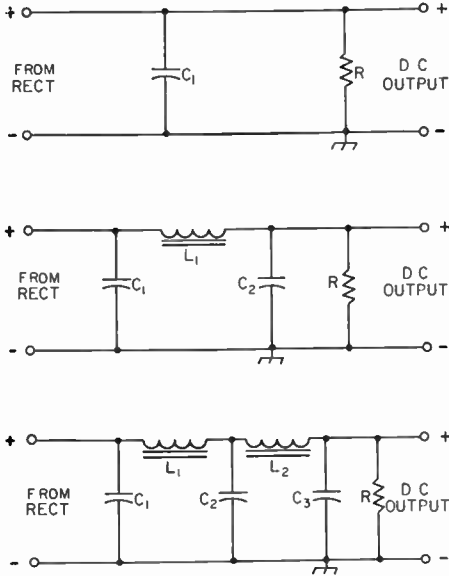

Fig. 7-4 — Capacitive-input filter circuits. A — Simple capacitive. B — Single-section. C — Double-section.

in respect to ripple. Better ripple reduction will be obtained when LC sections are added, as shown in Figs. 7-4B and C.

Output Voltage

To determine the approximate d.c. voltage output when a capacitive-input filter is used, reference should be made to the graph of Fig. 7-5.

Example:

- Transformer r.m.s. voltage — 350
- Input resistance — 200 ohms
- Maximum load current, including bleeder current — 175 ma.
- Load resistance = $\frac{350}{0.175} = 2000$ ohms approx.

From Fig. 7-5, for a load resistance of 2000 ohms and an input resistance of 200 ohms, the d.c. output voltage is given as slightly over 1

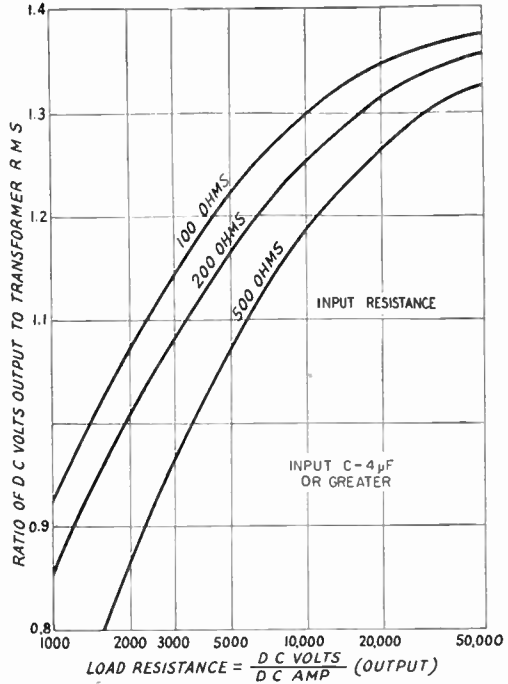

Fig. 7-5 — Chart showing approximate ratio of d.c. output voltage across filter input capacitor to transformer r.m.s. secondary voltage for different load and input resistances.

times the transformer r.m.s. voltage, or about 350 volts.

Regulation

If a bleeder resistance of 50,000 ohms is used, the d.c. output voltage, as shown in Fig. 7-5, will rise to about 1.35 times the transformer r.m.s. value, or about 470 volts, when the external load is removed. For greater accuracy, the voltage drops through the input resistance and the resistance of the chokes should be subtracted from the values determined above. For best regulation with a capacitive-input filter, the bleeder resistance should be as low as possible without exceeding the transformer, rectifier or choke ratings when the external load is connected.

Maximum Rectifier Current

The maximum current that can be drawn from a supply with a capacitive-input filter without exceeding the peak-current rating of the rectifier may be estimated from the graph of Fig. 7-6. Using values from the preceding example, the ratio of peak rectifier current to d.c. load current for 2000 ohms, as shown in Fig. 7-6 is 3. Therefore, the maximum load current that can be drawn without exceeding the rectifier rating is $\frac{1}{3}$ the peak rating of the rectifier. For a load current of 175 ma., as above, the rectifier peak current rating should be at least $3 \times 175 = 525$ ma.

With bleeder current only, Fig. 7-6 shows that the ratio will increase to over 8. But since the bleeder draws less than 10 ma. d.c., the rectifier peak current will be only 90 ma. or less.

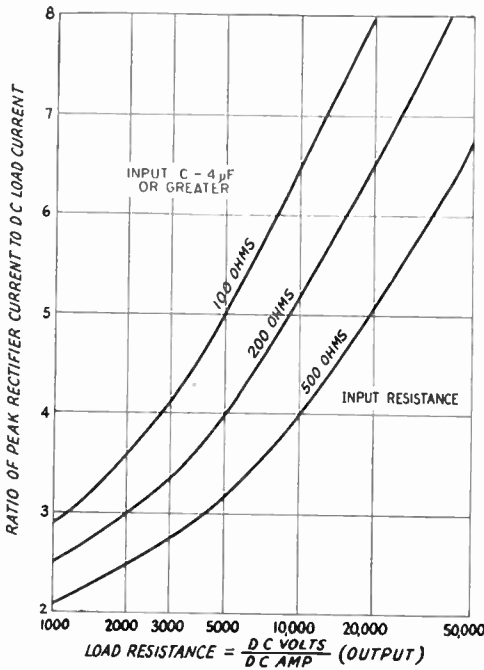

Fig. 7-6 — Graph showing the relationship between the d.c. load current and the rectifier peak plate current for various values of load and input resistance.

Ripple Filtering

The approximate ripple percentage after the simple capacitive filter of Fig. 7-4A may be determined from Fig. 7-7. With a load resistance of 2000 ohms, for instance, the ripple will be approximately 10% with an 8- μ f. capacitor or 20% with a 4- μ f. capacitor. For other capacitances, the ripple will be in inverse proportion to

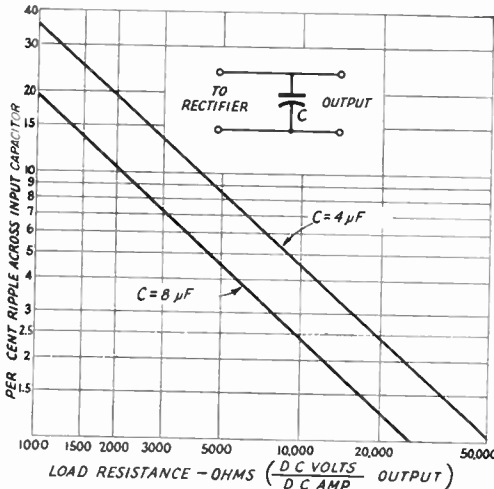

Fig. 7-7 — Showing approximate 120-cycle percentage ripple across filter input capacitor for various loads.

the capacitance, e.g., 5% with 16 μ f., 40% with 2 μ f., and so forth.

The ripple can be reduced further by the addition of LC sections as shown in Figs. 7-4B and C. Fig. 7-8 shows the factor by which the ripple from any preceding section is reduced depending on the product of the capacitance and inductance added. For instance, if a section composed of a choke of 5 h. and a capacitor of 4 μ f. were to be added to the simple capacitor of Fig. 7-4A, the product is $4 \times 5 = 20$. Fig. 7-8 shows that the original ripple (10% as above with 8 μ f. for example) will be reduced by a factor of about 0.08. Therefore the ripple percentage after the new section will be

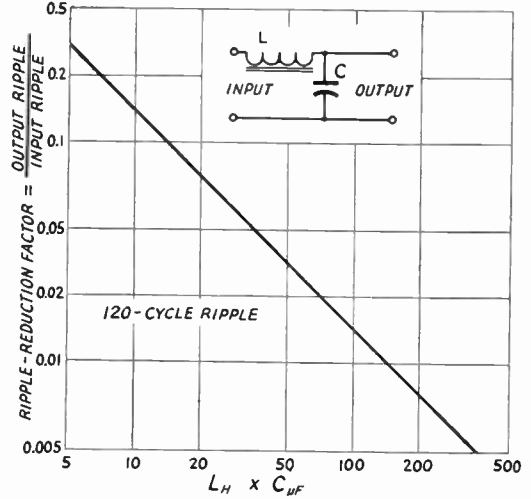

Fig. 7-8 — Ripple-reduction factor for various values of L and C in filter section. Output ripple = input ripple \times ripple factor.

approximately $0.08 \times 10 = 0.8\%$. If another section is added to the filter, its reduction factor from Fig. 7-8 will be applied to the 0.8% from the preceding section; $0.8 \times 0.08 = 0.064\%$ (if the second section has the same LC product as the first).

● **CHOKE-INPUT FILTERS**

Much better voltage regulation results when a choke-input filter, as shown in Fig. 7-9, is used. Choke input also permits better utilization of the rectifier, since a higher load current usually can be drawn without exceeding the peak current rating of the rectifier.

Minimum Choke Inductance

A choke-input filter will tend to act as a capacitive-input filter unless the input choke has at least a certain minimum value of inductance called the critical value. This critical value is given by

$$L_h = \frac{E \text{ VOLTS}}{I \text{ MA.}}$$

where E is the output voltage of the supply, and I is the current being drawn from the supply.

If the choke has at least the critical value, the output voltage will be limited to the average value of the rectified wave at the input to the

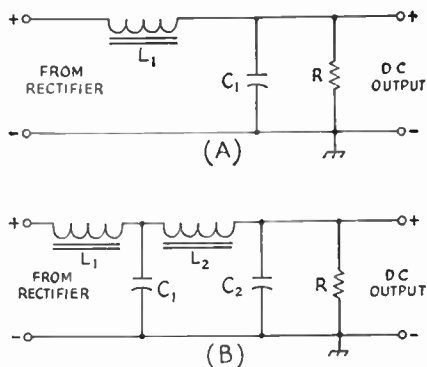

Fig. 7-9 — Choke-input filter circuits. A — Single-section. B — Double-section.

choke (see Fig. 7-2) when the current drawn from the supply is small. This is in contrast to the capacitive-input filter in which the output voltage tends to soar toward the peak value of the rectified wave at light loads. Also, if the input choke has at least the critical value, the rectifier peak plate current will be limited to about twice the d.c. current drawn from the supply. Most rectifier tubes have peak-current ratings of three to four times their maximum d.c. output-current ratings. Therefore, with an input choke of at least critical inductance, current up to the maximum output-current rating of the rectifier may be drawn from the supply without exceeding the peak-current rating of the rectifier.

Minimum-Load—Bleeder Resistance

From the formula above for critical inductance, it is obvious that if no current is drawn from the supply, the critical inductance will be infinite. So that a practical value of inductance may be used, some current must be drawn from the supply at all times the supply is in use. From the formula we find that this minimum value of current is

$$I_{MA} = \frac{E_{VOLTS}}{L_h}$$

Thus, if the choke has an inductance of 20 h., and the output voltage is 2000, the minimum load current should be 100 ma. This load may be provided, for example, by transmitter stages that draw current continuously (stages that are not keyed). However, in the majority of cases it will be most convenient to adjust the bleeder resistance so that the bleeder will draw the required minimum current. In the above example, the bleeder resistance should be $2000/0.1 = 20,000$ ohms.

From the formula for critical inductance, it is seen that when more current is drawn from the supply, the critical inductance becomes less. Thus, as an example, when the total current, including the 100 ma. drawn by the bleeder rises to 400 ma., the choke need have an inductance of only 5 h. to maintain the critical value. This is fortunate, because chokes having the required inductance for the bleeder load only and that will maintain this value of inductance for much larger currents are very expensive.

Swinging Chokes

Less costly chokes are available that will maintain at least critical value of inductance over the range of current likely to be drawn from practical supplies. These chokes are called **swinging chokes**. As an example, a swinging choke may have an inductance rating of 5/25 h. and a current rating of 225 ma. If the supply delivers 1000 volts, the minimum load current should be $1000/25 = 40$ ma. When the full load current of 225 ma. is drawn from the supply, the inductance will drop to 5 h. The critical inductance for 225 ma. at 1000 volts is $1000/225 = 4.5$ h. Therefore the 5/25-h. choke maintains at least the critical inductance at the full current rating of 225 ma. At all load currents between 40 ma. and 225 ma., the choke will adjust its inductance to at least the approximate critical value.

Table 7-1 shows the maximum supply output voltage that can be used with commonly-available swinging chokes to maintain critical inductance at the maximum current rating of the choke. These chokes will also maintain critical inductance for any lower values of voltage, or current down to the required minimum drawn by a proper bleeder as discussed above.

TABLE 7-1

L_h	Max. ma.	Max. volts	Max. R ¹	Min. ma. ²
3.5/13.5	150	525	13.5K	39
5/25	175	875	25K	35
2/12	200	400	12K	33
5/25	200	1000	25K	40
5/25	225	1125	25K	45
2/12	250	500	12K	42
4/20	300	1200	20K	60
5/25	300	1500	25K	60
3/17	400	1200	17K	71
4/20	400	1600	20K	80
5/25	400	2000	25K	80
4/16	500	2000	16K	125
5/25	500	2500	25K	100
5/25	550	2750	25K	110

¹ Maximum bleeder resistance for critical inductance.
² Minimum current (bleeder) for critical inductance.

In the case of supplies for higher voltages in particular, the limitation on maximum load resistance may result in the wasting of an appreciable portion of the transformer power capacity in the bleeder resistance. Two input chokes in series will permit the use of a bleeder of twice the resistance, cutting the wasted current in half. Another alternative that can be used in a c.w. transmitter is to use a very high-resistance bleeder for protective purposes and only sufficient fixed bias on the tubes operating from the supply to bring the total current drawn from the

supply, when the key is open, to the value of current that the required bleeder resistance should draw from the supply. Operating bias is brought back up to normal by increasing the grid-leak resistance. Thus the entire current capacity of the supply (with the exception of the small drain of the protective bleeder) can be used in operating the transmitter stages. With this system, it is advisable to operate the tubes at phone, rather than c.w., rating, since the average dissipation is increased.

Output Voltage

Provided the input-choke inductance is at least the critical value, the output voltage may be calculated quite closely by the following equation:

$$E_o = 0.9E_t - \frac{(I_b + I_L)(R_1 + R_2)}{1000} - E_r$$

where E_o is the output voltage; E_t is the r.m.s. voltage applied to the rectifier (r.m.s. voltage between center-tap and one end of the secondary in the case of the center-tap rectifier); I_b and I_L are the bleeder and load currents, respectively, in milliamperes; R_1 and R_2 are the resistances of the first and second filter chokes; and E_r is the drop between rectifier plate and cathode. The various voltage drops are shown in Fig. 7-12. At no load I_L is zero, hence the no-load voltage may be calculated on the basis of bleeder current only. The voltage regulation may be determined from the no-load and full-load voltages using the formula previously given.

Ripple with Choke Input

The percentage ripple output from a single-section filter (Fig. 7-9A) may be determined to a close approximation, for a ripple frequency of 120 cycles, from Fig. 7-10

Example: $L = 5$ h., $C = 4$ μ f., $LC = 20$.

From Fig. 7-10, percentage ripple = 5 per cent.

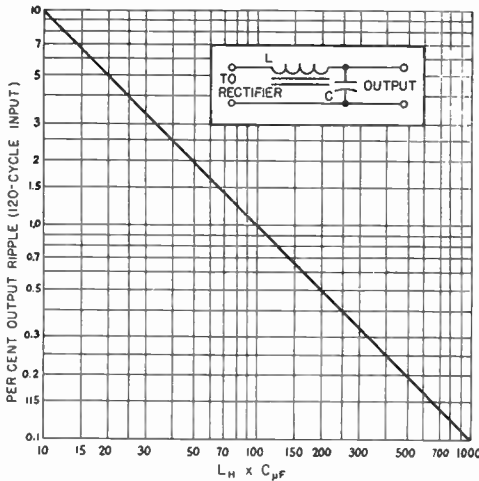

Fig. 7-10 — Graph showing combinations of inductance and capacitance that may be used to reduce ripple with a single-section choke-input filter.

Example: $L = 5$ h. What capacitance is needed to reduce the ripple to 1 per cent? Following the 1-per-cent line to the right to its intersection with the diagonal, thence downward to the LC scale, read $LC = 100, 100/5 = 20 \mu$ f.

In selecting values for the first filter section, the inductance of the choke should be determined by the considerations discussed previously. Then the capacitor should be selected that when combined with the choke inductance (minimum inductance in the case of a swinging choke) will bring the ripple down to the desired value. If it is found impossible to bring the ripple down to the desired figure with practical values in a single section, a second section can be added, as shown in Fig. 7-9B and the reduction factor from Fig. 7-8 applied as discussed under capacitive-input filters. The second choke should not be of the swinging type, but one having a more or less constant inductance with changes in current (smoothing choke).

● **OUTPUT CAPACITOR**

If the supply is intended for use with an audio-frequency amplifier, the reactance of the last filter capacitor should be small (20 per cent or less) compared with the other audio-frequency resistance or impedance in the circuit, usually the tube plate resistance and load resistance. On the basis of a lower a.f. limit of 100 cycles for speech amplification, this condition usually is satisfied when the output capacitance (last filter capacitor) of the filter has a capacitance of 4 to 8 μ f., the higher value of capacitance being used in the case of lower tube and load resistances.

● **RESONANCE**

Resonance effects in the series circuit across the output of the rectifier which is formed by the first choke (L_1) and first filter capacitor (C_1) must be avoided, since the ripple voltage would build up to large values. This not only is the opposite action to that for which the filter is intended, but also may cause excessive rectifier peak currents and abnormally-high inverse peak voltages. For full-wave rectification the ripple frequency will be 120 cycles for a 60-cycle supply, and resonance will occur when the product of choke inductance in henrys times capacitor capacitance in microfarads is equal to 1.77. The corresponding figure for 50-cycle supply (100-cycle ripple frequency) is 2.53, and for 25-cycle supply (50-cycle ripple frequency) 13.5. At least twice these products of inductance and capacitance should be used to ensure against resonance effects. With a swinging choke, the minimum rated inductance of the choke should be used.

● **RATINGS OF FILTER COMPONENTS**

Although filter capacitors in a choke-input filter are subjected to smaller variations in d.c. voltage than in the capacitive-input filter, it is

advisable to use capacitors rated for the peak transformer voltage in case the bleeder resistor should burn out when there is no load on the power supply, since the voltage then will rise to the same maximum value as it would with a filter of the capacitive-input type.

In a capacitive-input filter, the capacitors should have a working-voltage rating at least as high, and preferably somewhat higher, than the peak-voltage rating of the transformer. Thus, in the case of a center-tap rectifier having a transformer delivering 550 volts each side of the center-tap, the minimum safe capacitor voltage rating will be 550×1.41 or 775 volts. An 800-volt capacitor should be used, or preferably a 1000-volt unit.

Filter capacitors are made in several different types. Electrolytic capacitors, which are available for peak voltages up to about 800, combine high capacitance with small size, since the dielectric is an extremely-thin film of oxide on aluminum foil. Capacitors of this type may be connected in series for higher voltages, although the filtering capacitance will be reduced to the resultant of the two capacitances in series. If this arrangement is used, it is important that *each* of the capacitors be shunted with a resistor of about 100 ohms per volt of supply voltage, with a power rating adequate for the total resistor current at that voltage. These resistors may serve as all or part of the bleeder resistance (see choke-input filters). Capacitors with higher-voltage ratings usually are made with a dielectric of thin paper impregnated with oil. The **working voltage** of a capacitor is the voltage that it will withstand continuously.

The input choke may be of the swinging type, the required minimum no-load and full-load inductance values being calculated as described above. For the second choke (**smoothing choke**) values of 4 to 20 henrys ordinarily are used. When filter chokes are placed in the positive leads, the negative being grounded, the windings should be insulated from the core to withstand the full d.c. output voltage of the supply and be capable of handling the required load current.

Filter chokes or inductances are wound on iron cores, with a small gap in the core to prevent magnetic saturation of the iron at high currents. When the iron becomes saturated its permeability decreases, consequently the inductance also decreases. Despite the air gap, the in-

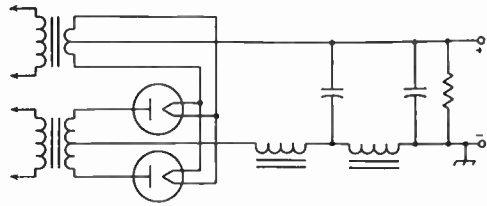

Fig. 7-11 — In most applications, the filter chokes may be placed in the negative instead of the positive side of the circuit. This reduces the danger of a voltage breakdown between the choke winding and core.

ductance of a choke usually varies to some extent with the direct current flowing in the winding; hence it is necessary to specify the inductance at the current which the choke is intended to carry. Its inductance with little or no direct current flowing in the winding may be considerably higher than the value when full load current is flowing.

● **NEGATIVE-LEAD FILTERING**

For many years it has been almost universal practice to place filter chokes in the positive leads of plate power supplies. This means that the insulation between the choke winding and its core (which should be grounded to chassis as a safety measure) must be adequate to withstand the output voltage of the supply. This voltage requirement is removed if the chokes are placed in the negative lead as shown in Fig. 7-11. With this connection, the capacitance of the transformer secondary to ground appears in parallel with the filter chokes tending to bypass the chokes. However, this effect will be negligible in practical application except in cases where the output ripple must be reduced to a very low figure. Such applications are usually limited to low-voltage devices such as receivers, speech amplifiers and v.f.o.'s where insulation is no problem and the chokes may be placed in the positive side in the conventional manner. In higher-voltage applications, there is no reason why the filter chokes should not be placed in the negative lead to reduce insulation requirements. Choke terminals, negative capacitor terminals and the transformer center-tap terminal should be well protected against accidental contact, since these will assume full supply voltage to chassis should a choke burn out or the chassis connection fail.

Plate and Filament Transformers

Output Voltage

The output voltage which the plate transformer must deliver depends upon the required d.c. load voltage and the type of filter circuit.

With a choke-input filter, the required r.m.s. secondary voltage (each side of center-tap for a center-tap rectifier) can be calculated by the equation:

$$E_s = 1.1 \left[E_o + \frac{I(R_1 + R_2)}{1000} + E_r \right]$$

where E_o is the required d.c. output voltage, I is the load current (including bleeder current) in milliamperes, R_1 and R_2 are the d.c. resistances of the chokes, and E_r is the voltage drop in the rectifier. E_s is the full-load r.m.s. secondary voltage; the open-circuit voltage usually

Fig. 7-12 — Diagram showing various voltage drops that must be taken into consideration in determining the required transformer voltage to deliver the desired output voltage.

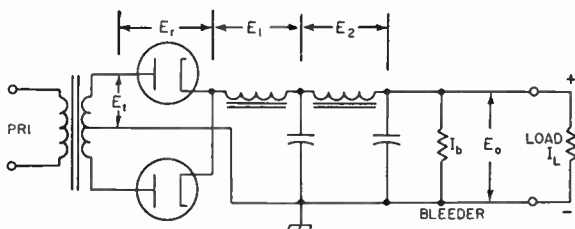

will be 5 to 10 per cent higher than the full-load value.

The approximate transformer output voltage required to give a desired d.c. output voltage with a given load with a capacitive-input filter system can be calculated with the help of Fig. 7-12.

Example:

Required d.c. output volts — 500
 Load current to be drawn — 100 ma.
 Load resistance = $\frac{500}{0.1} = 5000$ ohms.

If the rectifier resistance is 200 ohms, Fig. 7-5 shows that the ratio of d.c. volts to the required transformer r.m.s. voltage is approximately 1.15. The required transformer terminal voltage under load with chokes of 200 and 300 ohms is

$$E_s = \frac{E_o + I \left(\frac{R_1 + R_2 + R_r}{1000} \right)}{1.15}$$

$$= \frac{500 + 100 \left(\frac{200 + 300 + 200}{1000} \right)}{1.15}$$

$$= \frac{570}{1.15} = 495 \text{ volts.}$$

Volt-Ampere Rating

The volt-ampere rating of the transformer depends upon the type of filter (capacitive or choke input). With a capacitive-input filter the heating effect in the secondary is higher because of the high ratio of peak to average current, consequently the volt-amperes consumed by the transformer may be several times the watts delivered to the load. With a choke-input filter, provided the input choke has at least the critical inductance, the secondary volt-amperes can be

calculated quite closely by the equation:

$$\text{Sec. V.A.} = 0.00075EI$$

where E is the total r.m.s. voltage of the secondary (between the outside ends in the case of a center-tapped winding) and I is the d.c. output current in milliamperes (load current plus bleeder current). The primary volt-amperes will be 10 to 20 per cent higher because of transformer losses.

Filament Supply

Except for tubes designed for battery operation, the filaments or heaters of vacuum tubes used in both transmitters and receivers are universally operated on alternating current obtained from the power line through a step-down transformer delivering a secondary voltage equal to the rated voltage of the tubes used. The transformer should be designed to carry the current taken by the number of tubes which may be connected in parallel across it. The filament or heater transformer generally is center-tapped, to provide a balanced circuit for eliminating hum.

For medium- and high-power r.f. stages of transmitters, and for high-power audio stages, it is desirable to use a separate filament transformer for each section of the transmitter, installed near the tube sockets. This avoids the necessity for abnormally large wires to carry the total filament current for all stages without appreciable voltage drop. Maintenance of rated filament voltage is highly important, especially with thoriated-filament tubes, since under- or over-voltage may reduce filament life.

Typical Power Supplies

Figs. 7-13 and 7-14 show typical power-supply circuits. Fig. 7-13 is for use with transformers commonly listed as broadcast or television replacement power transformers. In addition to the high-voltage winding for plate supply, these transformers have windings that supply filament voltages for both the rectifier tube and the 6.3-volt tubes in the receiver or low-power transmitter or exciter. Transformers of this type may be obtained in ratings up to 600 volts r.m.s. each side of center tap, 200 d.c. ma. output.

Fig. 7-13 shows a two-section filter with capacitor input. However, depending upon the maximum hum level that may be allowable for a

particular application, the last capacitor and choke may not be needed. In some low-current applications, the first capacitor alone may provide adequate filtering. Table 7-11 shows the approximate full-load and bleeder-load output voltages and a.c. ripple percentages for several representative sets of components. Voltage and ripple values are given for three points in the circuit — Point A (first capacitor only used), Point B (last capacitor and choke omitted), and Point C (complete two-section filter in use). In each case, the bleeder resistor R should be used across the output.

Table 7-11 also shows approximate output voltages and ripple percentages for choke-input filters

TABLE 7-II
Capacitor-Input Power Supplies

T_1 Rating		V_1 Tube Type	C		L		R	Approximate Full-load d.c. Volts at			Approximate Ripple % at			Approx. Output Volts Bleeder Load	Useful Output Ma.*	
Volts R.M.S.	Ma. D.C.		μ f.	Volts	H.	Ohms	Ohms	Watts	A	B	C	A	B			C
325	40	5Y3GT	8	600	8	400	90K	5	375	360	345	2.5	0.08	0.002	450	36
325	40	5V4G	8	600	8	400	90K	5	410	395	375	2.5	0.08	0.002	450	36
350	90	5Y3GT	8	600	10	225	46K	10	370	350	330	6	0.1	0.002	460	82
350	90	5V4G	8	600	10	225	46K	10	410	390	370	6	0.1	0.002	460	82
375	150	5U4G	8	700	8	145	25K	10	375	350	330	9	0.2	0.006	500	136
375	150	5V4G	8	700	8	145	25K	10	425	400	380	9	0.2	0.006	500	136
400	200	5U4G	8	700	8	120	22K	20	375	350	325	12	0.3	0.008	550	184
Choke-Input Power Supplies																
325	40	5Y3GT	8	450	15	420	18K	10	—	240	225	—	0.8	0.01	265	25
325	40	5V4G	8	450	15	420	18K	10	—	255	240	—	0.8	0.01	280	25
350	90	5Y3GT	8	450	10	225	11K	10	—	240	220	—	1.25	0.02	250	68
350	90	5V4G	8	450	10	225	11K	10	—	270	250	—	1.25	0.02	280	68
375	150	5Y3GT	8	450	12	150	13K	20	—	265	245	—	1	0.015	325	125
375	150	5V4G	8	450	12	150	13K	20	—	280	260	—	1	0.015	340	125
400	200	5U4G	8	450	12	140	14K	20	—	275	250	—	1	0.015	350	175

* Balance of transformer current capacity consumed by bleeder resistor.

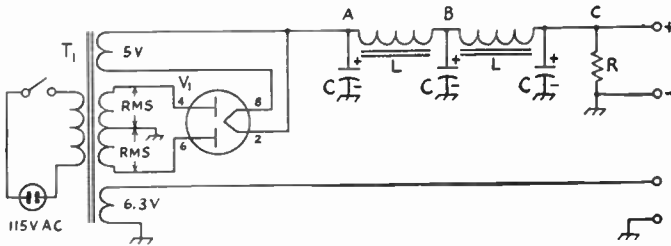

Fig. 7-13 — Typical a.c. power-supply circuit for receivers, excitors, or low-power transmitters. Representative values will be found in Table 7-11. The 5-volt winding of T_1 should have a current rating of at least 2 amp. for types 5Y3GT and 5V4G, and 3 amp. for 5U4G (GA, GB).

TABLE 7-III

Approx. D.C. Output		T_2 Rating		L_2 H.	Voltage Rating C_1, C_2	R Watts	Approx. Bleeder- Load Output Volts
Volts	Ma. ¹	Approx. V.R.M.S.	Ma.				
400/500	230	520/615	250	4	700	20	440/540
600/750	260	750/950	300	8	1000	50	650/800
1250/1500	240	1500/1750	300	8	2000	150	1300/1600
1250/1500	440	1500/1750	500	6	2000	150	1315/1615
2000/2500	200	2400/2900	300 ⁴	8	3000	320 ²	2050/2550
2000/2500	400	2400/2900	500	6	3000	320 ²	2065/2565
2500/3000	380	2500/3450	500 ⁵	6	4000	500 ³	2565/3065

¹ Balance of transformer current rating consumed by bleeder resistor.

² Use two 160-watt, 12,500-ohm units in series.

³ Use five 100-watt, 5000-ohm units in series.

⁴ Regulation will be somewhat better with a 400- or 500-ma. choke.

⁵ Regulation will be somewhat better with a 550-ma. choke.

Fig. 7-14 — Conventional power-supply circuit for higher-power transmitters. C_1, C_2 — 4 μ f. for approximately 0.5% output ripple; 2 μ f. for approximately 1.5% output ripple. C_2 should be 4 μ f. if supply is for modulator.

- R — 25,000 ohms.
- L_1 — Swinging choke: 5/25 h., current rating same as T_2
- L_2 — Smoothing choke: current rating same as T_2 .

- T_1 — 2.5 volts, 4 amp. for type 816; 2.5 volts, 10 amp. for 866A.
- T_2 — D.c. voltage rating same as output voltage.
- T_3 — Voltage and current rating to suit transmitter.

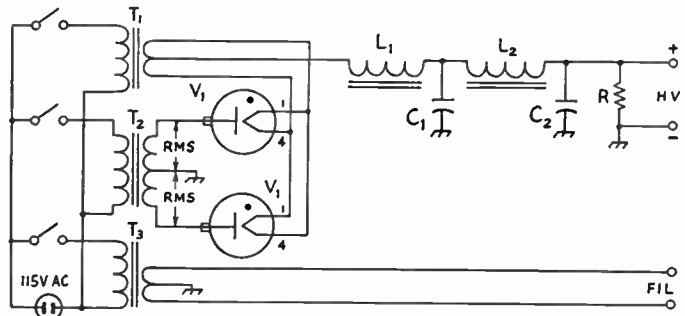

- V_1 — Type 816 for 400/500-volt supply; 866A for others shown in Table 7-11.
- See Table 7-III for other values.

(first filter capacitor omitted), for Point B (last capacitor and choke omitted), and Point C (complete two-section filter, first capacitor omitted).

Actual full-load output voltages may be somewhat lower than those shown in the table, since the voltage drop through the resistance of the transformer secondary has not been included.

Fig. 7-14 shows the conventional circuit of a transmitter plate supply for higher powers. A full-wave rectifier circuit, half-wave rectifier tubes, and separate transformers for high voltage, rectifier filaments and transmitter filaments are used. The high-voltage transformers used in

this circuit are usually rated directly in terms of d.c. output voltage, assuming rectifiers and filters of the type shown in Fig. 7-14. Table 7-III shows typical values for representative supplies, based on commonly-available components. Transformer voltages shown are representative for units with dual-voltage secondaries. The bleeder-load voltages shown may be somewhat lower than actually found in practice, because transformer resistance has not been included. Ripple at the output of the first filter section will be approximately 5 per cent with a 4- μ f. capacitor, or 10 per cent with a 2- μ f. capacitor.

Voltage Dropping

Series Voltage-Dropping Resistor

Certain plates and screens of the various tubes in a transmitter or receiver often require a variety of operating voltages differing from the output voltage of an available power supply. In most cases, it is not economically feasible to provide a separate power supply for each of the required voltages. If the current drawn by an electrode, or combination of electrodes operating at the same voltage, is reasonably constant under normal operating conditions, the required voltage may be obtained from a supply of higher voltage by means of a voltage-dropping resistor in series, as shown in Fig. 7-15A. The value of the series resistor, R_1 , may

be obtained from Ohm's Law, $R = \frac{E_d}{I}$, where

E_d is the voltage drop required from the supply voltage to the desired voltage and I is the total rated current of the load.

Example: The plate of the tube in one stage and the screens of the tubes in two other stages require an operating voltage of 250. The nearest available supply voltage is 400 and the total of the rated plate and screen currents is 75 ma. The required resistance is

$$R = \frac{400 - 250}{0.075} = \frac{150}{0.075} = 2000 \text{ ohms.}$$

The power rating of the resistor is obtained from P (watts) = $I^2R = (0.075)^2(2000) = 11.2$ watts. A 20-watt resistor is the nearest safe rating to be used.

Voltage Dividers

The regulation of the voltage obtained in this manner obviously is poor, since any change in current through the resistor will cause a directly-proportional change in the voltage drop across the resistor. The regulation can be improved somewhat by connecting a second resistor from the low-voltage end of the first to the negative power-supply terminal, as shown in Fig. 7-15B. Such an arrangement constitutes a voltage divider. The second resistor, R_2 , acts as a constant load for the first, R_1 , so that any variation in current from the tap becomes a smaller percentage of the total current through R_1 . The heavier the current drawn by the resistors when they alone are connected across the supply, the better will be the voltage regulation at the tap.

Such a voltage divider may have more than a single tap for the purpose of obtaining more than one value of voltage. A typical arrangement is shown in Fig. 7-15C. The terminal voltage is E , and two taps are provided to give lower voltages, E_1 and E_2 , at currents I_1 and I_2



Fig. 7-15 -- A -- Series voltage-dropping resistor. B -- Simple voltage divider. C -- Multiple divider circuit.

$$R_3 = \frac{E_1}{I_b}; R_4 = \frac{E_2 - E_1}{I_b + I_1}; R_5 = \frac{E - E_2}{I_b + I_1 + I_2}$$

respectively. The smaller the resistance between taps in proportion to the total resistance, the smaller the voltage between the taps. For convenience, the voltage divider in the figure is considered to be made up of separate resistances R_3, R_4, R_5 , between taps. R_3 carries only the bleeder current, I_b ; R_4 carries I_1 in addition to I_b ; R_5 carries I_2, I_1 and I_b . To calculate the resistances required, a bleeder current, I_b , must be assumed; generally it is low compared with the total load current (10 per cent or so). Then the required values can be

calculated as shown in the caption of Fig. 7-15C, I being in decimal parts of an ampere.

The method may be extended to any desired number of taps, each resistance section being calculated by Ohm's Law using the needed voltage drop across it and the total current through it. The power dissipated by each section may be calculated either by multiplying I and E or I^2 and R .

Voltage Stabilization

Gaseous Regulator Tubes

There is frequent need for maintaining the voltage applied to a low-voltage low-current circuit at a practically constant value, regardless of the voltage regulation of the power supply or variations in load current. In such applications, gaseous regulator tubes (OC3/VR105, OD3/VR150, etc.) can be used to good advantage. The voltage drop across such tubes is constant over a moderately wide current range. Tubes are available for regulated voltages near 150, 105, 90 and 75 volts.

The fundamental circuit for a gaseous regulator is shown in Fig. 7-16A. The tube is con-

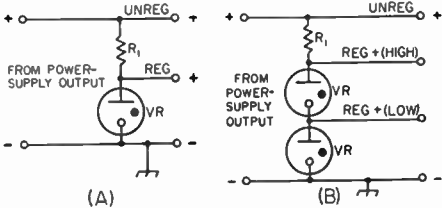

Fig. 7-16 -- Voltage-stabilizing circuits using VR tubes.

nected in series with a limiting resistor, R_1 , across a source of voltage that must be higher than the starting voltage. The starting voltage is about 30 to 40 per cent higher than the operating voltage. The load is connected in parallel with the tube. For stable operation, a minimum tube current of 5 to 10 ma. is re-

quired. The maximum permissible current with most types is 40 ma.; consequently, the load current cannot exceed 30 to 35 ma. if the voltage is to be stabilized over a range from zero to maximum load current.

The value of the limiting resistor must lie between that which just permits minimum tube current to flow and that which just passes the maximum permissible tube current when there is no load current. The latter value is generally used. It is given by the equation:

$$R = \frac{1000 (E_s - E_r)}{I}$$

where R is the limiting resistance in ohms, E_s is the voltage of the source across which the tube and resistor are connected, E_r is the rated voltage drop across the regulator tube, and I is the maximum tube current in milliamperes (usually 40 ma.).

Fig. 7-16B shows how two tubes may be used in series to give a higher regulated voltage than is obtainable with one, and also to give two values of regulated voltage. The limiting resistor may be calculated as above, using the sum of the voltage drops across the two tubes for E_r . Since the upper tube must carry more current than the lower, the load connected to the low-voltage tap must take small current. The total current taken by the loads on both the high and low taps should not exceed 30 to 35 milliamperes.

Voltage regulation of the order of 1 per cent

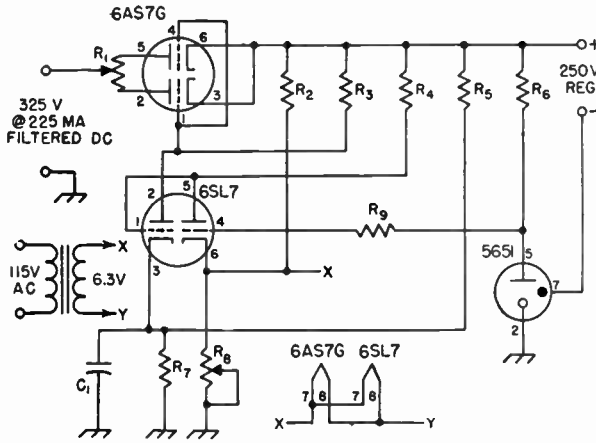

Fig. 7-17 — Electronic voltage-regulator circuit.

- C₁ — 0.1- μ f. 400-volt paper.
- R₁ — 160-ohm 10-watt potentiometer (balance).
- R₂, R₅ — 12,000 ohms, 2 watts.
- R₃, R₄ — 0.47 megohm, $\frac{1}{2}$ watt.
- R₆ — 68,000 ohms, 1 watt.
- R₇ — 15,000 ohms, 2 watts.
- R₈ — 10,000-ohm potentiometer (output control).
- R₉ — 1 megohm, $\frac{1}{2}$ watt.

can be obtained with these regulator circuits.

A single VR tube may also be used to regulate the voltage to a load current of almost any value so long as the *variation* in the current does not exceed 30 to 35 ma. If, for example, the average load current is 100 ma., a VR tube may be used to hold the voltage constant provided the current does not fall below 85 ma. or rise above 115 ma. In this case, the resistance should be calculated to drop the voltage to the VR-tube rating at the maximum load current to be expected plus about 5 ma. If the load resistance is constant, the effects of variations in line voltage may be eliminated by basing the resistance on the load current plus 15 ma. Voltage-regulator tubes may also be connected in parallel as described later in this chapter.

Electronic Voltage Regulation

Several circuits have been developed for regulating the voltage output of a power supply electronically. While more complicated than the VR-tube circuits, they will handle higher voltages and currents and the output voltage may be varied continuously over a wide range. In the circuit of Fig. 7-17, the 5651 regulator tube supplies the grid (4) of the 6SL7 with a constant reference voltage. When the load connected across the output terminals increases, the output voltage tends to decrease. This decreases the plate (5) voltage. Since grid (1) is connected directly to plate (5), grid (1) becomes less positive and that triode draws less plate current. The voltage drop across R₃ being less, the bias on the grids of the 6AS7G is reduced, decreasing the voltage drop across the

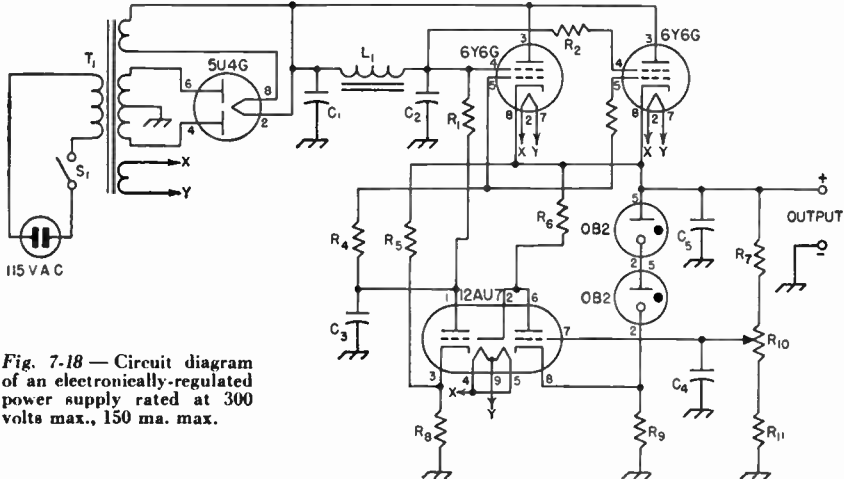

Fig. 7-18 — Circuit diagram of an electronically-regulated power supply rated at 300 volts max., 150 ma. max.

- C₁, C₂, C₅ — 16- μ f. 600-volt electrolytic.
- C₃ — 0.015- μ f. paper.
- C₄ — 0.1- μ f. paper.
- R₁ — 0.3 megohm, $\frac{1}{2}$ watt.
- R₂, R₃ — 100 ohms, $\frac{1}{2}$ watt.
- R₄ — 510 ohms, $\frac{1}{2}$ watt.
- R₅, R₈ — 30,000 ohms, 2 watts.
- R₆ — 0.24 megohm, $\frac{1}{2}$ watt.
- R₇ — 0.15 megohm, $\frac{1}{2}$ watt.

- R₉ — 9100 ohms, 1 watt.
- R₁₀ — 0.1-megohm potentiometer.
- R₁₁ — 43,000 ohms, $\frac{1}{2}$ watt.
- L₁ — 8-hy., 40-ma. filter choke.
- S₁ — S.p.s.t. toggle.
- T₁ — Power transformer: 375-375 volts r.m.s.; 160 ma.; 6.3 volts, 3 amps.; 5 volts, 3 amps. (Thor. 22R33).

6AS7G and thereby maintaining the original output voltage.

For a maximum regulated voltage output of 250, the filtered d.c. input voltage should be 325 volts at 225 ma. For a constant line voltage the output voltage will remain constant within 0.2 volt over a load-current range of 0 to 225 ma. With a line-voltage variation of plus or minus 10 per cent, the output voltage will vary less than 0.1 volt.

Another similar regulator circuit is shown in Fig. 7-18. The principal difference is that screen-grid regulator tubes are used. The fact that a screen-grid tube is relatively insensitive to changes in plate voltage makes it possible to obtain a reduction in ripple voltage adequate for many purposes simply by supplying filtered d.c. to the screens with a consequent saving in weight and cost. The accompanying table shows the

I	II	III	Output voltage — 300	
450 v.	22 ma.	3 mv.	150 ma.	2.3 mv.
425 v.	45 ma.	4 mv.	125 ma.	2.8 mv.
400 v.	72 ma.	6 mv.	100 ma.	2.6 mv.
375 v.	97 ma.	8 mv.	75 ma.	2.5 mv.
350 v.	122 ma.	9.5 mv.	50 ma.	3.0 mv.
325 v.	150 ma.	3 mv.	25 ma.	3.0 mv.
300 v.	150 ma.	2.3 mv.	10 ma.	2.5 mv.

performance of the circuit of Fig. 7-18. Column I shows various output voltages, while Column II shows the maximum current that can be drawn at that voltage with negligible variation in output voltage. Column III shows the measured ripple at the maximum current. The second part of the table shows the variation in ripple with load current at 300 volts output.

Bias Supplies

As discussed in the chapter on high-frequency transmitters, the chief function of a bias supply for the r.f. stages of a transmitter is that of providing protective bias, although under certain circumstances, a bias supply, or pack, as it is

sometimes called, can provide the operating bias if desired.

Simple Bias Packs

Fig. 7-19A shows the diagram of a simple bias supply. R_1 should be the recommended grid leak for the amplifier tube. No grid leak should be used in the transmitter with this type of supply. The output voltage of the supply, when amplifier grid current is not flowing, should be some value between the bias required for plate-current cut-off and the recommended operating bias for the amplifier tube. The transformer peak voltage (1.4 times the r.m.s. value) should not exceed the recommended operating-bias value, otherwise the output voltage of the pack will soar above the operating-bias value with rated grid current.

This soaring can be reduced to a considerable extent by the use of a voltage divider across the transformer secondary, as shown at B. Such a system can be used when the transformer voltage is higher than the operating-bias value. The tap on R_2 should be adjusted to give amplifier cut-off bias at the output terminals. The lower the total value of R_2 , the less the soaring will be when grid current flows.

A full-wave circuit is shown in Fig. 7-19C. R_3 and R_4 should have the same total resistance and the taps should be adjusted symmetrically. In all cases, the transformer must be designed to furnish the current drawn by these resistors plus the current drawn by R_1 .

Regulated Bias Supplies

The inconvenience of the circuits shown in Fig. 7-19 and the difficulty of predicting values in practical application can be avoided in most cases by the use of gaseous voltage-regulator tubes across the output of the bias supply, as shown in Fig. 7-20A. A VR tube

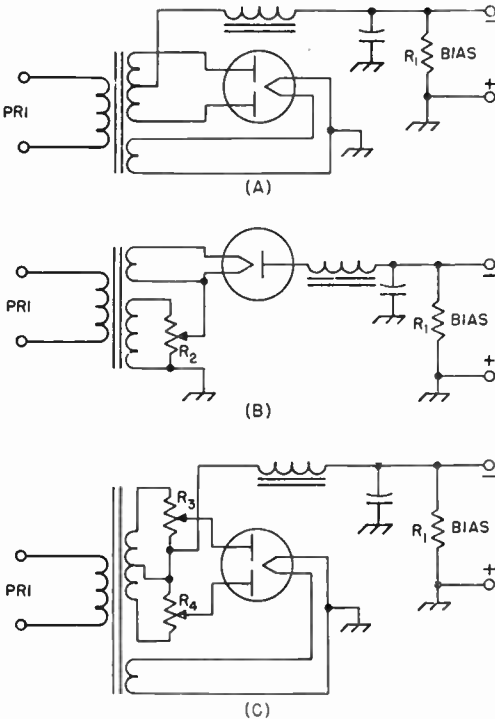

Fig. 7-19 — Simple bias-supply circuits. In A, the peak transformer voltage must not exceed the operating value of bias. The circuits of B (half-wave) and C (full-wave) may be used to reduce transformer voltage to the rectifier. R_1 is the recommended grid-leak resistance.

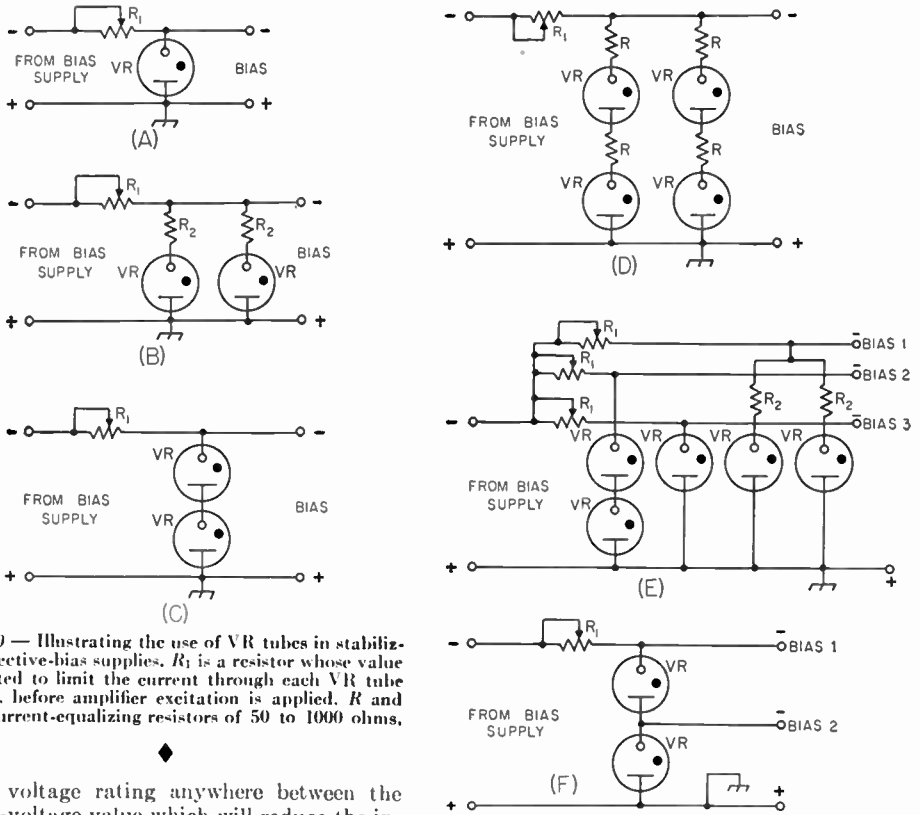

Fig. 7-20 — Illustrating the use of VR tubes in stabilizing protective-bias supplies. R_1 is a resistor whose value is adjusted to limit the current through each VR tube to 5 ma. before amplifier excitation is applied. R and R_2 are current-equalizing resistors of 50 to 1000 ohms.

with a voltage rating anywhere between the biasing-voltage value which will reduce the input to the amplifier to a safe level when excitation is removed, and the operating value of bias, should be chosen. R_1 is adjusted, without amplifier excitation, until the VR tube ignites and draws about 5 ma. Additional voltage to bring the bias up to the operating value when excitation is applied can be obtained from a grid leak resistor, as discussed in the transmitter chapter.

Each VR tube will handle 40 ma. of grid current. If the grid current exceeds this value under any condition, similar VR tubes should be added in parallel, as shown in Fig. 7-20B, for each 40 ma., or less, of additional grid current. The resistors R_2 are for the purpose of helping to maintain equal currents through each VR tube, and should have a value of 50 to 1000 ohms or more.

If the voltage rating of a single VR tube is not sufficiently high for the purpose, other VR tubes may be used in series (or series-parallel if required to satisfy grid-current requirements) as shown in the diagrams of Fig. 7-20C and D.

If a single value of fixed bias will serve for more than one stage, the biasing terminal of each such stage may be connected to a single supply of this type, provided only that the total grid current of all stages so connected does not exceed the current rating of the VR tube or tubes. Alternatively, other separate VR-tube branches may be added in any desired combination to the same supply, as shown

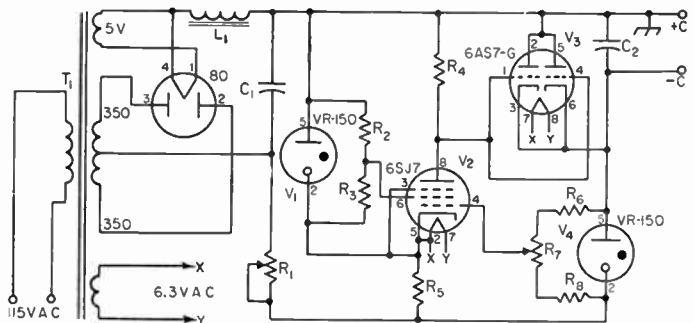

Fig. 7-21 — Circuit diagram of an electronically-regulated bias supply.

- C_1 — 20- μ f. 450-volt electrolytic.
- C_2 — 20- μ f. 150-volt electrolytic.
- R_1 — 5000 ohms, 25 watts.
- R_2 — 22,000 ohms, $\frac{1}{2}$ watt.
- R_3 — 68,000 ohms, $\frac{1}{2}$ watt.
- R_4 — 0.27 megohm, $\frac{1}{2}$ watt.
- R_5 — 3000 ohms, 5 watts.
- R_6 — 0.12 megohm, $\frac{1}{2}$ watt.
- R_7 — 0.1-megohm potentiometer.
- R_8 — 27,000 ohms, $\frac{1}{2}$ watt.
- L_1 — 20-hy. 50-ma. filter choke.
- T_1 — Power transformer: 350 volts r.m.s. each side of center, 50 ma.; 5 volts, 2 amp.; 6.3 volts, 3 amp.

in Fig. 7-20E, to adapt them to the needs of each stage.

Providing the VR-tube current rating is not exceeded, a series arrangement may be tapped for lower voltage, as shown at F.

The circuit diagram of an electronically-regulated bias-supply is shown in Fig. 7-21. The output voltage may be adjusted to any value between 20 volts and 80 volts and the unit will handle grid currents up to 200 ma. over the range of 30 to 80 volts, and 100 ma. over the remainder of the range. This will take care of the bias requirements of most tubes used in Class B amplifier service. The regulation will hold to about 0.001 volt per milliamper of grid current. The regulator operates as follows: Since the voltage drop across V_3 and V_4 is in parallel with the voltage drop across V_1 and R_5 , any change in voltage across V_3 will appear across R_5 because the voltage drops across both VR tubes remain constant. R_5 is a cathode biasing resistor for V_2 , so any voltage change across it appears as a grid-voltage change on V_2 . This change in grid voltage is amplified by V_2 and appears across R_4 which is connected to the plate of V_2 and the grids of V_3 . This change in voltage swings the grids of V_3 more positive or negative, and thus varies the internal resistance of V_3 , maintaining the voltage drop across V_3 practically constant.

Other Sources of Biasing Voltage

In some cases, it may be convenient to obtain the biasing voltage from a source other than a separate supply. A half-wave rectifier may be connected with reversed polarization to obtain biasing voltage from a low-voltage plate supply, as shown in Fig. 7-22A. In an-

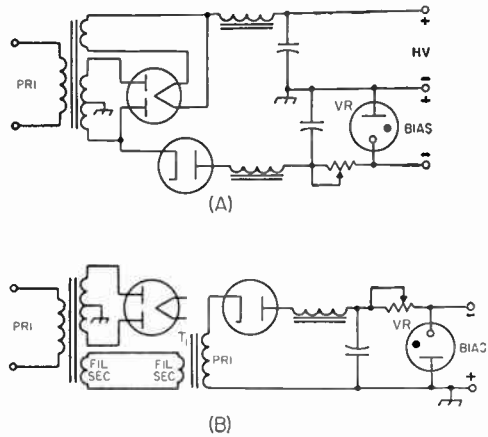

Fig. 7-22 — Convenient means of obtaining biasing voltage. A — From a low-voltage plate supply. B — From spare filament winding. T_1 is a filament transformer, of a voltage output similar to that of the spare filament winding, connected in reverse to give 115 volts r.m.s. output. If cold-cathode or selenium rectifiers are used, no additional filament supply is required.

other arrangement, shown at B, a spare filament winding can be used to operate a filament transformer of similar voltage rating in reverse to obtain a voltage of about 130 from the winding that is customarily the primary. This will be sufficient to operate a VR75 or VR90 regulator tube.

A bias supply of any of the types discussed requires relatively little filtering, if the output-terminal peak voltage does not approach the operating-bias value, because the effect of the supply is entirely or largely "washed out" when grid current flows.

Selenium-Rectifier Circuits

While the circuits shown in Figs. 7-23, 7-24 and 7-25 may be used with any type of rectifier, they find their greatest advantage when used with selenium rectifiers which require no filament transformer. These circuits must be used with caution, observing line polarity in the circuits so marked, to avoid shorting the line, since the negative output terminal should always be grounded. In circuits showing isolating transformers, the transformer is a requirement, since without the transformer, the negative output terminal cannot be grounded in following good practice for safety without shorting out part of the rectifier circuit. In the circuits which do not show a transformer, the transformer is preferable, since it avoids the necessity for correctly polarizing the connection to the power line to prevent a short circuit.

Fig. 7-23 is a straightforward half-wave rectifier circuit which may be used in applications where 115 to 130 volts d.c. is desired. It can be used for bias supply, for instance.

Fig. 7-24 shows several voltage-doubler circuits. Of the three, the one shown at A is the most desirable since there is no series capacitor. It is a full-wave circuit and there will be very little ripple voltage appearing at the output. The arrangement of circuit B is such that one side of the output may be grounded. In circuit C, the point X is common to both capacitors in the rectifier and filter, and a single-unit 3-section capacitor can be used to save space. If the load current is less than 100 ma., this is the best circuit.

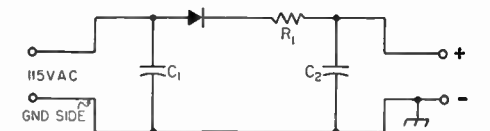

Fig. 7-23 — Simple half-wave circuit for selenium rectifier.
 C_1 — 0.05- μ f. 600-volt paper.
 C_2 — 40- μ f. 200-volt electrolytic.
 R_1 — 25 to 100 ohms.

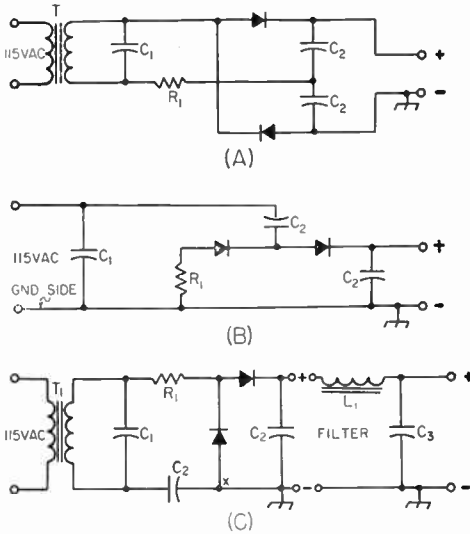

Fig. 7-24 — Voltage-doubling circuits for use with selenium rectifiers.
 C₁ — 0.05- μ f. 600-volt paper.
 C₂ — 40- μ f. 200-volt electrolytic.
 C₃ — Filter capacitor.
 R₁ — 25 to 100 ohms.
 L₁ — Filter choke.
 T₁ — Isolation transformer.

Fig. 7-25A shows a voltage tripler, and B and C quadruplers.

All components are standard. C₁ in all circuits is for "hash" filtering and its value is not critical. A 0.05- μ f. 600-volt-working capacitor should serve. All other capacitors should be 40- μ f. 200-volt units, except those in the tripler and quadrupler circuits. Those in the circuit of Fig. 7-25 should have a rating of 450 volts working. In the voltage multipliers and in other circuits where a capacitor is passing the full current, good capacitors should be used because the a.c. ripple mentioned above appears across the capacitor and increases as the load increases. If the current is allowed to

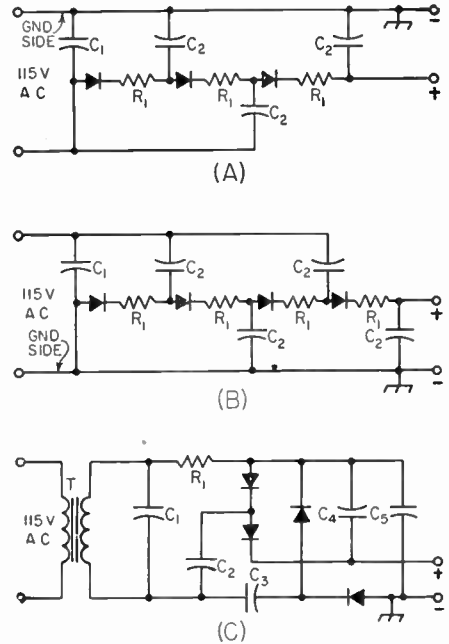

Fig. 7-25 — A — Tripler circuit. B — Half-wave quadrupler. C — Full-wave quadrupler.
 C₁ — 0.05- μ f. 600-volt paper.
 C₂ — 40- μ f. 150-volt electrolytic.
 C₃ — 100- μ f. 150-volt electrolytic.
 R₁ — 25 to 100 ohms. T₁ — Isolating transformer.

become too high, it will cause heating and deterioration of the capacitor. This can be kept to a minimum by using a capacitor of high value and making sure it is of good make. R₁ should be 25 ohms, but if it is found that the rectifier units are running a little too warm, this value may be increased to as high as 100 ohms, with a corresponding drop in output voltage, of course. A single-section filter, as shown in Fig. 7-24C, will provide sufficient smoothing for most applications.

Power-Line Considerations

● POWER-LINE CONNECTIONS

If the transmitter is rated at much more than 100 watts, special consideration should be given to the a.c. line running into the station. In some residential systems, three wires are brought in from the outside to the distribution board, while in other systems there are only two wires. In the three-wire system, the third wire is the **neutral** which is grounded. The voltage between the other two wires normally is 230, while half of this voltage (115) appears between each of these wires and neutral, as indicated in Fig. 7-23A. In systems of this type, usually it will be found that the 115-

volt household load is divided as evenly as possible between the two sides of the circuit, half of the load being connected between one wire and the neutral, while the other half of the load is connected between the other wire and neutral. Heavy appliances, such as electric stoves and heaters, normally are designed for 230-volt operation and therefore are connected across the two ungrounded wires. While both ungrounded wires should be fused, a fuse should never be used in the wire to the neutral, nor should a switch be used in this side of the line. The reason for this is that opening the neutral wire does not disconnect the equipment. It simply leaves the equipment on one

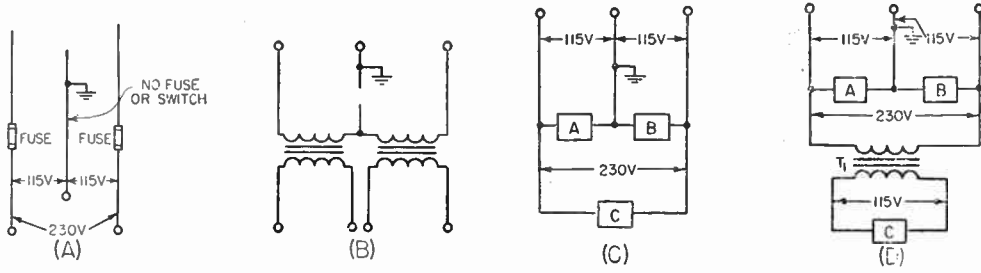

Fig. 7-26 — Three-wire power-line circuits. A — Normal 3-wire-line termination. No fuse should be used in the grounded (neutral) line. B — Showing that a switch in the neutral does not remove voltage from either side of the line. C — Connections for both 115- and 230-volt transformers. D — Operating a 115-volt plate transformer from the 230-volt line to avoid light blinking. T_1 is a 2-to-1 step-down transformer.

side of the 230-volt circuit in series with whatever load may be across the other side of the circuit, as shown in Fig. 7-26B. Furthermore, with the neutral open, the voltage will then be divided between the two sides in inverse proportion to the load resistance, the voltage on one side dropping below normal, while it soars on the other side, unless the loads happen to be equal.

The usual line running to baseboard outlets is rated at 15 amperes. Considering the power consumed by filaments, lamps, modulator, receiver and other auxiliary equipment, it is not unusual to find this 15-ampere rating exceeded by the requirements of a station of only moderate power. It must also be kept in mind that the same branch may be in use for other household purposes through another outlet. For this reason, and to minimize light blinking when keying or modulating the transmitter, a separate heavier line should be run from the distribution board to the station whenever possible. (A three-volt drop in line voltage will cause noticeable light blinking.)

If the system is of the three-wire type, the three wires should be brought into the station so that the load can be distributed to keep the line balanced. The voltage across a fixed load on one side of the circuit will increase as the load current on the other side is increased. The rate of increase will depend upon the resistance introduced by the neutral wire. If the resistance of the neutral is low, the increase will be correspondingly small. When the currents in the two circuits are balanced, no current flows in the neutral wire and the system is operating at maximum efficiency.

Light blinking can be minimized by using transformers with 230-volt primaries in the power supplies for the keyed or intermittent part of the load, connecting them across the two ungrounded wires with no connection to the neutral, as shown in Fig. 7-26C. The same can be accomplished by the insertion of a step-down transformer whose primary operates at 230 volts and whose secondary delivers 115 volts. Conventional 115-volt transformers may be operated from the secondary of the step-down transformer (see Fig. 7-26D).

When a special heavy-duty line is to be installed, the local power company should be

consulted as to local requirements. In some localities it is necessary to have such a job done by a licensed electrician, and there may be special requirements to be met in regard to fittings and the manner of installation. Some amateurs terminate the special line to the station at a switch box, while others may use electric-stove receptacles as the termination. The power is then distributed around the station by means of conventional outlets at convenient points. All circuits should be properly fused.

● LINE-VOLTAGE ADJUSTMENT

In certain communities trouble is sometimes experienced from fluctuations in line voltage. Usually these fluctuations are caused by a variation in the load on the line and, since most of the variation comes at certain fixed times of the day or night, such as the times when lights are turned on at evening, they may be taken care of by the use of a manually-operated compensating device. A simple arrangement is shown in Fig. 7-27A. A toy transformer is used to boost or buck the line voltage

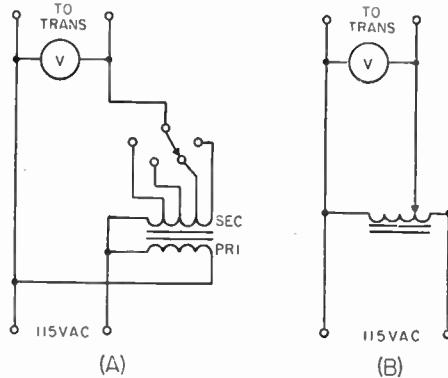

Fig. 7-27 — Two methods of transformer primary control. At A is a tapped toy transformer which may be connected so as to boost or buck the line voltage as required. At B is indicated a variable transformer or autotransformer (Variac) which feeds the transformer primaries.

as required. The transformer should have a tapped secondary varying between 6 and 20 volts in steps of 2 or 3 volts and its secondary should be capable of carrying the full load cur-

rent of the entire transmitter, or that portion of it fed by the toy transformer.

The secondary is connected in series with the line voltage and, if the phasing of the windings is correct, the voltage applied to the primaries of the transmitter transformers can be brought up to the rated 115 volts by setting the toy-transformer tap switch on the right tap. If the phasing of the two windings of the toy transformer happens to be reversed, the voltage will be reduced instead of increased. This connection may be used in cases where the line voltage may be above 115 volts. This method is preferable to using a resistor in the primary of a power transformer since it does not affect the voltage regulation as seriously. The circuit of 7-27B illustrates the use of a variable autotransformer (Variac) for adjusting line voltage to the desired value.

Another scheme by which the primary voltage of each transformer in the transmitter may be adjusted to give a desired secondary voltage, with a master control for compensating for changes in line voltage, is shown in Fig. 7-28.

This arrangement has the following features.

- 1) Adjustment of the switch S_1 to make the voltmeter read 105 volts automatically adjusts all transformer primaries to the predetermined correct voltage.
- 2) The necessity for having all primaries work at the same voltage is eliminated. Thus, 110 volts can be applied to the primary of one transformer, 115 to another, etc., as required to obtain the desired output voltage.
- 3) Independent control of the plate transformer is afforded by the tap switch S_2 . This permits power-input control and does not require an extra autotransformer.

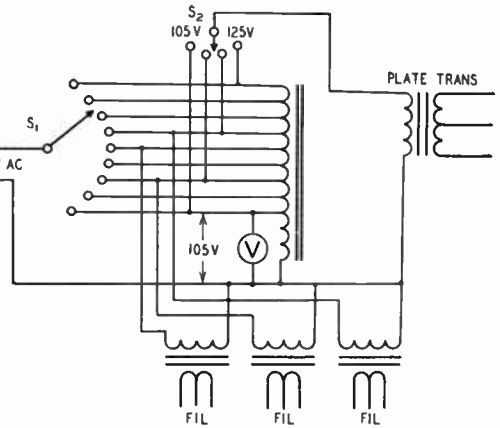

Fig. 7-28—With this circuit, a single adjustment of the tap switch S_1 places the correct primary voltage on all transformers in the transmitter. Information on constructing a suitable autotransformer at negligible cost is contained in the text. The light winding represents the regular primary winding of a revamped transformer, the heavy winding the voltage-adjusting section.

Constant-Voltage Transformers

Although comparatively expensive, special transformers called **constant-voltage transformers** are available for use in cases where it is necessary to hold line voltage and/or filament voltage constant with fluctuating supply-line voltage. They are rated over a range of 17 va. at 6.3 volts output, for small tube-heater demands, up to several thousand volt-amperes at 115 or 230 volts. In average figures, such transformers will hold their output voltages within one per cent under an input-voltage variation of 30 per cent.

Construction of Power Supplies

The length of most leads in a power supply is unimportant, so that the arrangement of components from this consideration is not a factor in construction. More important are the points of good high-voltage insulation, adequate conductor size for filament wiring, proper ventilation for rectifier tubes and — most important of all — safety to the operator. Exposed high-voltage terminals or wiring which might be bumped into accidentally should not be permitted to exist. They should be covered with adequate insulation or placed inaccessible to contact during normal operation and adjustment of the transmitter. Power-supply units should be fused individually. All negative terminals of plate supplies and positive terminals of bias supplies should be securely grounded to the chassis, and the chassis connected to a waterpipe or radiator ground. All transformer, choke, and capacitor cases should also be grounded to the chassis. A.c. power cords and chassis connectors should be arranged so that exposed contacts are never “live.” Starting at the

conventional a.c. wall outlet which is female, one end of the cord should be fitted with a male plug. The other end of the cord should have a female receptacle. The input connector of the power supply should have a male receptacle to fit the female receptacle of the cord. The power-output connector on the power supply should be a female socket. A male plug to fit this socket should be connected to the cable going to the equipment. The opposite end of the cable should be fitted with a female connector, and the series should terminate with a male connector on the equipment. If connections are made in this manner, there should be no “live” exposed contacts at any point, regardless of where a disconnection may be made.

Rectifier filament leads should be kept short to assure proper voltage at the rectifier socket, and the sockets should have good insulation and adequate contact surface. Plate leads to mercury-vapor tubes should be kept short to minimize the radiation of noise.

Where high-voltage wiring must pass

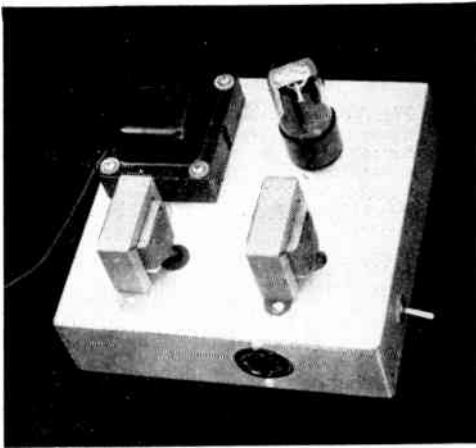

Fig. 7-29— A typical simple receiver power supply. Filament and plate voltages are taken from the multi-contact tube socket which serves as an outlet.

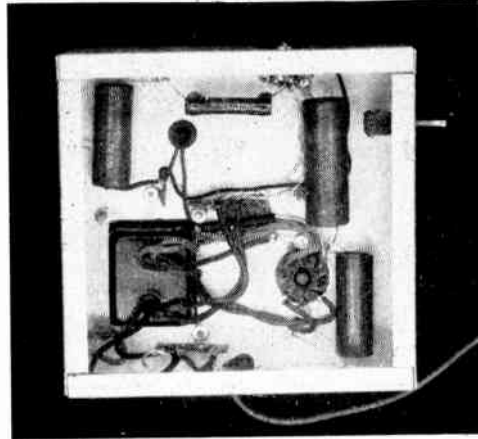

Fig. 7-30— Bottom view of the simple receiver power supply showing the cut-out for the flush-mounting transformer.

through a metal chassis, grommet-lined clearance holes will serve for voltages up to 500 or 750, but ceramic feed-through insulators should be used for higher voltages. Bleeder and voltage-dropping resistors should be placed where they are open to air circulation. Placing them in confined space reduces the rating.

It is highly preferable from the standpoint of operating convenience to have separate filament transformers for the rectifier tubes, rather than to use combination filament and plate transformers, such as those used in receivers. This permits the transmitter plate voltage to be switched on without the necessity for waiting for rectifier filaments to come up to temperature after each time the high voltage has been turned off. When using a combination power transformer, high voltage may be turned off without turning the filaments off by using a switch between the transformer center tap and chassis. This switch should be of the rotary type with good insulation between contacts. The shaft of the switch *must* be grounded.

● SAFETY PRECAUTIONS

All power supplies in an installation should be fed through a single main power-line switch so that all power may be cut off quickly, either before working on the equipment, or in case of an accident. Spring-operated switches or relays are not sufficiently reliable for this important service. Foolproof devices for cutting off all power to the transmitter and other equipment are shown in Fig. 7-33. The arrangements shown in Fig. 7-33A and B are similar circuits for two-wire (115-volt) and three-wire (230-volt) systems. *S* is an enclosed double-throw knife switch of the sort usually used as the entrance switch in house installations. *J* is a standard a.c. outlet and *P* a shorted plug to fit the outlet. The switch should be located prominently in plain sight and members of the household should be instructed in its location and use. *I* is a red lamp located alongside the switch. Its purpose is not so much to serve as a warning that the power is on as it is to help in identifying and quickly locating the switch

◆
Fig. 7-31 — A typical high-voltage transmitter power supply. The transformers, chokes and capacitors are inverted so that no terminals are exposed to accidental contact. The caps of the 866 rectifiers are the insulated type. A safety terminal (Millen) is used for the positive high-voltage connection.
◆

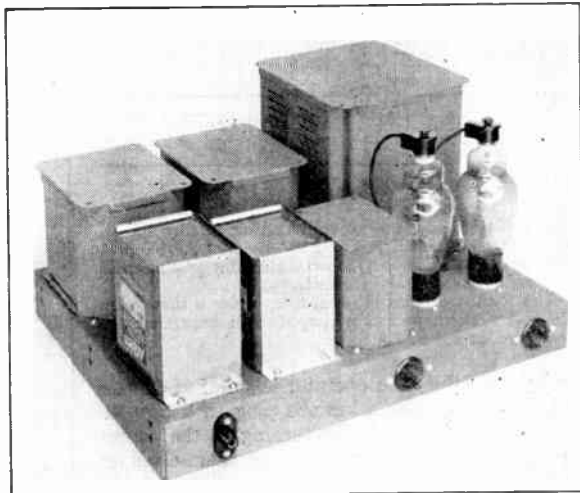

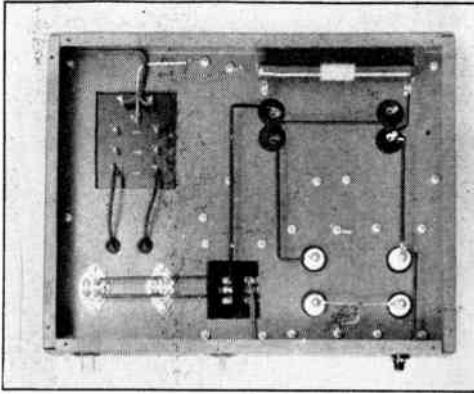

Fig. 7-32 — Bottom view of the transmitter power supply showing the cut-outs for the terminals. Separate power plugs are used for the rectifier-filament and plate transformers so that they may be switched independently from the control position.

should it become necessary for someone else to cut the power off in an emergency.

The outlet *J* should be placed in some corner out of sight where it will not be a temptation for children or others to play with. The shorting plug can be removed to open the power circuit if there are others around who might inadvertently throw

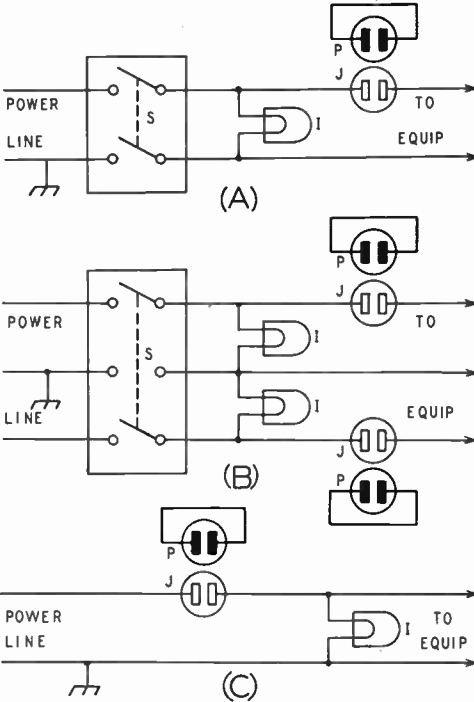

Fig. 7-33 — Reliable arrangements for cutting off all power to the transmitter. *S* is an enclosed double-pole knife-type switch, *J* a standard a.c. outlet, *P* a shorted plug to fit the outlet and *I* a red lamp.

A is for a two-wire 115-volt line, *B* for a three-wire 230-volt system, and *C* a simplified arrangement for low-power stations.

the switch while the operator is working on the rig. If the operator takes the plug with him, it will prevent someone from turning on the power in his absence and either injuring themselves or

the equipment or perhaps starting a fire. Of utmost importance is the fact that the outlet *J* must be placed in the *ungrounded* side of the line.

Those who are operating low power and feel that the expense or complication of the switch isn't warranted can use the shorted-plug idea as the main power switch. In this case, the outlet should be located prominently and identified by a signal light, as shown in Fig. 7-33C.

The test bench ought to be fed through the main power switch, or a similar arrangement at the bench, if the bench is located remote from the transmitter.

A bleeder resistor with a power rating giving a considerable margin of safety should be used across the output of all transmitter power supplies so that the filter capacitors will be discharged when the high-voltage transformer is turned off.

Selenium-Rectifier Table

All types listed below are rated as follows: Max. input r.m.s. volts — 130, Max. peak inverse volts — 380. Series resistors of 47 ohms are recommended for units rated at less than 65 ma., 22 ohms for 75- and 100-ma. units, 15 ohms for 150-ma. units, and 5 ohms for all higher-current units.

D.C. Ma. Output	Manufacturer					
	A	B	C	D	E	F
20	1159	8S20
30	8Y1
35	8S35
50	RS65Q	50
65	1002A	RS65	6S65	8J1	65	NA-5
75	1003A	RS75	6S75	5M4	75	NB-5
100	1004A	RS100	6S100	5M1	100	NC-5
150	1005A	RS150	6S150	5P1	150	ND-5
200	1006A	RS200	6S200	5R1	200	NE-5
250	1028A	RS250	6S250	5Q1	250	NF-5
300	1090A	RS300	6S300	6Q4	300
350	1023	RS350	6S350	5QS1	NK-5
400	1130	RS400	6S400	5S2	400	NH-5
450	RS450	6S450	NJ-5
500	1179	RS500	6S500	5S1	500
600	600
1000	RS1000

A — Federal. B — International. C — Mallory. D — Radio Receptor. E — Sarkes-Tarzian. F — Sylvania.

Keying and Break-In

SECTION 12.133 OF THE FCC REGULATIONS SAYS "... The frequency of the emitted ... wave shall be as constant as the state of the art permits." It also says "... spurious radiation shall not be of sufficient intensity to cause interference in receiving equipment of good engineering design including adequate selectivity characteristics, which is tuned to a frequency or frequencies outside the frequency band of emission normally required for the type of emission being employed by the amateur station."

If the FCC ever decided to enforce these regulations to the strict letter of the law, citations would be received by a large percentage of the current crop of stations. The state of the art is such that an emitted wave can be mighty stable, yet many code (and phone) stations show f.m. and chirp that leaves them open to a citation by the Commission. Key clicks (and splatter) represent violations of the spurious radiation clause, and it isn't hard to find evidences of them in any of the ham bands.

There are four factors that have to be considered in the keying of a transmitter. They are r.f. clicks, envelope shape, chirp and backwave.

R.F. Clicks

Whenever any circuit carrying d.c. or a.e. is closed or broken, the small or large spark (depending upon the voltage and current) generates a small amount of r.f. during the instant of make or break. This r.f. covers a frequency range of many megacycles. A typical example of this type of miniature transmitter is when a lamp or other appliance is switched off in the house; at that instant a click may be heard in the broadcast or short-wave radio. When a transmitter is keyed, of necessity some current must be handled by the key (and relay, if one is used), and the minute spark at the contacts usually causes a click in the receiver. *This click has no effect on the transmitter, although many amateurs think it has.* Since it occurs at the same time that a click (if any) appears on the transmitter output, it is obviously impossible for one to judge the clicks on his own transmitted signal by observation within the shack unless he has first removed the effects of these r.f. clicks. Fortunately, this is usually a simple matter, involving only a small r.f. filter at the contacts of the key (and relay, if used). Typical circuits and values are shown in Fig. 8-1. The effectiveness of the filter can be easily checked by interrupting the normal amount of current with the key and listening to observe if any click can be heard. In other words, if your key normally handles, for example, 50 ma. of current, the effectiveness of the filter can be checked by keying that amount of current, without the transmitter running. The current can be

obtained from your power supply through a suitable resistor (computed by Ohm's Law). If you don't care to go to this trouble, and often it isn't necessary, listen on a lower frequency band than your transmitter and see if applying an r.f. filter at the key reduces the clicks. Do this with the gain control of the receiver backed off and only a short length of wire connected to the receiver antenna terminal. This check will work if your transmitter keying is already fairly "soft," but it is not a sure-fire test like interrupting the normal amount of current with no radio transmitter running.

Envelope Shape

The key clicks that go out on the air with your signal, and which make up one of the forms of spurious radiations mentioned in the opening paragraph (the other two are harmonics and

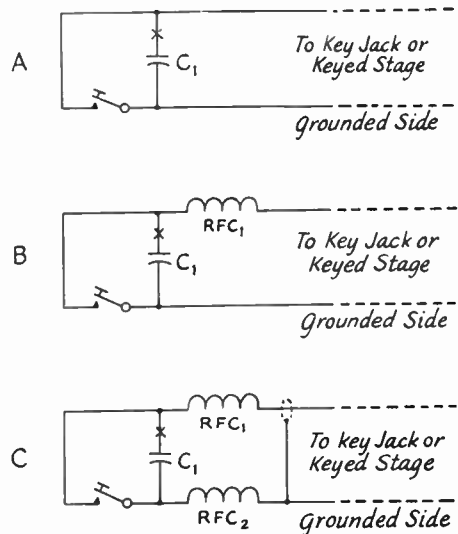

Fig. 8-1 — Typical filter circuits to apply at the key (and relay, if used) to minimize r.f. clicks. The simplest circuit (A) is a small capacitor mounted at the key. If this proves insufficient, an r.f. choke can be added to the ungrounded lead (B) or in both leads (C). The value of C_1 is .001 to .01 $\mu\text{f.}$, RFC_1 and RFC_2 can be 0.5 to 2.5 mh., with a current-carrying ability sufficient for the current in the keyed circuit. In difficult cases another small capacitor may be required on the other side of the r.f. choke or chokes. In all cases the r.f. filter should be mounted right at the key or relay terminals; sometimes the filter can be concealed under the key. When cathode or center-tap keying is used, the resistance of the r.f. choke or chokes will add cathode bias to the keyed stage, and in this case a high-current low-resistance choke may be required, or compensating reduction of the grid-leak bias (if it is used) may be needed.

A visible spark on "make" can often be reduced by the addition of a small (10 to 100 ohms) resistor in series with C_1 (inserted at point "x"). Too high a value of resistor reduces the arc-suppressing effect on "break."

parasitic oscillations), are controlled by the shape of the envelope of the signal. The envelope is simply the outline of the oscilloscope pattern of your transmitter output, but you don't need an oscilloscope to observe the effects. Fig. 8-2 shows representative scope patterns that might be obtained with a given transmitter under various

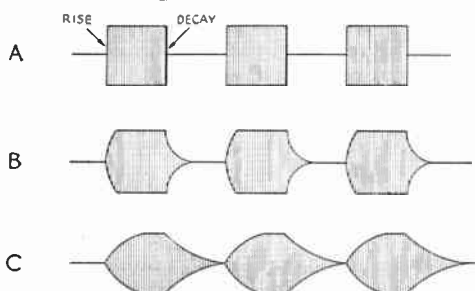

Fig. 8-2—Typical oscilloscope displays of a code transmitter. The rectangular-shaped dots (A) have serious key clicks extending many kc. either side of the transmitter frequency. Using proper shaping circuits increases the rise and decay times to give signals with the envelope form of B. This signal would have practically no key clicks. Carrying the shaping process too far, as in C, results in a signal that is too "soft" and is not easy to copy.

conditions. The pattern at Fig. 8-2A is the transmitter output with no envelope-shaping provisions. A signal like this has horrible clicks on the air, which are the inescapable result of turning the transmitter on and off too rapidly. The clicks can be reduced by providing circuits that cause the transmitter output to rise to full output and drop off to zero output relatively slowly each time the key is closed and opened. The pattern of such a transmitter might look like Fig. 8-2B, and it would be found that such a signal shows little if any clicks outside of the narrow receiver range over which the code signal can be heard. If the shaping process is carried too far, and a signal like Fig. 8-2C is obtained, it may be found that the keying is too "soft" and, while it shows no clicks anywhere, it is not too easy or pleasant to copy under weak-signal conditions.

At the moment it is sufficient to appreciate that the *on-the-air* clicks are determined by the shaping, while the r.f. clicks caused by the spark at the key can only be heard in the station receiver and possibly a broadcast receiver in the same house or apartment.

Chirp

The frequency-stability reference in the opening paragraph refers to the "chirp" observed on many signals. This is caused by a change in frequency of the signal during a single dot or dash. Chirp is an easy thing to detect if you know how to listen for it, although it is amazing how some operators will listen to a signal and say it has no chirp when it actually has. The easiest way to detect chirp is to tune in the code signal at a low beat note and listen for any change in frequency during a dash. The lower the beat note, the easier it is to detect the frequency

change. Listening to harmonics of the signal will multiply the frequency change and make any quite obvious.

The "state of the art" is such that code transmitters can be built with no chirp, and it is fortunate that the FCC hasn't seen fit to enforce the regulation. Actually, a small amount of chirp, while noticeable, does not prevent copy even under the sharpest selectivity conditions, although it is sometimes said that high-selectivity receivers can't hold chirpy signals. This just isn't true, unless the chirp is so bad that the signal shouldn't be on the air anyway. The main reason for minimizing chirp, aside from complying with the letter of the regulations, is one of pride, since a properly-shaped chirp-free signal is a pleasure to copy and is likely to attract attention by its rarity. Chirps cannot be observed on an oscilloscope pattern of the envelope.

Backwave

The last factor is "backwave," a signal during key-up conditions from some amplifier-keyed transmitters. It isn't a very important factor these days, since most amateurs are aware of it, although some operators listening in the shack to their own signals and hearing a backwave think that the backwave is heard on the air. It isn't

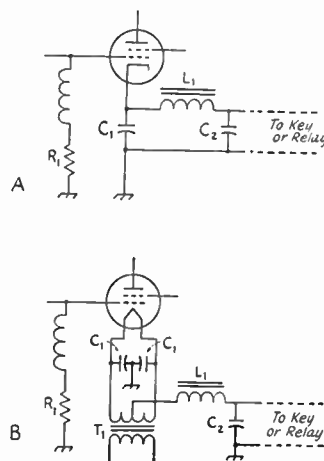

Fig. 8-3—The basic cathode (A) and center-tap (B) keying circuits. In either case C_1 is the r.f. return to ground, shunted by a larger capacitor for shaping. Voltage ratings at least equal to the cut-off voltage of the tube are required. T_1 is the normal filament transformer. C_2 can be about $0.01 \mu\text{f}$.

The shaping of the signal is controlled by the values of L_1 and C_1 . Increased capacitance at C_1 will make the signal softer on break; increased inductance at L_1 will make the signal softer on make. In many cases the make will be satisfactory without any inductance.

Values at C_1 will range from 0.5 to $4 \mu\text{f}$, depending upon the tube type and operating conditions. The value of L_1 will also vary with tube type and conditions, and may range from a fraction of a henry to several henrys. When tetrodes or pentodes are keyed in this manner, a smaller value can sometimes be used at C_1 if the screen-voltage supply is fixed and not obtained from the plate supply through a dropping resistor.

Oscillators keyed in the cathode circuit cannot be softened on break indefinitely by increasing the value of C_1 because the grid-circuit time constant enters into the action.

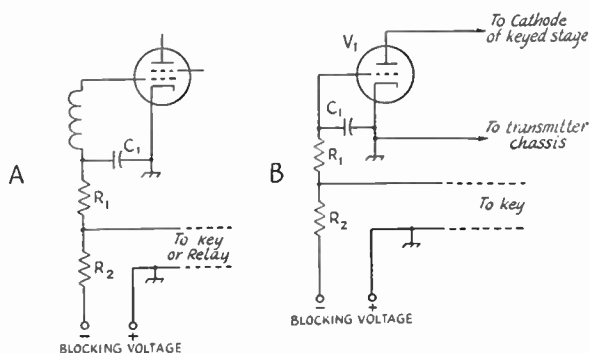

Fig. 8-4 — The basic circuit for blocked-grid keying is shown at A. R_1 is the normal grid leak, and the blocking voltage must be at least several times the normal grid bias. The click on make can be reduced by making C_1 larger, and the click on break can be reduced by making R_2 larger. Usually the value of R_2 will be 5 to 20 times the resistance of R_1 . The power supply current requirement depends upon the value of R_2 , since closing the key circuit places R_2 across the blocking voltage supply.

An allied circuit is the vacuum-tube keyer of B. The tube V_1 is connected in the cathode circuit of the stage to be keyed. The values of C_1 , R_1 and R_2 determine the keying envelope in the same way that they do for blocked-grid keying. Values to start with might be 0.47 megohm for R_1 , 4.7 megohm for R_2 and 0.0047 $\mu\text{f.}$ for C_1 .

The blocking voltage supply must deliver several hundred volts, but the current drain is very low. The 6B1-C or other low plate-resistance triode is suitable for V_1 . To increase the current-carrying ability of a tube keyer, several tubes can be connected in parallel.

A vacuum-tube keyer adds cathode bias and drops the supply voltages to the keyed stage and will reduce the output of the stage,

necessarily so, and the best way to check is with an amateur a mile or more away. If he can't hear a backwave on your S9+ signal, you can be sure that it isn't there when your signal is weaker. Backwave is undesirable on your signal because it makes your signal a little harder to copy, even with acceptable shaping and no chirp.

Amplifier Keying

You can look at keying an amplifier either as turning it on and off with the key (and shaping properly) or as "modulating" the carrier with the proper envelope. (The proper envelope might be something resembling Fig. 8-2B.) Using the latter approach, you recognize immediately that the applied modulation must have no effect on the oscillator frequency if chirp is to be avoided. In a phone transmitter this means having adequate isolating stages between modulated stage and oscillator, and it means *exactly* the same thing in a code transmitter. Many two-, three- and even four-stage transmitters are utterly incapable of completely chirp-free amplifier keying because the severe "modulation" of the output stage has an effect on the oscillator frequency and "pulls" through the several stages. This is particularly true when the oscillator stage is on the same frequency as the keyed output stage, but it can also happen when frequency multiplying is involved. Another source of reaction is the variation in oscillator supply voltage under keying conditions, although this can usually be handled by stabilizing the oscillator supply with a VR tube. If your objective is a completely chirp-free transmitter, the very first step is to make sure

stages) has no effect on the oscillator frequency. This can be checked by listening on the oscillator frequency while the amplifier stage is keyed. Be sure to listen for chirp on either size of zero beat to eliminate the possible effect of a chirpy receiver caused by line-voltage changes or pulling. If no chirp of the steadily-running oscillator can be detected, you know that the transmitter can be keyed without chirp in the stage or stages you used for the test. You have no assurance that the transmitter can be keyed in an earlier stage without chirp until you make the same test with the earlier stage. Be proud if your transmitter can be amplifier-keyed without chirp, but don't be surprised to find that it can't. Many transmitters, including some commercial designs, won't pass the test. They just don't have sufficient isolation and buffer action.

An amplifier can be keyed by any method that reduces the output to zero. Neutralized stages can be keyed in the cathode circuit, although where powers over 50 or 75 watts are involved it is often desirable to use a keying relay or vacuum tube keyer, to minimize the chances for electrical shock. Tube keying drops the supply voltages and adds cathode bias, points to be considered where maximum output is required. Blocked-

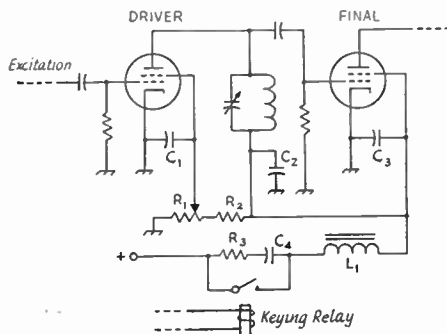

Fig. 8-5 — When the driver stage plate voltage is roughly the same as the screen voltage of a tetrode final amplifier, combined screen and driver keying is an excellent system. The envelope shaping is determined by the values of L_1 , C_4 , and R_3 , although the r.f. bypass capacitors C_1 , C_2 and C_3 also have a slight effect. R_1 serves as an excitation control for the final amplifier, by controlling the screen voltage of the driver stage. If a triode driver is used, its plate voltage can be varied for excitation control.

The inductor L_1 will not be too critical, and the secondary of a spare filament transformer can be used if a low-inductance choke is not available. The values of C_4 and R_3 will depend upon the inductance and the voltage and current levels, but good starting values are 0.1 $\mu\text{f.}$ and 50 ohms.

To minimize the possibility of electrical shock, it is recommended that a keying relay be used in this circuit, since both sides of the circuit are "hot." As in any transmitter, the signal will be chirp-free only if keying the driver stage has no effect on the oscillator frequency.

grid keying is applicable to many neutralized stages, but it presents problems in high-powered amplifiers and requires a source of negative voltage. Output stages that aren't neutralized, such as many of the tetrodes and pentodes in widespread use, will usually leak a little and show some backwave regardless of how they are keyed. In a case like this it may be necessary to key two stages to eliminate backwave. They can be keyed in the cathodes, with blocked-grid keying, or in the screens. When screen keying is used, it is not always sufficient to reduce the screen voltage to zero; it may have to be pulled to some negative value to bring the key-up plate current to zero, unless fixed negative control-grid bias is used. It should be apparent that where two stages are keyed, keying the earlier stage must have no effect on the oscillator frequency if completely chirp-free output is the goal.

Shaping of the keying is obtained in several ways. Blocked-grid and vacuum-tube keyers get suitable shaping with proper choice of resistor and capacitor values, while cathode and screen-grid keying can be shaped by using inductors and capacitors. Sample circuits are shown in Figs. 8-3, 8-4 and 8-5, together with instructions for their adjustment. There is no "best" adjustment, since this is a matter of personal preference and what you want your signal to sound like. Most operators seem to like the make to be heavier than the break. All of the circuits shown here are capable of a wide range of adjustment.

Oscillator Keying

The reader may wonder why oscillator keying hasn't been mentioned earlier, since it is widely used. The sad fact of life is that excellent oscillator keying is infinitely more difficult to obtain than is excellent amplifier keying. If the objective is no detectable chirp, it is probably impossible to obtain with oscillator keying, particularly on the higher frequencies. The reasons are simple. Any keyed-oscillator transmitter requires shaping at the oscillator, which involves changing the operating conditions of the oscillator over a significant period of time. The output of the oscillator doesn't rise to full value immediately, so the drive on the following stage is changing, which in turn may reflect a variable load on the oscillator. No oscillator has been devised that has no change in frequency over its entire operating voltage range and with a changing load. Furthermore, the shaping of the keyed-oscillator envelope usually has to be exaggerated, because the following stages will tend to sharpen up the keying and introduce clicks unless they are operated as linear amplifiers (as described in detail later).

Acceptable oscillator keying can be obtained on the lower-frequency bands, and the methods used to key amplifiers can be used, but chirp-free clickless oscillator keying is probably not possible at the higher frequencies. Occasionally some additional shaping of the signal will be introduced on make through the use of a clamp tube (and associated time constants) in the output stage, but it is no help on break.

Break-In Keying

The usual argument for oscillator keying is that it permits break-in operation, which is true. If break-in operation is not contemplated and as near perfect keying as possible is the objective, then keying an amplifier or two by the methods outlined earlier is the solution. For operating convenience, an automatic transmitter "turner-onner" (see Campbell, *QST*, Aug., 1956), which will turn on the power supplies and switch antenna relays and receiver muting devices, can be used. The station switches over to the complete "transmit" condition where the first dot is sent, and it holds in for a length of time dependent upon the setting of the delay. It is equivalent to voice-operated phone of the type commonly used by s.s.b. stations. It does not permit hearing the other station whenever the key is up, as does full break-in.

Full break-in with excellent keying is not easy to come by, but it is easier than many amateurs think. Many use oscillator keying and put up with a second-best signal.

Three solutions to chirp-free break-in keying have been developed. One is the "silent v.f.o.," which consists of a well-shielded oscillator and buffer stage running continuously at a low frequency. The output is keyed before it gets out of the shielded compartment, and in some applications several subsequent stages are also keyed. The system is still subject to sharpening by fol-

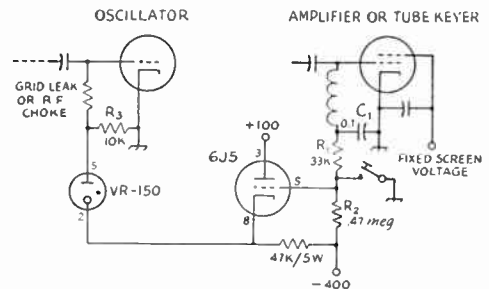

Fig. 8-6 — When satisfactory blocked-grid or tube keying of an amplifier stage has been obtained, this VR-tube break-in circuit can be applied to the transmitter to furnish differential keying. The constants shown here are suitable for blocked-grid keying of a 6146 amplifier; with a tube keyer the 6J5 and VR tube circuitry would be the same.

With the key up, sufficient current flows through R_3 to give a voltage that will cut off the oscillator tube. When the key is closed, the cathode voltage of the 6J5 becomes close to ground potential, extinguishing the VR tube and permitting the oscillator to operate. Too much shunt capacity on the leads to the VR tube, and too large a value of grid capacitor in the oscillator, may slow down this action, and best performance will be obtained when the oscillator (turned on and off this way) sounds "clicky." The output envelope shaping is obtained in the amplifier, and it can be made softer by increasing the value of C_1 . If the keyed amplifier is a tetrode or pentode, the screen voltage should be obtained from a fixed voltage source or stiff voltage divider, not from the plate supply through a dropping resistor.

A switch connected in series with the VR tube will, when opened, turn on the oscillator for "frequency spotting."

lowing stages, but it is quite satisfactory and is used in at least one commercial transmitter.

A second approach is to use a conversion exciter, in which two oscillators (one crystal-controlled, one v.f.o.) run continuously and their outputs, with suitable buffer stages intervening, are fed to a mixer stage. The mixer stage output is the sum or difference frequency of the two oscillator frequencies, which have been selected to give a sum or difference in an amateur band. When the mixer stage is turned off by keying, no output appears in the amateur band, and the effect is the same as keying an oscillator stage that cannot possibly chirp. The oscillator frequencies must be selected carefully so that none of their harmonics fall within an amateur band, and sufficient selectivity must be present in stages following the mixer to insure that no spurious signals are amplified. If the mixer alone is keyed, its envelope is subject to sharpening by later stages unless they are linear amplifiers.

A third approach is to turn the oscillator on fast before a keyed amplifier stage can pass any signal and turn off the oscillator fast after the keyed amplifier stage has cut off. The principle is called "differential keying" and a number of circuits have been devised for accomplishing the action. One of the simplest can be applied to any grid-block keyed amplifier or tube-keyed stage by the addition of a triode and a VR tube, as in Fig. 8-6. The triode is used as a cathode follower; with the key up a negative bias is applied to the oscillator grid through the VR tube and the 10,000-ohm resistor. When the key is closed, the 6J5 cathode goes immediately to ground potential, the VR tube is extinguished and the bias is removed from the oscillator. The oscillator turns on quickly. In the meantime, the amplifier bias, the voltage to which C_1 is charged, is discharging through R_1 , the amplifier grid leak. The oscillator is turned on before the amplifier bias has been reduced to a value low enough for conduction through the tube. When the key is opened, the oscillator continues to run until the grid of the cathode follower has reached a voltage of more than -175 volts, by which time the amplifier has stopped conducting. Using this keying system for break-in, the keying will be chirp-free if it is chirp-free with the VR tube removed from its socket, to permit the oscillator to run all of the

time. If the transmitter can't pass this test, it indicates that more isolation is required between keyed stage and oscillator.

Clicks in Later Stages

It was mentioned earlier that key clicks can be generated in amplifier stages following the keyed stage or stages. This is often a puzzling problem to an operator who has spent considerable time adjusting the keying in his exciter unit for clickless keying, only to find that the clicks are bad when the amplifier unit is added. There are two possible causes for the clicks: low-frequency parasitic oscillations and amplifier "clipping."

Under some conditions an amplifier will be momentarily triggered into low-frequency parasitic oscillations, and clicks will be generated when the amplifier is driven by a keyed exciter. If these clicks are the result of low-frequency parasitic oscillations, they will be found in "groups" of clicks occurring at 50- to 150-ke. intervals either side of the transmitter frequency. Of course low-frequency parasitic oscillations can be generated in a keyed stage, and the operator should listen carefully to make sure that the output of the exciter is clean before he blames a later amplifier. Low-frequency parasitic oscillations are usually caused by poor choice in r.f. choke values, and using more inductance in the plate choke than in the grid choke for the same stage is recommended.

When the clicks introduced by the addition of an amplifier stage are found only near the transmitter frequency, amplifier "clipping" is indicated. It is quite common when fixed bias is used on the amplifier and the bias is well past the "cut-off" value. The effect can usually be minimized or eliminated by using a combination of fixed and grid-leak bias for the amplifier stage. The fixed bias should be sufficient to hold the key-up plate current only to a low level and not to zero. In a triode amplifier, overdriving the amplifier can also result in clipping that will add key clicks, and the cure is to reduce the drive. The output won't suffer appreciably.

A linear amplifier (Class AB₁, AB₂ or B) will amplify the excitation without adding any clicks, and if clicks show up a low-frequency parasitic oscillation is probably the reason.

Testing Your Keying

The choice of a keying circuit is not as important as its complete testing. Any of the circuits shown in this section can be made to give satisfactory keying, but they must be adjusted properly.

The easiest way to find out what your keyed signal sounds like on the air is to trade stations with a near-by ham friend some evening for a short QSO. If he is a half mile or so away, that's fine, but any distance where the signals are still S9 will be satisfactory.

After you have found out how to work his rig, make contact and then have him send slow dashes, with dash spacing. (The letter "T" at about 5 w.p.m.) With the crystal filter out, cut the r.f. gain back just enough to avoid receiver overloading (the condition where you get crisp signals instead of mushy ones) and tune slowly from out of beat-note range on one side of the signal through to zero and out the other side. Knowing the tempo of the dashes, you can readily identify any clicks in the vicinity as

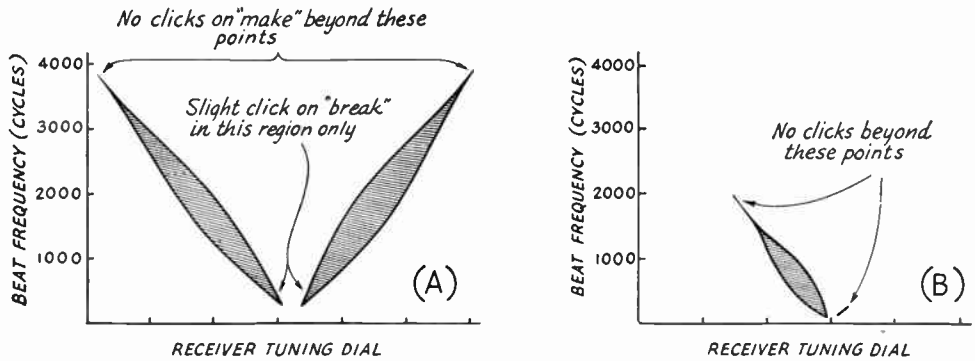

Fig. 8-7—Representations of a clean c.w. signal as a receiver is tuned through it. (A) shows a receiver with no crystal filter and the b.f.o. set in the center of the passband, and (B) shows the crystal filter in and the receiver adjusted for single-signal reception. The variation in thickness of the lines represents the relative signal intensity. The audio frequency where the signal disappears will depend upon the receiver selectivity characteristic and the strength of the signal.

yours or someone else's. A good signal will have a thump on "make" that is perceptible only where you can also hear the beat note, and the click on "break" should be practically negligible at any point. Fig. 8-7A shows how it should sound. If your signal is like that, it will sound good, provided there are no chirps. Then have him run off a string of 35- or 40-w.p.m. dots with the bug — if they are easy to copy, your signal has no "tails" worth worrying about and is a good one for any speed up to the limit of manual keying. If the receiver has poor selectivity with the crystal filter out, make one last check with the filter in (Fig. 8-7B), to see that the clicks off the signal are negligible even at high signal level.

If you don't have any convenient friends with whom to trade stations, you can still check your keying, although you have to be a little more careful. The first step is to get rid of the r.f. click at the key, as described earlier, because if you don't you cannot make further observations. Locally (meaning in your own receiver) this click will coincide in time with clicks that may or may not be on your signal, so there is just no way to observe your signal without first eliminating the r.f. click.

So far you haven't done a thing for your signal on the air and you still don't know what it sounds like, but you may have cleaned up some clicks in the Be set. Now disconnect the antenna from your receiver and short the antenna terminals with a short piece of wire. Tune in your own signal and reduce the r.f. gain to the point where your receiver doesn't overload. Detune any antenna trimmer the receiver may have. If you can't avoid overload within the r.f. gain-control range, pull out the r.f. amplifier tube and try again. If you still can't avoid overload, listen to the second harmonic as a last resort. Since an overloaded receiver can generate clicks, it is easy to realize the importance of eliminating overload during any tests or observations.

Describing the volume level at which you should set your receiver for these "shack" tests

is a little difficult. The r.f. filter should be effective with the receiver running wide open and with an antenna connected. When you turn on the transmitter and take the other steps mentioned to reduce the signal in the receiver, run the audio up and the r.f. down to the point where you can just hear a little "rushing" sound with the b.f.o. off and the receiver tuned to the signal. This is with the crystal filter in. At this level, a properly-adjusted keying circuit will show no clicks off the rushing-sound range. With the b.f.o. on and the same gain setting, there should be no clicks outside the beat-note range. When observing clicks, make the slow-dash and fast-dot tests outlined previously.

Now you know how your signal sounds on the air, with one possible exception. If keying your transmitter makes the lights blink, you may not be able to tell too accurately about the chirp on your signal. However, if you are satisfied with the absence of chirp when tuning *either side of zero beat*, it is safe to assume that your receiver isn't chirping with the light flicker and that the observed signal is a true representation. No chirp either side of zero beat is fine. Don't try to make these tests without first getting rid of the r.f. click at the key, because clicks can mask a chirp.

Exchanging stations temporarily with another interested amateur is probably the best way to check your keying. The second-best method is to check it in the shack as outlined above. The least satisfactory way is to ask another ham on the air how your keying sounds, although this seems to be a very popular method. The reason it is the least satisfactory is that many hams, for reasons of etiquette or QSL-card collecting, are reluctant to be highly critical of another amateur's signal. In a great many cases they don't actually know what to look for or how to describe any aberrations they may observe. Many can describe what they like to hear in the way of a clean code signal, but the little factors that soil a signal are indistinguishable. However, they can all be summed up as chirps and clicks on make and break. A signal can have none or all of these.

Vacuum-Tube Keyers

The practical tube-keyer circuit of Fig. 8-8 can be used for keying any stage of any transmitter. Depending upon the power level of the keyed stage, more or fewer Type 6B4-G tubes can be connected in parallel to handle the necessary current. The voltage drop through a single 6B4-G varies from about 70 volts at 50 ma. to 50 volts at 20 ma. Tubes added in parallel will reduce the drop in proportion to the number of tubes used.

When connecting the output terminals of the keyer to the circuit to be keyed, the grounded output terminal of the keyer must be connected to the transmitter ground. Thus the keyer can be used only in negative-lead or cathode keying. When used in cathode keying, it will introduce

associated resistors and capacitors, since they are incorporated only to allow the operator to select the combination he prefers. But once the values have been selected, they can be soldered permanently in place. The rule for adjusting the keying characteristic is the same as for blocked-grid keying.

A Low-Power Keyer

If a low-level stage running only a few watts is to be keyed, the tube-keyer circuit of Fig. 8-9 offers a simple solution. By using a 117L7 type tube, which incorporates its own rectifier, it is only necessary to connect to some existing power

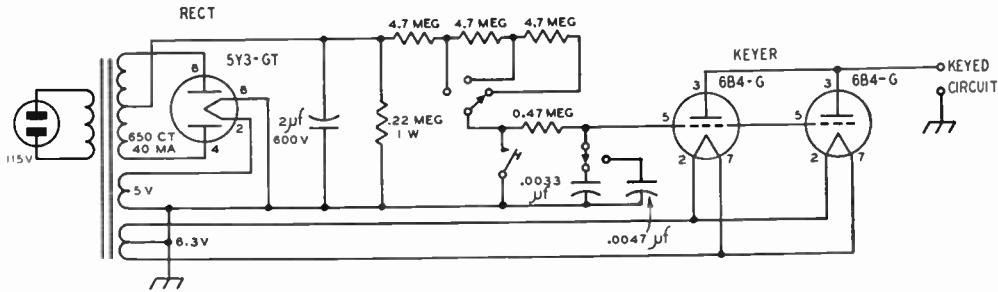

Fig. 8-8 — Wiring diagram of a practical vacuum-tube keyer.

cathode bias to the stage and reduce the output. This can be compensated for by a reduction in the grid-leak bias of the stage.

The negative-voltage supply can be eliminated if a negative voltage is available from some other source, such as a bias supply. A simplified version of this circuit could eliminate the switches and

their supply at the point marked "X". The keying characteristic will vary with many factors, so the values of R_1 and R_2 only represent starting points for experimentation.

When the key or keying lead has poor insulation, the resistance may become low enough (particularly in humid weather) to reduce the blocking voltage and allow the keyer tube to pass some current. This may cause a slight backwave, but it can be cured by better insulation, or by reduced values of resistors and increased values of capacitors.

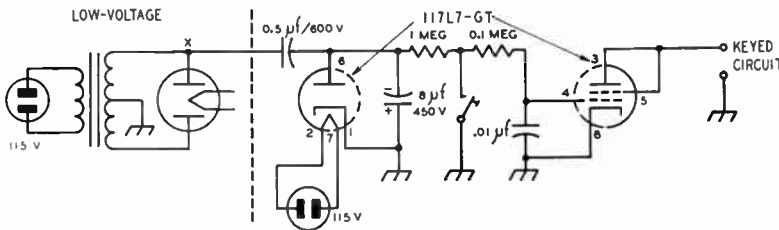

Fig. 8-9 — Simple low-power vacuum-tube keyer. Connect keyer to a low-voltage power supply at point "X".

Monitoring of Keying

In general, there are two common methods for monitoring one's "fist" and signal. The first, and perhaps more common type, involves the use of an audio oscillator that is keyed simultaneously with the transmitter.

The second method is one that permits receiving the signal through one's receiver, and this generally requires that the receiver be tuned to

the transmitter (not always convenient unless working on the same frequency) and that some method be provided for preventing overloading of the receiver, so that a good replica of the transmitted signal will be received. Except where quite low power is used, this usually involves a relay for simultaneously shorting the receiver input terminals and reducing the receiver gain.

“Little Oskey”—A Monitoring Oscillator and Keyer

Without modifying a receiver or cathode-keyed transmitter in any way, the unit shown in Figs. 8-10 and 8-12 blanks the receiver output and injects a sidetone in the headphones when the key is down. It can also be used as a code-practice oscillator. No changes are required when frequency or band is changed.

Referring to the schematic in Fig. 8-11, the left-hand section of the 12AU7 amplifier mixer handles the receiver output and delivers it to the phones jack. Its grid return is the 4.7-megohm resistor and the 0.27-megohm resistor. When the key is closed a negative voltage is placed across the 0.27-megohm resistor, and this bias cuts off the signal from receiver to phones jack. At the same time the voltage is applied to the audio oscillator section of the lower 12AU7, and any desired amount of the developed tone is applied to the phones jack via the right-hand section of the 12AU7 amplifier-mixer. The desired amount is controlled by the setting of the 0.5-megohm oscillator gain control. Two power supplies are used; plate voltage for the oscillator-mixer is provided by a selenium rectifier in a half-wave rectifier circuit, and the negative supply for the bias and oscillator is furnished by a voltage tripler using a section of a 12AU7 and two crystal diodes. Two small 6-volt filament transformers connected “back to back” are used for obtaining the necessary operating voltages. A switch, S2, permits keying the transmitter without blanking the receiver or introducing the audio sidetone, should this be required for frequency spotting or monitoring.

No special precautions are necessary in laying out the unit. In fact, the monitor may be built in a cabinet and placed alongside of the receiver. When wiring the unit, it is a good idea to keep the leads carrying a.c. away from the amplifier input to prevent hum. Care should also be taken

when soldering the crystal diodes. Holding the diode leads with a pair of long-nose pliers while soldering is good insurance against ruining a crystal. Terminal strips can be used conveniently for mounting parts such as the selenium rectifier and to serve as tie points for resistors, capacitors, etc.

The frequency of the sidetone audio oscillator can be adjusted by changing the grid capacitor, C₁. If the audio oscillator fails to oscillate, the primary leads of the interstage transformer should be reversed.

It is a very simple matter to insert the monitor into an existing station. The cable from the unit is plugged into the keyed circuit and the receiver output and head-phones are plugged into the unit. Switch S₁ is used to turn the unit off and on. If for some reason it is desired to operate temporarily without the unit (such as when zero-beating) the toggle switch, S₂, may be opened and the unit becomes inoperative.

With S₂ closed, everything is ready. When the key is up the receiver is heard; when the key is down a sidetone is heard and the transmitter is keyed. The oscillator tone level can be adjusted with the gain control on the unit, while the receiver level is controlled at the receiver. If the station being worked wishes to break in, his signals can be heard between the characters being transmitted.

Since the receiver is actually on during key-down conditions (even though in the headphones it appears to be off), care should be taken not to damage the receiver by r.f. overloading. The monitor has been used successfully with a cathode-keyed transmitter running as high as 200 watts input but separate transmitting and receiving antennas were used. The unit cannot be used with grid-block keyed transmitters — it is designed for cathode-keyed rigs only. How-



Fig. 8-10 — A combination c.w. monitor and code-practice oscillator that can be used without modification of the receiver or transmitter.

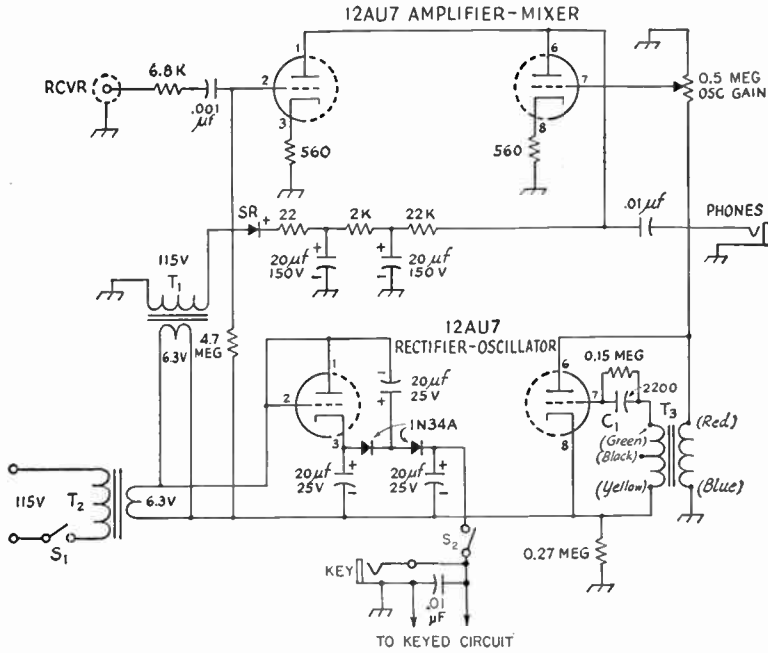

Fig. 8-11 — Schematic diagram of "Little Oskey." All resistors 1/2 watt. All capacitors in μf, unless specified otherwise. The tube heaters get their power from the 6.3-volt line between T₁ and T₂.

S₁ — S.p.s.t. on oscillator gain control.
 T₁, T₂ — 6.3-volt 1.2-amp. filament transformer (UTC FT-2).

SR — Low-current selenium rectifier (Federal 1002).
 T₃ — Interstage audio transformer, secondary-to-primary ratio 2:1 (Thorlarsen T-20A16).

ever, it is usually a simple matter to change the keying circuit of a transmitter. "Little Oskey" does nothing to the keying of the transmitter, and it must still be shaped by the methods outlined elsewhere in this chapter. In some installations it may not be possible to work full break-in because the receiver does not recover fast enough from the overload the transmitter places on it. In such cases it may be helpful to use a

smaller receiving antenna or one that is farther from the transmitting antenna, to reduce the transmitter pick-up and the receiver overload that is causing the long recovery time.

If the transmitter and receiver are turned off the monitor can be keyed and used as a code-practice oscillator. The sidetone will appear in the headphones as the unit is keyed.

(From *QST*, October, 1955.)

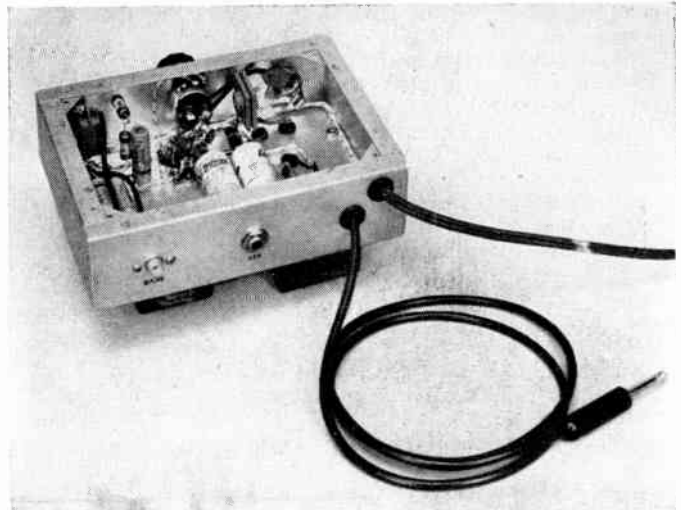

Fig. 8-12 — Under-chassis view of the monitor, showing the plug and cord that run to the transmitter key jack, the monitor key jack, and the phono jack where the receiver output is applied.

Break-In Operation

Break-in operation requires a separate receiving antenna, since none of the available antenna change-over relays is fast enough to follow keying. The receiving antenna should be installed as far as possible from the transmitting antenna. It should be mounted at right angles to the transmitting antenna and fed with low pick-up lead-in material such as coaxial cable or 300-ohm Twin-Lead, to minimize pick-up.

If a low-powered transmitter is used, it is often quite satisfactory to use no special equipment for break-in operation other than the separate receiving antenna, since the transmitter will not block the receiver too seriously. Even if the transmitter keys without clicks, some clicks will be heard when the receiver is

mitter oscillator. A filter at the key suppresses the clicks caused by the relay current.

The keying relay should be mounted on the receiver as close to the antenna terminals as possible, and the leads shown heavy in the diagram should be kept short, since long leads will allow too much signal to get through into the receiver. A good high-speed keying relay should be used.

Full descriptions of systems for break-in operation can be found in the following *QST* articles:

Hays, "Selenium Break-In Keying," July, 1955.

Miller and Meichner, "TVG — An Aid to Break-In," March, 1953.

Puckett, "'De Luxe' Keying Without Relays,"

Fig. 8-13 — Wiring diagram for smooth break-in operation. The lead shown as a heavy line and the lead from bottom relay contact to AT post on receiver should be kept as short as possible for minimum pick-up of the transmitter signal.

R_1 — Receiver manual gain control.
 R_2 — 5000- or 10,000-ohm wire-wound potentiometer.

Ry — S.p.d.t. keying relay.

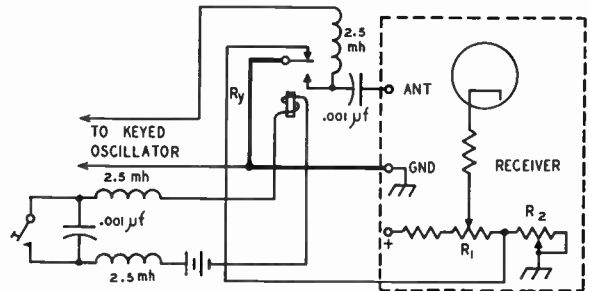

tuned to the transmitter frequency because of overload in the receiver. An output limiter, as described in Chapter Five, will wash out these clicks and permit good break-in operation even on your transmitter frequency.

When powers above 25 or 50 watts are used, special treatment is required for quiet break-in on the transmitter frequency. A means should be provided for shorting the input of the receiver when the code characters are sent, and a means for reducing the gain of the receiver at the same time is often necessary. The system shown in Fig. 8-13 permits quiet break-in operation for higher-powered stations. It requires a simple operation on the receiver but otherwise is perfectly straightforward. R_1 is the regular receiver r.f. and i.f. gain control. The ground lead is lifted on this control and run to a rheostat, R_2 , that goes to ground. A wire from the junction runs outside the receiver to the keying relay, Ry . When the key is up, the ground side of R_1 is connected to ground through the relay arm, and the receiver is in its normal operating condition. When the key is closed, the relay closes, which breaks the ground connection from R_1 and applies additional bias to the tubes in the receiver. This bias is controlled by R_2 . When the relay closes, it also closes the circuit to the trans-

September, 1953; Part II, Dec., 1953.

Puckett, "C.W. Man's Control Unit," Feb., 1955.

● ELECTRONIC KEYS

Electronic keys, as contrasted with mechanical automatic keys, use vacuum tubes or relays (or both) to form automatic dashes as well as automatic dots. Full descriptions of electronic keys can be found in the following *QST* articles:

Brann, "In Search of the Ideal Electronic Key," Feb., 1951.

Turrin, "Debugging the Electronic Bug," Jan., 1950.

Montgomery, "'Corkey' — A Tubeless Automatic Key," November, 1950.

Bartlett, "Compact Automatic Key Design," Dec., 1951.

Turrin, "The 'Tur-Key'," December, 1952. Correction, February, 1953.

Kaye, All-Electronic "Ultimate" Keyer, April, May, 1955.

Brann, "A Dot Anticipator for the Electronic Key," July, 1953.

Turrin, "The 'Tur-Key' in Miniature," September, 1954.

Speech Amplifiers and Modulators

The audio amplifiers used in radiotelephone transmitters operate on the principles outlined earlier in this book in the chapter on vacuum tubes. The design requirements are determined principally by the type of modulation system to be used and by the type of microphone to be employed. It is necessary to have a clear understanding of modulation principles before the problem of laying out a speech system can be approached successfully. Those principles are discussed under appropriate chapter headings.

The present chapter deals with the design of audio amplifier systems for communication purposes. In voice communication the primary objective is to obtain the most *effective* transmission; i.e., to make the message be understood at the receiving point in spite of adverse conditions created by noise and interference. The methods used to accomplish this do not necessarily coincide with the methods used for

other purposes, such as the reproduction of music or other program material. In other words, "naturalness" in reproduction is distinctly secondary to intelligibility.

The fact that satisfactory intelligibility can be maintained in a relatively narrow band of frequencies is particularly fortunate, because the width of the channel occupied by a phone transmitter is directly proportional to the width of the audio-frequency band. If the channel width is reduced, more stations can occupy a given band of frequencies without mutual interference.

In speech transmission, amplitude distortion of the voice wave has very little effect on intelligibility. Its importance in communication lies almost wholly in the fact that many of the audio-frequency harmonics caused by such distortion lie outside the channel needed for intelligible speech, and thus will create unnecessary interference to other stations.

Speech Equipment

In designing speech equipment it is necessary to know (1) the amount of audio power the modulation system must furnish and (2) the output voltage developed by the microphone when it is spoken into from normal distance (a few inches) with ordinary loudness. It then becomes possible to choose the number and type of amplifier stages needed to generate the required audio power without overloading or distortion anywhere in the system.

● MICROPHONES

The **level** of a microphone is its electrical output for a given sound intensity. Level varies greatly with microphones of different types, and depends on the distance of the speaker's lips from the microphone. Only approximate values based on averages of "normal" speaking voices can be given. The values given later are based on close talking; that is, with the microphone about an inch from the speaker's lips.

The **frequency response** or **fidelity** of a microphone is its relative ability to convert sounds of different frequencies into alternating current. For understandable speech transmission only a limited frequency range is necessary, and intelligible speech can be obtained if the output of the microphone does not vary more than a few decibels at any frequency within a range of about 200 to 2500 cycles. When the variation expressed in terms of decibels is small between two fre-

quency limits, the microphone is said to be flat between those limits.

Carbon Microphones

The carbon microphone consists of a metal diaphragm placed against an insulating cup containing loosely-packed carbon granules (**microphone button**). Current from a battery flows through the granules, the diaphragm being one connection and the metal backplate the other. Fig. 9-1A shows connections for carbon microphones. A variable resistor is included for adjusting the button current to the value as specified with the microphone. The primary of a transformer is connected in series with the battery and microphone.

As the diaphragm vibrates, its pressure on the granules alternately increases and decreases, causing a corresponding increase and decrease of current flow through the circuit, since the pressure changes the resistance of the mass of granules. The resulting change in the current flowing through the transformer primary causes an alternating voltage, of corresponding frequency and intensity, to be set up in the transformer secondary.

Good-quality carbon microphones give outputs ranging from 0.1 to 0.3 volt across 50 to 100 ohms; that is, across the primary winding of the microphone transformer. With the step-up of the transformer, a peak voltage of between 3 and 10 volts can be assumed to be available at the grid of the

amplifier tube. The usual button current is 50 to 100 ma.

Piezo-electric Microphones

The crystal microphone makes use of the piezoelectric properties of Rochelle salts crystals. This type of microphone requires no battery or transformer and can be connected directly to the grid of an amplifier tube. It is a popular type of microphone among amateurs, for these reasons as well as the fact that it has good frequency response and is available in inexpensive models. The input circuit for the crystal microphone is shown in Fig. 9-1B.

Although the level of crystal microphones varies with different models, an output of 0.03 volt or so is representative for communication types. The level is affected by the length of the cable connecting the microphone to the first amplifier stage; the above figure is for lengths of 6 or 7 feet. The frequency characteristic is unaffected by the cable, but the load resistance (amplifier grid resistor) does affect it; the lower frequencies are attenuated as the value of load resistance is lowered. A grid-resistor value of at least 1 megohm should be used for reasonably flat response, 5 megohms being a customary figure.

The ceramic microphone utilizes the piezoelectric effect in certain types of ceramic materials to achieve performance very similar to that of the crystal microphone. It is less affected by temperature and humidity. Output levels are similar to those of crystal microphones of the same type of frequency response.

Velocity and Dynamic Microphones

In a velocity or "ribbon" microphone, the element acted upon by the sound waves is a thin corrugated metallic ribbon suspended between the poles of a magnet.

Velocity microphones are built in two types, high impedance and low impedance, the former being used in most applications. A high-impedance microphone can be directly connected to the grid of an amplifier tube, shunted by a resistance of 0.5 to 5 megohms (Fig. 9-1C). Low-impedance microphones are used when a long connecting cable (75 feet or more) must be employed. In such a case the output of the microphone is coupled to the first amplifier stage through a suitable step-up transformer, as shown in Fig. 9-1D).

The level of the velocity microphone is about 0.03 to 0.05 volt. This figure applies directly to the high-impedance type, and to the low-impedance type when the voltage is measured across the secondary of the coupling transformer.

The dynamic microphone somewhat resembles a dynamic loudspeaker. A light-weight voice coil is rigidly attached to a diaphragm, the coil being suspended between the poles of a permanent magnet. Sound causes the diaphragm to vibrate, thus moving the coil back and forth between the magnet poles and generating an alternating voltage.

The dynamic microphone usually is built with high-impedance output, suitable for working directly into the grid of an amplifier tube. If the connecting cable must be unusually long, a low-impedance type should be used, with a step-up transformer at the end of the cable.

THE SPEECH AMPLIFIER

The audio-frequency amplifier stage that causes the r.f. carrier output to be varied is called the modulator, and all the amplifier stages preceding it comprise the speech amplifier. Depending on the modulator used, the speech amplifier may be called upon to deliver a power output ranging from practically zero (only voltage required) to 20 or 30 watts.

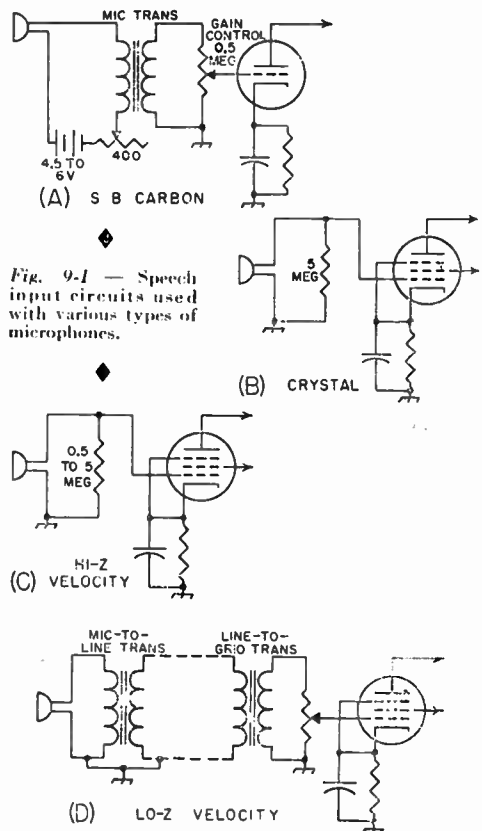

Fig. 9-1 — Speech input circuits used with various types of microphones.

Before starting the design of a speech amplifier, therefore, it is necessary to have selected a suitable modulator for the transmitter. This selection must be based on the power required to modulate the transmitter, and this power in turn depends on the type of modulation system selected, as described in other chapters. With the modulator picked out, its driving-power requirements (audio power required to excite the modulator to full output) can be determined from the tube tables in a later chapter. Generally speaking, it is advisable to choose a tube or tubes for the last stage of the speech amplifier that will be capable of

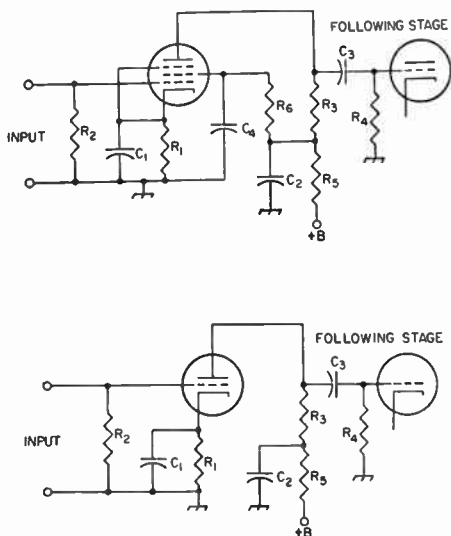

Fig. 9-2 — Resistance-coupled voltage-amplifier circuits. A, pentode; B, triode. Designations are as follows: C₁ — Cathode by-pass capacitor. C₂ — Plate by-pass capacitor. C₃ — Output coupling capacitor (blocking capacitor). C₄ — Screen by-pass capacitor. R₁ — Cathode resistor. R₂ — Grid resistor. R₃ — Plate resistor. R₄ — Next-stage grid resistor. R₅ — Plate decoupling resistor. R₆ — Screen resistor.

Values for suitable tubes are given in Table 9-1. Values in the decoupling circuit, C₂R₅, are not critical. R₅ may be about 10% of R₃; an 8- or 10- μ f. electrolytic capacitor is usually large enough at C₂.

developing at least 50 per cent more power than the rated driving power of the modulator. This will provide a factor of safety so that losses in coupling transformers, etc., will not upset the calculations.

Voltage Amplifiers

If the last stage in the speech amplifier is a Class AB₂ or Class B amplifier, the stage ahead of it must be capable of sufficient power output to drive it. However, if the last stage is a Class AB₁ or Class A amplifier the preceding stage can be simply a voltage amplifier. From there on back to the microphone, all stages are voltage amplifiers.

The important characteristics of a voltage amplifier are its **voltage gain**, **maximum undistorted output voltage**, and its **frequency response**. The voltage gain is the voltage-amplification ratio of the stage. The output voltage is the maximum a.f. voltage that can be secured from the stage without distortion. The amplifier frequency response should be adequate for voice reproduction; this requirement is easily satisfied.

The voltage gain and maximum undistorted output voltage depend on the operating conditions of the amplifier. Data on the popular types of tubes used in speech amplifiers are given in Table 9-1, for resistance-coupled amplification.

The output voltage is in terms of *peak* voltage rather than r.m.s.; this makes the rating independent of the waveform. Exceeding the peak value causes the amplifier to distort, so it is more useful to consider only peak values in working with amplifiers.

Resistance Coupling

Resistance coupling generally is used in voltage-amplifier stages. It is relatively inexpensive, good frequency response can be secured, and there is little danger of hum pick-up from stray magnetic fields associated with heater wiring. It is the most satisfactory type of coupling for the output circuits of pentodes and high- μ triodes, because with transformers a sufficiently high load impedance cannot be obtained without considerable frequency distortion. Typical circuits are given in Fig. 9-2 and design data in Table 9-1.

Transformer Coupling

Transformer coupling between stages ordinarily is used only when power is to be transferred (in such a case resistance coupling is very inefficient), or when it is necessary to couple between a single-ended and a push-pull stage. Triodes having an amplification factor of 20 or less are used in transformer-coupled voltage amplifiers. With transformer coupling, tubes should be operated under the Class A conditions given in the tube tables at the end of this book.

Representative circuits for coupling single-ended to push-pull stages are shown in Fig. 9-3. The circuit at A combines resistance and transformer coupling, and may be used for exciting the

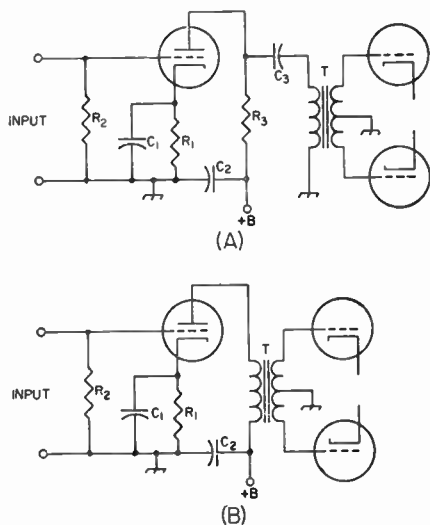

Fig. 9-3 — Transformer-coupled amplifier circuits for driving a push-pull amplifier. A is for resistance-transformation coupling; B for transformer coupling. Designations correspond to those in Fig. 9-2. In A, values can be taken from Table 9-1. In B, the cathode resistor is calculated from the rated plate current and grid bias as given in the tube tables for the particular type of tube used.

TABLE 9-1 — RESISTANCE-COUPLED VOLTAGE-AMPLIFIER DATA

Data are given for a plate supply of 300 volts. Departures of as much as 50 per cent from this supply voltage will not materially change the operating conditions or the voltage gain, but the output voltage will be in proportion to the ratio of the new voltage to 300 volts. Voltage gain is measured at 400 cycles. Capacitor values given are based on 100-cycle cutoff. For increased low-frequency response, all capacitors may be made larger than specified (cut-off frequency in inverse proportion to capacitor values provided all are changed in the same proportion). A variation of 10 per cent in the values given has negligible effect on the performance.

	Plate Resistor Megohms	Next-Stage Grid Resistor Megohms	Screen Resistor Megohms	Cathode Resistor Ohms	Screen Bypass μ f.	Cathode Bypass μ f.	Blocking Capacitor μ f.	Output Volts (Peak) ¹	Voltage Gain ²
6SJ7, 12SJ7	0.1	0.1	0.35	500	0.10	11.6	0.019	72	67
		0.25	0.37	530	0.09	10.9	0.016	96	98
		0.5	0.47	590	0.09	9.9	0.007	101	104
	0.25	0.25	0.89	850	0.07	8.5	0.011	79	139
		0.5	1.10	860	0.06	7.4	0.004	88	167
		1.0	1.18	910	0.06	6.9	0.003	98	185
0.5	0.5	2.0	1300	0.06	6.0	0.004	64	200	
	1.0	2.2	1410	0.05	5.8	0.002	79	238	
	2.0	2.5	1530	0.04	5.2	0.0015	89	263	
6J7, 7C7, 12J7-GT	0.1	0.1	0.44	500	0.07	8.5	0.02	55	61
		0.25	0.5	450	0.07	8.3	0.01	81	82
		0.5	0.53	600	0.06	8.0	0.006	96	94
	0.25	0.25	1.18	1100	0.04	5.5	0.008	81	104
		0.5	1.18	1200	0.04	5.4	0.005	104	140
		1.0	1.45	1300	0.05	5.8	0.005	110	185
0.5	0.5	2.45	1700	0.04	4.2	0.005	75	161	
	1.0	2.9	2200	0.04	4.1	0.003	97	200	
	2.0	2.95	2300	0.04	4.0	0.0025	100	230	
6AU6, 6SH7, 12AU6, 12SH7	0.1	0.1	0.2	500	0.13	18.0	0.019	76	109
		0.22	0.24	600	0.11	16.4	0.011	103	145
		0.47	0.26	700	0.11	15.3	0.006	129	168
	0.22	0.22	0.42	1000	0.1	12.4	0.009	92	164
		0.47	0.5	1000	0.098	12.0	0.007	108	230
		1.0	0.55	1100	0.09	11.0	0.003	122	262
0.47	0.47	1.0	1800	0.075	8.0	0.0045	94	248	
	1.0	1.1	1900	0.065	7.6	0.0028	105	319	
	2.2	1.2	2100	0.06	7.3	0.0018	122	371	
6AQ6, 6AQ7, 6AT6, 6Q7, 6SL7GT, 6SZ7, 6T8, 12AT6, 12Q7-GT, 12SL7, GT (one triode)	0.1	0.1	—	1500	—	4.4	0.027	40	34
		0.22	—	1800	—	3.6	0.014	54	38
		0.47	—	2100	—	3.0	0.0065	63	41
	0.22	0.22	—	2600	—	2.5	0.013	51	42
		0.47	—	3200	—	1.9	0.0065	65	46
		1.0	—	3700	—	1.6	0.0035	77	48
0.47	0.47	—	5200	—	1.2	0.006	61	48	
	1.0	—	6300	—	1.0	0.0035	74	50	
	2.2	—	7200	—	0.9	0.002	85	51	
6AV6, 12AV6, 12AX7 (one triode)	0.1	0.1	—	1300	—	4.6	0.027	43	45
		0.22	—	1500	—	4.0	0.013	57	52
		0.47	—	1700	—	3.6	0.006	66	57
	0.22	0.22	—	2200	—	3.0	0.013	54	59
		0.47	—	2800	—	2.3	0.006	69	65
		1.0	—	3100	—	2.1	0.003	79	68
0.47	0.47	—	4300	—	1.6	0.006	62	69	
	1.0	—	5200	—	1.3	0.003	77	73	
	2.2	—	5900	—	1.1	0.002	92	75	
6SC7, 12SC7 ³ (one triode)	0.1	0.1	—	750	—	—	0.033	35	29
		0.25	—	930	—	—	0.014	50	34
		0.5	—	1040	—	—	0.007	54	36
	0.25	0.25	—	1400	—	—	0.012	45	39
		0.5	—	1680	—	—	0.006	55	42
		1.0	—	1840	—	—	0.003	64	45
0.5	0.5	—	2330	—	—	0.006	50	45	
	1.0	—	2980	—	—	0.003	62	48	
	2.0	—	3280	—	—	0.002	72	49	
6J5, 7A4, 7N7, 6SN7-GT, 12J5-GT, 12SN7-GT (one triode)	0.047	0.047	—	1300	—	3.6	0.061	59	14
		0.1	—	1580	—	3.0	0.032	73	15
		0.22	—	1800	—	2.5	0.015	83	16
	0.1	0.1	—	2500	—	1.9	0.031	68	16
		0.22	—	3130	—	1.4	0.014	82	16
		0.47	—	3900	—	1.2	0.0065	96	16
0.22	0.22	—	4800	—	0.95	0.015	68	16	
	0.47	—	6500	—	0.69	0.0065	85	16	
	1.0	—	7800	—	0.58	0.0035	96	16	
0.047	0.047	—	870	—	4.1	0.065	38	12	
	0.1	—	1200	—	3.0	0.034	52	12	
	0.22	—	1500	—	2.4	0.016	68	12	
6C4, 12AU7 (one triode)	0.1	0.1	—	1900	—	1.9	0.032	44	12
		0.22	—	3000	—	1.3	0.016	68	12
		0.47	—	4000	—	1.1	0.007	80	12
	0.22	0.22	—	5300	—	0.9	0.015	57	12
		0.47	—	8800	—	0.52	0.007	82	12
		1.0	—	11000	—	0.46	0.0035	92	12

¹ Voltage across next-stage grid resistor at grid-current point.

² At 5 volts r.m.s. output.

³ Cathode-resistor values are for phase-inverter service.

grids of a Class A or AB₁ following stage. The resistance coupling is used to keep the d.c. plate current from flowing through the transformer primary, thereby preventing a reduction in primary inductance below its no-current value; this improves the low-frequency response. With low- μ triodes (6C5, 6J5, etc.), the gain is equal to that with resistance coupling multiplied by the secondary-to-primary turns ratio of the transformer.

In B the transformer primary is in series with the plate of the tube, and thus must carry the tube plate current. When the following amplifier operates without grid current, the voltage gain of the stage is practically equal to the μ of the tube multiplied by the transformer ratio. This circuit also is suitable for transferring power (within the capabilities of the tube) to a following Class AB₂ or Class B stage.

Phase Inversion

Push-pull output may be secured with resistance coupling by using phase-inverter or phase-splitter circuits as shown in Fig. 9-4.

The circuits shown in Fig. 9-4 are of the "self-balancing" type. In A, the amplified voltage

from V_1 appears across R_5 and R_7 in series. The drop across R_7 is applied to the grid of V_2 , and the amplified voltage from V_2 appears across R_6 and R_7 in series. This voltage is 180 degrees out of phase with the voltage from V_1 , thus giving push-pull output. The part that appears across R_7 from V_2 opposes the voltage from V_1 across R_7 , thus reducing the signal applied to the grid of V_2 . The negative feedback so obtained tends to regulate the voltage applied to the phase-inverter tube so that the output voltages from both tubes are substantially equal. The gain is slightly less than twice the gain of a single-tube amplifier using the same operating conditions.

In the single-tube circuit shown in Fig. 9-4B the plate load resistor is divided into two equal parts, R_9 and R_{10} , one being connected to the plate in the normal way and the other between cathode and ground. Since the voltages at the plate and cathode are 180 degrees out of phase, the grids of the following tubes are fed equal a.f. voltages in push-pull. The grid return of V_3 is made to the junction of R_8 and R_{10} so normal bias will be applied to the grid. This circuit is highly degenerative because of the way R_{10} is connected. The voltage gain is less than 2 even when a high- μ triode is used at V_3 .

Gain Control

A means for varying the over-all gain of the amplifier is necessary for keeping the final output at the proper level for modulating the transmitter. The common method of gain control is to adjust the value of a.c. voltage applied to the grid of one of the amplifiers by means of a voltage divider or potentiometer.

The gain-control potentiometer should be near the input end of the amplifier, at a point where the signal voltage level is so low there is no danger that the stages ahead of the gain control will be overloaded by the full microphone output. With carbon microphones the gain control may be placed directly across the microphone-transformer secondary. With other types of microphones, however, the gain control usually will affect the frequency response of the microphone when connected directly across it. Also, in a high-gain amplifier it is better to operate the first tube at maximum gain, since this gives the best signal-to-hum ratio. The control therefore is usually placed in the grid circuit of the second stage.

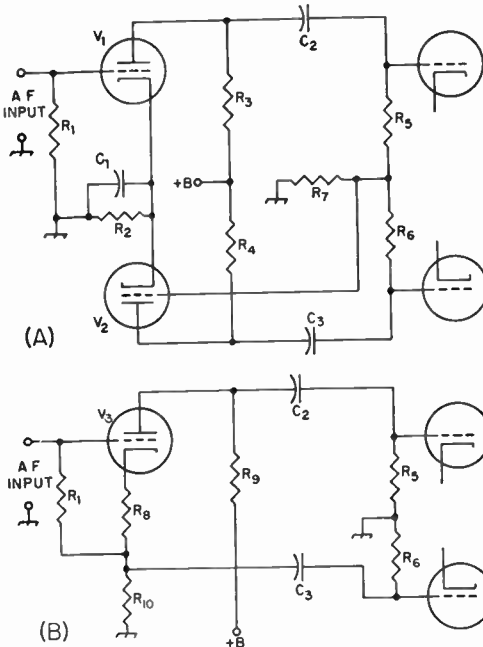

Fig. 9-4 — Self-balancing phase-inverter circuits. V_1 and V_2 may be a double triode such as the 12AU7 or 12AX7. V_3 may be any of the triodes listed in Table 9-1, or one section of a double triode.

- R_1 — Grid resistor (1 megohm or less).
- R_2 — Cathode resistor; use one-half value given in Table 9-1 for tube and operating conditions chosen.
- R_3, R_4 — Plate resistor; select from Table 9-1.
- R_5, R_6 — Following-stage grid resistor (0.22 to 0.47 megohm).
- R_7 — 0.22 megohm.
- R_8 — Cathode resistor; select from Table 9-1.
- R_9, R_{10} — Each one-half of plate load resistor given in Table 9-1.
- C_1 — 10- μ f. electrolytic.
- C_2, C_3 — 0.01- to 0.1- μ f. paper.

● **DESIGNING THE SPEECH AMPLIFIER**

The steps in designing a speech amplifier are as follows:

- 1) Determine the power needed to modulate the transmitter and select the modulator. In the case of plate modulation, a Class B amplifier may be required. Select a suitable tube type and determine from the tube tables at the end of this book the grid driving power required, if any.
- 2) As a safety factor, multiply the required driver power by at least 1.5.

3) Select a tube, or pair of tubes, that will deliver the power determined in the second step. This is the last or output stage of the speech-amplifier. Receiver-type power tubes can be used (beam tubes such as the 6L6 may be needed in some cases) as determined from the receiving-tube tables. If the speech amplifier is to drive a Class B modulator, use a Class A or AB₁ amplifier.

4) If the speech-amplifier output stage is also the modulator and must operate Class AB₂ to develop the required power output, use a medium- μ triode (such as the 6C4 or corresponding types) to drive it. In the extreme case of driving 6L6s to maximum output, two triodes should be used in push-pull in the driver. In either case transformer coupling will have to be used, and transformer manufacturers' catalogs should be consulted for a suitable type.

5) If the speech-amplifier output stage operates Class A or AB₁, it may be driven by a voltage amplifier. If the output stage is push-pull, the driver may be a single tube coupled through a transformer with a balanced secondary, or may be a dual-triode phase inverter. Determine the signal voltage required for full output from the last stage. If the last stage is a single-tube Class A amplifier, the peak signal is equal to the grid-bias voltage; if push-pull Class A, the peak signal voltage is equal to twice the grid bias; if Class AB₁, twice the bias voltage when fixed bias is used; if cathode bias is used, twice the bias figured from the cathode resistance and the maximum-signal cathode current.

6) From Table 9-I, select a tube capable of giving the required output voltage and note its rated voltage gain. A double-triode phase inverter (Fig. 9-4A) will have approximately twice the output voltage and twice the gain of one triode operating as an ordinary amplifier. If the driver is to be transformer-coupled to the last stage, select a medium- μ triode and calculate the gain and output voltage as described earlier in this chapter.

7) Divide the voltage required to drive the output stage by the gain of the preceding stage. This gives the peak voltage required at the grid of the next-to-the-last stage.

8) Find the output voltage, under ordinary conditions, of the microphone to be used. This information should be obtained from the manufacturer's catalog. If not available, the figures given in the section on microphones in this chapter will serve.

9) Divide the voltage found in (7) by the output voltage of the microphone. The result is the over-all gain required from the microphone to the grid of the next-to-the-last stage. To be on the safe side, double or triple this figure.

10) From Table 9-I, select a combination of tubes whose gains, when multiplied together, give approximately the figure arrived at in (9). These amplifiers will be used in cascade. If high gain is required, a pentode may be used for the first speech-amplifier stage, but it is *not* advisable to use a second pentode because of the possibility of feed back and self-oscillation. In most cases a

triode will give enough gain, as a second stage, to make up the total gain required. If not, a medium- μ triode, may be used as a third stage.

A high- μ double triode with the sections in cascade makes a good low-level amplifier, and will give somewhat greater gain than a pentode followed by a medium- μ triode. With resistance-coupled input to the first section the cathode of that section may be grounded (contact potential bias), which is helpful in reducing hum.

● SPEECH-AMPLIFIER CONSTRUCTION

Once a suitable circuit has been selected for a speech amplifier, the construction problem resolves itself into avoiding two difficulties — excessive hum, and unwanted feedback. For reasonably humless operation, the hum voltage should not exceed about 1 per cent of the maximum audio output voltage — that is, the hum should be at least 40 db. below the output level.

Unwanted feedback, if negative, will reduce the gain below the calculated value; if positive, is likely to cause self-oscillation or "howls." Feedback can be minimized by isolating each stage with "decoupling" resistors and capacitors, by avoiding layouts that bring the first and last stages near each other, and by shielding of "hot" points in the circuit, such as grid leads in low-level stages.

Speech-amplifier equipment, especially voltage amplifiers, should be constructed on steel chassis, with all wiring kept below the chassis to take advantage of the shielding afforded. Exposed leads, particularly to the grids of low-level high-gain tubes, are likely to pick up hum from the electric field that usually exists in the vicinity of house wiring. Even with the chassis, additional shielding of the input circuit of the first tube in a high-gain amplifier usually is necessary. In addition, such circuits should be separated as much as possible from power-supply transformers and chokes and also from any audio transformers that operate at fairly-high power levels; this will minimize magnetic coupling to the grid circuit and thus reduce hum or audio-frequency feedback. It is always safe, although not absolutely necessary, to separate the speech amplifier and its power supply, building them on separate chassis.

If a low-level microphone such as the crystal type is used, the microphone, its connecting cable, and the plug or connector by which it is attached to the speech amplifier, all should be shielded. The microphone and cable usually are constructed with suitable shielding; this should be connected to the speech-amplifier chassis, and it is advisable — as well as usually necessary — to connect the chassis to a ground such as a water pipe. With the top-cap tubes, complete shielding of the grid lead and grid cap is a necessity.

Heater wiring should be kept as far as possible from grid leads, and either the center-tap or one side of the heater-transformer secondary winding should be connected to the chassis. If the center-

tap is grounded, the heater leads to each tube should be twisted together to reduce the magnetic field from the heater current. With either type of connection, it is advisable to lay heater leads in the corner formed by a fold in the chassis, bringing them out from the corner to the tube socket by the shortest possible path.

When metal tubes are used, always ground the shell connection to the chassis. Glass tubes used in the low-level stages of high-gain amplifiers must be shielded; tube shields are obtainable for that purpose. It is a good plan to enclose the entire amplifier in a metal box, or at least provide it with a cane-metal cover, to avoid feed-back difficulties caused by the r.f. field of the transmitter. R.f. picked up on exposed wiring, leads or tube elements causes overloading, distortion, and self-oscillation of the amplifier.

When using paper capacitors as bypasses, be sure that the terminal marked "outside foil" is connected to ground. This utilizes the outside foil of the capacitor as a shield around the "hot" foil. When paper capacitors are used for coupling between stages, always connect the outside foil terminal to the side of the circuit having the lowest impedance to ground. Usually, this will be the plate side rather than the following-grid side.

● INCREASING THE EFFECTIVENESS OF THE PHONE TRANSMITTER

The effectiveness of an amateur phone transmitter can be increased to a considerable extent by taking advantage of speech characteristics. Measures that may be taken to make the modulation more effective include band compression (filtering), volume compression, and speech clipping.

Compressing the Frequency Band

Most of the intelligibility in speech is contained in the medium band of frequencies; that is, between about 500 and 2500 cycles. On the other hand, a large portion of speech power is normally found below 500 cycles. If these low frequencies are attenuated, the frequencies that carry most of the actual communication can be increased in amplitude without exceeding 100-per-cent modulation, and the effectiveness of the transmitter is correspondingly increased.

One simple way to reduce low-frequency response is to use small values of coupling capacitance between resistance-coupled stages, as shown in Fig. 9-5A. A time constant of 0.0005 second for the coupling capacitor and following-stage grid resistor will have little effect on the amplification at 500 cycles, but will practically halve it at 100 cycles. In two cascaded stages the gain will be down about 5 db. at 200 cycles and 10 db. at 100 cycles. When the grid resistor is 1/2 megohm a coupling capacitor of 0.001 μf. will give the required time constant.

The high-frequency response can be reduced by using "tone control" methods, utilizing a capacitor in series with a variable resistor connected across an audio impedance at some point in the

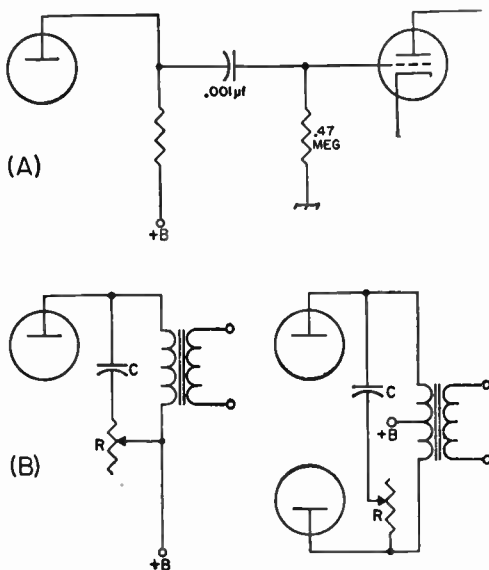

Fig. 9-5 — A, use of a small coupling capacitor to reduce low-frequency response; B, tone-control circuits for reducing high-frequency response. Values for C and R are discussed in the text; 0.01 μf. and 25,000 ohms are typical.

speech amplifier. The best spot for the tone control is across the primary of the output transformer of the speech amplifier, as in Fig. 9-5B. The capacitor should have a reactance at 1000 cycles about equal to the load resistance required by the amplifier tube or tubes, while the variable resistor in series may have a value equal to four or five times the load resistance. The control can be adjusted while listening to the amplifier, the object being to cut the high-frequency response as much as possible without unduly sacrificing intelligibility.

Restricting the frequency response not only puts more modulation power in the optimum frequency band but also reduces hum, because the low-frequency response is reduced, and helps reduce the width of the channel occupied by the transmission, because of the reduction in the amplitude of the high audio frequencies.

Volume Compression

Although it is obviously desirable to modulate the transmitter as completely as possible it is difficult to maintain constant voice intensity when speaking into the microphone. To overcome this variable output level, it is possible to use automatic gain control that follows the average (not instantaneous) variations in speech amplitude. This can be done by rectifying and filtering some of the audio output and applying the rectified and filtered d.c. to a control electrode in an early stage in the amplifier.

A practical circuit for this purpose is shown in Fig. 9-6. V₁, a medium-μ triode, has its grid connected in parallel with the grid of the last speech amplifier tube (the stage preceding the power stage) through the gain control R₁. The amplified output is coupled to a full-wave recti-

fier, V_2 . The rectified audio output develops a negative d.c. voltage across C_1R_3 , which has a sufficiently long time constant to hold the voltage at a reasonably steady value between syllables and words. The negative d.c. voltage is applied as control bias to the suppressor of the first tube in the speech amplifier (this circuit requires a pentode first stage), effecting a reduction in gain. The gain reduction is substantially proportional to the microphone output and thus tends to hold the amplifier output voltage at a constant level.

An adjustable bias is applied to the cathodes of V_2 to cut off the tube at low levels and thus prevent rectification until a desired output level is reached. R_2 is the "threshold control" which sets this level. R_1 , the gain control, determines the rate at which the gain is reduced with increasing signal level.

The hold-in time can be increased by increasing the capacitance of C_1 . C_2 and R_4 may not be necessary in all cases; their function is to prevent too-rapid gain reduction on a sudden voice peak. The "rise time" of this circuit can be increased by increasing C_2 and/or R_4 .

The over-all gain of the system must be high enough so that full output can be secured at a moderately low voice level.

Speech Clipping and Filtering

In speech wave forms the average power content is considerably less than in a sine wave of the same peak amplitude. Since modulation percentage is based on peak values, the modulation or side-band power in a transmitter modulated 100 per cent by an ordinary voice wave form will be considerably less than the side-band power in the same transmitter modulated 100 per cent by a sine wave. In other words, the modulation percentage with voice wave forms is determined by peaks having relatively low average power content.

If the low-energy peaks are clipped off, the remaining wave form will have a considerably higher ratio of average power to peak amplitude. More side-band power will result, therefore, when such a clipped wave is used to modulate the transmitter 100 per cent. Although clipping dis-

torts the wave form and the result therefore does not sound exactly like the original, it is possible to secure a worth-while increase in modulation power without sacrificing intelligibility. Once the system is properly adjusted it will be impossible to overmodulate the transmitter because the maximum output amplitude is fixed.

By itself, clipping generates the same high-order harmonics that overmodulation does, and therefore will cause splatter. To prevent this, the audio frequencies above those needed for intelligible speech must be filtered out, after clipping and before modulation. The filter required for this purpose should have relatively little attenuation at frequencies below about 2500 cycles, but high attenuation for all frequencies above 3000 cycles.

It is possible to use as much as 25 db. of clipping before intelligibility suffers; that is, if the original peak amplitude is 10 volts, the signal can be clipped to such an extent that the resulting maximum amplitude is less than one volt. If the original 10-volt signal represented the amplitude that caused 100-per-cent modulation on peaks, the clipped and filtered signal can then be amplified up to the same 10-volt peak level for modulating the transmitter.

There is a loss in naturalness with "deep" clipping, even though the voice is highly intelligible. With moderate clipping levels (6 to 12 db.) there is almost no change in "quality" but the voice power is increased considerably.

Before drastic clipping can be used, the speech signal must be amplified several times more than is necessary for normal modulation. Also, the hum and noise must be much lower than the tolerable level in ordinary amplification, because the noise in the output of the amplifier increases in proportion to the gain.

One type of clipper-filter system is shown in block form in Fig. 9-7A. The clipper is a peak-limiting rectifier of the same general type that is used in receiver noise limiters. It must clip both positive and negative peaks. The gain or clipping control sets the amplitude at which clipping starts. Following the low-pass filter for eliminating the harmonic distortion frequencies is a second gain control, the "level" or modulation control. This control is set initially so that the amplitude-limited output of the clipper-filter cannot modulate more than 100 per cent.

It should be noted that the peak amplitude of the audio wave form actually applied to the modulated stage in the transmitter is not necessarily held at the same relative level as the peak amplitude of the signal coming out of the clipper stage. When the clipped signal goes through the filter, the relative phases of the various frequency components that pass through the filter are shifted, particularly those components near the cut-off frequency. This may cause the peak amplitude out of the filter to exceed the peak amplitude of the clipped signal applied to the filter input terminals. Similar phase shifts can occur in amplifiers following the filter, especially if these amplifiers, including the modulator, do

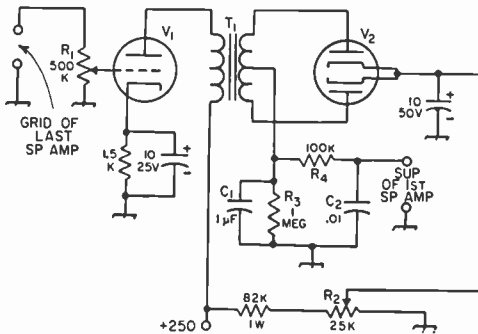

Fig. 9-6 — Speech-amplifier output limiting circuit.
 V_1 — 6C3, 6C5, 6J5, 12AU7, etc.
 V_2 — 6H6, 6AL5, etc.
 T_1 — Interstage audio, single plate to p.p. grids.

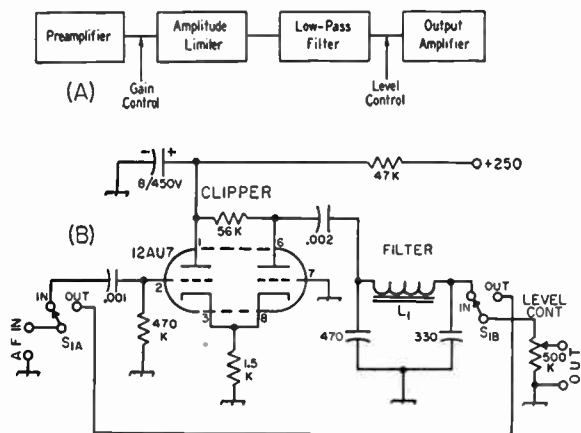

Fig. 9-7 — (A) Block diagram of speech-clipping and filtering amplifier. (B) Practical speech clipper circuit with low-pass filter. Capacitances below 0.001 μ f. are in μ mf. Resistors are $\frac{1}{2}$ watt. L_1 — 20 henrys, 900 ohms (Stancor C-1515). S_1 — D.p.d.t. toggle or rotary.

not have good low-frequency response. With poor low-frequency response the more-or-less "square" waves resulting from clipping tend to be changed into triangular waves having higher peak amplitude. Best practice is to cut the low-frequency response *before* clipping and to make all amplifiers following the clipper-filter as flat and distortion-free as possible.

The best way to set the modulation control in such a system is to check the actual modulation percentage with an oscilloscope connected as described in the chapter on modulation. With the gain control set to give a desired clipping level with normal voice intensity, the level control should be adjusted so that the maximum modulation does not exceed 100 per cent no matter how much sound is applied to the microphone.

A practical clipper-filter circuit is shown in Fig. 9-7B. It may be inserted between two speech-amplifier stages (but after the one having the gain control) where the level is normally a few volts. The cathode-coupled clipper circuit gives some overall voltage gain in addition to performing the clipping function. The filter constants are such as to give a cut-off characteristic that combines reasonably good fidelity with adequate high-frequency suppression.

High-Level Clipping and Filtering

Clipping and filtering also can be done at high level — that is, at the point where the modulation is applied to the r.f. amplifier — instead of in the low-level stages of the speech amplifier. In one rather simple but effective arrangement of this type the clipping takes place in the Class-B modulator itself. This is accomplished by carefully adjusting the plate-to-plate load resistance for the modulator tubes so that they saturate or clip peaks at the amplitude level that represents 100 per cent modulation. The load adjustment can be made by choice of output transformer ratio or by adjusting the plate-voltage/plate-

current ratio of the modulated r.f. amplifier. It is best done by examining the output wave form with an oscilloscope.

The filter for such a system consists of a choke coil and capacitors as shown in Fig. 9-8. The values of L and C should be chosen to form a low-pass filter section having a cut-off frequency of about 2500 cycles, using the modulating impedance of the r.f. amplifier as the load resistance. For this cut-off frequency the formulas are

$$L_1 = \frac{R}{7850} \quad \text{and} \quad C_1 = C_2 = \frac{63.6}{k}$$

where R is in ohms, L_1 in henrys, and C_1 and C_2 in microfarads. For example, with a plate-modulated amplifier operating at 1500 volts and 200 ma. (modulating impedance 7500 ohms) L_1 would be $7500/7850 = 0.96$ henry and C_1 or C_2 would be $63.6/7500 = 0.0085$ μ f. By-pass capacitors in the plate circuit of the r.f. amplifier

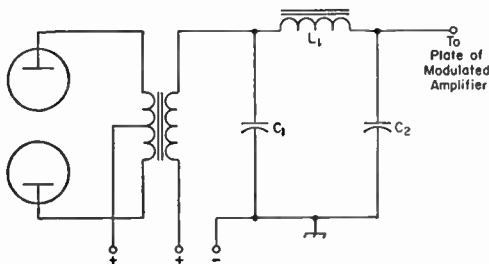

Fig. 9-8 — S-platter-suppression filter for use at high level, shown here connected between a Class B modulator and plate-modulated r.f. amplifier. Values for L_1 , C_1 and C_2 are determined as described in the text.

should be included in C_2 . Voltage ratings for C_1 and C_2 when connected as shown must be the same as for the plate blocking capacitor — i.e., at least twice the d.c. voltage applied to the plate of the modulated amplifier. L and C values can vary 10 per cent or so without seriously affecting the operation of the filter.

Besides simplicity, the high-level system has the advantage that high-frequency components of the audio signal fed to the modulator grids, whether present legitimately or as a result of amplitude distortion in lower-level stages, are suppressed along with the distortion components that arise in clipping. Also, the undesirable effects of poor low-frequency response following clipping and filtering, mentioned in the preceding section, are avoided. Phase shifts can still occur in the high-level filter, however, so adjustments preferably should be made by using an oscilloscope to check the actual modulation percentage under all conditions of speech intensity. (For further discussion see Bruene, "High-Level Clipping and Filtering", *QST*, November, 1951.)

Speech Amplifier with Push-Pull Triode Output

Fig. 9-9 is the circuit of a speech amplifier that is well suited to use as a driver for a push-pull triode Class B modulator. An output of about 13 watts can be realized with the power supply circuit shown (or any similar well-filtered supply delivering 300 volts under load). This is sufficient for driving most of the power triodes commonly used as modulators. The output stage uses push-pull 6B4Gs, which are especially suitable as Class B drivers because of their low plate resistance. The 6B4Gs are operated Class AB₁. The circuit provides several times the voltage gain needed for communications-type crystal or ceramic microphones.

The two sections of a 12AX7 tube are used in the first two stages of the amplifier. These are resistance coupled, the gain control being in the grid circuit of the second stage. Although the cathode of the first stage is grounded and there is no separate bias supply for the grid, the grid bias actually is about one volt because of "contact potential." The coupling capacitances between stages are chosen to cut off the lower voice frequencies for the reasons discussed earlier in this chapter. The higher frequencies are not attenuated in this amplifier since it is assumed that this will be done at the modulation transformer as recommended later in con-

nection with the design of Class B modulators.

The third stage uses a medium- μ triode which is coupled to the 6B4G grids through a transformer having a push-pull secondary. The ratio may be of the order of 2 to 1 (total secondary to primary) or higher; it is not critical since the gain is sufficient without a high step-up ratio.

The output transformer, T_2 , should be selected to couple between push-pull 6B4Gs (or 2A3s) and the grids of the particular modulator tubes used.

The power supply has a capacitor-input filter the output of which is applied to the 6B4G plates through T_2 . For the lower-level stages, additional filtering is provided by successive RC filters which also serve to prevent audio feedback through the plate supply.

Grid bias for the 6B4Gs is furnished by a separate supply using a small selenium rectifier and a TV "booster" transformer, T_4 . The bias may be adjusted by means of R_1 , and should be set to -62 volts or to obtain a total plate current of 80 ma. (as measured in the lead to the primary center tap of T_2) for the 6B4Gs.

In building an amplifier of this type the constructional precautions outlined earlier should be observed. The Class AB₁ modulators described subsequently in this chapter are representative of good constructional practice.

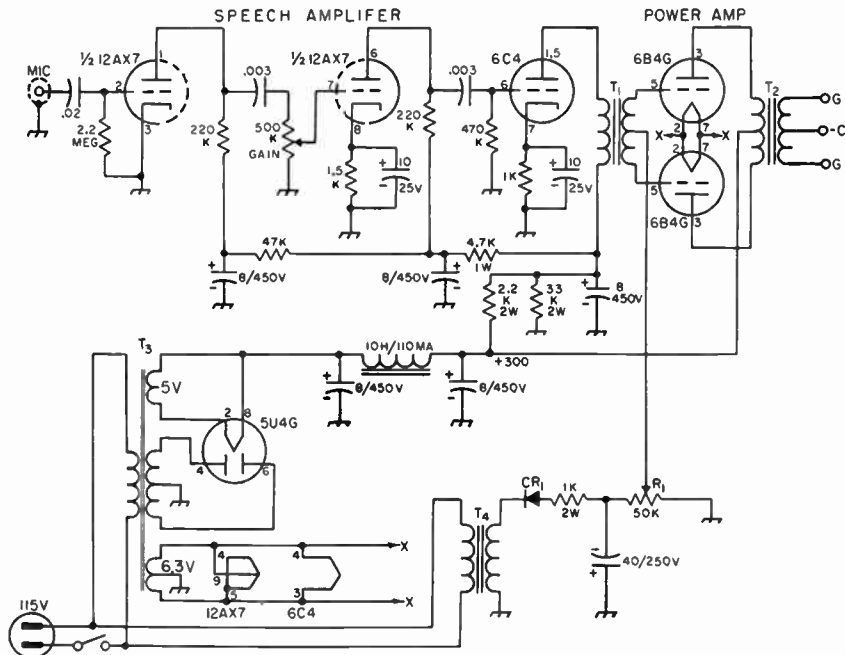

Fig. 9-9 — Speech-amplifier driver for 10-15 watts output. Capacitances are in μ f. Resistors are $\frac{1}{2}$ watt unless specified otherwise. Capacitors with polarity indicated are electrolytic; others may be paper or ceramic.

CR1 — Selenium rectifier, 20 ma.

R_1 — 50,000-ohm potentiometer, preferably wire wound.

T_1 — Interstage audio transformer, single plate to push-pull grids, turns ratio 2 to 1 or 3 to 1, total secondary to primary.

T_2 — Class-B driver transformer, 3000 ohms plate-to-

plate; secondary impedance as required by Class-B tubes used; 15 watt rating.

T_3 — Power transformer, 700 volts c.t., 110 ma.; 5 volts, 3 amp.; 6.3 volts, 4 amp.

T_4 — Power transformer, 125 volts, 20 ma.; 6.3 volts, 0.6 amp.

Low-Power Modulator

A modulator suitable for plate modulation of low-power transmitters or for screen or control-grid modulation of high-power amplifiers is pictured in Figs. 9-10 and 9-12. As shown in Fig. 9-11, it uses a pair of 6AQ5's in push-pull in the output stage. These are driven by a 6C4 phase inverter. A two-stage preamplifier using a 12AX7 brings the output voltage of a crystal or ceramic microphone up to the proper level for the 6C4 grid. A power supply is included on the same chassis.

The undistorted audio output of the amplifier is 7-8 watts. This is sufficient for modulating the plate of an r.f. amplifier running 10 to 15 watts input, or for modulating the control grids or screens of r.f. amplifiers using tubes having plate-dissipation ratings up to 250 watts. When screen modulation is used the screen power for the modulated amplifier (up to 250 volts) can be taken from the modulator power supply. The wiring shown in Fig. 9-11 provides for this, through an adjustable tap on the 25,000-ohm bleeder resistor, R_5 , in the power supply. If a separate screen supply is used, or if the modulator is used for grid-bias or plate modulation of an r.f. amplifier, the d.c. circuit should be opened at point "X" in Fig. 9-11.

The amplifier uses resistance coupling up to the output-stage grids. The first section, V_{1A} , of the 12AX7 has "contact-potential" bias. The gain control, R_1 , is in the grid circuit of the second section, V_{1B} , of the 12AX7. Negative feedback from the secondary of the output transformer, T_1 , is introduced at the cathode of this tube section. The feed-back voltage is dependent on the ratio of R_2 to R_3 , approximately, and with the

constants given is sufficient to result in a considerable reduction in distortion along with improved regulation of the audio output voltage. The latter is important when the unit is used for modulating a screen or control grid, as described in the chapter on amplitude modulation.

The phase inverter is of the split-load type described earlier in this chapter. It drives the push-pull 6AQ5's in the power amplifier. The output transformer used in the power stage is a multitap modulation transformer suitable for any of the types of modulation mentioned above.

Capacitor C_1 across the secondary of the output transformer, T_1 , is used to reduce the high-frequency response of the amplifier. Without it, self-oscillation is likely to occur at a high audio frequency (usually above audibility) because phase shift in the output transformer at the end of its useful frequency range causes the feedback to become positive.

The power supply uses a replacement-type transformer and choke with a capacitor-input filter. Voltage under the modulator and speech-amplifier load is 250. The decoupling resistance-capacitance networks in the plate circuits of V_{1A} and V_{1B} contribute additional smoothing of the d.c. for these low-level stages.

The unit includes provision for send-receive switching, S_1 being used for that purpose. S_{1B} can be used to control the r.f. section — for example, by being connected in parallel with the key used for c.w. operation. Simultaneously S_{1A} short-circuits the secondary of T_1 so the transformer will not be damaged by being left without load. If S_{1B} is connected across the transmitter key, S_1 also can be used as a phone-

◆
 Fig. 9-10 — Speech amplifier and low-power modulator suitable for screen or control-grid modulation of high-power amplifiers, or for plate modulation of an r.f. stage with up to 15 watts plate input. It is assembled on a 7 × 9 × 2 inch steel chassis, with the power supply occupying the left-hand section and the audio circuits the right. The 12AX7 preamplifier is at the lower right-hand corner, the 6C4 phase inverter is to its left, and the 6AQ5 power amplifiers are behind the two. Controls along the chassis edge are, left to right, the power switch, send-receive switch, gain control, and microphone jack.
 ◆

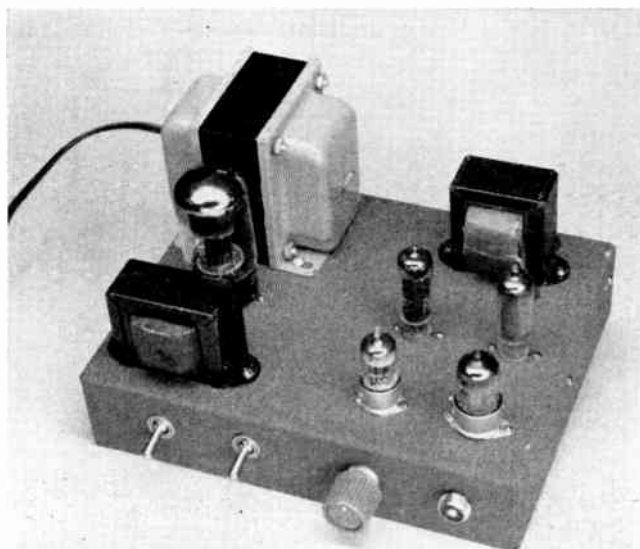

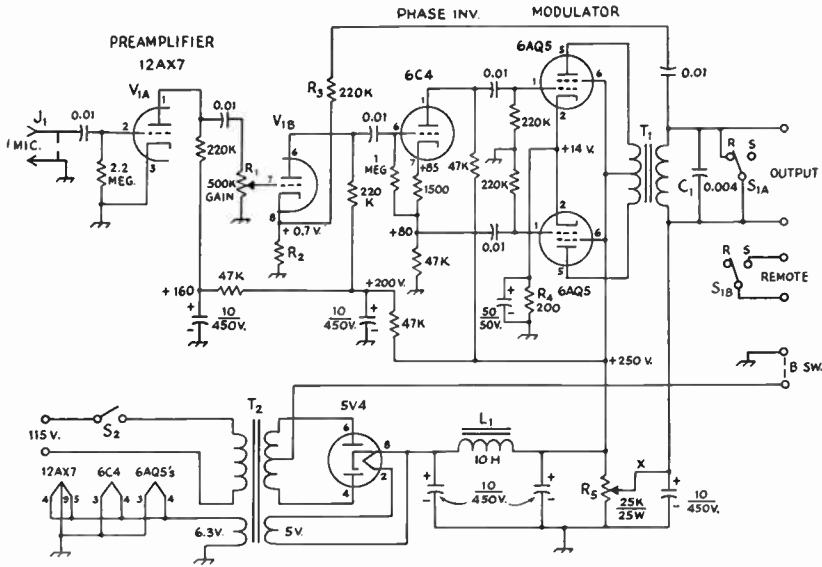

Fig. 9-11 — Circuit of the speech amplifier and modulator. All capacitances are in μf ; capacitors with polarities marked are electrolytic, others are ceramic. Resistors are $\frac{1}{2}$ watt except as noted below. Voltages measured to chassis with v.t. voltmeter.

- J₁ — Microphone connector (Amphenol 75-PC1M).
- L₁ — 10 henrys, 90 ma. (Triad C-7X).
- S₁ — D.p.d.t. toggle.
- S₂ — S.p.s.t. toggle.
- T₁ — Modulation transformer, tapped secondary, pri-

- mary 10,000 ohms plate to plate (Thordarson 21M68)
- T₂ — Power transformer, 525 v.c.t., 90 ma.; 6.3 v., 5 amp.; 5 v., 2 amp. (Triad R-10A).
- R₂ — 1500 ohms, $\frac{1}{2}$ watt.
- R₄ — App. 200 ohms, 2 watts (two 390-ohm 1-watt resistors in parallel).

e.w. switch, being left in the position that represents "off" or "receive" in phone operation.

The terminals marked "B Switch" should be short circuited (indicated by the dashed line) if S₁ is used as a send-receive switch. If a switch on the transmitter is used for send-receive, these terminals may be used for turning the plate voltage in the modulator on and off through an extra pair of contacts on the transmitter send-

receive switch. In that case S₁ should be left in the "send" position for phone operation.

The proper secondary taps to use on T₁ will depend on the impedance of the load to which the amplifier is connected. Methods for determining the modulating impedance with various types of modulation are given in the chapter on amplitude modulation, together with information on connecting the modulator to the r.f. stage.

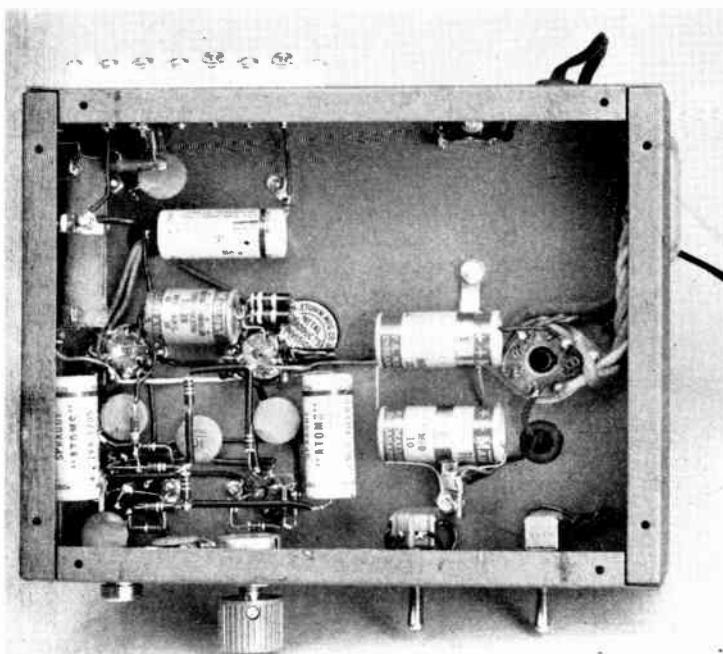

Fig. 9-12 — Below-chassis view of the modulator. The rectifier-tube socket and electrolytic filter capacitors are at the right in this view. The 12AX7 socket is at the lower left. Bleeder resistor R₅ is at the upper left, near the 6-terminal connection strip on the rear edge of the chassis. Placement of components is not critical, but the leads in the first two stages should be kept short and close to the chassis to minimize hum troubles.

25-Watt Modulator using Push-Pull 6BQ6GTs

The speech amplifier-modulator shown in Figs. 9-13 to 9-15, inclusive, can be used for plate modulation of low-power transmitters running 25 to 50 watts input to the final stage. The circuit as shown is capable of an audio output of 25 watts, but this can be increased to 30 watts by a simple modification. The 6BQ6s in the output stage are operated in Class AB₁. Inexpensive receiver-type replacement components are used throughout, except for the modulation transformer.

Circuit

The speech amplifier uses a pentode first stage resistance-coupled to a triode second stage. This combination gives sufficient gain for a crystal microphone. The pentode and triode are the two

keyed, S_{2B} may be used to control the transmitter plate voltage, usually by being connected in the 115-volt circuit to the plate-supply transformer.

The "phone-c.w." switch, S_3 , short-circuits the secondary of the modulation transformer, T_3 , when the transmitter is to be keyed, and also opens the center-tap of T_1 so plate voltage cannot be applied to the modulator.

The power supply uses a receiver replacement-type transformer with a capacitor-input filter. Additional filtering for the speech-amplifier stages is provided by the 10- μ f. capacitors and the series resistors in the plate circuits. Hum is also reduced by the VR-150 used to regulate the modulator screen voltage. Note that the regulator

Fig. 9-13 — A modulator for transmitters operating at plate input up to 50 watts. The speech amplifier and modulator are at the left in this view; power supply components are at the right. The chassis is 7 × 11 × 2 inches.



sections of a dual tube, the 6AN8. Transformer coupling is used between the triode and the modulator tubes, in order to get push-pull voltage for the 6BQ6GT grids. Cathode bias is used on the final stage.

A coupling capacitance between the first and second stages is purposely made small to reduce the low-frequency response, and the primary of the output transformer is shunted by C_2 to reduce the amplification at the high-frequency end. C_1 , on the first stage, also tends to reduce high-frequency response in addition to bypassing any r.f. that might be picked up on the microphone cord. These measures confine the frequency response to the most useful portion of the voice range.

S_2 is the "send-receive" switch. One section opens the power transformer center tap, thus cutting off the plate voltage during receiving periods. The other section can be connected to the key terminals on the transmitter, as indicated in the circuit diagram, to turn the transmitter on and off along with the modulator. If the transmitter is one in which the oscillator is not

tube is connected between the screens and cathodes so that the actual screen voltage is 150 and is not reduced by the drop in the cathode bias resistor. Maintaining full screen voltage is important if the rated output is to be secured.

Operating

The 6BQ6GT amplifier requires a plate-to-plate load of 4000 ohms, and the output transformer ratio must be chosen to reflect this load to the plates (see later section on matching a modulator to its load). For most small transmitters running 30 to 50 watts input to the final stage a 1-to-1 transformer ratio will be satisfactory, since the modulating impedance of such transmitters usually is in the neighborhood of 4000 ohms. The secondary of T_3 is connected in series with the d.c. lead to the plate (and screen, if a screen-grid tube) of the Class C amplifier to be modulated. For further details, see the chapter on amplitude modulation.

For checking the modulator operation a milliammeter (0-200 range satisfactory) may be connected in the lead to the center-tap of the

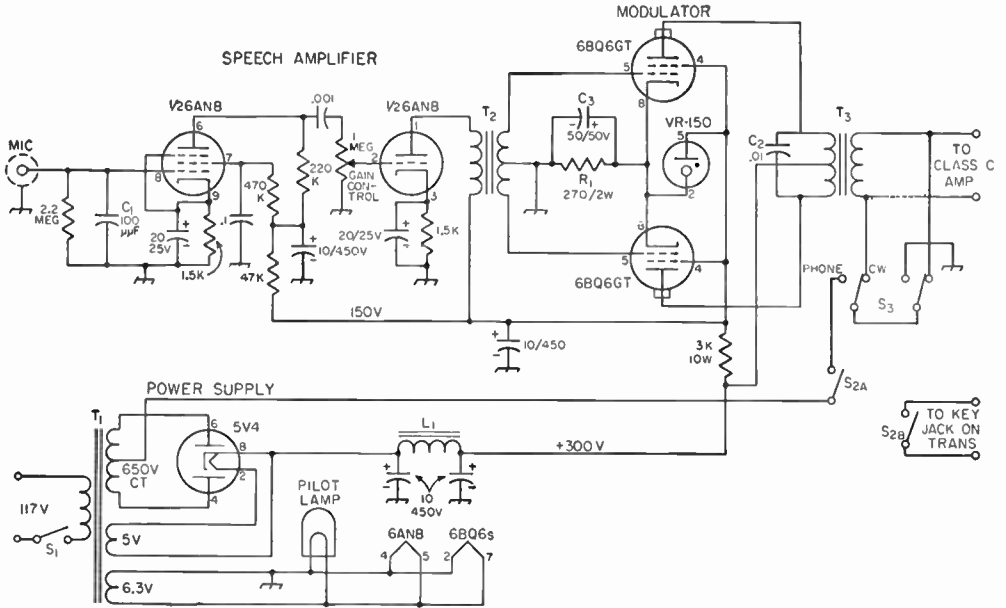

Fig. 9-11 — Circuit diagram of the 25-watt modulator. Capacitances below 0.001 μ f. are in μ μ f. Capacitors up to 0.01 μ f. are ceramic. Resistors are $\frac{1}{2}$ watt unless otherwise specified.

- L₁ — 8 henrys, 150 ma.
- S₁ — S.p.s.t. toggle.
- S₂ — D.p.d.t. toggle.
- S₃ — 2-pole 2-position rotary (Centralab PA-2003).
- T₁ — Power transformer, 650 volts c.t., 150 ma. 5

- volts, 3 amp.; 6.3 volts, 5 amp.
- T₂ — Interstage audio, single plate to p.p. grids, pri. to total sec. ratio 1 to 3.
- T₃ — Modulation transformer, multimatch type (UTC S-19).

primary of T₃. Without voice input to the microphone the plate current should be approximately 50 ma. When modulating the transmitter, the current should "kick" to 60 or 70 ma.; this will usually represent 100 per cent modulation. If the amplifier can be tested with a single-tone signal replacing the microphone, the plate current will be about 165 ma. at full output.

The audio power output can be increased to

about 30 watts, sufficient for modulating an 807 at its full phone rating, if the 6BQ6GT cathodes are grounded and bias of about 30 volts from a fixed source such as a small battery is applied to the grids. The battery may be substituted for the cathode resistor if the ground connection is moved from the center tap of the secondary of T₂ to the cathodes of the 6BQ6GTs.

(From *QST*, December, 1955.)

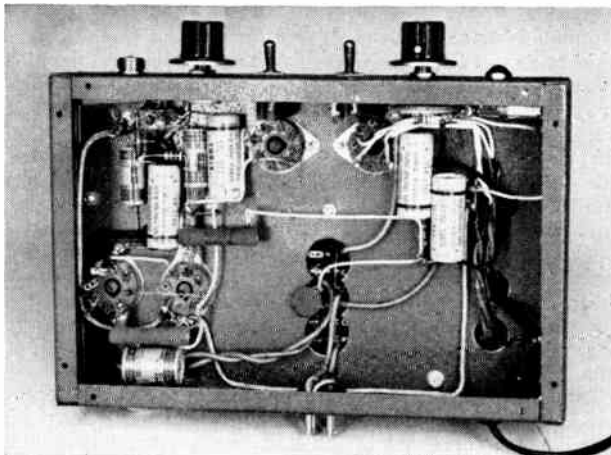

Fig. 9-15 — Under-chassis view of the 6BQ6GT modulator. The two large capacitors at the right are the filter capacitors in the power supply. The modulator bias resistor and by-pass capacitor (R₁C₃) are at lower left. Leads from the modulation transformer go through the three holes in the chassis. Shielded wire is used for heater, microphone input, and gain-control leads.

40-Watt Class AB₁ Modulator

The modulator unit shown in Figs. 9-16 to 9-18, inclusive, has an undistorted power output of somewhat better than 40 watts. It uses a pair of 807s as Class AB₁ power amplifiers and is complete with an inexpensive type of power supply. It may be used to modulate any Class C amplifier operating at a d.c. plate power input of 80 watts or less.

Speech Circuit

The speech amplifier uses a high- μ dual triode as a two-stage resistance-coupled amplifier, followed by a medium- μ triode. The latter is transformer-coupled to the modulator grids. The gain from the microphone input to the 807 grids is more than ample for crystal and other microphones of similar output level. Battery bias is used for the modulator grids since it is the simplest method and a small battery such as those made for hearing-aids can be used. Since no current is taken from the battery, its life is the same as the normal shelf life.

The frequency response of the amplifier is adjusted to put maximum energy in the range where it contributes most to speech intelligibility; that is, the output is highest between 500 and 1200 cycles and drops off gradually on either side. The lower frequencies are reduced by low values of coupling capacitance between the resistance-coupled stages, and the high-frequency end is attenuated by C_1 . Further high-frequency attenuation, with particular reference to such components generated in the modulator itself, is provided by capacitor C_2 , connected across the output terminals of the modulation transformer.

Power Supply

The power supply uses a replacement-type transformer with a bridge rectifier to obtain dual output voltages, nominally 250 and 600 volts. The bridge requires four rectifier elements but makes it possible to obtain twice the d.c. output

voltage that would be secured from a simple center-tap rectifier. The power transformer is not overloaded, however, partly because of the choke-input filter and partly because of the low average current drain of the modulator in normal voice operation.

A separate filament transformer is used for the two 6X5GT rectifiers, with its secondary connected to the center tap of the high-voltage winding of the power transformer. With this arrangement the peak heater-cathode voltage on each tube is about 500 volts, slightly over the rating for these tubes but not excessively so.

The higher output voltage from the bridge rectifier necessitates using filter capacitors having higher working ratings than the ordinary electrolytic, so two 450-volt units are connected in series for the high-voltage filter. A single-section filter is used for this voltage. The bleeder consists of two resistors connected as shown in order to divide the voltage equally between the two electrolytic capacitors.

The d.c. voltage at the center tap of the high-voltage winding of the power transformer is approximately half the d.c. output voltage from the bridge rectifier (with the 6X5GTs, the transformer secondary forms an "inverted" center-tap rectifier system) and so offers a convenient means for taking off a low voltage to operate the speech amplifier, the driver, and the modulator screens. This tap is more extensively filtered than the high-voltage supply, since better smoothing is needed for the low-level stages. Only the 8-henry, 100-ma. choke is common to both filters.

With the values shown in Fig. 9-17 the hum level (measured in the absence of signal) is about 40 db. below the full output of the modulator.

Control Circuits

With this type of power supply circuit it is important that the 6X5GT heaters be permitted

◆

Fig. 9-16 — Class AB₁ modulator using 807s for 40 watts audio output. The power-supply transformer and rectifier tubes occupy the left-hand section of the chassis. The speech amplifier is in the center and the modulator tubes and output transformer are at the right.

The controls, left to right, are the power switches, S_2 and S_3 , the send-receive switch, S_1 , microphone input connector, A_1 , gain control, R_1 , and at the far right, the pilot light.

◆

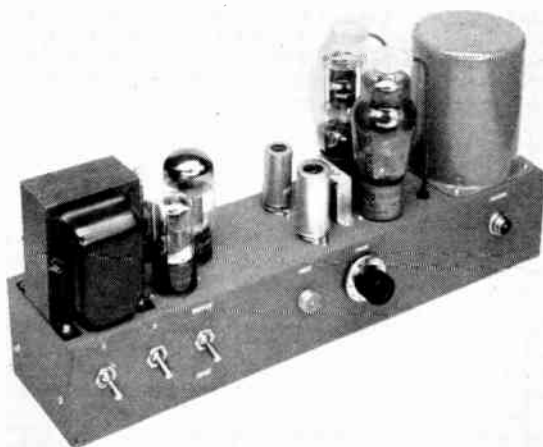

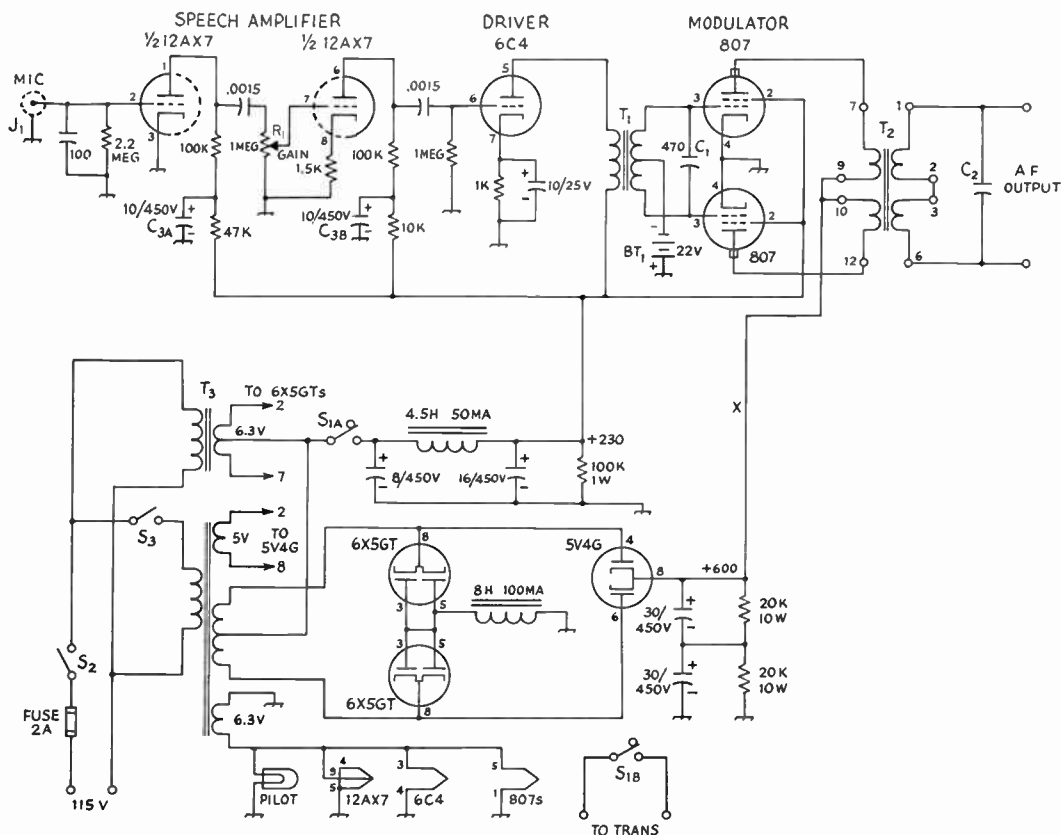

Fig. 9-17 — Circuit diagram of the 10-watt modulator. Capacitances below 0.001 $\mu\text{f.}$ are given in $\mu\text{f.}$; capacitors other than electrolytic may be either paper or ceramic, 600-volt rating. Resistors are $\frac{1}{2}$ watt unless otherwise indicated.

- C₂ — 0.002 to 0.004 $\mu\text{f.}$, 600 volts. Use higher value with lower Class C load resistances.
- C₃ — Dual electrolytic, 10-10 $\mu\text{f.}$, 450 volts.
- C₄ — Dual electrolytic, 8-16 $\mu\text{f.}$, 450 volts.
- R₁ — Carbon potentiometer, audio taper.
- J₁ — Microphone connector (Amphenol PC1M).
- T₁ — Interstage audio transformer, plate to push-pull grids; 10-ma. primary; 3 to 1 turns ratio, total secondary to primary.

- T₂ — Modulation transformer, adjustable ratio, app. 30-watt rating (UTC CVM-1).
- T₃ — Filament transformer, 6.3 volts at 1.2 amp.
- T₄ — Power transformer, 350 volts each side c.t., 90 ma.; 5 volts at 2 amp.; 6.3 volts at 3 amp.
- S₁ — D.p.d.t. toggle.
- S₂, S₃ — S.p.s.t. toggle.
- BT₁ — 22.5-volt battery (hearing-aid type satisfactory).

to come up to full operating temperature before plate voltage is applied. Power can be applied to the 6X5GT heaters by means of S₂; then after 10 or 15 seconds S₃ may be closed. Both switches are then left closed during the operating period.

Send-receive switching is accomplished by S₁. During receiving, S₁ is open so that S_{1A} removes the plate voltage from the speech-amplifier stages and the screen voltage from the 807s. This makes the modulator inoperative. S_{1B} can be used to control any suitable circuit in the transmitter; for example, it can substitute for the key, or can be used to turn the 115-volt circuit of the transmitter plate supply on and off.

Construction

The modulator is built on a 4 × 17 × 3-inch steel chassis, the 17-inch length being selected so

that a standard 19-inch relay-rack panel can be used for mounting the unit if desired. Other chassis sizes and layouts may be used if the builder prefers.

The principal constructional precaution to be observed is that the output transformer, T₂, should not be too close to the low-level speech amplifier circuits. Adequate separation will reduce feedback through stray coupling and thus reduce any possible tendency toward self-oscillation. The interstage transformer, T₁, should be kept well separated from the power transformer, to minimize hum pick-up.

The power transformer is mounted on top of the chassis with its leads running through holes with rubber grommets. The two chokes and the filament transformer are secured to the bottom and sides of the chassis, with the small (4.5-

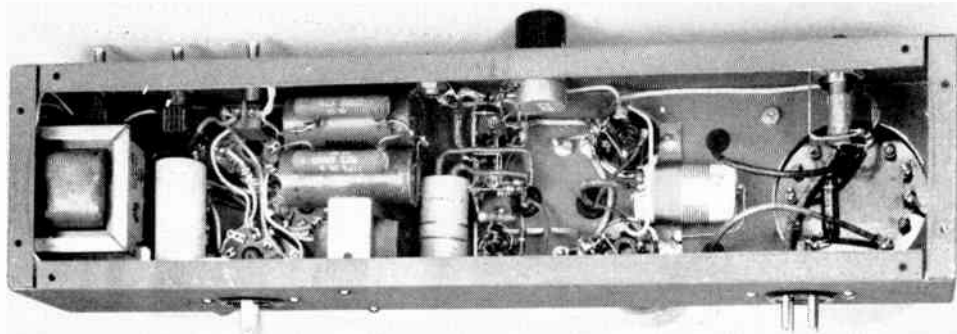

Fig. 9-18 — Bottom view of the 40-watt modulator. The 8-henry input choke of the power supply is at the extreme left, mounted on the chassis wall. Under it (not visible) is the 1.5-henry choke for the low-voltage supply. The dual filter capacitor, C_4 , is between the choke and the 6X5GT tube sockets. The 5V1G socket is hidden by the high-voltage filter capacitors and bleeder resistors. Just below them is the filament transformer, T_5 , mounted on the rear chassis wall.

The sockets for the speech-amplifier tubes are in the center, with the dual audio by-pass capacitor, C_3 , just to the left. The leads coming through the grommets are from the interstage transformer, T_1 . The bias battery and its mounting strap are to the right of the 807 sockets. C_2 is mounted on the modulation transformer terminals, at the right. Audio output and the leads from S_{1B} are connected to the external circuit through the four-prong chassis-mounting connector at the right-hand end of the rear chassis wall.

henry) choke held in place by two of the screws that mount the power transformer. It is necessary to cut a large hole — about 3 inches in diameter — for mounting the modulation transformer; all of the connecting lugs on this transformer are on the bottom of the case, so the hole must be large enough to allow the leads to be connected.

When mounting the two series-connected filter capacitors and their 20,000-ohm voltage-equalizing resistors, care should be taken to keep the resistors from physical contact with other components. These resistors operate at relatively high temperature and could damage other components by direct contact.

The hearing-aid battery that furnishes the 22½-volt bias for the 807s is fastened under the chassis by a small strap, made from brass or aluminum, held in place by the same screws that hold the 807 tube sockets.

In wiring the speech-amplifier section, leads to grids and plates should be kept short and separated as much as possible from heater wiring. The heater leads should be run along the chassis corner except where they must be brought out to reach the tube sockets. Shielded wire should be used for the lead from J_1 to the first grid, and also for the gain-control leads. All these measures help reduce stray hum pickup in the low-level stages.

Operating Values

The optimum plate-to-plate load resistance for 807s operating Class AB_1 with 600 volts on the plates and 250 volts on the screens is approximately 12,500 ohms. At full drive — peak value of signal between the grids equal to twice the bias voltage — the peak power output has a sine-wave equivalent of 48 watts. Not all of this can be realized, since there is some loss in the modula-

tion transformer, but the nominal 40-watt rating is conservative.

The modulation-transformer tap numbers indicated in Fig. 9-17 are recommended (assuming that the type of transformer specified is to be used) for use with transmitters having either a single 6146 or single 807 in the stage to be modulated. Although the reflected load resistance at the modulator plates is a little high in the case of either tube, the power output is still ample for plate-and-screen modulation of either the 6146 or 807 at their maximum phone ratings.

For other r.f. tubes or different voltages and currents, or for a different type of modulation transformer, the load resistance should be calculated as described in the chapter on amplitude modulation and the transformer taps chosen accordingly.

The d.c. power supply voltages in the modulator unit (line voltage 120) should measure 690 and 260 for the high and low supplies with no audio input. The voltages at full output are indicated on the diagram. The modulator idling current is about 50 ma. with a new 22.5-volt (actual voltage 24.5 volts) battery for bias. With tone input and the gain adjusted for maximum undistorted output, the modulator plate current is about 100 ma. (This current may be measured by inserting a milliammeter at point X in the diagram.) However, with speech the modulator plate current should not kick beyond 60 to 65 ma. on voice peaks; this represents full output on modulation peaks because of the lower average power content of voice waveforms as compared with a pure tone.

If c.w. as well as phone operation is to be employed, it is desirable to make provision either in the modulator or the i.f. unit for short-circuiting the modulation transformer secondary when the transmitter is being keyed.

6146 Modulator and Speech Amplifier

The modulator shown in the accompanying photographs uses a pair of 6146s in AB₁, and with the exception of the preamplifier unit is complete with power and bias supplies on a 7 × 17 × 3-inch chassis. The preamplifier is a separate unit so that the microphone input and gain control can be within easy reach at the operating position.

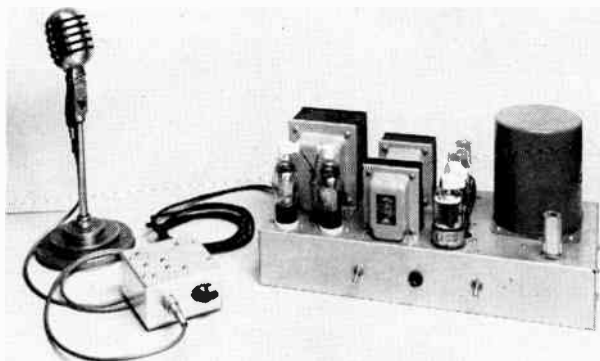

Fig. 9-19 — This Class AB₁ modulator is complete with all supplies. Using two 6146s, it is capable of audio outputs up to 120 watts, depending on the plate voltage selected. The first two stages of speech amplification are built into a small box that may be used at the operating position while the main chassis is installed in any convenient location.

Components on the chassis are, left to right, power transformer and 816 rectifiers, filament transformer and plate filter choke, 6146s and VR tubes, modulation transformer and, in the right foreground, the 6C4 final speech amplifier stage.

The modulator and power supply have no controls that need be manipulated, so can be installed in any convenient spot. The modulator-power supply unit includes one stage of speech amplification, and also is equipped with a splatter filter and an audio take-off for scope monitoring.

The audio power that can be obtained (based on measurements) is as follows:

Nominal Plate Voltage	Power Output	Plate-to-Plate Load Resistance
500 volts	75 watts	4200 ohms
600 volts	95 watts	5200 ohms
750 volts	120 watts	6700 ohms

Suitable sets of components for all three of the voltages listed above are readily available, so the power level can be selected to suit the Class C amplifier to be modulated. The modulator shown in the photographs is set up for 600-volt operation, but sufficient chassis area has been assigned to the power and modulation transformers to accommodate the next larger size of the same style. Other than these two transformers, all other components are the same regardless of the voltage level.

Preamplifier

The preamplifier circuit, shown in Fig. 9-22, is built in a 2 by 4 by 4 aluminum box. It uses a 12AX7 in two resistance-coupled triode stages. The 12AX7 is mounted on a small bracket fastened to one removable side of the box. With the exception of the microphone connector and gain control, which are on one edge of the box, and the connector, J_2 , on the opposite edge, all components are on this same plate, mounted between appropriate tube-socket pins and tie-point strips. Enough lead length is allowed from the components on the box itself to permit taking off

the plate to get at the wiring. Rubber feet are mounted on the other removable side of the box, which becomes the bottom when the unit is in use.

The preamplifier is connected to the modulator through a 10-foot length of cable (Alpha Wire Co. No. 1242) having one shielded and two unshielded conductors. The shielded wire, connected

to Pin 3 of J_2 in Fig. 9-22, is used for the audio output. The shield is the common ground connection through the cable. One of the other two wires is used for plate current and the last for filament current. The capacitance of the shielded

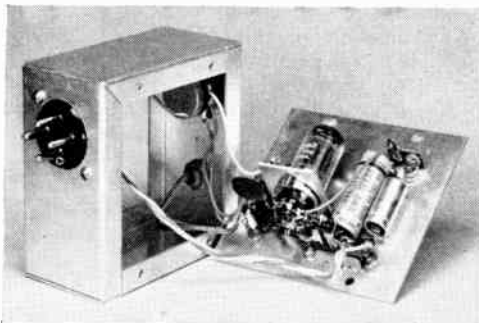

Fig. 9-20 — The preamplifier removed from its 2 by 4 by 4 box.

wire shunts the output circuit and thus reduces the high-frequency response. This is compensated for in the modulator unit.

Modulator and Power Supply

The circuit diagram of the modulator and power supply section is given in Fig. 9-23. The "high-boost" circuit, consisting of the two resistors and 270- μf . capacitor associated with the grid of the 6C4 speech amplifier, compensates for the drop in highs in the cable coming from the preamplifier. The modulation transformer is a multimatch type delivering output to the load through a splatter filter. The three 1-megohm resistors form a voltage divider for delivering about $\frac{1}{3}$ of the total audio output voltage direct to the horizontal plates of a monitoring scope for

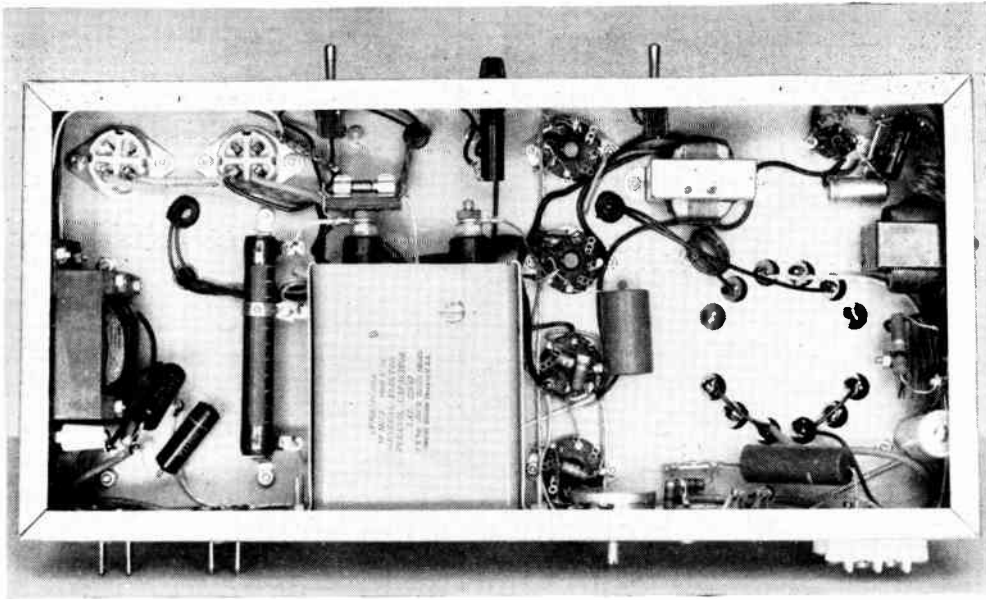

Fig. 9-21 — Bottom view of the modulator and power supply. The sockets at the upper left are for the 816s. The splatter filter choke is mounted on the left-hand chassis wall, using small cone standoffs as tie points for the high-voltage connections. The large resistor to the left of the filter capacitor is the dropping resistor for the low-voltage circuit; the filter capacitor is supported from the rear (lower, in this picture) chassis wall. The 6C4 speech amplifier circuit is at the upper right, with a shielded lead carrying the audio input to it from the four-prong socket, J_3 , mounted on the rear wall of the chassis. T_1 , the interstage audio transformer, is to the left of the 6C4 socket.

Bias-supply components, with the exception of the output potentiometer, R_1 , are mounted on the right-hand chassis wall. R_2 is on the rear wall, near the lowest of the four sockets in a vertical line. The scope take-off circuit is at the lower right.

forming a trapezoidal pattern without amplifiers in the scope. The resistor values can be varied, if necessary, to secure the proper pattern width, although the total resistance should be maintained in the neighborhood of 3 megohms for a 0.005- μ f. coupling capacitor. This capacitor should have a voltage rating equal to at least twice the d.c. plate voltage on the modulated amplifier; 6000-volt paper capacitors in this capacitance are readily available and inexpensive.

Plate power for all tubes is supplied from one transformer. A single-section choke-input filter is used for the high voltage applied to the plates of the 6146s. This is dropped through a resistor and a pair of VR-105s (0C3) in series to provide a regulated voltage of 210 for the 6146 screens. This voltage also is applied to the plate of the

6C4 speech amplifier and, with further filtering by the 4700-ohm resistor and 8- μ f. capacitor, to the preamplifier tube plates through Pin 2 of J_3 . The dropping resistor, R_2 , should be adjusted to approximately 5000 ohms with a 500-volt supply, 7000 ohms for 600 volts, and 10,000 ohms for 750 volts. This adjustment can be checked when the modulator is in operation by observing whether the VR tubes go out on voice peaks. Enough current should be bled through the regulators so that they stay ignited at all voice levels.

A pair of terminals is provided for connecting a milliammeter in series with the plate lead to the 6146s. The meter itself can be placed in any convenient spot. If it is not used, a jumper must be connected across the terminals. This circuit is fused to protect the meter.

The bias supply uses a small filament transformer, T_4 , operating from the regular filament transformer, T_3 , to provide 115 volts for the bias rectifier and filter. Bias is adjusted to the proper value by means of R_1 .

Separate a.c. input connectors are used for the filament and plate supplies; when S_1 and S_2 are closed these can be controlled by remote switches. The bias supply goes on with the filaments, and since there is no time lag in the selenium rectifier the 6146s are always protected.

Splatter Filter

The splatter filter constants should

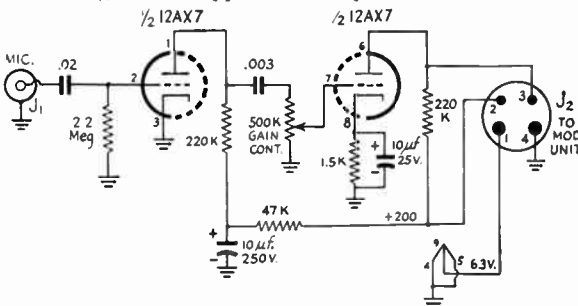

Fig. 9-22 — Preamplifier circuit. Fixed resistors are 1/2 watt. Capacitances in μ f.

J_1 — Microphone connector.
 J_2 — Four-prong connector, chassis mounting, male.

be based on the modulating impedance of the Class C amplifier as described earlier in this chapter.

The choke is a "television" power supply filter choke modified to obtain the desired inductance by widening the air gap, using paper and cardboard spacers. Measured values of inductance with various air gaps are shown in Table 9-II. In reassembling the choke do not use the "finishing" laminations that overlap the I sections on each side of the core. The choke in the photograph is held together by clamps made from tempered Presdwood. The Presdwood mounting also serves to insulate the core from the chassis.

Operating Data

With sine-wave input, the plate current at full output is 240 ma. when the load is adjusted to the appropriate value for the plate voltage in use, as listed earlier. This maximum current is practically the same at all plate voltages listed, since the plate dissipation rating of the 6146 does not permit using a bias value that gives a very large value of no-signal plate current. The grid bias

Air gap, inches	Inductance, henrys
0.003	0.71
0.010	0.62
0.020	0.48
0.025	0.46
0.050	0.36
0.075	0.31
0.100	0.28
0.125	0.26
0.15	0.24

should be adjusted for a total plate current that represents a no-signal input of slightly under 50 watts at the particular plate voltage used.

The voltage gain from the microphone input to the modulator grids is such that full output can be secured with an input voltage of about 3 millivolts, r.m.s.

(Originally described in *QST* for December, 1954.)

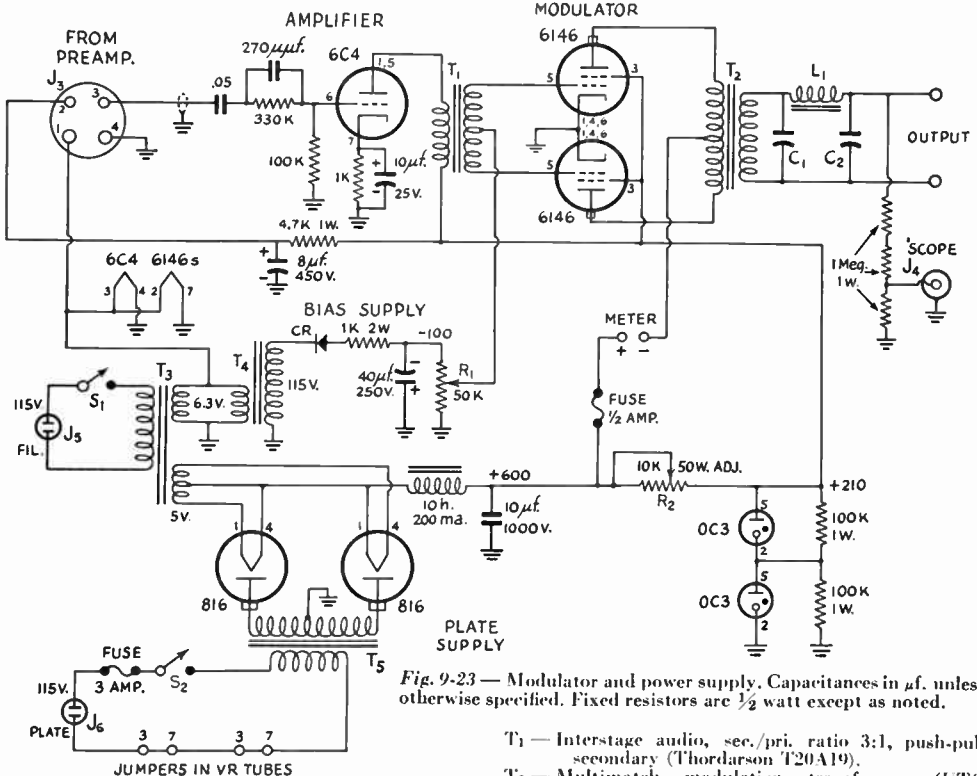

Fig. 9-23 — Modulator and power supply. Capacitances in $\mu\text{f.}$ unless otherwise specified. Fixed resistors are $\frac{1}{2}$ watt except as noted.

- C₁, C₂ — 1600-volt paper. See text.
- R₁ — (Bias control) 50,000-ohm potentiometer, preferably wire-wound.
- R₂ — 10,000 ohms, 50 watts, adjustable.
- L₁ — See text.
- CR — Selenium rectifier, 20 ma. or larger, for 115-volt operation.
- J₃ — Four-prong connector, chassis mounting, female.
- J₄ — Phono connector.
- J₅, J₆ — 115-volt connector, chassis mounting, male.
- S₁, S₂ — S.p.s.t. toggle switch.

- T₁ — Interstage audio, sec./pri. ratio 3:1, push-pull secondary (Thorndarson T20A19).
- T₂ — Multimatch modulation transformer (UTC CVM-2 or CVM-3, depending on audio output power level).
- T₃ — Filament transformer, 6.3 volts at 8 amp.; 5 volts at 3 amp. (Triad F-30A).
- T₄ — Filament transformer, 6.3 volts at $\frac{1}{2}$ amp. (Triad F-11X).
- T₅ — Plate transformer. For 500 volts d.c.: 1235 v. c.t., 310 ma. (Triad P-7A); for 600 volts d.c.: 1155 v. c.t., 310 ma. (Triad P-14A); for 750 volts d.c.: 1780 c.t., 310 ma. (Triad type P-13A).

Modulators and Drivers

● CLASS AB AND B MODULATORS

Class AB or B modulator circuits are basically identical no matter what the power output of the modulator. The diagrams of Fig. 9-24 therefore will serve for any modulator of this type that the amateur may elect to build. The triode circuit is given at A and the circuit for tetrodes at B. When small tubes with indirectly-heated cathodes are used, the cathodes should be connected to ground.

Modulator Tubes

The audio ratings of various types of transmitting tubes are given in the chapter containing the tube tables. Choose a pair of tubes that is capable of delivering sine-wave audio power equal to somewhat more than half the d.c. input to the modulated Class C amplifier. It is sometimes convenient to use tubes that will operate at the same plate voltage as that applied to the Class C stage, because one power supply of adequate current capacity may then suffice for both stages.

In estimating the output of the modulator, remember that the figures given in the tables are for the tube output only, and do not include output-transformer losses. To be adequate for modulating the transmitter, the modulator should have

a theoretical power capability 15 to 25 per cent greater than the actual power needed for modulation.

Matching to Load

In giving audio ratings on power tubes, manufacturers specify the plate-to-plate load impedance into which the tubes must operate to deliver the rated audio power output. This load impedance seldom is the same as the modulating impedance of the Class C r.f. stage, so a match must be brought about by adjusting the turns ratio of the coupling transformer. The required turns ratio, primary to secondary, is

$$N = \sqrt{\frac{Z_p}{Z_m}}$$

where N = Turns ratio, primary to secondary

Z_m = Modulating impedance of Class C r.f. amplifier

Z_p = Plate-to-plate load impedance for Class B tubes

Example: The modulated r.f. amplifier is to operate at 1250 volts and 250 ma. The power input is

$$P = EI = 1250 \times 0.25 = 312 \text{ watts}$$

so the modulating power required is $312/2 = 156$ watts. Increasing this by 25% to allow for losses and a reasonable operating margin gives $156 \times 1.25 = 195$ watts. The modulating impedance of the Class C stage is

$$Z_m = \frac{E}{I} = \frac{1250}{0.25} = 5000 \text{ ohms.}$$

From the tube tables a pair of Class B tubes is selected that will give 200 watts output when working into a 6000-ohm load, plate-to-plate. The primary-to-secondary turns ratio of the modulation transformer therefore should be

$$N = \sqrt{\frac{Z_p}{Z_m}} = \sqrt{\frac{6000}{5000}} = \sqrt{1.38} = 1.175:1.$$

The required transformer ratios for the ordinary range of impedances are shown graphically in Fig. 9-25.

Many modulation transformers are provided with primary and secondary taps, so that various turns ratios can be obtained to meet the requirements of particular tube combinations.

It may be that the exact turns ratio required cannot be secured, even with a tapped modulation transformer. Small departures from the proper turns ratio will have no serious effect if the modulator is operating well within its capabilities; if the actual turns ratio is within 10 per cent of the ideal value the system will operate satisfactorily. Where the discrepancy is larger, it is usually possible to choose a new set of operating conditions for the Class C stage to give a modulating impedance that

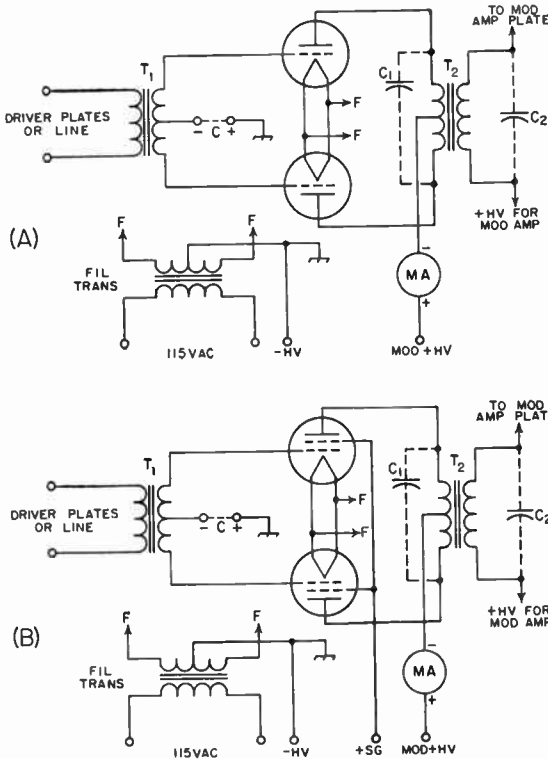

Fig. 9-24 — Modulator circuit diagrams. Tubes and circuit considerations are discussed in the text.

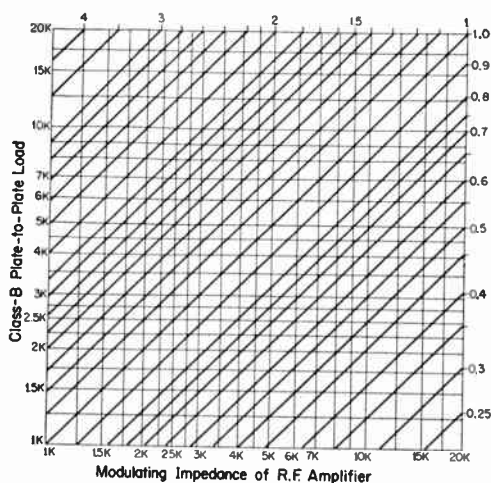

Fig. 9-25 — Transformer ratios for matching a Class C modulating impedance to the required plate-to-plate load for the Class B modulator. The ratios given on the curves are from total primary to secondary. Resistance values are in kilohms.

can be matched by the turns ratio of the available transformer. This may require operating the Class C amplifier at higher voltage and less plate current, if the modulating impedance must be increased, or at lower voltage and higher current if the modulating impedance must be decreased. However, this process cannot be carried very far without exceeding the ratings of the Class C tubes for either plate voltage or plate current, even though the power input is kept at the same figure.

Suppressing Audio Harmonics

Distortion in either the driver or Class B modulator will cause a.f. harmonics that may lie outside the frequency band needed for intelligible speech transmission. While it is almost impossible to avoid some distortion, it is possible to cut down the amplitude of the higher-frequency harmonics.

The purpose of capacitors C_1 and C_2 across the primary and secondary, respectively, of the Class B output transformer in Fig. 9-24 is to reduce the strength of harmonics and unnecessary high-frequency components existing in the modulation. The capacitors act with the leakage inductance of the transformer winding to form a rudimentary low-pass filter. The values of capacitance required will depend on the load resistance (modulating impedance of the Class C amplifier) and the leakage inductance of the particular transformer used. In general, capacitances between about 0.001 and 0.01 $\mu\text{f.}$ will be required; the larger values are necessary with the lower values of load resistance. The voltage rating of each capacitor should at least be equal to the d.c. voltage at the transformer winding with which it is associated. In the case of C_2 , part of the total capacitance required will be supplied by the plate by-pass or

blocking capacitor in the modulated amplifier.

A still better arrangement is to use a low-pass filter as shown in Fig. 9-9, even though clipping is not deliberately employed.

Grid Bias

Certain triodes designed for Class B audio work can be operated without grid bias. Besides eliminating the grid-bias supply, the fact that grid current flows over the whole audio cycle means that the load resistance for the driver is more constant. With these tubes the grid-return lead from the center-tap of the input transformer secondary is simply connected to the filament center-tap or cathode.

When the modulator tubes require bias, it should always be supplied from a fixed voltage source. Cathode bias or grid-leak bias cannot be used with a Class B amplifier; with both types the bias changes with the amplitude of the signal voltage, whereas proper operation demands that the bias voltage be unvarying no matter what the strength of the signal. When only a small amount of bias is required it can be obtained conveniently from a few dry cells. When greater values of bias are required, a heavy-duty "B" battery may be used if the grid current does not exceed 40 or 50 milliamperes on voice peaks. Even though the batteries are charged by the grid current rather than discharged, a battery will deteriorate with time and its internal resistance will increase. When the increase in internal resistance becomes appreciable, the battery tends to act like a grid-leak resistor and the bias varies with the applied signal. Batteries should be checked with a voltmeter occasionally while the amplifier is operating. If the bias varies more than 10 per cent or so with voice excitation the battery should be replaced.

As an alternative to batteries, a regulated bias supply may be used. This type of supply is described in the power supply chapter.

Plate Supply

In addition to adequate filtering, the voltage regulation of the plate supply should be as good as it can be made. If the d.c. output voltage of the supply varies with the load current, the voltage at maximum current determines the amount of power that can be taken from the modulator without distortion. A supply whose voltage drops from 1500 at no load to 1250 at the full modulator plate current is a 1250-volt supply, so far as the modulator is concerned, and any estimate of the power output available should be based on the lower figure.

Good dynamic regulation — i.e., with suddenly-applied loads — is equally as important as good regulation under steady loads, since an instantaneous drop in voltage on voice peaks also will limit the output and cause distortion. The output capacitor of the supply should have as much capacitance as conditions permit. A value of at least 10 $\mu\text{f.}$ should be used, and still larger values are desirable. It is better to use all the available capacitance in a single-section filter

rather than to distribute it between two sections.

It is particularly important, in the case of a tetrode Class B stage, that the screen-voltage power-supply source have excellent regulation, to prevent distortion. The screen voltage should be set as exactly as possible to the recommended value for the tube. The audio impedance between screen and cathode also must be low.

Overexcitation

When a Class B amplifier is overdriven in an attempt to secure more than the rated power, distortion increases rapidly. The high-frequency harmonics which result from the distortion modulate the transmitter, producing spurious side bands which can cause serious interference over a band of frequencies several times the channel width required for speech. (This can happen even though the modulation percentage, as defined in the chapter on amplitude modulation, is less than 100 per cent, if the modulator is incapable of delivering the audio power required to modulate the transmitter.)

As stated earlier, such a condition may be reached by deliberate design, in case the modulator is to be adjusted for peak clipping. But whether it happens by accident or intention, the splatter and spurious side bands can be eliminated by inserting a low-pass filter (Fig. 9-9) between the modulator and the modulated amplifier, and then taking care to see that the actual modulation of the r.f. amplifier does not exceed 100 per cent.

Operation Without Load

Excitation should never be applied to a Class B modulator until after the Class C amplifier is turned on and is drawing the value of plate current required to present the rated load to the modulator. With no load to absorb the power, the primary impedance of the transformer rises to a high value and excessive audio voltages are developed across it — frequently high enough to break down the transformer insulation. If the modulator is to be tested separately from the transmitter, a resistance of the same value as the modulating impedance, and capable of dissipating the full power output of the modulator, should be connected across the secondary.

● **DRIVERS FOR CLASS-B MODULATORS**

Class AB₂ and Class B amplifiers are driven into the grid-current region, so power is con-

sumed in the grid circuit. The preceding stage or driver must be capable of supplying this power at the required peak audio-frequency grid-to-grid voltage. Both of these quantities are given in the manufacturer's tube ratings. The grids of the Class B tubes represent a varying load resistance over the audio-frequency cycle, because the grid current does not increase directly with the grid voltage. To prevent distortion, therefore, it is necessary to have a driving source that will maintain the wave form of the signal without distortion even though the load varies. That is, the driver stage must have good regulation. To this end, it should be capable of delivering somewhat more power than is consumed by the Class B grids, as previously described in the discussion on speech amplifiers.

The driver transformer, *T* or *T*₂ in Fig. 9-26, may couple directly between the driver tubes and the modulator grids or may be designed to work into a low-impedance (200- or 500-ohm) line. In the latter case, a tube-to-line output transformer must be used at the output of the driver stage. This type of coupling is recommended only when the driver must be at a considerable distance from the modulator: the second transformer not only introduces additional losses but also impairs the voltage regulation of the driver stage.

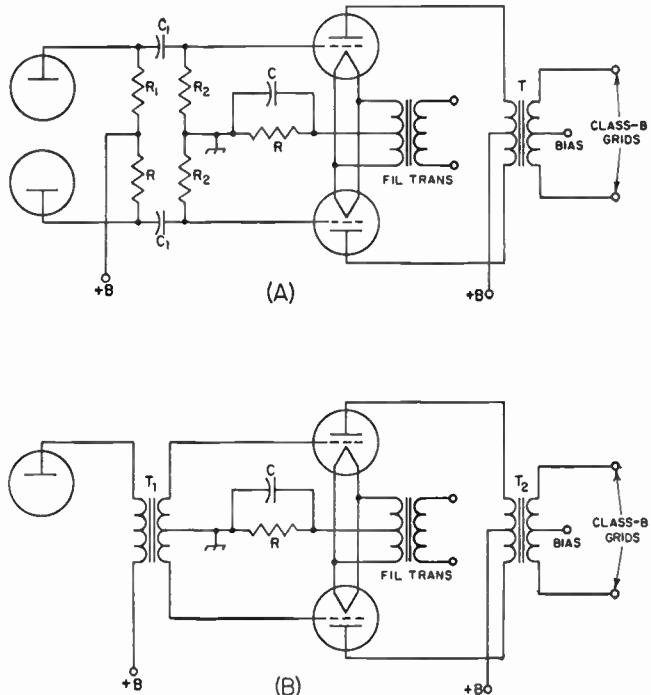

Fig. 9-26 — Triode driver circuits for Class B modulators. A, resistance coupling to grids; B, transformer coupling. *R*₁ in A is the plate resistor for the preceding stage, value determined by the type of tube and operating conditions as given in Table 9-1. *C*₁ and *R*₂ are the coupling capacitor and grid resistor, respectively; values also may be taken from Table 9-1. In both circuits the output transformer, (*T*, *T*₂) should have the proper turns ratio to couple between the driver tubes and the Class B grids. *T*₁ in B is usually a 2:1 transformer, secondary to primary. *R*, the cathode resistor, should be calculated for the particular tubes used. The value of *C*, the cathode bypass, is determined as described in the text.

Driver Tubes

To secure good voltage regulation the internal impedance of the driver, as seen by the modulator grids, must be low. The principal component of this impedance is the plate resistance of the driver tube or tubes as reflected through the driver transformer. Hence for low driving-source impedance the effective plate resistance of the driver tubes should be low and the turns ratio of the driver transformer, primary to secondary, should be as large as possible. The maximum turns ratio that can be used is that value which just permits developing the modulator grid-to-grid a.f. voltage required for the desired power output.

Low- μ triodes such as the 6B4G have low plate resistance and are therefore good tubes to use as drivers for Class AB₂ or Class B modulators. Tetrodes such as the 6V6 and 6L6 make very poor drivers in this respect when used without negative feedback, but with such feedback the effective plate resistance can be reduced to a value comparable with low- μ triodes.

In selecting a driver stage always choose Class A or AB₁ operation in preference to Class AB₂. This not only simplifies the speech-amplifier design but also makes it easier to apply negative feedback to tetrodes for reduction of plate resistance. It is possible to obtain a tube power output of approximately 25 watts from 6L6s without going beyond Class AB₁ operation; this is ample driving power for the popular Class B modulator tubes, even when a kilowatt transmitter is to be modulated.

The rated tube output as shown by the tube tables should be reduced by about 20 per cent to allow for losses in the Class B input transformer. If two transformers are used, tube-to-line and line-to-grids, allow about 35 per cent for transformer losses. Another 25 per cent should be allowed, if possible, as a safety factor and to improve the voltage regulation.

Fig. 9-26 shows representative circuits for a push-pull triode driver using cathode bias. If the amplifier operates Class A the cathode resistor need not be bypassed, because the a.f. currents from each tube flowing in the cathode resistor are out of phase and cancel each other. However, in Class AB operation this is not true; considerable distortion will be generated at high signal levels if the cathode resistor is not bypassed. The by-pass capacitance required can be calculated by a simple rule: the cathode resistance in ohms multiplied by the by-pass capacitance in microfarads should equal at least 25,000. The voltage rating of the capacitor should be equal to the maximum bias voltage. This can be found from the maximum-signal plate current and the cathode resistance.

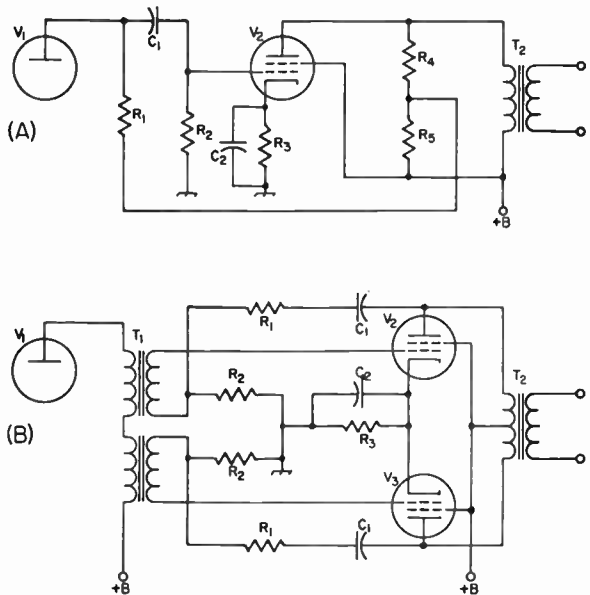

Fig. 9-27 — Negative-feedback circuits for drivers for Class B modulators. A — Single-ended beam-tetrode driver. If V_1 and V_2 are a 6J5 and 6V6, respectively, the following values are suggested: R_1 , 47,000 ohms; R_2 , 0.47 megohm; R_3 , 250 ohms; R_4 , R_5 , 22,000 ohms; C_1 , 0.01 μ f.; C_2 , 50 μ f.

B — Push-pull beam-tetrode driver. If V_1 is a 6J5 and V_2 and V_3 6L6s, the following values are suggested: R_1 , 0.1 megohm; R_2 , 22,000 ohms; R_3 , 250 ohms; C_1 , 0.1 μ f.; C_2 , 100 μ f.

Example: A pair of 6B4Gs is to be used in Class AB₁ self-biased. From the tube tables, the cathode resistance should be 780 ohms and the maximum-signal plate current 120 ma. From Ohm's Law,

$$E = RI = 780 \times 0.12 = 93.6 \text{ volts}$$

From the rule mentioned previously, the by-pass capacitance required is

$$C = 25,000/R = 25,000/780 = 32 \mu\text{f.}$$

A 40- or 50- μ f. 100-volt electrolytic capacitor would be satisfactory.

Negative Feedback

Whenever tetrodes or pentodes are used as drivers for Class B modulators, negative feedback should be used in the driver stage, for the reason discussed above.

Suitable circuits for single-ended and push-pull tetrodes are shown in Fig. 9-27. Fig. 9-27A shows resistance coupling between the preceding stage and a single tetrode, such as the 6V6, that operates at the same plate voltage as the preceding stage. Part of the a.f. voltage across the primary of the output transformer is fed back to the grid of the tetrode, V_2 , through the plate resistor of the preceding tube, V_1 . The total resistance of R_4 and R_5 in series should be ten or more times the rated load resistance of V_2 . Instead of the voltage divider, a tap on the transformer primary can be used to supply the feedback voltage, if such a tap is available.

The amount of feedback voltage that appears at the grid of tube V_2 is determined by R_1 , R_2 and the plate resistance of V_1 , as well as by the rela-

relationship between R_4 and R_5 . Circuit values for a typical tube combination are given in detail in Fig. 9-27.

The push-pull circuit in Fig. 9-27B requires an audio transformer with a split secondary. The feed-back voltage is obtained from the plate of each output tube by means of the voltage divider, R_1, R_2 . The blocking capacitor, C_1 , prevents the d.c. plate voltage from being applied to R_1R_2 ; the reactance of this capacitor should be low, compared with the sum of R_1 and R_2 , at the lowest audio frequency to be amplified. Also, the sum of R_1 and R_2 should be high (ten times or more) compared with the rated load resistance for V_2 and V_3 .

In this circuit the feed-back voltage that is developed across R_2 appears at the grid of V_2 (or V_3) through the transformer secondary and grid-cathode circuit of the tube, provided the tubes are not driven to grid current. The per cent feedback is

$$n = \frac{R_2}{R_1 + R_2} \times 100$$

where n is the feed-back percentage, and R_1 and R_2 are connected as shown in the diagram. The higher the feed-back percentage, the lower the effective plate resistance. However, if the percentage is made too high the preceding tube, V_1 , may not be able to develop enough voltage, through T_1 , to drive the push-pull stage to maximum output without itself generating harmonic distortion. Distortion in V_1 is not compensated for by the feed-back circuit.

If V_2 and V_3 are 6L6s operated self-biased in Class AB₁ with a load resistance of 9000 ohms, V_1 is a 6J5, and T_1 has a turns ratio of 2-to-1,

total secondary to primary, it is possible to use over 30 per cent feedback without going beyond the output-voltage capabilities of the 6J5. Twenty per cent feedback will reduce the effective plate resistance to the point where the output voltage regulation is better than that of 6B4Gs or 2A3s without feed-back.

If the grid-cathode impedance of the tubes is relatively low, as it is when grid current flows, the feed-back voltage decreases because of the voltage drop through the transformer secondary. The circuit should not be used with tubes that are operated Class AB₂.

● SPEECH-AMPLIFIER CIRCUIT WITH NEGATIVE FEEDBACK

A circuit for a speech amplifier suitable for driving a Class B modulator is given in Fig. 9-28. In this amplifier the 6L6s are operated Class AB₁ and will deliver up to 20 watts to the grids of the Class B amplifier. The feed-back circuit requires no adjustment, but does require an interstage transformer with two separate secondary windings (split secondary).

Any convenient chassis layout may be used for the amplifier provided the principles outlined in the section on speech-amplifier construction are observed. The over-all gain is ample for a communications-type crystal microphone.

The output transformer, T_2 , should be selected to work between a 9000-ohm plate-to-plate load and the grids of whatever Class B tubes will be used. The power-supply requirements for this amplifier are 145 ma. at 360 volts and 2.7 amp. at 6.3 volts.

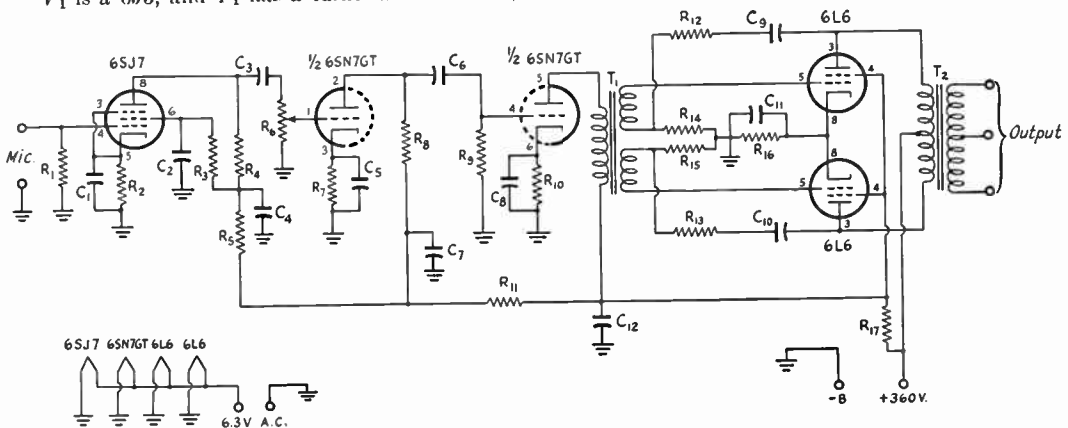

Fig. 9-28 — Circuit diagram of speech amplifier using 6L6s with negative feedback, suitable for driving Class B modulators up to 500 watts output.

- C_1, C_5, C_8 — 20- μ f. 25-volt electrolytic.
- $C_2, C_3, C_4, C_6, C_7, C_9, C_{10}, C_{11}, C_{12}$ — 0.1- μ f. 100-volt paper.
- C_3, C_6 — 0.01- μ f. 600-volt paper.
- C_4, C_7, C_{12} — 10- μ f. 450-volt electrolytic.
- C_{11} — 100- μ f. 50-volt electrolytic.
- R_1 — 2.2 megohms, $\frac{1}{2}$ watt.
- R_2, R_7 — 1500 ohms, $\frac{1}{2}$ watt.
- R_3 — 1.5 megohms, $\frac{1}{2}$ watt.
- R_4 — 0.22 megohm, $\frac{1}{2}$ watt.
- R_5, R_8 — 47,000 ohms, $\frac{1}{2}$ watt.
- R_6 — 1-megohm volume control.

- R_9 — 0.17 megohm, $\frac{1}{2}$ watt.
- R_{10} — 1500 ohms, 1 watt.
- R_{11} — 10,000 ohms, $\frac{1}{2}$ watt.
- R_{12}, R_{13} — 0.1 megohm, 1 watt.
- R_{14}, R_{15} — 22,000 ohms, $\frac{1}{2}$ watt.
- R_{16} — 250 ohms, 10 watts.
- R_{17} — 2000 ohms, 10 watts.
- T_1 — Interstage audio with split secondary winding (such as Thordarson T20A25).
- T_2 — Class B input transformer to suit modulator tubes.

Class B Modulator with Filter

Representative Class B modulator construction is illustrated by the unit shown in Figs. 9-29 and 9-31. This modulator includes a splatter



Fig. 9-29 — A typical Class B modulator arrangement. This unit uses a pair of 811 Vs, capable of an audio power output of 310 watts, and includes a splatter filter. The modulation transformer is at the left and the splatter choke at the right. All high-voltage terminals are covered so they cannot be touched accidentally.

filter, $C_1C_2L_1$ in the circuit diagram, Fig. 9-30, and also has provision for short-circuiting the modulation transformer secondary when c.w. is to be used.

The audio input transformer is not built into this unit, it being assumed that this transformer will be included in the driver assembly as is customary. If the modulator and speech amplifier-

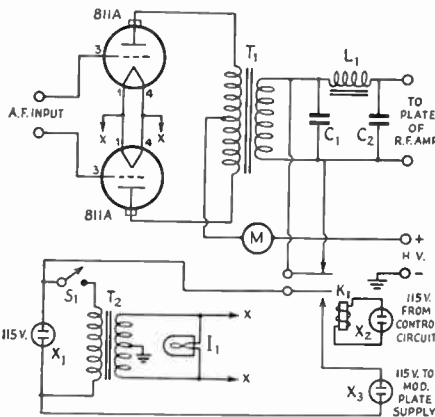

Fig. 9-30 — Circuit diagram of the Class B modulator. C_1 , C_2 , L_1 — See text. (L_1 is Chicago Transformer type SR-300.)

K_1 — D.p.d.t. relay, high-voltage insulation (Advance type 400).

M — 0–500 d.c. milliammeter, bakelite case.

T_1 — Variable-ratio modulation transformer (Chicago Transformer type CMS-1).

T_2 — Filament transformer, 6.3 v., 8 amp.

I_1 — 6.3-volt pilot light.

X_1 , X_2 — Chassis-type 115-volt plugs, male.

X_3 — Chassis-type 115-volt receptacle, female.

S_1 — S.p.s.t. toggle.

driver are mounted in the same rack or cabinet, the length of leads from the driver to the modulator grids presents no problem. The bias required by the modulator tubes at their higher plate-voltage ratings should be fed through the center tap on the secondary of the driver transformer. At a plate voltage of 1000 or less no bias is needed and the center-tap connection on the transformer can be grounded.

The values of C_1 , C_2 and L_1 depend on the modulating impedance of the Class C r.f. amplifier. They can be determined from the formulas given in this chapter in the section on high-level clipping and filtering. The splatter filter will be effective regardless of whether the modulator operating conditions are chosen to give high-level clipping, but it is worth while to design the system for clipping at 100 per cent modulation if the tube curves are available for that purpose. The voltage ratings for C_1 and C_2 should at least equal the d.c. voltage applied to the modulated r.f. amplifier.

A relay with high-voltage insulation (actually an antenna relay) is used to short-circuit the

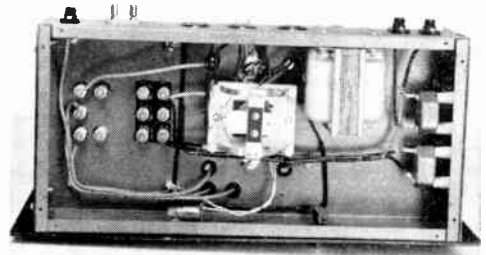

Fig. 9-31 — The filament transformer is mounted beneath the chassis. The relay is used as described in the text. C_1 and C_2 are mounted on small stand-off insulators on the chassis wall.

secondary of T_1 when the relay coil is not energized. A normally-closed contact is used for this purpose. The other arm is used to close the primary circuit of the modulator plate supply when the relay is energized. Shorting the transformer secondary is necessary when the r.f. amplifier is keyed, to prevent an inductive discharge from the transformer winding that would put "tails" on the keyed characters and, with cathode keying of the amplifier, would cause excessive sparking at the key contacts. The control circuit should be arranged in such a way that K_1 is not energized during c.w. operation but is energized by the send-receive switch during phone operation.

Careful attention should be paid to insulation since the instantaneous voltages in the secondary circuit of the transformer will be at least twice the d.c. voltage on the r.f. amplifier. Stand-off insulators are used in this unit wherever necessary, including the mounting for the relay.

Checking Amplifier Operation

An adequate job of checking speech amplifiers can be done with equipment that is neither elaborate nor expensive. A typical setup is shown in Fig. 9-32. The construction of a simple audio oscillator is described in the chapter on measurements. The audio-frequency voltmeter can be either a vacuum-tube voltmeter or a multirange volt-ohm-milliammeter that has a rectifier-type a.c. range. The headset is included for aural checking of the amplifier performance.

An audio oscillator usually will have an output control, but if the maximum output voltage is in excess of a volt or so the output setting may be rather critical when a high-gain speech amplifier is being tested. In such cases an attenuator such as is shown in Fig. 9-32 is a convenience. Each of the two voltage dividers reduces the voltage by a factor of roughly 10 to 1, so that the over-all attenuation is about 100 to 1. The relatively low value of resistance, R_4 , across the input terminals of the amplifier also will minimize stray hum pickup on the connecting leads.

As a preliminary check, cover the microphone input terminals with a metal shield (with the audio oscillator and attenuator disconnected) and, while listening in the headset, note the hum level with the amplifier gain control in the off position. The hum should be very low under these conditions. Then increase the gain-control setting to maximum and observe the hum; it will no doubt increase. Next connect the audio oscillator and attenuator and, starting from minimum signal, increase the audio input voltage until the voltmeter indicates full power output. (The voltage should equal \sqrt{PR} , where P is the expected power output in watts and R is the load resistance — R_6 in the diagram.) While increasing the input, listen carefully to the tone to see if there is any change in its character. When it begins to sound like a musical octave instead of a single tone, distortion is beginning. Assuming that the tone is substantially without audible distortion at full output, substitute the microphone for the audio oscillator and speak into it at moderate level while watching the voltmeter. Reduce the gain-control setting until the meter "kicks" nearly up to the

full-power reading on voice peaks. Note the hum level, as read on the voltmeter, at this point; the hum level should not exceed one or two per cent of the voltage at full output.

If the hum level is too high, the amplifier stage that is causing the trouble can be located by temporarily short-circuiting the grid of each tube to ground, starting with the output amplifier. When shorting a particular grid makes a marked decrease in hum, the hum presumably is coming from a preceding stage, although it is possible that it is getting its start in that particular grid circuit. If shorting a grid does not decrease the hum, the hum is originating either in the plate circuit of that tube or the grid circuit of the next. Aside from wiring errors, a defective tube, or

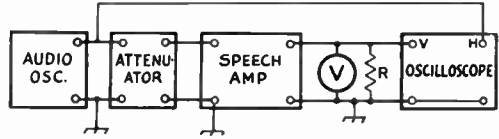

Fig. 9-33 — Test setup using the oscilloscope to check for distortion. These connections will result in the type of pattern shown in Fig. 9-31, the horizontal sweep being provided by the audio input signal. For wave-form patterns, omit the connection between the audio oscillator and the horizontal amplifier in the scope, and use the horizontal linear sweep.

inadequate plate-supply filtering, objectionable hum usually originates in the first stage of the amplifier.

If distortion occurs below the point at which the expected power output is secured, the stage in which it is occurring can be located by working from the last stage toward the front end of the amplifier, applying a signal to each grid in turn from the audio oscillator and adjusting the signal voltage for maximum output. In the case of push-pull stages, the signal may be applied to the primary of the interstage transformer — after disconnecting it from the plate-voltage source. Assuming that normal design principles have been followed and that all stages are theoretically working within their capabilities, the probable causes of distortion are wiring errors (such as accidental short-circuit of a cathode resistor), defective components, or use of wrong values of resistance in cathode and plate circuits.

Using the Oscilloscope

Speech-amplifier checking is facilitated considerably if an oscilloscope of the type having amplifiers and a linear sweep circuit is available. A typical setup for using the oscilloscope is shown in Fig. 9-33. With the connections shown, the sweep circuit is not required but horizontal and vertical amplifiers are necessary. Audio voltage from the oscillator is

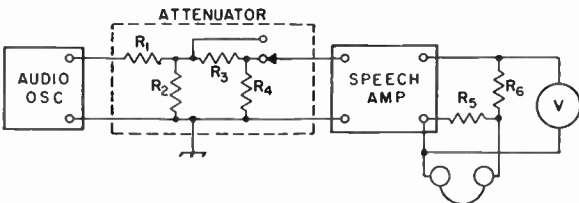

Fig. 9-32 — Simple test setup for checking a speech amplifier. It is not necessary that the frequency range of the audio oscillator be continuously variable; one or more "spot frequencies" will be satisfactory. Suitable resistor values are: R_1 and R_3 , 10,000 ohms; R_2 and R_4 , 1000 ohms; R_5 , rated load resistance for amplifier output stage; R_6 , determine by trial for comfortable headphone level (25 to 100 ohms, ordinarily); use two or more resistors in parallel as a safety precaution. V is a high-resistance a.c. voltmeter.

fed directly to one oscilloscope amplifier (horizontal in this case) and the output of the speech amplifier is connected to the other. The scope amplifier gains should be adjusted so that each signal gives the same line length with the other signal shut off.

Under these conditions, when the input and output signals are applied simultaneously they are compared directly. If the speech amplifier is distortion-free and introduces no phase shift, the resulting pattern is simply a straight line, as shown at the upper left in Fig. 9-34, making an angle of about 45 degrees with the horizontal and vertical axes. If there is no distortion but there is phase shift, the pattern will be a smooth ellipse, as shown at the upper right. The greater the phase shift the greater the tendency of the ellipse to grow into a circle. When there is even-harmonic distortion in the amplifier one end of the line or ellipse becomes curved, as shown in the second row in Fig. 9-34. With odd-harmonic distortion such as is characteristic of overdriven push-pull stages, the line or ellipse is curved at both ends.

Patterns such as these will be obtained when the input signal is a fairly good sine wave. They will tend to become complicated if the input wave form is complex and the speech amplifier introduces appreciable phase shifts. It is therefore advisable to test for distortion with an input signal that is as nearly as possible a sine wave. Also, it is best to use a frequency in the 500-1000 cycle range, since improper phase shift in the amplifier is usually least in this region. Phase shift in itself is not of great importance in an audio amplifier of ordinary design because it does not change the character of speech so far as the ear is concerned. However, if a complex signal is used for testing, phase shift may make it difficult to detect distortion in the oscilloscope pattern.

In amplifiers having negative feedback, excessive phase shift within the feed-back loop may cause self-oscillation, since the signal fed back may arrive at the grid in phase with the applied signal voltage instead of out of phase with it. Such a phase shift is most likely to be associated with the output transformer. Oscillation usually occurs at some frequency above 10,000 cycles, although occasionally it will occur at a very low frequency. If the pass band in the stage in which the phase shift occurs is deliberately restricted to the optimum voice range, as described earlier, the gain at both very high and very low frequencies will be so low that self-oscillation is unlikely, even with large amounts of feedback.

Generally speaking, it is easier to detect small amounts of distortion with the type of pattern shown in Fig. 9-34 than it is with the wave-form pattern obtained by feeding the output signal to the vertical plates and making use of the linear sweep in the scope. However, the wave-form pattern can be used satisfactorily if the signal from the audio oscillator is a reasonably good sine wave. One simple method is to examine the output of the oscillator alone and trace the pattern on a sheet of transparent paper. The pattern

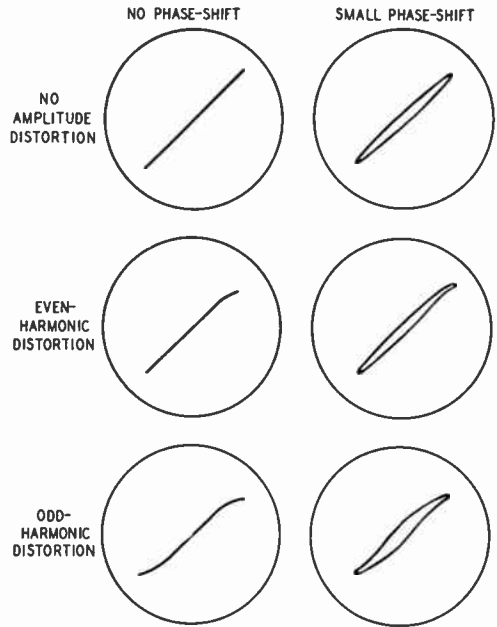

Fig. 9-34 — Typical patterns obtained with the connections shown in Fig. 9-33. Depending on the number of stages in the amplifier, the pattern may slope upward to the right, as shown, or upward to the left. Also, depending on where the distortion originates, the curvature in the second row may appear either at the top or bottom of the line or ellipse.

given by the output of the amplifier can then be compared with the "standard" pattern by adjusting the oscilloscope gain to make the two patterns coincide as closely as possible. The pattern discrepancies are a measure of the distortion.

In using the oscilloscope care must be taken to avoid introducing hum voltages that will upset the measurements. Hum pickup on the scope leads or other exposed parts such as the amplifier load resistor or the voltmeter can be detected by shutting off the audio oscillator and speech amplifier and connecting first one and then the other to the vertical plates of the scope, setting the internal horizontal sweep to an appropriate width. The trace should be a straight horizontal line when the vertical gain control is set at the position used in the actual measurements. Waviness in the line indicates hum. If the hum is not in the scope itself (check by disconnecting the leads at the instrument) make sure that there is a good ground connection on all the equipment and, if necessary, shield the hot leads.

The oscilloscope can be used to good advantage in stage-by-stage testing to check wave forms at the grid and plate of each stage and thus to determine rapidly where a source of trouble may be located. When the scope is connected to circuits that are not at ground potential for d.c., a capacitor of about 0.1 μf . should be connected in series with the hot oscilloscope lead. The probe lead should be shielded so that it will not pick up hum.

Amplitude Modulation

The type of modulation most commonly employed in amateur radiotelephony is called **amplitude modulation (a.m.)**. The name arises from the fact that the methods of generating a modulated wave of a particular type all accomplish the desired result by varying the instantaneous amplitude of the r.f. output of the transmitter.

As described in the chapter on circuit fundamentals, the process of modulation sets up groups of frequencies called **side bands**, which appear symmetrically above and below the frequency of the unmodulated signal or **carrier**. If the instantaneous values of all these frequencies are added together, the result is a **modulation envelope** which follows the amplitude variations of the audio-frequency signal that is being used to modulate the wave.

To produce this result it is not necessary that the component radio frequencies — carrier and side frequencies — vary in amplitude at the modulation rate. For example, a carrier modulated by a 1000-cycle tone will consist of three components — the lower side frequency, the carrier, and the upper side frequency — all of which are perfectly constant in amplitude when received on a system having enough selectivity to respond to each component separately while excluding the remaining two. When received by a system that responds equally well to all three *simultaneously*, the output of the demodulator *does* vary at the modulation rate, 1000 cycles in the example above. This is because the detector responds to the modulation envelope, when the band width is sufficient to pass all side bands along with the carrier, since the detector itself is an amplitude-operated device.

As a matter of fact, in amplitude modulation the carrier amplitude always is constant with or without modulation. The side frequencies likewise will be constant in amplitude if the modulation is a steady tone, even though the tone may be one consisting of a fundamental and series of harmonics. When the modulation is rapidly varying in wave form, as in the transmission of speech, the side frequencies will vary in distribution and amplitude.

The existence of the side bands along with the carrier can easily be demonstrated experimentally. It is perhaps easier to get an insight of the true nature of an a.m. signal by considering its modulation envelope to be the resultant of the instantaneous values of the carrier and sidebands than it is to attempt to visualize side bands as being generated by the process of varying the r.f. envelope amplitude, although the latter is actually the method used for modulation.

A.M. Side Bands and Channel Width

As described in the chapter on fundamentals, combining or mixing two frequencies in an ap-

propriate circuit gives rise to sum and difference frequencies. Speech can be electrically reproduced with high intelligibility, in a band of frequencies lying between approximately 100 and 3000 cycles. When these frequencies are combined with a radio-frequency carrier, the side bands occupy the frequency spectrum from about 3000 cycles below the carrier frequency to 3000 cycles above — a total band or “channel” of about 6 kilocycles. Actual speech frequencies extend up to 10,000 cycles or so, so it is possible to occupy a 20-ke. channel if no provision is made for reducing its width. For communication purposes such a channel width represents a waste of valuable spectrum space, since a 6-ke. channel is fully adequate for intelligibility. Occupying more than the minimum channel creates unnecessary interference, so speech equipment and transmitter adjustment and operation should be pointed toward maintaining the channel width at the minimum.

● THE MODULATION ENVELOPE

In Fig. 10-1, the drawing at A shows the unmodulated r.f. signal, assumed to be a sine wave of the desired radio frequency. The graph can be taken to represent either voltage or current.

In B, the signal is assumed to be modulated by the audio-frequency shown in the small drawing above. This frequency is much lower than the carrier frequency, a necessary condition for good modulation, and always the case in radiotelephony because the audio frequencies used are very low compared with the radio frequency of the carrier. When the modulating voltage is “positive” (above its axis) the envelope amplitude is increased *above* its unmodulated amplitude; when the modulating voltage is “negative” the envelope amplitude is *decreased*. Thus the signal grows larger and smaller with the polarity and amplitude of the modulating voltage.

The drawings at C shows what happens with stronger modulation. The envelope amplitude is doubled at the instant the modulating voltage reaches its positive peak. On the negative peak of the modulating voltage the envelope amplitude just reaches zero; in other words, the signal is completely modulated.

Percentage of Modulation

When a modulated signal is detected in a receiver, the detector output follows the modulation envelope. The stronger the modulation, therefore, the greater is the useful receiver output. Obviously, it is desirable to make the modulation as strong or “heavy” as possible. A wave modulated as in Fig. 10-1C would produce considerably more useful audio output than the one shown at B.

The "depth" of the modulation is expressed as a percentage of the unmodulated carrier amplitude. In either B or C, Fig. 10-1, X represents the unmodulated carrier amplitude, Y is the maximum envelope amplitude on the modulation up-peak, and Z is the minimum envelope amplitude on the modulation down-peak.

In a properly-operating modulation system the modulation envelope is an accurate reproduction of the modulating wave, as can be seen in Fig. 10-1 at B and C by comparing one side

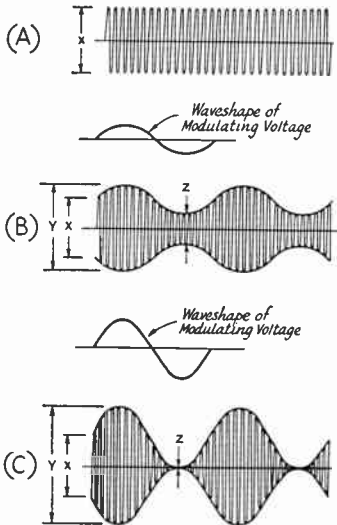

Fig. 10-1 — Graphical representation of (A) r.f. output unmodulated, (B) modulated 50%, (C) modulated 100%. The modulation envelope is shown by the thin outline on the modulated wave.

of the outline with the shape of the modulating wave. (The lower outline duplicates the upper, but simply appears upside down in the drawing.)

The percentage of modulation is

$$\% \text{ Mod.} = \frac{Y - X}{X} \times 100 \text{ (upward modulation), or}$$

$$\% \text{ Mod.} = \frac{X - Z}{X} \times 100 \text{ (downward modulation)}$$

If the wave shape of the modulation is such that its peak positive and negative amplitudes are equal, then the modulation percentage will be the same both up and down. If the two percentages differ, the larger of the two is customarily specified.

Power in Modulated Wave

The amplitude values shown in Fig. 10-1 correspond to current or voltage, so the drawings may be taken to represent instantaneous values of either. The power in the wave varies as the square of either the current or voltage, so at the peak of the modulation up-swing the instantaneous power in the envelope of Fig. 10-1C is four times the unmodulated carrier power (because the current and voltage both are doubled). At the peak of the down-swing the power is zero,

since the amplitude is zero. These statements are true of 100 per cent modulation no matter what the wave form of the modulation. The instantaneous envelope power in the modulated signal is proportional to the square of its envelope at every instant. This fact is highly important in the operation of every method of amplitude modulation.

It is convenient, and customary, to describe the operation of modulation systems in terms of sine-wave modulation. Although this wave shape is seldom actually used in practice (voice wave shapes depart very considerably from the sine form) it lends itself to simple calculations and its use as a standard permits comparison between systems on a common basis. With sine-wave modulation the average power in the modulated signal over any number of full cycles of the modulation frequency is found to be $1\frac{1}{2}$ times the power in the unmodulated carrier. In other words, the power output increases 50 per cent with 100 per cent modulation by a sine wave.

This relationship is very useful in the design of modulation systems and modulators, because any such system that is capable of increasing the average power output by 50 per cent with sine-wave modulation automatically fulfills the requirement that the instantaneous power at the modulation up-peak be four times the carrier power. Consequently, systems in which the additional power is supplied from outside the modulated r.f. stage (e.g., plate modulation) usually are designed on a sine-wave basis as a matter of convenience. Modulation systems in which the additional power is secured from the modulated r.f. amplifier (e.g., grid modulation) usually are more conveniently designed on the basis of peak envelope power rather than average power.

The extra power that is contained in a modulated signal goes entirely into the side bands, half in the upper side band and half in the lower. As a numerical example, full modulation of a 100-watt carrier by a sine wave will add 50 watts of side-band power, 25 in the lower and 25 in the upper side band. Supplying this additional power for the side bands is the object of all of the various systems devised for amplitude modulation.

No such simple relationship exists with complex wave forms. Complex wave forms such as speech do not, as a rule, contain as much average power as a sine wave. Ordinary speech wave forms have about half as much average power as a sine wave, for the same peak amplitude in both wave forms. For the same modulation percentage in both cases, the side-band power with ordinary speech will average only about half the power with sine-wave modulation, since it is the peak amplitude, not the average power, that determines the percentage of modulation.

Unsymmetrical Modulation

In an ordinary electric circuit it is possible to increase the amplitude of current flow indefinitely, up to the limit of the power-handling capability of the components, but it cannot very well be decreased to less than zero. The same

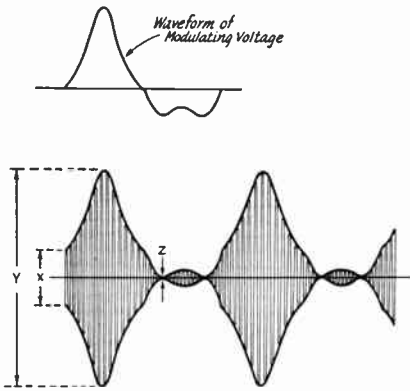

Fig. 10-2 — Modulation by an unsymmetrical wave form. This drawing shows 100% downward modulation along with 300% upward modulation. There is no distortion, since the modulation envelope is an accurate reproduction of the wave form of the modulating voltage.

thing is true of the amplitude of an r.f. signal; it can be modulated *upward* to any desired extent, but it cannot be modulated *downward* more than 100 per cent.

When the modulating wave form is unsymmetrical it is possible for the upward and downward modulation percentages to be different. A simple case is shown in Fig. 10-2. The positive peak of the modulating signal is about 3 times the amplitude of the negative peak. If, as shown in the drawing, the modulating amplitude is adjusted so that the peak downward modulation is just 100 per cent ($Z = 0$) the peak upward modulation is 300 per cent ($Y = 4X$). The carrier amplitude is represented by X , as in Fig. 10-1. The modulation envelope reproduces the wave form of the modulating signal accurately, hence there is no distortion. In such a modulated signal the increase in power output with modulation is considerably greater than when the modulation is symmetrical and has to be limited to 100 per cent both up and down. However, the peak envelope amplitude, Y , is four times the carrier amplitude, X , so the peak *power* is 16 times the carrier power. When the upward modulation is more than 100 per cent the peak power capacity of the modulating system obviously must be increased sufficiently to take care of the much larger peak amplitudes.

Overmodulation

If the amplitude of the modulation on the downward swing becomes too great, there will be a period of time during which the output is entirely cut off. This is shown in Fig. 10-3. The shape of the downward half of the modulating wave is no longer accurately reproduced by the modulation envelope, consequently the modulation is distorted. Operation of this type is called **overmodulation**. The distortion of the modulation envelope causes new frequencies to be generated (harmonics of the modulating frequency, which combine with the carrier to form new

side frequencies correspondingly spaced from the carrier frequency) that widen the channel occupied by the modulated signal. These spurious frequencies are commonly called "splatter."

It is important to realize that the channel occupied by an amplitude-modulated signal is dependent on the shape of the modulation envelope. If this wave shape is complex and can be resolved into a wide band of audio frequencies, then the channel occupied will be correspondingly large. The modulation-envelope wave shape shown in Fig. 10-3 will contain a large number of harmonics of the original sine-wave frequency of the modulating wave because of the sharp corners in the wave shape when it is "clipped" at the zero axis. However, if the original modulating wave had had this same shape the channel occupied by the modulating signal would be exactly the same. Basically, it is not the fact that the signal cannot be modulated more than 100 per cent downward that causes splatter, but the fact that *any* distorted modulation envelope contains higher frequencies than were present in the original modulating wave. A wave that is efficiently clipped, as is the case in Fig. 10-3, will contain a wider range of spurious frequencies than one in which there are no highly abrupt changes in amplitude.

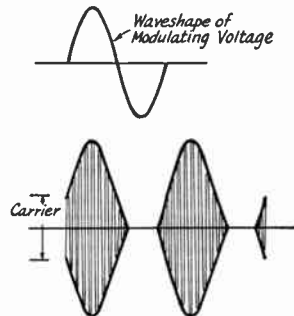

Fig. 10-3 — An overmodulated signal. The modulation envelope is not an accurate reproduction of the wave form of the modulating voltage. This or any type of distortion occurring during the modulation process generates spurious side bands of "splatter."

Because of this clipping action at the zero axis, it is important that care be taken to prevent applying too large a modulating signal in the downward direction. Overmodulation results in more splatter than is caused by most other types of distortion in a phone transmitter.

● GENERAL REQUIREMENTS

For proper operation of an amplitude-modulated transmitter there are a few general requirements that must be met no matter what particular method of modulation may be used. Failure to meet these requirements is accompanied by distortion of the modulation envelope. This in turn increases the channel width as compared with that required by the legitimate frequencies contained in the original modulating wave.

Frequency Stability

For satisfactory amplitude modulation, the carrier frequency must be entirely unaffected by modulation. If the application of modulation causes a change in the carrier frequency, the frequency will wobble back and forth with the modulation. This causes distortion and widens the channel taken by the signal. Thus unnecessary interference is caused to other transmissions.

In practice, this undesirable frequency modulation is prevented by applying the modulation to an r.f. amplifier stage that is isolated from the frequency-controlling oscillator by a **buffer amplifier**. Amplitude modulation applied directly to an oscillator always is accompanied by frequency modulation. Under existing FCC regulations amplitude modulation of an oscillator is permitted only on frequencies above 144 Mc. Below that frequency the regulations require that an amplitude-modulated transmitter be completely free from frequency modulation.

Linearity

At least up to the limit of 100 per cent upward modulation, the amplitude of the r.f. output should be directly proportional to the amplitude of the modulating wave. Fig. 10-4 is a graph of an ideal modulation characteristic, or curve showing the relationship between r.f. output amplitude and instantaneous modulation amplitude. The modulation swings the r.f. amplitude back and forth along the curve *A*, as the modulating voltage alternately swings positive and negative. Assuming that the negative peak of the modulating wave is just sufficient to reduce the r.f. output to zero (modulating voltage equal to -1 in the drawing), the same modulating voltage peak in the *positive* direction ($+1$)

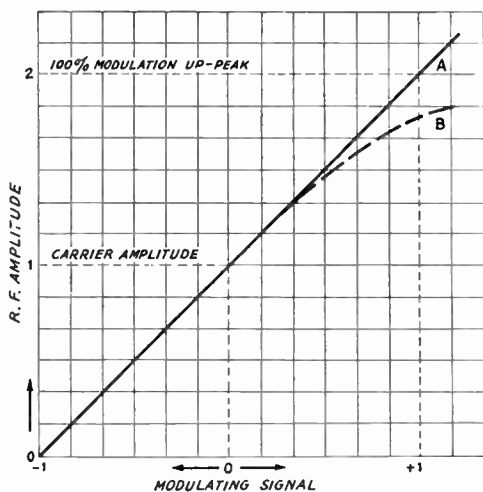

Fig. 10-4—The modulation characteristic shows the relationship between the instantaneous envelope amplitude of the r.f. output current (or voltage) and the instantaneous amplitude of the modulating voltage. The ideal characteristic is a straight line, as shown by curve *A*.

should cause the r.f. amplitude to reach twice its unmodulated value. The ideal is a straight line, as shown by curve *A*. Such a modulation characteristic is perfectly linear.

A **nonlinear** characteristic is shown by curve *B*. The r.f. amplitude does not reach twice the unmodulated carrier amplitude when the modulating voltage reaches its positive peak. A modulation characteristic of this type gives a modulation envelope that is "flattened" on the up-peak; in other words, the modulation envelope is not an exact reproduction of the modulating wave. It is therefore distorted and harmonics are generated, causing the transmitted signal to occupy a wider channel than is necessary. A nonlinear modulation characteristic can easily result when a transmitter is not properly designed or is misadjusted.

The **modulation capability** of the transmitter is the maximum percentage of modulation that is possible without objectionable distortion from nonlinearity. The maximum capability can never exceed 100 per cent on the down-peak, but it is possible for it to be higher on the up-peak. The modulation capability should be as close to 100 per cent as possible, so that the most effective signal can be transmitted.

Plate Power Supply

The d.c. power supply for the plate or plates of the modulated amplifier should be well filtered; if it is not, plate-supply ripple will modulate the carrier and cause annoying hum. The ripple voltage should not be more than about 1 per cent of the d.c. output voltage.

In amplitude modulation the plate current varies at an audio-frequency rate; in other words, an alternating current is superimposed on the d.c. plate current. The output filter capacitor in the plate supply must have low reactance, at the lowest audio frequency in the modulation, if the transmitter is to modulate equally well at all audio frequencies. The capacitance required depends on the ratio of d.c. plate current to plate voltage in the modulated amplifier. The requirements will be met satisfactorily if the capacitance of the output capacitor is at least equal to

$$C = 25 \frac{I}{E}$$

where C = Capacitance of output capacitor in μf .

I = D.c. plate current of modulated amplifier in milliamperes

E = Plate voltage of modulated amplifier

Example: A modulated amplifier operates at 1250 volts and 275 ma. The capacitance of the output capacitor in the plate-supply filter should be at least

$$C = 25 \frac{I}{E} = 25 \times \frac{275}{1250} = 25 \times 0.22 = 5.5 \mu\text{f}$$

Modulation Systems

An amplitude-modulated signal can be generated by a variety of methods, the only present-used ones being those in which a modulat-

ing voltage is applied to one or more tube elements in an r.f. amplifier. The proper object of all methods is to generate an r.f. signal having a modulation envelope which reproduces the wave form of the modulating voltage with as little distortion as possible.

The methods described in this chapter are the basic ones. There are many specialized variations, usually involving some form of grid modulation

with the object of increasing the rather low plate efficiency that is an inherent characteristic of grid modulation. Such systems, when they actually achieve substantially distortionless modulation, are rather complicated circuitwise, are difficult to adjust and are not well adapted to rapid frequency change. They have so far had little or no lasting application in amateur communication.

Amplitude Modulation Methods

● PLATE MODULATION

The most popular system of amplitude modulation is plate modulation. It is the simplest to apply, gives the highest efficiency in the modulated amplifier, and is the easiest to adjust for proper operation.

Fig. 10-5 shows the most widely-used system of plate modulation, in this case with a triode r.f. tube. A balanced (push-pull Class A, Class AB or Class B) modulator is transformer-coupled to the plate circuit of the modulated r.f. amplifier. The audio-frequency power generated by the modulator is combined with the d.c. power in the modulated-amplifier plate circuit by transfer through the coupling transformer, *T*. For 100 per cent modulation the audio-frequency power output of the modulator and the turns ratio of the coupling transformer must be such that the voltage at the plate of the modulated amplifier varies between zero and twice the d.c. operating plate voltage, thus causing corresponding variations in the amplitude of the r.f. output.

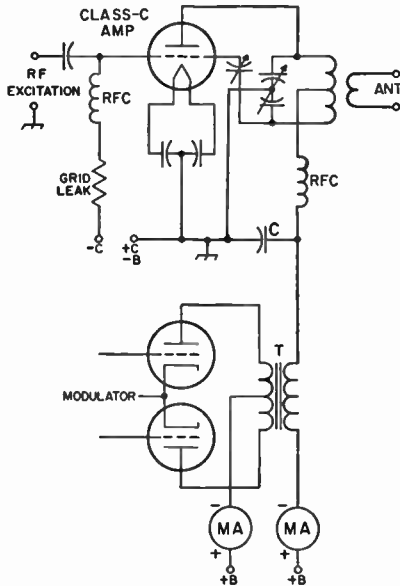

Fig. 10-5 — Plate modulation of a Class C r.f. amplifier. The r.f. plate by-pass capacitor, *C*, in the amplifier stage should have reasonably high reactance at audio frequencies. A value of the order of 0.001 μ f. to 0.005 μ f. is satisfactory in practically all cases. (See chapter on modulators.)

Audio Power

As stated earlier, the average power output of the modulated stage must increase during modulation. The modulator must be capable of supplying to the modulated r.f. stage sine-wave audio power equal to 50 per cent of the d.c. plate input. For example, if the d.c. plate power input to the r.f. stage is 100 watts, the sine-wave audio power output of the modulator must be 50 watts.

Modulating Impedance; Linearity

The modulating impedance, or load resistance presented to the modulator by the modulated r.f. amplifier, is equal to

$$Z_m = \frac{E_b}{I_p} \times 1000 \text{ ohms}$$

where E_b = D.c. plate voltage

I_p = D.c. plate current (ma.)

E_b and I_p are measured without modulation.

The power output of the r.f. amplifier must vary as the square of the instantaneous plate voltage (the r.f. output voltage must be proportional to the plate voltage) for the modulation to be linear. This will be the case when the amplifier operates under Class C conditions. The linearity depends upon having sufficient grid excitation and proper bias, and upon the adjustment of circuit constants to the proper values.

Adjustment of Plate-Modulated Amplifiers

The general operating conditions for Class C operation are described in the chapter on transmitters. The grid bias and grid current required for plate modulation usually are given in the operating data supplied by the tube manufacturer; in general, the bias should be such as to give an operating angle of about 120 degrees at the d.c. plate voltage used, and the grid excitation should be great enough so that the amplifier's plate efficiency will stay constant when the plate voltage is varied over the range from zero to twice the unmodulated value. For best linearity, the grid bias should be obtained partly from a fixed source of about the cut-off value, and then supplemented by grid-leak bias to supply the remainder of the required operating bias.

The maximum permissible d.c. plate power input for 100 per cent modulation is twice the sine-wave audio-frequency power output available from the modulator. This input is obtained by varying the loading on the amplifier (keeping its tank circuit tuned to resonance) until the

product of d.c. plate voltage and plate current is the desired power. The modulating impedance under these conditions must be transformed to the proper value for the modulator by using the correct output-transformer turns ratio. This point is considered in detail in the chapter on modulator design.

Neutralization, when triodes are used, should be as nearly perfect as possible, since regeneration may cause nonlinearity. The amplifier also must be completely free from parasitic oscillations.

Although the total power input (d.c. plus audio-frequency a.e.) increases with modulation, the d.c. plate current of a plate-modulated amplifier should not change when the stage is modulated. This is because each increase in plate voltage and plate current is balanced by an equivalent decrease in voltage and current on the next half-cycle of the modulating wave. D.c. instruments cannot follow the a.f. variations, and since the average d.c. plate current and plate voltage of a properly-operated amplifier do not change, neither do the meter readings. A change in plate current with modulation indicates nonlinearity. On the other hand, a thermocouple r.f. ammeter connected in the antenna or transmission line will show an increase in r.f. current with modulation, because instruments of this type respond to power rather than to current or voltage.

Screen-Grid Amplifiers

Screen-grid tubes of the pentode or beam-tetrode type can be used as Class C plate-modulated amplifiers by applying the modulation to both the plate and screen grid. The usual method of feeding the screen grid with the necessary d.c. and modulation voltage is shown in Fig. 10-6. The dropping resistor, R , should be of the proper value to apply normal d.c. voltage to the screen under steady carrier conditions. Its value can be calculated by taking the difference between plate and screen voltages and dividing it by the rated screen current.

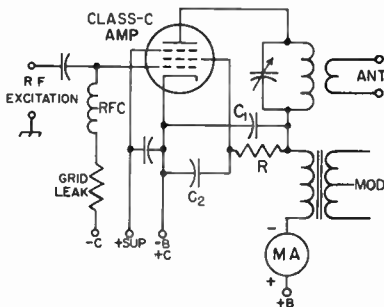

Fig. 10-6 — Plate and screen modulation of a Class C r.f. amplifier using a screen-grid tube. The plate r.f. by-pass capacitor, C_1 , should have reasonably high reactance at all audio frequencies; a value of 0.001 to 0.005 $\mu\text{f.}$ is generally satisfactory. The screen by-pass, C_2 , should not exceed 0.002 $\mu\text{f.}$ in the usual case.

When the modulated amplifier is a beam tetrode the suppressor connection shown in this diagram may be ignored. If a base terminal is provided on the tube for the beam-forming plates, it should be connected as recommended by the manufacturer.

The modulating impedance is found by dividing the d.c. plate voltage by the sum of the plate and screen currents. The plate voltage multiplied by the sum of the two currents gives the power input to be used as the basis for determining the audio power required from the modulator.

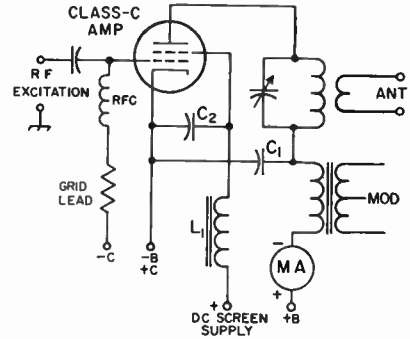

Fig. 10-7 — Plate modulation of a beam tetrode, using an audio impedance in the screen circuit. The value of L_1 is discussed in the text. See Fig. 10-6 for data on by-pass capacitors C_1 and C_2 .

Modulation of the screen along with the plate is necessary because the screen voltage has a much greater effect on the plate current than the plate voltage does. The modulation characteristic is nonlinear if the plate alone is modulated. However, beam tetrodes can be modulated satisfactorily by applying the modulating power to the plate circuit alone, provided the screen is "floating" at audio frequencies — that is, connected to its d.c. supply through an audio impedance. Under these conditions the screen becomes self-modulating, because of the variations in screen current that occur when the plate current is varied. The circuit is shown in Fig. 10-7. The choke coil L_1 is the audio impedance in the screen circuit; its inductance should be large enough to have a reactance (at the lowest desired audio frequency) that is not less than the impedance of the screen. The latter can be taken to be approximately equal to the d.c. screen voltage divided by the d.c. screen current.

Choke-Coupled Modulator

The choke-coupled Class A modulator is shown in Fig. 10-8. Because of the relatively low power output and plate efficiency of a Class A amplifier, this method is seldom used except for a few special applications. The audio power output of the modulator is combined with the d.c. power in the plate circuit, just as in the case of the transformer-coupled modulator. However, there is considerably less freedom in adjustment, since no transformer is available for matching impedances.

The modulating impedance of the r.f. amplifier must be adjusted to the value of load impedance required by the particular modulator tube used, and the power input to the r.f. stage should not exceed twice the rated a.f. power output of the modulator. A complication is the fact that the plate voltage on the modulator must be higher

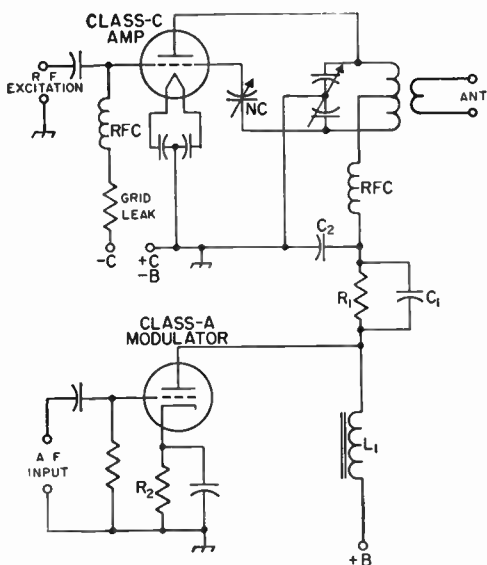

Fig. 10-8 — Choke-coupled Class A modulator. The cathode resistor, R_2 , should have the normal value for operation of the modulator tube as a Class A power amplifier. The modulation choke, L_1 , should be 5 henrys or more. A value of 0.001 to 0.005 $\mu\text{f.}$ is satisfactory at C_2 , the r.f. amplifier plate by-pass capacitor. See text for discussion of C_1 and R_1 .

than the plate voltage on the r.f. amplifier, for 100 per cent modulation. This is because the a.f. voltage developed by the modulator cannot swing to zero without a great deal of distortion. R_1 provides the necessary d.c. voltage drop between the modulator and r.f. amplifier, but its value cannot be calculated without using the published plate family of curves for the modulator tube used. The d.c. voltage drop through R_1 must equal the minimum instantaneous plate voltage on the modulator tube under normal operating conditions. C_1 , an audio-frequency bypass across R_1 , should have a capacitance such that its reactance at 100 cycles is not more than about one-tenth the resistance of R_1 . Without R_1C_1 the percentage of modulation is limited to 70 to 80 per cent in the average case.

● GRID MODULATION

The principal disadvantage of plate modulation is that a considerable amount of audio power is required. This requirement can be avoided by applying the modulation to a grid element in the modulated amplifier. However, the convenience and economy of the low-power modulator must be paid for, since no modulation system gives something for nothing. The increased power output that accompanies modulation is paid for, in the case of grid modulation, by a reduction in the carrier power output obtainable from a given r.f. amplifier tube, and by more rigorous operating requirements and more complicated adjustment.

The term "grid modulation" as used here applies to all types — control grid, screen, or suppressor — since the operating principles are ex-

actly the same no matter which grid is actually modulated. With grid modulation the plate voltage is constant, and the increase in power output with modulation is obtained by making both the plate current and plate efficiency vary with the modulating signal as shown in Fig. 10-9. For 100 per cent modulation, both plate current and efficiency must, at the peak of the modulation up-swing, be twice their carrier values. Thus at the modulation-envelope peak the power input is doubled, and since the plate efficiency also is doubled at the same instant the peak envelope output power will be four times the carrier power. The efficiency obtainable at the envelope peak depends on how carefully the modulated amplifier is adjusted, and sometimes can be as high as 80 per cent. It is generally less when the amplifier is adjusted for good linearity, and under average conditions a round figure of $\frac{2}{3}$, or 66 per cent, is representative. The efficiency without modulation is only half the peak efficiency, or about 33 per cent. Thus the carrier output is about one-fourth the power obtainable from the same tube in c.w. operation, and about one-third the carrier output obtainable from the tube with plate modulation.

The modulator is required to furnish only the audio power dissipated in the modulated grid under the operating conditions chosen. A speech amplifier capable of delivering 3 to 10 watts is usually sufficient.

Generally speaking, grid modulation does not give as linear a modulation characteristic as plate modulation, even under optimum operating conditions. When misadjusted the nonlinearity may be severe, resulting in bad distortion and splatter. However, with careful adjustment it is capable of quite satisfactory results.

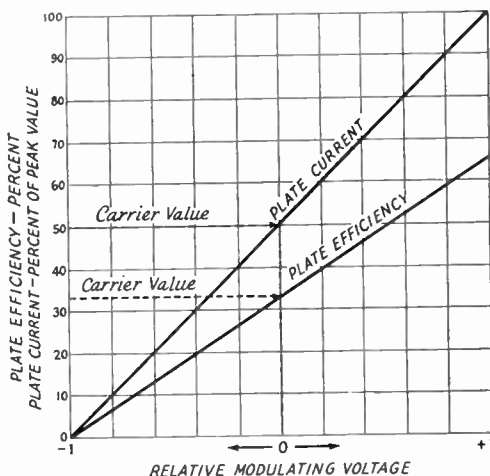

Fig. 10-9 — In a perfect grid-modulated amplifier both plate current and plate efficiency would vary with the instantaneous modulating voltage as shown. When this is so the modulation characteristic is as given by curve A in Fig. 10-1, and the peak envelope output power is four times the unmodulated carrier power. The variations in plate current with modulation, indicated above, do not register on a d.c. meter, so the plate meter shows no change when the signal is modulated.

Plate-Circuit Operating Conditions

The d.c. plate power input to the modulated amplifier, assuming a round figure of $\frac{1}{3}$ (33 per cent) for the plate efficiency, should not exceed $1\frac{1}{2}$ times the plate dissipation rating of the tube or tubes used in the modulated stage. It is generally best to use the maximum plate voltage permitted by the manufacturer's ratings, because the optimum operating conditions are more easily achieved with high plate voltage and the linearity also is improved.

Example: Two tubes having plate dissipation ratings of 55 watts each are to be used with grid modulation.

The maximum permissible power input, at 33% efficiency, is

$$P = 1.5 \times (2 \times 55) = 1.5 \times 110 = 165 \text{ watts}$$

The maximum recommended plate voltage for these tubes is 1500 volts. Using this figure, the average plate current for the two tubes will be

$$I = \frac{P}{E} = \frac{165}{1500} = 0.11 \text{ amp.} = 110 \text{ ma.}$$

At 33% efficiency, the carrier output to be expected is 55 watts.

The plate-voltage/plate-current ratio at *twice* carrier plate current is

$$\frac{1500}{220} = 6.8$$

The tank-circuit L/C ratio should be chosen on the basis of *twice* the average or carrier plate current. If the L/C ratio is based on the plate voltage/plate current ratio under carrier conditions the Q may be too low for good coupling to the output circuit.

Control-Grid Modulation

Control-grid modulation may be used with any type of r.f. amplifier tube. A typical triode circuit is given in Fig. 10-10. The same circuit can be used with screen-grid tubes merely by supplying the normal value of screen voltage by any convenient means; however, the screen should be bypassed for audio (1 μ f. or more) as well as radio frequencies. The audio signal is inserted, by means of transformer T , in series with the grid-bias lead. In a push-pull amplifier the transformer is connected in the common bias lead.

In control-grid modulation the d.c. grid bias is the same as in normal Class C amplifier service, but the r.f. grid excitation is somewhat smaller. The audio voltage superimposed on the d.c. bias changes the instantaneous grid bias at an audio rate, thus varying the operating conditions in the grid circuit and controlling the output and efficiency of the amplifier.

The change in instantaneous bias voltage with modulation causes the rectified grid current of the amplifier to vary, which places a variable load on the modulator. To reduce distortion, resistor R in Fig. 10-10 is connected in the output circuit of the modulator as a constant load, so that the over-all load variations will be minimized. This resistor should be equal to or somewhat higher than the load into which the modulator tube is rated to work at normal audio output. It is also recommended that the modulator circuit incorporate as much negative feedback as

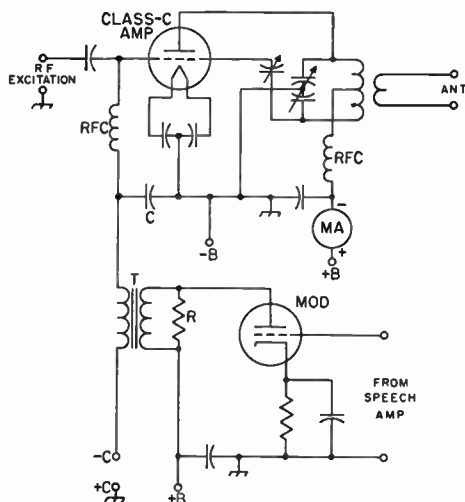

Fig. 10-10 — Control-grid modulation of a Class C amplifier. The r.f. grid by-pass capacitor, C , should have high reactance at audio frequencies (0.005 μ f. or less).

possible, as a further aid in reducing the internal resistance of the modulator and thus improving the "regulation" — that is, reducing the effect of load variations on the audio output voltage. The turns ratio of transformer T should be about 1 to 1 in most cases.

The load on the r.f. driving stage also varies with modulation. This in turn will cause the excitation voltage to vary and may cause the modulation characteristic to be nonlinear. To overcome it, the driver should be capable of two or three times the r.f. power output actually required to drive the amplifier. The excess power may be dissipated in a dummy load (such as an incandescent lamp of appropriate power rating) that then performs the same function in the r.f. circuit that resistor R does in the audio circuit.

The d.c. bias source in this system should have low internal resistance. Batteries or a voltage-regulated supply are suitable. Grid-leak bias should not be used.

Adjustment

A control-grid modulated amplifier should be adjusted with the aid of an oscilloscope connected as shown in Fig. 10-11. A tone source for modulating the transmitter is a convenience, since a steady tone will give a steady pattern on the oscilloscope. A steady pattern is easier to study than one that flickers with voice modulation.

Having determined the permissible carrier plate current as previously described, apply r.f. excitation and plate voltage and, without modulation, adjust the plate loading to give the required plate current (keeping the plate tank circuit tuned to resonance). Next, apply modulation and increase the modulating voltage until the modulation characteristic shows curvature (see later section in this chapter for use of the oscilloscope). If curvature occurs well below 100 per cent modulation, the plate efficiency is too

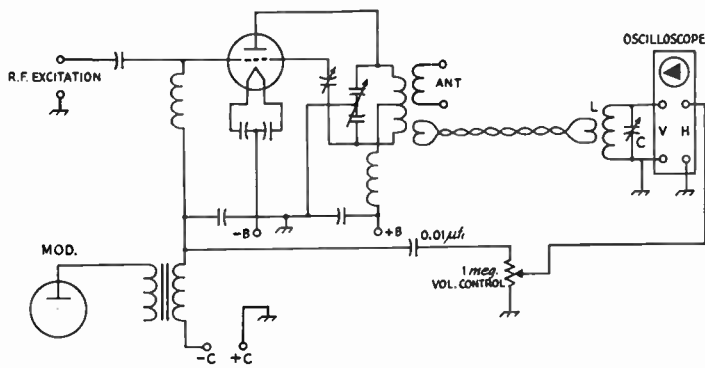

Fig. 10-11 — Using the oscilloscope for adjustment of a grid-modulated amplifier. The connections shown are for grid-bias modulation. With screen or suppressor modulation the connection to the horizontal plates of the scope should be taken from the grid being modulated; the r.f. pick-up arrangement remains unchanged. *L* and *C* should tune to the operating frequency, and may be coupled to the transmitter tank circuit through a twisted pair or coax, using single-turn links at each end. The 0.01- μ f. blocking capacitor that couples the audio voltage to the horizontal plates of the oscilloscope should have a voltage rating equal to at least twice the d.c. voltage on the grid that is being modulated.

high at the carrier level. Increase the plate loading slightly and reduce the excitation to maintain the same plate current; then apply modulation and check the characteristic again. Continue until the characteristic is as linear as possible from zero to twice the carrier amplitude.

Screen Modulation

Power tubes of the beam tetrode type have very good modulation characteristics when the modulating voltage is superimposed on the d.c. screen-grid voltage. The efficiency and plate current should vary with the modulating voltage as shown in Fig. 10-9.

In many ways screen modulation is more satisfactory than control-grid modulation, since the system does not require a fixed-bias supply for the control grid, and is not highly critical as to excitation voltage. However, the operating principles are identical, and the carrier output is limited to about one-half the plate dissipation rating of the tube or tubes used in the modulated amplifier.

The most satisfactory way to apply the modulating voltage to the screen is through a trans-

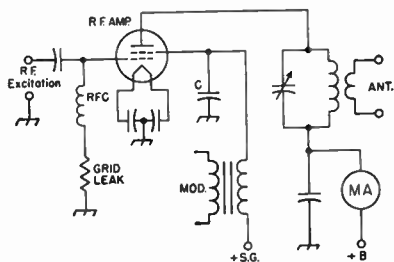

Fig. 10-12 — Screen-grid modulation of beam tetrode. Capacitor *C* is an r.f. by-pass capacitor and should have high reactance at audio frequencies. A value of 0.002 μ f. is satisfactory. The grid leak can have the same value that is used for c.w. operation of the tube.

former, as shown in Fig. 10-12. In an ideal beam tetrode the plate current and output should be completely cut off with zero screen voltage, but in practical tubes it is necessary to drive the screen somewhat negative with respect to the cathode to get complete cut-off. For this reason the peak modulating voltage required for 100 per cent modulation is usually 10 per cent or so greater than the d.c. screen voltage. The latter, in turn, is approximately half the rated screen voltage under maximum ratings for c.w. operation.

The audio power required is approximately one-fourth the d.c. power

input to the screen under c.w. operation, but varies somewhat with the operating conditions. A receiving-type audio power amplifier will suffice as the modulator for most transmitting

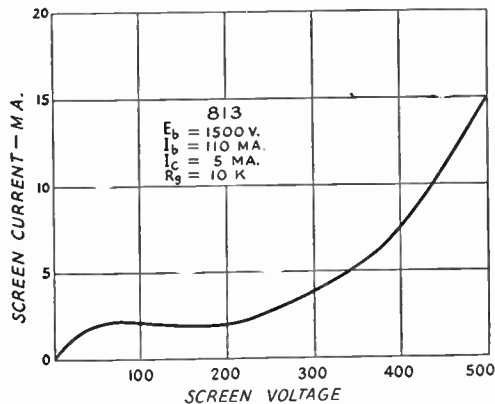

Fig. 10-13 — A typical screen voltage-current curve of a beam tetrode adjusted for optimum conditions for screen modulation.

tubes. Because the relationship between screen voltage and screen current is not linear (a typical curve giving this relationship is shown in Fig. 10-13) the load on the modulator varies over the audio-frequency cycle, and it is therefore highly advisable to use negative feedback in the modulator circuit. If excess audio power is available, it is also advisable to load the modulator with a resistance corresponding to *R* in Fig. 10-10, the value of *R* being adjusted to dissipate the excess power. Unfortunately, there is no simple way to determine the proper resistance except experimentally, by observing its effect on the modulation envelope with the aid of an oscilloscope.

On the assumption that the modulator will be fully loaded by the screen plus the additional load resistor *R*, the turns ratio required in the

coupling transformer may be calculated as follows:

$$N = \frac{E_d}{2.5 \sqrt{PR_L}}$$

where N is the turns ratio, secondary to primary; E_d is the rated screen voltage for c.w. operation; P is the rated audio power output of the modulator; and R_L is the rated load resistance for the modulator.

The best method of adjustment is to use an oscilloscope (the connections of Fig. 10-11 may be used, except that the audio sweep voltage is taken from the screen instead of the control grid) and adjust plate loading, grid excitation, and modulating voltage for the greatest output compatible with good linearity at 100 per cent modulation. The amplifier should be loaded heavily and the grid current should be kept down to the point where a further reduction decreases the r.f. output. Under proper operating conditions the plate-current dip as the amplifier plate circuit is tuned through resonance will be little more than just discernible.

In an alternative adjustment method not requiring an oscilloscope the r.f. amplifier is first tuned up for maximum output without modulation and the rated d.c. screen voltage (from a fixed-voltage supply) for c.w. operation applied. Use heavy loading and reduce the grid excitation until the output just starts to fall off, at which point the resonance dip in plate current should be small. Note the plate current and, if possible, the r.f. antenna or feeder current, and then reduce the d.c. screen voltage until the plate current is one-half its previous value. The r.f. output current should also be one-half its previous value at this screen voltage. The amplifier is then ready for modulation, and the modulating voltage may be increased until the plate current just starts to shift upward, which indicates that the amplifier is modulated 100 per cent. With voice modulation the plate current should remain steady, or show just an occasional small upward kick on intermittent peaks.

It is desirable to operate with the grid current as low as possible, since this reduces the screen current and thus reduces the amount of power required from the modulator. With proper adjustment the linearity is good up to about 90 per cent modulation. When the screen is driven negative for 100 per cent modulation there is a kink in the modulation characteristic at the zero-voltage point. This introduces a small amount of envelope distortion. The kink can be removed and the over-all linearity improved by applying a small amount of modulating voltage to the control grid simultaneously with screen modulation, but this requires adjustment with the oscilloscope.

"Clamp-Tube" Modulation

A method of screen-grid modulation that is convenient in transmitters provided with a screen protective tube ("clamp" tube) is shown in Fig. 10-14. Basically, the idea is that an audio-frequency signal is applied to the grid of the clamp tube, which then becomes a modulator. The

simplicity of the circuit is somewhat deceptive, since it is considerably more difficult from a design standpoint than the transformer-coupled arrangement of Fig. 10-12.

For proper modulation the clamp tube must be operated as a triode Class A amplifier, and it will be recognized that the method is essentially identical with the choke-coupled Class A plate modulator of Fig. 10-8 with a resistance, R_2 , substituted for the choke. R_2 in the usual case is the screen dropping resistor normally used for c.w. opera-

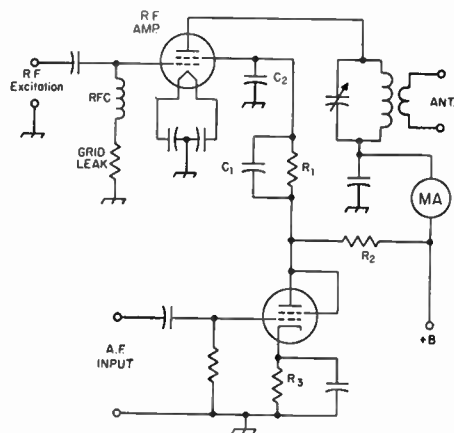

Fig. 10-11—Screen modulation by a "clamp" tube. The grid leak is the normal value for c.w. operation and C_2 should be 0.002 μ f. or less. See text for discussion of C_1 , R_1 , R_2 and R_3 . R_3 should have the proper value for Class A operation of the modulator tube, but cannot be calculated unless triode curves for the tube are available.

tion. Its value should be at least two or three times the load resistance required by the Class A modulator tube for optimum audio-frequency output. Unfortunately, relatively little information is available on the triode operation of the tubes most frequently used for screen-protective purposes.

Like the choke-coupled modulator, the clamp-tube modulator is incapable of modulating the r.f. stage 100 per cent unless the dropping resistor, R_1 , and audio bypass, C_1 , are incorporated in the circuit. The same design considerations hold, with the addition of the fact that the screen must be driven negative, not just to zero voltage, for 100 per cent modulation. The modulator tube must thus be operated at a voltage ranging from 20 to 40 per cent higher than the screen that it modulates. Proper design requires knowledge of the screen characteristics of the r.f. amplifier and a set of plate-voltage plate-current curves on the modulator tube as a triode.

Adjustment with this system, once the design voltages have been determined, is carried out in the same way as with transformer-coupled screen modulation, preferably with the oscilloscope. Without the oscilloscope, the amplifier may first be adjusted for c.w. operation as described earlier, but with the modulator tube removed from its

socket. The modulator is then replaced, and the cathode resistance, R_3 , adjusted to reduce the amplifier plate current to one-half its c.w. value. The amplifier plate current should remain constant with modulation, or show just a small upward flicker on occasional voice peaks.

Controlled Carrier

As explained earlier, a limit is placed on the output obtainable from a grid-modulation system by the low r.f. amplifier plate efficiency (approximately 33 per cent) under unmodulated carrier

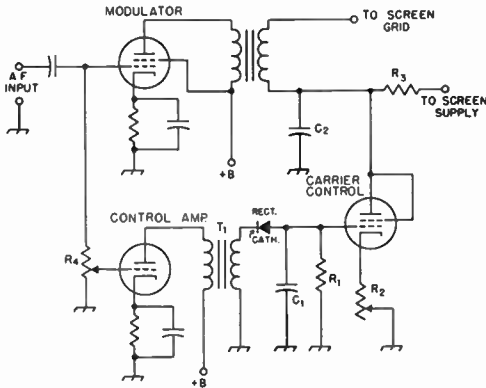

Fig. 10-15 — Circuit for carrier control with screen modulation. A small triode such as the 6J5 can be used as the control amplifier and a 6Y6G is suitable as a carrier-control tube. T_1 is an interstage audio transformer having a 1-to-1 or larger turns ratio. R_4 is a 0.5-megohm volume control and also serves as the grid resistor for the modulator. A germanium crystal may be used as the rectifier. Other values are discussed in the text.

conditions. The plate efficiency increases with modulation, since the output increases while the d.c. input remains constant, and reaches a maximum in the neighborhood of 50 per cent with 100 per cent sine-wave modulation. If the power input to the amplifier can be reduced during periods when there is little or no modulation, thus reducing the plate loss, advantage can be taken of the higher efficiency at full modulation to obtain higher effective output. This can be done by varying the power input to the modulated stage, in accordance with average variations in voice intensity, in such a way as to maintain just sufficient carrier power to keep the modulation high, but not exceeding 100 per cent, under all conditions. Thus the carrier amplitude is controlled by the voice intensity. Properly utilized, controlled carrier permits increasing the effective carrier output at maximum level to a value equal to the rated plate dissipation of the tube, or twice the output obtainable with constant carrier.

It is desirable to control the power input just enough so that the plate loss, without modulation, is safely below the tube rating. Excessive control is disadvantageous because the receiver's a.v.c. system must continually follow the variations in average signal level. The circuit of Fig. 10-15 permits adjustment of both the maximum

and minimum power input, and although somewhat more complicated than some circuits that have been used is actually simpler to operate because it separates the functions of modulation and carrier control. A portion of the audio voltage at the modulator grid is applied to a Class A "control amplifier" which drives a rectifier circuit to produce a d.c. voltage negative with respect to ground. C_1 filters out the audio variations, leaving a d.c. voltage proportional to the average voice level. This voltage is applied to the grid of a "clamp" tube to control the d.c. screen voltage and thus the r.f. carrier level. Maximum output is obtained when the carrier-control tube grid is driven to cut-off, the voice level at which this occurs being determined by the setting of R_4 . Minimum input is set to the desired level (usually about equal to the plate dissipation rating of the modulated stage) by adjusting R_2 . R_3 may be the normal screen-dropping resistor for the modulated beam tetrode, but in case a separate screen supply is used it need be just large enough to give sufficient voltage drop to reduce the no-modulation power input to the desired value.

C_1R_1 should have a time constant of about 0.1 second. The time constant of C_2R_3 should be no larger. Further details may be found in *QST* for April, 1951, page 64. An oscilloscope is required for proper adjustment.

Suppressor Modulation

Pentode-type tubes do not, in general, modulate well when the modulating voltage is applied to the screen grid. However, a satisfactory modulation characteristic can be obtained by applying the modulation to the suppressor grid. The circuit arrangement for suppressor-grid modulation of a pentode tube is shown in Fig. 10-16.

The method of adjustment closely resembles that used with screen-grid modulation. If an oscilloscope is not available, the amplifier is first adjusted for optimum c.w. output with zero bias on the suppressor grid. Negative bias is then applied to the suppressor and increased in value until the plate current and r.f. output current drop to half their original values. When this condition has been reached the amplifier is ready for modulation.

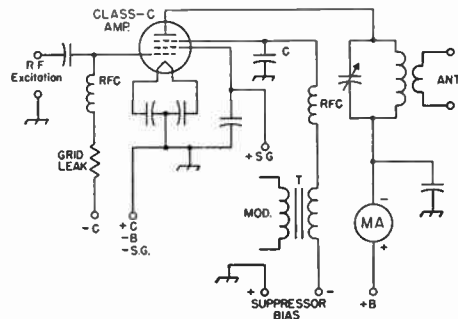

Fig. 10-16 — Suppressor-grid modulation of an r.f. amplifier using a pentode-type tube. The suppressor-grid r.f. by-pass capacitor, C , should be the same as the grid by-pass capacitor in control-grid modulation.

Since the suppressor is always negatively biased, the modulator is not required to furnish any power and a voltage amplifier can be used. The suppressor bias will vary with the type of pentode and the operating conditions, but usually will be of the order of -100 volts. The peak a.f. voltage required from the modulator is equal to the suppressor bias.

CATHODE MODULATION

Circuit

The fundamental circuit for cathode modulation is shown in Fig. 10-17. It is a combination of the plate and grid methods, and permits a carrier efficiency midway between the two. The audio power is introduced in the cathode circuit, and both grid bias and plate voltage are modulated.

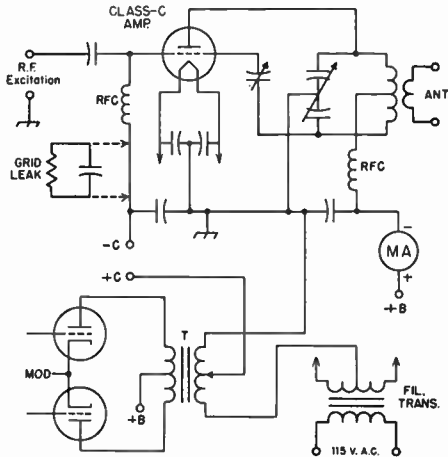

Fig. 10-17 — Circuit arrangement for cathode modulation of a Class C r.f. amplifier. Values of by-pass capacitors in the r.f. circuits should be the same as for other modulation methods.

Because part of the modulation is by the control-grid method, the plate efficiency of the modulated amplifier must vary during modulation. The carrier efficiency therefore must be lower than the efficiency at the modulation peak. The required reduction in efficiency depends upon the proportion of grid modulation to plate modulation; the higher the percentage of plate modulation, the higher the permissible carrier efficiency, and vice versa. The audio power required from the modulator also varies with the percentage of plate modulation, being greater as this percentage is increased.

The way in which the various quantities vary is illustrated by the curves of Fig. 10-18. In these curves the performance of the cathode-modulated r.f. amplifier is plotted in terms of the tube ratings for plate-modulated telephony, with the percentage of plate modulation as a base. As the percentage of plate modulation is decreased, it is assumed that the grid modulation is

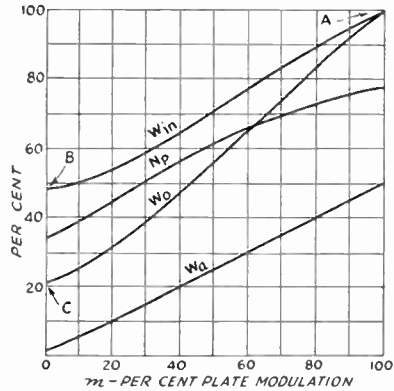

Fig. 10-18 — Cathode-modulation performance curves, in terms of percentage of plate modulation plotted against percentage of Class C telephony tube ratings. W_{in} — D.e. plate input watts in terms of percentage of plate-modulation rating. W_o — Carrier output watts in per cent of plate-modulation rating (based on plate efficiency of 77.5%). W_a — Audio power in per cent of d.e. watts input. N_p — Plate efficiency of the amplifier in percentage.

increased to make the over-all modulation reach 100 per cent. The limiting condition, 100 per cent plate modulation and no grid modulation, is at the right (A); pure grid modulation is represented by the left-hand ordinate (B and C).

Example: Assume that the r.f. tube to be used has a 100% plate-modulation rating of 250 watts input and will give a carrier power output of 190 watts at that input. Cathode modulation with 40% plate modulation is to be used. From Fig. 10-18, the carrier efficiency will be 56% with 40% plate modulation, the permissible d.e. input will be 65% of the plate-modulation rating, and the r.f. output will be 48% of the plate-modulation rating. That is,

$$\begin{aligned} \text{Power input} &= 250 \times 0.65 = 162.5 \text{ watts} \\ \text{Power output} &= 190 \times 0.48 = 91.2 \text{ watts} \end{aligned}$$

The required audio power, from the chart, is equal to 20% of the d.e. input to the modulated amplifier. Therefore

$$\text{Audio power} = 162.5 \times 0.2 = 32.5 \text{ watts}$$

The modulator should supply a small amount of extra power to take care of losses in the grid circuit. These should not exceed four or five watts.

Modulating Impedance

The modulating impedance of a cathode-modulated amplifier is approximately equal to

$$m \frac{E_b}{I_b}$$

where m = Percentage of plate modulation (expressed as a decimal)

E_b = D.e. plate voltage on modulated amplifier

I_b = D.e. plate current of modulated amplifier

Example: Assume that the modulated amplifier in the example above is to operate at a plate potential of 1250 volts. Then the d.e. plate current is

$$I = \frac{P}{E} = \frac{162.5}{1250} = 0.13 \text{ amp. (130 ma.)}$$

The modulating impedance is

$$m \frac{E_b}{I_b} = 0.4 \frac{1250}{0.13} = 3846 \text{ ohms}$$

The modulating impedance is the load into which the modulator must work, just as in the case of pure plate modulation. This load must be matched to the load required by the modulator tubes by proper choice of the turns ratio of the modulation transformer, as described in the chapter on speech equipment.

Conditions for Linearity

R.f. excitation requirements for the cathode-modulated amplifier are midway between those for plate modulation and control-grid modulation. More excitation is required as the percentage of plate modulation is increased. Grid bias should be considerably beyond cut-off; fixed bias from a supply having good voltage regulation is preferred, especially when the percentage of plate modulation is small and the amplifier is operating more nearly like a grid-bias modulated stage. At the higher percentages of plate modulation a combination of fixed and grid-leak bias can be used, since the variation in rectified grid current is smaller. The grid leak should be bypassed for audio frequencies. The percentage of grid modulation may be regulated by choice of a suitable tap on the modulation-transformer secondary.

The cathode circuit of the modulated stage

must be independent of other stages in the transmitter. When directly-heated tubes are modulated their filaments must be supplied from a separate transformer. The filament by-pass capacitors should not be larger than about 0.002 $\mu\text{f.}$, to avoid bypassing the audio-frequency modulation.

Adjustment of Cathode-Modulated Amplifiers

In most respects, the adjustment procedure is similar to that for grid-bias modulation. The critical adjustments are antenna loading, grid bias, and excitation. The proportion of grid-bias to plate modulation will determine the operating conditions.

Adjustments should be made with the aid of an oscilloscope connected in the same way as for grid-bias modulation. With proper antenna loading and excitation, the normal wedge-shaped pattern will be obtained at 100 per cent modulation. As in the case of grid-bias modulation, too-light antenna loading will cause flattening of the upward peaks of modulation as also will too-high excitation. The cathode current will be practically constant with or without modulation when the proper operating conditions have been established.

Checking A.M. Phone Operation

● USING THE OSCILLOSCOPE

Proper adjustment of a phone transmitter is aided immeasurably by the oscilloscope. The scope will give more information, more accurately, than almost any collection of other instruments that might be named. Furthermore, an oscilloscope that is entirely satisfactory for the purpose is not necessarily an expensive instrument; the cathode-ray tube and its power supply are about all that are needed. Amplifiers and linear sweep circuits are by no means necessary.

In the simplest scope circuit, radio-frequency voltage from the modulated amplifier is applied directly to the vertical deflection plates of the tube, and audio-frequency voltage from the modulator is applied to the horizontal deflection plates. As the instantaneous amplitude of the audio signal varies, the r.f. output of the transmitter likewise varies, and this produces a wedge-shaped pattern or **trapezoid** on the screen. If the oscilloscope has a built-in horizontal sweep, the r.f. voltage is applied to the vertical plates as before (never through an amplifier) and the sweep will produce a pattern that follows the modulation envelope of the transmitter output, provided the sweep frequency is lower than the modulation frequency. This produces a **wave-envelope modulation pattern**.

The Wave-Envelope Pattern

The connections for the wave-envelope pattern are shown in Fig. 10-19A. The vertical deflection

plates are coupled to the amplifier tank coil (or an antenna coil) through a twisted-pair line and pick-up coil. As shown in the alternative drawing, a resonant circuit tuned to the operating frequency may be connected to the vertical plates, using link coupling between it and the transmitter. This will eliminate r.f. harmonics, and the tuning control provides a convenient means for adjustment of the pattern height.

The position of the pick-up coil should be varied until an unmodulated carrier pattern, Fig. 10-20B, of suitable height is obtained. The horizontal sweep voltage should be adjusted to make the width of the pattern somewhat more than half the diameter of the screen. When voice modulation is applied, a rapidly-changing pattern of varying height will be obtained. When the maximum height of this pattern is just twice that of the carrier alone, the wave is being modulated 100 per cent. This is illustrated by Fig. 10-20D, where the point *X* represents the horizontal sweep line (reference line) alone, *YZ* is the carrier height, and *PQ* is the maximum height of the modulated wave.

If the height is greater than the distance *PQ*, as illustrated in *E*, the wave is overmodulated in the upward direction. Overmodulation in the downward direction is indicated by a gap in the pattern at the reference axis, where a single bright line appears on the screen. Overmodulation in either direction may take place even when the modulation in the other direction is less than 100 per cent.

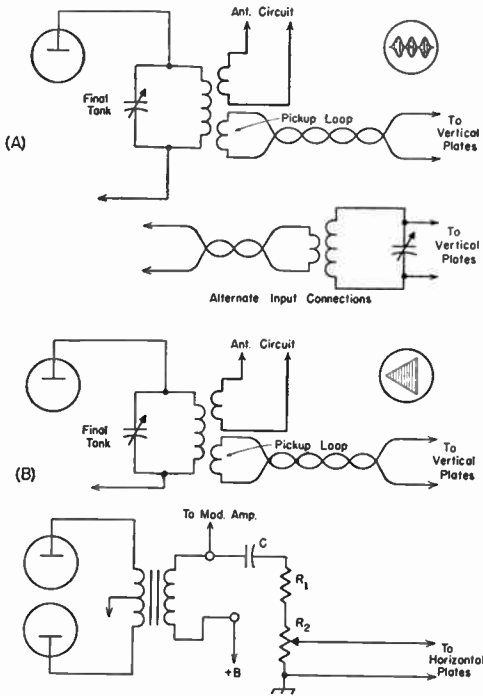

Fig. 10-19 — Methods of connecting the oscilloscope for modulation checking. A — connections for wave-envelope pattern with any modulation method; B — connections for trapezoidal pattern with plate modulation. See Fig. 10-11 for scope connections for trapezoidal pattern with grid modulation.

The Trapezoidal Pattern

Connections for the trapezoid or wedge pattern as used for checking plate modulation are shown in Fig. 10-19B. The vertical plates of the c.r. tube are coupled to the transmitter tank through a pick-up loop, preferably using a tuned circuit, as shown in the upper drawing, adjustable to the operating frequency. Audio voltage from the modulator is applied to the horizontal plates through a voltage divider, R_1R_2 . This voltage should be adjustable so a suitable pattern width can be obtained; a 0.25-megohm volume control can be used at R_2 for this purpose, with c.r. tubes up to the 3-inch size.

The resistance required at R_1 will depend on the d.c. plate voltage on the modulated amplifier. The total resistance of R_1 and R_2 in series should be about 0.25 megohm for each 100 volts of d.c. plate voltage. For example, if the modulated amplifier operates at 1500 volts, the total resistance should be 3.75 megohms, 0.25 megohm at R_2 and the remainder, 3.5 megohms, in R_1 . R_1 should be composed of individual resistors not larger than 0.5 megohm each, in which case 1-watt resistors will be satisfactory.

For good low-frequency coupling the capacitance, in microfarads, of the blocking capacitor, C , should at least equal $0.004/R$, where R is the total resistance ($R_1 + R_2$) in megohms. In the example above, where R is 3.75 megohms, the capacitance should be at least $0.004/3.75 = 0.001$

$\mu\text{f.}$, approximately. The voltage rating of the capacitor should be at least twice the d.c. voltage applied to the modulated amplifier. The capacitance can be made up of two or more similar units in series, so long as the total capacitance is equal to that required, in case a single unit of sufficient voltage rating is not available. Two or more units may be used in parallel if capacitors having adequate voltage rating but insufficient capacitance are available.

The corresponding scope connections for grid modulation were given in Fig. 10-11. This circuit will be satisfactory for checking screen-grid modulation (the audio connection of course being made to the screen grid rather than to the control grid) for d.c. screen voltages up to 200 volts or so, which will include most beam tetrodes. If the d.c. screen voltage, adjusted for proper modulation, exceeds 200 volts a voltage divider similar to that shown in Fig. 10-19 should be used, the values being calculated as described above using the screen voltage instead of the plate voltage.

Trapezoidal patterns for various conditions of modulation are shown in Fig. 10-20 at F to J, each alongside the corresponding wave-envelope pattern. With no signal, only the cathode-

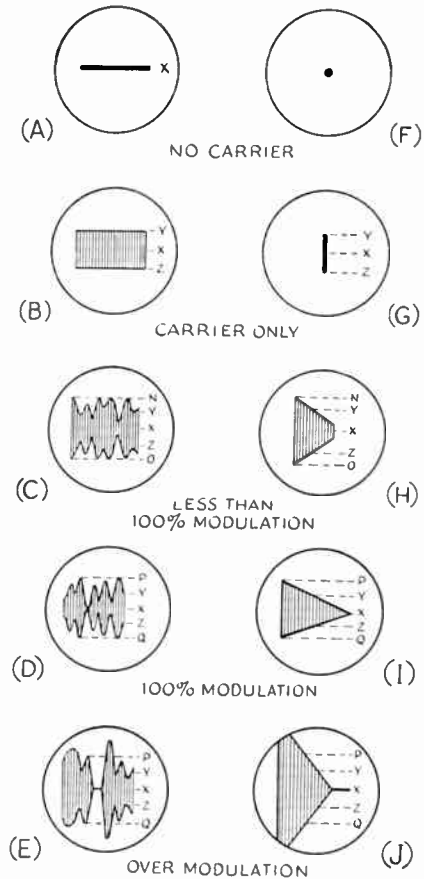

Fig. 10-20 — Wave-envelope and trapezoidal patterns representing different conditions of modulation.

ray spot appears on the screen. When the unmodulated carrier is applied, a vertical line appears; the length of the line should be adjusted, by means of the pick-up coil coupling, to a convenient value. When the carrier is modulated, the wedge-shaped pattern appears; the higher the modulation percentage, the wider and more pointed the wedge becomes. At 100 per cent modulation it just makes a point on the axis, X , at one end, and the height, PQ , at the other end is equal to twice the carrier height, YZ . Overmodulation in the upward direction is indicated by increased height over PQ , and in the downward direction by an extension along the axis X at the pointed end.

Checking Transmitter Performance

The trapezoidal pattern is far more useful than the wave-envelope pattern for checking the operation of a phone transmitter. The latter type of pattern is of use principally for checking modulation percentage, and even when the speech system is fed with a sine-wave tone for close examination of the pattern it is difficult to tell with sufficient accuracy whether the transmitter is operating linearly. Also, even when distortion is evident in the wave-envelope pattern there is no clue as to whether it is occurring in the modulated amplifier or is caused by a defect in the speech equipment.

On the other hand, the trapezoidal pattern is actually a graph of the modulation characteristic of the modulated amplifier. The sloping sides of the wedge show the r.f. amplitude for every value of instantaneous modulating voltage, exactly the type of curve plotted in Fig. 10-4. If these sides are perfectly straight lines, as drawn in Fig. 10-20 at H and I, the modulation characteristic is linear. If the sides show curvature, the characteristic is nonlinear to an extent that is shown by the degree to which the sides depart from perfect straightness. This is true regardless of the wave form of the modulating voltage.

If the speech system can be driven by a good audio sine-wave signal instead of a microphone, the trapezoidal pattern also will show the presence of even-harmonic distortion (the most common type, especially when the modulator is overloaded) in the speech amplifier or modulator. If there is no distortion in the audio system, the trapezoid will extend horizontally equal distances on each side of the vertical line representing the unmodulated carrier. If there is even-harmonic distortion the trapezoid will extend farther to one side of the unmodulated-carrier position than to the other. This is shown in Fig. 10-21. The probable cause is inadequate power output from the modulator, or incorrect load on the modulator.

An audio oscillator having reasonably good sine-wave output is highly desirable for testing both speech equipment and the phone transmitter as a whole. A very simple audio oscillator such as is shown in the chapter on measurements is quite adequate. With such an oscillator and the scope, the pattern is steady and can be studied closely to determine the effects of various operating adjustments.

The patterns shown in Figs. 10-21 and the top four groups of Fig. 10-22 show both correct and incorrect transmitter adjustments. The object of modulated-amplifier adjustment is to obtain a pattern closely resembling that in Fig. 10-22A, which shows excellent linearity (sides of wedge pattern quite straight) over the whole characteristic at 100 per cent modulation. Since no modulated amplifier is perfect, the sides will never be perfectly straight, but a close approach is possible. Different methods of modulation give different characteristic results. Fig. 10-22A is typical of correctly-operated plate modulation. With control-grid modulation the sides usually are somewhat concave, particularly near the point of the trapezoid, while screen modulation gives the characteristic pattern shown in Fig. 10-21. As mentioned earlier, it is necessary to drive the screen somewhat negative in order to reach complete plate-current cut-off and thus modulate 100 per cent downward.

Aside from overmodulation downward, Fig.

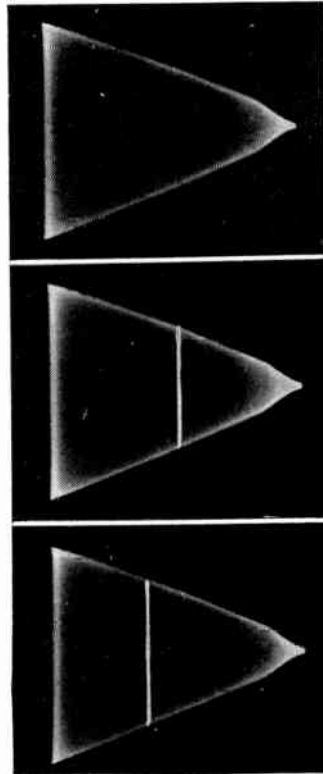
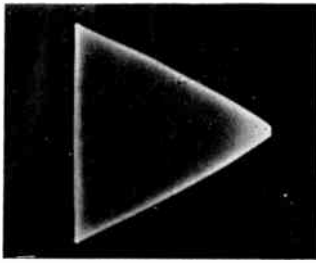
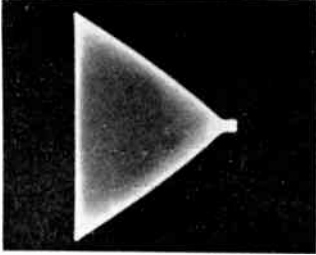
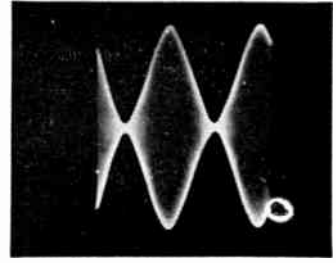

Fig. 10-21 — Top — a typical trapezoidal pattern obtained with screen modulation adjusted for optimum conditions. The sudden change in slope near the point of the wedge occurs when the screen voltage passes through zero. Center — If there is no audio distortion, the unmodulated carrier will have the height and position shown by the white line superimposed on the sine-wave modulation pattern. Bottom — Even-harmonic distortion in the audio system, when the audio signal applied to the speech amplifier is a sine wave, is indicated by the fact that the modulation pattern does not extend equal distances either side of the unmodulated carrier.



A
 Properly-operated phone transmitter modulated 100 per cent.



B
 Overmodulation of a transmitter having high modulation capability. Distortion occurs only on the down-peaks.

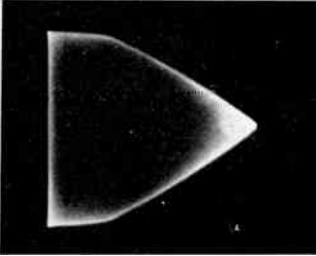
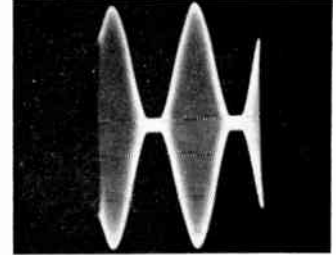

C
 Nonlinearity in modulated r.f. stage, frequently caused by insufficient excitation of a plate-modulated amplifier or overexcitation of a grid-bias modulated amplifier. The amplifier modulates linearly in the downward direction but the up-peaks are flattened.

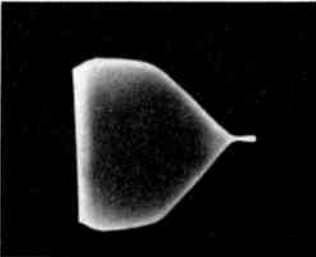
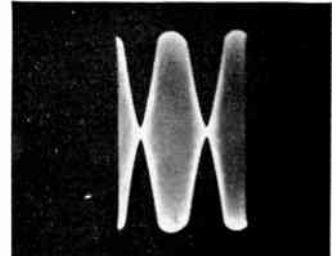

D
 Overmodulation and non-linear operation (insufficient modulation capability). These patterns are similar to those directly above, but with the modulation carried beyond 100 per cent in the downward direction.

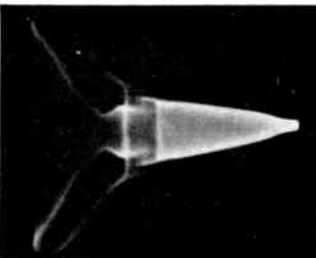
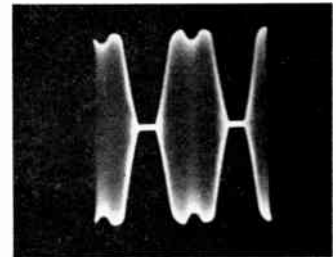

E
 Overmodulation and parasitic oscillations in the modulated amplifier. The trapezoidal pattern also shows phase distortion caused by incorrect coupling between the oscilloscope and audio system.

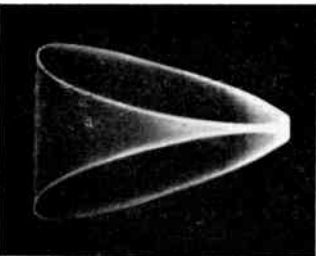
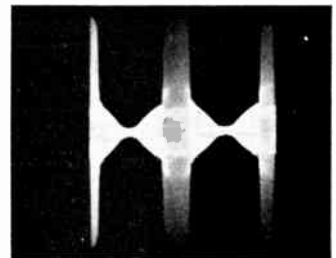

F
 Left — Phase distortion caused by incorrect coupling between audio system and oscilloscope. Right — Multiple pattern caused by incorrect setting of oscilloscope time-base control. In both cases the wave is modulated 100 per cent.

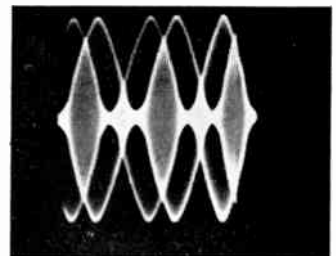

Fig. 10-22 — TYPICAL OSCILLOSCOPE PATTERNS

These photographs show various conditions of modulation as displayed by the wedge or trapezoidal patterns in the left-hand column and the wave-envelope patterns in the right-hand column.

(Photographs reproduced through courtesy of the Allen B. DuMont Laboratories, Inc., Passaic, N. J.)

10-22B, which is easily cured by keeping the speech amplifier gain or speech intensity below the point that causes it, the most common type of improper operation is shown by the pattern of Fig. 10-22C. The flattening at the large end of the trapezoid results from the inability of the modulated amplifier to deliver sufficient power output on the modulation up-peak. With plate modulation the most likely cause is insufficient grid excitation or incorrect grid bias or both. With grid modulation this flattening is the result of attempting to operate the amplifier at too-high carrier efficiency. In this case the remedy is to increase the loading on the output circuit and reduce the grid excitation, or both in combination, until the pattern sides are straight.

In this connection, it should be noted that while the trapezoidal pattern of Fig. 10-22C shows nonlinearity in the modulated amplifier, the corresponding wave-envelope pattern of the same figure could result *either* from this cause or from modulator overloading. With the trapezoidal pattern, modulator overloading will be evident by the fact that the position of the vertical line representing the unmodulated carrier will not be at the center of the pattern (when the modulating voltage is cut off); however, modulator overloading will not affect the *shape* of the trapezoid. This assumes that the audio signal is a sine wave.

Outward curvature near the point of the trapezoid, causing it to approach the horizontal axis more slowly than would occur with straight sides, indicates that the output power does not decrease rapidly enough in this region. It may be caused by r.f. leakage from the exciter through the final stage. This can be checked by removing the voltage from the modulated stage, when the carrier should disappear, leaving only the beam spot remaining on the screen (Fig. 10-20F). If a small vertical line remains, the amplifier should be carefully neutralized; if this does not eliminate the line, it is an indication that the scope is getting r.f. from lower-power stages, either by coupling through the final tank or via the pick-up loop.

Faulty Patterns

Figs. 10-20, 10-21, and 10-22A through D show what is normally to be expected in the way of pattern shapes when the oscilloscope is used to check modulation. If the actual patterns differ considerably from those shown, it may be that the pattern is faulty rather than the transmitter.

It is important that r.f. from the *modulated stage only* be coupled to the oscilloscope, and then only to the vertical plates. The effect of stray r.f. from other stages in the transmitter has been mentioned in the preceding section. If r.f. is present also on the horizontal plates, the pattern will lean to one side instead of being upright. If the oscilloscope cannot be moved to a position where the unwanted pick-up disappears, a small by-pass capacitor (10 $\mu\text{f.}$) should be connected across the horizontal plates as close to the cathode-ray tube as possible. An r.f.

choke (2.5 mh. or smaller) may also be connected in series with the ungrounded horizontal plate.

"Folded" trapezoidal patterns, and patterns in which the sides of the trapezoid are elliptical instead of straight, Fig. 10-22F (left), occur when the audio sweep voltage is taken from some point in the audio system other than that where the a.c. power is applied to the modulated stage. Such patterns are caused by a phase difference between the sweep voltage and the modulating voltage. The connections should always be as shown in Fig. 10-11 and 10-19B.

● MODULATION CHECKING WITH THE PLATE METER

The plate milliammeter of the modulated amplifier provides a simple and fairly reliable means for checking the performance of a phone transmitter, although it does not give nearly as definite information as the oscilloscope does. If the modulated amplifier is perfectly linear, its plate current will not change when modulation is applied if

- 1) the upward modulation percentage does not exceed the modulation capability of the amplifier,
- 2) the downward modulation does not exceed 100 per cent, and
- 3) there is no change in the d.c. operating voltages on the transmitter when modulation is applied.

The plate current should be constant, ideally, with any of the methods of modulation discussed in this chapter, with the single exception of the controlled-carrier system. The plate meter cannot give a reliable check on the performance of the latter system because the plate current increases with the intensity of modulation. With this system the plate-current variations should be correlated with the transmitter performance as observed on an oscilloscope, if the plate meter is to be used for checking modulation.

Plate Modulation

With plate modulation, a downward shift in plate current may indicate one or more of the following:

- 1) Insufficient excitation to the modulated r.f. amplifier.
- 2) Insufficient grid bias on the modulated stage.
- 3) The r.f. amplifier is not loaded properly to present the required value of modulating impedance to the modulator.
- 4) Insufficient output capacitance in the filter of the modulated-amplifier plate supply.
- 5) D.c. input to the r.f. amplifier, under carrier conditions, is in excess of the manufacturer's ratings for plate modulation. Alternatively, the filament emission of the amplifier tubes may be low.
- 6) In plate-and-screen modulation of tetrodes or pentodes, the screen is not being sufficiently modulated along with the plate. In systems in which the d.c. screen voltage is

obtained through a dropping resistor, a downward dip in plate current may occur if the screen by-pass capacitance is large enough to bypass audio frequencies.

- 7) Poor voltage regulation of the modulated-amplifier plate supply. This may be caused by voltage drop in the supply itself, when the modulated amplifier and a Class B amplifier are operated from the same supply, or may be caused by voltage drop in the primary supply from the power line when the modulator load is thrown on. It is readily checked by measuring the voltage with and without modulation. Poor line regulation will be shown by a drop in filament voltage with modulation.

Any of the following may cause an upward shift in plate current:

- 1) Overmodulation (excessive audio power, audio gain too high).
- 2) Incomplete neutralization of the modulated amplifier.
- 3) Parasitic oscillation in the modulated amplifier.

Grid Modulation

With any type of grid modulation, any of the following may cause a downward shift in modulated-amplifier plate current:

- 1) Too much r.f. excitation.
- 2) Insufficient grid bias, particularly with control-grid modulation. Grid bias is usually not critical with screen and suppressor modulation, the value of grid leak recommended for c.w. operation being satisfactory.
- 3) With control-grid modulation, excessive resistance in the bias supply.
- 4) Insufficient output capacitance in plate-supply filter.
- 5) Plate efficiency too high under carrier conditions; amplifier is not loaded heavily enough.

Because grid modulation is not perfectly linear (always less so than plate modulation) a properly-operating amplifier will show a small upward plate-current shift with modulation, 10 per cent or less with sine-wave modulation and amounting to an occasional upward flicker with voice. An upward plate current shift in excess of this may be caused by

- 1) Overmodulation (excessive modulating voltage).
- 2) Regeneration (incomplete neutralization).
- 3) With control-grid or suppressor modulation, bias too great.
- 4) With screen modulation, d.c. screen voltage too low.

In grid-modulation systems the modulator is not necessarily operating linearly if the plate current stays constant with or without modulation. It is readily possible to arrive at a set of operating conditions in which flattening of the up-peaks is just balanced by overmodulation downward, resulting in practically the same plate current as when the transmitter is unmodulated.

The oscilloscope provides the only certain check on grid modulation. While the same type of improper operation is possible with plate modulation, it occurs only rarely.

● COMMON TROUBLES IN THE PHONE TRANSMITTER

Noise and Hum on Carrier

Noise and hum may be detected by listening to the signal on a receiver, provided the receiver is far enough away from the transmitter to avoid overloading. The hum level should be low compared with the voice at 100 per cent modulation. Hum may come either from the speech amplifier and modulator or from the r.f. section of the transmitter. Hum from the r.f. section can be detected by completely shutting off the modulator; if hum remains when this is done, the power-supply filters for one or more of the r.f. stages have insufficient smoothing. With a hum-free carrier, hum introduced by the modulator can be checked by turning on the modulator but leaving the speech amplifier off; power-supply filtering is the likely source of such hum. If carrier and modulator are both clean, connect the speech amplifier and observe the increase in hum level. If the hum disappears with the gain control at minimum, the hum is being introduced in the stage or stages preceding the gain control. The microphone also may pick up hum, a condition that can be checked by removing the microphone from the circuit but leaving the first speech-amplifier grid circuit otherwise unchanged. A good ground (to a cold water pipe, for example) on the microphone and speech system usually is essential to hum-free operation.

Spurious Side bands

A superheterodyne receiver having a crystal filter is needed for checking spurious side bands outside the normal communication channel. The r.f. input to the receiver must be kept low enough, by removing the antenna or by adequate separation from the transmitter, to avoid overloading and consequent spurious receiver responses. An "S"-meter reading of about half scale is satisfactory. With the crystal filter in its sharpest position tune through the region outside the normal channel limits (3 to 4 kilocycles each side of the carrier) while another person talks into the microphone. Spurious side bands will be observed as intermittent "clicks" or crackles well away from the carrier frequency. Side bands more than 3 to 4 kilocycles from the carrier should be of negligible strength, compared with the carrier, in a properly-modulated phone transmitter. The causes are overmodulation or nonlinear operation.

With sine-wave modulation the relative intensity of side bands can be observed if a tone of 1000 cycles or so is used, since the crystal filter readily can separate frequencies of this order. The "S"-meter will show how the spurious side frequencies (those spaced more than the modulating frequency from the carrier) compare with the carrier itself. Without an "S"-meter, the a.v.c.

should be turned off and the b.f.o. turned on; then the r.f. gain should be set to give a moderately strong beat note with the carrier. The intensity of side frequencies can be estimated from the relative strength of the beats as the receiver is tuned through the spectrum adjacent to the carrier.

R.F. in Speech Amplifier

A small amount of r.f. current in the speech amplifier — particularly in the first stage, which is most susceptible to such r.f. pickup — will cause overloading and distortion in the low-level stages. Frequently also there is a regenerative effect which causes an audio-frequency oscillation or "howl" to be set up in the audio system. In such cases the gain control cannot be advanced very far before the howl builds up, even though the amplifier may be perfectly stable when the r.f. section of the transmitter is not turned on.

Complete shielding of the microphone, microphone cord, and speech amplifier is necessary to prevent r.f. pickup, and a ground connection separate from that to which the transmitter is connected is advisable.

● MODULATION MONITORING

It is always desirable to modulate as fully as possible, but 100 per cent modulation should not be exceeded — particularly in the downward direction — because harmonic distortion will be generated and the channel width increased. This causes unnecessary interference to other stations. The oscilloscope is the best instrument for continuously checking the modulation. However, simpler indicators may be used for the purpose, once calibrated.

A convenient indicator, when a Class B modulator is used, is the plate milliammeter in the Class B stage, since the plate current of the modulator fluctuates with the voice intensity. Using the oscilloscope, determine the gain-control setting and voice intensity that give 100 per cent modulation on voice peaks, and simultaneously observe the maximum Class B plate-milliammeter reading on the peaks. When this maximum reading is obtained, it will suffice to adjust the gain so that it is not exceeded.

A high-resistance (1000-ohms-per-volt or more) rectifier-type voltmeter (copper-oxide or germanium type) also can be used for modulation monitoring. It should be connected across the output circuit of an audio driver stage where the power level is a few watts, and similarly calibrated against the oscilloscope to determine the reading that represents 100 per cent modulation.

The plate milliammeter of the modulated r.f. stage also is of value as an indicator of overmodulation. As explained earlier, the d.c. plate current stays constant if the amplifier is linear. When the amplifier is overmodulated, especially in the downward direction, the operation is no longer linear and the average plate current will

change. A flicker of the pointer may therefore be taken as an indication of overmodulation or non-linearity. However, since it is possible that under some operating conditions the plate current will remain constant even though the amplifier is considerably overmodulated, an indicator of this type is not wholly reliable unless it has been checked against an oscilloscope.

Overmodulation Indicators

Overmodulation on negative peaks is usually the worst type, as explained earlier in this chapter. The milliammeter in the negative-peak indicator of Fig. 10-23 will show a reading on each peak that carries the instantaneous voltage on a

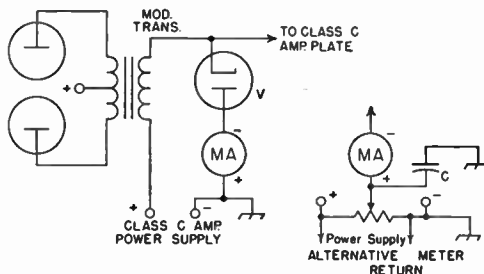

Fig. 10-23 — Negative-peak overmodulation indicator. The milliammeter *MA* may be any low-range instrument (up to 0–50 ma. or so). The inverse-peak-voltage rating of the rectifier, *V*, must be at least twice the d.c. voltage applied to the plate of the r.f. amplifier. The alternative meter-return circuit can be used to indicate modulation in excess of any desired value below 100 per cent. The reactance of the by-pass capacitor, *C*, at 100 cycles should be small compared with the resistance across which it is connected. An 8- μ f. electrolytic capacitor will be satisfactory if the resistance it shunts is 1000 ohms or more.

plate-modulated amplifier "below zero" — that is, negative. The rectifier, *V*, cannot conduct so long as the negative half-cycle of audio output voltage is less than the d.c. voltage applied to the r.f. tube.

The inverse-peak-voltage rating of the rectifier tube must be at least twice the d.c. plate voltage of the modulated amplifier. The filament transformer likewise must have insulation rated to withstand twice the d.c. plate voltage. Either mercury-vapor or high-vacuum rectifiers can be used. The 15-volt breakdown voltage of the former will introduce a slight error, since the plate voltage must go at least 15 volts negative before the rectifier will ionize, but the error is inconsequential at plate voltages above a few hundred volts.

The effectiveness of the monitor is improved if it indicates at somewhat less than 100 per cent modulation, as it will then warn of the danger of overmodulation before it actually occurs. It can be adjusted to indicate at any desired modulation percentage by making the meter return to a point on the power-supply bleeder as shown in the alternative diagram. The by-pass capacitor *C*, insures that the full audio voltage appears across the indicator circuit.

Frequency and Phase Modulation

It is possible to convey intelligence by modulating any property of a carrier. These properties are amplitude, frequency and phase. Amplitude modulation (a.m.) is described in another chapter. When the frequency of the carrier is varied in accordance with the variations in a modulating signal, the result is **frequency modulation (f.m.)**. Similarly, varying the phase of the carrier current is called **phase modulation (p.m.)**.

Frequency and phase modulation are not independent, since the frequency cannot be varied without also varying the phase, and vice versa. The difference is largely a matter of definition.

The effectiveness of f.m. and p.m. for communication purposes depends almost entirely on the receiving methods. If the receiver will respond to frequency and phase changes but is insensitive to amplitude changes, it will discriminate against most forms of noise, particularly impulse noise such as is set up by ignition systems and other sparking devices. Special methods of detection are required to accomplish this result. Since most amateur receivers do not incorporate the proper circuits, the noise-reducing properties of f.m. or p.m. reception are seldom realized in amateur work.

Modulation methods for f.m. and p.m. are simple and require practically no audio power. There is also the advantage that, since there is no amplitude variation in the signal, interference to broadcast reception of the type resulting from rectification in the audio circuits of the BC receiver is substantially eliminated. These two points represent the principal reasons for the use of f.m. and p.m. in amateur work. Unfortunately, the user of f.m. or p.m. is unable to get the benefit of the inherent noise-reducing advantages of the system, and is furthermore at a considerable disadvantage with respect to a.m. of the same power, because most of his communication will be with amateurs using receivers designed specifically for a.m.

Frequency Modulation

Fig. 11-1 is a representation of frequency modulation. When a modulating signal is applied, the carrier frequency is increased during one half-cycle of the modulating signal and decreased during the half-cycle of opposite polarity. This is indicated in the drawing by the fact that the r.f. cycles occupy less time (higher frequency) when the modulating signal is positive, and more time (lower frequency) when the modulating signal is negative. The change in the carrier frequency (frequency deviation) is proportional to the in-

stantaneous amplitude of the modulating signal, so the deviation is small when the instantaneous amplitude of the modulating signal is small, and is greatest when the modulating signal reaches its peak, either positive or negative. That is, the frequency deviation follows the instantaneous changes in the amplitude of the modulating signal.

As shown by the drawing, the amplitude of the signal does not change during modulation.

Phase Modulation

To understand the difference between f.m. and p.m. it is necessary to appreciate that the frequency of an alternating current is determined by the *rate at which its phase changes*.

If the phase of the current in a circuit is changed there is an instantaneous frequency change during the time that the phase is being shifted. The amount of frequency change, or deviation, depends on how rapidly the phase shift is accomplished. It is also dependent upon the total amount of the phase shift. In a properly-operating p.m. system the amount of phase shift is proportional to the instantaneous amplitude of the modulating signal. The rapidity of the phase shift is directly proportional to the frequency of the modulating signal. Consequently, the frequency deviation in p.m. is proportional to both the amplitude and frequency of the modulating signal. The latter represents the outstanding difference between f.m. and p.m., since in f.m.

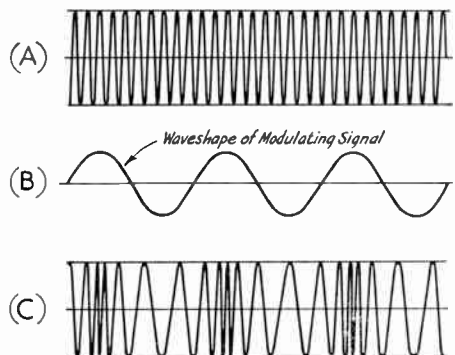

Fig. 11-1 — Graphical representation of frequency modulation. In the unmodulated carrier at A, each r.f. cycle occupies the same amount of time. When the modulating signal, B, is applied, the radio frequency is increased and decreased according to the amplitude and polarity of the modulating signal.

the frequency deviation is proportional only to the amplitude of the modulating signal.

Modulation Depth

Percentage of modulation in f.m. and p.m. has to be defined differently than for a.m. Practically, "100 per cent modulation" is reached when the transmitted signal occupies a channel just equal to the bandwidth for which the receiver is designed. If the frequency deviation is greater than the receiver can accept, the receiver distorts the signal. However, on another receiver designed for a different bandwidth the same signal might be equivalent to only 25 per cent modulation.

In amateur work "narrow-band" f.m. or p.m. (frequently abbreviated n.f.m.) is defined as having the same channel width as a properly-modulated a.m. signal. That is, the channel width does not exceed twice the highest audio frequency in the modulating signal. N.f.m. transmissions based on an upper audio limit of 3000 cycles therefore should occupy a channel no wider than 6 kc.

F.M. and P.M. Side Bands

The side bands set up by f.m. and p.m. differ from those resulting from a.m. in that they occur at integral multiples of the modulating frequency on either side of the carrier rather than, as in a.m., consisting of a single set of side frequencies for each modulating frequency. An f.m. or p.m. signal therefore inherently occupies a wider channel than a.m.

The number of "extra" side bands that occur in f.m. and p.m. depends on the relationship between the modulating frequency and the frequency deviation. The ratio between the frequency deviation, in cycles per second, and the modulating frequency, also in cycles per second, is called the **modulation index**. That is,

$$\text{Modulation index} = \frac{\text{Carrier frequency deviation}}{\text{Modulating frequency}}$$

Example: The maximum frequency deviation in an f.m. transmitter is 3000 cycles either side of the carrier frequency. The modulation index when the modulating frequency is 1000 cycles is

$$\text{Modulation index} = \frac{3000}{1000} = 3$$

At the same deviation with 3000-cycle modulation the index would be 1; at 100 cycles it would be 30, and so on.

In p.m. the modulation index is constant regardless of the modulating frequency; in f.m. it varies with the modulating frequency, as shown in the previous example. In an f.m. system the ratio of the *maximum* carrier-frequency deviation to the *highest* modulating frequency used is called the **deviation ratio**.

Fig. 11-2 shows how the amplitudes of the carrier and the various side bands vary with the modulation index. This is for single-tone modulation: the first side band (actually a pair, one above and one below the carrier) is displaced from the

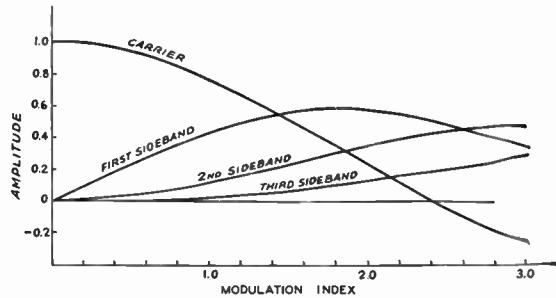

Fig. 11-2 — How the amplitude of the pairs of side bands varies with the modulation index in an f.m. or p.m. signal. If the curves were extended for greater values of modulation index it would be seen that the carrier amplitude goes through zero at several points. The same statement also applies to the side bands.

carrier by an amount equal to the modulating frequency, the second is twice the modulating frequency away from the carrier, and so on. For example, if the modulating frequency is 2000 cycles and the carrier frequency is 29,500 kc., the first side band pair is at 29,498 kc. and 29,502 kc., the second pair is at 29,496 kc. and 29,504 kc., the third at 29,494 kc. and 29,506 kc., etc. The amplitudes of these side bands depend on the modulation index, not on the frequency deviation. In a.m., regardless of the percentage of modulation (so long as it does not exceed 100 per cent) the side bands would appear *only* at 29,498 and 29,502 kc. under the same conditions.

Note that, as shown by Fig. 11-2, the carrier strength varies with the modulation index. (In amplitude modulation the carrier strength is constant; only the side-band amplitude varies.) At a modulation index of approximately 2.4 the carrier disappears entirely. It then becomes "negative" at a higher index, meaning that its phase is reversed as compared to the phase without modulation. In f.m. and p.m. the energy that goes into the side bands is taken from the carrier, the *total* power remaining the same regardless of the modulation index

Frequency Multiplication

Since there is no change in amplitude with modulation, an f.m. or p.m. signal can be amplified by an ordinary Class C amplifier without distortion. The modulation can take place in a very low-level stage and the signal can then be amplified by either frequency multipliers or straight amplifiers.

If the modulated signal is passed through one or more frequency multipliers, the modulation index is multiplied by the same factor that the carrier frequency is multiplied. For example, if modulation is applied on 3.5 Mc. and the final output is on 28 Mc. the total frequency multiplication is 8 times, so if the frequency deviation is 500 cycles at 3.5 Mc. it will be 4000 cycles at 28 Mc. Frequency multiplication offers a means for obtaining practically any desired amount of frequency deviation, whether or not the modulator itself is capable of giving that much deviation without distortion.

Narrow-Band f.m. and p.m.

"Narrow-band" f.m. or p.m., the only type that is authorized for use on the lower frequencies where the phone bands are crowded, is defined as f.m. or p.m. that does not occupy a wider channel than an a.m. signal having the same audio modulating frequencies. Narrow-band operation requires using a relatively small modulation index.

If the modulation index (with single-tone modulation) does not exceed about 0.6 the most important extra side band, the second, will be at least 20 db. below the unmodulated carrier level, and this should represent an effective channel width about equivalent to that of an a.m. signal. In the case of speech, a somewhat higher modulation index can be used. This is because the energy distribution in a complex wave is such that the modulation index for any one frequency component is reduced, as compared to the index with a sine wave having the same peak amplitude as the voice wave.

The chief advantage of narrow-band f.m. or p.m. for frequencies below 30 Mc. is that it eliminates or reduces certain types of interference to broadcast reception. Also, the modulating equipment is relatively simple and inexpensive. However, assuming the same unmodulated carrier power in all cases, narrow-band f.m. or p.m. is not as effective as a.m. with the methods of reception used by most amateurs. As shown by Fig. 11-2, at an index of 0.6 the amplitude of the first side band is about 25 per cent of the unmodulated-carrier amplitude: this compares with a side-band amplitude of 50 per cent in the case of a 100 per cent modulated a.m. transmitter. That is, so far as effectiveness is concerned, a narrow-band f.m. or p.m. transmitter is about equivalent to a 100 per cent modulated a.m. transmitter operating at one-fourth the carrier power.

Comparison of f.m. and p.m.

Frequency modulation cannot be applied to an amplifier stage, but phase modulation can: p.m. is therefore readily adaptable to transmitters

employing oscillators of high stability such as the crystal-controlled type. The amount of phase shift that can be obtained with good linearity is such that the maximum practicable modulation index is about 0.5. Because the phase shift is proportional to the modulating frequency, this index can be used only at the highest frequency present in the modulating signal, assuming that all frequencies will at one time or another have equal amplitudes. Taking 3000 cycles as a suitable upper limit for voice work, and setting the modulation index at 0.5 for 3000 cycles, the frequency response of the speech-amplifier system above 3000 cycles must be sharply attenuated, to prevent side-band splatter. Also, if the "tinny" quality of p.m. as received on an f.m. receiver is to be avoided, the p.m. must be changed to f.m., in which the modulation index decreases in inverse proportion to the modulating frequency. This requires shaping the speech-amplifier frequency-response curve in such a way that the output voltage is inversely proportional to frequency over most of the voice range. When this is done the maximum modulation index can only be used at some relatively low audio frequency, perhaps 300 to 400 cycles in voice transmission, and must decrease in proportion to the increase in frequency. The result is that the maximum linear frequency deviation is only one or two hundred cycles, when p.m. is changed to f.m. To increase the deviation for n.f.m. requires a frequency multiplication of 8 times or more.

It is relatively easy to secure a fairly large frequency deviation when a self-controlled oscillator is frequency-modulated directly. (True frequency modulation of a crystal-controlled oscillator results in only very small deviations and so requires a great deal of frequency multiplication.) The chief problem is to maintain a satisfactory degree of carrier stability, since the greater the inherent stability of the oscillator the more difficult it is to secure a wide frequency swing with linearity.

Methods of Frequency and Phase Modulation

● FREQUENCY MODULATION

The simplest and most satisfactory device for amateur f.m. is the reactance modulator. This is a vacuum tube connected to the r.f. tank circuit of an oscillator in such a way as to act as a variable inductance or capacitance.

Fig. 11-3 is a representative circuit. The control grid of the modulator tube, M , is connected across the oscillator tank circuit, C_1L_1 , through resistor R_1 and blocking capacitor C_2 . C_3 represents the input capacitance of the modulator tube. The resistance of R_1 is made large compared to the reactance of C_3 , so the r.f. current through R_1C_3 will be practically in phase with the r.f. voltage appearing at the terminals of the tank circuit. However, the voltage across C_3

will lag the current by 90 degrees. The r.f. current in the plate circuit of the modulator will be in phase with the grid voltage, and consequently is 90 degrees behind the current through C_3 , or 90 degrees behind the r.f. tank voltage. This lagging current is drawn through the oscillator tank, giving the same effect as though an inductance were connected across the tank. The frequency increases in proportion to the amplitude of the lagging plate current of the modulator. The audio voltage, introduced through a radio-frequency choke, RFC , varies the transconductance of the tube and thereby varies the r.f. plate current.

The modulated oscillator usually is operated on a relatively low frequency, so that a high order of carrier stability can be secured. Frequency

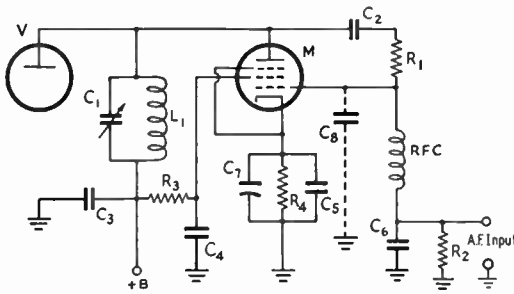

Fig. 11-3 — Reactance modulator using a high-transconductance pentode (6SG7, 6AG7, etc.).

- C₁ — R.f. tank capacitance (see text).
- C₂, C₃ — 0.001- μ f. mica.
- C₄, C₅, C₆ — 0.0017- μ f. mica.
- C₇ — 10- μ f. electrolytic.
- C₈ — Tube input capacitance (see text).
- R₁ — 47,000 ohms.
- R₂ — 0.17 megohm.
- R₃ — Screen dropping resistor; select to give proper screen voltage on type of modulator tube used.
- R₄ — Cathode bias resistor; select as in case of R₃.
- L₁ — R.f. tank inductance.
- RFC — 2.5-mh. r.f. choke.

multipliers are used to raise the frequency to the final frequency desired. The frequency deviation increases with the number of times the initial frequency is multiplied; for instance, if the oscillator is operated on 6.5 Mc. and the output frequency is to be 52 Mc., an oscillator frequency deviation of 1000 cycles will be raised to 8000 cycles at the output frequency.

A reactance modulator can be connected to a crystal oscillator as well as to the self-controlled type. However, the resulting signal is more phase-modulated than it is frequency-modulated, for the reason that the frequency deviation that can be secured by varying the tuning of a crystal oscillator is quite small.

Design Considerations

The sensitivity of the modulator (frequency change per unit change in grid voltage) depends on the transconductance of the modulator tube. It increases when R₁ is made smaller in comparison with C₈. It also increases with an increase in L C ratio in the oscillator tank circuit. Since the carrier stability of the oscillator depends on the L C ratio, it is desirable to use the highest tank capacitance that will permit the desired deviation to be secured while keeping within the limits of linear operation.

A change in any of the voltages on the modulator tube will cause a change in r.f. plate current, and consequently a frequency change. Therefore it is advisable to use a regulated plate power supply for both modulator and oscillator. At the low voltages used (250 volts) the required stabilization can be secured by means of gaseous regulator tubes.

Speech Amplification

The speech amplifier preceding the modulator follows ordinary design, except that no power is required from it and the a.f. voltage taken by the

modulator grid usually is small — not more than 10 or 15 volts, even with large modulator tubes. Because of these modest requirements, only a few speech stages are needed; a two-stage amplifier consisting of a pentode followed by a triode, both resistance-coupled, will more than suffice for crystal microphones.

● **PHASE MODULATION**

The same type of reactance-tube circuit that is used to vary the tuning of the oscillator tank in f.m. can be used to vary the tuning of an amplifier tank and thus vary the phase of the tank current for p.m. Hence the modulator circuit of Fig. 11-3 can be used for p.m. if the reactance tube works on an amplifier tank instead of directly on a self-controlled oscillator.

The phase shift that occurs when a circuit is detuned from resonance depends on the amount of detuning and the Q of the circuit. The higher the Q, the smaller the amount of detuning needed to secure a given number of degrees of phase shift. If the Q is at least 10, the relationship between phase shift and detuning (in kilocycles either side of the resonant frequency) will be substantially linear over a phase-shift range of about 25 degrees. From the standpoint of modulator sensitivity, the Q of the tuned circuit on which the modulator operates should be as high as possible. On the other hand, the effective Q of the circuit will not be very high if the amplifier is delivering power to a load since the load resistance reduces the Q. There must therefore be a compromise between modulator sensitivity and r.f. power output from the modulated amplifier. An optimum figure for Q appears to be about 20; this allows reasonable leading of the modulated amplifier and the necessary tuning variation can be secured from a reactance modulator without difficulty. It is advisable to modulate at a very low power level — preferably in a stage where receiving-type tubes are used.

Reactance modulation of an amplifier stage usually also results in simultaneous amplitude modulation because the modulated stage is detuned from resonance as the phase is shifted. This must be eliminated by feeding the modulated signal through an amplitude limiter or one or more "saturating" stages — that is, amplifiers that are operated Class C and driven hard enough so that variations in the amplitude of the grid excitation produce no appreciable variations in the final output amplitude.

For the same type of reactance modulator, the speech-amplifier gain required is the same for p.m. as for f.m. However, as pointed out earlier, the fact that the actual frequency deviation increases with the modulating audio frequency in p.m. makes it necessary to cut off the frequencies above about 3000 cycles before modulation takes place. If this is not done, unnecessary side bands will be generated at frequencies considerably away from the carrier.

Checking F.M. and P.M. Transmitters

Accurate checking of the operation of an f.m. or p.m. transmitter requires different methods than the corresponding checks on an a.m. set. This is because the common forms of measuring devices either indicate amplitude variations only (a d.c. milliammeter, for example), or because their indications are most easily interpreted in terms of amplitude. There is no simple measuring instrument that indicates frequency deviation in a modulated signal directly.

However, there is one favorable feature in f.m. or p.m. checking. The modulation takes place at a very low level and the stages following the one that is modulated do not affect the linearity of modulation so long as they are properly tuned. Therefore the modulation may be checked *without putting the transmitter on the air*, or even on a dummy antenna. The power is simply cut off the amplifiers following the modulated stage. This not only avoids unnecessary interference to other stations during testing periods, but also keeps the signal at such a

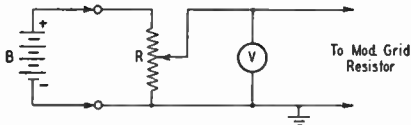

Fig. 11-4 — D.c. method of checking frequency deviation of a reactance-tube-modulated oscillator. A 500- or 1000-ohm potentiometer may be used at *R*.

low level that it may be observed quite easily on the station receiver. A good receiver with a crystal filter is an essential part of the checking equipment of an f.m. or p.m. transmitter, particularly for narrow-band f.m. or p.m.

The quantities to be checked in an f.m. or p.m. transmitter are the linearity and frequency deviation. Because of the essential difference between f.m. and p.m. the methods of checking differ in detail.

Reactance-Tube F.M.

It was explained earlier that in f.m. the frequency deviation is the same at any audio modulation frequency if the audio signal amplitude does not vary. Since this is true at *any* audio frequency it is true at zero frequency. Consequently it is possible to calibrate a reactance modulator by applying an adjustable d.c. voltage to the modulator grid and noting the change in oscillator frequency as the voltage is varied. A suitable circuit for applying the adjustable voltage is shown in Fig. 11-4. The battery, *B*, should have a voltage of 3 to 6 volts (two or more dry cells in series). The arrows indicate clip connections so that the battery polarity can be reversed.

The oscillator frequency deviation should be measured by using a receiver in conjunction with an accurately-calibrated frequency meter,

or by any means that will permit accurate measurement of frequency differences of a few hundred cycles. One simple method is to tune in the oscillator on the receiver (disconnecting the receiving antenna, if necessary, to keep the signal strength well below the overload point) and then set the receiver b.f.o. to zero beat. Then increase the d.c. voltage applied to the modulator grid from zero in steps of about $\frac{1}{2}$ volt and note the beat frequency at each change. Then reverse the battery terminals and repeat. The frequency of the beat note may be measured by comparison with a calibrated audio-frequency oscillator. Note that with the battery polarity positive with respect to ground the radio frequency will move in one direction when the voltage is increased, and in the other direction when the battery terminals are reversed. When several readings have been taken a curve may be plotted to demonstrate the relationship between grid voltage and frequency deviation.

A sample curve is shown in Fig. 11-5. The usable portion of the curve is the center part which is essentially a straight line. The bending at the ends indicates that the modulator is no longer linear; this departure from linearity will cause harmonic distortion and will broaden the channel occupied by the signal. In the example, the characteristic is linear 1.5 kc. on either side of the center or carrier frequency. This is the maximum deviation permissible at the frequency at which the measurement is made. At the final output frequency the deviation will be multiplied by the same number of times that the measurement frequency is multiplied. This must be kept in mind when the check is made at a frequency that differs from the output frequency.

A good modulation indicator is a "magic-eye" tube such as the 6E5. This should be connected across the grid resistor of the reactance modulator as shown in Fig. 11-6. Note its deflection (using the d.c. voltage method as in Fig. 11-4) at the maximum deviation to be used. This deflection represents "100 per cent

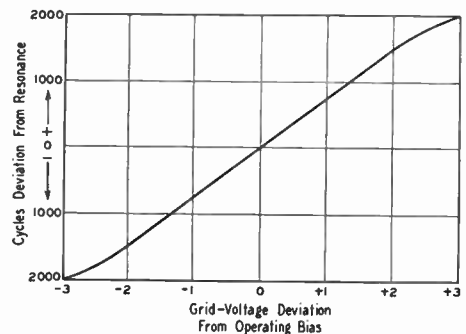

Fig. 11-5 — A typical curve of frequency deviation vs. modulator grid voltage.

modulation" and with speech input the gain should be kept at the point where it is just reached on voice peaks. If the transmitter is used on more than one band, the gain control should be marked at the proper setting for each band, because the signal amplitude that gives the correct deviation on one band will be either too great or too small on another. For narrow-band f.m. the proper deviation is approximately 2000 cycles (based on an upper a.f. limit of 3000 cycles and a deviation ratio of 0.7) at the final *output* frequency. If the output frequency is in the 29-Mc. band and the oscillator is on 7 Mc., the deviation at the *oscillator* frequency should not exceed $2000/4$, or 500 cycles.

Checking with a Crystal-Filter Receiver

With p.m. the d.c. method of checking just described cannot be used, because the frequency deviation at zero frequency also is zero. For narrow-band p.m. it is necessary to check the actual width of the channel occupied by the transmission. (The same method also can be used to check f.m.) For this purpose it is necessary to have a crystal-filter receiver and an a.f. oscillator that generates a 3000-cycle sine wave.

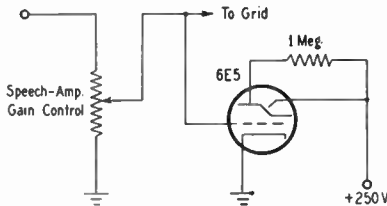

Fig. 11-6 — 6E5 modulation indicator for f.m. or p.m. modulators. To insure sufficient grid voltage for a good deflection, it may be necessary to connect the gain control in the modulator grid circuit rather than in an earlier speech-amplifier stage.

Keeping the signal intensity in the receiver at a medium level, tune in the carrier at the *output* frequency. Do not use the a.v.c. Switch on the beat oscillator, and set the crystal filter at its sharpest position. Peak the signal on the crystal and adjust the b.f.o. for any convenient beat note. Then apply the 3000-cycle tone to the speech amplifier (through an attenuator, if necessary, to avoid overloading; see chapter on audio amplifiers) and increase the audio gain until there is a small amount of modulation. Tuning the receiver near the carrier frequency will show the presence of side bands 3 kc. from the carrier on both sides. With low audio input, these two should be the only side bands detectable.

Now increase the audio gain and tune the receiver over a range of about 10 kc. on both sides of the carrier. When the gain becomes high enough, a second set of side bands spaced 6 kc. on either side of the carrier will be detected. The signal amplitude at which these side bands become detectable is the maximum speech am-

plitude that should be used. If the 6E5 modulation indicator is incorporated in the modulator, its deflection with the 3000-cycle tone will be the "100 per cent modulation" deflection for speech.

When this method of checking is used with a reactance-tube-modulated f.m. (not p.m.) transmitter, the linearity of the system can be checked by observing the *carrier* as the a.f. gain is slowly increased. The beat-note frequency will stay constant so long as the modulator is linear, but nonlinearity will be accompanied by a shift in the average carrier frequency that will cause the beat note to change in frequency. If such a shift occurs at the same time that the 6-kc. side bands appear, the extra side bands may be caused by modulator distortion rather than by an excessive modulation index. This means that the modulator is not capable of shifting the frequency over a wide-enough range. The 6-kc. side bands should appear *before* there is any shift in the carrier frequency.

R.F. Amplifiers

The r.f. stages in the transmitter that follow the modulated stage may be designed and adjusted as in ordinary operation. In fact, there are no special requirements to be met except that all tank circuits should be carefully tuned to resonance (to prevent unwanted r.f. phase shifts that might interact with the modulation and thereby introduce hum, noise and distortion). In neutralized stages, the neutralization should be as exact as possible, also to minimize unwanted phase shifts. With f.m. and p.m., all r.f. stages in the transmitter can be operated at the manufacturer's maximum c.w.-telegraphy ratings, since the average power input does not vary with modulation as it does in a.m. phone operation.

The output of the transmitter should be checked for amplitude modulation by observing the antenna current. It should not change from the unmodulated-carrier value when the transmitter is modulated. If there is no antenna ammeter in the transmitter, a flashlight lamp and loop can be coupled to the final tank coil to serve as a current indicator. If the carrier amplitude is constant, the lamp brilliance will not change with modulation.

Amplitude modulation accompanying f.m. or p.m. is just as much to be avoided as frequency or phase modulation that accompanies a.m. A mixture of a.m. with either of the other two systems results in the generation of spurious side bands and consequent widening of the channel. If the presence of a.m. is indicated by variation of antenna current with modulation, the cause is almost certain to be nonlinearity in the modulator. In very wide-band f.m. the selectivity of the transmitter tank circuits may cause the amplitude to decrease at high deviations, but this condition is not likely to occur on amateur frequencies at which wide-band f.m. would be used.

Single Side Band

The most significant development in amateur radiotelephony in the past several years has been the increased use of single-side-band suppressed-carrier transmissions. This system has tremendous potentialities for increasing the effectiveness of phone transmission and for reducing interference. Because only one of the two side bands normally produced in modulation is transmitted, the channel width is immediately cut in half. However, when only one side band is transmitted, the carrier — which is essential in double-side-band transmission — no longer is necessary; it can be supplied without too much difficulty at the receiver. With the carrier eliminated there is a great saving in power at the transmitter — or, from another viewpoint, a great increase in effective power output. Assuming that the same final-amplifier tube or tubes are used either for normal a.m. or for single side band, carrier suppressed, it can be shown that the use of s.s.b. can give an effective gain of up to 9 db. over a.m. — equivalent to increasing the transmitter power 8 times. Eliminating the carrier also eliminates the heterodyne interference that wrecks so much communication in congested phone bands.

● SUPPRESSING THE CARRIER

The carrier can be suppressed or nearly eliminated by an extremely sharp filter or by using a **balanced modulator**. The basic principle in any balanced modulator is to introduce the carrier in such a way that it does not appear in the output but so that the side bands will. This requirement is satisfied by introducing the audio in push-pull and the r.f. drive in parallel, and connecting the output (plate circuit) of the tubes in push-pull, as shown in Fig. 12-1A. Balanced modulators can also be connected with the r.f. drive and audio inputs in push-pull and the output in parallel (Fig. 12-1B) with equal effectiveness. The choice of a balanced modulator circuit is generally determined by constructional considerations and the method of modulation preferred by the builder. Screen-grid modulation is shown in the examples in Fig. 12-1, but control-grid or plate modulation can be used equally as well. Balanced-modulator circuits using four rectifiers (germanium, copper oxide, or thermionic) in "bridge" or "ring" circuits are often used, particularly in commercial applications. Two-rectifier circuits are also available, and they are widely used in amateur s.s.b. equipment. Rectifier-type balanced modulators are shown in Figs. 12-2 and 12-3.

In any of the vacuum-type circuits, there will be no output with no audio signal because the circuits are balanced. The signal from one tube is balanced or cancelled in the output circuit by the signal from the other tube. The circuits are thus balanced for any value of *parallel* audio signal.

When push-pull audio is applied, the modulating voltages are of opposite polarity, and one tube will conduct more than the other. Since any modulation process is the same as "mixing" in receivers, sum and difference frequencies (side bands) will be generated. The modulator is not balanced for the side bands, and they will appear in the output.

The amount of carrier suppression is dependent upon the matching of the two tubes and their associated circuits. Normally two tubes of the same type will balance closely enough to give at least 15 or 20 db. carrier suppression without any adjustment. If further suppression is required, trimmer capacitors to balance the grid-plate capacities and separate bias adjustments for setting the operating points can be used.

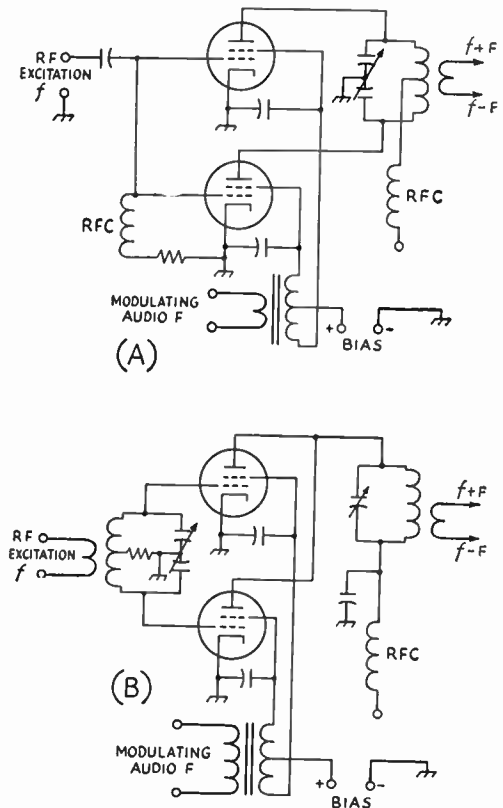

Fig. 12-1 — Two examples of balanced-modulator circuits using screen-grid modulation. In A the r.f. excitation is in parallel in both tubes, and the audio and output are in push-pull. In B the excitation and audio are in push-pull, the output is in parallel. In either case, the carrier frequency, f , does not appear in the output circuit — only the two side-band frequencies, $f + F$ and $f - F$, will appear. The bias on the screens is a practical requirement with all screen-grid tubes for low-distortion operation, and is not a special requirement of balanced modulators.

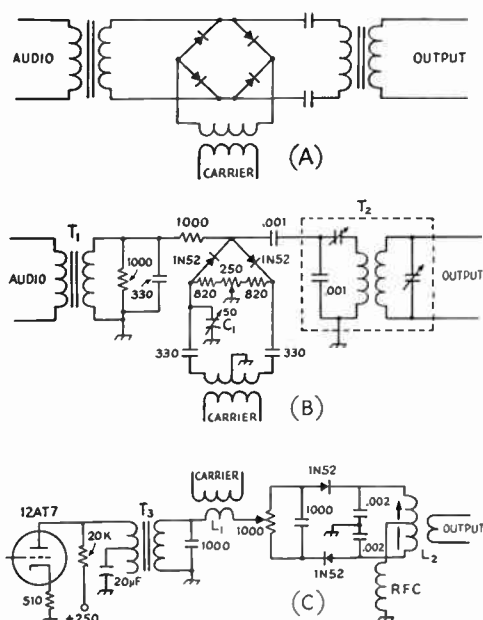

Fig. 12-2 — Typical rectifier-type balanced modulators. The circuit at A is called a "bridge" balanced modulator and has been widely used in commercial work.

The balanced modulator at B is shown with constants suitable for operation at 150 kc. T_1 is a transformer designed to work from the audio source into a 600-ohm load, and T_2 is an ordinary i.f. transformer with the trimmer reconnected in series with a 0.001- μ f. capacitor, for impedance-matching purposes from the modulator. The carrier input should be sufficient to develop several volts across the resistor string.

The balanced modulator circuit at C is shown with constants suitable for operation at 3.9 Mc. T_3 is a small step-down output transformer (UTC R-38A), shunt-fed to eliminate d.c. from the windings. L_1 can be a small coupling coil wound on the "cold" end of the carrier-oscillator tank coil, with sufficient coupling to give two or three volts of r.f. across its output. L_2 is a slug-tuned coil that resonates to the carrier frequency with the effective 0.001 μ f. across it. The 1000-ohm potentiometer is for carrier balance.

In the rectifier-type balanced modulators shown in Fig. 12-2, the diode rectifiers are connected in such a manner that, if they have equal forward resistances, no r.f. can pass from the carrier source to the output circuit via either of the two possible paths. The net effect is that no r.f. energy appears in the output. When audio is applied, it unbalances the circuit by biasing the diode (or diodes) in one path, depending upon the instantaneous polarity of the audio, and hence some r.f. will appear in the output. The r.f. in the output will appear as a double-side-band suppressed-carrier signal. (For a more complete description of diode-modulator operation, see "Diode Modulators," *QST*, April, 1953, p. 39.)

In any diode modulator, the r.f. voltage should be at least 6 or 8 times the peak audio voltage, for

minimum distortion. The usual operation involves a fraction of a volt of audio and several volts of r.f. The diodes should be matched as closely as possible — ohmmeter measurements of their forward resistances is the usual test.

(The circuit of Fig. 12-2B is described more fully in Weaver and Brown, "Crystal Lattice Filters for Transmitting and Receiving," *QST*, August, 1951. The circuit of Fig. 12-2C is suitable for use in a double-balanced-modulator circuit and is so described in "SSB, Jr.," *General Electric Ham News*, September, 1950.)

Vacuum-tube diodes can also be used in the two- and four-diode balanced-modulator circuits, and many operators consider them superior to the dry rectifier circuits. A typical balanced modulator circuit using a twin diode (6AL5, 6H6, etc.) is shown in Fig. 12-3. In phasing-type s.s.b. generators (described later) two of these modulators are required, and they are usually worked

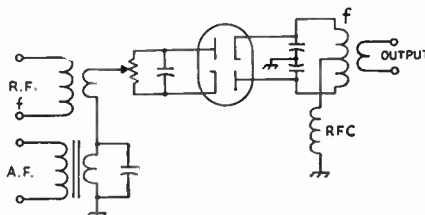

Fig. 12-3 — A twin diode balanced modulator circuit. This is essentially the same as the circuit in Fig. 12-2C, and differs only in that a twin diode is used instead of dry rectifiers. The heater circuit for the twin diode can be connected in the usual way (one side grounded or center tap grounded).

into a common output circuit. (For a description of a complete s.s.b. exciter using 6AL5 balanced modulators, see Vitale, "Cheap and Easy S.S.B.," *QST*, March, 1956.)

● SINGLE-SIDE-BAND GENERATORS

Two basic systems for generating s.s.b. signals are shown in Fig. 12-4. One involves the use of a bandpass filter having sufficient selectivity to pass one side band and reject the other. Filters having such characteristics can only be constructed for relatively low frequencies, and most filters used by amateurs are designed to work somewhere between 10 and 20 kc. Good side-band filtering can be done at frequencies as high as 500 kc. by using multiple-crystal or electromechanical filters. The low-frequency oscillator output is combined with the audio output of a speech amplifier in a balanced modulator, and only the upper and lower side bands appear in the output. One of the side bands is passed by the filter and the other rejected, so that an s.s.b. signal is fed to the mixer. The signal is there mixed with the output of a high-frequency r.f. oscillator to produce the desired output frequency. For additional amplification a linear r.f. amplifier (Class A or Class B) must be used. When the s.s.b. signal is generated at 10 or 20 kc., it is generally first heterodyned to somewhere around 500 kc. and then to the operat-

ing frequency. This simplifies the problem of rejecting the "image" frequencies resulting from the heterodyne process. The problem of image frequencies in the frequency conversions of s.s.b. signals differs from the problem in receivers because the beating-oscillator frequency becomes important. Either balanced modulators or sufficient selectivity must be used to attenuate these frequencies in the output and hence minimize the possibility of unwanted radiations.

The second system is based on the phase relationships between the carrier and side bands in a modulated signal. As shown in the diagram, the audio signal is split into two components that are identical except for a phase difference of 90 degrees. The output of the r.f. oscillator (which may

Properly adjusted, either system is capable of good results. Arguments in favor of the filter system are that it is somewhat easier to adjust without an oscilloscope, since it requires only a receiver and a v.t.v.m. for alignment, and it is more likely to remain in adjustment over a long period of time. The chief argument against it, from the amateur viewpoint, is that it requires quite a few stages and at least one frequency conversion after modulation. The phasing system requires fewer stages and can be designed to require no frequency conversion, but its alignment and adjustment are often considered to be a little "trickier" than that of the filter system. This probably stems from lack of familiarity with the system rather than any actual difficulty, and now that

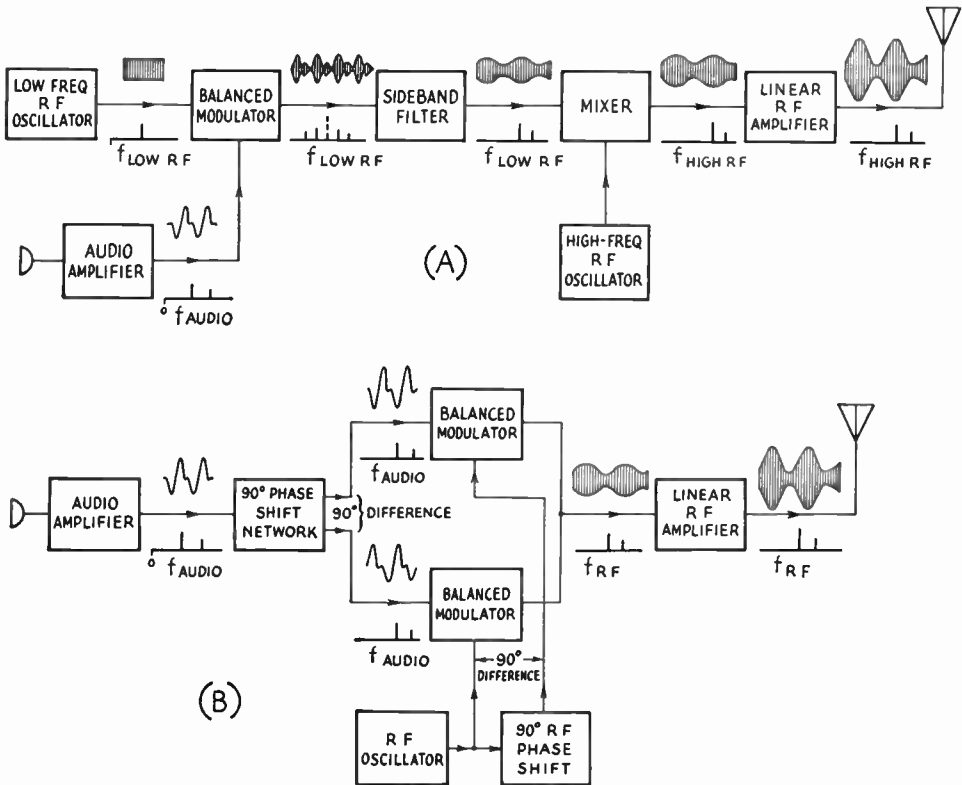

Fig. 12-4—Two basic systems for generating single-side-band suppressed-carrier signals. Representations of a typical envelope picture (as seen on an oscilloscope) and spectrum picture (as seen on a very selective panoramic receiver) are shown above and below the connecting links.

be at the operating frequency, if desired) is likewise split into two separate components having a 90-degree phase difference. One r.f. and one audio component are combined in each of two separate balanced modulators. The carrier is suppressed in the modulators, and the relative phases of the side bands are such that one side band is balanced out and the other is accentuated in the combined output. If the output from the balanced modulators is high enough, such an s.s.b. exciter can work directly into the antenna, or the power level can be increased in a following amplifier.

commercially-available preadjusted audio-phasing networks are available, most of the alignment difficulty has been eliminated. In most cases the phasing system will cost less to apply to an existing transmitter.

Regardless of the method used to generate a s.s.b. signal of 5 or 10 watts, the minimum cost will be found to be higher than for an a.m. transmitter of the same low power. However, as the power level is increased, the s.s.b. transmitter becomes more economical than the a.m. rig, both initially and from an operating standpoint.

● AMPLIFICATION OF S.S.B. SIGNALS

When an s.s.b. signal is generated at some frequency other than the operating frequency, it is necessary to change frequency by heterodyne methods. These are exactly the same as those used in receivers, and any of the normal mixer or converter circuits can be used. One exception to this is the case where the original signal and the heterodyning oscillator are not too different in frequency (as when heterodyning a 20-ke. signal to 500 kc.) and, in this case, a balanced mixer should be used, to eliminate the heterodyning oscillator frequency in the output.

To increase the power level of an s.s.b. signal, a **linear amplifier** must be used. A linear amplifier is one that operates with low distortion, and the low distortion is obtained by the proper choice of tube and operating conditions. Physically there is little or no difference between a linear amplifier and any other type of r.f. amplifier stage. The simplest form of linear amplifier (r.f. or audio) is the Class A amplifier, which is used almost without exception throughout receivers and low-level speech equipment. (See Chapter Three for an explanation of the classes of amplifier operation.) While its linearity can be made relatively good, it is inefficient. The theoretical limit of efficiency is 50 per cent, and most practical amplifiers run 25-35 per cent efficient at full output. At low levels this is not worth worrying about, but when the 2- to 10-watt level is exceeded something else must be done to improve this efficiency and reduce tube, power-supply and operating costs.

Class AB₁ amplifiers make excellent linear amplifiers if suitable tubes are selected. Primary advantages of Class AB₁ amplifiers are that they give much greater output than straight Class A amplifiers using the same tubes, and they do not require any grid driving power (no grid current drawn at any time). Although triodes can be used for Class AB₁ operation, tetrodes or pentodes are usually to be preferred, since Class AB₁ operation requires high peak plate current without grid current, and this is easier to obtain in tetrodes and pentodes than in most triodes.

To obtain maximum output from tetrodes, pentodes and most triodes, it is necessary to operate them in Class AB₂. Although this produces maximum peak output, it increases the driving-power requirements and, what is more important, requires that the **driver regulation** (ability to maintain wave form under varying load) be good or excellent. The usual method to improve the driver regulation is to add fixed resistors across the grid circuit of the driven stage, to offer a load to the driver that is modified only slightly by the additional load of the tube when it is driven into the grid-current region. This increases the driver's output-power requirements. Further, it is desirable to make the grid circuit of the Class AB₂ stage a high-*C* circuit, to improve regulation and simplify coupling to the driver. A "stiff" bias source is also required, since it is important that the bias remain constant, whether or not grid current is drawn.

Class B amplifiers are theoretically capable of 78.5 per cent efficiency at full output, and practical amplifiers run at 60-70 per cent efficiency at full output. Tubes normally designed for Class B audio work can be used in r.f. linear amplifiers and will operate at the same power rating and efficiency provided, of course, that the tube is capable of operation at the radio frequency. The operating conditions for r.f. are substantially the same as for audio work — the only difference is that the input and output transformers are replaced by suitable r.f. tank circuits. Further, in r.f. circuits it is readily possible to operate only one tube if only half the power is wanted — push-pull is not a necessity in Class B r.f. work. However, the r.f. harmonics may be higher in the case of the single-ended amplifier, and this should be taken into consideration if TVI is a problem.

For proper operation of Class B amplifiers, and to reduce harmonics and facilitate coupling, the input and output circuits should not have a low *C*-to-*L* ratio. A good guide to the proper size of tuning capacitor will be found in Chapter Six; in case of any doubt, it is well to be on the high-capacitance side. If zero-bias tubes are used in the Class B stage, it may not be necessary to add much "swamping" resistance across the grid circuit, because the grids of the tubes load the circuit at all times. However, with other tubes that require bias, the swamping resistor should be such that it dissipates from five to ten times the power required by the grids of the tubes. This will insure an almost constant load on the driver stage and good regulation of the r.f. grid voltage of the Class B stage.

Before going into detail on the adjustment and loading of the linear amplifier, a few general considerations should be kept in mind. If proper operation is expected, it is essential that the amplifier be so constructed, wired and neutralized that no trace of regeneration or parasitic instability remains. Needless to say, this also applies to the stages driving it.

The bias supply to the Class B linear amplifier should be quite stiff, such as batteries or some form of voltage regulator. If nonlinearity is noticed when testing the unit, the bias supply may be checked by means of a large electrolytic capacitor. Simply shunt the supply with 100 μ f. or so of capacity and see if the linearity improves. If so, rebuild the bias supply for better regulation. *Do not rely on a large capacitor alone.*

Where tetrodes or pentodes are used, the screen supply should have good regulation and its voltage should remain constant under the varying current demands. If the maximum screen current does not exceed 30 or 35 ma., a string of VR tubes in series can be used to regulate the screen voltage. If the current demand is higher, it may be necessary to use an electronically-regulated power supply or a heavily-bled power supply with a current capacity of several times the current demand of the screen circuit.

Where VR tubes are used to regulate the screen supply, they should be selected to give a

TABLE 12-1—LINEAR-AMPLIFIER TUBE-OPERATION DATA FOR SINGLE SIDE BAND

Except where otherwise noted, ratings are manufacturers' for audio operation. Values given are for one tube. Driving powers represent tube losses only—circuit losses will increase the figures.

Tube	Class	Plate Voltage	Screen Voltage	D.C. Grid Voltage	Zero-Sig. D.C. Plate Current	Max.-Sig. D.C. Plate Current	Zero-Sig. D.C. Screen Current	Max.-Sig. D.C. Screen Current	Peak R.F. Grid Voltage	Max.-Sig. D.C. Grid Current	Max.-Sig. Driving Power	Max.-Rated Screen Dissipation	Max.-Rated Grid Dissipation	Avg. Plate Dissipation	Max.-Sig. Useful Power Output
2E26 6893	A ₁	250	200	— 14	35	42	7	10	14	—	0	2.5	—	10	5
	AB ₂	400 500	125 125	— 15 — 15	10 11	75 75	— —	16 16	30 30	— —	.2 .2	2.5 2.5	— —	10 12.5	21 27
6146 6883	AB ₁	600 750	200 200	— 50 — 50	26 29	120 114	.6 .5	13 14	50 50	— —	0 0	3 3	— —	25 25	47 60
	AB ₂	600 750	185 165	— 50 — 45	21 18	135 120	.5 .3	15 11	57 51	.4 .4	.02 .02	3 3	— —	25 25	58 65
807 1625	AB ₂	600 750	300 300	— 30 — 32	30 26	100 120	.4 .3	6 8	39 46	— —	.1 .1	3.5 3.5	— —	25 30	40 60
		1000 1250 1500	— — —	0 0 — 4.5	22 27 16	175 175 157	— — —	— — —	93 88 85	13	3.8 3.0 2.2	— — —	— — —	65 65 65	124 155 170
4-65A	AB ₁	1500 2000 2500	480 450 405	— 105 ¹ — 100 ¹ — 90 ¹	30 22 17	90 (70) ⁴ 80 (60) ⁴ 70 (50) ⁴	— — —	13 (4.2) ⁴ 11 (3.0) ⁴ 8.5 (2.5) ⁴	105 100 90	— — —	2.5 1.6 1.1	10 10 10	5 5 5	65 63 63	85 125 135
		1500 2000 2500	300 400 500	— 55 ¹ — 80 ¹ — 105 ¹	35 25 20	200 ¹ 270 ¹ 230 ¹	— — —	45 ² 65 ² 45 ²	150 190 165	15 20 8	2.3 ⁷ 3.8 ⁷ 1.3 ⁷	10 10 10	5 5 5	60 65 65	150 300 325
		2000 2250 2500	750 750 750	— 90 — 90 — 95	20 23 18	158 158 180	.8 .8 .6	29 29 28	115 115 118	— — —	.1 .1 .2	22 22 22	— — —	100 100 125	228 258 325
	4-125A	AB ₁	2000 2500 3000	615 555 510	— 105 ¹ — 100 ¹ — 95 ¹	40 35 30	135 (100) ⁴ 120 (85) ⁴ 105 (75) ⁴	— — —	14 (4.0) ⁴ 10 (3.0) ⁴ 6.0 (1.5) ⁴	105 100 95	0 0 0	0 0 0	20 20 20	— — —	150 180 200
1500 2000 2500			350 350 350	— 41 ¹ — 45 ¹ — 43 ¹	44 36 47	200 150 130	0 0 0	17 3 3	141 105 89	9 7 6	1.25 .7 .5	20 20 20	5 5 5	125 125 122	175 175 200
2500 3000 3500 4000			660 600 555 510	— 115 — 110 — 105 — 100	65 55 45 40	230 (170) ⁴ 210 (150) ⁴ 185 (130) ⁴ 165 (115) ⁴	— — — —	15 (3.5) ⁴ 12 (2.5) ⁴ 9.5 (2.0) ⁴ 7.5 (1.5) ⁴	115 110 105 100	0 0 0 0	0 0 0 0	35 35 35 35	— — — —	335 400 425 450	
4-250A	AB ₂	1500 2000 2500 3000	300 300 300 300	— 48 ¹ — 48 ¹ — 51 ¹ — 53 ¹	50 60 60 63	243 255 250 237	0 0 0 0	17 13 12 17	96 99 100 99	11 12 11 10	1.1 1.2 1.1 1.0	35 35 35 35	10 10 10 10	150 185 205 190	214 325 420 520
		1500 2000 2500 3000	— — — —	— 118 ¹ — 170 ¹ — 230 ¹ — 290 ¹	135 100 80 65	286 273 242 222	— — — —	— — — —	118 170 230 290	— — — —	0 0 0 0	— — — —	— — — —	128 245 305 365	
		2500 3500 4000	— — —	— 60 ¹ — 90 ¹ — 105 ¹	40 30 24	300 270 250	— — —	— — —	180 220 205	80 68 42	70 ⁴ 75 ⁴ 60 ⁴	— — —	— — —	550 760 800	
		PL-6569	B ³	2500 3500 4000	— — —	— 60 ¹ — 90 ¹ — 105 ¹	40 30 24	300 270 250	— — —	— — —	180 220 205	80 68 42	70 ⁴ 75 ⁴ 60 ⁴	— — —	— — —

¹ Adjust to give stated zero-signal plate current.

² Single-side-band suppressed-carrier linear amplifier ratings, voice signal.

³ Approximate value.

⁴ Values in parentheses are with two-tone test signal.

⁵ Grounded-grid circuit.

⁶ Includes bias loss, grid dissipation, and feed-through power.

regulated voltage as close as possible to the tube's rated voltage, but it does not have to be exact. Minor differences in idling plate current can be made up by readjusting the grid bias.

One should bear in mind that the same amplifier can be operated in several classes of operation by merely changing the operating conditions (bias, loading, drive, screen voltage, etc.). However, when the power sensitivity of an amplifier is increased, as by changing the operation from Class B to Class A, the stability requirements for the amplifier become stringent.

From the standpoint of ease of adjustment and availability of proper operating voltages, a linear amplifier with Class AB₁ tetrodes or pentodes or one with zero-bias Class B triodes would be first choice. The Class B amplifier would require more driving power. (For examples of Class AB₁ tetrode amplifiers, see Russ, "The 'Little Fire-cracker' Linear Amplifier," *QST*, September, 1953, and Eckhardt, "The Single Side-Saddle Linear," *QST*, November, 1953.)

Table 12-1 lists a few of the more popular tubes commonly used for s.s.b. linear-amplifier operation. Except where otherwise noted, these ratings are those given by the manufacturer for audio work and as such are based on a sine-wave signal. These ratings are adequate ones for use in s.s.b. amplifier design, but they are conservative for such work and hence do not necessarily represent the maximum powers that can be obtained from the tubes in voice-signal s.s.b. service. In no case should the *average* plate dissipation be exceeded for any considerable length of time, but the nature of a s.s.b. signal is such that the average plate dissipation of the tube will run well below the peak plate dissipation. Hence in s.s.b. operation the *peak* plate dissipation of an amplifier tube may exceed the average plate dissipation by several times.

Getting the most out of a linear amplifier is done by increasing the peak power without exceeding the average plate dissipation over any appreciable length of time. This can be done by raising the plate voltage or the peak current (or both), provided the tube can withstand the increase. For example, the 6146 is shown with 750 volts maximum on the plate, and it is quite likely that this can be increased to 900 or 1000 volts without any appreciable shortening of the life of the tube. However, the manufacturers have not released any data on such operation, and any extrapolation of the audio ratings is at the risk of the amateur. A 35- to 50-per cent increase above plate-voltage ratings should be perfectly safe in most cases. In a tetrode or pentode, the peak plate current can be boosted some by raising the screen voltage.

When running a linear amplifier at considerably higher than the audio ratings, the "two-tone test signal" (described later) should never be applied at full amplitude for more than a few seconds at any one time. The above statements about working tubes above ratings apply only when a voice signal is used — a prolonged whistle or two-tone test signal may damage the tube.

● VOICE-CONTROLLED BREAK-IN

Although it is possible for two s.s.b. stations operating on widely different frequencies to work "duplex" if the carrier suppression is great enough (inadequate carrier suppression would be a violation of the FCC rules), most s.s.b. operators prefer to use voice-controlled break-in and operate on the same frequency. This overcomes any possibility of violating the FCC rules and permits "round table" operation.

Many various systems of voice-controlled break-in are in use, but they are all basically the same. Some of the audio from the speech amplifier is amplified and rectified, and the resultant d.c. signal is used to key an oscillator and one or more stages in the s.s.b. transmitter and "blank" the receiver at the time that the transmitter is on. Thus the transmitter is on at any and all times that the operator is speaking but is off during the intervals between sentences. The voice-control circuit must have a small amount of "hold" built into it, so that it will hold in between words, but it should be made to turn on rapidly at the slightest voice signal coming through the speech amplifier. Both tube and relay keyers have been used with good success. Some voice-control systems require the use of headphones by the operator, but a loudspeaker can be used with the proper circuit. (See Nowak, "Voice-Controlled Break-In . . ." and a Loudspeaker," *QST*, May, 1951, and Hunter, "Simplified Voice Control with a Loudspeaker," *QST*, October, 1953.)

Restriction of Audio Range

In either type of s.s.b. generator, it is good practice to restrict the frequency range of the audio amplifier. In the filter-type exciter, reducing the response below 300 or 400 cycles makes it easier for the filter to eliminate the unwanted side frequencies below this range. In the phasing-type exciter, restricting the range of the audio amplifier to the frequencies at which the network gives its best performance (usually about 300 to 3000 cycles) reduces the possibility of generating unwanted side frequencies outside this range. High-frequency audio cut-off is not as important in the filter-type exciter because the filter takes care of the higher frequencies.

When a restricted audio range is used, it is a good idea to make a number of checks on the system, in an effort to obtain the best compromise between naturalness and intelligibility. Voice characteristics differ from operator to operator, and it is sometimes preferable to accentuate the "highs" slightly to give better intelligibility. No standards can be given here — it is a subject for experimentation and checking under varied conditions.

The simplest means for reducing the low-frequency response in the audio amplifier is to reduce the values of the coupling capacitors. High-frequency response can be reduced by adding capacitance across grid resistors. More elaborate means require the use of filters using inductance and capacitance combinations.

Phasing-Type S.S.B. Exciters

It should be obvious that a phasing-type s.s.b. exciter can take many forms, but in general it will consist of a speech amplifier, audio phase-shift network, audio amplifier, balanced modulators, r.f. source, r.f. phase-shift network, and r.f. amplifier. If operation on a band other than that of the r.f. source, a mixer stage will also be required, for heterodyning the signal to the desired frequency. Since there are several balanced-modulator, audio- and r.f. phasing circuits, it is apparent that many different combinations are available. One of the simplest of all combinations is that shown in Fig. 12-5.

Referring to Fig. 12-5, the speech amplifier builds up the signal from a crystal microphone

to a useful level. The audio signal is then fed to an audio phase-shift network, *PSN*, which applies equal-amplitude audio signals 90 degrees out of phase to the grids of the 12AT7 audio amplifier. The two audio signals, 90 degrees out of phase, are applied to two balanced modulators that have their outputs in parallel (L_3). The r.f. excitation to the balanced modulators is also 90 degrees out of phase, obtained by coupling from the two tuned circuits at L_1 and L_2 . A 6AG7 linear amplifier, operating Class AB₁, follows the balanced-modulator stage and provides about 5 watts peak envelope output.

The gain control in the speech amplifier sets the gain to the proper level, depending upon the

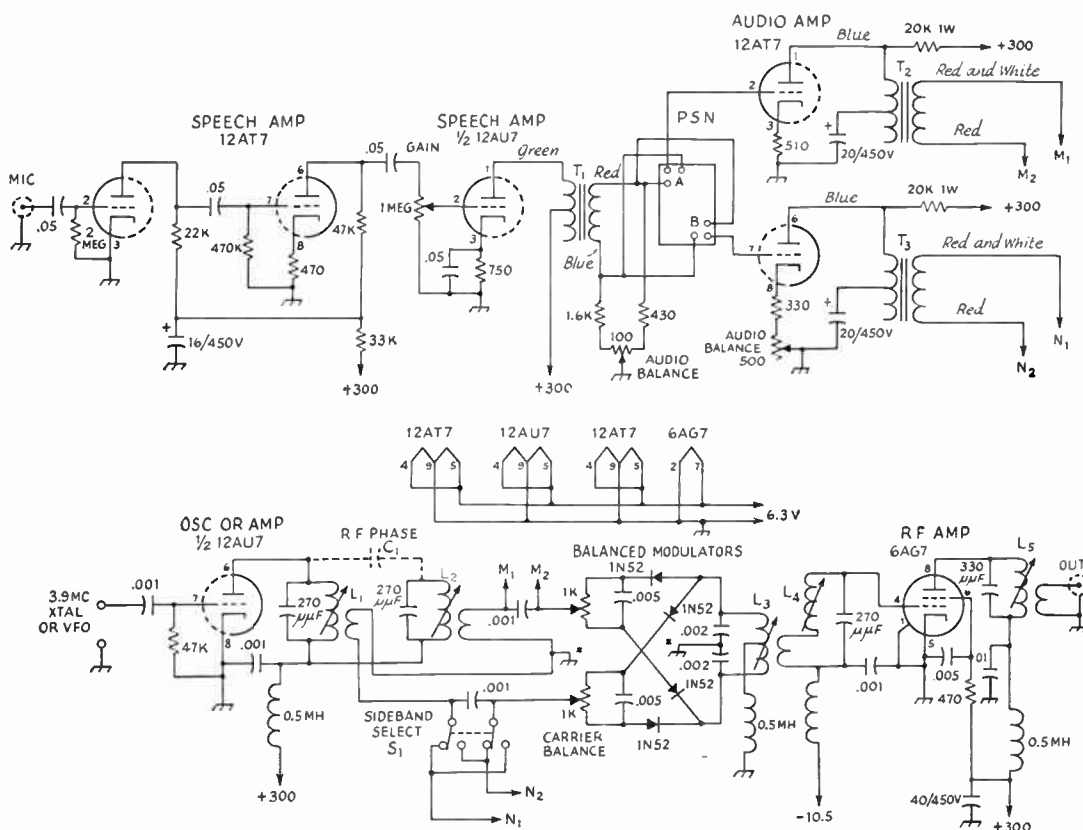

Fig. 12-5 — Schematic of a phasing-type s.s.b. exciter. Capacitance in μf , unless otherwise noted — resistors are $\frac{1}{2}$ -watt unless otherwise noted. Chassis grounds marked * should be the same.

C_1 — 5 or 10 μf , if inductive coupling between L_1 and L_2 not sufficient.

T_1 — Single plate to push-pull grid, 1:3 ratio (Stancor A53C).

T_2, T_3 — 6-watt universal output transformer, 30 ohms output (UTC R-38A).

L_1, L_2 — 32 turns No. 22 enam. closewound on $\frac{1}{2}$ -inch diameter iron-core tuned form (Millen 69046). Link turn is 6 turns hook-up wire wound adjacent to cold end.

L_3 — 16 turns No. 22 enam., spaced to occupy 1-inch length on $\frac{1}{2}$ -inch diameter iron-core-tuned form (Millen 69046), tapped at center. One-turn link wound at center.

L_4 — Same as L_1 ; no link.

L_5 — 25 turns No. 22 enam. closewound on $\frac{1}{2}$ -inch iron-core-tuned form (Millen 69046). Link of 4 turns at cold end.

S_1 — D.p.d.t. toggle or rotary.

PSN — Audio phase-shift network (Millen 75012). See Fig. 12-6.

microphone and how the operator uses it. Since the audio phase-shift network, *PSN*, has unequal gains through its two channels, unequal-amplitude audio is required at the input to

or the output of this unit can be heterodyned to the different band.

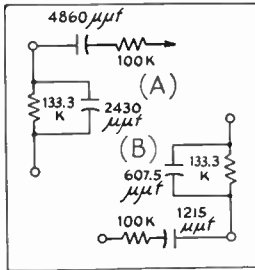

Fig. 12-6 — Schematic of the phase-shift network marked *PSN* in Fig. 12-5. Resistors and capacitors should be within 1 per cent of values shown.

obtain equal signals in the output. This is obtained through proper adjustment of the 100-ohm input audio balance control. To compensate for lack of uniformity in audio-amplifier gains, a 500-ohm audio balance control is provided in the cathode of a 12AT7 section. R.f. carrier balance is obtained by proper setting of the 1000-ohm carrier balance controls. The side band in use (upper or lower) is selected by *S*₁, which reverses the audio signal in one of the channels. The r.f. phasing adjustment is obtained by the tuning of *L*₁ and *L*₂.

Construction

There are a few constructional precautions that should be observed in a unit of this type. Transformers *T*₂ and *T*₃ should preferably be mounted at right angles to each other, to minimize stray coupling. The 1N52 germanium diodes used in the balanced modulator should be checked for forward and back resistance with an ohmmeter, and the forward resistances (the lower readings) should agree within 10 per cent. The leads from the coupling loops at *L*₁ and *L*₂ should return to the balanced modulator stage in twisted pairs, and the grounding precaution mentioned in Fig. 12-5 should be observed. Coils *L*₁ and *L*₂ should be mounted parallel to each other and with a separation of about 1½ diameters — *L*₃ and *L*₄ should be mounted to minimize coupling between them and *L*₅ and the oscillator coils. This can be accomplished by providing shielding or using the chassis deck to separate them.

Although slug-tuned coils are shown in the schematic, capacitance-tuned circuits can of course be used. Approximately the same *L/C* ratios should be retained, however. If operation on another amateur band is desired, the tuned circuits can be modified accordingly, retaining the same *L/C* ratios,

Adjustment

If v.f.o. operation is to be used, the v.f.o. signal should furnish at least 10 volts r.m.s. at the terminals. With crystal control, plug in a crystal and tune *L*₁ until the circuit oscillates, as indicated by a signal in a receiver tuned to the proper frequency, and then tune the circuit to a slightly higher frequency. With v.f.o. operation, the circuit is resonated in the usual manner, as indicated by a plate-current minimum.

The output from the 6AG7 stage can be checked on an oscilloscope or on a receiver. The method of coupling an oscilloscope or receiver to the exciter is shown in Fig. 12-7. When connecting to an oscilloscope, a tuned circuit is required, and the r.f. voltage developed across the tuned circuit is applied directly to the vertical deflection plates. The receiver is connected by coupling loosely through a loop and length of shielded cable; when further attenuation is required it is obtained through the use of resistors at the receiver input terminals.

With the oscillator running, tune the balanced modulator and 6AG7 circuits for maximum output — this resonates these circuits. Next adjust the carrier balance potentiometers for minimum output. Then introduce a single audio tone of around 1000 cycles at the microphone terminal. Here again it may be necessary to use a resistance voltage divider to hold the signal down and prevent overload. Advance the gain control and check the voltage at Pins 2 and 7 of the 12AT7 audio amplifier with a v.t.v.m. If they are not

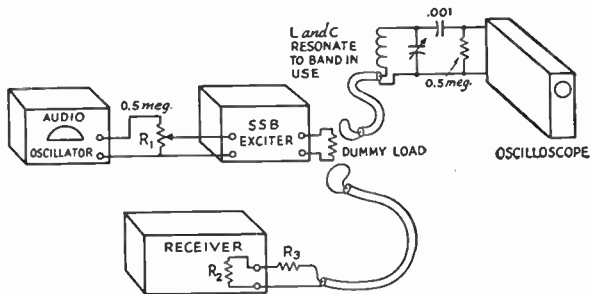

Fig. 12-7 — Fundamental arrangement for using an oscilloscope and/or receiver when testing an s.s.b. exciter or transmitter. An audio oscillator is required to furnish the audio signal, and its output is best controlled by the external control *R*₁. The audio volume control in the s.s.b. exciter should not be turned on too far, or it should be set at the normal position if you know that position, and all volume controlling should then be done with *R*₁ and the output attenuator of the audio oscillator. This will reduce the chances of over-loading the audio and other amplifier stages in the exciter, a common cause of distortion.

The oscilloscope is coupled to the dummy load through a loop, length of coaxial line, and an *L-C* circuit tuned to the operating frequency. It is necessary to go directly to the vertical deflection plates of the oscilloscope rather than through the vertical amplifier.

The receiver is coupled to the dummy load through a loop and a length of shielded line. If too much signal is obtained this way, an attenuator, *R*₂*R*₃, can be added to the input terminals of the receiver. Small values of *R*₂ and large values of *R*₃ give the most attenuation; in some cases *R*₂ might be merely a few inches of solid wire.

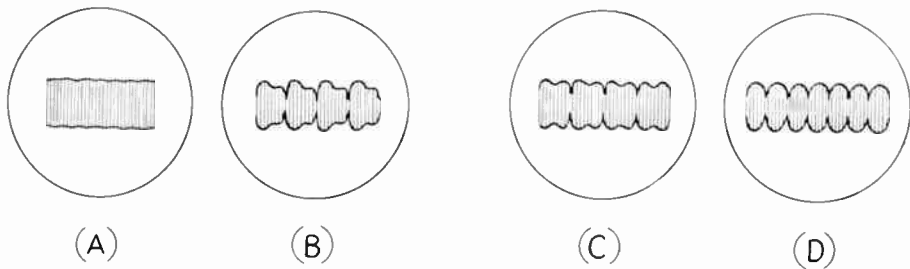

Fig. 12-8—Sketches of the oscilloscope face showing different conditions of adjustment of the exciter unit. (A) shows the substantially clean carrier obtained when all adjustments are at optimum and a sine-wave signal is fed to the audio input. (B) shows improper r.f. phase and unbalance between the outputs of the two balanced modulators. (C) shows improper r.f. phasing but outputs of the two balanced modulators equal. (D) shows proper r.f. phasing but unbalance between outputs of two balanced modulators.

equal, adjust the 100-ohm audio balance control until they are. Listening to the signal, from the 6AG7, or looking at it on the scope, should give a modulated signal. Try various settings of L_2 until the modulation is minimized, as well as touching up the 500-ohm audio balance control. With the v.t.v.n. check the r.f. voltages at the arms of the 1000-ohm carrier balance potentiometers — they should be about the same. If not, they can be brought into this condition by readjustment of the tuning conditions which, however, must be kept consistent with minimum modulation on the output signal.

The s.s.b. signal with single-tone audio input is a steady unmodulated signal. While it may not be possible to eliminate the modulation entirely, it will be possible to get it down to a satisfactorily low level. Conditions that will prevent this are improper r.f. phasing, lack of carrier balance (suppression), distortion in the audio signal (at the source or through overload in the speech

amplifier), and lack of audio balance at the 12AT7 audio amplifier. Of these, the r.f. phasing is perhaps the most critical.

A final check on the signal can be made with the receiver in its most selective condition. The spectrum testing described below cannot be done with a broad receiver. Examining the spectrum near the signal, the side signals other than the main one (carrier, unwanted side bands, and side bands from audio harmonics) should be at least 30 db. down from the desired signal. This checking can be done with the S-meter and the a.v.c. on — in the earlier tests the a.v.c. should be off but the r.f. gain reduced low enough to avoid receiver overload.

Examples of the proper and improper scope patterns are shown in Fig. 12-8.

(For an extensive treatment of the alignment of commercial phasing-type s.s.b. exciters, see Ehrlich, "How to Adjust Phasing-Type S.S.B. Exciters," *QST*, November, 1956.)

Filter-Type S.S.B. Exciters

The basic configuration of a filter-type s.s.b. exciter was shown earlier in this chapter (Fig. 12-4). Suitable filters, sharp enough to reject the unwanted side band above a few hundred cycles, can be built in the range 20 to 500 kc. (In England a few amateurs have used crystal filters at 5 Mc.) The low-frequency filters generally use iron-cored inductors, and the new toroid forms find considerable favor at frequencies up to 50 or 60 kc. These filters are of normal band-pass constant- k and m -derived configuration. In the range 450 to 500 kc., either crystal-lattice or electromechanical filters are used. Low-frequency filters are manufactured by Barker & Williamson and by Burnell & Co., and electromechanical filters are made by the Collins Radio Co. Crystal-lattice filters are generally home-made, and crystals from war-surplus equipment are a ready source of supply.

The frequency of the filter determines how many conversions must be made before the operating frequency is reached. For example, if the

filter frequency is 30 kc. or so, it is wise to convert first to 500 or 600 kc. and then convert to the 3.9-Mc. band, to avoid the image that would almost surely result if the conversion from 30 to 3900 kc. were made without the intermediate step. When a filter at 500 kc. is used, only one conversion is necessary to operate in the 3.9-Mc. band, but 14-Mc. and higher-frequency operation would require at least two conversions to hold down the images and make them easy to eliminate.

The choice of converter circuit depends largely on the frequencies involved and the impedance level. At low frequencies (up to 500 kc.) and low impedances, rectifier-type balanced modulators are often used for mixers, because the balanced modulator does not show the local-oscillator frequency in its output and one source of spurious signal is minimized. At frequencies at high impedance levels, and at the higher frequencies, vacuum tubes are generally used, in straight converter or balanced-modulator circuits, de-

pending upon the need for minimizing the local-oscillator frequency in the output.

Low-frequency side band filters in the 30- to 50-ke. range are usually low-impedance devices, and rectifier-type balanced modulators are common practice. Side-band filters in the i.f. range

this can be nothing more elaborate than a shielded b.f.o. unit. The signal should be introduced at the balanced modulator, and an output indicator connected to the plate circuit of the vacuum tube following the filter. With the crystals out of the circuit, the transformers can be

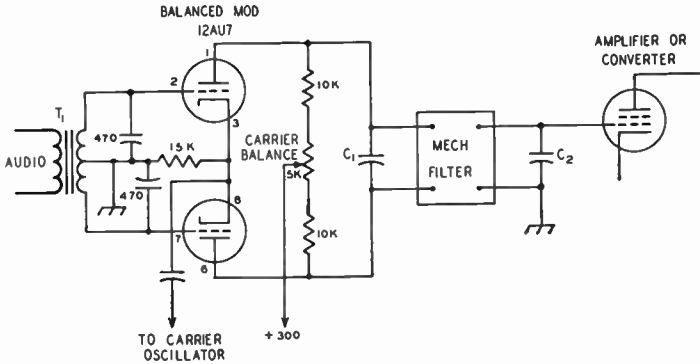

Fig. 12-9 — One type of balanced-modulator circuit that can be used with a mechanical filter (Collins F455-31 or F500-31 series) in the i.f. range. The filters are furnished in various types of mountings, and the values of C_1 and C_2 will depend upon the type of filter selected.
 T_1 — Plate-to-push-pull grids audio transformer.

are higher-impedance circuits and vacuum-tube balanced modulators are the rule in this case. An example of one that can be used with the high-impedance (15,000 ohms) mechanical filter is shown in Fig. 12-10. The filter can be followed by a converter or amplifier tube, depending upon the signal level. Some models of the mechanical filters have a 23-db. insertion loss, while others have only 10.

Crystal-lattice filters are also used to reject the unwanted side band. These filters can be

brought close to frequency by plugging in small capacitors (10 to 25 $\mu\text{f.}$) in one crystal socket in each stage and then tuning the transformers for peak output at one of the two crystal frequencies. The small capacitors can then be removed and the crystals replaced in their sockets.

Tuning the signal source slowly across the pass band of the filter and watching the output indicator will show the selectivity characteristic of the filter. The objective is a fairly flat response for about two ke. and a rapid drop-off outside

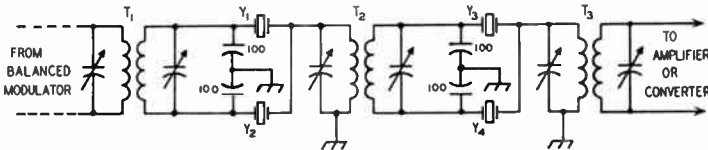

Fig. 12-10 — A cascaded half-lattice crystal filter that can be used for side-band selection. The crystals are surplus type in FT-243A holders. Y_1 and Y_3 should be the same frequency and Y_2 and Y_4 should be 1.8 ke. higher. T_1, T_2, T_3 — 150-ke. i.f. transformers.

made from crystals in the i.f. range — many of these are still available from stores selling military surplus. The most popular configuration is the “cascaded half lattice” shown in Fig. 12-10. The crystals used in this filter can be obtained at frequencies in the i.f. range, and ones that are within the ranges of the modified i.f. transformers will be satisfactory. Two 100- $\mu\text{f.}$ capacitors are connected across the secondary winding of two of the transformers to give push-pull output. The crystals should be obtained in pairs 1.8 ke. apart. The i.f. transformers can be either capacitor-tuned as shown, or they can be slug-tuned.

A variable-frequency signal generator of some kind is required for alignment of the filter, but

this range. It will be found that small changes in the tuning of the transformers will change the shape of the selectivity characteristic, so it is wise to make a small adjustment of one trimmer, swing the frequency across the band, and observe the characteristic. After a little experimenting it will be found which way the trimmers must be moved to compensate for the peaks that will rise when the filter is out of adjustment.

The (suppressed) carrier frequency must be adjusted so that it falls properly on the slope of the filter characteristic. If it is too close to the filter mid-frequency the sideband rejection will be poor; if it is too far away there will be a lack of “lows” in the signal.

A Class AB₁ Linear Amplifier

The amplifier shown in Figs. 12-11, 12-12 and 12-14 is designed to utilize the advantages of Class AB₁ operation. It requires very little driving power, the bias supply is simple, and the grid-current meter is a positive "overmodulation" indicator. A low-cost power supply permits a peak power input of 280 watts to the amplifier in s.s.b. service. Under these conditions the indicated d.c. input is about 150 watts.

As can be seen from Fig. 12-13, the amplifier uses four tetrodes in push-pull parallel, with shunt feed to remove the d.c. from the plug-in plate coils. A fixed-tune grid circuit is used and gives substantially uniform response over a 200-ke. band centered at 3900 kc. R_1 and R_2 are not "swamping" resistors — while they load the driver to about 1 watt, they are for the purpose of "broad-banding" the grid circuit. Since the load is constant, it is possible to adjust L_2 , the coupling coil, to offer a definite input impedance to the connecting line from the exciter. This can be done quite easily with a s.w.r. bridge (the amplifier tubes do not have to be lit). The inductances of the coils were adjusted to give close to a 1-to-1 s.w.r. in 75-ohm line at the band center. This method of coupling is a great convenience, since the exciter and amplifier can be connected by any length of 75-ohm line with no change in the coupling conditions.

Parasitic oscillations were eliminated by L_3 , L_4 , L_5 and L_6 . The circuit is cross-neutralized by means of C_3 and C_4 , although the amplifier is stable under most conditions without the neutralization.

One disadvantage of operating tubes in push-pull in a linear amplifier is the necessity for very good balance in the driving voltages applied to each side of the circuit. If the driving voltage is higher on one side than the other, the tube or tubes on that side will be driven to peak output before those on the other side, and will start saturating or "flattening" before the full output of the amplifier is realized. The capacitors in the grid tank circuit, C_1 and C_2 , should be matched in capacitance within a percent or two, and the usual precautions as to maintaining circuit bal-

ance should be observed. The r.f. voltage balance can be checked with an r.f. probe and v.t. voltmeter.

An "economy-type" power supply is used with the amplifier, as shown in Fig. 12-15. (See "More Effective Utilization of the Small Power Transformer," *QST*, November, 1952.) The r.f. tubes should not be biased beyond cut-off during receiving periods but should continue to run at

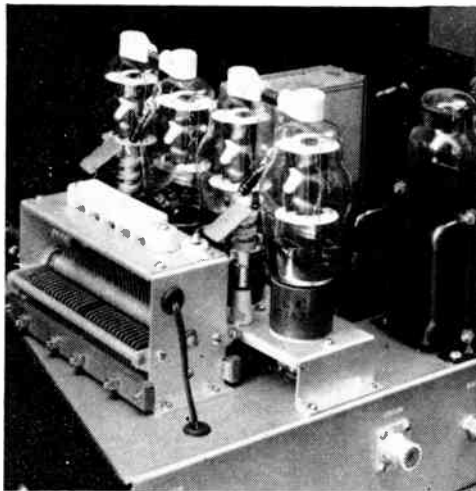

Fig. 12-12 — Close-up view of the plate circuit with the tank coil removed to show the blocking capacitors, parallel-feed plate chokes and parasitic-suppressor coils. The double lead through the grommets runs from the output-circuit coil to the coupling capacitor and coax connector underneath the chassis.

normal operating bias, because their idling current of 110 ma., plus the 40-ma. drain through the VR tubes, serves as the only "bleed" on the power supply, and the voltage would rise too high if this drain were removed.

The plate efficiency obtainable with Class AB₁ operation under the described conditions is such that the total plate loss at peak output is well under the maximum plate dissipation rating of

Fig. 12-11 — The power supply occupies the right-hand half of the 17 × 10 × 3-inch chassis and the r.f. section the left-hand half in this view. The power transformer and filter choke is at the edge of the chassis next to the voltage-regulator tubes. The panel is 10½ by 19 inches.

The four r.f. tubes are mounted on an elevated sub-chassis so that the cathodes can be directly grounded to the top of the main chassis. The plug-in grid circuit is in the can to the right of the tubes. The small ceramic stand-offs visible beneath the subchassis support the metal tabs which form one of the neutralizing capacitors. A similar pair, hidden by the shielded grid circuit, supports the other neutralizing capacitor.



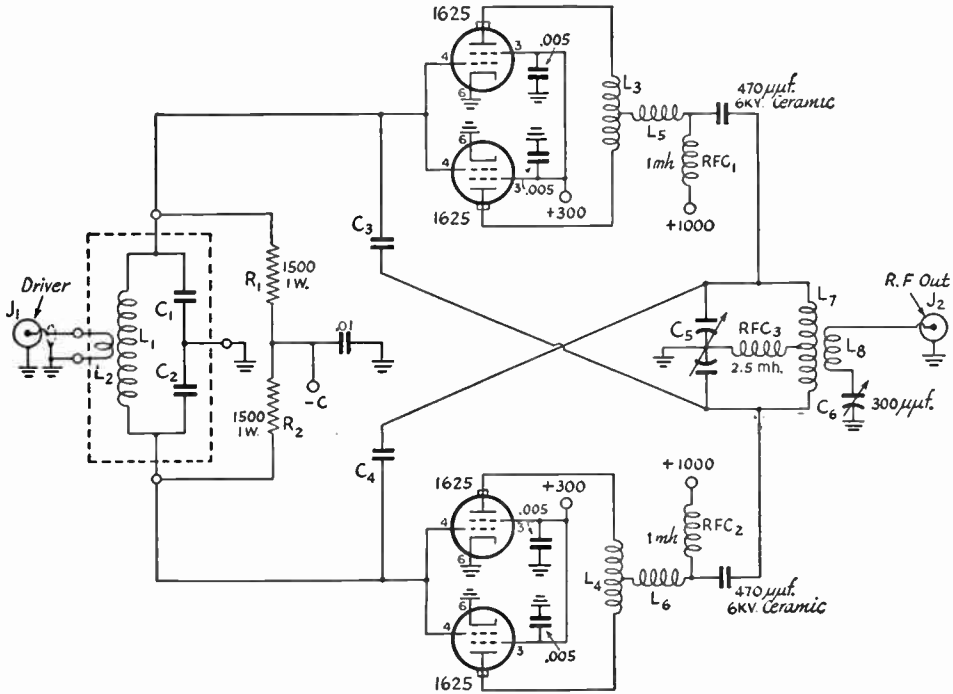

Fig. 12-13 — Circuit of the r.f. portion of the linear amplifier unit. Unless otherwise specified, capacitances are in μf .
 C₃, C₄ — Copper tabs $\frac{3}{8}$ " wide, app. $\frac{1}{4}$ " separation, $\frac{1}{2}$ " overlap.

- C₅ — 180- μf ., per-section, 0.07-inch spacing.
- C₆ — 300 μf ., receiving spacing.
- L₃, L₄ — 18 turns No. 22 enam. on 1-watt resistor (any high value) as form, tapped at center.
- L₅, L₆ — 12 turns No. 22 enam. on same type form.
- RFC₁, RFC₂ — Millen 34107, 1 mh.

L₂ wound over L₁ at center on 3.5 and 7 Mc.; interwound with L₁ on 14-Mc. coil. Coil forms 1-inch diam.
 L₇ and L₈ made from B & W coil stock, L₇ 2-inch diam. (3907 and 3900), L₈ 2½-inch diam. (3906), assembly mounted on Millen 10305 plug base.

The grid tuned circuit, enclosed by dashed line, is mounted in Millen 74400 plug-in base and shield.

120 watts for the four tubes. With the bias set for near-maximum dissipation with no signal, the tubes run cooler when driven. However, in selecting the resting plate current by adjustment of the bias voltage it is advisable to make sure that no one tube is overloaded. This can occur even though the total input is less than 120 watts, since there is some variation in the plate currents taken by various tubes at the same bias voltage. Test the tubes individually and, if a selection is

Tuned Circuits

	3.8-4.0 Mc.	7.2-7.3 Mc.	14 Mc.
L ₁	31 turns No. 22 enam. close-wound	17 turns No. 22 enam. close-wound	12 turns No. 22 enam. length $\frac{5}{8}$ -in.
L ₂	4½ turns No. 22	2⅔ turns No. 22	2¼ turns No. 22
C ₁ , C ₂	200 μf ., silver mica	100 μf ., silver mica	50 μf ., silver mica
L ₇	26 turns No. 16	18 turns No. 14	8 turns No. 14
L ₈	10 turns/in. No. 14	8 turns/in. No. 14	8 turns/in. No. 14
	8 turns/in.	8 turns/in.	8 turns/in.

possible, choose four that take substantially the same plate current.

The preferable method of adjusting the amplifier tuning for optimum output and linearity is of course to use an oscilloscope with the two-tone test. If the audio oscillator generates a good sine wave and the distortion in the exciter itself is low, the optimum conditions should be secured with a plate current of 180 to 190 ma. when the driving voltage is just at the point where a trace (a few microamperes) of grid current shows. A fairly good job of adjustment can be done without

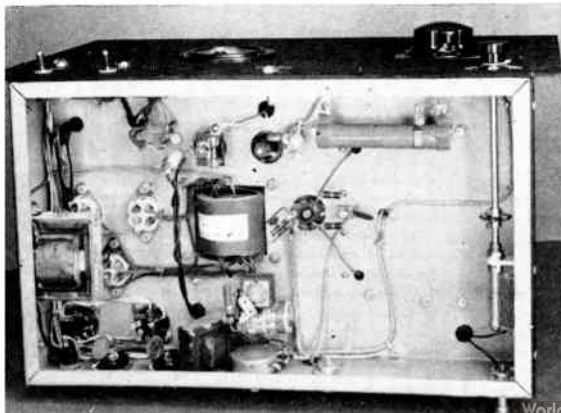

Fig. 12-16 — The only r.f. components underneath the chassis are the socket for the grid tank, grid loading resistors, and the variable capacitor for output coupling adjustment. The bias supply is the group of components in the lower center in this view. The 12.6-volt filament transformer is mounted on the left chassis wall and the filament transformer for the 83 rectifiers projects through the chassis near the center. The latter transformer is a homewound job, but transformers of similar ratings are available ready-made.

Fig. 12-15 — Power and bias supplies. Capacitance values are in μf . unless otherwise specified.

- T₁ — Filament transformer, 12.6 volts, 2 amp.
- T₂ — Rectifier filament transformer, three 5-volt 3-amp. secondaries.
- T₃ — 600-volt 200-ma. replacement-type transformer. Filament windings not used except for pilot light.
- T₄ — Filament transformer, 6.3 volts, 1 amp.

the scope, provided the two-tone test can be used and there is independent assurance that the distortion in the exciter is low. Simply maintain the driving voltage just at the grid-current point and adjust the antenna coupling, keeping the plate circuit at resonance, for about 180 ma. plate current. The off-resonance plate current should be only 10 ma. or so larger than the "intune" current. Some sort of r.f. output indicator, such as an antenna ammeter, is helpful; the output should start to drop immediately on even a slight reduction in driving voltage. If the output tends to stay up when the driving voltage is cut slightly, the amplifier is saturating on the peaks and is not loaded heavily enough. The trick is to get the loading just right so that the maximum output is obtained (too-heavy loading will reduce both the output and plate efficiency) at exactly the point where a bit more drive will cause flattening.

Although the usual constructional practice of shielded wiring with disk bypasses was followed as a matter of course, the amplifier was not shielded for TVI. Shielding is not necessary for 75 meters, but is likely to be required for 14-Mc. — and perhaps 7-Mc. — operation in localities where a harmonic falls directly in a channel having a weak TV signal. Class AB₁ operation does help — it is only necessary to look at the TV screen while the driving voltage is nudged into the grid-current region to see that — but it is not a complete panacea for the tough cases. Should shielding be needed, it should not be much of a constructional problem to add it around the r.f. section, both top and bottom.

The amplifier should be neutralized by the usual method of adjusting for minimum r.f. in the plate circuit with r.f. voltage on the grids but with plate and screen voltages off. A sensitive indicator such as a crystal detector and low-range milliammeter should be used; they may be

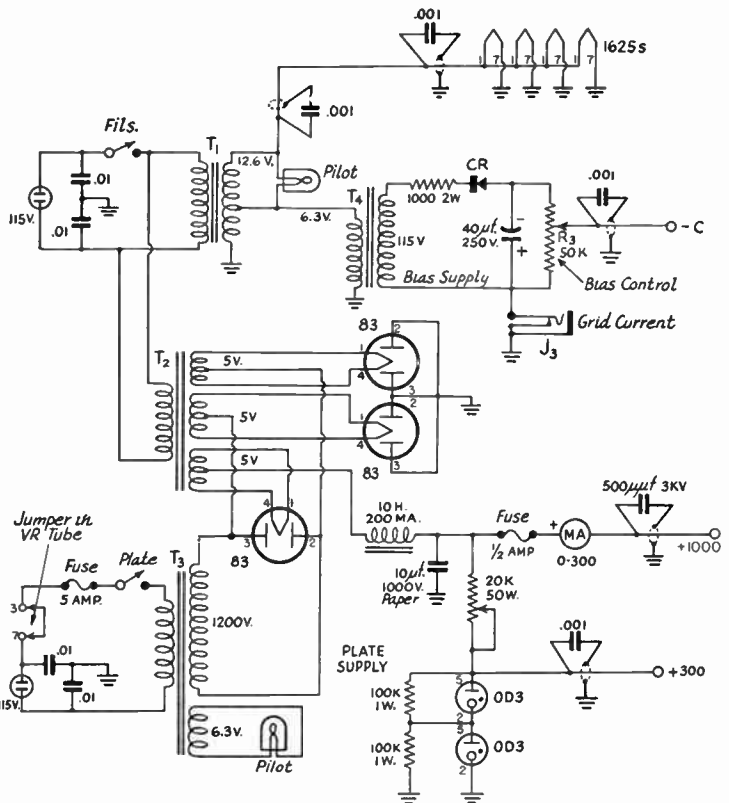

connected to the r.f. output terminals for convenience. C₃ and C₄ are adjusted by bending the metal tabs from which they are constructed, to vary the spacing. This should be done with an insulating tool; one can easily be devised in such a way as to permit getting at the plates. (Originally described in April, 1954, QST.)

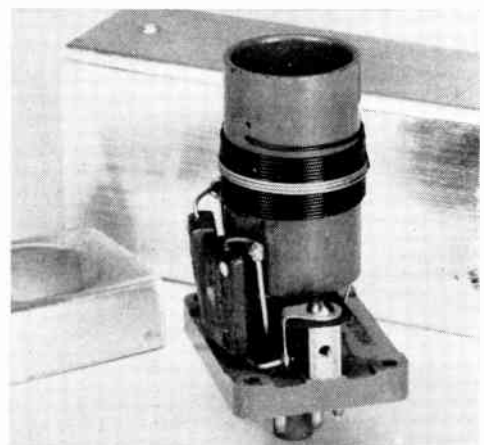

Fig. 12-16 — Construction of the plug-in grid tanks. The inductances of the two coils are adjusted for an input impedance of 75 ohms at the center of the band. Final pruning of the r.f. coil can be by adjusting the spacing of an end turn as in this 7-Mc. assembly. The coil form is mounted on a thin insulating strip which is mounted on the studs at the sides of the plug-in base.

A Grounded-Grid Linear Amplifier

Grounded-grid amplification in linear service has several advantages over conventional circuits. The amplifier is degenerative, which adds to the stability. It has been found that it produces slightly better linearity than conventional circuits using the same tubes. The greater part of the power required to drive the grounded-grid

capacitors to the plate. This couples the input and output circuits and causes instability. It is possible, however, to stabilize an amplifier with these tubes by grounding the beam-forming plates directly, since this helps to isolate the input and output circuits. In some makes of 1625s the beam-forming plate lead is attached

Fig. 12-17 — This linear amplifier uses four parallel-connected tetrodes in a grounded-grid circuit. It can be driven by an s.s.b. exciter capable of 20 watts peak envelope power output. The cabinet is 14½ by 9 by 10 inches deep.



amplifier appears in the output along with the amplified signal. The disadvantage of using the 807 or 1625 in this type of operation is that the beam-forming plates are connected to the cathode. The signal appears on the cathode, and the beam-forming plates form good coupling ca-

to the cathode lead in the cathode pin. Such tubes can be modified by first removing the old base by applying heat from a large torch, separating the cathode and beam-plate leads, and reinstalling the base or a new one. Tube-base cement can be used to secure the base to the tube, and the assembly can then be baked in an oven at 90 degrees C. to harden the seal.¹

¹ The modified tubes can be obtained from P & H Electronics, 5 N. Earl Ave., Lafayette, Ind. Cement for doing the job can be obtained from the same source.

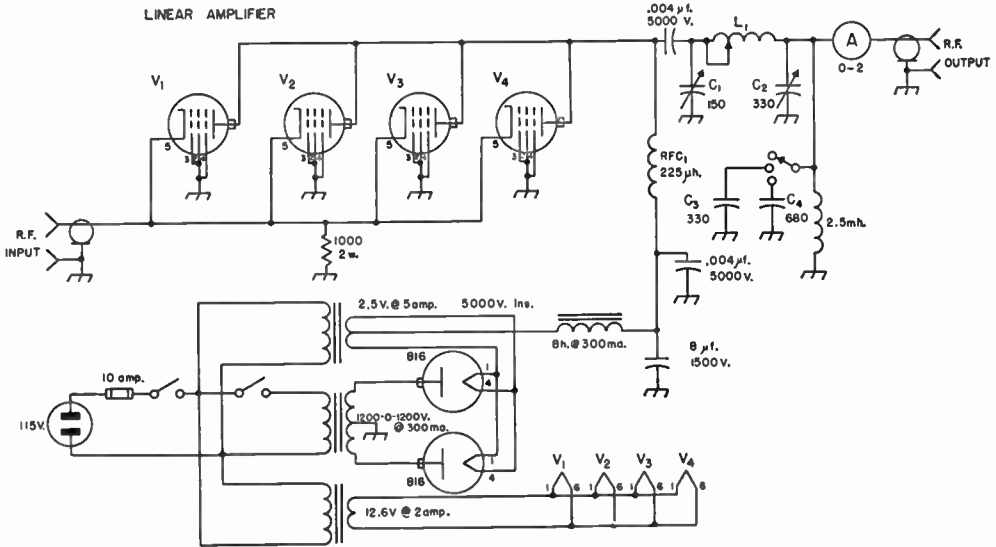

Fig. 12-18 — Schematic diagram of the grounded-grid amplifier. Capacitor values in $\mu\text{f.}$ unless otherwise specified. C₃, C₄ — 600-volt silvered mica capacitor. RFC₁ — National R-175A. V₁, V₂, V₃, V₄ — Modified 1625 — see text.

Fig. 12-19 — A top view of the linear amplifier shows the r.f. tubes at the left, clustered around the r.f. choke. The two small tubes are the 816 rectifiers used in the 1200-volt power supply. The variable inductor is the antenna loading coil from a BC-158 Command transmitter.



The schematic of an amplifier using these modified tubes is shown in Fig. 12-18 with photographs of the unit in Figs. 12-17, 12-19 and 12-20. Since the input circuit of the grounded-grid amplifier is a low-impedance load for the driver, it is possible to do away with any input tuned circuit; the d.c. return for the 1625s is made through the exciter output tap or link. A word of caution here — be sure there is no d.c. on the exciter link, because the 1000-ohm resistor would short it to the chassis.

No bias or screen voltage is required at 1200 volts on the plate. Each tube draws about 10 ma., so the power supply is constantly bled with 40 ma., thus eliminating the need for a bleeder.

With no screen and bias supply and no input tuned circuit, it is possible to build a compact

amplifier. The unit in Fig. 12-17 uses the pi-network output circuit with variable inductor to cover 75, 40 and 20 meters. Operation on 15 and 10 meters is impractical because of the high output capacitance of the four tubes used in parallel.

Construction

The unit is constructed on a 10 × 14 × 3-inch chassis, and a 5¼ × 5¼-inch subchassis on which are mounted the plate r.f. choke and four 6-pin tube sockets. This subchassis is mounted 1¼ inches below the main chassis deck. The cold end of the r.f. choke is by-passed through a 0.004- μ f. capacitor to a soldering lug at the center of the subassembly. The lug is mounted beneath a 1-inch stand-off insulator.

Fig. 12-20 — This bottom view shows how the four r.f. tube sockets are mounted on a small platform. The 2.5-mh. choke across the output circuit is to prevent accidental shock from the antenna system in the event that the plate-blocking capacitor should short circuit. Filament transformers are mounted on the side of the chassis.

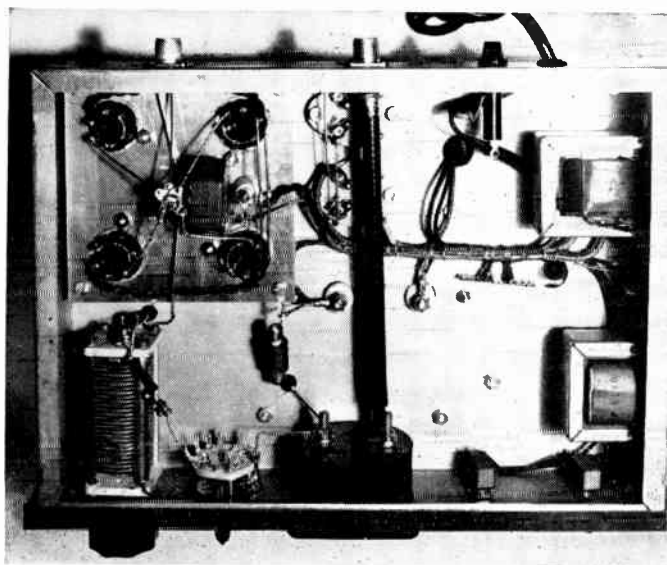

and a single stud screw holds the choke and stand-off to the subchassis. A feed-through insulator on the subchassis feeds d.c. to the choke and also serves as a tie point for the "hot side" of the by-pass capacitor. The screen grid, grid, and beam plate are grounded to the subchassis as close as possible to each tube socket. The cathodes are connected at the central stand-off insulator, which is also the tie point for the r.f. input lead.

The cabinet is 10 by 14½ by 8¾ inches with a panel to fit. The rotor indicator of the inductor and input capacitor are mounted on the panel and the panel secured by the output rotor switch, meter and toggle switches. The 0.004-μf. d.c. blocking capacitor mounts on the rear of the input-tuning capacitor, C₁.

An r.f. choke is included across the output of the pi-network, so that in the event of a shorted d.c. plate blocking capacitor the power supply fuse will blow. This keeps 1200 volts d.c. off the antenna system.

If plate voltage were applied with no input connection for the cathode return, full plate voltage would appear between cathode and filament. A 1000-ohm resistor is connected from cathode to ground to prevent this from occurring.

Operation

The tune-up procedure is the same as for any pi-network amplifier. The whole coil is used for 75 meters, about half for 40 meters, and one-fourth for 20 meters. Initial tuning adjustments are made with about half the available r.f. drive power. Twenty watts of drive will put a good signal on the air.

The input and output circuits in this design are well shielded by the grounded grid, screen, and beam-forming plates, and no trouble with fundamental or v.h.f. instability should be experienced. Although this amplifier is designed primarily for s.s.b., it may also be used to amplify a low-powered a.m. or c.w. signal.

(From June, 1955, *QST*.)

Grounded-Grid Amplifiers With Filament-Type Tubes

It is not necessary to use indirectly-heated cathode type tubes in the grounded-grid circuits, and filament-type tubes can be used just as effectively. However, it is necessary to raise the filament above r.f. ground, and one way is shown in Fig. 12-21. Here filament chokes are used between the filament transformers and the tube socket. The inductance of the r.f. chokes does not have to be very high, and 5 to 10 μh. will usually suffice from 80 meters on down. The current-carrying

filament transformer can be used, with its primary voltage cut down until the voltage at the tube socket is within the proper limits.

Filament chokes can be wound on ceramic or wooden forms, using a wire size large enough to carry the filament current without undue heating. Large cylindrical ceramic antenna insulators can be used for the forms. If enameled wire is used, it should be spaced from half the diameter to the diameter of the wire; heavy string can be used for this purpose. The separate chokes indicated in Fig. 12-21 are not essential; the two windings can be wound in parallel. In this case it is not necessary to space all windings; the two parallel wires can be treated as one wire, winding them together with a single piece of string to space the turns. Enameled wire can be used because the enamel insulation to handle the filament voltage.

When considerable power is available for driving the grounded-grid stage, the matching between driver stage and the amplifier is not too important. However, when the driving power is marginal or when the driver and amplifier are to be connected by a long length of coaxial cable, a pi network matching circuit can be used in the input of the grounded-grid amplifier. The input impedance of a grounded-grid amplifier is in the range of 100 to 400 ohms, depending upon the tube or tubes and their operating conditions. When data for grounded-grid operation is available (as for one tube in Table 12-1), the input impedance can be computed from

$$Z_{in} = \frac{(\text{peak r.f. driving voltage})^2}{2 \times \text{driving power}}$$

From this and the equations for a pi network, a suitable network can be devised.

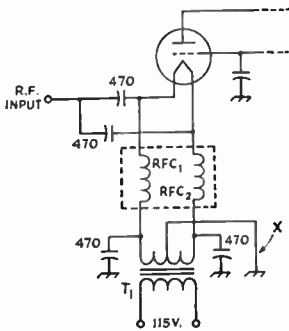

Fig. 12-21 — When filament-type tubes are used in a grounded-grid circuit, it is necessary to use filament chokes to keep the filament above r.f. ground. In the portion of a typical circuit shown here, the filament chokes, RFC₁ and RFC₂, can be a manufactured unit (e.g., B&W FC15 or FC30) or homemade as described in the text. Total plate and grid current can be read on a milliammeter inserted at x.

capacities of the r.f. chokes must be adequate for the tube or tubes in use, and if the resistance of the chokes is too high the filament voltage at the tube socket may be too low and the tube life will be endangered. In such a case, a higher-voltage

Adjustment of Amplifiers

The two critical adjustments for obtaining proper operation from the linear amplifier are the plate loading and the grid drive. Since these adjustments are preferably made with power on, it is a matter of convenience to have both controls readily available during initial tune-up.

The scope can show misadjustment at a glance and will greatly facilitate all adjustments. In addition, it is the most reliable instrument for observing modulation amplitude and, once used, is likely to become the most nearly essential instrument in the shack. It can be coupled to the amplifier as in Fig. 12-7.

With single side band, 100 per cent modulation with a single tone is a pure r.f. output with no modulation envelope, and the point of amplifier overload is difficult to observe. However, if the input signal consists of two sine waves of different frequencies (for example, 1000 c.p.s. difference) but equal amplitudes, the output of the single-side-band transmitter should have the envelope shown in Fig. 12-22. This is called a "two-tone" test signal to distinguish it from other test signals. Its first advantage lies in the fact that any flattening of the positive peaks is readily discernible, which makes the adjustment of the linear-amplifier drive and output coupling as simple a procedure as that for a.m. systems. Flattening of the peaks (to be avoided) is illustrated in Fig. 12-23.

Those who use the filter method for obtaining single side band can obtain such a test signal by feeding a single audio tone to the balanced modulator and jumping the filter. Those using the phasing method of single-side-band signal generation will recognize the pattern as that obtained when a single test tone is applied to *one* of the balanced modulators. For this latter group a two-tone test signal may be readily obtained by disabling one of the balanced modulators in the exciter and applying a single-frequency audio tone at the input.

Suppose that the linear amplifier has been coupled to a dummy load and the single-side-band exciter has been connected to its input. By observing the oscilloscope coupled to the amplifier output, it will be possible to adjust the drive and output coupling so that the peaks of the two-tone

test signal wave form are on the verge of flattening. The peak input power may now be checked. This is readily possible, for with the two-tone test signal applied, the peak input power will be 1.57 times the d.c. power input to the linear amplifier. Should this be different from the design value for the particular linear amplifier, the drive and loading adjustments can be quickly changed in the proper direction (always adjusting the loading so that the peaks of the envelope are on the verge of flattening) and the proper value reached.

As a final check, before coupling the linear amplifier to the antenna, the single-side-band operator will do well to check the linearity of the system, since distortion in the linear amplifier probably will result in the generation of side bands on the side that was suppressed in the exciter. Here again the two-tone test signal will be of great help, since distortion of the signal will be readily recognized. A check of the bias supply has already been recommended. (See Amplification of S.S.B. Signals). The next most likely form of distortion will be caused by curvature of the tube characteristic near cut-off, and will be recognizable from a two-tone test pattern that looks like Fig. 12-24. A slight readjustment of bias (or applying a few volts of positive or negative bias, in the case of zero-bias tubes) will usually straighten out the kink that exists where the pattern crosses the zero axis. Make this adjustment with special care, however, because the dissipation of the tubes with no input signal will be very sensitive to this adjustment. There are a few tubes that will not permit this adjustment to be carried to the point where the kink is entirely eliminated without exceeding the rated plate dissipation.

The antenna may now be coupled to the linear amplifier until the plate input with the excitation as determined above is the same as that obtained with the dummy load. The system has now been adjusted for optimum performance, although it is well to monitor it with a scope.

(For further reading on linear amplifiers, see Long, "Sugar-Coated Linear-Amplifier Theory," *QST*, October, 1951, and Ehrlich, "How To Test and Align a Linear Amplifier," *QST*, May, 1952.)

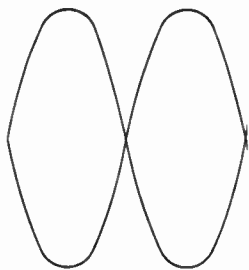

Fig. 12-22 — Oscillogram of a two-tone test signal through a linear amplifier.

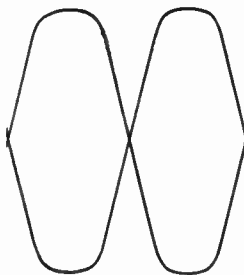

Fig. 12-23 — Flattening caused by overdrive or insufficient plate loading.

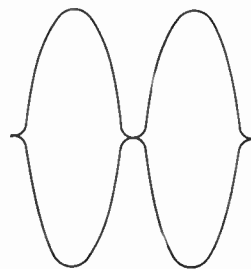

Fig. 12-24 — The distorted pattern obtained when the bias voltage is incorrect.

Frequency Conversion

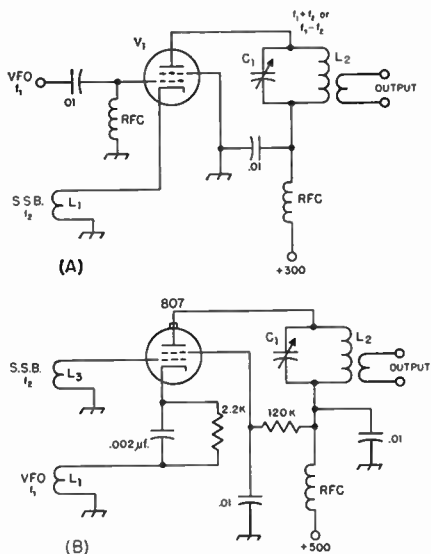

Fig. 12-25 — Two examples of "high-level" mixer circuits. The circuit at A has been used with 6V6, 6L6, 6AQ5 and 6Y6 type tubes. With 300 volts on the plate the idling current is about 15 ma., kicking as high as 30 ma. with the s.s.b. signal.

The circuit in B operates with a positive screen voltage and some cathode bias, and is capable of somewhat more output than the circuit shown in A.

In either case the output circuit, C_1L_2 , is tuned to the sum or difference frequency of the oscillator and s.s.b. signal. Coupling coils L_1 and L_3 will usually be three or four turns coupled to their respective driving sources.

The preferred s.s.b. transmitter is probably one that generates the s.s.b. signal at some suitable frequency and then heterodynes the signal into the desired amateur bands, although a few designs exist that generate the s.s.b. signal at the operating frequency and consequently eliminate the need for heterodyning. When the heterodyning is done at low level (involving an s.s.b. signal of not more than a few volts), standard receiving techniques are satisfactory. The converter tubes operated at manufacturer's ratings leave little to be desired.

When high-level heterodyning is required, as when an exciter delivering from 5 to 20 watts on a single band is available and multiband operation is desired, a high-level converter is used. Since the efficiency of a converter is only about one-fourth that of the same tube or tubes used in Class AB_2 , using a converter stage as the output stage is not very economical, and the high-level converter is generally used to drive the output stage.

Reference to tube manuals will disclose no information of the operation of small transmitting tubes as mixers. However, it has been found that most of the tetrodes in the 15- to 35-watt plate-dissipation class make acceptable mixers, and tubes like the 6V6, 6L6, 807 and 6146 have been used successfully. The usual procedure is to feed one of the signals (oscillator or s.s.b.) to the control grid and the other to the cathode or screen grid. Typical circuits are shown in Fig. 12-25.

Transmission Lines

The place where r.f. power is generated is very frequently not the place where it is to be utilized. A transmitter and its antenna are a good example: The antenna, to radiate well, should be high above the ground and should be kept clear of trees, buildings and other objects that might absorb energy, but the transmitter itself is most conveniently installed indoors where it is readily accessible. There are many other instances where power must be delivered from one point to another.

The means by which power is transported

from point to point is the r.f. transmission line. At radio frequencies a line exhibits entirely different characteristics than it does at commercial power frequencies. This is because the speed at which electrical energy travels, while tremendously high as compared with mechanical motion, is not infinite. The peculiarities of r.f. transmission lines result from the fact that a time interval comparable with an r.f. cycle must elapse before energy leaving one point in the circuit can reach another just a short distance away.

Operating Principles

Suppose we have a battery and a pair of parallel wires extending to a very great distance. At the moment the battery is connected to the wires, electrons in the wire near the positive terminal will be attracted to the battery, and the same number of electrons in the wire near the negative battery terminal will be repelled outward along the wire.

Thus a current flows in each wire near the battery at the instant the battery is connected. However, a definite time interval will elapse before these currents are evident at a distance from the battery. The time interval may be very small. For example, one-millionth of a second (one microsecond) after the connection is made the currents in the wires will have traveled 300 meters, or nearly 1000 feet, from the battery terminals.

The current is in the nature of a charging current, flowing to charge the capacitance between the two wires. But unlike an ordinary capacitor, the conductors of this "linear" capacitor have appreciable inductance. In fact,

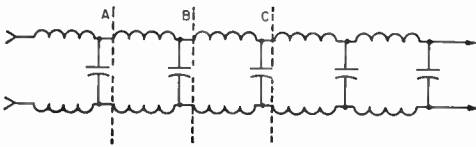

Fig. 13-1 — Equivalent of a transmission line in lumped circuit constants.

we may think of the line as being composed of a whole series of small inductances and capacitances connected as shown in Fig. 13-1, where each coil is the inductance of a very short section of one wire and each capacitor is the capacitance between two such short sections.

Characteristic Impedance

An infinitely-long chain of coils and capacitors connected as in Fig. 13-1, where each L is the same as all others and all the C s have the

same value, has an important property. To an electrical impulse applied at one end, the combination appears to have an impedance — called the **characteristic impedance** or **surge impedance** — that is approximately equal to $\sqrt{L/C}$, where L and C are the inductance and capacitance per unit length. This impedance is purely resistive.

In defining the characteristic impedance as $\sqrt{L/C}$, it is assumed that the conductors have no inherent resistance — that is, there is no I^2R loss in them — and that there is no power loss in the dielectric surrounding the conductors. In other words, it is assumed there is no power loss in or from the line no matter how great its length. This does not seem consistent with calling the characteristic impedance a pure resistance, which implies that the power supplied is all dissipated in the line. But in an infinitely-long line the effect, so far as the source of power is concerned, is exactly the same as though the power were dissipated in a resistance, because the power leaves the source and travels outward forever along the line.

The characteristic impedance determines the amount of current that can flow when a given voltage is applied to an infinitely-long line, in exactly the same way that a definite value of actual resistance limits current flow when a given voltage is applied.

The inductance and capacitance per unit length of line depend upon the size of the conductors and the spacing between them. The closer the two conductors and the greater their diameter, the higher the capacitance and the lower the inductance. A line with large conductors closely spaced will have low impedance, while one with small conductors widely spaced will have relatively high impedance.

"Matched" Lines

Actual transmission lines do not extend to infinity but have a definite length and are connected to, or terminate in, a load at the "output"

end, or end to which the power is delivered. If the load is a pure resistance of a value equal to the characteristic impedance of the line, the current traveling along the line to the load does not find conditions changed in the least when it meets the load; in fact, the load just looks like still more transmission line of the same characteristic impedance. Consequently, connecting such a load to a short transmission line allows the current to travel in exactly the same fashion as it would on an infinitely-long line.

In other words, a short line terminated in a purely-resistive load equal to the characteristic impedance of the line acts just as though it were infinitely long. Such a line is said to be **matched**. In a matched transmission line, power travels outward along the line from the source until it reaches the load, where it is completely absorbed.

R.F. on Lines

The discussion above, although based on direct-current flow from a battery, also holds when an r.f. voltage is applied to the line. The difference is that the alternating voltage causes the amplitude of the current at the input terminals of the line to vary with the voltage, and the direction of current flow also periodically reverses when the polarity of the applied voltage reverses. In the time of one cycle the energy will travel a distance of one wave length along the line wires. The current at a given instant at any point along the line is the result of a voltage that was applied at some earlier instant at the input terminals. Hence the instantaneous amplitude of the current is different at all points in a one-wave-length section of line; in fact, the current flows in opposite directions in the same wire in adjacent half-wavelength sections. However, at any given point along the line the current goes through similar variations with time that the current at the input terminals did.

The result of all this is that the current (and voltage) travels along the wire as a series of waves having a length equal to the velocity of travel divided by the frequency of the a.c. voltage. On an infinitely-long line, or one properly matched at the load, an ammeter inserted anywhere in the line will show the same current, since the ammeter averages out the variations in current during a cycle. It is only when the line is not properly matched that the wave motion becomes apparent. This is discussed in the next section.

● STANDING WAVES

In the infinitely-long line (or its matched counterpart) the impedance is the same at any point on the line because the ratio of voltage to current is always the same. However, the impedance at the end of the line in Fig. 13-2 is zero — or at least extremely small — because the line is short-circuited at the end. The outgoing power, on meeting the short-circuit, reverses its direction of flow and goes back along the transmission line toward the input end. There is a large current in the short-circuit, but substantially no voltage

across the line at this point. We now have a voltage and current representing the power going outward (**incident power**) toward the short-circuit, and a second voltage and current representing the **reflected power** traveling back toward the source.

The reflected current travels at the same speed as the outgoing current, so its instantaneous value will be different at every point along the line, in the distance represented by the time of one cycle. At some points along the line the phase of the outgoing and reflected currents will be such that the currents cancel each other while at others the amplitude will be doubled. At in-between points the amplitude is between these two extremes. The points at which the currents are in and out of phase depend only on the *time* required for them to travel and so depend only on the *distance* along the line from the point of reflection.

In the short-circuit at the end of the line the two current components are in phase and the total current is large. At a distance of one-half wave length back along the line from the short-circuit the outgoing and reflected components will again be in phase and the resultant current will again have its maximum value. This is also

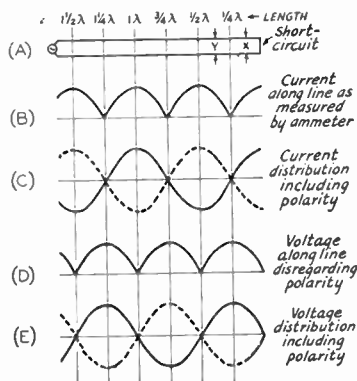

Fig. 13-2 — Standing waves of voltage and current along short-circuited transmission line.

true at any point that is a multiple of a half-wave length from the short-circuited end of the line.

The outgoing and reflected currents will cancel at a point one-quarter wave length, along the line, from the short-circuit. At this point, then, the current will be zero. It will also be zero at all points that are an *odd* multiple of one-quarter wave length from the short-circuit.

If the current along the line is measured at successive points with an ammeter, it will be found to vary about as shown in Fig. 13-2B. The same result would be obtained by measuring the current in either wire, since the ammeter cannot measure phase. However, if the phase could be checked, it would be found that in each successive half wave length section of the line the currents at any given instant are flowing in opposite directions, as indicated by the solid line in Fig. 13-2C. Furthermore, the current in the second wire is flowing in the opposite direction to the current

in the adjacent section of the first wire. This is indicated by the broken curve in Fig. 13-2C. The variations in current intensity along the transmission line are referred to as **standing waves**. The point of maximum line current is called a **current loop** or **current antinode** and the point of minimum line current a **current node**.

Voltage Relationships

Since the end of the line is short-circuited, the voltage at that point has to be zero. This can only be so if the voltage in the outgoing wave is met, at the end of the line, by a reflected voltage of equal amplitude and opposite polarity. In other words, the phase of the voltage wave is *reversed* when reflection takes place from the short-circuit. This reversal is equivalent to an extra half cycle or half wave length of travel. As a result, the outgoing and returning voltages are in phase a quarter wave length from the end of the line, and again out of phase a half wave length from the end. The standing waves of voltage, shown at D in Fig. 13-2, are therefore displaced by one-quarter wave length from the standing waves of current. The drawing at E shows the voltages on both wires when phase is taken into account. The polarity of the voltage on each wire reverses in each half wave length section of transmission line. A voltage maximum is called a **voltage loop** or **antinode** and a voltage minimum is called a **voltage node**.

Open-Circuited Line

If the end of the line is open-circuited instead of short-circuited, there can be no current at the end of the line but a large voltage can exist. Again the incident power is reflected back toward the source. In this case, the incident and reflected components of *current* must be equal and opposite in phase in order for the total current at the end of the line to be zero. The incident and reflected components of voltage are in phase and add together. The result is that we again have standing waves, but the conditions are reversed as compared with a short-circuited line. Fig. 13-3 shows the open-circuited line case.

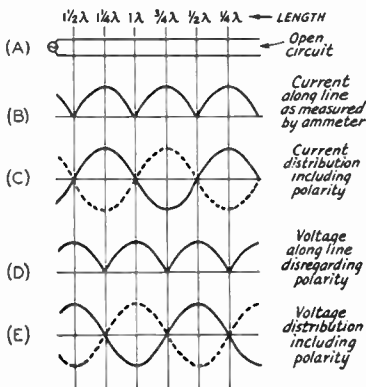

Fig. 13-3—Standing waves of current and voltage along an open-circuited transmission line.

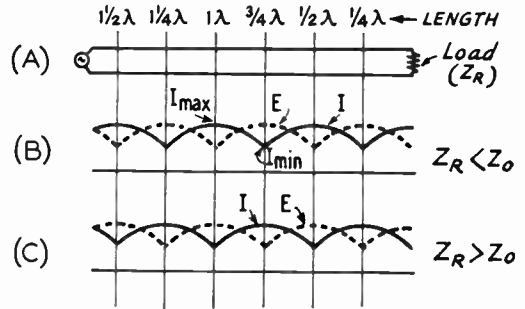

Fig. 13-4—Standing waves on a transmission line terminated in a resistive load.

Lines Terminated in Resistive Load

Fig. 13-4 shows a line terminated in a resistive load. In this case at least part of the incident power is absorbed in the load, and so is not available to be reflected back toward the source. Because only part of the power is reflected, the reflected components of voltage and current do not have the same magnitude as the incident components. Therefore neither voltage nor current cancel completely at any point along the line. However, the *speed* at which the incident and reflected components travel is not affected by their amplitude, so the phase relationships are similar to those in open- or short-circuited lines.

It was pointed out earlier that if the load resistance, Z_R , is equal to the characteristic impedance, Z_0 , of the line all the power is absorbed in the load. In such a case there is no reflected power and therefore no standing waves of current and voltage. This is a special case that represents the change-over point between “short-circuited” and “open-circuited” lines. If Z_R is less than Z_0 , the current is largest at the load, while if Z_R is greater than Z_0 the voltage is largest at the load. The two conditions are shown at B and C, respectively, in Fig. 13-4.

The resistive termination is an important practical case. The termination is seldom an actual resistor, the most common terminations being resonant circuits or resonant antenna systems, both of which have essentially resistive impedances. If the load is reactive as well as resistive, the operation of the line resembles that shown in Fig. 13-4, but the presence of reactance in the load causes two modifications: The loops and nulls are shifted toward or away from the load; and the amount of power reflected back toward the source is increased, as compared with the amount reflected by a purely resistive load of the same total impedance. Both effects become more pronounced as the ratio of reactance to resistance in the load is made larger.

Standing-Wave Ratio

The ratio of maximum current to minimum current along a line, Fig. 13-5, is called the **standing-wave ratio**. The same ratio holds for maximum voltage and minimum voltage. It is a measure of the mismatch between the load and the line, and is equal to 1 when the line is per-

fectly matched. (In that case the "maximum" and "minimum" are the same, since the current and voltage do not vary along the line.) When the line is terminated in a purely-resistive load, the standing-wave ratio is

$$S.W.R. = \frac{Z_R}{Z_0} \text{ or } \frac{Z_0}{Z_R} \quad (13-A)$$

Where *S.W.R.* = Standing-wave ratio

Z_R = Impedance of load (must be pure resistance)

Z_0 = Characteristic impedance of line

Example: A line having a characteristic impedance of 300 ohms is terminated in a resistive load of 25 ohms. The s.w.r. is

$$S.W.R. = \frac{Z_0}{Z_R} = \frac{300}{25} = 12 \text{ to } 1$$

It is customary to put the larger of the two quantities, Z_R or Z_0 , in the numerator of the fraction so that the s.w.r. will be expressed by a number larger than 1.

It is easier to measure the standing-wave ratio than some of the other quantities (such as the

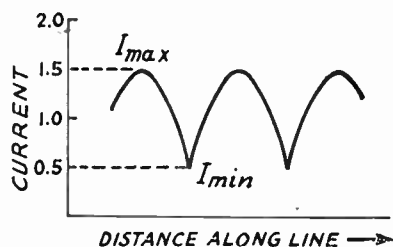

Fig. 13-5 — Measurement of standing-wave ratio. In this drawing, I_{max} is 1.5 and I_{min} is 0.5, so the s.w.r. = I_{max}/I_{min} = 1.5/0.5 = 3 to 1.

impedance of an antenna) that enter into transmission-line computations. Consequently, the s.w.r. is a convenient basis for work with lines. The higher the s.w.r., the greater the mismatch between line and load. In practical lines, the power loss in the line itself increases with the s.w.r.

● INPUT IMPEDANCE

The input impedance of a transmission line is the impedance seen looking into the sending-end or input terminals; it is the impedance into which the source of power must work when the line is connected. If the load is perfectly matched to the line the line appears to be infinitely long, as stated earlier, and the input impedance is simply the characteristic impedance of the line itself. However, if there are standing waves this is no longer true; the input impedance may have a wide range of values.

This can be understood by referring to Figs. 13-2, 13-3, or 13-4. If the line length is such that standing waves cause the voltage at the input

terminals to be high and the current low, then the input impedance is higher than the Z_0 of the line, since impedance is simply the ratio of voltage to current. Conversely, low voltage and high current at the input terminals mean that the input impedance is lower than the line Z_0 . Comparison of the three drawings also shows that the range of input impedance values that may be encountered is greater when the far end of the line is open- or short-circuited than it is when the line has a resistive load. In other words, the higher the s.w.r. the greater the range of input impedance values when the line length is varied.

In addition to the variation in the absolute value of the input impedance with line length, the presence of standing waves also causes the input impedance to contain both reactance and resistance, even though the load itself may be a pure resistance. The only exceptions to this occur at the exact current loops or nodes, at which points the input impedance is a pure resistance. These are the only points at which the outgoing and reflected voltages and currents are exactly in phase: At all other distances along the line the current either leads or lags the voltage and the effect is exactly the same as though a capacitance or inductance were part of the input impedance.

The input impedance can be represented either by a resistance and a capacitance or by a resistance and an inductance, as shown in Fig. 13-6. Whether the impedance is inductive or capacitive depends on the characteristics of the load and the length of the line. It is possible to represent the equivalent circuit by resistance and reactance either in series or parallel, so long as the total impedance and phase angle are the same in either case. For a given impedance and phase angle, different values of resistance and reactance are required in the series case as compared with the parallel case.

The magnitude and character of the input impedance is quite important, since it determines the method by which the power source must be coupled to the line. The calculation of input impedance is rather complicated and its measurement is not feasible without special equipment. Fortunately, in amateur work it is unnecessary either to calculate or measure it. The proper coupling can be achieved by relatively simple methods described later in this chapter.

Unterminated Lines

The input impedance of a short-circuited or open-circuited line not an exact multiple of one-quarter wave length long is practically a pure reactance. This is because there is very little power lost in the line. Such lines are frequently used as "linear" inductances and capacitances.

If a shorted line is less than a quarter wave long, as at X in Fig. 13-2, it will have inductive reactance. The reactance increases with the line length up to the quarter-wave point. Beyond that, as at Y, the reactance is capacitive, high near the quarter-wave point and becoming lower as the half-wave point is approached. It then alternates between inductive and capacitive in successive

quarter-wave sections. Just the reverse is true of the open-circuited line.*

At exact multiples of a quarter wave length the impedance is purely resistive. It is apparent, from examination of B and D in Fig. 13-2, that at points that are a multiple of a half wave length — i.e., $\frac{1}{2}$, 1, $1\frac{1}{2}$ wave lengths, etc. — from the short-circuited end of the line the current and

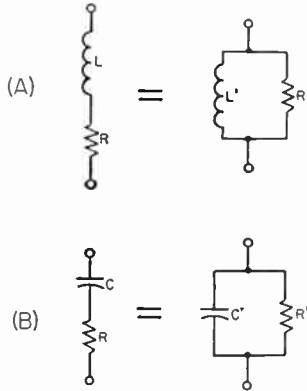

Fig. 13-6 — Series and parallel equivalents of a line whose input impedance has both reactive and resistive components. The series and parallel equivalents do not have the same values; e.g., in A, L does not equal L' and R does not equal R' .

voltage have the same values that they do at the short circuit. In other words, if the line were an exact multiple of a half wave length long the generator or source of power would “look into” a short circuit. On the other hand, at points that are an odd multiple of a quarter wave length — i.e., $\frac{1}{4}$, $\frac{3}{4}$, $1\frac{1}{4}$, etc. — from the short circuit the voltage is maximum and the current is zero. Since $Z = E/I$, the impedance at these points is theoretically infinite. (Actually it is very high, but not infinite. This is because the current does not actually go to zero when there are losses in the line. Losses are always present, but usually are small.)

Impedance Transformation

The fact that the input impedance of a line depends on the s.w.r. and line length can be used to advantage when it is necessary to transform a given impedance into another value.

Study of Fig. 13-4 will show that, just as in the open- and short-circuited cases, if the line is one-half wave length long the voltage and current are exactly the same at the input terminals as they are at the load. This is also true of lengths that are integral multiples of a half wave length. It is also true for all values of s.w.r. Hence the input impedance of any line, no matter what its Z_0 , that is a multiple of a half wave length long is exactly the same as the load impedance. Such a line can be used to transfer the impedance to a new location without changing its value.

When the line is a quarter wave length long, or an odd multiple of a quarter wave length, the load impedance is “inverted.” That is, if the current is low and the voltage is high at the load, the input impedance will be such as to require high

current and low voltage. The relationship between the load impedance and input impedance is given by:

$$Z_s = \frac{Z_0^2}{Z_R} \tag{13-B}$$

where Z_s = Impedance looking into line (line length an odd multiple of one-quarter wave length)

Z_R = Impedance of load (must be pure resistance)

Z_0 = Characteristic impedance of line

Example: A quarter-wave-length line having a characteristic impedance of 500 ohms is terminated in a resistive load of 75 ohms. The impedance looking into the input or sending end of the line is

$$Z_s = \frac{Z_0^2}{Z_R} = \frac{(500)^2}{75} = \frac{250,000}{75} = 3333 \text{ ohms}$$

If the formula above is rearranged, we have

$$Z_0 = \sqrt{Z_s Z_R} \tag{13-C}$$

This means that if we have two values of impedance that we wish to “match,” we can do so if we connect them together by a quarter-wave transmission line having a characteristic impedance equal to the square root of their product. A quarter-wave line, in other words, has the characteristics of a transformer.

Resonant and Nonresonant Lines

The input impedance of a line operating with a high s.w.r. is critically dependent on the line length, and resistive only when the length is some integral multiple of one-quarter wave length. Lines cut to such a length and operated with a high s.w.r. are called “tuned” or “resonant” lines. On the other hand, if the s.w.r. is low the input impedance is close to the Z_0 of the line and does not vary a great deal with the line length. Such lines are called “flat,” or “untuned,” or “nonresonant.”

There is no sharp line of demarcation between tuned and untuned lines. If the s.w.r. is below 1.5 to 1 the line is essentially flat, and the same input coupling method will work with all line lengths. If the s.w.r. is above 3 or 4 to 1 the type of coupling system, and its adjustment, will depend on the line length and such lines fall into the “tuned” category.

It is always advantageous to make the s.w.r. as low as possible. A resonant line becomes necessary only when a considerable mismatch between the load and the line has to be tolerated. The most important practical example of this is when a single antenna is operated on several harmonically-related frequencies, in which case the antenna impedance will have widely-different values on different harmonics.

● **RADIATION**

Whenever a wire carries alternating current the electromagnetic fields travel away into space with the velocity of light. At power-line frequencies the field that “grows” when the current is

increasing has plenty of time to return or "collapse" about the conductor when the current is decreasing, because the alternations are so slow. But at radio frequencies fields that travel only a relatively short distance do not have time to get back to the conductor before the next cycle commences. The consequence is that some of the electromagnetic energy is prevented from being restored to the conductor; in other words, energy is radiated into space in the form of electromagnetic waves.

The amount of energy radiated depends, among other things, on the length of the conductor in relation to the frequency or wave length of the r.f. current. If the conductor is very short compared to the wave length the energy radiated (for a given current) will be small. However, a transmission line used to feed power to an antenna is not short; in fact, it is almost always an appreciable fraction of a wave length long and may have a length of several wave lengths.

The lines previously considered have consisted of two parallel conductors of the same diameter. Provided there is nothing in the system to destroy symmetry, at every point along the line the current in one conductor has the same intensity as the current in the other conductor at that point, but the currents flow in opposite directions. This

was shown in Figs. 13-2C and 13-3C. It means that the fields set up about the two wires have the same intensity, but *opposite directions*. The consequence is that the total field set up about such a transmission line is zero; the two fields "cancel out." Hence no energy is radiated.

Actually, the fields do not completely cancel out because for them to do so the two conductors would have to occupy the same space, whereas they are slightly separated. However, the cancellation is substantially complete if the distance between the conductors is very small compared to the wave length. Transmission line radiation will be negligible if the distance between the conductors is 0.01 wave length or less, provided the currents in the two wires actually are balanced as described.

The amount of radiation also is proportional to the current flowing in the line. Because of the way in which the current varies along the line when there are standing waves, the effective current, for purposes of radiation, becomes greater as the s.w.r. is increased. For this reason the radiation is least when the line is flat. However, if the conductor spacing is small and the currents are balanced, the radiation from a line with even a high s.w.r. is inconsequential. A small unbalance in the line currents is far more serious.

Practical Line Characteristics

The foregoing discussion of transmission lines has been based on a line consisting of two parallel conductors. Actually, the **parallel-conductor** line is but one of two general types. The other is the **coaxial** or **concentric** line. The coaxial line consists of a conductor placed in the center of a tube. The inside surface of the tube and the outside surface of the smaller inner conductor form the two conducting surfaces of the line.

In the coaxial line the fields are entirely inside the tube, because the tube acts as a shield to prevent them from appearing outside. This reduces radiation to the vanishing point. So far as the electrical behavior of coaxial lines is concerned, all that has previously been said about the operation of parallel-conductor lines applies. There are, however, practical differences in the construction and use of parallel and coaxial lines.

● PARALLEL-CONDUCTOR LINES

A common type of parallel-conductor line used in amateur installations is one in which two wires (ordinarily No. 12 or No. 14) are supported a fixed distance apart by means of insulating rods called "spacers." The spacings used vary from two to six inches, the smaller spacings being necessary at frequencies of the order of 28 Mc. and higher so that radiation will be minimized. The construction is shown in Fig. 13-7. Such a line is said to be **air-insulated**. Typical spacers are shown in Fig. 13-8. The characteristic impedance of such "open-wire" lines is between 400 and 600 ohms, depending on the wire size and spacing.

Parallel-conductor lines also are sometimes constructed of metal tubing of a diameter of $\frac{1}{4}$ to $\frac{1}{2}$ inch. This reduces the characteristic impedance

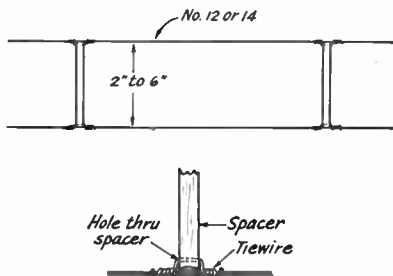

Fig. 13-7—Typical construction of open-wire line. The line conductor fits in a groove in the end of the spacer, and is held in place by a tie-wire anchored in a hole near the groove.

of the line. Such lines are mostly used as quarter-wave transformers, when different values of impedance are to be matched.

Prefabricated parallel-conductor line with air insulation, developed for television reception, can be used in transmitting applications. This line consists of two conductors separated one-half to one inch by molded-on spacers. The characteristic impedance is 300 to 450 ohms, depending on the wire size and spacing.

A convenient type of manufactured line is one in which the parallel conductors are imbedded in low-loss insulating material (polyethylene). It is commonly used as a TV lead-in and has a charac-

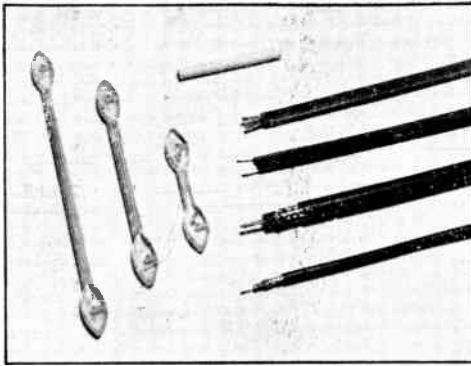

Fig. 13-8 — Typical manufactured transmission lines and spacers.

teristic impedance of 300 ohms. It is sold under various names, the most common of which is "Twin-Lead." This type of line has the advantages of light weight, close and uniform conductor spacing, flexibility and neat appearance. However, the losses in the solid dielectric are higher than in air, and dirt or moisture on the line tends to change the characteristic impedance. Moisture effects can be reduced by coating the line with silicone grease. A special form of 300-ohm Twin-Lead for transmitting uses a polyethylene tube with the conductors molded diametrically opposite; the longer dielectric path in such line reduces moisture troubles.

In addition to 300-ohm line, Twin-Lead is obtainable with a characteristic impedance of 75 ohms for transmitting purposes. Light-weight 75- and 150-ohm Twin-Lead also is available.

Characteristic Impedance

The characteristic impedance of an air-insulated parallel-conductor line is given by:

$$Z_0 = 276 \log \frac{b}{a} \quad (13-D)$$

- where Z_0 = Characteristic impedance
- b = Center-to-center distance between conductors
- a = Radius of conductor (in same units as b)

It does not matter what units are used for a and b so long as they are the *same* units. Both quantities may be measured in centimeters, inches, etc. Since it is necessary to have a table of common logarithms to solve practical problems, the solution is given in graphical form in Fig. 13-9 for a number of common conductor sizes.

In solid-dielectric parallel-conductor lines such as Twin-Lead the characteristic impedance cannot be calculated readily, because part of the electric field is in air as well as in the dielectric.

Unbalance in Parallel-Conductor Lines

When installing parallel-conductor lines care should be taken to avoid introducing electrical unbalance into the system. If for some reason the current in one conductor is higher than in the other, or if the currents in the two wires are not

exactly out of phase with each other, the electromagnetic fields will not cancel completely and a considerable amount of power may be radiated by the line.

Maintaining good line balance requires, first of all, a balanced load at its end. For this reason the antenna should be fed, whenever possible, at a point where each conductor "sees" exactly the same thing. Usually this means that the antenna system should be fed at its electrical center. Even though the antenna appears to be symmetrical, physically, it can be unbalanced electrically if the part connected to one of the line conductors is inadvertently coupled to something (such as house wiring or a metal pole or roof) that is not duplicated on the other part of the antenna. Every effort should be made to keep the antenna as far as possible from other wiring or sizable

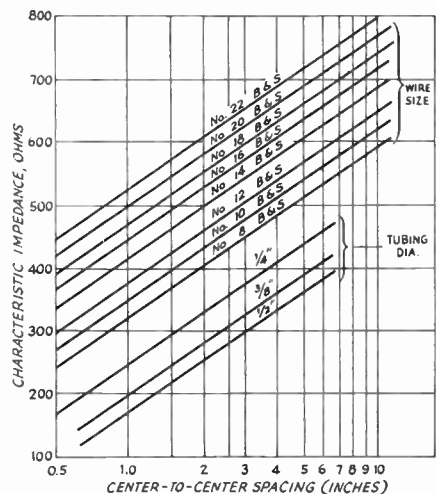

Fig. 13-9 — Chart showing the characteristic impedance of spaced-conductor parallel transmission lines with air dielectric. Tubing sizes given are for outside diameters.

metallic objects. The transmission line itself will cause some unbalance if it is not brought away from the antenna at right angles to it for a distance of at least a quarter wave length.

In installing the line conductors take care to see that they are kept away from metal. The minimum separation between either conductor and all other wiring should be at least four or five times the conductor spacing. The shunt capacitance introduced by close proximity to metallic objects can drain off enough current (to ground) to unbalance the line currents, resulting in increased radiation. A shunt capacitance of this sort also constitutes a reactive load on the line, causing an impedance "bump" that will prevent making the line actually flat.

● **COAXIAL LINES**

The most common form of coaxial line consists of either a solid or stranded-wire inner conductor surrounded by polyethylene dielectric. Copper braid is woven over the dielectric to form the

outer conductor, and a waterproof vinyl covering is placed on top of the braid. This cable is made in a number of different diameters. It is moderately flexible, and so is convenient to install. Some different types are shown in Fig. 13-8. This solid coaxial cable is commonly available in impedances approximating 50 and 70 ohms.

Air-insulated coaxial lines have lower losses than the solid-dielectric type, but are less used in amateur work because they are expensive and difficult to install as compared with the flexible cable. The common type of air-insulated coaxial line uses a solid-wire conductor inside a copper tube, with the wire held in the center of the tube by means of insulating "beads" placed at regular intervals.

Characteristic Impedance

The characteristic impedance of an air-insulated coaxial line is given by the formula

$$Z_0 = 138 \log \frac{b}{a} \quad (13-E)$$

where Z_0 = Characteristic impedance
 b = Inside diameter of outer conductor
 a = Outside diameter of inner conductor
 (in same units as b)

Curves for typical conductor sizes are given in Fig. 13-10.

The formula for coaxial lines is approximately correct for lines in which bead spacers are used, provided the beads are not too closely spaced. When the line is filled with a solid dielectric, the characteristic impedance as given by the chart should be multiplied by $1/\sqrt{K}$, where K is the dielectric constant of the material.

ELECTRICAL LENGTH

In the discussion of line operation earlier in this chapter it was assumed that currents traveled along the conductors at the speed of light. Actually, the velocity is somewhat less, the reason being that electromagnetic fields travel more

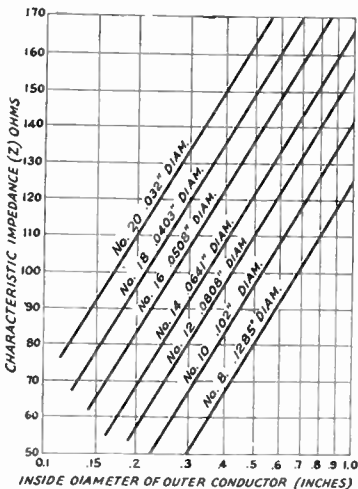

Fig. 13-10 — Chart showing characteristic impedance of various air-insulated concentric lines.

Type	Description or Type Number	Characteristic Impedance	Velocity Factor	Capacitance per foot; $\mu\mu\text{f.}$
Coaxial	Air-insulated	50-100	0.85 ¹	
	RG-8/U	53	0.66	29.5
	RG-58/U	53	0.66	28.5
	RG-11/U	75	0.66	20.5
	RG-59/U	73	0.66	21.0
Parallel-Conductor	Air-insulated	200-600	0.975 ²	
	214-080 ³	75	0.68	19.0
	214-023 ³	75	0.71	20.0
	214-079 ³	150	0.77	10.0
	214-056 ³	300	0.82	5.8
	214-076 ³	300	0.84	3.9
	214-022 ³	300	0.85	3.0

¹ Average figure for small-diameter lines with ceramic beads.
² Average figure for lines insulated with ceramic spacers at intervals of a few feet.
³ Amphenol type numbers and data. Line similar to 214-056 is made by several manufacturers, but rated loss may differ from that given in Fig. 13-11. Types 214-023, 214-078, and 214-022 are made for transmitting applications.

slowly in material dielectrics than they do in free space. In air the velocity is practically the same as in empty space, but a practical line always has to be supported in some fashion by solid insulating materials. The result is that the fields are slowed down; the currents travel a shorter distance in the time of one cycle than they do in space, and so the wave length along the line is less than the wave length would be in free space at the same frequency.

Whenever reference is made to a line as being so many wave lengths (such as a "half wave length" or "quarter wave length") long, it is to be understood that the *electrical* length of the line is meant. Its actual physical length as measured by a tape always will be somewhat less. The physical length corresponding to an electrical wave length is given by

$$\text{Length in feet} = \frac{984}{f} \cdot V \quad (13-F)$$

where f = Frequency in megacycles
 V = Velocity factor

The **velocity factor** is the ratio of the actual velocity along the line to the velocity in free space. Values of V for several common types of lines are given in Table 13-I.

Example: A 75-foot length of 300-ohm Twin-Lead is used to carry power to an antenna at a frequency of 7150 kc. From Table 13-I, V is 0.82. At this frequency (7.15 Mc.) a wave length is

$$\begin{aligned} \text{Length (feet)} &= \frac{984}{f} \cdot V = \frac{984}{7.15} \times 0.82 \\ &= 137.6 \times 0.82 = 112.8 \text{ ft.} \end{aligned}$$

The line length is therefore $75/112.8 = 0.665$ wave length.

Because a quarter-wave length line is frequently used as a linear transformer, it is con-

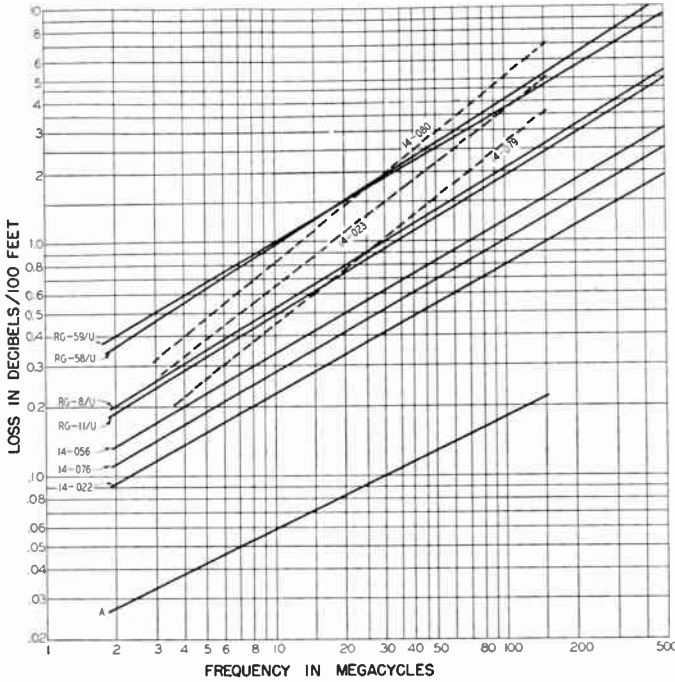

Fig. 13-11 — Attenuation data for common types of transmission lines. Curve A is the nominal attenuation of 600-ohm open-wire line with No. 12 conductors, not including dielectric loss in spacers nor possible radiation losses. Additional line data are given in Table 13-1.

venient to calculate the length of a quarter-wave line directly. The formula is

$$\text{Length (feet)} = \frac{246}{f} \cdot V \quad (13-G)$$

where the symbols have the same meaning as above.

● LOSSES IN TRANSMISSION LINES

There are three ways by which power may be lost in a transmission line: by radiation, by heating of the conductors (I^2R loss), and by heating of the dielectric, if any. Radiation losses are in general the result of “antenna currents” on the line, resulting from undesired coupling to the radiating antenna. They cannot readily be estimated or measured, so the following discussion is based only on conductor and dielectric losses.

Heat losses in both the conductor and the dielectric increase with frequency. Conductor losses also are greater the lower the characteristic impedance of the line, because a higher current flows in a low-impedance line for a given power input. The converse is true of dielectric losses because these increase with the voltage, which is greater on high-impedance lines. The dielectric loss in air-insulated lines is negligible (the only loss is in the insulating spacers) and such lines operate at high efficiency when radiation losses are low.

It is convenient to express the loss in a transmission line in decibels per unit length, since the loss in db. is directly proportional to the line length. Losses in various types of lines operated without standing waves (that is, terminated in a resistive load equal to the characteristic imped-

ance of the line) are given in graphical form in Fig. 13-11. In these curves the radiation loss is assumed to be negligible.

When there are standing waves on the line the power loss increases as shown in Fig. 13-12. Whether or not the increase in loss is serious depends on what the original loss would have been if the line were perfectly matched. If the loss with perfect matching is very low, a large s.w.r. will not greatly affect the efficiency of the line — i.e.,

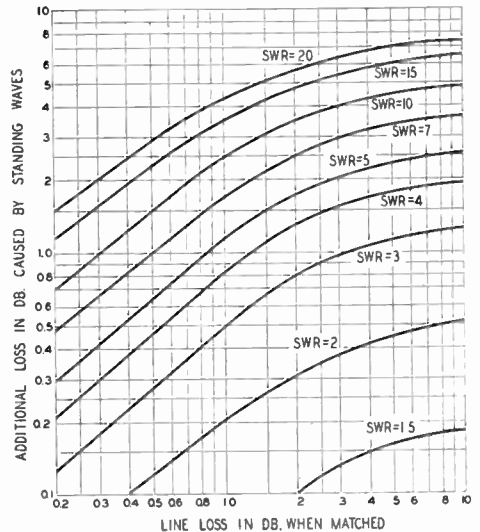

Fig. 13-12 — Effect of standing-wave ratio on line loss. The ordinates give the additional loss in decibels for the loss, under perfectly-matched conditions, shown on the horizontal scale.

the ratio of the power delivered to the load to the power put into the line.

Example: A 150-foot length of RG-11/U cable is operating at 7 Mc. with a 5-to-1 s.w.r. If perfectly matched, the loss from Fig. 13-11 would be $1.5 \times 0.4 = 0.6$ db. From Fig. 13-12 the additional loss because of the s.w.r. is 0.73 db. The total loss is therefore $0.6 + 0.73 = 1.33$ db.

An appreciable s.w.r. on a solid-dielectric line may result in excessive loss of power at the higher frequencies. Such lines, whether of the

parallel-conductor or coaxial type, should be operated as nearly flat as possible, particularly when the line length is more than 50 feet or so. As shown by Fig. 13-12, the increase in line loss is not too serious so long as the s.w.r. is below 2 to 1, but increases rapidly when the s.w.r. rises above 3 to 1. Tuned transmission lines such as are used with multiband antennas always should be air-insulated, in the interests of highest efficiency.

Matching the Load to the Line

The load for a transmission line may be any device capable of dissipating r.f. power. When lines are used for transmitting applications the most common type of load is an antenna, but there are also practical cases where the grid circuit of a power amplifier may represent the load. When a transmission line is connected between an antenna and a receiver, the receiver input circuit (not the antenna) is the load, because the power taken from a passing wave is delivered to the receiver.

Whatever the application, the conditions existing at the load, and *only* the load, determine the standing-wave ratio on the line. If the load is purely resistive and equal in value to the characteristic impedance of the line, there will be no standing waves. If the load is not purely resistive, and/or is not equal to the line Z_0 , there will be standing waves. No adjustments that can be made at the input end of the line can change the s.w.r., nor is it affected by changing the line length.

Only in a few special cases is the load inherently of the proper value to match a practicable transmission line. In all other cases it is necessary either to operate with a mismatch and accept the s.w.r. that results, or else to take steps to bring about a proper match between the line and load by means of transformers or similar devices. Impedance-matching transformers may take a variety of physical forms, depending on the circumstances.

Note that it is essential, if the s.w.r. is to be made as low as possible, that the load at the point of connection to the transmission line be purely resistive. In general, this requires that the load be tuned to resonance. If the load itself is not resonant at the operating frequency the tuning sometimes can be accomplished in the matching system.

● THE ANTENNA AS A LOAD

Every antenna system, no matter what its physical form, will have a definite value of impedance at the point where the line is to be connected. The problem is to transform this **antenna input impedance** to the proper value to match the line. In this respect there is no one "best" type of line for a particular antenna system, because it is possible to transform impedances in

any desired ratio. Consequently, any type of line may be used with any type of antenna. There are frequently reasons other than impedance matching that dictate the use of one type of line in preference to another, such as ease of installation, inherent loss in the line, and so on, but these are not considered in this section.

Although the input impedance of an antenna system is seldom known very accurately, it is often possible to make a reasonably close estimate of its value. The information in the chapter on antennas can be used as a guide.

Matching circuits may be constructed using ordinary coils and condensers, but are not used very extensively because they must be supported at the antenna and must be weatherproofed. The systems to be described use **linear transformers**.

The Quarter-Wave Transformer or "Q" Section

As described earlier in this chapter, a quarter-wave transmission line may be used as an impedance transformer. Knowing the antenna impedance and the characteristic impedance of the

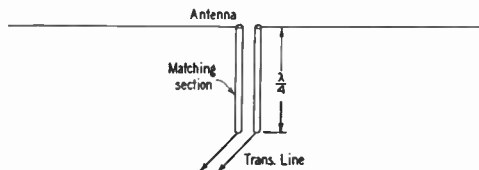

Fig. 13-13 — "Q" matching section, a quarter-wave impedance transformer.

transmission line to be matched, the required characteristic impedance of a matching section such as is shown in Fig. 13-13 is

$$Z = \sqrt{Z_1 Z_0}$$

where Z_1 is the antenna impedance and Z_0 is the characteristic impedance of the line to which it is to be matched.

Example: To match a 600-ohm line to an antenna presenting a 72-ohm load, the quarter-wave matching section would require a characteristic impedance of $\sqrt{72 \times 600} = \sqrt{43,200} = 208$ ohms.

The spacings between conductors of various sizes of tubing and wire for different surge impedances are given in graphical form in Fig. 13-9. (With

½-inch tubing, the spacing in the example above should be 1.5 inches for an impedance of 208 ohms.)

The length of the quarter-wave matching section is given by Equation 13-G.

The antenna must be resonant at the operating frequency. Setting the antenna length by formula is amply accurate with single-wire antennas, but in other systems, particularly close-spaced arrays, the antenna should be adjusted to resonance before the matching section is connected.

When the antenna input impedance is not known accurately, it is advisable to construct the matching section so that the spacing between conductors can be changed. The spacing then may be adjusted to give the lowest possible s.w.r. on the transmission line.

Stub Matching

When a transmission line is not matched by the load, the impedance looking into the line toward the load varies with the distance from the load, as discussed earlier in this chapter. Considering the

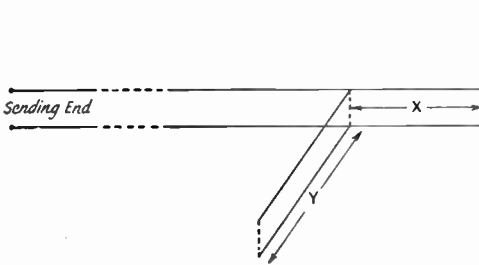

Fig. 13-14 — Matching the antenna to the line by means of a stub. Y. Curves for determining the lengths X and Y are given in Figs. 13-15 and 13-16, for the case where the line, section X and section Y all have the same characteristic impedance.

input impedance to be equivalent to a resistance in parallel with a reactance, at some distance along the line such as X in Fig. 13-14 the resistive part of the input impedance will be equal to the Z_0 of the line. If at this point a reactance equal to the reactive part of the input impedance, but of the opposite type, is connected across the line, the reactances will cancel and leave only the resistive component. From this point back to the transmitter or other source of energy the line will be matched.

The reactances used for matching in this way are usually **linear reactances**—sections of transmission line—called **stubs**. Stubs may be open or closed, depending on whether the free end is left open or is short-circuited, according to the type of reactance required in a particular case. The type and length of stub, as well as the point at which it should be attached to the line, can be found without any knowledge of the antenna input impedance, providing that the s.w.r. on the line can be measured before the stub is attached, and providing that the position of a current node (voltage loop) can be determined under the same conditions.

When the s.w.r. and the position of a current node are known Figs. 13-15 and 13-16 give the

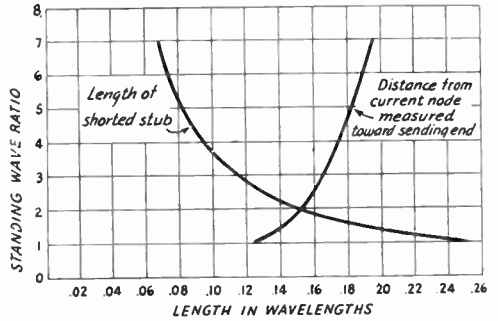

Fig. 13-15 — Graph for determining position and length of a shorted stub. Dimensions may be converted to linear units after values have been taken from the graph.

stub information necessary for impedance matching. Stub lengths are given in wave lengths, which may be converted to feet with the help of Equation 13-F. The data in Figs. 13-15 and 13-16 are based on the assumption that the line and stub both have the same Z_0 .

If the antenna is resonant a current loop or node will occur at the feed point. The distance X therefore may be measured from the antenna if the antenna is fed at a current node (high-voltage point). If the antenna is fed at a current loop use Fig. 13-16 and subtract 0.25 wave length from the distance given.

Folded Dipoles

A half-wave antenna element can be made to match various line impedances if it is split into two or more parallel conductors with the transmission line attached at the center of only one of them. Various forms of such “folded dipoles” are shown in Fig. 13-17. Currents in all conductors are in phase in a folded dipole, and since the conductor spacing is small the folded dipole is equivalent in radiating properties to an ordinary single-conductor dipole. However, the current flowing into the input terminals of the antenna from the line is the current in one conductor only, and the entire power from the line is delivered at this value of current. This is equivalent to saying that the input impedance of the

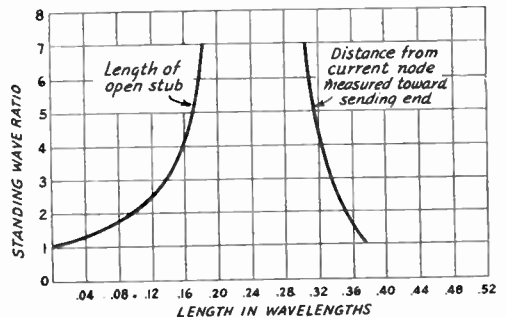

Fig. 13-16 — Graph for determining position and length of an open stub. Dimensions may be converted to linear units after values have been taken from the graph.

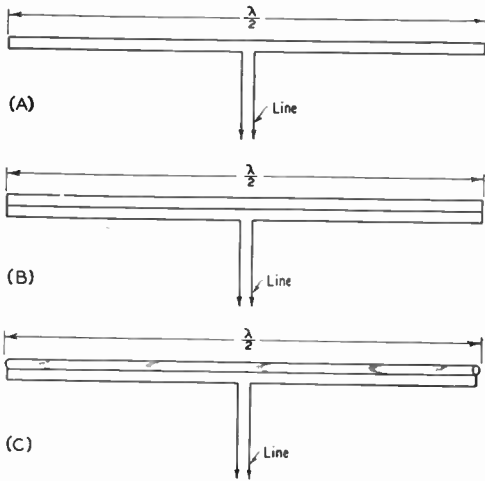

Fig. 13-17 — The folded dipole, a method for using the antenna element itself to provide an impedance transformation.

antenna has been raised by splitting it up into two or more conductors.

The ratio by which the input impedance of the antenna is stepped up depends not only on the number of conductors in the folded dipole but also on their relative diameters, since the distribution of current between conductors is a function of

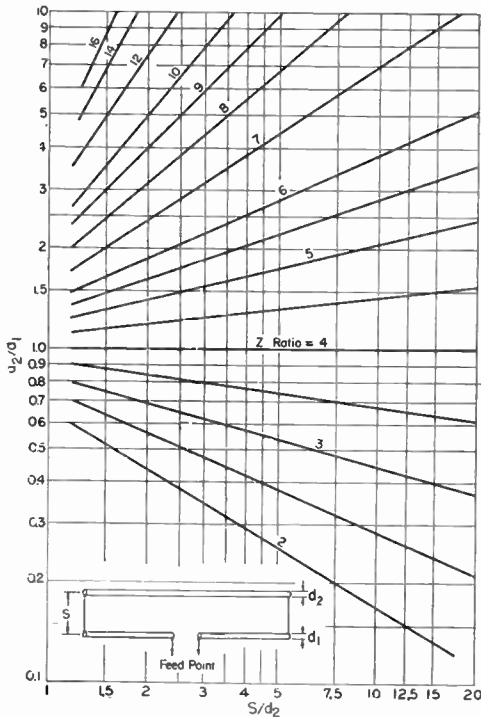

Fig. 13-18 — Impedance transformation ratio, two-conductor folded dipole. The dimensions d_1 , d_2 and s are shown on the inset drawing. Curves show the ratio of the impedance (resistive) seen by the transmission line to the radiation resistance of the resonant antenna system.

their diameters. (When one conductor is larger than the other, as in Fig. 13-17C, the larger one carries the greater current.) The ratio also depends, in general, on the spacing between the conductors, as shown by the graphs of Figs. 13-18 and 13-19. An important special case is the 2-conductor dipole with conductors of equal diameter; as a simple antenna, not a part of a directive array, it has an input resistance close enough to 300 ohms to afford a good match to 300-ohm Twin-Lead.

The required ratio of conductor diameters to give a desired impedance ratio using two conductors may be obtained from Fig. 13-18. Similar information for a 3-conductor dipole is given in Fig. 13-19. This graph applies where all three conductors are in the same plane. The two conductors not connected to the transmission line must be equally spaced from the fed conductor, and must have equal diameters. The fed conductor may have a different diameter, however. The unequal-conductor method has been found particularly useful in matching to low-impedance

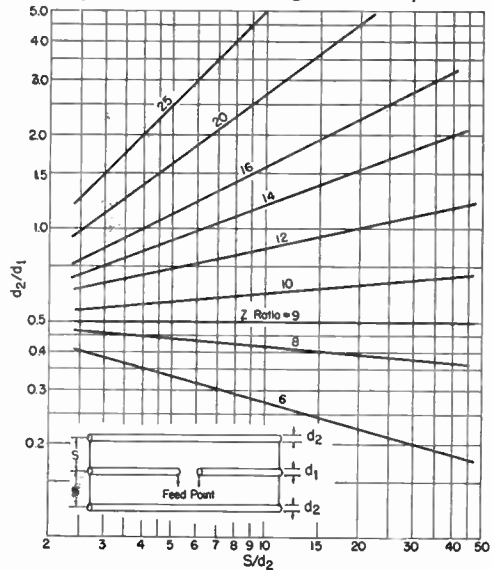

Fig. 13-19 — Impedance transformation ratio, three-conductor folded dipole. The dimensions d_1 , d_2 and s are shown on the inset drawing. Curves show the ratio of the impedance (resistive) seen by the transmission line to the radiation resistance of the resonant antenna system.

antennas such as directive arrays using close-spaced parasitic elements.

The length of the antenna element should be such as to be approximately self-resonant at the median operating frequency. The length is usually not highly critical, because a folded dipole tends to have the characteristics of a "thick" antenna and thus has a relatively broad frequency-response curve.

"T" and "Gamma" Matching Sections

The method of matching shown in Fig. 13-20A is based on the fact that the impedance

between any two points along a resonant antenna is resistive, and has a value which depends on the spacing between the two points. It is therefore possible to choose a pair of points between which the impedance will have the right value to match a transmission line. In practice, the line cannot

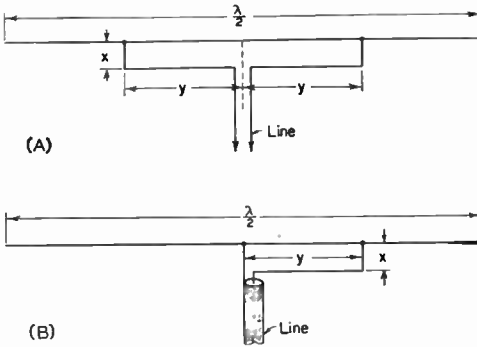

Fig. 13-20—The "T" match and "gamma" match.

be connected directly at these points because the distance between them is much greater than the conductor spacing of a practicable transmission line. The "T" arrangement in Fig. 13-20A overcomes this difficulty by using a second conductor paralleling the antenna to form a matching section to which the line may be connected.

The "T" is particularly suited to use with a parallel-conductor line, in which case the two points along the antenna should be equidistant from the center so that electrical balance is maintained.

The operation of this system is somewhat complex. Each "T" conductor (y in the drawing) forms with the antenna conductor opposite it a short section of transmission line. Each of these transmission-line sections can be considered to be terminated in the impedance that exists at the point of connection to the antenna. Thus the part of the antenna between the two points carries a transmission-line current in addition to the normal antenna current. The two transmission-line matching sections are in series, as seen by the main transmission line.

If the antenna by itself is resonant at the operating frequency its impedance will be purely resistive, and in such case the matching-section lines are terminated in a resistive load. However, since these sections are shorter than a quarter wave-length their input impedance — i.e., the impedance seen by the main transmission line looking into the matching-section terminals — will be reactive as well as resistive. This prevents a perfect match to the main transmission line, since its load must be a pure resistance for perfect matching. The reactive component of the input impedance must be tuned out before a proper match can be secured.

One way to do this is to detune the antenna just enough, by changing its length, to cause reactance of the opposite kind to be reflected to the input terminals of the matching section, thus cancelling the reactance introduced by the latter. Another

method, which is considerably easier to adjust, is to insert a variable capacitor in series with the matching section where it connects to the transmission line, as shown in Fig. 13-21. A capacitor having a maximum capacitance of 150 μf . or so will be about right in the average case, for 14 Mc. and higher. The capacitor must be protected from the weather.

The method of adjustment commonly used is to cut the antenna for approximate resonance and then make the spacing x some value that is convenient constructionally. The distance y is then adjusted, while maintaining symmetry with respect to the center, until the s.w.r. on the transmission line is as low as possible. If the s.w.r. is not below 2 to 1 after this adjustment, the antenna length should be changed slightly and the matching-section taps adjusted again. This process may be continued until the s.w.r. is as close to 1 to 1 as possible.

When the series-capacitor method of reactance compensation is used (Fig. 13-21) the antenna should be the proper length to be resonant at the operating frequency. Trial positions of the matching-section taps are taken, each time adjusting the capacitor for minimum s.w.r., until the

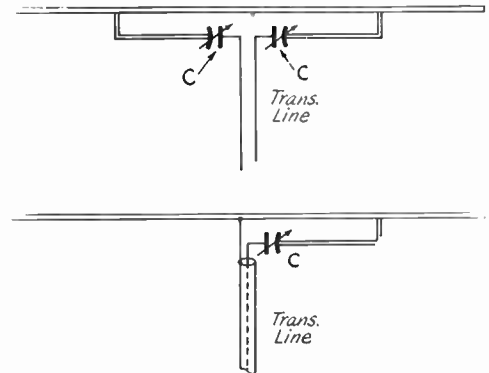

Fig. 13-21—Using series capacitors for tuning out reactance in the matching section with the "T" match and "gamma" match. The capacitor C should have a maximum capacitance of approximately 150 μf . for 14 Mc. and may have proportionately lower capacitances for shorter wave lengths. Receiving-type capacitors can be used for powers up to a few hundred watts.

standing waves on the transmission line are brought down to the lowest possible value.

The unbalanced ("gamma") arrangement in Fig. 13-20B is similar in principle to the "T," but is adapted for use with single coax line. The method of adjustment is the same.

The "Delta" Match

The matching system in Fig. 13-22 is based on the variation in impedance between two points symmetrically located with respect to the center of the antenna, as in the case of the "T" match, but uses a different matching section. If the two conductors of a transmission line are fanned out, the triangular section thus formed will act as an impedance-matching transformer if the proper

dimensions are used. The system is not as readily adjustable as the "T" or "gamma" but is more convenient constructionally when used with a wire antenna. A certain amount of radiation takes place from the "delta" because the two conductors are not sufficiently close together for cancellation of the fields set up by the currents flowing in them.

Dimensions a and b in Fig. 13-22 depend on the antenna impedance (whether it is a simple half-

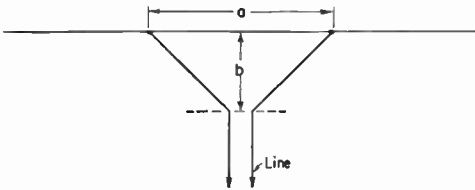

Fig. 13-22 — The "delta" matching section.

wave antenna or the driven element of a multielement beam), the size of the conductors in the delta, and the Z_0 of the transmission line to be matched. Methods for calculation are not available, but dimensions for practical cases are given in the chapters on antennas.

BALANCING DEVICES

An antenna with open ends, of which the half-wave type is an example, is inherently a balanced radiator. When opened at the center and fed with a parallel-conductor line this balance is maintained throughout the system, including the transmission line, so long as the causes of unbalance discussed earlier in this chapter are avoided.

If the antenna is fed at the center through a coaxial line, as indicated in Fig. 13-23A, this balance is upset because one side of the radiator is connected to the shield while the other is connected to the inner conductor. On the side connected to the shield, a current can flow down over the *outside* of the coaxial line, and the fields thus set up cannot be canceled by the fields from the inner conductor because the fields *inside* the line cannot escape through the shielding afforded by the outer conductor. Hence these "antenna" currents flowing on the outside of the line will be responsible for radiation.

Linear Baluns

Line radiation can be prevented by a number of devices whose purpose is to detune or decouple the line for "antenna" currents and thus greatly reduce their amplitude. Such devices generally are known as **baluns** (a contraction for "balanced to unbalanced"). Fig. 13-23B shows one such arrangement, known as a **bazooka**, which uses a sleeve over the transmission line to form, with the outside of the outer line conductor, a shorted quarter-wave line section. As described earlier in this chapter, the impedance looking into the open end of such a section is very high, so that the end of the outer conductor of the coaxial line is effectively insulated from the part of the line below the sleeve. The length is an *electrical* quarter

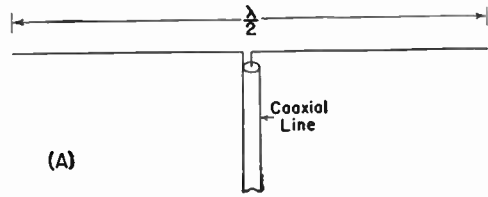

(A)

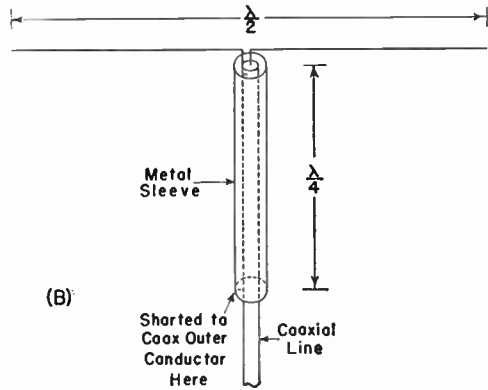

(B)

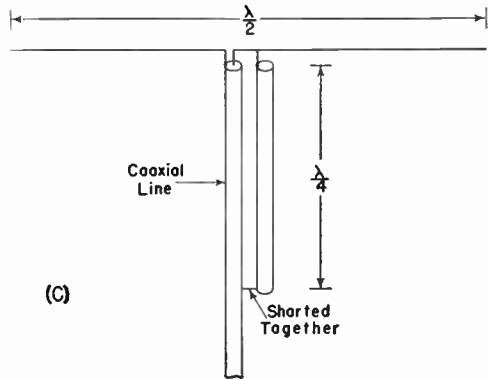

(C)

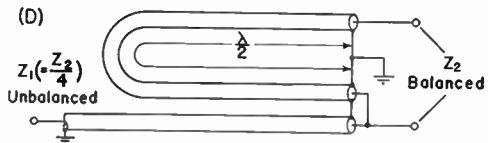

Fig. 13-23 — Radiator with coaxial feed (A) and methods of preventing unbalance currents from flowing on the outside of the transmission line (B and C). The half-wave phasing section shown at D is used for coupling between an unbalanced and a balanced circuit when a 4-to-1 impedance ratio is desired or can be accepted.

wave, and may be physically shorter if the insulation between the sleeve and the line is other than air. The bazooka has no effect on the impedance relationships between the antenna and the coaxial line.

Another method that gives an equivalent effect is shown at C. Since the voltages at the antenna terminals are equal and opposite (with reference to ground), equal and opposite currents flow on the surfaces of the line and second conductor. Beyond the shorting point, in the direction of the transmitter, these currents combine to cancel out. The balancing section "looks like" an open circuit to the antenna, since it is a quarter-wave parallel-conductor line shorted at the far end, and thus has no effect on the normal antenna operation. However, this is not essential to the line-balancing function of the device, and baluns of this type are sometimes made shorter than a quarter wave length in order to provide the shunt inductive reactance required in certain types of matching systems.

Fig. 13-23D shows a third balun, in which equal and opposite voltages, balanced to ground, are taken from the inner conductors of the main transmission line and half-wave phasing section. Since the voltages at the balanced end are in series while the voltages at the unbalanced end are in parallel, there is a 4-to-1 step-down in impedance from the balanced to the unbalanced side. This arrangement is useful for coupling between a balanced 300-ohm line and a 75-ohm coaxial line, for example.

Coil Baluns

Another form of linear balun is shown in the upper drawing of Fig. 13-24. Two transmission lines of equal length having a characteristic impedance Z_0 are connected in series at one end and in parallel at the other. At the series-connected end the lines are balanced to ground and will match an impedance equal to $2Z_0$. At the parallel-connected end the lines will be matched by an impedance equal to $Z_0/2$. One side may be connected to ground at the parallel-connected end, provided the two lines have a length such that, considering each line as a single wire, the balanced end is effectively decoupled from the parallel-connected end. This requires a length that is an odd multiple of $\frac{1}{4}$ wave length. The impedance transformation from the series-connected end to the parallel-connected end is 4 to 1.

A definite line length is required only for decoupling purposes, and so long as there is adequate decoupling the system will act as a 4-to-1 impedance transformer regardless of line length. If each line is wound into a coil, as in the lower drawing, the inductances so formed will act as choke coils and will tend to isolate the series-connected end from any ground connection that may be placed on the parallel-connected end. Balun coils made in this way will operate over a wide frequency range, since the choke inductance is not critical. The lower frequency limit is where the coils are no longer effective in isolating one line from the other; the length of line in each coil

should be about equal to a quarter wave length at the lowest frequency to be used.

The principal application of such coils is in going from a 300-ohm balanced line to a 75-ohm coaxial line. This requires that the Z_0 of the lines forming the coils be 150 ohms. Design data for winding the coils are not available; however, Equation 13-D can be used for determining the approximate wire spacing. Allowance should be made for the fact that the effective dielectric constant will be somewhat greater than 1 if the coil is wound on a form. The proximity effect between turns can be reduced by making the turn spacing somewhat larger than the conductor spacing. For operation at 3.5 Mc. and higher frequencies the length of each conductor should be about 60 feet. The conductor spacing can be adjusted to the proper value by terminating each line in a resistor equal to its characteristic impedance and adjusting the spacing until an impedance bridge at the input end shows the line to be matched.

A balun of this type is simply a fixed-ratio transformer and does not make up for inaccurate

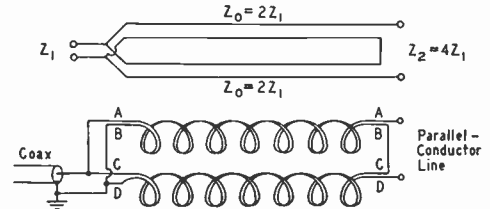

Fig. 13-24 — Baluns for matching between push-pull and single-ended circuits. The impedance ratio is 4 to 1 from the push-pull side to the unbalanced side. Coiling the lines as shown in the lower drawing increases the frequency range over which satisfactory operation is obtained.

matching elsewhere in the system. With a "300-ohm" line on the balanced end, for example, a 75-ohm coax cable will not be matched unless the 300-ohm line actually is terminated in a 300-ohm load.

NONRADIATING LOADS

Important practical cases of nonradiating loads for a transmission line are the grid circuit of a power amplifier (considered in the chapter on transmitters), the input circuit of a receiver, and another transmission line. This last case includes the "antenna tuner" — a misnomer because it is actually a device for coupling a transmission line to the transmitter. Because of its importance in amateur installations, the antenna coupler is considered separately in a later section of this chapter.

Coupling to a Receiver

A good match between an antenna and its transmission line does not guarantee a low standing-wave ratio on the line when the antenna system is used for receiving. The s.w.r. is determined wholly by what the line "sees" at the receiver's antenna-input terminals. For minimum s.w.r. the receiver input circuit must be matched to the

line. The rated input impedance of a receiver is a nominal value that varies over a considerable range with frequency. Methods for bringing about a proper match are discussed in the chapter on receivers.

It should be noted that *if* the receiver is matched to the line, then it is desirable that the antenna and line also be matched, since this results in maximum signal transfer from the antenna to the line. If the receiver is *not* matched to the line, the input impedance of the line (at the terminals of the antenna itself) in turn cannot match the antenna impedance. In such a case the signal input to the receiver depends on the coupling system used between the line and the receiver. For greatest signal strength the coupling system has

to be adjusted to the best compromise between receiver input impedance and load appearing at the input (antenna) end of the line. The proper adjustments must be determined by experiment.

A similar situation exists when the receiver input impedance inherently matches the line Z_0 , but the line and antenna are mismatched. Under these conditions perfect matching at the receiver does not result in greatest signal strength; a deliberate mismatch has to be introduced so that the maximum power will be taken from the antenna.

The most desirable condition is that in which the receiver is matched to the line Z_0 and the line in turn is matched to the antenna. This transfers maximum power from the antenna to the receiver with the least loss in the transmission line.

Coupling the Transmitter to the Line

The type of coupling system that will be needed to transfer power adequately from the final r.f. amplifier to the transmission line depends almost entirely on the input impedance of the line. As shown earlier in this chapter, the input impedance is determined by the standing-wave ratio and the line length. The simplest case is that where the line is terminated in its characteristic impedance so that the s.w.r. is 1 to 1 and the input impedance is merely the Z_0 of the line, regardless of line length.

Coupling systems that will deliver power into a flat line are readily designed. For all practical purposes the line can be considered to be flat if the s.w.r. is no greater than about 1.5 to 1. That is, a coupling system designed to work into a pure resistance equal to the line Z_0 will have enough leeway to take care of the small variations in input impedance that will occur when the line length is changed, if the s.w.r. is higher than 1 to 1 but no greater than 1.5 to 1.

Coupling circuits suitable for coaxial lines are discussed in the chapter on transmitters. As stated in that chapter, an untuned "pick-up" or "link" coil connected directly to the transmission line should have an inductance such that the reactance at the operating frequency is approximately equal to the Z_0 of the line, to assure adequate coupling to a line that is actually flat. While this condition is sometimes met well enough at the higher frequencies, at least for coaxial lines, by manufactured link coils, it is definitely not met when a parallel-conductor line having a Z_0 of 300 ohms or more is used. The optimum pick-up coil for coupling to such lines will have about the same inductance as the plate tank coil itself.

Amateurs are frequently successful in coupling power into a line even though the pick-up coil is quite small and is loosely coupled to the amplifier tank coil. When such coupling is possible it is an indication that the line is operating at a fairly high s.w.r. and that the line

length is such as to bring a current loop near the input end. It is customary to "prune" the line length in such cases until adequate coupling is secured—a practice that has given rise to the wholly fallacious belief, on the part of many, that pruning the line reduces the standing-wave ratio and that a flat line will load an amplifier with a small link and very loose coupling. Pruning the line accomplishes nothing if the line is actually flat because, as explained earlier in this chapter, the input impedance of a matched line is equal to its Z_0 regardless of the line length. If the line is not flat, pruning changes the input impedance and eventually results in a value such that the link or pick-up coil is actually tuned to the operating frequency by the line, a condition that will give maximum power transfer with minimum coupling. The higher the s.w.r. the more loose the coupling can be. Although there is nothing inherently wrong with this method of adjustment, it works only when the s.w.r. is fairly high and will not work with a line that actually is flat.

Tuned Coupling

A tuned coupling circuit has the same advantages, when used with properly-terminated parallel-conductor lines, that were outlined in the transmitting chapter in connection with coaxial lines. The principles are the same as well, but a resistance of 300 to 600 ohms is too high to be connected in series with a tuned circuit. Consequently, parallel-tuned circuits must be used with

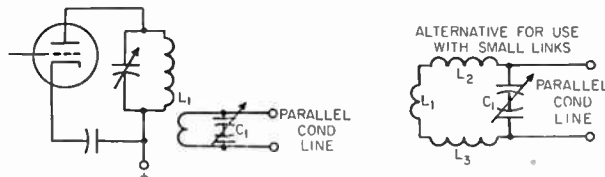

Fig. 13-25 — Tuned circuits for coupling to a flat parallel-conductor line. Values for C_1 are given in Table 13-II; L_1 is chosen to resonate with the value given at the operating frequency. In the alternative circuit the total inductance of L_1 , L_2 and L_3 should equal L_1 in the circuit at the left.

these lines. Typical arrangements are shown in Fig. 13-25. The capacitance values given in Table 13-II are for a Q of 2 and are the *minimum* values that should be used unless the coupling between the coils can be made very tight. The Q may be increased, permitting full power transfer with looser coupling between the coils, by increasing the capacitance and decreasing the inductance correspondingly to maintain resonance.

The capacitance values given are the total required, so if a balanced capacitor is used as indicated at C_1 in Fig. 13-25 each section should have twice the capacitance given. A single-ended capacitor may be used if care is taken to mount it far enough away from the chassis or any other grounded conductor so that the capacitance from stator and frame to ground is small. In such case it should be tuned by an insulated extension shaft.

The series-tuned circuit shown in the transmitter chapter for coax line can be adapted to use with 75-ohm parallel-conductor line by removing the ground connection and using two variable capacitors, one in each line conductor and each having twice the capacitance specified. This is the best arrangement for maintaining balance to ground, but if reasonable care is taken to mount the capacitor as described in the preceding paragraph, a single capacitor may be used. In that case the only circuit difference is that neither side of the line should be grounded.

Link Coupling

The coupling arrangements for parallel-conductor line shown in Fig. 13-25 are not entirely satisfactory from a constructional standpoint. It is usually more convenient to build the coupling apparatus separate from the final amplifier, and this leads to greater operating flexibility as well. For lines operating at a low standing-wave ratio this is easily accomplished by connecting the amplifier and coupling circuits through a short length of transmission line or "link." With proper design and adjustment, the tuning of both circuits will be completely independent of the length of the line connecting them. This method has the further advantage that, if the connecting line is coaxial cable, it offers an ideal spot for the insertion of a low-pass filter for preventing harmonic interference to television and f.m. reception.

The circuit for coax-link coupling is given in Fig. 13-26. The constants of the tuned circuit C_1L_3 are not particularly critical; the principal requirement is that the circuit must be capable of being tuned to the operating frequency. Constants similar to those used in the plate tank circuit will be satisfactory. The construction of L_3 must be such that it can be tapped at least every turn. L_2 must be tightly coupled to L_3 , and the inductance of L_2 should be approxi-

TABLE 13-II
Capacitance in $\mu\text{f.}$ Required for Coupling to 300- and 600-Ohm Flat Lines with Parallel-Tuned Coupling Circuit

Frequency Band Mc.	Characteristic Impedance of Line	
	300 ohms	600 ohms
1.8	600	300
3.5	300	150
7	150	75
14	75	40
28	40	20

Note: Inductance in circuit must be adjusted to resonate at operating frequency.

mately the value that gives a reactance equal to the Z_0 of the connecting line at the frequency in use. An average reactance of about 60 ohms will suffice for either 52- or 75-ohm coaxial line.

When the system is properly designed and operated, the circuit formed by $L_2L_3C_1$ acts purely as a matching device to transform the input impedance of the main transmission line to a value equal to the Z_0 of the coaxial link. The coupling circuit at the amplifier end is merely designed and adjusted for working into a flat coaxial line, as described in the transmitter chapter.

The most satisfactory way to set up the system initially is to connect a coaxial s.w.r. bridge in the link as shown in Fig. 13-26. The "Moni-match" type of bridge, which can handle the full transmitter power and may be left in the line for continuous monitoring, is excellent for this purpose. However, a simple resistance bridge such as is described in the chapter on measurements is perfectly adequate, requiring only that the transmitter output be reduced to a very low value so that the bridge will not be overloaded. Take a trial position of the line taps on L_3 , keeping them equidistant from the center of the coil, and adjust C_1 for minimum s.w.r. as indicated by the bridge. If the s.w.r. is not close to 1 to 1, try new tap positions and adjust C_1 again, continuing this procedure until the s.w.r. is practically 1 to 1. The setting of C_1 and the tap positions may then be logged for future reference. At this point

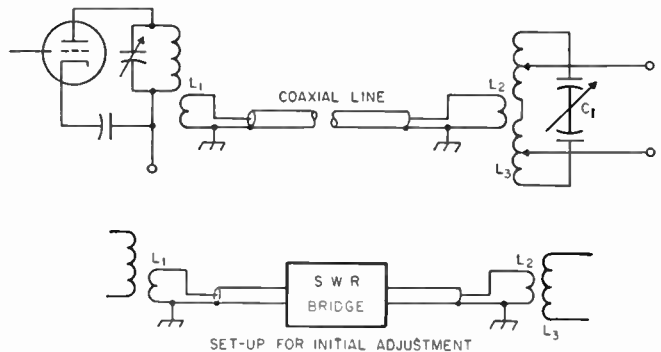

Fig. 13-26 — Matching circuits using a coaxial link, for use with parallel-conductor transmission lines. Adjustment setup using an s.w.r. bridge is shown in the lower drawing. Design considerations and method of adjustment are discussed in the text.

check the link s.w.r. over the frequency range normally used in that band, without changing the setting of C_1 . No readjustment will be required if the s.w.r. does not exceed 1.5 to 1 over the range, but if it goes higher it is advisable to note as many settings of C_1 as may be necessary to keep the s.w.r. below 1.5 to 1 at any part of the band. Changes in the link s.w.r. are caused chiefly by changes in the s.w.r. on the main transmission line with frequency, and relatively little by the coupling circuit itself. A single setting of C_1 at midfrequency will suffice if the antenna itself is broad-tuning.

If it is impossible to get a 1-to-1 s.w.r. at any settings of the taps or C_1 , the s.w.r. on the main transmission line is high and the line length is probably unfavorable. Ordinarily there should be no difficulty if the transmission-line s.w.r. is not more than about 3 to 1, but if the line s.w.r. is higher it may not be possible to bring the link s.w.r. down except by using the methods for reactance compensation described in a subsequent section.

The matching adjustment can be considerably facilitated by using a variable capacitor in series with the matching-circuit coupling coil as shown in Fig. 13-27. The additional adjustment thus

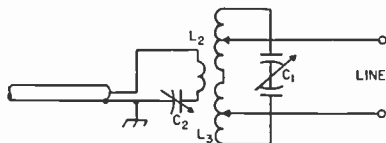

Fig. 13-27 — Using a series capacitor for control of coupling between the link and line circuits with the coax-coupled matching circuit.

provided makes the tap settings on L_3 much less critical since varying C_2 has the effect of varying the coupling between the two circuits. For optimum control of coupling, L_2 should be somewhat larger than when C_2 is not used — perhaps twice the reactance recommended above — and the reactance of C_2 at maximum capacitance should be the same as that of L_2 at the operating frequency. L_3 and C_1 are the same as before. The method of adjustment is the same, except that for each trial tap position C_1 and C_2 are alternately adjusted, a little at a time, until the s.w.r. is brought to its lowest possible value. In general, the adjustment sought should be the one that keeps C_2 at the largest possible capacitance, since this broadens the frequency response. Also, the taps on L_3 should be kept as far apart as possible, while still permitting a match, since this also broadens the frequency response of the circuit.

Once the matching circuit is properly adjusted, the s.w.r. bridge may be removed, if necessary, and full power applied to the transmitter. The input should be adjusted by the coupling or loading control built into the transmitter, never by making any changes in the settings of the matching circuit, $C_1L_2L_3$. If an amplifier having a parallel-tuned tank circuit will not load properly, tuned coupling should be used into the coax link.

It is possible to use a circuit of this type without initially setting it up with the s.w.r. bridge. In such a case it is a matter of cut-and-try until adequate power transfer between the amplifier and main transmission line is secured. However, this method frequently results in a high s.w.r. in the link, with consequent power loss, "hot spots" in the coaxial cable, and tuning that is critical with frequency. The bridge method is simple and gives the optimum operating conditions quickly and with certainty.

● "TUNED" LINES

If the s.w.r. on a transmission line is high enough to cause the input impedance to change appreciably as the applied frequency is varied, the coupling between the transmitter and the line must be changed accordingly if the amplifier loading is to be constant. So far as the coupling apparatus is concerned, the principal difference between flat and tuned lines is that the system can be designed for relatively constant impedance for flat lines, but must be capable of coupling into a wide range of impedances if the line is "tuned."

As mentioned earlier, a simple coil can be used for coupling to a line having a high standing-wave ratio providing the line length is adjusted so there is a current loop near the point where it connects to the pick-up coil. The coupling will be maximum, for a given degree of separation between the pick-up coil and the amplifier tank coil, if the line is pruned to a length such that the input impedance is just sufficiently capacitive to cancel the inductive reactance of the pick-up coil. This can be done by cut-and-try. The higher the s.w.r. on the line the easier it becomes to load the amplifier with loose coupling between the two coils. Whether or not good loading can be obtained over a band of frequencies depends on the characteristics of the antenna system. The sharper the antenna and the higher the line s.w.r. the more difficult it becomes to operate over a band without progressively changing the line length.

Series and Parallel Tuning

Rather than adjusting the line length to fit a given coupling coil, it is more practical to adjust the coupling circuit to fit the conditions existing at the input end of the transmission line.

A high standing-wave ratio occurs principally on parallel-conductor lines, either because no attempt has been made at matching the antenna and the line or because the system is used for multiband operation, which precludes such matching. In the latter case, cutting the line length to a multiple of a quarter wave length will bring either a current or voltage loop near the input terminals of the transmission line (assuming that the antenna itself is resonant) depending on the termination and the line length. If there is a current loop near the input end the impedance will be lower than the line Z_0 ; if a voltage loop, the input impedance will be higher than the line Z_0 . In both cases the input impedances will be essentially resistive.

Under these conditions the circuit arrangements shown in Fig. 13-28 will work satisfactorily. Series tuning is used when a current loop occurs at the input end of the line; parallel tuning when there is a voltage loop at the input end. In the series case, the circuit formed by L_1 , C_1 and C_2 with the line terminals short-circuited should tune to the operating frequency. C_1 and C_2 should be maintained at equal capacitance. In the parallel case, the circuit formed by L_1 and C_1 should tune to resonance with the line disconnected.

The L/C ratio in either circuit depends on the transmission line Z_0 and the standing-wave ratio. With series tuning, a high L/C ratio must be used if the s.w.r. is relatively low and the line Z_0 is high. With parallel tuning, a low L/C ratio must be used if the s.w.r. is relatively low and the transmission-line Z_0 also is low. With either series or parallel tuning the L/C ratio becomes less critical when the s.w.r. is high. As a first approximation, coil and capacitor values of the same order as those used in the plate tank circuit may be tried.

To adjust the series-tuned circuit, first couple L_1 loosely to the amplifier tank coil and then vary C_1 and C_2 , keeping their capacitances equal, until the setting is found that makes the amplifier plate current kick upward. Keep adjusting the amplifier tank capacitor, C , for minimum plate current while this is being done. When the proper settings are found, increase the coupling between the two coils until the minimum plate current is the normal operating value for the amplifier. It is unnecessary to readjust C_1 and C_2 when the coupling is increased. Keep the coupling between the coils at the smallest value that will load the amplifier properly. If full loading cannot be obtained with the tightest possible coupling, use a coil of more inductance at L_1 .

The same adjustment procedure is used with parallel tuning, except that there is only one capacitor, C_1 . If full loading cannot be secured, reduce the inductance of L_1 and increase C_1 correspondingly to maintain the same frequency, until the amplifier loads properly.

The r.f. ammeters shown in Fig. 13-28 are not strictly necessary, but are useful for indicating maximum output. They may be omitted if desired: in most cases the amplifier plate current is a good enough indication of output, providing the amplifier is operating at normal ratings and efficiency.

In case full loading cannot be obtained even when the L/C ratio is varied, the type of tuning in use probably is not suitable and should be changed; e.g., from series to parallel. If satisfactory loading still cannot be secured, the probability is that the s.w.r. is quite low and the coupling methods designed for flat lines, described earlier, should be used.

Two capacitors are used in the

series-tuned circuit in order to keep the line balanced to ground. This is because two identical capacitors, both connected with either their stators or rotors to the line, will have the same capacitance to ground. A single unit would be perfectly usable so far as the operation of the coupling circuit is concerned, but will slightly unbalance the circuit because the frame has more capacitance to ground than the stator. The unbalance is not especially serious unless the capacitor is mounted near a large mass of metal, such as a chassis or shield assembly.

A balanced capacitor is used in the parallel circuit, in preference to a single unit, for the same reason. An alternative scheme to maintain balance is to use two single-ended capacitors in parallel, but with the frame of one connected to one side of the line and the frame of the other connected to the other side of the line. The same two capacitors may be switched in series when series tuning is to be used.

Link Coupling

The circuits shown in Fig. 13-28 require a means for varying the coupling between two sizable coils, a thing that is somewhat inconvenient constructionally. It is easier to use separate fixed mountings for the final tank and antenna coils and couple them by means of a link. As explained in the chapter on circuit fundamentals, a short link is equivalent to providing mutual inductance between two tuned circuits. Typical arrangements for series and parallel tuning are shown in Fig. 13-29. Although these drawings show variable coupling at both ends of the link, a fixed link coil can be used at either end so long as variable coupling is available at the other.

There is no essential difference between the tuning procedures with these circuits and those of Fig. 13-28. The only change is that the coupling is adjusted by means of a link instead of by varying the spacing between L and L_1 .

In cases where the link will be more than a few inches long, or when coaxial cable is to be

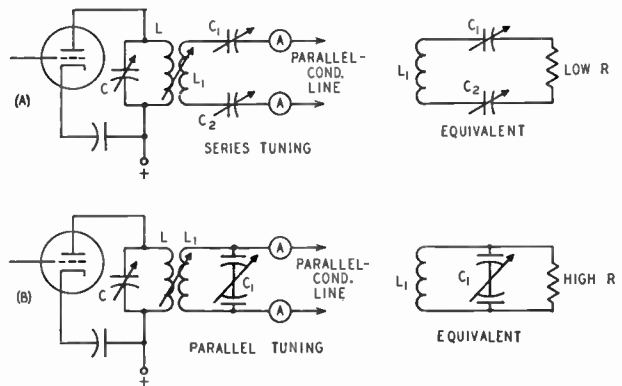

Fig. 13-28 — Series and parallel tuning. This method is useful with resonant lines when the length is such as to bring either a current or voltage loop near the input end. Design data and methods of adjustment are given in the text.

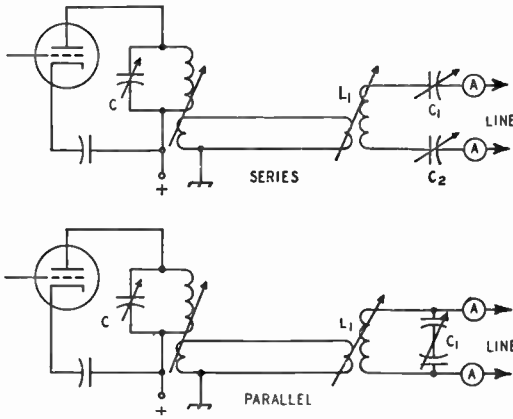

Fig. 13-29 — Link-coupled series and parallel tuning.

used for the link, it is much better to consider the link as a transmission line that should be properly matched. The circuit of Fig. 13-26 is recommended in that case, except that either a series- or parallel-tuned circuit is substituted for C_1L_3 in that figure. The same considerations apply with respect to the sizes of the link coils, and the best adjustment procedure is that using an s.w.r. bridge.

Lines of Random Length

Series or parallel tuning will always work satisfactorily with lines having a high standing-wave ratio so long as the electrical length of the line is approximately a multiple of a quarter wave length. However, it is not always possible to couple satisfactorily when intermediate line lengths are used. This is because at some lengths the input impedance of the line has a considerable reactive component, and because the resistive component is too large to be connected in series with a tuned circuit and too low to be connected in parallel.

The coupling system shown in Fig. 13-26 is capable of handling the resistive component of the input impedance of the transmission lines used in most amateur installations, regardless of the standing-wave ratio on the line. Consequently, it can generally be used wherever either series or parallel tuning would normally be called for, simply by setting the taps properly on the coil. (A possible exception is where the s.w.r. is considerably higher than 10 to 1 and the line length is such as to bring a current loop at the input end. In such a case the resistance may be only a few ohms, which is difficult to match by means of taps on a coil.)

Within limits, the same circuit is capable of being adjusted to compensate for the reactive component of the input impedance; this merely means that a 1-to-1 s.w.r. in the link will be obtained at a different setting of C_1 (Fig. 13-26) than would be the case if the line "looked like" a pure resistance. Sometimes, however, C_1 does

not have enough range available to give complete compensation, particularly when (as is the case with some line lengths when the s.w.r. is high) the input impedance is principally reactive.

Under such conditions it is necessary, if the line length cannot be changed to a more satisfactory value, to provide additional means for compensating for or "canceling out" the reactive component of the input impedance. As described earlier in this chapter (Fig. 13-6) the input impedance can be considered to be equivalent to a circuit consisting either of resistance and inductance or resistance and capacitance. It is generally more convenient to consider these elements as a parallel combination, so if the line "looks like" L/R at A in Fig. 13-6, it is apparent that if we connect a capacitance of the right value across L' the circuit will become resonant and will appear to be a pure resistance of the value R' . Similarly, connecting an inductance of the right value across C' in Fig. 13-6B will resonate the circuit and the impedance will be equal to R' . The resistive impedance that remains can easily be matched to the coax link by means of the circuit of Fig. 13-26.

The practical application of this principle is shown in Fig. 13-30, where L and C are the reactances required to cancel out the line reactance, L for cases where the line is capacitive, C for lines having inductive reactance. The amount of either inductance or capacitance required is easily determined by trial, using the s.w.r. bridge in the coax link. First disconnect the main transmission line from L_3 and connect a noninductive resistor in its place. A 1-watt carbon resistor of about the same resistance as the line Z_0 will do, if a low-power bridge of the resistance type is used. With the "Monimatch" bridge, a suitable load may be made by connecting carbon resistors in parallel; for example, five 1500-ohm 2-watt resistors in parallel will make a 300-ohm load capable of handling 10 watts of r.f. Adjust the coil taps and C_1 for a 1-to-1 standing-wave ratio in the link, as described earlier. This determines the proper setting of C_1 for a purely resistive load. Then take off the resistor and connect the line, again adjusting the taps and C_1 to make the s.w.r. as low as possible, and compare the

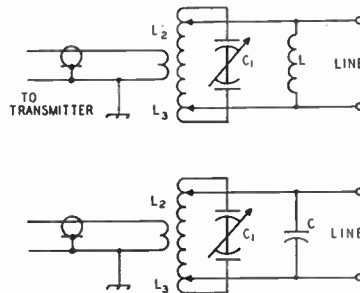

Fig. 13-30 — Reactance cancellation on random-length lines having a high standing-wave ratio.

new setting of C_1 with the original setting. If the capacitance has increased, the line reactance is inductive and a capacitor must be connected at C in Fig. 13-30. The amount of capacitance needed to bring the proper setting of C_1 near the original setting can be determined by trial. On the other hand, if the capacitance of C_1 is less than the original, an inductance must be connected at L . Trial values will show when the proper tuning conditions have been reached.

It is not necessary that C_1 be at exactly the

original setting after the compensating reactance has been adjusted; it is sufficient that it be in the same vicinity.

Using this procedure practically any length of line can be coupled properly to the transmitter, even when the line s.w.r. is quite high. Unfortunately, no specific values can be suggested for L and C , since they vary widely with line length and s.w.r. Their values usually are comparable with the values used in the regular coupling circuits at the same frequency.

Coupler or Matching-Circuit Construction

The design of matching or "antenna coupler" circuits has been covered in the preceding section, and the adjustment procedure also has been outlined. Since circuits of this type are most frequently used for transferring power from the transmitter to a parallel-conductor transmission line, a principal point requiring attention is that of maintaining good balance to ground. If the coupler circuit is appreciably unbalanced the currents in the two wires of the transmission line will also be unbalanced, resulting in radiation from the line.

In most cases the matching circuit will be built on a metal chassis, following common practice in the construction of transmitting units. The chassis, because of its relatively large area, will tend to establish a "ground" — even though not actually grounded — particularly if it is assembled with other units of the transmitter in a rack or cabinet. The components used in the coupler, therefore, should be placed so that they are electrically symmetrical with respect to the chassis and to each other.

In general, the construction of a coupler circuit should physically resemble the tank layouts used with push-pull amplifiers. In parallel-tuned circuits a split-stator capacitor should be used. The capacitor frame should be insulated from the chassis because, depending on line length and other factors, harmonic reduction and line balance may be improved in some cases by grounding and in others by not grounding. It is therefore advisable to adopt construction that permits either. Provision also should be made for grounding the center of the coil, for the same reason. The coil in a parallel-tuned circuit should be mounted so that its hot ends are symmetrically placed with respect to the chassis and other components. This equalizes stray capacitances and helps maintain good balance.

When the coupler is of the type that can be shifted to series or parallel tuning as required, two separate single-ended capacitors will be satisfactory. As described earlier, they should be connected so that both frames go to corresponding parts of the circuit — i.e., either to the coil or to the line — for series tuning, and when used in parallel for parallel tuning should be connected frame-to-stator.

A coupler designed and adjusted so that the connecting link acts as a matched transmission line may be placed in any convenient location. Some amateurs prefer to install the coupler at the point where the main transmission line enters the station. This helps maintain a tidy station layout when an air-insulated parallel-conductor transmission line is used. With solid-dielectric lines, which lend themselves well to neat installation indoors, it is probably more desirable to install the coupler where it can be reached easily for adjustment and band-changing. The use of coax-

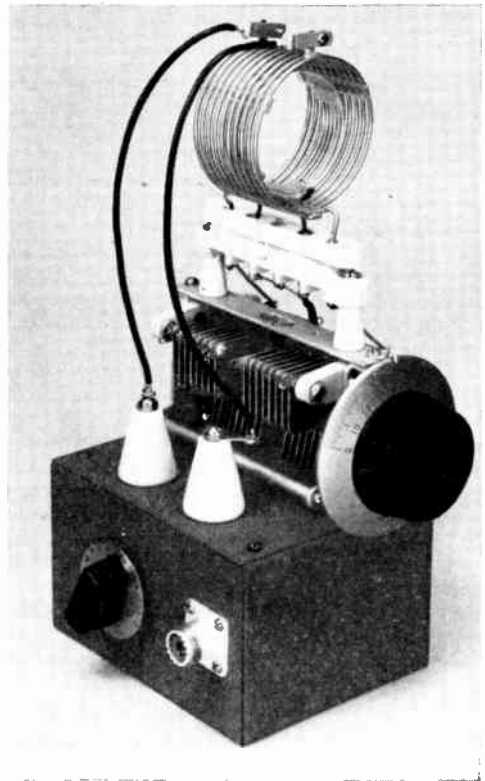

Fig. 13-31 — A coax-coupled matching circuit of simple construction. The entire circuit is mounted on a 3 by 5 box. C_1 is inside; C_2 and the plug-in coil assembly are mounted on top.

ial line between the transmitter and coupler is strongly recommended if the link line is more than a few inches long, for the reasons outlined in the preceding section.

● COAX-COUPLED MATCHING CIRCUIT

The matching unit shown in Fig. 13-31 is constructed according to the design principles outlined earlier in this chapter. It uses a parallel-tuned circuit with taps for matching a parallel-conductor line through a link coil to a coaxial line to the transmitter. It will handle about 500 watts of r.f. power and will work, without modification, into lines of any length if the s.w.r. is below 3 or 4 to 1. If the s.w.r. is high, it may be necessary to compensate for the reactive part of the input impedance of the line, at certain line lengths, by using an additional coil or capacitor as discussed earlier. The necessity for such compensation can be avoided, on lines having a high s.w.r., by making the electrical length of the line a multiple of a quarter wave-length.

As shown by the circuit diagram, Fig. 13-32, the link circuit is adjusted by means of a variable

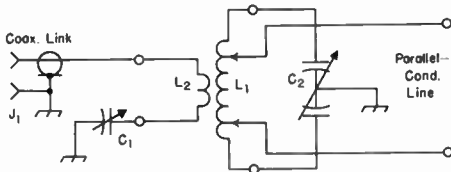

Fig. 13-32—Circuit diagram of the coax-coupled matching circuit.
 C₁—300- μ f. variable, approximately 0.024" spacing.
 C₂—100 μ f. per section, 1500 volts.
 J₁—Chassis-type coax connector.

capacitor, C₁, to facilitate matching the main transmission line to the coax link. The coils are constructed from commercially-available coil material, and the link inductances are chosen to provide adequate coupling for flat lines. The link

going into the end prongs of the plug from the tank coil. Short lengths of spaghetti tubing are slipped over the leads to the link coil where they go between the tank coil turns to reach the plug.

Taps on the tank coil for connection to a parallel-conductor transmission line are made by bending ordinary soldering lugs around the wire and soldering them in place. The clips are Johnson type 235-860, adjusted so that they fit snugly over the taps when pushed on sidewise. Used this way, the clips provide an easy and rapid method of connecting and disconnecting the line. The proper positions for the taps may be determined by first using the clips in the normal fashion.

The maximum length of coil that can be mounted satisfactorily on the plugs is about 4 inches. Alternative coils of this length are shown in Fig. 13-32 for 3.5 Mc.; one requires the addition of 75 μ f. fixed capacitance across the circuit.

The matching circuit should be adjusted with the aid of an s.w.r. bridge, as described earlier in this chapter. In general, the tuning will be less critical, and the circuit will work over a wider frequency range without readjustment, if the taps are kept as far toward the ends of the coil as possible and C₁ is set at the largest capacitance that will permit bringing the s.w.r. in the coax link down to 1 to 1.

● A "UNIVERSAL" MATCHING CIRCUIT

The matching circuit shown in Fig. 13-33 offers considerable flexibility in that it can be used as a tapped-coil matching network of the same type as that just described, and also can be used as either a series- or parallel-tuned "antenna coupler." It can also be adapted to other types of coupling by simple changes in the plug-connection arrangement of the coils.

Two capacitors are used in the tank circuit. Their rotors are insulated from each other but are turned simultaneously by a right-angle drive unit. When used either for parallel tuning or the tapped-coil method of matching, the rotors are

Coil Data								
Band, Mc.	L ₁			L ₂				
	Turns	Wire Size	Dia., In.	Turns/In.	Turns	Wire Size	Dia., In.	Turns/In.
3.5	44	16	2½	10	10	16	2	10
3.5*	24	12	2½	6	10	16	2	10
7	18	12	2½	6	6	16	2	10
14	10	12	2½	6	3	16	2	10
21-28	6	12	2½	6	2	16	2	10

* Alternate coil; requires addition of 75 μ f. total in parallel with C₂.

coil, of smaller diameter than the tank coil, is mounted inside the latter at the center. Duco cement is used to hold the coils together at their bottom tie strips. The coils are mounted on Millen type 40305 plugs and require no other support than the stiffness of the short lengths of wire

connected together to form a split-stator capacitor having a maximum capacitance of 150 μ f. When used for series tuning the capacitor frames connect to the parallel-conductor transmission line, the jumper that connects the rotors together being removed.

The unit is built on a 7 by 9 by 2 aluminum chassis and has a 7 by 10 panel. The tank capacitors are mounted on small aluminum plates supported on 3/4-inch stand-off insulators, to insulate the frames from the chassis; this method is preferable to mounting the capacitors directly on the insulators as it lessens the mechanical strain on the latter. Soldering lugs projecting from the capacitor frames provide means for connecting the line clips for series and parallel tuning. The jumper for connecting the rotors together is in the foreground; it uses banana plugs that fit into jacks mounted on the capacitor mounting plates. The link capacitor is located underneath the chassis.

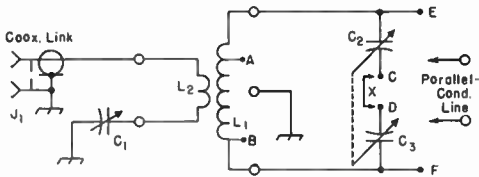

Fig. 13-33 — Circuit diagram of the "universal" coax-coupled matching network. For use as a tapped matching circuit, connect the line to taps on L_1 , as at $A-B$, and connect the jumper, X , to $C-D$; the jumper is also used for parallel tuning but with the line connected to $E-F$. For series tuning, remove the jumper and connect the line to $C-D$. The ground connection to the middle prong of the coil socket is provided for cases where it is desirable to ground the center of L_1 .

C_1 — 300- μmf . variable, approximately 0.024" spacing.
 C_2, C_3 — 300- μmf . variable, 1000 volts (National TMS-300).
 J_1 — Chassis-type coax connector.

Band	Coil Data	
	L_1 , turns	L_2 , turns
3.5-7 Mc.	20 (14 $\mu\text{h.}$)	10 (5 $\mu\text{h.}$)
7-14 Mc.	10 (5 $\mu\text{h.}$)	6 (2.5 $\mu\text{h.}$)
14-28 Mc.	4 (1.5 $\mu\text{h.}$)	2

L_1 — No. 12 tinned wire, 2 1/2 inches dia., 6 turns per inch (B & W 3905-1).
 L_2 — No. 16 wire, 2 inches dia., 10 turns per inch (B & W 3907 or 3907-1).

The coils shown are designed primarily for use in the tapped matching circuit or for parallel tuning, but will also be satisfactory for series

tuning if the transmission line length is such as to bring a current loop near the input end. Coil taps are made in the same way as in the coupler previously described. Because of the fairly large value of maximum capacitance available when the tank capacitors, C_2 and C_3 , are used together as a split-stator capacitor, it is possible to cover a 2-to-1 frequency range. Consequently, only three coil assemblies are needed to cover the 3.5- to 30-Mc. range, and each one can be used for two (in the case of the smallest coil, three) adjacent amateur bands.

As a tapped matching circuit, adjustment is the same as for the unit just described. When using either series or parallel tuning, the s.w.r. bridge should be used as before, adjusting C_1 and C_2-C_3 for minimum s.w.r. in the coax link. (Originally described in March, 1953, *QST*.)

● MATCHING CIRCUIT WITH MULTIBAND TUNER

The coupling network shown in Fig. 13-35 uses a multiband tuner (see chapter on transmitters for other examples) to cover the 3.5-30 Mc. range without coil changing or switching. The matching circuit is shown in Fig. 13-36, and consists of the multiband circuit $C_1L_1L_3$, the coupling coils L_2 and L_4 , and the series capacitor C_2 . The input impedance of a balanced (parallel-conductor) line connected to the output terminals, A or B , can be matched to a coaxial line connected to the transmitter through J_1 . Proper matching can be achieved over the usual range of impedances encountered with practical antenna systems.

In the average case, the transmission line will be connected to the "A" terminals on 3.5 and 7 Mc., and to the "B" terminals on 14 through 28 Mc. However, there may be special cases where a better match can be obtained, on a given band, by using the other set of terminals in preference to the one mentioned above. This must be determined by trial.

The operation of this circuit can be resolved into the equivalent of an "L" network (see chapter on circuit fundamentals). The multiband cir-

Fig. 13-34 — A coupler or matching network that can also be used for series or parallel tuning of tuned lines.

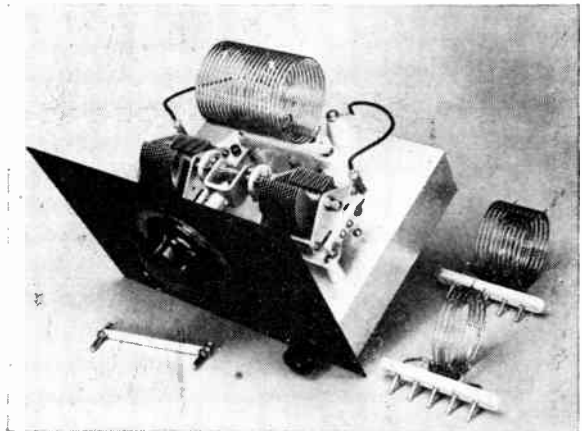

cuit is equivalent to a parallel-resonant circuit having shunted across it a load resistance reflected to it through the coupling coil from the actual load. C_2 is then the series arm of the "L" network and the multiband circuit is slightly detuned to the inductive side of reso-

stiffen the assembly. The two pairs of coils should be mounted with their axes at right angles in order to minimize coupling between them.

Adjustment

Proper adjustment of the matching circuit calls

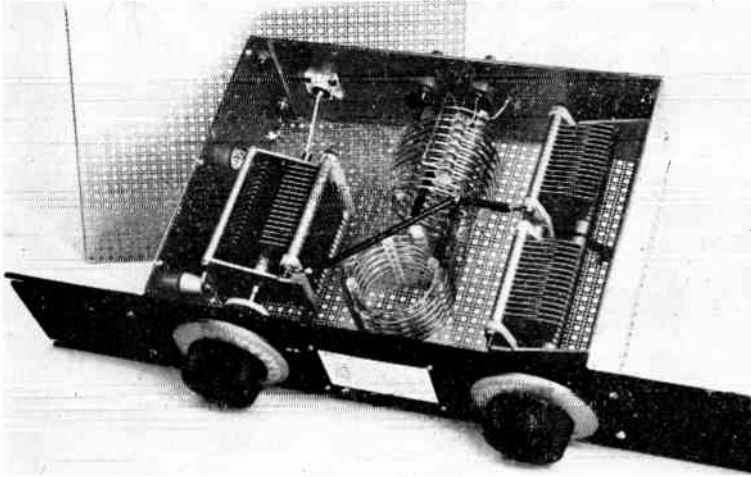

Fig. 13-35 — Matching circuit using multiband tuner principle for covering 3.5–30 Mc. without coil changing. It is assembled on a standard relay-rack panel $3\frac{1}{2}$ inches high, using a homemade U-shaped support made of sheet aluminum. The components in this unit are suitable for about 500 watts.

nance to provide the necessary value of shunt reactance for matching.

Construction

The principal members of the supporting framework in the unit shown in Fig. 13-35 are two sheet-aluminum brackets, $3\frac{1}{2}$ inches wide, with lips at both ends. The front lips are bolted to the panel and those at the rear are tied together by a third $3\frac{1}{2}$ -inch wide piece of aluminum 11 inches long. The over-all depth is 8 inches. The top and bottom shields are made of "do-it-yourself" perforated aluminum available at most hardware stores. These covers have bent-over edges fitting around the support frame and may be held in place with self-tapping screws, or 6-32 machine screws threaded into the supports.

C_2 is mounted on small ceramic cone insulators from the left-hand support. This capacitor must be insulated from the support, and is turned through an insulated coupling. C_1 is mounted directly on the right-hand supporting member. The coaxial connector and output terminals — the latter are standard binding-post assemblies — are mounted on the rear piece.

The multiband circuit coils are supported by the wiring connecting them to the capacitors and terminals. This method of support requires the use of heavy conductors (No. 14 or larger) and short leads. The coupling coils, which are mounted around the centers of the tuned-circuit coils, may be cemented to the latter. This will

for using an s.w.r. indicator such as the "Moni-match" shown in the chapter on measurements. The setup is as given in Fig. 13-37.

Connect the transmission line to one of the two pairs of terminals, apply power from the transmitter, and adjust C_1 and C_2 for minimum reflected-voltage indication on the s.w.r. bridge. The two controls will interlock to some extent, but after a few trials a good null should be

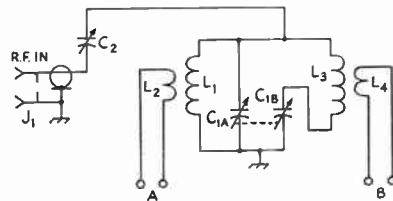

Fig. 13-36 — Circuit diagram of the multiband matching circuit.

C_1 — 300 $\mu\text{f.}$ per section, 0.045-inch spacing (Johnson 300FD20).

C_2 — 350 $\mu\text{f.}$ variable, 0.045 inch spacing (Johnson 350FD20).

J_1 — Coaxial connector, chassis-mounting type.

L_1 — 3.2 $\mu\text{h.}$; 11 turns No. 12, diameter 2 inches, length $2\frac{3}{4}$ inches (Air Dux 1604).

L_2 — 2.1 $\mu\text{h.}$; 6 turns No. 12, diameter $2\frac{1}{2}$ inches, length $1\frac{1}{2}$ inches (Air Dux 2004) concentric with L_1 .

L_3 — 1.1 $\mu\text{h.}$; $5\frac{1}{2}$ turns No. 12, diameter 2 inches, length $1\frac{1}{4}$ inches (Air Dux 1604).

L_4 — 1.6 $\mu\text{h.}$; 5 turns No. 12, diameter $2\frac{1}{2}$ inches, length $1\frac{1}{4}$ inches (Air Dux 2004) concentric with L_3 .

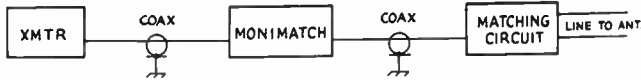

Fig. 13-37 — Adjustment setup using the “Monimatch.” This setup applies with any type of matching circuit designed to match a coaxial line from the transmitter.

secured. If the meter reading cannot be brought down to zero, try connecting the balanced line to the other pair of output terminals.

When the null is obtained the system is ready for use. With the “Monimatch,” the meter switch can then be thrown to the “forward”

position and the transmitter tuned for maximum output as shown by the “Monimatch” meter. Output adjustments should be made only at the transmitter, not at the matching circuit after it has once been adjusted for minimum reflected voltage.

Antennas

An *antenna system* can be considered to include the antenna proper (the portion that radiates the r.f. energy), the feed line, and any coupling devices used for transferring power from the transmitter to the line and from the line to the antenna. Some simple systems may omit the transmission line or one or both of the coupling devices. This chapter will describe the antenna proper, and in many cases will show popular types of lines, as well as line-to-antenna couplings where they are required. However, it should be kept in mind that *any* antenna proper can be used with *any* type of feedline if a suitable coupling is used between the antenna and the line. Changing the line does not change the type of antenna.

Selecting an Antenna

In selecting the type of antenna to use, the majority of amateurs are somewhat limited through space and structural limitations to simple antenna systems, except for v.h.f. operation where the small space requirements make the use of multielement beams readily possible. This chapter will consider antennas for frequencies as high as 30 Mc. — a later chapter will describe the popular types of v.h.f. antennas. However, even though the available space may be limited, it is well to consider the propagation characteristics of the frequency band or bands to be used, to insure that best possible use is made of the available facilities. The propagation characteristics of the amateur-band frequencies are described in Chapter Fifteen. In general, antenna construction and location become more critical and important on the higher frequencies. On the lower frequencies (3.5 and 7 Mc.) the vertical angle of radiation and the plane of polarization may be of relatively little importance; at 28 Mc. they may be all-important. On a given frequency, the type of antenna best suited for long-distance communication may not be as good for shorter-range work as a different type.

Definitions

The **polarization** of a straight-wire antenna is determined by its position with respect to the earth. Thus a vertical antenna radiates vertically-polarized waves, while a horizontal antenna radiates horizontally-polarized waves in a direction broadside to the wire and vertically-polarized waves at high vertical angles off the ends of the wire. The wave from

an antenna in a slanting position, or from the horizontal antenna in directions other than mentioned above, contains both horizontal and vertical components.

The **vertical angle of maximum radiation** of an antenna is determined by the free-space pattern of the antenna, its height above ground, and the nature of the ground. The angle is measured in a vertical plane with respect to a tangent to the earth at that point, and it will usually vary with the horizontal angle, except in the case of a simple vertical antenna. The **horizontal angle of maximum radiation** of an antenna is determined by the free-space pattern of the antenna.

The **impedance** of the antenna at any point is the ratio of the voltage to the current at that point. It is important in connection with feeding power to the antenna, since it constitutes the load to the line offered by the antenna. It can be either resistive or complex, depending upon whether or not the antenna is resonant.

The **field strength** produced by an antenna is proportional to the current flowing in it. When there are standing waves on an antenna, the parts of the wire carrying the higher current have the greater radiating effect. All resonant antennas have standing waves — only terminated types, like the terminated rhombic and terminated "V," have substantially uniform current along their lengths.

The ratio of power required to produce a given field strength with a "comparison" antenna to the power required to produce the same field strength with a specified type of antenna is called the **power gain** of the latter antenna. The field is measured in the optimum direction of the antenna under test. The comparison antenna is generally a half-wave antenna at the same height and having the same polarization as the antenna under consideration. Gain usually is expressed in decibels.

In unidirectional beams (antennas with most of the radiation in only one direction) the **front-to-back ratio** is the ratio of power radiated in the maximum direction to power radiated in the opposite direction. It is also a measure of the reduction in received signal when the beam direction is changed from that for maximum response to the opposite direction. Front-to-back ratio is usually expressed in decibels.

The **band width** of an antenna refers to the frequency range over which the gain and impedance are substantially constant.

Ground Effects

The radiation pattern of any antenna that is many wave lengths distant from the ground and all other objects is called the **free-space pattern** of that antenna. The free-space pattern of an antenna is almost impossible to obtain in practice, except in the v.h.f. and u.h.f. ranges. Below 30 Mc., the height of the antenna above ground is a major factor in determining the radiation pattern of the antenna.

When any antenna is near the ground the free-space pattern is modified by reflection of radiated waves from the ground, so that the actual pattern is the resultant of the free-space pattern and ground reflections. This resultant is dependent upon the height of the antenna, its position or orientation with respect to the surface of the ground, and the electrical characteristics of the ground. The effect of a perfectly-reflecting ground is such that the

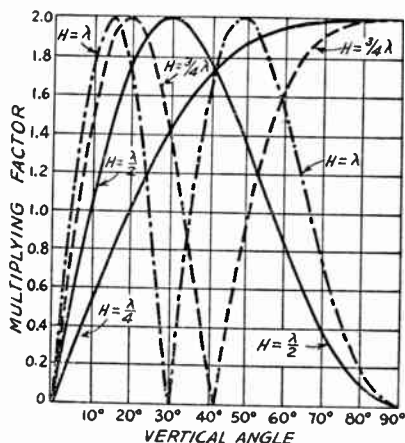

Fig. 14-1 — Effect of ground on radiation of horizontal antennas at vertical angles for four antenna heights. This chart is based on perfectly-conducting ground.

original free-space field strength may be multiplied by a factor which has a maximum value of 2, for complete reinforcement, and having all intermediate values to zero, for complete cancellation. These reflections only affect the radiation pattern in the vertical plane — that is, in directions upward from the earth's surface — and not in the horizontal plane, or the usual geographical directions.

Fig. 14-1 shows how the multiplying factor varies with the vertical angle for several representative heights for horizontal antennas. As the height is increased the angle at which complete reinforcement takes place is lowered, until for a height equal to one wave length it occurs at a vertical angle of 15 degrees. At still greater heights, not shown on the chart, the first maximum will occur at still smaller angles.

Radiation Angle

The vertical angle of maximum radiation is of primary importance, especially at the higher

frequencies. It is advantageous, therefore, to erect the antenna at a height that will take advantage of ground reflection in such a way as to reinforce the space radiation at the most desirable angle. Since low angles usually are most effective, this generally means that the antenna should be high — at least one-half wave length at 14 Mc., and preferably three-quarters or one wave length, and at least one wave length, and preferably higher, at 28 Mc. The physical height required for a given height in wave lengths decreases as the frequency is increased, so that good heights are not impracticable; a half wave length at 14 Mc. is only 35 feet, approximately, while the same height represents a full wave length at 28 Mc. At 7 Mc. and lower frequencies the higher radiation angles are effective, so that again a useful antenna height is not difficult of attainment. Heights between 35 and 70 feet are suitable for all bands, the higher figures being preferable.

Imperfect Ground

Fig. 14-1 is based on ground having perfect conductivity, whereas the actual earth is not a perfect conductor. The principal effect of actual ground is to make the curves inaccurate at the lowest angles; appreciable high-frequency radiation at angles smaller than a few degrees is practically impossible to obtain over horizontal ground. Above 15 degrees, however, the curves are accurate enough for all practical purposes, and may be taken as indicative of the result to be expected at angles between 5 and 15 degrees.

The effective ground plane — that is, the plane from which ground reflections can be considered to take place — seldom is the actual surface of the ground but is a few feet below it, depending upon the character of the soil.

Impedance

Waves that are reflected directly upward from the ground induce a current in the an-

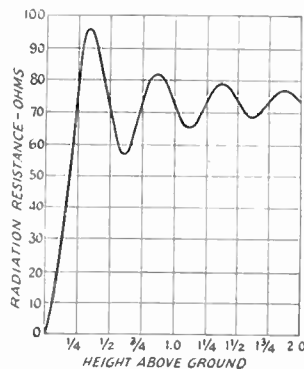

Fig. 14-2 — Theoretical curve of variation of radiation resistance for a half-wave horizontal antenna, as a function of height in wave length above perfectly-reflecting ground.

tenna in passing, and, depending on the antenna height, the phase relationship of this induced current to the original current may be such as either to increase or decrease the total current in the antenna. For the same power input to the antenna, an increase in current is equivalent to a decrease in impedance, and vice versa. Hence, the impedance of the antenna varies with height. The theoretical curve of variation of radiation resistance for a half-wave antenna above perfectly-reflecting ground is shown in Fig. 14-2. The impedance approaches the free-space value as the height becomes large, but at low heights may differ considerably from it.

Choice of Polarization

Polarization of the transmitting antenna is generally unimportant on frequencies between

3.5 and 30 Mc. However, the question of whether the antenna should be installed in a horizontal or vertical position deserves consideration for other reasons. A vertical half-wave or quarter-wave antenna will radiate equally well in all horizontal directions, so that it is substantially nondirectional, in the usual sense of the word. If installed horizontally, however, the antenna will tend to show directional effects, and will radiate best in the direction at right angles, or broadside, to the wire. The radiation in such a case will be least in the direction toward which the wire points.

The vertical angle of radiation also will be affected by the position of the antenna. If it were not for ground losses at high frequencies, the vertical half-wave antenna would be preferred because it would concentrate the radiation horizontally.

The Half-Wave Antenna

The fundamental form of antenna is a single wire whose length is approximately equal to half the transmitting wave length. It is the unit from which many more-complex forms of antennas are constructed. It is known as a dipole or Hertz antenna.

The length of a half-wave in space is:

$$\text{Length (feet)} = \frac{492}{\text{Freq. (Mc.)}} \quad (14-A)$$

The actual length of a half-wave antenna will not be exactly equal to the half-wave in space, but depends upon the thickness of the conductor in relation to the wave length as shown in Fig. 14-3, where *K* is a factor that must be multiplied by the half-wave length in free space to obtain the resonant antenna length. An additional shortening effect occurs with wire antennas supported by insulators at the ends because of the capacitance added to the system by the insulators (end effect). The following formula is sufficiently accurate for wire antennas at frequencies up to 30 Mc.:

$$\text{Length of half-wave antenna (feet)} = \frac{492 \times 0.95}{\text{Freq. (Mc.)}} = \frac{468}{\text{Freq. (Mc.)}} \quad (14-B)$$

Example: A half-wave antenna for 7150 kc. (7.15 Mc.) is $\frac{468}{7.15} = 65.45$ feet, or 65 feet 5 inches.

Above 30 Mc. the following formulas should be used, particularly for antennas constructed from rod or tubing. *K* is taken from Fig. 14-3.

$$\text{Length of half-wave antenna (feet)} = \frac{492 \times K}{\text{Freq. (Mc.)}} \quad (14-C)$$

$$\text{or length (inches)} = \frac{5905 \times K}{\text{Freq. (Mc.)}} \quad (14-D)$$

Example: Find the length of a half-wave length antenna at 29 Mc., if the antenna is made of 2-inch diameter tubing. At 29 Mc., a half-wave length in space is $\frac{492}{29} = 16.97$ feet, from Eq.

14-A. Ratio of half-wave length to conductor diameter (changing wave length to inches) is $\frac{16.97 \times 12}{2} = 101.8$. From Fig. 14-3, *K* = 0.963 for this ratio. The length of the antenna, from Eq. 14-C, is $\frac{492 \times 0.963}{29} = 16.34$ feet, or 16 feet 4 inches. The answer is obtained directly in inches by substitution in Eq. 14-D: $\frac{5905 \times 0.963}{29} = 196$ inches.

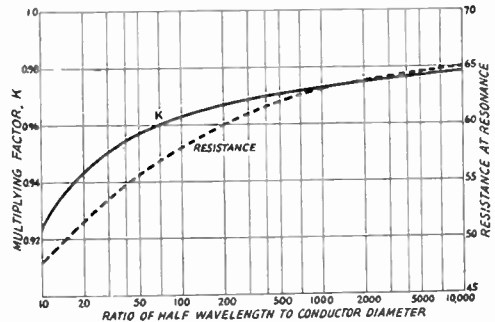

Fig. 14-3 — Effect of antenna diameter on length for half-wave resonance, shown as a multiplying factor, *K*, to be applied to the free-space half-wave length (Equation 14-A). The effect of conductor diameter on the impedance measured at the center also is shown.

Current and Voltage Distribution

When power is fed to a half-wave antenna, the current and voltage vary along its length. The current is maximum at the center and nearly zero at the ends, while the opposite is true of the r.f. voltage. The current does not actually reach zero at the current nodes, because of the end effect; similarly, the voltage is not zero at

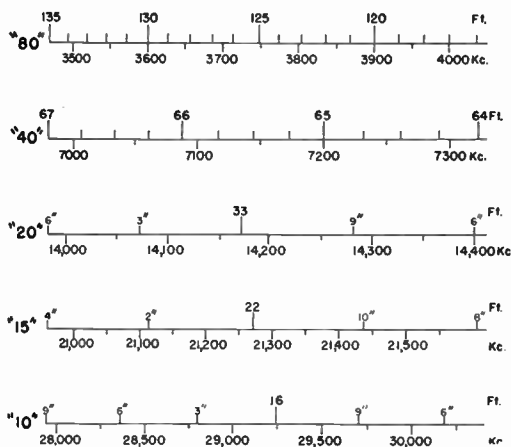

Fig. 14-4 — The above scales, based on Eq. 14-B, can be used to determine the length of a half-wave antenna of wire.

its node because of the resistance of the antenna, which consists of both the r.f. resistance of the wire (*ohmic resistance*) and the radiation resistance. The radiation resistance is an *equivalent* resistance, a convenient conception to indicate the radiation properties of an antenna. The radiation resistance is the equivalent resistance that would dissipate the power the antenna radiates, with a current flowing in it equal to the antenna current at a current loop (maximum). The ohmic resistance of a half-wave length antenna is ordinarily small enough, in comparison with the radiation resistance, to be neglected for all practical purposes.

Impedance

The radiation resistance of an infinitely-thin half-wave antenna in free space is 73 ohms, approximately. The value under practical conditions is commonly taken to be in the neighborhood of 70 ohms, although it varies with height as shown in Fig. 14-2. It increases toward the ends. The actual value at the ends will depend on a number of factors, such as the height, the physical construction, the insulators at the ends, and the position with respect to ground.

Conductor Size

The impedance of the antenna also depends upon the diameter of the conductor in relation to the wave length, as shown in Fig. 14-3. If the diameter of the conductor is made large, the capacitance per unit length increases and the inductance per unit length decreases. Since the radiation resistance is affected relatively little, the decreased *L/C* ratio causes the *Q* of the antenna to decrease, so that the resonance curve becomes less sharp. Hence, the antenna is capable of working over a wide frequency range. This effect is greater as the diameter is increased, and is a property of some importance at the very-high frequencies where the wave length is small.

Radiation Characteristics

The radiation from a dipole is not uniform in all directions but varies with the angle with respect to the axis of the wire. It is most intense in directions perpendicular to the wire and zero along the direction of the wire, with intermedi-

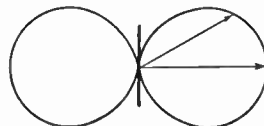

Fig. 14-5 — The free-space radiation pattern of a half-wave antenna. The antenna is shown in the vertical position. This is a cross-section of the solid pattern described by the figure when rotated on its vertical axis. The "doughnut" form of the solid pattern can be more easily visualized by imagining the drawing glued to a piece of cardboard, with a short length of wire fastened on it to represent the antenna. Twirling the wire will give a visual representation of the solid radiation pattern.

ate values at intermediate angles. This is shown by the sketch of Fig. 14-5, which represents the radiation pattern in free space. The relative intensity of radiation is proportional to the length of a line drawn from the center of the figure to the perimeter. If the antenna is vertical, as shown in the figure, then the field strength will be uniform in all horizontal directions; if the

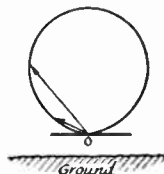

Fig. 14-6 — Illustrating the importance of vertical angle of radiation in determining antenna directional effects. Off the end, the radiation is greater at higher angles. Ground reflection is neglected in this drawing of the free-space pattern of a horizontal antenna.

antenna is horizontal, the relative field strength will depend upon the direction of the receiving point with respect to the direction of the antenna wire. The variation in radiation at various vertical angles from a half wave length horizontal antenna is indicated in Figs. 14-6 and 14-7.

● **FEEDING THE DIPOLE**

Direct Feed

If possible, it is advisable to locate the antenna at least a half wave length from the transmitter and use a transmission line to carry the power from the transmitter to the antenna. However, in many cases this is impossible, particularly on the lower frequencies, and direct feed must be used. Three examples of direct feed are shown in Fig. 14-8. In the method shown at A, *C*₁ and *C*₂ should be about 150 $\mu\mu\text{f.}$ each for the 3.5-Mc. band, 75 $\mu\mu\text{f.}$ each at 7 Mc., and proportionately smaller at the higher frequencies. The antenna coil connected between them should resonate to 3.5 Mc. with about 60 or 70 $\mu\mu\text{f.}$, for the 80-meter band, for 40 meters it should resonate with 30 or 35 $\mu\mu\text{f.}$, and so on. The circuit is adjusted by using loose coupling between the antenna coil and the transmitter tank coil and

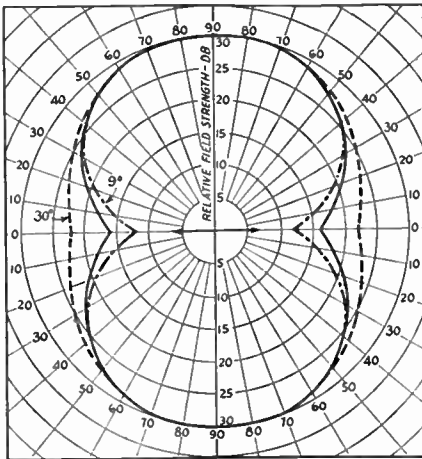

Fig. 14-7—Horizontal pattern of a horizontal half-wave antenna at three vertical radiation angles. The solid line is relative radiation at 15 degrees. Dotted lines show deviation from the 15-degree pattern for angles of 9 and 30 degrees. The patterns are useful for shape only, since the amplitude will depend upon the height of the antenna above ground and the vertical angle considered. The patterns for all three angles have been proportioned to the same scale, but this does not mean that the maximum amplitudes necessarily will be the same. The arrow indicates the direction of the horizontal antenna wire.

adjusting C_1 and C_2 until resonance is indicated by an increase in plate current. The coupling between the coils should then be increased until proper plate current is drawn. It may be necessary to re-resonate the transmitter tank circuit as the coupling is increased, but the change should be small.

The circuits in Fig. 14-8B and C are used when only one end of the antenna is accessible. In B, the coupling is adjusted by moving the

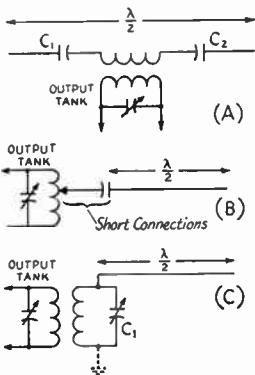

Fig. 14-8—Methods of directly exciting the half-wave antenna. A, current feed, series tuning; B, voltage feed, capacitive coupling; C, voltage feed, with inductively-coupled antenna tank. In A, the coupling circuit is not included in the effective electrical length of the antenna system proper. Link coupling can be used in A and C.

tap toward the “hot” or plate end of the tank coil—the capacitor C may be of any convenient value that will stand the voltage, and it doesn’t have to be variable. In the circuit at C, the antenna tuned circuit (C_1 and the antenna coil) should be similar to the transmitter tank circuit. The antenna tuned circuit is adjusted to resonance with the antenna connected but with loose coupling to the transmitter. Heavier loading of the tube is

then obtained by tightening the coupling between the antenna coil and the transmitter tank coil.

Of the three systems, that at A is preferable because it is a symmetrical system and generally results in less r.f. power “floating” around the shack. The system of B is undesirable because it provides practically no protection against the radiation of harmonics, and it should only be used in emergencies.

Transmission-Line Feed for Dipoles

Since the impedance at the center of a dipole is in the vicinity of 75 ohms, it offers a good match for 75-ohm two-wire transmission lines. Several types are available on the market, with different power-handling capabilities. They can be connected in the center of the antenna, across a small strain insulator to provide a convenient connection point. Coaxial line of 75 ohms impedance can also be used, but it is heavier and thus not as

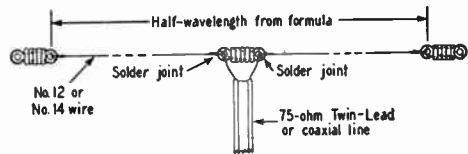

Fig. 14-9—Construction of a dipole fed with 75-ohm line. The length of the antenna is calculated from Equation 14-B or Fig. 14-4.

convenient. In either case, the transmission lines should be run away at right angles to the antenna for at least one-quarter wave length, if possible, to avoid current unbalance in the line caused by pick-up from the antenna. The antenna length is calculated from Equation 14-B, for a half wave length antenna. When No. 12 or No. 14 enameled wire is used for the antenna, as is generally the case, the length of the wire is the over-all length measured from the loop through the insulator at each end. This is illustrated in Fig. 14-9.

The use of 75-ohm line results in a “flat” line over most of any amateur band. However, by making the half-wave antenna in a special manner, called the two-wire or folded dipole, a good match is offered for a 300-ohm line. Such an antenna is shown in Fig. 14-10. The open-wire line shown in Fig. 14-10 is made of No. 12 or No. 14 enameled wire, separated by

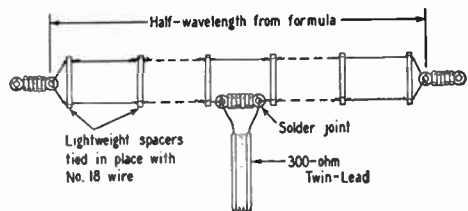

Fig. 14-10—The construction of an open-wire folded dipole fed with 300-ohm line. The length of the antenna is calculated from Equation 14-B or Fig. 14-4.

lightweight spacers of Lucite or other material (it doesn't have to be a *low-loss* insulating material), and the spacing can be on the order of from 4 to 8 inches, depending upon what is convenient and what the operating frequency is. At 14 Mc., 4-inch separation is satisfactory, and 8-inch spacing can be used at 3.5 Mc.

The half wave length antenna can also be made from the proper length of 300-ohm line, opened on one side in the center and connected to the feedline. After the wires have been soldered together, the joint can be strengthened by molding some of the excess insulating material (polyethylene) around the joint with a hot iron, or a suitable lightweight clamp of two pieces of Lucite can be devised.

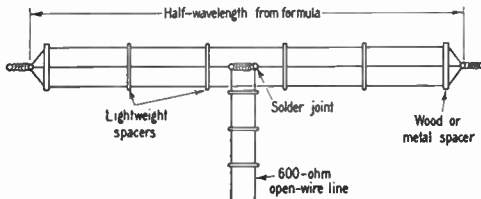

Fig. 14-11 — The construction of a 3-wire folded dipole is similar to that of the 2-wire folded dipole. The end spacers may have to be slightly stronger than the others because of the greater compression force on them. The length of the antenna is obtained from Equation 14-B or Fig. 14-4. A suitable line can be made from No. 14 wire spaced 5 inches, or from No. 12 wire spaced 6 inches.

Similar in some respects to the two-wire folded dipole, the three-wire folded dipole of Fig. 14-11 offers a good match for a 600-ohm line. It is favored by amateurs who prefer to use an open-wire line instead of the 300-ohm insular proper should all be of the same diameter.

Another method for offering a match to a 600-ohm open-wire line with a half-wave length antenna is shown in Fig. 14-12. The system is called a **delta match**. The line is "fanned" as it approaches the antenna, to have a gradually-increasing impedance that equals the antenna impedance at the point of connection. The dimensions are fairly critical, but careful measurement before installing the antenna and matching section is generally all that is necessary. The length of the antenna, *L*, is calcu-

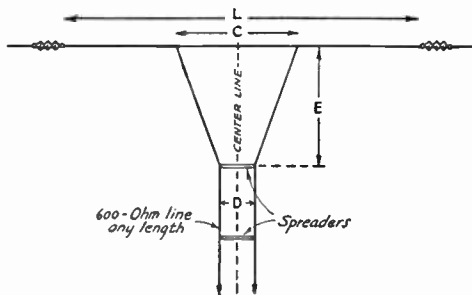

Fig. 14-12 — Delta-matched antenna system. The dimensions *C*, *D*, and *E* are found by formulas given in the text. It is important that the matching section, *E*, come straight away from the antenna without any bends.

lated from Equation 14-B or Fig. 14-4. The length of section *C* is computed from:

$$C \text{ (feet)} = \frac{118}{\text{Freq. (Mc.)}} \quad (14-E)$$

The feeder clearance, *E*, is found from

$$E \text{ (feet)} = \frac{148}{\text{Freq. (Mc.)}} \quad (14-F)$$

Example: For a frequency of 7.1 Mc., the length

$$L = \frac{468}{7.1} = 65.91 \text{ feet, or } 65 \text{ feet } 11 \text{ inches.}$$

$$C = \frac{118}{7.1} = 16.62 \text{ feet, or } 16 \text{ feet } 7 \text{ inches.}$$

$$E = \frac{148}{7.1} = 20.84 \text{ feet, or } 20 \text{ feet } 10 \text{ inches.}$$

Since the equations hold only for 600-ohm line, it is important that the line be close to this value. This requires 5-inch spaced No. 14 wire, 6-inch spaced No. 12 wire, or 3¾-inch spaced No. 16 wire.

If a half-wave length antenna is fed at the center with other than 75-ohm line, or if a two-wire dipole is fed with other than 300-ohm line, standing waves will appear on the line and coupling to the transmitter may become awkward for some line lengths, as described in the preceding chapter. However, in many cases it is not convenient to feed the half-wave antenna with the correct line (as is the case where multiband operation of the same antenna is desired), and sometimes it is not convenient to feed the antenna at the center. Where multiband operation is desired (to be discussed later) or when the antenna must be

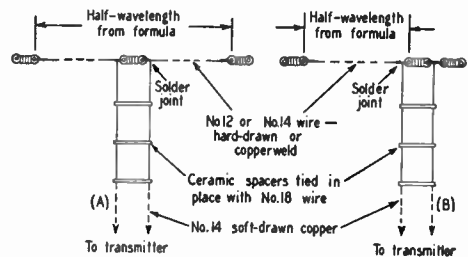

Fig. 14-13 — The half-wave antenna can be fed at the center or at the end with an open-wire line. The antenna length is obtained from Equation 14-B or Fig. 14-4.

fed at one end by a transmission line, an open-wire line of from 450 to 600 ohms impedance is generally used. The impedance at the end of a half-wave length antenna is in the vicinity of several thousand ohms, and hence a standing-wave ratio of 4 or 5 is not unusual when the line is connected to the end of the antenna. It is advisable, therefore, to keep the losses in the line as low as possible. This requires the use of ceramic or Micalex feeder spacers, if any appreciable power is used. For low-power installations in dry climates, dry wood spacers boiled in paraffin are satisfactory. Mechanical details of half-wave length antennas fed with open-wire lines are given in Fig. 14-13. If the power is below 100 watts or so, 300-ohm Twin-Lead can be used in place of the open line.

Long-Wire Antennas

An antenna will be resonant so long as an integral number of standing waves of current and voltage can exist along its length; in other words, so long as its length is some integral multiple of a half-wave length. When the antenna is more than a half-wave long it usually is called a long-wire antenna, or a harmonic antenna.

Current and Voltage Distribution

Fig. 14-14 shows the current and voltage distribution along a wire operating at its fundamental frequency (where its length is

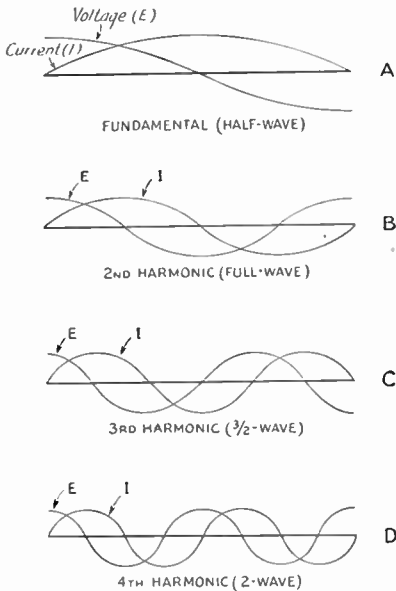

Fig. 14-14 — Standing-wave current and voltage distribution along an antenna when it is operated at various harmonics of its fundamental resonant frequency.

equal to a half-wave length) and at its second, third and fourth harmonics. For example, if the fundamental frequency of the antenna is 7 Mc., the current and voltage distribution will be as shown at A. The same antenna excited at 14 Mc. would have current and voltage distribution as shown at B. At 21 Mc., the third harmonic of 7 Mc., the current and voltage distribution would be as in C; and at 28 Mc., the fourth harmonic, as in D. The number of the harmonic is the number of half waves contained in the antenna at the particular operating frequency.

The polarity of current or voltage in each standing wave is opposite to that in the adjacent standing waves. This is shown in the figure by drawing the current and voltage curves successively above and below the antenna (taken as a zero reference line), to indicate that the polarity reverses when the current or voltage goes through zero. Currents

flowing in the same direction are *in phase*; in opposite directions, *out of phase*.

It is evident that one antenna may be used for harmonically-related frequencies, such as the various amateur bands. The long-wire or harmonic antenna is the basis of multiband operation with one antenna.

Physical Lengths

The length of a long-wire antenna is not an exact multiple of that of a half-wave antenna because the end effects operate only on the end sections of the antenna; in other parts of the wire these effects are absent, and the wire length is approximately that of an equivalent portion of the wave in space. The formula for the length of a long-wire antenna, therefore, is

$$\text{Length (feet)} = \frac{492 (N - 0.05)}{\text{Freq. (Mc.)}} \quad 14-G$$

where *N* is the number of *half-waves* on the antenna.

Example: An antenna 4 half-waves long at 14.2 Mc. would be $\frac{492 (4 - 0.05)}{14.2} = \frac{492 \times 3.95}{14.2} = 136.7$ feet, or 136 feet 8 inches.

It is apparent that an antenna cut as a half-wave for a given frequency will be slightly off resonance at exactly twice that frequency (the second harmonic), because of the decreased influence of the end effects when the antenna is more than one-half wave length long. The effect is not very important, except for a possible unbalance in the feeder system and consequent

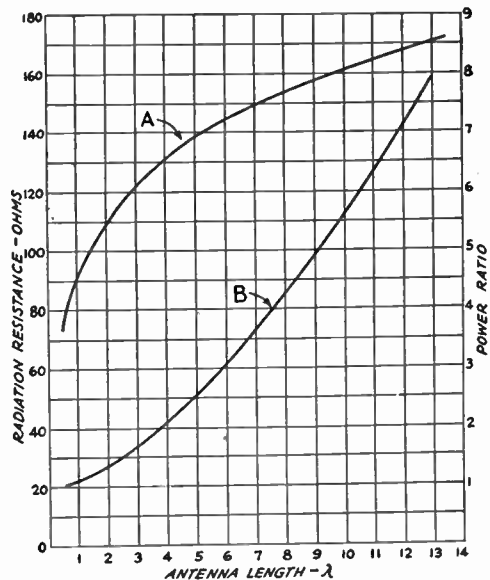

Fig. 14-15 — Curve A shows variation in radiation resistance with antenna length. Curve B shows power in lobes of maximum radiation for long-wire antennas as a ratio to the maximum radiation for a half-wave antenna.

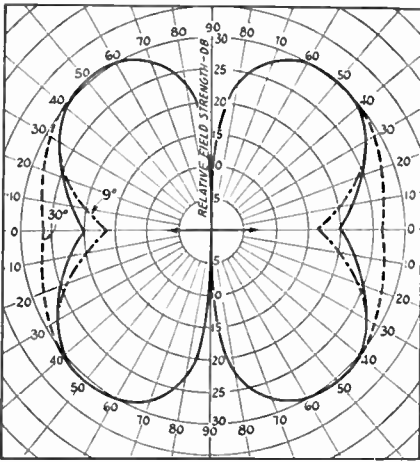

Fig. 14-16 — Horizontal patterns of radiation from a full-wave antenna. The solid line shows the pattern for a vertical angle of 15 degrees; dotted lines show deviation from the 15-degree pattern at 9 and 30 degrees. All three patterns are drawn to the same relative scale; actual amplitudes will depend upon the height of the antenna.

radiation from the feedline. If the antenna is fed in the exact center, no unbalance will occur at any frequency, but end-fed systems will show an unbalance in all but one frequency, the frequency for which the antenna is cut.

Impedance and Power Gain

The radiation resistance as measured at a current loop becomes higher as the antenna length is increased. Also, a long-wire antenna radiates more power in its most favorable direction than does a half-wave antenna in its most favorable direction. This power gain is secured at the expense of radiation in other

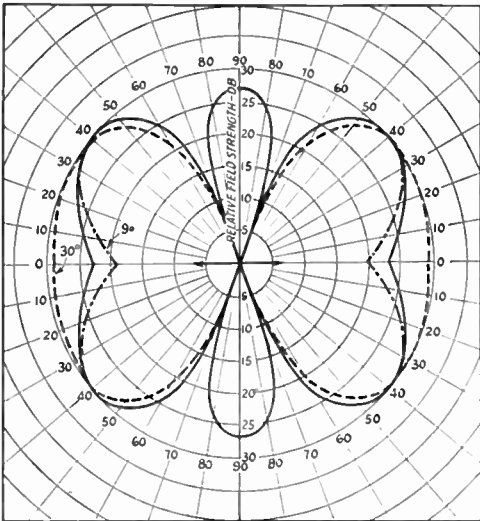

Fig. 14-17 — Horizontal patterns of radiation from an antenna three half-waves long. The solid line shows the pattern for a vertical angle of 15 degrees; dotted lines show deviation from the 15-degree pattern at 9 and 30 degrees. Minor lobes coincide for all three angles

directions. Fig. 14-15 shows how the radiation resistance and the power in the lobe of maximum radiation vary with the antenna length.

Directional Characteristics

As the wire is made longer in terms of the number of half wave lengths, the directional effects change. Instead of the "doughnut" pattern of the half-wave antenna, the directional characteristic splits up into "lobes" which make various angles with the wire. In general, as the length of the wire is increased the direction in which maximum radiation occurs tends to approach the line of the antenna itself.

Directional characteristics for antennas one wave length, three half-wave lengths, and two wave lengths long are given in Figs. 14-16, 14-17 and 14-18, for three vertical angles of radiation. Note that, as the wire length in-

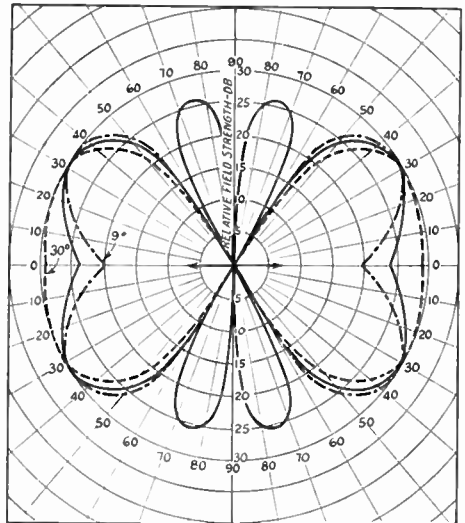

Fig. 14-18 — Horizontal patterns of radiation from an antenna two wavelengths long. The solid line shows the pattern for a vertical angle of 15 degrees; dotted lines show deviation from the 15-degree pattern at 9 and 30 degrees. The minor lobes coincide for all three angles.

creases, the radiation along the line of the antenna becomes more pronounced. Still longer antennas can be considered to have practically "end-on" directional characteristics, even at the lower radiation angles.

Methods of Feeding

In a long-wire antenna, the currents in adjacent half-wave sections must be out of phase, as shown in Fig. 14-14. The feeder system must not upset this phase relationship. This requirement is met by feeding the antenna at either end or at any current loop. A two-wire feeder cannot be inserted at a current node, however, because this invariably brings the currents in two adjacent half-wave sections in phase. A long wire is usually made a half wave length at the lowest frequency and fed at the end.

Multiband Antennas

As suggested in the preceding section, the same antenna may be used for several bands by operating it on harmonics. When this is done it is necessary to use tuned feeders, since the impedance matching for nonresonant feeder operation can be accomplished only at one frequency unless means are provided for changing the length of a matching section and shifting the point at which the feeder is attached to it.

A half-wave antenna that is center-fed by a solid-dielectric line is useless for even harmonic operation; on all even harmonics there is a voltage maximum occurring right at the feed point, and the resultant impedance mismatch causes a large standing-wave ratio and consequently high losses arise in the solid dielectric. It is wise not to attempt to use on its even harmonics a half-wave antenna center-fed with coaxial cable. On odd harmonics, as between 7 and 21 Mc., a current loop will appear in the center of the antenna and a fair match can be obtained. High-impedance solid-dielectric lines such as 300-ohm Twin-Lead may be used, provided the power does not exceed a few hundred watts.

When the same antenna is used for work in several bands, it must be realized that the directional characteristic will vary with the band in use.

Simple Systems

The most practical simple multiband antenna is one that is a half wave length long at the lowest frequency and is fed either at the center or one end with an open-wire line. Although the standing wave ratio on the feedline will not approach 1.0 on any band, if the losses in the line are low the system will be efficient. From the standpoint of reduced feedline radiation, a center-fed system is superior to one that is end-fed, but the end-fed arrangement is often more convenient and should not be ignored as a possibility. The center-fed antenna will not have the same radiation pattern as an end-fed one of the same length, except on frequencies where the length of the antenna is a half wave length. The end-fed antenna acts like a long-wire antenna on all bands (for which it is longer than a half wave length), but the center-fed one acts like two antennas of half that length fed in phase. For example, if a full-wave length antenna is fed at one end, it will have a radiation pattern as shown in Fig. 14-16, but if it is fed in the center the pattern will be somewhat similar to Fig. 14-7, with the maximum radiation broadside to the wire. Either antenna is a good radiator, but if the radiation pattern is a factor, the point of feed must be considered.

Since multiband operation of an antenna does not permit matching of the feedline, some attention must be paid to the length of the feedline if convenient transmitter-coupling ar-

rangements are to be obtained. Table 14-I gives some suggested antenna and feeder lengths for multiband operation. In general, the length of the feedline can be other than that indicated, but the type of coupling circuit may change.

Open-wire line feed is recommended for an antenna of this type, since the losses will run too high in solid-dielectric line. For low-power applications up to a few hundred watts, open-wire TV line is convenient and satisfactory to use. However, for high-power installations up to the kilowatt limit, an open-wire line with No. 14 or No. 12 conductors should be used. This must be built by the amateur, using soft-drawn enameled wire and ceramic or other suitable spacers.

Antennas for Restricted Space

If the space available for the antenna is not large enough to accommodate the length necessary for a half wave at the lowest frequency to be used, quite satisfactory operation can be secured by using a shorter antenna and making up the missing length in the feeder system. The antenna itself may be as short as a quarter wave length and will radiate fairly well, although of course it will not be as effective as one a half wave long. Nevertheless, such a system is useful where operation on the desired band otherwise would be impossible.

Tuned feeders are a practical necessity with such an antenna system, and a center-fed antenna will give best all-around performance.

TABLE 14-I
Multiband Tuned-Line-Fed Antennas

Antenna Length (Ft.)	Feeder Length (Ft.)	Band	Type of Coupling Circuit
<i>With end feed:</i>			
135	45	3.5 - 21 28	Series Parallel
67	45	7 - 21 28	Series Parallel
<i>With center feed:</i>			
135	42	3.5 - 21 28	Parallel Series
135	77½	3.5 - 28	Parallel
67	42½	3.5 7 - 28	Series Parallel
67	65½	3.5, 14, 28 7, 21	Parallel Series

Antenna lengths for end-fed antennas are approximate and should be cut to formula length at favorite operating frequency.

Where parallel tuning is specified, it will be necessary in some cases to tap in from the ends of the coil for proper loading — see Chapter 13 for examples of antenna couplers.

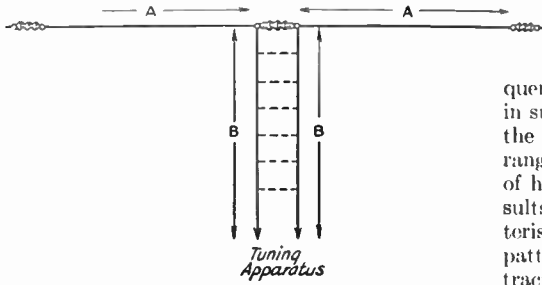

Fig 14-19—Practical arrangement of a shortened antenna. When the total length, $A + B + B + A$, is the same as the antenna length plus twice the feeder length of the center-fed antennas of Table 14-I, the same type of coupling circuit will be used. When the feeder length or antenna length, or both, makes the sum different, the type of coupling circuit may be different but the effectiveness of the antenna is not changed, unless $A + A$ is less than a quarter wave length.

With end feed the feeder currents become badly unbalanced.

With center feed, practically any convenient length of antenna can be used. If the total length of antenna plus twice feed line is the same as in Table 14-I, the type of tuning will be the same as stated. This is illustrated in Fig. 14-19. If the total length is not the same, different tuning conditions can be expected on some bands. This should not be interpreted as a fault in the antenna, and any tuning system (series or parallel) that works well without any trace of heating is quite satisfactory. Heating will sometimes result when the taps with parallel tuning are made too close to the center of the coil—it can often be corrected by using less total inductance.

Bent Antennas

Since the field strength at a distance is proportional to the current in the antenna, the high-current part of a half-wave antenna (the center quarter wave, approximately) does most of the radiating. Advantage can be taken of this fact when the space available does not permit building an antenna a half-wave long. In this case the ends may be bent, either horizontally or vertically, so that the total length equals a half wave, even though the straightaway horizontal length may be as short as a quarter wave. The operation is illustrated in Fig. 14-20. Such an antenna will be a somewhat better radiator than a quarter wave length antenna on the lowest fre-

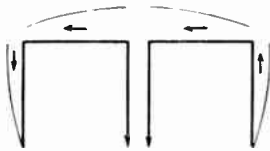

Fig. 14-20—Folded arrangement for shortened antennas. The total length is a half-wave, not including the feeders. The horizontal part is made as long as convenient and the ends dropped down to make up the required length. The ends may be bent back on themselves like feeders to cancel radiation partially. The horizontal section should be at least a quarter wave long.

quency, but is not so desirable for multi-band operation because the ends play an increasingly important part as the frequency is raised. The performance of the system in such a case is difficult to predict, especially if the ends are vertical (the most convenient arrangement) because of the complex combination of horizontal and vertical polarization which results as well as the dissimilar directional characteristics. However, the fact that the radiation pattern is incapable of prediction does not detract from the general usefulness of the antenna. For one-band operation, end-loading with coils (5 feet or so in from each end) is practical and efficient.

“Window” or Off-Center-Fed Antenna

A multiband antenna that enjoyed considerable popularity in the 1930s is the “off-center feed” or “Window,” named after the amateur who wrote a comprehensive article about it. Shown in Fig. 14-21A, it consists of a half wave length antenna on the lowest-frequency band to be used, with a *single-wire* feeder connected 14% off center. The antenna will operate satisfactorily

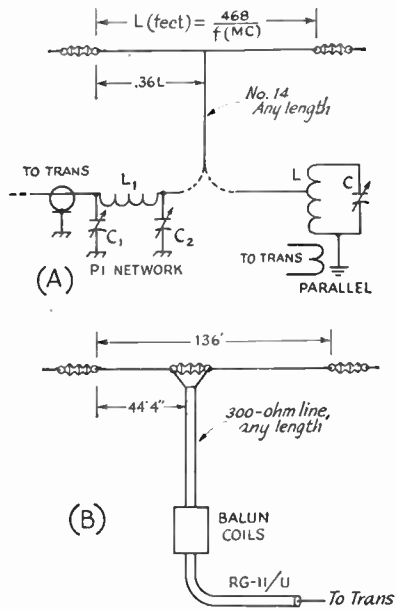

Fig. 14-21—Two versions of the off-center-fed antenna.

(A) Single-wire feed shows approximately 600 ohms impedance to ground and is most conveniently coupled to the transmitter as shown. The pi-network coupling will require more capacity at C_1 than at C_2 . L_1 is best found by experiment—an inductance of about the same size as that used in the output stage is a good starting point. The parallel-tuned circuit will be a tuned circuit that resonates at the operating frequency with L and C close to those used in the output stage. The tap is found by experiment, and it should be as near the top of L as it can and still give good loading of the transmitter.

(B) Two-wire off-center feed uses 300-ohm TV line. Although the 300-ohm line can be coupled directly to some transmitters, it is common practice to step down the impedance level to 75 ohms through a pair of “balun” coils.

on the even-harmonic frequencies, and thus a single antenna can be made to serve on the 80-, 40-, 20-, and 10-meter bands. The single-wire feeder shows an impedance of approximately 600 ohms to ground, and consequently the antenna coupling system must be capable of matching this value to the transmitter. A tapped parallel-tuned circuit or a properly-proportioned pi-network coupler is generally used. Where TVI is a problem, the antenna coupler is required, so that a low-pass filter can be used in the connecting link of coaxial line.

Although theoretically the feed line can be of any length, some lengths will tend to give trouble with "too much r.f. in the shack," with the consequence that r.f. sparks can be drawn from the transmitter's metal cabinet and/or v.f.o. notes will develop serious modulation. If such is found to be the case, the feeder length should be changed.

A newer version of the off-center-feed antenna uses 300-ohm TV Twin-Lead to feed the antenna, as shown in Fig. 14-21B. It is claimed that the antenna offers a good match for the 300-ohm line on four bands and, although this is more wishful thinking than actual truth, the system is widely used and does work satisfactorily. It is subject to the same feed line length and "r.f.-in-the-shack" troubles that the single-wire version enjoys. However, in this case a pair of "balun" coils can be used to step down the impedance level to 75 ohms and at the same time alleviate some of the feed line troubles. This antenna system is popular among amateurs using multiband transmitters with pi-network-tuned output stages.

With either of the off-center-fed antenna systems, the feed line should run away from the antenna at right angles for as great a distance as possible before bending. No sharp bends should be allowed anywhere in the line.

Multiband Operation with Coaxial Line Feed

The proper use of coaxial line requires that the standing-wave ratio be held to a low value, preferably below 2:1. Since the impedance of an ordi-

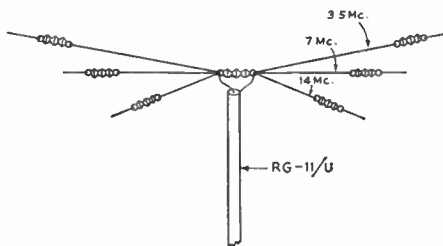

Fig. 14-22 — An effective "all-band" antenna fed with a single length of coaxial line can be constructed by joining several half wave length antennas at their centers and feeding them at the common point. In the example above, a low s.w.r. will be obtained on 80, 40, 20 and 15 meters. (The 7-Mc. antenna also works at 21 Mc.) If a 28-Mc. antenna were added, 10-meter operation could also be included.

The antenna lengths can be computed from formula 14-B. The shorter antennas can be suspended a foot or two below the longest one,

and the antenna changes widely from band to band, it is not possible to feed a simple antenna with coaxial line and use it on a number of bands without tricks of some kind. The single exception to this is the use of 75-ohm coaxial line to feed a 7-Mc. half-wave antenna, as in Fig. 14-19; this antenna can also be used on 21 Mc. and the s.w.r. in the line will not run too high.

One approach to a solution is the use of parallel-tuned circuits installed in the antenna at the right points to "divorce" the remainder of the antenna from the center section (part fed by coaxial line) as the transmitter is changed to a higher-frequency band. The support and adjustment of these tuned circuits presents a problem, but the method has been used. The same principle has also been applied to a vertical antenna. (See Pemberton, *QST*, December 1955, for an example of both horizontal and vertical antennas using this principle. For information on the construction of the traps, see Greenberg, "Simple Trap Construction for the Multiband Antenna," *QST*, Oct., 1956.)

The principle of the "divorcing" circuits is utilized in a commercial "all-band" vertical antenna, and a 5-band kit for horizontal antennas using the method is also available commercially.

The divorcing circuits are also used in several commercial multiband beams for the 14-, 21- and 28-Mc. bands. The design and adjustment of these circuits is difficult without suitable equipment and assistance, and the pre-tuned commercial versions are recommended to anyone who lacks the time and equipment for the experimental work.

One multiband antenna system that can be used by anyone without much trouble is shown in Fig. 14-22. Here separate dipoles are connected to one feedline. The 7-Mc. dipole also serves on 21 Mc. A low s.w.r. will appear on the feedline in each band if the dipoles are of the proper length. The antenna system can be built by suspending one set of elements from the one above, using insulator-terminated wood spreaders about one foot long. An alternative is to let one antenna droop several feet under the other, bring ropes attached to the insulators back to a common support point. It has been found that a separation of only an inch or two between dipoles is satisfactory. By using a length of the Twin-Lead used for folded dipoles (one Copperweld conductor and one soft-drawn), the strong wire can be used for the low-frequency dipole. The soft-drawn wire is then used on a higher band, supported by the solid dielectric.

Another approach to multiband operation with coaxial line feed is the use of a vertical antenna (a maximum length of 0.6 wave length at the highest frequency band) and the use at the base of suitable matching sections for each band. The matching sections can be housed in a weather-proof box and changed manually or by stepping relays; their form will vary from parallel-tuned circuits to L sections. (See McCoy, *QST*, December, 1955, for a description of the L-section coupler.)

Vertical Antennas

A vertical quarter wave length antenna is often used in the low-frequency amateur bands to obtain low-angle radiation. It is also used when there isn't enough room for the supports for a

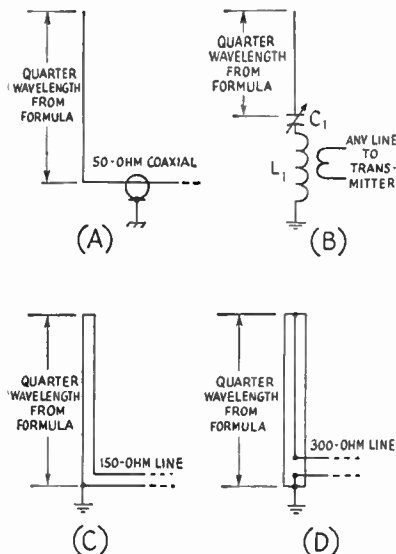

Fig. 14-23 — A quarter wave length antenna can be fed directly with 50-ohm coaxial line (A) with a low standing-wave ratio, or a coupling network can be used (B) that will permit a line of any impedance to be used. In (B), L_1 and C_1 should resonate to the operating frequency, and L_1 should be larger than is normally used in a plate tank circuit at the same frequency.

By using multiwire antennas, the quarter-wave vertical can be fed with (C) 150- or (D) 300-ohm line.

horizontal antenna. For maximum effectiveness it should be located free of nearby objects and it should be operated in conjunction with a good ground system, but it is still worth trying where these ideal conditions cannot be obtained.

Four typical examples and suggested methods for feeding a vertical antenna are shown in Fig. 14-23. The antenna may be wire or tubing supported by wood or insulated guy wires. When tubing is used for the antenna, or when guy wires (broken up by insulators) are used to reinforce the structure, the length given by the formula is likely to be long by a few per cent. A check of the standing-wave ratio on the line will indicate the frequency at which the s.w.r. is minimum, and the antenna length can be adjusted accordingly.

A good ground connection is necessary for the most effective operation of a vertical antenna (other than the ground-plane type). In some cases a short connection to the cold-water system of the house will be adequate. But maximum performance usually demands a separate ground system. A single 4- to 6-foot ground rod driven into the earth at the base of the antenna is usually not sufficient, unless the soil has exceptional conductivity. A minimum ground system that

can be depended upon is 6 to 12 quarter wave length radials laid out as the spokes of a wheel from the base of the antenna. These radials can be made of heavy aluminum wire, of the type used for grounding TV antennas, buried at least 6 inches in the ground. This is normally done by slitting the earth with a spade and pushing the wire into the slot, after which the earth can be tamped down.

The examples shown in Fig. 14-23 all require an antenna insulated from the ground, to provide for the feed point. A grounded tower or pipe can be used as a radiator by employing "shunt feed," which consists of tapping the inner conductor of the coaxial-line feed up on the tower until the best match is obtained, in much the same manner as the "gamma match" (described later) is used on a horizontal element. If the antenna is not an electrical quarter wave length long, it is necessary to tune out the reactance by adding capacity or inductance between the coaxial line and the shunting conductor. A metal tower supporting a TV antenna or rotary beam can be shunt-fed only if all of the wires and leads from the supported antenna run down the center of the tower and underground away from the tower.

● THE GROUND-PLANE ANTENNA

A ground-plane antenna is a vertical quarter wave length antenna using an artificial metallic ground, usually consisting of four rods or wires

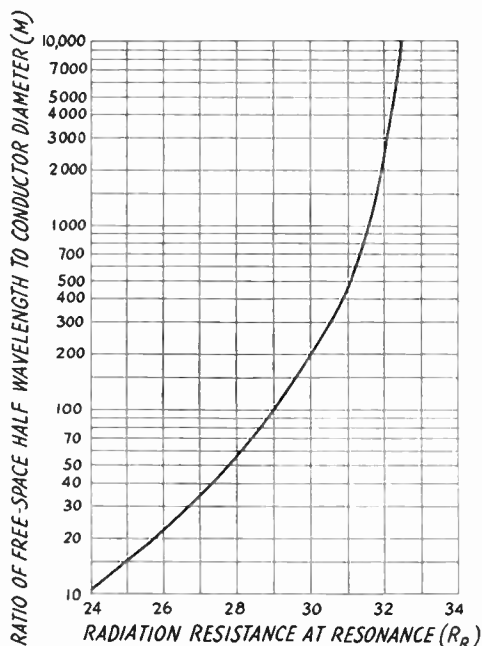
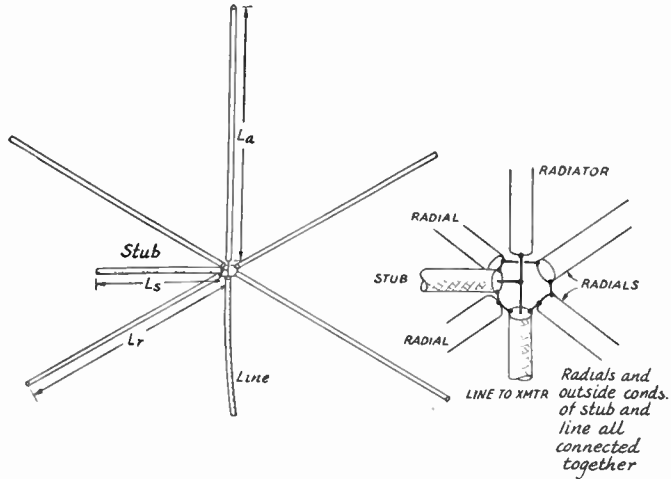

Fig. 14-24 — Radiation resistance of a quarter-wave antenna (with ground plane or grounded) as a function of M . The values apply only when the antenna is of the resonant length.

Fig. 14-25 — The ground-plane antenna with shunt matching. The antenna length, L_a , matching stub length, L_s , and radial length, L_r , are determined as described in the text, for matching a transmission line of given characteristic impedance. As shown in the insert, the radials and the outside conductors of the stub and line are all connected together.



perpendicular to the antenna and extending radially from its base. Unlike the quarter wave length vertical antennas without an artificial ground, the ground-plane antenna will give low-angle radiation regardless of the height above actual ground. However, to be a true ground-plane antenna, the plane of the radials should be at least a quarter wave length above ground. Despite this one limitation, the antenna is useful for DX work in any band below 30 Mc.

The vertical portion of the ground-plane antenna can be made of self-supported aluminum tubing, or a top-supported wire, depending upon the necessary length and the available supports. The radials are also made of tubing or heavy wire, depending upon the available supports and necessary lengths. They need not be exactly symmetrical about the base of the vertical portion.

The radiation resistance of a ground-plane antenna varies with the diameter of the vertical element, as shown in Fig. 14-24. Since the radiation resistance is usually in the vicinity of 30 to 32 ohms, the antenna can be fed with 75-ohm coaxial line if a quarter wave length matching section of 50-ohm coaxial line is used between the line and the antenna. (See Chapter Thirteen, "Quarter-Wave Transformers.")

For multiband operation, a ground-plane antenna can be fed with tuned open-wire line.

It is also possible to feed the ground-plane antenna with coaxial line and a "shunt" matching section, as shown in Fig. 14-25. The various values required for proper matching will depend on the particular type of line used, as well as on the radiation resistance, resonant length, and reactance per unit length of the antenna. The necessary information for design purposes is given in Figs. 14-24, 14-26 and 14-27.

Determining the antenna dimensions can be reduced to a series of steps, as follows:

First determine M , the ratio of a free-space half wave length to the conductor diameter. The following formula may be used:

$$M = \frac{5906}{FD}$$

where F = frequency in megacycles,
 D = conductor diameter in inches.

Using this value of M , read the length factor (K_a) from Fig. 14-26, the reactance change per 1 per cent change in length (K_x) from Fig. 14-27, and the radiation resistance (R_r) from Fig. 14-24.

Since the antenna is to be shortened, these values must be modified appropriately. The actual radiation resistance, after the antenna is properly shortened, will be

$$R_o = R_r - \frac{Z_1}{4R_r} \text{ ohms,}$$

where R_o = radiation resistance after shortening,
 Z_1 = characteristic impedance of transmission line to be matched.

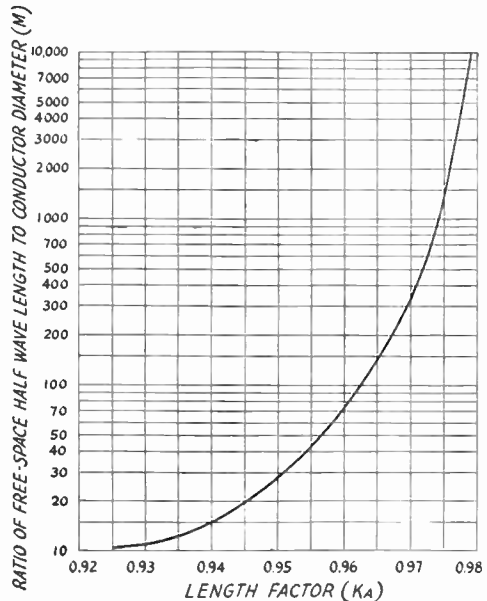

Fig. 14-26 — The antenna-length factor as a function of the ratio of a free-space half wave length to the conductor diameter. The length factor multiplied by a free-space quarter wave length is the length of a quarter-wave radiator resonant at the selected frequency.

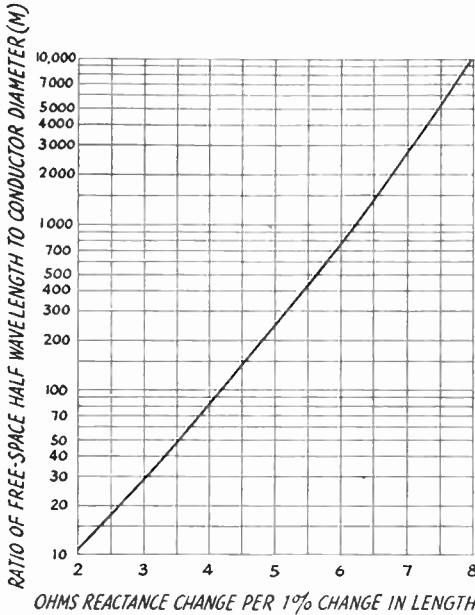

Fig. 14-27 — Reactance change with antenna length as a function of M , for quarter-wave ground-plane (or grounded) antennas. If the antenna is longer than the resonant length the reactance is inductive; if shorter, the reactance is capacitive. The curve is accurate for lengths within 10 per cent of the resonant length. Multiply reactance values by 2 for half-wave antennas.

The proper value of capacitive reactance in the shortened antenna is given by

$$X_a = SR_o \text{ ohms,}$$

where X_a = capacitive reactance of antenna, and

$$S = \sqrt{\frac{Z_1}{R_o} - 1}$$

The antenna length that gives the proper capacitive reactance is

$$L_a = \frac{2953K_aK_b}{f'} \text{ inches,}$$

where L_a = required antenna length, and

$$K_b = 1 - \frac{X_a}{100K_x}$$

The only remaining steps are to find the dimensions of the inductive stub and the length of the radial ground-plane rods.

The required stub reactance is given by

$$X_s = \frac{Z_1}{S} \text{ ohms,}$$

where X_s = inductive reactance of stub.

The length of the shorted stub is

$$L_s = \frac{32.81L}{f'} \text{ inches,}$$

where L_s = stub length,

V = velocity factor of line used in stub,

L = length of stub in electrical degrees having required X_s .

L is equal to the angle whose tangent is X_s/Z_s , where Z_s is the characteristic impedance of the stub.

The length of each radial is given by

$$L_r = \frac{2953K_a}{f'} \text{ inches,}$$

the length being measured from the center line of the radiator to the tip of the radial.

If the radials have a different diameter than the radiator (a common practice) the M and K_a for radials and antenna must be considered separately. The preceding formulas apply when the radials are horizontal, although the antenna can be built with "drooping" radials.

Example: Assume a ground-plane antenna to be constructed with a vertical radiator of 2-inch diameter tubing and radials of No. 10 (0.10-inch diam.) wire, for a frequency of 7.1 Mc. and to be matched to 72-ohm RG-11/U coaxial line by using a stub of the same material.

$$f = 7.1 \text{ Mc., } D = 2 \text{ inches, } Z_1 = Z_s = 72 \text{ ohms, } V = 0.66, M = 5906 \div (7.1 \times 2) = 416.$$

From Figs. 14-26, 14-27 and 14-24, it is found that

$$K_a = 0.971, K_x = 3.5, R_r = 30.9.$$

From the formula,

$$R_o = 30.9 - \frac{72}{4 \times 30.9} = 30.3 \text{ ohms}$$

and the factor

$$S = \sqrt{\frac{72}{30.3} - 1} = 1.175$$

Hence $X_a = 1.175 \times 30.3 = 35.65$

$$\text{Also, } K_b = 1 - \frac{35.65}{100 \times 3.5} = 0.935$$

Thus the antenna length,

$$L_a = \frac{2953 \times 0.971 \times 0.935}{7.1} = 377 \text{ inches} = 31 \text{ feet } 5 \text{ inches}$$

To find the stub dimensions,

$$X_s = \frac{72}{1.175} = 61.3$$

L is the angle whose tangent is $61.3 \div 72 = 0.852$, and from a table of tangents is found to be 40.4 degrees

$$\text{Then } L_s = \frac{32.8 \times 0.66 \times 40.4}{7.1} = 123 \text{ inches} = 10 \text{ feet } 3 \text{ inches,}$$

For the radials,

$$M = 5906 \div (7.1 \times 0.1) = 8340, K_a = 0.9785.$$

$$\text{Hence } L_r = \frac{2953 \times 0.9785}{7.1} = 407 \text{ inches} = 33 \text{ feet } 11 \text{ inches.}$$

Antennas for 160 Meters

Results on 1.8 Mc. will depend to a large extent on the antenna system and the time of day or night. Almost any random long wire that can be tuned to resonance will work during the night but it will generally be found very ineffective during the day. A vertical antenna — or rather an antenna from which the radiation is predominantly vertically po-

larized — is probably the best for 1.8-Mc. operation. A horizontal antenna (horizontally-polarized radiation) will give better results during the night than the day. The vertically-polarized radiator gives a strong ground wave that is effective day or night, and it is to be preferred on 1.8 Mc.

The low-angle radiation from a horizontal

antenna $\frac{1}{8}$ or $\frac{1}{4}$ wave length above ground is almost insignificant. Any reasonable height is small in terms of wavelength, so that a horizontal antenna on 160 meters is a poor radiator at angles useful for long distances ("long," that is, for this band). Its chief usefulness is over relatively short distances at night.

Bent Antennas

Since ideal vertical antennas are generally out of the question for practical amateur work, the best compromise is to bend the antenna in such a way that the high-current portions of the antenna run vertically. It is advisable to place the antenna so that the highest currents in the antenna occur at the highest points above actual ground. Two antenna systems designed along these lines are shown in Fig. 14-28. The antenna of Fig. 14-28B uses a full half wave length of wire but is bent so that the high-current portion runs vertically. The horizontal portion running to L_1C_1 should run 8 or 10 feet above ground.

Grounds

A good ground connection is generally important on 160 meters. The ideal system is a number of wire radials buried a foot or two underground and extending 50 to 100 feet from the central connection point. As many radials as possible should be used; six is a minimum.

If the soil is good (not rocky or sandy) and generally moist, a low-resistance connection to the cold-water pipe system in the house will often serve as an adequate ground system. The connection should be made close to where the pipe enters the ground, and the surface of the pipe should be scraped clean before tightening the ground clamp around the pipe.

A 6- or 8-foot length of 1-inch water pipe, driven into the soil at a point where there is considerable natural moisture, can be used for the ground connection. Three or four pipes driven into the ground 8 or 10 feet apart and all joined

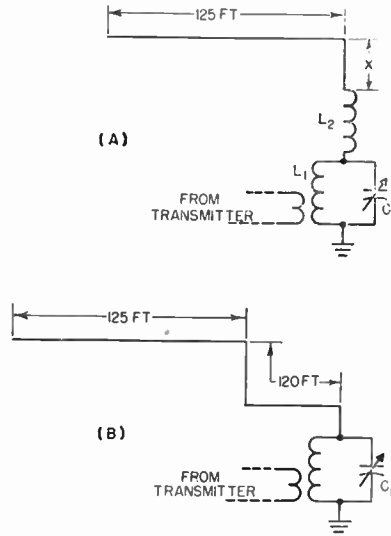

Fig. 14-28 — Bent antenna for the 160-meter band. In the system at A, the vertical portion (length X) should be made as long as possible. In either antenna system, L_1C_1 should resonate at 1900 kc., roughly. To adjust L_2 in antenna A, resonate L_1C_1 alone to the operating frequency, then connect it to the antenna system and adjust L_2 for maximum loading. Further loading can be obtained by increasing the coupling between L_1 and the link.

together at the top with heavy wire are more effective than the single pipe.

The use of a counterpoise is recommended where a buried system is not practicable or where a pipe ground cannot be made to have low resistance because of poor soil conditions. A counterpoise consists of a number of wires supported from 6 to 10 feet above the surface of the ground. Generally the wires are spaced 10 to 15 feet apart and located to form a square or polygonal configuration under the vertical portion of the antenna.

Long-Wire Directive Arrays

● **THE "V" ANTENNA**

As the antenna length is increased, the lobe of maximum radiation makes a more acute angle with the wire. Two long wires may be combined in the form of a horizontal "V" so that the main lobes from each wire will reinforce along a line bisecting the angle between the wires. This increases both gain and directivity, since the lobes

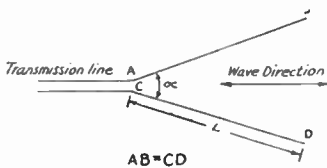

Fig. 14-29 — The basic "V" antenna, made by combining two long wires.

in directions other than along the bisector tend to cancel. The horizontal "V" antenna therefore transmits best in either direction (is bidirectional) along a line bisecting the "V" made by the two wires. The power gain depends upon the length in wave lengths of the wires. Provided the necessary space is available, the "V" is a simple antenna to build and operate. It can also be used on harmonics, so that it is suitable for multiband work. A top view of the "V" antenna is shown in Fig. 14-29.

Fig. 14-30 shows the dimensions that should be followed for an optimum design to obtain maximum power gain for different-sized "V" antennas. The longer systems give good performance in multiband operation. Angle α is approximately equal to twice the

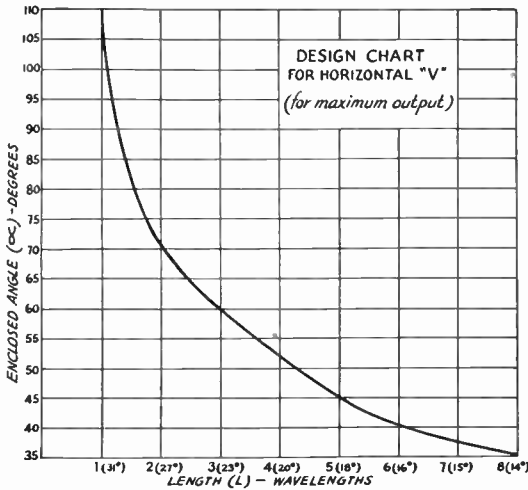

Fig. 14-30 — Design chart for horizontal "V" antennas, giving the enclosed angle between sides vs. the length of the wires. Values in parentheses represent approximate wave angle for height of one-half wave length.

angle of maximum radiation for a single wire equal in length to one side of the "V."

The wave angle referred to in Fig. 14-30 is the vertical angle of maximum radiation. Tilting the whole horizontal plane of the "V" will tend to increase the low-angle radiation off the low end and decrease it off the high end.

The gain increases with the length of the wires, but is not exactly twice the gain for a single long wire as given in Fig. 14-15. In the longer lengths the gain will be somewhat increased, because of mutual coupling between the wires. A "V" eight wave lengths on a log, for instance, will have a gain of about 12 db. over a half-wave antenna, whereas twice the gain of a single eight-wave-length wire would be only approximately 9 db.

The two wires of the "V" must be fed out of phase, for correct operation. A resonant line may simply be attached to the ends, as shown in Fig. 14-29. Alternatively, a quarter-wave matching section may be employed and the antenna fed through a nonresonant line. If the antenna wires are made multiples of a half wave in length (use Equation 14-G for computing the length), the matching section will be closed at the free end. A stub can be connected across the resonant line to provide a match, as described in the preceding chapter.

● THE RHOMBIC ANTENNA

The horizontal rhombic or "diamond" antenna is shown in Fig. 14-31. Like the "V," it requires a great deal of space for erection, but it is capable of giving excellent gain and directivity.

It also can be used for multiband operation. In the terminated form shown in Fig. 14-31, it operates like a nonresonant transmission line, without standing waves, and is unidirectional. It may also be used without the terminating resistor, in which case there are standing waves on the wires and the antenna is bidirectional.

The important quantities influencing the design of the rhombic antenna are shown in Fig. 14-31. While several design methods may be used, the one most applicable to the conditions existing in amateur work is the so-called "compromise" method. The chart of Fig. 14-32 gives design information based on a given length and wave angle to determine the remaining optimum dimensions for best operation. Curves for value of length of two, three and four wavelengths are shown, and any intermediate values may be interpolated.

With all other dimensions correct, an increase in length causes an increase in power gain and a slight reduction in wave angle. An increase in height also causes a reduction in wave angle and an increase in power gain, but not to the same extent as a proportionate increase in length. For multiband work, it is satisfactory to design the rhombic antenna on the basis of 14-Mc. operation, which will permit work from the 7- to 28-Mc. bands as well.

A value of 800 ohms is correct for the terminating resistor for any properly-constructed rhombic, and the system behaves as a pure resistive load under this condition. The terminating resistor must be capable of safely dissipating one-half the power output (to eliminate the rear pattern), and should be noninductive. Such a resistor may be made up from a carbon or graphite rod or from a long 800-ohm transmission line using resistance wire. If the carbon rod or a similar form of lumped resistance is used, the device should be suitably protected from weather effects; i.e., it should be covered with a good asphaltic compound and sealed in a small lightweight box or fiber tube. Suitable nonreactive terminating resistors are also available commercially.

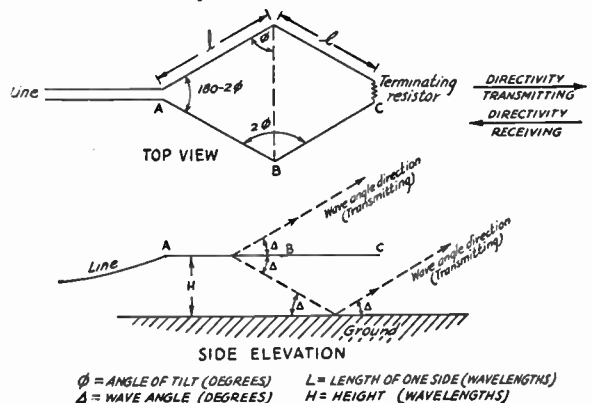

Fig. 14-31 — The horizontal rhombic or diamond antenna, terminated. Important design dimensions are indicated; details in text.

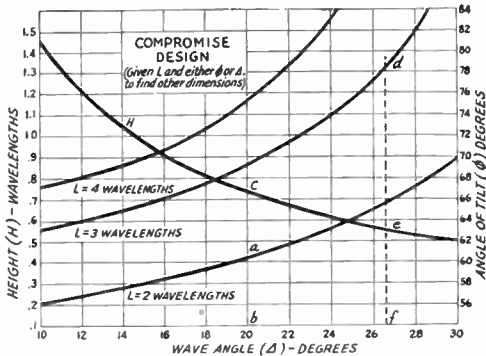

Fig. 14-32 — Compromise-method design chart for rhombic antennas of various leg lengths and wave angles. The examples at the right illustrate the use of the chart:



For feeding the antenna, the antenna impedance will be matched by an 800-ohm line, which may be constructed from No. 16 wire spaced 20 inches or from No. 18 wire spaced 16 inches. The 800-ohm line is somewhat ungainly to install, however, and may be replaced by an ordinary 600-ohm line with only a negligible mismatch. Alternatively, a matching section may be installed between the antenna terminals and a low-impedance line. However, when such an arrangement is used, it will be necessary to change the matching-section constants for each different band on which operation is contemplated.

Beams with Driven Elements

By combining individual half-wave antennas into an **array** with suitable spacing between the antennas (called **elements**) and feeding power to them simultaneously, it is possible to make the radiation from the elements add up along a single direction and form a beam. In other directions the radiation tends to cancel, so a power gain is obtained in one direction at the expense of radiation in other directions. There are several methods of arranging the elements. If they are strung end to end, so that all lie on the same straight line, the elements are said to be **collinear**. If they are parallel and all lying in the same plane, the elements are said to be **broadside** when the phase of the current is the same in all, and **end-fire** when the currents are not in phase.

Collinear Arrays

Simple forms of collinear arrays, with the current distribution, are shown in Fig. 14-33. The two-element array at A is popularly known as "two half-waves in phase." It will be recognized as simply a center-fed dipole operated at its second

- (1) Given:
 Length (L) = 2 wave lengths
 Desired wave angle (Δ) = 20° .
 To Find: H , Φ .
 Method:
 Draw vertical line through point a ($L = 2$ wave lengths) and point b on abscissa ($\Delta = 20^\circ$). Read angle of tilt (Φ) for point a and height (H) from intersection of line ab at point c on curve H .
 Result:
 $\Phi = 60.5^\circ$.
 $H = 0.73$ wave length.
- (2) Given:
 Length (L) = 3 wave lengths.
 Angle of tilt (Φ) = 78° .
 To Find: H , Δ .
 Method:
 Draw a vertical line from point d on curve $L = 3$ wavelengths at $\Phi = 78^\circ$. Read intersection of this line on curve H (point e) for height, and intersection at point f on the abscissa for Δ .
 Result:
 $H = 0.56$ wave length.
 $\Delta = 26.6^\circ$.

The same design details apply to the unterminated rhombic as to the terminated type. When used without a terminating resistor, the system is bidirectional. Tuned feeders are generally used with the unterminated rhombic. A nonresonant line may be used by incorporating a matching section at the antenna, but is not readily adaptable to satisfactory multiband work or over an appreciable band of frequencies.

Rhombic antennas will give a power gain of 8 to 12 db, or more for leg lengths of two to four wave lengths, when constructed according to the charts given. In general, the larger the antenna, the greater the power gain.

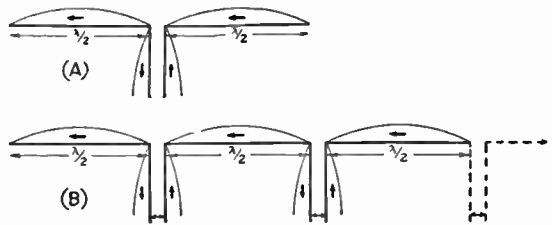

Fig. 14-33 — Collinear half-wave antennas in phase. The system at A is generally known as "two half-waves in phase." B is an extension of the system; in theory the number of elements may be carried on indefinitely, but practical considerations usually limit the elements to four.

TABLE 14-II
Theoretical Gain of Collinear Half-Wave Antennas

Spacing between centers of adjacent half-waves	Number of half-waves in array vs. gain in db.				
	2	3	4	5	6
$\frac{1}{2}$ wave	1.8	3.3	4.5	5.3	6.2
$\frac{3}{4}$ wave	3.2	4.8	6.0	7.0	7.8

it is difficult to construct a suitable phase-reversing system when the ends of the antenna elements are widely separated. The half-wave spacing is most generally used in actual practice.

Collinear arrays may be mounted either horizontally or vertically. Horizontal mounting gives increased horizontal directivity, while the vertical directivity remains the same as for a single element at the same height. Vertical mounting gives the same horizontal pattern as a single element, but concentrates the radiation at low angles.

Broadside Arrays

Parallel antenna elements with currents in phase may be combined as shown in Fig. 14-34 to form a **broadside array**, so named because

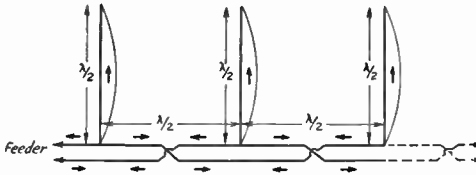

Fig. 14-34 — Broadside array using parallel half-wave elements. Arrows indicate the direction of current flow. Transposition of the feeders is necessary to bring the antenna currents in phase. Any reasonable number of elements may be used. The array is bidirectional, with maximum radiation "broadside" or perpendicular to the antenna plane (perpendicularly through this page).

the direction of maximum radiation is broadside to the plane containing the antennas. Again the gain and directivity depend upon the number of elements and the spacing, the gain for different spacings being shown in Fig. 14-35. Half-wave spacing generally is used, since it simplifies the problem of feeding the system when the array has more than two elements. Table 14-III gives theoretical gain as a function of the number of elements with half-wave spacing.

Broadside arrays may be suspended either with the elements all vertical or with them horizontal and one above the other (**stacked**). In the former case the horizontal pattern becomes quite sharp, while the vertical pattern is the same as that of one element alone. If the array is suspended horizontally, the horizontal pattern is equivalent to that of one element while the vertical pattern is sharpened, giving low-angle radiation.

Broadside arrays may be fed either by resonant transmission lines or through quarter-wave match-

ing sections and nonresonant lines. In Fig. 14-34, note the "crossing over" of the feeders, which is necessary to bring the elements into proper phase relationship.

Combined Broadside and Collinear Arrays

Broadside and collinear arrays may be combined to give both horizontal and vertical directivity, as well as additional gain. The

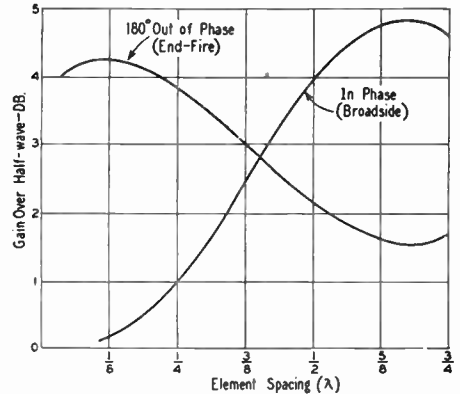

Fig. 14-35 — Gain vs. spacing for two parallel half-wave elements combined as either broadside or end-fire arrays.

general plan of constructing such antennas is shown in Fig. 14-36. The lower angle of radiation resulting from stacking elements in the vertical plane is desirable at the higher frequencies. In general, doubling the number of elements in an array by stacking will raise the gain from 2 to 4 db., depending upon whether vertical or horizontal elements are used — that is, whether the stacked elements are of the broadside or collinear type.

The arrays in Fig. 14-36 are shown fed from one end, but this is not especially desirable in the case of large arrays. Better distribution of energy between elements, and hence better over-all performance, will result when the feeders are attached as nearly as possible to the center of the array. Thus, in the eight-element array at A, the feeders could be introduced at the middle of the transmission line between the second and third set of elements, in which case the connecting line would not be transposed between the second and third set of elements.

A four-element array, known as the "lazy-II" antenna, has been quite frequently used. This

TABLE 14-III
Theoretical Gain vs. Number of Broadside Elements (Half-Wave Spacing)

No. of elements	Gain
2	4 db.
3	5.5
4	7
5	8
6	9

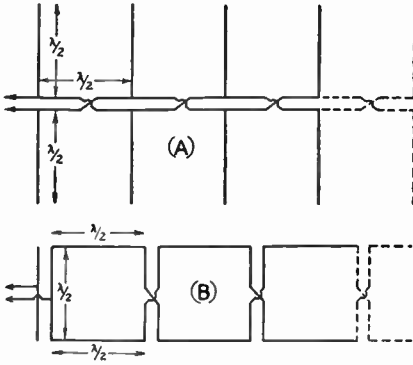

Fig. 14-36 — Combination broadside and collinear arrays. A, with vertical elements; B, with horizontal elements. Both arrays give low-angle radiation. Two or more sections may be used. The gain in db. will be equal, approximately, to the sum of the gain for one set of broadside elements (Table 14-IV) plus the gain of one set of collinear elements (Table 14-III). For example, in A each broadside set has four elements (gain 7 db.) and each collinear set two elements (gain 1.8 db.), giving a total gain of 8.8 db. In B, each broadside set has two elements (gain 4 db.) and each collinear set three elements (gain 3.3 db.), making the total gain 7.3 db. The result is not strictly accurate, because of mutual coupling between the elements, but is good enough for practical purposes.

arrangement is shown, with the feed point indicated, in Fig. 14-37. For best results, the bottom section should be at least a half wavelength above ground.

End-Fire Arrays

Fig. 14-38 shows a pair of parallel half-wave elements with currents out of phase. This is known as an end-fire array because it radiates best along the plane of the antennas, as shown.

The end-fire array may be used either vertically or horizontally (elements at the same height), and is well adapted to amateur work because it gives maximum gain with relatively close element spacing. Fig. 14-35 shows how the gain varies with spacing. End-fire elements may be combined with additional collinear and broadside elements to give a further increase in gain and directivity.

Either tuned or untuned lines may be used with this type of array. Untuned lines preferably are matched to the antenna through a quarter-wave matching section or phasing stub.

Phasing

Figs. 14-36 and 14-38 illustrate a point in connection with feeding a phased antenna system which sometimes is confusing. In Fig. 14-38, when the transmission line is connected as at A there is no crossover in the line connecting the two antennas, but when the transmission line is connected to the center of the connecting line the crossover becomes necessary (B). The same thing is true of the untransposed line of Fig. 14-36B. Note that, under these conditions, the antenna elements are in phase when the line is not transposed, and out of phase when the transposition is made.

Adjustment of Arrays

With arrays of the types just described, using half-wave spacing between elements, it will usually suffice to make the length of each element that given by Equations 14-B or 14-C.

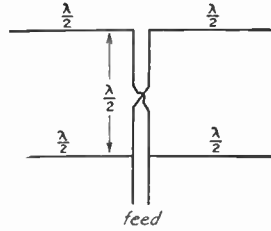

Fig. 14-37 — A four-element combination broadside-collinear array, popularly known as the "lazy-H" antenna. A closed quarter-wave stub may be used at the feed point to match into an untuned transmission line, or tuned feeders may be attached at the point indicated. The gain over a half-wave antenna is 5 to 6 db.

The phasing lines between the parallel elements should be of open-wire construction, and their length can be calculated from:

$$\text{Length of half-wave line (feet)} = \frac{480}{\text{Freq. (Mc.)}} \tag{14-H}$$

Example: A half-wave length phasing line for 28.8 Mc. would be $\frac{480}{28.8} = 16.66$ feet = 16 feet 8 inches.

The spacing between elements can be made equal to the length of the phasing line. No special adjustments of line or element length

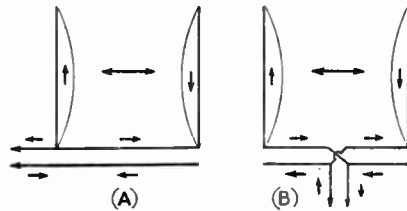

Fig. 14-38 — End-fire arrays using parallel half-wave elements. The elements are shown with half-wave spacing to illustrate feeder connections. In practice, closer spacings are desirable, as shown by Fig. 14-35. Direction of maximum radiation is shown by the large arrows.

or spacing are needed, provided the formulas are followed closely.

With collinear arrays of the type shown in Fig. 14-33B, the same formula may be used for the element length, while the length of the quarter-wave phasing section can be found from the following formula:

$$\text{Length of quarter-wave line (feet)} = \frac{240}{\text{Freq. (Mc.)}} \tag{14-I}$$

Example: A quarter-wave length phasing line for 14.25 Mc. would be $\frac{240}{14.25} = 16.84$ feet = 16 feet 10 inches.

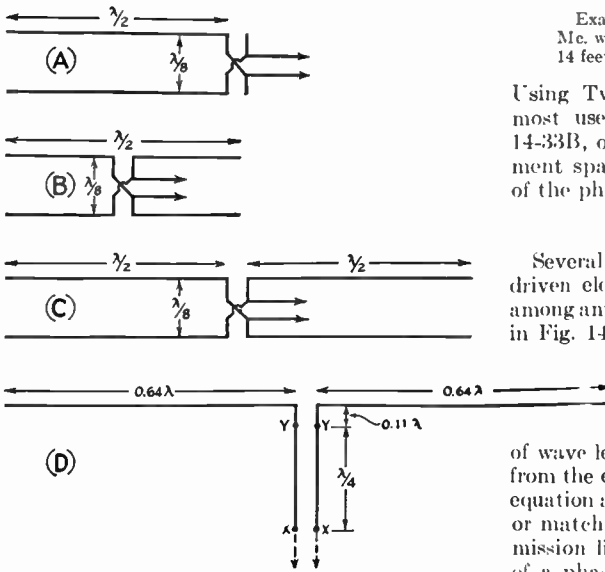

Fig. 14-39 — Simple directive-antenna systems. A is a two-element end-fire array; B is the same array with center feed, which permits use of the array on the second harmonic, where it becomes a four-element array with quarter-wave spacing. C is a four-element end-fire array with $\frac{1}{8}$ -wave spacing. D is a simple two-element broadside array using extended in-phase antennas ("extended double-Zepp"). The gain of A and B is slightly over 4 db. On the second harmonic, B will give about 5 db. gain. With C, the gain is approximately 6 db., and with D, approximately 3 db. In A, B and C, the phasing line contributes about $\frac{1}{8}$ wave length to the transmission line; when B is used on the second harmonic, this contribution is $\frac{1}{8}$ wave length. Alternatively, the antenna ends may be bent to meet the transmission line, in which case each feeder is simply connected to one antenna. In D, points Y-Y indicate a quarter-wave point (high current) and X-X a half-wave point (high voltage). The line may be extended in multiples of quarter waves if resonant feeders are to be used. A, B and C may be suspended on wooden spreaders. The plane containing the wires should be parallel to the ground.

If the array is fed in the center it should not be necessary to make any adjustments, although, if desired, the whole system can be resonated by connecting an r.f. ammeter in the shorting link of each phasing section and moving the link back and forth to find the maximum-current position. This refinement is hardly necessary, however, so long as all elements are the same length and the system is symmetrical.

The phasing sections can be made of 300-ohm Twin-Lead, if low power is used. However, the lengths of the phasing sections must then be only 84 per cent of the length obtained in the two formulas above.

Directive Arrays with Parasitic Elements

Parasitic Excitation

The antenna arrays previously described are bidirectional; that is, they will radiate in directions both to the "front" and to the "back"

Example: The half-wave-length line for 28.8 Mc. would become $0.84 \times 16.66 = 13.99$ feet = 14 feet 0 inches.

Using Twin-Lead for the phasing sections is most useful in arrays such as that of Fig. 14-33B, or any other system in which the element spacing is not controlled by the length of the phasing section.

Simple Arrays

Several simple directive-antenna systems using driven elements have achieved rather wide use among amateurs. Four of these systems are shown in Fig. 14-39. Tuned feeders are assumed in all

cases; however, a matching section readily can be substituted if a nonresonant transmission line is preferred. Dimensions given are in terms of wave length; actual lengths can be calculated from the equations for the antenna and from the equation above for the resonant transmission line or matching section. In cases where the transmission line proper connects to the midpoint of a phasing line, only *half* the length of the latter should be added to the line to find the quarter-wave point.

At A and B are two-element end-fire arrangements using close spacing. They are electrically equivalent; the only difference is in the method of connecting the feeders. B may also be used on the second harmonic, although the spacing is not optimum (Fig. 14-35) for such operation.

A close-spaced four-element array is shown at C. It will give about 2 db. more gain than the two-element array.

The antenna at D, commonly known as the "extended double-Zepp," is designed to take advantage of the greater gain possible with collinear antennas having greater than half-wave center-to-center spacing, but without introducing feed complications. The elements are made longer than a half-wave. The gain is 3 db. over a single half-wave antenna, and the broadside directivity is fairly sharp.

The antennas of A and B may be mounted either horizontally or vertically; horizontal suspension (with the elements in a plane parallel to the ground) is recommended, since this tends to give low-angle radiation without an unduly sharp horizontal pattern. Thus these systems are useful for coverage over a wide horizontal angle. The system at C, when mounted horizontally, will have a sharper horizontal pattern than the two-element arrays because of the effect of the collinear arrangement. The vertical pattern will be the same as that of the antennas in A and B.

of the antenna system. If radiation is wanted in only one direction, it is necessary to use different element arrangements. In most of these arrangements the additional elements receive

power by induction or radiation from the driven element, generally called the "antenna," and reradiate it in the proper phase relationship to achieve the desired effect. These elements are called *parasitic* elements, as contrasted to the driven elements which receive power directly from the transmitter through the transmission line.

The parasitic element is called a *director* when it reinforces radiation on a line pointing to it from the antenna, and a *reflector* when the reverse is the case. Whether the parasitic element is a director or reflector depends upon the

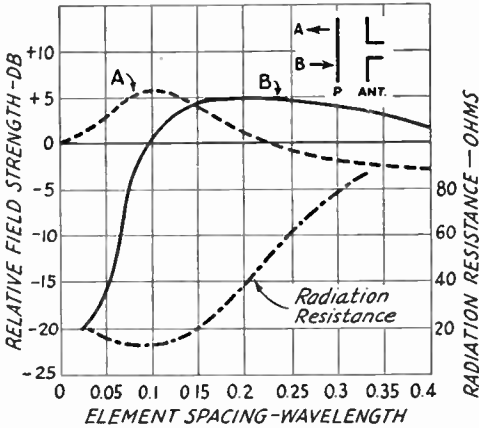

Fig. 14-40 — Gain vs. element spacing for an antenna and one parasitic element. The reference point, 0 db., is the field strength from a half-wave antenna alone. The greatest gain is in direction A at spacings of less than 0.14 wave length, and in direction B at greater spacings. The front-to-back ratio is the difference in db. between curves A and B. Variation in radiation resistance of the driven element also is shown. These curves are for a self-resonant parasitic element. At most spacings the gain as a reflector can be increased by slight lengthening of the parasitic element; the gain as a director can be increased by shortening. This also improves the front-to-back ratio.

parasitic-element tuning, which usually is adjusted by changing its length.

Gain vs. Spacing

The gain of an antenna with parasitic elements varies with the spacing and tuning of the elements, and thus for any given spacing there is a tuning condition that will give maximum gain at this spacing. The maximum front-to-back ratio seldom, if ever, occurs at the same condition that gives maximum forward gain. The impedance of the driven element also varies with the tuning and spacing, and thus the antenna system must be tuned to its final condition before the match between the line and the antenna can be completed. However, the tuning and matching may interlock to some extent, and it is usually necessary to run through the adjustments several times to insure that the best possible tuning has been obtained.

Two-Element Beams

A 2-element beam is useful where space or other considerations prevent the use of the

larger structure required for a 3-element beam. The general practice is to tune the parasitic element as a reflector and space it about 0.15 wave length from the driven element, although some successful antennas have been built with 0.1-wave-length spacing and director tuning. Gain vs. element spacing for a 2-element antenna is given in Fig. 14-40, for the special case where the parasitic element is resonant. It is indicative of the performance to be expected under maximum-gain tuning conditions.

Three-Element Beams

Where room is available for an over-all length greater than 0.2 wave length, a 3-element beam is preferable to one with only 2 elements. Once the over-all length has been decided upon, the curves of Fig. 14-41 can be used to determine the proper spacing of director and reflector. If, for example, the distance between director and reflector can be made 0.4 wave length, Fig. 14-41 shows that a spacing of 0.15D-0.25R gives a gain of 7.8 db., and a spacing of 0.25D-0.15R gives a gain of 8.2 db. Obviously the latter is the better choice, although the practical difference might be difficult to measure, and practical (mechanical) considerations might call for using the more balanced 0.2D-0.2R construction and a gain of 8.1 db.

When the over-all length has been decided upon, and the element spacing has been determined, the element lengths can be found by referring to Fig. 14-42. It must be remembered that the lengths determined by these charts will vary slightly in actual practice with the element diameter and the method of supporting the elements, and the tuning of a beam should always be checked after installation. However, the lengths obtained by the use of the charts will be

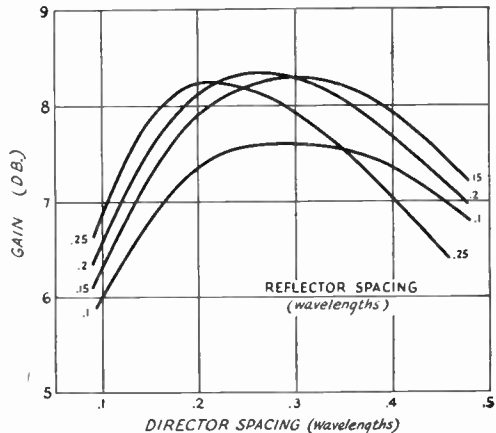

Fig. 14-41 — Gain vs. element spacing for 3-element beams using a driven element and a director and a reflector. The 0-db. reference level is the field strength from a half-wave-length antenna alone. These curves are for the system tuned for maximum forward gain.

The element spacing shown is the fraction of a wavelength determined by $\frac{984}{f \text{ (Mc.)}}$. Thus a wave length at 11.2 Mc. = $984/11.2 = 69.3$ feet. A spacing of 0.15 wave length at 11.2 Mc. would be $0.15 \times 69.3 = 10.1$ feet = 10 feet 5 inches.

close to correct in practically all cases, and they can be used without checking if the beam is difficult of access.

The preferable method for checking the beam is by means of a field-strength meter or the S-meter of a communications receiver, used in conjunction with a dipole antenna located at

least 10 wave lengths away and as high as or higher than the beam that is being checked. A few watts of power fed into the antenna will give a useful signal at the observation point, and the power input to the transmitter (and hence the antenna) should be held constant for all of the readings. Beams tuned on the ground and then lifted into place are subject to tuning errors and cannot be depended upon. The impedance of the driven element will vary with the height above ground, and good practice dictates that all final matching between antenna and line be done with the antenna in place at its normal height above ground.

Simple Systems: the Rotary Beam

Two- and 3-element systems are popular for rotary-beam antennas, where the entire antenna system is rotated, to permit its gain and directivity to be utilized for any compass direction. They may be mounted either horizontally (with the plane containing the elements parallel to the earth) or vertically.

A 4-element beam will give still more gain than a 3-element one, provided the support is sufficient for at least 0.2 wave-length spacing between elements. The tuning for maximum gain involves many variables, and complete gain and tuning data are not available.

The elements in close-spaced (less than one-quarter wave-length element spacing) arrays preferably should be made of tubing of one-half to one-inch diameter. A conductor of large diameter not only has less ohmic resistance but also has lower *Q*; both these factors are important in close-spaced arrays because the impedance of the driven element usually is quite low compared to that of a single half-wave dipole. With 3- and 4-element close-spaced arrays the radiation resistance of the driven element may be so low that ohmic losses in the conductor can consume an appreciable fraction of the power.

Feeding Close-Spaced Arrays

Any of the usual methods of feed may be applied to the driven element of a parasitic array. The preferred methods are shown in Fig. 14-43. Tuned feeders are not recommended for lengths greater than a half wave length unless open lines of copper-tubing conductors are used.

Four versions of the popular T-match are shown, for two-wire lines of Twin-Lead at A, for single coaxial line at B and D, and for double coaxial line at C. The match is adjusted by moving the shorting bars, keeping them equidistant from the center, until the minimum s.w.r. is obtained on the line. If the s.w.r. minimum is not 1.5 or less, the transmitter frequency should be shifted to find the frequency where the minimum s.w.r. occurs. If it is higher than the original test frequency, increase the antenna element length slightly. The parasitic element lengths taken from Fig. 14-42 should not require much adjustment unless considerably different spacing is used, but it may

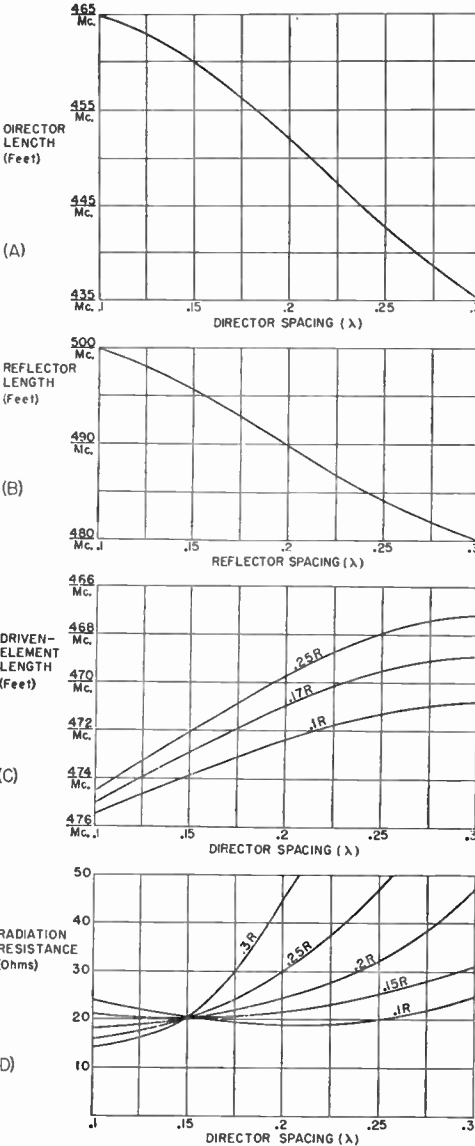

Fig. 14-42 — Element lengths for a 3-element beam. These lengths will hold closely for tubing elements supported at or near the center. The radiation resistance (D) is useful information in planning for a matching system, but it is subject to variation with height above ground and must be considered an approximation.

The driven-element length (C) may require modification for tuning out reactance if a T- or gamma-match feed system is used, as mentioned in the text.

A 0.21D-0.2R beam cut for 28.6 Mc. would have a director length of $452/28.6 = 15.8 = 15$ feet 10 inches, a reflector length of $490/28.6 = 17.1 = 17$ feet 1 inch, and a driven-element length of $470.5/28.6 = 16.45 = 16$ feet 5 inches.

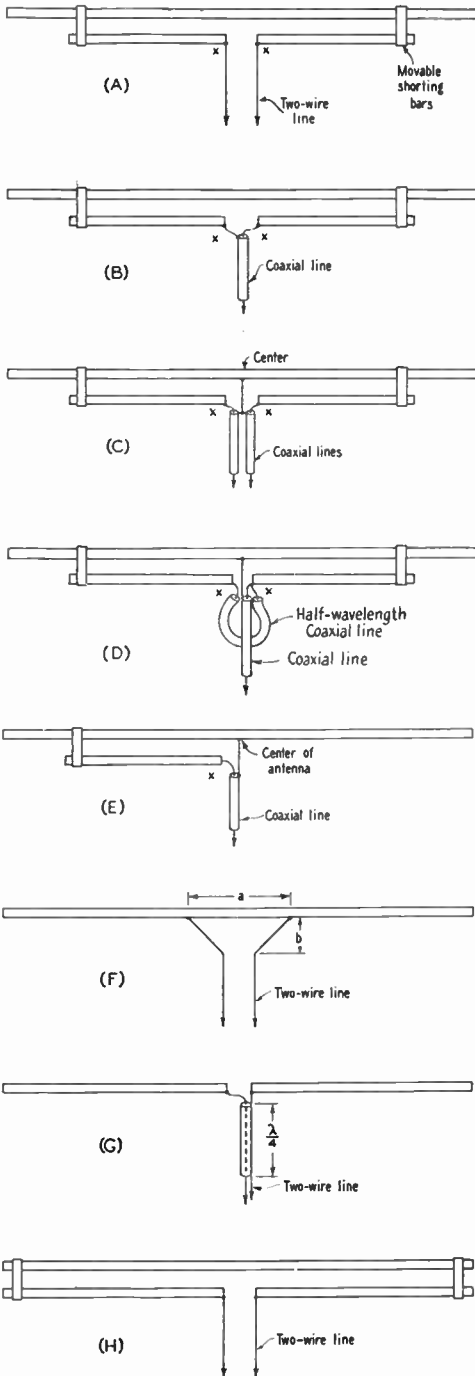

Fig. 14-43 — Recommended methods of feeding the driven antenna element in close-spaced parasitic arrays. The parasitic elements are not shown. A, B, C, D, "T" match; E, "gamma" match; F, delta matching transformer; G, coaxial-line quarter-wave matching section; H, folded dipole. Adjustment is discussed in the text. Variable capacitors can be installed at "x" to simplify matching.

be necessary to change the position of the shorting bars and the length of the antenna element once or twice before the s.w.r. at the test frequency is acceptable. The matching section may be made of the same type of conductor as the element and spaced a few inches from it. The length of the matching section will be greater with higher-impedance lines and with wider element spacing. A good starting point for a 28-Mc. wide-spaced (0.2D-0.15R) beam fed with 300-ohm Twin-Lead is 28 inches each side of center. A similar antenna and line on 14 Mc. might require about 56 inches each side.

The gamma match, shown in Fig. 14-43E, can be considered as one-half a "T" match, and the same principles hold. However, when the length of the element is changed, in an effort to minimize the s.w.r., only the side to which the movable bar is connected should be changed — the other side should remain at one-half the length obtained from Fig. 14-42. With 52-ohm coaxial line feed, the length of the matching element may run around 15 to 20 inches in a 28-Mc. beam, and twice this value in a 14-Mc. array.

An alternative to adjusting the element length for tuning out the residual reactance is to use a small variable capacitor in series at the junction of the coaxial cable and the matching section of the gamma or "T" match. A small 140- $\mu\mu\text{f}$. receiving-type variable is adequate at powers of a few hundred watts, and it can be weatherproofed by mounting it in a small plastic cup. The T-match of Fig. 14-43 A, B, C or D requires two capacitors, one in each side.

The delta matching transformer shown at F is probably easier to install, mechanically, than any of the others. The positions of the taps (dimension *a*) must be determined experimentally, along with the length, *b*, by checking the standing-wave ratio on the line as adjustments are made. Dimension *b* should be about 15 per cent longer than *a*.

The coaxial-line matching section at G will work with fair accuracy into a close-spaced parasitic array of 2, 3 or 4 elements without necessity for adjustment. The line is used as a quarter-wave-length transformer, and, if its characteristic impedance is 70 ohms (RG-11/U), it will give a good match to a 600-ohm line when the resistance at the termination is about 8.5 ohms. Over a range of 5 to 15 ohms the mismatch, and therefore the standing-wave ratio, will be less than 2-to-1. The length of the quarter-wave section may be calculated from

$$\text{Length (feet)} = \frac{246V}{f} \tag{14-J}$$

where *V* = Velocity factor
f = Frequency in Mc.

Example: A quarter-wave transformer of RG-11/U is to be used at 28.7 Mc. From the table in Chapter Thirteen, *V* = 0.66.

$$\text{Length} = \frac{246 \times 0.66}{28.7} = 5.67 \text{ feet} \\ = 5 \text{ feet } 8 \text{ inches}$$

The folded-dipole antenna, Fig. 14-43H, presents a good match for the line when properly designed. Details are given in Chapter Thirteen. Different impedance step-up ratios can be obtained by varying the number of conductors or their diameter ratio.

Sharpness of Resonance

Peak performance of a multielement parasitic array depends upon proper phasing or tuning of the elements, which can be exact for one frequency only. In the case of close-spaced arrays, which because of the low radiation resistance usually are quite sharp-tuning, the frequency range over which optimum results can be secured is only of the order of 1 or 2 per cent of the resonant frequency, or up to about 500 kc. at 28 Mc. However, the antenna can be made to work satisfactorily over a wider frequency range by adjusting the director or directors to give maximum gain at the highest frequency to be covered, and by adjusting the reflector to give optimum gain at the lowest frequency. This sacrifices some gain at all frequencies, but maintains more uniform gain over a wider frequency range.

As mentioned in the preceding paragraphs, the use of large-diameter conductors will broaden the response curve of an array because the larger diameter lowers the Q . This causes the reactances of the elements to change rather slowly with frequency, with the result that the tuning stays near the optimum over a considerably wider frequency range than is the case with wire conductors.

Combination Arrays

It is possible to combine parasitic elements with driven elements to form arrays composed of collinear driven and parasitic elements and combination broadside-collinear-parasitic elements. Thus two or more collinear elements might be provided with a collinear reflector or director set, one parasitic element to each driven element. Or both directors and reflectors might be used. A broadside-collinear array can be treated in the same fashion.

RECEIVING ANTENNAS

Nearly all of the properties possessed by an antenna as a radiator also apply when it is used for reception. Current and voltage distribution, impedance, resistance and directional characteristics are the same in a receiving antenna as if it were used as a transmitting antenna. This reciprocal behavior makes possible the design of a receiving antenna of optimum performance based on the same considerations that have been discussed for transmitting antennas.

The simplest receiving antenna is a wire of random length. The longer and higher the wire, the more energy it abstracts from the wave. Be-

cause of the high sensitivity of modern receivers, sometimes only a short length of wire strung around the room is used for a receiving antenna, but such an antenna cannot be expected to give good performance, although it is adequate for loud signals on the 3.5- and 7-Mc. bands. It will serve in emergencies, but a longer wire outdoors is always better.

The use of a tuned antenna improves the operation of the receiver, because the signal strength is greater than with a wire of random length. Where local electrical noise is a problem, as from an electrical appliance, a measure of relief can often be obtained by locating the antenna as high above and as far as possible from the noise source and power lines. The lead-in wire, from the center of the antenna, should be a coaxial line or shielded twin-conductor cable (RG-62/U). If the twin-conductor cable is used, the conductors connect to the antenna binding posts and the shield to the ground binding post of the receiver.

Antenna Switching

Switching of the antenna from receiver to transmitter is commonly done with a change-over relay, connected in the antenna leads or the coupling link from the antenna tuner. If the relay is one with a 115-volt a.c. coil, the switch or relay that controls the transmitter plate power will also control the antenna relay. If the convenience of a relay is not desired, porcelain knife switches can be used and thrown by hand.

Typical arrangements are shown in Fig. 14-44. If coaxial line is used, the use of a coaxial relay is recommended, although on the lower-frequency bands a regular switch or change-over relay will work almost as well.

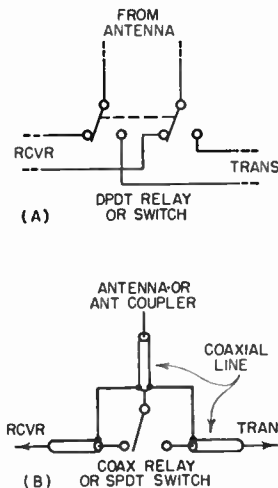

Fig. 14-44 — Antenna changeover for receiving and transmitting in two-wire line (A) and coaxial line (B). The low-pass filter for TVI reduction should be connected between switch or relay and the transmitter.

Antenna Construction

The use of good materials in the antenna system is important, since the antenna is exposed to wind and weather. To keep electrical losses low, the wires in the antenna and feeder system must have good conductivity and the insulators must have low dielectric loss and surface leakage, particularly when wet.

For short antennas, No. 14 gauge hard-drawn enameled copper wire is a satisfactory conductor. For long antennas and directive arrays, No. 14 or No. 12 enameled copper-clad steel wire should be used. It is best to make feeders and matching stubs of ordinary soft-drawn No. 14 or No. 12 enameled copper wire, since hard-drawn or copper-clad steel wire is difficult to handle unless it is under considerable tension at all times. The wires should be all in one piece; where a joint cannot be avoided, it should be carefully soldered. Open-wire TV line is excellent up to several hundred watts.

In building a two-wire open line, the spacer insulation should be of as good quality as in the antenna insulators proper. For this reason, good ceramic spacers are advisable. Wooden dowels boiled in paraffin may be used with untuned lines, but their use is not recommended for tuned lines. The wooden dowels

In most cases poles or masts are desirable to lift the antenna clear of surrounding buildings, although in some locations the antenna will be sufficiently in the clear when strung from one chimney to another or from a house-top to a tree. Small trees usually are not satisfactory as points of suspension for the antenna because of their movement in windy weather. If the antenna is strung from a point near the center of the trunk of a large tree, this difficulty is not so serious. Where the antenna wire must be strung from one of the smaller branches, it is best to tie a pulley firmly to the branch and run a rope through the pulley to the antenna, with the other end of the rope attached to a counterweight near the ground. The counterweight will keep the tension on the antenna wire reasonably constant even when the branches sway or the rope tightens and stretches with varying climatic conditions.

Telephone poles, if they can be purchased and installed economically, make excellent supports because they do not ordinarily require guying in heights up to 40 feet or so. Many low-cost television-antenna supports are now available, and they should not be overlooked as possible antenna aids.

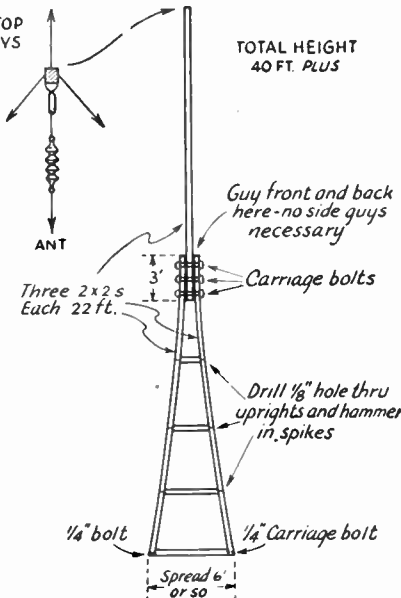

Fig. 14-45 — Details of a simple 40-foot "A"-frame mast suitable for erection in locations where space is limited.

can be attached to the feeder wires by drilling small holes and binding them to the feeders.

At points of maximum voltage, insulation is most important, and Pyrex glass or ceramic insulators with long leakage paths are recommended for the antenna. Insulators should be cleaned once or twice a year, especially if they are subjected to much smoke and soot.

● "A"-FRAME MAST

The simple and inexpensive mast shown in Fig. 14-45 is satisfactory for heights up to 35 or 40 feet. Clear, sound lumber should be selected. The completed mast may be protected by two or three coats of house paint.

If the mast is to be erected on the ground, a couple of stakes should be driven to keep the bottom from slipping and it may then be "walked up" by a pair of helpers. If it is to go on a roof, first stand it up against the side of the building and then hoist it from the roof, keeping it vertical. The whole assembly is light enough for two men to perform the complete operation — lifting the mast, carrying it to its permanent berth, and fastening the guys — with the mast vertical all the while. It is entirely practicable, therefore, to erect this type of mast on any small, flat area of roof.

By using 2 × 3s or 2 × 4s, the height may be extended up to about 50 feet. The 2 × 2 is too flexible to be satisfactory at such heights.

● SIMPLE 40-FOOT MAST

The mast shown in Fig. 14-46 is relatively strong, easy to construct, readily dismantled, and costs very little. Like the "A"-frame, it is suitable for heights of the order of 40 feet.

The top section is a single 2 × 3, bolted at the bottom between a pair of 2 × 3s with an overlap of about two feet. The lower section thus has two legs spaced the width of the narrow side of a 2 × 3. At the bottom the two

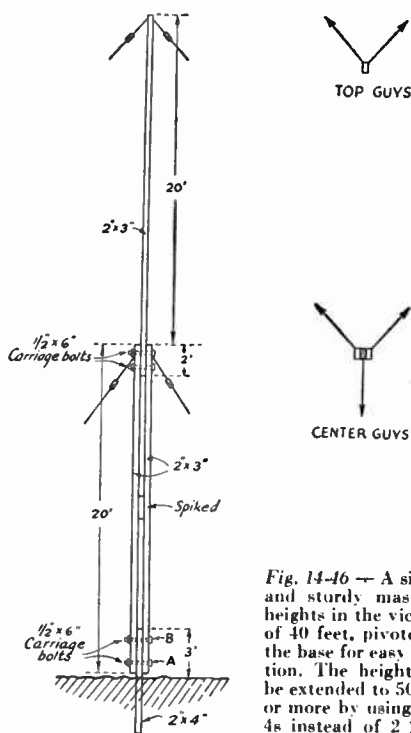

Fig. 14-16 — A simple and sturdy mast for heights in the vicinity of 40 feet, pivoted at the base for easy erection. The height can be extended to 50 feet or more by using 2×4 s instead of 2×3 s.

legs are bolted to a length of 2×4 which is set in the ground. A short length of 2×3 is placed between the two legs about halfway up the bottom section, to maintain the spacing.

The two back guys at the top pull against the antenna, while the three lower guys prevent buckling at the center of the pole.

The 2×4 section should be set in the ground so that it faces the proper direction, and then made vertical by lining it up with a plumb bob. The holes for the bolts should be drilled beforehand. With the lower section laid on the ground, bolt A should be slipped in place through the three pieces of wood and tightened just enough so that the section can turn freely on the bolt. Then the top section may be bolted in place and the mast pushed up, using a ladder or another 20-foot 2×3 for the job. As the mast goes up, the slack in the guys can be taken up so that the whole structure is in some measure continually supported. When the mast is vertical, bolt B should be slipped in place and both A and B tightened. The lower guys can then be given a final tightening, leaving those at the top a little slack until the antenna is pulled up, when they should be adjusted to pull the top section into line.

● GUYS AND GUY ANCHORS

For masts or poles up to about 50 feet, No. 12 iron wire is a satisfactory guy-wire material. Heavier wire or stranded cable may be used for taller poles or poles installed in locations where the wind velocity is likely to be high.

More than three guy wires in any one set usually are unnecessary. If a horizontal antenna is to be supported, two guy wires in the top set will be sufficient in most cases. These should run to the rear of the mast about 100 degrees apart to offset the pull of the antenna. Intermediate guys should be used in sets of three, one running in a direction opposite to that of the antenna, while the other two are spaced 120 degrees either side. This leaves a clear space under the antenna. The guy wires should be adjusted to pull the pole slightly back from vertical before the antenna is hoisted so that when the antenna is pulled up tight the mast will be straight.

When raising a mast that is big enough to tax the available facilities, it is some advantage to know nearly exactly the length of the guys. Those on the side on which the pole is lying can then be fastened temporarily to the anchors beforehand, which assures that when the pole is raised, those holding opposite guys will be able to pull it into nearly-vertical position with no danger of its getting out of control. The guy lengths can be figured by the right-angled-triangle rule that "the sum of the squares of the two sides is equal to the square of the hypotenuse." In other words, the distance from the base of the pole to the anchor should be measured and squared. To this should be added the square of the pole length to the point where the guy is fastened. The square root of this sum will be the length of the guy.

Guy wires should be broken up by strain insulators, to avoid the possibility of resonance at the transmitting frequency. Common practice is to insert an insulator near the top of each guy, within a few feet of the pole, and then cut each section of wire between the insulators to a length which will not be resonant either on the fundamental or harmonics. An insulator every 25 feet will be satisfactory for frequencies up to 30 Mc. The insulators should be of the "egg" type with the insulating material under compression, so that the guy will not part if the insulator breaks.

Twisting guy wires onto "egg" insulators may be a tedious job if the guy wires are long and of large gauge. The simple time- and finger-saving

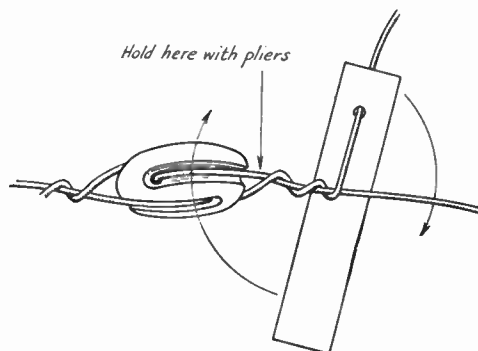

Fig. 14-17 — Using a lever for twisting heavy guy wires.

device (piece of heavy iron or steel) can be made by drilling a hole about twice the diameter of the guy wire about a half inch from one end of the piece. The wire is passed through the insulator, given a single turn by hand, and then held with a pair of pliers at the point shown in the sketch. By passing the wire through the hole in the iron and rotating the iron as shown, the wire may be quickly and neatly twisted.

Guy wires may be anchored to a tree or building when they happen to be in convenient spots. For small poles, a 6-foot length of 1-inch pipe driven into the ground at an angle will suffice. Additional bracing will be provided by using two pipes, as shown in Fig. 14-48.

● HALYARDS AND PULLEYS

Halyards or ropes and pulleys are important items in the antenna-supporting system. Particular attention should be directed toward the

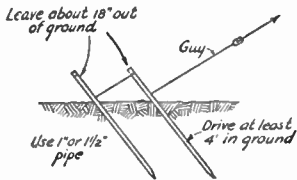

Fig. 14-48 — Pipe guy anchors. One pipe is sufficient for small masts, but two installed as shown will provide the additional strength required for the larger poles.

choice of a pulley and halyards for a high mast since replacement, once the mast is in position, may be a major undertaking if not entirely impossible.

Galvanized-iron pulleys will have a life of only

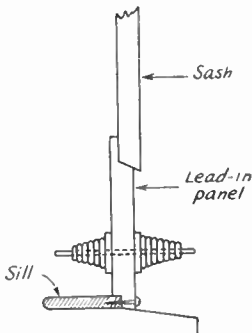

Fig. 14-49 — An antenna lead-in panel may be placed over the top sash or under the lower sash of a window. Substituting a smaller height sash in half the window will simplify the weatherproofing problem where the sash overlap.

a year or so. Especially for coastal-area installations, marine-type pulleys with hardwood blocks and bronze wheels and bearings should be used.

For short antennas and temporary installations, heavy clothesline or window-sash cord may be used. However, for more permanent jobs, 3/8-inch or 1/2-inch waterproof hemp rope should be used. Even this should be replaced about once a year to insure against breakage.

It is advisable to carry the pulley rope back up to the top in "endless" fashion in the manner of a flag hoist so that if the antenna breaks close

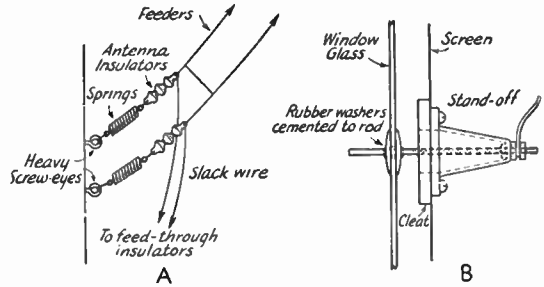

Fig. 14-50 — A — Anchoring feeders takes the strain from feed-through insulators or window glass. B — Going through a full-length screen, a cleft is fastened to the frame of the screen on the inside. Clearance holes are cut in the cleft and also in the screen.

to the pole, there will be a means for pulling the hoisting rope back down.

● BRINGING THE ANTENNA OR FEED LINE INTO THE STATION

The antenna or transmission line should be anchored to the outside wall of the building, as shown in Fig. 14-50, to remove strain from the lead-in insulators. Holes cut through the walls of the building and fitted with feed-through insulators are undoubtedly the best means of bringing the line into the station. The holes should have plenty of air clearance about the conducting rod, especially when using tuned lines that develop high voltages. Probably the best place to go through the walls is the trimming board at the top or bottom of a window frame which provides flat surfaces for lead-in insulators. Cement or rubber gaskets may be used to waterproof the exposed joints.

Where such a procedure is not permissible,

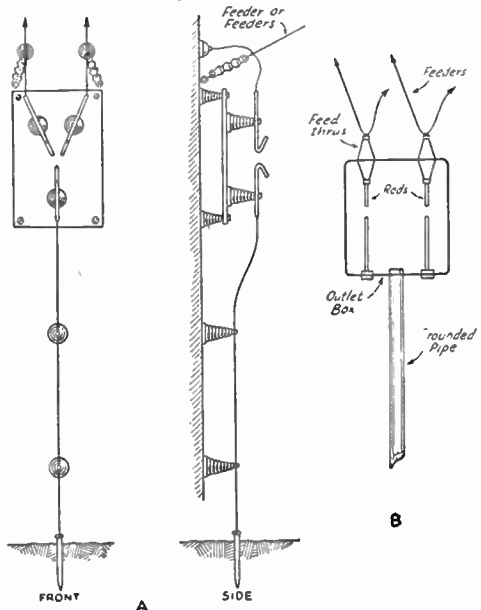

Fig. 14-51 — Low-loss lightning arresters for transmitting-antenna installations.

the window itself usually offers the best opportunity. One satisfactory method is to drill holes in the glass near the top of the upper sash. If the glass is replaced by plate glass, a stronger job will result. Plate glass may be obtained from automobile junk yards and drilled before placing in the frame. The glass itself provides insulation and the transmission line may be fastened to bolts fitting the holes. Rubber gaskets will render the holes waterproof. The lower sash should be provided with stops to prevent damage when it is raised. If the window has a full-length screen, the scheme shown in Fig. 14-50B may be used.

As a less permanent method, the window may be raised from the bottom or lowered from the top to permit insertion of a board which carries the feed-through insulators. This lead-in arrangement can be made weatherproof by making an overlapping joint between the board and window sash, as shown in Fig. 14-49, or by using weather-strip material where necessary.

Coaxial line can be brought through clearance holes without additional insulation.

Rotary-Beam Construction

It is a distinct advantage to be able to shift the direction of a beam antenna at will, thus securing the benefits of power gain and directivity in any desired compass direction. A favorite method of doing this is to construct the antenna so that it can be rotated in the horizontal plane. The use of such rotatable antennas is usually limited to the higher frequencies — 14 Mc. and above — and to the simpler antenna-element combinations if the structure size is to be kept within practicable bounds. For the 14-, 21- and 28-Mc. bands such antennas usually consist of two to four elements and are of the parasitic-array type described earlier in this chapter. At 50 Mc. and higher it becomes possible to use more elaborate arrays because of the shorter wavelength and thus obtain still higher gain. Antennas for these bands are described in another chapter.

The problems in rotary-beam construction are those of providing a suitable mechanical support for the antenna elements, furnishing a means of rotation, and attaching the transmission line so that it does not interfere with the rotation of the system.

Elements

The antenna elements usually are made of metal tubing so that they will be at least partially self-supporting, thus simplifying the supporting structure. The large diameter of the conductor is beneficial also in reducing resistance, which becomes an important consideration when close-spaced elements are used.

Aluminum alloy tubes are generally used for the elements. The elements frequently are constructed of sections of telescoping tubing making

● LIGHTNING PROTECTION

An ungrounded radio antenna, particularly if large and well elevated, is a lightning hazard. When grounded, it provides a measure of protection. Therefore, grounding switches or lightning arresters should be provided. Examples of construction of low-loss arresters are shown in Fig. 14-51. At A, the arrester electrodes are mounted by means of stand-off insulators on a fireproof asbestos board. At B, the electrodes are enclosed in a standard steel outlet box. The gaps should be made as small as possible without danger of breakdown during operation. Lightning-arrester systems require the best ground connection obtainable.

The most positive protection is to ground the antenna system when it is not in use; grounded flexible wires provided with clips for connection to the feeder wires may be used. The ground lead should be of short length and run, if possible, directly to a driven pipe or water pipe where it enters the ground outside the building.

length adjustments for tuning quite easy. Electrician's thin-walled conduit also is suitable for rotary-beam elements.

The element lengths are made adjustable by sawing a 6- to 12-inch slot in the ends of the larger-diameter tubing and clamping the smaller tubing inside. Homemade clamps of aluminum can be built, or hose clamps of suitable size can be used. An example of this construction is shown in Fig. 14-52. If steel clamps are used, they should be cadmium- or zinc-plated before installation.

If steel elements are used, special precautions should be taken to prevent rusting. The elements should be coated both inside and out with slow-drying aluminum paint. For coating the inside, the paint may be poured in one end while rotating the tubing. The excess paint may be caught as it comes out the bottom end and poured through again until it is certain that the entire inside wall has been covered. The ends should then be plugged up with corks sealed with glyptal varnish.

Supports

The supporting framework for a rotary beam usually is made of wood or metal, using as light-weight construction as is consistent with the required strength. Generally, the frame is not required to hold much weight, but it must be extensive enough so that the antenna elements can

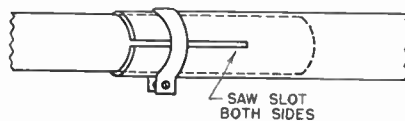

Fig. 14-52 — Details of telescoping tubing for beam elements.

be supported without excessive sag, and it must have sufficient strength to stand up under the maximum wind in the locality. The design of the frame will depend on the size and strength of the elements and the method used to rotate the antenna.

The general preference is for horizontal elements, primarily because less height is required to clear surrounding obstructions when all the antenna elements are in the horizontal plane. This is important at 14 and 21 Mc. where the elements are fairly long.

The support may be coupled to the mast by any convenient means which permits rotation or, alternatively, it may be firmly fastened to the mast and the latter rotated in bearings affixed to the side of the house.

Metal is commonly used to support the elements of the rotary beam. For 28 Mc., a piece of 2-inch diameter duraluminum tubing makes a good "boom" for supporting the elements. The elements can be made to slide through suitable holes in the boom, or special clamps and brackets can be fashioned to support the elements. Fittings for TV antennas can often be used on 21- and 28-Mc. beams.

Most of the TV antenna rotators are satisfactory for turning the smaller beams.

With all-metal construction, delta, "gamma" or "T"-match are the only practical matching methods to use to the line, since anything else requires opening the driven element at the center, and this complicates the support problem for that element.

"Plumber's-Delight" Construction

The lightest beam to build is the so-called "plumber's delight" — an array constructed entirely of metal, with no insulating members between the elements and the supporting structure. Suggested constructional details are shown in Figs. 14-53, 14-54, 14-55, 14-56 and 14-57.

The boom can be built of two lengths of 3-inch diameter 618-T6 dural tubing of 0.072-inch wall thickness, as shown in Fig. 14-53. The two sections are spliced together with a three-foot length of 6 x 6 oak, turned down at each end to fit inside the tubing. The center of the block is left square to provide a flat surface to attach to the vertical rotating pipe. At each extremity of this boom is cut a hole the exact diameter of the parasitic elements. A two-foot length of 3/4-inch pipe, complete with flange mounting plate, is bolted to the top surface of the oak block, and a single guy wire is run to each end of the boom. An egg insulator and a turnbuckle are placed in

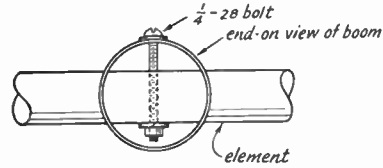

Fig. 14-54 — The center element section is held in the boom with a 1/4-28 machine screw, nut and lock washer. The guy wire attaches to the head of the bolt.

each guy. The turnbuckles should be tightened until there is no sag in the boom when it is supported at the center, and then safety-wired. Finally the center block should be given a good coat of paint or varnish.

The elements can be made of three 12-foot lengths of dural tubing, the two outside lengths telescoping inside the center section. The ends of the center section should be slotted for a distance of about 4 inches with a haek saw, but it is advisable to do the slotting after the center sections have been assembled on the boom. The parasitic-element center sections are fastened to the boom with 1/4-inch bolts, as shown in Fig. 14-54, while the driven element is secured in a cradle made of half sections of iron pipe welded together, as shown in Fig. 14-55. The cradle is bolted to the boom with three 1/4-inch bolts, and the driven element is held fast with two bolts or with adjustable air-craft-tubing clamps.

The feed line for the antenna can be any balanced line, of from 200 to 600 ohms impedance, and it is most conveniently coupled through a "T"-match. This "T"-match assembly can be made from two 4-foot lengths of dural tubing joined together by a piece of broomstick, as shown in Fig. 14-57. The "T" is connected to the antenna by two clamps fashioned of 1-inch-wide brass strip.

A convenient method for supporting the boom atop the pipe used to rotate the beam is shown in Fig. 14-56. A "U"-channel into which the boom will fit is welded to the end of the pipe. Holes are drilled in the side of the channel corresponding to holes in the boom. The boom is hoisted up and positioned between the two flanges and a bolt run through the flanges and the boom. The boom can then be swung into a horizontal position and the second bolt put in place.

Feeder Connections

For beams that rotate only 360 degrees, it is common to bring off feeders by making a short section of the feeder, just where it leaves the rotating member, of flexible wire. Enough slack should be left so that there is no danger of break-

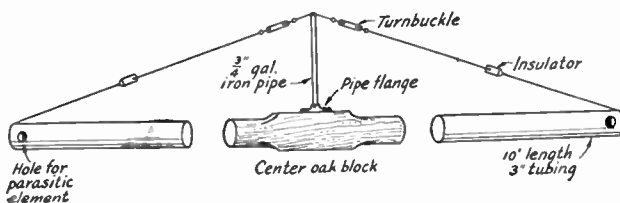

Fig. 14-53 — The boom is made of two 10-foot lengths of dural tubing slipped over a 3-foot oak block and held in place with 2-inch wood screws. Guy wires from the center add strength to the boom structure.

ing or twisting. Stops should be placed on the rotating shaft of the antenna so that it will be impossible for the feeders to "wind up."

For continuous rotation, the sliding contact is simple and, when properly built, quite practicable. The chief points to keep in mind are that the contact surfaces should be wide enough to take care of wobble in the rotating shaft, and that the contact surfaces should be kept clean. Spring contacts are essential, and an "umbrella" or other scheme for keeping rain off the contacts is a desirable addition. Sliding contacts preferably should be used with nonresonant open-wire lines, so that the line current is low.

The possibility of poor connections in sliding contacts can be avoided by using inductive coupling at the antenna, with one coil rotating on the antenna and the other fixed in position, the two coils being arranged so that the coupling does not change when the antenna is rotated. A quarter-wave feeder system is connected to a tuned pick-up circuit whose inductance is coupled to a link. The link coil connects to a twisted-pair transmission line, but any type of line such as flexible coaxial cable can be used.

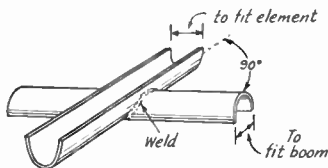

Fig. 14-55 — The clamp for the driven element is made by splitting 1-foot lengths of iron pipe and welding them as shown.

The circuit would be adjusted in the same way as any link-coupled circuit, and the number of turns in the link should be varied to give proper loading on the transmitter. The rotating coupling circuit tunes to the transmitting frequency. The system is equivalent to a link-coupled antenna tuner mounted on the pole, using a parallel-tuned tank at the end of a quarter-wave line to center-feed the antenna. For constant coupling, the two coils should be rigid and the pole should rotate without wobble. The two coils might be made a part of the upper bearing assembly holding the rotating pole in position.

There are other variations of the inductive-coupled system. The tuned circuit might, for instance, be placed at the end of a 600-ohm line, and a one-turn link used to couple directly to the center of the antenna, if the construction of the rotary member permits. In this case the coupling can be varied by changing the L/C ratio in the tuned circuit. For mechanical strength the coupling coils preferably should be made of $\frac{1}{4}$ -inch copper tubing, braced with insulating strips to keep them rigid.

Fig. 14-57 — Details of the "T"-match assembly.

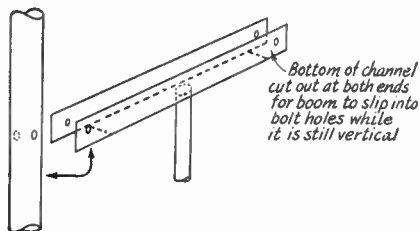
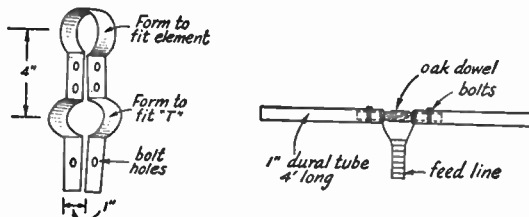

Fig. 14-56 — The mounting plate is made from a length of "U"-channel iron cut and drilled as shown. The boom is raised vertically until one set of bolt holes is in line and a bolt is slipped through. The boom is then swung into its horizontal position and the other bolt is put in place.

Rotation

It is convenient but not essential to use a motor to rotate the beam. If a rope-and-pulley arrangement can be brought into the operating room or if the pole can be mounted near a window in the operating room, hand rotation will work.

If the use of a rope and pulleys is impracticable, motor drive is about the only alternative. There are several complete motor driven rotators on the market, and they are easy to mount, convenient to use, and require little or no maintenance. Generally speaking, light-weight units are better because they reduce the tower load.

The speed of rotation should not be too great — one or $1\frac{1}{2}$ r.p.m. is about right. This requires a considerable gear reduction from the usual 1750-r.p.m. speed of small induction motors; a large reduction is advantageous because the gear train will prevent the beam from turning in weather-vane fashion in a wind. The usual beam does not require a great deal of power for rotation at slow speed, and a $\frac{1}{8}$ -hp. motor will be ample. A reversible motor should be used. War-surplus "prop pitch" motors have found wide application for rotating 14-Mc. beams, while TV rotators can be used with many 28-Mc. light-weight beams.

Driving motors and gear housings will stand the weather better if given a coat of aluminum paint followed by two coats of enamel and a coat of glyptal varnish. Even commercial units will last longer if treated with glyptal varnish. Be sure that the surfaces are clean and free from grease before painting. Grease can be removed by brushing with kerosene and then squirting the surface with a solid stream of water. The work can then be wiped dry with a rag.

The power and control leads to the rotator should be run in electrical conduit or in lead covering, and the metal should be grounded.

A Compact 14-Mc. 3-Element Beam

A 20-meter beam no larger than the usual 10-meter beam can be made by using center-loaded elements and close spacing. Such an antenna will show good directivity and can be rotated with a TV-antenna rotator.

Constructional details of the elements are

clamps can be used for this purpose. The boom is a 12-foot length of 1½-inch o.d. 61ST aluminum tubing, with 0.125-inch wall.

The line is coupled and matched at the center of the driven element through adjustment of the link wound on the outside of the Lucite tubing.

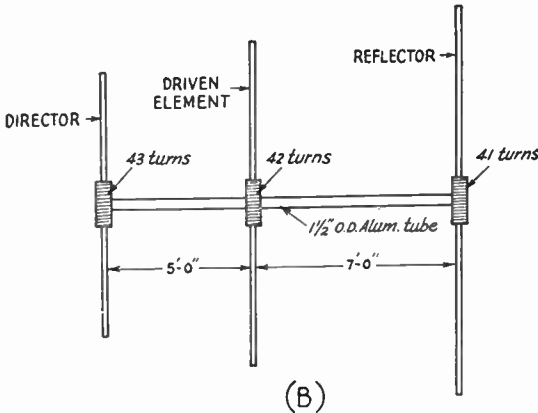
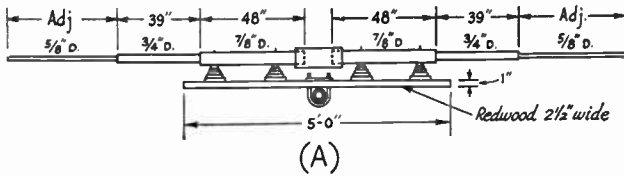

Fig. 14-58 — Dimensions of a compact 14-Mc. beam. A — Side view of a typical element. TV-antenna "U" clamps hold the support arms to the boom. Birnbaach 4176 insulators support the elements. B — Top plan of the beam showing element spacing and loading-coil dimensions. Elements are made of aluminum tubing. Construction of the loading coils and adjustment of the elements are discussed in the text. End-section lengths of 41 inches for the reflector, 40 inches for the driven element, and 40 inches for the director will be close to optimum.

shown in Figs. 14-58 and 14-59. The loading coils are space-wound by interwinding plumb line (sometimes known as chalk line) with the No. 12 wire coils. The coil ends are secured by drilling small holes through the polystyrene bar, as shown in Fig. 14-59. The coils should be sprayed or painted with Krylon before installing the protective Lucite tubes.

The beam will require 4-foot lengths of the tubings indicated in Fig. 14-58A. For good telescoping, element wall thickness of 0.058 inch is recommended. The ends of the tubing sections should be slotted to permit adjustment, and secured with clamps, so that the joints will not work loose in the wind. Perforated ground

in any beam, the s.w.r. will depend upon this adjustment and not on any that can be made at the transmitter. Transmitter coupling is the usual for any coaxial line. (From *QST*, May, 1954.)

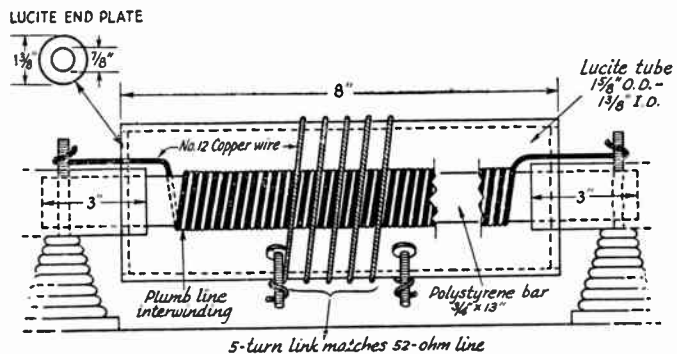

Fig. 14-59 — Detailed sketch of the loading and coupling coils at the center of the driven element, and its mounting. Similar loading coils (see text) are used at the centers of the director and reflector.

A "One-Element Rotary" for 21 Mc.

The directional properties of a simple half-wave-length antenna become more apparent at higher frequencies, and it is possible to take advantage of this fact to build a "one-element rotary" for 21 or 28 Mc. To take advantage of the directional properties of the antenna, it is only necessary to rotate it 180 degrees. It can be rotated by hand, as will be described, or by a small TV antenna rotator.

The antenna is made from two pieces of 1/2-inch diameter electrical thin-wall steel tubing or conduit. This tubing is readily available at any electric supply shop. It comes in 10-foot lengths and, while 20 feet is short for a half-wave antenna at 21 Mc., with loading the length is just about right for 52-ohm line feed. (A half-wave-length antenna would normally be fed with 72-ohm cable, since the antenna offers a good match for this impedance value. In this antenna system, the shorter elements, plus the small coil, offer a good match for 52-ohm cable.) If aluminum tubing is available, it can be used in place of the conduit, and the antenna will be lighter in weight. As shown in Figs. 14-60 and 14-61, the two pieces of tubing are supported by four stand-off insulators on a four foot long 2 by 2. The coax fitting for the feed line is mounted on the end of one of the lengths of tubing. A mounting point is made by flattening the end of the tubing for a length of about 1 1/2 inches. The tubing can be flattened by squeezing it in a vise or by laying the end of the tubing on a hard surface and then hammering it flat. This will provide enough space to accommodate the coax fitting (Amphenol type 83-1R). A 5/8-inch hole will be needed in the flat section to clear the shell of the coax fitting.

The coil, L_1 , is made from 1/8-inch diameter

copper tubing. It consists of 5 turns spaced 1/4 inch apart and is 1 inch inside diameter. The coil is connected in series with the inner conductor pin on the coax fitting and the other half of the antenna. To secure a good connection at the coax fitting, the coil lead should be wound around the inner-conductor pin and soldered. The other end of the coil can be connected with a screw and nut.

Mounting

The antenna can be mounted on a 1-inch floor flange and held in place by two 2-inch bolts, as shown in Fig. 14-60. The floor flange can be connected to a 12-foot length of 1-inch pipe which will serve as a mast. Television antenna wall mounts can be used to support the mast.

In the installation shown in Fig. 14-62, 19-inch wall mounts were used in order to clear the eaves of the house. A 2-inch long piece of 1 1/4-inch pipe was used as a sleeve, and it was clamped in the U bolt on the bottom wall mount. A 1/4-inch hole was drilled through the mast pipe approximately 6 inches from the bottom. Then a 1 1/2-inch bolt was slipped through the hole and the mast was then mounted in the sleeve on the bottom wall mount. The bolt acted as a bearing point against the top of the sleeve. Another 1/4-inch hole was drilled through the mast about three feet above the bottom wall mount. A piece of 1/4-inch metal rod, six inches long, was forced through the hole so that the rod projected on each side of the mast. To turn the mast, a piece of rope was attached to each end of the rod and the rope was brought into the shack, so that the antenna could be rotated by the "arm-strong" method. Obviously, one could spend more money for a "de luxe" version and use a TV antenna rotator and mast.

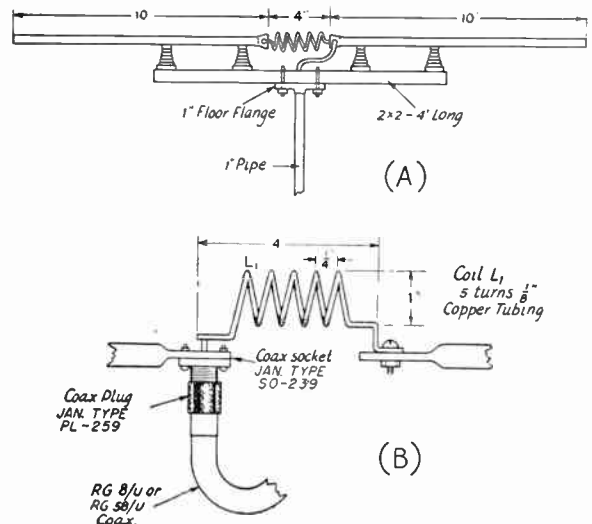
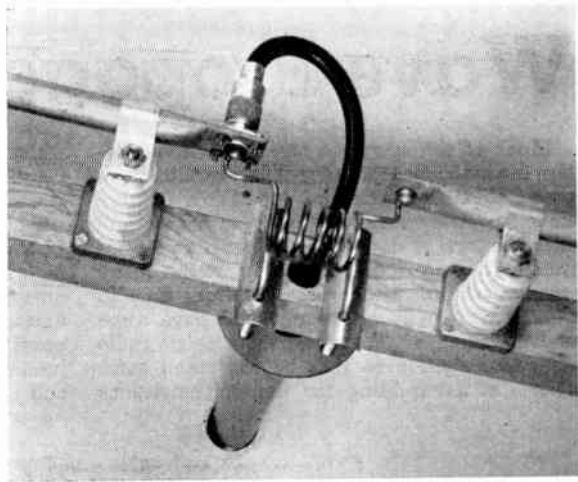

Fig. 14-60 — (A) Diagram of the 21-Mc. antenna and mounting. The 1 bolts that hold the 2 by 2 to the floor flange are standard 2-inch TV mast type bolts. (B) A more detailed drawing of the coil and coax-fitting mountings. The 1/4-inch spacing between turns is not critical, and they can vary as much as 1/16 inch without any apparent harm to the match.

◆
Fig. 14-61—A close-up of the coil and coax fitting mountings. Be sure that the coil doesn't short out to the outer conductor when soldering the coil end to the inner conductor pin on the coax fitting.

◆



RG-8, U 52-ohm coax cable is recommended to feed the antenna. For power inputs up to 100 watts, the smaller and less expensive RG-58 U can be used. However, when you buy RG-58 U, be sure that the line is made by a reputable manufacturer (such as Amphenol or Belden). Some of the line made for TV installations is of inferior quality and is likely to have higher losses. The feedline was fed up through the mast pipe and through a $\frac{3}{4}$ -inch hole in the 2 by 2. An Amphenol 83-1SP fitting on the end of the coax line connects to the female fitting on the antenna.

Coupling to the Transmitter

It may be found that, when the feed line is coupled to the transmitter, the antenna won't take power. Since the line is terminated at the

antenna in its characteristic impedance of 52 ohms, the output of the final r.f. amplifier must be adjusted to couple into a 52-ohm load. Where the output coupling device is a variable link, all that may be needed is the correct setting of the link. If the link is fixed, one end of the link can be grounded to the transmitter chassis and the other end of the link connected in series with a small variable capacitor to the inner conductor of the feed line. The outer conductor of the coax is grounded to the transmitter chassis. The capacitor is tuned to the point where the final amplifier is properly loaded. For transmitters having a pi-network output circuit, it is merely a matter of adjusting the network to the point where the amplifier is properly loaded.

(From *QST*, January, 1955.)



◆
Fig. 14-62—Over-all view of the antenna and mounting. The feed line comes out of the bottom of the mast and through the wall into the shack.

Wave Propagation

Much of the appeal of amateur communication lies in the fact that the results are not always predictable. Transmission conditions on the same frequency vary with the year, season and with the time of day. Although these variations usually follow certain established patterns, many peculiar effects can be observed from time to time. Every radio amateur should have some understanding of the known facts about radio wave propagation so that he will stand some chance of interpreting the unusual conditions

when they occur. The observant amateur is in an excellent position to make worthwhile contributions to the science, provided he has sufficient background to understand his results. He may discover new facts about propagation at the very-high frequencies or in the microwave region, as amateurs have in the past. In fact, it is through amateur efforts that most of the extended-range possibilities of various radio frequencies have been discovered, both by accident and by long and careful investigation.

Characteristics of Radio Waves

Radio waves, like other forms of electromagnetic radiation such as light, travel at a speed of 300,000,000 meters per second in free space, and can be reflected, refracted, and diffracted.

As described in the chapter on fundamentals, an electromagnetic wave is composed of moving fields of electric and magnetic force. The lines of force in the two fields are at right angles, and are

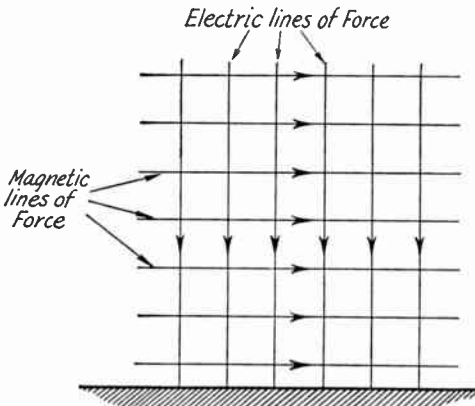

Fig. 15-1 — Representation of electrostatic and electromagnetic lines of force in a radio wave. Arrows indicate instantaneous directions of the fields for a wave traveling toward the reader. Reversing the direction of one set of lines would reverse the direction of travel.

mutually perpendicular to the direction of travel. A simple representation of a wave is shown in Fig. 15-1. In this drawing the electric lines are perpendicular to the earth and the magnetic lines are horizontal. They could, however, have any position with respect to earth so long as they remain perpendicular to each other.

The plane containing the continuous lines of electric and magnetic force shown by the grid- or mesh-like drawing in Fig. 15-1 is called the wave front.

The medium in which electromagnetic waves travel has a marked influence on the speed with

which they move. When the medium is empty space the speed, as stated above, is 300,000,000 meters per second. It is almost, but not quite, that great in air, and is much less in some other substances. In dielectrics, for example, the speed is inversely proportional to the dielectric constant of the material.

When a wave meets a good conductor it cannot penetrate it to any extent (although it will travel through a dielectric with ease) because the electric lines of force are practically short-circuited.

Polarization

The polarization of a radio wave is taken as the direction of the lines of force in the electric field. If the electric lines are perpendicular to the earth, the wave is said to be vertically polarized; if parallel with the earth, the wave is horizontally polarized. The longer waves, when traveling along the ground, usually maintain their polarization in the same plane as was generated at the antenna. The polarization of shorter waves may be altered during travel, however, and sometimes will vary quite rapidly.

Spreading

The field intensity of a wave is inversely proportional to the distance from the source. Thus if one receiving point is twice as far from the transmitter as another, the field strength at the more distant point will be just half the field strength at the nearer point. This results from the fact that the energy in the wave front must be distributed over a greater area as the wave moves away from the source. This inverse-distance law is based on the assumption that there is nothing in the medium to absorb energy from the wave as it travels, which is true in free space but not in practical communication along the ground and through the atmosphere.

Types of Propagation

According to the altitudes of the paths along which they are propagated, radio waves may

be classified as **ionospheric waves**, **tropospheric waves** or **ground waves**.

The **ionospheric wave** or **sky wave** is that part of the total radiation that is directed toward the ionosphere. Depending upon variable conditions in that region, as well as upon transmitting wave length, the ionospheric wave may or may not be returned to earth by the effects of refraction and reflection.

The **tropospheric wave** is that part of the total radiation that undergoes refraction and reflection in regions of abrupt change of dielectric constant in the troposphere, such as the boundaries between air masses of differing temperature and moisture content.

The **ground wave** is that part of the total radi-

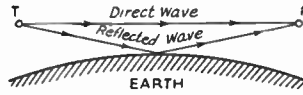

Fig. 15-2 — Showing how both direct and reflected waves may be received simultaneously.

tion that is directly affected by the presence of the earth and its surface features. The **ground wave** has two components. One is the **surface wave**, which is an earth-guided wave, and the other is the **space wave** (not to be confused with the ionospheric or sky wave). The space wave is itself the resultant of two components — the **direct wave** and the **ground-reflected wave**, as shown in Fig. 15-2.

Ionospheric Propagation

● PROPERTIES OF THE IONOSPHERE

Except for distances of a few miles, nearly all amateur communication on frequencies below 30 Mc. is by means of the sky wave. Upon leaving the transmitting antenna, this wave travels upward from the earth's surface at such an angle that it would continue out into space were its path not bent sufficiently to bring it back to earth. The medium that causes such bending is the **ionosphere**, a region in the upper atmosphere, above a height of about 60 miles, where free ions and electrons exist in sufficient quantity to have an appreciable effect on the speed at which the waves travel.

The ionization in the upper atmosphere is believed to be caused by ultraviolet radiation from the sun. The ionosphere is not a single region but is composed of a series of layers of varying densities of ionization occurring at different heights. Each layer consists of a central region of relatively dense ionization that tapers off in intensity both above and below.

Refraction

The greater the intensity of ionization in a layer, the more the path of the wave is bent. The bending, or refraction (often also called reflection), also depends on the wave length; the longer the wave, the more the path is bent for a given degree of ionization. Thus low-frequency waves are more readily bent than those of high frequency. For this reason the lower frequencies — 3.5 and 7 Mc. — are more "reliable" than the higher frequencies — 14 to 28 Mc.; there are times when the ionization is of such low value that waves of the latter frequency range are not bent enough to return to earth.

Absorption

In traveling through the ionosphere the wave gives up some of its energy by setting the ionized particles into motion. The energy **absorption** from this cause increases with the wavelength; that is, absorption is greater at lower frequencies. It also increases with the intensity of ionization,

and with the density of the atmosphere in the ionized region.

Virtual Height

Although an ionospheric layer is a region of considerable depth it is convenient to assign to it a definite height, called the **virtual height**. This is the height from which a simple reflection would give the same effect as the gradual bend-

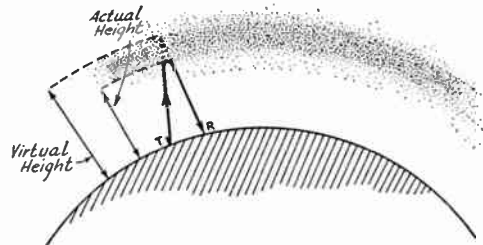

Fig. 15-3 — Bending in the ionosphere, and the echo or reflection method of determining virtual height.

ing that actually takes place, as illustrated in Fig. 15-3. The wave traveling upward is bent back over a path having an appreciable radius of turning, and a measurable interval of time is consumed in the turning process. The virtual height is the height of a triangle having equal sides of a total length proportional to the time taken for the wave to travel from T to R.

Normal Structure of the Ionosphere

The lowest useful ionized layer is called the **E layer**. The average height of the region of maximum ionization is about 70 miles. The air at this height is sufficiently dense so that the ions and electrons set free by the sun's radiation do not travel far before they meet and recombine to form neutral particles, so the layer can maintain its normal intensity of ionization only in the presence of continuing radiation from the sun. Hence the ionization is greatest around local noon and practically disappears after sunset.

In the daytime there is a still lower ionized

area, the *D* region. *D*-region ionization is proportional to the height of the sun and is greatest at noon. The lower amateur-band frequencies (1.8 and 3.5 Mc.) are almost completely absorbed by this layer, and only the high-angle radiation is reflected by the *E* layer. (Lower-angle radiation travels farther through the *D* region and is absorbed.)

The second principal layer is the *F* layer which has a height of about 175 miles at night. At this altitude the air is so thin that recombination of ions and electrons takes place very slowly. The ionization decreases after sundown, reaching a minimum just before sunrise. In the daytime the *F* layer splits into two parts, the *F*₁ and *F*₂ layers, with average virtual heights of, respectively, 140 miles and 200 miles. These layers are most highly ionized at about local noon, and merge again at sunset into the *F* layer.

● SKY-WAVE PROPAGATION

Wave Angle

The smaller the angle at which a wave leaves the earth, the less the bending required in the ionosphere to bring it back. Also, the smaller the angle the greater the distance between the point where the wave leaves the earth and that at which it returns. This is shown in Fig. 15-4. The vertical angle that the wave makes with a tangent to the earth is called the **wave angle** or **angle of radiation**.

Skip Distance

More bending is required to return the wave to earth when the wave angle is high, and at times the bending will not be sufficient unless the wave angle is smaller than some critical value. This is illustrated in Fig. 15-4, where *A* and smaller angles give useful signals while waves sent at higher angles penetrate the layer and are not returned. The distance between *T* and *R*₁ is, therefore, the shortest possible distance, at that particular frequency, over which communication by ionospheric refraction can be accomplished.

The area between the end of the useful ground wave and the beginning of ionospheric-wave reception is called the **skip zone**, and the distance from the transmitter to the nearest point where the sky wave returns to earth is called the **skip distance**. The extent of the skip zone depends upon the frequency and the state of the ionosphere, and also upon the height of the layer in which the refraction takes place. The higher layers give longer skip distances for the same wave angle. Wave angles at the transmitting and receiving points are usually, although not always, approximately the same for any given wave path.

Critical and Maximum Usable Frequencies

If the frequency is low enough, a wave sent vertically to the iono-

sphere will be reflected back down to the transmitting point. If the frequency is then gradually increased, eventually a frequency will be reached where this vertical reflection just fails to occur. This is the **critical frequency** for the layer under consideration. When the operating frequency is below the critical value there is no skip zone.

The critical frequency is a useful index to the highest frequency that can be used to transmit over a specified distance — the **maximum usable frequency (m.u.f.)**. If the wave leaving the transmitting point at angle *A* in Fig. 15-4 is, for example, at a frequency of 14 Mc., and if a higher frequency would skip over the receiving point *R*₁, then 14 Mc. is the m.u.f. for the distance from *T* to *R*₁.

The greatest possible distance is covered when the wave leaves along the tangent to the earth; that is, at zero wave angle. Under average conditions this distance is about 4000 kilometers or 2500 miles for the *F*₂ layer, and 2000 km. or 1250 miles for the *E* layer. The distances vary with the layer height. Frequencies above these limiting m.u.f.'s will not be returned to earth at any distance. The 4000-km. m.u.f. for the *F*₂ layer is approximately 3 times the critical frequency for that layer, and for the *E* layer the 2000-km. m.u.f. is about 5 times the critical frequency.

Absorption in the ionosphere is least at the maximum usable frequency, and increases very rapidly as the frequency is lowered below the m.u.f. Consequently, best results with low power always are secured when the frequency is as close to the m.u.f. as possible.

It is readily possible for the ionospheric wave to pass through the *E* layer and be refracted back to earth from the *F*, *F*₁ or *F*₂ layers. This is because the critical frequencies are higher in the latter layers, so that a signal too high in frequency to be returned by the *E* layer can still come back from one of the others, depending upon the time of day and the existing conditions.

Multihop Transmission

On returning to the earth the wave can be reflected upward and travel again to the ionosphere. There it may once more be refracted, and

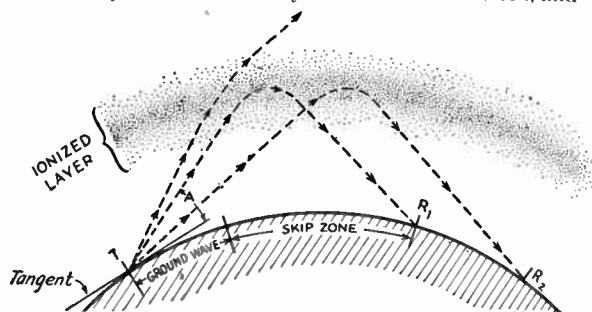

Fig. 15-4 — Refraction of sky waves, showing the critical wave angle and the skip zone. Waves leaving the transmitter at angles above the critical (greater than *A*) are not bent enough to be returned to earth. As the angle is decreased, the waves return to earth at increasingly greater distances.

again bent back to earth. This process may be repeated several times. **Multihop** propagation of this nature is necessary for transmission over great distances because of the limited heights of the layers and the curvature of the earth, which restrict the maximum one-hop distance to the values mentioned in the preceding section. However, ground losses absorb some of the energy from the wave on each reflection (the amount of the loss varying with the type of ground and being least for reflection from sea water), and there is also absorption in the ionosphere at each reflection. Hence the smaller the number of hops the greater the signal strength at the receiver, other things being equal.

Fading

Two or more parts of the wave may follow slightly different paths in traveling to the receiving point, in which case the difference in path lengths will cause a phase difference to exist between the wave components at the receiving antenna. The total field strength will be the sum of the components and may be larger or smaller than one component alone, since the phases may be such as either to aid or oppose. Since the paths change from time to time, this causes a variation in signal strength called **fading**. Fading can also result from the combination of single-hop and multihop waves, or the combination of a ground wave with an ionospheric or tropospheric wave. The latter condition produces an area of severe fading in the region where the two waves have about the same intensity; better reception is obtained at either shorter or longer distances where one component of the wave is considerably stronger than the other.

Fading may be either rapid or slow, the former type usually resulting from rapidly-changing conditions in the ionosphere, the latter occurring when transmission conditions are relatively stable.

It frequently happens that transmission conditions are different for waves of slightly different frequencies, so that in the case of voice-modulated transmission, involving side bands differing slightly from the carrier in frequency, the carrier and various side band components may not be propagated in the same relative amplitudes and phases they had at the transmitter. This effect, known as **selective fading**, causes severe distortion of the signal.

Scatter

Even though the operating frequency is above the m.u.f. for a given distance, it is usually possible to hear signals from within the skip zone. This phenomenon, called **scatter**, is caused by random reflections from distances beyond the skip zone. Such reflections can occur when the transmitted energy strikes the earth at a distance and some of it is reflected back into the skip zone to the receiver. Other possible scatter sources are "patches" of ionization of different density than the average, or **sporadic-E** clouds (see later section). Scatter signals are weaker

than those normally propagated, and also have a rapid fade or "flutter" that makes them easily recognizable.

OTHER FEATURES OF IONOSPHERIC PROPAGATION

Cyclic Variations in the Ionosphere

Since ionization depends upon ultraviolet radiation, conditions in the ionosphere vary with changes in the sun's radiation. In addition to the daily variation, seasonal changes result in higher critical frequencies in the *E* layer in summer, averaging about 4 Mc. as against a winter average of 3 Mc. The *F* layer shows little variation, the critical frequency being of the order of 4 to 5 Mc. in the evening. The *F*₁ layer, which has a critical frequency near 5 Mc. in summer, usually disappears entirely in winter. The daytime maximum critical frequencies for the *F*₂ are highest in winter (10 to 12 Mc.) and lowest in summer (around 7 Mc.). The virtual height of the *F*₂ layer, which is about 185 miles in winter, averages 250 miles in summer. These values are representative of latitude 40 deg. North in the Western hemisphere, and are subject to considerable variation in other parts of the world.

Very marked changes in ionization also occur in step with the **11-year sunspot cycle**. Although there is no apparent direct correlation between sunspot activity and critical frequencies on a given day, there is a definite correlation between *average* sunspot activity and critical frequencies. The critical frequencies are highest during sunspot maxima and lowest during sunspot minima. During the period of minimum sunspot activity the lower frequencies — 7 and 3.5 Mc. — frequently are the only usable bands at night. At such times the 28-Mc. band is seldom useful for long-distance work, while the 14-Mc. band performs well in the daytime but is not ordinarily useful at night.

Ionosphere Storms

Certain types of sunspot activity cause considerable disturbances in the ionosphere (**ionosphere storms**) and are accompanied by disturbances in the earth's magnetic field (**magnetic storms**). Ionosphere storms are characterized by a marked increase in absorption, so that radio conditions become poor. The critical frequencies also drop to relatively low values during a storm, so that only the lower frequencies are useful for communication. Ionosphere storms may last from a few hours to several days. Since the sun rotates on its axis once every 28 days, disturbances tend to recur at such intervals, if the sunspots responsible do not become inactive in the meantime. Absorption is usually low, and radio conditions therefore good, just preceding a storm.

Sporadic-E Ionization

Scattered patches or clouds of relatively dense ionization occasionally appear at heights approximately the same as that of the *E* layer, for rea-

sons not yet known. This sporadic-*E* ionization is most prevalent in the equatorial regions, where it is substantially continuous. In northern latitudes it is most frequent in the spring and early summer, but is present in some degree a fair percentage of the time the year 'round. It accounts for a good deal of the night-time short distance work on the lower frequencies (3.5 and 7 Mc.) and, when more intense, for similar work on 14 and 28 Mc. Exceptionally intense sporadic-*E* ionization is responsible for work over distances exceeding 400 or 500 miles on the 50-Mc. band.

There are indications of a relationship between sporadic-*E* ionization and average sunspot activity, but it does not appear to be directly related to daylight and darkness since it may occur at any time of the day. However, there is an apparent tendency for the ionization to peak at mid-morning and in the early evening.

Tropospheric Propagation

Changes in temperature and humidity of air masses in the lower atmosphere often permit work over greater than normal ground-wave distances on 28 Mc. and higher frequencies. The effect can be observed on 28 Mc., but it is generally more marked on 50 and 144 Mc. The subject is treated in detail later.

● PREDICTION CHARTS

The Central Radio Propagation Laboratory of National Bureau of Standards offers prediction charts three months in advance, by means of which it is possible to predict with considerable accuracy the maximum usable frequency that will hold over any path on the earth during a monthly period. The charts can be obtained from the Superintendent of Documents, U. S. Government Printing Office, Washington 25, D. C. for 10 cents a copy or \$1.00 per year. They are called "CRPL-D Basic Radio Propagation Predictions."

● PROPAGATION IN THE 3.5 TO 30-MC. BANDS

The 1.8-Mc., or "160-meter," band offers reliable working over ranges up to 25 miles or so during daylight. On winter nights, ranges up to several thousand miles are not impossible. Only small sections of the band are currently available to amateurs, because of the presence of the loran service in that part of the spectrum. The pulse-type interference sometimes caused by loran can be readily eliminated by using an audio limiter in the receiver.

The 3.5-Mc., or "80-meter," band is a more useful band during the night than during the daylight hours. In the daytime, one can seldom hear signals from a distance of greater than 200 miles or so, but during the darkness hours distances up to several thousand miles are not unusual, and transoceanic contacts are regularly made during the winter months. During the summer, the static level is high in some parts of the world.

The 7-Mc., or "40-meter," band has many of the same characteristics as 3.5, except that the distances that can be covered during the day and night hours are increased. During daylight, distances up to a thousand miles can be covered under good conditions, and during the dawn and dusk periods in winter it is possible to work stations as far as the other side of the world, the signals following the darkness path. The winter months are somewhat better than the summer ones. In general, summer static is much less of a problem than on 80 meters, although it can be serious in the semitropical zones.

The 14-Mc., or "20-meter," band is probably the best one for long-distance work. During the high portion of the sunspot cycle it is open to some part of the world during practically all of the 24 hours, while during a sunspot minimum it is generally useful only during daylight hours and the dawn and dusk periods. There is practically always a skip zone on this band.

The 21-Mc., or "15-meter," band shows highly variable characteristics depending on the sunspot cycle. During sunspot maxima it is useful for long-distance work during a large part of the 24 hours, but in years of low sunspot activity it is almost wholly a daytime band, and sometimes unusable even in daytime. However, it is often possible to maintain communication over distances up to 1500 miles or more by sporadic-*E* ionization (described later), which may occur either day or night at any time in the sunspot cycle.

The 27-Mc. ("11-meter") and 28-Mc. ("10-meter") bands are generally considered to be DX bands during the daylight hours and good for local work during the hours of darkness, for about half the sunspot cycle. At the very peak of the sunspot cycle, they may be "open" into the late evening hours for DX communication. At the sunspot minimum these bands are usually "dead" for long-distance communication, by means of the F_2 layer, in the northern latitudes. Nevertheless, sporadic-*E* propagation is likely to occur at any time, just as in the case of the 21-Mc. band.

Propagation Above 50 Mc.

The importance to the amateur of having some knowledge of wave propagation was stressed at the beginning of this chapter. An understanding of the means by which his signals reach their destination is an even greater aid to the v.h.f.

worker. Each of his bands shows different characteristics, and knowledge of their peculiarities is as yet far from complete. The observant user of the amateur v.h.f. assignments has a good opportunity to contribute to that knowledge, and

his enjoyment of his work will be greatly enhanced if he knows when to expect unusual propagation conditions.

● CHARACTERISTICS OF THE V.H.F. BANDS

An outstanding feature of our bands from 50 Mc. up is their ability to provide consistent and interference-free communication within a limited range. All lower frequencies are subject to varying conditions that impair their effectiveness for work over distances of 100 miles or less at least part of the time, and the heavy occupancy they support results in severe interference problems in areas of dense population. The v.h.f. bands, being much wider, can handle many times the amateur population without crowding, and their characteristics for local work are more stable. It is thus to the advantage of amateur radio as a whole to make use of 50 Mc. and higher bands for short-range communication wherever possible.

In addition to reliable local coverage, the v.h.f. bands also exhibit several forms of long-distance propagation at times, and use of 50 and 144 Mc. has been taken up in recent years by many isolated amateurs who must depend on these propagation peculiarities for all or most of their contacts. It is particularly important to these operators that they understand common propagation phenomena. The material to follow supplements information presented earlier in this chapter, dealing with wave propagation only as it affects the occupants of the world above 50 Mc. First let us consider the bands individually.

50 to 54 Mc.: This band is borderline territory between the DX frequencies and those normally employed for local work. Thus just about every form of wave propagation found throughout the radio spectrum appears, on occasion, in the 50-Mc. region. This has contributed greatly to the popularity of the 50-Mc. band.

During the peak years of a sunspot cycle it is occasionally possible to work 50-Mc. DX of world-wide proportions, by reflection of signals from the F_2 layer. Sporadic-E skip provides contacts over distances from 400 to 2500 miles or so during the early summer months, regardless of the solar cycle. Reflection from the aurora regions allows 100- to 600-mile work during pronounced ionospheric disturbances. The ever-changing weather pattern offers extension of the normal coverage to as much as 300 to 500 miles. This develops most often during the warmer months, but may occur at any season. In the absence of any favorable propagation, the average well-equipped 50-Mc. station should be able to work regularly over a radius of 75 to 100 miles or more, depending on local terrain.

144 to 148 Mc.: Ionospheric effects are greatly reduced at 144 Mc. F_2 -layer reflection is unlikely, and sporadic-E skip is rare. Aurora DX is fairly common, but signals are generally weaker than on 50 Mc. Tropospheric effects are more pro-

nounced than on 50 Mc., and distances covered during favorable weather conditions are greater than on lower bands. Air-mass boundary bending has been responsible for communication on 144 Mc. over distances in excess of 1100 miles, and 500-mile work is fairly common in the warmer months. The reliable range under normal conditions is slightly less than on 50 Mc., with comparable equipment.

220 Mc. and Higher: Ionospheric propagation is unlikely at 220 Mc. and up, but tropospheric bending is more prevalent than on lower bands. Amateur experience on 220 and 420 Mc. is showing that they can be as useful as 144 Mc., when comparable equipment is used. Under minimum conditions the range may be slightly shorter, but when signals are good on 144 Mc., they may be better on 220 or 420. Even above 1000 Mc. there is evidence of tropospheric DX.

● PROPAGATION PHENOMENA

The various known means by which v.h.f. signals may be propagated over unusual distances are discussed below.

F_2 -Layer Reflection: Most contacts made on 28 Mc. and lower frequencies are the result of reflection of the wave by the F_2 layer, the ionization density of which varies with solar activity, the highest frequencies being reflected at the peak of the 11-year solar cycle. The maximum usable frequency (m.u.f.) for F_2 reflection also follows other well-defined cycles, daily, monthly, and seasonal, all related to conditions on the sun and its position with respect to the earth.

At the low point of the 11-year cycle, such as in the early '50s, the m.u.f. may reach 28 Mc. only during a short period each spring and fall, whereas it may go to 60 Mc. or higher at the peak of the cycle. The fall of 1946 saw the first authentic instances of long-distance work on 50 Mc. by F_2 -layer reflection, and as late as 1950 contacts were made in the more favorable areas of the world by this medium. The rising curve of the current solar cycle again made F_2 DX on 50 Mc. possible in the low latitudes in the winter of 1955-6. It is expected to spread farther north and south in the following two to three years. Loss of the 50-Mc. band to television in Europe and Australia will limit the scope of 50-Mc. DX in years to come.

The F_2 m.u.f. is readily determined by observation, and it may be estimated quite accurately for any path at any time. It is predictable for months in advance, enabling the v.h.f. worker to arrange test schedules with distant stations at propitious times. As there are numerous commercial signals, both harmonics and fundamental transmissions, on the air in the range between 28 and 50 Mc., it is possible to determine the approximate m.u.f. by careful listening in this range. Daily observations will show if the m.u.f. is rising or falling, and once the peak for a given month is determined it can be assumed that another will occur about 27 days later, this cycle coinciding with the turning of

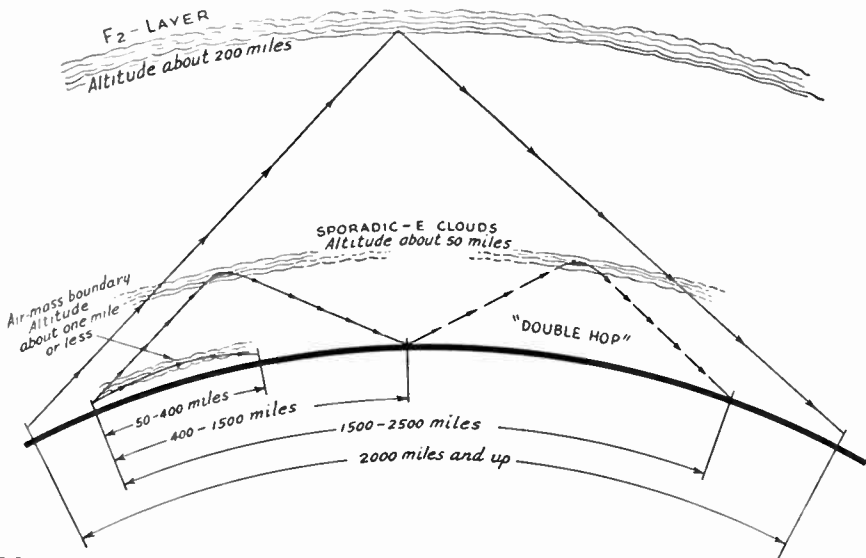

Fig. 15-5 — The principal means by which v.h.f. signals may be returned to earth, showing the approximate distances over which they are effective. The F_2 layer, highest of the reflecting layers, may provide 50-Mc. DX at the peak of the 11-year sunspot cycle. Such communication may be world-wide in scope. Sporadic ionization of the E region produces the familiar "short skip" on 28 and 50 Mc. It is most common in early summer and in late December, but may occur at any time, regardless of the sunspot cycle. Refraction of v.h.f. waves also takes place at air-mass boundaries in the lower atmosphere, making possible communication over distances of several hundred miles on all v.h.f. bands. Normally it exhibits no skip zone.

the sun on its axis. The working range, via F_2 skip, is roughly comparable to that on 28 Mc., though the *minimum* distance is somewhat longer. Two-way work on 50 Mc. by reflection from the F_2 layer has been accomplished over distances from 2200 to 11,000 miles. The maximum frequency for F_2 reflection is believed to be about 70 Mc.

Sporadic-E Skip: Patchy concentrations of ionization in the E -layer region are often responsible for reflection of signals on 28 and 50 Mc. This is the popular "short skip" that provides fine contacts on both bands in the range between 400 and 1300 miles. It is most common in May, June and July, during morning and early evening hours, but it may occur at any time or season. Multiple-hop effects may appear, when ionization develops simultaneously over large areas, making possible work over distances of more than 2500 miles.

The upper limit of frequency for sporadic- E skip is not positively known, but scattered instances of 144-Mc. propagation over distances in excess of 1000 miles indicate that E -layer reflection, possibly aided by tropospheric effects, may be responsible.

Aurora Effect: Low-frequency communication is occasionally wiped out by absorption in the ionosphere, when ionospheric storms, associated with variations in the earth's magnetic field, occur. During such disturbances, however, v.h.f. signals may be reflected back to earth, making communication possible over distances not normally workable in the v.h.f. range. Magnetic storms may be accompanied by an aurora-borealis display, if the disturbance occurs at night and visibility is good. Aiming a directional array at

the auroral curtain will bring in signals strongest, regardless of the true direction to the transmitting station.

Aurora-reflected signals are characterized by a rapid flutter, which lends a "dribbling" sound to 28-Mc. carriers and may render modulation on 50- and 144-Mc. signals completely unreadable. The only satisfactory means of communication then becomes straight e.w. The effect may be noticeable on signals from any distance other than purely local, and stations up to about 800 miles in any direction may be worked at the peak of the disturbance. Unlike the two methods of propagation previously described, aurora effect exhibits no skip zone. It is observed frequently on 50 and 144 Mc. in northeastern U. S. A., usually in the early evening hours. The highest frequency for auroral reflection is not yet known, but pronounced disturbances have permitted work by this medium in the 220-Mc. band.

Tropospheric Bending: The most common form of v.h.f. DX is the extension of the normal operating range associated with easily observed weather phenomena. It is the result of the change in refractive index of the atmosphere at the boundary between air masses of differing temperature and humidity characteristics. Such air-mass boundaries usually lie along the western or southern edges of a stable slow-moving area of high barometric pressure (fair calm weather) in the period prior to the arrival of a storm.

A typical upper-air sounding showing temperature and water-vapor gradients favorable to v.h.f. DX is shown in Fig. 15-6. An increase in temperature and a sharp drop in water-vapor

gradient are seen at about 4000 feet, in comparison to the U. S. Standard Atmosphere curves at the left.

Such a favorable condition develops most often in the late summer or early fall, along the junction between air masses that may have come together from such widely-separated points as the Gulf of Mexico and Northern Canada. Under stable weather conditions the two air masses may retain their original character for several

wave range, and there is good evidence to indicate that our assignments in the u.h.f. and s.h.f. portions of the frequency spectrum may someday support communication over distances far in excess of the optical range.

Scatter: Forward scatter, both ionospheric and tropospheric, may be used for marginal communication in the v.h.f. bands. Both provide very weak but consistent signals over distances that were once thought impossible on frequencies

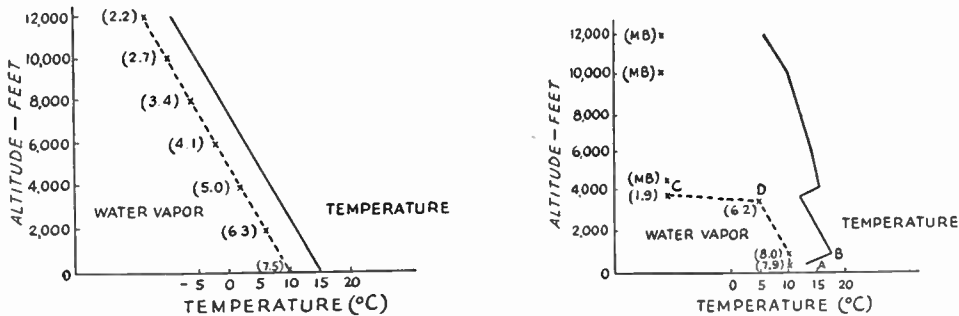

Fig. 15-6 — Upper-air conditions that produce extended-range communication on the v.h.f. bands. At the left is shown the U. S. Standard Atmosphere temperature curve. The humidity curve (dotted) is that which would result if the relative humidity were 70 per cent from the ground level to 12,000 feet elevation. There is only slight refraction under this standard condition. At the right is shown a sounding that is typical of marked refraction of v.h.f. waves. Figures in parentheses are the "mixing ratio" — grams of water vapor per kilogram of dry air. Note the sharp break in both curves at about 4000 feet. (From Collier, "Upper-Air Conditions for 2-Meter DX," QST, September, 1955.)

days at a time, usually moving slowly eastward across the country. When the path between two v.h.f. stations separated by fifty to several hundred miles lies along such a boundary, signal levels run far above the average value.

Many factors other than air-mass movement of a continental character provide increased v.h.f. operating range. The convection along coastal areas in warm weather is a good example. The rapid cooling of the earth after a hot day in summer, with the air aloft cooling more slowly, is another, producing a rise in signal strength in the period around sundown. The early-morning hours, when the sun heats the air aloft, before the temperature of the earth's surface begins to rise, may be the best of the day for extended v.h.f. range, particularly in clear, calm weather, when the barometer is high and the humidity low.

The v.h.f. enthusiast soon learns to correlate various weather manifestations with radio-propagation phenomena. By watching temperature, barometric pressure, changing cloud formations, wind direction, visibility, and other easily-observed weather signs, he can tell with a reasonable degree of accuracy what is in prospect on the v.h.f. bands.

The responsiveness of radio waves to varying weather conditions increases with frequency. The 50-Mc. band is more sensitive to weather variations than is the 28-Mc. band, and the 144-Mc. band may show strong signals from far beyond visual distances when lower frequencies are relatively inactive. It is probable that this tendency continues on up through the micro-

higher than about 30 Mc.

Tropospheric scatter is prevalent all through the v.h.f. and microwave regions, and is usable over distances up to about 400 miles. Ionospheric scatter, augmented by meteor bursts, brings in signals over 600 to 1300 miles, on frequencies up to about 100 Mc. Either form of scatter requires high power, large antennas and c.w. technique to provide effective communication.

Back scatter, of the type heard on lower bands, is also heard occasionally on 50 Mc., when F_2 or sporadic-E skip is present.

Reflections from Meteor Trails: Probably the least-known means of v.h.f. wave propagation is that resulting from the passage of meteors across the signal path. Reflections from the ionized meteor trails may be noted as a Doppler-effect whistle on the carrier of a signal already being received, or they may cause bursts of reception from stations not normally receivable. Ordinarily such reflections are of little value in communication, since the increases in signal strength are of short duration, but meteor showers of considerable magnitude and duration may provide fluttery signals from distances up to 1500 miles or more on both 50 and 144 Mc.

As meteor-burst signals are relatively weak, their detection is greatly aided if high power and high-gain antennas are used. Two-way communication of sorts has been carried on by this medium on 50 and 144 Mc. over distances of 600 to 1300 miles, through the use of short c.w. transmissions and frequent repetition.

V.H.F. Receivers

Good receiving facilities are all-important in v.h.f. work. High sensitivity, adequate stability and good signal-to-noise ratio, necessary attributes in a receiving system for 50 Mc. and higher frequencies, are most readily attained through the use of a converter working into a communications receiver designed for lower frequencies. Though receivers and converters for the v.h.f. bands are available on the amateur market, the amateur worker can build his own with fully as good results, usually at a considerable saving in cost.

Basically, modern v.h.f. receiving equipment is little different from that employed on lower frequencies. The same order of selectivity may be used on all amateur frequencies up to at least 450 Mc. The greatest practical selectivity should be employed in v.h.f. reception, as it not only allows more stations to operate in a given band, but is an important factor in improving the signal-to-noise ratio. The effective sensitivity of a receiver having "communication" selectivity can be made much better than is possible with broadband systems.

This rules out converted radar-type receivers and others using high intermediate frequencies. The superregenerative receiver, a simple but broadband device that was popular in the early days of v.h.f. work, is now used principally for portable operation, or for other applications where high sensitivity and selectivity are not of prime importance. It is capable of surprising performance, for a given number of tubes and components, but its lack of selectivity, its poor signal-to-noise ratio, and its tendency to radiate a strong interfering signal have eliminated the superregenerator as a fixed-station receiver in areas where there is appreciable v.h.f. activity.

R. F. AMPLIFIER DESIGN

The noise generated within the receiver itself is an important factor in the effectiveness of v.h.f. receiving gear. At lower frequencies, and to a considerable extent on 50 Mc., external noise is a limiting factor. At 144 Mc. and higher the receiver noise figure, gain and selectivity determine the ability of the system to respond to weak signals. Proper selection of r.f. amplifier tubes and appropriate circuit design aimed at low noise figure are more important in the v.h.f. receiver "front end" than mere gain.

Triode or Pentode?

Certain triode tubes have been developed with this end in view. Their superiority over pentode types is more pronounced as we go

higher in frequency. Because of the limitation on sensitivity imposed by external noise at that frequency, triode or pentode r.f. amplifiers give about the same results at 50 Mc. Thus the pentode types, which offer the advantages of better selectivity and simpler circuitry, are often used for 50-Mc. work. But at 144 Mc., the newer triodes designed for r.f. amplifier service give fully as much gain as the pentodes, and with lower internal noise. With the exception of the simplest unit, the equipment described in the following pages incorporates low-noise r.f. amplifier techniques.

Neutralizing Methods

When triodes are used as r.f. amplifiers some form of neutralization of the grid-plate capacitance is required. This can be capacitive, as is commonly used in transmitting applications, or inductive. The alternative to neutralization is the use of grounded-grid technique. Circuits for v.h.f. triode r.f. amplifier stages are given in Figs. 16-1 through 16-4.

A dual triode operated as a neutralized push-pull amplifier is shown at 16-1. This ar-

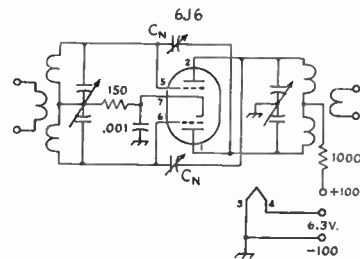

Fig. 16-1—Schematic diagram of a push-pull r.f. amplifier for v.h.f. applications. This circuit is well-suited to use with antenna systems having balanced lines. Coil and capacitor values not given depend on the frequency at which the amplifier is to be used. Neutralizing capacitance, C_N , may be built up by twisting ends of insulated leads together.

range is well adapted to v.h.f. preamplifier applications, or as the first stage in a converter, particularly when a balanced transmission line such as the popular 300-ohm Twin-Lead is used. It is relatively selective and may require resistive loading of the plate circuit, when used as a preamplifier. The loading effect of the following circuit may be sufficient to give the required band width, when the push-pull stage is inductively coupled to the mixer.

A triode amplifier having excellent noise figure and broadband characteristics is shown in Fig.

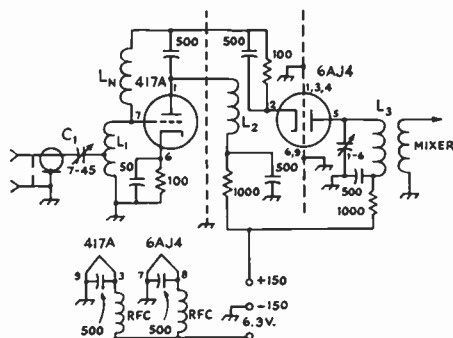

Fig. 16-2 — Circuit of the cascode r.f. amplifier. Coupling capacitor, C_1 , may be omitted if spurious receiver responses are not a problem. Neutralizing winding, L_N , should resonate at the signal frequency with the grid-plate capacitance of the first tube. Base connections are for 417A and 6AJ4, but other small triodes may be used.

16-2. Commonly called the cascode, it uses a triode or triode-connected pentode followed by a triode grounded-grid stage. This circuit is extremely stable and uncritical in adjustment. At 50 Mc. and higher its over-all gain is at least equal to the best single-stage pentode amplifier and its noise figure is far lower.

Neutralization is accomplished by the coil L_N , whose value is such that it resonates at the signal frequency with the grid-plate capacitance of the tube. Its inductance is not critical; it may be omitted from the circuit without the stage going into oscillation, but neutralization results in a lower noise figure than is possible without it. Any of several v.h.f. tubes may be used in the cascode circuit. The example shown in Fig. 16-2 uses the 417A, followed by a 6AJ4. Two 6AJ4s would work almost equally well, as would the 6AM4, 6AN4 and 6J4. Pin connections in Fig. 18-2 should be changed to suit the tubes selected.

A simplified version of the cascode, using a dual triode tube designed especially for this application, is shown in Fig. 16-3. By reducing stray capacitance, through direct coupling between the two triode sections, this circuit makes for improved performance at the frequencies above 100 Mc. The two sections of the tube are in series, as far as plate voltage is concerned, so

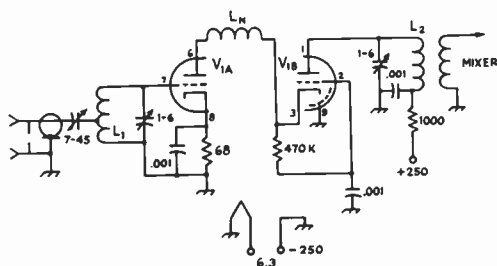

Fig. 16-3 — Simplified cascode circuit for use with dual triodes having separate cathodes. Coil and capacitance values not given depend on frequency. Bifilar r.f. chokes are occasionally used in heater leads.

it requires higher voltage than the other circuits shown.

The neutralization process for the cascode and neutralized-triode amplifiers is somewhat similar. With the circuit operating normally the neutralizing adjustments (capacitance of C_N in Fig. 16-1; inductance of L_N in Figs. 16-2 and 16-3) can be set for best signal-to-noise ratio. The best results are obtained using a noise generator, adjusting for lowest noise figure, but careful adjustment on a weak signal provides a fair approximation. Noise generators and their use in v.h.f. receiver adjustment are treated in July, 1953, *QST*, p. 10.

Grounded-grid r.f. amplifier technique is illustrated in Figs. 16-4 and 16-25. Here the input is in the cathode lead, with the grid of the tube grounded, to act as a shield between cathode and plate. The grounded-grid circuit is stable and easily adjusted, and is well adapted to broadband applications. The gain per stage is low, so that two or more stages may be required.

Tubes well-suited to grounded-grid amplifier service include the 6J4, 6AN4, 6AJ4, 6AM4, 6BC4, 417A and 416B. Disk-seal tubes such as the "lighthouse" and "pencil tube" types are often used as r.f. amplifiers above 500 Mc., and the new ceramic tubes show great possibilities for r.f. amplifier service in the u.h.f. range.

Great care should be used in adjusting the r.f. portion of a v.h.f. receiver, whatever circuit is used. If it is working properly it will control the noise figure of the entire system.

Reducing Supurious Responses

In areas where there is a high level of v.h.f. activity or extensive use of other frequencies in the v.h.f. range, the ability of the receiver to operate properly in the presence of strong signals may be an important consideration. Special tube types, otherwise similar to older numbers, have been developed for low overload and cross-modulation susceptibility. The 6BC8, which may be used as a replacement for the 6BQ7A or 6BZ7, is one of these.

Modification of the converter design can also improve performance in these respects. In general, the gain ahead of the mixer stage should be made no more than is necessary to achieve good noise figure characteristics. The plate voltage on the r.f. amplifier should be kept as high as practical, to prevent easy overloading.

Rejection of signals outside the desired frequency range can be improved by the use of high-Q tuned circuits ahead of the first r.f. amplifier stage. Television transmitters are particularly troublesome in this respect, and one or more coaxial-type circuits inserted in the lead from the antenna to the converter may be necessary to keep such signals from interfering with normal reception.

A common cause of unwanted signals appearing in the tuning range is the presence of oscillator harmonics in the energy being fed to the mixer of a crystal-controlled converter. This may be prevented by using a high oscillator frequency, to

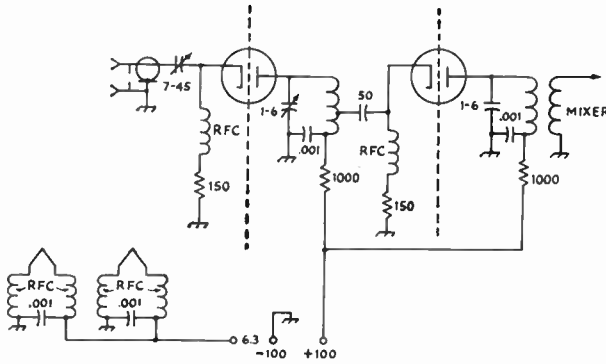

Fig. 16-4 — Grounded-grid amplifier. Position of tap on plate coil should be adjusted for lowest noise figure. Low gain with this circuit makes two stages necessary for most applications. R.f. choke and coil values depend on frequency.

keep down the number of multiplications, and by shielding the oscillator and multiplier stages from the rest of the converter.

Signals at the intermediate frequency may ride through a converter. This can be prevented by keeping down capacitive interstage coupling in the r.f. circuitry, and by shielding the converter and the receiver antenna terminals. The problem of receiver responses is dealt with in "Communications Receiver Hints for the V.h.f. Man," *QST*, April, 1955, p. 56.

MIXER CIRCUITS

The mixer in a v.h.f. converter may be either a pentode or a triode tube. Pentodes give generally higher output, and may require less injection. When used without a preceding r.f. amplifier stage, the triode mixer may provide a better noise figure. With either tube, the grid circuit is tuned to the signal frequency, and the plate circuit to the intermediate frequency.

A simple pentode mixer is shown in Fig. 16-5A, with a triode mixer at B. A dual-triode version (push-push mixer) is shown at C. The push-push mixer is well adapted to use at 420 Mc., and may, of course, be used at any lower frequency. Dual tubes may be used as both mixer and oscillator, combining the circuits of Figs. 16-5 and 16-6. A 6U8 could use its pentode as a mixer (16-5A) and the oscillator portion (16-6A) would be a triode. Dual-triode tubes (6J6, 12AT7 and many others) would combine 16-5B and 16-6A. In dual triodes having separate cathodes some external coupling may be required, but the common cathode of the 6J6 will provide sufficient injection in most cases. If the injection is more than necessary it can be reduced by dropping the oscillator plate voltage, either directly or by increasing the value of the dropping resistor.

A pentode mixer is less subject to oscillator pulling than a triode, and it will probably require less injection voltage. In a pentode mixer, its plate current should be held to the lowest usable value, to reduce tube noise. This may be controlled by varying the the mixer screen voltage. A

common use of pentode mixers in v.h.f. work is in the interest of simplicity of circuit layout, as in multi-band converters employing band-switching.

Occasionally oscillation near the signal frequency may be encountered in v.h.f. mixers. This usually results from stray lead inductance in the mixer plate circuit, and is most common with triode mixers. It may be corrected by connecting a small capacitance from plate to cathode, *directly* at the tube socket. Ten to 25 $\mu\text{f.}$ will be sufficient, depending on the signal frequency.

OSCILLATOR STABILITY

When a high-selectivity i.f. system is employed in v.h.f. reception, the stability of the oscillator is extremely important. Slight variations in oscillator frequency that would not be noticed when a broadband i.f. amplifier is used become intolerable when the passband is reduced to crystal-filter proportions.

One satisfactory solution to this problem is the use of a crystal-controlled oscillator, with frequency multipliers if needed, to supply the injection voltage. Such a converter usually employs one or more broadband r.f. amplifier stages, and tuning is done by tuning the receiver with which the converter is used to cover the desired intermediate frequency range.

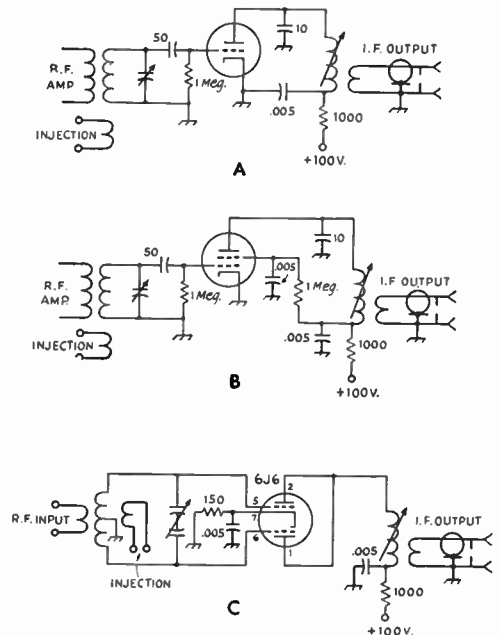
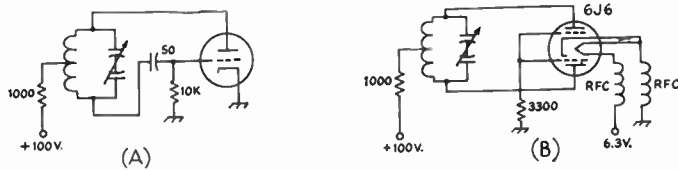

Fig. 16-5 — Typical v.h.f. mixer circuits for pentode (A), single triode (B) and push-push triode (C). Circuits A and B may be used with one portion of various dual-purpose tubes. Plate current of pentode (A) should be held at lowest usable value.

Fig. 16-6 — Recommended oscillator circuits for tunable v.h.f. converters. Dual-triode-version (B) is recommended for 220 or 420 Mc. R.f. choke coil and capacitor values not given depend on frequency.



When a tunable oscillator and a fixed intermediate frequency are used, special attention must be paid to the oscillator design, to be sure that it is mechanically and electrically stable. The tuning capacitor should be solidly built, preferably of the double-bearing type. Split-stator capacitors specifically designed for v.h.f. service, usually having ball-bearing end plates and special construction to insure short leads, are well worth their extra cost. Leads should be made with stiff wire, to reduce vibration effects. Mechanical stability of air-wound coils can be improved by tying the turns together with narrow strips of household cement at several points.

Recommended oscillator circuits for v.h.f. work are shown in Fig. 16-6. The single-ended oscillator may be used for 50 or 144 Mc. with good results. The push-pull version is recommended for higher frequencies and may also be used on the two lower bands, as well. Circuit A works well with almost any small triode, or one half of a 6J6 or 12AT7. The 6J6 is well suited to push-pull applications, as shown in circuit 16-6B.

● THE I.F. AMPLIFIER

Superheterodyne receivers for 50 Mc. and up should have fairly high intermediate frequencies, to reduce both oscillator pulling and image response. Approximately 10 per cent of the signal frequency is commonly used, with 10.7 Mc. being set up as the standard i.f. for commercially-built f.m. receivers. This particular frequency has a disadvantage for 50-Mc. work, in that it makes the receiver subject to image response from 28-Mc. signals, if the oscillator is on the low side of the signal frequency. A spot around 7 Mc. is favored for amateur converter service, as practically all communications receivers are capable of tuning this range.

For selectivity with a reasonable number of i.f. stages, double conversion is usually employed in complete receivers for the v.h.f. range. A 7-Mc. intermediate frequency, for instance, is changed to 455 kc., by the addition of a second mixer-oscillator. This procedure is, of course, inherent in the use of a v.h.f. converter ahead of a communications receiver.

If the receiver so used is lacking in sensitivity, the over-all gain of the converter-receiver combination may be inadequate. This can be corrected by building an i.f. amplifier stage into the converter itself. Such a stage is useful even when the gain of the system is adequate without it, as the gain control can be used to permit operation of the converter with receivers of

widely-different performance. If the receiver has an S-meter, its adjustment may be left in the position used for lower frequencies, and the converter gain set so as to make the meter read normally on v.h.f. signals.

Where reception of wide-band f.m. or unstable signals of modulated oscillators is desired, a converter may be used ahead of an f.m. broadcast receiver. A superregenerative detector operating at the intermediate frequency, with or without additional i.f. amplifier stages, also may serve as an i.f. and detector system for reception of wide-band signals. By using a high i.f. (10 to 30 Mc. or so) and by resistive loading of the i.f. transformers, almost any desired degree of band width can be secured, providing good voice quality on all but the most unstable signals. Any of these methods may be used for reception in the microwave region, where stabilized transmission is extremely difficult at the current state of the art.

● THE SUPERREGENERATIVE RECEIVER

The simplest type of v.h.f. receiver is the superregenerator. It affords fair sensitivity with few tubes and elementary circuits, but its weaknesses, listed earlier, have relegated it to applications where small size and low power consumption are important considerations.

Its sensitivity results from the use of an alternating quenching voltage, usually in the range between 20 and 200 kc., to interrupt the normal oscillation of a regenerative detector. The regeneration can thus be increased far beyond the amount usable in a straight regenerative circuit.

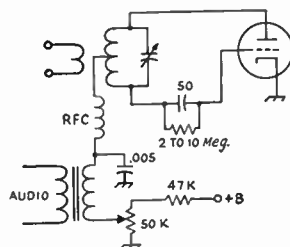

Fig. 16-7 — Superregenerative detector circuit for self-quenched detector. Pentode tube may be used, varying screen voltage by means of the potentiometer to control regeneration.

The detector itself can be made to furnish the quenching voltage, or a separate oscillator tube can be used. Regeneration is usually controlled by varying the late voltage in triode detectors, or the screen voltage in the case of pentodes. A typical circuit is shown in Fig. 16-7.

Crystal-Controlled Converters for 50, 144 and 220 Mc.

The family of converters shown in Figs. 16-8 through 16-16 was designed to provide optimum reception on all v.h.f. bands. Crystal-controlled injection is used to insure stability, and the r.f. circuit design provides the lowest practical noise figure for each frequency. Special attention has been paid to the reduction of spurious responses, often a troublesome point in broadband converter design. A separate converter section for each band connects to a common i.f. amplifier and power supply by means of a single plug and cable. This carries the mixer output, and plate and filament voltages.

The R.F. Circuits

A pentode r.f. amplifier (6CB6) is used in the 50-Mc. converter in the interest of simplicity. With proper design, such a stage can be made to deliver a satisfactory noise figure at 50 Mc. Its performance is quite adequate; it will be found that outside noise picked up by the antenna will be the limiting factor in weak-signal reception, even in a quiet receiving location.

The 144- and 220-Mc. converters have modified cascode circuits with dual triodes (6BQ7A, 6BK7 or 6BZ7) in the first stages. The 220-Mc. converter has an additional pentode stage, to build up the gain and improve the ability of the converter to reject unwanted frequencies. It will be noted that the converters differ somewhat as to circuitry in other respects, but this was done primarily to show examples of various circuit techniques, rather than because of any superiority of one approach over another. This applies particularly to the methods of coupling between stages.

When a fixed injection frequency is used with a variable intermediate frequency, the r.f. and i.f.

circuits of the converter must be made broadband, to avoid the need for readjusting them as the receiver with which the converter is used is tuned across the i.f. range. Spurious responses, both at the i.f. range and at frequencies adjacent to the desired signal frequencies, pose a special problem. Band-pass characteristics are attained through the use of over-coupled double-tuned circuits in the converter r.f. circuits. These circuits present a high impedance at the signal frequency, but they look like a short circuit to signals in the i.f. range that are picked up by the antenna.

Spurious responses that might develop as the result of the injection of unwanted frequencies at the mixer grid are reduced by the use of a separate tube for the mixer, and coupling the injection voltage from the multiplier stage through a link. Isolation of the mixer and multiplier stages is further increased in the 144- and 220-Mc. converters by the installation of a shield partition along the middle of the base plate.

Crystal Oscillator Details

Crystal frequencies were selected so that all bands would start at the same spot on the communications receiver dial; in this case 7000 kc. Crystal frequencies, multiplier details and i.f. tuning ranges are shown in Table 16-1. Other i.f. tuning ranges that may be better suited to some communications receivers may be employed by suitable alteration of the crystal and multiplier frequencies.

A fairly high oscillator frequency is desirable, to reduce the possibility of oscillator harmonics appearing in the tuning range, as well as to keep down the number of multiplier stages. Each con-

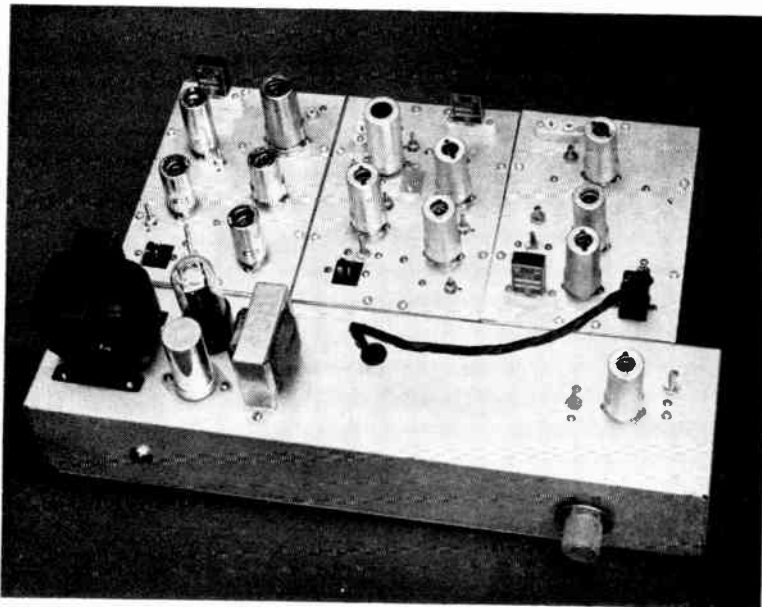

Fig. 16-8 — Crystal-controlled converters for 220, 144 and 50 Mc. (l. to r.) with their common i.f. amplifier and power supply. All chassis are standard sizes, requiring a minimum of metal work.

verter in this series uses a readily-obtainable crystal operating on its third overtone. This may result in a frequency of oscillation that is not exactly three times that marked on the crystal, but it is close enough for ordinary calibration purposes. Overtone crystals of the desired frequency may be obtained on order, at somewhat higher prices than for fundamental-type crystals. Conventional operation of crystals in the 7-Mc. range, making up the multiplication with additional stages, is not recommended because of the difficulty in avoiding birdies from crystal harmonics. In the overtone circuit, no frequency lower than the overtone at which the crystal oscillates is heard.

Layout

Each converter is built on a single 5 × 7-inch aluminum plate, and mounted on a standard chassis that serves as shielding and case. The three 5 × 7 × 3-inch chassis are bolted to the back of the i.f. unit, to be described later. In this way each converter is a separate entity, permitting the constructor to build any one of them, omitting those bands in which he may not be interested. The shape of the i.f. unit is not important, and it could very readily be built in more compact fashion if less than the three converters are planned. The method of construction shown requires a minimum of metal work, and a converter can be rebuilt or replaced without affecting the operation of the others.

As only three tubes are used in the 50 Mc. converter they are arranged in a single line down the middle of the base plate. The other models have the oscillator-multiplier and amplifier-mixer sections separated by a vertical shield partition.

● THE 50-MC. CONVERTER

The simplest of the three converters is the 50-Mc. unit, shown in Figs. 16-9 and 16-10. The r.f. and mixer stages use 6CB6 pentodes and a 6J6 serves as crystal oscillator and multiplier. A

TABLE 16-I
Crystal-Controlled Converter Data

Band (Mc.)	Injection (Mc.)	I.F. (Mc.)	Crystal (kc.)	Overtone & Multiplication
50	43	7-11	7166	3rd × 2
144	137	7-11	7611	3rd × 3 × 2
220	213	7-12	7100	3rd × 5 × 2
420*	382	50-54*	7074	3rd × 3 × 3 × 2
420*	406	26-30*	7518	same

* For covering 432 to 436 Mc. only. To tune the rest of the band additional crystal frequencies or a wider i.f. tuning range must be used.

somewhat lower noise figure could have been obtained with a triode r.f. amplifier, but the design shown has a noise figure under 5 db. With the considerable external noise picked up by the antenna at 50 Mc., even in a quiet location, there is little to be gained in weak-signal reception by going lower than this figure.

The bottom view of the converter, Fig. 16-9, shows the r.f. amplifier socket and components at the left side. A small shield across the socket isolates the grid and plate circuits. The r.f. plate tuning capacitor, C_2 , is near the center. The plate coil, L_3 , is the lower of the two coils in the middle of the photograph, with the mixer grid coil, L_4 , just above it. An enameled-wire link may be seen running from this coil to the doubler plate coil, L_{10} , at the lower right. The oscillator inductance, L_9 , is at the upper right corner.

Two methods of antenna coupling are shown in the schematic, Fig. 16-10, but the constructor need install only the one that is suited to the type of transmission line he intends to use to feed his antenna system. If coax is used, connection is made directly to the r.f. amplifier grid coil, L_2 . This same type of connection may be used with a balun for balanced lines, or the coupling winding, L_1 , may be added. In some instances it may be desirable to connect a trimmer between J_1 and L_2 , as shown in the 220-Mc. converter, if spurious signals are a problem

◆
◆
Fig. 16-9 — Bottom view of the 50-Mc. converter. The r.f. amplifier socket, divided by a shield partition, is at the left. Crystal oscillator and multiplier components are at the right, with the mixer in the middle.

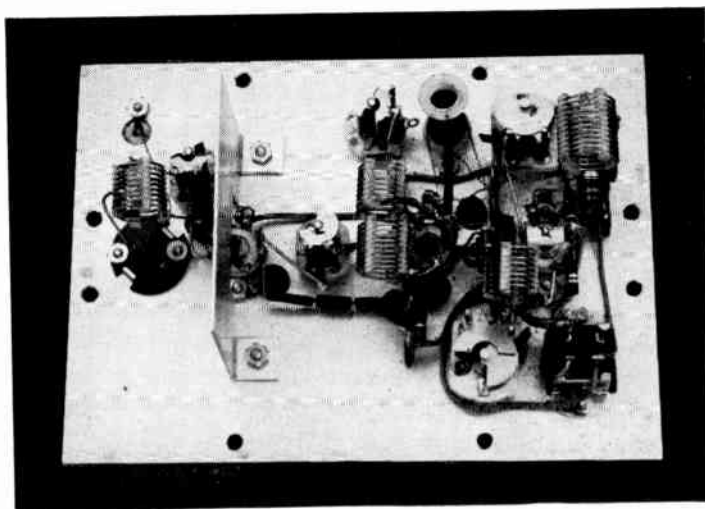

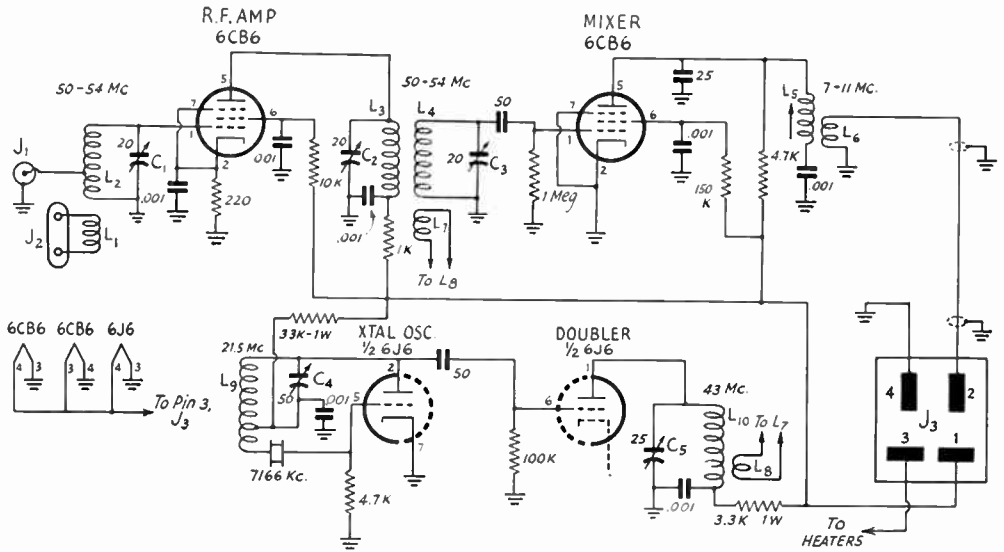

Fig. 16-10 — Schematic diagram of the 50-Mc. crystal-controlled converter.

- C₁, C₂, C₃ — 20- μ mf. min. variable (Johnson 20M11).
- C₄ — 50- μ mf. min. paddler (Hammarlund MAPC 50).
- C₅ — 25- μ mf. min. paddler (Hammarlund MAPC 25).
- L₁ — 3 turns fine ins. wire wound over cold end of L₂.
- L₂, L₄ — 9 turns No. 20 tinned, 1/2-inch diam., 3/8 inch long (B & W Miniductor No. 3003).
- L₃ — 10 1/2 turns similar to L₂. These coils are mounted in line with their cold ends 1/2 inch apart.
- L₅ — No. 28 enameled wire close-wound one inch on 3/4-inch slug-tuned form (National XR-91). Lacquer and dry before winding L₆. Wind on upper portion of form.

- L₆ — 10 turns same wound over cold end of L₅.
- L₇, L₈ — Loop of No. 22 enameled wire inserted in cold ends of L₄ and L₁₀, connected by link of same material. Fasten in place with cement.
- L₉ — 13 turns No. 20 tinned, 5/8-inch diam., 3/4 inch long, tapped at 3 1/2 turns from crystal end (B & W No. 3007).
- L₁₀ — 8 turns similar to L₂.
- J₁ — Coaxial fitting.
- J₂ — Crystal socket for antenna terminal.
- J₃ — 4-pin male chassis fitting (Jones P-304-AB).

Adjustment of the converter is very simple. First the oscillator and multiplier are tuned up, with the r.f. and mixer tubes out of their sockets, or with their plate voltage removed. Proper adjustment of the overtone oscillator follows practice outlined in the introductory portion of Chapter Seventeen, and the doubler portion need only be resonated for maximum output initially. This can be checked with a 60-ma. pilot lamp connected across a one-turn loop coupled to the cold end of L₁₀. The frequency of the output should be checked to be sure that the right overtone and harmonic are being used, and the oscillator tested to see that it is controlled by the crystal.

Now a signal source will be helpful. This can be a signal generator, an amateur signal, or the harmonic of a receiver or transmitter oscillator of known frequency. If the signal is derived locally it should be possible to hear it with only the mixer and oscillator-multiplier stages running, and with no pick-up antenna. If a weak signal is used it may be necessary to put a temporary coupling winding (similar to L₁) on the mixer grid coil, L₄. Peak this circuit and the slug in the mixer plate circuit for maximum response. The plate voltage should be removed from the r.f. stage during this period, but the tube should be left in the socket with the heater voltage on.

Next feed the signal into the r.f. stage, by either of the coupling methods shown, and peak L₂ and L₃ for maximum response. There should be a considerable rise in noise as the adjustments

are made, so the noise level can be used as an indication of resonance in the absence of a test signal.

The converter is now ready for final adjustment, for best signal-to-noise ratio and uniform response across the band. The first can best be done with a noise generator, though a test signal can be used. Noise figure will be affected principally by the tuning of the first stage, and by the adjustment of the antenna coupling. Watch for improvements in the margin of signal over noise, rather than maximum gain, as these two characteristics may not occur coincidentally. The coupling between L₃ and L₄ affects the passband of the system and the tuning of these circuits and the slug in the mixer winding can be staggered to provide uniform response across the band. Peaking of the input circuit may be necessary as the receiver is tuned across the entire band, though a setting can be made for the middle of the range most used and this will hold for at least a megacycle either way. Receiver noise can be used as a check on the uniformity of response, in the absence of signals.

The amount of injection from the multiplier should be set at the least that will provide satisfactory performance. This will not be at all critical, but more injection than needed will increase the tendency to spurious response. It is controlled by the size and position of the coupling loops, L₇ and L₈. In the original model they are about two-thirds the diameter of the windings in which they

V.H.F. RECEIVERS

Fig. 16-11 — The 144-Mc. converter is separated into two parts by a shield partition. At the top are the r.f. and mixer stages, with the oscillator and multiplier portion below the shield.

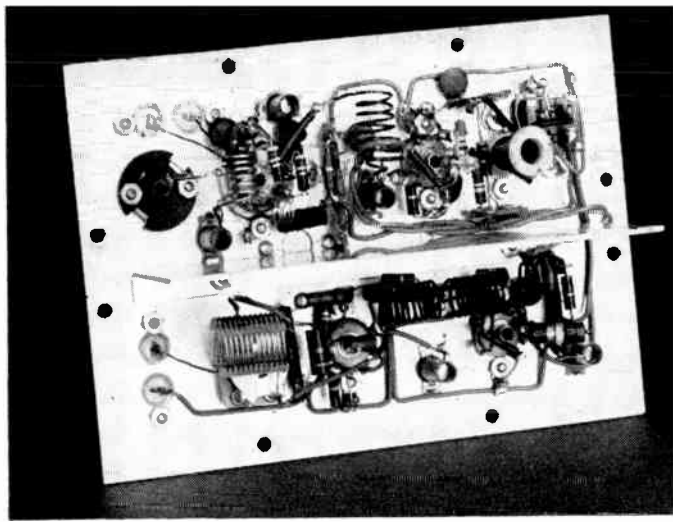

are inserted. The loop can be made small enough to slip through between the strips of polystyrene on the Miniductor, and then spread to give the desired coupling. Cement the loops in place when this is achieved.

THE 144-MC. CONVERTER

The 2-meter converter is shown in Figs. 16-11 and 16-12. From the photograph it may be seen

that the r.f. and mixer components are separated from the oscillator-multiplier chain by a shield partition. The r.f. portion is in the upper half of the picture. Use of small plastic trimmers for the tuned circuits saves enough space so that the additional tube is handled without crowding.

The r.f. circuit is the simplified cascode, using any of the several dual triodes designed for this application. Double-tuned circuits in the r.f. plate and mixer grid provide bandpass response

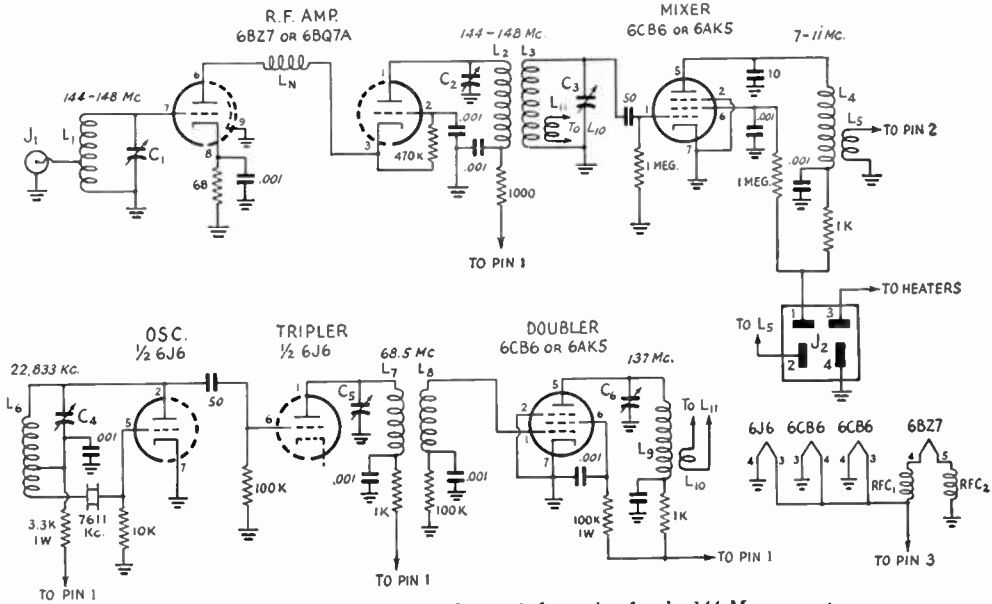

Fig. 16-12 — Schematic diagram and parts information for the 144-Mc. converter.

C₁, C₂, C₃, C₅, C₆ — 1- to 8- μ f. plastic trimmer (Erie 832-10).

C₄ — 50- μ f. min. trimmer (Hammarlund MAPC-50). L₈ — 5 turns No. 20 tinned, $\frac{1}{4}$ -inch diam. Adjust spacing for neutralizing; see text.

L₁ — 6 turns No. 20 tinned, $\frac{1}{4}$ -inch diam., turns spaced diam. of wire. Tap at $2\frac{1}{2}$ turns.

L₂ — 4 turns No. 20 enam., $\frac{3}{8}$ -inch diam., $\frac{3}{8}$ inch long.

L₃ — 3 turns No. 20 enam., $\frac{3}{8}$ -inch diam., $\frac{3}{16}$ inch long. L₂ and L₃ are in line, with their cold ends $\frac{1}{8}$ inch apart.

L₄ — No. 28 enam. close wound 1 inch on $\frac{3}{8}$ -inch slotted form (National XR-91). Lacquer and dry before winding L₅. Wind on upper portion of form.

L₅ — 10 turns, same, wound over cold end of L₄.

L₆ — 12 turns No. 20 tinned, spaced diam. of wire, $\frac{5}{8}$ -inch diam. Tap at $3\frac{1}{2}$ turns.

L₇ — 11 turns No. 20 enam., $\frac{3}{8}$ -inch diam., $\frac{3}{4}$ inch long.

L₈ — 8 turns like L₇, $\frac{5}{8}$ inch long. L₇ and L₈ are in line with their cold ends $\frac{3}{16}$ inch apart.

L₉ — 4 turns like L₇, $\frac{3}{8}$ inch long.

L₁₀, L₁₁ — 1 turn insulated wire at each end, linking L₃ with L₉.

J₁ — Coaxial fitting.

J₂ — 4-pin male chassis fitting (Jones P-304-AB).

RFC₁, RFC₂ — Bifilar-wound r.f. chokes. Twist two pieces of No. 26 enameled wire together and wind 15 turns on $\frac{1}{4}$ -inch diameter.

and help to attenuate unwanted signals on other frequencies. The oscillator-multiplier circuit is similar to the 50-Mc. converter, except that the second half of the 6J6 is a tripler. This is coupled through another pair of double-tuned circuits to an additional doubler stage.

The order of frequency multiplication can be altered to take care of local interference conditions. Should it turn out that unwanted signals are brought in as a result of frequencies appearing in the multiplier chain, the second stage can be made a doubler and the pentode a tripler. The use of link coupling, and the isolation afforded by the shield, should reduce spurious responses to negligible proportions in most locations, however.

The first steps in adjustment of the 141-Mc. converter are similar to those outlined for the 50-Mc. model. The only additional work required is the neutralization of the 6BQ7 stage. This is done by adjusting the spacing of the turns in L_N for lowest noise figure, as indicated with a noise generator, or by best signal-to-noise ratio on a test signal. The inductance is not extremely critical, and it may be set somewhat on the low-inductance side of the largest value that can be used without oscillation developing in the r.f. stage.

Other than the neutralization, only the tuning of the input circuit will affect the noise figure materially. This is also best done with a noise generator. It will be found that best results will be obtained with L_1C_1 resonated somewhat on the low-frequency side of the point that produces maximum gain. The tap on L_1 should be set higher on the coil than the point that gives maximum signal response. The objective, as in the other adjustments outlined above, is best signal-to-noise ratio, rather than maximum gain.

Uniform response across the band can be attained by stagger-tuning the r.f. plate, mixer grid and mixer plate circuits. Injection coupling should be set as low as will deliver optimum performance. This can be controlled by the position

of the coupling loops, L_{10} and L_{11} , or by varying the output of the pentode stage by raising or lowering the value of the screen dropping resistor.

● THE 220-MC. CONVERTER

Circuitry and layout for the 220-Mc. converter, Figs. 16-13 and 16-14, are very similar to the 141-Mc. model, except that an additional stage is used following the cascode, and an additional shield divides the socket of this stage. This helps to make up for the somewhat lower gain of the cascode at the higher frequency, and it improves the rejection of unwanted signals considerably. The latter condition has been found to be troublesome in 220-Mc. work, particularly in areas where TV and f.m. broadcasting stations are in operation.

No tuning capacitors are used in the r.f. circuits, the coils being tuned to the desired frequency by adjusting the turn spacing until they resonate properly with the tube capacitances that appear across them. A variation on the double-tuned circuit is used in which a center-tapped coil serves as both grid and plate inductance. This type of circuit is well adapted to use at frequencies where tube capacitance becomes a limiting factor in the performance of r.f. amplifiers.

A different form of i.f. output coupling is shown in this converter, though it works identically to the method used in the other models. Note that the mixer plate coil is loaded by a 4700-ohm resistance in this case. The i.f. must cover from 7 to 12 Mc. for the 220-Mc. band, so a broader response is required. The value of this resistance can be altered to attain the desired degree of uniformity, though lower values than the one shown will result in lower over-all gain.

The tuning capacitor in the input circuit tunes out the reactance of the line to the antenna. It may not be necessary in some installations, but it is likely to be helpful in reducing spurious responses. The same technique may also be applied

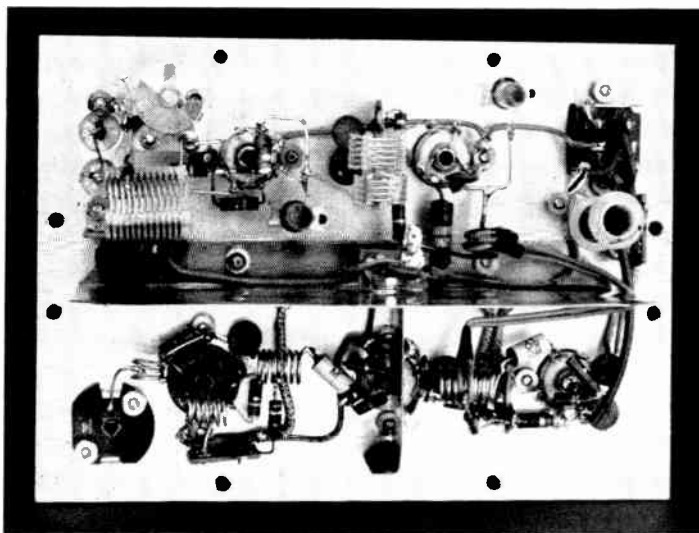

Fig. 16-13 — The 220-Mc. crystal-controlled converter. Note that two shields are used; one separating the injection and r.f. chains, the other dividing the socket for the 6AK5 r.f. stage. R.f. components occupy the lower half of the assembly.

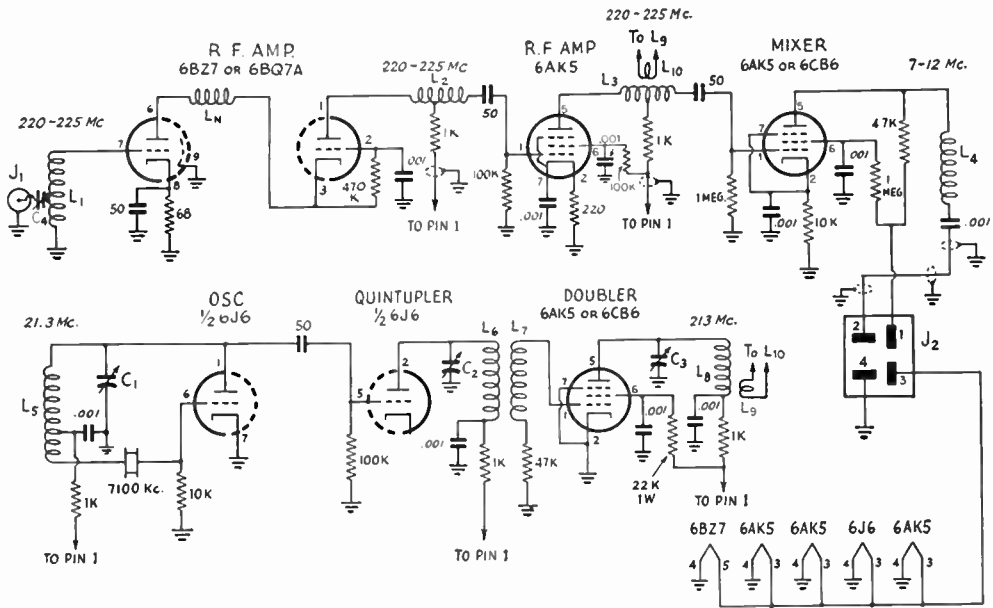

Fig. 16-14 — Schematic diagram and parts information for the 220-Mc. converter.

- C₁ — 50- μ f. miniature variable (Hammarlund MAPC-50).
- C₂ — 8- μ f. plastic trimmer (Eric 532-10).
- C₃ — 5- μ f. plastic trimmer (Eric 532-08-OR5).
- C₄ — 3-30- μ f. mica trimmer.
- L₁ — 3 turns No. 20 tinned, $\frac{1}{4}$ -inch diam., $\frac{1}{4}$ inch long, center tapped.
- L_N — 5 turns No. 20 tinned, $\frac{1}{4}$ -inch diam. Adjust spacing for neutralization; see text.
- L₂, L₃ — 7 turns No. 20 tinned, spaced 1 diam., $\frac{1}{4}$ -inch diam., center-tapped.
- L₄ — No. 28 enam. wound one inch on $\frac{3}{8}$ -inch slug-tuned form (National NR-91).

- L₅ — 12 turns No. 20 tinned, spaced one diam., $\frac{5}{8}$ -inch diam., tapped at $3\frac{1}{2}$ turns (B & W No. 3007).
- L₆ — 4 turns No. 20 tinned, $\frac{1}{2}$ -inch diam., $\frac{1}{4}$ inch long (B & W Miniductor No. 3003).
- L₇ — 5 turns like L₆. L₆ and L₇ are in line with their cold ends spaced $\frac{1}{8}$ inch.
- L₈ — $2\frac{1}{2}$ turns No. 20 enam., $\frac{1}{4}$ inch long.
- L₉, L₁₀ — 2 turns insulated wire between turns of L₈ and L₃, connected by link of same material.
- J₁ — Coaxial fitting.
- J₂ — Male 4-prong chassis fitting (Jones P-304-AB).

to advantage in the other converters, when spurious signals are bothersome.

Adjustment procedure is similar to that outlined for the 144-Mc. model, except that the spacing of the turns in the r.f. coils must be adjusted, rather than tuning them by capacitors. As in the 144-Mc. converter, the order of frequency multiplication can be altered to take care of any extreme local interference problems resulting from near-by TV, f.m. or other high-powered stations that may ride through as spurious responses. The oscillator can be operated on its fifth overtone instead of the third, making the second and third stages operate as doubler and tripler, or vice versa. Fifth-overtone operation of the oscillator will require more care in adjustment of feedback than is the case with the third.

The coupling between L₈ and L₃ will be a factor in holding down spurious responses. It should be set at the lowest value that will allow satisfactory performance, by altering the position of the coupling loops, L₉ and L₁₀, or by varying the value of the screen-dropping resistor in the last frequency-multiplier stage.

If a noise generator is available, and care is used in making the adjustments, it should be possible to achieve noise figures under 6 db. for the 220-Mc. converter and 5 db. for the 144- and 50-Mc. models.

● V.H.F. RECEIVING BALUNS

As pointed out in the preceding converter descriptions, coaxial antenna input circuits are preferable in v.h.f. receivers where single-ended circuitry is employed. Where long transmission lines must be used, however, the losses in coaxial line discourage its use in feeding the antenna system. Particularly on 144 Mc. and higher, many amateurs prefer close-spaced open-wire lines for runs of 50 feet or more between the operating position and the antenna.

The advantages of coaxial input coupling and the low losses of open-wire balanced lines can both be retained if some means of coupling between the balanced line and the unbalanced receiver input circuit is provided. Such a device, usually called a "balun," is shown in Fig. 13-23D. V.h.f. receiver baluns are usually made of small coaxial line such as RG-59/U, and installed at the converter input terminal. The propagation factor of the line should be taken into account, making the actual length of the folded portion 65 per cent of a half-wave. The straight portion may be any convenient length, though it is usually a wave length or less.

A 3-band balun for v.h.f. receiving use may also be made by using the coils from a so-called "elevator transformer" for this purpose that can

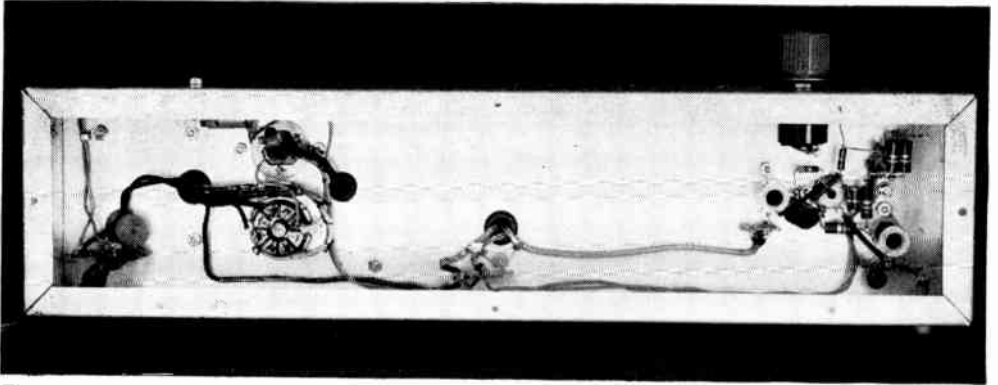

Fig. 16-15 — Bottom view of the i.f. and power supply unit with bottom cover removed. Power components are at the left. A smaller chassis may be used if less than the three converters are to be built.

be obtained from some TV receiver parts distributors. Such a balun would consist of two pairs of coils, connected in parallel at one end and in series at the other. The parallel end is wired to a coaxial connector and the series end to a crystal socket or a pair of binding posts. The assembly should be housed in a copper or aluminum box that may be as small as $1 \times 1\frac{1}{2} \times 2\frac{1}{2}$ inches.

Like the coaxial-line balun, this converts from balanced to unbalanced termination, and provides a 4-to-1 impedance transformation in the process. The coils are designed for use across the v.h.f. TV range, 54 to 216 Mc., so they will serve well for all three amateur v.h.f. bands, 50, 141 and 220 Mc. See Fig. 13-24 for connections.

● THE I.F. AMPLIFIER AND POWER SUPPLY

The i.f. amplifier (Figs. 16-15 and 16-16) serves two useful purposes. It builds up the gain, for receivers that may be poor performers at 7 Mc., and it provides a means of controlling the over-all gain of the system without disturbing the gain or S-meter controls on the receiver itself. The receiver may thus be operated exactly as it would be on 7 Mc., and the gain of the converter adjusted so that v.h.f. signals will be received

similarly to those on lower frequency bands.

It is obvious from the photographs that the i.f. and power supply unit could have been built in a smaller space. If the builder is considering only one or two of the converters he may wish to do this, but where all three are used the arrangement shown is a convenient one. The i.f. chassis is a standard size, $3 \times 4 \times 17$ -inch aluminum, to which a bottom plate is added for shielding. Rubber feet can be attached to the two ends of the base, and one on each of the converters at the rear, to prevent the combination from marring a receiver top.

The heater voltage, the plate voltage and the i.f. input lead are all carried on shielded wire to a 4-pin plug. This is connected to whichever converter is to be used at the moment, and no other changes other than plugging the antenna into the proper jack are required in changing from one v.h.f. band to another. The shielded wires in the cable are bonded together several times and then wrapped with plastic tape. The coaxial fitting for the connection to the receiver is at the extreme right on the rear wall of the i.f. chassis.

The only adjustment required in the i.f. unit is to set the coil slugs (on noise or signal) so that the response will be as nearly flat as possible across 7 to 11 Mc.

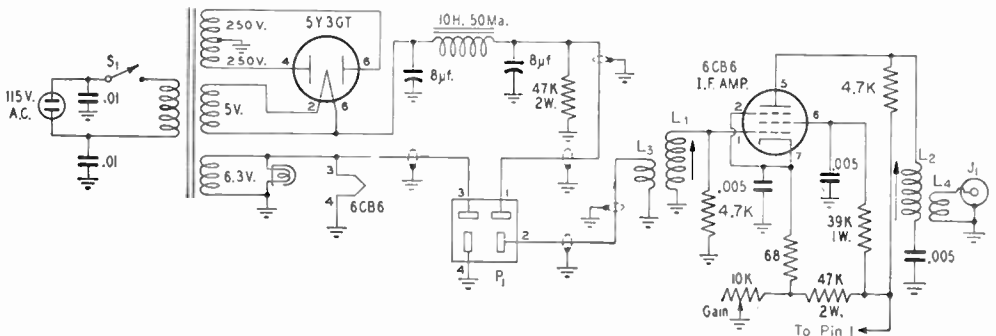

Fig. 16-16 — Schematic diagram and parts information for the i.f. and power supply unit used with the crystal-controlled converters.

L₁, L₂ — No. 28 enameled wire close wound 1 inch on $\frac{3}{8}$ -inch slug-tuned form (National NR-91). Lacquer and dry before adding coupling winding. Wind on upper portion of form.

L₃, L₄ — 10 turns same wound over cold ends of L₁ and L₂.

J₁ — Coaxial fitting.

P₁ — Female 4-pin on end of cable (Jones S-304-CCT).

A One-Tube Converter for 21, 28, 50, 144 or 220 Mc.

The crystal-controlled converters described on the previous pages are typical of the type of equipment that must be used in v.h.f. reception if optimum results are to be expected. It is possible to start in with simpler devices, however, and still do an acceptable job. The one-tube converter shown in Figs. 16-17, 16-18 and 16-19 is designed for the beginner or casual v.h.f. operator who wants the simplest thing that will give usable reception.

Provision is made for any amateur band from 21 to 220 Mc., but the converter should not be thought of as a multiband device in the usual sense. To keep its construction as simple as possible, and to make it work satisfactorily on 144 or 220 Mc., the coils are not made plug-in.

volts d.c. at about 12 ma. will be required. A simple selenium-rectifier supply can be built for the converter, as shown, if the necessary power cannot be taken from the receiver.

Construction

The converter was designed with an absolute minimum of parts. Note that it is shown without a panel, for instance. One can be added if the builder wishes, but it is by no means a necessity. A standard $5 \times 7 \times 2$ -inch aluminum chassis (premier ACH-426) is used, and no brackets or other metal parts need be made. Fig. 16-20 shows the locations of all holes. The front-view photograph shows the tuning capacitor, C_6 , on top of the chassis with the trimmer (C_5) and

◆
 Fig. 16-17 - One-tube converter, with 144-Mc. oscillator tuned circuit in place. Selenium rectifier power supply, shown plugged onto rear of the converter, may be omitted if power is taken from the receiver.
 ◆

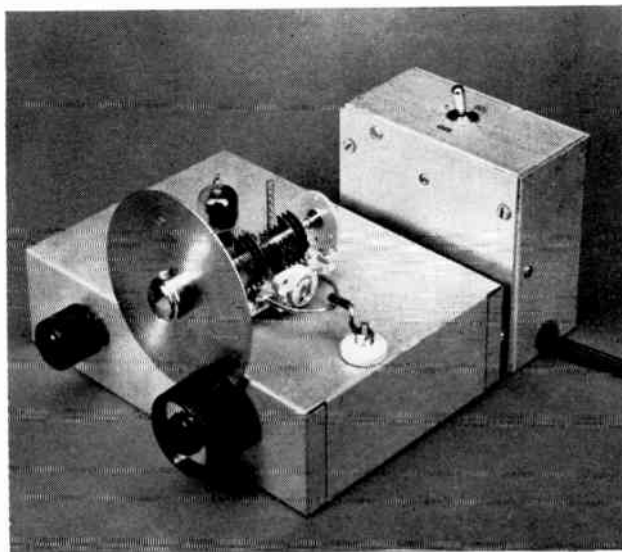

To change from one band to another the coils must be unsoldered and another pair installed in their place. The 21- and 28-Mc. bands are covered with a single pair of coils by resetting the associated trimmer capacitors, but separate sets of coils are needed for 50, 144 or 220 Mc.

A single 6J6 tube serves as mixer and oscillator. The input circuit, L_1C_1 , tunes to the signal frequency. Energy from the oscillator, tuned by $L_2C_5C_6$, beats with the signal to produce the intermediate frequency, approximately 7 Mc., in the plate circuit of the mixer stage. The coil L_3 is tuned to this frequency, and the output is fed into a communications receiver through L_4 and a coaxial cable attached to J_2 . The oscillator tunes 7 Mc. lower than the signal frequency.

The converter power can be taken from the communications receiver in most cases. Receivers usually have an accessory socket on the rear wall for this purpose. Consult the receiver instruction book for the type of plug and connections needed. An a.c. voltage of 6.3 at 0.45 amp. and 75 to 150

144-Mc. coil soldered in place. The feed-through bushing near the edge of the chassis serves as a tie point for R_3 and holds the coil rigidly in position. Immediately behind C_6 the 6J6 and the tuning adjustment for L_3 are visible. The dial is a National type K. Note that a large knob (National type HRT-M) is substituted for the one that comes with the dial to smooth out the tuning. The dial index is mounted below on the front wall of the chassis instead of above, for obvious reasons. The 0 to 100 scale may be used for logging, or a calibration may be drawn on stiff white paper and cemented to the dial surface. The small knob to the left is the mixer grid circuit trimmer, C_1 .

A power supply is shown plugged into the back of the converter. If the power plugs are positioned so that this is possible, it will save making up a connecting cable. The supply is built in a $4 \times 2 \times 2$ -inch utility cabinet. The layout is not important, and it can be built in some other form if desired.

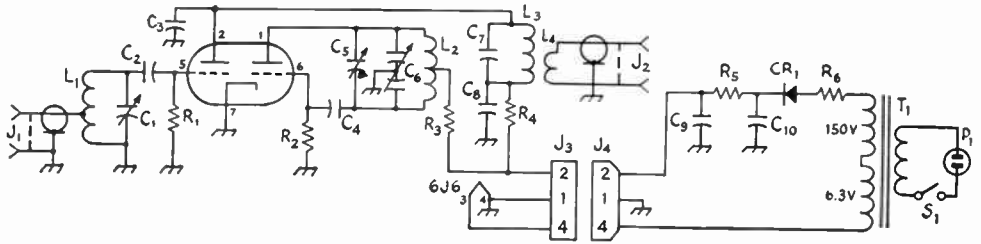

Fig. 16-18 — Schematic diagram and parts information for the simple converter.

- C₁ — 15- μ f. variable (Hammarlund HF-15).
- C₂, C₇ — 100- μ f. ceramic.
- C₃ — 10- μ f. ceramic (connect close to plate pin).
- C₄ — 47- μ f. ceramic.
- C₅ — 45- μ f. ceramic trimmer (Mallory ST-557-N; one for each band required).
- C₆ — Split-stator variable, about 12- μ f. per section (Hammarlund HF1-15X with 2 rotor plates and 1 stator plate removed from each section).
- C₈ — 0.001- μ f. ceramic.
- C₉, C₁₀ — 16- μ f. 250-v. electrolytic.
- R₁ — 1 megohm $\frac{1}{2}$ watt.
- R₂ — 10,000 ohms, $\frac{1}{2}$ watt.
- R₃ — 1000 ohms, $\frac{1}{2}$ watt.
- R₄ — 33,000 ohms, $\frac{1}{2}$ watt.
- R₅ — 3300 ohms, $\frac{1}{2}$ watt.
- R₆ — 22 ohms, $\frac{1}{2}$ watt.
- L₁ — 21, 28 Mc. — 16 turns No. 20 tinned, $\frac{3}{4}$ -inch diam., 1 inch long, tapped 4 turns from ground end. (B & W Miniductor No. 3011.)
- 50 Mc. — 7 turns No. 20 tinned, $\frac{5}{8}$ -inch diam., $\frac{1}{8}$ inch long, tapped 2 turns from ground end. (B & W 3007.)
- 144 Mc. — 2 turns $\frac{1}{2}$ -inch diam. No. 12 tinned wire, spaced $\frac{1}{4}$ inch, tapped $\frac{3}{4}$ turn from ground end.
- 220 Mc. — 1 turn $\frac{1}{4}$ -inch diam. No. 12 tinned wire, tapped near center.
- L₂ — 21, 28 Mc. — 15 turns B & W 3011 e.t. Add C₅ as in photo.
- 50 Mc. — 7 turns B & W 3007 e.t. Add C₅ as in photo.
- 144 Mc. — Hairpin loop of No. 12 tinned wire 1 inch long, 1 inch wide, e.t. Connect C₅ to C₆ terminals.
- 220 Mc. — Hairpin loop of No. 12 tinned wire, $\frac{3}{4}$ inch long, $\frac{3}{8}$ inch wide with $\frac{3}{8}$ -inch leads, e.t. Connect C₅ $\frac{5}{8}$ inch from capacitor terminals; see photo.
- L₃ — 24 turns No. 24 enamel on $\frac{3}{8}$ -inch iron-slug form (National XR-91).
- L₄ — 4 turns No. 24 d.c.c. or enamel at cold end of L₃.
- J₁, J₂ — Phono jacks (Cinch 81B or two Cinch 81A single jacks).
- J₃ — 4-contact male chassis fitting (Amphenol 86RCP1).
- J₄ — 4-contact female chassis fitting (Amphenol 78RS1).
- P₁ — 115-volt line plug.
- S₁ — S.p.s.t. toggle switch.
- CR₁ — 20-ma. selenium rectifier (Federal 1159).
- T₁ — Power transformer, 150 volts at 25 ma.; 6.3 volts at 0.5 amp. (Merit P-3046).

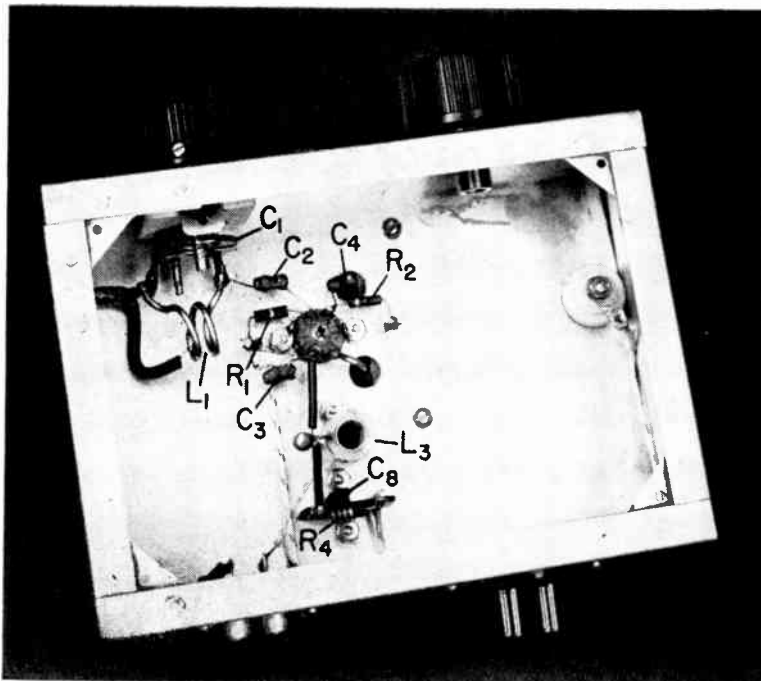

Fig. 16-19 — Bottom view of the converter, showing the principal parts numbered as they appear on the schematic diagram.

and so on. The trimmer capacitor, C_5 , and, if necessary, the coil, L_2 , are adjusted to set the oscillator to the proper range. Actually coverage will be somewhat more than the width of the band, and the desired range should be centered on the dial by varying C_5 . The coverage mentioned above is obtained by rotating C_5 , of course.

Now connect the converter output to the receiver antenna terminals. The converter is normally operated on top of the communications receiver, or close alongside it, in a convenient operating position. A coaxial cable is made up with a male phono-type coaxial fitting on one end, with enough cable to reach from the converter to the receiver antenna terminals. Most receivers have a three-terminal antenna connection block. One of these terminals is grounded. The middle one and the one at the opposite end from the grounded one are normally used for doublet antenna connections. Connect the middle one and the grounded terminal together, and make this combination the point of connection for the outer conductor of the coaxial cable. The inner conductor goes on the remaining antenna terminal.

The mixer plate coil, L_3 , may be tuned to about 7 Mc. with a grid-dip meter, or it can be peaked on noise with the receiver set at this frequency and the converter running. The grid circuit, L_1C_1 , may be checked with a grid-dip meter. It may also be peaked for maximum response to a signal generator connected to the input, or it can be peaked on noise or signals with the antenna connected to the converter. Some improvement on weak signals may be possible through adjustment of the position of the tap on the grid coil, and the mixer plate voltage should be checked to see that it is somewhere near 75 volts. On the higher bands tuning C_1 will shift the oscillator frequency, so that retuning the signal as this adjustment is made may be required.

The exact frequency used for the i.f. is not important, so it can be set to suit two requirements. First, it should not be at such a spot that a strong local 7-Mc. signal will ride through.

Should interference develop at any time on the intermediate frequency, the setting of the main receiver dial may be changed slightly to clear the trouble. It is also usually easier to shift the i.f. slightly than to reset the oscillator, in order to make the dial calibration come out right. With a signal of known frequency available, the converter dial can be set for that spot and the main receiver returned to make the signal come in at the desired spot.

The 15-, 11-, and 10-meter bands are covered by one pair of coils. It is necessary, of course, to reset the oscillator trimmer, C_5 , for each band to the proper range. An alternative would be to use separate coils and trimmers for each band as is done on the higher ranges. Bandspread obtained with the original converter using a 7-Mc. i.f. was as follows: 21.0–21.45 Mc. — 65 divisions; 26.96–27.23 Mc. — 12 divisions; 28.0–29.7 Mc. — 67 divisions; 50–54 Mc. — 75 divisions; 144–148 Mc. — 65 divisions; and 220–225 Mc. — 30 divisions. More bandspread can be obtained on the higher ranges by removing more plates from the tuning capacitor, but this will not permit full coverage on the lower bands.

Performance

On 21 and 28 Mc., at least, this simple converter will usually provide all the sensitivity that can be used, as external noise is normally the limiting factor in weak-signal reception on these bands. At 50 Mc. and higher the noise generated within the converter tends to limit the overall sensitivity. Thus the addition of a low-noise r.f. amplifier may make a considerable improvement in reception in the v.h.f. ranges.

A cascode-type preamplifier, such as that shown in Fig. 16-22, is ideal for 144-Mc. use, and the same basic circuit may be used for 50 and 220 Mc. amplifiers as well.

The greatest difficulty with tunable converters is instability in the oscillator. For most v.h.f. operators the only satisfactory solution to this problem is the use of crystal-controlled converters such as those shown elsewhere in this chapter.

(Originally described in October, 1955, *QST*, page 27.)

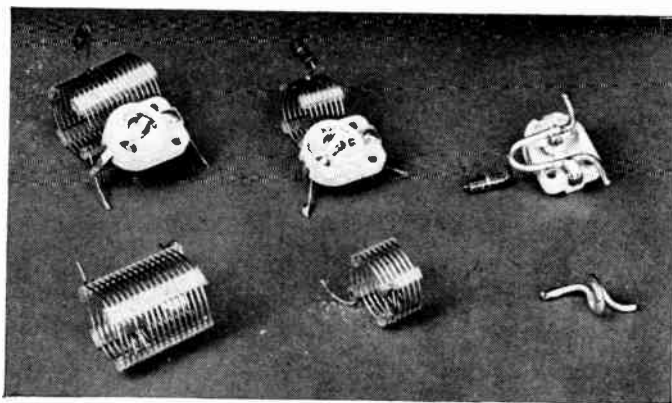

Fig. 16-21 — Coils for the one-tube converter. Top row are the oscillator coils, with trimmers (C_5) attached. Corresponding mixer coils below. Left to right sets for 21 to 28 Mc., 50 Mc. and 220 Mc. The 144-Mc. coils appear in the converter photographs.

Low-Noise Preamplifier for 144 Mc.

The triode preamplifier shown in Figs. 16-22 to 16-24 will improve the sensitivity and signal-to-noise ratio of receivers or converters for 144 Mc.

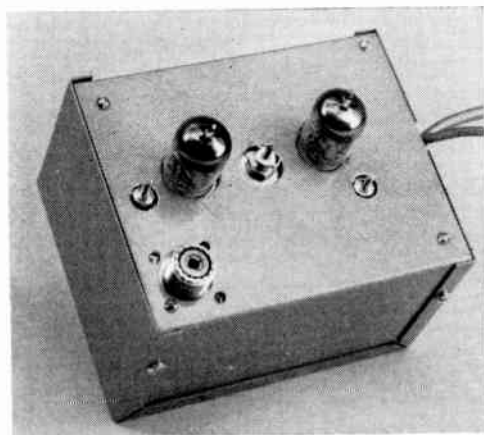

Fig. 16-22 — Two-meter preamplifier using two 6AJ4 tubes. Adjustments are (left to right) input tuning capacitor, slug of neutralizing winding, and the plate tuning capacitor of the second stage.

that are deficient in these respects. Two separate triode tubes are shown, but any of the dual triodes designed for v.h.f. amplifier service may be used similarly. The circuit may be adapted to use on

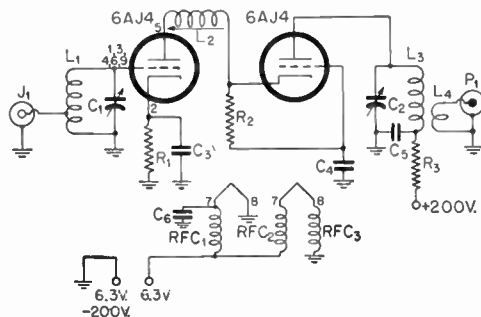

Fig. 16-23 — Schematic diagram and parts list for the low-noise preamplifier.

- C_1, C_2 — Plastic trimmer, 1 to 8 $\mu\text{f.}$ (Eric style 532-10).
- C_3, C_4, C_5, C_6 — 0.001- $\mu\text{f.}$ disk ceramic.
- R_1 — 68 ohms, $\frac{1}{2}$ watt, carbon.
- R_2 — 0.47 megohm, $\frac{1}{2}$ watt.
- R_3 — 470 ohms, $\frac{1}{2}$ watt, carbon.
- L_1 — 1 turns No. 16 tinned, $\frac{1}{4}$ -inch diam., spaced 1 diameter, tapped at $1\frac{3}{4}$ turns from ground end.
- L_2 — 4 turns No. 24 on $\frac{1}{4}$ -inch slug-tuned form.
- L_3 — 5 turns No. 18 enam., $\frac{1}{4}$ -inch diam., spaced half diameter.
- L_4 — 2 turns insulated wire wound over cold end of L_3 .
- J_1 — Coaxial antenna fitting.
- P_1 — Coaxial plug on cable of suitable length to reach converter input.
- RFC_1 — 22 turns No. 22 enam., $\frac{3}{16}$ -inch diam., close-wound.
- $\text{RFC}_2, \text{RFC}_3$ — 18 turns each, No. 24 enam., $\frac{1}{4}$ -inch diam. Twist wires together before winding. Coat turns with household cement.

50 or 220 Mc., by suitable alteration of coil and capacitor values.

Pin connections given on the schematic diagram, Fig. 16-23, are for the 6AJ4 or 6AM4. Other tubes such as the 6AN4 and 417A will work equally well, if pin connections shown in the tube data section of this *Handbook* are followed. Slightly different values of cathode bias resistor may be needed if tubes other than the 6AJ4 are used.

The preamplifier is housed in a standard $3 \times 4 \times 5$ -inch aluminum utility box. The components were mounted on a sheet of flashing copper and the preliminary work of wiring was done with this plate as a chassis. The plate was later fastened to the inside of the top of the box. The parts could be mounted on the box directly, but they are more accessible if the work is done as described above.

Looking at the interior view, Fig. 16-24, we see the coax fitting, the first tube socket and the input circuit at the left. Between the tube sockets, at the center of the copper base plate, is the slug-tuned neutralizing winding, L_2 . A small copper shield divides the second socket, isolating the input and output circuits. This shield is not always needed, but it may be an aid to neutralization. At the far right are the output circuit and the bifilar-wound r.f. chokes for the heater circuit of the second stage. The tuning capacitors, C_1 and C_2 , are plastic trimmers of a design that allows a saving in space and offers lower minimum capacitance and lead inductance than conventional flat-plate trimmers.

The five grid pins of the 6AJ4 may be strapped together or used individually, as layout requirements dictate. In this instance, Pin 4 is used for

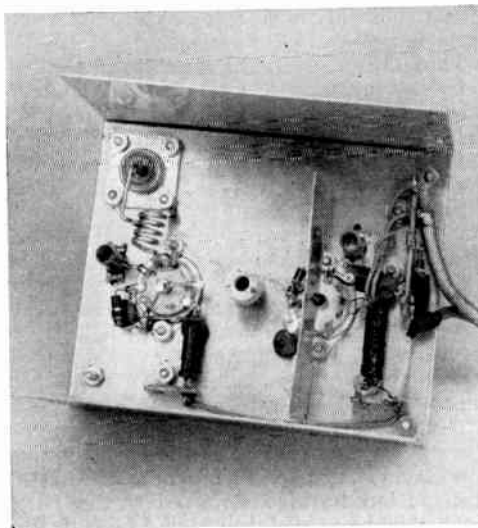

Fig. 16-24 — Interior view of the 144-Mc. r.f. amplifier. A small shield across the second tube socket isolates the input and output circuits. The amplifier is built on a copper plate, which is then fitted to the top of a standard aluminum utility box.

the hot end of L_1 , with the trimmer, C_1 , connected to Pin 3. In the second stage, Pins 3 and 4 are tied to the grid side of R_2 , and Pin 1 is by-passed by C_4 . See Aug., 1953, *QST* for details.

Adjustment

A noise generator will make the adjustment of the amplifier easy, as it is then only necessary to peak the plate circuit (by C_2) for maximum gain, and then adjust the inductance of L_3 and the setting of C_1 for lowest noise figure. It is possible to follow this routine using signals or a signal generator, but it is a more difficult process.

If a signal is to be used, peak the second plate circuit for maximum response first. Then tune the input circuit for maximum also, if the amplifier does not oscillate. If it should oscillate, vary the setting of the slug in L_2 to stop it, before attempting to peak any other adjustments. In adjusting

the input circuit, watch for best signal-to-noise ratio, now, rather than for maximum gain. This will show up somewhat on the high-capacity side of the maximum-gain point, as the rotor of C_1 is turned into the stator.

The position of the tap on L_1 can be adjusted in the same way. The optimum point will be higher on the coil than the point at which maximum gain is observed. If the amplifier is adjusted at 146 Mc. it should not be necessary to repeak it across the entire band.

An amplifier of this sort should not be expected to produce a large improvement in reception when it is used ahead of a converter that already has a good triode front end, but installed ahead of a pentode amplifier, and particularly a converter having a band-switching r.f. circuit, it will help considerably in the reception of weak signals, by increasing the margin of the signal over noise.

Receivers for 420 Mc.

For best signal-to-noise ratio, receivers for any frequency should have the highest degree of selectivity that can be used successfully at the frequency in question. With crystal control or its equivalent in stability accepted as standard practice on all bands up through 148 Mc., there is little point in using more bandwidth in receivers for these frequencies than is necessary for satisfactory voice reception, a maximum of about 10 kc. Such communication selectivity is now being used successfully by most workers on 220 and 420 Mc., too, but it imposes several problems not encountered on lower bands.

First is the matter of oscillator instability in the converter. Even the best tunable oscillator at 420 Mc. suffers from vibration and hand-capacity effects sufficiently to make it difficult to hold the signal in a 10-ke. i.f. band width.

Then, there are still some unstable transmitters being used in work on 220 and 420 Mc. It is out of the question to copy these on a selective receiver.

Last, searching a band 30 megacycles wide is excessively time-consuming when communications-receiver selectivity is used in the i.f. system.

There is no single solution to these problems, but the best approach appears to be that of breaking up of the band into segments for different types of operation. This is being done by mutual agreement among 420-Mc. operators at present, as follows: 420 to 432 Mc. — modulated oscillators and wide band f.m., 432 to 436 Mc. — crystal-controlled c.w., a.m. and narrow-band f.m.; 436 to 450 — television.

The first segment can be covered with a super-regenerative receiver, a superheterodyne having a wideband i.f. system, or a converter used ahead of an f.m. broadcast receiver. The high selectivity required for best use of the middle portion makes a crystal-controlled or otherwise highly stable converter and communications receiver combination almost mandatory. Amateur TV is usually received with a converter ahead of a standard TV

receiver, tuned to some channel that is not in use locally.

Many of the tubes used on the v.h.f. bands are useless at 420 Mc., and the performance of even the best u.h.f. tubes is down compared to lower bands. Only the lighthouse or pencil-triode tubes and a few of the miniatures are usable, and these require modifications of conventional circuit technique to produce satisfactory results.

Crystal diodes are often used as mixers in 420-Mc. receivers, as in this frequency range they work nearly as well as vacuum tubes. The over-all gain of a converter having a crystal mixer is about 10 db. lower than one using a tube, so this difference must be made up in the i.f. amplifier. The noise figure of a receiver having a crystal mixer and no r.f. stage includes the noise figure of the i.f. amplifier following the mixer, so best results require that the i.f. amplifier employ low-noise techniques discussed earlier in this chapter. If the i.f. is 50 Mc. or higher it is particularly important that a low-noise triode be used for the first i.f. stage.

Crystal diodes of the type used in radar mixers, such as the 1N21 series, are well suited to 420-Mc. mixer service, though care must be taken to avoid damage from transmitter r.f. energy. Other types of crystal diodes such as the 1N72 and CK710 will stand higher values of crystal current, and their use is recommended.

Few conventional vacuum tubes work well as mixers at 420 Mc. and higher. The 6J6 is useful where a balanced input circuit is desired, as in Fig. 16-5B. For single-ended circuitry the 6AM4 and 6AN4 are recommended. They may be used in grounded-grid or grounded-cathode circuits.

For high-selectivity coverage of the 432- to 436-Mc. segment of the band, a common practice is to use a crystal-controlled converter working into another converter for either the 50- or 144-Mc. band, tuning the latter for the four-megacycle tuning range.

● A 420-MC. R.F. AMPLIFIER

The r.f. amplifier shown in Figs. 16-25 through 16-27 is capable of a gain of more than 15 db. and its noise figure can be as low as 6 db. with careful adjustment. It will make a large improvement in the sensitivity of any converter or receiver that has no r.f. stage, or one that is working poorly.

The design shown is for either the 6AJ4 or 6AM4, but with suitable socket and pin-connection changes the 417A and 6AN4 will work equally well. It is a grounded-grid amplifier with a half-wave line in the plate circuit. The antenna is connected to the cathode of the tube through a coupling capacitor. As the input impedance of the grounded-grid stage is low, nothing is gained by the use of a tuned circuit in the cathode lead. Output is taken off through a coupling loop at the point of lowest r.f. voltage along the line.

The amplifier is built in a frame of flashing copper that serves as the outer conductor of the tank circuit. The whole assembly is 10 inches long and 1 1/4 inches square, except for the bottom, which is about 1 3/4 inches wide. Edges are folded over with lips 1/4 inch wide which slide into a bottom cover made from copper sheet 2 1/4 by 10 inches in size, with its edges bent up 1/4 inch wide on each side.

The plate circuit is made of 1/4-inch copper tubing tuned by a copper-tab capacitor at the far end from the tube. Plate voltage is fed in at the point of minimum r.f. voltage, which in this

instance is about 5 inches from the open end. The antenna is connected to the cathode through a coupling capacitor. The input impedance of the grounded-grid amplifier is so low that nothing is gained by using a tuned circuit at this point. The cathode and heater are maintained above ground potential by small air-wound r.f. chokes.

The tube socket is two inches in from the end of the trough, and is so oriented that its plate connection, Pin 5, is in the proper position to connect to the line with the shortest possible lead. A copper shielding fin is mounted across

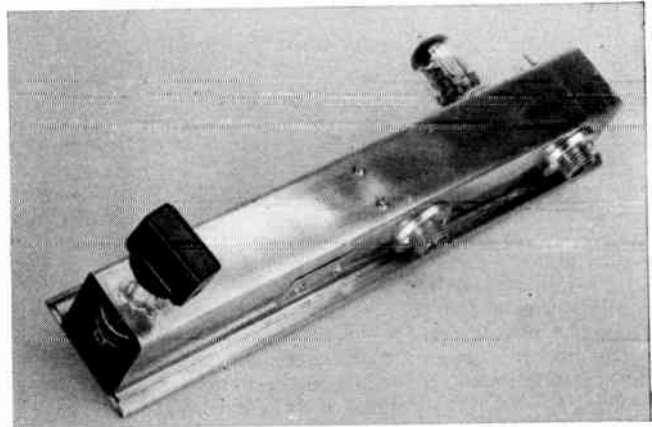

Fig. 16-25 — A highly effective r.f. amplifier for 420 Mc. The tank circuit is a half-wave line made of flashing copper. Coaxial fittings are for input and output connections. Heater and plate voltages are brought in on feed-through by-pass capacitors just visible on either side of the 6AJ4 tube.

the interior of the trough 2 1/8 inches from the end, dividing the socket so that Pins 3, 4, 5 and 6 are on the plate side of the partition.

Minimum grid-lead inductance is important. This was insured by bending all the grid prongs down against the ceramic body of the socket, and then making the mounting hole just big enough to pass this part of the socket and the prongs. They were soldered to the wall of the trough.

Input and output connections are coaxial fittings mounted on the side wall of the trough. B-plus and heater voltage are brought into the assembly on feed-through capacitors mounted on the same side of the trough as the tube. Connection to the inner conductor of the line is made with a grid clip, so that the point of connection can be adjusted for optimum results.

The copper tubing is slotted at the plate end with a hack saw to a depth of about 1/4 inch, and a strip of flashing copper soldered into this slot to make the plate connection. A copper tab about the size of a one-cent piece is soldered to the other end of the tubing to provide the stationary plate of C₄. The line is supported near the low-voltage point by a 1/4-inch-thick block of polystyrene. This is centered at a point 5 1/4 inches in from the tube end of the trough assembly. The hole for the B-plus feed-through is 4 1/4 inches from the same end.

The movable plate of C₄ is soldered to a screw running through a nut soldered to the upper

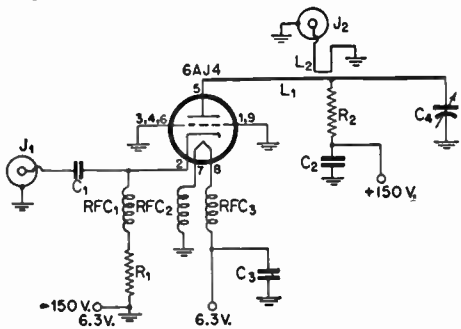

Fig. 16-26 — Schematic diagram of the 420-Mc. r.f. amplifier.

- C₁ — 500- μ mf. ceramic.
- C₂, C₃ — 1000- μ mf. ceramic feed-through (Eric style 2404).
- C₄ — Copper tabs, 3/8-inch diam.; see text and photographs.
- R₁ — 150 ohms, 1/2 watt.
- R₂ — 470 ohms, 1/2 watt.
- L₁ — 1/4-inch copper tubing, 7 3/8 inches long, tapped 2 3/8 inches from plate end.
- L₂ — Loop of insulated wire adjacent to L₁ for 3/4 inch.
- J₁, J₂ — Coaxial fitting.
- RFC₁, RFC₂, RFC₃ — 9 turns No. 22, 3/8-inch diam., spaced one diam.

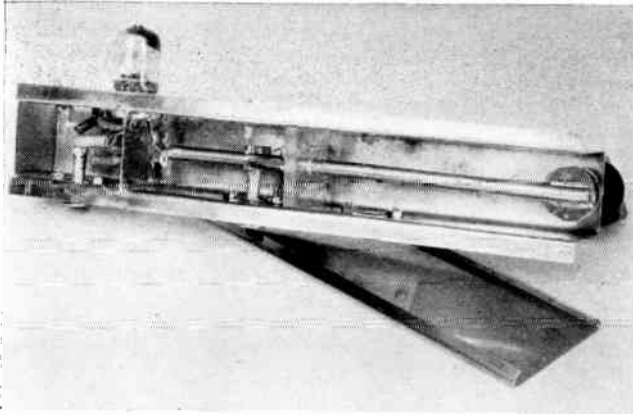

Fig. 16-27 — Bottom view of the 420-Mc. r.f. amplifier, with the slip-on cover removed. The inner conductor of the tank circuit is held in place by a block of polystyrene, mounted near the low-voltage point on the line. The plate-voltage feedthrough and output coupling loop may be seen at the left of this support. Heater, cathode and antenna-circuit components are in a separate compartment at the tube end of the assembly. The line is tuned at the opposite end by a handmade copper-tab capacitor.



surface of the trough at a point $\frac{3}{8}$ inch in from the open end. If a fine-thread screw is available for this purpose it will make for easier tuning, though a 6/32 thread was used in this model. This made a wobbly contact, so a coil spring was installed between the top of the trough and the knob to keep some tension on the adjusting screw.

Adjustment of the 420-Mc. amplifier is made easier if a noise generator is used, though it is not as important as in the case amplifiers with tuned input circuits. If the amplifier is working properly there will be an appreciable rise in noise as the plate circuit is tuned through resonance, and it may break into oscillation if operated without load. When connected to a following stage, with a reasonably-matched antenna plugged into J_1 , the amplifier should not oscillate unless the coupling loop, L_2 , is much too far from the inner conductor.

When the amplifier is operating stably and tuned to a test signal (or to a peak of response to a noise generator), the next step is to locate the optimum position for feeding the plate voltage into the line. This may be done by running a pencil lead slowly up and down the inner conductor, until a spot is found where touching the lead to the line has little or no effect on the operation of the amplifier. The plate voltage clip should be placed at this point and the process repeated, moving the clip slightly until it is at the minimum-voltage point precisely. This adjustment should be made at the midpoint of the tuning range over which the amplifier is to be used.

The position of the coupling loop should then be adjusted for best signal-to-noise ratio. This will probably turn out to be with the insulated wire lying against the inner conductor for a distance of about $\frac{3}{4}$ to 1 inch, starting at the minimum-voltage point just located.

● **A CRYSTAL-CONTROLLED CONVERTER FOR 432 MC.**

The converter shown in Figs. 16-28 through 16-31 is designed to provide high sensitivity and signal-to-noise ratio in reception of signals in the 432- to 436-Mc. range. It uses a grounded-grid r.f. amplifier stage similar to the one shown in Fig. 16-25, working into a crystal-diode mixer.

The intermediate frequency, with the design constants given, is 50 to 54 Mc., though lower frequencies could be used by suitable modification of the injection chain.

Crystal-controlled injection on 382 Mc. is provided by two 6J6s operating as overtone oscillator-tripler and tripler-doubler, respectively. As only a small amount of r.f. is required at 382 Mc.,

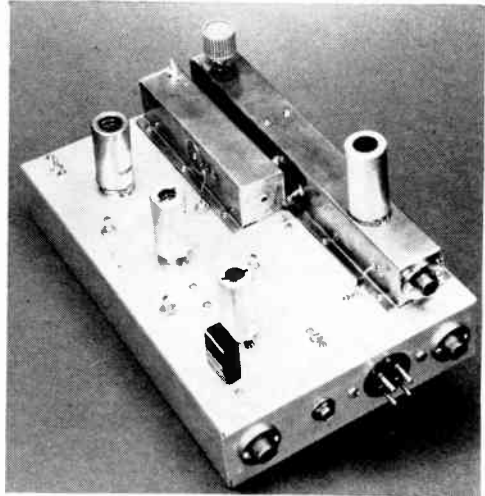

Fig. 16-28 — A crystal-controlled converter for 432 to 436 Mc. R.f. and mixer stages are in copper sub-assemblies at the right. Oscillator, multiplier and i.f. amplifier are on the left side.

this line-up is not difficult to build or adjust. An inexpensive 7-Mc. crystal is used. An i.f. pre-amplifier stage follows the crystal mixer. This may or may not be needed, depending on the performance of the receiver or converter that will serve as the tunable i.f. Low-noise amplification in the i.f. stage is a factor in the over-all performance of the system, so use of the built-in i.f. stage is recommended.

Construction

The converter is built on a 7 × 11 × 2-inch aluminum chassis, with the r.f. and mixer portions in a copper subassembly that mounts on the top of the chassis, at the right side as seen in

Fig. 16-29 — Interior view of the r.f. amplifier and mixer assemblies. The r.f. circuit is a half-wave line. The shorter assembly is the quarter-wave line using a crystal diode mixer.

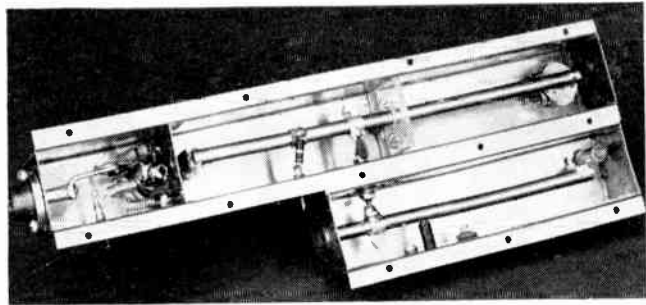

Fig. 16-28. The oscillator-tripler and tripler-doubler 6J6s are at the left front, with the 6BQ7A i.f. amplifier at the rear. The mixer line is the short portion of the copper assembly, with the r.f. amplifier line at the right. In the bottom view, Fig. 16-29, the injection-chain and i.f. amplifier components are visible.

Fig. 16-29 is an interior view of the r.f. and mixer lines. These are made as two separate assemblies, joined by short length of copper tubing that is visible in the top view. Both tank circuits are $1\frac{1}{4}$ inches square, with $\frac{1}{4}$ -inch copper tubing inner conductors. They are made from sheets of flashing copper $4\frac{1}{4}$ inches wide. The mixer compartment is $5\frac{1}{2}$ inches long and the r.f. portion is 10 inches long.

The r.f. amplifier is similar structurally to the one described previously, except for the method of coupling between it and the crystal mixer. This is done with a grid clip on each line and a ceramic coupling capacitor. The lead from the capacitor, inside the amplifier line, is brought through a half-inch length of copper tubing that is soldered into the walls of both lines. The lead is insulated with spaghetti sleeving.

The B-plus feed to the r.f. stage should be at the point of minimum r.f. voltage, $1\frac{1}{8}$ inches from the plate end of the copper tubing. The coupling tap is one inch out from the B-plus feed-point. The coupling point on the mixer line is 1 inch from the ground end. The crystal diode is inserted in a small hole in the mixer inner conductor, $1\frac{3}{4}$ inches from the ground end. The inner conductors of the r.f. and mixer lines are

$7\frac{3}{16}$ and 5 inches long, respectively. Mixer tuning is done with a small plastic trimmer, C_{10} , while the r.f. plate circuit is tuned with a hand-made tab capacitor, C_9 , similar to C_4 in Fig. 16-26.

Note the r.f. bypass, C_8 , on the outside of the mixer line. This is made from a piece of copper $\frac{7}{8}$ inch in diameter, insulated from the line housing by a piece of vinyl plastic. Two thicknesses of the material commonly used for small parts envelopes are satisfactory. The crystal, which may be any of the u.h.f. diodes, is slipped through a close-fit hole and is held in place by the wire soldered to its outside terminal.

Plate and filament voltages are fed into the assembly on feed-through by-pass capacitors, visible in the top-view photograph. Antenna connection is made through a coaxial fitting on the end of the r.f. assembly. A crystal-current jack, a 4-pin power fitting and two i.f. connectors are on the end wall of the chassis. The second coaxial connector was installed so that tests could be made with and without the i.f. amplifier stage.

Wiring in the power circuits is done with shielded wire, in case that TVI might result from the oscillator or multiplier stages. The addition of a bottom plate and power-lead filtering would then be effective. Injection and i.f. coupling leads are also made of shielded wire, this serving in place of coax line that is harder to handle.

The output of the injection chain is coupled into the mixer line by means of a loop, L_8 , that is not visible in the photographs. This loop is mounted on the copper base plate that is under

Fig. 16-30 — Bottom view of the 432-Mc. converter, showing the oscillator, multiplier and i.f. amplifier circuits.

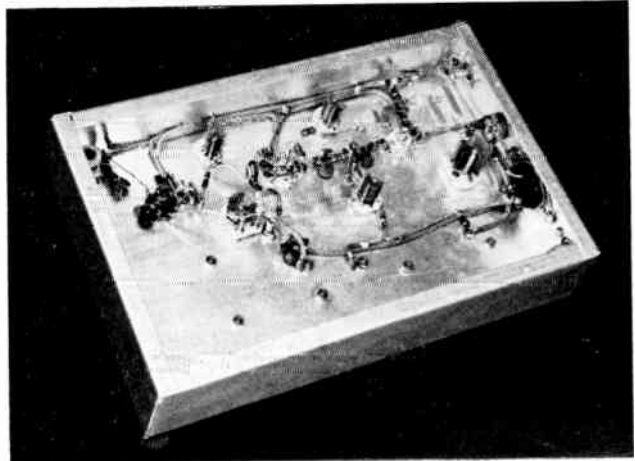

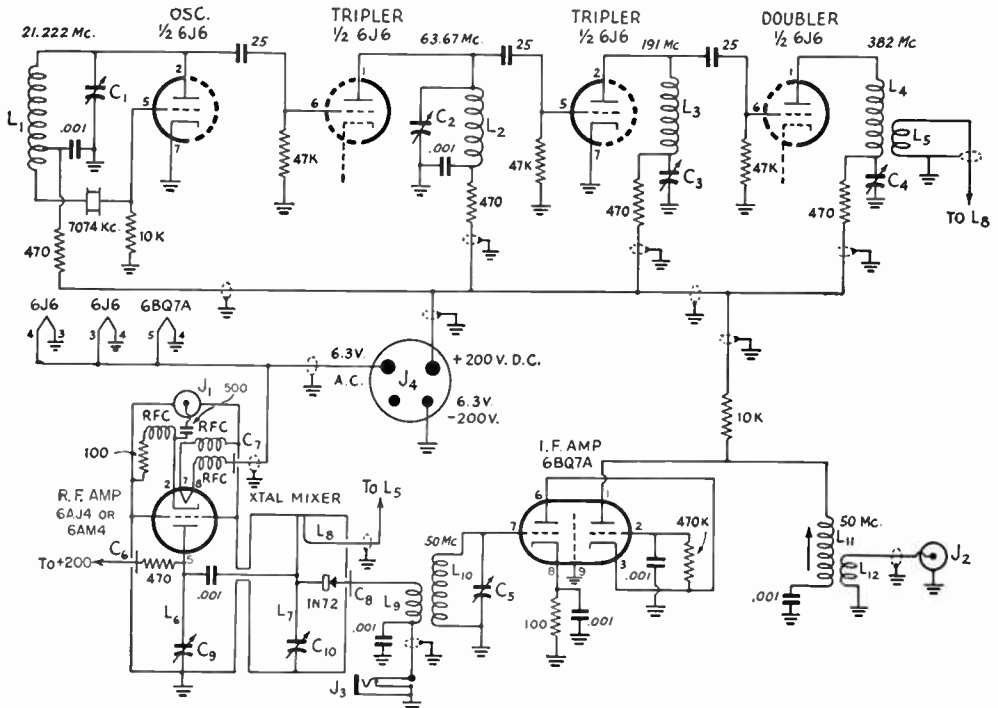

Fig. 16-31 — Wiring diagram and parts list for the 432-Mc. crystal-controlled converter. Values given are for an i.f. of 50 to 54 Mc.

- C₁ — 75- μ f. miniature trimmer (Hammarlund MAPC-75).
- C₂, C₃, C₄ — 20- μ f. miniature trimmer (Johnson 20M11).
- C₅ — 25- μ f. miniature trimmer (Hammarlund MAPC-25).
- C₆, C₇ — 500- μ f. feed-through ceramic (Centralab MFT-500).
- C₈ — Handmade copper-tab bypass; see text.
- C₉ — Handmade copper-tab variable; see text.
- C₁₀ — 0.5- to 5- μ f. plastic trimmer (Eric style 532-08-OR5).
- L₁ — 13½ turns No. 20 tinned, ⅝-inch diam., 7⅞ inch long, tapped at 4½ turns (B & W Miniductor No. 3007).
- L₂ — 5 turns No. 20 tinned, ½-inch diam., ⅜ inch long (B & W Miniductor No. 3003).
- L₃ — 2¾ turns similar to L₂.
- L₄ — 2 turns No. 12 tinned, ¼-inch diam., ¼ inch long.
- L₅ — 1 turn ins. wire between turns of L₄. May be inner conductor of shielded wire, with braid removed.
- L₆ — Half-wave line, ¼-inch copper tubing, 73/16 inches long.
- L₇ — Quarter-wave line, ¼-inch copper tubing, 5 inches long.
- L₈ — Loop of insulated wire 1 inch long and ½ inch high projecting through base plate on which line assemblies are mounted. May be made from inner conductor of shielded wire, with braid removed from last two inches.
- L₉ — 2 turns No. 22 enam. around cold end of L₁₀.
- L₁₀ — 6 turns similar to L₂.
- L₁₁ — 11 turns No. 22 enam. close-wound on ⅜-inch slug-tuned form (National XR-91).
- L₁₂ — 4 turns No. 28 silk or enamel wound over cold end of L₁₁.
- J₁, J₂ — Coaxial fitting.
- J₃ — Closed-circuit jack.
- J₄ — 4-pin male chassis fitting.
- RFC — 10 turns No. 22 tinned, ⅝-inch diam. Space turns diam. of wire.

the mixer and r.f. assembly. Its size and proximity to the mixer inner conductor are not particularly critical, as there is a surplus of injection under ordinary conditions of operation.

Adjustment

The first step in putting the converter into operation is to tune up the oscillator and multiplier stages. This process is similar to the adjustment of a transmitter and will not be detailed here. Check to see that the proper frequencies appear as indicated on the schematic diagram. Only enough power at 382 Mc. is needed to develop about 0.5 ma. of crystal current. Anything from 0.2 to 1.0 ma. is satisfactory. Adjustments should be made with no plate voltage on the r.f. stage.

Now connect the converter to a 50-Mc. receiver or converter and peak the i.f. amplifier

circuits at about 52 Mc. on noise. Next apply plate voltage and feed a signal into the r.f. stage. Peak the r.f. and mixer capacitors for maximum response at about 434 Mc. These adjustments can be made on noise also, if the circuits were close to resonance originally. If a noise generator is not available, the margin of signal over receiver noise that is obtained on a received signal is also usable, if adjustments are made with care.

The points of connection for the B-plus and the coupling taps on the r.f. and mixer lines are critical adjustments, but if the dimensions given above are followed carefully the points should be close to optimum. Adjustments can be made and checked readily if the r.f.-mixer assembly is mounted in place temporarily with a few self-tapping screws. (Originally described in January, 1954, *QST*, p. 24.)

V.H.F. Transmitters

Transmitter stability regulations for the 50-Mc. band are the same as for lower bands, and proper design may make it possible to use the same rig for 50, 28, 21, and even 14 Mc., but incorporation of 144 Mc. and higher in the usual multiband transmitter is generally not feasible. Rather, it is usually more satisfactory to combine 50 and 144 Mc., since the two bands are close to a third-harmonic relationship. At least the exciter portion of the transmitter may be made to cover the requirements for both these bands very readily.

Though no stability restrictions are imposed by law on operation at 144 Mc. and higher amateur bands (other than that the entire emission must be kept within the limits of the band in question), experience has demonstrated the value of using crystal control or its equivalent in v.h.f. work. Crystal-controlled transmitters and receivers having the minimum band width necessary for voice communication make it possible for hundreds of stations to operate without undue interference in a band that would appear crowded if occupied by a dozen or less stations using broad-band receivers and unstable transmitters.

The use of narrow-band communications systems also pays off in improved efficiency in both transmitter and receiver. It is this factor, perhaps more than the interference potentialities of the wide-band systems, which makes it desirable to employ advanced techniques at 220 and even 420 Mc. Stabilized transmitters for these bands are not too difficult to build, and their use is highly recommended.

Choice of tubes suitable for this type of work is quite limited, but the advanced amateur who is

interested in making the most of the interesting possibilities afforded by this developing field will be satisfied with nothing less. The 420-Mc. band is much wider than our lower v.h.f. assignments, however, and interference is not likely to become a limiting factor in this band for a long time to come. Thus it may be more important, in many localities, to get activity rolling with any sort of gear, leaving perfection in design to come along as the need develops.

At 420 Mc. and in the higher amateur assignments most standard tubes cannot be used with any degree of success, and special tubes designed for these frequencies must be employed. These types have extremely close electrode spacing, to reduce transit-time effects, and are constructed with leads having virtually no inductance. Several more-or-less conventional tubes are now available which will operate with fair efficiency up to about 500 Mc., but best performance is obtained with the "lighthouse," "pencil tube," or coaxial-electrode types built especially for u.h.f. applications, and requiring specially-designed tank circuits.

Frequency modulation may be used throughout the v.h.f. and higher bands, wide-band emission being permitted above 52.5 Mc. and narrow-band f.m. anywhere. Where suitable receivers are available to make best use of such emissions, either wide-band or narrow-band f.m. can provide effective v.h.f. communication. Their use is particularly advantageous in congested areas where the freedom from interference to broadcast and television reception they enjoy may permit operation when an amplitude-modulated transmitter of any power would be a constant source of trouble.

Transmitter Technique

The low-power stages of a transmitter for the v.h.f. bands need not be greatly different in design from those used for lower bands, and many of the ideas in Chapter Six may be used to good advantage in the initial stages of the v.h.f. rig. The constructor has the choice of starting at some lower frequency, usually around 6, 8 or 12 Mc., multiplying to the operating frequency in one or more additional stages, or he can use a high initial frequency and thus reduce the number of multiplier stages required or eliminate them entirely. The first approach has the virtue of employing low-cost crystals, and it usually results in better stability, but high-frequency crystals may effect a considerable economy in power consumption, an important factor in portable or emergency-powered gear.

● CRYSTAL OSCILLATORS

Crystal oscillator stages for v.h.f. transmitters may make use of any of the circuits shown in Chapter 6, when crystals up to 12 Mc. are employed, but certain variations are helpful for higher frequencies. Crystals for 12 Mc. or higher are usually of the overtone variety. Their frequency of oscillation is an approximate multiple of some lower frequency, for which the crystal is actually ground. Thus 24-Mc. crystals commonly used in 144-Mc. work are 8-Mc. cuts, specially treated for overtone characteristics. Until recent years such crystals were tricky in operation and subject to excessive drift if operated at high crystal current. The overtone crystals now being supplied are approximately as stable as those

designed for fundamental operation, and they are easy to handle in properly designed circuits.

Best results are usually obtained with overtone crystals if some regeneration is added. This makes for easy starting under load and greater output than would be obtainable in a simple triode or tetrode circuit. Regenerative circuits, with constants for 8- or 24-Mc. crystals, are shown in Figs. 17-20 and 16-10. Triodes are shown, but the same arrangement may be used with tetrode or pentode tubes. The important point in either case is the amount of regeneration, controlled by the number of turns below the tap in L_9 of Fig. 16-10 or the capacitance of the smaller of the two bypasses in the B + lead to the oscillator in Figs. 17-20 and 17-23. There should be only enough feedback to assure easy crystal starting and satisfactory operation under load; too much will result in random oscillation not under the control of the crystal.

Overtone operation is possible with standard fundamental-type crystals, using these circuits. Practically all will oscillate on their third overtones, and fifth and higher odd overtones may be possible. Adjustment of regeneration is more critical, however, if the crystals are not ground for overtone characteristics. It should also be noted that the frequency may not be an exact multiple of that marked on the crystal holder, so care should be used in working with crystals that are near a band edge.

Crystals ground for overtone service can be made to oscillate on other overtones than the one marked on the holder. A 24-Mc. crystal, actually an 8-Mc. cut, may be made to oscillate on 40, 56, 72 Mc. or even higher odd multiples of its 8-Mc. fundamental frequency. The circuits shown in the constructional material later in this chapter may be used in this way, but there are several circuits that have been developed especially for use with high-order overtones that may serve the purpose better. For a more complete discussion of overtone oscillator techniques, see *QST* for April, 1951, page 56, and March, 1955, page 16.

Crystals are now available for frequencies up to around 100 Mc. They are somewhat more expensive and more critical in operation than those for 30 Mc. and lower, however, so they have not been used widely in amateur work, except where a saving in power is important. Use of 50-Mc. crystals is made occasionally as a means of preventing radiation of the harmonics of lower frequency crystals that might cause interference to television reception.

● FREQUENCY MULTIPLIERS

Frequency multiplying stages in a v.h.f. transmitter follow standard practice, the principal precaution being arrangement of components for short lead length and minimum stray capacitance. This is particularly important at 144 Mc. and higher. To reduce the possibility of radiation of oscillator harmonics on frequencies that might interfere with television or other services, the lowest satisfactory power level should be used.

Low-powered stages are easier to shield or filter, in case such steps become necessary.

Common practice in v.h.f. exciter design is to make the tuned circuits capable of operation over the whole range from 48 to 54 Mc., so that the output stage can drive either an amplifier at 50 to 54 Mc. or a tripler from 48 to 144 Mc. Tripling is often done with push-pull stages, particularly when the output frequency is to be 144 Mc. or higher. The output capacitances of the tubes in such push-pull circuits are in series, permitting a better L/C ratio than is possible with single-ended circuits.

● AMPLIFIERS

Most transmitting tubes now used by amateurs will work on 50 Mc., but for 144 Mc. and higher the tube types are limited to those having low input and output capacitances and compact physical structure. Leads must be as short as possible, and soldered connections should be avoided in high-powered circuits, where heating may be great enough to reach the melting point of the solder used.

Plug-in coils and their associated sockets or jack bars are generally unsatisfactory for use at 144 Mc. and higher because of the stray inductance and capacitance they introduce. One way around this trouble is the dual tank circuit shown in Figs. 17-24 and 17-25. Here the tank circuit for 144 Mc. is a conventional tuned line, with its shorting bar made as a removable plug. When the stage is to be used on another band the short is removed and a coil is plugged into the jack, the line then serving as a pair of plate leads. Such an arrangement will operate as efficiently on 144 Mc. as if it were designed for that band alone, yet it can be made to work properly on any lower band.

At 220 Mc. and higher it may be necessary to employ half-wave lines as tuned circuits, as shown in Fig. 17-29 (P_1 in place). Here the tuning capacitance, instead of being connected directly in parallel with the output capacitance of the tube, is at the far end of a half-wave line. Plate voltage is fed into the line near the middle, at the point where the r.f. voltage is lowest. The proper point can be located by first operating the stage with the voltage fed in near the middle of the line, and then touching a pencil point along the line to locate the spot where the least effect on the grid or plate current is noted. This check should be made with the pencil in an insulating mount, if dangerous values of plate voltage are used.

Neutralization of triode amplifiers for 50 and 144 Mc. can follow standard practice, but the stray inductance and capacitance introduced by the neutralizing circuits may be excessive for 220 Mc. and higher. In such instances grounded-grid amplifiers may be used as shown in Fig. 16-25, modified for transmitting use. Driving power is applied to the cathode circuit, with the grid acting as a shield. Grounded-grid amplifiers are stable, but they require high driving power. Some of the drive appears in the output, so both

the driver and amplifier must be modulated when amplitude modulation is used. For this reason the grounded-grid amplifier is used mainly for f.m. applications.

Tetrode and pentode amplifiers may operate without neutralization, but it is advisable to plan for it in the original layout. With such tubes as the 829 or 832 enough neutralizing capacitance can be obtained by running short lengths of stiff wire up through the chassis alongside the tube plates, crossing them over to the opposite grid terminals below the chassis. Neutralization is adjusted by trimming or bending the wires.

Instability shows up frequently in tetrode amplifiers as the result of ineffective screen bypassing, in which case conventional cross-over neutralization will accomplish little or nothing. The solution lies in series-resonating the screen circuits to ground, as shown in Fig. 17-25. The r.f. choke and capacitor values vary with frequency, so screen neutralization is essentially a one-band device.

● FREQUENCY MODULATION

Though f.m. has not enjoyed great popularity in v.h.f. operation, probably because of lack of suitable receivers in most v.h.f. stations, its possibilities should not be overlooked, particularly for the higher bands. At 420 Mc., for instance, the efficiency of most amplifiers is so low that it is often difficult to develop sufficient grid drive for proper a.m. service. With f.m. any amount of grid drive may be used without affecting the audio quality of the signal, and the modulation process adds nothing to the plate dissipation. Thus considerably higher power can be run with f.m. than with a.m. before damage to the tubes develops or the signal is of poor quality.

Frequency modulation also simplifies transmitter design. The principal obstacle to greater use of f.m. in v.h.f. work is the wide variation in selectivity of v.h.f. receivers, making it difficult for the operator to set up his deviation so that it will be satisfactory for all listeners.

● TVI PREVENTION AND CURE

Interference to television reception is not ordinarily so serious a problem with v.h.f. gear as with equipment for lower amateur bands, where more harmonics of the operating frequency fall within the television channels. The principal causes of TVI from v.h.f. transmitters are as follows:

- 1) Adjacent-channel interference in Channel 2 from 50 Mc.
- 2) Fourth harmonic of 50 Mc. in Channels 11, 12 or 13, depending on the operating frequency.
- 3) Radiation of unused harmonics of the oscillator or multiplier stages. Examples are 9th harmonic of 6 Mc., and 7th harmonic of 8 Mc. in Channel 2; 10th harmonic of 8 Mc. in Channel 6; 7th harmonic of 25-Mc. stages in Channel 7; 4th harmonic of 48-Mc. stages in

Channel 9 or 10; and many other combinations. This may include i.f. pickup, as in the cases of 24-Mc. interference in receivers having 21-Mc. i.f. systems, and 48-Mc. trouble in 45-Mc. i.f.'s.

4) Fundamental blocking effects, including modulation bars, usually found only in the lower channels, from 50-Mc. equipment.

5) Image interference in Channel 2 from 144 Mc. in receivers having a 45-Mc. i.f.

6) Sound interference (picture clear in some cases) resulting from r.f. pickup by the audio circuits of the TV receiver.

There are many other possibilities, and u.h.f. TV in general use will add to the list, but nearly all can be corrected completely, and the rest can be substantially reduced.

Items 1, 4 and 5 are receiver faults, and nothing can be done at the transmitter to reduce them, except to lower the power or increase separation between the transmitting and TV antenna systems. Item 6 is also a receiver fault, but it can be alleviated at the transmitter by using f.m. or e.w. instead of a.m. phone.

Treatment of the various harmonic troubles, Items 2 and 3, follows the standard methods detailed elsewhere in this *Handbook*. It is suggested that the prospective builder of new v.h.f. equipment familiarize himself with TVI prevention techniques, and incorporate them in new construction projects.

Use as high a starting frequency as possible, to reduce the number of harmonics that might cause trouble. Select crystal frequencies that do not have harmonics in TV channels in use locally. Example: The 10th harmonic of 8-Mc. crystals used for operation in the low part of the 50-Mc. band falls in Channel 6, but 6-Mc. crystals for the same frequency range have no harmonic in that channel.

If TVI is a serious problem, use the lowest transmitter power that will do the job at hand. Much interesting work can be done on the v.h.f. bands with but a few watts output, particularly if a good antenna system is used.

Keep the power in the multiplier and driver stages at the lowest practical level, and use link coupling in preference to capacitive coupling, particularly in the later stages.

Plan for complete shielding and filtering of the r.f. sections of the transmitter, should these steps become necessary.

Use coaxial line to feed the antenna system, and locate the radiating portion as far as possible from TV receivers and antenna systems.

Some v.h.f. TV tuners have removable strips that can be replaced with double-conversion inserts for u.h.f. reception. For a number of channels the first conversion frequency may then fall in or near the 144-Mc. band. Where this method is employed for u.h.f. reception the receiver is very sensitive to 144-Mc. interference. The cure for this receiver fault is to replace the strips with others having a different conversion frequency, or use a conventional u.h.f. converter for reception of the channels from 14 up.

High-Power Transmitter for 50 and 144 Mc.

The gear described in the next several pages shows how transmitting equipment for two v.h.f. bands can be coordinated in design so as to work from a single exciter. If the builder so desires, the station may be operated from one set of power supplies and speech equipment, with a single set of meters measuring the important currents in both transmitters. Each item can be used by itself, or they combine readily to cover both 50 and 144 Mc., at a power level approaching the legal limit.

In order of their description they are an exciter capable of delivering up to 40 watts output at 48 to 54 Mc., a companion amplifier for the 50-Mc. band, a tripler-driver-amplifier for 144 Mc., and a dual antenna coupler for feeding 50- and 144-Mc. antennas having balanced lines. Their physical appearance is such that they combine neatly for rack mounting, as seen in Fig. 17-1.

● THE EXCITER

Though it is shown mounted on the same panel as the 50-Mc. amplifier in Fig. 17-2, the exciter unit might well be used alone, as a versatile 50-Mc. transmitter capable of running up to about

65 watts input. Provision is made for taking off 48-Mc. output at two power levels, through J_3 or J_2 , the latter being used for driving the 144-Mc. tripler to be described later.

The exciter is completely shielded, and its power leads are filtered to prevent radiation of harmonics by the power cable. In addition, there are built-in traps to absorb unwanted oscillator harmonics that might otherwise be passed on to the amplifier, or to the antenna. Harmonics of this kind are particularly troublesome when they fall in Channel 2, which is so close to the operating frequency that a filter in the antenna line is relatively ineffective against them.

The interstage coupling circuits are of band-pass design. Once they are properly adjusted they require no further tuning, when the frequency is changed over a 4-Mc. range. Thus only the crystal switch and the output plate circuit need be adjusted when changing frequency.

Circuit Details

The oscillator is a 5763, using crystals above 6, 8, 12, or 24 Mc. for 144-Mc. operation, or 6.25, 8.34, 12.5 or 25 Mc. for 50 Mc. Its plate circuit tunes 24 to 27 Mc., quadrupling, tripling or doubling the crystal frequency. (Crystals at 24 to 27 Mc. are overtone cuts that oscillate at one-third the marked frequency in this circuit.) A series-tuned trap, L_1C_1 , in the oscillator plate circuit absorbs the third harmonic of 6-Mc. crystals. This 18-Mc. energy otherwise would pass on to the next stage, where it would be tripled to a frequency in Channel 2. This harmonic has been found to be a common cause of 50-Mc. TVI in Channel 2 areas.

The doubler is also a 5763. A second trap, C_4L_4 , in the grid circuit, is tuned to the 7th harmonic of 8-Mc. crystals. The two traps thus prevent radiation of energy in Channel 2, the most critical transmitter problem a 6-meter man is likely to encounter in correcting TVI. They can be modified for other fre-



Fig. 17-1 — A high-power r.f. section for a 50- and 144-Mc. station. Equipment includes a band-pass exciter for both bands, a 50-Mc. r.f. amplifier built on the same panel, a tripler-driver-amplifier for 144 Mc., and a dual antenna coupler for both frequencies. Units can be operated with a single set of power supplies, and with common speech equipment and meters.

Fig. 17-2 - The 50 Mc. r.f. unit. Exciter, left portion on the assembly, also serves on 144 Mc. Amplifier utilizes a 4-125A, 4-250A or 4-100A.



quencies to suit local problems. An example is the 10th harmonic of 8-Mc. crystals, that falls in Channel 6. A trap for the 5th harmonic of the crystal frequency should take care of this.

The 6146 amplifier stage has a shunt-fed pi-network plate circuit. For best stability over the entire operating range the stage is neutralized. The choke, RFC_4 , is provided to short out the d.c. voltage that would appear on the output circuit if C_9 should break down. The choke in the plate lead, RFC_5 , is for parasitic oscillation suppression. Note that each of the three cathode leads is bypassed separately at the socket. The exciter may be keyed in the 6146 cathode jack, J_4 .

Double-tuned band-pass circuits between the oscillator and doubler, and between the doubler and final, provide essentially flat response from 48 to 52 Mc., or 50 to 54 Mc. A potentiometer in the doubler screen circuit provides excitation control for the 6146, and may be used to compensate for variations in drive that may appear at some spots in the band.

The link winding on the doubler plate circuit, L_6 , is for the purpose of taking off low-level 48-Mc. output to drive the tripler in the 144-Mc. r.f. unit. Note that the keying jack in the 6146 cathode circuit is the open-circuit type. Removing the key thus disables the 6146 stage, when the first two stages are being used in this way. Separate heater and filament switches on all units allow them to be operated separately. High-voltage supplies may be left connected to all r.f. units, energizing only the filaments and heaters in the ones being used.

Construction

The exciter is built on a 5 × 10 × 3-inch aluminum chassis, with a bottom plate and a perforated aluminum cage to complete the shielding. The small knobs at the lower left of the front view are for the crystal switch and the excitation control. The crystal switch has 12 positions. Ten are for the crystals on the multiple crystal socket

(Johnson No. 126-120-1). One more crystal position is provided on the front panel (a convenience if you want to use a frequency not covered by the 10 crystals in the multiple socket), and the 12th switch position is for an external v.f.o. It connects the 5763 grid to the coaxial v.f.o. input fitting, and shorts out RFC_1 and its parallel capacitor. The stage then functions as a frequency multiplier. The output frequency of the v.f.o. could thus be in the 6-, 8- or 12-Mc. range. Above the excitation control may be seen the knobs for the 6146 plate and output coupling capacitors.

Three coaxial connectors are on the rear wall of the exciter. The one at the outside edge is for v.f.o. input. The others are the doubler and 6146 output fittings. Two 4-terminal steatite strips handle the various power and metering leads. Adjacent to each terminal except the ground connection is a feed-through by-pass capacitor to take the power lead through the chassis.

TVI that might result from radiation of harmonics by the power leads is prevented by filtering of each lead. The feed-through bypasses are connected to the exciter circuits through r.f. chokes, the inner ends of which are again bypassed with small disk ceramic capacitors. All power leads are made with shielded wire, bonded at intervals to the chassis.

The side view shows the multiple crystal socket at the front of the chassis. Separate crystal sockets may be used if desired. The oscillator and doubler tubes are in the foreground. The trap capacitors, C_1 and C_4 , are adjacent to these tubes, while C_2 and C_3 are between them, a bit off their center line. To the rear of the 5763 doubler are C_5 and C_7 . The grid tuning capacitor for the 6146, C_6 , is just visible inside the amplifier compartment.

A separate lead is provided for each power circuit. Fixed bias for the 6146 is brought in from the bias supply that is part of the high-power amplifier assembly. This bias is desirable to prevent the plate current from rising too high when

the excitation is backed off. If the exciter is used alone, fixed bias is unnecessary. External meters can be connected in any of the circuits at the terminal strips.

The sides, back and top of the amplifier cage are Reynolds "Do-It-Yourself" perforated aluminum sheet, now available in many hardware stores. The pieces are joined together at the corners with lengths of $\frac{3}{8}$ -inch aluminum angle which can be bought or bent up from sheet stock. The tuning and loading capacitors are mounted on the front of the cage, so this part should be a piece of solid sheet stock rather than the perforated material. The dimensions of the cage are not critical. The original is $5\frac{3}{4}$ inches deep, $2\frac{5}{8}$ inches across, and $4\frac{1}{4}$ inches high. Make provision for removing the top and outside sheets of perforated stock for convenience in servicing, when the exciter is mounted against the amplifier unit. Extension shafts and couplings bring out the amplifier controls to the panel.

Inside the cage, the 6146 can be seen with its socket mounted above the chassis on $\frac{1}{2}$ -inch metal sleeves. The cathode and screen bypasses should connect to separate ground lugs on the top of the chassis, with the shortest possible leads. This wiring can be done conveniently before the socket is mounted on the chassis if nuts are used temporarily to hold the ground lugs in place over the socket mounting screws. The neutralizing adjustment, C_8 , is mounted on the rear wall of the cage, and wired to the 6146 plate clip and the feed-through bushing with $\frac{3}{8}$ -inch wide strips of thin copper. A ceramic insulator mounted on the wall near the 6146 plate cap supports the junction of RFC_5 , RFC_3 , and C_9 .

An ordinary tie point supports the other end of RFC_3 and the shielded power lead. The plate coil, L_8 , can be seen in back of the 5763 doubler tube, wired between the stators of C_{10} and C_{11} . C_{12} and RFC_4 are mounted near C_{11} , and hooked between its stator bar and a ground lug. A short length of RG-58/U coax runs down through a hole in the chassis from C_{11} over to J_3 .

Most of the parts visible in the below-chassis view can be identified from our description of the panel, rear, and topside layouts. The oscillator cathode choke, RFC_1 , can be seen mounted upright near the oscillator tube and crystal sockets. Both 5763 sockets should be oriented so that Pins 4 and 5 are adjacent to the outside chassis wall. L_1 is visible between C_1 and the oscillator tube socket. L_2 and L_3 run between this socket and that of the doubler. These coils are made from a single length of Miniductor stock with the specified number of turns removed to provide spacing between them. The same applies to L_5 and L_7 . These are to the left of the 6146 socket. L_4 is between the doubler socket and C_4 . The trap coils are mounted with their axes vertical, to minimize coupling to the band-pass coils. L_6 is wound around and cemented to the by-passed end of L_5 .

The power lead r.f. chokes are mounted between single-terminal tie points on the rear lip of the chassis and the feed-through capacitors. The disk ceramic bypasses are then applied at the tie points. A single-terminal tie point mounted under RFC_1 holds one end of the 3300-ohm doubler screen resistor and the lead over to the terminal strip at the rear. A double tie point is mounted between the two 5763 sockets to support the by-passed ends of L_2 and L_3 . Another over nearer the rear of the chassis supports the cold end of L_5 and the bottom of the doubler grid resistor.

Wiring will be simplified by the following procedure. Before mounting the crystal switch, ground one terminal of each crystal socket through a bus wire. Connect short lengths of tinned wire to the other terminal of each socket that will be under the switch. Then when the latter is installed, the wires can be run to the proper contacts and soldered in place. Note that the front wafer of the switch is used for shorting out RFC_1 , while the crystal socket connections are made to the rear wafer, which is more accessible. The v.f.o. input socket is connected to the proper switch contact with a length of RG-58/U coax.

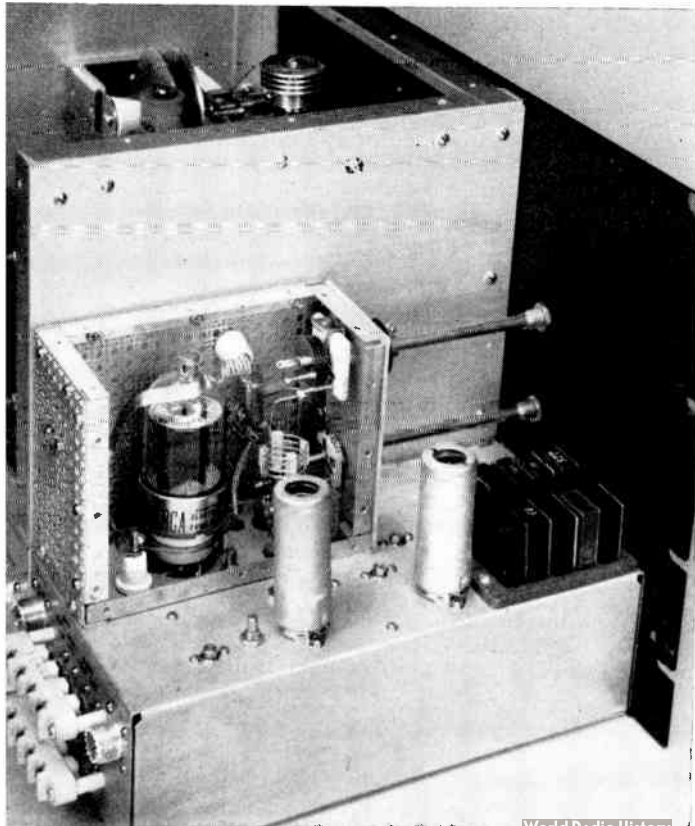

Fig. 17-3 — Side view of the exciter, with cover removed. Band-pass coupling circuits eliminate front-panel tuning controls except for crystal switch and output stage tuning.

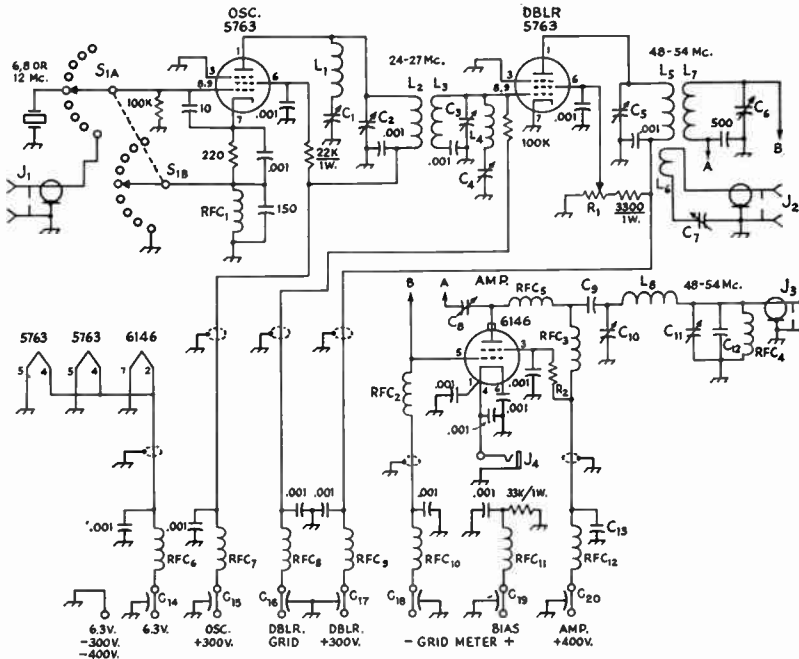

Fig. 17-1 — Schematic diagram of 48-54-Mc. exciter. All capacitances less than .001 μ f. are in μ f. All .001- μ f. capacitors are disk ceramic. All resistors are $\frac{1}{2}$ watt unless otherwise specified.

- C₁, C₂, C₃ — 35- μ f. miniature trimmer (Hammarlund MAPC-35).
- C₄ — 10- μ f. miniature variable (Hammarlund MAC-10).
- C₅, C₆ — 20- μ f. miniature variable (Hammarlund MAC-20).
- C₇ — 50- μ f. miniature trimmer (Hammarlund MAPC-50).
- C₈ — 15- μ f. miniature trimmer (Hammarlund MAPC-15).
- C₉, C₁₃ — .001- μ f. 3000-volt disk ceramic.
- C₁₀ — 35- μ f. miniature variable (Hammarlund HF-35).
- C₁₁ — 100- μ f. miniature variable (Hammarlund MAPC-100B).
- C₁₂ — 100- μ f. 1000-volt mica.
- C₁₄—C₂₀ — .001- μ f. feed-through-type ceramic (Centralab FT-1000).
- L₁ — 16 turns No. 24, $\frac{5}{8}$ -inch diam., 32 t.p.i. (B & W Miniductor No. 3008).
- L₂, L₃ — 12 turns each No. 20, $\frac{5}{8}$ -inch diam., 16 t.p.i. (B & W Miniductor No. 3007). Make from one piece of Miniductor with 5 turns removed between coils. Cold ends are adjacent.

- L₄ — 2 turns No. 20, $\frac{1}{2}$ -inch diam., 16 t.p.i. (B & W Miniductor No. 3003).
- L₅, L₇ — 6 turns No. 20, $\frac{1}{2}$ -inch diam., 16 t.p.i. (B & W Miniductor No. 3003). Make from one piece of Miniductor with 3 turns removed between coils.
- L₆ — 2 turns hookup wire wound around cold end of L₅ and cemented in place.
- L₈ — 4 turns No. 18, $\frac{3}{4}$ -inch diam., 8 t.p.i. (B & W Miniductor No. 3010).
- J₁, J₂, J₃ — Coaxial chassis fitting (Amphenol 83-1R).
- J₄ — Open-circuit phone jack.
- R₁ — 25,000-ohm 4-watt pot.
- R₂ — 33,000-ohm 3-watt (3 100,000-ohm 1-watt in parallel).
- RFC₁ — 2.5-mh. r.f. choke (National R-100S).
- RFC₂, RFC₃, RFC₄ — 7- μ hy. solenoid v.h.f. choke (Ohmite Z-50).
- RFC₅ — 6 turns No. 22 tinned wire, $\frac{1}{4}$ -inch diam., spaced one-wire diam.
- RFC₆—RFC₁₂ — 15 turns No. 24 enam. close-wound on high value 1-watt resistor.
- S₁ — 2-pole 12-position miniature ceramic rotary (Centralab PA-2005).

In assembling the power lead filtering components at the rear of the chassis, the disk ceramic bypasses can most easily be mounted on the tie points before the latter are fastened inside the chassis. Wiring up the power leads should be done before the r.f. chokes are mounted in place.

● THE 50-MC. AMPLIFIER

Though the exciter and amplifier are pictured on a single panel, the possibility of using either by itself should not be overlooked. The exciter will make a fine low-powered transmitter, and the final amplifier may be used with any exciter delivering 15 watts or more.

It will take up to the legal limit of power with a 4-400A tube, 750 watts with a 4-250A, or 400 watts with a 4-125A.

The plate circuit is a larger version of the one used in the 6146 stage of the exciter, a shunt-fed pi-network. Operation is completely stable without neutralization, probably because the natural neutralized frequency of the tubes is close to 50 Mc. Provision was originally made for neutralization, but it was found to be unnecessary. Parasitic suppression devices were not required, but if the layout is varied appreciably from that shown, the builder should check for both types of instability with great care.

The jack in the filament center-tap lead is for keying, or for insertion of a grid-bias modulator. A bias supply that delivers about 50 volts negative for the 6146 and 150 for the final amplifier is included in the final stage assembly. Filament transformers for the exciter and final are also part of this unit. Separate filament switches are in-

cluded; one for the exciter and the other for the final tube and the blower motor. Power leads except the high voltage, are brought in on an 8-pin plug.

Building the Amplifier

A 12 × 10 × 3-inch aluminum chassis is used for the amplifier unit. Thus, it may be combined with the exciter on a 10½-inch rack panel, if desired. The amplifier controls mounted near the panel bottom are, left to right, the input link reactance capacitor, C_1 ; the grid tuning capacitor, C_2 ; and S_1 and S_2 . S_1 applies a.c. to the transformer for the exciter heaters and to the bias supplies. S_2 applies a.c. to the filament transformer of the amplifier and starts the cooling fan. Above the switches on the panel are the amplifier plate tuning and loading controls.

On the rear of the chassis, coaxial connectors for r.f. input and output are mounted at either end. Between them are the high-voltage connector for the plate supply, the cathode circuit jack, and a fitting for the remaining power and meter leads.

Above the chassis, the 4-250A tube is seen near the front of the chassis. Note that its socket is mounted on ½-inch sleeves. Holes ⅜ inch in diameter are drilled in the chassis directly underneath those provided in the socket for the passage of cooling air. Holes are also drilled adjacent to the cathode, grid, and screen pins to pass their

leads. Bypassing of cathode and screen is done above the chassis. The heat radiating plate connector for the 4-250A was cut down to four fins to reduce the over-all height requirement. The filament transformer, T_3 , and the screen modulation choke, L_4 , are also topside.

The amplifier plate circuit components are to the left of the tube. The tuning capacitor, C_7 , originally a neutralizing capacitor, is mounted on the side wall of the shielding assembly. Two modifications should be made to the neutralizing unit before mounting. The circular plates supplied should be replaced with larger ones, 3 inches in diameter, to increase the available tuning range. The bearing assembly of the rotor disk must be temporarily removed, and a strap of copper run between the screw holding the bearing in place and the opposite (grounded) end of the square ceramic insulating pillar. This grounds the capacitor rotor. Two copper straps must be inserted between the stator disk and its insulator, to connect the stator with the blocking capacitor, C_5 , and with L_3 .

The blocking capacitor, the shunt-feed r.f. choke, RFC_2 , and the high-voltage bypass, C_6 , are assembled into one unit before mounting in the amplifier. This is done with the aid of the hardware supplied with the TV-type high voltage capacitors. The by-pass capacitor, on the bottom of the stack, is equipped with one threaded terminal and one tapped one. The latter is on the bottom end, for fastening the assembly to the chassis. The threaded terminal screws into the 2½-inch ceramic insulator upon which RFC_2 is wound. The ends of the choke winding are secured by lugs at each end of the insulator. C_5 should be fitted with a threaded terminal at the lower end for screwing into the top of the insulator. This also serves to fasten the ¾-inch wide strip of copper which runs up to the 4-250A plate cap. Finally, the longer of the two copper strips coming from the stator of C_7 is screwed to the top of C_5 . A ½-inch feed-through bushing brings the high-voltage up to the hot side of C_6 . The loading capacitor, C_8 , is mounted on the chassis directly underneath C_7 . The plate coil, L_3 , gets rather warm when the rig is operated at high power level, so both of its ends must be bolted in place rather than soldered. One end is bent around and fastened under a

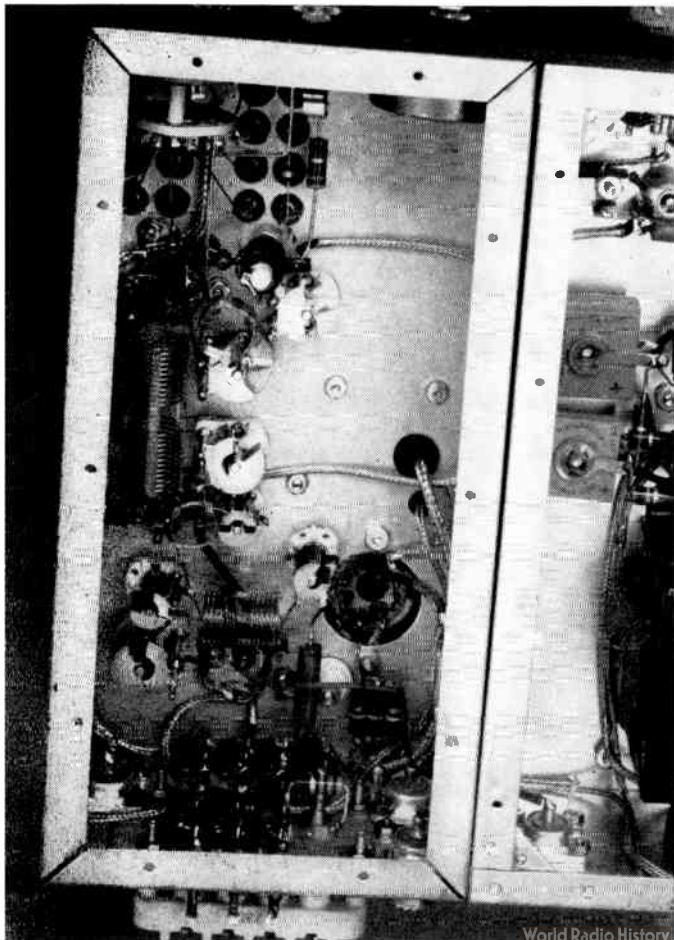

Fig. 17-5—Bottom view of the 30-Mc. exciter, showing band-pass circuits and TVI protective measures.

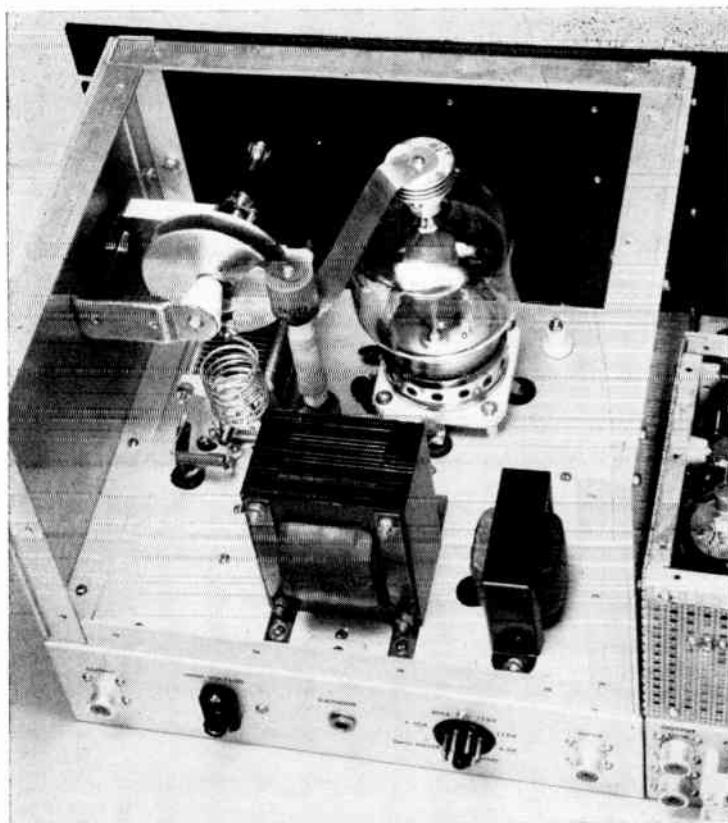

Fig. 17-6—Interior of the 50-Mc. final amplifier. Plate tuning capacitor is modified neutralizing unit, left.

nut provided on the stator of C_8 . The other is bolted to the short length of copper strap previously fastened to the stator of C_7 . A length of RG-8 U coaxial cable is run between C_8 and J_2 . At the capacitor end, this cable is connected to lugs under the stator and frame mounting screws.

Solid sheet aluminum is used for the enclosure of this unit, as it must be reasonably airtight except for holes directly above the tube itself. The side that supports C_7 must be of fairly heavy stock for rigidity. Home-bent $\frac{3}{4}$ -inch angle stock was used to hold the assembly together. If the over-all height of the unit is kept to just about that of the $10\frac{1}{2}$ -inch rack panel, there will be enough clearance above the tube plate connector.

Most of the under-chassis components are visible in the bottom view. The grid circuit is near the front edge of the chassis. Copper strap connects the tube socket grid pin with the stator of C_2 . L_2 then is soldered between this strap and a tie point. L_1 is slid inside the cold end of L_2 , and cemented lightly in place.

The cooling fan sucks air in from the side of the amplifier near the back corner. The motor is mounted on an aluminum bracket. The fan as supplied will blow, rather than suck, so the blades must be bent back to reverse their pitch. A small piece of aluminum window screening shields the hole cut in the chassis side for the fan.

Bias supply components occupy the lower left

quarter of the bottom view. Layout and wiring of this portion of the rig is anything but critical. Shielded wire was used for all power leads. Bypassing at the power connector should be done with very short leads, and C_{14} should be mounted as close as possible to the high-voltage connector.

Adjustment and Operation

An initial setting of the exciter controls can be made before power is applied, if a grid-dip meter is available. The series traps, L_1C_1 and L_4C_4 , introduce varying amounts of reactance across the tuned circuits when they are adjusted, so some further adjustment will be needed after these are set up finally, but the following procedure will result in a close approximation.

Disconnect one end of L_3 , Fig. 17-4. Couple the grid-dip meter to L_2 and tune it with C_2 to about 24.5 Mc. Leaving the setting of C_2 at that position, lift one end of L_2 . Reconnect L_3 and resonate C_3L_3 to about 25.5 Mc. Reconnect L_2 , and the circuits should be set for operation on 48 to 52 Mc. For 50 to 54 Mc., the frequencies should be 25.5 and 26.5 Mc.

Procedure for the second band-pass circuit is similar except for the frequencies involved. For 48 to 52 Mc., disconnect L_7 and tune C_5L_5 to 49 Mc. Reconnect L_7 and disconnect L_5 , tuning L_7C_6 to 51 Mc. Reconnect L_5 . For the 50- to 54-Mc. range these frequencies would be about 51 and 53 Mc.

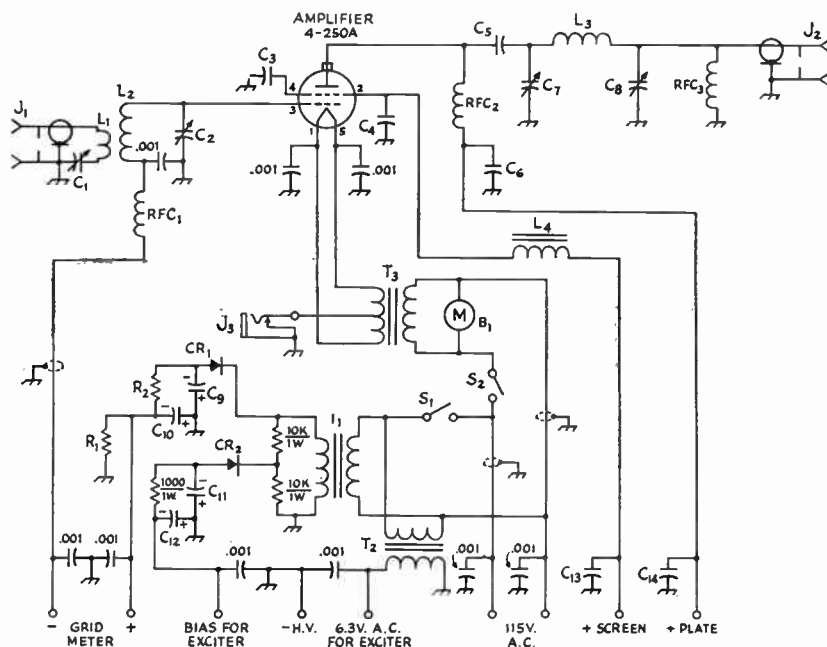

Fig. 17-7—Schematic diagram and parts list for the 4-250A amplifier. All capacitors marked .001 $\mu\text{f.}$ are 600-volt disk ceramic.

- C_1 —50- $\mu\text{f.}$ miniature variable (Hammarlund HF-50).
 C_2 —15- $\mu\text{f.}$ miniature variable, double-spaced (Hammarlund HF-15X).
 C_3, C_4, C_{13} —.001- $\mu\text{f.}$ 1000-volt disk ceramic.
 C_5, C_6, C_{14} —500- $\mu\text{f.}$ 20,000-volt ceramic (Cornell-Dubilier MM120T5).
 C_7 —Disk-type capacitor with 3-inch diam. plates (made from Millen 15011).
 C_8 —250- $\mu\text{f.}$ variable, double-spaced (Johnson 250-F20).
 $C_9, C_{10}, C_{11}, C_{12}$ —12- $\mu\text{f.}$ 250-volt electrolytic.
 J_1, J_2 —Coaxial chassis fitting (Amphenol 83-1R).
 J_3 —Closed-circuit phone jack.
 CR_1 —65-ma. selenium rectifier (Federal 1002 A).
 CR_2 —20-ma. selenium rectifier (Federal 1159).
 L_1 —5 turns No. 24, $\frac{1}{2}$ -inch diam., 32 t.p.i. (B & W Miniductor No. 3004).
 L_2 —4 turns No. 18, $\frac{3}{4}$ -inch diam., 8 t.p.i. (B & W Miniductor No. 3010).
 L_3 —6 turns No. 12 tinned wire, 1-inch diam., spaced twice wire diam.
 L_4 —Filter choke, about 10-hy. 100-ma. (Triad C-10X).
 B_1 —Blower motor and fan (Allied cat. No. 72P715).
 R_1 —20,000 ohms 10 watts.
 R_2 —500 ohms 2 watts (2 1000-ohm 1-watt resistors in parallel).
 RFC_1, RFC_3 —7- $\mu\text{h.}$ solenoid choke (Ohmite Z-50).
 RFC_2 —Solenoid choke, 42 turns No. 244 d.c.c. close-wound on $\frac{1}{2}$ -inch diam., 2 $\frac{1}{2}$ -inch long insulator (National GS-2).
 S_1, S_2 —Single-pole single-throw toggle switch.
 T_1 —Power transformer, 135 volts at 50 ma. (Triad R-30X).
 T_2 —Filament transformer, 6.3 volts at 3 amp. (Triad F-16X).
 T_3 —Filament transformer, 5.2 volts e.t. at 15 am. (Triad F-11U).

Connect a source of 6.3 volts a.c. at 2.5 amperes or more between the ground and heater terminals, and a low-range meter from the doubler grid return terminal to ground. Insert crystals for the desired frequency range. Apply about 200 volts d.c. to the oscillator plate-screen terminal through a 50- or 100-ma. meter. Current should be 20 to 30 ma., and grid current in the following stage should be about 0.5 ma., when the voltage is increased to the normal 300 volts. Touch up the tuning of the band-pass circuit, if necessary, to get uniform response across the desired range.

The trap circuits can be adjusted at this point, tuning for minimum signal at the frequency to be attenuated in each case. A receiver tuning to the harmonic frequencies is helpful. These will be about 18 to 20.25 Mc. for the first trap and 56 to 60 Mc. for the second, if they are for Channel 2. A TV receiver on the channels to be protected may also be used, merely tuning the traps for minimum TVI. Some slight readjustment of the

band-pass circuit may be needed after the final trap tuning is done.

Now remove the grid current meter and ground the metering terminal in the doubler grid circuit. Connect a meter (0 to 5 ma. or more) between the terminals provided for measuring the 6146 grid current. Set the screen potentiometer, R_1 , to about the middle of its range and apply about 200 volts to the doubler plate-screen input terminal. Adjust the band-pass circuit, L_5C_5, L_7C_6 for nearly uniform response across the desired range, using the 6146 grid current as the output indication. There should be at least 2 ma. across a 4-Mc. range when the doubler plate voltage is raised to 300. Note that the screen potentiometer controls the input to the doubler, and through it the excitation to the 6146.

The 48-Mc. output coupling adjustment, L_6C_7 , may be checked at this time. The line to a 144-Mc. tripler stage should be connected to J_2 , and the series capacitor, C_7 , adjusted for maximum grid current in the driven stage. Recheck the

adjustment of the band-pass circuit after this is done.

The 6146 amplifier stage had to be neutralized for stable operation. Its adjustment was not critical, however, and C_8 could be set anywhere near minimum capacitance with good results. Start out with its plates meshed about $\frac{1}{8}$ inch. With grid drive applied but no plate or screen voltage, tune the 6146 plate circuit through resonance, trying various settings of C_8 until there is no grid current dip at resonance.

A load for the 6146 output circuit is now required. This can be a 40- or 60-watt lamp, with a 50- μf . capacitor in series to tune out its reactance. Adjust it for minimum reflected power, as indicated on an s.w.r. bridge. With the load connected and grid drive on, apply 300 to 400 volts to the amplifier plate and screen terminal. Tune C_{10} for maximum indicated output. Loading can be adjusted by varying C_{11} , retuning C_{10} after each movement of C_{11} .

Recheck for neutralization at this point, working for a setting of C_8 at which minimum plate current, maximum grid current, and maximum output all occur at the same setting of the plate tuning capacitor, C_{10} . The input can be run up to about 65 watts with plate modulation and 35-40 watts output should be obtained. Higher input can be run on c.w. Plate voltage should not exceed about 400 with plate modulation, though it can be somewhat more for c.w.

Now make a final check on the trap circuits, if necessary. In case TVI is experienced, adjust the traps while someone watches the TV screen, and see whether any improvement is possible. Remember that the traps shown were designed primarily to reduce Channel 2 interference. Where the trouble is with other channels, the traps can be modified to reduce the offending harmonic as required. A low-pass filter or a 4th harmonic trap will be needed if there is harmonic interference in Channels 11-13.

The amplifier as shown furnishes heater voltage and protective bias for the exciter. Hook together the 6.3-volt and ground terminals of the two units, and connect the bias output pin on the amplifier to the 6146 grid return in the exciter.

Apply 115 volts a.c. to the appropriate pins on the amplifier power plug. When S_1 , Fig. 17-7, is closed, the exciter heaters and the bias supplies are energized. The bias voltages are about 50 and 150 negative for the driver and amplifier, respectively. Closing S_2 lights the amplifier filament and starts the fan motor.

For the initial testing of the amplifier disconnect its fixed bias supply, by lifting the connection between R_1 and R_2 , so that instability will be more evident. Connect the output of the exciter through a length of coaxial cable to J_1 . Hook a 0-25- or 0-50-ma. meter to the terminals provided for measuring grid current. Turn on the exciter and adjust the driver output and amplifier input for maximum grid current. Set this current between 10 and 15 ma. with the excitation control, R_1 , in the exciter. To insure proper adjustment of the amplifier grid circuit, insert an s.w.r. bridge unit such as a Micromatch in the coax connecting the driver and amplifier, and tune C_1 and C_2 in the amplifier alternately for minimum reflected power. Adjust the driver tuning for maximum forward power.

Never apply screen voltage without having the plate voltage on also, and do not operate the amplifier without load. Either will result in excessive screen dissipation, and almost certain tube failure if continued for any length of time. A usable dummy load for testing can be made by connecting two or more 100-watt lamps in parallel. A variable series capacitor, 50 μf . or more, will be helpful in making the lamp load something like 50 ohms, resistive, at this frequency.

It is well to start with something less than maximum voltages in testing. If the plate voltage is under 1000 and the screen voltage about 200 to 300 volts, little harm can result if something is not quite right. With the dummy load connected, apply plate and screen voltages. Set C_8 near the middle of its range and tune C_7 for maximum output. If this occurs at or close to the end of the tuning range of C_7 , adjust the spacing of the turns in the plate coil accordingly. Adjust C_8 for maximum output, returning C_7 as required. If the grid current dropped below 10 ma. under load,

Fig. 17-8 — Bottom view of 50-Mc. exciter and amplifier. Note that the two units are built separately, though they mount together on a single panel. Amplifier unit includes bias and filament supplies for both.

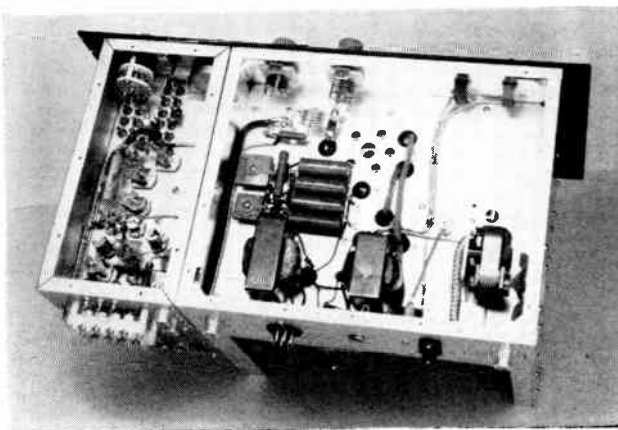

increase the drive with the doubler screen potentiometer in the exciter.

Check now for stability. Briefly cut off the drive and see if the amplifier grid current drops to zero. If it doesn't, the amplifier either needs neutralization, or it has a parasitic oscillation. If no grid current shows with drive removed, note whether, when drive is applied and the amplifier is tuned properly, maximum output, minimum plate current and maximum grid current all occur at the same plate tuning. If they do, the amplifier is operating satisfactorily.

If oscillation does show up, check its frequency. If it is much higher than the operating frequency (probably over 150 Mc.) v.h.f. parasitic suppression measures are in order. If it is in the 50-Mc. region, neutralization will be required. These troubles are most common in multiband designs, and unlikely in a layout of this sort. Neutralization of the capacity-bridge type, like that in the exciter, can be incorporated readily, and parasitic suppression is covered in detail elsewhere in this *Handbook*. Neutralization may require *additional* grid-plate capacitance in some layouts. Provision was made for neutralization in the original layout (explaining the plugged hole in the front panel), but it was found to be unnecessary.

When the amplifier is operating stably, the plate and screen voltages may be increased in accordance with the tube manufacturer's ratings, for the type of operation intended. Operating conditions are different for the three tubes which can be used and they should follow the manufacturer's recommendations. This is not to say that variations from the published data are unsafe or undesirable. Any of the values can be varied over quite a range if the maximum rating for each tube element concerned is not exceeded. In this connection, it is highly desirable to provide continuous metering for the grid, screen, and plate currents. This, with a knowledge of the applied voltages, will help insure proper operation and make correct adjustment a simple matter.



● A 144-MC. DRIVER-AMPLIFIER

The unit shown in Figs. 17-9 through 17-14 is a three-stage tripler-driver-amplifier that may be used with the exciter just described. Driving power at 48 Mc. may be taken from the doubler stage (by connecting to J_2 in Fig. 17-4) or from the output stage, running at low power. Almost any 50-Mc. transmitter of 3 to 5 watts output could be used by substituting a suitable crystal and retuning the stages for operation at 48 to 49.3 Mc. If a small 144-Mc. transmitter is available, the tripler stage may be dispensed with, in which case about 5 watts drive on 144 Mc. is required.

This section of the station is built in two parts. The tripler and driver stages are in the small portion at the right of Fig. 17-9, with the final stage at the left. All are push-pull stages, the tripler and driver using dual tetrodes. The tripler is an Amperex 6360, followed by an RCA 6524 straight-through amplifier. This drives a pair of 4-125As in the final stage.

Input to the 4-125As can be up to 600 watts on a.m. phone, or 800 watts on c.w. or f.m. By suitable adjustment of screen and plate voltages the power can be dropped as low as 150 watts input and still maintain good efficiency. Some means of reducing power is highly desirable, as most operation on 144 Mc. can be carried on satisfactorily with low power.

The Driver Portion

The tripler and driver stages, Figs. 17-11 and 17-12, both operate well below their maximum ratings. Self-tuned grid circuits are used in each stage. This simplifies construction, and in the case of the driver stage, reduces the possibility of self-oscillation. With a surplus of drive available, the grid circuit of the 6524 may be resonated as low as 130 Mc. There is little tendency to tuned-plate tuned-grid oscillation, therefore, and neutralization is not required.

Tripler and driver are built on a standard $5 \times 10 \times 3$ -inch aluminum chassis, with the tripler at the back. Its plate circuit is tuned from the front panel by an extension shaft. Omission of the screen bypass on the tripler is intentional as the stage works satisfactorily without screen bypassing.

The 6524 is easily over driven. This may be corrected by squeezing the driver grid coil turns

◆
Fig. 17-9 — The high-power 2-meter rig, with shielding enclosures in place. The small unit at the right houses the tripler and driver stages.
◆

closer together, lowering the resonant frequency until the desired 2.5 to 3.5 mc. is obtained across the band. The farther it can be resonated below 144 Mc. the less likelihood there is of self-oscillation in the driver stage.

The 6524 is mounted horizontally, and holes are drilled in the chassis under the tube to allow for air circulation. Plate leads are made of thin phosphor bronze or copper, bent into a semicircle, connecting the butterfly capacitor and the heat-dissipating connectors. This allows the latter to be removed for changing tubes, without putting undue strain on the plate pins. The connectors have to be sawed or filed down on the insides to fit on the 6524 pins. The coupling link at the driver plate circuit is tuned, to provide efficient transfer of energy to the amplifier grids.

Small feed-through bypasses are used in the driver screen circuit. C_5 is mounted in the aluminum plate that supports the 6524 socket, and C_6 is in the chassis surface.

Amplifier Features

Design of the 4-125A grid circuit is important in achieving efficient transfer of energy from the driver stage. The input capacitance of the large tetrodes is so high that a tuned grid circuit of conventional design cannot be used at 144 Mc., so a half-wave line is substituted, as shown in Figs. 17-13 and 17-14. The input coupling link is series tuned, permitting adjustment for minimum standing wave ratio on the coaxial line connecting it to the driver stage output link. The grid line, L_1L_2 , is made of $\frac{1}{4}$ -inch copper tubing, to reduce heat losses.

Maintaining the 4-125A screens and filament leads at ground potential for r.f. is necessary for stability. To this end, the tube sockets are mounted above the chassis, rather than below. They are elevated only enough to allow the socket contacts to clear the chassis, and are mounted corner to corner, with the inner corners almost touching. The grid line is brought up through $\frac{1}{2}$ -inch chassis holes and soldered directly to the grid contacts. This determines the line spacing, about $1\frac{1}{2}$ -inches center to center.

The inner filament terminals on each socket are grounded to the chassis. The others connect to feed-through bypasses with the shortest possible leads. These are joined under the chassis with a shielded wire and tied to the filament transformer. The r.f. chokes in the screen leads are

under the chassis, their wire leads coming up through Millen type 32150 feed-through bushings inserted in chassis holes under the screen terminals. The two screen terminals on each socket are strapped together with a $\frac{3}{8}$ -inch wide strip of flashing copper. The screen neutralizing capacitor is mounted as close to the sockets as possible and still leave room for the shaft coupling on its rotor. Leads to its stators are about one half inch long.

More compact and symmetrical design is possible if a modified single-section capacitor is used for C_6 . It should be the type having supports at both ends of the rotor shaft. The Millen 19140 and Hammarlund MC140 are suitable units for the purpose. The stator bars are sawed at each side of the center stator plate. The front rotor plate is removed, making a split-stator variable with 4 plates on each stator and 8 on the rotor. This procedure may not be applicable to all 140- μ f. capacitors, but any method that results in a balanced unit having about 50 μ f. per section should do.

Construction of the final plate circuit should be clear from Fig. 17-10. Tuning is done with parts of a disk-type neutralizing capacitor (Millen 15011) mounted on ceramic stand-offs $3\frac{1}{2}$ inches high. These are made of one 1-inch and one $2\frac{1}{2}$ -inch stand off each, fastened together with a threaded insert. Connection to the lines is made with copper or silver strap, $4\frac{1}{2}$ inches from the plate end. Silver plating of all tank circuit parts is a worth-while investment, though it should not be considered a necessity. A shaft coupling designed for high-voltage service is attached to the threaded shaft of the movable plate, and this is rotated with a shaft of insulating material brought out to the front panel.

A word about the extension shafts is in order at this point. If they are of metal they may have a serious detuning effect in some circuits, even though they are connected through insulating couplings. Bakelite rod is fine, but since the insulating qualities are of no importance, $\frac{1}{4}$ -inch wooden doweling will do the job just as well. Lucite or polystyrene rod will not stand

Fig. 17-10 — Rear view of the 4-125A final stage. The split-stator capacitor near the middle of the picture is the screen neutralizing adjustment. The plate line is tuned with a capacitor made from parts of a neutralizing unit, mounted on ceramic stand offs.

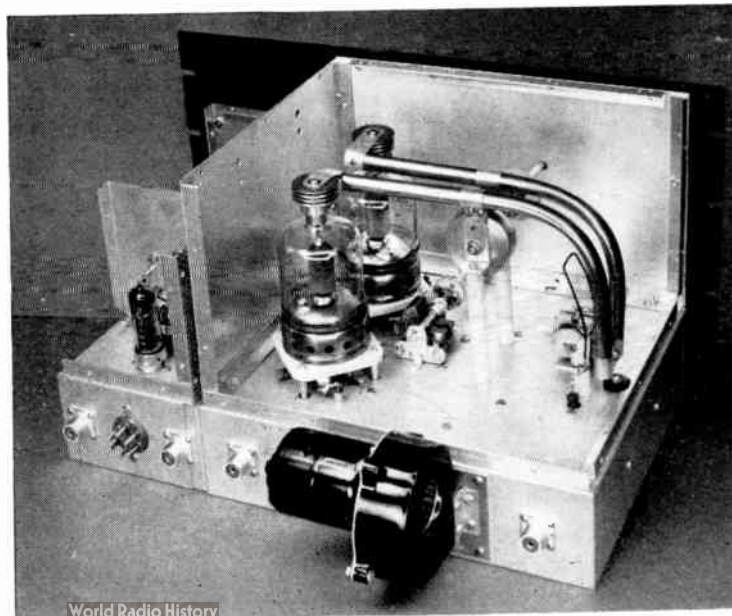

The somewhat random appearance of the front panel is the result of the development of the unit in experimental form. A slight rearrangement of some of the noncritical components could be made to achieve a symmetrical panel layout readily enough.

Operation

The two units have their own filament transformers. Plate supply requirements are 300 volts at 50 ma. for the tripler, 400 volts at 100 ma. for the driver, 300 to 400 volts at 75 ma. for the final screens and 1000 to 2500 volts at 400 ma. for the final plates. The driver plates and final screens may be run from the same supply, but more flexibility is possible if they are supplied separately. A variable-voltage supply for the final screens is a fine way to control the power level.

In putting the rig on the air the stages are fired up separately, beginning with the tripler. A jack (J_3 , in Fig. 17-11) is provided on the front panel for measuring the 6360 grid current. About 1 ma. through the 150,000-ohm grid resistor is plenty of drive. The series capacitor, C_3 , in the link can be used as a drive adjustment, if more than necessary is available.

Next plug the grid meter into the 6524 grid current jack, J_4 , and tune the 6360 plate circuit for maximum grid current. If it is higher than 3 to 4 ma. increase the inductance of the grid coil, L_6 , by squeezing its turns closer together. Now apply plate and screen voltage to the 6524, and check for signs of self-oscillation. If the plate circuit is tuned down to the same frequency as that at which the grid coil resonates with the tube capacitance, the stage may oscillate, but if it is stable across the intended tuning range there should be no operating difficulty resulting from a tendency to oscillate lower in frequency, and no neutralization should be needed.

Connect a coaxial line between the driver output and the final grid input preferably with a standing-wave bridge connected to indicate the standing-wave ratio on this line. Tune the driver plate circuit and its series-tuned link for maximum grid current in the final amplifier. Adjust the final grid tuning, C_1 , for maximum grid current, and the series capacitor, C_3 , in the link for minimum reflected power on the s.w.r. bridge. Adjust the coupling loop position for maximum transfer of power, using the least coupling that will achieve this end.

Adjust the screen neutralizing capacitor, C_6 ,

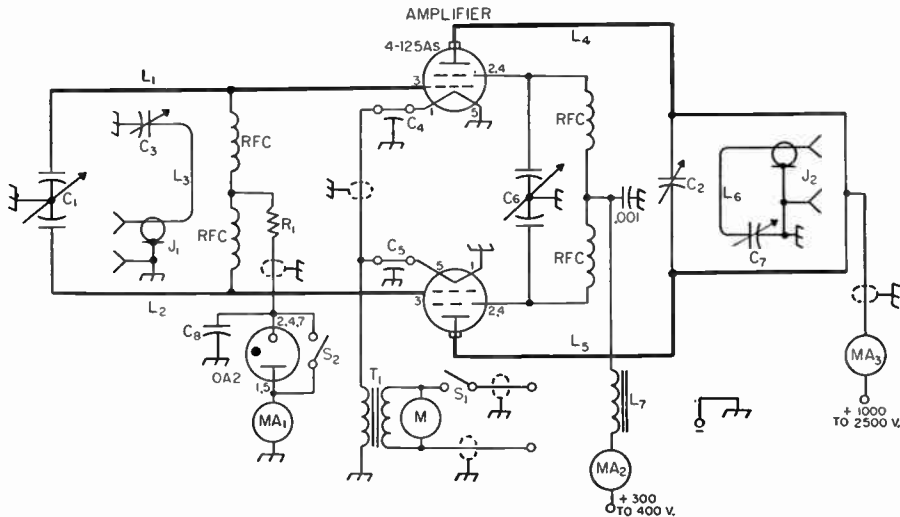

Fig. 7-13 — Schematic diagram of the 4-125A amplifier for 144 Mc.

- C_1 — 30- μ f.-per-section split-stator variable (Hammarlund HPD-30N).
- C_2 — Plate tuning capacitor made from Millen 15011 neutralizing unit; see text and photo.
- C_3 — 25- μ f. miniature variable (Bud LC-1612).
- C_4, C_5 — 500- μ f. feed-through by-pass (Centralab FT-500).
- C_6 — Approx. 50- μ f.-per-section split-stator variable. Make from Millen 19110 or Hammarlund MC-140; see text.
- C_7 — 25- μ f. variable (Johnson 25L15).
- C_8 — 0.25- μ f. tubular.
- R_1 — 5000 ohms, 10 watts.
- L_1, L_2 — $\frac{1}{4}$ -inch copper tubing, 12 inches long, spaced $1\frac{1}{2}$ inches center to center. Bend around $1\frac{1}{2}$ -inch radius, 1 inch from grid end.
- L_3 — Loop made from 5 inches No. 14 enamel. Portion coupled to line is 1 inch long each side, about $\frac{3}{8}$ -inch from line.

- L_4, L_5 — $\frac{1}{2}$ -inch copper tubing 12 inches long, spaced $1\frac{1}{2}$ inches center to center. Bend around 2-inch radius to make line 4 inches high. Attach C_2 $1\frac{1}{2}$ inches from plate end.
- L_6 — Loop made from 7 inches No. 14 enamel. Sides spaced $1\frac{1}{4}$ inches.
- L_7 — 5-hy. (min.) 100-ma. rating filter choke.
- J_1, J_2 — Coaxial fitting, female (Amphenol 83-11R).
- MA_1, MA_2, MA_3 — External meters, not shown; 100, 200 and 500 ma.
- M — Motor-blower assembly, 17 c.f.m. (Ripley Inc., Middletown, Conn., Type 8133).
- RFC — V.h.f. solenoid choke (Ohmite Z-144). Four required.
- S_1 — Toggle switch.
- S_2 — Rotary jack-type switch (Mallory 720).
- T_1 — Filament transformer, 5-volt 13-amp. (Chicago FO-513).

for maximum final grid current, with the plate and screen voltages off. Do not attempt to run the final stage without load. With a fixed screen supply the screen dissipation goes very high when the plate load is removed or made too light. It is important to meter the screen current at all times. With 4-125As danger to the plates can be detected by their color, but the screen current is the only indication of possible damage to that element.

There is no suitable inexpensive dummy load for testing a v.h.f. rig of this power level. The best load is probably an antenna. This can be an indoor gamma-matched dipole, fed with coax. Its series capacitor should be adjusted for a standing-wave ratio close to 1:1. The Micro-match can be used in this operation, but adjustments should be made at less than full power. Watch for any sign of heating in the bridge unit.

The position of the coupling loop, L_6 , should be adjusted for maximum transfer of energy to the antenna, keeping the coupling as loose as possible. The series capacitor, C_7 , can be used as a loading adjustment thereafter. If the screen voltage is continuously variable it will be found that there is an optimum value around 325 to 350 volts.

Below are some conditions under which the rig has been operated experimentally:

Stage	E_p	I_p	E_{sc}	I_{sc}	I_g
Tripler	300 v.	35 ma.	—	—	1.5 ma.
Driver	100 v.	92 ma.	—	8 ma.	3-4 ma.
Final	1000 v.	300 ma.	400 v.	60 ma.	22 ma.
Final	2000 v.	350 ma.	350 v.	45 ma.	20 ma.
Final	2500 v.	400 ma.	320 v.	40 ma.	18 ma.

The first and third conditions given for the final stage represent extremes, both exceeding the tubes' ratings in some way, so they are not recommended. At low plate voltages the screen has to be run above recommended ratings to make the tubes draw their full rated plate current and operate efficiently. At high plate voltages the screen dissipation drops markedly. The use of 4-125As at a full kilowatt input exceeds the manufacturer's maximum ratings, and is done at

the user's risk. To operate safely, the maximum plate voltage for voice work at 144 Mc. should probably not go over 2000. At this level the tubes will handle 600 watts input on voice, and 750 watts on c.w. easily.

Modulation and Keying

Keying is done in the screen circuit of the driver stage, and in the screen and plate circuits of the tripler. Cathode keying of the driver was attempted, but it caused instability troubles, so was abandoned. The screen method makes the key hot, so an insulated key or a keying relay must be used in the interest of safety. The keying jack must be insulated from the panel.

Fixed bias for the final amplifier is provided by the VR-tube method. When the tube ignites at the application of drive, the capacitor C_8 charges. Removing excitation stops the flow through the VR tube and leaves the negative charge in the capacitor applied to the amplifier grids. The effectiveness of this system requires a low-leakage capacitor for C_8 .

Modulation is applied to the plates only. A choke of about 10 henrys is connected in the screen lead, or the modulation can be supplied through a screen winding on the modulation transformer. The by-pass value in the screen circuit should be low enough to avoid affecting the higher audio frequencies. Occasionally audio resonance in the screen choke may cause a singing effect on the modulation. If this develops, the choke may be shunted with a resistor. Use the highest value that will stop the singing.

In neutralizing the 4-125As it may be found that what appears to be the best setting of the screen capacitor will result in a very large drop in grid current when plate voltage is applied. The setting may be altered slightly, raising the full-load grid current, without adversely affecting the stability of the amplifier. The final check for neutralization is twofold. There should be no oscillation when drive is removed; and maximum grid current, minimum plate current and maxi-

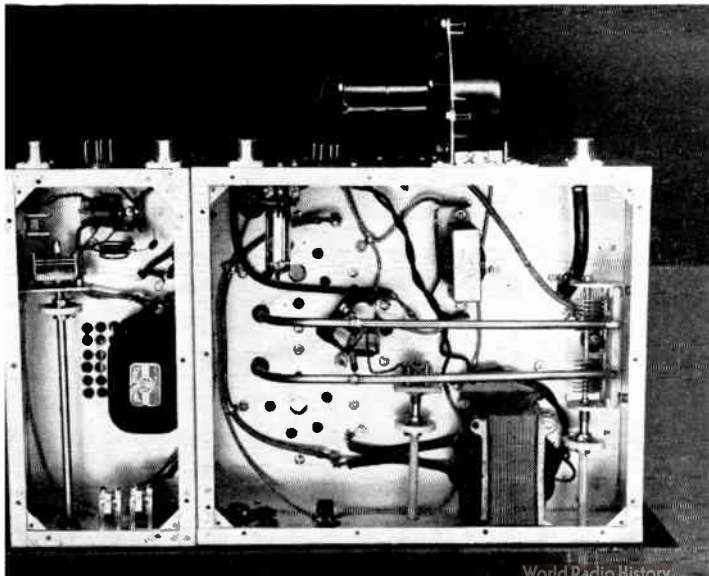

Fig. 17-14 — Under-chassis view of the 2-meter transmitter. Tripler grid and plate circuits are at the upper left. Only two of the three jacks on the front panel show in the lower left. The half-wave line used in the 4-125A grid circuit is the main item of interest in the amplifier section. Both units are fitted with bottom covers, to provide shielding and confine the flow of cooling air to the desired areas.

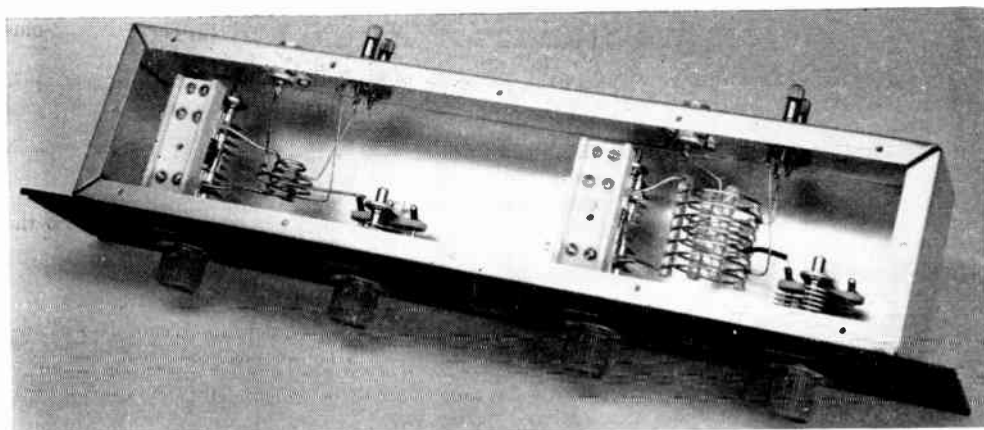

Fig. 17-15 — Antenna couplers for 50 and 144 Mc. designed for use with the high-power transmitters on the previous pages.

imum output should all show at one setting of the plate tuning capacitor. The latter condition may be observed only when the amplifier is operated without fixed bias.

● ANTENNA COUPLERS FOR 50 AND 144 MC.

The antenna couplers shown in Figs. 17-15, and at the top of Fig. 17-1, can be used with 52-ohm or 75-ohm coaxial line, and with balanced lines of any impedance from 200 to 600 ohms or more. They were designed for use with the high-power transmitters described previously, but may be used at any power level.

Construction

The two couplers are identical circuitwise. They are built inside a standard 3 by 4 by 17-inch aluminum chassis, with a bottom plate to complete the shielding. The panel is 3½ inches high. If only one coupler is required, a 3 by 4 by 6-inch utility box can be used. Terminals on the back of the chassis include a coaxial input fitting and a two-post output fitting for each coupler. The circuit diagram, Fig. 17-16, serves for both.

The 50-Mc. coils are cut from commercially-available stock, though they can be made by hand if desired. The coupling winding, L_1 , is inserted inside the tuned circuit. The polyethylene strips on which the coils are wound keep the two coils from making electrical contact, so no support other than the wire leads is needed.

Leads to L_1 are brought out between the turns of L_2 , and are insulated from them by two sleeves of spaghetti, one inside the other. Do not use the soft vinyl type of sleeving, as it will melt too readily if, through an accident to the antenna system, the coil should run hot. In the 144-Mc. coupler the positions of the coils are reversed, with the tuned circuit, L_2 , at the center, and the coupling coil outside it.

Similar tuning capacitors are used in both couplers, but some of the plates are removed from the one in the 144-Mc. circuit. This provides easier tuning, though it has little effect on

the minimum capacitance, and therefore on the size of the coil.

Adjusting the Couplers

An antenna coupler can be adjusted properly only if some form of standing-wave bridge is connected in the line between the transmitter and the coupler. If it is a power-indicating type, so much the better, as it then can be used for adjusting the transmitter loading, and the work can be done at normal transmitter power.

With the bridge set to read forward power, adjust the coupler capacitors and the transmitter tuning roughly for maximum indication. Now set the bridge to read reflected power, and adjust the antenna coupler capacitors, first one and then the other, until minimum reflected power is

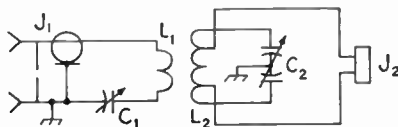

Fig. 17-16 — Circuit and parts information for the v.h.f. antenna couplers.

C_1 — 100- μ mf. variable for 50 Mc., 50- μ mf. for 144 Mc. (Hammarlund MC-100 and MC-50).

C_2 — 35- μ mf. per-section split-stator variable, 0.07-inch spacing (Hammarlund MCD-35SX). Reduce to 4 stator and 4 rotor plates in each section in 144-Mc. coupler for easier tuning; see text.

J_1 — Coaxial fitting, female.

J_2 — Two-post terminal assembly (National FWH).

L_1 — 50 Mc.: 4 turns No. 18 tinned, 1 inch diameter, ½-inch spacing (Air-Dux No. 808T).

144 Mc.: 2 turns No. 14 enam., 1 inch diameter, ½-inch spacing. Slip over L_2 before mounting.

L_2 — 50 Mc.: 7 turns No. 14 tinned, 1½ inch diameter, ¼ inch spacing (Air Dux No. 1204). Tap 1½ turns from each end.

144 Mc.: 5 turns No. 12 tinned, ½ inch diameter, inch long. Tap 1½ turns from each end.

achieved. Unless the line input impedance is very highly reactive, it should be possible to get the reflected power down to zero, or very close to it. Adjustment of the coupler is now complete. Tuning for maximum transfer of power from the transmitter is done *entirely* at the transmitter.

Progressive Station for 50 and 144 Mc.

The three units shown in Fig. 17-17 are designed to serve several purposes. The two smaller ones are complete r.f. sections for use on 50 and 144 Mc. at the 15- to 25-watt level. The other is an amplifier capable of running up to 125 watts, phone or c.w., on both bands. The exciters may be keyed or modulated also, and their low power consumption makes them ideal for mobile service or home-station operation at moderate power.

The separate 25-watt rigs are as similar as possible, mechanically and electrically, the tubes and many of the parts being interchangeable. Circuitry is similar, and their design is aimed at moderate duplication cost and ease of construction. Both are assembled on 5×10 -inch aluminum plates that fasten to standard 3-inch chassis of the same size. Covers of perforated aluminum $3\frac{1}{2}$ inches high provide shielding and prevent damage to components when the rigs are used for mobile service.

Circuitry

The oscillators use a third-overtone circuit, with 8- or 24-Mc. crystals for 144 Mc. and 8.4- or 25-Mc. crystals for 50 Mc. in one half of a 12AT7 dual triode. The other triode doubles to 50 Mc. or triples to 72 Mc. The 50-Mc. doubler drives a 2E26 amplifier. An extra stage is needed in the 144-Mc. rig. This is another 12AT7, with its triodes connected in parallel, doubling to 144 Mc. The amplifier is a 2E26. Neutralization and interstage coupling methods differ in the two amplifier stages, but operating conditions are generally similar.

The amplifier for higher power has a pair of 6146 tetrodes, with changeable tank circuits for operation on both bands. Input and output capacitances of such tubes are too high to permit use of ordinary plug-in coil arrangements on 144 Mc., so a quarter-wave line for 144 Mc. and a plug-in coil for 50 Mc. are used in the plate circuit. No tuning capacitance is used in the

grid circuit, the plug-in inductances being resonated by the input capacitance of the tubes alone.

Figs. 17-24 and 17-25 show how the plate circuit works. A 144-Mc. line of strips of flashing copper is completed at the far end from the tubes by means of a combined plug-in short and B-plus connection, P_2-L_4 . The tuning capacitor, C_2 , is tapped down the line 2 inches to minimize its loading effect on the line at 144 Mc. At 50 Mc. the line is merely the pair of connecting leads to the plug-in coil assembly, L_4-L_5 . Separate output coupling arrangements are provided for the two bands, but these are tuned by a common series capacitor, C_3 . The 144-Mc. coupling loop is fitted with a 300-ohm-line plug, fitting into the crystal socket, J_4 , visible in Fig. 17-24. It is removed when the 50-Mc. coil is plugged into the coil socket, J_3 .

Of special interest is the protective circuit used to keep the 6146 plate current within bounds when drive is removed. A 12AU7 serves as a combined cathode follower (right in Fig. 17-25) and d.c. amplifier (left). Normally the d.c. amplifier is cut off by the bias developed across the amplifier grid leak. Voltage applied to the cathode follower is determined by the voltage divider. Its cathode follows the voltage on its grid, so adjustment of the potentiometer allows the desired voltage to be applied to the 6146 screens. Loss of drive removes bias, causing the d.c. amplifier to conduct heavily. Voltage drops across the 1-megohm resistor in its plate circuit, and this low voltage is applied to the 6146 screens through the cathode follower.

This simple device not only protects the amplifier tubes in case of drive failure, but it serves as a convenient means of controlling input, for tuning up or for local work where less than full power may be desirable. With a 400-volt supply, input to the 6146s can be varied from 20 to more than 125 watts without changing loading adjustments.

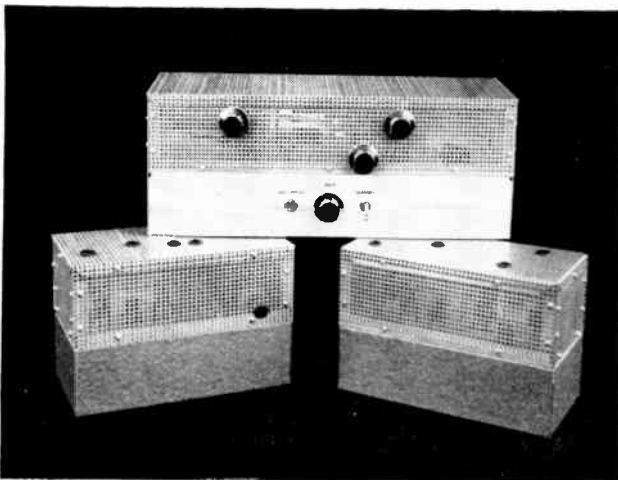

Fig. 17-17 — A 120-watt transmitter for 50 and 144 Mc. The top unit is the amplifier, the two lower units are r.f. sections for driving the amplifier on either band.

● BUILDING THE EXCITERS

Parts layout for the low-power rigs is not particularly critical, except that 144-Mc. r.f. leads must be kept extremely short. All parts except the output and power connectors are mounted on the aluminum plates. Leads to the connectors

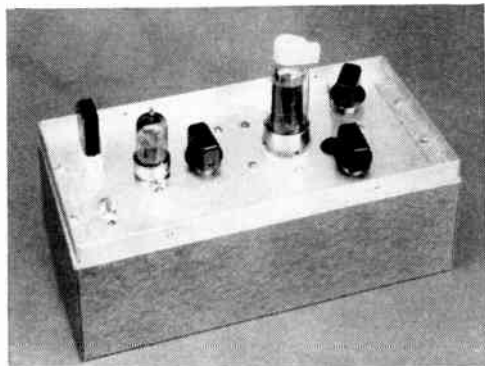

Fig. 17-18 — Top view of the 50-Mc. rig, with cover removed.

are made long enough so that they can be fastened in place on the back wall of the chassis and still permit the plate to be lifted for adjustment or servicing. Wiring of all power leads is done with shielded wire as an aid to TVI prevention.

Oscillator components are arranged identically in the two units. Looking at the top view of the 50-Mc. rig, Fig. 17-18, we see, left to right, the crystal, oscillator-doubler tube, doubler plate tuning, 2E26, final plate tuning (front) and antenna series trimmer (rear). The screw adjustment in the lower left corner is the oscillator plate-coil slug.

The 2-meter rig is photographed the other way around, to show the power connector and coaxial fitting. The 12AT7 parallel doubler is in the middle. Just in back of it is the adjustment for C_2 . The 2E26 grid trimmer, C_3 , is to the right and in back of the amplifier tube. The plate coil, upper left, partially hides its trimmer. In the foreground is the antenna series trimmer, C_5 .

The 50-Mc. bottom view, Fig. 17-19, shows the oscillator-doubler parts at the right. Doubler plate and amplifier grid coils are near the middle. The 2E26 plate coil is to the left of the tube's socket; the tuning capacitor below. The smaller coil is L_5 , with C_3 above. The 144-Mc. bottom view is more open, and requires little explanation. Note the difference in the mounting of the interstage coupling coils in the two units.

Testing the 50-Mc. Rig

Checking the operation of the transmitters is made easy by the power connection method shown in Fig. 17-20. Each power lead is brought out to a separate terminal on the power fitting, J_2 , so that meters can be connected temporarily in each circuit. A power supply delivering 6.3 volts a.c. or d.c. at 1.5 amp. and 200 to 300 volts at 100 ma. is suitable for test work.

Apply plate voltage through a 50- or 100-ma. meter and Pin 3, and check for oscillation, tuning the slug in L_1 for a kick in plate current. Current will be 10 to 15 ma. Listen to the note in a receiver tuned to the frequency of oscillation (25 to 27 Mc.) or a harmonic thereof. If the oscillator is crystal controlled, there should be no more than a slight shift in frequency as the hand or a metal object is moved near the plate coil, L_1 .

Next connect the supply directly to Pin 3 and feed Pin 4 through the test meter. If a low-range meter, 0-10 ma. or so, is available, connect it between Pin 5 and ground to measure the 2E26 grid current at the same time. Tune the doubler plate circuit, C_1 , and the oscillator plate coil slug for maximum grid current. It should be possible to develop 2 ma. or more with these circuit peaked. Plate current in the doubler will be 15 ma. or less.

The position of the doubler plate and amplifier grid coils (see Fig. 17-19) is not critical, but they should not be end to end as in the 144-Mc. unit. Resonance in the 2E26 grid circuit can be checked with brass and powdered-iron slugs. Inserting either should cause the grid current to drop. A rise with a brass slug indicates that L_2 is too large. A rise with the iron slug shows that it is too small.

Neutralization is the next step. The mounting clip of the plastic-sleeve trimmer, C_4 , is soldered to the stator post of C_2 . It should be adjusted to the point where tuning the plate circuit

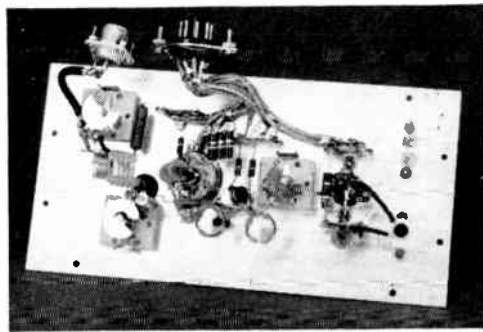

Fig. 17-19 — Bottom of the 50-Mc. r.f. section. Note that power and output connectors are wired to their respective cables, for mounting in the chassis.

through resonance with drive (but no plate voltage) applied causes no kick in grid current. A change in the value of the grid bypass is required if neutralization is not complete within the range of adjustment on C_4 . If C_4 is set at minimum when neutralization is approaching, increase the value of the grid by-pass to about 500 μf . and try again.

Now connect the plate supply to Pins 3, 4 and 7, and run the metered lead to Pin 8, to measure final plate current. Use a 15- or 25-watt lamp for a load, tuning C_2 for minimum plate current. Tune C_3 for greatest lamp brilliance, checking C_2 again for minimum plate current. If neutralization is exactly right, minimum

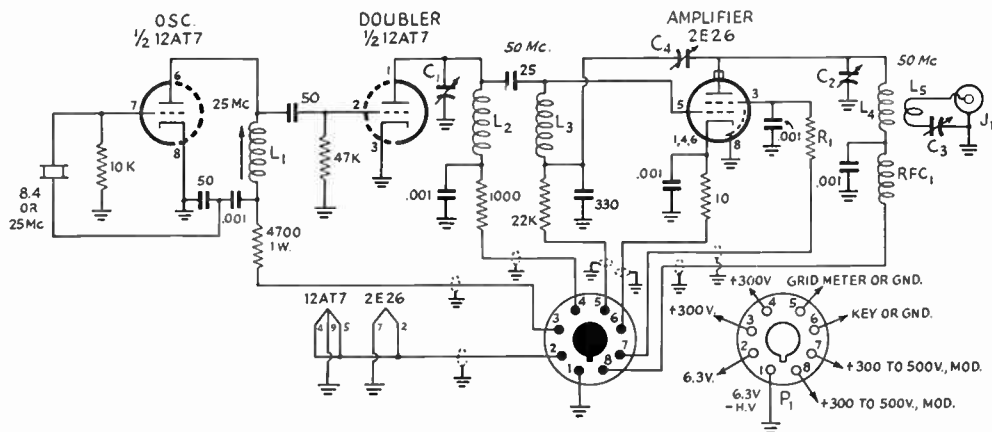

Fig. 17-20 — Schematic diagram and parts information for the 50-Mc. transmitter.

- C_1 — 15- μ mf. midget variable (Hammarlund HF-15).
 C_2 — 15- μ mf. midget variable, double spaced (Hammarlund HF-15X).
 C_3 — 50- μ mf. midget variable (Hammarlund HF-50).
 C_4 — 1-8- μ mf. plastic trimmer (Eric 532-10).
 R_1 — 33,000 ohms, 3 watts (3 100,000-ohm 1-watt resistors in parallel).
 L_1 — 21 turns No. 30 enam. closewound on $\frac{3}{8}$ -inch slug-tuned form (National XR-91).
 L_2 — 5 $\frac{3}{4}$ turns No. 20, $\frac{5}{8}$ -inch diam., $\frac{3}{8}$ inch long

- (B & W Miniductor No. 3007).
 L_3 — Same as L_2 , but 6 $\frac{3}{4}$ turns.
 L_4 — 5 turns No. 20, $\frac{3}{4}$ -inch diam., $\frac{1}{2}$ inch long (B & W No. 3010).
 L_5 — 6 turns No. 20, $\frac{1}{2}$ diam., $\frac{3}{8}$ inch long (B & W No. 3003).
 J_1 — Coaxial output fitting (Amphenol 83-1R).
 J_2 — 8-pin male power fitting (Amphenol 86-RCP8).
 P_1 — 8-pin female cable connector (Amphenol 78-PF8).
 RFC_1 — Solenoid 50-Mc. r.f. choke (Ohmite Z-50).

plate current and maximum grid current will show at the same setting of C_2 . Failing to achieve this exactly, set C_4 so that no grid current appears when drive is removed and plate and screen voltages are left on. Check this only briefly, as the plate current will be excessive under this condition if the tube is not oscillating.

The rig is now ready for operation. For voice work, apply modulated voltage to the plate and screen through Pins 7 and 8. For c.w., the transmitter may be keyed in the cathode lead, Pin 6 to ground, directly, or in the screen lead, Pin 7 to B-plus, with a relay or shock-proof key. Should screen keying not cut the 2E26 off completely, the doubler plate lead can be keyed at the same time, provided both are fed from the same supply. The oscillator and doubler, or the doubler alone, can be keyed if fixed bias is connected between Pin 5 and ground.

Approximate operating conditions follow. With 300-volt plate supply, input will be about 15 watts at best loading. Off-resonance plate current — 70 ma. Grid current — 2 ma. Screen current — 4 to 5 ma. Plate current, 12AT7 stages — 15 ma. each or less. Plate and screen may be fed from separate source of 400 to 500 volts. Maximum input should then not exceed about 35 watts.

The 144-Mc. Transmitter

Except for the extra doubler stage and the differences made necessary by the higher frequency, the 2E26 rigs are built, tested and operated quite similarly. Straight inductive coupling is used between the doubler plate and 2E26 grid circuits in the 2-meter transmitter, and the spacing of the two coils must be adjusted

for maximum energy transfer. The amplifier plate circuit is mounted above the deck, for short plate leads. The 2E26 is neutralized by inserting a small inductance in series with the screen lead (L_5 in Fig. 17-23).

The amplifier tank circuits are series tuned. Output coupling is done with a single-turn loop, L_7 , made of the inner conductor of the coax used to complete the circuit to the output connector, J_1 .

The oscillator circuit is identical to the 50-Mc. rig, except that both oscillator and tripler plate circuits are fed from a single pin on J_2 . The cable connections for the 50-Mc. rig still apply, except that the 4700-ohm resistor in the tripler plate lead must be disconnected temporarily to measure the oscillator plate current.

Testing the oscillator, tripler and doubler stages is routine otherwise. Adjust the spacing between L_3 and L_4 , and check neutralization before applying plate voltage to the 2E26. Check



Fig. 17-21 — Top rear view of the 144-Mc. exciter-transmitter, showing power and output connectors on back of the chassis.

for neutralization as in the 50-Mc. rig, altering the number of turns or turn spacing in L_5 , if necessary.

The amplifier may be keyed in the screen lead, but no provision is made for opening the

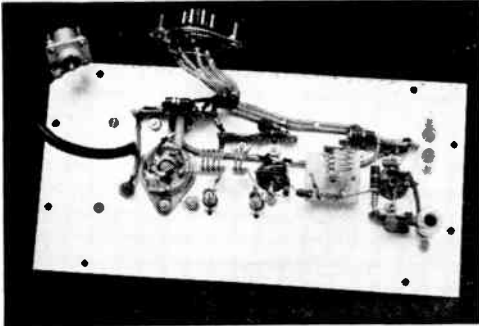

Fig. 17-22 — The 2-meter rig is laid out in similar fashion, except that the final plate circuit is above the chassis.

cathode lead as this often leads to instability at 144 Mc. Note here a stability precaution that may be needed is the addition of external grounding clips on the 2E26 shield ring. These are visible in the photograph, Fig. 17-21. If screen keying does not completely cut off the 2E26 plate current, additional stages may be keyed simultaneously. Fixed bias connected between Pin 5 and ground may also be used if earlier stages than the screen are keyed.

Best-sounding c.w. will be had if the 12AT7 doubler plate and amplifier screen are keyed and the oscillator is run from a separate source, preferably regulated. The power cable setup shown allows the power supply problem to be

solved in any of several ways, to suit one's own requirements. A convenient operating setup for two bands is to leave both rigs connected to a common power source, energizing the heater circuits of the one to be used at the moment.

All 1/4-inch shafts are fitted with knobs for adjustment when the covers are removed. The top surface of each knob is slotted with a hack saw, to a depth of about 1/16 inch, to allow for screwdriver adjustment with the covers in place. Holes fitted with rubber grommets are placed over each adjustment.

(This equipment originally described in October, 1954, *QST*, page 16.)

● THE 2-BAND 125-WATT AMPLIFIER

The excitors just described were designed as separate rigs so that anyone interested in just one of the bands can make his low-powered rig for that band only. The convenience and performance obtainable with the two rigs more than offsets the small extra cost.

In going to a higher power level, however, the investment in tubes and parts needed is great enough so that building for both bands in a single unit becomes attractive economically. The amplifier shown in Fig. 17-21 sacrifices little in performance to achieve its two-band operation, and the cost is only slightly more than for a similar setup for either band alone.

Construction

The amplifier is built on a 6 × 17 × 3-inch aluminum chassis, with sides of perforated aluminum fastened in place by aluminum angle stock brackets in a manner similar to the excitors, except that controls are brought out through the

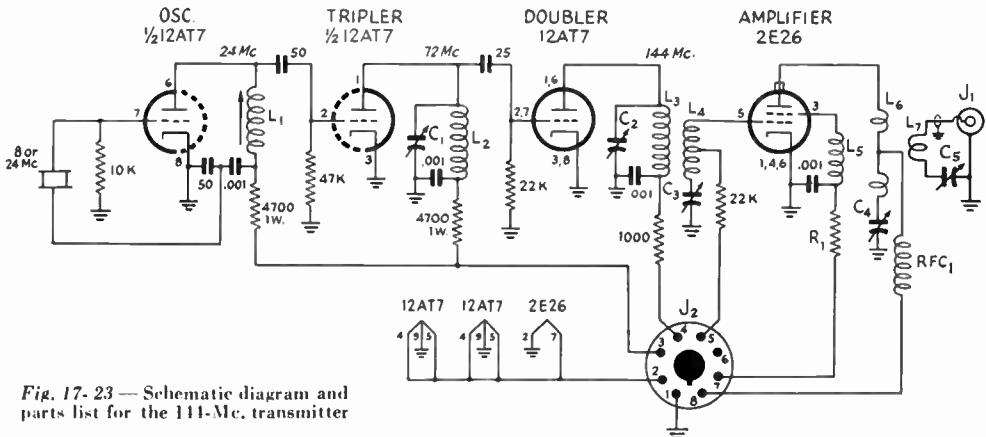

Fig. 17-23 — Schematic diagram and parts list for the 144-Mc. transmitter

- C₁ — 15- μ f. variable (Hammarlund HF-15).
- C₂, C₃ — 1-8- μ f. plastic trimmer (Eric 532-10).
- C₄ — 15- μ f. double-spaced variable (Hammarlund HF-15X).
- C₅ — 50- μ f. variable (Hammarlund HF-50).
- R₁ — 33,000 ohms, 3 watts (3 100K 1-watt in parallel).
- L₁ — 20 turns No. 28 enam. on 3/8-inch slug-tuned form (National NR-91).
- L₂ — 1 turns No. 20 tinned, 1/2-inch diam., spaced twice wire diam. (B & W No. 3002).
- L₃ — 2 turns No. 3002.

- L₄ — 4 turns No. 3002, center-tapped.
- L₅ — 27 turns No. 30 enam. on 1-watt resistor (Ohmite Z-235).
- L₆ — 4 turns No. 12 tinned, spaced 1/4 inch, 3/4-inch diam., center-tapped.
- L₇ — 1 turn 3/4-inch diam., made from inner conductor of RG-59/U coax connecting to J₁.
- RFC₁ — Ohmite Z-114.
- J₁ — Coaxial output fitting, female (Amphenol 83-1R).
- J₂ — 8-pin power fitting, male (Amphenol 78-PF8).

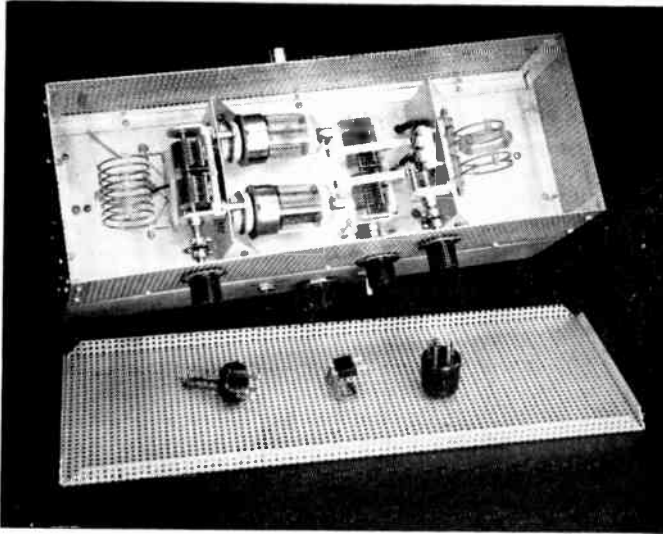

Fig. 17-24 — The push-pull 6146 amplifier for 50 and 144 Mc. The 50-Mc. coils are in place. On the cover in the foreground are the grid coil, the antenna coupling loop and the plate-line shorting plug, all for 144-Mc. operation.

front on insulated flexible couplings. A grid-current jack, a filament switch and the screen-voltage control are on the front wall of the chassis. On the back are coaxial fittings, power connector and the 12AU7 socket. Underside are the filament transformer, screen audio choke, a few resistors and the power wiring.

Two aluminum mounting brackets are required. These are $4\frac{1}{2}$ inches wide and $2\frac{3}{4}$ inches high when folded as shown in Fig. 17-21. Dimensions otherwise are not important. The 6146 sockets are $2\frac{1}{2}$ inches apart, centered $1\frac{1}{2}$ inches above the chassis. Note that they are on the *tube* side of the bracket. Three $\frac{3}{8}$ -inch holes under each socket pass the screen, control grid and heater connections. The cathode and the cold side of the heater circuit are grounded directly to the bracket on the tube side.

The screen neutralizing capacitor, C_1 , is held in place by the same screws that hold the sockets. The grid coil socket, J_2 , the two screen r.f. chokes and their 0.001- μ f. bypass are hidden from view by C_1 . This whole assembly should be made and wired before mounting it in place. It is 5 inches from the end of the chassis, and the other bracket, with J_3 , J_4 and C_3 , is $7\frac{1}{2}$ inches to the right of the first one. Note that the plate tuning capacitor, C_2 , is mounted on a polystyrene plate with its rotor above ground. A grounded rotor at this point may introduce stray resonances and cause parasitic oscillations higher than the operating frequency.

Though shielding may not be too important in the operation of the exciters, other than for mechanical protection and for TVI prevention, use of a cover is definitely recommended for the amplifier. Tests with and without the shielding have shown that stable operation is attained much more readily with the shielding in place.

Testing and Use

A single supply of 400 volts or less may be used on both plates and screens of the 6146s for

testing. Higher than 400 volts may be applied to the plates alone, if a separate supply of 300 volts is available for the screens. Higher than 400 volts should not be applied to both elements as the clamp tube will not hold the plate current within safe limits if drive is removed.

Without plate or screen voltage on the amplifier, check the grid circuit to see that drive can be obtained on either 50 or 144 Mc. There should be at least 5 to 6 ma. grid current with either 2E26 driver running at 300 volts on the plate. There will be a surplus of drive on 50 Mc., ordinarily, so if the grid circuit is not exactly resonated it may not be too important. The 144-Mc. grid circuit can be resonated for maximum grid current by changing the shape of the loop, L_2 . Spreading its sides farther apart lowers the resonant frequency; bringing them closer together raises it. The position of the coupling loop, L_1 , should be adjusted for maximum grid current as this is done.

With grid drive applied, tune the plate circuit through resonance and watch for variation in grid current. Adjust the screen neutralization trimmer, C_1 , until there is no kick in grid current at plate resonance. The required setting may be different for the two bands.

Next test the clamp circuit operation. Apply plate and screen voltage as shown in Fig. 17-25 and measure 6146 plate current with no drive applied. With the potentiometer arm set at the ground end, the plate current should be 125 ma. or less with no excitation. At 400 volts this is 50 watts input, the maximum safe plate dissipation for a pair of 6146s. The tubes should not be operated in this way for long periods, but it is safe for c.w. keying or normal short tests.

Now connect a 100-watt lamp across the output coaxial fitting. Apply drive and plate and screen voltage. Tune C_2 for minimum plate current or maximum lamp brilliance. Adjust C_3 for greatest output, retuning C_2 for minimum plate current meanwhile. Set the coupling so

Simple Transmitter for 220 and 420 Mc.

The transmitter in Figs. 17-27-17-30 is for the newcomer who wants to start with simple gear, going on to something better when he has gained construction and operating experience. It is built in two units, with the idea that the modulator can be retained when the r.f. portion is discarded.

The r.f. section is a simple oscillator with two 6AF4 or 6AT4 tubes in push-pull. Its plate

pending on the plate voltage and whether a 6V6 or 6L6 tube is used. It may be considered as a long-term investment that will be suitable for use with any r.f. section of up to 20 watts input that may be constructed at a later date.

Construction

The two units are built on identical 5 by 7 by 2-inch aluminum chassis, connecting by

◆
Fig. 17-27 — The simple transmitter for 220 and 420 Mc. is made in two parts. The modulator, *left*, may be retained for use with more advanced r.f. sections than the simple oscillator shown at the right. The two units may be plugged together or connected by a cable.
 ◆

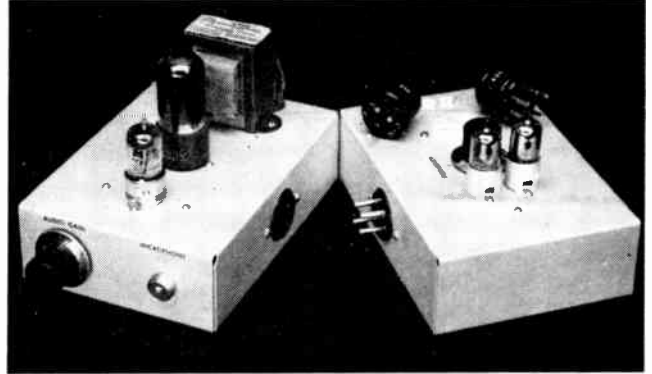

circuit is changed from a quarter-wave line at 220 Mc. to a half-wave line at 420 Mc. by plugging in suitable terminations at the end of the tuned circuit.

Because the oscillator is modulated directly it will have considerable frequency modulation, and the signal will not be readable on selective receivers unless the modulation is kept at a very low level. Where a broader receiver is in use at the other end of the path a higher modulation level can be employed.

The modulator is designed for a crystal microphone. It delivers 3 to 10 watts output, de-

means of a plug on the oscillator and a socket on the modulator. Power is fed through a similar plug on the back of the modulator. Arrangement of parts in the modulator is not critical, but the oscillator should be exactly as shown.

Sockets for the tubes are one inch apart center to center, $2\frac{3}{16}$ inch in from the end of the chassis. C_1 is at the exact center of the chassis, with J_2 $1\frac{1}{2}$ inches to its left, as seen in Fig. 17-28. At the far left is a crystal socket, used for the antenna terminal, J_1 . One-inch ceramic standoffs are mounted on the screws that hold J_2 in place. These support the antenna coupling loop, L_2 .

Testing and Use

A power supply delivering about 200

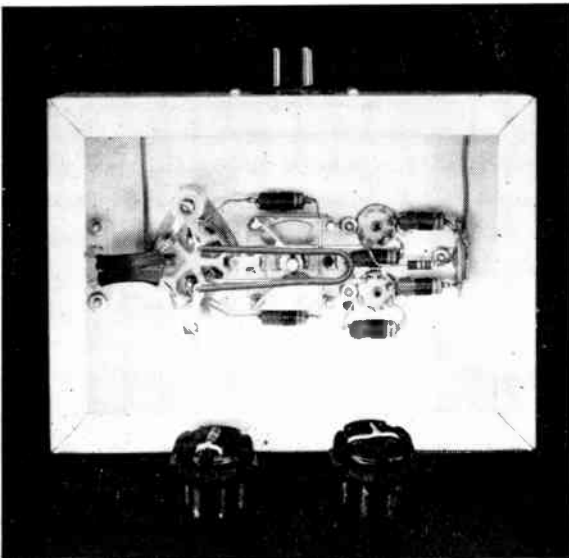

◆
Fig. 17-28 — Bottom view of the oscillator unit, showing the two-band tank circuit. The line terminations, with their protecting caps removed, are in the foreground. At the left is the 220-Mc. plug, with the 120-Mc. one at the right.
 ◆

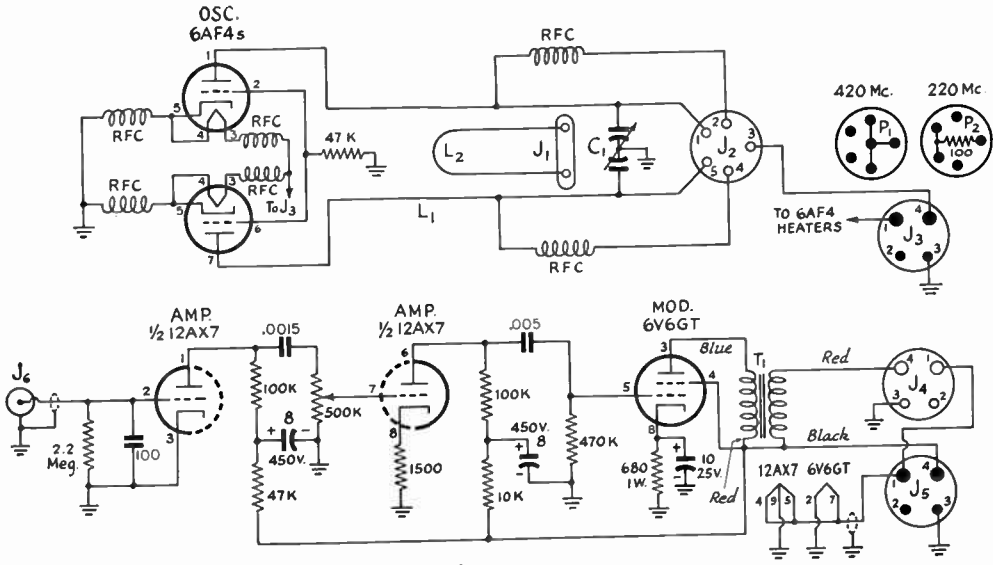

Fig. 17-29 — Schematic diagram and parts information for the two-band oscillator and modulator.

- C₁ — 10.5- μ mf.-per-section butterfly variable (Johnson 101.B15).
- L₁ — 2 3½ inch pieces No. 12 tinned, spaced ½ inch. Bend down ¾ inch at tube end and ½ inch at socket end. R.f. chokes connect ⅝ inch from bend at tube end. Connect C₁ at 1 inch from bend at socket end.
- L₂ — Hairpin loop 2¼ inches long and ½ inch wide, No. 16, covered with insulating sleeving.
- J₁ — Crystal socket used for antenna terminal.

- J₂ — 5-contact ceramic socket (Amphenol 49-RSS5).
- J₃, J₅ — 4-contact male fitting (Amphenol 86-RCP4).
- J₄ — 1-contact female chassis fitting (Amphenol 78-S4 or RS4).
- J₆ — Microphone connector (Amphenol 75-PC1M).
- P₁ — 5-contact male cable connector (Amphenol 86-PM5) with Pins 2, 3 and 4 joined together.
- P₂ — Same as P₁, but with Pins 1 and 5 joined. Connect 100-ohm resistor between these and Pin 3.
- RFC (6 required) — 12 turns No. 28 enamel close-wound on high-value 1-watt resistor.
- T₁ — 10-watt modulation trans. (Merit A-3008).

volts d.c. at 50 ma. or more and 6.3 volts at 1 amp. or more is needed. Plug the units together or connect them by a cable. With a cable, a milliammeter may be connected between the No. 4 pins to measure the oscillator plate current. Otherwise the meter should be connected temporarily between Pin 4 of J₃ and Pin 3 of J₂, in place of the wire shown in Fig. 17-29.

Plate current should be about 25 to 30 ma. If the stage is oscillating there will be a fluctuation in current as the plate line is touched with an insulated metal object. Do not hold the metal in the hands for this test! The frequency is best checked by means of Lecher wires, a technique that is covered in the chapter on measurements.

With the dimensions given the range with P₁ plugged in should be about 405 to 450 Mc. With P₂ plugged in the frequency should fall within the 220-Mc.

band with C₁ set in the same position as it was for the middle of the 420-Mc. band. Some alteration of the connection point for C₁ on L₁ may be necessary to achieve this.

In using the transmitter it is well to stay between 221 and 224 Mc. to avoid out-of-band operation. On 420, keep the transmitter below 432 Mc. to avoid interference with the high-selectivity work that is done between 432 and 436 Mc. (Further details on this transmitter in *QST* for December, 1954.)

Fig. 17-30 — Looking at the underside of the modulator.

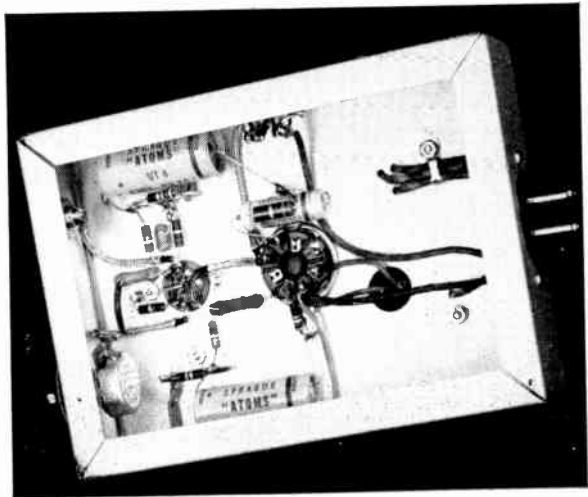

A Tripler-Amplifier for 432 Mc.

Only tubes designed especially for u.h.f. service will work satisfactorily at 420 Mc. and higher. The various small receiving triodes made for u.h.f. TV use will work well in low-powered frequency multipliers and r.f. amplifiers for transmitting, but the trend is to tetrodes. Several of the latter are now available.

The tripler-amplifier shown in Figs. 17-31 to 17-33 delivers up to 20 watts output on 432 Mc.

◆
Fig. 17-31 — A tripler-amplifier for 432 Mc. using dual tetrodes. Shielded construction and forced-air cooling are employed.

holes in the top cover. Holes are drilled in the chassis under the amplifier tube, and in the cover over it. With a bottom plate fitted to the chassis there should be enough air flowing through both top vents to lift a paper briskly when the fan is started.

Half-wave lines are used in all 432-Mc. circuits. The grid circuit of the amplifier is capacitively coupled to the tripler plate line, the two over-



when driven on 144 Mc. by any 2-meter unit delivering 10 watts output or more. In plate-modulated service the output is 12 watts. Tubes are RCA 6524 dual tetrodes, but with slight modification Amperex 6252s or 5894s may be used. With 6252s the output will be about the same as with the 6524. The 5894 will deliver up to 40 watts with higher plate voltages. The 832A may also be used, but the output will be no more than 4 or 5 watts. Forced-air cooling and shielding are recommended.

The tripler tube is mounted vertically, at the left, with its socket $1\frac{1}{2}$ inches below the chassis. There is just room under the socket for the self-resonant input circuit, L_2 . The amplifier is horizontal, with its socket mounted in back of a plate that is 8 inches from the left edge of the $3 \times 1 \times 17$ -inch aluminum chassis. The shielding enclosure is $3\frac{1}{4}$ inches wide by $3\frac{1}{2}$ inches high. A cooling fan is mounted on the rear wall of the chassis. Air circulates around the tripler tube through its 2-inch hole, flowing out through

lapping about $1\frac{1}{4}$ inches. The spacing between them must be adjusted carefully for maximum grid drive. Plate voltage is fed to the lines through small resistors. These should be connected at the point of lowest r.f. voltage on the lines. The amplifier grid r.f. chokes are connected at the tube socket.

Note that the plate line capacitors, C_1 and C_2 , have their rotors floating. This is important. Grounding the rotors, or use of capacitors having metal end plates, may introduce multiple r.f. paths and circuit unbalance. The capacitors have small metal mounting brackets that are not connected directly to the rotors, but even so it was necessary to resort to polystyrene mounting plates for best circuit balance and efficiency. Holes $\frac{3}{4}$ inch in diameter are punched in the front wall to pass the rotor shafts.

Testing

The tripler-amplifier is designed to operate in conjunction with a 144-Mc. transmitter such as

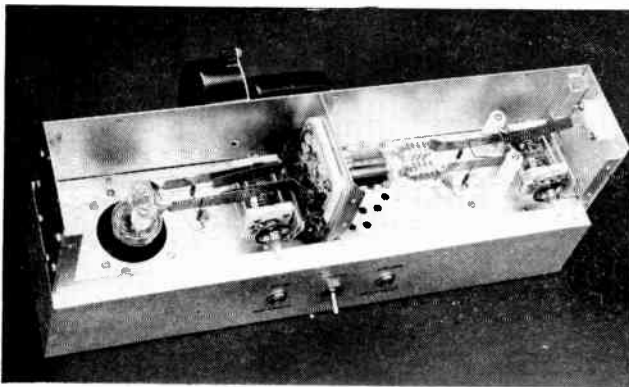

◆
Fig. 17-32 — Looking into the tripler-amplifier with the top cover and front plate removed.

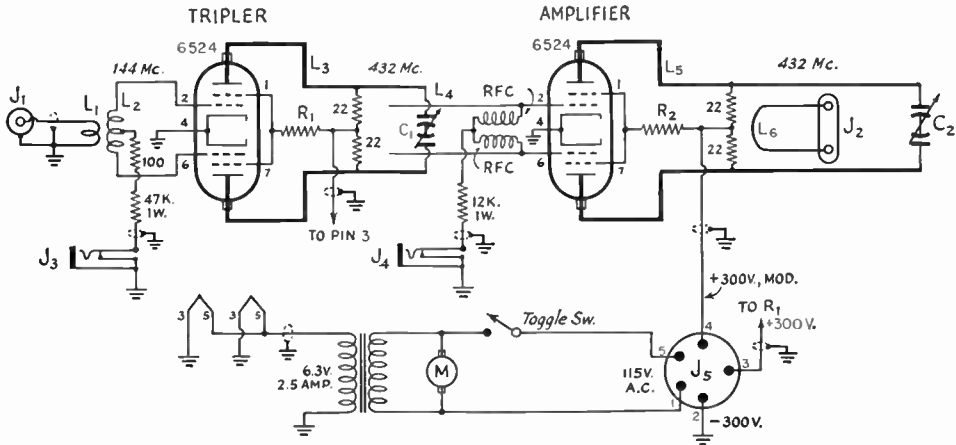

Fig. 17-33 — Schematic diagram for the 432-Mc. tripler-amplifier.

- C₁, C₂ — 10- μ mf., per-section split stator, double spaced (Bud I.C.1664). Do not use metal end-plate or grounded-rotor types.
- R₁, R₂ — 23,500 ohms, 2 watts (two 47,000 ohm 1-watt resistors in parallel).
- L₁ — 2 turns No. 20 enam., $\frac{1}{2}$ -inch diam. Insert between turns of L₂.
- L₂ — 4 turns No. 16 enam., $\frac{1}{2}$ -inch diam., $\frac{1}{2}$ inch long, center-tapped.
- L₃ — Copper strap on heat-dissipating connectors, $3\frac{1}{2}$ inches long. Twist 90 degrees $\frac{1}{2}$ inch from plate end. Space $\frac{3}{4}$ inch.
- L₄ — Copper strap $2\frac{7}{8}$ inches long, soldered to grid terminals. Space about $\frac{1}{2}$ inch.

- L₅ — Copper strap $3\frac{7}{8}$ inches long, fastened to heat-dissipating connectors. Space $\frac{3}{4}$ inch. All tank circuits of flashing copper $\frac{1}{2}$ inch wide.
- L₆ — Coupling loop, No. 20 enam. U-shaped portion is 1 inch long and $\frac{5}{8}$ inch wide. Mount on 3-inch ceramic stand-offs.
- J₁ — Coaxial input fitting (Amphenol 83-1R).
- J₂ — Crystal socket used for antenna terminal.
- J₃, J₄ — Closed-circuit jack.
- J₅ — 5-pin male chassis connector (Amphenol 86-RCP5).
- M — Motor-blower assembly, 17 c.f.m. (Ripley Inc., Middletown, Conn., Type 8133.)

the 2E26 rig shown in Fig. 17-23. A plate supply of 300 volts at 200 ma. is needed (400 volts may be used with 5894s). Apply power to the 144-Mc. driver stage and adjust the spacing of the turns in L₂ and the degree of coupling between L₁ and L₂ for maximum tripler grid current. This should be about 3 ma.

Next apply plate and screen voltage to the tripler and tune C₁ for maximum grid current in the amplifier, with no plate or screen voltage to the latter. Adjust the position of the grid lines with respect to the plate circuit, readjusting C₁ whenever a change is made, until at least 1 ma. grid current is obtained.

Now connect a lamp load across the output terminal, J₂. Ordinary house lamps are not suitable. A fair load can be made by connecting 6 or more blue-head pilot lamps in parallel. This can be done by wrapping a $\frac{1}{4}$ -inch copper strap

around the brass bases and soldering them all together. Then another strap should be soldered to the lead terminals. Apply plate and screen voltage and tune C₂ for maximum lamp brilliance. It should be possible to develop a very bright glow in the 6-lamp load with a plate current of about 100 ma. at 300 volts.

Cut drive very briefly to check for oscillation in the final stage. Grid current should drop to zero. The screen and grid resistors shown are for operation with plate modulation. More input can be run if the screen or grid resistance is decreased, but this should be done only when the rig is to be used for f.m. or c.w. service.

Operating conditions are about as follows: tripler grid current — 2 to 3 ma.; amplifier grid current — 3 to 4 ma.; tripler plate and screen current — 90 ma.; amplifier plate and screen current — 110 ma.; output — 12 watts.

Fig. 17-34 — Bottom view of the 432-Mc. transmitter.

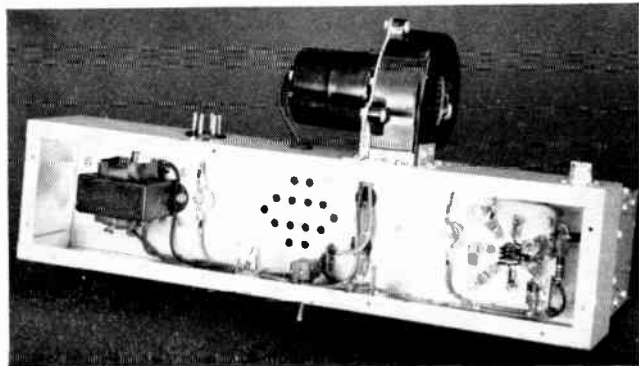

Exciter-Transmitter for 220 Mc.

Construction of a stable transmitter for 220 Mc. is not difficult, and while simple oscillator-type rigs such as the one shown in Fig. 17-29 may suffice for short-range work, a crystal-controlled or otherwise stabilized rig is highly worth while. A low-powered transmitter of stable design need not be costly, as inexpensive tubes can be used throughout. A further economy can be made by selecting a crystal frequency in the lower part of the band, so that the same crystal may be employed for the upper portion of the 2-meter band as well.

The transmitter shown in Figs. 17-35, 17-36 and 17-37 delivers 5 to 10 watts output. The final stage may be modulated for voice work, or the unit may be used as an exciter to drive higher-powered stages. Four tubes are required. The first two are 6CL6s, serving as oscillator-multiplier and single-ended tripler. The third stage is a push-pull tripler using an Amperex 6360 dual tetrode. This drives a similar tube as a straight-through amplifier on 220 Mc.

Crystal frequencies should lie between 8.15 and 8.33 Mc., or 12.22 to 12.5 Mc. If the same crystal is to be useful for 2-meter work it must be between 8.15 and 8.22 Mc. or 12.22 and 12.33 Mc.

A balanced plate circuit is used in the multiplier, so that its output can be capacitively coupled to the 6360 tripler grids. In case of insufficient grid drive to the 6360 tripler, try putting a small plastic trimmer between the low side of L_2 and ground, to balance up the capacitances on either side. It was not needed in the original, but it would be well to remember the suggestion.

The 6360 push-pull tripler to 220 Mc. is inductively coupled to the push-pull final stage. No neutralization is shown in Fig. 17-36. Should neutralization be needed, a method for achieving it is given later. Output from the final 6360 plate circuit is taken off through coax, and provision is made for tuning out the reactance of the link, with C_4 .

Construction

The transmitter is built on a flat plate of sheet aluminum 5 by 10 inches in size. This is screwed to a standard aluminum chassis of the same dimensions, that serves as both case and shielding. If more complete shielding is required, a perforated metal cover may be made to go over the top, as was done with the 6- and 2-meter rigs in Fig. 17-17. All parts except the power and coaxial output connectors are mounted on the top plate. The two connectors mount in holes in the rear wall of the chassis. The mounting screws are held in place on the fittings with nuts and other nuts on the outside of the chassis hold the fittings in position.

The tube sockets are along the centerline of the plate, two inches center to center, with the oscillator socket $1\frac{3}{8}$ inch in from the right end, as seen in the photographs. The crystal socket and the oscillator plate coil, L_1 , may be seen at the lower and upper right, respectively, in the bottom view. The tripler plate tuning capacitors are midway between their respective sockets.

Except for the power leads, there is no "wiring" in the usual sense, as all r.f. leads should be extremely short. The decoupling resistors and r.f. chokes in the various power circuits are supported on tie points. Three single-lug strips and two double-lug ones are needed. All the power wiring is done with shielded wire, as an aid to TVI prevention. The coils L_2 , L_3 and L_4 are soldered directly to the stator support bars of their trimmers, with the shortest possible leads.

Adjustments

The power supply should deliver at least 3 amperes at 6.3 volts, a.c. or d.c., and 200 to 300 volts d.c., at 200 ma. If a 300-volt supply is used for the testing, the tubes can be protected from excessive drain by connecting a 5000-ohm 10-watt resistor in series with the power supply lead. The power connectors, J_1 and P_1 , make provision for metering all plate circuits except those of the oscillator and first tripler. The power

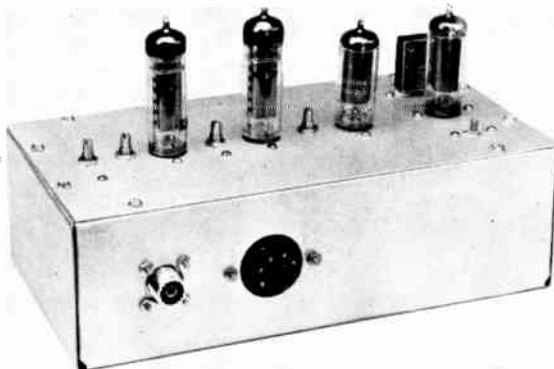

Fig. 17-35 — The 220-Mc. tetrode transmitter. At the right are the 6CL6 crystal oscillator and multiplier stages, with the 6360 tripler and amplifier in the center and left, respectively. The rig is built on a sheet of aluminum which is screwed to an inverted chassis.

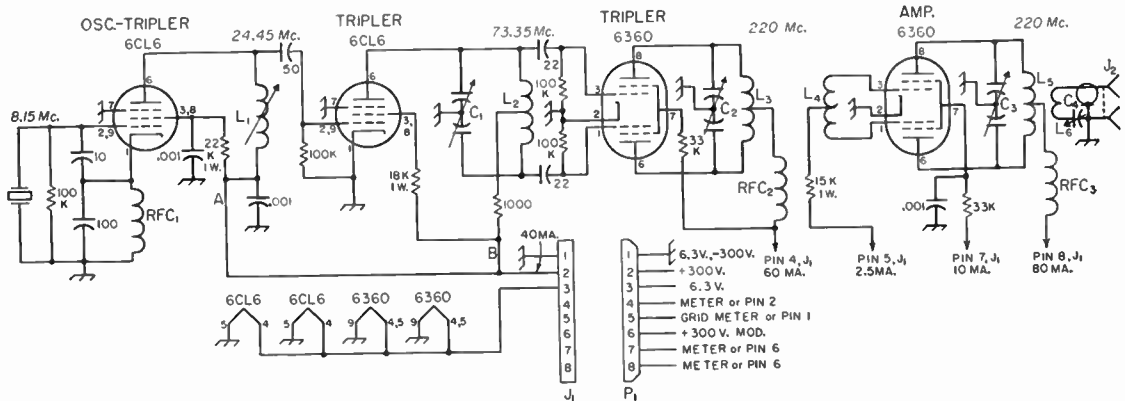

Fig. 17-36 — Schematic diagram and parts information for the 220-Mc. tetraode transmitter. Resistors are half watt unless otherwise specified. Capacitor values below 0.001 are in $\mu\text{f.}$; all ceramic.

- C_1 — 11- $\mu\text{f.}$ miniature butterfly variable (Johnson 11MB11).
- C_2, C_3 — 5- $\mu\text{f.}$ miniature butterfly variable (Johnson 5MB11).
- C_4 — 15- $\mu\text{f.}$ miniature (Johnson 15M11).
- L_1 — 14 turns No. 28 enam. on $\frac{3}{8}$ -inch iron-slug form (National XR-91).
- L_2 — 7 turns No. 20, $\frac{1}{2}$ -inch diam., $\frac{7}{16}$ inch long, center-tapped (B & W Miniductor No. 3003).
- L_3, L_5 — 4 turns No. 18 enam., $\frac{3}{16}$ -inch diam., center-tapped. Space twice diameter of wire, except for $\frac{1}{8}$ -inch space at center.

- L_4 — 2 turns same as L_3 , center-tapped. Adjust turns spacing and degree of coupling to L_3 for maximum grid current.
- L_6 — 2 turns same as L_5 , close-wound. Adjust position at center of L_5 for maximum output.
- J_1 — 8-pin male chassis fitting (Amphenol 86-RCP8).
- J_2 — Coaxial fitting, female (Amphenol 83-1R).
- P_1 — 8-contact power cable connector, female (Amphenol 78-RS8).
- RFC_1 — 750- $\mu\text{h.}$ r.f. choke (National R-33).
- $\text{RFC}_2, \text{RFC}_3$ — 17 turns No. 28 enam. on high value 1-watt resistor, or use Ohmite Z-235.

leads to these are shown connected together, to Pin 2 of J_1 , but during testing they should be fed separately through a milliammeter, as described below.

Connect a 0-50 or 0-100 milliammeter between Pin 2 of J_1 and the oscillator plate-screen circuit, at the low side of the 22,000-ohm screen-dropping resistor, point A on the schematic. Be sure that the tripler plate and screen resistors are disconnected for the time being, to prevent this stage from drawing current. Apply 200 to 300 volts d.c. through Pin 2 of P_1 , and tune the plate circuit of the oscillator to the third harmonic of the crystal frequency. Listening on this frequency (24.45 to 25 Mc., depending on choice of crystal) a large increase in signal strength should be noted as the coil is tuned through resonance. A double check on frequency with a calibrated grid-dip or absorption wave meter is recommended. Oscillator plate-screen current will be about 20 ma.

Now connect the oscillator plate-screen power lead directly to Pin 2 on J_1 , and insert the meter in the lead to the tripler plate-screen circuit, point B on the diagram. Apply voltage and tune the tripler plate circuit for maximum output at 73.35 to 75 Mc. A 2-volt 60-ma. pilot lamp with a single-turn loop of insulated wire, about a half inch in diameter, may be coupled to L_2 to serve as an output indicator. The 6CL6 tripler plate-screen current will be about the same as the oscillator, around 20 ma. at 300 volts.

Now wire the power leads to these two stages as shown in the diagram. Leave the 300-volt lead connected to Pin 2 of P_1 , and connect a 100-ma. meter between Pins 2 and 4, to measure the 6360 tripler plate-screen current. A low-range milliam-

meter, about 0-10 ma., should be connected between Pin 5 and Pin 1, to measure final grid current. Tune C_2 for maximum indication on this meter. With no plate voltage on the final stage, there should be at least 3 ma. grid current. Adjust the spacing between L_3 and L_4 carefully, retuning C_2 each time, for maximum grid current.

Solder a jumper between Pins 2 and 4 on J_1 , so that voltage will be supplied to the 6360 tripler. Connect a temporary jumper between Pin 2 and Pin 7, to feed voltage to the final screen, and connect the 0-100 milliammeter between Pins 2 and 8, to measure final plate current. A 10- or 15-watt light bulb may be used as a temporary dummy load, connected to J_2 . Apply voltage and tune C_3 for minimum plate current, or for maximum output as indicated in the lamp load. Adjust C_4 for best output. The setting of C_4 and the degree of coupling between L_5 and L_6 will be different for an antenna, however, as the lamp is not a good load at this frequency.

If the stage is completely stable, maximum output, maximum grid current and minimum plate current should all occur at the same setting of the plate tuning capacitor, C_3 . Another check for neutralization is to cut the drive for a brief period by removing plate and screen voltage from the tripler. Grid current should drop to zero when this is done. If it does not, the final stage is oscillating, and must be neutralized. In the original model, there was no actual self oscillation, but the stage was not completely stable until a small amount of neutralization was added.

This is done very simply with the 6360. The leads are so arranged within the tube that all that is required for neutralization is a very

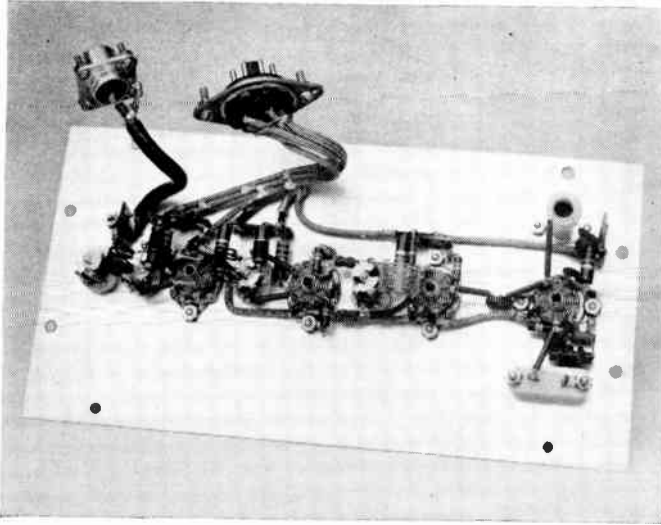

◆
 Fig. 17-37 — Bottom view of the 220-Mc. transmitter, showing all parts except the tubes and crystal. Note the method of attaching the power and coaxial fittings. Nuts hold their mounting screws in place, so that they can be fastened to the rear wall of the chassis.
 ◆

small capacitance between Pins 3 and 6, and between Pins 1 and 8. A stub of No. 18 wire about $\frac{3}{8}$ inch long is soldered to Pin 6, with its opposite end "looking" at Pin 3. A similar stub is soldered to Pin 8, with its free end adjacent to Pin 1. The ends can then be bent toward or away from the grid pins to give the required capacitance.

When all stages have been adjusted correctly, the plate voltage may be increased to 300 on all stages, to run the maximum power of which the tubes are capable. Current drains indicated on the schematic diagram are for 300-volt operation. Staying at 250 volts or less allows more conservative operation, and may be well worth while, in the interest of longer tube life. There is no great advantage to be gained from pushing the tubes excessively, as doubling the power output will net less than one S unit improvement in signal level at the receiving end.

In feeding power to an antenna system using coaxial line, it is merely necessary to connect the coax to the output fitting, J_2 , and adjust the coupling and C_4 for maximum radiated power. If 300-ohm Twin-Lead or open-wire line is used to feed the antenna, coupling to the transmitter is done with a coaxial balun. An antenna system

designed for 300-ohm balanced lines may be fed with 75-ohm coax similarly.

If the rig is to be used as a complete transmitter r.f. section, the final plate and screen will probably be modulated. This is done by running the lead to Pin 6 on the power plug to the secondary of the output transformer of the modulator. Any modulator unit capable of supplying about 10 watts of audio power may be used.

One or more amplifier stages may be added to build up the r.f. power level. As interstage coupling efficiency is likely to be poor at this frequency the following stage should not operate at as high a power level as would be accepted practice on lower frequencies. Suitable tubes for 220-Mc. amplifier stages following this exciter are the 832A, the 6252 and the 5894A or 9903. An amplifier using the 6252 was described in *QST* for May, 1954, page 18. Other *QST* references that may be of interest to 220-Mc. workers are listed below.

"Coaxial Tank Amplifier for 220 and 420 Mc." — May, 1951, page 39.

"220-Mc. Station for the Beginner," — October, November and December, 1953.

"Crystal Control on 220 Mc." (All-triode transmitter, 10 watts) — February, 1954, page 16.

V.H.F. Antennas

While the basic principles of antenna design remain the same at all frequencies where conventional elements and transmission lines are used, certain aspects of v.h.f. work call for changes in antenna techniques above 50 Mc. Here the physical size of arrays is reduced to the point where some form of antenna having gain over a simple halfwave dipole can be used in almost any location, and the rotatable high-gain directional array has become a standard feature of all well-equipped v.h.f. stations. The importance of antenna gain in v.h.f. work cannot be over-emphasized. By no other means can so large a return be obtained from a small investment as results from the erection of a good directional array.

● DESIGN CONSIDERATIONS

At 50 Mc. and higher it is usually important to have the antenna work well over all or most of the band in question, and as the bands are wider than at lower frequencies the attention of the designer must be focused on broad frequency response. This may be attained in some instances through sacrificing other qualities such as high front-to-back ratio.

The loss in a given length of transmission line rises with frequency. V.h.f. feedlines should be kept as short as possible, therefore. Matching of the impedances of the antenna and transmission line should be done with care, and in open locations a high-gain antenna at relatively low height may be preferable to a low-gain system at great height. Wherever possible, however, the v.h.f.

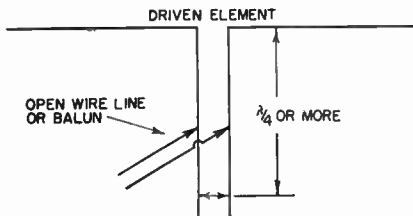

Fig. 18-1 — Combination tuning and matching stub for v.h.f. arrays. Sliding short is used to tune out reactance of the driven element. Transmission line, either balanced or coax, is connected at the point of lowest standing-wave ratio. Adjustment procedure is outlined in text.

array should be well above heavy foliage, buildings, power lines or other obstructions.

The physical size of a v.h.f. array is usually more important than the number of elements. A 4-element array for 432 Mc. may have as much gain over a dipole as a similarly-designed array for 144 Mc., but it will intercept only one-third as

much energy in receiving. Thus to be equal in communication, the 432-Mc. array must equal the 144-Mc. antenna in *capture area*, requiring three times as many elements, if similar element configurations are used in both.

Polarization

Early v.h.f. work was done with simple antennas, and since the vertical dipole gave as good results in all directions as its horizontal counterpart offered in only two directions, vertical polarization became the accepted standard. Later when high-gain antennas came into use it was only natural that these, too, were put up vertical in areas where v.h.f. activity was already well established.

When the discovery of various forms of long-distance propagation stirred interest in v.h.f. operation in areas where there was no previous experience, many newcomers started in with horizontal arrays, these having been more or less standard practice on frequencies with which these operators were familiar. As use of the same polarization at both ends of the path is necessary for best results, this lack of standardization resulted in a conflict that, even now, has not yet been completely resolved.

Tests have shown no large difference in results over long paths though evidence points to a slight superiority for horizontal in certain kinds of terrain, but vertical has other factors in its favor. Horizontal arrays are generally easier to build and rotate. Where ignition noise and other forms of man-made interference are present, horizontal systems usually provide better signal-to-noise ratio. Simple 3- or 4-element arrays are more effective horizontal than vertical, as their radiation patterns are broad in the plane of the elements and sharp in a plane perpendicular to them.

Vertical systems can provide uniform coverage in all directions, a feature that is possible only with fairly complex horizontal arrays. Gain can be built up without introducing directivity, an important feature in net operation, or in locations where the installation of rotatable systems is not possible. Mobile operation is simpler with vertical antennas. Fear of increased TVI has kept v.h.f. men in some densely-populated areas from adopting horizontal as a standard.

The factors favoring horizontal have been predominant on 50 Mc., and today we find it the standard for that band, except for emergency net operation involving mobile units. The slight advantage it offers in DX work has accelerated the trend to horizontal on 144 Mc. and higher bands, though vertical polarization is still widely used. The picture on 144, 220 and 420 Mc. is still confused, the tendency being to follow the local

trend. The newcomer should check with local amateurs to see which polarization is in general use in the area he expects to cover. Eventual standardization should be a major objective, and to this end it is recommended that horizontal polarization be established in areas where activity is developing for the first time.

● IMPEDANCE MATCHING

Because line losses increase with frequency it is important that v.h.f. antenna systems be matched to their transmission lines carefully. Lines commonly used in v.h.f. work include open-wire, usually 300 to 500 ohms impedance, spaced $\frac{1}{2}$ to two inches; polyethylene-insulated flexible lines, available in 300, 150 and 72 ohms impedance; and coaxial lines of 50 to 90 ohms impedance.

The various methods of matching antenna and line impedance are described in detail in the chapter on transmission lines. Matching devices commonly used in v.h.f. arrays fed with balanced lines include the folded dipole in its various forms, Fig. 13-17, the "T" Match, Fig. 13-21, the "Q" section, Fig. 13-13, and the adjustable stub, Fig. 18-1. The gamma match, useful for feeding the driven element of a parasitic array with coaxial line, is shown in schematic form in Fig. 13-21. Balanced loads such as a split dipole or a folded dipole can be fed with coax through a balun, as shown in Fig. 13-23D. Practical examples of the use of these devices are shown in the following pages. The principles upon which their operation depends are explained in Chapter 13, with the exception of the adjustable stub of Fig. 18-1.

The Corrective Stub

The adjustable stub shown in Fig. 18-1 provides a means of matching the antenna to the transmission line and also tuning out reactance in the driven element. It is, in effect, a tuning device to which the transmission line may be connected at the point where impedances match. Both the shorting stub and the point of connection are made adjustable, though once the proper points are found the connections may be made permanent.

For antenna experiments the stub may be made of tubing, and the connections made with sliding clips. In a permanent installation a stub of open-wire line, with all connections soldered, may be more satisfactory mechanically. The transmission line may be open-wire or Twin-lead, connected directly to the stub, or coaxial line of any impedance, which should be connected through a balun.

To adjust the stub start with the short at a point about a quarter wave length below the antenna, moving the point of connection of the transmission line up and down the stub until the lowest standing-wave ratio is achieved. Then move the shorting stub a small amount and readjust the line connection for lowest s.w.r. again. If the minimum s.w.r. is lower than at

the first point checked the short was moved in the right direction. Continue in that direction, readjusting the line connection each time, until the s.w.r. is as close to 1:1 as possible. When adjustments are completed the portion of the stub below the short can be cut off, if this is desirable mechanically.

● TYPES OF V.H.F. ARRAYS

Directional antenna systems commonly used in amateur v.h.f. work are of three general types, the collinear, the Yagi, and the plane reflector

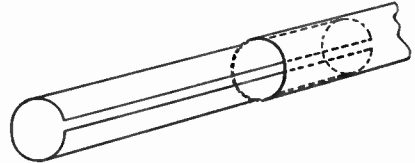

Fig. 18-2 — Inserts for the ends of the elements in a v.h.f. array provide a means of adjustment of length for optimum performance. Short pieces of the element material are sawed lengthwise and compressed to fit inside the element ends.

array. Collinear systems have two or more driven elements end to end, fed in phase, usually backed up by parasitic reflectors. The Yagi has a single driven element, with one or more parasitic elements in front and in back of the driven element, all in the same plane. The plane-reflector array has a large reflecting surface in back of its driven element or elements. This may be a sheet of metal, a metal screen, or closely-spaced rods or wires. The reflector may be a flat plane, or it can be bent into several forms, such as the corner and the parabola.

Examples of all three types are described, and each has points in its favor. The collinear systems such as the 12- and 16-element arrays of Figs. 18-12 and 18-13 require little or no adjustment and they present few feed problems. They work well over a wide band of frequencies. Yagi, or parasitic arrays, Figs. 18-5 to 18-9, depend on fairly precise tuning of their elements for gain, and thus work over a narrower frequency range. They are simple mechanically, however, and usually offer more gain for a given number of elements than do the collinear systems. Plane- and corner-reflector arrays are broadband devices, having broad forward lobes and high front-to-back ratio. They are easily adjusted, but somewhat cumbersome mechanically.

● ELEMENT LENGTHS AND SPACINGS

Designing a v.h.f. array presents both mechanical and electrical problems. The electrical problems are basic, and their solution involves choosing the type of performance most desired. Mechanical design, on the other hand, can be subject to almost endless variations, and the form that the array will take can usually be decided by the materials and tools available. One common

TABLE 18-1

Dimensions for V.H.F. Arrays in Inches

Freq. (Mc.)	52*	146*	222.5*	435*
Driven Element	106.5	38	24 $\frac{7}{8}$	12 $\frac{3}{4}$
Change per Mc.*	2	0.25	0.12	0.03
Reflector	111 $\frac{1}{2}$	40	26 $\frac{1}{8}$	13 $\frac{3}{8}$
1st Director	101 $\frac{1}{2}$	36	23 $\frac{5}{8}$	12 $\frac{1}{8}$
2nd Director	99 $\frac{1}{2}$	35 $\frac{3}{4}$	23 $\frac{3}{8}$	12
3rd Director	97 $\frac{1}{2}$	35	23	11 $\frac{7}{8}$
1.0 Wave length	234	81	52	27
0.625 Wave length	147	50 $\frac{1}{2}$	32.5	16 $\frac{3}{4}$
0.5 Wave length	117	40 $\frac{1}{2}$	26	13.5
0.25 Wave length	58 $\frac{1}{2}$	20 $\frac{1}{4}$	13	6 $\frac{3}{4}$
0.2 Wave length	47	16	10 $\frac{1}{2}$	5 $\frac{3}{4}$
0.15 Wave length	35	12	7 $\frac{3}{4}$	4
Balun loop (coax)	76	26.5	16 $\frac{3}{4}$	8 $\frac{3}{4}$

* Dimensions given for element lengths are for the middle of each band. For other frequencies adjust lengths as shown in the third line of table. Example: A dipole for 50.0 Mc. would be $106.5 \div 4 = 110.5$ inches.

Apply change figure to parasitic elements as well.

For phasing lines or matching sections, and for spacing between elements, the midband figures are sufficiently accurate. They apply only to open-wire lines.

Parasitic element lengths are optimum for 0.2 wave-length spacing.

source of materials for amateur arrays is commercially-built TV antennas. They can often be revamped for the amateur v.h.f. bands with a minimum of effort and expense.

Dimensions for Yagi or collinear arrays and their matching devices can be taken from Table 18-1. The driven element is usually cut to the formula:

$$\text{Length (in inches)} = \frac{5540}{\text{Freq. (Mc.)}}$$

This is the basis of the lengths in Table 18-1, which are suitable for the tubing or rod sizes commonly used. Arrays for 50 Mc. usually have $\frac{1}{2}$ to 1-inch elements. For 144 Mc. $\frac{1}{4}$ to $\frac{1}{2}$ -inch stock is common. Rod or tubing $\frac{1}{8}$ to $\frac{3}{8}$ inch in diameter is suitable for 220 and 420 Mc. Note that the element lengths in the table are for the middle of the band concerned. For peaked performance at other frequencies the element lengths

should be altered according to the figures in the third line of the table.

Reflector elements are usually about 5 percent longer than the driven element. The director nearest the driven element is 5 percent shorter, and others are progressively shorter, as shown in the table. Parasitic elements should also be adjusted according to Line 3 of the table, if peak performance is desired at some frequency other than midband.

Parasitic element lengths of Table 18-1 are based on element spacings of 0.2 wave length. This is most often used in v.h.f. arrays, and is suitable for up to 4 or 5 elements. Other spacings can be used, however. If the element lengths are adjusted properly there is little difference in gain with reflector spacings of 0.15 to 0.25 wave length. The closer the reflector is to the driven element,

Fig. 18-3 — Omnidirectional vertical array for 144 Mc. Elements of aluminum clothes-line wire are mounted on ceramic standoff insulators screwed to a wooden pole. Feedline shown is 52-ohm coax, with a balun at the feed-point. Twin-lead or other 300-ohm balanced line may also be used, but it should be brought away horizontally from the supporting pole and elements for at least a quarter wavelength. Coax may be taped to the support.

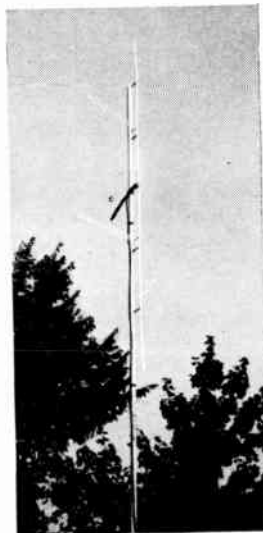

the shorter it must be for optimum forward gain, and the greater will be its effect on the driven element impedance.

Directors may also be spaced over a similar range. Closer spacing than 0.2 wave length for arrays of two or three elements will require a longer director than shown in Table 18-1. Thus it can be seen that close-spaced arrays tend to work over a narrower frequency range than wide-spaced ones, when they are tuned for best performance. They also result in lower driven-element impedance, making them more difficult to feed properly. Spacings less than 0.15 wave length are not commonly used in v.h.f. arrays for these reasons.

Practical Designs for V.H.F. Arrays

The antenna systems pictured and described herewith are examples of ways in which the information in Table 18-1 can be used in arrays of proven performance. Dimensions can be taken from the table, except where otherwise noted. If

the builder wishes to experiment with element adjustment, a simple method is shown in Fig. 18-2. With elements $\frac{1}{2}$ inch or larger diameter a piece of the element material can be used. It is sawed lengthwise and then compressed to make

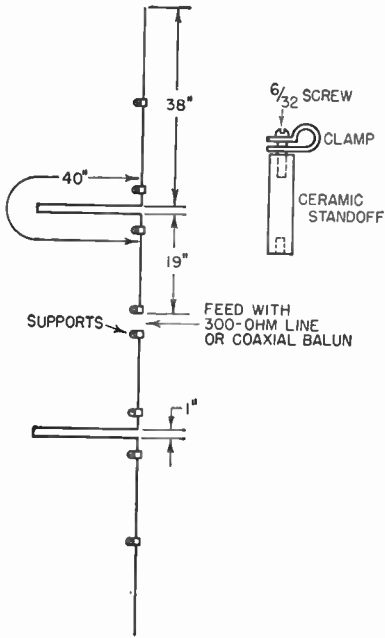

Fig. 18-4 — Dimensions and supporting method for the 144-Mc. vertical array.

a tight fit inside the end of the element.

A readily-available material often used for elements in arrays for 144 Mc. and higher is aluminum clothesline wire. This is a stiff hard-drawn wire about $\frac{1}{8}$ inch in diameter. It should be used in preference to a similar-appearing wire commonly sold for TV grounding purposes. The latter is too soft to make satisfactory elements if the length is more than about two feet.

A Collinear Array for 144 Mc.

Where a vertically-polarized array having some gain over a dipole is needed, yet directivity is undesirable, collinear halfwave elements may be mounted vertically and fed in phase, as shown in Figs. 18-3 and 18-4. Such an array may have 3 elements, as shown, or 5. The impedance at the center is approximately 300 ohms, permitting it to be fed directly with TV-type line, or through a coaxial balun, as in the model shown. Either 52- or 72-ohm line may be employed without serious mismatch.

The array is made from two pieces of aluminum clothesline wire about 97 inches long overall. These are bent to provide a 38-inch top section, a folded-back 40-inch phasing loop, and a 19-inch center section. These elements are mounted on ceramic pillars, which are fastened to a round wooden pole. Small clamps of sheet aluminum are wrapped around the elements and screwed to the stand-offs. A cheaper but somewhat less desirable method of mounting is to use TV screweye insulators to hold the elements in place.

Feeding the array at the center with a coaxial balun makes a neat arrangement. The balun loop may be taped to the vertical support, and the

coaxial line likewise taped at intervals down the mast. The same type of construction can be applied to a 220-Mc. vertical collinear array, using the lengths for that band given in Table 18-I.

● PARASITIC ARRAYS

Single-bay arrays of 2 to 5 elements are widely used in 50-Mc. work. These may be built in many different ways, using the dimensions given in the table. Probably the strongest and lightest structure results from use of aluminum or dural tubing (usually $1\frac{1}{4}$ to $1\frac{1}{2}$ inches in diameter) for the boom, though wood is also usable. If the elements are mounted at their midpoints there is no need to use insulating supports. Usually the elements are run through the boom and clamped in place in a manner similar to that shown in Fig. 18-10. Where a metal boom is used the joints between it and the elements must be tight, as any movement at this point will result in noisy reception.

2-Element 50-Mc. Array

The 2-element antenna of Fig. 18-5 was designed for portable use, but it is also suitable for fixed-station work with minor modification. The 2-meter array above it is described later. The elements are made in three sections, for portability, using inserts similar to that shown in Fig. 18-2. The driven element is gamma matched for coax feed, and the parasitic element is a 0.15-wave length spaced director. Details of



Fig. 18-5 — Two-element 50-Mc. and four-element 144-Mc. arrays designed for portable use. Support is sectional TV masting clamped to car door handle. Elements of 50-Mc. array are made in three sections, for stowing in back of car. Antenna for 144 Mc. is cut-down TV array. Both use gamma match, as shown in Fig. 18-6.

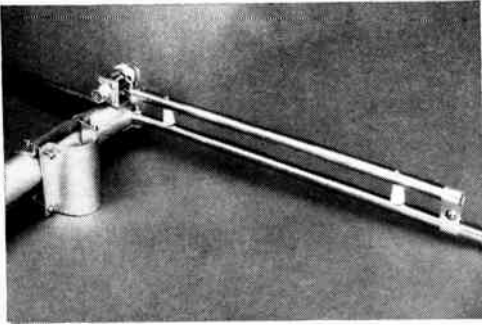

Fig. 18-6 — Details of the gamma match for the 50-Mc. portable array. In a permanent installation the variable capacitor should be mounted in an inverted plastic cup or other device to protect it from the weather. The gamma arm is about 12 inches long for 50 Mc., 5 inches for 144 Mc.

the gamma section, the boom and its supporting clamp are shown in Fig. 18-6. The arm is about 12 inches long, and the capacitor is a 50- μ mf. variable. Clean, tight connections between the arm and element are important. Where the array is to be mounted permanently outdoors the capacitor may be protected from the weather by mounting it in an inverted plastic cup. More details on this array are given in August, 1955, *QST*.

3-Element Lightweight Array

The 3-element 50-Mc. array of Fig. 18-7 weighs only 5 pounds. It uses the closest spacing that is practical for v.h.f. applications, in order to make an antenna that could be used individually or stacked in pairs without requiring a cumbersome support. The elements are half-inch aluminum tubing of 1/16-inch wall thickness, attached to the 1 1/4-inch dural boom with aluminum castings made for the purpose. (Willard Radcliff, Fostoria, Ohio, Type HASL.) By limiting the element spacing to 0.15 wave length the boom is only 6 feet long. Two booms for a stacked array (Fig. 18-11) can thus be cut from a single 12-foot length of tubing.

The folded-dipole driven element has No. 12 wire for the fed portions. These are mounted on 3/4-inch cone standoff insulators and joined to the outer ends of the main portion by means of metal pillars and 6/32 screws and nuts. When the wires are pulled up tightly and wrapped around the screw, solder should be sweated over the nuts and screw ends to seal the whole against weather corrosion. The same treatment should be used at each standoff. Mount a soldering lug on the ceramic cone and wrap the end of the lug around the wire and solder the whole assembly together. These joints and other portions of the array may be sprayed with clear lacquer as an additional protection.

The inner ends of the folded dipole are 1 1/2 inches apart. Slip the dipole into its aluminum casting, and then

drill through both element and casting with a No. 36 drill, and tap with 6/32 thread. Suitable inserts for mounting the stand-offs can be made by cutting the heads off 6/32 screws. Taper the cut end of the screw slightly with a file and it will screw into the standoff readily.

Cut the dipole length according to Table 18-1, for the middle of the frequency range you expect to use most. The reflector and director will be approximately 4 percent longer and shorter, respectively. The closer spacing of the parasitic elements (0.15 wave length) makes this deviation from the dimensions of the table desirable.

The single 3-element array has a good impedance of about 200 ohms at its resonant frequency. Thus it may be fed with 52-ohm coax and a balun. A gamma-matched dipole may also be used, as in the 2-element array. If the gamma match and 72-ohm coax are used, a balun will convert to 300-ohm balanced feed, if Twinlead or 300-ohm open-wire TV line feed is desired. If the dimensions are selected for optimum performance at 50.5 Mc. the array will show good performance and fairly low standing-wave ratio over the range from 50 to 51.5 Mc.

A closeup of a mounting method for this or any other array using a round boom is shown in Fig. 18-8. Four TV-type U bolts clamp the horizontal and vertical members together. The metal plate is about 6 inches square. If 1/4-inch sheet aluminum is available it may be used alone, though the photograph shows a sheet of 1/4-inch stock backed up by a piece of wood of the same size for stiffening.

High-Performance 4-Element Array

The 4-element array of Fig. 18-9 was designed for maximum forward gain, and for direct feed with 300-ohm balanced transmission line. The parasitic elements may be any diameter from 1/2 to 1 inch, but the driven element should be made as shown in the sketch. The same general arrangement may be used for a 3-element array, except that the solid portion of the dipole should

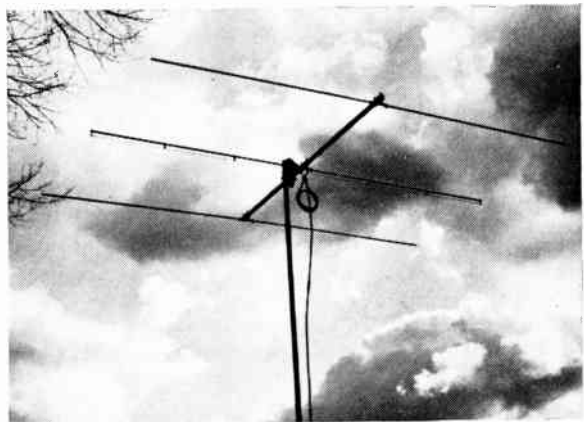

Fig. 18-7 — Lightweight 3-element 50-Mc. array. Feedline is 52-ohm coax, with a balun for connection to the folded-dipole driven element. Balun may be coiled as shown, or taped to supporting pipe.

be $\frac{3}{4}$ -inch tubing instead of 1-inch. With the element lengths given the array will give nearly uniform response from 50 to 51.5 Mc., and usable gain to above 52 Mc. It may be peaked for any portion of the band by using the information in Table 18-I.

If a shorter boom is desired, the reflector spacing can be reduced to 0.15 wave length and both

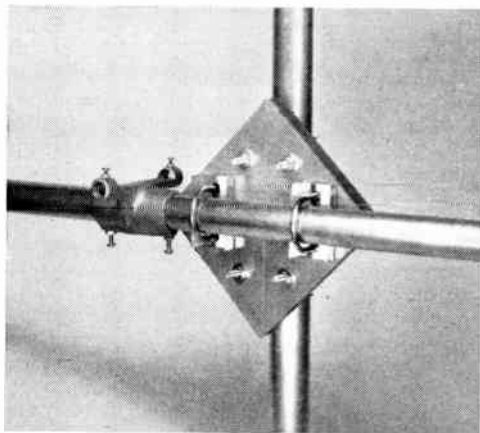

Fig. 18-8 — Closeup photograph of the boom mounting for the 50-Mc. array. A sheet of aluminum 6 inches square is backed up by a piece of wood of the same size. TV-type U clamps hold the boom and vertical support together at right angles. At the left of the mounting assembly is one of the aluminum castings for holding the beam elements.

directors spaced 0.2 wave length, with only a slight reduction in forward gain and bandwidth. Such a 4-element array is shown in Fig. 18-16.

5. Element 50-Mc. Array

As aluminum or dural tubing is usually sold in 12-foot lengths this dimension imposes a practical limitation on the construction of a 50-Mc. beam. A 5-element array that makes optimum use of a 12-foot boom may be built according to Table 18-1. If the aluminum casting method of mounting elements shown for the 3-element array is employed the weight of a 5-element beam can be held to under 10 pounds. The gamma match and coaxial line are recommended for feeding such an array, though a balun and 72-ohm coax can be used for the rotating portion of the line, converting to balanced feed at the anchor point, as shown in Fig. 18-20.

Elements should be spaced 0.15 wave length, or about 36 inches. With 5 or more elements, good bandwidth can be secured by tapering the element lengths properly. A dipole 110 inches long, with a 116-inch reflector, and directors of 105, 103 and 101 inches respectively will work well over the first two megacycles of the band, provided that the s.w.r. is adjusted for optimum at 51 Mc.

● 144-MC. PARASITIC ARRAYS

The main features of the arrays described above can be adapted to 144-Mc. antennas, but

the small physical size of arrays for this frequency makes it possible to use larger numbers of elements with ease. Few 2-meter antennas have less than 4 or 5 elements, and most stations use more, either in a single bay or in stacked systems.

Parasitic arrays for 144 Mc. can be made readily from TV antennas for Channels 4, 5 or 6. The relatively close spacing normally used in TV arrays makes it possible to approximate the recommended 0.2 wave length at 144 Mc., though the element spacing is not a critical factor. A 4-element array for 144 Mc. made from a Channel 6 TV Yagi is shown in Fig. 18-5. It is fed with a gamma match and 52-ohm coax, and was designed primarily for portable work. As most TV antennas are designed for 300-ohm feed the same feed system can be employed for the 2-meter array that is made from them.

If one wishes to build his own Yagi antennas from available tubing sizes, the boom of a 2-meter antenna should be $\frac{3}{4}$ to 1 inch aluminum or dural. Elements can be $\frac{1}{4}$ to $\frac{1}{2}$ -inch stock, fastened to the boom as shown in Fig. 18-10. Recommended spacing for up to 6 elements is 0.2 wave length, though this is not too critical. Gamma match feed is recommended for coax, or a folded dipole and balun may be used. If balanced line is to be used the folded dipole is

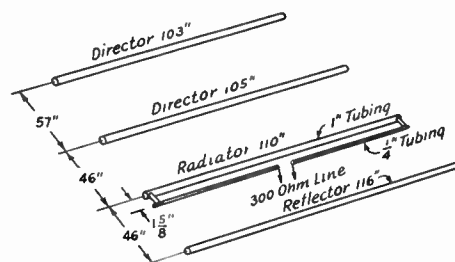

Fig. 18-9 — Details of a 4-element 50-Mc. array designed for 300-ohm balanced feed. Element lengths and spacings were derived experimentally for optimum performance over the first 1.5 megacycles of the band.

recommended, the 4 to 1 ratio of conductor sizes being about right for most designs.

Very high gain can be obtained with long Yagi-type arrays for 144 Mc. and higher frequencies, though the bandwidth of such antennas is considerably narrower than for those having up to 4 or 5 elements. The first two directors are usually spaced about 0.1 wavelength. The third is spaced about 0.2, increasing to 0.4 wave length or so for the forward directors. Highest gain is obtained when all directors are made the same length, but better front-to-back ratio and lower side lobe content results if the director lengths are tapered $\frac{1}{8}$ to $\frac{1}{4}$ inch per director. Tapering the element lengths also widens the effective bandwidth. There is more on long Yagis in *QST* for January and September, 1956.

● STACKED YAGI ARRAYS

The gain (in power) obtainable from a single Yagi array can be more than doubled by stacking

two or more of them vertically and feeding them in phase. This refers to horizontal systems, of course. Vertically-polarized bays are usually stacked side by side. The principles to follow apply in either case.

The spacing between bays should be at least one half wave length, and more is desirable. For dipoles or Yagis of up to three elements optimum spacing between bays is about $\frac{5}{8}$ wave length, but with longer Yagis the spacing can be increased to one wave length or more. Bays of 5 elements or more, spaced one wave length, are commonly used in antennas for 144 Mc. and higher frequencies. Optimum spacing for long Yagis is about two wave lengths.

Where half-wave stacking is to be employed, the phasing line between bays can be treated as a double "Q" section. If two bays, each designed for 300-ohm feed, are to be stacked a half wave length apart and fed at the midpoint between them, the phasing line should have an impedance of about 380 ohms. No. 12 wire spaced one inch will do for this purpose. The midpoint then can be fed either with 300-ohm line, or with 72-ohm coax and a balun.

When a spacing of $\frac{5}{8}$ wave length between bays is employed, the phasing lines can be coax. (The velocity factor of coax makes a full wave length of line actually about $\frac{5}{8}$ wave length physically.) The impedance at the midpoint between two bays is slightly less than half the impedance of either bay alone, due to the coupling between bays. This effect decreases with increased spacing.

When two bays are spaced a full wave length the coupling is relatively slight. The phasing line can be any open-wire line, and the impedance at the midpoint will be approximately half that of the individual bays. Predicting what it will be with a given set of dimensions is difficult, as many factors come into play. It will usually be of a value that can be fed through the combination of a "Q" section and a transmission line of 300 to 450 ohms impedance. An adjustable "Q" section, or an adjustable stub like the one shown in Fig. 18-1, may be used when the antenna impedance is not known.

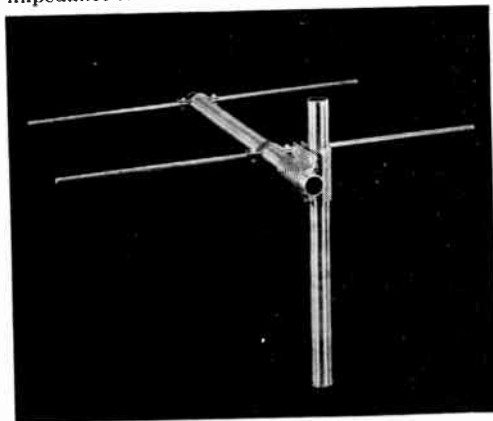

Fig. 18-10 — Model showing method of assembling all-metal arrays for 144 Mc. and higher frequencies. Dimensions of clamps are given in Fig. 18-15.

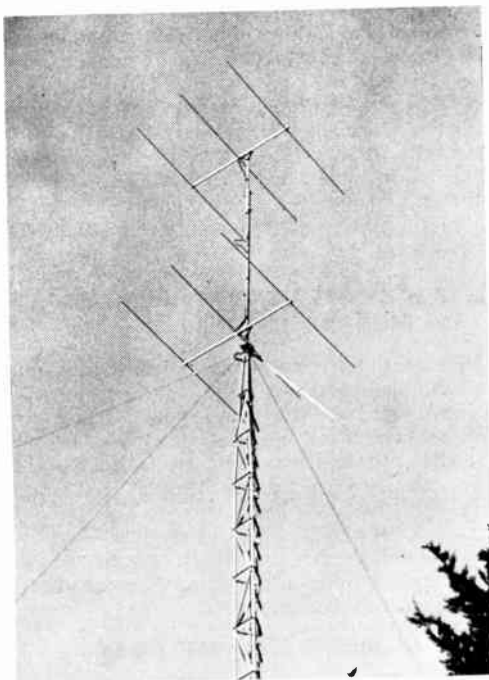

Fig. 18-11 — Stacked array for 50 Mc. using two of the 3-element bays of Fig. 18-7. Phasing system and flexible section for rotation are of coaxial line. A "Q" section matches this to 450-ohm open-wire line for run to the station.

The stacked 3-over-3 for 50 Mc., Fig. 18-11, uses a coaxial phasing line and an additional section of coax to provide for the flexible portion of the feedline. Each bay is fed with a balun and halfwave section of RG-8 U cable. These are joined at the center between bays with a Tee fitting. As each bay has an impedance of 200 ohms, two 50-ohm leads are paralleled at the center, resulting in an impedance of about 20 ohms, when the coupling effect between bays is included. A flexible section of 50-ohm coax one wave length long, with a balun at the end, steps this up to about 80 ohms. A "Q" section of $\frac{1}{4}$ -inch tubing $\frac{3}{4}$ inch center to center steps this up to the point where it can be fed with 450-ohm open-wire TV line.

The "Twin-Five" for 144 Mc.

A popular stacked array for 144-Mc. work is the Twin Five, originally developed by W2PAU¹. In this design two 5-element arrays of standard design are stacked a full wave length apart. If the folded-dipole driven elements are constructed so that the individual bays have a feed impedance of about 400 ohms the midpoint of the open-wire phasing line can be fed with 52-ohm coax and a balun. Where open-wire line is desired, the impedances can be matched through a "Q" section of about 300 ohms impedance. If the constructor is in doubt as to the actual feed impedance to be matched, the stub arrangement of Fig. 18-1 will

¹ Brown — "The Wide-Spread Twin-Five" CQ, March, 1950.

take care of a wide range of impedances and lines to be matched. Dimensions can be taken from Table 18-I.

An effective 20-element array can be made by using two of these arrays side by side, with full-wave spacing horizontally also. The impedance at the midpoint of the horizontal phasing line will then be about 100 ohms, which is still well within the range of "Q" sections of practical dimensions.

● LARGE COLLINEAR ARRAYS FOR 144 MC. AND HIGHER

High gain and very broad frequency response are desirable characteristics found in curtains of halfwave elements fed in phase and backed up by reflectors. The reflector can be made up of parasitic elements, or it can be a screen extending approximately a quarter wave length beyond the ends of the driven elements. There is not a large difference between the two types of reflectors, except that higher front-to-back ratio and somewhat broader frequency response are achieved with the plane reflector.

12- and 16-Element Arrays

Two collinear systems that may be used on 144, 220 or 420 Mc. are shown in Figs. 18-12 and 18-13. Either may be fed directly with 300-ohm transmission line, or through coaxial line and a balun. In the 12-element array, Fig. 18-12, the reflectors are spaced 0.15 wave length in back of the driven elements, while the 16-element array, Figs. 18-13 and 18-16, uses 0.2 wavelength spacing. Dimensions may be taken from Table 18-I, and figures for the middle of the band will give good performance across either band.

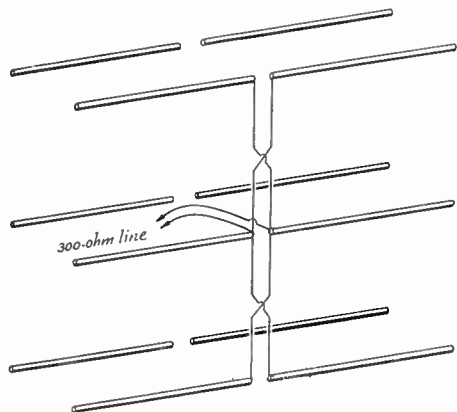

Fig. 18-12 — Element arrangement and feed system of the 12-element array. Reflectors are spaced 0.15 wave length behind the driven elements.

The supporting frame for either array may be made of wood or metal. Details of a metal support for the 12-element array are shown in Figs. 18-14 and 18-15. Note that all elements are mounted at their midpoints, and that no insulators are used. The elements are mounted in front of the supporting frame, to keep metal out of the field of

the array. This method is preferable to that wherein mechanical balance is maintained through mounting the driven elements in front and the reflectors in back of the supporting structure.

Two 12-element arrays may be mounted one above the other and fed in phase, to form a 24-element array. This is done in the 420-Mc. array

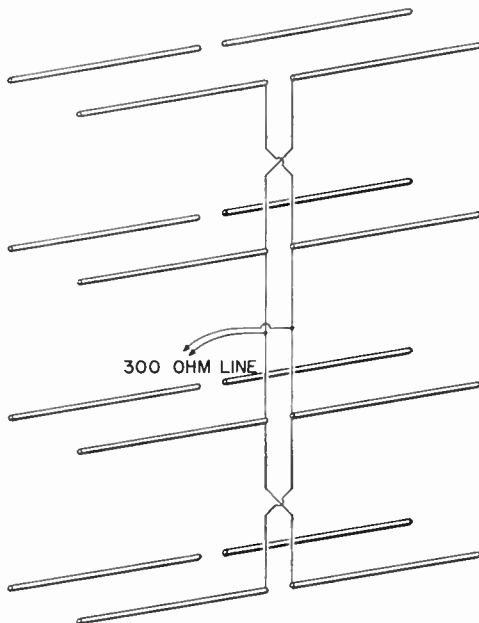

Fig. 18-13 — Schematic drawing of a 16-element array. A variable "Q" section may be inserted at the feed point if accurate matching is desired. Reflector spacing is 0.2 wave length.

of Fig. 18-17. The two midpoints are connected through a phasing line one wave length long, and the center of this phasing line fed through a "Q" section. The impedance at the midpoint is about 150 ohms, requiring a 255-ohm "Q" section for feeding with 450-ohm open-wire line.

Combination of collinear arrays may be carried further. Pairs of 16-element systems fed in phase are common, and even 64-element arrays (4 16-element beams fed in phase) are used in some leading stations on 144 Mc. Configurations of 32 to 64 elements are not difficult to build and support at 220 or 420 Mc. Examples of 16- and 24-element arrays for 220 and 420 Mc. are shown mounted back to back in Fig. 18-17.

● ARRAYS FOR 220 AND 420 MC.

The use of high-gain antenna systems is almost a necessity if work is to be done over any great distance on 220 and 420 Mc. Experimentation with antenna arrays for these frequencies is fascinating indeed, as their size is so small as to permit trying various element arrangements and feed systems with ease. Arrays for 420 Mc., particularly, are convenient for investigation and

demonstration of antenna principles, as even high-gain systems may be of table-top proportions.

Any of the arrays described previously may be used on these bands, but those having large num-

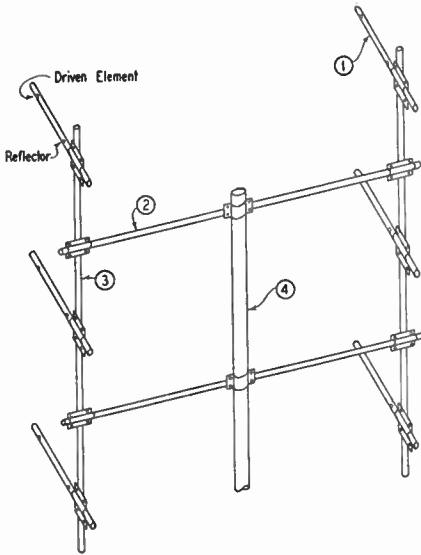

Fig. 18-14 — Supporting framework for a 12-element 141-Mc. array of all-metal design. Dimensions are as follows: element supports (1) $\frac{3}{4}$ by 16 inches; horizontal members (2) $\frac{3}{4}$ by 46 inches; vertical members (3) $\frac{3}{4}$ by 86 inches; vertical support (4) 1 $\frac{1}{2}$ -inch diameter, length as required; reflector-to-driven-element spacing 12 inches. Parts not shown in sketch: driven elements $\frac{3}{4}$ by 38 inches; reflectors $\frac{3}{4}$ by 40 inches; phasing lines No. 18 spaced 1 inch, 80 inches long, fanned out to 3 $\frac{1}{2}$ inches at driven elements (transpose each half-wave section).

bers of driven elements in phase are more readily adjusted for maximum effectiveness.

A 16-element array for 220 Mc. and a 24-element array for 420 Mc. are shown mounted back-to-back in Fig. 18-17. The 220-Mc. portion follows the 16-element design already described. It is fed at the center of the system with 300-ohm tubular Twin-Lead, matched to the center impedance of the array through a "Q" section of $\frac{7}{16}$ -inch tubing, spaced about 1 $\frac{1}{2}$ inches center to center. This spacing was adjusted for minimum standing-wave ratio on the line.

Elements in the array shown are of $\frac{7}{16}$ -inch aluminum fuel-line tubing, which is very light in weight and easily worked. The supporting structure is dural tubing, using the clamp assembly methods of Fig. 18-14.

The 420-Mc. array uses two 12-element assemblies similar to Fig. 18-12, mounted one above the other, about one half wave length separating the bottom of one from the top of the other. The two sets of phasing lines are joined by means of one-wavelength sections of Twin-Lead at the middle of the array. This junction, which has an impedance of around 150 ohms, is fed with 300-ohm tubular Twin-Lead through an adjustable "Q" section.

Elements in the 420-Mc. array are cut from

thin-walled $\frac{1}{4}$ -inch tubing. Their supports are the $\frac{7}{16}$ -inch stock used for the 220-Mc. elements. Slots were cut in the ends of these supports to take the elements, and a 4-40 screw was run through both pieces and drawn up tightly with a nut. The horizontal supports were fastened in holes drilled in the vertical members, and were also held in place with a 6/32 screw and nut. The small size and light weight of the 420-Mc. array did not require the use of clamps to make a strong assembly.

The two one-wavelength sections of 300-ohm line are 21 $\frac{3}{4}$ inches long, taking the propagation factor into account. The "Q" section may be any convenient size tubing, $\frac{1}{4}$ to $\frac{1}{2}$ inch diameter. It should be made adjustable, as matching is important at this frequency. Dimensions for both arrays can be taken from Table 18-I.

MISCELLANEOUS ANTENNA SYSTEMS

Coaxial Antennas

At v.h.f. the lowest possible radiation angle is essential, and the coaxial antenna shown in Fig. 18-18 was developed to eliminate feeder radiation. The center conductor of a 70-ohm concentric transmission line is extended one-quarter wave beyond the end of the line, to act as the upper half of a half-wave antenna. The lower half is provided by the quarter-wave sleeve, the upper end of which is connected to the outer conductor of the concentric line. The sleeve acts as a shield about the transmission line and very

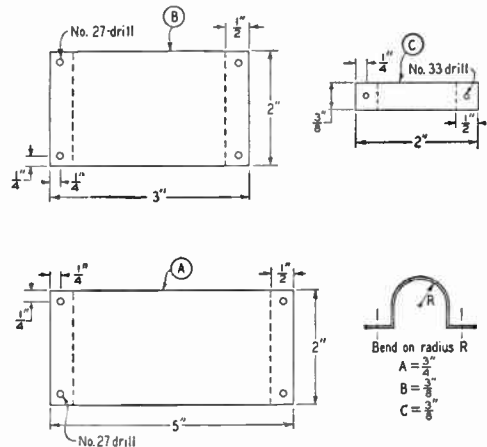

Fig. 18-15 — Detail drawings of the clamps used to assemble the all-metal 2-meter array. A, B and C are before bending into "U" shape. The right-angle bends should be made first, along the dotted lines as shown, then the plates may be bent around of piece of pipe of the proper diameter. Sheet stock should be $\frac{3}{16}$ -inch or heavier aluminum.

little current is induced on the outside of the line by the antenna field. The line is non-resonant, since its characteristic impedance is the same as the center impedance of the half-wave antenna. The sleeve may be made of copper or brass tubing of suitable diameter to clear the transmission

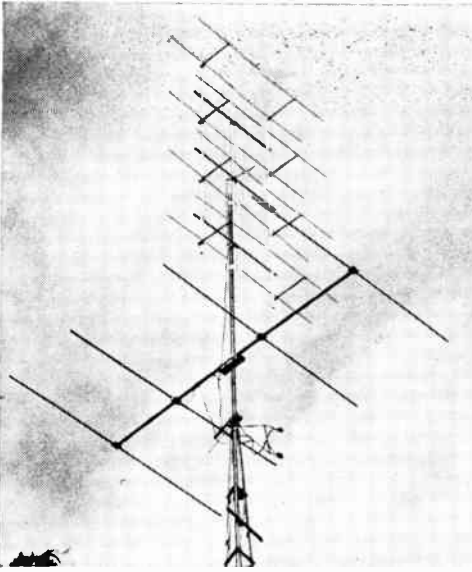

Fig. 18-16 — A 16-element array for 141 Mc. using the all-metal construction methods outlined in Figs. 18-11 to 18-13. The 4-element array for 50 Mc. below is also all-metal design.

line. The coaxial antenna is somewhat difficult to construct, but is superior to simpler systems in its performance at low radiation angles.

Broadband Antennas

Certain types of antennas used in television are of interest because they work across a wide band of frequencies with relatively uniform response. At very-high frequencies an antenna made of small wire is purely resistive only over a very small frequency range. Its Q , and therefore its selectivity, is sufficient to limit its optimum performance to a narrow frequency range, and readjustment of the length or tuning is required for each narrow slice of the spectrum. With tuned transmission lines, the effective length of the antenna can be shifted by retuning the whole system. However, in the case of antennas fed by matched-impedance lines, any appreciable frequency change requires an actual mechanical adjustment of the system. Otherwise, the resulting mismatch with the line will be sufficient to cause significant reduction in power input to the antenna.

A properly designed and constructed wide-band antenna, on the other hand, will exhibit very nearly constant input impedance over several megacycles.

The simplest method of obtaining a broadband characteristic is the use of what is termed a "cylindrical" antenna. There is no more than a conventional doublet in which large-diameter tubing is used for the elements. The use of a relatively large diameter-to-length ratio lowers the Q of the antenna, thus broadening the resonance characteristic.

As the diameter-to-length ratio is increased, end effects also increase, with the result that

the antenna must be made shorter than thin-wire antenna resonating at the same frequency. The reduction factor may be as much as 20 per cent with the tubing sizes commonly used for amateur antennas at v.h.f.

Plane-Reflector Arrays

At 220 Mc. and higher, where their dimensions become practicable, plane-reflector arrays are widely used. Except as it affects the impedance of the system, as shown in Fig. 18-19, the spacing between the driven elements and the reflecting plane is not particularly critical. Maximum gain occurs around 0.1 to 0.15 wave length, which is also the region of lowest impedance. Highest impedance appears at about 0.3 wave length. A plane reflector spaced 0.22 wave length in back of the driven elements has no effect on their feed impedance. As the gain of a plane-reflector array is nearly constant at spacings from 0.1 to 0.25 wave length, it may be seen that the spacing may be varied to achieve an impedance match.

An advantage of the plane reflector is that it may be used with two driven element systems, one on each side of the plane, providing for two-band operation, or the incorporation of horizontal and vertical polarization in a single structure. The gain of a plane-reflector array is slightly higher than that of a similar number of driven elements backed up by parasitic reflectors. It also has a broader frequency response and higher front-to-back ratio. To achieve these ends, the reflecting plane must be larger than the area of

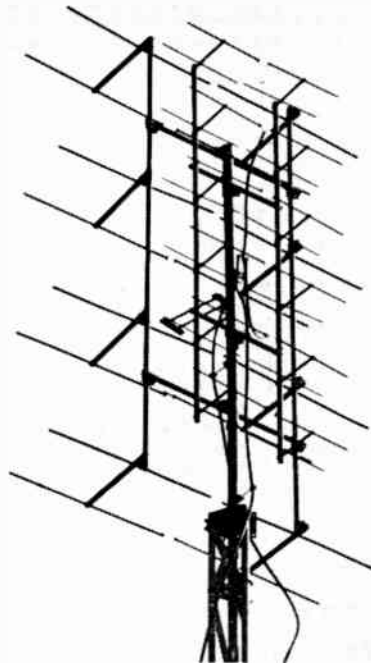

Fig. 18-17 — A 24-element array for 420 Mc. and a 16-element for 220 mounted back-to-back on a single support.

the driven elements, extending at least a quarter wave length on all sides. Chicken wire on a wood or metal frame makes a good plane reflector. Closely-spaced wires or rods may be substituted,

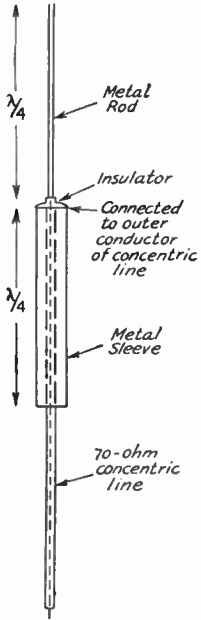

Fig. 18-18 — Coaxial antenna. The insulated inner conductor of the 70-ohm concentric line is connected to the quarter-wave metal rod which forms the upper half of the antenna.

with the spacing between them running up to 0.1 wave length without appreciable reduction in effectiveness.

Corner Reflectors

In the corner reflector two plane surfaces are set at an angle, usually between 45 and 90 degrees, with the antenna on a line bisecting this angle. Maximum gain is obtained with the antenna 0.5 wave length from the vertex, but compromise designs can be built with closer spacings. There is no focal point, as would be the case for a parabolic reflector. Corner angles greater than 90 degrees can be used at some sacrifice in gain. At less than 90 degrees the gain increases, but the size of the reflecting sheets must be increased to realize this gain.

At a spacing of 0.5 wave length from the vertex, the impedance of the driven element is approximately twice that of the same dipole in free space. The impedance decreases with smaller spacings and corner angles, as shown in Fig. 18-19. The gain of a corner-reflector array with a 90-degree angle, 0.5 wave length spacing and sides 1 wave-length long is approximately 10 db. Principal advantages of the corner reflector are broad frequency response and high front-to-back ratio.

Cone Antennas

From the cylindrical antenna various specialized forms of broadly-resonant radiators have been evolved, including the ellipsoid, spheroid, cone, diamond and double diamond. Of these, the conical antenna is perhaps the most interesting. With large angles of revolu-

tion, the variation in the characteristic impedance with changes in frequency can be reduced to a very low value, making such an antenna suitable for extremely wide-band operation. The cone may be made up either of sheet metal or of multiple wire spines. A variation of this form of conical antenna is widely used in TV reception.

Parabolic Reflectors

A plane sheet may be formed into the shape of a parabolic curve and used with a driven radiator situated at its focus, to provide a highly-directive antenna system. If the parabolic reflector is sufficiently large so that the distance to the focal point is a number of wave lengths, optical conditions are approached and the wave across the mouth of the reflector is a plane wave. However, if the reflector is of the same order of dimensions as the operating wave length, or less, the driven radiator is appreciably coupled to the reflecting sheet and minor lobes occur in the pattern. With an aperture of the order of 10 or 20 wave lengths, sizes that may be practical for microwave work, a beam-width of approximately 5 degrees may be achieved.

A reflecting paraboloid must be carefully designed and constructed to obtain ideal performance. The antenna must be located at the focal point. The most desirable focal length of the parabola is that which places the radiator along the plane of the mouth; this length is equal to one-half the mouth radius. At other focal distances interference fields may deform the pattern or cancel a sizable portion of the radiation.

FEEDLINE IDEAS FOR ROTATABLE ARRAYS

Where arrays are to be rotated, the method of connecting the transmission line may present a

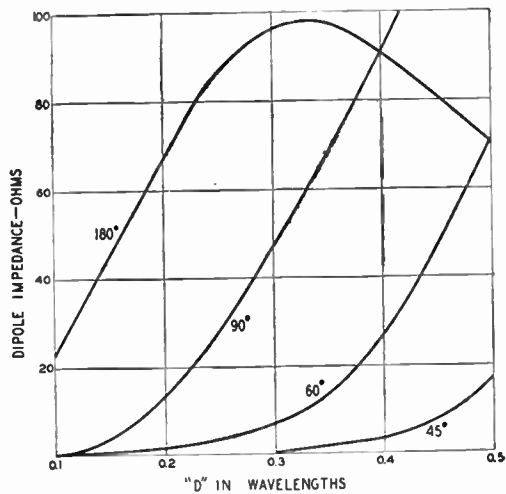

Fig. 18-19 — Feed impedance of the driven element in a corner-reflector array for corner angles of 180 (flat sheet), 90, 60 and 45 degrees. "D" is the dipole-to-vertex spacing.

problem, particularly if open-wire line is used. This can be handled in several ways, some of which may also take care of matching problems at the same time.

If coaxial line is employed throughout the entire run from antenna to rig the rotation problem can be taken care of by making a few turns of coax around the tower or supporting

line. However, if the array and its main transmission line are other than 300 ohms impedance, the same method may be employed by making the connecting line between the two baluns any multiple of a half wave length long. Either 52- or 75-ohm coax can be used in this case, as the antenna impedance will be repeated at the anchor point.

There may be antenna and line impedance combinations that can be matched with the use of "Q" sections of 72, 150 or 300 ohms. If any of these values is suitable for a matching section, the functions of matching and flexible rotating sections can be combined in a "Q" section of Twin-lead of suitable impedance, as shown in Fig. 18-20B. The flexible section should then be an odd multiple of a quarter wave length long. A section of Twin-lead one half wavelength or multiple thereof may also be used as an impedance-repeating flexible lead. The tubular line

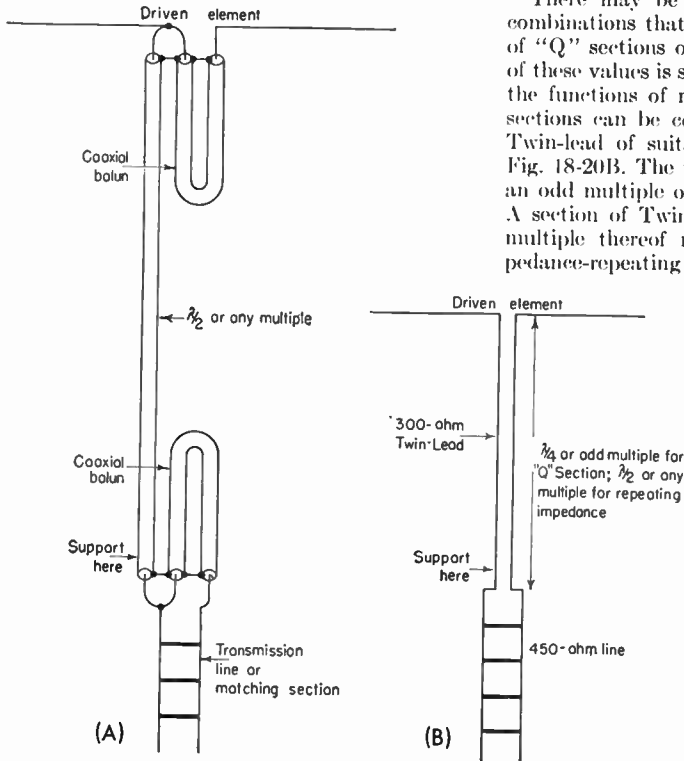

Fig. 18-20 — Flexible sections of line for rotatable arrays may be made of coax (A) or Twin-lead (B). If the rotating sections are a half wavelength or any multiple thereof the antenna impedance is repeated at the anchor point. If they are a quarter wavelength or odd multiple thereof they may be employed as matching sections. If the driven element in A is designed for coaxial feed the upper balun should be omitted.

mast between the antenna and a fixed anchor point just below it. Coaxial line may also be used for the rotating portion of an array that is designed to be fed with open-wire or other balanced line, as shown in Fig. 18-20A.

If the feed impedance of the array is 300 ohms, and the line is that impedance, 75-ohm coax may be used for the baluns and connecting lead. The latter may be any length in that case, as impedances will be matched all along the

of the heavy-duty variety normally used for transmitting purposes is most suitable for these applications.

Where a long run of open-wire line is to be used from the tower anchor point to the station, it should be supported on strain insulators, one in each conductor, at both ends of the run. The polyethylene spreaders used in TV line are not sufficiently strong to be used for supporting the line in runs of more than a few feet.

Mobile and Portable-Emergency Equipment

The amateur who goes in for mobile operation will find plenty of room for exercising his individuality and developing original ideas in equipment. Each installation has its special problems to be solved.

Most mobile receiving systems are designed around the use of a h.f. converter working into a standard car broadcast receiver tuned to 1500 kc. which serves as the i.f. and audio amplifiers. The car receiver is modified to take a noise limiter and provide power for the converter.

While a few mobile transmitters may run an input to the final amplifier as high as 100 watts or more, an input of about 30 watts normally is considered the practical limit unless the car is equipped with a special battery-charging system. The majority of mobile operators use phone.

In contemplating a mobile installation, the car should be studied carefully to determine the most suitable spots for mounting the equipment. Then the various units should be built in a form that will make best use of that space. The location of the converter should have first consideration. It should be placed where the controls can be operated conveniently without distracting attention from the wheel. The following list suggests spots that may be found suitable, depending upon the individual car.

On top of the instrument panel

Attached to the steering post

Under the instrument panel

In a unit made to fit between the lower lip of the instrument panel and the floor at the center of the car

The transmitter power control can be placed close to the receiver position, or included in the converter unit. This control normally operates relays, rather than to switch the power circuit directly. This permits a

minimum length of heavy-current battery circuit. Frequency within any of the phone bands sometimes is changed remotely by means of a stepping-switch system that switches crystals. In most cases, however, it is necessary to stop the car to make the several changes required in changing bands.

Depending upon the size of the transmitter unit, one of the following places may be found convenient for mounting the transmitter:

In the glove compartment

Under the instrument panel

In a unit in combination with or without the converter, built to fit between the lower edge of the instrument panel and the floor at the center

On the ledge above the rear seat

In the trunk

Most mobile antennas consist of a vertical whip with some system of adjustable loading for the lower frequencies. Power supplies are of the vibrator-transformer-rectifier or motor-generator type operating from the car storage battery.

Units intended for use in mobile installations should be assembled with greater than ordinary care, since they will be subject to considerable vibration. Soldered joints should be well made and wire wrap-arounds should be used to avoid dependence upon the solder for mechanical strength. Self-tapping screws should be used wherever feasible, otherwise lock-washers should be provided. Any shafts that are normally operated at a permanent or semi-permanent setting should be provided with shaft locks so they cannot jar out of adjustment. Where wires pass through metal, the holes should be fitted with rubber grommets to prevent chafing. Any cabling or wiring between units should be securely clamped in place where it cannot work loose to interfere with the operation of the car.

Noise Elimination

Electrical-noise interference to reception in a car may arise from several different sources. As examples, trouble may be experienced with ignition noise, generator and voltage-regulator hash, or wheel and tire static.

A noise limiter added to the car broadcast receiver will go far in reducing some types, especially ignition noise from passing cars as well as your own. But for the satisfactory reception of weaker signals, some investigation and treat-

ment of the car's electrical system will be necessary.

Ignition Interference

Fig. 19-1 indicates the measures that may be taken to suppress ignition interference. The capacitor at the primary of the ignition coil should be of the coaxial type; ordinary types are not effective. It should be placed as close to the coil terminal as possible. In stubborn cases, two

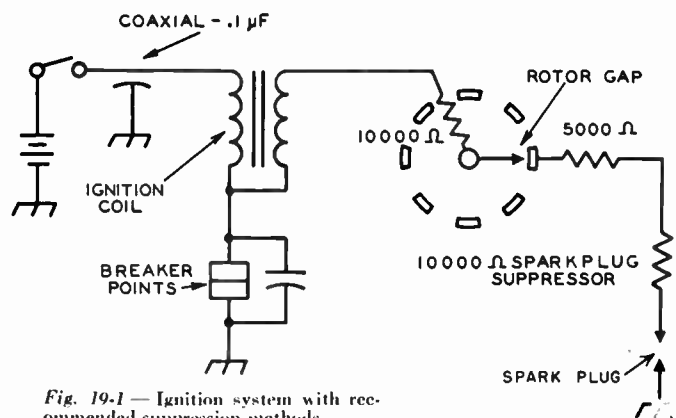

Fig. 19-1— Ignition system with recommended suppression methods.

of these capacitors with an r.f. choke between them may provide additional suppression. The size of the choke must be determined experimentally. The winding should be made with wire heavy enough to carry the coil primary current. A 10,000-ohm suppressor resistor should be inserted at the center tower of the distributor, a 5,000-ohm suppressor at each spark-plug tower on the distributor, and a 10,000 ohm suppressor at each spark plug. The latter may be built-in or external. A good suppressor element should be molded of material having low capacitance. Several concerns manufacture satisfactory suppressors. In extreme cases, it may be necessary to use shielded ignition wire. The 1951 Pontiac car was equipped with suppressor ignition wires, the resistance being distributed throughout the length of the wire. This is somewhat superior to lumped resistance and may be used if the lead lengths are right to fit your car. They should not be cut, but used as they are sold.

Generator Noise

Generator hash is caused by sparking at the commutator. The pitch of the noise varies with the speed of the motor. This type of noise may be eliminated by using a 0.1- to 0.25- μ f. coaxial capacitor in the generator armature circuit. This capacitor should be mounted as near the armature terminal as possible and directly

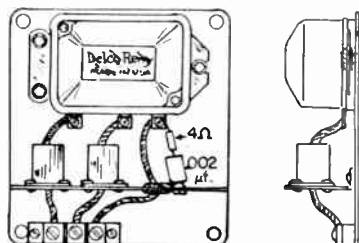

Fig. 19-2— The right way to install bypasses to reduce interference from the regulator. A capacitor should never be connected across the generator field lead without the small series resistor indicated.

on the frame of the generator.

To reduce the noise at 28 Mc., it may be necessary to insert a parallel trap, tuned to the middle of the band, in series with the generator output lead. The coil should have about 8 turns of No. 10 wire, space-wound on a 1-inch diameter and should be shunted with a 30- μ f. mica trimmer. It can be pretuned by putting it in the antenna lead to the home-station receiver tuned to the middle of the band, and adjusting the trap to the point of minimum noise. The tuning may need to be peaked up after installing in the car, since it is fairly critical.

Voltage-Regulator Interference

In eliminating voltage-regulator noise, the use of two coaxial capacitors, and a resistor-mica-capacitor combination, as shown in Fig. 19-2, are effective. A 0.1- to 0.25- μ f. coaxial capacitor should be placed between the battery terminal of the regulator and the battery, with its case well grounded. Another capacitor of the same size and type should be placed between the generator terminal of the regulator and the generator. A 0.002- μ f. mica capacitor with a 4-ohm carbon resistor in series should be connected between the field terminal of the regulator and ground. Never use a capacitor across the field contacts or between field and ground without the resistor in series, since this greatly reduces the life of the regulator. In some cases, it may be necessary to pull double-braid shielding over the leads between the generator and regulator. It will be advisable to run new wires, grounding the shielding well at both ends. If regulator noise persists, it may be necessary to insulate the regulator from the car body. The wire shielding is then connected to the regulator case at one end and the generator frame at the other.

Wheel Static

Wheel static shows up as a steady popping in the receiver at speeds over about 15 m.p.h. on smooth dry streets. Front-wheel static collectors are available on the market to eliminate this variety of interference. They fit inside the dust cap and bear on the end of the axle, effectively grounding the wheel at all times. Those designated particularly for your car are preferable, since the universal type does not always fit well. They are designed to operate without lubrication and the end of the axle and dust cap should be cleaned of grease before the installation is made. These collectors require replacement about every 10,000 miles.

Rear-wheel collectors have a brush that bears against the inside of the brake drum. It

may be necessary to order these from the factory through your dealer.

Tire Static

This sometimes sounds like a leaky power line and can be very troublesome even on the broadcast band. It can be remedied by injecting an antistatic powder into the inner tubes through the valve stem. The powder is marketed by Chevrolet and possibly others. Chevrolet dealers can also supply a convenient injector for inserting the powder.

Tracing Noise

To determine if the receiving antenna is picking up all of the noise, the shielded lead-in should be disconnected at the point where it connects to the antenna. The motor should be started with the receiver gain control wide open. If no noise is heard, all noise is being picked up via the antenna. If the noise is still heard with the antenna disconnected, even though it may be reduced in strength, it indicates that some signal from the ignition system is being picked up by the antenna transmission line. The lead-in may not be sufficiently well shielded, or the shield not properly grounded. Noise may also be picked up through the battery circuit, although this does not normally happen if the receiver is provided with the usual r.f.-choke-and-bypass capacitor filter.

In case of noise from this source, a direct wire from the "hot" battery terminal to the receiver is recommended.

Ignition noise varies in repetition rate with engine speed and usually can be recognized by that characteristic in the early stages. Later, however, it may resolve itself into a popping noise that does not always correspond with engine speed. In such a case, it is a good idea to remove all leads from the generator so that the only source left is the ignition system.

Regulator and generator noise may be detected by racing the engine and cutting the ignition switch. This eliminates the ignition noise. Generator noise is characterized by its musical whine contrasted with the ragged raspy irregular noise from the regulator.

With the motor running at idling speed, or slightly faster, checks should be made to try to determine what is bringing the noise into the field of the antenna. It should be assumed that any control rod, metal tube, steering post, etc., passing from the motor compartment through an insulated bushing in the firewall will carry noise to a point where it can be radiated to the antenna. All of these should be bonded to the firewall with heavy wire or braid. Insulated wires can be stripped of r.f. by bypassing them to ground with 0.5- μ f. metal-case capacitors. The following should not be overlooked: battery lead at the ammeter, gasoline gauge, ignition switch, headlight, backup and taillight leads and the wiring of any accessories running from the motor compartment to the instrument panel or outside the car.

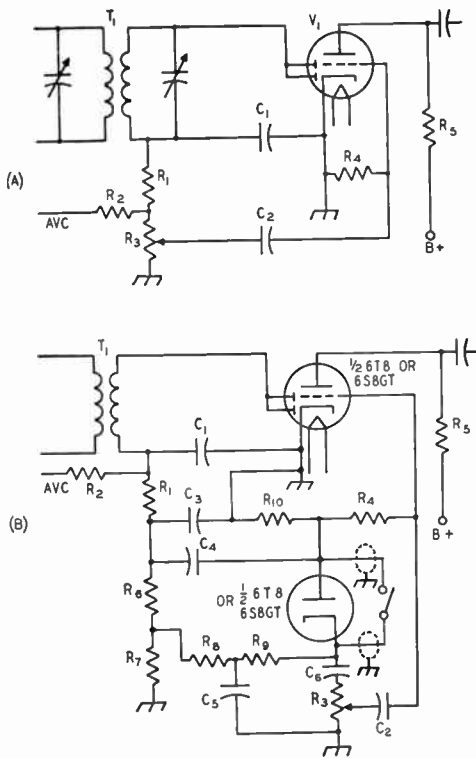

Fig. 19-3 — Diagrams showing addition of noise limiter to car receiver, A — Usual circuit. B — Modification.

- C₁, C₃ — 100- μ f. mica.
- C₂, C₄, C₆ — 0.01- μ f. paper.
- C₅ — 0.1- μ f. paper.
- R₁ — 47,000 ohms.
- R₂, R₁₀ — 1 megohm.
- R₃ — 1/2 megohm.
- R₇, R₈, R₉ — 0.47 megohm.
- R₄ — 10 megohms.
- R₅ — 1/4 megohm.
- R₆ — 0.1 megohm.
- T₁ — I.f. transformer.
- V₁ — Second detector.

The firewall should be bonded to the frame of the car and also to the motor block with heavy braid. If the exhaust pipe and muffler are insulated from the frame by rubber mountings, they should likewise be grounded to the frame with flexible copper braid.

Noise Limiter

Fig. 19-3 shows the alterations that may be made in the existing car-receiver circuit to provide for a noise limiter. The usual diode-triode second detector is replaced with a type having an extra independent diode. If the car receiver uses octal-base tubes, a 6S8GT may be substituted. The 7X7 is a suitable replacement in receivers using loktal-type tubes, while the 6T8 may be used with miniatures.

The switch that cuts the limiter in and out of the circuit may be located for convenience on or near the converter panel. Regardless of its placement, however, the leads to the switch should be shielded to prevent hum pick-up.

A Bandswitching Crystal-Controlled Converter

Figures 19-4 through 19-8 show a bandswitching crystal-controlled mobile converter covering bands from 80 to 10 meters. The tuning of the oscillator is fixed, and the r.f. amplifier is broadbanded. Signals across the band are tuned in by adjusting the broadcast receiver which is used as a tunable i.f. amplifier. Frequency stability is much superior to that of the usual tunable converter. Coils and crystals for unneeded bands may be omitted.

While the converter draws 20 ma. at 150 volts, tests have shown that the performance is essentially unchanged with the plate input reduced to 5 ma. at 45 volts. If you are reluctant to dig into the receiver to bring out a B+ lead, you can operate the converter from a small B battery.

The Circuit

The circuit diagram is shown in Fig. 19-5. A 6AK5 is used as an r.f. amplifier, and a 6J6 dual triode as the frequency converter. The r.f. circuits consist of slug-cored coils tuned by the tube capacitances. However, a trimmer, C_3 , is included so that the amplifier grid circuit can be peaked up for the particular antenna in use, or in going from one end of the band to the other.

A pair of wave traps, C_1L_1 and C_2L_2 , at the input are provided to minimize interference from local broadcast stations.

For frequencies above 7 Mc., the oscillator section of the converter works at harmonics of the crystal frequency. At these frequencies an oscillator circuit is used which limits the oscillator output essentially to the desired harmonic frequency. On 3.5 and 7 Mc., the crystals work at the fundamental, and the circuit is a simple Pierce, L_6 being eliminated on these bands.

For the sake of simplicity in the diagram, only a single set of coils (the 14-Mc. set) is shown. Other coils and crystals are wired similarly to their respective switch points. Switch section S_{2E} is not used as an active switch, its point terminals merely serving as a most convenient tie-point strip for supporting the junction of the crystals and L_6 coils. In the case of the 7- and 3.5-Mc. positions, where no L_6 coil is used, the corresponding switch points are simply wired together, as indicated.

S_{1A} and S_{1B} shift the antenna from the converter to the broadcast receiver, while S_{1C} turns off the converter filaments.

An accompanying table shows the crystal frequency, the h.f. oscillator frequency, and the range over which the broadcast receiver must be tuned to cover each of the ham bands.

Since the range of the broadcast receiver is approximately 1000 kc. (1500-550 kc.), the tuning range with any single crystal is limited to 1 Mc. However, this is more than adequate for all except the 10-meter band. For full coverage of this band, two crystals are used, as indicated in the table. The 11-meter band is not normally included, but values are given so that this band may be substituted for one of the 10-meter ranges if desired.

Construction

The converter is built into a $2 \times 7 \times 7$ -inch aluminum chassis. The top cover (actually a bottom plate for the chassis and not shown in the photographs) is a flat piece of aluminum measuring 7 by 9 inches. The extra inch of overlap on each side provides lips for fastening the converter to the bottom cover of the broadcast receiver by means of machine screws and metal spacers.

The aluminum bracket for the large subassembly should be made first. This subassembly is shown to the left of the bandswitch in Fig. 19-4, and in Figs. 19-7 and 19-8. The latter identify the components, indicating the holes that must be drilled for the tubes, coils and r.f. chokes.

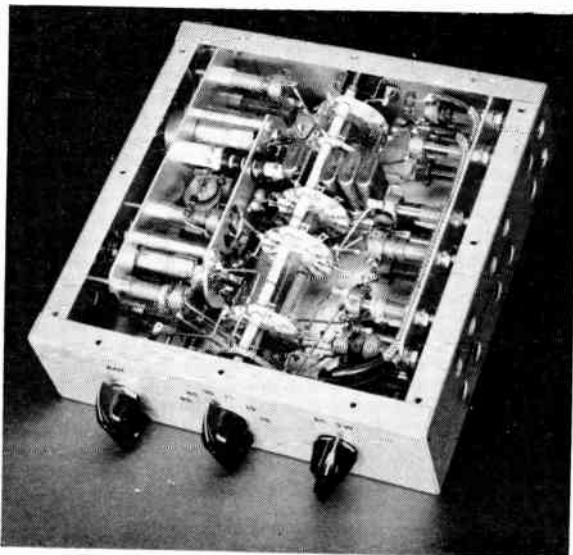

Fig. 19-4 — Front view of the bandswitching crystal-controlled mobile converter. The unit is built into a $7 \times 7 \times 2$ -inch aluminum chassis. The subassembly, shown in Figs. 19-7 and 19-8, is to the left of the bandswitch. It includes the 28-Mc. coils, the tubes, and most of the small components. The second subassembly to the right contains all remaining coils. The controls for C_3 to the left, and S_1 to the right, are spaced 2 inches from the bandswitch shaft. Holes along the right side are for adjusting the coil slugs. Bandswitch wafers are in alphabetical order, S_{2A} to S_{2F} , front to rear.

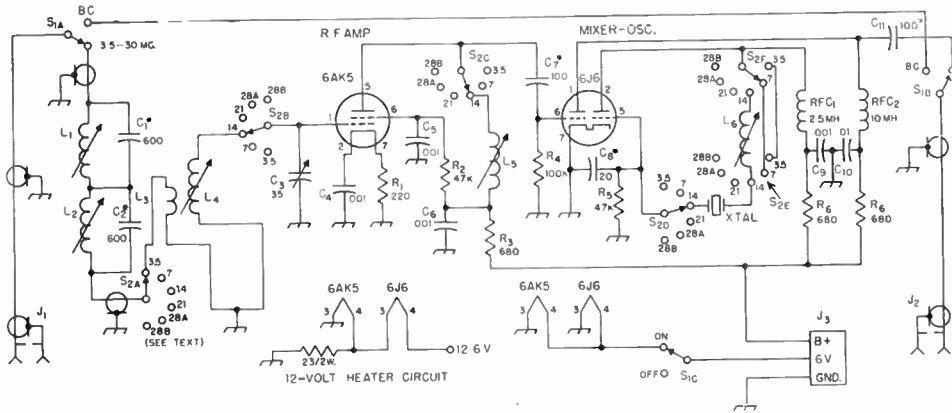

Fig. 19-5—Circuit diagram of the crystal-controlled mobile converter. All resistors $\frac{1}{2}$ watt. * Indicates a tubular ceramic capacitor; all other fixed capacitors disk

C_3 — 35- μ f. variable (Hammarlund HF-35).
 L_1 through L_6 — See coil chart.
 J_1, J_2 — RCA-type phono jack.
 J_3 — 3-prong male chassis connector (Cinch-Jones P-303AB).
 RFC_1 — 2.5-mh. r.f. choke (National R-100S).
 RFC_2 — 10-mh. r.f. choke (National R-100S).

* Indicates a ceramic. Values below 0.001 μ f. are in μ μ f.
 S_1 — 3-pole 5-position (used as 3-p.d.t.) selector switch (Centralab PA-2007 or PA-5 wafer mounted on PA-300 index).
 S_2 — 6-pole 6-position selector switch (6 Centralab PA-18 wafers mounted on PA-302 index).
 $XTAL$ — See chart (James Knights type H-17 or International crystal type FA-9).

When the bracket has been drilled, place it against the rear wall of the chassis, $\frac{3}{4}$ inch in from the left side, and mark the mounting holes in the chassis. Then slide the bracket against the left-hand side of the chassis and spot the slug-adjusting holes and the 1-inch holes that permit removal of the tubes.

Before assembling the unit, the antenna coils (L_3) should be wound on each of the two L_4 forms. Each of the North Hills coil forms has an extra set of terminals that may be used as tie points for the switch ends of the L_3 windings.

At the conclusion of the wiring of the subassembly, connect power leads that will run to S_{1C} and J_3 , and attach a 2-inch length of wire to Pin 5 of the 6J6. The free end of the latter will be connected to S_{2D} later.

The remaining slug-tuned coils are mounted as a second subassembly on a bracket the same in size as the first, although the mounting lips must be bent in the opposite directions. The coils are arranged in three groups of four coils. The coils are centered at the corners of a $\frac{3}{4}$ -inch square. The first square is centered on the strip and at $\frac{5}{8}$ inch from the front edge of the strip. The second square is centered $2\frac{1}{2}$ inches from the front edge, and the last square is centered $3\frac{5}{8}$ inches back. At the center of each of the two squares toward the front, a hole is drilled for a 1-inch 6-32 screw. A soldering lug and a $\frac{3}{4}$ -inch metal spacer are slid over the screw to provide convenient grounding terminals.

Before the coils are mounted, this bracket should be placed against the rear wall of the chassis, and $\frac{3}{4}$ inch from the right-hand side and its mounting holes marked in the chassis. Then,

as before, it should be slid against the right-hand side of the chassis while the slug-adjusting holes are spotted in the wall of the chassis.

The first group of coils toward the front are the r.f. grid coils, L_3 - L_4 , and the plate coils, L_5 , are in the second group. With the slug screws facing you, the 80-meter coils are at the upper left, the 40-meter coils are at the upper right, the 20-meter coils at the lower left, and the 15-meter coils at the lower right. The third group of coils at the rear include the trap coils, L_2 , at the upper left, and L_1 at the upper right. Below are the 20-meter oscillator coil (L_6) to the left, and the 15-meter oscillator coil to the right. The antenna coils, L_3 , should be wound on their corresponding grid-coil forms (L_4) before assembling.

Coil Chart for the Mobile Converter

Band	Turns, L_3	Ind. Range, μ h.		Type No.	
		L_4 - L_5	L_6	L_4 - L_5	L_6
3.5-4	30	64-105	—	120-G	—
7-7.3	8	18-36	—	120-E	—
14-14.35	4	5-9	18-36	120-C	120-E
21-21.45	3	3-5	5-9	120-B	120-C
26.93 27.23	3	2-3	3-5	120-A	120-B
28-28.9	3	2-3	3-5	120-A	120-B
28.75-29.7	3	2-3	3-5	120-A	120-B

NOTE: L_1 and L_2 , Fig. 19-5, are Types 120-F (36-64 μ h.) and 120-E, respectively. L_3 is wound with fine magnet wire (20-30) at grounded end of L_4 .

Frequency Chart for the Mobile Converter			
Band, Mc.	Crystal Freq., Kc.	Oscillator Freq., Mc.	I.F. Range, Kc.
3.5-4	2900	2.9	600-1100
7-7.3	6400	6.4	600-900
14-14.35	6700	13.4	600-950
21-21.45	6800	20.4	600-1050
26.96-27.23	6575	26.3	660-930
28-28.9	6850	27.4	600-1500
28.75-29.7	7050	28.2	550-1500

NOTE: I.f. range indicates broadcast receiver tuning range necessary for covering the associated amateur frequencies.

Only a single by-pass capacitor is shown in the diagram as C_6 . Actually, there are three of them. One is at the junction of the cold ends of the two 10-meter coils, one for the 3.5- and 7-Mc. coils, and one for the 14- and 21-Mc. coils.

The Bandswitch

The bandswitch is made up from Centralab Switchkit parts as indicated under Fig. 19-5. In assembling the switch, all wafers should be placed on the assembly rods so that the rotor or "arm" terminal is the second terminal to the left of the upper assembly rod, as viewed from the front.

The crystals can be soldered to the switch contacts before the switch is mounted in the chassis.

Prongs taken from an octal socket and slid over the crystal-holder pins are a good means of connecting the crystals to the switch wafers.

The fiber mountings of the input and output

phono connectors will need to be clipped off so that they will fit between the chassis and the subassembly brackets. These jacks should be mounted next, and the coax leads run to S_{1A} and S_{1B} , keeping the leads along the bottom corners of the chassis.

Then the two subassemblies can be mounted and connections made to the bandswitch. In addition to the connections shown in the diagram, the bandswitch terminals immediately to the left of the upper tie rod (as viewed from the front) on S_{2A} and S_{2B} should be connected together, and then to the ground terminal at the socket of the 6AK5. This grounds the inactive L_3 and L_4 coils.

As a last operation, the power leads are fished out through the mounting hole for J_3 , and connections to J_3 are made before it is mounted.

Power Supply

The converter requires 0.625 ampere at 6 volts for the heaters, and anything between 5 ma. at 45 volts to 20 ma. at 150 volts for the plate supply. This can be taken most conveniently from the car broadcast receiver by connecting two leads to an audio-output-stage socket. Plate voltage should be taken from the screen terminal. This voltage will usually be about 200, and can be dropped down to the desired value with a series resistor. A 10,000-ohm 2-watt resistor will usually be about right — at least, it will serve as a starting point for adjustment to the desired value. The hot filament and plate-supply leads, plus a ground lead, can be brought to a connector mounted on the broadcast receiver, or run in the form of a cable. Shielded wire should be used for the cable.

Adjustment

With a small antenna, such as a mobile whip, tight coupling to the antenna is essential for best signal response. It is also important in avoiding regeneration in the r.f.-amplifier stage. Therefore, especially when the antenna is a small one, it

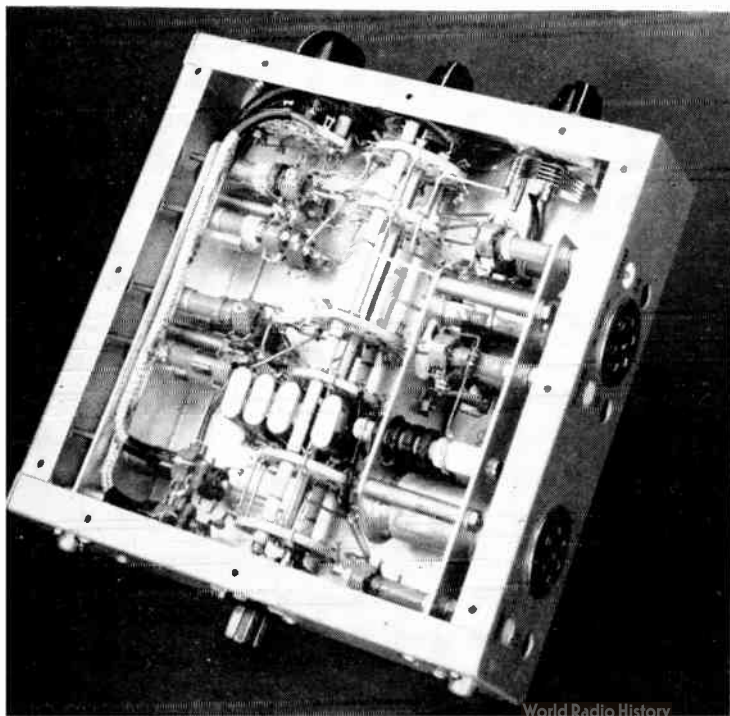
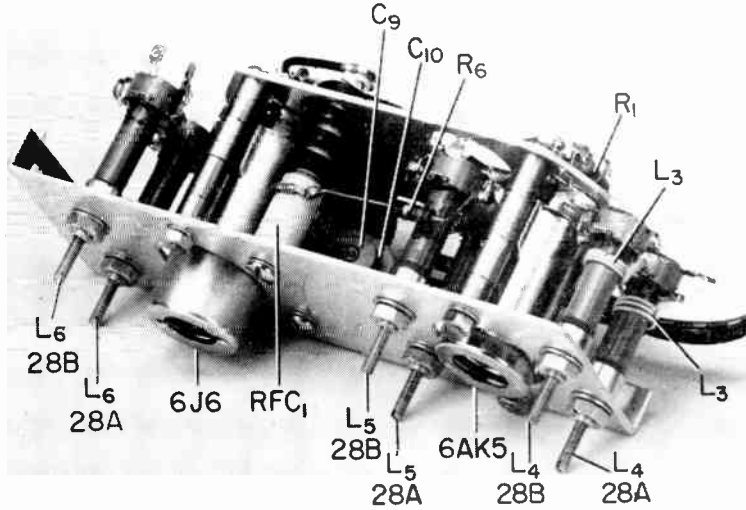

Fig. 19-6 — Space between the bandswitch index head and the front wafer is $\frac{5}{16}$ inch. Succeeding spacings between wafers, front to rear, are $\frac{1}{16}$ inch, $\frac{1}{16}$ inch, $\frac{1}{16}$ inch, and $\frac{1}{16}$ inches. The tail of the shaft is cut off close to the last wafer to provide space for J_3 at the rear, but the assembly rods extend through the rear of the chassis. Shield phono jacks at the rear are for antenna to the right, and broadcast receiver to the left. Capped holes along the right-hand side are for tube removal. The smaller ones are for 10-meter slug adjustment. Crystals, between S_{2B} and S_{2C} , left to right, are for 3.5, 7, 21, and the high end of 28 Mc. Those for 14 Mc. and the low end of 28 Mc., mounted horizontally, are hidden by the three crystals to the left.

Fig. 19-7 — The bracket for this sub-assembly is $5\frac{1}{2}$ by $17\frac{1}{8}$ inches, with $\frac{3}{8}$ -inch lips. Tube-removal holes are 1 inch in diameter. Spacing between bracket and rear plate is $1\frac{3}{8}$ inches.



should be resonant. This is usually the case in a mobile installation where the antenna must be made resonant for transmitting.

The high-frequency oscillator should be checked first, listening on a communications receiver at the oscillator frequencies listed in the table. No adjustment of the oscillator is necessary at 3.5 and 7 Mc., but at the higher frequencies the slugs of the L_6 coils must be adjusted for most stable output. Set the receiver to the desired frequency and adjust the slug until the oscillator signal is heard. To make sure that the oscillator is crystal-controlled, jar the converter. If the signal is crystal-controlled, no amount of jarring should change the frequency. If it is not crystal-controlled, the slug should be adjusted carefully until the oscillator locks in with the crystal.

The r.f. amplifier may now be lined up, band by band, by tuning in a signal from a generator or the antenna, and then adjusting the amplifier

grid and plate coils for maximum response. The grid-coil slug should be adjusted with signals near the high-frequency end of the band, and with C_3 set near minimum capacitance. The antenna coupling should then be adjusted to the point where a slight peak in a signal or background noise is heard within the range of C_3 .

When interference from local broadcasting stations is experienced, the slug of L_1 should be adjusted to minimize the strongest broadcast signal toward the low-frequency end of the broadcast band, while the slug of L_2 should be likewise adjusted for the strongest signal toward the high-frequency end of the band. These two adjustments will usually serve to attenuate most other broadcast signals in between the two extremes of frequency. However, other combinations may be advisable, depending on the frequencies of the local stations.

(Originally described in *QST*, January, 1955.)

Fig. 19-8 — The tube-socket mounting plate is $3\frac{3}{4}$ by $13\frac{1}{4}$ inches overall. The ends are rounded to clear the outer coil forms. Holes opposite the inner coil forms are $\frac{3}{4}$ inch; those clearing the r.f. chokes are $\frac{5}{8}$ inch. Small components should be kept close to the plate, so as to clear the bandswitch.

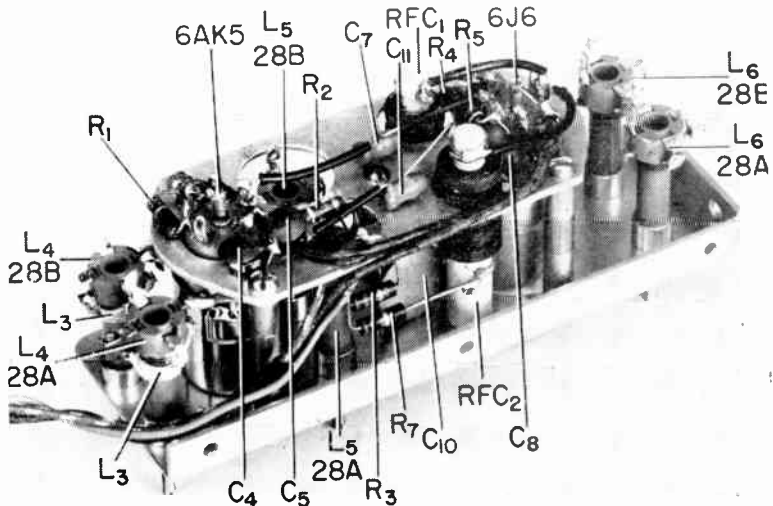

A Crystal-Controlled Converter for 50 Mc.

The 50-Mc. mobile converter shown in Figs. 19-9 through 19-13 combines simplicity with up-to-date v.h.f. design practice. Although only three tubes are used, the converter includes a stage of r.f. amplification plus dual conversion with crystal-controlled oscillators. The choice of i.f. results in a high order of image rejection. A car broadcast receiver is used as the tunable i.f. for the unit and also supplies the necessary plate power.

An antenna peaking capacitor is the only operating-type control on the converter. Four low-frequency crystals, any one of which may be plugged into the front of the unit, provide selection of 1-Mc. segments of the 6-meter range. With this arrangement, a tuning range of 1 Mc. is obtained with each full swing of the broadcast receiver tuning dial.

The circuit diagram is shown in Fig. 19-10. A 6DC6 is used as an r.f. amplifier. C_1 is the grid-circuit peaking capacitor. Output from the 6DC6 is coupled through a simple band-pass circuit, $C_5L_3C_6L_4$, to a 12AT7 mixer. The second half of the 12AT7 is operated as a crystal oscillator at 43.5 Mc. to provide injection voltage for the mixer. Thus, the i.f. output for the mixer is set by the frequency of the incoming 50-Mc. signal and will fall within the 6.5- to 10.5-Mc. range.

A second band-pass circuit, $C_3C_{10}C_{11}L_5L_6$, is connected between the plate of the mixer and the grid of a Type 6BA7 converter tube. The oscillator section of the 6BA7 uses crystals ground for 5.95, 6.95, 7.95 and 8.95 Mc. These crystals, in the order listed, provide 1-Mc. i.f. ranges (from the 6BA7) beginning at 0.55 Mc. L_7 is a slug-tuned plate coil for the converter tube.

A resistor, R_6 , is connected between the control grid of the 6BA7 and ground. Its purpose is to flatten out the response of the low-frequency (6.5 to 10.5 Mc.) coupling circuit. S_1 performs the switching necessary in shifting from 50 Mc. to

broadcast input. Heater circuits for both 6.3- and 12.6-volt are shown in Fig. 19-10.

Construction

The converter is built into a $2 \times 5 \times 7$ -inch aluminum chassis. The top cover (actually a bottom plate for the chassis, and not shown in the photographs) is a flat piece of aluminum measuring 5 to 9 inches. The extra inch of overlap on each side provides lips for fastening the converter to the bottom of the broadcast receiver by means of machine screws and metal spacers.

The subassembly is shown centered in the chassis in Figs. 19-9 and 19-11, and in two detail photographs, Figs. 19-12 and 19-13 identify the components in the subassembly. When the bracket has been bent and drilled, place it against the inside bottom surface of the chassis and mark the mounting holes in the chassis. Then place the bracket against the rear wall of the chassis and use it as a template to mark the position of the 1-inch holes that permit removal of the tubes.

The positions of J_1 , J_2 and the cable grommet may now be marked on the rear wall of the chassis and mounting holes for C_1 , S_1 and the crystal socket for Y_2 may be spotted on the front wall. Mount C_1 with the shaft hardware and with the threaded mounting foot facing toward S_1 .

When mounting components in the subassembly, orient the tube sockets in the following manner: Pins 3 and 4 of V_1 facing toward the top of the bracket; Pin 7 of V_2 , and Pins 1 and 5 of V_3 pointing toward the bottom of the bracket. One-terminal tie-point strips, held in place by the socket hardware, should be mounted at the bottom of V_1 , to the right of V_2 (as seen in Fig. 19-13) and at the top of V_3 . A 2-terminal tie-point strip should be mounted to the right of V_1 .

The $\frac{1}{2}$ -inch clearance holes for L_5 and L_6 are spaced $\frac{7}{8}$ -inch between centers and are located in between the sockets for V_2 and V_3 . A rubber grommet, mounted in the bracket just above the socket for V_3 , passes a lead between Pin 9 of the 6BA7 and the plate coil, L_7 .

Fig. 19-12 shows the socket for V_1 mounted above the 12AT7. Adjustment screws for C_5 , C_6 , C_3 and C_{16} are also visible in this view. A 3-terminal tie-point strip to the right of V_3 supports the



Fig. 19-9. The input tuning capacitor (C_1), the antenna-heater switch (S_1), and the low-frequency crystal (Y_2) are in line from left to right on the front wall of the chassis. A metal partition, mounted along the center line of the chassis, supports the tubes, the v.h.f. crystal (Y_1), and most of the r.f. components.

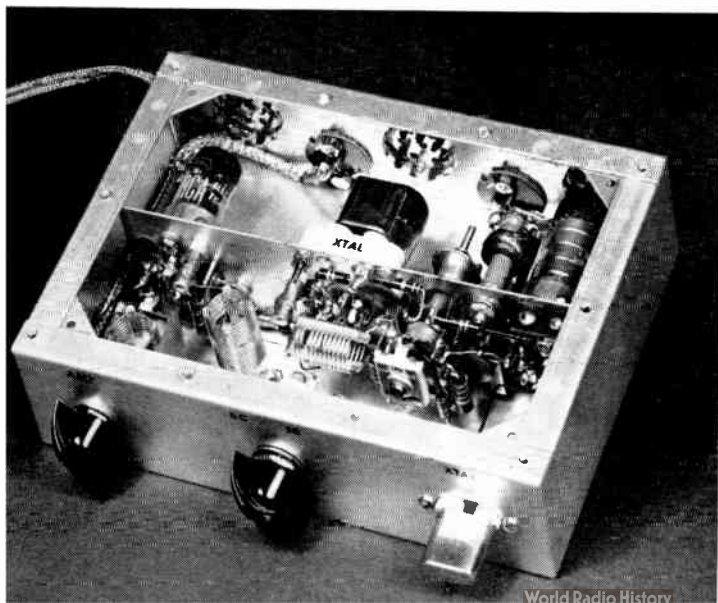

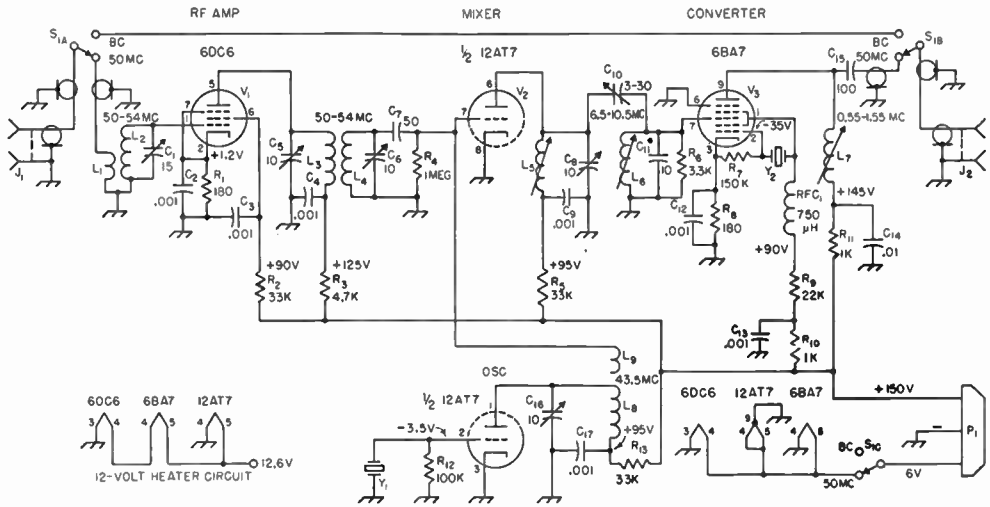

Fig. 19-10 — Circuit diagram of the 50-Mc. crystal-controlled mobile converter. All resistors $\frac{1}{2}$ watt. * Indicates a mica capacitor; all other fixed capacitors disk ceramic. Values below $0.001 \mu\text{f.}$ are in $\mu\text{f.}$

- C₁ — 15- $\mu\text{f.}$ variable (Hammarlund HF-15).
- C₅, C₆, C₇, C₁₀ — 1.5–10- $\mu\text{f.}$ tubular trimmer (Centralab 829-10).
- C₁₀ — 3–30- $\mu\text{f.}$ ceramic trimmer (National M-30).
- L₁ — $4\frac{1}{2}$ turns insulated magnet wire (20–30), close-wound over grounded end of L₂.
- L₂, L₃, L₄ — 7 turns No. 20 tinned, $\frac{1}{16}$ inch long, $\frac{1}{2}$ -inch diam. (B & W 3003). See text.
- L₅, L₆ — 9–18- $\mu\text{H.}$ slug-tuned coil (North Hills Electric 120-11).
- L₇ — 105–200- $\mu\text{H.}$ slug-tuned coil (North Hills Electric 120-11).

- L₈ — 9 turns No. 20 tinned, $\frac{1}{16}$ inch long, $\frac{1}{2}$ -inch diam. (B & W 3003).
- L₉ — 2 turns No. 20 tinned, $\frac{1}{8}$ inch long, $\frac{1}{2}$ -inch diam. (B & W 3003). See text.
- J₁, J₂ — RCA-type phono jack.
- P₁ — 3-prong male plug (Cinch-Jones P-303-CCT).
- RFC₁ — 750- $\mu\text{H.}$ r.f. choke (National R-33).
- S₁ — 3-pole 5 position (used as 3 p.d.t.) selector switch (Centralab PA-2007 or PA-5 wafer mounted on PA-300 index).
- Y₁, Y₂ — Crystals. See text (International Crystal type FA-9).

output end of C₁₅ and the associated coax lead, the grounded sides of the coaxial cable and capacitor C₁₄, and the B+ end of R₁₁.

To assure mechanical stability, the coils for the first band-pass circuit (L₃ and L₄), and those of the 43.5-Mc. oscillator (L₈ and L₉) are made up as follows: L₃L₄ is made from an 18-turn length of type 3003 Miniductor having 4 turns removed at the exact center. Do not break the support bars when removing the turns, and be sure to leave leads approximately $\frac{3}{4}$ inch long at both ends of each winding; L₈L₉ is made from a 12-turn length of Type 2003 Miniductor having the tenth turn removed (without breaking the supports), thus leaving a 9-turn coil for the oscillator plate circuit (L₈) and a 2-turn (L₉) for coupling injection voltage to the mixer grid.

When the subassembly has been completed, it may be mounted and the interchassis wiring completed. However, the alignment of the tuned circuits is more conveniently handled if the subassembly is worked on out in the open. This procedure necessitates that the input circuit, C₁L₁L₂, be mounted temporarily at one corner of the bracket (adjacent to V₁).

Testing

The converter requires 0.9 ampere at 6 volts — or 0.45 ampere at 12 volts — for the heaters,

Fig. 19-11. Connectors J₁ and J₂ are mounted in that order, from right to left, on the rear wall of the converter. Shielded power leads pass through a rubber grommet at the lower right-hand corner. One-inch holes, covered with snap-in ventilating plugs, permit the removal of tubes. A copper plate, located inside the unit at the upper right-hand corner, provides shielding between the grid and plate coils for the r.f. amplifier.

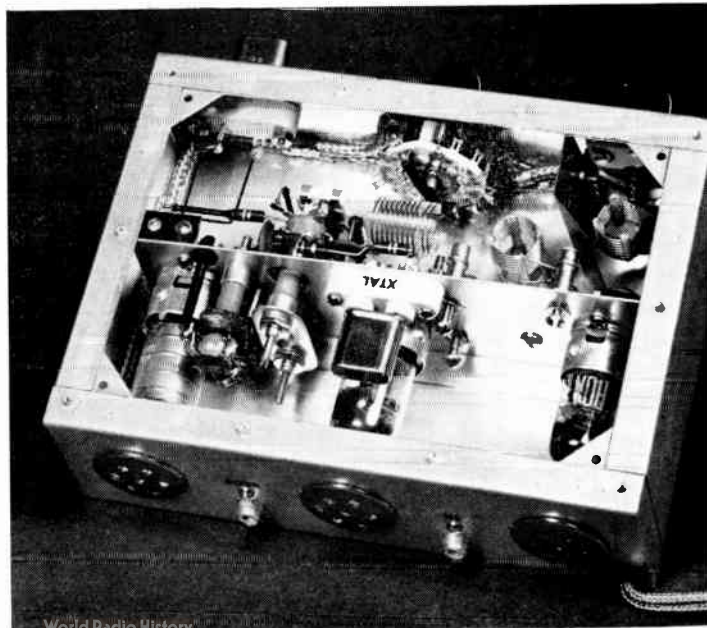

A Simple Mobile Converter for 144 Mc.

The 144-Mc. mobile converter shown in Figs. 19-14 through 19-16 may be operated from the receiver power supply. The output frequency of the converter is 1.5 Mc., permitting it to be used with an automobile broadcast receiver.

Two 12AT7 twin-triodes are used, each as a mixer-oscillator, the first converting the signal frequency to 11.4 Mc., the second working from this frequency to 1500 kc. Plate voltage for all circuits is stabilized by an 0B2 regulator tube. The sensitivity of the converter is quite good, and satisfactory image rejection is obtained through the double conversion.

Circuit Details

The first mixer has a tuned grid coil and its plate circuit is tuned to 11.4 Mc. by C_2 and L_3 . The oscillator tunes from 132.6 to 136.6 Mc. It uses the second section of the first 12AT7 and, beating with the incoming signal, produces an i.f. of 11.4 Mc. which is then capacitance coupled to the grid of the second mixer. C_5 is the band-set capacitor and C_7 is the band-spread capacitor. Stray coupling between grid pins at the socket gives adequate injection.

The second 12AT7 serves as another mixer-oscillator combination, converting the 11.4-Mc. i.f. to 1500 kc. for working into a car radio. A trap (C_3L_4) is connected in series with the coupling capacitor between the two mixer circuits. This trap is tuned to 14.4 Mc. and attenuates image response at a frequency removed from the signal frequency by 3000 kc.

The plate circuit of the mixer is tuned to 1500 kc. by L_5 , and a fixed capacitor, C_6 . A short length of coaxial cable is used between the output jack, J_2 , and the receiver.

The oscillator for the second mixer is crystal controlled at 12.9 Mc. and has its plate circuit tuned by means of C_8 and L_7 .

Construction

Figs. 19-14 and 19-16 illustrate how the converter is built into a HAMCAB (Perfect Mfg. Co.) Type A-10-A chassis-cabinet assembly.

◆
 Fig. 19-14—The chassis for the 144-Mc. converter measures $1\frac{1}{2}$ by $\frac{1}{8}$ by $6\frac{7}{8}$ inches and the panel is 5 inches square. The cover (not shown in the photograph) measures 5 by 5 by 7 inches. A National AM vernier dial, mounted on the panel, is used for tuning the band-spread capacitor, C_7 . Control knobs for C_1 and S_1 are at the bottom of the panel. L_3 , L_4 and L_5 are mounted on a small aluminum strip to the left of J_2 . J_1 is located at the front of the chassis, just to the left of C_7 . The 0B2 regulator tube is at the rear of the converter. V_1 and L_7 are located to the right of L_2 .

The photographs clearly show the arrangement of parts and the only real precautions to be observed is that of providing adequate isolation between L_7 and the rest of the coils.

A three-terminal tie-point strip, mounted to the rear of the 0B2 socket (Fig. 19-16), provides terminals for the d.c. input leads and support for R_3 . A two-terminal tie-point strip is mounted between the socket for V_2 and the front panel and is used for the support and termination of R_1 , R_2 , C_9 , C_{10} and RFC_1 . Many of the other components are mounted directly on the terminals of the slug-tuned coil forms. C_6 is mounted directly above C_7 by means of leads made with $\frac{3}{8}$ -inch copper strap.

The rear wall of the chassis (see Fig. 19-16) must be added to the commercial chassis.

Testing

Power requirements for the converter are 150 volts at 17 ma. and 6 volts at 0.6 ampere (or 12 volts at 0.3 ampere). A receiver capable of tuning to 1500 kc. should be coupled to the converter by a short length of coaxial cable and the receiver adjusted for normal operation at this frequency. If a signal generator is to be used, it is connected to the input jack, J_1 , and if a generator is not available, the converter should be coupled to a low-impedance antenna system.

If preliminary testing is to be done with noise, the converter and the receiver are turned on and the converter output coil, L_5 , adjusted until the noise level is at maximum. The low-frequency oscillator should now be adjusted by means of L_7 until a further increase in noise level is heard.

Now introduce a test signal at 146 Mc. With C_7 set at half capacitance, C_6 is adjusted until

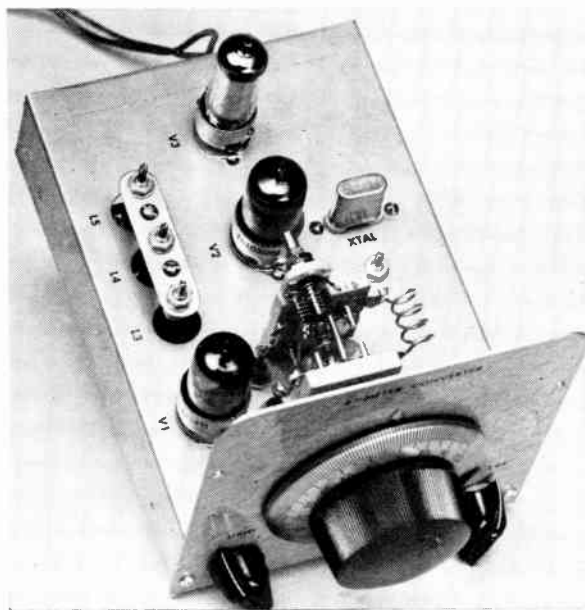

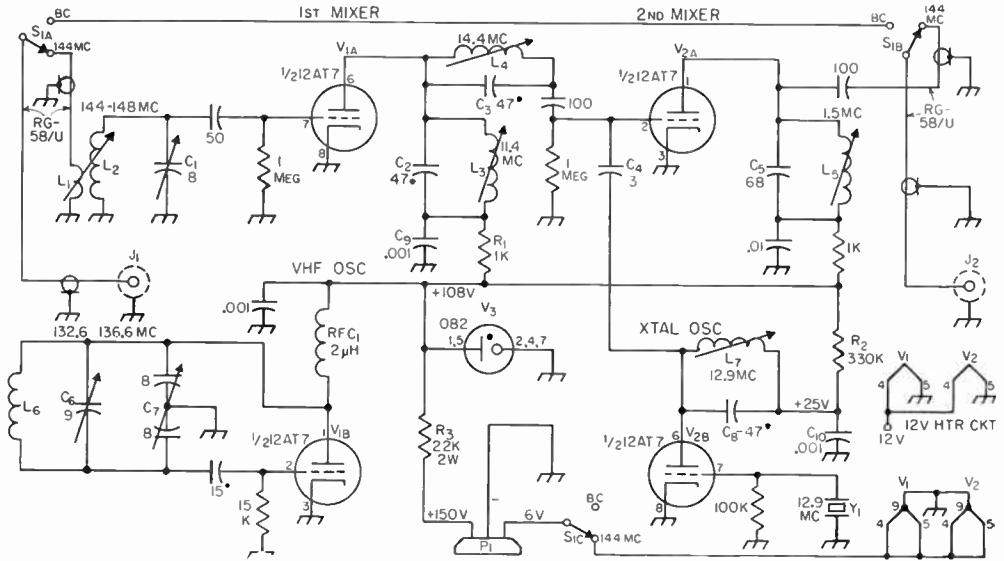

Fig. 19-15 — Schematic diagram for the 144-Mc. mobile converter. All resistors $\frac{1}{2}$ watt unless otherwise specified. Capacitor values below 0.001 μ f. are in μ mf. All 0.001 and 0.01 capacitors are disk ceramic. * Indicates a silver-mica capacitor. Other fixed capacitors are tubular ceramic.

- C₁ — Approx. 8- μ f. variable (Hammarlund HF-15 reduced to 2 stator and 1 rotor plate).
- C₆ — 9- μ f. miniature variable (Johnson 9M11).
- C₇ — 8- μ f.-per-section variable (Bud LC-1659).
- L₁ — 4 turns No. 22 enam. interwound between turns at cold end of L₂.
- L₂ — 4 $\frac{1}{2}$ turns No. 16 tinned. $\frac{3}{8}$ -inch diam., $\frac{1}{2}$ inch long.
- L₃, L₄, L₇ — Slug-tuned; inductance range 2-3 μ h. (North Hills Electric type 120-A).

- L₅ — Slug-tuned; inductance range 64-105 μ h. (North Hills Electric type 120-G).
- L₆ — 4 turns No. 16, $\frac{5}{16}$ -inch diam., $\frac{3}{4}$ -inch long.
- J₁, J₂ — RCA-type phono jack.
- P₁ — 3-prong male plug (Cinch-Jones P-303-CCT).
- RFC₁ — 2- μ h. r.f. choke (National R-60).
- S₁ — 3-pole 5-position (used as 3-p.d.t.) selector switch (Centralab PA-2007 or PA-5 wafer mounted on PA-300 index).
- Y₁ — 12.9-Mc. crystal (International type FA-9).

the test signal is heard. Check the high-frequency oscillator at this point to make sure that it is adjusted to the low-frequency side of the 144-Mc. band. C₁, L₃, L₅ and L₇ should now be tuned for maximum converter sensitivity.

The converter bandspread can be adjusted by changing the L/C ratio of the first oscillator, by altering the spacing between turns of L₆. C₆ must be reset each time the inductance of the coil is varied. The coupling between L₁ and L₂ should be adjusted for maximum response.

The 14.4-Mc. trap is adjusted by tuning to the high side of the signal frequency until the image is heard, and by then adjusting L₄ until the image response is attenuated. (Originally described in QST, Dec., 1955.)

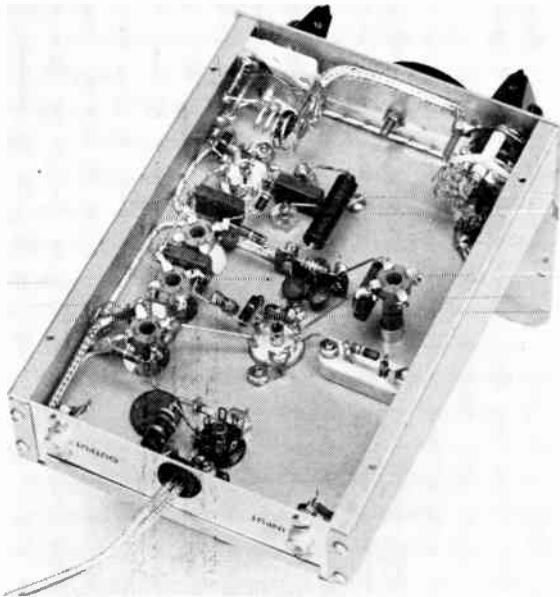

Fig. 19-16 — Holes of $\frac{5}{8}$ -inch diameter, punched in the chassis to the left of the socket for L₂, clear the forms for L₃, L₄ and L₅. Feed-through bushings, mounted in the chassis to the right of V₁, carry r.f. leads between V_{1A} and C₇. A two-terminal tie-point strip, supported by the mounting foot of C₁, is used to terminate the leads for L₁ and the grounded end of L₂. J₁, J₂ and a grommet for the d.c. input cable are located on the rear wall of the chassis.

A 6-Band Mobile R.F. Assembly

The circuit and constructional details of a 6-band transmitter for mobile work are shown in Figs. 19-17 through 19-21. Maximum power input will vary from about 30 watts with a 300-volt supply to approximately 65 watts at 600 volts.

Multiband tuners in the output circuits of the last two stages cover all 6 bands. The two tuners are ganged to a single control. The output circuit of the oscillator covers the 3.5- and 7-Mc.

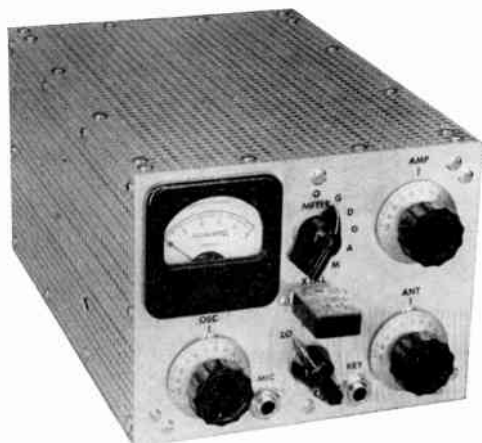

Fig. 19-17 — Front view of the 6-band mobile transmitter. The control knob for S_2 is located in between the meter and the dial for C_3 and C_4 . S_1 is directly below the crystal socket, with the knobs for C_2 and C_5 to the left and right, respectively. J_1 and J_5 are at the bottom of the $4\frac{1}{8} \times 6\frac{1}{4}$ -inch panel. The perforated aluminum cover is $9\frac{3}{8}$ inches deep and has a hole punched in the left side to permit adjustment of C_1 .

bands with a single coil. C_1 adjusts feedback for best crystal performance. C_2 may be used as an excitation control. L_2 and L_5 are v.h.f. parasitic suppressors. R_3 is important in leveling off and broadening the response of the driver output circuit. It is also an important aid in stabilizing

the last two stages. C_5 provides a tracking adjustment. S_{1A} , in the central position, grounds the screen of the 6146 while adjusting the two preceding stages, and S_{1B} selects either of two output links, L_7 for 80- and 40-meter output, and L_9 for the other bands. Loading can be adjusted by C_6 .

S_2 switches the 10-ma. meter to read plate current of each stage, grid current of either of the last two stages, or modulator plate current. R_1 and R_2 increase the meter reading to a maximum of 50 ma. Similarly, R_5 and R_6 increase the full-scale meter reading to 250 ma. J_4 is the connector for the power-supply cable, while J_3 takes a cable from the modulator unit (see Fig. 19-23). J_5 is a microphone jack with a contact for a push-to-talk circuit.

The types 6417 and 6883 are 12-volt versions of the types 5763 and 6146, respectively, and may be used without modification of the circuit.

Construction

The panel, chassis plate, partition and connector-mounting bracket are made from Alcoa 2SH-14 aluminum sheet 0.064 inch thick. The cover that houses the unit is cut from perforated aluminum sheet 0.051 inch thick. Lengths of $\frac{1}{2} \times \frac{1}{2} \times \frac{1}{16}$ -inch aluminum angle stock are used in the assembly.

The panel is $4\frac{1}{8}$ by $6\frac{1}{4}$ inches, and a rear-view sketch is shown in Fig. 19-20. Lengths of angle stock, drilled and tapped to accommodate machine screws, are fastened along the four edges of the panel, on the inside. The strips of angle must be set in from the edges of the panel by the thickness of the cover material. The angles are fastened to the back of the panel by 6-32 screws in the No. 28 holes skirting the edges of the panel. The two pieces that meet at the upper right-hand corner (rear view) must be filed out to clear the round ease of the meter. They must also be drilled to clear the No. 4 screws used to mount the instrument.

Fig. 19-18 — As seen in this top view of the mobile transmitter, J_1 is located to the right of the milliammeter, just above J_2 . L_3 is mounted on a 1-inch cone insulator to the right of S_2 , and L_4 is supported by the stator terminals of C_3 . C_3 , R_{11} and RFC_4 are grouped to the lower right of a feed-through insulator used for the plate lead of J_2 . The 6146 is mounted on the right side of the aluminum partition, and L_5 , C_4 , C_5 and RFC_5 are in line below the tube.

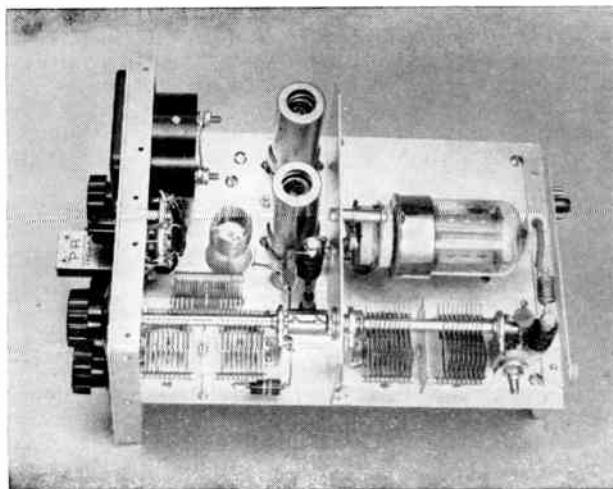

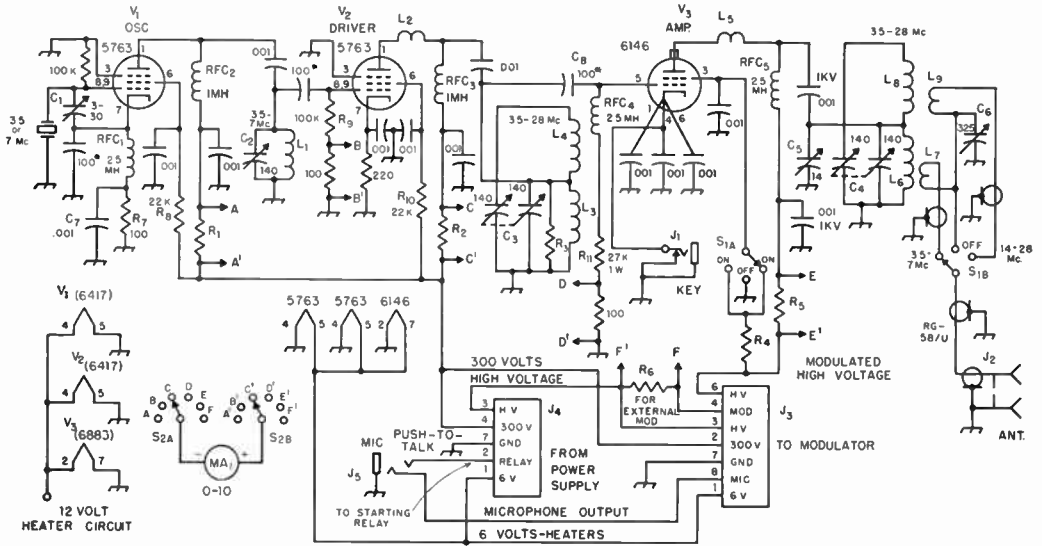

Fig. 19-19 — Wiring diagram of the six-band mobile transmitter.

- C₁ — 3-30- μ f. trimmer.
- C₂ — 110- μ f. variable (Hammarlund MC-110-S).
- C₃, C₄ — 140- μ f. per-section variable (Hammarlund MCD-140-M). (Ganged to single control.)
- C₅ — 11- μ f. midget variable (Johnson 15M11).
- C₆ — 325- μ f. variable (Hammarlund MC-325-M).
- R₁, R₂ — 5-times meter shunt; 60 inches No. 34 enam., scramble-wound on 1-megohm, 1/2-watt resistor.
- R₅, R₆ — 25-times meter shunt; three 32 1/2-inch lengths No. 34 enam., connected in parallel and scramble-wound on 1-megohm, 1/2-watt resistor.
- L₁ — 11 μ h.: 13 turns No. 24, 1 1/8 inches long, 5/8-inch diam. (B & W 3008).
- L₂ — Parasitic choke; 4 turns No. 16, 1/4-inch diam., turns spaced wire diam.
- L₃ — 6 μ h.: 20 turns No. 24, 5/8 inch long, 3/4-inch diam. (B & W 3012).
- L₄ — 2.85 μ h.: 21 turns No. 20, 1 1/8 inches long, 5/8-inch diam. (B & W 3007).
- L₅ — Parasitic choke; 6 turns No. 16, 1/4-inch diam., turns spaced wire diam.
- L₆ — 6 μ h.: 20 turns No. 20, 1 1/4 inches long, 1-inch diam. (B & W 3015).
- L₇ — 5.2 μ h.: 18 1/2 turns No. 24, 3/16 inch long, 3/4-inch diam. (B & W 3012).

- L₈ — 2.85 μ h.: 16 1/2 turns No. 20, 1 inch long, 3/4-inch diam. (B & W 3011).
 - L₉ — 0.1 μ h.: 4 turns No. 20, 1/4 inch long, 3/4-inch diam. (B & W 3011).
- NOTE: See text for additional data on L₈ and L₉.
- J₁ — Midget closed-circuit jack.
 - J₂ — Coaxial-cable connector (Amphenol 83-1R).
 - J₃ — 8-prong female chassis connector (Amphenol 78-S8).
 - J₄ — 8-prong male chassis connector (Amphenol 86-C1P8).
 - J₅ — Midget 2-circuit microphone jack.
 - MA₁ — 0-10-ma. d.c. meter (Simpson Model 127).
 - S_{1A} — 1-pole 6-position (3 used) selector switch (Centralab PA-1).
 - S_{1B} — 1-pole 11-position (3 used) selector switch (Centralab PA-11).

NOTE: S_{1A} and S_{1B} mounted on Centralab PA-300 index assembly.

S₂ — 2-pole 6-position selector switch (Centralab PA-2003 or PA-3 section on PA-300 index).

Unless otherwise specified, all resistors are 1/2 watt, and all fixed capacitors are disk ceramic. * Indicates a mica capacitor. All values below 0.001 μ f. are in μ f.

Holes marked A and B are used for fastening a 5 1/8-inch length of angle across the back of the panel to serve as a support for the front edge of the chassis plate. The holes in the angle should be located so that the top surface of the chassis plate will be 2 5/32 inches up from the bottom edge of the panel. The chassis plate must be notched so that its front edge will fit flush against the back of the panel.

The partition on which the 6146 is mounted is made from a 5 3/32 x 3-inch piece of aluminum. Bend a 3/8-inch mounting lip along the bottom edge, and then clip or round off the two top corners to clear the cover when it is slipped on.

Now fasten the chassis-supporting angle to the panel. Slip the front edge of the chassis plate over the angle, and hold it there while you slide the partition up against the back of the panel, keeping the bottom lip of the partition tight against the chassis. Then, using the panel as a template, scribe a hole in the partition that matches hole C

(Fig. 19-20) in the panel. Notch out the mounting lip of the partition to clear the ceramic base of the rear tuning capacitor when the latter is mounted.

The 6146 socket is centered on the partition with its mounting holes in a vertical line, and the grid terminal to the left as viewed from the rear of the partition. The socket is mounted on 3/4-inch spacers. A 1/2-inch clearance hole should be drilled in the partition opposite the grid terminal.

Considerable time will be saved if the disk ceramics and leads connecting to the socket are attached and soldered before the socket is mounted permanently.

The partition is placed 4 3/16 inches from the panel, and another 1/2-inch hole, lined with a rubber grommet, is drilled in the chassis, directly below the socket, to pass filament, cathode, and screen leads.

The bracket that supports J₂, J₃ and J₄ (see bottom view) should now be fabricated. Use a

3 of J_4 , and a dropping resistor connected between Terminals 3 and 4. This resistor should have a value of 50 ohms for each volt that the power supply delivers above 300 volts. Thus, a power supply delivering 350 volts should have a dropping resistance of $50 \times 50 = 2500$ ohms. The negative terminal of the supply should be connected to Terminal 7 of J_4 . Heater connections are made at Terminals 1 and 7 of J_4 .

For 3.5- and 7-Mc. output, 3.5-Mc. crystals may be used, 6-Mc. crystals are used for 27-Mc. output, and 7-Mc. crystals may be used for 14-, 21-, and 28-Mc. operation. The oscillator output circuit may be resonated at any of these crystal frequencies by adjustment of C_2 . If crystal operation appears to be sluggish, C_1 should be adjusted for maximum activity. At 300 volts, the oscillator off-resonance plate current should be about 30 ma. At resonance, the plate current should drop to about 6 ma., and the grid current to V_2 should simultaneously peak at 1.5 to 2 ma.

With excitation at the grid of V_2 , the output circuit of V_2 can be resonated by adjustment of the gang-tuning control. Resonance at 3.5 Mc. should be found with the ganged tuning condensers set well toward maximum capacitance. Resonance at 14 Mc. should occur at about 75 per cent of maximum capacitance. Resonance at 21, 7, and 28 Mc., in that order, should come at approximately 35, 20, and 10 per cent of maximum. This stage is operated straight through on 3.5 Mc., and as a doubler to 7 Mc., using a 3.5-Mc. crystal. With a 7-Mc. crystal, it is used as a doubler to 14 Mc., a tripler to 21 Mc., and as a quadrupler to 28 Mc. It is also used as a quadrupler in obtaining output at 27 Mc., using 6-Mc. crystals in the oscillator.

At resonance, the plate current to V_2 should be approximately 10 ma., and grid current to the 6146 should run 4 ma. or more on 3.5 and 7 Mc., and at least 3 ma. on the remaining bands.

Plate voltage can be applied to the amplifier by placing a jumper between Terminals 3 and 6 of J_3 . Whenever it is desired to cut off the amplifier while adjusting the preceding stages, this can be done by turning S_1 to the central position in which S_{1A} grounds the screen of the 6146.

For preliminary tracking adjustments, C_5 should first be set at minimum capacitance. Normal-grid current for the 6146 is approximately 3 ma. If it exceeds this value appreciably, excitation may be reduced by detuning C_2 in the oscillator circuit slightly to the high-frequency side of resonance.

With proper excitation applied, the meter switch should now be turned to read amplifier plate current, and the gang control adjusted to resonance as indicated by the dip in plate current. The loading should then be adjusted, by means of C_6 , so that the plate current at resonance is as close to 100 ma. as possible.

With the gang control adjusted accurately to amplifier plate-current dip, the meter should be switched to read the grid current of V_3 . If a readjustment of the gang control is necessary to obtain maximum grid current to V_3 , C_5 should be readjusted slightly, and the process repeated. If the load is not too seriously reactive, an adjustment of C_5 should be found where maximum grid current and minimum plate current in V_3 occur at the same setting of the gang control. So long as the load is very close to resistive, this same adjustment should hold for all bands. (Originally described in *QST*, Oct., 1954 and Feb., 1955.)

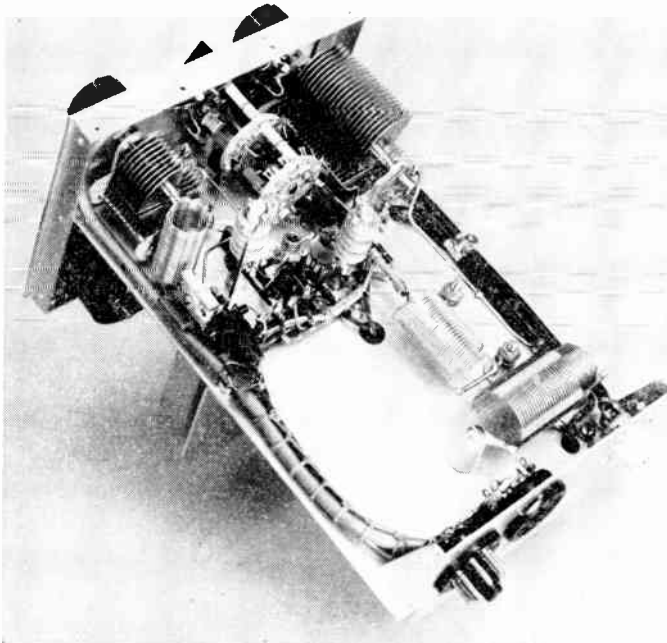

Fig. 19-21—In this bottom view of the mobile transmitter, C_2 and C_6 are to the left and the right, respectively, of S_1 . S_{1A} is the section closest to the panel. L_1 (mounted on a $\frac{1}{2}$ -inch cone insulator), C_1 and RFC_2 form a triangle to the rear of C_2 . The plate-circuit feed-through, RFC_2 , and the tube socket — all for V_2 — are to the rear of S_{1B} . L_6 and L_7 are mounted parallel with the rear of the chassis and the L_8-L_9 assembly is supported by feed-through insulator above and to the left of L_6 . J_2 , J_3 and J_4 are mounted on an aluminum bracket shown at the bottom of the photograph.

A 25-Watt Mobile Modulator

Figs. 19-22 through 19-25 show a 25-watt mobile modulator. While designed primarily for use with the preceding r.f. assembly, it is obvious that it can be used with any mobile or fixed-station transmitter whose input does not exceed 50 watts.

Fig. 19-23 shows the schematic of the modulator with an input circuit suitable for a crystal microphone. A resistance-coupled speech amplifier using a single 12AX7 drives a pair of 6L6s operating as Class AB₁ amplifiers. R_5 is the gain control. Bias for the 6L6s is developed across R_7 .

Fig. 19-21 shows the changes in the speech-amplifier circuit necessary to adapt it for use with a carbon microphone. D.c. voltage for the microphone is obtained by connecting the microphone in series with the speech-amplifier cathodes.

J_1 is used for all of the voltage leads entering and leaving the audio chassis. The pin numbering and the wiring of J_1 are arranged to correspond with those of J_3 of the r.f. unit.

Two photographs of the unit show how a large sheet of plain aluminum is bent to form a chassis measuring 1½ by 4¼ by 6¼ inches. Lengths of ½-inch angle, fastened flush with the bottom edges of the end walls, provide surfaces to which the bottom cover may be fastened.

The two 6L6 sockets are mounted in line with 2¼ inches between centers, and are centered back from the front of the chassis by a distance of 2⅞ inches. The interstage transformer, T_1 , is centered 1¾ inches back from the front of the chassis. The

12AX7 occupies the space between T_1 and the front edge of the chassis. T_2 is centered over the cut-out to the rear of the 6L6s.

The arrangement of parts shown in Fig. 19-25 is the one used when the speech amplifier is wired for crystal-microphone input. Resistors R_1 , R_2 , R_3 and R_6 (Fig. 19-23) are grouped around the 12AX7 tube socket, and C_1 is connected between

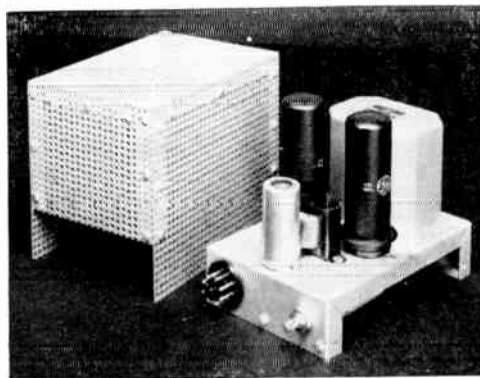

Fig. 19-22 — The modulator in the foreground is laid out on a homemade chassis measuring 1½ by 4¼ by 6¼ inches, with ½-inch lips along the sides. The interstage transformer, T_1 , is centered between the shielded 12AX7 and the 6L6s. The modulation transformer is at the rear of the chassis. J_1 and the gain control are mounted on the front wall of the unit. The sides of the chassis are enclosed by the perforated cover when the latter is slipped in place.

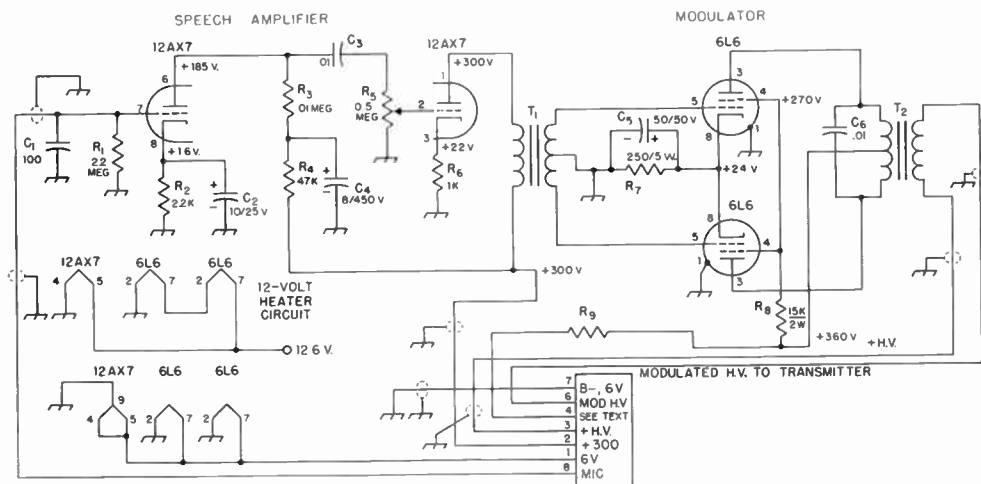

Fig. 19-23 — Circuit diagram of the 25-watt modulator wired for crystal-microphone input. Unless otherwise specified, all resistors ½ watt. R_9 — See text. J_1 — 8-prong male connector (Amphenol 86-CP8).

T_1 — Interstage audio transformer, single plate to push-pull grids, secondary-to-primary turns ratio 3 to 1 (Triad A-31X).
 T_2 — Universal modulation transformer, 30 watts (UTC S-19).

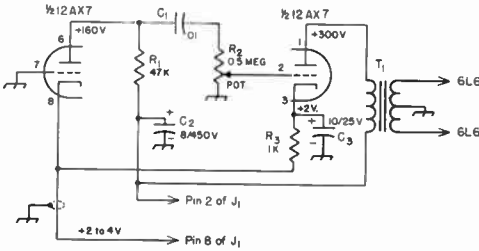

Fig. 19-24 — Circuit diagram of the carbon-microphone input circuit for the 25-watt modulator. All resistors, 1/2 watt. T₁ same as T₁ in Fig. 19-23.

Pin 7 of the socket and ground, with the shortest leads possible. The interstage coupling capacitor, C₃, mounted parallel with the front wall of the chassis, is supported by Pin 6 of the socket at one end and by the input terminal of the gain control, R₅, at the other end. A one-terminal tie-point strip, located directly above the right-hand 6L6 socket (Fig. 19-25) serves as the common connection point for R₃, R₄ and C₄. Belden type 8885 wire is used wherever shielded leads are shown in the circuit diagram.

The top view of the modulator shows the perforated cover in the background. Lengths of 1/2-inch angle, held in place by means of self-tapping screws, are run along the closed edges (inside) to hold the box together.

Testing

If the modulator is to be bench tested before it is installed in a vehicle, it is convenient to use a.c. for the heaters. In this case, the 6.3-volt transformer should be rated at not less than 2 amp. and must be connected to Terminals 1 and 7 of J₁. Plate voltage for the 12AX7 may be obtained directly from a 300-volt supply connected to Terminal 2 of J₁, or it may be taken from the 6L6 plate supply via a dropping resistor connected between Terminals 2 and 4 of J₁. If the plate supply for the 6L6s delivers 360 volts — the most desirable voltage for the tubes — the 1-watt dropping resistor should have a value of 22,000

ohms, provided the speech amplifier has been wired for crystal-microphone input. If the grounded-grid input circuit has been used, a 15,000-ohm resistor will be satisfactory. If the voltage applied to Terminal 4 of J₁ is other than 360 volts, the correct value of dropping resistance may be based on a combined plate-current flow for the 12AX7 of either 4.5 ma. (crystal-microphone input) or 6.6 ma. (carbon-microphone input).

If a 360-volt supply is connected to Terminal 4 of J₁, it is not necessary to employ R₉ of Fig. 19-23. On the other hand, if the plate supply output is in excess of 360 volts by any substantial amount, it is advisable to reduce the plate voltage for the 6L6s by means of a resistor (R₉). This resistor should have a value of 10 ohms for each volt that the power supply delivers above 360 volts.

During the bench testing of the audio circuits, it is convenient to load the secondary of T₂ with a slider-type 25-watt resistor having a value equal to the r.f. load impedance (Z_m) with which the modulator will eventually work (see Chapter 10).

The chart furnished with the universal modulation transformer should be consulted for the connections that will permit a match between the 9000-ohm plate-to-plate load of the 6L6s and the anticipated r.f. load resistance.

Methods of testing audio circuits are treated in detail in the modulator equipment chapter. However, a quick-and-easy test of this unit can be made by tapping either a speaker or a pair of headphones across a portion of a 25-watt load resistor. The resistor should be connected across Terminals 3 and 6 of J₁ and the slider should be adjusted to give reasonable output level. Of course, it is both *dangerous* and *unnecessary* to apply d.c. voltage to the secondary of T₂ during this check.

The microphone should be connected between Terminals 7 and 8 of J₁ and power applied. Figs. 19-23 and 19-24 show the approximate potentials that may be expected throughout the circuit provided that all 3 tubes are behaving properly. Plate current for the 6L6s should idle at approximately 88 ma. and should rise to 100 ma. or so with the application of voice modulation. If a milliammeter has been inserted in the plate-voltage lead external to Terminal 4 of J₁, it will register the 6L6 screen-current swing of 5 to 17 ma. as well as the plate drain.

In an actual mobile installation, the modulator unit may be separated from the r.f. assembly by any convenient distance. The cable used to connect J₁ of the modulator with J₃ of the r.f. section should be made with individually-shielded leads. (Originally described in *QST*, Nov. 1954 and Feb., 1955.)

Fig. 19-25 — Bottom view of the 25-watt modulator. A cut-out measuring 1 3/4 by 2 1/4 inches, located at the end of the chassis, provides access to the modulation transformer terminals. C₅ and R₅ are mounted on a tie-point strip at the lower left-hand corner and C₆ and R₆ are centered between the cutout and the 6L6 tube sockets. C₄ is located at the upper right-hand corner, just to the right of C₂. Component symbols refer to Fig. 19-23.

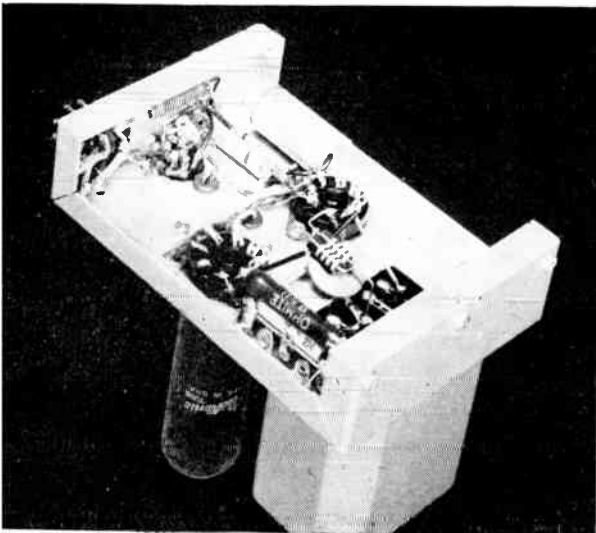

A 10-Watt 50-Mc. Mobile Transmitter

The crystal-controlled mobile transmitter shown in Figs. 19-26 through 19-30 is complete with speech amplifier and modulator circuits. The r.f. amplifier operates with a d.c. input of 10 to 12 watts, and the entire transmitter loads the car battery only slightly more than does a standard automobile broadcast receiver.

A meter-switching circuit is included and provision is made for push-to-talk control of external antenna and power relays. An inexpensive

Circuits

The oscillator-doubler section of the transmitter uses a type 12AT7 dual triode as shown in the circuit diagram, Fig. 19-28. One half of the tube, V_{1A} , operates in an overtone oscillator using a 25-Mc. crystal. The plate circuit, C_1L_1 , is resonated at 25 Mc, and output from the stage is capacitance coupled to the doubler tube, V_{1B} .

The doubler circuit is resonated at 50-Mc. by

Fig. 19-26—The 50-Mc. mobile transmitter is built into a 7 × 11 × 3-inch aluminum chassis (Premier ACH-125). S_1 on the front wall is flanked by the meter at the left and J_1 and S_2 at the right. The control shaft for C_1 is centered in between the crystal socket and the multiplier tuning control, C_2 . The amplifier tuning capacitor, C_3 , is at the lower right-hand corner directly below the output capacitor, C_4 .



vibrator-type supply rated at 300 volts and 100 ma. will power the complete transmitter.

The exciter and the audio tubes may be wired for either 6- or 12-volt operation. A 12-volt equivalent (type 6417) may be substituted for the type 5763 in the r.f. amplifier without modification of the circuit,

the parallel-tuned plate tank, C_2L_2 . Output from the doubler is capacitance coupled to the r.f. amplifier tube, V_2 .

The r.f. amplifier works straight through at 50 Mc., uses grid-leak bias and has a balanced plate circuit (C_3L_3) so that a conventional neutralizing system may be used. C_{10} is the neutralizing

Fig. 19-27—An interior view of the 50-Mc. mobile transmitter with the 7 × 11-inch bottom cover removed. As seen in this view, the r.f. sub-assembly at the right is 3 inches down from the top of the unit. The bracket supporting the audio components at the left is 4 inches down from the top edge. J_2 and J_3 are mounted on the wall to the rear of the r.f. tubes.

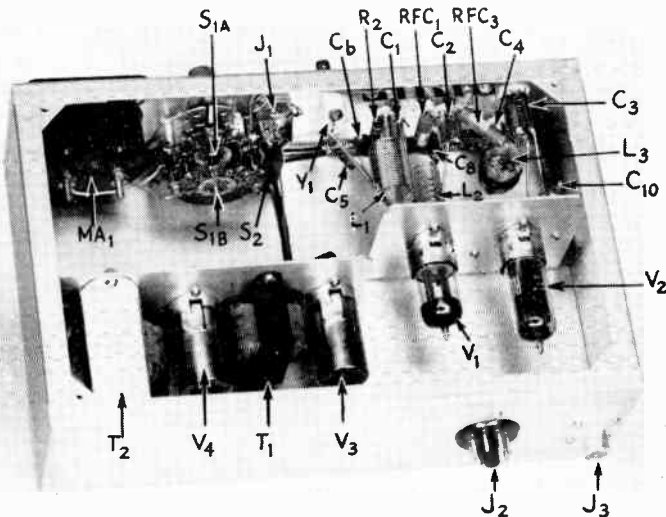

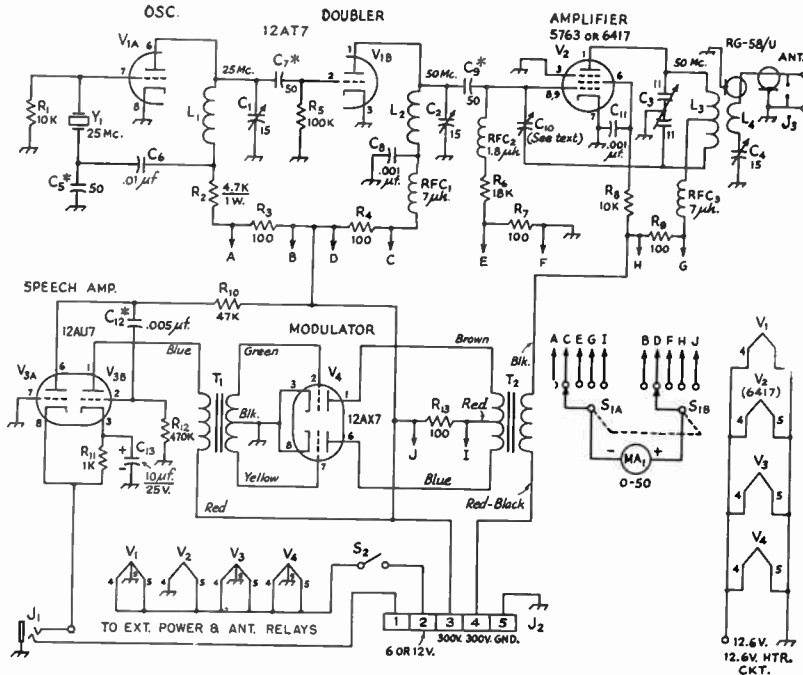

Fig. 19-28 — Schematic diagram of the 50-Mc. mobile transmitter. Capacitors below 0.001 are in $\mu\mu\text{f}$. C_{13} is an electrolytic capacitor. * Indicates a tubular ceramic. All other capacitors not identified below are disk ceramic. All resistors except R_2 are $\frac{1}{2}$ watt.

- C_1, C_2, C_4 — 15- $\mu\mu\text{f}$. midget variable (Hammarlund MAC-15).
- C_3 — 11- $\mu\mu\text{f}$.-per-section butterfly variable (Hammarlund MACBF-11).
- C_{10} — Approx. 0.4 — 5 $\mu\mu\text{f}$.: see text (Eric 532-B).
- J_1 — Three-circuit microphone jack.
- J_2 — 8-contact (5 used) male connector (Amphenol 86-RCP8).
- J_3 — Coaxial-cable connector (SO-239).
- L_1 — 2.2 μh ., 18 turns No. 20, $\frac{5}{8}$ -inch diam., $1\frac{1}{8}$ inches long (B&W 3007).
- L_2 — 0.25 μh ., 7 turns No. 18, $\frac{1}{8}$ -inch diam., $\frac{7}{8}$ inch long (B&W 3002).
- L_3 — 1.2 μh ., 12 turns No. 20, tapped at center, $\frac{5}{8}$ -inch diam., $\frac{3}{4}$ inch long (B&W 3007).

- L_4 — Output link, 3 turns No. 20 insulated wire, close-wound over center of L_3 .
- MA_1 — 0.50-ma. d.c. milliammeter (Triplett 227-T).
- RFC_1, RFC_3 — 7- μh . r.f. choke (Ohmite Z-50).
- RFC_2 — 1.8- μh . r.f. choke (Ohmite Z-114).
- S_1 — 2-pole 5-position phenolic selector switch (Centralab 1411 or 2 Type II wafers mounted on P-121 index).
- S_2 — S.p.s.t. toggle switch.
- T_1 — Driver transformer, single plate to Class B grids (Thordarson 20D76).
- T_2 — 10-watt modulation transformer, variable ratio, primary rating 70 ma., secondary rating 60 ma. (Merit A-3008).
- Y_1 — 25-Mc. crystal (International Type FA-9).

ing capacitor. Output from the amplifier is coupled to the antenna feedline via a series-tuned coupler, C_4L_4 , and the output jack, J_3 .

One half of a type 12AU7 is used in the grounded-grid input circuit of the speech amplifier. The second half of the tube, V_{3B} , operates in a Class A driver stage which is, in turn, transformer-coupler to a Class B modulator. The modulator tube, V_4 , is a type 12AX7. D.c. voltage for a s.b. carbon microphone is obtained by connecting the microphone in series with the cathodes of the 12AU7.

S_1 switches the 50-ma. meter to read plate current of the r.f. stages, grid current of the r.f. amplifier, or modulator plate current.

S_2 is the heater on-off switch. Heater circuits for both 6- and 12-volt operation are shown in Fig. 19-28. The push-to-talk contact of the microphone may be returned through J_1 to terminal No. 1 of J_2 for the control of external antenna and power relays.

Construction

Figs. 19-26, 19-27, 19-29 and 19-30 show clearly the arrangement of all components. Before the parts are mounted on the subassemblies, it is advisable to use the brackets as templates for locating and marking the bracket-mounting holes in the main chassis.

The tubular trimmer, C_{10} , used as the neutralizing capacitor has a rated minimum capacitance of 1 $\mu\mu\text{f}$. The minimum is reduced to approximately 0.4 $\mu\mu\text{f}$. (suitable for neutralizing a 5763 or 6417) by sliding the tubular stator plate out and away from the tuning-slug end until only half of the plate rests on the plastic form.

Leads between the r.f. subassembly and the panel-mounted components should be made with No. 14 tinned wire. Ordinary hookup wire is used for all other wiring except for the coaxial lead (RG-58/U) between L_4 and J_3 .

Meter shunts R_3, R_4, R_7, R_9 and R_{13} are mounted directly between sections of S_1 . A 5-terminal

◆
Fig. 19-29—The bracket for the r.f. subassembly measures $2\frac{7}{8}$ by 4 inches and has a $\frac{1}{2}$ -inch mounting lip at the bottom end. The timed wires extending away from the unit should be about $2\frac{1}{2}$ inches long, and the insulated leads at the lower left-hand corner should be approximately 15 inches long. Pin 9 of each socket faces toward the bottom of the assembly.

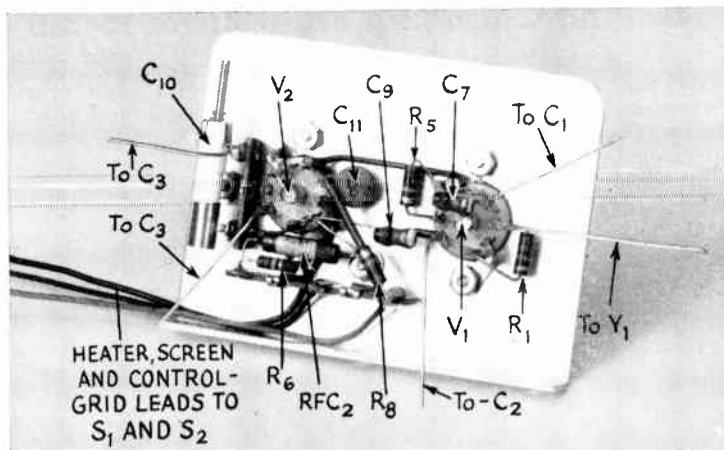

(1 terminal unused) tie-point strip, mounted above C_1 and C_2 as shown in Fig. 19-27, is used to support the coaxial-cable end of L_4 and the B+ ends of R_2 , RFC_1 and RFC_3 .

◆
Testing

A standard a.c. power supply that will deliver 300 volts at 100 ma. may be used during testing of the transmitter. Heater-current requirements are 1.65 amp. for 6-volts operation and 0.825 amp. for the 12-volt circuit. Do not connect the plate supply to the r.f. amplifier power terminal (Pin 4 of J_2) at this time. An overtone crystal ground for 25 Mc. must be placed in the crystal socket and a dummy load should be available. Five No. 44 pilot lamps connected in parallel with short leads provide a good load for testing.

To test the exciter (remember that plate power is not to be fed to the amplifier at this time), turn on the heater supply, close S_2 and switch the meter to read oscillator plate current. After a few seconds of warm-up, apply plate voltage to V_1 and, as quickly as possible, tune C_1 for minimum plate current. To repeat, perform this operation rapidly because V_{1B} runs without bias unless the oscillator is delivering output. Switch the meter across R_4 and then tune C_2 for minimum doubler-stage plate current. Now switch the meter to the amplifier grid circuit and retune C_1 and C_2 for maximum grid cur-

rent. Current readings now available should show oscillator and doubler plate currents of 10 ma. each and an amplifier grid current of 3 ma. or so.

Now, slowly rotate the amplifier plate capacitor, C_3 , through its full range while observing the grid-current reading. If the current suddenly fluctuates during the tuning of C_3 , adjust the neutralizing capacitor, C_{10} , until this effect is eliminated.

Turn off the plate supply and connect a jumper between Pins 3 and 4 of J_2 . Connect the dummy load to J_3 , adjust C_4 to minimum capacitance, switch the meter across R_9 , and then turn the plate supply on. Adjust C_3 for minimum amplifier plate current—approximately 25 ma. Simultaneously increase the capacitance of C_4 and readjust C_3 for plate-circuit resonance until the plate current is 35 to 40 ma. and the lamp load indicates maximum output.

Voice signals applied to the microphone should cause the lamp load to show increased brilliance, and the modulator plate current should rise 20 to 25 ma. above the no-signal value of 6 ma.

Either a 50-Mc. whip or a 54-inch broadcast antenna may be coupled to the transmitter in the mobile installation.

If the microphone has no push-to-talk switch, the relays may be operated by means of a s.p.s.t. toggle switch connected between J_1 and ground. (Originally described in *QST*, Dec., 1956.)

◆
Fig. 19-30—The $2\frac{7}{8} \times 6$ -inch bracket for the audio section has a $\frac{1}{2}$ -inch mounting lip along the bottom edge. Tube sockets for V_3 and V_4 are mounted with Pin 9 of each facing toward the top of the assembly. Wires for connection to B+, J_1 and S_2 should be 9 or 10 inches long.

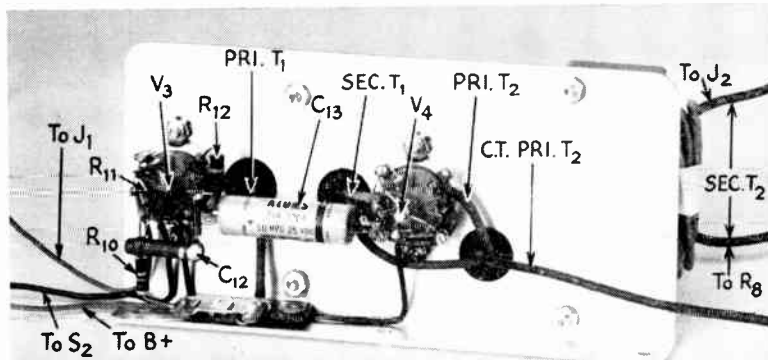

A Band-Changing Transmitter for 50 and 144 Mc.

Figs. 19-31 through 19-35 show circuits and constructional details of a compact transmitter covering the 6- and 2-meter bands. Band-changing is done entirely by the panel controls. The

circuit resonant at approximately 15 Mc. C_5 has sufficient range to tune the oscillator output circuit from 24 through 36 Mc. This circuit is tuned to 25 Mc. for 50-Mc. output from the transmitter,



Fig. 19-31 — The crystal is mounted above the meter switch, to the left of the amplifier grid-tuning control. The tuning knob for the oscillator is at the lower left-hand side of the output switch, S_1 . Controls for the output and amplifier plate circuits are at the right. The unit may be used vertically by orientating the meter. Ventilating holes should be drilled in the end used as the top.

unit is only 3 inches deep, and therefore is suitable for instrument-panel mounting.

Output on either band may be obtained using crystals in the 8-, 12-, or 25-Mc. ranges. Although it is possible to operate the 2E26 output stage at higher voltage, the unit is designed primarily to work from a 300-volt 100-ma. supply. A single 200-ma. supply should take care of both this unit and a modulator in the latter case. Changing from one band to the other is accomplished through the use of wide-range tanks in the exciter, and a multicircuit tuner in the output. Metering circuits are included.

Circuit

The circuit of the unit is shown in Fig. 19-33. Type 5763s are used in the Tri-tet oscillator and the driver stage. The oscillator has a fixed cathode

and may be tuned to either 24 or 36 Mc. for final output at 144 Mc.

The multiplier output circuit, $C_{12}L_3$, covers the range of 48 to 72 Mc., and operates as a doubler to 50 Mc., or as either a doubler or tripler (depending on the oscillator output frequency) to 72 Mc. for final output at 144 Mc. The multiplier is capacity-coupled to the 2E26 amplifier grid. This stage operates straight through at 50 Mc., and as a doubler to 144 Mc. A combination of fixed bias and grid leak is used. The value of fixed bias is not critical — 22 to 45 volts. The 22K screen resistor gives proper screen voltage over a supply-voltage range of 300 to 400 volts.

The plate tuner for the amplifier consists of a capacitor, C_{17} , and inductors L_4 and L_5 . Output from the amplifier is transferred to J_1 by a series-tuned circuit consisting of C_{18} , L_6 and S_1 . L_6 is electrically subdivided by a tap which connects to C_{18} . That portion of L_6 above the tap provides output coupling at 50 Mc., and the lower section of the coil couples to L_5 when S_1 is set for 144-Mc. operation.

Provision for connecting either a single or a pair of supplies to the transmitter is made at J_2 . If a single 300-volt pack is used for the entire unit, it is necessary to connect a jumper between Pins 3 and 5 of J_2 . With separate supplies for exciter and final, connect the 300-volt supply to Pin 3 and the amplifier supply to Pin 5. When a

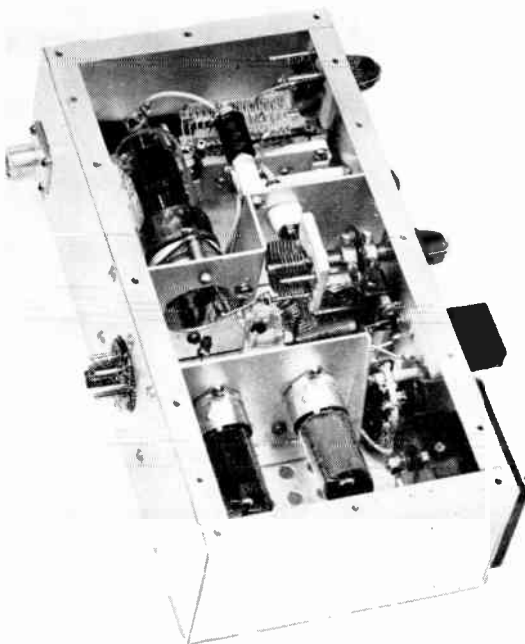

Fig. 19-32 — In this view the perforated top cover has been removed to show the completed transmitter. The input and output connectors are on the rear chassis wall and the 5763 subassembly is in the foreground, to the left of the meter switch. The Z-shaped partition supports C_{12} , RFC4 and the 2E26. C_{12} is mounted on a feed-through bushing. The oscillator tuning capacitor, C_5 , is panel-mounted directly below C_{12} . The output switch, S_1 , is partially hidden by the Z-shaped plate. The multicircuit tuner is at the upper end of the chassis, just below the link tuning condenser, C_{18} .

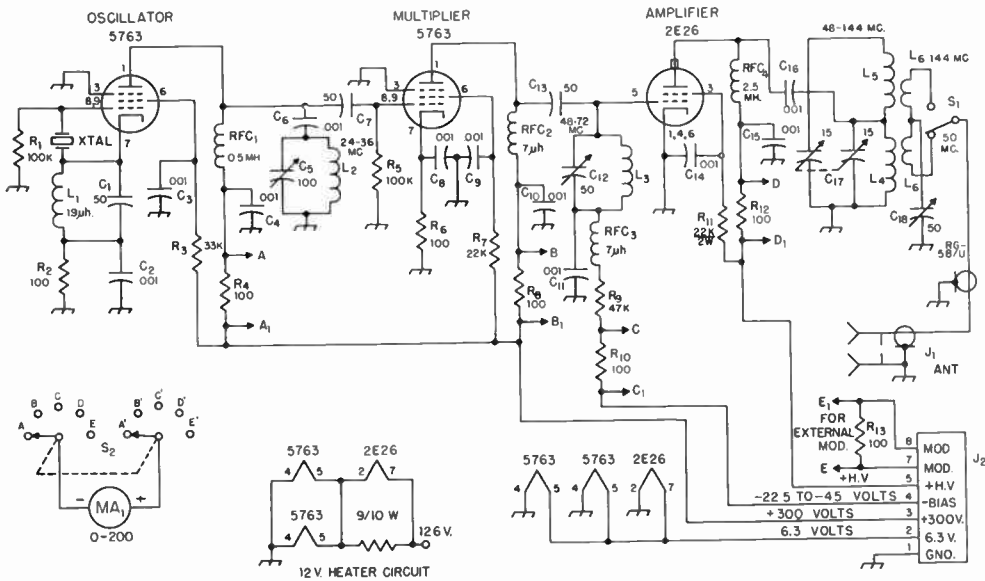

Fig. 19-33 — Circuit diagram of the v.h.f. mobile transmitter. Unless otherwise specified, all resistors $\frac{1}{2}$ watt. Values below $0.001 \mu\text{f}$. are in μm f.

- C₅ — 100- μm f. variable (Hammarlund HF-100).
- C₁₂, C₁₅ — 50- μm f. variable (Hammarlund HF-50).
- C₁₇ — 15- μm f.-per-section variable (Hammarlund HF1-15-X).
- L₁ — 1.9 μh ., 34 turns No. 22 enam., $\frac{1}{4}$ -inch diam., close-wound.
- L₂ — 0.44 μh ., 6 turns No. 20 tinned, $\frac{1}{2}$ -inch diam., $\frac{3}{8}$ inch long (B & W 3003).
- L₃ — 0.155 μh ., 3 turns No. 18 tinned, $\frac{1}{2}$ -inch diam., $\frac{3}{8}$ inch long (B & W 3002).

- L₄ — 0.36 μh . (see text).
- L₅ — 0.2 μh . (see text).
- L₆ — See text.
- J₁ — Amphenol coaxial connector.
- J₂ — 8-prong male connector.
- RFC₁ — National type R-50 r.f. choke.
- RFC₂, RFC₃ — Ohmite type Z-50 r.f. choke.
- RFC₄ — National type R-100S r.f. choke.
- S₁, S₂ — 2-pole 6-position miniature selector switch. S₁ used as s.p.d.t. (Centralab PA-2003).

modulator is connected to the transmitter, connect the secondary of the modulation transformer between Pins 5 and 8 of J₂, connect +h.v. to the 2E26 to Pin 8, and then return the +h.v. lead of the modulation-transformer primary to Pin 7.

Construction

A 3 × 5 × 10-inch aluminum chassis is used as the housing for the transmitter. The construction is made easier through the use of subassemblies. Fig. 19-34 is a view of the oscillator-multiplier section. The bracket supporting the components has $\frac{3}{8}$ -inch lips along the right and bottom edges for fastening to the chassis.

Fig. 19-32 shows a Z-shaped partition spanning the chassis. This can be made and installed most easily in two pieces overlapping and fastened together at the center. The height is made to fit the chassis depth. In Fig. 19-32, the segment lengths, from left to right, are 2 $\frac{1}{2}$, 1 $\frac{1}{8}$, and 2 $\frac{1}{2}$ inches. Lips are bent at the ends and along the bottom for fastening to the chassis. A 1 $\frac{1}{4}$ -inch

hole is punched in the center of the segment on which the 2E26 is mounted, while a small feed-through bushing (Millen 32100) is set in the other segment. Position this bushing so that C₁₂, which is mounted on it, will be at the right level, and clear of the partition segment to the rear. The 2E26 socket is mounted on $\frac{5}{8}$ -inch spacers. Prongs 1, 2, 4, 6 and 8, and the screen bypass, C₉, should be returned directly to ground on the socket side of the partition. A 2-terminal tie point to the rear of the socket supports the heater lead and the h.v. end of the screen resistor, R₁₁.

Fig. 19-34 — This subassembly measures 2 $\frac{1}{16}$ by 3 $\frac{1}{2}$ inches and supports most of the components for the exciter stages. C₁₂, with one end floating free, is at the upper right-hand corner. The wire leaders at the bottom of the plate connect to the oscillator tank, meter switch and power connector, as shown by Fig. 19-33.

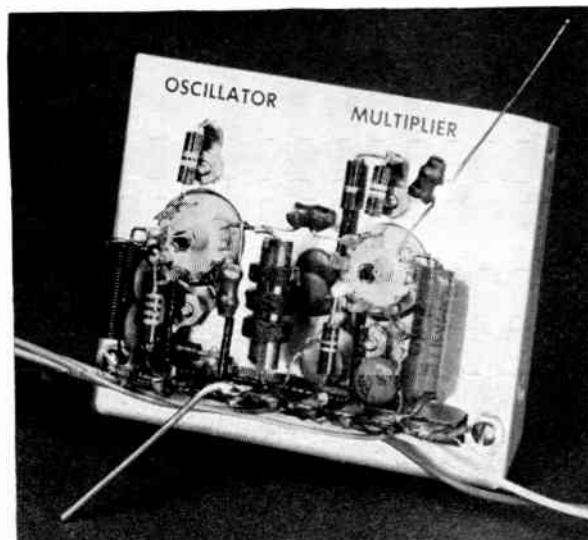

Voltage and Current Chart for the V.H.F. Mobile Transmitter												
Oscillator				Multiplier				Amplifier				
Crystal Freq., Mc.	E_g	I_p , Ma.	Freq., Mc.	E_g	E_o	I_p , Ma.	Freq., Mc.	E_g	I_g , Ma.	E_o	I_p , Ma.	Freq., Mc.
8.3	210	20	25	-80	210	25	50	-190	4	135	45	50
12.5	235	15	"	-120	215	27	"	-210	4.5	120	"	"
25.0	210	20	"	-60	240	25	"	-185	4	145	"	"
8.0	210	20	24	-85	250	25	72	-155	3.2	170	50	144
12.0	220	16	24	-140	255	27	"	-190	4	155	47	"
"	225	18	36	-115	245	"	"	-215	4.5	150	"	"
24.0	210	21	24	-65	250	"	"	-140	3	180	50	"

inches from same end.

Testing

For 50-Mc. operation, the crystal frequency must lie within one of the following ranges: 8.333 to 9.0 Mc.; 12.5 to 13.5 Mc.; 25.0 to 27.0 Mc. With a small B battery for fixed bias and a 300-volt supply connected to the exciter, but not the amplifier, tuning of the exciter at 50 Mc. requires only that the oscillator and the multiplier be reso-

In constructing the multicircuit tuner, first reduce the 3006 B & W Miniductor to a total of 14 1/4 turns. Without breaking the supporting bars, clip the winding at points that will leave 5 full turns at one end and 3 1/4 turns at the opposite end. The 6 turns left intact between end windings are used as the output coupling inductance, L_6 . Short leads of No. 16 wire should now be soldered to the free ends of the three windings. Also, solder a short lead 1 1/4 turns in from the 144-Mc. end of the coupling coil. This should place the tap at the top of the coil when it is mounted.

In mounting parts on the chassis, center J_2 on the rear wall 1 1/4 inches from the exciter end of the chassis, and J_1 in the lower corner of the amplifier end. On the panel side, the shafts for C_{17} and C_{18} are 1 inch from the right end. S_1 is centered 2 7/8 inches from the right end, while the controls for C_5 and C_{12} are 4 3/4 inches in. A panel bearing is needed for C_{12} , which is fitted with an insulating shaft coupling. The remaining two controls are 6 5/8 inches from the right-hand end. The meter is at the left-hand end.

The subassemblies may now be positioned while the mounting holes are marked. The bracket for the 5763s is placed 3 1/4 inches from the left-hand end of the chassis, while the rear end of the Z-shaped partition for 2E26 comes at 5 1/8

nated at 25 and 50 Mc. respectively.

Before testing the amplifier, turn the supply off and connect a jumper between Pins 3 and 5 of J_2 , and connect a 115-volt 10-watt lamp to the output connector. S_1 should be set at the 50-Mc. position. Apply power and resonate C_{17} , indicated by a dip in plate current. This should come well toward minimum capacitance. Set C_{18} near full capacitance and retune C_{17} for resonance. (The amplifier data in the chart were taken with the dummy load. In operation, the currents will depend upon loading.) If biasing voltages are checked, use a v.t.v.m., or a general-purpose test instrument with a radio-frequency choke inductance of at least 1 mh. connected in series.

In tuning up for 144-Mc. output, work with the exciter stages only at first, using a crystal in any one of the following frequency ranges: 8.0 to 8.222 Mc.; 12.0 to 12.333 Mc.; 24 to 24.666 Mc. If a 12-Mc. crystal is selected, the oscillator may be tuned to either 24 or 36 Mc. In either case, the multiplier must be tuned to 72 Mc. by C_{12} . The oscillator is always tuned to 24 Mc. with crystals in the 8- and 24-Mc. ranges.

Fig. 19-35 shows the circuit of an appropriate modulator.

(R.f. section originally described in *QST*, Nov., 1953.)

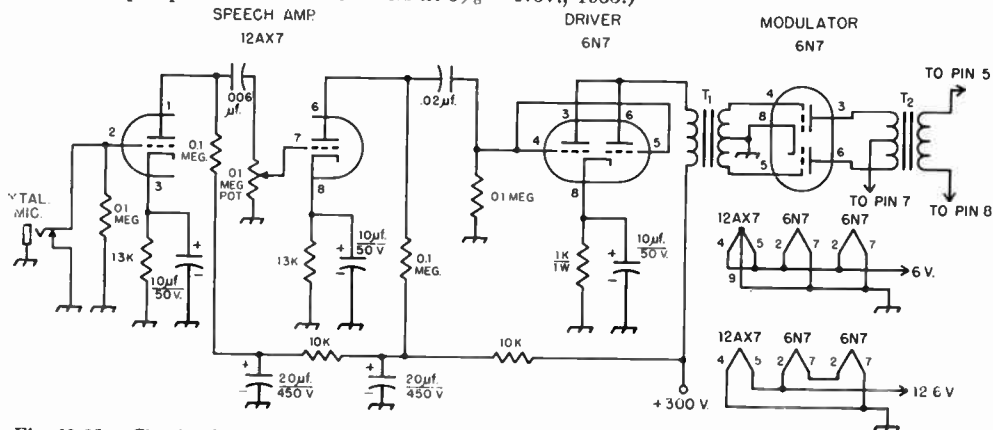

Fig. 19-35 — Circuit of a modulator for the 50- and 144-Mc. mobile transmitter. Pin numbers on modulation transformer leads refer to J_2 in Fig. 19-33.

- T_1 — Driver transformer; parallel 6N7 to Class B 6N7 grids (Stancor A-1702).
- T_2 — Class B modulation transformer (Stancor A-3815; 5000-ohm tap).

The Mobile Antenna

For mobile operation in the range between 1.8 and 30 Mc., the vertical whip antenna is almost universally used. Since longer whips present mechanical difficulties, the length is usually limited to a dimension that will resonate as a quarter-wave antenna in the 10-meter band. The car body serves as the ground connection. This antenna length is approximately 8 feet.



Fig. 19-36 — The quarter-wave whip at resonance will show a pure resistance at the feed point X.

With the whip length adjusted to resonance in the 10-meter band, the impedance at the feed point, X, Fig. 19-36, will appear as a pure resistance at the resonant frequency. This resistance will be composed almost entirely of radiation resistance (see index), and the efficiency will be high. However, at frequencies lower than the resonant frequency, the antenna will show an increasingly large capacitive reactance and a decreasingly small radiation resistance.

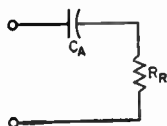

Fig. 19-37 — At frequencies below the resonant frequency, the whip antenna will show capacitive reactance as well as resistance. R_R is the radiation resistance, and C_A represents the capacitive reactance.

The equivalent circuit is shown in Fig. 19-37. For the average 8-ft. whip, the reactance of the capacitance, C_A , may range from about 150 ohms at 21 Mc. to as high as 8000 ohms at 1.8 Mc., while the radiation resistance, R_R , varies from about 15 ohms at 21 Mc. to as low as 0.1 ohm at 1.8 Mc. Since the resistance is low, considerable current must flow in the circuit if any appreciable power is to be dissipated as radiation in the resistance. Yet it is apparent that little current can be made to flow in the circuit so long as the comparatively high series reactance remains.



Fig. 19-38 — The capacitive reactance at frequencies lower than the resonant frequency of the whip can be canceled out by adding an equivalent inductive reactance in the form of a loading coil in series with the antenna.

Eliminating Reactance

The capacitive reactance can be canceled out by connecting an equivalent inductive reactance, L_L , in series, as shown in Fig. 19-38, thus tuning the system to resonance.

Unfortunately, all coils have resistance, and this resistance will be added in series, as indicated at R_C in Fig. 19-39. While a large coil may radiate some energy, thus adding to the radiation resistance, the latter will usually be negligible compared to the loss resistance introduced. However, adding the coil makes it possible to feed power to the circuit.

Ground Loss

Another element in the circuit dissipating power is the ground-loss resistance. Fundamentally, this is related to the nature of the soil in the area under the antenna. Little information

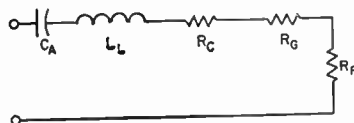

Fig. 19-39 — Equivalent circuit of a loaded whip antenna. C_A represents the capacitive reactance of the antenna, L_L an equivalent inductive reactance. R_C is the loading-coil resistance, R_G the ground-loss resistance, and R_R the radiation resistance.

is available on the values of resistance to be expected in practice, but some measurements have shown that it may amount to as much as 10 or 12 ohms at 4 Mc. At the lower frequencies, it may constitute the major resistance in the circuit.

Fig. 19-39 shows the circuit including all of the elements mentioned above. Assuming C_A lossless and the loss resistance of the coil to be represented by R_C , it is seen that the power output of the transmitter is divided among three resistances — R_C , the coil resistance; R_G , the ground-loss resistance; and R_R , the radiation resistance. Only the power dissipated in R_R is radiated. The power

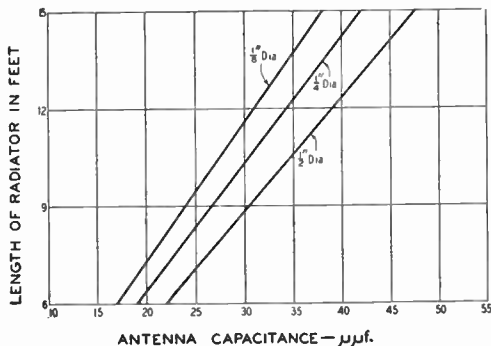

Fig. 19-40 — Graph showing the approximate capacitance of short vertical antennas for various diameters and lengths. These values should be approximately halved for a center-loaded antenna.

Approximate Values for 8-ft. Mobile Whip						
Base Loading						
f_{kc}	Loading Luh.	R_C (Q50) Ohms	R_C (Q300) Ohms	R_R Ohms	Feed R^* Ohms	Matching Luh.*
1800	345	77	13	0.1	23	3
3500	77	37	6.1	0.35	16	1.2
7200	20	18	3	1.35	15	0.6
14,200	4.5	7.7	1.3	5.7	12	0.28
21,250	1.25	3.4	0.5	11.8	16	0.28
29,000	36	0.23

Center Loading						
f_{kc}	Loading Luh.	R_C (Q50) Ohms	R_C (Q300) Ohms	R_R Ohms	Feed R^* Ohms	Matching Luh.*
1800	700	158	23	0.2	34	3.7
3800	150	72	12	0.8	22	1.4
7200	40	36	6	3	19	0.7
14,200	8.6	15	2.5	11	19	0.35
21,250	2.5	6.6	1.1	27	29	0.29

R_C = Loading-coil resistance; R_R = Radiation resistance.
 * Assuming loading coil $Q = 300$, and including estimated ground-loss resistance.
 Suggested coil dimensions for the required loading inductances are shown in a following table.

developed in R_C and R_R ; is dissipated in heat. Therefore, it is important that the latter two resistances be minimized.

MINIMIZING LOSSES

There is little that can be done about the nature of the soil. However, poor electrical contact between large surfaces of the car body, and especially between the point where the feed line is grounded and the rest of the body, can add materially to the ground-loss resistance. For example, the feed line, which should be grounded as close to the base of the antenna as possible, may be connected to the bumper, while the bumper may have poor contact with the rest of the body because of rust or paint.

Loading Coils

The accompanying table shows the approximate loading-coil inductance required for the various bands. The graph of Fig. 19-40 shows the approximate capacitance of whip antennas of various average diameters and lengths. For 1.8, 4 and 7 Mc., the loading-coil inductance required (when the loading coil is at the base) will be approximately the inductance required to resonate in the desired band with the whip capacitance taken from the graph. For 14 and 21 Mc., this rough calculation will give more than the required inductance, but it will serve as a starting point for final experimental adjustment that must always be made.

Also shown in the table are approximate values of radiation resistance to be expected with an

8-ft. whip, and the resistances of loading coils — one group having a Q of 50, the other a Q of 300. A comparison of radiation and coil resistances will show the importance of reducing the coil resistance to a minimum, especially on the three lower-frequency bands.

To minimize loading-coil loss, the coil should have a high ratio of reactance to resistance, i.e., high Q . A 4-Mc. loading coil wound with small wire on a small-diameter solid form of poor quality, and enclosed in a metal protector, may have a Q as low as 50, with a resistance of 50 ohms or more. High- Q coils require a large conductor, "air-wound" construction, turns spaced, the best insulating material available, a diameter not less than half the length of the coil (not always mechanically feasible), and a minimum of metal in the field. Such a coil for 4 Mc. may show a Q of 300 or more, with a resistance of 12 ohms or less. This reduction in loading-coil resistance may be equivalent to increasing the transmitter power by 3 times or more. Most low-loss transmitter plug-in coils of the 100-watt size or larger, commercially produced, show a Q of this order. Where larger inductance values are required, lengths of low-loss space-wound coils are available.

Suggested Loading-Coil Dimensions					
Req'd Luh.	Turns	Wire Size	Diam. In.	Length In.	Form or B & W Type
700	190	22	3	10	Polystyrene
345	135	18	3	10	Polystyrene
150	100	16	2½	10	Polystyrene
77	75	14	2½	10	Polystyrene
77	29	12	5	4¼	160T
40	28	16	2½	2	80B less 7 t.
40	34	12	2½	4¼	80T
20	17	16	2½	1¼	80B less 18 t.
20	22	12	2½	2¾	80T less 12 t.
8.6	16	14	2	2	40B less 4 t.
8.6	15	12	2½	3	40T less 5 t.
4.5	10	14	2	1¼	40B less 10 t.
4.5	12	12	2½	4	40T
2.5	8	12	2	2	15B
2.5	8	6	2¾	4¼	15T
1.25	6	12	1¾	2	10B
1.25	6	6	2¾	4¼	10T

Center Loading

The radiation resistance of the whip can be approximately doubled by placing the loading coil at the center of the whip, rather than at the base, as shown in Fig. 19-41. (The optimum position varies with ground resistance. The center is optimum for average ground resistance.) However, the inductance of the loading coil must be



Fig. 19-41 — Placing the loading coil at the center of the whip antenna, instead of at the base, increases the radiation resistance, although a larger coil must be used.

approximately doubled over the value required at the base to tune the system to resonance. For a coil of the same Q , the coil resistance will also be doubled. But, even if this is the case, center loading represents a gain in antenna efficiency, especially at the lower frequencies. This is because the ground-loss resistance remains the same, and the increased radiation resistance becomes a larger portion of the total circuit resistance, even though the coil resistance also increases. However, as turns are added to a loading coil (other factors being equal) the inductance (and therefore the reactance) increases at a greater rate than the resistance, and the larger coil will usually have a higher Q .

Top Loading Capacitance

Since the coil resistance varies with the inductance of the loading coil, the coil resistance can be reduced by reducing the number of turns. This can be done, while still maintaining resonance, by adding capacitance to the portion of the antenna above the coil. This capacitance can be provided by attaching a capacitive surface as high up on the antenna as is mechanically feasible. Capacitive "hats," as they are usually

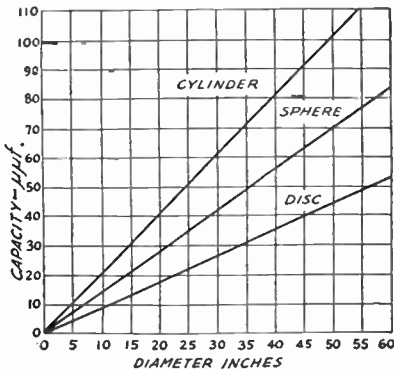

Fig. 19-42 — Capacitances of spheres, disks and cylinders in free space. These values are approximately those to be expected when used with top-loaded whip antennas. The cylinder length is assumed to be equal to its diameter.

called, may consist of a light-weight metal ball, cylinder, disk, or wheel structure as shown in Fig. 19-43. Fig. 19-42 shows the approximate added capacitance to be expected from top-loading devices of various forms and dimensions. This should be added to the capacitance of the whip above the loading coil (from Fig. 19-40) in determining the approximate inductance of the loading coil.

When center loading is used, the amount of capacitance to be added to permit the use of the same loading inductance required for base loading is not great, and should be seriously considered, since the total gain made by moving the coil to the center of the antenna may be quite marked.

Tuning the Band

Especially at the lower frequencies, where the resistance in the circuit is low compared to the coil reactance, the antenna will represent a very high- Q circuit, making it necessary to retune for relatively small changes in frequency. While many methods have been devised for tuning the whip over a band, one of the simplest and most efficient is shown in the sketches of Figs. 19-44 and 19-45, and the photograph of Fig. 19-46. In this case, a standard B & W plug-in coil is used as the loading coil. A length of large-diameter



Fig. 19-43 — The top-loaded 4-Mc. antenna used by W6SCX. The loading coil is a B & W transmitting coil. The coil can be tuned by the variable link which is connected in series with the two halves of the coil.

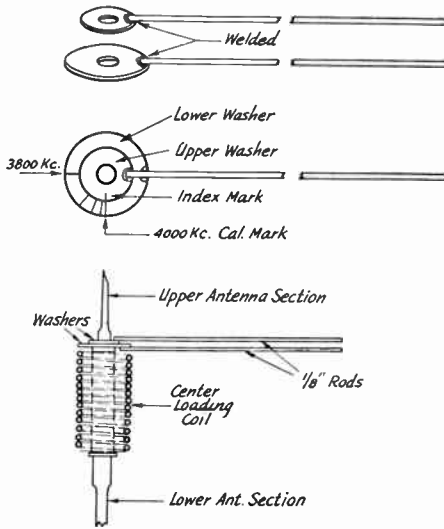

Fig. 19-44 — Details of rod construction. Dimensions can be varied to suit the whip diameter and the builder's convenience. Adjustment of rod lengths is described in the text.

polystyrene rod is drilled and tapped to fit between the upper and lower sections of the antenna. The assembly also serves to clamp a pair of metal brackets on each side of the polystyrene block that serve both as support and connections to the loading-coil jack bar.

A 1/8-inch steel rod, about 15 inches long, is brazed to each of two large-diameter washers with holes to pass the threaded end of the upper

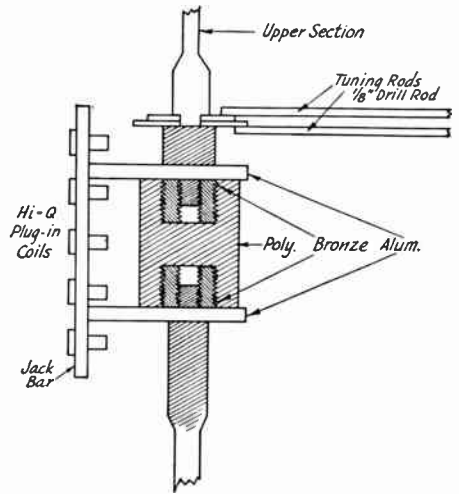

Fig. 19-45 — Construction details of the mounting for the rods and plug-in coil.

section. The rods form a loading capacitance that varies as the upper rod is swung away from the lower one, the latter being stationary. Enough variation in tuning can be obtained to cover the 80-meter band. Fig. 19-44 shows the top washer slightly smaller to facilitate marking a frequency scale on the stationary washer, after the upper washer has been marked with an index. After the movable rod has been set, it is clamped in position by tightening up the upper antenna section. (Original description appeared in *QST*, September, 1953.)

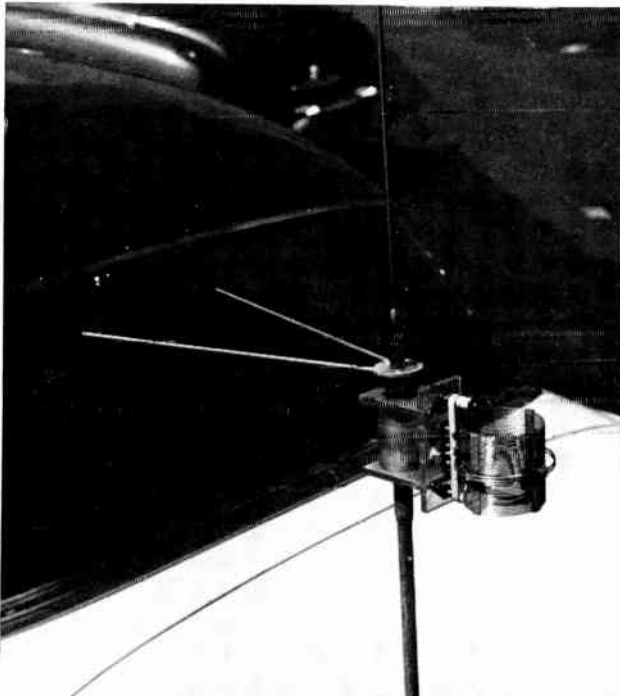

Fig. 19-46 — WBAUN's adjustable capacity hat for tuning the whip antenna over a band. The coil is a B & W type B 160-meter coil, with a turn or two removed. Spreading the rods apart increases the capacitance. This simple top loader has sufficient capacitance to permit the use of approximately the same loading-coil inductance at the center of the antenna as would normally be required for base loading.

● FEEDING THE ANTENNA

It is usually found most convenient to feed the whip antenna with coax line. Unless very low- Q loading coils are used, the feed-point impedance will always be appreciably lower than 52 ohms — the characteristic impedance of the commonly-used coax line, RG-8/U or RG-58/U. Since the length of the transmission line will seldom exceed 10 ft., the losses involved will be negligible, even at 29 Mc., with a fairly-high s.w.r. However, unless a line of this length is made reasonably flat, difficulty may be encountered in obtaining sufficient coupling with a link to load the transmitter output stage.

One method of obtaining a match is shown in Fig. 19-47. A small inductance, L_M , is inserted at

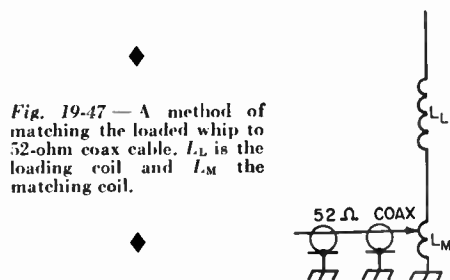

Fig. 19-47 — A method of matching the loaded whip to 52-ohm coax cable. L_L is the loading coil and L_M the matching coil.

the base of the antenna, the loading-coil inductance being reduced correspondingly to maintain resonance. The line is then tapped on the coil at a point where the desired loading is obtained. The table (page 472) shows the approximate inductance to be used between the line tap and ground. It is advisable to make the experimental matching coil larger than the value shown, so that there will be provision for varying either side of the proper position. The matching coil can also be of the plug-in type for changing bands.

Adjustment

For operation in the bands from 29 to 1.8 Mc., the whip should first be resonated at 29 Mc. with the matching coil inserted, but the line disconnected, using a grid-dip oscillator coupled to the matching coil. Then the line should be attached, and the tap varied to give proper loading, using a link at the transmitter end of the line whose reactance is approximately 52 ohms at the operating frequency, tightly coupled to the output tank circuit. After the proper position for the tap has been found, it may be necessary to readjust the antenna length slightly for resonance. This can be checked on a field-strength meter several feet away from the car.

The same procedure should be followed for each of the other bands, first resonating, with the g.d.o. coupled to the matching coil, by adjusting the loading coil.

After the position of the matching tap has been found, the size of the matching coil can be reduced to only that portion between the tap and ground, if desired. If turns are removed here, it

will be necessary to reresonate with the loading coil.

If an entirely flat line is desired, a s.w.r. indicator should be used while adjusting the line tap. With a good match, it should not be necessary to readjust for resonance after the line tap has been set.

It should be emphasized that the figures shown in the table are only approximate and may be altered considerably depending on the type of car on which the antenna is mounted and the spot at which the antenna is placed.

● ANTENNAS FOR 50 AND 144 MC.

A common type of antenna employed for mobile operation on 50 and 144 Mc. is the quarter-wave radiator which is fed with a coaxial line. The antenna, which may be a flexible telescoping "fish pole," is mounted in any of several places on the car. Quite a good match may be obtained by this method with the 50-ohm coaxial line now available; however, it is well to provide some means of tuning the system, so that all variables can be taken care of. The simplest tuning arrangement consists of a variable capacitor connected between the low side of the transmitter coupling coil and ground, as shown in Fig. 19-48. This capacitor should have a maximum capacitance of 75 to 100 $\mu\mu\text{f.}$ for 50 Mc., and should be adjusted for maximum loading with the least coupling to the transmitter. Some

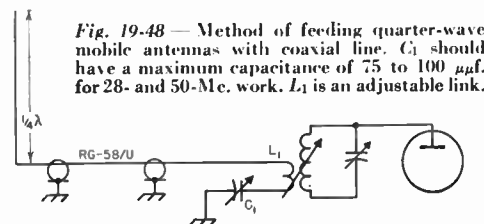

Fig. 19-48 — Method of feeding quarter-wave mobile antennas with coaxial line. C_1 should have a maximum capacitance of 75 to 100 $\mu\mu\text{f.}$ for 28- and 50-Mc. work. L_1 is an adjustable link.

method of varying the coupling to the transmitter should be provided.

Bibliography

- Swafford, "Improved Coax Feed for Low-Frequency Mobile Antennas," *QST*, Dec., 1951.
- Berge & McConnell, "Let's Go High Hat!," *QST*, Jan., 1952.
- Belrose, "Short Antennas for Mobile Operation," *QST*, Sept., 1953.
- Dinsmore, "The 'Hot-Rod' Mobile Antenna," *QST*, Sept., 1953.
- Picken & Wambsganss, "Remote Mobile-Antenna Resonating," *QST*, Dec., 1953.
- Webster, "Mobile Loop Antennas," *QST*, June, 1954.
- Tilton, "Have You Tried V.H.F. Mobile?" *QST*, Sept., 1954.
- Hargrave, "Automatic Mobile Antenna Tuning," *QST*, May, 1955.
- Morgan, "Tuning the Mobile Antenna from the Driver's Seat," *QST*, Oct., 1955.

A Signal/Field-Strength Meter for Mobile Use

Separate meters for measuring signal and field strength are used in many mobile installations. The unit shown in Figs. 19-49 through 19-51 permits a single 1-ma. meter to be used for making both types of measurements. The cost of the dual-purpose indicator is very little more than that of either instrument alone.

The unit is small enough for mounting either above or under the dashboard of a car, or it may be stored in the glove compartment when not in use. It is housed in a $4 \times 5 \times 3$ -inch gray hammertone box. A simple toggle switch changes from one function to the other. Power drawn from the broadcast receiver for the S-meter circuit is less than $2\frac{1}{4}$ watts.

The field-strength meter can be used installed in the car as an antenna-resonance indicator or as an output indicator for transmitter adjustments, or it can easily be removed for antenna-pattern plotting, adjustment of other mobile installations or even for use in the home station. The sensitivity adjustment makes the indicator useful over a wide range of field strengths.

One handy feature of the S-meter arrangement is the sensitivity control. This control can be adjusted to prevent extremely strong signals from pinning the meter. When working with weak signals, the control may be adjusted to provide a noticeable meter deflection.

The circuit of the indicator is shown in Fig. 19-50. A 12AX7 is used in the S-meter section. One grid is returned directly to chassis and the second grid is connected to the sensitivity control, R_1 . The input end of R_1 is returned, via J_2 and a shielded cable, to the a.v.c. line in the broadcast receiver. The plates of the 12AX7 are connected in parallel and then, through a single lead, to J_2 . Fig. 19-50 shows heater wiring for both 6- and 12-volt operation. Pin 9 of the tube is not used in the 12-volt circuit.

For S-meter operation, the meter and R_2 are switched across the cathode terminals of the tube by S_1 . The 500-ohm potentiometer, R_2 , becomes a zero-adjust control. Zero reading is obtained with R_2 adjusted for equal voltage at Pins 3 and 8 of the 12AX7. After an initial zero adjustment, the application of a.v.c. voltage through R_1 will drive the cathode of V_{1A} negative with respect to the cathode of V_{2B} , thus upsetting the balance and causing an upward deflection. For a given a.v.c. voltage, the amplitude of the deflection will be controlled by R_1 .

The circuit of the field-strength section is made active by switching the meter and R_2 into the circuit and by applying r.f. through J_1 . The amount of r.f. fed to the circuit may be controlled by adjusting the length of the pick-up antenna attached to J_1 . R_2 is a shunt to prevent off-scale readings when measuring strong r.f. fields.

Construction

As shown in Fig. 19-49, the Triplet model 227-T meter is mounted on the front panel of the utility box. S_1 and R_2 are below the meter with a $1\frac{1}{2}$ -inch space between mounting centers. Each control is centered $1\frac{3}{8}$ inches up from the bottom of the panel.

The bottom view shows the U-shaped chassis made from $\frac{1}{4}$ -inch thick aluminum stock. The width, depth and height of the chassis are $2\frac{7}{8}$, 3 and $1\frac{1}{16}$ inches, respectively. Panel-mounted controls (R_2 and S_1) clamp the chassis against the rear of the front panel as shown in Fig. 19-51.

The socket for the 12AX7 is centered 1 inch in from the rear edge of the chassis. L_1 is located just to the front of the tube socket as seen in Fig. 19-49. L_1 is a North Hills type 120-H inductor having an inductance range of 105 to 200 μ h. However, any coil that will resonate around 3.9 Mc. (and still fit into the chassis) with the



Fig. 19-49 — A front view of the signal/field-strength meter. The zero-adjust control is to the right of the toggle switch, S_1 . The meter registers either signal or field strength, depending upon the setting of the toggle switch.

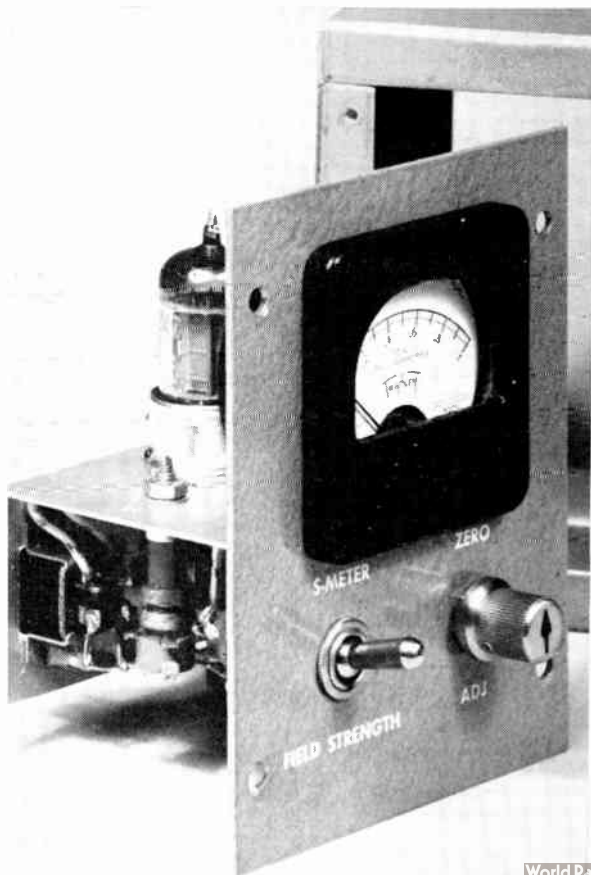

circuit capacitance may be used. A hole in the front of the socket, fitted with a rubber grommet, passes the leads between the meter and the toggle switch. R_1 , J_1 and J_2 are mounted on the rear wall of the chassis.

Fig. 19-51 shows the r.f. choke and the disk capacitors for the field-strength circuit mounted on a 2-terminal tie-point strip at the right side of the unit. The extra terminals on the slug-tuned coil are used for mounting the 1N34 crystal diode.

Installation

Heater, plate and a.v.c. voltages for the S-meter are obtained from the car broadcast receiver and should be brought to the indicator through shielded leads. The heater lead may be tapped onto the hot side of any receiver tube (it is a good idea to stay clear of the rectifier tube) close to a hole or receptacle provided for the output cable. The plate lead may be connected to the screen pin of an audio output tube socket or to any other point delivering approximately 150 volts (higher voltages merely increase the current drain unnecessarily). A series resistor may also be used to drop the voltage.

It is frequently possible to spot the a.v.c. line by tracing back from the control grid of either the r.f. amplifier tube or the converter. The grid of each tube is usually returned to the a.v.c. bus through a $\frac{1}{2}$ - to 1-megohm resistor. If you test a junction for a.v.c. voltage, just connect a high-resistance d.c. voltmeter between the point and ground and watch for a negative reading that increases with increased signal input. Local broadcast stations can supply the test signals.

After the interunit cabling has been completed, the receiver may be returned to the dash of the car. The performance of the S-meter may now be

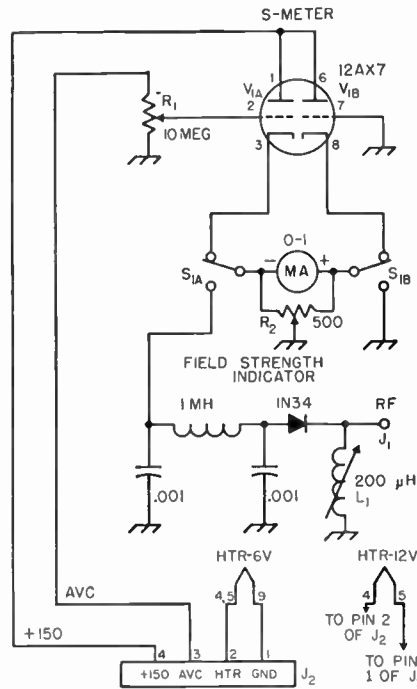

Fig. 19-50 — Circuit diagram of the signal/field-strength meter.

checked by tuning in signals — either amateur or broadcast — and observing the deflection of the meter. If broadcast station signals cause only a small deflection, it indicates that R_1 is adjusted toward minimum sensitivity. In that case, re-adjust R_1 , zero the meter by means of R_2 , and try again. It is necessary to reset the zero-adjust control each time that the sensitivity control setting is altered. If signals tend to pin the meter, the sensitivity can be reduced by adjustment of R_1 .

The field-strength meter can be most quickly tested by using the mobile transmitter as the source of signal. Either a short length of wire, the broadcast antenna, or an insulated fender guide may be used as the r.f. pick-up. Just terminate the pick-up antenna at J_1 , throw S_1 to the proper position, adjust R_2 for maximum resistance across the milliammeter, turn on the transmitter and watch the needle. Lengthen the pick-up antenna if the meter deflection is not great enough, or regulate the shunt, R_2 , if the reading is too high.

L_1 should ordinarily require adjustment only if the indicator is used for checking at 75 meters. In that case, it is advisable to increase the sensitivity to maximum by resonating the coil. (Originally described in *QST*, Sept., 1955.)



Fig. 19-51 — R_1 is at the rear of the unit, just below the 1-mh. r.f. choke. J_1 , on the rear wall of the chassis, is a miniature nylon tip jack. The back cover for the metal box that normally encloses the meter is punched to clear the components mounted on the rear wall of the chassis.

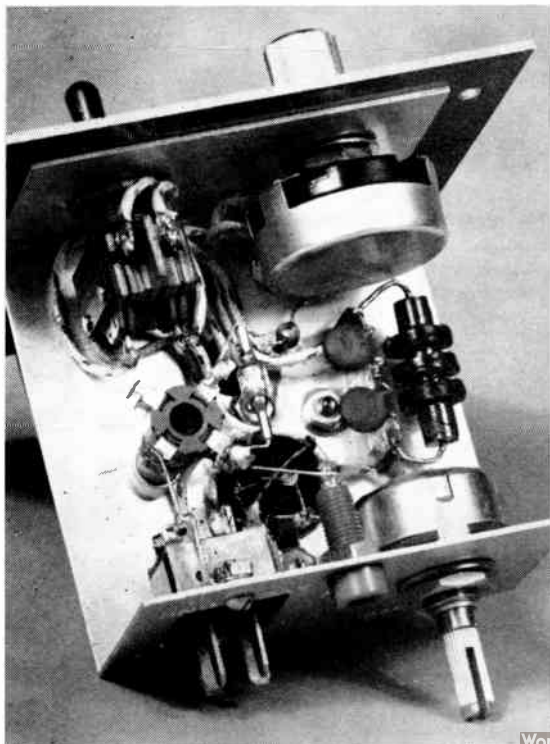

Mobile Power Supply

By far the majority of amateur mobile installations depend upon the car storage battery as the source of power. The tube types used in equipment are chosen so that the filaments or heaters may be operated directly from the battery. High voltage may be obtained from a supply of the vibrator-transformer-rectifier type or from a small motor-generator operating from the battery.

Filaments

Because tubes with directly-heated cathodes (filament-type tubes) have the advantage that they can be turned off during receiving periods and thereby reduce the average load on the battery, they are preferred by some for transmitter applications. However, the choice of types with direct heating is limited, especially among those for 6-volt operation, and the saving may not always be as great as anticipated, because directly-heated tubes may require greater filament power than those of equivalent rating with indirectly-heated cathodes. In most cases, the power required for transmitter filaments will be quite small compared to the total power consumed.

Plate Power

Under steady running conditions, the vibrator-transformer-rectifier system and the motor-generator-type plate supply operate with approximately the same efficiency. However, for the same power, the motor-generator's over-all efficiency may be somewhat lower because it draws a heavier starting current. On the other hand, the output of the generator requires less filtering and sometimes trouble is experienced in eliminating interference from the vibrator.

Converter units, both in the vibrator and rotating types, are also available. These operate at 6 or 12 volts d.c. and deliver 115 volts a.c. This permits operating standard a.c.-powered equipment in the car. Although these systems have the advantage of flexibility, they are less efficient than the previously-mentioned systems because of the additional losses introduced by the transformers used in the equipment.

Mobile Power Considerations

Since the car storage battery is a low-voltage source, this means that the current drawn from the battery for even a moderate amount of power will be large. Therefore, it is important that the resistance of the battery circuit be held to a minimum by the use of heavy conductors, no longer than necessary, and good solid connections. A heavy-duty relay should be used in the line between the battery and the plate-power unit. An ordinary toggle switch, located in any convenient position,

may then be used for the power control. A second relay may sometimes be advisable for switching the filaments. If the power unit must be located at some distance from the battery (in the trunk, for instance) the 6- or 12-volt cable should be of the heavy military type.

A complete mobile installation may draw 30 to 40 amperes or more from the 6-volt battery or better than 20 amperes from a 12-volt battery. This requires a considerably increased demand from the car's battery-charging generator. The voltage-regulator systems on cars of recent years will take care of a moderate increase in demand if the car is driven fair distances regularly at a speed great enough to insure maximum charging rate. However, if much of the driving is in urban areas at slow speed, or at night, it may be necessary to modify the charging system. Special communications-type generators, such as those used in police-car installations, are designed to charge at a high rate at slow engine speeds. The charging rate of the standard system can be increased within limits by tightening up slightly on the voltage-regulator and current-regulator springs. This should be done with caution, however, checking for excessive generator temperature or abnormal sparking at the commutator. The average 6-volt car generator has a rating of 35 amperes, but it may be possible to adjust the regulator so that the generator will at least hold even with the transmitter, receiver, lights, etc., all operating at the same time.

Another scheme that has been used to increase generator output at slow driving speeds is to decrease slightly the diameter of the generator pulley. This means, of course, that the generator will be running above normal at high driving speeds. Some generators will not stand the higher speed without damage.

If higher transmitter power is used, it may be necessary to install an a.c. charging system. In this system, the generator delivers a.c. and works into a rectifier. A charging rate of 75 amperes is easily obtained. Commutator trouble often experienced with d.c. generators at high current is avoided, but the cost of such a system is rather high.

Some mobile operators prefer to use a separate battery for the radio equipment. Such a system can be arranged with a switch that cuts the auxiliary battery in parallel with the car battery for charging at times when the car battery is lightly loaded. The auxiliary battery can also be charged at home when not in use.

A tip: many mobile operators make a habit of carrying a pair of heavy cables five or six feet long, fitted with clips to make a connection to the battery of another car in case the operator's battery has been allowed to run too far down for starting.

The Automobile Storage Battery

The success of any mobile installation depends to a large extent upon intelligent use and maintenance of the car's battery.

The storage battery is made up of units consisting of a pair of coated lead plates immersed in a solution of sulphuric acid and water. Cells, each of which delivers about 2 volts, can be connected in series to obtain the desired battery voltage. A 6-volt battery therefore has three cells, and a 12-volt battery has 6 cells. The average stock car battery has a rated capacity of 600 to 800 watt-hours, regardless of whether it is a 6-volt or 12-volt battery.

Specific Gravity and the Hydrometer

As power is drawn from the battery, the acid content of the electrolyte is reduced. The acid content is restored to the electrolyte (meaning that the battery is recharged) by passing a current through the battery in a direction opposite to the direction of the discharge current.

Since the acid content of the electrolyte varies with the charge and discharge of the battery, it is possible to determine the state of charge by measuring the specific gravity of the electrolyte.

An inexpensive device for checking the s.g. is the hydrometer which can be obtained at any automobile supply store. In checking the s.g., enough electrolyte is drawn out of the cell and into the hydrometer so that the calibrated bulb floats freely without leaning against the wall of the glass tube.

While the readings will vary slightly with batteries of different manufacture, a reading of 1.275 should indicate full charge or nearly full charge, while a reading below 1.150 should indicate a battery that is close to the discharge point. More specific values can be obtained from the car or battery dealer.

Readings taken immediately after adding water, or shortly after a heavy discharge period will not be reliable, because the electrolyte will not be uniform throughout the cell. Charging will speed up the equalizing, and some mixing can be done by using the hydrometer to withdraw and return some of the electrolyte to the cell several times.

A battery should not be left in a discharged condition for any appreciable length of time. This is especially important in low temperatures when there is danger of the electrolyte freezing and ruining the battery. A battery discharged to an s.g. of 1.100 will start to freeze at about 20 degrees F., at about 5 degrees when the s.g. is 1.150 and at 16 below when the s.g. is 1.200.

If a battery has been run down to the point where it is nearly discharged, it can usually be fast-charged at a battery station. Fast-charging rates may be as high as 80 to 100 amperes for a 6-volt battery. Any 6-volt battery that will accept a charge of 75 amperes at 7.75 volts during the first 3 minutes of charging, or any 12-volt battery that will accept a charge of 40 to 45 amperes at 15.5 volts, may be safely fast-charged

up to the point where the gassing becomes so excessive that electrolyte is lost or the temperature rises above 125 degrees.

A normal battery showing an s.g. of 1.150 or less may be fast-charged for 1 hour. One showing an s.g. of 1.150 to 1.175 may be fast-charged for 45 minutes. If the s.g. is 1.175 to 1.200, fast-charging should be limited to 30 minutes.

Care of the Battery

The battery terminals and mounting frame should be kept free from corrosion. Any corrosive accumulation may be removed by the use of water to which some household ammonia or baking soda has been added, and a stiff-bristle brush. Care should be taken to prevent any of the corrosive material from falling into the cells. Cell caps should be rinsed out in the same solution to keep the vent holes free from obstructing dirt. Battery terminals and their cable clamps should be polished bright with a wire brush, and coated with mineral grease.

The hold-down clamps and the battery holder should also be checked occasionally to make sure that they are tight so that the battery will not be damaged by pounding when the car is in motion.

Voltage Checks

Although the readings of s.g. are quite reliable as a measure of the state of charge of a normal battery, the necessity for frequent use of the hydrometer is an inconvenience and will not always serve as a conclusive check on a defective battery. Cells may show normal or almost normal s.g. and yet have high internal resistance that ruins the usefulness of the battery under load.

When all cells show satisfactory s.g. readings and yet the battery output is low, service stations check each cell by an instrument that measures the voltage of each cell under a heavy load. Under a heavy load the cell voltages should not differ by more than 0.15 volt.

A load-voltage test can also be made by measuring the voltage of each cell while closing the starter switch with the ignition turned off. In many cars it is necessary to pull the central distributor wire out to prevent the motor starting.

Electrolyte Level

Water is evaporated from the electrolyte, but the acid is not. Therefore water must be added to each cell from time to time so that the plates are always completely covered. The level should be checked at least once per week, especially during hot weather and constant operation.

Distilled water is preferred for replenishing, but clear drinking water is an acceptable substitute. Too much water should not be added, since the gassing that accompanies charging may force electrolyte out through the vent holes in the caps of the cells. The electrolyte expands with temperature. (From *QST*, August, 1955.)

Emergency and Independent Power Sources

Emergency power supply which operates independently of a.c. lines is available, or can be built in a number of different forms, depending upon the requirements of the service for which it is intended.

The most practical supply for the average individual amateur is one that operates from a car storage battery. Such a supply may take the form of a small motor generator (often called a genemotor), a rotary converter, or a vibrator-transformer-rectifier combination.

Dynamotors

A dynamotor differs from a motor generator in that it is a single unit having a double armature winding. One winding serves for the driving motor, while the output voltage is taken from the other. Dynamotors usually are operated from 6-, 12-, 28- or 32-volt storage batteries and deliver from 300 to 1000 volts or more at various current ratings.

Genemotor is a term popularly used when making reference to a dynamotor designed especially for automobile-receiver, sound-truck and similar applications. It has good regulation and efficiency, combined with economy of operation. Standard models of genemotors have ratings ranging from 250 volts at 50 ma. to 400 volts at 375 ma. or 600 volts at 250 ma. The normal efficiency averages around 50 per cent, increasing to better than 60 per cent in the higher-power units.

Successful operation of dynamotors and genemotors requires heavy direct leads, mechanical isolation to reduce vibration, and thorough r.f. and ripple filtration. The shafts and bearings should be thoroughly "run in" before regular operation is attempted, and thereafter the tension of the bearings should be checked occasionally to make certain that no looseness has developed.

In mounting the genemotor, the support should be in the form of rubber mounting blocks, or equivalent, to prevent the transmission of vibration mechanically. The frame of the genemotor should be grounded through a heavy flexible connector. The brushes on the high-voltage end of the shaft should be bypassed with 0.002- μ f. mica capacitors to a common point on the genemotor frame, preferably to a point inside the end cover close to the brush holders. Short leads are essential. It may prove desirable to shield the entire unit, or even to remove the unit to a distance of three or four feet from the receiver and antenna lead.

When the genemotor is used for receiving, a filter should be used similar to that described for vibrator supplies. A 0.01- μ f. 600-volt (d.c.) paper capacitor should be connected in shunt across the output of the genemotor, followed by a 2.5-mh. r.f. choke in the positive high-voltage lead. From this point the output should be run to the receiver power terminals through a smooth-

ing filter using 4- to 8- μ f. capacitors and a 15- or 30-henry choke having low d.c. resistance.

D.C.-A.C. Converters

In some instances it is desirable to utilize existing equipment built for 115-volt a.c. operation. To operate such equipment with any of the power sources outlined above would require a considerable amount of rebuilding. This can be obviated by using a rotary converter capable of changing the d.c. from 6-, 12- or 32-volt batteries to 115-volt 60-cycle a.c. Such converter units are built to deliver outputs ranging from 40 to 250 watts, depending upon the battery power available.

The conversion efficiency of these units averages about 50 per cent. In appearance and operation they are similar to genemotors of equivalent rating. The over-all efficiency of the converter will be lower, however, because of losses in the a.c. rectifier-filter circuits and the necessity for converting heater (which is supplied directly from the battery in the case of the genemotor) as well as plate power.

Vibrator Power Supplies

The vibrator type of power supply consists of a special step-up transformer combined with a vibrating interrupter (vibrator). When the unit is connected to a storage battery, plate power is obtained by passing current from the battery through the primary of the transformer. The circuit is made and reversed rapidly by the vibrator contacts, interrupting the current at regular intervals to give a changing magnetic field which induces a voltage in the secondary. The resulting square-wave d.c. pulses in the primary of the transformer cause an alternating voltage to be developed in the secondary. This high-voltage a.c. in turn is rectified, either by a vacuum-tube rectifier or by an additional synchronized pair of vibrator contacts. The rectified output is pulsating d.c., which may be filtered by ordinary means. The smoothing filter can be a single-section affair, but the output capacitance should be fairly large — 16 to 32 μ f.

Fig. 19-52 shows the two types of circuits. At A is shown the **nonsynchronous** type of vibrator. When the battery is disconnected the reed is midway between the two contacts, touching neither. On closing the battery circuit the magnet coil pulls the reed into contact with one contact point, causing current to flow through the lower half of the transformer primary winding. Simultaneously, the magnet coil is short-circuited, deenergizing it, and the reed swings back. Inertia carries the reed into contact with the upper point, causing current to flow through the upper half of the transformer primary. The magnet coil again is energized, and the cycle repeats itself.

The synchronous circuit of Fig. 19-52B is

provided with an extra pair of contacts which rectify the secondary output of the transformer, thus eliminating the need for a separate rectifier tube. The secondary center-tap furnishes the positive output terminal when the relative polarities of primary and secondary windings are correct. The proper connections may be determined by experiment.

The buffer capacitor, C_2 , across the transformer secondary, absorbs the surges that occur on breaking the current, when the magnetic field collapses practically instantaneously and hence causes very high voltages to be induced in the secondary. Without this capacitor excessive sparking occurs at the vibrator contacts, shortening the vibrator life. Correct values usually lie between 0.005 and 0.03 $\mu\text{f.}$, and for 250-300-volt supplies the capacitor should be rated at 1500 to 2000 volts d.c. The exact capacitance is critical, and should be determined experimentally. The optimum value is that which results in least battery current for a given rectified d.c. output from the supply. In practice the value can be determined by observing the degree of vibrator sparking as the capacitance is changed. When the system is operating properly there should be practically no sparking at the vibrator contacts. A 5000-ohm resistor in series with C_2 will limit the secondary current to a safe value should the capacitor fail.

Vibrator-transformer units are available in a variety of power and voltage ratings. Representative units vary from one delivering 125 to 200 volts at 100 ma. to others that have a 400-volt output rating at 150 ma. Most units come supplied with "hash" filters, but not all of them have built-in ripple filters. The requirements for ripple filters are similar to those for a.c. supplies. The usual efficiency of vibrator packs is in the vicinity of 70 per cent, so a 300-volt 200-ma. unit will draw approximately 15 amperes from a 6-volt storage battery. Special vibrator transformers are also available from transformer manufacturers so that the amateur may build his own supply if he so desires. These have d.c. output ratings varying from 150 volts at 40 ma. to 330 volts at 135 ma.

Vibrator-type supplies are also available for operating standard a.c. equipment from a 6- or 12-volt storage battery in power ratings up to 100 watts continuous or 125 watts intermittent.

"Hash" Elimination

Sparking at the vibrator contacts causes r.f. interference ("hash," which can be distinguished from hum by its harsh, sharper pitch) when used with a receiver. To minimize this, r.f. filters are incorporated, consisting of RFC_1 and C_1 in the battery circuit, and RFC_2 with C_3 in the d.c. output circuit.

Equally as important as the hash filter is thorough shielding of the power supply and its connecting leads, since even a small piece of wire or metal will radiate enough r.f. to cause

interference in a sensitive amateur receiver.

Testing in connection with hash elimination should be carried out with the supply operating a receiver. Since the interference usually is picked up on the receiving-antenna leads by radiation from the supply itself and from the battery leads, it is advisable to keep the supply and battery as far from the receiver as the connecting cables will permit. Three or four feet should be ample. The microphone cord likewise should be kept away from the power supply and its leads.

The power supply should be built on a metal chassis, with all unshielded parts underneath. A bottom plate to complete the shielding is advisable. The transformer case, vibrator cover and the metal shell of the tube all should be grounded to the chassis. If a glass tube is used it should be enclosed in a tube shield. The battery leads should be evenly twisted, since these leads are more likely to radiate hash than any other part of a well-shielded supply. Experimenting with different values in the hash filters should come after

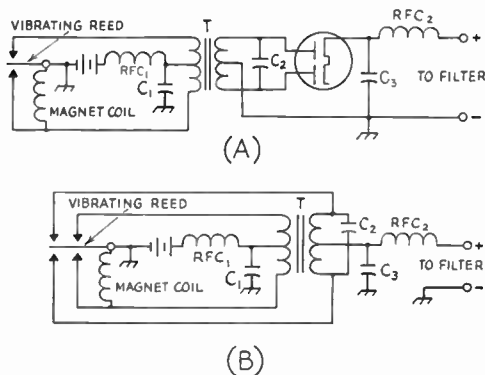

Fig. 19-52 — Basic types of vibrator power-supply circuits. A — Nonsynchronous. B — Synchronous.

radiation from the battery leads has been reduced to a minimum. Shielding the leads is not often found to be particularly helpful.

● **PRACTICAL VIBRATOR-SUPPLY CIRCUITS**

A vibrator-type power supply may be designed to operate from a storage battery only, or in a combination unit which may be operated interchangeably from either battery or 115 volts a.c.

An example of the latter-type circuit is shown in Fig. 19-53. It consists essentially of two transformer-rectifier systems — one for 115 volts a.c. and the other a vibrator system to operate from a 6-volt storage battery. A common filter is used for the two systems. In interchanging between a.c. and d.c. operation, the rectifier tube is shifted to the appropriate socket, while the filament connections are made to the proper output terminals. If desired, two rectifier tubes may be used and the changeover made through suitable switches.

Fig. 19-53 — Circuit of a combination a.c.-d.c. power supply for emergency work.

- C₁ — 0.01- μ f. 600-volt paper.
- C₂ — 8- μ f. 450-volt electrolytic.
- C₃ — 32- μ f. 450-volt electrolytic.
- C₄ — 0.005- to 0.01- μ f. 1600-volt paper.
- C₅ — 500- μ f. electrolytic, 25 volts or higher.
- C₆ — 100- μ f. 600-volt mica.
- R₁ — 4700 ohms, 1 watt.
- L₁ — 10- to 12-hy. filter choke, 100 ma. (not over 100 ohms) (Stancor C-2303 or equivalent).
- RFC₁ — 2.5-mh. r.f. choke.
- RFC₂ — 55 turns No. 12 on 1-inch form, close-wound.
- S₁, S₂ — Toggle switch.
- T₁ — Power transformer: 275 to 300 volts r.m.s. each side of center tap, 100 to 150 ma., 6.3-volt filament winding.
- T₂ — Vibrator transformer (Stancor P-6131 or similar).
- VIB — Vibrator unit (Mallory 500P, 294, etc.).

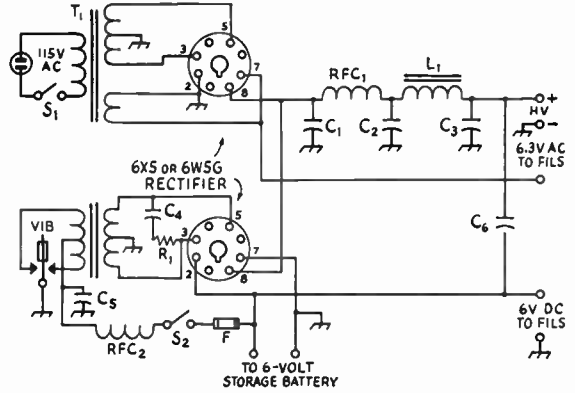

R.f. filters for reducing hash are incorporated in both primary and secondary circuits. The secondary filter consists of a 0.01- μ f. paper capacitor directly across the rectifier output, with a 2.5-mh. r.f. choke in series ahead of the smoothing filter. In the primary circuit a low-inductance choke and high-capacitance capacitor are needed because of the low impedance of the circuit. A choke of the specifications given should be adequate, but if there is trouble with hash it may be beneficial to experiment with other sizes. The wire should be large — No. 12, preferably, or No. 14 as a minimum. Manufactured chokes such as the Mallory RF583 are more compact and give higher inductance for a given resistance because they are bank-wound, and may be substituted if obtainable. C₅ should be at least 500 μ f.; even more capacitance may help in bad cases of hash.

The compactness of selenium rectifiers and

the fact that they do not require filament voltage make them particularly suited to compact lightweight power supplies for portable emergency work.

Fig. 19-55 shows the circuit of a vibrator pack that will deliver an output voltage of 400 at 200 ma. It will work with either 115-volt ac. or 6-volt battery input. The circuit is that of the familiar voltage tripler whose d.c. output voltage is, as a rough approximation, three times the peak voltage delivered by the transformer or line. An interesting feature of the circuit is the fact that the single transformer serves as the vibrator transformer when operating from 6-volt d.c. supply and as the filament transformer when operating from an a.c. line.

The vibrator transformer, T₁, is a dual-secondary 6.3-volt filament transformer con-

Fig. 19-54 — A typical combination a.c.-d.c. power pack for low-power emergency work. The two transformers are mounted at either end of the chassis. The filter capacitor is at the left, the two rectifier sockets at the center and the vibrator to the rear. The circuit is shown in Fig. 19-53.

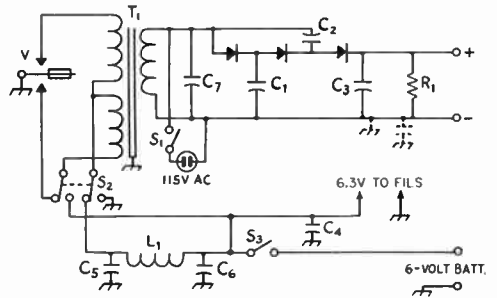

Fig. 19-55 — Circuit diagram of a compact vibrator-a.c. portable power supply using selenium rectifiers.

- C₁ — 60- μ f. 200-volt electrolytic.
- C₂ — 60- μ f. 100-volt electrolytic.
- C₃ — 60- μ f. 600-volt electrolytic.
- C₄ — 25- μ f. 25-volt electrolytic.
- C₅, C₆ — 0.5- μ f. 25-volt paper.
- C₇ — 0.007- μ f. 1500-volt paper.
- R₁ — 25,000 ohms, 10 watts.
- L₁ — 25- μ h. 20-amp. choke.
- S₁ — 115-volt toggle switch.
- S₂ — D.p.d.t. heavy-duty knife switch.
- S₃ — 25-amp. s.p.s.t. switch.
- T₁ — See text (UTC S-63).
- V — Heavy-duty vibrator (Cornell-Dub. 4123).

needed in reverse. The filament windings must have a rating of 10 amperes if the full load current of 200 ma. is to be used. The vibrator also must be capable of handling the current. The hash-filter choke, L_1 , must carry a current of 20 amperes.

The following table shows the output voltage to be expected at various load currents, depending upon the size of capacitors used at C_1 , C_2 and C_3 .

C_1, C_2, C_3 ($\mu f.$)	Output Voltage at			
	50 ma.	100 ma.	150 ma.	200 ma.
60	455	430	415	395
40	425	390	360	330
20	400	340	285	225

In operating the supply from an a.c. line, it is always wise to determine the plug polarity with respect to ground. Otherwise the rectifier part of the circuit and the transformer circuit cannot be connected to actual ground except through bypass capacitors.

(Originally described in *QST* by W9CO.)

● GASOLINE-ENGINE DRIVEN GENERATORS

For higher-power installations, such as for communications control centers during emergencies, the most practical form of independent power supply is the gasoline-engine driven generator which provides standard 115-volt 60-cycle supply.

Such generators are ordinarily rated at a minimum of 250 or 300 watts. They are available up to ten kilowatts, or big enough to handle the highest-power amateur rig. Most are arranged to charge automatically an auxiliary 6- or 12-volt battery used in starting. Fitted with self-starters and adequate mufflers and filters, they represent a high order of performance and efficiency. Many of the larger models are liquid-cooled, and they will operate continuously at full load.

The output frequency of an engine-driven generator must fall between the relatively narrow limits of 50 to 60 cycles if standard 60-cycle transformers are to operate efficiently from this source. A 60-cycle electric clock provides a means of checking the output frequency with a fair degree of accuracy. The clock is connected across the output of the generator and the second hand is checked closely against the second hand of a watch. The speed of the engine is adjusted until the two second hands are in synchronism.

Output voltage should be checked with a voltmeter since a standard 115-volt lamp bulb, which is sometimes used for this purpose, is very inaccurate.

Noise Elimination

Electrical noise which may interfere with receivers operating from engine-driven a.c. generators may be reduced or eliminated by taking proper precautions. The most important point is that of grounding the frame of the

generator and one side of the output. The ground lead should be short to be effective, otherwise grounding may actually increase the noise. A water pipe may be used if a short connection can be made near the point where the

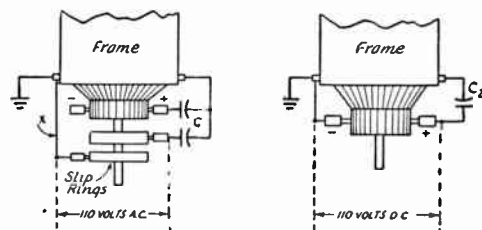

Fig. 19-56 — Connections used for eliminating interference from gas-driven generator plants. C_1 should be 1 $\mu f.$, 300 volts, paper, while C_2 may be 1 $\mu f.$ with a voltage rating of twice the d.c. output voltage delivered by the generator. X indicates an added connection between the slip ring on the grounded side of the line and the generator frame.

pipe enters the ground, otherwise a good separate ground should be provided.

The next step is to loosen the brush-holder locks and slowly shift the position of the brushes while checking for noise with the receiver. Usually a point will be found (almost always different from the factory setting) where there is a marked decrease in noise.

From this point on, if necessary, bypass capacitors from various brush holders to the frame, as shown in Fig. 19-56, will bring the hash down to within 10 to 15 per cent of its original intensity, if not entirely eliminating it. Most of the remaining noise will be reduced still further if the high-power audio stages are cut out and a pair of headphones is connected into the second detector.

● POWER FOR PORTABLES

Dry-cell batteries are the only practical source of supply for equipment which must be transported on foot. From certain considerations they may also be the best source of voltage for a receiver whose filaments may be operated from a storage battery, since no problem of noise filtering is involved.

Their disadvantages are weight, high cost, and limited current capability. In addition, they will lose their power even when not in use, if allowed to stand idle for periods of a year or more. This makes them uneconomical if not used more or less continuously.

Dry "B" batteries are made in a variety of sizes and shapes, from a 45-volt unit weighing about 1 lb. that has an intermittent service rating of 20 hours at a drain of 20 ma., to a 12-lb. unit rated at 130 hours at 40 ma. "A" batteries for filament service range from a 6-volt unit weighing 1½ lbs. delivering in intermittent service an average of 60 ma. for 150 hours, to a 6¼-lb. 1.5-volt unit having a service life of 870 hours at 200 ma. Miniature batteries, suitable for hand-portable use, are also available.

Construction Practices

● TOOLS AND MATERIALS

While an easier, and perhaps a better, job can be done with a greater variety of tools available, by taking a little thought and care it is possible to turn out a fine piece of equipment with only a few of the common hand tools. A list of tools which will be indispensable in the construction of radio equipment will be found on this page. With these tools it should be possible to perform any of the required operations in preparing

panels and metal chassis for assembly and wiring. It is an excellent idea for the amateur who does constructional work to add to his supply of tools from time to time as finances permit.

Several of the pieces of light woodworking machinery, often sold in hardware stores and mail-order retail stores, are ideal for amateur radio work, especially the drill press, grinding head, band and circular saws, and joiner. Although not essential, they are desirable should you be in a position to acquire them.

INDISPENSABLE TOOLS

Long-nose pliers, 6-inch.
 Diagonal cutting pliers, 6-inch.
 Wire stripper.
 Screwdriver, 6- to 7-inch, $\frac{1}{4}$ -inch blade.
 Screwdriver, 4- to 5-inch, $\frac{1}{8}$ -inch blade.
 Scratch awl or scriber for marking lines.
 Combination square, 12-inch, for laying out work.
 Hand drill, $\frac{1}{2}$ -inch chuck or larger, 2-speed type preferable.
 Electric soldering iron, 100 watts, $\frac{1}{4}$ -in. tip.
 Hack saw, 12-inch blades.
 Center punch for marking hole centers.
 Hammer, ball-peen, 1-lb. head.
 Heavy knife.
 Yardstick or other straightedge.
 Carpenter's brace with adjustable hole cutter or socket-hole punches (see text).
 Large, coarse, flat file.
 Large round or rat-tail file, $\frac{1}{2}$ -inch diameter.
 Three or four small and medium files—flat, round, half-round, triangular.
 Drills, particularly $\frac{1}{4}$ -inch and Nos. 18, 28, 33, 42 and 50.
 Combination oil stone for sharpening tools.
 Solder and soldering paste (noncorroding).
 Medium-weight machine oil.

ADDITIONAL TOOLS

Bench vise, 4-inch jaws.
 Tin shears, 10-inch, for cutting thin sheet metal.
 Taper reamer, $\frac{1}{2}$ -inch, for enlarging small holes.
 Taper reamer, 1-inch, for enlarging holes.
 Countersink for brace.
 Carpenter's plane, 8- to 12-inch, for woodworking.
 Carpenter's saw, crosscut.
 Motor-driven emery wheel for grinding.
 Long-shank screwdriver with screw-holding clip for tight places.
 Set of "Spintite" socket wrenches for hex nuts.
 Set of small, flat, open-end wrenches for hex nuts.
 Wood chisel, $\frac{1}{2}$ -inch.
 Cold chisel, $\frac{1}{2}$ -inch.
 Wing dividers, 8-inch, for scribing circles.
 Set of machine-screw taps and dies.
 Dusting brush.
 Socket punches, esp. $\frac{5}{8}$ ", $\frac{3}{4}$ ", $1\frac{1}{8}$ " and $1\frac{1}{4}$ ".

Twist Drills

Twist drills are made of either high-speed steel or carbon steel. The latter type is more common and will usually be supplied unless specific request is made for high-speed drills. The carbon drill will suffice for most ordinary equipment construction work and costs less than the high-speed type.

While twist drills are available in a number of sizes those listed in bold-faced type in Table 20-1 will be most commonly used in construction of amateur equipment. It is usually desirable to purchase several of each of the commonly-used sizes rather than a standard set, most of which will be used infrequently if at all.

Care of Tools

The proper care of tools is not alone a matter of pride to a good workman. He also realizes the energy which may be saved and the annoyance which may be avoided by the possession of a full kit of well-kept sharp-edged tools.

Drills should be sharpened at frequent intervals so that grinding is kept at a minimum each time. This makes it easier to maintain the rather critical surface angles required for best cutting with least wear. Occasional oilstoning of the cutting edges of a drill or reamer will extend the time between grindings.

The soldering iron can be kept in good condition by keeping the tip well tinned with solder and not allowing it to run at full voltage for long periods when it is not being used. After each period of use, the tip should be removed and cleaned of any scale which may have accumulated. An oxidized tip may be cleaned by dipping it in sal ammoniac while

hot and then wiping it clean with a rag. If the tip becomes pitted, it should be filed until smooth and bright, and then tinned immediately by dipping it in solder.

Useful Materials

Small stocks of various miscellaneous materials will be required in constructing radio apparatus, most of which are available from hardware or radio-supply stores. A representative list follows:

Sheet aluminum, solid and perforated, 16 or 18 gauge, for brackets and shielding.

1/2 x 1/2-inch aluminum angle stock.

1/4-inch diameter round brass or aluminum rod for shaft extensions.

Machine screws: Round-head and flat-head, with nuts to fit. Most useful sizes: 4-36, 6-32 and 8-32, in lengths from 1/4 inch to 1 1/2 inches. (Nickel-plated iron will be found satisfactory except in strong r.f. fields, where brass should be used.)

Bakelite, lucite and polystyrene scraps.

Soldering lugs, panel bearings, rubber grommets, terminal-lug wiring strips, varnished-cambric insulating tubing.

Shielded and unshielded wire.

Tinned bare wire, Nos. 22, 14 and 12.

Machine screws, nuts, washers, soldering lugs, etc., are most reasonably purchased in quantities of a gross.

● **CHASSIS WORKING**

With a few essential tools and proper procedure, it will be found that building radio gear on a metal chassis is no more of a chore than building with wood, and a more satisfactory job results. Aluminum is to be preferred to steel, not only because it is a superior shielding material, but because it is much easier to work and to provide good chassis contacts.

The placing of components on the chassis is shown quite clearly in the photographs in this *Handbook*. Aside from certain essential dimensions, which usually are given in the text, exact duplication is not necessary.

Much trouble and energy can be saved by spending sufficient time in planning the job. When all details are worked out beforehand

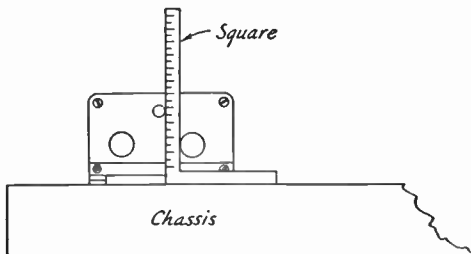

Fig. 20-1 — Method of measuring the heights of capacitor shafts, etc. If the square is adjustable, the end of the scale should be set flush with the face of the head.

TABLE 20-1
Numbered Drill Sizes

Number	Diameter (mils)	Will Clear Screw	Drilled for Tapping Iron, Steel or Brass*
1	228.0	—	—
2	221.0	12-24	—
3	213.0	—	14-24
4	209.0	12-20	—
5	205.0	—	—
6	201.0	—	—
7	201.0	—	—
8	199.0	—	—
9	196.0	—	—
10	193.5	10-32	—
11	191.0	10-24	—
12	189.0	—	—
13	185.0	—	—
14	182.0	—	—
15	180.0	—	—
16	177.0	—	12-24
17	173.0	—	—
18	169.5	8-32	—
19	166.0	—	12-20
20	161.0	—	—
21	159.0	—	10-32
22	157.0	—	—
23	154.0	—	—
24	152.0	—	—
25	149.5	—	10-24
26	147.0	—	—
27	144.0	—	—
28	140.0	6-32	—
29	136.0	—	8-32
30	128.5	—	—
31	120.0	—	—
32	116.0	—	—
33	113.0	4-36, 4-40	—
34	111.0	—	—
35	110.0	—	6-32
36	106.5	—	—
37	104.0	—	—
38	101.5	—	—
39	99.5	3-48	—
40	98.0	—	—
41	96.0	—	—
42	93.5	—	4-36, 4-40
43	89.0	2-56	—
44	86.0	—	—
45	82.0	—	3-48
46	81.0	—	—
47	78.5	—	—
48	76.0	—	—
49	73.0	—	2-56
50	70.0	—	—
51	67.0	—	—
52	63.5	—	—
53	59.5	—	—
54	55.0	—	—

*Use one size larger for tapping bakelite and hard rubber.

the actual construction is greatly simplified.

Cover the top of the chassis with a piece of wrapping paper or, preferably, cross-section paper, folding the edges down over the sides of the chassis and fastening with adhesive tape. Then assemble the parts to be mounted on top of the chassis and move them about until a satisfactory arrangement has been found, keeping in mind any parts which are to be mounted underneath, so that interferences in mounting may be avoided. Place capacitors and other parts with shafts extending through the panel first, and arrange them so that the controls will

form the desired pattern on the panel. Be sure to line up the shafts squarely with the chassis front. Locate any partition shields and panel brackets next, and then the tube sockets and any other parts, marking the mounting-hole centers of each accurately on the paper. Watch out for capacitors whose shafts are off center and do not line up with the mounting holes. Do not forget to mark the centers of socket holes and holes for leads under i.f. transformers, etc., as well as holes for wiring leads. The small holes for socket-mounting screws are best located and center-punched, using the socket itself as a template, after the main center hole has been cut.

By means of the square, lines indicating accurately the centers of shafts should be extended to the front of the chassis and marked on the panel at the chassis line, the panel being fastened on temporarily. The hole centers may then be punched in the chassis with the center punch. After drilling, the parts which require mounting underneath may be located and the mounting holes drilled, making sure by trial that no interferences exist with parts mounted on top. Mounting holes along the front edge

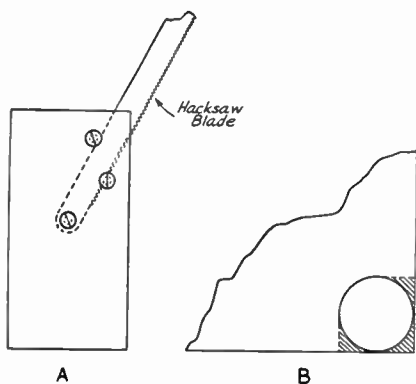

Fig. 20-2—To cut rectangular holes in a chassis corner, holes may be filed out as shown in the shaded portion of B, making it possible to start the hack-saw blade along the cutting line. A shows how a single-ended handle may be constructed for a hack-saw blade.

of the chassis should be transferred to the panel, by once again fastening the panel to the chassis and marking it from the rear.

Next, mount on the chassis the capacitors and any other parts with shafts extending to the panel, and measure accurately the height of the center of each shaft above the chassis, as illustrated in Fig. 20-1. The horizontal displacement of shafts having already been marked on the chassis line on the panel, the vertical displacement can be measured from this line. The shaft centers may now be marked on the back of the panel, and the holes drilled. Holes for any other panel equipment coming above the chassis line may then be marked and drilled, and the remainder of the apparatus mounted. Holes for terminals etc., in the rear edge of the chassis should be marked and drilled at the same time that they are done for the top.

Drilling and Cutting Holes

When drilling holes in metal with a hand drill it is important that the centers first be located with a center punch, so that the drill point will not "walk" away from the center when starting the hole. When the drill starts to break through, special care must be used. Often it is an advantage to shift a two-speed drill to low gear at this point. Holes more than $\frac{1}{4}$ inch in diameter may be started with a smaller drill and reamed out with the larger drill.

The chuck on the usual type of hand drill is limited to $\frac{1}{2}$ -inch drills. Although it is rather tedious, the $\frac{1}{4}$ -inch hole may be filed out to larger diameters with round files. Another method possible with limited tools is to drill a series of small holes with the hand drill along the inside of the diameter of the large hole, placing the holes as close together as possible. The center may then be knocked out with a cold chisel and the edges smoothed up with a file. Taper reamers which fit into the carpenter's brace will make the job easier. A large rat-tail file clamped in the brace makes a very good reamer for holes up to the diameter of the file, if the file is revolved counterclockwise.

For socket holes and other large round holes, an adjustable cutter designed for the purpose may be used in the brace. Occasional application of machine oil in the cutting groove will help. The cutter first should be tried out on a block of wood, to make sure that it is set for the correct diameter. The most convenient device for cutting socket holes is the socket-hole punch. The best type is that which works by turning a take-up screw with a wrench.

Rectangular Holes

Square or rectangular holes may be cut out by making a row of small holes as previously described, but is more easily done by drilling a $\frac{1}{2}$ -inch hole inside each corner, as illustrated in Fig. 20-2, and using these holes for starting and turning the hack saw. The socket-hole punch and the square punches which are now available also may be of considerable assistance in cutting out large rectangular openings. The burrs or rough edges which usually result after drilling or cutting holes may be removed with a file, or sometimes more conveniently with a sharp knife or chisel. It is a good idea to keep an old wood chisel sharpened and available for this purpose. A burr reamer will also be useful.

CONSTRUCTION NOTES

If a control shaft must be extended or insulated, a flexible shaft coupling with adequate insulation should be used. Satisfactory support for the shaft extension can be provided by means of a metal panel bearing made for the purpose. Never use panel bearings of the non-metal type unless the capacitor shaft is grounded. The metal bearing should be connected to the chassis with a wire or grounding strip.

This prevents any possible danger of shock.

The use of fiber washers between ceramic insulation and metal brackets, screws or nuts will prevent the ceramic parts from breaking.

Cutting and Bending Sheet Metal

If a sheet of metal is too large to be cut conveniently with a hack saw, it may be marked with scratches as deep as possible along the line of the cut on both sides of the sheet and then clamped in a vise and worked back and forth until the sheet breaks at the line. Do not carry the bending too far until the break begins to weaken; otherwise the edge of the sheet may become bent. A pair of iron bars or pieces of heavy angle stock, as long or longer than the width of the sheet, to hold it in the vise will make the job easier. "C"-clamps may be used to keep the bars from spreading at the ends. The rough edges may be smoothed up with a file or by placing a large piece of emery cloth or sandpaper on a flat surface and running the edge of the metal back and forth over the sheet.

Bends may be made similarly. The sheet should be scratched on both sides, but not so deeply as to cause it to break.

Finishing Aluminum

Aluminum chassis, panels and parts may be given a sheen finish by treating them in a caustic bath. An enamelled container, such as a dishpan or infant's bathtub, should be used for the solution. Dissolve ordinary household lye in cold water in a proportion of $\frac{1}{4}$ to $\frac{1}{2}$ can of lye per gallon of water. The stronger solution will do the job more rapidly. Stir the solution with a stick of wood until the lye crystals are complete dissolved. Be very careful to avoid any skin contact with the solution. It is also harmful to clothing. Sufficient solution should be prepared to cover the piece completely. When the aluminum is immersed, a very pronounced bubbling takes place and ventilation should be provided to disperse the escaping gas. A half hour to two hours in the solution should be sufficient, depending upon the strength of the solution and the desired surface.

Remove the aluminum from the solution with sticks and rinse thoroughly in cold water while swabbing with a rag to remove the black deposit.

DECIMAL EQUIVALENTS OF FRACTIONS

1/3203125	17/3253125
1/160625	9/165625
3/3209375	19/3259375
1/8125	5/8625
5/3215625	21/3265625
3/161875	11/166875
7/3221875	23/3271875
1/425	3/475
9/3228125	25/3278125
5/163125	13/168125
11/3234375	27/3284375
3/8375	7/8875
13/3240625	29/3290625
7/164375	15/169375
15/3246875	31/3296875
1/25	1	1.0

Then wipe off with a rag soaked in vinegar to remove any stubborn stains or fingerprints. (See May, 1950, *QST* for a method of coloring and anodizing aluminum.)

Soldering

The secret of good soldering is in allowing time for the *joint*, as well as the solder, to attain sufficient temperature. Enough heat should be applied so that the solder will melt when it comes in contact with the wires being joined, without touching the solder to the iron. Always use rosin-core solder, never acid-core. Except where absolutely necessary, solder should never be depended upon for the mechanical strength of the joint; the wire should be wrapped around the terminals or clamped with soldering terminals.

When soldering crystal diodes or carbon resistors in place, especially if the leads have been cut short and the resistor is of the small $\frac{1}{2}$ -watt size, the resistor lead should be gripped with a pair of pliers up close to the resistor so that the heat will be conducted away from the resistor. Overheating of the resistor while soldering can cause a permanent resistance change of as much as 20 per cent. Also, mechanical stress will have a similar effect, so that a small resistor should be mounted so that there is no appreciable mechanical strain on the leads.

Trouble is sometimes experienced in soldering to the pins of coil-forms or male cable plugs. It helps first to tin the inside of the pins by applying soldering paste to the hole, and then flowing solder into the pin. Then immediately clear the solder from the hot pin by a whipping motion or by blowing through the pin from the inside of the form or plug. Before inserting the wire in the pin, file the nickel plate from the tip. After soldering, round the solder tip off with a file.

When soldering to sockets, it is a good idea to have the tube or coil form inserted to prevent solder running down into the socket prongs. It also helps to conduct the heat away when soldering to polystyrene sockets, which often soften under the heat of the iron.

Wiring

The wire used in connecting up amateur equipment should be selected considering both the maximum current it will be called upon to handle and the voltage its insulation must stand without breakdown. Also, from the consideration of TVI, the power wiring of all transmitters should be done with wire that has a braided shielding cover. Receiver and audio circuits may also require the use of shielded wire at some points for stability, or the elimination of hum.

No. 20 stranded wire is commonly used for most receiver wiring (except for the high-frequency circuits) where the current does not exceed 2 or 3 amperes. For higher-current heater circuits, No. 18 is available. Wire with cellulose acetate insulation is good for voltages up to about 500. For higher voltages, thermoplastic-insulated wire should be used. Inexpensive wire strippers that make the removal of insulation from hook-up

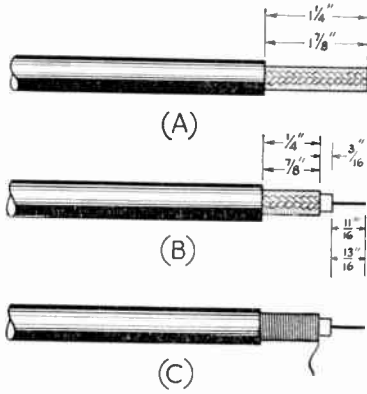

Fig. 20-3 — Cable-stripping dimensions for Jones Type P-101 plugs. Smaller dimensions are for 1/4-inch plugs, the larger dimensions for 1/2-inch plugs. As indicated in C, the remaining copper braid is wound with bare or tinned wire to make a snug fit in the sleeve of the plug.

wire an easy job are available on the market. In cases where power leads have several branches in the chassis, it is convenient to use fiber-insulated tie points or "lug strips" as anchorages or junction points. Strips of this type are also useful as insulated supports for resistors, r.f. chokes and capacitors. High-voltage wiring should have exposed points held to a minimum, and those which cannot be avoided should be rendered as inaccessible as possible to accidental contact or short-circuit.

Where shielded wire is called for and capacitance to ground is not a factor, Belden type 8885 shielded grid wire may be used. If capacitance must be minimized, it may be necessary to use a piece of car-radio low-capacitance lead-in wire, or coaxial cable.

For wiring high-frequency circuits, rigid wire is often used. Bare soft-drawn tinned wire, sizes 22 to 12 (depending on mechanical requirements), is suitable. Kinks can be removed by stretching a piece 10 or 15 feet long and then cutting into short lengths that can be handled conveniently. R.f. wiring should be run directly from point to point with a minimum of sharp bends and the

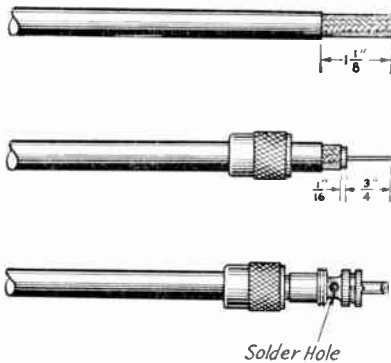

Fig. 20-4 — Dimensions for stripping 1/2-inch cable to fit Amphenol Type 83-1SP (PL-259) plug.

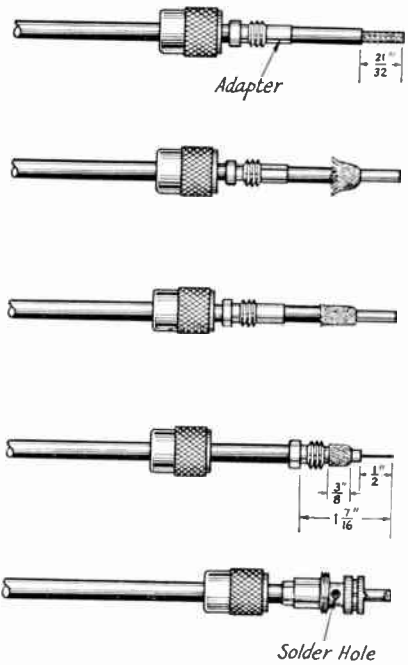

Fig. 20-5 — Method of assembling 1/4-inch cable, Amphenol Type 83-1SP (PL-259) plug and adapter.

wire kept well spaced from the chassis or other grounded metal surfaces. Where the wiring must pass through the chassis or a partition, a clearance hole should be cut and lined with a rubber grommet. In case insulation becomes necessary, varnished cambric tubing (spaghetti) can be slipped over the wire.

In transmitters where the peak voltage does not exceed 2500 volts, the shielded grid wire mentioned above should be satisfactory for power circuits. For higher voltages, Belden type 8656, Birnbach type 1820, or shielded ignition cable can be used. In the case of filament circuits carrying heavy current, it may be necessary to use No. 10 or 12 bare or enameled wire, slipped through spaghetti, and then covered with copper braid pulled tightly over the spaghetti. The chapter

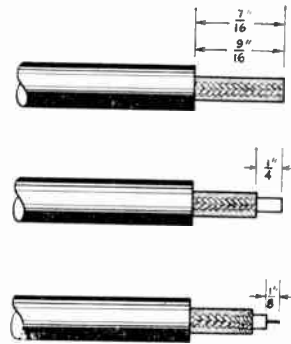

Fig. 20-6 — Stripping dimensions for Amphenol 82-830 and 82-832 plug-in connectors. The longer exposed braid is for the first type.

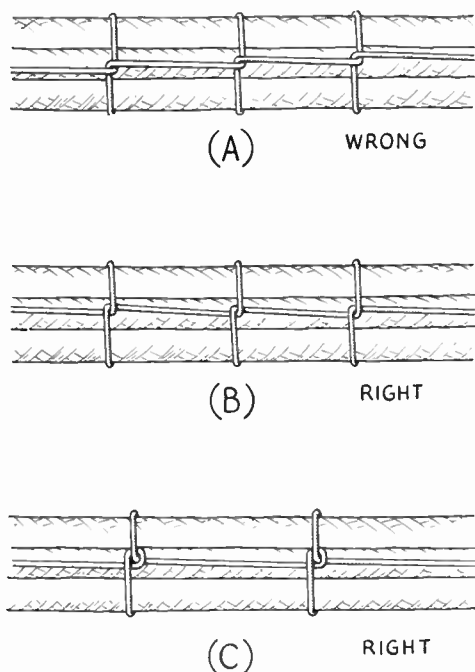

Fig. 20-7—Methods of lacing cables. The method shown at C is more secure, but takes more time than the method of B. The latter is usually adequate for most amateur requirements.

on TVI shows the manner in which shielded wire should be applied. If the shielding is simply slid back over the insulation and solder flowed into the end of the braid, the braid usually will stay in place without the necessity for cutting it back or binding it in place. The braid should be burnished with sandpaper or a knife so that solder will take with a minimum of heat to protect the insulation underneath.

R.F. wiring in transmitters usually follows the method described above for receivers with due respect to the voltages involved.

Power and control wiring external to the transmitter chassis preferably should be of shielded wire bound into a cable. Fig. 20-7 shows the correct methods of lacing cables.

Coaxial Plug Connections

Considerable time and trouble can be saved in making cable connections to coaxial plugs by starting out with the correct stripping dimensions. Fig. 20-3 shows how the end of the cable should be prepared for connecting to Jones Type P-101 plugs. After the exposed braid has been wound, it should be carefully tinned, applying no more heat than is necessary, to avoid melting the inner insulation. A small amount of solder also should be flowed into the sleeve of the plug. Then, when the cable is inserted in the sleeve, the connection can be made secure by holding the iron against the sleeve until the solder inside melts. While joining the two, the plug may be

held by inserting it in a hole drilled in a board. Figs. 20-1, 20-5 and 20-6 show details of connections to different types of Amphenol plugs and adapters. In Fig. 20-1, it is easiest to cut through to the wire with a sharp knife at a distance of $\frac{1}{16}$ inch from the end of the wire and remove the insulation and shielding in one piece. Then slice off a $\frac{1}{16}$ -inch piece of polyethylene which may be slid back onto the wire.

After the braid in Fig. 20-5 has been frayed back, it will be necessary to file the braid down as much as possible to make it fit the plug.

● **COMPONENT VALUES**

Values of composition resistors and small capacitors (mica and ceramic) are specified throughout this *Handbook* in terms of "preferred values." In the preferred-number system, all values represent (approximately) a constant-percentage increase over the next lower value. The base of the system is the number 10. Only two significant figures are used. Table 20-II shows the preferred values based on tolerance steps of 20, 10 and 5 per cent. All other values are expressed by multiplying or dividing the base figures given in the table by the appropriate power of 10. (For example, resistor values of 33,000 ohms, 6800 ohms, and 150 ohms are obtained by multiplying the base figures by 1000, 100, and 10, respectively.)

"Tolerance" means that a variation of plus or minus the percentage given is considered satisfactory. For example, the actual resistance of a "1700-ohm" 20-per-cent resistor can lie anywhere between 3700 and 5600 ohms, approximately. The permissible variation in the same resistance value with 5-per-cent tolerance

20% Tolerance	10% Tolerance	5% Tolerance
10	10	10
		11
		12
		13
15	15	15
		16
		18
		20
		22
		24
		27
		30
33	33	33
		36
		39
		43
47	47	47
		51
		56
		62
68	68	68
		75
		82
		91
100	100	100

would be in the range from 4500 to 4900 ohms, approximately.

Only those values shown in the first column of Table 20-II are available in 20-per-cent tolerance. Additional values, as shown in the second column, are available in 10-per-cent tolerance; still more values can be obtained in 5-per-cent tolerance.

In the component specifications in this *Handbook*, it is to be understood that when no tolerance is specified the *largest* tolerance available in that value will be satisfactory.

Values that do not fit into the preferred-number system (such as 500, 25,000, etc.) easily can be substituted. It is obvious, for example, that a 5000-ohm resistor falls well within the tolerance range of the 4700-ohm 20-per-cent resistor used in the example above. It would not, however, be usable if the tolerance were specified as 5 per cent.

● COLOR CODES

Standardized color codes are used to mark values on small components such as composition resistors and mica capacitors, and to identify leads from transformers, etc. The resistor-capacitor number color code is given in Table 20-III.

Fixed Capacitors

The methods of marking "postage-stamp" mica capacitors, molded paper capacitors, and tubular ceramic capacitors are shown in Fig. 20-8. Capacitors made to American War Standards or Joint Army-Navy specifications are marked with the 6-dot code shown at the top. Practically all surplus capacitors are in this category. The 3-dot RETMA code is used for capacitors having a rating of 500 volts and $\pm 20\%$ tolerance only; other ratings and tolerances are covered by the 6-dot RETMA code.

Examples: A capacitor with a 6-dot code has the following markings: Top row, left to right, black, yellow, violet; bottom row, right to left, brown, silver, red. Since the first color in the top row is black (significant figure zero) this is the AWS code and the capacitor has mica dielectric. The significant figures are 4 and 7, the decimal multiplier 10 (brown, at right of second row), so the capacitance is 470 μf . The tolerance is $\pm 10\%$. The final color, the characteristic, deals with temperature coefficients and methods of testing, and may be ignored.

A capacitor with a 3-dot code has the following colors, left to right: brown, black, red. The significant figures are 1, 0 (10) and the multiplier is 100. The capacitance is therefore 1000 μf .

A capacitor with a 6-dot code has the following markings: Top row, left to right, brown, black, black; bottom row, right to left, black, gold, blue. Since the first color in the top row is neither black nor silver, this is the RETMA code. The significant figures are 1, 0, 0 (100) and the decimal multiplier is 1 (black). The capacitance is therefore 100 μf . The gold dot shows that the tolerance is $\pm 5\%$ and the blue dot indicates 600-volt rating.

Ceramic Capacitors

Conventional markings for ceramic capaci-

tors are shown in the lower drawing of Fig. 20-8. The colors have the meanings indicated in Table 20-IV. In practice, dots may be used instead of the *narrow* bands indicated in Fig. 20-8.

Example: A ceramic capacitor has the following markings: Broad band, violet; narrow bands or dots, green, brown, black, green. The significant figures are 5, 1 (51) and the decimal multiplier is 1, so the capacitance is 51 μf . The temperature coefficient is -750 parts per million per degree C., as given by the broad band, and the capacitance tolerance is $\pm 5\%$.

Fixed Composition Resistors

Composition resistors (including small wire-wound units molded in cases identical with the composition type) are color-coded as shown in

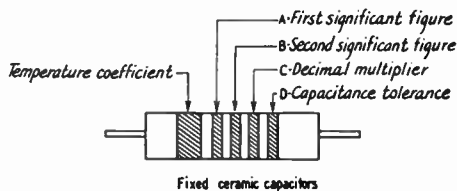
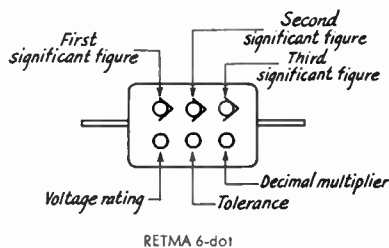
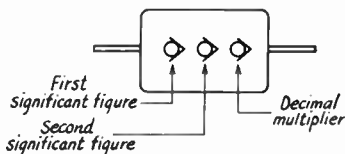
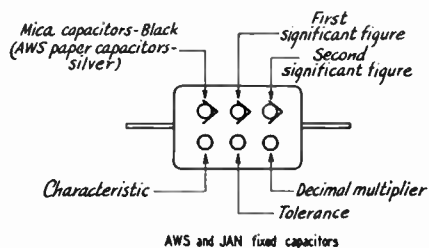

Fig. 20-8 — Color coding of fixed mica, molded paper, and tubular ceramic capacitors. The color code for mica and molded paper capacitors is given in Table 20-III. Table 20-IV gives the color code for tubular ceramic capacitors.

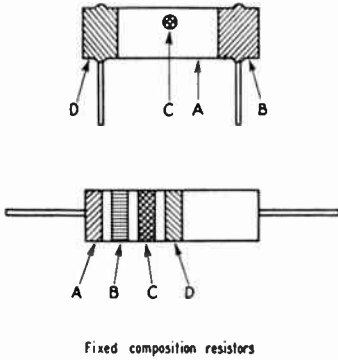

Fig. 20-9 — Color coding of fixed composition resistors. The color code is given in Table 20-III. The colored areas have the following significance:

- A — First significant figure of resistance in ohms.
- B — Second significant figure.
- C — Decimal multiplier.
- D — Resistance tolerance in per cent. If no color is shown, the tolerance is $\pm 20\%$.

Fig. 20-9. Colored bands are used on resistors having axial leads; on radial-lead resistors the colors are placed as shown in the drawing. When bands are used for color coding the body color has no significance.

Examples: A resistor of the type shown in the lower drawing of Fig. 20-9 has the following color bands: A, red; B, red; C, orange; D, no color. The significant figures are 2, 2 (22) and the decimal multiplier is 1000. The value of resistance is therefore 22,000 ohms and the tolerance is $\pm 20\%$.

A resistor of the type shown in the upper drawing has the following colors: body (A), blue; end (B), gray; dot, red; end (D), gold. The significant figures are 6, 8 (68) and the decimal multiplier is 100, so the resistance is 6800 ohms. The tolerance is $\pm 5\%$.

I.F. Transformers

- Blue — plate lead.
- Red — “B” + lead.
- Green — grid (or diode) lead.
- Black — grid (or diode) return.

NOTE: If the secondary of the i.f.t. is center-tapped, the second diode plate lead is green-

Color	Significant Figure	Decimal Multiplier	Tolerance (%)	Voltage Rating*
Black	0	1	-	-
Brown	1	10	1*	100
Red	2	100	2*	200
Orange	3	1000	3*	300
Yellow	4	10,000	4*	400
Green	5	100,000	5*	500
Blue	6	1,000,000	6*	600
Violet	7	10,000,000	7*	700
Gray	8	100,000,000	8*	800
White	9	1,000,000,000	9*	900
Gold	-	0.1	5	1000
Silver	-	0.01	10	2000
No color	-	-	20	500

* Applies to capacitors only.

Color	Significant Figure	Decimal Multiplier	Capacitance Tolerance		Temp. Coeff. p.p.m./deg C.
			More than 10 $\mu\text{mf.}$ (in %)	Less than 10 $\mu\text{mf.}$ (in $\mu\text{mf.}$)	
Black	0	1	± 20	2.0	0
Brown	1	10	± 1		-30
Red	2	100	± 2		-80
Orange	3	1000			-150
Yellow	4				-220
Green	5		± 5	0.5	-330
Blue	6				-470
Violet	7				-750
Gray	8	0.01		0.25	30
White	9	0.1	± 10	1.0	500

and-black striped, and black is used for the center-tap lead.

A.F. Transformers

- Blue — plate (finish) lead of primary.
- Red — “B” + lead (this applies whether the primary is plain or center-tapped).
- Brown — plate (start) lead on center-tapped primaries. (Blue may be used for this lead if polarity is not important.)
- Green — grid (finish) lead to secondary.
- Black — grid return (this applies whether the secondary is plain or center-tapped).
- Yellow — grid (start) lead on center-tapped secondaries. (Green may be used for this lead if polarity is not important.)

NOTE: These markings apply also to line-to-grid and tube-to-line transformers.

Loudspeaker Voice Coils

- Green — finish.
- Black — start.

Loudspeaker Field Coils

- Black and Red — start.
- Yellow and Red — finish.
- Slate and Red — tap (if any).

Power Transformers

- 1) Primary Leads..... Black
If tapped:
Common..... Black
Tap..... Black and Yellow Striped
Finish..... Black and Red Striped
- 2) High-Voltage Plate Winding..... Red
Center-Tap... Red and Yellow Striped
- 3) Rectifier Filament Winding..... Yellow
Center-Tap... Yellow and Blue Striped
- 4) Filament Winding No. 1..... Green
Center-Tap... Green and Yellow Striped
- 5) Filament Winding No. 2..... Brown
Center-Tap... Brown and Yellow Striped
- 6) Filament Winding No. 3..... Slate
Center-Tap... Slate and Yellow Striped

COPPER-WIRE TABLE

Wire Size A.W.G. (B & S)	Diam. in Mils ¹	Circular Mil Area	Turns per Linear Inch ²				Turns per Square Inch ²			Feet per Lb.		Ohms per 1000 ft. 25° C.	Current Carrying Capacity ³ at 700 C.M. per Amp.	Diam. in mm.	Nearest British S.W.G. No.
			Enamel	S.S.C. ⁴	D.S.C. ⁵ or S.C.C. ⁶	D.C.C. ⁷	S.C.C.	Enamel S.C.C.	D.C.C.	Bare	D.C.C.				
1	289.3	83990	—	—	—	—	—	—	—	3.947	—	.1264	119.6	7.348	1
2	257.6	66370	—	—	—	—	—	—	—	4.977	—	.1593	94.8	6.544	3
3	229.4	52610	—	—	—	—	—	—	—	6.276	—	.2009	75.2	5.827	4
4	204.3	41740	—	—	—	—	—	—	—	7.914	—	.2533	59.6	5.189	5
5	181.9	33100	—	—	—	—	—	—	—	9.980	—	.3195	47.3	4.621	7
6	162.0	26250	—	—	—	—	—	—	—	12.58	—	.4028	37.5	4.115	8
7	144.3	20820	—	—	—	—	—	—	—	15.87	—	.5080	29.7	3.665	9
8	128.5	16510	7.6	—	7.4	7.1	—	—	—	20.01	19.6	.6405	23.6	3.264	10
9	114.1	13090	8.6	—	8.2	7.8	—	—	—	25.23	24.6	.8077	18.7	2.906	11
10	101.9	10380	9.6	—	9.3	8.9	87.5	84.8	80.0	31.82	30.9	1.018	14.8	2.588	12
11	90.74	8234	10.7	—	10.3	9.8	110	105	97.5	40.12	38.8	1.284	11.8	2.305	13
12	80.81	6530	12.0	—	11.5	10.9	136	131	121	50.59	48.9	1.619	9.33	2.053	14
13	71.96	5178	13.5	—	12.8	12.0	170	162	150	63.80	61.5	2.042	7.40	1.828	15
14	64.08	4107	15.0	—	14.2	13.8	211	198	183	80.44	77.3	2.575	5.87	1.628	16
15	57.07	3257	16.8	—	15.8	14.7	262	250	223	101.4	97.3	3.247	4.65	1.450	17
16	50.82	2583	18.9	18.9	17.9	16.4	321	306	271	127.9	119	4.094	3.69	1.291	18
17	45.26	2048	21.2	21.2	19.9	18.1	397	372	329	161.3	150	5.163	2.93	1.150	18
18	40.30	1624	23.6	23.6	22.0	19.8	493	454	399	203.4	188	6.510	2.32	1.024	19
19	35.89	1288	26.4	26.4	24.4	21.8	592	553	479	256.5	237	8.210	1.81	.9116	20
20	31.96	1022	29.4	29.4	27.0	23.8	775	725	625	323.4	298	10.35	1.46	.8118	21
21	28.46	810.1	33.1	32.7	29.8	26.0	940	895	754	407.8	370	13.05	1.16	.7230	22
22	25.35	642.4	37.0	36.5	34.1	30.0	1150	1070	910	514.2	461	16.46	.918	.6438	23
23	22.57	509.5	41.3	40.6	37.6	31.6	1400	1300	1080	648.4	584	20.76	.728	.5733	24
24	20.10	404.0	46.3	45.3	41.5	35.6	1700	1570	1260	817.7	745	26.17	.577	.5106	25
25	17.90	320.4	51.7	50.4	45.6	38.6	2060	1910	1510	1031	903	33.00	.458	.4547	26
26	15.94	254.1	58.0	55.6	50.2	41.8	2500	2300	1700	1300	1118	41.62	.363	.4049	27
27	14.20	201.5	64.9	61.5	55.0	45.0	3030	2780	2020	1639	1422	52.48	.288	.3606	27
28	12.64	159.8	72.7	68.6	60.2	48.5	3670	3350	2310	2067	1759	66.17	.228	.3211	30
29	11.26	126.7	81.6	74.8	65.4	51.8	4300	3900	2700	2607	2207	83.44	.181	.2859	31
30	10.03	100.5	90.5	83.3	71.5	55.5	5040	4660	3020	3287	2534	105.2	.144	.2546	33
31	8.928	79.70	101	92.0	77.5	59.2	5920	5280	—	4145	2768	132.7	.114	.2268	34
32	7.950	63.21	113	101	83.6	62.6	7060	6250	—	5227	3137	167.3	.090	.2019	36
33	7.080	50.13	127	110	90.3	66.3	8120	7360	—	6591	4697	211.0	.072	.1798	37
34	6.305	39.75	143	120	97.0	70.0	9600	8310	—	8310	6168	266.0	.057	.1601	38
35	5.615	31.52	158	132	104	73.5	10900	8700	—	10480	6737	335.0	.045	.1426	38-39
36	5.000	25.00	175	143	111	77.0	12200	10700	—	13210	7877	423.0	.036	.1270	39-40
37	4.453	19.83	198	154	118	80.3	—	—	—	16660	9309	533.4	.028	.1131	41
38	3.965	15.72	224	166	126	83.6	—	—	—	21010	10666	672.6	.022	.1007	42
39	3.531	12.47	248	181	133	86.6	—	—	—	26500	11907	848.1	.018	.0897	43
40	3.145	9.88	282	194	140	89.7	—	—	—	33410	14222	1069	.014	.0799	44

¹ A mil is 1/1000 (one-thousandth) of an inch. ² The figures given are approximate only, since the thickness of the insulation varies with different manufacturers. ³ 700 circular mils per ampere is a satisfactory design figure for small transformers, but values from 500 to 1000 C.M. are commonly used. For 1000 C.M./amp. divide the circular mil area (third column) by 1000; for 500 C.M./amp. divide circular mil area by 500. ⁴ Single silk-covered. ⁵ Double silk-covered. ⁶ Single cotton-covered. ⁷ Double cotton-covered.

Measurements

It is practically impossible to operate an amateur station without making measurements at one time or another. Although quite crude measurements often will suffice, more refined equipment and methods will yield more and better information. With adequate information at hand it becomes possible to adjust a piece of equipment for optimum performance quickly and surely, and to design circuits along established principles rather than depending on cut-and-try.

Measuring and test equipment is valuable during construction, for testing components before installation. It is practically indispensable in the initial adjustment of radio gear, not only for establishing operating values but also for tracing possible errors in wiring. It is likewise needed for locating breakdowns and defective components in existing equipment.

The basic measurements are those of current, voltage, and frequency. Determination of the values of circuit elements — resistance, inductance and capacitance — are almost equally im-

portant. The inspection of wave form in audio-frequency circuits is highly useful. For these purposes there is available a wide assortment of instruments, both complete and in kit form; the latter, particularly, compare very favorably in cost with strictly home-built instruments and are frequently more satisfactory both in appearance and calibration. The home-built instruments described in this chapter are ones having features of particular usefulness in amateur applications, and not ordinarily available commercially.

In using any instrument it should always be kept in mind that the accuracy depends not only on the inherent accuracy of the instrument itself (which, in the case of commercially built units is usually within a few per cent, and in any event should be specified by the manufacturer) but also the conditions under which the measurement is made. Large errors can be introduced by failing to recognize the existence of conditions that affect the instrument readings. This is particularly true in certain types of r.f. measurements, where stray effects are hard to eliminate.

Voltage, Current, and Resistance

● D.C. MEASUREMENTS

A direct-current instrument — voltmeter, ammeter, milliammeter or microammeter — is a device in which magnetic force is used to deflect a pointer over a calibrated scale in proportion to the current flowing. In the **D'Arsonval** type a coil of wire, to which the pointer is attached, is pivoted between the poles of a permanent magnet, and when current flows through the coil it causes a magnetic field that interacts with that of the magnet to cause the coil to turn. The turning force is exerted against a spiral spring attached to the coil and the pointer deflection is directly proportional to the current.

A less expensive type of instrument is the **moving-vane** type, in which a pivoted soft-iron vane is pulled into a coil of wire by the magnetic field set up when current flows through the coil. The farther the vane extends into the coil the greater the magnetic force on it, for a given change in current, so this type of instrument does not have "linear" deflection — that is, the scale is cramped at the low-current end and spread out at the high-current end.

The same basic instrument is used for measuring either current or voltage. Good-quality instruments are made with fairly high **sensitivity** —

that is, they give full-scale pointer deflection with very small currents — when intended to be used as voltmeters. The sensitivity of instruments intended for measuring large currents can be lower, but a highly sensitive instrument can be, and frequently is, used for measurement of currents much greater than needed for full-scale deflection.

Panel-mounting instruments of the D'Arsonval type will give a lower deflection when mounted on iron or steel panels than when mounted on nonmagnetic material. Readings may be as much as ten percent low. Specially calibrated meters should be obtained for mounting on such panels.

● VOLTMETERS

Only a fraction of a volt is required for full-scale deflection of a sensitive instrument (1 milliamperer or less full scale) so a high resistance is connected in series with it. Fig. 21-1, for measuring voltage. Knowing the current and the resistance, the voltage can easily be calculated from Ohm's Law. The meter is calibrated in terms of the voltage drop across the series resistor or multiplier. Practically any desired full-scale

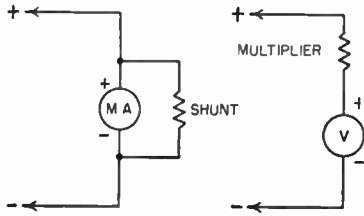

Fig. 21-1 — How voltmeter multipliers and milliammeter shunts are connected to extend the range of a d.c. meter.

voltage range can be obtained by proper choice of multiplier resistance, and voltmeters frequently have several ranges selected by a switch.

The sensitivity of the voltmeter is usually expressed in "ohms per volt." A sensitivity of 1000 ohms per volt means that the resistance of the voltmeter is 1000 times the full-scale voltage, and by Ohm's Law the current required for full-scale deflection is 1 milliampere. A sensitivity of 20,000 ohms per volt, another commonly used value, means that the instrument is a 50-microampere meter. The higher the resistance of the voltmeter the more accurate the measurements

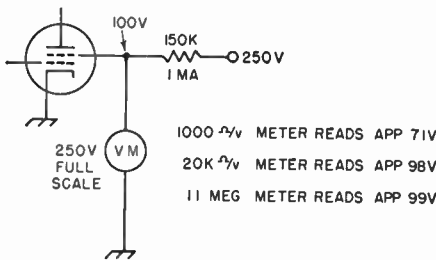

Fig. 21-2 — Effect of voltmeter resistance on accuracy of readings. It is assumed that the d.c. resistance of the screen circuit is constant at 100 kilohms. The actual current and voltage without the voltmeter connected are 1 ma. and 100 volts. The voltmeter readings will differ because the different types of meters draw different amounts of current through the 150-kilohm resistor.

in high-resistance circuits. This is because the current flowing through the voltmeter will cause a change in the voltage between the points across which the meter is connected, compared with the voltage with the meter absent, as shown in Fig. 21-2.

Multipliers

The required multiplier resistance is found by dividing the desired full-scale voltage by the current, in amperes, required for full-scale deflection of the meter alone. Strictly, the internal resistance of the meter should be subtracted from the value so found, but this is seldom necessary (except perhaps for very low ranges) because the meter resistance will be negligibly small compared with the multiplier resistance. An exception is when the instrument is already provided with an internal multiplier, in which case the multiplier resistance required to extend the range is

$$R = R_m(n - 1)$$

where R is the multiplier resistance, R_m is the total resistance of the instrument itself, and n is the factor by which the scale is to be multiplied. For example, if a 1000-ohms-per-volt voltmeter having a calibrated range of 0-10 volts is to be extended to 1000 volts, R_m is $1000 \times 10 = 10,000$ ohms, n is $1000/10 = 100$, and $R = 10,000(100 - 1) = 990,000$ ohms.

If a milliammeter is to be used as a voltmeter, the value of series resistance can be found by Ohm's Law:

$$R = \frac{1000E}{I}$$

where E is the desired full-scale voltage and I the full-scale reading of the instrument in milliamperes.

Accuracy

The accuracy of a voltmeter depends on the calibration accuracy of the instrument itself and the accuracy of the multiplier resistors. Good-quality instruments are generally rated for an accuracy within plus or minus 2 percent. This is also the usual accuracy rating of the basic meter movement.

When extending the range of a voltmeter or converting a low-range milliammeter into a voltmeter the rated accuracy of the instrument is retained only when the multiplier resistance is precise. Precision wire-wound resistors are used in the multipliers of high-quality instruments. These are relatively expensive, but the home constructor can do quite well with 1% tolerance composition resistors. They should be "derated" when used for this purpose — that is, the actual power dissipated in the resistor should not be more than 1/4 to 1/2 the rated dissipation — and care should be used to avoid overheating the body of the resistor when soldering to the leads. These precautions will help prevent permanent change in the resistance of the unit.

Ordinary composition resistors are generally furnished in 10% or 5% tolerance ratings. If possible errors of this order can be accepted, resistors of this type may be used as multipliers. They should be operated below the rated power dissipation figure, in the interests of long-time stability.

● **MILLIAMMETERS AND AMMETERS**

A microammeter or milliammeter can be used to measure currents larger than its full-scale reading by connecting a resistance shunt across its terminals as shown in Fig. 21-1. Part of the current flows through the shunt and part through the meter. Knowing the meter resistance and the shunt resistance, the relative currents can easily be calculated.

The value of shunt resistance required for a given full-scale current range is given by

$$R = \frac{R_m}{n - 1}$$

where R is the shunt, R_m is the internal resistance of the meter, and n is the factor by which the

original meter scale is to be multiplied. The internal resistance of a milliammeter is preferably determined from the manufacturer's catalog, but if this information is not available it can be determined by the method shown in Fig. 21-3. Do not attempt to use an ohmmeter to measure the internal resistance of a milliammeter; it may ruin the instrument.

Homemade milliammeter shunts can be constructed from any of the various special kinds of resistance wire, or from ordinary copper wire if no resistance wire is available. The Copper Wire Table in this *Handbook* gives the resistance per 1000 feet for various sizes of copper wire. After computing the resistance required, determine the smallest wire size that will carry the full-scale current (250 circular mils per ampere is a satisfactory figure for this purpose).

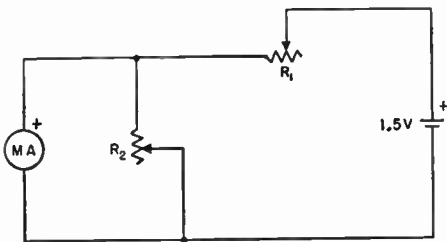

Fig. 21-3 — Determining the internal resistance of a milliammeter or microammeter. R_1 is an adjustable resistor having a maximum value about twice that necessary for limiting the current to full scale with R_2 disconnected; adjust it for exactly full-scale reading. Then connect R_2 and adjust it for exactly half-scale reading. The resistance of R_2 is then equal to the internal resistance of the meter, and the resistor may be removed from the circuit and measured separately. Internal resistances vary from a few ohms to several hundred ohms, depending on the sensitivity of the instrument.

Measure off enough wire to provide the required resistance. Accuracy can be checked by causing enough current to flow through the meter to make it read full scale without the shunt; connecting the shunt should then give the correct reading on the new full-scale range.

Current Measurement with a Voltmeter

A current-measuring instrument should have very low resistance compared with the resistance of the circuit being measured; otherwise, inserting the instrument will cause the current to differ from its value with the instrument out of the circuit. (This does not matter if the instrument is left permanently in the circuit.) However, the resistance of many circuits in radio equipment is quite high and the circuit operation is affected little, if at all, by adding as much as a few hundred ohms in series. In such cases the voltmeter method of measuring current, shown in Fig. 21-4, is frequently convenient. A voltmeter — or low-range milliammeter provided with a multiplier and operating as a voltmeter — having a full-scale voltage range of a few volts, is used to measure the voltage drop across a compara-

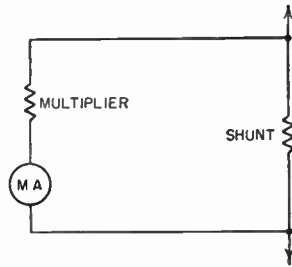

Fig. 21-4 — Voltmeter method of measuring current. This method permits using relatively large values of resistance in the shunt, standard values of fixed resistors frequently being usable. If the multiplier resistance is 20 times the shunt resistance (or more) the error in assuming that all the current flows through the shunt will not be of consequence in most practical applications.

tively high resistance acting as a shunt. The formula previously given is used for finding the proper value of shunt resistance for a given scale-multiplying factor, R_m in this case being the multiplier resistance.

D.C. Power

Power in direct-current circuits is determined by measuring the current and voltage. When these are known, the power is equal to the voltage in volts multiplied by the current in amperes. If the current is measured with a milliammeter, the reading must be divided by 1000 to convert it to amperes.

RESISTANCE MEASUREMENTS

Measurement of d.c. resistance is based on measuring the current through the resistance when a known voltage is applied, then using Ohm's Law. A simple circuit is shown in Fig. 21-5.

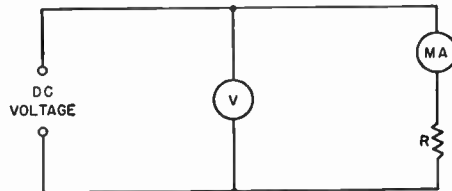

Fig. 21-5 — Measuring resistance with a voltmeter and milliammeter. If the approximate resistance is known the voltage can be selected to cause the milliammeter, MA , to read about half scale. If not, additional resistance should be first connected in series with R to limit the current to a safe value for the milliammeter. The set-up then measures the total resistance, and the value of R can be found by subtracting the known additional resistance from the total.

The internal resistance of the ammeter or milliammeter, MA , should be low compared with the resistance, R , being measured, since the voltage read by the voltmeter, V , is the voltage across MA and R in series. The instruments and the d.c. voltage should be chosen so that the readings are in the upper half of the scale, if possible, since the percentage error is less in this region.

An ohmmeter is an instrument consisting

fundamentally of a voltmeter (or milliammeter, depending on the circuit used) and a small dry battery as a source of d.c. voltage, calibrated so the value of an unknown resistance can be read directly from the scale. Typical ohmmeter circuits are shown in Fig. 21-6. In the simplest type, shown in Fig. 21-6A, the meter and battery are connected in series with the unknown resistance. If a given deflection is obtained with terminals *A-B* shorted, inserting the resistance to be measured will cause the meter reading to decrease. When the resistance of the voltmeter is known, the following formula can be applied:

$$R = \frac{eR_m}{E} - R_m$$

where *R* is the resistance under measurement,
e is the voltage applied (*A-B* shorted),
E is the voltmeter reading with *R* connected, and
R_m is the resistance of the voltmeter.

The circuit of Fig. 21-6A is not suited to measuring low values of resistance (below a hundred ohms or so) with a high-resistance voltmeter. For such measurements the circuit of Fig. 21-6B can be used. The milliammeter should be a 0-1 ma. instrument, and *R₁* should be equal to the battery voltage, *e*, multiplied by 1000. The unknown resistance is

$$R = \frac{I_2 R_m}{I_1 - I_2}$$

where *R* is the unknown,
R_m is the internal resistance of the milliammeter,
I₁ is the current in ma. with *R* disconnected from terminals *A-B*, and
I₂ is the current in ma. with *R* connected.

The formula is approximate, but the error will be negligible if *e* is at least 3 volts so that *R₁* is at least 3000 ohms.

A third circuit for measuring resistance is shown in Fig. 21-6C. In this case a high-resistance voltmeter is used to measure the voltage drop across a reference resistor, *R₂*, when the unknown resistor is connected so that current flows through it, *R₂* and the battery in series. By suitable choice of *R₂* (low values for low resistance, high values for high-resistance unknowns) this circuit will give equally good results on all resistance values in the range from one ohm to several megohms, provided that the voltmeter resistance, *R_m*, is always very high (50 times or more) compared with the resistance of *R₂*. A 20,000-ohms-per-volt instrument (50-μamp. movement) is generally used. Assuming that the current through the voltmeter is negligible compared with the current through *R₂*, the formula for the unknown is

$$R = \frac{eR_2}{E} - R_2$$

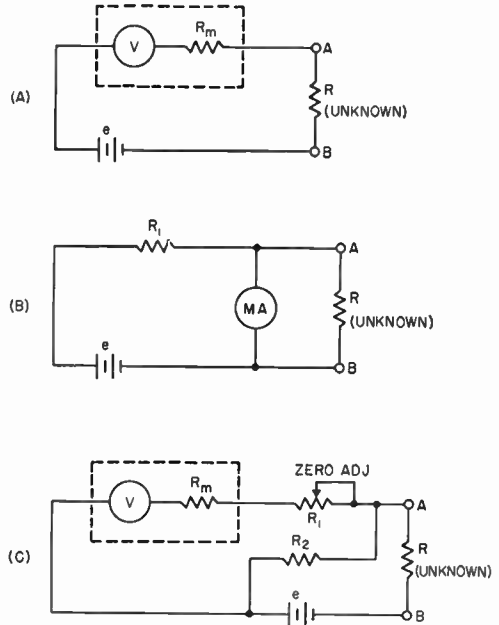

Fig. 21-6 — Ohmmeter circuits. Values are discussed in the text.

where *R* and *R₂* are as shown in Fig. 21-6C,
e is the voltmeter reading with *A-B* shorted, and
E is the voltmeter reading with *R* connected.

The “zero adjuster,” *R₁*, is used to set the voltmeter reading exactly to full scale when the meter is calibrated in ohms. A 10,000-ohm variable resistor is suitable with a 20,000-ohms-per-volt meter. The battery voltage is usually 3 volts for ranges up to 100,000 ohms or so and 6 volts for higher ranges.

A. C. Measurements

Several types of instruments are available for measurement of low-frequency alternating currents and voltages. The better-grade panel instruments for power-line frequencies are of the dynamometer type. This compares with the D'Arsonval movement used for d.c. measurements, but instead of a permanent magnet the dynamometer movement has a field coil which, together with the moving coil, is connected to the a.c. source. Thus the force on the moving coil will be exerted in the same direction on both halves of the a.c. cycle.

Moving-vane type instruments, described earlier, also are used for a.c. measurements. This is possible because the pull exerted on the vane is in the same direction regardless of the direction of current through the coil. The calibration of a moving-vane instrument on a.c. will, in general, differ from its d.c. calibration.

For measurements in the audio-frequency range, and in applications where high impedance is required, the rectifier-type a.c. instrument is

generally used. This is essentially a sensitive d.c. meter of the type previously described, provided with a rectifier for converting the a.c. to d.c. A typical rectifier-type voltmeter circuit is shown in Fig. 21-7. The half-wave meter rectifier, CR_1 , is generally of the copper-oxide type. Such a rectifier is not "perfect" — that is, the application of a voltage of reversed polarity will result in a small current flow — and so CR_2 is used for eliminating the effect of reverse current in the meter circuit. It does this by providing a low-resistance path across CR_1 and the meter during the a.c. alternations when CR_1 is not conducting.

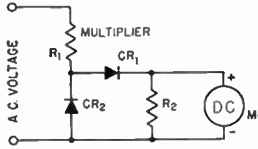

Fig. 21-7 — Rectifier-type a.c. voltmeter circuit, with "linearizing" resistor and diode for back-current correction.

Resistor R_2 shunted across M_1 is used for improving the linearity of the circuit. The effective resistance of the copper-oxide rectifier decreases with increasing current through the rectifier, leading to a calibration scale with nonuniform divisions. This is overcome to a considerable extent by "bleeding" several times as much current through R_2 as flows through M_1 so the rectifier is always carrying a fairly large current.

Because of these expedients and the fact that with half-wave rectification the average current is only 0.45 times the r.m.s. value of a sine wave producing it, the impedance of a rectifier-type voltmeter is rather low compared with the resistance of a d.c. voltmeter using the same meter. Values of 1000 ohms per volt are representative, when the d.c. instrument is a 0-200 microammeter.

The d.c. instrument responds to the average value of the rectified alternating current. This average current will vary with the shape of the a.c. wave applied to the rectifier, and so the meter reading will not be the same for different wave forms having the same maximum values or

the same r.m.s. values. Hence a "wave-form error" is always present unless the a.c. wave is very closely sinusoidal. The actual calibration of the instrument usually is in terms of the r.m.s. value of a sine wave.

Modern rectifier-type a.c. voltmeters are capable of good accuracy, within the wave-form limitations mentioned above, throughout the audio-frequency range.

COMBINATION INSTRUMENTS — THE V.O.M.

Since the same basic instrument is used for measuring current, voltage and resistance, the three functions can readily be combined in one unit using a single meter. Various models of the "v.o.m." (volt-ohm-milliammeter) are available commercially, both completely assembled and in kit form. The less expensive ones use a 0-1 milliammeter as the basic instrument, providing voltmeter ranges at 1000 ohms per volt. The more elaborate meters of this type use a microammeter — 0-50 microamperes, frequently — with voltmeter resistances of 20,000 ohms per volt. With the more sensitive instruments it is possible to make resistance measurements in the megohms range. A.c. voltmeter scales also are frequently included.

The v.o.m., even a very simple one, is among the most useful instruments for the amateur. Besides current and voltage measurements, it can be used for checking continuity in circuits, for finding defective components before installation — shorted capacitors, open or otherwise defective resistors, etc. — shorts or opens in wiring, and many other checks that, if applied during the construction of a piece of equipment, save much time and trouble. It is equally useful for servicing, when a component fails during operation.

THE VACUUM-TUBE VOLTMETER

The usefulness of the vacuum-tube voltmeter (v.t.v.m.) is based on the fact that a vacuum tube can amplify without taking power from the source of voltage applied to its grid. It is therefore possible to have a voltmeter of extremely high resist-

- C_1 — 0.002- to 0.005- μ f. mica.
- C_2 — 0.01 μ f., 1000 to 2000 volts, paper or mica.
- R_1 — 1 megohm, $\frac{1}{2}$ watt.
- R_2 to R_5 , inclusive — To give desired voltage ranges, totaling 10 megohms.
- R_6, R_7 — 2 to 3 megohms.
- R_8 — 10,000-ohm variable.
- R_9, R_{10} — 2000 to 3000 ohms.
- R_{11} — 5000- to 10,000-ohm potentiometer.
- R_{12} — 10,000 to 50,000 ohms.
- R_{13}, R_{14} — App. 25,000 ohms.
- A 50,000-ohm slider-type wire-wound can be used.
- R_{15} — 10 megohms.
- R_{16} — 3 megohms.
- R_{17} — 10-megohm variable.
- M — Microammeter, range from 0-200 μ amp. to 0-1 ma.
- V_1 — Dual triode, 6SN7 or 12AU7.
- V_2 — Dual diode, 6116 or 6AL5

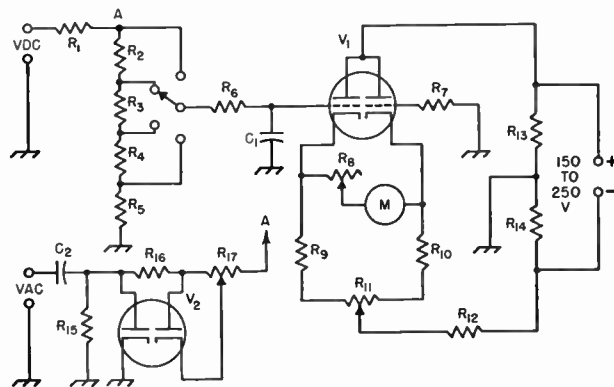

Fig. 21-8 — Vacuum-tube voltmeter circuit.

ance, and thus take negligible current from the circuit under measurement, without using a d.c. instrument of exceptional sensitivity.

The v.t.v.m. has the disadvantage that it requires a source of power for its operation, as compared with a regular d.c. instrument. Also, it is susceptible to r.f. pick-up when working around an operating transmitter, unless well shielded and filtered. The fact that one of its terminals is grounded is also disadvantageous in some cases, since a.c. readings in particular may be inaccurate if an attempt is made to measure a circuit having both sides "hot" with respect to ground. Nevertheless, the high resistance of the v.t.v.m. more than compensates for these disadvantages, especially since in the majority of measurements they do not apply.

While there are several possible circuits, the one commonly used is shown in Fig. 21-8. A dual triode, V_1 , is arranged so that, with no voltage applied to the left-hand grid, equal currents flow through both sections. Under this condition the two cathodes are at the same potential and no current flows through M . The currents can be adjusted to balance by potentiometer R_{11} , which takes care of variations in the tube sections and in the values of cathode resistors R_9 and R_{10} . When a d.c. voltage is applied to the left-hand grid the current through that tube section changes but the current through the other section remains unchanged, so the balance is upset and the meter indicates. The sensitivity of the meter is regulated by R_8 , which serves to adjust the calibration. R_{12} , common to the cathodes of both tube sections, is a feed-back resistor that stabilizes the system and makes the readings linear. R_6 and C_1 form a filter for any a.c. component that may be present, and R_6 is balanced by R_7 connected to the grid of the second tube section.

To stay well within the linear range of operation the scale is limited to 3 volts or less in the average commercial instrument. Higher ranges are obtained by means of the voltage divider formed by R_1 to R_5 , inclusive. As many ranges as desired can be used. Common practice is to use 1 megohm at R_1 , and to make the sum of R_2 to R_5 , inclusive, 10 megohms, thus giving a total resistance of 11 megohms, constant for all voltage ranges. R_1 should be at the probe end of the d.c. lead to minimize capacity loading effects.

Values to be used in the circuit depend considerably on the supply voltage and the sensitivity of the meter, M . R_{12} , and R_{13} - R_{14} , should be adjusted so that the voltmeter circuit can be brought to balance, and to give full-scale deflection on M with about 3 volts applied to the grid. The meter connections can be reversed to read voltages that are negative with respect to ground.

A.C. Voltage

For measuring a.c. voltages the rectifier circuit shown at the lower left of Fig. 21-9 is used. One section of the double diode, V_2 , is a half-wave rectifier and the second half acts as a balancing device, adjustable by R_{17} , to eliminate contact

potential effects that would cause a constant d.c. voltage to appear at the v.t.v.m. grid.

The rectifier output voltage is proportional to the peak amplitude of the a.c. wave, rather than to the average or r.m.s. values. Since the positive and negative peaks of a complex wave may not have equal amplitudes, a different reading may be obtained on such wave forms when the voltmeter probe terminals are reversed. This "turn-over" effect is inherent in any peak-indicating device, but is not necessarily a disadvantage. The fact that the readings are not the same when the voltmeter connections are reversed is an indication that the wave form under measurement is unsymmetrical. In some measurements, as in audio amplifiers, a peak measurement is more useful than an r.m.s. or average-value measurement because amplifier capabilities are based on the peak amplitudes that must be handled.

The scale calibration usually is based on the r.m.s. value of a sine wave, R_8 being set so that the same scale can be used either for a.c. or d.c. The r.m.s. reading can easily be converted to a peak reading by multiplying by 1.41.

● CALIBRATION

When extending the range of a d.c. instrument calibration usually is necessary, although resistors for voltmeter multipliers often can be purchased to close-enough tolerances so that the new range will be accurately known. However, in calibrating an instrument such as a v.t.v.m. a known voltage must be available to provide a starting point. Fresh dry cells have an open-circuit terminal voltage of approximately 1.6 volts, and one or more of them may be connected in series to provide several calibration points on the low range. Gas regulator tubes in a power supply, such as the 0C3, 0D3, etc., also provide a stable source of voltage whose value is known within a few per cent. Once a few such points are determined the voltmeter ranges may be extended readily by adding multipliers or a voltage divider as appropriate.

Shunts for a milliammeter may be adjusted by first using the meter alone in series with a source of voltage and a resistor selected to limit the current to full scale. For example, a 0-1 milliammeter may be connected in series with a dry cell and a 2000-ohm variable resistor, the latter being adjusted to allow exactly 1 milliampere to flow. Then the shunt is added across the meter and its resistance adjusted to reduce the meter reading by exactly the scale factor, n . If n is 5, the shunt would be adjusted to make the meter read 0.2 milliampere, so the full-scale current will be 5 ma. Using the new scale, the second shunt is added to give the next range, the same procedure being followed. This can be carried on for several ranges, but it is advisable to check the meter on the highest range against a separate meter used as a standard, since the errors in this process tend to be cumulative.

Measurement of Frequency and Wave Length

● ABSORPTION FREQUENCY METERS

The simplest possible frequency-measuring device is a resonant circuit, tunable over the desired frequency range and having its tuning dial calibrated in terms of frequency. It operates by extracting a small amount of energy from the oscillating circuit to be measured, the frequency being determined by the tuning setting at which the energy absorption is maximum (Fig. 21-9).

Although such an instrument is not capable of

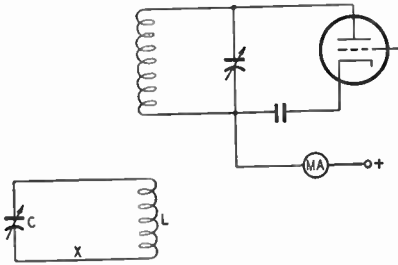

Fig. 21-9 — Absorption frequency meter and a typical application. The meter consists simply of a calibrated resonant circuit L_1C_1 . When coupled to an amplifier or oscillator the tube plate current will rise when the frequency meter is tuned to resonance. A flashlight lamp may be connected in series at X to give a visual indication, but it decreases the selectivity of the instrument and makes it necessary to use rather close coupling to the circuit being measured.

very high accuracy, because the Q of the tuned circuit cannot be high enough to avoid uncertainty in the exact setting and because any two coupled circuits interact to some extent and change each others' tuning, the absorption wave meter or frequency meter is nevertheless a highly useful instrument. It is compact, inexpensive, and requires no power supply. There is no ambiguity in its indications, as is frequently the case with the heterodyne-type instruments described later.

When an absorption meter is used for checking a transmitter, the plate current of the tube connected to the circuit being checked can provide the necessary resonance indication. When the frequency meter is loosely coupled to the tank circuit the plate current will give a slight upward flicker as the meter is tuned through resonance. The accuracy is greatest when the loosest possible coupling is used.

A receiver oscillator may be checked by tuning in a steady signal and heterodyning it to give a beat note as in ordinary c.w. reception. When the frequency meter is coupled to the oscillator coil and tuned through resonance the beat note will change. Again, the coupling should be made loose enough so that a just-perceptible change in beat note is observed.

An approximate calibration for the wave meter, adequate for most purposes, may be obtained by comparison with a calibrated receiver. The usual receiver dial calibration is

sufficiently accurate. A simple oscillator circuit covering the same range as the frequency meter will be useful in calibration. Set the receiver to a given frequency, tune the oscillator to zero beat at the same frequency, and adjust the frequency meter to resonance with the oscillator as described above. This gives one calibration point. When a sufficient number of such points has been obtained a graph may be drawn to show frequency *vs.* dial settings on the frequency meter.

● INDICATING WAVE METERS

The plain absorption meter requires fairly close coupling to the oscillating circuit in order to affect the plate current of a tube sufficiently to give a visual indication. However, by adding a rectifier and d.c. microammeter or milliammeter, the sensitivity of the instrument can be increased to the point where very loose coupling will suffice for a good reading. A typical circuit for this purpose is given in Fig. 21-10, and Figs. 21-11 and 21-12 show how such an instrument can be constructed.

The rectifier, a crystal diode, is coupled to the tuned circuit L_1C_1 through a coupling coil, L_2 , having a relatively small number of turns. The step-down transformer action from L_1 to L_2 provides for efficient energy transfer from the high-impedance tuned circuit to the low-impedance rectifier circuit. The number of turns on L_2 can be adjusted for maximum reading on the d.c.

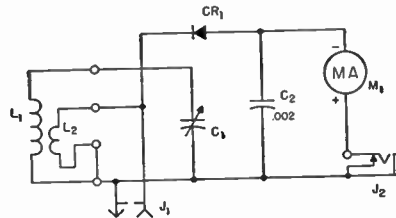

Fig. 21-10 — Circuit diagram of indicating wave meter.

C_1 — 50- μ mf. variable (Johnson 50R12).

C_2 — 0.002- μ f. disk ceramic.

CR1 — General purpose germanium diode (1N34, etc.)

J1 — Phono jack.

J2 — Closed-circuit phone jack.

M1 — D.c. microammeter or 0-1 milliammeter.

Freq. Range	Coil Data		Coil Length, In.
	Turns, L_1	Turns, L_2	
3-6 Mc.	60	5	close-wound
6-12 Mc.	29	5	1 1/4
12-25 Mc.	13	2	1
23-50 Mc.	5 1/4	1	1/2
50-100 Mc.	1 1/2	1/2	1/4
90-225 Mc.	See below		

All except 90-225-Mc. coil wound with No. 24 enam. wire on 1-inch diameter 4-prong forms (Millen 45004). L_2 interwound at bottom of L_1 , using smaller wire where necessary. The 90-225-Mc. coil consists of a hairpin loop of No. 11 tinned wire just clearing the bottom of the coil form, which is cut to 5/8-inch length. L_2 is a similar hairpin of No. 16 wire bent over so it almost touches L_1 .

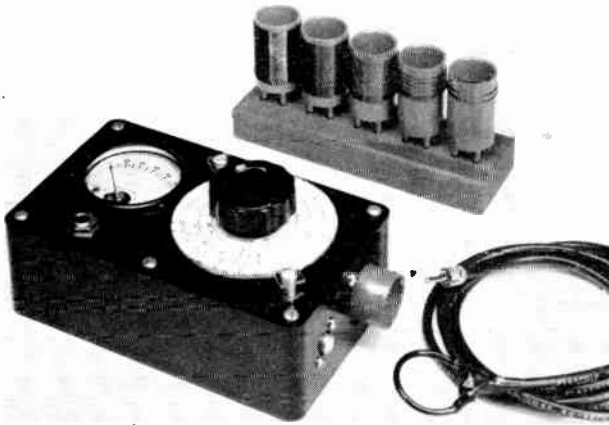

Fig. 21-11—The indicating wave meter, plug-in coils, and pick-up cables. The meter is built in a bakelite meter case measuring $6\frac{3}{4} \times 3\frac{3}{4} \times 2$ inches. The 3-inch dial is cut from a piece of aluminum and has a paper hand-calibrated scale cemented on. Hairline indicators are clear plastic mounted on small metal pillars. A 2-inch d.c. instrument is used. Pick-up loops are one turn of No. 11, spaghetti covered, soldered to the ends of the cables. The longer cable (5 feet) is useful to 30 Mc.; the shorter (13 inches) can be used for the full frequency range. Both are RG-58/U.

millimeter; when doing this, use a fixed value of coupling between L_1 and the source of energy. The proper number of turns for this purpose will depend on the sensitivity of M_1 . The coil dimensions given in Fig. 1 are for a 0-500 microammeter but will also be satisfactory for a 0-1 millimeter. Less than optimum coupling is preferable, in most cases, since heavy loading lowers the Q of the tuned circuit L_1C_1 and makes it less selective. The coupling is reduced by reducing the number of turns on L_2 .

The wave meter can be used with a pick-up loop and coaxial line connected to J_1 . Energy picked up by the loop is fed through the cable to L_2 and thence coupled to L_1C_1 . This is a convenient method of coupling the wave meter to circuits where it would be physically difficult to secure inductive coupling to L_1 . The pick-up cable should not be self-resonant, as a transmission-line section, at any frequency within the range in which it is to be used, so two cable lengths are provided. The longer one is useful up to 30 Mc. and the shorter at all frequencies up to the maximum useful frequency of the wave meter (225 Mc.).

By plugging a headset into the output jack (phones having 2000 ohms or greater resistance

should be used for greatest sensitivity) the wave meter can be used as a monitor for modulated transmissions.

The bakelite case is a desirable feature since the instrument can be brought close to circuits being checked without the danger of short-circuiting any of their wiring. This could occur with a metal-cased unit.

In addition to the uses mentioned earlier, a meter of this type may be used for final adjustment of neutralization in r.f. amplifiers. For this purpose the pick-up loop may be loosely coupled to the plate tank coil. In this case L_1 may be removed from its socket and the meter used as an untuned rectifier. This reduces the sensitivity and insures that the r.f. pickup is only from the tank coil to which the loop is closely coupled.

● LECHER WIRES

At very-high and ultrahigh frequencies it is possible to determine frequency by actually measuring the length of the waves generated. The measurement is made by observing standing waves on a two-wire parallel transmission line or Lecher wires. Such a line shows pronounced resonance effects, and it is pos-

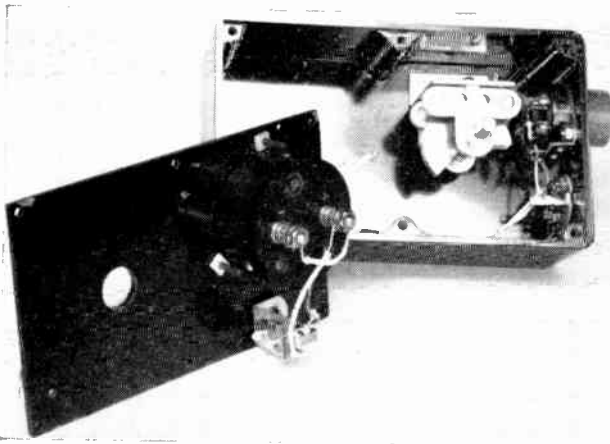
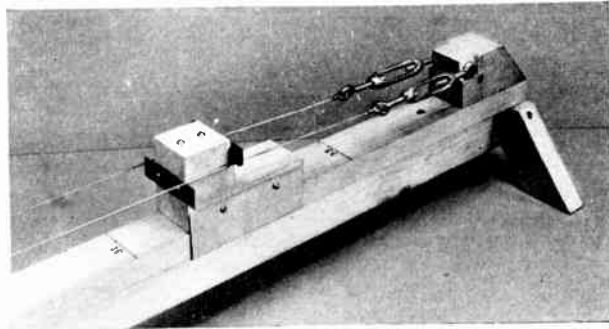

Fig. 21-12—Inside the wave meter. Only the millimeter and phone jack are mounted on the removable panel. The tuning capacitor is mounted vertically on an aluminum bracket fastened to the bottom of the case. The crystal diode is mounted between a coil-socket prong and a tie point. The phono jack for the pick-up cables is at the lower right.

◆
 Fig. 21-13 — One end of a typical Lecher wire system. The wire is No. 16 bare solid-copper antenna wire (hard-drawn). The turn-buckles are held in place by a $\frac{3}{16} \times 2$ -inch bolt through the anchor block. The other end of the line, which is connected to the pick-up loop, should be insulated.
 ◆



sible to determine quite accurately the current loops (points of maximum current). The physical distance between two consecutive current loops is equal to one-half wave length. Thus the wave length can be read directly in meters (39.37 inches = 1 meter; 0.3937 inch = 1 cm.), or in centimeters for the very short wave lengths.

The Lecher-wire line should be at least a wave length long—that is, 7 feet or more on 144 Mc.—and should be entirely air-insulated except where it is supported at the ends. It may be made of copper tubing or of wires stretched tightly. The spacing between wires should not exceed about 2 per cent of the shortest wave length to be measured. The positions of the current loops are found by means of a “shorting bar,” which is simply a metal strip or knife edge which can be slid along the line to vary its effective length.

Making Measurements

For measuring the frequency of a transmitter, a convenient and fairly sensitive indicator can be made by soldering the ends of a one-turn loop of wire, of about the same diameter as the transmitter tank coil, to a low-current flashlight bulb. The loop should be coupled to the tank coil to give a moderately bright glow. A coupling loop should be connected to the ends of the Lecher wires and brought near the tank coil, as shown in Fig. 21-14. Then the shorting bar should be slid along the wires outward from the transmitter until the lamp gives a sharp dip in brightness. This point should be marked and the shorting bar moved out until a second dip is obtained. The distance between the two points will be equal to half the wave length. If the measurement is made in inches, the frequency will be

$$F_{Mc.} = \frac{590.5}{\text{length (inches)}}$$

If the length is measured in meters,

$$F_{Mc.} = \frac{150}{\text{length (meters)}}$$

In checking a superregenerative receiver, the Lecher wires may be similarly coupled to the receiver coil. In this case the resonance indication may be obtained by setting the receiver just to the point where the hiss is obtained, then as the bar is slid along the wires

a spot will be found where the receiver goes out of oscillation. The distance between two such spots is equal to a half wave length.

The shorting bar must be kept at right angles to the two wires. A sharp edge on the bar is

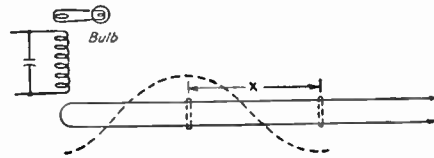

Fig. 21-14 — Coupling a Lecher wire system to a transmitter tank coil. Typical standing-wave distribution is shown by the dashed line. The distance X between the positions of the shorting bar at the current loops equals one-half wave length.

desirable, since it not only helps make good contact but also definitely locates the *point* of contact.

Accurate readings result when the loosest possible coupling is used between the line and the tank coil. Careful measurement of the exact distance between two current loops also is essential.

● **HETERODYNE METHODS**

Heterodyne methods of frequency measurement make use of a stable oscillator generating either a known frequency or one that is variable over a known range. Measurement consists in comparing the unknown frequency with the known frequency of the oscillator, using an ordinary receiver for detecting both. This method is more accurate than others, because frequency differences of less than a cycle can be observed by aural (beat-note) methods, and the oscillator can be calibrated to practically any degree of precision by comparison with standard frequencies transmitted from WWV and WWVH.

Care must be used in heterodyne frequency measurement because in most cases harmonics are used and the measured frequency can be in error by a large factor if the wrong harmonic is picked. Also, a superheterodyne receiver will give many spurious responses in the presence of a strong signal and harmonics, so these must be recognized and ignored in making measurements. In general, heterodyne methods are most useful in measuring frequency to a high degree of accuracy *after* the frequency is known approxi-

mately from other methods. The absorption wave meter is useful for making the first approximation and thus eliminating the possible gross errors.

Frequency Measurement with the Receiver

An ordinary receiver has the essential elements needed for frequency measurement. Its dial readings must be calibrated in terms of frequency, of course, before measurements can be made. Manufactured receivers are generally so calibrated: the accuracy of the calibration will vary with the receiver model, but if the receiver is well made and has good inherent stability, a bandspread dial calibration can be relied upon to within perhaps 0.2 per cent. For most accurate measurement, maximum response in the receiver should be determined by means of a carrier-operated tuning indicator (such as an S-meter), the receiver beat oscillator being turned off. If the receiver has a crystal filter, it should be set in a fairly "sharp" position to increase the accuracy.

When checking the frequency of your own transmitter, the receiving antenna should be disconnected so the signal will not overload or "block" the receiver. Also, the r.f. gain should be reduced as a further precaution against overloading. If the receiver still blocks without an antenna the frequency may be checked by turning off the power amplifier and tuning in the oscillator alone. It is difficult to avoid blocking under almost any conditions with a regenerative receiver, and so this type is not very suitable for checking the frequency of one's own transmitter.

THE HETERODYNE FREQUENCY METER

The heterodyne frequency meter is an oscillator with a precise frequency calibration. The oscillator must be so designed and constructed that it can be accurately calibrated and will retain its calibration over long periods of time.

The oscillator used in the frequency meter must be very stable. Mechanical considerations are most important in its construction. No matter how good the instrument may be electrically, its accuracy cannot be depended upon if the mechanical construction is flimsy. Frequency stability can be improved by avoiding the use of phenolic and thermoplastic insulating materials (bakelite, polystyrene, etc.) in the oscillator circuit, employing only high-grade ceramics instead. Plug-in coils ordinarily are not acceptable; instead, a solidly-built and firmly-mounted tuned circuit should be permanently installed. The oscillator panel and chassis should be as rigid as possible.

For amateur purposes the most useful type of meter is one covering the amateur bands only. The v.f.o.'s described in the chapter on transmitters are typical of the circuits and construction since they are designed with the same considerations in mind — i.e., to be highly stable

both electrically and mechanically. Hence a good v.f.o., if accurately calibrated in frequency, is also a good heterodyne frequency meter.

Calibration must be done by comparing the oscillator frequency at various points in its range with signals of known frequency. The best method is to calibrate from a secondary frequency standard, described in the next section, at intervals of, say, 100 kc. and fill in the calibration curve by interpolation. The oscillator usually works over the approximate range 1750–2000 kc., harmonics being used for the higher amateur bands. If the calibration is done on the highest range — 28–32 Mc. — at intervals of 100 kc. it is equivalent to having calibration points at intervals of $100/16 = 6.25$ kc. on the fundamental-frequency range.

THE SECONDARY FREQUENCY STANDARD

The secondary frequency standard is a highly-stable oscillator generating a fixed frequency, usually 100 kc. It is nearly always crystal-controlled, and inexpensive 100-kc. crystals are available for the purpose. Since the harmonics are multiples of 100 kc. throughout the spectrum, some of them can be compared directly with the standard frequencies transmitted by WWV.

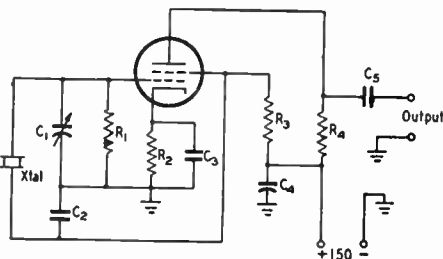

Fig. 21-15 — Circuit for crystal-controlled frequency standard. Tubes such as the 6SK7, 6SH7, 6AU6, etc., are suitable.

- C₁ — 50- μ f. variable.
- C₂ — 150- μ f. mica.
- C₃ — 0.0022- μ f. mica.
- C₄ — 0.01- μ f. paper.
- C₅ — 22- μ f. mica.
- R₁ — 0.47 megohm, $\frac{1}{2}$ watt.
- R₂ — 1000 ohms, $\frac{1}{2}$ watt.
- R₃ — 0.1 megohm, $\frac{1}{2}$ watt.
- R₄ — 0.15 megohm, $\frac{1}{2}$ watt.

The edges of most amateur bands also are exact multiples of 100 kc., so it becomes possible to determine the band edges very accurately. This is an important consideration in amateur frequency measurement, since the only regulatory requirement is that an amateur transmission be inside the assigned band, not on a specific frequency.

Intervals of 100 kc. are sometimes too close for accurate identification of a given harmonic, so special crystals that operate at both 1000 and 100 kc. are available. Intervals of 1000 kc. are sufficiently far apart to avoid confusion, since the average receiver calibration is good enough to provide positive identification. Once the 1000-kc. harmonics are spotted, it is easy to

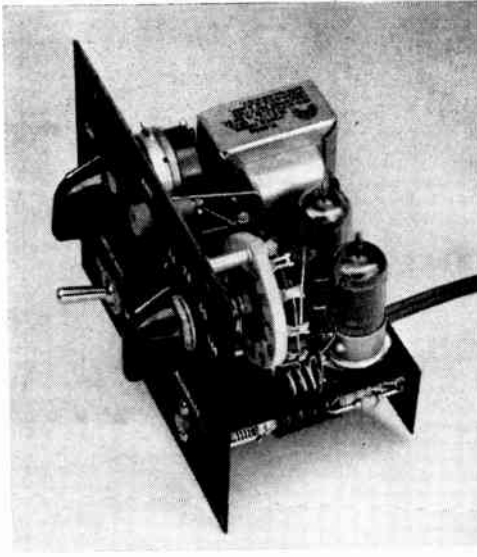

Fig. 21-16 — A compact frequency standard and harmonic amplifier for generating either 100- or 1000-ke. intervals throughout the spectrum to 150 Mc. It has a self-contained power supply using the transformer shown in the upper part of the photo. The output control is at the upper left, and the rotary switch in the foreground is the harmonic-amplifier band switch. The dual crystal is between the band switch and output control. The toggle switch at the lower left corner of the panel selects either 1000- or 100-ke. intervals.

count off the 100-ke. intervals from the known 1000-ke. points.

Manufacturers of 100-ke. crystals usually supply circuit information for their particular crystals. The circuit given in Fig. 21-15 is representative, and will generate usable har-

monies up to 30 Mc. or so. The variable capacitor, C_1 , provides a means for adjusting the frequency to exactly 100 ke. Harmonic output is taken from the circuit through a small capacitor, C_5 . There are no particular constructional points to be observed in building such a unit. Power for the tube heater and plate may be taken from the supply in the receiver with which the unit is to be used. The plate voltage is not critical, but it is recommended that it be taken from a VR-150 regulator if the receiver is equipped with one.

Sufficient signal strength usually will be secured if a wire is run between the output terminal connected to C_5 and the antenna post on the receiver. At the lower frequencies a metallic connection may not be necessary.

Figs. 21-16 through 21-18 show a compact standard, complete with power supply, that will give usable harmonics from both 100 and 1000 ke. up through the 144-Mc. band. It uses a dual crystal, either fundamental frequency being selected by a switch, S_1 , and the output of the oscillator is fed to a crystal-diode rectifier to increase the amplitude of the high-order harmonics. These harmonics are then amplified in the second tube, a stage having broadly-tuned plate circuits centering in the higher-frequency amateur bands, switched in or out as required. A gain control, R_7 , is provided in the amplifier circuit for regulating the output amplitude. The whole unit is constructed in a $5 \times 3 \times 4$ box of the type having its own chassis, the small size being used so the unit can be squeezed into limited space on the operating table. It can be put on a larger chassis and box if desired, since the construction is not critical. Sufficient signal strength in the receiver should be secured by connecting a short

Fig. 21-17 — Circuit diagram of the frequency standard and harmonic amplifier.

- C_1 — 25- μ f. midget variable (Hammarlund MAPC 25).
- C_2 — 3 μ f. ($2\frac{1}{2}$ inches of 75-ohm Twin-Lead).
- C_3, C_4 — 0.1- μ f. paper, 400 volts.
- C_5 — 250- μ f. ceramic.
- C_6, C_7, C_9 — 0.001- μ f. disk ceramic.
- C_8 — 100- μ f. ceramic.
- C_{10}, C_{11} — 20- μ f. electrolytic, 250 volts.
- R_1 — 1.7 megohm, $\frac{1}{2}$ watt.
- R_2 — 22,000 ohms, $\frac{1}{2}$ watt.
- R_3, R_4, R_5 — 0.47 megohm, $\frac{1}{2}$ watt.
- R_6 — 470 ohms, $\frac{1}{2}$ watt.
- R_7 — 5000-ohm potentiometer.
- R_8 — 17,000 ohms, 1 watt.
- R_9 — 1000 ohms, 1 watt.
- L_1 — 1-mh. r.f. choke (National R-50).
- L_2 — 4- μ h r.f. choke (National R-60).
- L_3 — 2- μ h r.f. choke (National R-60).
- L_4 — 0.5 μ h. (1- μ h. r.f. choke, National R-33, with 10 turns removed).
- L_5 — 3 turns No. 16, $\frac{1}{4}$ -inch diam., $\frac{3}{8}$ inch long.
- CR — 65-ma. selenium rectifier.
- J_1 — Tip jack.
- RFC $_1$ — 0.5-mh. r.f. choke (National R-50).

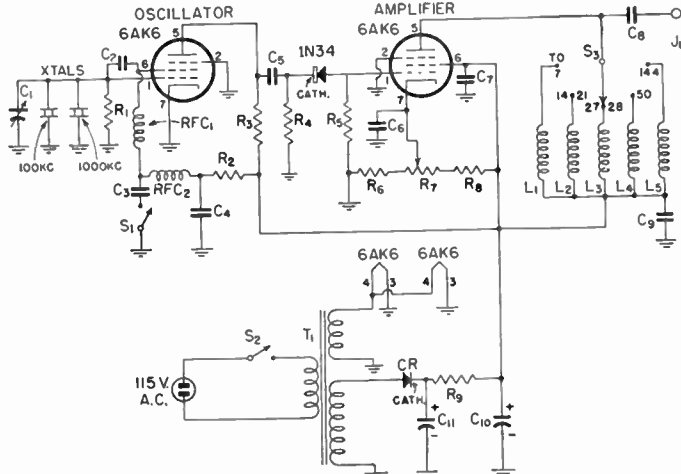

- RFC $_2$ — 5-mh. r.f. choke (National R-100S).
- S_1 — S.p.s.t. toggle switch.
- S_2 — S.p.s.t. toggle switch mounted on R_7 .
- S_3 — 1-pole 6-position selector switch; shorting type (Centralab 2500).
- T_1 — Power transformer, 150 volts, 25 ma.: 6.3 volts, 0.5 amp. (Merit P-3046).
- XTAL — 100-1000-ke. dual frequency crystal (Valpyco DFS).

STANDARD FREQUENCIES AND TIME SIGNALS

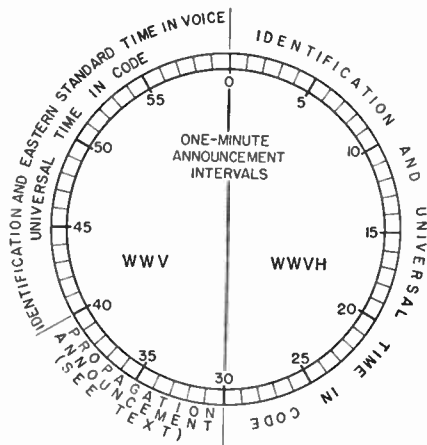
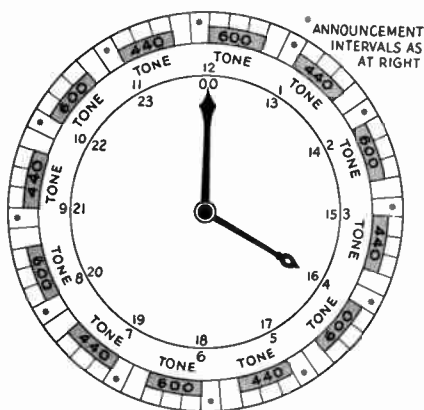

Accuracy

Transmitted frequencies are accurate within 1 part in 100 million.

Propagation Notices

During the announcement intervals at 19½ and 49½ minutes after the hour, propagation notices applying to transmission paths over the north Atlantic are transmitted from WWV on 2.5, 5, 10, 15, 20, and 25 Mc. Similar forecasts for the North Pacific are transmitted from WWVH during the announcement intervals at 9 and 39 minutes after the hour.

These notices, in telegraphic code, consist of the letter N, W, or U followed by a number. The letter designations apply to propagation conditions as of the time of the broadcast, and have the following significance:

- W — Ionospheric disturbance in progress or expected.
- U — Unstable conditions, but communication possible with high power.
- N — No warning.

The number designations apply to expected propagation conditions during the subsequent 12 hours and have the following significance:

Digit	Forecast
1	Impossible
2	Very Poor
3	Poor
4	Fair to Poor
5	Fair
6	Fair to Good
7	Good
8	Very Good
9	Excellent

Standard radio and audio frequencies are broadcast continuously from WWV, operated by the Central Radio Propagation Laboratory, National Bureau of Standards, Washington, D. C., on the following radio frequencies: 2.5, 5, 10, 15, 20 and 25 megacycles per second. Similar broadcasts are given from WWVH, Puunene, T. H., on 5, 10 and 15 Mc. The modulations consist of 1-c.p.s. pulses and 440 or 600 c.p.s. tone.

Transmissions are as shown above, with the following exceptions: The WWV transmissions are interrupted for a 4-minute period beginning at approximately 45 minutes after the hour; the WWVH transmissions are interrupted for 4 minutes following each hour and half hour, and for periods of 34 minutes beginning at 1900 Universal Time.

Time Signals

The 1-c.p.s. modulation is a 5-millisecond pulse at intervals of precisely one second, and is heard as a tick. The pulse transmitted by WWV consists of 5 cycles of 1000 cycle tone; that transmitted by WWVH consists of 6 cycles of 1200-cycle tone. On the WWV transmissions, the 440- or 600-cycle tone is blanked out beginning 10 milliseconds before and ending 25 milliseconds after the pulse. On the WWVH transmissions, the pulse is superimposed on the tone. The pulse on the 59th second is omitted, and for additional identification the zero-second pulse is followed by another 100 milliseconds later.

piece of wire to the output terminal, but on very high frequencies it may be necessary to connect the wire to one antenna post on the receiver.

Adjusting to Frequency

In either Fig. 21-15 or 21-17 the frequency can be adjusted exactly to 100 kc. by making use of the WWV transmissions tabulated in this chap-

ter. Select the WWV frequency that gives a good signal at your location at the time of day most convenient. Tune it in with the receiver b.f.o. off and wait for the period during which the modulation is absent. Then switch on the 100-ke. oscillator and adjust its frequency, by means of C₁, until its harmonic is in zero beat with WWV. The exact setting is easily found by ob-

◆

Fig. 21-B — Below-chassis view of the frequency standard. The 1N31A harmonic generator is at the upper left. The variable capacitor at the bottom is for adjustment of the oscillator frequency to exactly 100 kc. At the upper right, mounted on the rear lip of the chassis, is the selenium rectifier for the power supply. The filter capacitor is just below it. Small resistors and capacitors are grouped around the tube sockets.

◆

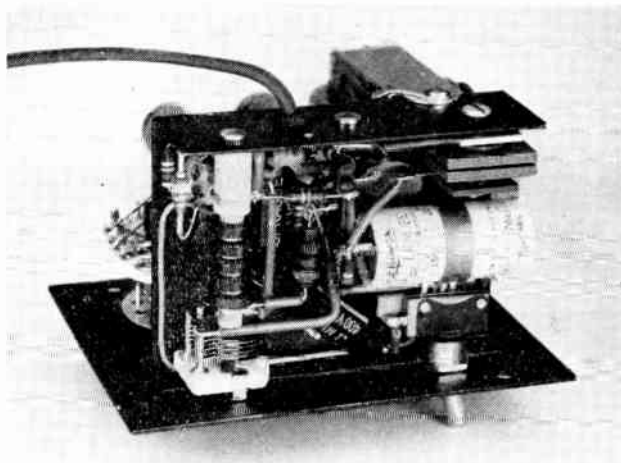

serving the slow pulsation in background noise as the harmonic comes close to zero beat, and adjusting to where the pulsation disappears or occurs at a very slow rate. The pulsations can be observed even more readily by switching on the receiver's b.f.o., after approximate zero beat has been secured, and observing the rise and fall in intensity (not frequency) of the beat tone. For best results the WWV signal and the signal from the 100-ke. oscillator should be about the same strength. It is advisable not to try to set the 100-ke. oscillator during the periods when the WWV signal is tone-modulated, since it is difficult to tell whether the harmonic is being adjusted to zero beat with the carrier or with one of the side bands.

Frequency Checking

The secondary standard provides signals of known frequency that can be tuned in on the station receiver. Determination of the frequency of a transmitter is then carried out by the method described earlier under "Frequency Measurement with the Receiver," using these points as positive identification of band edges. By using the known 100-ke. points the receiver calibration can be corrected so that, by interpolation, the frequency of a signal lying between the calibration points can be determined with good accuracy.

More Precise Methods

The methods described in this section are quite adequate for the primary purpose of amateur frequency measurements — that is, determining whether or not a transmitter is operating inside the limits of an amateur band, and the approximate frequency inside the band. For measurement of an unknown frequency to a high degree of accuracy more advanced methods can be used. Accurate signals at closer intervals can be obtained by using a multivibrator in conjunction with the 100-ke. standard, and thus obtaining signals at intervals of, say, 10 kc. or some other integral divisor of 100. Temperature control is frequently used on the 100-ke. oscillator to give a high order of stability (Collier, "What Price Precision?", *QST*, September and October, 1952). Also, the secondary standard can be used in conjunction with a variable-frequency interpolation oscillator to fill in the standard intervals (Woodward, "A Linear Beat-Frequency Oscillator for Frequency Measurement," *QST*, May, 1951). An interpolation oscillator and standard can be combined in one instrument, one application of this type having been described in *QST* for May, 1949 (Grammer, "The Additive Frequency Meter").

Test Oscillators

● THE GRID-DIP METER

The grid-dip meter is a simple vacuum-tube oscillator to which a microammeter or low-range milliammeter has been added to read the oscillator grid current. A 0-1 milliammeter is sensitive enough in most cases. The grid-dip meter is so called because if the oscillator is coupled to a tuned circuit the grid current will show a decrease or "dip" when the oscillator is tuned through resonance with the unknown circuit. The reason for this is that the external circuit will

absorb energy from the oscillator when both are tuned to the same frequency; the loss of energy from the oscillator circuit causes the feedback to decrease and this in turn is accompanied by a decrease in grid current. The dip in grid current is quite sharp when the circuit to which the oscillator is coupled has reasonably high Q .

The grid-dip meter is most useful when it covers a wide frequency range and is compactly constructed so that it can be coupled to circuits in hard-to-reach places such as in a transmitter or receiver chassis. It can thus be used to check

tuning ranges and to find unwanted resonances of the type described in the chapter on TVI. Since it is its own source of r.f. energy it does not, like the absorption wave meter, require the circuit being checked to be energized. In addition to resonance checks, the grid-dip meter also can be used as a signal source for receiver alignment and, as described later in this chapter, is useful in measurement of inductance and capacitance in the range of values used in r.f. circuits.

Figs. 21-19 to 21-21, inclusive, show a grid-dip meter of quite compact construction using plug-in



Fig. 21-19 — A compact and light-weight grid-dip meter for one-hand operation. It is built in a $1\frac{5}{8} \times 2\frac{1}{4} \times 4$ -inch "Channel-lock" box and uses six plug-in coils to cover the range 1600 kc. to 160 Mc. The power supply and milliammeter for reading grid current are in a separate unit.

coils to cover a continuous frequency range of 1600 kc. to 160 Mc., and thus useful in all amateur bands up through 144 Mc. as well as for checking for resonances in the low group of v.h.f. TV channels, the most important from the standpoint of harmonic TVI. It is small and light, and can be held and tuned with one hand since the dial extends slightly over the edges of the box so it can be operated with the thumb. The milliammeter is not contained in the oscillator itself but can be mounted separately in any convenient spot for viewing. Fig. 21-22 shows the milliammeter mounted in a standard meter case which also contains the power supply for the oscillator. The cable connecting the two units can be any desired length.

The oscillator circuit, shown in Fig. 21-20, is a grounded-plate Hartley, with the cathode tap adjusted for maximum sensitivity — that is, for greatest change in grid current when tuning through resonance with a coupled circuit — rather than for maximum grid current. For satisfactory operation at the highest frequency, the leads in the tuned circuit should be kept as short as possible, and the tuning capacitor, C_1 , is mounted so that its rotor and stator terminals are practically touching the corresponding pins on the coil socket. The tube socket is mounted on a bracket made from aluminum and placed at an angle so that the tube can be removed. The cathode connection between the tube socket and

the coil socket is made of flat copper strip to reduce its inductance as much as possible.

Coils for the two low-frequency ranges are wound on the outsides of the forms in normal fashion, but with the exception of the highest range the remaining coils are lengths of B & W Miniductor mounted inside the forms. A hairpin-shaped coil is used for the highest range. As the coil forms are polystyrene, which softens at relatively low temperatures, care must be used in soldering to the pins. It is helpful to drill a metal plate, a few inches square and $\frac{1}{16}$ inch or so thick, so the coil pins will fit snugly; then if the plate is pressed firmly against the bottom of the form during soldering the heat will be conducted away from the polystyrene rapidly enough to prevent softening, if the soldering operation is not prolonged.

A transparent dial cut from a piece of $\frac{1}{8}$ -inch Plexiglas (obtainable at hobby stores) is used so the calibration can be placed on top of the box, where there is more room for lettering. A hairline indicator is scratched on the dial, which is also provided with a standard small knob, fastened to it by small machine screws threaded in from the bottom.

The power supply shown in Fig. 21-22 uses a miniature power transformer with a selenium rectifier and a simple filter to give approximately 120 volts for the oscillator plate. The potentiometer shown in Fig. 21-23 is for adjustment of plate voltage. In any grid-dip meter the grid current will be different in different parts of the frequency range, with fixed plate voltage, so it is ordinarily necessary to choose a plate voltage that will keep the reading on scale in the part of

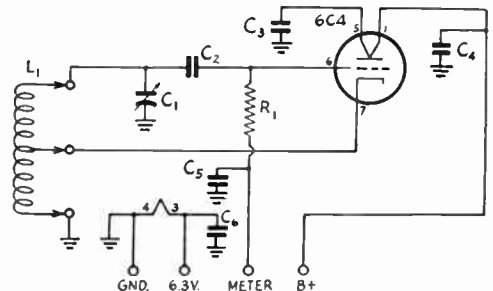

Fig. 21-20 — Circuit diagram of the grid-dip meter.

- C_1 — 50- μ mf. midget variable (Hammarlund HF-50).
 C_2 — 100- μ mf. ceramic.
 C_3, C_4, C_6 — 0.001- μ f. disk ceramic.
 C_5 — 0.01- μ f. disk ceramic.
 R_1 — 22,000 ohms, $\frac{1}{2}$ watt.

Freq. Range	Coil Data, L_1				
	Turns	Wire	Diameter	Turns/inch	Tap*
1.59-3.5 Mc.	139	32 enam.	$\frac{3}{4}$ in.	Close-wound	32
3.45-7.8 Mc.	40	32 enam.	$\frac{3}{4}$ in.	Close-wound	12
7.55-17.5 Mc.	40	24 tinned	$\frac{1}{2}$ in. \ddagger	32	14
17.2-40 Mc.	15	20 tinned	$\frac{1}{2}$ in. \ddagger	16	5
37-85 Mc.	4	20 tinned	$\frac{1}{2}$ in. \ddagger	16	$1\frac{1}{2}$
78-160 Mc.		Hairpin of No. 14 wire, $\frac{3}{16}$ in. spacing, 2 inches long including coil form pins. Tapped $1\frac{1}{2}$ in. from ground end.			

* Turns from ground end.

\ddagger B. & W. Miniductor or equivalent.

Coil forms are Amphenoil 24-5H, $\frac{3}{4}$ -in. diameter.

Fig. 21-21 — The grid-dip oscillator is built on the U-shaped portion of the box. C_3 , C_4 and C_6 are grounded to a soldering lug at the left of the socket. Wires in the power and meter cable terminate at a 1-point terminal strip at the left.

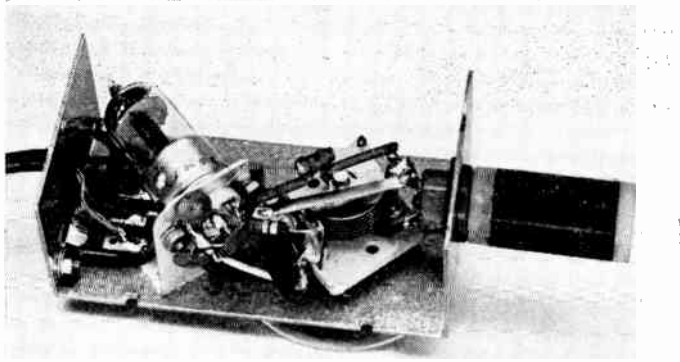

the range where the grid current is highest. This usually results in rather low grid current at some other part of the range. With variable plate voltage this compromise is unnecessary.



Fig. 21-22 — Power supply and milliammeter for the grid-dip meter are contained in a meter case. The control on top is for varying the plate voltage to maintain the grid current in the proper region.

The instrument may be calibrated by listening to its output with a calibrated receiver. The calibration should be as accurate as possible, although "frequency-meter accuracy" is not required in the applications for which a grid-dip meter is useful.

The grid-dip meter may be used as an indicating-type absorption wave meter by shutting off the plate voltage and using the grid and cathode of the tube as a diode. However, this type of circuit is not as sensitive as the crystal-detector type shown earlier in this chapter, because of the high-resistance grid leak in series with the meter.

In using the grid-dip meter for checking the resonant frequency of a circuit the coupling

should be kept to the point where the dip in grid current is just perceptible. This reduces interaction between the two circuits to a minimum and gives the highest accuracy. With too-close coupling the oscillator frequency may be "pulled" by the circuit being checked, in which case different readings will be obtained when resonance is approached from the high side as compared with approaching from the low side.

● AUDIO-FREQUENCY OSCILLATORS

A useful accessory for testing audio-frequency amplifiers and modulators is an audio-frequency signal generator or oscillator. Checks for distortion, gain, and the ordinary troubles that occur in such amplifiers do not require elaborate equipment; the principal requirement is a source of one or more audio tones having a good sine wave form, at a voltage level adjustable from a few volts down to a few millivolts so the oscillator can be substituted for the type of microphone to be used.

An easily-constructed oscillator of this type is shown in Figs. 21-24 to 21-26, inclusive. Three audio frequencies are available, approximately 200, 900 and 2500 cycles. These three frequencies are sufficient for testing the frequency response of an amplifier over the range needed for voice communication.

The circuit uses a double triode as a cathode-coupled oscillator, the second section of the tube providing the feedback necessary for oscillation through the common cathode connection. The 3-watt lamp in this feedback loop acts as a variable resistance to control the oscillation amplitude and thus maintain the operating conditions at the point where the best wave form is generated. This operating point is set by the "oscillation control," R_1 . The frequency is determined by the resistance and capacitance in the coupling circuit between the first-section plate and second-section grid. Various values of capacitance can be selected by means of S_1 to set the frequency. The actual frequencies measured in the unit shown in the photographs are given on the diagram. They may be either increased or decreased by using smaller or larger capacitances, respectively.

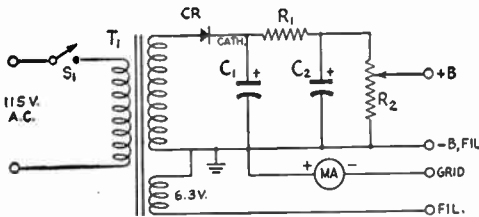

Fig. 21-23 — Circuit diagram of the power supply for the grid-dip meter.

- C_1 , C_2 — 16- μ f. electrolytic, 150 volts.
- R_1 — 1000 ohms, $\frac{1}{2}$ watt.
- R_2 — 0.1-megohm potentiometer.
- T_1 — Power transformer, 6.3 volts and 125 to 150 volts. (Merit P-3016 or equivalent.)
- CR — 20-ma. selenium rectifier.
- MA — 0-1 d.c. milliammeter.

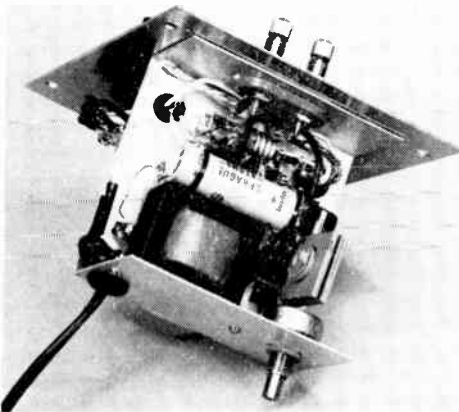

Fig. 21-24 — Bottom view of the audio oscillator, showing the power-supply components and amplitude-control lamp, I_1 . The lamp is mounted by wires soldered to its base. The selenium rectifier is supported by a tie-point strip. Placement of resistors, which are hidden by the other components, is not critical. The unit fits in a $4 \times 5 \times 6$ inch box.

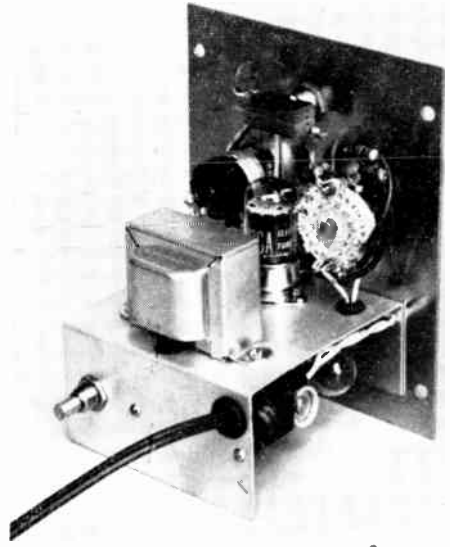

Fig. 21-26 — Inside view of the audio oscillator. The a.e. switch, S_1 , is mounted on the output control at the left on the panel. The ceramic capacitors in the frequency-determining circuits are mounted on the rotary switch, S_2 , at the right, S_3 is above the tube, and T_1 is on the near edge of the chassis, which is a U-shaped piece of aluminum $3\frac{1}{2}$ inches deep with $1\frac{1}{2}$ inch lips. R_1 is mounted on the near lip at the left.

Output is taken from the cathode of the second triode section. Either the full output, 1.5 volts, or approximately one-tenth of it can be selected by S_2 . On either of these two ranges smooth control of output is provided by R_2 .

The self-contained power supply uses a small transformer and a selenium rectifier to develop approximately 150 volts. Hum is reduced to a negligible level by the filter consisting of the 8-henry choke and 20- μ f. capacitors.

An oscilloscope is useful for preliminary

checking of the oscillator since it will show wave form. R_1 should be set at the point that will ensure oscillation on all three frequencies when switching from one to the other.

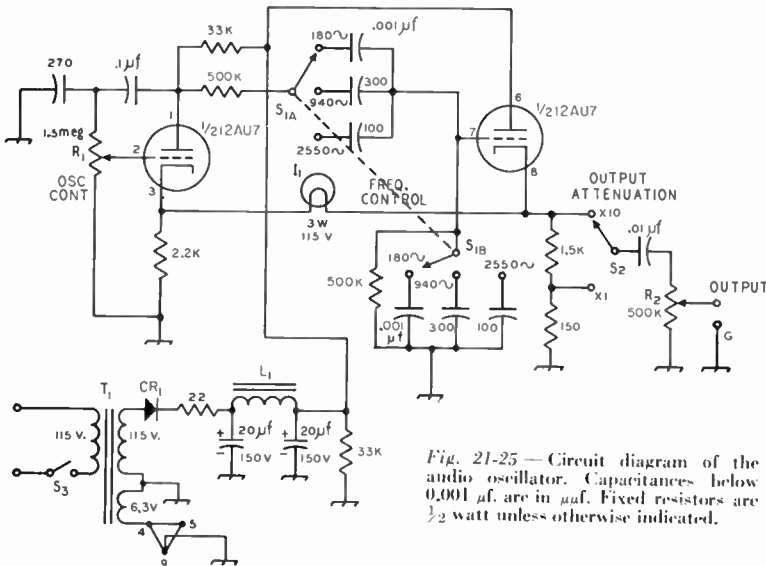

Fig. 21-25 — Circuit diagram of the audio oscillator. Capacitances below 0.001 μ f. are in μ mf. Fixed resistors are $\frac{1}{2}$ watt unless otherwise indicated.

- CR_1 — 20-ma. selenium rectifier.
- I_1 — 3-watt, 115-volt lamp (G.E. 3S6).
- L_1 — 8 henrys, 40 ma. (Thoradson 20C52).
- R_1, R_2 — Volume controls.
- S_1 — 2-pole 5-position (3 used) rotary switch.

- S_2 — D.p.d.t. toggle.
- S_3 — S.p.s.t. toggle (mounted on R_1).
- T_1 — Power transformer, 150 volts, 25 ma.; 6.3 volts, 0.5 amp. (Merit P-3016).

R.F. Measurements

R.F. CURRENT

R.f. current-measuring devices use a **thermocouple** in conjunction with an ordinary d.c. instrument. The thermocouple is made of two dissimilar metals which, when heated, generate a small d.c. voltage. The thermocouple is heated by a resistance wire through which the r.f. current flows, and since the d.c. voltage developed is proportional to the heating, which in turn is proportional to the power used by the heating element, the deflections of the d.c. instrument are proportional to power rather than to current. This causes the calibrated scale to be compressed at the low-current end and spread out at the high-current end. The useful range of such an instrument is about 3 or 4 to 1; that is, an r.f. ammeter having a full-scale reading of 1 ampere can be read with satisfactory accuracy down to about 0.3 ampere, one having a full scale of 5 amperes can be read down to about 1.5 amperes, and so on. No single instrument can be made to handle a wide range of currents. Neither can the r.f. ammeter be shunted satisfactorily, as can be done with d.c. instruments, because even a very small amount of reactance in the shunt will cause the readings to be highly dependent on frequency.

R.F. VOLTAGE

An **r.f. voltmeter** is a rectifier-type instrument in which the r.f. is converted to d.c., which is then measured with a d.c. instrument. The best type of rectifier for most applications is a crystal diode, such as the 1N34 and similar types, because its capacitance is so low as to have little effect on the behavior of the r.f. circuit to which it is connected. The principal limitation of these rectifiers is their rather low value of safe inverse peak voltage. Vacuum-tube diodes are considerably better in this respect, but their size, shunt capacitance, and the fact that power is required for heating the cathode constitute serious disadvantages in many applications. Typical circuits for crystal-diode r.f. voltmeters are given in Fig. 21-27.

One of the principal uses for such voltmeters is as null indicators in r.f. bridges, as described later in this chapter. Another useful application is in measurement of the voltage between the conductors of a coaxial line, to show when a transmitter is adjusted for optimum output. In either case the voltmeter impedance should be high compared with that of the circuit under measurement, to avoid taking appreciable power, and the relationship between r.f. voltage and the reading of the d.c. instrument should be as linear as possible—that is, the d.c. indication should be directly proportional to the r.f. voltage at all points of the scale.

All rectifiers show a variation in resistance with applied voltage, the resistance being highest

when the applied voltage is small. These variations can be fairly well “swamped out” by using a high value of resistance in the d.c. circuit of the rectifier. A resistance of at least 10,000 ohms

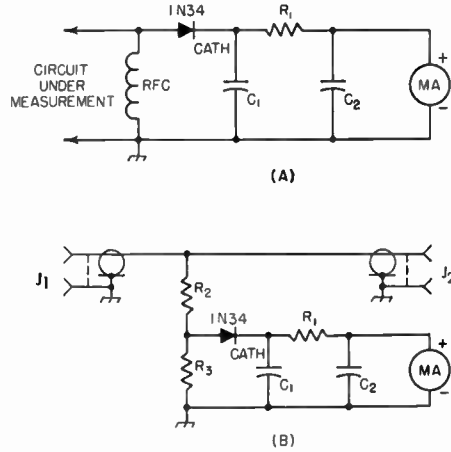

Fig. 21-27 — R.f. voltmeter circuits using a crystal rectifier and d.c. microammeter or 0-1 milliammeter. The circuit at A is suitable for measuring low voltages — up to about 20 volts maximum. B is for measuring the voltage between the conductors of a coaxial line. The total resistance of R_2 and R_3 should be of the order of 7500 ohms, with the ratio of R_2 to R_3 chosen to apply not more than 10 volts (for an s.w.r. of 1 to 1) to the crystal circuit, based on the unmodulated carrier power in the line. R_1 should be not less than 10,000 ohms for a 0-1 milliammeter, and should be increased in proportion to the sensitivity of the meter (e.g., 20,000 ohms for a 0-500 microammeter, 100,000 ohms for a 0-100 microammeter). C_1 and C_2 should be 0.001 μ f. or more. In B, J_1 and J_2 are coaxial connectors. The voltmeter is preferably built in a shielded box, the 2 × 4 × 4 size being large enough to contain the whole instrument.

is necessary for reasonably good linearity, and higher values are beneficial. For this reason a fairly sensitive d.c. instrument should be used — if possible, a 0-100 microammeter, although a 0-1 milliammeter will serve quite well in many cases. A v.t.v.m. is ideal for the purpose since its extremely high input resistance exceeds anything that is practical with an ordinary microammeter. High resistance in the d.c. circuit also raises the impedance of the r.f. voltmeter and reduces its power consumption.

The basic voltmeter circuit is shown in Fig. 21-27A, and is simply a half-wave rectifier with a meter and a resistor, R_1 , for improving the linearity. The time constant of C_1R_1 should be large compared with the period of the lowest radio frequency to be measured — a condition that can easily be met if R_1 is 10,000 ohms and C_1 is 0.001 μ f. or more — so C_1 will stay charged near the peak value of the r.f. voltage. The radio-frequency choke may be omitted if there is a low-resistance d.c. path through the circuit being measured. C_2 provides additional r.f. filtering for the d.c. circuit.

A practical arrangement for measuring the r.f. voltage in a coaxial line from a transmitter is shown at B. A voltage divider, R_2R_3 , is connected across the line, the resistance values being chosen so the inverse peak voltage rating of the rectifier is not exceeded. This rating is 60 volts for the 1N34, which limits the r.m.s. voltage that may be applied to the crystal to a maximum of 21 volts. If the approximate power carried by the line is known, the voltage can easily be calculated if the line is flat. A standing-wave ratio of 4 to 1 will cause the voltage to be twice the calculated value at a voltage loop, and 100 per cent modulation also doubles the voltage. Since it is unlikely that the s.w.r. will exceed 4 to 1 in a properly operated coax line, the safety factor will be adequate if the voltage divider is designed on the basis of applying one-fourth the rated value of voltage, or about 5 volts, to the crystal. The total resistance in the divider should be about 100 times the line impedance so the power consumed by the voltmeter will not exceed 1 per cent of the power in the line. Composition resistors should be used, allowing 1 watt dissipation in R_2 (which usually dissipates practically all the voltmeter power) for each 100 watts in the line. The necessary dissipation can be built up by using resistors in series.

In constructing such a voltmeter care must be used to prevent stray coupling between the line and any part of the voltmeter, and also between the voltage divider and the crystal rectifier circuit. Also, the resistor or resistors comprising R_2 should be kept away from grounded metal, in order to reduce stray capacitance.

Calibration

Calibration is not necessary for purely comparative measurements. A calibration in actual voltage requires a known resistive load and an r.f. ammeter. The setup is the same as for r.f. power measurement as described later, and the voltage calibration is obtained by calculation from the known power and known load resistance, using Ohm's Law: $E = \sqrt{PR}$. As many points as possible should be obtained, by varying the power output of the transmitter, so that the linearity of the voltmeter can be checked.

Different voltage ranges may be secured, with a fixed voltage divider, by changing the value of R_1 . It is advisable to calibrate on the lowest range and then, with a fixed value of power in the line, increase R_1 until the desired scale factor is obtained.

R.F. POWER

Measurement of r.f. power requires a resistive load of known value and either an r.f. ammeter or a calibrated r.f. voltmeter. The power is then either I^2R or E^2/R , where R is the load resistance in ohms.

The simplest method of obtaining a load of known resistance is to use an antenna system with coax-coupled matching circuit of the type described in the chapter on transmission lines. When the circuit is adjusted, by means of an

s.w.r. bridge, to bring the s.w.r. down to 1 to 1 the load is resistive and of the value for which the bridge was designed (52 or 75 ohms). Fig. 21-28 shows a convenient way of mounting an r.f. ammeter for measuring current in a coaxial line.



Fig. 21-28 — R.f. ammeter mounted for connecting into a coaxial line for measuring power. A "2-inch" instrument will fit into a $2 \times 4 \times 1$ metal box. The shunt capacitance of an ammeter mounted in this way has a negligible effect on the accuracy at frequencies as high as 30 Mc. if the instrument has a bakelite case. Metal-cased meters should be mounted on a bakelite panel which can in turn be mounted in a cut-out which clears the meter case by about $\frac{1}{4}$ inch.

The instrument can be inserted in the line in place of the s.w.r. bridge after the matching has been completed, and the transmitter is then adjusted — without touching the matching circuit — for maximum current. A 0-1 ammeter is useful for measuring the approximate range 5-50 watts in 52-ohm line, or 7.5-75 watts in 75-ohm line; a 0-3 instrument can be used for 13-450 watts in 52-ohm line and 20-675 watts in 75-ohm line. The accuracy is usually greatest in the upper half of the scale.

An r.f. voltmeter of the type described in the preceding section also can be used for power measurement in a similar setup. It has the advantage that, because its scale is substantially linear, a much wider range of powers can be measured with a single instrument.

INDUCTANCE AND CAPACITANCE

The ability to measure inductance and capacitance frequently saves time that might otherwise be spent in cut-and-try. A convenient instrument for this purpose is the grid-dip oscillator, described earlier in this chapter.

For measuring inductance, the coil is con-

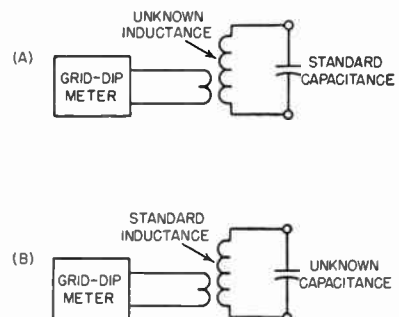

Fig. 21-29 — Setups for measuring inductance and capacitance with the grid-dip meter.

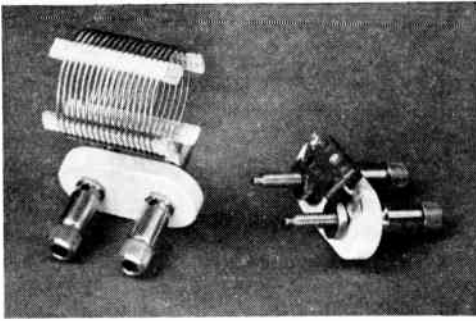

Fig. 21-30 — A convenient mounting, using binding-post plates, for L and C standards made from commercially-available parts. The capacitor is a 100- μf . silver mica unit, mounted so the lead length is as nearly zero as possible. The inductance standard, 5 μh ., is 17 turns of No. 3015 B & W Miniductor, 1-inch diameter, 16 turns per inch.

nected to a capacitance of known value as shown at A in Fig. 21-29. With the unknown coil connected to the standard capacitor, the pick-up loop is coupled to the coil and the oscillator frequency adjusted for the grid-current dip, using the loosest coupling that gives a detectable indication. The inductance is then given by the formula

$$L_{\mu\text{h}} = \frac{25,330}{C_{\mu\text{f}} \cdot f_{\text{Mc}}^2}$$

The reverse procedure is used for measuring capacitance — that is, a coil of known inductance is used as a standard as shown at B. The unknown capacitance is

$$C_{\mu\text{f}} = \frac{25,330}{L_{\mu\text{h}} \cdot f_{\text{Mc}}^2}$$

The accuracy of this method depends on the accuracy of the grid-dip meter calibration and the accuracy with which the standard values of L and C are known. Postage-stamp silver-mica capacitors make satisfactory capacitance standards, since their rated tolerance is ± 5 per cent. Equally good inductance standards can be made from commercial machine-wound coil material.

A single pair of standards will serve for measuring the L and C values commonly used in amateur equipment. A good choice is 100 μf . for the capacitor and 5 μh . for the coil. Based on these values the chart of Fig. 21-31 will give the unknown directly in terms of the resonant frequency registered by the grid-dip meter. In measuring the frequency the coupling between the grid-dip meter and resonant circuit should be kept at the smallest value that will give a definite indication.

A correction should be applied to measurements of very small values of L and C to include the effects of the shunt capacitance of the mounting for the coil, and for the inductance of the leads to the capacitor. These amount to approximately 1 μf . and 0.03 μh ., respectively, with the method of mounting shown in Fig. 21-30.

Coefficient of Coupling

The same equipment can be used for measurement of the coefficient of coupling between two coils. This simply requires two measurements of inductance (of one of the coils) with the coupled coil first open-circuited and then short-circuited. Connect the 100- μf . standard capacitor to one coil and measure the inductance with the terminals of the second coil open. Then short the terminals of the second coil and again measure

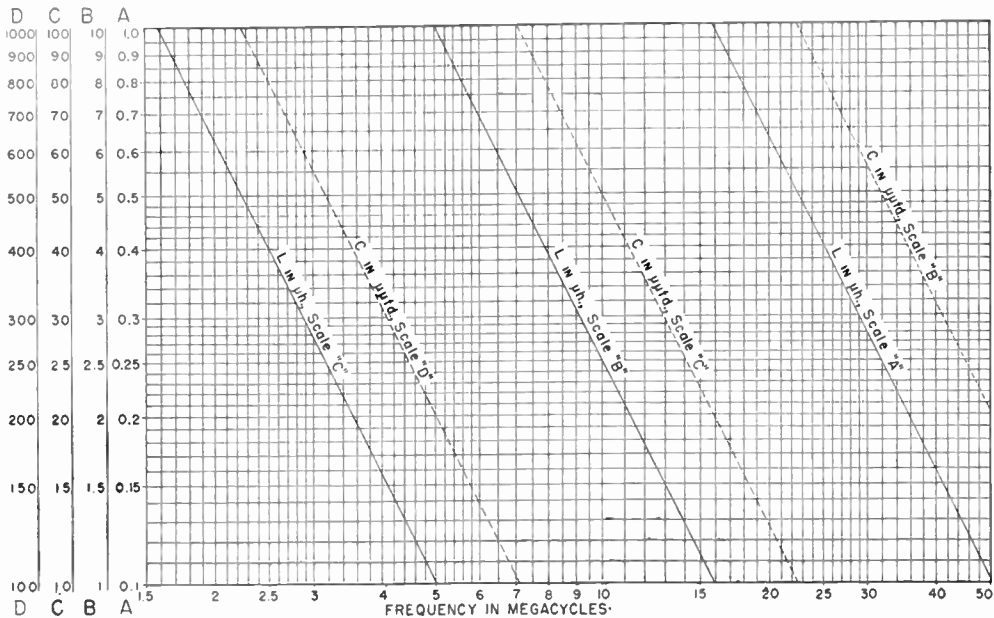

Fig. 21-31 — Chart for determining unknown values of L and C in the range 0.1 to 100 μh . and 2 to 1000 μf ., using standards of 100 μf . and 5 μh .

the inductance of the first. The coefficient of coupling is given by

$$k = \sqrt{1 - \frac{L_2}{L_1}}$$

where k = coefficient of coupling

L_1 = inductance of first coil with terminals of second coil open

L_2 = inductance of first coil with terminals of second coil shorted.

● R.F. RESISTANCE

Aside from the bridge methods used in transmission-line work, described later, there is relatively little need for measurement of r.f. resistance in amateur practice. Also, measurement of resistance by fundamental methods is not practical with simple equipment. Where such measurements are made, they are usually based on known characteristics of available resistors used as standards.

Most types of resistors have so much inherent reactance and skin effect that they do not act like "pure" resistance at radio frequencies, but instead their effective resistance and impedance vary with frequency. This is especially true of wire-wound resistors. Composition (carbon) resistors as a rule have negligible inductance for frequencies up to 100 Mc. or so and the skin effect also is small, but the shunt capacitance cannot be neglected in the higher values of these resistors, since it reduces their impedance and makes it reactive. However, for most purposes the capacitive effects can be considered to be negligible in composition resistors of values up to 1000 ohms, for frequencies up to 50 to 100 Mc., and the r.f. resistance of such units is practically the same as their d.c. resistance. Hence they can be considered to be practically pure resistance in such applications as r.f. bridges, etc., provided they are mounted in such a way as to avoid magnetic coupling to other circuit components, and are not so close to grounded metal parts as to give an appreciable increase in shunt capacitance.

Antenna and Transmission-Line Measurements

Two principal types of measurements are made on antenna systems: (1) the standing-wave ratio on the transmission line, as a means for determining whether or not the antenna is properly matched to the line (alternatively, the input resistance of the line or antenna may be measured); (2) the comparative radiation field strength in the vicinity of the antenna, as a means for checking the directivity of a beam antenna and as an aid in adjustment of element tuning and phasing. Both types of measurements can be made with rather simple equipment.

● FIELD-STRENGTH MEASUREMENTS

The radiation intensity from an antenna is measured with a device that is essentially a very simple receiver equipped with an indicator to give a visual representation of the comparative signal strength. Such a **field-strength meter** is used with a "pick-up antenna" which should always have the same polarization as the antenna being checked — e.g., the pick-up antenna should be horizontal if the transmitting antenna is horizontal. Care should be taken to prevent stray pickup by the field-strength meter itself or by any transmission line that may connect it to the pickup antenna.

Field-strength measurements preferably should be made at a distance of several wave lengths from the transmitting antenna being tested. Measurements made within a wave length of the antenna may be misleading, because of the possibility that the measuring equipment may be responding to the combined induction and radiation fields of the antenna, rather than to the radiation field alone. Also, if the pick-up antenna

has dimensions comparable with those of the antenna under test it is likely that the coupling between the two antennas will be great enough to cause the pick-up antenna to tend to become part of the radiating system and thus result in misleading field-strength readings.

A desirable form of pick-up antenna is a dipole installed at the same height as the antenna being tested, with low-impedance line such as 75-ohm Twin-Lead connected at the center to transfer the r.f. signal to the field-strength meter. The length of the dipole need only be great enough to give adequate meter readings. A half-wave dipole will give maximum sensitivity, but such length will not be needed unless the distance is several wave lengths and a relatively insensitive meter is used.

Field-Strength Meters

The crystal-detector wave meter described earlier in this chapter may be used as a field-strength meter. It may be coupled to the transmission line to the pick-up antenna through the coaxial-cable jack, J_1 .

The indications with a crystal wave meter connected as shown in Fig. 21-10 will tend to be "square law" — that is, the meter reading will be proportional to the square of the r.f. voltage. This exaggerates the effect of relatively small adjustments to the antenna system and gives a false impression of the improvement secured. The meter reading can be made more linear by connecting a fairly large resistance in series with the milliammeter (or microammeter). About 10,000 ohms is required for good linearity. This considerably reduces the sensitivity of the meter, but the lower sensitivity can be compensated for by making the pick-up antenna sufficiently large.

Transistorized Wave Meter and Field-Strength Meter

A sensitive field-strength meter can be made by using a transistor as a d.c. amplifier following the crystal rectifier of a wave meter. A circuit of this type is shown in Fig. 21-32. Depending on

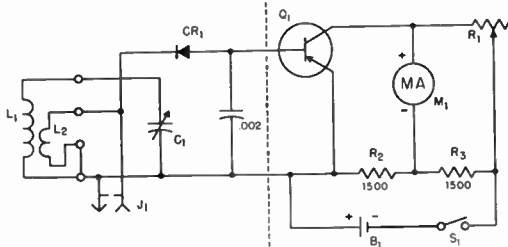

Fig. 21-32 — Transistor d.c. amplifier applied to the wave meter of Fig. 21-10 to increase sensitivity. Components not listed below are the same as in Fig. 21-10.

- B₁ — Small flashlight cell.
- Q₁ — 2N107, CK 722, etc.
- R₁ — 0.1-megohm volume control.
- R₂, R₃ — 1500 ohms, ½ watt.
- S₁ — S.p.s.t. toggle (on-off switch).

the characteristics of the particular transistor used, the amplification of current may be 10 or more times, so that a 0-1 milliamper d.c. instrument becomes the equivalent of a sensitive microammeter.

The circuit to the left of the dashed line in Fig. 21-32 is the same as the wave-meter circuit of Fig. 21-10, and the transistor amplifier can easily be accommodated in the case shown in Figs. 21-11 and 21-12.

The transistor is connected in the common-emitter circuit with the rectified d.c. from the crystal diode flowing in the base-emitter circuit. Since there is a small residual current in the collector circuit with no current flowing in the base-emitter circuit, the d.c. meter is connected in a bridge arrangement so the residual current can be balanced out. This is accomplished, in the absence of any signal input to the transistor base, by adjusting R_1 so that the voltage drop across it is equal to the voltage drop from collector to emitter in the transistor. R_2 and R_3 , being of the same resistance, have equal voltage drops across them and so there is no difference of potential across the meter terminals until the collector current increases because of current flow in the base-emitter circuit.

The collector current in a circuit of this type is not strictly proportional to the base current, particularly for low values of base current. The meter readings are not directly proportional to the field strength, therefore, but tend toward "square law" response just as in the case of a simple diode with little or no resistance in its d.c. circuit. For this reason the d.c. meter, M_1 , should not have too-high sensitivity if reasonably linear response is desired. A 0-1 milliammeter will be satisfactory.

The zero balance should be checked at intervals while the instrument is in use, since the

residual current of the transistor is sensitive to temperature changes.

● IMPEDANCE AND STANDING-WAVE RATIO

Adjustment of antenna matching systems requires some means either of measuring the input impedance of the antenna or transmission line, or measuring the standing-wave ratio. "Bridge" methods are suitable for either measurement.

There are many varieties of bridge circuits, the two shown in Fig. 21-33 being among the most popular for amateur purposes. The simple resistance bridge of Fig. 21-33A consists essentially of two voltage dividers in parallel across a source of voltage. When the voltage drop across R_1 equals that across R_S the drops across R_2 and R_L are likewise equal and there is no difference of potential between points A and B. Hence the voltmeter reading is zero and the bridge is said to be "balanced." If the drops across R_1 and R_S are not equal, points A and B are at different potentials and the voltmeter will read the difference. The operation of the circuit of Fig. 21-33B is similar, except that one of the voltage dividers is capacitive instead of resistive.

Because of the characteristics of practical components at radio frequencies, the circuit of Fig.

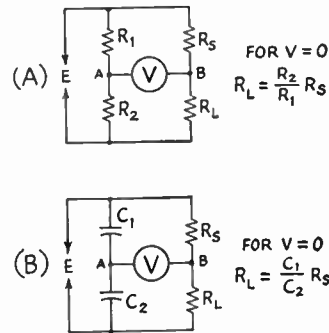

Fig. 21-33 — Basic bridge circuits. (A) Resistance bridge; (B) resistance-capacitance bridge. The latter circuit is used in the "Micromatch" with R_S a very low resistance (1 ohm or less) and the ratio C_1/C_2 adjusted accordingly for a desired line impedance.

21-33A is best suited to applications where the ratio R_1/R_2 is fixed. This type of bridge is particularly well suited to measurement of standing-wave ratio. The circuit of Fig. 21-33B is well adapted to applications where a variable voltage divider is essential (since C_1 and C_2 may readily be made variable) as in measurement of unknown values of R_L .

S.W.R. Bridge

In the circuit of Fig. 21-33A, if R_1 and R_2 are made equal, the bridge will be balanced when $R_L = R_S$. This is true whether R_L is an actual resistor or the input resistance of a perfectly matched transmission line, provided R_S is chosen to equal the characteristic impedance of the line. Even if the line is not properly matched, the bridge will still be balanced for power traveling

outward on the line, since outward-going power sees only the Z_0 of the line until it reaches the load. However, power reflected back from the load does not "see" a bridge circuit and the reflected voltage registers on the voltmeter. From the known relationship between the outgoing voltage and the reflected voltage, the s.w.r. is easily calculated:

$$S.W.R. = \frac{V_o + V_r}{V_o - V_r}$$

where V_o is the outgoing voltage and V_r is the reflected voltage. The outgoing voltage is equal to $E/2$ since R_s and R_L (the Z_0 of the line) are equal. It may be measured either by disconnecting R_L or shorting it.

Measuring Voltages

For the s.w.r. formula above to apply with reasonable accuracy (particularly at high standing-wave ratios) the current taken by the voltmeter must be inappreciable compared with the currents through the bridge "arms." The voltmeter used in bridge circuits employs a crystal diode rectifier (see discussion earlier in this chapter) and in order to meet the above requirement — as well as to have linear response, which is equally necessary for calibration purposes — should use a resistance of at least 10,000 ohms in series with the milliammeter or microammeter.

Since the voltage applied to the line is measured by shorting or disconnecting R_L (the line input terminals), while the reflected voltage is measured with R_L connected, the load on the source of voltage E is different in the two measurements. If the regulation of the voltage source is not perfect, the voltage E will not remain the same under these two conditions. This can lead to large errors. Such errors can be avoided by using a second voltmeter to maintain a check on the voltage applied to the bridge, readjusting the

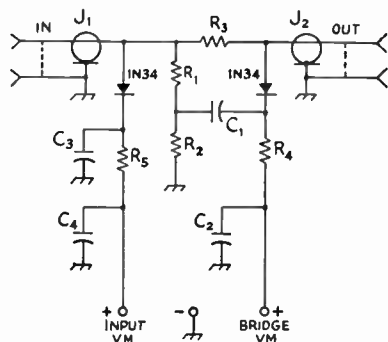

Fig. 21-34 — Bridge circuit for s.w.r. measurements. This circuit is intended for use with a d.c. voltmeter, range 5 to 10 volts, having a resistance of 10,000 ohms per volt or greater.

C_1, C_2, C_3, C_4 — 0.005- or 0.01- μ f. disk ceramic.
 R_1, R_2 — 47-ohm composition, $\frac{1}{2}$ or 1 watt.
 R_3 — 52- or 75-ohm (depending on line impedance) composition, $\frac{1}{2}$ or 1 watt; precision type preferred.
 R_4, R_5 — 10,000 ohms, $\frac{1}{2}$ watt.

J_1, J_2 — Coaxial connectors.

Meter connects to either "input" or "bridge" position as required.

coupling to the voltage source to maintain constant applied voltage during the two measurements. Since the "input" voltmeter is simply used as a reference, its linearity is not important, nor does its reading have to bear any definite relationship to that of the "bridge" voltmeter, except that its range has to be at least twice that of the latter.

A practical circuit incorporating these features is given in Fig. 21-34.

If the bridge is to be used merely for antenna adjustment, where the object is to secure the lowest possible s.w.r. rather than to measure the s.w.r. accurately, the voltmeter requirements are not stringent. In this case the object is to get as close to a "null" or balance (that is, zero reading)

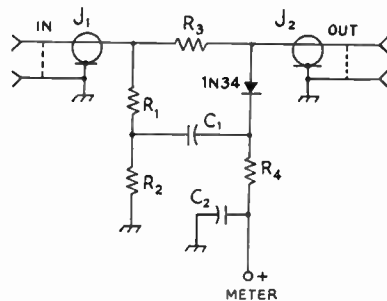

Fig. 21-35 — A simple bridge circuit useful for impedance-matching in coaxial lines.

C_1, C_2 — 0.005- or 0.01- μ f. disk ceramic.

R_1, R_2 — 47-ohm composition, $\frac{1}{2}$ watt.

R_3 — 52- or 75-ohm (depending on line impedance) composition, $\frac{1}{2}$ watt; precision type preferred.

R_4 — 1000-ohm composition, $\frac{1}{2}$ watt.

J_1, J_2 — Coaxial connector.

The meter may be a 0-1 milliammeter or d.c. voltmeter of any type having a sensitivity of 1000 ohms per volt or greater, and a full-scale range of 5 to 10 volts. Negative side of meter connects to ground.

as possible. At or near exact balance the voltmeter impedance is not important. Neither is it necessary to maintain constant input voltage to the bridge. This simplifies the bridge circuit considerably, Fig. 21-35 being a practical example. The construction of a bridge of this type suitable for antenna and transmission line adjustments is shown in Fig. 21-36.

Bridge Construction

A principal point in the construction of an s.w.r. bridge is to avoid coupling between the resistors forming the bridge arms, and between the arms and the voltmeter circuit. This can be done by keeping the resistance arms separated and at right angles to each other, and by placing the crystal and its connecting leads so that the loop so formed is not in inductive relationship with any loops formed by the bridge arms. Shielding between the bridge arms and the crystal circuit is helpful in reducing such couplings, although it is not always necessary. The two resistors forming the "ratio arms," R_1 and R_2 , should have identical relationships with metal parts, to keep the shunt capacitances equal, and also should have the same lead lengths

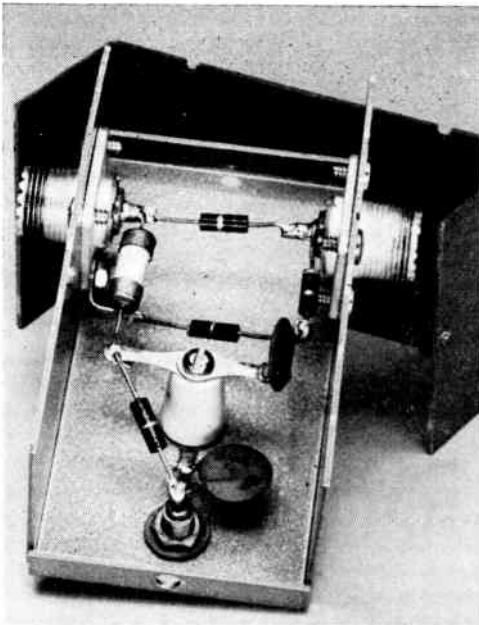

Fig. 21-36 — An inexpensive bridge for matching adjustments using the circuit of Fig. 21-35. It is built in a 1½ × 2½ × 1-inch "Channel-lock" box. The standard resistor, R_3 , bridges the two coax connectors. A pin jack is provided for connection to the d.c. meter, 0-1 ma. or 0-500µa.; the meter negative can be connected to the case or to one of the coax fittings.

so the inductances will balance. Leads should be kept as short as possible.

Testing and Calibration

In a bridge intended for s.w.r. measurement (Fig. 21-34) rather than simple matching, the first check is to apply just enough r.f. voltage, at the highest frequency to be used, so that the bridge voltmeter reads full scale with the load terminals open. Observe the input voltage, then short-circuit the load terminals and readjust the input to the same voltage. The bridge voltmeter should again register full scale. If it does not, the ratio arms, R_1 and R_2 , probably are not exactly equal. These two resistors should be carefully matched, although their actual value is not critical. If a similar test at a low frequency shows better balance, the probable cause is stray inductance or capacitance in one arm not balanced by equal strays in the other.

After the "short" and "open" readings have been equalized, the bridge should be checked for null balance with a "dummy" resistance, equal to the line impedance, connected to the load terminals. It is convenient to mount a half- or 1-watt resistor of the proper value in a coax connector, keeping it centered in the connector and using the minimum lead length. The bridge voltmeter should read zero at all frequencies. A reading above zero that remains constant at all frequencies indicates that the "dummy" resistor is not matched to R_3 , while readings that vary with

frequency indicate stray reactive effects or stray coupling between parts of the bridge.

When the operation is satisfactory on the two points just described, the null should be checked with the dummy resistor connected to the bridge through several different lengths of transmission line, to ensure that R_3 actually matches the line impedance. If the null is not complete in this test both the dummy resistor and R_3 will have to be adjusted until a good match is obtained. With care, composition resistors can be filed down to raise the resistance, so it is best to start with resistors somewhat low in value. With each change in R_3 , adjust the dummy resistor to give a good null when connected directly to the bridge, then try it at the end of several different lengths of line, continuing until the null is satisfactory under all conditions of line length and frequency.

With a high-impedance voltmeter, the s.w.r. readings will closely approximate the theoretical curve of Fig. 21-37. The calibration can be checked by using composition resistors as loads. Adjust the transmitter coupling so that the bridge voltmeter reads full scale with the output terminals open, and then check the input voltage. Connect various values of resistance across the output terminals, making sure that the input voltage is readjusted to be the same in each case, and note the reading with the meter in the bridge position. The s.w.r. is given by

$$S.W.R. = \frac{R_L}{R_0} \text{ or } \frac{R_0}{R_L}$$

where R_0 is the line impedance for which the bridge has been adjusted to null, and R_L is

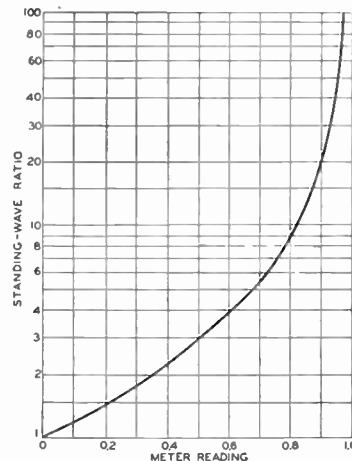

Fig. 21-37 — Standing-wave ratio in terms of meter reading (relative to full scale) after setting outgoing voltage to full scale.

the resistance used as a load. Use the formula that places the larger of the two resistances in the numerator. If the readings do not correspond exactly for the same s.w.r. when appropriate resistors above and below the line impedance for which the bridge is designed are used, a possible reason is that the current taken by the voltmeter is affecting the measurements.

Using a 0-100 microammeter, a 20,000-ohms-per-volt meter on a 5-volt or higher range, or a v.t. voltmeter, the difference between "up" and "down" s.w.r. measurements should be negligible, provided the load resistors used for this test can be measured (at d.c.) with sufficient accuracy. Values over 1000 ohms or so should not be used at the higher frequencies.

Using the Bridge

The operating procedure is the same whether the bridge is used for matching or for s.w.r. measurement. Apply power with the load terminals either open or shorted, and adjust the input until the bridge voltmeter reads full scale. Because the bridge operates a very low power level it may be necessary to couple it to a low-power driver stage rather than to the final amplifier. Alternatively, the plate voltage and excitation for the final amplifier may be reduced to the point where the power output is of the order of a few watts. Then connect the load and observe the voltmeter reading. For matching, adjust the matching network until the best possible null is obtained. For s.w.r. measurement, note the r.f. input voltage to the bridge after adjusting for full-scale with the load terminals open or shorted, then connect the load and readjust the transmitter for the same input voltage. The bridge voltmeter then indicates the standing-wave ratio as given by Fig. 21-37.

Antenna systems are in general resonant systems and thus exhibit a purely-resistive impedance at only one frequency or over a small band of frequencies. In making bridge measurements, this will cause errors if the r.f. energy used to operate the bridge is not free from harmonics and other spurious components, such as frequencies lower than the desired operating frequency that may be fed through the final amplifier from a frequency-doubler stage. When a good null cannot be secured in, for example, the course of adjusting a matching section for 1-to-1 s.w.r., a check should be made to ensure that only the desired measurement frequency is present. A crystal wave meter coupled to the load usually will show whether energy on undesired frequencies is present in significant amounts. If so,

additional selectivity must be used between the source of power and the measuring circuit.

Bridge for Monitoring S.W.R.

The low power level at which resistance-type bridges must operate is a disadvantage when the bridge is used as an operating adjunct — e.g., for the adjustment of matching circuits when changing bands, or for readjustment of such circuits within a band. For this purpose a bridge is needed that will carry the full power output of the transmitter without absorbing an appreciable fraction of it.

The bridge shown in Figs. 21-38 to 21-40, inclusive, is such a device. It makes use of the combined effects of inductive and capacitive coupling between the center conductor of a coaxial line and a length of wire parallel to it. When the coupled wire is properly terminated in a resistance, the voltage induced in it by power travelling along the line in one direction will be balanced out in the crystal-rectifier r.f. voltmeter circuit, but power travelling along the line in the opposite direction will cause a voltmeter indication. If the bridge is adjusted to match the Z_0 of the coaxial line being used, the voltmeter will respond only to the reflected voltage, just as in the case of the resistance-type bridges. The power consumed in the bridge is below one watt, even at the maximum power permitted amateur transmitters.

The sensitivity of this type of bridge is proportional to frequency, so higher power is required for a given voltmeter deflection at low than at high frequencies. Typical values of rectified current are as follows, with a bridge adjusted for a characteristic impedance of 52 ohms:

Band	10 Watts R.F.	50 Watts R.F.
1.8 Mc.	25 μ a.	100 μ a.
3.5 Mc.	70 μ a.	250 μ a.
7 Mc.	200 μ a.	1 ma.
14 Mc.	750 μ a.	Over 1 ma.
21-28 Mc.	Over 1 ma.	Over 1 ma.

A current of 1 ma. on 3.5 Mc. can be obtained with a power level of somewhat over 200 watts.

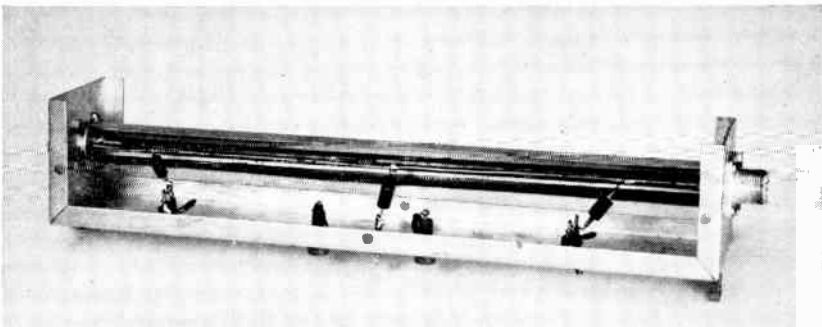

Fig. 21-38 — S.w.r. bridge ("Monimatch") that can be left in the coax line for continuous monitoring of matching and power output. The box is a slip-cover type (Premier AMC-1014) measuring 12 by 2½ by 2 inches. The layout is the same as the circuit diagram, Fig. 21-39.

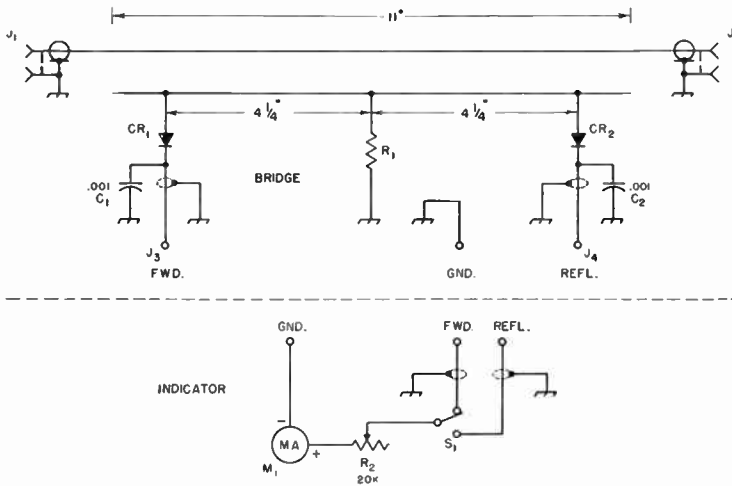

Fig. 21-39 — Circuit of the "Monimatch" s.w.r. and power indicator. Approximate distances between R_1 , CR_1 and CR_2 along the coupling wire are subject to final adjustment as described in the text.

C_1 , C_2 — Disk ceramic.

CR_1 , CR_2 — Crystal diode, general-purpose type (1N31, etc.)

J_1 , J_2 — Coax receptacles, chassis-mounting type.

J_3 , J_4 — Insulated tip jacks.

R_1 — For 52-ohm line: 68 ohms, 1-watt composition; for 75-ohm line: 47 ohms, 1-watt composition.

R_2 — Volume control.

S_1 — S.p.d.t. toggle.

These currents are for R_2 , the resistance in series with the d.c. meter, equal to zero.

The circuit of Fig. 21-39 has two such bridge circuits back-to-back so either the incident or reflected voltage can be read simply by throwing S_1 to the proper position.

The essential construction details are given in Figs. 21-39 and 21-40. The line section consists of a trough made of thin sheet copper or aluminum (for the coaxial outer conductor) with an inner conductor of $1/4$ -inch copper tubing. A tubing length of slightly over 11 inches is required, as shown in Fig. 21-39. Its ends are soldered to the inner terminals of the chassis-type coaxial fittings.

The coupling wire is supported by R_1 at its center and by CR_1 and CR_2 towards its outer ends. The leads to these components should be

kept short. Tie points are used to support the cathode-connection ends of the diodes and the by-pass capacitors C_1 and C_2 . Connections to the d.c. milliammeter are through pin jacks in the unit shown.

A dummy antenna of the same resistance as the Z_0 of the line should be used to adjust the bridge. A suitable dummy may be made by connecting four 220-ohm 1-watt composition resistors in parallel for 52-ohm line (or four 300-ohm resistors for 75-ohm line), keeping the connecting leads as short as possible. The transmitter may be used as a source of power providing its output can be reduced to about 4 watts, or a 10-watt lamp may be connected in series in the line from the transmitter to the bridge if the transmitter power cannot be reduced below 50 watts. With

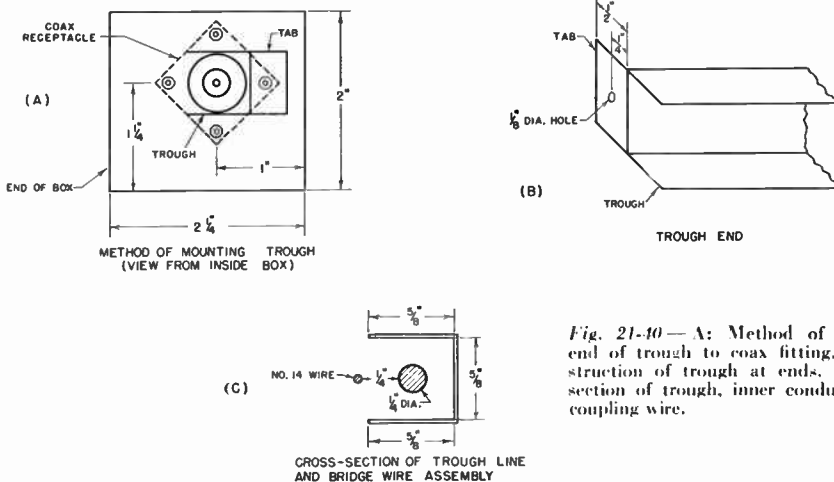

Fig. 21-40 — A: Method of mounting end of trough to coax fitting. B: Construction of trough at ends. C: Cross-section of trough, inner conductor, and coupling wire.

power applied (preferably at 28 Mc.) through J_1 and the dummy connected to J_2 , adjust the position at which CR_1 is connected to the coupling wire until the meter reading is zero with S_1 in the "reflected" position. Then apply power through J_2 with the dummy connected to J_1 and make a similar adjustment to the position of CR_2 with the meter switch in the "incident" position. The bridge is then ready for use with the normal connections (r.f. input to J_1 , line connected to J_2).

With S_1 in the "incident" position the meter gives a relative indication of power output, and thus is useful for transmitter tuning. With S_1 in the "reflected" position the meter reading will be zero when the line is properly matched.

(Described in October, 1956, *QST*.)

Impedance Bridge

The bridge shown in Figs. 21-41 to 21-43, inclusive, uses the basic circuit of Fig. 21-33B and incorporates a "differential" capacitor to obtain

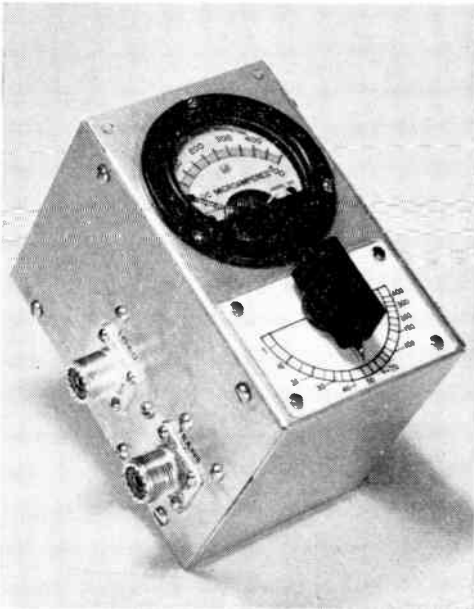

Fig. 21-41 — An RC bridge for measuring unknown values of impedance. The bridge operates at an r.f. input voltage level of about 5 volts. The aluminum box is 4 by 5 by 6 inches.

an adjustable ratio. When a load of unknown value is connected in place of R_L , the $C_1 C_2$ ratio may be varied to attain a balance, as indicated by a null reading. The capacitor settings can be calibrated in terms of resistance at R_L , so the unknown value can be read off the calibration.

The differential capacitor consists of two identical capacitors on the same shaft, arranged so that when the shaft is rotated to increase the capacitance of one unit, the capacitance of the other decreases. The practical circuit of the bridge is given in Fig. 21-42. Satisfactory operation hinges on observing the same constructional precautions as in the case of the s.w.r. bridge. Although a high-impedance voltmeter is not essential, since the bridge is always adjusted for a null, the use of such a voltmeter is advisable because its better linearity (particularly at the low readings) makes the actual null settings more accurately observable.

With the circuit arrangement and capacitor shown, the useful range of the bridge is from about 5 ohms to 400 ohms. The calibration is such that the percentage accuracy of reading is approximately constant at all parts of the scale. The midscale value is in the range 50-75 ohms, to correspond with the Z_0 of coaxial cable. The reliable frequency range of the bridge includes all amateur bands from 3.5 to 54 Mc.

Checking and Calibration

A bridge constructed as shown in the photographs should show a complete null at all frequencies within the range mentioned above when a 50-ohm "dummy" load of the type described earlier in connection with the s.w.r. bridge is connected to the load terminals. The bridge may be calibrated by using a number of 1/2-watt composition resistors of different values in the 5-400 ohm range as loads, in each case balancing the bridge by adjusting C_1 for a null reading on the meter. For highest accuracy, the test resistors should be measured on a precision resistance bridge, if possible, since the best tolerance normally obtainable in such resistors is ± 5 per cent. The leads between the test resistor and J_2 should be as short as possible, and the calibration preferably should be done in the 3.5-Mc. band where stray inductance and capacitance will have the least effect. The calibration should be checked on the highest-frequency band to be used and

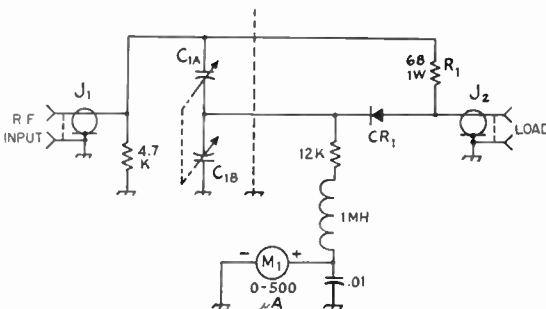

Fig. 21-42 — Circuit of the impedance bridge. Resistors are composition, 1/2 watt except as noted. Fixed capacitors are ceramic.

C_1 — Differential capacitor, 11-161 $\mu\text{f.}$ per section (Millen 28801).

CR_1 — Germanium diode (1N34, 1N48, etc.).

J_1, J_2 — Coaxial connectors, chassis type.

M_1 — 0-500 microammeter.

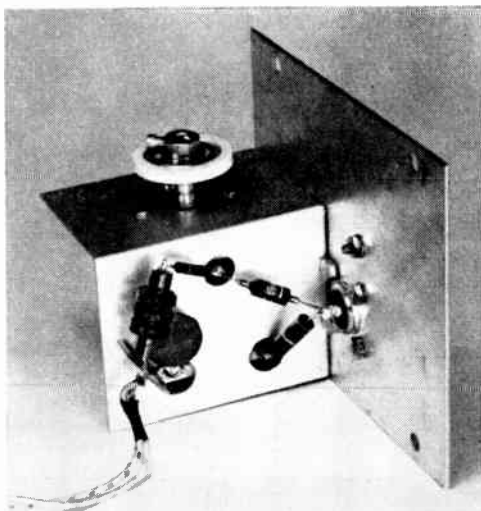

Fig. 21-43 — All components except the meter are mounted on one of the removable sides of the box. The variable capacitor is mounted on an L-shaped piece of aluminum (with half-inch lips on the inner edge for bolting to the box side) 2 inches wide, 2½ inches high and 2¾ inches deep, to shield the capacitor from the other components. The terminals project through holes as shown, with associated components mounted directly on them and the load connector, J_2 . Since the rotor of C_1 must not be grounded, the capacitor is operated by an extension shaft and insulated coupling.

The lead from J_1 to C_{1A} should go directly from the input connector to the capacitor terminal (lower right) to which the 68-ohm resistor is attached. The 4700-ohm resistor is soldered across J_1 .

the dial readings should be identical with the low-frequency calibration. At 30 to 50 Mc. the null may not be quite complete at the extremes of the resistance range because at these frequencies stray inductance and capacitance in the test resistor and its leads are not negligible. However, the current indicated by the meter at the minimum point should not be more than about 5 per cent of the current indicated when the bridge is thrown as far out of balance as possible by varying C_1 .

Using the Bridge

Strictly speaking, a simple bridge can measure only purely resistive impedances. When the load is a pure resistance, the bridge can be balanced to a good null (meter reading zero). If the load has a reactance component the null will not be complete; the higher the ratio of reactance to resistance in the load the poorer the null reading. The operation of the bridge is such that when an exact null cannot be secured, the readings approximate the resistive component of the load for very low values of impedance, and approximate the total impedance at very high values of impedance. In the mid-range the approximation to either is poor, for loads having considerable reactance.

In using the bridge for adjustment of matching networks C_1 is set to the desired value (usually the Z_0 of the coaxial line) and the matching network is then adjusted for the best possible null.

● **PARALLEL-CONDUCTOR LINES**

Bridge measurements made directly on parallel-conductor lines are frequently subject to considerable error because of "antenna" currents flowing on such lines. These currents, which are either induced on the line by the field around the antenna or coupled into the line from the transmitter by stray capacitance, are in the same phase in both line wires and hence do not balance out like the true transmission-line currents. They will nevertheless actuate the bridge voltmeter, causing an indication that has no relationship to the standing-wave ratio.

S.W.R. Measurements

The effect of "antenna" currents on s.w.r. measurements can be largely overcome by using a coaxial bridge and coupling it to the parallel-conductor line through a properly-designed impedance-matching circuit. A suitable circuit is given in Fig. 21-44. An antenna coupler can be used for the purpose. In the balanced tank circuit the "antenna" or parallel components on the line tend to balance out and so are not passed on to the s.w.r. bridge. It is essential that L_1 be coupled to a "cold" point on L_2 to minimize capacitive coupling, and also desirable that the center of L_2 be grounded to the chassis on which the circuit is mounted. Values should be such that L_2C_2 can be tuned to the operating frequency and that L_1 provides sufficient coupling, as described in the transmission-line chapter. The measurement procedure is as follows:

Connect a noninductive (½- or 1-watt carbon) resistor, having the same value as the characteristic impedance of the parallel-conductor line, to the "line" terminals. Apply r.f. to the bridge, adjust the taps on L_2 (keeping them equidistant

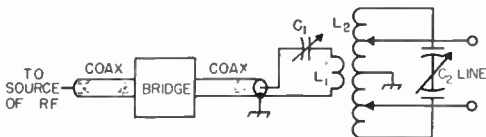

Fig. 21-44 — Circuit for using coaxial s.w.r. bridge for measurements on parallel-conductor lines. Values of circuit components are identical with those used for the similar "antenna-coupler" circuit discussed in the chapter on transmission lines.

from the center), while varying the capacitance of C_1 and C_2 , until the bridge shows a null. After the null is obtained, do not touch any of the circuit adjustments. Next, short-circuit the "line" terminals and adjust the r.f. input until the bridge voltmeter reads full scale. Remove the short-circuit and test resistor, and connect the regular transmission line. The bridge will then indicate the standing-wave ratio on the line.

The circuit requires rematching, with the test resistor, whenever the frequency is changed appreciably. It can, however, be used over a portion of an amateur band without readjustment, with negligible error.

Impedance Measurements

Measurements on parallel-conductor lines and other balanced loads can be made with the impedance bridge previously described by using a balun of the type shown schematically in Fig. 21-15. This is an autotransformer having a 2-to-1 turns ratio and thus provides a 4-to-1 step-down

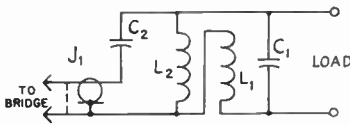

Fig. 21-15 — Tuned balun for coupling between balanced and unbalanced lines. L_1 and L_2 should be built as a bifilar winding to get as tight coupling as possible between them. Typical constants are as follows:

Freq., Mc.	L_1, L_2	C_1	C_2
28	3 turns each on 2-inch form, equally spaced over $7/16$ inch, total.	1 $\mu\text{f.}$	120 $\mu\text{f.}$
14	Same as 28 Mc.	39 $\mu\text{f.}$	0.0015 $\mu\text{f.}$
7	8 turns of 150-ohm Twin-Lead, no spacing between turns, on $2\frac{3}{4}$ -inch dia. form.	None	0.001 $\mu\text{f.}$
3.5	Same as 7 Mc.	62 $\mu\text{f.}$	0.0015 $\mu\text{f.}$

Capacitors in unit shown in Fig. 21-16 are NPO disk ceramic. Units may be paralleled to obtain proper capacitance.

in impedance from a balanced load to the output circuit of the bridge, one side of which is grounded. L_1 and L_2 must be as tightly coupled as possible, and so should be constructed as a bifilar winding. The circuit is resonated to the operating frequency by C_1 , and C_2 serves to tune out any residual reactance that may be present because the coupling between the two coils is not quite perfect.

Fig. 21-16 shows one method of constructing such a balun. The two interwound coils are made as nearly identical as possible, the "finish" end of the first being connected to the "start" end of the second through a short lead running under the winding inside the form. The center of this lead is tapped to give the connection to the shell side of the coax connector. C_1 should be chosen to resonate the circuit at the center of the band

for which the balun is designed with J_1 open, and C_2 is adjusted to resonate the circuit to the same frequency with both J_1 and the "load" terminals shorted. The frequency checks may be made with a grid-dip meter. (For further details, see *QST* for August, 1955.)

With the balun in use the bridge is operated in the same way as previously described, except that all impedance readings must be multiplied by 4. The balun also may be used for s.w.r. measurements on 300-ohm line in conjunction with a resistance bridge designed for 75-ohm coaxial line.

The "Twin-Lamp"

A simple and inexpensive standing-wave indicator for 300-ohm line is shown in Fig. 21-17. It consists only of two flashlight lamps and a short piece of 300-ohm line. When laid flat against the line to be checked, the coupling is

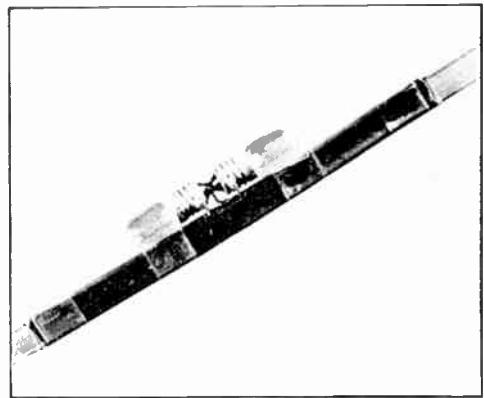
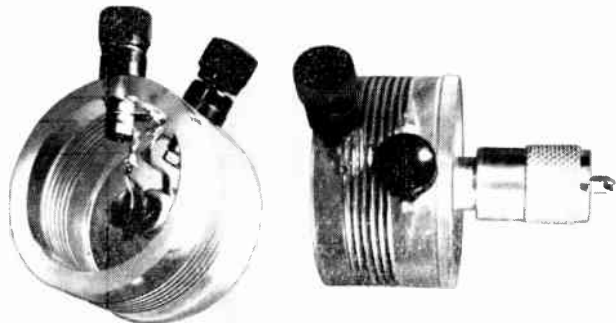

Fig. 21-17 — The "twin-lamp" standing-wave indicator mounted on 300-ohm Twin-Lead. Scotch tape is used for fastening.

such that outgoing power on the line causes the lamp nearest to the transmitter to light, while reflected power lights the lamp nearest the load. The power input to the line should be adjusted to make the lamp nearest the transmitter light to full brilliance. If the line is properly matched and the reflected power is very low, the lamp toward the antenna will be dark. If the s.w.r. is high, the two lamps will glow with practically equal brilliance.

The length of the piece of 300-ohm line needed in the twin-lamp will depend on the transmitter

Fig. 21-16 — Balun construction (W2FE). 150-ohm Twin-Lead may be used for the bifilar winding in place of the ordinary wire shown. Symmetrical construction with tight coupling between the two coils is essential to good performance.



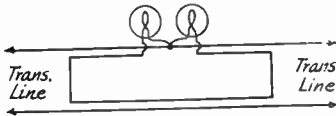

Fig. 21-48 — Wiring diagram of the "twin-lamp" standing-wave indicator.

power and the operating frequency. A few inches will suffice with high power at high frequencies, while a foot or two may be needed with low power and at low frequencies.

In constructing the twin-lamp, cut one wire in the exact center of the piece and peel the ends back on either side just far enough to provide leads to the flashlight lamps. Remove about 1/4 inch of insulation from one wire of the main transmission line at some convenient point. Use the lowest-current flashlight bulbs or dial lamps available. Solder the tips of the bulbs together and connect them to the bare point in the transmission line, then solder the ends of the cut portion of the short piece to the shells of the bulbs.

The Oscilloscope

The cathode-ray oscilloscope gives a visual representation of signals at both audio and radio frequencies and can therefore be used for many types of measurements that are not possible with instruments of the types discussed earlier in this chapter. In amateur work, one of the principal uses of the scope is for displaying an amplitude-modulated signal so a phone transmitter can be adjusted for proper modulation and continuously monitored to keep the modulation percentage within proper limits. For this purpose a very simple circuit will suffice, and an oscilloscope de-

Figs. 21-47 and -48 should make the construction clear.

Installing the twin-lamp on a line introduces a discontinuity in the line impedance which causes the s.w.r. from the twin-lamp back to the transmitter to differ from the s.w.r. existing between the antenna and twin-lamp. For this reason it is desirable to remove it after s.w.r. checks have been made. It is convenient to mount the twin-lamp on a short length of line fitted to a 300-ohm plug at one end and a mating socket at the other. If similar plugs and sockets are used on the transmitter and regular transmission line, the whole test unit can be inserted and taken out at will.

The twin-lamp will respond to "antenna" currents on the transmission line in much the same way as the bridge circuits discussed earlier. There is therefore always a possibility of error in its indications, unless it has been determined by other means that "antenna" currents are inconsequential compared with the true transmission-line current.

with that of a home-built instrument of comparable design, they are recommended for serious consideration by those who have need for or are interested in the wide range of measurements that is possible with a fully-equipped scope.

● CATHODE-RAY TUBES

The heart of the oscilloscope is the cathode-ray tube, a vacuum tube in which the electrons emitted from a hot cathode are first accelerated to give them considerable velocity, then formed

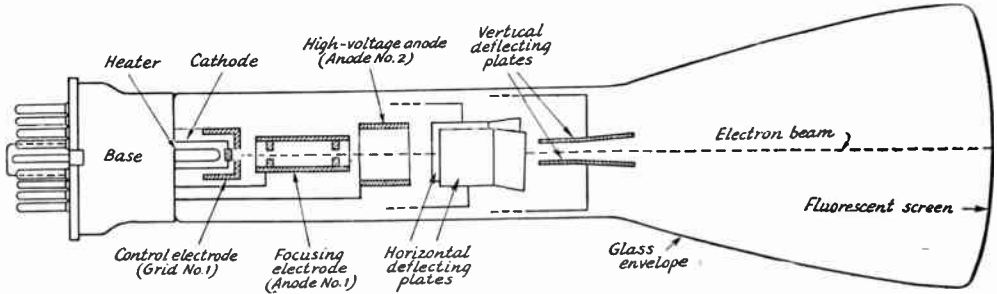

Fig. 21-49 — Typical construction for a cathode-ray tube of the electrostatic-deflection type.

signed expressly for this purpose is described in this section.

The versatility of the scope can be greatly increased by adding amplifiers and linear deflection circuits, but the design and adjustment of such circuits tends to be complicated if optimum performance is to be secured, and is somewhat outside the field of this chapter. Special components are generally required. Oscilloscope kits for home assembly are available from a number of suppliers, and since their cost compares very favorably

into a beam, and finally allowed to strike a special translucent screen which *fluoresces*, or gives off light at the point where the beam strikes. A beam of moving electrons can be moved laterally, or *deflected*, by electric or magnetic fields, and since its weight and inertia are negligibly small, it can be made to follow instantly the variations in periodically-changing fields at both audio and radio frequencies.

The electrode arrangement that forms the electrons into a beam is called the **electron gun**.

In the simple tube structure shown in Fig. 21-49, the gun consists of the cathode, grid, and anodes Nos. 1 and 2. The intensity of the electron beam is regulated by the grid in the same way as in an ordinary tube. Anode No. 1 is operated at a positive potential with respect to the cathode, thus accelerating the electrons that pass through the grid, and is provided with small apertures through which the electron stream passes. On emerging from the apertures the electrons are traveling in practically parallel straight-line paths. The electrostatic fields set up by the potentials on anode No. 1 and anode No. 2 form an **electron lens** system which makes the electron paths converge or focus to a point at the fluorescent screen. The potential on anode No. 2 is usually fixed, while that on anode No. 1 is varied to bring the beam into focus. Anode No. 1 is, therefore, called the **focusing electrode**.

Electrostatic deflection, the type generally used in the smaller tubes, is produced by **deflecting plates**. Two sets of plates are placed at right angles to each other, as indicated in Fig. 21-49. The fields are created by applying suitable voltages between the two plates of each pair. Usually one plate of each pair is connected to anode No. 2, to establish the polarities of the vertical and horizontal fields with respect to the beam and to each other.

Formation of Patterns

When periodically-varying voltages are applied to the two sets of deflecting plates, the path traced by the fluorescent spot forms a **pattern** that is stationary so long as the amplitude and phase relationships of the voltages remain unchanged. Fig. 21-50 shows how such patterns are formed. The horizontal sweep voltage is assumed to have the "sawtooth" waveshape indicated. With no voltage applied to the vertical plates the trace simply sweeps from left to right across the screen along the horizontal axis $X-X'$ until the instant H is reached, when it reverses direction and returns to the starting point. The sine-wave voltage applied to the vertical plates similarly would trace a line along the axis $Y-Y'$ in the absence of any deflecting voltage on the horizontal plates. However, when both voltages are present the position of the spot at any instant depends upon the voltages on both sets of plates at that instant. Thus at time B the horizontal voltage has moved the spot a short distance to the right and the vertical voltage has similarly moved it upward, so that it reaches the actual position B' on the screen. The resulting trace is easily followed from the other indicated positions, which are taken at equal time intervals.

Types of Sweeps

A sawtooth sweep-voltage wave shape, such as is shown in Fig. 21-50, is called a **linear sweep**, because the deflection in the horizontal direction is directly proportional to time. If

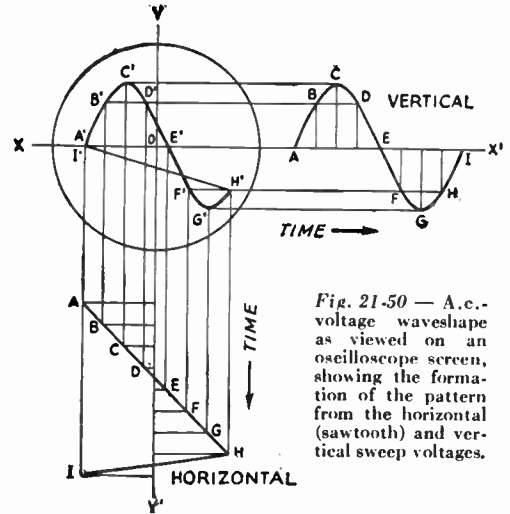

Fig. 21-50 — A.c.-voltage waveshape as viewed on an oscilloscope screen, showing the formation of the pattern from the horizontal (sawtooth) and vertical sweep voltages.

the sweep were perfect the **fly-back** time, or time taken for the spot to return from the end (H) to the beginning (I or A) of the horizontal trace, would be zero, so that the line III would be perpendicular to the axis $Y-Y'$. Although the fly-back time cannot be made zero in practicable sweep-voltage generators it can be made quite small in comparison to the time of the desired trace AII , at least at most frequencies within the audio range. The line II' is called the **return trace**; with a linear sweep it is less brilliant than the pattern, because the spot is moving much more rapidly during the fly-back time than during the time of the main trace.

The linear sweep shows the shape of the wave in the same way that it is usually represented graphically. If the period of the a.c. voltage applied to the vertical plates is considerably less than the time taken to sweep horizontally across the screen, several cycles of the vertical or "signal" voltage will appear in the pattern.

For many amateur purposes a satisfactory horizontal sweep is simply a 60-cycle voltage of adjustable amplitude. In modulation monitoring (described in the chapter on amplitude modulation) audio-frequency voltage can be taken from the modulator to supply the horizontal sweep. For examination of audio-frequency wave forms, the linear sweep is essential. Its frequency should be adjustable over the entire range of audio frequencies to be inspected on the oscilloscope.

Lissajous Figures

When sinusoidal a.c. voltages are applied to the two sets of deflecting plates in the oscilloscope the resultant pattern depends on the relative amplitudes, frequencies and phase of the two voltages. If the ratio between the two frequencies is constant and can be expressed in integers a stationary pattern will be produced. This makes it possible to use the oscilloscope for determining an unknown frequency, provided a variable frequency standard is available, or for

determining calibration points for a variable-frequency oscillator if a few known frequencies are available for comparison.

The stationary patterns obtained in this way are called **Lissajous figures**. Examples of some of the simpler Lissajous figures are given in Fig. 21-51. The frequency ratio is found by counting the number of loops along two adjacent edges. Thus in the third figure from the top there are three loops along a horizontal edge and only one along the vertical, so the

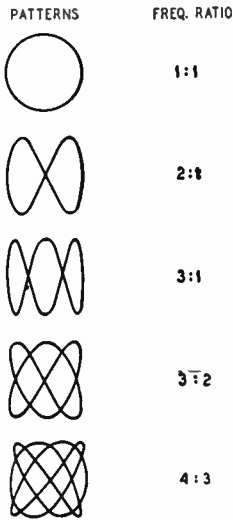

Fig. 21-51 — Lissajous figures and corresponding frequency ratios for a 90-degree phase relationship between the voltages applied to the two sets of deflecting plates.

ratio of the vertical frequency to the horizontal frequency is 3 to 1. Similarly, in the fifth figure from the top there are four loops along the horizontal edge and three along the vertical edge, giving a ratio of 4 to 3. Assuming that the known frequency is applied to the horizontal plates, the unknown frequency is

$$f_2 = \frac{n_2}{n_1} f_1$$

where f_1 = known frequency applied to horizontal plates,

f_2 = unknown frequency applied to vertical plates,

n_1 = number of loops along a vertical edge, and

n_2 = number of loops along a horizontal edge.

An important application of Lissajous fig-

ures is in the calibration of audio-frequency signal generators. For very low frequencies the 60-cycle power-line frequency is held accurately enough to be used as a standard in most localities. The medium audio-frequency range can be covered by comparison with the 440- and 600-cycle modulation on the WWV transmissions. An oscilloscope having both horizontal and vertical amplifiers is desirable, since it is convenient to have a means for adjusting the voltages applied to the deflection plates to secure a suitable pattern size. It is possible to calibrate over a 10-to-1 range, both upwards and downwards, from each of the latter frequencies and thus cover the audio range useful for voice communication.

● **SIMPLE OSCILLOSCOPE FOR MODULATION CHECKING**

The 2-inch oscilloscope shown in Fig. 21-52 includes all the features necessary for modulation checking and monitoring, including tuned-circuit r.f. input to the vertical plates. A filament supply and source of a.c. sweep voltage are incorporated, so the only external requirement is the d.c. supply for the c.r. tube anodes. This may be taken from the transmitter power supply, since the current drain is negligible. Although the tube will operate with as little as 500 volts, at least 750 volts is recommended for sufficient pattern brightness, and voltages up to 2500 are permissible.

For constructional convenience, compactness, and inexpensive magnetic shielding of the tube, the unit is constructed in a 3 × 4 × 17-inch steel chassis, which is mounted on a 3½ × 19-inch relay-rack panel. The tube face is viewed through a 2-inch hole in the panel and chassis, using a small mirror to reflect the image. A chart frame with a clear window is used to cover the panel hole.

The right-hand section of Fig. 21-53 shows the tube connections. Controls are provided for spot intensity, focusing, and horizontal and vertical centering of the pattern. The values specified for the voltage-divider string are satisfactory for voltages up to about 1500 d.c., but for voltages between 1500 and 3000 an additional 1-megohm 1-watt resistor should be connected in series with the one shown. This may require inserting additional resistance (0.1 to 0.25 megohm) in series at "X" to make the focus control cover the proper range. The fixed capacitors should have a voltage rating appropriate to the voltage actually used. Capacitance values are not critical; up to 0.01 μf. may be used if available in the proper voltage rating.

Fig. 21-52 — Two-inch oscilloscope for rack mounting. Everything needed for modulation monitoring is included except the high-voltage d.c. supply, which can be obtained from the transmitter.

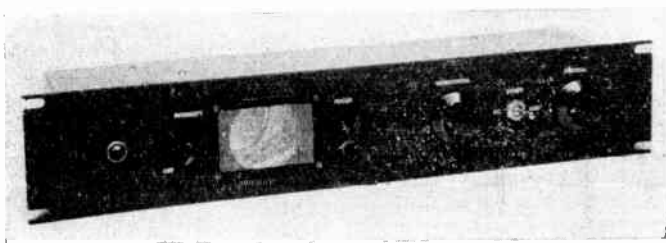

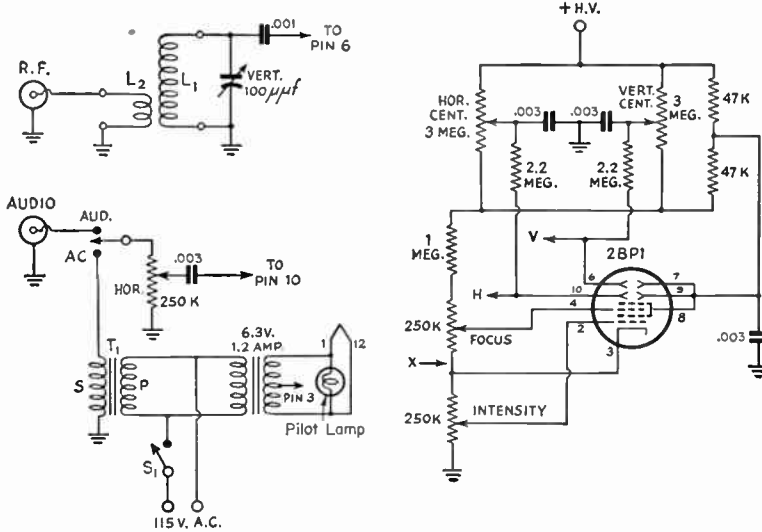

Fig. 21-53 — Circuit of the 2-inch oscilloscope. Fixed resistors are 1/2 watt except the 1-megohm unit, which is 1 watt. Capacitances are in μf . unless indicated otherwise. Fixed capacitors are ceramic, 1000 volts working or higher, according to d.c. voltage used. See text for explanation of "X."

- T₁ — Small audio transformer, 1-to-1 turns ratio.
- L₁ — 1.75 Mc.: 3/4 inch winding of No. 30 enam.
- 3.5 to 7.9 Mc.: 30 turns No. 22 enam., close-wound.

- 13 to 30 Mc.: 7 turns No. 22, length 3/4 in.
- L₂ — 2 or more turns as necessary for sufficient coupling.
- All coils wound on 1-inch diameter forms (Millen 15001).

A tuned input circuit is provided, using plug-in coils to cover the various bands. The 100- μf . capacitor makes a convenient "Height" control for the pattern, and the tuned circuit insures adequate pattern height even from a low-power transmitter. The r.f. may be picked up with a

held by two semicircular brackets made from aluminum strips 1/2 inch wide and mounted on 1-inch stand-off insulators. The mirror, which is held to a wood strip by Duco cement, the strip in turn being bolted to the chassis, should be cut to block off the left-hand (internal view) section

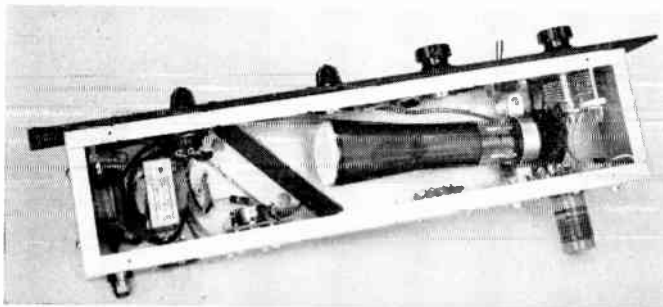

Fig. 21-54 — The oscilloscope is constructed in a 3 by 4 by 17 chassis mounted on a 3 1/2-inch relay rack panel. The steel chassis with bottom plate (not shown) shields the tube from stray magnetic fields.

1- or 2-turn link at the transmitter tank or antenna tank circuit, if the latter is used, and connected to the scope through a length of small coax cable.

Line-frequency a.c. is used for the horizontal sweep for obtaining a wave-envelope pattern. An input is also provided for audio from the modulator, for the trapezoidal pattern. Full deflection requires about 75 volts (peak) for each 1000 volts used on the c.r. tube, using the deflection plate connections shown in Fig. 21-53.

The parts layout is such as to give short connections between the r.f. circuit and the vertical deflection plate terminals on the tube socket, and to place the two transformers as far as possible from the tube and thus reduce the possibility of trouble from stray fields. The tube socket is

of the chassis, which contains the pilot light.

The centering potentiometers do not require frequent handling and are controlled from the rear. Because they are at high voltage they are insulated from the chassis by mounting them on a bakelite plate fastened to the rear wall by half-inch pillars. The shafts are cut short and slotted for screwdriver adjustment. An insulated screwdriver should be used. The intensity and focusing controls are mounted on the panel either side of the window. The a.c. switch is on the intensity control.

The d.c. supply used preferably should be one that does not vary in output voltage during modulation; e.g., the Class C amplifier supply is preferable to the Class B modulator supply.

Assembling a Station

The actual location inside the house of the "shack" — the room where the transmitter and receiver are located — depends, of course, on the free space available for amateur activities. Fortunate indeed is the amateur with a separate room that he can reserve for his hobby, or the few who can have a special small building separate from the main house. However, most amateurs must share a room with other domestic activities, and amateur stations will be found tucked away in a corner of the living room, a bedroom, a large closet, or even under the kitchen stove! A spot in the cellar or the attic can almost be classed as a separate room, although it may lack the "finish" of a normal room.

Regardless of the location of the station, however, it should be designed for maximum operating convenience and safety. It is foolish to have the station arranged so that the throwing of several switches is required to go from "receive" to "transmit," just as it is silly to have the equipment arranged so that the operator is in an uncomfortable and cramped position during his operating hours. The reason for building the station as safe as possible is obvious, if you are interested in spending a number of years with your hobby!

● CONVENIENCE

The first consideration in any amateur station is the operating position, which includes the operator's table and chair and the pieces of equipment that are in constant use

(the receiver, send-receive switch, and key or microphone). The table should be as large as possible, to allow sufficient room for the receiver or receivers, frequency-measuring equipment, monitoring equipment, control switches, and keys and microphones, with enough space left over for the logbook, a pad and pencil, and perhaps a *large* ash tray. Suitable space should be included for radiogram blanks and a call book, if these accessories are in frequent use. If the table is small, or the number of pieces of equipment is large, it is often necessary to build a shelf or rack for the auxiliary equipment, or to mount it in some less convenient location in or under the table. If one has the facilities, a semicircular "console" can be built of wood, or a simpler solution is to use two small wooden cabinets to support a table top of wood or Masonite. A flush-type door will make an excellent table top. Home-built tables or consoles can be finished in any of the available oil stains, varnishes, paints or lacquers. Many operators use a large piece of plate glass over part of their table, since it furnishes a good writing surface and can cover miscellaneous charts and tables, prefix lists, operating aids, calendar, and similar accessories.

If the major interests never require frequent band changing, or frequency changing within a band, the transmitter can be located some distance from the operator, in a location where the meters can be observed from time to time (and the color of the tube plates noted!). If frequent band or frequency changes are a part

◆

This station shows a logical arrangement of the units, combined with adequate operating space and storage room for magazines and books. Power supplies and modulator are at the right, with switches in the top panel. On the desk, from left to right, 150-watt transmitter, v.c.o. and receiver. All of the equipment in this station is built from *The Radio Amateur's Handbook* designs. (W 3SMQ, Lansdowne, Pa.)

◆

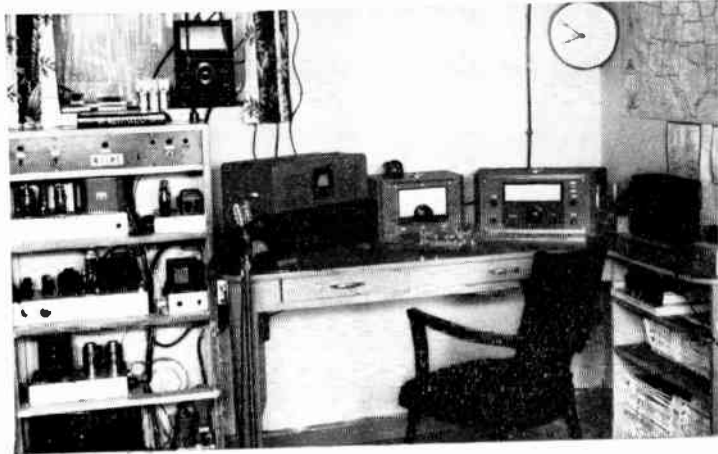

of the usual operating procedure, the transmitter should be mounted close to the operator, either along one side or above the receiver, so that the controls are easily accessible without the need for leaving the operating position.

A compromise arrangement would place the v.f.o. or crystal-switched oscillator at the operating position and the transmitter in some convenient location not adjacent to the operator. Since it is usually possible to operate over a portion of a band without retuning the transmitter stages, an operating position of this type is an advantage over one in which the operator must leave his position to make a change in frequency.

Controls

The operator has an excellent chance to exercise his ingenuity in the location of the operating controls. The most important controls in the station are the receiver tuning dial and the send-receive switch. The receiver tuning dial should be located four to eight inches above the operating table, and if this requires mounting the receiver off the table, a small shelf or bracket will do the trick. With the single exception of the amateur whose work is almost entirely in traffic or rag-chew nets, which require little or no attention to the receiver, it will be found that the operator's hand is on the receiver tuning dial most of the time. If the tuning knob is too high or too low, the hand gets cramped after an extended period of operating, hence the importance of a properly-located receiver. The majority of c.w. operators tune with the left hand, preferring to leave the right hand free for copying messages and handling the key, and so the receiver should be mounted where the knob can be reached by the left hand. Phone op-

erators aren't tied down this way, and tune the communications receiver with the hand that is more convenient.

The hand key should be fastened securely to the table, in a line just outside the right shoulder and far enough back from the front edge of the table so that the elbow can rest on the table. A good location for the semiautomatic or "bug" key is right next to the hand-key, although some operators prefer to mount the automatic key in front of them on the left, so that the right forearm rests on the table parallel to the front edge.

The best location for the microphone is directly in front of the operator, so that he doesn't have to shout across the table into it, or run up the speech-amplifier gain so high that all manner of external sounds are picked up. If the microphone is supported by a boom or by a flexible "goose neck," it can be placed in front of the operator without its base taking up valuable table space.

In any amateur station worthy of the name, it should be necessary to throw no more than one switch to go from the "receive" to the "transmit" condition. In phone stations, this switch should be located where it can be easily reached by the hand that isn't on the receiver. In the case of c.w. operation, this switch is most conveniently located to the right or left of the key, although some operators prefer to have it mounted on the left-hand side of the operating position and work it with the left hand while the right hand is on the key. Either location is satisfactory, of course, and the choice depends upon personal preference. Some operators use a foot-controlled switch, which is a convenience but doesn't allow too much freedom of position during long operating periods.

If the microphone is hand-held during

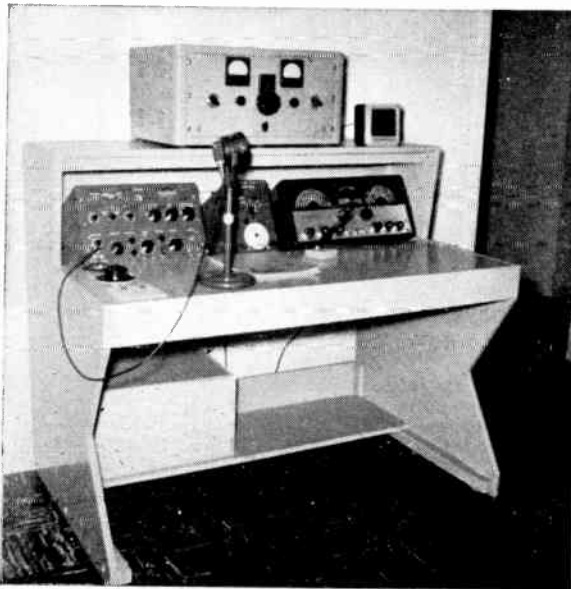

Here's an operating console that was designed with operating convenience in mind. WTEBG built it almost entirely out of $\frac{3}{4}$ " plywood, with strips of 2×2 along the bottom edges for caster supports. It is assembled with bolts so that it can be readily dismantled for shipping. Overall dimensions are 48" wide, $40\frac{1}{2}$ " high, with the horizontal desk top 16" wide and the sloping portion 15" wide.

phone operation, a "push-to-talk" switch on the microphone is convenient, but hand-held microphones tie up the use of one hand and are not too desirable, although they are widely used in mobile and portable work.

The location of other switches, such as those used to control power supplies, filaments, phone/c.w. change-over and the like, is of no particular importance, and they can be located on the unit with which they are associated. This is not strictly true in the case of the phone/c.w. DX man, who sometimes has need to change in a hurry from c.w. to phone. In this case, the change-over switch should be at the operating table, although the actual change-over should be done by a relay controlled by the switch.

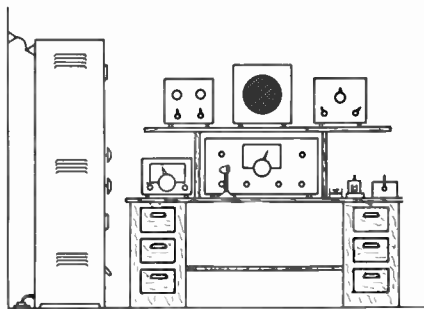

Fig. 22-1 — In a station assembled for maximum ease in frequency or band changing, the transmitter should be located next to the operating position, as shown above. On the operating table, the receiver is in front of the operator and v.f.o. or crystal-switching oscillator on the left. (The v.f.o. or crystal oscillator could be part of the transmitter proper, but most operators seem to prefer a separate v.f.o.)

The frequency standard and other auxiliary equipment can be mounted on a shelf above the receiver. The operating table can be an old desk, or a top supported by two small wooden cabinets. The "send-receive" switch is to the right of the telegraph keys — other switches are on the transmitter or the individual units.

The above arrangement can be made to look cleaner by arranging all of the equipment on the table behind a single panel or a set of panels. In this case, provision must be made for getting behind the panel for servicing the units.

If a rotary beam is used the control of the beam should be convenient to the operator. The direction indicator, however, can be located anywhere within sight of the operator, and does not have to be located on the operating table unless it is included with the control.

Frequency Spotting

In a station where a v.f.o. is used, or where a number of crystals is available, the operator should be able to turn on only the oscillator of his transmitter, so that he can spot accurately his location in the band with respect to other stations. This allows him to see if he has anything like a clear channel, or to see what his frequency is with respect to another station. Such a provision can be part of the "send-receive"

switch. Switches are available with a center "off" position, a "hold" position on one side, for turning on the oscillator only, and a "lock" position on the other side for turning on the transmitter and antenna relays. If oscillator keying is used, the key serves the same purpose, provided a "send-receive" switch is available to turn off the high-voltage supplies and prevent a signal going out on the air during adjustment of the oscillator frequency.

For phone operation, the telegraph key or an auxiliary switch can control the transmitter oscillator, and the "send-receive" switch can then be wired into the control system so as to control the oscillator as well as the other circuits.

Comfort

Of prime importance is the comfort of the operator. If you find yourself getting tired after a short period of operating, examine your station to find what causes the fatigue. It may be that the chair is too soft or hasn't a straight back or is the wrong height for you. The key or receiver may be located so that you assume an uncomfortable position while using them. If you get sleepy fast, the ventilation may be at fault. (Or you may need sleep!)

● POWER CONNECTIONS AND CONTROL

Following a few simple rules in wiring your power supplies and control circuits will make it an easy job to change units in the station. If the station is planned in this way from the start, or if the rules are recalled when you are rebuilding, you will find it a simple matter to revise your station from time to time without a major rewiring job.

It is neater and safer to run a single pair of wires from the outlet over to the operating table or some central point, rather than to use a number of adapters at the wall outlet.

Interconnections

The wiring of any station will entail two or three common circuits, as shown in Fig. 22-3. The circuit for the receiver, monitoring equipment and the like, assuming it to be taken from a wall outlet, should be run from the wall to an inconspicuous point on the operating table, where it terminates in a multiple outlet large enough to handle the required number of plugs. A single switch between the wall outlet and the receptacle will then turn on all of this equipment at one time.

The second common circuit in the station is that supplying voltage to rectifier- and transmitter-tube filaments, bias supplies, and anything else that is not switched on and off during transmit and receive periods. The coil power for control relays should also be obtained from this circuit. The power for this circuit can come from a wall outlet or from the transmitter line, if a special one is used.

The third circuit is the one that furnishes

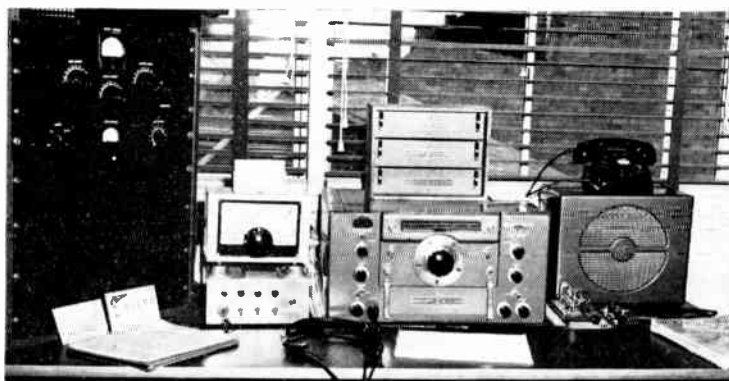

Contest operating is the major interest at this station, and to that end all controls are within easy reach of the operator. The "tubeless v.f.o." to the left of the receiver sits on the power-control panel. (Ex-W2QMO, Levittown, L. I., N. Y.)

power to the plate-supply transformers for the r.f. stages and for the modulator. (See chapter on Power Supplies for high-power considerations.) When it is opened, the transmitter is disabled except for the filaments, and the transmitter should be safe to work on. However, one always feels safer when working on the transmitter if he has turned off every power supply pertaining to the transmitter.

With these three circuits established, it becomes a simple matter to arrange the station for different conditions and with new units. Anything on the operating table that runs all the time ties into the first circuit. Any new power supply or r.f. unit gets its filament power from the second circuit. Since the third circuit is controlled by the send-receive switch (or relay), any power-supply primary that is to be switched on and off for send and receive connects to circuit No. 3.

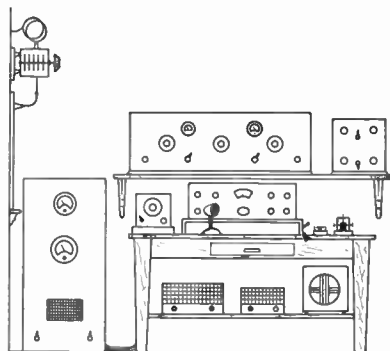

Fig. 22-2 — When little space is available for the amateur station, the equipment has to be spotted where it will fit. In the above arrangement, the transmitter, modulator and power supplies (separate units) are sandwiched in alongside the operating table and on a shelf above the table. The antenna tuning unit is mounted over the feed-through insulators that bring the antenna line into the "shack," and loudspeaker and small power supplies are mounted under the table. The operating position is clean, however, with the v.f.o., receiver and keys at table level. The tuning knob of this receiver would be uncomfortably low if the receiver weren't raised by the wooden arch, and the "send-receive" switch is mounted on the right-hand side of this arch, next to the hand key. Interconnecting leads should be cabled along the back of the table and table legs, to keep them inconspicuous.

Break-In and Push-To-Talk

In c.w. operation, "break-in" is any system that allows the transmitting operator to hear the other station's signal during the "key-up" periods between characters and letters. This allows the sending station to be "broken" by the receiving station at any time, to shorten calls, ask for "fills" in messages, and speed up operation in general. With present techniques, it requires the use of a separate receiving antenna or a "TR box" and, with high power, some means for protecting the receiver from the transmitter when the key is "down." Several methods, applicable to high-power stations, are described in Chapter Eight. If the transmitter is low-powered (50 watts or so), no special equipment is required except the separate receiving antenna and a receiver that "recovers" fast. Where break-in operation is used, there should be a switch on the operating table to turn off the plate supplies when adjusting the oscillator to a new frequency, although during all break-in work this switch will be closed.

"Push-to-talk" is an expression derived from the "push" switch on some microphones, and it means a phone station with a single control for all change-over functions. Strictly speaking, it should apply only to a station where this single send-receive switch must be held in place during transmission periods, but any fast-acting switch will give practically the same effect. A control switch with a center "off" position, and one "hold" and one "lock" position, will give more flexibility than a straight "push" switch. The one switch must control the transmitter power supplies, the receiver "on-off" circuit and, if one is used, the antenna change-over relay. The receiver control is necessary to disable its output during transmit periods, to avoid acoustic feedback.

Switches and Relays

It is dangerous to use an overloaded switch in the power circuits. After it has been used for some time, it may fail, leaving the power on the circuit even after the switch is thrown to the "off" position. For this reason, large switches, or relays with adequate ratings, should be used to control the plate power. Relays are rated by

coil voltages (for their control circuits) and by their contact current ratings.

When relays are used, the send-receive switch closes the circuit to their coils, thus closing the relay contacts. The relay contacts are in the power circuit being controlled, and thus the switch handles only the relay-coil current.

● SAFETY

Of prime importance in the layout of the station is the personal safety of the operator and of visitors, invited or otherwise, during normal operating practice. If there are small children in the house, every step must be taken to prevent their accidental contact with power leads of any voltage. A locked room is a fine idea, if it is possible, otherwise housing the transmitter and power supplies in metal cabinets is an excellent, although expensive, solution. Lacking a metal cabinet, a wooden cabinet or a wooden framework covered with wire screen is the next-best solution. Many stations have the power supplies housed in metal cabinets in the operating room or in a closet or basement, and this cabinet or entry is kept locked — with the key out of reach of everyone but the operator. The power leads are run through conduit to the transmitter, using ignition cable for the high-voltage leads. If the power supplies and transmitter are in the same cabinet, a lock-type main switch for the incoming line power is a good precaution.

A simple substitute for a lock-type main switch is an ordinary line plug with a short

A modern home-made cabinet can be used to house the entire station if it is designed closely around the transmitter and receiver. This cabinet is made of $\frac{3}{4}$ -inch plywood and, with the doors closed, conceals the ham station. At least one-inch air space should be left around each unit for air circulation and, for the same reason, the backs of the compartments should be left open. The receiver compartment also houses the microphone, key, Q5-er and switch control panel. (W1KZF, Ludlow, Ky.)

connecting wire between the two pins. By wiring a female receptacle in series with the main power line in the transmitter, the shorting plug will act as the main safety lock. When the plug is removed and hidden, it will be impossible to energize the transmitter, and a stranger or child isn't likely to spot or suspect the open receptacle.

An essential adjunct to any station is a shorting stick for discharging any high voltage to ground before any work or coil changing is done in the transmitter. Even if interlocks and power-supply bleeders are used, the failure of one or more of these components may leave the transmitter in a dangerous condition. The shorting stick is made by mounting a small metal hook, of wire or rod, on one end of a dry stick or bakelite rod. A piece of ignition cable or other well-insulated wire is then run from the hook on the stick to the chassis or common ground of the transmitter, and the stick is hung alongside the transmitter. Whenever the power is turned off in the transmitter to work on the rig, or to change coils, the shorting stick is first used to touch the several high-voltage leads (tank capacitor, filter capacitor, tube plate connection, etc.) to insure that there is no high voltage at any of these points. This simple device has saved many a life. Use it!

Fusing

A minor hazard in the amateur station is the possibility of fire through the failure of a component. If the failure is complete and the component is large, the house fuses will gen-



erally blow. However, it is unwise and inconvenient to depend upon the house fuses to protect the lines running to the radio equipment, and every power supply should have its primary circuit individually fused, at about 150 to 200 per cent of the maximum rating of the supply. Circuit breakers can be used instead of fuses if desired.

Wiring

Control-circuit wires running between the operating position and a transmitter in another part of the room should be hidden, if possible. This can be done by running the wires under the floor or behind the base molding, bringing the wires out to terminal boxes or regular wall fixtures. Such construction, however, is generally only possible in elaborate installations, and the average amateur must content himself with trying to make the wires as inconspicuous as possible. If several pairs of leads must be run from the operating table to the transmitter, as is generally the case, a single piece of rubber- or vinyl-covered multiconductor cable will always look neater than several pieces of rubber-covered lamp cord, and it is much easier to sweep around or dust.

The antenna wires always present a problem, unless coaxial-line feed is used. Open-wire line from the point of entry of the antenna line should always be arranged neatly, and it is generally best to support it at several points. Many operators prefer to mount their antenna-tuning assemblies right at the point of entry of the feedline, together with an antenna change-over relay (if one is used), and then the link from the tuning assembly to the transmitter can be made of inconspicuous coaxial line or

Twin-Lead. If the transmitter is mounted near the point of entry of the line, it simplifies the problem of "What to do with the feeders?"

Underwriters' Code

The National Electrical Safety Code, Pamphlet 70, Standard of the National Board of Fire Underwriters, deals with electric wiring and apparatus. The Code was set up to protect persons and buildings from the electrical hazards arising from the use of electricity, radio, etc. Article 810 is entitled "Radio Equipment." The scope of this article, section 8101, says, "The article applies to radio and television receiving equipment and to amateur radio transmitting equipment, but not to the equipment used in carrier-current operation."

The Board of Fire Underwriters sets up the code as a minimum standard for good practice. Most cities adopt the code, or parts of it, either entirely or with certain amendments which may apply to that particular city. It is up to the city to enforce these rules. When a violation is reported, periodic checks are made by an inspector until a correction is made and to insure against future recurrence. The National Electric Code is only a minimum standard, and compliance with its rules will assure less operating failures and hazards, and greater safety.

A copy of the pamphlet is available by writing the National Board of Fire Underwriters in your city, or at 85 John Street, New York 38, New York. Ask for pamphlet No. 70.

Parts of the Underwriters' Code deal with power wiring and, in addition to the requirement of the use of Underwriters Laboratory approved materials and fittings, have the following to say of direct interest to amateurs:

Although the operating console pictured below is a pretty large item as it stands, the method of construction is such that it can be broken down into three easily-movable sections. WIRHL built this from 2 x 2 stock for the frames, 1/2-inch plywood for the desk top, and masonite for the sides and tops. Careful finishing (plenty of elbow grease with sandpaper and a good paint job), together with a formica top and some chrome trim, produces a very striking console. Setups such as this can make your ham operating a real pleasure.

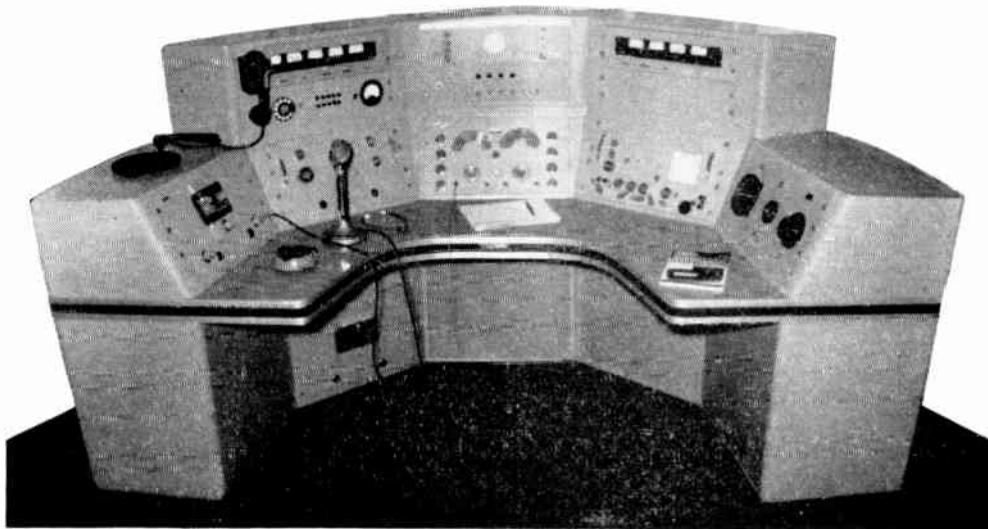

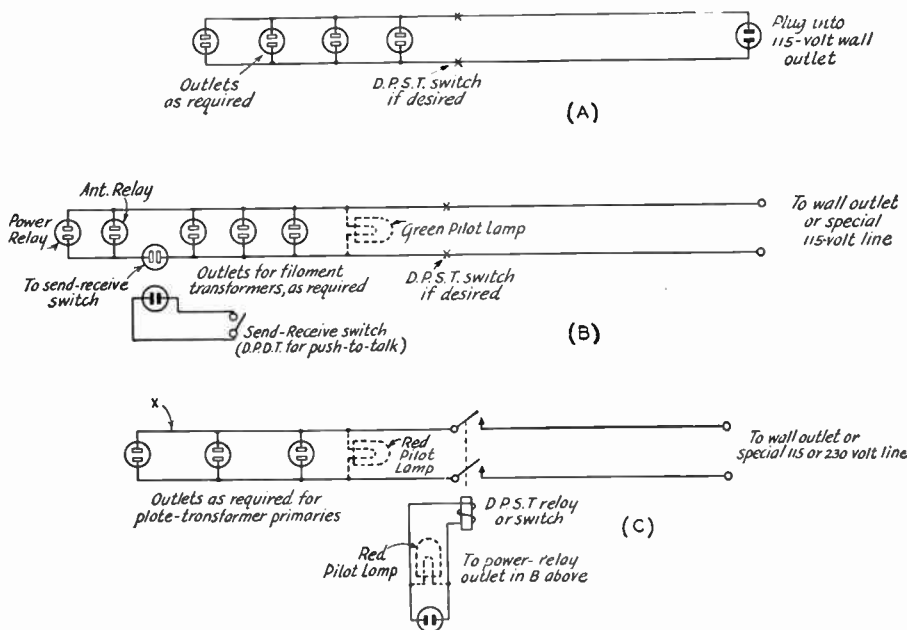

Fig. 22-3 — Power circuits for a high-power station. A shows the outlets for the receiver, monitoring equipment, speech amplifier and the like. The outlets should be mounted inconspicuously on the operating table. B shows the transmitter filament circuits and control-relay circuits, if the latter are used. C shows the plate-transformer primary circuits, controlled by the power relay. Where 230- and 115-volt primaries are controlled simultaneously, point "X" should connect to the "neutral" or common. A heavy-duty switch can be used instead of the relay, in which case the antenna relay would be connected in circuit C.

If 115-volt pilot lamps are used, they can be connected as shown. Lower-voltage lamps must be connected across suitable windings on transformers.

With "push-to-talk" operation, the "send-receive" switch can be a d.p.d.t. affair, with the second pole controlling the "on-off" circuit of the receiver.

"All switches shall indicate clearly whether they are open or closed.

"All (switch) handles throughout a system . . . shall have uniform open and closed positions.

". . . supply circuits shall not be designed to use the grounds normally as the sole conductor for any part of the circuit."

The latter means that wire conductor should be used for all parts of the power circuit. Dependence should not be placed on water pipes, etc., as one side of a circuit.

General

You can check your station arrangement by

asking yourself the following questions. If all of your answers are an honest "Yes," your station will be one of which you can be proud.

- 1) Is your station safe, under normal operating conditions, both for the operator and the visitor?
- 2) Is the operating position comfortable, even after several hours of operating?
- 3) Do you throw not more than one switch to go from "receive" to "transmit"?
- 4) Does it take only a short time to explain to another amateur how to work your station?
- 5) Do you show your station to visiting amateurs or laymen without apologizing for its appearance?

BCI and TVI

Every amateur has the obligation to make sure that the operation of his station does not, because of any shortcomings in equipment, cause interference with other radio services. It is unfortunately true that much interference is directly the fault of broadcast and TV receiver construction. Nevertheless, the amateur can and should help to alleviate interference even though the responsibility for it does not lie with him.

Successful handling of interference cases requires winning the listener's cooperation. Here are a few pointers on how to go about it.

Clean House First

The first step obviously is to make sure that the transmitter has no radiations outside the bands assigned for amateur use. The best check on this is your own a.m. or TV receiver. It is always convincing if you can say — and demonstrate — that you do not interfere with reception in your own home.

Don't Hide Your Identity

Whenever you make equipment changes — or shift to a hitherto unused band or type of emission — that might be expected to change the interference situation, check with your neighbors. If no one is experiencing interference, so much the better; it does no harm to keep the neighborhood aware of the fact that you are operating without bothering anyone.

Should you change location, announce your presence and conduct occasional tests on the air, requesting anyone whose reception is being spoiled to let you know about it so steps may be taken to eliminate the trouble.

Act Promptly

The average person will tolerate a limited amount of interference, but no one can be expected to put up with frequent and extended interruptions to programs. The sooner you take steps to eliminate the interference, the more agreeable the listener will be; the longer he has to wait for you, the less willing he will be to cooperate.

Present Your Story Tactfully

When you interfere, it is natural for the complainant to assume that your transmitter is at fault. If you are certain that the trouble is not caused by harmonics or other spurious emissions from your transmitter, explain to the listener that if it is simply the presence of your strong signal on his receiving antenna that causes the difficulty, and that some modifications will have to be made in the receiver if he is to expect interference-free reception.

Arrange for Tests

Most listeners are not very competent observers of the various aspects of interference. If at all possible, enlist the help of another amateur and have him operate your transmitter while you see what happens at the affected receiver. You can then determine for yourself where the trouble is most likely to be.

Avoid Working on the Receiver

If your tests show that the fault has to be remedied in the receiver itself, *do not offer to work on the receiver*. It is not your fault that the receiver design is defective. Recommend that the work be done by a reliable serviceman, and offer to advise the latter as to the cause and cure if necessary.

In General

In this "public relations" phase of the problem a great deal depends on your own attitude. Most people will be willing to meet you half way, particularly when the interference is not of long standing, if you as a person make a good impression. Your personal appearance is important. So is what you say about the receiver — no one takes kindly to hearing his possessions derided. If you discuss your interference problems on the air, do it in a constructive way — one calculated to increase listener cooperation, not destroy it.

Causes and Cure of BCI

Interference with a.m. broadcasting usually falls into one or more rather well-defined categories. A knowledge of the general types of interference and the methods required to eliminate it will lead to a rapid appraisal of the situation and will avoid much cut-and-try in finding a cure.

Transmitter Defects

Out-of-band radiation is something that must be cured at the transmitter. Parasitic oscillations are a frequently unsuspected

source of such radiations, and no transmitter can be considered satisfactory until it has been thoroughly checked for both low- and high-frequency parasitics. Very often parasitics show up only as transients, causing key clicks in c.w. transmitters and "splashes" or "burps" on modulation peaks in a.m. transmitters. Methods for detecting and eliminating parasitics are discussed in the transmitter chapter.

In c.w. transmitters the sharp make and break that occurs with unfiltered keying causes

transients that, in theory, contain frequency components through the entire radio spectrum. Practically, they are often strong enough in the immediate vicinity of the transmitter to cause serious interference to broadcast reception. Key clicks can be eliminated by the methods detailed in the chapter on keying.

A distinction must be made between clicks generated in the transmitter itself and those set up by the mere opening and closing of the key contacts when current is flowing. The latter are of the same nature as the clicks heard in a receiver when a wall switch is thrown to turn a light on or off, and may be more troublesome nearby than the clicks that actually go out on the signal. A filter for eliminating them usually has to be installed as close as possible to the key contacts.

Overmodulation in a.m. phone transmitters generates transients similar to key clicks. It can be prevented either by using automatic systems for limiting the modulation to 100 per cent, or by continuously monitoring the modulation. Methods for both are described in the chapter on amplitude modulation. In this connection, the term "overmodulation" means any type of nonlinear modulation that results from overloading or inadequate design. This can occur even though the actual modulation percentage is less than 100.

BCI is frequently made worse by radiation from the transmitter, power wiring, or the r.f. transmission line. This is because the signal causing the interference, in such cases, is radiated from wiring that is nearer the broadcast receiver than the antenna itself. In such cases much depends on the method used to couple the transmitter to the antenna, a subject that is discussed in the chapters on transmission lines and antennas. If it is at all possible the antenna itself should be placed so that it is not in close proximity to house wiring, telephone and power lines, and similar conductors.

Image and Oscillator-Harmonic Responses

Relatively few superhet broadcast receivers have any r.f. amplification preceding the mixer, so that the selectivity at the signal frequency is not especially high. The result is that strong signals from nearby transmitters, even though the transmitting frequency is far removed from the broadcast band, can force themselves to the mixer grid. They will normally be eliminated by the i.f. selectivity, except in cases where the transmitter frequency is the image of the broadcast signal to which the receiver is tuned, or when the transmitter frequency is so related to a harmonic of the broadcast receiver's local oscillator as to produce a beat at the intermediate frequency.

These image and oscillator-harmonic responses tune in and out on the broadcast receiver dial just like a broadcast signal, except that in the case of harmonic response the tuning rate is more rapid. Since most receivers use an intermediate frequency in the neighbor-

hood of 450 kc., the interference is a true image only when the amateur transmitting frequency is in the 1750-ke. band. Oscillator-harmonic responses occur from 3.5- and 7-Mc. transmissions, and sometimes even from higher frequencies.

The problem is to reduce the amplitude of the amateur signal in the front end of the BC receiver. If the receiver uses an external antenna a wavetrapp at the receiver antenna terminals may help. It may also be helpful to reduce the length of the receiving antenna — and particularly to avoid a length that might be near resonance at the transmitter frequency — or to change its direction with respect to the transmitting antenna. If the signal is being picked up by the antenna it will disappear when the antenna is disconnected. If it is still present under these circumstances the pick-up is in the set wiring or the power circuits. A line filter may be tried for the latter. Pick-up on the set wiring can only be cured by installing some shielding around the r.f. circuits. Copper window screening cut and fitted to size will usually do the trick.

Since images and harmonic responses occur at definite frequencies on the receiver dial, it is always possible to choose an operating frequency that will not give such a response on top of the broadcast stations that are favored in the vicinity. While your signal may still be heard when the receiver is tuned off the local stations, it will at least not interfere with program reception.

Cross-Modulation

With phone transmitters, there are occasionally cases where the voice is heard whenever the broadcast receiver is tuned to a BC station, but there is no interference when tuning between stations. This is cross-modulation, a result of rectification in one of the early stages of the receiver. Receivers that are susceptible to this trouble usually also get a similar type of interference from regular broadcasting if there is a strong local BC station and the receiver is tuned to some *other* station.

The remedy for cross-modulation in the receiver is the same as for images and oscillator-harmonic responses — reduce the strength of the amateur signal at the receiver by means of a wave-trap, line filter, or shielding, as required. The trouble is not always in the receiver, however, since cross modulation can occur in any rectifying circuit — such as a poor contact in water or steam piping, gutter pipes, and other conductors in the strong field of the transmitting antenna.

Audio-Circuit Rectification

The most frequent cause of interference from operation at the higher frequencies is from rectification of a signal that by one means or another gets into the audio system of the receiver. In the milder cases an amplitude-modulated signal will be heard with reasonably good quality, but is not tunable — that is, it is present no matter what the frequency to

which the receiver dial is set. An unmodulated carrier may have no observable effect in such cases beyond causing a little hum. However, if the signal is very strong there will be a reduction of the audio output level of the receiver whenever the carrier is thrown on. This causes an annoying "jumping" of the program when the interfering signal is keyed. With phone transmission the change in audio level is not so objectionable because it occurs at less frequent intervals. Also, ordinary rectification gives no audio output from a frequency-modulated signal, so the interference can be made almost completely unnoticeable if f.m. or p.m. is used instead of a.m.

Interference of this type is most prevalent in a.c.-d.c. receivers. The pickup may occur in the audio-circuit wiring or the interfering signal may get into the audio circuits by way of the line cord. Power-line pickup can be treated by means of line filters, but pickup in the receiver wiring requires individual attention. Remedies that have been found successful are described in the sections following.

● CHECKING AND CURING BCI

When a case of broadcast interference comes to your attention, set a definite time to conduct tests and then prepare to do the job as expeditiously as possible. As suggested before, get another amateur to operate your transmitter while you do the actual observing and testing at the listener's receiver. If you have a small broadcast receiver of your own that does not show interference, take it with you to demonstrate to the listener that the trouble is not in your transmitter but in his receiver. The procedure outlined below will save time in getting at the source of the trouble and eliminating it.

1) Determine whether the interference is tunable or not. This will usually indicate the methods required for elimination of the trouble, as it will show which of the general types of interference discussed above is present.

2) If the set has an external antenna, disconnect it and turn the volume control up full. If the interference is no longer present, it is merely necessary to prevent the r.f. appearing on the antenna from entering the set. If wave traps reduce the amplitude of the interfering signal but do not eliminate it entirely, try a short piece of wire as a receiving antenna. Alternatively, the antenna may be relocated. It should be placed as far as possible from the transmitting antenna, and should run at right angles to it to minimize coupling.

3) If the interference persists after the antenna is disconnected, check for r.f. on the power line by using a sensitive wave meter such as that described in the chapter on measurements to probe along the a.c. cord that connects the set to the power source. (This test also should be made with receivers using built-in loops.) Checks should be made at the transmitter frequency, and also at harmonic frequencies. If r.f. is detected in

the line, bypass both sides of the a.c. line to ground with 0.005- μ f. ceramic capacitors at the point where the line cord enters the set. (A simple plug-and-socket adapter can be made up for this purpose.) If this does not completely eliminate the interference, try a line filter designed for the operating frequency.

4) If it is evident that the interference is being picked up on the receiver wiring, explain the situation to the owner and tell him that the exact cause cannot be determined without removing the chassis from the cabinet, and that, in any event, the receiver will have to be modified if the interference is to be eliminated. Recommend that the actual work be done by a radio serviceman. Offer to check into the cause yourself, if he will allow you to take the set to your shop (with the understanding that you will not make any changes in the receiver without his express permission) so the serviceman can be told what needs to be done.

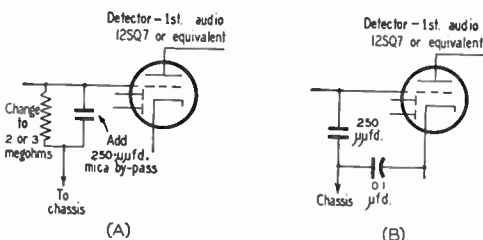

Fig. 23-1 — Two methods of eliminating r.f. from the grid of a combined detector/first-audio stage. At A, the value of the grid leak is reduced to 2 or 3 megohms, and a mica bypass capacitor is added. At B, both grid and cathode are bypassed.

5) In the event that the owner allows you to take the receiver, set it up near your transmitter and check to see if the amplitude of the interfering signal is changed by various settings of the receiver volume control. If it is, the r.f. is entering the set *ahead* of the volume control. If it is unaffected by the volume control, it is getting into the audio stages at a point following the volume control.

6) Pin the source down, if it is ahead of the volume control, by removing one tube at a time until one is found that kills the interference when it is removed. In sets using series-connected filaments, this will be possible only if a tube of equal heater rating, and with all but the heater pins clipped off, is *substituted* for the tube.

7) Determine which element (or elements) of the tube is picking up the interference by touching each tube pin with a test lead about three feet long. The lead, acting as an antenna, will cause the interference to increase when it is placed on a tube pin that is contributing to the interference. Once the sensitive points have been determined, the trouble can be eliminated by shielding the leads connected to the tube element that is affected, and by shielding the tube itself. Grid leads are the principal offenders, especially the long leads that run

from a tube cap to a tuning capacitor terminal.

8) If the pickup is found to be in the audio system — as is the case in many sets, especially when the transmitter is operating at 28 Mc. or higher — it can be eliminated by one or another of the methods shown in Figs. 23-1 and

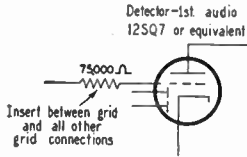

Fig. 23-2 — Using a 75,000-ohm resistor to form a low-pass filter with the tube capacitance. The resistor must be mounted at the tube pin, between the grid and all other grid connections.

23-2. Fig. 23-1A is a method that has proved successful with many a.c.-d.c. receivers. The value of the grid leak in the combined detector/first-audio tube (usually a 12SQ7 or its equivalent) is reduced to 2 or 3 megohms. The grid is then bypassed for r.f. with a 250- $\mu\mu\text{f}$. mica condenser. Fig. 23-1B is a similar method. A third method that has worked in a.c.-d.c. receivers requires only that the heater of the detector/first-audio stage be bypassed to ground with a 0.001- μf . capacitor. The method shown in Fig. 23-2 uses a 75,000-ohm $\frac{1}{2}$ -watt resistor to form, with the tube capacitance, a low-pass filter. The resistor is connected between the grid pin of the tube and all other wires connected to the grid. In all cases, both sides of the a.c. line should be bypassed to chassis with 0.001- to 0.01- μf . capacitors.

Wave Traps and A.C. Line Filters

A wave trap consists of a parallel-tuned circuit that is connected in series with the broad-

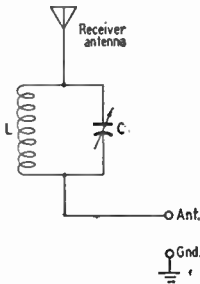

Fig. 23-3 — A simple wave trap circuit. L and C must resonate at the frequency of the interfering signal. Suitable constants are tabulated below.

Band	C	L
3.5	110 $\mu\mu\text{f}$.	16 μh ., 32 turns #22, 1" diam., 1" long
7	100 $\mu\mu\text{f}$.	6 19 #22, 1" 1"
14	50 $\mu\mu\text{f}$.	3.5 14 #18, 1" 1"
21	3.3 $\mu\mu\text{f}$.	2.2 12 #18, 1" 1"
28	2.5 $\mu\mu\text{f}$.	1.5 9 #18, 1" 1"

cast antenna and the antenna post of the receiver. It should be designed to resonate at the frequency of the interfering signal. The circuit of a simple trap is shown in Fig. 23-3. If interference results from operation in more than one amateur band several traps may be connected in series, each tuned to the center of one of the

bands in which operation is contemplated. To adjust the wave trap, have another licensed amateur operate the transmitter while you tune the trap for maximum attenuation of the interference.

A common form of a.c. line filter is shown in Fig. 23-4. This type of filter will usually do some good if the signal is being picked up on the house wiring and transferred to the set by way of the line cord. The values used for the coils and capacitors are in general not critical. The effectiveness of the filter will depend considerably on the ground connection used, and it may be necessary to try grounding to several different possible ground connections to secure

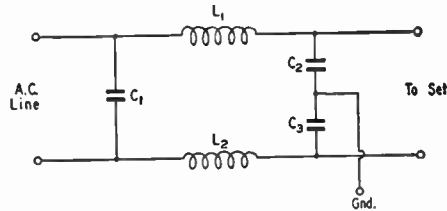

Fig. 23-4 — A.c. line filter for receivers. The values of C_1 , C_2 and C_3 are not generally critical; capacitances from 0.001 to 0.01 μf . can be used. L_1 and L_2 can be a 2-inch winding of No. 18 enameled wire on a half-inch diameter form.

the best results. A filter of this type will usually not be very helpful if the signal is being picked up on the line cord itself, which may be the case when the transmitter is on v.h.f. In such a case it should be installed inside the receiver chassis and grounded to the chassis at the point where the line cord enters.

The tuned filter shown in Fig. 23-5 is often more effective than the untuned type when only one frequency needs to be eliminated. After installation, the condenser is simply adjusted to reduce the interference to the greatest possible extent. It is advisable to mount either type of filter in a small shield box, to prevent pickup in the filter and to make it less conspicuous.

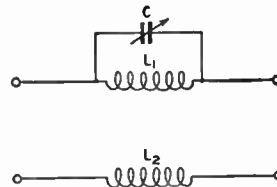

Fig. 23-5 — Resonant filter for the a.c. line. A single capacitor tunes both L_1 and L_2 , which are uncoupled, one wound on top of the other. Constants for amateur bands are tabulated below.

Band	C	$L_1 \cdot L_2$
3.5	110 + 150 (fixed)	25 t. No. 18, 1 1/4" dia. \times 2 3/8" long
7	110 $\mu\mu\text{f}$.	18 t. No. 18, 1 1/4" dia. \times 2 3/8" long
14	100 $\mu\mu\text{f}$.	12 t. No. 18, 1 1/4" dia. \times 2 3/8" long
21	50 $\mu\mu\text{f}$.	10 t. No. 18, 1 1/4" dia. \times 2 3/8" long
28	25 $\mu\mu\text{f}$.	9 t. No. 18, 1 1/2" dia. \times 2 3/8" long

D.c.e. wire is recommended for all coils.

Interference with Television

Interference with the reception of television signals usually presents a more difficult problem than interference with a.m. broadcasting. In BCI cases the interference almost always can be attributed to deficient selectivity or spurious responses in the BC receiver. While similar deficiencies exist in many television receivers, it is also true that amateur transmitters generate harmonics that fall inside many or all television

channels. These spurious radiations cause interference that ordinarily cannot be eliminated by anything that may be done at the receiver, so must be prevented at the transmitter itself.

The over-all situation is further complicated by the fact that television broadcasting is in three distinct bands, two in the v.h.f. region and one in the u.h.f.

V.H.F. Television

For the amateur who does most of his transmitting on frequencies below 30 Mc. the TV band of principal interest is the low v.h.f. band between 54 and 88 Mc. If harmonic radiation can be reduced to the point where no interference is caused to Channels 2 to 6, inclusive, it is almost certain that any harmonic troubles with channels above 174 Mc. will disappear also.

The relationship between the v.h.f. television channels and harmonics of amateur bands from 14 through 28 Mc. is shown in Fig. 23-6. Harmonics of the 7- and 3.5-Mc. bands are not shown because they fall in every television channel. However, the harmonics above 54 Mc. from these bands are of such high order that they are usually rather low in amplitude, although they may be strong enough to interfere if the television receiver is quite close to the amateur transmitter. Low-order harmonics — up to about the sixth — are usually the most difficult to eliminate.

Of the amateur v.h.f. bands, only 50 Mc. will have harmonics falling in a v.h.f. television channel (channels 11, 12 and 13). However, a transmitter for any amateur v.h.f. band may cause interference if it has multiplier stages either tuned to or having harmonics in one or more of the v.h.f. TV channels. The r.f. energy on such frequencies can be radiated directly from the transmitting circuits or coupled by stray means to the transmitting antenna.

Frequency Effects

The degree to which transmitter harmonics or other undesired radiation actually in the TV channel must be suppressed depends principally on two factors, the strength of the TV signal on the channel or channels affected, and the relationship between the frequency of the spurious radiation and the frequencies of the TV picture and sound carriers within the channel. If the TV signal is very strong, interference can be eliminated by

comparatively simple methods. However, if the TV signal is very weak, as in "fringe" areas where the received picture is visibly degraded by the appearance of set noise or "snow" on the screen, it may be necessary to go to extreme measures.

In either case the intensity of the interference depends very greatly on the exact frequency of the interfering signal. Fig. 23-7 shows the placement of the picture and sound carriers in the standard TV channel. In Channel 2, for example, the picture carrier frequency is $54 + 1.25 = 55.25$ Mc. and the sound carrier frequency is $60 - 0.25 = 59.75$ Mc. The second harmonic of 28,010 kc. (56,020 kc. or 56.02 Mc.) falls $56.02 - 54 = 2.02$ Mc. above the low edge of the channel and is in the region marked "Severe" in Fig. 23-7. On the other hand, the second harmonic of 29,500 kc. (59,000 kc. or 59 Mc.) is $59 - 54 = 5$ Mc. from the low edge of the channel and falls in the region marked "Mild." Interference at this frequency has to be about 100 times as strong as at 56,020 kc. to cause effects of equal intensity.

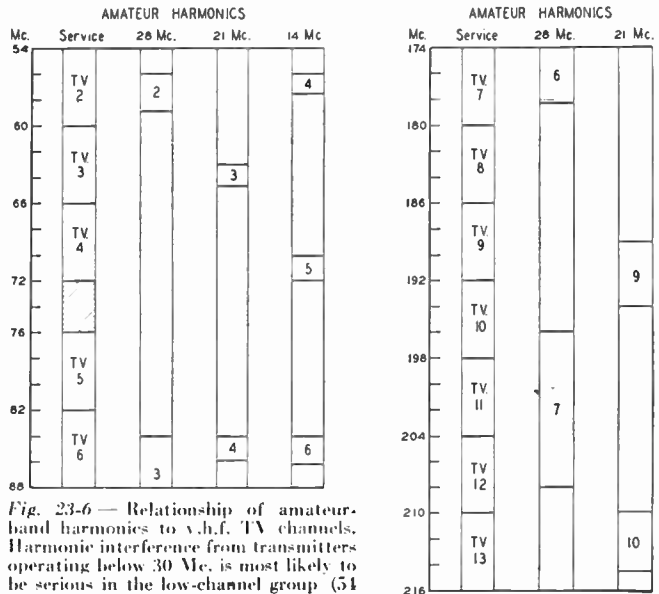

Fig. 23-6 — Relationship of amateur-band harmonics to v.h.f. TV channels. Harmonic interference from transmitters operating below 30 Mc. is most likely to be serious in the low-channel group (54 to 88 Mc.).

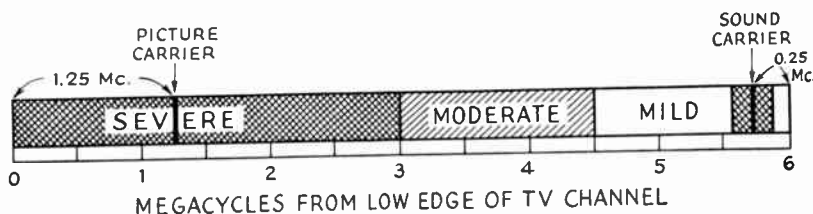

Fig. 23-7 — Location of picture and sound carriers in a monochrome television channel, and relative intensity of interference as the location of the interfering signal within the channel is varied without changing its strength. The three regions are not actually sharply defined as shown in this drawing, but merge into one another gradually.

Thus an operating frequency that puts a harmonic near the picture carrier requires about 40 db. more harmonic suppression in order to avoid interference, as compared with an operating frequency that puts the harmonic near the upper edge of the channel.

For a region of 100 kc. or so either side of the sound carrier there is another "Severe" region where a spurious radiation will interfere with reception of the sound program, and this region also should be avoided. In general, a signal of intensity equal to that of the picture carrier will not cause noticeable interference if its frequency is in the "Mild" region shown in Fig. 23-7, but the same intensity in the "Severe" region will utterly destroy the picture.

Interference Patterns

The visible effects of interference vary with the type and intensity of interference. Complete "blackout," where the picture and sound disappear completely, leaving the screen dark, occurs only when the transmitter and receiver are quite close together. Strong interference ordinarily causes the picture to be broken up, leaving a jumble of light and dark lines, or turns the picture "negative" — the normally white parts of the picture turn black and the normally black parts turn white. "Cross-hatching" — diagonal bars or lines in the picture — accompanies the

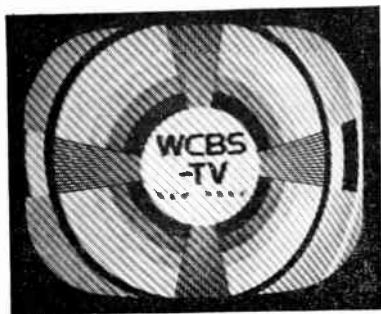

Fig. 23-8 — "Cross-hatching," caused by the beat between the picture carrier and an interfering signal inside the TV channel.

latter, usually, and also represents the most common type of less-severe interference. The bars are the result of the beat between the harmonic frequency and the picture carrier frequency. They are broad and relatively few in number if the beat frequency is comparatively low — near the picture carrier — and are numerous and very

fine if the beat frequency is very high — toward the upper end of the channel. Typical cross-hatching is shown in Fig. 23-8. If the frequency falls in the "Mild" region in Fig. 23-7 the cross-hatching may be so fine as to be visible only on close inspection of the picture, in which case it may simply cause the apparent brightness of the screen to change when the transmitter carrier is thrown on and off.

Whether or not cross-hatching is visible, an amplitude-modulated transmitter may cause

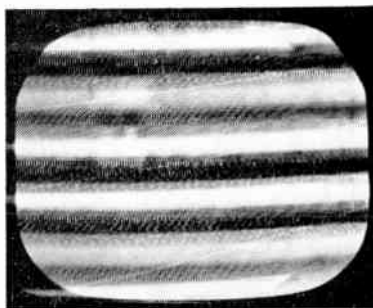

Fig. 23-9 — "Sound bars" or "modulation bars" accompanying amplitude modulation of an interfering signal. In this case the interfering carrier is strong enough to destroy the picture, but in mild cases the picture is visible through the horizontal bars. Sound bars may accompany modulation even though the unmodulated carrier gives no visible cross-hatching.

"sound bars" in the picture. These look about as shown in Fig. 23-9. They result from the variations in the intensity of the interfering signal when modulated. Under most circumstances modulation bars will not occur if the amateur transmitter is frequency- or phase-modulated. With these types of modulation the cross-hatching will "wobble" from side to side with the modulation.

Except in the more severe cases, there is seldom any effect on the sound reception when interference shows in the picture, unless the frequency is quite close to the sound carrier. In the latter event the sound may be interfered with even though the picture is clean.

Reference to Fig. 23-6 will show whether or not harmonics of the frequency in use will fall in any television channels that can be received in the locality. It should be kept in mind that not only harmonics of the final frequency may interfere, but also harmonics of any frequencies that may be present in buffer or frequency-multiplier

stages. In the case of 144-Mc. transmitters, frequency-multiplying combinations that require a doubler or tripler stage to operate on a frequency actually in a low-band v.h.f. channel in use in the locality should be avoided.

Harmonic Suppression

Effective harmonic suppression has three separate phases:

- 1) Reducing the amplitude of harmonics generated in the transmitter. This is a matter of circuit design and operating conditions.
- 2) Preventing stray radiation from the transmitter and from associated wiring. This requires adequate shielding and filtering of all circuits and leads from which radiation can take place.
- 3) Preventing harmonics from being fed into the antenna.

It is impossible to build a transmitter that will not generate *some* harmonics, but it is obviously advantageous to reduce their strength, by circuit design and choice of operating conditions, by as large a factor as possible before attempting to prevent them from being radiated. Harmonic radiation from the transmitter itself or from its associated wiring obviously will cause interference just as readily as radiation from the antenna, so measures taken to prevent harmonics from reaching the antenna will not reduce TVI if the transmitter itself is radiating harmonics. But once it has been found that the transmitter itself is free from harmonic radiation, devices for preventing harmonics from reaching the antenna can be expected to produce results.

● REDUCING HARMONIC GENERATION

Since reasonably-efficient operation of r.f. power amplifiers always is accompanied by harmonic generation, good judgment calls for operating all frequency-multiplier stages at a very low power level — plate voltages not exceeding 250 or 300. When the final output frequency is reached, it is desirable to use as few stages as possible in reaching the output power level, and to use tubes that require a minimum of driving power.

Circuit Design and Layout

Harmonic currents of considerable amplitude flow in both the grid and plate circuits of r.f. power amplifiers, but they will do relatively little harm if they can be effectively bypassed to the cathode of the tube. Fig. 23-10A shows the paths followed by harmonic currents in an amplifier circuit; because of the high reactance of the tank coil there is little harmonic current in it, so the harmonic currents simply flow through the tank capacitor, the plate (or grid) blocking capacitor, and the tube capacitances. The lengths of the leads forming these paths is of great importance, since the inductance in this circuit will resonate with the tube capacitance at some frequency in the v.h.f. range (the tank and blocking capaci-

tances usually are so large compared with the tube capacitance that they have little effect on the resonant frequency). If such a resonance happens to occur at or near the same frequency as one of the transmitter harmonics, the effect is just the same as though a harmonic tank circuit

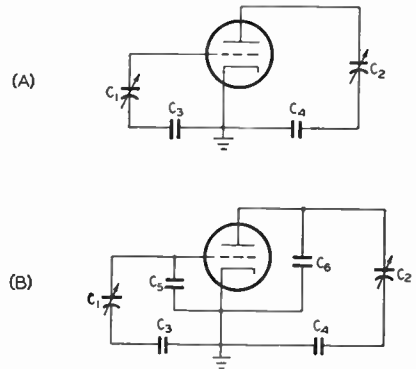

Fig. 23-10 — (A) A v.h.f. resonant circuit is formed by the tube capacitance and the leads through the tank and blocking capacitors. Regular tank coils are not shown, since they have little effect on such resonances. (B) Using low-inductance capacitors shunting the tube elements to lower the resonance point below the TV channels. C_5 and C_6 usually are 15 to 50 μf . and either of vacuum or tubular construction.

had been deliberately introduced: the harmonic at that frequency will be tremendously increased in amplitude.

Such resonances are unavoidable, but by keeping the path from plate to cathode and from grid to cathode as short as is physically possible, the resonant frequency usually can be raised above 100 Mc. in amplifiers of medium power. This puts it between the two groups of television channels.

In low-frequency transmitters where physically-short return paths from plate or grid to cathode are difficult because of the shape and size of tubes and tank capacitors, the arrangement shown in Fig. 23-10B is frequently helpful. Capacitors C_5 and C_6 should be of the vacuum or tubular type and should be mounted as close as possible to the tube connections. They form resonant circuits in themselves with the tube capacitance, but generally at a sufficiently high frequency so that no harm is done. At lower frequencies than this self-resonance, they effectively add to the tube capacitance and thus tune the inductance of the leads through the regular tank and blocking capacitors to a considerably lower frequency than the tube alone. The resonance therefore can be shifted to a frequency below 54 Mc. and again is outside the TV range. This method is most useful at 3.5 and 7 Mc. because it increases the tank capacitance to the point where there may be very little tank coil left, at the higher frequencies.

It is easier to place grid-circuit v.h.f. resonances where they will do no harm when the amplifier is link-coupled to the driver stage, since this generally permits shorter leads and more favorable conditions for bypassing the harmonics than is

the case with capacitive coupling. Link coupling also reduces the coupling between the driver and amplifier at harmonic frequencies, thus preventing driver harmonics from being amplified.

The inductance of leads from the tube to the tank capacitor can be reduced not only by shortening but by using flat strip instead of wire conductors. It is also better to use the chassis as the return from the blocking capacitor to cathode, since a chassis path will have less inductance than almost any other form of connection.

The v.h.f. resonance points in amplifier tank circuits can be found by coupling a grid-dip meter covering the 50-250 Mc. range to the grid and plate leads. If a resonance is found in or near a TV channel, methods such as those described above should be used to move it well out of the TV range. The grid-dip meter also should be used to check for v.h.f. resonances in the tank coils, because coils made for 14 Mc. and below usually will show such resonances. In making the check, disconnect the coil entirely from the transmitter and move the grid-dip meter coil along it while exploring for a dip in the 5-88 Mc. band. If a resonance falls in a TV channel that is in use in the locality, changing the number of turns will move it to a frequency where it will not be troublesome.

In many r.f. amplifiers the cathode connection of the tube is below chassis while the plate (and sometimes the grid) connection frequently is above. In such a case the blocking capacitor should be mounted *below* chassis. If the ground return is made to the top, the r.f. current has to flow over the top and either through the hole for the tube socket or else entirely over the chassis surface before it reaches the cathode. This condition is highly undesirable not only because of v.h.f. resonances but because such chassis currents frequently cause instability in the amplifier.

Operating Conditions

Grid bias and grid current have an important effect on the harmonic content of the r.f. currents in both the grid and plate circuits. In general, harmonic output increases as the grid bias and grid current are increased, but this is not necessarily true of a *particular* harmonic. The third and higher harmonics, especially, will go through fluctuations in amplitude as the grid current is increased, and sometimes a rather high value of grid current will minimize one harmonic as compared with a low value of grid current. This characteristic can be used to advantage where a particular harmonic is causing interference, keeping in mind that the operating conditions that minimize one harmonic may greatly increase another.

For equal operating conditions, there is little or no difference between single-ended and push-pull amplifiers in respect to harmonic generation. Push-pull amplifiers are frequently trouble-makers on even harmonics because with such amplifiers the even-harmonic voltages are in phase at the ends of the tank circuit and hence appear with equal amplitude across the whole tank coil,

if the center of the coil is not grounded. Under such circumstances the even harmonics can be coupled to the output circuit through stray capacitance between the tank and coupling coils. This does not occur in a single-ended amplifier if the coupling coil is placed at the cold end of the tank.

Harmonic Traps

If a harmonic in only one TV channel is particularly bothersome — frequently the case when the transmitter operates on 28 Mc. — a trap tuned to the harmonic frequency may be installed in the plate lead as shown in Fig. 23-11. At the harmonic frequency the trap represents a very high impedance and hence reduces the amplitude of the harmonic current flowing through the tank circuit. In the push-pull circuit both traps have the same constants. The L/C ratio is not critical but a high- C circuit usually will have least effect on the performance of the plate circuit at the normal operating frequency.

Since there is a considerable harmonic voltage across the trap, it may radiate unless the transmitter is well shielded. Traps should be placed so that there is no coupling between them and the amplifier tank circuit.

A trap is a highly-selective device and so is useful only over a small range of frequencies. A

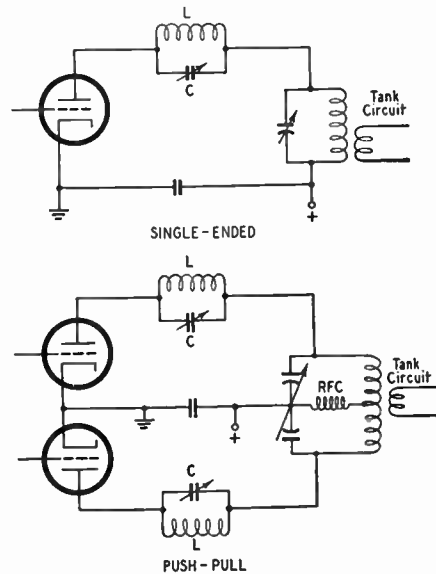

Fig. 23-11 — Harmonic traps in an amplifier plate circuit. L and C should resonate at the frequency of the harmonic to be suppressed. C may be a 25- to 50- μmf . midget, and L usually consists of 3 to 6 turns about $\frac{1}{2}$ inch in diameter for Channels 2 through 6. The inductance should be adjusted so that the trap resonates at about half capacity of C before being installed in the transmitter. It may be checked with a grid-dip meter. When in place, it is adjusted for minimum interference to the TV picture.

second- or third-harmonic trap on a 28-Mc. tank circuit usually will not be effective over more than 50 kc. or so at the fundamental frequency, depending on how serious the interference is without the trap. Because they are critical of adjust-

ment, it is better to prevent TVI by other means, if possible, and use traps only as a last resort.

● PREVENTING RADIATION FROM THE TRANSMITTER

The extent to which interference will be caused by direct radiation of spurious signals depends on the operating frequency, the transmitter power level, the strength of the television signal, and the distance between the transmitter and TV receiver. Transmitter radiation can be a very serious problem if the TV signal is weak, if the TV receiver and amateur transmitter are close together, and if the transmitter is operated with high power.

Shielding

Direct radiation from the transmitter circuits and components can be prevented by proper shielding. To be effective, a shield must completely enclose the circuits and parts and must have no openings that will permit r.f. energy to escape. Unfortunately, ordinary metal boxes and cabinets do not provide good shielding, since such openings as louvers, lids, holes for running in connections, and so on, allow far too much leakage.

A primary requisite for good shielding is that all joints must make a good electrical connection along their entire length. A small slit or crack will let out a surprising amount of r.f. energy; so will ventilating louvers and large holes such as those used for mounting meters. On the other hand, small holes do not impair the shielding very greatly, and a limited number of ventilating holes may be used if they are small — not over $\frac{1}{4}$ inch in diameter. Also, wire screen makes quite effective shielding if the wires make good electrical connection where they cross over, so the leakage through large openings can be very much reduced by covering such openings with screening, well bonded to all edges of the opening.

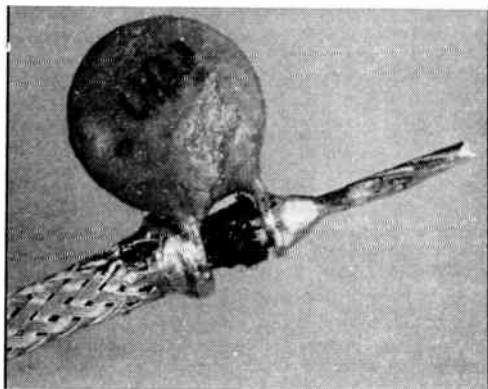

Fig. 23-12 — Proper method of bypassing the end of a shielded lead using disk ceramic capacitor. The 0.001 μ f. size should be used for 1600 volts or less; 500 μ f. at higher voltages. The leads are wrapped around the inner and outer conductors and soldered, so that the lead length is negligible. This photograph is about four times actual size.

The intensity of r.f. fields about coils, capacitors, tubes and wiring decreases very rapidly with distance, so shielding is more effective, from a practical standpoint, if the components and wiring are not too close to it. It is advisable to have a separation of several inches, if possible, between "hot" points in the circuit and the nearest shielding.

For a given thickness of metal, the greater the conductivity the better the shielding. Copper is best, with aluminum, brass and steel following in that order. However, if the thickness is adequate for structural purposes (over 0.02 inch) and the shield and a "hot" point in the circuit are not in close proximity, any of these metals will be satisfactory. Greater separation should be used with steel shielding than with the other materials not only because it is considerably poorer as a shield but also because it will cause greater losses in near-by circuits than would copper or aluminum at the same distance. Wire screen used as a shield should also be kept at some distance from high-voltage or high-current r.f. points, since there is considerably more leakage through the mesh than through solid metal.

Where two pieces of metal join, as in forming a corner, they should overlap at least a half inch and be fastened together firmly with screws or bolts spaced at close-enough intervals to maintain firm contact all along the joint. The contact surfaces should be clean before joining, and should be checked occasionally — especially steel, which is almost certain to rust after a period of time.

The leakage through a given size of aperture in shielding increases with frequency, so such points as good continuous contact, screening of holes, and so on, become even more important when the radiation to be suppressed is in the high band — 174–216 Mc. — than in the low TV band. Hence 50- and 144-Mc. transmitters, which in general will have frequency-multiplier harmonics of relatively high intensity in this region, require special

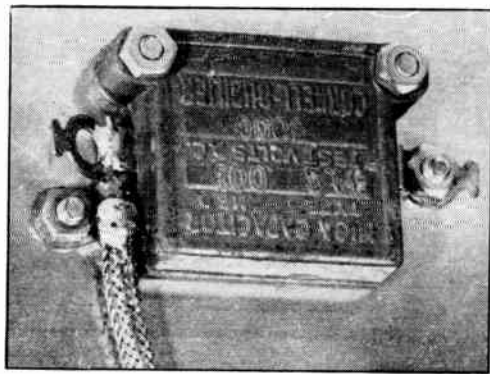

Fig. 23-13 — Bypassing the end of a high-voltage lead. The end of the shield braid is soldered to a lug fastened to the chassis directly underneath. The other terminal of the capacitor is similarly bolted directly to the chassis. When the bypass is used at a terminal connection block the "hot" lead should be soldered directly to the terminal, if possible, but in any event connected to it by a very short lead.

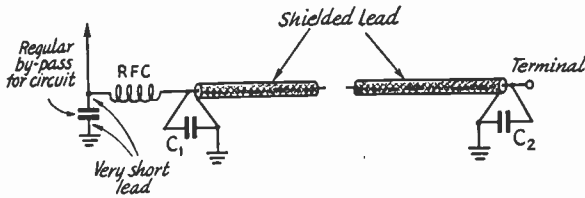

Fig. 23-14 — Additional r.f. filtering of supply leads may be required in regions where the TV signal is very weak. The r.f. choke should be physically small, and may consist of a 1-inch winding of No. 26 enameled wire on a $\frac{1}{4}$ -inch form, close-wound. Manufactured single-layer chokes having an inductance of a few microhenrys also may be used.

attention in this respect if the possibility of interfering with a channel received locally exists.

Lead Treatment

Even very good shielding can be made completely useless when connections are run from external power supplies and other equipment to the circuits inside the shield. Every conductor so introduced into the shielding forms a path for the escape of r.f., which is then radiated by the connecting wires. Hence a step that is essential in every case is to prevent harmonic currents from flowing on the leads leaving the shielded enclosure.

Harmonic currents always flow on the d.c. or a.c. leads connecting to the tube circuits. A very effective means of preventing such currents from being coupled into other wiring, and one that provides desirable bypassing as well, is to use shielded wire for all such leads, maintaining the shielding from the point where the lead connects to the tube or r.f. circuit right through to the point where it is about to leave the chassis. The shield braid should be grounded to the chassis at both ends and at frequent intervals along the path.

Good bypassing of shielded leads also is essential. Bearing in mind that the shield braid about the conductor confines the harmonic currents to the *inside* of the shielded wire, the object of bypassing is to prevent their escape. Figs. 23-12 and 23-13 show the proper way to bypass. The small-type 0.001- μ f. ceramic disk capacitor, when mounted on the end of the shielded wire as shown in Fig. 23-12, actually forms a series-resonant circuit in the 54-88-Mc. range and thus represents practically a short-circuit for low-band TV harmonics. The exposed wire to the connection terminal should be kept as short as is physically possible, to prevent any possible harmonic pick-up exterior to the shielded wiring. Disk capacitors of this capacitance are available in several voltage ratings up to 1600 volts. For higher voltages, the maximum capacitance available is approximately 500 $\mu\mu$ f., which is large enough for good bypassing of harmonics. Alternatively, mica capacitors may be used as shown in Fig. 23-13, mounting the capacitor flat against the chassis and grounding the end of the shield braid directly to chassis, keeping the exposed part as short as possible. Either 0.001- μ f. or 470- $\mu\mu$ f. (500 $\mu\mu$ f.) capacitors should be used. The larger capacitance is series-resonant in Channel 2 and the smaller in Channel 6.

These bypasses are essential at the connection-block terminals, and desirable at the tube ends of the leads also. Installed as shown with shielded

wiring, they have been found to be so effective that there is usually no need for further harmonic filtering. However, if a test shows that additional filtering is required, the arrangement shown in Fig. 23-14 may be used. Such an r.f. filter should be installed at the tube end of the shielded lead, and if more than one circuit is filtered care should be taken to keep the r.f. chokes separated from each other and so oriented as to minimize coupling between them. This is necessary for preventing harmonics present in one circuit from being coupled into another.

In difficult cases involving Channels 7 to 13 — i.e., close proximity between the transmitter and receiver, and a weak TV signal — additional lead-filtering measures may be needed to prevent radiation of interfering signals by 50- and 144-Mc. transmitters. A recommended method is shown in Fig. 23-15. It uses a shielded lead bypassed

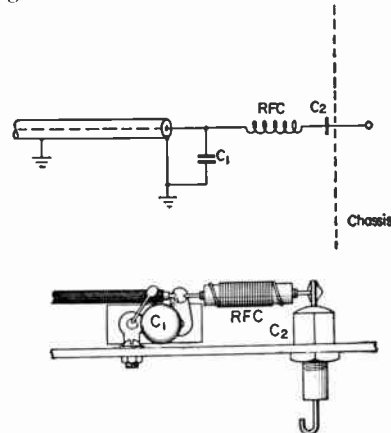

Fig. 23-15 — Additional lead filtering for harmonics or other spurious frequencies in the high v.h.f. TV band (174-216 Mc.).

C₁ — 0.001- μ f. disk ceramic.

C₂ — 0.001- μ f. feed-through bypass (Eric Style 326).
(For 500-2000-volt lead, substitute Plasticon Glass mike, LSG — 251, for C₂.)

RFC — 14 inches No. 26 enamel close-wound on $\frac{3}{16}$ inch diam. form or resistor.

with a ceramic disk as described above, with the addition of a low-inductance feed-through type capacitor and a small r.f. choke, the capacitor being used as a terminal for the external connection. For voltages above 400, a capacitor of compact construction (as indicated in the caption) should be used, mounted so that there is a very minimum of exposed lead, inside the chassis, from the capacitor to the connection terminal.

As an alternative to the series-resonant bypassing described above, feed-through type condensers such as the Sprague "Hypass" type may

be used as terminals for external connections. The ideal method of installation is to mount them so they protrude through the chassis, with thorough bonding to the chassis all around the hole in which the capacitor is mounted. The principle is illustrated in Fig. 23-16.

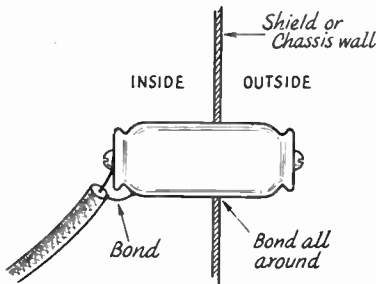

Fig. 23-16 — The best method of using the "Hypass" type feed-through capacitor. Capacitances of 0.01 to 0.1 $\mu\text{f.}$ are satisfactory. Capacitors of this type are useful for high-current circuits, such as filament and 115-volt leads, as a substitute for the r.f. choke shown in Fig. 23-14, in cases where additional lead filtering is needed.

Meters that are mounted in an r.f. unit should be enclosed in shielding covers, the connections being made with shielded wire with each lead bypassed as described above. The shield braid should be grounded to the panel or chassis immediately outside the meter shield, as indicated in Fig. 23-17. A bypass may also be connected across the meter terminals, principally to prevent any fundamental current that may be present from flowing through the meter itself. As an alternative to individual meter shielding the meters may be mounted entirely behind the panel, and the panel holes needed for observation may be covered with wire screen that is carefully bonded to the panel all around the hole.

Care should be used in the selection of shielded wire for transmitter use. Not only should the insulation be conservatively rated for the d.c. volt-

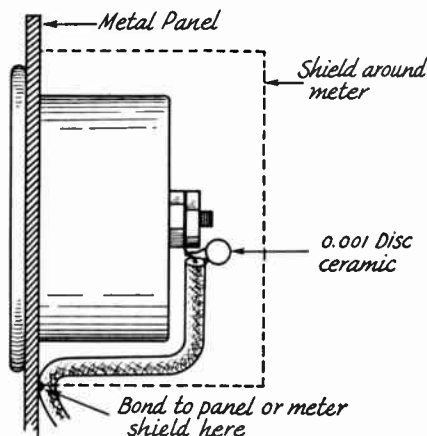

Fig. 23-17 — Meter shielding and bypassing. It is essential to shield the meter mounting hole since the meter will carry r.f. through it to be radiated. Suitable shields can be made from 2½- or 3-inch diameter shield cans of the type made for enclosing coils.

age in use, but the insulation should be of material that will not easily deteriorate in soldering. The r.f. characteristics of the wire are not especially important, except that the attenuation of harmonics in the wire itself will be greater if the insulating material has high losses at radio frequencies; in other words, wire intended for use at d.c. and low frequencies is preferable to cables designed expressly for carrying r.f. The attenuation also will increase with the length of the wire; in general, it is better to make the leads as long as circumstances permit rather than to follow the more usual practice of using no more lead than is actually necessary. Where the wiring crosses or runs parallel, the shields should be spot-soldered together and connected to the chassis. For high voltages, automobile ignition cable covered with shielding braid is recommended.

Proper shielding of the transmitter requires that the r.f. circuits be shielded entirely from the external connecting leads. A situation such as is shown in Fig. 23-18, where the leads in the r.f. chassis have been shielded and properly filtered

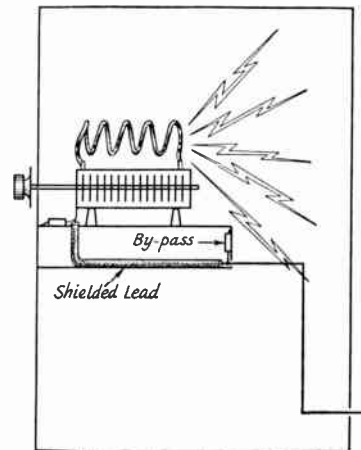

Fig. 23-18 — A metal cabinet can be an adequate shield, but there will still be radiation if the leads inside can pick up r.f. from the transmitting circuits.

but the chassis is mounted in a large shield, simply invites the harmonic currents to travel over the chassis and on out over the leads *outside* the chassis. The shielding about the r.f. circuits should make complete contact with the chassis on which the parts are mounted.

Checking Transmitter Radiation

A check for transmitter radiation always should be made before attempting to use low-pass filters or other devices for preventing harmonics from reaching the antenna system. The only really satisfactory indicating instrument is a television receiver. In regions where the TV signal is strong an indicating wave meter such as one having a crystal or tube detector may be useful; if it is possible to get any indication at all on harmonics either on supply leads or around the transmitter itself, the harmonics are probably strong enough to cause interference. However, the absence of

any such indication does not mean that harmonic interference will not be caused. If the techniques of shielding and lead filtering described in the

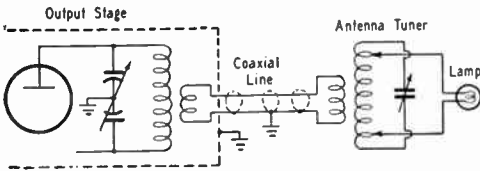

Fig. 23-19 — Dummy-antenna circuit for checking harmonic radiation from the transmitter and leads. The matching circuit helps prevent harmonics in the output of the transmitter from flowing back over the transmitter itself, which may occur if the lamp load is simply connected to the output coil of the final amplifier. See transmission-line chapter for details of the matching circuit. Tuning must be adjusted by cut-and-try, as the bridge method described in the transmission-line chapter will not work with lamp loads because of the change in resistance when the lamps are hot.

preceding section are followed, the harmonic intensity on any external leads should be far below what any such instruments can detect.

Radiation checks should be made with the transmitter delivering full power into a dummy antenna, such as an incandescent lamp of suitable power rating, preferably installed inside the shielded enclosure. If the dummy must be external, it is desirable to connect it through a coax-matching circuit such as is shown in Fig. 23-19. Shielding the dummy antenna circuit is also desirable, although it is not always necessary.

Make the radiation test on all frequencies that are to be used in transmitting, and note whether or not interference patterns show in the received picture. (These tests must be made while a TV signal is being received, since the beat patterns will not be formed if the TV picture carrier is not present.) If interference exists, its source can be detected by grasping the various external leads (by the insulation, not the live wire!) or bringing the hand near meter faces, louvers, and other possible points where harmonic energy might escape from the transmitter. If any of these tests cause a *change* — not necessarily an *increase* — in the intensity of the interference, the presence of harmonics at that point is indicated. The location of such "hot" spots usually will point the way to the remedy. If the TV receiver and the transmitter can be operated side-by-side, a length of wire connected to one antenna terminal on the receiver can be used as a probe to go over the transmitter enclosure and external leads. This device will very quickly expose the spots from which serious leakage is taking place.

As a final test, connect the transmitting antenna or its transmission line terminals to the outside of the transmitter shielding. Interference created when this test is applied indicates that weak currents are on the outside of the shield and can be conducted to the antenna when the normal antenna connections are used. Currents of this nature represent interference that can be conducted *over* low-pass filters, etc., and which therefore cannot be eliminated by such filters.

● PREVENTING HARMONICS FROM REACHING THE ANTENNA

The third and last step in reducing harmonic TVI is to keep the spurious energy generated in or passed through the final stage from traveling over the transmission line to the antenna. It is seldom worthwhile even to attempt this until the radiation from the transmitter and its connecting leads has been reduced to the point where, with the transmitter delivering full power into a dummy antenna, it has been determined by actual testing with a television receiver that the radiation is below the level that can cause interference. If the dummy antenna test shows enough radiation to be seen in a TV picture, it is a practical certainty that harmonics will be coupled to the antenna system no matter what preventive measures are taken.

In inductively-coupled output systems, some harmonic energy will be transferred from the final amplifier through the mutual inductance between the tank coil and the output coupling coil. Harmonics of the output frequency transferred in this way can be greatly reduced by providing sufficient selectivity between the final tank and the transmission line. A good deal of selectivity, amounting to 20 to 30 db. reduction of the second harmonic and much higher reduction of higher-order harmonics, is furnished by a matching circuit of the type shown in Fig. 23-19 and described in the chapter on transmission lines. An "antenna coupler" is therefore a worthwhile addition to the transmitter.

In 50- and 144-Mc. transmitters, particularly, harmonics not directly associated with the output frequency — such as those generated in low-frequency early stages of the transmitter — may get coupled to the antenna by stray means. For example, a 144-Mc. transmitter might have an oscillator or frequency multiplier at 48 Mc., followed by a tripler to 144 Mc. Some of the 48-Mc. energy will appear in the plate circuit of the tripler, and if passed on to the grid of the final amplifier will appear as a 48-Mc. modulation on the 144-Mc. signal. This will cause a spurious signal at 192 Mc., which is in the high TV band, and the selectivity of the tank circuits may not be sufficient to prevent its being coupled to the antenna. Spurious signals of this type can be reduced by using link coupling between the driver stage and final amplifier (and between earlier stages as well) in addition to the suppression afforded by using an antenna coupler.

Capacitive Coupling

Harmonics and other spurious signals transferred from the tank by stray capacitance are not suppressed by an antenna coupler to the same extent as those transferred by pure inductive coupling. The upper drawing in Fig. 23-20 shows the link-coupled system as it might be used to couple into a parallel-conductor line. Inasmuch as a coil is a sizable metallic object, there is capacitance between the final tank coil and its associated link coil, and between the antenna tank

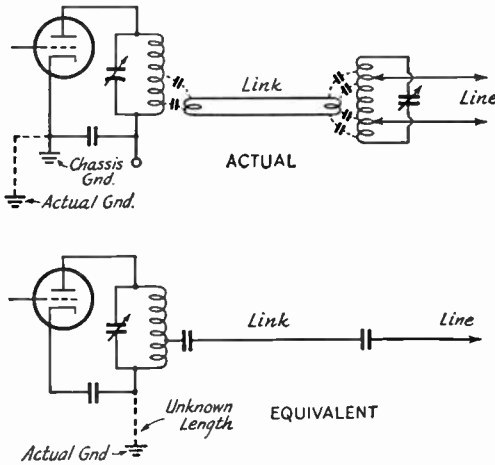

Fig. 23-20 — The stray capacitive coupling between coils in the upper circuit leads to the equivalent circuit shown below, for v.h.f. harmonics.

coil and its link. Energy coupled through these capacitances travels over the link circuit and the transmission line as though these were merely single conductors. The tuned circuits simply act as masses of metal and offer no selectivity at all for capacity-coupled energy. Although the actual capacitances are small, they offer a very good coupling medium for frequencies in the v.h.f. range.

Capacitive coupling can be reduced by coupling to a "cold" point on the tank coil — the end connected to ground or cathode in a single-ended stage. In push-pull circuits having a split-stator capacitor with the rotor grounded for r.f., all parts of the tank coil are "hot" at even harmonics, but the center of the coil is "cold" at the fundamental and odd harmonics. If the center of the tank coil, rather than the rotor of the tank capacitor, is grounded through a by-pass condenser the center of the coil is "cold" at all frequencies, but this arrangement is not very desirable because it causes the harmonic currents to flow through the coil rather than the tank capacitor and this increases the harmonic transfer by pure inductive coupling.

With either single-ended or balanced tank circuits the coupling coil should be grounded to the chassis by a short, direct connection as shown in Fig. 23-21. If the coil feeds a balanced line or link,

Fig. 23-21 — Methods of coupling and grounding link circuits to reduce capacitive coupling between the tank and link coils. Where the link is wound over one end of the tank coil the side toward the hot end of the tank should be grounded, as shown at B.

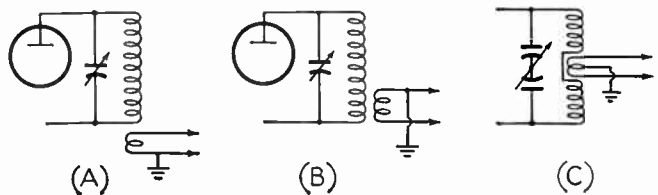

it is preferable to ground its center, but if it feeds a coax line or link one side may be grounded. Coaxial output is much preferable to balanced output, because the harmonics have to stay *inside* a properly installed coax system and tend to be attenuated by the cable before reaching the antenna coupler.

At high frequencies — and possibly as low as 14 Mc. — capacitive coupling can be greatly reduced by using a shielded coupling coil as shown in Fig. 23-22. The inner conductor of a length of coaxial cable is used to form a one-turn coupling coil. The outer conductor serves as an open-circuited shield around the turn, the shield being grounded to the chassis. The shielding has no effect on the inductive coupling. Because this construction is suitable only for one turn, the coil is not well adapted for use on the lower frequencies where many turns are required for good coupling. Shielded coupling coils having a larger number of turns are available commercially. A shielded coil is particularly useful with push-pull amplifiers when the suppression of even harmonics is important.

A shielded coupling coil or coaxial output will not prevent stray capacitive coupling to the antenna if harmonic currents can flow over the *outside* of the coax line. In Fig. 23-23, the arrangement at either A or C will allow r.f. to flow over the outside of the cable to the antenna system. The proper way to use coaxial cable is to shield the transmitter completely, as shown at B, and make sure that the outer conductor of the cable is a continuation of the transmitter shielding. This

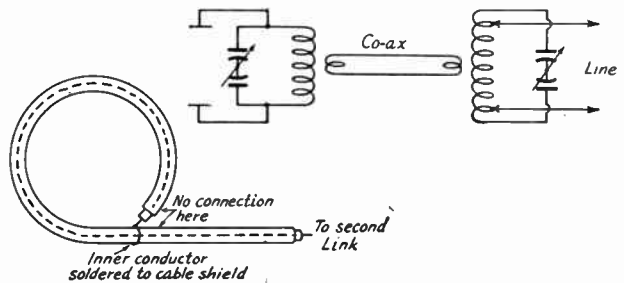

Fig. 23-22 — Shielded coupling coil constructed from coaxial cable. The smaller sizes of cable such as RG-59/U are most convenient when the coil diameter is 3 inches or less, because of greater flexibility. For larger coils RG-8/U or RG-11/U can be used.

prevents r.f. inside the transmitter from getting out by any path except the *inside* of the cable. Harmonics flowing *through* a coax line can be stopped from reaching the antenna system by an antenna coupler or by a low-pass filter installed in the line.

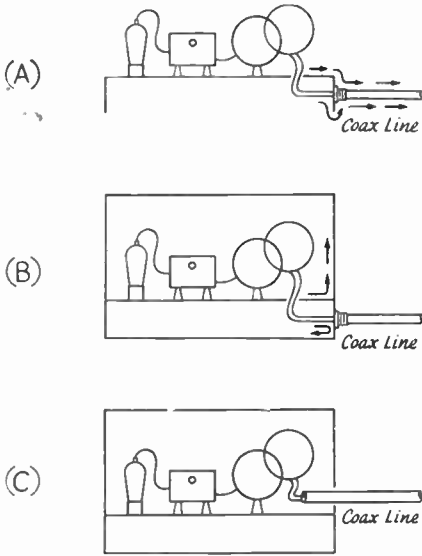

Fig. 23-23 — Right (B) and wrong (A and C) ways to connect a coaxial line to the transmitter. In either A or C, harmonic energy coupled by stray capacitance to the outside of the cable will flow without hindrance to the antenna system. In B the energy cannot leave the shield and hence can flow out only through, not over, the cable.

Low-Pass Filters

A low-pass filter properly installed in a coaxial line, feeding either a matching circuit (antenna coupler) or feeding the antenna directly, will provide very great attenuation of harmonics. When the main transmission line is of the parallel-conductor type, the coax-coupled matching-circuit arrangement is highly recommended as a means for using a coax low-pass filter.

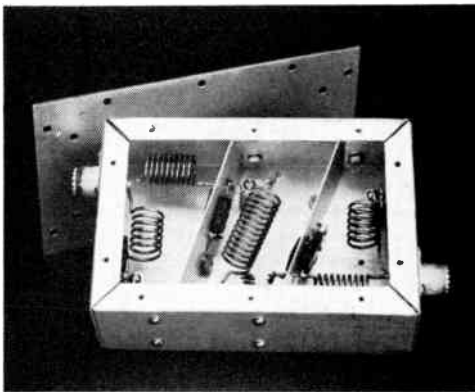

Fig. 23-24 — An inexpensive low-pass filter using silver-nica postage-stamp capacitors. The box is a 2 by 4 by 6 aluminum chassis. Aluminum shields, bent and folded at the sides and bottom for fastening to the chassis, form shields between the filter sections. The diagonal arrangement of the shields provides extra room for the coils and makes it easier to fit the shields in the box, since bending to exact dimensions is not essential. The bottom plate, made from sheet aluminum, extends a half inch beyond the ends of the chassis and is provided with mounting holes in the extensions. It is held on the chassis with sheet-metal screws.

A properly-designed low-pass filter will not introduce appreciable power loss at the fundamental frequency if the coaxial line in which it is inserted is terminated so that the s.w.r. is low. (The s.w.r. can easily be measured by means of a simple bridge as described in the chapters on measurements and transmission lines.) Such a filter has the property of passing without loss all frequencies below its "cut-off" frequency, but simultaneously has large attenuation for all frequencies above the cut-off frequency.

Low-pass filters of simple and inexpensive construction for use with transmitters operating below 30 Mc. are shown in Figs. 23-24 and 23-26. The former is designed to use mica capacitors of readily-available capacitance values, for compactness and low cost. Both use the same circuit, Fig. 23-25, the only difference being in the *L* and *C* values. Technically, they are three-section filters having two full constant-*k* sections and two *m*-derived terminating half-sections, and their attenuation in the 54-88-Mc. range varies from over 50 to nearly 70 db., depending

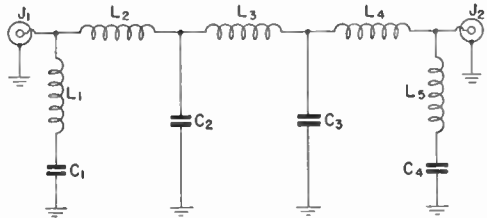

Fig. 23-25 — Low-pass filter circuit for attenuating harmonics in the TV bands. *J*₁ and *J*₂ are chassis-type coaxial connectors. In the table below the letters refer to the following:

- A — Using 100- and 70- μ mf. 500-volt silver mica capacitors in parallel for *C*₂ and *C*₃.
- B — Using 70- and 50- μ mf. silver mica capacitors in parallel for *C*₂ and *C*₃.
- C — Using 100- and 50- μ mf. mica capacitors, 1200-volt (case-style CM-45) in parallel for *C*₂ and *C*₃.
- D and E — Using variable air capacitors, 500- to 1000-volt rating, adjusted to values given (see measurements chapter for data on measuring capacitance).

	A	B	C	D	E	
<i>Z</i> ₀	52	75	52	52	75	ohms
<i>f</i> _c	36	35.5	41	40	40	Mc.
<i>f</i> _∞	44.4	47	54	50	50	Mc.
<i>f</i> ₁	25.5	25.2	29	28.3	28.3	Mc.
<i>f</i> ₂	32.5	31.8	37.5	36.1	36.1	Mc.
<i>C</i> ₁ , <i>C</i> ₄	50	40	50	46	32	μ mf.
<i>C</i> ₂ , <i>C</i> ₃	170	120	150	154	106	μ mf.
<i>L</i> ₁ , <i>L</i> ₅	5½	6	4	5	6½	turns*
<i>L</i> ₂ , <i>L</i> ₄	8	11½	7	7	9½	turns*
<i>L</i> ₃	9	13	8	8½	11½	turns*

* No. 12 or No. 14 wire, ½ inch inside diameter, 8 turns per inch.

¹ A 9-turn coil with closer turn spacing to give the same inductance is shown in Fig. 23-24.

on the frequency and the particular set of values used. Above 174 Mc. the theoretical attenuation is better than 85 db., but will depend somewhat on internal resonant conditions associated principally with the lead lengths to the condensers. These leads should be kept as short as is physically possible.

The power that filters using mica capacitors can handle safely is determined by the voltage and current limitations of the capacitors. The power capacity is least at the highest frequency. The unit using postage-stamp silver mica capacitors is capable of handling approximately 50 watts in the 28-Mc. band, when working into a properly-matched line, but is good for about 150 watts at 21 Mc. and 300 watts at 14 Mc. and lower frequencies. A filter with larger mica capacitors (case type CM-45) will carry about 250 watts safely at 28 Mc., this rating increasing to 500 watts at 21

Mc. and a kilowatt at 14 Mc. and lower. If there is an appreciable mismatch between the filter and the line into which it works, these ratings will be considerably decreased, so in order to avoid capacitor failure it is highly essential that the line on the output side of the filter be carefully matched by its load. This can be done with an s.w.r. bridge, and the matching is easy to control if the line from the filter terminates in a matching circuit of the type described in the chapter on transmission lines.

The power capacity of these filters can be in-

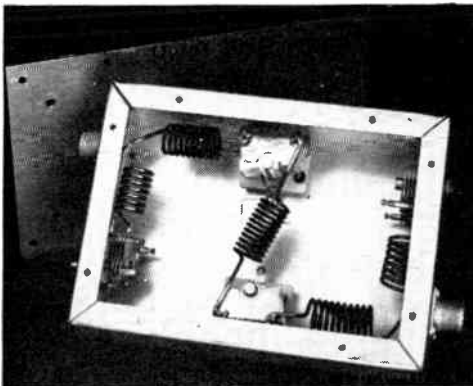
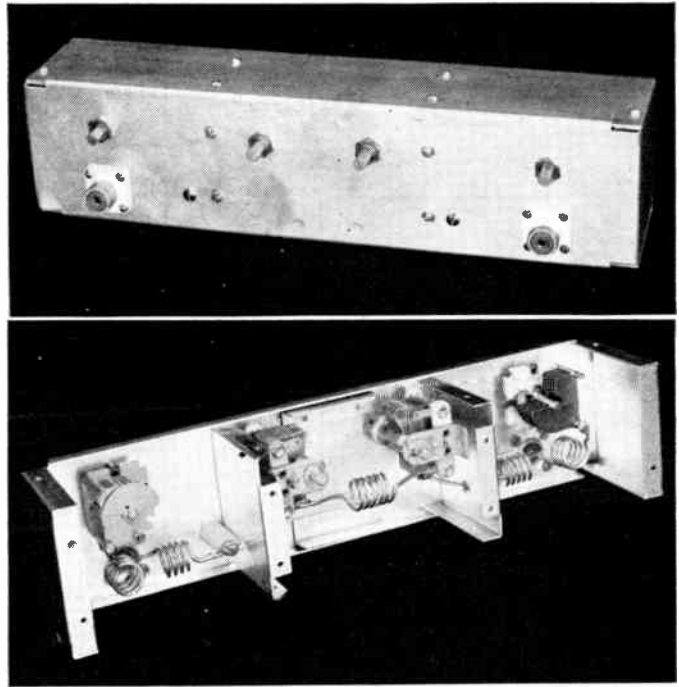

Fig. 23-26 — Low-pass filter using variable air capacitors. The box is a 2 by 5 by 7 aluminum chassis, fitted with a bottom plate of similar construction to the one used in Fig. 23-24.



Figs. 23-27 — Low-pass filter for use with 50-Mc. transmitters and 52-ohm line. It uses variable air capacitors adjusted to the proper capacitance values and is suited to powers up to a kilowatt.

creased considerably by substituting r.f. type fixed capacitors (such as the Centralab 850 series) or variable air capacitors, in which event the power capability will be such as to handle the maximum amateur power on any band. The construction can be modified to accommodate variable air capacitors as shown in Fig. 23-26.

Using fixed capacitors of standard tolerances, there should be little difficulty in getting proper filter operation. A grid-dip meter with an accurate calibration should be used for adjustment of the coils. First, wire up the filter without L_2 and L_4 . Short-circuit J_1 at its inside end with a screwdriver or similar conductor, couple the grid-dip meter to L_1 and adjust the inductance of L_1 , by varying the turn spacing, until the circuit resonates at f_∞ as given in the table. Do the same thing at the other end of the filter with L_5 . Then couple the meter to the circuit formed by L_3 , C_2 and C_3 , and adjust L_3 to resonate at the frequency f_1 as given by the table. Then remove L_3 , install L_2 and L_4 and adjust L_2 to make the circuit formed by L_1 , L_2 , C_1 and C_2 (without the short across J_1) resonate at f_2 as given in the table. Do the same with L_4 for the circuit formed by L_4 , L_5 , C_3 and C_4 . Then replace L_3 and check with the grid-dip meter at any coil in the filter; a distinct resonance should be found at or very close to the cut-off frequency, f_c . The filter is then ready for use.

The filter constants suggested at D and E in Fig. 23-25 are based on the optimum design for good impedance characteristics — that is, with $m = 0.6$ in the end sections — and a cut-off fre-

quency below the RETMA standard i.f. for television receivers (sound carrier at 41.25 Mc.; picture carrier at 45.75 Mc.). This is to avoid possible harmonic interference from 21 Mc. and below to the receiver's intermediate amplifier. The other designs similarly cut off at 41 Mc. or below, but *m* in these cases is necessarily based on the capacitances available in standard fixed capacitors.

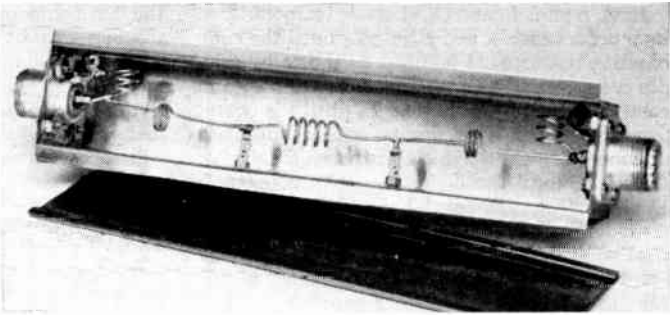
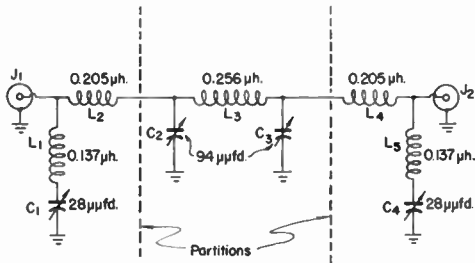

Fig. 23-29 — A 52-ohm low-pass filter for 144-Mc. transmitters.

Filters for 50- and 144-Mc. Transmitters

Since a low-pass filter must have a cut-off frequency above the frequency on which the transmitter operates, a filter for a v.h.f. transmitter cannot be designed for attenuation in all television channels. This is no handicap for v.h.f. work but means that the filter will not be effective when used with lower-frequency transmitters, unless it happens that no TV channels in use in the locality fall inside the pass-band of the filter.

Fig. 23-27 shows a filter for 52-ohm coax suitable for a 50-Mc. transmitter of any power up to the authorized limit. The circuit diagram is given in Fig. 23-28. If the values of inductance



Figs. 23-28 — Circuit diagram of the low-pass filters for 50- and 144-Mc. transmitters. Values on the drawing are for the 50-Mc. filter. Partitions are not used in the 144-Mc. unit.

- C₁, C₄ — 50 Mc.: 50-μμfd. variable, shaft-mounted, set to middle of tuning range (Johnson 501.15).
144 Mc.: 11-μμfd. ceramic (10-μμfd. v. seable).
- C₂, C₃ — 50 Mc.: 100-μμfd. variable, shaft-mounted, set with rotor 1/4 inch out of stator (Bud MC-905).
144 Mc.: 38-μμfd. stand-off bypass (Eric Style 721A).
- 50-Mc. coil data:
L₁, L₅ — 3 1/2 turns 5/8 inch long. Top leads 3/4 inch, bottom leads 1/4 inch long.
L₂, L₄ — 4 1/2 turns 5/8 inch long. Leads 1/2 inch long each end.
L₃ — 5 1/2 turns 7/8 inch long. Leads 1 inch long each.
All 50-Mc. coils No. 12 tinned, 1/2-inch diam., coil length measured between right-angle bends where leads begin.
- 144-Mc. coil data:
L₁, L₅ — 3 turns 1/4 inch long. Leads 1/4 inch long each end.
L₂, L₄ — 2 turns 1/8 inch long. Leads 1 inch long each end.
L₃ — 5 turns 3/4 inch long. Leads 5/8 inch long each end.
All 144-Mc. coils No. 18 tinned, 1/4-inch diam., lengths measured as for 50-Mc. coils.
- J₁, J₂ — Coaxial fitting.

and capacitance can be measured (see chapter on measurements) the components can be preset and assembled without further adjustment. Alternatively, the grid-dip meter method described earlier may be used. The resonant frequencies are:

$L_1 C_1$ (J_1 shorted)	} 81.5 Mc.
$L_5 C_4$ (J_2 shorted)	
$L_3 C_2 C_3$ (L_2 and L_4 disconnected)	} 46 Mc.
$L_1 L_2 C_1 C_2$ (L_3 disconnected)	} 58.5 Mc.
$L_4 L_5 C_3 C_4$ (L_3 disconnected)	

The cut-off frequency is approximately 65 Mc.

The case for the 50-Mc. filter is a standard box (ICA Slip-cover, No. 29100) measuring 3 1/8 by 13 by 2 5/8 inches. The two end capacitors, C₁ and C₄, are mounted with their two stator posts toward the ends of the filter. The two larger units are mounted in the center compartment with their rotor shafts toward the middle. The top leads from coils L₁ and L₅ are wrapped around the stator terminals of C₁ and C₄, and the bottom leads fit directly into the coaxial input and output fittings. The outer ends of coils L₂ and L₄ are soldered to the coaxial fitting terminals, and their inner ends are soldered to lugs supported on one-inch ceramic stand-off insulators. Leads from the stand-offs go through holes in the partitions to the bottom stator lugs on C₂ and C₃. L₃ is soldered to the two upper lugs on these two capacitors, thus completing the filter circuit. Lead lengths for the coils given in the parts list are the total lengths to be left when the winding is completed, including the portions that will be used in soldering operations.

This filter will give high attenuation in Channels 4-6 and all the high-band channels, and thus will take care of most of the spurious signals generated in a 50-Mc. transmitter.

A filter for low-power 144-Mc. transmitters is shown in Fig. 23-29. It is designed for maximum attenuation in the 190-215 Mc. region to suppress the spurious radiations in that range that frequently occur with 144-Mc. transmitters, but also has good attenuation for all frequencies above 170 Mc. Optimum capacitance values are given in Fig. 23-28. If possible, several units of the nearest standard values available should be measured and those having values closest to the optimum used. The inductance values are too small to be measured with sufficient accuracy, so the filter should be adjusted by the following method:

First, mount L_1 and C_1 , short J_1 temporarily at its inner terminals, and adjust L_1 until the combination resonates at 200 Mc. as shown by grid-dip meter. Next, remove the short from J_1 and connect L_2 and C_2 , adjusting L_2 until the circuit formed by $L_1L_2C_1C_2$ resonates at 144 Mc. Then disconnect L_2 and mount L_3 between C_2 and C_3 . Adjust L_3 until the circuit $L_3C_2C_3$ resonates at 112 Mc. Next, disconnect L_3 and follow a similar procedure starting from the other end with L_5 and C_4 . Finally, reconnect all coils and a check at any point in the filter should show resonance at 160 Mc., the approximate cut-off frequency.

The case for the 144-Mc. filter is made from flashing copper and is $1\frac{1}{2}$ inches square by $7\frac{1}{2}$ inches long. The main portion of the case is cut from a single piece with the end tabs folded down and soldered to the sides. Flanges are folded over at the bottom, and a cover is made to slip over these.

Filter Installation

In order to give the harmonic attenuation of which it is capable, a low-pass filter must be installed in such a way that *all* the output of the transmitter flows through it. If harmonic currents are permitted to flow on the outside of the connecting coaxial cables, they will simply flow over the filter and on up to the antenna, and the filter does not have an opportunity to stop them. That is why it is so important to reduce the radiation from the transmitter and its leads to negligible proportions.

Fig. 23-30 shows the proper way to install a filter between a shielded transmitter and a matching circuit. Note that the coax, together with the shields about the transmitter and filter, forms a continuous shield to keep all the r.f. inside. It is thus forced to flow through the filter and the harmonics are attenuated. If there is no harmonic energy left after passing through the filter, shielding from that point on is not necessary; consequently, the matching circuit or antenna coupler does not need to be shielded. However, the antenna-coupler chassis arrangement shown in Fig. 23-30 is desirable because it will tend to prevent fundamental-frequency energy from flowing from the matching circuit back over the transmitter; this helps eliminate feed-back troubles in audio systems.

If the antenna is driven through coaxial line the matching circuit shown in Fig. 23-30 may be omitted. In that case the line goes directly from the filter to the antenna.

When a filter does not seem to give the harmonic attenuation of which it should be capable, the probable reason is that harmonics are bypassing it because of improper installation and inadequate transmitter shielding, including lead filtering. However, occasionally there are cases where the circuits formed by the cables and the apparatus to which they connect become resonant at a harmonic frequency. This greatly increases

the harmonic output at that frequency. Such troubles can be completely overcome by substituting a slightly different cable length. The most critical length is that connecting the transmitter to the filter. Checking with a grid-dip meter at the final amplifier output coil usually will show whether an unfavorable resonance of this type exists.

● SUMMARY

The methods of harmonic elimination outlined in this chapter have been proved beyond doubt to be effective even under highly unfavorable conditions. It must be emphasized once more, however, that the problem must be solved one step at a time, and the procedure must be in logical order. It cannot be done properly without two items of simple equipment: a grid-dip meter and wavemeter covering the TV bands, and a dummy antenna.

The proper procedure may be summarized as follows:

1) Take a critical look at the transmitter on the basis of the design considerations outlined under "Reducing Harmonic Generation".

2) Check all circuits, particularly those connected with the final amplifier, with the grid-dip meter to determine whether there are any resonances in the TV bands. If so, rearrange the circuits so the resonances are moved out of the critical frequency region.

3) Connect the transmitter to the dummy antenna and check with the wavemeter for the presence of harmonics on leads and around the transmitter enclosure. Seal off the weak spots in the shielding and filter the leads until the wavemeter shows no indication at any harmonic frequency.

4) At this stage, check for interference with a TV receiver. If there is interference, determine the cause by the methods described previously and apply the recommended remedies until the interference disappears.

5) When the transmitter is completely clean on the dummy antenna, connect it to the regular antenna and check for interference on the TV receiver. If the interference is not bad, an antenna coupler or matching circuit installed as previously described should clear it up. Alternatively, a low-pass filter may be used. If neither the antenna coupler nor filter makes any difference in the interference, the evidence is strong that the interference, at least in part, is being caused by receiver overloading because of the strong funda-

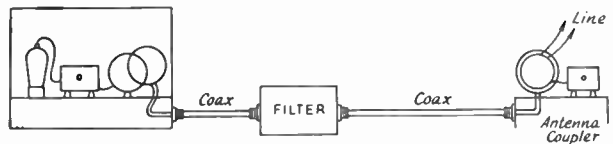

Fig. 23-30 — The proper method of installing a low-pass filter between the transmitter and antenna coupler or matching circuit. If the antenna is fed through coax the matching circuit may be omitted but the same construction should be used between the transmitter and filter. The filter should be thoroughly shielded.

mental-frequency field about the TV antenna and receiver. (See later section for identification of fundamental-frequency interference.) A coupler and/or filter, installed as described above, will invariably make a difference in the intensity of the interference if the interference is caused by transmitter harmonics alone.

6) If there is still interference after installing the coupler and/or filter, and the evidence shows that it is probably caused by a harmonic, more attenuation is needed. A more elaborate filter may be necessary. However, it is well at this stage to assume that part of the interference may be caused by receiver overloading, and take steps to alleviate such a condition before trying highly-elaborate filters, traps, etc., on the transmitter.

● HARMONICS BY RECTIFICATION

Even though the transmitter is completely free from harmonic output it is still possible for interference to occur because of harmonics generated outside the transmitter. These result from rectification of fundamental-frequency currents induced in conductors in the vicinity of the transmitting antenna. Rectification can take place at any point where two conductors are in poor electrical contact, a condition that frequently exists in plumbing, downspouting, BX cables crossing each other, and numerous other places in the ordinary residence. It also can occur in any exposed vacuum tubes in the station, in power supplies, speech equipment, etc., that may not be enclosed in the shielding about the r.f. circuits. Poor joints anywhere in the antenna system are especially bad, and rectification also may take place in the contacts of antenna change-over relays. Another common cause is overloading the front end of the communications receiver when it is used with a separate antenna (which will radiate the harmonics generated in the first tube) for break-in.

Rectification of this sort will not only cause harmonic interference but also is frequently responsible for cross-modulation effects. It can be detected in greater or less degree in most locations, but fortunately the harmonics thus generated are not usually of high amplitude. However, they can cause considerable interference in the immediate vicinity in fringe areas, especially when operation is in the 28-Mc. band. The amplitude decreases rapidly with the order of the harmonic, the second and third being the worst. It is ordinarily found that even in cases where destructive interference results from 28-Mc. operation the interference is comparatively mild from 14 Mc., and is negligible at still lower frequencies.

There is nothing that can be done at either the transmitter or receiver when rectification occurs. The remedy is to find the source and eliminate the poor contact either by separating the conductors or bonding them together. A crystal wave meter (tuned to the fundamental frequency) is useful for hunting the source, by showing which conductors are carrying r.f. and, comparatively, how much.

Interference of this kind is frequently intermittent, since the rectification efficiency will vary with vibration, the weather, and so on. The possibility of corroded contacts in the TV receiving antenna should not be overlooked, especially if it has been up a year or more.

● TV RECEIVER DEFICIENCIES

Front-End Overloading

When a television receiver is quite close to the transmitter, the intense r.f. signal from the transmitter's fundamental may overload one or more of the receiver circuits to produce spurious responses that cause interference.

If the overload is moderate, the interference is of the same nature as harmonic interference; it is caused by harmonics generated in the early stages of the receiver and, since it occurs only on channels harmonically related to the transmitting frequency, is difficult to distinguish from harmonics actually radiated by the transmitter. In such cases additional harmonic suppression at the transmitter will do no good, but any means taken at the receiver to reduce the amateur fundamental strength fed to the first tube will effect an improvement. With more severe overloading interference also will occur on channels *not* harmonically related to the transmitting frequency, so such cases are easily identified.

Cross-Modulation

Under some circumstances overloading will result in cross-modulation or mixing of the amateur signal and that from a local f.m. or TV station. For example, a 14-Mc. signal can mix with a 92-Mc. f.m. station to produce a beat at 78 Mc. and cause interference in Channel 5, or with a TV station on Channel 5 to cause interference in Channel 3. Neither of the channels interfered with is in harmonic relationship to 14 Mc. Both signals have to be on the air for the interference to occur, and eliminating either at the TV receiver will eliminate the interference.

There are many combinations of this type, depending on the band in use and the local frequency assignments to f.m. and TV stations. The interfering frequency is equal to the amateur fundamental frequency either added to or subtracted from the frequency of some local station, and when interference occurs in a TV channel that is not harmonically related to the amateur transmitting frequency the possibilities in such frequency combinations should be investigated.

I. F. Interference

Some TV receivers do not have sufficient selectivity to prevent strong signals in the intermediate-frequency range from forcing their way through the front end and getting into the i.f. amplifier. The once-standard intermediate frequency of, roughly, 21 to 27 Mc., is subject to interference from the fundamental-frequency output of transmitters operating in either the 21-

and 27-Mc. bands. Transmitters on 28 Mc. sometimes will cause this type of interference as well.

A form of i.f. interference peculiar to 50-Mc. operation near the low edge of the band occurs with some receivers having the standard "41-Mc." i.f., which has the sound carrier at 41.25 Mc. and the picture carrier at 45.75 Mc. A 50-Mc. signal that forces its way into the i.f. system of the receiver will cause a beat with the i.f. picture carrier that falls on or near the i.f. sound carrier, even though the interfering signal is not actually in the nominal pass-band of the i.f. amplifier.

There is a type of i.f. interference unique to the 144-Mc. band in localities where certain u.h.f. TV channels are in operation, affecting only those TV receivers in which double-conversion type plug-in u.h.f. tuning strips are used. The design of these strips involves a first intermediate frequency that varies with the TV channel to be received and, depending on the particular strip design, this first i.f. may be in or close to the 144-Mc. amateur band. Since there is comparatively little selectivity in the TV signal-frequency circuits ahead of the first i.f., a signal from a 144-Mc. transmitter will "ride into" the i.f., even when the receiver is at a considerable distance from the transmitter. The channels that can be affected by this type of i.f. interference are as follows:

<i>Receivers with 21-Mc. second i.f.</i>	<i>Receivers with 41-Mc. second i.f.</i>
Channels 14-18, inc.	Channels 20-25, inc.
Channels 41-48, inc.	Channels 51-58, inc.
Channels 69-77, inc.	Channels 82 and 83.

If the receiver is not close to the transmitter, a trap of the type shown in Fig. 23-33 will be effective. However, if the separation is small the 144-Mc. signal will be picked up directly on the receiver circuits and the best solution is to readjust the strip oscillator so that the first i.f. is moved to a frequency not in the vicinity of the 144-Mc. band. This has to be done by a competent technician.

I.f. interference is easily identified since it occurs on all channels — although sometimes the intensity varies from channel to channel — and the cross-hatch pattern it causes will rotate when the receiver's fine-tuning control is varied. When the interference is caused by a harmonic, overloading, or cross modulation, the structure of the interference pattern does not change as the fine-tuning control is varied, although its intensity may change.

High-Pass Filters

In all the above cases the interference can be eliminated if the fundamental signal strength can be reduced to a level that the receiver can handle. To accomplish this with signals on bands below 30 Mc., the most satisfactory device is a high-pass filter having a cut-off frequency between 30

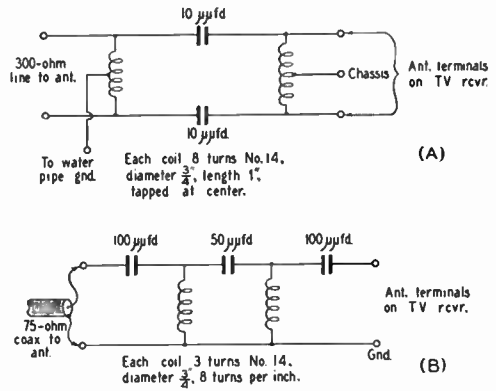

Fig. 23-31 — High-pass filters for installation at the TV receiver antenna terminals. A — balanced filter for 300-ohm line, B — for 75-ohm coaxial line. Important: Do not use a direct ground on the chassis of a transformerless receiver. Ground through a 0.001-μf. mica capacitor.

and 50 Mc., installed at the tuner input terminals of the receiver. Circuits that have proved effective are shown in Figs. 23-31 and 23-32. Fig. 23-32 has one more section than the filters of Fig. 23-31 and as a consequence has somewhat better cut-off characteristics. All the circuits given are designed to have little or no effect on the TV signals but will attenuate all signals lower in frequency than about 40 Mc. These filters preferably should be constructed in some sort of shielding container, although shielding is not always necessary. The dashed lines in Fig. 23-32 show how individual filter coils can be shielded from each other. The capacitors can be

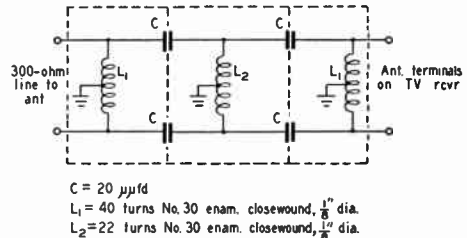

Fig. 23-32 — Another type of high-pass filter for 300-ohm line. The coils may be wound on 1/8-inch diameter plastic knitting needles. Important: Do not use a direct ground on the chassis of a transformerless receiver. Ground through a 0.001-μf. mica capacitor.

tubular ceramic units centered in holes in the partitions that separate the coils.

Simple high-pass filters cannot be applied successfully in the case of 50-Mc. transmissions, because they do not have sufficiently-sharp cut-off characteristics to give both good attenuation at 50-54 Mc. and no attenuation above 54 Mc. A more elaborate design capable of giving the required sharp cut-off has been described (Ladd, "50-Mc. TVI — Its Causes and Cures," *QST*, June and July, 1954). This article also contains other information useful in coping with the TVI problems peculiar to 50-Mc. operation. As an alternative to such a filter, a high-Q wave-

trap tuned to the transmitting frequency may be used, suffering only the disadvantage that it is quite selective and therefore will protect a receiver from overloading over only a small range of transmitting frequencies in the 56-Mc. band. A trap of this type using quarter-wave sections of Twin-Lead is shown in Fig. 23-33. These "suck-out" traps, while absorbing energy at the frequency to which they are tuned, do not affect the receiver operation otherwise. The assembly should be slid along the TV antenna lead-in until the most effective position is found, and then fastened securely in place with Scotch Tape. An

Fig. 23-33 — Absorption-type wave trap using sections of 300-ohm line tuned to have an electrical length of $\frac{1}{4}$ wave length at the transmitter frequency. Approximate physical lengths (dimension *A*) are 40 inches for 50 Mc. and 11 inches for 144 Mc., allowing for the loading effect of the capacitance at the open end. Two traps are used in parallel, one on each side of the line to the receiver.

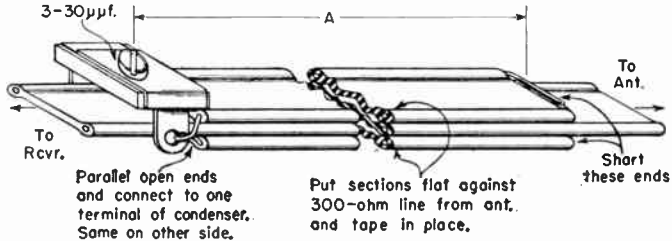

insulated tuning tool should be used for adjustment of the trimmer capacitor, since it is at a "hot" point and will show considerable body-capacity effect.

High-pass filters are available commercially at moderate prices. In this connection, it should be understood by all parties concerned that while an amateur is responsible for harmonic radiation from his transmitter, it is no part of his responsibility to pay for or install filters, wave traps, etc. that may be required at the receiver to prevent interference caused by his *fundamental* frequency. The set owner should be advised to get in touch with the organization from which he purchased the receiver or which services it, to make arrangements for proper installation. Proper installation usually requires that the filter be installed right at the input terminals of the r.f. tuner of the TV set and not merely at the antenna terminals, which may be at a considerable distance from the tuner. The question of cost is one to be settled between the set owner and the organization with which he deals. Some of the larger manufacturers of TV receivers have instituted arrangements for cooperating with the set dealer in installing high-pass filters at no cost to the receiver owner. FCC-sponsored TVI Committees, now operating in many cities, have all the information necessary for effectuating such arrangements.

If the fundamental signal is getting into the receiver by way of the line cord a line filter such as that shown in Fig. 23-4 may help. To be most effective it should be installed inside the receiver chassis at the point where the cord enters, making the ground connections directly to chassis at this point. It may not be so helpful if placed between the line plug and the wall socket unless the r.f. is actually picked up on the house wiring rather than on the line cord itself.

Antenna Installation

Many television receivers will respond strongly to parallel currents on the receiving transmission line. Usually, the transmission line picks up a great deal more energy from a near-by transmitter than the television receiving antenna itself, causing parallel currents that should be, but are not, rejected by the receiver's input circuit. This situation can be improved by using shielded transmission line — coax or, in the balanced form, "twinax" — on the receiving installation. For best results the line should terminate in a

coax fitting on the receiver chassis, but if this is not possible the shield should be grounded to the chassis right at the antenna terminals.

The use of shielded transmission line for the receiver also will be helpful in reducing response to harmonics actually being radiated from the transmitter or transmitting antenna. In most receiving installations the transmission line is very much longer than the antenna itself, and is consequently far more exposed to the harmonic fields from the transmitter. Much of the harmonic pickup, therefore, is on the receiving transmission line when the transmitter and receiver are quite close together. Shielded line, plus relocation of either the transmitting or receiving antenna to take advantage of directive effects, often will result in reducing overloading, as well as harmonic pickup, to a level that does not interfere with reception.

● U.H.F. TELEVISION

Harmonic TVI in the u.h.f. TV band is far less troublesome than in the v.h.f. band. Harmonics from transmitters operating below 30 Mc. are of such high order that they would normally be expected to be quite weak; in addition, the components, circuit conditions and construction of low-frequency transmitters are such as to tend to prevent very strong harmonics from being generated in this region. However, this is not true of amateur v.h.f. transmitters, particularly those working in the 144-Mc. and higher bands. Here the problem is quite similar to that of the low v.h.f. TV band with respect to transmitters operating below 30 Mc.

There is one highly favorable factor in u.h.f. TV that does not exist in the most of the v.h.f. TV band: If harmonics are radiated, it is possible to move the transmitter frequency sufficiently

TABLE 23-1
Harmonic Relationship—Amateur V.H.F. Bands and U.H.F. TV Channels

<i>Amateur Band</i>	<i>Harmonic</i>	<i>Fundamental Freq. Range</i>	<i>U.H.F. TV Channel Affected</i>	<i>Amateur Band</i>	<i>Harmonic</i>	<i>Fundamental Freq. Range</i>	<i>U.H.F. TV Channel Affected</i>
<i>144 Mc.</i>	4th	114.0-144.5	31	<i>220 Mc.</i>	3rd	220-220.67	45
		144.5-146.0	32			220.67-222.67	46
		146.0-147.5	33			222.67-224.67	47
		147.5-148.0	34			224.67-225	48
	5th	144.0-144.4	55	<i>420 Mc.</i>	2nd	420-421	75
		144.4-145.6	56			421-421.7	76
		145.6-146.8	57			421.7-422.9	77
		146.8-148	58			422.9-424.1	78
	6th	144-144.33	79			430-433	79
		144.33-145.33	80			433-436	80
		145.33-147.33	81			436-439	81
		147.33-148	82			439-442	82
					442-448	83	

(within the amateur band being used) to avoid interfering with a channel that may be in use in the locality. By restricting operation to a portion of the amateur band that will not result in harmonic interference, it is possible to avoid the necessity for taking extraordinary precautions to prevent harmonic radiation.

The frequency assignment for u.h.f. television consists of seventy 6-megacycle channels (Nos. 14 to 83, inclusive) beginning at 470 Mc. and ending at 890 Mc. The harmonics from amateur bands above 50 Mc. span the u.h.f. channels as shown in Table 23-1. Since the assignment plan calls for a minimum separation of six channels between any two stations in one locality, there is ample opportunity to choose a fundamental frequency that will move a harmonic out of range of a local TV frequency.

● COLOR TELEVISION

The color TV signal includes a subcarrier spaced 3.58 megacycles from the regular picture carrier (or 4.83 Mc. from the low edge of the channel) for transmitting the color information. Harmonics which fall in the color subcarrier region can be expected to cause break-up of color in the received picture. This modifies the chart of Fig. 23-7 to introduce another "severe" region centering around 4.8 Mc. measured from the low-frequency edge of the channel. Hence with color television reception there is less opportunity to avoid harmonic interference by choice of operating frequency. In other respects the problem of eliminating interference is the same as with black-and-white television.

● INTERFERENCE FROM TV RECEIVERS

The TV picture tube is swept horizontally by the electron beam 15,750 times per second, using a waveshape that has very high harmonic content. The harmonics are of appreciable amplitude even at frequencies as high as 30 Mc., and when radiated from the receiver can cause considerable

interference to reception in the amateur bands. While in some receivers measures have been taken to suppress radiation of this nature, many sets have had no such treatment. The interference takes the form of rather unstable, a.c.-modulated signals spaced at intervals of 15.75 kc.

Studies have shown that the radiation takes place principally in three ways, in order of their importance: (1) from the a.c. line, through stray coupling to the sweep circuits; (2) from the antenna system, through similar coupling; (3) directly from the picture tube and sweep-circuit wiring. Line radiation often can be reduced by bypassing the a.c. line cord to the chassis at the point of entry, although this is not completely effective in all cases since the coupling may take place outside the chassis beyond the point where the by-passing is done. Radiation from the antenna is usually suppressed by installing a high-pass filter on the receiver. The direct radiation requires shielding of high-potential leads and, in some receivers, additional by-passing in the sweep circuit; in severe cases, it may be necessary to line the cabinet with screening or similar shielding material.

It is usually possible to reduce interference very considerably, without modifying the TV receiver, simply by having a good amateur-band receiving installation. The principles are the same as those used in reducing "hash" and other noise — use a good antenna, such as the transmitting antenna, for reception; install it as far as possible from a.c. circuits; use a good feeder system such as a properly balanced two-wire line or coax with the outer conductor grounded; use coax input to the receiver, with a matching circuit if necessary; and check the receiver to make sure that it does not pick up signals or noise with the antenna disconnected. These measures not only reduce interference from sweep radiation and a.c. line noise, but also build up the strength of the desired signal, so that the overall improvement in signal-to-interference ratio is very much worth-while.

Operating a Station

The enjoyment of our hobby usually comes from the operation of our station once we have finished its construction. Upon the *station* and its *operation* depend the communication records that are made. The standing of individuals as amateurs and respect for the capabilities of the whole institution of amateur radio depends to a considerable extent on the practical communications established by amateurs, the aggregate of all our station efforts.

An operator with a slow, steady, clean-cut method of sending has a big advantage over the poor operator. The technique of speaking in connected thoughts and phrases is equally important for the voice operator. Good sending is partly a matter of practice but patience and judgment are just as important qualities of an operator as a good "fist."

Operating knowledge embracing standard procedures, development of skill in employing c.w. to expand the station range at operating effectiveness at minimum power levels and some net know-how are all essentials in achieving a triumphant amateur experience with top station records, personal results, and demonstrations of what our stations can do in practical communications.

● OPERATING COURTESY AND TOLERANCE

Normal operating interests in amateur radio vary considerably. Some prefer to rag-chew, others handle traffic, others work DX, others concentrate on working certain areas, countries or states and still others get on for an occasional contact only to check a new transmitter or antenna.

Interference is one of the things we amateurs have to live with. However, we can conduct our operating in a way designed to alleviate it as much as possible. *Before putting the transmitter on the air, listen on your own frequency.* If you hear stations engaged in communication on that

frequency, stand by until you are sure no interference will be caused by your operations, or *shift to another frequency.* No amateur or any group of amateurs has any *exclusive* claim to any frequency in any band. We must work together, each respecting the rights of others. Remember, those other chaps can cause you as much interference as you cause them, sometimes more!

In this chapter we'll recount some fundamentals of operating success, cover major procedures for successful general work and include proper forms to use in message handling and other fields. Note also the sections on special activities, awards and organization. These permit us all to develop through our organization more success together than we could ever attain by separate uncoordinated efforts that overlooked the precepts established through operating experience.

● C.W. PROCEDURE

The best operators, *both* those using voice and c.w., observe certain operating procedures regarded as "standard practice."

1) *Calls.* Calling stations may call efficiently by transmitting the call signal of the station called three times, the letters DE, followed by one's own station call sent three times. (Short calls with frequent "breaks" to listen have proved to be the best method.) Repeating the call of the station called four or five times and signing not more than two or three times has proved excellent practice, thus: WØBY WØBY WØBY WØBY DE W1AW W1AW AR.

CQ. The general-inquiry call (CQ) should be sent not more than five times without interspersing one's station identification. The length of repeated calls is carefully limited in intelligent amateur operating. (CQ is not to be used when testing or when the sender is not expecting or looking for an answer. Never send a CQ "blind." Always be sure to listen on the transmitting frequency first.)

The directional CQ: To reduce the number of useless answers and lessen QRM, every CQ call should be made informative when possible.

Examples: A United States station looking for any Hawaiian amateur calls: CQ KH6 CQ KH6 CQ KH6 DE W4IA W4IA K. A Western station with traffic for the East Coast when looking for an intermediate relay station calls: CQ EAST CQ EAST CQ EAST DE W5IGW W5IGW W5IGW K. A station with messages for points in Massachusetts calls: CQ MASS CQ MASS CQ MASS DE W7CZY W7CZY W7CZY K.

Hams who do not raise stations readily may find that their sending is poor, their calls ill-timed or judgment in error. When conditions are right



to bring in signals from the desired locality, you can call them. Reasonably short calls, with appropriate and brief breaks to listen, will raise stations with minimum time and trouble.

2) *Answering a Call*: Call three times (or less); send DE; sign three times (or less); after contact is established decrease the use of the call signals of both stations to *once or twice*. When a station receives a call but does not receive the call letters of the station calling, QRZ? may be used. It means "By whom am I being called?" QRZ should not be used in place of CQ.

3) *Ending Signals and Sign-Off*: The proper use of AR, K, KN, SK and CL ending signals is as follows:

AR — End of transmission. Recommended after call to a specific station before contact has been established.

Example: W6ABC W6ABC W6ABC W6ABC
W6ABC DE W9LMN W9LMN AR. Also at the end of transmission of a radiogram, immediately following the signature, preceding identification.

K — Go ahead (any station). Recommended after CQ and at the end of each transmission during QSO when there is no objection to others breaking in.

Example: CQ CQ CQ DE W1ABC W1ABC
K or W9XYZ DE W1ABC K.

KN — Go ahead (specific station), all others keep out. Recommended at the end of each transmission during a QSO, or after a call, when calls from other stations are not desired and will not be answered.

Example: W4FGH DE XU6GRL KN.

SK — End of QSO. Recommended before signing *last* transmission at end of a QSO.

Example: . . . SK W8LMN DE W5BCD.

CL — I am closing station. Recommended when a station is going off the air, to indicate that it will not listen for any further calls.

Example: . . . SK W7HIJ DE W2JKL CL.

4) *Test signals* to permit another station to adjust receiving equipment may consist of a series of Vs with the call signal of the transmitting station at frequent intervals. Remember that a test signal can be a totally unwarranted cause of QRM, and *always listen first* to find a clear spot if possible.

5) *Receiving* for conversation or traffic: Never receipt for a transmission until it has been entirely received. "R" means "transmission received as sent." Use R *only* when *all* is received correctly.

6) *Repeats*. When most of a transmission is lost, a call should be followed by correct abbreviations to ask for repeats. When a few words on the end of a transmission are lost, the *last word received correctly* is given after ?AA, meaning "all after." When a few words at the beginning of a transmission are lost, ?AB for "all before" a stated word should be used. The quickest way to ask for a fill in the middle of a transmission is to send the last word received correctly, a ques-

tion mark, then the next word received correctly. Another way is to send "?BN [word] and [word]."

Do not send words twice (QSZ) unless it is requested. Send single. Do not fall into the bad habit of sending double *without a request* from fellows you work. Don't say "QRM" or "QRN" when you mean "QRS." Don't CQ unless there is definite reason for so doing. When sending CQ, use judgment.

General Practices

When a station has receiving trouble, the operator asks the transmitting station to "QSV." The letter "R" is often used in place of a decimal point (e.g., "3R5 Mc.") or the colon in time designation (e.g., "2R30 PM"). A long dash is sometimes sent for "zero."

The law concerning superfluous signals should be noted. If you *must* test, disconnect the antenna system and use an equivalent "dummy" antenna. Send your call frequently when operating. Pick a time for adjusting the station apparatus when few stations will be bothered.

The up-to-date amateur station uses "break-in." For best results send at a medium speed. Send evenly with proper spacing. The standard-type telegraph key is best for all-round use. Regular daily practice periods, two or three periods a day, are best to acquire real familiarity and proficiency with code.

No excuse can be made for "garbled" copy. Operators should copy what is sent and refuse to acknowledge a whole transmission until every word has been received correctly. *Good operators do not guess*. "Swing" in a fist is *not* the mark of a good operator. Unusual words are sent twice, the word repeated following the transmission of "?". If not *sure*, a good operator systematically asks for a fill or repeat. Sign your call frequently, interspersed with calls, and at the end of all transmissions.

On Good Sending

Assuming that an operator has learned sending properly, and comes up with a precision "fist" — not fast, but clean, steady, making well-formed rhythmical characters and spacing beautiful to listen to — he then becomes subject to outside pressures to his own possible detriment in everyday operating. He will want to "speed it up" because the operator at the other end is going faster, and so he begins, unconsciously, to run his words together or develops a "swing."

Perhaps one of the easiest ways to get into bad habits is to do too much playing around with special keys. Too many operators spend only enough time with a straight key to acquire "passable" sending, then subject their newly-developed "fists" to the entirely different movements of bugs, side-swipers, electronic keys, or what-have-you. All too often, this results in the ruination of what may have become a very good "fist."

Think about your sending a little. Are you satisfied with it? You should not be — ever. Nobody's sending is perfect, and therefore *every*

operator should continually strive for improvement. Do you ever run letters together — like Q for MA, or P for AN — especially when you are in a hurry? Practically everybody does at one time or another. Do you have a “swing”? Any recognizable “swing” is a deviation from perfection. Strive to send like tape sending; copy a WIAW Bulletin and try to send it with the same spacing using a local oscillator on a subsequent transmission.

Check your spacing in characters, between characters and between words occasionally by making a recording of your fist on an inked tape recorder. This will show up your faults as nothing else will. Practice the correction of faults.

● USING A BREAK-IN SYSTEM

Break-in avoids unnecessarily long calls, prevents QRM, gives more communication per hour of operating. Brief calls with frequent short pauses for reply can approach (but not equal) break-in efficiency.

A separate receiving antenna facilitates break-in operation. It is only necessary with break-in to pause just a moment with the key up (or to cut the carrier momentarily and pause in a phone conversation) to listen for the other station. The click when the carrier is cut off is as effective as the word “break.”

C.w. telegraphy break-in is usually simple to arrange. With break-in, ideas and messages to be transmitted can be pulled right through the holes in the QRM. Snappy, efficient amateur work with break-in usually requires a separate receiving antenna and arrangement of the transmitter and receiver to eliminate the necessity for throwing switches between transmissions.

In calling, the transmitting operator sends the letters “BK” at frequent intervals during his call so that stations hearing the call may know that break-in is in use and take advantage of the fact. *He pauses at intervals* during his call, to listen for a moment for a reply. If the station being called does not answer, the call can be continued.

With a tap of the key, the man on the receiving end can interrupt (if a word is missed). The other operator is constantly monitoring, awaiting just such directions. It is not necessary that *you* have perfect facilities to take advantage of break-in when the stations you work are break-in-equipped. After any invitation to *break* is given (and at each pause) press your key — and contact can start *immediately*.

● VOICE OPERATING

The use of proper procedure to get best results is just as important as in using code. In telegraphy words must be spelled out letter by letter. It is therefore but natural that abbreviations and shortcuts should have come into widespread use. In voice work, however, abbreviations are not necessary, and should have less importance in our operating procedure.

Voice-Operating Hints

- 1) Listen before calling.
- 2) Make short calls with breaks to listen. Avoid long CQs; do not answer any.
- 3) Use push-to-talk. Give essential data concisely in first transmission.
- 4) Make reports honest. Use definitions of strength and readability for reference. Make your reports informative and useful. Honest reports and full word description of signals save amateur operators from FCC trouble.
- 5) Limit transmission length. Two minutes or less will convey much information. When three or more stations converse in round tables, brevity is essential.
- 6) Display sportsmanship and courtesy. Bands are congested . . . make transmissions meaningful . . . give others a break.
- 7) Check transmitter adjustment . . . avoid a.m. overmodulation and splatter. Do not radiate when moving v.f.o. frequency or checking n.f.m. swing. Use receiver b.f.o. to check stability of signal. Complete testing before busy hours!

The letter “K” has been agreed to in telegraphic practice so that the operator will not have to pound out the separate letters that spell the words “go ahead.” The voice operator can *say* the words “go ahead” or “over,” or “come in please.”

One laughs on c.w. by spelling out III. On phone *use* a laugh when one is called for. Be natural as you would with your family and friends.

The matter of reporting *readability* and *strength* is as important to phone operators as to those using code. With telegraph nomenclature, it is necessary to spell out words to describe signals or use the abbreviated signal reporting system (RST . . . see Chapter Twenty-Five). Using voice, we have the ability to “say it with words.” “Readability four, Strength eight” is the best way to give a quantitative report. Reporting can be done so much more meaningfully with ordinary words: “You are weak but you are in the clear and I can understand you, so go ahead,” or “Your signal is strong but you are buried under local interference.” Why not say it with words?

Voice Equivalents to Code Procedure

Voice	Code	Meaning
Go ahead; over	K	Self-explanatory
Wait; stand by	AS	Self-explanatory
Received	R	Receipt for a correctly-transcribed message or for “solid” transmission with no missing portions

Phone-Operating Practice

Efficient voice communication, like good c.w. communication, demands good operating. Adherence to certain points “on getting results” will go a long way toward improving our phone-band operating conditions.

Use push-to-talk technique. Where possible arrange on-off switches, controls or voice-controlled break-in for fast back-and-forth exchanges that emulate the practicality of the wire telephone.

This will help reduce the length of transmissions and keep brother amateurs from calling you a "monologist" — a guy who likes to hear himself talk!

Listen with care. Keep noise and "backgrounds" out of your operating room to facilitate good listening. It is natural to answer the strongest signal, but take time to listen and give some consideration to the *best* signals, regardless of strength. Every amateur cannot run a kilowatt, but there is no reason why every amateur cannot have a signal of good quality, and utilize uniform operating practices to aid in the understandability and ease of his own communications.

Interpose your call regularly and at frequent intervals. Three short calls are better than one long one. In calling CQ, one's call should certainly appear at least once for every five or six CQs. Calls with frequent breaks to listen will save time and be most productive of results. In identifying, always transmit your *own* call *last*. Don't say "This is W1ABC standing by for W2DEF"; say "W2DEF, this is W1ABC, over." FCC regulations show the call of the transmitting station sent *last*.

Include country prefix before call. It is not correct to say "9RRX, this is 1BDL." Correct and legal use is "W9RRX, this is W1BDL." FCC regulations require proper use of calls; stations have been cited for failure to comply with this requirement.

Monitor your own frequency. This helps in timing calls and transmissions. Transmit when there is a chance of being copied successfully — not when you are merely "more QRM." Timing transmissions is an art to cultivate.

Keep modulation constant. By turning the gain "wide open" you are subjecting anyone listening to the diversion of whatever noises are present in or near your operating room, to say nothing of the possibility of feed-back, echo due to poor acoustics, and modulation excesses due to sudden loud noises. Speak near the microphone, and don't let your gaze wander all over the station causing sharply-varying input to your speech amplifier; at the same time, keep far enough from the microphone so your signal is not modulated by your breathing. Change distance or gain only as necessary to insure uniform transmitter performance without overmodulation, splatter or distortion.

Make connected thoughts and phrases. Don't mix disconnected subjects. Ask questions consistently. Pause and get answers.

Have a pad of paper handy. It is convenient and desirable to jot down questions as they come in the course of discussion in order not to miss any. It will help you to make intelligent to-the-point replies.

Steer clear of inanities and soap-opera stuff. Our amateur radio and also our personal reputation as a serious communications worker depend on us.

Avoid repetition. Don't repeat back what the other fellow has just said. Too often we hear a conversation like this: "Okay on your new antenna there, okay on the trouble you're having

with your receiver, okay on the company who just came in with some ice cream, okay . . . [etc.]." Just *say* you received everything OK. Don't try to prove it.

Use phonetics only as required. When clarifying genuinely doubtful expressions and in getting your call identified positively we suggest use of the ARRL Phonetic List. Limit such use to really-necessary clarification.

The speed of radiotelephone transmission (with perfect accuracy) depends almost entirely upon the skill of the two operators involved. One must learn to speak at a rate allowing perfect understanding as well as permitting the receiving operator to copy down the message text, if that is necessary. Because of the similarity of many English speech sounds, the use of alphabetical word lists has been found necessary. All voice-operated stations should use a *standard* list as needed to identify call signals or unfamiliar expressions

ARRL Word List for Radiotelephony

ADAM	JOHN	SUSAN
BAKER	KING	THOMAS
CHARLIE	LEWIS	UNION
DAVID	MARY	VICTOR
EDWARD	NANCY	WILLIAM
FRANK	OTTO	X-RAY
GEORGE	PETER	YOUNG
HENRY	QUEEN	ZEBRA
IDA	ROBERT	

Example: W1AW . . . W1 ADAM WILLIAM . . . W1AW

Round Tables. The round table has many advantages if run properly. It clears frequencies of interference, especially if all stations involved are on the same frequency, while the enjoyment value remains the same, if not greater. By use of push-to-talk, the conversation can be kept lively and interesting, giving each station operator ample opportunity to participate without waiting overlong for his turn.

Round tables can become very unpopular if they are not conducted properly. The monologist, off on a long spiel about nothing in particular, cannot be interrupted; *make your transmissions short and to the point.* "Butting in" is discourteous and unsportsmanlike; *don't enter a round table, or any contact between two other amateurs, unless you are invited.* It is bad enough trying to copy through prevailing interference without the added difficulty of poor voice quality; *check your transmitter adjustments frequently.* In general, follow the precepts as hereinbefore outlined for the most enjoyment in round tables as well as any other form of radiotelephone communication.

● WORKING DX

Most amateurs at one time or another make "working DX" a major aim. As in every other phase of amateur work, there are right and wrong ways to go about getting best results in working foreign stations, and it is the intention of this section to outline a few of them.

The ham who has trouble raising DX stations

readily may find that poor transmitter efficiency is not the reason. He may find that his sending is poor, or his calls ill-timed, or his judgment in error. When conditions are right to bring in the DX, and the receiver sensitive enough to bring in several stations from the desired locality, the way to work DX is to use the appropriate frequency and timing and *call these stations*, as against the common practice of calling "CQ DX."

The call CQ DX means slightly different things to amateurs in different bands:

a) On v.h.f., CQ DX is a general call ordinarily used only when the band is open, under favorable "skip" conditions. For v.h.f. work such a call is used for looking for new states and countries, also for distances beyond the customary "line-of-sight" range on most v.h.f. bands.

b) CQ DX on our 7-, 14-, 21- and 28-Mc. bands may be taken to mean "General call to any foreign station." The term "foreign station" usually refers to any station in a foreign continent. (*Experienced amateurs in the U. S. A. and Canada do not use this call, but answer such calls made by foreign stations.*)

c) CQ DX used on 3.5 Mc. under winter-night conditions may be used in this same manner. At other times, under average 3.5-Mc. propagation conditions, the call may be used in domestic work when looking for new states or countries in one's own continent, usually applying to stations located over 1000 miles distant from you.

The way to work DX is not to use a CQ call at all (in our continent). Instead, use your best tuning skill — and listen — and listen — and listen. *You have to hear them before you can work them.* Hear the desired stations first; time your calls well. Use your utmost skill. A sensitive receiver is often more important than the power input in working foreign stations. If you can hear stations in a particular country or area, chances are that you will be able to work someone there.



“...DO A LOT OF SNOOPING”

DX OPERATING CODE (For W/VE Amateurs)

Some amateurs interested in DX work have caused considerable confusion and QRM in their efforts to work DX stations. The points below, if observed by all W/VE amateurs, will go a long way toward making DX more enjoyable for everybody.

1. Call DX only after he calls CQ, QRZ?, signs SK, or phone equivalents thereof.
2. Do not call a DX station:
 - a. On the frequency of the station he is working until you are *sure* the QSO is over. This is indicated by the ending signal SK on c.w. and any indication that the operator is listening, on phone.
 - b. Because you hear someone else calling him.
 - c. When he signs KN, AR, CL, or 'phone equivalents.
 - d. Exactly on his frequency.
 - e. After he calls a directional CQ, unless of course you are in the right direction or area.
3. Keep within frequency-band limits. Some DX stations operate outside. Perhaps they can get away with it, but you cannot.
4. Observe calling instructions of DX stations. "10U" means call ten kc. up from his frequency, "15D" means 15 kc. down, etc.
5. Give honest reports. Many foreign stations depend on W and VE reports for adjustment of station and equipment.
6. Keep your signal clean. Key clicks, chirps, hum or splatter give you a bad reputation and may get you a citation from FCC.
7. Listen for and call station you want. Calling CQ DX is not the best assurance that the rare DX will reply.
8. When there are several W or VE stations waiting to work a DX station, avoid asking him to "listen for a friend." Let your friend take his chances with the rest. Also avoid engaging DX stations in rag-chews against their wishes.

One of the most effective ways to work DX is to know the operating habits of the DX stations sought. Doing too much transmitting on the DX bands is not the way to do this. Again, *listening* is effective. Once you know the operating habits of the DX station you are after you will know when and where to call, and when to remain silent waiting your chance.

Some DX stations indicate where they will tune for replies by use of "10U" or "15D." (See point 4 of the DX Operating Code.) In voice work the overseas operator may say "listening on 14,225 kc." or "tuning upward from 28,500 kc." Many a DX station will not reply to a call on his exact frequency.

ARRL has recommended some operating procedures to DX stations aimed at controlling some of the thoughtless operating practices sometimes used by W/VE amateurs. A copy of these recommendations (Operating Aid No. 5) can be obtained free of charge from ARRL Headquarters.

In any band, particularly at line-of-sight frequencies, when directional antennas are used, the directional CQ such as CQ W5, CQ north, etc., is the preferable type of call. Mature amateurs agree that CQ DX is a wishful rather than a practical type of call for most stations in the North Americas looking for foreign contacts. Ordinarily, it is a cause of unnecessary QRM.

Conditions in the transmission medium make all field strengths from a given region more nearly equal at a distance, irrespective of power used. In general, the higher the frequency band, the less important power considerations become. This accounts in part for the relative popularity of the 14-, 21- and 28-Mc. bands among amateurs who like to work DX.

DATE TIME	STATION CALLED	CALLED BY	MIS FREQ OR DIAL	MIS SIGNALS RST	MY SIGNALS RST	FREQ. MC.	EMIS. SION TYPE	POWER INPUT WATTS	TIME OF ENDING QSO	OTHER DATA
11-16-53										
6:15 PM	WOTQD	x	3.65	589	569x	3.5	A1	250	6:43	Tfc-rec'd 6, sent 10
7:20	CQ	x				7				
7:21	x W4TWI		7.16	369	579				7:32	Vy heavy QRM on me
9:25	W8UKS	x	3.93	59	47	3.9	A3	100	10:05	Ham
11-18-53										
7:05 AM	W4HEL	x	14.03			14	A1	250		Answered a W6
7:09	ZL2ACV	x	14.07	339	559x				7:20	
7:21	x KA2KW		14.07	469x	349				7:33	First KA
7:36	CQ	x								
7:37	x W6TI		14.01	589	589c				8:12	

KEEP AN ACCURATE AND COMPLETE STATION LOG AT ALL TIMES! F.C.C. REQUIRES IT.

A page from the official ARRL log is shown above, answering every Government requirement in respect to station records. Bound logs made up in accord with the above form can be obtained from Headquarters for a nominal sum or you can prepare your own, in which case we offer this form as a suggestion. The ARRL log has a special wire binding and lies perfectly flat on the table.

● **KEEPING AN AMATEUR STATION LOG**

The FCC requires every amateur to keep a complete station operating record. It may also contain records of experimental tests and adjustment data. A stenographer's notebook can be ruled with vertical lines in any form to suit the user. The Federal Communications Commission requirements are that a log be maintained that shows (1) the date and time of each transmission, (2) all calls and transmissions made (whether two-way contacts resulted or not), (3) the input

power to the last stage of the transmitter, (4) the frequency band used, (5) the time of ending each QSO and the operator's identifying signature for responsibility for each session of operating. Messages may be written in the log or separate records kept — but record must be retained for one year as required by the FCC. For the convenience of amateur station operators ARRL stocks both logbooks and message blanks, and if one uses the official log he is sure to comply fully with the Government requirements if the precautions and suggestions included in the log are followed.

Message Handling

Amateur operators in the United States and a few other countries enjoy a privilege not available to amateurs in most countries — that of handling third-party message traffic. In the early history of amateur radio in this country, some amateurs who were among the first to take advantage of this privilege formed an extensive relay organization which became known as the American Radio Relay League.

Thus, amateur message-handling has had a long and honorable history and, like most services, has gone through many periods of development and change. Those amateurs who handled traffic in 1914 would hardly recognize it the way some of us do it today, just as equipment in those days was far different from that in use now. Progress has been made and new methods have been developed in step with advancement in communication techniques of all kinds. Amateurs who handled a lot of traffic found that organized operating schedules were more effective than random relays, and as techniques advanced and messages increased in number, trunk lines were organized, spot frequencies began to be used, and there sprang into existence a number of traffic nets in which many stations operated on the same frequency to effect wider cov-

erage in less time with fewer relays; but the old methods are still available to the amateur who handles only an occasional message.

Although message handling is as old an art as is amateur radio itself, there are many amateurs who do not know how to handle a message and have never done so. As each amateur grows older and gains experience in the amateur service, there is bound to come a time when he will be called upon to handle a written message, during a communications emergency, in casual contact with one of his many acquaintances on the air, or as a result of a request from a non-amateur friend. Regardless of the occasion, if it comes to you, you will want to rise to it! Considerable embarrassment is likely to be experienced by the amateur who finds he not only does not know the form in which the message should be prepared, but does not know what to do with the message once it has been filed or received in his station.

Traffic work need not be a complicated or time-consuming activity for the casual or occasional message-handler. Amateurs may participate in traffic work to whatever extent they wish, from an occasional message now and then to becoming a part of organized traffic systems.

This chapter explains some principles so the reader may know where to find out more about the subject and may exercise the message-handling privilege to best effect as the spirit and opportunity arise.

Responsibility

Amateurs who originate messages for transmission or who receive messages for relay or delivery should first consider that in doing so they are accepting the responsibility of clearing the message from their station on its way to its destination in the shortest possible time. Forty-eight hours after filing or receipt is the generally-accepted rule among traffic-handling amateurs, but it is obvious that if every amateur who relayed the message allowed it to remain in his station this long it might be a long time reaching its destination. Traffic should be relayed or delivered as quickly as possible.

Message Form

Once this responsibility is realized and accepted, handling the message becomes a matter of following generally-accepted standards of form and transmission. For this purpose, each message is divided into four parts: the preamble, the address, the text and the signature. Some of these parts themselves are subdivided. It is necessary in preparing the message for transmission and in actually transmitting it to know not only what each part is and what it is for, but to know in what *order* it should be transmitted, and to know the various procedure signals used with it when sent by c.w. If you are going to send a message, you may as well send it right.

Standardization is important! There is a great deal of room for expressing originality and individuality in amateur radio, but there are also times and places where such expression can only cause confusion and inefficiency. Recognizing the need for standardization in message form and message transmitting procedures, ARRL has long since recommended such standards, and most traffic-interested amateurs have followed them. In general, these recommendations, and the various changes they have undergone from year to year, have been at the request of ama-

teurs participating in this activity, and they are completely outlined and explained in *Operating an Amateur Radio Station*, a copy of which is available upon request or by use of the coupon at the end of this chapter.

Clearing a Message

Amateurs not experienced in message handling should depend on the experienced message-handler to get a message through, if it is important; but the average amateur can enjoy operating with a message to be handled either through a local traffic net or by free-lancing. The latter may be accomplished by careful listening for an amateur station at desired points, directional CQs, use of the National Calling and Emergency frequencies, or by making and keeping a schedule with another amateur for regular work between specified points. He may well aim at learning and enjoying through doing. The joy and accomplishment in thus developing one's operating skill to top perfection has a reward all its own.

The best way to clear a message is to put it into one of the many organized traffic networks, or to give it to a station who can do so. There are many amateurs who make the handling of traffic their principal operating activity, and many more still who participate in this activity to a greater or lesser extent. The result is a system of traffic nets which spreads to all corners of the United States and covers most U. S. possessions and Canada. Once a message gets into one of these nets, regardless of the net's size or coverage, it is systematically routed toward its destination in the shortest possible time.

If you decide to "take the bull by the horns" and put the message into a traffic net yourself (and more power to you if you do!), you will need to know something about how traffic nets operate, and the special Q signals and procedure they use to dispatch all traffic with a maximum of efficiency. Reference to net lists in *QST* (usually in the November and January issues) will give you the frequency and operating time of the net in your section, or other net into which your message can go. Listening for a few minutes at the time and frequency indicated should acquaint you with enough fundamentals to enable you to report into the net and indicate your traffic. From that time on you follow the instructions of the net control station, who will tell you when and to whom (and on what frequency, if different from the net frequency) to send your message. Since most nets use the special "QN" signals, it is usually very helpful to have a list of these before you (list available from ARRL Hq.).

Network Operation

About this time, you may find that you are enjoying this type of operating activity and want to know more about it, and to increase your proficiency. Many amateurs are happily "addicted" to traffic handling after only one or two brief exposures to it. Most traffic nets are at present being conducted by c.w., since this mode of

THE AMERICAN RADIO RELAY LEAGUE		RADIOGRAM	
Via Amateur Radio			
TO	FROM	DATE	TIME
TO	FROM	DATE	TIME
PLEASE LET US KNOW YOUR PLANS FOR SOONER VISIT STOP LOVE			
RITA			
RECD	FORWARDED	DATE	TIME
SENT	RECAL	DATE	TIME

Here is an example of a plain-language message in correct ARRL form. The preamble is always sent as shown: number, station of origin, check, place of origin, time filed, date.

communication seems to be more popular for record purposes — but this does not mean that high code speed is a necessary prerequisite to working in traffic networks. There are many nets organized specifically for the slow-speed amateur, and most of the so-called “fast” nets are usually glad to slow down to accommodate slower operators, especially those nets at state or section level.

The significant facet of net operation, however, is that code speed alone does *not* make for efficiency — sometimes quite the contrary! A high-speed operator who does not know net procedure can “foul up” a net much more completely and more quickly than can a slow operator. It is a proven fact that a bunch of high-speed operators who are not “savvy” in net operation cannot accomplish as much during a specified period as an equal number of slow operators who *know* net procedure. Don't let low code speed deter you from getting into traffic work. Given a little time, your speed will reach the point where you can compete with the best of them. Concentrate first on learning net procedure, for most traffic nowadays is handled on nets.

Much traffic is also being handled on phone nowadays. This mode is exceptionally well suited to short-range traffic work and requires knowledge of phonetics and procedure peculiar to voice operation. Procedure is of paramount importance on phone, since the public may be listening. The major problem, of course, is QRM.

Teamwork is the theme of net operation. The net which functions most efficiently is the net in which all participants are thoroughly familiar with the procedure used, and in which operators refrain from transmitting except at the direction of the net control station, and do not occupy time with extraneous comments, even exchange of pleasantries. There is a time and place for everything. When a net is in session it should concentrate on handling traffic until all traffic is cleared. Before or after the net is the time for rag-chewing and discussion. Some details of net operation are included in *Operating an Amateur Radio Station*, mentioned earlier, but the whole story cannot be told. There is no substitute for actual participation.

Emergency Communication

One of the most important ways in which the amateur serves the public, thus making his existence a national asset, is by his preparation for and his participation in communications emergencies. Every amateur, regardless of the extent of his normal operating activities, should give some thought to the possibility of his being the only means of communication should his community be cut off from the outside world. It has happened many times, often in the most unlikely places; it has happened without warning, finding some amateurs totally unprepared; it can happen to *you*. Are you ready?

There are two principal ways in which any amateur can prepare himself for such an eventuality. One is to provide himself with equip-

The National Traffic System

To facilitate and speed the movement of message traffic, there is in existence an integrated national system by means of which originated traffic will normally reach its destination area the same day the message is originated. This system uses the local section net as a basis. Each section net sends a representative to a “regional” net (normally covering a call area) and each “regional” net sends a representative to an “area” net (normally covering a time zone). After the area net has cleared all its traffic, its members then go back to their respective regional nets, where they clear traffic to the various section net representatives. By means of connecting schedules between the area nets, traffic can flow both ways so that traffic originated on the West Coast reaches the East Coast with a maximum of dispatch, and vice versa. In general local section nets function at 1900, regional nets at 1945, area nets at 2030 and the same or different regional personnel again at 2130. Some section nets conduct a late session at 2200 to effect traffic delivery the same night. Local standard time is referred to in each case.

The NTS plan somewhat spreads traffic opportunity so that casual traffic may be reported into nets for efficient handling one or two nights per week, early or late; or the ardent traffic man can operate in *both* early and late groups and in between to roll up impressive totals and speed traffic reliably to its destination. Old-time traffic men who prefer a high degree of organization and teamwork have returned to the traffic game as a result of the new system. Beginners have shown more interest in becoming part of a system nationwide in scope, in which *anyone* can participate. The National Traffic System has vast and intriguing possibilities as an amateur service. It is open to any amateur who wishes to participate.

The above is but the briefest résumé of what is of necessity a rather complicated arrangement of nets and schedules. Complete details of the System and its operation are available to anyone interested. Just drop a line to ARRL Headquarters.

ment capable of operating on any type of emergency power (i.e., either a.c. or d.c.), and equip-



ment which can readily be transported to the scene of disaster. Mobile equipment is especially desirable in most emergency situations.

Such equipment, regardless of its elaborateness or modernness, is of little use, however, if it is not used properly and at the right times; and so another way for an amateur to prepare himself for emergencies, by no means less important than the first, is to *learn to operate efficiently*. There are many amateurs who feel that they know how to operate efficiently who find themselves considerably handicapped at the crucial time by not knowing proper procedure, by being unable due to years of casual amateur operation to adapt themselves to snappy, abbreviated transmissions, and by being unfamiliar with message form and routing procedures. It is dangerous to overrate your ability in this respect: it is far better to assume that you have much to learn.

In general it can be said that there is more emergency equipment available than there are operators who know properly how to operate during emergency conditions, for such conditions require clipped, terse procedure with complete break-in on c.w. and fast push-to-talk on phone. The casual rag-chewing aspect of amateur radio, however enjoyable and worth-while in its place, must be forgotten at such times in favor of the business at hand. There is only one way to gain experience in this type of operation, and that is by practicing it. During an emergency is no time for practice; it should be done beforehand, as often as possible, on a regular basis.

This leads up to the necessity for emergency organization and preparedness. ARRL has long recognized this necessity and has provided for it. The Section Communications Manager (whose

address appears on page 6 of any recent issue of *QST*) is empowered to appoint certain qualified amateurs in his section for the purpose of coordinating emergency communication organization and preparedness in specified areas or communities. This appointee is known as an Emergency Coordinator for the city or town. One is specified for each community. For coordination and promotion at section level a Section Emergency Coordinator arranges for and recommends the appointments of various Emergency Coordinators at activity points throughout the section. Emergency Coordinators organize amateurs in their communities according to local needs for emergency communication facilities.

The community amateurs taking part in the local organization are members of the Amateur Radio Emergency Corps (AREC). All amateurs are invited to register in the AREC, whether they are able to play an active part in their local organization or only a supporting rôle. Application blanks are available from your EC, SEC, SCM or direct from ARRL Headquarters. In the event that inquiry reveals no Emergency Coordinator appointed for your community, your SCM would welcome a recommendation either from yourself or from a radio club of which you are a member. By holding an amateur operator license, you have the responsibility both to your community and to amateur radio to uphold the traditions of the service.

Among the League's publications is a booklet entitled *Emergency Communications*. This booklet, while small in size, contains a wealth of information on AREC organization and functions and is invaluable to any amateur participating in emergency or civil defense work. It is free to AREC members and should be in every ama-

Before Emergency

PREPARE yourself by providing a transmitter-receiver setup together with an emergency power source upon which you can depend.

TEST both the dependability of your emergency equipment and your own operating ability in the annual ARRL Simulated Emergency Test and the several annual on-the-air contests, especially Field Day.

REGISTER your facilities and your availability with your local ARRL Emergency Coordinator. If your community has no EC, contact your local civic and relief agencies and explain to them what the Amateur Service offers the community in time of disaster.

In Emergency

LISTEN before you transmit. Never violate this principle.

REPORT at once to your Emergency Coordinator so that he will have up-to-the-minute data on the facilities available to him. Work with local civic and relief agencies as the EC suggests, offer these agencies your services directly in the absence of an EC.

RESTRICT all on-the-air work in accordance with FCC regulations, Sec. 12.156, whenever FCC "declares" a state of communications emergency.

QRRR is the official ARRL "land SOS," a distress call for emergency only. It is for use *only* by a station seeking assistance.

RESPECT the fact that the success of the amateur effort in emergency depends largely on circuit discipline. The established Net Control Station should be the supreme authority for priority and traffic routing.

COOPERATE with those we serve. Be ready to help, but stay off the air unless there is a specific job to be done that you can handle more efficiently than any other station.

COPY all bulletins from WIAW. During time of emergency special bulletins will keep you posted on the latest developments.

After Emergency

REPORT to ARRL Headquarters as soon as possible and as fully as possible so that the Amateur Service can receive full credit. Amateur Radio has won glowing public tribute in many major disasters since 1919. Maintain this record.

teur's shack. Drop a line to the ARRL Communications Department if you want a copy, or use the coupon at the end of this chapter.

The Radio Amateur Civil Emergency Service

In order to be prepared for any eventuality, FCC and the Federal Civil Defense Administration (FCDA), in collaboration with ARRL, have promulgated the Radio Amateur Civil Emergency Service. RACES is a temporary peacetime service, intended primarily to serve civil defense and to continue operation during any extreme national emergency, such as war. It shares certain segments of frequencies with the regular Amateur Service on a nonexclusive basis. Its regulations have been made a sub-part of the familiar amateur regulations; that is, the present regulations have become sub-part A, the new RACES regulations being added as sub-part B. Copies of both parts are included in the latest edition of the ARRL *License Manual*.

If every amateur participated, we would still be far short of the total operating personnel required properly to implement RACES. As the service which bears the responsibility for the successful implementation of this important new function, we face not only the task of installing (and in some cases building) the necessary equipment, but also of the training of thousands of additional people. This can and should be a

function of the local unit of the Amateur Radio Emergency Corps under its EC and his assistants, working in close collaboration with the local civil defense organization.

The first step in organizing RACES locally is the appointment of a Radio Officer by the local civil defense director, possibly on the recommendation of his communications officer. A complete and detailed communications plan must be approved successively by local, state and FCDA regional directors, by the FCDA National office, and by FCC. Once this has been accomplished, applications for station authorizations under this plan can be submitted direct to FCC. *QST* will carry further information from time to time, and ARRL will keep its field officials fully informed by bulletins as the situation requires. A complete bibliography of *QST* articles dealing with the subject of civil defense and RACES is available upon request from the ARRL Communications Department.

In the event of war, civil defense will place great reliance on RACES for radio communications. RACES is an Amateur Service. Its implementation is logically a function of the Amateur Radio Emergency Corps — an *additional* function in peacetime, but probably an exclusive function in wartime. Therefore, your best opportunity to be of service will be to register with your local EC, and to participate *actively* in the local AREC/RACES program.

ARRL Operating Organization

Amateur operation must have point and constructive purpose to win public respect. Each individual amateur is the ambassador of the entire fraternity in his public relations and attitude toward his hobby. ARRL field organization addspoint and purpose to amateur operating.

The Communications Department of the League is concerned with the practical operation of stations in all branches of amateur activity. Appointments or awards are available for rag-chewer, traffic enthusiast, phone operator, DX man and experimenter.

There are seventy-three ARRL Sections in the League's field organization, which embraces the United States, Canada and certain other territory. Operating affairs in each Section are supervised by a Section Communications Manager elected by members in that section for a two-year term of office. Organization appointments are made by the section managers, elected as provided in the Rules and Regulations of the Communications Department, which accompany the League's By-Laws and Articles of Association. Section communications managers' addresses for all sections are given in full in each issue of *QST*. SCMs welcome monthly activity reports from all amateur stations in their jurisdiction.

Whether your activity embraces phone or telegraphy, or both, there is a place for you in League organization.

● LEADERSHIP POSTS

To advance each type of station work and group interest in amateur radio, and to develop practical communications plans with the greatest success, appointments of leaders and organizers in particular single-interest fields are made by SCMs. Each leadership post is important. Each provides activities and assistance for appointee groups and individual members along the lines of natural interest. Some posts further the general ability of amateurs to communicate efficiently at all times, by pointing activity toward networks and round tables, others are aimed specifically at establishment of provisions for organizing the amateur service as a stand-by communications group to serve the public in disaster, civil defense need or emergency of any sort. The SCM appoints the following in accordance with section needs and individual qualifications:

- PAM Phone Activities Manager. Organizes activities for OPSs and voice operators in his section. Promotes phone nets and recruits OPSs.
- RM Route Manager. Organizes and coordinates c.w. traffic activities. Supervises and promotes nets and recruits ORSs.
- SEC Section Emergency Coordinator. Promotes and administers section emergency radio organization.
- EC Emergency Coordinator. Organizes amateurs of a community or other area for emergency radio service; maintains liaison with officials and agencies served; also with other local communication facilities.

STATION APPOINTMENTS

ARRL's field organization has a place for every active amateur who has a station. The Communications Department organization exists to increase individual enjoyment and station effectiveness in amateur radio work, and we extend a cordial invitation to every amateur to participate fully in the activities and to apply to the SCM for one of the following station appointments. ARRL Membership and the General Class license or VE equivalent is prerequisite to appointments, except OPS is available to Novice/Technician grades.

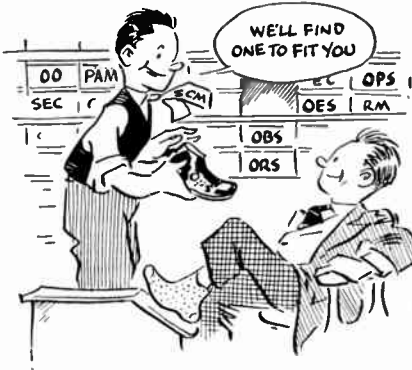

- OPS Official Phone Station. Sets high voice operating standards and procedures, furthers phone nets and traffic.
- ORS Official Relay Station. Traffic service, operates c.w. nets; noted for 15 w.p.m. and procedure ability.
- OBS Official Bulletin Station. Transmits ARRL and FCC bulletin information to amateurs.
- OES Official Experimental Station. Experimental operating, collects and reports v.h.f.-u.h.f.-s.h.f. propagation data, may engage in facsimile, TT, TV, etc., experiments working on 50 Mc. and/or above.
- OO Official Observer. Sends cooperative notices to amateurs to assist in frequency observance, insures high-quality signals, and prevents FCC trouble.

Emblem Colors

Members wear the emblem with black-enamel background. A red background for an emblem will indicate that the wearer is SCM. SECs, ECs, RMs, PAMs may wear the emblem with green background. Observers and all station appointees are entitled to wear blue emblems.

SECTION NETS

Amateurs can add much experience and pleasure to their own amateur lives, and substance and accomplishment to the credit of all of amateur radio, when organized into effective inter-connection of cities and towns.

The successful operation of a net depends a lot on the Net Control Station. This station should be chosen carefully and be one that will not hesitate to enforce each and every net rule and set the example in his own operation.

A progressive net grows, obtaining new members both directly and through other net members. Bulletins may be issued at intervals to keep in direct contact with the members regarding

general net activity, to keep tab on net procedure, make suggestions for improvement, keep track of active members and weed out inactive ones.

A National Traffic System is sponsored by ARRL to facilitate the over-all expeditious relay and delivery of message traffic. The system recognizes the need for handling traffic beyond the section-level networks that have the popular support of both phone and c.w. groups (OPS and ORS) throughout the League's field organization. Area and regional provisions for NTS are furthered by Headquarters correspondence. The ARRL Net Directory, revised in December each year, includes the frequencies and times of operation of the hundreds of different nets operating on amateur band frequencies.

Radio Club Affiliation

ARRL is pleased to grant affiliation to any amateur society having (1) at least 51% of the voting club membership as full members of the League, and (2) at least 51% of members government-licensed radio amateurs. In high school radio clubs bearing the school name, the first above requirement is modified to require one full member, ARRL, in the club. Where a society has common aims and wishes to add strength to that of other club groups and strengthen amateur radio by affiliation with the national amateur organization, a request addressed to the Communications Manager will bring the necessary forms and information to initiate the application for affiliation. Such clubs receive field-organization bulletins and special information at intervals for posting on club bulletin boards or for relay to their memberships. A travel plan providing communications, technical and secretarial contact from the Headquarters is worked out seasonally to give maximum benefits to as many as possible of the several hundred active affiliated radio clubs. Papers on club work, suggestions for organizing, for constitutions, for radio courses of study, etc., are available on request.

Club Training Aids

One section of the ARRL Communications Department handles the Training Aids Program. This program is a service to ARRL affiliated clubs. Material is aimed at education, training and entertainment of club members. Interesting quiz material is available.

Training Aids include such items as motion-picture films, film strips, slides, and lecture outlines. Also, code-proficiency training equipment such as recorders, tape transmitters and tapes will be loaned when such items are available.

All Training Aids materials are loaned free (except for shipping charges) to ARRL affiliated clubs. Numerous groups use this ARRL service to good advantage. If your club is affiliated but has not yet taken advantage of this service, you are missing a good chance to add the available features to your meeting programs and general club activities. Watch club bulletins and *QST* or write the ARRL Communications Department for full details.

● WIAW

The Maxim Memorial Station, WIAW, is dedicated to fraternity and service. Operated by the League headquarters, WIAW is located about four miles south of the Headquarters offices on a seven-acre site. The station is on the air daily, except holidays, and available time is divided between different bands and modes.



Telegraph and phone transmitters are provided for all bands from 1.8 to 144 Mc. The normal frequencies in each band for c.w. and

voice transmissions are as follows: 1885, 3555, 3945, 7080, 7255, 14,100, 14,280, 21,010, 21,330, 28,060, 28,768, 50,900 and 145,600 kc. Operating-visiting hours and the station schedule are listed every other month in *QST*.

Operation is roughly proportional to amateur interest in different bands and modes, with one kw, except on 160 and v.h.f. bands. WIAW's daily bulletins and code practice aim to give operational help to the largest number.

All amateurs are invited to visit WIAW, as well as to work the station from their own shacks. The station was established to be a living memorial to Hiram Percy Maxim and to carry on the work and traditions of amateur radio.

● OPERATING ACTIVITIES

Within the ARRL field organization there are several special activities. The first Saturday and Sunday of each month is set aside for all ARRL officials, officers and directors to get together over the air from their own stations. This activity is known to the gang as the LO party. For all appointees, other quarterly tests are scheduled to develop operating ability and a spirit of fraternalism.

In addition to these special activities for appointees and members, ARRL sponsors various other activities open to all amateurs. The DX-minded amateur may participate in the Annual ARRL International DX Competition during February and March. This popular contest may bring you the thrill of working new countries. Then there is the ever-popular Sweepstakes in November. Of domestic scope, the SS affords the opportunity to work new states for that WAS award. A Novice activity is planned annually. The interests of v.h.f. enthusiasts are also provided for in special activities planned by ARRL.

As in all our operating, the idea of having a good time is combined in the Annual Field Day with the more serious thought of preparing ourselves to render public service in times of emergency. A premium is placed on the use of equip-

ment without connection to commercial power sources. Clubs and individual groups always have a good time in the "FD," learn much about the requirements for operating under knockabout conditions afield.

ARRL contest activities are diversified to appeal to all operating interests, and will be found announced in detail in issues of *QST* preceding the different events

● AWARDS

The League-sponsored operating activities heretofore mentioned have useful objectives and provide much enjoyment for members of the fraternity. Achievement in amateur radio is recognized by various certificates offered through the League and detailed below.

WAS Award

WAS means "Worked All States." This award is available regardless of affiliation or nonaffiliation with any organization. Here are the rules to follow in applying for WAS:

1) Two-way communication must be established on the amateur bands with each of the states; any and all amateur



bands may be used. A card from the District of Columbia may be submitted in lieu of one from Maryland.

2) Contacts with all states must be made from the same location. Within a given community one location may be defined as from places no two of which are more than 25 miles apart.

3) Contacts may be made over any period of years, and may have been made any number of years ago, provided only that all contacts are from the same location.

4) QSL cards, or other written communications from stations worked confirming the necessary two-way contacts, must be submitted by the applicant to ARRL headquarters.

5) Sufficient postage must be sent with the confirmations to finance their return. No correspondence will be returned unless sufficient postage is furnished.

6) The WAS award is available to all amateurs.

7) Address all applications and confirmations to the Communications Department, ARRL, 38 La Salle Road, West Hartford, Conn.

DX Century Club Award

Here are the rules under which the DX Century Club Award will be issued to amateurs who have worked and confirmed contact with 100 countries in the postwar period. If you worked fewer than 100 countries before the war and have since worked and confirmed a sufficient number to make the 100 mark, the DXCC is still available to you under the rules detailed on page 73 of March, 1956, *QST*.

1) The Century Club Award Certificate for confirmed contacts with 100 or more countries is available to all amateurs everywhere in the world.

2) Confirmations must be submitted direct to ARRL headquarters for all countries claimed. Claims for a total of 100 countries must be included with first application. Confirmation from foreign contest logs may be requested in the case of the ARRL International DX Competition only, subject to the following conditions:

a) Sufficient confirmations of other types must be submitted so that these, plus the DX Contest confirmations, will total 100. In every case, Contest confirmations must not be requested for any countries from which the applicant has regular confirmations. That is, contest confirmations will be granted only in the case of countries from which applicants have no regular confirmations.

b) Look up the contest results as published in *QST* to see if your man is listed in the foreign scores. If he isn't, he did not send in a log and no confirmation is possible.

c) Give year of contest, date and time of QSO.

d) In future DX Contests do not request confirmations until after the final results have been published, usually in one of the early fall issues. Requests before this time must be ignored.

3) The ARRL Countries List, printed periodically in *QST*, will be used in determining what constitutes a "country." The Miscellaneous Data chapter of this *Handbook* contains the Postwar Countries List.

4) Confirmations must be accompanied by a list of claimed countries and stations to aid in checking and for future reference.

5) Confirmations from additional countries may be submitted for credit each time ten additional confirmations are available. Endorsements for affixing to certificates and showing the new confirmed total (110, 120, 130, etc.) will be awarded as additional credits are granted. ARRL DX Competition logs from foreign stations may be utilized for these endorsements, subject to conditions stated under (2).

6) All contacts must be made with amateur stations working in the authorized amateur bands or with other stations licensed to work amateurs.

7) In cases of countries where amateurs are licensed in the normal manner, credit may be claimed only for stations using regular government-assigned call letters. No credit may be claimed for contacts with stations in any country in which amateurs have been temporarily closed down by special government edict where amateur licenses were formerly issued in the normal manner.

8) All stations contacted must be "land stations" . . . contacts with ships, anchored or otherwise, and aircraft, cannot be counted.

9) All stations must be contacted from the same call area, where such areas exist, or from the same country in cases where there are no call areas. One exception is allowed to this rule: where a station is moved from one call area to another, or from one country to another, all contacts must be made from within a radius of 150 miles of the initial location.

10) Contacts may be made over any period of years from November 15, 1945, provided only that all contacts be made under the provisions of Rule 9, and by the same station licensee; contacts may have been made under different call letters in the same area (or country), if the licensee for all was the same.

11) All confirmations must be submitted exactly as received from the stations worked. Any altered or forged confirmations submitted for CC credit will result in disqualification of the applicant. The eligibility of any DXCC applicant who was ever barred from DXCC to reapply, and the conditions for such application, shall be determined by the Awards Committee. Any holder of the Century Club Award submitting forged or altered confirmations must forfeit his right to be considered for further endorsements.

12) OPERATING ETHICS: Fair play and good sportsmanship in operating are required of all amateurs working toward the DX Century Club Award. In the event of specific objections relative to continued poor operating ethics an individual may be disqualified from the DXCC by action of the ARRL Awards Committee.

13) Sufficient postage for the return of confirmations must be forwarded with the application. In order to insure the safe return of large batches of confirmations, it is suggested that enough postage be sent to make possible their return by first-class mail, registered.

14) Decisions of the ARRL Awards Committee regard-

ing interpretation of the rules as here printed or later amended shall be final.

15) Address all applications and confirmations to the Communications Department, ARRL, 38 La Salle Road, West Hartford 7, Conn.

WAC Award

The International Amateur Radio Union issues WAC (Worked All Continents) certificates to members of member-societies who submit proof of two-way communication with one station on each of the six continents. Foreign amateurs submit their proof direct to member-societies of the IARU. U.S. and Canadian amateurs must be members of the League, and should make application to ARRL, headquarters society of the Union. Amateurs residing in countries not represented in the Union may apply to ARRL, and enclose .50, or 6 IRC's, A c.w. and a phone certificate are available. The c.w. certificate will be issued for all c.w., or a combination of phone and c.w. confirmations. Special endorsements are available for 3.5 Mc., and s.s.b.

Code Proficiency Award

Many hams can follow the general idea of a contact "by ear" but when pressed to "write it down" they "mull" the copy. The Code Proficiency Award invites every amateur to prove himself as a proficient operator, and sets up a system of awards for step-by-step gains in copying proficiency. It enables every amateur to check his code proficiency, to better that proficiency, and to receive a certification of his receiving speed.

This program is a whale of a lot of fun. The League will give a certificate to any licensed radio amateur who demonstrates that he can copy perfectly, for at least one minute, plain-language Continental code at 10, 15, 20, 25, 30 or 35



words per minute, as transmitted during special monthly transmissions from W1AW and W6OWP.

As part of the ARRL Code Proficiency program W1AW transmits plain-language practice material each evening at speeds from 5 to 35 w.p.m. All amateurs are invited to use these transmissions to increase their code-copying ability. Non-amateurs are invited to utilize the lower speeds, 5, 7½ and 10 w.p.m., which are transmitted for the benefit of persons studying the code in preparation for the amateur license

examination. Refer to any issue of *QST* for details of the practice schedule.

Rag Chewers Club

The Rag Chewers Club is designed to encourage friendly contacts and discourage the "hello-good-by" type of QSO. Its purpose is to bond together operators interested in honest-to-goodness rag-chewing over the air. Membership certificates are available.

How To Get in: (1) Chew the rag with a member of the club for at least a solid half hour. This does not mean a half hour spent in trying to get a message over through bad QRM or QRN, but a solid half hour of conversation or message handling. (2) Report the conversation by card to The Rag Chewers Club, ARRL, Communications Department, West Hartford, Conn., and ask the member station you talk with to do the same. When both reports are received you will be sent a membership certificate entitling you to all the privileges of a Rag Chewer.

How To Stay in: (1) Be a conversationalist on the air instead of one of those tongue-tied infants who don't know any words except "cuagn" or "cul," or "QRU" or "nil." Talk to the fellows you work with and get to know them. (2) Operate your station in accordance with the radio laws and ARRL practice. (3) Observe rules of courtesy on the air. (4) Sign "RCC" after each call so that others may know you can talk as well as call.

A-1 Operator Club

The A-1 Operator Club should include in its ranks every good operator. To become a member, one must be nominated by at least two operators who already belong. General keying or voice technique, procedure, copying ability, judgment and courtesy all count in rating candidates under the club rules detailed at length in *Operating an Amateur Radio Station*. Aim to make yourself a fine operator, and one of these days you may be pleasantly surprised by an invitation to belong to the A-1 Operator Club, which carries a worth-while certificate in its own right.

Brass Pounders League

Every individual reporting more than a specified minimum in official monthly traffic totals is given an honor place in the *QST* listing known as the Brass Pounders League and a certificate

to recognize his performance is furnished by the SCM. In addition, a *BPL Traffic Award* (medal) is given to individual amateurs working at their own stations after the third time they "make BPL" by reports duly reported through the SCM and reported for *QST*.

The value to amateurs in operator training, and the utility of amateur message handling to the members of the fraternity itself as well as to the general public, make message-handling work of prime importance to the fraternity. Fun, enjoyment, and the feeling of having done something really worth while for one's fellows is accentuated by pride in message files, records, and letters from those served.

Old Timers Club

The Old Timers Club is open to anyone who holds an amateur call at the present time, and who held an amateur license (operator or station) 20-or-more years ago. Lapses in activity during the intervening years are permitted.

If you can qualify as an "Old Timer," send us a brief chronology of your ham career, being sure to indicate the date of your first amateur license, and your present call. If the evidence submitted proves you eligible for the OTC, you will be added to the roster and will receive a membership certificate.

● INVITATION

Amateur radio is capable of giving enjoyment, self-training, social and organization benefits in proportion to what the individual amateur puts into his hobby. All amateurs are invited to become ARRL members, to work toward awards, and to accept the challenge and invitation offered in field-organization appointments. Drop a line to ARRL Headquarters for the booklet *Operating an Amateur Radio Station*, which has detailed information on the field-organization appointments and awards. Accept today the invitation to take full part in all League activities and organization work.

CONELRAD COMPLIANCE

FCC has promulgated additional rules for the Amateur Service concerned with observance of certain requirements in the event of enemy attack. These rules are contained in the ARRL *License Manual* as part of the amateur regulations, Sections 12.190 through 12.196. Read them. They concern you.

Amateurs are required to *shut down* when a Conelrad Radio Alert is indicated. FCC requires monitoring, by some means, of a broadcast station while you operate. By use of proper equipment, each amateur can make his Conelrad compliance routine and almost automatic. You will find descriptions of such devices, most of them quite simple, elsewhere in this *Handbook*.

Amateur Conelrad rules are effective and mandatory as of January 2, 1957.



► *Operating an Amateur Radio Station* covers the details of practical amateur operating. In it you will find information on Operating Practices, Emergency Communication, ARRL Operating Activities and Awards, the ARRL Field Organization, Handling Messages, Network Organization, "Q" Signals and Abbreviations used in amateur operating, important extracts from the FCC Regulations, and other helpful material. It's a handy reference that will serve to answer many of the questions concerning operating that arise during your activities on the air.

► *Emergency Communications* is the "bible" of the Amateur Radio Emergency Corps. Within its eight pages are contained the fundamentals of emergency communication which every amateur interested in public service work should know, including a complete diagrammatical plan adaptable for use in any community, explanation of the role of the American Red Cross and FCC's regulations concerning amateur operation in emergencies. The Radio Amateur Civil Emergency Service (RACES) comes in for special consideration, including a complete table of RACES frequencies on the front cover. If you don't already have an up-to-date copy of this manual, we suggest you take steps to obtain one immediately.

The two publications described above may be obtained without charge by any *Handbook* reader. Either or both will be sent upon request.

AMERICAN RADIO RELAY LEAGUE
 38 La Salle Road
 West Hartford 7, Connecticut, U. S. A.

Please send me, without charge, the following:

- OPERATING AN AMATEUR RADIO STATION**
- EMERGENCY COMMUNICATIONS**

Name.....
 (Please Print)

Address.....

.....

Miscellaneous Data

● Q SIGNALS

Given below are a number of Q signals whose meanings most often need to be expressed with brevity and clearness in amateur work. (Q abbreviations take the form of questions only when each is sent followed by a question mark.)

- QRG Will you tell me my exact frequency (or that of.....)? Your exact frequency (or that of.....) is.....ke.
- QRH Does my frequency vary? Your frequency varies.
- QRI How is the tone of my transmission? The tone of your transmission is..... (1. Good; 2. Variable; 3. Bad).
- QRK What is the readability of my signals (or those of.....)? The readability of your signals (or those of.....) is..... (1. Unreadable; 2. Readable now and then; 3. Readable but with difficulty; 4. Readable; 5. Perfectly readable).
- QRL Are you busy? I am busy (or I am busy with.....). Please do not interfere.
- QRM Are you being interfered with? I am interfered with.
- QRN Are you troubled by static? I am being troubled by static.
- QRQ Shall I send faster? Send faster (..... words per min.).
- QRS Shall I send more slowly? Send more slowly (.... w.p.m.).
- QRT Shall I stop sending? Stop sending.
- QRU Have you anything for me? I have nothing for you.
- QRV Are you ready? I am ready.
- QRW Shall I tell.....that you are calling him on.....ke.? Please inform.....that I am calling him on.....ke.
- QRX When will you call me again? I will call you again at.....hours (on.....ke.).
- QRZ Who is calling me? You are being called by..... (on.....ke.).
- QSA What is the strength of my signals (or those of.....)? The strength of your signals (or those of.....) is..... (1. Scarcely perceptible; 2. Weak; 3. Fairly good; 4. Good; 5. Very good).
- QSB Are my signals fading? Your signals are fading.
- QSD Is my keying defective? Your keying is defective.
- QSG Shall I send.....messages at a time? Send..... messages at a time
- QSL Can you acknowledge receipt? I am acknowledging receipt.
- QSM Shall I repeat the last message which I sent you, or some previous message? Repeat the last message which you sent me (or message(s) number(s).....).
- QSO Can you communicate with.....direct or by relay? I can communicate with.....direct (or by relay through.....).
- QSP Will you relay to.....? I will relay to....
- QSV Shall I send a series of Vs on this frequency (or.....ke.)? Send a series of Vs on this frequency (or.....ke.).
- QSW Will you send on this frequency (or on.....ke.)? I am going to send on this frequency (or on.....ke.).
- QSX Will you listen to.....on.....ke.? I am listening to.....on.....ke.

- QSY Shall I change to transmission on another frequency? Change to transmission on another frequency (or on.....ke.).
- QSZ Shall I send each word or group more than once? Send each word or group twice (or.....time-).
- QTA Shall I cancel message number.....as if it had not been sent? Cancel message number.....as if it had not been sent.
- QTB Do you agree with my counting of words? I do not agree with your counting of words; I will repeat the first letter or digit of each word or group.
- QTC How many messages have you to send? I have.... messages for you (or for.....).
- QTH What is your location? My location is.....
- QTR What is the exact time? The time is.....

Special abbreviations adopted by ARRL:

- QST General call preceding a message addressed to all amateurs and ARRL members. This is in effect "CQ ARRL."
- QRRR Official ARRL "land SOS." A distress call for emergency use only by a station in an emergency situation.

THE R-S-T SYSTEM

READABILITY

- 1 — Unreadable.
- 2 — Barely readable, occasional words distinguishable.
- 3 — Readable with considerable difficulty.
- 4 — Readable with practically no difficulty.
- 5 — Perfectly readable.

SIGNAL STRENGTH

- 1 — Faint signals, barely perceptible.
- 2 — Very weak signals.
- 3 — Weak signals.
- 4 — Fair signals.
- 5 — Fairly good signals.
- 6 — Good signals.
- 7 — Moderately strong signals.
- 8 — Strong signals.
- 9 — Extremely strong signals.

TOPE

- 1 — Extremely rough hissing note.
- 2 — Very rough a.e. note, no trace of musicality.
- 3 — Rough low-pitched a.e. note, slightly musical.
- 4 — Rather rough a.e. note, moderately musical.
- 5 — Musically-modulated note.
- 6 — Modulated note, slight trace of whistle.
- 7 — Near d.e. note, smooth ripple.
- 8 — Good d.e. note, just a trace of ripple.
- 9 — Purest d.e. note.

If the signal has the characteristic steadiness of crystal control, add the letter X to the RST report. If there is a chirp, the letter C may be added to so indicate. Similarly for a click, add K. The above reporting system is used on both c.w. and voice, leaving out the "tone" report on voice.

A.R.R.L. COUNTRIES LIST • Official List for ARRL DX Contest and the Postwar DXCC

AC3	Sikkim	KC4	(See CE9)	VP4	Trinidad & Tobago
AC4	Tibet	KC4	Navassa Island	VP5	Cayman Islands
AC5	Bhutan	KC6	Eastern Caroline Islands	VP5	Jamaica
AP	Pakistan	KC6	Western Caroline Islands	VP5	Turks & Caicos Islands
BV (C3)	Formosa	KG1	(See OX)	VP6	Barbados
C (unofficial)	China	KG4	Guantanamo Bay	VP7	Bahama Islands
C3	(See BV)	KG6	Mariana Islands	VP8	(See CE9)
CE	Manchuria	KH6	Hawaiian Islands	VP8	Falkland Islands
CE	Chile	KJ6	Johnston Island	VP8, LU-Z	South Georgia
CE9, KC4, LU-Z, VK1, VP8	Antarctica	KL7	Alaska	VP8, LU-Z	South Orkney Islands
CE9	Easter Island	KM6	Midway Islands	VP8, LU-Z	South Sandwich Islands
CM, CO	Cuba	KP4	Puerto Rico	VP8, LU-Z	South Shetland Islands
CN2, KT1	Tangier Zone	KP6	Palmyra Group, Jarvis Island	VP9	Bermudas
CN8	French Morocco	KR6	Ryukyu Islands (e.g., Okinawa)	VQ1	Zanzibar
CP	Bolivia	KS4	Swan Island	VQ2	Northern Rhodesia
CR4	Cape Verde Islands	KS6	American Samoa	VQ3	Tanganyika Territory
CR5	Portuguese Guinea	KT1	(See CN2)	VQ4	Kenya
CR5	Principe, Sao Thome	KV4	Virgin Islands	VQ5	Uganda
CR6	Angola	KW6	Wake Island	VQ6	British Somaliland
CR7	Mozambique	KX6	Marshall Islands	VQ8	Chagos Islands
CR8	Goa (Portuguese India)	KZ5	Canal Zone	VQ8	Mauritius
CR9	Macao	LA, LB	Jan Mayen	VQ9	Seychelles
CR10	Portuguese Timor	LA, LB	Norway	VR1	British Phoenix Islands
CT1	Portugal	LA, LB	Svalbard (Spitzbergen)	VR1	Gilbert & Ellice Islands & Ocean Island
CT2	Azores	LU	Argentina	VR2	Fiji Islands
CT3	Madeira Islands	LU-Z	(See CE9, VP8)	VR3	Fanning & Christmas Islands
CX	Uruguay	LX	Luxembourg	VR4	Solomon Islands
DJ, DL, DM	Germany	LZ	Bulgaria	VR5	Tonga (Friendly) Islands
DU	Philippine Islands	M1	San Marino	VR6	Pitcairn Island
EA	Spain	MP4	Bahrain Island	VS1	Singapore
EA6	Balearic Islands	MP4	Kuwait	VS2	Malaya
EA8	Canary Islands	MP4	Qatar	VS4	Sarawak
EA9	Ifni	MS4	Trucial Oman	VS5	Brunei
EA9	Rio de Oro	OA	(See I5)	VS6	Hong Kong
EA9	Spanish Morocco	OD5	Peru	VS9	Alden & Socotra
EA9	Spanish Guinea	OE	Lebanon	VS9	Maldives Islands
EI	Republic of Ireland	OH	Austria	VS9	Sultanate of Oman
EL	Liberia	OH0	Finland	VU2	India
EQ	Iran	OK	Aland Islands	VU4	Laccadive Islands
ET2	Eritrea	ON4	Czechoslovakia	VU5	Andaman and Nicobar Islands
ET3	Ethiopia	OQ5, 6	Belgian Congo	W	(See K)
F	France	OX, KG1	Greenland	XE	Mexico
FA	Algeria	OY	Faeroes	XE4	Revilla Gigedo
FB8	Amsterdam & St. Paul Islands	OZ	Denmark	XW8	Laos
FB8	Comoro Islands	PA0	Netherlands	XZ2	Burma
FB8	Kerguelen Islands	PJ2	Netherlands West Indies	YA	Afghanistan
FB8	Madagascar	PJ2M	Sint Maarten	YI	Iraq
FB8	Tromelin Island	PK1, 2, 3	Java	YJ	(See F'U8)
EC	Corsica	PK4	Sumatra	YK	Syria
ED	French Togoland	PK5	Netherlands Borneo	YN	Nicaragua
EE8	French Cameroons	PK6	Celebes & Molucca Islands	YO	Romania
EF8	French West Africa	PX	Andorra	YS	Salvador
EG	Guadeloupe	PY	Brazil	YU	Yugoslavia
EL8	French Indo-China	PZ1	Netherlands Guiana	YV	Venezuela
EK8	New Caledonia	SM	Sweden	YV0	Aves Islands
FL8	French Somaliland	SP	Poland	ZA	Albania
FM	Martinique	ST	Sudan	ZB1	Malta
FN	French India	SU	Egypt	ZB2	Gibraltar
FO8	Clipperton Island	SV	Crete	ZC2	Cocos Island
FO8	French Oceania (e.g., Tahiti)	SV	Dodecanese (e.g., Rhodes)	ZC3	Christmas Island
FP8	St. Pierre & Miquelon Islands	TA	Greece	ZC4	Cyprus
FQ8	French Equatorial Africa	TE	Turkey	ZC5	British North Borneo
FR7	Reunion Island	TF	Iceland	ZC6	Palestine
FS7	Saint Martin	TG	Guatemala	ZC7	(See JY)
FU8, YJ	New Hebrides	TI	Costa Rica	ZD1	Sierra Leone
FW8	Wallis & Futuna Islands	TI9	Cocos Island	ZD2	Nigeria
FY7	French Guiana & Inini	UA1, 3, 4, 6	European Russian Socialist Federated Soviet Republic	ZD3	Gambia
G	England	UA1	Franz Josephland	ZD4	Gold Coast, Togoland
GC	Channel Islands	UA9, 0	Asiatic Russian S.F.S.R.	ZD6	Nyasaland
GD	Isle of Man	UB5	Ukraine	ZD7	St. Helena
GI	Northern Ireland	UC2	White Russian Soviet Socialist Republic	ZD8	Astension Island
GM	Scotland	UD6	Azerbaijan	ZD9	Tristan da Cunha & Gough Islands
GW	Wales	UF6	Georgia	ZE	Southern Rhodesia
HA	Hungary	UG6	Armenia	ZK1	Cook Islands
HBI, 9	Switzerland	UI8	Turkoman	ZK2	Niue
HC	Ecuador	UI8	Uzbek	ZL	Kermadec Islands
HC8	Galapagos Islands	UJ8	Tadzhik	ZL	New Zealand
HE	Liechtenstein	UL7	Kazakh	ZM6	British Samoa
HH	Haiti	UM8	Kirghiz	ZM7	Tokelau (Union) Islands
III	Dominican Republic	UN1	Karelo-Finnish Republic	ZP	Paraguay
HK	Colombia	UO5	Moldavia	ZS1, 2, 4, 5, 6	Union of South Africa
HK0	Archipelago of San Andres and Providencia	UP2	Lithuania	ZS2	Prince Edward & Marion Islands
III	Korea	UQ2	Latvia	ZS3	Southwest Africa
IP	Panama	UR2	Estonia	ZS7	Swaziland
IR	Honduras	VE, VO	Canada	ZS8	Basutoland
IS	Siam	VK	Australia (including Tasmania)	ZS9	Bechuanaland
IV	Vatican City	VK1	(See CE9)	3A	Monaco
IIZ	Saudi Arabia	VK1	Heard Island	3V8	Tunisia
I1	Italy	VK1	Macquarie Island	4S7	Ceylon
I1	Trieste	VK9	Nauru Island	4W1	Yemen
I5	Italian Somaliland	VK9	Norfolk Island	4X4	Israel
IS1	Sardinia	VK9	Papua Territory	5A	Libya
JA, KA	Japan	VK9	Territory of New Guinea	9S4	Saar
JY, ZC7	Jordan	VO	(See VE)		
JZ0	Netherlands New Guinea	VP1	British Honduras		Aldaba Islands
K, W	United States of America	VP2	Leeward Islands		Cambodia
KA	(See JA)	VP2	Windward Islands		Mongolia
KA0	Bonin & Volcano Islands	VP3	British Guiana		Nepal
B6	Baker, Howland & American Phoenix Islands				Viet Nam
					Wrangel Island

INTERNATIONAL PREFIXES

AAA-AIZ	United States of America	SSA-SUZ	Egypt
AMA-AOZ	Spain	SVA-SZZ	Greece
APA-ASZ	Pakistan	TAA-TCZ	Turkey
ATA-AWZ	India	TDA-TDZ	Guatemala
AXA-AXZ	Commonwealth of Australia	TEA-TEZ	Costa Rica
AYA-AZZ	Argentina Republic	TFA-TFZ	Iceland
BAA-BZZ	China	TGA-TGZ	Guatemala
CAA-CEZ	Chile	THA-THZ	France and Colonies and Protectorates
CFA-CKZ	Canada	TIA-TIZ	Costa Rica
CLA-CMZ	Cuba	TJA-TJZ	France and Colonies and Protectorates
CNA-CNZ	Morocco	UAA-UQZ	Union of Soviet Socialist Republics
COA-COZ	Cuba	URA-UTZ	Ukrainian Soviet Socialist Republic
CPA-CPZ	Bolivia	UA-UZZ	Union of Soviet Socialist Republics
CQA-CRZ	Portuguese Colonies	VAA-VGZ	Canada
CNA-CUZ	Portugal	VHA-VNZ	Commonwealth of Australia
CVA-CXZ	Uruguay	VOA-VOZ	Newfoundland
CYA-CZZ	Canada	VPA-VSZ	British Colonies and Protectorates
DAA-DMZ	Germany	VTA-VWZ	India
DNA-DQZ	Belgian Congo	VXA-VYZ	Canada
DRA-DTZ	Bielorussian Soviet Socialist Republic	VZA-VZZ	Commonwealth of Australia
DUA-DZZ	Republic of the Philippines	WAA-WZZ	United States of America
EAA-EHZ	Spain	XAA-XIZ	Mexico
EIA-EJZ	Ireland	XJA-XOZ	Canada
EKA-EKZ	Union of Soviet Socialist Republics	XPA-XPZ	Denmark
ELA-ELZ	Republic of Liberia	XQA-XRZ	Chile
EMA-EOZ	Union of Soviet Socialist Republics	XSA-XSZ	China
EPA-EQZ	Iran	XUA-XUZ	Cambodia
ERA-ERZ	Union of Soviet Socialist Republics	XVA-XVZ	Viet-Nam
ESA-ESZ	Estonia	XWA-XWZ	Laos
ETA-ETZ	Ethiopia	XXA-XXZ	Portuguese Colonies
EUA-EZZ	Union of Soviet Socialist Republics	XYA-XZZ	Burma
FAA-FZZ	France and Colonies and Protectorates	YAA-YAZ	Afghanistan
GAA-GZZ	Great Britain	YBA-YHZ	Indonesia
HAA-HAZ	Hungary	YIA-YIZ	Iraq
HBA-HBZ	Switzerland	YJA-YJZ	New Hebrides
HCA-HDZ	Ecuador	YKA-YKZ	Syria
HEA-HEZ	Switzerland	YLA-YLZ	Latvia
HFA-HFZ	Poland	YMA-YMZ	Turkey
HGA-HGZ	Hungary	YNA-YNZ	Nicaragua
HHA-HHZ	Republic of Haiti	YOA-YRZ	Roumania
HIA-HIZ	Dominican Republic	YSA-YSZ	Republic of El Salvador
HJA-HKZ	Republic of Colombia	YTA-YUZ	Yugoslavia
HLA-HMZ	Korea	YVA-YYZ	Venezuela
HNA-HNZ	Iraq	YZA-YZZ	Yugoslavia
HOA-HPZ	Republic of Panama	ZAA-ZAZ	Albania
HQA-HRZ	Republic of Honduras	ZBA-ZJZ	British Colonies and Protectorates
HSA-HSZ	Siam	ZKA-ZMZ	New Zealand
HTA-HTZ	Nicaragua	ZNA-ZOZ	British Colonies and Protectorates
HUA-HUZ	Republic of El Salvador	ZPA-ZPZ	Paraguay
HVA-HVZ	Vatican City State	ZQA-ZQZ	British Colonies and Protectorates
HWA-HYZ	France and Colonies and Protectorates	ZRA-ZUZ	Union of South Africa
HZA-HZZ	Kingdom of Saudi Arabia	ZVA-ZZZ	Brazil
IAA-IZZ	Italy and Colonies	2AA-2ZZ	Great Britain
JAA-JSZ	Japan	3AA-3AZ	Principality of Monaco
JTA-JVZ	Mongolian People's Republic	3BA-3FZ	Canada
JWA-JXZ	Norway	3GA-3GZ	Chile
JYA-JYZ	Hashimite Kingdom of Jordan	3HA-3UZ	China
JZA-JZZ	Netherlands New Guinea	3VA-3VZ	Tunisia
KAA-KZZ	United States of America	3WA-3WZ	Viet-Nam
LAA-LNZ	Norway	3YA-3YZ	Norway
LOA-LWZ	Argentina Republic	3ZA-3ZZ	Poland
LXA-LXZ	Luxembourg	4AA-4CZ	Mexico
LYA-LYZ	Lithuania	4DA-4IZ	Republic of the Philippines
LZA-LZZ	Bulgaria	4JA-4LZ	Union of Soviet Socialist Republics
MAA-MZZ	Great Britain	4MA-4MZ	Venezuela
NAA-NZZ	United States of America	4NA-4OZ	Yugoslavia
OAA-OCZ	Peru	4PA-4SZ	Ceylon
ODA-OIZ	Republic of Lebanon	4TA-4TZ	Peru
OEA-OEZ	Austria	4UA-4UZ	United Nations
OFA-OJZ	Finland	4VA-4VZ	Republic of Haiti
OKA-OMZ	Czechoslovakia	4WA-4WZ	Yemen
ONA-OTZ	Belgium and Colonies	4XA-4XZ	Israel
OUA-OZZ	Denmark	4YA-4YZ	International Civil Aviation Organization
PAA-PIZ	Netherlands	5AA-5AZ	Libya
PJA-PJZ	Curacao	5CA-5CZ	Morocco
PKA-POZ	Indonesia	5LA-5LZ	Liberia
PPA-PYZ	Brazil	6AA-6ZZ	(Not allocated)
PZA-PZZ	Surinam	7AA-7ZZ	(Not allocated)
QAA-QZZ	(Service abbreviations)	8AA-8ZZ	(Not allocated)
RAA-RZZ	Union of Soviet Socialist Republics	9AA-9AZ	San Marino
SAA-SMZ	Sweden	9NA-9NZ	Nepal
SNA-SRZ	Poland	9SA-9SZ	Saar

ABBREVIATIONS FOR C.W. WORK

Abbreviations help to cut down unnecessary transmission. However, make it a rule not to abbreviate unnecessarily when working an operator of unknown experience.

AA	All after	OB	Old boy
AB	All before	OM	Old man
ABT	About	OP-OPR	Operator
ADR	Address	OSC	Oscillator
AGN	Again	OT	Old timer; old top
ANT	Antenna	PBL	Preamble
BCI	Broadcast interference	PSE-PLS	Please
BCL	Broadcast listener	PWR	Power
BK	Break; break me; break in	PX	Press
BN	All between; been	R	Received as transmitted; are
B4	Before	RAC	Rectified alternating current
C	Yes	RC'D	Received
CFM	Confirm; I confirm	REF	Refer to; referring to; reference
CK	Check	RPT	Repeat; I repeat
CL	I am closing my station; call	SED	Said
CLD-CLG	Called; calling	SEZ	Says
CUD	Could	SIG	Signature; signal
CUL	See you later	SINE	Operator's personal initials or nickname
CUM	Come	SKED	Schedule
CW	Continuous wave	SRI	Sorry
DL'D-DL'VD	Delivered	SVC	Service; prefix to service message
DX	Distance	TFC	Traffic
ECO	Electron-coupled oscillator	TMW	Tomorrow
FB	Fine business; excellent	TNX-TKS	Thanks
GA	Go ahead (or resume sending)	TT	That
GB	Good-by	TU	Thank you
GBA	Give better address	TVI	Television interference
GE	Good evening	TVL	Television listener
GG	Going	TXT	Text
GM	Good morning	UR-URS	Your; you're; yours
GN	Good night	VFO	Variable-frequency oscillator
GND	Ground	VY	Very
GUD	Good	WA	Word after
HI	The telegraphic laugh; hugh	WB	Word before
HR	Here; hear	WD-WDS	Word; words
HV	Have	WKD-WKG	Worked; working
HW	How	WL	Well; will
LID	A poor operator	WUD	Would
MHS	Milliamperes	WX	Weather
MSG	Message; prefix to radiogram	XMTR	Transmitter
N	No	XTAL	Crystal
ND	Nothing doing	YF (XYL)	Wife
NIL	Nothing; I have nothing for you	YL	Young lady
NR	Number	73	Best regards
NW	Now; I resume transmission	88	Love and kisses

W PREFIXES BY STATES

Alabama	W4	Nebraska	W0
Arizona	W7	Nevada	W7
Arkansas	W5	New Hampshire	W1
California	W6	New Jersey	W2
Colorado	W0	New Mexico	W5
Connecticut	W1	New York	W2
Delaware	W3	North Carolina	W4
District of Columbia	W3	North Dakota	W0
Florida	W4	Ohio	W8
Georgia	W4	Oklahoma	W5
Idaho	W7	Oregon	W7
Illinois	W9	Pennsylvania	W3
Indiana	W9	Rhode Island	W1
Iowa	W0	South Carolina	W4
Kansas	W0	South Dakota	W0
Kentucky	W4	Tennessee	W4
Louisiana	W5	Texas	W5
Maine	W1	Utah	W7
Maryland	W3	Vermont	W1
Massachusetts	W1	Virginia	W1
Michigan	W8	Washington	W7
Minnesota	W0	West Virginia	W8
Mississippi	W5	Wisconsin	W9
Missouri	W0	Wyoming	W7
Montana	W7		

● FILTERS

The filter sections shown on the facing page can be used alone or, if greater attenuation and sharper cut-off are required, several sections can be connected in series. In the low- and high-pass filters, f_c represents the cut-off frequency, the highest (for the low-pass) or the lowest (for the high-pass) frequency transmitted without attenuation. In the band-pass filter designs, f_1 is the low-frequency cut-off and f_2 the high-frequency cut-off. The units for L , C , R and f are henrys, farads, ohms and cycles, respectively.

All of the types shown are for use in an unbalanced line (one side grounded), and thus they are suitable for use in coaxial line or any other unbalanced circuit. To transform them for use in balanced lines (e.g., 300-ohm transmission line, or push-pull audio circuits), the series reactances should be equally divided between the two legs. Thus the balanced constant- k π -section low-pass filter would use two inductors of a value equal to $L_k/2$, while the balanced constant- k π -section high-pass filter would use two capacitors of a value equal to $2C_k$.

If several low- (or high-) pass sections are to be used, it is advisable to use m -derived end sections on either side of a constant- k center section, although an m -derived center section can be used. The factor m relates the ratio of the cut-off frequency f_c and f_∞ , a frequency of high attenuation. Where only one m -derived section is used, a value of 0.6 is generally used for m , although a deviation of 10 or 15 per cent from this value is not too serious in amateur work. For a value of $m = 0.6$, f_∞ will be $1.25f_c$ for the low-pass filter and $0.8f_c$ for the high-pass filter. Other values can be found from

$$m = \sqrt{1 - \left(\frac{f_c}{f_\infty}\right)^2} \text{ for the low-pass filter and}$$

$$m = \sqrt{1 - \left(\frac{f_\infty}{f_c}\right)^2} \text{ for the high-pass filter.}$$

The filters shown should be terminated in a resistance = R , and there should be little or no reactive component in the termination.

Simple audio filters can be made with powdered-iron-core chokes and paper capacitors. Sharper cut-off characteristics will be obtained with more sections. The values of the components can vary by $\pm 5\%$ with little or no reduction in performance. The more sections there are to a filter the greater is the need for accuracy in the values of the components. High-performance audio filters can be built with only two sections by winding the inductors on toroidal powdered-iron forms — it generally takes three sections to obtain the same results when using other inductors.

Side-band filters are often designed to operate in the range 10 to 20 kc. Their attenuation requirements are such that usually at least a five-

section filter is required. The coils should be as high- Q as possible, and mica is the most suitable capacitor dielectric.

Low-pass and high-pass filters for harmonic suppression and receiver-overload prevention in the television frequencies range are usually made with self-supporting coils and mica or ceramic capacitors, depending upon the power requirements.

In any filter, there should be no magnetic or capacitive coupling between sections of the filter unless the design specifically calls for it. This requirement makes it necessary to shield the coils from each other in some applications, or to mount them at right angles to each other.

Further information on filter design can be found in the following articles:

Bennett, "Audio Filters for Eliminating QRM," *QST*, July, 1949.

Berry, "Filter Design for the Single-Side-band Transmitter," *QST*, June, 1949.

Buehheim, "Low-Pass Audio Filters," *QST*, July, 1948.

Grammer, "Pointers on Harmonic Reduction," *QST*, April, 1949; "High-Pass Filters for TVI Reduction," *QST*, May, 1949.

Mann, "An Inexpensive Side-band Filter," *QST*, March, 1949.

Rand, "The Little Slugger," *QST*, February, 1949.

Smith, "Premodulation Speech Clipping and Filtering," *QST*, February, 1946; "More on Speech Clipping," *QST*, March, 1947.

GREEK ALPHABET

<i>Greek Letter</i>	<i>Greek Name</i>	<i>English Equivalent</i>
A α	Alpha	a
B β	Beta	b
Γ γ	Gamma	g
Δ δ	Delta	d
E ε	Epsilon	e
Z ζ	Zeta	z
H η	Eta	é
Θ θ	Theta	th
I ι	Iota	i
K κ	Kappa	k
Λ λ	Lambda	l
M μ	Mu	m
N ν	Nu	n
Ξ ξ	Xi	x
O ο	Omicron	ö
Π π	Pi	p
Ρ ρ	Rho	r
Σ σ	Sigma	s
Τ τ	Tau	t
Υ υ	Upsilon	u
Φ φ	Phi	ph
Χ χ	Chi	ch
Ψ ψ	Psi	ps
Ω ω	Omega	ö

LOW-PASS FILTERS

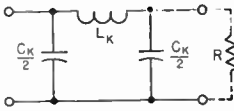

Constant- k π section

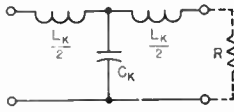

Constant- k T section

$$L_k = \frac{R}{\pi f_c} \quad C_k = \frac{1}{\pi f_c R}$$

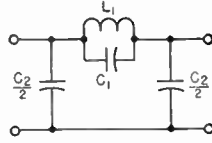

m -derived π section

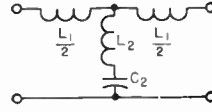

m -derived T section

$$L_1 = m L_k \quad C_1 = \frac{1-m^2}{4m} C_k$$

$$L_2 = \frac{1-m^2}{4m} L_k \quad C_2 = m C_k$$

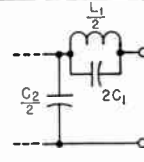
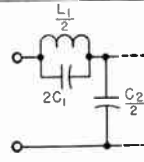

m -derived end sections for use with intermediate π section

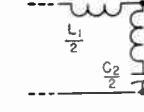
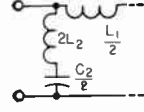

m -derived end sections for use with intermediate T section

$$L_1 = m L_k \quad C_1 = \frac{1-m^2}{4m} C_k$$

$$L_2 = \frac{1-m^2}{4m} L_k \quad C_2 = m C_k$$

HIGH-PASS FILTERS

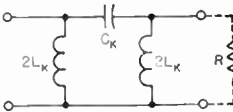

Constant- k π section

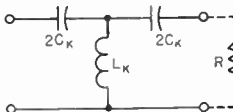

Constant- k T section

$$L_k = \frac{R}{4\pi f_c} \quad C_k = \frac{1}{4\pi f_c R}$$

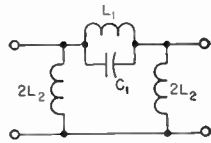

m -derived π section

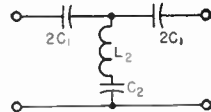

m -derived T section

$$L_1 = \frac{4m}{1-m^2} L_k \quad C_1 = \frac{C_k}{m}$$

$$L_2 = \frac{L_k}{m} \quad C_2 = \frac{4m}{1-m^2} C_k$$

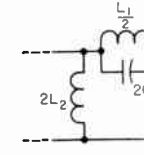
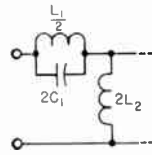

m -derived end sections for use with intermediate π section

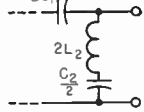
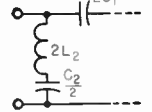

m -derived end section for use with intermediate T section

$$L_1 = \frac{4m}{1-m^2} L_k \quad C_1 = \frac{C_k}{m}$$

$$L_2 = \frac{L_k}{m} \quad C_2 = \frac{4m}{1-m^2} C_k$$

BANDPASS FILTERS

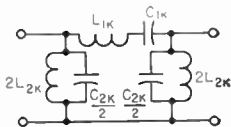

Constant- k π section

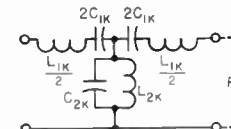

Constant- k T section

$$L_{1k} = \frac{R}{n(f_2 - f_1)} \quad C_{1k} = \frac{f_2 - f_1}{4\pi f_1 f_2 R}$$

$$L_{2k} = \frac{(f_2 - f_1)R}{4\pi f_1 f_2} \quad C_{2k} = \frac{1}{n(f_2 - f_1)R}$$

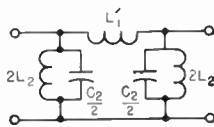

Three-element π section

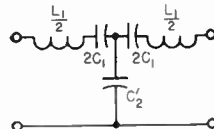

Three-element T section

$$L_1 = L_{1k} \quad L_1' = \frac{R}{n(f_1 + f_2)}$$

$$C_1 = \frac{f_2 - f_1}{4\pi f_1^2 R} \quad L_2 = \frac{(f_2 - f_1)R}{4\pi f_1^2}$$

$$C_2 = C_{2k} \quad C_2' = \frac{1}{n(f_1 + f_2)R}$$

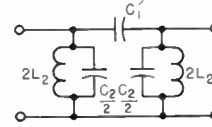

Three-element π section

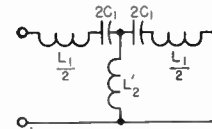

Three-element T section

$$L_1 = \frac{f_1 R}{n f_2 (f_2 - f_1)} \quad C_1 = C_{1k}$$

$$C_1' = \frac{f_1 + f_2}{4\pi f_1 f_2 R} \quad L_2 = L_{2k}$$

$$L_2' = \frac{(f_1 + f_2)R}{4\pi f_1 f_2} \quad C_2 = \frac{f_1}{n f_2 (f_2 - f_1)R}$$

In the above formulas R is in ohms, C in farads, L in henrys, and f in cycles per second.

● RESPONSE OF COUPLED TUNED CIRCUITS

The chart shows the response or selectivity curves for various degrees of coupling between

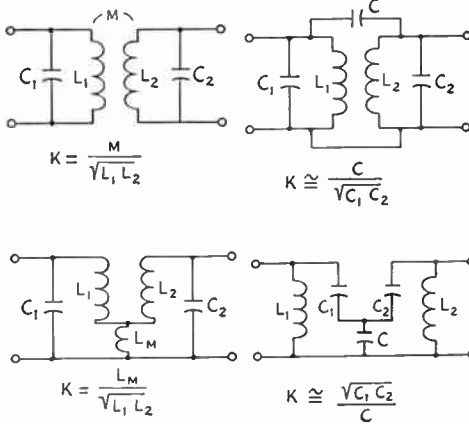
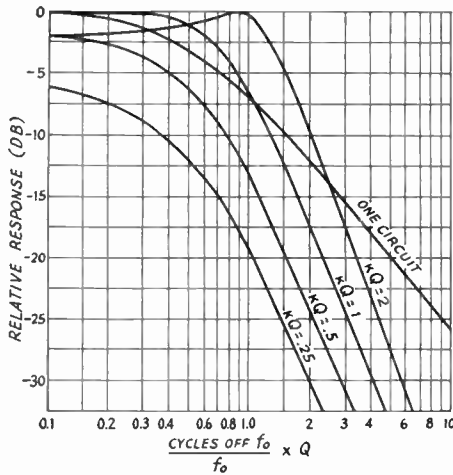

two circuits tuned to a frequency f_0 . Equal Q s is assumed in both circuits, although the curves are representative if the Q s differ by ratios up to 1.5 or even 2 to 1. In these cases, a value of $Q = \sqrt{Q_1 Q_2}$ should be used.

The coefficient of coupling, k , is given for several different types of circuits in the figure. Only the first circuit uses any inductive coupling between L_1 and L_2 .

● TUNED-CIRCUIT RESPONSE

The graph below gives the response and phase angle of a high- Q parallel-tuned circuit.

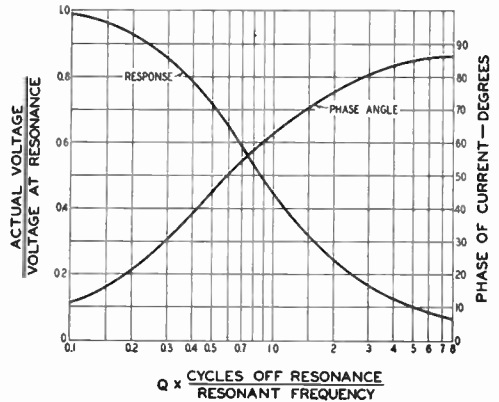

Circuit Q is equal to

$$2\pi fRC \text{ or } \frac{R}{2\pi fL}$$

where L and C are the inductance and capacitance at the resonant frequency, f , and R is the parallel resistance across the circuit. The curves above become more accurate as the circuit Q is higher, but the error is not especially great for values as low as $Q = 10$.

ELECTRICAL CONDUCTIVITY OF METALS

	Relative Conductivity ¹	Temp. Coef. ² of Resistance		Relative Conductivity	Temp. Coef. ² of Resistance
Aluminum (2S; pure).....	59	0.0049	Lead.....	7	0.0041
Aluminum (alloys):			Manganin.....	3.7	0.00002
Soft-annealed.....	45-50		Mercury.....	1.66	0.00089
Heat-treated.....	30-45		Molybdenum.....	33.2	0.0033
Brass.....	28	0.002-0.007	Monel.....	4	0.0019
Cadmium.....	19		Nichrome.....	1.45	0.00017
Chromium.....	55		Nickel.....	12-16	0.005
Climax.....	1.83		Phosphor Bronze.....	36	0.004
Cobalt.....	16.3		Platinum.....	15	
Constantin.....	3.24	0.00002	Silver.....	106	0.001
Copper (hard drawn).....	89.5	0.004	Steel.....	3-15	
Copper (annealed).....	100		Tin.....	13	0.0042
Everdur.....	6		Tungsten.....	28.9	0.0045
German Silver (18%).....	5.3	0.00019	Zinc.....	28.2	0.0035
Gold.....	65				
Iron (pure).....	17.7	0.006			
Iron (cast).....	2-12				
Iron (wrought).....	11.4				

¹ At 20° C., based on copper as 100. ² Per °C, at 20° C.

Approximate relations

- An increase of 1 in A. W. G. or B. & S. wire size increases resistance 25%.
- An increase of 2 increases resistance 60%.
- An increase of 3 increases resistance 100%.
- An increase of 10 increases resistance 10 times.

● VACUUM TUBE AMPLIFIER GAIN

The gain through a vacuum tube amplifier stage can be computed by the formulas shown in

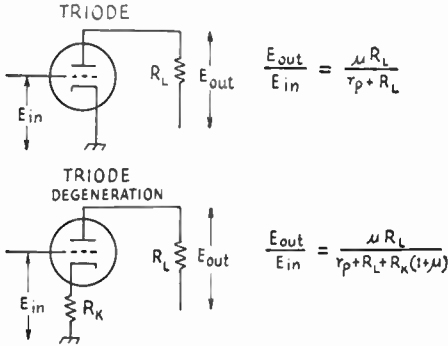

the figure below. The values of r_p (plate resistance), μ (amplification factor) and g_m (mutual conductance) for the operating point can be obtained from a vacuum tube manual.

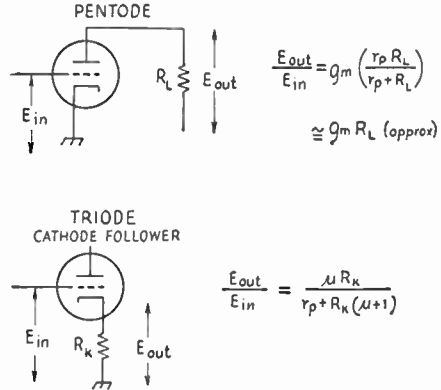

STANDARD METAL GAUGES























































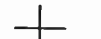

Gauge No.	American or B. & S. ¹	U. S. Standard ²	Birmingham or Stubbs ³
1	.2893	.28125	.300
2	.2576	.265625	.284
3	.2294	.25	.259
4	.2043	.234375	.238
5	.1819	.21875	.220
6	.1620	.203125	.203
7	.1443	.1875	.180
8	.1285	.171875	.165
9	.1144	.15625	.148
10	.1019	.140625	.134
11	.09074	.125	.120
12	.08081	.109375	.109
13	.07196	.09375	.095
14	.06408	.078125	.083
15	.05707	.0703125	.072
16	.05082	.0625	.065
17	.04526	.05625	.058
18	.04030	.05	.049
19	.03589	.04375	.042
20	.03196	.0375	.035
21	.02846	.034375	.032
22	.02535	.03125	.028
23	.02257	.028125	.025
24	.02010	.025	.022
25	.01790	.021875	.020
26	.01594	.01875	.018
27	.01420	.0171875	.016
28	.01264	.015625	.014
29	.01126	.0140625	.013
30	.01003	.0125	.012
31	.008928	.0109375	.010
32	.007950	.01013625	.009
33	.007080	.009375	.008
34	.006350	.00859375	.007
35	.005615	.0078125	.005
36	.005000	.00703125	.004
37	.004453	.006640626
38	.003965	.00625
39	.003531
40	.003145

¹ Used for aluminum, copper, brass and nonferrous alloy sheets, wire and rods.
² Used for iron, steel, nickel and ferrous alloy sheets, wire and rods.
³ Used for seamless tubes; also by some manufacturers for copper and brass.

PILOT-LAMP DATA

Lamp No.	Bead Color	Base (Miniature)	Bulb Type	RATING	
				Volts	Amp.
40	Brown	Screw	T-3½	6-8	0.15
40A ¹	Brown	Bayonet	T-3½	6-8	0.15
41	White	Screw	T-3½	2.5	0.5
42	Green	Screw	T-3½	3.2	**
43	White	Bayonet	T-3½	2.5	0.5
44	Blue	Bayonet	T-3½	6-8	0.25
45	*	Bayonet	T-3½	3.2	**
46 ²	Blue	Screw	T-3½	6-8	0.25
47 ¹	Brown	Bayonet	T-3½	6-9	0.15
48	Pink	Screw	T-3½	2.0	0.06
49 ³	Pink	Bayonet	T-3½	2.0	0.06
4	White	Screw	T-3½	2.1	0.12
49A ³	White	Bayonet	T-3½	2.1	0.12
50	White	Screw	G-3½	6-8	0.2
51 ²	White	Bayonet	G-3½	6-8	0.2
—	White	Screw	G-4½	6-8	0.4
55	White	Bayonet	G-4½	6-8	0.4
292 ⁵	White	Screw	T-3½	2.9	0.17
292A ⁵	White	Bayonet	T-3½	2.9	0.17
1455	Brown	Screw	G-5	18.0	0.25
1455A	Brown	Bayonet	G-5	18.0	0.25

¹ 40A and 47 are interchangeable.
² Have frosted bulb.
³ 49 and 49A are interchangeable.
⁴ Replace with No. 48.
⁵ Use in 2.5-volt sets where regular bulb burns out too frequently.
 * White in G.E. and Sylvania; green in National Union, Raytheon and Tung-Sol.
 ** 0.35 in G.E. and Sylvania; 0.5 in National Union, Raytheon and Tung-Sol.

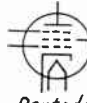
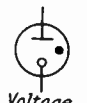
 ANTENNA	  Single cell Multicell BATTERIES		    Fixed Variable Split-stator Feed-through CAPACITORS					
 QUARTZ CRYSTAL	MALE → FEM. ← Contacts Receptacle Plug Coaxial Receptacle Coaxial Plug Female 115V. Male Jack Plug CONNECTORS							
 FUSE	 GROUND	 HEADSET	     Basic Coil Air Core Iron Core Tapped Adjustable INDUCTORS					
 KEY	  Incandescent Pilot LAMPS			* Insert Appropriate Designations:  A - Ammeter  V - Voltmeter  MA - Milliammeter etc.  M - Motor  G - Generator etc. METERS MACHINES				
 MICROPHONE	 S.P.  D.P.  S.P.D.T. Normally Open Normally Open RELAYS			 CONTACT RECTIFIER	   Fixed Tapped Adjustable RESISTORS			
 General  Enclosure  Shielded Wire  Shielded Multiconductor  Coaxial Cable SHIELDING					 SPEAKER	 S.P.S.T. Toggle  S.P.D.T. Multipoint SWITCHES		
 Air Core  Iron Core  Adjustable Inductance  Adjustable Coupling  With Link TRANSFORMERS					 VIBRATOR	 Terminal  Crossing Conductors not joined  Conductors joined  Chassis Connection WIRING		
 Heater or Filament  Indirectly Heated Cathode  Cold Cathode  Grid  Plate  Deflection Plates  Gas Filled ELECTRON TUBE ELEMENTS							 Triode  Pentode  Voltage Regulator EXAMPLES	

Standard circuit symbols (ASA Y32.2 — 1954). In cases where identification is necessary or desirable, the curved line in the capacitor symbol represents the outside electrode (marked "outside foil" or "ground") in paper-dielectric capacitors, and the negative electrode in electrolytic capacitors. In variable capacitors the curved line usually represents the movable plate or plates.

In a number of circuits in this *Handbook*, prepared before adoption of the standard, some symbols are not quite identical with those above. However, in practically all cases the intent of the symbol will be easily recognized. In the older circuits the ground symbol is generally used to indicate a connection to chassis.

Vacuum Tubes and Semiconductors

For the convenience of the designer, the receiving-type tubes listed in this chapter are grouped by filament voltages and construction types (glass, metal, miniature, etc.). For example, all miniature tubes are listed in Table I, all metal tubes are in Table II, all lock-in base tubes are in Table IV, and so on.

Transmitting tubes are divided into triodes and tetrodes-pentodes, then listed according to rated plate dissipation. This permits direct comparison of ratings of tubes in the same power classification.

For quick reference, all tubes are listed in numerical-alphabetical order in the index beginning on the following page.

Tube Ratings

Vacuum tubes are designed to be operated within definite maximum (and minimum) ratings. These ratings are the maximum safe operating voltages and currents for the electrodes, based on inherent limiting factors such as permissible cathode temperature, emission, and power dissipation in electrodes.

In the transmitting-tube tables, maximum ratings for electrode voltage, current and dissipation are given separately from the typical operating conditions for the recommended classes of operation. In the receiving-tube tables, because of space limitations, ratings and operating data are combined. Where only one set of operating conditions appears, the positive electrode voltages shown (plate, screen, etc.) are, in general, also the maximum rated voltages for those electrodes.

For certain air-cooled transmitting tubes, there are two sets of maximum values, one designated as CCS (Continuous Commercial Service) ratings, the other ICAS (Intermittent Commercial and Amateur Service) ratings. Continuous Commercial Service is defined as that type of service in which long tube life and reliability

of performance under continuous operating conditions are the prime consideration. Intermittent Commercial and Amateur Service is defined to include the many applications where the transmitter design factors of minimum size, light weight, and maximum power output are more important than long tube life. ICAS ratings are considerably higher than CCS ratings. They permit the handling of greater power, and although such use involves some sacrifice in tube life, the period over which tubes will continue to give satisfactory performance in intermittent service can be extremely long.

The plate dissipation values given for transmitting tubes should not be exceeded during normal operation. In plate modulated amplifier applications, the maximum allowable carrier-condition plate dissipation is approximately 66 percent of the value listed and will rise to the maximum value under 100-percent sinusoidal modulation.

Typical Operating Conditions

The typical operating conditions given for transmitting tubes represent, in general, maximum ICAS ratings where such ratings have been given by the manufacturer. They do not represent the *only* possible method of operation of a particular tube type. Other values of plate voltage, plate current, grid bias, etc., may be used so long as the maximum ratings for a particular voltage or current are not exceeded.

Equivalent Tubes

The equivalent tubes listed in Table VIII are, in general, designed for industrial, military and other special-purpose applications. These tubes are generally not directly interchangeable with their prototypes because of mechanical and/or electrical differences involving basing, heater characteristics, maximum ratings, interelectrode capacitances, etc.

INDEX TO TUBE TABLES

I — Miniature Receiving Tubes	V15	IX — Control and Regulator Tubes	V23
II — 6.3-Volt Metal Receiving Tubes	V18	X — Rectifiers	V24
III — 6.3-Volt Glass Tubes with Octal Bases	V19	XI — Triode Transmitting Tubes	V25
IV — 6.3-Volt Lock-In Base Tubes	V20	XII — Tetrode and Pentode Transmitting Tubes	V28
V — 1.5-Volt Battery Tubes	V20	XIII — Electrostatic Cathode-Ray Tubes	V30
VI — High-Voltage Heater Tubes	V21	XIV — Transistors	V31
VII — Special Receiving Tubes	V21	XV — Germanium Crystal Diodes	V32
VIII — Equivalent Tubes	V22		

INDEX TO VACUUM-TUBE TYPES

Base-diagram section pages V5-V14. Classified data pages V15-V32.

Type	Page	Base	Type	Page	Base	Type	Page	Base	Type	Page	Base
00-A	—	4D	2B25	V24	3T	3-25A3	V25	3G	5V4G	V24	5L
01-A	—	4D	2B2A	V22	7EG	3-25D3	V25	2D	5V4GA	V22	5L
0A2	V23	5B0	2BP1-11	V30	12E	3-50A4	V26	3G	5V6GT	V26	3G
0A3	V24	4AJ	2C4	—	5AS	3-50P4	V26	2D	5V7P	V20	11N
0A4G	V23	4X	2C5	V21	7BH	3-50Q2	V26	2D	5V8GT	V30	5L
0A5	V23	Fig. 19	2C22	V19	4AM	3-75A2	V26	2D	5X3	V24	4C
0B2	V23	5B0	2C25	—	4D	3-75A3	V26	2D	5X4G	V24	5Q
0B3	V24	4AJ	2C26A	—	4BB	3-100A2	V26	2D	5XP1	V30	14P
0C3	V24	4AJ	2C34	V25	Fig. 20	3-100A4	V26	2D	5XP1A-11A	V30	14P
0D3	V24	4AJ	2C36	V25	Fig. 21	3X-100A11	V26		5X8	V22	9AK
0G3	—	5B0	2C37	V25	Fig. 21	3-150A2	V27	4BC	5Y3C-GT	V24	5T
0Y4	—	4BU	2C39	V26		3-150A3	V26	4BC	5Y3W-GT	V24	5T
0Z4A	—	4R	2C40	V25	Fig. 11	3-200A3	V27	Fig. 28	5Y4G-GT	V24	5Q
1	—	4G	2C43	V25	Fig. 11	3-250A2	V27	2N	5Y1P1	V30	14Q
1A3	V15	5AP	2C51	V15	8CJ	3-250A4	V27	2N	5Z3	V24	4C
1A4P	—	4M	2C52	V21	8BD1	3-300A2	V27	4BC	5Z4	V24	5L
1A4T	—	4K	2D21	V23	7BN	3-300A3	V27	4BC	5-125B	V29	7BM
1A5G-T	V20	6X	2E5	6R	4A6C	4BC5	V22	7BD	6A3	4D	
1A6	—	6L	2E22	V28	5J	4BC8	V22	7BD	6A4	—	5B
1A7G-T	V20	7Z	2E24	V28	7CL	4BCN	V22	9AJ	6A5C-T	V19	6T
1A85	—	5BF	2E25	V28	5BJ	4BN6	V22	7DF	6A6	V22	7B
1A86	V15	7DH	2E26	V28	7CK	4BQ7A	V22	9AJ	6A7	V22	7C
1A9C	V15	7BH	2E30	V15	7CQ	4B88	V22	9AJ	6A8	V18	8A
1A94	V15	6AR	2E30	V28	7CQ	4B18	V22	9AJ	6A84	V15	5CE
1A9F	V15	6AR	2S/4S	—	5D	4BN8	V22	9AJ	6A87	6R	
1AF5	V15	6AU	2T4	V22	7DK	4BZ7	V22	9AJ	6A88G	—	7AU
1AH5	V15	6AU	2V2	—	8FV	4BZ8	V22	9AJ	6A87	V18	8N
1AJ4	V15	6AR	2V3G	—	4Y	4C32	V27	2N	6A88	V15	9AT
1AN2	—	9Y	2W3	—	4X	4C34	V27	2N	6AC5GT	V19	6Q
1B3GT	—	6X	2X2	—	4AB	4C36	—	Fig. 31	6AC6G	7AU	
1B4	—	4M	2X2-A	V24	4AB	4C86	V22	7CM	6A87G	V18	8N
1B5	—	6M	2Y2	V24	4AB	4CE5	V22	7BD	6AD5G	—	6Q
1B7GT	—	7Z	2Z2	V24	4B	4CX7	V22	9FC	6AD6G	—	7AG
1B8GT	—	8AW	3A2	—	9DT	4CX300A	V29		6AD7G	V19	8AY
1C3	V15	3CF	3A3	—	8E2	4D21	V29	5BK	6AD8	V15	9T
1C5GT	—	6X	3A4	V15	7BN	4D22	V29	Fig. 26	6AE5G	—	6Q
1C6	—	6L	3A5	V15	7BC	4D23	V29	Fig. 27	6AE6G	—	7AH
1C7G	—	7Z	3A8GT	—	8AS	4D32	V29	Fig. 27	6AE7GT	—	7AX
1C21	—	4V	3AC-P1-7-11	V30	14J	4DT6	V22	7EN	6AE8	V22	8DI
1D5G-P	—	5Y	3AF1A	V22	7DK	4E27	V29	7BM	6AF4	—	7DK
1D5GT	—	5R	3AL1A	V22	7BT	4E27A	V29	7BM	6AF4A	V15	7DK
1D7G	—	7Z	3AL15-G	V22	7AN	4X150A	V29	Fig. 75	6AF5G	—	6Q
1D8GT	—	7Z	3AP1A	V30	7CE	4X150-G	V29	Fig. 75	6AF6G	—	7AG
1D9P1-4-7-11	V30	9CU	3AU6	V22	7BK	4X250B	V29	Fig. 75	6AF7G	—	8AG
1E3	V15	9BG	3AV6	V22	7BT	4-65A	V29	Fig. 25	6AG5	V15	7BD
1E4G	—	5S	3B4	—	7CY	4-125A	V29	5BK	6AG6G	—	7B
1E5G-P	—	5Y	3B5GT	—	7AP	4-250A	V29	5BK	6AG7	V18	8Y
1E7G	—	8C	3B6	V20	7BE	4-400A	V29	5BK	6AH4GT	V19	8EL
1F4	V30	1IV	3B7A	V24	Fig. 49	5A6	—	9L	6AH5G	V19	6AP
1F5G	—	6X	3B25	—	4P	5ADP1-7-11	V30	14J	6A87	V15	8BE
1F6	—	6W	3B26	—	Fig. 18	5AJP1	V30	Fig. 78	6AJ4	V15	9BX
1F7G	—	7AD	3B27	—	4P	5AM8	V22	9CY	6AJ5	V15	7BD
1G4GT	—	5S	3B28	—	4P	5AMP1	V30	14A	6AJ7	V15	8N
1G5G	—	4X	3B28	V22	7C	5AN5	V22	9DU	6AJ8	V15	9CA
1G6GT	V20	7AB	3B29	V22	7BD	5AN6	V22	9DU	6AJ9	V15	7BD
1H4G	—	5S	3BE6	V22	7BD	5AQ1	V30	14G	6AK6	V15	7BK
1H5GT	V20	5Z	3BN4	V22	7EG	5AQ5	V22	7BZ	6AK7	—	8Y
1H6G	—	7AA	3BN6	V22	7DF	5AS4	V24	5T	6AK8	V15	9E
1J5G	—	6X	3BP1-4-11	V30	14A	5AS5	V22	9AJ	6AL5	V15	6BT
1J6GT	—	6X	3BP1A	V30	14G	5AS8	V22	9DS	6AL6G	—	6AM
1K5	V15	6AR	3BY6	V22	7CH	5ATP1-11	V30	14V	6AM4	V19	8UD
1L6	V15	7DC	3BZ6	V22	7CM	5AU4	V24	5T	6AM5	V15	6CH
1LA4	—	5AD	3C4	V15	6BX	5AV8	V22	9DZ	6AM6	V15	7DB
1LA6	V20	7AK	3C5GT	—	7AQ	5AW4	V24	5T	6AM8	V15	9CY
1LB4	V20	5AD	3C6	V21	7BW	5AX4GT	—	5T	6AM8A	V22	9CY
1LB6	V20	8AX	3C22	V26	Fig. 17	5AZ5	V22	9EC	6AN4	V15	7TD
1LC3	—	5AO	3C24	V25	2D	5B2A	V22	9EJ	6AN6	V15	7BJ
1LC6	V20	7AK	3C28	V25	2D	5B2B	V15	9EG	6AN7	V15	9Q
1LD5	V20	6AX	3C34	V25	3G	5BK7A	V22	9AJ	6AN8	V15	9DA
1LE3	V20	4AA	3C36	V22	7CM	5BP1	V30	11A	6AN8A	V22	9DA
1LF3	V22	4AA	3C37	V22	7CM	5BP1A	V30	11N	6AQ8	V15	7DT
1LG5	V20	7AO	3C45	V22	7CM	5BQ7A	V22	9AJ	6AQ9	V15	7BZ
1LH5G	V20	7AO	3CP1	V30	11C	5BR8	V22	9FA	6AQSA	V22	7BZ
1LN5	V20	7AO	3CP6	V22	7CH	5BT8	V22	9FE	6AQ6	V15	7BT
1N5GT	V20	5Y	3D6	V20	6BB	5BZ7	V22	9AJ	6AQ7GT	V19	8CK
1N6G	—	7AM	3D23	—	Fig. 30	5CG8	V22	9GF	6AR5	V15	6CC
1P5GT	—	5Y	3D24	V29	Fig. 75	5CL8	V22	9FX	6AR6	V19	6BQ
1R4	V20	4AH	3D1P	V30	14C	5CM8	V22	9Z	6AR7GT	V19	7DE
1R5	V15	7AT	3D1A	V30	14H	5CP7A	V30	14J	6AR8	V15	9DP
1S4	V15	7AV	3DP7	V30	14H	5CP1-11	V30	14B	6AN5	V15	7CV
1S5	V15	6AU	3DT6	V22	7EN	5CP1A	V30	14J	6AN6	V15	7CM
1S46GT	—	6CA	3DX3	—	Fig. 24	5CP1B-11B	V30	14J	6AN7G	V19	8BD
1S46GT	—	6CB	3E5	V15	6BX	5CP7A	V30	14J	6AN7GA	V22	8BD
1T4	V15	6AR	3E6	V20	7CJ	5CP1A	V30	14J	6AN8	V15	9DS
1T5GT	V20	6X	3E22	V28	8BY	5CP12	V30	14J	6AT6	V15	7BT
1U4	V15	6AR	3E29	V28	7BP	5D22	V29	5BK	6AT8	V15	9DW
1U5	V15	6BR	3EP1	V30	11N	5GPI	V30	11A	6AU4GT	—	4CG
1U6	V15	7DC	3FP7	V30	14B	5HP1-4	V30	11A	6AU5GT	V19	6CK
1-V	—	4G	3FP7A	V30	14J	5HP1A	V30	11N	6AU6	V15	7BK
1V2	V24	9U	3GP1-4-5-11	V30	11A	5J6	V22	7BF	6AU6A	V22	7BK
1X2	—	4BZ	3GP1A	V30	11M	5J4G-11	V30	11A	6AU7	V15	7BT
1X2A	—	9Y	3GP4A	V30	11N	5JP1A-4A	V30	11N	6AU8	V16	9DX
1X2B	—	9Y	3JP1-24	V30	14J	5LP1-11	V30	11F	6AV4	V24	5BS
1Y2	—	4P	3JP1A-7A	V30	14J	5LP1A-11	V30	11T	6AV5GA	V22	6CK
1Z2	—	7DB	3JP7-11-12	V30	14J	5MP1-11	V30	7AN	6AV6	V16	7BT
2A4G	—	5S	3JP1A-11	V30	14J	5NPI-4	V30	11A	6AV6GT	V16	9D
2A5	—	6B	3LE4	V22	6BA	5R4GYA	V24	5T	6AW8A	V16	9DX
2A6	—	6G	3LF4	V22	6BB	5RP1-11	V30	14P	6AN4GT	—	4CG
2A7	—	7C	3MP1	V30	12F	5RP1A	V30	14P	6AN5GT	V24	6S
2A7A	—	7DK	3Q4	V15	7BA	5SP1-4	V30	14K	6AN6G	V15	7Q
2A7A	V22	7DK	3Q5GT	V21	7AP	5T4	V24	5T	6AN7	V22	9A
2AP1-11	V30	11B	3P1	V30	9D	5T8	V22	9AE	6AN8	V16	9AE
2AP1A	V30	11L	3RP1A	V30	12E	5T4G	V24	5T	6AN8A	V16	9ED
2B4	—	5A	3S4	V15	7BA	5U4GB	V24	5T	6H4G	V22	5S
2B6	—	7J	3SP1-4-7	V30	12E	5U8	V22	9AE	6B5	—	6AS
2B7	—	7D	3UP1	V30	12E	5U8	V22	9AE	6H6G	—	7V
2B22	V19	Fig. 22	3V4	V22	6BX	5UP1-11	V30	12E	6H7	V18	8E
						5V3	V24	5T	6H8	V18	8E

VACUUM-TUBE DATA

V3

Type	Page	Base	Type	Page	Base	Type	Page	Base	Type	Page	Base			
61D7	—	7H	6X6G	—	7H	12BA7	—	V22 7HK	19X3	—	9BM	70A7GT	—	SAB
61D8G	—	8A	6X8	—	V17 9AK	12BA7	—	V22 8CT	19X8	—	9AK	70L7GT	—	8AA
61D9E	V17	7CM	6X8A	—	V22 9AK	12BD16	—	V22 7BK	19Y3	—	9BM	71-A	—	4D
61D9G	V17	7CM	6Y3G	—	4AC	12BF6	—	V22 7CH	20	—	4D	72	—	4P
61D9H	V17	7CM	6Y5	—	6J	12BF6E	—	V22 7BT	20A1-4	—	12A	73	—	4Y
61D9HGT	V19	7S	6Y6G	—	V20 7S	12BH7	—	V17 9A	20A8GM	—	8H	75	—	V23 6G
61N6E	V19	8BT	6Y6GA	—	V22 7S	12BH7A	—	V22 9A	21A6	—	8AS	75TH	—	V28 2D
61D98A	V19	8AM	6Y6GT	—	V22 7S	12BK5	—	V22 8Q	21A7	—	8AR	75TL	—	V26 2D
61D7E	V17	7EN	6Y7G	—	8B	12BK6	—	V22 7BT	22	—	4K	76	—	5A
61E5	—	6R	6Z3	—	V24 4G	12BN6	—	V22 7DF	24-A	—	5E	77	—	6F
61E6	—	7H	6Z4	—	V24 5D	12BQ6GA	—	V22 6AM	24-G	—	V25 2D	78	—	V23 6F
61E7	—	7H	6Z5	—	6K	12BQ6GT	—	V22 6AM	24XH	—	Fig. 1	79	—	6H
61E8G	—	80	6Z7G	—	8B	12BQ6GTB	—	V22 6AM	25A6	—	7S	80	—	V24 4C
61E4	V21	7BR	6Z7G	—	6S	12BR7	—	V17 9CF	25A7GT	—	8T	81	—	4B
61E5	V25	7BR	7A4	—	V22 5AS	12BR7	—	V17 9CF	25A5GT	—	V21 6Q	82	—	4C
61E5	V18	5M	7A5	—	V20 6AA	12BL6	—	V22 7BT	25A55GA	—	V23 6CK	83	—	V24 4C
61E6	V18	7AC	7A6	—	V22 7AJ	12BW4	—	V22 9DJ	25A55GT	—	V23 6CK	83-V	—	V24 4AD
61E7	7E	7F	7A7	—	V22 8V	12BV7	—	V17 9BF	25A54GT	—	4CG	84/6Z4	—	V24 5D
61E8G	V20	8E	7A8	—	V20 8U	12BY7	—	V17 9BF	25B5	—	1D	85	—	6G
61E9	—	80	7A9	—	V20 8HO	12BY7A	—	V22 9BF	25B6G	—	7S	85AS	—	6C
61E6G	V20	7S	7AB7	—	8V	12BZ7	—	V22 9V	25B8GT	—	8T	89	—	6F
61H1GT	—	5AF	7AD7	—	V20 8V	12C1	—	V22 8V	25BK5	—	9BQ	90C1	—	V23 5BO
61E5	—	6R	7AG7	—	V20 8V	12C8	—	V22 8E	25BQ6GA	—	V23 6AM	99	—	4D
61E6	V18	7Q	7AH7	—	V20 8V	12CA5	—	V22 7CV	25BQ6GT	—	V23 6AM	100TH	—	V26 2D
61E8G	V20	8E	7AJ7	—	9V	12CM6	—	V22 9CK	25BQ6GTB	—	V23 6AM	100TL	—	V26 2D
61E4	V18	6Q	7AK7	—	V20 9A	12CR6	—	V18 7EA	25C5	—	V23 7CV	101H	—	2D
61E5	V18	6Q	7AL7	—	V20 9A	12C85	—	22 9CK	25C6	—	V23 7CV	112-A	—	7AC
61E6	V17	7BF	7B4	—	V22 5AC	12CS6	—	V22 7CH	25C6A5	—	V23 7CV	1171.7GT	—	V21 8AO
61E6	V25	7BF	7B5	—	V22 6AE	12CS6	—	V22 9DA	25C1D6G	—	V23 5BT	1171.7GT	—	V24 8AO
61E6A	V22	7BF	7B6	—	V22 8W	12CU5	—	V22 7CV	25C1D6GA	—	V23 5BT	117M7GT	—	V21 8AO
61E7	V18	7R	7B7	—	V20 8V	12CU6	—	V22 6AM	25C1D6G	—	V23 6AM	117M7GT	—	V24 8AO
61E8G	—	8H	7B8	—	V22 8X	12CQ6A	—	V22 6AM	25D8GT	—	8AF	117N7GT	—	V21 8AV
61E5GT	—	8H	7C4	—	V22 4AH	12D5GT	—	6Q	25D8G	—	V23 6AM	117N7GT	—	V24 8AV
61E6GT	V20	7S	7C5	—	V22 6AA	12F5GT	—	6M	25E5	—	V18 7CV	117P7GT	—	V23 8AV
61E7	V18	7R	7C6	—	V20 8W	12F5GT	—	6M	25F5	—	V18 7CV	117P7GT	—	V24 8AV
61E8	V18	8K	7C7	—	V20 8V	12FP7	—	14E	25L6GT	—	V23 7S	117Z3	—	V24 4CB
61E4	V21	7BR	7D7	—	8AR	12G4	—	V22 6BG	25N6G	—	7W	117Z4	—	5AA
61E5G	—	8C	7E5	—	V21 8BN	12G7G	—	V21 7V	25S	—	6M	117Z6GT	—	7Q
61E6	V18	6Q	7E6	—	8W	12G8	—	V18 9CZ	25T	—	V25 3G	128AS	—	5A
61E6GA	V22	7S	7E7	—	V20 8AE	12GP7	—	V18 14S	25W4GT	—	V23 4CG	1527-A	—	V26 4B
61E6GB	V22	7S	7E8	—	V30 11N	12H4	—	V18 7BW	25W6GT	—	V23 7S	1527H	—	V26 4BC
61E6GX	—	7S	7E9	—	V22 8AC	12H6	—	V22 7Q	25X6GT	—	7Q	1527L	—	V27 4BC
61E7	V19	7T	7F8	—	V20 8HW	12HP7	—	11J	25Y4GT	—	5AA	182-B	—	4D
61E5	V17	9N	7G7	—	8V	12J5GT	—	V22 6Q	25Y5	—	6E	183	—	4D
61E6GT	V20	7S	7G8	—	8V	12J7GT	—	V22 7R	25Z3	—	V24 4G	203-A	—	4E
61E8GT	V20	7R	7G9A	—	V30 14G	12K5	—	V18 7EK	25Z4	—	6AA	203-H	—	3N
61E8GT	—	8AU	7H7	—	V22 8V	12K7GT	—	V22 7R	25Z5	—	V24 6E	205-D	—	Fig. 39
6N4	V17	7CA	7J7	—	V20 8BL	12K8	—	V22 8K	25Z6	—	V24 7Q	205-D	—	4D
6N4	V25	7CA	7J1-4-7	—	V30 14R	12L6GT	—	V21 7S	26	—	4D	211	—	V26 4E
6N5	—	6R	7K7	—	V20 8BF	12L8GT	—	8BU	26A6	—	7BK	212-E	—	Fig. 43
6N6G	—	7AU	7L7	—	V20 8V	12L9GT	—	V22 7V	26A7GT	—	8BU	217-A	—	4AT
6N7	V19	8S	7M7	—	V30 14R	12M5	—	V18 7CV	26B8K6	—	7BT	217-C	—	4AT
6N7	V25	8H	7Q7	—	V22 8AL	12R5	—	V22 8CB	26C6	—	7BT	227-A	—	Fig. 53
6N8	V17	9T	7H7	—	8AE	12S8GT	—	V22 8CB	26C6G	—	7BK	241-B	—	Fig. 44
6P5GT	—	6Q	7S7	—	8BL	12S8A7	—	V22 8R	26D6	—	7CH	242-A	—	4E
6P7G	—	7K	7T7	—	8V	12S8F7	—	V22 6AB	26Z5W	—	9HS	242-B	—	4E
6P8G	V20	8K	7V7	—	V20 8V	12SF7	—	V22 7AZ	27	—	5A	242-C	—	4E
6Q4	V17	8S	7X7	—	V30 14R	12SG7	—	V22 8BK	28D7	—	V21 8BS	249-B	—	Fig. 29
6Q6G	—	6Y	7W7	—	8BJ	12SH7	—	V22 8BK	28Z5	—	5AB	250TH	—	V27 2N
6Q6G	—	6Y	7X6	—	7AJ	12SH7	—	V22 8BK	30	—	4D	257L	—	V27 2N
6Q7	V19	7V	7X7	—	V20 8BZ	12S7	—	V22 8N	31	—	4D	254	—	V26 2N
6R4	V17	9R	7Y4	—	5AB	12S7GT	—	V22 8BD	32	—	4K	254-A	—	Fig. 57
6R6G	V19	6AW	7Z4	—	V25 5AB	12S7GT	—	V22 8BD	32L7GT	—	8Z	254-B	—	Fig. 57
6H7	V19	9E	8A8	—	V25 8DX	12S7GT	—	V22 8BD	33	—	4I	261-A	—	4E
6H8	V17	9E	8A8A	—	V25 8DX	12S7GTA	—	V22 8BD	34	—	4I	270-A	—	Fig. 39
684	V17	9AC	8BA8A	—	V22 9DX	12S7GT	—	V22 8Q	35/51	—	5E	276-A	—	4E
684A	V22	9AC	8BH8	—	V22 9DX	12S7GT	—	V22 8Q	35/51	—	V21 6AA	282-A	—	Fig. 57
686GT	V20	5AK	8HN8	—	V22 9ER	12S7GT	—	V22 8Q	35B5	—	V18 7BZ	284-B	—	3N
687	V19	7R	8HP4	—	V22 14G	12S7GT	—	V22 8Q	35C5	—	V23 7CV	284-D	—	4E
688GT	V20	7FB	8CG7	—	V22 9AJ	12S7GT	—	V22 8R	35C5	—	V23 7S	295-A	—	2E
68A7	V19	8R	8CN7	—	V22 9EN	12U7	—	V18 9A	35L6GT	—	V26 2D	300T	—	4N
68B7Y	V19	8R	8CN7	—	V22 9EN	12V6GT	—	7S	35T	—	V26 3G	303-A	—	4E
68C7	V19	8S	8CS7	—	V22 9EF	12W6GT	—	V22 7S	35TG	—	V26 2D	303-A	—	Fig. 39
68D7GT	V20	8N	88N7GTB	—	V22 8BD	12X3	—	4G	35W4	—	V24 5BQ	304-B	—	2D
68E7GT	—	8N	9AU7	—	V22 9A	12Z3	—	4G	35Y3	—	4Z	304TH	—	V27 4BC
68E5	V19	6AN	9HM5	—	7BZ	1446	—	5AC	35Z4GT	—	V24 5AA	304TL	—	V27 4BC
68E7	V19	6AN	9Y7	—	6AM	14A4	—	5AC	35Z5GT	—	V24 6AD	305-A	—	Fig. 59
68G7	V19	8BK	9NP1	—	6BN	14A5	—	6AA	35Z6G	—	7Q	306-A	—	Fig. 63
68H7	V19	8BK	9R8A	—	V22 9AE	14A7	—	V23 8V	35Z6G	—	3E	307-A	—	Fig. 43
68H7L	—	8BK	10	—	4D	14AF7-4	—	V23 8AC	36	—	3F	307-B	—	Fig. 43
68J7	V19	8N	10GP4	—	14G	14AF7-4	—	V23 8AC	37	—	5F	310	—	4D
68J7Y	V19	8N	10HP4	—	14G	14B8	—	V23 8AC	39/44	—	6A	311	—	V26 4E
68K7	V20	8BD	10Y7	—	V25 4F	14C5	—	8X	40	—	4D	311CH	—	Fig. 32
68L7GT	V20	8BD	11/12	—	4F	14C5	—	8X	40Z5GT	—	6AD	312-A	—	Fig. 68
68N7GT	V20	8BD	12A4	—	V17 9AG	14C7	—	8V	41	—	V23 6B	312-E	—	Fig. 44
68N7GTA	V22	8BD	12A5	—	7F	14E6	—	8W	42	—	V23 6B	316-A	—	V25
68N7GTB	V22	8BD	12A6	—	V21 7S	14E7	—	8AE	43	—	V21 6B	327-A	—	Fig. 50
68Q7	V19	8Q	12A7	—	7K	14F7	—	V23 8AC	45	—	4D	327-B	—	Fig. 50
68R7	V19	8Q	12A8GT	—	V22 8A	14H8	—	8V	45Z3	—	5AM	342-B	—	4E
68S7	V19	8N	12A15	—	V17 9EU	14H7	—	8V	45Z5GT	—	6AD	356-A	—	Fig. 55
68T7	V19	8Q	12A16	—	V17 7BK	14J7	—	V23 8AC	46	—	5C	361-A	—	4E
68U7GTY	—	8BD	12A16	—	V17 7BK	14K7	—	V23 8AL	47	—	5B	376-A	—	4E
68V7	V19	7AZ	12A17	—	V17 9A	14N7	—	8AE	48	—	5B	417	—	V23 9V
68Z7	—	8Q	12A16E	—	V17 7BK	14M7	—	8BL	49	—	5C	482-B	—	4D
6T4	V17	7DK	12A17	—	V17 7BK	14N7	—	V23 8V	50	—	4D	483	—	4D
6T5	—	6Z	12A17GT	—	V17 8BF	14W7	—	8BJ	50A5	—	V23 6AA	485	—	5A
6T6GM	—	7V	12A18	—	V17 9RP	14X7	—	V23 8BZ	50AX6G	—	7Q	527	—	Fig. 53
6T8	V17	9E	12A15	—	V22 6BT	14Y3	—	5AB	50B5	—	V18 7BZ	559	—	Fig. 10
6T8A	V22	9E	12A05	—	V17 7BZ	14Z3	—	4G	50BK5					

Type	Page	Base	Type	Page	Base	Type	Page	Base	Type	Page	Base	Type	Page	Base
813	—	V29 5BA	1608	—	4D	5895	—	V25 Fig. 21	9002	—	V18 7BS	KY21	—	V24
814	—	V29 5BA	1609	—	V21 5B	5894A	—	V28 Fig. 7	9002	—	V28 7BS	NU2C35	—	Fig. 23
815	—	V28 8BY	1610	—	Fig. 62	5910	—	V23 6AR	9003	—	V18 7BD	PE3340	—	5BK
816	—	V24 4P	1611	—	7S	5915	—	V23 7CH	9004	—	V21 4BJ	PL6549	—	V29 Fig. 14
822	—	3N	1612	—	V19 7T	5920	—	7BF	9005	—	V21 5BG	PL6569	—	V27 Fig. 3
823	—	5N	1613	—	V28 7Z	5933	—	V28 5AZ	9006	—	V18 6AH	RK10	—	3G
826	—	V26 7BO	1614	—	V28 7AC	5961	—	V19 8R	AT-340	—	—	RK11	—	3G
828	—	V29 5J	1616	—	4P	5962	—	V23 2AG	AX9900	—	V26 Fig. 3	RK12	—	3G
829	—	7BP	1619	—	V28 Fig. 74	5963	—	V23 9A	AX9901	—	V27 Fig. 3	RK15	—	4D
829A	—	7BP	1620	—	V19 7R	5964	—	V23 7BF	AX9903	—	V28 Fig. 7	RK16	—	5A
829B	—	V28 7BP	1621	—	V19 7AC	5965	—	V23 9A	AX9905	—	V28 Fig. 20	RK17	—	5F
830	—	9D	1622	—	V19 7AC	5993	—	Fig. 35	AX9910	—	V28 Fig. 7	RK18	—	4AT
830B	—	V26 3C	1623	—	V25 3G	5998	—	V23 8BD	BA	—	—	RK19	—	4AT
831	—	Fig. 40	1624	—	V28 Fig. 66	6005	—	7BZ	BH	—	4J	RK20	—	Fig. 61
832	—	V28 7BP	1625	—	V28 5AZ	6023	—	9CD	BR	—	4H	RK20A	—	Fig. 61
832A	—	V28 7BP	1626	—	6Q	6026	—	V25	C1220	—	4P	RK21	—	4P
833A	—	V27 Fig. 41	1627	—	2N	6028	—	V18 7BD	CK1005	—	5AQ	RK22	—	Fig. 52
834	—	2D	1628	—	Fig. 54	6045	—	V18 7BF	CK1006	—	4C	RK23	—	6BM
835	—	7AN	1629	—	6RA	6046	—	V23 7AC	CK1007	—	Fig. 73	RK24	—	4D
836	—	V24 4P	1631	—	V23 7AC	6057	—	V23 9A	DR3B27	—	4P	RK25	—	V28 6BM
837	—	V28 6BM	1632	—	V23 7S	6058	—	V23 6BT	DR123C	—	Fig. 15	RK25B	—	6BM
838	—	4E	1633	—	8BD	6059	—	V23 9BC	DR200	—	Fig. 15	RK28	—	5J
840	—	5J	1634	—	V23 8S	6060	—	V23 9A	EP50	—	9C	RK28A	—	5J
841	—	4D	1635	—	V20 8B	6061	—	V23 9AM	FL23A	—	Fig. 15	RK30	—	2D
841A	—	3C	1641	—	Fig. 52	6062	—	9G	GL27A	—	Fig. 15	RK31	—	3G
8418W	—	3G	1642	—	7RII	6063	—	V24 7CF	G8	—	—	RK32	—	2D
843	—	5A	1644	—	Fig. 4	6064	—	V23 7DB	GL2C39A	—	V26	RK33	—	Fig. 69
844	—	5AW	1654	—	2Z	6065	—	V23 7DB	GL2C39B	—	V26	RK34	—	V25 Fig. 61
849	—	Fig. 39	1802P1-11	—	V30 11A	6066	—	V23 7BT	GL2C44	—	Fig. 9	RK35	—	2D
850	—	Fig. 47	1805P1-4	—	V30 11A	6067	—	V23 9A	GL5C24	—	V27 Fig. 15	RK36	—	2D
852	—	Fig. 47	1806P1	—	V30 11N	6072	—	V23 9A	GL146	—	V26 Fig. 56	RK37	—	2D
860	—	Fig. 58	1851	—	7R	6073	—	V23 6BO	GL152	—	V26 Fig. 56	RK38	—	2D
861	—	Fig. 42	1852	—	V18 8N	6074	—	V23 5BO	GL159	—	Fig. 56	RK39	—	5AW
864	—	4D	1853	—	V18 8N	6080	—	V23 8BD	GL169	—	Fig. 56	RK41	—	5AW
865	—	Fig. 57	2001	—	V30 4AA	6082	—	V21 8BD	GL446A	—	Fig. 11	RK42	—	4D
866	—	4P	2002	—	V30 Fig. 1	6084	—	—	GL446B	—	Fig. 11	RK43	—	4D
866A AX	—	V24 4P	2005	—	V30 4B	6085	—	—	GL464A	—	Fig. 9	RK44	—	4BM
866B	—	V24 4P	2050	—	V28 8BA	6086	—	—	9BK	—	Fig. 10	RK46	—	Fig. 61
866Bj	—	V24 4B	2051	—	8BA	6087	—	—	5L	—	GL-6442	RK47	—	Fig. 64
871	—	4P	2523N/128A	—	5A	6101	—	V23 7BF	GL6463	—	9CZ	RK48	—	Fig. 64
872A/872	—	V24 4AT	5514	—	V26 4BO	6132	—	V23 9BA	GL8012A	—	V25 Fig. 54	RK48A	—	Fig. 64
872A	—	4AT	5516	—	V28 7CL	6135	—	6BG	HL2030A	—	3N	RK49	—	6A
874	—	4P	5517	—	5BU	6136	—	V23 7BK	HP60	—	2D	RK51	—	3G
878	—	4P	5556	—	4D	6137	—	V19 8N	HP75	—	3D	RK52	—	3G
879	—	4AB	5562	—	Fig. 30	6140	—	9BY	HP100	—	2D	RK56	—	5AW
884	—	V23 9Q	5590	—	V18 7BD	6141	—	—	HP120	—	4F	RK57	—	3N
885	—	5A	5591	—	V23 7BD	6146	—	V28 7CK	HP140	—	4F	RK58	—	3N
902A	—	V30 8D	5608	—	V18 7BD	6155	—	V29 5BK	HP175	—	Fig. 46	RK59	—	Fig. 60
905	—	V30 5BP	5608A	—	7B	6156	—	V29 5BK	HP200	—	2N	RK59	—	V24
905A	—	V30 5BR	5608G	—	V18 6CG	6157	—	Fig. 36	HP201A	—	V27 Fig. 15	RK62	—	2N
906P1-11	—	V30 7AN	5618	—	7CU	6158	—	9A	HK201A	—	Fig. 15	RK63	—	4D
907	—	V30 5BP	5651	—	V23 5BO	6159	—	V28 7CK	HK300	—	V27 2N	RK63A	—	2N
908A	—	V30 7CE	5654	—	V23 7BD	6173	—	V21 Fig. 34	HK24	—	V25 3G	RK64	—	5AW
909	—	5BP	5656	—	V18 9F	6197	—	9BV	HK54	—	V26 2D	RK65	—	Fig. 48
910	—	7AN	5662	—	V28 Fig. 79	6201	—	V23 9A	HK57	—	V29 Fig. 33	RK66	—	Fig. 61
911	—	7AN	5663	—	V23 7E	6211	—	9A	HK154	—	2D	RK65	—	Fig. 61
912	—	V30 912	5670	—	V23 8CJ	6216	—	V18 Fig. 37	HK158	—	2D	RK100	—	Fig. 67
913	—	V30 913	5675	—	V25 Fig. 21	6218	—	9CG	HK252L	—	4BC	RK705A	—	Fig. 45
914A	—	6BF	5679	—	V23 7CX	6227	—	V18 9BA	HK253	—	4AT	RK866	—	4P
930B	—	V26 3G	5686	—	V18 9C	6252	—	V28 Fig. 7	HK254	—	2N	T20	—	V25 3G
938	—	4E	5687	—	V18 9C	6263	—	V25	HK257	—	V29 7BM	T20	—	V25 3G
950	—	5K	5690	—	Fig. 38	6264	—	V25	HK257B	—	V29 7BM	T40	—	V25 3G
951	—	4M	5691	—	V23 8BD	6265	—	V23 7CM	HK304L	—	4BC	T55	—	V26 3G
954	—	V21 5BB	5692	—	V23 8BD	6267	—	V18 9C-T	HK354C	—	2N	T60	—	2D
955	—	V21 5BC	5693	—	V19 8N	6287	—	—	HK354D	—	2N	T100	—	2D
955	—	V25 5BC	5694	—	V20 8CS	6299	—	—	HK354E	—	2N	T125	—	2N
956	—	V21 5BB	5696	—	V23 7BN	6308	—	V23 8FX	HK354F	—	2N	T200	—	V27 2N
957	—	5BD	5722	—	V18 5CB	6350	—	V23 9CZ	HK354E	—	2N	T300	—	V27 2N
958	—	5BD	5725	—	V23 7CM	6354	—	V24 Fig. 12	HK354F	—	2N	T814	—	V27
958A	—	V21 5BD	5726	—	V23 6BT	6360	—	V28 Fig. 13	HK454H	—	2N	T822	—	3N
958A	—	V25 5BD	5727	—	7BN	6374	—	9BW	HK454L	—	2N	T835	—	Fig. 30
959	—	V21 5BE	5731	—	V21 5BC	6386	—	V18 8CC	HV12	—	3N	TU F20	—	2T
967	—	V23 3G	5749	—	V23 7BK	6417	—	V28 9K	HV18	—	3N	TW75	—	2T
975A	—	4AT	5750	—	V23 7CH	6443	—	9BW	HV27	—	3N	TW450	—	3N
991	—	V23 4AT	5751	—	V23 9A	6485	—	V23 7BK	HY12	—	6Q	T220	—	V25 3G
1003	—	4R	5755	—	9J	6524	—	V28 Fig. 76	HY65GTX	—	Fig. 7	T240	—	V25 3G
1005	—	5AQ	5763	—	V28 9K	6660	—	V23 7CC	HY16L6GTX	—	4D	U1100	—	2D
1006	—	4C	5764	—	V25 Fig. 21	6661	—	V23 7CM	HY21	—	2D	U1468	—	Fig. 32
1201	—	V21 8BN	5765	—	V25 Fig. 21	6662	—	V23 7CM	HY25	—	3G	U135	—	3G
1203	—	4AH	5766	—	See 2C37	6663	—	V23 6BT	HY30Z	—	4BO	U140	—	2D
1204	—	8BO	5767	—	See 2C37	6669	—	V23 7BZ	HY31Z	—	V25 Fig. 60	U151	—	2D
1206	—	8BV	5768	—	Fig. 21	6677	—	V23 9BV	HY40	—	3G	V70	—	3G
1221	—	V23 6F	5794	—	Fig. 21	6679	—	V23 9A	HY40Z	—	3G	V70A	—	3N
1223	—	V23 7R	5812	—	7CQ	6680	—	V23 9A	HY51A	—	3G	V70B	—	3G
1229	—	4K	5814	—	9A	6691	—	V23 9A	HY51B	—	3G	V70C	—	3G
1230	—	4D	5814A	—	V23 9A	6829	—	V23 9A	HY51Z	—	4BO	V70D	—	V26 3G
1231	—	V20 8V	5823	—	V23 4CK	6850	—	V28 Fig. 76	HY51Z	—	3G	V71D	—	V26 3G
1232	—	8V	5824	—	V21 7P	6883	—	V28 7CK	HY60	—	5AW	VR90	—	V24 4AJ
1265	—	V23 4AJ	5825	—	4P	6893	—	V28 7CK	HY61	—	Fig. 72	VR105	—	V24 4AJ
1266	—	V23 4AJ	5839	—	6S	6897	—	V23	HY65	—	Fig. 72	VR150	—	V24 4AJ
1267	—	V23 4V	5842	—	V18 9V	7000	—	V23 7R	HY67	—	Fig. 65	VT52	—	4D
1273	—	V20 8V	5844	—	7BF	8000	—	V27 2N	HY69	—	Fig. 64	VT127A	—	V26 Fig. 53
1274	—	6S	5845	—	6CA	8001	—	V29 7BM	HY75	—	2T	W191	—	V25
1275	—	4C	5847	—	V18 9V	8002	—	V26 3N	HY75A	—	V25 2T	W33A	—	2D
1276	—	4D	5852	—	6S	8003	—	V26 3G	HY75B	—	V25 2T	X6030	—	Fig. 2
1280	—	8V	5857	—	9AB	8005	—	V26 3G	HY615	—	V25 Fig. 71	XXB	—	Fig. 6
1284	—	V21 8V	5866	—	V26 Fig. 3	8008	—	Fig. 8	HY801A	—	4D	XXD	—	V23 8AC
1291	—	V20 7BE	5867	—	V27 Fig. 3	8012	—	Fig. 54	HY866jr	—	4P	XXL	—	V25 5AC
1293	—	V20 4AA	5871	—	V23 C	8013-A	—							

Type	Page	Type	Page	Type	Page	Type	Page	Type	Page
1N109	V32	1N152	V32	2N63	V31	2N139	V31	2N222	V31
1N110	V32	1N153	V32	2N64	V31	2N140	V31	2N223	V31
1N111	V32	1N158	V32	2N68	V31	2N141	V31	2N224	V31
1N112	V32	1N172	V32	2N76	V31	2N143	V31	2N226	V31
1N113	V32	1N175	V32	2N78	V31	2N167	V31	2N255	V31
1N114	V32	1N191	V32	2N81	V31	2N188A	V31	2N256	V31
1N115	V32	1N192	V32	2N94A	V31	2N189A	V31	CK722	V31
1N116	V32	1N198	V32	2N105	V31	2N170	V31	CK760	V31
1N117	V32	1N285	V32	2N106	V31	2N175	V31	CK761	V31
1N118	V32	1N287	V32	2N107	V31	2N186	V31	CK762	V31
1N120	V32	1N288	V32	2N109	V31	2N186A	V31	CX1	V31
1N126	V32	1N290	V32	2N112	V31	2N187A	V31	GT14H	V31
1N127	V32	1N290	V32	2N113	V31	2N188	V31	GT20H	V31
1N128	V32	1N291	V32	2N114	V31	2N188A	V31	GT34	V31
1N132	V32	1N292	V32	2N116	V31	2N189	V31	GT81	V31
1N133	V32	1N335	V32	2N123	V31	2N190	V31	GT83	V31
1N139	V32	2N34	V31	2N130	V31	2N191	V31	GT87	V31
1N140	V32	2N35	V31	2N132	V31	2N192	V31	HP-1	V31
1N141	V32	2N39A	V31	2N133	V31	2N193	V31	H5	V31
1N142	V32	2N43	V31	2N135	V31	2N194	V31	1P-1	V31
1N143	V32	2N43A	V31	2N136	V31	2N200	V31	1P-1	V31
1N147	V32	2N44	V31	2N137	V31	2N211	V31	SH100	V31
1N151	V32	2N45	V31	2N138	V31	2N212	V31	ZJ-13	V31

VACUUM-TUBE BASE DIAGRAMS

Socket connections correspond to the base designations given in the column headed "Base" in the classified tube-data tables. Bottom views are shown throughout. Terminal designations are as follows:

- | | | | |
|------------------|----------------------|--------------------------------|----------------------------|
| A = Anode | D = Deflecting Plate | IS = Internal Shield | RC = Ray-Control Electrode |
| B = Beam | F = Filament | K = Cathode | Ref = Reflector |
| BP = Bayonet Pin | FE = Focus Elect. | NC = No Connection | S = Shell |
| BS = Base Sleeve | G = Grid | P = Plate (Anode) | TA = Target |
| C = Ext. Coating | H = Heater | P ₁ = Starter-Anode | U = Unit |
| CL = Collector | IC = Internal Con. | P _{BF} = Beam Plates | ● = Gas-Type Tube |

Alphabetical subscripts D, P, T and HX indicate, respectively, diode unit, pentode unit, triode unit or hexode unit in multi-unit types. Subscript CT indicates filament or heater tap.

Generally when the No. 1 pin of a metal-type tube in Table II, with the exception of all triodes, is shown connected to the shell, the No. 1 pin in the glass (G or G^T) equivalent is connected to an internal shield.

R.E.T.M.A. TUBE BASE DIAGRAMS

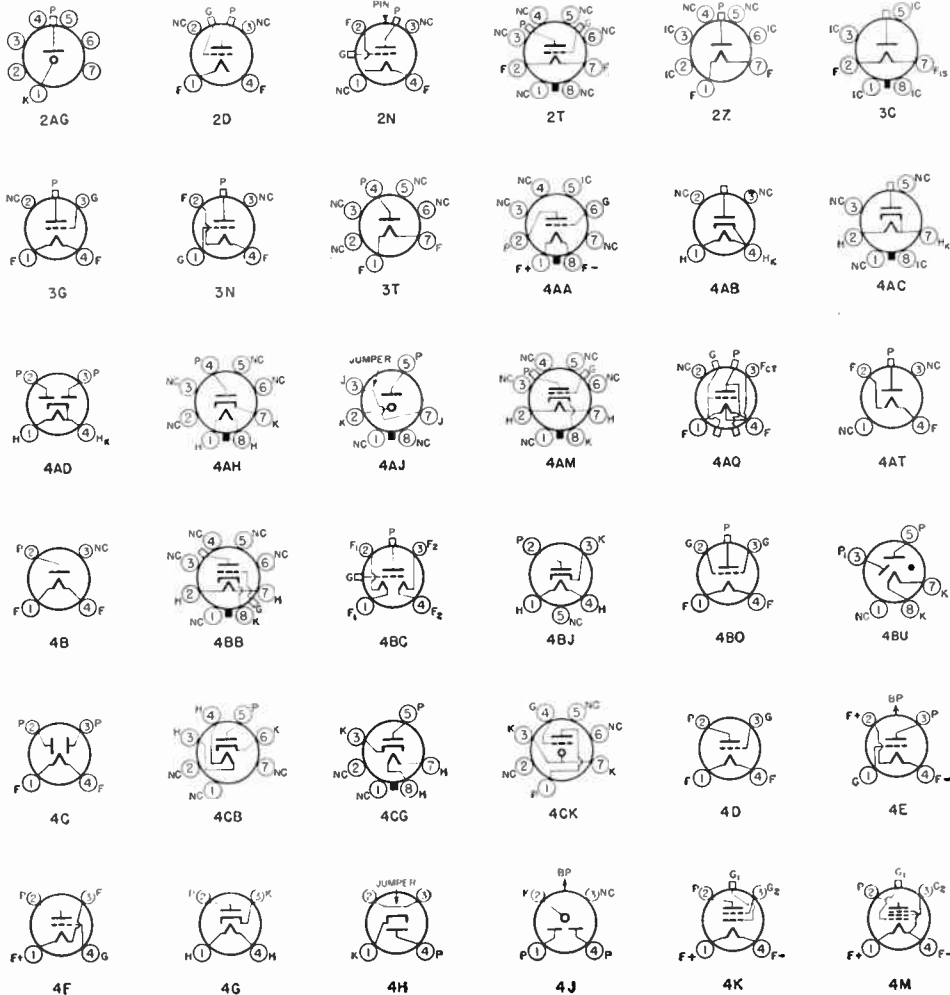

TUBE BASE DIAGRAMS

Bottom views are shown. Terminal designations on sockets are given on page V5.

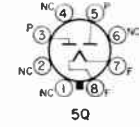
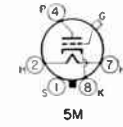
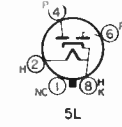
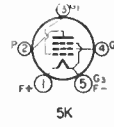
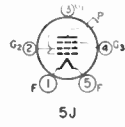
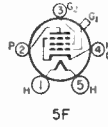
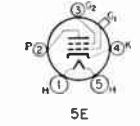
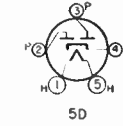
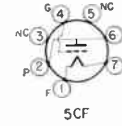
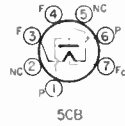
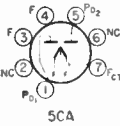
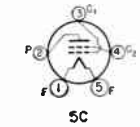
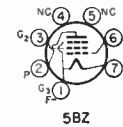
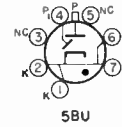
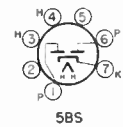
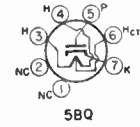
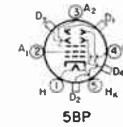
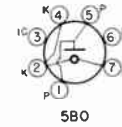
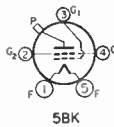
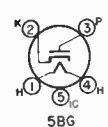
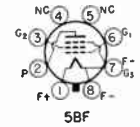
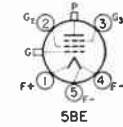
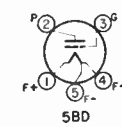
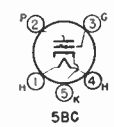
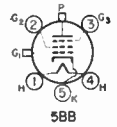
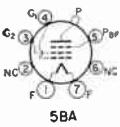
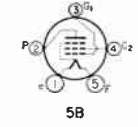
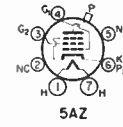
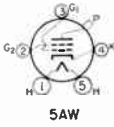
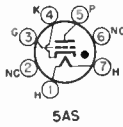
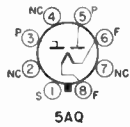
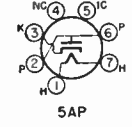
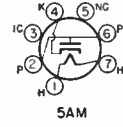
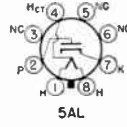
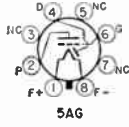
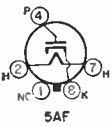
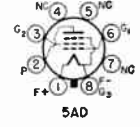
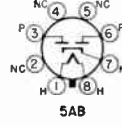
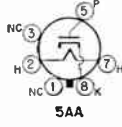
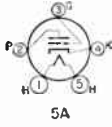
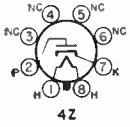
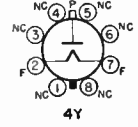
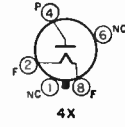
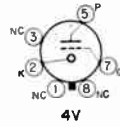
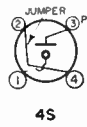
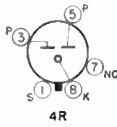
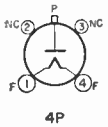

TUBE BASE DIAGRAMS

Bottom views are shown. Terminal designations on sockets are given on page V3.

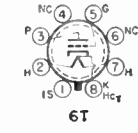
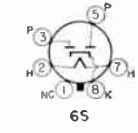
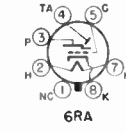
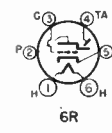
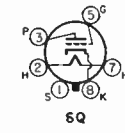
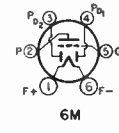
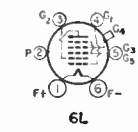
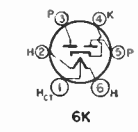
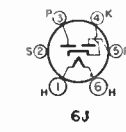
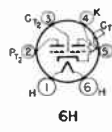
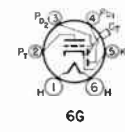
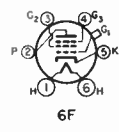
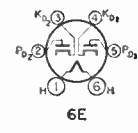
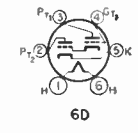
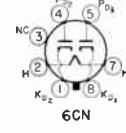
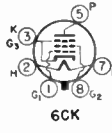
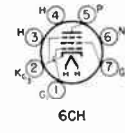
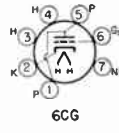
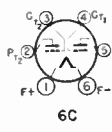
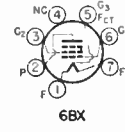
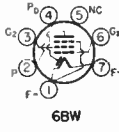
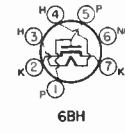
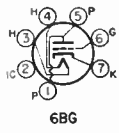
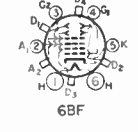
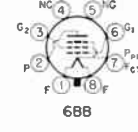
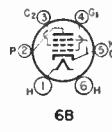
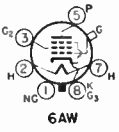
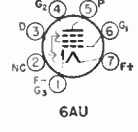
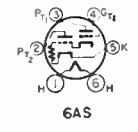
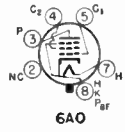
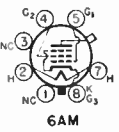
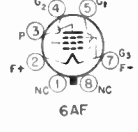
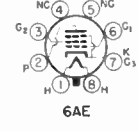
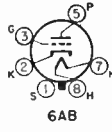
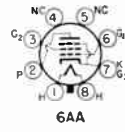
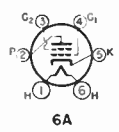
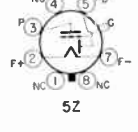
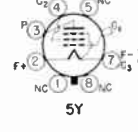
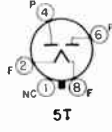
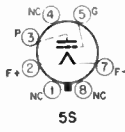
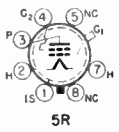

TUBE BASE DIAGRAMS

Bottom views are shown. Terminal designations on sockets are given on page V5.

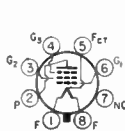
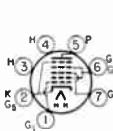
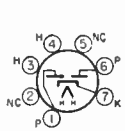
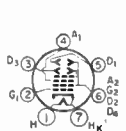
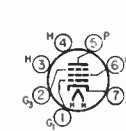
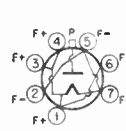
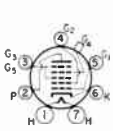
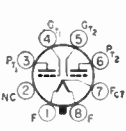
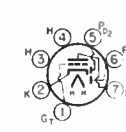
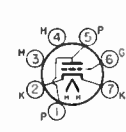
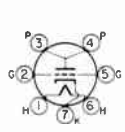
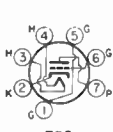
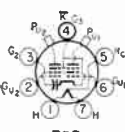
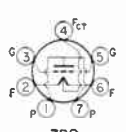
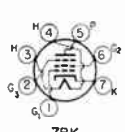
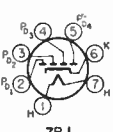
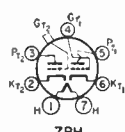
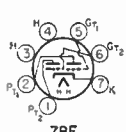
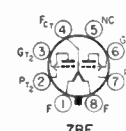
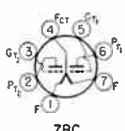
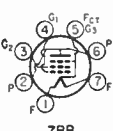
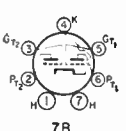
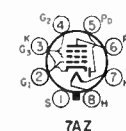
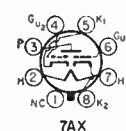
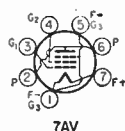
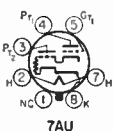
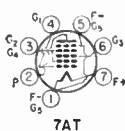
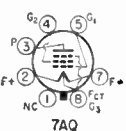
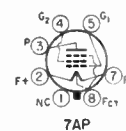
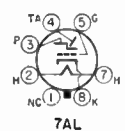
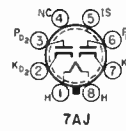
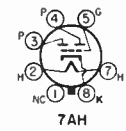
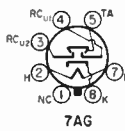
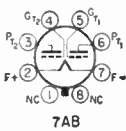
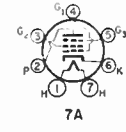
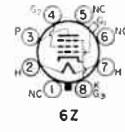
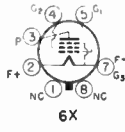

TUBE BASE DIAGRAMS

Bottom views are shown. Terminal designations on sockets are given on page V5.

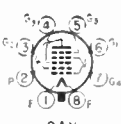
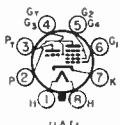
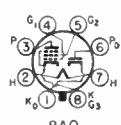
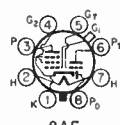
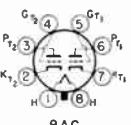
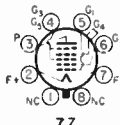
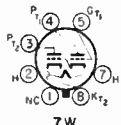
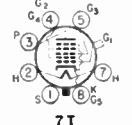
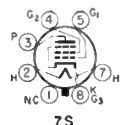
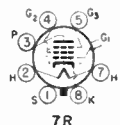
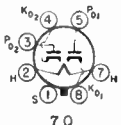
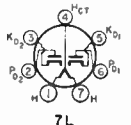
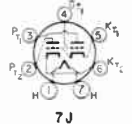
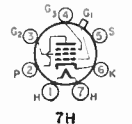
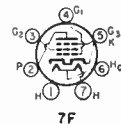
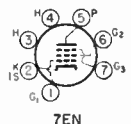
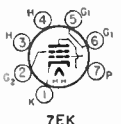
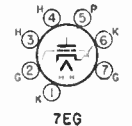
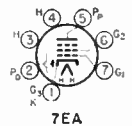
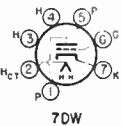
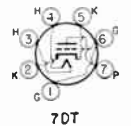
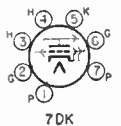
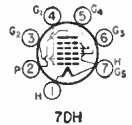
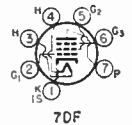
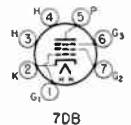
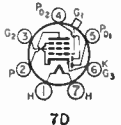
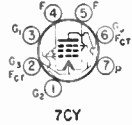
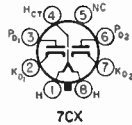
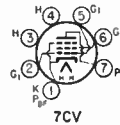
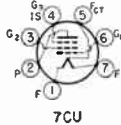
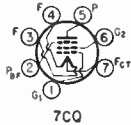
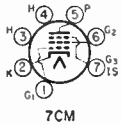

TUBE BASE DIAGRAMS

Bottom views are shown. Terminal designations on sockets are given on page V5.

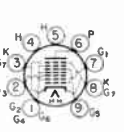
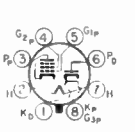
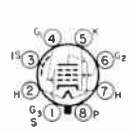
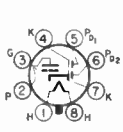
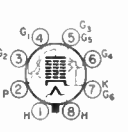
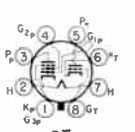
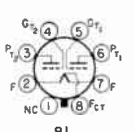
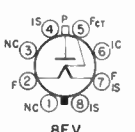
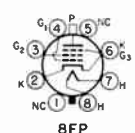
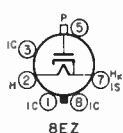
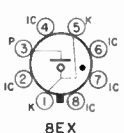
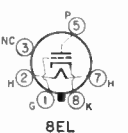
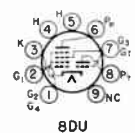
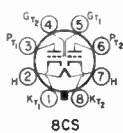
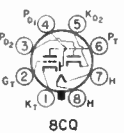
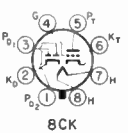
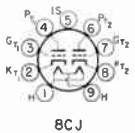
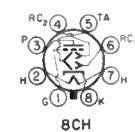
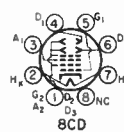
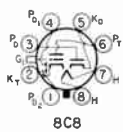
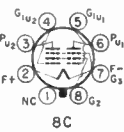
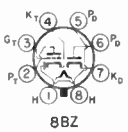
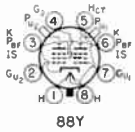
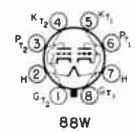
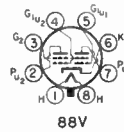
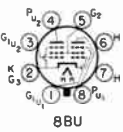
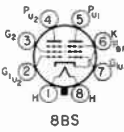
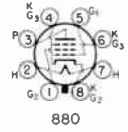
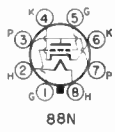
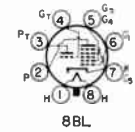
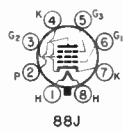
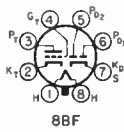
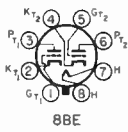
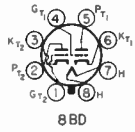

TUBE BASE DIAGRAMS

Bottom views are shown. Terminal designations on sockets are given on page V5.

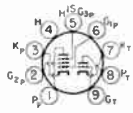

9ED



9EF

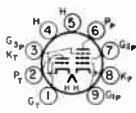

9EG

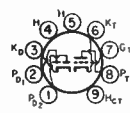

9EN

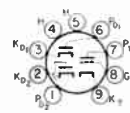

9ER



9ES

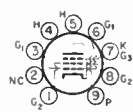

9EU

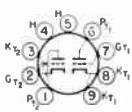

9EW



9F



9FA

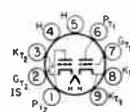

9FC



9FE

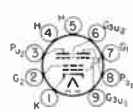

9FG



9FH



9FJ



9FT

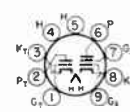

9FX



9FZ

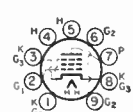

9G



9GF

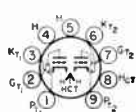

9H

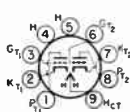

9J



9K



9L



9M

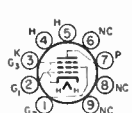

9N



9Q

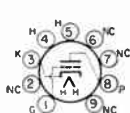

9R



9S



9T

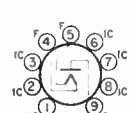

9U

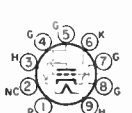

9V



9X

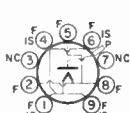

9Y

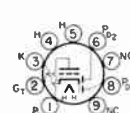

9Z

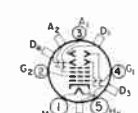

9I2



9I3



11A



11B



11C



11E



11F



11J



11L



11M



11N



11S



11T

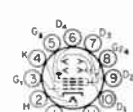

11V

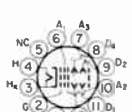

12A



12E



12F



12J



14A

TUBE BASE DIAGRAMS

Bottom views are shown. Terminal designations on sockets are given on page V5.



14 B



14 C



14 E



14 F



14 G



14 H



14 J



14 K



14 P

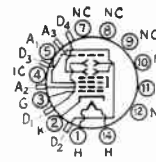

14 Q

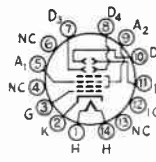

14 R

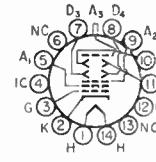

14 S



14 U

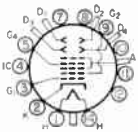

14 V

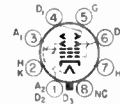

FIG. 1

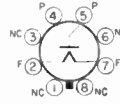

FIG. 2

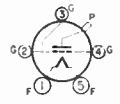

FIG. 3



FIG. 4

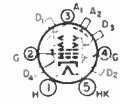

FIG. 5

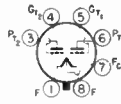

FIG. 6

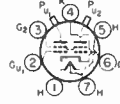

FIG. 7

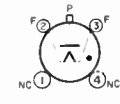

FIG. 8

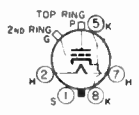

FIG. 9

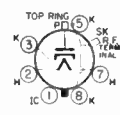

FIG. 10



FIG. 11

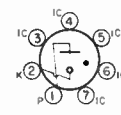

FIG. 12



FIG. 13



FIG. 14

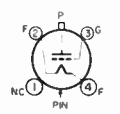

FIG. 15



FIG. 16

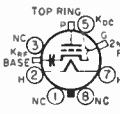

FIG. 17

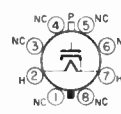

FIG. 18

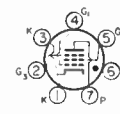

FIG. 19

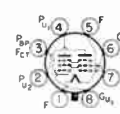

FIG. 20

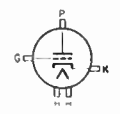

FIG. 21

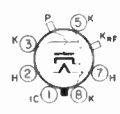

FIG. 22

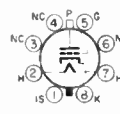

FIG. 23

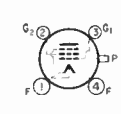

FIG. 24

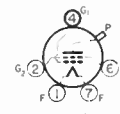

FIG. 25



FIG. 26

TUBE BASE DIAGRAMS

Bottom views are shown. Terminal designations on sockets are given on page V5.

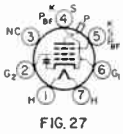

FIG. 27

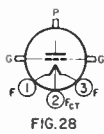

FIG. 28

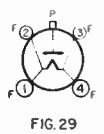

FIG. 29

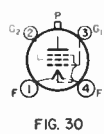

FIG. 30

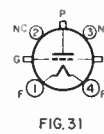

FIG. 31

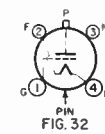

FIG. 32

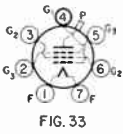

FIG. 33

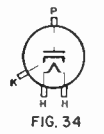

FIG. 34



FIG. 35



FIG. 36



FIG. 37

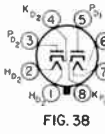

FIG. 38

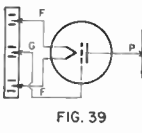

FIG. 39

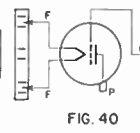

FIG. 40

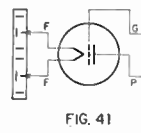

FIG. 41

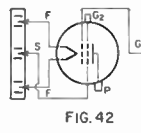

FIG. 42



FIG. 43

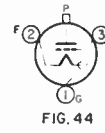

FIG. 44

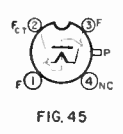

FIG. 45

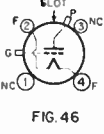

FIG. 46

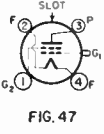

FIG. 47

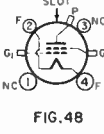

FIG. 48

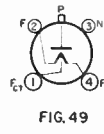

FIG. 49

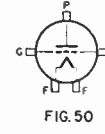

FIG. 50

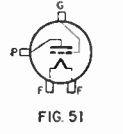

FIG. 51

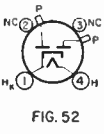

FIG. 52

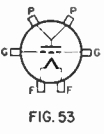

FIG. 53

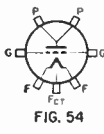

FIG. 54

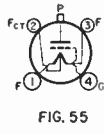

FIG. 55

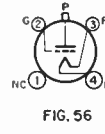

FIG. 56

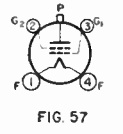

FIG. 57

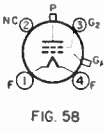

FIG. 58

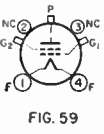

FIG. 59

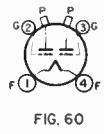

FIG. 60

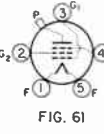

FIG. 61



FIG. 62

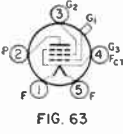

FIG. 63

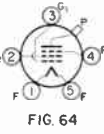

FIG. 64

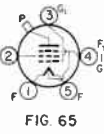

FIG. 65

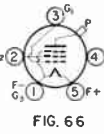

FIG. 66

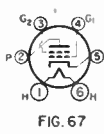

FIG. 67

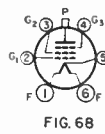

FIG. 68



FIG. 69

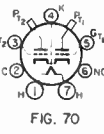

FIG. 70

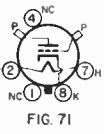

FIG. 71



FIG. 72

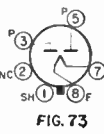

FIG. 73



FIG. 74



FIG. 75



FIG. 76



FIG. 77



FIG. 78



FIG. 79

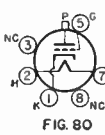

FIG. 80

TABLE I—MINIATURE RECEIVING TUBES

Type	Name	Base	Fil. or Heater		Capacitances $\mu\text{f.}$			Plate Supply V.	Grid Bias	Screen Volts	Screen Me.	Plate Me.	Plate Res. Ohms	Transcon-ductance ¹	Amp. Factor ⁴	Load Res. Ohms	Watts Output	
			V.	Amp.	C _g	C _{sc}	C _p											
1A3	H.f. Diode	5AP	1.4	0.15	—	—	—	Max. a.c. voltage per plate — 117. Max. output current — 0.5 ma.										
1AB6	Pentagrid Conv.	7DH	1.4	0.025	7.6	8.4	0.36	64	0	64	0.16	0.6	900K	275	—	—	—	
1AC6	Pentagrid Conv.	7DH	1.4	0.05	7.5	8.4	0.36	63.5	0	63.5	0.15	0.7	900K	—	—	—	—	
1AE4	Sharp Cut-off Pent.	6AR	1.25	0.1	3.6	4.4	0.008	90	0	90	1.2	3.5	500K	1550	—	—	—	
1AF4	Sharp Cut-off Pent.	6AR	1.4	0.025	3.8	7.6	0.009	90	0	90	0.55	1.8	1.8 meg.	1050	—	—	—	
1AF5	Diode-Pentode	6AU	1.4	0.025	2.3	2.8	0.17	90	0	90	0.4	1.1	2 meg.	600	—	—	—	
1AH5	Diode A.f. Pent.	6AU	1.4	0.025	2.1	2.9	0.3	85	10 meg. Ω	35	0.015	0.05	1 meg.	—	62	—	—	
1AJ4	R.f. Pentode	6AR	1.4	0.025	3.3	7.8	0.01	64	0	64	0.55	1.65	1 meg.	750	—	—	—	
1C3	Triode	5CF	1.4	0.05	0.9	4.2	1.8	90	-3	—	—	1.4	19K	760	14.5	—	—	
1E3	U.h.f. Triode	9BG	1.25	0.22	1.25	0.75	1.5	150	-3.5	—	—	20	—	3500	14	—	—	
1L4	Sharp Cut-off Pent.	6AR	1.4	0.05	3.6	7.5	0.008	90	0	90	2.0	4.5	350K	1025	—	—	—	
1L6	Pentagrid Conv.	7DC	1.4	0.05	7.5	12	0.3	90	0	45	0.6	0.5	650K	300	—	—	—	
1R5	Pentagrid Conv.	7AT	1.4	0.05	7.0	12	0.3	90	0	67.5	3.5	1.5	400K	280	Grid No. 1 100K			
1S4	Pentagrid Pwr. Amp.	7AV	1.4	0.1	—	—	—	90	-7.0	67.5	1.4	7.4	100K	1575	—	8K	0.270	
1S5	Diode—Pentode	A ₁ Amp. R.f. Amp. 6AU	1.4	0.05	—	—	—	67.5	0	67.5	0.4	1.6	600K	625	—	—	—	
								90	0	90	Screen Resistor 3 meg., grid 10 meg.			1 meg.	0.050			
1T4	Variable- μ Pent.	6AR	1.4	0.05	3.6	7.5	0.01	90	0	67.5	1.4	3.5	500K	900	—	—	—	
1U4	Sharp Cut-off Pent.	6AR	1.4	0.05	3.6	7.5	0.01	90	0	90	0.5	1.6	1 meg.	900	—	—	—	
1U5	Diode Pentode	6BW	1.4	0.05	—	—	—	67.5	0	67.5	0.4	1.6	600K	625	—	—	—	
1U6	Pentagrid Conv.	7DC	1.4	0.025	7	12	0.5	90	0	45	0.6	0.6	500K	300	—	—	—	
2C31	Medium- μ Twin Triode ¹⁰	8CJ	6.3	0.3	2.2	1.0	1.3	150	-2	—	—	8.2 ¹	6.5K	5500	35	—	—	
2E30	Beam Pwr. Pent.	A ₁ Amp. A ₁ Amp. ³ AB ₁ Amp. ³ AB ₂ Amp. ³ 7CQ	6.0	0.65	9.5	6.6	0.2	250	450*	250	3.3/7.4	44 ²	63K	3700	40 ⁵	4.5K	4.5	
								250	225*	250	6.6/14.8	88 ²	—	—	80 ⁵	9K*	9	
								250	-25	250	3/13.5	82 ²	—	—	48 ⁵	8K*	12.5	
								250	-30	250	4/20	120 ²	—	—	40 ⁵	3.8*	17	
3A4	Pwr. Amp. Pent.	7BB	1.4	0.2	4.8	4.2	0.34	135	-7.5	90	2.6	14.9 ²	90K	1900	—	8K	0.6	
								2.8	0.1	150	-8.4	90	2.2	14.1 ²	100K	—	0.7	
3A5	H.f. Twin Triode ¹⁰	7BC	1.4	0.22	0.9	1.0	3.2	90	-2.5	—	—	3.7	8.3K	1800	15	—	—	
								2.8	0.11	—	—	—	—	—	—	—	—	—
3C4	Power Pentode	6BX	1.4	0.05	4.9	4.4	0.3	85	-5.2	85	1.1	5	125K	1350	—	13K	0.2	
3E5	Pwr. Amp. Pent.	6BX	1.4	0.05	—	—	—	90	-7	90	1.6	8.0	100K	1550	—	8K	0.25	
								2.8	0.025	90	-7	90	1.4	6.8	120K	1450	—	9K
3Q4	Pwr. Amp. Pent.	7BA	1.4	0.1	5.5	3.8	0.2	90	-4.5	90	—	2.1	9.5	100K	2150	—	10K	0.27
								2.8	0.05	—	—	—	1.7	7.7	120K	2000	—	10K
3S4	Pwr. Amp. Pent.	7BA	1.4	0.1	—	—	—	90	-7	67.5	1.4	7.4	100K	1575	—	8K	0.27	
								2.8	0.05	—	—	—	1.1	6.1	1425	—	—	0.235
5BE8 [†]	Triode	9EG	4.7	0.6	2.8	1.5	1.8	150	56*	—	—	18	5K	8500	40	—	—	
								250	68*	110	3.5	10	400K	5200	—	—	—	
6AB4	U.h.f. Triode	5CE	6.3	0.15	2.2	0.5	1.5	250	200*	—	—	10	10.9K	5500	60	—	—	
								100	-2	—	—	4	—	1350	18	—	—	
6AB8	Triode—Pentode	9AT	6.3	0.3	—	—	—	200	-7.7	200	3.3	17.5	150K	3400	—	11K	1.4	
								250	-2	85	2.3	6.7	1 meg.	1100	—	—	—	
6AD8	Dual Diode—Pent.	9T	6.3	0.3	4.0	4.6	0.002	80	150*	—	—	16	2.27K	6600	15	—	—	
								100	10K Ω	—	0.4*	22	—	—	—	—	—	
6AF4A	U.h.f.—Triode	A ₁ Amp. Osc. 950 Mc. 7DK	6.3	0.225	2.2	0.45	1.9	250	180*	150	2.0	6.5	800K	5000	—	—	—	
								100	180*	100	1.4	4.5	600K	4550	—	—	—	
6AG5	Sharp Cut-off Pent.	7BD	6.3	0.3	6.5	1.8	0.03	300	160*	150	2.5	10	500K	9600	—	—	—	
6AH6	Sharp Cut-off Pent.	Pent. Amp. Triode Amp. 7BK	6.3	0.45	10	2.0	0.03	150	160*	—	—	12.5	3.6K	11K	40	—	—	
								125	68*	—	—	16	4.2K	10K	42	—	—	
6AJ4	U.h.f. Triode	9BX	6.3	0.225	4.4	0.18	2.4	28	-1	28	1.0	2.7	100K	2550	250	—	—	
6AJ5	Sharp Cut-off Pent.	R.f. Amp. AB Amp. ³ 7BD	6.3	0.175	4.0	2.1	0.3	180	-7.5	75	—	—	—	—	—	28K ⁴	1.0	
								100	-2	—	3.8	6.5	700K	2400	—	—	—	
6AJ8	Triode Heptode	9CA	6.3	0.3	—	—	—	250	0	102	—	—	13.5	5.9K	3700	22	—	—
								180	200*	120	2.4	7.7	690K	5100	—	—	—	
6AK5	Sharp Cut-off Pent.	7BD	6.3	0.175	4.0	2.8	0.02	150	330*	140	2.2	7	420K	4300	—	—	—	
								120	200*	120	2.5	7.5	340K	5000	—	—	—	
								180	-9	180	2.5	15	200K	2300	—	—	10K	1.1
6AK6	Pwr. Amp. Pent.	7BK	6.3	0.15	3.6	4.2	0.12	250	-3	—	—	1	58K	1200	70	—	—	
6AK8	Triple Diode Triode	9E	6.3	0.45	1.9	1.6	2.2	250	-3	—	—	—	—	—	—	—	—	
6AL5	Twin Triode ¹⁰	6BT	6.3	0.3	—	—	—	Max. r.m.s. voltage — 117. Max. d.c. output current — 9 ma. ¹										
6AM4	U.h.f. Triode	9BX	6.3	0.225	4.4	0.16	2.4	150	100*	—	—	7.5	10K	9000	90	—	—	
6AM5	Pwr. Amp. Pent.	6CH	6.3	0.2	—	—	—	250	-13.5	250	2.4	16	130K	2600	—	16K	1.4	
6AM6	Sharp Cut-off Pent.	7DB	6.3	0.3	7.5	3.25	0.01	250	-2	250	2.5	10	1 meg.	7500	—	—	—	
6AM8	Diode—Sharp Cut-off Pent.	9CY	6.3	0.45	6.0	2.6	0.015	200	120*	150	2.7	11.5	600K	7000	—	—	—	
6AN4	U.h.f. Triode	7DK	6.3	0.225	2.8	0.28	1.7	200	100*	—	—	13	—	10K	70	—	—	
6AN5	U.h.f. Triode	7BD	6.3	0.45	9.0	4.8	0.075	120	120*	120	12	35	12.5K	8000	—	—	2.5K	
6AN5	Beam Pwr. Pent.	7BD	6.3	0.45	9.0	4.8	0.075	120	120*	120	12	35	12.5K	8000	—	—	2.5K	
6AN7	Triode—Hexode Conv.	9Q	6.3	0.23	Osc.—22K Ω			250	-2	85	3	3	1 meg.	750	Osc. E _{bb} — 250 V ¹²	—	—	—
6AN8	Medium- μ Triode	9DA	6.3	0.45	2.0	2.7	1.5	200	-6	—	—	13	5.75K	3300	—	—	—	
								200	180*	150	2.8	9.5	30K	6200	—	—	—	
6AQ4	Sharp Cut-off Pent.	7DT	6.3	0.3	8.5	0.2	2.5	250	-1.5	—	—	10	12K	8500	100	—	—	
6AQ5	High- μ Triode	7DT	6.3	0.3	8.5	0.2	2.5	180	-8.5	180	3/4	30 ²	58K	3700	29 ³	5.5K	2.0	
								250	-12.5	250	4.5/7	47 ²	52K	4100	45 ³	5K	4.5	
6AQ6	Dual Diode—High- μ Triode	7BT	6.3	0.15	1.7	1.5	1.8	100	-1	—	—	0.8	61K	1150	70	—	—	
								250	-3	—	—	1	58K	1200	70	—	—	
6AR5	Pwr. Amp. Pent.	6CC	6.3	0.4	—	—	—	250	-16.5	250	5.7/10	35 ²	65K	2400	34 ³	7K	3.2	
								250	-18	250	5.5/10	33 ²	68K	2300	32 ³	7.6K	3.4	
6AR8	Sheet Beam	9DP	6.3	0.3	—	—	—	TV Color Ckts.—Synchronous Detector—Burst Gate										
6AS5	Beam Pwr. Amp.	7CV	6.3	0.8	12	6.2	0.6	150	-8.5	110	2/6.5	36 ²	—	5600	35 ³	4.5K	2.2	

TABLE I—MINIATURE RECEIVING TUBES—Continued

Type	Name	Base	Fil. or Heater		Capacitances $\mu\text{f.}$			Plate Supply V.	Grid Bias	Screen Volts	Screen Ma.	Plate Ma.	Plate Res. Ohms	Transcon- ductance ¹	Amp. Factor ²	Load Res. Ohms	Watts Output
			V.	Amp.	C _g	C _o	C _{sp}										
6AU8†	Medium- μ Triode Sharp Cut-off Pent.	9DX	6.3	0.6	2.6	0.34	2.2	150	150*	—	—	9	8.2K	4900	40	—	—
6AV6	Dual Diode—High- μ Triode	7BT	6.3	0.3	7.5	2.4	0.044	200	82*	125	3.4	15	150K	7000	—	—	—
6AW8A†	High- μ Triode Sharp Cut-off Pent.	9DX	6.3	0.6	2.2	0.32	2.2	200	—	—	—	4	17.5K	4000	70	—	—
6AX8	Medium- μ Triode Sharp Cut-off Pent.	9AE	6.3	0.45	2.5	1	1.8	150	56*	150	3.5	13	400K	9000	—	—	—
6AZ8	Medium- μ Triode Semiremote Cut-off Pent.	9ED	6.3	0.45	5	3.5	0.006	250	120*	110	3.5	10	400K	4800	—	—	—
6BA6	Remote Cut-off Pent.	7BK	6.3	0.3	2	1.7	1.7	200	—	—	—	13	5.75K	3300	19	—	—
6BA7	Pentagrid Conv.	8CT	6.3	0.3	6.5	2.2	0.02	200	180*	150	3	9.5	300K	6000	—	—	—
6BA8A†	Medium- μ Triode Sharp Cut-off Pent.	9DX	6.3	0.6	2.5	0.7	2.2	250	—	100	10	3.8	1 meg.	4400	—	—	—
6BC4	U.h.f. Medium- μ Triode	9DR	6.3	0.225	2.9	0.26	1.6	160	100*	—	—	14.5	4.8K	10K	48	—	—
6BC5	Sharp Cut-off Pent.	7BD	6.3	0.3	6.5	1.8	0.03	250	68*	100	4.2	11	1 meg.	4400	—	—	—
6BC7	Triple Diode	9AX	6.3	0.45	Max. diode current per plate = 12 Ma. Max. htr.-cath. volts = 200												
6BC8	Medium- μ Dual Triode ¹⁰	9AJ	6.3	0.4	2.5	1.3	1.4	150	220*	—	—	10	—	6200	35	—	—
6BD6	Remote Cut-off Pent.	7BK	6.3	0.3	4.3	5.0	0.005	100	—	100	5	13	150K	2550	—	—	—
6BD7	Dual Diode—High- μ Triode	9Z	6.3	0.23	2.4	1.3	1.3	250	—	3	100	3	9	800K	2000	—	—
6BE6	Pentagrid Conv.	7CH	6.3	0.3	Osc.—20K Ω			250	—1.5	100	6.8	2.9	1 meg.	475	—	—	—
6BE7	Heptode Limiter—Disc.	9AA	6.3	0.2	E ₂₃ , E ₂₅ = 12 v. r.m.s.			250	—4.4	20	1.5	0.28	5 meg.	—	—	470K	—
6BE8	Medium- μ Triode Sharp Cut-off Pent.	9EG	6.3	0.45	2.8	1.5	1.8	150	56*	0	—	18	5K	8500	40	—	—
6BF5	Beam Pwr. Amp.	7BZ	6.3	1.2	4.4	2.6	0.04	250	68*	110	3.5	10	400K	5200	—	—	—
6BF6	Dual Diode—Medium- μ Triode	7BT	6.3	0.3	1.8	0.8	2	250	—	9	—	9.5	8.5K	1900	16	10K	0.3
6BH5	Remote Cut-off Pent.	9AZ	6.3	0.2	4.9	5.5	0.002	250	—2.5	100	1.7	6.0	1.1 meg.	2200	—	—	—
6BH6	Sharp Cut-off Pent.	7CM	6.3	0.15	5.4	4.4	0.0035	250	—1	150	2.9	7.4	1.4 meg.	4600	—	—	—
6BH8†	Medium- μ Triode Sharp Cut-off Pent.	9DX	6.3	0.6	2.6	0.38	2.4	150	—5	—	—	9.5	5.15K	3300	17	—	—
6BJ5	Pwr. Amp. Pent.	6CH	6.3	0.64	—	—	—	250	—5	250	5.5	35	40K	10.5K	420	7K	4
6BJ6	Remote Cut-off Pent.	7CM	6.3	0.15	4.5	5.5	0.0035	250	—1	100	3.3	9.2	1.3 meg.	3800	—	—	—
6BJ7	Triple Diode	9AX	6.3	0.45	Max. peak inverse plate voltage = 330 V. Max. d.c. plate current each diode = 1.0 Ma.												
6BJ8†	Dual Diode—Medium- μ Triode	9ER	6.3	0.6	2.8	0.38	2.6	250	—9	—	—	8	7.15K	2800	20	—	—
6BK5	Beam Pwr. Pent.	9BQ	6.3	1.2	13	5	0.6	250	—5	250	3.5/10	37 ²	100K	8500	35 ²	6.5 ²	3.5
6BK6	Dual Diode—High- μ Triode	7BT	6.3	0.3	—	—	—	250	—2	—	—	1.2	62.5K	1600	100	—	—
6BK7A	Medium- μ Dual Triode ¹⁰	9AJ	6.3	0.4	3	1	1.8	150	56*	—	—	18	4.6K	9300	43	—	—
6BM5	Pwr. Amp. Pent.	7BZ	6.3	0.45	8	5.5	0.5	250	—6	250	3	30 ²	60K	7000	—	7K	3.5
6BN4	Medium- μ Triode	7EG	6.3	0.2	3.2	1.4	1.2	150	220*	—	—	9	6.3K	6800	43	—	—
6BN6	Gated-Beam Pent.	7DF	6.3	0.3	4.2	3.3	0.004	80	—1.3	60	5	0.23	—	—	—	68K	—
6BN7	Dual Triode ¹⁰	9AJ	6.3	0.75	5.5 ²	1.6 ²	3 ²	250	—15	—	—	24	2.2K	5500	12	—	—
6BN8†	Dual Diode—High- μ Triode	9ER	6.3	0.6	3.6	0.32	2.5	250	—3	—	—	1.6	28K	2500	70	—	—
6BQ7A	Medium- μ Dual Triode ¹⁰	9AJ	6.3	0.4	2.85	1.35	1.15	150	220*	—	—	9	6.1K	6400	39	—	—
6BR7	Sharp Cut-off Pent.	9BC	6.3	0.15	4.25	4	0.01	250	—3	100	0.6	2.1	2.5 meg.	1250	—	—	—
6BR8	Medium- μ Triode Sharp Cut-off Pent.	9FA	6.3	0.45	2.5	0.4	1.8	150	56*	—	—	18	5K	8500	40	—	—
6BS5	Beam Pwr. Amp.	9BK	6.3	0.75	9.5	4.5	0.3	250	—7.5	250	6.0	50 ²	17K	7000	120	5K	4.5
6BS7	Sharp Cut-off Pent.	9BB	6.3	0.15	4	4	0.01	200	—3	100	0.7	2	1.5 meg.	1100	—	—	—
6BS8	Low-Noise Dual Triode ¹⁰	9AJ	6.3	0.4	2.6	1.35	1.15	150	220*	—	—	10	5K	7200	36	—	—
6BT6	Dual Diode—High- μ Triode	7BT	6.3	0.3	—	—	—	250	—3	—	—	1	58K	1200	70	—	—
6BT8	Dual Diode—Pent.	9FE	6.3	0.45	7	2.3	0.04	200	180*	150	2.8	9.5	300K	6200	—	—	—
6BU6	Dual Diode—Low- μ Triode	7BT	6.3	0.3	—	—	—	250	—9	—	—	9.5	8.5K	1900	16	10K	0.3
6BU8	Dual Pent. ¹⁰	9FG	6.3	0.3	6	3†	—	100†	—	67.5	3.3	2.2	—	—	—	—	—
6BV7	Dual Diode—Pwr. Amp. Pent.	9BU	6.3	0.8	11.5	9.5	0.5	250	—5	250	6	38 ²	100K	10K	—	8K	4
6BV8†	Dual Diode—Medium- μ Triode	9FJ	6.3	0.6	3.6	0.4	2	200	330*	—	—	11	5.9K	5600	33	—	—
6BW6	Beam Pwr. Pent.	9AM	6.3	0.45	—	—	—	315	—13	225	2.2	34 ²	77K	3750	—	8.5K	5.5
6BW7	Sharp Cut-off Pent.	9AQ	6.3	0.3	10	3.5	0.01	180	100*	180	3.8	10	600K	9000	—	—	—
6BX6	R.f. Pent.	9AQ	6.3	0.3	7.2	3.4	0.007	170	—2	170	2.5	10	400K	8200	—	—	—
6BX8	Dual Triode ¹⁰	9AJ	6.3	0.4	—	—	1.4	65	—1	—	—	9	—	6700	25	—	—
6BY6	Pentagrid Amp.	7CH	6.3	0.3	5.4	7.6	0.08	250	—2.5	100	9	6.5	E ₂₃ = 2.5 V.	1900	—	—	—
6BY7	Remote Cut-off R.f. Pent.	9AQ	6.3	0.3	7.2	3.7	0.007	250	—2	100	2.5	10	500K	6000	—	—	—
6BY8†	Diode—Sharp Cut-off Pent.	Fig. 77	6.3	0.6	5.5	5	0.0035	250	68*	150	4.3	10.6	1 Meg.	5200	—	—	—
6BZ6	Semiremote Cut-off Pent.	7CM	6.3	0.3	7.5	1.8	0.02	200	180*	150	2.6	11	600K	6100	—	—	—
6BZ7	Medium- μ Dual Triode ¹⁰	9AJ	6.3	0.4	2.5	1.35	1.15	150	220*	—	—	10	5.6K	6800	38	—	—
6BZ8	Dual Triode ¹⁰	9AJ	6.3	0.4	—	—	—	125	100*	—	—	10 ²	5.6K	8000	45	—	—
6C4	Medium- μ Triode	6BG	6.3	0.15	1.8	1.3	1.6	250	—8.5	—	—	10.5	7.7K	2200	17	—	—
6CA5	Beam Pent.	7CV	6.3	1.2	15	9	0.5	125	—4.5	125	4/11	36 ²	15K	9200	37 ²	4.5K	1.5
6CB6	Sharp Cut-off Pent.	7CM	6.3	0.3	6.5	1.9	0.02	200	180*	150	2.8	9.5	600K	6200	—	—	—
6CE5†	R.f. Pent.	7BD	6.3	0.3	6.5	1.9	0.03	200	180*	150	2.8	9.5	600K	6200	—	—	—
6CF6	Sharp Cut-off Pent.	7CM	6.3	0.3	6.3	1.9	0.02	200	180*	150	2.8	9.5	600K	6200	—	—	—
6CG6	Semiremote Cut-off Pent.	7BK	6.3	0.3	5	5	0.008	250	—8	150	2.3	9	720K	5000	—	—	—
6CG7†	Medium- μ Dual Triode ¹⁰	9AJ	6.3	0.6	2.3	2.2	4	250	—8	—	—	9	7.7K	2600	20	—	—
6CG8	Medium- μ Triode Sharp Cut-off Pent.	9GF	6.3	0.45	2.6	0.05	1.5	100	100*	—	—	8.5	6.9K	5800	40	—	—
6CH6	R.f. Pent.	9BA	6.3	0.75	14	5	0.25	250	—4.5	250	6	40	50K	11K	—	—	—
6CH8	Medium- μ Triode Sharp Cut-off Pent.	9FT	6.3	0.45	1.9	1.6	1.6	200	—6	—	—	13	5.75K	3300	19	—	—
6CJ6	Pwr. Amp. Pent.	9A5	6.3	1.05	14.7	6	0.8	250	—38.5	250	2.4	32	15K	4600	—	—	—
6CK6	Pwr. Amp. Pent.	9AR	6.3	0.71	11.2	6.6	0.1	240	—5.5	250	5	36	130K	10K	—	—	—
6CL6	Pwr. Amp. Pent.	9BV	6.3	0.65	11	5.5	0.12	240	—3	140	7.7	31 ²	140K	11K	30 ²	7500	28

TABLE I—MINIATURE RECEIVING TUBES—Continued

Type	Name	Base	Fil. or Heater		Capacitances $\mu\text{f.}$			Plate Supply V.	Grid Bias	Screen Volts	Screen Ma.	Plate Ma.	Plate Res. Ohms	Transcon- ductance ¹⁾	Amp. Factor ⁴	Load Res. Ohms	Watt's Output	
			V.	Amp.	C _{in}	C _{out}	C _{sp}											
6CL8†	Triode	9FX	6.3	0.45	2.7	0.4	1.8	125	56*	—	—	15	5K	8000	40	—	—	
	Tetrad		5	2	0.028	125	—	1	125	4	12	100K	5800	—	—	—	—	
6CM6	Beam Pwr. Amp.	9CK	6.3	0.45	8	8.5	0.7	315	—13	225	2.2/6	35†	80K	3750	34‡	8.5K	5.5	
6CM7‡	Medium- μ Dual Triode	9ES	6.3	0.6	2	0.5	3.8	200	—7	—	—	5	11K	2000	20	—	—	
	Triode No. 1 Triode No. 2		3.5	0.4	3	250	—8	—	—	10	4.1K	4400	18	—	—	—	—	
6CM8‡	High- μ Triode	9FZ	6.3	0.45	1.6	0.22	1.9	250	—2	—	—	1.8	50K	2000	100	—	—	
	Sharp Cut-off Pent.		6	2.6	0.02	200	180*	150	2.8	9.5	300K	6200	—	—	—	—	—	
6CN7‡	Dual Diode—High- μ Triode	9EN	6.3	0.3	1.5	0.5	1.8	100	—1	—	—	0.8	54K	1300	70	—	—	
			3.15	0.6	—	—	—	250	—3	—	—	1	58K	1200	70	—	—	
6CQ6	Remote Cut-off Pent.	7DB	6.3	0.2	7	4.5	0.01	250	—2.5	200	2	7.8	—	2500	—	—	—	
6CR6	Diode—Remote Cut-off Pent.	7EA	6.3	0.3	—	—	—	250	—2	100	3	9.5	200K	1950	—	—	—	
6CS5	Beam Pwr. Pent.	9CK	6.3	1.2	15	9	0.5	200	180*	125	2.2	47‡	28K	8000	—	4K	3.8	
6CS6	Pentagrid Amp.	7CH	6.3	0.3	5.5	7.5	0.05	100	—1	30	1.1	0.75	1 meg.	9.50	E ₃ = 0 V.	—	—	
6CS7‡	Medium- μ Triode	9EF	6.3	0.6	1.8	0.5	2.6	250	—8.5	—	—	10.5	7.7K	2200	17	—	—	
	Triode No. 1 Triode No. 2		3.0	0.5	2.6	250	—10.5	—	—	19	3.45K	4500	15.5	—	—	—	—	
6CUS	Beam Pwr. Pent.	7CV	6.3	1.2	13.2	8.6	0.7	120	—8	110	4 B.5	50‡	10K	7500	—	2.5K	2.3	
6CX7	Medium- μ Dual Triode ¹⁰	9FC	6.3	0.4	2.47	1.37	1.27	150	220*	—	—	9	—	6400	39	—	—	
6DB6	Sharp Cut-off Pent.	7CM	6.3	0.3	6	5	0.0035	150	—1	150	6.6	5.8	50K	2050	E ₃ = -3 V.	—	—	
6DC6	Semiremote Cut-off Pent.	7CM	6.3	0.3	6.5	2	0.02	200	180*	150	3	9	500K	5500	—	—	—	
6DE6	Sharp Cut-off Pent.	7CM	6.3	0.3	6.3	1.9	0.02	200	180*	150	2.8	9.5	600K	6200	—	—	—	
6DT6	Sharp Cut-off Pent.	7EN	6.3	0.3	5.8	—	0.02	150	560*	100	2.1	1.1	150K	615	—	—	—	
6J4	Grounded-Grid Triode	7BQ	6.3	0.4	7.5	3.9	0.12	150	100*	—	—	15	4.5K	12K	55	—	—	
6J6	Medium- μ Dual Triode	7BF	6.3	0.45	2.2	0.4	1.6	100	50*	—	—	8.5	7.1K	5300	38	—	—	
	A ₁ Amp. Mixer		150	810*	—	—	4.8	10.2K	1900	Osc. peak voltage = 3 V.	—	—	—	—	—	—	—	
6M5	Pwr. Amp. Pent.	9N	6.3	0.71	10	6.2	1	250	170*	250	5.2	36	40K	10K	—	7K	3.9	
6N4	U.h.f. Triode	7CA	6.3	0.2	3	1.6	1.1	180	—3.5	—	—	12	5.4K	6000	32	—	—	
6N8	Dual Diode—Pent.	9T	6.3	0.3	4	4.6	0.002	250	295*	85	1.75	5	1.6 meg.	2200	35	—	—	
6Q4	H.f. Triode	9S	6.3	0.48	5.4	0.06	3.4	250	—1.5	—	—	15	—	12K	80	—	—	
6R4	H.f. Triode	9R	6.3	0.2	1.7	0.5	1.5	150	—2	—	—	30	—	5500	16	—	—	
6R8	Triple Diode-Triode	9E	6.3	0.45	1.5	1.1	2.4	250	—9	—	—	9.5	8.5K	1900	16	10K	0.3	
6S4	Medium- μ Triode	9AC	6.3	0.6	4.2	0.9	2.6	250	—8	—	—	26	3.6K	4500	16	—	—	
6T4	U.h.f. Triode	7DK	6.3	0.225	2.6	0.25	1.7	80	150*	—	—	18	1.86K	7000	13	—	—	
6T8	Triple Diode-High- μ Triode	9E	6.3	0.45	1.6	1	2.2	100	—1	—	—	0.8	54K	1300	70	—	—	
			250	—3	—	—	1	58K	1200	70	—	—	—	—	—	—	—	
6U8	Medium- μ Triode	9AE	6.3	0.45	2.5	0.4	1.8	150	56*	—	—	18	5K	8500	40	—	—	
	Sharp Cut-off Pent.		5	2.6	0.01	250	68*	110	3.5	10	400K	5200	—	—	—	—	—	
6V8	Triple Diode—Triode	9AH	6.3	0.45	—	—	—	100	—1	—	—	0.8	54K	1300	70	—	—	
			250	—3	—	—	1	58K	1200	70	—	—	—	—	—	—	—	
6X8	Medium- μ Triode	9AK	6.3	0.45	2.0	0.5	1.4	100	100*	—	—	8.5	6.9K	—	40	—	—	
	Sharp Cut-off Pent.		4.3	0.7	0.09	250	200*	150	1.6	7.7	750K	—	—	—	—	—	—	
12A4	Medium- μ Triode	9AG	12.6	0.3	4.9	0.9	5.6	250	—9	—	—	23	2.5K	8000	20	—	—	
			6.3	0.6	—	—	—	250	—12.5	—	—	4.4	—	—	—	—	—	—
12AB5	Beam Pwr. Amp.	A ₁ Amp. A _{B1} Amp.‡	9EU	12.6	0.2	8	8.5	0.7	250	—12.5	250	4.5/7	47‡	50K	4100	45‡	5K	4.5
				250	—15	250	5/13	79‡	60K ¹	3750	70‡	10K ⁴	10	—	—	—	—	
12AC6	Remote Cut-off Pent.	7BK	12.6	0.15	4.3	5	0.005	12.6	0	12.6	0.2	0.55	500K	730	—	—	—	
12AD6	Pentagrid Conv.	7CH	12.6	0.15	8	8	0.3	12.6	0	12.6	1.5	0.45	1 Meg.	260	—	Grid No. 112 33K	—	
12AD7	Dual High- μ Triode ¹⁰	9A	12.6	0.225	1.67	0.57	1.87	250	—2	—	—	1.25	62.5K	1600	100	—	—	
			6.3	0.45	1.6 ⁸	0.45 ⁸	1.8 ⁸	—	—	—	—	—	—	—	—	—	—	
12AE6	Dual Diode—Medium- μ Triode	7BT	12.6	0.15	1.8	1.1	2	12.6	0	—	—	0.75	15K	1000	15	—	—	
12AF6	R.I. Pent.	7BK	12.6	0.15	5.5	4.8	0.006	12.6	0	12.6	0.35	0.75	300K	1150	—	—	—	
12AG6	Pentagrid Conv.	7CH	12.6	0.15	6.5	7.5	0.28	12.6	0	12.6	1	0.35	—	240	—	Grid No. 112 20K	—	
12AH8	Triode-Heptode Converter	9BP	12.6	0.15	—	—	—	250	—3	100	4.4	2.6	1.5 meg.	550	—	E ₃ Triode Osc. = 100 V. I _b Triode = 5.3 ma.	—	
			6.3	0.3	—	—	—	—	—	—	—	—	—	—	—	—	—	
12AQ5	Beam Pwr. Amp.	A ₁ Amp. A _{B1} Amp.‡	7BZ	12.6	0.225	8.3	8.2	0.35	250	—12.5	250	4.5/7	47‡	52K	4100	45‡	5K	4.5
				250	—15	250	5/13	79‡	60K ¹	3750	70‡	10K ⁴	10	—	—	—	—	
12AT7	High- μ Dual Triode ¹⁰	9A	12.6	0.15	2.27	0.57	1.57	100	270*	—	—	3.7	15K	4000	60	—	—	
			6.3	0.3	2.2 ⁸	0.4 ⁸	1.5 ⁸	250	200*	—	—	10	10.9K	5500	60	—	—	
12AU7A	Medium- μ Dual Triode ¹⁰	9A	12.6	0.15	1.67	0.57	1.57	100	0	—	—	11.8	6.25K	3100	19.5	—	—	
			6.3	0.3	1.6 ⁸	0.35 ⁸	1.5 ⁸	250	—8.5	—	—	10.5	7.7K	2200	17	—	—	
12AV7	Medium- μ Dual Triode ¹⁰	9A	12.6	0.225	3.17	0.57	1.97	100	120*	—	—	9	6.1K	6100	37	—	—	
			6.3	0.45	3.1 ⁸	0.4 ⁸	1.9 ⁸	150	56*	—	—	18	4.8K	8500	41	—	—	
12AW6	Sharp Cut-off Pent.	7CM	12.6	0.15	6.5	1.5	0.025	250	200*	150	2	7	800K	5000	42	—	—	
12AX7	High- μ Dual Triode	9A	12.6	0.15	1.67	0.46†	1.77	250	—2	—	—	1.2	62.5K	1600	100	—	—	
	A ₁ Amp. Class B		6.3	0.3	1.6 ⁸	0.34 ⁸	1.7 ⁸	300	0	—	—	40‡	—	—	—	14‡	16K ⁴	7.5
12AY7	Medium- μ Dual Triode ¹⁰	9A	12.6	0.15	1.3	0.6	1.3	250	—4	—	—	3	—	1750	40	—	—	
	A ₁ Amp. Dual Triode ¹⁰ Low-Level Amp.		150	2700*	—	—	—	—	—	—	—	—	—	—	—	—	—	
12AZ7	High- μ Dual Triode ¹⁰	9A	12.6	0.225	3.17	0.57	1.97	100	270*	—	—	3.7	15K	4000	60	—	—	
			6.3	0.45	3.1 ⁸	0.4 ⁸	1.9 ⁸	250	200*	—	—	10	10.9K	5500	60	—	—	
12B4	Low- μ Triode	9AG	12.6	0.3	5	1.5	4.8	150	—17.5	—	—	34	1.03K	6300	6.5	—	—	
			6.3	0.6	—	—	—	—	—	—	—	—	—	—	—	—	—	—
12BH7	Medium- μ Dual Triode ¹⁰	9A	12.6	0.3	3.27	0.57	2.67	250	—10.5	—	—	11.5	5.3K	3100	16.5	—	—	
			6.3	0.6	3.2 ⁸	0.4 ⁸	2.6 ⁸	—	—	—	—	—	—	—	—	—	—	—
12BR7	Dual Diode—Medium- μ Triode	9CF	12.6															

TABLE I—MINIATURE RECEIVING TUBES—Continued

Type	Name	Base	Fil. or Heater		Capacitances $\mu\mu\text{f.}$			Plate Supply V.	Grid Bias	Screen Volts	Screen Ma.	Plate Ma.	Plate Res. Ohms	Transcon-ductance ¹⁾	Amp. Factor ⁴	Load Res. Ohms	Watt's Output
			V.	Amp.	C ₁	C _{out}	C _{sp}										
12CR6	Diode—Remote Cut-off Pent.	7EA	12.6	0.15	—	—	—	250	-2	100	2.6	9	333K	2200	—	—	—
12F8	Dual Diode—Remote Cut-off Pent.	9FH	12.6	0.15	4.5	3	0.06	12.6	0	12.6	0.38	1	333K	1000	—	—	—
12G8	Dissimilar Dual Triode Direct Coupled Amp.	9CZ	12.6	0.4	—	—	—	12.6 ⁷	0 ²	—	—	3 3.77 7.2 7.4 ⁸	8.5K	2600	22	8.5K	0.025
12H4	General Purpose Triode	7DW	12.6	0.15	—	—	—	90	0	—	—	10	—	3000	20	—	—
12K5	Tetrode (Pwr. Amp. Driver)	7EK	12.6	0.45	—	—	—	250	-8	—	—	9	—	2600	20	—	—
12RS ⁵	Beam Pwr. Pent.	7CV	12.6	0.6	13	9	0.55	110	-8.5	110	3.3	40	13K	7000	—	—	—
12U7	Dual Medium- μ Triode ¹⁰	9A	12.6	0.15	1.67 ⁹	0.47	1.57 ⁹	12.6	0	—	—	1	12.5K	1600	20	—	—
25F5	Beam Pwr. Pent.	7CV	25	0.15	12	6	0.57	110	-7.5	110	3/7	36 37	16K	5800	—	2.5K	1.2
35B5	Beam Pwr. Amp.	7BZ	35	0.15	11	6.5	0.4	110	-7.5	110	3/7	41 ²	—	5800	40 ³	2.5K	1.5
50B5	Beam Pwr. Amp.	7BZ	50	0.15	13	6.5	0.5	110	-7.5	110	4/8.5	50 ²	14K	7500	49 ³	2.5K	1.9
5590	R.f. Pent.	7BD	6.3	0.15	3.4	2.9	0.01	90	820*	90	1.4	3.9	300K	2000	—	—	—
5608	Sharp Cut-off Pent.	7BD	6.3	1.75	4	2.9	0.02	120	-12	120	2.5	7.5	340K	5000	—	—	—
5610	Triode	6CG	6.3	0.15	—	—	—	90	-1.5	—	—	17	3.5K	4000	14	—	—
5656	Twin Tetrode ¹⁰	9F	6.3	0.4	3.6	1.5	0.06	150	-2	120	2.7	15	60K	5800	—	—	—
5686	Beam Pwr. Pent.	9G	6.3	0.35	6.4	8.5	0.11	250	-12.5	250	3 ³	27 ³	45K	3100	—	9K	2.7
5687	Medium- μ Dual Triode ¹⁰	9H	12.6	0.45	4 ⁷	0.67	4 ⁷	120	-2	—	—	36	1.7K	11K	18.5	—	—
5722	Noise Generating Diode	5CB	6.3	1.5	—	2.2	—	200	—	—	—	35	—	—	—	—	—
5842	High- μ Triode	9V	6.3	0.3	1.6	0.5	1.5	150	62*	—	—	26	1.8K	24K	43	—	—
5847	Sharp Cut-off Pent.	9X	6.3	0.3	7.1	2.9	0.04	160	-8.5	160	4.5	—	—	12.5K	—	—	—
5879	Sharp Cut-off Pent.	9AD	6.3	0.15	2.7	2.4	0.15	250	-3	100	0.4	1.8	2 meg.	1000	—	—	—
6028	Sharp Cut-off Pent.	7BD	20	0.05	4	2.8	0.02	120	180*	120	2.5	7.5	300K	5000	—	—	—
6045	Medium- μ Dual Triode ¹⁰	7BF	6.3	0.35	2	0.45	1.3	100	50*	—	—	9	5.9K	6400	38	—	—
6216	Beam Pwr. Amp.	Fig. 37	6.3	1.2	12.3	6.7	0.37	200	-6	100	2/4	51 ²	38K	8800	47 ³	4.5K	3.8
6227	Pwr. Pent.	9BA	6.3	0.75	11.5	7	—	200	130*	200	4.1	30	90K	9000	—	—	2.8
6287	Beam Pwr. Amp.	9CT	6.3	0.6	8	9	1.1	250	-12.5	250	5/10.5	48 ²	55K	4100	46 ³	6K	4.5
6386	Medium- μ Dual Triode ¹⁰	8CJ	6.3	0.35	2	1.1	1.2	100	200*	—	—	9.6	4.25K	4000	17	—	—
9001	Sharp Cut-off Pent.	7BD	6.3	0.15	3.6	3	0.01	250	-3	100	0.7	2	1 meg.+	1400	—	—	—
9002	U.h.f. Triode	7BS	6.3	0.15	1.2	1.1	1.4	250	-7	—	—	6.3	11.4K	2200	25	—	—
9003	Remote Cut-off Pent.	7BD	6.3	0.15	3.4	3	0.1	250	-3	100	2.7	6.7	700K	1800	—	—	—
9006	U.h.f. Diode	6BH	6.3	0.15	—	—	—	—	—	—	—	—	—	—	—	—	—

† Controlled heater warm-up characteristic. ¹ Per. Plate. ³ No signal plate ma. ⁹ Oscillator grid current ma.
² Oscillator gridleak or screen-dropping resistor ohms. ² Maximum-signal current for full-power output. ⁴ Effective plate-to-plate. ¹⁰ Values for each section.
^{*} Cathode resistor ohms. ³ Values are for two tubes in push-pull. ⁷ Triode No. 1. ¹¹ Micromhos.
^{**} Grid No. 1 (Space-charge grid). ⁴ Unless otherwise noted. ⁸ Triode No. 2. ¹² Through 33K.

TABLE II—METAL RECEIVING TUBES

Characteristics given in this table apply to all tubes having type numbers shown, including metal tubes, glass tubes with "G" suffix, and bantam tubes with "GT" suffix. For "G" and "GT" tubes not listed (not having metal counterparts), see Tables III, V, VI and VIII.

Type	Name	Base	Fil. or Heater		Capacitances $\mu\mu\text{f.}$			Plate Supply V.	Grid Bias	Screen Volts	Screen Ma.	Plate Ma.	Plate Res. Ohms	Transcon-ductance ¹⁾	Amp. Factor ¹⁵	Load Res. Ohms	Watt's Output
			V.	Amp.	C ₁	C _{out}	C _{sp}										
6A8	Pentagrid Conv.	8A	6.3	0.3	—	—	—	250	-3	100	2.7	3.5	360K	550	—	—	—
6AB7 1853	Remote Cut-off Pent.	8N	6.3	0.45	8	5	0.15	300	-3	200	3.2	12.5	700K	5000	—	—	—
6AC7 1852	Sharp Cut-off Pent.	8N	6.3	0.45	11	5	0.15	300	160*	150	2.5	10	700K	5000	—	—	—
6AG7	Pwr. Amp. Pent.	8Y	6.3	0.65	13	7.5	0.06	300	160*	60K ⁸	2.5	10	1 meg.	9000	—	—	—
6BB	Dual-Diode—Pent.	8E	6.3	0.3	6	9	0.005	300	-3	150	7/9	30/31	130K	11K	—	10K	3
6C5	Medium- μ Triode	A ₁ Amp. Biased Detector	6Q	6.3	0.3	3	11	2	250	-8	—	8	10K	2000	20	—	—
6F5	High- μ Triode	5M	6.3	0.3	5.5	4	2.4	250	-17	—	—	—	—	—	—	—	—
6F6	Pwr. Amp. Pent.	A ₁ Amp. ³ A ₂ Amp. ¹ , ⁶ A ₁ Amp. ³ A ₂ Amp. ⁶	5M	6.3	0.3	5.5	4	2.4	250	-2	—	0.9	66K	1500	100	—	—
			250	-20	20 ¹⁰	—	31/34	2.6K	2600	6.8	4K	0.85					
			350	730*	132 ¹¹	—	50/60	—	—	—	10K ⁷	9					
			350	-38	123 ¹¹	—	48/92	—	—	—	6K ⁷	13					
250	-16.5	250	6/11	34/36	80K	2500	—	7K	3.2								
285	-20	285	7/13	38/40	78K	2500	—	7K	4.8								
375	-26	250	5/20	34/82	—	—	—	82 ¹¹	10K ⁷	18.5							
375	340*	250	8/18	54/77	—	—	—	94 ¹¹	10K ⁷	19							

Max. o.c. voltage per plate = 150 r.m.s. Max. output current 8.0 ma. d.c.

Zero signal cathode current = 0.43 ma.

Osc. peak volts = 7

I_{g1} (Osc.) = 0.15 ma.

Type	Name	Base	Fil. or Heater		Capacitances $\mu\text{f.}$			Plate Supply V.	Grid Bias	Screen Volts	Screen Ma.	Plate Ma.	Plate Res. Ohms	Transcon-ductance ¹²	Amp. Factor ¹⁵	Lead Res. Ohms	Watts Output	
			V.	Amp.	C_k	C_{sw}	C_{sp}											
6L6 ²	Beam Pwr. Amp. A ₁ ratings on page V18	AB ₁ Amp. ⁶ Self Bias AB ₂ Amp. ⁶ Fixed Bias AB ₃ Amp. ⁶ Fixed Bias	7AC	6.3	0.9	10	12	0.4	360	270*	270	5/17	88/100	—	—	40.6 ¹¹	9K ⁷	24.5
									360	-22.5	270	5/11	88/140	—	—	45 ¹¹	3.8K ⁷	18
									360	-22.5	270	5/15	88/132	—	—	45 ¹¹	6.6K ⁷	26.5
									360	-18	225	3.5/11	78/142	—	—	52 ¹¹	6K ⁷	31
									360	-22.5	270	5/16	88/205	—	—	72 ¹¹	3.8K ⁷	47
6L7	Pentagrid—Mixer Amp.	A ¹ Amp. Mixer	7T	6.3	0.3	—	—	—	250	-3	100	6.5	5.3	600K	1100	-3 ¹⁴	—	—
									250	-6	150	9.2	3.3	1 meg.+	350	-15 ¹⁴	—	—
									300	0	—	—	35/70	—	82 ¹¹	8K ⁷	10	
6N7	Class-B Twin Triode	B Amp. ⁹ A ₁ Amp. ¹⁷	8B	6.3	0.8	—	—	—	250	-5	—	—	6	11.3K	3100	—	—	
6Q7	Dual Diode—High- μ Triode		7V ²	6.3	0.3	5	3.8	1.4	250	-3	—	—	1	58K	1200	70	—	
6R7	Dual Diode—Triode		7V ²	6.3	0.3	4.8	3.8	2.4	250	-9	—	—	9.5	8.5K	1900	16	10K	
6S7	Remote Cut-off Pent.		7R ²	6.3	0.15	6.5	10.5	0.005	250	-3	100	2	8.5	1 meg.	1750	—	—	
6SA7	Pentagrid Conv.		8R ²	6.3	0.3	9.5	12	0.13	250	0 ³	100	8	3.4	800K	—	Grid No. 1 resistor 20K.	—	
									100	-1	100	10.2	3.6	50K	900	—	—	
									250	-1	100	10	3.8	1 meg.	950	—	—	
6SB7Y	Pentagrid Conv.		8R	6.3	0.3	9.6	9.2	0.13	250	-22K ⁸	12K ⁸	12/13	6.8/6.5	—	Osc. Section in 88-108 Mc. Service.	—	—	
6SC7	High- μ Dual Triode ¹		8S	6.3	0.3	2	3	2	250	-2	—	—	2	53K	1325	70	—	
6SF5	High- μ Triode		6AB ²	6.3	0.3	4	3.6	2.4	250	-2	—	—	0.9	66K	1500	100	—	
6SF7	Diode—Variable- μ Pent.		7AZ	6.3	0.3	5.5	6	0.004	250	-1	100	3.3	12.4	700K	2050	—	—	
6SQ7	H.f. Amp. Pent.		8BK	6.3	0.3	8.5	7	0.003	250	-2.5	150	3.4	9.2	1 meg.+	4000	—	—	
6SH7	H.f. Amp. Pent.		8BK	6.3	0.3	8.5	7	0.003	250	-1	150	4.1	10.8	900K	4900	—	—	
6SJ7 ⁴	Sharp Cut-off Pent.		8N	6.3	0.3	6	7	0.005	250	-3	100	0.8	3	1 meg.+	1650	—	—	
6SK7	Variable- μ Pent.		8N	6.3	0.3	6	7	0.003	250	-3	100	2.6	9.2	800K	2000	—	—	
6SQ7	Dual Diode—High- μ Triode		8Q	6.3	0.3	3.2	3	1.6	250	-2	—	—	0.9	91K	1100	100	—	
6SR7	Dual Diode—Triode		8Q	6.3	0.3	3.6	2.8	2.4	250	-9	—	—	9.5	8.5K	1900	16	—	
6SS7	Variable- μ Pent.		8N	6.3	0.15	5.5	7	0.004	250	-3	100	2	9	1 meg.	1850	—	—	
6ST7	Dual Diode—Triode		8Q	6.3	0.15	2.8	3	1.5	250	-9	—	—	9.5	8.5K	1900	—	—	
6SV7	Diode—R.f. Pent.		7AZ	6.3	0.3	6.5	6	0.004	250	-1	150	2.8	7.5	1.5 meg.	3600	—	—	
									180	-8.5	180	3/4	29/30	50K	3700	8.5 ¹⁰	5.5K	
									250	-12.5	250	4.5/7	45/47	50K	4100	12.5 ¹⁰	5K	
									315	-13	225	2.2/6	34/35	80K	3750	13 ¹⁰	8.5K	
									250	-15	250	5/13	70/79	60K	3750	30 ¹¹	10K ⁷	
									285	-19	285	4/13.5	70/92	70K	3600	38 ¹¹	8K ⁷	
6V6	Beam Pwr. Amp.	A ₁ Amp. ⁵ AB ₁ Amp. ⁶	7AC	6.3	0.45	10	11	0.3	250	-3	100	6.5	9.3	600K	1100	-3 ¹⁴	—	
1612	Pentagrid Amp.		7T	6.3	0.3	7.5	11	0.001	250	-3	100	5	2	1 meg.+	1225	—	—	
1620	Sharp Cut-off Pent.		7R	6.3	0.3	7	12	0.005	250	-3	100	0.5	2	1 meg.+	1225	—	—	
									330	500*	—	—	55/59	—	54 ¹¹	5K ⁷	2	
1621	Pwr. Amp. Pent.	A ₁ Amp. ¹⁴ A ₁ Amp. ⁶	7S	6.3	0.7	7.5	11.5	0.2	300	-30	300	6.5/13	38/69	—	60 ¹¹	4K ⁷	5	
									300	-30	300	6.5/13	38/69	—	60 ¹¹	4K ⁷	5	
1622	Beam Pwr. Amp. ⁶		7AC	6.3	0.9	10	12	0.4	300	-20	250	4/10.5	86/125	—	40 ¹¹	4K ⁷	10	
5693	Sharp Cut-off Pent.		8N	6.3	0.3	5.3	6.2	0.005	250	-3	100	0.85	3	1 meg.	1650	—	—	
5961	Pentagrid Conv.		8R	6.3	0.3	—	—	—	250	-2	100	8.5	3.5	1 meg.	450	Osc. grid ⁸ 20K.	—	
6137	Remote Cut-off Pent.		8N	6.3	0.3	5	6.5	0.003	250	-3	100	2.6	9.2	800K	2000	—	—	

* Cathode resistor-ohms.

¹ Screen tied to plate.

² No connection to Pin No. 1 for 6L6G, 6Q7G, 6R7GT/G, 6S7G, 6SA7GT/G and 6SF5-GT.

³ Grid bias = 2 volts if separate oscillator excitation is used.

⁴ Also Type "6SJ7Y."

⁵ Values are for single tube or section.

⁶ Values are for two tubes in push-pull.

⁷ Plate-to-plate value.

⁸ Osc. grid leak—Scr. res.

⁹ Values for two units.

¹⁰ Peak a.f. grid voltage.

¹¹ Peak a.f. G-G voltage.

¹² Micromhos.

¹³ Ohms.

¹⁴ Watts.

¹⁵ Unless otherwise noted.

¹⁶ G_s voltage.

¹⁷ Units connected in parallel.

TABLE III—6.3-VOLT GLASS TUBES WITH OCTAL BASES

(For "G" and "GT"-type tubes not listed here, see equivalent type in Tables II and VIII; characteristics and connections will be similar)

Type	Name	Base	Fil. or Heater		Capacitances $\mu\text{f.}$			Plate Supply V.	Grid Bias	Screen Volts	Screen Ma.	Plate Ma.	Plate Res. Ohms	Transcon-ductance ¹⁰	Amp. Factor	Lead Res. Ohms	Watts Output	
			V.	Amp.	C_k	C_{sw}	C_{sp}											
2B22	Disc—Seal Diode	Fig. 22	6.3	0.75	—	2.2	—	—	Average Cathode Ma. = 5; Output Volts = 50 d.c.								10K	—
2C22	Triode	4AM	6.3	0.3	2.2	0.7	3.6	300	-10.5	—	—	11	6.6K	3000	20	—	—	
								250	-45	—	—	60*	0.8K	5250	4.2	2.5K	3.75	
6ASGT	Triode Pwr. Amp.	A ₁ Amp. ³ A ₁ Amp. ⁴	6T	6.3	1.25	—	—	—	325	-68	—	—	80*	—	—	3K	15	
6ACSGT	Triode Pwr. Amp.	AB Amp. ⁴	6Q	6.3	0.4	—	—	—	250	0	—	—	54	36.7K	3400	125	10K ⁵	
									250	-25	—	—	4	19K	325	6	—	
6AD7G	Triode—Pwr. Amp. Pent.	Triode Pent.	8AY	6.3	0.85	—	—	—	250	-16.5	250	6.5/10.5	34/36	80K	2500	—	7K	
									250	-23	—	—	30	1.78K	4500	8	—	
6AH4GT	Medium- μ Triode		8EL	6.3	0.75	7	1.7	4.4	250	-23	—	—	30	1.78K	4500	8	—	
6AH7GT	Medium- μ Dual Triode ¹		8BE	6.3	0.3	—	—	—	180	-6.5	—	—	7.6	8.4K	1900	16	—	
6AL7GT	Electron-Ray Indicator		8CH	6.3	0.15	—	—	—	Outer edge of any of the three illuminated areas displaced $\frac{1}{16}$ in. outward with +5 volts to its electrode. Similar inward disp. with -5 volts. No pattern with -6 volts grid.								—	—
6AQ7GT	Dual Diode—High- μ Triode		8CK	6.3	0.3	2.8	3.2	3	250	-2	—	—	2.3	44K	1600	70	—	
6AR6	Beam Pent.		6BQ	6.3	1.2	11	7	0.55	250	-22.5	250	5	77	21K	5400	—	—	
6AR7GT	Dual Diode—Remote Pent.		7DE	6.3	0.3	5.5	7.5	0.003	250	-2	100	1.8	7	1.2 meg.	2500	—	—	
6AS7G	Low- μ Twin Triode—D.C. Amp. ¹		8BD	6.3	2.5	6.5	2.2	7.5	135	250*	—	—	125	0.28K	7000	2	—	
6AUSGT	Beam Pwr. Amp. ⁸		6CK	6.3	1.25	11.3	7	0.5	115	-20	175	6.8	60	6K	5600	—	—	
6AVSGT	Beam Pwr. Amp. ⁸		6CK	6.3	1.2	14	7	0.7	250	-22.5	150	2.1	55	20K	5500	—	—	
6BDSGT	Beam Pwr. Amp. ⁸		6CK	6.3	0.9	—	—	—	310	-200 ⁷	310	—	90 ⁹	—	—	—	—	
6BG6G	Beam Pwr. Amp. ⁸		8BT	6.3	0.9	12	6.5	0.34	250	-15	250	4	75	25K	6000	—	—	
									250	-15	250	4	75	25K	6000	—	—	
6BL7GT	Medium- μ Dual Triode ¹		8BD	6.3	1.5	5	3.2	4.2	250	-9	—	—	40	2.15K	6200	15	—	
6BQ6GT	Beam Pwr. Amp. ⁸		6AM	6.3	1.2	15	7.5	0.6	250	-22.5	150	2.1	55	20K	5500	—	—	
6BX7GT	Dual Triode ¹		8BD	6.3	1.5	5	3.4	4.2	250	390*	—	—	42	1.3K	7600	10	—	
6C8G	Medium- μ Twin Triode ¹		8G	6.3	0.3	2.6												

TABLE III—6.3-VOLT GLASS TUBES WITH OCTAL BASES—Continued

Type	Name	Base	Fil. or Heater		Capacitances $\mu\text{f.}$			Plate Supply V.	Grid Bias	Screen Volts	Screen Ma.	Plate Ma.	Plate Res. Ohms	Transcon- distance ⁶	Amp. Factor	Load Res. Ohms	Watts Output	
			V.	Amp.	C _{in}	C _{out}	C _{sp}											
6FBG	Dual Triode ¹	8G	6.3	0.6	—	—	—	250	-8	—	9	7.7K	2600	20	—	—		
6G6G	Beam Pwr. Amp.	A ₁ Amp. A ₂ Amp. ²	7S	6.3	0.15	5.5	7	0.5	180	-9	180	2.5 ³	15 ⁴	175K	2300	—	10K	1.1
			8E	6.3	0.3	—	—	—	180	-12	—	—	11	4.75K	2000	9.5	12K	0.25
6HBG	Dual Diode—High- μ Triode	8E	6.3	0.3	—	—	—	250	-2	—	—	8.5	650K	2400	—	—	—	
6K6GT	Pwr. Amp. Pent.	7S	6.3	0.4	5.5	6	0.5	315	-21	250	4/9	25/28	110K	2100	—	9K	4.5	
6M7G	R.f. Pentode	7R	6.3	0.3	—	—	—	250	-2.5	125	2.8	10.5	900K	3400	—	—	—	
6PBG	Triode-Hexode Conv.	8K	6.3	0.8	—	—	—	250	-2	75	1.4	1.5	E _{bb} Triode = 100 V. I _b Triode = 2.2 ma.	—	—	—	—	
6S6GT	Remote Cut-off Pent.	5AK	6.3	0.45	—	—	—	250	-2	100	3	13	350K	4000	—	—	—	
6S8GT	Triple-Diode—Triode	8CB	6.3	0.3	1.2	5	2	250	-2	—	—	—	91K	1100	100	—	—	
6SD7GT	Semi-Remote Pent.	8N	6.3	0.3	9	7.5	0.0035	250	-2	125	3	9.5	700K	4250	—	—	—	
6SL7GT	High- μ Dual Triode ¹	8BD	6.3	0.3	3.4	3.8	2.8	250	-2	—	—	2.3	44K	1600	70	—	—	
6SN7GT	Medium- μ Dual Triode ¹	8BD	6.3	0.6	3	1.2	4	250	-8	—	—	9	7.7K	2600	20	—	—	
6U6GT	Beam Pwr. Amp.	7AC	6.3	0.75	—	—	—	200	-14	135	3/13	55/62	20K	6200	—	3K	5.5	
6V5GT	Beam Pwr. Amp.	6AO	6.3	0.45	9	10	0.6	315	-13	225	2/2/6	34/35	77K	3750	—	8.5K	5.5	
6W6GT	Beam Pwr. Amp.	7AC	6.3	1.2	15	9	0.5	200	18.*	125	2/8.5	46/47	28K	8000	—	4K	3.8	
6X6G	Electron-Ray Indicator	7AL	6.3	0.3	—	—	—	250	0 v. for 300 ² , 2 ma. -8 v. for 0 ² , 0 ma.	—	—	—	0 ma. Vane grid 125 v.	—	—	—	—	
6Y6G	Beam Pwr. Amp.	7S	6.3	1.25	15	1	0.7	200	-14	35	2/2/9	61/66	18.3K	7100	—	2.6K	6	
717A	H.f. Pentode	8BK	6.3	0.175	—	—	—	120	-2	120	2.5	7.5	250K	4000	—	—	—	
1635	High- μ Dual Triode	8B	6.3	0.6	—	—	—	300	0	—	—	—	6.6/54	—	—	12K ³	10.4	
5694	Medium- μ Dual Triode	8CS	6.3	0.8	Sections in parallel			300	-6	—	—	7	11K	3200	35	—	—	

* Cathode resistor-ohms.
¹ Per section.
² Screen tied to plate.
³ Values are for single tube.
⁴ Values are for two tubes in push-pull.
⁵ Plate-to-plate value.
⁶ No signal current.
⁷ Max. value.
⁸ Horiz. Deflection Amp.
⁹ Cathode current.
¹⁰ Micromhos.

TABLE IV—6.3-VOLT LOCK-IN-BASE TUBES

For other lock-in-base types see Tables V, VI, and VII

Type	Name	Base	Fil. or Heater		Capacitances $\mu\text{f.}$			Plate Supply V.	Grid Bias	Screen Volts	Screen Ma.	Plate Ma.	Plate Res. Ohms	Transcon- distance ⁶	Amp. Factor	Load Res. Ohms	Watts Output
			V.	Amp.	C _{in}	C _{out}	C _{sp}										
7A5	Beam Pwr. Amp.	6AA	6.3	0.75	13	7.2	0.44	125	-9	125	3/9.5	44/45	17K	6000	—	2.7K	2.2
7A8	Octode Conv.	8U	6.3	0.15	7.5	9	0.15	250	-3	100	3.2	3	50K	Anode grid 250 Volts max. ¹	—	—	—
7AD7	Pwr. Amp. Pent.	8V	6.3	0.6	11.5	7.5	0.03	300	68*	150	7	28	300K	9500	—	—	—
7AF7	Medium- μ Dual Triode ²	8AC	6.3	0.3	2.2	1.6	2.3	250	-10	—	—	9	7.6K	2100	16	—	—
7AG7	Sharp Cut-off Pent.	8V	6.3	0.15	7	6	0.005	250	250*	250	2	6	750K	4200	—	—	—
7AH7	Remote Cut-off Pent.	8V	6.3	0.15	7	6.5	0.005	250	250*	250	1.9	6.8	1 meg.	3300	—	—	—
7AK7	Sharp Cut-off Pent.	8V	6.3	0.8	12	9.5	0.7	150	0	90	21	41	11.5K	5500	—	—	—
7B7	Remote Cut-off Pent.	8V	6.3	0.15	5	6	0.007	250	-3	100	1.7	8.5	750K	1750	—	—	—
7C6	Dual Diode—High- μ Triode	8W	6.3	0.15	2.4	3	1.4	250	-1	—	—	1.3	100K	1000	100	—	—
7C7	Sharp Cut-off Pent.	8V	6.3	0.15	5.5	6.5	0.007	250	-3	100	0.5	2	2 meg.	1300	—	—	—
7E7	Dual Diode—Pent.	8AE	6.3	0.3	4.6	5.5	0.005	250	330*	100	1.6	7.5	700K	1300	—	—	—
7F8	Medium- μ Dual Triode ²	8BW	6.3	0.3	2.8	1.4	1.2	250	500*	—	—	6	14.5K	3300	48	—	—
7J7	Triode—Heptode Conv.	8BI	6.3	0.3	4.6	3.2	0.03	250	-3	100	2.8	1.4	1.5 meg.	E _{bb} osc. plate = 250 V. ¹	—	—	—
7K7	Dual Diode—High- μ Triode	8BF	6.3	0.3	2.4	2	1.7	250	-2	—	—	2.3	44K	1600	70	—	—
7L7	Sharp Cut-off Pent.	8V	6.3	0.3	8	6.5	0.01	250	250*	100	1.5	4.5	1 meg.	3100	—	—	—
7V7	Sharp Cut-off Pent.	8V	6.3	0.45	9.5	6.5	0.004	300	160*	150	3.9	10	300K	5800	—	—	—
7X7	Dual Diode—High- μ Triode	8BZ	6.3	0.3	—	—	—	250	-1	—	—	1.9	67K	1500	100	—	—
1231	Pwr. Amp. Pent.	8V	6.3	0.45	8.5	6.5	0.015	300	200*	150	2.5	10	700K	5500	—	—	—
1273	Nonmicrophonic Pent	8V	6.3	0.32	6	6.5	0.007	250	-3	100	0.7	2.2	1 meg.	1575	—	—	—
XXL	Triode Osc.	5AC	6.3	0.3	3.4	2.6	2	250	-8	—	—	8	8.7K	2300	20	—	—

* Cathode resistor-ohms.
¹ Through 20K resistor.
² Each section.
³ Micromhos.

TABLE V—1.5-VOLT FILAMENT BATTERY TUBES

See also Table VII for Special 1.4-volt Tubes

Type	Name	Base	Fil. or Heater		Capacitances $\mu\text{f.}$			Plate Supply V.	Grid Bias	Screen Volts	Screen Ma.	Plate Ma.	Plate Res. Ohms	Transcon- distance ⁶	Amp. Factor	Load Res. Ohms	Watts Output	
			V.	Amp.	C _{in}	C _{out}	C _{sp}											
1A5GT	Pwr. Amp. Pent.	6X	1.4	0.05	—	—	—	90	-4.5	90	0.8/1.1	4	300K	850	—	25K	0.115	
1A7GT	Pentagrid Conv.	7Z	1.4	0.05	7	10	0.5	90	0	45	0.7	0.6	600K	E _{bb} Anode-grid = 90 Volts.	—	—	—	
1G6GT	Dual Triode	A ₁ Amp. ¹ B Amp.	7AB	1.4	0.1	—	—	—	90	0	—	—	1	45K	675	30	—	—
			90	0	—	—	—	90	0	—	—	2/14	Peak G-G voltage = 42	12K ²	0.675	—	—	
1H5GT	Diode High- μ Triode	5Z	1.4	0.05	1.1	4.6	1	90	0	—	—	0.15	240K	275	65	—	—	
1LA6	Pentagrid Conv.	7AK	1.4	0.05	7.7	8	0.4	90	0	45	0.6	0.55	750K	E _{bb} Anode-grid = 90 Volts.	—	—	—	
1LB4	Pwr. Amp. Pent.	5AD	1.4	0.05	—	—	—	90	-9	90	1	5	250K	925	—	12K	0.2	
1LB6	Heptode Conv.	8AX	1.4	0.05	—	—	—	90	0	67.5	2.2	0.4	Grid No. 4 = 67.5 v., No. 5 = 0 v.	—	—	—	—	
1LC6	Pentagrid Conv.	7AK	1.4	0.05	9	5.5	0.28	90	0	35	0.7	0.75	650K	E _{bb} Anode-grid = 45 Volts.	—	—	—	
1LD5	Diode—Sharp Cut-off Pent.	6AX	1.4	0.05	3.2	6	0.18	90	0	45	0.1	0.6	750K	575	—	—	—	
1LE3	Medium- μ Triode	4AA	1.4	0.05	1.7	3	1.7	90	-3	—	—	1.4	19K	760	—	—	—	
1LG5	Remote Cut-off Pent.	7AO	1.4	0.05	3.2	7	0.007	90	-1.5	90	0.9	3.7	500K	1150	—	—	—	
1LN5	Sharp Cut-off Pent.	7AO	1.4	0.05	3	8	0.007	90	0	90	0.35	1.6	1.1 meg	800	—	—	—	
1NSGT	R.f. Pentode	5Y	1.4	0.05	3	10	0.007	90	0	90	0.3	1.2	1.5 meg	750	—	—	—	
1R4/1294	U.h.f. Diode	4AH	1.4	0.15	—	—	—	—	—	—	—	—	—	—	—	—	—	
1T5GT	Beam Pwr. Amp.	6X	1.4	0.05	4.8	8	0.5	90	-6	90	0.8/1.5	6.5	250K	1150	—	14K	0.17	
3B7/1291	U.h.f. Dual Triode ⁴	7BE	2B ³	0.11	1.4	1.8	2.6	135	0	19 ³	—	18/22	—	1900 ¹	20 ¹	16K	1.5	
3D6/1299	Beam Pwr. Ama.	6BB	2B ³	0.11	7.5	5.5	0.3	150	-4.5	90	1/1.8	9.9/10.2	—	2400	—	14K	0.6	
3E6	Sharp Cut-off Pent.	7CJ	2B ³	0.05	5.5	8	0.007	90	0	90	1.2	2.9	325K	1700	—	—	—	
1293	U.h.f. Triode	4AA	1.4	0.11	1.7	3	1.7	90	—	—	—	4.7	10.75K	1300	14	—	—	

¹ Each section.
² Plate-to-plate value.
³ Center-tap filament permits 1.4 volt operation.
⁴ Class AB² Amp.
⁵ Grid driving voltage (r.m.s.).
⁶ Micromhos.

TABLE VI—HIGH-VOLTAGE HEATER TUBES

See also Table VIII.

Type	Name	Base	Fil. or Heater		Capacitances $\mu\text{f.}$			Plate Supply V.	Grid Bias	Screen Volts	Screen Ma.	Plate Ma.	Plate Res. Ohms	Transcon-ductance ⁴	Amp. Factor	Load Res. Ohms	Watts Output
			V.	Amp.	C _{ca}	C _{cc}	C _{cp}										
2C52	High- μ Twin Triode ¹	8BD	12.6	0.3	2.3	0.75	2.7	250	-2	—	—	1.3	—	1900	100	—	—
12A6	Beam Pwr. Amp.	75	12.6	0.15	8	9	0.3	250	-12.5	250	3.5/5.5	30/32	70K	3000	—	7.5K	3.4
12AH7GT	Medium- μ Dual Triode ¹	8BE	12.6	0.15	3.2	3	3	180	-6.5	—	—	7.6	8.4K	1900	16	—	—
12B6M	Diode—Triode	6Y	12.6	0.15	—	—	—	250	-2	—	—	0.9	91K	1100	100	—	—
12B7	Remote Cut-off Pent.	8V	12.6	0.15	5.5	7	0.005	250	-3	100	2.4	9.2	800K	2000	—	—	—
12G7G	Duo Diode—Triode	7V	12.6	0.15	—	—	—	250	-3	—	—	—	58K	1200	70	—	—
12L6GT†	Beam Pwr. Pent.	75	12.6	0.6	15	10	0.6	110	-7.5	110	4/10	49/50	13K	8000	—	2K	2.1
								200	180*	125	2.2/8.5	46/47	28K	8000	—	4K	3.8
125Y7	Heptode Conv.	8R	12.6	0.15	Osc.—Grid leak 20K.			250	-2	8.5	3.5	—	1 meg.	450	—	—	—
					2.6	0.9	3.4	250	-8	—	—	9	7.7K	2600	20	—	—
15A8†	Medium- μ Triode Beam Pent.	8GS	15	0.6	11	5	0.7	110	-7.5	110	—	45	13K	7300	—	—	—
18A5†	Beam Pwr. Pent.	6CK	18.5	0.3	13	7	0.7	200	-17	125	1.1	40	27K	4800	—	—	—
25AC5GT	High- μ Triode	6Q	25	6.3	Dynamic Coupled			110	+15	—	—	45	15.2	3800	58	2K	2
28D7	Dual Beam—A ₂ Amp. ¹ Pwr. Amp. A ₂ Amp. ²	8BS	28	0.4	—	—	—	28	-3.5	28	1/1.9	12.5/8	4.2K	3400	—	4K	0.1
								28	180*	28	1.2/2.5	18.5/14	—	—	—	—	—
35A5	Beam Pwr. Amp.	6AA	35	0.15	—	—	—	110	-7.5	110	3/7	40/41	16K	5800	—	2.5K	1.5
43	Pwr. Amp. Pent.	6B	25	0.3	8.5	12.5	0.2	160	-18	120	6.5/12	33/36	42K	2375	—	5K	2.2
50C6GT	Beam Pwr. Amp.	75	50	0.15	—	—	—	200	-14	135	2.2/9	61/66	18.3K	7100	—	2.6K	6
117L7GT/117M7GT	Rectifier—Beam Pwr. Amp.	8AO	117	0.09	—	—	—	105	-5.2	105	4/5.5	43	17K	5300	—	4K	0.85
								100	-6	100	5	51	16K	7000	—	3K	1.2
117N7GT	Rect.—Beam Pwr. Amp.	8AV	117	0.09	Rect. same as 117L7GT			105	-3	100	2.5	9	800K	2000	—	—	—
1284	U.h.f. Pentode	8V	12.6	0.15	5	6	0.01	250	-3	100	2.5	9	800K	2000	—	—	—
5824	Beam Pwr. Pent.	75	25	0.3	—	—	—	135	-22	135	2.5/14.5	61/69	15K	5000	—	1.7K	4.3
6082	Low- μ Dual Triode ¹	8BD	26.5	0.6	6	2.2	8	135	250*	—	—	125	0.28K	7000	2	—	—

* Cathode resistor-ohms.

† Controlled heater warm-up characteristic.

¹ Each section.
² P.P. operation.

³ Plate-to-plate.

⁴ Micromhos.

TABLE VII—SPECIAL RECEIVING TUBES

Type	Name	Base	Fil. or Heater		Capacitances $\mu\text{f.}$			Plate Supply V.	Grid Bias	Screen Volts	Screen Ma.	Plate Ma.	Plate Res. Ohms	Transcon-ductance ⁴	Amp. Factor	Load Res. Ohms	Watts Output
			V.	Amp.	C _{ca}	C _{cc}	C _{cp}										
3C6	Medium- μ Dual Triode	7BW	28 ²	0.05	—	—	—	90	0	—	—	4.5	11.2K	1300	14.5	—	—
3Q5GT	Beam Pwr. Amp.	7AP	28 ²	0.05	8	6.5	0.6	90	-4.5	90	1.3	9.5	90K	2200	—	8K	0.27
4A6G	Dual Triode ¹	8L	4 ³	0.06	—	—	—	90	-1.5	—	—	1.2	28K	900	25	—	—
6B74	Ceramic U.h.f. Triode	—	6.3	0.25	2	0.007	0.7	200	200*	—	—	5	16.7K	6000	—	—	—
6F4	Acorn Triode	7BR	6.3	0.225	2	0.6	1.9	80	150*	—	—	13	2.9K	5800	17	—	—
6L4	Acorn Triode	7BR	6.3	0.225	1.8	0.5	1.6	80	150*	—	—	9.5	4.4K	6400	28	—	—
7E5/1201	H.f. Triode	8BN	6.3	0.15	3.6	2.8	1.5	180	-3	—	—	5.5	12K	3000	36	—	—
								250	-3	100	0.7	2	1 meg. +	1400	—	—	—
954	Detector Amp.—A ₁ Amp. Pentode (Acorn) Detector	5BB	6.3	0.15	3.4	3	0.007	250	-6	100	1 $\frac{1}{2}$ adjusted to 0.1 ma. with no signal.		—	—	—	250K	—
								250	-7	—	—	6.3	11.4K	2200	25	—	—
								90	-2.5	—	—	2.5	14.7K	1700	25	—	—
955	Medium- μ Triode (Acorn)	5BC	6.3	0.15	1	0.6	1.4	250	-3	100	2.7	6.7	700K	1800	—	—	—
956	Remote Cut-off Pent (Acorn) Mixer	5BB	6.3	0.15	3.4	3	0.007	250	-10	100	Oscillator peak volts -7 min.		—	—	—	—	—
958-A	Medium- μ Triode (Acorn)	5BD	1.25	0.1	0.6	0.8	2.6	135	-7.5	—	—	3	10K	1200	12	—	—
959	Sharp Cut-off Pent. (Acorn)	5BE	1.25	0.05	1.8	2.5	0.015	135	-3	67.5	0.4	1.7	800K	600	—	—	—
1609	Amplifier Pentode	5B	1.1	0.25	7	7	1	135	-1.5	67.5	0.65	2.5	400K	725	—	—	—
5731	Pwr. Amp Triode (Acorn)	5BC	6.3	0.15	1	0.4	1.3	250	-7	—	—	6.3	11.4K	2200	25	—	—
5768	U.h.f. "Rocker" Triode	Fig. 21	6.3	0.4	1.2	0.01	1.3	250	-1	—	—	9.3	—	4500	85	—	—
6173	U.h.f. "Pencil" Diode	Fig. 34	6.3	0.135	Plate to K=1.1			Peak inverse—375 Volts. Peak I _p —50 Ma. Max. d.c. output—5.5 Ma.									
6299	Low Noise U.h.f. Triode	—	6.3	0.35	3.5	0.01	1.7	175	200-ohm var. cathode res.		10	Operation at 1200 Mc.					
9004	U.h.f. Diode (Acorn)	4BJ	6.3	0.15	Plate to K=1.3			Max. a.c. voltage—117. Max. d.c. output current—5 ma.									
9005	U.h.f. Diode (Acorn)	5BG	3.6	0.165	Plate to K=0.8			Max. a.c. voltage—117. Max. d.c. output current—1 ma.									

* Cathode resistor-ohms. Each section.

² Center-tap filament permits 1.4-volt operation.
³ Center-tap filament permits 2-volt operation.

⁴ Micromhos.

TABLE VIII—EQUIVALENT TUBES

•	Type	Prototype and Table	Base	E ₁ ¹	I ₁ ²	Type	Prototype and Table	Base	E ₁ ¹	I ₁ ²		
1LF3		1E3	V	4AA	1.4	0.05	6SU7GY	6S17GT	III	8BD	6.3	0.3
1LH4		1H5GT	V	5AG	1.4	0.05	6T8A‡	6T8	I	9E	6.3	0.45
2AF4A‡		6AF4A	I	7DK	2.35	0.6	6U8A‡	6U8	I	9AE	6.3	0.45
2BN4‡		6BN4	I	7EG	2.1	0.6	6V6GTA‡	6V6	III	75	6.3	0.45
2T4‡		6T4	I	7DK	3.15	0.6	6X8A‡	6X8	I	9AK	6.3	0.45
3AF4A‡		6AF4A	I	7DK	3.2	0.45	6Y6GA	6Y6G	III	75	6.3	1.25
3AL5‡		6AL5	I	6BT	3.15	0.6	6Y6GT	6Y6G	III	75	6.3	1.25
3AU6‡		6AU6	I	7BK	3.15	0.6	7A4	6J5	III	5AS	6.3	0.3
3AV6‡		6AV6	I	7BT	3.15	0.6	7A6	6H6	II	7AJ	6.3	0.15
3BA6‡		6BA6	I	7CC	3.15	0.6	7A7	6SK7	II	8V	6.3	0.3
3BC5‡		6BC5	I	7BD	3.15	0.6	7AU7‡ ¹	12AU7A	I	9A	7	0.3
3BE6‡		6BE6	I	7BD	3.15	0.6	7B4	6F5	II	5AC	6.3	0.3
3BN4‡		6BN4	I	7EG	2.8	0.45	7B5	6K6GT	III	6AE	6.3	0.4
3BN6‡		6BN6	I	7DF	3.15	0.6	7B6	6SQ7	II	8W	6.3	0.3
3BU8‡		6BU8	I	9FG	3.15	0.6	7B8	6A8	II	8X	6.3	0.3
3BY6‡		6BY6	I	7CH	3.15	0.6	7C5	6V6	II	6AA	6.3	0.45
3BZ6‡		6BZ6	I	7CM	3.15	0.6	7F7	6S17GT	III	8AC	6.3	0.3
3CB6‡		6CB6	I	7CM	3.15	0.6	7H7	6SG7	II	8V	6.3	0.3
3CE5‡		6CE5	I	7CM	3.15	0.6	7N7	6SN7GT	III	8AC	6.3	0.6
3CF6‡		6CF6	I	7CM	3.15	0.6	7Q7	6SA7	III	8AL	6.3	0.3
3CS6‡		6CS6	I	7CH	3.15	0.6	8AU8‡	6AU8	I	9DX	8.4	0.45
3DT6‡		6DT6	I	7EN	3.15	0.6	8AW8A‡	6AW8A	I	9DX	8.4	0.45
3LF4‡		3Q5GT	VII	6BB	2.8	0.05	8BA8A‡	6B8A	I	9DX	8.4	0.45
3V4‡		3Q4	I	6BX	2.8	0.05	8BH8‡	6BH8	I	9DX	8.4	0.45
4BC5‡		6BC5	I	7BD	4.2	0.45	8BN8‡	6BN8	I	9ER	8.4	0.45
4BC8‡		6BC8	I	9AJ	4.2	0.6	8CG7‡	6CG7	I	9AJ	8.4	0.45
4BN6‡		6BN6	I	7DF	4.2	0.45	8CM7‡	6CM7	I	9ES	8.4	0.45
4BQ7A‡		6BQ7A	I	9AJ	4.2	0.6	8CN7‡	6CN7	I	9EN	8.4	0.225
4BS8‡		6BS8	I	9AJ	4.5	0.6	8CS7‡	6CS7	I	9EF	8.4	0.45
4BU8‡		6BU8	I	9FG	4.2	0.45	8SN7GTB‡	6SN7GT8	VIII	8BD	8.4	0.45
4BX8‡		6BX8	I	9AJ	4.5	0.6	9AU7‡ ¹	7AU7	VIII	9A	9.4	0.225
4BZ7‡		6BZ7	I	9AJ	4.2	0.6	9UBA‡	6UB	I	9AE	9.45	0.3
4BZ8‡		6BZ8	I	9AJ	4.2	0.6	12A8GT	6A8	II	8A	12.6	0.15
4CB6‡		6CB6	I	7CM	4.2	0.45	12AL5	6AL5	I	6BT	12.6	0.15
4CE5‡		6CE5	I	7BD	4.2	0.45	12AT6	6AT6	I	7BT	12.6	0.15
4CX7‡		6CX7	I	9FC	4.2	0.6	12AU6	6AU6	I	7BK	12.6	0.15
4DT6‡		6DT6	I	7EN	4.2	0.45	12AV5GA‡	6AV5GT	III	6CK	12.6	0.6
5AM8‡		6AM8	I	9CY	4.7	0.6	12AV6	6AV6	I	7BT	12.6	0.15
5AN8‡		6AN8	I	9DA	4.7	0.6	12BA4‡	12B4	I	9AG	12.6	0.3
5AQ5‡		6AQ5	I	7BZ	4.7	0.6	12BA6	6BA6	I	7BK	12.6	0.15
5AS5‡		6AS5	I	9AJ	4.7	0.6	12BA7	6BA7	I	8CT	12.6	0.15
5AS8‡		6AS8	I	9DS	4.7	0.6	12BD6	6BD6	I	7BK	12.6	0.15
5AT8‡		6AT8	I	9DW	4.7	0.6	12BE6	6BE6	I	7CH	12.6	0.15
5AV8‡		6AV8	I	9DZ	4.7	0.6	12BF6	6BF6	I	7BT	12.6	0.15
5B8‡		6AN8	I	9EC	4.7	0.6	12BH7A‡ ¹	12BH7	I	9A	12.6	0.3
5BK7A‡		6BK7A	I	9AJ	4.7	0.6	12BK5‡	6BK5	I	9BQ	12.6	0.6
5BQ7A‡		6BQ7A	I	9AJ	5.6	0.45	12BK6	6BK6	I	7BT	12.6	0.15
5BR8‡		6BR8	I	9FA	4.7	0.6	12BN6	6BN6	I	7DE	12.6	0.15
5BT8‡		6BT8	I	9FE	4.7	0.6	12BQ6GA‡	6BQ6GT	III	6AM	12.6	0.6
5BZ7‡		6BZ7	I	9AJ	5.6	0.45	12BQ6GT‡	6BQ6GT	III	6AM	12.6	0.6
5CG8‡		6CG8	I	9GF	4.7	0.6	12BQ6GTB‡	6BQ6GT	III	6AM	12.6	0.6
5CL8‡		6CL8	I	9FX	4.7	0.6	12BT6	6BT6	I	7BT	12.6	0.15
5CM8‡		6CM8	I	9FZ	4.7	0.6	12BU6	6BU6	I	7BT	12.6	0.15
5J6‡		6J6	I	7BF	4.7	0.6	12BW4	6BW4	X	9DJ	12.6	0.45
5T8‡		6T8	I	9E	4.7	0.6	12BY7A‡ ¹	12BY7	I	9BF	12.6	0.3
5U8‡		6U8	I	9AE	4.7	0.6	12C5‡	5OB5	I	7CV	12.6	0.6
5V4GA		5V4G	X	5L	5.0	3.0	12C8	6B8	III	8E	12.6	0.15
5V6GT‡		6V6	II	75	4.7	0.6	12CA5‡	6CA5	I	7CV	12.6	0.6
5X8‡		6X8	I	9AK	4.7	0.6	12CM6	6CM6	I	9CK	12.6	0.225
6A6		6N7	II	7B	6.3	0.8	12CS5‡	6CS5	I	9CK	12.6	0.6
6A7		6A8	II	7C	6.3	0.3	12CS6	6CS6	I	7CH	12.6	0.15
6AE8		6K8	II	8DU	6.3	0.3	12CT8‡	6AU8	I	9DA	12.6	0.3
6AM8A‡		6AM8	I	9CY	6.3	0.45	12CU5‡	6CUS	I	7CV	12.6	0.6
6AN8A‡		6AN8	I	9DA	6.3	0.45	12CU6	6CU6	III	6AM	12.6	0.6
6AQ5A‡		6AQ5	I	7BZ	6.3	0.45	12DQ6A‡	6DQ6A	III	6AM	12.6	0.6
6AS7GA		6AS7G	III	8BD	6.3	2.5	12G4	6J5	II	6BQ	12.6	0.15
6AU6A‡		6AU6	I	7BK	6.3	0.3	12H6	6H6	II	7Q	12.6	0.15
6AU7‡		12AU7	I	9A	3.15	0.6	12J5GT	6J5	II	6Q	12.6	0.15
6AV5GA		6AV5GT	III	6CK	6.3	1.2	12J7GT	6J7	II	7R	12.6	0.15
6AX7‡ ¹		12AX7	I	9A	6.3	0.3	12K7GT	6K7	II	7R	12.6	0.15
6B4G		6A3	III	55	6.3	1.0	12K8	6K8	II	8K	12.6	0.15
6BG6GA		6BG6G	III	5BT	6.3	0.9	12Q7GT	6Q7	II	7V	12.6	0.15
6BK7B‡		6BK7A	I	9AJ	6.3	0.45	12S8GT	6S8GT	III	8CB	12.6	0.15
6BQ6GA		6BQ6GT	III	6AM	6.3	1.2	12SA7	6SA7	II	8R	12.6	0.15
6BQ6GTA		6BQ6GT	III	6AM	6.3	1.2	12SC7	6SC7	II	85	12.6	0.15
6BQ6GTB/6CU6		6BQ6GT	III	6AM	6.3	1.2	12SF5	6SF5	II	6AB	12.6	0.15
6C6		6J7	II	6F	6.3	0.3	12SF7	6SF7	II	7AZ	12.6	0.15
6CB5A		6CB5	III	8GD	6.3	2.5	12SG7	6SG7	II	8BK	12.6	0.15
6CB6A‡		6CB6	I	7CM	6.3	0.3	12SH7	6SH7	II	8BK	12.6	0.15
6CD6GA		6CD6G	III	5BT	6.3	2.5	12SJ7	6SJ7	II	8N	12.6	0.15
6CG8A‡		6CG8	I	9GF	6.3	0.45	12SK7	6SK7	II	8N	12.6	0.15
6J6A‡		6J6	I	7BF	6.3	0.45	12SL7GT	6SL7GT	III	8BD	12.6	0.15
6L6GA		6L6	II	75	6.3	0.9	12SN7GT	6SN7GT	III	8BD	12.6	0.3
6L6GB		6L6	II	75	6.3	0.9	12SN7GTA	6SN7GT	III	8BD	12.6	0.3
654A‡		654	I	9AC	6.3	0.6	12SQ7	6SQ7	II	8Q	12.6	0.15
6SN7GA		6SN7GT	III	8BD	6.3	0.6	12SR7	6SR7	II	8Q	12.6	0.15
6SN7GTB‡		6SN7GTA	VIII	8BD	6.3	0.6	12W6GT‡	6W6GT	III	75	12.6	0.6

TABLE VIII—EQUIVALENT TUBES—Continued

Type	Prototype and Table	Base	E ₁ ¹	I ₂ ²	Type	Prototype and Table	Base	E ₁ ¹	I ₂ ²		
4A7	6SK7	II	8V	12.6	0.15	5691	6SU7GT	III	8BD	6.3	0.6
4AF7	7AF7	IV	8AC	12.6	0.15	5692	6SN7GT	III	8BD	6.3	0.6
4B6	6SQ7	II	8W	12.6	0.15	5725	6AS6	I	7CM	6.3	0.175
4F7	6SU7GT	III	8AC	12.6	0.15	5726	6AL5	I	6BT	6.3	0.3
4N7	6SN7GT	III	8AC	12.6	0.6	5749	6BA6	I	7BK	6.3	0.3
4Q7	6SA7	II	8AL	12.6	0.15	5750	6BX6	I	7CH	6.3	0.3
4V7	7V7	IV	8V	12.6	0.225	5751 ³	12AX7	I	9A	12.6	0.175
4X7	7X7	IV	8BZ	12.6	0.15	5814A ³	12SN7GT	VI	9A	12.6	0.175
7AV5GA†	6AV5GA	VIII	6CK	16.8	0.45	5871	6V6	II	7AC	6.3	0.9
7CS‡	5OC5	VIII	7CV	16.8	0.45	5881	6L6	II	7AC	6.3	0.9
7DQ6‡	6DQ6A	III	6AM	16.8	0.45	5910	1U4	I	6AR	1.4	0.05
7RS‡	12RS	I	7CV	16.8	0.45	5915	6BY6	I	7CH	6.3	0.3
9BG6GA	6BG6GA	VIII	5BT	18.9	0.3	5963 ³	12AU7	I	9A	12.6	0.15
15AV5GA	6AV5GT	III	6CK	25	0.3	5964	6J6	I	7BF	6.3	0.45
15AV5GT	6AV5GT	III	6CK	25	0.3	5965 ³	12AV7	I	9A	12.6	0.225
15BQ6GA	6BQ6GT	III	6AM	25	0.3	6046	12L6GT	VI	7AC	25	0.3
15BQ6GT	6BQ6GT	III	6AM	25	0.3	6057 ³	12AX7	I	9A	12.6	0.15
15BQ6GTB‡	6BQ6GT	III	6AM	25	0.3	6058	6AL5	I	6BT	6.3	0.3
15CS	5OC5	VIII	7CV	25	0.3	6059	6I7	II	9BC	6.3	0.15
15CA5	6CA5	I	7CV	25	0.3	6060 ³	12AT7	I	9A	12.6	0.15
25CD6G	6CD6G	III	5BT	25	0.6	6061	6V6	II	9AM	6.3	0.45
25CD6GA‡	6CD6G	III	5BT	25	0.6	6064	6AM6	I	7DB	6.3	0.3
25CU6	6CU6	III	6AM	25	0.3	6065	6BH6	I	7DB	6.3	0.2
25DN6‡	6DN6	III	5BT	25	0.6	6066	6AT6	I	7BT	6.3	0.3
25DQ6	6DQ6A	III	6AM	25	0.3	6067 ³	12AU7	I	9A	12.6	0.15
25L6GT	12L6GT	VI	7S	25	0.3	6080	6AS7G	III	8BD	6.3	2.5
25W6GT	6W6GT	III	7S	25	0.3	6101	6I6	I	7BF	6.3	0.45
35CS	3585	I	7CV	35	0.15	6132	6C16	I	9BA	6.3	0.75
35I6GT	3585	I	7S	35	0.15	6136	6AU6	I	7BK	6.3	0.3
41	6K6GT	III	6B	6.3	0.4	6201 ³	12AT7	I	9A	12.6	0.15
42	6F6	II	6B	6.3	0.7	6265	6BH6	I	7CM	6.3	0.175
50A5	12L6GT	VI	6AA	50	0.15	6350 ³	12BH7	I	9CZ	12.6	0.3
50BK5	6BK5	I	9BQ	50	0.15	6485	6AH6	I	7BK	6.3	0.45
50CS	50B5	I	7CV	50	0.15	6660	6BA6	I	7CC	6.3	0.3
50L6GT	12L6GT	VI	7AC	50	0.15	6661	6BH6	I	7CM	6.3	0.15
75	6SQ7	II	6G	6.3	0.3	6662	6BJ6	I	7CM	6.3	0.15
78	6K7	II	6F	6.3	0.3	6663	6AL5	I	6BT	6.3	0.3
117P7GT	117I7GT	VI	8AV	117	0.09	6669	6AQ5	I	7BZ	6.3	0.45
417A	5842	I	9V	6.3	0.3	6677	6C16	I	9BV	6.3	0.65
1221	6J7	II	6F	6.3	0.3	6679 ³	12AT7	I	9A	12.6	0.15
1223	6J7	II	7R	6.3	0.3	6680 ³	12AU7A	I	9A	12.6	0.15
1631	6L6	II	7AC	12.6	0.45	6681 ³	12AX7	I	9A	12.6	0.15
1632	12L6GT	VI	7S	12.6	0.6	6829 ³	5965	VIII	9A	12.6	0.225
1634	6SC7	II	85	12.6	0.15	6897	2C39	XI	—	6.3	1.05
5591	6AK5	I	7BD	6.3	0.15	7000	6J7	II	7R	6.3	0.3
5654	6AK5	I	7BD	6.3	0.175	7700	6I7	II	6F	6.3	0.3
5670	2C51	I	8CJ	6.3	0.35	KT-66 ⁴	6L6	II	7AC	6.3	1.27
5679	6H6	II	7CX	6.3	0.15	X ³	7AF7	IV	8AC	12.6	0.15

† Controlled heater warm-up characteristics.

¹ Filament or heater voltage.

² Filament or heater current.

³ Heater center-tapped for operation at half voltage shown.

⁴ British version of 6L6.

TABLE IX—CONTROL AND REGULATOR TUBES

Type	Name	Base	Cathode	Fil. or Heater		Peak Anode Voltage	Max. Anode Ma.	Minimum Supply Voltage	Operating Voltage	Operating Ma.	Grid Resistor	Tube Voltage Drop
				Volts	Amp.							
OA2	Voltage Regulator	5B0	Cold	—	—	—	—	185	150	5-30	—	—
6073	Gas Triode Starter-Anode Type	4V	Cold	—	—	With 105-120-volt a.c. anode supply, peak starter-anode a.c. voltage is 70 peak r.f. voltage 55. Peak d.c. ma. = 100. Average d.c. ma. = 25.						
OA4G	Gas Pentode	Fig. 19	Cold	—	—	Plate -750 V., Screen -90 V., Grid +3 V., Pulse -85 V.						
OB2	Voltage Regulator	5B0	Cold	—	—	—	—	133	108	5-30	—	—
6074	Grid-Controlled Rectifier Relay Tube	7BN	Htr.	6.3	0.6	650	500	—	650	100	0.1-10 ⁴	8
2D21	Control Tube	5AY	Htr.	6.3	0.25	400	—	—	—	—	1.0 ⁴	—
6D4	Voltage Regulator	5B0	Cold	—	—	E _p = 350; Grid volts = -50; Avg. Ma. = 25; Peak Ma. = 100; Voltage drop = 16.						
90C1	Gas Triode Grid Type	6Q	Htr.	6.3	0.6	300	300	—	—	2	25000	—
884	Grid-Controlled Rectifier	3G	Fil.	2.5	5.0	350	300	—	—	7.5	25000	—
967	Voltage Regulator	4AJ	Cold	—	—	2500	500	-5 ²	—	—	—	10-24
991	Voltage Regulator	4AJ	Cold	—	—	—	—	87	55-60	2.0	—	—
1265	Voltage Regulator	4AJ	Cold	—	—	—	—	130	90	5-30	—	—
1266	Relay Tube	4V	Cold	—	—	Characteristics same as OA4G						
1267	Grid-Controlled Rectifier	8BA	Htr.	6.3	0.6	650	500	—	—	100	0.1-10 ⁴	8
2050	Voltage Regulator	5B0	Cold	—	—	115	—	115	87	1.5-3.5	—	—
5651	Thyatron-Fuse	Fig. 79	Htr.	6.3	1.5	200 ³	—	—	—	—	—	—
5662	Control and Relay	7CE	Htr.	6.3	0.15	Ik to fuse = 150 Amp., 60 cycle, half-wave 50 V. Max. peak inv. volts = 500; Peak Ma. = 100; Avg. Ma. = 20.						
5696	Relay Service	7BN	Htr.	6.3	0.15	500 ³	—	—	—	—	—	—
5823	Relay or Trigger	4CK	Cold	—	—	100 ma. peak current; 25-ma. average. Max. peak inv. volts = 200; Peak Ma. = 100; Avg. Ma. = 25.						
5890	Shunt Regulator	12J	Htr.	6.3	0.6	E _{g1} = -60 volts; E _{g2} = 200 volts; E _{g3} = 5500 volts. E _p = 30000 volts; I _{g2} = 0 Ma.; I _p Max. = 0.5 Ma.						
5962	Voltage Regulator	2AG	Cold	—	—	—	—	730	700	5/55 ⁵	—	—
5998	Series Regulator	8BD	Htr.	6.3	2.4	250	125	—	110	100	350 ⁶	—
6308	Voltage Regulator	8EX	Cold	—	—	—	—	3.5	115	87	—	—

TABLE IX—CONTROL AND REGULATOR TUBES—Continued

Type	Name	Base	Cathode	Fil. or Heater		Peak Anode Voltage	Max. Anode Ma.	Minimum Supply Voltage	Operating Voltage	Operating Ma.	Grid Resistor	Tube Voltage Drop
				Volts	Amp.							
6354	Voltage Regulator	Fig. 12	Cold	—	—	—	—	180	150	5-15	—	—
KY21	Grid-Controlled Rectifier	—	Fil.	2.5	10.0	—	—	—	3000	500	—	—
RK61	Radio-Controlled Relay	— ¹	Fil.	1.4	0.05	45	1.5	30	—	0.5-1.5	3 ⁴	30
OA3/VR75	Voltage Regulator	4AJ	Cold	—	—	—	—	105	75	5-40	—	—
OB3/VR90	Voltage Regulator	4AJ	Cold	—	—	—	—	125	90	5-40	—	—
OC3/VR105	Voltage Regulator	4AJ	Cold	—	—	—	—	135	105	5-40	—	—
OD3/VR150	Voltage Regulator	4AJ	Cold	—	—	—	—	185	150	5-40	—	—

¹ No base. Tinned wire leads.

² At 1000 anode volts.

³ Peak inverse voltage.

⁴ Megohms.

⁵ Values in μ amperes.

⁶ Cathode resistor-ohms.

TABLE X—RECTIFIERS—RECEIVING AND TRANSMITTING

See Also Table IX—Control and Regulator Tubes

Type	Name	Base	Cathode	Fil. or Heater		Max. A.C. Voltage Per Plate	D.C. Output Current Ma.	Max. Inverse Peak Voltage	Peak Plate Current Ma.	Type
				Volts	Amp.					
1V2	Half-Wave Rectifier	9U	Fil.	0.625	0.3	—	0.5	7500	10	HV
2B25	Half-Wave Rectifier	3T	Fil.	1.4	0.11	1000	1.5	—	9	HV
2X2-A	Half-Wave Rectifier	4AB	Htr.	2.5	1.75	4500	7.5	—	—	HV
2Y2	Half-Wave Rectifier	4AB	Fil.	2.5	1.75	4400	5.0	—	—	HV
2Z2/G84	Half-Wave Rectifier	4B	Fil.	2.5	1.5	350	50	—	—	HV
3B24	Half-Wave Rectifier	Fig. 49	Fil.	5.0	3.0	—	60	20000	300	HV
				2.5 ⁴	3.0	—	30	20000	150	
5AU4	Full-Wave Rectifier	5T	Fil.	5.0	4.5	300 ³	350 ³	1400	1075	HV
						400 ³	325 ³			
						500 ⁴	325 ⁴			
5AW4	Full-Wave Rectifier	5T	Fil.	5.0	4.0	450 ³	250 ³	1550	750	HV
						550 ⁴	250 ⁴			
						900 ³	150 ³			
5R4GY	Full-Wave Rectifier	5T	Fil.	5.0	2.0	950 ⁴	175 ⁴	2800	650	HV
5T4						Full-Wave Rectifier	5T			
5U4G	Full-Wave Rectifier	5T	Fil.	5.0	3.0	—	—	—	—	HV
5U4GA	Full-Wave Rectifier	5T	Fil.	5.0	3.0	300 ³	275 ³	1550	900	HV
						450 ³	250 ³			
						550 ⁴	250 ⁴			
5SA4	Full-Wave Rectifier	5T	Fil.	5.0	3.0	300 ³	300 ³	1550	1000	HV
						450 ³	275 ³			
						550 ⁴	275 ⁴			
5V3	Full-Wave Rectifier	5T	Htr.	5.0	3.8	425 ³	350	1400	1200	HV
5V4G	Full-Wave Rectifier	5L	Htr.	5.0	2.0	—	—	—	—	HV
5W4GT	Full-Wave Rectifier	5T	Fil.	5.0	1.5	350	110	1000	—	HV
5X4G	Full-Wave Rectifier	5Q	Fil.	5.0	3.0	—	—	—	—	HV
5Y3-G-GT	Full-Wave Rectifier	5T	Fil.	5.0	2.0	—	—	—	—	HV
5Y4-G-GT	Full-Wave Rectifier	5Q	Fil.	5.0	2.0	—	—	—	—	HV
5Z3	Full-Wave Rectifier	4C	Fil.	5.0	3.0	500	250	1400	—	HV
5Z4	Full-Wave Rectifier	5L	Fil.	5.0	2.0	400	125	1100	—	HV
6AV4	Full-Wave Rectifier	5B5	Htr.	6.3	0.95	—	90	1250	250	HV
6AX5GT	Full-Wave Rectifier	6S	Htr.	6.3	1.2	450	125	1250	375	HV
6BW4	Full-Wave Rectifier	9DJ	Htr.	6.3	0.9	450	100	1275	350	HV
6BX4	Full-Wave Rectifier	5B5	Htr.	6.3	0.6	—	90	1350	270	HV
6BY5G	Full-Wave Rectifier	6CN	Htr.	6.3	1.6	375 ³	175	1400	525	HV
6U4GT	Half-Wave Rectifier	4CG	Htr.	6.3	1.2	—	138	1375	660	HV
6V4	Full-Wave Rectifier	9M	Htr.	6.3	0.6	350	90	—	—	HV
6X4/6063	Full-Wave Rectifier	7CF	Htr.	6.3	0.6	325 ³	70	1250	210	HV
6X5GT		6S	Htr.	6.3	0.6	450 ⁴	70	1250	210	
6Z3	Half-Wave Rectifier	4G	Fil.	6.3	0.3	350	50	—	—	HV
12X4	Full-Wave Rectifier	5B5	Htr.	12.6	0.3	650 ³	70	1250	210	HV
						900 ⁴	70	1250	210	
25Z3	Half-Wave Rectifier	4G	Htr.	25	0.3	250	50	—	—	HV
25Z5	Rectifier-Doubler	6E	Htr.	25	0.3	125	100	—	500	HV
25Z6	Rectifier-Doubler	7Q	Htr.	25	0.3	125	100	—	500	HV
35W4	Half-Wave Rectifier	5BQ	Htr.	35 ¹	0.15	125	60	330	600	HV
35Z4GT	Half-Wave Rectifier	5AA	Htr.	35	0.15	250	100	700	600	HV
35Z5G	Half-Wave Rectifier	6AD	Htr.	35 ¹	0.15	125	60	—	—	HV
50Y6GT	Full-Wave Rectifier	7Q	Htr.	50	0.15	125	85	—	—	HV
50Z6G	Voltage Doubler	7Q	Htr.	50	0.3	125	150	—	—	HV
80	Full-Wave Rectifier	4C	Fil.	5.0	2.0	350 ³	125	1400	375	HV
83	Full-Wave Rectifier	4C	Fil.	5.0	3.0	500	250	1400	800	MV
83-V	Full-Wave Rectifier	4AD	Htr.	5.0	2.0	400	200	1100	—	HV
84/6Z4	Full-Wave Rectifier	5D	Htr.	6.3	0.5	350	60	1000	—	HV
117L7GT/117M7GT	Rectifier-Tetrad	8AO	Htr.	117	0.09	117	75	—	—	HV
117N7GT	Rectifier-Tetrad	8AV	Htr.	117	0.09	117	75	350	450	HV
117P7GT	Rectifier-Tetrad	8AV	Htr.	117	0.09	117	75	350	450	HV
117Z3	Half-Wave Rectifier	4CB	Htr.	117	0.04	117	90	330	—	HV
816	Half-Wave Rectifier	4P	Fil.	2.5	2.0	2200	125	7500	500	MV
836	Half-Wave Rectifier	4P	Htr.	2.5	5.0	—	—	5000	1000	HV
866-A-AX	Half-Wave Rectifier	4P	Fil.	2.5	5.0	3500	250	10000	1000	MV
866B	Half-Wave Rectifier	4P	Fil.	5.0	5.0	—	—	8500	1000	MV
866 Jr.	Half-Wave Rectifier	4B	Fil.	2.5	2.5	1250	250 ²	—	—	MV
872A/872	Half-Wave Rectifier	4AT	Fil.	5.0 ²	7.5	—	1250	10000	5000	MV

¹ Tapped for pilot lamps.
² Per pair with (h) & i input.

³ Condenser input.
⁴ Filament input

⁵ Using only one-half of filament

TABLE XI—TRIODE TRANSMITTING TUBES

Type	Maximum Ratings						Cathode			Capacitances			Base	Typical Operation							
	Plate Dissipation Watts	Plate Voltage	Plate Current Ma.	D.C. Grid Current Ma.	Freq. Mc. Full Ratings	Amplification Factor	Volts	Amperes	C _{gk} μμf.	C _{gp} μμf.	C _{pk} μμf.	Class of Service ¹		Plate Voltage	Grid Voltage	Plate Current Ma.	D.C. Grid Current Ma.	Approx. Driving Power Watts	Plate-Pin Lead Ohms	Approx. Output Power Watts	
958-A	0.6	135	7	10	500	12	1.25	0.1	0.6	2.6	0.8	5BD	C-T-O	135	-20	7	1.0	0.035	—	0.6	
616 ²	1.5	300	30	16	250	32	6.3	0.45	2.2	1.6	0.4	7BF	C-T	150	-10	30	1.6	0.35	—	3.5	
9002	1.6	250	8	20	250	25	6.3	0.15	1.2	1.4	1.1	7BS	C-T-O	180	-35	7	1.5	—	—	0.5	
955	1.6	180	8	20	250	25	6.3	0.15	1.0	1.4	0.6	5BC	C-T-O	180	-35	7	1.5	—	—	0.5	
HY114B	1.8	180	12	30	300	13	1.4	0.155	1.0	1.3	1.0	2T	C-T-O	180	-30	12	2.0	0.2	—	1.4 ³	
													C-P	180	-35	12	2.5	0.3	—	1.4 ³	
6F4	2.0	150	20	80	500	17	6.3	0.225	2.0	1.9	0.6	7BR	C-T-O	150	-15	20	7.5	0.2	—	1.8	
															550*						
12AU7 ²	2.75 ⁴	350	12 ⁶	3.5 ⁶	54	18	6.3	0.3	1.5	1.5	0.5	9A	C-T-O	350	-100	24	7	—	—	6.0	
6N4	3.0	180	12	—	500	32	6.3	0.2	3.1	2.35	0.55	7CA	C-T-O	180	—	—	—	—	—	—	
6026	3.0	150	30	10	400	24	6.3	0.2	2.2	1.3	0.38	—	C-T-O	135	1300*	20	9.5	—	—	1.25	
HY615 HY-E114B	3.5	300	20	40	300	20	6.3	0.175	1.4	1.6	1.2	Fig. 71	C-T-O	300	-35	20	7.0	0.4	—	4.0 ³	
													C-P	300	-35	20	3.0	0.8	—	3.5 ³	
6C4	5.0	350	25	8.0	54	18	6.3	0.15	1.8	1.6	1.3	6BG	C-T-O	300	-27	25	7.0	0.35	—	5.5	
2C36	5	1500 ³	—	—	1200	25	6.3	0.4	1.4	2.4	0.36	Fig. 21	C-T-O ¹⁰	1000 ³	0	900 ³	—	—	—	200 ³	
2C37	5	350	—	—	3300	25	6.3	0.4	1.4	1.85	0.02	Fig. 21	C-T-O ¹²	150	3000*	1.5	3.6	—	—	0.5	
5764	5	1500 ³	11.5	—	3300	25	6.3	0.4	1.4	1.85	0.02	Fig. 21	C-T-O ¹⁶	1000 ³	0	1300 ³	—	—	—	200 ³	
5765	5	350	—	—	2900	25	6.3	0.4	1.3	2.1	0.03	Fig. 21	C-T-O ¹⁷	180	10000*	25	—	—	—	0.225	
5675	5	165	30	8	3000	20	6.3	0.135	2.3	1.3	0.09	Fig. 21	G-G-O	120	-8	25	4	—	—	0.05	
6N7 ²	5.5 ⁴	350	30 ⁶	5.0 ⁶	10	35	6.3	0.8	—	—	—	8B	C-T-O ¹¹	350	-100	60	10	—	—	14.5	
5876	6.25	300	25	—	1700	56	6.3	0.135	2.5	1.4	0.035	Fig. 21	G-G-O	250	-2	23	3	—	—	0.75	
													C-M	300	-70	17.3	7	—	—	2.0	
2C40	6.5	500	25	—	500	36	6.3	0.75	2.1	1.3	0.05	Fig. 11	C-T-O	250	-5	20	0.3	—	—	0.075	
5893	8.0	400	40	13	1000	27	6.0	0.33	2.5	1.75	0.07	Fig. 21	C-T	350	-33	35	13	2.4	—	6.5	
													C-P	300	-45	30	12	2.0	—	6.5	
GL-6442	8.0	350	35	15	2500	47	6.3	0.9	5.0	2.3	0.03	—	C-T	350	-50	35	15	—	—	—	
													C-P	275	-50	35	15	—	—	—	
2C34/ RK34 ²	10	300	80	20	250	13	6.3	0.8	3.4	2.4	0.5	Fig. 70	C-T-O	300	-36	80	20	1.8	—	1.6	
2C43	12	500	40	—	1250	48	6.3	0.9	2.9	1.7	0.05	Fig. 11	C-T-O	470	—	38 ²	—	—	—	9 ²	
6263	13	400	55	25	500	27	6.3	0.28	2.9	1.7	0.08	—	C-T	350	-58	40	15	3	—	10	
													C-P	320	-52	35	12	2.4	—	8	
6264	13	400	50	25	500	40	6.3	0.28	2.95	1.75	0.07	—	C-T	350	-45	40	15	3	—	8	
													C-T-O	450	-100	65	15	3.2	—	19	
10Y	15	450	65	15	8	8.0	7.5	1.25	4.1	7.0	3.0	4D	C-P	350	-100	50	12	2.2	—	12	
													C-T	450	-140	90	20	5.2	—	21	
HY75A	15	450	90	25	175	9.6	6.3	2.6	1.8	2.6	1.0	2T	C-P	400	-140	90	20	5.2	—	26	
													C-T	600	-150	65	15	4.0	—	25	
801-A/801	20	600	70	15	60	8.0	7.5	1.25	4.5	6.0	1.5	4D	C-P	500	-190	55	15	4.5	—	18	
													B ⁷	600	-75	130	320*	3.0*	10K	45	
T20	20	750	85	25	60	20	7.5	1.75	4.9	5.1	0.7	3G	C-T	750	-85	85	18	3.6	—	44	
													C-P	750	-140	70	15	3.6	—	38	
T220	20	750	85	30	60	62	7.5	1.75	5.3	5.0	0.6	3G	C-T	750	-40	85	28	3.75	—	44	
													C-P	750	-100	70	23	4.8	—	38	
15E1 ⁴	20	—	—	—	600	25	5.5	4.2	1.4	1.15	0.3	Fig. 51	C-T-O	2000	-130	63	18	4.0	—	100	
														1500	-95	67	13	2.2	—	75	
25T 3-25A3	25	2000	75	25	60	24	6.3	3.0	2.7	1.5	0.3	3G		1000	-70	72	9	1.3	—	47	
													B ⁷	2000	-80	16.80	270*	0.7*	55.5K	110	
3C28 ¹ 3C34 ¹ 3-25D3 24G	25	2000	75	25	100	23	6.3	3.0	2.1	1.8	0.1	Fig. 31	C-T-O	2000	-170	63	17	4.5	—	100	
														1500	-110	67	15	3.1	—	75	
3C24	25	2000	75	25	150	23	6.3	3.0	2.0	1.6	0.2	2D		1000	-80	72	15	2.6	—	47	
													B ⁷	2000	-85	16.80	290*	1.1*	55.5K	110	
HK24	25	2000	75	30	60	25	6.3	3.0	2.5	1.7	0.4	3G	C-T	2000	-130	63	18	4	—	100	
													C-P	1600	-170	53	11	3.1	—	68	
8025	30	1000	65	20	500	18	6.3	1.92	2.7	2.8	0.35	4AQ	AB ⁷	1250	-42	24	130	270*	3.4*	21.4K	112
													C-T	2000	-140	56	18	4.0	—	90	
HY312 ² HY12312 ²	30	500	150	30	60	45	6.3	3.5	5.0	5.5	1.9	Fig. 60	C-T	450	—	80	12	—	—	7.5	
													C-P	400	—	80	12	—	—	6.5	
316A VT-191	30	450	80	12	500	6.5	2.0	3.65	1.2	1.6	0.8	—	C-T	1000	-75	100	25	3.8	—	75	
													C-P	400	—	80	12	—	—	6.5	
809	30	1000	125	—	60	50	6.3	2.5	5.7	6.7	0.9	3G	C-T	750	-60	100	32	4.3	—	55	
													B ⁷	1000	-9	40	200	155*	2.7*	11.6K	145
1623	30	1000	100	25	60	20	6.3	2.5	5.7	6.7	0.9	3G	C-T-O	1000	-90	100	20	3.1	—	75	
													C-P	750	-125	100	20	4.0	—	55	
8012 GL-8012-A	40	1000	80	20	500	18	6.3	2.0	2.7	2.8	0.35	Fig. 54	B ⁷	1000	-40	30	200	230*	4.2*	12K	145
													C-T-O	1000	-90	50	14	1.6	—	35	
T40	40	1500	150	40	60	25	7.5	2.5	4.5	4.8	0.8	3G	C-P	800	-105	40	10.5	1.4	—	22	
													G-M-A	1000	-135	50	4.0	3.5	—	20	
T240	40	1500	150	45	60	62	7.5	2.5	4.8	5.0	0.8	3G	C-T-O	1500	-140	150	28	9.0	—	158	
													C-P	1250	-115	115	20	5.25	—	104	
													C-T-O	1500	-90	150	38	10	—	165	
													C-P	1250	-100	125	30	7.5	—	116	
													B ⁷	1500	-9	250*	285*	6.0*	12K	250	

1 See page V27 for Key to Class-of-Service abbreviations.

TABLE XI—TRIODE TRANSMITTING TUBES—Continued

Type	Maximum Ratings							Cathode		Capacitances			Base	Typical Operation							
	Plate Dissipation Watts	Plate Voltage	Plate Current Ma.	D.C. Grid Current Ma.	Freq. Mc. Full Ratings	Amplification Factor	Volts	Amps	C _g μμf.	C _{gp} μμf.	C _{out} μμf.	Class of Service ¹		Plate Voltage	Grid Voltage	Plate Current Ma.	D.C. Grid Current Ma.	Approx. Driving Power Watts	P _{to-P} Load Ohms	Approx. Output Power Watts	
3-50A4 35T	50	2000	150	50	100	39	5.0	4.0	4.1	1.8	0.3	3G	C-T	2000	-135	125	45	13	—	200	
3-50D4 35TG									2.5		0.4		2D	C-P	1500	-150	90	40	11	—	105
HK54	50	3000	150	30	100	27	5.0	5.0	1.9	1.9	0.2	2D	B [†]	2000	-40	4/167	255 [†]	4.0 [†]	27.5K	235	
													C-T	3000	-290	100	25	10	—	250	
T55	55	1500	150	40	60	20	7.5	3.0	5.0	3.9	1.2	3G	C-P	2500	-250	100	20	8.0	—	210	
													B [†]	2500	-85	20/150	360 [†]	5.0	40K	275	
811	55	1500	150	50	60	160	6.3	4.0	5.5	5.5	0.6	3G	C-T	1500	-170	150	18	6.0	—	170	
													C-P	1500	-195	125	15	5.0	—	145	
812	55	1500	150	35	60	29	6.3	4.0	5.3	5.3	0.8	3G	C-T	1500	-113	150	35	8.0	—	170	
													C-P	1250	-125	125	50	11	—	120	
826	55	1000	140	40	250	31	7.5	4.0	3.0	2.9	1.1	7B0	B [†]	1500	-9	20/200	150 [†]	3.0 [†]	17.6K	220	
													C-T	1500	-175	150	25	6.5	—	170	
830B 930B	60	1000	150	30	15	25	10	2.0	5.0	11	1.8	3G	C-P	1250	-125	125	25	6.0	—	120	
													B [†]	1500	-45	50/200	232 [†]	4.7 [†]	18K	220	
811-A ¹⁹	65	1500	175	50	60	160	6.3	4.0	5.9	5.6	0.7	3G	C-T	1000	-70	130	35	5.8	—	90	
													C-P	1000	-160	95	40	11.5	—	70	
812-A	65	1500	175	35	60	29	6.3	4.0	5.4	5.5	0.77	3G	G-M-A	1000	-125	65	9.5	8.2	—	25	
													C-T	1000	-110	140	30	7.0	—	90	
5514	65	1500	175	60	60	145	7.5	3.0	7.8	7.9	1.0	4B0	C-P	800	-150	95	20	5.0	—	50	
													B [†]	1000	-35	20/280	270 [†]	6.0 [†]	7.6K	175	
3-75A3 75TH	75	3000	225	40	40	20	5.0	6.25	2.7	2.3	0.3	2D	C-T	1500	-70	173	40	7.1	—	200	
													C-P	1250	-120	140	45	10.0	—	135	
3-75A2 75TL	75	3000	225	35	40	12	5.0	6.25	2.6	2.4	0.4	2D	B [†]	1500	-4.5	32/313	170 [†]	4.4 [†]	12.4K	340	
													C-T	1500	-120	173	30	6.5	—	190	
8005	85	1500	200	45	60	20	10	3.25	6.4	5.0	1.0	3G	C-P	1250	-115	140	35	7.6	—	130	
													B [†]	1500	-48	28/310	270 [†]	5.0	13.2K	340	
V-70-D	85	1750	200	45	30	—	7.5	3.25	4.5	4.5	1.7	3G	C-T	1500	-106	175	60	12	—	200	
													C-P	1250	-84	142	60	10	—	135	
3-100A4 100TH	100	3000	225	60	40	40	5.0	6.3	2.9	2.0	0.4	2D	B [†]	1500	-4.5	350 [†]	88 [†]	6.5 [†]	10.5K	400	
													C-T	2000	-200	150	32	10	—	225	
3-100A2 100TL	100	3000	225	50	40	14	5.0	6.3	2.3	2.0	0.4	2D	C-P	2000	-300	110	15	6	—	170	
													B [†]	2000	-90	50/225	350 [†]	3 [†]	19.3K	300	
VT127A	100	3000	—	—	150	15.5	5.0	10.4	2.7	2.3	0.35	Fig. 53	C-T	2000	-300	150	21	8	—	225	
													C-P	2000	-190	50/250	600 [†]	5 [†]	18K	350	
211 311	100	1250	175	50	15	12	10	3.25	6.0	14.5	5.5	4E	C-T	1500	-130	200	32	7.5	—	220	
									6.0	9.25	5.0		C-P	1250	-195	190	28	9.0	—	170	
254	100	4000	225	60	—	25	5	7.5	2.5	2.7	0.4	2N	B [†]	1500	-70	40/310	310 [†]	4.0	10K	300	
													C-T	1750	-100	170	19	3.9	—	225	
8003	100	1500	250	50	30	12	10	3.25	5.8	11.7	3.4	3N	C-P	1500	-90	165	19	3.9	—	195	
													B [†]	2500	-360	168	40	23	—	335	
3X100A11 2C39	100	1000	60	40	500	100	6.3	1.1	6.5	1.95	0.03	—	C-T-O	1350	-180	245	35	11	—	250	
													C-P	1100	-260	200	40	15	—	167	
GL2C39A GL2C39B	100 ¹⁵	1000	125 ¹⁴	50	500	100	6.3	1.0	6.5	1.9	0.035	—	B [†]	1350	-100	40/490	480 [†]	10.5 [†]	6K	460	
	70 ¹⁵												7.0	1.9	0.035	C-T-O	900	-40	90	30	—
3C22	125	1000	150	70	500	40	6.3	2.0	4.9	2.4	0.05	Fig. 17	C-P	600	-150	100 ¹⁴	50	—	—	—	
GL146	125	1500	200	60	15	75	10	3.25	7.2	9.2	3.9	Fig. 56	C-T-O	1000	-200	150	70	—	—	65	
													C-T-O	1250	-150	180	30	—	—	150	
GL152	125	1500	200	60	15	25	10	3.25	7.0	8.8	4.0	Fig. 56	B [†]	1000	-200	160	40	—	—	100	
													C-P	1000	-200	160	40	—	—	100	
805	125	1500	210	70	30	40/60	10	3.25	8.5	6.5	10.5	3N	C-T	1250	-40	16/320	—	—	8.4K	250	
													B [†]	1500	-105	200	40	8.5	—	215	
AX9900/ 5866 ¹⁵	135	2500	200	40	150	25	6.3	5.4	5.8	5.5	0.1	Fig. 3	C-P	1250	-160	160	60	16	—	140	
													B [†]	1500	-16	84/400	280 [†]	7.0 [†]	8.2K	370	
3-150A3 152TH	150	3000	450	85	40	20	5.0	12.5	5.7	4.8	0.4	4BC	C-T	2500	-200	200	40	16	—	390	
													C-P	2500	-225	127	40	16	—	204	
							10	6.25					B [†]	2500	-90	80/330	350 [†]	14 [†]	15.68K	560	
													C-T	3000	-300	250	70	27	—	600	
													C-P	2500	-350	200	30	15	—	400	
													B [†]	2500	-125	40/340	390 [†]	16 [†]	17K	600	

¹ See page V27 for Key to Class-of-Service abbreviations.

Type	Maximum Ratings						Cathode		Capacitances			Base	Typical Operation							
	Plate Dissipation Watts	Plate Voltage	Plate Current Ma.	D.C. Grid Current Ma.	Freq. Mc. Full Ratings	Amplification Factor	Volts	Amps	C _{in} μf.	C _g μf.	C _{out} μf.		Class of Service ¹	Plate Voltage	Grid Voltage	Plate Current Ma.	D.C. Grid Current Ma.	Approx. Driving Power Watts	P-to-P Load Ohms	Approx. Output Power Watts
3-150A2 152TL	150	3000	450	75	40	12	5	12.5	4.5	4.4	0.7	4BC	C-T	3000	-400	250	40	20	—	600
							10	6.25					B ⁷	3000	-260	65/335	675 ⁹	3.0*	20.4K	700
HF201A	150	2500	200	50	30	18	10-11	4.0	8.8	7.0	1.2	Fig. 15	C-T	2500	-300	200	18	8	—	380
													C-P	2000	-350	160	20	9	—	250
810	175	2500	300	75	30	36	10	4.5	8.7	4.8	1.2	2N	B ⁷	2500	-130	60/360	460 ⁹	8*	16K	600
													C-T	2500	-180	300	60	19	—	575
8000	175	2500	300	45	30	16.5	10	4.5	5.0	6.4	3.3	2N	C-P	2000	-350	250	70	35	—	380
													G-M-A	2250	-140	100	2.0	4.0	—	75
GL-5C24	160	1750	107	—	—	8	10	5.2	5.6	8.8	3.3	Fig. 15	B ⁷	2250	-60	70/450	380 ⁹	13*	11.6K	725
													C-T-O	2500	-240	300	40	18	—	575
T200	200	2500	350	80	30	16	10	5.75	9.5	7.9	1.6	2N	C-P	2000	-370	250	37	20	—	380
													G-M-A	2250	-265	100	0	2.5	—	75
592/15 3-200A3	200	3500	250	25 ¹³	150	25	10	5.0	3.6	3.3	0.29	Fig. 28	B ⁷	2250	-130	65/450	560 ⁹	7.9*	12K	725
													C-T	3000	-400	250	28	16	—	600
4C34 HF300	200	3000	275	60	60/20	23	11-12	4.0	6.0	6.5	1.4	2N	C-P	2000	-300	250	36	17	—	385
													B ⁷	3000	-115	60/360	450 ⁹	13*	20K	780
T-300	200	3000	300	—	—	23	11	6.0	6.0	7.0	1.4	—	C-T	3000	-400	250	28	20	—	600
													C-P	2000	-300	250	36	17	—	385
806	225	3300	300	50	30	12.6	5.0	10	6.1	4.2	1.1	2N	B ⁷	2500	-100	60/450	—	7.5*	—	750
													C-T	3300	-600	300	40	34	—	780
3-250A4 250TH	250	4000	350	40 ¹³	40	37	5.0	10.5	4.6	2.9	0.5	2N	C-T-O	2000	-100	357	94	29	—	464
													C-P	3000	-150	332	90	32	—	750
3-250A2 250TL	250	4000	350	35 ¹³	40	14	5.0	10.5	3.7	3.0	0.7	2N	C-T	2000	-160	250	60	22	—	335
													C-P	2500	-180	225	45	17	—	400
5867 AX-9901	250	3000	400	80	100	25	5.0	14.1	7.7	5.9	0.18	Fig. 3	B ⁷	3000	-200	200	38	14	—	435
													C-T-O	1500	0	220/700	460 ⁹	46*	4.2K	630
PL-6569 ¹⁹	250	4000	300	120	30	45	5.0	14.5	7.6	3.7	0.1	Fig. 3	C-T	2000	-200	350	45	22	—	455
													C-P	3000	-350	335	45	29	—	750
3-300A3 304TH	300	3000	900	60 ¹³	40	20	5.0	25	13.5	10.2	0.7	4BC	C-T	2000	-520	250	29	24	—	335
													C-P	2500	-520	225	20	16	—	400
3-300A2 304TL ¹⁰	300	3000	900	50 ¹³	40	12	5.0	25	12.1	8.6	0.8	4BC	B ⁷	1500	-65	1065*	330 ⁹	25*	2.84K	1000
													C-T-O	1500	-250	665	90	33	—	700
833A	350	3300	500	100	30	35	10	10	12.3	6.3	8.5	Fig. 41	C-T	2000	-300	600	85	36	—	900
													C-P	2500	-500	250	30	18	—	410

* Cathode resistor in ohms
¹ KEY TO CLASS-OF-SERVICE ABBREVIATIONS
 A₁ = Class-A₁ AF modulator.
 AB₁ = Class-AB₁ push-pull AF modulator.
 AB₂ = Class-AB₂ push-pull AF modulator.
 B = Class-B push-pull AF modulator.
 CM = Frequency multiplier.
 C = Class-C plate-modulated telephone.
 C-T = Class-C telegraph.
 C-T-O = Class-C amplifier-osc.
 G-G-A = Grounded-grid class-C amp.
 G-G-O = Grounded-grid osc.

G-I-C = Grid-isolation circuit.
 G-M-A = Grid-modulated amp.
² Twin triode. Values, except interelement capacitances, are for both sections in push-pull.
³ Output at 112 Mc.
⁴ Grid leak resistor in ohms.
⁵ Peak values.
⁶ Per section.
⁷ Values are for two tubes in push-pull.
⁸ Max. signal value.
⁹ Peak a.f. grid-to-grid volts.
¹⁰ Plate-pulsed 1000-Mc. osc.

¹¹ Class-B data in Table II.
¹² 1000-Mc. C.W. osc.
¹³ Max. grid dissipation in watts.
¹⁴ Max. cathode current in ma.
¹⁵ Forced-air cooling required.
¹⁶ Plate-pulsed 3300-Mc. osc.
¹⁷ 1900-Mc. C.W. osc.
¹⁸ No Class-B data available.
¹⁹ Linear-amplifier tube-operation data for single sideband in Chapter 12, Table 12-1.
²⁰ Includes bias loss, grid dissipation, and feed-through power

TABLE XII—TETRODE AND PENTODE TRANSMITTING TUBES

Type	Maximum Ratings					Cathode		Capacitances			Base	Typical Operation											
	Plate Dissipation Watts	Plate Voltage	Screen Dissipation Watts	Screen Voltage	Freq. Mc. Full Ratings	Volts	Amps	C _{in} μf.	C _{sp} μf.	C _{out} μf.		Class of Service ¹	Plate Voltage	Screen Voltage	Suppressor Voltage	Grid Voltage	Plate Current Ma.	Screen Current Ma.	Grid Current Ma.	Approx. Driving Power Watts	P _{to-P} Load Ohms	Approx. Output Power Watts	
RK25	10	500	8	250	—	2.5 6.3	2 0.9	10	0.2	10	6BM	C-T	500	200	45	-90	55	38	4	0.5	—	22	
1613	10	350	2.5	275	45	6.3	0.7	8.5	0.5	11.5	7S	C-P	400	150	0	-90	43	30	6	0.8	—	13.5	
2E30	10	250	2.5	250	160	6	0.7	10	0.5	4.5	7CQ	C-T	350	200	—	-35	50	10	3.5	0.22	—	9	
837	12	500	8	300	20	12.6	0.7	16	0.2	10	68M	C-T	275	200	—	-35	42	10	2.8	0.16	—	6	
5763 6417	13.5	350	2	250	50	6.0 12.6	0.75 0.375	9.5	0.3	4.5	9K	C-T	250	200	—	-50	50	10	2.5	0.2	—	7.5	
802	13	600	6	250	30	6.3	0.9	12	0.15	8.5	68M	AB ₂ ⁴	250	250	—	-30	40	120	4/20	2.37	0.2	3.8K	17
2E24	13.5	500 600	2.3 2.5	200 200	125	6.3 ⁴	0.65	8.5	0.11	6.5	7CL	C-T	500	200	40	-70	80	15	4	0.4	—	28	
2E26 ¹³ 6893	13.5	600 500	2.5 2.3	200 200	125	6.3 12.6	0.8 0.4	12.5	0.2	7	7CK	C-P	400	140	40	-40	45	20	5	0.3	—	11	
6360 ³	14	300	2	200	200	6.3 12.6	0.82 0.41	6.2	0.1	2.6	Fig. 13	C.T.	350	250	—	-28.5	48.5	6.2	1.6	0.1	—	12	
2E25	15	450	4	250	125	6	0.8	8.5	0.15	6.7	5BJ	C-P	300	250	—	-42.5	50	6	2.4	0.15	—	10	
832 ²	15	500	5	250	200	6.3 12.6	1.6 0.8	7.5	0.05	3.8	7BP	C-M ²	300	250	—	-75	40	4	1	0.6	—	2.1	
832A ³	15	750	5	250	200	6.3 12.6	1.6 0.8	8	0.07	3.8	7BP	C-M ⁴	300	235	—	-100	35	5	1	0.6	—	1.3	
1619	15	400	3.5	300	45	2.5	2	10.5	0.35	12.5	Fig. 74	C-T	600	250	40	-120	55	16	2.4	0.30	—	23	
5516	15	600	5	250	80	6	0.7	8.5	0.12	6.5	7CL	C-P	500	245	40	-40	40	15	1.5	0.10	—	12	
6252/ AX9910 ²	20	750	4	300	200	6.3 12.6	1.3 0.65	6.5	—	2.5	Fig. 7	C-P	400	180	—	-45	50	8	2.5	0.15	—	13.5	
1614	25	450	3.5	300	80	6.3	0.9	10	0.4	12.5	7AC	C-T	500	200	—	-45	54	9	2.5	0.15	—	18	
815 ²	25	500	4	200	125	6.3 12.6	1.6 0.8	13.3	0.2	8.5	8BY	AB ₂ ⁴	500	125	—	-15	22	150	327	—	0.367	8K	54
1624	25	600	3.5	300	60	2.5	2	11	0.25	7.5	Fig. 66	C-T	300	200	—	-45	100	3	3	0.2	—	18.5	
6146 ¹³						6.3	1.25					C-P	200	100	—	15K ¹	86	3.1	3.3	0.2	—	9.8	
6883	25	750	3	250	60	12.6	0.625	13.5	0.22	8.5	7CK	C-M ¹¹	300	150	—	-100	65	3.5	3.8	0.45	—	4.8	
6159						26.5	0.3					AB ₁	300	200	—	-21.5	30	72	1/12.6	43.5 ⁸	—	10K	12
6524 ² 6850	25	600	—	300	100	6.3 12.6	1.25 0.625	7	0.11	3.4	Fig. 76	AB ₂	300	200	—	-21.5	30	100	1/11.4	64 ⁸	0.04	6.5K	17.5
3E22 ²	30	560	6	225	200	6.3 12.6	1.6 0.8	14	0.22	8.5	8BY	C-T-O	450	250	—	-45	75	15	3	0.4	—	24	
807 ¹³ 807W 5933 1625 ¹³	30	750	3.5	300	60	6.3	0.9	12	0.2	7	SAW	C-P	400	200	—	-45	60	12	3	0.4	—	16	
2E22	30	750	10	250	—	6.3	1.5	13	0.2	8	5J	AB ₂ ⁴	400	200	—	-45	150	17	2.5	0.13	—	56	
AX-9903 ³ 5894A	40	600	7	250	150	6.3 12.6	1.8 0.9	6.7	0.08	2.1	Fig. 7	C-T	500	250	—	-65	36	16	2.6	0.16	—	17	
829B ³ 3E29 ²	40	750	7 7	240	200	6.3 12.6	2.25 1.125	14.5	0.12	7	7BP	C-T	400	300	—	-55	75	10.5	5	0.36	—	19.5	
HY1269	40	750	5	300	6	6.3 12.6	3.5 1.75	16	0.25	7.5	Fig. 65	C-P	325	285	—	-50	62	7.5	2.8	0.18	—	13	
												AB ₂ ⁴	400	300	0	-16.5	75/150	6.5/11.5	—	0.47	—	6K	36
												C-T	600	250	—	-60	75	15	5	0.5	—	32	
												C-P	475	250	—	-90	63	10	4	0.5	—	22	
												AB ₂ ⁴	600	25	—	-25	36/140	1/24	47	0.16	10.5K	67	
												C-T	600	250	—	-60	140	14	4	2.0	—	67	
												C-P	500	250	—	-80	100	12	3	4	—	40	
												B	500	250	—	-26	25/73	0.7/16	52 ⁸	—	20K	23.5	
												C-T	450	250	—	-45	100	8	2	0.15	—	31	
												C-P	375	250	—	-50	93	7	2	0.15	—	24.5	
												AB ₁ ⁴	530	340	—	-36	60/160	207	—	—	—	7.2K	50
												C-T-O	500	200	—	-45	150	17	2.5	0.13	—	56	
												C-P	400	175	—	-45	150	15	3	0.16	—	45	
												AB ₂	500	125	—	-15	22	150	327	—	0.367	8K	54
												C-T	600	300	—	-60	90	10	5	0.43	—	35	
												C-P	500	275	—	-50	75	9	3.3	0.25	—	24	
												AB ₂ ⁴	600	300	—	-25	42/180	5/15	106 ⁸	1.27	7.5K	72	
												C-T	500	170	—	-66	135	9	2.5	0.2	—	48	
												C-T	600	180	—	-71	150	10	2.8	0.3	—	66	
												C-T ¹²	750	160	—	-62	120	11	3.1	0.2	—	70	
												C-T	400	190	—	-54	150	10.4	2.2	3	—	35	
												C-P	400	150	—	-87	112	7.8	3.4	0.4	—	32	
												C-P	475	135	—	-77	94	6.4	2.8	0.3	—	34	
												AB ₂ ⁴	600	150	—	-87	112	7.8	3.4	0.4	—	52	
												AB ₂ ⁴	400	175	—	-41	33/232	1.1/18	1.67	0.2	3.7K	62	
												AB ₂ ⁴	600	190	—	-48	28/270	1.2/20	2 ⁷	0.03	5K	113	
												AB ₁ ⁴	750	165	—	-46	22/240	0.3/20	2.67	0.04	7.4K	131	
												C-T	750	195	—	-50	23/220	1/26	100 ⁸	0	8K	120	
												C-T	600	200	—	-44	120	8	3.7	0.2	—	56	
												C-P	500	200	—	-61	100	7	2.5	0.2	—	40	
												AB ₂	500	200	—	-26	20/116	0.1/10	2.6	0.1	11.1K	40	
												C-T	600	200	—	-55	160	20	7	0.45	—	72	
												C-P	560	200	—	-50	160	20	6.5	0.4	—	67	
												C-T	750	250	—	-45	100	6	3.5	0.22	—	50	
												C-P	600	275	—	-90	100	6.5	4	0.4	—	42.5	
												AB ₂ ⁴	750	300	—	-32	60/240	5/10	92 ⁸	0.27	6.95K	120	
												B ¹⁰	750	—	—								

Type	Maximum Ratings					Cathode		Capacitances			Base	Typical Operation										
	Plate Dissipation Watts	Plate Voltage	Screen Dissipation Watts	Screen Voltage	Freq. Mc. Full Ratings	Volts	Amperes	C _m μf.	C _{sp} μf.	C _{out} μf.		Class of Service ¹⁴	Plate Voltage	Screen Voltage	Suppressor Voltage	Grid Voltage	Plate Current Ma.	Screen Current Ma.	Grid Current Ma.	Approx. Driving Power Watts	P-to-P Lead Ohms	Approx. Output Power Watts
3D24	45	2000	10	400	125	6.3	3	6.5	0.2	2.4	Fig. 75	C-T-O	2000 375	—	-300	90	20	10	4	—	140	
													1500 375	—	-300	90	22	10	4	—	105	
HK-57	50	3000	25	500	200	5	5	7.29	0.05	3.13	Fig. 33	C-T	2000 450	30	-145	110	2	1	0.15	—	166	
												C-P	2000 450	30	-145	88	2	1.5	0.2	—	135	
804	50	1500	15	300	15	7.5	3	16	0.01	14.5	Fig. 61	C-T	1500 300	45	-100	100	35	7	1.95	—	110	
												C-P	1250 250	50	-90	75	20	6	0.75	—	65	
4D22	50	750	14	350	60	12.6	1.6	28	0.27	13	Fig. 26	C-T	750 300	—	-100	240	26	12	1.5	—	135	
						25.2	0.8					600 300	—	-100	215	30	10	1.25	—	100		
4D32						6.3	3.75				Fig. 27	C-P	600	—	-100	220	28	10	1.25	—	100	
													550	—	-100	175	17	6	0.6	—	70	
814	65	1500	10	300	30	10	3.25	13.5	0.1	13.5	Fig. 64	AB ₂ ⁴	600 250	—	-25	100 365	26 ⁷	70 ⁸	0.45 ⁵	3K	125	
												C-T	1500 300	—	-90	150	24	10	1.5	—	160	
												C-P	1250 300	—	-150	145	20	10	3.2	—	130	
													600 250	—	-75	150	40	18	3.1	—	45	
4-65A ¹³	65	3000	10	400	150	6	3.5	8	0.08	2.1	Fig. 25	C-T-O	1500 250	—	-85	150	40	18	3.2	—	165	
		2500		400								3000 250	—	-100	115	22	10	1.7	—	280		
		3000		600								600 250	—	-120	120	40	15	3.2	—	45		
												C-P	1500 250	—	-125	120	40	16	3.5	—	140	
													2500 250	—	-135	110	25	12	2.6	—	230	
													600 250	—	-40	60/300	80 ⁷	240 ⁸	7.4 ⁷	3.6K	90	
													1800 250	—	-50	50/250	30 ⁷	180 ⁸	2.6 ⁷	20K	270	
4E27/8001	75	4000	30	750	75	5	7.5	12	0.06	6.5	7BM	C-T	2000 500	60	-200	150	11	6	1.4	—	230	
HK257	75	4000	25	750	75	5	7.5	13.8	0.04	6.7	7BM	C-P	1800 400	60	-130	135	11	8	1.7	—	178	
HK257B												C-T	2000 400	70	-125	150	12	5	0.8	—	270	
PL-6549	75	2000	10	600	175	6	3.5	7.5	0.09	3.4	Fig. 14	C-P	2000 400	70	-140	125	15	4	0.7	—	200	
												AB ₁ ⁴	2000 600	70	-120	30/120	0.1/9	170 ⁸	—	19.8K	27.5	
												AB ₂ ⁴	2000 400	70	-85	30/225	0.1/10	180 ⁸	0.05 ⁷	19K	325	
												C-T	1500 400	75	-100	180	28	12	2.2	—	200	
828	80	2000	23	750	30	10	3.25	13.5	0.05	14.5	5J	C-P	1250 400	75	-140	160	28	12	2.7	—	150	
												AB ₁ ⁴	2000 750	60	-120	50/270	2/60	240	0	18.5K	385	
													1250 300	0	-75	180	35	12	1.7	—	170	
813 ¹³	125	2500	20	400	30	10	5	16.3	0.25	14	5BA	C-T-O	2000 400	0	-120	180	45	10	1.9	—	275	
		2000		400								2250 400	0	-155	220	40	15	4	—	375		
		2500		800								1250 300	0	-160	150	35	13	2.9	—	140		
												C-P	1600 300	0	-160	150	30	12	2.7	—	180	
													2000 350	0	-175	200	40	16	4.3	—	300	
												AB ₂ ⁴	2000 750	0	-90	40/315	1.5/58	230 ⁸	0.1 ⁷	16K	455	
													2500 750	0	-95	35/360	1.2/55	235 ⁸	0.35 ⁷	17K	650	
4-125 ¹³	125	3000	20	400	120	5	6.5	10.8	0.05	3.1	5BK	C-T-O	2000 350	—	-100	200	50	12	2.8	—	275	
4D21		2500		400								2500 350	—	-150	200	40	12	3.8	—	375		
6155		3000		400								3000 350	—	-150	167	30	9	2.5	—	375		
												C-P	2000 350	—	-220	150	33	10	3.8	—	225	
													2500 350	—	-210	152	30	9	3.3	—	300	
												AB ₂ ⁴	1500 350	—	-41	87/400	0/34	282 ⁸	2.5 ⁷	7.2K	350	
													2500 350	—	-43	93/260	0/6	178 ⁸	1.0 ⁷	7.2K	400	
												AB ₁ ⁴	2500 600	—	-96	50/232	0.3/8.5	192 ⁸	0	20.3K	330	
4E27A/5-125B	125	4000	20	750	75	5	7.5	10.5	0.08	4.7	7BM	C-T	3000 500	60	-200	167	5	6	1.6	—	375	
													1500 500	60	-130	200	11	8	1.6	—	215	
													1000 750	0	-170	160	21	3	0.6	—	110	
803	125	2000	30	600	20	10	5	17.5	0.15	29	5J	C-T	2000 500	40	-90	160	45	12	2	—	215	
													C-P	1600 400	100	-80	150	45	25	5	—	155
4-X150A	150 ⁹	1250	12	300	500	6	2.6	15.5	0.03	4.5	Fig. 75	C-T-O	1250 250	—	-90	200	20	10	0.8	—	195	
4-X150G ¹⁵		1000		300								C-P	1000 250	—	-105	200	20	15	2	—	140	
		1250	400	400		2.5	6.25	27	0.035	4.5	—	AB ₂ ⁴	1250 300	—	-44	47.5 ⁷	0/65	100 ⁸	0.15 ⁷	5.6K	425	
4-250A ¹³	250 ⁹	4000	35	400	600	110	5	14.5	12.7	0.12	4.5	5BK	C-T-O	2500 500	—	-150	300	60	9	1.7	—	575
5D22		3200		400									3000 500	—	-180	345	60	10	2.6	—	800	
6156		4000		400									2500 400	—	-200	200	30	9	2.2	—	375	
												C-P	3000 400	—	-310	225	30	9	3.2	—	510	
												AB ₂ ⁴	1500 300	—	-48	48.5 ⁷	0/34	192 ⁸	4.7 ⁷	5.4K	428	
													2000 300	—	-48	510 ⁷	0/26	198 ⁸	5.5 ⁷	8K	650	
												AB ₁ ⁴	1500 600	—	-95	400 ⁷	0.4/23	128 ⁸	0	6.25K	310	
													2500 600	—	-110	430 ⁷	0.3/13	180 ⁸	0	11.4K	625	
4-X250B	250 ⁹	2000	12	300	175	6	2.1	18.5	0.04	4.7	Fig. 75	C-T-O	2000 250	—	-90	250	25	27	2.8	—	410	
		1500		400								C-P	1500 250	—	-100	200	25	17	2.1	—	250	
		2000		300								AB ₁ ⁴	2000 350	—	-50	500 ⁷	30 ⁷	100 ⁸	0	8.26K	650	
		2000		400								C-T	2000 250	—	-90	250	25	27	2.8	—	410	
4CX-3000A	300 ⁹	1500	12	300	500	6	2.75	29.5	0.04	4.8	—	C-P	1500 250	—	-100	200	25	17	2.1	—	250	
		2000		400								AB ₁ ⁴	2000 350	—	-50	500 ⁷	30 ⁷	100 ⁸	0	8.26K	650	
4-400A	400 ⁹	4000	35	600	110	5	14.5	12.5	0.12	4.7	5BK	C-T-C-P	4000 300	—	-170	270	22.5	10	10	—	720	

TABLE XIII—ELECTROSTATIC CATHODE-RAY TUBES

Type ^c	Heater		Base	Anode No. 2 Voltage	Anode No. 1 Voltage ¹	Anode No. 3 Voltage	Cut-off Grid Voltage ²	Deflection Avg. Volts DC/Inch	
	Volts	Amp.						D ₁ D ₂	D ₃ D ₄
1DP1-4-7-11	6.3	0.215	9CU	600	150	—	-100	280	280
1EP1	6.3	0.6	11V	1000	100/300	—	-14/-42	210/310	240/350
2AP1-11	6.3	0.6	11B	1000	250	—	-30/-90	230	196
2AP1A			11L						
2BP1-11	6.3	0.6	12E	2000	300/560	—	-135	270	174
3ACP1-7-11	6.3	0.6	14J	2000	545	4000	-45/-75	180/220	133/163
3AP1-4-906-P1-4-5-11	2.5	2.1	7AN	1500	430	—	-25/-75	114	109
3AP1A			7CE						
3BP1-4-11	6.3	0.6	14A	2000	575	—	-30/-90	200	148
3BP1A			14G						
3CP1	6.3	0.6	11C	2000	575	—	-30/-90	124	165
3DP1	6.3	0.6	14C	2000	575	—	-30/-90	220	148
3DP1A-3DP7			14H						
3EP1-1806-P1	6.3	0.6	11N	2000	575	—	-30/-90	221	165
3FP7	6.3	0.6	14B	2000	575	4000	-30/-90	250	180
3FP7A			14J						
3GP1-4-5-11	6.3	0.6	11A	1500	350	—	-25/-75	120	105
3GP1A-3GP4A	6.3	0.6	11N	1500	245/437	—	-25/-75	96/144	84/126
3JP1-2-4-7-11-12	6.3	0.6	14J	2000	400/690	4000	-30/-90	170/230	125/270
3JP1A-7A-11A	6.3	0.6	14J	2000	400/690	4000	-45/-75	180/220	133/163
3KP1-4-11	6.3	0.6	11M	2000	320/600	—	-0/-90	100/136	76/104
3MP1	6.3	0.6	12F	2000	400/700	—	-126	230/290	220/280
3QP1	6.3	0.6	9D	1200	240/480	—	-31/-74	214/290	133/181
3RP1-3RP1A	6.3	0.6	12E	2000	330/620	—	-135	146/198	104/140
3SP1-4-7	6.3	0.6	12E	2000	330/620	—	-28/-135	146/198	104/140
3UP1	6.3	0.6	12F	2000	320/620	—	-126	240/310	232/296
5ABP1-7-11	6.3	0.6	14J	2000	400/690	4000	-52/-87	26/34	18/24
5ADP1-7-11	6.3	0.6	14J	1500	300/515	3000	-34/-56	40/50	30.5/37.5
5AJP1	6.3	0.6	Fig. 7B	500	400/900	6000	-30/-60	230	230
5AMP1	6.3	0.6	14U	2500	0/300	—	-34/-56	40/50	20/25
5AP1-1805-P1	6.3	0.6	11A	1500	430	—	-31/-57	93	90
5AP4-1805-P4	6.3	0.6	11A	1500	430	—	-17.5/-57	93	90
5AQP1	6.3	0.6	14G	2500	0/300	—	-34/-56	40/50	31.5/38.5
5ATP1-2-7-11	6.3	0.6	14V	6000	0/700	—	-34/-56	94/116	34/42
5BP1-1802-P1-2-4-5-11	6.3	0.6	11A	2000	425	—	-52/-60	84	76
5BP1A	6.3	0.6	11N	2000	450	—	-20/-60	84	76
5BP7A	6.3	0.6	11N	2000	375/560	—	-20/-60	70/98	63/89
5CP1-2-4-5-7-11	6.3	0.6	14B	2000	575	4000	-30/-90	92	78
5CP1A			14J						
5CP1B-2B-7B-11B	6.3	0.6	14J	2000	400/690	4000	-45/-75	83/101	70/86
5CP7A-11A-12	6.3	0.6	14J	2000	575	4000	-30/-90	92	74
5GP1	6.3	0.6	11A	2000	425	—	-24/-56	36	72
5HP1-4	6.3	0.6	11A	2000	425	—	-20/-60	84.8	77
5HP1A	6.3	0.6	11N	2000	450	—	-20/-60	84	76
5JP1-2-4-5-11	6.3	0.6	11E	2000	520	4000	-45/-105	96	96
5JP1A-4A	6.3	0.6	11S	2000	335/630	4000	-45/-105	77/115	77/115
5LP1-2-4-5-11	6.3	0.6	11F	2000	500	—	-30/-90	103	90
5LP1A-4A	6.3	0.6	11T	2000	376/633	4000	-30/-90	83/124	72/108
5MP1-4-5-11	2.5	2.1	7AN	1500	375	—	-15/-45	66	60
5NP1-4	6.3	0.6	11A	2000	450	—	-20/-60	84	76
5RP1-2-4-7-11	6.3	0.6	14F	2000	528	20000	-30/-90	140/210	131/197
5RP1A-4A	6.3	0.6	14P	2000	362/695	20000	-30/-90	140/210	131/197
5SP1-4	6.3	0.6	14K	2000	363/695	4000	-30/-90	74/110	62/94
5UP1-7-11	6.3	0.6	12E	2000	340/360	—	-90	56/77	46/62
5VP7	6.3	0.6	11N	2000	315/562	—	-20/-60	70/98	63/89
5XP1	6.3	0.6	14P	2000	362/695	20000	-30/-90	140/210	46/68
5XP1A-2A-11A	6.3	0.6	14P	2000	362/695	12000	-45/-75	130/159	42/52
5YP1	6.3	0.6	14Q	2000	541/1040	6000	-45/-135	108/162	36/54
7EP4	6.3	0.6	11N	3000	546/858	—	-43/-100	106/158	91/137
7GP4 ³	6.3	0.6	14G	3000	810/1200	—	-36/-84	93/123	75/102
7JP1-P4-P7	6.3	0.6	14R	6000	1620/2400	—	-72/-168	186/246	150/204
7VP1	6.3	0.6	14R	3000	800/1200	—	-84	93/123	75/102
24XH	6.3	0.6	Fig. 1	600	120	—	-60	0.145	0.165
902-A	6.3	0.6	8CD	600	150	—	-30/-90	139	117
905	2.5	2.1	5BP	2000	450	—	-17.5/-52.5	115	97
905-A			5BR						
907			5BP						
908-A	2.5	2.1	7CE	1500	430	—	-25/-75	114	109
912	2.5	2.1	912	15000	3000	#2 Grid 250	-30/-90	915	750
913	6.3	0.6	913	500	1000	—	-20/-60	299	221
2001	6.3	0.6	4AA	500	1000	—	-20/-60	299	221
2002	6.3	0.6	Fig. 1	600	120	—	—	0.165	0.175
2005	2.5	0.6	Fig. 1 ⁴	2000	1000	200	-35	0.55	0.565

¹ Bogen value for focus. Voltage should be adjustable about value shown.

² Bias for visual extinction of undeflected spot. Voltage should be adjustable from 0 to the higher value shown.

³ Discontinued.

⁴ Cathode connected to Pin 7.

⁵ In mm./volt d.c.

⁶ Phosphor characteristics:

Designation	Color and persistence	Application
P1	Green medium	Oscilloscope.
P2	Blue-green medium	Special oscilloscopes and radar.
P4	White medium	Television.
P5	Blue very short	Photographic recording of high speed traces.
P7	Blue-white short	Radar indicators.
	Yellow long	
P11	Blue short	Oscilloscope.
P12	Orange long	Radar indicators

TABLE XIV—TRANSISTORS

No.	Type	Maximum Ratings				Characteristics				Typical Operation Common Emitter Circuit				
		Diss. Mw.	Collector	Emitter		Noise Figure Db.	Input Res. Ohms ¹	Freq. Cutoff Mc.	Use	Collector		Power Gain Db.	Output Load R. Ohms	Power Output Mw.
			Ma.	Volts	Ma.					Volts	Ma.			
2N34	PNP	50	-10	-25	10	18	1000	0.6	Audio	-1.0	-6	40	30K	—
2N35	NPN	50	10	25	-10	16	1000	0.8	Audio	1.0	6	40	30K	—
2N38A	PNP	125	-20	-25	—	16	1000	—	Audio	-1.0	-6	32	30K	—
2N43	PNP	150	-50	-45	50	—	—	1.0	Audio	-1.0	-5	44	—	—
2N43A	PNP	—	-50	-45	50	—	—	1.0	Audio	—	—	—	—	—
2N44	PNP	150	-50	-45	50	—	—	1.0	Audio	-1.0	-5	43	—	—
2N45	PNP	150	-50	-45	50	—	—	1.0	Audio	-1.0	-5	30	—	—
2N63	PNP	125	-20	-25	—	16	1000	—	Audio	-1.0	-6	38	30K	—
2N64	PNP	125	-20	-25	—	16	1000	—	Audio	-1.0	-6	39	30K	—
2N68	PNP	2500	-1500	-25	1500	—	—	0.4	Audio	-150	-12	23	100	600
2N76	PNP	50	-10	-20	10	18	600	1.0	Audio	-1.0	-5	38	30K	—
2N78	NPN	75	20	20	-20	—	—	5.0	I.F.-R.F.	—	—	—	—	—
2N81	PNP	50	-15	-20	—	—	—	—	Audio	—	—	—	—	—
2N94A	NPN	50	50	20	—	15	—	5.0	I.F.-R.F.	0.5	6	25	100K	—
2N105	PNP	35	-15	-25	15	4.5	2300	.014	Audio	-0.7	-4	42	20K	—
2N106	PNP	160	-10	-6	—	6.0	—	0.8	Audio	—	—	—	—	—
2N107	PNP	50	-10	-12	10	22	700	1.0	—	-1.0	-5	38	30K	—
2N109	PNP	50	-35	-12	35	—	750	—	Audio ²	-35	-4.5	30	200	75
2N112	PNP	—	-5	6	—	25	600	5.0	I.F.-R.F.	-1.0	-6	—	25K	—
2N113	PNP	—	-5	-10	5	—	600	10.0	I.F.-R.F.	-1.0	-6	33	25K	—
2N114	PNP	—	-5	-10	—	25	600	20.0	R.F.	-1.0	-6	—	25K	—
2N116	NPN	50	50	15	—	15	—	3.0	I.F.-R.F.	—	—	—	—	—
2N123	PNP	—	-150	-20	150	—	—	7.5	Switch	-5.0	-15	—	—	—
2N130	PNP	130	-10	-12	—	25	—	0.6	Audio	—	—	—	—	—
2N132	PNP	130	-10	-12	—	20	1000	1.2	Audio	-1.0	-6	42	30K	—
2N133	PNP	130	-10	-15	—	10	—	0.8	Audio	—	—	—	—	—
2N135	PNP	100	-50	-20	50	—	—	4.5	I.F.-R.F.	-1.0	-5	29	—	—
2N136	PNP	100	-50	-20	50	—	—	6.5	I.F.-R.F.	-1.0	-5	31	—	—
2N137	PNP	100	-50	-10	50	—	—	10.0	I.F.-R.F.	-1.0	-5	33	—	—
2N138	PNP	130	-20	-12	—	—	—	—	Audio	—	—	—	—	—
2N139	PNP	35	-15	-16	15	4.5	500	—	I.F.	-1.0	-9	30	30K	—
2N140	PNP	35	-15	-16	15	—	700	—	I.F.-R.F.	-0.4	-9	27	75K	—
2N141	PNP	1500	-800	-30	—	—	100	0.4	Audio	-75	-24	26	400	600
2N143	PNP	1000	-800	-30	—	—	100	0.4	Audio	-75	-24	26	400	600
2N167	NPN	65	75	30	—	—	—	8.0	I.F.-R.F.	—	—	—	—	—
2N168A	NPN	65	20	15	-20	—	350	8.0	I.F.-R.F.	1.0	5	30	15K	—
2N169A	NPN	55	20	25	-20	—	500	5.0	I.F.-R.F.	1.0	5	27	15K	—
2N170	NPN	25	20	6	-20	—	—	2.5	I.F.	—	—	12	—	—
2N175	PNP	20	-2	-10	2	6	3570	—	Audio	-0.5	-4	43	—	—
2N186	PNP	75	-200	-25	—	—	1200	0.8	Audio ²	—	-12	28	—	300
2N186A	PNP	180	-200	-25	—	—	—	0.8	Audio ²	—	-12	30	—	750
2N187A	PNP	180	-200	-25	—	—	2000	1.0	Audio ²	—	-12	32	—	750
2N188	PNP	75	-200	-25	—	—	2600	1.2	Audio ²	—	-12	32	—	300
2N188A	PNP	180	-200	-25	—	—	2600	1.2	Audio ²	—	-12	34	—	750
2N189	PNP	75	-50	-25	—	15	1000	0.8	Audio	—	-12	37	—	—
2N190	PNP	75	-50	-25	—	15	1400	1.0	Audio	—	-12	39	—	—
2N191	PNP	75	-50	-25	—	15	1800	1.2	Audio	—	-12	41	—	—
2N192	PNP	75	-50	-25	—	15	2200	1.5	Audio	—	-12	43	—	—
2N193	NPN	50	50	15	—	—	—	3.0	I.F.-R.F.	—	—	—	—	—
2N194	NPN	50	50	15	—	15	—	4.0	I.F.-R.F.	—	—	—	—	—
2N200	PNP	100	-100	-30	—	12	—	1.0	Audio	—	—	40	—	—
2N211	NPN	50	50	10	—	—	—	—	I.F.-R.F.	—	—	—	—	—
2N212	NPN	50	50	10	—	15	—	5.0	I.F.-R.F.	—	—	—	—	—
2N222	PNP	70	-10	-12	10	24	700	—	—	-1.0	-5	36	30K	—
2N223	PNP	100	-60	-18	—	—	—	—	Audio	-2.0	-4.5	—	—	—
2N224	PNP	100	-150	-25	—	—	—	—	Audio	-100	-0.6	—	—	—
2N226	PNP	100	-150	-25	—	—	—	—	Audio	-100	-0.6	—	—	—
2N255	PNP	1500	-3000	-15	—	—	20	0.2	Audio ²	500	-6	27	—	5 ³
2N256	PNP	1500	-3000	-30	—	—	20	0.2	Audio ²	500	-12	27	—	10 ³
CK722	PNP	—	-10	-22	10	25	800	—	—	-1	-6	39	20K	—
CK760	PNP	—	-5	-6	—	25	600	5.0	I.F.-R.F.	-1.0	-6	—	25K	—
CK761	PNP	—	-5	-10	5	—	600	10.0	I.F.-R.F.	-1.0	-6	33	25K	—
CK762	PNP	—	-5	-10	—	25	600	20.0	R.F.	-1.0	-6	—	25K	—
CQ1	PNP	150	-10	-40	10	33	—	0.5	—	-1.0	-6	30	—	—
GT14H	PNP	130	-10	-22	—	25	—	0.6	Audio	—	—	—	—	—
GT20H	PNP	90	—	-12	—	12	—	—	Audio	—	—	—	—	—
GT34	PNP	125	-20	-25	—	16	1000	—	Audio	-1.0	-6	32	30K	—
GT81	PNP	125	—	-25	—	16	—	—	Audio	—	—	42	—	—
GT83	PNP	125	—	-25	—	16	—	0.7	Audio	—	—	42	—	—
GT87	PNP	125	—	-25	—	16	—	0.5	Audio	—	—	36	—	—
HF-1	PNP	75	-8	-20	8	22	—	5.0	I.F.-R.F.	-1	-6	28	—	—
H5	PNP	20000	-3000	-80	—	—	—	—	Audio	-2000	-30	—	—	—
IF-1	PNP	—	-8	-25	8	11	—	3.0	I.F.	-1	-6	40	—	—
JP-1	PNP	350	-50	-45	50	15	—	—	Audio	-15	-22	20	—	150
SB100	SB	10	-5	-4.5	—	—	—	30	R.F.	-0.5	-3	—	25K	—
ZJ-13	NPN	30	20	15	—	5	—	16	R.F.	—	—	—	—	—

1 Common emitter circuit
 2 Two transistors in Class B
 3 Power output watts

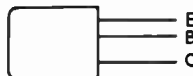

Code for identifying junction transistors. The leads are marked C—collector, B—base and E—emitter.

TABLE XV—GERMANIUM CRYSTAL DIODES

Type	Use	Max. Inverse Volts	Max. Average Ma.	Min. Forward Ma. ¹	Max. Reverse μ -Amp.	Type	Use	Max. Inverse Volts	Max. Average Ma.	Min. Forward Ma. ¹	Max. Reverse μ -Amp.
1N34	General	60	50	5.0	800 (<i>t_s</i> — 50 V.	1N92	Pwr. Rectifier	65	100	310 (@ 0.5 V.	1900 (@ — 200 V.
1N34A	General	60	50	5.0	500 (<i>t_s</i> — 50 V.	1N93	Pwr. Rectifier	100	75	250 (@ 0.5 V.	1200 (@ — 300 V.
1N38	100-Volt Diode	100	50	3.0	625 (<i>t_s</i> — 100 V.	1N94	Pwr. Rectifier	185	500	1570 (@ 0.7 V.	800 (@ — 380 V.
1N38A	100-Volt Diode	100	50	4.0	500 (<i>t_s</i> — 100 V.	1N95	Diode	60	250	10	500 (@ — 50 V.
1N39	200-Volt Diode	200	50	1.5	800 (<i>t_s</i> — 200 V.	1N96	Diode	60	250	20	500 (@ — 50 V.
1N39A	200-Volt Diode	200	40	3.0	800 (<i>t_s</i> — 200 V.	1N97	Diode	80	250	10	100 (@ — 50 V.
1N43	General	60	40	5.0	900 (<i>t_s</i> — 50 V.	1N98	Diode	80	250	20	100 (@ — 50 V.
1N44	General	115	35	3.0	410 (<i>t_s</i> — 50 V.	1N99	Diode	60	300	10	50 (<i>t_s</i> — 50 V.
1N45	General	5	35	3.0	400 (<i>t_s</i> — 50 V.	1N100	Diode	60	300	20	50 (<i>t_s</i> — 50 V.
1N46	General	50	40	3.0	1500 (<i>t_s</i> — 50 V.	1N105	Vid. Detector	25	50	—	—
1N47	General	115	30	3.0	410 (<i>t_s</i> — 50 V.	1N106	Hi-Back Voltage	300	—	20	200 (@ — 300 V.
1N48	General	70	50	4.0	830 (<i>t_s</i> — 50 V.	1N107	Hi-Forward Current	10	—	150	200 (@ — 10 V.
1N49	Detector	50	50	4.0	200 (<i>t_s</i> — 20 V.	1N108	General	50	—	50	200 (@ — 50 V.
1N50	Detector	50	50	4.0	80 (<i>t_s</i> — 20 V.	1N109	Harmonic Gen.	15	50	8.5	20 (@ — 3 V.
1N51	General	40	25	2.5	1300 (<i>t_s</i> — 40 V.	1N110	U.h.f. Mixer	—	—	—	Noise Figure: 10 db at 750 Mc.
1N52	General	70	50	4.0	150 (<i>t_s</i> — 50 V.	1N111	Rectifier	70	25	5.0	125 (<i>t_s</i> — 50 V.
1N54	Hi-Back Resistance	35	50	5.0	10 (<i>t_s</i> — 10 V.	1N112	Rectifier	70	25	5.0	250 (@ — 50 V.
1N54A	Hi-Back Resistance	50	50	5.0	100 (<i>t_s</i> — 50 V.	1N113	Rectifier	70	25	2.5	125 (<i>t_s</i> — 50 V.
1N55	150-Volt Diode	150	50	3.0	800 (<i>t_s</i> — 150 V.	1N114	Rectifier	70	25	2.5	250 (@ — 50 V.
1N55A	150-Volt Diode	150	50	4.0	500 (<i>t_s</i> — 150 V.	1N115	Rectifier	70	25	2.5	500 (<i>t_s</i> — 50 V.
1N55B	150-Volt Diode	150	50	5.0	500 (<i>t_s</i> — 150 V.	1N116	Diode	60	30	5	100 (@ — 50 V.
1N56	Hi-Conduction	40	60	15.0	300 (<i>t_s</i> — 30 V.	1N117	Diode	60	30	10	100 (@ — 50 V.
1N56A	Hi-Conduction	40	60	15.0	300 (<i>t_s</i> — 30 V.	1N118	Diode	60	30	20	100 (@ — 50 V.
1N57	Diode	80	40	3.6	500 (<i>t_s</i> — 75 V.	1N120	Computer	60	25	5	—
1N58	100-Volt Diode	100	50	4.0	800 (<i>t_s</i> — 100 V.	1N126	Diode	60	30	5	850 (<i>t_s</i> — 50 V.
1N58A	100-Volt Diode	100	50	4.0	600 (<i>t_s</i> — 100 V.	1N127	Diode	100	30	3	300 (<i>t_s</i> — 50 V.
1N59	250-Volt Diode	250	40	3.0	800 (<i>t_s</i> — 250 V.	1N128	Diode	40	30	3	10 (@ — 10 V.
1N60	Vid. Detector	25	50	5.0	40 (<i>t_s</i> — 20 V.	1N132	Vid. Detector	25	50	—	—
1N60A	Vid. Detector	25	5	5.0	800 (<i>t_s</i> — 50 V.	1N133	U.h.f. Mixer	5	50	3 at 0.5 V.	300 (<i>t_s</i> — 6 V.
1N61	Diode	130	40	5.0	700 (<i>t_s</i> — 125 V.	1N139	Hi-Forward Conduction	40	70	20	1500 (<i>t_s</i> — 50 V.
1N62	Diode	110	40	5.0	700 (<i>t_s</i> — 100 V.	1N140	Hi-Forward Conduction	70	85	40	300 (<i>t_s</i> — 50 V.
1N63	Hi-Back Resistance	100	50	4.0	50 (<i>t_s</i> — 50 V.	1N141	Hi-Forward Conduction	70	70	20	50 (<i>t_s</i> — 50 V.
1N64	Vid. Detector	20	50	0.1	2.5 (<i>t_s</i> — 1.3 V.	1N142	Hi-Peak Inverse	100	60	5	100 (<i>t_s</i> — 100 V.
1N64A	Vid. Detector	25	5	5.0	800 (<i>t_s</i> — 50 V.	1N143	Hi-Peak Inverse	100	85	40	100 (@ — 100 V.
1N65	Hi-Back Resistance	70	50	2.5	200 (<i>t_s</i> — 50 V.	1N147	U.h.f. Mixer	55	25	—	—
1N66	General	60	50	5.0	800 (<i>t_s</i> — 50 V.	1N151	TV Model ²	30	5000	1570 (<i>t_s</i> 0.7 V.	2400 (<i>t_s</i> — 100 V.
1N67	Hi-Back Resistance	80	35	4.0	50 (<i>t_s</i> — 50 V.	1N152	TV Model ²	65	500	1570 (<i>t_s</i> 0.7 V.	1900 (<i>t_s</i> — 200 V.
1N67A	Hi-Back Resistance	60	50	5.0	50 (<i>t_s</i> — 50 V.	1N153	TV Model ²	100	500	1570 (<i>t_s</i> 0.7 V.	1200 (<i>t_s</i> — 300 V.
1N68	Hi-Back Resistance	80	35	3.0	625 (<i>t_s</i> — 100 V.	1N158	Pwr. Rectifier	185	—	—	D.c. output current = 500 ma.
1N68A	General	80	50	5.0	625 (<i>t_s</i> — 100 V.	1N172	U.h.f. Mixer	—	—	—	Low noise and low conversion loss.
1N69	General	60	40	5.0	850 (<i>t_s</i> — 50 V.	1N175	Hi-Back Voltage	200	—	20	200 (<i>t_s</i> — 200 V.
1N70	General	100	30	3.0	300 (<i>t_s</i> — 50 V.	1N191	Computer	90	30	5	25 (<i>t_s</i> — 10 V.
1N72	U.h.f. Mixer	2	25	1.6	800 (<i>t_s</i> — 0.5 V.	1N192	Computer	70	30	5	50 (<i>t_s</i> — 10 V.
1N75	Varistor	100	50	2.5	50 (<i>t_s</i> — 50 V.	1N198	Hi-Temperature	80	30	5	250 (<i>t_s</i> — 50 V.
1N81	General	40	30	3.0	10 (<i>t_s</i> — 10 V.	1N285	U.h.f. Mixer	—	—	—	Noise Figure: 12.5 at 870 Mc.
1N86	General	70	50	4.0	833 (<i>t_s</i> — 50 V.	1N287	General	40	70	20	1500 (@ — 50 V.
1N87	Vid. Detector	25	5	2.1 ³	—	1N288	General	70	85	40	350 (@ — 50 V.
1N87A	Vid. Detector	25	5	5.0	800 (<i>t_s</i> — 50 V.	1N289	General	70	70	20	50 (@ — 50 V.
1N88	Restorer	85	5	2.5	100 (<i>t_s</i> — 50 V.	1N290	General	100	60	5	100 (@ — 100 V.
1N89	Restorer	80	30	3.5	100 (<i>t_s</i> — 50 V.	1N291	General	100	85	40	100 (@ — 100 V.
1N90	General	60	30	5.0	500 (@ — 50 V.	1N292	General	60	—	100	200 (@ — 50 V.
1N91	Pwr. Rectifier	30	150	470 (@ 0.5 V.	2700 (@ — 100 V.	1N335	Diode	80	50	4	50 (@ — 50 V.

Average shunt capacitance — 0.8 μ f.

¹ At +1 Volt

² Max. operating frequency 50 Kc.

³ At 5V.

V32



The Catalog Section



In the following pages is a catalog file of products of the principal manufacturers and the principal distributors who serve the radio field: industrial, commercial, amateur. All firms whose advertising has been accepted for this section have met The American Radio Relay League's rigid standards for established integrity; their products and engineering methods have received the League's approval.



34th EDITION 1957

INDEX OF ADVERTISERS

★ CATALOG SECTION ★

The Radio Amateur's Handbook

	Page		Page
Allied Radio Corp.....	65	Instructograph Co.....	112
American Electronics Co.....	105	Insuline Corp. of America.....	120
American Radio Relay League, Inc.	85-88, 133	International Crystal Mfg. Co., Inc.....	49-52
American Television & Radio Co.....	101	International Rectifier Corp.....	109
Amperex Electronic Corp.....	76, 77	International Resistance Co.....	56-59
Amphenol Electronics Corp.....	92		
Antenna Engineering Co.....	130	Johnson Co., E. F.....	26-31
Arrow Electronics, Inc.....	111		
Ashe Radio Co., Walter.....	106	Lampkin Laboratories, Inc.....	97
		Lockheed Aircraft Corp.....	136
Barker & Williamson, Inc.....	66, 67		
Belden Manufacturing Co.....	104	Mallory & Co., Inc., P. R.....	13
Bliley Electric Co.....	80	Master Mobile Mounts, Inc.....	95
Burstein-Applebee Co.....	94	Measurements Corp.....	127
		Millen Mfg. Co., Inc., James.....	14-23
Cameradio Co., Inc.....	100	Mosley Electronics, Inc.....	114
Candler System Co.....	99	Multi-Products Co.....	126
Cannon Electric Co.....	60		
Centralab.....	32	National Co., Inc.....	38-41
Collins Radio Co.....	33-36	National Schools.....	117
Communications Co., Inc.....	119	Newark Electric Co.....	98
Editors & Engineers, Ltd.....	115	Ohmite Manufacturing Co.....	82
Eitel-McCullough, Inc.....	68, 69		
Eldico Electronics.....	72, 73	Par-Metal Products Corp.....	90
Electro-Voice, Inc.....	129		
Electronic Technical Institute.....	110	Radio Corporation of America.....	24, 25
Elmar Electronics.....	121	Radio Shack Corp.....	103
Erie Resistor Corp.....	116	RCA International Div.....	84, 131
E-Z Way Towers, Inc.....	70, 71		
		Shurite Meters.....	102
Ft. Orange Radio Distributing Co., Inc.....	108		
Freed Transformer Co., Inc.....	113	Technical Materiel Corp.....	43-48
Fretco, Inc.....	107	Triplett Electrical Instr. Co.....	132
General Electric Co.....	37, 89, 91	United Transformer Co.....	42
Gonset.....	78, 79	Universal Distributors, Inc.....	124
Hallicrafters Co., The.....	3-12	Valley Electronic Supply Co.....	96
Hammarlund Mfg. Co., Inc.....	64	Vesto Co., Inc.....	125
Harrison Radio Corp.....	83	Vibroplex Co., Inc.....	93
Harvey Radio Co., Inc.....	74, 75		
Heath Co.....	53-55	Ward Products Corp.....	118
Henry Radio Stores.....	81	Waterman Products Co.....	134, 135
Hudson Radio & Television Corp.....	123	Wile, Eugene G.....	128
		World Radio Laboratories, Inc.....	61-63
		Wyco Metal Products.....	122

The
New Ideas
in communications
are born at

hallicrafters

- In the limitless world of communications, *new ideas* are the real measure of leadership.

Over the past quarter-century, Hallicrafters engineers have brought to amateurs, novices and listeners more than 100 major communications designs—over five times as many as any other manufacturer.

That is why Hallicrafters is the unchallenged leader in the design and manufacture of communication equipment...acknowledged by more than 1,000,000 satisfied users.

The **hallicrafters** Company

4401 West Fifth Avenue, Chicago, Illinois



MODEL SX-101

New heavyweight champion!

MODEL SX-101 is all amateur and as rugged as they come! It is the first complete answer to ham reception . . . incorporating every essential feature needed for today and wanted for the future.

FREQUENCY COVERAGE: Band 1—1.8-2.4 Mc. Band 2—3.2-4.1 Mc. Band 3—7.0-7.3 Mc. Band 4—14.0-14.4 Mc. Band 5—21.0-21.5 Mc. Band 6—26.95-27.35 Mc. and 28.-29.7 Mc. Band 7—10 Mc. WWV.

FEATURES: Complete coverage of seven ham bands—160, 80, 40, 20, 15, 11-10 meters. Large slide rule dial. Band-in-use scales individually illuminated. Illuminated S-meter. Dual scale S-meter. S-meter zero point independent of sensitivity control. S-meter functions with AVC off. Special 10 Mc position for WWV. Coverage of most important M.A.R.S. frequencies. Local oscillator output available for use in heterodyne V.F.O. Dual conversion. Exclusive Hallicrafters upper-lower side band selection. Second conversion oscillators quartz crystal controlled. Tee-notch filter. Full gear drive from tuning knob to gang condensers—absolute reliability. 40:1 tuning knob ratio. Built-in precision 100 kc evacuated marker crystal. Vernier pointer adjustment. Five steps of selectivity from 500 cycles to 5000 cycles. Precision temperature compensation plus Hallicrafters exclusive production heat cycling for lowest drift. Direct coupled series

noise limiter for improved noise reduction. Sensitivity—one microvolt or less on all bands. 52 ohm antenna input. Antenna trimmer. Relay rack panel. Heaviest chassis in the industry—.089 cold rolled steel. Double space gang condenser. 13 tubes plus voltage regulator and rectifier. Powerline fuse.

FRONT PANEL CONTROLS: Main tuning knob with 0-100 logging dial and 2000° counter. Pointer reset, antenna trimmer, tee-notch frequency, tee-notch depth, sensitivity, band selector, volume selectivity, pitch (BFO), response—(upper-lower-side band and tone). AVC on/off, BFO on/off, ANL on/off, Marker on/off, Rec./standby.

TUBES AND FUNCTIONS: 6CB6, R.F. amplifier—6BY6, 1st converter—12AU7A, high frequency oscillator and coupling tube—6BA6, 1650 kc i.f. amplifier—12AT7, dual crystal controlled 2nd conversion oscillator—6BA6, 2nd converter—6C4, 1st 50.5 kc. i.f. amplifier—6BA6, 2nd 50.5 kc. i.f. amplifier—6BJ7, detector, A.N.L., A.V.C.—6SC7, 1st audio amplifier & B.F.O.—6K6, audio power output—6BA6, S-meter amplifier—6AU6, 100 kc. crystal oscillator—OA2, voltage regulator—5Y3, rectifier.

PHYSICAL DATA: 20" wide, 10½" high and 16" deep—Panel size 8¾" x 19"—weight approximately 74 lbs. (Conforms to F.C.D.A. specifications.)

The New Ideas in communications

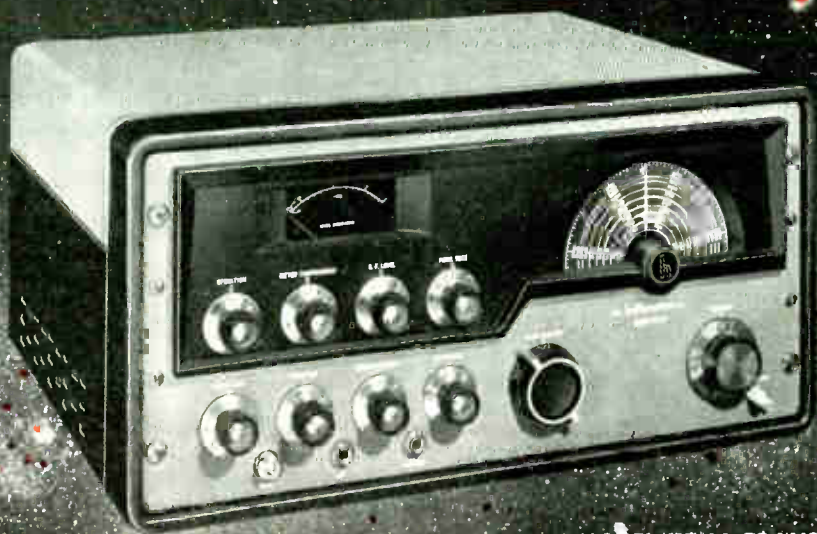

MODEL HT-32 TRANSMITTER

Cleanest signal on the air!

MODEL HT-32 is a new complete table top, high efficiency amateur band transmitter providing S.S.B. AM or CW output on 80, 40, 20, 15, 11 and 10 meter bands. This unit incorporates two new exclusive features in S.S.B. generation techniques. First, a piezo electric filter which cuts unwanted sideband 50 db. or more. Second, a newly developed bridged-tee modulator which makes the HT-32 extremely stable.

FEATURES: New piezo electric sideband filter—rejection 50 db. or more. Bridged-tee sideband modulator. C.T.O. direct reading in kilocycles to less than 300 cycles from reference point. 144 watts plate input (P.E.P. two-tone). Six band output (80, 40, 20, 15, 11-10 meters). All modes of transmission—CW, AM, S.S.B. Unwanted sideband down 50 db. or more. Distortion products down 30 db. or more. Carrier suppression down 50 db. or more. Both sidebands transmitted on AM. Precision gear driven C.T.O. Exclusive Hallicrafters patented sideband selection. Logarithmic meter for accuracy tuning and carrier level adjustment. Ideal CW keying and break-in operation. Full voice control system built in.

FRONT PANEL CONTROLS, FUNCTIONS AND CONNECTIONS:

Operation—power off, standby, Mox., Cal., Vox. Audio level 0-10. R.F. level 0-10. Final tuning 80, 40, 20, 15, 11-10 meters. Function—Upper side band, lower side band, DSB, CW. Meter compression. Calibration level 0-10. Driver tuning 0-5. Band selector—80, 40, 20, 15, 11-10 meters. High stability, gear driven V.F.O. with dial drag. Microphone connector. Key jack. Headphone monitor jack.

TUBES AND FUNCTIONS: 2-6146 Power output amplifier. 6CB6 Variable frequency oscillator. 12BY7 R. F. driver. 6AH6 2nd Mixer. 6AH6 3rd Mixer. 6AB4 Crystal oscillator. 12AX7 Voice control. 12AT7 Voice control. 6AL5 Voice control. 12AX7 Audio Amplifier. 12AU7 Audio amp and carrier Oscillator. 12AU7 Diode Modulator. 12AT7 Sideband selecting oscillator. 6AH6 1st Mixer. 6AH6 4.95 Mc. Amplifier. 6AU6 9.00 Mc. Amplifier. 5R4GY HV Rectifier. 5V4G LV Rectifier. OA2 Voltage Regulator.

REAR CHASSIS: Co-ax antenna connector. Line fuse. Control connector. AC power line cord.

are born at **hallicrafters**

*The New Ideas in communications
are born at*
hallicrafters

MODEL HT-33 Linear Kilowatt Amplifier



Longer life, greater dependability!

MODEL HT-33 Linear Kilowatt Amplifier is the first to use the new, ceramic power tubes. Ceramic tubes mean: Consistently higher performance and reliability over a longer life as well as 100 watts greater plate dissipation. Greater overload safety. Unbelievably rugged (they'll withstand repeated 11 milli-second shocks of 50g).

SPECIFICATIONS: Power input—1000 watts S.S.B. and 700 watts A. M. Power Output S.S.B.—625 watts. Power Output C.W.—575 watts. Power Output A. M.—285 carrier with D.S.B. Driver Power S.S.B.—8 watts P.E.P. Drive Power C.W.—6.5 watts. Drive Power A. M.—6.0 watts.

FEATURES: Ceramic tubes—longer life, greater overload capacity, higher efficiency. Six Ham Bands—80, 40, 20, 15, 11-10 meters. Pi-network output system for high harmonic suppression. All control leads filtered. Full metering of all important circuits. Relay rack panel. Quiet, high efficiency, low speed blower. Built-in power supply. One knob band switching. 52 Ohm coaxial output. 52 Ohm coaxial input with VSWR less than 1.5:1.

CIRCUIT DETAILS: This power amplifier

employs two ceramic 4CX300A power tetrodes. These new rugged, low inductance tubes assure high efficiency and excellent stability. The grid circuit is designed for 52 Ohms input and is condenser tuned. Band switching is by one knob which simultaneously selects the proper grid coil and plate tank inductance. The output circuit is a pi-network for fixed 52 Ohm output impedance. The high voltage for plates and screens is obtained from 2-866A rectifiers. Screen voltage is regulated by 2-OB2 and 1-OA2. Plates and screen currents can be measured by the meter.

TUBES: 2—4CX300A Ceramic tetrodes. 2—866A Rectifiers. 2—OB2, 1—OA2 Screen regulators.

FRONT PANEL CONTROLS: Band selector. Grid tuning. Plate tuning. Power on/off. Tune/operate. High voltage on/off. Meter switch screen/plate.

REAR CHASSIS: Co-ax input. Co-ax output. Grid bias control, A.C. line fuse. Cut off bias relay terminals. 8 $\frac{3}{4}$ " x 19" relay rack panel. Cabinet 12 $\frac{3}{8}$ " x 20" x 16" deep. Approximate weight 115 lbs.

Just plug it in and start working!

MODEL SR-1000 brings you *three* brilliant new chassis with professional efficiency in the *only complete kilowatt* amateur radio station available. Just plug it in . . . and you're in business! Organized, compact and efficient. Convenient external connections for your microphone and antenna . . . rugged construction . . . keylock . . . casters . . . safety features—even space for additional equipment.

The inside story of the SR-1000:

1. MODEL SX-101 RECEIVER. New *heavy-weight* champion of the industry! All-amateur receiver: 7 bands on slide-rule dial. Famous Hallicrafters Tee-notch filter . . . special 10 mc position for W.W.V. . . . 2000 disc logging counter . . . all other features of famous SX-100. (Complete description on page 4).

2. MODEL HT-32 TRANSMITTER EXCITER. Introduces two major SSB developments: (1) exclusive piezo electric crystal filter cuts spurious sideband down 50 db. or more; (2) new bridged-tee modulator provides carrier suppression of 50 db. or more. *Result: cleanest signal on the air.* (Complete description on page 5).

3. HT-33 LINEAR KILOWATT AMPLIFIER. New, and exclusively Hallicrafters—*ceramic power tubes* provide plate dissipation 100 watts greater than ever before possible . . . consistently higher performance over a longer life. Advanced design—extremely compact (only 12³/₈ inches high!) Full frequency coverage (complete description on opposite page).

Also available in custom, desk-style cabinet.



MODEL SR-1000

Everything for the DX enthusiast!

MODEL SX-99

FREQUENCY COVERAGE: Broadcast Band 540-1680 kc plus three short-wave bands covers 1680 kc-34 mc.

FEATURES: Over 1000° of calibrated electrical bandspread over the 10, 11, 15, 20, 40 and 80 meter amateur bands. Separate bandspread tuning condenser, crystal filter, antenna trimmer, "S" Meter, one r-f, two i-f stages.

INTERMEDIATE FREQUENCY: 455 kc.

TUNING ASSEMBLY AND DIAL DRIVE MECHANISM: Ganged, 3 section tuning capacitor assembly with electrical bandspread. Circular main tuning dial is calibrated in megacycles and has 0-100 logging scale.

AUDIO OUTPUT IMPEDANCE: 3.2 and 500 ohms.

TUBE COMPLEMENT: Seven tubes plus one rectifier: 65G7, r-f amplifier—65A7, Converter—6SG7, 1st i-f amplifier—6SK7, 2nd i-f amplifier—6SC7, BFO and audio amplifier—6K6GT, Audio output—6H6, ANL-AVC-detector—6Y3GT, rectifier.

AUDIO POWER OUTPUT: 2 watts.

POWER SUPPLY: 105/125 V. 50/60 cycle AC.

PHYSICAL DATA: Gray black steel cabinet with brushed chrome trim and piano hinge top. Size 18½" wide x 8½" high x 11" deep. Shipping weight approximately 32½ lbs.



MODEL SX-99

MODEL SX-100

Incomparable value!

MODEL SX-100

FREQUENCY COVERAGE: 540 kc—34 Mc. Band 1: 538 kc-1580 kc—Band 2: 1720 kc-4.9 Mc—Band 3: 4.6 Mc-13 Mc—Band 4: 12 Mc-34 Mc. Bandspread dial is calibrated for the 80, 40, 20, 15 and 11-10 meter amateur bands.

TYPE OF SIGNALS: AM—CW—SSB.

FEATURES: Selectable side band operation. "Tee-Notch" Filter—provides a stable non-regenerative system for the rejection of unwanted heterodyne. Also produces an effective steepening of the already excellent 500 Cycles i-f pass band and further increases the effectiveness of the advanced exalted carrier type reception. Notch depth control for maximum null adjustment. Antenna trimmer. Plug-in laboratory type evacuated 100 kc quartz crystal calibrator—included in price. Logging dials for both tuning controls. Full precision gear drive dial system. Second conversion oscillator crystal controlled—provides greater stability and additional temperature compensation of high

frequency oscillator circuits. Phono jack. Socket for D.C. and remote control.

INTERMEDIATE FREQUENCY: 1650 kc and 50 kc.

AUDIO OUTPUT IMPEDANCE: 3.2/500 ohms; **AUDIO POWER OUTPUT:** 1.5 watts with 10% or less distortion. **POWER SUPPLY:** 105/125 V., 50/60 cycle AC.

TUBE COMPLEMENT: 6CB6 R.F. amplifier; 6AU6, 1st converter; 6C4, H. F. oscillator; 6BA6, 2nd converter; 12AT7, Dual crystal second converters; (2) 6BA6, 50 kc and 1650 kc i-f amplifiers; 6BJ7, AVC-noise limiter; 6SC7, 1st audio and BFO; 6K6, Power output; 5Y3; Rectifier; OA2, Voltage regulator; 6C4, i-f amplifier—(50 kc); 6AU6, 100 kc XTAL marker.

PHYSICAL DATA: Gray black steel cabinet with brushed chrome knob trim, patterned silver back plate and red pointers. Piano hinge top. Size 18¾" wide x 8½" high x 10½" deep. Shipping weight approximately 42 lbs.

The New Ideas in communications

For the complete listener!

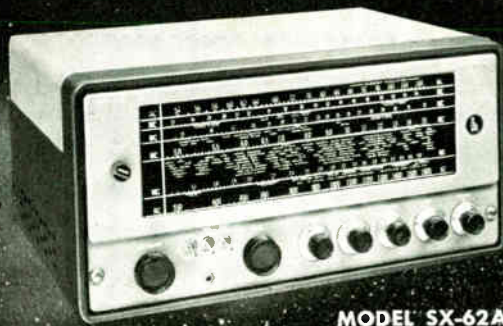

MODEL SX-62A



MODEL HT-30

MODEL SX-62A

FREQUENCY COVERAGE: Standard Broadcast from 550 kc through 1620 kc, three short wave bands, 1.62 mc-32 mc and FM or AM from 27 mc to 109 mc.

FEATURES: Single tuning control covers wide-vision dial with one band lighting at a time. A 500 kc crystal calibration oscillator built-in to check dial pointer accuracy. Temperature compensated, voltage regulated. Audio flat 50-15,000 cycles, 10 watt push-pull audio output. Automatic Noise Limiter; Series diode.

TYPE OF SIGNALS: Bands 1, 2, 3, and 4; AM/CW. Bands 5 and 6; AM/FM/CW.

CONTROLS: Band selector 550 kc-1620 kc, 1.62 mc-4.9 mc, 4.9 mc-15 mc, 15 mc-32 mc, 27 mc-56 mc, 54 mc-109 mc. Receive/standby, calibration osc. on/off, noise limiter, tuning, AF gain, Phono/FM/AM/CW, six-position selectivity, four-position tone, r-f gain, calibration reset.

INTERMEDIATE FREQUENCIES: Bands 1, 2, 3, and 4; 455 kc. Bands 5 and 6; 10.7 mc.

ANTENNA INPUT IMPEDANCE: 52 to 600 ohms.

AUDIO OUTPUT IMPEDANCE: 3.2/8/500

TUBE COMPLEMENT: Fourteen tubes plus voltage regulator and rectifier. (2) 6AG5, r-f amp.-7F8, conv.-6SK7, i-f amp.-6SG7, i-f amp.-6SG7, FM limiter and AM det.-6H6, FM det.-6J5, BFO-6H6, ANL-6SL7, phase inverter-(2) 6V6, push-pull audio output-6C4, calibration osc.-VR-150, regulator-5U4G, rectifier.

POWER SUPPLY: 105/125 V., 50/60 cycle AC.

PHYSICAL DATA: Satin black steel cabinet with light gray front panel and chrome trim. Piano hinge top. Size 20" wide x 10½" high x 16" deep. Shipping weight approximately 64 lbs.

Standard of comparison for SSB!

MODEL HT-30

FREQUENCY COVERAGE: 80, 40, 20, 10 meter bands.

TYPE OF SIGNALS: AM-CW-SSB.

FEATURES: Built in V.F.O. reads directly in kilocycles. Selective filter system is used for reliable sideband selection. Hum, noise and unwanted side band are down 40 db or more, while undesired beat frequency is down at least 60 db. 50 db range meter for constant monitoring of r-f output and carrier suppression. Voice control system with adjustable delay and anti-trip features.

CONTROLS: Band selector 80, 40, 20, 10 meters, driver tuning, final tuning, speech level, carrier injection—0 to 100%, meter compression, calibration level, power switch—power off, warm-up, stand-by, transmit. Operation control—MOX, calibrate, VOX. Function selector—CW, DSB, upper side band, lower side band. Tuning—VFO. 4X mult. Tuning, VFO—XTAL switch.

TUBE COMPLEMENT: 12AT7, ½-50 kc Oscillator, ½ Phase splitter; (2) 6BY6 Balanced modulators; 6BH6 50 kc. amplifier; 6BH6 Mixer (1675/1775 kc with 50 kc.), 6BH6 1725 kc. Amplifier; 12AT7 (½-1675 kc oscillator, ½-1775 kc oscillator); 6AH6 V.F.O. Mixer; 6CB6 V.F.O. Oscillator; 6U8 (½-Crystal oscillator (fixed frequency operation) ½-4X multiplier); 6CB6 r-f amplifier; 12BY7 driver, (2) 6146 final amplifier; 12AX7 1st audio amplifier and VOX amplifier; 12AT7—relay tube and anti-trip amplifier; 12AU7—2nd audio amplifier and phase splitter. 5R4GY—high voltage rectifier; 5V4G—low voltage rectifier; OA2 voltage regulator.

POWER SUPPLY: 105/125 V. 50/60 cycle AC.

POWER OUTPUT: SSB—P.E.P.—35 watts, CW—35 watts, AM—9 watt carrier.

PHYSICAL DATA: Cabinet black steel, brush chrome trim, 18" x 9¾" x 12". Shipping weight approximately 61 lbs.

are born at **hallicrafters**

The radio man's idea of a radio!

MODEL S-38D

FREQUENCY COVERAGE. Standard Broadcast from 540-1650 kc plus international reception on 3 short wave bands covering 1650 kc-32 mc.

FEATURES: Large easy-to-read overseas dial. Oscillator for reception of code. Built in 5" PM speaker. Phone tip jacks. Two section tuning gang with electrical band-spread. Vernier driven slide rule dial.

INTERMEDIATE FREQUENCY: 455 kc.

TUBE COMPLEMENT: Four tubes plus one rectifier; 12SA7, converter—12SG7, i-f amplifier and BFO—12SQ7 or 125Q7-GT/G detector and audio amplifier—50L6GT, audio output—35Z5GT, rectifier.

AUDIO POWER OUTPUT: One watt.

POWER SUPPLY: 105/125 V, 50/60 cycle AC/DC. Line cord (87D1566) for 220 V. AC/DC operation available.

PHYSICAL DATA: Gray steel cabinet with silver dial frame and knob trim. Size 12 $\frac{7}{8}$ " wide x 7" high x 7 $\frac{1}{4}$ " deep. Shipping weight approximately 14 lbs.

MODEL S-38D



MODEL



MODEL S-94, S-95

The New Ideas in communications are

The thrill of emergency radio!

MODEL S-94 AND S-95

FREQUENCY COVERAGE: S-94: 30-50 mc-S-95: 152-173 mc.

FEATURES: Super sensitive, greatly increased audio power output plus adjustable built-in relay squelch system. Low noise grounded grid r-f amplifier, separate high gain d.c. amplifier for squelch system, wide impedance range antenna input system for excellent performance with any antenna. Low oscillator radiation, greater frequency stability, sensitivity under 1 $\frac{1}{2}$ micro-volts, 2 i-f stages and built-in 5" PM speaker. Phone tip jacks and terminals for single or twin lead antenna, switch for speaker/headphones on rear. External antenna provided.

CONTROLS: Tuning with special logging scale assuring accuracy in logging or re-

lating stations. On-off/volume, squelch/off.

INTERMEDIATE FREQUENCY: 10.7 mc.

TUBE COMPLEMENT: Eight tubes plus one rectifier; 6AB4, Grounded grid low noise r-f amplifier-12AT7, High frequency oscillator/mixer-(2) 12BA6, 1st and 2nd i-f amplifier-12AL5, Ratio detector-6BH6, Audio amplifier-50L6GT, Audio output-12AU7, Squelch-Selenium rectifier.

AUDIO POWER OUTPUT: 1.5 watts maximum.

POWER SUPPLY: 105/125 V., 50/60 cycle AC/DC. Mobile operation possible with external power converter.

PHYSICAL DATA: Gray steel cabinet with silver trim panel and red pointer. Size 12 $\frac{7}{8}$ " wide x 7" high x 7 $\frac{1}{4}$ " deep. Shipping weight approximately 13 lbs.

Over 1000° calibrated bandspread!

MODEL S-85, S-86

FREQUENCY COVERAGE: Broadcast band 540-1680 kc plus three S/W bands 1680 kc-34mc.

FEATURES: Bandspread calibrated in over 1000° on 10, 11, 15, 20, 40 and 80 meter amateur bands. One r-f, two i-f and separate bandspread tuning condenser. Temperature compensated oscillator, audio response to 10,000 cycles and built-in speaker.

CONTROLS: Sensitivity, band selector, tuning, bandspread, volume, AVC, noise limiter, AM/CW, on/off/tone, pitch control, standby/receive.

INTERMEDIATE FREQUENCY: 455 kc.

AUDIO OUTPUT IMPEDANCE: Voice coil impedance 3.2 ohms. High impedance headset output.

TUBE COMPLEMENT: S-85: Seven tubes plus rectifier: 6SG7, r-f amplifier—6SA7,

converter—6SK7, 1st i-f amplifier—6SK7, 2nd i-f amplifier—6SC7, BFO and audio amplifier—6K6GT, audio output—6H6, ANL, AVC, and detector—5Y3GT, Rectifier. S-86 substitutes 25L6 for 6K6 and 25Z6 for 5Y3 and add ballast.

EXTERNAL CONNECTIONS: Terminals for single or doublet antenna on rear. External antenna provided. Headphone jack on front.

AUDIO POWER OUTPUT: 2 watts.

POWER SUPPLY: Model S-85: 105/125 V., 50/60 cycle AC. Model S-86: 105-125 V., AC/DC.

PHYSICAL DATA: Gray-black steel cabinet with brushed chrome trim and red pointers. Piano hinge top. Size 18½" wide x 8¾" high x 10" deep. Shipping weight approximately 32 lbs.

S-85, S-86

born at **hallicrafters**



MODEL SX-104, SX-105



New switch on emergency band receivers!

MODELS SX-104 AND SX-105 supplement the Civil-Patrol Models S-94 and S-95. Model SX-104 covers 25 to 50 megacycles. Model SX-105 covers 152 to 173 megacycles. In addition, they provide quartz crystal control. Both receivers have an AC transformer.

FEATURES: Both tunable and crystal controlled. 6 db greater sensitivity than S-94 or S-95. Slide-rule dial with service assignments. Dual-edge lighted dial. Headphone connections provided. Low-drift tunable, no drift crystal. Built-in adjustable squelch. Greater audio power output. Headphone output with speaker disabling. Nine tubes plus rectifier.

TUBES AND FUNCTIONS: 6AB4 grounded grid r.f. stage. 12AT7 tunable oscillator and converter. 2—6AB6 i.f. amplifiers. 6AL5 ration detector. 6BH6 1st audio amplifier. 12AU7 squelch amplifier. 6BH6 quartz crystal oscillator. 6K6 power output amplifier. 5Y3 rectifier.

QUARTZ CRYSTAL: Type CR-23 third overtone. Unit may be used without crystal as a tunable receiver. Crystal not supplied.

FRONT PANEL CONTROLS: Tuning Function switch—tunable crystal. Squelch on/off—sensitivity. Audio volume—AC—on/off.

PHYSICAL DATA: Size: 12¾" wide x 7" high x 7¾" Hinged top for easy insertion of crystal. Speaker in top. Shipping weight: Approximately 18½ lbs.



MODEL S-102, S-106

MODELS S-102, S-106. Here are two new Hallicrafters models that are the only inexpensive complete receivers for 2 and 6 meter bands on the market today. MODEL S-102 has 2 meter band coverage in its tuning range from 143 to 149 Mc. while MODEL S-106 covers the 6 meter band in its tuning range from 49 to 55 Mc. Features: Both have 7 tubes plus rectifier, built-in 5" PM speaker, low frequency drift, good sensitivity, compact bandspread design, and high circuit efficiency. **CONTROLS:** both models are identical and include: Noise limited, on/off; Receive/Stand-by; Tuning, Volume—AC on/off. **EXTERNAL CONNECTIONS:** Antenna Input Terminals (coax-twin lead); Stand-by Terminals: Phone Tip Jacks; Speaker—5".

MODEL S-53A. Standard Broadcast from 540-1630 kc plus 4 short wave bands over 2.5-31 and 48-54.5 mc. Intermediate frequency: 455 kc. Separate electrical bandspread with 0-100 logging scale plus mc. calibration for 48-54.5 mc band. Sensitivity control, noise limiter, two-position tone switch. Separate 2-section tuning capacitor assemblies for main tuning and bandspread tuning. Slide rule dial. Phonograph jack, headphone tip jacks. Five inch PM speaker. Seven tubes plus one rectifier: 6C4, Osc.—6BA6, Mixer — (2) 6BA6, i-f amplifier—6H6, Det., AVC and ANL—6SC7, BFO and AF amp.—6K6GT, Output—5Y3GT, rectifier. Audio power output, one watt. Power Supply, 105/125 V., 50/60 cycle AC. Sturdy satin black steel cabinet with brushed chrome trim. Piano hinge top. Size 12 $\frac{7}{8}$ " wide x 7" high x 7 $\frac{3}{4}$ " deep. Shipping weight approximately 18 $\frac{1}{2}$ lbs.



MODEL S-53A



MODEL R-46B

MODEL R-46B. Precision-built communications speaker. This 10" PM speaker is the matching unit for any Hallicrafters or other receiver having a 3.2 ohm output. Featuring an 80 to 5000 cycle range and 3.2 ohm speaker voice coil impedance. Gray black steel cabinet measuring 15" wide x 10 $\frac{3}{8}$ " high x 10 $\frac{7}{8}$ " deep. Shipping weight approximately 15 lbs.

The
hallicrafters
Company

4401 W. Fifth Ave., Chicago 24, Ill.

For
Performance
Specify
MALLORY

- Capacitors
- Controls
- Vibrators
- Switches
- Resistors
- Rectifiers
- Power Supplies
- Filters
- Mercury Batteries
- Zinc-Carbon Batteries

Ask your distributor for a copy
of the complete Mallory Cata-
log of electronic components.

P. R. MALLORY & CO. Inc.
MALLORY

P. R. MALLORY & CO. Inc., INDIANAPOLIS 6, INDIANA

JAMES MILLEN

MALDEN · MASSACHUSETTS



90901

ONE INCH INSTRUMENTATION OSCILLOSCOPE

Miniaturized, packaged panel mounting cathode ray oscilloscope designed for use in instrumentation in place of the conventional "pointer type" moving coil meters uses the 1" tube. Panel bezel matches in size and type the standard 2" square meters. Magnitude, phase displacement, wave shape, etc. are constantly visible on scope screen.
 No. 90901, 1CP1, less tube
 No. 90911, 1EP1, less tube

POWER SUPPLY FOR OSCILLOSCOPE

750 volts d.c. at 3 ma. and 6.3 volts a.c. at 600 ma. 117 volts 50-60 cycle input. Designed especially for use with No. 90901 and No. 90911 one inch instrumentation oscilloscopes. 5 in. high x 2 1/2 x 2 in. Octal plug for input and output. Entire assembly including rectifier is encapsulated.
 No. 90202 Power Supply (complete)



90202



90651

GRID DIP METER

The No. 90651 MILLEN GRID DIP METER is compact and completely self contained. The AC power supply is of the "transformer" type. The drum dial has seven calibrated uniform length scales from 1.7 MC to 300 MC with generous over laps plus an arbitrary scale for use with special application inductors. Internal terminal strip permits battery operation for antenna measurement.
 No. 90651, with tube

Additional Inductors for Lower Frequencies

- No. 46702—925 to 2000 KC
- No. 46703—500 to 1050 KC
- No. 46704—325 to 600 KC
- No. 46705—220 to 350 KC

LABORATORY SYNCHROSCOPES

The 5" laboratory synchroscopes are available with and without detector-video strips.
 Model P-4-2, with tubes
 Model P-4E-2, with tubes

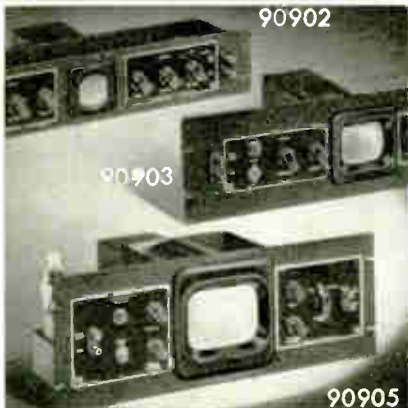

90902

90903

90905

MINIATURE SYNCHROSCOPE

The compact design of the No. 90952, measuring only 7 1/2" x 5 3/4" x 1 3/4", and weighing only 17 lbs., makes available for the first time a truly DESIGNED FOR APPLICATION "field service" Synchroscope
 No. 90952 with tubes

CATHODE RAY OSCILLOSCOPES

The No. 90902, No. 90903 and No. 90905 Rack Panel Oscilloscopes, for two, three and five inch tubes, respectively, are inexpensive basic units comprising power supply, brilliancy and centering controls, safety features, magnetic shielding, switches, etc. As a transmitter monitor, no additional equipment or accessories are required. The well-known trapezoidal monitoring patterns are secured by feeding modulated carrier voltage from a pickup-loop directly to vertical plates of the cathode ray tube and audio modulating voltage to horizontal plates. By the addition of such units as sweeps, pulse generators, amplifiers, servo sweeps, etc., all of which can be conveniently and neatly constructed on companion rack panels, the original basic 'scope unit may be expanded to serve any conceivable industrial or laboratory application.

- No. 90902, less tubes
- No. 90903, less tubes
- No. 90905, less tubes



90952



90921

SCOPE AMPLIFIER—SWEEP UNIT

Vertical and horizontal amplifiers along with hard tube, saw tooth sweep generator. Complete with power supply mounted on a standard 5 1/4" rack panel.
 No. 90921, with tubes

FLAT FACE OSCILLOSCOPE

90905-B 5-inch Rack Mounting Basic Oscilloscope features include: balanced deflection, front panel input terminals, rear panel input terminals, astigmatism control, blanking input terminals, flat face precision tolerance Dumont SADP1 tube, 1800 or 2500 volts accelerating, good sensitivity, sharp focus, horizontal selector switch, 60 cycle sine wave sweep available, power supply available to operate external equipment, minimum control interaction, rugged construction, light filter. 7 x 19 in. panel.
 No. 90905-B Oscilloscope, less tubes



90905-B

JAMES MILLEN

MALDEN · MASSACHUSETTS



90672

STANDING WAVE RATIO BRIDGE

The Millen S.W.R. bridge provides easy and inexpensive measurement of standing wave ratio on antennas using co-ax cable. As assembled the bridge is set up for 52 ohm line. A calibrated 75 ohm resistor is mounted inside the case for substitution in the circuit when 75 ohm line is used.

No. 90671.....

BALUNS

The No. 46672 (1 for each amateur band) wound Balun is an accurate 2 to 1 turns ratio, high Q auto transformer with the residual reactances tuned out and with very tight coupling between the two halves of the total winding. The points of series and parallel resonance are selected so that each Balun provides an accurate 4 to 1 impedance ratio over the entire band of frequencies for which it was designed. Suitable for use with the No. 90672 Antenna Bridge or medium power transmitters.

No. 46672-80/40/20/15/10.....

ANTENNA BRIDGE

The Millen 90672 Antenna Bridge is an accurate and sensitive bridge for measuring impedances in the range of 5 to 500 ohms (or 20 to 2000 ohms with balun) at radio frequencies up to 200 mc. The variable element is an especially designed differential variable capacitor capable of high accuracy and permanency of calibration. Readily driven by No. 90651 Grid Dipper.

No. 90672.....

50 WATT EXCITER-TRANSMITTER

Modern design includes features and shielding for TVI reduction, bandswitching for 4 7-14-21-28 megacycle bands, circuit metering. Conservatively rated for use either as a transmitter or exciter for high power PA stages. 5763 oscillator-buffer-multiplier and 6146 power amplifier. Rack mounted.

No. 90801, less tubes.....

VARIABLE FREQUENCY OSCILLATOR

The No. 90711 is a complete transmitter control unit with 6SK7 temperature compensated, electron coupled oscillator of exceptional stability and low drift, a 6SK7 broad-band buffer or frequency doubler, a 6AG7 tuned amplifier which tracks with the oscillator tuning, and a regulated power supply. Output sufficient to drive a 6146 is available on 160, 80 and 40 meters and reduced output is available on 20 meters. Since the output is isolated from the oscillator by two stages, zero frequency shift occurs when the output load is varied from open circuit to short circuit. The entire unit is unusually solidly built so that no frequency shift occurs due to vibration. The keying is clean and free from annoying chirp, quick drift, jump, and similar difficulties often encountered in keying variable frequency oscillators.

No. 90711, with tubes.....

HIGH VOLTAGE POWER SUPPLY

The No. 90281 high voltage power supply has a d.c. output of 700 volts, with maximum current of 235 ma. In addition, a.c. filament power of 6.3 volts at 4 amperes is also available so that this power supply is an ideal unit for use with transmitters, such as the Millen No. 90801, as well as general laboratory purposes. The power supply uses two No. 816 rectifiers. The panel is standard 8 3/4" x 19" rack mounting.

No. 90281, less tubes.....

HIGH FREQUENCY RF AMPLIFIER

A physically small unit capable of a power output of 70 to 85 watts on 160 or 87 to 110 watts on C-W on 20, 15, 11, 10, 6 or 2 meter amateur bands. Provision is made for quick band shift by means of the No. 48000 series VHF plug-in coils. The No. 90811 unit uses either an 829-B or 3E29.

No. 90811 with 10 meter band coils, less tube.....

RF POWER AMPLIFIER

This 500 watt amplifier may be used as the basis of a high power amateur transmitter. The No. 90881 RF power amplifier is wired for use with the popular "812A" type tubes. Other popular tubes may be used. The amplifier is of unusually sturdy mechanical construction, on a 10 1/2" relay rack panel. Plug-in inductors are furnished for operation on 10, 20, 40 or 80 meter amateur bands. The standard Millen No. 90801 exciter unit is an ideal driver for the No. 90881 RF power amplifier.

No. 90881, with one set of coils, but less tubes.....



90671



46672 -

10
15
20
40
80



90801



90711



90281



0811



90881

JAMES MILLEN

MALDEN · MASSACHUSETTS



90201

REGULATED POWER SUPPLY

A compact, uncooled, regulated power supply, either for table use in the laboratory or for incorporation as an integral part of larger equipment. 250 v.d.c. unregulated at 115 ma. 105 v.d.c. regulated at 35 ma. Minus 105 v.d.c. regulated bias at 4 ma. 6.3 v. a.c. at 4.2 amps.
No. 90201, with tubes.....

INSTRUMENT DIAL

The No. 10030 is an extremely sturdy instrument type indicator. Control shaft has 1 to 1 ratio. Veeder type counter is direct reading in 99 revolutions and vernier scale permits readings to 1 part in 100 of a single revolution. Has built-in dial lock and $\frac{1}{4}$ " drive shaft coupling. May be used with multi-revolution transmitter controls, etc., or through gear reduction mechanism for control of fractional revolution capacitors, etc., in receivers or laboratory instruments.
No. 10030.....



10030

PHASE-SHIFT NETWORK

A complete and laboratory aligned pair of phase-shift networks in a single compact 2" x 1 7/8" x 4" case with characteristics so as to provide a phase shift between the two networks of 90° ± 1.3° over a frequency range of 225 cycles to 2750 cycles. Well adapted for use in either single sideband transmitter or receiver. Possible to obtain a 40 db suppression of the unwanted sideband. The No. 75012 precision adjusted phase-shift network eliminates the necessity of complicated laboratory equipment for network adjustment.
No. 75012.....

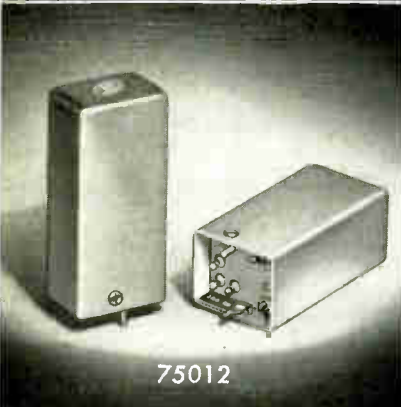

75012

DELAY LINES

No. 34751—Sealed flexible distributed constants line. Excellent rise time. 1350 ohms, 22 inches per microsecond or 550 ohms, 50 inches per mu.-sec. Delay cut to specifications.
No. 34700—Hermetically sealed enclosed line. Good rise time. 0-0.45 mu.-sec. 1350 ohm line or 0.22 mu.-sec. 500 ohm line in 1" x 1" x 5/2" in case. Also larger standard cases and cases made to order. Special impedances 400 to 2200 ohms.
No. 34600—Lumped delay line built to specifications. Delays .05 mu.-sec. to 250 mu.-sec. Impedance 30 ohms to 2000 ohms.

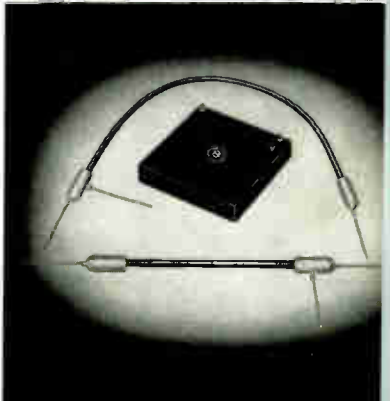

PHOTO MULTIPLIER SHIELDS MU-METAL

The photo multiplier tube operates most effectively when perfectly shielded. Careful study has proven that mu-metal provides superior shielding. Millen Mu-Metal shields are available from stock for the most popular tubes.
No. 80801B for the 1P21.....
No. 80802B for the 5819, 6217, 6292, 6343.....
No. 80802C for the 6199, 6291, 6497...
No. 80802E for the 6066.....
No. 80803J for the 6363.....
No. 80805M for the 6364.....

BEZELS FOR CATHODE RAY TUBES

Standard types are of satin finish black plastic. 5" size has neoprene support cushion and green lucite filter. 3" and 2" sizes have integral cushioning.
No. 80075—5".....
No. 80073—3".....
No. 80072—2".....
No. 80071—1".....



80070-SERIES

CATHODE RAY TUBE SHIELDS

For many years we have specialized in the design and manufacture of magnetic metal shields of nicolai and mumetal for cathode ray tubes in our own complete equipment, as well as for applications of all other principal complete equipment manufacturers. Stock types as well as special designs to customers' specifications promptly available.
No. 80045—Nicolai for 58P1.....
No. 80055—Nicolai for 5CP1.....
No. 80043—Nicolai for 3" tube.....
No. 80042—Nicolai for 2" tube.....

SHIELD CASES ALUMINUM

Effective RF shielding for coils and transformers can be provided by Millen Aluminum cans. Available in several sizes from stock.
No. 80003—1 3/4" x 1 3/8" x 4".....
No. 80004—1 3/4" x 1 3/8" x 4 1/2".....
No. 80005—2" x 2" x 4 7/8".....
No. 80006—2 1/4" round x 4".....
No. 80007—2 1/4" round x 2 3/4" open ends

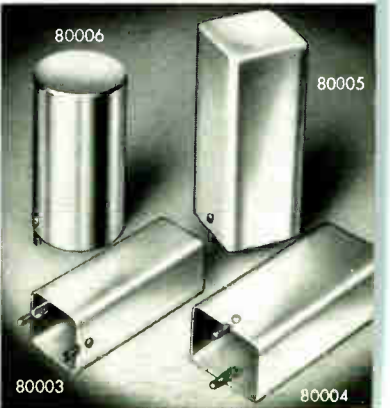

80003

80004



80805-M

80802-E

80802-C

80803-J

80802-B2

80801-B



JAMES MILLLEN

MALDEN · MASSACHUSETTS



PANEL DIALS

The No. 10035 illuminated panel dial has 12 to 1 ratio; size, 8½" x 6½". Small No. 10039 has 8 to 1 ratio; size, 4" x 3¼". Both are of compact mechanical design, easy to mount and have totally self-contained mechanism, thus eliminating back of panel interference. Provision for mounting and marking auxiliary controls, such as switches, potentiometers, etc., provided on the No. 10035. Standard finish, either size, flat black art metal.

- No. 10039
- No. 10035

WORM DRIVE UNIT

Cast aluminum frame may be panel or base mounted. Spring loaded split gears to minimize back lash.

- Standard ratio 16:1. Also in 48:1 on request.
- No. 10000—(state ratio)

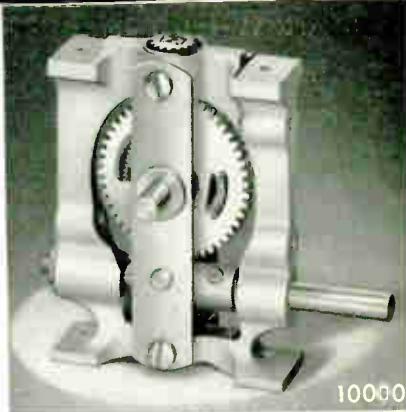

DIALS AND KNOBS

Just a few of the many stock types of small dials and knobs are illustrated herewith. 10007 is 1½" diameter, 10009 is 2¾" and 10008 is 3½".

- No. 10002
- No. 10007
- No. 10008
- No. 10009
- No. 10015
- No. 10018
- No. 10021
- No. 10065

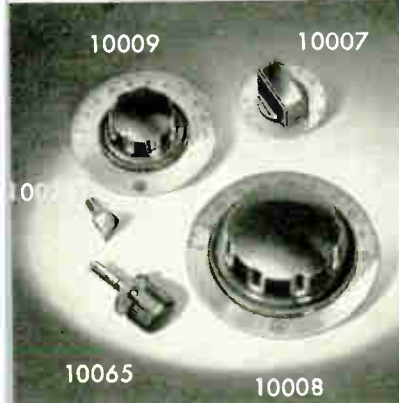

RIGHT ANGLE DRIVE

Extremely compact, with provisions for many methods of mounting. Ideal for operating potentiometers, switches, etc., that must be located, for sharp leads, in remote parts of chassis.

- No. 10012

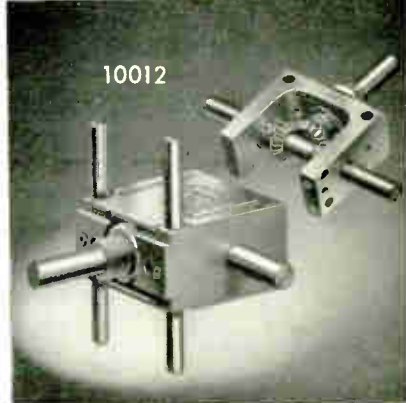

HIGH VOLTAGE INSULATED SHAFT EXTENSION

No. 10061 shaft locks and the No. 39023 insulated high voltage potentiometer extension mountings are available as a single integrated unit—the No. 39024. The proper shaft length is independent of the panel thickness. The standard shaft has provision for screw driver adjustment. Special shaft arrangements are available for industrial applications. Extension shaft and insulated coupling are mated as a single unit to provide accuracy of alignment and ease of installation.

- No. 39023, non locking type
- No. 39024, locking type

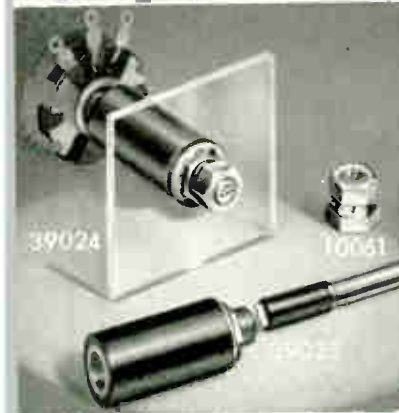

SHAFT LOCKS

In addition to the original No. 10060 and No. 10061 "DESIGNED FOR APPLICATION" shaft locks, we can also furnish such variations as the No. 10062 and No. 10063 for easy thumb operation as illustrated above. The No. 10061 instantly converts any plain "¼" shaft" volume control, condenser, etc. from "plain" to "shaft locked" type. Easy to mount in place of regular mounting nut.

- No. 10060
- No. 10061
- No. 10062
- No. 10063



TRANSMISSION LINE PLUG

An inexpensive, compact, and efficient polystyrene unit for use with the 300 ohm ribbon type polyethylene transmission lines. Fits into standard Millen No. 33102 (crystal) socket. Pin spacing ½", diameter .095".

- No. 37412



DIAL LOCK

Compact, easy to mount, positive in action, does not alter dial setting in operation! Rotation of knob "A" depresses finger "B" and "C" without imparting any rotary motion to Dial. Single hole mounted.

- No. 10050



JAMES MILLEN

MALDEN · MASSACHUSETTS

TUBE SOCKETS DESIGNED FOR APPLICATION

MODERN SOCKETS for MODERN TUBES! Lang Flashover path to chassis permits use with transmitting tubes, 866 rectifiers, etc. Lang leakage path between contacts. Contacts are type proven by hundreds of millions already in government, commercial and broadcast service, to be extremely dependable. Sockets may be mounted either with or without metal flange. Mounts in standard size chassis hole. All types have barrier between contacts and chassis. All but octal and crystal sockets also have barriers between individual contacts in addition.

The No. 33888 shield is for use with the 33008 octal socket. By its use, the electrostatic isolation of the grid and plate circuits of single-ended metal tubes can be increased to secure greater stability and gain.

The 33087 tube clamp is easy to use, easy to install, effective in function. Available in special sizes for all types of tubes. Single hole mounting. Spring steel, cadmium plated.

Cavity Socket Contact Discs, 33446 are for use with the "Lighthouse" ultra high frequency tube. This set consists of three different size unhardened beryllium copper multifinger contact discs. Heat treating instructions forwarded with each kit for hardening after spinning or forming to frequency requirements.

Voltage regulator dual contact bayonet socket, 33991 black phenolic insulation and 33992 with low loss high leakage mica filled phenolic insulation.

- No. 33004—4 Pin Tube Socket
- No. 33005—5 Pin Tube Socket
- No. 33006—6 Pin Tube Socket
- No. 33008—8 Pin Tube Socket
- No. 33888—Shield for 33008
- No. 33087—Tube Clamp
- No. 33002—Crystal Socket $\frac{3}{4}$ " x .125"
- No. 33102—Crystal Socket .487" x .095"
- No. 33202—Crystal Socket $\frac{1}{2}$ " x .125"
- No. 33302—Crystal Socket .487" x .050"
- No. 33446—Contact Discs
- No. 33991—Socket for 991
- No. 33992—Socket for 991
- No. 33207—829 Socket
- No. 33305—Acorn Socket
- No. 33307—Miniature Socket and Shield, ceramic
- No. 33309—Naval Socket and Shield, ceramic
- No. 33405—5 Pin Socket Eimac
- No. 33407—Miniature Socket only, ceramic
- No. 33409—Naval Socket only, ceramic

STAND-OFF INSULATORS

Steatite insulators are available in a variety of sizes—Listed below are some of the most popular.

- No. 31001—Stand-off $\frac{1}{2}$ " x 1"
- No. 31002—Stand-off $\frac{1}{2}$ " x 2 $\frac{1}{4}$ "
- No. 31003—Stand-off $\frac{3}{4}$ " x 2"
- No. 31004—Stand-off $\frac{3}{4}$ " x 3 $\frac{1}{2}$ "
- No. 31006—Stand-off $\frac{1}{2}$ " x $\frac{7}{8}$ "
- No. 31007—Stand-off $\frac{3}{8}$ " x 1"
- No. 31011—Cone $\frac{3}{4}$ " x $\frac{1}{2}$ " (box of 5)
- No. 31012—Cone 1" x 1"
- No. 31013—Cone 1 $\frac{1}{4}$ " x 1"
- No. 31014—Cone 2" x 1"
- No. 31015—Cone 3" x 1 $\frac{1}{2}$ "

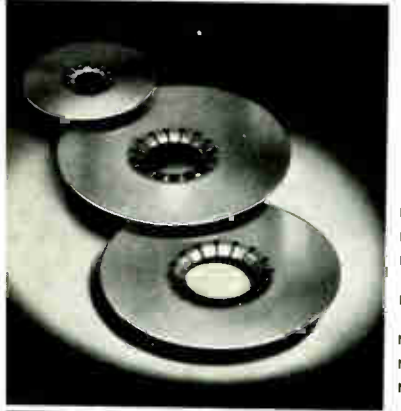

JAMES M MILLEN

MALDEN MASSACHUSETTS

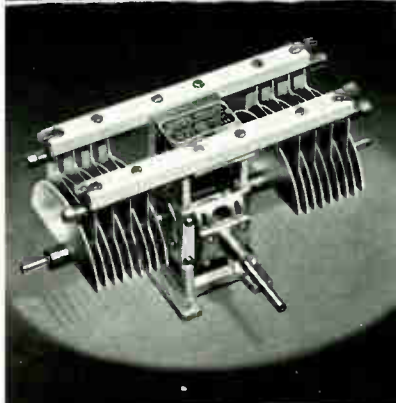

04000 and 11000 SERIES TRANSMITTING CONDENSERS

Another member of the "Designed for Application" series of transmitting variable air capacitors is the 04000 series with peak voltage ratings of 3000, 6000, and 9000 volts. Right angle drive, 1-1 ratio. Adjustable drive shaft angle for either vertical or sloping panels. Sturdy construction, thick, round-edged, polished aluminum plates with $1\frac{3}{4}$ " radius. Constant impedance, heavy current, multiple finger rotor contactor of new design. Available in all normal capacities.

The 11000 series has 16/1 ratio center drive and fixed angle drive shaft.

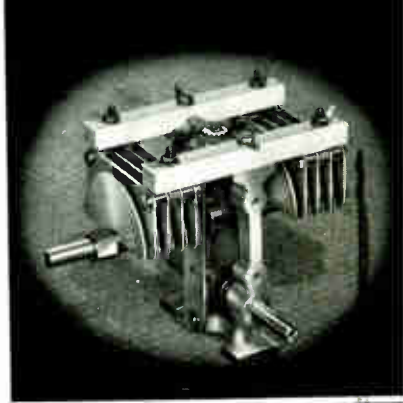

12000 and 16000 SERIES TRANSMITTING CONDENSERS

Rigid heavy channeled aluminum end plates. Isolantite insulation, polished or plain edges. One piece rotor contact spring and connection lug. Compact, easy to mount with connector lugs in convenient locations. Some plate sizes as 11000 series above.

The 16000 series has same plate sizes as 04000 series. Also has constant impedance, heavy current, multiple finger rotor contactor of new design. Both 12000 and 16000 series available in single and double sections and many capacities and plate spacing.

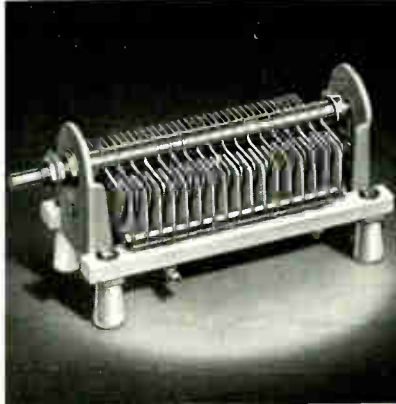

THE 28000-29000 SERIES VARIABLE AIR CAPACITORS

"Designed for Application," double bearings, steatite end plates, cadmium or silver plated brass plates. Single or double section .022" or .066" air gap. End plate size: 1 9/16" x 1 11/16". Rotor plate radius: 3/4". Shaft lock, rear shaft extension, special mounting brackets, etc., to meet your requirements. The 28000 series has semi-circular rotor plate shape. The 29000 series has approximately straight frequency line rotor plate shape. Prices quoted on request. Many stock sizes.

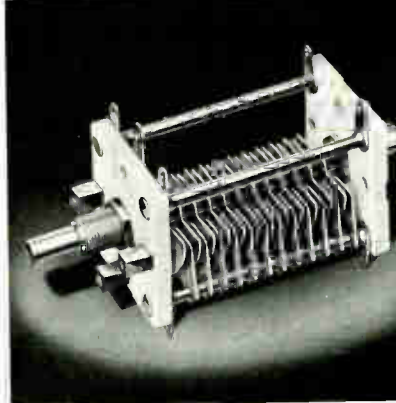
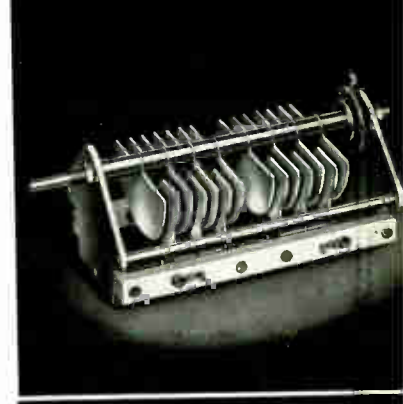

NEUTRALIZING CAPACITOR

Designed originally for use in our own No. 90881 Power Amplifier, the No. 15011 disc neutralizing capacitor has such unique features as rigid channel frame, horizontal or vertical mounting, fine thread over-size lead screw with stop to prevent shattering and rotor lock. Heavy rounded-edged polished aluminum plates or 2" diameter. Glazed Steatite insulation.

No. 15011.....

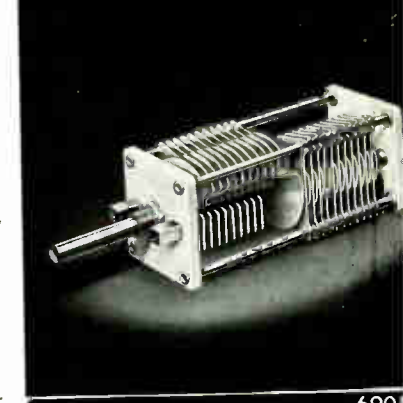

PERMEABILITY TUNED CERAMIC FORMS

In addition to the popular shielded plug-in permeability tuned forms, 74000 series, the 69040 series of ceramic permeability, tuned unshielded forms are available as standard stock items. Winding diameters available from 3/16" to 1/2" and winding space from 1 1/2" to 1 1/2".

- No. 69041—(Copper Slug).....
- No. 69042—(Iron Core).....
- No. 69043—(Copper Slug).....
- No. 69044—(Iron Core).....
- No. 69045—(Copper Slug).....
- No. 69046—(Iron Core).....
- No. 69047—(Copper Slug).....
- No. 69048—(Iron Core).....
- No. 69051—(Copper Slug).....
- No. 69052—(Iron Core).....
- No. 69054—(Iron Core).....
- No. 69055—(Copper Slug).....
- No. 69056—(Iron Core).....
- No. 69057—(Copper Slug).....
- No. 69058—(Iron Core).....
- No. 69061—(Copper Slug).....
- No. 69062—(Iron Core).....

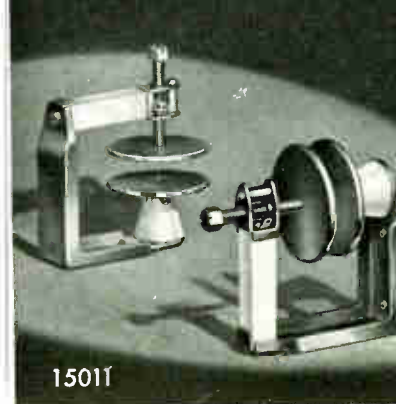

15011

JAMES MILLEN

MALDEN · MASSACHUSETTS

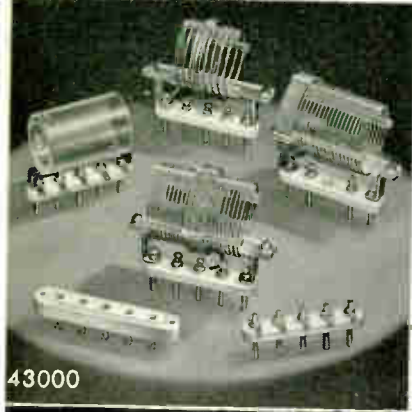

43000

TRANSMITTING TANK COILS

A full line—all popular wattages for all bands. Send for special catalog sheet.

TUNABLE COIL FORM

Standard octal base of low loss mica-filled bakelite, polystyrene 1/2" diameter coil form, heavy aluminum shield, iron tuning slug of high frequency type, suitable for use up to 35 mc. Adjusting screw protrudes through center hole of standard octal socket.

- No. 74001, with iron core
- No. 74002, less iron core

RF CHOKES

Many have copied, few have equalled, and none have surpassed the genuine original design Millen Designed for Application series of midget RF Chokes. The more popular styles now in constant production are illustrated herewith. Special styles and variations to meet unusual requirements quickly furnished.

Figures 1 and 4 illustrate special types of RF chokes available on order. The popular 34300 and 34200 series are shown in figures 2 and 3 respectively.

General Specifications: 2.5 mH, 250 mA for types 34100, 34101, 34102, 34103, 34104 and 1 mH, 300 mA for types 34105, 34106, 34107, 34108, 34109.

- No. 34100
- No. 34101
- No. 34102
- No. 34103
- No. 34104

MIDGET COIL FORMS

Made of low loss mica filled brown bakelite. Guide funnel makes for easy threading of leads through pins.

- No. 45000
- No. 45004
- No. 45005

OCTAL BASE AND SHIELD

Low loss phenolic base with octal socket plug and aluminum shield can 1 1/8" x 1 1/8" x 3 1/8".

- No. 74400

MINIATURE POWDERED IRON CORE RF INDUCTANCES

The No. J300—Miniature powdered iron core inductances. 0.107 in. dia. x 3/8 in. long. Inductances from 25 microhenries to 2.5 millihenries = 5%. RETMA standard values plus 25, 50, 150, 250, 350, 500, and 2500 microhenries. Three layer solenoids from 25 to 350 microhenries. 1/4 in. wide single pi from 360 to 2500 microhenries. Current rating 50 milliamperes. Special coils on order.

PHENOLIC FORM RF INDUCTANCES

The No. 34300 Inductances—Phenolic coil form with axial leads. Inductances from 1 microhenry to 2.5 millihenries = 5%. RETMA standard values plus 25, 50, 150, 250, 350, 500, and 2500 microhenries. Solenoids from 1 to 16 microhenries. Single pi from 18 to 300 microhenries. Multiple pi for higher inductances. Forms 7/32" dia. x 7/16 in. long, 3/16" x 3/8", 1/4" x 3/4", and 1/4" x 1". Current rating 250 milliamperes. Special coils on order.

MINIATURE IF TRANSFORMERS

Extremely high Q—approximately 200 Variable Coupling—(under, critical, and over) with all adjustments on top. Small size 1 1/4" x 1 1/4" x 1 1/4" Malted terminal base. Air capacitor tuned. Coils completely enclosed in cup cores. Topped primary and secondary. Rugged construction. High electrical stability.

- No. 61455, 455 kc. Universal Trans.
- No. 61453, 455 kc. BFO.
- No. 61160, 1600 kc. Universal Trans.
- No. 61163, 1600 kc. BFO.

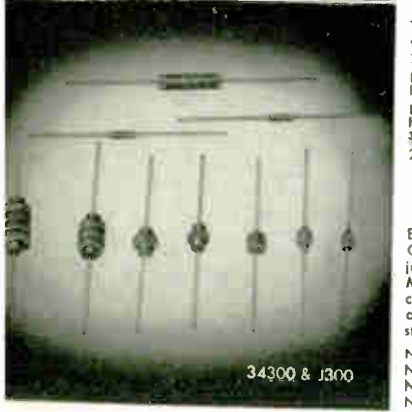
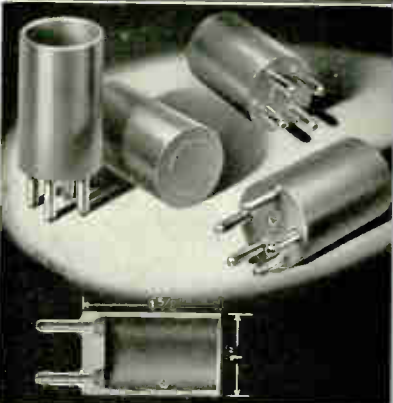

JAMES M MILLEN

MALDEN · MASSACHUSETTS

FLEXIBLE COUPLINGS

The No. 39000 series of Millen "Designed for Application" flexible coupling units include, in addition to improved versions of the conventional types, also such exclusive original designs as the No. 39001 insulated universal joint and the No. 39006 "slide-action" coupling (in both steatite and bakelite insulation).

The No. 39006 "slide-action" coupling permits longitudinal shaft motion, eccentric shaft motion and out-of-line operation, as well as angular drive without backlash.

The No. 39005 and 39005-B (high torque) are similar to the No. 39001, but are not insulated. The steatite insulated No. 39001 has a special anti-backlash pivot and sasket grip feature. All of the above illustrated units are for 1/4" shaft and are standard production type units. The No. 39016 incorporates features which have long been desired in a flexible coupling. No Back Lash—Higher Flexibility—Higher Breakdown Voltage—Smaller Diameter—Shorter Length—Higher Alignment Accuracy—Higher Resistance to Mechanical Shock—Solid Insulating Barrier Diaphragm—Molded as a Single Unit.

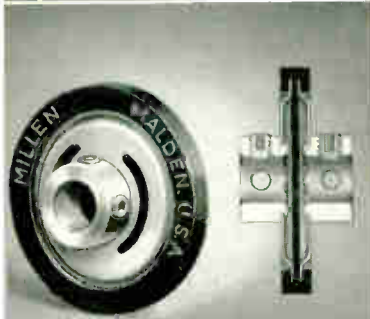
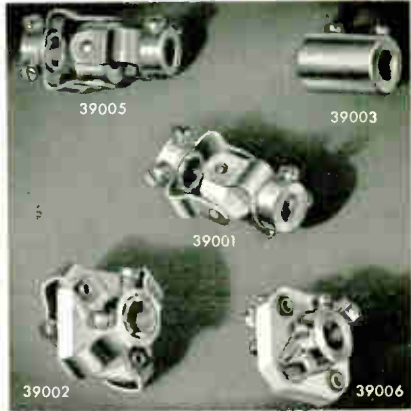

39016

CERAMIC PLATE OR GRID CAPS

Soldering lug and contact one-piece. Lug ears annealed and solder dipped to facilitate each combination "mechanical plus soldered" connection of cable.

- No. 36001—1/4"
- No. 36002—3/8"
- No. 36004—1/4"



SNAP LOCK PLATE CAP

For Mobile, Industrial and other applications where tighter than normal grip with multiple finger 360° low resistance contact is required. Contact self-locking when cap is pressed into position. Insulated snap button at top releases contact grip for easy removal without damage to tube.

- No. 36011—3/16"
- No. 36012—3/8"



SAFETY TERMINAL

Combination high voltage terminal and thru-bushing. Tapered contact pin fits firmly into conical socket providing large area, low resistance connection. Pin is swivel mounted in cap to prevent twisting of lead wire.

- No. 37001, Black or Red
- No. 37501, Low loss

THRU-BUSHING

Efficient, compact, easy to use and neat appearing. Fits 1/4" hole in chassis. Held in place with a drop of solder or a "nick" from a crimping tool.

- No. 32150

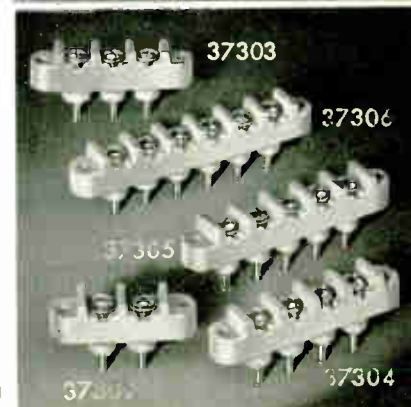

POSTS, PLATES, AND PLUGS

The No. 37200 series, including both insulated and non-insulated binding posts with associated plates and plugs, provide various combinations to meet most requirements. The posts have captive heads and keyed mounting.

The No. 37291 and No. 37223 are standard in black or red with other colors on special order. No. 37201, No. 37202, and No. 37204 and No. 37222 are available in black, red, or low loss. The No. 37202 is also available in steatite.

- No. 37201—Single plates, pr.
- No. 37291—Single plates (tapered), pr.
- No. 37202—Dual plates, pr.
- No. 37204—Double dual plates, pr.
- No. 37212—Dual plug, pr.
- No. 37222—Non-insulated binding post, eo.
- No. 37223—Insulated binding posts, ea.



STEATITE TERMINAL STRIPS

Terminal and lug are one piece. Lugs are Navy turret type and are free floating so as not to strain steatite during wide temperature variations. Easy to mount with series of round holes for integral chassis bushings.

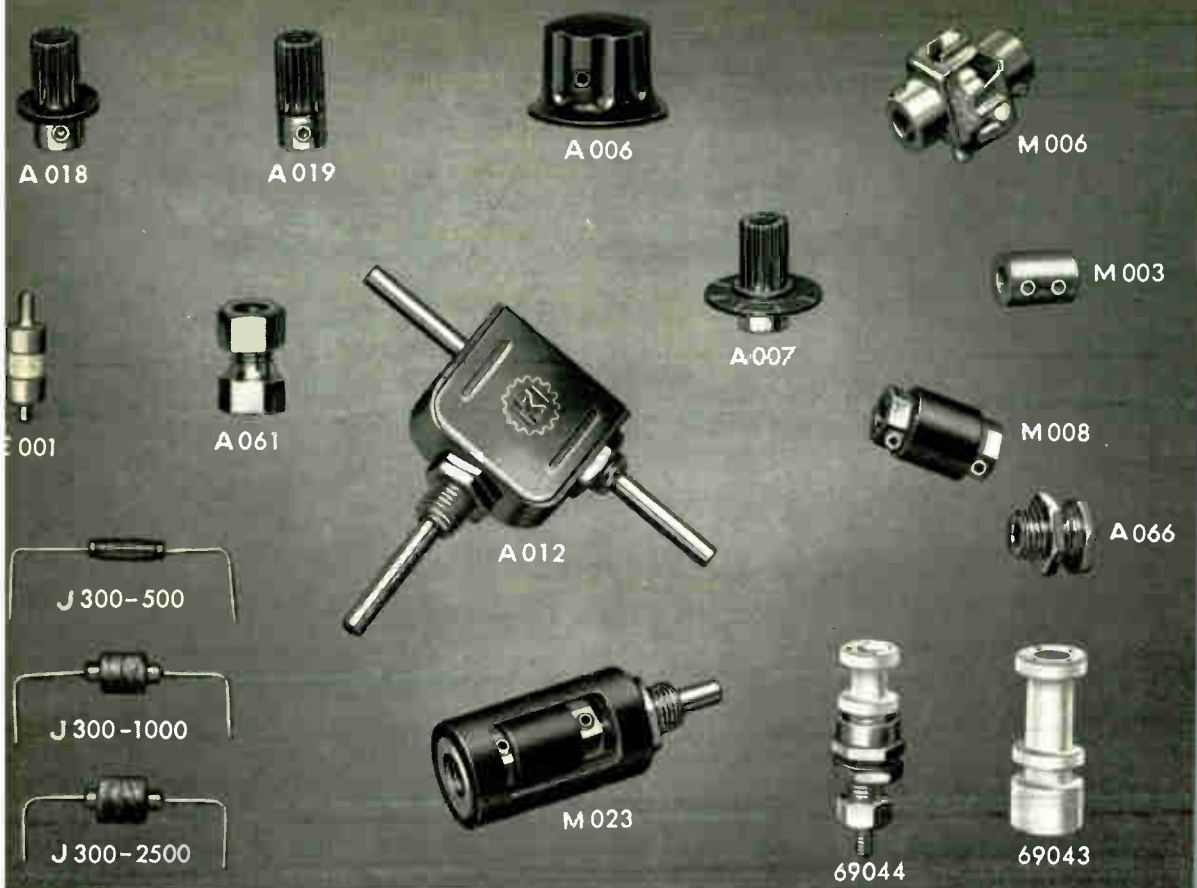

MINIATURIZED COMPONENTS

DESIGNED for APPLICATION miniaturized components developed for use in our own equipment such as the 90901 Oscilloscope, are now available for separate sale. Many of these parts are similar in most details except size with their equivalents in our standard component parts group and in certain devices where complete miniaturization is not paramount, a combination of standard and miniature components may possibly be used to advantage. For convenience, we have also listed on this page the extremely small sized coil forms from our standard catalogue. Additional miniature and subminiature components are in process of design and will be announced shortly.

CODE	DESCRIPTION
A006	Matches standard knobs in style. Black plastic with brass insert. For 1/8" shaft. Overall height 1/2". Diameter 3/4".
A007	Same as A018 except for 3/8" diameter plastic dial with 5 index lines.
A012	Right angle drive. 1/8" diameter shafts. Single hole mounting bushing 1/4"-32 diameter.
A018	1/4" diameter black plastic knob with brass insert for 1/8" shaft. Skirt diameter 3/8". Overall height 3/4". Unique design has screwdriver slot in top.

CODE	DESCRIPTION
A019	Similar to A018, but without flange.
A061	Shaft lock for 1/8" diameter shaft. 1/4"-32 bushing. Nickel plated brass.
A066	Shaft bearing, for 1/8" diameter shafts. Nickel plated brass. Fits 1/4" diameter hole.
E001	Steatite standoff or tie-point integral mounting eyelet. .205 overall diameter. Box of five.
J300-500	Iron core RF choke 500 uh.
J300-1000	Iron core RF choke 1000 uh.
J300-2500	Iron core RF choke 2 1/2 mh.
M003	Solid coupling for 1/8" diameter shaft. Nickel plated brass.
M006	Universal joint style flexible coupling. Spring finger. Steatite insulation. Nickel plated brass for 1/8" diameter shafts.
M008	Insulated coupling, with nickel plated brass inserts for 1/8" diameter shafts.
M023	Insulated shaft extension for mounting sub miniature potentiometer with 1/8" diameter shafts and 1/4"-32 bushing.
69043	Steatite coil form. Adjustable core. Top tuned. Tapped 4-40 hole in base for mounting. Winding space 1/4" diameter x 1/32" length.
69044	Steatite coil form. Adjustable brass core. Bottom tuned. Mounting by No. 10-32 brass base. Winding space .187 diameter by 3/4" length.

JAMES MILLEN MFG. CO., INC.
 MAIN OFFICE AND FACTORY
 MALDEN, MASSACHUSETTS, U. S. A.



90601



90600



90619



90608

Midget Absorption Frequency Meters

Many amateurs and experimenters do not realize that one of the most useful "tools" of the commercial transmitter designer is a series of very small absorption type frequency meters. These handy instruments can be poked into small shield compartments, coil cans, corners of chassis, etc., to check harmonics; parasitics; oscillator-doubler, etc., tank tuning; and a host of other such applications. Quickly enables the design engineer to find out what is really "going on" in a circuit.

Types 90604 thru 90610 are extremely small and designed primarily for engineering laboratory use where they

will be handled with reasonable care. The most useful combination being the group of four under code No. 90600 and covering the total range of from 3.0 to 140 megacycles. When purchased in sets of four under code No. 90600 a convenient carrying and storage case is included. Series 90601 are slightly larger and very much more rugged. They are further protected by a contour fitting transparent polystyrene case to protect against damage and dirt. This latter series is designed primarily for field use and are not quite as convenient for laboratory use as the 90605 thru 90608 types. All types have dials directly calibrated in frequency.

Code	Description	Net Price
90604	Range 160 to 210 mc.	
90605	Range 3.0 to 10 mc.	
90606	Range 9.0 to 23 mc.	
90607	Range 23 to 60 mc.	
90608	Range 50 to 140 mc.	
90609	Range 130 to 170 mc.	
90610	Range 105 to 150 mc.	
90611	Range 1.5 to 3.5 mc.	
90612	Range 3.5 to 8 mc.	
90613	Range 8 to 18.5 mc.	
90614	Range 18 to 41 mc.	
90619	Range 0.35 to 1.0 mc.—Near Indicator	
90620	Range 0.15 to 0.35 mc.—Near Indicator	
90625	Range 2 to 6 mc.—Near Indicator	
90626	Range 5.5 to 15 mc.—Near Indicator	
90600	Complete set of 90605 thru 90608, in case	
90601	Complete set Field Type Frequency Meters in metal carrying case 1.5 to 40 mc.	

DISTRICT SALES OFFICES

NEW YORK
Cooper-DiBlosi
90 Main Street
Port Washington
Long Island

PHILADELPHIA
L. D. Lowery
50 E. Wynnewood Rd.
Wynnewood

SEATTLE
V. Jensen
2616 Second Avenue

INDIANAPOLIS
V. MacNabb
820 E. 64th Street

SAN FRANCISCO
Mouthtrap & Hunter
165—11th Street

CHICAGO
G. G. Ryan
549 W. Washington Blvd.

BOSTON
Gerber Sales
48 Pearl Street
Brookline

DALLAS
Jack Yaunt
1431 Pleasant Drive

LOS ANGELES
W. Bert Knight
10373 W. Pico Blvd.

KANSAS CITY
J. O. Schmitz
34th & Broadway Aves.

CANADA
H. R. Gray
46 Danforth Rd.
Toronto

EXPORT
Technical Equipment Co.
155 E. Milton Ave.
Rohway, N. J.

JAMES MILLEN
MAIN OFFICE

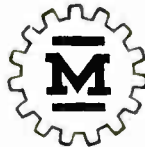

MFG. CO., INC.
AND FACTORY

150 EXCHANGE ST., MALDEN, MASSACHUSETTS, U. S. A.

Copyrighted 1957 by J. M. Mfg. Co., Inc. Printed in U. S. A.



B & W L-1000A
Table-Top KW Amplifier



GONSET COMMUNICATOR
Portable or Fixed 2-Way UHF

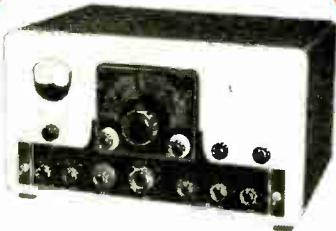

JOHNSON "VALIANT"
For Phone, CW, and SSB

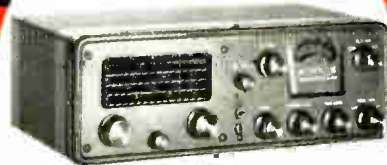

MORROW MB-560-A
For Mobile, Portable,
or Fixed Operation



HAM TIPS

A favorite among hams since 1938, "RCA HAM TIPS" features articles on theory, practice, equipment construction, and up-to-date ICAS data on tubes of special interest to radio amateurs. See your RCA TUBE DISTRIBUTOR.



**RCA TRANSMITTING
TUBE MANUAL—TT-4**

256 fact-filled pages covering 108 power-tube types and 13 rectifier types. Includes theory, data, installation, application, and useful circuits. See your RCA Tube Distributor. Or send \$1.00 to RCA, Commercial Engineering Section A11M, Harrison, N. J.



DESIGNED FOR "100% QSO" ...they use RCA TUBES

Known by the signals they deliver—and the brand of tubes they use—these remarkable "leading designs" are making amateur-communication history. And their designers know that top-quality equipment requires *top-quality tubes in the sockets*.

"100% QSO" calls for tubes that can *hold up* under a wide variety of operating conditions with healthy *power in reserve*, tubes with *electrical uniformity* for easy replacement with minimum circuit realignment.

These facts—*plus the fact that RCA TUBES are available* just about everywhere—are a few of the important reasons why many of the leading designers and manufacturers of amateur radio equipment use RCA TUBES.



TUBES FOR AMATEURS

Radio Corporation of America
Tube Division • Harrison, N. J.

25

Your best buy!

Johnson Amateur Equipment
...For Full Communication
POWER!

Top performance isn't simply a matter of watts. Only carefully integrated equipment design can be relied on to develop effective power that punches your signal home every time. That's what we call "communication power" . . . and your Viking transmitter will deliver it in full measure!



Yours on request...the newest Johnson amateur catalog. Write for your copy today!



VIKING "ADVENTURER" 50 WATT TRANSMITTER—Used to earn first Navice WACI (Worked All Continents.) Self-contained, effectively TVI suppressed, instant bandswitching 80, 40, 20, 15, 11, and 10 meters. Operates by crystal or external VFO. An octal power receptacle located on the rear apron provides full 450 VDC at 150 ma. and 6.3 VAC at 2 amp. output of supply to power auxiliary equipment such as a VFO, signal monitor, or modulator for phone operation. This receptacle also permits using the full output of the supply to power other equipment when the transmitter is not operating. Wide range pi-network output handles virtually any antenna without separate antenna tuner. Break-in keying is clean and crisp. Designed for easy assembly. With tubes, less crystals and key. Dimensions: 7 $\frac{3}{8}$ " x 10 $\frac{3}{8}$ " x 8 $\frac{1}{8}$ ".

Cat. No. 240-181-1..Kit..... Amateur Net \$54.95



VIKING "RANGER" TRANSMITTER—This outstanding amateur transmitter will also serve as an RF and audio exciter for high power equipment. As an exciter, it will drive any of the popular kilowatt level tubes. No internal changes necessary to switch from transmitter to exciter operation. Self-contained, 75 watts CW or 65 watts phone input . . . instant bandswitching 160, 80, 40, 20, 15, 11, and 10 meters. Extremely stable, built-in VFO or crystal control—effectively TVI suppressed—high gain audio—timed sequence (break-in) keying—adjustable wave shaping. Pi-network antenna load matching from 50 to 500 ohms. Easily assembled— with tubes, less crystals, key and microphone.

Cat. No. 240-161-1..Kit..... Amateur Net \$214.50

Cat. No. 240-161-2..Wired and tested..... Amateur Net \$293.00



VIKING "VALIANT" TRANSMITTER—Designed for outstanding flexibility and performance. 275 watts input on CW and SSB (with auxiliary SSB exciter), 200 watts AM. Instant bandswitching 160 through 10 meters—operates by built-in VFO or crystal control. Pi-network tank circuit will match antenna loads from 50 to 600 ohms—final tank coil is silver-plated. Other features: TVI suppressed—timed sequence (break-in) keying—high gain push-to-talk audio system—low level audio clipping—built-in low pass audio filter—self-contained power supplies. With tubes, less crystals, key, and microphone. Dimensions: 11 $\frac{1}{8}$ " x 21 $\frac{1}{8}$ " x 17 $\frac{3}{8}$ ".

Cat. No. 240-104-1..Kit..... Amateur Net \$349.50

Cat. No. 240-104-2..Wired and tested..... Amateur Net \$439.50

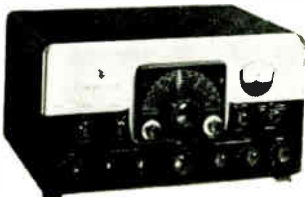

VIKING "PACEMAKER" TRANSMITTER—This exciting transmitter offers you the ultimate in single sideband . . . 90 watts SSB and CW input . . . 35 watts AM. Self-contained—effectively TVI suppressed. Instant bandswitching on 80, 40, 20, 15, and 10 meters. Excellent stability and suppression. Temperature compensated built-in VFO . . . separate crystal control provided for each band. VOX and anti-trip circuits provide virtually "fail-proof" voice controlled operation. Pi-network output matches antenna loads from 50 to 600 ohms. More than enough power to drive the Viking Kilowatt or grounded-grid kilowatt amplifiers. (Requires use of Cat. No. 250-34 Power Divider when used with Viking Kilowatt.) With tubes and crystals, less key and microphone. Dimensions: 11 $\frac{1}{8}$ " x 21 $\frac{1}{8}$ " x 17 $\frac{3}{8}$ ".

Cat. No. 240-301-2..Wired and tested..... Amateur Net \$495.00

VIKING "FIVE HUNDRED" TRANSMITTER—Rated a full 600 watts CW . . . 500 watts phone and SSB. (With auxiliary SSB exciter.) All exciter stages ganged to VFO tuning. Two compact units: RF unit small enough to place on your operating desk beside receiver—power supply/modulator unit may be placed in any convenient location. Crystal or built-in VFO control—instant bandswitching 80 through 10 meters—TVI suppressed—high gain push-to-talk audio system—low level audio clipping. Pi-network output circuit with silver-plated final tank coil will load virtually any antenna system. With tubes, less crystals, key, and microphone. Dimensions: RF Unit—1 3/8" x 2 1/8" x 1 7/8". Power Supply—10 1/8" x 20 3/8" x 1 5/8".

Cat. No. 240-500-1 . . . Kit Amateur Net \$649.50*
 Cat. No. 240-500-2 . . . Wired and tested Amateur Net \$799.50*

*Price subject to revision at time of delivery.



VIKING "6N2" TRANSMITTER—Instant bandswitching on 6 and 2 meters, this compact VHF transmitter is rated at 150 watts CW and 100 watts AM phone. Completely shielded and TVI suppressed, the "6N2" may be used with the Viking "Ranger," Viking I, Viking II, or similar power supply/modulator combinations capable of at least 6.3 VAC at 3.5 amp., 300 VDC at 70 ma., 300 to 750 VDC at 200 ma. and 30 or more watts audio. May be operated by built-in crystal control or external VFO with 8-9 mc. output. With tubes, less crystals, key, and microphone. Dimensions: 13 1/8" x 8 3/8" x 8 1/2".

Cat. No. 240-201-1 . . . Kit Amateur Net \$119.50*
 Cat. No. 240-201-2 . . . Wired and tested Amateur Net \$159.50*

*Price subject to revision at time of delivery.



VIKING "MOBILE" TRANSMITTER—This power-packed mobile is rated at 60 watts maximum PA input. Instant bandswitching 75 through 10 meters. Coupling system engineered for maximum power transfer to antenna—all stages ganged to a single tuning knob. Powerful PP807 modulator is designed for extra audio punch! Under-dash mounting—all controls readily accessible. Specify 6 or 12 volt operation. Less tubes, crystals, microphone, and power supply. Dimensions: 6 7/8" x 7 1/8" x 10 1/8".

Cat. No. 240-141-1 . . . Kit Amateur Net \$99.50
 Cat. No. 240-141-2 . . . Wired and tested on special order only.



VIKING AUDIO AMPLIFIER—A self-contained 10-watt speech amplifier complete with power supply. Speech clipping and filtering designed to raise average modulated carrier level . . . improves the performance and effectiveness of your AM transmitter. Inputs provided for microphone, phone patch, or line. Complete with tubes. Dimensions: 8" x 5 1/2" x 13 3/8".

Cat. No. 250-33-1 . . . Kit Amateur Net \$73.50
 Cat. No. 250-33-2 . . . Wired and tested Amateur Net \$99.50



*P.E.P.

VIKING "KILOWATT" AMPLIFIER—Baldly styled, effectively TVI suppressed—contains every conceivable feature for safety, operating convenience, and peak performance. Full 1000 watts or low power AM, CW, or SSB with the flip of a switch. Continuous tuning 3.5 to 30 mc.—no coil change necessary. Compact pedestal contains complete kilowatt—rolls out for adjustment or maintenance. Excitation requirements: 30 watts RF and 10 watts audio for AM; 2-3 watts peak for SSB. Completely wired and tested with tubes. Dimensions: 29 1/2" high x 19 3/4" wide x 32 3/8" deep. With accessory desk top, back, and three drawer pedestal: 29 1/2" high x 63 1/2" wide x 32 3/8" deep.

Cat. No. 240-1000 . . . Wired and tested Amateur Net \$1595.00

Matching accessory desk, top, back and three drawer pedestal . . . Cat. No. 251-101-1 FOB Cory, Pa. \$123.50

POWER DIVIDER—Provides up to 35 watts continuous dissipation. Designed to provide the proper output loading of the "Pacemaker" SSB Transmitter when used to drive the Viking Kilowatt Amplifier.

Cat. No. 250-34 Amateur Net \$24.95

POWER REDUCER—Provides up to 20 watts continuous dissipation when used with 100-150 watt transmitters such as the Johnson Viking, Collins 32V, or others, permitting them to serve as exciters for the Viking "Kilowatt." Completely shielded—equipped with SO-239 coaxial connectors. Dimensions: 3 1/2" long x 2 1/4" diameter.

* Cat. No. 250-29 . . . Amateur Net \$13.95



The E. F. Johnson Company reserves the right to change prices and specifications without notice and without incurring obligation.



E.F. Johnson Company

120 SECOND AVENUE S.W. - WASECA, MINNESOTA

Your best buy!

Johnson Station Accessories

...For Outstanding

PERFORMANCE!

Many useful operating accessories are shown on these two pages. Not just "gadgets," they are of proven value, performance-wise and dollar-wise. These supplementary units are designed to work with any amateur gear . . . but when used with your Johnson equipment they provide an integrated transmitting system.

Yours on request . . . the newest Johnson amateur catalog. Write for your copy today!



TWO METER VFO—Designed to replace 8 mc. crystals in most two meter equipment, including types using overtone oscillators. Temperature compensated—exceptionally stable. Output range: 7.995 mc. to 8.235 mc.—edge-lighted, lucite dial is calibrated 144 to 148 mc. Power requirements: 6.3 volts at .3 amp. and 250-325 volts at 10 ma.—may be easily obtained from transmitter. Power cable and octal power plug furnished. With tubes and pre-calibrated dial. Dimensions: 4" x 4½" x 5".
Cat. No. 240-132-1 . . . Kit Amateur Net \$29.50
Cat. No. 240-132-2 . . . Wired and tested Amateur Net \$46.50

MOBILE VFO—Diminutive variable frequency oscillator designed specifically for mobile use. Rugged construction minimizes frequency shift due to road shock and vibration . . . small size permits steering post mounting. Temperature compensated and voltage regulated. Calibrated 75 through 10 meters . . . 3.75 to 4 mc. output for 75 meters and 7.05 to 7.45 for 40 to 10 meters. 10.5 mc. output also available for doubling to 15 meters. With tubes. Dimensions: 4" x 4¼" x 5".
Cat. No. 240-152-1 . . . Kit Amateur Net \$33.95
Cat. No. 240-152-2 . . . Wired and tested Amateur Net \$49.95

DYNAMOTOR POWER SUPPLIES—Supplies plate voltages for Viking "Mobile" and VFO. Rated: 500 volts, 200 ma. intermittent. Base kits accommodate PE-103, Carter, and others.
Cat. No. Amateur Net
239-102 Dynamotor Power Supply, 6 volt Wired and tested \$98.50
239-104 Dynamotor Power Supply, 12 volt Wired and tested 99.50
239-101 6 volt base kit only 16.50
239-103 12 volt base kit only 17.40

"WHIPLoad-6"—Provides high efficiency base loading for mobile whips with instant bandswitch selection of 75, 40, 20, 15, 11, and 10 meters. On 75 meters a special capacitor with dial scale permits tuning entire band. Covers other bands without tuning. Air-wound coil provides extremely high "Q." Fibre-glass housing protects assembly. Mounts on standard mobile whip.
Cat. No. 250-26 Wired and tested Amateur Net \$19.50

VIKING KILOWATT "MATCHBOX"—Bandswitching 80, 40, 20, 15, and 10-11 meters—self-contained. Use with transmitters up to 1000 watts input—handles unbalanced line impedances from 50 to 1200 ohms and balanced line impedances from 50 to 2000 ohms. No coils to change, no "tapping down" on the inductor. Transmit receive relay grounds receiver antenna terminals in "transmit" position. Adjustment for matching antenna to receiver input. Fully shielded. Provision for RF probe. Dimensions: 17¼" x 12¼" x 10¼".
Cat. No. 250-30 Wired and tested Amateur Net \$124.50

VIKING 275 WATT "MATCHBOX"—Performs all antenna loading and switching functions required in medium power amateur stations. Bandswitching 80, 40, 20, 15, and 10-11 meters. Matches balanced antennas from 25 to 1250 ohms and unbalanced or single wire antennas from 25 to 3000 ohms. Input impedance, 52 ohms, rated 275 watts. Built-in transmit receive relay grounds receiver antenna terminals in "transmit" position. Independent adjustment for matching antenna to receiver input. Fully shielded. Provision for RF probe. Dimensions: 9¾" x 10½" x 7".
Cat. No. 250-23 Amateur Net \$49.85

SWR BRIDGE—Measures standing wave ratios for effective use of a low pass filter and antenna coupler. 52 ohms impedance can be changed to 70 ohms or other value. SO-239 connectors and polarized meter jacks. Dimensions: 4½" long x 2¾" diameter.
Cat. No. 250-24 . . . Wired and tested Amateur Net \$9.75

"SIGNAL SENTRY"—Monitors CW or phone signals on all frequencies to 50 mc. without tuning. Energized by transmitter RF. Mutes receiver audio for break-in. May be used as code practice oscillator with simple circuit modification. Requires 250 VDC at 5 ma.; and 6.3 VAC at .6 amp. from receiver or other source. With tubes: Dimensions: 3 7/8" x 3 3/4" x 3 3/4".
Cat. No. 250-25. .Wired and tested..... Amateur Net \$18.95

CRYSTAL CALIBRATOR—Provides accurate 100 kc. check points to 55 mc. Requires 6.3 volts at .15 amps. and 150-300 volts at 2 ma. With tube, military-type crystal, power cable and extension leads. Dimensions: 1 3/8" x 2 1/2" x 1 1/2". (Over-all height to top of tube is 3 3/8".)
Cat. No. 250-28. .Wired and tested..... Amateur Net \$17.25

LCW PASS FILTER—Handles more than 1000 watts RF—provides 75 db or more attenuation above 54 mc. Insertion loss less than .25 db. Replaceable Teflon insulated fixed capacitors. SO-239 coaxial connectors. Wired and pre-tuned. Dimensions: 9" long x 2 3/4" diameter.
Cat. No. 250-20. .Wired and pre-tuned 52 ohms..... Amateur Net \$13.50
Cat. No. 250-35. .Wired and pre-tuned 72 ohms..... Amateur Net \$13.50

INDUCTORS—Johnson manufactures a complete line of high power variable, rotary, edge-wise wound "HI-Q" and swinging link inductors for commercial and amateur use. For complete information write today.

KEYS AND PRACTICE SETS—Johnson also manufactures a complete line of semi-automatic, high speed, standard, heavy duty and practice keys; code practice sets and buzzers. See your distributor for complete information.

PRE-TUNED BEAMS—Rugged, semi-wide spaced pre-tuned beams with balun matching sections. For 20, 15 and 10 meters. Approximately 9.0 db gain over tuned dipole—greater than 27 db front-to-back ratio with low SWR. Pattern is uni-directional, beam width is 55°. No adjustments required. Boom assemblies are of 2" galvanized steel tubing, elements are aluminum alloy tubing. No loading devices needed for flutter dampening or corona discharge.

Cat. No. (With 3 elements, boom and balun)	Amateur Net
138-420-3 20 Meter Beam—20' Boom.....	\$139.50
138-415-3 15 Meter Beam—13'7" Boom.....	110.00
138-410-3 10 Meter Beam—10' Boom.....	79.50

ROTOMATIC ROTATOR—Supports beam antenna weighing up to 175 pounds even under heavy icing conditions or high wind loading. Rotates 1 1/4 RPM—over-all gear reduction, 1200 to 1. Rotator housing is cast aluminum, with 3/4" steel rotating table. Unit hinged to tilt 90°. Includes desk top control box with selsyn indicator.

Cat. No.	Amateur Net
139-112-1 With slip rings for continuous 360° rotation.....	\$354.00
138-112-51 With limit switches for 370° rotation.....	354.00

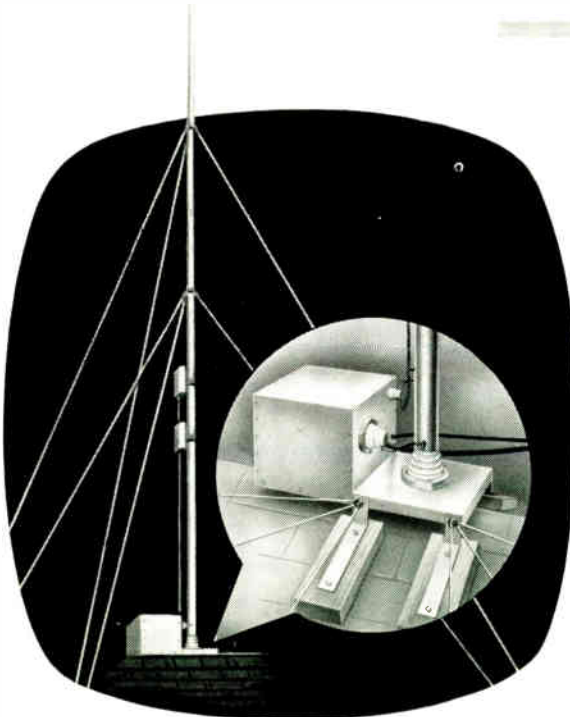

VIKING "MATCHSTICK"—A major advance in amateur radial! Pre-tuned multi-band vertical antenna system—remotely motor-driven from transmitter location—bandswitching 80 through 10 meters. Pre-tuned at factory—no adjustment required. Low SWR (less than 2 to 1) on all bands. Low vertical radiation angle for DX. Inconspicuous appearance—simple installation. Mounts on rooftop or in limited space location. Vertical mast is 2" diameter, hard-temper aluminum tubing—most sections separated by steelite insulators. Antenna tuning network enclosed in weatherproof aluminum cabinet at base of antenna. Six nylon guy ropes furnished—will not affect field pattern. Impedance: 52 ohms, all bands. Less transmission line, 6 conductor control cable and ground radial wire. Complete instructions for installation and operation are included.

Cat. No. 137-102..... Amateur Net \$129.50

SEE YOUR DISTRIBUTOR—It's easy to own even the finest amateur equipment, since most authorized Johnson distributors offer liberal terms. Often as little as 10% down puts you on the air . . . and your used equipment (especially if it's Johnson) is always worth top dollar in trade. See your distributor for a plan tailored to your personal budget requirements.

The E. F. Johnson Company reserves the right to change prices and specifications without notice and without incurring obligation.



E. F. Johnson Company

120 SECOND AVENUE S.W. - WASECA, MINNESOTA

Your best buy!

Johnson Components...Tops For

QUALITY!

Johnson's complete line of more than 5,000 quality components serves all segments of the electronics industry. Write for our catalog which gives full details on crystal sockets, shaft couplings, flexible shafts and panel bearings—in addition to a complete line of fixed and rotary RF inductors for broadcast, RF heating, antenna phasing, and other commercial applications.

For detailed information on the complete line of Johnson Electronic Components, write for your free copy of the new Johnson Components Catalog today!



KNOBS AND DIALS—A distinctive line of matching knobs and dials, derived from a new basic knob design and suitable for the finest electronic equipment. Available with phenolic skirts, etched and anodized aluminum skirts with markings, or flat dial scales engraved and filled. All plastic is tough phenolic meeting MIL-P-14 specifications, with heavy brass inserts for $\frac{1}{4}$ " shafts.

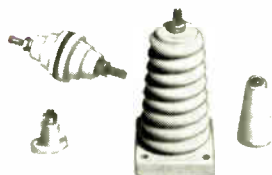

INSULATORS—High quality steatite and porcelain insulators. Heavily glazed surfaces and heavy nickel-plated brass hardware suitable for exposed application. May be supplied with screws and nuts or with jacks to accommodate standard banana plugs. Through-panel and stand-off types. Also antenna insulators, bushings, and feeder insulators.



PILOT LIGHTS—A complete selection of standardized pilot lights. Faceted jewel or wide-angle lucite lens types; enclosed or open body styles; standard bayonet, candelabra, or miniature screw types, and a wide variety of mounting brackets and assemblies. Jewels available in clear, red, green, amber, blue, and opal. All Johnson pilot lights are described in detail in Pilot Light Catalog 750—send for your copy!



CONNECTORS—A complete line of new nylon connectors is available in addition to standard banana jacks and plugs. Nylon components include insulated solderless tip and banana plugs, tip and banana jacks, tip jack and sleeve assemblies, and a new 6-way binding post. In thirteen bright colors—nylon components are designed to operate through an extremely wide temperature range and high relative humidity conditions. (Voltage breakdown up to 11,000 volts.) Solderless nylon plugs are easy to assemble—both plugs and jacks require a minimum amount of mounting space.

TYPE "M"—These diminutive capacitors provide the perfect answer to problems encountered in the design of compact radio frequency equipment. Bridge-type stator terminal provides extremely low inductance path to both stator supports. Soldered bearing and heavily anchored stator supports insure extreme rigidity.

TYPE "S"—Midway between types "M" and "K" in size, design is compact and construction rugged. Equipped with DC-200 treated steatite end frame and nickel-plated brass plates—an excellent choice where higher capacity values than provided in "M" types is required in small space.

TYPES "C" AND "D"—Functional favorites built to exacting standards for medium power RF equipment. Dual types have centered rotor connection for balance. End frames tapped for panel mounting. Brackets furnished for chassis mounting.

TYPES "E" AND "F"—Rugged units provide a large amount of capacity per cubic inch and extremely low capacity to the chassis. Panel or chassis mounting.

TYPE "G"—Neutralizing capacitors for medium and low-powered stages constructed on the rotor-stator principle. Panel or chassis mounting.

TYPE "J"—Heavy-duty miniature type has wider spacing than most small air variables, yet occupies little more space. Useful for small space plate tank circuits and low power stages where standard miniatures have insufficient plate spacing.

TYPE "K"—Widely used for military and many commercial applications, the Johnson type "K" features DC-200 impregnated steatite end frames, slotted stator contacts, and extra-rigid soldered plate construction.

TYPE "L"—A superior quality general purpose capacitor embodying important advances in design and construction. The rotor bearing and stator support rods are actually soldered directly to the ceramic (steatite) end frames, making the capacitor virtually vibration-proof.

TYPE "N"—Extremely high voltage rating in proportion to size requiring a small mounting area. Constant voltage rating throughout full capacity range. These are of the aluminum cup and cylinder type of construction and are supported by a steatite frame with cast aluminum mounting bracket.

TYPE "R"—The rugged Johnson version of a popular standardized capacitor. Featuring extra heavy steatite stator support insulators and soldered .023" thick brass plates; all metal parts heavily nickel-plated for corrosion-resistance.

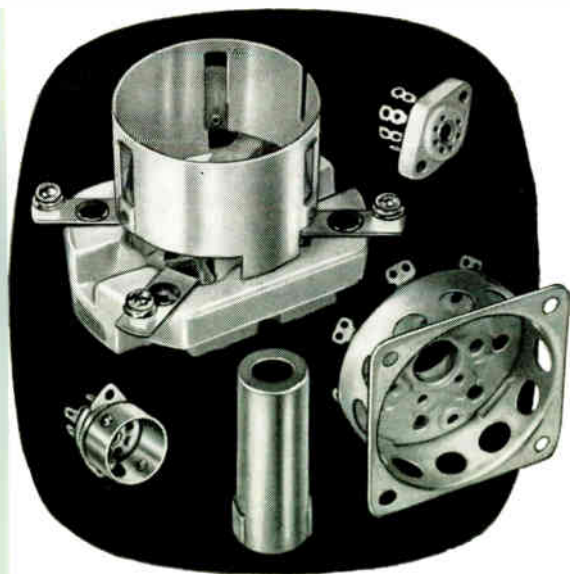
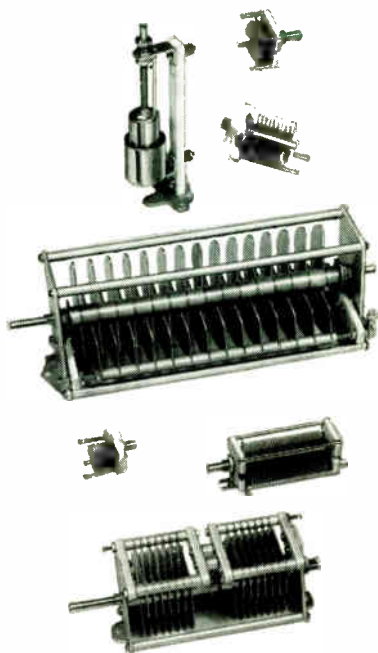

TUBE SOCKETS

Johnson steatite and porcelain tube sockets are available in three grades: Standard, Industrial, and Military. All are manufactured to rigidly controlled specifications, and all are made of only the highest quality materials.

Bayonet types—include Medium, Jumbo, and Super Jumbo 4 pin models.

Steatite Wafer Types—available in 4, 5, 6, 7, and 8 pin standard sockets as well as Super Jumbo 4 pin, Giant 5 and 7 pin models and VHF transmitting Septar base types.

Miniature Types—are steatite insulated and available in Miniature 7 and 9 pin models. Matching miniature shields also available.

Special Purpose Types—include sockets for tubes such as the 204A and 849, the 833A, 304TL, 5D21, 705A, and other special types.

New! Two new tube sockets have been recently added to the Johnson line. A new shielded base septar socket (Cat. No. 122-105) for tubes such as the 5894, 6524, and 6252, and a new Kel-F insulated octal socket (Cat. No. 124-108) for 4X150A and similar tubes. For complete information on this new socket or any other Johnson sockets—write for your copy of Tube Socket Standardization Booklet No. 536.



E.F. Johnson Company

120 SECOND AVENUE S.W. - WASECA, MINNESOTA

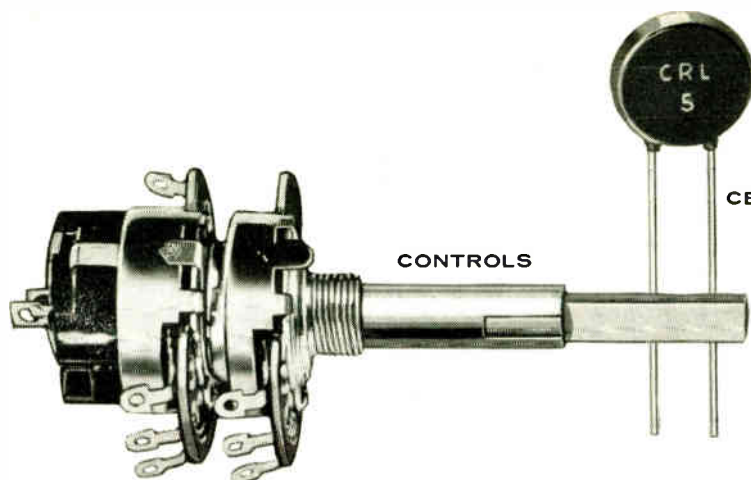

CONTROLS

CERAMIC CAPACITORS



STEATITE
INSULATORS

Centralab

**America's five most complete,
dependable lines
of electronic components**

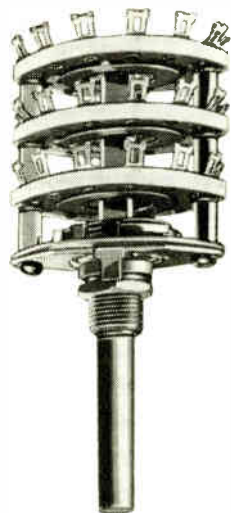

SWITCHES

For fixed, mobile, miniature,
and experimental rigs.

An advertised name you can
count on for guaranteed
dependability.

The brand to ask for—to get
higher, safer rated
voltages; closer tolerances;
compactness; low price.

Stock up at your
Centralab distributor.

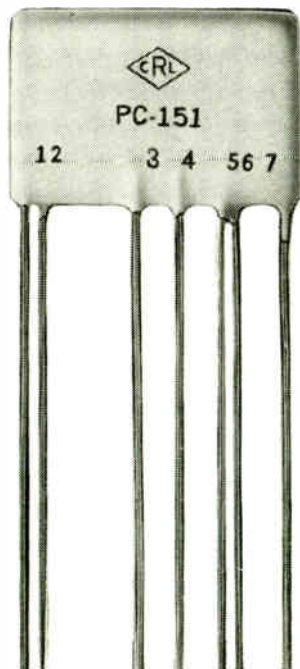

Centralab

A Division of Globe-Union Inc.
Milwaukee 1, Wisconsin

In Canada: 804 Mt. Pleasant Rd., Toronto 12, Ont.

PACKAGED ELECTRONIC CIRCUITS

G-355A



Performance...
Economy... Collins

SSB

The steady move to single sideband operation is definite, and naturally leading the trend is Collins, the sideband pioneer.

Collins forward-thinking design work has produced the top-performing team on the air. In the advantages of SSB—greater talk power, less distortion and decreased bandwidth—the KWS-1/75A-4 combination

is unmatched in performance.

Considering this performance, you can operate Collins for *less than anything else you can buy or build!* Actual cost-per-day figures—the difference between purchase price and trade-in value—prove this. Taking advantage of a convenient time payment plan, you can have Collins in your shack now. Ask your distributor for the figures.



KWS-1 Transmitter

most versatile kilowatt
ever produced



Unprecedented compactness is achieved without undue crowding. Exciter and RF power amplifier are in a single receiver-size housing which can be placed on the operating desk or mounted on top of the power supply cabinet. Proved circuit applications and components—extremely accurate 70E VFO, Pi-L output network and Collins Mechanical Filter—give you unmatched performance, accuracy and stability in SSB, AM and CW operation.

KWS-1 SPECIFICATIONS

POWER AMPLIFIER INPUT—1 kw peak envelope power SSB, 1 kw CW operation. Equivalent to 1 kw on AM when using narrow bandwidth receiver.

R-F OUTPUT IMPEDANCE—52 ohms.

MAXIMUM PERMISSIBLE STANDING WAVE RATIO—2.5 to 1.

FREQUENCY RANGE—80, 40, 20, 15, 11, 10 meters.

EMISSION—SSB, AM carrier plus one sideband, CW.

FREQUENCY CONTROL—70E-23 Master Oscillator.

HARMONIC AND SPURIOUS RADIATION—(Other than 3rd order distortion products.) Intra-channel radiation is at least 50 db down. All spurious radiation at least 40 db down at output of exciter. Second harmonic at least 40 db down; all other harmonics at least 60 db down.

DISTORTION—SSB, 3rd order products approximately 35 db down at 1 kw PEP.

FREQUENCY STABILITY—Warmup: After 15 minutes warmup, within 300 cps of starting frequency. Dial Accuracy: 350 cps after calibration.

AUDIO CHARACTERISTICS—Response: ± 3 db, 200 to 3,000 cps. Noise and hum: 40 db or more below reference output level. Input: .01 volts for rated power output.

MICROPHONE INPUT—Will match high impedance dynamic or crystal.

PHONE PATCH IMPEDANCE—600 ohms, unbalanced to ground.

CIRCUIT PROTECTION—Overload relay and fuses.

WEIGHT—210 pounds.

SIZE—40½" high, 17¼" wide, 15½" deep.

RACK MOUNTING—Angle brackets kits available for RF Unit and power supply.

TUNING CONTROLS—Bandswitching, frequency selector, PA tuning, PA loading.

OTHER CONTROLS—Filament power, plate power, filament adjust, PA bias voltage, tune-ometer, multimeter switch, VOX speaker gain, VOX speech gain, band change, audio gain, sideband select, emission selector, dial lock, zero set, ALC adjust.

ACCESSORIES REQUIRED—High impedance microphone, telegraph key, 52 ohm antenna.

POWER SOURCE—230 v, 3 wire, 50/60 cycle, single phase, grounded neutral; or 115 v, 2 wire, 50/60 cycle, single phase, 1500 W 1 kw input CW.

Net price, complete with tubes—\$2,095.00

75A-4 Receiver

applies time-proven features
to SSB techniques



Designed for best SSB reception without sacrificing top efficiency in other modes, the 75A-4 has the top features proved in earlier models—excellent image rejection through double conversion, precise dial calibration and high stability of Collins VFO and crystal-controlled first injection oscillator, and the ideal selectivity of Collins Mechanical Filter in the IF strip.

75A-4 SPECIFICATIONS

FREQUENCY RANGE—160, 80, 40, 20, 15, 11, 10 meters

SIZE—10½" high, 17¼" wide, 15½" deep.

WEIGHT—35 pounds.

RACK MOUNTING—Angle mounting kit available.

NUMBER OF TUBES—22, including rectifiers.

SENSITIVITY—1.0 microvolt for 6 db signal-to-noise ratio with 3 kc bandwidth.

AVC CHARACTERISTICS—Audio rise less than 3 db for inputs of 5 to 200,000 uv.

AVC TIME CONSTANTS—Rise Time—.01 second.
Release Time—.1 second (fast), 1 second (slow).

IMAGE AND IF REJECTION—Image ratio at center of each band 50 db or better. IF rejection at center of each band 70 db or better.

AUDIO CHARACTERISTICS—Output—.75 watts with a 3.0 uv signal, 30% modulated. Output impedance—500 ohms, 4 ohms. Response of audio circuits—± 3 db 100 cps to 5,000 cps. Distortion—less than 10%.

MUTING—Provisions for muting the Receiver during key-down operation are provided. A muting voltage of +20 volts must be supplied by transmitter.

FREQUENCY STABILITY (at 14 mc)—Temperature—Less than 1200 cycles drift from 0 to ±60°C.
Warmup drift—Less than 300 cycles after 15

minute operation. Line voltage coefficient—Less than 100 cycles for ±10% change. Dial Accuracy—350 cycles after calibration.

Net price, complete with gear Reduction Tuning Knob, 3.1 kc Mechanical Filter, tubes and instruction book—\$645.00



MECHANICAL FILTERS

Collins F455J-Series Mechanical Filters are available as accessories for the 75A-4 Receiver. The F455J-05 Filter, bandwidth of 500 cycles, is recommended for CW reception; the F455J-15 (1.5 kc) for RTTY; the F455J-60 (6.0 kc) for AM where interference is not a problem; and the F455J-21 (2.1 kc) and F455J-31 (3.1 kc) for AM and SSB. The F455J-31 is supplied as standard equipment in the Receiver.

Net price, F455J-05—\$50.00

Net price, F455J-15, J-21, J-31, J-60—\$45.00

GEAR REDUCTION TUNING KNOB

Provides new ease and accuracy in tuning SSB signals. Operating on a 4 to 1 ratio, it eliminates Dial Drag and has no detectable backlash. Simple installation on KWS-1 and all 75A models.

Net price—\$15.00



SC-101 Station Control

provides smooth coordination
of complete SSB station

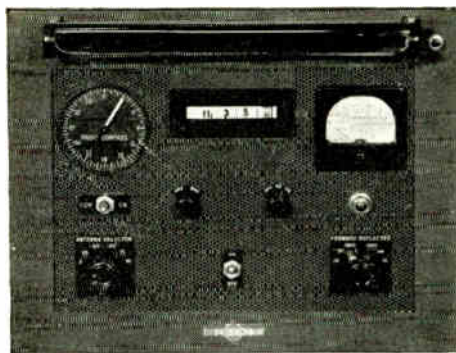

SPEAKER/CONTROL

The 312A-1 Speaker/Control Unit includes loudspeaker and has space for the extra control functions necessary in a complete installation. Unit is furnished with removable perforated steel front panel insert with no cutouts; operator can remove panel and install any control functions such as beam direction indicators, clocks, switches, etc. A 10" speaker is submounted behind the front panel and a lumiline lamp above. Rear of the unit is open and across the bottom is a terminal strip.

Net price—\$39.50

SPEAKER

The 270G-3 cabinet and 10" PM speaker assembly is attractively finished to match the 75A-4 Receiver.

Net price—\$22.00

The SC-101 provides the necessary equipment to connect the Transmitter and Receiver, beam direction indicator, beam control, phone patch circuit, standing wave ratio meter and remote selection of any one of six antennas.

The System is composed of three units:

312A-2 SPEAKER/CONTROL UNIT

This desk-top unit includes a 10" speaker, beam direction indicator, SWR meter, 24-hour numeral clock, lumiline operating lamp, phone patch unit, auxiliary power supply for control circuits, and terminal boards for interconnecting all units. A synchro control unit for tower mounting is also supplied, as is a directional coupler for use with the SWR unit.

68Y-1 ANTENNA SELECTOR

Mounted on wall near desk, the 68Y includes the antenna transfer relay, two coax relays for antenna selection, mounting bracket for directional coupler and necessary interconnecting coax cables.

534A-1 WIRING DUCT & HARNESS

This metal duct mounts along back of desk or table and houses all interconnecting cables. Along the top of the duct are ac utility outlets. Also included is a cable harness with wires necessary to connect the Transmitter, Receiver and extra control functions.

Net price—\$695.00

Collins

CREATIVE LEADER IN COMMUNICATION





- 'How Electronic Tubes Work.' ETI-6A. Basic explanation of tube operation. Industrial types are described.
- 'The Thyatron and How It Works.' ETI-22. Simple explanation of thyatron operation. Applications and tube ratings.



- 'Interchangeability List for G-E Power Tubes.' ETI-719-C. Complete replacement guide to more than 2500 power tubes of all makes.
- 'Quick Selection Chart of G-E 450-600 Milli-ampere Series-String Tubes.' ETD-1163-D. Characteristics of all G-E 450 ma and 600 ma types.

G-E TUBE PUBLICATIONS ARE UP-TO-THE-MINUTE DESIGN GUIDES



- 'Power Tubes for Industry and Broadcast.' ETX-10-J. Essential characteristics, warranties for all G-E transmitting and other power tubes.
- 'G-E 5-Star Tubes.' ETD-1276-A. High-reliability tube features, advantages, applications. Essential characteristics of all G-E types.

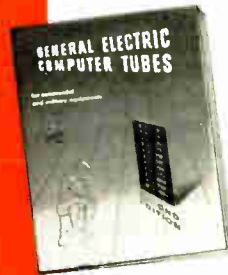

- 'G-E Computer Tubes and Their Applications.' ETD-1140-A. Complete technical data on G-E computer tubes—Standard and 5-Star types.
- 'Description and Rating Sheets.' Complete ratings and characteristics, operating conditions, outline drawings for individual General Electric tubes.

Ask for copies!

Radio amateur or design engineer, you will find General Electric tube publications valuable reference material to have.

These fact-filled booklets put the latest tube data at your fingertips. And you can be sure it is the very latest. Each booklet is up-dated periodically to include last-minute design improvements, new tube types, etc.

Order your copies now! Jot the numbers of the publications you want on the handy order coupon at right. Then clip out and mail! *Electronic Components Division, General Electric Company, Schenectady 5, New York.*

Progress Is Our Most Important Product

GENERAL  ELECTRIC
166-1C1

... ALSO AVAILABLE FROM YOUR LOCAL GENERAL ELECTRIC TUBE DISTRIBUTOR:

- 'Essential Characteristics.' ETR-15-F. Ratings, bulb outlines, typical circuits for more than 2000 receiving and picture tubes, and semiconductors.
- 'Ham News'
- 'Tele-Clues'
- 'Techni-Talk,' on AM, FM, TV Servicing
- 'Picture Tube Replacement Guide'

General Electric Company
Tube Sales, Building 3, CART
Schenectady 5, New York

Send following publications: _____

Send Description and Rating Sheets of these G-E tubes _____ to:

NAME _____

ADDRESS _____

CITY _____ STATE _____

**you
should
know
ED MACDONALD
...he can
save you
money**

Ed is Product Manager for National Company's Components Division, and one of our busiest men. Through his department pass hundreds of bid requests and special orders from just about every electronics firm in the nation. Ed's job is to provide fast, efficient service that results in substantial customer savings.

While everyone knows National makes a complete line of components — our catalog lists over 300 items — many do not realize that over 60 per cent of our components business is in "other than catalog items."

At their fingertips Ed's group have all the facilities necessary to fulfil your requirements:

1. Fully staffed Engineering Components Department for the design and development of new or special components to your specifications or to meet overall objectives.
2. Complete electrical and mechanical model shop services.
3. Complete facilities, staffed by qualified engineers, for reliability testing of components, sub-assemblies and electronic devices. U.S.A.F. approved environmental test facilities are included.
4. Complete, modern facilities for speedy, economical quantity production of all types of components.
5. A newly expanded order-service department providing fast, reliable handling of bids and special orders.

These National services can save you money! Put National's 42 years of experience and their expanded new facilities to work for you by taking your problems to Ed MacDonal. You can rely on Ed to quickly come up with the right answer and always at the right price. Drop him a line or call him at Malden 2-7950... you'll like doing business with National and Ed.

Model shop No. 1



Model shop No. 2

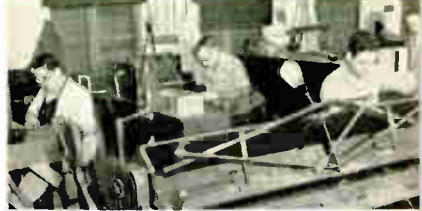

Assembly line, components division



Order service and sales, components division



Testing components along assembly lines



Engineers at work in components lab. No. 3

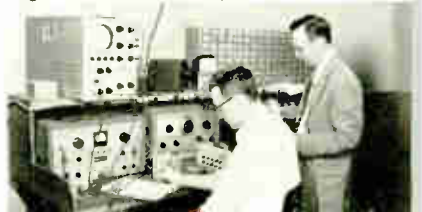

Eight out of every 10 U.S. Navy ships use National Receivers

National 
MALDEN 48, MASS.

tuned to tomorrow

Burton Browne / New York

tuned to tomorrow

National HRO-60



Latest and greatest of a great series featuring the widest frequency coverage of any receiver currently available (50 kc to 54 mc). Voice CW, NFM (with adaptor). Dual conversion on all frequencies above 7 mc.

FEATURES:

FCDA approved

- Twelve permeability-tuned circuits in the three 455 kc IF stages for sharp selectivity.
- Current-regulated heaters in the high frequency oscillator and first mixer.
- High frequency oscillator and S-meter amplifier are voltage regulated.
- Extra coil sets available to provide additional frequency coverage on special ranges.
- Crystal filter provides several degrees of selectivity with phasing notch to reject heterodyne interference.
- Has double-ended automatic noise limiter which is equally effective on both voice code reception.
- Has two RF stages for better sensitivity and selectivity (image ratio).
- Single knob controls reception of CW, AM, or NBFM signals or connects audio amplifier to Phono input.
- Adjustable CW oscillator control for C reception.
- Panel-controlled antenna input trimmer.
- Panel switch for choice of 100 kc or 10 kc calibration marker signals.

COVERAGE

COIL SET	GENERAL COVERAGE	BANDSPREAD
A	14.0—30.0 mc.	27.0—30.0 mc. (11, 10 meters)
B	7.0—14.4 mc.	14.0—14.4 mc. (20 meters)
C	3.5—7.3 mc.	7.0—7.3 mc. (40 meters)
D	1.7—4.0 mc.	3.5—4.0 mc. (80 meters)
*E	900—2050 kc.	
*F	480—960 kc.	
*G	180—430 kc.	
*H	100—200 kc.	
*J	50—100 kc.	
*AA		27.0—30 mc. (11, 10 meters)
*AB	25—35 mc.	
*AC		21.0—21.5 mc. (15 meters)
*AD		50—54 mc. (6 meters)

*Optional accessories.

TUNING SYSTEM

PW knob has worm gear drive box. Large dial with changing numbers gives a logging scale from 0—500, equivalent to a scale length of 12 feet. In addition, a slide-rule direct-reading scale is ganged with the PW dial to show frequency setting directly. The scale drum can be rotated to change scales. Plug-in coils for separate ranges.

AUDIO SYSTEM

A push-pull audio output stage delivers 8 watts at less than 10% distortion. Output impedance is 8 and 500 ohms. A high impedance phono-jack is located on the chassis, and a phone jack is provided on the receiver panel.

SENSITIVITY

1.5 microvolts from 2 to 30 mc (with 300-ohm dummy antenna and 10 db signal/noise ratio.)

SELECTIVITY

NORMAL (Crystal off)	6 db—3.5 kc
	60 db—10.5 kc
CRYSTAL IN POSITION #5	6 db—100 cycles
	60 db—7 kc

IMAGE REJECTION (At high end of band)

BAND	IMAGE RATIO
A	65 db
B	80+ db
C	80+ db
D	80+ db

CONTROLS

Band Switch; Oscillator; Tone; Antenna Trimmer; Dimmer; AV Limiter; Calibration; CW; Phasing; Selectivity; AF Gain/AF ON-OFF; RF Gain; AM-NFM-Phono.; B+ ON/OFF.

TUBE COMPLEMENT

1st RF Amp.	6BA6
2nd RF Amp.	6BA6
1st Frequency Conv.	6BE6
High-Frequency Osc.	6C4
2nd Frequency Conv.	6BE6
1st IF Amp.	6SG7
2nd IF Amp.	6SG7
3rd IF Amp.	6SG7
Det.—AVC	6H6
Noise Limiter	6H6
S-Meter Amp.—Phase Inverter	6SN7GT
1st AF Amp.	6SJ7
Audio Output (2)	6V6GT
BFO Oscillator	6SJ7
Voltage Reg.	OB2
Current Reg.	4H-4C
Rectifier	5V4G

OTHER SPECIFICATIONS

Antenna Input: 50—300 ohms, balanced or unbalanced.

Size: Table 19 3/4" wide x 10 1/2" high x 16" deep.

Back 18" wide x 10 1/2" high x 17 1/2" from rear of front panel incl. 1 1/4" handle.

Finish: Smooth gray enamel.

Shipping Weight: 88 lbs.

Optional Accessories:

- HRO-60R — Rack model receiver with A, B, C, D coil sets.
- HRO-60T — Table model receiver with A, B, C, D coil sets.
- HRO-60RS — Rack Model Speaker.
- HRO-60TS — Table Model Speaker.
- HRO-60 — Deluxe Receiving Installation. (Consists of HRO-60R with A, B, C, D coil sets, HRO-60-SC2 speaker and coil container MRR-2 Table Rack.)
- HRO-60-SC2 — Speaker as container for 10 coil sets.
- HRO-60-XCU-2 — 100/1000 crystal calibrator.
- HRO-650S — 6 V. vibrator type supply.
- MRR-2 — Table Rack.
- NFM-83-50 — Narrow Band F Modulator Adaptor.
- Coils—E, F, G, H, J, AA, AC, AD.

NATIONAL COMPANY, INC., 61 SHERMAN STREET, MALDEN 48, MASS.

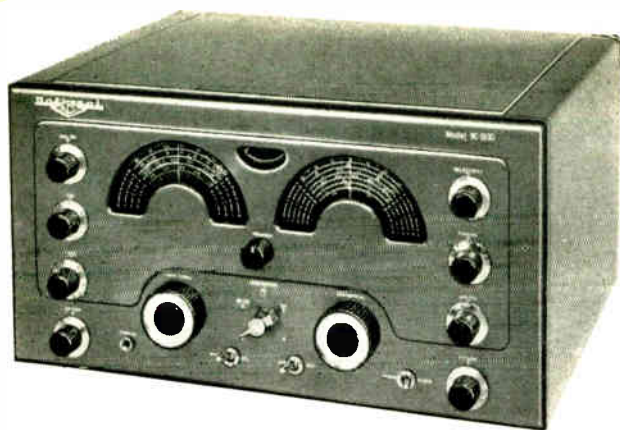

tuned to tomorrow
National 
NC-183D

Incorporates every feature you want in a truly modern receiver! Dual conversion on the three highest ranges (including 6, 10, 11, 15, 20, and 40 meter ham bands). Complete coverage from 540 kc up to 30 mc, plus 50-54 mc 6-meter ham band. Voice, CW, NFM (with adaptor).



FEATURES:

- Two stages of RF provides extremely high image ratio.
- Dual conversion on all bands above 4.4 mc.
- Bandspread on all amateur bands through six meters.
- Three stage sharp IF (12 permeability-tuned circuits) no sacrifice in noise selectivity, high degree of skirt selectivity.
- Push-pull audio output.
- Indirectly lighted lucite dial scales.
- Rack and table models available.
- HF oscillator voltage regulated.
- Crystal filter provides several degrees of selectivity with phasing notch to reject heterodyne interference.
- New bi-metallic temperature — compensated tuning condenser for drift-free operation.
- New miniature tubes.
- FCDA Approved.

COVERAGE

BAND	GENERAL COVERAGE	BANDSPREAD
A		47—55 mc. (6 meters)
B	12—31 mc.	26.5—30 mc. (11, 10 meters) 20.0—21.5 mc. (15 meters) 14.0—14.4 mc. (20 meters)
C	4.4—12 mc.	6.9—7.3 mc. (40 meters)
D	1.55—4.4 mc.	3.5—4 mc. (80 meters)
E	0.54—1.55 mc.	

TUNING SYSTEM

The main tuning and bandspread tuning capacitors are connected in parallel on all bands. This arrangement permits bandspread tuning at any frequency within the range of the receiver. Two RF stages are employed on all bands, and the trimmer for the first RF stage is controlled from the front panel.

AUDIO SYSTEM

A push-pull audio output delivers 8 watts at less than 10% distortion. A high impedance phono-jack is located on the chassis, and a phone jack is provided on the receiver panel.

IMAGE REJECTION (AT HIGH END OF BAND)

BAND	IMAGE RATIO
A	40 db
B	65 db
C	80 db
D	80 db
E	80 db

SENSITIVITY

Better than 3.5 microvolts (with 300-ohm dummy antenna and 10 db signal/noise ratio).

SELECTIVITY

NORMAL (Crystal off)	6 db—3.5 kc
CRYSTAL IN POSITION #5	60 db—12.5 kc
	6 db—100 cycles
	60 db—7 kc

CONTROLS

CW Switch; CWO control; Tone Control; Limiter Control; Main Tuning; Bandspread Tuning; Band Switch; RF Gain; AC ON-OFF; AF Gain; Send Receive Switch; AVC MVC Switch; Radio/Phono Switch; Phone Jack; Phasing Control; Selectivity Switch; Antenna Trimmer.

TUBE COMPLEMENT

1st RF Amp.	6BA6 ⁷
2nd RF Amp.	6BA6
1st Conv.	6BE6
2nd Conv.	6BE6
1st IF Amp.	6BA6
2nd IF Amp.	6BA6
3rd IF Amp.	6BA6
2nd Det.—AVC	6AL5
AVC Amp.	6AH6
Beat Freq. Osc.	6SJ7
Noise Limiter	6AL5
1st Audio	6SN7
Phase Inverter—S Meter Amp.	6V6GT G)
Audio Output (2)	OB2
Voltage Reg.	5U4G
Rectifier	

OTHER SPECIFICATIONS

- Antenna Input:** 50-300 ohms, balanced or unbalanced.
- Size:** 10¼" high x 19¾" wide x 16¾" deep
- Finish:** Smooth gray enamel.
- Shipping Weight:** 65 lbs.
- Optional Accessories:** NFM-83-50 Adaptor.
NC-183DTS Table Speaker.
NC-183DRS Rack Speaker.

NATIONAL COMPANY, INC., 61 SHERMAN STREET, MALDEN 48, MASS.

tuned to tomorrow

National NC-300



HAM RECEIVER

National's famous "Dream Receiver." An extremely sensitive, highly stable receiver with exceptional calibration accuracy. Has eight electrical bands, 160 through 10 meters, plus a special 30-35 mc range used as a tunable IF for 6, 2, and 1 1/4 meters.

FEATURES:

- Ten dial scales for coverage of 160 to 1 1/4 meters with National's exclusive new converter provision with the receiver scales calibrated for 6, 2, 1 1/4 meters using a special 30-35 mc tunable IF band.
- Longest slide-rule dial ever! More than a foot long! Easily readable to 2 kc without interpolation up to 21.5 mc.
- Three-position IF selector—.5 kc, 3.5 kc, 8 kc—provides super selectivity, gives optimum band width for CW, phone, phone net or VIF operation.
- Separate linear detector for single sideband... decreases distortion by allowing AVC "on" with single sideband... will not block with RF gain full open.
- Hi-speed, smooth inertia tuning dial with 40 to 1 ratio! Provides easier, more accurate tuning. Smoothest dial you've ever used.
- Exclusive optional RF gain provision for best CW results allows independent control of IF gain!
- Giant, easy to read "S" meter!
- Provision for external control of RF gain automatically during transmitting periods.
- Muting provisions for CW break-in operation.
- Calibration reset adjustable from front panel to provide exact frequency setting!
- Dual conversion on all bands!
- Crystal filter with phasing control and three-position bandwidth control!
- Wide range tone control, for control of both low frequency and high frequency end of response curve!
- Socket for crystal calibrator plus accessory socket for powering converters and future accessories!
- First IF frequency—2215 kc.
- Second IF frequency—80 kc.
- Selectivity at 6 db down 500 cycles, 3.5 kc and 8 kc. Selectable from the front panel without additional accessories! Nothing extra to buy!
- Crystal filter at 2215 kc provides notching plus three bandwidth positions in addition to the three IF selectivity positions. No other receiver has this versatility.

COVERAGE

BAND DESIGNATION AND LENGTH

160 meters—	1.8 to	2.0 mc.
80 meters—	3.5 to	4.0 mc.
40 meters—	7.0 to	7.3 mc.
20 meters—	14.0 to	14.4 mc.
15 meters—	21.0 to	21.5 mc.
11 meters—	26.5 to	27.5 mc.
10 meters—	28.0 to	29.7 mc.
6 meters—	49.5 to	54.5 mc.*
2 meters—	143.5 to	148.5 mc.*
1 1/4 meters—	220 to	225 mc.*

*Usable with Accessory Converters:

TUNING SYSTEM

Combination gear/pinch for smooth inertia tuning.

AUDIO SYSTEM

The audio amplifier uses a single 6AQ5 output tube delivering 1.0 watts at less than 10% distortion. Has front panel phone jack. Output impedance is 8 ohms.

SENSITIVITY

Under 1.5 microvolts (with 300-ohm dummy antenna and 10 db signal/noise ratio).

SELECTIVITY

	SHARP	MEDIUM	BROAD
6 db	0.5 kc	3.5 kc	8.0 kc
60 db	3 kc	12 kc	30 kc

IMAGE REJECTION

BAND	IMAGE RATIO
160	80 db
80	80 db
40	60 db
20	75 db
15	55 db
10	50 db
11	50 db

CONTROLS

RF Gain and AC ON/OFF; AF Gain and RF Tube Gain Switch; Tone Control; AM-CW-SSB-ACC Switch; CW Pitch; Main Tuning; Calibration Correct; Antenna Trimmer; Crystal Calibrator ON/OFF; Limiter; IF Selectivity; Crystal Selectivity; Crystal Phasing; Band Switch; Phono-Jack.

TUBE COMPLEMENT

1st RF Amp.	6BZ6
1st Mixer	6BA7
1st Osc.	6AH6
2nd Mixer	6BE6
1st IF Amp.	6BJ6
2nd IF Amp.	6BJ6
ANL and Det.	6AL5
CWO/SSB Det.	6BE6
1st Audio and S Meter Amp.	12AT7
Audio Output	6AQ5
Current Regulator	4H4-C
Voltage Regulator	OB2
Rectifier	5Y3

OTHER SPECIFICATIONS

Antenna Input: 50-300 ohms, balanced or unbalanced.

Size: 19 1/2" wide x 11 1/4" high x 15" deep (19" rack out of cabinet)

Finish: Two-tone gray enamel.

Shipping Weight: (Legal) 64 lbs.

Optional Accessories:

Converters

NC-300C6 for 6-meter band.
NC-300C2 for 2-meter band.
NC300C1 for 1 1/4 meter band.

NC-300-CC Converter Cabinet

NC-300TS Speaker.
XCU-300 Plug-in Crystal Calibrator.

NATIONAL COMPANY, INC., 61 SHERMAN STREET, MALDEN 48, MASS.

The Most Complete Transformer Line in the World . . . FROM STOCK



A quarter century of specialized experience and original research has gone into the development of UTC catalog items. Covering the range from tenth ounce units to others weighing hundreds of pounds, UTC stock items are available for virtually every application in the electronics field. Each of these items carries a plus value . . . UTC RELIABILITY, highest in the field.

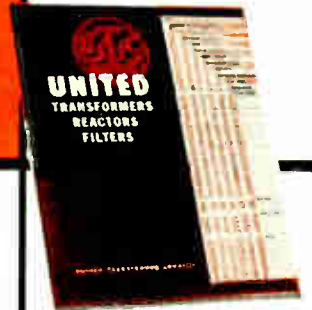

Write for your Copy of Catalog '56



PERMALLOY DUST TOROIDS
Maximum Accuracy and Stability

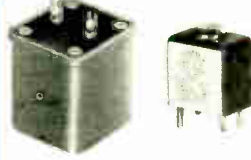

VARIABLE INDUCTORS
Standard and Hermetic



LOW FREQUENCY INDUCTORS and INDUCTANCE DECADES



LOW PASS, HIGH PASS and BAND PASS FILTERS . . . HERMETIC



HERMETIC
Power, Plate, Filament Transformers and Reactors



HERMETIC AUDIO COMPONENTS
for Every Application



MAGNETIC AMPLIFIERS . . . HERMETIC



PULSE TRANSFORMERS



DOTS
Transistor Transformers
Smallest Size—Highest Power



SUB and SUB-SUB DUNCER TRANSFORMERS
Audio Miniatures



DUNCER and PLUG-IN UNITS



LINEAR STANDARD SERIES
Tops in Fidelity



HIPERMALLOY and ULTRA COMPACT
High Fidelity Favorites



COMMERCIAL GRADE AUDIO and POWER COMPONENTS
for Industrial Use



SPECIAL SERIES . . . Audio and Power Components for the "Ham"



REPLACEMENT TYPES

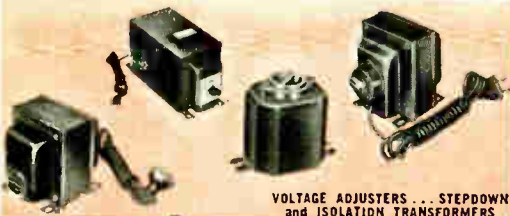

VOLTAGE ADJUSTERS . . . STEPDOWN and ISOLATION TRANSFORMERS



PHOTOFASH TRANSFORMERS
MIKE-CABLE TRANSFORMERS



EQUALIZERS

UNITED TRANSFORMER COMPANY

138 Varick Street, New York 13, N. Y. • EXPORT DIVISION: 12 E. 40th St., New York 14, N. Y., CABLE: "ARLAP"

THE HOME OF THE GPR-90

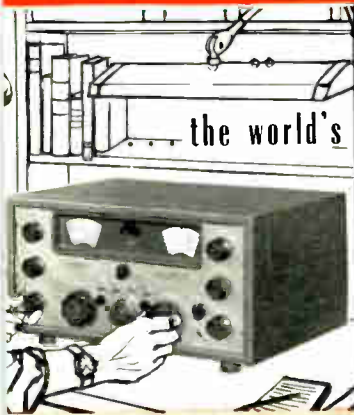

the world's finest communication equipment . . .

Quality Products



THE TECHNICAL MATERIEL CORP.
MAMARONICK, NEW YORK

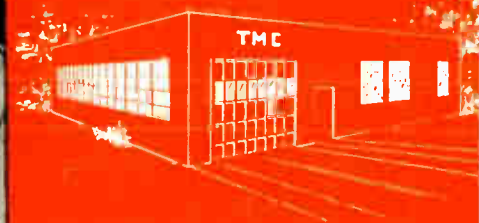
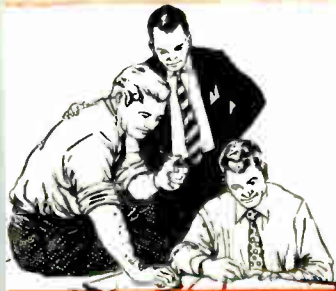

THE TECHNICAL MATERIEL CORPORATION

COMMUNICATION RECEIVER

The Model GPR-90 Receiver is a professional, general purpose communications receiver of the double conversion superheterodyne type covering the frequency range of .54 to 31 mcs. The receiver features low noise, excellent selectivity, a highly stable HFO and BFO, accuracy in calibration, the finest components, and is designed for ease of servicing.

New and novel features such as low noise grounded grid broadbanded ferramic input stage, low intermodulation, delayed AVC, audio selectivity and excellent audio response make this the finest receiver in its class.

FREQUENCY RANGE: .54 to 31 mcs in six bands. **TYPE OF RECEPTION:** AM, CW, MCW, FS and SSB. **TUNING SYSTEM:** Accurately calibrated main tuning dial plus full electrical bandspread. **SENSITIVITY:** Better than 1 microvolt for 10 db signal to noise ratio. **IMAGE RATIO:** Average 85 db. **CRYSTAL CALIBRATOR:** Provides 100 kcs markers through tuning range. **STABILITY:** Better than .002% first three bands and .003% remainder of range.

RADIO TRANSMITTER

The Model GPT-750 Radio Transmitter is a general purpose transmitter providing radio-telephone, telegraph, frequency shift, facsimile and Single Sideband operation on all frequencies within the range 2 to 32 Mcs.

The transmitter is completely bandswitched. It contains a high stability direct reading master oscillator. The transmitter is constructed on a building block basis, using slide-in drawers thereby permitting economic combinations to suit a particular service.

FREQUENCY RANGE: 2 to 32 Megacycles bandswitched. **POWER RATINGS:** 1000 watts output CW and FS, 750 watts output Radio Telephone, 750 watts PEP Single Sideband.

FREQUENCY CONTROL: Direct Reading Master Oscillator plus three crystal positions. **MASTER OSCILLATOR STABILITY:** Better than 20 parts per million. **FREQUENCY CALIBRATION:** By means of a built-in oven controlled 100 kcs crystal oscillator with visual Zero Beat indication. **COOLING:** Forced Filtered Air in a steel pressurized cabinet. **RUGGEDNESS:** Designed for mobile application, with the addition of shock mounts.

SINGLE SIDEBAND ADAPTER

The Model GSB-1 Single Sideband Adapter is a filter type slicer permitting accurate and simple tuning of Single Sideband, AM, CW and MCW signals. The unit incorporates features which will improve any receiving system. The filter provides additional selectivity and pass-band tuning. Additional AVC (FAST/SLOW) prevents powerful local stations from over-loading the receiving system. The noise limiter reduces impulse peaks.

Electrical bandspread eliminates the critical frequency adjustments characteristic of single sideband tuning. Upper and lower sidebands are selected by a flip of a switch:

FREQUENCY RANGE: 452 to 458 kcs. **RECEPTION:** AM, SSB (upper or lower), CW, and exalted carrier. **INPUT:** 0.1 to 10 volts. **OUTPUT:** One Watt into 6, 8, 16 or 600 ohms. **TUNING:** Bandspread control calibrated in cycles.

REMOTE CONTROL AMPLIFIER

The Model RTC Remote Control Amplifier is a multi-purpose unit providing amplification for a low level microphone, selectable peak clipping and variable tone output for MCW. The unit also makes possible remote keying, break-in and other semi-remote transmitter control functions.

The peak clipping feature may be switched into operation by means of a front panel switch. The clipping characteristic is continuously adjustable 0 to 20 db, and high and low pass filters are provided.

INPUT LEVEL: Minus 50 db for full output. **OUTPUT LEVEL:** 0 volts to plus 6 dbm, continuously variable. **FREQUENCY RESPONSE:** Plus/Minus 2 db from 100 to 7500 cps. **DISTORTION:** Less than 2% total harmonic. **CLIPPING:** 0 to 20 db continuously adjustable.



(FCDA APPROVED)

GPR-90



BULLETIN 179



(FCDA APPROVED)

GPT-750



BULLETIN



GSB-1



BULLETIN 194



(FCDA APPROVED)

RTC



BULLETIN 183

THE TECHNICAL MATERIEL CORPORATION

ANTENNA TUNING UNIT



BULLETIN 163

TAC



The Model TAC Antenna Tuning Unit matches the 70 ohm unbalanced output of a radio transmitter to balanced or unbalanced loads ranging from 50 to 1200 ohms over the frequency spectrum 2 to 30 Mcs.

The Tuning Unit incorporates a unique, continuously variable, contact type inductance with switched taps to control the loading of the transmitter over the frequency range. Capacitor spacing and teflon insulation prevents flash-over.

FREQUENCY RANGE: 2 to 30 Mcs. INPUT IMPEDANCE: Nominal 75 ohms unbalanced. OUTPUT IMPEDANCE: 50 to 1200 balanced or unbalanced. RF POWER RATING: 1000 watts input.

COMMUNICATIONS RECEIVER

(AN/FRR-49(V))

The Model FFR is a highly versatile receiver, covering the frequency range 50 Kcs to 32 Mcs and is used for dependable, unattended continuous reception of AM, CW, MCW, FS and SSB signals. Provision is made for Crystal, Internal and External operation of the HFO and BFO. Rapid frequency change is made possible by means of accurately calibrated pretuned plug-in 'front ends'. Remote control and diversity features are incorporated as standard features. The Receiver is also available with squelch (CODAN), and for Beacon Monitoring purposes.

BULLETIN 124



FFR



FREQUENCY RANGE: 50 to 400 kcs, 500 kcs, 2 to 32 mcs. BAND CHANGE: By means of pretuned, preheated, receiver front ends. TYPE OF RECEPTION: AM, CW, MCW, FS and SSB. CONTROL: Manual or remote. FREQUENCY CONTROL: Crystal or VFO. SENSITIVITY: Better than 1.0 microvolt for 10 db Signal to Noise Ratio. OVERALL SELECTIVITY: 2 to 32 mcs—Less than 5 kc at 6 db down. Variable Selectivity—50 kc - 400 kc. 5, 1.3, 0.5, 0.3 kc at 6 db down.

PORTABLE MASTER OSCILLATOR

(O-459/URT)

The Model PMO Portable Master Oscillator and Heterodyne Frequency Meter is a highly stable, precision, direct reading device used as a transmitter exciter, frequency meter or receiver calibrator. It provides output over the range 2 to 8 mcs and is directly calibrated by means of a counter-dial system over the range of 2 to 4 mcs. An oven controlled 100 kc oscillator provides visual calibration of the unit.

BULLETINS 173 & 193



PMO



FREQUENCY RANGE: 2 to 8 mcs. OUTPUT: 3 Watts adjustable into 70 ohms. STABILITY: Better than 20 parts per million for a 30 degree C change in ambient. CALIBRATION: Direct reading in cycles 2-4 mcs. READABILITY: Resealability, 30 parts per million to a previously calibrated frequency. CALIBRATION: Against a calibrator controlled 100 kc crystal oscillator with visual indication.

VARIABLE FREQUENCY OSCILLATOR

(O-330/FR)

The Model VOX Variable Frequency Oscillator is a direct reading, precision variable frequency device designed to replace the crystal oscillator of a diversity receiver or of a transmitter. This oscillator is also used as a secondary standard.

The VOX provides a continuously variable output over the range 2 to 64 mcs, with direct reading calibration over the basic oscillator range with better than .002% long term stability. Frequency calibration is provided by means of an oven controlled 100 kc crystal oscillator with visual Zero Beat indication.

BULLETIN 134



VOX-2



FREQUENCY RANGE: 2 to 64 mcs. OUTPUT: 3 - 75 ohm coaxial outputs. STABILITY: Better than 20 parts per million for Zero to 50 degrees C change in ambient. RESETABILITY: Better than 20 parts per million to a calibrated frequency. ADDITIONAL FEATURES: 1. Crystal BFO for receiver control provided. 2. Crystal IFO for receiver control provided. 3. Three HFO crystal positions provided.

THE TECHNICAL MATERIEL CORPORATION

FREQUENCY SHIFT CONVERTER

The Model CFA Frequency Shift Converter is an audio type, dual channel converter for use with diversity or single receiver systems, used to convert the mark and space tones of a frequency shifted signal into DC pulses capable of operating a teletypewriter.

The CFA is a compact equipment incorporating visual monitoring, wide signal drift acceptance, mark hold and bias correction. The unit is available for optimized narrow shift applications.

INPUT LEVEL: Minus 30 to plus 30 dbm. **LIMITING:** 50 to 60 db per channel. **INPUT FREQUENCY DRIFT LIMITS:** Up to 1500 cycles. **KEYING SPEEDS:** Up to 600 wpm. **TUNING INDICATOR:** Two inch cathode ray tube. **OUTPUT CIRCUIT:** Neutral, either side grounded or floating.



CFA



BULLETIN 120

FREQUENCY SHIFT EXCITER

The Model XFK Frequency Shift Exciter is a high stability radio frequency oscillator which replaces the crystal oscillator in the transmitter and provides the mark and space pulses necessary for the transmission of teleprinter, telegraph, narrow band FM telephone, facsimile or telephoto intelligence. The XFK features two precision temperature controlled ovens providing the high stability required for unattended operation.

FREQUENCY RANGE: 1 to 6.9 mcs. **FREQUENCY SHIFT:** Linear to 1000 cycles. **OUTPUT:** 3 Watts adjustable into 70 ohms. **CONTROLS:** Directly calibrated in frequency. **FREQUENCY CONTROL:** 3 crystal positions and one external oscillator position. **KEYING SPEED:** 1000 wpm. **STABILITY:** 10 cycles for an ambient change of 50 degrees C. **TRANSMITTER MULTIPLICATION:** Automatic by means of a unique patching system.



XFK



BULLETIN 118

RHOMBIC ANTENNA COUPLER

The Model RAC Rhombic Antenna Coupler is a broadbanded transformer covering the frequency range 2 to 60 megacycles and is used to match an unbalanced transmission line to a balanced antenna. The coupler is housed in a cast aluminum weather-tight case.

Lightning protection and DC continuity is provided.

FREQUENCY RANGE: 2 to 60 megacycles. **INPUT IMPEDANCE:** 700 and 200 ohms balanced. **OUTPUT IMPEDANCE:** 70 ohms unbalanced. **FREQUENCY RESPONSE:** Within 3 db over frequency range. **LIGHTNING PROTECTION:** By means of adjustable or gas filled gaps.



RAC

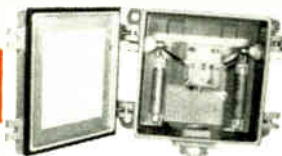

BULLETIN 112

TRANSMITTING ANTENNA DISSIPATORS TERMINATING RESISTORS AND DUMMY LOADS

The TER Series are special non-inductive resistive elements packaged for indoor or outdoor use as transmitting terminators, dissipators and dummy loads. The resistors are of a new design providing a minimum of reactance. The entire assembly is shock mounted in a plastic case and may be quickly removed for service. The resistors may be instantly brought up to full rated output power at minus 40 degree C without harm.

FREQUENCY RANGE: DC to 30 megacycles. **POWER RATINGS:** 500, 1750 and 5000 watts. **IMPEDANCES:** 70 or 600 ohms balanced or unbalanced. **COOLING:** Natural Air Cooling. **OPERATING TEMPERATURE:** Minus 40 to plus 100 degrees C.



SERIES TER



BULLETIN 188

THE TECHNICAL MATERIEL CORPORATION

DIVERSITY RECEIVING PACKAGE

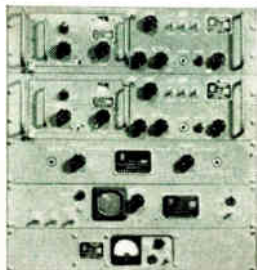

BULLETIN 170

DRP-1



The Model DRP-1 Diversity Receiving Package combines the Model FFR (AN/FRR-49(V) Receiver, the Model CFA, FS Converter, and the Model P5P, Power Supply, into a compact, easy to operate system capable of receiving AM, FS, CW and MCW signals in diversity within the frequency range of 50 to 400 Kcs and 2 to 32 Mcs. Either SPACE or FREQUENCY Diversity may be used. Pre-tuned, plug-in, receiver 'front ends' provide quick frequency change. The package may be remotely controlled by use of the Model RCR (AN/FRA-501) Remote Control System.

FREQUENCY RANGE: 50 to 400 Kcs and 2 to 32 Mcs. **RECEPTION:** AM, FS, CW and MCW. **FREQUENCY CONTROL:** Crystal, Internal or External VFO and BFO. **REMOTE CONTROL:** By means of Model RCR Remote Control System. **DIVERSITY COMBINING:** AM-MCW-CW—Common diode load, FS-CW—Audio type converter Model CFA. **OUTPUT:** Audio output 8 or 600 ohms, teletypewriter output DC into 2000 ohms.

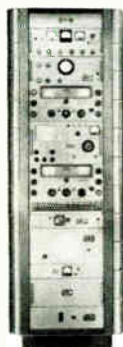

BULLETIN 190

DDR-3



DUAL DIVERSITY RECEIVER

The Model DDR-3 Dual Diversity Receiver is an all-purpose receiving system, covering the frequency range of .54 to 31 mcs, for the reception of AM, FS, CW, MCW and SSB signals in diversity. The system incorporates the new Model GPR-90 Receiver in conjunction with the VOX Variable Frequency Oscillator, a unique diversity combining unit and a visual tuning indicator.

FREQUENCY RANGE: .54 to 31 mcs. **RECEPTION:** AM, FS, CW, MCW and SSB. **FREQUENCY CONTROL:** Crystal or high stability VFO. **DIVERSITY COMBINING:** AM, CW and SSB—By means of Model DCU Combining Unit, FS—Audio type converter, Model CFA.

ANTENNA MULTICOUPLER

BULLETIN 155



AMC-6



(CU-5013/SRR)

The Model AMC-6 is a broadbanded branching amplifier which permits the connection of six high frequency receivers to one antenna. The unit provides excellent isolation between receivers and effectively prevents re-radiation into the antenna system. By use of the AMC, the overall noise figure of a receiver system is improved throughout the operating band and the receiver sensitivities are usually increased. Cascade operation will provide up to 36 receiver outputs.

FREQUENCY RANGE: 2 to 30 Mcs optimum, 100 Kcs to 30 Mcs with reduced efficiency. **GAIN:** 10 db plus or minus 2 db, 2 to 30 Mcs. **NOISE FACTOR:** Less than 4.5 **INTER-MODULATION:** Down at least 55 db for two 10,000 uv signals. **IMPEDANCES:** 50, 70 balanced or unbalanced, and 300 ohm balanced inputs to 50 or 70 ohm unbalanced outputs.

BULLETINS 178-180

SERIES TRC

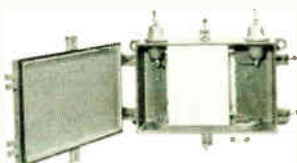

SERIES TRC



The TRC Series are transmitting type broadbanded antenna couplers for transferring RF Power from unbalanced inputs to balanced outputs over the frequency range 2 to 30 Mcs. These are passive transformer devices requiring no tubes, power supplies or tuning adjustments.

TRC 100	100 watts
TRC 500	500 watts
TRC 3500	3500 watts

THE TECHNICAL MATERIEL CORPORATION



SERIES
5700

PACKAGE STATION

... a complete station, approved for FCDA Funds, consisting of the GPT-750, the GPR-90, the RTC and all accessories including choice of antenna, microphone and key.

ALL THE ILLUSTRATED EQUIPMENT IS FCDA APPROVED



The TECHNICAL MATERIEL CORPORATION

(MAIN OFFICE AND PLANT @)

700 FENIMORE ROAD
MAMARONECK, NEW YORK

(FOR THE WORLDWIDE)

TMC (Canada) Ltd.
TMC Industrial Corp.
TECHNICAL MATERIEL DEVELOPMENT

(Canada) Ltd.



PRINTED IN U.S.A.



Choosing YOUR CRYSTAL

Remember — Just any crystal and just any oscillator will not combine to produce spot frequencies.

Several facts should be considered other than frequency. The final oscillating frequency of the crystal is affected by the associated oscillator circuit through the reactive load and drive levels. For close tolerance operation and oven use, the ambient temperature also must be considered. Table I below indicates the magnitude of change in the frequency of a given crystal when varying the load capacitance into which it is operating.

TABLE I	OSCILLATOR LOAD CAPACITANCE			
	50 mmf	32 mmf	20 mmf	10 mmf
MEASURED CRYSTAL	1999.950	2000	2000.060	2000.200
FREQUENCY IN	3999.700	4000	4000.400	4001.000
KC	6999.200	7000	7001.200	7003.300
	13998.0	14000	14003.1	14008.1

In the manufacture of crystals, certain limits must be adhered to when finishing the unit. Such limits are often held to better than .001% for commercial applications. Tolerances of this magnitude mean nothing unless the oscillator in which

the crystal is to operate is an exact reproduction of the oscillator in which the crystal was calibrated. This same thing applies to wider tolerances. Persons doing work where close tolerances are required, (Broadcast, Commercial Two-Way, Civil Defense, CAP, etc.) should keep this in mind.

For overtone operation, crystal units especially processed for mode operation produce better results than fundamental types. Overtone crystals are calibrated on their overtone frequency and, therefore, are accurate frequency control units. Overtone crystals are valuable for receiver-converter applications and are normally not used in transmitters, since only a small amount of power is available under stable operating conditions. Overtone crystals are calibrated either for series resonance or parallel resonance operation.

Temperature—All crystals processed by International use "Zero Coefficient" cuts. Blank angles are held to closer tolerance in the F-6 units and, therefore, will change less over a given temperature range than the FA units. Tolerances are listed in the table below.

TYPE	LOAD CAPACITANCE or OSCILLATOR	CALIBRATING TOLERANCE IN SPECIFIED LOAD	TEMP. TOLERANCE —30°C to +60°C
F-6 (fundamental)	Specified by customer (Use in commercial equipment)	±.0025%	±.002%
F-6 (overtone)	Specified by customer (Use in commercial equipment)	±.0025%	±.002%
FA (fundamental)	32 mmf (only)	±.01%	±.01%
FA (overtone)	Anti-resonate operation without additional load. (See circuit with crystal)	±.01%	±.01%
FX-1	FO-1A or FO-1B Oscillator	Available from .001% to .01% as required	±.002%

● Send for FREE Catalog covering International's complete line. Crystals available from 100 KC to 100 MC.

International/CRYSTAL Mfg. Co., Inc. 18 N. Lee Phone FO 5-1165
OKLAHOMA CITY, OKLA.

International CRYSTALS - ONE DAY PROCESSING



FA-9 for AMATEUR USE

Spot Frequencies 1500 KC to 90 MC

.01% TOLERANCE—Wire mounted, plated crystals for use by amateurs and experimenters, where tolerances of .01% are permissible and wide range temperatures are not encountered.

PRICES FA-9* (Pin Diameter .093)*
FA-5 (Pin Diameter .050)

Pin Spacing .486 (*FA-9 fits same socket as FT-243)

.01% TOLERANCE

FREQUENCY RANGE	PRICE
Fundamental Crystals	
1,500— 1,799 KC	\$4.50
1,800— 1,999 KC	\$4.00
2,000— 9,999 KC	\$3.00
10,000—15,000 KC	\$4.00
Overtone Crystals	
(For 3rd Overtone Operation)	
15 MC—29.99 MC	\$3.00
30 MC—54 MC	\$4.00
(For 5th Overtone Operation)	
55 MC—75 MC	\$4.50
76 MC—90 MC	\$6.50

Holders: Metal, hermetically sealed, available in .093 diameter pins (FA-9) or .050 diameter pins (FA-5).

Frequency Range: 1500 KC to 90 MC

Calibration Tolerance: $\pm .01\%$ of nominal at 30° C.

Temperature Range: -40° C to +70° C.

Tolerance over temperature range from frequency at 30° C: $\pm .01\%$.

Circuit: Designed to operate into a load capacitance of 32 mmf on the fundamental between 1500 KC and 15 MC. Designed to operate at anti-resonance on 3rd overtone modes into a grid circuit without additional capacitance load. 5th overtone crystals are designed to operate at series resonance. (Write for recommended circuits).

Crystals are guaranteed only when operated under the conditions specified or in circuits recommended by International Crystal.

F-6 COMMERCIAL USE

Precision Crystals 1000 KC to 60 MC

Delivery:

ONE DAY PROCESSING

All orders of less than five units of any one frequency in the range 1000 KC to 60 MC will be mailed within 24 hours from the time received.

Wire mounted, plated crystals, for use in commercial equipment where close tolerances must be observed. All units are calibrated for the specific load presented by equipment.

Holders: Metal, hermetically sealed. Pin spacing .486

Calibration Tolerance: $\pm .0025\%$ at nominal at 30° C.

Tolerance over Temp. $\pm .005\%$ from -55° to +90° C.

Range: $\pm .002\%$ from -30° C to +60° C.

Circuit: As specified by customer. Crystals are available for all major two-way equipments. In most cases the necessary correlation data is on file.

Drive level: Maximum—10 milliwatts for fundamental, 5 milliwatts for overtone.

Send for FREE Catalog covering International's complete line. Crystals available from 100 KC to 100 MC.



F-605

Pin dia. .093

Pin Ingh. .238



F-609

Pin dia. .095

Pin Ingh. .445



F-612

Pin dia. .125

Pin Ingh. .620

Pin spacing on each of above is .486

International CRYSTAL Mfg. Co., Inc. 18 N. Lee Phone FO 5-1165
OKLAHOMA CITY, OKLA.

OSCILLATOR ASSEMBLIES

International CRYSTAL

FO-1 PRINTED CIRCUIT OSCILLATOR



FO-1

OSCILLATOR SPECIFICATIONS

	FO-1 (fundamental)	FO-1B (overtone)
Freq. Range	200 KC- 15,000 KC	15 MC-60 MC (in 5 ranges)
RF Output	3 to 10 volts into 1200 ohms	2 to 7 volts into 18000 ohms
Plate Power	210 volts @ 5 ma	150 volts @ 8 ma
Heater Power	6.3 volts @ 150 ma	6.3 volts @ 175 ma
Tube	6BH6	6AK5
Maximum Drift	40°F to 120°F— ±.002% incl. crystal* (*except 200 to 500 KC ± .02%)	
Maximum Drift with (+) Plate Voltage Change	(±20%) .0002%	(±10%) .0015%
Calibration Tolerance	.001% to .01% depending on FX-1 crystal used	.001% to .01%
Size	4"x4"x3" overall	4"x4"x3" overall
Mounting	4 holes (with brackets provided)	

for Generating Spot Frequencies with GUARANTEED Tolerance from 200 KC to 60MC

Since the operating tolerance of a crystal is greatly affected by the associated operating circuit, the use of the FO-1 Oscillator in conjunction with the FX-1 Crystal will guarantee close tolerance operation. Tolerances as close as .001 percent can be obtained.

FO-1 for Fundamental Operation 200 KC to 15,000 KC

- FO-1—Oscillator Kit (less tube and crystal)\$3.95
- FO-1A—Oscillator, factory wired & tested with tube (less crystal) ...\$6.95

FO-1B for Overtone Operation 15 MC to 60 MC

- FO-1B—Oscillator Kit (less tube and crystal)\$3.95*
- FO-1BA—Oscillator, factory wired & tested with tube (less crystal) \$6.95*

*Includes coil in one of four ranges: 15-20 MC, 21-30 MC, 31-40 MC, or 41-60 MC, specify when ordering. Extra coils 35¢ each.

USES

AMATEUR

- Net Operation
- Frequency Standards
- Close band-edge operation

COMMERCIAL

- Frequency Standards
- Signal Generators for alignment purposes
- Oscillators in new equipment



FO-1L

FO-1L 100 KC OSCILLATOR

Printed circuit oscillator for band-edge calibrator and frequency standard use.

Kit, complete with tube & crystal..... \$12⁹⁵
Wired & tested..... \$15⁹⁵

Additional requirements:
Power 6.3 volts AC @ 150 ma
150 volts DC @ 8 ma



For crystal prices consult table below:



FMV-1

FMV-1 10 KC Multivibrator (for use with FO-1L 100 KC Oscillator)

Used in conjunction with the FO-1L 100 KC Oscillator to form a complete secondary frequency standard. When the FO-1L 100 KC Oscillator is accurately tuned to zero beat with WWV transmissions, precise frequency measurements to 30 MC can be made.

Kit, less tube \$5⁹⁵

Wired & tested, with tube..... \$8⁹⁵

Additional Requirements:
Tube—12AT7
Power—6.3 Volts AC @ 300 ma
150 Volts DC @ 15 ma

FX-1 CRYSTAL FOR USE WITH FO-1 OSCILLATORS

The FX-1 Crystal is designed for use only with the FO-1 Oscillator. For tolerances of .01% and .005%, any FX-1 Crystal can be used with any FO-1 Oscillator.

For tolerances closer than .005% the Oscillator and Crystal must be purchased together. The Oscillator is factory wired and the crystal custom calibrated for the specific oscillator.

TOLERANCE	200-499 KC	500-999 KC	1000-1499 KC	1500-1999 KC	2000-9999 KC	10,000-15,000 KC	15 MC-29.9 MC	30 MC-60MC
.01%	\$ 8.75	\$12.50	\$ 5.25	\$ 3.75	\$ 2.50	\$ 3.25	\$ 3.00	\$ 4.00
.005%	\$12.50	\$15.00	\$ 6.00	\$ 4.50	\$ 3.00	\$ 4.00	\$ 5.00	\$ 6.50
(.0025% and .001% tolerances are available only by purchasing the FO-1 Oscillator and Crystal together)								
.0025%	\$17.50*	\$17.50*	\$ 6.75*	\$ 5.25*	\$ 3.75*	\$ 4.75*	\$ 6.50*	\$ 8.50*
.001%	\$25.00*	\$25.00*	\$ 8.00*	\$ 6.50*	\$ 5.00*	\$ 6.00*	\$10.00*	\$15.00*

*Prices are for crystal only. To insure tolerances closer than .005% crystal must be purchased with oscillator factory wired and tested. For total price add \$6.95 to price of crystal desired.

International CRYSTAL Mfg. Co., Inc. 18 N. Lee Phone FO 5-1165
OKLAHOMA CITY, OKLA.

International CRYSTAL PRINTED CIRCUITS

IVC-1 CRYSTAL CONTROLLED CONVERTER



for 6 METERS and 2 METERS

- Compact • No alignment necessary
- Simple to assemble • Output IF frequency can be changed by merely changing the crystal (crystal range of 40 MC to 50 MC).

Kit (with crystal less tubes) \$10⁹⁵

Complete, wired & tested, with tubes & crystals \$15⁹⁵

Frequency Range:

6 Meters: 50-54 MC
2 Meters: 144-148 MC

Sensitivity 1 microvolt or better
*Specify IF when ordering.

Output IF* (1) 600 KC to 1500 KC
(2) 7 MC to 11 MC

(3) Special—write for information
Plate Power 150 volts to 250 volts
DC @ 15 ma to 20 ma

Heater Power 6.3 volts @ 60 ma
Tubes 6AK5 RF Amplifier
6J6 Mixer Oscillator
Size (overall) 4"x3½"x3½"
Weight 3 ounces

FO-6 OSCILLATOR ASSEMBLY

for 6 METER and 2 METER

achieve **STABLE CRYSTAL CONTROL**
with High Frequency Crystals

6U8 Tube

Crystal Oscillator Range

48 MC to 54 MC

Output 50-54 MC or 144-148 MC

(Specify when ordering)

Crystal Required — 3rd Overtone FA-5

Plate Voltage — 250 volts @ 20 ma

Filament Voltage — 6.3 volts @ 450 ma

Size — 2"x2½"

Midget 6 Meter Transmitter — Provisions are made for separate B+ connections to the buffer stage for modulation.

Driver Unit for a higher power 6 meter transmitter. Will work into 5763 tube which will provide ample drive for a 6146 final. For 2 meter operation the unit can operate straight through on 48 MC and drive a 5763 tube as a tripler.

Receiver Local Oscillator for 2 Meters. By using the pentode section of the FO-6 as a tripler, this unit will provide injection voltage for 2 meter converters.



Kit (less tube & crystal)..... \$5⁹⁵

Wired & Tested with tube (less crystal)..... \$9⁹⁵

C-12 ALIGNMENT OSCILLATOR

For Connecting Standard Signals in Alignment of IF and RF Circuits.
12 MOST USED FREQUENCIES INSTANTLY AVAILABLE!



The Model C-12 Test Oscillator has 11 internal crystal positions and 1 external, enabling a number of different crystals to be included in one unit for quick selection. Accommodates FX-1 crystals from 200 KC to 15,000 KC. Built-in Attenuator has both coarse and fine controls. A compact, self-contained unit complete with power supply.

Oscillator (less Crystals) ... \$49⁵⁰

200 KC to 15,000 KC Range
For Crystals see FX-1

(External Crystal Socket accommodates crystals having .093 pin diameter and .486 pin spacing. International Types F-609 or FA-5).

RC-100 TRANSMITTER UNIT

Kit Form, includes tube & Crystal, less batteries..... \$9⁹⁵

Wired & Tested, less batteries..... \$13⁹⁵

For Model Radio Control Use

Measuring 3½"x4", the Model RC-100 Transmitter Unit is designed for coupling maximum power into the antenna to obtain LONGER RANGE of model control. With Snap-On connections, uses 3A5 tube in oscillator-multiplier circuit.

THE MOST ECONOMICAL QUALITY TRANSMITTER ON THE MARKET!

Crystal controlled at 27,255 MC. Low price kit, easily assembled, complete instructions.

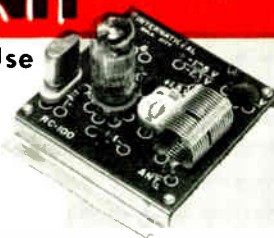

ORDER BY MAIL: Postage will be prepaid when cash accompanies the order. Otherwise shipments are C.O.D.

FO-100 TRANSMITTER UNIT

Similar to RC-100 except for output in 50-54 range.

Kit Form, with tube, less crystal & batteries... \$7⁹⁵

Wired & Tested, less crystal & batteries..... \$10⁹⁵

Uses FA-5 crystal in 25 MC range.

International/CRYSTAL Mfg. Co., Inc. 18 N. Lee - Phone FO 5-1165 OKLAHOMA CITY, OKLA.

HEATHKITS®

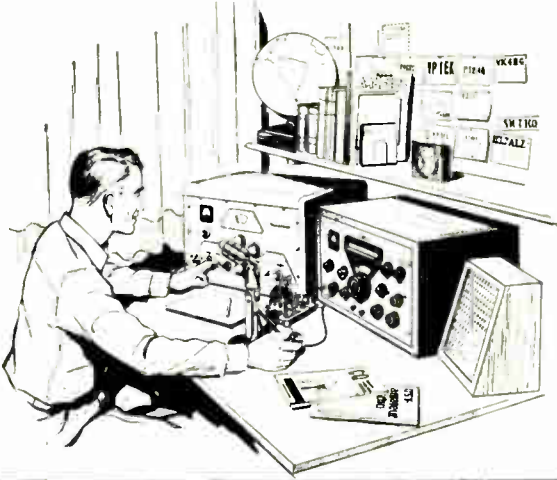

*The world's fine
ham equipment
in kit form . . .
designed especially to
meet your requirements!*

Heath amateur radio gear is designed by hams—for hams, to insure maximum "on the air" enjoyment. Good design and top-quality components guarantee reliability. Heathkits are easy to build and are easy on your budget! You save by dealing direct, and you may use the Heath Time Payment Plan on orders totaling \$90.00 or more. Write for complete details.

HEATHKIT

DX-100

TRANSMITTER KIT

PHONE
AND CW

- ▶ *Phone or CW—160 through 10 meters.*
- ▶ *100 watts RF on phone—120 watts CW—parallel 6146 final.*
- ▶ *Built-in VFO—pi network output circuit.*
- ▶ *Easy to build—TVI suppressed*



MODEL DX-100

\$189⁵⁰

\$18.95 dwn., \$15.92 mo.
Shpg. Wt. 107 Lbs.

Shipped motor freight unless
otherwise specified.
\$50.00 deposit required
on c.o.d. orders.

The Heathkit DX-100 phone-CW transmitter offers features far beyond those normally received at this price level. It has a built-in VFO, built-in modulator, and built-in power supplies. It is TVI suppressed, and uses pi network interstage coupling and output coupling. Matches antenna impedances from approximately 50 to 600 ohms. Provides a clean strong signal on either phone or CW, with RF output in excess of 100 watts on phone, and 120 watts on CW. Completely bandswitching from 160 through 10 meters. A pair of 1625 tubes are used in push-pull for the modulator, and the final consists of a pair of 6146 tubes in parallel. VFO dial and meter face are illuminated. High-quality components throughout! The DX-100 is very easy to build, even for a beginner, and is a proven, trouble-free rig that will insure many hours of enjoyment in your ham shack.



HEATH COMPANY BENTON HARBOR 9, MICHIGAN

A Subsidiary of Daystrom, Inc.

HEATHKIT **DX-35** TRANSMITTER KIT

PHONE AND CW

This transmitter features a 6146 final amplifier to provide 65 watt plate power input on CW, with controlled-carrier modulation peaks up to 50 watts on phone. Modulator and power supplies are built in, and the rig covers 80, 40, 20, 15, 11 and 10 meters with a single band-change switch. Pi network output coupling provides for matching various antenna impedances. Employs 12BY7 oscillator, 12BY7 buffer and 6146 final. Speech amplifier is a 12AX7, and a 12AU7 is employed as modulator. Panel control provides switch selection of three different crystals, reached through access door at rear. Panel meter indicates final grid current or final plate current. A perfect low-power transmitter both for the novice or the more experienced amateur. A remarkable power package for the price. The price includes tubes, and all other parts necessary for construction. Comprehensive instruction manual insures successful assembly.



MODEL DX-35

\$56⁹⁵

Shpg. Wt.
24 Lbs.

\$5.70 dwn., \$4.78 mo.

- ▶ Phone or CW—80 through 10 meters.
- ▶ 65 watts CW—50 watts peak on phone—6146 final amplifier.
- ▶ Pi network output to match various antenna impedances.
- ▶ Tremendous dollar value—easy to build.

BRAND NEW

HEATHKIT **DX-20** CW TRANSMITTER KIT



MODEL DX-20

\$35⁹⁵

\$3.60 dwn., \$3.02 mo.

Shpg. Wt. 18 Lbs.

- ▶ Designed exclusively for CW work.
- ▶ 50 watts plate power input—80 through 10 meters.
- ▶ Pi network output circuit to match various antenna impedances.
- ▶ Attractive and functional styling—easy to build.

Here is a straight-CW transmitter that is one of the most efficient rigs available today. It is ideal for the novice, and even for the advanced-class CW operator. This 50 watt transmitter employs a 6DQ6A final amplifier, a 6CL6 oscillator, a 5U4GB rectifier and features one-knob bandswitching to cover 80, 40, 20, 15, 11 and 10 meters. It is designed for crystal excitation, but may be excited by an external VFO. A pi network output circuit is employed to match antenna impedances between 50 and 1000 ohms. Employs top-quality parts throughout, including "potted" transformers, etc. If you appreciate a good signal on the CW bands, this is the transmitter for you!



HEATH COMPANY BENTON HARBOR 9, MICHIGAN

A Subsidiary of Daystrom, Inc.

HEATHKIT

COMMUNICATIONS-TYPE, ALL BAND

RECEIVER KIT

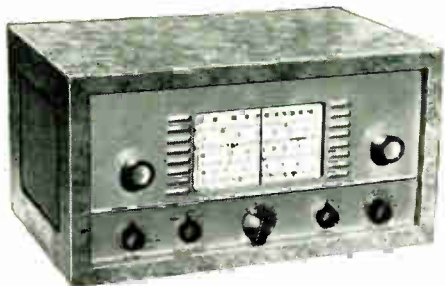

This receiver covers 550 kc to 30 mc in four bands, and is ideal for the short wave listener or beginning amateur. It provides good sensitivity and selectivity, combined with fine image rejection. Amateur bands are clearly marked on the illuminated dial scale. Features transformer-type power supply—electrical band spread—antenna trimmer—separate RF and AF gain controls—noise limiter—headphone jack—and AGC. Has built-in BFO for CW reception.

MODEL AR-3

\$29⁹⁵

incl. excise tax
(less cabinet)

\$3.00 dwn., \$2.52 mo.

Shpg. Wt. 12 Lbs.

CABINET: Fabric covered cabinet with aluminum panel as shown. Part 91-15A. Shipping Wt. 5 Lbs. \$3.50 dwn., \$4.95

A HEATHKIT VFO KIT MODEL VF-1

Covers 160, 80, 40, 20, 15, 11 and 10 meters with three basic oscillator frequencies. Better than 10 volt average RF output on fundamentals. Requires 250 VDC at 15 to 20 ma, and 6.3 VAC at 0.45A. Incorporates regulator tube for stability and illuminated frequency dial. Shpg. wt. 7 lbs. \$1.95 dwn., \$1.64 mo. **\$19.50**

B HEATHKIT GRID DIP METER KIT MODEL GD-1B

Continuous coverage from 2 mc to 250 mc with prewound coils. 500 ua panel meter for indication. Use to locate parasitics, for neutralizing, determining resonant frequencies, etc. Will double as absorption-type wavemeter. Shpg. wt. 4 lbs. \$2.00 dwn., \$1.68 mo. **\$19.95**

C HEATHKIT ANTENNA IMPEDANCE METER KIT MODEL AM-1

The AM-1 covers 0 to 600 ohms for RF tests. Functions up to 150 mc. Used in conjunction with a signal source, will determine antenna resistance and resonance, match transmission lines for minimum SWR, determine input impedance, etc. Shpg. wt. 2 lbs. \$1.45 dwn., \$1.22 mo. **\$14.50**

D HEATHKIT "Q" MULTIPLIER KIT MODEL QF-1

Functions with any receiver having IF frequency between 450 and 460 kc that is not AC DC type. Operates from receiver power supply, requiring only 6.3 volts AC at 300 ma (or 12.6 vac at 150 ma), and 150 to 250 vdc at 2 ma. Simple to connect with cable and plugs supplied. Provides extra selectivity for separating signals, or will reject one signal to eliminate heterodyne. Effective Q of approximately 4000. Shpg. wt. 3 lbs. \$1.00 dwn., \$.84 mo. **\$9.95**



HOW TO ORDER...

It's simple—just identify the kit you desire by its model number and send your order to the address listed below. Or, if you would rather budget your purchase, send for details of the Heath Time Payment Plan for orders totaling \$90.00 or more.



HEATH COMPANY BENTON HARBOR 9, MICHIGAN

A Subsidiary of Daystrom, Inc.



In building, modifying or repairing ham equipment, it pays to select resistors and related components from the IRC line. As the largest manufacturer of resistance units, IRC offers more types . . . more sizes . . . and a wide choice of terminals. You're bound to find the unit that meets your circuit, space, and terminal requirements at a reasonable price. With IRC components, you also receive exceptional uniformity and stability of performance . . . extras made possible by the most advanced component engineering in the industry.

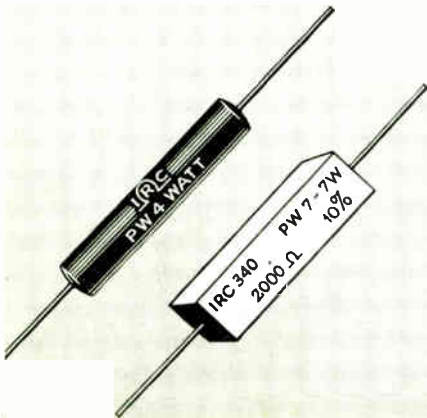

Components

to make our waves behave

RESISTORS

Fixed Composition Resistors



Type BT resistors are preferred by electronic designers as the basic resistor for most circuits. They are compact and low in cost, yet they provide good stability and frequency characteristics. Low operating temperature and excellent power dissipation are other features. Element is fully insulated and protected by molded housing. $\frac{1}{8}$, $\frac{1}{2}$, 1 and 2 watt ratings (40° C. ambient). Resistance values from 10 ohms to 22 megohms. $\pm 5\%$ or 10% tolerance. SEND FOR CATALOG B-1.

Low Power Wire Wound Resistors

Type BW resistors provide exceptional stability over the lower resistance ranges. The wire element is automatically wound on an insulated core, and completely enclosed by a compact molded housing. Operating temperature is unusually low for a wire wound unit. Overloads have little permanent effect upon the resistance value. $\frac{1}{2}$, 1 and 2 watt ratings. Values from 0.24 to 8200 ohms. $\pm 5\%$ or 10% tolerance. FULL DETAILS IN CATALOG B-5.

Medium Power Wire Wound Resistors

Conservatively rated, Type PW wire wound resistors can be operated continuously at full rated power. In addition, they are completely insulated and protected, have axial leads for easier installation, and are clearly and permanently identified. The PW-4 is a four-watt type with molded housing. The PW-7 and PW-10, rated at 7 and 10 watts respectively, are high temperature resistors with a rectangular ceramic case. Resistance values from 1 to 25,000 ohms. $\pm 10\%$ tolerance. ASK FOR CATALOGS P-1 & P-2.



High Power Wire Wound Resistors

IRC's tubular power resistors are accepted everywhere as the standard in high power circuit applications. The resistance element is uniformly wound on a strong ceramic core, and insulated by an exclusive IRC coating. This coating gives maximum heat dissipation and utmost protection from environmental conditions. To meet varied requirements, the resistors are available in fixed and adjustable types . . . with mounting lug, soldering lug, or wire lead terminals . . . in 10, 25, 50, 80, 100 and 200 watt ratings. Resistance values from 1 to as high as 100,000 ohms. WRITE FOR CATALOG C-1



Deposited Carbon Resistors

The combination of 1% accuracy, stability, and economy make Type DC resistors a logical choice for precision circuit applications. These compact units offer excellent load and long-time stability. At the same time, extremely low inductive and capacitive effects make them ideally suited for high frequency applications. Packed in protective plastic tubes. 1/2, 1 and 2 watt ratings. Resistance values from 10 ohms to 100 megohms. REQUEST CATALOG B-4.

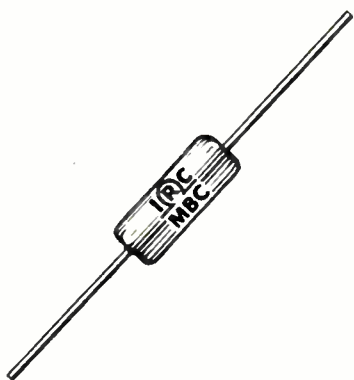

Molded Boron Carbon Resistors

The Type MBC resistor offers many features in addition to 1% accuracy, high stability on load, and excellent HF characteristics. For example, it provides unusual stability of resistance under varying temperature conditions. Furthermore, it has a molded housing which improves load life characteristics by permitting increased heat dissipation. This same housing also minimizes moisture effects and protects the resistor from mechanical damage. Rated at 1/2 watt, the Type MBC is available in values from 10 to 510,000 ohms. DESCRIBED IN CATALOG B-8.



Precision Wire Wound Resistors

The exceptional stability and relatively low inductance of Type WWJ resistors is a direct product of IRC's advanced winding techniques. The element is automatically wound under uniform tension to eliminate "shorted turns" and strains. In addition, the element is impregnated by a special insulating compound which minimizes the effects of temperature changes. Type WWJ resistors include lug and lead terminal types. Resistance values from 0.1 ohm to 2.5 megohms. $\pm 1\%$ tolerance standard. SEND FOR CATALOG D-1.

CONTROLS

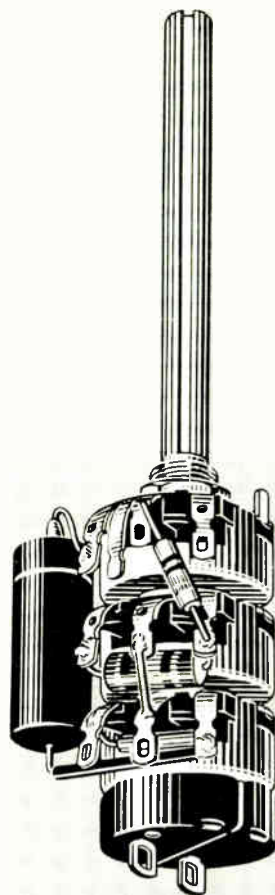
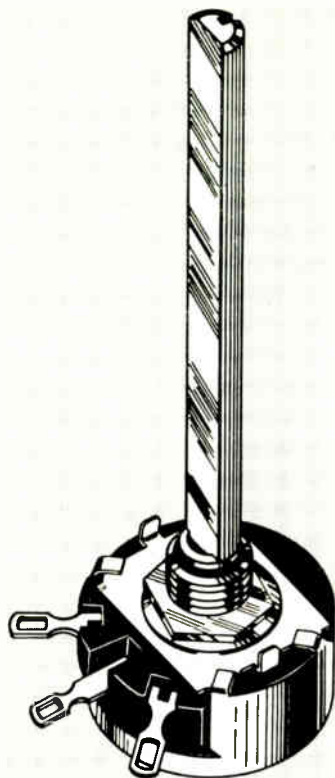
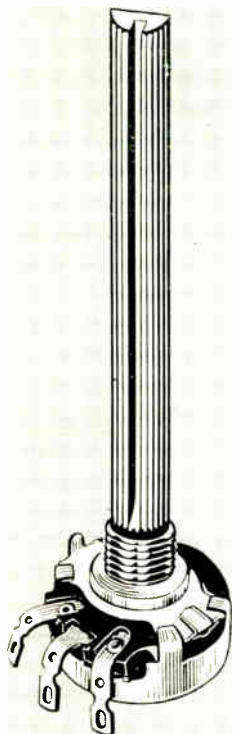

Type Q Volume Controls

IRC Type Q carbon control is extremely popular because of its "cushioned" turn, its compact size, and quality construction. To meet mounting requirements, it is available with a Universal Knob Master Shaft or any one of 16 other fixed shafts. To meet electrical requirements, it can be supplied plain or tapped, in 103 resistance values, and with 7 standard tapers. The versatile Type Q can also be supplied with IRC power switches or made into dual, triple, or tab mount controls. SEND FOR CATALOG DLR-56.

Universal Wire Wound Controls

With IRC's new universal controls, it now takes only one compact unit to handle all requirements from 2 to 4 watts. This improved design also offers a greater range of resistance values—56 in all, from 10 to 25,000 ohms. The Type WPK, a plain control, has a 3" long Knob Master Shaft to fit all knobs. The Type WPS, available either plain or tapped, has a $\frac{3}{4}$ " long slotted and knurled shaft. Both offer a choice of 3 standard tapers, and can be supplied with IRC switches. Multisections can be added to make dual or triple controls. WRITE FOR CATALOG DLR-56.

Type LC-1 Loudness Control

This continuously compensated control boosts lows and highs as volume is decreased—maintains depth and brilliance even at whisper level. The Type LC-1 eliminates makeshift compensating units with all their limitations. It automatically maintains proper balance of all frequencies in the audio spectrum at any listening level. Simplicity itself—as easy to wire into an audio circuit as any standard three-terminal volume control. IRC switches can be added. SEE CATALOG DLR-56.

Other Products

MICROSTAK Selenium Diodes

Type GA diodes are the best way to obtain very high back resistance and low forward resistance in low current circuits. Because of special IRC production techniques, their miniature cells are extremely uniform. These cells make possible a diode of small size, yet provide the unit area characteristics of larger high grade plates. In addition, the diodes are hermetically sealed. All these factors make Type GA diodes ideal for many applications, including high frequency circuits up to 1 megacycle. REQUEST CATALOG SR-1.

Insulated Chokes

Type CL chokes are available in four sizes and dozens of characteristic combinations to meet a wide variety of space and electrical requirements. The winding is completely enclosed and fully insulated by a compact molded housing. This housing protects them from humidity, abrasion, and physical damage. It also prevents any possibility of "shorting" to chassis. All Type CL chokes are color coded for easy identification. They cover a range of inductance from .22 to 39 microhenrys. FULL DETAILS IN CATALOG H-1.

Tension-Grip Nut Drivers

The popular IRC nut driver ends slipping and dropping without the obvious disadvantage of magnetic action. A special steel band holds hex nuts or screws in a vise-like grip. This permits holding and driving in one operation... or automatic removal without dropping. Nut driver shaft is drilled to a depth of 1 1/4". Handle is made of a special shockproof plastic. Six socket sizes available: 1/4", 3/8", 1/2", 5/8", 3/4" and 1". SEE CATALOG DLR-56.

FOR COMPLETE INFORMATION

You can buy any of the products described here or get full details from your local IRC distributor. Or write to IRC for informative bulletins.

IRC Also Manufactures...

molded deposited carbon resistors • unmolded boron carbon resistors • high voltage resistors • high frequency resistors • voltmeter multipliers • encapsulated precision wire wound resistors • resistance strips & discs • hermetic sealing terminals

Wherever the Circuit Says



INTERNATIONAL RESISTANCE CO

Dept. 44, 401 N. Broad St., Philadelphia 8, Pa.
In Canada: International Resistance Co., Ltd., Toronto, Licensee

FOR **RAPID DISCONNECT**

IN RADIO • SOUND • TV AND RELATED FIELDS USE

Multi-Contact
Electric Connectors

TOP QUALITY
CANNON PLUGS

MIL-SPEC

AN is the prefix for Military Specification electric connector assemblies. Reasonably priced because of extensive tooling and world-wide demand. Light weight shells. Interchangeable inserts.



AN Series

260 different insert layouts. 15 diameters, 6 shell styles, 22 to 245 amp. contacts. Thermocouple and coaxial contacts available. Cable clamps, conduit fittings, telescoping bushings, junction shells, dust caps, dummy receptacles, potting kits. Majority of assemblies available from shelf stock.

HIGH-TEMPERATURE... FOR AIRCRAFT AND INDUSTRIAL USE. Firewall connectors in standard steel shell varieties and insert combinations. Maintain circuitry for 5 minutes at 2000 F.

VIBRATIONPROOF-MOISTUREPROOF APPLICATIONS. With resilient inserts, interfacial sealing.

HERMETICALLY SEALED APPLICATIONS. Steel shells, glass-fused inserts. Standard, miniature, and sub-miniature sizes. For control, relay, power, instrument applications.

PRESSURIZED APPLICATIONS. AN-C pressurized for 30 psi. Cannon K's, pressurized. Wide variety for different conditions.

Also, heavy-duty watertight units; external power plugs and receptacles; high-voltage types; special breakaway designs.

MINIATURES

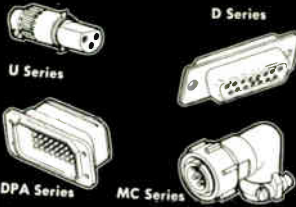

Cannon miniatures and sub-miniatures are designed for amplifiers, miniature indicators, computer circuits, telemetering equipment, small pre-amps, and general instrumentation where space is limited and current requirements are generally not over 5 amperes. Variety of shell styles, junction shell, and insert arrangements. 3 to 50 contacts, plus coaxials.

UNIT PLUG-IN'S

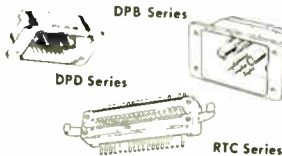

for RACK / PANEL / CHASSIS

Permit quick disconnect, interchange, replacement, testing and inspection of assemblies and sub-assemblies. For transmitters, TV cameras, control equipment, radar, etc. Rack-and-panel, integral clamp, shell-less types, bail-and-gear disconnects, center-screw extraction. 10 to 156 contacts including high voltage.

Printed circuit connectors in 5 sizes, 10 to 44 gold-plated contacts, Zytel shells.

AUDIO

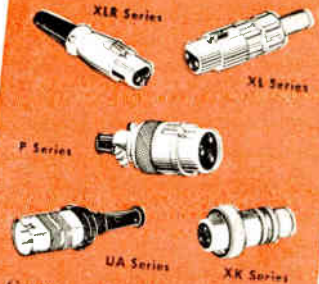

Cannon audio connectors give you the highest quality... in the greatest variety to meet your every need. Standard on leading microphones. Straight, angle 90°, oval; wall-mounting, panel, locknut mounting, adapter receptacles, single and two-gang receptacles; latch-lock, 5-to-30-amp. contacts, coaxials.

INFORMATION AVAILABLE

Ask for Literature
by Application

Cannon also makes plugs for switching and patching, test point jacks, external power connectors, missile launching connectors, buffer connectors, cable terminals, dc solenoids.

PLEASE REFER TO DEPT. 138

CANNON PLUGS



Cannon Electric Co., 3208 Humboldt St., Los Angeles 31 Calif.
Factories in Los Angeles; East Haven, Toronto, Can.; London, Eng.;
Melbourne, Australia. Licensees in Paris, France; Tokyo, Japan.

Cannon Connectors are available from
more than 1000 audio-industrial-electrical
distributors from coast to coast

PRESENTING THE GREAT

World Radio **LINE!**



- ✓ **Completely Bandswitching**
- ✓ **Covers 160-10M**
- ✓ **540 Watts on CW, Fone & SSB (P.E.P.)***
- ✓ **Built-In VFO**



THE WRL GLOBE KING 500B

You Pay Only \$69.90 Down
Cash Price: \$699.00

ONLY \$38¹⁰ PER MO.

- ★ Pi-Network matches most antennas from 52-500 ohms
- ★ Electronic Grid-Block keying for maximum clarity of signal (time sequence operation)
- ★ New audio compression circuit holds modulation at high level without usual clipping distortion
- ★ RF Section enclosed with complete shielding for TVI-Suppression
- ★ Special Exterior air ventilating system
- ★ Separate power supply for Modulator, allowing better overall voltage regulation
- ★ Many other top features, including 500 ohm input, push-to-talk, built-in antenna changeover relay, etc.

THE GLOBE KING AUDIO SPEAKS FOR ITSELF!

*with external exciter

THE WRL



ONLY \$24⁴⁷ PER MO.

Pay Only \$44.90 Down
Cash Price: \$449.00

KIT FORM:

Only \$19.02 Per Mo.
Pay \$34.90 Down
Cash Price: \$349.00

GLOBE CHAMPION 300

Completely Bandswitching, 160-10M.

- ★ Built-in VFO, push-to-talk, and antenna changeover relay
- ★ Improved Time-Sequence (grid-block) Keying
- ★ Pi-Network Output circuit, 48-700 ohms
- ★ Extensively TVI-shielded, filtered and bypassed
- ★ High level Class "B" Modulation with splatter suppression; new audio compression circuit holds modulation at high level without usual clipping distortion
- ★ Ready to go on SSB, with any external Exciter
- ★ 350 watts CW, 275 watts fone, and 300 watts on SSB (P.E.P.)*
- ★ Provisions for power reduction to 75 watts for Nuvee use
- ★ Two new Amperex 9909 Final tubes (1000 volts on plates) allow 33 $\frac{1}{3}$ % safety factor

*with external exciter

FREE WRL 1957 CATALOG!

Here's a big catalog chock full of bargain items for the ham, experimenter, hi-fi fan, and electronics enthusiast. More than 10,000 top quality items. Contains complete information on E-2 Pay Plan.

**SEND FOR YOUR COPY TODAY!
SEE YOUR NEAREST WRL DEALER!**



World Radio Laboratories

34th & Broadway
Council Bluffs,
Iowa

WRL'S GLOBE SCOUT 65B



65 WATTS CW . . . 55 WATTS FONE

- ★ Completely bandswitching, 160-10M
- ★ Low cost, high quality, new cabinet restyling
- ★ Popular high level modulation (plate modulated)
- ★ Pi-Network antenna tuner (matches most antennas from 52-600 ohms)
- ★ Built-in power supply
- ★ Full modulation of Final
- ★ Compact; may be adapted for mobile operation
- ★ TVI-shielded cabinet

ONLY
\$795

PER MO.

Pay Only \$10.00 Down
Cash Price: \$99.95
KIT FORM: \$9.00 Down
Only \$7.16 Per Mo.;
Cash Price: \$89.95

WRL'S GLOBE CHIEF KIT Model 90



90 Watt Xmtrr.; — 75 Watts for
Novice Use

POWER SUPPLY INCLUDED!

- ★ Completely bandswitching, 160-10M
- ★ Built-in power supply, well-filtered
- ★ Pi-Network matches most antennas, 52-600 ohms
- ★ Modified Grid-Block keying for maximum safety
- ★ Provisions for VFO input and operation
- ★ Meter and cabinet fully shielded for TVI reduction
- ★ Easy to assemble! Kit contains complete simplified manual, pre-punched chassis, and all parts with wires pre-cut and pre-tinned
- ★ Scale indication shows legal maximum of 75 watts for Novice use

ONLY
\$500

PER MO.

Pay Only \$5.00 Down
Cash Price: \$49.95
COMPLETELY WIRED:
Only \$5.17 Per Mo.; \$6.50 Down
Cash Price: \$64.95

WRL'S SCREEN MODULATOR KIT

(with printed circuit)

Designed specifically for use with WRL Globe Chief; may be used with other Xmtrrs. such as Heath AT-1, Johnson Adventurer, Knight 50 watt, etc. Permits radio-foam operation of CW Xmtrr. at minimum cost. Self contained. All connections to Xmtrr. included. Completely detailed instruction manual for simplified assembly.



ONLY \$13.95



WRL'S CONELRAD KIT

(with printed circuit)

As of January 2, 1957, each radio amateur must have some means of determining when a Conelrad Alert is in force! Here's a new, completely automatic device for turning off your Xmtrr. under Alert Conditions. Fail-Safe!

\$22.50

Completely Wired: \$29.50

WRL'S STANDING WAVE RATIO BRIDGE

Wired and tested. Designed for 52 ohms (furnished for 72 ohms when requested). High power, handling up to 800 watts fone, 1000 watts CW input when line has low standing wave ratio. May be used with any VOM, VTVM, Microammeter or (recommended) 0-1 Milliammeter. Accurate well past 30 Megacycles.



ONLY \$16.95



WRL'S TRANSISTOR CODE OSCILLATOR

(with printed circuit)

Utilizes printed circuit for ease in assembly. Pleasant audio tone. Screw terminal input for key; output jacks receive standard phone tips. Complete with two pen cell batteries and detailed assembly instructions. Grey hammerstone cabinet: 15x4x4. Shp. wt.: 1 lb.

\$3.95

WRL'S 6 METER CONVERTER

Compact, highly stable, crystal-controlled, guaranteed for top performance with any receiver capable of tuning output frequencies 10-14 mc. Any 4 mc. band of frequencies within range of 7-35 mc. available on special order for \$10.00 additional, on Wired Model only. Has cascade RF stage, bandpass coupling, shielded input and output.



ONLY \$24.95
KIT: \$16.95



WRL'S MODEL 755 VFO

Completely bandswitching, calibrated on 100, 80, 40, 20, 15, 11 and 10M; output on 160 and 40M. Complete with built-in power supply. Calibrate switch for zero beating signal frequencies or tuning to desired frequency without turning Xmtrr. on. Temperature compensated; approx. 100 RF volts output; plugs directly into crystal socket of Xmtrr. Compact.

ONLY \$59.95 \$6.00 Down — \$5.00 per mo.
KIT: \$49.95 \$5.00 Down — \$5.00 per mo.

HERE THEY ARE; — THE NEW WRL Wonder Beams . . .

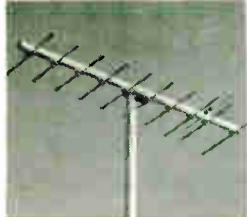

2M, 10 ELEMENT
Only \$995



6M, 5 ELEMENT
Only \$1495

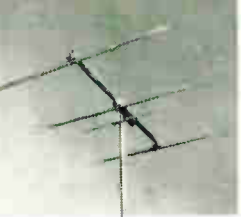

10M, 3 ELEMENT
Only \$1995



20M, 3 ELEMENT
Only \$4995



15M, 3 ELEMENT
Only \$2995

Shown above are just four of the new Globe Spanner Beams. Also available: — 2 M, 5 Element (\$7.95); 15 M, 3 Element (\$27.95); M Spannette (\$54.95), and 5 Band Variable Doublet (\$24.50), or Individual Doublet Coils at \$12.50 per pair. All Globe Spanners are guaranteed for top construction, top performance, and lowest cost. Send for detailed brochure today!



LOOK AT THESE FEATURES!

The 10, 15 and 20M Spanners, and all Triple Globe Spanners have this specially designed "carpet beater" end of aluminum wire to reduce fatigue caused by vibration and increase the broad band characteristics.

Ruggedly designed Boom/Mast clamp with 4-way U-bolt 12 GA galvanized steel channel for positive grip. Also used as Element/-Boom clamps in the 15 and 20M Spanners, the Spannette and the Triple Spanner Series.

10, 15 & 20M beams include this carefully designed dipole, combination T or gamma match for any line balanced or coax 52-450 ohms. Insulation is molded polyethylene and cycloac; matching unit is factory pre-assembled.

THE TRIPLE SPANNERS

2-ELEMENT TRI-BAND: For the ham with limited space, wishing top transmission on 10, 15 and 20 meters without stacking beams. Maximum gain in minimum space. Single transmission line. Spacing, .1 reflector on 20M. Pay only \$6.00 per mo.

3-ELEMENT TRI-BAND: The performance standard of all tri-band antennas in the ham field. Spacing, .15 director, .1 reflector on 20M. Single transmission line. All Triple Spanners factory pre-tuned, pre-matched and pre-adjusted. \$8.00 per mo.

5-ELEMENT TRI-BAND: Champion of beams, the best plus a little extra. All heavy duty construction. 2x3" rectangular aluminum boom. Spacing, .1 all reflectors and directors. Outperforms any beam in its class, bar none. Only \$19.50 per mo.



Only \$6950

Only \$9975

Only \$34950

Amateur Band	Model Number	Description	Gain in DB Over Dipole	F/B Ratio in DB	Horizontal Beam Width	Boom Length	Boom Diameter	Element Diameter	Element Wall	Element Alloy	Max. Mast Diameter	Longest Element	Approx. Net Wt.
10, 15, 20 METER BANDS (Triple Globe Spanners)	152T-2	2 Elem.	5.6 Av.	14 Av.	68°	90"	1 1/2"	1 1/8, 1 1/8, 3/8, 3/8"	.058 .049 .035	6061S16 Ant 41	1 1/2"	29'	36#
	152T-3	3 Elem.	8 Av.	20 Av.	59°	216"	1 1/2"	"	"	"	1 1/2"	30.7'	58#
	152T-5	5 Elem.	12 Av.	22 Av.	54°	36 ft.	2 x 3 Rect.	1 1/8, 1 1/8, 3/8, 3/8"	"	"	2"	30.7'	96#

WRL'S NEW Roto Brake

FOR THE 1ST TIME
AN EFFICIENT BRAKE
at an
Unbelievably
LOW COST!

A spring-actuated, solenoid released braking unit, mounting between the rotator and antenna (in most cases, without taking antenna down). Performs two basic functions; — provides positive braking action and thrust and radial bearing surfaces to convert any TV or other type rotator to the finest ham antenna rotating assembly available.

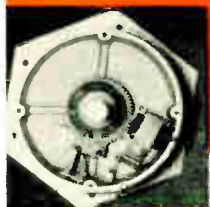

Customary photo of positive gear and mesh braking action. Prevents coasting and damage to rotator. Brake will support 150 lbs. of antennas against 5000 inch.-lbs. of torque, yet is released automatically when rotator is energized.

Photo shows RotoBrake mounted internally in tower at least 10" in diameter. Adapter kits are available for mounting Brake on masts up to 2" in diameter, towers less than 10" in diameter, and telephone-type poles. The RotoBrake is extremely easy to adapt to all of the above mountings, and may be put into operation within a very short time. Write immediately for complete

Tiger on WRL's new RotoBrake, showing full details and ordering instructions.

ONLY \$5⁹³ PER MO.

Just \$7.45 Down
Cash Price: \$74.50

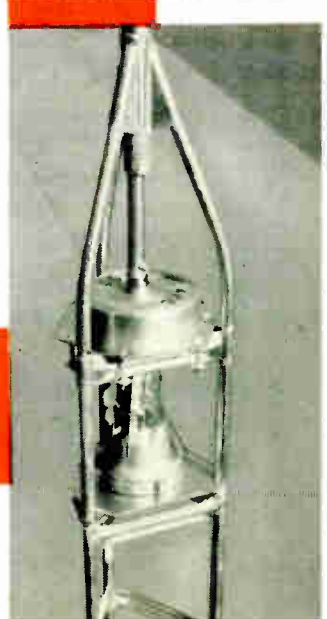

YOUR BEST BUYS...

HQ-100

Q-multiplier for continuously variable selectivity. Electrical bandspread tuning. 10-tube superheterodyne with noise limiter. Auto-response circuit for finest fidelity under all conditions. Optional Telechron Timer. Completely voltage regulated and temperature compensated. Continuously tunable from 540 KCS to 30 MCS.



\$16900
(Timer \$10 extra)

HQ-140-XA

New, smooth-as-silk tuning. Crystal filter for extreme selectivity. Electrical bandspread tuning. Extremely high signal-to-noise ratio. Positive noise limiter. Full 2-watt undistorted output. Continuously tunable from 540 KCS to 30 MCS with adequate selectivity to separate crowded signals.

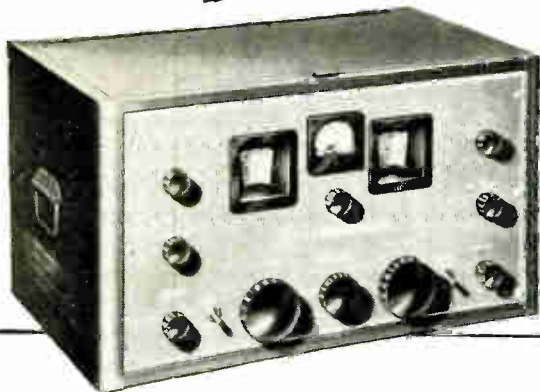

\$24900

HQ-150

A really different receiver. Combines Q-multiplier with crystal filter to provide the widest range of tuning techniques. Extra fine superheterodyne circuit with full noise limiter. Full 2-watt output. New, improved S meter with illuminated scale. Built-in crystal calibrator.



\$29400



Established 1910

See these Outstanding Buys at your Hammarlund Dealer,
or write for literature on all three . . . Bulletin HB57
Hammarlund Manufacturing Company, Inc.,
460 West 34th Street, New York 1, N. Y.
International Division; 13 East 40th Street, New York 16, N. Y.

HAMMARLUND SETS THE PACE

ALLIED RADIO
100 N. WESTERN AVENUE • CHICAGO 80, ILL.
Telephone MAymarket 1-6800

Everything in Electronics

OUR 36TH YEAR



CATALOG
NO. 160
1957

IMAGE ON
PAGE 100

the most widely used
buying guide to
everything in Electronics
KEEP IT HANDY

ALLIED gives you every buying advantage

HIGHEST TRADES: get the absolute top trade on your old equipment at ALLIED. Tell us what you've got and what you want—we'll come up with the best deal anywhere.

Reconditioned Gear—large selection, new set guarantee. Ask for latest list—lowest prices on top reconditioned equipment.

LARGEST STOCKS: get *everything* from our largest stocks of Amateur Gear and industrial electronic supplies—all the nationally-known dependable lines.

EASY-PAY TERMS: only 10% down, or your trade-in as down payment (pay in 60 days and get full carrying charge refund). Use our money-saving easy-pay plan. Extra: 15-day trial on all receivers.

HAM-TO-HAM HELP: our staff of 35 Amateurs goes all-out to give you the straight dope you want. You'll like the kind of personal attention Amateurs have enjoyed at ALLIED for so many years.

ALLIED RADIO

100 N. WESTERN AVE., CHICAGO 80, ILLINOIS

Serving the Amateur for 36 Years



B & W

PRODUCTS of the YEAR



L-1000A

1 KW Grounded Grid Linear Amplifier—Model L-1000A

- Outstanding performance on all bands 80 through 10 meters • Peak envelope power 1 KW SSB, 875 watts CW • Heavy duty pi-network output circuit allows precise adjustment and loading on all bands • Broadbanded input requires no tuning • Contains own power supply • All power switching operations controlled by a single front panel switch • Ideal for use with 5100-B or 51SB-B/5100-B combinations and other commercial or home built transmitters • Full output with r-f excitation of only 80 watts. Power Source 117 VAC 60 cycles.

NET PRICE\$460.00



5100-B

Medium Powered Transmitter 5100-B

- Completely self-contained including power supply and VFO • Bandswitching on the 80-40-20-15-11/10 meter bands. Peak envelope power 180 watts CW-SSB; 145 watts AM. • Excellent SSB when used with the 51SB-B described below. • Stable VFO accurately calibrated for all amateur bands including 10 meters. Bias system provides complete cut-off under key-up conditions • Excellent TVI suppression • Pi-network output • Output receptacle on the back for powering other units including the 51SB-B. • Plenty of audio for 100% AM modulation at all times.

NET PRICE\$475.00



51SB-B/51SB

Single Sideband Generator 51SB-B/51SB

- Excellent SSB with your present transmitter • Provides push-to-talk, speaker deactivating circuit, TVI suppression • Complete bandswitching on 80-40-20-15-11/10 meters • Utilizes frequency control method of your present rig • R-F portion has 90° phase shift network, double balanced modulator, and two class "A" r-f voltage amplifiers. • All operating controls on the front panel • Input impedance 50 ohms resistive; input voltage 1.5-2.0 RMS on all bands.

MODEL 51SB-B—For use with B & W 5100-B from which it derives all operating power.

NET PRICE\$265.00

MODEL 51SB—Similar to 51SB-B, but contains own power supply. For use with other commercial or home built rigs.

NET PRICE\$279.00

*All prices subject to change without notice

B & W

BARKER & WILLIAMSON, INC.
Bristol, Pennsylvania

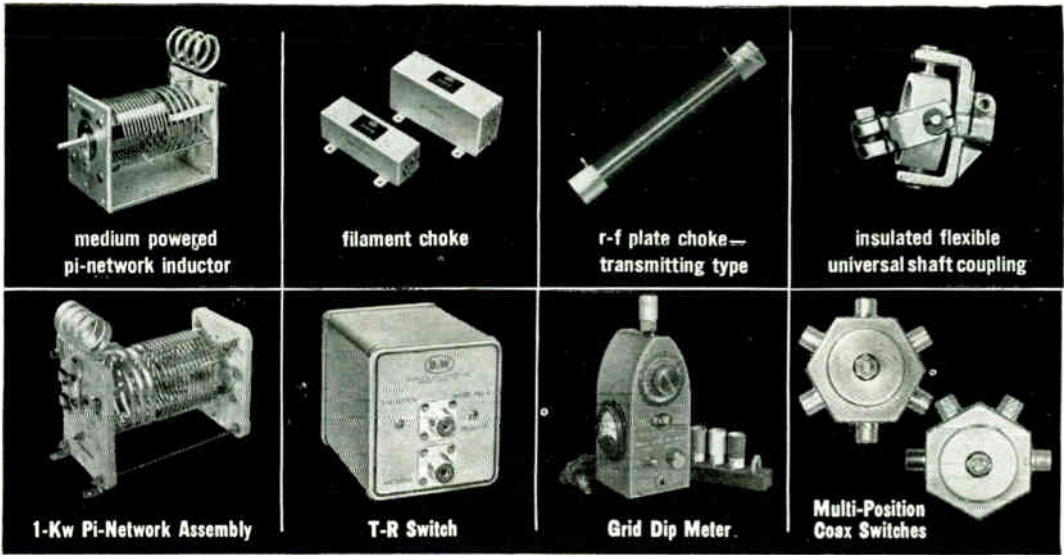

8 new quality products from B&W

MODEL 851 Medium Powered Bandswitched Pi-Network Inductor Assembly

An ultra-compact, highly efficient, integrally bandswitched pi-network inductor assembly for single or parallel tube operation 80 through 10 meters. Rated for 2000 VDC at 250 ma input SSB-CW... 1250 VDC at 200 ma input for AM. Minimum measured "Q" of 300.

NET PRICE \$16.50

R-F Plate Choke—Transmitting Type

Ideal for parallel or series fed circuits. High quality grooved steatite form. Operates 80 through 10 meters. Rated for 2500 VDC at 500 ma.

NET PRICE \$ 3.75

Microphone Adapter Unit

Provides all necessary circuitry for switching a single microphone and push-to-talk features on transmitter-SSB generator combinations.

Use Model 51MCA with B&W 5100-5/51SB-B

Use Model 51MCA-B with B&W 5100/51SB

Use Model 51MCA-C with Collins 32V/B&W 51SB

NET PRICE \$15.00

Tuning Knobs

Satin-etched, machined aluminum knobs dress up any piece of equipment... give it a professional appearance. Four sizes available, one plain, three skirted. Models 900-903.

NET PRICE	900	\$ 3.00
	901	\$ 1.50
	902	\$ 0.60
	903	\$ 0.45

1-KW Pi-Network Assembly

A high-power, integral bandswitched tank coil for 80 to 10 meter operation. Ideal for class C or linear operation using triodes or tetrodes in conventional or grounded grid circuits. Minimum "Q" of 300. Model 850.

NET PRICE \$35.00

T-R Switch

Fully automatic electronic antenna switching from transmitter to receiver and vice-versa. For power applications up to the legal limit. Ideal for fast break-in operation on SSB, AM, or CW. Receiver gain 6 db at 3.5 mc. Broad-banded... no tuning required. Model 380B.

NET PRICE \$23.70

Grid Dip Meter

A highly accurate, sensitive instrument. May be used as a grid-dip oscillator, signal generator, or absorption wavemeter. Five color-coded plug-in coils cover 1.75 to 260 mc. Color-coded dial easily read. Operates from 110 VAC. Easy to use in hard-to-get-at places. Model 600.

NET PRICE \$39.75

Multi-Position Coax Switches

For 75 or 52 ohm line. Instantly switches coax lines... no screwing or unscrewing coax connectors. Handles up to 1 KW modulated power. Max. cross-talk —45db at 30 mc. Model 550A 5-position switch. Model 551A 2-pole, 2-position switch.

NET PRICE	550A	\$8.25
	551A	\$7.95

Prices subject to change without notice.

BARKER & WILLIAMSON, INC.

Bristol, Pennsylvania



4X250B



4-250A



4CX300A

The World's Largest

4-65A Radial-Beam Power Tetrode

Smallest of the Eimac internal anode tetrodes, the 4-65A has a plate dissipation rating of 65 watts and is ideal for deluxe mobile as well as fixed-station service.

	CW	AM	SSB
Plate Voltage	3000v	2500v	3000v
Driving Power	1.7w	2.6w	0
Power Input	345w	270w	195w

4-400A Radial-Beam Power Tetrode

Highest powered of the Eimac Big Six, it will easily deliver a kilowatt per tube in CW, AM or SSB application. Forced-air cooling is required.

	CW	AM	SSB
Plate Voltage	3000v	3000v	3000v
Driving Power	6.1w	3.5w	0
Power Input	1050w	825w	900w

4E27A Radial-Beam Power Pentode

The 4E27A gives outstanding performance in all types of operation. When suppressor-grid modulated, it will deliver 75 watts at carrier conditions.

	CW	AM	SSB
Plate Voltage	2500v	2500v	3000v
Driving Power	2.3w	2.0w	0
Power Input	460w	380w	345w

Information on Eimac tubes and their applications is available free upon request from our Amateur Service Bureau. Write today for copies of our Quick Reference Catalogue, Application Bulletin No. 8 "Power Tetrodes," Application Bulletin No. 9 "Single Sideband," and other valuable literature.

4X250B Radial-Beam Power Tetrode

A compact, rugged tube unilaterally interchangeable in nearly all cases with the famous 4X150A, with the advantages of higher power and easier cooling.

	CW	AM	SSB
Plate Voltage	2000v	1500v	2000v
Driving Power	2.8w	2.1w	0
Power Input	500w	300w	500w

4-125A Radial-Beam Power Tetrode

The versatile tube that made screen grid transmitting tubes popular. This favorite for commercial, military and amateur use is radiation cooled.

	CW	AM	SSB
Plate Voltage	2500v	2500v	3000v
Driving Power	3.8w	3.3w	0
Power Input	500w	380w	315w

4-250A Radial-Beam Power Tetrode

A high power output tube with low driving requirements. A pair of Eimac 4-250A's easily handle a kilowatt input in AM, CW or SSB service.

	CW	AM	SSB
Plate Voltage	3000v	3000v	3000v
Driving Power	2.6w	3.2w	0
Power Input	1035w	675w	630w

4CX300A Ceramic Power Tetrode

A new all ceramic-metal high power tetrode designed for rugged service. Will withstand heavy shock and vibration and operate with envelope temperatures to 250° centigrade.

	CW	AM	SSB
Plate Voltage	2000v	1500v	2000v
Driving Power	2.8w	2.1w	0w
Power Input	500w	300w	500w



3KM3000LA

UHF Modulating Anode Klystron



4-125A



4-85A



4E27A/5-125B



2C39B



750T



4X5000A

Eimac

Manufacturer of Transmitting Tubes

TRIODES

2C39A	100TH
2C39B	100TL
3C24	152TH
3W5000A3	152TL
3W5000F3	250TH
3W10,000A3	250TL
3X2500A3	304TH
3X2500F3	304TL
3X3000A1	450TH
3X3000F1	450TL
6C21	592/3-200A3
25T	750TL
35T	1000T
35TG	1500T
75TH	2000T
75TL	

DIODES - RECTIFIERS HIGH VACUUM

2-01C
2-25A
2-50A
2-150D
2-240A
2-2000A
2X3000F
250R
253
8020 (100R)
2CL10A

MERCURY VAPOR RX21A

KLYSTRONS

1K015CA
1K015CG
1K015XA
1K015XG
3K2500SG
3KM3000LA
3K3000LQ
3K20,000LA
3K20,000LF
3K20,000LK
3K50,000LA
3K50,000LF
3K50,000LK
3K50,000LQ
4K50,000LQ

CERAMIC RECEIVING TUBES

5C2A
33C3A2

HEAT DISSIPATING CONNECTORS

AIR SYSTEM SOCKETS

SK-100
SK-110
SK-200
SK-300
SK-400 (4-400A/4000)
SK-500 (4-1000A/4000)
SK-600 (4X150A/4000)
SK-610 (4X150A/4010)
SK-620
SK-630
SK-640

AIR SYSTEM SOCKET CHIMNEYS

SK-406 (4-400A/4006)
SK-506 (4-1000A/4006)
SK-606 (4X150A/4006)

VACUUM CAPACITORS

VC6-20	VC50-20
VC6-32	VC50-32
VC12-20	VVC60-20
VC12-32	VVC2-60-20
VC25-20	VVC4-60-20
VC25-32	

IONIZATION GAUGE

VACUUM SWITCH AND COILS

VS-2
VS-5
VS-6
12 Volt Coil
24 Volt Coil

PREFORMED CONTACT FINGER STOCK

Available in 8 widths, single or double sided.

TUBE EXTRACTOR

SK-601 (for 4X150 and 4X250 tubes)

TETRODES

4-65A	4X150D
4-125A	4X150G
4-250A	4X250B
4-400A	4X250F
4-1000A	4X250M
4CX300A	4X500A
4PR60A	4X500F
4W300B	4X5000A
4W20,000A	
4X150A	

PENTODE

4E27A/5-125B



4K50,000LQ UHF Klystron

EITEL-McCULLOUGH, INC.

SAN BRUNO, CALIFORNIA



8020



1K015XA



X963

HERE'S YOUR CHRISTMAS TREE!

The Heavy Duty E-Z WAY "Z" Series

3 Heights . . . 40 Ft. . . . 50 Ft. . . . 60 Ft. Plus 17 Ft. of Mast

Especially designed to withstand heavy-wind-loads, these are full crank-up and tilt-over towers for stacking the multiple band arrays. Three models, each of which will adequately support a "Christmas Tree" installation at full height in 60 MPH wind without guy wires.

The rotating mast, designed to support these heavy arrays, is 2" OD — 1/4" wall cold drawn seamless tube (1025 tensile) 20-ft. long. When installed in the top section, the antenna mast will nest down into the tower so that, with the beams stacked 8-ft. apart, the top beam will be just 17-ft. above the tower. Two adjustable self-aligning bearings spaced 3 ft. apart at the top of the tower make it easy to plumb the rotating mast.

Tower Height	A	B	C	X	Z
40	38'	21'	10'	10" wide 1.05 legs	14" wide 1.315 legs
50	50'	28'	13'	14" wide 1.315 legs	20" wide 1.66 legs
60	60'	33'	15'	same	same

The E-Z WAY GROUND POST is the secret of our quick, guy-less installation. Heavy-welded on plates as cross-fins below the ground level resist movement sideways when dirt is firmly tamped around them. Top of post has big, welded-on steel plate with full 3/4-inch diameter steel pin. Just below the hinge on the ground post is a big husky retainer plate, matching a cross plate on the tower itself. When erected, two 5/8-inch diameter bolts slip through these two plates, to reinforce the hinge. Full-width 5/8-inch rod locks bottom to ground-post, too, relieving tilt cable and winch of strain until put into actual use.

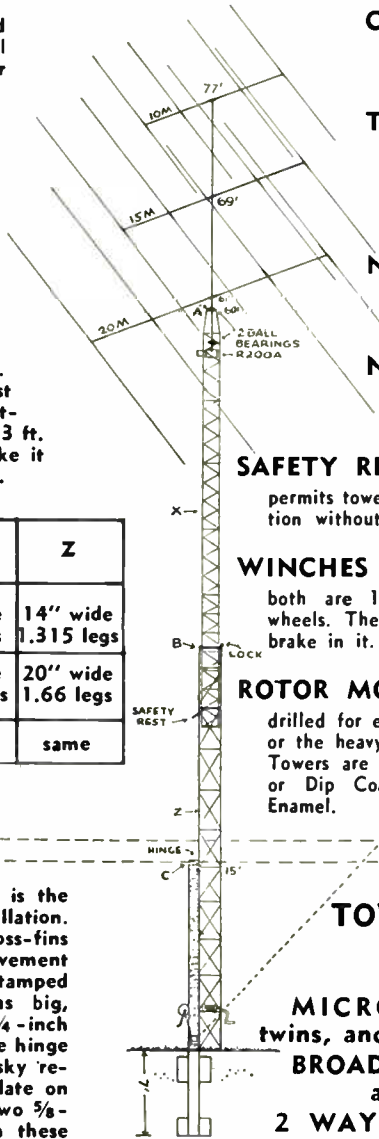

CRANKS UP & DOWN

for easy erection and maintenance.

TILTS OVER

to the horizontal making both the installation and adjustment of the array a simple matter.

NO GUY WIRES

Takes less than 4 square feet of space in yard.

NO CONCRETE

when set in hard clay or comparable soil.

SAFETY REST

permits tower to stop at any desired elevation without strain on the lifting cable.

WINCHES

both are 1500 lb. capacity with spur wheels. The tilt over winch also has a brake in it.

ROTOR MOUNTING PLATE

drilled for either a Telrex R 200 Rotator or the heavy-duty type Prop-Pitch Motor. Towers are available Hot Dip Galvanized or Dip Coat (rubber base) Aluminum Enamel.

TOWERS ARE OUR BUSINESS —

all types

MICRO WAVE — H type, twins, and single guyed towers.

BROADCASTING AM, FM and TV guyed towers.

2 WAY COMMUNICATION, HAM RADIO and HOME TV

—crank-up, tilt-over, self-supporting and guyed types.

E-Z WAY TOWERS, INC.

P. O. Box 5491 - 5901 E. Broadway - Tampa 5, Florida - Phone 4-2171

Cable address: E-Z Way Tower

"TOWERS ARE OUR BUSINESS"

E-Z WAY TOWERS

FOR EXTRA STRENGTH - EXTRA SAFETY

E-Z WAY TOWERS are easy to erect yet strong enough to withstand a wind load of 40-60 lbs. per sq. ft. The new E-Z Way portable gin pole makes it easy to erect a 120 ft. tower in one piece without leaving the ground. Thousands of E-Z Way Towers are giving outstanding service in all parts of the country and abroad.

SPECIFICATIONS

- 1. Aero Dynamic Design**—Triangular towers built of Cylindrical steel rod and tubing, combine to give greatest strength with least wind resistance.
- 2. Continuous Diagonal Bracing** gives greatest resistance against twisting.
- 3. Built-in Ladder** on one side. No obstructions to interfere with easy climbing.
- 4. High Tensile Steel (110,000)** for greater strength.
- 5. Wide Spread Legs**, 10 to 36 inches for greater rigidity.
- 6. Electric Arc Welded**—Long fillets at every weld point.
- 7. Saves Time**—Four to six sections can be raised in one piece. Additional sections may be added to top.
- 8. Dual Lightning Rod** extends 3 feet above beacon.
- 9. Hot Dipped Galvanized** after fabrication — also available dip coated in Goodyear Plialite S-5 (Rubber Base) aluminum enamel at lower prices.
- 10.** All towers, except C-10, use flange-type connectors as pictured. C-10 supplied with outside bolted couplings.

Width 36"	20"	14"	10½"	10"
Legs 2"–2½" 3" Pipe	1½"–1½" 2" Pipe	1" Pipe	¾" Pipe	½" Pipe
Weight Per Ft. 21 to 30 lb.	15.5 to 22 lb.	9.00 lb	5.5 lb.	4.5 lb.
Max. Guy Spacing 100 ft.	80 ft.	50 ft.	40 ft.	35 ft.
Height Maxi- mum 500 ft.	350 ft.	220 ft.	160 ft.	120 ft.
Diagonal Bracing ½" Rod	¾" Rod	5/16" Rod	5/16" Rod	¼" Rod
Horizontal Bracing 1½"–1½" 2" Pipe	¾"–1" 1½" Pipe	½" Rod	7/16" Rod	7/16" Rod
C-300 Series	C-200 Series	C-15	C-12	C-10

*Based on an assumed wind load of 40 lbs. per sq. ft.



2" O.D. Mast
4-¾" set
screws



Typical
Coupling
and Guy Point



Insulated
base
C-15 shown



Ball and
Socket
Type Base
C-20 shown



8-men (1200 lbs) test the strength
of a C-10 section placed 15 feet
between horses.

TOWERS ARE OUR BUSINESS —
all types

MICRO WAVE — H type, twins, and
single guyed towers.

BROADCASTING AM, FM and TV
guyed towers.

**2 WAY COMMUNICATION, HAM
RADIO and HOME TV** — crank-up,
tilt-over, self-supporting and guyed
types.

E-Z WAY TOWERS, INC.

P. O. Box 5491 — 5901 E. Broadway — Tampa 5, Florida — Phone 4-2171

Cable address: E-Z Way Tower

one name stands



SSB-100F Exciter/Transmitter

Frequency Range:

80 meter band	3,500 to 4,000 Mc
40 meter band	7,000 to 7,500 Mc
20 meter band	14,000 to 14,500 Mc
15 meter band	21,000 to 21,500 Mc
11 meter band	26,900 to 27,400 Mc
10 meter band	28,000 to 30,000 Mc

Tube Lineup: 22 tubes, including two rectifiers, one voltage regulator, one oscilloscope and one 5894 power amplifier.

Type of Emission: CW — AM — LSB — HSB

Power Ratings: DC average input SSB-100 watts; AM input (two tone test)-60 watts. Peak envelope power input SSB-144 watts.
Peak envelope power output SSB-100 watts.

Audio Characteristics: Response: ± 3 db from 400 to 3300 cycles.
Noise and hum: 50 db or more below PEP level.

Audio Input: .05 volts for rated power output (any high impedance crystal or dynamic microphone).

Harmonics and Spurious Responses: Spurious mixer products—40 db or more down. Third order distortion products—35 db or more down. Carrier suppression—50 db or more down. TV interference suppression—40 db or more second harmonic, 60 db or more higher harmonics.

Frequency Stability: Control oscillator—(800 to 1300 kc)— ± 100 cycles after two minute warm up period. Output frequency—within 300 cycles after five minute warm up period. Dial accuracy— ± 2 kc after calibration.

Cabinet: Receiver type table model with hinged cover.

Finish: Flat gray.

Size: 17 $\frac{1}{4}$ " long by 10 $\frac{3}{4}$ " high by 15" deep.

Weight: 58 lbs.

Shipping Weight: 65 lbs.

ELDICO Electronics

out . . .

ELDICO

SSB-1000 Linear Amplifier

Frequency Range: 80, 40, 20, 15, and 10 meters.

Tube Lineup: 9 tubes; two 866, two OA-2, one OB-2, one 6AU6, one 1CP1, two 4X250B.

Power Rating: 1000 watts PEP input and 750 watts AM input.

Finish: Flat gray enamel.

Cabinet: Receiver type table model with interlocked hinge cover.

Weight: 88 lbs.

Shipping Weight: 95 lbs.

**Write for Free Illustrated
Literature on
SSB Equipment**



ELDICO presents

A division of Dynamics Corporation of America

72 East Second Street, Mineola, L. I., N. Y., PLoneer 6-5212

HARVEY



AUTHORIZED DISTRIBUTORS



RCA Tubes and Harvey Service... For Double Dependability!

HARVEY's line of RCA tubes is so complete, that HARVEY can fill virtually any requirement . . . right from stock . . . and deliver at almost a moment's notice.

This is particularly important to AM, FM, and TV Broadcasters, Industrial and Commercial users, Amateurs, and Service-Technicians, all of whom depend on tubes for sustained operation of important electronic equipment.

Write, Wire or Phone for
PROMPT HARVEY SERVICE

Visit Harvey's New **AUDIO-torium** at 1123 Avenue of the Americas (6th Avenue) in New York City.

Telephone  JUdson 2-1500

HARVEY

RADIO COMPANY, INC.
103 West 43rd St., New York 36, N. Y.

...that's why
NOVICES,
AMATEURS,
ENGINEERS,
 and
EXPERIMENTERS
Across the Nation
RELY UPON
HARVEY
 for all their
ELECTRONIC and
COMMUNICATION
REQUIREMENTS!

Telephone **hrc** JUdson 2-1500
HARVEY
RADIO COMPANY, INC.
 103 West 43rd St., New York 36, N. Y.

For the Best in Test and Maintenance



RCA
Test Equipment

For the Best
in Service and Supply



HARVEY
Radio Company

Whatever your individual or company requirement, whether it be as a ham, experimenter, technician, or commercial and industrial engineer, Harvey Radio has the manpower and facilities to take care of your parts and equipment needs. Complete stocks and a pin-pointed inventory control system place your order on its way hours after it is received. And you can depend upon Harvey that what you receive is exactly as ordered, and that it will function and perform to your complete satisfaction.

Remember, you are always welcome at Harvey's. So, when in New York, make it a point to come in and say "Hello."

Harvey is Always at Your Service

AUTHORIZED DISTRIBUTORS OF



RECEIVING AND
 NON-RECEIVING TUBES
 BATTERIES • TEST EQUIPMENT
 TELEVISION COMPONENTS
 SERVICE PARTS

... and all the products of all the famous names in radio and electronics



Amperex®



AX5868



6229-6330



5924

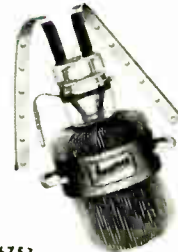

6757



6551-A

RADIATION DETECTION • SPECIAL PURPOSE



2-0C72

1N478,9



5894



0G3/85A2



5870



6252

SEMICONDUCTORS • INDUSTRIAL • ELECTRO-MEDICAL



6507



6360



6333



6339



230N-240N

COMMUNICATION • RECTIFICATION • AMATEUR



268



6155



EL84



6693

HELPFUL CHARTS & LITERATURE FREE:

Write for CONDENSED TUBE CATALOG, information at a glance, rapid tube data reference tables, 28 pages of condensed information arranged for quick reference. Address your distributor or Amperex direct.

Detailed Data Sheets on any of these tubes, and application engineering service are yours for the asking.

ELECTRON TUBES

Detailed Data Sheets
on any of these tubes,
and
application engineering
service are yours
for the asking.

Type No. Price

BEAM POWER TUBES	
813	\$18.00
829B	16.25
6146	5.75

VACUUM CONDENSERS

VC25/20	20.00
VC25/32	23.25
VC50/20	24.25
VC50/32	27.50
VC100/20	30.00
VC100/32	33.00
VC250/32	70.00

DECADE COUNTER

E1T/6370	16.50
----------	-------

GEIGER COUNTERS

75N	10.00
75NB3	10.00
90NB	20.00
100C	35.00
100N	35.00
100NB	37.50
120C	75.00
120N	75.00
120NB	77.50
150N	50.00
150NB	52.50
153C	65.00
200C	45.00
200CB	47.50
200N	45.00
200NB	47.50
230N	30.00
240C	35.00
240N	35.00
912NB	35.00

CLIPPER DIODE

6339	35.00
------	-------

IGNITRONS

5550	41.00
5551-A/652	65.00
5552/651	99.00
5552A	99.00
5553B/655	216.00
5554/679	163.00
5555/653B	316.00
5822	116.00

INDICATOR TUBE

DM70/1M3	.95
----------	-----

Type No. Price

REFLEX KLYSTRON	
2K25	\$39.50

MAGNETRONS

2148	250.00
2155	165.00
2156	165.00
4347	500.00
4352	275.00
4357	270.00
4358	270.00
4359	270.00
5586	417.00
5657	417.00
6229	550.00
6230	550.00
6507	**
6589	**
6823	**
6824	**
6828	**

PENTODES

†E81L	5.00
†E83F	4.50
E180F	8.00
828	20.95
6084	3.75
†6227	3.75
AX9909/6083	13.50

PENTODES—HI-FI

6CA7	4.35
EL84	2.40
EF86	2.75

PENTODES

Secondary Emission	
EFP60	8.75

PENTODES

Subminiature	
6007/5913	1.50
6008/5911	1.50

HI-FI VACUUM

RECTIFIERS	
GZ34	3.50
EZ80	1.50
EZ81	1.60

Type No. Price

MERCURY RECTIFIERS

255B	\$145.00
575A	20.00
673	20.00
8578	218.00
866AX	2.45
869B	138.00
872AX	8.20
6508	80.00
6693	30.00
8008	8.25

VACUUM RECTIFIERS

5R4GY	2.65
8080	24.00

XENON RECTIFIERS

3828	7.60
4832	12.00

VOLTAGE

REFERENCE TUBES

0E3/85A1	2.50
0G3/85A2	2.50
5651	2.30

VOLTAGE REGULATORS

0A2	1.75
0B2	1.90
90C1	2.50
6354/15082	3.00

TETRODES

4X150A	38.95
807	2.90
6075/AX9907	225.00
6076/AX9907R	275.00
6079/AX9908	60.00
6155/AX4-125A	27.50
6156/AX4-250A	37.50

TWIN TETRODES

832A	14.26
5894/AX9903	22.00
6360	4.00

THYRATRONS

3C23	11.98
632B	28.00

Type No. Price

HYDROGEN THYRATRONS

4C35	\$32.50
3C22	37.50
†6268/AX9911	32.50
†6279/AX9912	45.00

INERT GAS THYRATRONS

2021	2.00
5727	2.90

MERCURY THYRATRONS

FG17/1701/ 967/5557	8.50
AX105/FG105	49.50
678	47.00
5559	22.00
5560/FG95	28.00
5869/AGR9950	25.00
5870/AGR9951	100.00
6786	200.00

XENON THYRATRONS

2050	2.55
5544	27.00
5545	29.40
5685/C6J	26.40

TRIODES

2C39A	22.50
3X2500A3	198.00
3X2500F3	198.00
6Q4	3.25
6R4	2.50
HF200	35.00
HF201A/468	28.50
203H	30.00
207	240.00
220C	365.00
228A	325.00
250TH	33.00
250TL	33.00
279A	355.00
HF300	35.00
450TH	77.00
450TL	77.00
501R/5759	225.00
502/5760	210.00
502R/5761	235.00
504R	245.00
508/6246	500.00
750TL	137.50
805	15.90
810	19.50

Type No. Price

811-A	5.65
812A	5.65
833A	49.00
834	14.50
838	16.00
845	15.95
849	145.00
849A	145.00
880	545.00
889A	210.00
889A	330.00
891	260.00
891R	410.00
892	255.00
892R	405.00
ZB3200	350.00
5604	570.00
5619	410.00
5666	250.00
5667	330.00
5736	160.00
5771	540.00
5866/AX9900	20.00
5867/AX9901	30.00
5868/AX9902	50.00
5923/AX9904	150.00
5924/AX9904R	1900.00
6077/AX9906	1675.00
6333	245.00
6445	390.00
6446	290.00
6447	430.00
6617	360.00
6618	495.00
6756	388.00
6757	535.00

GLOW DISCHARGE

TRIODE—Miniature	
5823	2.50

HI-FI TWIN TRIODES

ECC81/12A7	2.60
ECC82/12AU7	2.20
ECC83/12AX7	2.30

TWIN TRIODES

†E92CC	1.75
†5920	2.00
†6084	3.75
†6085	3.75
†6252/AX9910	22.00

TUNGAR BULBS

1163	5.50
1164	10.00

* These prices currently apply when a new tube is purchased and the old tube radiator in original shipping container is returned prepaid in good condition with the replacement order.

† The Amperex types 6268/AX-9911 and 6279/AX-9912 are improved versions but completely interchangeable in every respect with the standard types 4C35 and 5C22 respectively. They have a minimum guaranteed life of 1000 hours due to the self-contained, self-regulating source of hydrogen.

** Price on request.

† 10,000 hour life tubes.

Prices subject to change without notice.

Retube with AMPEREX

Amperex ELECTRONIC CORP.



230 Duffy Ave., Hicksville, Long Island, N. Y.

In Canada: Rogers Majestic Electronics Ltd.
11-19 Brantcliffe Road, Leaside (Toronto 17)



RECEIVERS... TRANSMITTERS... Antennas..Accessories...

2 and 6 METER STANDARD COMMUNICATORS ...



The very well known Communicator is now available in several different models to meet fully the varied requirements of amateur, CAP, C-D, Commercial and Airport services. Each model is a complete station—superhet receiver with "Cascode" RF, crystal controlled transmitter. (VFO is also available separately.) Self contained power supply for 115V AC and 6V DC. (Also 115V AC and 12V DC.) Modulator may also be used as a PA system, mobile or fixed. All models highly compact, 7³/₄" x 10³/₈" x 9¹/₂". All are light in weight, portable.

2 METER DE LUXE COMMUNICATOR

Tunable receiver, crystal controlled transmitter. (AM) covers 144-148.3 mcs. 2E26 final delivers 6-7 watts output. Has adjustable squelch, (silent standby) famous Ganset noise clipper, phone jack and speaker muting, dial light switch.

115V AC/6V DC#3025 Net 229.50
115V AC/12V DC#3057 Net 229.50

2 METER STANDARD COMMUNICATOR

Same as above except less squelch, phone jack, etc.

115V AC/6V DC (less squelch, etc.) #3026 ... Net 209,50

6 METER DE LUXE COMMUNICATOR

Operates on amateur 6 meter band. Has "Cascode" front end, double conversion for increased selectivity usable on 6 meters. Transmitter delivers 6 to 8 watts output. De luxe models only.

115V AC/6V DC#3049 Net 229.50
115V AC/12V DC#3058 Net 229.50



RF LINEAR AMPLIFIERS ...

RF linear amplifiers for 2 and 6 meter Communicators to increase carrier output to 50-60 watts. No alterations required on Communicator. Tune-up is easy, foolproof, with no danger to tubes. Switching the Communicator to transmit automatically activates the amplifier including the internal antenna relay. Amplifier uses 2-826 VHF triodes with forced-air cooling. Heavy-duty power supply employs 2-5U4G rectifiers.

2 METERS#3063. 149.50
6 METERS#3064. 149.50

G-66B FIXED-MOBILE RECEIVER ...

The Ganset G-66B is a high performance communications receiver whose small physical size and universal power supply adapts it equally to fixed station or mobile operation. Six bands—including standard broadcast—each amateur band individually calibrated, each spread across the easy-to-read slide rule dial scale.

Desirable features include:

Outstanding operation on all reception modes: AM, CW, SSB with a new high order of stability for mobile CW and SSB made possible by stabilized HF and BF oscillators and by crystal controlled second conversion oscillator.

Double conversion with 2050 kc 1st I-F.

262 kc 2nd I-F with B high "Q" tuned circuits gives 3.5 kc band width at 6 db down, together with steep skirt selectivity.

6 bands—Standard BC, 80-40-20-15-10 meters.

Universal "3 way" power supply attaches and plugs into rear of receiver as cabinet extension. May also be mounted separately and connected with patch cable.

G-66B receiver. Less power supply..... 189.50

"3 way" (6V, 12V DC and 115V AC) power supply/
speaker unit. Specify 6 or 12 volt operation.....44.50



G-66

GONSET BURBANK, CALIF.

"Communicator"... The complete VHF station "Package"

C-D ... 2 and 6 METER COMMUNICATORS

Now available ... special Communicator models which exactly meet applicable FCDA specifications.

These units are similar to their commercial-type 2 and 6 meter counterparts, are the same size but are finished in an attractive yellow color. Because of their extreme compactness and the fact that they will operate from car battery or AC mains, these units have great utility as mobile or fixed stations in Civil Defense applications.

Receiver is a sensitive superhetrodyne with "Cascode" RF and three stages of I-F. Six meter models incorporate double conversion for added selectivity desirable in this lower frequency range. Receivers of both models are tunable, the 2 meter model covering 144-148.3 mcs., the 6 meter model 49-54 mcs. Noise clipper, adjustable squelch, pilot light on-off switch, earphone jack with speaker muting, are all desirable features. Transmitter uses 2E26 output tube delivering about 6 watts of carrier output with AM modulation. Four crystal controlled frequencies are provided by means of a selector switch on the panel.

2 METER (FCDA ITEM No. U-16)		
6V DC/115V AC	#3087	299.50
12V DC/115V AC	#3077	299.50

6 METER (FCDA ITEM No. U-14)		
6V DC/115V AC	#3088	299.50
12V DC/115V AC	#3079	299.50

Prices include tubes, microphone, one crystal, canvas carrying case and portable antenna.



C-D RF LINEAR AMPLIFIERS ...

A new linear RF amplifier to match the Gonset C-D Communicators. These new amplifiers have the same front panel size and are finished in the same bright yellow color with blue and red C-D emblems.

They are similar to the Gonset commercial version linear, will increase C-D Communicator output carrier power to 50 watts. They are easy to adjust, foolproof, non-critical. Push pull 826 VHF triodes with forced air cooling are used.

2 METERS	#3089	199.50
6 METERS	#3090	199.50

All prices subject to change.



G-77 MOBILE TRANSMITTER

An exceptional, new mobile transmitter with every desirable feature. Designed as a companion unit for the G-66, is same size and general appearance. Power supply for 6 and 12 volt operation is built into separate compact unit with modulator and speech amplifier of advanced design.

Transmitter covers 80-40-20-15-10 meters, has built-in stable, calibrated VFO with crystal control optional. Power input is 50-60 watts, modulated. Pi network output circuit. Full press-to-talk operation with built-in antenna relay.

Features exceptionally low drain on both transmit and on standby. Has high speech gain for dynamic or crystal mikes. Modulator incorporates integral speech clipping.

Output voltage is 500-600 volts full load. Rectifiers and circuitry used eliminate standby drain.

G-77 with power supply.....net 279.50



G77

DIVISION OF THE L.A. YOUNG SPRING & WIRE CORP.

World Radio History

BLILEY NOVICE BAND CRYSTALS



AX2

BAND	MULTIPLIER	CRYSTAL FREQ. RANGE	TYPE	PRICE
80 Meters	1	3700.0 to 3750.0 kc's	AX2	\$2.95
40 Meters	2	3587.5 to 3600.0 kc's	AX2	2.95
40 Meters	1	7175.0 to 7200.0 kc's	AX2	2.95
15 Meters	1	21,100 to 21,250.0 kc's	SR10	8.50
15 Meters	3	7033.33 to 7083.33 kc's	AX2	2.95
15 Meters	6	3516.66 to 3541.66 kc's	AX2	2.95
7 Meters	6	24,166.66 to 24,500.0 kc's	SR10	8.50



SR10



BLILEY CRYSTALS FOR SPOT FREQUENCIES IN NET OPERATIONS



MC9

TYPE	APPLICATION	TOLERANCE	PRICE
MC9	3 mc-12 mc experimental frequencies	± .03%	\$6.50
SR10	12 mc-27.5 mc experimental frequencies	± .03%	8.50



SR10



BLILEY CRYSTALS FOR AMATEUR · EXPERIMENTAL CITIZEN'S BAND · SINGLE SIGNAL FILTERS



KV3



SR10



CF6



AX2



MC9

TYPE	APPLICATION	TOLERANCE	PRICE
KV3	Reference Frequency 100 kc	± .005%	\$8.50
MC9	Marker Frequency 1000 kc	± .05%	8.00
MC9	13.6275 mc (Multiplier to 27.255 mc) CITIZEN'S RADIO SERVICE (CLASS "C")	± .04%	5.50
SR10	27.255 mc (3rd Overtone Crystal) CITIZEN'S RADIO SERVICE (CLASS "C")	± .04%	5.50
CF6	455 kc — 456 kc — 465 kc Single Signal Filters	± 5 kc	4.50
AX2	1800-1825 kc; 1875-1900 kc; 1900-1925 kc; 1975-2000 kc	See Note A	3.75
AX2	3500-4000 kc; 7000-7425 kc; 8000-9000 kc	See Note A	2.95
AX2	14-14.5 mc	± 10 kc	3.95

Note A: We will supply to integral spot frequencies (no fractions) as ordered; calibration ± 500 cycles in factory test oscillator.

NEW HIGH STABILITY PACKAGE WITH 100 kc AND 1000 kc CRYSTALS

This compact temperature controlled package provides a high stability reference source at both 100 kc and 1000 kc. Precision reference for general amateur use.

TYPE	DESCRIPTION	STABILITY	PRICE
TCO-2L	6.3V Oven	75°C ± 5°C	\$ 9.00
BH6A Crystal	1000 kc	± .0002%	12.50
BH9A Crystal	100 kc	± .0005%	11.00

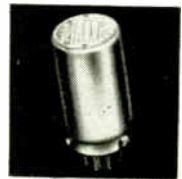

TCO-2L

Crystal units described are calibrated in recommended oscillator circuit—adjustable to zero beat (at 75°C) in this circuit.

BLILEY ELECTRIC CO. UNION STATION BUILDING ERIE, PA.

Major producers of crystal units, crystal ovens, oscillator assemblies and solid ultrasonic delay lines for commercial and military equipment.



If It's Shown In This Handbook **Henry Has It!**

*Henry gets the
new equipment
— First —*

- Complete Stocks** Henry has *everything* in the amateur equipment field, new or used . . . transmitters or receivers, and Henry has the NEW equipment FIRST.
- Long Trades** Henry *wants* to trade and he trades *big*. YOU get truly liberal allowances on your equipment. Tell us what you want to trade. We also pay cash for used equipment.
- Low Terms** You get the best terms anywhere because Henry finances all the terms with his easy time payment plan. 10% down (or your trade-in accepted as down payment), 20 months to pay.
- 100% Satisfaction** Henry gives you a guarantee of "100% satisfaction" or your money back at the end of a 10 day trial.
- 10 Day Trial** Try any receiver or transmitter for 10 days. If you are not perfectly satisfied, return it and all you pay are shipping costs.
- Fast Delivery** Shipments 4 hours after receipt of order. Send only \$5.00 with order, and shipment will be made COD immediately . . . Order from either store TODAY!
- Low Prices** Henry's large purchasing power means low prices to you. You just can't beat our wholesale prices.

Write, wire, phone or visit either store today.

Butler 1, Missouri
Phone 395



Bob Henry,
WØARA



Henry Radio Stores

BRodshow 2-2917

11240 West Olympic Blvd. Los Angeles 64



Ted Henry
W6UOU



"World's Largest Distributors of Short Wave Receivers."

Where Dependability counts— Use OHMITE!

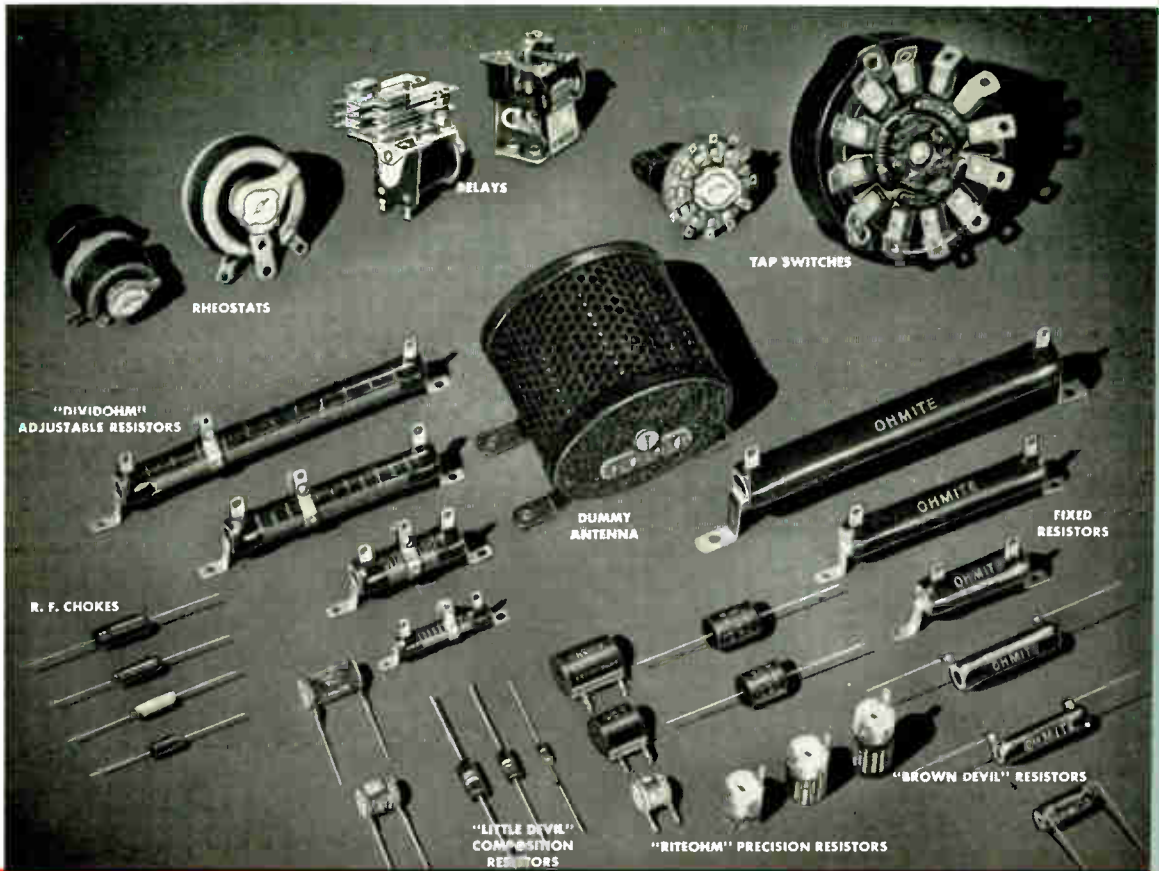

RHEOSTATS

Linear permanently smooth, close control. All-weather vitreous enameled. 25, 50, 75, 100, 125, 211, 300, 500, 750, and 1000-watt sizes.

AMERCON RELAYS

Classic Amercon relays in four stock models—BOE, DO, DOSY, and CRU, in 45 different types. At 115 VAC or 32 VDC, noninductive load. Model BOE and DOSY have a contact rating of 15 amp; Model DO, 10 amp; Model CRU, 5 amp. Wide range of coil operating voltages.

"LITTLE DEVIL" RESISTORS

Modular composition resistors—each marked with resistance and voltage— $\frac{1}{2}$, 1, and 3-watt sizes, $\pm 10\%$ or $\pm 5\%$, 10 Ohms to 22 megohms.

FIXED RESISTORS

Vitreous enameled fixed resistors. Stock sizes: 25, 50, 100, 160, 300 watts; values 1 to 250,000 ohms. "Brown Devil" fixed resistors in 5, 10, and 20-watt sizes; values from 0.4 to 100,000 ohms.

ADJUSTABLE RESISTORS

Vitreous enameled. Quickly adjustable to the value needed. Adjustable legs can be attached for multi-tap resistors and voltage dividers. Sizes 10 to 300 watts, to 100,000 ohms.

R. F. CHOKES

Single-layer-wound on low perme factor cores with moisture-proof coating. Seven stock sizes, 3 to 120 mc. Two coils rated 600 ma, others 1000 ma.

TAP SWITCHES

Compact, high-current rotary selector for $\frac{1}{2}$ - $\frac{1}{4}$ sec. All contacts self-cleaning silver-to-silver contacts. Rated at 15, 15, 25, 30, and 100 amperes.

PRECISION RESISTORS

Three types available: vitreous-enameled, vacuum-impregnated, or encapsulated. Tolerances in $\pm 0.1\%$, $\pm 1\%$, $\pm 2\%$, and $\pm 5\%$ sizes, from 0.1 to 2,000,000 ohms.

DUMMY ANTENNA

Three rugged, vitreous-enameled units are precisely manufactured within their recommended frequency range. In 100 and 125-watt sizes, 22 to 600 ohms, $\pm 1\%$.

Write for
Stock Catalog

OHMITE MANUFACTURING COMPANY
3608 W. Howard St., Skokie, Ill., (Suburb of Chicago)

Be Right with

OHMITE®

RHEOSTATS • RESISTORS • RELAYS • TAP SWITCHES • TANTALUM CAPACITORS

ALL ROADS LEAD TO

LOWEST PRICES!

ALL TOP BRANDS!

10% DOWN

CHARGE IT!
Ask for Account

EASY TERMS!

TRADE-IN BARGAINS!
Come see the positively biggest
and best array of good equipment—
at real money-saving reductions!

FREE PARKING!

COMPLETE STOCK!



BECAUSE ...

Here, at Harrison's, in the World's Largest Trading Center, is where you get the most for your money!—The newest equipment, the best friendly service, the greatest values, the easiest terms, the "hottest" trade-in deals!

Nowhere else can you see such a tremendous array of all the latest and finest Ham gear, waiting for you to inspect, select, try out, then take safely home with you.

So, hurry on in (it really is a shorter trip than you think!) to HAM HEADQUARTERS, U.S.A. Bring along your old rig, for my tip-top trade-in deal. I guarantee you'll go home happy!

73, Bill Harrison, W2AVA,

(Of course, if you can't visit us, my mail and phone order service is still the best in the world!)

INDUSTRIAL? Certainly!

The Electronics Industry is in a large measure based on Radio Amateurs, and their accomplishments.

It logically follows that HAM HEADQUARTERS, USA is also the dependable supply center for all

INDUSTRIAL ELECTRONIC MATERIEL!

For quicker service (at factory prices) have your PA rely upon our,

**INDUSTRIAL SALES DEPARTMENT
TWX NY1-177 • Cable "Harrisorad"**

HARRISON

"Ham Headquarters, USA ... Since 1925"

225 GREENWICH STREET, NEW YORK 7, N. Y.

Barclay 7-7777

**NEW JERSEY, Delaware 3-8780
LONG ISLAND, Republic 9-4102
HILLSIDE AVE. at 145 St., JAMAICA**

Factory-calibrated · Stable · Reliable · Quick set-up · Easy-to-read

RCA VOLTOHMYSTS®

professional test instruments

**FOR LABORATORY...SERVICE...PRODUCTION
PREFERRED AROUND THE WORLD**

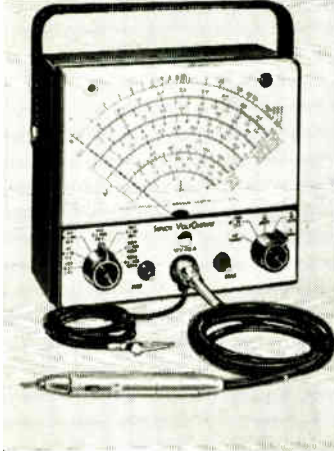

RCA-WV98A... SENIOR VOLTOHMYST...incorporates all the important time-proved performance features of earlier VoltOhmysts including direct peak-to-peak readings of complex waveforms. Has improved circuit providing great accuracy, and a BIG full-vision meter face with the easiest-to-read scales ever designed into a VTVM! Supplied complete with WG-299A DC/AC-Ohms probe and cable, and most detailed instructions.



RCA-WV-77-C... JUNIOR VOLTOHMYST...biggest value in vacuum-tube voltohmeters. Embodies new design features in addition to operational characteristics which have made VoltOhmysts the choice of thousands in radio and TV servicing, industry, electronics, communications, broadcasting, and the armed forces. Supplied complete with WG-299A DC/AC-Ohms probe and cable, and complete instruction book.



RCA-WV-87-B... MASTER VOLTOHMYST...Truly a Master VoltOhmyst, it features a 7" wide-face meter and $\pm 3\%$ accuracy on all ranges. Easy-to-read peak-to-peak scales are particularly useful for TV, radar, and other types of pulse work. Has accuracy and stability necessary for most applications. Supplied complete with new, slim WG-299C probe and flexible cable, current leads, ground lead, complete instructions.

Modern engineering, testing, and production techniques demand test instruments with high precision, *practical* operating features. RCA VoltOhmysts are especially suited for operation over extended periods under rigorous production-line and field conditions: electronically protected meters; accuracy unaffected by normal line voltage fluctuations; easy-to-read expanded scales; one zero-setting holds for all voltage and resistance ranges; accessory probes extend all DC voltages, and extend frequency response to 250 Mc. All RCA VoltOhmysts are tested and calibrated to the highest laboratory standards. Remember, only RCA makes the VoltOhmyst.

CHOOSE THE VOLTOHMYST THAT SUITS YOUR NEEDS

Features	Master VoltOhmyst WV-87B	Senior VoltOhmyst WV-98A	Junior VoltOhmyst WV-77C
Measurements:			
DC Voltage	0.02-1500v	0.02-1500v	0.05-1200v
AC (rms) Voltage	0.1-1500v	0.1-1500v	0.1-1200v
AC (peak-to-peak) Voltage	0.2-4200v	0.2-4200v	—
Resistance	0.2-1000 meg.	0.2-1000 meg.	0.2-1000 meg.
Current	10 uamp.-15 amp.	—	—
Accuracy: **			
DC current	$\pm 3\%$	—	—
DC Voltage	$\pm 3\%$	$\pm 3\%$	$\pm 3\%$
AC Voltage	$\pm 3\%$	$\pm 3\%$	$\pm 5\%$
	**At full-scale points		

SEND THIS COUPON FOR COMPLETE INFORMATION

RCA INTERNATIONAL DIVISION—DEPT. TE-33-A
RADIO CORPORATION OF AMERICA
30 Rockefeller Plaza
New York 20, N.Y., U.S.A.

Please send details and descriptions on VoltOhmysts

MY NAME _____

COMPANY _____

ADDRESS _____



RCA INTERNATIONAL DIVISION
RADIO CORPORATION OF AMERICA
30 Rockefeller Plaza, New York 20, N. Y. U. S. A.
Trademarks®Registered



You'll Find it
in a
LEAGUE PUBLICATION

THE AMERICAN RADIO RELAY LEAGUE, through its publications in the field of amateur radio, is acknowledged as the leading contributor to this fascinating art. The whole picture of amateur radio, from basic fundamentals through the most complex phases of this appealing hobby, is covered in the League library. The newcomer who succumbs to the first nibbles of the radio bug can find his "gateway" to amateur radio in such introductory booklets as *How to Become a Radio Amateur*, *Learning the Radiotelegraph Code*, and the *License Manual*. Other League publications, especially that all-time radio best seller, *The Radio Amateur's Handbook*, are storehouses of information for everybody interested in electronics and radio communication. Supplies such as log books, world map, calculators, message blanks and binders are specially designed for the needs of active operating amateurs.

Whether novice or old-time amateur, student or engineer, League publications will help you to keep abreast of the times in the ever-expanding field of electronics. Most of the publications described in the following pages are handled by your radio dealer. If you cannot obtain them locally, they may be ordered direct from League Headquarters.

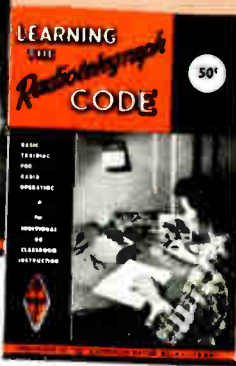
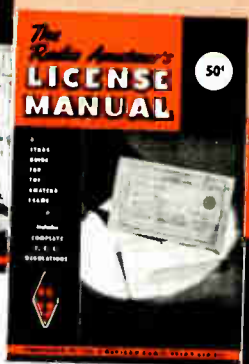
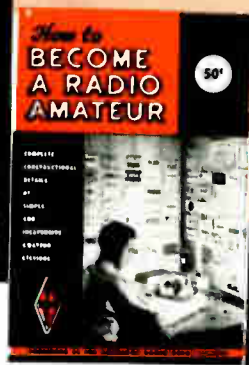
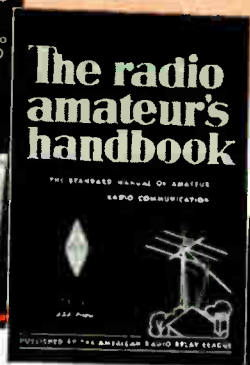
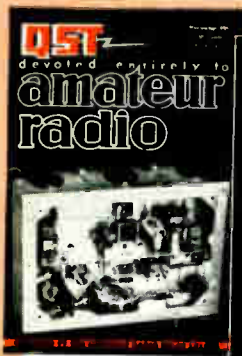

QST

QST has been the radio amateur's own journal since 1915. Although primarily a ham magazine, it is found on the desks and library shelves of engineers, technicians and others in the electronics field who wish to keep in touch with the development of the art. There is something for everyone in QST, from the Novice to the Old Timer.

QST and ARRL membership \$4.00 in U.S.A., \$4.25 in Canada, \$5.00 elsewhere

THE RADIO AMATEUR'S HANDBOOK

Internationally recognized, universally consulted. The all-purpose volume of radio. Packed with information useful to the amateur and professional alike. Written in a clear, concise manner, contains hundreds of photos, diagrams, charts and tables.

\$3.50 U.S.A., \$4.00 U.S. Poss. and Canada, \$4.50 elsewhere; Buckram Edition, \$6.00 Everywhere.

HOW TO BECOME A RADIO AMATEUR

Tells what amateur radio is and how to get started in this fascinating hobby. Special emphasis is given to the needs of the Novice licensee, with three complete simple amateur stations featured. 50¢

THE RADIO AMATEUR'S LICENSE MANUAL

Study guide and reference book, points the way toward the coveted amateur license. Complete with typical questions and answers to all of the FCC amateur exams—Novice, Technician, General and Extra Class. Continually kept up to date. 50¢

LEARNING THE RADIOTELEGRAPH CODE

For those who find it difficult to master the code, this publication supplies the key to the problem. Designed to help the beginner overcome the main stumbling block to a ham license. Contains practice material for home study and classroom use. 50¢

SINGLE SIDEBAND FOR THE RADIO AMATEUR

A digest of the best SSB articles from QST. The newcomer to Single Sideband as well as the experienced SSB user will find it indispensable. Includes discussions of theory and practical "how-to-build-it" descriptions of equipment. Covers both reception and transmission.

\$1.50 U.S.A. proper, \$1.75 elsewhere

THE ARRL ANTENNA BOOK

Containing 16 chapters and profusely illustrated, the Antenna Book includes all necessary information on theory and operation of antennas for all amateur bands; simple doublets, multi-element arrays, rotaries, long wires, rhombics, mobile whips, etc.

\$2.00 U.S.A. proper, \$2.25 elsewhere

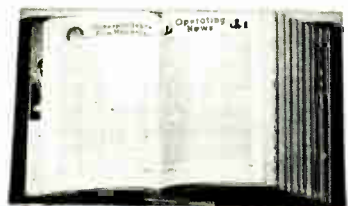
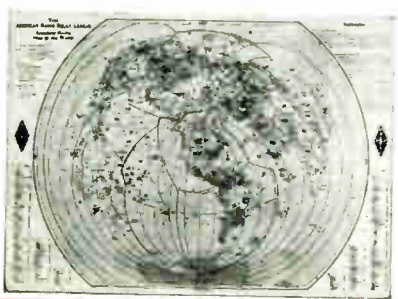

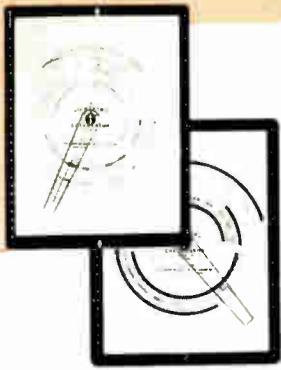

A COURSE IN RADIO FUNDAMENTALS

A complete course of study for use with the *Radio Amateur's Handbook*, enables the student to learn the principles of radio by following the principle of "learning by doing." Applicable to individual home study or class use.
\$1 U.S.A. proper, \$1.25 elsewhere

HINTS AND KINKS

If you build equipment and operate an amateur radio station, you'll find this a mighty valuable book in your shack and workshop. More than 300 practical ideas.
\$1 U.S.A. proper, \$1.25 elsewhere

THE MOBILE MANUAL FOR RADIO AMATEURS

This manual is a useful and informative guide to mobile radio. It is a collection of articles on tried and tested equipment that have appeared in *QST*. Contents include a section on receivers, transmitters, antennas and power supplies. A "must" for the bookshelf of anyone interested in

the installation, maintenance and operation of mobile stations.
\$2.50 U.S.A. proper, \$3.00 elsewhere

ARRL WORLD MAP

Printed in eight colors on heavy map paper with 267 countries clearly outlined. Continental boundaries, time zones, amateur prefixes, plainly marked. Size: 30 x 40 inches. **\$2.00**

QST BINDERS

No need to let your copies of *QST* rest in a disordered pile. A *QST* binder will keep them neat and orderly. Each holds a one-year file.
\$3.00 (available in U.S. and Possessions only).

LIGHTNING CALCULATORS

Quick and accurate answers with ARRL Lightning Calculators! Type A for problems involving frequency, inductance, capacity. Type B for resistance, voltage, current and power. **\$1.25 each**

SUPPLIES

Active amateurs need these supplies: ARRL Logbook, 50¢ U.S.A., 60¢ elsewhere. *Minilog*, 30¢ U.S.A., 35¢ elsewhere. Radiogram blanks, 35¢ per pad postpaid. Message delivery cards, 4¢ each stamped, 2¢ each unstamped. Members' stationery, 100 sheets \$1.00; 250 sheets \$2.00; 500 sheets \$3.00.

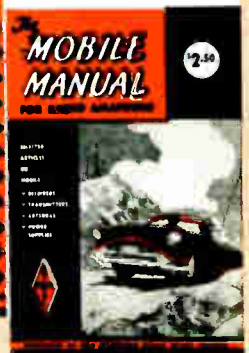
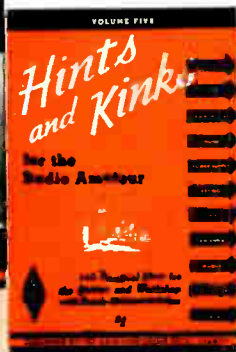
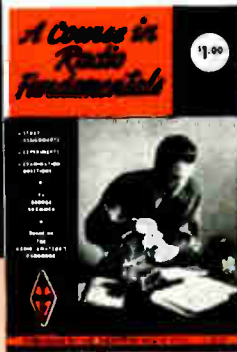
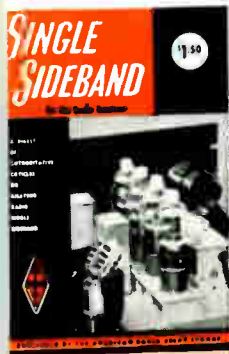



Application for Membership

AMERICAN RADIO RELAY LEAGUE

Administrative Headquarters: West Hartford, Connecticut, U. S. A.

.....19.....

AMERICAN RADIO RELAY LEAGUE,
West Hartford, Conn., U. S. A.

Being genuinely interested in Amateur Radio, I hereby apply for membership in the American Radio Relay League, and enclose \$4.00* in payment of one year's dues, \$2.00 of which is for a subscription to *QST* for the same period. [Subscription to *QST* alone cannot be entered for one year for \$2.00, since membership and subscription are inseparable.] Please begin my subscription with theissue.

The call of my station is.....

The class of my operator's license is.....

I belong to the following radio societies.....

.....

Send my Certificate of Membership or Membership Card (Indicate which) to the address below:

Name.....

.....

.....

A bona fide interest in amateur radio is the only essential requirement, but full voting membership is granted only to licensed radio amateurs of the United States and Canada. Therefore, if you have a license, please be sure to indicate it above.

*\$4.00 in the United States and Possessions.
\$4.25, U. S. funds, in Canada.
\$5.00, U. S. funds, in all other countries.

MORE AND MORE HAMS ARE PUTTING THEIR SKILL TO WORK SERVICING MOBILE RADIO SYSTEMS



SAM SEMEL, W2SHE, servicing the mobile two-way radio of an ambulance, just one of the 200 mobile units he maintains regularly as a General Electric Communication Equipment Authorized Service Station. A ham for 12 years, Sam has been a General Electric Service Station for four years.



SERVICING A MOBILE UNIT in his Elmira, N. Y. shop, Sam utilizes his years of radio knowledge and basic test equipment. He is kept up-to-date on all latest techniques by General Electric Product Service Section, which provides constant flow of information based on experiences in all parts of the country, as well as from General Electric engineering laboratories.

HUNDREDS OF HAMS are now helping to keep public safety agencies, transportation companies and industrial companies "on the air." Hams are finding an increasing call for skilled service men to maintain the many thousands of mobile radio units now used in police cars, fire engines, light delivery cars and trucks, heavy tractor trailers, and an expanding variety of industrial vehicles.

Thousands of new mobile radio systems are installed every year, and manufacturers as well as users have turned to the amateur ranks as a source of well-trained communications service specialists. And it's not always a full time job, either. Some hams maintain a few systems in their spare time. Others have taken on additional systems until today, they operate highly successful service stations specializing in mobile radio maintenance. Nearly all of the many hundreds of stations servicing G-E communication systems, are operated by licensed amateurs.

G-E 2-way radio equipment is designed with the serviceman in mind. Take G.E.'s new Progress Line of 2-way radio, for example. The transmitter, receiver, power supply and optional chassis are individually rack-mounted in a new triple-rigid case. Rapid inter-changeability is provided by this rack construction and true plug-in chassis connections. You change either a transmitter or receiver plug-in chassis right in the vehicle in five minutes—using *only a screwdriver!*

To hams interested in G-E 2-way mobile units, we will gladly send typical bulletins, and a booklet, normally given to new users, "How to Operate Your Two-Way Radio."

General Electric Company,
Communication Equipment,
Section C577, Electronics Park
Syracuse, New York.



Progress Is Our Most Important Product

GENERAL  ELECTRIC

The most complete line of

RACKS

for ELECTRONIC APPARATUS

presented in our **NEW CATALOG**



Write for your copy now!

PAR-METAL Racks and Rack Assembly embody an important advance in functional design and adaptability of this type of unit.

Featured in our latest *Catalog No. 55* are Par-Metal universal type Cabinet Racks. They are available in a wide range of practical sizes; with open or closed sides; with or without front doors. They may be used singly or grouped, as illustrated.

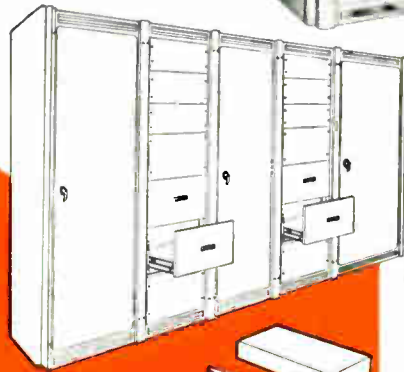

A complete line of Utility Desk Assemblies is described in our Bulletin C2.

PAR-METAL universal type Cabinet Racks offer a highly styled, engineered product of custom-built quality at a considerably lower cost. They are made for 19" and 24" wide panels, are 18" or 24" deep, and are listed in various heights and models. These Racks have provisions for attaching chassis support brackets, fixed or sliding shelves, without drilling or fitting.

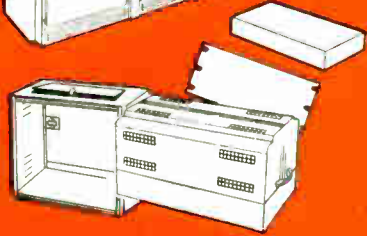

For your copy of our 20-page catalog write today to:

PAR-METAL PRODUCTS CORPORATION

32-52 49th STREET, LONG ISLAND CITY 3, N. Y. • Telephone: AStoria 8-8905

Manufacturers of Quality Metal Products Since 1926.

GENERAL ELECTRIC OFFERS WIDEST SELECTION OF SEMICONDUCTORS AVAILABLE ANYWHERE

HIGH & LOW FREQUENCY PNP TRANSISTORS

High gain, medium power audio: 2N43, 2N44, 2N45. For USAF requirements: 2N43A. Commercial equivalent: 4JD1A17. Computer switching: 2N123. RF and IF amplifiers and oscillators: 2N135, 2N136, 2N137. Hobbyist type at low cost: 2N107.



HIGH & LOW FREQUENCY NPN TRANSISTORS

RF and IF amplifiers for broadcast receivers: 2N168, 2N169, 2N169A. Converters: 2N168A. Reliable industrial/military linear amplifiers: 2N78. Computer switching: 2N167. Low level amplifiers at low cost: 2N170.



SILICON POWER TRANSISTOR

8 watt dissipation at 85° centigrade.



SILICON HIGH FREQUENCY TRANSISTOR

15 megacycle operation. Designed for printed circuit board insertion.



SILICON UNIUNCTION TRANSISTOR

Operation up to 200°C. Replaces 2 junction transistors in computer circuits.



NPN TETRODE TRANSISTOR

Up to 150 megacycle operation.



NPN HIGH FREQUENCY TRIODE TRANSISTOR

15 megacycle operation at temperatures up to 85°C.



SILICON LOW CURRENT RECTIFIER

¼ amp per cell, 150°C. rated free ambient, 175°C. storage temperature. Designed for machine assembly.



GERMANIUM JUNCTION RECTIFIERS

For 99% rectification efficiency: 1N91, 1N92, 1N93. Single cell unit ratings are increased up to 5 times by adding single copper fin. For 500 ma output current: 1N151, 1N152, 1N153.



GERMANIUM RECTIFIER STACKS

More than 160 circuit possibilities for use up to 900 volts and 10 amperes.

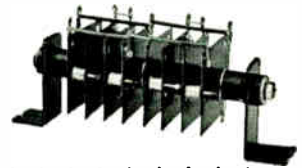

Now, a greatly expanded line of General Electric transistors and rectifiers provides greater power performance at extended frequency range and temperature limits.

Recent G-E developments in germanium and silicon for semiconductors have opened roads to new appli-

cations, industrial and military.

See your General Electric Semiconductor Specialist for detailed specifications of the Semiconductors shown here, or write today to: *General Electric Company, Semiconductor Products, Section S577, Electronics Park, Syracuse, New York.*

Progress Is Our Most Important Product

GENERAL  ELECTRIC

You can depend on

AMPHENOL
Quality

The AMPHENOL Amateur Antenna has been designed to meet your need for a simple, effective folded dipole antenna system. The efficiency of the AMPHENOL Antenna for both transmitting and receiving has been demonstrated by years of satisfied amateur use. The Amateur Antenna is available in an economical, easy-to-assemble kit form. All the kits are pre-cut to band length and are ready for final assembly and installation. Complete assembly instructions are included.

AMATEUR ANTENNA KIT



AMPHENOL twin-lead, flat or tubular, is made of the finest materials available, manufactured with constant and rigid inspection. The brown pigmented virgin polyethylene assures a minimum of signal loss and constant impedance.

AMPHENOL flat twin-lead is available in a variety of types and sizes. AIR-CORE Tubular twin-lead (U.S. Pat. No. 2,543,696) is a must for UHF television lead-in purposes.

FLAT and TUBULAR TWIN-LEAD

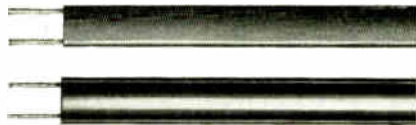

AMPHENOL cables are produced in strict conformity to the rigid military specifications. Constant checks and inspections are made to assure the best in mechanical and electrical construction.

Most of the R F cables in the AMPHENOL line have top grade polyethylene dielectric for low-loss, flexibility and mechanical stability. For high temperature applications, cables are also available with other types of dielectric, including Teflon.

COAXIAL CABLE



AMPHENOL R F connectors are unsurpassed for mechanical design and electrical efficiency. They provide low-loss continuity in critical R F circuits with little or no impedance change or increase in voltage standing wave ratio.

AMPHENOL R F connectors are available in every popular Series. New Solderless R F plugs 83-850 and 83-851 are ideal for amateur use, being completely re-usable; both eliminate braid soldering—the 83-850 eliminates contact soldering also.

RF CONNECTORS

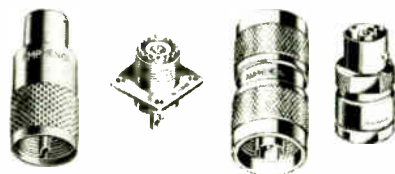

Four separate series of microphone connectors are manufactured by AMPHENOL. Newest of the new are the sensational QWIKs. These 3 and 4 contact bullet-shaped connectors add modern efficiency and modern design to every mike application. The 75 series connectors function as either male or female fitting, include jacks, plugs, receptacles, adapters and switches. The 80 series 1 and 2 contact connectors are designed for use with shielded cable. Obtainable in any combination of male or female cable connectors or chassis units. The 91 series include 3 and 4 contact connectors, polarized to prevent incorrect insertion.

MICROPHONE CONNECTORS

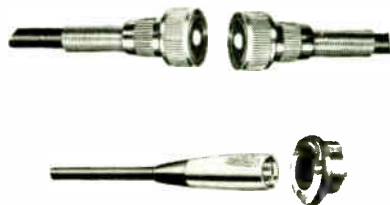

AMPHENOL ELECTRONICS CORPORATION

AMPHENOL

chicago 50, illinois

World's EASIEST AND BEST WAY TO SEND

**Famous
Easy-Working
Semi-automatic**

VIBROPLEX

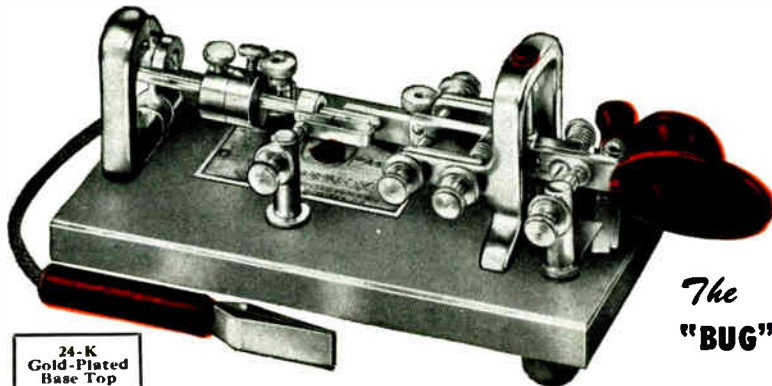

**24-K
Gold-Plated
Base Top**

PRESENTATION — Made to fine instrument standards with exclusive features destined to make keying not only easier but better, including a super-speed control mainspring for greater speed range and to permit slowest sending without additional weights. Has polished chromium parts, 24-K gold-plated base top, red trim and jewel movement. The most attractive and easiest working key ever built. You'll be proud to own this key. With circuit closer, cord and wedge. \$29.95.

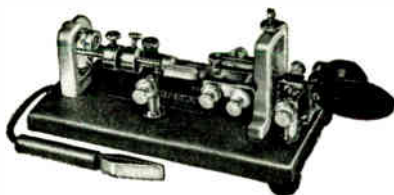

ORIGINAL — Famous the world over for signal quality, ease of operation and all around keying excellence, by thousands of the world's finest operators and amateurs. Built for long life and rough usage. This key can take it. With circuit closer, cord and wedge. Standard, \$19.95; DeLuxe, \$23.95.



CARRYING CASE — Black, simulated morocco. Cloth-lined. Reinforced corners. Flexible leather handle. Protects key from dust, dirt and moisture, and insures safe-keeping when not in use. With lock and key, \$6.75.

Avoid imitations!
The "BUG" Trade Mark
identifies the
Genuine Vibroplex
Accept no substitute

Does all the hard, arm-tiring work for you

- That's because its semi-automatic action performs for you with an ease beyond comparison
- Vibroplex also gives fast relief from nervous and muscular tension caused by continued use of old-fashioned keys
- Requires no special skill
- Adjustable to your own speed
- Precision built for long life and rough usage
- Ends sending fatigue forever
- Provides lifetime keying ease and enjoyment

*The
"BUG"*

Standard Models have
Black crystal base, chrome top parts

DeLuxe Models have
Polished chromium base and top parts,
red trim, jewel movement

All Vibroplex keys have 3/16" contacts

LIGHTNING BUG — Handsome, rugged, reliable. With many exclusive features contributing to easier operation and better signals, including a flat pendulum bar, slotted weights can't work loose; bridged damper frame to protect key from damage, and many others. A strong favorite with thousands. With circuit closer, cord and wedge. Standard, \$18.95; DeLuxe, \$22.95.



BLUE RACER — Small, compact, handy to carry. Built extra sturdy like the Original, but only half the size. Wt. 2 lbs. 8 oz. Has all the features of the famous Original key. If your preference is for a smaller key that's TOPS in keying performance — this is it. With circuit closer, cord and wedge. Standard, \$19.95; DeLuxe, \$23.95.

All Vibroplex keys are available for left-hand operation, \$2.50 additional

**NEW SPECIAL ENLARGED Edition of
PHILLIPS CODE, \$2.75 Postpaid**

Also includes:
Radio Code Signals
International Morse
American Morse
Russian, Greek, Arabic
Turkish and Japanese
Morse Codes
World Time Chart

United States Time Chart
Commercial "Z" Code
Aeronautical "Q" Code
Miscellaneous Abbreviations. Used on international wire, submarine cable and radio telegraph circuits.



All Vibroplex keys are precision machined, designed to meet the most exacting operating conditions, and to provide you with a lifetime of trouble-proof sending ease and enjoyment. Write for FREE folder.

Prices subject to change without notice



THE VIBROPLEX CO., Inc., 833 Broadway, New York 3, N. Y.

W. W. ALBRIGHT, President

IF YOU SEND YOU SHOULD USE THE VIBROPLEX



YOU

NEED THIS . . .

FREE GIANT ALL NEW 1957 BA CATALOG

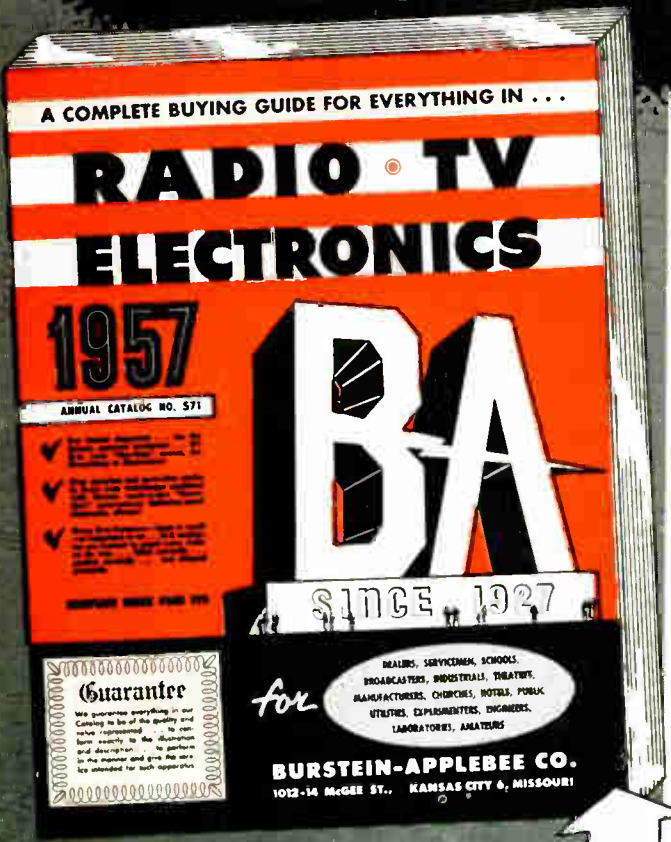

172 BIG PAGES LOADED WITH EVERYTHING YOU NEED

- Complete selection of everything in Ham equipment, electronic parts, tools and supplies right at your fingertips in this one big, handy book.
- Save \$\$\$ with B-A's EXCLUSIVE "Free-Finance Plan"! Take a full year to pay for your receiver or transmitter . . . the total you pay equals no more than the net cash price. No interest or finance charges, no hidden extras . . . it's purely a B-A accommodation!
- B-A ships only factory-fresh, spanking new merchandise. Never will your equipment have been out on trial. Every set is fully guaranteed by the maker and backed by B-A's 30 years of square-dealing.
- Check the 21 big pages of special money-saving buys in parts and equipment, not found in any other catalog.
- Count on B-A for fastest, most complete shipment available anywhere . . . at always lowest prices.

SEND FOR YOUR COPY TODAY!

BURSTEIN-APPLEBEE CO.
1012-14 MCGEE ST., KANSAS CITY 6, MISSOURI

Master Mobile's PRODUCTS OF THE YEAR!

with all new improved features!

BUMPER MOUNTS

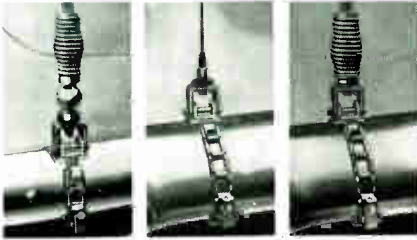

No. 444 \$17.80 No. 445 \$7.95 No. 446 \$13.45

Adjustable to any bumper. No holes to drill, easy to attach. High-polished Chrome Plated $\frac{3}{8}$ "-24 thread, to fit all antennas. Precision engineered.

NEW! . . . SILVER-PLATED ROLLER WITH POSITIVE ACTION, STAY-PUT CONTACT



No. "333" MASTER MIGHTY-MIDGET

... engineered to provide the highest "Q" consistent with good design. Compact, extremely rugged, yet lightweight, its operation assures precision tuning with the new adjustable silver-plated roller that stays put! Perfect for 40-20-15-11-10 meters. "Get 5 Bands Plus on 1 Coil."

\$9.95

Amateur net

HY "Q" construction with wider spacing of turns for high frequency bands. Use as center or base loaded antenna with 60" whip.

No. 750

MASTER ALL-BANDER

- Covers 10 thru 75 and all intermediate frequencies
- Silverplated single turn contact, positive spring.
- Eccentric cam contact, easy selection of turn.
- Automatic lock prevents damage to coil.

Size - $2\frac{3}{4}$ " Dia x $1\frac{3}{4}$ " Long



AMATEUR NET **\$14.95** EA.

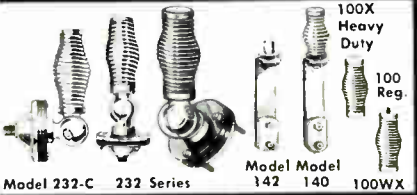

Model 232-C 232 Series 100X Heavy Duty 100 Reg. Model 142 140 100WX

Master Ultra-Hi "Q" COILS For 80-40-20 & 15 Meters



After many years of experimentation, here is the coil with the highest "Q" ever obtained. Tested and found to have a "Q" of well over 515. Use with 36" base section, 60" whip.

- Ruggedized construction
- Precision made
- Greater efficiency
- 2 1/2" Diameter

\$5.25 ea.

Any Band . . . Amateur net

MICRO-Z-MATCH No. 825

Micrometer Impedance Matching Inductance for Mobile Antennas



Body mounts sold separately from \$8.75 up.

Used on all bands with coax cable to match any mobile antenna or Master

Matcher. Roller coil construction with rear cap rotating the inductance in case. 4 microhenries max. ind. Infinite adjustment, positive setting.



Complete with kit **\$7.95**

GROUND PLANE (Drooping Type) FOR 6 METERS No. MGP-6

Aluminum alloy tubing, coax cable connector. For medium or low powered trans.



Amateur Net **\$14.95**



No. 321 BODY MOUNT

Swivel base body mount, less spring. Specially constructed diagonal ball joint for maximum strength. Amateur Net **\$7.95**

MOUNTS

MOUNT SPECIFICATIONS

MODEL	(All types are tapped for 3/8" Steel Fitting on Antenna End. Shipping Weight Approx. 3 lbs.)	NET PRICE
232 or 232C*	Body Mount—Double Tapered—Spring Swivel Base	\$8.75
232X or 232XC*	Body Mount—Heavy Duty—Double Tapered—Spring Swivel Base	9.85
232SS or 232SSC*	Body Mount—Special Stainless	12.95
232XS or 232XSXC*	Body Mount—H. D. Special Stainless	14.95
232XXC* or 232XX	Body Mount—Extra Heavy Duty—Double Tapered Spring—Swivel Base	10.85
232XXSSC*	Body Mount—Extra Heavy Duty—Stainless Steel	15.95
321 or 321C*	Body Mount—Swivel Base—Without Spring	7.95
140	Bumper Mount—Double Tapered Spring	6.95
140X	Bumper Mount—Heavy Duty—Double Tapered Spring	7.95
140XX	Bumper Mount—Extra Heavy Duty	8.95
140XXSS	Bumper Mount—Extra Heavy Duty—Special Stainless	11.95
140SS	Bumper Mount—Special Stainless	9.65
140XSS	Bumper Mount—Special Heavy Duty Stainless	10.95
142	Bumper Mount—less spring, with insulator for Direct Mounting by Series 100 ant or 92 Est and 106 Antennas	3.95
446SS	Bumper Mount—Special Stainless—Chain Mount	14.90
446XSS	Bumper Mount—Heavy Duty—Special Stainless—Chain Mount	15.90
446XSSS	Bumper Mount—Extra Heavy Duty—Special Stainless—Chain Mount	16.90
446	Bumper Mount—Heavy Duty Spring—Chain Mount	13.45
446L	Bumper Mount—Double Tapered Spring—Chain Mount	12.45
446XX	Bumper Mount—Extra Heavy Duty Double Tapered Spring—Chain Mount	14.45
444	Bumper Mount—Heavy Duty Spring—Swivel Base—Chain Mount	17.80
444L	Bumper Mount—Double Tapered Spring—Swivel Base—Chain Mount	16.70
444XX	Bumper Mount—Extra Heavy Duty Spring—Swivel Base—Chain Mount	18.80
444SS	Bumper Mount—Special Stainless—Swivel Base—Double Top Sp—Chain Mt.	20.90
444XSS	Bumper Mount—Special Stainless—Heavy Duty—Swivel Base—Chain Mount	22.90
444XSSS	Bumper Mount—Extra Heavy Duty Special Stain. Swivel Base—Chain Mount	23.90
445	Bumper Mount—Threaded, 3/8"-24—Chain Mount	7.95



MASTER MATCHER & FIELD STRENGTH METER

Automatically tunes the entire band from the drivers seat!

6 or 12 volt models **\$24.95**



Master Mobile Mounts, Inc.

P.O. BOX 36317 - LOS ANGELES, CALIFORNIA
WARFHOUSE AND SHIPPING ADDRESS: 1306 BOND STREET

AT LEADING RADIO JOBBERS EVERYWHERE

Partner, if you're aimin' to "load up"
and get 'em when you call 'em,
come on down to either of our two
stores and get the "final word"
on new or used ham equipment,
trade-ins and credit.

Whether it's transmitters,
receivers, antennas or
accessories for fixed or mobile
operation, you'll find
Valley Electronic Supply is
unquestionably the
"final word."

In addition to having the
largest selection of
electronic equipment for
amateurs in the west,
we've got over 40 hired
hands (including
16 hams) whose skill in
every phase of
electronics is at
your service.

So next time you're
by, why not tie up
to our hitching
post and come in
and look around?

**"FINAL
WORD"
IN THE
WEST!**



FREE Novice Classes
at Both stores
W6QJI and W6LTY
Instructors.



VALLEY Electronic Supply Company

1302 West Magnolia Blvd., Burbank, Calif. • Phone Victoria 9-8841
17647 Sherman Way, Van Nuys, Calif. • Phone Dickens 2-5143

Commercial MOBILE-RADIO MAINTENANCE is a *Paying Proposition!*

Get into this rapidly growing field with
2nd Class Ticket and **LAMPKIN METERS!**



LAMPKIN 105-B MICROMETER
FREQUENCY METER

FREQUENCY RANGE — uses only one crystal to measure all transmitters 0.1 to 175 mc., crystal-controlled transmitters to 500 mc. MEETS FCC SPECS—Accuracy guaranteed better than 0.0025%. CALIBRATION—Calibration Table for each meter. Charts show percentage transmitter off frequency from FCC assignment. DIAL—4" circular dial with 8000 dial divisions spread over 42 feet. TEMPERATURE COMPENSATION—crystal thermometer on panel, automatically indicates dial checkpoint for any temperature. SIGNAL GENERATOR—a pinpoint CW source for mobile-receiver final alignment.

You can buy
these meters on

**EASY
TERMS**



LAMPKIN 205-A
FM MODULATION METER

FREQUENCY RANGE—continuous 25 mc. to 500 mc. No coils to change. Rough and vernier tuning controls. MEETS FCC SPECS—reads peak voice deviation directly, 0-25 kc., positive or negative. No charts or tables. ACCURATE—within 10% at full scale. FIELD STRENGTH METER—reads relative transmitter output. PROTECTED—Panel components recessed behind edges of the case. PORTABLE—just a 2-finger load.

FREE! NEW BOOKLET "HOW TO MAKE MONEY IN MOBILE-RADIO MAINTENANCE!" For your copy—plus complete technical data and prices on Lampkin meters—**MAIL COUPON TODAY!**

Just these two meters—with no additional crystals or factory adjustments—are all you need to make FCC required checks on any number of commercial mobile transmitters on hundreds of different frequencies. Lampkin meters are used by many municipalities—by agencies of 41 states—by the service organizations of most two-way radio manufacturers—and by hundreds of independent mobile-service engineers. They are guaranteed to please you, too, or your money will be refunded.



Measurements Section
Lampkin Laboratories, Inc.
Bradenton, Florida

At no obligation to me, please send

- "How To Make Money in Mobile-Radio Maintenance!"
 Technical data and prices on Lampkin Meters

Name _____
Address _____
City _____ Zone _____ State _____

LAMPKIN LABORATORIES, INC.
BRADENTON, FLORIDA

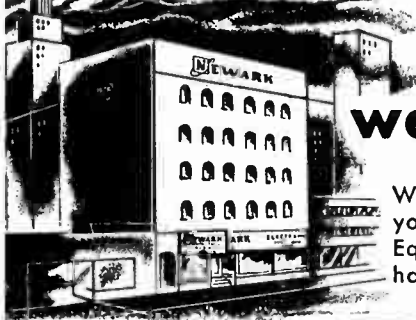

welcome to **NEWARK** ELECTRIC COMPANY

We are as close to you as your mail box . . . ready to fill your request for the latest and finest in Amateur Radio Equipment. Join the ranks of thousands of hams who have enjoyed Newark service for more than 32 years.



RME *Electro-Voice* AMATEUR EQUIPMENT



4301



4300

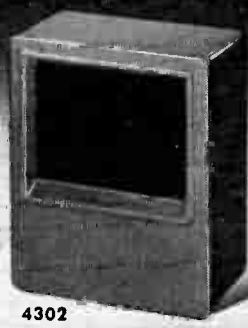

4302

RME 4300 Communications Receiver

Featuring New Stability, Sensitivity and tuning ease. Covers 6 amateur bands, 1.76 to 29.9 mc. on an evenly graduated dial averaging 8 1/2" in length. Stability assured by the use of temperature compensated components and heavy duty chassis and cabinet. Drift is confined to .01% for first 20 min., practically zero drift thereafter. "S" meter calibrated in 6 db steps from S1 to S9 and up to 10 db above. Selectivity: bandwidth is 2.8 kc with steep skirts. Sensitivity: 2 microvolts for 10 db signal-to-noise ratio. Other quality features: 1 to 1 or 75 to 1 ratio planetary drive for easy tuning; Xtal filter with phasing control, separate BFO with variable control for BFO injection voltage. Automatic Noise Limiter, peaked type, set for 85% modulation. Triple spaced tuning condenser reduces microphonics and increases mechanical stability. Provision for Single Side Band adapter with jacks on rear chassis, front panel calibration control, Ant. trimmer, RF gain calibrated 6 db each 5° rotation. 16 1/2"W, 10"H, 10"D. Shpg. wt., 36 lbs.

97F076. NET **194.00**

4301 Side Band Detector-Selector

An efficient and effective unit for improving the reception of AM, CW, and Single Side Band signals adding up to 15 db sensitivity. Operates with any communication receiver having an IF of 455 kc. Feed some of the IF voltage from the associated receiver to the input circuit of the unit and then its output to the audio circuit of the receiver. Plugs directly into jacks on rear of the Model 4300. Contains its own power supply, stable BFO, balanced detector circuit and accurate phase shift network. Adder and subtractor circuits for single side band reception of either upper or lower sideband. AM phone interference can be reduced 50% by selecting the proper sideband. Vernier for fine adjustment of inverted carrier frequency. Provides approx. 40 db attenuation of unwanted sideband. With all cables. Size: 8 1/2 x 10 1/4 x 10 1/4" Shpg wt., 16 lbs.

97F077. NET **75.00**

Model 4302 Matching Speaker

Illustrated above 4-ohm input. 10x8 1/2 x 5 1/2"

97F075. NET **17.50**

FOB Chicago or Inglewood. Include shipping and insurance charges.

TOP DOLLAR TRADE-INS

Newark offers higher dollar value for your outdated-outgrown amateur gear. Your old equipment can help substantially in paying for the newest, most advanced rig in amateur radio. Write today . . . tell us what you have and what you want to buy.

Send for FREE Newark Catalog

308 pages full of the newest developments in Amateur, Radio, TV, High Fidelity and Electronics Equipment. See the latest in communications receivers, transmitters and amateur gear. Write today for your copy.



RME 100 Speech Clipper Prevents over modulation. Operates directly into push-to-talk mike input. Clipping: 3-20 db adjustable in 6 steps. Response: 200-3000 cycles. With tubes.

97F078. 5x7 7/8 x 6". Wt., 9 lbs. NET **39.50**

DB23 Preselector Increases gain and signal-to-noise ratio. Minimum gain: 25 db, 3.5-30 mc. Three tube broad-band circuit has bandswitching and antenna peaking controls. Input: 75-300 ohms impedance, coax, or twin lead. Output: 150-300 ohms internal power supply.

97F079. 5x7 7/8 x 6". 6 1/2 lbs. NET **49.50**

MC-55 Mobile Converter Professional unit can be hooked to auto radio. Covers all Amateur bands from 3.5 to 30 mc. 1.25 microvolt overall sensitivity. Output freq., 1550 kc. Separate input connector and switch for BC antenna. Panel switch cuts out noise limiter for BC reception. 6 or 12 volt operation. Requires 150-180 volts at 25 ma.

97F085. 4 7/8 x 5 9/4 x 5 1/4". 6 lbs. NET **69.50**

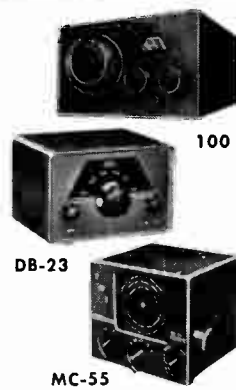

100

DB-23

MC-55



Dept. HB-7, 223 West Madison Street, Chicago 6, Illinois
Dept. HB-7, 4736 W. Century Blvd., Inglewood, California

THE FAST, EASY WAY YOU CAN Learn Code!



Prepare for Your BIG Opportunity...

Picture yourself at your own transmitter . . . sending out radio code, messages that will be received around the globe. Yes, operators like you are waiting to communicate with you today, tonight or anytime. The knowledge of the world . . . intimate friendships you will gain . . . may help you in your business, may be a stepping stone to success.

Wouldn't you like to be the invaluable link with the outside world in time of disaster? Wouldn't you like to serve in a national or local emergency? Be ready for service when the opportunity arises! Learn telegraphy now—the Candler way.

Every day trained code operators are finding their dreams of success coming true. Get ready for your big chance now. Learn code the modern, easy CANDLER way. Get maximum speed and efficiency to qualify as an operator in the quickest, easiest way—the CANDLER SYSTEM OF CHAMPIONS.

For forty-six years the CANDLER SYSTEM has trained beginners for all telegraphing requirements, all operator licenses, highest ratings, and F.C.C. specifications, both amateur and commercial. The record of famous amateurs and expert operators who learned the Candler way is proof of what the Candler System offers you. Find out how you can save time and money learning code and developing skill with the CANDLER SYSTEM. Send for Free Candler Radio Telegraphy today.

CANDLER SYSTEM, P.O. BOX 928
DEPT. 57, DENVER 1, COLORADO, U.S.A.

WORLD CHAMPION TED McELROY SAYS THIS ABOUT THE FAMOUS CANDLER SYSTEM:

"My skill and speed are the result of the exclusive, scientific training Walter Candler gave me. Practice is necessary, but without proper training to develop Concentration, Co-ordination and a keen Perceptive Sense, practice is of little value. One is likely to practice the wrong way."

McElroy is the Official Champion Radio Operator, 75.2 W.P.M. won at Asheville Code Tournament.



SPECIAL COURSES FOR BEGINNERS & OPERATORS

The SCIENTIFIC CODE COURSE, especially designed for the beginner. Teaches the basic principles of sending and receiving code scientifically. Prepares for the following F.C.C. Code License Examinations:

Amateur: Novice (5 w.p.m.) Technician (5 w.p.m.)
General (13 w.p.m.) Amateur Extra (20 w.p.m.)

Commercial: Second and Third Class (16 w.p.m.)

The HIGH SPEED TELEGRAPHING COURSE for high speed and proficiency.

The HIGH SPEED TYPEWRITING COURSE for mastering touch typing, speed and accuracy.

CANDLER SYSTEM • P.O. Box 928
DEPT. 57, DENVER 1, COLO., U.S.A.

FREE BOOKLET . . .

To those seriously interested in learning code, typewriting, or improving these skills to highest proficiency . . . send immediately!

Candler SYSTEM Dept. 57
P. O. Box 928, Denver 1, Colorado

Or 52b, Abingdon Rd., London W.8, England

I am a beginner. I am an operator.

Gentlemen: Yes . . . I am interested in the CANDLER Code Training. Please rush my FREE copy of CANDLER Radio Telegraphy.

Name
Address
City Zone State

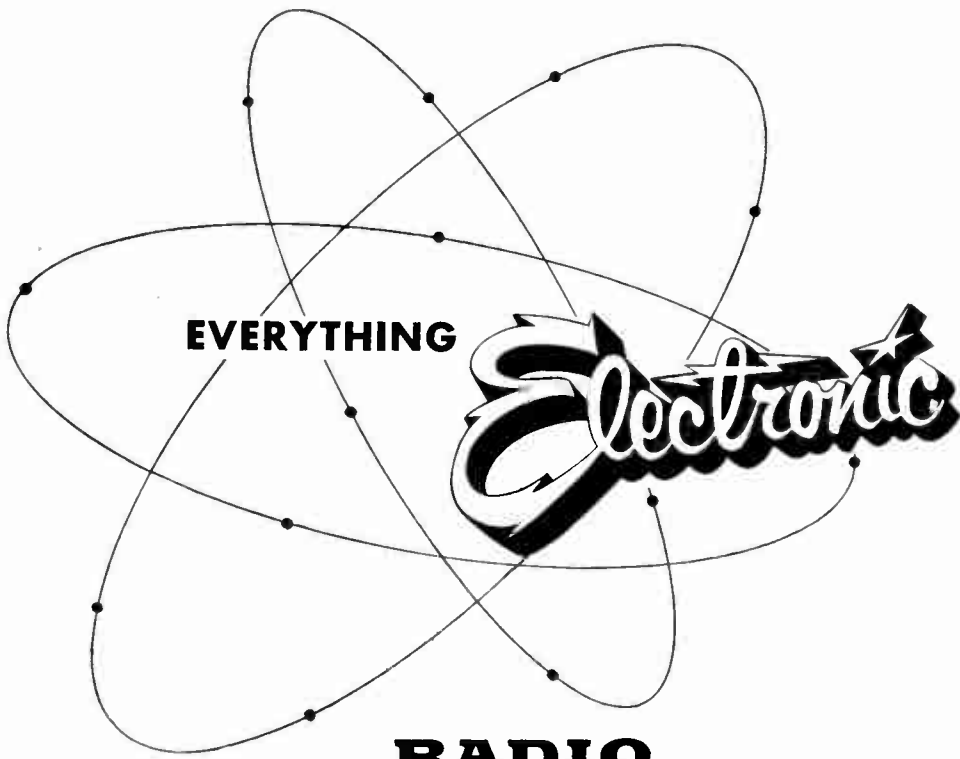

RADIO

INDUSTRY

RESEARCH

EDUCATION

Cameradio, with over 250 Nationally Advertised lines, is recognized as one of the Nation's leading suppliers of electronic equipment and parts.

Over 38 years of experience has earned us a reputation for prompt and efficient service. The next time you need anything electronic . . . call on Cameradio.

Write at once for our FREE 1957 catalogue showing the complete Cameradio line.



Featuring:
Nationally Recognized Products

100

Established 1919

Cameradio

1121 Penn Avenue, Pittsburgh 22, Pa.
Express 1-4000

ATR

Be prepared for any EMERGENCY

INVERTERS

FOR EMERGENCY POWER TO OPERATE
110 VOLT AC HAM GEAR IN YOUR CAR,
boat or plane

EMERGENCY AC POWER!

make your car,
boat or plane a
"rolling power plant"

with

ATR

INVERTERS



for changing your
storage battery
current to A. C.

*Household
ELECTRICITY
Anywhere
in your own car!*

Plugs into
Cigarette Lighter
Receptacle on Dash

\$ 19⁹⁵
AND UP
LIST PRICE



ATR INVERTERS . . .

especially designed for operating
standard 110 volt A. C. . . .

- TAPE RECORDERS • DICTATING MACHINES
- WIRE RECORDERS • ELECTRIC RAZORS
- RADIO SETS • TRANSMITTER SETS
- TEST EQUIPMENT

*See your jobber
or write factory*

ATR

- ✓ NEW MODELS
 - ✓ NEW DESIGNS
 - ✓ NEW LITERATURE
- "A" Battery Eliminators, DC-AC Inverters, Auto Radio Vibrators

AMERICAN TELEVISION & RADIO Co.

Quality Products Since 1931

SAINT PAUL 1, MINNESOTA — U. S. A.

EMERGENCY LIGHTING!

THIS COULD HAPPEN!



Ideal for
Emergency Lighting
and Power Applications
for Civil Defense, Red
Cross, Rescue Work, etc.
Simply Using Extension
Cords.



EASY
TO
INSTALL
EASY
TO
OPERATE

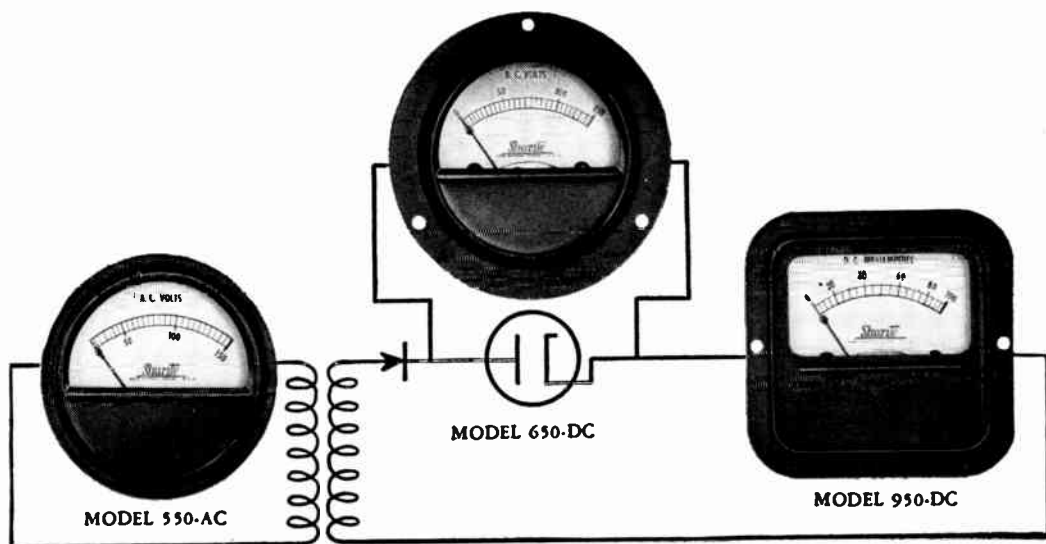

Shurite PANEL METERS ARE POPULAR WITH HAMS BECAUSE THEY'RE . . .

RUGGED Exceptionally high ratio, torque to weight, for fast pointer response. Sturdy construction throughout. Molded inner units with internal and external locking nuts for maximum rigidity.

GOOD LOOKING Dials are metal so they stay attractive in spite of age and moisture. All metal cases have rich telephone black finish. Concealed coils and good, readable scales.

WELL DESIGNED AC meters are double-vane repulsion type using hair-spring and jeweled bearing. Most DC meters are polarized-vane solenoid type. High internal resistance voltmeters available in popular ranges. Accuracy well within 5%.

PRICED RIGHT For instance, the meters pictured are priced at
 Model 950, 0-100 DC Ma. . . . \$1.60
 Model 650, 0-150 DC Volts . . . 2.10
 Model 550, 0-150 AC Volts . . . 3.40
 Other meters are correspondingly reasonable in price, starting at \$1.55. You get the benefit

of low costs made possible by large quantity production.

GUARANTEED For one year from date of purchase against defective workmanship and material, and will be repaired or replaced if sent to the factory postpaid with 40¢ handling charge.

A COMPLETE LINE All of these features are available in over 220 ranges and types; AC, DC, Voltmeters, Ammeters, Milliammeters, Resistance Meters. For instance, DC Milliammeters are made in 65 types and ranges. The newest meters are a 0-3 DC Milliammeter with 500 ohms internal resistance and built-in zero adjuster with ten times the sensitivity of previous 0-3 DC Milliammeters, also a 0-1 DC Milliammeter with 1000 ohms internal resistance and zero adjuster

AVAILABLE Stocked by leading electronic parts distributors in a wide variety of types and ranges. For prompt shipment, contact the authorized Shurite distributor nearest you.

THEY'RE TODAY'S BEST VALUE

Ask for Bulletin No. 57

Shurite

SHURITE METERS • 85 Hamilton Street, New Haven 8, Conn.

the world of electronics is yours!!

FREE!

- RADIO & TV SERVICE
- TRANSISTOR COMPONENTS
- INDUSTRIAL ELECTRONICS
- EXPERIMENTERS' KITS
- AMATEUR RADIO
- HIGH FIDELITY

**RADIO SHACK
212 PG. CATALOG**

57

- Comprehensive Product Listings
- Quick Reference Thumb Index
- Manufacturer And Product Index
- Radio Shack Bargain Specials!



**NEW! EASY CREDIT
"PLAY AS YOU PAY" PLAN**

Only 10% down up to 18 months to pay! Credit available on all orders over \$35.00. Rapid service, no fussing, no red tape!

RADIO SHACK

167 WASHINGTON ST.
BOSTON 8, MASS.

230 CROWN ST.
NEW HAVEN, CONN.

Radio Shack Corp., 167 Washington St., Boston 8, Mass.

Please Send FREE Catalog 57RH to:

Name

Address

City State

Mil. Spec.

If it's worth
engineers'
time...

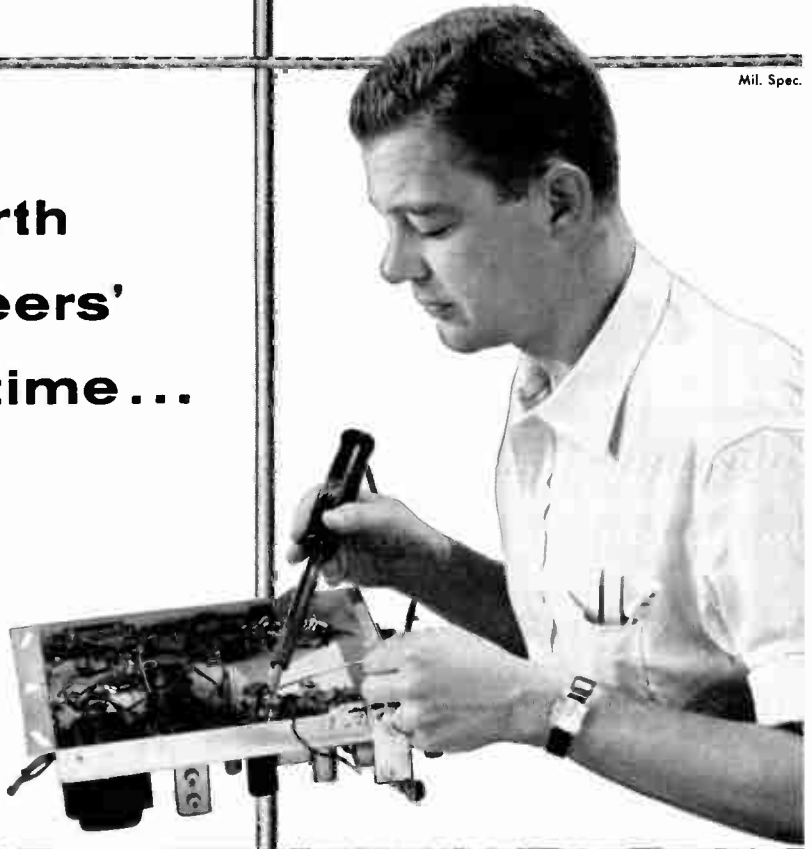

Mil. Spec.

Belden
ELECTRONIC
WIRE

The complete packaged line
—easy to use. Be sure of
the right wire engineered
for the job.

There are 1001 Belden
wires for every Radio and
Electronic requirement.

...it's worth
engineered
electronic wire

Belden

WIREMAKER FOR INDUSTRY
SINCE 1902
CHICAGO

6-8

Magnet Wire • Lead and Fixture Wire • Power Supply Cords, Cord Sets and Portable Cord • Aircraft Wires
Welding Cable • Electrical Household Cords • Electronic Wires • Automotive Wire and Cable

for a CAREER in communications
... to pass FCC amateur exams

LEARN CODE
and Theory

\$3.95
up



EASY, FAST HOME STUDY
with 78 R.P.M. Phonograph Records

PASS COMMERCIAL AND AMATEUR CODE EXAMS, AMATEUR THEORY EXAMS, FOR YOUR FCC LICENSE!

4 AMECO Courses Available:

No. 1 — NOVICE CODE COURSE. You get and keep 10 recordings (alphabet through 8 W.P.M.). Includes typical FCC type code exams. Free instruction book on learning how to send and receive code the simplest, fastest way; plus charts to check your receiving accuracy; plus an album; all for the low price of only..... **\$7.95**

No. 2 — SENIOR CODE COURSE. You get and keep everything given in the Novice Course except that you get 22 recordings (alphabet through 18 W.P.M.), plus typical FCC type code exams for General class and 2nd class commercial telegraph licenses. All this for only..... **\$12.95**

No. 3 — COMPLETE RADIO THEORY COURSE. A complete, simplified home study theory course in radio covering the Novice, Technician, conditional and general classes — all under one cover — with nearly four hundred typical FCC type questions to prepare you for license exam. No technical background required. You also get, FREE, a guide to setting up your own Ham station. All for the amazing low, low price of..... **\$3.95**

No. 4 — NEW ADVANCED COURSE. Prepares Novice operators for the amateur general class and second class commercial license tests. Contains 12 recordings (8 through 18 W.P.M.) PLUS the complete code book — PLUS typical FCC code examinations for general and commercial tests. ALL for only..... **\$6.95**

No. 5 — RADIO AMATEUR QUESTIONS & ANSWER LICENSE GUIDE. A "must" if preparing for Novice, Technician or general class exams. Approx. 200 questions & answers (most multiple choice type) similar to ones given on FCC exams. Has 2 typical FCC type exams. Other questions by subjects, easier to study. Low, low price of..... **50¢**

DELUXE CODE PRACTICE OSCILLATOR

In Kit Form or Wired



The AMECO Code Practice Oscillator, for 110 volts AC or DC, with a built-in 4 inch speaker, produces a pure, steady tone with no clicks or chirps. It can take a large number of headphones or keys. After the code has been learned, the AMECO code practice oscillator is easily converted to an excellent c.w. monitor.

Other features include:

- Variable tone control
- Volume control
- Sturdy grey hammetone cabinet
- Lowest prices

In Kit Form, with Instruction, less tubes (Model CPS-KL) **\$11.75**
Completely Wired & Tested, less tubes (Model CPS-WL) **\$12.95**
Set of two tubes (35W4 and 50C5) **\$ 1.80**

NEW AMECO TRANSMITTER



- Pi-network Output circuit
- Includes Heavy-duty AC power supply
- 6V6 Oscillator and 6X5 Rectifier
- 15 watts input
- For 40 and 80 meters CW
- Crystal controlled
- Attractive grey hammetone finish with white lettering and red knobs
- Simple and Educational building instructions

in kit form **\$16.95*** only

The new AMECO transmitter kit is an ideal unit for the beginner or novice who requires a reliable transmitter. It is a high quality rig containing a heavy-duty transformer choke power supply. It has a Pi section output circuit to work into any random length of antenna wire. **NO ANTENNA TUNER IS NECESSARY.** Keying is clean and chirp-free. TVI suppression features have been included in unit. Kit is low in cost, simple to build, and easy to operate. Units are complete with punched chassis, hardware and instructions.

* Model AC-1 with coil kit for any 1 band, less tubes and crystal..... **\$16.95**
Extra coil kit CK-1..... **.50**
Set of tubes for above (6V6 & 6X5)..... **2.13**

BEAT TVI

STAY ON THE AIR!

The AMECO low cost way!

AMECO LOW PASS FILTER



The AMECO low pass filter suppresses the radiation of all spurious signals above 40 Mc. from the transmitter. The filter uses a Constant K Circuit, and is designed for Coaxial cable (52 to 72 ohms). Other features include:

- Negligible Insertion Loss • 35 Db and more attenuation of harmonic & spurious frequencies above 50 Mc. • Will handle up to 200 watts of RF power • Each unit complete with bracket, and instructions

Model LN1 with 2 RCA phono jacks..... **\$1.95**
Deluxe Model LN2 with 2 50-239 Coax. Connectors..... **\$3.45**

HIGH PASS FILTER



The AMECO high pass filter is placed in series with the TV receiver's antenna to prevent the transmitter's signal from entering the receiver. All frequencies above 45 Mc are passed through without loss. The AMECO high pass filter is designed for use with the common 300 ohm twin line.

OTHER FEATURES INCLUDE:

- 40 db and more attenuation at 14 Mc. and below; 20 db attenuation at 10 meters.
- Negligible insertion loss
- Filter uses balanced constant K circuit

At the amazing low, low price of **89¢** Ametour Net

AMERICAN ELECTRONICS CO.

1203 1/2 Bryant Ave., New York 59, N.Y. For Export Inquire Dept. H

SAVE WITH OUR SURPRISE TRADE-IN ALLOWANCES!

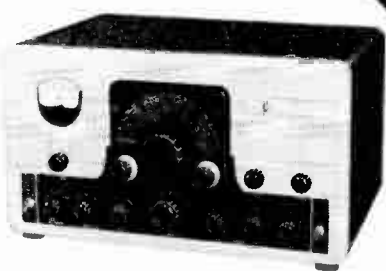

The trend is up-Up-UP on trade-ins at Walter Ashe. Our "Surprise" trade-in allowances were never higher than now. That means far lower prices for you on the new equipment of your choice.



STOP DREAMIN' - GET YOUR TRADE-IN DEAL WORKIN' TODAY!

ASK ABOUT OUR TIME PAYMENT PLAN

Get your trade-in deal working today. Just let us know the make and model number of the used equipment you have to trade and the make and model number of the new gear you are interested in. You'll have our answer by return mail.

TRADES CONFINED TO EQUIPMENT MANUFACTURED SINCE 1945

Walter Ashe
RADIO CO.
 1125 PINE ST. • ST. LOUIS 1, MO.

FRETLINE

THE READY MADE OPEN WIRE

H. F. TRANSMISSION LINE

NOW AVAILABLE IN HEAVY DUTY SIZES

Fretline type F6-12-2 a 600 ohm impedance transmission line for high power transmitting duty at high or low frequencies. It is constructed with quality in mind. Recommended where exact impedance is wanted and maximum strength.

Prices on request.

Fretline type F6-12-4 a 600 ohm impedance transmission line for high power transmitting duty at high or low frequencies. Heavy duty construction.

Prices on request.

Fretline type F12-6-1 a 600 ohm impedance transmission line for medium power transmitting duty at high or low frequencies. Quality constructed, exact impedance, maximum strength.

Dealer Net Price \$.38 a ft.

Fretline type F12-6-3 a 600 ohm impedance transmission line for medium power transmitting duty. Economically constructed with maximum strength.

Dealer Net Price \$.14 a ft.

Fretline type F16-3.75-2 a 600 ohm impedance transmission line for light transmitting duty. Rugged construction.

Dealer Net Price \$.10 a ft.

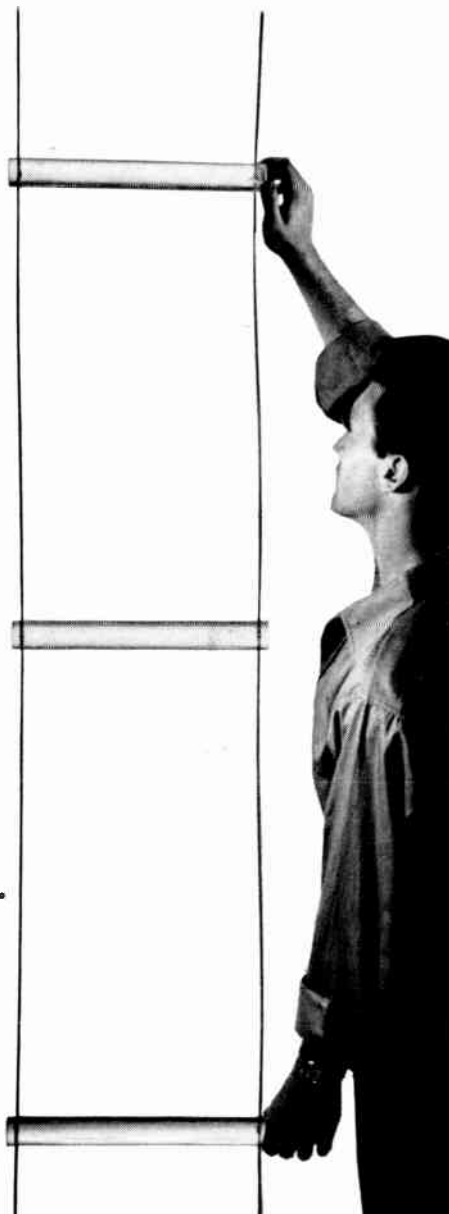

Type E and type BC Fretline still available and remains

THE LEADING LINE AROUND THE WORLD.



406 NORTH CRAIG STREET, PITTSBURGH 13, PENNSYLVANIA

Fretline is manufactured under Fretco patents. Other patents pending.

*Trade Mark Reg. U. S. Pat. C.



FORT ORANGE
Radio Distributing Co. INC.
 904 BROADWAY, ALBANY 4, N. Y., U. S. A
 AMATEUR HEADQUARTERS

National

tuned to tomorrow



NC 300 HAM RECEIVER

National's famous "Dream Receiver." An extremely sensitive, highly stable receiver with exceptional calibration accuracy. Has eight electrical bands, 160 through 10 meters, plus a special 30-35 mc range used as a tunable IF for 6, 2, and 1 1/4 meters.
 Amateur Net \$399.95.

THE NC 300 FEATURES

Razor-sharp selectivity, reliable frequency stability, and sensitivity of better than 1.5 microvolts are yours in the fabulous NC-300 "dream receiver". Complete the dream by assembling a rig especially designed for the NC-300. Or if you're considering a new receiver, consider the exceptional flexibility you'll get when you buy the NC-300 with the full set of accessories.

Ask UNCLE DAVE about our easy payment plan that gives you up to 18 months to pay after downpayment. Life insurance included at no extra cost.

Write Uncle Dave
WZAPF
 with your needs
 and problems.

WE SPECIALIZE IN FOREIGN TRADE

PLUS —
 these
 "dream rig"
 accessories...

NC-300TS SPEAKER. Perfectly matched to the receiver in a two-tone grey enamel case with black and silver grille cloth. 8" dia. cone. Amateur Net \$17.00

NC-300CC CONVERTER CABINET. Attractive matching cabinet for housing the three accessory converters for the 6, 2, and 1 1/4 meter bands. Eliminates unplugging of converters. Switches all power and IF output leads. Amateur Net \$17.95



XCU-300 PLUG-IN CRYSTAL CALIBRATOR. Plugs into NC-300 receiver where its operating power is derived. Provides calibrating signal every 100 kc up to 29.7 mc. Is factory pre-set at exactly 100 kc. Amateur Net \$19.95

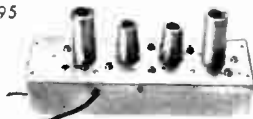

CRYSTAL CONVERTERS. When fitted into converter cabinet (above), these converters need not be unplugged or shut off to change bands. Can be used with 3 separate antennas, thus eliminating the need for changing antennas when switching bands. Tube complement: 6BZ7, 6AK5, 6AK5, 6U8. Output frequency: 30-35 mc. Input impedance: 50-70 ohms. Output impedance: 50 ohms. Power required: 6.3 volts at 1.2 amps, 150 volts at 25 ma derived from NC-300 receiver. Amateur Net \$39.95

24 HR. SERVICE
 on stock items

International Rectifiers

SELENIUM · GERMANIUM · SILICON



SUB-MINIATURE SELENIUM DIODES

Developed for use in limited space at ambient temperatures ranging from -50°C to $+100^{\circ}\text{C}$. Encapsulated to resist adverse environmental conditions. Output voltages from 20 to 160 volts; output currents of 100 microamperes to 11 MA. Bulletin SD-1B



GERMANIUM DIODES

This series of general purpose, high quality point contact diodes provide excellent rectification efficiency for very high frequency applications. Special "RED DOT" series available for ambient temperatures from -55°C to $+100^{\circ}\text{C}$. Bulletin GD-2

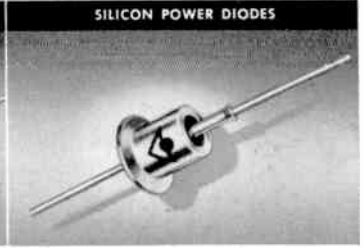

SILICON POWER DIODES

For temperature applications to 150°C , these fused junction diodes withstand exposure from -55°C to $+170^{\circ}\text{C}$. Peak inverse voltage rating from 50 volts to 600 volts. Welded, hermetically sealed construction. Four types. Bulletin SR-132



HIGH VOLTAGE CARTRIDGE RECTIFIERS

Designed for long life and reliability in Half-Wave, Voltage Doubler, Bridge, Center-Tap Circuits, and 3-Phase Circuit Types. Phenolic Cartridge and Hermetically Sealed types available. Operating temperature range: -65°C to $+100^{\circ}\text{C}$. Specify Bulletin H-2



TV AND RADIO RECTIFIERS

The widest range in the industry! Designed for Radio, Television, TV booster, UHF converter and experimental applications. Input ratings from 25 to 195 volts AC and up. DC output current 10 to 1,200 MA. Write for application information. Bulletin ER-178-A



SELENIUM PHOTOCELLS - SUN BATTERIES

Self-generating photocells available in standard or custom sizes, mounted or unmounted. Optimum load resistance range: 10 to 10,000 ohms. Output from .2 MA to 60 MA in ave. sunlight. Ambient temperature range -65°C to $+100^{\circ}\text{C}$. Bulletin PC 649

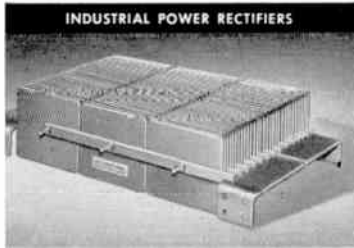

INDUSTRIAL POWER RECTIFIERS

For all DC power needs from microwatts to kilowatts. Features: long life; compact, light weight and low initial cost. Ratings: to 250 KW, 50 ma to 2,300 amperes and up. 6 volts to 30,000 volts and up. Efficiency to 87%. Power factor to 95%. Bulletin C-349

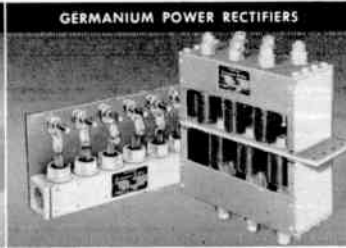

GERMANIUM POWER RECTIFIERS

3 Styles featuring efficiency to 97%, low forward drop, high reverse to forward current ratio, unlimited life. Ratings: 26 to 66AC input v. per junction. 150 to 100,000 amps DC output. Operating temperature range: -55°C to $+75^{\circ}\text{C}$. Bulletin GPR-1



SILICON POWER RECTIFIERS

High power-5 amp to 100 amp-silicon fused junction type. Input ratings to 200 PIV. Temp. range: up to 150°C case temperature. Available in individual diodes or all usual power rectifier circuits. Data available on models for forced air and liquid cooling.

Bulletin SPR-1

a world of difference
through research!



For bulletins on products described WRITE ON YOUR LETTERHEAD
to our PRODUCT INFORMATION DEPARTMENT

International Rectifier

C O R P O R A T I O N

EXECUTIVE OFFICES: 1521 E. GRAND AVE., EL SEGUNDO, CALIFORNIA • PHONE OREGON 8-6281

WORLD'S LARGEST SUPPLIER OF INDUSTRIAL METALLIC RECTIFIERS

109

LEARN

*The Fast
Scientific Way!*

CODE

An Exclusive, Recorded System Developed by ETI and used by the Armed Forces.

- Learn By Sound Only.
- Correct Speeds From the Start.
- Static and Interference Records.
- 36 Extra Long Playing Time Records.
- 3 Albums:

- #1 Alphabet, Number, Punctuation
- #2 Four through ten words per minute.
- #3 Eleven through twenty words per minute.

\$12.00 Per Album
 Complete Set **\$33.00**
Free Grading Service Included

NOVICE

Get Your Novice License!
 Complete Novice Course — Only **\$29.95**
 Code — 5 WPM

ELECTRONICS COMMUNICATION ENGINEERING

*Learn Electronics By
Photo-Sound. The Complete
Audio-Visual Course Available
through:*

- Resident School.
- Home Study.

This is a Scientifically planned Course. Basic Electronics Through Radar, Loran, and FCC Preparation.

ETI Provides Laboratory Training to both the Home Study and Resident Student.

Complete Math-Training and Refresher.

ETI also furnishes this Photo-Sound Method to the Armed Forces.

Approved For Veterans

SEE YOUR LOCAL JOBBER OR WRITE US FOR FREE INFORMATION

Electronic Technical Institute
 970 West Manchester Avenue Dept. AR-1
 Inglewood, California
 Gentlemen: I am interested in your training
 Course in Code Novice Electronics
 Send Information:

Name.....
 Address.....
 City.....Zone.....State.....

ELECTRONIC TECHNICAL INSTITUTE

970 W. Manchester Ave.
 Inglewood, California

*Serving the Amateur and Industry
for Over a Quarter Century!*

ARROW..... First With Everything

in HAM EQUIPMENT

**OUR
HAM
Dept.**

W2IEK

W2JBA

W2HCZ

W2SME

W2UUE

- Complete Stocks Of All Standard Brands.
- Quick Personalized Service.
- Lowest Prices.
- Same Day Mail Order Service.



EXPORT Dept.

THORDARSON

World Wide Service For Everything In Industrial Electronics, Amateur Equipment, High-Fidelity And Television & Radio Parts.

Just a letter or cable will bring you a fast quotation for all your electronic needs. All export orders get fast personalized service regardless of how large or small. Quotations made by ARROW will be itemized as to your cost of merchandise, shipping, export packing, insurance and complete documentation.

Western Union FAX Mineola, N. Y. Teletype G CY N. Y. 460

Cable Address "AROELECTRO-N.Y."

FREE!

With any purchase from Arrow. Amateur band frequency allocation chart in color.

ARROW ELECTRONICS, INC.

65 Cortlandt St., New York 7, N. Y. • Dlgby 9-3790
525 Jericho Turnpike, Mineola, N. Y. • Pioneer 6-8686

Learn Code the EASY Way

Beginners, Amateurs and Experts alike recommend the INSTRUCTOGRAPH, to learn code and increase speed.

Learning the INSTRUCTOGRAPH way will give you a decided advantage in qualifying for Amateur or Commercial examinations, and to increase your words per minute to the standard of an expert. The Government uses a machine in giving examinations.

Motor with adjustable speed and spacing of characters on tapes permit a speed range of from 3 to 40 words per minute. A large variety of tapes are available — elementary, words, messages, plain language and coded groups. Also an "Airways" series for those interested in Aviation.

MAY BE PURCHASED OR RENTED

The INSTRUCTOGRAPH is made in several models to suit your purse and all may be purchased on convenient monthly payments if desired. These machines may also be rented on very reasonable terms and if when renting you should decide to buy the equipment the first three months rental may be applied in full on the purchase price.

ACQUIRING THE CODE

It is a well-known fact that practice and practice alone constitutes ninety per cent of the entire effort necessary to "Acquire the Code," or, in other words, learn telegraphy either wire or wireless. The Instructograph supplies this ninety per cent. It takes the place of an expert operator in teaching the student. It will send slowly at first, and gradually faster and faster, until one is just naturally copying the fastest sending without conscious effort.

BOOK OF INSTRUCTIONS

Other than the practice afforded by the Instructograph, all that is required is well directed practice instruction, and that is just what the Instructograph's "Book of Instructions" does. It supplies the remaining ten per cent necessary to acquire the code. It directs one how to practice to the best advantage, and how to take advantage of the few "short cuts" known to experienced operators, that so materially assists in acquiring the code in the quickest possible time. Therefore, the Instructograph, the tapes, and the book of instructions is everything needed to acquire the code as well as it is possible to acquire it.

MACHINES FOR RENT OR SALE



The Instructograph

ACCOMPLISHES THESE PURPOSES:

FIRST: *It teaches you to receive telegraph symbols, words and messages.*

SECOND: *It teaches you to send perfectly.*

THIRD: *It increases your speed of sending and receiving after you have learned the code.*

With the Instructograph it is not necessary to impose on your friends. It is always ready and waiting for you. You are also free from Q.R.M. experienced in listening through your receiver. This machine is just as valuable to the licensed amateur for increasing his speed as to the beginner who wishes to obtain his amateur license.

Postal Card *WILL BRING FULL PARTICULARS IMMEDIATELY*

THE INSTRUCTOGRAPH CO.

4707 SHERIDAN ROAD

CHICAGO 40, ILLINOIS

FREED

offers for Immediate Delivery

MAGNETIC AMPLIFIERS AND SATURABLE TRANSFORMERS

FAST RESPONSE MAGNETIC AMPLIFIERS

2 $\sqrt{2}$ response Phase reversible

Cat. No.	Supply Freq. in C.P.S.	Power Out. Watts	Volt. Out. V. AC	AO or DC signal voltage req'd for full output.	
MAF-1	60	13	110	1.0	—
MAF-6	400	5	57.5	1.2	0.4
	400	10	57.5	1.6	0.6
MAF-7	400	15	57.5	2.5	1.0

SINGLE ENDED MAGNETIC AMPLIFIERS

Cat. No.	Supply Freq. C.P.S.	Power Out. Watts	Sig. req'd for full outp. MA-DC	Total res. Contr. wdg. K Ω	Load res. ohms
MAO-1	60	4.5	3.u	1.2	3800
MAO-2	60	20	1.8	1.3	700
MAO-4	60	400	9.0	10.0	25
MAO-5	60	575	6.0	10.0	25

PUSH-PULL MAGNETIC AMPLIFIERS

Phase reversible

Cat. No.	Supply Freq. C.P.S.	Power Out. Watts	Volt. Out. V. AC	Sig. req'd for full outp. MA-DC	Total res. contr. wdg. K Ω
MAP-1	60	5	—	1.2	1.2
MAP-2	60	15	115	1.6	2.4
MAP-3	60	50	115	2.0	0.5
MAP-3-A	60	50	115	7.0	2.9
MAP-4	60	175	115	8.0	6.0
MAP-7	400	15	115	0.6	2.8
MAP-8	400	50	110	1.75	0.6

SATURABLE TRANSFORMERS

Phase reversible

Cat. No.	Supply Freq. C.P.S.	Power Out. Watts	Volt. Out. V. AC	Sig. req'd for full outp. MA-DC	Total res. contr. wdg. K Ω
MAS-1	60	15	115	6.0	27
MAS-2	400	6	115	4.0	10
MAS-5	400	2.7	26	4.0	3.2
MAS-6	400	30	115	4.0	8.0
MAS-7	400	40	115	5.5	8.0

All units designed for 115V-AC operation

VARIABLE TEST VOLTAGE MEGOHMMETER NO. 1620

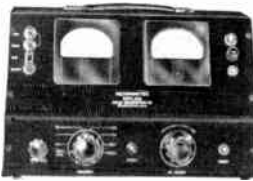

The Freed Type 1620 Megohmmeter is a versatile insulation resistance measurement instrument with a continuously variable DC test potential from 50 to 1000 volts. Components such as transformers, condensers, motors, printed circuits, cables and insulation material can be tested at their rated voltage and above, for safety factor. Resistance — 0.1 megohms to 4,000,000 megohms.

Voltage — variable, 50-1000 volts. Accurate — plus or minus 5% on all ranges.

Simple — for use by unskilled operators. Safe — high voltage relay controlled. Self contained — AC operated.

ALSO AVAILABLE:

Type 1620C MEGOHMMETER — a type 1620 with additional circuitry for testing capacitors.

Type 1020B MEGOHMMETER — a 500 volt fixed test potential. Range 1 megohm to 2 million megohms.

Type 2030 PORTABLE MEGOHMMETER — battery operated, 500 volt test potential. Range 1 megohm to 10 million megohms.

FOR PRECISION LABORATORY OR PRODUCTION TESTING



1110-AB INCREMENTAL INDUCTANCE BRIDGE AND ACCESSORIES

Accurate inductance measurement with or without superimposed D.C., for all types of iron core components.

Inductance: 1 Millihenry to 1000 Henry
Frequency: 20 to 10,000 Cycles
Accuracy: 1% to 1000 Cycle, 2% to 10K

Conductance: 1 Micromho to 1 MHO

"Q": 0.5 to 100

Superimposed D.C.: Up to 1 Ampere

Direct Reading: For use by unskilled operators.

ACCESSORIES AVAILABLE:

1140-A Null Detector

1210-A Null Detector — V.T.V.M.

1170 D.C. Supply and 1180 A.C. Supply

MIL-T-27A POWER, FILAMENT, PULSE & AUDIO TRANSFORMERS

POWER TRANSFORMERS-STANDARD

All primaries 105/115/125 v., 60 c.p.s.

Cat. No.	Hi Volt Sec.	ct	DC Volts	Filament #1		Filament #2		MIL Case Size
				Volt	Amp.	Volt	Amp.	
MGP1	400/200	✓	185 .070	6.3/5	2	6.3	3	MA
MGP2	650	✓	260 .070	6.3/5	2	6.3	4	JB
MGP3	650	✓	245 .150	6.3	5	5.0	3	KB
MGP4	800	✓	318 .175	5.0	3	6.3	8	LB
MGP5	900	✓	345 .250	5.0	3	6.3	8	MB
MGP6	700	✓	255 .250					KB
MGP7	1100	✓	419 .250					LB
MGP8	1600	✓	640 .250					NB

FILAMENT TRANSFORMERS-STANDARD

All primaries 105/115/125 v., 60 c.p.s.

Cat. No.	Secondary		Test VRMS	MIL Case
	Volt	Amp		
MGF1	2.5	3.0	2,500	EB
MGF2	2.5	10.0	2,500	GB
MGF3	5.0	3.0	2,500	FB
MGF4	5.0	10.0	2,500	HB
MGF5	6.3	2.0	2,500	FB
MGF6	6.3	5.0	2,500	GB
MGF7	6.3	10.0	2,500	JB
MGF8	6.3	20.0	2,500	KB
MGF9	2.5	10.0	10,000	JB
MGF10	5.0	10.0	10,000	KB

PULSE TRANSFORMERS

Cat. No.	Blockg. Disc.	Int. Coupling	Low. Pow. Out.	Pulse Voltage Kilovolts	Pulse Duration Microseconds	Duty Rate	No. of Wdgts.	Test Volt. VRMS	Char. Imp. Ohms
MPT1	✓	✓	✓	0.25/0.25/0.25	0.2-1.0	.004	3	0.7	250
MPT2	✓	✓	✓	0.25/0.25	0.2-1.0	.004	2	0.7	250
MPT3	✓	✓	✓	0.5/0.5/0.5	0.2-1.5	.002	3	1.0	250
MPT4	✓	✓	✓	0.5/0.5	0.2-1.5	.002	2	1.0	250
MPT5	✓	✓	✓	0.5/0.5/0.5	0.5-2.0	.002	3	1.0	500
MPT6	✓	✓	✓	0.5/0.5	0.5-2.0	.002	2	1.0	500
MPT7	✓	✓	✓	0.7/0.7/0.7	0.5-1.5	.002	3	1.5	200
MPT8	✓	✓	✓	0.7/0.7	0.5-1.5	.002	2	1.5	200
MPT9	✓	✓	✓	1.0/1.0/1.0	0.3-3.5	.002	3	2.0	200
MPT10	✓	✓	✓	1.0/1.0	0.3-3.5	.002	2	2.0	200
MPT11	✓	✓	✓	1.0/1.0/1.0	1.0-5.0	.002	3	2.0	500
MPT12	✓	✓	✓	0.15/0.15/0.3/0.3	0.2-1.0	.004	4	0.7	700

AUDIO TRANSFORMERS

Freq. resp. 300 to 10000 cps — 2 DB.

All Case Sizes A1

Catalog No.	Application	Prim. Ohms	Impedance		P. S. Ohms	P. S. Ohms	Max. I. Amps	Max. I. Ohms
			CL	DC				
MGA1	Single or P.P. Plates — to Single or P.P. Grids	10K	✓	90K Split	✓	10	10	15
MGA2	Line to Voice Coil	600 Split		4, 8, 16		0	0	33
MGA3	Line to Single or P.P. Grids	600 Split		135K	✓	0	0	15
MGA4	Line to Line	400 Split		600 Split		0	0	15
MGA5	Single Plate to Line	7.6K 4.8T		600 Split		40	40	33
MGA6	Single Plate to Voice Coil	7.0K 4.8T		4, 8, 16		40	40	33
MGA7	Single or P.P. Plates to Line	15K	✓	600 Split		10	10	33
MGA8	P.P. Plates to Line	24K	✓	600 Split		10	1	30
MGA9	P.P. Plates to Line	40K	✓	600 Split		10	1	27

Write for detailed listing, or special requirements, and copies of complete Transformer and Laboratory Test Instrument Catalogs

FREED TRANSFORMER CO., INC.

1718-36 WEIRFIELD ST., BROOKLYN (Ridgewood) 27, N. Y.

All From One Source

These four quality lines of Electronic Components may be obtained quickly and conveniently from Distributors who stock ERIE RESISTOR CORPORATION products.



ERIE Electronic Components enjoy the reputation of having the highest quality and make up the most complete line of Ceramic Replacement Capacitors. Distributor Stock items are representative of the most common types used by dealers, servicemen, experimenters, amateurs, laboratories, project engineers, and industrials.



CORNING Glass Electronic Components include the complete line of Fixed Glass Capacitors, Direct Traverse and Midget Rotary Glass Trimmer Capacitors, and various types of Low Power, Precision and High Power Glass Resistors.



ERIE-Chemelec Teflon Electronic Components are made of the most nearly perfect insulating material available, and are ideally suited to withstand high humidity, high or low temperatures, high altitudes, high voltages, and high frequency operation. It is serviceable at any temperature from -110° to 550°F for long periods with negligible change in critical electrical characteristics.



GRIGSBY-ALLISON Switches are known throughout the industry for dependable quality and smooth performance. They include a complete variety of styles for all types of applications.

ORDER NOW
From Your
ERIE
DISTRIBUTOR



ERIE ELECTRONICS DISTRIBUTOR DIVISION

ERIE RESISTOR CORPORATION

Main Offices: ERIE, PA.

Factories: ERIE, PA. • LONDON, ENGLAND • TRENTON, ONTARIO

**GREATEST
ADVANCE IN
SHOP-METHOD
HOME TRAINING**

EARN MORE MONEY...GET INTO TELEVISION ELECTRONICS-RADIO

Learn ALL 8 PHASES in ONE MODERN HOME-STUDY COURSE
At Home - In Spare Time

YOU GET ALL THIS NEWEST PRACTICAL EQUIPMENT

- Parts to build a modern TV set, including all tubes plus a large screen Picture Tube
- Parts to build a powerful Superhet Receiver, standard broadcast and short wave
- Parts to conduct many experiments and build Continuity Checker, RF Oscillator, TV Circuits, Audio Oscillator, TRF Receiver, Signal Generator
- A Valuable Professional Multitester

**19 BIG KITS
YOURS TO KEEP**

YOUR NATIONAL SCHOOLS TELERAMA COURSE COVERS ALL 8 PHASES

- | | |
|------------------------------------|--------------------------------|
| 1. TELEVISION, INCLUDING COLOR TV | 5. PREPARATION FOR FCC LICENSE |
| 2. RADIO, FM AND AM | 6. AUTOMATION |
| 3. INDUSTRIAL ELECTRONICS | 7. RADAR AND MICRO WAVES |
| 4. SOUND RECORDING AND HI FIDELITY | 8. COMMUNICATIONS |

YOU ARE NEEDED IN THE TELEVISION-ELECTRONICS-RADIO INDUSTRY!

You can build a secure future for yourself if you get into Electronics NOW! Today's shortage of trained technicians creates tremendous opportunities. National Schools Shop-Method trained technicians are in constant and growing demand for high-pay jobs in Broadcasting and Communications, Electronic Research, Servicing and Repair, and many other branches.

Let National Schools, a Resident Technical School for over 50 years train you for today's unlimited opportunities in electronics! Our Shop Method trains you to be a MASTER-TECHNICIAN. Completely up to date, developed by experienced instructors and engineers, your Telerama Course will teach you all phases of the industry quickly, clearly and correctly. You can master the most modern projects, such as Color TV, printed circuits - even prepare for FCC License without taking a special

course. You can handle sales, servicing, manufacturing, or make good money in your own business. SEND FOR FACTS TODAY!

EARN AS YOU LEARN. Many of our students earn their entire tuition and more in Spare Time jobs we show them how to do while learning.

YOU GET EVERYTHING YOU NEED - Clear, profusely illustrated lessons, shop-tested manuals, modern circuit diagrams, practical job projects - all the valuable equipment shown above

- many other materials and services - consultation privilege with our qualified staff, and Graduate Employment Service. EVERYTHING YOU NEED for outstanding success in Electronics.

RESIDENT TRAINING AT LOS ANGELES

If you wish to take your training in our Resident School at Los Angeles, the world's TV capital, start NOW in our big, modern Shops, Labs and Radio-TV Studios. Here you work with latest Electronic equipment - professionally installed - finest, most complete facilities offered by any school. Expert, friendly instructors. Personal attention. Graduate Employment Service. Help in finding home near school - and part time job while you learn. Check box in coupon for full information.



MEMBER



FREE! Fully illustrated "Career" Book in TV-Radio-Electronics. PLUS actual sample lesson - yours at no cost, no obligation. CLIP COUPON NOW... MAIL IT TODAY!

APPROVED FOR G. I. TRAINING NATIONAL SCHOOLS

4000 S. FIGUEROA ST., LOS ANGELES 37, CALIF.
187 N. LA SALLE ST., CHICAGO 1, ILL.
IN CANADA: 811 W. HASTINGS ST., VANCOUVER, B. C.

NATIONAL SCHOOLS

TECHNICAL TRADE TRAINING SINCE 1903
LOS ANGELES 37, CALIFORNIA

GET FAST SERVICE - MAIL NOW TO OFFICE NEAREST YOU!

NATIONAL SCHOOLS, DEPT. RIS-17
4000 S. FIGUEROA ST. OR 187 N. LA SALLE ST.
LOS ANGELES 37, CALIF. OR CHICAGO 1, ILL.
Rush free TV-Radio "Opportunity" Book and sample lesson. No salesman will call.

NAME _____ AGE _____
ADDRESS _____
CITY _____ ZONE _____ STATE _____

Check if interested ONLY in Resident School training at Los Angeles.
VETERANS Give date of Discharge _____

Same **HIGH** Quality
NEW LOW PRICES!

Antenna Masts—Highest grade stainless steel—17-7 Ph. Exceptional high strength and corrosion resistance. 84½" mast can be bent to bring tip and base 30" apart at base level without distortion! Taper ground, 57" to 96" lengths. Model WCA-3B. Specify length.



Heavy-Duty Antenna Base—Any vertical position can be obtained from adjustable swivel ball design. Positive positioning of the antenna assured under most severe vibration and shock conditions. High "Q" bakelite insulator. Wrenches, ground, and solder lugs included. Model WCA-3.

Heavy-Duty Spring—Barrel type for long life and extra strength. Bends 100° without damage. Heavy cadmium plating protects against rust and corrosion. Non-corroding center conductor. Tightening wrenches supplied. Model WCA-3A.



WARD COMMUNICATION ANTENNAS

**quality antennas for
your mobile
application**

Ward high-quality, heavy-duty, mobile antennas are completely reliable with an unsurpassed field record of service. Prices, new, reduced as much as 20%.

Write today for new catalog

Ward also manufactures disguise antennas and ground plane antennas. Other new products to be announced soon. Ask your supplier for new catalog containing complete specifications and information on our product line, or write us.

Ask your supplier about Ward's New Complete Line of amateur mobile antennas and mounts.

WARD PRODUCTS CORPORATION
DIVISION OF THE GABRIEL CO.

1148 EUCLID AVE. • CLEVELAND 15, OHIO



TWO-WAY RADIO

communications equipment

VHF-FM FOR:

MOBILE
AIRCRAFT
MARINE
MOTORCYCLE
PORTABLE
BASE

VHF-AM FOR:

AIRPORT VEHICLES
GROUND STATIONS
POINT-TO-POINT

VHF

ANTENNAS
REMOTE CONTROLS
ACCESSORIES



FLIGHTCOM

MODEL 400-12/24 SERIES

VHF-FM for AIRCRAFT

Provides communications between ground FM systems and executive, patrolling and utility aircraft. Used by fishing fleets, petroleum producers, pipe line helicopters, State police, Conservation departments, crop dusters, power companies and departments of the U. S. government.

All FLIGHTCOM models are on FCC "List of equipment acceptable for licensing" and are certified with the Federal Civil Defense Administration.



Model
400-12/24
Chassis

FLIGHTCOM PACKAGE

FEATURES:

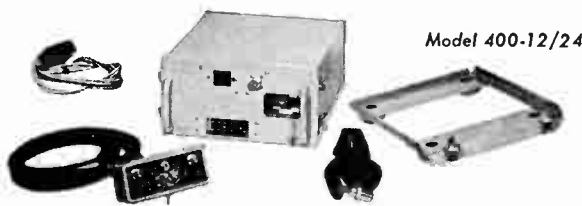

Model 400-12/24

- **COMPACT** . . . Case size 14" x 11 1/2" x 6 1/2"
- **LIGHT** . . . 22 lbs. (without antenna and speaker)
- **POWERFUL** . . . 25 watts output
- **UNIVERSAL** . . . instantly changed from 12 volt to 24 volt operation
- **EFFICIENT** . . . low battery drain: on 12 volt—total standby. 4.5 amps, transmitting 10 amps. on 24 volt—total standby 2.5 amps, transmitting 5 amps.
- **LOUD** . . . 1 watt minimum with less than 8% distortion.
- **PERFORMANCE** . . . identical with ground systems.
- **QUALITY** . . . exceptional value/price ratio.

ATTENTION DEALERS!
Write for available territories.



DESIGNERS AND MANUFACTURERS OF

RADIO COMMUNICATIONS EQUIPMENT

COMMUNICATIONS COMPANY, Inc.

FOUNDED 1938

CORAL GABLES, MIAMI 34, FLORIDA

CABINETS

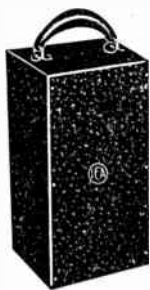

ALUMINUM OR STEEL
PORTABLE CABINETS
Series No. 29860



DE LUXE SLOPING PANEL
CABINETS
Series No. 3990



COMPOSITE SPEAKER
CABINET
Series No. 3986

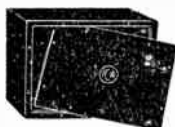

ALUMINUM OR STEEL
CABINETS
Series No. 29840

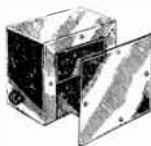

UTILITY CABINETS WITH
BUILT-IN-CHASSIS
Series No. 3816

CHASSIS

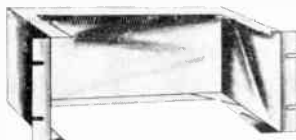

Panel Chassis
Series No. 29060

CASES



DE LUXE METER CASES
Series No. 3995



STREAMLINED METER
CASES
Series No. 3997



MIDGET SPEAKER
CASES
Series No. 3986

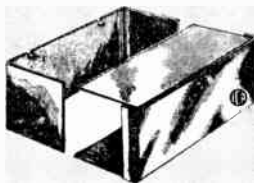

CHANNEL-LOCK ALUMINUM
BOXES
Series No. 29200

insuline
Corporation of America
186 Granite St., Manchester N.H.
(Van Norman Industries)

Insuline distributors every-
where stock the line of metal
 housings, antennas and elec-
tronic components.

BOXES

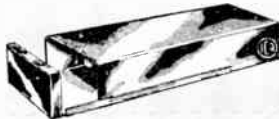

SLIP COVER ALUMINUM
BOXES
Series No. 29130



"FLEXI-MOUNT" ALUMINUM
CASES
Series No. 29435

CODE SETS



SIGNA-TONE CLASSROOM
MODEL
No. 4301



DELUXE SIGNA-TONE
No. 4300



"TRIPLEX" RADIO AND
TELEGRAPH PRACTICE SET
No. 70



UNBREAKABLE MORSE CODE
RECORD SET
Series No. 1800

COMMUNICATION ANTENNAS (NEMCO DIV.)

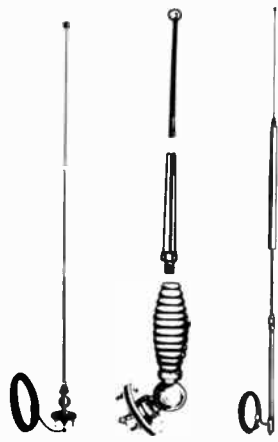

NP 85

NC 89

NC 88

Serving the entire Western Region . . . Alaska . . . and the Pacific Area . . .

The Elmar Pattern*

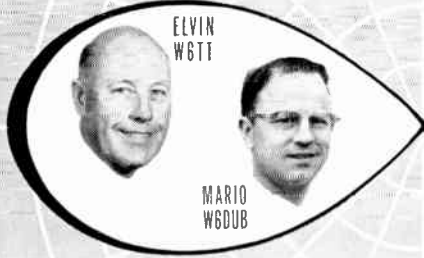

*

PLOT YOUR ANTENNA PATTERN

Request brings you convenient 8 1/2" x 11" polar-type paper. Name and address please. Free . . . no charge.

ELMAR

electronics



You can order with fullest confidence from ELMAR

pace setting West Coast suppliers of radio and electronic parts, sets, antennas and equipment.

ELMAR . . . a reliable firm

where long-continuing customer confidence and satisfaction are responsible, in good part, for today's very large sales volume

where, for example, the most expensive communications receivers move by hundreds . . . not by dozens

where trade-ins, (and generous allowances) are routine, many-times-daily matters . . . not special events

where easy-payment, extended-period terms are the rule . . . not the exception

where stock—every national brand—is completely maintained so that you may have *what* you want, *when* you want it.

You can order with fullest confidence from ELMAR

140 Eleventh Street, Oakland 7, Calif. HIgate 4-7011

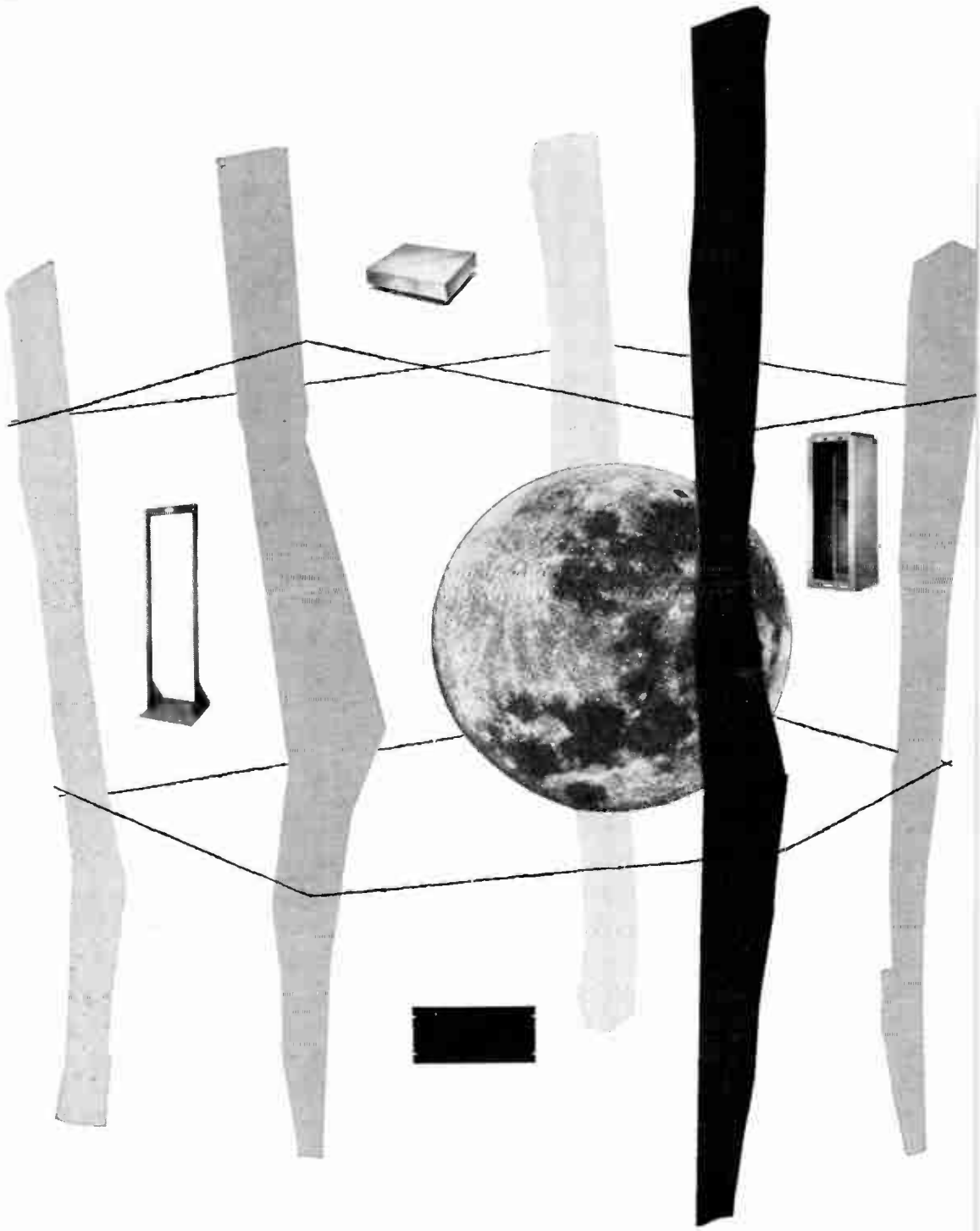

**WE'RE SELLING SPACE
WITH A FENCE AROUND IT!**

The largest, most complete line of
racks, cabinets, panels and chassis
manufactured in the West for the electronics industry.
Contact your jobber for price, availability and catalog.

 **wyco** METAL PRODUCT

6918 Beck Ave., North Hollywood, Calif

122

TOP FAVORITE WITH RADIO AMATEURS



TEST EQUIPMENT

TUBES PARTS BATTERIES

DISTRIBUTED BY

Hudson

"The Ham's Favorite Supplier!"

the Popular "88"



5" SCOPE
Model WO-88A
NOW ONLY **\$169⁵⁰**

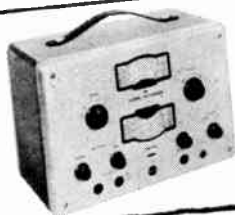

RF SIGNAL GENERATOR
WR-49A **\$59⁵⁰**



JUNIOR VOLTOHMYST
Model WV-77B
now only **\$47⁵⁰**

TRADE IN YOUR OLD HAM GEAR

For the best "deal" of all, come to HUDSON! Get your new equipment now, and get highest trade-in allowance on your old equipment. If you can't come, write us today, about your old gear, and the new gear you want. We will answer fast — and you'll be pleased!

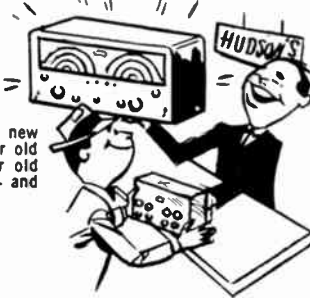

COMPLETE STOCKS

ALL STANDARD BRANDS including:

NATIONAL	ELMAC	RME
HAMMARLUND	GONSET	LYSCO
HALLICRAFTERS	MORROW	SONAR
BARKER-WILLIAMSON	E. F. JOHNSON	ELDICO

COLLINS (At Newark Branch Only)

EASY TERMS!



COMPLETE STOCKS
RCA TUBES
Always on Hand!



the famous
BOB GUNDERSON
W2J10

invites you to write or come in for a chat, at our

UPTOWN store: FRIDAYS
DOWNTOWN store: SATURDAYS
NEWARK store: WEDNESDAYS

Meet the rest of our ham gang, too!

Joe Prestia—K2GZX Sid Heller—K2CWQ
Clark Prestia K2KJS Budd Meyer, K2PMA
Bill Szabo, W2VAV

FREE! Our latest Supplements on Ham Gear and Accessories. Send name and address on post-card to Dept. AR-5

AUTHORIZED FACTORY DISTRIBUTORS

Hudson

RADIO & TELEVISION CORP.
ELECTRONIC & SOUND EQUIPMENT

Adjoining Radio City 48 W. 48th St. New York 36, N. Y.	Downtown N.Y.C. 212 Fulton St. New York 7, N. Y.	In New Jersey 35 William St. Newark 2, N. J.
--	--	--

Circle 7-4907 Digby 9-1192 Market 4-5154



VISIT "THE ATTIC" YOUR WEST COAST HAM HAVEN

WHEN IN LOS ANGELES DROP IN AND
QSO ON OUR COLLINS KWS-1

WRITE OR WIRE FOR
OUR LATEST CATALOG



7.5A-4 \$645.00
KWS-1 \$2,095.00



NEW HAMMARLUND HQ-150 RE-
CEIVER. Net.....\$294.00

Personal Service

Easy Terms



BIG

TRADE-IN

Fast Delivery

ALLOWANCE



JOHNSON VIKING "PACEMAKER".
SSB transmitter-exciter. Wired and
tested only. Net.....\$495.00



6 BANDS: 540-2000 kcs. 3500-4000 kcs. 7000-7300 kcs. 14,000,14,350 kcs.
21,000-21,450 kcs. 28,000-29,700 kcs.



JOHNSON VIKING "VALIANT".
Complete kit w-tubes. Net \$349.50
Wired and tested. Net.....\$439.50



MODEL 4300 RME
Receiver . . . \$194.00
MODEL 4301 RME
Sideband
Detector
Selector \$75.00
MODEL 4302 RME
Matching
Speaker . . \$17.50

**4642 W. CENTURY BLVD. INGLEWOOD 2, CALIF.
PHONE ORCHARD 4-5740**

MORE SIGNALS PER DOLLAR WITH VESTO STEEL TOWERS

For Both Amateur and Commercial Users

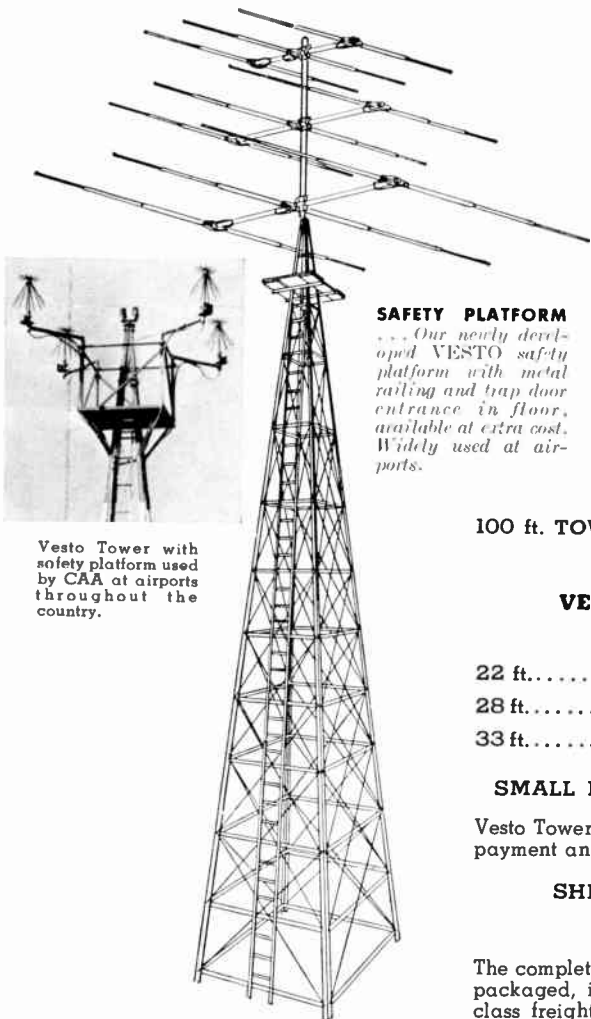

SAFETY PLATFORM

... Our newly developed VESTO safety platform with metal railing and trap door entrance in floor, available at extra cost. Widely used at airports.

Vesto Tower with safety platform used by CAA at airports throughout the country.

Telrex 10/15/20 meter beams on 61-ft. Vesto Tower. Width of base equal to 1/5 height.

Attractive—No Guy Wires!—Self-supporting Vesto Tower takes up only a few feet of ground space. No unsightly supporting wires to trip over or pull loose.

4-Leg Construction!—Better balanced—sturdier—more anchorage, more support. This extra strong design has been proved for years—in thousands of towers!

Permanent!—Vesto Towers are made from heavy steel protected against rust by a thick layer of galvanizing.

Safe!—A strong steel ladder is securely bolted in place. Reaches from ground to platform at top.

Easy to Erect!—One man can do it! Tower arrives in compact bundles. Parts fit perfectly. Complete, easy-to-follow directions.

Withstands Heavy Winds!—No Vesto Tower has ever blown down! They have stood through hurricanes and gales with winds in excess of 100 miles per hour.

100 ft. TOWER...\$895 77 ft. TOWER...\$662
61 ft. TOWER...\$339

VESTO 4-Leg Towers are Priced as Low as \$104!

22 ft.....\$104	39 ft.....\$182
28 ft.....\$127	44 ft.....\$208
33 ft.....\$149	50 ft.....\$259

SMALL DOWN PAYMENT — EASY TERMS!

Vesto Towers can be purchased for only a small down payment and nominal monthly payments.

SHIPPED DIRECT — ANY PLACE IN THE WORLD!

The complete Vesto Tower, knocked down and securely packaged, is shipped FOB Kansas City, Mo., by 4th class freight rate. Prices subject to change, so order now. Send check or money order, or write for full information.

Quality pays! When you buy a VESTO tower, you buy the best. VESTO towers are sold to you direct, saving you many costs of distribution. Write us now.

VESTO COMPANY, INC.

20th & Clay, North Kansas City, Mo.

Cable Address "VESTO"

VESTO Towers are used in all 48 states and many foreign countries!

MULTI-ELMAC



PMR-7 RECEIVER

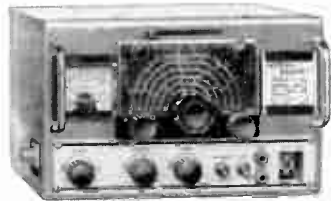

AF-67 TRANS-CITER

MULTI-ELMAC POWER SUPPLIES AND ACCESSORIES

The PSR-117 and PSR-612 power supplies are designed especially for the Multi-Elmac PMR-7 Receiver. The PSR-117 is furnished with "S" meter and is for 115 volt 60 cycle operation. The PSR-612 is for either 6V or 12V D.C. operation. An external "S" meter (ESS-3) may be added to the PSR-612.

The PS-2V 115 Volt 60 Cycle Universal Power Supply is designed to be used with Multi-Elmac AF-67 Trans-Citer or a variety of other applications. CFS-1 Cable Complete cable, plug, and fanning strip to connect the PS-2V to the AF-67 Trans-citer.

PTR-1 Kit Includes rectifier, relay and filter condenser to allow "Push-to-talk" operation of your station from an AC supply.

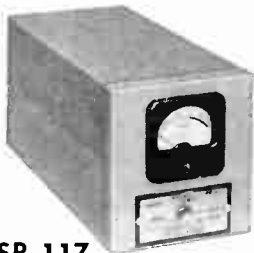

PSR-117

NOW -

MOBILE, PORTABLE, AND FIXED STATION OPERATION AT ITS TROUBLE-FREE BEST

... with the MULTI-ELMAC PMR-7
RECEIVER and AF-67 TRANS-CITER

PMR-7 RECEIVER

*Multi-Elmac Features
Plus Many More . . .*

- New Slide Rule Dial.
- Sensitivity and noise figure exceeds many fixed station receivers.
- Dual conversion. Crystal controlled. 2238 KC 1st I.F. 262 KC 2nd I.F.
- Adjustable squelch. Operates on ½ Micro Volt.
- Variable beat frequency oscillator.
- Built-in noise limiter.
- 7 BANDS—(1) 28.0 to 29.7 mc—(2) 21.0 to 21.45 mc—(3) 14.0 to 14.35 mc—(4) 7.0 to 7.3 mc—(5) 3.5 to 4.0 mc—(6) 1.8 to 2.0 mc—(7) 540 to 1650 kc(broadcast)

AF-67 TRANS-CITER

*Multi-Elmac Features
Plus Many More . . .*

- Designed as an exciter, speech amplifier, driver and as a V.F.O. or crystal controlled low power transmitter.
- Two crystal positions make this unit ideal for use in the novice frequencies.
- V.F.O. is temperature compensated.
- SEVEN AMATEUR BANDS—1.75—2.00MC, 3.50—4.00MC, 7.00—7.30MC, 14.00—14.35MC, 21.00—21.45 MC, 26.96—27.23MC (Xtal Only), 28.00—29.70MC.

The AF-67 TRANS-CITER operates from 6, 12 volts etc., D.C. or 115 V.A.C.

PS-2V
POWER
SUPPLY



MULTI-PRODUCTS COMPANY
21470 COOLIDGE HIGHWAY • OAK PARK 37, MICHIGAN
PHONE: JORDAN 6-2377

MEASUREMENTS CORPORATION



Laboratory Standards

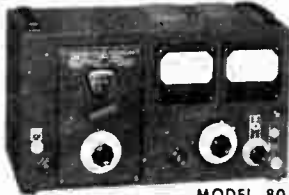

MODEL 80
STANDARD SIGNAL GENERATOR

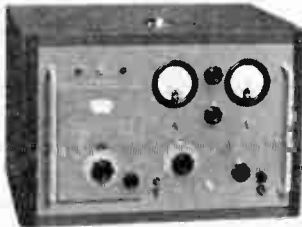

MODEL 95
STANDARD SIGNAL GENERATOR

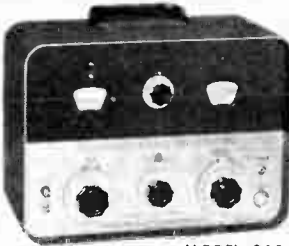

MODEL 210-A
FM STANDARD SIGNAL GENERATOR



MODEL 71
SQUARE WAVE GENERATOR



MODEL 67
PEAK-TO-PEAK VOLTMETER

STANDARD SIGNAL GENERATORS

MODEL	FREQUENCY RANGE
65-B	75 Kc to 30 Mc
80	2 Mc to 400 Mc
80-R	5 Mc to 475 Mc
82	20 Cycles to 200 Kc 80 Kc to 50 Mc
84-R	300 Mc to 1000 Mc
84-TVR	400 Mc to 1000 Mc
95	50 Mc to 400 Mc
210-A	86 Mc to 108 Mc

SQUARE WAVE GENERATOR

MODEL	FREQUENCY RANGE
71	6 to 100,000 Cycles Continuously variable

PULSE GENERATOR

MODEL	FREQUENCY RANGE
79-B	60 to 100,000 pulses per second

VHF FIELD STRENGTH METER

MODEL	FREQUENCY RANGE
58-AS	15 Mc to 150 Mc

HIGH FREQUENCY BARRETTER

MODEL	FREQUENCY RANGE
202-C	2 Mc to 1000 Mc

VACUUM TUBE VOLTMETERS

MODEL	FREQUENCY RANGE
62	30 cps to over 150 Mc
67	5 to 100,000 sine-wave cps.

MEGACYCLE "GRID-DIP" METERS

MODEL	FREQUENCY RANGE
59 LF	0.1 Mc to 4.5 Mc
59	2.2 Mc to 420 Mc
59 UHF	420 Mc to 940 Mc

CRYSTAL CALIBRATORS

MODEL	FREQUENCY RANGE
111	250 Kc to 1000 Mc
111-B	100 Kc to 1000 Mc



MODEL 59
MEGACYCLE "GRID-DIP" METER



MODEL 111
CRYSTAL CALIBRATOR

STANDARD TEST SET for TRANSISTORS



MODEL 505

Tests PNP and NPN small-signal, medium-power and switching transistors.

Checks for short-circuited emitter-collector junctions.

Measures collector-to-emitter leakage current.

Measures collector current and d-c gain.

Case Dimensions: 10" high x 14" wide x 7 1/4" deep.

Power Supply: Two F4BP 6-volt dry batteries.

Weight: Approximately 9 pounds without batteries.

MEASUREMENTS CORPORATION

BOONTON • NEW JERSEY

COMPLETE OUTFITTERS

FOR THE

▶ **HAM**

▶ **COMMUNICATIONS**

▶ **ELECTRONIC
ENGINEERS**

EUGENE G. WILE

218-220 South 11th St.

Philadelphia 7, Pa.

WAlnut 3-1343

Distributors of

Nationally Advertised Lines of

RADIO, TELEVISION and ELECTRONIC Parts

If you operate 'phone YOU WON'T BE SATISFIED UNTIL YOU OWN



the completely new
664 VARIABLE D*
CARDIOID
 DYNAMIC MICROPHONE



The 664 will equal a useful power increase of four times over commonly-used peaked microphones, and could well be the best investment, dollar-wise, in your shack

Here is a totally new concept in microphones for amateur phone communication.

The cardioid (high directivity at all frequencies) pickup pattern enables you to have a *real* "arm chair QSO." The forward gain of 5 db** allows you to speak at nearly twice the distance you have been working to a conventional microphone. Unwanted sounds in the shack are rejected nearly twice as effectively as by ordinarily-used non-directional microphones.

The response curve is tailored to put the highest degree of intelligibility on your carrier. Your 100% modulation is all speech . . . in full character . . . with bite and punch. This curve, compared to ordinary microphones, will give you up to 12 db more usable audio—without splatter or hash.

We invite you to prove to yourself that the 664 will outperform your present mike by a direct comparison. If it doesn't out-hurdle QRM, your distributor will refund the purchase price without qualification.

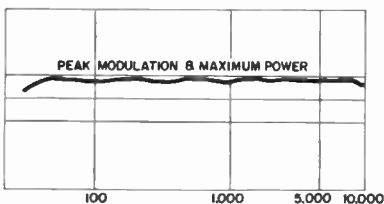
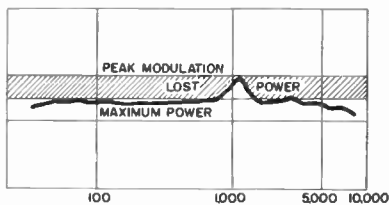

A peak in the response curve limits modulation to the peak value. A peak-free response brings the full power level to 100% modulation gaining an intelligibility increase equal to the peak in the average mike. The 664 is peak-free and gives the highest usable power of any microphone for AM, NFM and SSB.

New Variable D* Dynamic Microphone operates on the principle of multiple sound paths to the diaphragm. Spaced apertures to the rear of the diaphragm are phased to provide cancellation of rear sounds and give full response to sound from the front.

This new principle enables the curve to be free from peaks or dips. Insures freedom of blasting and boominess from close talking. Eliminates effect from mechanical shock. High level —55 db. Acoustallooy diaphragm. Switch easily changed to relay control, if desired. Absolutely unaffected by moisture, humidity, or temperature.

- Model 664, Without Stand Net Price \$49.50
- Model 419, Desk Stand Net 6.00
- Model 419S, Desk Stand, (Switch on Base) Net 9.00

**Forward gain is that compared to a pressure mike; actual front-to-back hemisphere pick-up ratio is 20 db.

*Patent Pending

See your E-V Distributor,
 or write for Specification Sheet HB57

Electro-Voice®

ELECTRO-VOICE, INC. • BUCHANAN, MICH. • Export: 13 E. 40th St., N. Y. 16

Your Rig is only as effective as the Antenna you tie it to!

$$\frac{\partial(\epsilon_3 E_w)}{\partial v} - \frac{\partial(\epsilon_2 E_v)}{\partial \omega} = -j\omega\mu_2 \epsilon_3 E_w$$

$$\frac{\partial(\epsilon_3 H_w)}{\partial v} - \frac{\partial(\epsilon_2 H_v)}{\partial \omega} = j\omega\epsilon_2 \epsilon_3 E_w$$

$$\frac{\partial(\epsilon_2 E_v)}{\partial \omega} - \frac{\partial(\epsilon_1 E_w)}{\partial v} = -j\omega\mu_2 \epsilon_2 H_w$$

$$\frac{\partial(\epsilon_2 H_v)}{\partial \omega} - \frac{\partial(\epsilon_1 H_w)}{\partial v} = j\omega\epsilon_2 \epsilon_1 E_w$$

Out of ANTENNA ENGINEERING LABORATORIES, where Radiation experts and Scientists have developed the E. D.* principle for Military, Commercial and Marine use, comes the

IMPROVED ALL-BAND "E. D." ROBOT SKYHOOK!

AMATEUR & COMMERCIAL

THE V-37

- V-37**
80 THRU 10 MTRS
- V-72**
40 THRU 10 MTRS
- V-70**
40 THRU 10 MTRS

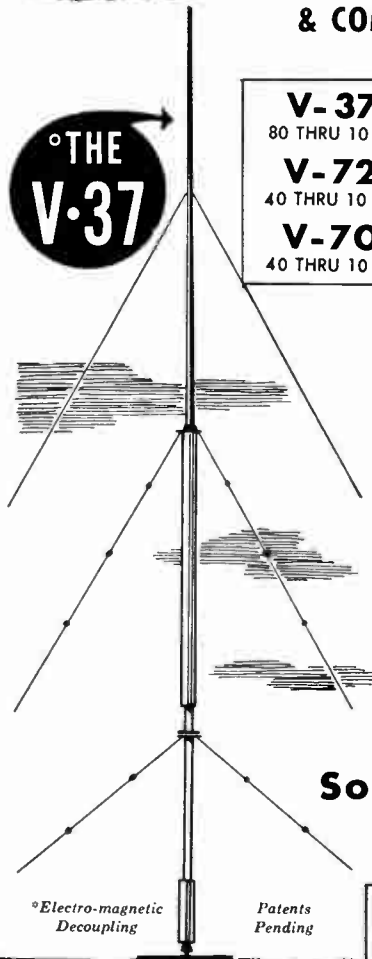

- This New type, All-band Antenna, precision-manufactured by ANTENNA ENGINEERING COMPANY, does exactly what has long been considered a virtual IMPOSSIBILITY.*

Do you want

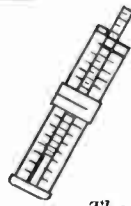

- AUTOMATIC** all-band coverage including Novice, C.D. & MARS
- AUTOMATIC IMPEDANCE-MATCHING** on EVERY BAND
- AUTOMATIC** Radiation-pattern Control
- AUTOMATIC** Colinear Array on 15 and 10 meters (V-37)
- ALL** with maximum operational **EFFICIENCY** and convenience

Then YOU want—and can NOW HAVE—your CHOICE of a VARIETY OF MODELS of "E. D." All-Banders which are time proven Standard Antennas for MARS, Commercial, Amateur and Military Service.



DESIGNED by Antenna Scientists
DEVELOPED at the A. E. C. ANTENNA LABORATORY
PRECISION-MANUFACTURED for Quality Control at the A. E. C. FACTORY.

Sooooo

For Radio Communication at its BEST... For a THRILL as New & Potent as an "H" bomb... For the TOPS in operating efficiency & convenience.

WRITE US FOR DETAILS, LITERATURE AND PRICES

*Electro-magnetic Decoupling

Patents Pending

CIVIL DEFENSE DIRECTOR:
The V-37 Antenna is **APPROVED FOR MATCHING FUND** By F.C.D.A.!

ANTENNA ENGINEERING COMPANY
5021 WEST EXPOSITION BLVD., LOS ANGELES 16, CALIF.
TELEPHONE: REpublic 4-7807

**World-Famous for Proven
Reliability and Performance**

RCA SHORT- WAVE and MEDIUM- WAVE

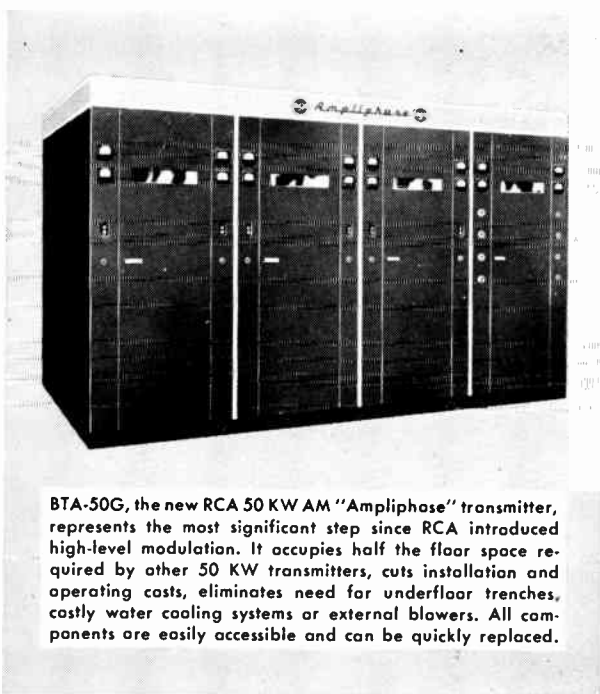
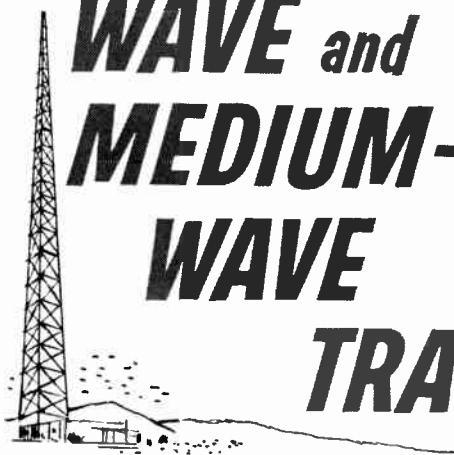

BTA-50G, the new RCA 50 KW AM "Ampliphase" transmitter, represents the most significant step since RCA introduced high-level modulation. It occupies half the floor space required by other 50 KW transmitters, cuts installation and operating costs, eliminates need for underfloor trenches, costly water cooling systems or external blowers. All components are easily accessible and can be quickly replaced.

TRANSMITTERS

Since its formation in 1919, Radio Corporation of America has been in the forefront of major advances in radio communications of every type. In virtually every corner of the globe RCA short-wave and medium-wave broadcast transmitters are providing day-in, day-out dependability under all extremes of climatic and operational conditions.

As the producer of the finest in transmitters, its experience in the radio industry is unparalleled.

At its research and engineering laboratories, RCA engineers conceive and develop the most advanced and improved circuits and mechanical components.

New RCA electron tubes and semi-conductors are being developed and produced to meet the changing needs of the entire industry, as well as specific RCA equipment.

For over a quarter of a century, RCA scientists have provided a constant flow of technical knowledge to the expanding radio and electronic industry ...and products, facilities, and services to the world.

The RCA monogram is universally recognized as

a symbol of the radio age, that has brought new pleasures in entertainment, new techniques of communication, and new opportunities to millions of people throughout the world. It is a mark of quality and superior craftsmanship.

RCA broadcast transmitters have proven their economy and dependability in many years of long service for many types of broadcasters, such as the National Broadcasting Company network, the Finnish Broadcasting Company, Radio Pakistan, Radio Istanbul, and hundreds of private broadcasters.

RCA short-wave communications transmitters are preferred by many governmental and private communications organizations. Transmitters up to 1.2 megawatts of output have been built by RCA, and are used around the world to provide every type of radio communications.

For the best investment in short and medium-wave transmitters see your RCA Distributor or write to Dept. BE-33-A, RCA International Division, Radio Corporation of America, 30 Rockefeller Plaza, New York 20, N.Y., U.S.A.



**RCA INTERNATIONAL DIVISION
RADIO CORPORATION OF AMERICA
30 ROCKEFELLER PLAZA, NEW YORK 20, N. Y., U. S. A.**

TRADEMARK © REGISTERED

VOLT-OHM-MILLIAMMETERS

for your every need



MODEL 310 MIGHTY MITE the only complete miniature V-O-M (AC-DC)

The same valuable tool professionals use for:

- current measurements . . . voltage measurements . . . resistance measurements
 - checking for defective components (shorted condensers, open resistors, etc.) both before and after installation
 - checking for shorts or opens in wiring
- Tells all about everything electrical and electronic—all essential ranges.
- 20,000 ohms per volt, D.C.
 - 5,000 ohms per volt, A.C.



TRIPLETT MODEL 630

- Large 5½ Inch Meter in special molded case under panel.
- Resistance Scale Markings from .2 Ohms to 100 Megohms: Zero Ohms control flush with panel
- Only one switch. Has extra large knob 2½" long, easy to turn flush with panel surface.

- New molded selector switch, contacts are fully enclosed
- All resistors are precision film or wire wound types, all sealed in molded compartments.
- Unit construction—Resistors, Shunts, Rectifier, Batteries all are housed in a molded base built right over the switch. Provides direct connections without cabling. No chance for shorts.
- Batteries easily replaced—New Double Suspended Contacts.
- Ranges: DC Volts 0 to 6,000, 20,000 Ohm/Volt; AC Volts 0 to 6,000, 5,000 Ohm/Volt; DB: —30 to +70; Direct Current from 0-60 Microamp. to 0-12 Amps; Resistance: 0-1,000-10,000 Ohms, 0-1-100 Megs.

A COMPLETE LINE OF METERS



Triplet panel and portable meters are available in more than 26 case styles—round, square and fan—2" to 7" sizes Included are voltmeters, ammeters, milliammeters, millivoltmeters, microammeters, thermo-ammeters, DB meters, VU meters and electro-dynamometer type instruments

Address all inquires to Dept Q-57

MODEL 666-R

For your AC and DC Voltage, Direct Current and Resistance analyses to 3 Megohms. Enclosed selector switch and molded construction keeps dirt out. Retains contact alignment permanently Unit Construction—All Resistors, shunts, rectifier and batteries housed in a molded base integral with the switch. Eliminates chance for shorts. Direct connections. No cabling. All precision film or wire-wound resistors, mounted in their own compartment—assures greater accuracy. Easy to read scales. Precalibrated rectifier unit. Self-contained batteries.

RANGES: AC-DC Volts: 1-10-50-250-1000-5000, 1000 Ohms/Volt; Direct Current: 10-10-100 Ma., 0-1 Amp; Resistance: 0-3000-300,000 Ohms, 3 Meg. Black molded case, completely insulated, 3-1/16" x 5 7/8" x 2-9/16". White panel markings.

ABSORPTION MODEL 3256 FREQUENCY METER

A band-switching, tuned absorption type frequency meter that covers five amateur bands. Has Germanium crystal and a DC Milliammeter indicator for greater sensitivity Direct calibration on panel—no coils to change. Switching permits instantaneous band change. Audio jack provides for monitoring of phone signals—another new feature Calibration is in Megacycles in following bands: 3.5-4 MC, 7-7.3 MC, 14-14.4 MC, 20-21.5 MC, 28-30 MC Coil is removable and other coils may be substituted for special bands Useful for checking: Fundamental frequency of oscillating circuits; Presence, order and relative amplitude of harmonics; Parasitic oscillations, etc. Size: 7 1/2" x 2 1/2" x 2 1/4" Metal case with gray enamel finish black trim



POCKET SIZE

TRIPLETT
TRIPLETT ELECTRICAL INSTRUMENT CO.
Bluffton, Ohio

To Manufacturers and Distributors of Products Used in Short-Wave Radio Communication

THE RADIO AMATEUR'S HANDBOOK is the standard reference on the technique of high-frequency radio communication. Now in its thirty-fourth annual edition, it is used universally by radio engineers and technicians as well as by thousands of amateurs and experimenters. Year after year it has sold more widely, and now the Handbook has an annual distribution greater than any other technical handbook in any field of human activity. To manufacturers whose integrity is established and whose products meet the approval of the American Radio Relay League technical staff, and to distributors who sell these products, we offer use of space in the Handbook's Catalog Advertising Section. This section is the standard guide for amateur, commercial and government buyers of short-wave radio equipment. Particularly valuable as a medium through which complete data on products can be made easily available to the whole radio engineering and experimenting field, it offers an inexpensive method of producing and distributing a catalog impossible to attain by any other means. We solicit inquiries from qualified manufacturers and distributors.

ADVERTISING DEPARTMENT . . .

American Radio Relay League
WEST HARTFORD 7, CONNECTICUT

Waterman POCKETSCOPE

The Pocket-Size Oscilloscope

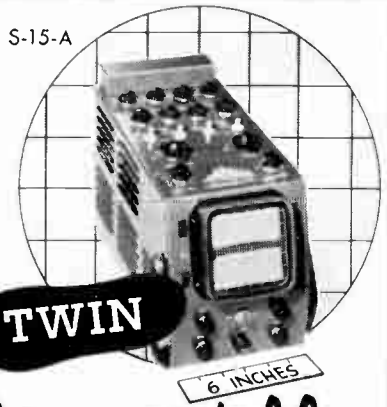

...light... compact... accurate... portable

Featuring small size, light weight and outstanding performance the HIGH, WIDE and TWIN POCKETSCOPES have become the "triple threat" of the oscilloscope field. Their incomparable versatility, reliability and accuracy have skyrocketed this team of truly portable instruments into unparalleled demand. Each oscilloscope features DC coupled amplifiers in both vertical and horizontal channels.

HIGH

The S-14-A H I - G A I N P O C K E T -

SCOPE provides the optimum in oscilloscope flexibility for analysis of low-level electrical impulses. Extremely light weight (12 $\frac{3}{4}$ lbs.), compact in size (12 x 5 $\frac{3}{4}$ x 7 in.), dependable and accurate in performance. Vertical and horizontal channels: 10mv rms/inch with response within 2DB from DC to 200 KC and pulse rise of 1.8 μ s . . . non-frequency discriminating attenuators and gain controls with internal calibration of trace amplitude . . . repetitive or trigger time base with linearization from $\frac{1}{2}$ cycle to 50 KC with \pm sync or trigger.

WIDE

The S-14-B W I D E B A N D P O C K E T S C O P E is ideal for investigations of transient signals, DC signals, aperiodic pulses or recurrent waveforms. Vertical channel: 50 mv rms/in. within -2DB from DC to 700 KC . . . pulse rise time of 0.35 μ s. Horizontal channel: 0.15v rms/in. within -2DB from DC to 200 KC . . . pulse rise of 1.8 μ s. Attenuators and gain controls are non-frequency discriminating . . . trace amplitude calibration . . . repetitive or triggered time base from $\frac{1}{2}$ cycle to 50 KC . . . \pm sync or trigger . . . trace expansion, filter graph screen and many other features . . . 14 lbs. . . 12 x 6 x 7 inches.

TWIN

The S - 1 5 - A P O C K E T S C O P E is a portable, twin tube, high sensitivity oscilloscope with two independent vertical as well as horizontal channels. It is indispensable for investigation of electronic circuits in industry, school and laboratory. Vertical channels 10

mv rms/in. with response within -2DB from DC to 200 KC and pulse rise time of 1.8 μ s . . . horizontal channels 1v rms/in. within -2DB from DC to 150 KC . . . non-frequency discriminating controls . . . internal signal amplitude calibration . . . linear time base from $\frac{1}{2}$ cycle to 50 KC, triggered or repetitive, for both horizontal channels.

S-11-A

The S-11-A I N D U S T R I A L P O C K E T S C O P E is a small, compact (5x7x11 inches), and lightweight (8 $\frac{3}{4}$ lbs.) instrument for observing electrical circuit phenomena. The flexibility of the POCKETSCOPE permits its use for AC measurements as well as for DC. The vertical and horizontal amplifiers are capable of reproducing within -2DB from DC to 200 KC with a sensitivity of 0.1v rms/in. . . . repetitive time base from 3 cycles to 50 KC continuously variable throughout its range . . . variations of input impedance, line voltage or controls do not "bounce" the signal—the scope stabilizes immediately.

RAYONIC CATHODE RAY TUBES BY WATERMAN

TUBE	PHYSICAL DATA		STATIC VOLTAGE		DEFLECTION*		LIGHT OUTPUT**
	FACE	LENGTH	A3	A2	VERT	HOR	
3JP1	3"	10"	3000	1500	111	150	352
3MP1	3"	8"		750	99	104	33
3RP1	3"	9.12"		1000	61	86	44
3SP1	1.5x3"	9.12"		1000	61	86	44
3XP1	1.5x3"	8.875"		2000	33	80	218

The basic properties of the cathode ray tube that concern the designer or the user are: deflection sensitivity, unit line brightness, line width, static voltage requirements and physical size. A comparison between cathode ray tubes manufactured by Waterman Products Company is shown in the table adjoining. These tubes are available in P1, P2, P7 and P11 phosphors. 3JP1, 3JP7, 3SP1 and 3XP1 are available as JAN tubes.

*Deflection of volts per inch. **Light output of an element of a raster line (one mm long and not exceeding .65 mm in width) in microlumens.

Write for your complimentary copy of "POCKETSCOOP" • Official Waterman publication.

PULSESCOPE

by

Waterman

The Oscilloscope that Portrays the Pulse

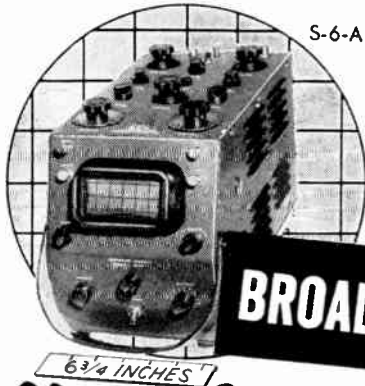

S-6-A

BROAD

6 3/4 INCHES

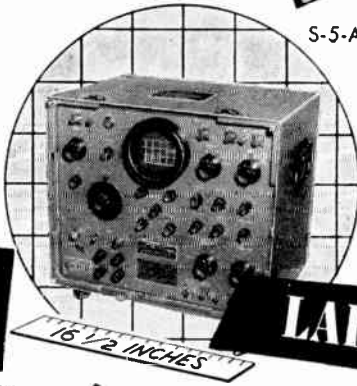

S-5-A

LAB

16 1/2 INCHES



S-4-C

SAR

9 1/8 INCHES

Classic Examples of Precision Engineering...

The PULSESCOPES are cathode ray tube oscilloscopes that portray the attributes of the pulse: shape, amplitude, duration and time displacement. All PULSESCOPES have internally generated markers with the basic difference that in the SAR PULSESCOPE the markers initiate the sweep while in the others the sweep starts the markers.

BROAD

The S-6-A BROAD BAND Scope is a PULSESCOPE

in performance, POKETSCOPE in size. The instrument measures DC as well as AC signals. Unique DC calibration methods permit rapid measurements of either positive or negative, AC or DC signals. Vertical amplifier sensitivity of 0.2v rms/inch, and response to 5 mc within 3DB... pulse rise time of 0.1 μ s... internal markers from 1 to 1000 μ s... repetitive or trigger sweep from 5 cycles to 500 KC with 5X sweep expansion... sweep, marker and DC calibrating voltage available externally. Size 8 1/2 x 6 3/4 x 13 3/4 in. Weight 22 lbs. Operates from 50 to 400 cycles at 115 volts AC.

LAB

The S-5-A LAB PULSESCOPE is a JANized (Gov't Model No. OS-26)

portable, AC, wide band-pass, laboratory oscilloscope ideal for pulse as well as general purpose measurements. Internal delay of 0.55 μ s permits observation of pulse leading edge. Includes precision amplitude calibration, 10X sweep expansion, internal trace intensity time markers, internal trigger generators and many other features. Video amplifier 0.1v p to p/inch... pulse rise time of .035 μ s or response to 11 mc. 1.25 to 125,000 μ s triggered or repetitive sweep... internally generated markers from 0.2 to 500 μ s... trigger generator from 50 to 5000 pps. for internal and external triggering. Operates from 50 to 400 cycles at 115 volts AC.

SAR

The S-4-C SAR PULSESCOPE is a JANized (Gov't Model No. OS-4)

portable instrument (31.5 lbs.) for precision pulse measurements for radar, TV and all electronic measurements. Portrays all attributes of the pulse... internal crystal controlled markers of 10 and 50 μ s available for self-calibration... in R operation a small segment of the A sweep is expandable for detailed observation with a direct-reading calibrated dial accurate to 0.1%. Video amplifier band-pass up to 11 mc... optional video delay 0.55 μ s... pulse rise and fall time better than 0.07 μ s... R pedestal (sweep) 2.4 to 24 μ s... video sensitivity of 0.5v. p to p/inch. Easily convertible from μ s to yards. Operates from 50 to 400 cycles at 115 volts AC.

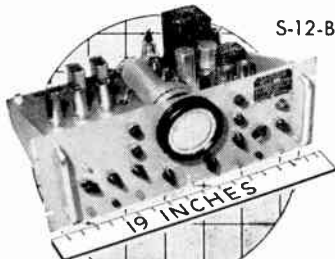

S-12-B

19 INCHES

RAKSCOPE

Because the panel is only 7" high and fits any standard rack, the S-12-B RAKSCOPE admirably fills the need for a small oscilloscope of wide versatility. With all the features of the S-11-A POKETSCOPE, the RAKSCOPE is JANized (Gov't Model No. OS-11), and has many additional advantages; the sweep, from 5 cycles to 50 KC, is either repetitive or triggered... vertical and horizontal amplifiers are 50 mv rms/inch with band-pass from 0 to 200 KC... special phasing circuitry for frequency comparison.

WATERMAN PRODUCTS CO., INC.

PHILADELPHIA 25, PENNA., U.S.A.

CABLE ADDRESS, POKETSCOPE, PHILA.



Manufacturers of POKETSOPES® • RAKSCOPES® • PULSESCOPES® and RAYONIC® TUBES

MISSILE SYSTEMS

Research and Development

The continuing expansion program of Lockheed Missile Systems Division will create many new positions each month during 1957 for engineers and scientists. Assignments will be on missile systems projects of a most advanced nature.

COMPUTERS

SYSTEMS ENGINEERING

RADAR

TELEMETERING

ELECTROMECHANICAL DESIGN

COMMUNICATIONS

TEST EQUIPMENT DESIGN

INSTRUMENTATION

STRUCTURES ENGINEERING

NUCLEAR PHYSICS

MECHANICAL ENGINEERING

ANTENNA DESIGN

AERONAUTICAL ENGINEERING

OPERATIONS RESEARCH

STRESS ENGINEERING

Those who wish to advance their professional stature while contributing to a group effort of utmost importance are invited to write.

Lockheed

MISSILE SYSTEMS DIVISION

research and engineering staff

LOCKHEED AIRCRAFT CORPORATION

VAN NUYS • PALO ALTO • SUNNYVALE, CALIFORNIA

Index

	PAGE		PAGE
Charts and Tables			
Abbreviations for C.W. Work	571	Inductance, Capacitance and Frequency Charts	36, 48
Alphabet, Greek	572	Inductance of Small Coils	27, 28
Amateur Frequency-Bands	14	Inductive Reactance	48
Amateur's Code, The	8	Inductors, Dimensions of	28
Antenna and Feeder Lengths	346, 351, 358, 359	International Amateur Prefixes	569
Antenna Diameter vs. Length	345, 355, 356	International Morse Code	13
Antenna Gain	360, 363	International Prefixes	570
Antenna Length Factor	345, 355, 356	<i>L-C</i> Computation	511
Attenuation of Transmission Lines	326	<i>L/R</i> Time Constant	31
Band-Pass Filters	573	Linear Amplifier Tube-Operation Data	304
Band Width, Typical I.F.	86, 104	Loading-Coil Data	472
Beam Element Lengths	364	Log, Station	558
Breakdown Voltages	23	Long-Wire Antenna Lengths	349
Call Areas	569, 571	Low-Pass Filter Data	545
Capacitance of Short Vertical Antennas	471	Metals, Relative Resistivity of	18
Capacitance, Top-Loading	473	Mobile-Antenna Data	472
Capacitive Reactance	48	Modulation Index	295
Capacitor Color Code	490, 491	Modulator Characteristic Chart	278, 281, 286
Capacitor-Input Power Supplies	225	Nomenclature of Frequencies	18
Capacitor, Plate Spacings	168	Open Stubs, Position and Length	328
Cathode and Screen-Dropping Resistors for R.F. and I.F. Amplifiers	98	Operating Values, Converter Tubes	95
Cathode-Modulation Performance Curves	286	Peak-Rectifier-Current D.C.-Load-Current Ratio	220
Characteristic Impedance	324, 325	Percentage Ripple Across Input Capacitor	220
Choke-Input Power Supplies	225	Phonetic List	556
Circuit and Operating Values for Converter Tubes	95	Pilot-Lamp Data	575
<i>C-L</i> Computation	511	Power Supplies, Typical	225, 226
Coaxial Line Data	325	Prefixes	569, 570, 571
Coils, Dimensions of	28	Puncture Voltages, Dielectric	23
Coils, Wire Sizes for Transmitting	169	<i>Q</i> Signals	568
Color Code for Radio Parts	490, 491	<i>RC</i> Time Constant	31, 32
Conductivity of Metals	574	RST System	568
Construction Tools	484	Radiation Angles	347
Continental Code	13	Radiation Patterns	347, 350
Conversion of Fractional and Multiple Units	20	Radiation Resistance	344, 349, 354, 363, 364
Copper-Wire Table	492	Reactance Change with Antenna Length	356
Corner-Reflector Antenna Feed Impedance	145	Reactance Charts	36, 48
Countries List, ARRL	569	Relationship of Amateur-Band Harmonics	536, 552
Coupled Tuned Circuit Response	574	Resistance-Coupled Voltage-Amplifier Data	250
Coupling-Coefficient Curves	50	Resistivity of Metals, Relative	18
Coupling to Flat Lines	334	Resistor Color Code	490, 491
Critical Inductance, Bleeder Resistance and Current for	221	Response, Tuned-Circuit	574
Crystal Diodes	V-32	Rhombic Antenna Design	359
Decay, Voltage	32	Schematic Symbols	576
Decibel	43	Screen-Dropping and Cathode Resistors for R.F. and I.F. Amplifiers	98
Decimal Equivalents of Fractions	487	Selenium Rectifiers	236
Dielectric Constants	23	Shorted Stubs, Position and Length	328
Drill Sizes	485	Signal-Strength, Readability and Tone Scales	568
DX Operating Code	557	Standard Component Values	489
Effect of Ground on Horizontal Antennas	344	Standard Metal Gauges	575
Electrical Conductivity of Metals	574	Standing-Wave Ratio	326
Electrical Quantities, Symbols for	576	Station Log	558
Emergency Points	561	Stub Position and Length	328
Filters	572	S.W.R. Calibration	515
Folded Dipole Nomogram	329	Symbols for Electrical Quantities	576
Frequency-Spectrum Nomenclature	18	Tank-Circuit Capacitance	149, 157
Gain of Directive Antennas	360, 363	Tap Sizes	485
Gauges, Standard Metal	575	Time, Capacitor Charge and Discharge	31, 32
Germanium Crystal Diodes	V-32	Time Constant, <i>CR</i>	31, 32
Half-Wave Antenna Lengths	346	Time Constant, <i>L/R</i>	31
Impedance Step-Up in Folded Dipoles	329	Tools for Construction	484
Index, Modulation	295	Top-Loading Capacitance	473
Inductance and Capacitance for Ripple Reduction	222	Transformer Color Code	491
		Transformer Ratios	268

	PAGE
Transistors	80, V-32
Transistor Symbols	82
Transmission-Line Data	325
Transmission-Line Losses	326
Transmission Lines, Spacing	324, 325
Tuned-Circuit Response	567, 574
V-Antenna Design Chart	358
V.H.F. Arrays	437
Vacuum Tubes and Semiconductors (Index to Tables)	V-1
Velocity Factor and Attenuation of Transmission Lines	325, 326
Voltage Decay	32
Voltage-Output Transformer-Voltage Ratio	219
W Prefixes by States	571
Wire Table, Copper	492
Word List for Accurate Transmission	556
WWV and WWVH Schedules	504

Formulas

A.C. Average, Effective R.M.S. and Peak Values	17
Amplifier Gain, Vacuum-Tube	575
Antenna Length	345, 349, 355, 356, 437
Capacitance	24
Capacitance Measurement	511
Capacitive Reactance	34
Cathode-Bias Resistor	73
Cathode Follower Output Impedance	72
Cavity Resonator Dimensions	57
Characteristic Impedance	324
Coaxial-Line Matching Section	365
Critical Inductance	220
Decibels, Gain in	43
Delta-Matching Transformer Design	348
Efficiency, Power	22-23
Energy, Electrical	23
Feed-Back Percentage	271
Feeder Length	326
Filter Design	218-223, 572
Folded Dipole, Driven-Element Length	437
Frequency, Resonant	44
Frequency-Wavelength Conversion	18
Gain, Vacuum-Tube Amplifier	575
Grid Impedance	156
Ground-Plane Antenna Design	355, 356
Half-Wave Antenna, Length	345
Half-Wave Phasing Section, Length	361
High-Pass Filter	573
Impedance Matching	42
Impedance Matching, <i>L</i> Networks	51
Impedance Matching, Pi Networks	51
Impedance Ratios	41, 322
Impedance, Resistive at Resonance	45, 47
Impedance, Transformer	218
Index, Modulation	295
Inductance Calculation	27
Inductance, Critical	220
Inductance Measurement	511
Inductive Reactance	35
Input Capacitance, Tube	70
Input Resistance, Power Supply	218
<i>L</i> Networks	51
<i>LC</i> Constant	48
Lecher Wires	501
Lissajous Figures, Frequency	523
Long-Wire Antenna, Length	349
Low-Pass Filter	573
<i>L/R</i> Time Constant	31
Modulation Impedance	267, 279
Modulation Index	295

	PAGE
Modulation Percentage	276
Modulation Transformers, Turns Ratio	267
Multiplier, Meter	494
Ohm's Law (A.C.)	35, 37
Ohm's Law (D.C.)	20, 22
Output Capacitor for Modulated Amplifier Plate Power Supply	278
Parasitic Element Spacing	363, 364
Pi Networks	51
Power	22
Power-Supply Output Voltage	222, 223
Power-Supply Transformer Voltage	224
<i>Q</i>	45, 46, 47, 574
<i>Q</i> -Section Transformer	327
Quarter-Wave Phasing Section Length	361
<i>RC</i> Time Constant	31
Radiation Resistance	355
Reactance, Capacitive	34
Reactance, Inductive	35
Regulation	218
Resistance Measured by Voltmeter	496
Resonance	44
Resonant Frequency	44
Rhombic Antenna	359
Ripple	220, 222
Screen-Dropping Resistor	74
Series, Parallel and Series-Parallel Capacitances	25, 26
Series, Parallel and Series-Parallel Inductances	29, 30
Series, Parallel and Series-Parallel Resistances	21, 22
Shunts, Meter	494
Standing-Wave Ratio	321, 514, 515
Surge Impedance	318, 321, 325
Time Constant, <i>CR</i> , <i>L/R</i>	31
Transformer Current	40
Transformer Efficiency	41
Transformer Impedance	218
Transformer Voltage	40
Transformer Volt-Ampere Rating	224
Transmission-Line Length	325
Transmission-Line Output Impedance	322
Turns Ratio	40, 267
Vacuum-Tube Amplifier Gain	575
Voltage Decay Time	32
Voltage Dividers	227
Voltage-Dropping Series Resistor	226
Voltage Regulation	218
Voltage-Regulator Limiting Resistor	227
Wave-Guide Dimensions	57
Wavelength	18
Wavelength-Frequency Conversion	18

Text

"A" Battery	60
"A"-Frame Mast	367
A-1 Operator Club	566
A.C.	16, 32-42
A.C.-D.C. Converters	480
A.C. Line Filters	535
A.M. (see "Amplitude Modulation")	
ARRL Emblem Colors	563
ARRL Operating Organization	562-566
Abbreviations for C.W. Work	571
Absorption Frequency Meters	499
Absorption of Radio Waves	376
Additive Frequency Meter	505
Affiliation, Club	563
Air-Insulated Lines	323
Alignment, Receiver	110-112
"All-Band" Antenna	353
Alternating Current	16, 32-42

	PAGE
Alternations	16
Aluminum Finishing	487
Amateur Band Operating Characteristics	380-383
Amateur Bands	14
Amateur Radio Emergency Corps	560-562
Amateur Radio History	9-12
Amateur Operator and Station Licenses	13
Amateur Regulations	13
Amateur's Code, The	8
American Radio Relay League:	
Headquarters	12-13
Hiram Percy Maxim Memorial Station	12, 564, 565
Joining the League	566
Ampere	17
Amplification	62, 63, 68, 82, 83
Amplification Factor, Current	82
Amplification Factor, Voltage	63
Amplifier Adjustment	166-167, 316
Amplifier Classifications	66-68
Amplifier Gain, Vacuum Tube	575
Amplifier Keying	239-240
Amplifier, Linear	303-305, 310-315
Amplifier, Speech	248-253
Amplifiers (see basic classifications, e.g., "Receivers," "Transmitters," "Radiotelephony," and "V.H.F.")	
Amplifiers, Class A, B, C	66-68, 303-305
Amplifiers, Transistors	83-84
Amplitude, Current	15-16
Amplitude Modulation	59, 275-293
Angle of Radiation	343, 344, 346
Anode	60
Antenna Construction	367-375, 437-446
Antenna Couplers	130, 131, 333-342, 421
Antenna for 80 and 40 Meters	172
Antenna Input Impedance	327, 436
Antenna Length	345-346, 349-350, 357-359, 436-437
Antenna Masts	367-368
Antenna Matching	327-332, 346-354, 364-366, 436, 446, 472-475
Antennas:	343-375, 435-446, 471-475
Beams	359-366
Bent	352-357
Construction	367-375
Compact 14 Mc. 3-Element Beam	373
Rotary Beams	370-372
One-Element Rotary for 21 Mc.	374-375
Supports	367-370
Dipole	345-348
Ground-Plane	354-356
Half-Wave	345-348
Long-Wire	349-350, 357-359
Mobile	471-475
Multiband	351-353
Off-Center Fed.	352-353
Receiving	366
Restricted Space	351-352
Rhombic	358-359
V-Beam	357-358
Vertical	354-356
V.H.F.	435-446
"Windom"	352-353
160-Meter	356-357
Antenna Switching	366
Antinode	320
Antistatic Powder	449
Appointments, Leadership	562
Appointments, Station	563
Array	359-362, 436
Arrays in Combination	366, 436, 437-446
Assembling a Station	525-531
Atmospheric Bending	372-383
Atoms	16
Audio-Amplifier Classifications	66-68
Audio-Circuit Rectification	533-534
Audio Converters	96
Audio Frequencies	17
Audio Harmonies, Suppression of	268
Audio Image	103
Audio Limiting	101
Audio Oscillators	507-508

	PAGE
Audio Power	279
Audio Squelch	106
Auroral Reflection	382
Autodyne Reception	85, 90
Automobile Storage Battery	479
Automatic Volume Control	100-101
Autotransformer	43, 520
Average-Current Value	17
Awards	564-566
"B" Battery	60
Back Current	80, 81
Back-E.M.F.	26
Back Resistance	80, 81
Backwave	238-239
Baffle Shields	55
Balanced Circuit	55
Balanced Modulator	300-301, 309
Balun	331-332, 393-394, 520
Band-Changing Receivers	92
Band-Pass Filters	573
Bands, Amateur	14
Bandsreading	92
Band Width	86
Band Width, Antenna	343
Base, Transistor	82, 83-84
<i>Basic Radio Propagation Predictions</i>	380
Battery	16, 60, 63, 479, 483
Bazooka	331
BCI	532-535
BPL	566
Beam Antennas	343, 359-366, 436-445
Beam Tetrodes	71
Beat Frequencies	59
Beat Note	85
Beat Oscillator	99-100
Bending, Tropospheric	380, 382-383
Bent Antennas	352, 357
Bias	64, 73, 154, 239, 268
Bias Modulation	281-282
Bias Supplies	229-231
"Birdies"	94, 112
Bleeder	218, 221
Blocked-Grid Keying	239
Blocking Capacitor	53, 169
Body Capacitance	91
Booms, Rotary Beam	370-371
Brass Pounders League	566
Breakdown Voltage	25
Break-In	240-241, 246, 305, 528
Bridge Rectifiers	216
Bridge-Type Standing-Wave Indicators	513-519
Bridge, Impedance	518
Broadband Antennas	444
Broadcast Interference, Elimination of	534-535
Broadside Arrays	359, 360-361
Buffer Amplifier	143, 278
Buffer Capacitors	481
Buncher	78
Buttou, Microphone	247
Buzzer Code-Practice Set	14
By-Pass Capacitors	53-54, 169
Bypassing	53-54, 169, 540-542
"C" Battery	63
C (Capacitance)	23
C/R and L/R Time Constants	30-32
Cable Lacing	489
Canadian Director	12
Capacitance and Capacitors	23-26
Capacitance:	
Distributed	54
Feedback	70
Inductance, and Frequency Charts	48
Interlextrode	69-70, 159-160
Measurement	510-511
Specific Inductive	23
Tube Input	69-70
Tube Output	70
Capacitance-Resistance Time Constant	30-32
Capacitive Coupling	48-49, 158, 543-544
Reactance	33-34, 48

	PAGE		PAGE
Capacitor-Input Filter	219-220	Cold-Cathode Rectifiers	216
Capacitors:		Collector	82, 83-84
Bandspread	92	Collinear Arrays	359-360, 436, 438, 442
Buffer	481	Color Codes, RETMA	490-491
Bypass	53-54, 169	Colpitts Circuit	74, 145-146
Ceramic	169	Combined A.C. and D.C.	53-55
Electrolytic	25	Combination Arrays	360-361, 366
Filter	219-220, 222-223	Compact Antennas	351-353, 357
Fixed	24-25	Compact 14 Mc. 3-Element Beam	373
Main-Tuning	92	Complex Waves	17, 39
Neutralizing	160	Component Ratings and Installation	167-169
Padding	92	Component Values	489-490
Trimmer	92	Compression, Speech Amplifier	253-254
Variable	24-25	Concentric-Line Matching Section	364-365
Carbon Microphone	247-248	Concetric Transmission Line	323
Carrier	59, 275	Condenser (see Capacitor)	23
Carrier Suppression	300-301	Conductance	16
Cascade Amplifiers	67	Conductance, Mutual	63
Cascode R.F. Amplifier	385	Conductivity	16, 574
Catcher	78	Conductor Size, Antennas	346
Cathode	60-61	Conductors	16
Cathode-Bias Calculation	73	Cone Antennas	445
Cathode-Coupled Clipper	77	Conelrad	141, 566
Cathode Follower	71, 72	Constant, Time	30-32, 100-101
Cathode Injection	94	Constants, LC	48
Cathode Keying	238	Constant-Voltage Transformers	234
Cathode-Ray Oscilloscopes	521-524	Construction, Antenna	367-375
Catwhisker	81, 82	Construction, Coupler	338-342
Cavity Resonators	57-58	Construction Practice	484-492
Cell	16	Contact-Potential Bias	73-74
Center-Fed Antenna	345-348	Continental Code	13-14
Center Loading	473	Control Circuits, Station	526-527
Center-Tap, Filament	72	Control Grid	62
Center-Tap Full-Wave Rectifier	214-215	Controlled Carrier	285
Center-Tap Keying	238	Conversion Efficiency	94
Center-Tap Modulation	286-287	Conversion Exciter	241
Ceramic Microphone	248	Conversion, Frequency	317
Channel	275	Converters, D.C.-A.C.	480
Characteristic Curves	62-63, 81, 83	Converters, Audio	96
Characteristic Impedance	318, 325	Converters, Frequency	94-96, 107-108
Characteristics, Dynamic	63	Converters, H. F.	124-129
Characteristics of Amateur Bands	380-383	Converters, V.H.F.	388-398, 402-404, 454-458
Characteristics of Radio Waves	376-377	Copper-Wire Table	492
Charges, Electrical	15-16	Cores	27, 28-29, 40, 42-43
Chassis Layout	485-486	Corner Reflector Antenna	445
Chirp, Keying	146-147, 238	Corrective Stub	436
Choke:		Counterpoise	357
Coil	26, 220	Countries List, ARRL	569
Filter	220	Coupled Circuits	48-51
Radio-Frequency	26, 53, 169	Coupled Tuned Circuit Response	574
Swinging	221	Couplers, Antenna	130, 131, 333-342
Choke-Coupled Modulation	280-281	Construction	338-342
Choke-Input Filter	220-222	Coupling	30
Circuits, Multiband Tank	152-153	Coupling:	
Circuit Symbols	576	Antenna to Receiver	91, 130, 131, 332-333, 393-394
Circuit Tracking	92-93, 106	Amplifier-Output	148-153
Clamp Tubes	155-156	Antenna to Transmitter	333-342
Clamp Tube Modulation	284-285	Capacitive	48-49, 158, 543-544
Clapp Oscillator	145-146	Choke	65
Class A Amplifiers	66	Circuits	48-51, 65
Class AB Amplifiers	68	Close	30
Class B Amplifiers	67-68	Coefficient of	30, 50, 511-512
Class B Modulators	267-271	Capacitor	65
Class C Amplifiers	68	Critical	50
Clicks, Keying	237, 241-242	Impedance	65
Clipping Circuits	76-77	Inductive	49, 156-158
Clipping-Filter Circuit	133-134, 255	Interstage	156-159
Clipping, Speech	253-255	Link	50-51, 156-158, 334-335, 336-337
Closed Stub	328	Loose	30
Club Affiliation	563	Pi-Section	159
Coax-Coupled Matching Circuit	339	Resistance	65
Coaxial Antennas	443-444, 445	Transformer	49-50, 65, 327-332
Coaxial-Electrode Tubes	143	To Transmission Lines	149-152
Coaxial-Line Circuits	56	To Wave Guides and Cavity Resonators	58
Coaxial-Line Matching Section	364-365	Tuned	150, 330, 333-338
Coaxial Plug Connections	489	Critical:	
Coaxial Transmission Lines	323, 324-325	Angle	378
Code (Continental) and Code Practice	13-14	Coupling	50
Code Proficiency Award	565	Frequency	378
Code, Underwriters	530-531	Inductance	220-221
Coefficient of Coupling	30, 50, 511-512	Cross-Modulation	105-106, 533, 549
Coefficient, Temperature	19	Cross-Talk	533
Coil (see "Inductance")			

	PAGE		PAGE
Crystal:		Direct Current	16-17
Diodes	80-81, V-32	Direct Feed for Antennas	346-348
Filters	104	Directive Antennas	357-366
Microphones	248	Directivity, Antenna	346, 347, 350, 357-366
Oscillators	143, 144-145, 405-406	Director, Antenna	363
Rectifiers	80	Directors, ARRL	12
Resonator	52	Discharging, Capacitor	23
Crystal-Controlled Converters	388-393, 402-404, 450-456	Discriminator	109
Crystal-Controlled Oscillators	143, 144, 145, 405-406	Disk-Seal Tubes	77
Crystal Detector	80-81, 87	Dissipation, Plate and Screen	153
Crystal Filter, Tuning with	104, 108	Distortion, Harmonic	64-65
Crystal, Germanium	80-81	Distributed Capacitance and Inductance	54
Crystal-Lattice Filter	309	Dividers, Voltage	226-227
Crystals, Overtone	405-406	Divisions, ARRL	12
Crystals, Piezoelectric	52	Doubler, Frequency	143
Current:		Double-Humped Resonance Curve	50
Alternating	16, 32-43	Double Superheterodyne	94
Amplification Factor	82	Drift, Frequency	75, 145, 147
Antenna	345	Drift Space	78
Direct	16	Drill Sizes (Table)	485
Distribution, Antenna	345	Driven-Element Directive Antennas	359-362
Eddy	29	Driver	67, 143, 269-270
Effective	17	Driver Power	248-249
Electric	15-16	Driver Regulation	303
Feed for Antennas	345-346, 347, 350	Drivers for Class B Modulators	267-271
Gain	82	Driver Voltage	153, 154
Lag and Lead	32-39	Dummy Antenna	167, 543
Line	318-319	DXCC	564-565, 569
Loop	320	DX Century Club Award	564-565
Magnetizing	40	DX Operating Code	557
Measurement	494-495	Dynamic:	
Node	320	Characteristics	63
Plate	61	Instability	75
Pulsating	16, 53	Microphones	248
Ratio, Decibel	43	Dynamometer Movement	496
Values	17	Dynamotors	480
Curve, Resonance	44-45, 50	Dynatron-Type Oscillator	78
Curves, Transistor Characteristic	83	E (Voltage)	17
Curves, Tube-Characteristic	62-63	E Layer	377
Cut-Off Frequency	82, 572	E.M.F., Back	26
Cut-Off, Plate-Current	62-63, 71, 154-156	E.M.F., Induced	26
C.W. Abbreviations	571	Eddy Current	29
C.W. Procedure	553-555	Effective Current Value	17
C.W. Reception	108	Efficiency	22-23
Cycle	16, 32	Conversion	94
Cyclic Variations in Ionosphere	379	Transformer	41
Cylindrical Antennas	444-445	Electric Current	15-16
D'Arsonval Movement	493	Electrical Charge	15-16
D Region	378	Electrical Laws and Circuits	15-59
Data, Miscellaneous	568-576	Electrical Quantities, Symbols for	576
D.C.	16-17	Electrical Safety Code, National	530-531
D.C. Instruments	493-497	Electrode	60
D.C. Measurements	493	Electrode Voltages, Sources	154-156
Dead Spots	91	Electrolytic Capacitor	25
Decay, Voltage	32	Electromagnetic:	
Decibel	43	Deflection	521
Decoupling	98	Field	15
Deflection Plates	522	Waves	15, 17, 376
Degeneration	68-69	Electromotive Force (E.M.F.)	16
Degree, Phase	32	Electron:	
Delta Matching Transformer	330-331, 348, 365	Gun	521
Demodulation	58	Lens	522
Density, Flux	15	Transit Time	77, 78
Design of Speech Amplifiers	251-252	Electronic:	
Detection	58, 86-91, 93, 99-100	Conduction	16, 80
Detectors	86-91, 93, 99-100	Keys	246
Deviation Ratio	294	Voltage Regulation	228-229
Diagrams, Schematic Symbols for	576	Electrons	15, 80
Diamond Antenna	358-359	Electrostatic:	
Dielectric	23	Deflection	521-522
Dielectric Constants	23	Field	15
Difference of Potential	15, 16	Waves	376
Differential Keying	240, 241	Element Spacing, Antenna	359-364, 436-437
Diffused Junction Transistors	82	Elements, Antenna	359, 363, 436-437
Diode Clippers	76	Elements, Vacuum Tube	60
Diode Detectors	87-88	Emergency Communication	560-562
Diodes	61	Emergency Communications	561, 567
Diodes, Crystal	80	Emergency Coordinator	561, 562
Dipole, Folded	328-329, 347-348	Emergency Power Supply	480-483
Dipole	345-348	Emission:	
		Electron	60
		Secondary	70

	PAGE		PAGE
Thermionic	60	Index, Modulation	295
Emitter, Transistor	82, 83	Methods	296-297
End Effect	345	On V.H.F.	407
End-Fire Arrays	359, 361-362	Principles	294-295
Energy	22-23	Reactance Modulator	296-297
Envelope, Modulation	275-277	Reception	109-110
Excitation	156	Transmitter Checking	298-299
Exciter Units (see "Transmitters")		Frequency Response, Microphone	247
Exciting Voltage	66	Frequency-Wavelength Conversion	18
Extended Double-Zepp Antenna	362	Front-to-Back Ratio	343
F.M. (see "Frequency Modulation")		Full-Wave Bridge Rectifiers	216
F-Layer	378, 381-382	Full-Wave Center-Tap Rectifiers	215-216
Fading	379	Fusing	529-530
"Fail-Proof" Conecrad Alarm	141-142	Gain Control	107, 251
Farad	24	Gain, Vacuum Tube Amplifier	575
Feedback	68-69, 105, 270-271	"Gamma" Match	329-330, 365
Feed, Series and Parallel	53	Ganged Tuning	92-93
Feeders and Feed Systems	318-342, 346-348, 350, 352-353, 354, 364-365, 369	Gaseous Regulator Tubes	227-228
Feeding Close-Spaced Antenna Arrays	364-365	Gasoline-Engine-Driven Generators	483
Feeding Dipole Antennas	346-348	Genemotors	480
Feeding Long-Wire Antennas	350	Generator	16
Feedlines for Rotatable Arrays	445-446	Generator Noise	448
Fidelity	86, 97-98, 247	Germanium Crystals	80-81
Field Direction	15	Grid	62
Field, Electromagnetic	15	Bias	72-74, 154-155, 229-231, 268
Field, Electrostatic	15	Capacitor	74, 168
Field Intensity	15, 343	Current	62, 156
Field, Magnetostatic	15	Excitation	75
Field Strength	343	Injection, Mixer	94
Field-Strength Meter	476-477, 512-513	Keying	239, 240
Filament	60-61	Leak	74, 89, 154-155
Filament Center-Tap	72	Resistor	65, 74
Filament Hum	72	Suppressor	70
Filament Supply	224	Voltage	62
Filament Voltage	154	Grid-Bias Modulation	281-284, 292
Filter Component Ratings	222-223	Grid-Cathode Capacitance	69-70
Filter, Crystal	104, 108	Grid-Dip Meters	505-507
Filter Resonance	222	Grid-Input Impedance	156
Filters	572-573	Grid-Leak Detectors	89-91
Audio	254-255	Grid-Plate Capacitance	69-70
Crystal-Lattice	309	Grid-Plate Crystal Oscillator	145
High-Pass	550-551, 572-573	Grid-Plate Transconductance	63
Keying	237	Grid-Separation Circuit	71-72
Line	535	Ground	54, 344-345
Lead	541-542	Ground Effects	344-345
Low-Pass	545-548, 572-573	Ground-Plane Antenna	354-356
Power-Supply	218-223	Ground Point, R.F.	76
R.F.	237	Ground Potential	54
Filtering, Audio	254-255	Ground Waves	377
Filtering, Negative-Lead	223	Grounded Antennas	354-356, 357
Filter-Type S.S.B. Exciters	301-302, 308-309	Grounded-Base Circuit	83
Finishing Aluminum	487	Grounded-Collector Circuit	84
First Detector	93	Grounded-Emitter Circuit	84
Fixed Capacitor	24-25	Grounded-Grid Amplifier	71-72, 313-315, 385-386
Flat Lines	322	Grounds	357
Flux Density, Magnetic	15, 28-29	Guy's, Antenna	368-369
Flux, Leakage	41	Half-Lattice Crystal Filter	309
Flux Lines	15	Half-Wave Antenna	345-348
Fly-Back	522	Half-Wave Line	406
Focusing Electrode	522	Half-Wave Rectifiers	215
Folded Dipole	328-329, 347-348	Halyards, Antenna	369
Force, Electromotive	16	Harmonic	17
Force, Lines of	15	Antenna	349-353, 357-359
Form, Log	558	Distortion	64-65
Form, Message	559	Generation	538-539
Forward Resistance	81	Operation of Antennas	349-353, 357-359
Fractions, Decimal Equivalents	487	Reduction	407, 538-539, 543-548
Free-Space Pattern	344	Suppression, Audio	268
Frequency	16	Traps	539, 551
Frequency Bands, Amateur	114	Hartley Circuit	74, 76, 145-146
Frequency Measurement:		Hash Elimination	481
Absorption Frequency Meters	499-450	Heater	61
Frequency Standards	502-505	Heating Effect	17
Heterodyne Frequency Meters	502	Henry	26
Interpolation-Type Frequency Meter	505	Hertz Antenna	345
Lecher Wires	500-501	Heterodyne Frequency Meters	501-502
WWV and WWVH Schedules	504	Heterodyne Reception	85
Frequency and Phase Modulation	294-299, 407	Heterodyning	59
Narrow-Band Reactance-Modulator Unit	296-297	High-C	47-48, 75
Deviation Ratio	294	High Frequencies	17-18
Discriminator	109	High-Frequency Oscillator	93, 96-97

	PAGE
High-Frequency Receivers.....	85-142
High-Frequency Transmitters.....	143-214
High-Pass Filters.....	550-551
High-Q Circuit.....	46
High-Vacuum Rectifiers.....	61-62, 216-217
High- μ Tubes.....	63
Hiram Percy Maxim Memorial Station, 12, 564, 565	
History of Amateur Radio.....	9-12
Hole Cutting.....	486
Holes.....	80
Horizontal Angle of Radiation.....	343
Horizontal Polarization of Radio Waves.....	376, 435-436
Hum.....	72, 91, 274, 292
Hysteresis.....	29
<i>I</i> (Current).....	15-16
Ignition Interference.....	447-448
Image.....	93, 103
Image Ratio.....	93
Image Response.....	533
Impedance.....	37-39
Antenna.....	327, 343, 344, 345, 350, 436
Bridge.....	518-519
Characteristic.....	318, 325
Complex.....	37
Grid Input.....	156
Input.....	71, 321-322, 327
Matching.....	42, 51-52, 267-268, 436
Measurements.....	520
Modulating.....	279
Output.....	71
Ratio.....	41-42
Surge.....	318, 325
Transformation.....	322
Transformer.....	327-329
Transformer Ratio.....	40, 267-268
Transmission-Line.....	318, 325
Impedance-Coupled Amplifiers.....	65
Imperfect Ground.....	344
Improving Receiver Performance.....	112
Impulse Noise.....	101
Incident Power.....	319
Index, Modulation.....	295
Indicating Wave Meters.....	499-500
Indicators, Tuning.....	102-103
Induced E.M.F.....	26
Inductance.....	26-30
Capacitance and Frequency Charts.....	48
Critical.....	220-221
Distributed.....	54
Leakage.....	41
Measurement.....	510-512
Mutual.....	30
Slug-Tuned.....	93
Small Coil.....	27
Inductance-Resistance Time Constant.....	31-32
Inductance in Series and Parallel.....	29-30
Inductive Capacitance, Specific.....	23
Inductive Coupling.....	49, 156-158
.....	334-335, 336-337
Inductive Neutralization.....	159-160, 162-163
Inductive Reactance.....	34-35
Inductor.....	26
Infinite-Impedance Detector.....	88-89
Input Choke.....	220-221
Input Impedance.....	71, 321-322, 327
Input, Plate Power.....	153
Instability, Receiver.....	86, 112
Instantaneous Current Value.....	17
Insulators.....	16
Interelectrode Capacitances.....	69-70
Interference Patterns.....	537
Intermediate Frequency.....	93
Intermediate Frequency Amplifier.....	97-99, 103-105, 387
Intermediate-Frequency Bandwidths, Table.....	99
Intermediate-Frequency Interference.....	549-550
Intermediate-Frequency Transformers.....	98-99
Intermittent Direct Current.....	16, 61
International Prefixes.....	571
Interpolation-Type Frequency Meter.....	505
Interstage Coupling.....	156-159

	PAGE
Interstage Transformer.....	99
Inverse-Distance Law of Propagation.....	376
Inverse Peak Voltage.....	217
Inversion, Phase.....	251
Inversion, Temperature.....	383
Ionization.....	15, 377
Ionosphere.....	377-378, 379-380, 381-382
Ionosphere Storms.....	379, 382
Ionospheric Propagation.....	377-378, 379-380, 381-382
Ions.....	15, 377
Iron-Core Coils.....	28-29, 40, 41
Isolating Amplifiers.....	146-147
ITV.....	552
Junction Transistors.....	82
Keeping a Log.....	558
Key Chirps.....	146-147, 238
Key Clicks.....	237, 241
Keyer Tubes.....	240-241
Keyers, Vacuum-Tube.....	243
Keying:	
Amplifier.....	239-240
Back Wave.....	238-239
Break-In.....	240-241, 246
Electronic Keys.....	246
Key-Click Reduction.....	237-238, 241
Methods.....	237-243
Monitoring.....	243-245
Oscillator.....	240
Testing.....	241-242
Kilocycle.....	17
Kilohm.....	22
Kilovolt.....	22
Kilowatt.....	22
Kilowatt Hour.....	23
Klystrons.....	78
<i>L</i> (Inductance).....	26-30
<i>L/C</i> Constants.....	48
<i>L/C</i> Ratios.....	48, 148-149, 282
<i>L</i> Network.....	51
<i>L/R</i> Time Constant.....	31-32
"L"-Section Filters.....	573
Lacing Cable.....	489
Lag Circuits.....	237-238
Lag, Current or Voltage.....	32-39
Laminations.....	29
Laws Concerning Amateur Operations.....	13
Laws, Electrical.....	15-59
Lazy-H Antenna.....	360-361
Lead, Current or Voltage.....	32-39
Lead-In, Antenna.....	369-370
Leakage Flux.....	41
Leakage Inductance.....	41
Leakage Reactance.....	41
Lecher Wires.....	500-501
Level, Microphone.....	247
<i>License Manual, The Radio Amateur's</i>	13
Licenses, Amateur.....	13
"Lighthouse" Tubes.....	77, 385, 405
Lightning Protection.....	369, 370
Limiter Circuits.....	76-77
Limiters, Noise.....	101-102, 447, 449
Limiting Resistor.....	227
Line Current.....	39
Line Filters.....	535
Line, Open-Circuited.....	320
Line Radiation.....	322-323
Line-Voltage Adjustment.....	233-234
Linear-Amplifier Tube — Operation Data.....	304
Linear Amplifiers.....	67-68, 303-305, 310-315
Linear Baluns.....	331-332
Linear Reactances.....	328, 347, 364-365
Linear Sweep.....	522
Linear Transformers.....	327-331
Linearity.....	64, 278, 279
Lines, Coaxial.....	323, 324-325
Lines, Matched.....	318-319
Lines of Force.....	15
Lines, Nonresonant and Resonant.....	322
Lines, Parallel Conductor.....	323-324

	PAGE		PAGE
Lines, Transmission	318-342	Mobile:	
Lines, Unterminated	321-322	Antennas	471-475
Link Coupling	50-51, 156-158, 334-335, 336-337	Power Supply	478-479
Link Neutralization	159-160, 162-163	Receivers:	
Lissajous Figures	523	Bandswitching Crystal-Controlled Converter	450-453
"Little Oskey"	244-245	Crystal-Controlled Converter for 50 Mc.	454-456
Load	22, 63-64, 327	Simple Mobile Converter for 144 Mc.	457-458
Load Impedance	267-268	Transmitters:	
Load Isolation, VFO	146-147	Band-Changing Transmitter for 50 and 144 Mc.	468-470
Load Resistor	22, 61, 63-64	6-Band Mobile R.F. Assembly	459-462
Loaded Circuit Q	47	10-Watt 50-Mc. Mobile Transmitter	465-467
Local Oscillator	93, 96-97	25-Watt Mobile Modulator	463-464
Locking-In	91	Signal Field-Strength Meter	476-477
Log, Station	558	Modes of Propagation	56-57
Long-Wire Antennas	349-350, 357-359	Modulation, Heterodyning and Beats	58-59
Long-Wire Directive Arrays	357-359	Modulation:	
Loops, Current and Voltage	320	Amplitude Modulation	58, 275
Losses, Hysteresis	29	Capability	278
Losses in Transmission Lines	326-327	Cathode Modulation	286-287
Loudspeaker Coil Color Code	491	Characteristic	278
Low-C	48	Checking A.M. Phone Operation	273-274, 287-292
Low Frequencies	17-18	Choke-Coupled Modulation	280-281
Low-Pass Filters	254, 545-548, 573	Clamp-tube	284-285
Low-Q	46-47	Controlled-Carrier Systems	285
Low- μ Tubes	63	Depth	275-276, 295
M. U. F. (see "Maximum Usable Frequency")		Driving Power	248, 269-270
Magnetic Storms	379, 382	Envelope	275-277
Magnetizing Current	40	Frequency Modulation	294, 407
Magnetrons	78-79	Grid-Bias Modulation	281-283
Marker Frequencies	502-505	Impedance	279, 286
Masts	367-368	Index	295
Matched Lines	318-319	Linearity	278, 279
Matching, Antenna	327-332, 346-348	Methods	278-287
350, 352-353, 354, 364-365, 436, 446, 472-475		Monitoring	293
Matching-Circuit Construction	338-342	Narrow-Band Frequency	296
Maximum Average Rectified Current	81	Percentage of	275-276
Maximum Inverse Peak Voltage	217	Phase Modulation	294, 296, 297
Maximum Safe Inverse Voltage	81	Plate Modulation	279-281, 291-292
Maximum Usable Frequency	378, 381	Plate Supply	278, 291-292
Measurements:		Power	276
Antenna	509-510, 512-521	Screen-Grid Amplifiers	283-284
Capacitance	510-511	Suppressor-Grid Modulation	285-286
Current	494-495	Test Equipment	273-274, 287-292
Field Strength	476-477, 512-513	Velocity Modulation	77-78
Frequency	499-505	Wave Forms	274, 276, 277, 288-289
Impedance	518, 520	Modulator Tubes	267
Inductance	510-512	Modulators (see "Radiotelephony")	267-272
Modulation	273-274, 287-292	"Monimatch"	342, 516-518
Output Power	167	Monitors	243-245, 293
Phase	33	Motorboating	112
Power	510	Moving-Vane Instrument	493
Resistance	495-498, 512	Mu (μ)	63
Standing-Wave Ratio	513-521	Mu, Variable	71
Voltage	493-494, 497-498, 509-510	Multiband Antennas	351-353
Measuring Instruments	493	Multiband Tank Circuits	152-153
Medium of Propagation	376	Multihop Transmission	378-379, 382
Medium- μ Tubes	63	Multimatch Antenna	353
Megacycle	17	Multimeters	497-498
Megohm	20	Multipliers, Frequency	143, 164-165, 406
Mercury-Vapor Rectifiers	217	Multipliers, Voltmeter	493-494
Message Form	559	Multirange Meters	497-498
Message Handling	558-560	Mutual Conductance	63, 71
Meteor Trails	383	Mutual Inductance	30
Metering	165-166	N-Type Material	80
Meters, Volt-Ohm-Milliamperere	497-498	N.F.M. Reception	109
Meter Switching	166	Narrow-Band Frequency Modulation	296
Mho	19, 63	National Electrical Safety Code	530-531
Microampere	20	National Traffic System	560
Microfarad and Micromicrofarad	24	Natural Resonances	54
Microhenry	27	Negative Feedback	69, 270
Micromho	19, 63	Negative-Lead Filtering	223
Microphones	247-248	Negative-Resistance Oscillators	78
Microvolt	20	Network Operation	559-560
Microwaves	77	Neutralization	152, 159-160
Miller Effect	69	Neutral Wire	232
Milliammeters	61, 494-495	Nodes	320
Milliamperere	20	Noise Figure	86
Millihenry	27		
Millivolt	20		
Milliwatt	22		
Miscellaneous Data	568-576		
Mixers	94-96, 317, 386		

	PAGE
Noise-Limiter Circuits	101-102, 449
Noise, Receiver	86, 101-102
Noise Elimination, Mobile	447-449
Noise Reduction	101-102, 481, 483
Nomenclature, Frequency-Spectrum	17-18
Nonconductors	16
Nonlinearity	64, 86, 278, 279
Nonradiating Loads	332-333
Nonresonant Lines	322, 323-325
Nonsynchronous Vibrators	480-481
Nucleus	16
Off-Center Fed Antenna	352-353
Official Bulletin Station	563
Official Experimental Station	563
Official Observer	563
Official Phone Station	563
Official Relay Station	563
Ohm	18
Ohm's Law	19-20
Ohm's Law for A.C.	35-36, 38
Ohmmeters	495-497
Old Timers Club	566
Open-Circuited Line	320
Open Stub	328
Open-Wire Line	323-324
Operating an Amateur Radio Station	559, 560, 567
Operating Angle, Amplifier	68
Operating a Station	553-566
Operating Bias	154
Operating Conditions, R.F. Amplifier-Tube	153-172
Operating Point	64
Operator License, Amateur	13
Oscillation	69, 74-76, 84, 89-91, 111
Oscillations, Parasitic	161, 163
Oscillator Keying	240, 241
Oscillators	74-76
Audio	507-508
Beat-Frequency	99-100
Crystal	143, 144-145, 405-406
Grid-Dip	505-507
Heterodyne	93, 96-97, 99-100
Overtone	405-406
Test	505-508
Transistor	84
V.F.O.	143, 145-148
Oscilloscope Patterns	274, 276, 277, 288-289, 308, 316, 523
Oscilloscopes	273-274, 287-291, 521-524
Output Capacitor, Filter	222
Output Limiting	254-255
Output Power	66, 167
Output Voltage	249
Output Voltage, Power Supply	222, 223
Overexcitation, Class B Amplifier	269
Overloading, TV Receiver	549
Overmodulation	277, 293
Overmodulation Indicators	293
Overtone Oscillators	405-406
Oxide-Coated Cathode	61
<i>P</i> (Power)	22
P-Type Material	80
P.M. (see "Phase Modulation")	
Padding Capacitor	92
Parabolic Reflectors	445
Parallel Amplifiers	66-67, 162
Parallel Antenna Tuning	335-337, 351-352
Parallel Capacitances	25
Parallel Circuits	25-26, 29-30, 33
Parallel-Conductor Line	323-324
Parallel-Conductor Line Measurements	519-521
Parallel Feed	53
Parallel Impedance	38-39, 45-46
Parallel Inductances	29-30
Parallel Resistances	20-22
Parallel Resonance	44-45
Parallel Tuning	335-337
Parasitic Elements, Antenna Arrays with	362-366, 438-443
Parasitic Excitation	362-363
Parasitic Oscillations	161, 163
Patterns, Oscilloscope	274, 276, 277, 288-289, 308

	PAGE
Patterns, Radiation	346, 347, 350
Patterns, TVI	537
Peak-Current Value	17
Peak-Voltage Rating	217
Pencil Tubes	385, 405
Pentagrid Converters	95
Pentode Amplifiers	70-71
Pentode Crystal Oscillators	144-145
Pentodes	70
Percentage of Modulation	275-276
Per Cent Ripple	218, 220, 222
Permeability	28-29
Phase	32-33
Phase Inversion	251
Phase Modulation (see also "Frequency and Phase Modulation")	294-295, 296, 297
Phase-Modulation Reception	109
Phase Relations, Amplifiers	64
Phase Shift	294
Phase-Splitter Circuit	251
Phased Antennas	359-362
Phasing-Type S.S.B. Exciters	306-308
Phone Activities Manager	562
Phone Reception	108-109
Phonetic Alphabet	556
Pilot Lamp Data (Table)	575
Pi-Section Coupling	158, 159, 163-164
Pi-Section Filters	573
Pi-Section Tank Circuit	51-52, 151-152
Pierce Oscillator	144-145
Piezo-Electric Crystals	52
Piezo-Electric Microphone	248
Piezoelectricity	52
Plane-Reflector Antennas	444-445
Plate-Cathode Capacitance	70
Plate-Current Shift	291-292
Plate-Grid Capacitance	67-68, 159
Plate	60
Blocking Capacitor	169
Current	61
Detectors	88
Dissipation	153
Efficiency	66
Modulation	279-281
Neutralization	159-160
Resistance	63
Resistor	65
Supply, Audio	268-269, 278
Plate Transformer	223-224
Plate Tuning, Power-Amplifier	166-167
Plates, Deflection	522
"Plumber's Delight" Antenna	371-372
Point-Contact Transistor	80, 82
Polarization	343, 345, 376, 435-436
Positive Feedback	69
Potential Difference	15, 16
Potential, Ground	54
Powder, Antistatic	449
Power	22-23
Power Amplification	66-68
Power-Amplification Ratio	66
Power Connections and Control	527-529
Power Gain, Antenna	343, 350
Power, Incident	319
Power Input	61
Power-Line Connections	232-233
Power Measurement	22-23, 495, 510
Power Output	66, 167
Power Ratio, Decibel	43
Power, Reactive	37
Power, Reflected	319-320
Power Sensitivity	66
Power-Supply Construction Data	224-226, 234-236
Power Supplies:	
Bias Supplies	229-231
Combination A.C.-Storage Battery Supplies	481-483
Construction	234-236
Constructional (see Chapters Five and Six)	
D.C.-A.C. Converters	480
Dry Batteries	483
Dynamotors	480
Emergency Power Supply	480-483

	PAGE		PAGE
Filament Supply	224	Speech-Amplifier with Push-Pull Triodes	256
Genemotors	480	25-watt Modulator using Push-Pull	
Heavy-Duty Regulated Power Supply	229-230	6BQ6GTs	259-260
Noise Elimination	481, 483	40-Watt Class AB ₁ Modulator	261-263
Plate Supply	268-269, 278	6146 Modulator and Speech Amplifier	264-266
Principles	215-216	Driver Stages	269-271
Safety Precautions	235-236	Measurements	273-274, 287-293
Selenium Rectifiers	231-232, 236	Microphones	247-248
Typical	225-226	Modulation	275
Vibrators	480-481	Modulators and Drivers	267-272
Vibrator Supplies	481-483	Monitors	293
Preamplifier, Receiver	107	Output Limiting	254-255
Prediction Charts	380	Overmodulation Indicators	293
Preferred Values, Component	489	Principles	275
Prefixes	569-571	Reception	108-109
Preselectors	107	Resistance-Coupled Speech-Amplifier Data	250
Primary Coil	40	Single-Side-Band Transmission	300-301
Procedure, C. W.	553-555, 571	Speech Amplifiers	248-253, 256
Procedure, Voice	555-556	Volume Compression	253-254
Product Detector	89, 96	Radio Waves, Characteristics of	376-377, 380-383
Propagation, Ionospheric	377-378, 379-380, 381-382	Rag Chewers Club	566
Propagation Modes	56-57	Range, V.H.F.	381
Propagation Patterns	346, 347, 350	Ratio, Deviation	295
Propagation Phenomena	381-383	Ratio, Image	93
Propagation Predictions	380, 381	Ratio, Impedance	41-42
Propagation, Tropospheric	377, 380, 382-383	Ratio, Turns	40
Propagation, V.H.F.	380-383	Ratio, Power-Amplification	66
Protective Bias	154-156	Ratio, Standing Wave	319-321, 513-521
Public Relations, BCI-TV	532	Ratio, Transformer	267-268
Public Service	10-11	Ratio, Voltage-Amplification	64
Pulleys, Antenna	369	Ratio, <i>L/C</i>	17-18, 148-149, 151-152, 282
"Pulling"	91, 93	Reactance, Capacitive	34
Pulsating Current	53	Reactance, Inductive	34-35
Puncture Voltage	23, 25	Reactance, Leakage	41
Push-Pull Amplifier	66-67, 162-163	Reactance, Linear	327, 347, 364-365
Push-Pull Multiplier	165	Reactance Modulator	296-297, 298
Push-Push Multiplier	165	Reactance, Transmission-Line	318-319
Push-to-Talk	528	Reactive Power	37
Q	45-48, 93, 104, 148-153	Readability Scale	568
Q, Loaded Circuit	47	Receiver, Coupling to	332-333
Q, Mobile Antenna	472-474	Receiver Servicing	110-112
"Q"-Section Transformer	327-328	Receivers, High-Frequency (See Also "V.H.F.")	85-142
Q Signals	568	Antennas for	366
QST	12	Constructional:	
Quarter-Wave Transformer	327-328	Antenna Coupling Unit for Receiver	131
Quenching	387	Clipper/Filter for C.W. or Phone	133-134
R (Resistance)	18-22	Converters for 7, 14, 21 and 28 Mc.	126-129
RACES	562	"Fail-Proof" Conelrad Alarm	141-142
RC Circuits	30-31	Regenerative Preselector for 7 to 30 Mc.	135
RCC Certificate	566	Selective Converter for 80 and 40	124-125
R.F.	17	Selective I.F. Amplifier for Phone and C.W.	137-140
R.M.S. Current Value	17	"Selectoject"	132
RST System	568	Squelch Circuit	106
Radials	355-356	Two-Band Five-Tube Superhet	119-123
Radiation, Transmission Line	322-323	Two-Band Three-Tube Superhet	116-118
Radiation Angle	343, 344	Variable-Coupling Antenna Tuning Unit	130
Radiation Characteristics	346, 350	1-Tube Regenerative Receiver	113-115
Radiation from Transmitter	540-543	Converters	94-96
Radiation Patterns	346, 347, 350	Detectors	86-91
Radiation Resistance	346	Extending Range of	107-108
Radio Amateur Civil Emergency Service	562	Improving Performance of	112
Radio Frequency	17-18	Noise Reduction	101
Radio Frequency Choke	26, 53, 169	Regenerative Detectors	89-91
Radiotelegraph Operating Procedure	553-555, 571	Selectivity	103-106
Radiotelephone Operating Procedure	555-556	Sensitivity	106-107
Radiotelephony:		Superheterodyne	93-100
Adjustments and Testing	273-274, 287-293	Tuning	92-93, 108-109
Audio-Harmonic Suppression	268	Reception, N.F.M., F.M. and P.M.	109
Checking A.M. Transmitters	287-293	Reception, Single-Side-Band	110
Checking F.M. and P.M. Transmitters	298-299	Rectification	61-62
Constructional:		In Non-Linear Conductors	549
Class B Modulator	272	Rectified A.C.	61
Clipper-Filter	254-255	Rectifiers	215-217, 231-232, 236
Low-Power Modulator	257-258	Rectifiers, Mercury-Vapor	217
Narrow-Band Reactance Modulator	296-297, 298	Rectifiers, Selenium	217, 231-232, 236
Phasing-Type S.S.B. Exciters	306-308	Rectifier-Type Voltmeter	496-497
Screen Modulator Circuit	258	Reflected Power	319
Speech Amplifier Circuit with Negative Feedback	271	Reflected Waves	319, 381-383
		Reflection of Radio Waves	381-383
		Reflection from Meteor Trails	383
		Reflection, Ground	314, 377

	PAGE
Reflector, Antenna	363
Refraction of Radio Waves	377, 382-383
Regeneration	68-69, 103-104, 107
Regenerative Detectors	89-91
Regenerative I.F.	112
Regenerative R.F. Stage, Receiver	105
Regulation, Driver	303
Regulation, Voltage	218, 219, 227-229
Regulations, Amateur	13-14, 566
Regulations, Conelrad	141, 566
Regulator Tubes	227-228
Regulator, Voltage	227-229
Relays	528-529
Resistance	18-22
Resistance, Back	81
Resistance, Forward	81
Resistance-Bridge Standing-Wave Indicator	513-516
Resistance-Capacitance Time Constant	30-31
Resistance-Coupled Amplifier Data (Chart)	250
Resistance in Series and Parallel	20-22
Resistivity	18
Resistor	19
Resistor Color Code	490-491
Resistor Wattage	22
Resonance	44-47, 49-50
Resonance Curve	44, 45, 50, 574
Resonance, Filter	222
Resonance, Sharpness of	44-45, 366
Resonant-Line Circuits	55-56
Resonant Transmission Lines	322
Resonator, Cavity	57-58
Response, Flat	50, 69
Response, Frequency	50, 69, 247, 249
Response, Tuned-Circuit	574
Restricted-Space Antennas	351-353
Restriction of Frequency Response	253-255, 305
Return Trace	522
Rhombic Antenna	358-359
"Ribbon" Microphone	248
Ripple Frequency and Voltage	218, 220, 222
RMS Voltage	17
Rochelle Salts Crystals	52, 248
Rotary Antennas	364
Rotary Antennas, feedlines for	445-446
Rotary-Beam Construction	370-375
Route Manager	362
<i>Z</i> -Meters	102-103, 476-477
<i>Z</i> Scale	568
<i>Z</i> , <i>B</i> , Exciters	306-309
Safety	235-236, 529-531
Safety Code, National Electric	530-531
Saturation	29, 223
Saturation Point	61
Sawtooth Sweep	522
Scatter	379, 383
Schematic Symbols	576
Screen By-Pass Condenser	74
Screen Circuits, Tuned	407, 427
Screen Dissipation	153
Screen Dropping Resistor	74
Screen-Grid Amplifiers	155-156, 280
Screen-Grid Keying	239
Screen-Grid Modulation	283-285
Screen-Grid Neutralization	152, 159-160
Screen-Grid Tube Protection	155-156
Screen-Grid Tubes	70-71
Screen-Voltage Supply	74
Second Detector	93, 99-100
Secondary Coil	40
Secondary Emission	70
Secondary Frequency Standard	502-505
Section Communications Manager	561, 562
Section Emergency Coordinator	561, 562
Section Nets	563
Selective Fading	379
Selectivity	50, 86, 104-105
Selectivity Control	104
Selectivity, Receiver	86, 104-105
Selenium Rectifiers	217, 231-232, 236
Self-Bias	154
Self-Controlled Oscillators	143
Self-Inductance	26

	PAGE
Self-Oscillation	70
Self-Quenching	387
Semiconductors	80-84
Sending	554-555
Sensitivity, Receiver	85-86, 106-107
Series Antenna Tuning	335-336, 351
Series Capacitances	25-26
Series Circuits	20-22, 25-26, 29-30
Series Feed	53
Series Inductances	29-30
Series-Parallel Resistances	21-22
Series Resistances	20-21
Series Resonance	44
Series Voltage-Dropping Resistor	226
Servicing Superhet Receivers	110-112
Sharp Cut-Off Tubes	71
Sheet Metal Cutting and Bending	487
Shielding	55, 70, 540-542
Shields	55
Short Skip	382
Shorting Stick	529
Short-Circuiting	23
Shot Noise	101
Shunt Matching, Ground-Plane Antenna	355
Shunts, Meter	493-494
Side-Band Cutting	97-98
Side-Band Interference	275, 277
Side Bands	59, 275
Side Bands, F.M. and P.M.	295
Side Frequencies	59, 275
Signal Envelope Shape	237-238
Signal Generators	505-508
Signal-Handling Capability	87
Signal-to-Image Ratio	93
Signal Monitor	244-245
Signal Monitoring	243, 293
Signal-Strength Indicators	102-103, 476-477
Signal-Strength Scale	568
Signal Voltage	63
Silencers, Noise	101-102
Silicon Diodes	80-81
Sine Wave	17, 33
Single-Ended Circuits	54-55
Single Side Band (see also "Radiotelephony"):	
Adjustment	307, 316
Amplification	303-305, 310-315
Exciters	306-309
Generators	301-302
Mixers	317
Signal Reception	103, 110
Transmission	300-317
Single-Signal Reception	103-104
Skin Effect	19
Skip Distance	378, 382
Skip Zone	378
Skirt Selectivity	86
Sky Wave	377
Slug-Tuned Inductance	93
Smoothing Choke	228
Solar Cycle	379, 382
Soldering	487
Space Charge	60, 61
Space Wave	377
Spark Plug Suppressors	447-448
Specific Inductive Capacity	23
Spectrum, Frequency	17, 18
Speech Amplifiers	248-253
Speech-Amplifier Construction	252-253
Speech Amplifier Design	251-252
Speech Clipping and Filtering	254-255
Speech Compression	253-254
Speech Equipment	247-255
Splatter	277
Splatter-Suppression Filter	255
Sporadic-E Layer Ionization	379-380, 382
Sporadic-E Skip	382
Spreading of Radio Waves	376
Spurious Responses	93, 94, 109, 549-550
Spurious Side Bands	292-293
Squegging	97
Squelch Circuits	106
Stability, Amplifier	159-161
Stability, Oscillator	75

	PAGE
Stabilization, Voltage	227-229
Stacked Arrays	360-362, 440-443
Stage, Amplifier	67
Stage, Driver	67
Stagger-Tuning	50
Standard Component Values	489
Standards, Frequency	502-505
Standing Waves	319-321
Standing-Wave Ratio	320-321, 513-521
Starting Voltage	227
States, W Prefixes by	571
Static Characteristics	63
Static Collectors	448-449
Station Appointments	563
Station Control Circuits	531
Storage Battery, Automobile	479
Straight Amplifier	143
Stray Receiver Rectification	533-534
Stubs, Antenna-Matching	328, 435, 436
Sunspot Cycle	379, 382
Superheterodyne	93-94
Superhigh Frequencies (see also "Very High Frequencies")	18
Superimposed A.C. on D.C.	53
Superregeneration	387
Superregenerative Receiver	387
Suppressor Grid	70
Suppressor-Grid Modulation	285-286
Suppressor, Noise	101-102
Surface Wave	377
Surge Impedance	318, 325
Sweep Circuits	522
Sweep Wave Forms	522-523
Swing, Grid	63
Swinging Choke	221
Switch	236
Switches, Power	528-529
Switching, Antenna	366
Switching, Meter	166
Symbols for Electrical Quantities	576
Symbols, Schematic	576
Symbols, Transistor	82
Synchronous Vibrators	480-481
"T"-Match to Antennas	329-330
"T"-Section Filters	573
Tank-Circuit Q	45-48, 93, 104, 148-153
Tank Circuits, Multiband	152-153
Tank Constants	148-153
Television Interference, Eliminating	407, 536-552
Temperature Effects	19
Temperature Inversion	383
Termination, Line	318-319, 320
Tertiary Winding	99
Tetrode	70
Tetrode Amplifiers	155-156
Tetrode Neutralization	152, 159-160
Tetrodes, Beam	70
Thermal-Agitation Noise	85
Thermionic Emission	60
Thermocouple	509
Thoriated-Tungsten Cathodes	61
Tickler Coil	90-91
Time Base	522
Time Constant	30-32
Tire Static	449
Tone Control	253
Tools	481-486
Top Loading	473
Trace, Cathode-Ray	522
Tracing Noise	449
Tracking	92, 106
Tracking Capacity	92, 106
Tracking Aids	563
Transatlantics	10
Transconductance, Grid-Plate	63
Transformation, Impedance	47
Transformers	40-43
Transformer Color Codes	491
Transformer Coupling	48-50, 65, 248, 249-251
Transformer, Delta-Matching	330-331, 348, 365
Transformer Efficiency	41
Transformer, Gamma	329-330, 365

	PAGE
Transformer, Linear	327-331
Transformer, "Q"-Section	327-328
Transformer Ratio	267-268
Transformer, T-Match	329-330, 365
Transformerless Power Supplies	231-232
Transformers:	40-43
Air-Tuned	98-99
Constant-Voltage	234
Filament	224
I.F.	98-99
Permeability-Tuned	98-99
Plate	223-224
Triple-Tuned	100
Variable-Selectivity	100
Transistors	81-84
Transit Time	77, 78
Transmission Lines	318-342
Transmission Lines as Circuit Elements	55-56
Transmission-Line Construction	323-324
Transmission-Line Coupling	149-152
Transmission-Line Feed for Half-Wave Antennas	346-348
Transmission Line Losses	326-327
Transmission, Multihop	378-379, 382
Transmitters: (see also "Very-High Frequencies", "Ultrahigh Frequencies" and "Mobile")	
Constructional:	
Parallel 807 Amplifier	204-206
Remotely-Tuned V.F.O.	198-200
Single-Tube 75-Watt Novice Transmitter	173-175
Single 6146 Amplifier	201-203
Single 813 Amplifier	207-209
1-Tube 2-Band Transmitter for the Novice (7 to 10 Watts)	170-172
4-250As in a 1-Kw Final	210-214
500-Watt Multiband V.F.O. Transmitter	192-197
7-Band 90-Watt Transmitter	179-183
75 to 300 Watts with V.F.O. Control	184-191
75 Watts on Four Bands	176-178
Line-Voltage Adjustment	233-234
Metering	165-166
Principles and Design	143-214
Transverse-Electric and Magnetic Mode	57
Trapezoidal Pattern	287-291
Traveling-Wave Tube	79
Trimmer Capacitor	92
Triodes	62-63
Triode Amplifiers	163-164
Triode Clippers	76-77
Triode-Hexode Converter	95
Triple-Detection Superheterodyne	107
Tripler, Frequency	143, 165
Tri-Tet Oscillator	144, 145
Troposphere Propagation	377, 380, 382-383
Tropospheric Bending	380, 382-383
Tropospheric Waves	377, 380
Trouble Shooting (Receivers)	110-112
Tube Amplifier Gain	575
Tube Elements	60
Tube Keyer	243
Tube Noise	85
Tubes, Driver	270
Tube Ratings, Transmitting	153-154
Tubes, Modulator	267
Tuned-Circuit Response	574
Tuned Coupling	150, 330, 333-338
Tuned Screen Circuits	407, 427
Tuned-Grid Tuned-Plate Circuit	75
Tuned-Line Tank Circuit	55-56, 406
Tuned Transmission Lines	322, 335-338
Tuners, Antenna, Construction of:	
Coax-Coupled Matching Circuit	338-339
Matching Circuit with Multiband Tuner	340-342
Receiver Coupler	130, 131
"Universal" Antenna Coupler	339-340
Tuning Indicators	102-103
Tuning R.F. Amplifiers	166-167
Tuning Range, Extending the Receiver	107-108
Tuning Receivers	91, 92-93, 108-109
Tuning Slug	93

	PAGE
Tuning Transmitters	166-167
Turns Ratio	40
TVI	407, 536-552
TV Receiver Deficiencies	549-551, 552
"Twin-Five" Array	441-442
"Twin-Lamp" Standing-Wave Indicator	520-521
Twin-Lead	323-324
Ultra-High-Frequencies:	
Cavity Resonators	57-58
Klystrons	78
"Lighthouse" Tubes	77, 385, 405
Magnetrons	78-79
Pencil Tubes	385
Tank Circuits	55-58
Transmission-Line Tanks	55-58
Traveling-Wave Tubes	77-79
Tubes	77-79
Velocity Modulation	77-78
Wave Guides	56-58
Unbalance in Amplifiers	163
Unbalance in Transmission Lines	324, 331-332
Undewriters' Code	530-531
"Universal" Antenna Coupler	339-340
Unsymmetrical Modulation	276-277
Untuned Transmission Lines	322
Upward Modulation	276-277
"V" Antennas	357-358
VR Tube Break-In System	240-241
VR Tubes	227-228
Vacuum Tubes and Semiconductors (Index to Tables)	V1
Vacuum Tube Amplifier Gain	575
Vacuum-Tube Keyers	243
Vacuum-Tube Principles	60-79
Vacuum-Tube Voltmeter	497-498
Variable Capacitor	24-25
Variable-Frequency Oscillators	143, 145-148
Variable- μ Tubes	71
Variable Selectivity	104-105
Velocity Factor	325-326
Velocity Microphone	248
Velocity-Modulated Tubes	78
Velocity Modulation	77-78
Velocity of Radio Waves	18, 376
Vertical Amplifiers	522
Vertical Angle of Radiation	343
Vertical Antennas	354-356, 437, 438
Vertical Polarization of Radio Waves	376, 435-436
Very-High Frequencies (V.H.F.):	
Antenna Coupler	421
Antenna Systems	435-446, 475
Receivers:	
Crystal-Controlled Converter for 432 Mc.	402-404
Crystal-Controlled Converter for 50 Mc. Mobile Use	454-456
Crystal-Controlled Converters for 50, 144 and 220 Mc.	388-394
I.F. Amplifier and Power Supply	394
Low-Noise Preamplifier for 144 Mc.	399-400
One-tube Converter for 21, 28, 50, 144 or 220 Mc.	395
Receivers for 420 Mc.	400-404
R.F. Amplifiers for 420 Mc.	401-402
Simple Mobile Converter for 144 Mc.	457-458
V.H.F. Baluns	393-394
Transmitters:	
High-Power Transmitter for 50 and 144 Mc.	408-416
50-Mc. Amplifier	411-416
144-Mc. Driver-Amplifier	416-421
Progressive Station for 50 and 144 Mc.	422-427
Building the Exciters	423-425
2-Band 125-Watt Amplifier	425-427
Simple Transmitter for 220 and 420 Mc.	428-429
Transmitter-Exciter for 220 Mc.	432-434
Triple-Amplifier for 432 Mc.	430-431
10-Watt 50-Mc. Mobile Transmitter	465-467
50-144 Mc. Band-Changing Crystal- Controlled Transmitter	468-470

	PAGE
144-Mc. Driver-Amplifier	416-421
Propagation	381-383
Receiver Considerations	384
Superregenerative Receiver	387
Transmitter Design	405-407
V.H.F. Receiver Design	384-387
V.F.O.	143, 145-148
Vibrator Power Supplies	480-483
Virtual Height	377
Voice-Controlled Break-In	305
Voice Operating	555-556
Volt	17
Volt-Amperes	37, 39
Volt-Ampere Rating	214
Voltage Amplification	63-64, 249
Voltage Amplifier	66
Voltage Breakdown	23, 25
Voltage Decay	32
Voltage Dividers	226-227
Voltage Distribution, Antenna	315-346, 349
Voltage Drop	21, 226
Voltage Feed for Antennas	346
Voltage Gain	65, 249
Voltage Loop	320
Voltage-Amplification Ratio	64
Voltage Multiplier Circuits	231-232
Voltage Node	320
Voltage Ratio	43
Voltage-Turns Ratio, Transformer	40
Voltage Regulation	218, 219, 227-229
Voltage-Regulator Interference	448
Voltage Ripple	218, 220, 222
Voltage Rise	45
Voltage-Stabilized Power Supplies	227-229
Voltmeters	493-494, 497-498, 509-510
Volume Compression	253-254
W Prefixes by States	571
WIAW	12, 564, 565
WAC Award	565
WAS Award	564
Watt	22
Watt-Hour	23
Watt-Second	23
Wave Angle	343, 344, 346, 378
Wave-Envelope Pattern	276-277, 287
Wave Front	376
Wave, Ground	377
Wave Guides	56-58
Wave Meters	499-500
Wave Propagation	376-383
Wave, Sine	17, 33
Wave, Sky	377
Wave Form	17
Wavelength	17-18
Wavelength-Frequency Conversion	18
Wavelength Performance	380-381
Wavelengths, Amateur	14
Waves, Complex	39
Waves, Distorted	64
Waves, Electromagnetic	15
Wave Traps	535, 539, 551
Wheel Static	448-449
Wide-Band Antennas	444
"Window" Antenna	352-353
Wire Table	492
Wiring Diagrams, Symbols for	576
Wiring, Station	530
Wiring, Transmitter	487-489
Word Lists for Accurate Transmission	556
Working DX	556-557
Working Voltage, Condenser	223
Workshop Practice	484-492
WWV and WWVH Schedules	504
X (Reactance)	33-37
"Y"-Matching Transformer	330-331, 348, 365
"Yagi" Antennas	436, 440-442
Z (Impedance)	37-39
Zero Beat	91
Zero-Bias Tubes	67

