

PRACTICAL WIRELESS, January, 1942.

## THREE-VALVE EMERGENCY RECEIVER

# Practical Wireless <sup>9<sup>D</sup></sup> EVERY MONTH

Editor  
F. J. CAMM

and PRACTICAL TELEVISION

Vol. 18. No. 427.

NEW SERIES.

JANUARY, 1942.

**Still keep  
going  
when the  
rest have  
stopped'**



# Exide BATTERIES

• THE CHLORIDE ELECTRICAL STORAGE COMPANY LTD.  
Grosvenor Gardens House, Grosvenor Gardens, London,  
S.W.1

Telephone: VICTORIA 2299. 'Grams: Chloridic, Sotwest, London

# Lord Hankey's Appeal

## TO THE WIRELESS TRADE

Multi-range Measuring Instruments wanted immediately for vital war training work.

"I . . . appeal to you to-day to assist by selling or presenting this type of equipment if you have any surplus or if you know of any of your retailer friends whom you can persuade to part with such apparatus. The instruments I refer to are of the AvoMeter and AvoMinor class. . . ."

LORD HANKEY AT THE R.M.A. LUNCHEON, Sept. 17.

Radio is playing a vital part in the war. . . . Thousands more men must be trained as wireless mechanics—the schools and instructors are there—but multi-range measuring instruments are needed at once. Lord Hankey has appealed to wireless engineers and traders to help. If you have a meter of the type required that is not doing a full day's work every day, please give or sell it immediately.

*This announcement appears by courtesy of the Automatic Coil Winder and Electrical Equipment Co., Ltd. (Makers of "Avo" Instruments), to reinforce Lord Hankey's recent appeal, which is urgent and essential to the war effort.*



46-range Model 7 Universal AvoMeter

**TYPES OF INSTRUMENT REQUIRED:** The instruments most urgently needed are multi-range A.C. and D.C. meters such as the Model 7 AvoMeter, the Model 40 AvoMeter, and the Universal AvoMinor. Offers of other makes of multi-range instruments of similar grades and capabilities are also welcomed.

**WHAT TO DO:** If you can release any of these types of instrument please communicate at once with Mr. R. P. Browne, B.Sc., Secretary, Radio Manufacturers' Association, 59, Russell Square, London, W.C.1, giving the details enumerated below. Only instruments in working order should be offered. Do not send the actual meter until advised.

**PLEASE GIVE THESE DETAILS:** (1) Type of instrument. (2) Approximate age and condition. (3) Whether it is a gift or for sale. (4) If the latter, the price desired. (5) Name and full address.

## PREMIER RADIO

Please Note.—All Short-wave Kits include Purchase Tax

### NEW PREMIER S.W. A.C. RECEIVER

In response to many requests we have now produced an A.C. version of the popular Premier Short Wave SG3 Kit. Circuit: Pentode H.F. Stage Pentode Detector, Pentode Output, and F.W. Rectifier. 200-250 v. A.C. Operation. Built-in Power Pack. Hum-free operation. For use with 'Phones or P.M. Speaker. Complete Kit of Parts with drilled chassis, all components, Plug-in Coils covering 13-170 metres, 4 valves and full instructions and circuits **£6.14.6**

Battery Version also available, Kit £4/15/4.  
★ "The Wireless World" said they were "very much impressed. . . ."  
See full Test Report, pp. 492-3, December issue, Send for details.

### DE LUXE S.W. KITS FOR BATTERY OPERATION

Complete Kit of Parts, with Ready Drilled Chassis, 4 Coils Tuning from 13 to 170 metres, Valves and Diagrams.

- 1 Valve Receiver or Adaptor Kit, 24/6
- 2 Valve Short-wave Receiver Kit, 35/6
- 1 Valve Battery Converter Kit, 28/-

### PREMIER BATTERY CHARGERS FOR A.C. MAINS

- 6 volts at 1 amp., 26/-
- 12 volts at 1 amp., 28/-
- 6 volts at 2 amp., 43/6

### MATCHMAKER UNIVERSAL OUTPUT TRANSFORMERS

- Will match any output valves to any speaker impedance. 11 ratios from 13 : 1 to 80 : 1.
- 5/7 watts, 16/10.
  - 10/15 watts, 21/10.
  - 20-30 watts, 35/10.
  - 60 watts, 49/6.
  - Push - Pull Driver Transformers 3 : 1 Ratio . . . 6/6
  - Universal Output Transformers 11 Ratios. Single or Push-Pull . . . 6/6

### "LEARNING MORSE?"

Then purchase one of the new practice Oscillators. Supplied complete with valve, on steel chassis . . . **27/6**  
Practice Key, 3/3; TX Key 5/9.

### PREMIER 1941 HIGH FIDELITY AMPLIFIERS

Each amplifier is individually tested and supplied with specially matched valves. All diagrams and instructions. Completely Wired and Tested.

- 4-watt A.C. Amplifier . . . . . £3 11 6
- 15-watt A.C. Amplifier . . . . . 29 8 0

Black Crackle Steel Cabinet 17/6 extra.

### PREMIER MICROPHONES

Transverse-Current Mike. High grade large output unit. Response 45-7,500 cycles. Low hiss level, 23/-.

Moving Coil Mike. Permanent magnet model requiring no energising. Response 90-5,200 cycles. Output .25 volt average. Excellent reproduction of speech and music, 49/-.

Microphone Transformers. Suitable for all mikes. Tapped primaries. A, 20 and 40 : 1; B, 30 and 60 : 1; C, 50 and 100 : 1, 6/6 each.

### SHORT-WAVE CONDENSERS

Trolital insulation. Certified superior to ceramic.

All-brass construction. Easily ganged.

- 15 m.mfd. . . . . 2/4 100 m.mfd. . . . . 3/-
- 25 m.mfd. . . . . 2/6 100 m.mfd. . . . . 3/7
- 40 m.mfd. . . . . 2/8 250 m.mfd. . . . . 4/-

ALL ENQUIRIES MUST BE ACCOMPANIED BY 2½d. STAMP.  
ALL ORDERS LESS THAN 5/- 6d. POST EXTRA.

ALL POST ORDERS TO: JUBILEE WORKS, 167, LOWER CLAPTON ROAD, LONDON, E.5. (Amherst 4723)  
CALLERS to: Jubilee Works, or 169, Fleet Street, E.C.4. (Central 2833), or 50, High Street, Clapham, S.W.4. (Macaulay 2381)

# Practical Wireless

EVERY MONTH

Vol. XVIII. No. 427. JANUARY, 1942.

and PRACTICAL TELEVISION

Editor F. J. CAMM

 Staff:  
 L. O. SPARKS.  
 FRANK PRESTON.

BY THE EDITOR

## COMMENTS OF THE MONTH

# Government Appeal for Waste Paper

LORD BEAVERBROOK is appealing for 100,000 tons of waste paper, and so urgent is the need that this journal is asked to co-operate in inviting its readers to conduct a cellar to attic search for all the waste paper they can find—old periodicals, old books bound and unbound, novels and sheet music, old picture postcards, correspondence, price lists, catalogues, almanacs and time-tables, odd rolls of wall-paper, cardboard boxes, cartons, cigarette packets, in fact anything which is paper or cardboard.

Waste should not be placed in dustbins, where it is likely to become dirty, wet and useless. Staek it in a dry place, tie it up in bundles to facilitate easier handling, and if you can find the time, do a little sorting. Keep the newspapers, the periodicals, and all kinds of white paper separate from cardboard and brown paper, and other coloured paper. This will greatly help the sorting authorities.

When you turn out the correspondence and your private files, tear it up if you fear that someone is going to read it. The paper mills will not mind. If you do not wish to do this, you can rest assured that the correspondence will be torn up by people who have no time to read it, nor any desire to do so.

Waste paper is urgently wanted now. There is not one household in the country which cannot contribute to this vital and urgent national appeal. Waste paper is now a precious war material. It is remanufactured into new paper, and paper is needed for scores of purposes directly connected with the war effort—shell containers, shell fuse components, mine assemblies, dust covers for aero-engines, cut-out targets, boxes for aero-cannon shells, machine-gun belts, radio sets, and even for wall boards for building army huts. It is your duty to go through your house and your garden sheds and cupboards, to collect together all the waste paper you can find and to place the bundles of books and newspapers by the dustbin for collection by your local Council. The Boy Scouts and the Girl Guides are helping in the collection. All local Councils have been instructed to organize the collection of paper. It is in their interests to do so, for it helps the rates. Councils are paid for the waste paper, and after deducting the collecting and sorting costs there is a useful balance to go towards the relief of rates.

If you find that your Council is not promptly and effectively collecting the paper, you should write to me as follows: F. J. Camm, PRACTICAL WIRELESS, George Newnes, Ltd., Tower House, Southampton Street, Strand, W.C.2. Mark your envelope "Waste Paper." I will see that every case is reported to the Ministry of Supply. In the interests of economy I shall not be able to acknowledge every letter, but I give you my assurance

that every complaint will be taken up in the proper quarter.

Wood pulp, which is the chief raw material for paper-making, came largely from Scandinavia and Finland before the war. That supply has now been stopped, and ships cannot be spared to bring the material from the other side of the Atlantic. At present we have to employ 25,000 tons of shipping in order to import from abroad paper for the purposes we have enumerated. If we can collect that waste paper in this country, ships can be diverted to the important purpose of carrying munitions to Russia. The need, as already stated, is urgent and vital. Readers of this journal will, I hope, conduct the search now, or get a relative to do it for them. The smallest quantity of waste paper is of use. Do not think that your small supply will make no difference. Every few pounds counts, but please make the search now!

### Reduction in Broadcasting?

IF the suggestion of the Select Committee on National Expenditure to restrict the hours of broadcasting is adopted, there will be shorter daily programmes. The Committee is concerned with the coal position, and they are anxious to reduce consumption of electricity. The Committee said that one of the most effective methods of bringing to the constant notice of the public the need for economy in the use of coal, gas and electricity, is to enlist the co-operation of the B.B.C. and their listeners. Valuable economies might well be secured if it were found practicable to close down Home Broadcasting, as distinct from Empire and foreign news, at an earlier hour. The Committee also suggests that the news broadcast at 8 o'clock in the morning would effect an economy if discontinued.

The suggestion savours of straining at a gnat and swallowing a camel. The report would have been taken a little more seriously had some statistics been given as to the consumption of power necessary to make the broadcasts which it is proposed to discontinue.

### Lord Mayor's Air Raid Distress Fund

THE Lord Mayor of London appeals for funds to enable him to continue his work of providing for those who have suffered as a result of air raids. The Fund was inaugurated on September 11th, 1940, and during its first year it reached the magnificent total of £3,200,000. He asks everyone to contribute to it in the form of "Penny-a-day" for a peaceful night and "Twopence a day for a blitz." The money should be stored and sent in an envelope marked "Thank-Offering" to the Lord Mayor every quarter, at Mansion House, London, E.C. We hope our readers will respond to this Fund, which does not turn any legitimate claim away.

Editorial and Advertisement Offices:  
 "Practical Wireless," George Newnes, Ltd.,  
 Tower House, Southampton Street, Strand,  
 W.C.2. Phone: Temple Bar 4363  
 TELEGRAMS: NEWNES, RADL, LONDON.  
 Registered at the G.P.O. for transmission by  
 Canadian Magazine Post.

The Editor will be pleased to consider articles of a practical nature suitable for publication in PRACTICAL WIRELESS. Such articles should be written on one side of the paper only, and should contain the name and address of the author. What the Editor does not hold himself responsible for manuscripts every effort will be made to return them if a stamped and addressed envelope is enclosed. All correspondence intended for the Editor should be addressed: The Editor, PRACTICAL WIRELESS, George Newnes, Ltd., Tower House, Southampton Street, Strand, W.C.2.

Owing to the rapid progress in the design of wireless apparatus and to our efforts to keep our readers in touch with the latest developments, we give no warranty that apparatus described in our columns is not the subject of letters patent.

Copyright in all drawings, photographs and articles published in PRACTICAL WIRELESS is specifically reserved throughout the countries signatory to the Berne Convention and the U.S.A. Reproductions or imitations of any of these are therefore expressly forbidden. PRACTICAL WIRELESS incorporates "Amateur Wireless."

The fact that goods made of raw materials in short supply owing to war conditions are advertised in this paper should not be taken as an indication that they are necessarily available for export.

# ROUND THE WORLD OF WIRELESS

## Baird Joins Cable and Wireless

**JOHN LOGIE BAIRD**, of television fame—the first man in the world to design and build a practical television—is now technical adviser to Cable and Wireless, Ltd. We understand that Mr. J. L. Baird, who has perfected colour television, and made it a commercial proposition, hopes to offer the public—after the war—a receiver at a price within the reach of all, if the B.B.C. extend their television activities to colour transmissions.

## B.B.C. Changes

**FOLLOWING** the rearrangement of the B.B.C. overseas services, a number of changes have been announced. Mr. Ivone Kirkpatrick will be B.B.C. adviser on policy affecting all programmes. Sir Stephen Tallents, overseas division controller, has been released for other duties. Mr. A. P. Ryan will become controller for the co-ordination of news services in English, and B.B.C. adviser on home policy affecting programmes.

## Commissions for Women Research Workers

**THE** rule that all women must enter the Women's Auxiliary Air Force through the ranks is waived in the case of a branch in which special qualifications are required, namely, radiolocation.

A woman under 41 with a university degree in physics or mathematics can obtain a commission in the W.A.A.F. as supervisor of the radio operators. She should have had some research or laboratory experience involving measurement work. Research in physics is the best apprenticeship.

## Winter Music Fare

**LOVERS** of fine music are promised a lot of good things in B.B.C. programmes during the winter.

Performances by the leading orchestras in London and the provinces will be broadcast, and, in addition, listeners will hear twelve fortnightly symphony concerts, a series of fortnightly lunch-time concerts, six monthly special concerts of modern music and frequent studio opera broadcasts.

Among the well-known organisations which will be heard are the London Philharmonic Orchestra, the London Symphony Orchestra, Northern Philharmonic, Liverpool Philharmonic, Beecham Sunday Concerts, City of Birmingham Orchestra, Hallé Society, Scottish Choral and Orchestra Union and Sadler's Wells.

## Radio Mines

**IT** is reported that mines left by the Russians in Kieff were exploded by radio days after the Germans entered, destroying a quarter of the city.

## Popularity of Broadcasts to Schools

**DESPITE** the war, a record number of schools in England and Wales are taking the school broadcasting service. The total has grown to 10,000, compared with 6,847 in 1936-37.

Figures for Scotland show that the number of "listening schools" there is 1,065, equal to the peace-time level.

The growing use of the service may be regarded as proof that it has been well adapted to meet war-time conditions, and that, in general, schools appreciate its quality and continuity.

## New Radio Buoy

**THE** U.S. Navy has recently been using a new radio device called the Sono-Radio Buoy, which can give a ship her exact position when it is impossible to take sights or to see landmarks, provided that the buoy has been moored in a known position beforehand. In the body of the buoy is a submarine signalling receiver, connected with a wireless transmitter. The ship sends out a submarine sound signal, which is picked up by the buoy's receiver and passed on to the wireless set, which automatically sends it out. The ship can work out her precise distance from the buoy by timing the receipt of the wireless signal, while the direction-finder gives the exact bearing.

## Wireless Mechanics Urgently Needed

**RADIO/WIRELESS** mechanics are still urgently needed in the R.A.F. for checking and testing radio gear. Men, age 18-34, of sound elementary education will receive training from the start. Older men will be accepted if they know something about radio. Full particulars can be obtained from the Air Ministry Information Bureau, Kingsway, London, W.C.2.

## Australian S.W. Broadcast Schedules

**MELBOURNE** short-wave stations now use the following wavelengths and call signs: Call Signs: 6.30-10.15 a.m., VLR8; 12.0-6.15 p.m., VLR3; 6.30-11.30 p.m., V.L.R. Wavelengths: 25.51 metres; 25.25 metres; 31.32 metres. Frequencies: 11,760 k/cs.; 11,880 k/cs.; 9,580 k/cs. Power: 2 kilowatts.

Call Signs: 6.30 a.m.-6.15 p.m., VLG6; 6.30 p.m.-1.0 a.m., VLG5; 1.25 a.m.-2.10 a.m., VLG; 2.25 a.m.-2.55 a.m., VLG5. Wavelengths: 19.66 metres; 25.25 metres; 31.315 metres; 25.25 metres. Frequencies: 12,230 k/cs.; 11,880 k/cs.; 9,580 k/cs.; 11,880 k/cs. Power: 10 kilowatts.

Location: Lyndhurst, near Melbourne. The times are Australian Eastern Standard Time.

All mail matter should be addressed to: Australian Broadcasting Commission, Short-wave Section, Box 1686, G.P.O., Melbourne, Australia. Cables and Telegrams, "Abcom," Melbourne.



This busy room, crowded with radio apparatus and recording instruments, is the H.Q. of the British Monitoring service, somewhere in the country. Operators listen throughout the day and night to broadcasts from all over the world.

# Radio Examination Papers—II

A Further Selection of Typical Questions and Answers. Read the Questions and Attempt Your Own Answers Before Reading Those Supplied by The Experimenters

WE hope that you were successful in answering the questions which we set last month, and that the suggested replies which we gave proved helpful.

On this page is another set of typical questions, suitable answers to which we give below. At this stage we invite readers to forward any questions of a pattern similar to those which we have set; should they be of interest to other readers we shall be pleased to deal with them in this feature. It should be made quite clear, however, that if replies are required through the post, the questions should not be addressed to us, but sent to the Free Advice Bureau in the normal manner. We do not undertake to deal with all questions received—only with those which require more detailed explanation than can be given in a letter, and those which will be of interest to a majority of readers.

Here are our replies:

## 1.—Forms of Interference

Adjacent-channel interference is the kind of inter-

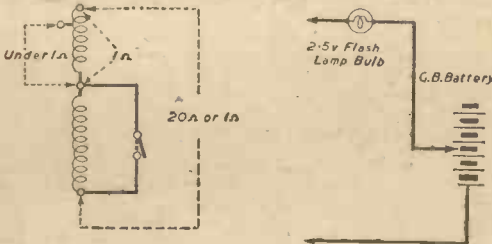

Fig. 1.—The diagram on the left shows the method of checking the resistance of a coil between various points, and with the wave-change switch open and closed. The figures given are comparative only, and will vary very widely in practice. The diagram on the right shows how a simple tester can be devised, using a battery and a bulb.

ference experienced due to two stations working on nearby wavelengths or frequencies. Provided that there is a frequency difference of a few kilocycles the two transmissions can be separated by the use of a sufficiently selective circuit. This is not always practicable, however, because when the receiver is made sufficiently selective to separate transmissions differing in frequency by less than about 9 kilocycles per second there is an inevitable loss of "quality" due to the cutting of the higher audio frequencies.

Second-channel interference arises only when using a superhet receiver, and is experienced when two stations are working on frequencies separated by twice the intermediate frequency. It will be remembered that in the superhet the oscillator is tuned to a frequency above or below the signal frequency by the I.F. In most practical cases the oscillator is designed to tune to a frequency equal to the signal frequency plus the inter-

mediate frequency. For example, when using 465 kc/s I.F. transformers, if the aerial circuit were tuned to 1,000 kc/s the oscillator would be tuned to 1,465 kc/s.

But if the input circuits were sufficiently unselective a station on 1,930 kc/s could also produce an I.F. of 465 kc/s. Consequently, two transmissions on 1,000 and 1,930 kc/s respectively could interfere with each other.

In practice, it is hardly likely that the input circuits would be so flatly tuned that they would "accept" two such widely-separated frequencies at the same time. But if the set were working on an I.F. of, say, 110 kc/s the two interfering stations need be separated by only 220 kc/s and second-channel interference would be more likely, especially if the unwanted transmission were exceptionally strong.

Second-channel interference can be eliminated by the use of selective input tuning circuits, by effective screening and by the use of a comparatively high intermediate frequency. There are other methods of preventing interference of this kind, but they will not be fully dealt with here.

## 2.—Testing a Tuner

A dual-range tuning coil can be tested electrically by making sure that the windings are continuous (with the wave-change switch in both positions) by seeing that the resistance of the windings is greater in the long-wave than in the medium-wave position of the wave-

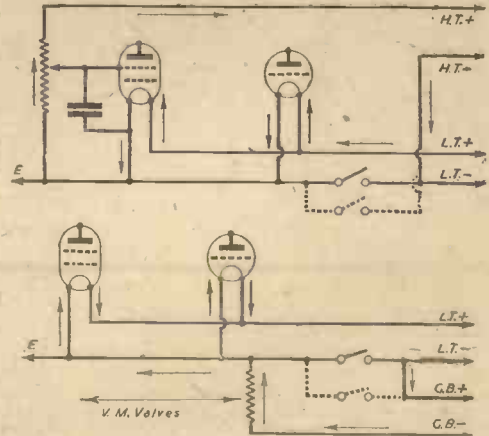

Fig. 2.—These two simplified diagrams show why switching of the H.T. and G.B. is necessary when using potentiometers for H.T. and for V.M. grid bias supply. Arrows indicate how the circuits are completed if only a single-pole switch is used, while broken lines show the connections to the additional switch sections. In both cases a three-point shorting switch could be used instead of a two-pole on-off switch.

## TYPICAL QUESTIONS

- 1.—What is the difference between adjacent-channel and second-channel interference?
- 2.—How would you carry out a simple test of a dual-range tuner of which the connections were known?
- 3.—Why is a two-pole or even a three-pole on-off switch required for some types of battery set, while a single-pole switch is quite suitable for others?
- 4.—Show how the choice of intermediate frequency affects the selectivity of a superhet.
- 5.—What do you understand by the term "oscillatory circuit"?
- 6.—Explain very simply the essentials of push-pull amplification, and calculate the required ratio for an output transformer suitable for matching a pair of valves each having an optimum load of 10,000 ohms to a moving-coil speaker having a rated impedance of 8 ohms at an average audio frequency.

change switch, and by making sure that no section of the windings is short-circuited.

These tests can obviously be made most satisfactorily when a resistance meter is available, but this is not essential. When using a meter it should be connected between the two ends of the tuning windings, as shown in Fig. 1. With the wave-change switch in the medium-wave position the resistance should be no more than a few ohms (.5 to 2 ohms fairly average), but the value obviously depends to a large extent on the gauge of wire used. If the switch is moved to the long-wave position the resistance reading should increase by about ten times. When there areappings on the coil, resistance measurements should be made between theappings and the ends of the coils. The readings should be proportional to the number of turns between theappings and the end of the windings.

If a meter is not available use can be made of a flash-lamp bulb and a G.B. battery, noting the brightness of the bulb when the switch is in different positions, and when the battery-bulb circuit is wired betweenappings and the end of the winding. It may be necessary to increase the effective voltage of the battery from 3 to 6 or 9 when checking the long-wave winding, but a start should always be made, using a voltage not greater than that for which the bulb is intended. A short-circuit would be indicated if the bulb glowed just as brightly when in series with the winding as when connected directly to the battery.

In both cases, if the resistance remained unaltered when the wave-change switch were operated it would indicate either that the switch contacts were not closing, or that they were not opening. In the former event the resistance would be high, and in the latter it would be low.

### 3.—Single- or Two-Pole Switch ?

A single-pole on-off switch is suitable when there are no potentiometers in the high-tension or grid-bias circuits. In such conditions the breaking of the filament circuit is all that is required, since there can be no current flow through the valves when the filament is not being heated; a valve is an insulator until its cathode emits electrons.

But if a potentiometer is used to feed the screening grid of one or more valves, as shown in Fig. 2, it is necessary to break the H.T. circuit separately. If this were not done, there would be a gradual drain of H.T. current through the potentiometer, valve filaments and accumulator, when the set was switched off; the potentiometer, filaments and L.T. supply would serve to complete the H.T. circuit. To avoid this a two-pole switch could be wired as shown in Fig. 2.

When using a potentiometer for variable-mu control a similar case arises, although this time it is the G.B. battery which would be discharged if its circuit were not broken when the set was switched off. If there is a potentiometer across each of the batteries, a three-pole switch would be required to ensure that all circuits are broken. An example of the method of connecting such a switch is given in Fig. 2.

### 4.—Effect of I.F. on Selectivity

The adjacent-channel selectivity of a superhet is increased as the intermediate frequency is reduced. This can best be shown by an example. Assume that the intermediate frequency is 110 kc/s, and that an unwanted transmission is on a frequency differing by, say, 15 kc/s from the wanted transmission. The wanted transmission would produce an intermediate frequency of 110 kc/s assuming that the receiver were correctly aligned and

tuned, while the unwanted one would produce an I.F. of, say, 125 kc/s.

The ratio between the difference frequency of 15 kc/s and the intermediate frequency is 15/110. Now assume that the I.F. is 465 kc/s, and that the frequency difference between the wanted and unwanted transmissions remains at 15 kc/s. The ratio now becomes 15/465, which is considerably smaller than the previous ratio. From this it may be seen that the "discrimination" in the former case need be only about one-quarter that required in the latter to give similar separation.

### 5.—Oscillatory Circuit

An oscillatory circuit is one in which there is inductance and capacity. Such a circuit can be said to resonate at a certain frequency, or at any desired frequency over a definite range. Because of this, an oscillatory circuit is generally described as a tuning circuit. It is necessary to appreciate the difference between an oscillatory circuit and an oscillator circuit, since the latter must have, in addition to the oscillatory circuit, a device for producing sustained oscillations; a valve is normally employed for this.

The best-known arrangement of oscillatory circuit is that having a coil in parallel with a condenser, as shown diagrammatically in Fig. 3. If a potential is applied across the ends of the circuit for an instant, the condenser is charged and a magnetic field is set up round the coil. Since the coil is in parallel with the condenser, the condenser starts to discharge through it, so assisting the magnetic field. But as the field is cut by the turns of the coil, back-E.M.F. results and the field collapses. The back-E.M.F. then causes the condenser to be charged again, but with an opposite polarity. This charge is then passed back through the coil, around which a magnetic field is again set up. The complete action is repeated time after time, and were it not for the resistance of the windings on the coil and the losses in the condenser, this would continue indefinitely. In practice, the oscillations very soon die out unless the circuit is constantly re-energised.

It will also be seen that the energising must be by means of repeated pulses. What is more, these must be applied at a certain frequency dependent upon the characteristics of the tuned circuit; that is, upon the capacity of the condenser and the inductance of the coil, which together govern the time taken for the cycle of operations described above to take place. Thus,

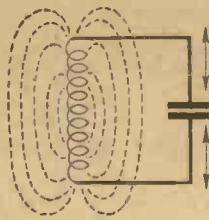

Fig. 3.—An oscillatory circuit, showing how a magnetic field is built up round the coil, and how the current flows backward and forward in the circuit.

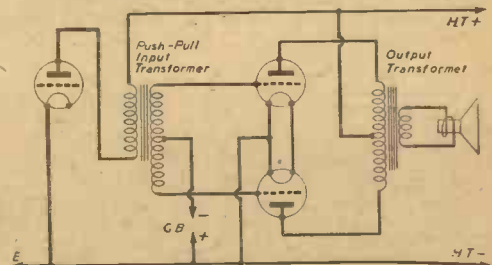

Fig. 4.—The essentials of a push-pull amplifier. Practical details, such as decoupling, are omitted for simplicity.

if the capacity is increased, the frequency will be reduced, because a greater length of time will be taken for the condenser to charge up. Conversely, if the inductance is reduced the frequency will be increased, due to the shorter time taken for the magnetic field to build up.

### 6.—Push-Pull Amplification

Push-pull amplification is employed in receivers for L.F. stages. Two valves are fed from opposite ends of a transformer secondary winding, with the result that the grid of one is positive at the same instant as the grid of the other is negative. Thus, the anode

current through one rises while that through the other falls. It is because of this that one valve may be said to be "pushing," while the other is "pulling."

A representative push-pull circuit is shown in Fig. 4, where it will be seen that the grids are fed from a transformer having a centre-tapped secondary. The centre tapping is used to apply grid bias to both valves at the same time. There is also an output transformer, which serves to combine the output from the two valves. This has a centre-tapped primary, and a single secondary winding which feeds into the loudspeaker.

Since the anode circuits of the two valves are virtually in series, the anode-to-anode impedance is twice the impedance of either valve. In the same manner, the total optimum load is twice that of either valve.

To obtain correct matching between an amplifier and a loudspeaker the transformer used must have a ratio equal to the square root of the optimum load of the output stage divided by the impedance of the speaker speech coil. In the question set, therefore, it will be seen that the ratio is equal to :

$$\sqrt{\frac{\text{Twice the Optimum Load of One Valve}}{\text{Speaker Impedance}}}$$

We can substitute the figures quoted, when we get :

$$\sqrt{\frac{20,000}{8}} \text{ or } \sqrt{2,500}, \text{ which is } 50. \text{ This means that the output transformer should have a step-down ratio of } 50 : 1.$$

# Electron-coupled Regeneration

Describing the Principles of This Highly-efficient Form of Reaction

Circuit and Its Use in a Battery-operated S.W. Receiver

By L. O. SPARKS

IN a "straight" type of circuit, designed for the reception of short-waves, the detector stage is the vital part. This applies equally to sets of the 0-V-1 or 1-V-1 class, as it is essential, if a satisfactory degree of selectivity and sensitivity is to be obtained, to provide some means whereby the damping imposed by the valve on the preceding tuned circuit—especially if a triode is used—can be reduced to a figure consistent with such characteristics of the tuned circuit as are required to produce the desired results. The usual way to secure this is to make use of a certain amount of regeneration or reaction between the input and output circuits of the detector. An examination of a representative number of circuits of battery operated S.W. receivers reveals that the majority use the well-known capacity controlled reaction circuit in one form or other. Whilst these arrangements can be made satisfactory they do possess, however, certain inherent defects, the chief ones being mentioned below.

It is not consistent over a wide frequency band, tending, in particular, to become erratic on the high-frequency end of the scale. It is often difficult to adjust matters so that the reaction control is perfectly smooth, and bearing in mind sensitivity and weak signals and the reception of C.W., this becomes an important requirement. Fierceness or harshness of the regeneration and "backlash" are quite common defects, especially when an H.F. buffer stage does not precede the detector.

## Electron-coupled System

Many amateurs use a S.G. or an H.F. pentode as a detector but still retain the reaction circuits mentioned above; although a tetrode or pentode—when used under correct conditions—will eliminate many of the defects associated with a triode, very few amateurs, by comparison, use the electron-coupled system of regeneration which is shown in Fig. 1. This might be due to the fact that the arrangement is usually associated with mains (indirectly heated) valves. It will be shown, however, that it is equally applicable to battery operated types, and that it approaches the ideal form of reaction as near as practical considerations will allow.

Those readers familiar with the Hartley circuit will

see that Fig. 1 is simply a modification of it, but for the benefit of those not conversant with the basic principles, a brief description is here given.

When considering the circuit as an oscillator, the normal control grid, Gc, acts as the grid of the oscillator, and the screening grid becomes its anode, thus by controlling the D.C. potential of that electrode the operating conditions can be regulated. As it is necessary for this anode to be kept at earth potential as regards H.F. currents, the condenser Cs must be of a value which will offer negligible reactance to such currents, and it is essential for the connections to be as short and direct as possible.

The actual anode of the S.G. valve forms the output, and if it receives a positive H.T. potential, then it will receive a flow of electrons from the cathode through the screening grid (i.e., the oscillator anode) and the electron flow will be actually modulated by the oscillations produced, in what we can call the Hartley section of the valve, namely, the control grid, screening grid and cathode. We have seen that the oscillator anode is tied down to earth as regards H.F., in other words, it cannot vary, therefore, the cathode (C) which is returned through the coil L and kept at an H.F. potential above that of the earth line, will vary and it will be found that the tapping point "t" has a direct effect on the degree of regeneration obtained.

This whole system is rendered simple to achieve owing to the use of a mains-type valve having a separate cathode (indirectly heated) which could be kept at an H.F. potential whilst the heater could be at zero or earth potential. To secure the same effect with a battery operated valve, a slightly different circuit has to be used, this being shown in Fig. 2.

## With a Battery Valve

The cathode tapping point on the coil L (Fig. 1) is now replaced by returning the negative side of the filament through the coil, and by adopting this arrangement, the filament is still able to receive its L.T. supply but, as regards H.F. potentials, it is maintained above that of earth. This, of course, is only made possible if some means are provided to ensure that the positive L.T.

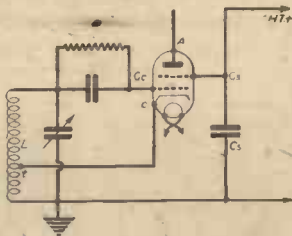

Fig. 1.—The fundamental circuit of an electron-coupled oscillator using an indirectly heated cathode.

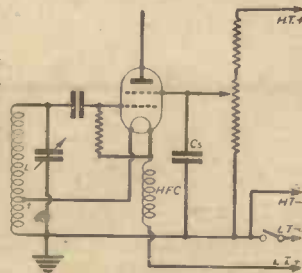

Fig. 2.—An adaptation of the circuit for use with a battery-operated valve, having a control for screening-grid voltage.





# Analysing a Simple Circuit

An Article Written in Non-technical Language to Show the Beginner How to Read and Understand a Theoretical Diagram

**T**HE reading of theoretical diagrams and the various symbols used on them presents difficulties to most beginners. Unfortunately, they cannot be ignored; the would-be enthusiast must master them if he is to make any progress in his new hobby, and it is well to note that an early study of such matters will mean a better understanding of the subject, and open up a much greater field of activity.

Many new readers are at a loss as to the meaning of the abbreviation O-V-2, to quote but one arrangement of it. It is simply a form of radio shorthand used to denote the valve arrangement of a receiver, the basis of it being the capital V which always denotes a detector. The figures shown on each side of the V indicate whether any valve(s) proceed or follow the detector. Those on the left-hand side represent high-frequency, and those on the right low-frequency stages, but more about those later on.

Instead of writing "My receiver is a three-valver, having one H.F. stage, a detector and an output valve," the radio enthusiast or engineer would state, as many readers will have seen in the correspondence published in PRACTICAL WIRELESS, "My receiver is a 1-V-1." Thus, at a glance, one can see the total number of valves used, and how they are arranged. The abbreviation

first quoted, O-V-2, signifies that no H.F. stage is in use, and that the detector is followed by two L.F. valves. It is quite possible, that if the letter had been written by an enthusiastic amateur, the word receiver would not have been used as he would, no doubt, just use the letters Rx, which mean the same thing.

## Dividing a Circuit

For simplicity, let us examine an average circuit of the 1-V-1 type, such as that shown in Fig. 1. It will be seen that it has been divided into three sections by the vertical dotted lines, and this denotes that such a circuit can be split into three parts, each of which has its own particular and independent function to perform.

Let us consider the centre section first, that is, the detector stage. The valve employed in this position is used to make the signals transmitted from the broadcasting station audible to the ear. In more technical terms, it would be described as being used to rectify or convert the high-frequency alternating currents, of which the signal is formed, into signals of identically the same character as regards sounds, etc., but of a frequency which is audible to the human ear when reproduced by headphones or loudspeaker.

The detector circuit shown is using a triode valve and what is known as the leaky-grid method of detection, this depending on the small fixed condenser C (grid condenser) and the resistor R (grid-leak) for its operation. Note that this explains the meaning of two widely used symbols, the names in brackets being those given to the two components when used in the grid circuit of a valve. There are, of course, other methods of detection

and other types of valve can be used as a detector, but these will be described in further articles.

The grid of the valve is denoted by the dotted lines: the filament by the curved one, and the anode by the short, thick one. They are marked by the letters G, F and A respectively.

## The H.F. Stage

The useful or effective range of reception of a detector valve is governed by the strength of the signals reaching its grid. If, therefore, it is desired to increase the range, use is made of another valve, which is incorporated in the circuit between the aerial and the detector. The purpose of this valve is to amplify the signal and then pass it on to the detector for rectification, and, as the signal consists of high-frequency alternating currents, we refer to the additional valve as a high-frequency or H.F. amplifier. It is possible to use more than one of these amplifiers in a set, according to its design and purpose.

The signal from the aerial reaches the aerial coil L, which is tuned by the variable condenser C.1. The coil shown is of the dual-range type, i.e., medium and long waves, and consists of three windings, namely, the aerial

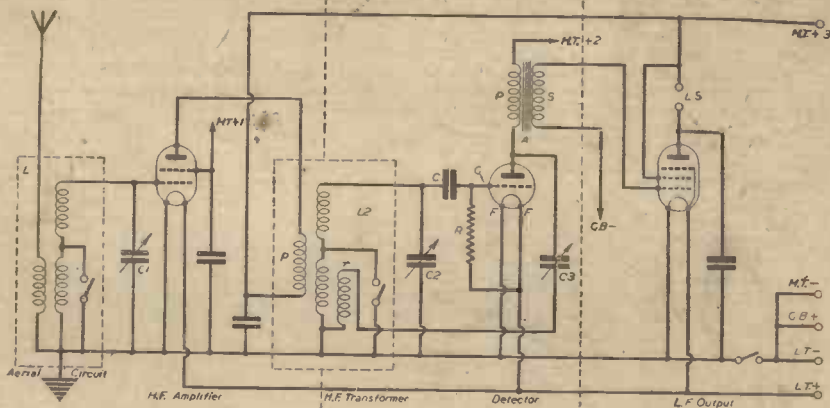

Fig. 1.—A three-valver of the 1-V-1 type, showing how such a circuit can be split into three distinct sections.

coupling winding and the medium- and long-wave windings, the latter having a single-pole switch connected across it to short-circuit it when it is desired to receive medium waves.

The coil and the variable condenser form what is known as a tuned circuit.

## L.F. Amplifiers

The signal on reaching the grid of the H.F. valve is amplified and passed on to the detector by means of the H.F. transformer L.2. This coil consists of four windings, the primary P, the medium- and long-wave sections as in the aerial coil, and the reaction winding R. A tuning condenser, C.2, is used to complete the tuned circuit, and another variable condenser, C.3, is incorporated to control the reaction circuit.

At the detector grid, the signals are rectified and, with a triode valve in the circuit shown, amplified by the time they reach the anode.

At the above point in the circuit, the signal is now capable of operating a pair of 'phones, i.e., it is of a low

frequency nature. If greater volume is required, then another valve can be brought into the circuit between the detector and the 'phones or loudspeaker (L.S.). The valve will have the effect of amplifying the signals and, as such are at low frequency, this amplifier is called an *L.F. amplifier* to differentiate it from its counterpart preceding the detector.

The signal is passed from the anode of the detector to the grid of the *output* valve, via an *L.F. transformer* (note the symbol for this component), which consists of two windings, a primary (P), which is connected between

the H.T. supply and the anode of the detector, and a *secondary* (S), which is joined to the grid of the output valve—in this case a *pentode*, and the negative side of a grid-bias battery. Unlike the H.F. transformer, the L.F. component has a laminated metal core running through the bobbins on which the two windings are wound, therefore, its theoretical symbol has the vertical lines between the two windings, so that it is not confused with an H.F. transformer.

(To be continued.)

## Choosing Resistances

Specially Written for Beginners, This Article Explains How the Correct Value of a Resistance for Any Purpose Can Be Selected

**W**ITH the evolution of modern circuits, resistances (or more correctly resistors) are required in rapidly increasing numbers. A few years ago the only resistance that one was likely to find in a standard type of receiver was the grid leak, but nowadays quite an ordinary three-valve battery set might have as many as a dozen, whilst more complicated circuits (especially those for mains working) frequently contain a score of resistances of various patterns. There is no doubt that, although many of the resistances are not absolutely essential, they do improve the performance of the set, in addition to simplifying the operation to a considerable extent. That is all very well for the advanced experimenter who understands the function of each component, but the beginner is very apt to find himself quite "at sea" in trying to decide upon the correct type and pattern for any particular purpose. It is hoped to remove any such difficulty by explaining the applications of each pattern, and showing how the resistance value can most easily be determined.

### Types of Resistances

In the first place let us consider the principal varieties of resistances. First, there is the wire-wound one which is generally employed in positions where a good deal of current has to be carried, and where a certain amount of self-inductance is of no consequence. Then there is the so-called metallised resistance, which usually consists of a thin "lead" of metallised material running through the centre of a porcelain rod which has metal connecting caps or wires at each end. Another type of resistance is the "composition" one in which the resistance element consists of a composition made principally of finely divided carbon, this being enclosed in a bakelite, glass or porcelain tube. Lastly there is the so-called spaghetti resistance in which the element is very thin wire wound in a helical fashion on a core of asbestos string. This kind of component is very convenient, since it can generally be connected directly to the terminals of other components; but it is somewhat fragile, due to the very thin resistance wire which must be used in making it. Consequently, it cannot carry heavy currents, and it is liable to be fractured if it is "kinked" or bent to a sharp angle, therefore it has now been superseded by the other types mentioned.

### Advantages

Neglecting the spaghetti resistance for a moment, it can be broadly stated that the wire-wound component is most suitable for carrying heavy currents, partly because the wire has a higher current-carrying capacity than have carbon compositions, and partly because the heat developed can more readily be dissipated. Moreover, this kind of resistance is "permanent" and cannot cause crackling sounds due to its resistance value fluctuating frequently. The carbon composition type, on the other hand, is more liable to introduce crackling sounds, due to the variable contact between the particles

of conducting material. In making this statement it should be pointed out that there are a few composition resistances on the market which are practically as reliable as wire-wound ones, especially when they have to deal with comparatively low currents. Metallised resistances are rather similar in their properties to composition ones, but on the whole they are probably more reliable. The last kind of resistances, those in which a conductive film is deposited on a porcelain or similar rod, can be classed along with metallised ones, since their properties are found to be very similar indeed. It would appear that they would better be able to dissipate any heat developed, but this does not seem to be the case in practice.

### Variable Resistances

All the above remarks have actually been applied to fixed resistances, but most of them are equally applicable to variable resistances and potentiometers, the only difference being that there are but two general types of variable resistances. One type is wire-wound, and should be used when there is any appreciable current (more than 1 milliamp. or so) to be carried, and the other is the

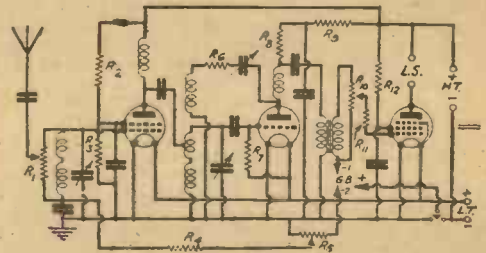

Fig. 1.—Circuit diagram showing the various resistances referred to in the text.

carbon composition type, where a layer or film of carbon is traversed by a rotating arm. For illustrations of the various types of resistances mentioned see Fig. 2.

### Finding the Correct Value

The first thing that the beginner requires to know about resistances is how the correct value for any particular requirement can easily be determined. This brings us to the old favourite, Ohm's Law, which states that the current flowing in a circuit is equal to the applied voltage divided by the circuit's resistance; the three factors must be in amperes, volts, and ohms. As, however, it is generally milliamps. which are dealt with in a wireless set, it is better to modify the law by saying that the current (in milliamps.) is equal to the applied voltage multiplied by a thousand, and divided by the resistance in ohms. By rearranging the expressions in the formula we can get the equation that the voltage dropped by a

resistance is equal to the current (in milliamps.) multiplied by the resistance in ohms and divided by a thousand. Similarly we can obtain the equation that the resistance required for any circuit (in thousands of ohms) is equal to the voltage to be dropped divided by the current in milliamps.

### The Wattage Rating

Another factor which must be decided before a resistance is bought, is its required wattage rating. Every reader will have noticed that resistances are stated as being of  $\frac{1}{2}$ , 1, 2, 3, watts, etc., and will perhaps have wondered what is the meaning of this. Power, in watts, is determined by multiplying voltage by current (in amps.); thus a valve filament which takes .1 amp. at 2 volts consumes .1 multiplied by 2, or .2 watt. On the other hand, a resistance which, when passing 20 milliamps., "drops" 100 volts will consume .02 (20 milliamps. expressed in amps.) multiplied by 100, or 2 watts. Another way of finding the power consumption of a resistance is by squaring the current which it passes (in amps.), and multiplying that by the ohmic value of the resistance. For example, a resistance of 5,000 ohms which carries a current of 20 milliamps, must have a power rating of .02-squared multiplied by 5,000, or .0004 times 5,000 which is just 2 watts.

### Resistances in H.T. Circuits

The simple calculations which have been explained are applicable to most resistances required in the high- and low-tension supply circuits of a wireless set, but are of little value when deciding upon the resistances called for in high-frequency circuits. These latter require rather special consideration, and their functions will best be understood by making reference to the more or less standard circuit arrangement for a three-valve variable- $\mu$  H.F. detector-pentode receiver such as that shown at Fig. 1. All the resistances, both fixed and variable, have been numbered for easy reference. The purpose of R.1 is to act as a volume control by varying the amount of signal energy passed on to the first tuned circuit from the aerial. Its total resistance must be much higher than the (high-frequency) impedance of the tuning coil, and a value of from 100,000 to 250,000 ohms is generally correct. The resistance element must be entirely non-inductive or else it will create various "resonance peaks" which will affect tuning; it has not to carry any D.C. current, and therefore a component of the composition type is to be preferred on every count.

R.2 and R.3 act together as a fixed potentiometer, their purpose being to apply the correct potential to the screening grid of the first valve. Assuming that they had to carry no D.C. current at all, their resistances would be in the same ratio as that of the S.G. potential to the total voltage of the H.T. battery. For example, if the screening grid required 50 volts and the battery gave 100 volts, the two components should be of equal value; if the screening grid required 40 volts, and the battery gave 120 volts, R.2 should be half the resistance of R.3, or one-third of the sum of the resistances of R.2 and R.3. Actually, R.2 does carry a small D.C. current, and this fact modifies the calculation slightly, although for most purposes this can safely be ignored. It is generally best to choose R.2 and R.3 so that their combined resistance is approximately 100,000 ohms.

### Non-inductive Resistors

R.4 and R.11 are for the purpose of preventing the passage of H.F. currents, although they must offer little impedance to L.F.; values from 25,000 ohms upwards would serve the purpose. Both resistances should be non-inductive, but as they have to deal with alternating current only, this is not any disadvantage.

R.6 is to prevent the passage of L.F. into the reaction circuit, and may have a value of between 100 and 500 ohms.

R.5 is a potentiometer, the purpose of which is to apply a variable potential to the grid of the first valve. Theoretically, it could have any value from about 5 to

100,000 ohms, but if the value were so low as the first figure the G.B. battery would rapidly be exhausted, whilst if it were so high as the latter it would not provide the "nicety" of control that is desirable. Thus the value generally chosen is either 25,000 or 50,000 ohms, and it does not matter very much whether the component is wire-wound or of the composition type, although the former is likely to be somewhat more reliable. It is also desirable that R.5 should be "graded" in order that its resistance value should change by a lesser amount for any given movement of the knob when the latter approaches the "positive" position.

### Other Considerations.

R.8 is used to couple the detector valve to the L.F. transformer, and it should have a resistance equal to from two to two and a half times the impedance of the valve. In most cases it will have to carry but a small D.C. current, and therefore any type of half or 1-watt component will serve. Where the valve operates on the power-grid principle, the current will be considerably higher, so that in some cases a 2-watt resistance will be

called for; that can be decided by making the calculation previously described.

R.9 decouples the anode circuit of the detector, and at the same time reduces the total H.T. voltage to a figure suitable for the anode of the detector. Generally its value will require to be between 10,000 and 50,000 ohms, but this can be determined by calculation,



Fig. 2.—Various types of resistances.

as also can the necessary voltage rating.

R.10 is an L.F. volume control, and varies the amount of L.F. signal current passed from the transformer secondary to the grid of the output pentode. Its function is comparable to that of R.1, although low-frequency, instead of high-frequency, current is being handled. The maximum resistance should be considerably higher than the impedance of the transformer, or else there will be some loss in the way of high-note response. A good value for general use is 250,000 ohms, and the component may be either wire-wound or otherwise; the former type is liable to be a bit "noisy" when the control is in use, but the latter might—if not of very sound construction—be productive of crackling noises. As in the case of R.5, it is an advantage to have this resistance of the "graded" type so that the resistance variation near the "full-volume" (grid) end of the element is less than at the other end.

### Decoupling

R.12 is for decoupling the priming grid of the pentode, and it also cuts down the voltage to a suitable figure; the method of deciding upon its value is similar to that employed for R.9. It should be added, however, that an average value is about 2,000 ohms, which serves to prevent the passage of low-frequency alternating currents without "dropping" the voltage.

## NEWNES' SHORT-WAVE MANUAL

6/-, or 6/6 by post from

George Newnes, Ltd., Tower House, Southampton St., London, W.C.2.

# Applications of the C.R. Oscillograph

How the Cathode-ray Tube is Employed for Checking Distortion, Comparing Alternating Voltages and Examining Wave-forms

By FRANK PRESTON

UNTIL high-definition television transmissions were started, the cathode-ray tube was not very widely known and by no means as extensively used as it has been in recent years. Even now, there are probably many amateurs—and also professional service engineers—who are not familiar with the action and use of C.R. tubes. In conjunction with fairly simple apparatus, a cathode-ray tube can be used for studying the distortion which takes place in an amplifier, and for checking the degree of distortion at different points in the amplifier. It can also be used for measuring output if used in conjunction with a scale which has previously been calibrated against a known A.C. voltage.

## Valve Technique

First, it is necessary to understand the construction and action of the tube itself, and this is not difficult for anyone with a knowledge of the operation of the thermionic valve. Fig. 1 shows a pictorial section through a representative tube of the kind used for television and similar purposes, but there are slight modifications in the arrangement of the focusing electrodes for special purposes. If we start at the left-hand end of the diagram we find that there is a cathode and heater of similar type to the corresponding electrodes in an indirectly-heated valve. Instead of the whole cathode being coated with an oxide material, however, there is just a "blob" of this material on the end of the cathode.

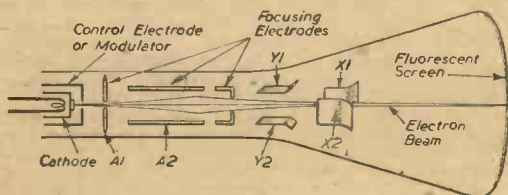

Fig. 1.—Pictorial diagram of a representative cathode-ray tube. The arrangement of the focusing electrodes varies slightly in different tubes.

Next to the cathode is the so-called control electrode or modulator, and this corresponds in all important respects with the control grid of a valve. Next to the modulator is an anode system, which is made positive in the same manner as is a valve anode. Thus it will be seen that if the cathode is heated and joined to H.T. negative, while the anode is connected to H.T. positive, electrons will be drawn from the cathode by the anode. It is possible to control or regulate the number of electrons flowing by varying the potential on the modulator, which acts in the same way as a grid. Thus, if the grid were at the same potential as the cathode a fairly dense stream of electrons would pass through the hole in its centre toward the positively-charged anodes. But if the grid were made sufficiently negative the electron flow could be stopped.

With the earlier C.R. tubes, and also with the large tubes of the kind used for television, a comparatively high H.T. voltage is required. In the case of the smaller tubes developed for use in oscillographs, however, the design is such that a cathode-anode potential of as little as 250 volts may be used.

## The Fluorescent Screen

For the moment, we can ignore the electrodes marked X1, X2, Y1 and Y2 in Fig. 1, and see what

happens when the "triode" section of the valve is connected to its supplies. Essentially, a beam or ray of electrons is drawn from the cathode and caused to pass through the anode system (because of the velocity attained) right to the end of the tube. Now the inside end of the tube is coated with a fluorescent material, which has the property of glowing visibly when struck by a stream of electrons. Consequently, there would simply be a bright spot of light visible on the outside of the tube. The colour of the light depends upon the particular fluorescent powder used in the manufacture of the tube, although a greenish-yellow is most usual. By varying the potential of the focusing electrode it is possible to vary the size of the light spot: in other words, to make it either small and clearly defined or larger and blurred. Hence the name, focusing electrode.

If the tube were left switched on in this way for any length of time the fluorescent coating would be damaged at the point of fluorescence due to the intense electronic bombardment. In practice, therefore, it is important that the beam should be stopped when the X and Y electrodes are not in circuit. This may be done quite simply by applying a heavy negative bias to the modulator, and a variable control (actually a potentiometer) is normally provided for this purpose.

## Action of the Deflectors

Now we come to the deflector plates marked X and Y in Fig. 1. These are in pairs, and if A.C. is connected to one pair, the light spot will be caused to move backward and forward in a straight line across the end of the tube. This is because the electron beam, being negative, can be attracted by a positive charge and repelled by a negative charge. Suppose, therefore, that the A.C. mains were connected to the X plates with the tube in the position shown in Fig. 1. There would be a horizontal line across the tube, as shown in Fig. 2. The reason is that while one plate is positive, the other is negative, and the polarity of each is being repeatedly reversed. As a result, the beam is bent toward the plate which is, at any given instant, positive.

It is due to the horizontal "scan," by the way, that the name X is given to the plates producing it; it will be remembered that the horizontal ordinate of a graph is called the X axis, to differentiate between it and the vertical or Y axis. If our A.C. supply were transferred from the X to the Y plates, we should have a vertical light trace, as shown in Fig. 3.

## The Time Base

In practice, an alternating potential is applied to both plates at the same time, so that whereas the X plates tend

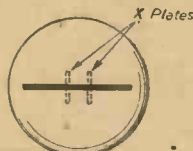

Fig. 2.

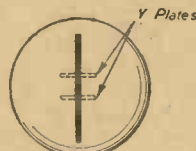

Fig. 3.



Fig. 4.

Fig. 2.—The "X" or horizontal "scan" provided by applying a "saw-tooth" oscillation to the X plates. Fig. 3.—The "Y" or vertical scan obtained by applying an alternating potential to the Y plates. Fig. 4.—This diagram gives an impression of the "picture" seen on the tube when a "saw-tooth" oscillation is applied to the X plates and, at the same time, a sine wave alternating voltage to the Y plates.

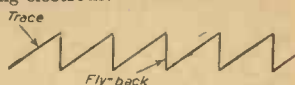

Fig. 5.—The "saw-tooth" wave which constitutes the output from the time base.

to cause the line of light to move across the screen, the Y plates tend to make it move up and down. We apply a particular form of A.C. to the X plates, and connect the A.C. which we wish to "examine" to the Y plates. When this is done we may have a "picture" on the screen similar to that shown in Fig. 4, where it is assumed that a sine-wave supply is on the Y plates, and that the X plates are fed from what is known as a time base due to the fact that it can be arranged to cause a trace or line to take place in a required length of time—generally a very small fraction of a second.

The oscillation provided by the time base should be of the "saw-tooth" form, as indicated in Fig. 5. This illustration shows that the voltage rises gradually in a positive direction, and then "flies-back" in a negative direction very rapidly. It is this "fly-back" which gives

the faint horizontal line joining the ends of the sine-wave in Fig. 4.

**C.R. Tube Connections**

Fig. 6 shows the theoretical connections to the C.R. tube (where the anode system is somewhat simpler than that shown in Fig. 1), and from this the method of controlling the voltage on the focusing electrode A1 and on the grid

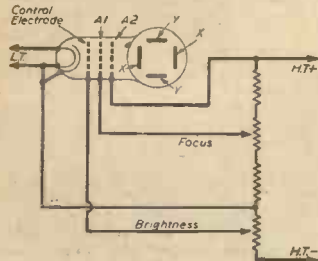

Fig. 6.—Theoretical diagram showing the type of cathode-ray tube normally used in an oscillograph, and how its electrodes are fed.

can be seen. The anode marked A2 is generally described as the accelerator anode, since it has the effect of speeding up the electron stream, and is given the full H.T. voltage.

**Generating the "Saw-tooth" Wave**

A fairly usual circuit arrangement for a time-base amplifier is illustrated in Fig. 7. From this it may be seen that there is a gas-filled relay, followed by a form of push-pull amplification. It is the relay, in conjunction with the resistance R and one of the condensers marked C1, C2 and C3 which generates the "saw-tooth" wave. A gas-filled relay is in effect a triode valve which has a small amount of inert gas such as argon within the glass envelope. The gas gives the valve a peculiar property: it passes negligible anode current until the anode voltage reaches a critical figure, and when that figure is reached the internal resistance drops suddenly and the anode current rises in consequence. The action is sometimes described as "triggering" for fairly obvious reasons. If the grid is maintained at a steady potential it assists in preventing the passage of any anode current before the critical anode voltage (generally something under 20) is reached.

**Frequency Control**

The anode resistance R has a value in the region of 2 megohms so that the voltage normally applied to the anode is too low to cause the valve to "discharge." But in parallel with the anode-cathode circuit of the valve we have a fixed condenser, and this is charged from the H.T. supply through the resistor R. Once the condenser is charged there is a sufficiently high voltage across it to cause the relay to discharge. When this has happened, however, the voltage between anode and cathode immediately falls and the flow of electrons within the relay is stopped. The speed at which the condenser may charge is governed by the value of the anode resistor and by the capacity of the condenser. We can therefore regulate the frequency of the saw-toothed oscillations by alteration of R and by switching in a different fixed condenser. If the condensers have capacities between about .002 and 1.0 mfd. it is

possible to cover a frequency range of approximately 10 to 10,000 cycles per second.

The rather unorthodox push-pull amplifier shown in Fig. 7 is convenient and obviates the need for transformer coupling. A portion of the output from the first valve is passed to the grid of the second, so that the output from both is similar in amplitude, while the two are 180 degrees out of phase. Sometimes a single phase-splitting valve, of the type used in a paraphase amplifier, is used in place of the two push-pull valves, when the X plates are fed from the anode and cathode respectively. In that case, of course, similar resistors would be included in the anode and cathode leads.

**Synchronising**

Using a time-base amplifier connected to the X plates, we can apply the A.C. which is under examination to the Y plates and study its form, amplitude and freedom from distortion. If it is wished to keep the "picture" stationary on the screen it is generally necessary to apply synchronising impulses which "bias-out" the cathode-ray tube for small fractions of a second every few cycles to ensure that the trace appears at the same place on the tube throughout. The arrangement of the synchroniser need not be fully explained here, for it will suffice to point out that a synchronising control is fitted to a cathode-ray oscillograph for the purpose explained.

**Voltage Measurement**

An important point is that the deflection of the beam is directly proportional to the deflecting voltage. Because of this it is an easy matter to fit a transparent screen in front of the cathode-ray tube and to calibrate it with a linear scale for a known A.C. voltage. Other voltages, such as the output voltage from a receiver, can then be measured.

Due to the fact that the electron beam does not possess any inertia, the C.R. tube is unaffected by the frequency of the voltage under examination, and most of the usual sources of error in A.C. voltage measurement are obviated. Also due to the lack of inertia it is possible to examine the most complex wave-forms in a manner which is not possible with any other device.

It might be well to point out that different types of fluorescent screen have different degrees of "after-glow," although for most oscillograph purposes a tube is required which has no "after-glow"; that is, one on which the light trace disappears immediately the electron beam producing it has been moved.

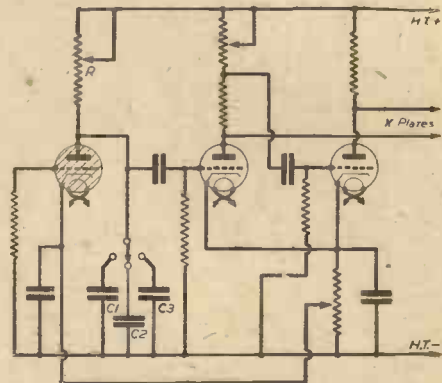

Fig. 7.—Simplified diagram of a time-base oscillator and push-pull amplifier using a gas-filled relay followed by two power triodes.

**Radio Engineer's Vest Pocket Book**

3/6, or 3/9 by post, from  
 GEORGE NEWNES LTD., Tower House,  
 Southampton Street, Strand, London, W.C.2.

# New Push-pull Feed-back Amplifier

An Ingenious Circuit Using a Paraphrasing Valve

**A**N interesting development from the R.C.A. Laboratories is an ingenious feedback circuit for push-pull amplifiers using a paraphrasing valve in which the number of circuit elements is reduced to a minimum.

The amplifier, which is designed for low-frequency operation, includes a driver and inverter stage combined in one valve or having common cathode connection. The feedback is applied to the driver stage to the exclusion of the inverter stage.

Fig. 1 is a circuit diagram of the amplifier. The driver and inverter stages are afforded by a single valve  $V_1$  (the R.O.A. 6Z7-G type), having two triode sections with a common cathode. The two grids of valve  $V_1$  are biased in common due to the provision of resistor GB of 500 ohms in the cathode lead, this resistor being connected to the positive pole of the battery at B through a suitable bleeder resistor which may be of about 50,000 ohms.

### Anode Couplings

Input to the valve  $V_1$  is effected through a volume control circuit VC connected to the control grid of the driver stage. The output anode of this stage is resistance-coupled to the control-grid of one of the push-pull output valves  $V_2$  of the R.C.A. 6-V-6-type. The output anode of the inverter section of valve  $V_1$  is likewise resistance-coupled to the control-grid of the other valve  $V_2$ . The output from valves  $V_2$  is applied through transformer T to the loudspeaker LS, feedback to the driver stage being effected from the secondary side of

feedback voltage with respect to the inverter grid is of the order of 40 DB, being given by

$$\sqrt{\frac{R_{FR}}{\left(\frac{1}{\omega C}\right)^2 + R_{FR}^2}}$$

so that the inverter stage is effectively decoupled against feedback.

The feedback resistance has connected intermediate its ends a co-operating feedback control FC, which provides for reduction of feedback when operating conditions are severe. The nature of the arrangement FC will be obvious. The ratio of the left part of resistance FB (about 2,200 ohms) to the right hand part of that resistance (about 80 ohms) and to the shunt resistance in circuit FC is about 30:1. The by-pass capacitor in FC has a value of .05 microfarad. When the switch in circuit FC is closed, the gain of the amplifier is increased by about 3 DB.

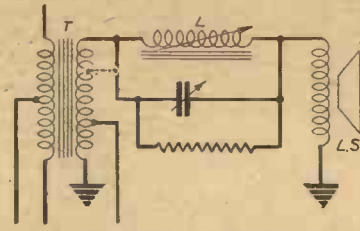

Fig. 2.—Showing how frequency response can be modified in the speaker circuit.

### Frequency Response

It will be observed that the input VC in Fig. 1 is provided with a tone control network TC. Alternatively, tone control can be provided in the loudspeaker circuit, as shown in Fig. 2. The arrangement of Fig. 2 comprises a suitable combination of inductance, capacity and resistance, the feedback voltage being taken from near the earth end of the secondary winding of transformer T. Since the inverse feedback connection tends to provide the amplifier with a substantially flat frequency response characteristic, the response can be modified by the arrangement of Fig. 2 without introducing distortion. For example, the arrangement can be made to operate in such a way that the high frequency signals are divided between the inductance L and the voice coil in the loudspeaker LS, to attenuate the high frequency signals in any desired manner. Alternatively, the arrangement may be adjusted to attenuate or accentuate any other frequency range. The resistance of the inductance L is preferably low compared with that of the inductance of the voice coil, and the value of the resistance in parallel with

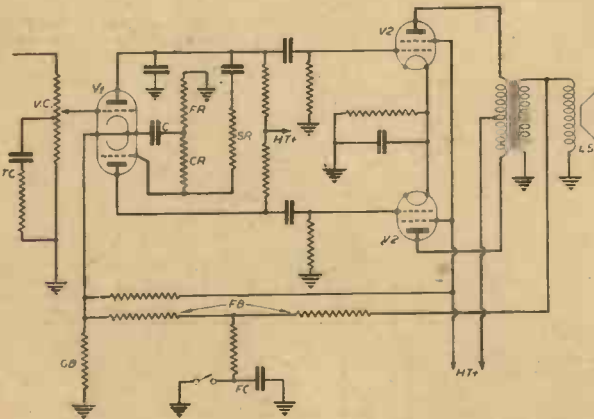

Fig. 1.—The push-pull amplifier circuit discussed in this article.

transformer T to the cathode of valve  $V_1$  through resistance FB. The inverter stage is fed from the anode of the driver stage through a resistor SR of 680,000 ohms to an input circuit, including two resistors CR and FR, or about 18,000 ohms and a megohm respectively. The biases of the two grids of  $V_1$  are equal. The resistor FR is decoupled with respect to the cathode of  $V_1$  through a condenser C of 0.25 microfarad capacity. The relation between the resistors SR, CR and FR should be such that the quantity

$$\frac{RCR + RFR}{RCR + RFR + RSR}$$

is the reciprocal of the gain of the inverter section of valve  $V_1$ . With this arrangement the attenuation of

inductance L is preferably several times that of the impedance of the inductance. The curves A, B and C of Fig. 3 are suitable response curves which may be obtained for various settings of the arrangement of Fig. 2, the rejection frequency in curve B being about 5,000 cycles. Curve A is the response for normal operation.

These show the effectiveness of the arrangement, and the wide range of control obtainable.

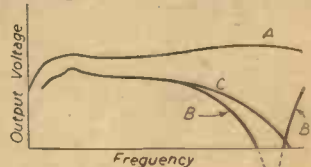

Fig. 3.—Frequency response curves.



# ON YOUR WAVELENGTH

By THERMION

## "Picofarad"

I REFERRED to this comparatively new technical term last month, inviting readers to send details as to its derivation. I have not had any letters except from a colleague now on active service, who suggests that the word should be *picofarad*, not *picofarad* as printed last month. I have checked one or two sources, and find that it is variously spelt as *picafarad*, *picofarad* and *picofarad*. My colleague was unable to help me regarding the derivation, so I have been conducting a little research on my own account. In my view, the technical dictionary in which I found the term has misspelt it. The word, in my opinion, should be *picafarad*, and I am making the suggestion that the word was derived from the printer's word *pica*, a technical term meaning a size of type equal to 12 point. As a *picafarad* is equal to .000,000,000,001 (12 digits) there is some justification for the use of the prefix *pica*, which means 12-point type (there are 72 points to the inch). It is, therefore, as *picafarad* that the word will appear in this journal and in our various technical books.

## Less Broadcasting?

SO the Select Committee thinks we could save much money by closing down our broadcasting stations earlier, or by cutting out some of the early morning programmes. I suppose we might save a few hundred pounds a year in this way. The Select Committee should confine its attention to saving thousands and millions. I ask for a reduction in the number of programme hours on another account altogether, namely, that they are a waste not only of the power used to radiate them, but also of B.B.C. money, which is public money, and of time. I do not want to listen to the 8 o'clock news; I do not want to listen to inane postscripts, silly epilogues, crooners, dance bands, stupid people brought to the microphone because they happen to be in Town to-night; I do not want to listen to the worthless views of people who have jockeyed themselves into the limelight, and are therefore considered by the B.B.C. to have worthwhile views on subjects they can know nothing about. I do not want to listen to the views of a professional singer on religion, I do not want even to listen to the views of a parson on religion (I can go to Church for that). I do not want our programmes to be used in any way for publicity purposes for particular individuals. I do not wish to listen to cycling broadcasts, nor reports of football matches; I do not want to know the names of the announcers; I do not think that the B.B.C. should devote programme space to religious services, nor do I think it should devote any further time to the Brains Trust. They have had a fair show, they have been given the opportunity to answer a fair number of questions, but they have not, in my view, contributed anything new to the world's heritage of knowledge, nor have they answered the questions in many cases satisfactorily. As a form of entertainment it does not entertain. I am suggesting also that there should be some new blood in the programmes. John Hilton has had a fair run, and so have many others.

## Broadcast Advertising?

MR. GLADSTONE MURRAY, General Manager of the Canadian Broadcasting Company, who has recently been on a visit to Great Britain, is reported in an American journal to have told American broadcasting officials that the B.B.C. is to go on to a commercial basis after the war. He said that advertising is to be broadcast as American stations have been doing since the beginning. Great Britain will do this not only

for the revenue, but also because it is realised that Britain's home and short-wave facilities will be needed in the era of intense economic and business competition that is to be expected. The American report continues that plans are already laid for expanding British radio throughout the Empire operated solely or partly on a commercial basis. When asked about this, the B.B.C. stated that the matter had never been discussed.

It may be forgotten that the B.B.C. did at one time broadcast what it called "sponsored programmes." It did not, however, give the sponsors a chance for reasonable publicity. The programmes were prefaced by the remark, "This is a programme of music (or variety, etc.), sponsored by Messrs. So-and-So, manufacturers of so-and-so." Then followed an excellent programme which carried no advertising value at all. It cost some hundreds of pounds to put on a programme of this sort, and in view of the limited acknowledgment at the start of each programme there is little wonder that firms who had tried the experiment were not anxious to renew it. I preserve an open mind on the question, but the B.B.C. will have to suffer a change of heart before commercial broadcasting can be a success in this country. It will have to regard itself as a public servant, and not a master of the public, and equally it will have to consider itself as a public entertainer, rather than a religious and educational body.

## Government Gus Protests

[News item.—The Press and public have been ahead of Government complacency and the official lack of initiative and imagination.]

I SAY, dash it all, old fellow,

I'm feelin' most f'rightfully soah,  
The bally old papahs are makin' a fuss—  
I'm shuah you'd agwee it's a boah.

They simplah ignoah ouah status,  
And ouah theories hold up to fun,  
The boundahs are even suggestin'  
It's time that we got somethin' done!

We'chaps in the Circumlocution Branch  
Are not to be hustled like that!  
We've too fine a sense of ouah dignity,  
The Pweess must accept that—quite flat!

They say we are always two jumps behind;  
Supine! Till the people insist!  
By gad! That looks jolly like mutiny  
To us. We must stwongly weesit.

We must put all these newspap chappies  
Quite twirly wight back in their place.  
When they and the people start gwowsin',  
We ouahselves, dear old chappie, lose face!

Don't we always follow the lead they give?  
What moah do the boundahs require?  
That leaders should always be f'wound in Fwunt!  
'Tisn't done, not with us, dear old fellow!

To that we shall nevah as-piah!

— "Torch."

## Our Roll of Merit

Readers on Active Service—Twenty-first List

R. S. Andrews (A.C.I., R.A.F.), Gosport.  
F. Procter (Signalman, R.C. of S.), Home Forces.  
L. Lear (A.C.I., R.A.F.), Fifehire.  
A. J. Lougher (17th Royal Fusiliers), Nutter.  
R. Coyles (Sapper, R.E.), Chelwood Corner.  
J. G. Woodhead (Sapper, No. 1 R.T.C., R.E.), Liss.  
R. Hill (L/Bdr., 26th T.T.G.), Coventry.  
F. Wilkinson (L.A.C., R.A.F.), East Dean.

# Problems of Mains Supply

Items which Must be Considered when Modifying or Constructing

## Mains-operated Receivers

IT does not require a great deal of experience before the average constructor feels capable of making or modifying a battery-operated receiver, but when it

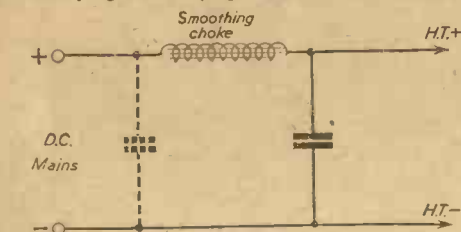

Fig. 1.—The smoothing circuit for the H.T. when D.C. mains are used.

is a question of attempting the same work on a mains-operated set, then certain doubts and snags arise.

Firstly, there is the question of the type of mains. At present there are both A.C. and D.C. mains facilities available to listeners in various parts of the country, although it is intended eventually that only A.C. supplies will be in use. At the moment, however, a listener may live in one locality which is supplied with A.C., and may then change his residence to a situation that has D.C., with the result that his original receiver may be rendered useless. A change in the opposite direction may not be quite so serious as it may not be a difficult matter to modify the receiver so that the D.C. mains may be utilised. This depends, as we shall see later, on the type of receiver. There are three types of mains receiver—the A.C., the D.C., and the Universal. As the titles indicate, these are designed solely for A.C. mains operation or solely for D.C. operation, or by a special arrangement may be used on either A.C. or D.C. without alteration. It might appear at first sight that the latter is obviously the best arrangement, but whilst this is true from a utility point of view, it does not permit the most to be obtained from a mains receiver as will now be indicated.

### Increasing the Voltage

The mains supplies in this country range from 200 to 250 volts, according to the district. The D.C. mains supply has a fixed polarity, that is, one mains lead is positive and the other is negative, and it may thus be connected direct to a receiver—except for a smoothing circuit to take out any ripple or unevenness which is present. An A.C. supply, however, is constantly changing its polarity, and thus it must be converted into a direct-current supply before it can be used for operating a receiver. This means that a special mains unit must be employed, in which a valve or metal rectifier must be used. Now, an important property of alternating current is that it may be transferred from one inductive coil to another without any direct connection, and if the coil to which it is transferred is larger in size than the direct-fed coil, the voltage induced into the coil will be greater—the gain being proportional to the sizes of the coil. A transformer is used for the purpose, as this gives maximum coupling between the two coils, and it is thus

possible to obtain voltages as high as 700 or more for feeding a receiver. It must be remembered, however, that when a transformer is used in this manner it is not possible to get something for nothing, and although the voltage is stepped up the current is stepped down so that the wattage is not increased. There is actually a slight loss, dependent upon the design of the transformer. The ability to obtain increased voltage, however, enables the A.C. user to build a more powerful receiver, using valves capable of a much greater output than may be obtained with other types of valve, and thus the A.C. receiver is generally the most efficient.

### D.C. Circuits

The A.C./D.C. or Universal receiver suffers from the same defect as the D.C. receiver in that no transformer can be included, and thus the total voltage available for operating the receiver is not greater than the mains voltage, namely, 250 volts maximum. Figs. 1, 2 and 3 show the mains sections of the three types, from which it will be gathered that the D.C. is the cheapest arrangement, the A.C./D.C. is next, and the A.C. the most expensive. The transformer is, of course, an expensive item, the cost depending upon the output for which it is designed.

Apart from the problem of the H.T. there is also the heater (or filament) supply, and in A.C. circuits this is a low voltage, and the valves designed for A.C. use operate with the raw A.C. supply. This may be obtained in the same manner as the H.T. initial voltage, from a winding on the transformer, either 4 or 6.3 volts being the most usual now in use. The D.C. or A.C./D.C. valves are available in various types, taking from 6.3 to 40 volts for the heater supply. This is usually obtained by including a

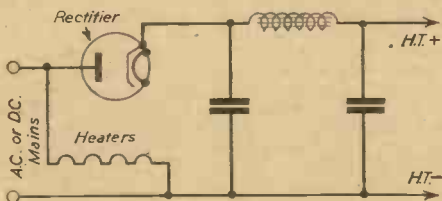

Fig. 2.—The rectifier and smoothing arrangements of a Universal set. Note the valve heaters connected in series. The mains voltage dropping resistance is not shown.

resistance in series with the mains supply leads (Fig. 4), the resistance sometimes being a large wire-wound unit mounted on the chassis where adequate ventilation can be provided, or by means of a special length of wire incorporated in the mains leads for the receiver. This is known as a "line cord," and it is wrapped with asbestos so that no damage can occur, although it gets very hot in use. It will be obvious

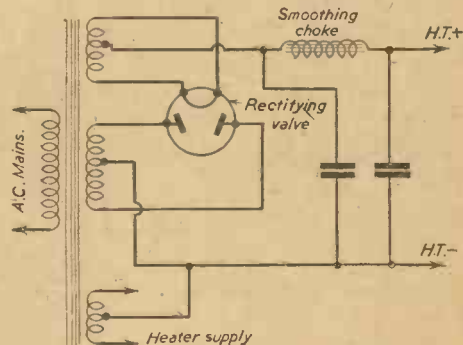

Fig. 3.—The basic circuit of a full-wave rectifier for use on A.C. mains only.



that the supply of the heaters of D.C. or Universal valves is a wasteful process, as the wattage which has to be dissipated in order to obtain the low voltage is merely given off in the form of heat which plays no part in the operation of the receiver.

**Grid Bias Supplies**

There is one other voltage supply needed for the operation of the receiver, namely, grid bias, and this is

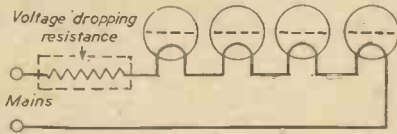

Fig. 4.—The valve heater circuit of a D.C. or Universal set, showing the mains voltage dropping resistance connected in series.

obtained automatically by means of resistances included in the circuit. The arrangement follows somewhat the lines indicated in the article on battery receivers last month, except that the position of the resistance is slightly different. The mains types of valve are now universally of the indirect-heated type (except for certain

types of output valve) and this means that there is a heater which is used only to make the cathode hot, and it is the cathode which gives off the electron stream, and which is connected to the H.T. negative supply. Thus, by including a resistance between the cathode and H.T. negative the anode current will cause a voltage drop along the resistance exactly as in the case of the battery circuits dealt with in the previous article. Where the directly-heated output valves are used, however, it is usual to use a separate heater secondary winding on the transformer for these, and then the bias resistor is included between the centre-tap of the heater winding and H.T. negative. All heater windings are provided with a centre-tapped winding, and this point is joined to the earth line to avoid hum troubles. It is possible in some cases (for instance, the heater of the rectifier) to dispense with the centre-tap, but hum troubles may be introduced if this is done, and therefore it is usual to use the tapped winding. If a transformer without a tapped winding is obtained, an artificial centre-tap may be provided by connecting a small variable resistance across the winding, and connecting the arm of the component to earth. It may then be adjusted so that an exact electrical centre is found, and hum balanced out. The value of such a component is generally about 20 or 30 ohms, and it is known as a hum-dinger.

# Motor-operated Press-button Tuner

An Improved Arrangement for Facilitating Quick Adjustments

**M**OST of us are quite familiar with motor-operated press-button tuned receivers of the kind in which, upon actuation of a press button, a motor rotates the tuning condenser to select a predetermined transmitting station under control of a commutator-type selecting switch coupled to the tuning condenser. With many of the receivers fitted with tuning apparatus of this kind adjustment of the station-selecting switch must be done from the back of the cabinet. This operation is simplified if the operator can adjust both the station-selecting switch and the manual tuning control without changing his position, and this is particularly the case if the tuning indicator and the station-selecting switch contacts can be viewed simultaneously.

This can be achieved by arranging the contacts of the commutator switch adjacent to an aperture in a wall of the cabinet of the receiver, this aperture being closed normally by the indicator panel which is displaceable to permit access to the switch when adjustments are necessary. A convenient arrangement of this kind is shown in the accompanying drawings of a radio receiver in which Fig. 1 shows a front sectional view, and Fig. 2 a side sectional view.

**Constructional Details**

The manual control spindle 1 is coupled by

suitable gear wheels or friction wheels, 2, 3, 4 and 5, to the condenser shaft 5a. This shaft also supports a drum 8 for a driving cable 6 which is secured to the carriage 6a carrying the indicator pointer 10. Also mounted on the condenser shaft 5a is the commutator disc 20 of the station-selecting switch, and the stator of this switch, which supports adjustable stator contacts 18 is indicated at 17. The carriage 6a for the pointer 10 is slidably mounted to move along the upper horizontal edge of the indicator panel 9, which is suitably inscribed with station names or other markings. The indicator panel 9 is

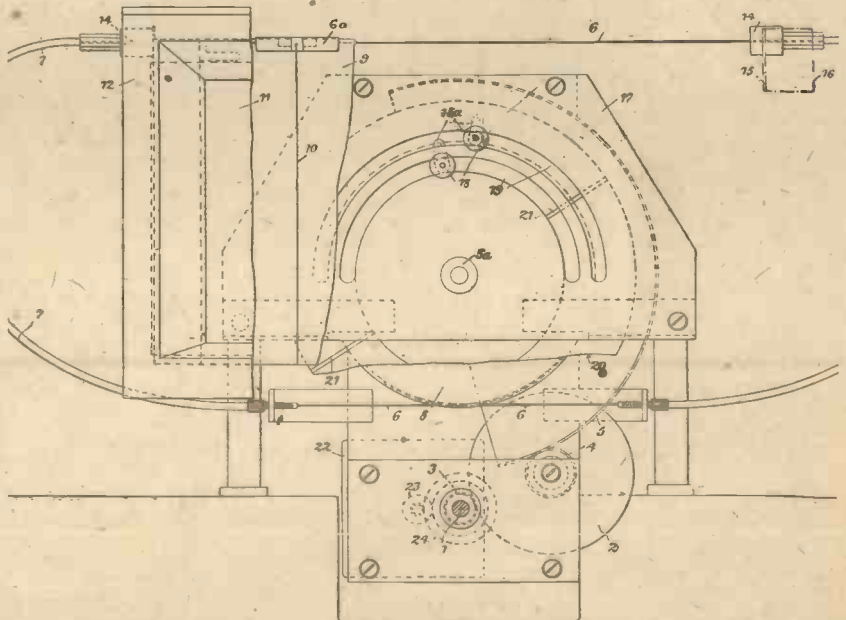

Fig. 1.—A front part-sectional view of the tuning indicator of a press-button tuner.

protected by a glass panel 11 and is carried by a frame 12 which is pivotally mounted in an opening 13 in the cabinet. The horizontal pivots 14 are arranged at the top of the aperture of the cabinet so that the indicator panel 9 can be swung upwardly and outwardly to expose the contacts 18 of the station-selecting switch while still remaining visible. The pivots 14 are provided with bores through which the driving cable 6 for the pointer passes. This cable is thus coaxial with the axis of rotation of the indicator so that the pointer can be moved and the receiver tuned manually regardless of the angular position of the tuning scale. Means (not shown) may be provided to support the indicator at any suitable inclination when adjustment of the commutator switch becomes necessary, and the adjustments can be carried out through aperture 13.

#### Driving Motor

A reversible electric driving motor is indicated at 22 and is adapted to be coupled to the condenser spindle 5a through the friction clutch 23, 24, as a result of axial displacement of the motor shaft which occurs when the motor is energised through operation of one or other of the press buttons (not shown).

Referring to the station-selecting switch the insulating segments of the commutator are indicated at 21 (Fig. 1) and a pilot lamp (not shown) may be provided which can be coupled temporarily, in known manner, to one or other of the stator contacts 18 so that it lights up when the segmented contact bears against one of the insulating segments 21.

It will be apparent with this construction that the ability of an operator to glance at both the tuning indicator and the pilot lamp, or commutator switch contacts, without changing his position simplifies the operation of adjusting the selector switch contacts and shortens the time of the operation.

This system was developed in the laboratories of Electric and Musical Industries, Ltd.

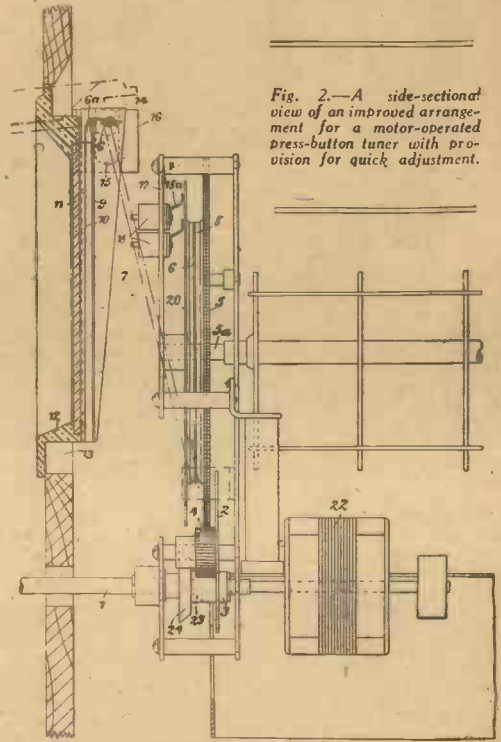

Fig. 2.—A side-sectional view of an improved arrangement for a motor-operated press-button tuner with provision for quick adjustment.

## BOOKS RECEIVED

**AIR CADETS HANDBOOK No. 1. NAVIGATION AND SIGNALLING.** By W. J. D. Allan. Published by George Allen and Unwin. 80 pages. Price 2s. net.

**T**HIS handy little book is intended for the young men who are now joining the Air Training Corps. The author, who has had many years' experience of air navigation training, deals with the subject in a very comprehensive manner. There are seven chapters, the first six covering subjects including The Form of the Earth; Rhumb Lines; Conical Projections; Mercator's Projections; Use of Maps; Drift; Map Reading; Deviation; Compasses; and Time and Speed Scales. The seventh chapter deals with Signalling; The Aldis Lamp and the Morse Code. Various parts of the text are illustrated with explanatory diagrams.

**RADIO RECEIVER SERVICING AND MAINTENANCE.** By E. J. G. Lewis. Published by Sir Isaac Pitman and Sons. 252 pages. Price 8s. 6d. net.

**T**HIS book, which is a second edition, is a practical manual specially written for the radio dealer, salesman, and the keen experimenter. Dealers who are trying to carry on their service departments without their technical staff will find the information in this book invaluable. For them particularly, there is a chapter on Press-button Tuning, and A.F.C. which will help to dispel the mystery surrounding some of these automatic devices. Other chapters cover such subjects as Valves and Their Faults; Circuits; Servicing Equipment; The Superhet; All-wave Receivers; Radiograms; and Aerials, Earths and Interference. The book is well illustrated with line and half-tone illustrations, and also contains a full index. The many radio enthusiasts now serving in the Forces will find this comprehensive volume a great help in their work.

## THERMAL DELAY SWITCHES

**A**N interesting note has been received from Messrs. Bulgin and Co., Ltd.—who include in their most extensive range of components a thermal delay switch of proved efficiency—concerning methods of connecting these switches. It will be remembered that in our issue for November, on page 45, the use of these components was discussed, and one simple method of connection shown: If the circuit is examined, it will be seen that the full H.T. potential (peak and R.M.S.) as may occur in the circuit, is applied between the bi-metal strip and the winding which heats it. Whilst the mica insulation, as Messrs. Bulgin point out, will undoubtedly withstand this initially, the heating effect on the mica is likely to cause a deterioration of its insulating properties, so far as its voltage-standing ability is concerned. It is always possible to wire thermal delay switches so that they perform their functions satisfactorily, but with a minimum voltage difference between strip and heater, thus prolonging the useful life of the component.

When a valve rectifier is in use, it is advisable to connect the strip heater circuit to the transformer winding, which feeds the rectifier filament, the centre-tap of which, i.e., the positive H.T. supply, is then taken through the switch section.

### "Improved Band-set Dial": Correction

**I**N the description of an "Improved Band-set Dial" on the "Practical Hints" page of the October issue, the condenser values were given as microfarads. These should, of course, have been expressed as micro-microfarads, or picofarads.

# Condenser Calculations

The Use of the Tables Compiled in This Article will Greatly Facilitate the Problem

**C**HOICE of the capacity of fixed condensers in a wireless circuit, though usually not very critical, has to be made with due regard to the function which each condenser has to perform, and to the values of the other components with which it is associated. This usually means a small amount of calculation—not of a very elaborate nature—since some very useful rules of thumb have been evolved to simplify these calculations to the lowest terms.

Before dealing with some of these simple rules there are one or two types of calculations which every constructor has to perform on occasion, and which can be further simplified for him in ways to be described. For example, having ascertained that a fixed condenser of a particular capacity is required in a certain position, the constructor may find that he has not just the right size in his possession. If, however, he happens to have a selection of other sizes at hand, it is quite possible that he may be able to make up the required capacity by using two or more condensers of smaller or even larger value.

### Combinations

In the case where the condensers available are smaller than the required capacity, all that is necessary is to select two or more condensers whose combined capacities when added together make up the total required, and to connect them all in parallel. For example, a 2 mfd. by-pass condenser could be made up of two 1 mfd. condensers in parallel.

But supposing all the condensers available are larger than the desired value—how can a smaller capacity be made up? The answer is, by connecting two or more condensers in series, and it is here that the first small calculations are necessary. The actual formula for finding the capacity of two condensers in series is to multiply the two values together and to divide the result by their sum, and for three condensers the calculation, though no more difficult, is a little more complicated. Moreover, since, in order to obtain the desired value, it may be necessary to work out the capacities of several different combinations, and select the nearest to the required value, the process becomes a little more tedious.

| Capacity in Mfd. | Reciprocal | Capacity in Mfd. | Reciprocal |
|------------------|------------|------------------|------------|
| .0001            | 10,000     | .005             | 200        |
| .00015           | 6,666      | .006             | 166        |
| .0002            | 5,000      | .01              | 100        |
| .0003            | 3,333      | .02              | 50         |
| .0005            | 2,000      | .05              | 20         |
| .001             | 1,000      | .1               | 10         |
| .0015            | 666        | .2               | 5          |
| .002             | 500        | .25              | 4          |
| .003             | 333        | .5               | 2          |
| .004             | 250        |                  |            |

### A Helpful Table

The above Table 1, however, reduces the amount of calculation very considerably. It consists of two columns, the first of which is headed "Capacity in mfd." and the second "Reciprocal." To find the capacity of any combination of condensers in series it is first of all necessary to write down the number in the "Reciprocal" column corresponding to each of the condensers. These numbers must then be added together, after which the combined capacity will be found in the first column opposite the number in the "Reciprocal" column corresponding to the sum of the reciprocals already obtained.

For example, suppose that two condensers, each of .01 mfd., are connected in series.

The reciprocal of .01 from the table is 100, and as

| Grid Leak (megohms) | Coupling Condenser (mfd.) |
|---------------------|---------------------------|
| 1.0                 | .006                      |
| 0.5                 | .012                      |
| 0.25                | .024                      |
| 0.1                 | .06                       |

there are two such condensers we must add another 100, giving a total of 200. The capacity in column 1 corresponding to 200 in the "Reciprocal" column is .005 mfd.

It will probably happen that when the sum of the reciprocals has been obtained it will be found that there is no number in the "Reciprocal" column exactly

| Capacity (mfd.) | Reactance    |               |
|-----------------|--------------|---------------|
|                 | at 50 cycles | at 100 cycles |
| .25             | 13,000       | 6,500         |
| .5              | 6,500        | 3,250         |
| 1.0             | 3,250        | 1,600         |
| 2.0             | 1,600        | 800           |
| 4.0             | 800          | 400           |
| 8.0             | 400          | 200           |
| 12.0            | 250          | 120           |
| 25.0            | 120          | 60            |
| 60.0            | 50           | 25            |

corresponding to this figure, but in these circumstances the nearest figure must be taken. This does not very much matter, for, as already explained, the values of fixed condensers in wireless circuits are seldom very critical. For example, a .01 and a .02 mfd. condenser in series correspond to reciprocals of 100 and 50 respectively; these two numbers added together give 150. The nearest to this in column 2 is 166, and this corresponds with a condenser of .006. Therefore, a condenser of .01 mfd. in series with a condenser of .02 mfd. can be considered as approximately the equivalent of a .006 mfd. condenser, although, if the values were worked out mathematically their actual capacity would be .0066. The error is only about 10 per cent., which is of the same order as the manufacturing tolerance of these small condensers.

### Coupling Condensers

We now come to cases in which a little calculation is required to arrive at the best value for a fixed condenser. This usually occurs in connection with the coupling condenser in a resistance-capacity amplifier. A full discussion of the factors governing the design of such couplings is outside the scope of the present article, and in any case they have been dealt with before in these columns, and it must suffice to remark that the liability to pass the lower audio-frequencies without serious bass attenuation suggests a fairly large capacity, while an upper limit is set by the necessity of avoiding choking the grid circuit, due to the inability of the grid leak to discharge the coupling condenser rapidly enough.

There is a fairly generally accepted rule of thumb governing the size of such a condenser. Briefly stated, it is that the capacity of the coupling condenser in microfarads, multiplied by the resistance of the grid leak in megohms, should not be less than .006, and it may also be added that the grid leak should not be less than four times the value of the anode load of the preceding valve and not greater than .5 megohm, or such lower value as may be recommended by the valve-maker. (See Table 2.)

TABLE 4  
REACTANCE OF SMALL COUPLING AND BYPASS CONDENSERS

| Capacity (mfd.) | Reactance (ohms) (approx.) |                 |
|-----------------|----------------------------|-----------------|
|                 | at 50 cycles               | at 1,000 cycles |
| .001            | 3,250,000                  | 160,000         |
| .002            | 1,600,000                  | 80,000          |
| .003            | 1,100,000                  | 50,000          |
| .004            | 800,000                    | 40,000          |
| .005            | 650,000                    | 32,500          |
| .006            | 500,000                    | 25,000          |
| .01             | 325,000                    | 16,000          |
| .02             | 160,000                    | 8,000           |
| .05             | 65,000                     | 3,250           |
| .1              | 32,500                     | 1,600           |

According to this formula, therefore, the correct size of condenser for use with a .25 megohm grid leak would be .024 mfd. as a minimum, but in actual practice a rather larger value would be chosen, such as the standard .05 mfd. component.

#### By-pass Condensers

The next case is that of the by-pass condensers in smoothing and decoupling circuits and for automatic grid-bias arrangement. The requirement is that the condensers shall have a low reactance to the frequencies it is desired to by-pass, compared with the impedance to those frequencies offered by the smoothing choke or decoupling resistance. Now the reactance, or opposition offered by a condenser to an alternating current, varies with the frequency, being less at high frequencies than at low frequencies. It is very desirable, therefore, to be able to calculate the reactance of a condenser at any particular frequency. This can be done by multiplying

together the capacity of the condenser in mfd., the frequency in question in cycles per second, and the number 6.28, and dividing the result into 1,000,000. The answer will be the reactance of the condenser at that particular frequency expressed in ohms.

It is true that this calculation involves only simple arithmetic, but in order to reduce the necessity for such calculations as much as possible, a further group of tables have been prepared giving the reactances of commonly used sizes of condenser at frequencies with which they are usually expected to deal. Table 3 gives the reactance of the larger by-pass condensers from .25 mfd. upwards at 50 and 100 cycles. Table 4 gives the reactances of smaller coupling and by-pass condensers at 50 and 1,000 cycles, the latter being an average kind of audio-frequency, while Table 5 gives the reactances of condensers between .0001 and .01 mfd. at 1,000 kc/s (400 metres) and 200 kc/s (1,500 metres).

TABLE 5  
REACTANCE OF CONDENSERS AT RADIO FREQUENCIES

| Capacity (mfd.) | Reactance     |             |
|-----------------|---------------|-------------|
|                 | at 1,000 kc/s | at 200 kc/s |
| .0001           | 1,000         | 8,000       |
| .0002           | 500           | 4,000       |
| .0003           | 333           | 2,667       |
| .0004           | 250           | 2,000       |
| .0005           | 200           | 1,600       |
| .001            | 100           | 800         |
| .002            | 50            | 400         |
| .003            | 33            | 267         |
| .004            | 25            | 200         |
| .005            | 20            | 160         |
| .01             | 10            | 80          |

## Selectivity Considerations

Factors Governing Selectivity are Explained in the Article which Also Shows How it Affects a Receiver's Performance

**P**OOR selectivity is one thing that annoys a set-builder more than a run-down battery. To have spent hours in making a good job of a set and then to hear one or more stations spreading half-way round the dial takes much of the satisfaction from the performance. The greatest offender is the set which the beginner usually makes his first—namely, that with a detector and one or two low-frequency stages. Sets with an S.G. stage are usually more selective, due to the use of more than one tuning circuit; but even with these receivers some little alteration may be needed to prevent the "break-through" of a powerful station.

#### What Selectivity Means

The term selectivity means the space on the tuning scales over which a signal can be heard. Or, perhaps more correctly, selectivity refers to the ratio of signal strength when in "tune" to signal strength so much on either side of tune position.

In Fig. 1 we have examples showing the relative amplification of three tuned circuits: A with a resistance of 15 ohms, B of 20 ohms, and C of 30 ohms. With the lowest resistance circuit the amplification 9 kilocycles off tune compared with that when in tune is, say, in the ratio of 8 to 1. The ratio with the highest resistance is 5 to 1. The approximate station separation is 9 kilocycles, hence it will be seen from these examples that the tendency for interference from an unwanted station is less when low-resistance circuits are used. By resistance is meant the total opposition to the high-frequency signal, and not merely the resistance of the coils and circuit to D.C. or low-frequency currents. Due to a peculiar property of H.F. currents—they travel on the surface of a conductor—the H.F. resistance is much higher than the D.C. resistance. It would therefore seem to be an advantage to lower this resistance by

increasing the size of wire used in wiring the coils, and also always to wire the set with thick wire. In practice, the set wiring may be done with quite thin wire, and a change to heavier gauge would not make any noticeable difference to the total resistance of the circuit. It is a case of strengthening the weakest link, as a high-efficiency coil is no advantage without efficient circuit arrangements.

#### Reducing Losses

Means of reducing the "damping losses" and so the total resistance may be considered, but only briefly, as in themselves we cannot always find a cure for poor selectivity. When an aerial is joined direct to the

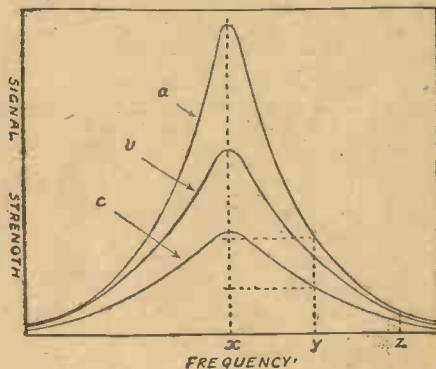
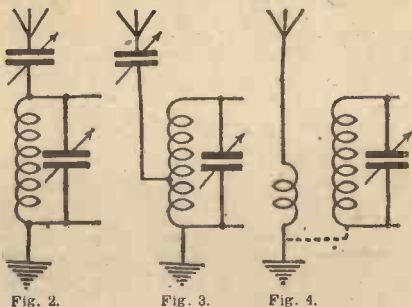

Fig. 1.—The response curves of three coils having different resistances.

"top" end of a coil it has a damping effect on the tuned circuit. In many cases this damping is so great as to make reaction difficult, and under these conditions steps should be taken to remedy the fault. A partial remedy is found by inserting a condenser in the aerial lead, but it is probable that reducing the aerial length somewhat would give better results. The old idea of roof length of aerial is dead, but there still seems a great disinclination to cut down aerial length. Especially in the case of a long, straggling indoor aerial would a reduction to about soft be beneficial. Less aerial losses mean less effective tuned-circuit resistance.

A variable condenser in series with the aerial is a fairly common arrangement for controlling selectivity,



Figs. 2, 3, and 4.—Various methods of coupling the aerial. The first method gives only moderate selectivity, whilst the second method is a great improvement. The third diagram represents a very good arrangement, and one which is to be preferred.

but the capacity should be chosen with some thought to the aerial length. With a very short indoor aerial any capacity less than 0.0002 mfd. would effect too great a reduction of signal strength to be of practical use. When long and high outdoor aerials are used, a smaller capacity of 0.0001 mfd. could be used with advantage. A small variable or "pre-set" type is useful in this position.

**The Importance of the Earth**

It is often the case that a new earth connection gives louder signals and not unlikely an increase in selectivity, if the resistance of the earth connection can be lowered. A water-pipe connection to a cold water pipe nearest to the main supply is usually the best choice. The pipe should be thoroughly cleaned before joining the lead from the set. In Fig. 4 another method of controlling the aerial coupling is indicated. The aerial coupling coil may consist of twenty to thirty turns wound on a separate former and slipped over the grid tuning coil. If a new coil is being wound, a tapping may be made or a coupling coil may be wound alongside the medium-wave grid coil. The switching arrangements with the latter method are made complicated, as for long-wave reception either a larger coupling coil is needed, or the aerial tap arrangement is required for satisfactory reception.

Possibly the best method we have for reducing resistance and increasing selectivity is reaction. Whatever the damping losses in the grid circuit, these can be reduced by use of reaction. In the case of an S.G. set not fitted for reaction, some advantage can be gained by joining the lead from the coupling condenser to a tapping on the tuned grid coil (Fig. 5). This may be ten or twelve turns from the grid end of the coil. Also, it has been explained before in these pages that the H.F. choke is virtually in parallel with the tuning coil, hence the choke should be chosen with a low resistance—that is, with a high ratio of inductance to resistance.

**The Effect of Reaction**

When reaction can be used, selectivity is greatest when the set is just on the verge of continuous oscillation,

but at the same time the quality will fall off. This applies to every case where selectivity is attained by reducing the resistance or damping of the tuned circuits. Reference once more to Fig. 1 shows how amplification falls off on either side of the tuned frequency. Because reception occurs on a group of frequencies known as sidebands, one above and the other below the tuned frequency, all the audio-frequencies will not be amplified to the same extent. Reaction and reduction of damping, in other words sharply-tuned circuits, produce an output of sound lacking in brilliancy. The top notes are missing and the reproduction tends to be boomy if not counteracted in the amplifier.

To some extent this disadvantage may be reduced if not altogether done away with, and without a great deal of expense. In commercial sets with two S.G. stages, the high degree of selectivity obtainable with numerous tuned circuits would cause a very unrealistic output, but these tuned stages are slightly detuned so that a band-pass effect or flat-top tuning curve is approached. If you are operating a home-built set with a three-gang condenser, quality may be considerably heightened by slightly mistuning the trimmers. This is only practical if there is volume to spare, as any mistuning will give some reduction of amplification. With a detector and two L.F. stage receiver there is usually some volume to spare on any stations which are received well enough to allow of efficient rectification. With one only L.F. stage there is insufficient volume to spare, unless the detector is preceded by an S.G. stage. Only when some volume can be sacrificed can we attack the problem without adding another stage of H.F. amplification.

The efficiency of the detector on average signals depends upon the square of the signal voltage. If the signal is too weak, it cannot operate the detector with any success. Assume two signals being received at such strength that one, untuned, interferes with the other, tuned. If the ratio of signal strength between the tuned and the untuned signal is 4 to 2, then the output from

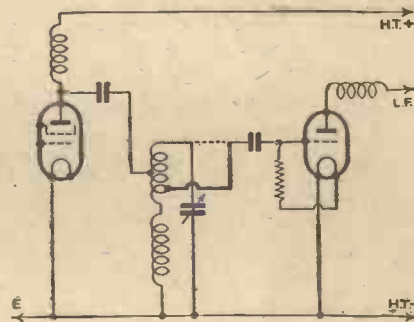

Fig. 5.—To remove damping and thus improve selectivity when an H.F. stage is employed, the grid coil should be tapped, as shown here.

the detector as passed to the amplifier is 16 to 4, or 4 to 1, so that the interfering signal has a strength which will make it annoying. Now assume we loosen the aerial coupling by means of a series condenser or a coupling coil, and at the same time make use of reaction as sparingly as is consistent with good volume. If the input to the detector from the two signals is reduced to a ratio of 3 to 1, then the detector output for amplification is in the ratio of 9 to 1, so that now the interfering signal is considerably weaker compared with the wanted signal. It follows that signal strength is reduced all round, but this is a practical method of gaining better selectivity provided the L.F. stages can make up in amplification what is taken from the detector output. Therefore, if you at present control volume, in the L.F. stages, transfer the volume control to the aerial end and so gain extra selectivity.

# Volume Levels and Tonal Response

An Interesting Discussion on the Effects of Simple Volume Control Arrangements on the Tonal Balance of the Reproduction

PROBABLY every listener has noticed that as the volume control on a receiver is operated, the balance of the tone from the loud-speaker also varies in some manner and does not maintain the same quality throughout the complete range of volume control. It will no doubt also have been noticed that when approaching a band in the open air, certain instruments may be heard long before others, and in our own homes it often becomes noticeable that the drums in a dance band may be heard from a neighbour's receiver, although no other instruments or music may appear to accompany them. The question of this balance of tone and volume is a very complex one, and is much too intricate to be gone into here. Suffice it to say that it is due not only to our sense of hearing and the "response curve" of our musical sense, but it is found to be due also to the frequency response of the receiver, the loud-speaker, and the acoustics of the room in which the reproduction takes place. Furthermore, the balance of the musical instruments and their position before the microphone, in conjunction with the characteristics of the microphone and its associated circuits, will also affect the output from our loud-speaker when the volume is varied over the range from silence to maximum.

## Tone Control Essential

From the preceding remarks it becomes apparent that in order to maintain a balanced reproduction through the complete movement of the volume control, it is also necessary to vary the frequency response of the receiver, and at first sight it might appear that some difficulty would be experienced in ascertaining the degree of correction which is required. Fortunately, our ear is very accommodating, and certain well-known principles may be incorporated in order to deceive the ear, and thus give an effect of complete correction where, in fact, such correction is far from complete. If the volume control of your receiver is adjusted whilst you stand well away from the speaker, you will find that in your particular case either the top or the bass, or both, are cut, the middle frequencies remaining apparently unaltered, although the reduction in volume is apparent. That is to say, as the degree of volume of the middle frequencies gradually decreases, the bass notes or the top notes fall away much quicker, with the result that before the tune is inaudible certain instruments will appear to have ceased playing. The actual degree of cut-off will vary with different receivers and different speakers, but it will certainly be found that the cut-off is clearly defined at one end of the scale or the other. In an extreme case, of course, both high notes and bass notes will be lost, but this is not usual, and points to rather bad matching between receiver and speaker.

## High-note Gain

Dealing first with high-note gain, this may be said to be the most important, as the majority of receivers suffer from a weak high-note response due to the use of reaction, H.F. by-pass condensers, and other losses. Sharply-tuned circuits also present a source of high-note loss, and therefore it is as well, where quality is desired, to replace the higher frequencies by artificial means, irrespective of volume control. This will permit of a more natural reproduction which will probably be

maintained throughout the full movement of the volume control, although further compensation may be added as stated in a later paragraph.

When a condenser is connected across an inductance, a resonant circuit is formed, and it should not be difficult, therefore, to design a circuit, having a resonance in the region of 3,000 cycles or so, to give added amplification to frequencies about this figure, and so produce the desired effect. Such a resonant circuit must be included in the low-frequency side of the receiver, and its effect will be dependent upon the L.F. couplings as well as upon the valve with which it is associated. Where a quality receiver, using resistance-capacity coupling (Fig. 1) is in use, the necessary inductance may be connected in series with the anode resistance, a small parallel condenser completing the tone-control circuit. Fig. 2 illustrates the arrangement, and the choke should have some value between .3 henries and 1 henry. Some experiment may be necessary to find the most suitable value for the particular combination in use.

When transformer-coupling is employed a somewhat different arrangement is called for. The resonant circuit should still be connected in the anode circuit, but the presence of the transformer primary will modify the response, and it becomes necessary to select the value of the resistance with great care. As a guide to the values which might be found desirable  $L$  may be selected from the values previously stated, namely .3 to 1 henry;  $C$  may be some value between .01 and .005 mfd., whilst  $R$  may be between 500 and 5,000 ohms. As already stated, experiment is essential in order to find the balance required by the particular response of the receiver and associated reproducer. (Fig. 3.)

## Combined Control Effects

A more ambitious arrangement is to be found in the fitting of a circuit which varies as the volume control is adjusted, and although it is possible to gang two or more components to produce the desired effect, there is a much simpler solution.

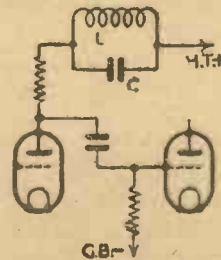

Fig. 2.—Showing the resonant circuit connected in the anode circuit of a R.C. coupled stage.

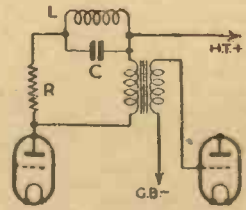

Fig. 3.—Using the tone booster in conjunction with L.F. transformer coupling.

Dealing again with resistance-capacity coupling, the volume control generally takes the form of a variable grid-leak, joined in the first L.F. stage. By connecting the resonant circuit already referred to in the grid lead (as shown in Fig. 4), the variation of the tapping point on the grid leak will at the same time modify the total effect of the control and thus, as the volume is reduced, the low notes will this time be strengthened, and therefore the effect is exactly opposite to the previously-described arrangement. Obviously, the two circuits could be combined in one receiver where the results justified such a combination.

In Fig. 5 is seen an arrangement which forms both a high- and a low-note strengthener, and this is a most effective device and is, in fact, incorporated in a well-known commercial receiver. With this arrangement the reduction of signal strength by the volume control  $R_1$  is more rapid on the middle frequencies than on the high and low frequencies and thus preserves an admirable balance. The values chosen for the various parts are as follow:—

- $R_1$ —500,000 ohm potentiometer.
- $R_2$ —50,000 ohm resistance in series with potentiometer.
- $R_3$ —5,000 ohm resistance.
- $L$ —3 henries.
- $C_1$ —.05 mfd.
- $C_2$ —.or mfd.

If a suitable volume-control potentiometer may be obtained, the combination of  $R_1$  and  $R_2$  may be automatically obtained by making a tapping on the resistance winding. In this case a .5 megohm potentiometer should be obtained and the tapping point should be made at a point about one-sixth to one-tenth of the distance from the minimum volume end.

I have not dealt with circuits designed to modify the loud-speaker response, as these are more intricate and in general will require some modification of the speaker transformer to be made, but the combination of two loud-speakers, one of which is designed especially for high-note response, and which is fed by means of a tuned circuit which passes on to it all frequencies above a certain figure, may be included in the general schemes here outlined.

**Filters**

It is obvious that when one of the devices which increases the strength of the high notes is fitted to a receiver of the super-heterodyne type, there will be a tendency for an over-accentuation of whistles which might be introduced by the circuit. Similarly where two broadcasting stations are working on a very near-by wavelength there will be possibility of heterodyne whistles or side-band splash being over-emphasised. It will obviously, therefore, be unsuitable to fit a high note

strengthenener where it has already been found that these difficulties exist. It is not a difficult matter to construct a circuit which acts in an opposite manner from those given in this article, that is to say, which reduces the strength of certain frequencies or bands of frequencies. By suitable choice of chokes and condensers, a circuit may be constructed to have a definite cut-off at a certain point in order to remedy the above defects, but obviously it will not be possible to obtain high-quality reproduction while these filters are in use. Similarly, any resonances which occur in the speaker or cabinet may be modified in the same way, but it should be the aim of the con-

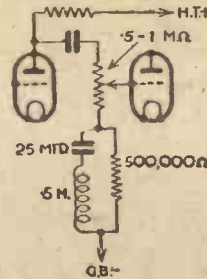

Fig. 4.—A method of obtaining better tonal balance when the volume is varied.

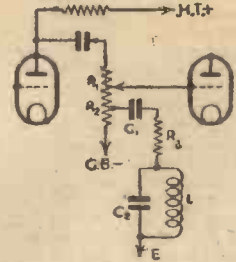

Fig. 5.—A more elaborate arrangement combining high- and low-note boosters.

structor to choose a circuit, speaker and components which give as near a straight line response as possible, when the addition of the compensating circuits given in the early part of this article will enable a very high standard of reproduction to be obtained under all circumstances from a number of broadcasting stations. The reproduction of gramophone records may require treatment on a different line owing to the restricted frequencies dealt with on the disc.

## NEWS AND NOTES

**“How the R.A.F. Works”**

THIS is the title of a handy guide to all the various activities of the Air Force and the associated air defences of Britain, including radiolocation and A.A. The author, who is Air Correspondent of *The Times*, was for some time one of the Service Press Officers of the R.A.F. and manifestly knows his subject well.

Without trimmings, the work explains the organisation of the Air Ministry and the various Commands, shows how the different parts of the great machine works, and how the R.A.F. is equipped for its manifold jobs. It deals faithfully with the human side of Britain's Air Forces. The author gives some useful facts about the Empire Air Training Scheme and the A.T.C., which are shown as important contributions to the solution of the problem of providing personnel for Britain's ever-growing air power.

**Conductor of Midland Light Orchestra**

MR. RICHARD CREAN, conductor of the newly-formed Midland Light Orchestra, was born in Dublin, where he had his musical training at the Royal Irish Academy of Music. After two world tours with the Quinlan Opera Company, he went to Covent Garden, to assist the late Percy Pitt during the 1924 season, and since then has conducted in almost every theatre in London for many shows, including C. B. Cochran's “Evergreen” at the Adelphi. For seven years he was conductor of the London Palladium Orchestra, and during that time he had six Command performances to his credit. Subsequently he went to the New Opera House at Blackpool, moving later to the Winter Gardens,

and for last year's season to the Tower Ballroom. He has broadcast frequently during the past six years.

**London to Canada**

CROWDED into a wooden hut on an aerodrome are fifty or sixty men of a Canadian squadron of the R.A.F. Coastal Command, each with a little message scribbled on a sheet of paper. In the centre of the hut stands a commentator from the Canadian Broadcasting Corporation, microphone in hand. A cable leads out to a car full of recording apparatus, parked on the aerodrome. One by one the Canadians step to the microphone.

It takes half an hour or so to record this greetings programme—a treasured link between Canadian airmen fighting over here and their parents, wives and sweethearts back at home in Canada. From London the records are transmitted by radio beam to Canada, and rebroadcast there, the relatives of all the speakers having been told when to listen. The Canadians send a great variety of messages, making the most of their few minutes. A few stand out for their originality.

“I figure,” draws one, “it'll take me just about a month longer than I reckoned to finish off this war.”

One airman, with unrivalled boldness, turns his few minutes into a verbal love-letter to his girl, while the others of his squadron banter him good-naturedly. Quite unruffled, he steadily protests his love, to be broadcast over the Atlantic. The man who gets the most laughs, however, is he who deals with the tobacco problem.

“Hello, Ma,” he calls. “I'm smoking ‘Three Nones’ tobacco over here now—none yesterday, none to-day and none to-morrow.”

# Winding Plug-in S.W. Coils

Last Month We Gave Details About Medium-wave Coils, Therefore, This Article is Written to Provide Data for the S.W. Bands

**T**HE winding of coils suitable for use in an average S.W. receiver is a much easier proposition than constructing those for medium-wave reception. The standard plug-in coils which are now in use employ either 4 or 6 pins on the base. In some cases a 7-pin base is adopted, but only 6 pins are connected. The latter type of coil may be plugged into a standard 7-pin valve-holder, whilst a 4-pin coil may be used in conjunction with a 4-pin valve-holder.

The 6-pin coil requires a special 6-pin coil base, and these are obtainable from B.T.S., Eddystone, and other makers of short-wave apparatus. The 4-pin type of coil generally consists of two windings only, and these may be employed as grid and reaction, or as an H.F. transformer. The remaining type of coil utilises three windings, and these provide the same arrangement as in the 4-pin coil, with the addition of a winding which may serve as primary or reaction, as desired; the standard pin connections are shown in Figs. 1 and 2.

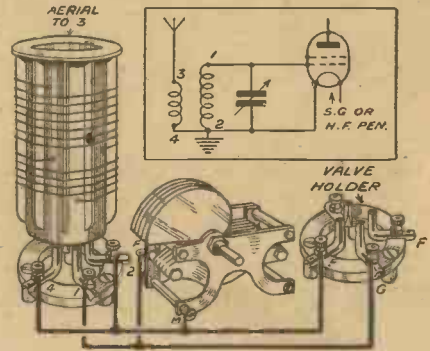

Fig. 4.—Arrangement of a 4-pin coil in an aerial circuit.

## Four-pin Coils

|        | Secondary | Primary |
|--------|-----------|---------|
| Coil 1 | 4 turns   | 2 turns |
| Coil 2 | 8 turns   | 5 turns |
| Coil 3 | 25 turns  | 9 turns |

The wire used for Coils 1 and 2, and for the secondary of Coil 3, should be 22-gauge, either tinned or enamelled. In order to accommodate the total winding for Coil 3, the primary may be wound with a much finer gauge, and a slot should be cut at the lower end of the former into which the turns are wound. In each case the earthed end of the secondary is nearest the pins, and the primary is not joined to the secondary at all. By this means it may be employed with a reaction condenser earthed direct, or may be used for an aerial coupling coil, or as the primary in an H.F. valve anode circuit, without difficulty.

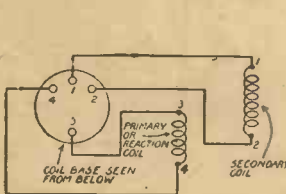

Fig. 1.—Connections for a standard 4-pin coil.

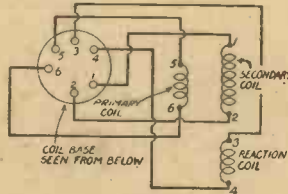

Fig. 2.—Connections for a standard 6-pin coil.

## Winding Your Own Coils

For those who wish to wind their own coils, coil formers can be obtained from B.T.S., Eddystone or Raymart, and these will be found to have an overall diameter (over the ribs) of approximately 1 1/4 in. The most useful short-wave ranges may be said to extend from 10 to 100 metres, and this range may be covered by means of a short-wave tuning condenser having a maximum capacity of .00015 or .00016 mfd. and a set of three coils. It must be emphasised that wavelengths can only be given approximately, as there are considerable modifications due to stray capacities. Furthermore, the minimum wavelength of a given coil will be governed by the minimum capacity of the tuning condenser, and thus the better the condenser the lower will be the minimum wavelength. The three coils may be wound to cover from 11 to 25 metres, from 22 to 47 metres, and from 45 to 100 metres. A slight overlap on each coil will ensure that the total range is covered without any dead areas, and the following table gives the number of turns for these three coils, for both primary and secondary. The coil formers are, of course, fitted with 4 pins, and the type which is provided with threaded ribs should be selected in order that the turns of wire may be spaced and kept firmly in position.

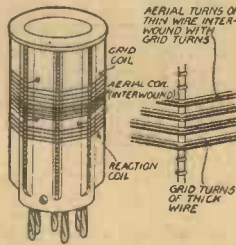

Fig. 3.—Diagrams showing how the ends of the coils are passed through for anchoring and how the aerial coil is interwound.

## Seven-pin Coils

To accommodate a further winding in order that a complete H.F. transformer with reaction may be employed, a fine-gauge covered wire will have to be obtained, and No. 28 should prove quite suitable. This should be interwound with the lower turns of the secondary winding, and should normally be employed as the primary, with the reaction winding as given for the 4-pin coils. Exactly the same number of turns may be employed. It is, however, quite possible to interchange these two windings, and experiments may be conducted with each receiver to find the most suitable combination.

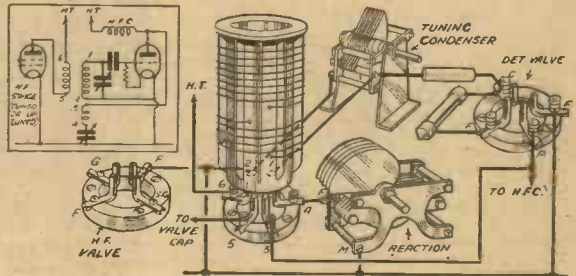

Fig. 5.—Circuit and pictorial arrangement of a 6-pin coil used as an H.F. transformer with reaction.



|           | Secondary | Primary | Reaction |
|-----------|-----------|---------|----------|
| Coil 1 .. | 4 turns   | 2 turns | 2 turns  |
| Coil 2 .. | 8 turns   | 5 turns | 5 turns  |
| Coil 3 .. | 25 turns  | 9 turns | 9 turns  |

The standard connections are given in Figs. 4, 5 and 6, which show the use of the 4- and of the 6-pin coils in the most common types of circuit.

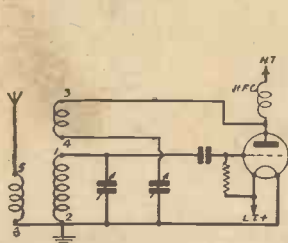

Fig. 6.—A 6-pin coil used in a simple detector stage, with reaction.

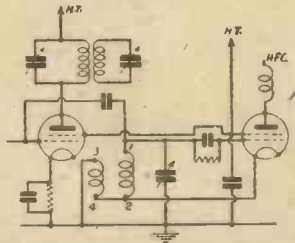

Fig. 7.—How a 4-pin coil is used in an electron-coupled oscillator circuit.

The ends of each winding should be passed through a small hole drilled in the former and then threaded down through the pins, which are hollow and are provided with a hole at the extremity. If enamelled wire be used the enamel should be scraped off and the wire then soldered neatly on the point of the pin. The surplus is then cut off. Between the two windings a small space should be left, and in most cases it will be found that one space as indicated by the grooves on the ribs will be found most suitable. It will often pay the experimenter, however, to carry out a few tests with a view to finding the best arrangement for his individual circuit and his aerial-earth

system. The same thing applies to the actual size of the primary (or coupling) winding. When used in the aerial circuit, for instance, it may often prove worth while to ignore this winding, and to connect the aerial through a fixed or pre-set condenser to the "top" of the secondary winding, but by making the coils as here described more or less standard components will be obtained which will form the basis for experiments and the design of a good short-wave receiver.

**Marking the Coils**

The coils should, of course, be identified so that they may be readily selected when a change in wavelength is required, and if the numbers 1, 2 and 3 above given are kept in mind it will suffice to scratch or paint these numbers on the top of the coil former. If, however, the Raymart coil formers are obtained it will be found that there is a groove or recess in the top of the coil former and a disc of thin cardboard may be cut to fit into this groove. This may then be marked with the actual wavelengths which the coil is found to cover after it has been tested, and it will form a permanent record. The disc should be  $\frac{1}{16}$  in. in diameter.

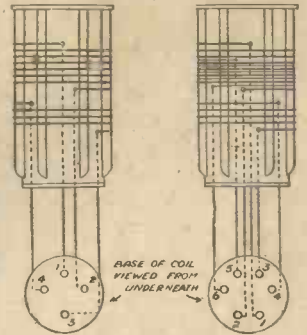

Fig. 8.—Diagrams showing connections and coil arrangements of 4- and 6-pin coils.

**Soviet Radiolocation**

**S**PEAKING recently at Shiregreen Working Men's Club, Sheffield, Professor J. B. S. Haldane said that Soviet scientists had developed radiolocation some years ago to help ships in the Arctic Ocean. That was why Moscow air raids had been beaten off. Dealing with wages in the Soviet Union he said that they varied, but no one received an income of £5,000 a year. The average skilled worker received £15 to £20 a month. A man might have his own house built, said Professor Haldane, but he could not let it and make rent.

**St. Louis Calling R.A.F., London.**

**D**URING the presentation of the film, "A Yank in the R.A.F.," at St. Louis, Missouri, the father of an American pilot serving in a fighter squadron of the R.A.F. spoke direct from the theatre to his son in England. For a few minutes this real-life Yank in the R.A.F. was in contact with his folks back home, 4,000 miles away. When the first request came through it was found that the pilot was on 24 hours' leave "somewhere in London." Clubs, theatres and hotels were combed for the young American. A few minutes before midnight he was located at his hotel, and rushed to the telephone just as the performance was starting.

**Music for the Forces**

**I**N building programmes for the Forces the B.B.C. is mindful of the fact that facilities for listening vary greatly and that in some cases only background listening is possible; yet the B.B.C. does not ignore the wishes of the many music-lovers in the Services, as a glance at the programmes will show. Artists who have been

heard, or who will be heard shortly, include such well-known names as Eda Kersey, Roy Henderson, John Hunt, Ivor Newton, Frank Titterton, Robert Easton, Laelia Finneberg, Mary Jarred, Clifford Curzon, Florence Austral.

Val Drewry, who has had considerable experience of concerts for the Forces, has been assured that there is a strong demand for broadcast concerts of classical music. Mr. Drewry, who is now on the staff of the B.B.C., has arranged recitals in nearly every county in England, in the camps of the Army and Air Force, the Rest Centres of "blitzed" cities, in hospitals, nursing homes, factories and shelters.



A.T.S. girls overhauling wireless apparatus at an R.A.O.C. depot.

# Three-valve Eme

An Efficient Three-valve T  
Using Coils which can be

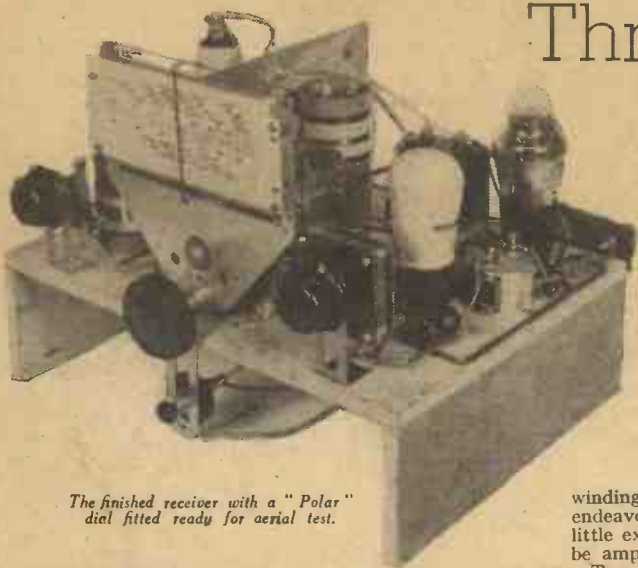

The finished receiver with a "Polar" dial fitted ready for aerial test.

**T**O satisfy the many demands from our readers for a receiver capable of putting up a good performance on medium waves, and having a component specification of such latitude that the minimum of difficulty would be experienced in obtaining the parts, we have produced the design described in detail below.

The conditions imposed naturally limit the valve arrangement and circuit refinements, so after giving all considerations our careful thought, we decided that three valves would be the most satisfactory number to make the set as universal as possible and, to cater for reception in all areas, under average conditions, one T.R.F. stage would be necessary. The circuit, therefore, is as shown in Fig. 1, where it will be seen that it is perfectly straightforward, and shorn of those refinements which would normally have been incorporated in times when components were easily and quickly obtainable. The question of valve supply has not been overlooked, and we think that the valves required, namely, 1 S.G. or H.F. pen., 1 medium impedance triode and an economy L.F. pentode, are those most likely to be to hand in the majority of constructors' dens, or obtainable from those firms who deal in surplus or second-hand components, etc.

Although we give the complete list of the components used in our test receiver, we do not make it a "solus" specification, thus allowing the constructor every latitude in that direction, provided, of course, that such parts as are finally used are capable of carrying out the work for which they were originally designed.

For those who

have a well-stocked spares-box, the circuit shown could be used as a basis for one having a more ambitious specification, but more about that later.

## The Coils

Last month we published an article dealing with the construction of coils, and it is hoped that those interested in such work will by now have had the opportunity of gaining some experience of the subject, as they will then be able to wind the coils described below without any doubt about their efficiency.

It can be said that these components form the king-pin of the design, so we advise every builder of this receiver to go about the coil winding and construction in a careful manner, and endeavour to make a thoroughly sound and neat job. A little extra care and time devoted to, the process will be amply repaid by the improved results obtained.

Two coils have to be made, one for the aerial circuit and the other for the R.F. coupling. To simplify matters, and bearing in mind the absence of long-wave transmissions, the windings are designed to cover only the medium-wave band, so even the veriest beginner should not experience any difficulty in carrying out the necessary work.

For the coil formers a length of tubing having an external diameter of 1½ ins. will be required. We used Paxolin tubing, but ebonite, fibre, or even well-dried and shellacked cardboard postal tubes can be used, provided their walls are stiff enough to allow them to retain their circular shape. The better the insulating properties of the formers the better will be the coils.

For the aerial section, cut off a length of 2½ ins., and for the R.F. transformer 4 ins. will be required. Finish off the ends, and then drill three pin-holes, parallel with and ¼ in. from one edge of the formers.

These form the anchoring holes for the start of the grid windings, the wire being threaded through them as explained in the article in our December issue.

Using 26 S.W.G. enamelled wire, wind on—and this applies to each coil—63 (sixty-three) turns, keeping the wire taut, free from kinks and with each turn tight up against the previous one. When making the first turn see that it is parallel, all the way round, with the edge of the former.

Count the turns carefully, and when the winding is complete, drill three more pin-holes through which the end of the wire is then fastened, leaving a length of ¼ ins.

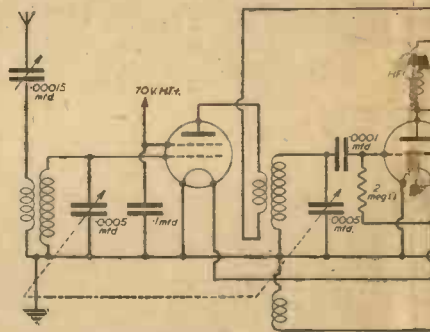

The theoretical circuit, which shows that the design is



The R.F. transformer in completed form, and before adding primary and reaction windings.

# Emergency Receiver

R.F. Medium-wave Receiver,  
Made by the Constructor

for connections. Now, the start of the winding forms, on each coil, the grid connection, and the finish the earth connection, so these can be marked if so desired.

### Primary Winding

It will be seen in the theoretical circuit that a primary winding is required for each coil. In the aerial circuit it is connected to form an aerial coupling coil, but on the R.F. coupling it is used as a normal primary connected in the anode circuit of the S.G. valve.

Taking the four-inch length of former first, proceed in the following manner. Cut a strip of Empire cloth or, failing this, smooth-finish stout brown paper, 1in. wide and 8in. in length. Wind this firmly round the centre of the winding just completed, and, starting approximately  $\frac{1}{4}$ in. from the edge of the Empire cloth, wind on—in the same direction as the other winding—15 turns of 34 S.W.G. enamelled wire. This calls for a little care, especially the anchoring of the ends of the winding. The best way of doing this is as described in the article to which previous reference has been made, but for the benefit of those without that issue brief details are given here. Before commencing the winding, cut two strips of Empire cloth  $\frac{1}{4}$ in. wide and 2in. in length. Fold them in half, and through the fold of one thread round a couple of times the 34 S.W.G. wire, leaving four or five inches free. Place the folded strip flat on the wide band of Empire cloth, so that the wire rests a quarter of an inch in from the edge. Alongside it, but with the fold pointing the other way, place the other narrow strip, then, holding both in position with one hand, wind on a complete turn of wire so that it holds them down. It will now be found that the rest of the winding can be completed, taking care not to exert too much tension on the wire, and to see that all turns are adjacent.

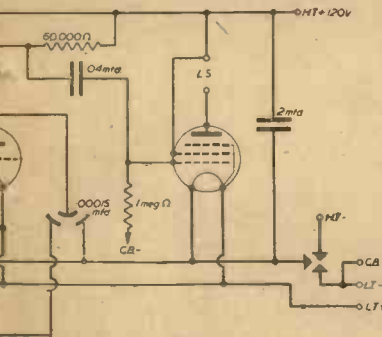

When the winding is finished, cut off the wire, leaving a free end of four or five inches, and repeat the method of anchoring the wire through and round the loop formed by the second folded strip of Empire cloth. After this, grip the ends of the strip and gently pull them until the loop and wire are tight up against the winding. To complete, cut off the spare ends of cloth.

For the aerial coil—i.e., the short former—repeat the whole procedure but, instead of only 15 turns, wind on 25 turns of 34 S.W.G.

When the above instructions have been carried out,

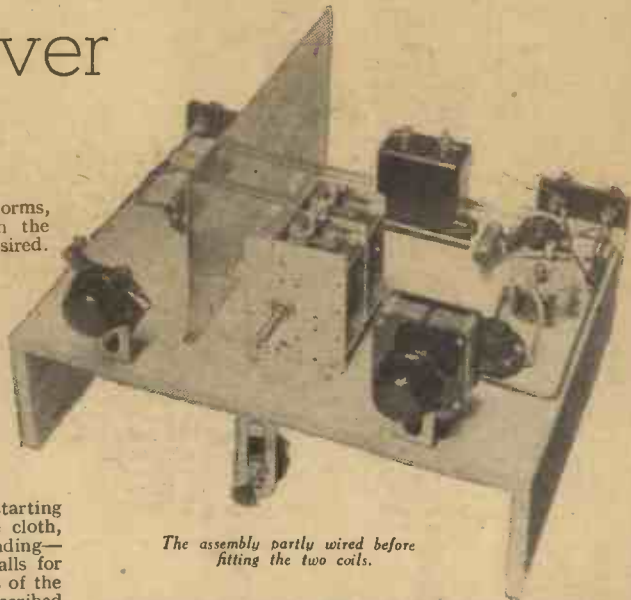

The assembly partly wired before fitting the two coils.

the third and last winding can be put on the R.F. transformer, this being to form the reaction circuit.

### Reaction Winding

This winding is started half an inch from the earth end of the grid coil, the wire being anchored by the three-hole method already described. The turns are put on in the same direction as the other windings, and the wire used has the same gauge as the primaries, namely, 34 S.W.G. enamelled. For this section only 19 turns are required.

This now completes all the winding work, so the finishing details can be attended to.

On the aerial coil the bottom end of the primary and secondary  
(Continued on next page)

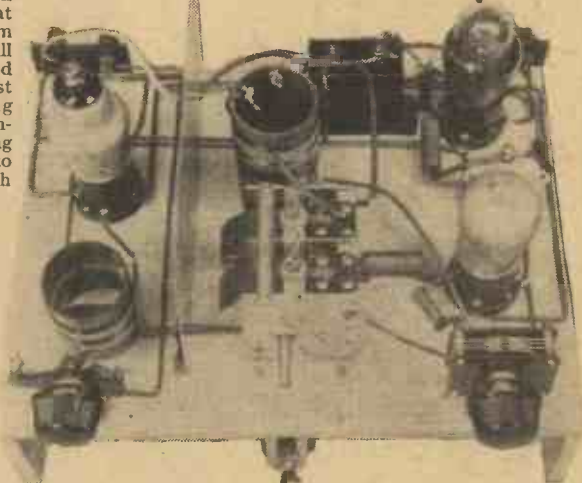

Showing the coils in position and all wiring completed. Note anchoring knots of R.F. transformer primary leads.

(or grid coil) have to be connected to earth, therefore these wires can be made common to each other on the coil, thus leaving only one connection to be made to earth when wiring the coil into the set. Where the end of the grid winding leaves its anchoring holes, strip off its enamel for a half inch; cut the wire from the bottom end of the primary so that it is long enough to reach that point, then, after cleaning it, solder the two together, making sure that there is no strain on the finer wire, and that the joint is perfectly sound. For fixing this coil in position, cut off a length of half-inch square wood so that it just fits inside the bottom end of the coil former, to which it is anchored by means of a screw on each side passing through the walls of the tubing. This completes the aerial coil.

#### Finishing the R.F. Coil

After anchoring the bottom end of the grid winding, take the free end down through the inside of the former and make another anchoring point—two holes will be sufficient for this—finishing with the end outside the former. The top end of the reaction winding can also be passed down through the inside of the tube and brought out through the same bottom anchoring holes as the end of the grid winding. These two wires are common to earth, so they can be soldered together as described for the aerial coil.

To allow clearance of the wooden fixing block, these lower anchoring holes must be at least  $\frac{1}{16}$  in. from bottom end of coil former.

The ends of the primary winding should be taken to auxiliary anchoring holes at the top of the former, an inch being allowed between the two fixings. For strength, it is best to terminate these connections by short lengths of insulated flexible wire, these being passed inside the former, through holes adjacent to anchoring points of the fine wires, and, after making a single small

knot in them (to take any strain), they can be soldered to the ends of the primary winding. This method is visible in the illustration showing the top view of the completed set and the plan drawing. When this, and the fixing of the wooden block in the bottom of the former has been done, the R.F. coil is completed.

#### Constructing the Set

Unlike our normal designs, we have used for this receiver a baseboard, thus simplifying assembly and wiring from the point of view of visibility and, of course, the beginner. In case this statement appears to contradict the illustrations, which show what might be classified as a chassis, let us make it quite clear that all components (bar the on-off switch) are mounted on the baseboard, and all the wiring, except the leads to the switch, are above the baseboard. The two side runners are purely optional. The switch could be located elsewhere, and then the runners dispensed with, but we used them to allow an H.T. battery to be housed under the set, and to give clearance to the control knob of the particular slow-motion drive we used. Details like this depend solely on individual requirements.

The baseboard is 12 ins. by 9 ins., and was cut from a piece of 5-ply wood. The metal screen, which is essential, is 7 ins. by 4 ins., plus  $\frac{1}{8}$  in. turn up for fixing. We were able to use a piece of thin aluminium, and this is to be recommended if available, but failing this, zinc—plain or perforated—or a piece of tinfoil could be used.

Little can be said about locating the components, as their relative positions are clearly indicated on the plan drawing. A word about the screen and coils is, perhaps, advisable, as it is essential for these to be fixed in the positions shown otherwise instability might be produced, due to the fact that the coils themselves are not enclosed in screening cans.

(Continued on page 77)

## Wiring Diagram of Three-valve Emergency Receiver

### LIST OF COMPONENTS

- Two medium wave coils (see text).
- One two-gang .0005 mfd. condenser.
- One .00015 mfd. variable differential condenser.
- One .00015 mfd. variable condenser.
- One slow-motion dial.
- Three component mounting brackets (if panel is not used).
- One 0.1 mfd. fixed condenser.
- One .0001 mfd. fixed condenser.
- One .04 mfd. fixed condenser.
- One 2.0 mfd. fixed condenser.
- One 2 megohm resistor,  $\frac{1}{2}$  watt.
- One 1 megohm resistor,  $\frac{1}{2}$  watt.
- One 60,000 ohm resistor,  $\frac{1}{2}$  watt.
- One screened H.F. choke.
- One three-point on-off switch.
- Two four-pin baseboard valve-holders.
- One five-pin baseboard valve-holders.
- Two terminal strips.
- Four terminals A, E, and L.S. positive and negative.
- One baseboard 12 x 9 ins.
- One metal screen 7  $\frac{1}{2}$  x 4  $\frac{1}{2}$  ins.
- One Cossor 210 S.P.T. (metalised).
- One Cossor 210 H.F. (metalised).
- One Cossor 220 H.P.T.
- One Exide 2-volt accumulator.
- One 120-volt H.T.
- One 9-volt G.B.
- Flexible wire, screws, tinned copper wire, soldering tags, Systoflex.

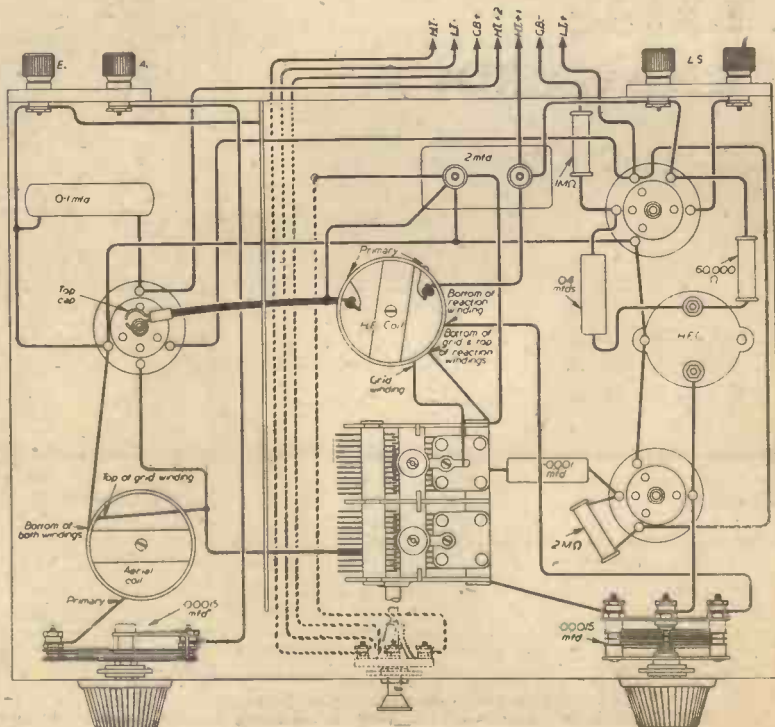

# THE RAF *wants* YOU

If you are keen on radio, the R.A.F. needs your services for Radiolocation and other vital radio work.

This is a wonderful opportunity for you to get into a highly specialised job and gain experience which can be of tremendous value to you after the war.

If you are not liable for military service, there are excellent opportunities for you to earn good money in your spare time as a Radio Service Engineer.

Never before has there been such a demand for trained radio men.

Even if you know nothing about radio, we can train you. You can study at home in your spare time and become a qualified Radio Engineer.

Now, more than ever before, the outstanding merit of our method of tuition is being proved. Remember, we specialise in Radio, and our Courses are praised and approved by leading Radio Authorities.

Waste no time, but post coupon now for free details of our Modern Home-Study Courses in Radio, Radiolocation and Radio Mathematics.

## T. & C. RADIO COLLEGE

29, Market Place, READING.

(Post in unsealed envelope, 1d. stamp.)

Please send me free details of your Home-Study Radio Courses.

NAME .....

ADDRESS .....

P.23

# RADIO KNOWLEDGE

THE PRACTICAL WIRELESS ENCYCLOPEDIA By F. J. CAMM

3rd Edition. Forms a complete guide, in alphabetical order, to the construction, repair and principles of every type of wireless receiver; including formulae and complete instructions on the making and testing of various wireless components. Illustrations include a complete series of circuits for every type of modern receiver. 10/6 net (By post 11/-)

PRACTICAL WIRELESS SERVICE MANUAL By F. J. CAMM

5th Edition. Chapters on Choice and Types of Instruments. Fault Tracing Without Instruments, Measuring Resistance, Trimming and Aligning Receivers, Testing Valves, Distortion, Interference, etc. 8/6 net (By post 9/-)

RADIO ENGINEER'S VEST-POCKET BOOK By F. J. CAMM

Contains in easily consultable form nearly every fact, figure, and formulae which service engineers, students, circuit designers, radio operators, transmitters, constructors and manufacturers require. 3/6 net (By post 3/9)

Of all Booksellers, or by post from GEORGE NEWNES, LTD. (Book Dept.), Tower House, Southampton Street, London, W.C.2.

**NEWNES—Famous for Technical Books**

## YES! BE PREPARED

Times are difficult, but that is no reason why you should not be looking confidently forward to the future. Your future will be what you make it. Use your spare time to increase your earning power, then war or no war your future will be secure.



EARNING POWER IS A SOUND INVESTMENT

DO ANY OF THESE SUBJECTS INTEREST YOU?

- |   |                                   |
|---|-----------------------------------|
| Accountancy Examinations                              | Metallurgy                        |
| Advertising and Sales Management                      | Mining. All subjects              |
| Agriculture   | Mining. Electrical Engineering    |
| A.M.I. Fire E. Examinations                           | Motor Engineering                 |
| Applied Mechanics                                     | Motor Trade                       |
| Army Certificates                                     | Municipal and County Engineers    |
| Auctioneers and Estate Agents                         | Naval Architecture                |
| Aviation Engineering                                  | Novel Writing                     |
| Aviation Wireless                                     | Pattern Making                    |
| Banking   | Play Writing                      |
| Blue Prints   | Police, Special Course            |
| Boilers   | Preceptors, College of            |
| Book-keeping, Accountancy and Modern Business Methods | Press Tool Work                   |
| B.Sc. (Eng.)  | Production Engineering            |
| Building, Architecture and Clerk of Works             | Pumps and Pumping Machinery       |
| Builders' Quantities                                  | Radio Communication               |
| Cambridge Senior School Certificate                   | Radio Service Engineering         |
| Civil Engineering                                     | R.A.F. Special Courses            |
| Civil Service   | Road Making and Maintenance       |
| All Commercial Subjects                               | Salesmanship, I.S.M.A.            |
| Commercial Art  | Sanitation                        |
| Common Prelim. E.J.E.B.                               | School Attendance Officer         |
| Concrete and Structural Engineering                   | Secretarial Exams.                |
| Draughtsmanship. All Branches.                        | Sheet Metal Work                  |
| Engineering. All branches, subjects and examinations  | Shipbuilding                      |
| General Education                                     | Shorthand (Pitman's)              |
| G.P.O. Eng. Dept.                                     | Short-Story Writing               |
| Heating and Ventilating                               | Speaking in Public                |
| Industrial Chemistry                                  | Structural Engineering            |
| Institute of Housing                                  | Surveying                         |
| Insurance   | Teachers of Handicrafts           |
| Journalism  | Telephony and Telegraphy          |
| Languages   | Television                        |
| Mathematics   | Transport Inst. Exams.            |
| Matriculation   | Viewers, Gaugers, Inspectors      |
|   | Weights and Measures Inspector    |
|   | Welding                           |
|   | Wireless Telegraphy and Telephony |
|   | Works Managers                    |

If you do not see your own requirements above, write to us on any subject. Full particulars free.

IF YOU ATTEND TO THIS NOW IT MAY MAKE A WONDERFUL DIFFERENCE TO YOUR FUTURE

### COUPON

CUT THIS OUT



To DEPT. 104, THE BENNETT COLLEGE, LTD., SHEFFIELD.

Please send me (free of charge)

Particulars of ..... } (Cross out line  
Your private advice ..... } which does  
about ..... } not apply.)

PLEASE WRITE IN BLOCK LETTERS

Name .....

Address .....

# The Importance of Capacity

Wanted and Unwanted Capacity Plays a Vital Part in the Design and Efficiency of a Circuit, as this Brief Review of the Subject will Show

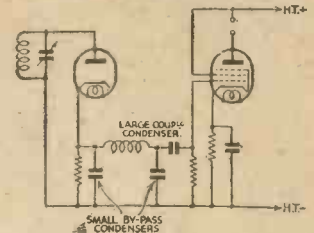

Fig. 2.—A diode detector circuit with an H.F. filter between the detector and the following valve.

**I**N many cases capacity is not only beneficial, but essential to the correct functioning of circuits, but in others it is a disadvantage, and every step must be taken to avoid unwanted condenser effects, or, at any rate, to reduce them to the minimum.

In addition to properly made and proportioned condensers deliberately introduced into a circuit, there will be many "accidental" or incidental condensers consisting of wiring, coils, parts of other components, the chassis and so forth for the metal portions or "plates," and the normal insulating materials in the set, or even air, as the dielectric.

## An Energy Content

When a voltage is applied between the plates of a condenser there is a sudden rush of current into it, resulting in the dielectric being brought to a condition of electrical stress. The current cannot pass through the condenser because the plates are separated by insulating material, but the energy of the current flowing into it is "stored" in the form of the state of stress mentioned. The first point to note is that when the voltage is first applied it is comparatively easy for the current to flow into the condenser, but as the condenser soon becomes more and more completely charged the charging current becomes less until it ceases. An increase in voltage will, however, result in more current flowing in and a larger charge being built up.

If the charging voltage is removed suddenly energy will remain stored in the condenser, but can be withdrawn by providing a suitable conducting circuit.

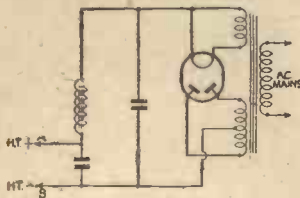

Fig. 1.—The smoothing choke and condenser may be regarded as an A.C. potentiometer in this filter circuit.

If, instead of applying a direct current supply to a condenser a source of A.C. is used, the charging voltage will grow and die away, and then reverse, grow, and die away, and the charging current will follow the same cycle from the point of view of magnitude and direction.

The effect upon the circuit, therefore, is exactly as if it was completely conducting, which accounts for the rather loose, but nevertheless generally accepted phrase—a condenser will not allow a direct current, but will allow an alternating current, to pass.

## Opposition

It has already been explained that the charging current falls off as the condenser becomes charged, and in scientific language this is expressed by saying that the current is proportional to the rate at which the voltage is changing. A moment's thought will show that, in the case of an alternating voltage, the rate of change is greatest at the beginning and end of each half-cycle, and is zero at the instant when the voltage reaches its maximum and commences to decrease. This explains the fact that the current flowing into a condenser is an

alternating one which follows a cycle leading the voltage cycle by one quarter of a period.

Lastly, it must be remembered that although the existence of a condenser in series with an A.C. supply does not prevent the flow of current, it does offer some opposition—generally known as "reactance" which is measured in ohms, in the same way as the resistance of a wire. This reactance depends upon two quantities—one, the condenser size or capacity, expressed in microfarads, where the larger the capacity the less becomes the reactance and, two, the frequency of the A.C. voltage applied, the reactance being greater at low frequencies than at high frequencies.

## Developing a Voltage

The first example of the advantageous use of capacity is, of course, the familiar process of tuning. It must be understood that a coil offers opposition to alternating current, but the phase relationship of the current through its "impedance" is one quarter of a period behind the voltage, and thus exactly opposite in phase to that through a condenser. Moreover, the impedance of a coil, also measured in ohms, depends upon the inductance of the coil (a function of its dimensions) and the frequency, being higher at high frequencies. Taking any given coil, therefore, it is possible to find one particular value of capacity which, if placed in parallel with the coil, will make a combination offering (theoretically) infinite impedance at one particular frequency. A tuning system consists of a coil of fixed inductance and a variable condenser in parallel, the condenser being adjusted to give a combined impedance as close to the theoretical infinite value as possible at the frequency of the station it is desired to receive. Resistance and other losses make infinite impedance impossible of achievement, but values of several hundred thousand ohms are obtainable with good components. As signals of many different frequencies exist in the aerial circuit, the voltage drop corresponding to each depends upon the signal strength and the impedance at each particular frequency, and as the impedance of the circuit is adjusted to be a maximum at the frequency of the wanted station, the voltage developed across the tuned circuit will also be a maximum for the wanted station.

## Filters

The next way in which capacity can serve a useful purpose is to provide a path for alternating currents, while preventing the flow of direct currents. The technical name for such an arrangement is a "filter." Filters are of many types, but can be divided roughly into those where it is the alternating current which is required and the direct current which it is desired to eliminate, and those in which the direct current is wanted and it is necessary to filter out the alternating current component. A good example of the first type is the coupling condenser between the anode circuit of one valve and the grid circuit of another. The anode current of the first valve is, of course, a direct current with a superimposed alternating current modulation—either high frequency, in the case of an H.F. amplifier, or low frequency in the case of a detector or audio-frequency valve. It is desired to transfer the A.C. impulses from the anode circuit of the first valve to the grid circuit of

the next, but it is essential that the D.C. high tension voltage at the anode shall be isolated from the following grid circuit. This is done by inserting a condenser of suitable capacity in the lead joining the anode circuit to the following grid circuit.

The simplest example of the reverse process is the smoothing circuit used in a mains H.T. unit, shown simply in Fig. 1. The output of the rectifier unit is a direct current with a fairly heavy A.C. ripple. The smoothing choke offers a high impedance to the A.C. component, but only a small resistance to the D.C., whereas the condensers provide an easy path for the ripple, but will not pass the direct current. Another way of looking at such a smoothing circuit is to consider the choke and condenser as a potentiometer so far as the A.C. component is concerned, the total ripple voltage being developed across the two in series. Owing to the much higher impedance of the choke as compared with the reactive impedance of the condenser, the A.C. voltage drop across the choke is much greater than across the condenser, so that the ripple voltage across A-B (that is, across the H.T. output terminals) is very small.

Not only can a condenser be employed for separating A.C. from D.C., but alternating currents of two different frequencies may be separated. A familiar example is the high-frequency filter used to avoid H.F. reaching the grid of a low-frequency valve, and thus overloading it, or giving rise to instability. Fig. 2 shows part of the circuit of a diode detector, in which a high-frequency choke and bypass condensers are employed in the lead to the L.F. valve grid. It is important to note, in this case, that the capacity of the bypass condenser must be small or its reactance at the higher audio-frequencies may be small enough to bypass some of the treble notes, thus spoiling the quality of reproduction. Even among the so-called low frequencies, condensers may be employed as filter or selective circuits, as, for example, where a condenser (usually in series with a variable resistance) is connected in parallel with a speaker to reduce the higher frequencies or treble notes by bypassing them instead of allowing them to pass through the voice-coil of the speaker.

#### Unwanted Effects

The most familiar "nuisance" examples are where

### THREE-VALVE EMERGENCY RECEIVER

(Continued from page 74)

After the valve holders, H.F. choke, two-gang condenser, terminal strips, and component brackets have been fitted, the screen can be screwed in position, but only after the four holes have been drilled in it to allow the filament wires, the anode connection, and one lead to the fixed vanes of the front section of the two-gang condenser, to pass through. The fixing and wiring of the coils should be left to last, otherwise there will always be present the danger of damaging them. Their connections are shown quite clearly on the wiring plan.

It is essential to see that all connections, especially those to earth, are electrically sound, and we strongly advise soldering. A poor or intermittent connection can ruin the efficiency of any circuit, therefore, if terminals are used, see that their contacting surfaces are bright and clean, and that the head is firmly screwed down.

#### Variable Factors

It will have been noted that the primary windings of the aerial and R.F. coils are not the same. This is due to the fact that the turns on the R.F. transformer were adjusted to give a degree of coupling satisfactory for a certain measure of selectivity and transference of energy.

The turns on the aerial coupling coil were likewise governed by selectivity, bearing in mind the varying types of aerial with which the set is likely to be used, and the widely differing locations. If, therefore, in any particular district a greater degree of selectivity is

incidental capacity provides a path for alternating currents (usually high-frequency signals) and thus permits them to go where they are not wanted. The classic case is, of course, the capacity existing between the electrodes of a radio valve, and particularly the older types. At one time high-frequency amplification was almost impossible because the H.F. signals in the anode circuit of the amplifying valve, returned to the grid circuit *via* inter-electrode capacity, were re-amplified and, the process being cumulative, instability of the circuit resulted. In modern screen-grid and screened pentode valves this trouble is reduced to an almost negligible amount for ordinary wavelengths, but for short- and ultra-short-wave working special care must be taken in selecting valves of very low inter-electrode capacity, and special types of valve for this purpose are now being made.

#### Signal Leakage

Then serious losses of R.F. signal can occur by the bypassing effects of incidental capacities. For example, the turns of a high-frequency choke have capacity between each other—self-capacity it is termed, so that, although the choke is intended to offer a high impedance to H.F. signals, part of the signal energy escapes *via* this self-capacity instead of being diverted to the desired path. When selecting H.F. chokes, therefore, a type should be chosen which is designed to have low self-capacity.

Similarly, signal strength may be lost due to aerials or aerial leads running close to earthy objects.

In addition to causing signal leakage, capacity may result in the introduction of interference. It is clear that if signals can leak away through a condenser or through parts of the circuit which act like condensers, unwanted signals can just as easily enter by the same path. For this reason, H.F. components are placed in screening boxes and H.F. wiring well spaced from other circuits. Here again, long grid leads are a fruitful source of trouble, as they may pick up unwanted signals from other parts of the circuit. But care must be exercised in using screening, since the screen itself acts as one plate of a condenser with the wire or component as the other, so that, although an earthed screen may prevent the entrance of unwanted signals, it may prove an easy leakage path.

required, a few turns can be removed from the coupling coil, but it must be remembered that signal strength will also be reduced.

Two separate .005 mfd. tuning condensers can be used in place of the two-gang component, but if this is done then they must be located so that the screen comes between them.

#### Operation

After completing all wiring, have a final visual examination and, if possible, apply a simple continuity test to satisfy yourself that no short-circuit exists between the H.T. positive lines and the L.T. or earth, before connecting batteries, etc.

For H.T. positive 1 use 120 volts H.T., for H.T. positive 2, 60 to 70 volts, and with the output valve specified  $4\frac{1}{2}$  volts grid bias. After connecting aerial and earth, accumulator and speaker, set the reaction control (the right-hand variable condenser) to minimum setting and switch on by means of the push-pull switch.

Rotate the two-gang condenser control until a transmission is heard; open the aerial series condenser to reduce volume, and then adjust the trimmers on the ganged condenser until the best result is obtained. Now close aerial condenser, and bringing up reaction until the circuit is *just below point* of oscillation, search for a signal towards the upper end of the tuning scale, i.e., ganged condenser closing. After making sure that no oscillation is present, again adjust trimmers to see if results can be improved. Repeat the procedure on a transmission at the lower end of the tuning scale, the idea being to obtain the most satisfactory trimming adjustment for the whole medium-waveband.

# Circuit Time Constants

Important Factors in Inductance-resistance and Capacity-resistance Circuits

By G. W. BROWN

**T**HE radio-wireless mechanics of the R.A.F. are having excellent opportunities of studying the circuit diagrams of up-to-date equipment, including new transmitters, ground and aircraft receivers and transceivers. A favourite method of study is to take a new diagram and to analyse it with a view to discovering, as far as possible, why the designers have specified the various component values indicated—an excellent form of exercise which draws on knowledge of the many technical and practical aspects of the science. Thus, information is shared and, consequently, multiplied—the sound principle on which all radio societies are founded.

One aspect of the subject, however, which I have found often leading to analytical error during these discussions, is that of time constants of inductance-resistance and capacity-resistance circuits. The relations  $L/R$  and  $CR$  are well enough known, but wrong inferences cause faulty deductions; so perhaps it would be worth while to examine these time constants anew, and see how they are derived and, more particularly, exactly what they imply. And let me say at once that there is nothing in the mathematics that should deter the enthusiastic, though essentially practical, reader. The only term likely to cause difficulty to the non-mathematician is "e," the base of the Napierian logarithms; but for our purpose it is sufficient to know that it is approximately equal to 2.717 and can be treated in much the same way as we treat  $\pi$ . Note also that if  $e = 2.717$ , the term  $e^{-1}$  simply expresses the reciprocal, which works out to 0.368.

## Inductance-resistance Circuit

Consider first a circuit as shown in the accompanying diagram containing resistance  $R$  and inductance  $L$ . When the switch is made, the battery EMF is applied to the combination and current begins to flow. It does not, however, at once attain its maximum ( $E/R$ ) value, due to the effect of the inductance, which uses up energy in creating a magnetic field. That is, some time must elapse before  $I = E/R$ . The exact time depends on the values of  $L$  and  $R$ . It can be shown that, after a time  $t$  seconds, the instantaneous current ( $i$ )

$$= \frac{E}{R} (1 - e^{-k}), \text{ where } k = \frac{Rt}{L}$$

$$\text{That is, } i = I (1 - e^{-k}).$$

Now, since  $k = (Rt)/L$ , we can see that if  $t$  were equal to  $L/R$  seconds,  $k$  becomes unity. Thus, after  $L/R$  seconds the instantaneous current ( $i$ )

$$= I (1 - e^{-1}) \\ = 0.632I \text{ or } 63.2 \text{ per cent. of } I.$$

Thus,  $L/R$  can be used as a measure of the speed at which a current will rise in this circuit.

Similarly, when the switch is broken, the current does not immediately fall to zero, since the magnetic energy associated with the inductance tends to maintain the flow. The instantaneous current in this case is obtained from the formula

$$i = Ie^{-k} \text{ (where } k = (Rt)/L \text{)}$$

Here, after a time  $L/R$  seconds,  $i = Ie^{-1} = 0.368I = 36.8 \text{ per cent. of } I$ .

Again we see that  $L/R$  can be used as a time measure of current decay.

## Capacity-resistance Circuit

Replace the inductance by a capacity and make the switch. As the condenser charges up it exerts a voltage in opposition to the battery voltage. This opposing voltage obviously takes time to build up to a final value (equal to the battery voltage, causing current to stop flowing in the circuit). The final charge that the condenser will hold is obtained from the relation:

$$Q = C.V \text{ (capacity times applied voltage)}$$

which is theoretically only true after infinite time.

But in a circuit of this sort the charge at any instant is obtained from:

$$q = C.V (1 - e^{-k})$$

where  $k$  this time equals  $t/CR$ . After  $CR$  seconds,  $k = 1$ .

That is,  $q = C.V (1 - e^{-1})$  after  $CR$  seconds.

$$= 63.2 \text{ per cent. of } C.V, \text{ the final value of charge.}$$

Now we see that  $CR$  is a time constant of the circuit, being the time during which the condenser acquires a definite, fixed amount of charge.

Similarly, during discharge in this circuit, the value of the charge remaining on the condenser at any instant is given by:

$$q = C.V.e^{-k} \text{ (where } k = t/CR \text{)}$$

Here, the relation  $CR$  gives us the time required for the condenser to discharge to 36.8 per cent. of its original maximum value.

Another point worth noting is that the time taken for the voltage across the condenser to fall from, say,  $V_1$  to  $V_2$ , is given by

$$t = C.R. \log_e \frac{V_1}{V_2}.$$

Here again time is directly proportional to  $CR$ .

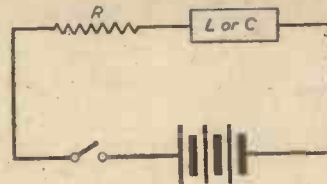

Simple inductance-resistance circuit

## Practical Aspects

Now, what conclusions of practical importance can we derive from these time constants? First of all, let us consider the time constant,  $L/R$ . Assume that we have a circuit containing a total inductance of  $200\mu\text{H}$

and a total resistance of  $0.1$  ohms. From the relation  $L/R$ , we find that the time taken for the current in that circuit to grow to 63.2 per cent. of its maximum value (or to fall to 36.8 per cent. during decay) is  $200 \times 10^{-6}$  henry  $\div 0.1$  ohm, which works out to one five-hundredth of a second. If the inductance is doubled, the time is doubled (if the resistance of the circuit remains unchanged). Note that the effect of an inductance is minimised by the resistance of the circuit—a fact of importance in coil construction, for example.

In the case of capacity-resistance circuits (leaky-grid arrangements, for instance), we know from the time constant  $CR$  that the time of growth and decay of charge (and, incidentally, of voltage and current) is directly proportional to both capacity and resistance. Thus, when either is increased, the "lag" is increased.

The exact formulae quoted above are seldom, if ever, used in a practical case, since they are obviously derived from purely hypothetical considerations that cannot be satisfied in practice. It is practically impossible to produce a circuit containing only two of the phenomena—resistance, inductance, capacity. All circuits contain all three factors to some degree. Thus the derivation of these formulae are of purely technical rather than of practical interest. However, it is when we come to examine the implications of the formulae that we discover facts of great practical importance. These time constants play a great part, not only in radio, but in general electrical theory, as those readers who are not solely radio specialists will appreciate. For those who are new to time constants, it is worth emphasising once more that they do not represent anything absolute; they indicate a proportionate time—but, as such, can still be accurately used as a measure of the speed of growth and decay of current, voltage and charge in the respective circuits described above.



# Practical Hints

## Two-gang Condenser

HERE is a small two-gang low-capacity condenser for band-spreading in S.W. sets employing two tuned stages. Its advantages are its low cost (as only one condenser is required) and compactness.

The materials required are: one

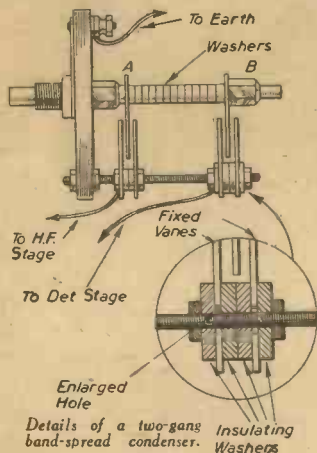

Now take two more fixed vanes and enlarge their fixing holes with a round file. Replace these at the other end B of the spindle, as before, except using insulating washers, as shown, so that the two vanes are insulated from the screwed rod. In use, the moving vanes are earthed, and the fixed vanes are connected respectively to the two tuning condensers in the normal manner.—J. POPE (Forest Hall).

## Simple Selector Switch

THE base of this switch consists of three fibre discs. In one, small holes equally spaced and large enough to take the brass-type paper-clips are made. The paper-clips are then pushed through the holes and the tabs

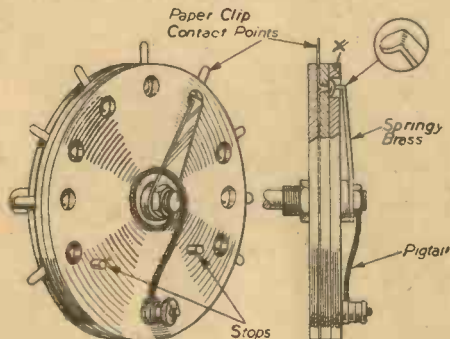

An easily-made rotary selector switch.

bent over so that one of the tabs can be used as a soldering tag. On top of this is placed another disc with holes placed the same distance apart and a little larger than the heads of the paper-clips. The idea of this second disc is to act as a stop to keep the contact arm on the right contact; and, therefore, the thickness of this disc must be slightly greater than the depth of the paper-clip head. The diameter of the holes, the thickness of the

## THAT DODGE OF YOURS!

Every Reader of "PRACTICAL WIRELESS" must have originated some little dodge which would interest other readers. Why not pass it on to us? We pay £1-10-0 for the best hint submitted, and for every other item published on this page we will pay half-a-guinea. Turn that idea of yours to account by sending it in to us addressed to the Editor, "PRACTICAL WIRELESS," George Newnes, Ltd., Tower House, Southampton Street, Strand, W.C.2. Put your name and address on every item. Please note that every notion sent in must be original. Mark envelopes "Practical Hints." DO NOT enclose Queries with your hints.

## SPECIAL NOTICE

All hints must be accompanied by the coupon cut from page 83.

S.W. variable condenser, some insulating washers, and a few extra nuts. First of all, dismantle the condenser, then replace two fixed vanes and one moving vane as for a normal bandspreading condenser at the end of the spindle A.

is soldered to the handle of the actual lights. When the lighter is needed it is lifted from off the hook and the contacts controlled by a piece of clock spring, close, thus making the circuit, which, in turn, heats the element. The weight of the lighter when replaced opens the contacts and breaks the circuit.—T. E. BROWN (Ashington).

## An Amplifying System

BEING dissatisfied with the point-source quality of one loudspeaker when reproducing a full orchestra, I tried two loudspeakers in different parts of the room. This did not suit entirely, however, so I rigged up the scheme shown in the diagram.

It will be seen that there are two transformers fed from the detector valve, both being arranged for the parallel-feed system. One of these is fed through a small condenser of .01 mfd., while the other is fed through a large condenser of 2 mfd. The former offers little resistance to notes of high frequency, but a high impedance to notes of low frequency. In addition a pentode valve, very lightly tone-controlled, is used in this stage.

The other stage is designed to bring out the low notes. For this reason a good transformer should be used, having a response down to at least 50 cycles per second.—WM. NIMMONS (Belfast).

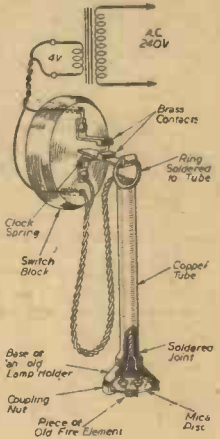

An automatic cigarette lighter.

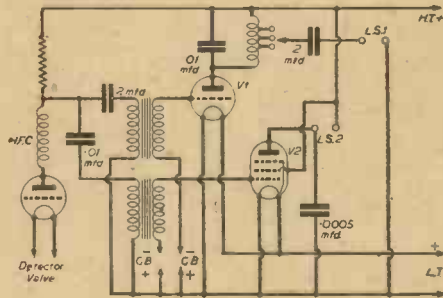

Circuit diagram of an improved amplifying system.

# A Frequency Modulation Receiver

A New Receiver Arrangement for Changing Over from Frequency Demodulation to Amplitude Demodulation

**T**HIS article describes a new frequency or phase modulation limiter, discriminator and detecting system, and improved means for changing the detector circuit so that it may be used to demodulate amplitude modulated waves.

The accompanying circuit diagram is that of a combined frequency or amplitude modulated-wave receiver.

Frequency or amplitude modulated waves are fed to the terminals 10, from the intermediate-frequency amplifier of a superheterodyne receiver. The first amplifier valve 16 is coupled at its input to an impedance 12 across the terminals 10, and at its output to the grid 20 of a cathode-driven limiter valve 24, by means of a tuned impedance coupling 30 which is suitably damped by resistance 31 so as to be substantially flat over the frequency range of the received signal. The cathode-driven limiter is resistance-coupled by coupling condenser 32 to the valve 16 and by condenser 34 to an amplifier valve 36. The output of the first limiter is fed through a potentiometer 38 to the second amplifier 36, which feeds the second limiter valve 39. The limiter 39 is resistance-coupled to valve 36 and this valve has a tuned circuit 40 similar to tuned circuit 30. The potentiometer 38 adjusts the level from the output of the first limiter 24 to the optimum level which produces the best limiting effect in the second limiter 39. In this way, the maximum degree of overall limiting is obtained.

## Second Limiter Output

The output of the second limiter 39 is fed to the switch S which cuts the limiter in and out through a fixed potentiometer 44. That is, when the switch S is on contact 45, excitation is supplied directly to the grid 50 of valve 52, whereas with the switch S on contact 46, the limiters are in the path 10 and the grid 50 of the valve 52. The switch S is placed on contact 45 when amplitude modulated waves are being received. With this fixed potentiometer 44 and the two potentiometers 38 and 53, which are in the input of the first amplifier 16, and the input of the amplifier 52, the input to the limiter may be adjusted to optimum with the aid of diode currents in the following manner: First, the limiter is switched in, by moving switch S to point 46, and the input to the first amplifier is set, by adjusting potentiometer 12 to the point which gives the best limiting. The word limiter as used here designates

the apparatus between input 10 and potentiometer 53 or the separate limiters 24 and 36 the particular meaning being apparent from the context. The potentiometer 38 at the input of the second amplifier 36 is also set at its optimum position:

This optimum setting is obtained by applying an amplitude modulation signal to the limiter input 10, and measuring the reduction in percentage of amplitude modulation which is effected by the limiter. With the limiter so adjusted, a constant output will appear at the output of the final limiter valve, and this constant output will be limited to a maximum degree when a certain voltage, which we will call E, is applied to the input potentiometer 12 feeding the first amplifier 16. It is the purpose of the fixed potentiometer 44 to reduce this constant output to a value which is equal to the signal input voltage E, to the first amplifier input potentiometer 12. The input at 10 to the limiter will then be at its proper level when the diode currents with the limiter in are the same as the diode currents with the limiter out. Such a procedure is necessary so that the optimum input level will be fed to the limiter.

The individual cathode-driven limiters 24 and 39 operate to effect limiting of the negative and positive half cycles of the wave energy impressed thereon, in respect differing from the usual type of limiter.

## Amplifier Valve

The amplifier valve 52 has in its output a discriminator circuit which converts the phase or frequency modulations on the wave energy to amplitude modulations and is similar in the circuit used in automatic frequency control practice.

This discriminator circuit includes a transformer 54 having a tuned primary 56 coupled to the anode 58 of valve 52, and a tuned secondary 60 coupled to the grids 62 and 64 of a pair of infinite-impedance detector valves V1 and V2. A point on the secondary winding 60 is connected by a resistance 65 to the cathodes of valves V1 and V2, while the cathodes are connected together by output resistances 66 and 68. Output voltages which represent the frequency modulations are supplied from the high audio-frequency ends of resistances 66 and 68 (when frequency modulation is received) to filter circuits F1 and F2, and thence to the grids 74 and 76 of amplifier valves 70 and 72.

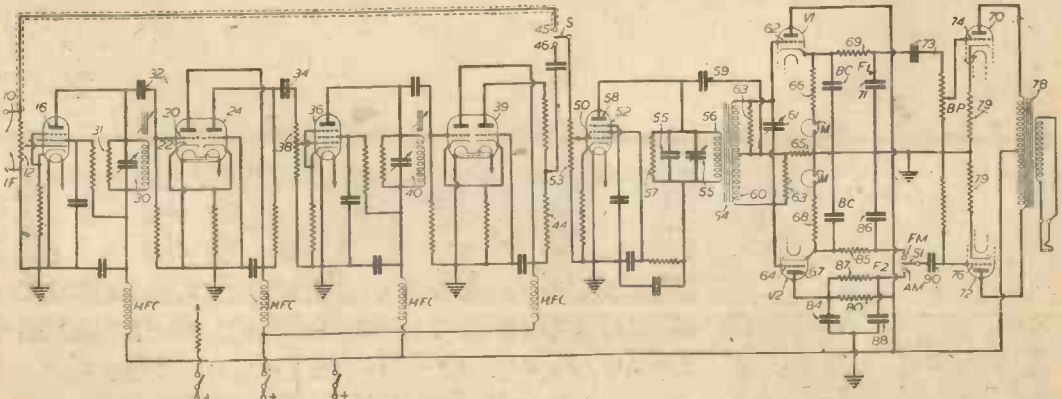

Theoretical circuit diagram of a combined frequency or amplitude modulated-wave receiver.

The "Fluxite Quins" at Work

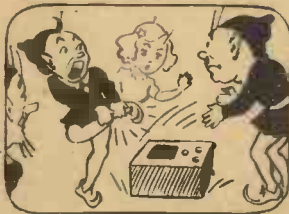

"That's a fine place to drop it, by gum!"  
 "I won't hurt—it's FLUXITED, chum!"  
 "Won't hurt! why 't was put"—  
 gasped O!—on my foot  
 "My toe'll need FLUXITE—it's numb!"

See that FLUXITE is always by you—in the house—garage—workshop — wherever speedy soldering is needed. Used for 30 years in government works and by leading engineers and manufacturers. Of Ironmongers—in tins, 4d., 8d., 1/4 and 2/8.

Ask to see the FLUXITE SMALL-SPACE SOLDERING SET—compact but substantial—complete with full instructions, 7/6. Write for Free Book on the art of "soft" soldering and ask for Leaflet on CASE-HARDENING STEEL and TEMPERING TOOLS with FLUXITE.

To CYCLISTS! Your wheels will NOT keep round and true unless the spokes are tied with fine wire at the crossings and SOLDERED. This makes a much stronger wheel. It's simple—with FLUXITE—but IMPORTANT.

THE FLUXITE GUN puts FLUXITE where you want it by a simple pressure. Price 1/6, or filled, 2/6.

FLUXITE LTD. (DEPT. W.P.),  
 BERMONDSEY ST., S.E.1.

**FLUXITE**  
 SIMPLIFIES ALL SOLDERING

COMMUNICATIONS DEPEND ...

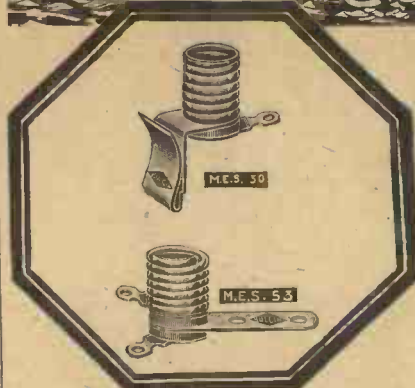
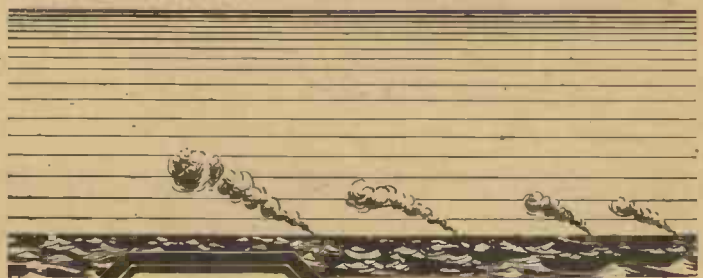

ON SMALL PARTS...

In countless instances quite intricate pieces of apparatus are wholly dependent on the proved reputation and reliability of their component parts.

All products from the House of Bulgin are pre-eminent for superior design and workmanship, and every article bearing our Trade Mark has to pass exacting and exhaustive tests during the course of its production.

We ask the kind indulgence of the public in delivery until peaceful conditions return.

*The Choice of Critics*

BULGIN FOR LAMP HOLDERS

THE largest and most extensive range in the World. All kinds of lamp-caps, are accommodated, including M.E.S. and E.S., to B.S.S. 98, and M.B.C. (the new miniature bayonet cap, single-contact). In the large range, there is a full choice of fixing-brackets, -strips, and -clips, both "live" and "dead." The screw types are made in rolled, drawn-and-embossed spring-grip, etc. A lamp-holder for every use.

ALWAYS DEPEND ON

**BULGIN**

REGISTERED • TRADE • MARK

A. F. BULGIN & CO., LTD., BY-PASS RD., BARKING, ESSEX  
 TEL, RIPPLEWAY 3474 (4 lines).

The particular discriminator shown in the diagram is somewhat different from the usual type. The usual type has a choke coil from the mid-tap of the secondary winding 60 to ground, but here a resistor 65 is used. The use of a resistor in this position is made possible by the fact that infinite-impedance diodes  $V_1$  and  $V_2$  are used. This type of diode has a high input impedance which does not draw current so that a resistance in the return circuit may be used, and yet no potential drop be produced therein. The primary winding 56 is tuned to pass a band of frequencies, and the band-pass characteristics are improved by the damping resistance 57. The secondary winding 60 is similarly tuned and damped.

The wave energy is supplied by coupling condenser 59 cophasally to the grids 62 and 64, and also induced into winding 60 and supplied antiphasally to the grids 62 and 64. When the frequency changes due to modulation, there is no change in the phase of the voltages supplied by 59 to the detectors, but there is a change in the phase of the induced voltages supplied by 60 to the detectors. This produces on the detectors resultant voltage the amplitude of which varies as the frequency modulations on the wave energy from the output of valve 52 vary.

### Phase Reversal

The infinite-impedance detectors are connected so that a phase reversal of the detected output is obtained by switching one of the push-pull amplifier valves  $V_2$  from the cathode output resistor 66 to the plate 67 of the same detector  $V_2$ . This allows the reception of either frequency or amplitude modulation by merely throwing switches  $S$  and  $S_1$ . Thus, amplitude modulation is received by switching the limiter out by means of  $S$ , and throwing the amplifier input switch to the point A-M. This produces a phase reversal of the output of valve  $V_2$  and connects the push-pull amplifier so that it is fed with the amplitude modulation signal in the proper push-pull relationship to produce the desired output. The phase reversal required for this proper relationship is obtained by taking the output of one detector, say  $V_1$ , from its cathode circuit and the output of the other detector, say  $V_2$ , from its plate circuit. The primary 56 of the discriminator transformer 54 is tuned with a fixed condenser 53 and a trimmer condenser 55. Damping of the primary is accomplished partially by the resistor 57 across it and partially by the resistor 65, which is connected between the high side of the primary and ground through the blocking condenser 59. The variable condenser 61 tunes the secondary 60 which has the sections on either side of the mid-tap damped by resistor 63. Valves  $V_1$  and  $V_2$  are the two triodes, of a twin-triode, which are used as infinite-impedance diodes for the differential detectors. Cathode resistors 66 and 68 are used, and the meters  $M$  in the cathode circuits are used to aid in tuning since their currents indicate the in-tune condition by a balance. The condensers  $BC$  across the cathode resistors are the diode by-pass condensers. The output of the upper diode is fed directly from the cathode through a filter  $F_1$  for removing the carrier voltage. This filter consists of the resistor 69 and the condenser 71 to earth. The output of the filter feeds the balancing potentiometer  $BP$  through a blocking condenser 73. This balancing potentiometer is used for balancing the detected outputs from the two differential detectors. A second twin-triode 70, 72 is used as an audio-amplifier with its plate circuits connected in push-pull by the transformer 78. The cathode biasing resistors 79 are bypassed so that inverse feed-back is obtained.

### Carrier Filters

The plate circuit output of  $V_2$  is taken from the plate resistor 80 which is bypassed by condenser 84. The carrier filters consisting of a series resistor 85 and 87, shunt capacitors 86 and 88 feed the detected energy from the cathode and plate circuits of the valve to the two points of the switch marked F-M and A-M (indicating "Frequency Modulation" and "Amplitude Modula-

tion," respectively). The arm of the switch  $S_1$  feeds the grid 76 of the audio-amplifier 72 through blocking condenser 90.

The resistors 69 and 85, together with the condensers 71 and 86 form resistance filters which remove the intermediate-frequency from the grids of the audio-amplifiers.

When frequency modulation is being received, the limiter is switched in by closing  $S$  on contact 46 and the amplifier switch  $S_1$  is placed on the F-M position. This connects the detected outputs in push-pull so that they will be properly added. The push-pull relationship is required for frequency modulation reception because of the back-to-back action produced by the discriminator. In this action voltages, passed by sloping filters of opposite slope are fed to the detectors so that the resulting amplitude modulations will be 180 degrees out of phase and will oppose and cancel.

An important advantage of this type of phase reversal, which is accomplished by switching from the cathode to the plate circuit of one of the detector valves, is the fact that the amplifiers following the detectors may be connected in push-pull. This tends to reduce harmonic distortion encountered in the amplifiers, and also allows a better fidelity for a given amount of iron and copper in the output transformer due to the fact that the magnetising effect of the permanent plate current is balanced out.

This system was developed in the laboratories of the Radio Corporation of America.

## PRIZE PROBLEMS

### Problem No. 427

**S**MITH was making up a four-valve battery-operated receiver, using one stage of H.F. amplification, a S.G. valve as a detector, followed by an E.C. coupled L.F. stage which fed a pentode in the output. He wished to incorporate automatic grid-bias to provide 2 volts and 7 volts for the L.F. valves. The current consumption is as follows: H.F. stage, anode 5 mA., screen 1½ mA., Det. S.G., anode 2 mA. and screen ½ mA., First L.F., 8 mA. and output pentode 15 mA. in the anode circuit and 2 mA. for the screen. H.T. was 120 volts. What was the total value of the bias network, and how was the bias obtained? Give a theoretical diagram and the values of the resistances forming the biasing circuit.

Three books will be awarded for the first three correct solutions opened. Entries should be addressed to The Editor, PRACTICAL WIRELESS, George Newnes, Ltd., Tower House, Southampton Street, Strand, London, W.C.2. Envelopes must be marked Problem No. 427 in the top left-hand corner and must be posted to reach this office not later than the first post on Monday, December 16th, 1941.

### Solution to Problem No. 426

Jones overlooked the fact that through using enamelled wire he actually formed a small inductance round the anode lead to the S.G. No screening effect would be obtained; in fact, his trouble would be aggravated, as the coil formed by the enamelled wire would tend to increase interaction.

The following three readers successfully solved Problem No. 425 and books have accordingly been forwarded to them: W. N. Wheatcraft, 354, Old Road, Chesterfield; V. Lamb, 52, Inglemire Avenue, Hull; G. Stone, 77, Almond Street, Grangemouth, Stirlingshire.

### RADIO EXAMINATION PAPERS No. 1: A Correction

**I**N the issue for December the formula for the reactance of a condenser is given on the right of page 20. At the end of the explanation of the working of the formula, the writer states: "And our .00000001 (eight-noughts-one) is  $10^9$ , but we can transfer this from the bottom of the equation to the top and change the minus sign to a plus, because dividing the bottom line by  $10^9$  is the same as multiplying the top line by  $10^9$ ." This should read, "And our .00000001 (eight-noughts-one) is  $10^{-9}$  . . . because dividing the bottom line by  $10^{-9}$  is the same. . . ."

## PRACTICAL WIRELESS SERVICE MANUAL

By F. J. CAMM

From all Booksellers 8/6 net, or by post 9/- direct from the Publishers, George Newnes, Ltd. (Book Dept.), Tower House, Southampton St., Strand, London, W.C.2



**MUSIC**  
*while you*  
**WORK!**



**A TREAT  
WORTH  
WAITING FOR**

War-time has tremendously increased the popularity of Stentorian Extension Speaker listening. Women in particular have very quickly appreciated the pleasures given by music while (and where) they work. But although the demand has increased, fewer can be made—please do not blame your dealer if he cannot supply immediately. Stentorian Extension Speaker listening is a treat worth waiting for.



# Stentorian

**THE PERFECT EXTRA SPEAKER FOR ANY SET**  
WHITELEY ELECTRICAL RADIO CO. MANSFIELD, NOTTS

## FREE ADVICE BUREAU COUPON

This coupon is available until January 31st, 1942, and must accompany all Queries and Hints.  
PRACTICAL WIRELESS, January, 1942.



## FOR THE RADIO SERVICE MAN, DEALER AND OWNER

The man who enrolls for an I. C. S. Radio Course learns radio thoroughly, completely, practically. When he earns his diploma, he will KNOW radio. We are not content merely to teach the principles of radio, we want to show our students how to apply that training in practical, every-day, radio service work. We train them to be successful!

### INTERNATIONAL CORRESPONDENCE SCHOOLS

Dept. 94, International Buildings,  
Kingsway, London, W.C.2.

Please explain fully about your instruction in the subject marked X.

Complete Radio Engineering  
Radio Service Engineers  
Elementary Radio  
Television

If you wish to pass a Radio examination, indicate it below.  
Institute of Radio Engineers

P.M.G. Certificate for Wireless Operators  
Provisional Certificate in Radio Telephony and  
Telegraphy for Aircraft  
City and Guilds Telecommunications

Name..... Age.....

Address.....

(Use penny stamp on unsealed envelope.)

**Two Books  
for  
Radio Men  
in the  
Services**

### RADIO TRAINING MANUAL FOR THE SERVICES AND THE TRADE

Edited by F. J. Camm

Deals with Radio as a career, including Radio in the Forces, Production Servicing, Laboratory, etc., Electrical Units Explained, Radio Formulae Simplified, Principles of Receiver Design, a Guide to Servicing, etc. 6/- net (By post 6/6)

### MASTERING MORSE

By F. J. Camm

Thousands of technicians now entering the radio branches of the various services need an expert knowledge of the Morse code. This handbook, written with special regard for service requirements by an acknowledged expert, will enable even the beginner rapidly to become proficient in sending and receiving messages in Morse. 11/- net (By post 11/2)

Of all Booksellers, or by post from GEORGE NEWNES, LTD. (Book Dept.), Tower House, Southampton Street, London, W.C.2.

# Simple Intercommunication Telephone System

A Neat Installation which will Prove of Great Use to Most Amateurs Requiring Room-to-room or Shack-to-shack Communication

AS there appears to be great interest in simple but efficient inter-communication telephones, I give below the details of a system I have had in use for some time.

The only disadvantage, and that only arises if the stations are a great distance apart, is that three wires are required for the "line."

The sketch, Fig. 1, shows that the constructional work involved is not difficult, and that the materials required are those likely to be found in most amateurs' work-boxes. Ordinary headphone ear pieces of the 2,000-ohm type can be used, thus avoiding the purchase of special low-resistance ones. Two buzzers are required, one for each station, and if one does not wish to get commercial products, they can easily be made from old electric-bell movements.

If the units are assembled in small wooden or metal cases, each containing buzzer, battery and 'phone switching arm, they can be arranged to hang on the wall, and look neat and comparable with a commercial article.

### Switch Arm

The switch-arm calls for a few remarks, although its constructional details are clearly illustrated. The two shorting contacts, X and Y, can be made from any springy metal, such as the contacts strips from a 4-volt battery. It is necessary to see that the arm does make contact with them, when the 'phone is hanging on its hook, otherwise the resistance of the 'phone winding will be in circuit, and, owing to its high resistance, would prevent the buzzer from operating.

The coil spring need only be strong enough to lift the arm so that the far end moves away from the contacts X and Y,

and the hook end makes contact with stud B, when the 'phone is removed for use. The schematic diagram, Fig. 2, makes the reason for this quite clear.

### Operation

When both 'phones are on their hooks, i.e., switch arm down, both buzzers are in parallel; when one 'phone is lifted, it completes one of the battery circuits and causes the buzzer at the remote station to operate, thus making "calling" automatic. As soon as the 'phone is lifted from the remote station, the buzzer circuit is broken and the batteries are connected in parallel.

It should be noted that the two ends of the switch arm are insulated from each other, this being achieved by using a strip of fibre, ebonite or even dry hard wood to link the two together. The pivot bearing can be made from a suitable size bolt, having spring washers fitted each side of the moving arm.

The pigtail connection, between point C and the hook end of the arm, can be made from flexible wire or a short length of metallised sleeving, such as used for receiver wiring. The Studs A and B are the two contacts which, with the arm, form the

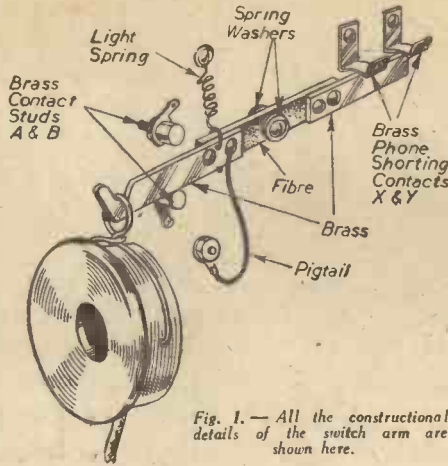

Fig. 1.—All the constructional details of the switch arm are shown here.

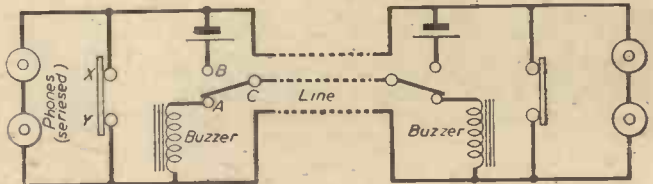

Fig. 3.—Showing how each unit is wired and the connections for the three-wire "line."

single-pole change-over switch shown as A.B.C. in Fig. 3. The whole system will work successfully over distances up to half a mile.—L. G.

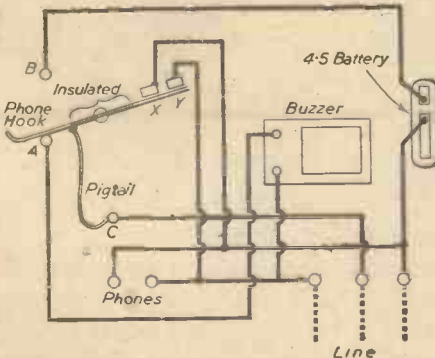

Fig. 2.—The complete circuit for two stations. All switching can be checked against this diagram.

## MASTERING the MORSE CODE

By the Editor of  
PRACTICAL WIRELESS

This handbook, written with special regard for service requirements, will enable even the beginner rapidly to become proficient in sending and receiving.

1/-  
net

Of all Booksellers, or by post 1/2 from  
GEORGE NEWNES, LTD. (Book Dept.),  
Tower House, Southampton Street,  
London, W.C.2

1/-  
net

# Impressions on the Wax

## Review of the Latest Gramophone Records

### H.M.V.

**A**MONG the many interesting records issued by H.M.V. this month is one by those two famous singers, Anne Ziegler and Webster Booth. They have recorded "When We Are Married" from "The Belle of New York" and "The Keys of Heaven," on *H.M.V. B9226*. During last summer they sang for more than three months to thirty thousand people a week at Blackpool. The day after their show finished they came to London to make the above record—a worthy successor to the series with which they have delighted their thousands of admirers in recent months.

Alan Murray's "I'll Walk Beside You" is probably the most popular ballad of the last twenty years. To these splendid recordings of this song by John McCormack and Webster Booth H.M.V. now add Doris Arnold's arrangement, which is sung by the Kentucky Minstrels, on *H.M.V. BD969*. Both this, and "The Rose of Tralee," which is on the reverse side, are laid out for men's voices unaccompanied.

For several months past Maggie Teyte has been touring the country as the star of an E.N.S.A. party, but she has found time this month to make a recording of "Comin' Thro' the Rye" and "Oft in the Stilly Night," on *H.M.V. DA1804*. She was an operatic star at an age when most girls are thinking of taking singing lessons.

This month Bernard Miles, the famous character actor, has made a good follow up to his last record with "The Truth About Tristan" and "The Lowdown on Hamlet," on *H.M.V. C3257*. He never distorts facts to get his comic effect, but rather gives us a new angle on the actual subject. As an example, in his "Truth About Tristan" his description of the opera is without exaggeration, and does, in fact, give a true picture of the libretto; but when Mr. Miles tells the story as it might be told by a London cockney the libretto becomes a masterpiece of humour.

Other humorous records are supplied by Vic Oliver, with Vic Oliver's "Twists" (two parts), on *H.M.V. B9169*, and Ronald Frankau with "But She Knows all the Answers Now" and "Song—and Patter," on *H.M.V. B9224*.

### Parlophone

Richard Tauber has chosen an old favourite for his latest recording on *Parlophone R020502*. It is "Silent Night, Holy Night," which he sings in English with choir, organ and violin accompaniment. The coupling is "O Sanchissima," which is also sung in English.

Those two famous pianists, Dave Kaye and Ivor Morton, have made yet another "Tin Pan Alley Medley" on *Parlophone F1868*. This is another typical recording by these two artists, introducing the latest hit tunes of the moment. They are "My Sister and I," "You're Lovely To-night," "Hearts Don't Lie," "Mr. Brown of London Town," "Daddy" and "All Alone With My Shadow." Another interesting combination, "The Organ, the Danceband and Me," or, better still, H. Robinson Cleaver, Billy Thorburn and Helen Clare, record two popular tunes, "When You Dance With an Old Sweetheart" and "Beneath the Lights of Home," *Parlophone F1867*. It is hardly necessary for me to say who plays the organ and the piano in this record, but I will add that Helen Clare sings the vocals.

The latest release in the "Jazz Classic Series" is "That Da Da Strain" and "Jack Hits the Road," played by Bud Freeman and his Famous-Chicagoans, on *Parlophone R2820*. Other interesting orchestral

recordings are "Cherokee" and "Love's Last Word is Spoken," played by Felix Mendelssohn and his Hawaiian Serenaders, on *Parlophone FB2699*, "Woodland Serenade" and "Marie," on *Parlophone F1871*, and "When the Sun Comes Out" and "Corn Silk," on *Parlophone F1869*, both of which are played by Geraldo and his Orchestra, and finally "Tony's Wife" and "La Cucaracha," played by Xavier Cugat and his Waldorf-Astoria Orchestra, on *Parlophone R2821*.

### Columbia

A record which I'm sure will appeal to most readers is "La Bohème" (Act III), which was recorded at the Belle Vue Gardens, Manchester. It features Joan Hammond singing "Mimi's Farewell," whilst, on the reverse side, is a duet sung by Joan Hammond and David Lloyd from Act I of the same opera. The song is "Lovely Maid in the Moonlight," and the number of the record is *Columbia DX1039*.

Other new releases which I recommend are the Western Brothers in more humour, "No One to Read Out the News" and (a) "Going up the Line" (b) "The Writings on the Wall," on *Columbia DB2050*, "She Reminds Me of You" and "Straight From the Shoulder," sung by Bing Crosby, on *Columbia DB2049*; "Sand in My Shoes" and "You Started Something," played by Carroll Gibbons and his Savoy Hotel Orpheans, on *Columbia FB2712*; and "Count of Luxembourg" and "Blue Danube," played by Victor Silvester's Strings for Dancing, on *Columbia FB2705*.

### Decca and Brunswick

An old favourite makes a welcome return to the Decca list this month—none other than Gracie Fields. The songs she has chosen are the famous "Ave Maria" and "An Old Violin," both of which were recorded in America, with Victor Young and his Orchestra, and the number is *Decca F808*. Other star vocalists who have made new recordings this month are Vera Lynn, accompanied by Mantovani and Orchestra, singing "My Sister and I" and "You and I" on *Decca F8014*; the Street Singer, better known as Arthur Tracy, singing two songs from the film "Let's Make Music"—"Chapel in the Valley" and "You Forgot About Me," on *Decca F8018*; Tony Martin singing "Intermezzo" and "Taboo," on *Decca F8024*, and lastly the Merry Macs singing "Kiss the Boys Good-bye" and "Honk, Honk," on *Decca F8017*.

Medley records of popular tunes are supplied by Charlie Kunz with "Piano Medley No. D50" on *Decca F8022*, which introduces "I Hear a Rhapsody," "My Sister and I," "Aurora," "Beneath the Lights of Home," "Russian Rose" and "Down Forget-me-not Lane," and Sidney Torch at the organ of the State Cinema, Kilburn, playing "Torch Parade No. 6." This record, which is *Decca F8019*, introduces "Corn Silk," "Russian Rose," "Oasis," "Down Forget-me-not Lane," "I Hear a Rhapsody" and "Aurora."

In the Brunswick list we have the Andrews Sisters singing "The Boogie Woogie Piggy" and "The Nickel Serenade," on *Brunswick 03254*, and Mary Martin singing "Kiss the Boys Goodbye" and "Please Do It Again," on *Brunswick 03253*. Dance music is supplied by Guy Lombardo and his Royal Canadians with "You and I" and "Yip-i-addy-i-ay," on *Brunswick 03250*, Johnny Long and his Orchestra with "Kiss the Boys Goodbye" and "Don't Take Your Love From Me," on *Brunswick 03251*, and Jimmie Lunceford and his Orchestra with "Flamingo" and "Siesta at the Fiesta," on *Brunswick 03252*.

# Coil Testing

After Winding Your Own Coils, Certain Tests Should be Applied, and These are Described in This Article

WHEN winding coils, it is advisable to leave the final constructional details until tests have been applied to determine whether the component satisfies the original requirements, or whether modifications could be made to improve its overall characteristics. As long as the ends of the windings are anchored securely, the use of soldering tags and bolts, etc., can well be left until after the tests, thus simplifying any alterations which might have to be made, and preventing the coil from being damaged by the too-frequent use of the soldering iron.

Without going into all the characteristics of a tuning coil, there are three items with which every constructor will be concerned, namely, tuning range, sensitivity and selectivity. The apparatus required for determining these factors (with an accuracy sufficient for our purpose) is not difficult or costly to make, in fact, all the parts will be found in most spares-boxes.

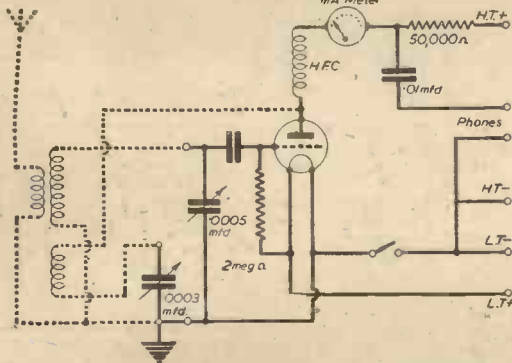

Fig. 1.—The circuit of the test unit, the broken lines indicating coil under test.

## Tuning Range

This refers to the waveband enclosed within the maximum and minimum wavelengths to which the coil will tune with a given variable condenser. On short and medium wavelengths the maximum and minimum capacity of the condenser are not the true values, as one should—if taking the matter to a fine point—add the capacity created by the wiring, the aerial and the self-capacity of the coil and the coil-holder. However, as these values are usually very small, when compared with a tuning condenser of 0.0005 mfd., and as we are chiefly concerned with the medium waveband in this article, they can be ignored at this stage. It is possible to calculate the two extremes of the waveband by using the maximum and minimum capacities of the tuning condenser in the standard formula for wavelength, namely,  $\lambda = 1885 \sqrt{LXC}$ . A practical method is to use a receiver incorporating a normal dual-range coil or coils and, by making it oscillate at various points on its tuning dial, use it to heterodyne against the single-valve test circuit (Fig. 1) in which the coil under test is connected. If the test circuit is operated so that it is almost in a state of oscillation, a distinct whistle will be heard in the 'phones when it is tuned to the same frequency or wavelength as the broadcast set. The latter must not be of the 'superhet type, and should preferably have a dial marked in wavelengths, thus allowing easy identification of the wavelengths being used as checking points. If one possesses a calibrated

oscillator, then the whole process is made much easier and more accurate.

## Sensitivity

An approximate estimation can be made as to the sensitivity of a coil by using it in a simple receiving circuit and tuning in various transmissions, judging the sensitivity by the signal strength in the 'phones. This, of course, is only suitable when it is possible to make a quick changeover from a standard coil to the one under test, to enable a comparison to be made. As it is very difficult to judge the efficiency of a circuit by the resultant signal strength produced in the 'phones, owing to the fact that the ears of an average person cannot appreciate quite large changes in power output, the following method is more indicative of any changes in sensitivity.

The test circuit shown in Fig. 1 will be recognised as a simple single-valve plus a milliammeter in its anode circuit. The meter should have a maximum reading of, say, 5 mA.s, as one having a larger scale reading will not indicate so clearly any changes in the current value.

The coil to be tested is connected across the grid circuit in the usual manner, and its reaction coil—if one is provided—joined to the anode and reaction condenser. A reasonable aerial is required, if one is any distance from a transmitter, as the greater the input the larger will be the meter deflection. As the circuit is of the leaky-grid detector type, the application of a signal across the grid circuit, having, of course, the same frequency as that to which the grid circuit is tuned, will cause a decrease in the anode current reading, and as this will vary according to the strength of the signal developed across the grid coil, it provides a simple means of comparing the efficiency of coils. When a signal is tuned in, the meter reading will decrease, and as the tuning point is passed the meter needle will return to the normal standing current. The tuning should, therefore, be adjusted with care, and a note made of the maximum dip of the needle or minimum reading of the meter. The circuit should not be in or near a state of oscillation. For a given input, the coil across which is developed the greatest signal voltage, i.e., having, as it were, the greatest sensitivity, will produce the lowest meter reading.

## Selectivity

As mentioned above, the meter needle will fall and then rise again as a signal is tuned in and out. This can be used to give a fair indication of the selectivity of the tuned circuit, as the following will explain.

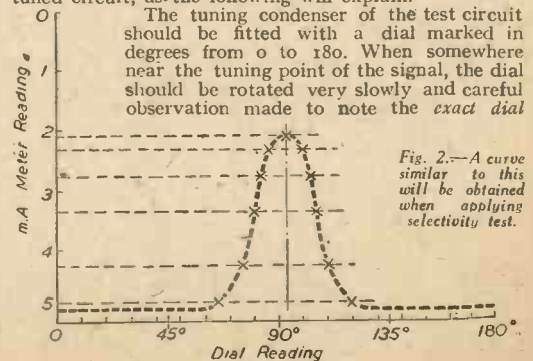

Fig. 2.—A curve similar to this will be obtained when applying selectivity test.



reading when the meter needle starts to move. This figure must then be jotted down, together with the current reading, and the procedure repeated, say, every two or three degrees until the lowest meter reading is obtained, and then until it has returned to its normal maximum.

The dial and meter readings thus obtained should now be plotted to form a graph, as shown in Fig. 2, the points marked by X's being obtained by taking the individual dial readings along the horizontal scale

and proceeding vertically until their meter readings (vertical scale) are reached, the point of intersection being marked with a small cross or dot. These are then linked up so as to produce a curve similar to that shown. Now the coil having the greatest selectivity will produce a curve having a narrow base and steep sides, or, in other words, the whole process will have been covered by the smallest number of degrees on the dial. Tests with various types of coil will soon prove this explanation.

# Morse Practice Set Improvements

## Details of a Simple Arrangement for Group Working

**T**HE apparatus described below is designed to be connected to the Morse Practice Set described in the November issue, and in use will enable any number of Morse amateurs to practice in pairs independently of one another.

It can also be used to give instruction simultaneously from a separate table by a tutor, who can listen if desired to any one student sending. The complete arrangement should therefore prove very useful to any organised class or group of students.

The materials required for each group (Fig. 1) are: One 6ft. by 2ft. deal table, six morse keys, six single-pole on-off switches, six 'phone terminal blocks, or jacks if preferred, and one two-pin plug (two if more than one table is to be constructed).

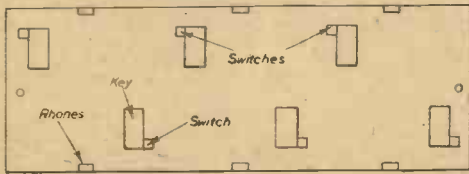

Fig. 1.—A table arranged for students' use for Morse practice.

The various components should first be mounted on the table as shown (Fig. 1), and then wired as indicated in the circuit (Fig. 2). The instructor's table, if it is required, can be any convenient size, and is wired as shown in Fig. 3.

### Group Working

The various methods of working are as follow: (assuming only one students' table to be in use, the instructions are the same for each table if more than one are connected).

For three two-way send-receive, six students are seated, three on each side, and work in pairs opposite one another, the one sending opening his switch(S), and his partner closing his switch(S), reversing the switches to change over to send-receive.

For instructor operating and six students receiving,

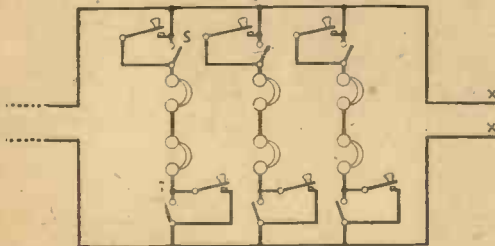

Fig. 2.—Wiring diagram for the keys and 'phones.

all switches(S) are closed, and the instructor's switches (B) and (C) are opened, when all six and the instructor will receive from the instructor's key.

When the instructor receives from a single student, the procedure is a little more involved, although very simple in practice. The instructor's switch (B) is closed, and all the switches (S) are in the first place opened. Then the partner of the student to send closes his switch (S), when the instructor, the student sending, and the partner will hear the signals sent by the student.

Further tables are added by simply plugging into the sockets at the end of the previous table. The instructor's table, if not required, can be left out, in which case the oscillator terminals A and B are connected direct to the plug on the table, and three pairs of two-way send-receive communication can be carried on.

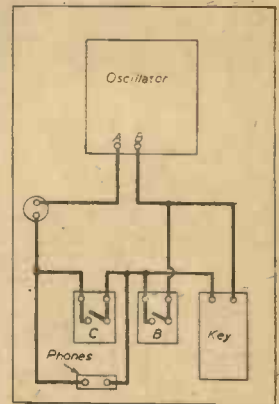

Fig. 3.—Wiring diagram for the instruments on the instructor's table.

## A COMPLETE LIBRARY OF STANDARD WORKS

By F. J. CAMM

- MASTERING MORSE 1/-, by post 1/3.
- GEARS AND GEAR CUTTING 5/-, by post 5/6.
- WATCHES : ADJUSTMENT AND REPAIR 6/-, by post 6/6.
- NEWNES' ENGINEERS' MANUAL 6/-, by post 6/6.
- PRACTICAL MOTORISTS' ENCYCLOPEDIA 10/6, by post 11/-.
- MOTOR CAR PRINCIPLES AND PRACTICE 6/-, by post 6/6.
- PRACTICAL WIRELESS ENCYCLOPEDIA 10/6, by post 11/-.
- RADIO TRAINING MANUAL 6/-, by post 6/6.
- EVERYMAN'S WIRELESS BOOK 6/-, by post 6/6.
- PRACTICAL WIRELESS CIRCUITS 5/-, by post 5/6.
- COILS, CHOKES AND TRANSFORMERS 5/-, by post 5/6.
- PRACTICAL WIRELESS SERVICE MANUAL 6/6, by post 9/-.
- WORKSHOP CALCULATIONS, TABLES & FORMULAE 5/-, by post 5/6.
- NEWNES' SHORT-WAVE MANUAL 6/-, by post 6/6.
- WIRELESS TRANSMISSION 5/-, by post 5/6.
- DICTIONARY OF METALS AND THEIR ALLOYS 6/-, by post 6/6.
- THE SUPERSET MANUAL 6/-, by post 6/6.
- PRACTICAL MECHANICS HANDBOOK 10/6, by post 11/-.
- RADIO ENGINEER'S VEST-POCKET BOOK 3/6, by post 3/6.
- WIRE AND WIRE GAUGES (Vest Pocket Book) 3/6, by post 3/6.
- DIESEL VEHICLES : OPERATION, MAINTENANCE AND REPAIR 5/-, by post 5/6.
- NEWNES' ENGINEERS' VEST POCKET BOOK 7/6, by post 8/-.

All obtainable from or through Newsagents or from Geo. Newnes, Ltd., Tower House, Southampton Street, Strand, W.C.2.

# Items of Interest

## Radio Saves Pilot's Life

A RADIO warning from his squadron leader saved the life of an Australian sergeant pilot and added another Me. 109 to the squadron's bag in a recent fight over Northern France.

The sergeant had attacked and set fire to one Messerschmitt when, over the radio telephone, came an urgent instruction from the squadron leader to break away to the left.

"I did so immediately," said the sergeant, "and saw three Me's diving on me from behind. I continued to turn and just before I got into position for a head-on-attack one of them opened fire. I straightened out, opened up with cannon and machine-guns and almost collided with him.

"I then broke away, but the Me. continued straight down and crashed to the ground. The other one I fired at was also seen to crash by the squadron leader."

## Midland Region Features Producer

MR. PETER WATTS has been appointed Features Producer, Midland Region. He is a Scots Canadian and most of his early life was spent in the Dominion. In this country he has had a good deal of experience of the theatre. For eight years he stage-managed at the old Vic. Then he was producer first at the Repertory Theatre in Plymouth and later, until the outbreak of war, at the Perth Repertory Theatre. He has travelled extensively in Europe and the Middle East. Before he came to the B.B.C. four months ago he was an Admiralty Courier carrying secret dispatches in this country and abroad.

## Posts for Women in the B.B.C.

WOMEN are taking an increasing part in B.B.C. affairs and now hold a number of executive posts. A recent appointment is that of Miss Gweneth M. Freeman as Staff Welfare Officer (Health). Apart from dealing with special problems connected with billeting and accommodation in many parts of the country, Miss Freeman will deal with questions relating to the health of the entire B.B.C. staff.

Coming from Sydney, New South Wales, she joined the B.B.C. as a secretary in 1924, but resigned in 1927 and went to Canada in order to enlarge her experience, working her way across the country from the Atlantic to the Pacific. In 1931 she returned to the B.B.C. as Woman Staff Administrator.

Her successor in the latter post is Miss Gladys Burlton, who since April, 1940, has been with the Postal and Telegraph Censorship Department as Assistant Establishment Officer, responsible for the recruitment of both men and women and for women's questions in general. She has long been prominent as an expert in the industrial world, having published several technical books. She has also been on the Council and Executive Committee of the Industrial Welfare Society for the last ten years. Miss Burlton was born in South India, but was educated in this country. She has broadcast on several occasions.

## Northern Programmes Heard Overseas

NORTHERNERS in all parts of the world are kept in touch with current events at home by special programmes broadcast from the North in the Overseas Services. These programmes cover a variety of subjects, ranging from Northern news stories and talks by Northern personalities to concerts broadcast specially for Overseas listeners by the B.B.C. Northern Orchestra. One particularly popular Northern feature broadcast regularly since the beginning of the year is "Northern Lights,"



British troops in Cyprus using a portable radio set.

a magazine programme heard monthly by Northerners Overseas.

The extent to which this particular programme has been heard—and appreciated—is shown by the post-bag which has brought letters from all parts of the world. A recent batch of letters received by Wilfred Pickles, who has been acting as compère for this programme, come from as far afield as Ceylon, Australia, South Africa and the United States.

Many of these letters paint an interesting picture of the life led by exiled Northerners. One letter, for instance, from the Rev. C. Thorp, of Ceylon, is couched in good round Yorkshire dialect. Mr. Thorp describes how he heard a Northern Lights programme from Manchester as he was sitting on the veranda of his bungalow 7,000 miles away, looking out over the sea, with a new moon setting through the coconut palms. A Lancastrian, writing also from Ceylon, talks of the glorious bowls of roses they have there, reminding him of his native county. A Northerner in Australia wrote from a beauty spot, Malacoota, on the coast. An Army officer serving in the Middle East began his letter, "I am sitting in my dug-out in the Western Desert." He asked, "Are the Piccadilly Gardens still in bloom or do you grow vegetables there now?" A nurse, a Mancunian, now working in Southern Rhodesia, was another listener who wrote to say how much she enjoyed these programmes.

One point about many of these programmes for Overseas is that they are broadcast on four or five separate occasions to cover the East, North America, South Africa and the Pacific, etc.

## B.B.C. Jam Enemy Stations

IT was announced in the House of Commons recently that the B.B.C. had already taken steps which had had the effect of reducing interference with British broadcasts.

**PITMAN'S TECHNICAL**

**BOOKS**

**CATHODE RAY OSCILLO-GRAPHS.**

By J. H. Reyner, B.Sc. (Hons.), A.C.G.I., A.M.I.E.E., M.Inst.R.E. Here is an easily understood guide to the practical application of Cathode Ray Tubes to numerous purposes, including the examination of oscillations or wave forms. Radio men, and particularly those about to enter the services, will find this book a genuine and invaluable guide. It has been given the highest recommendations both for students and teachers. 8s. 6d. net.

**RADIO RECEIVER CIRCUITS HANDBOOK.**

By E. M. Squire. A useful guide to circuits for members of the radio industry, and radio amateurs. By dealing with the receivers in stages the author has achieved the utmost clarity and conciseness. The text is liberally illustrated with circuit drawings and other diagrams. 4s. 6d. net.

**THERMIONIC VALVES IN MODERN RADIO RECEIVERS.**

By Alfred T. Wits, A.M.I.E.E. Notes on the use of aligned grids, output, tetrodes, negative feedback and phase splitters for push-pull amplifiers have been added to the text of this new edition, which has been substantially modernised generally. 10s. 6d. net. Second Edition.

**PITMAN'S,**  
Parker Street, KINGSWAY

*Of Vital Importance to Students*

**101 ELECTRICAL EXAMINATION QUESTIONS: WITH MODEL ANSWERS**

By **W. T. PERKINS**, Lecturer and Honoursman in Technical Electricity.

Of all Booksellers 7/6 net, or by post 8/- from **GEORGE NEWNES, LTD.** (Book Dept.), Tower House, Southampton St., London, W.C.2

**RELAYS**

Ask for Leaflet SPN/PBW.

**LONDEX LTD.**

ANERLEY WORKS,  
207, ANERLEY RD.,  
LONDON, S.E.20.  
\*Phone: SYD. 6258/9



**TAYLOR ELECTRICAL INSTRUMENTS**

The range of Taylor British-made precision built instruments includes the following: **UNIVERSAL METERS - VALVE TESTERS - SIGNAL GENERATORS - AND THE TAYLOR OSCILLOSCOPE**

**TAYLOR** Electrical Instruments, Ltd., 419-422, Montrose Avenue, SLOUGH, BUCKS.

**LONDON CENTRAL**  
*for RADIO & TELEVISION*  
**SUPPLIES**

**6 Volt BATTERY CHARGERS**

A new set of well-made heavy duty battery chargers. First-class components only with metal rectification on solid base board. Will give years of service. Input 200/245 volts A.C. Output 1½ amps. at 6 volts. As illustrated. Each 35/-.

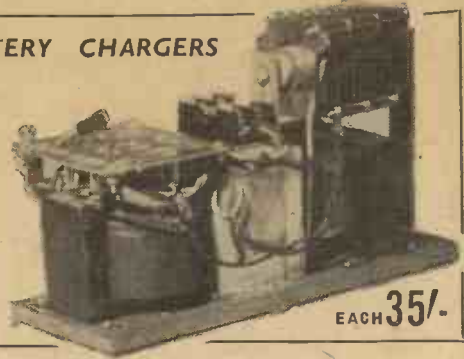

**COSSOR TELEVISION POWER PACKS**, and amplifier

Impossible to obtain through ordinary channels. Complete instrument includes time base and sound chassis (television sound waveband only), H.T. transformer for tube supply, transformer for heater and valves, 8-in. energised speaker, 13 valves, 7 variable resistances for volume, contrast, trimming, etc., banks of condensers, resistances, etc. On heavy metal chassis, 17½ in. x 10 in. x 3 in. All completely wired ready for use with C.R. tube electrostatic deflection and focus type, No. 3244, overall length approx. 19 in., diameter of tube, approx. 6 in., in beautiful walnut table cabinet, measuring approx. 12 in. x 21 in. x 16½ in. Price £17, plus 2/6 for packing, carriage forward.

chassis, complete with mains and high voltage transformers and all components and coils. See December issue for details. Brand new, 67/6, plus 2/6 packing.

**TIME BASE CHASSIS.**

For 18-in. C.R. Tube. Complete with all components. See December issue for details. Price 30/- each. Complete circuit and service manual, 6d. Carriage forward plus 2/6 packing.

**VISION UNITS** to fit above time base. With all components and four valves, 55/6. See December issue for details. Carriage forward plus 2/6 packing. Circuit and service manual, 6d.

**FINE XMAS GIFT**

"Oxford" Utility Electric Dry Shaver. 220-250 volts A.C. Complete in soft leather case with flex, sockets and full instructions. A popular Christmas gift. Made in U.S.A. Brand new in original boxes. Pre-war price, 55/- 12 only to clear at 50/- each.

**SCREENED CABLE**, for television. Brand new, highly insulated. Single flex, 1/9 yard. Four-way flex, 2/3 yard. Minimum 12 yard lengths.

**REMOTE CONTROLS** made by Murphy Radio. Complete with motor and all accessories in full working order. Made to sell at £££'s. To clear, 35/-.

**CATHODE RAY TUBES**

Magnetic Type Cathode Ray Tubes available from stock. Unobtainable from ordinary sources, they have many electrical and scientific applications. As examples, we quote the following, all subject to being unsold. Approximately 8-in. diameter, £4; 10-in., £5; 12-in., £6. Cannot be repeated. All tubes must be collected by purchaser. No responsibility accepted for carriage.

**TRANSFORMERS.**

Made by Standard Telephones. Beautiful job, weight 12 lb., 5½ in. by 4½ in., 350-0-350 v., 120 m.a. Four tappings giving 4 v. 2 amps., 4 v. 8 amps., 3 v. 3 amps., and 20 v. 1 amp. Brand new. 25/- each, carriage forward. Ex-Television manufacturer. Heavy duty mains transformer. Input 240 v. A.C. Tappings at 5,000 v. max. 20 amps., and for supplying filament of Mullard HVR 2 (6.3 v. at .65 amps.). Shrouded in metal box, 10/6 each, carriage forward.

N.B.—Unless items are marked carriage forward or collection by purchaser, sufficient postage must be included with all orders. London readers are invited to inspect our stocks. See also our classified advertisement on page 96.

**LONDON CENTRAL RADIO STORES**  
23, LISLE STREET, LONDON, W.C.2.  
GERRARD 2969

# BRITISH LONG DISTANCE LISTENERS' CLUB



## We Acknowledge

WE extend our thanks and appreciation to all members who have written to us during the last month, and as space prevents us from publishing all letters, we give extracts from some of them taken at random.

Radio Brazzaville (French Eq. Africa).—Member 6,472 sends us the following details regarding this station. He has just received a verification of a report sent in about six months ago.

Frequency, 11,970 kc/s; metres, 25.06; call sign, FZ1; all times G.M.T.

06.00-06.15/20—First news.

13.30-14.15—Second news and music.

19.45-20.00—Commentaries in English.

20.00-20.30—Music.

20.30-21.00—Third news and commentaries.

21.00-21.15—Family news.

03.00-03.15—Commentaries in French for Canada.

03.15-03.45—Music.

03.45-04.00—Commentaries in English for the U.S.A.

He finishes his letter with the request for contacts with other London members who are interested in S.W. work. Letters should be addressed to 8, Turret Grove, Clapham, S.W.4.

## A Neat Layout

THE illustration on the right shows the equipment and layout of the receiving station operated by J. Cripps (No. 6,989), of Cheltenham. In his letter, which we are forced to condense, he says:

"I think the sketch is self-explanatory, except for the large gramophone cabinet which I use to house a Milnes H.T. unit, batteries, spares and the resistance lamps for the charger, operated off a low-voltage D.C. supply, which I use to keep the H.T. unit and L.T. cells in a fully charged condition. The Rx is a four-valver with the following line up: Tuned R.F., using an H.F. pentode, with its transformer coupled to a triode detector (Mullard PM1 HL), which is R.C. coupled to the first L.F. stage. The output from this valve is fed into a power output triode by an A.F.3 L.F. transformer parallel-fed. The volume control consists of a 0.5 megohm potentiometer connected across the grid circuit of the first L.F. valve. The Rx is of my own design, and it commenced its activities nearly two years ago as a humble two-valver. Scarcely a week passes but what some small alteration is made, all my experiments being directed towards obtaining maximum sensitivity. I keep a detailed log of all modifications and results, and I find it much better to use the weaker transmissions in S.E. Asia (ZHP, etc.) as a 'standard,' as they seem to be more reliable and do not fade so quickly as more usual American stations. By the way, I would welcome any information concerning some of the Latin-American transmissions if any member can oblige.

"... Finally, I should like to endorse your, and other members', remarks about co-operation between members."

## The Spirit of the Amateurs

FROM Member 6,385 (Jack Woad), of 4, Seniors Yard, Preston Street, Batley, Yorks, comes the following invitation: "The old adage that a good amateur is a well-balanced individual, and that the true 'ham' spirit is bound up with a feeling of good fellowship, which draws together amateurs of every nationality and creed, is certainly still true, even at a time of upheaval and trouble. I would like to extend to all amateurs, within a reasonable travelling distance of my QRA, an invitation to visit me and discuss matters relating to our mutual hobby and interests. I would add that I am only a S.W.L., and, like many more enthusiasts, must remain

so until peace returns, when the amateur movement will once again get back into its stride." (We regret that this letter has been unavoidably held over from previous issues.—HON. SEC.)

## An Idea from Natal

WE welcome the first letter from a new member in Natal, and we hope that it is the forerunner of a bigger mail and membership list from S. Africa. He is Member 6,994 (John Hotchkiss), and we give extracts from his letter below:

"... As I expect you know, in Natal amateur radio is still very much in its youth. This is not so much due to lack of keen amateurs as lack of available parts or components for set building. My friends and I find it a paying proposition to buy any old commercial sets and strip them down for the parts, instead of buying new ones, as this works out much cheaper."

## Change of Address

MEMBER 6,800, G. Booth, informs us that his new QRA is North Lodge Stables, Melton Mowbray, Leics. Will contact members please note.

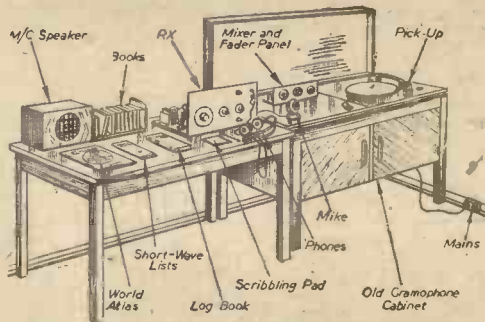

A useful and neat layout which allows comfortable operation of all equipment. Station owned by Member No. 6989.

## Edinburgh

MEMBER 6,628, who, we now hope, has completely recovered from his spell in hospital, says in his letter: "I don't agree with Member 6,960's suggestion that you change the name of the club. There are hundreds of radio clubs but only one B.L.D.L.C., which title tells you at a glance exactly what it is. R.A.C. is most indefinite, and might mean anything from Royal Automobile Club to Royal Archery Club, so long live the B.L.D.L.C."

ANOTHER view on this matter is given by Member 6,975 in his very interesting letter. His opinion is: "I read with interest the suggestion put forward in the November issue of 'P.W.' that the name of the B.L.D.L.C. be changed to something simpler, and I think it is a good idea."

## Contacts Wanted

RUSWARP, nr. Whitby, Yorks.—Member 6,941, Brook View House.

St. Albans.—J. C. Babbage, 104, Cambridge Road.

Bury, Lancs.—Member 7,064, 11, Birch Street.

Passenham Lane, nr. Stony Stratford.—Member 6,785.

Edinburgh, 8.—Member 6,879, 3, Abercorn Road.

Cleveys.—Member 6,971, "Ricadene," 8, Clegg Avenue.

Leicester.—Member 6,307 (B. J. Thrupp, now in the

R.A.F.), 137, Lancaster Street.

Salisbury, Wilts.—Member 7,068, Charlton All Saints.

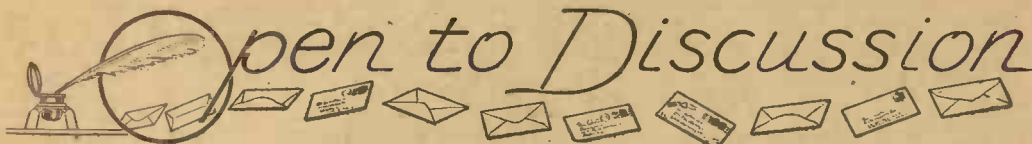

The Editor does not necessarily agree with the opinions expressed by his correspondents. All letters must be accompanied by the name and address of the sender (not necessarily for publication).

### An Appreciation

**SIR**,—May I express my appreciation of PRACTICAL WIRELESS.

I find the "Replies to Queries" and "Open to Discussion" pages very interesting, but the B.L.D.L.C. page most of all, as, being a member of that club, I like to keep in touch with the activities of its members.

The constructional and explanatory articles are also very instructive, and I hope that the present pre-war standard will be kept up, and that I will again be able to take an active part in experimental wireless construction after this war is over.—R. S. ANDREWS (Gosport).

### Motor-operated Station-selecting Mechanism

**SIR**,—With reference to the article on above subject in the November issue, the suggested remedies designed to overcome the difficulties encountered through motor inertia certainly add to the complication of the instrument. Desiring a simple single-button controlled device, I employ a claw and ratchet wheel drive, operated by vibrating armature pivoted between the poles of an electro magnet. This device is momentum free.

The ratchet wheel shaft carries the pinion 15 and thence via wheel 14 to condenser shaft as outlined in the article mentioned.—F. S. TROUTMAN (Birmingham).

### Photo-electric Cell

**SIR**,—In mid-August, while experimenting in my workshop with a photo-electric cell, I came across a very strange phenomenon.

Reflecting the rays of the sun by means of a mirror on to the P.E. cell, which was amplified by a three-stage amplifier, I was puzzled by some peculiar noises which were coming from the loudspeaker. These noises became louder when I put a lens between the mirror and the P.E. cell.

The noises sounded very much like a short-wave receiver being tuned quickly over the top of some very loud stations.

I would be obliged if any of your readers could offer any information on the subject, either fact or theory, which would help to make further experiment possible.—JAMES HAMILTON (Houghton-le-Spring).

### Measuring Instruments

**SIR**,—May I, as a regular reader of PRACTICAL WIRELESS since No. 1, suggest that a series of articles giving constructional details of the whole gamut (i.e., within the scope of home constructors) of measuring instruments would be greatly appreciated by the vast majority of your regular readers.

The range could cover: Multi-range voltage resistance and current meters, utilising valve, tuning indicator and/or meters. A mirror (light-beam reflector) galvanometer—this I believe can be used for current and voltage measurement and is especially suitable for small currents. Capacity and resistance meters utilising the ordinary electric cooker indicator (Osglim 200-250 A.C.) and/or Wheatstone bridge circuits.

Many articles have, I know, been published on this subject, but not, I believe, as a complete series that can be kept for reference.

Perhaps other readers have suggestions or criticisms to offer on the subject.—G. A. BARBER (Kingston-on-Thames).

### Radio Brazzaville

**SIR**,—Although serving with the R.A.F. I find time now and then to look round the S.W. bands. F. Rayer, of Longden, wants to know about Brazzaville on the 25m. band. I heard a transmission from that station at 20.45, 30/10/41, Signal R.5. My Rx. was a 4v. battery superhet. I cannot give details of the transmission, as only the concluding announcement was heard.

I trust this may be of use to Mr. Rayer. I have been a regular reader of PRACTICAL WIRELESS for six years, and I wish it success in its new form.—L. A. WEBB (Cholderton).

### S.W. Broadcasts

**SIR**,—I am pleased with the new edition of the magazine. Its size is just right. From the viewpoint of one who is more interested in short-wave listening I think a page of short-wave news wouldn't be amiss. I sincerely hope you will be able to include one.

In reply to K. R. Veasy, his "voice of the Andes" is HCJB (Ecuador), 24.08 m. Further American S.W. B.C. news includes WNBI, 19.81 m. and 25.34 m., WRUL, 16.91 m. (1,773 mc/s), WRCA, 16.87 m. Belgian Congo (Leopoldville) operates daily from 18.55 G.M.T. on a new frequency about 32.55 m. All announcements are in French. Its 14.97 m. channel operates daily from 10.55 G.M.T. HVJ (Vatican Radio) broadcasts English prisoner-of-war letters each Tuesday at 08.00 G.M.T. Stations logged here during this month include ZHP, VUD2, WCBX (19.65 m.), WNBI (19.81 m.), XGOA? (30.85 m.), OPL (32.55 m.), WGEO (31.48 m.), KZRM, WRUL (16.91 m. and 19.67 m.).

Information would be appreciated on a Singapore station operating irregularly in the 15 m. band. It was acting as a "point" for a broadcast to London on October 3rd, 1941, at 11.30 G.M.T. For identification it used "Malayan B.C. Co." and "Singapore calling," mentioning two frequencies: 11,730 kc/s and 6,175 kc/s. I have no data on those frequencies or its 15 m. channel.—R. W. BALL (Langold).

### Approved

**SIR**,—I wish to convey my thanks to you for the splendid new edition of PRACTICAL WIRELESS. I have been reading this paper now for about four years, and I think this is one of the best I have read. Some of the best items in the new issue are, I consider, Radio Exam. Papers, which I hope you will continue, and also the Aircraft D.F. article.

Many thanks, also, for the knowledge I have received from your books, "Sixty Tested Wireless Circuits," "Wireless Transmission," and "Practical Wireless Encyclopaedia," which I have read and studied.—R. GOULD (Watford).

**SIR**,—I congratulate you on your latest PRACTICAL WIRELESS. In its present size it is very handy for bookbinding, as it is not too large, and will not make a clumsy volume. I do not begrudge the extra price, as I think it is well worth it, and I hope other readers agree with me.—G. V. DOWN (Hove).

### "Who is the Doyen?"

**SIR**,—I have been interested in the various accounts which have appeared in recent issues of PRACTICAL WIRELESS regarding "Who is the Doyen." In this

connection I beg to submit my own amateur experience. My earliest experiments in wireless commenced in 1908, at the age of 20. Apparatus at that time comprised spark coils, with the usual condensers, discharging rods, key, etc., and the receiver consisted of the coherer with relay, tapping device and bell. In 1914, on the outbreak of the last war, I was visited by a representative of the Post Office, and a certain amount of my apparatus was taken away.

In 1919 I applied to the Post Office for the renewal of my licence to experiment in wireless telegraphy, and I well remember the formality involved. The licence was issued to me on January 28th, 1920, and I still have it here. In the same year I constructed a two-valve set, H.F. and detector, nearly all the components of which were home-made. The set is still in my possession.

I have never yet purchased a ready-made receiver, but have continued experimental and constructional work of all kinds, making many sets in the process.

I have most of the books on wireless recommended by

PRACTICAL WIRELESS, and have been a reader for many years.

May I offer my congratulations on the new style of PRACTICAL WIRELESS, and at the same time claim to be your "oldest reader"?—EDWIN C. DEAVIN (Dartford).

### Back Number Wanted

**D. OAKLEY**, 17, Lee Street, Station Road, New Southgate, N.11, will be grateful if any reader who has a spare copy of PRACTICAL WIRELESS for June 4th, 1938, will forward it to above address. Postage, etc., will be refunded.

### Correspondents Wanted

**T. A. THOMAS**, 18, Oakholme Road, Sheffield, 10, would like to get in touch with a short-wave fan with the desire of making friends and exchanging ideas, etc.

**B. Meaden**, 10, Alfriston Road, West Derby, Liverpool, 12, is anxious to correspond with a young S.W. beginner.

## TRADE NOTES

### Oscillator Units

**T**HE instruments shown in the accompanying illustrations have been specifically produced to meet the ever-increasing demand for equipment for Morse code instruction. In pre-war days the amateur endeavoured to master the code without any special instructional facilities, and, naturally, a long time was taken to reach a reasonable speed. At the present time, however, things are rather different; thousands now wish to

requirements the buzzer is now being replaced by valve oscillators capable of producing a pleasing low-frequency note.

### Mains-operated Units

**T**HE unit shown in the first illustration consists of an L.F. oscillator designed for A.C. mains operation and primarily intended for class work, as it has an output in the region of 2 watts. It is provided with a distribution panel at the back, which enables six circuits to be operated, thus catering for quite a varied arrangement of a class, i.e. group or individual student listening.

A variable volume control and a variable tone control are provided, thus the instructor is able to cater for all requirements. The on-off mains switch and a pilot light are fitted to the front panel, where is also located the jack for easy and rapid connection of the key. The unit is housed in a well-made iron case and finished off in grey enamel. The price of this model is £7 15s.

A smaller unit, which is shown in the second illustration, is also available, this being housed in a sturdy black crackle-finished metal case. Like the larger unit, it is designed for A.C. mains operation, but it is not provided with volume or tone control. The note produced, however, is quite pleasing, if not as clear cut as in the previous case. Its output is adequate for several phones; in fact, judging by our own tests, we think two or three speakers could be operated at satisfactory volume, though such an item as this naturally depends on local conditions and requirements. This unit is priced at 45s. Both models are supplied fitted with mains connecting lead and 5-amp. plugs.

For more detailed information application should be made to Messrs. Webb's Radio, of 14, Soho Street, London, W.1.

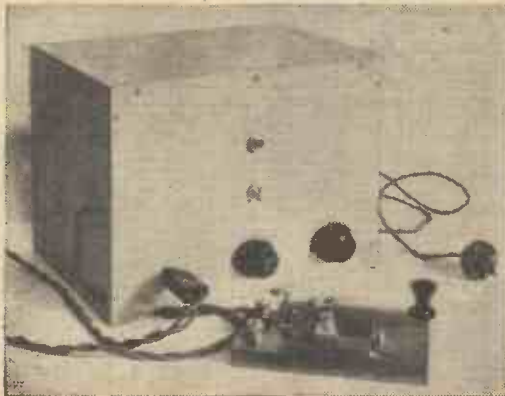

An L.F. oscillator for mains operation.

become proficient in sending and reading, and time has become a very important factor. Class instruction is now the order of the day, but this can only be satisfactory if reliable and powerful equipment is to hand. Messrs. Webb's Radio are, as usual, well to the fore in catering for all requirements connected with radio, and we have recently had the opportunity of testing some of their latest products designed for Morse code instruction.

These consist of two well-made Morse keys, one being priced at 8s. 6d., and the other, a superior article of first-class workmanship, and fitted with precision adjustments, costs 17s. 6d. Both of the models are thoroughly satisfactory for private or class instruction, and owing to the material used and their robust design they will stand up to a lot of heavy work, which, in the early days of mastering the art, is often unavoidable.

The production of a pure note, having the correct pitch and sufficient power for perfect audibility by all present in a class, is of vital importance, and to satisfy these



A smaller oscillator unit.

# Replies to Queries

## Magneto to Dynamo

"I am converting a magneto into a dynamo for a wind-driven accumulator charger, the output of which I wanted to be suitable for charging 2-volt cells at 0.5 amps.

"I have taken all the wire off the armature, and I would like to know if the formula Area of Core equals  $\frac{A \times B \times 3.14}{2 \times 2}$  is correct when the core is an ellipse.

"I show on the diagram the essential dimensions and I make the core area to be 11/32 sq. ins. I would also like to know what gauge wire I should use and how many turns."—J. H. Slatter (Lee, S.E.12).

**YOUR** magnetic core being in the form of an ellipse would have a cross section calculated as below:—

$$\text{Area} = T \times C \times \pi$$

Where T = one semi-transverse axis.

Where C = the semi-conjugate axis.

Where  $\pi = 3.1416$ .

Calculation of the windings will not help you much on such a very small scale, and the best practical advice we can give you for the winding, in order to charge 2-volt accumulators at as low a speed as possible, is to wind the armature channels full with No. 22 S.W.G. enamel covered copper. With an H-type armature there will be two points in each revolution where the E.M.F. drops to zero, and this will lead to considerable discharge from the accumulators unless you interpose two "lead" segments between the two halves of the ordinary 2-part commutator, so as to interrupt the charging current before it reverses.

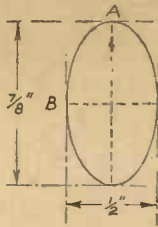

Diagram indicating shape of magnet core of dynamo.

## Aerial Considerations

"I am about to erect a new aerial, and as I wish to make it as efficient as possible, I shall be glad if you will settle a point about which I am not certain. I have ample length of garden and could suspend a full 100 feet of aerial wire, but owing to local conditions I shall have to use a pole at each end for suspension. I am wondering if I can avoid using long poles by making use of the full length of the garden. Is height an important factor?"—G. K. (Bristol).

**THE** effective height, i.e., the actual height of the aerial above earthed objects, of an aerial is a very important matter, and in the case in question, we would advise you to use poles of reasonable length, say 25ft. to 35ft., and restrict the horizontal length of the aerial to 50 to 60 feet. Such an arrangement will be much more effective than an aerial of 100 feet in length having a height of 15 to 20 feet.

## Filament Supply

"I have a trickle charger which I use to keep my 2 volt accumulator charged, but it now seems that the cell has reached the end of its period of useful service. Is it possible, therefore, for me to supply the filaments of the 2 volt valves in the set with their required voltage and current direct from the trickle charger?"—H. Q. S. (Slough).

**NO**, we would not advise you to adopt that method of filament supply as it is not satisfactory. Many readers get the impression that because a charger is supplying D.C. to a 2 volt accumulator, it should be quite in order for the filaments. The chief reasons against the idea are: The output from the charger is not pure D.C. in the same sense as the smoothed output from a full-wave rectifier used for H.T. purposes, therefore, a pronounced hum will be produced. To incorporate satisfactory smoothing one would need very low resistance chokes and high capacity condensers. The voltage output is always greater than two volts, especially if the load is less than that imposed by the average cell, so care would have to be taken in correcting that item otherwise there would be the danger of overrunning the filaments. We would most certainly advise you to purchase another accumulator rather than expend money and time on experimenting with the idea of eliminating the cell.

## Pick-ups and Universal Sets

"I have a small set which can be operated off A.C. or D.C., but it is not fitted with sockets for P.U. connection. It has a very powerful output and I would like to be able to use it to reproduce gramophone records but a friend has told me that certain precautions have to be taken. Is this so, and can you tell me what they are?"—W. J. B. (Birmingham).

## RULES

We wish to draw the reader's attention to the fact that the Queries Service is intended only for the solution of problems or difficulties arising from the construction of receivers described in our pages, from articles appearing in our pages, or on general wireless matters. We regret that we cannot, for obvious reasons:—

- (1) Supply circuit diagrams of complete multi-valve receivers.
- (2) Suggest alterations or modifications of receivers described in our contemporaries.
- (3) Suggest alterations or modifications to commercial receivers.
- (4) Answer queries over the telephone.
- (5) Grant interviews to querists.

A stamped, addressed envelope must be enclosed for the reply. All sketches and drawings which are sent to us should bear the name and address of the sender.

Requests for Blueprints must not be enclosed with queries, as they are dealt with by a separate department.

Send your queries to the Editor, PRACTICAL WIRELESS, George Newnes, Ltd., Tower House, Southampton Street, Strand, London, W.C.2. The Coupon on page 83 must be enclosed with every query.

**WITH** an A.C.-D.C. type of set, the chassis is common to one side of the mains, therefore there is always the risk of obtaining a shock if one makes connection between the chassis and earth. If it is a commercial receiver you are using, we would suggest that you get in touch with the makers and obtain their advice. In most cases, it is sufficient to insert a mica dielectric fixed condenser, having a capacity of 0.005 mfd., in series with each lead from the pick-up, before connecting them to the grid of the detector valve and chassis. The grid-leak must be left connected to the grid, otherwise that electrode will not receive its bias.

## Transformer Ratio

"I am thinking of altering the output of my receiver as I wish to obtain the best possible reproduction, and I understand that two valves in push-pull will give the most satisfactory results. I have a transformer with a centre-tapped secondary but I am not sure whether it is suitable as its ratio is indicated as 9 : 1. Do you think I could use it with two super-power valves in the output stage?"—S. H. (Putney).

**FROM** the details provided, the transformer is evidently intended for Q.P.P. operation, therefore as we note that you wish to use two super-power valves in the output stage and want the best quality of reproduction, we would not advise you to use it. For ordinary Class A push-pull circuits, the input transformer should have a fairly low ratio, and this is usually in the neighbourhood of 2.5 : 1 to 3.5 : 1. You could use the transformer you have if you care to use a normal Q.P.P. circuit and two pentodes in the output stage.

## Two L.F. Transformers

"I have just completed a four-valve battery operated set using a S.G. valve as an H.F. amplifier, a triode detector, an L.F. valve and a pentode in the output, L.F. transformers being used for coupling. I am using a mains eliminator for the H.T. and although all voltages seem to be correct, I cannot get satisfactory results, a continual howl being received the whole time the set is on. The tuning and reaction controls do not affect this howl, and although I have tried many ways to find the cause and cure, I have been unsuccessful. Can you help me?"—T. B. D. (Boscombe).

**AS** the howl is present all the time, and as the tuning and reaction controls do not affect it, it is very evident that the trouble is in the L.F. side of the circuit. The fact that you are using two L.F. transformers might be responsible, especially if they are so located that they can react on each other. Try reversing the connections to the primary of one of them, and if this does not improve matters, experiment with the placing and orientation of one of them. If you are not already using anode decoupling in the H.T. circuits of the second and third valves, we would advise you to do so. For satisfactory results, we would recommend resistance-capacity coupling between detector and first L.F. valve (incorporating a volume control) as with the present circuit there is great danger of overloading the output pentode.

It would be advisable to test the set as an o-V-1 at first and make quite sure that the detector and first L.F. stages are working properly, paying particular attention to reaction and operating voltages. After this, add the output valve, making the circuit o-V-2; be careful to watch for overloading and L.F. instability. Finally, bring the H.F. stage into circuit, adjust operating voltages, trim tuned circuits and test for H.F. instability.

## Classified Advertisements

ADVERTISEMENTS are accepted for these columns at the rate of 2s. per line or part of a line. Minimum charge 4s. All advertisements must be prepaid and addressed to Advertisement Manager, "Practical Wireless," Tower House, Southampton Street, London, W.C.2.

### CABINETS

WE regret that, owing to all our employees having joined H.M. forces, we are unable to accept orders for cabinets except to callers. Limited stock only. We have a large stock of radio components.—H. L. Smith & Co., Ltd., 289, Edgware Road, London, W.2. Tel.: Pad. 5891.

### LOUDSPEAKER REPAIRS

LOUDSPEAKER repairs, British, American, any make, moderate prices.—Sinclair Speakers, 12, Pembroke Street, Copenhagen Street, N.1.

### LITERATURE, MAPS, etc.

AMATEUR Radio Handbook. Second edition now on sale. 328 pages, price 4s.—Radio Society of Great Britain, 16, Ashridge Gardens, London, N.13.

WEBB'S Radio Map of the World. Locates any station heard. Size 40" by 30", 4/6, post 6d. On linen, 10/6, post 6d. WEBB'S Radio Globe—12" model. Radio prefixes, zones, etc., 27/6.—Webb's Radio, 14, Soho Street, London, W.1. Phone: GERard 2089.

RADIO SOCIETY OF GREAT BRITAIN invites all keen amateurs to join. Reduced war-time subscriptions. Send 1s. for latest "T. & R. Bulletin" and details.—16, Ashridge Gardens, London, N.13.

### MORSE EQUIPMENT

FULL range of Transmitting Keys, practice sets and other equipment for Morse training.—Webb's Radio, 14, Soho Street, London, W.1. Phone: GERard 2089.

### NEW LOUDSPEAKERS

3,000 Speakers, P.M. and energised, 4in. to 14in., including several Epoch 18in.—Sinclair Speakers, 12, Pembroke Street, Copenhagen Street, N.1.

### PUBLIC APPOINTMENTS

#### WIRELESS TECHNICAL INSTRUCTORS REQUIRED IN ARMY UNITS

Emoluments.—Pay 8s. 9d. per day (7 days a week). Clothing, rations and accommodation or, if this cannot be provided, allowances at authorised rates. If married and otherwise eligible family allowance payable in respect of wife and children, subject to allotment from pay. Candidates should preferably be under 35 and over 24 and—

(a) Hold one of the following qualifications:

Graduateship of the Institute of Electrical Engineers.

Final (Grade III) Certificate of City and Guilds of London Institute Examination in Radio Communication.

Higher National Certificate in Electrical Engineering.

Certificate of City and Guilds of London Institute of Radio Service Work.

OR

(b) Be able to pass an examination on the following syllabus:

(Continued at top of column 3.)

## AUTHORITATIVE ENGINEERING TRAINING

25 FIRST PLACES and Hundreds of Passes were gained by T.I.G.B. students at recent examinations for A.M.Inst.C.E., A.M.I.Mech.E., A.M.I.E.E., A.F.R.Ae.S., C. & G., etc.

Write to-day for "The Engineer's Guide to Success," containing world's widest choice of home-study engineering courses—Wireless, Television, Electrical, Mechanical, Aeronautical, Automobile, Building, Civil, Chemical, Gas, etc., and which alone gives the Regulations governing admission to the Recognised Engineering Institutions. Mention branch, post or qualification that interests you. The T.I.G.B. Guarantees training until Successful for the one fee.

The Technological Institute of Gt. Britain, 21, Temple Bar House, London, E.C.4. (Founded 1917. 20,000 Successes.)



### ELECTRADIX

Mains "Nitday" Chargers The Lexid "NITDAY" is the cheapest and best CHARGER. Any mains voltage between 100 to 250 volts A.C. steel chassis. Transformers, all-metal Rectifiers, all-British.

Model N/A 24 Radio Home Charger. To charge 2 volts 1 amp. 15/6; N/A 6/1 3 cell Trickle Charger 9 volts 1 amp. 22/-; N/B 6/1 Car Trickle. 6 volts 1 amp. 30/-; N/B 6/1 Car Battery Charger. 6 volts 1 amp. 34/8; N/C 6/2 Car Battery Charger. 6 volts 2 amps. 46/6; N/D 12/1 H.M. Car Charger. 12 volts 1 amp. 47/6; N/D 12/2 N.K. Car Charger. 12 volts 2 amps. 68/6; N/E 2 Doubler Twin Rate Charger. 6 volts and 12 volts 2 amps. 81/6.

8-WAY Lucas-Rotax Switch boxes. 8 levers and fuses for charging, etc. 3/6.

ALTERNATOR term. Magnet Alternator. Hand driven. 3 volts. 25 m/a. Useful tester. 10/6.

SIGNAL GEAR.—Morse Keys. B1. 5/-; Model M. 6/6. Type PF. 9/6. Type IV. 12/6. Full set Govt. Key 17/6.

BUZZERS.—Practice 3/6. Brass cased, 4/6. Bakelite boxed, 5/6. D3 Govt. (no contacts, 5/-). Townsend shrill note wavemeter type, 10/-; Phones and Field Cable.

DYNAMOS and MOTORS. D.C. Double Current. H.P. Gens. 25/-, 50/7, volts, 3 amps. 1/6 h.p., 35/-, 100/110 volts. 1 amp. ball bearing enclosed, 1/12 h.p., 25/-; Ditto. 200/250 volts. 1 amp. 17/6.

MOTORS.—Miero Motors. A.C. split phase 50 cycles motors, squirrel cage rotor. 1in. dia. Dog clutch drive to reduction gear from 2,000 revs. to 58 r.p.m. Voltage 15 to 20 volts, reversible, double shaft, enclosed, laminated, new. Suit model drive. Tuning drive, etc. 8/-, post free. D.C. Motor Gen.—100 volts to 17 volts. 6 amps. 24 7s. 6d. Ditto, 220 volts to 16 volts 5 amps. 25 8s.

ELECTRIC DRILLS on Bench stand, to 1in. hole. 26. 110 volts.

CRYSTAL SETS.—Model B; 2 controls, plug-in coils, in mahogany case, 15/-, post free.

ELECTRADIX RADIOS  
19, BROUGHTON STREET,  
QUEENSTOWN ROAD, LONDON, S.W.8.

Telephone: Macaulay 2159

(Continued from column 1.)

Simple algebra, including quadratic equations; simple trigonometrical ratios and identities; vectors.

Properties of electrical currents; heating of conductors; magnetic fields; unit of current; Ohm's Law; resistance in series and parallel; potentiometers.

Magnetic effect of current; fields due to parallel wires; field due to a solenoid; electro-magnets. Meters.

Induction; effect of rotating a coil in a magnetic field.

Mutual and self induction and inductance; effect of inductance on growth and delay of current.

Capacity; charging storage and discharge of condensers; through resistance and inductance.

Alternating currents; vector diagrams; effect of resistance variation; effects of L and C in A.C. circuit; phase difference of currents; resonance in a series circuit; parallel circuit of L and C; Q factor.

Elementary knowledge of valves; simple theory of amplifiers; oscillators and detectors; general principles of radio practice.

Suitable Candidates will be interviewed at local centres, and, if successful, will be enlisted and appointed Acting Sergeant Tradesmen. For those who are on the Schedule of Reserved Occupations, special arrangements will be made to enable them to be enlisted. In the event of any applicant found to be reserved under Schedule of Reserved Occupations special application will be made for relaxation of the Schedule. No guarantee can be given that this application will be successful.

Application Forms may be obtained by post card from the Under Secretary of State, The War Office (A.G.6c), Whitehall, S.W.1.

### RECEIVERS AND COMPONENTS

COULPHONE Radio, New Longton, Preston.—Brand new goods only. Latest type P.M. Speakers, with transformers. 8in. Goodman, 20/-. 10in. Rola, 25/-. Electrolytic, 500v. 8 mfd., 3/6; 8+8 mfd., 5/9; 16+8 mfd., 7/3; 50 mfd. 50v., 3/3. Cosmocrad Crystal Pick-ups, 30/-. Erie and Dubilier 1-watt resistors, 7/6 doz. Volume controls with switch, 4/9. Tubulars, valve holders, etc. S.A.E. for list.

SOUTHERN Radio's Wireless Bargains—5/- Parcel. Ass'd. Components. Valve Holders, Volume Controls, Wire, Resistances, Condensers, Circuits, etc., 5/- 15/- Service kit of Components. Resistances, Tubular and Electrolytic, Condensers, Volume Controls, Chokes, etc., 15/-

25/- Small trader's Parcel of Components, 100 saleable items, 25/-

ORMOND Loud Speaker Units, balanced armature type, 6/6; smaller Bakelite type, 3/6; unshrouded type, 2/6; Wireless Crystals, 6d. each, 5/- per dozen tins;

Ace P.O. Microphones, complete ready for use with any set, 6/6 each; Westectors W2, 2/6; Mica Condensers, assorted sizes, 3/- dozen; assorted terminals, plugs and tag ends, 6/9 gross; Telsen Radio Magazines, complete with 4 blue prints, 6d. post free; Valve Holders, assorted, 9-7, 5-, 4-piñ, 3/- dozen; thousands of bargains for callers; all goods guaranteed;

please add postage to amount of order, approximate postage 7d. on 5/-, to 1/1 on 25/-.

SOUTHERN Radio Supply Co., 46, Lisle Street, London, W.C.2. Gerrard 6653.



**RECEIVERS AND COMPONENTS**

**RELIANCE RADIO SERVICE,**  
8, Kennington Park Road, S.E.11.  
Phone: REL. 1360.

**GRILLES.** Chromium-plated. Modern design. Improve the appearance of your set. 8x9. 1/- each.

**SCREENED LEADS.** Long, with earthing connection. 2d. each or 1/6 doz.

**SHORT-WAVE COILS** on Paxolin former, 2in. long by 1in. dia., mounted on metal bracket. Grid and reaction winding. 6d. each.

**I.F. TRANSFORMERS.** In 2in. cans with trimmers. 1/- each.

**ASSORTED COILS.** I.F., S.W. tuning coils of all descriptions, 3 for 1/6.

**VALVE SCREENS.** Fit all English valves and some U.S.A. Bargain at 6d. each.

**PAXOLIN PANELS.** Handy for fixing resistances and condensers, with soldering tags. 3in. by 5in. 6d. each, 5/- doz.

**MICROPHONES.** Table model can be used with any radio set, that can be switched to gram. Or with phones in conjunction with a grid bias battery. Complete with transformer. Boxed with instructions. Brand-new stock. 7/6 each.

**CHASSIS.** Small metal chassis as used in Midget sets, fitted with 5 octal base valve holders, with mains adjusting and voltage panel complete, 2/6.

**ROTARY SWITCHES.** 2-way 12 contact. Very good for use in home-constructed test meter. 6d. each. Also a 2-way 9 contact wave change switch, 6d. each.

**SUPERHET COIL KITS.** Consisting of tuning coils, Det. and Osc. with range of 200 to 2,000 metres, and 3 I.F. transformers, completely shielded with trimmers. Complete kit 4/- 3-gang condensers to suit above kit, 2/- each.

**TUBULAR CONDENSERS.** 1 mfd. 350 volts working 3d. each, 2/6 doz. 25 mfd. bias condensers, -15 volts working, 4d. each, 3/- dozen.

**VOLTAGE REGULATOR** and Fuse Panel, ebonite on metal brackets, 6d. each.

**MICA CONDENSERS,** tag end, 12 assorted, our selection, 2/6.

**DUAL-RANGE** tuning coil. Lovely job with screen tuning. Range, 200-2,000 metres. 1/6 each.

**COIL FORMERS.** 1in. by 3in. cardboard formers. Ideal for winding short-wave coil. 1/- dozen.

**PUSH BUTTON UNITS.** Six buttons with knobs, complete, new, 2/6 each.

**TRIMMERS.** Set of 6 on strip to suit above unit. 9d. each.

**TRIMMERS.** Twin on ceramic base, 250 x 250 mfd., new, 4d. each.

**PYE CHOKES.** Massive job, completely enclosed, bargain at 4/- each.

**METAL RECTIFIERS.** 16v., 1 amp. output. Brand new stock, 9/6 each.

**VALVE HOLDERS.** 5-pin, British type, chassis mounting, 3d. each, also 5-pin adaptors, 1/- each.

**SPEAKER SILK.** 1 foot square, modern design, 6d. each.

**T.C.C. Condensers.** Tubular, .1 mfd., 6,000 v. working, 3/6 each. Asstd. Mains-bridge type, .002, .05, .02, .1, etc., etc., 1/- doz.

**TELSEN** reaction condensers, .0003, new, 1/3 each.

Postage must be included with all orders. Regret cannot accept C.O.D. orders.

All letters should be addressed to:  
**RELIANCE RADIO SERVICE,**  
Mail Order Dept., 8, Kennington Park Rd., S.E.11. Phone: REL. 1360.

**RADIO SERVICE CO.**—Valves, all types. Callers or C.O.D. only.—223, Eversleigh Road, London, S.W.11. Telephone: Battersca 2148.

**LEARN MORSE**  
**THE "CANDLER" WAY**

"MASTERING MORSE"

Mr. F. J. Camm, Editor of "Practical Wireless" and the author of "Mastering Morse," says:—

"The ten Lessons which comprise the 'Junior' Course appealed to me as being sound in that it starts out with a very definite principle upon which success in learning code is based" . . . "I also had the opportunity of reading a number of reports from Candler students and they fully confirmed that the Candler method of code training is one which can and does make a good operator provided the learner faithfully follows out the step-by-step instructions lucidly explained in the carefully prepared lessons."

Read these extracts from students' letters.

**AFTER TWO LESSONS**

"After studying the first two lessons I am able to read at 5 w.p.m. and to send at 8 w.p.m."—W. P.

NOTE: 5 weeks later this student reported as follows: "Am now able to read at 10 w.p.m. and to send at 12-15 words per minute." Ref. No. 2453. W. P.

**SECURED A GOVERNMENT POST**

"I had no knowledge of Morse before taking the Candler Course . . . I have a perfect 100% receiving speed of 27 w.p.m. code, 29.4 plain language, figure speeds 19 groups per min. (5 figs. per group) and 24 groups per min. short numerals . . . I have a knowledge of 67 different O signals and nearly all the abbreviated signals listed in your course. Rugby Press comes in like reading a book. . . . I have secured a Government post as a Telegraphist, thanks to the Candler System." Ref. No. 3171. R. G. S.

Original letters of above can be seen on request.

There are Courses for Beginners and Operators. Full details are given in the Candler "Book of Facts," Free for a Postcard request. Write to:—

**THE CANDLER SYSTEM CO.**  
(Room 5 L.O.), 121, KINGSWAY,  
LONDON, W.C.2.  
Candler System Co., Denver, Colorado, U.S.A.

142

**E.D.C. ROTARY**  
**CONVERTOR**

For Sale, in brand new condition, almost unused, E.D.C. rotary convertor, 100/110 volt D.C. input, giving 230 volt A.C. output, 50/100 watt capacity. Complete with radio filter unit on solid base with airtight sound-proof cabinet. Bargain at £12 10s. 0d. Write—Advertiser, Box 261, PRACTICAL WIRELESS, Tower House, Southampton Street, London, W.C.2.

Covers the whole theory and practice of Wireless Reception. On the Official Admiralty List, and recommended to Wireless Operators.

**THE OUTLINE**  
**OF WIRELESS**

By RALPH STRANGER.—Deals with Matter and Energy, Electronic Contents, Magnetism, and Electro-Magnetism, Batteries and Accumulators, Wireless Communication and Broadcasting, Modern Valves, Wireless Signals, Wireless Receiving Circuits, Wireless Measuring Instruments, etc. 836 pages. Over 500 illustrations.

15/- net. (By post 15/9)

Of all Booksellers, or by post from GEORGE NEWNES, LTD. (Book Dept.), Tower House, Southampton Street, London, W.C.2.

**RECEIVERS AND COMPONENTS**

**FRED'S RADIO CABIN,**  
75, Newington Butts, S.E.11.  
Phone: Rodney 2180.

REMARKABLE PURCHASE ENABLES US TO OFFER THE FOLLOWING BRAND NEW GOODS AT LESS THAN PRE-WAR PRICE. NO PURCHASE TAX, EVERY LINE BRAND NEW.

**RECTIFIERS.** Standard Telephones metal type, 12-volt 3 amp., 10/6 each. New.

**VALVE-HOLDERS.** Clix Chassis mounting, 4-pin and 7-pin, 3d. each, 2/9 dozen. New.

**TRIMMERS.** 100 m.mfd. small type or paxolin case, 4d. each, 3/9 dozen. New.

**PUSH BUTTON** control, 6-way, complete with knobs—a really fine job. 2/6 each. New.

**MAINS CHOKES.** 150 ohms, 50 m.a., 2/9 each. New.

**BULGIN** 2-way fuse holders, 8d. each. New.

**T.C.C. Tubular** condensers, .5 mfd. 350 volt working, 1/2 each. New.

**T.C.C. Tubular** condensers, 50 mfd. 12 volt working, also 25 mfd. 25 volt working, 1/3 each. New.

**T.C.C. Tubular** condensers, 2 mfd. 200 volt working, 1/3 each. New.

**REACTION** Condensers, .00015 mfd., 1/3 each. New.

**T.C.C. Condensers,** 1,000 mfd. 12 volt working, 2/6 each. New.

**ESCUTCHEONS.** Chromium frames, 5in. x 5in., 1/- each. New.

**TRIMMERS.** Set of four—100/100 m.mfd., 6d. set. New.

**VARIABLE** Condensers. Single gang, .0005 mfd., 2/- each. New.

**CRYSTAL** Detectors, permanent type, 1/6 each. New. Also replacement crystals at 1/- per set.

**AYE** 20 henry chokes at 3/6 each. New.

**DUBILIER** Tubular condensers, .1 mfd. 6,000 volt test, 3/- each. New.

**OCTAL** Base valve grid clips. New, 2/- dozen.

**TUBULAR** Condensers, .05 mfd., 6d. each. New.

**TRIMMERS,** twin 300/300 m.mfd. on ceramic base. 6d. each, new.

**T.C.C. 1 mfd.** condensers, 200 volt working, 1/- each. New.

**AND NOW FOR OUR USED BARGAINS,** USUAL "CABIN" QUALITY, FROM

**MAKERS, CHASSIS AND SURPLUS:—**

**MICA CONDENSERS.** All useful values, 12 assorted, 2/- dozen.

**TRIMMERS,** Straight line type, capacity 3-35 m.mfd., 6d. each.

**SPEAKER GRILLES,** 7in. x 3½in., Chromium plated, cheap to clear, 1/6 each.

**VARIABLE CONDENSERS,** mica dielectric, .0003 mfd., also .0005 mfd., 6d. each.

**COIL FORMERS.** Cardboard, 1in. diameter. To clear at 1/- dozen.

**VARIABLE CONDENSERS.** Parcel of 3 gross to clear, solid job, first-class condition, 2-gang, .0005 mfd., 9d. each.

**CRYSTAL** and Catswhisker in metal box. New stock at low price of 6d. each.

**PUSH-PULL** Switches, 3-point—a good line, cheap, 6d. each.

**TWIN BINOCULAR** H.F. Chokes, brand new, to clear at 6d. each, 5/- dozen.

**CHASSIS.** Size 8in. x 12in. x 2½in., includes two 7-pin and two 5-pin valve-holders, A.E., L.S. and Gram. sockets, 2/6 each.

Postage must be included with all orders. Regret cannot accept C.O.D. orders.

**FRED'S RADIO CABIN FOR BARGAINS,** 75, Newington Butts, S.E.11. Rodney 2180. New branch at 17, Hamilton Parade, London Road, North Cham, Surrey.

**VALVES** from 3/-. Mixed resist. 3/- doz. 2½d. stamp for component list.—77, Holme-lacy Road, Hereford.

## RECEIVERS AND COMPONENTS

ENGLAND'S GREATEST BUYERS OF SURPLUS RADIO AND ELECTRICAL GEAR. ASSEMBLED FROM GOVERNMENT, G.P.O., ARMY, R.A.F. AND PROMINENT MANUFACTURERS.

GOODMAN'S 8" P.M. Speakers, brand new, boxed, complete with universal transformer, 18/6 each.

ROLA 10" Energised Speakers. 300 ohms, less transformer. With field coil, 12/6, without field coil, 8/6.

PHILIPS Speech transformers for pentode output, 3/6 each.

UNIVERSAL "TEMPOVOX." A.C./D.C. Chassis, 5-valve, as above, less valves and speaker, 22/6.

MORSE KEYS. Don't confuse these with inferior junk. It's a super job. 8/6 each.

VALVES are in short supply. Stock of Mullard TSP 4's and HVR 2's to be cleared at 12/6 each. First come, first served.

TELEVISION diode valves. Surplus quantity to clear at low price. Unused Mullard Type EA50, midget type, size 69 mm. x 12 mm. overall. 6.3 v. heater at 45 amp., 10/6 each.

CONDENSERS.—Special offer of brand new metal-cased paper condensers, 300 v. working. All brand new and unused. 2 mfd., 1/9; 1 mfd. x 1 mfd., 1/9; 1 mfd. 1/2; 5, 25 and 1 mfd., 8d.

RESISTORS, 10 watt, 100 ohm vitreous enamelled mains resistors, 1/3 each.

EX-BAIRD. Short-wave coil 7.25 metres mounted on ceramic trimmer, 1/- each.

A big range of volume controls, 1 ohm, 200 ohm, 600 ohm, all values 2/6 each.

FLEXIBLE DRIVES. Well made, shielded cable drives for remote control. Ideal for radiogramophones. Approx. 2' long.

To clear, 4/- each.

ELECTRO-MAGNETIC COUNTERS. Resistance 500 ohms. From 1-12,999. Size 4 1/2" x 2" x 1 1/2". Ex-G.P.O. Invaluable for countless purposes, 9/6 each. A smaller type, 1-1,999, size 4 1/2" x 1 1/2" x 1 1/2", 5/6.

VALVE-HOLDERS. Belling-Lee special H.F. 5-pin, chassis mounting in black bakelite, 1/- each, 10/6 doz.

PLESSEY small block type condensers, two tappings, .0005 and 0.1 mfd., 350 v. test, 1/- each, 10/6 doz.

VARIABLE CONDENSERS. Well made heavy 3-gang superhet condensers. Die cast frames in first class condition. 2/6 each.

SMALL REVERSIBLE A.C. MOTORS (as used for motor tuning). 25-30 volts A.C. Built-in reduction gear spindle. Speed about 60 r.p.m., 8/6.

AUDAK CUTTING HEADS. Heavy duty type. 3-5 ohm coil. A really high-class instrument, 17/6.

YAXLEY type switches, 2-way, 1/-; 2 bank 3-way, 2/-; 4-way, 4/-.

SCREENING shields in aluminium, 6 1/2" x 5" x 5 1/2", brand new and unused, 2/6 pair.

OUTPUT TRANSFORMERS. Primary 300 ohms D.C. Secondary .5 ohm D.C. Brand new, manufacturer's type, 4/6. Also new chokes, 30 henry, 150 ohms, 3/- each.

RESISTANCES. Assorted values and makes, Eric, T.C.C. American, etc. Low price of 1/6 doz.

B.I. CONDENSERS. Block type oil filled in metal cases with terminals. High quality components. 1 mfd. 1,000 v. D.C. test, 2/6 each and 0.25 mfd. 1,000 v. D.C. test, 2/6 each.

RELAYS. Small relays for operation on 2 v. D.C. with 6-way make and break switches. Brand new, 5/- each.

TRIMMERS. Twin trimmers on ceramic base, brand new, to clear, 6d. each, 5/- doz.

COIL FORMERS. Cardboard and Paxolin. Assorted sizes, useful for experimenters, 1/6 doz.

(Continued at top of column 2.)

## RECEIVERS AND COMPONENTS

CONDENSERS. Metal-cased non-inductive, .5 mfd., 1/6; 1 mfd., 1/9; 1 mfd. x 1 mfd., 2/-; 2 mfd., 2/-.

METAL Rectifiers, by Standard Telephones. Brand new, 12 v. 3 amp., 12/6 each.

ACCUMULATORS. Ediswan 2v. 60 amp. Brand new, in ebonite cases. Size 8" x 4 1/2" x 2 1/2". Callers only. 17/6 each.

CHARGERS. Small trickle chargers, metal rectification. Input 200/220v. A.C. Output 2v. 1/2 amp. Shockproof, 17/6. Ditto in metal case, for mounting, 19/6.

SPEAKER Mesh, 10 1/2" x 9 1/2", 1/6; also chromium escutcheons, without dial, 7 1/2" x 5 1/2", 1/- each.

TUBULAR Wire-end condensers. Brand new, first quality components, .0003 mfd., 8d.; .005 mfd., 9d.; .01 mfd., 10d.; .1 mfd., 1/- each.

CHASSIS. Beautifully finished, highly polished, new cadmium-plated Chassis. Superbly made, 16 1/2" x 13 1/2" x 4". Drilled for 6 valves, transformer, etc., 4/- each.

Also heavy gauge metal chassis, finished battleship grey, 12" x 5 1/2" x 2 1/2", 1/3 each. Also 9" x 10" x 2", 1/3 each, and 15" x 9" x 2 1/2", 1/6 each. All drilled for valves, etc.

SPEAKERS. Ex Government. Special horn type projection Speakers. Ideal for factories, A.R.P. and outdoor P.A. Super 6" P.M. unit, aluminium horn, 4 1/2" long, with flare 32" diameter. Impedance 20 ohms. Few only to clear, 27/18/6.

AMPLIFIERS. Three-valve, 3-watt, 220-250 v. A.C. Gramophone Amplifiers. Made for R.A.F. to Government specification. Slightly used. Pentode output, three-position tone control, super P.M. Speaker in mahogany cabinet, 55/5-.

AUTO-TRANSFORMERS. 100/220 volt 60 watt, 19/6 each.

G.E.C. Fractional H.P. Motors, 225 volts, single phase, 50 cycles, 1/100 h.p., 1,400 r.p.m. To clear, 47/6 each.

PAXOLIN PANELS. 7 1/2" x 2 1/2" x 1/2" thick, 7/6 doz., also thin panels, similar size, 5/6 doz.

SEE ALSO DISPLAY ADVT. PAGE 89. POSTAGE MUST BE INCLUDED. NO C.O.D. ORDERS.

LONDON CENTRAL RADIO STORES, 23, LISLE STREET, LONDON, W.C.2.

Phone: Gerrard 2969.

GEE GEE GEE GEE GEE GEE GEE 15, LITTLE NEWPORT STREET, W.C.2.

THE HOUSE FOR QUALITY COMPONENTS AT LOW PRICES

AMERICAN AND B.V.A. VALVES. Many types available. Send lists for quotation.

EX-PHILCO Battery Valves, Type 1A4E, 4/- each.

CONDENSERS, T.C.C., .1 mfd., tubular, 350v., 7/6 doz. Also Wego .1mfd. 400v., 5/- doz. (Dozens only.)

VALVE-HOLDERS. 4-pin, 5-pin, 7-pin, and 9-pin chassis type, 6d. each, 5/- doz., or 50/- gross, assorted.

MAINS DROPPERS. 2 amp., suitable for Lissen, Pye, etc. Brand new, 3/9 each.

VOLUME CONTROLS. Small type Dubilier, .5 megohm, with switch, 4/- each.

RESISTANCES. 68 ohms, can be used as 50's, 1 watt, cheap at 3/6 dozen.

STAMPED ENVELOPE must accompany all enquiries.

GEE ELECTRIC, 15, LITTLE NEWPORT STREET, W.C.2.

AMATEURS. S/wave gear, valves, etc.; everything.—3, Carlaw Road, Birkenhead.

VALVES and components. State wants. S.A.E.—2, Wavertree House, Bluns Road, Liverpool.

## RECEIVERS AND COMPONENTS

## GALPINS ELECTRICAL STORES

ELEC. LIGHT CHECK METERS, small, late type, good makers, fine condition, electrically guaranteed, 200/250 volts 50 cy. 1 ph. A.C., 5 amp., 10/-; 10 amp., 12/6; 20 amp., 15/-; post free.

D.C. ELEC. LIGHT CHECK METERS, 200/250 v., 5 and 10 amps., 7/6, post free.

AUTO. CHARGING CUT OUT AND VOLTAGE REGULATOR, ex-R.A.F., suit any dynamo up to 20 v. at 15 amps, fully adjustable, with wiring instructions, complete in metal case, 3/6, post 9d.

SOLID BRASS LAMPS fitted small B.C. double contact holder and 12 volt bulb, price 3/-, post free.

110 VOLT D.C. MOTOR, totally enclosed, rated at 8 amps., ball bearing, in new condition, make good slow-speed dynamo, weight approx. 7 1/2 lbs., price 45/-, carriage forward.

FLOODLIGHTS, 12in. dia., mild iron, margin reflector in centre, take any bulb, 15/-, carriage paid.

MILLIAMMETER by "Werton" 2 1/2in., flush fitting, moving coil, reading 0-200 m/a, 30/-, post free.

BLOCK CONDENSER, large size, 1 MF., 4,000 v. working, 10/-, carriage 2/-.

2 kW Transformer, complete with clamps, suitable for rewinding, 25/- each; 1 kW. ditto, 17/-, both carriage paid.

STEEL CABINETS, suitable for amplifiers, partly fitted racks, size 40ins. high, 24ins. wide and 16ins. deep, in clean condition, price 30/- each, carriage forward.

DYNAMO for lighting or charging, shunt wound and interpole, output 110 volts 60 amps., price 220, carriage forward.

ZENITH VITREOUS Resistances, assorted, useful sizes, all good, 12/6 per doz., post free.

GALPINS ELECTRICAL STORES, 21, WILLIAM STREET, SLOUGH, BUCKS.

Cash or C.O.D.

Telephone: Slough 20855.

## SHORT-WAVE EQUIPMENT

"H.A.C." Short-wave Receivers.—Famous for over 8 years. Improved one-valve model now available. Complete kit of precision components, accessories, with full instructions, requiring no soldering, only 16/-, postage 6d. Immediate despatch.

Illustrated catalogue free.—A. L. Bacchus, 109, Hartington Road, S.W.3.

## TUITION

FREE. "Book of Facts," tells you all about The Candler System of Code training. Courses for Beginners and Operators.—Write: Candler System Co. (L), 121, Kingsway, London, W.C.2.

"RADIOLOCATION."—Students of both sexes trained for important war-time Radio Appointments. Also for peace-time careers in all branches of Radio and Television. Boarders accepted. Low inclusive fees. College in ideal peaceful surroundings. Prospectus free.—Wireless College, Colwyn Bay.

PRACTICAL Postal Radio Courses; coaching for I.P.R.E. exams.; qualifying for R.A.F. and A.I.D. posts; booklet free.—Secretary, I.P.R.E., Bush House, Walton Avenue, Henley-on-Thames.

## WANTED

S.W. Preselector (A.C. Mains).—G. Hayes, "Electra," Brampton Avenue, Belvedere, Kent.

MOVING COIL 0-1 mA. milliammeter. Details, etc.—Edwards, "Broome," St. Andrews Road, Bridport.

WANTED—Colvern Coils KTF and KGR for Double Diode Triode Three.—Smith, 12, Coplow Avenue, Leicester.

# Practical Wireless BLUEPRINT SERVICE

PRACTICAL WIRELESS No. of  
Date of Issue. Blueprint.

**CRYSTAL SETS**

Blueprints, 6d. each.  
1937 Crystal Receiver . . . . . PW71  
The "Junior" Crystal Set . . . . . PW94

**STRAIGHT SETS. Battery Operated.**

One-valve: Blueprints, 1s. each.  
All-Wave Unipen (Pentode) . . . . . PW31A  
Beginners' One-valver . . . . . PW85  
The "Pyramid" One-valver (HF Pen) . . . . . PW93

Two-valve: Blueprint, 1s.  
The Signet Two (D & LF) . . . . . PW76

Three-valve: Blueprints, 1s. each.  
Selectone Battery Three (D, 2 LF (Trans)) . . . . . PW10

Sixty Shilling Three (D, 2 LF (RC & Trans)) . . . . . PW34A

Summit Three (HF Pen, D, Pen) All Pentode Three (HF Pen, D (Pen), Pen) . . . . . PW37

Hall-Mark Three (SG, D, Pow) . . . . . PW39  
Hall Mark Cadet (D, LF, Pen (RC) F. J. Camm's Silver Souvenir (HF Pen, D (Pen), Pen) (All-Wave Three) . . . . . PW49

Cameo Midget Three (D, 2 LF (Trans)) . . . . . PW61

1936 Sonotone Three-Four (HF Pen, HF Pen, Westcopter, Pen) Battery All-Wave Three (D, 2 LF (RC)) . . . . . PW63

The Monitor (HF Pen, D, Pen) . . . . . PW65  
The Tutor Three (HF Pen, D, Pen) . . . . . PW62  
The Centaur Three (SG, D, P) . . . . . PW64

F. J. Camm's Record All-Wave Three (HF Pen, D, Pen) . . . . . PW89

The "Colt" All-Wave Three (D, 2 LF (RC & Trans)) . . . . . PW72

The "Rapid" Straight 3 (D, 2 LF (RC & Trans)) . . . . . PW82

F. J. Camm's Oracle All-Wave Three (HF, Det, Pen) . . . . . PW78

1938 "Eriband" All-Wave Three (HF Pen, D, Pen) . . . . . PW84

F. J. Camm's "Sprite" Three (HF Pen, D, Det) . . . . . PW87

The "Hurricane" All-Wave Three (SG, D (Pen), Pen) . . . . . PW89

F. J. Camm's "Push-Button" Three (HF Pen, D (Pen), Tet.) . . . . . PW92

Four-valve: Blueprints, 1s. each.  
Fury Four (2 SG, D, Pen) . . . . . PW11  
Beta Universal Four (SG, D, LF, Cl B) . . . . . PW17

Nucleon Class B Four (SG, D (SG), LF, Cl B) . . . . . PW34B  
Fury Four Super (SG, SG, D, Pen) . . . . . PW34C

Factory Hall-Mark 4 (HF Pen, D, Push-Pull) . . . . . PW46

F. J. Camm's "Limit" All-Wave Four (HF Pen, D, LF, F) . . . . . PW67

"Acme" All-W. 4 (HF Pen, D (Pen), LF, Cl B) . . . . . PW83

The "Admiral" Four (HF Pen, HF Pen, D, Pen (RC)) . . . . . PW90

**Mains Operated**

Two-valve: Blueprints, 1s. each.  
A.C. Twin (D, Pen), Pen) . . . . . PW18  
A.C. D.C. Two (Sl. Pow) . . . . . PW31

Selectone A.C. Radiogram Two (D, Pow) . . . . . PW19

Three-valve: Blueprints, 1s. each.  
Double-Diode-Triode Three (HF Pen, DDT, Pen) . . . . . PW23

D.C. Ace (SG, D, Pen) . . . . . PW25  
A.C. Three (SG, D, Pen) . . . . . PW29  
A.C. Leader (HF Pen, D, Pow) . . . . . PW35C  
D.C. Premier (HF Pen, D, Pen) . . . . . PW35B  
Unique (HF Pen, D (Pen), Pen) . . . . . PW38A

Armada Mains Three (HF Pen, D (Pen)) . . . . . PW38

F. J. Camm's A.C. All-Wave Silver Souvenir Three (HF Pen, D, Pen) "All-Wave" A.C. Three (D, 2 LF (RC)) . . . . . PW54

A.C. 1936 Sonotone (HF Pen, HF Pen, Westcopter, Pen) . . . . . PW56

Mains Record All-Wave 3 (HF Pen, D, Pen) . . . . . PW70

Four-valve: Blueprints, 1s. each.  
A.C. Fury Four (SG, SG, D, Pen) . . . . . PW20  
A.C. Fury Four Super (SG, SG, D, Pen) . . . . . PW34D  
A.C. Hall-Mark (HF Pen, D, Push-Pull) . . . . . PW45  
Universal Hall-Mark (HF Pen, D, Push-Pull) . . . . . PW47

**SUPERHETS.**

Battery Sets: Blueprints, 1s. each.  
E3 Superhet (Three-valve) . . . . . PW40  
F. J. Camm's 2-valve Superhet . . . . . PW52

Mains Sets: Blueprints, 1s. each.  
A.C. E3 Superhet (Three-valve) . . . . . PW43  
D.G. E3 Superhet (Three-valve) . . . . . PW42

Universal E3 Superhet (Three-valve) . . . . . PW44  
F. J. Camm's A.C. Superhet 4 . . . . . PW59

F. J. Camm's Universal 4 Superhet 4 "Qualitone" Universal Four . . . . . PW60  
Four-valve: Double-sided Blueprint, 1s. 6d. . . . . PW73

Push Button 4, Battery Model . . . . . } 22.10.38 PW05  
Push Button 4, A.C. Mains Model . . . . . }

**SHORT-WAVE SETS. Battery Operated.**

One-valve: Blueprint, 1s.  
Simple S.W. One-valver . . . . . 23.12.39 PW88

Two-valve: Blueprints, 1s. each.  
Midget Short-wave Two (D, Pen) The "Fleet" Short-wave Two (D (HF Pen), Pen) . . . . . 27.8.38 PW91

Three-valve: Blueprints, 1s. each.  
Experimenter's Short-wave Three (SG, D, Pow) . . . . . PW30A

The Prefect 3 (D, 2 LF (RC and Trans)) . . . . . PW63  
The Band-Spread S.W. Three (HF Pen, D (Pen), Pen) . . . . . PW68

**PORTABLES**

Three-valve: Blueprints, 1s. each.  
F. J. Camm's LLF Three-valve Portable (HF Pen, D, Pen) . . . . . PW65

Parvo Flyweight Midget Portable (SG, D, Pen) . . . . . 3.6.39 PW77

Four-valve: Blueprint, 1s.  
"Imp" Portable 4 (D, LF, LF, (Pen)) . . . . . PW86

**MISCELLANEOUS.**

Blueprint, 1s.  
S.W. Converter-Adapter (1 valve) . . . . . PW45A

**AMATEUR WIRELESS AND WIRELESS MAGAZINE CRYSTAL SETS.**

Blueprints, 6d. each.  
Four-station Crystal Set . . . . . 23.7.38 AW427  
1934 Crystal Set . . . . . AW444  
150-mik Crystal Set . . . . . AW450

**STRAIGHT SETS. Battery Operated.**

One-valve: Blueprint, 1s.  
B.B.Q. Special One-valver . . . . . AW387

Two-valve: Blueprints, 1s. each.  
Melody Ranger Two (D, Det, Pen) . . . . . AW388  
Full-volume Two (SG Det, Pen) . . . . . AW392  
Lucerne Minor (D, Pen) . . . . . AW426

A Modern Two-valver . . . . . WM409

Three-valve: Blueprints, 1s. each.  
E5 5s. SG. 3 (SG, D, Trans) . . . . . AW412  
Lucerne Ranger (SG, D, Trans) . . . . . AW423

E5 5s. Three: De Luxe Version (SG, D, Trans) . . . . . 19.5.34 AW435

Lucerne Straight Three (SG, D, RC) . . . . . AW437

Transportable Three (SG, D, Pen) . . . . . WM271  
Simple-Tune Three (SG, D, Pen) . . . . . WM327

Economy Pentode Three (SG, D, Pen) . . . . . WM337  
"W.M." 1934 Standard Three (SG, D, Pen) . . . . . WM351

E3 3s. Three (SG, D, Trans) . . . . . WM354  
1935 £6 6s. Battery Three (SG, D, Pen) . . . . . WM371

PTP Three (Pen, D, Pen) . . . . . WM389  
Certainty Three (SG, D, Pen) . . . . . WM393

Minute Three (SG, D, Trans) . . . . . Oct. '35 WM396  
All-Wave Winning Three (SG, D, Pen) . . . . . WM400

Four-valve: Blueprints, 1s. 6d. each.  
55s. Four (SG, D, RC, Trans) . . . . . AW370  
2HF Four (SG, D, Pen) . . . . . AW421

Self-contained Four (SG, D, LF, Cl B) . . . . . Aug. '38 WM331

Lucerne Straight Four (SG, D, LF, Trans) . . . . . WM350

E5 5s. Battery Four (HF, D, 2 LF) . . . . . Feb. '35 WM381  
The H.K. Four (SG, SG, D, Pen) . . . . . WM384

The Auto Straight Four (HF, Pen, HF Pen, DDT, Pen) . . . . . Apr. '36 WM404

Five-valve: Blueprints, 1s. 6d. each.  
Super-quality Five (2 HF, D, RC, Trans) . . . . . WM320

Class B Quadradyne (2 SG, D, LF, Class B) . . . . . WM344  
New Class B Five (2 SG, D, LF, Class B) . . . . . WM340

**Mains Operated.**

Two-valve: Blueprints, 1s. each.  
Conoelectric Two (D, Pen) A.C. Economy A.C. Two (D, Trans) A.C. Unicorn A.C.-D.C. Two (D, Pen) . . . . . WM394

Three-valve: Blueprints, 1s. each.  
Home Lover's New All-Electric Three (SG, D, Trans) A.C. . . . . AW383

These Blueprints are drawn full size. Copies of appropriate issues containing descriptions of these sets can in some cases be supplied at the following prices which are additional to the cost of the Blueprint. A dash before the Blueprint Number indicates that the issue is out of print.

Practical Wireless (issues dated prior to June 1st, 1940) . . . . . 4d. Post Paid (Issues dated June 1st to July 27th, 1940) . . . . . 5d. Post Paid (Issues dated September, 1940, to November, 1941) . . . . . 7d. Post Paid (Issues dated December, 1941, and after) . . . . . 10d. Post Paid  
Amateur Wireless . . . . . 4d. " " Wireless Magazine . . . . . 1/4 " " "

The index letters which precede the Blueprint Number indicate the period in which the description appears: Thus P.W. refers to PRACTICAL WIRELESS, A.W. to Amateur Wireless, W.M. to Wireless Magazine. Send (preferably) a postal order to cover the cost of the Blueprint, and the issue (unless over 6d. unacceptable) to PRACTICAL WIRELESS Blueprint Dept., George Newnes, Ltd., Godwin House, Southampton Street, Strand, W.C.2.

Mantovani A.C. Three (HF, Pen, D, Pen) . . . . . WM374

£15 15s. 1936 A.C. Radiogram (HF, D, Pen) . . . . . Jan. '36 WM401

Four-valve: Blueprints, 1s. 6d. each. All Metal Four (2 SG, D, Pen) . . . . . WM329  
Harris' Jubilee Radiogram (HF, Pen D, LF, F) . . . . . May '35 WM386

**SUPERHETS.**

Battery Sets: Blueprints, 1s. 6d. each.  
Modern Super Senior . . . . . WM375  
"Variety Four" . . . . . Oct. '35 WM385  
The Request All-Wave . . . . . June '36 WM407

1935 Super Five Battery (Superhet) . . . . . WM379  
Mains Sets: Blueprints, 1s. each.  
Heptode Super Three A.C. . . . . May '34 WM359  
"W.M." Radiogram Super A.C. . . . . WM366

**PORTABLES.**

Four-valve: Blueprints, 1s. 6d. each.  
Holiday Portable (SG, D, LF, Class B) . . . . . AW393

Family Portable (HF, D, RC, Trans) . . . . . AW447  
Two H.F. Portable (2 SG, D, OP21) . . . . . WM363

Tyers Portable (SG, D, 2 Trans) . . . . . WM367

**SHORT-WAVE SETS. Battery Operated.**

One-valve: Blueprints, 1s. each.  
S.W. One-valver for America P.W.15.10.38 AW429  
Roma Short-wave . . . . . AW452

Two-valve: Blueprints, 1s. each.  
Ultra-short Battery Two (SG, det, Pen) . . . . . Feb. '36 WM402

Home-made Coll Two (D, Pen) . . . . . AW440

Three-valve: Blueprints, 1s. each.  
World-ranger Short-wave 3 (D, RC, Trans) . . . . . AW355

Experimenter's 5-metre Set (D, Trans. Super-regen) . . . . . 30.6.34 AW458

The Carrier Short-wave (SG, D, P) July '35 WM390

Four-valve: Blueprints, 1s. 6d. each.  
A.W. Short-wave World-beater (HF, Pen, D, RC, Trans) . . . . . AW436

Empire Short-wave (SG, D, RC, Trans) . . . . . WM313

Standard Four-valve Short-wave (SG, D, LF, F) . . . . . P.W.22.7.39 WM368

Superhet: Blueprint, 1s. 6d.  
Simplified Short-wave Super . . . . . WM387

**Mains Operated.**

Two-valve: Blueprints, 1s. each.  
Two-valve Mains Short-wave (D, Pen) A.C. . . . . P.W.13.1.40 AW453

"W.M." Long-wave Converter . . . . . WM380

Three-valve: Blueprints, 1s. each.  
Enligerator (SG, D, Pen) A.C. . . . . WM352

Four-valve: Blueprint, 1s. 6d.  
Standard Four-valve A.C. Short-wave (SG, D, RC, Trans) . . . . . WM391

**MISCELLANEOUS.**

S.W. One-valve Converter (Price 6d.) . . . . . AW399

Enthusiast's Power Amplifier (1/6) . . . . . WM387  
Listener's 5-watt A.C. Amplifier (1/6) . . . . . WM392

Radio Unit (2v. f.c. WM 392 (1/-)) . . . . . WM398  
Harris Electrogram battery amplifier (1/-) . . . . . WM399

De Luxe Concert A.C. Electrogram (1/-) . . . . . WM403

New Style Short-wave Adapter (1/-) . . . . . WM388  
Trickle Charger (6d.) . . . . . AW482

Short-wave Adapter (1/-) . . . . . AW456  
Superhet Converter (1/-) . . . . . AW457  
B.I.D.L.G. Short-wave Converter (1/-) . . . . . May '36 WM405

Wilson Tone Master (1/-) . . . . . June '36 WM406  
The W.M. A.C. Short-wave Converter (1/-) . . . . . WM408

# FREE!



## This IMPORTANT GUIDE to SUCCESSFUL ENGINEERING CAREERS

After months of intensive effort and research we are pleased to announce that the new edition of our Handbook, "**ENGINEERING OPPORTUNITIES**," is now out of the publishers' hands and ready for *free distribution*.

Containing 208 pages of practical guidance, this book is, beyond argument, the finest and most complete handbook on Successful Engineering Careers ever compiled. It is a book that should be on the bookshelf of every person interested in engineering whatever his age, position, or experience.

The Handbook contains among other intensely interesting matter, details of **B.Sc., A.M.I.C.E., A.M.I.Mech.E., A.M.I.E.E., A.M.I.A.E., A.M.I.P.E., A.M.I.Brit.R.E., CIVIL SERVICE,** and other important Engineering Examinations, outlines courses in all branches of **CIVIL, MECHANICAL, ELECTRICAL, AUTOMOBILE, RADIO, TELEVISION, AERONAUTICAL** and **PRODUCTION ENGINEERING, GOVERNMENT EMPLOYMENT, BUILDING** (the great after-war career), **R.A.F. MATHS.**, etc., and explains the unique advantages of our Employment Department.

**WE DEFINITELY GUARANTEE  
"NO PASS—NO FEE"**

If you are earning less than £10 per week you cannot afford to miss reading "**ENGINEERING OPPORTUNITIES**."

In your own interests we advise you to write (or forward the coupon) for your copy of this enlightening guide to well-paid posts—NOW.

*There is no cost or obligation of any kind.*

## BRITISH INSTITUTE OF ENGINEERING TECHNOLOGY

Principal: Professor A. M. LOW

409a, SHAKESPEARE HOUSE,  
17, 18 & 19, STRATFORD PLACE, LONDON, W.1

## R.A.F. PILOTS OBSERVERS etc.

Special rapid Home-study courses in the essential branches of Mathematics. For full details of this scheme apply or write—

**B.I.E.T.**  
(Dept. M 409)  
17, STRATFORD PL.  
LONDON, W.1

TEAR OFF HERE

## FREE COUPON

British Institute of  
Engineering Technology,

409a, Shakespeare House,  
17-19, Stratford Place, W.1.

Please forward Free of cost or obligation of any kind your 208-page Handbook, "**ENGINEERING OPPORTUNITIES**."

NAME .....

ADDRESS .....