

MAKING YOUR OWN COILS— See Page 419

Practical and Amateur Wireless

3^p
EVERY
WEDNESDAY

Edited by F.J. CAMM

A GEORGE
NEWNES
Publication

Vol. 13. No. 329.
January 7th, 1939.

AND PRACTICAL TELEVISION

Sets for **OLD COMPONENTS**



Every Practical Wireless Service Man Should Have This Book

PRACTICAL WIRELESS SERVICE MANUAL

By F. J. CAMM.

A Complete, Practical and Up-to-date Work on the Testing of all Types of Wireless Receivers. 288 PAGES and OVER 220 PHOTOGRAPHS, DIAGRAMS and PLANS.

From all Booksellers 5/- net. or by post 5/6 direct from the Publishers, George Newnes, Ltd. (Book Dept.), Tower House, Southampton Street, London, W.C.2.

ADVT.

“Acoustic Aberration”

or

The effect of old valves on receiver performance

A series of articles by “An Expert”

EVERY valve on its way through life must reach a point where changes in some characteristic or other will start to take place, so that it eventually differs substantially from the original manufacturers' specification. Normally such changes take place so gradually as to be imperceptible unless a direct comparison is made with the performance of a similar valve fully complying with the original specification.

Modern valves are made to such exacting manufacturing methods and inspection that early failures are a rarity.

The former articles dealt with the High Frequency portions of a Radio Receiver. We now come to the stage in which “Detection” of the Radio frequency signals takes place, converting a supersonic or Radio frequency input into an audio frequency output consisting of frequencies within the musical or “audio” range.

No. 3 THE DETECTOR VALVE

There are two forms of detection commonly used in commercial receivers, namely the “Leaky Grid” Detector using either a triode or a pentode valve, and the Diode Detector which uses a double diode-triode or double diode-pentode valve.

With the leaky grid detector, deterioration in mutual conductance caused by falling electron emission will have a similar effect to that in the H.F. valve with an additional disadvantage of both cutting down the L.F. amplification and introducing L.F. distortion. A falling off in the insulating properties of the valve may also occur as it grows older, giving rise to the occurrence of background noise which in this case may also interfere with the reception of local stations. In the diode detector, deterioration is even more important as this valve has usually also to fulfil the function of A.V.C.* If the A.V.C. voltage is insufficient, serious overloading will occur on reception of strong signals, giving rise to distortion in the H.F. amplifier. When the diode is combined with an amplifying stage, such

as in a diode-triode valve, falling emission will introduce distortion also into the L.F. amplifier.

Thus regular replacement of the detector, whether of the “Leaky Grid” or of the diode type (either separate diode or multiple diode-amplifier), is strongly advised in order to maintain both the quality of reproduction and the range of the receiver.

Osram Valves

MADE IN ENGLAND

REDUCED PRICES

OSRAM DETECTORS

2-VOLT BATTERY

| | |
|--------------------------------|-----|
| HL2 TRIODE | 4/9 |
| VP21 PENTODE | 9/- |
| HD23 DOUBLE DIODE-TRIODE | 7/6 |

A.C. MAINS 4-VOLT

| | |
|---------------------------------|------|
| MH4 TRIODE..... | 7/6 |
| MSP4 PENTODE | 10/6 |
| MHD4 DOUBLE DIODE-TRIODE | 9/6 |
| DN41 DOUBLE DIODE-PENTODE | 12/6 |

Above are suitable for servicing receivers which have been on the market for the past three or four years.

D.C.-A.C. 0.3 AMP. UNIVERSAL RANGE

| | |
|--------------------------------|------|
| H30 Triode | 12/6 |
| DH30 DOUBLE DIODE-TRIODE | 12/6 |
| KTZ63 H.F. PENTODE | 10/6 |
| DH63 DOUBLE DIODE-TRIODE..... | 9/6 |

Above are for servicing sets with International Range valves.

WRITE FOR FREE VALVE GUIDE TO :

OSRAM VALVE TECHNICAL DEPT. of The General Electric Co., Ltd., Magnet House, Kingsway, London, W.C.2.

* A.V.C. Automatic Volume Control.

Advt. of The General Electric Co., Ltd., Magnet House, Kingsway, London, W.C.2.

ELECTRO-MUSICAL INSTRUMENTS - SEE PAGE 427



Practical and Amateur Wireless

Edited by **F. J. CAMM**

Technical Staff:
W. J. Delaney, H. J. Barton Chapple, Wh.Sch.,
B.Sc., A.M.I.E.E., Frank Preston.

Vol. XIII, No. 329. January 7th, 1939.

ROUND the WORLD of WIRELESS

Amplifying Musical Instruments

MANY existing instruments are capable of giving much better results when reproduced through some form of radio amplifier. Many dance bands are to-day using electrically amplified guitars, and in some cases the banjo has been similarly modified. In capable hands some very delightful tone effects may be obtained, especially if some form of foot-operated volume control is incorporated in the amplifier. Crescendo and legato effects may be obtained which normally cannot be carried out by ordinary means, and it would appear that before long many instruments will be made to extend this type of reproduction. In this issue we describe how to make a device which may be added to any guitar without impairing the normal musical quality or tone of the instrument, and when plugged into a good amplifier this will be found a very effective device. Remember, however, that the amplifier must be of good design capable of doing justice to the harmonics of the instrument, otherwise much of the characteristic tone will be lost. An amplifier and speaker may be assembled in a single cabinet and the length of lead to the instrument is not very critical. The only point to watch is that the lead should be screened where there is a risk of picking up hum from A.C. mains or apparatus in the vicinity.

London Police Radio

LATEST statistics issued by Scotland Yard reveal that the total number of arrests which have been made as a result of the use of the police radio now amount to 4,000.

German Progress

ANEW television O.B. van has been built in Germany and is entirely self-contained. The power supply is incorporated in a trailer and thus little difficulty will be experienced in getting to any public demonstrations or other events and relaying a reliable picture. A wavelength of about 2 metres is employed. The number of radio receivers sold during October in Germany was 420,000, nearly 285,000 being fully paid sets and the remainder being People's sets.

Swedish Licence Regulations

AREVISION in the charges and conditions relating to broadcast licences is proposed in Sweden. It is stated that

additional payment for more than one set will be demanded, and that some charge may be made for car radio installations.

French Television

AS a result of the experience gained during recent test transmissions, we understand that the authorities in France have decided to adopt the British E.M.I. system and the equipment is accordingly

of his four talks, which is distinct from the subsequent three, will be entitled National Emergency, 1803, and will tell listeners of another Crisis when, all over the country, and particularly London, frantic preparations were being made for the defence of England against the invasion of Bonaparte.

When Day is Done

THIS feature, which will be broadcast in the Welsh programme on January 6th, follows on the lines of previous shows in this series and will consist of a musical sequence of ballads and dance music of the quieter and more soothing types suitable for the ending of the day.

The Elettra

THE late Marchesi Marconi's yacht *Elettra* has been purchased by the Italian Government, and the equipment which had been installed on board, and which was the joint property of the English and the Italian Marconi Companies, has been presented to the Italian Government in memory of their President.

Bristol Recital

MMARGARET WINTERFLOOD (soprano), and Maurice Hardy (violin-cello) will broadcast a recital from a Bristol studio on January 7th.

Jessie Matthews in "Star-gazing"

JJESSIE MATTHEWS, happily recovered from the indisposition which necessitated the postponement of the broadcast, is to feature in the B.B.C.'s next "Star-gazing" programme on January 10th (National) and 11th (Regional), immediately prior to her appearance in her new stage production.

At a time when pantomime is getting well into its stride there will be a specially topical appeal in the real-life Cinderella story of the chorus girl who became a star. She will re-live the "high-spots" of her career during a broadcast packed with human interest that has been compiled by Leslie Baily, script writer of the B.B.C. Variety Department—the tenth broadcast in the series that has already included radiobiographies of José Collins, Davy Burnaby, Edith Day, Huntley Wright, Marie Burke, W. H. Berry, and Anna Neagle.

| ON OTHER PAGES | |
|---|------|
| | Page |
| Making Your Own Components | 419 |
| Sets for Old Components | 421 |
| Short-wave Section | 423 |
| A Novel Use for Visual Tuning Indicator | 424 |
| On Your Wavelength | 425 |
| Electro-musical Instruments | 427 |
| Readers' Wrinkles | 429 |
| Practical Television | 430 |
| Notes from the Trade | 432 |
| Readers' Letters | 435 |
| Queries and Enquiries | 439 |

being changed over. It is also announced that television will be the subject of a tremendous publicity campaign during 1939.

New B.B.C. Empire Announcer

FORMERLY chief announcer and manager of the English transmissions from Radio Normandie, Mr. J. F. Sullivan is the latest addition to the ranks of B.B.C. Empire announcers at Broadcasting House.

Talks on Old London

ASERIES of talks, in the London Regional programme from January 7th to 28th, will be given by Mr. T. A. M. Bishop who is the City of Westminster Archivist. His profession provides him with material that would make any social historian go green with envy. The first

ROUND the WORLD of WIRELESS (Continued)

I.E.E. Meetings

FORTHCOMING meetings of the Institution of Electrical Engineers, Savoy Place, Victoria Embankment, W.C.2, are as follow:

Wireless Section meeting, Wednesday, January 4th, 1939, at 6 p.m. Lecture on "Broadcasting and Television," by Sir Noel Ashbridge, B.Sc.

Members of the Section are specially invited to a meeting of the Meter and Instrument Section, to be held on Friday, January 6th, 1939, at 7 p.m., when a paper on "Instruments Incorporating Thermionic Valves, and their Characteristics," by Messrs. E. G. James, Ph.D., B.Sc., G. R. Polgreen, B.Sc., and G. W. Warren, B.Sc., will be read and discussed.

"Western Magazine"

THE opening number of "Western Magazine," a weekly programme by and for West Country people, devised and produced by Pat Beech, will bring entertainment, interest and information on



Mr. Reginald Foot, the popular organist, seated at the console of his new theatre organ with which he is touring the country.

January 6th, including "If I had a Million," by S. P. B. Mais, "West Country Visitors' Book," and other topical talks. Victor Fawkes will be the compère.

Sunken Treasure

J. W. EMERSON MERRETT will give a talk on January 7th, in the Northern Ireland programme, about the shipwrecks and sunken treasure along the Irish coast. He will deal not only with lost Spanish galleons which were fleeing home to Spain, but also with the more recent losses during the Great War, and the attempts that have been made to salvage their treasures. There was, for instance, the *Laurentic*, which was torpedoed in Lough Swilly in 1917, and went down with £5,000,000 of gold on board.

"Les Misérables"

HENRY AINLEY, whose magnificent performance in the title rôle of Flecker's "Hassan" will be within the memory of many listeners, is to play lead in the B.B.C.'s new serial drama production. Victor Hugo's "Les Misérables," the pro-

INTERESTING and TOPICAL NEWS and NOTES

duction of which in serial form was postponed this autumn, will be heard every Sunday, from January 8th, for twelve weeks. The part of Jean Valjean, the ex-convict who, by the triumph of sheer will and personality over appalling obstacles, becomes an important man of affairs, is one that demands acting qualities of the highest order. Henry Ainley's regular appearances at the microphone throughout the serial should assure it a wide popularity. The producer will be John Cheate. This broadcast will be given in the National programme.

"Hail 1939!"

VICTOR SMYTHE is planning a big outside broadcast entertainment tour round Blackpool, entitled "Hail 1939!"

corded shortly before the broadcast. Claud Bránston is the entertainer-compère of each edition of "Northern Notions."

Famous Music Halls

THE North is to provide a second theatre for the Regional series of entertainment-pageants, "Famous Music Halls," when the Palace Theatre, Halifax, is featured on January 6th. This series brings



A blind listener, with her Braille "Radio Times," tuning in with the aid of a Braille-marked dial.

to the microphone great figures of the past and present at some of Britain's most historic variety theatres.

Sports Special

"SPORTS SPECIAL" No. 19, a feature for fans edited by "Jem Belcher," will include: Soccer, "The Cup and the West," Third Round; Rugger, Devonport Services v. Exeter; and a talk on the Inter-County Squash Championships by W. F. M. Jones. This programme, from the West of England, will be produced by Pat Beech.

SOLVE THIS!

PROBLEM No. 329

Martin had a commercial A.C. receiver which he had used successfully for some time. He changed his address, and at the new house only D.C. mains were available. He therefore decided that he could use his old set by cutting out the mains transformer and rectifier, and connecting the D.C. mains direct to the smoothing choke. He used a 4-volt accumulator for the heaters, but although he could obtain signals they were very weak, and results were very poor indeed. Why was this? Three books will be awarded for the first three correct solutions opened. Address your envelopes to The Editor, PRACTICAL AND AMATEUR WIRELESS, Geo. Newnes, Ltd., Tower House, Southampton Street, Strand, London, W.C.2. Envelopes must be marked Problem No. 329 in the top left-hand corner, and must be posted to reach this office not later than the first post on Monday, January 9th, 1939.

Solution to Problem No. 328

When Jagers connected his transformers in series he overlooked the fact that they were of different ratios and, accordingly, the "centre tap" was not in the centre and an unbalanced output was fed to the two valves.

The following three readers successfully solved Problem No. 327, and books have accordingly been forwarded to them: D. Pettet, 100, Roch Street, Chatham, Kent. F. C. Jones, 23, Manor Road, Brackley, Northants. A. B. Trewin, The Vicarage, Exminster, Devon.

which is to be broadcast on January 6th for Northern and Regional listeners. In this forty-five-minute programme the microphone will visit a number of places of entertainment in Blackpool.

B.B.C. Scottish Orchestra

ON January 7th (Regional) the B.B.C. Scottish Orchestra will give a concert of "Music of the Far North," by Norwegian composers, and Warwick Braithwaite will conduct the B.B.C. Orchestra in a programme of operatic music, in which Lisa Perli will be the soloist.

Pantomime Broadcast

WHEN the New Year edition of "Northern Notions" is broadcast on January 6th, one of the items will be a visit by microphone to the New Manchester Hippodrome where "Red Riding Hood" will be playing. Victor Smythe arranges and produces these popular programmes, which come partly from the studios, and partly from outside broadcast points and sometimes include topical interviews re-

Making Your Own Components—1

Constructional Details of an Efficient Type of Coil Suitable for Use in Many Modern Circuits are given in this Article - - By FRANK PRESTON

DESPITE the low prices at which all components can now be bought, it is evident from our post-bag that there are many real constructors who are just as keen to make their own as there were in the "good old days." There are, of course, many components that can be made at home successfully and fairly easily, but there are many others which cannot well be made without access to accurate test gear. Among the parts that the enthusiastic constructor can make without great difficulty are tuning coils, H.F. chokes, L.F. chokes, transformers, fixed condensers. Even with these it must be remembered that, unless they are for use in comparatively simple circuits, it is well-nigh impossible for the average home constructor to ensure the high degree of accuracy which is necessary.

For example, it is easy enough to make a tuning coil for a det.-L.F. receiver, or even a pair of coils for a simple type of H.F.-det.-L.F. receiver, but many difficulties would arise if an attempt were made to construct a set of matched coils for use in a sensitive superhet.

Double Circuit with Reaction

Tuning coils are always popular with con-

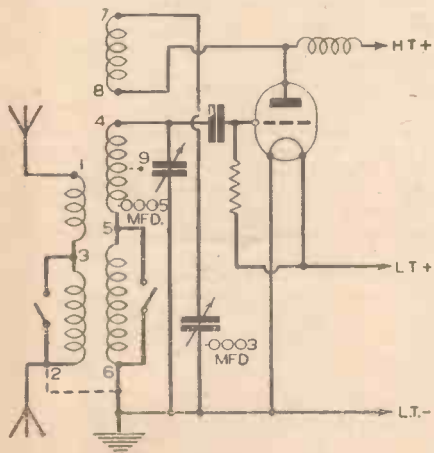

Fig. 1. Diagram of the coil described when used in a simple detector circuit.

structors, and rightly so, so I will start by giving details of one so designed that it can be used successfully in a variety of circuits. The simplest use of the coil is shown by the circuit at Fig. 1, where it comprises an input tuner for a grid-leak detector with reaction. It will be seen that there are three windings, two of which are divided; the third is for reaction. One particular advantage to be gained by using an aperiodic aerial winding entirely disconnected from the tuned grid winding is that a doublet type of aerial can be used. As most readers are aware, this type of aerial is especially valuable as a means of minimising certain forms of interference.

Additionally, it is particularly satisfactory on short waves, so that it is an excellent compromise for general use.

This aerial winding is divided into two sections, both of which are in series. The upper- or medium-wave section has about half as many turns as the lower, long-wave, portion. A double winding is also used for the tuning circuit, but in this case the long-wave section has about three times as many turns as the medium-wave portion. A two-pole switch is required for wave-changing, although two ganged single-pole on-off switches could be used if preferred. A switch such as the Bulgin S.126 is generally suitable, although this is of the Q.M.B. type and primarily intended for mains switching.

Reaction is obtained with a "Reinartz" winding, which is used in conjunction with a .0003-mfd. variable condenser. A .0005-mfd. condenser is suitable for tuning, of course.

It will be seen in Fig. 1 that a broken line is shown between the lower ends of the aerial and grid windings; this additional connection can be made if it is not proposed to use a doublet aerial system. Another broken line is shown brought out to a terminal marked 9. This is an additional

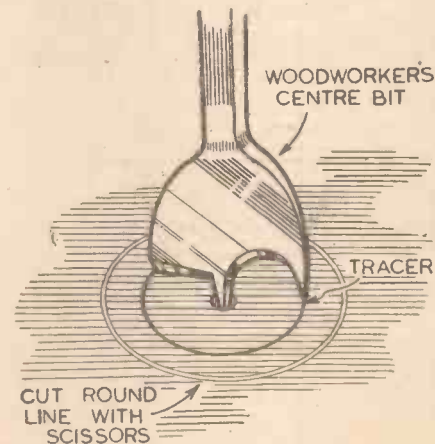

Fig. 3.—A simple method of making the paxolin or card spacing washers, using a sharp centre bit.

grid tapping suitable for use when a rather higher degree of selectivity is required, especially with a leaky-grid detector.

A Suitable Former

And now for the constructional details. It would, of course, be possible to use almost any diameter of former, but I suggest that the amateur will nearly always find that it is better to use one of not less than 1½ in. in diameter. When smaller tubes are employed it becomes necessary to use a larger number of turns, this in turn making it desirable to use unnecessarily fine wire.

If a paxolin tube 1½ in. in diameter is used the medium-wave tuned winding

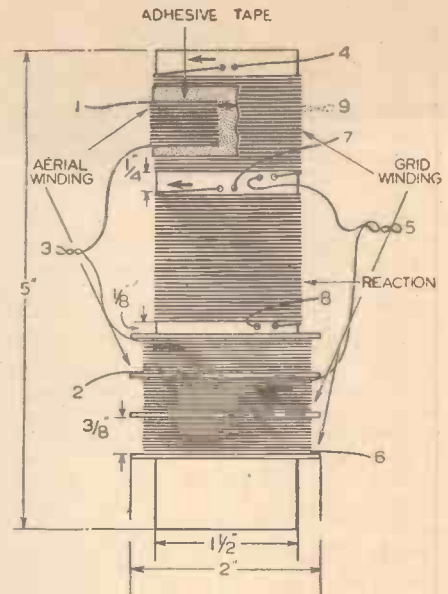

Fig. 2.—Winding details of the coil connections are as follow:

- 1.—Aerial or one side of doublet.
- 2.—Earth or other side of doublet.
- 3.—W/C switch.
- 4.—Grid and tuning condenser fixed vanes.
- 5.—W/C switch.
- 6.—Earth and moving vanes of tuning condenser.
- 7.—Fixed vanes of reaction condenser.
- 8.—Detector anode.
- 9.—Alternative grid tapping.

(between terminals 4 and 5) will require 75 turns of 30 s.w.g. enamelled wire, the long-wave section of this winding (between terminals 5 and 6) needing 210 turns of 36 s.w.g. d.c.c. wire. For the aerial winding a total of 90 turns of 30 s.w.g. enamelled wire will generally prove most satisfactory, of which 30 turns will be for medium waves (between terminals 1 and 3) and 60 turns for long waves (between 3 and 2). For reaction, a total of 100 turns of 30 s.w.g. enamelled wire will be just about right to ensure steady reaction over the whole of both wavebands. The total amount of wire required is approximately ¼ oz. of 36 d.c.c. and ¾ oz. of 30 enamelled.

The Grid Winding

Fig. 2 shows a suitable and convenient arrangement of the windings. A start is made by putting on the medium-wave grid winding, this being started about ¼ in. from one end of the tube. Make two small holes with a sharp pricker and thread the end of the wire through these. Then wind on the 75 turns, make two more holes and anchor the wire by passing it through these. Note that the turns are placed side by side and as close together as possible. Next, the reaction winding is made by winding on 100 turns of the finer wire. Start ¼ in. below the end of the medium-wave grid winding, making two holes as before and winding the wire in the same direction as the tuned winding. Anchor the end of the wire after winding, and leave a few inches of wire for later connections.

Spacing Washers

It will be seen from Fig. 2 that four spacing washers are used to separate the two sections of the long-wave tuned winding and the long-wave section of the aerial winding. These can be made and fitted after putting on the two windings already referred to. These washers, which are

MAKING YOUR OWN COMPONENTS

(Continued from previous page)

2in. in outside diameter, can be made from a sheet of paxolin or from thin, stiff card which has been given a couple of coats of shellac varnish. Apply the varnish as a thin coat, and allow to dry thoroughly before putting on the second coat. It is an advantage finally to bake the card by placing it in a warm—not very hot—oven.

Then mark out a few rings by drawing concentric circles 1½ and 2in. in diameter. The inner circles can then be cut most conveniently by using a 1½in. joiner's centre bit, as shown in Fig. 3. Place the card on a flat wooden surface, and rotate the centre bit, which should have a really sharp tracer projecting beyond the cutter, with a joiner's brace. This should make a clean cut, but if the tracer is not quite long enough the card may be turned over after cutting part-way through it from one side. After making the holes the washers can be cut to the outside circle with a pair of scissors. Take care not to buckle the card or paxolin, because it must be a tight fit on the tube.

After making the four washers they can be attached to the tube with good fish glue. Set them straight and at right-angles to the tube, with the uppermost one ½in. below the lower end of the reaction winding. The washers should be placed ½in. apart. Allow the glue to set thoroughly before proceeding with the pile windings. Also, should it be

found that the washers are not rigidly attached, it is a good plan to wind a single layer of adhesive tape or insulating tape between each pair and also above and below the top and bottom washer.

Long-wave Grid Winding

Next put on the long-wave winding, dividing it equally between the two lower compartments. It will not be essential to anchor the end of the wire, because it will be held in place by the subsequent turns. If it is preferred to anchor it, it can be passed through a small hole pierced through one of the washers. Take great care that the winding is in the same direction as that of the two previous windings. The finishing end can be anchored by passing it through a hole, by winding a strip of adhesive tape over the complete winding.

It remains to add the aerial winding. Cover the medium-wave grid winding with adhesive tape or with a trip of waxed paper, and then wind thirty turns over the centre of the grid winding. The end of the wire can be anchored by passing a looped strip of paper round it and arranging this so that the paper is held in place by the subsequent turns. The finishing end can best be anchored by passing it through a pair of small holes made in the tube. It is very important that the aerial winding be wound in the opposite direction to the others.

Finally, the long-wave portion of the aerial winding must be put on, placing this in the space formed between the two

uppermost separating washers. It is wound in the same direction as the medium-wave aerial winding, and in the opposite direction to the tuning and reaction windings.

Making Connections

If the coil is to be unshielded—and screening is not necessary for a detector-L.F. receiver—it can be attached to an ebonite base plate fitted with nine terminals. The leads from the windings should then be soldered to small soldering tags fitted under the terminals. Of course, if the grid tapping (terminal 9) is not used only eight terminals will be required. With regard to this tapping, it should be mentioned that it is made by forming a twisted loop in the 30-gauge wire after winding on 25 turns of the medium-wave tuned winding. The end of the loop is scraped bare of insulation and soldered to the appropriate terminal.

One method of mounting the coil on the base plate is by means of small brass angle brackets. Another method is to screw to the baseboard of the receiver a disc of wood over which the coil tube fits tightly; in the second case, two small terminal strips, having four and five terminals respectively, could be attached to the baseboard alongside the coil.

Methods of screening the coil, and details of circuits in which it can be used, will be given in a later article, in which constructional details of other components will also be supplied.

(To be continued.)

IMPORTANT BROADCASTS OF THE WEEK

NATIONAL (261.1 m. and 1,500 m.)
Wednesday, January 4th.—The Island of Sark; an account of the lives and customs of the people from recordings made on the Island.

Thursday, January 5th.—Coal and Oil, a discussion.

Friday, January 6th.—Arctic Excursion, by E. A. Harding; the diary of a journey through Lapland from Rovaniemi to Petsamo, illustrated with records.

Saturday, January 7th.—Variety Show.

REGIONAL (342.1 m.)

Wednesday, January 4th.—Salvation Army Band programme.

Thursday, January 5th.—Pantomime Peeps: A short excerpt from Mother Goose, from the New Theatre, Oxford.

Friday, January 6th.—Famous Music-Halls, No. 7—Palace Theatre, Halifax.

Saturday, January 7th.—News of Winter, an hour to spend in the North in which the men and women of moor and town will speak of their life and themselves, from Northern.

MIDLAND (297.2 m.)

Wednesday, January 4th.—Pantomime Peeps—2, Aladdin, from the Opera House, Leicester.

Thursday, January 5th.—Pantomime Peeps—3, Mother Goose, from the New Theatre, Oxford.

Friday, January 6th.—Folly to be Wise, a revue.

Saturday, January 7th.—Pantomime Peeps—4, Dick Whittington, from the Grand Theatre, Wolverhampton.

WEST OF ENGLAND (285.7 m.)

Wednesday, January 4th.—Variety from the Colston Hall, Bristol.

Thursday, January 5th.—Twelfth Night

Party; a further episode in the lives of Miss Hetty Wiffin and her musical friends.

Friday, January 6th.—Western Magazine—the opening broadcast of a new feature.

Saturday, January 7th.—Sports Special, a feature for Fans—No. 19

WELSH (373.1 m.)

Wednesday, January 4th.—Band Concert.

TELEVISION FEATURE

Bertram Mills' Circus

TELEVISION pays a return visit to Bertram Mills' Circus at Olympia this month, and the transmissions, made at varying times, will cover the entire show with the exception of certain acrobatic acts which, for technical reasons, cannot be adequately shown.

In this, the nineteenth season of the circus, Charlie Rivals, the "Charlie Chaplin of the Trapeze," returns after an absence of eight years. Fast camera work will be needed to show the Cristianis, an Italian family of bare-back riders, who come from America. John Roland and his troupe of sea lions, Little Fred's Footballing Dogs, Hagenbeck's Polar Bears on their first London visit, Mroczkowski's new Liberty Horses and Genia Lipkowska's Arabs will also be seen, and the company of acrobats, tumblers, jugglers and trapezists should make an exciting spectacle on the television screen.

The television transmissions will be in the evening on January 5th, 6th and 7th, with an additional afternoon session on January 7th.

Thursday, January 5th.—Orchestral programme.

Friday, January 6th.—Choral programme.

Saturday, January 7th.—Chamber music concert.

NORTHERN (449.1 m.)

Wednesday, January 4th.—Tommy Matthews and his Concert Orchestra.

Thursday, January 5th.—Hail 1939, an entertainment tour of Blackpool.

Friday, January 6th.—Famous Music-Halls—No. 7, The Palace Theatre, Halifax.

Saturday, January 7th.—News of Winter, an hour to spend in the North in which the men and women of moor and town will speak of their life and themselves.

SCOTTISH (391.1 m.)

Wednesday, January 4th.—Scottish Dance Music.

Thursday, January 5th.—The Tay Bridges, the story of the bridging of the Firth of Tay.

Friday, January 6th.—An organ recital from the Caird Hall, Dundee.

Saturday, January 7th.—Scottish Football, a survey of the first half of Season 1938-39.

NORTHERN IRELAND (307.1 m.)

Wednesday, January 4th.—Pantomime, Cinderella, from the Hippodrome, Belfast.

Thursday, January 5th.—The Wild Goose, a play by Teresu Deevy.

Friday, January 6th.—Accent on Rhythm, a programme of tunes in quick succession.

Saturday, January 7th.—Orchestral Concert (in co-operation with Belfast City Y.M.C.A.) from the Wellington Hall, Belfast.

SETS FOR OLD COMPONENTS

There are Many Components Lying Idle in Junk Boxes which May be Used in Modern Sets. This Article Deals with the Suitability of Some Old Components - - By W. J. DELANEY

WE receive hundreds of requests for blueprints or circuits which will enable readers to make up receivers utilising old components which they have unearthed from their junk boxes. In most cases we are unfortunately unable to recommend one of our published designs simply because these have been built round certain components and we are thus able to guarantee the set. If substitutes are employed we are unable to guarantee the performance, and thus we must insist that these receivers are built from our specified parts. We fully realise, however, that there are thousands of old parts lying idle, and many of these are certainly still useful in modern sets, and as announced last week we propose to describe various receivers which may be built from these parts. Before

list of stations you will see that you are missing several below 235 metres which are available on a modern coil going down to 200 metres. The coil may, however, still be used if you do not require wavelengths below 235 and the remaining ranges are perfectly suitable for modern requirements.

Other Components

Amongst the other components which are likely to be available are L.F. transformers. At one time these were turned out to have various response curves to suit valves and circuits then available. To-day the increase in knowledge has resulted in a more efficient component giving a wider range of frequencies, although in one or two cases it may be found that

receiver has been dismantled there is always the possibility that one or more of the condensers or resistances has been damaged due to an 'overload or misuse, and thus if these are introduced into a new set the trouble is also introduced. Therefore, if you contemplate using any parts dismantled from a receiver, take the precaution of testing them first. We have described various test instruments which will be suitable for the purpose, or you can perhaps get a local radio dealer to try them for you.

Valves also become worn out in due course, and this fact also must be remembered when you are using up your old parts. It may prove very uneconomical to use some valves in a modern or new receiver, simply because they are no longer giving good emission, and thus L.T. and H.T. are being wasted on perhaps three or four valves where two modern new valves would give better results at less cost.

Loudspeakers of very old vintage may give weak results, simply because they need remagnetising or because they are not capable of being matched to a modern output valve. Early type moving-coil speakers will also be found much less sensitive than modern components, even although they may be in perfect condition. Therefore, do not expect to wire up a three-valver with old parts and connect an old balanced-armature speaker to it



Fig. 1.—Condenser vanes have been produced with various shapes to follow special laws—as shown here.

doing so, however, it is necessary to point out that some of these parts are unsuitable for various reasons, and in this preliminary article we will deal with this point.

The most important parts of a receiver are the tuning coils and condenser, as it is upon these that the wave-range of the receiver depends, and the losses incurred in this part of the set will govern the amount of energy which is passed on for subsequent amplification.

Old Coils

In the early days coils were simply wound to rough specifications and covered various waveranges. One manufacturer would adopt one form of winding, whilst another would use some different scheme which might include lower wavelengths or run to a higher range. To-day all coils are standardised, the inductance values for medium-wave coils being 157 μ H for the medium waves and 2,200 μ H for the long waves. Furthermore, all manufacturers of variable condensers make these of such a design that they give a certain variation in frequency with those coils for each movement of the vanes, and the waverange covered with a modern coil and condenser is therefore from 200 to 550 and from 1,000 to 2,100 metres. Therefore, you will see that if you use some old pattern condenser which is not built to modern design, you may not cover this range, and furthermore the shape of the plates used in some old condensers will result in all the wavelengths being packed together at the lower end of the dial so that you will find great difficulty in separating stations on closely adjacent wavelengths. As an instance, you will see a coil on our cover illustration this week which was at one time very popular. It is a Leweos band-pass filter, and this was designed to tune on the medium waveband from 235 to 550 metres. If you refer to a modern

the manufacturer still sells an identical article to that available many years ago. Leaving out these particular instances,

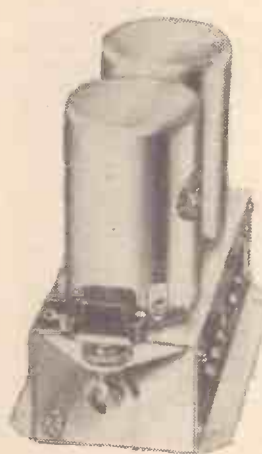

| LW | | | | | | | | | | | |
|-----|------|------|------|------|------|------|------|------|------|------|------|
| 900 | 1000 | 1100 | 1200 | 1300 | 1400 | 1500 | 1600 | 1700 | 1800 | 1900 | 2000 |
| 0 | 20 | 40 | 60 | 80 | 100 | 120 | 140 | 160 | 180 | 200 | |
| MW | | | | | | | | | | | |
| 200 | 250 | 300 | 350 | 400 | 450 | 500 | 550 | | | | |

Figs. 2 and 3.—Wavelengths with modern coils and condensers will be distributed as shown above. Old coils may, of course, still be used, provided the waverange is borne in mind.

the old transformer should be discarded where good quality reproduction is required, although, as in the case of the coils and condensers, provided that the limitations of the components are borne in mind, there is not the slightest objection in using them.

Fixed condensers and resistances do not go out of date, except in one small detail. In many parts of a modern circuit a non-inductive condenser or resistance is called for. Old-pattern Mansbridge condensers will be found to be inductive and may introduce trouble, whilst the same thing applies to wire-wound resistances such as the spaghetti type, which was once very popular. With these two types of component there is another important point which must be mentioned, and that is regarding their soundness. When an old

and hear signals comparable with those given by a modern set with a modern moving-coil speaker. A very good plan, when you wish to use old parts, is to make a two-valver—say, simple detector and L.F. stage. This arrangement, if wired on a flat baseboard, will enable you to make comparisons by permitting easy replacement of the various parts, and incidentally various circuit arrangements may be tried.

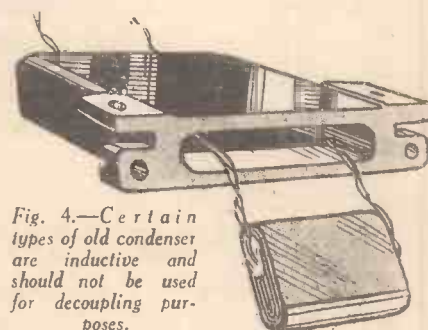

Fig. 4.—Certain types of old condenser are inductive and should not be used for decoupling purposes.

Where a large number of parts is available much interesting information may be gathered by this simple scheme, merely by using the alternative parts in quite standard circuit schemes. With the addition of a good milliammeter such a circuit may be used as a simple test instrument, but this and the subject of circuits will be dealt with in our next issue.

P. & A. W. RECEIVERS

In this Article a Description of the A.C. Leader Three is Given, Together with Details Concerning the Use of the Improved Type of Coil

IN 1934 we described a very efficient three-valve A.C. receiver, utilising the standard H.F., Detector and L.F. circuit. This arrangement has already been proved by thousands of listeners to be the most suitable for general domestic use where the cost of equipment is a consideration. It gives quite a good range and choice of stations, and provided that the output stage is correctly chosen the quality of reproduction is very good indeed. In the Leader the output valve was a triode so that no tone correction devices had to be

on the primary winding, whereas in the original coils the terminal in question was merely in contact with the casing of the coils and thus completed the screening.

Switch Connections

To obtain maximum results from the new coils it is necessary to switch the primary windings in addition to the secondaries and this means that care will have to be exercised in the choice of the switch. The reason for this is that the primary of the second coil, or H.F. transformer, is not

simple as it could be. There is a minimum number of connecting wires, and no awkward corners which are difficult to get into. The 4-volt leads from the mains transformer to the filament of the rectifier and also to the heaters of the receiving valves are of rubber-covered flex, and come direct from the transformer. A metallised chassis is used, as in the case of all PRACTICAL AND AMATEUR WIRELESS designs, and this is used for a number of earth-returns, thus simplifying the constructional work.

A number of soldered joints are used, since we know that most of our readers prefer them, but there is no reason why anyone who is not accustomed to soldering should be afraid to make the set on that account. Practically all the soldering could be obviated if desired by attaching the ends of resistances, condensers, and other components to small terminals. Additionally, the larger fixed condensers, although they are supplied with soldering tags, can be adapted for terminal connections by fitting neat little clips which are supplied by the makers, if required.

The chassis can be obtained already drilled, but in case any reader wishes to drill his own, it might be mentioned that the fixing nuts of the two 20-mfd. electrolytic condensers must be recessed by making holes about $\frac{1}{16}$ in. diameter and $\frac{1}{4}$ in. deep on the underside of the chassis baseboard.

In mounting the components it will be

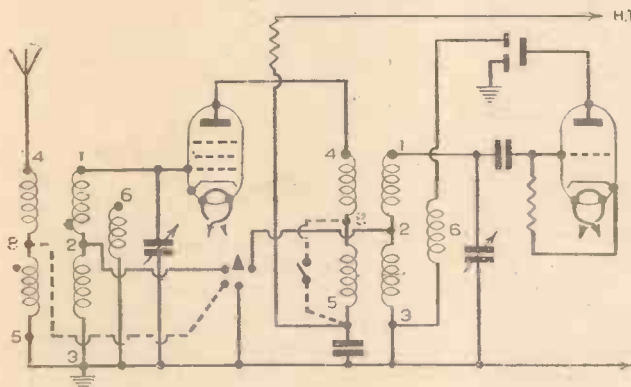

Fig. 1.—Coil connections for the A.C. Leader Three, showing the additional tapping and switching necessary for the Unigen coils.

incorporated. The rated output of the valve specified is 1 watt, and for all normal purposes this will be found adequate. Bearing in mind the cost of a receiver of this nature it may be stated that it forms a very good basis for the beginner who wishes to build an A.C. mains receiver for general family use.

The blueprint which is available, No. PW. 35C, shows all the wiring, and the only difficulty which may be met to-day is in the coil connections. The components originally specified were the Wearite Universal coils, and these are not to-day available. In their place are Unigen coils, which differ slightly in connections and design. It is important to note that the connections on the original coils provided for an earth contact to one of the terminals, and this point is, on the new coils, taken to a tapping

earthed direct, and therefore a separate insulated section of a switch will have to be used for this. The accompanying illustrations show the new coil arrangements and how the switching must be arranged, together with a diagram of a multi-contact switch which may be used for the purpose. It is of the utmost importance to isolate the section of the switch referred to or the H.T. will be short-circuited to earth with consequent damage to components.

The mains transformer should have three secondary windings—4-0-4 volts at 1 amp. for the rectifier heater: 250-0-250 volts at 60 mA. for the H.T., and 4-0-4 volts at 3 amps. for the valve heaters.

Simple Construction

It need scarcely be explained that the construction of the A.C. Leader is as

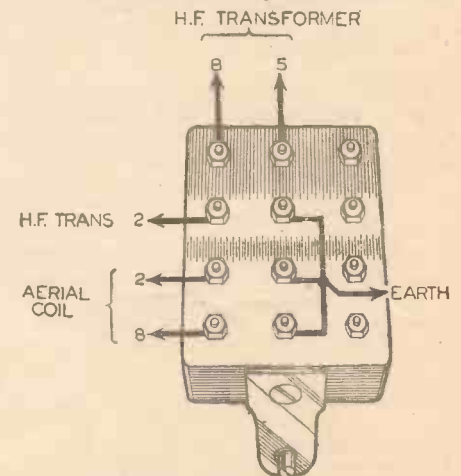

Fig. 2.—How a multi-contact switch may be wired to avoid short-circuiting the H.T.

found best to start by attaching all those parts which are fitted on the underside of the chassis, such as the double 4-mfd. smoothing condenser, low-frequency transformer, H.F. choke, 2-mfd. fixed condenser, and the component bracket which holds the on-off switch. It will be seen from the wiring plans that the tubular condensers and fixed resistances are not directly attached to the chassis, but are held in place by the wiring; they can therefore be ignored until later. The next step is to fit the terminal socket strips to the back edge of the chassis, after which the valve holders can be screwed in place on the top. The mains transformer, smoothing choke, and fixed condensers can next be attended to, leaving the tuning condenser and coils until last.

LIST OF COMPONENTS FOR THE A.C. LEADER THREE

One Jackson Bros. Double-gang Condenser .0005 "Nugang" Type A (C1 and C2).
Two Wearite "Unigen" Screened Coils.
One Jackson Bros. .00015 mfd. Differential Reaction Condenser (C7).
One Bulgin Junior On-off Switch, Type S.38.
One Varley "Nictet" 5-1 L.F. Transformer.
One B.T.S. Reaction Type H.F. Choke.
One Heayberd "Leader" Mains Transformer.
One Wearite Smoothing Choke, Type H.T.25.
Three 2in. Component Brackets, Peto Scott.
Two Clix Terminal Socket Strips (one marked Aerial and Earth, and one marked L.S. and P.U.).
Six Solid Clix Plugs for use with terminal strips.
One Claude Lyons "B.A.T." Type 728-L.T. Switch.
Four W.B chassis mounting 5-pin valve-holders.
One Claude Lyons "B.A.T." 100,000-Ohm Resistor, Type R.1 (R9).
One Claude Lyons "B.A.T." 50,000-Ohm Resistor, Type R.1 (R7).
One Claude Lyons "B.A.T." 40,000-Ohm Resistor, Type R.1 (R2).
One Claude Lyons "B.A.T." 30,000-Ohm Resistor, Type R.1 (R1).

One Claude Lyons "B.A.T." 5,000-Ohm Resistor, Type R.1 (R4).
One Claude Lyons "B.A.T." 1,000-Ohm Resistor, Type R.1 (R6).
One Claude Lyons "B.A.T." 350-Ohm Resistor, Type R.34 (R8).
One Claude Lyons "B.A.T." 250-Ohm Resistor, Type R.1 (R3).
One Claude Lyons "B.A.T." 1-megohm Resistor, Type R.1 (R5).
Two Dubilier 20 mfd. Electrolytic Condensers, Type 401 (C8 and C10).
One T.M.C. 4 x 4 mfd. fixed Condenser, Type 40 (C11 and C12).
One T.M.C. 2 mfd. fixed Condenser, Type 40 (C9).
One T.M.C. .0001 mfd. tubular fixed Condenser (C6).
Two T.M.C. .1 mfd. tubular fixed Condensers (C4 and C3).
One T.M.C. 1 mfd. tubular fixed Condenser (C5).
One Peto-Scott Metallised Chassis, 16in. x 10in. with $\frac{3}{16}$ in. runners.
One Cossor MS-PEN Valve.
One Cossor 41.MH Valve.
One Cossor 41.MP Valve.
One Cossor 506.BU Rectifier.
Wire, screws, flex, etc.

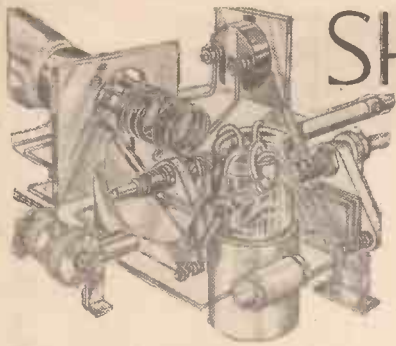

SHORT-WAVE SECTION

THE SHORT-WAVES AND LUNAR PHENOMENA

The Possibility of the Moon's Influence on S.W. Reception is Discussed in this Article.

By A. W. MANN.

THE study of phenomena as associated with the propagation of short-wave wireless signals is one of absorbing interest. Much is known and understood relative to fading, skip distance, signal routes, etc., whilst sun spots, and the eleven years cycle theory, is given much attention and study.

Apart from the findings and opinions of isolated investigators, little of interest is heard relative to lunar effects, and the influence of the moon with respect to the reception of short-wave signals.

As this is a branch of phenomena research within the province of the amateur and short-wave listener, the writer proposes to discuss it from various angles, together with suggestions as to the procedure which should be adopted by those who are interested, and desire to study the problem in a practical manner.

Simple Equipment

In carrying out investigations of this nature the amateur has not laboratory conditions under which to carry on his work, neither has he laboratory equipment. Under the circumstances he must make the fullest use of the available equipment, and by methodical preparation leave nothing to chance.

The first essential is a reliable receiver of at least average sensitivity, together with some means of measuring signal strength. An almanac showing the phases of the moon, log book, and a pad of graph paper, are also required. During the observation period nothing should be altered in the receiver. The voltages should be kept constant, wiring, component, and valve changes should be avoided. These precautionary measures will assure that so far as is possible the conditions under which the work is carried out remain constant.

Taking Observations

Observations cannot be carried out by indiscriminate listening. One station within a particular band should be chosen, and in doing so avoid those which are of low power, inconsistent, and of an experimental nature. A long distance station working to a daily schedule, and which is more or less consistently received is most desirable, as for example W8XK (25.26 metres) scheduled at the time of writing as 21.00-03.00 G.M.T. daily.

Listening must be carried out during the same period nightly. Signal strength, moonphase, audibility, weather and climatic conditions and changes should be recorded in the log book, and a signal-strength graph under the particular moon phase conditions should be plotted against the data recorded. The same applies to audibility.

From a series of observations undertaken by the writer and an American friend some years ago, there would appear to be a definite relationship between lunar variations, and signal strength on the short-wave

bands between twenty-five and forty-nine metres, as observed by us at different locations separated by a distance of three thousand six hundred miles.

When the moon was not visible, signal volume was comparatively low, and receiving conditions definitely bad, this being a new moon period. As the moon slowly appeared, however, conditions started to improve, and signal volume to build up consistently as the first quarter phase (see Fig. 1), was reached. Between this period, and the full moon (see Fig. 2), DX conditions prevailed, signal volume gradually increasing and peaking during the full moon period. As phase conditions changed,



FIRST QUARTER

Fig. 1.

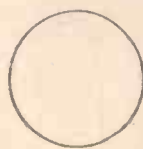

FULL MOON

Fig. 2.



LAST QUARTER

Fig. 3.

Diagrams illustrating three phases of the moon.

signal volume of the reliable stations decreased and DX transmissions were inaudible, and as the last quarter phase was reached receiving conditions became extremely poor.

Improved Reception Conditions

On one particular occasion the writer noticed that the moon, which was midway between the three quarters and full phases, was of a size denoting that it was much nearer the earth than usual, was crimson in colour between seven-thirty and eight thirty, but at nine p.m. was higher in the heavens, and yellow in colour. Reception conditions showed a distinct improvement over the previous night, and American, European and South American transmissions were receivable at good volume, and with only slight fading, on the 28 metres-32 metres band.

The most unusual feature in this instance was, however, the reception of the U.S.A. and South American stations during the same period at the writer's location, as this had previously been impossible, and with the same apparatus under identical conditions was never repeated, although possible nowadays, owing to higher power and better receiving equipment.

Phase Changes

With reference to theoretical opinions concerning lunar effects it would appear that the changes in phase have a definite relation to signal strength, and it may be that ray reflection influences the Heaviside layer, or sets up changes in atmospheric conditions. The writer, however, is prepared to retain an open mind on the subject.

In addition, phase changes, the fact that the moon is at one period nearer the earth than usual, and at another period farther away, should also be taken into consideration.

Passing again to practical considerations, tabulated data in complete form is most useful, but if converted into graphical form enables the how and why of the subject to be seen and appreciated at a glance, and nothing is left to the imagination. This applies especially to signal strength measurement and variations.

Fig. 4 shows a graph in which the variations in signal strength are plotted against the reception strength of one particular station, received nightly at the same time, over a period of one month.

Variations in R Strengths

This graph is not based on actual observations, but is especially drawn to illustrate a wide range of signal variations in R strengths. A detailed examination will give some idea as to its usefulness.

The time is 9 p.m. G.M.T. for all observations. On the first of the month signals are received at R7, on the second they show a decrease to R6; the five following days show that signal strength remained at a constant level of R6 at 9 p.m., whatever variations took place in the intervals. In order to determine the R strength on any particular day all that is necessary is to run up the vertical line above the date; as, for example, on the 23rd day signal strength was R9, and on the 31st R2. This principle can also be applied to audibility, humidity, and barometric readings, if the observer is in a position to take them. The question, why not make the listening period cover a quarter of an hour or more may arise. The reason why this procedure is not recommended is that observations could only be based on average signal strengths the peaks of which, like the minimums, would occur at different times. By working to a definite time a higher standard of accuracy is assured which, taking into consideration that we are dealing with different phases of the moon, and using amateur equipment to compute a series of complex observation records, is most desirable.

(Continued on page 435.)

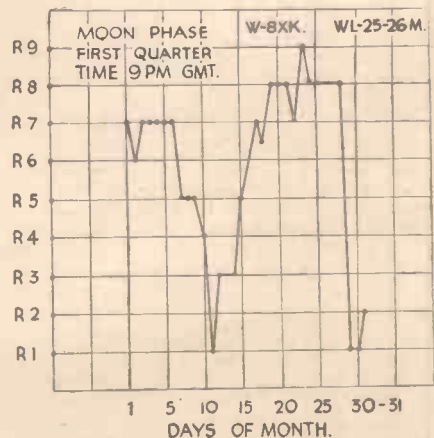

Fig. 4.—A graph representing signal strength of a particular station over one month.

A Novel Use for Visual Tuning Indicators

How a Standard Cathode-ray Tuning Indicator may be Used as an Indicator for Absorption Frequency Meters

SOME time ago we published details of an unusual application of a standard visual tuning indicator for purposes other than the normal one of identifying accurate tuning positions in a broadcast receiver. It would appear that this particular type of indicator may be used for many purposes, and Philips Radio technical department have supplied the following details concerning the application of the EMI indicator in frequency meters.

Despite the popularity of "oscillator" frequency meters, the absorption type is still a useful device for a number of applica-

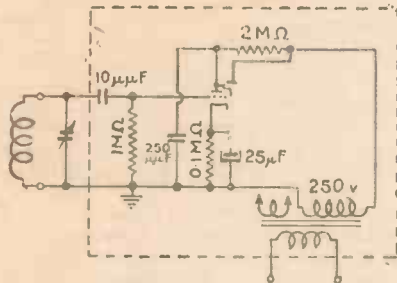

Circuit showing the application of the EMI as indicator for a frequency meter.

tions. An important feature of this latter type is its relative simplicity, since it comprises only an accurately-calibrated tuned circuit and an indicator to show resonance.

It is important for such a measuring instrument to have as high a sensitivity as possible, together with a minimum of damping due to the indicator. Generally a thermo-ammeter such as a hot wire or a thermo-couple meter of compact and robust design has found favour as an indicator. Since instruments of this type consume a certain amount of energy, they exercise a damping effect on the tuned circuit, which restricts the accuracy of calibration by widening the response curve.

IN PRACTICAL AND AMATEUR WIRELESS, dated December 17th, 1938, details were given of the transmitting aerial system used at Alexandra Palace, this being a précis of a paper on that subject read recently before the Institution of Electrical Engineers. Unless very elaborate precautions had been taken there would have been very serious reflection phenomena in the long feeder cables used to transfer the wide side-band-modulated high-frequency television signals on the 45 megacycle carrier from the output stage of the ultra-short-wave radio transmitter to the aerial array on the lattice mast seated on the reinforced tower. This is partly because the time of transmission of the wave along the feeder is comparable with the time periods of the modulation frequencies. In a normal domestic installation such difficulties do not arise, since the length of feeder cable required is relatively short. This question of impedance matching cannot be neglected,

The cathode-ray tuning indicator type EMI which was introduced for use with receiving sets can also be used to advantage as an indicating instrument for other applications.

EMI makes Excellent Indicator

An interesting circuit arrangement is given for using the EMI as an indicator for a frequency meter. It was expected that the EMI would require a rectifier system for supplying the necessary operating voltages, but it has been found that an alternating voltage can be applied to the plate and target electrodes. In this way the dimensions of the apparatus can be reduced, and the elimination of the rectifier valve means lower costs.

An instrument built according to the circuit diagram will give improved sensitivity compared with a frequency meter employing a current-operated indicator—and another important feature of this new instrument is sharper tuning. In addition, the EMI offers the advantage of instantaneous indication without lag, a feature of considerable value where the tuning is subject to rapid variation.

Can be added to Existing Equipment

The cathode ray indicator and associated components can be added to an existing frequency meter, but this will alter the original calibration, which must be corrected. The General Radio absorption wavemeter can readily be modified in this way, and the additional parts can be conveniently built into an independent casing and provided with lug contacts to clamp to the normal coil terminals.

From the circuit for the frequency meter employing the cathode ray indicator, it will be seen that the triode section of the EMI is connected as an anode-bend detector. A resistance of 0.1 megohm is recommended for the cathode.

The high-tension supply has been simplified by employing an alternating voltage.

As a result, the EMI functions only during the small part of each cycle, viz., during the time the target and plate electrodes receive a positive potential of adequate magnitude. Fortunately it has been found that a steady pattern free from flicker is obtained on the fluorescent screen.

As a result, the EMI functions only during the small part of each cycle, viz., during the time the target and plate electrodes receive a positive potential of adequate magnitude. Fortunately it has been found that a steady pattern free from flicker is obtained on the fluorescent screen.

No Rectifier Needed

The addition of a rectifier would improve the sensitivity of the apparatus, but the advantage gained hardly justifies the extra components. The self-rectification circuit described here is recommended, since it represents the best compromise.

In this frequency meter circuit, the average plate current of the EMI increases with increasing strength of the radio frequency input, due to the anode bend detection. The voltage applied to the deflector plates drops (as a result of the series resistance) and the pattern becomes smaller with increasing signal strength. In other words, resonance is indicated when the pattern is tuned to a minimum.

Will withstand Heaviest Overloads

An advantage of considerable importance in the field is that the tuning indicator can withstand almost every conceivable overload, a claim which cannot be made for the majority of current indicators. If it is found that the minimum deflection is rapidly realised, and that no further variation occurs over a section of the tuning control, the coupling between the frequency meter and the source under investigation should be reduced until a sharp resonant point occurs.



This is the EMI visual tuning indicator.

IMPEDANCE MATCHING

however, otherwise the received picture is liable to exhibit a marked ghost or "ringing" effect which is very annoying to the viewer. According to the nature of the feeder cable, that is, whether it is of the concentric type, using a "live" centre conductor, and a braided metal shield as the second connection; shielded twin or an unbalanced feeder, so the cable will have a certain characteristic impedance which can be stated as an average ohmic value within the band of frequencies which it is designed to handle. This value should

equal the input impedance of the television receiver to which it is connected, and the longer the feeder cable employed the more important does this factor become. Whenever there is a demonstration of television reception at which sets of various makes and types are to be employed, it is quite common to make up a small resistance network at each termination to ensure that this matching criterion is met. At the same time, or additional to this function, there are attenuator pad boxes to reduce the value of the signal input to a quantity which the set will handle efficiently without overloading. Factors of this character are watched carefully for undertakings such as Radiolympia or the recent Royal Photographic Society dinner where a few dozen sets are in operation simultaneously. By "padding down" to a certain attenuation value it prevents any feed-back into the line; an occurrence which would upset the performance of neighbouring receivers.

ON YOUR WAVELENGTH



By *Thermion*

Your Old Components

I WAS particularly interested in the announcement made by the Editor that he proposes to publish a series of designs incorporating components not now on the market. I am certain that some quite expensive, yet still efficient components, such as coils, chokes, transformers and valves still repose in the limbos of constructors, because most of the designs now published are intended, and of course, rightly so, for components which can be readily purchased. If we publish designs which only make use of components not now on the market we should receive complaints from readers who were unable to obtain them, just as I have been receiving for a long time past suggestions from readers who do possess these old components and do not wish to purchase new ones.

The Editor's policy of continuing to give designs suitable for components on the market, and to augment that policy with designs suitable for old components, is eminently sound. I have discussed the matter with him, and I find that his difficulty is that he does not wish to publish designs for components which the majority do not possess. I therefore ask you to let me know what old components you have on hand, stating the make and the designating number, if any, on each. Thus, the Editor will be able to prepare designs which will suit the majority. Will you look through your junk box, make a list of the components, assign the make and number to each, and let me have them as soon as possible? And please regard the matter as urgent.

The Radio and the Fireside

AS I write these notes we are experiencing a heavy fall of snow, and one of the coldest snaps for over 10 years. Many books have been written around the charm of the fireside, and the yule log, and the warmth of the old country inn. I wonder if we ever stop to consider how much the pleasure of the fireside has been augmented by the introduction of radio? Can you now imagine a home without a radio set? It is true that we may criticise the programmes, but even so, we must agree that the radio has developed our critical faculties. Tens of thousands of readers who have never visited the theatre have been able to hear famous artistes, and to hear more of them than they ever would be able to do if they did go to the theatre. The microphone brings every important artiste and personality before you, and as comparison is the mother of opinion it is inevitable that we should all become critical of radio, after 15 or more years of it. Many of the critics go all continental—or should I say continental! The continental programmes have in my view degenerated, for they are now too blatantly advertising.

A Dickens winter may look very nice on Christmas cards, but I do not think that we should really enjoy it. I have always abhorred snow, perhaps after bitter memories of my early apprenticeship days, and a 16-mile bicycle ride to start work at six o'clock in the morning. I owned a

motor-cycle after the third year of my apprenticeship, and I can assure you that it is not a pleasant experience to ride on ice and snowbound roads at five o'clock in the morning.

Competition

AS my previous contests have been so successful I shall be pleased to offer prizes of books for what I consider to be the best essays, not exceeding 300 words in length, on "My Radio Mistakes." Entries should reach me not later than Saturday, January 21st, and the envelopes should bear the word "Mistake" in the top left-hand corner, and be addressed to Thermion, PRACTICAL AND AMATEUR WIRELESS, George Newnes, Ltd., Tower House, Southampton Street, Strand, W.C.2.

Club Journals

I GRATEFULLY acknowledge the receipt of some well-produced and well-edited journals published by some of the more progressive of the wireless clubs. These are packed with humour and leg-pulls, and although some of the humour is lost on me for the simple reason that I do not know the people concerned, I can still see the good will which pervades the pages. I recommend every club to publish a journal and, moreover, I advise the members to keep those copies, and to have them bound each year. They are interesting to browse through in years to come, and provide a fund of memories of friends who for one reason or another will desert the fold, either because they have moved out of the district or gone abroad. It is an astonishing thing that few of the keen enthusiasts ever lose their interest in the great hobby, and even though they may give up active participation in it, they keep up correspondence even when distance and years separate them. I place a great deal of reliance upon the club movement, and I advise manufacturers to do the same. A well-run club is a fine advertisement for the hobby.

Many of these journals are produced at great effort on duplicating machines, whilst a few of them are turned out by a printer. I congratulate those clubs.

"Practical Mechanics"

I DO not know how many of my readers purchase our live companion journal, *Practical Mechanics*, but I do, and I was most interested in an article in the current issue which deals with the principles of Automatic Traffic Signals. Incidentally, I have learnt a great deal about conjuring

from its pages, and I observe that my old friends, Bassett-Lowke, E. W. Twining, and many other well-known experts, contribute to its pages. It is the only journal of its type in this country. I see that in it there is an interesting series by that well-known broadcaster, Maurice Reeve, explaining the new method of learning the piano; another article describes a dividing plate for the lathe; there is an interesting series on watch repairing and adjusting; a valuable series on tool making and tool design; article on repairing domestic electrical apparatus; a most thoughtful article on the interesting subject of travelling in time; model aero topics; making a cannonette table; drilling for oil; magical cookery; experiments with colloids; new inventions; and a valuable feature is devoted to replies to readers' questions on almost every mechanical, scientific, electrical, and chemical subject. At sixpence a month it is unique.

Some QRM!

I HAVE culled the following interesting little story from the current issue of the "News-Reel," the official organ of the Cardiff and District Short-wave Club.

"W6KFC had been troubled for years with terrific electrical interference at intervals and finally it became so annoying, when occurring in the middle of a QSO, that he borrowed a crystal receiver from a friend and took it around the neighbours to try and trace the noise.

"Imagine his very great surprise when he discovered an aerial with sparks jumping across the insulators. Investigation showed that an ex-operator was running a spark transmitter in an effort to close down the local BCL receivers who were keeping his baby awake! The QRM has now ceased. R.I.P."

B.B.C. Music Productions Plans

IT is interesting to note that three operas, namely, "Lakmé," by Delibes, "Manon," by Massenet, and "Der Freischütz," by Weber, are among the outstanding programmes scheduled for broadcasting during the January to March quarter by the B.B.C. Music Productions Unit.

"Lakmé," which has not been broadcast from the studios since 1929, will be produced in St. George's Hall during January. It is one of the most popular French operas and one of the best that Delibes composed. Its music includes the famous "Bell Song."

Stanford Robinson, Director of the Music Productions Unit, has decided to repeat "Manon" during February in response to many requests from listeners; it was the first big opera broadcast from a B.B.C. studio after the formation of the Music Productions Unit.

In March, listeners are to hear two performances of "Der Freischütz," a work which is thoroughly representative of German romantic opera. A good deal of the music, including practically all the arias, is very well known. It provides ample scope for the introduction of melodrama, especially in the Wolf's Glen scene, in which the Magician appears.

INCREASING THE VOLUME

Practical Suggestions Relating to Additional L.F. Amplification

By Radio Engineer

MOST constructors experience the desire to increase the efficiency of their receiver by making it capable of "pulling in" the more distant transmissions or by modifying the low-frequency section so that greater amplification of the signals received at the detector anode can be obtained.

The effective range or sensitivity of a set can only be improved by increasing the strength of the signal before it reaches the

used. For this purpose, then, a stage or even two stages of L.F. amplification should be added, provided one is prepared to increase the H.T. supply to 120 volts.

If the single-valver is being used solely for quality headphone reception and is located close to a transmitter which, due to its power, causes interference when other stations are tuned-in, then the best proposition is a stage of H.F. amplification with a band-pass aerial input circuit.

the possibility of a burnt-out winding is removed and, generally speaking, the overall characteristics of the component are improved.

When it is decided to use two transformers in the same receiver, every care should be taken to see that their "fields" do not interact, otherwise instability and distortion will result. See that they are well spaced and that their cores are at right-angles to each other. If an L.F. whistle is produced, reverse the connections to the secondary side of one of the transformers. If they are not of the same ratio, use the one having the higher value in the first stage and see that adequate anode decoupling is provided.

If space and cost are considerations, one cannot do better than use R.C. coupling throughout; what is even more important, this method also has many strong features so far as quality reproduction is concerned.

All the above details must also be noted when dealing with the average three-valver of the H.F., Det. and L.F. type. With this combination, however, it is possible for the signal to reach a strength, especially on a powerful station, which will cause serious overloading if L.F. amplification is added without thought of the final output valve.

The modern high-slope pentode, for example, does not need a large input to fully load it; therefore, in the case of a three-valver where good average strength is already being obtained, it would be advisable to consider the conversion of the output stage to a large triode power valve or, better still, two power valves in push-pull.

The three common L.F. couplings shown in the diagrams can be used for the cases already suggested, the left-hand valve-holder in each diagram representing either the existing detector or L.F. stage, while that on the right indicates the holder for the additional valve.

Do not make the mistake of leaving the output valve, in the case of a two- or three-valver, in its original holder. It must be removed and fitted into the new output position and a valve of the L.F. type plugged into the then-vacant holder.

Fig. 1.—Resistance-capacity coupling, efficient, compact, and cheap.

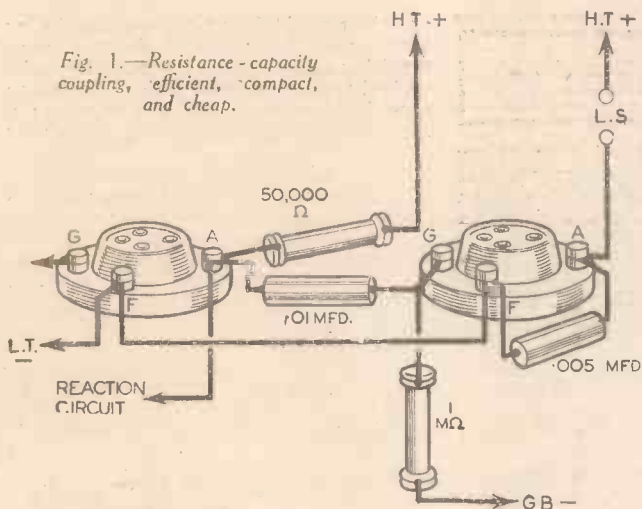

detector grid. This can be done by employing one or more valves so arranged as to form high-frequency or H.F. amplifiers between the aerial input and the detector stage.

Full details of this type of circuit were given in the article appearing in the issue for December 31st under the title of "Making a Range-getter," therefore it is unnecessary to elaborate on the subject further.

There is, however, one point which must be clearly understood regarding H.F. and L.F. amplification, as many readers still make the mistake of confusing one with the other and, likewise, put themselves to a lot of trouble without getting the results they desired. To put it briefly, H.F. amplification should be used when any increase in selectivity and sensitivity is required, while L.F. amplification is solely intended to increase the volume or power of the sound reproduced by the loudspeaker or headphones. It is not possible to give any hard-and-fast rule as to when H.F. or L.F. amplification should be applied, as so much depends on the circuit under consideration, the location of the receiving station, and the actual requirements of the operator. It is possible, however, to give some guidance on the matter, so let us consider the more simple sets in general use.

One-valver

With a set of this type, unless it is being used very close to a transmitting station, it is often necessary to increase the volume sufficiently to enable a loudspeaker to be

hand, the "parallel-feed" method shown in Fig. 3. Another way to avoid trouble is to remove the first L.F. transformer and substitute a resistance-capacity coupling and use the former, either plain or "parallel-feed" for the second stage.

The object of the "parallel feed" method is to eliminate any direct current from the primary winding of the transformer, as by so doing the maximum inductance value is obtained,

Two-valver

The average two-valver is of the Det. and L.F. type, and as such lends itself to amplification on either side of the detector. Assuming that it is again a question of more volume, a stage of L.F. amplification can be added, but certain items have to be watched to avoid distortion and instability.

If a transformer is used for the original L.F. coupling it is always advisable to use resistance-capacity coupling (Fig. 1) for the additional stage, or if another transformer is to

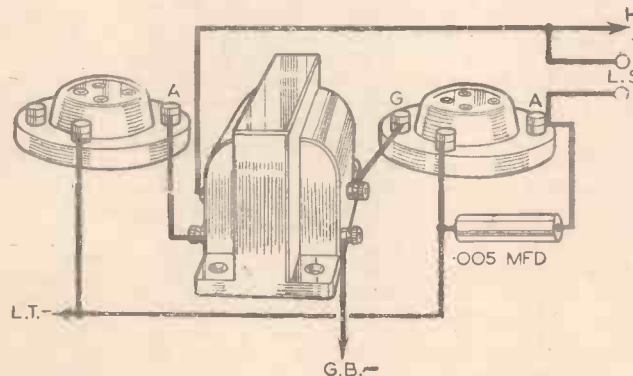

Fig. 2.—The fundamental L.F. transformer coupling. Response affected by design of component.

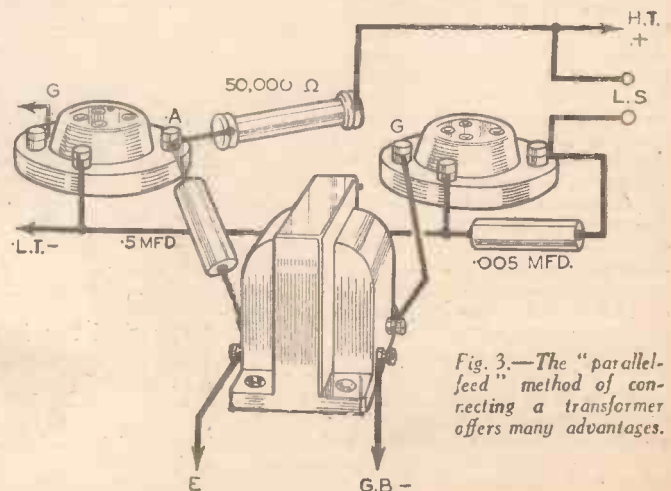

Fig. 3.—The "parallel-feed" method of connecting a transformer offers many advantages.

Fig. 1.—The electric guitar plugged into a standard broadcast receiver.



ELECTRO-MUSICAL INSTRUMENTS

How to Modify Simple Stringed Instruments so that They May be Used in Conjunction With Standard Amplifiers for Reproduction Purposes

TO avoid a wrong impression being created by the title of this article, I wish to stress that it does not refer to automatic musical reproducers operated by electricity, but to instruments which depend on electrical oscillations, of an audible musical frequency, for the creation of a certain band or range of musical tones.

Since the development of the thermionic valve as an oscillator and amplifier of audible frequencies, there have been many systems developed for the production of musical tones, but for some unknown reason they do not appear to have attained any degree of popularity.

Many will remember the broadcasts given by Professor Theremin with his electrical instrument, the range of frequencies of which is governed by a variation in the capacity of an oscillatory circuit, such variation being obtained by the position of the player's hand with relation to a small rod which projects from the top of the instrument.

A Remarkable Instrument

Other systems which made use of the oscillating properties of the thermionic valve were those developed by Dr. Trautwein—the Trautonium, a most remarkable instrument; B. Helberger and P. Lertes invented the Hellertion, while J. Mager—who was one of the first scientists to investigate the subject—produced the Sphaerophone.

All of the above are of the "single note" type, by which I mean it was not possible to produce, at the same moment, a number of tones or a chord, although it is possible to arrange the operating devices so that more than one instrument is under the operator's—I suppose I should say player's—control, thus allowing simple chords to be produced.

While such developments were concerned solely with the valve as an oscillator—the resultant notes being, of course, amplified by other valves—other investigators proceeded along rather different lines, namely, the conversion of mechanical vibrations of a musical frequency into electrical variations.

The Electro-mechanical Method

In this direction, it is interesting to note—after the foreign inventors of the other system—that as far back as 1929 J. Compton, an Englishman, applied for patents relating to the method about to be described.

One might describe this method as electro-mechanical as against the purely electrical arrangements employing the characteristics of a valve or valves, for the simple reason that it depends for its operation on the vibration of the material (strings or wires) which normally produce musical notes, creating weak electrical currents of an identical frequency which are then amplified and reproduced by means of a loudspeaker.

The sound produced by any string instrument is, normally, very weak unless good use is made of a sounding-board, it being well known that the tonal quality and amplification of the sound produced is governed solely by the efficiency and design of such sounding-boards. One has only to consider such examples as the violin, cello, or piano.

Bearing in mind the craftsmanship and selection of material—apart from time—necessary to produce a high-grade sounding-board, it will be appreciated that the initial cost is bound to be high. It is, therefore,

in that direction that the electrical equivalent differs and scores most, as the whole sounding-board system can be dispensed with entirely.

Instruments Fitted with Microphones

One is not concerned with sound but purely the vibrations, and it will be seen, later, that it is immaterial whether the strings are mounted on a length of planking or the finest piece of mahogany. I might add at this stage that certain instruments have been classified as electrical when they are nothing more than a standard instrument fitted with a microphone. Apart from this mention, they are not worthy of inclusion in this article, as the tonal response is not likely to satisfy a critical musician.

The First Instrument

The first instrument I made was, strangely enough, not for use in a musical sense. It was not made with the idea of being played, but merely to assist in certain experiments I was then carrying out with loudspeakers. It was only at a later date that I applied the same idea to musical instruments, the guitar being selected because of its appeal and popularity.

The sketch (Fig. 4) shows the basic idea of the system, and it will be recognised by

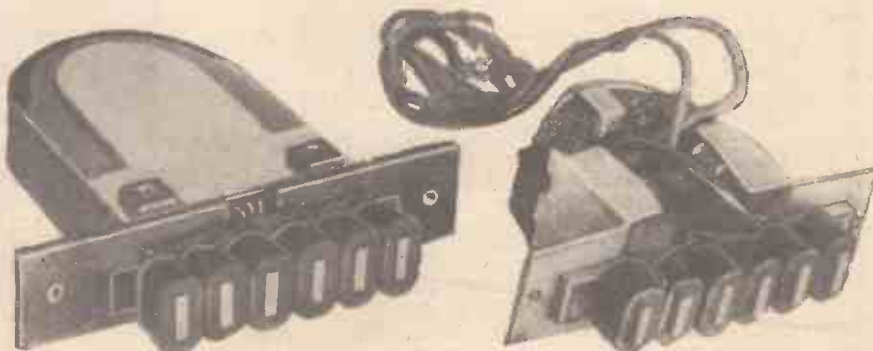

Fig. 3.—(Right) The first guitar unit made. (Left) A view of the unit which is fitted to the guitar.

anyone with any knowledge of the elementary principles of electricity, as an application of the theory of the early dynamos.

The wire *s* represents the "string" of the instrument, it being firmly fixed between the two points *a-b*, with a simple device to vary the tension fitted at *a*.

The vertical metal strip *c* acts as the "bridge," and maintains the wire at a certain distance above the baseboard *d*, which in the first model was a piece of ordinary pine wood.

At the point *u* is fitted the unit which is shown in detail by Fig. 5. It will be seen that the unit consists of a horseshoe magnet *m*, to which is bolted two soft-iron pole-pieces carrying the bobbins *e* and *f* which house spools of very fine wire.

The unit is so fixed to the instrument that the wire *s* is free to vibrate in the gap *g*, between the pole-pieces, thus creating in *e* and *f* minute electrical currents having a frequency identical to that of the vibration of *s*.

Producing Notes

If it is desired to produce notes other than the fundamental, i.e., the note produced by the open string, it is only a matter of sliding a finger along *s* and depressing it against the base-board, after the method adopted with a one-string fiddle.

The weak electrical currents have to be amplified before they are capable of operating a loudspeaker, and it is necessary to see that both the amplifier and speaker are capable of handling—without distortion—the frequencies under consideration.

Those interested in carrying out tests of apparatus at certain musical frequencies will see how the apparatus readily lends itself to such work, as it is capable of producing notes over a very wide range.

The one-string fiddle effect mentioned above tempted me to convert one of those instruments to the electrical method, and I must say that the effects produced—when it is in the hands of a capable player—are very different from those usually associated with such an instrument. As a point of interest, I once had it played—by a musician—in a large dance hall, and although I was using only a 5-watt amplifier, I had to keep the control well down, otherwise the intensity of sound was more in keeping with that of a small organ.

The Guitar

The next instrument I converted was an ordinary, very cheap guitar. I selected a

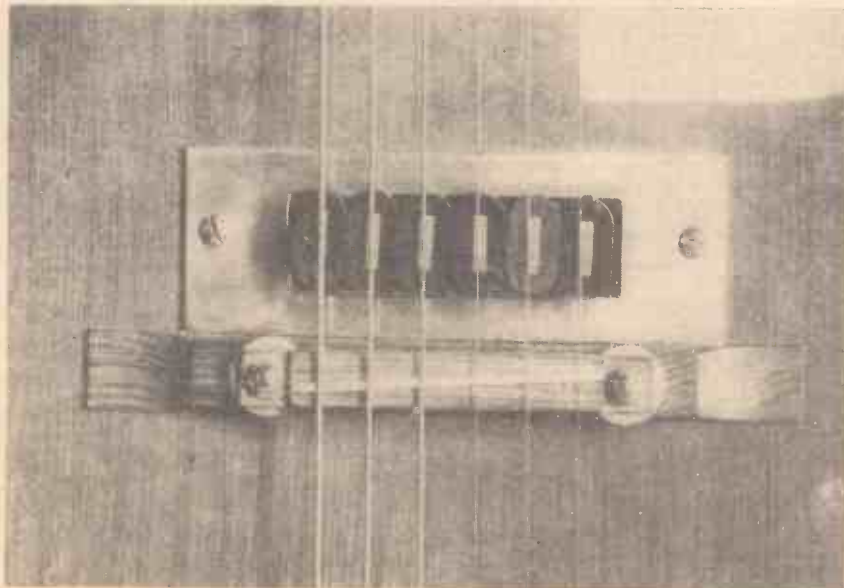

Fig. 2.—How the magnets are placed beneath the strings.

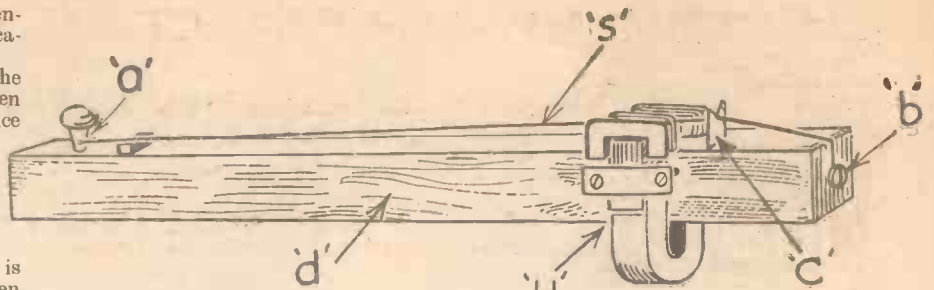

Fig. 4.—A one-string fiddle with the unit fitted into place.

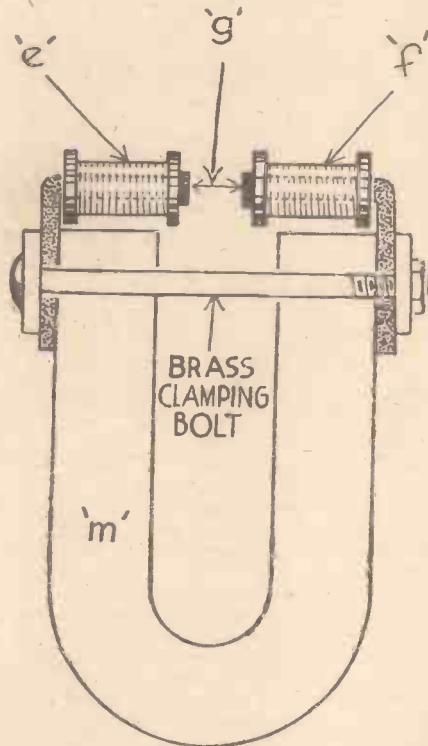

Fig. 5.—Details of the unit used for the one-string fiddle.

cheap model for two reasons. Firstly, I did not wish to pay a big price for something to be used for experimental work and, secondly, I wished to prove that the quality

of the belly or sounding-board would not affect the tonal response.

The big snag with the making of the unit was to provide six pole-pieces each having similar flux densities; bearing in mind that the complete magnetic system had to be compact and light and that space—the distance between strings—was rather limited.

The arrangement used for the one-string fiddle could not be used; therefore I devised the unit shown in Fig. 3 for my first model.

The belly of the guitar was cut just in front of the bridge, and a slot made sufficiently large enough to take the bobbins, the unit being bolted on to the belly. It was soon found, however, that such an arrangement was not good enough to satisfy a critical musical ear.

There was the question of relative output of each string, owing to the vast difference in fundamental frequencies. There was also the question of microphonic noises and the little matter of sustained notes and plectrum "flick." However, these snags were eventually removed, and the resultant unit was such that it could be fitted to any guitar; and, providing the instrument was suitable, it could be used for Spanish or Hawaiian fashion, some really beautiful effects being possible once the player has mastered the technique of an electrified instrument.

Separate Pick-up Coils

Many of the commercial models—chiefly American—do not make use of a separate pick-up coil for each string, but rely on one pick-up arrangement covering the complete range of frequencies. Again, many of them have taken advantage of the fact that a sounding-board is not required, making the body or belly of the guitar out of metal. That is quite in order, but if—as I have seen happen—the associated amplifier packs up during a performance, the instrument cannot be used as an acoustic model as my design allows.

The photograph of the complete guitar—arranged for Hawaiian playing—shows that the unit is neither unsightly nor cumbersome. In fact, it does not affect, in any way, the playing of the instrument as an ordinary model if so desired.

Personally, I favour finger playing, but if a plectrum is used I would suggest that one be made from fairly stiff material with a soft surface, such as rubber, felt, or leather.

NOW READY!

**WORKSHOP CALCULATIONS,
TABLES AND FORMULÆ**

By **F. J. CAMM**

3/6, by post 3/10, from George Newnes,
Ltd., Tower House, Southampton Street,
Strand, W.C.2.

A PAGE OF PRACTICAL HINTS

SUBMIT YOUR IDEA

READERS WRINKLES

THE HALF-GUINEA PAGE

A "Band-spreading" Dial

I WANTED a dial with more scope, so that instead of about a 4in. space per metre, I should have about one to one-and-a-half inches, to allow me to tune to decimals of a metre. As commercial models for this purpose were too expensive, I contrived the device shown in the sketch. The arrangement works quite satisfactorily.

Constructional details are clearly shown in the sketch in which A is a red line showing the end of a tape (which is inci-

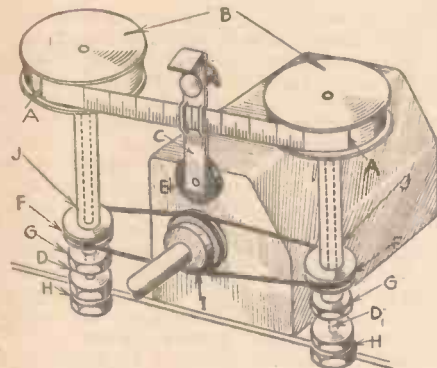

A novel "band-spreading" dial arrangement.

dentally an old tape measure). Two old typewriter ribbon reels B are sweated on to pieces of brass tubing J, 3/32 in. inside diameter, 5/32 in. outside diam. A strip of tin 1in. wide, about 22 G, is slotted and drilled, as shown in sketch, to hold a bulb, and also at the same time to hold the tape straight. D is a 1/16 in. diameter rod, length according to height of tuning condenser, and is threaded for 1in. at one end. E is an insulating washer, and F, F, are brass pulleys sweated on to the tubes J, J. Nuts G on the rod, at the extreme end, hold the tube firmly, while nuts H hold the rods on to the chassis A. Brass pulley I is fastened to the condenser spindle by a grub screw. The ratio of I to F is according to the space per metre required.—R. BADDOCK (Meersbrook).

A Novel Test Board

AS I carry out a lot of experimenting I often wish to test coils, chokes and condensers, etc., and being on D.C. mains I have made use of these as a source of supply. The accompanying illustration shows how I have made up a neat test board incorporating a flasher bulb, a carbon lamp, switch and fuses, and the circuit is inset. The test leads should, of course, be well insulated, and it is a good plan to use the safety type of prod with a recoiling point on one of them. The flasher bulb is readily obtainable at this time of the year, and is of the type used for Xmas decorations. They may be found at the local sixpenny stores.—C. DICKSON (Belfast).

THAT DODGE OF YOURS!
Every Reader of "PRACTICAL AND AMATEUR WIRELESS" must have originated some little dodge which would interest other readers. Why not pass it on to us? We pay £1-10-0 for the best wrinkle submitted, and for every other item published on this page we will pay half-a-guinea. Turn that idea of yours to account by sending it in to us addressed to the Editor, "PRACTICAL AND AMATEUR WIRELESS," George Newnes, Ltd., Tower House, Southampton Street, Strand, W.C.2. Put your name and address on every item. Please note that every notion sent in must be original. Mark envelopes "Radio Wrinkles." DO NOT enclose Queries with your wrinkles.

SPECIAL NOTICE
All wrinkles in future must be accompanied by the coupon cut from page iii of cover.

Frame Aerial Direction Logging Mechanism

I HAVE been carrying out some rather interesting experiments round the 160-metre band, and with an outside frame aerial.

From the accompanying sketches, it will be seen that with some soft steel strips, an 18-gauge aluminium disc 10in. diameter, and a few cogs obtained from a well-known mechanical constructional toy, I have managed to obtain a well balanced friction drive, the vertical aerial shaft being coupled by a strong cord, via two grub-screw fitted pulleys.

The friction drive was quite simple, comprising a couple of rubber disc wheels, also obtained from a toy.

It was at first a little difficult to decide upon a suitable form of weather-proofing for the external aerial—which, by the way, is mounted through the shed roof—but I eventually got over the trouble by passing the vertical driving rod through another piece of tubing, this being clamped to the roof internally.

My logs, I, of course, had to modify to

include the compass readings, and for clarity, the divisioning of the paper record was arranged in 1/4ths between each indication, such as from NNE to NE, etc. The leads from the frame aerial had to pass through the brass tube down to the receiver, and I realised that unless allowance was made for the take-up in the directional

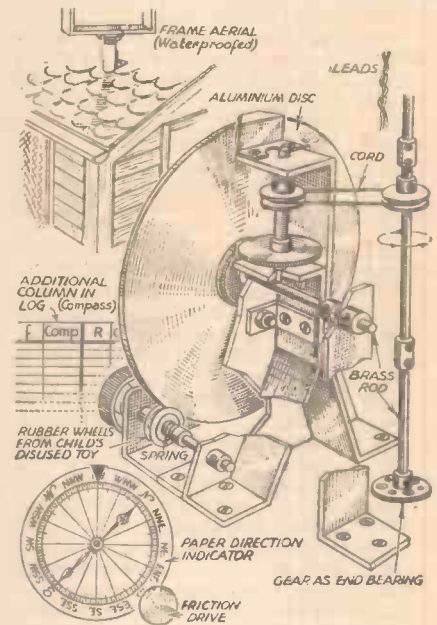

An interesting frame-aerial direction logging device.

mechanism, these leads would either foul the vertical rod, and thus restrict its movement, or the edge of the tube near the frame would chafe the insulation of the wire; I therefore gauged the amount of take-up first of all, then made sure that apart from the protection afforded by bevelling the edge of the tube the connections to the frame aerial were kept reasonably clear by allowing about 1in. between the top or edge of the tube, and the points of connection to the frame.

The down leads were prevented from getting caught up with the pulleys, etc., by simply anchoring them near the receiver with an elastic band (not shown in the sketch).

Finally, the principle can be used quite satisfactorily down to about 100 metres, provided that the lengths of the down leads are taken into consideration when winding the aerial, but below this the increase in frequency cannot be handled with stability.—I. D. LENNOCK (Enfield.)

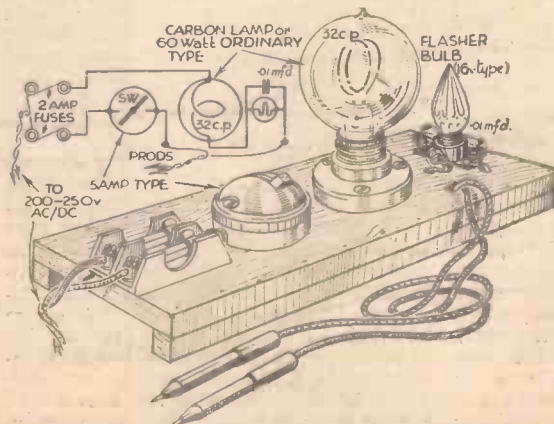

A simple test board for experimental work.



Practical Television

January 7th, 1939. Vol. 3. No. 133.

Screen Brightness

IN Germany, recently, a series of experiments were undertaken on the problem of screen brightness in cinema theatres. The results after careful collation showed that the threshold sensitivity of the eye varied considerably according to the time allowed for the adaptation of the eye to the new conditions. In addition, it was noticed that acuity of vision increased rapidly up to 5ft. candles, but after this it remained nearly constant. The perception of picture contrast, however, increased to a maximum of 70ft. candles, while the perception of flicker was approximately proportional to the logarithm of the light intensity. The importance of these observations is brought to the fore when consideration is given to any form of big-screen television picture reproduction for mass entertainment in a cinema, on lines similar to those which have already been undertaken in recent demonstrations. According to measurements which have been made in some of the modern London cinemas the high light illumination in lux falling on a screen, say 16ft. by 12ft., varies from between 40 to 150 lux. Corresponding figures for a home cine projector using a 4ft. by 3ft. screen are 10 to 50 lux. With a simple form of screen 8ft. by 6ft., and using a straightforward cathode-ray tube projection receiver, the last published figure for high light illumination was 5 lux, but since this is about 20 times what it was two years ago, it is reasonable to suppose that if the same rate of progress is maintained then the minimum figure mentioned for the cinema screen will soon be reached, although it must be borne in mind that the television screen is one quarter of the cinema screen area. If special beaded or directional screens are employed (the Fernseh screen in Germany is an example of the latter), then this figure is multiplied by three and five, respectively. It will be seen, therefore, that the television cinema screen, over quite a short period of development, is making good progress towards the high standards to which the public have become accustomed as a result of what has been shown through the medium of standard talking film presentation and technique.

Multipliers Again

THE application of the principles of electron multiplication is becoming of increasing importance, and evidence in support of this is clearly defined in the various sections of industrial equipment where apparatus based on the working of these devices is incorporated. Because of this, research engineers are devoting much of their time to increasing the efficiency of this electron unit. For example, in the case of the successive type, where progressive electron impacts occur on separate surfaces down the tube, there is always a tendency for a certain proportion of the electrons to move down an axial field, and by avoiding impact, fail to add their quota of secondary emission to the final output current. There

are several ways in which this effect can be reduced or eliminated, and one of the most interesting is to insert open mesh electrodes between the successive target plates. The application of suitable biasing voltages to these electrodes ensures that the electron stream is forced to follow a path that will make certain that target impacts take place. There is an added advantage, however, this being based on the Weiss principle of electron multiplication. The open mesh grids are coated with a secondary emissive substance so that in passing through, the electron stream, by impact on the grid network, releases additional secondary electrons, and these increase the value of the final electron current still more.

Still a Rival Industry

THERE are still certain sections of professional stage artists who regard television as a rival industry which will bring harm to their legitimate activities. This is surely the wrong attitude to adopt towards a new invention which must perforce use the artists' "wares" in order to produce programmes of sustained entertainment value. The domestic television set is, of course, a new device which provides additional pleasure in the home, but it is certain that the average housewife regards her recreation as something which takes her away from the domestic environment in which she exists for such a long time each day. The television broadcast of excerpts or even whole plays has not reduced the box office takings, but on the contrary has stimulated them in a manner which astute managers are already beginning to realise. Co-operation in the early days of this new television art will have its repercussions in the most favourable manner as it progresses. Opposition breeds ill-will and forces the adoption of substitutes which defeat the objects of the obstructive force. A quiet but sensible readjustment of ideas and outlooks as far as public entertainment is concerned is wanted, and only by taking a long view of the matter, and allowing wise counsels to predominate, will every party fit in with the new order of things which is slowly but surely shaping the lives of everyone.

Midland Controversy

IN the Sheffield district there has been a good deal of controversy lately concerning the suitability of the city as a site for a television transmitter. Many ultra-short-wave surveys and tests have been undertaken with relatively low power in an effort to arrive at some definite conclusion. One point which is so often overlooked, however, is the different nature of the ultra-short-wave propagation characteristics of a carrier which is modulated with audio frequencies, and one which is modulated with the complicated picture frequencies, and their accompanying injected synchronising pulses. Electrical interference certainly has a marked bearing

on the problem as well, but already steps are being taken to minimise this by more efficient aerial arrays, while the promised Government legislation will advance the solution to the difficulties a stage farther. The activities of the serious experimenter should be encouraged in every way, but it would be wrong to attempt to draw up any definite conclusions until the collation of data over a wide area and a long period of time has been undertaken using the correct form of radiated signal on which all the tests are based. That good television pictures have been received in the Sheffield neighbourhood has already been established, and it seems certain that when a transmitter is made available within easier reach, then the results achieved will be better than the sanguine forecasts based on present conditions.

A Fluorescent Combination

THE aim to achieve brighter pictures has resulted in many different schemes being proposed, and tried, to achieve what is regarded as the most satisfactory solution. In the case of the projection type cathode-ray tube receiver it is often found that the degree of brilliance required on the small tube screen, with its fluorescent powder coating, is so high, in order to secure a good magnification on the remote screen, that the life of the tube suffers, due to an actual burning of the powder under the influence of the intense electronic bombardment. An alternative solution which has been suggested to meet this difficulty takes advantage of a combination of screen powders which fluoresce at different colours owing to their varied chemical combinations. For example, the first screen on which the brilliant picture is produced is made with a calcium tungstate base, and this produces a brilliant but too predominating blue image. This, however, is then focused on to a second screen having a zinc and calcium-sulphide composition which gives, under normal electronic bombardment, a red-orange picture. By being subjected to the blue light of the first picture, however, the final result of the colour combination is one which very closely approximates to a black-and-white picture. Other schemes of a radically different character are being tried with every hope of success, and no doubt in due course the economically suitable one will be developed.

A Disappointing Statement

IT is a matter of extreme regret that the Postmaster-General's reply to a recent question in the House of Commons could not have been more explicit. For some time it has been felt that an extension of the Television Service to the Midlands was reasonably near, but the P.M.G. was very non-committal. While agreeing that the Television Advisory Committee had given the matter consideration, he was advised that further research had to be undertaken before any recommendations could be made. This attitude of withholding any positive statement on the position has persisted for some time now, and surely the public were justified in feeling that they should be at least informed of the progress made in the research which is being carried out by the Post Office. Certain sections of the radio trade may feel that since there is no immediate prospect of a service in the Midlands, then anyone who may have deferred the purchase of new sets will now spend. This is not a logical conclusion, however, and the uncertainty may still exist because there is still no idea given of the time factor involved before the claims of the provinces are met in full.

TROPHY Short Wave RECEIVERS

*A Thrill a Second guaranteed—even for the Beginner—
on an Easy-to-Buy TROPHY Communication Type Set*

12 Months' Guarantee



Trophy 8 rear chassis view.

NEVER before has short-wave listening been so interesting—enjoyable—thrilling as it is to-day and whatever TROPHY you choose, you are guaranteed amazing results. All-British TROPHY communication types incorporating special refinements and the popular TROPHY 3-valvers—all in the low price field, are demanded now by DX Hams and beginners. Don't wait . . . Secure your TROPHY—NOW. You'll find it the best set you've ever operated—the ideal 2nd receiver for home use.

TROPHY 8

A.C. COMMUNICATION TYPE RECEIVER

- 8 Valves, 5 Wave-bands, 43 M.C. to 545 K.C. Complete coverage.
- Continuous Band-Spread Dial.
- R.F. on all bands.
- A.V.C. and B.F.O. on-off switches.
- Beat Frequency Oscillator with separate pitch control.
- High impedance output socket for generally preferred separate P.M. speaker.
- Headphone Jack.



SPECIFICATION—The TROPHY 8 communication type receiver with a continuous wave range of 7-550 metres, is confidently recommended to all short-wave enthusiasts. Maximum results are assured by a band-spreading tuning arrangement and by the incorporation of special refinements—appreciated by the most critical—and guaranteeing by practical and scientific methods, the reception of those highly interesting and thrilling transmissions always to be found on the Short Waves. Supplied complete in cabinet as illustrated above, accurately aligned and ready for immediate use. Fully Guaranteed. For A.C. mains only, 200/250 volts, 40/100 cycles. CASH or C.O.D. 12 Gns. Terms: 15/6 down and 18 monthly payments of 15/7.

15/6
DOWN

TROPHY 3 Battery and A.C. SHORT-WAVE SETS

6-550 METRES

- Proved amazingly sensitive circuits.
- New and improved slow-motion tuning method free from backlash.
- High-fidelity incorporated speaker.
- Phone Jack.

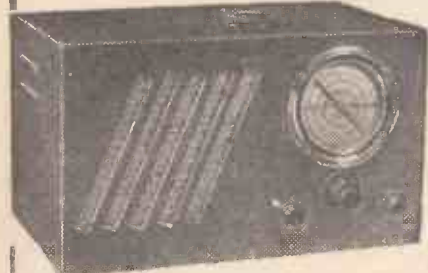

The TROPHY 3 is available for A.C. mains and battery use, employs a metro calibrated scale and is housed in a pleasing finish steel cabinet. Supplied with self-locating inductors for 12-52 metres.

7/- DOWN
BATTERY Less batteries, Cash or C.O.D., £5 15s., or 7/- down and 18 monthly payments of 7/-.

A.C. Cash or C.O.D. £6 6s., or 7/6 down and 18 monthly payments of 7/9.

7/6 DOWN

Features

- 5 valves.
- Wave range 10-550 metres continuous.
- Improved method of Bandspread tuning.
- A.V.C. and B.F.O. on-off switches.
- For single wire or doublet aerial use.
- Built-in speaker and Phone Jack.

TROPHY 5

12 months' guarantee



The TROPHY 5-valve A.C. junior communication receiver as illustrated is proving most popular among experienced DX operators and enthusiasts in general where a moderately priced and efficient short-wave receiver has been needed for use on A.C. supplies. The wide coverage and improved method of bandspread tuning are two only of the outstanding features which have contributed to the success of the TROPHY 5. Entirely self-contained. Ready for immediate use. CASH or C.O.D. £9. Yours for 10/9 down and 18 monthly payments of 10/9.

10/9 DOWN

● SEND NOW for Trophy and complete Short-wave radio lists.

PETO-SCOTT CO. LTD. 77 (Pr.21), CITY ROAD, LONDON, E.C.1. Tel. Clissold 9875. 41 (Pr.21), HIGH HOLBORN, LONDON, W.C.1. Tel. Holborn 3248.

PRACTICAL MECHANICS

Contents of the January Number include:—

A MIRACLE OF ENGINEERING
AUTOMATIC TRAFFIC SIGNALS—HOW THEY WORK

MAKING A "CANNONETTE" TABLE
REPAIRING ELECTRICAL DOMESTIC APPARATUS

WATCH REPAIRING AND ADJUSTING

THE WORLD OF MODEL AVIATION
TOOLMAKING AND TOOL DESIGN

COMEDY ILLUSIONS

Of all Newsagents and Bookstalls

6^D JAN.

NOTES FROM THE TRADE

New Philips Short-wave Receivers

MESSRS. PHILIPS announce a special range of short-wave receivers, of which limited quantities are available through appointed Philips dealers. In view of their exceptional short-wave performance and wide coverage, these will have a particular appeal to amateur transmitting circles, short-wave clubs and similar bodies.



Model 803 which may be used as a floor or table model.

Model 361A is a table model superhet, with wooden cabinet. It has a horizontal adjustable dial, edge lit, and incorporates the "E" series of valves. The bands are from 9.5 to 570 metres, divided into four separate sections. Inverse feed-back is provided in the L.F. stages and there are extension speaker and pick-up connections. A very efficient A.V.C. circuit is included. The price is 15 gns., and the set is for A.C. operation.

Model 771A is substantially the same but it has a console cabinet and is fitted with a special concert-type speaker. The price of this model is 23 gns.

Model 362A is a table model with very similar characteristics, but tunes down to 5 metres and up to 580 in five separate stages. The price of this model is 20 gns.

All three models may be readily adapted for operation on D.C. mains by the addition of a special converter.

New Erie Components

THE 1939 programme of the Erie Resistor Company is now announced, and in addition to the fact that they are now distributing their products direct from the works there are several interesting details to be observed. For the service

engineer, a modification of the volume control design will prove of value. This is now fitted with a long duralumin spindle which can be cut with a knife or notched with a file, and broken easily to any required length, thus saving the expense of stocking many different types of volume controls in different spindle lengths.

To eliminate the risks of short-circuits the $\frac{1}{2}$ -watt and 1-watt resistors are now fitted with a ceramic case. Vitreous wirewound resistors are available in all standard ohmic values. Silver ceramic condensers, and silver mica condensers are also added to the list. Prices have also been reduced—in the case of the carbon resistances the reduction being 50% and in the case of ear radio suppressors the reduction is from 3s. and 3s. 6d. to 1s. 6d. A catalogue will shortly be available, but in the meantime we can announce that carbon resistors will cost from 3d. upwards (from $\frac{1}{2}$ watt to 5 watt); wirewound resistors from 2s. 6d. to 9s. and tone controls from 3s. to 5s. 6d.

New McMichael Receivers

THE accompanying illustrations show two new McMichael receivers, models 386 and 803. The former is an 8-stage all-wave radiogram and the latter a similar model designed as a floor or table set. The wave-ranges are from 16 to 2,000 metres, and all the usual refinements, such as A.V.C., etc., are incorporated. Model 386 delivers an output of 5 watts from a beam tetrode final stage to a concert-grand speaker, and a tone-compensated volume control and super-fidelity 4-way tone control



Model 386—a combined radiogram.

are provided. Separate edge-lighted tuning scales are provided for each waveband and the mains consumption is 70 watts. Model 803 has a waverange from 19 to 2,000 metres and also has separate scales. The extra-speaker sockets are switched and there are special constant-gain high-performance aerial couplings, etc. This also has a mains consumption of 70 watts. Prices are 20 gns. for the Model 386 and 16½ gns. for 803. The stand shown in the illustration of the latter model costs 2 gns. extra.

ITEMS OF INTEREST

New Method of Giving Road Reports

WE are informed that the A.A., the R.A.C. and the B.B.C. News Department have decided to adopt a new method of giving to listeners who are interested in road reports a rough idea of conditions all over the country in the shortest possible time.

In future when the weather is bad the B.B.C., after broadcasting weather news, will give information designed to reassure listeners who may have to travel in those parts of the country which are unaffected by the weather.

The announcer will first try to indicate clear areas by asking listeners to imagine lines between well-known points and will use only the points which appear on a map which has been specially prepared for the B.B.C. by the A.A. in collaboration with the R.A.C.

The B.B.C. hopes that this map will prove useful to listeners, and suggests that it should be kept by them for future reference. Copies will be sent free to all who apply for them to any office of the A.A. or the R.A.C.

After dealing with districts which are clear, the B.B.C. will take badly affected areas, and will indicate which of the main roads in them are still passable for motor traffic.

London Music Festival, 1939

IT is interesting to note that the B.B.C. Symphony Orchestra will give nine Beethoven concerts in the Queen's Hall

next May, seven of which will be conducted by Toscanini, and two by Sir Adrian Boult. These concerts will be the main contribution of the B.B.C. towards this year's London Music Festival, which will open on April 23rd, as already announced, and continue until the end of May.

The Festival this year will be on a larger scale than ever before, and all the leading orchestras and concert-giving organisations in London and nearby centres will take part in it. The programmes and dates of the seven Beethoven concerts to be conducted by Toscanini, which will include all the nine Symphonies, are as follows:

| | |
|---|---------------|
| Overtures "Egmont" and "Prometheus"; Symphonies Nos. 1 and 2 | May 3 |
| Overture "Coriolan"; Symphonies Nos. 3 and 4 | May 8 |
| Symphonies Nos. 5 and 6 | May 12 |
| Overture "Leonora No. 1"; Symphonies Nos. 7 and 8 | May 17 |
| Overture "Leonora No. 3"; Adagio and Allegretto "Prometheus" Ballet Music; Symphony No. 9 | May 22 |
| Mass in D | May 26 and 28 |

The two concerts which Sir Adrian Boult will conduct include the Third and Fifth Pianoforte Concertos, with Wilhelm Backhaus as soloist (May 7th); and the Fourth Pianoforte Concerto and Violin Concerto, with Solomon and Adolf Busch (May 21st). All the concerts will be broadcast.

PATENTS AND TRADE MARKS.

Any of our readers requiring information and advice respecting Patents, Trade Marks or Designs, should apply to Messrs. Raynor and Co., Patent Agents of Bank Chambers, 29, Southampton Buildings, London, W.C.2, who will give free advice to readers mentioning this paper.

Notes from the Test Bench

Trimming a Superhet

WHEN a superhet has been built it is necessary to align accurately all the various circuits before maximum results can be obtained. Usually, this means that the I.F. transformers (two circuits to each), the aerial coil and the oscillator coil have all to be adjusted to a certain position, and in many cases it has been found that the constructor merely adjusts the I.F. transformers. The result of this is that signals can be received, often at several points on the dial, merely because the transformers have been adjusted

so that they are set to the frequency obtained by the balance between oscillator and aerial coils. It must not be overlooked, however, that the oscillator tuning condenser, together with the value of the oscillator coil inductance, are designed to give a definite frequency separation throughout the tuning scale, and until this has been correctly adjusted a different frequency will be obtained at various settings.

Multi-electrode Valves

THERE are several valves on the market at the present time in which there are, in effect, combinations in one envelope of the electrodes of two or more valves. It is often possible to use these individually, ignoring for some particular reason the electrodes relating to one section. For instance, a double-diode-pentode is on the market which possesses unusual charac-

teristics in the pentode section, and it is possible to use this as a straight pentode.

Push-button Tuning

THE majority of push-button tuned sets provide separate stations for each button. Where, however, the push-button mechanism does not operate the wave-change switch it is possible by careful adjustment of coil and condenser values to obtain two stations for each button—one on the medium and the other on the long waves. In that case, of course, the appropriate button is operated, and the wave-change switch then provides the alternative station. In some standard receivers it is now found, for instance, that Luxembourg and one medium-wave station require a similar setting on the dial and thus these are readily obtainable without modification, provided that separate wave-change switching is provided.

MORE N.T.S. NEW YEAR BARGAINS

COSMOCORD PICK-UP BARGAIN



LIST VALUE 15/- **6/6** POST FREE
Limited stocks now, you must hurry. Brand new COSMOCORD highly sensitive pick-ups, complete with Arm Rest and Screened Lead. Only an exceptional purchase allows us to offer at less than list price. An excellent opportunity for you to fit an improved pick-up for electrically reproducing your gramophone records. A real bargain at 6/6, cash or C.O.D.

SENSATIONAL OFFERS

Here is your chance to secure components of well-known manufacture at fraction of usual list prices: parts that you can use NOW and handy always to have by you for repairs and replacements. N.T.S. again passes on the benefits obtained by favourable purchases. ORDER NOW.

BARGAIN 4/11

List 35/- Post 9d. extra
Bargain parcels, list value 35/-, comprising universally ready-drilled brand-new steel chassis, transformer, 6 resistances, fixed condensers, 2- or 3-gang tuning condenser, reaction condenser, potentiometer, and coil; for battery or mains sets. State which when ordering.

SERVICEMEN—CONSTRUCTORS, this is AMAZING VALUE—SAVING YOU £££s

BARGAIN 6/11

Value 35/- to £2 Post 9d. extra
Comprising: 2 brand new screened iron-core Dual-range coils, each size 3in. by 2 1/2in., with solid contacts and leads. 1 brand new 2-gang bartype .00043 mfd. condenser for broadcast or all-wave sets. 1 brand new shrouded L.F. transformer with terminals. 1 steel chassis. Tested circuit S.G.3 diagram showing all coil connections. **S.G.3 KIT**

BARGAIN VALVES

You are advised to order NOW the types below offered to you at special prices. Send also for complete replacement chart covering over 100 different types for all replacement purposes. Orders over 10/-, postage paid British Isles.
MAINS VALVES, British, 4-volt I.H. ACL and ACHL, 4/3. AC/VS. AC/V5. AC/VMSG, AC/HP and High Slope Output Pentodes, DH Full Wave Rectifiers 350-0-350v. 120 mA and 1H Full Wave 400-0-400v. 120 mA., 5/-.
Battery 2-volt British Valves, Det., L.F., and H.F., 2/3. Power and Super Power, 2/9. 5G, V.M., HF and LF Pentodes and Class "B" 5/-. Frequency Changers, 7/-.
B.T.S. ULTRA S.W. TUNING CONDENSER. Maximum capacity 67 mmfd. heavily silver-plated vanes and spacers. Improved method for contacting moving vanes ensuring low impedance. Usual price 7/6. BARGAIN, 3/6.
B.T.S. ULTRA S.W. TUNING COILS. Comprising 2 coils (1 3-turn and 1 2-turn) employing self-supporting 15 swg copper wire silver-plated to reduce resistance to HF currents. Ready mounted with connections on low-loss block. Usual price 2/9. BARGAIN, 1/6.
SPEAKERS, P.M.'s, well-known makes, 8in. cone, for Power or Pentode, 12/6. Goodmans and Celestion 6in. P.M.'s, 7/6. Mains TRICKLE CHARGER, 2r. 1 amp. Model, Metal Rectifier, 10/-.
STRAIGHT THREE Chassis, less valves, fully tested, 12/6.
KNOBS, 1 doz. assorted control knobs, 1/-.
VOLUME CONTROLS, POTENTIOMETERS. Well-known makes, all values up to 1 meg., 2/-; with switch, 2/6.

STILL AVAILABLE !!

5v. A.C. All-Wave RADIOGRAM CHASSIS LIST VALUE £8 : 18 : 6 BARGAIN £4:17:6

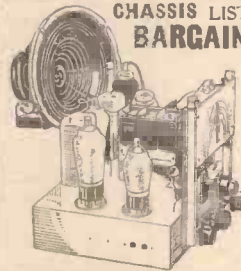

- 6-stage s/hct. circuit.
- All waves, 18-2,100 metres.
- Station-name dial.
- A.V.C. and tone control.
- 3 Watts output.
- Fully guaranteed. Complete with 5 valves, and knobs, Teas speaker. Yours for 5/- down, balance in 18 monthly payments of 6/3. To tour the world is

simple on this amazingly efficient 6-stage all-wave superhet. Wonderful selectivity and quality reproduction. F.V. sockets. No-trouble wave-change and grammo switching. Chassis size, 11 1/2 ins. wide, 8 1/2 ins. high, 8 1/2 ins. deep. Ready to play; for A.C. mains only, 200,250 v. With matched moving coil speaker. Cash or C.O.D. £8/5/-, or 5/- down & 18 monthly payments of 7/11.

5/- DOWN

1939 All-wave Battery S.G.3

AMAZING FAMOUS-NAME OFFER LIST VALUE £8 : 15 : 0 BARGAIN £4 : 19 : 6

5/- secures, balance in 18 monthly payments of 6/4

This superb Super All-Wave Battery S.G.3 receiver, as illustrated, will give you programmes from all over the world. Circuit comprises V.M.H.F. Pentode, High Efficiency Detector and Harries distortionless output Pentode. 4 Wave-ranges, 18-2,100 metres. Station-name dial. Exquisite walnut cabinet measuring 19 1/2 ins. high, 16 1/2 ins. wide, 11 1/2 ins. deep. Tone-compensated moving-coil speaker fitted. Less batteries.



HURRY! SECURE THIS GREAT SET WHILE STOCKS LAST.

IMPOSSIBLE TO REPEAT POWERFUL CLASS "B4" ALL-WAVE CHASSIS Complete with Valves

LIST VALUE £7:0:0

Bargain 79/6

or 5/- down, balance in 15 monthly payments of 6/-. A snip not to be missed. Volume and range equal to a mains set. 3 wavebands, 18-2,100 metres. Efficient S.G. Bandpass circuit. Station-name dial. Screened coils. Chassis size 11 1/2 ins. wide, 9 1/2 ins. high, 8 1/2 ins. deep. Complete with 4 matched valves. Guaranteed, fully tested. Available with matched moving-coil speaker, cash or C.O.D., £4/19/6, or 5/- down and 18 monthly payments of 6/3.



ONLY A FEW LEFT

COMPLETE Your GEAR

WITH A BARGAIN S/WAVER

Tour the World on 9-200 Metres.



YOURS FOR 2/6
DOWN VALVES GIVEN FREE

N.T.S. Battery Bandspread Short-Wave Kits include only first-class component parts and are supplied absolutely complete with all coils for 12-94 metres—matched and tested valves GIVEN FREE. For those who wish to use existing A.C. supply an N.T.S. Eliminator is at the moment available at the special bargain price of 15/6. ORDER EARLY.
3-Valve BANDSPREAD. Amazingly efficient 3-valve Pentode output model. All-World phone and loudspeaker reception. Complete kit with FREE VALVES. List value 87/6. BARGAIN. 42/- or 2/6 down and 12 monthly payments of 3/9.
4-Valve S.G. BANDSPREAD. Powerful S.G. Det., L.F. and Pentode output receiver. Bandspreading ensures all-band reception. Complete kit with 4 FREE VALVES. List value 89/6. BARGAIN: 42/6 or 3/6 down and 12 monthly payments of 4/3.
1-Valve SHORT-WAVER. A marvellous single valve receiver providing wide-world short-wave results on 12/84 metres. As a special introductory offer to beginners this kit is available with all coils, pair of lightweight phones and FREE matched valve. List value 55/-. BARGAIN. £17/6 or 2/6 down and 11 monthly payments of 2/6.

SPECIAL OFFER

New light weight super-type HEADPHONES, recommended for short-wave work and testing. LIST VALUE 15/- BARGAIN 3/6 Postage 6d. extra.



3 MATCHED VALVES (VALUE 35/-) FOR 5/6!

Complete with 3 valveholders, and post free. AN investment for every set owner and constructor, 3 A matched, brand-new world-famous Philips 2-volt battery-type valves, comprising 2 S.G. H.F.'s and 1 Output Pentode, packed in original cartons. Three different valve types, indispensable for modern constructor's circuits (available on request) using any number of valves, invaluable also for replacement purposes. Offered to you at a fraction of manufacturing cost... a real scoop in N.T.S. bargains. Order now while supplies hold out!

★ FREE! NEW N.T.S. SHORT BOOK

Containing full descriptions with photographs of the complete range of bargain Bandspread and World kits and amplifiers with useful data for enthusiasts. SEND NOW for your FREE copy and also Receiver and chassis lists, and Bargain Valve Replacement chart.

NEW TIMES SALES CO.
56 (Pr.W.21), LUDGATE HILL, LONDON, E.C.4
Phone: City 5510. Est. 1924.
SEND FOR BARGAIN LISTS

GREAT NEW DOUBLE-CHANCE CARD GAME



ASK in the shops, anywhere, or a good card game and at once you will be handed **SOCCER**—for **SOCCER** stands right out as the best card game for years. And why? Because it can be played by all—father, mother and the whole family. There's a grand football flavour about **SOCCER**, but remember, you need not know anything about football itself to be able to play **SOCCER** and win! It's new—it's bright—it's skilful but easy! Just the thing for parties and evenings at home.

SOMEONE MUST WIN EVERY HAND

THERE ARE TWO WAYS TO WIN

YOU CAN WIN BOTH WAYS!

The fascination of **SOCCER** is that you'll never tire of it. It's got that something extra.

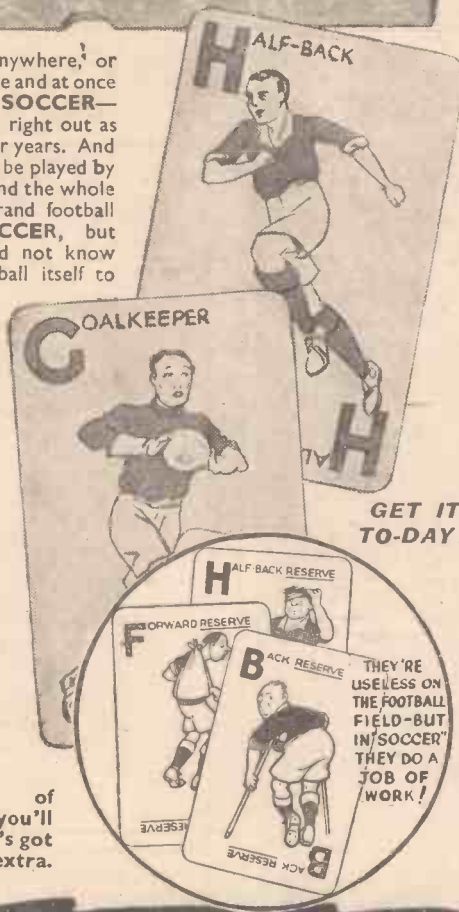

GET IT TO-DAY!

SOCCER

THE GREAT NEW CARD GAME

Made by Waddington's—
makers of **LEXICON**,
MONOPOLY, etc.

SOCCER is stocked by all stationers, stores, bookstalls, and fancy goods dealers, etc.

2/6

*Player's
Please*

EVERYONE



MEDIUM OR MILD

BOTH BLENDS ARE
CORK-TIPPED or PLAIN
10 for 6^D 20 for 11^D

N.G.C. 451F

QUALIFY FOR THE CIVILIAN RADIO RESERVE

with this wonderful book
**WIRELESS TRANSMISSION
FOR AMATEURS**

By F. J. CAMM

The importance of amateur transmitting has been recognised by the Government, as well as by radio manufacturers. This recognition has been implemented by the formation by Sir Kingsley Wood of the Civil Wireless Reserve, which invites all amateur transmitters to join. This is work of first National importance, and there is a big demand amongst experimenters for a book which will explain, not only how to build amateur transmitting sets, but also how to learn the morse code and obtain the licence. **WIRELESS TRANSMISSION FOR AMATEURS** deals with the subject in a simple yet fascinating way, and the text is rendered even more lucid by the use of many practical and easily understood diagrams.

HAND THIS FORM TO YOUR BOOKSELLER

who will get you **WIRELESS TRANSMISSION FOR AMATEURS** for 2/6, thus saving postage. Alternatively send the form with 2/6 to the Publishers and the book will be sent direct to you by return.

The Book Publisher, **GEORGE NEUNES, LTD.**, Tower House, Southampdon Street, Strand, London, W.C.2.
Please send me by return one copy of **WIRELESS TRANSMISSION FOR AMATEURS**, for which I enclose Postal Order for 2/6.
P.O. No. is _____
Name _____
Address _____

George Neunes, Ltd.

P.W. 71.39

LETTERS FROM READERS

The Editor does not necessarily agree with the opinions expressed by his correspondents. All letters must be accompanied by the name and address of the sender (not necessarily for publication).

VK-NZ Exchange Club

SIR,—I received recently a letter from Cyril Alsop, Opunake Road, Stratford, New Zealand (Representative of the VK-NZ Exchange Club). He says that owing to a recent serious illness he has been unable to reply to British S.W.L.'s who have sent him cards to be exchanged. He offers his sincere apologies, and guarantees a reply to all concerned in the next few weeks. Any listener interested in the Exchange Club can obtain information from either C. Alsop or myself.—J. CHRISTMAS (32, Foxcroft Road, Whitehall, Bristol, 5).

Back Numbers Wanted

SIR,—I would be glad to get in touch with a reader who has a spare issue of PRACTICAL AND AMATEUR WIRELESS, dated December 12th, 1936.—H. MOONEY (42, Captain Street, Greenock).

SIR,—I shall be glad to get in touch with any reader who has an unwanted copy of PRACTICAL AND AMATEUR WIRELESS dated October 27th, 1934.—H. COUSSENS (72, Rowan Avenue, Hove, 4, Sussex).

Television Picture Quality

SIR,—I enclose a photograph I have taken of my television screen, which I think shows the sharpness and quality put out at Alexandra Palace. The set is a Marconi No. 702, and as we are in the Thames valley, situated very low, I think the picture very good. As some people seem to complain about lack of brightness, etc., I can only come to the conclusion that their sets are at fault, and not the A.P. transmissions.—J. JEFFERY (Marlow, Bucks).

Amateur Transmitting — The Friendly Spirit!

SIR,—In the December 3rd issue a correspondent gave his experiences in trying to obtain an amateur licence, and deplored the attitude of established amateurs. Why, he should ask himself, is he without a single friend or acquaintance in this hobby? Is it because he wishes to jump straight into these ranks without any preliminary introduction? It must be so if he knows not a single amateur. I doubt whether there is a single short-wave listener studying amateur workings who isn't at least on "nodding terms" with an amateur. It is merely a process of evolution. There is no question of luck in joining the "cliques," as he calls them, because as G3SL points out, he has only to join the R.S.G.B. to obtain the introduction. The snag, however, is that it must be bought, in this case for a pound or so. Why should it be necessary to go to this for the privilege required? I suggest that he spends a little time in reporting on signals received on the 1.7 mc/s and 56 mc/s amateur bands, and keeps at it. If this isn't too humble and time-

wasting for him, he will surely make friends simply by introducing himself; an introduction never to be scorned as useless. There definitely is, in my opinion, a superiority complex in the ranks, but what is more important, it is not based on mere snobbishness. Most of us laugh secretly at the thought of "research work," but we are experimenters, and the more one appears to be the easier it is to be accepted as such. The next best thing to being an engineer is to look like one, and if one hasn't the imagination enough to set ideas down on paper, then there is little chance of one's ability to put those ideas into practice.



This illustration, from a photograph sent in by a reader, Mr. J. Jeffery, shows the clear definition and quality of a television transmission from Alexandra Palace.

If the correspondent referred to is within reasonable travelling distance from me, or by mail, I should be honoured and delighted to assist him in any way.—W. A. CLEMENSON (G6KQ) (West Hampstead, London, N.W.2).

"Schoolboy Director-General"!

SIR,—I am in agreement with your correspondent, E. J. Yolden, about our budding "Schoolboy Director-General." It must be fairly obvious that a schoolboy does not know his own mind.

I should also like to say that the bells he hears on the radio are the famous Bow Bells, and as for suggesting a dead silence, I am sure there is not one reader in a thousand who agrees with him.

I would like to correspond with a reader abroad. My chief interests are short-wave listening and servicing.—ARTHUR LARTY (23, Altham Road, West Derby, Liverpool, 11).

Correspondents Wanted

SIR,—I am 15 years of age and a beginner in wireless, and should be glad to get in touch with another wireless enthusiast in

Slough, or, if possible, in the Manor Park district.—H. SHURLEY (24, Beechwood Road, Manor Park, Slough, Bucks).

SIR,—I am a regular reader of your paper, and should be glad if you could put me in touch with a reader in my vicinity. I should like to make friends with a reader who is well up in wireless with whom I can pass my evenings in experimenting.—T. LEWIS (58, Howard Road, Olton, Birmingham).

The Editor will be pleased to consider articles of a practical nature suitable for publication in PRACTICAL AND AMATEUR WIRELESS. Such articles should be written on one side of the paper only, and should contain the name and address of the sender. Whilst the Editor does not hold himself responsible for manuscripts, every effort will be made to return them if a stamped and addressed envelope is enclosed. All correspondence intended for the Editor should be addressed: The Editor, PRACTICAL AND AMATEUR WIRELESS, George Newnes, Ltd., Tower House, Southampton Street, Strand, W.C.2.

Owing to the rapid progress in the design of wireless apparatus and to our efforts to keep our readers in touch with the latest developments, we give no warranty that apparatus described in our columns is not the subject of letters patent.

Copyright in all drawings, photographs and articles published in PRACTICAL AND AMATEUR WIRELESS is specifically reserved throughout the countries signatory to the Berne Convention and the U.S.A. Reproductions or imitations of any of these are therefore expressly forbidden.

SHORT-WAVE SECTION

(Continued from page 423)

Signal Strength Measurement

The subject of signal strength measurement is one which requires careful consideration, bearing in mind the wide range of receiving apparatus used by amateurs, from the simple detector and one L.F. stage to the specially designed crystal filter superheterodyne.

In some instances a calibrated signal-strength meter is fitted or provision made for the use of a separate instrument. In the case of less elaborate setups the amateur wires an mA meter in the I.F. stages. The simple regenerative, and T.R.F. types, however, are a different problem, and signal strength measurement is a matter of compromise.

A useful suggestion is to fit an L.F. volume control, and a nine division dial scale calibrated in reverse, taking the loudest signal under average conditions, say 2R0, which it is possible to receive with the volume control all in as R9, and thus the transmission which requires the volume control fully open to be heard at all would be R1. The calibrated and built-in meter is admittedly the best and most practical arrangement, where it is possible to use it, but the method outlined for small receivers of comparatively low output is a useful compromise, in that it is better than pure guesswork, and all that is required in this instance is some standard of comparison.

In conclusion, observations as outlined in this article will prove to be full of interest to those who desire a break away from listening, and logging, of world-wide short-wave transmissions, and will provide new problems for the lone listener, and useful material for discussion amongst the club fraternity who care to organise their researches, and observations, on a collective basis.

NEWNES' TELEVISION AND SHORT-WAVE HANDBOOK

3/6, or 4/- by post from

GEORGE NEWNES, Ltd.,
Tower House, Southampton St., Strand,
London, W.C.2.

What will you be doing - ONE YEAR FROM TODAY



Three hundred and sixty-five days from now—where will you be?

Still struggling along in the same old job at the same old salary—worried about the future—often unable to make both ends meet?

Don't do it, man—don't do it! There's no greater tragedy than that of the man who stays sunk in a rut all his life, when with just a little effort he could get out of it and advance.

There are thousands of successful, prosperous men in every business and industry who owe much of their success to the International Correspondence Schools.

They found that the I.C.S. offered them comprehensive yet simplified Instruction Manuals prepared by outstanding authorities, together with personal guidance and expert understanding tuition.

That wonderful I.C.S. Service, which has led the field in training by post for nearly 50 years, can do for you what it has done for others.

Write to us to-day for full information or use the attached coupon.

COUPON FOR FREE BOOKLET

INTERNATIONAL CORRESPONDENCE SCHOOLS LTD. Dept. 94, International Buildings, Kingsway, London, W.C.2.

Please send me free booklet describing I.C.S. Courses in the subject I have marked X. I assume no obligation.

RADIO ENGINEERING RADIO RADIO SERVICING TELEVISION

Also

- ACCOUNTANCY, ADVERTISING, AERONAUTICAL ENG., AGRICULTURE, AIR CONDITIONING, ARCHITECTURE, BOOK-KEEPING, BUILDING, BUSINESS TRAINING, CHEMICAL ENG., COMMERCIAL ART, CIVIL ENGINEERING, DIESEL ENGINEERING, DRAUGHTSMANSHIP, ELECTRICAL ENG., GENERAL EDUCATION, HORTICULTURE, INSURANCE, JOURNALISM, MECHANICAL ENG., MOTOR ENGINEERING, SALESMANSHIP, SANITARY ENG., SECRETARIAL WORK, SHORT-STORY WRITING, SURVEYING, TEXTILE MANUF'G, WINDOW DRESSING, WOODWORKING, WORKS MANAGEMENT

EXAMINATIONS:

Technical, Professional, Civil Service, Matriculation (including Inst. Wireless Tech., P.M.G. Certif. for Wireless Operators, City and Guilds Radio Comm., and Prov. Certif. in Radio Telephony and Telegraphy for Aircraft).

State your Exam. here

Name Age

Address

Greatest, largest and most famous of all institutions devoted to spare-time training by the postal method. Branches in 30 countries, students in 50.



B.L.D.L.C. The British Long-Distance Listeners' Club

Mains Aerial Advantages

WHEN making long-distance reception tests it is often found that atmospheric or local electrical interference renders it very difficult to hear a weak signal through the background of noise which is obtained. In many such cases it

MAINS TRANSFORMER

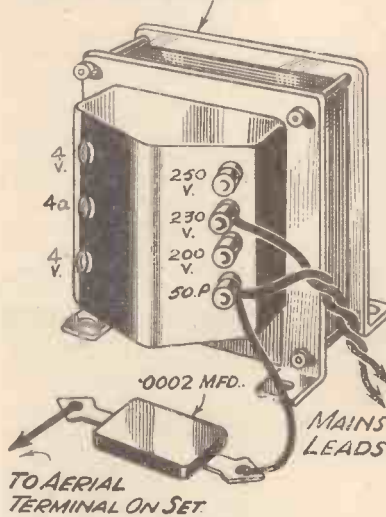

Adding a fixed condenser to a mains set to act as a mains aerial device.

will be found that a reduction in the size of the aerial, or a rearrangement of the aerial itself, will cut down the interference without in any way weakening the signals. Even when it is found that this cuts down signal strength it may be found that the reaction control will enable it to be brought up to suitable volume without giving the same increase to interference or other noises. A short vertical wire suspended outside the house, a good indoor aerial, or even a mains aerial will provide the necessary pick-up in the majority of cases, and the latter should not be overlooked where the mains are quiet. Many modern receivers are in use to-day without any external aerial, the mains device giving all the pick-up required and enabling all worth-while

stations to be received. As some members are still unfamiliar with this type of aerial it may be mentioned that it merely consists in using the wiring of the mains supply as an aerial, and to avoid damage a fixed condenser is joined between the mains input and the aerial terminal on the set. The accompanying illustration shows in pictorial form how the condenser should be placed, and in the interests of safety it should be a mica dielectric component, designed to have a working voltage of 500 or so. In some cases it may be found desirable to try each side of the mains input in order to obtain the quietest background.

Curing Instability

WHEN an H.F. detector type of receiver is in use it is often found that before maximum volume can be obtained, instability sets in, and many constructors have found difficulty in stabilising a home-made set of this type. Provided that the coils are properly screened and wired, and that the correct working voltages are applied to the valves, this trouble should not be experienced, and it will probably be found that the reason is that interaction is taking place between components such as H.F. chokes. Two simple ideas, which prove in the majority of cases a cure for the trouble are indicated on the diagram below. First, short-circuit the reaction choke in the detector stage. If this stops the instability, then the choke is responsible and its position should be changed, or a screened component should be used in its place. It is also found in many cases that the addition of a fixed condenser across the H.F. choke will also prove effective and the position is also indicated in the illustration. In some cases this condenser may be joined direct to earth, and a little experiment with various capacities should be carried out to ascertain a suitable value. If neither of these arrangements is effective, then attention must be paid to the layout and the positions of interconnecting wires, moving the latter about with an insulated tool until the trouble stops. Excessive screening should be avoided as this will merely be overcoming the trouble, rather than removing the cause.

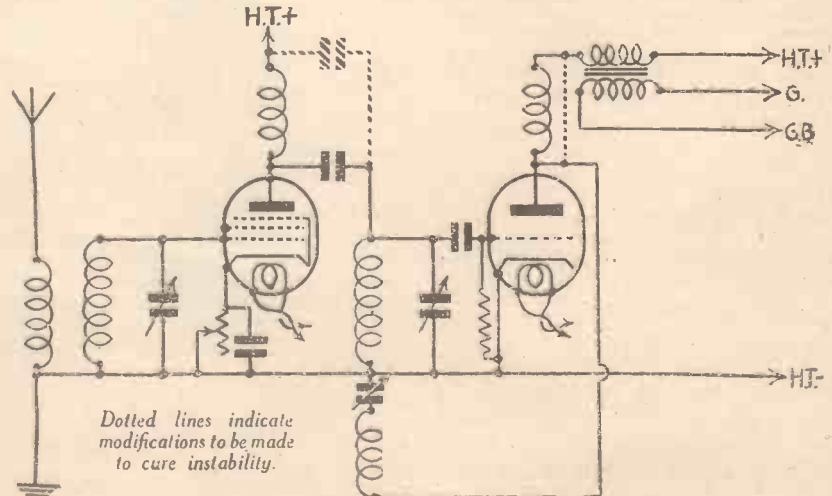

RADIO CLUBS & SOCIETIES

Club Reports should not exceed 200 words in length and should be received First Post each Monday morning for publication in the following week's issue.

THE CROYDON RADIO SOCIETY

Headquarters: St. Peter's Hall, Ledbury Road, S. Croydon.

Meetings: Tuesdays at 8 p.m.

Hon. Sec.: Mr. E. L. Cumbers, 14, Campden Road, S. Croydon.

A GUEST lecturer, Mr. Davidson, of the British Sound Recording Association, visited the Croydon Radio Society on Tuesday, December 6th, in St. Peter's Hall, Ledbury Road, S. Croydon. He was supported by members of his Association, and the visit was a return for that which the Croydon Society paid his Association some time ago. Mr. P. G. Clarke presided, and announced another distinguished visitor, Mr. Stuart Davis, of the Davis Cinema, Croydon. In the course of the lecture it was suggested that sound recording was to-day like wireless just after the war, and in the demonstration Mr. Appleby, a member of the Association, let the meeting hear his home-made record of a blackbird singing outside his window, and results were most effective. Mr. Davidson then suggested that although the Croydon Radio Society's voices might not have the same musical quality as the winged songster, their owners might like to have them recorded, and played back just to warn people what they sounded like. Most recordings were successful, as, for instance, that of Dr. R. A. Bailey, vice-chairman, who feared his Lancashire accent might reveal itself.

An attendance worthy of the occasion greeted Mr. H. O. Salter, vice-president, who presented a popular musical programme on records on Tuesday, December 13th. The reproducing apparatus had been assembled by Mr. Glaisher and Mr. Dives. It included a crystal pick-up, Magnavox 33 loudspeaker, and the output valve was a PX4, with power of 2 watts. Two low-frequency stages were resistance coupled. Very seasonably, Coleridge Taylor's Christmas Overture opened the programme, and there followed the first of many comedy items. Among classical orchestral works, Corelli's Christmas Overture, played by the Berlin State Opera Orchestra, the Carmen Ballet music, and Sir Edward Elgar conducting his "Pomp and Circumstance" March were much appreciated. The next meeting will be held on Tuesday, January 10th. The New Year programmes are rapidly taking shape, and the society looks forward to greeting readers of PRACTICAL AND AMATEUR WIRELESS when activities are resumed.

RADIO, PHYSICAL AND TELEVISION SOCIETY

Headquarters: 72A, North End Road, West Kensington, W.14.

Meetings: Friday evenings.

Hon. Sec.: C. W. Edmans, 15, Cambridge Road, North Harrow, Middx.

ON Friday, December 10th, a party of members of the society paid a visit to an exhibition of students' work at the Borough Polytechnic.

Before visiting the Radio section, members were shown an exhibition of cable jointing and wiring for power, lighting and telephones. Next the electrical workshops and dynamo rooms were visited, where demonstrations were given which included experiments with the high-voltage apparatus. In the advanced electrical laboratory there was arranged an exhibition of apparatus for various purposes, including stroboscopes and magneto and car-testing apparatus. The radio section was extremely interesting. In addition to transmitting and receiving apparatus, there were also on exhibition such instruments as signal generators and beat-frequency oscillators. Several instruments made by Messrs. A. C. Cossor, Ltd., of Highbury, were also

FIRST MOBILE AUTOMATIC TELEPHONE EXCHANGE

THE world's first Mobile Telephone Exchange was inaugurated at the General Post Office last month by the Postmaster-General. The new exchange is housed in a large green trailer, and a careful inspection will reveal a telephone cable leading into this solid-looking vehicle, while listening will disclose the faint clicking of the switches of a complete automatic telephone mechanism, which enables 100 subscribers to dial their calls to one another, and to the Trunk Operators at a neighbouring exchange.

The Mobile Telephone Exchange has double steel walls, roof and floors; the space between is filled with heat insulating material to prevent condensation of water

on show. These included some exceedingly fine cathode-ray oscillographs and ganging oscillators. Further particulars may be obtained from the hon. secretary.

THE ILFORD AND DISTRICT RADIO SOCIETY

Hon. Sec.: C. E. Largen, 44, Trelawney Road, Barkingside, Essex.

A VERY interesting and well-attended meeting was held at the society's headquarters on December 8th, when Mr. Betteridge, of Messrs. Marconi's Wireless Telegraph Co., Ltd., gave a lecture on cathode-ray tubes. His demonstration on the latest seven-inch tube was of even greater interest, in that his time-base was built up of "junk" (some five years old) which might be found in any amateur's possession, and using ordinary valves (no special types—such as Gas Relays, etc.).

On December 15th Mr. Greaves, of the Mullard Wireless Service Co., delivered a lecture in which he dealt mainly with the latest types of valves. Mr. Greaves approached the subject from a completely original angle, and was successful, by the use of lantern slides, in explaining his subject in a very interesting manner.

BRADFORD SHORT-WAVE CLUB

Headquarters: Bradford Moor Council School, Leeds Road, Thornbury, Bradford.

Hon. Sec.: G. Walker, 33, Napier Road, Thornbury, Bradford, Yorks.

THIS club has a very interesting session approaching, and a number of lectures have been arranged for the next quarter. These commence on Friday, January 27th, with a talk on station operation by Mr. C. A. Sharpe (G6KU), to be followed on February 10th with "Short-wave Receiver Design," which is to be given by Mr. Beaumont, of the Ambassador Radio Co., Brighouse. A demonstration of the Milnes Thermo Coupler (better known as gas-operated receiver) will be given on Friday, February 17th, by Mr. H. Milnes, whilst on the following Friday, February 24th, Mr. J. H. Bateman (G6BX) will give a talk on "A.C. Operation."

Meetings are held as usual on Friday evenings, and fortnightly on Sunday mornings for transmissions on the 160-metre band. A hearty welcome is given to anyone interested in short-wave transmissions and reception. Further details may be obtained from the secretary.

KING'S LYNN SHORT-WAVE CLUB

Secretary: G. Rogers, 112A, High Street.

CONTINUING their winter activity, the members paid a visit to Cranwell Aerodrome, where they were welcomed by OSOL. They visited the shack of G8FC, the Cranwell A.R.S., and met operators they had heard and contacted over the air. They were able to inspect some of the official R.A.F. wireless gear, but owing to the Official Secrets Act it was not possible to ask any technical details. After being entertained to tea the 50-mile journey home was begun and in spite of the very wet weather an enjoyable time was had by all.

ASHTON AND DISTRICT AMATEUR RADIO SOCIETY

Headquarters: Commercial Hotel, 86, Old Street, Ashton-under-Lyne.

Secretary: K. Gooding (G3PM), 7, Broadbent Avenue, Ashton-under-Lyne.

TWENTY-FOUR members attended the meeting on December 14th, when Mr. W. P. Green gave a highly instructive lecture on "Electrolytic Condensers." To illustrate various points several types of electrolytics were stripped, and members were given the opportunity of seeing what happens when their power packs blow up!

The secretary was instructed to attend to the matter of affiliation with the R.S.G.B.

The Morse classes have now been put on a proper basis and G3FF has been appointed official Morse instructor. (Wednesdays, beginners; Fridays, advanced.) There is now no need to bring 'phones, as 2CDY has provided a mains L.S. audio-oscillator.

A party of 20 made a trip to the B.B.C. station at Moorside on December 17th, 1938, and an enjoyable time was had by all.

Mr. Collinge, of Messrs. Ferranti, Ltd., is to give a lecture on "Electrical Measuring Instruments" on January 25th.

vapour in the exchange. It is quite self-contained, with its own lighting and power supply and every technical aid that could be desired. Even the rain water which falls from the roof is collected automatically for the radiator of the petrol engine which charges the apparatus, and shuts itself off as soon as the battery is fully charged. The twin traction type batteries from which the exchange works will each drive the automatic switches for a week without attention, and then they can be recharged by the petrol engine or from the electric-light mains if they should be available. Except for the weekly visits to start the recharging of the batteries and to inspect the mechanism, the Mobile Exchange will work by itself night and day until yet another permanent exchange can be built and brought into the public service.

Varley

Tuning Coils

BP80 Duo-Nicore Aerial Coil 6/-

A tuning coil specially designed for baseboard mounting and for use with an external three or four point switch. Suitable for use in simple straight sets or super-heterodyne sets. Existing coils can easily be replaced by this coil. CIRCUIT DIAGRAM OF STRAIGHT 2 VALVE SET suitable for beginners is available. PRICE 4d.

BP114 Nicore 2 Gang Coil Unit 13/6

This efficient tuning unit is designed for simple battery receivers having one S.G. stage. Self contained wave change switch embodied in unit. BLUEPRINT OF 3 VALVE S.G. RECEIVER giving full constructional details and complete list of parts. PRICE 6d.

* WRITE FOR CATALOGUE NO. 13

VARLEY (Proprs. OLIVER PELL CONTROL LTD.)
CAMBRIDGE ROW : WOOLWICH : S.E.18

MEISSNER

A.R.P. ASSEMBLY

3-VALVE
BATTERY
KIT



29/6
COMPLETE KIT

These new MEISSNER kits are remarkable radio receivers, efficient in operation and design as the big multi-band MEISSNER kits. Each kit is supplied with a plug-in coil to cover the broadcast band. Additional plug-in coils are available at nominal cost. There is a Regeneration Control together with a large bakelite tuning dial. The set can use either headphones or a magnetic or permanent-magnet speaker with excellent results. The kit comes to you in a carton which contains all parts necessary for the construction of a complete receiver, including panel, chassis, sockets, resistors, condensers, wire, hardware and Broadcast band plug-in coil. Does not include valves or batteries.

Full instructions with each kit. Send your order now for immediate delivery. Cash with order or C.O.D.

ANGLO-AMERICAN RADIO (& MOTORS) LTD.
Dept. D20,
Albion House, 59, New Oxford Street, W.C.1.
(Representatives of Meissner Man. Co. U.S.A.)

LATEST PATENT NEWS

Group Abridgments can be obtained from the Patent Office, 25, Southampton Buildings, London, W.C.2, either sheet by sheet as issued on payment of a subscription of 5s. per Group Volume or in bound volumes price 2s. each.

MULTIPLEX WIRELESS SIGNALLING.—Ferranti, Ltd., and Tomlin, G. M. No. 492398.

Sound and vision carriers are applied together with local oscillations from a coil 23, to the broadly tuned input circuit 2, 3 of a frequency changer pentode 5, the vision intermediate frequency being taken from a tuned transformer 6, 10 in the anode circuit and the sound intermediate frequency from the screen grid circuit 12, which is coupled through a coil 17, concentric conductor 18 and coil 19 to the tuned input circuit 20 of a following amplifier. Specification 474684 is referred to.

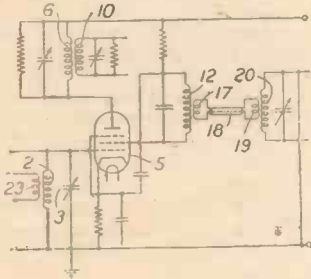

Fig. 1

VALVE CIRCUITS.—Lorenz Akt.-Ges., C. No. 492641.

In a screened high-frequency arrangement of the kind comprising separately screened stages 1, 8, connected by a screening tube through which connections pass, disturbances due to connection of the valve cathodes to the individual screens, caused by interference potential S, are eliminated by connecting the cathodes directly to each other by insulated leads 12.

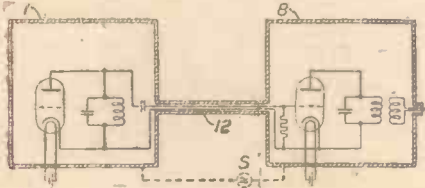

Fig. 2

CATHODE-RAY TUBES.—Thomson, E. E., and Miller, H. No. 492442.

A cathode-ray television transmitting tube comprises an electrode adapted to be rendered light sensitive by deposition thereon of light-sensitizing material, and an additional electrode arranged so as to receive a deposit of light-sensitizing material during the initial deposition and to be heated to a high temperature without heating parts of the tube to a temperature at which deleterious gases are evolved, so as to liberate its deposited light-sensitizing material for further deposition on the light-sensitive electrode. In the tube shown, which is of the iconoscope type, the mosaic screen 4 (cut away) is formed from a mica sheet covered with silver evaporated from heated filaments 8 and aggregated. The additional electrode may be a ring, or, in the form shown, two nickel discs 11 which also receive a silver deposit. After oxidation of the silver, caesium is admitted to

photo-sensitize the mosaic and is also deposited on electrodes 11. If, after testing or working, the mosaic is insufficiently sensitized, the electrodes 11 may be heated by induction to provide an additional supply of caesium. The filaments 8 and the electrodes 11 are supported on a mica framework 9, 10 which surrounds the window 6. The Provisional Specification refers also to apparatus similar to cathode-ray television transmitting tubes.

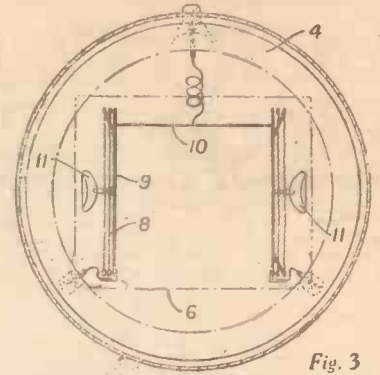

Fig. 3

NEW PATENTS

These particulars of New Patents of interest to readers have been selected from the Official Journal of Patents and are published by permission of the Controller of H.M. Stationery Office. The Official Journal of Patents can be obtained from the Patent Office, 25, Southampton Buildings, London, W.C.2, price 1s. weekly (annual subscription £2 10s.).

Latest Patent Applications

- 36141.—Baird Television, Ltd., and Grayson, H. — Radio-receivers. December 12.
- 36045.—Baird Television, Ltd., and Hill, F. L.—Thermionic valve circuits. December 10.
- 36248.—Cole, Ltd., E. K., and Garth, E.—Automatic potentiometers. December 13.
- 35850.—Cossor, Ltd., A. C., and Jofeh, L.—Electric circuits. December 8.
- 35993.—Harris, R., and Goldberger, K.—Indicators for wireless sets, etc. December 9.
- 35968.—Kolster-Brandes, Ltd., and Shannon, D. S. B.—Laminated magnetic cores. December 9.
- 36325.—Kolster-Brandes, Ltd., and Smyth, C. N.—Cathode ray tubes. December 13.
- 36158.—Magyar Wolframlampá Gyar Kremenezky Janos, R. T.—Method, etc., of the suppression of interference in radio receivers. December 12.
- 36462.—Murphy Radio, Ltd., and Davies, K. S.—Synchronization of television receiving apparatus. December 14.
- 35766.—Postlethwaite, A. E., and Postlethwaite, H.—Radio interference eliminator. December 8.
- 36326.—Standard Telephones and

Cables, Ltd. (Polydoroff).—Aerial systems for wireless communication. December 13.

- 36118.—Telefunken Ges fur Drahtlose Telegraphie.—Electrical control of tuning means for wireless receiving apparatus. December 12.
- 36218.—Telefunken Ges fur Drahtlose Telegraphie.—Directional radio receiver systems. December 12.

Specifications Published

- 496872.—White, E. L. C., and Hardwick, J.—Thermionic-valve amplifiers.
 - 496874.—General Electric Co., Ltd., Gosden, R., Hunter, S. G., and Mercer, E. L.—Tuning-indicators for wireless receivers. (Cognate Application, 31335/37.)
 - 496756.—Zeiss Ikon Akt.-Ges.—Scanning devices for television and the like.
 - 497004.—Percival, W. S.—Thermionic valve repeating arrangements.
 - 496883.—Blumlein, A. D.—Thermionic-valve amplifying circuits.
 - 497069.—Scophony, Ltd., and Walton, G. W.—Light-modulating devices.
 - 496964.—Scophony, Ltd., and Jeffree, J. H.—Television receivers.
 - 497071.—Radioakt. Ges. D. S. Loewc.—Synchronization generator for television systems.
 - 497035.—Standard Telephones and Cables, Ltd. (Pierce, R.).—Protective systems for radio transmitters.
- Printed copies of the full Published Specifications may be obtained from the Patent Office, 25, Southampton Buildings, London, W.C.2, at the uniform price of 1s. each.



Replies in Brief

The following replies to queries are given in abbreviated form either because of non-compliance with our rules, or because the point raised is not of general interest.

- W. J. K. (Aughrim). We will bear your suggestion in mind when considering future articles.
- W. T. (E.6). It would be preferable to build a special short-wave set or endeavour to re-design the present set in a modern all-wave type.
- P. R. G. (S.E.26). "The Wireless Constructor's Encyclopedia" is the most valuable book in your case, and you can study this in conjunction with the articles published in these pages.
- T. H. (Musselburgh). The coils were specially designed by a contemporary no longer on the market, and we cannot supply blueprints or other details.
- S. W. (York). Details are reprinted on page 422 of this issue.
- M. S. (Cape Province). We publish an article on page 424 which will be of interest to you on the subject.
- A. C. S. (Derby). The bandset condenser is the larger capacity and the bandspreader is the smaller. The tank is merely another name for the bandset component.

G. T. (Sheffield). Although the valve might work under the conditions mentioned we do not recommend it in this particular case.

A. F. A. (E.C.2). The circuit was not one of our designs, and the paper is no longer on the market. We regret that we are unable to assist you in this particular case.

E. F. N. (Co. Wexford). The fading is no doubt due to your particular local conditions, and the only satisfactory cure would be to build a powerful receiver, such as a superhet with an efficient A.V.C. circuit.

W. C. (Glasgow). We are considering the design of a set on the lines mentioned, and details will appear in due course.

A. J. R. (E.16). An aerial can be erected clear of the interference, and a screened feeder used if necessary. This is the only satisfactory cure, and the makers of your set can supply a suitable anti-interference aerial of this type.

F. M. (Gillingham). A push-pull stage could certainly be added, but the mains section would have to be re-designed to deliver the necessary additional current. The existing L.F. valve could be retained for use as the driver.

J. M. C. (W.14). As the set is an old commercial model the best plan is to communicate with the makers as it may be some particular fault with which they are familiar.

W. V. H. (West Bromwich). The only solution we can offer is that you replace the coils by standard components. We have no details of the particular components now in use which were designed by a contemporary no longer on the market and, therefore, regret that we cannot assist you.



QUERIES and ENQUIRIES

Battery Set on the Mains

"I have an S.G., D., P. battery set run from an eliminator and accumulator. I wish to dispense with the accumulator so I have decided to use a 60-volt tapping, reducing this either to two volts (parallel wiring) or 6-volts series wiring. I know how to use the formula for calculating resistance values, but I am rather at a loss as how to apply it in my case. Would I require a special dropping resistance, or would an ordinary anode one meet the case?"—R. J. (Accrington).

THE standard battery valve has a filament rated at .1 amps—in some cases more than this. .1 amps is equivalent to 100 milliamps, and therefore you will see that it is impossible to make use of the tapping on the eliminator, which is no doubt rated at about 15 or 20 milliamps. Even so, the output from the eliminator at this point [would not be sufficiently smooth to feed filaments of battery valves, where the slightest irregularity in the supply will result in a fluctuation in the anode current and thus give rise to hum or erratic signals. If you wish to make the set "all mains" the most satisfactory plan is to obtain a trickle charger and re-charge the accumulator yourself.

Medium Waveband Defective

"I have bought a secondhand 5-valve battery set and find I can receive the long waves and the short-waves quite well, but am unable to pick up the medium waves. The set has one screen-grid valve. I don't remember reading how to service a set so as to make it receive on the three wavebands."—L. C. R. (Helston).

IF the set works on the long waves it is fairly safe to assume that the coils are in order, as the usual arrangement for wavechange switch for medium and long is merely to short-circuit part of the winding for medium waves. Therefore, all of the coil must be in circuit on the long waves, and a defect would thus reveal itself on the long. Therefore, the most likely cause of your trouble is a defective switch, which in the "open" position (long waves) leaves the coil in circuit, but when turned to medium-waves, fails to close and thus leaves either one coil or more than one still in the long-wave position. You should, therefore, examine the switch and associated wiring.

Increasing Output

"I have a commercial all-wave 5-valve set with an output of approximately 3 watts. My desire is to increase the output and to secure deeper tone. Is it possible to give the necessary information?"—G. O'D. (New Barnet).

AS the set is rated to give 3 watts, we imagine it is an all-mains model, and therefore it would be impracticable to change the output stage to obtain a greater volume. The only satisfactory way of doing this would be to use push-pull (or push-pull parallel), and this would mean an added current drain which would

necessitate modification of the mains section, and perhaps replacement of the rectifying valve. We therefore suggest that you leave the set as it is, or, if you must have a greater output, obtain a separate self-contained amplifier which would handle the input from the set. If you added such a unit you could incorporate a tone control circuit.

Push-button Four

"Could you tell me if the 2 brackets, 1 dial and 1 pointer, is the correct amount for the 4s. lot No. 5 in the list of components for the A.C. Push-Button Four?"—W. H. S. (Crewe).

THE parts for this receiver are supplied either as a complete kit or in separate units. The tuning unit is made up of a number of separate parts, and a special station-name dial (or scale) with drive,

RULES

We wish to draw the reader's attention to the fact that the Queries Service is intended only for the solution of problems or difficulties arising from the construction of receivers described in our pages, from articles appearing in our pages, or on general wireless matters. We regret that we cannot, for obvious reasons—

- (1) Supply circuit diagrams of complete multi-valve receivers.
- (2) Suggest alterations or modifications of receivers described in our contemporaries.
- (3) Suggest alterations or modifications to commercial receivers.
- (4) Answer queries over the telephone.
- (5) Grant interviews to querists.

A stamped addressed envelope must be enclosed for the reply. All sketches and drawings which are sent to us should bear the name and address of the sender.

Requests for Blueprints must not be enclosed with queries as they are dealt with by a separate department.

Send your queries to the Editor, PRACTICAL AND AMATEUR WIRELESS, George Newnes, Ltd., Tower House, Southampton Street, Strand, London, W.C.2. The Coupon must be enclosed with every query.

brackets, driving drum pointer and the necessary cord is supplied for 4s. If you have bought the parts separately, you may have obtained some parts attached to the condenser and should look to this point.

Anode By-pass

"I have a battery portable originally designed to use an S.G. valve as detector, and while using this valve a .002 mfd. fixed condenser was connected from anode to earth for decoupling. Subsequently I used an ordinary valve as detector and was puzzled why reaction was so much impaired as to preclude oscillation, until one evening as I was looking over the circuit I remembered the condenser referred to. When this was removed the set behaved as usual, with a considerably reduced amount of capacity for reaction. It occurs to me that possibly this could be used in one of your weekly problems."—K. H. (Blackrock, Co. Dublin).

THE detector valve generally requires a by-pass condenser joined from anode to earth, and for all normal purposes a low value is found most suitable. Generally a .0001 or .0002 mfd. condenser is employed. This may, however, be dispensed with by using a differential reaction condenser, but if this is not used the process of rectification is rendered inefficient unless some by-pass is used across the valve. The high value formerly in use may have been found necessary to stabilise the circuit when the higher efficiency of the S.G. valve was employed. On the other hand, you may now be obtaining insufficient H.T. for the valve, as the high anode load which may have been used, in conjunction with a higher anode current now obtained with a triode, will provide a greater voltage drop.

Tone Control Choke

"I have a balanced-armature speaker but I should like to boost up the bass without losing any volume. I note in "Practical and Amateur Wireless" dated October 8th that this can be done with a tone control choke, and I should like to know where these chokes can be obtained and how it should be connected."—F. S. K. (Newhaven).

THE choke referred to was a Bulgin component, list No. L.F. 43, and the price is 7s. 6d. The makers supply a leaflet giving connection details, and this should answer your purpose.

H.T. from L.T.

"Could you tell me if it is practicable to take the H.T. current for a wireless set from a 12-volt motor-car accumulator by means of a transformer or any other method. If so, could you suggest a handbook on the subject or on the installation?"—H. N. G. (Wivenhoe).

YOU cannot step up the output from a D.C. supply, but if it is first interrupted (or converted to A.C.) it may then be passed through a transformer. The wattage will, of course, not be increased. A special unit consisting of the interrupter combined with a rectifying section (so that the output from the transformer may be converted back to D.C.) may be obtained from Messrs. Bulgin, who can also supply an appropriate transformer. We have published an article on the subject but we do not know of any books dealing with this particular scheme.

Unselective Receiver

"I should like some information regarding my aerial. I have one which is none too good, being screened by the houses. I have a 5-valve set but the stations overlap and I wanted to know if you think this aerial could be improved."—C. P. (Mountsorrel).

AN improved aerial would not cure poor selectivity—rather would it aggravate the matter. When a set is unselective you must use a rather poor aerial or the increased input to the receiver will give still further trouble from "overlap." We would suggest that you consider a vertical aerial, or a good indoor arrangement. We note, however, that the receiver is a 5-valve model, and it is rather unlikely that such a set would be likely to give trouble from poor selectivity and therefore think that it is incorrectly trimmed or adjusted. We advise you to look to this point before going to the trouble of trying to modify the aerial system.

PRACTICAL WIRELESS SERVICE MANUAL

By F. J. CAMM.

From all Booksellers 5/- net, or by post 5/6 direct from the Publishers, George Newnes, Ltd., (Book Dept.), Tower House, Southampton Street, London, W.C.2.

The coupon on page iii of cover must be attached to every query.

Miscellaneous Advertisements

Advertisements are accepted for these columns at the rate of 3d. per word. Words in black face and/or capitals are charged double this rate (minimum charge 3/- per paragraph). Display lines are charged at 6/- per line. All advertisements must be prepaid. All communications should be addressed to the Advertisement Manager, "Practical and Amateur Wireless," Tower House, Southampton Street, Strand, London, W.C.2.

RECEIVERS, COMPONENTS AND ACCESSORIES
Surplus, Clearance or Secondhand, etc.

ALL lines previously advertised still available.—Radio Clearance, Ltd., 63, High Holborn, W.C.1. Holborn 4631.

CONVERSION UNIT for operating D.C. Receivers from A.C. Mains, improved type, 120 watt output at £2/10/0. Send for our comprehensive list of speakers, resistances and other components. WARD, 46, Farringdon Street, London, E.C.4. Telephone: Holborn 9703.

ALL goods previously advertised are standard lines still available. Post card for list free. VAUXHALL UTILITIES, 163a, Strand, W.C.2. Over Denny's the Booksellers. (Temple Bar 9338.)

SOUTHERN RADIO, 46, LISLE STREET, LONDON, W.C.2, extend Seasonable Greetings to their many Customers. All goods previously advertised still available. Send for comprehensive lists, 2d. stamp. SOUTHERN RADIO, 46, Lisle Street, London, W.C.2. Gerrard 6653.

NEW RECEIVERS, COMPONENTS AND ACCESSORIES

BANKRUPT BARGAINS.—Brand new 1938 radio sets in makers' cartons with guarantees at less than half retail prices; send 1d. stamp for list bargains.—261-3, Lichfield Road, Aston, Birmingham.

NEW RECEIVERS AND CHASSIS

ALL ARMSTRONG Radio chassis, including Press Button models, exhibited at Radiolympia can be seen and heard at our Showrooms. Demonstrations daily. Armstrong chassis are sent on 7 days' approval, carriage and packing free. Armstrong Company have fully illustrated technical catalogue describing all models.—Armstrong Company, 100, St. Pancras Way (formerly Kings Road), Camden Town, London, N.W.1. Gulliver 3105.

SITUATIONS VACANT

WANTED.—Ambitious young men to prepare for well-paid posts in TELEVISION, the great career of the future. Apply for free booklet from BRITISH INSTITUTE OF ENGINEERING TECHNOLOGY, 18P, Stratford Place, W.1.

ENGINEERING—FREE OFFER. The new 1939 GUIDE explains how all the best jobs are secured. It shows how to obtain such valuable qualifications as A.M.I.Mech.E., A.M.I.E.E., etc., and describes numerous diploma courses for entrance and promotion in draughtsmanship; electrical, aero, wireless and auto engineering, civil service, etc. For FREE copy and details of remarkable SUCCESS GUARANTEE, write NATIONAL INSTITUTE OF ENGINEERING (Dept. 3), Staple Inn Buildings, W.C.1.

ROYAL AIR FORCE

Expert instructors will teach you a skilled trade in the R.A.F.

Men of good education are now required for enlistment and training as WIRELESS OPERATORS and ARMOURERS. Age limits 17-35.

Apply for free booklet "A Life for Men," to R.A.F. Recruiting Depot, Victory House, Kingsway, W.C.2, or to any R.A.F. Recruiting Depot or Post Office.

PREMIER
1938-1939
RADIO

PREMIER BATTERY CHARGERS. Westinghouse Rectifications. Complete ready for use. To charge 2 volts at 1 amp., 10/-; 6 volts at 1 amp., 16/6; 6 volts at 1 amp., 19/6; 12 volts at 1 amp., 21/-; 6 volts at 2 amps., 32/6. MOVING COIL SPEAKERS. Magnavox 8in. P.M.s with Output Transformer, 10/6. Magnavox 8in. Energised 2,500 ohm field with Transformer, 9/11. Rola 8in. P.M. with Transformer, 15/-. Rola 10in. P.M., 19/11. B.T.H. 10in. Energised L.S., 1,650 ohm field, less Transformer, 9/11. Rola G.12 12in. High-Fidelity Speakers with Output Transformer, Energised, 1,250 or 2,500 ohm field, 59/6. P.M. model, 79/6.

VALVES

AMERICAN VALVES. We hold the largest stocks of U.S.A. tubes in this country and are sole British Distributors for TRIAD High-grade American Valves. All types in stock. Standard types, 5/6 each. All the new Metal-Class Octal Base tubes at 6/6 each; 210 and 250, 8/6 each. EUROPA MAINS VALVES, 4 v. A.C. [Types: A.C./H.L., A.C./L., A.C./S.G., A.C./V.M.S.G., A.C./H.P., A.C./V.H.P., A.C./P., and 1 watt D.H. Pentodes, all 4/6 each. A.C./Pens., I.H., 5/6; A.C./P.X.4, 6/6; Oct. Freq. Changers, 8/6; Double Diode Triodes, 7/6; Triode H. ex. Freq. Ch., 8/6; Tri. Grid Pen., 10/6; 3A-watt D.H. Triode, 7/6; 350 v. and 500 v. F.W. Rect., 5/6. 13 v. 2 amp. Gen. Purpose Triodes, 5/6; H.F. Pens. and Var.-Mu. H.F. Pens., Double Diode Triodes, Oct. Freq. Changers, 7/6 each. Full-wave and Half-wave Rectifiers, 5/9 each.

Premier Short-Wave Kits

Complete to the last detail including all Valves and coils, as well as theoretical and wiring diagrams and lucid instructions for building and working. Each Kit is supplied with a steel Chassis and Panel and uses plug-in coils to tune from 13 to 170 metres. 1 Valve Short-wave Receiver or Adaptor Kit 17/6 1 Valve Short-Wave Superhet Converter Kit 20/- 1 Valve Short-Wave A.C. Superhet Converter Kit 22/6 2 Valve Short-Wave Receiver Kit 25/- 3 Valve Short-Wave Screen Grid and Pentode Kit 58/6 UTILITY Micro Cursor Dials, Direct and 100-1 Ratios, 3/9. PREMIER Short-wave Condensers, all-brass construction with Treflul insulation. 15 mmf., 1/6; 25 mmf., 1/7; 40 mmf., 1/9; 100 mmf., 2/-; 100 mmf., 2/3; 250 mmf., 2/6. PREMIER S.W. H.F. Chokes, 10-100 metres, 9d. each. Pie-wound, 1/6 each. Screened, 1/6 each. SHORT-WAVE COILS, 4- and 6-pin types, 19-26, 22-47, 41-94, 73-170 metres, 1/9 each, with circuit. Special set of S.W. Coils, 14-150 metres, 4/- set, with circuit. Premier 3-band S.W. coil, 11-25, 19-43, 38-86 metres. Suitable any type circuit, 2/6. COIL FORMERS, 4- or 6-pin low-loss, 1/- each. Have you had our 1938 Catalogue, Handbook and Valve Manual? 90 pages of Radio Bargains and Interesting Data. Price 6d.

ALL POST ORDERS to: Jubilee Works, 167, Lower Clapton Road, London, E.5. Amherst 4723. CALLERS to: Jubilee Works, or 165, Fleet Street, E.C.4. Central 2833. or 50, High Street, Clapham, S.W.4. Maccusly 2381.

Engineers' Guide To Success

Write TO-DAY for this great Guide, containing world's widest choice of home-study courses in engineering covering all branches including Radio, Television, Sound Reproduction, etc., and which alone give the Regulations for Qualifications such as A. M. I. E. E. A. M. I. R. E. A.M.I.W.T., C. & G. etc. Training until Successful Guarantee!

THE TECHNOLOGICAL INSTITUTE OF GREAT BRITAIN, 42, Temple Bar House, London, E.C.4 (Founded 1917). 20,000 Successes.

Free!



200 Courses

LOUDSPEAKER REPAIRS

REPAIRS in Moving Coil Speakers, Cones and Coils fitted and Rewound. Fields altered. Prices Quoted including Eliminators. Loudspeakers Repaired, 4/-; L.F. and Speech Transformers, 4/-, post free. Trade invited. Guaranteed. Satisfaction. Prompt Service, Estimates Free.—L.S. Repair Service, 5, Balham Grove, London, S.W.12. Battersea 1321.

LOUDSPEAKER repairs, British, American, any make, 24-hour service, moderate prices.—Sinclair Speakers, Alma Grove, Copenhagen Street, London, N.1.

VALVES

AMERICAN Valves in Sealed Cartons, all types 5/6 post paid.—Valves, 661/3, Harrow Road, N.W.10.

LOUDSPEAKERS

3,000 SPEAKERS from 5/6 each, P.M. and energised 4" to 14", including several Epoch 18".—Sinclair Speakers, Alma Grove, Copenhagen Street, N.1.

MISCELLANEOUS

BESTERTH Earthing System. Particulars, John Holmes and Sons, 16, Isleworth Drive, Chorley.

CHASSIS in any metal and finish to your own specification. Keen prices and prompt service. Satisfaction guaranteed.—The Universal Productions, Rigby Lane, Bromsgrove, Worcs.

THERE'S MONEY IN RADIO!—If you understand radio you can make substantial profits in spare time. For hints and ideas get MONEY-MAKING MADE EASY, by L. Harvey Wood. Available from all booksellers, 2/6 net, or by post, 2/10, from the Publisher, C. Arthur Pearson, Ltd., Tower House, Southampton Street, London, W.C.2.

THE OUTLINE OF WIRELESS," by Ralph Stranger. Fifth Edition, 8s. 6d.—This book which covers the subject from A to Z, is to be recommended to all who desire to master the theory of Modern Wireless. At all Booksellers and Newsagents, or by post us, from George Newnes, Ltd. (Book Dept.), Tower House, Southampton Street, Strand, London, W.C.2.

EASY TERMS WE OFFER THE LOWEST TERMS

ARMSTRONG CHASSIS SPECIALITY

FOR ALL RADIO SETS, RADIOGRAMS, LOUDSPEAKERS, VALVES, ALL COMPONENTS and ACCESSORIES, also ELECTRIC CLOCKS, FIRES, LAMPS, CLEANERS, etc. It will pay you to secure our quotation.—

Write stating requirements and we will quote by return. Prompt Delivery Guaranteed. Also Cash and C.O.D. Orders. (Phone National 6828-9)

LONDON RADIO SUPPLY
EST. COMPANY 1925
11, OAT LANE, NOBLE STREET, LONDON, E.C.2

FREE ADVICE BUREAU COUPON

This coupon is available until January 14th, 1939, and must accompany all Queries and Wrinkles.
PRACTICAL AND AMATEUR WIRELESS
7/1/39.

ADVERTISEMENT INDEX

| | |
|---|------------|
| Anglo-American Radio (& Motors), Ltd. | Page 437 |
| British Institute of Engineering Technology | Back Cover |
| General Electric Co., Ltd. | Cover ii |
| International Correspondence Schools | 436 |
| London Radio Supply Co. | Cover iii |
| New Times Sales Co. | 433 |
| Peto-Scott Co., Ltd. | 431 |
| Player's Cigarettes | 434 |
| Premier Supply Stores | Cover iii |
| R.A.F. | Cover iii |
| Technological Institute of Great Britain | Cover iii |
| Varley | 437 |

FREE!



This IMPORTANT GUIDE to SUCCESSFUL ENGINEERING CAREERS

After months of intensive effort and research, we are pleased to announce that the new edition of our Handbook, "ENGINEERING OPPORTUNITIES," is now out of the publishers' hands and ready for *free distribution*. Containing 268 pages of practical guidance, this book is, beyond argument, the finest and most complete handbook on Successful Engineering Careers ever compiled. It is a book that should be on the bookshelf of every person interested in engineering, whatever his age, position or experience.

The Handbook contains, among other intensely interesting matter, details of **B.Sc., A.M.I.C.E., A.M.I.Mech.E., A.M.I.E.E., A.M.I.A.E., A.M.I.W.T., A.M.I.R.E., CIVIL SERVICE,** and other important Engineering Examinations; outlines courses in all branches of **CIVIL, MECHANICAL, ELECTRICAL, AUTOMOBILE, RADIO, TELEVISION, and AERONAUTICAL ENGINEERING, BUILDING, GOVERNMENT EMPLOYMENT,** etc., and explains the unique advantages of our Employment Department.

WE DEFINITELY GUARANTEE "NO PASS-NO FEE"



If you are earning less than £10 per week you cannot afford to miss reading "ENGINEERING OPPORTUNITIES." In your own interests we invite you to write (or forward the coupon) for your copy of this enlightening guide to well-paid posts -NOW.

There is no cost or obligation of any kind.

BRITISH INSTITUTE OF ENGINEERING TECHNOLOGY

409A, SHAKESPEARE HOUSE, 17, 18, & 19, STRATFORD PLACE, LONDON, W.1.

----- TEAR OFF HERE -----
FREE COUPON

BRITISH INSTITUTE OF ENGINEERING TECHNOLOGY,

409A, Shakespeare House, 17-19, Stratford Place, W.1.

Please forward, Free of cost or obligation of any kind, your 268 page Handbook.

NAME.....

ADDRESS

.....

.....