

The

Call Letter

January, 2012
Vol. 38 – No. 1

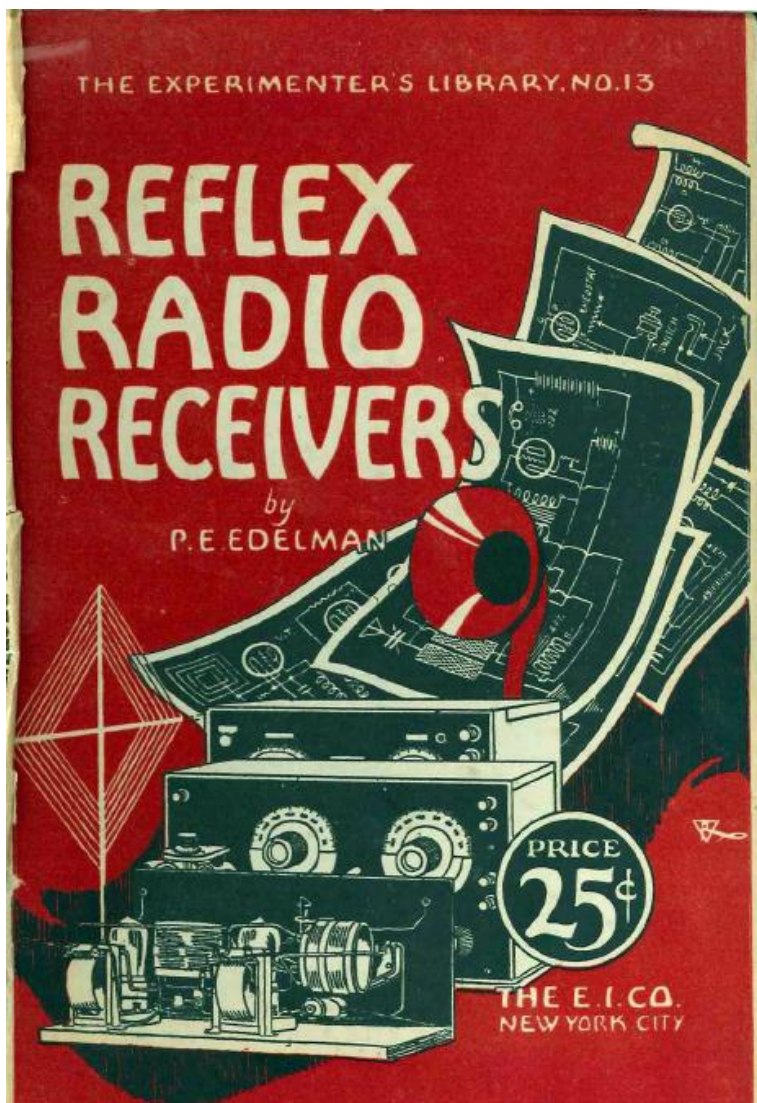

Celebrating **35** years in print!

The Northwest Vintage Radio Society

Post Office Box 82379

Portland, Oregon 97282-0379

The Northwest Vintage Radio Society is a non-profit historical society incorporated in the State of Oregon. Since 1974 the Society has been dedicated to the preservation and enjoyment of "Vintage radio" and wireless equipment.

Membership in the Society is open to all who are actively interested in historic preservation. The dues are \$25.00 for domestic membership, due on January 1st of each year (prorated quarterly).

The Call Letter has been a monthly publication since 1974. It was originated with the founder, Bob Bilbie, and our first president, Harley Perkins. Through several editors and with the assistance of numerous society members, the Call Letter has continued to be a publication that informs members of the society's business and that supports the hobby of collecting, preserving, and restoring vintage radios.

Society meetings are held the second Saturday of each month at the Abernethy Grange Hall at 15745 S. Harley Ave. in Oregon City, Oregon. They convene at or about 10 AM for the purpose of displaying radios, conducting Society business, and exchanging information. Guests are welcome at all Society meetings and functions (except board meetings).

Other Society functions include guest speakers, auctions, radio shows, and radio sales which are advertised in the Call Letter and are held in and around Portland.

With each issue of the Call Letter, we remember Jim Mason, a charter member of the society who remained active until his death in 1999. A generous bequest from Jim's estate ensures the vitality of the Northwest Vintage Radio Society, and continued publication of the Call Letter.

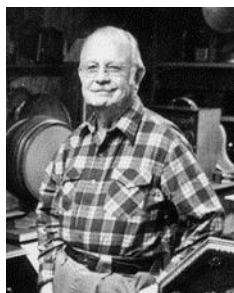

Society Officers for 2012:

President	Mark Moore	(503) 286-5224 mark@pdxhistory.com
Vice-President	Mike McCrow	(503) 730-4639 tranny53@comcast.net
Treasurer	Cliff Tuttle	(503) 666-7005 kiptuttle@comcast.net
Recording Secretary	Charlie Kent	(503) 281-9335 radkent@onemain.com
Corresponding Secretary	Jim Harper	(503) 538-8738 JLHarperclan@aol.com
Board member at large	Dick Bixler	(503) 690-2557 rf2af@comcast.net
Call Letter Editor	Tony Hauser	(503) 438-0297 abhauser@aol.com
Librarian	Robert Robinson	(503) 255-3585 srrobins@comcast.net

January 2012

Table of Contents

From the Editor 2

From the President 3

NWVRS Meeting Minutes..... 4

NWVRS Calendar of Events..... 5

Three Tubes Do The Work of Five or Six! 7

An Interview With Charley Austin 9

Roster Updates 10

The Langhorne Infradyne Set 11

Holiday Party Photos 13

Swap Shop 15

On the cover: This issue’s cover is the cover from Reflex Radio Receivers by P. E. Edelman, number 13 in The Experimenter’s Library series. Sid Saul included it to accompany his article in this month’s Call Letter.

The next meeting is January 14, 2012.

January Monthly Feature: Component Restoration

Visit our web site at <http://nwvrs.org>.

Next Call Letter deadline: January 31, 2012.

The *Call Letter* is the official publication of the Northwest Vintage Radio Society. Circulation is limited to the membership and guests of the Society. The Society is not responsible for the material contributed for publication, nor the quality, timeliness, or accuracy of the items or services offered for sale in the SWAP SHOP. By common agreement of the board of directors, the buyer assumes all responsibility for the satisfaction of any transaction.

From the Editor

by *Call Letter* editor, Tony Hauser

Well it's certainly strange to see a name other than Rick Walton at the top of this column. As you all know Rick has been our *Call Letter* editor for the last 15 years. Maintaining his level of excellence will not be an easy task. I'd like to take this opportunity to express our deep gratitude to Rick for his years of hard work to create a publication of such high quality.

Another long-term changing of the guard has been brought to my attention. John Bucholtz is stepping down as our Librarian after 10+ years of service. Robert Robinson will be taking over as Society Librarian. Robert can be reached at 503-255-3585 and by email at srrobins@comcast.net. The library listings are on the Society website so if you find something of interest on the list contact Robert so he can bring it to the next meeting.

Art Redman has contributed two articles this month; an interview with Charles Austin from 1978, and an article about the Langhorne Radio Company of Portland. And Sid Saul has submitted another article. This time it covers reflex radio and the Crosley Trirdyn.

Please keep you articles, submissions, and ideas coming. It's the best way to insure The Call Letter remains such an enjoyable part of our Society and vital form of communication for our membership. I will be moving the submission deadline up by a few days while I continue the transition to full responsibility of Editor duties. Please send submissions to my email address: abhouser@aol.com.

I look forward to serving you all as your new Editor.

Remember, the dial stops here.

Tony

From the President

by Mark Moore, NWVRS President

Happy New Year greetings to our members and friends. I hope everyone got the radios they wanted for Christmas. A new year is upon us and I want to take this opportunity to thank everyone who has made the Northwest Vintage Radio Society such a vibrant and exciting place to meet and become acquainted with others who have similar yet diverse interests. Having joined the NWVRS for the first time in 1975 and serving as secretary and Call Letter editor for a short time, I have fond memories of being the youngest member at the age of 20. I am so proud to belong to such a well-run organization.

As your incoming president, I will have big shoes to fill. Dick Bixler has accomplished much during his tenure as president and because of his vision and foresight; we were able to establish the NWVRS Archives. Dick helped us get off the ground by contributing many items to our archives. Dick has kept our meetings fun and lively, and steered us toward a period of stability and growth. To my knowledge, attendance is as high as it has ever been and the club is ready for the next level. During Dick's tenure, we have had several informative and interesting talks and presentations. We hope to continue this trend. I look forward to more of Sid Saul's interesting monthly features.

I am looking forward to working with our officers this coming year and want to welcome the new members to the board. I will continue to manage our archives until we find a permanent home for all of our items. Thanks to all who have donated items to our archives, I want to especially thank Bob Campbell for his many contributions. The next task is to scan items in our collection so more can enjoy them. We welcome help from anyone wanting to help with scanning. We currently have a flash drive with many images already. I admit most of the scans are from my personal collection which I hope to donate to the NWVRS Archives if we ever have a place to display the original items.

NWVRS Meeting Minutes

Recorded by Secretary Liles Garcia

President Dick Bixler called the December 10, 2011 meeting of the NorthWest Vintage Radio Society to order at 10:00 AM. He welcomed everyone to our meeting today. Members introduced the guests that they brought with them. Everyone gave our guests a round of applause. To save time, Liles did not read the November meeting minutes and Cliff did not give the Treasurer's report. Dick thanked Liles Garcia for his long service as our Society Recording Secretary. There were 76 people at our meeting today.

Society Elections

Dick read the list of candidates and each person stood so that members would know who they are voting for. He then asked for any additional nominations and there were none. Vice-President Tony Hauser passed out ballots to all members. After all ballots were voted, they were collected. Cliff Tuttle, Jo Beth Tuttle, and Liles Garcia counted the ballots. The following members were elected to be our Society officers for Year 2012:

President—Mark Moore

Vice-President—Mike McCrow

Treasurer—Cliff Tuttle

Corresponding Secretary—Jim Harper

Recording Secretary—Charlie Kent

Dick adjourned the meeting and everyone enjoyed a great pot-luck lunch!!

Program Topic

We did not discuss this at our meeting, but just a reminder that the Program Topic for January will be "Component Restoration". This program topic includes radio parts that have been rebuilt and/or restored to be a working part. For the Program Topic display, the component may be in a radio.

NWVRS Calendar of Events

Most of the hamfest and ham swap meet information comes from:
PNW Hamfair web page at www.n7cfo.com/amradio/hf/hf.htm

- January 14** NWVRS monthly meeting 10 am; tailgate swap 8:30.
- February 11** NWVRS monthly meeting 10 am; tailgate swap 8:30.
- February 18** Salem Hamfair & Computer/Electronics Swapmeet. Rickreall, Oregon at the Polk County Fairgrounds.
<http://www.w7sra.com>. Flyer:
<http://www.w7sra.com/flyer/Flyer%202012%20Final%20-%202011-10-18b.pdf> (588K) or a low resolution flyer (142K)
- March 10** NWVRS monthly meeting 10 am; tailgate swap 8:30.
- March 10** Mike & Key Swap Meet. Puyallup fairgrounds exhibition hall, Puyallup, WA. For information, contact dmdink@yahoo.com or n7wa@arrl.net.
<http://www.mikeandkey.org/flea.htm>. Flyer in PDF. (298K)
- March 31** MicroHAMS Digital Conference. Redmond, WA.
<http://www.microhams.com/softcontent.aspx?scId=58>
- April 14** NWVRS monthly meeting 10 am; tailgate swap 8:30.
- April 14** Yakima Hamfest. Yakima, Washington. Selah Civic Center, 216 South 1st Street, Selah, WA. This is an ARRL sanctioned event. For information, contact Lindsay Kooser (509)965-6612 n7rhw@arrl.net.
<http://w7aq.org/>
- April 14** Communications Academy. Seattle, WA. This is an ARRL sanctioned event. <http://www.commacademy.org>
- April 20-22** Idaho State Convention. Boise, ID, Voice of Idaho ARC. ARRL sanctioned. Info, Lynn Rasmussen, W7RAZ, (208)550-7710, w7raz24@gmail.com.
<http://www.idahostateconvention.com/>
- May 12** NWVRS Spring Swap/Sale at Aurora American Legion Hall, Aurora, Oregon.

May 2012

Stanwood Camano Amateur Radio Club Hamfest, Stanwood Middle School, Stanwood, WA. Always the 2nd Saturday in May. Contact Vic, N7KRE (360) 387-7705) nwecop@tgi.net <http://www.scarcwa.org/>

June 1-3

Sea-Pac Hamfest. Seaside Convention Center, Seaside, Oregon. ARRL sanctioned. ai9q@arrl.net
www.seapac.org/

June 9

NWVRS monthly meeting 10 am; tailgate swap 8:30.

June 9

KARS Hamfest. Kootenai Amateur Radio Society. Always the 2nd Sat in June. For information contact Contact Thomas, KD7JUS at (208)773-3135 or email kd7jus@arrl.net. <http://k7id.org>

July 14

NWVRS monthly meeting 10 am; tailgate swap 8:30.

July 28

Chehalis Valley ARS 13th Annual Swap. Lewis County Fairgrounds. Contact John Ellingson, K7OSK. k7osk@boatanchor.com; <http://www.cvars.org/>

August 11

NWVRS monthly meeting 10 am; tailgate swap 8:30.

August 18

Antique Radio Swap Meet. Puget Sound Antique Radio Association. 9 AM to 1 PM. Shoreline Senior Activity Center, 18560 1st Northeast, Shoreline, WA 98155. Free admission.
<http://www.eskimo.com/~hhagen/psara/swap.html>

September 8

NWVRS monthly meeting 10 am; tailgate swap 8:30.

October 2012

Swap-Tober-Fest. Mid-Valley ARES. Polk County Fairgrounds, Rickreall, OR. Contact: Don sch, k7un@swaptoberfest.net
. <http://www.swaptoberfest.net>

October 13

NWVRS Fall Swap/Sale at Aurora American Legion Hall, Aurora, Oregon.

November 10

NWVRS monthly meeting 10 am; tailgate swap 8:30. Nomination of officers for 2013.

December 8

NWVRS annual Holiday party 10 am. Election of officers for 2013.

Three Tubes Do The Work of Five or Six!

By Sid Saul

The Reflex radio circuit was one of a handful of circuits used in the early days of radio. As Crosley advertised, 3 tubes would do the work of 5.

With the high cost of tubes in those days, anything that would keep the tube count down was a popular idea. A 2-tuber Reflex with a crystal diode that could also drive a horn speaker was something to consider!

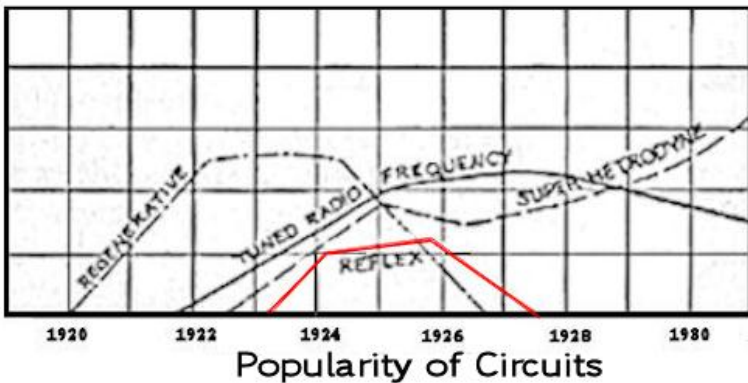

As the popularity chart shows, Reflex was seen throughout the mid-twenties. Reflex simply means the mixing of both audio as well as radio frequencies within the same tube. We are all familiar with our modern Superhet mixing, but with reflexing, we need to shift our thinking down to include audio.

Crosley survived the period after the reflexing fad, where many others like Electrical Research Labs ERLA did not. During this time, ERLA ads for their reflex were found in all the popular publications, but not having other circuit patents to fall back on as did Crosley, ERLA dropped out in 1928.

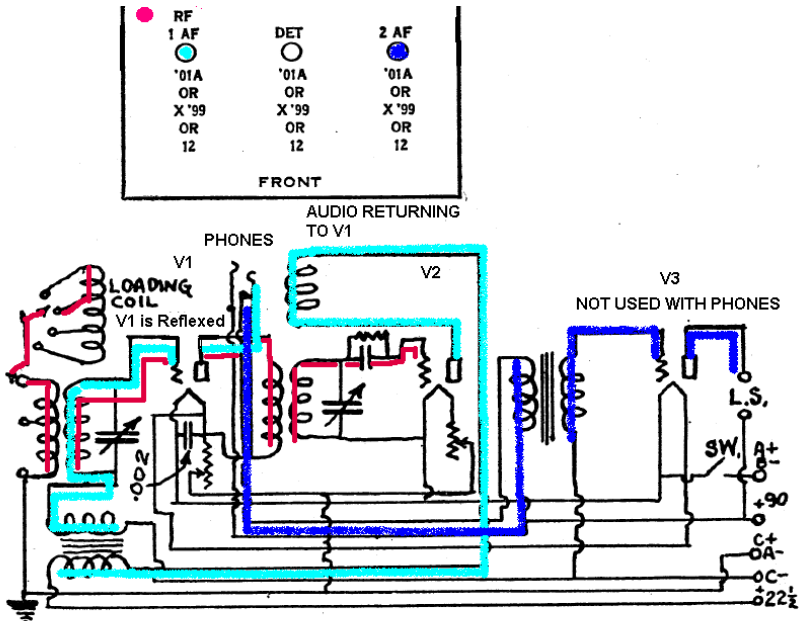

MODEL TRIRDYN

The Crosley Trirdyn uses 3 tubes. As you can see, V1 is reflexed with RF in red, and with AF shown in light blue in the schematic. V2 the detector, and V3 the 2nd audio tube are not reflexed at all. V3 is not used or needed if using headphones, another cost saving benefit. With tube prices falling and with better designs, Reflex was not to remain viable. Funny thing is, it reemerged at the beginning of the transistor age when prices for semi-conductors were high, again to reduce cost. I wonder if we have seen the end to this story. Reflex anyone?

See you in the New Year.

An Interview With Charley Austin

by Art Redman

Charley L. Austin, according to Oregon radio historian Crag Adams, is the father of Oregon radio. He was born in Clinton, Iowa and came to Portland at the age of twelve. He went to the Hawthorne Grammar School and graduated from East Portland High School, which later became Washington High.

He was the first disc jockey in Oregon playing records, advertising records on his amateur radio station 7XF in 1921, and broadcasting on KGG in 1922 becoming the second radio station in Oregon to broadcast on a published schedule. In 1921, he started the Northwest Radio Manufacturing Company and the Model Aircraft Works in 1930. He retired after twenty-five years with the city of Portland where he was the police radio operator and engineer for station KGPP.

The Oregonian sent out reporter Frank Everett to interview the seventy-nine year old retiree at his home at 1944 SE 58th Avenue on August 29, 1978. Everett noted that Austin the “retired ham does not miss it a bit”.

Everett: “When did you enlist in the navy?”

Austin: “When President Wilson declared war I thought the navy was the best place to get over there fast and deliver a knockout punch to “Old Kaiser Bill.”

Everett: “What was your role in radio during World War I?”

Austin: “During the war I had to hire all the operators and I was in charge of all the codes for all the naval vessels in this district.”

Everett: “Tell us about how you installed a radio transmitter for the Forest Service at the summit of Mt. Hood?”

Austin: “It took C.M. Allen and myself about five days to pack all junk up to the top. Everything had to be taken apart and be rebuilt up there. The station operated all during the first summer.”

Everett: “What other things are you most proud?”

Austin: “ Police radio was a wonderful thing and I am happy to think that over the years I have been a part of it. Also I taught a radio school at the YMCA and probably helped a couple hundred people get their license.”

Everett: I heard you have made a model locomotive in your basement. How many hours did it take you to complete the engine?”

Austin: “I’ve got more than 3000 hours of hard work in that baby. It is a perfect scale model of the Hudson type 4-6-4 oil fired locomotive exactly which were used by the Union Pacific and the Southern Pacific in the old days. The boiler has been tested to 150 pounds of steam.”

Everett: “Can you still pound the old key”?”

Austin: “Sure I can, that is something a guy will never forget.”

Everett: “Do you have any radio stuff around the house”?”

Austin: “Heck, no. I have had enough of that for this life, all I want to do know is sit in a good easy chair and watch the ‘Idiot Box’ .”

Roster Updates

Change of address:

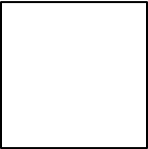

White, Myron
10447 NW Valley Vista RD
Hillsboro, OR 97124
myron.white@gmail.com

R

Information update:



Harris, Lloyd
503-784-7188
loydharris3832@gmail.com

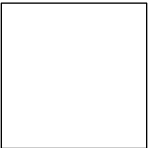

Weigel, Bill
3035 NE 52nd
Portland, OR 97213
503-281-8000
bill_weigel@hotmail.com

The Langhorne Infradyne Set

by Art Redman

The Langhorne Radio Company of Portland located in the Commonwealth Building on SW Sixth Avenue and SW Stark began manufacturing Super-Heterodyne parts, and long wave transformers for oscillators, which sold for \$5.50 each in early 1924. Their motto as advertised in the Oregon Journal on March 9, 1924 was "Reception With a Smile". They invited the radio kit builder to bring in or mail their unworkable transformer and coil and "we will balance them for you"

Langhorne never labeled the front panel or had model numbers. Instead, they labeled their IF transformers and coils, which are the only way to identify their fifteen radios that went by circuits and types. It appears Langhorne just went on trying to improve one basic radio circuit. By November, 1924 they marketed in the Portland Telegram their new Super long distance receiver by the list of DX stations received: WJAR, WGR, WGY, WJAS, WEAY, KFKB, KFDX, KYDM, CJCA, CKCK, CRY and Mexico.

The Infradyne IF amplifier made by Remler was introduced in the August 1926 issue of Radio magazine. The Infradyne came in either a three or four tube model with Bakelite panel and copper case. Thomas J. Langhorne used both models in his late 1926 receivers where it was inserted into the radio just ahead of the detector with an IF frequency of 3.2 MHz. This high frequency IF was created by using the sum of the incoming signal and Langhorne's local oscillator of 48 kHz instead of the frequency difference between the two as in other superhets.

The problem in the Remler Infradyne as designed by E.M. Sargent, was the amplifier used UX-199 triodes, which never really worked well at higher frequencies. A three-element tube or triode tended to oscillate at frequencies above 1.5 MHz due to inter-electrode capacity. Sargent used the residual leakage of the 199 tubes to an advantage to ground all the grid circuits through a capacitor network with no return to ground or other voltage known as a "floating ground".

As a company, Remler actively sent representatives in the field to recruit radio manufacturers to work around the RCA superhetrodyne patents and did not just rely on magazine ads and mail order. LC. Rayment of the Remler Company of San Francisco branch visited Portland and the Langhorne laboratory in September 1926 to appoint Langhorne the official service station for the Pacific Northwest territory of the Infradyne receiver when it was announced in the November 13th newspapers. He also visited the Stubbs Electric Company to successfully pitch the Infradyne Amplifier and manuals, which Stubbs sold as improvement to any trf or neutradyne set or as an item to build into the new Infradyne circuit for \$28.00.

It is not known whether Rayment ever visited the Long Brothers in Cornelius to help develop the Long Superhet Model S-8 in 1925. The Long set is a Remler assembled eight tube kit similar to the set made and sold by Doctor Orrin Heathcock of LaGrande, Oregon.

One other West Coast radio connection is that Langhorne recruited Ralph Love from the Gilfillan Company of Los Angeles to build their cabinets. Other Portland radio companies like the Sonometer Speaker Company relied the local Lents Cabinet Shop and the Universal Wood Working Company for cabinet construction and finishing.

Holiday Party Photos

Photos by Rick Walton

Tony Hauser and Rick Walton



Dick Karman at the mike!



O Tannenbaum!



The Power Supply --- and George!



Cliff and Liles



Holiday Party Photos

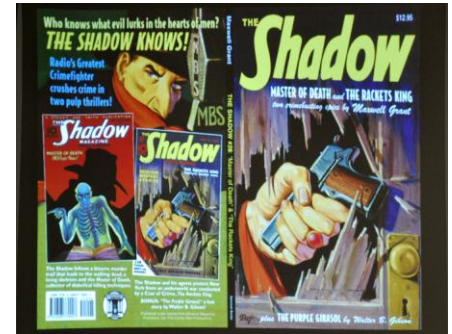

Swap Shop

FOR SALE: Thousands of tubes, hundreds of radio parts, panels, meters, surplus, etc. R5-D3 electronic surplus, Bob Lee, 9770 S.E. Stanley Ave., Milwaukie, OR 97222, (503) 513-0410

WANTED: **I am searching for the “cat-whisker” part of a Westinghouse crystal detector as used in the DB Detector or the Aeriola Jr. Crystal set.

Thanks in advance.

Dick Howard, 9999 S. E. French Acres Drive, Portland 503-775-6697

WANTED: **I need one wooden, band-change knob for a Zenith model 635. Dick Bixler 503-690-2557

FOR SALE: **I have this wonderful 1940s Zenith 12S471 console radio for sale. It has been electronically restored and is in excellent working condition. The cabinet is sound and is in very nice original condition, with no veneer damage or broken parts. However, it does have some scratches and bumps around the base and areas on top where the finish shows roughness due to potted plants, but not bad? I'm asking \$1,000.00 cash or as close to that amount as possible. The radio is located, for pick up, in So. Seattle Wa. My phone number is 206-244-6428 or you can e-mail me at radiosbergie@q.com if your interested. I have over 600 radios in my collection, who knows, I might have something else that interests you, if not this great old Zenith?



Leads and Needs

Questions about restoration of vintage radio? Visit Radiolaguy's web site often for this information plus lots of other interesting displays, photos, virtual museum plus lots of other information on vintage radio and television. Oh, yes, there are items for sale as well and NVRS members get a substantial discount on most of these items. Thank You, Sonny the Radiola Guy

Visit my vintage radio web site: <http://www.radiolaguy.com>

NEED: Cabinet for my slant front HALOWAT All wave 5. Panel 7inches high X 21" long. The panel height is the one that I must match...the 21"length can be worked out by fancy extensions on each end if needed and the panel must slant back, the usual amount. Dick Bixler 503-690-2557.

NEED: I'm looking for some knobs for a Crosley model 175. Thank you, Robbie Robinson.

LEAD: I have a “Majestic”, Grigsby-Grunow Co., Model 90-B, Serial #9B-627575 that I’m trying to find a good home for. I cut the electrical cord on it years ago as it was pretty frayed. It has a complete set of new replacement tubes. Contact John Ekberg, Corbett, Oregon. Phone is 503-695-5547 and the e-mail is friedafolks@yahoo.com.

Radio Service

These members have indicated they are willing to perform radio repairs:

Roger Brown – (503) 693-6089

Bruce Baur - (503)-708-4537, brucebaur@comcast.net

Blake Dietze – (360) 944-7172, wb6jihj@ix.netcom.com

Jack Doyle – (503) 305-8097

Pat Hickman – (503) 887-9015 Web: www.classictubeaudio.com

Email: phickman@comcast.net

Todd Ommert – (503) 246-4141 Web: www.burlingame-radio.com

Email: burltv@msn.com

Tony Ranft – (360) 944-8489 or walterranft@hotmail.com – General repairs.

Dave Wise – (503) 648-0897, david_wise@phoenix.com

If you are willing to repair radios, give your name, phone and/or e-mail, and any comments to the *Call Letter* editor.

The Northwest Vintage Radio Society is not responsible in any disputes arising from services provided by members listed here. By common agreement of the board of directors, the buyer assumes all responsibility for the satisfaction of any transaction.

Meeting Location

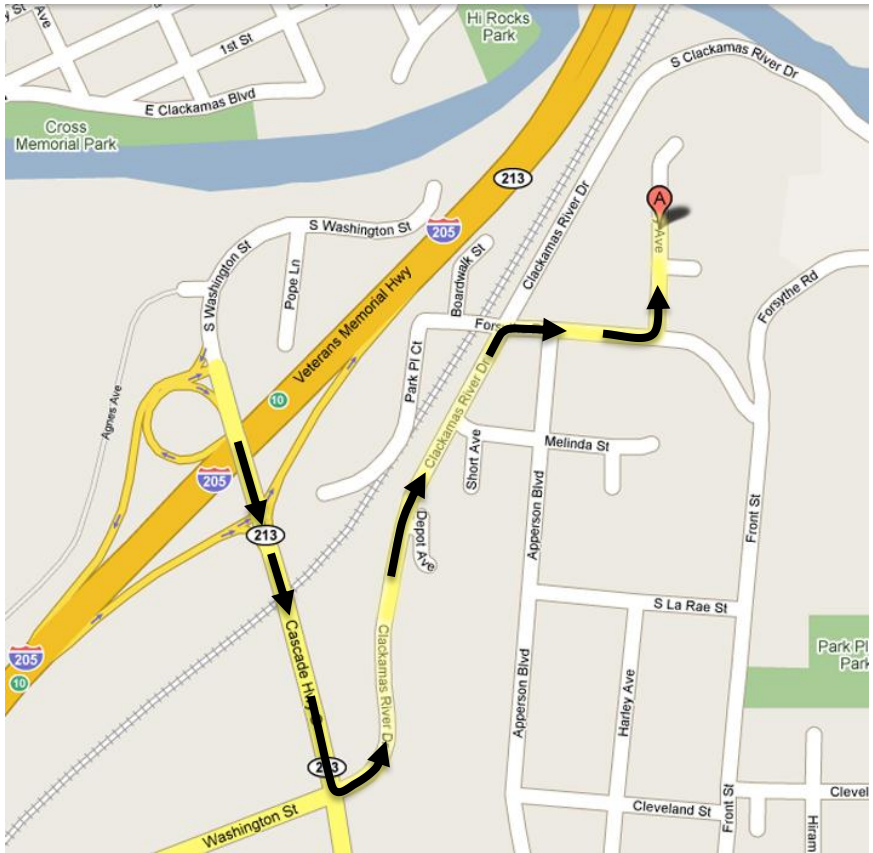

To get to the Abernethy Grange Hall:

1. Exit I-205 at SR-213 (Exit 10 to Molalla) and head south on 213.
2. At the first intersection (the traffic light), turn left onto Clackamas River Dr.
3. Turn right at Forsythe Rd.
4. Turn left onto Harley Ave. The Grange Hall is on the left about a block and a half.



NW Vintage Radio Society
P.O. Box 82379
Portland, Oregon 97282-0379

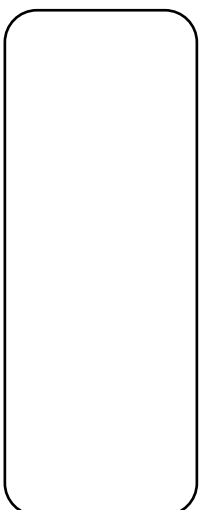
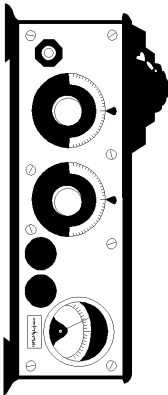

FIRST CLASS MAIL