

# electronics

electron tubes—their radio, audio, visio and industrial applications

radio  
 sound pictures  
 telephony  
 broadcasting  
 telegraphy  
 carrier systems  
 beam transmission  
 photo-electric cells  
 facsimile  
 amplifiers  
 phonographs  
 measurements  
 receivers  
 therapeutics  
 television  
 counting, grading  
 musical instruments  
 traffic control  
 metering  
 machine control  
 electric recording  
 analysis  
 aviation  
 metallurgy  
 beacons, compasses  
 automatic processing  
 crime detection  
 geophysics

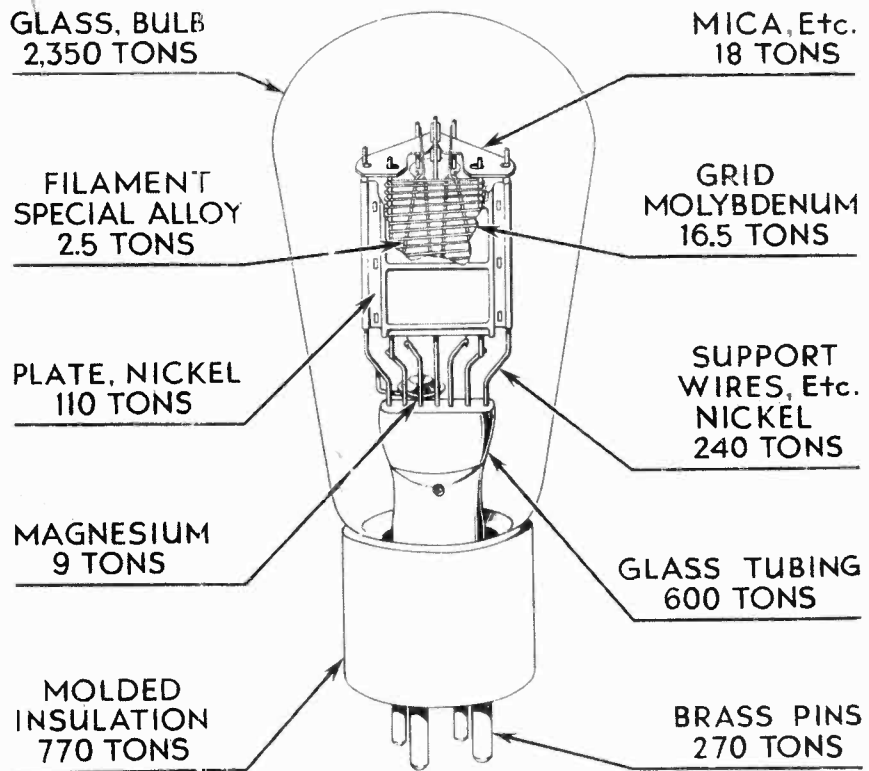

Raw materials in tube manufacture Page 366  
 Sound "dubbing" in motion pictures Page 371  
 Detection in super-heterodynes Page 386

A MCGRAW-HILL PUBLICATION

Price 35 Cents

NOVEMBER 1930



# electronics

M. E. HERRING  
Publishing Director



M. CLEMENTS  
Sales Manager

## Contents for November, 1930

Copyright, 1930, by McGraw-Hill Publishing Company, Inc.

The march of the electronic arts .....	363
Raw materials and costs in tube manufacture .....	366
Electronic control of complex auditorium lighting ..	368
BY DEAN H. HOLDEN	
Sound "tricks" in picture production .....	371
BY CARL DREHER	
A simplified harmonic analyzer .....	374
BY A. W. BARBER	
Developments in ultra-high frequency generation ...	376
BY C. W. LOEBER	
Measuring the heart's E M F .....	377
The phototube in automatic weaving .....	378
BY ARTHUR KORN	
Sound film reproduction without mechanical slit ...	380
Design of the output transformer .....	381
BY R. C. HITCHCOCK and W. O. OSBON	
Sound-picture engineers discuss economics, progress and new problems of industry .....	384
Linear detection of heterodyne signals .....	386
BY F. E. TERMAN	
The rôle of barium in vacuum tubes .....	390
BY J. A. BECKER	
Sound recording under difficulties .....	397
With electronics' camera .....	400

### DEPARTMENTS

High lights on electronic devices in industry .....	388
Editorials .....	392
Review of electronic literature here and abroad ...	394
News of the electron industries .....	401
New products .....	402
Patents .....	405

McGRAW-HILL PUBLISHING COMPANY INC., Tenth Ave. at 36th St., New York, N. Y.

Cable Address: "Machinist, N. Y."

McGRAW, Chairman of the Board  
MUIR, President  
McGRAW, JR., Vice-Pres. and Treas.  
MERRIN, Vice-President  
C. H. THOMPSON, Secretary

MASON BRITTON, Vice-President  
EDGAR KOBAK, Vice-President  
HAROLD W. MCGRAW, Vice-President  
H. C. PARMELEE, Editorial Director

New York District Office, 285 Madison Ave.  
WASHINGTON, National Press Building  
CHICAGO, 520 North Michigan Ave.  
PHILADELPHIA, 1600 Arch Street  
CLEVELAND, Guardian Building  
ST. LOUIS, Bell Telephone Building

SAN FRANCISCO, 883 Mission Street  
BOSTON, 1427 Statler Bldg.  
GREENVILLE, S. C., 1301 Woodside Bldg.  
DETROIT, 2-257 General Motors Bldg.  
LOS ANGELES, 639 Chamber of Com. Bldg.  
LONDON, 6 Boulevard St., London, E. C. 4

# electronics

A MCGRAW-HILL PUBLICATION

New York, November, 1930



O. H. CALDWELL  
Editor

FRANKLIN S. IRBY, Ph. D.  
Associate Editor

KEITH HENNEY, M.A.  
Associate Editor

## The march of the electronic arts

### radio case Supreme Court

In the welter of litigation in which the Federal Radio Commission has been involved, the Supreme Court of the United States will get the case of a tiny small Chicago broadcasting station this year for the first real showdown on the basic radio law.

Decided at No. 29 on its fall calendar, the case of WCRW is expected to be before the highest tribunal in the country some time this month or next. The case, arising out of an order of the Commission reducing the power of the radio station from 500 to 100 watts, is expected to definitely determine the constitutionality of the Radio Act of 1927 which gave birth to the commission and under which it has been functioning for the past three years.

Another point raised in this case is whether the waiver of vested or priority rights, as required by each station owner in applying for a federal license, is constitutional. In certifying the case to the Supreme Court, the Court of Appeals did not certify whether the Commission's order was void; in fact stated nothing concerning the Commission's authority, but that the station has been in status since it reduced its power.

In the case of WMBB-WOK, also of Chicago, a 5,000-watt station which was taken off the air altogether in one of the earliest decisions of the Commission, the case has been combined with the WCRW case inasmuch as many of the same questions are involved. Besides the question of property issue, however, the WMBB-WOK case raises the point that interstate commerce is not interstate commerce and that the validity of the Davis amendment equalizing broadcasting facilities between the zones and states.

The standards prescribed for radio stations in the radio act are also a point of issue.

### U. S. radio exports ahead of last year

United States exports of radio apparatus during the eight months ended August 31, 1930 registered a gain over the corresponding period of last year, according to the Electrical Division, Department of Commerce.

Total exports of radio apparatus during the 1930 period amounted to \$11,904,171, an increase of \$15,050 over the total for the eight months of 1929.

Shipments of receiving sets alone totaled \$5,583,301 during the 1930

period as compared with \$4,620,922 for the eight months of 1929; receiving tubes \$1,592,578 in comparison with \$1,112,096, and receiving set components, \$2,201,736 as against \$2,194,200.

Canada was the leading market for radio apparatus during the first eight months of 1930. Italy is becoming an increasingly more important market for radio apparatus and during the month of August shipments of receiving sets to that country were valued at \$52,325 and receiving set components at \$38,128, while shipments of loudspeakers amounted to \$11,436. Mexico imported \$89,379 worth of radio receiving sets from the United States and New Zealand, \$77,727 worth. Argentina and Uruguay each took approximately \$39,000 worth of these sets. Argentina also imported \$32,223 worth of American receiving set components.

### DR. R. A. MILLIKAN



with the electroscope he used at the north magnetic pole to determine effect of earth's field on cosmic rays

### Atom is X-rayed by new process

Invention of a new X-ray tube which takes "snapshots of atoms" was announced to the New York section of the American Chemical Society at a meeting in the Engineering Society Building Oct. 17. The new tube takes in one minute difficult pictures that formerly required 100 hours and in one-fiftieth of a second "simple" pictures that took two hours.

The pictures are not the familiar shadow photos, such as taking the bones of a human hand, but a newer branch of X-ray photography known as diffraction patterns. These are pictures which show the arrangement of atoms in crystals. The tube was developed by Dr. George L. Clark, Professor of Chemistry of the University of Illinois. Dr. Clark stated the new tube would have wide applications in industrial development.

## Fifty-one cities to use radio to catch criminals

So useful has radio proven in the apprehension of criminals in the larger cities that the Federal Radio Commission has been besieged with applications from smaller cities for radio stations. At present there are 29 cities utilizing short-wave communication service and 22 other cities hold construction permits.

Stories of robbers being caught within a few minutes after they had held up a bank or forced a safe continue to multiply in the municipalities where this radio service is in operation. Radio-equipped automobiles patrol the city and are ready to speed to the scene of a crime immediately upon receipt of the signal. Thus the chances of a criminal escaping are greatly lessened from those of the time when police had to be reached by telephone or dispatched from headquarters or a precinct station. The service is being adopted in a few instances by Fire Departments.

The national capital is one of the most recent cities to obtain a permit to erect a station and equip its police cars with receivers. The contract has just been let, and the service is expected to be in operation before many weeks.

Construction permits have been awarded to Berkeley, Calif.; Philadelphia, Pa.; Beaumont, Texas; Buffalo, N. Y.; Chicago, Ill.; Auburn, N. Y.; Youngstown, Ohio; Lansing, Mich.; State of Missouri; Kansas City, Kan.; Portland, Ore.; Rochester, N. Y.; San Antonio, Texas; San Francisco, Calif.;

Toledo, Ohio; Seattle, Wash.; Akron, Ohio; Washington, D. C.; Vallejo, Calif.; Oklahoma City, Okla.; New York Fire Department and El Paso, Texas.

## PHOTOTUBE ALARM AT N. Y. BUSINESS SHOW

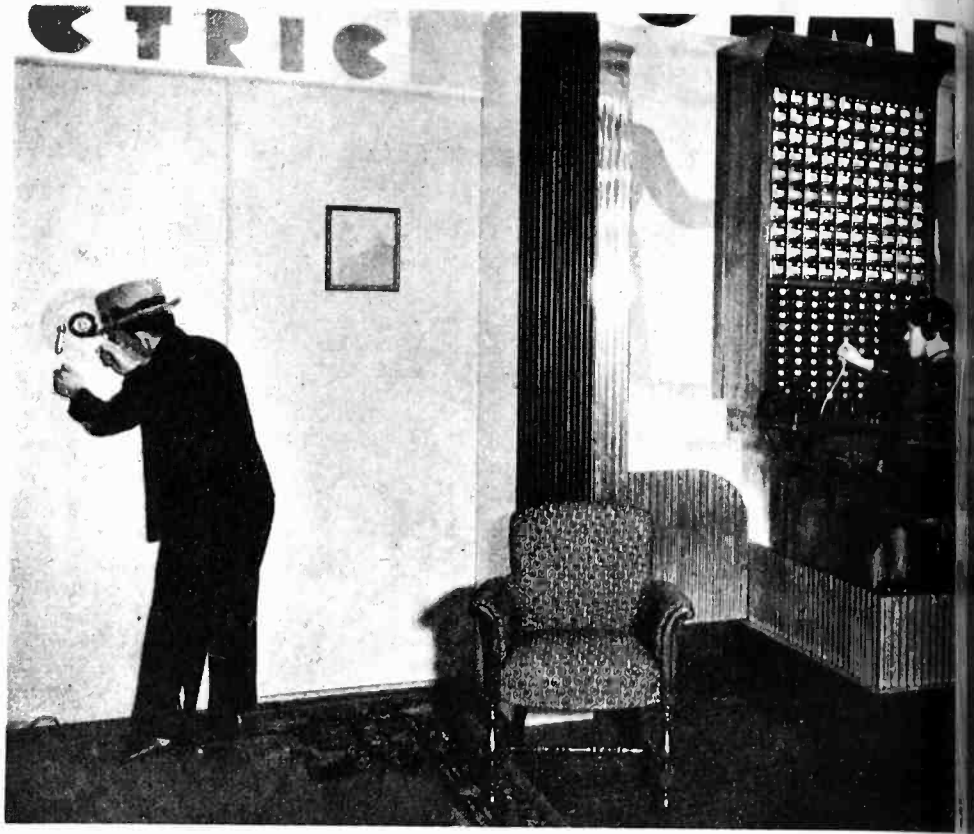

As yeggman unknowingly obstructs invisible light beam an alarm is sent to switchboard. Device demonstrated by Holmes Electric Protective Company at New York Business Show, October 20-25

♦ ♦ ♦

## NBC admits practicability of synchronizing

In a statement to the Federal Commission, October 20, M. H. Aylesworth, president, National Broadcasting Company, reported the success of experiments in synchronizing the stations of WEAJ, WGY and KDKA on the 660-kc. channel, under the direction of C. W. Horn, chief engineer.

These experiments thus indicate a nation-wide broadcasting chain operated on one or two broadcast wave lengths—instead of the present of 15 to 25 wave lengths, all carrying the same program (which results in a mid-west listener hearing the Evening Hour at 25 different places on his radio).

How the new "synchronization" is to be commercially applied remains to be seen. Undoubtedly some of the large broadcasters will willingly transfer to the chain wave length for regular operation and thus become more outlets. Other owners will certainly insist on keeping their stations' own frequency, making it necessary for the management to build its own high power transmitters to cover such regions at an estimated total expense of \$35,000.

In any event, as pointed out by Mr. Aylesworth, the development will be a slow evolution, involving considerable reallocation of present broadcast frequencies, resulting in many more regional programs of high signal intensity.

## POLISH RADIO STATION TO HOWL DOWN REDS

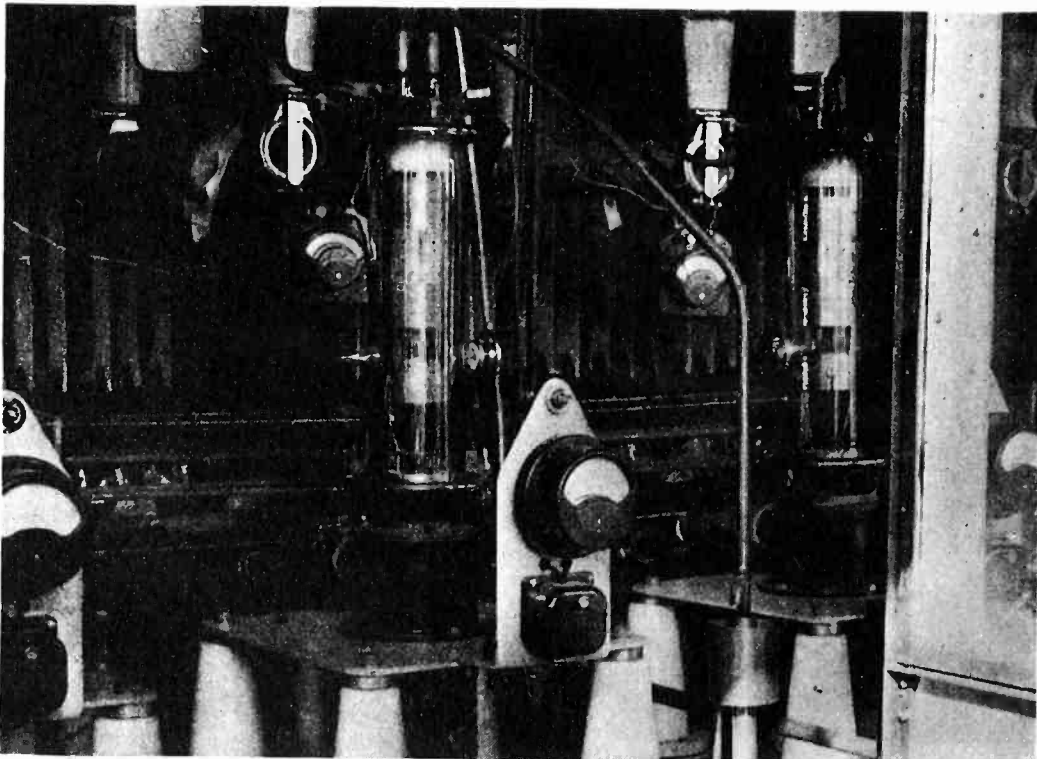

To combat Soviet propaganda broadcast from Moscow, Poland is building one of the most powerful stations in Europe. Six 100-kilowatt water-cooled tubes built by the Marconi works will be used

ican College of  
ons favors  
ronic knife"

mary results of a survey by the  
an College of Surgeons to deter-  
e actual worth of the electrical  
n combating disease were the  
of an enthusiastic report at a  
um on electro-surgery conducted  
15, at Philadelphia, Pa. during  
ical congress of the college. The  
was made to determine the merits  
nstrument specifically in neuro-  
and the surgery of malignant

Howard A. Kelly of Baltimore  
d that electro-surgery was as far  
f scalpel surgery "as the modern  
tram is ahead of the lumbering  
ar."

asserted that the new technique  
the extension of surgery of the  
to delicate areas not dreamed of  
and opens up the possibility of  
extending the application of  
measures to the spinal cord.  
never is electro-surgery halted  
of hemorrhage, he said.

Ernest Sachs of St. Louis de-  
the development of the electrical  
s one of the three great epochal  
eries for assisting the neuro-  
in his work. Where hitherto  
sometimes necessary to use sixty  
enty silver clips for ligating  
blood vessels, large tumors are  
moved without recourse to clips.

ical transcriptions are  
e used by many  
stations

broadcast stations are experi-  
ing with a new form of program  
station. This new form which is  
electrical transcriptions consists  
ck-up from a disc record. These  
are not played on regular phono-  
but by a special reproducing ma-  
esigned to meet the requirements  
dcasting.

sponsors of this type of enter-  
nt see numerous advantages to  
age them. In the first place, the  
can be made in a studio designed  
best accoustical effects. If an  
akes an error the record can be  
gain which would not be possible  
normal broadcasting conditions.  
r advantage claimed is that the  
m may be presented at the se-  
hour for any station. This of  
is not possible with present na-  
nook-ups for big programs with a  
nce of three hours in time from  
to coast. Also the expense of  
ines to connect stations is elimi-  
y using the record system.

BROADCASTING SPORTS

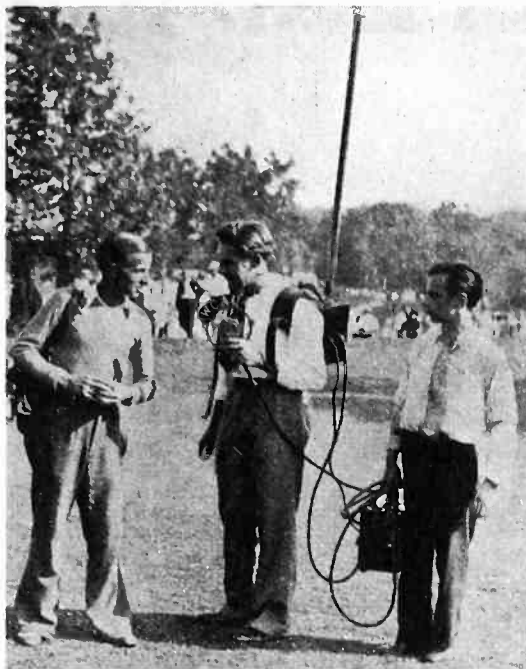

Designed for short wave use this trans-  
mitter may be easily carried by two  
persons in following athletic events

Carrier-current talk  
reaches 445 miles

Carrier-current communication for regu-  
lar operating service has been installed  
between Pine Bluff, Ark., and New

Orleans, a distance of 445 miles. This  
is said to be the longest communication  
distance ever covered in this way for  
regular service.

Incident to the construction of a  
10-kv. line between Amite, La., and  
New Orleans, forming the final connect-  
ing link in the interconnection between  
the Market Street plant of the New  
Orleans Public Service, Inc., and the  
Sterlington steam plant of the Louisiana  
Power & Light Company, in the north-  
ern part of Louisiana, General Electric  
carrier-current equipment is used to  
permit communication between New  
Orleans and Amite, La.; Jackson and  
Indianola, Miss., and Pine Bluff, Ark.

Soviets spending millions  
on radio

A network of 62 radiotelegraph stations,  
furnishing service to strategic points  
throughout Soviet Russia, is planned by  
the Soviet government as part of its  
revised five-year program for the de-  
velopment of communications, the De-  
partment of Commerce has learned.  
The entire communications program of  
the Commissariat for Posts and Tele-  
graphs involves capital investments  
aggregating about \$683,000,000. Soviet  
Russia is paying particular attention to  
"wired wireless" or the transmission of  
radio programs along telephone wires.

NAVY ADOPTS RADIO-OPERATED TYPEWRITER

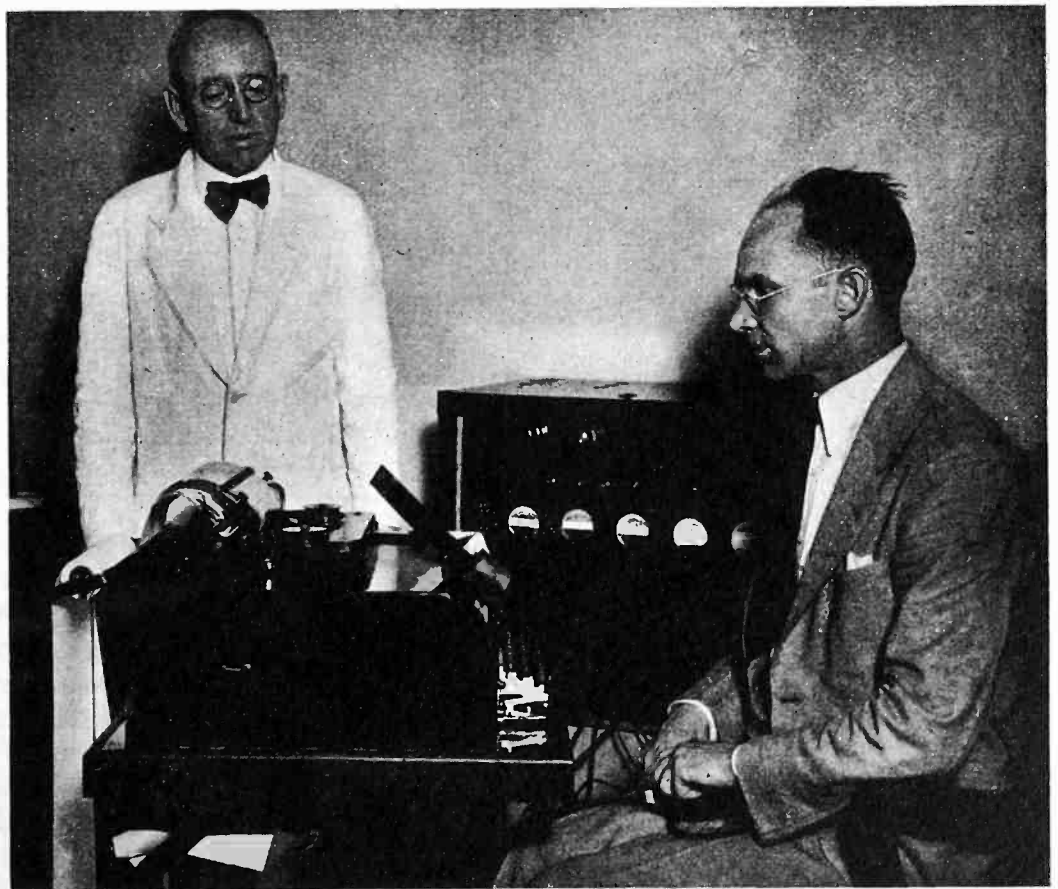

Radio impulses are used to transmit typewritten messages direct  
from the Navy Department, Washington, to the Naval Operating  
Base, Hampton Roads, Va. Captain S. C. Hooper, Chief of  
Naval Communications is shown standing

# RAW MATERIALS, COSTS

Price ranges  
over ten-year period.  
Labor and overhead factors  
in finished cost

**C**ONSERVATIVE estimates indicate that 69,000,000 tubes of the types used in radio receivers were produced during 1929 and that the 1930 production will be of the order of 80,000,000.

The first "big" year of vacuum-tube production was 1923, when 4,500,000 tubes were made; since then the production has had an annual increase of about 10,000,000 tubes. During this period the costs of raw materials, labor, and other expenses have changed, with the results shown here. At the same time greater use of automatic machinery, coupled with quantity production, has lowered the tube cost; manufacturing experience and research during this period have given the consumer better tubes.

This vast assembly of glass, rare earths and common metals has consumed thousands of tons of raw materials

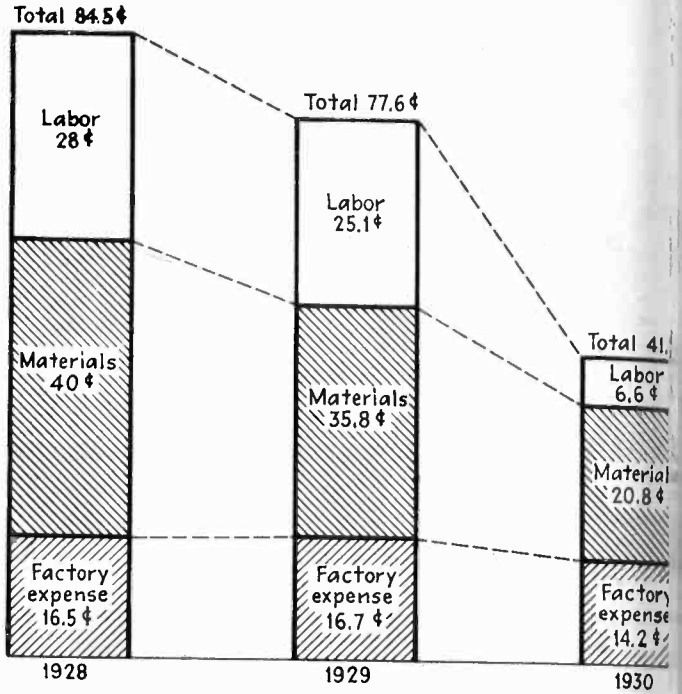

How the factors entering into manufacturing cost of tubes have been reduced since 1928. Material costs have come down, but owing to automatic machinery the labor cost per tube has been even more greatly reduced

made from 37 of the 90-odd elements found in the universe. Some of these elements are used in extremely minute quantities, but at great saving to the user are the tubes, strontium, barium, and thorium, for example (see page 390, this issue of *ELECTRONICS*); other elements are used in enormous quantities. In ten years the prices of these raw materials have fluctuated appreciably; the chart presented herewith shows these variations and points out how low present prices are.

## Kaleidoscopic changes in industry

During this decade the uses of some of the elements entering into vacuum-tube production have increased. At the same time there has been a change in the materials used for specific parts of tubes, so that the entire picture of ten-year history is rather kaleidoscopic. The production of molybdenum is an interesting example. In 1923 three sales were made by one company. The prices were 80 cents, \$1 and 60 cents. At that time very little molybdenum had been found for the now well-known "moly." Since then other uses than tube manufacture have appeared so that the stock on hand of one company is sufficient for the last tube manufacturers about 200 years. Molybdenum is mined in Colorado as molybdenum sulphide (MoS<sub>2</sub>), the concentration of the ore being about 85 per cent. This sulphide, about 60 per cent of which is molybdenum, is sold to chemical concerns, which in turn sell it to tube manufacturers and suppliers of tube parts as ammonium molybdate. From this material the grid wires are wound.

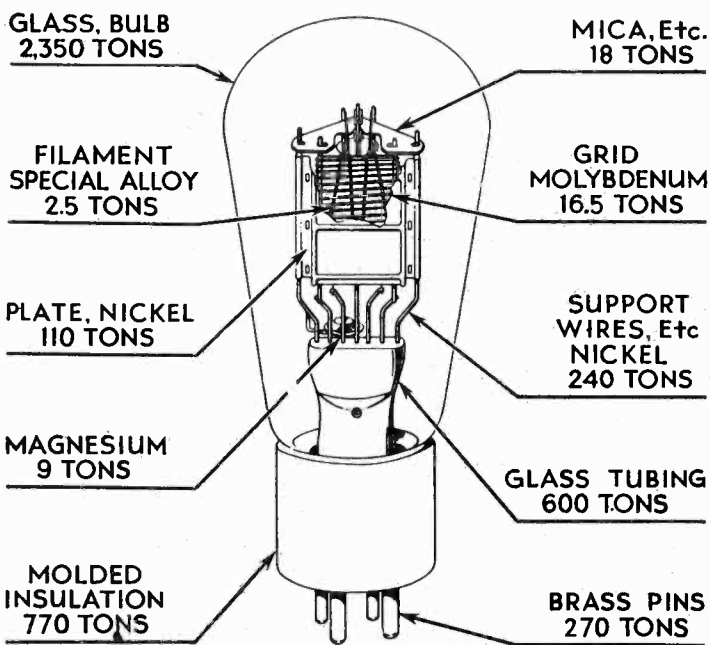

Total material used in 69 million receiving tubes

	Tons		Tons
Glass	2,950	Magnesium	8.9
Nickel	350	Copper-steel	50
Molybdenum	16.5	Molded material (base)	770
Brass	280	Barium, strontium compounds	

# TUBE MANUFACTURE

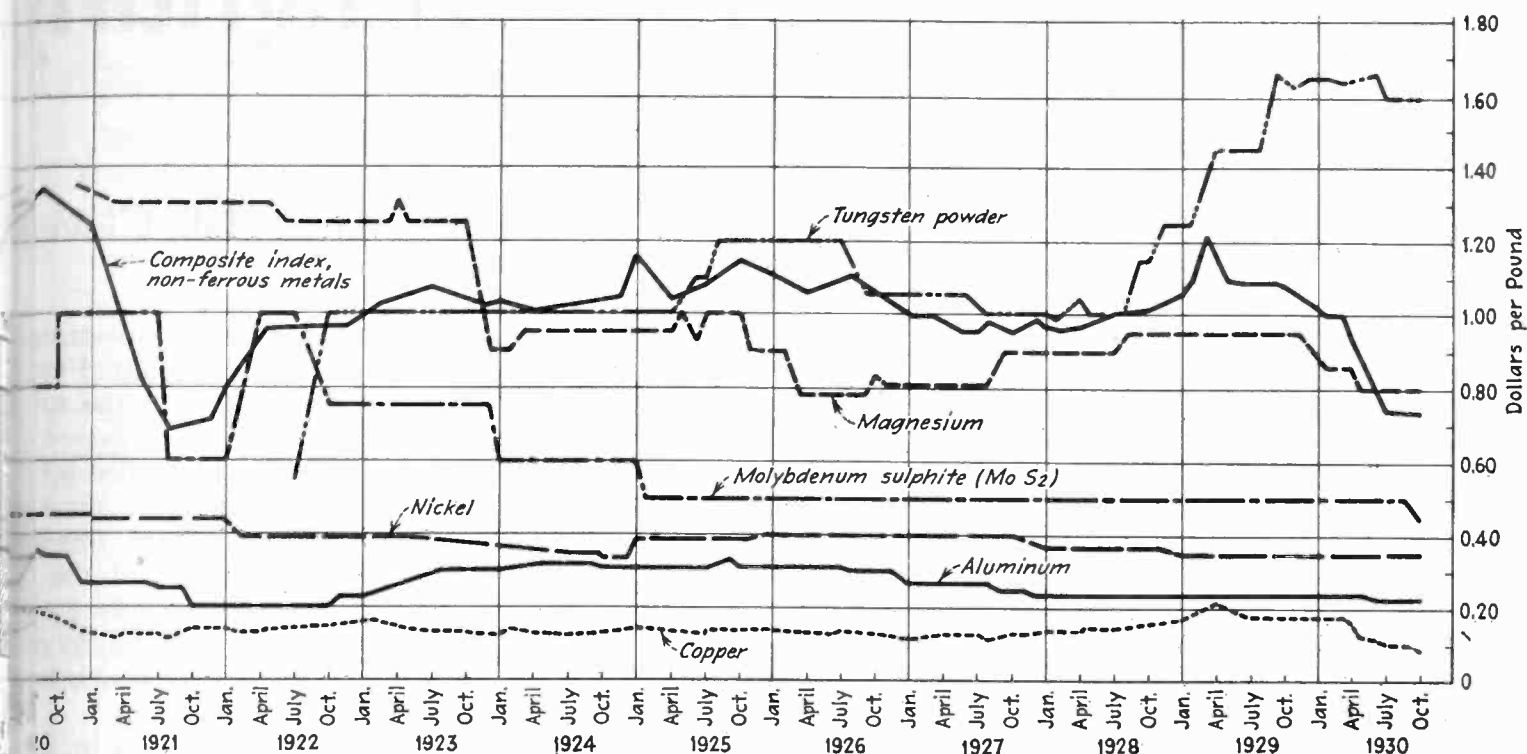

How the prices of some of the raw materials and commercial metals entering into the electronic-tube industry have varied during the past decade. In general, the price movement is seen to have been downward. As the chart shows, prices for most materials are now at the lowest point reached during the past ten years

years the prices of tubes have dropped appreciably due to development of automatic machinery, construction, or other economies. As an example, the cost to produce a 227 by a well-known manufacturer in the month of September in three successive years is given here. It is broken down into labor, material, and factory expense, the latter item including depreciation and replacement of machinery at the rate of \$100 per year, rent, light, heat, power, etc., in the factory. The most startling reduction in cost is due to labor, occasioned by the greater use of automatic machinery. This cost has been cut in four; at the same time the materials cost has been halved in three years. The over-all cost has been halved, and at the same time the better and better tubes have been made.

## Estimates of material consumed

Quantities of material indicated here as entering into the production of 69,000,000 tubes were estimated in the following manner: The weight of material used in producing 227, 224, and 245 types of tube were averaged and this value multiplied by 69,000,000. It is a relative but not accurate estimate of the tons of material consumed by tube manufacturers in 1929. It does not include power tubes of the types used in transmitters, telephone repeater tubes (of which there are several million in use), or special tubes of various types sold by hundreds or thousands for various purposes.

## Roll-Call of Materials Entering Into Electronic Tubes

<b>Glass</b>		<b>Supports</b>
Silica	Iron	Glass
Sodium carbonate	Titanium	Mica
Calcium oxide	Silicon	Lava
Sodium nitrate	Barium carbonate	Isolantite
Lead oxide	Strontium carbonate	Nickel
Borax	Calcium	Molybdenum
Zinc oxide	Barium nitrate	Monel
Cobalt oxide	Strontium	
Potassium carbonate		
	<b>Grids</b>	<b>Getters</b>
<b>Base</b>	Nickel	Magnesium
Bakelite	Monel	Calcium
Porcelain	Molybdenum	Strontium
Glass	Copper	Barium
Wood fiber	Chromium	Sodium
Zinc		Potassium
Copper	<b>Plates</b>	Caesium
Nickel	Nickel	Phosphorus
Tin	Monel	Carbon
Marble flour	Molybdenum	Tantalum
Ethyl alcohol	Iron	Mischmetal
	Tantalum	
<b>Filament</b>	<b>Leads</b>	<b>Gases</b>
Tungsten	Zinc	Hydrogen
Thorium nitrate	Iron	Helium
Carbon	Nickel	Neon
Nickel	Copper	Argon
Cobalt	Borax	Nitrogen
		Oxygen

# Complex auditorium lighting

By DEAN H. HOLDEN\*

Keyboard manipulation of color effects in great new Severance Hall, Cleveland

WITH much of the success of the decoration of Severance Hall dependent on the subtle control of its light, the main switchboard required very special design. The synthetic system of red, green and blue lights, combined to give any hue, necessitated proportional dimming. A dimming preset mechanism with simple control of fadeout and fadein from setup to setup was vitally essential.

Basically, the intent of the designers of this system was to make it possible for a single operator, seated at a movable console, of organ type, to control, singly and in combination, all lighting circuits of the main auditorium and stage in a manner analogous to an organist's control of sound. All operating devices are in easy reach of hand or foot, and of sizes consonant with the finger or foot, respectively. The operation of all moving parts is not unlike the touch of a typewriter or organ.

All this is a far cry from the average switchboard of today, which has been aptly likened to a fourteenth century organ, struck with clenched fists. It was, then, the thought that centuries of development by organ builders could be applied to lighting control, and in the completed board in Cleveland there will be many standard organ parts. In fact most of the console equipment has been borrowed direct from either radio, telephone or organ practice.

## Reactor and vacuum-tube system

Down in the basement apparatus room is a rack some twenty feet long and seven feet high which contains 114 reactors and their associated tube units. One reactor per load is provided. To make the operation of these units clear we will take any reactance dimmer as an example. The a.-c. load current flowing in the reactor is directly dependent on the d.-c. saturation current flowing in the other coil of the same unit. This d.-c. is sup-

plied by two neon-filled rectifier tubes. Incidently, life of these tubes should be several thousand hours. Means are provided for compensation as the tubes age as well as for easy testing.

The output of these rectifiers is controlled by their grid bias. This is accomplished by a small conventional radio amplifier type. In turn, this amplifier has its output controlled by a variation of the conventional radio "C" battery bias on its grid control wires to this grid come from one of the ordered and ten vertical busses on a relay panel, the center of the cross connecting mechanism.

The relay cross-connecting panel is also in the apparatus room, very near to the tube system. It contains 36 horizontal rows of relays, 110 in each row. Each horizontal row is connected with one of the 36 control drums on the console. Each vertical row is connected to a one-tube control unit, its associated load and in turn, load. It will be seen that by closing a relay at the intersection of a horizontal with a vertical bus, any one of the 3,960 possible connections can be made.

## Operating console

It was obviously impossible to run four thousand feet of wire to the console or accommodate that number of switches. The architects developed a diagram wherein the 110 load switches and 36 control selectors at the console. The operation of connecting loads No. 3 and No. 91 to control No. 17 is as follows:

- (1) Throw load switches No. 3 and No. 91 to the common.
- (2) Touch control selector button No. 17 which completes the circuit to the closing coils of the appropriate relays, which are then automatically latched closed. Had the operator touched selector No. 2 instead, then these loads would have been connected to control drum No. 2. The

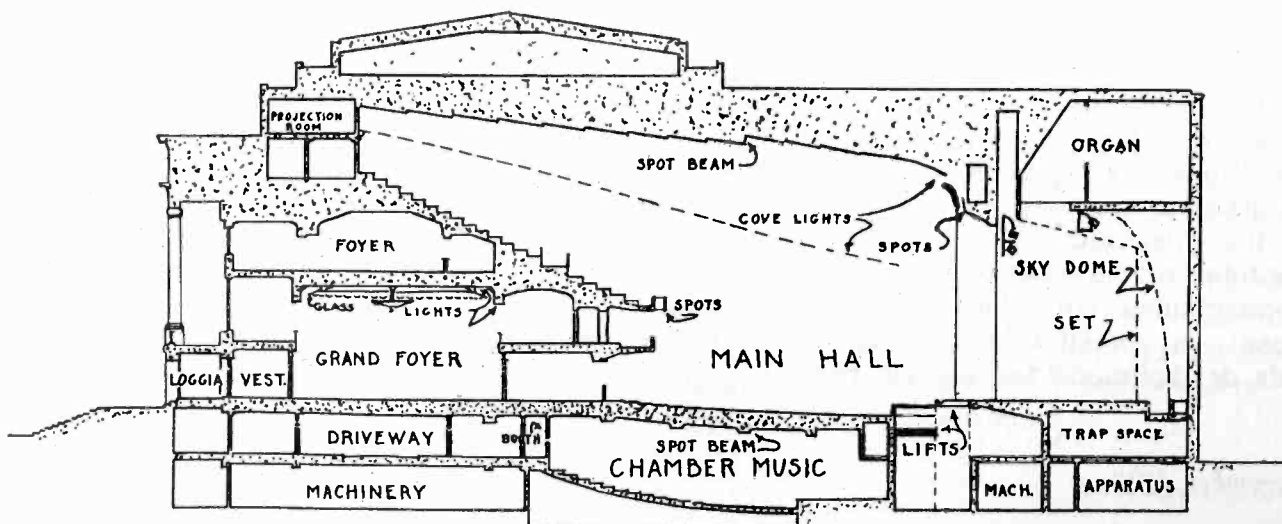

Cross-section main auditorium which seats hundred people



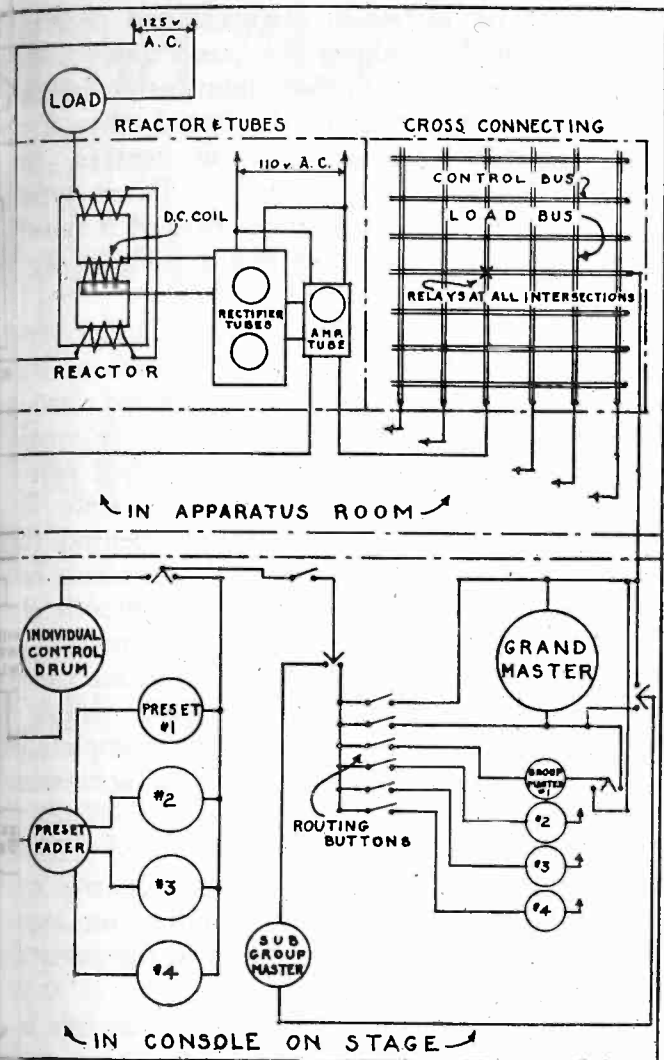

Diagram of control circuits, showing method of vacuum-tube supply of direct current to third leg of reactor, to produce magnetic saturation of core

operation is continued until all needed loads are connected to appropriate controls. Of course, after setting up a given control bus, all load switches, as No. 3 and No. 91 above are returned to neutral. To clear the board, all active load switches are thrown to "Off" and the hand run rapidly over the control selector buttons thus actuating the opening coils of all active relays.

There is an additional contact on each relay, which is a pilot light. On the console are 36 buttons connected with the dimmer control selectors. By closing these, pilots glow at each load switch whose relay is thus giving a visual picture of the board setup. In appearance closely resembling in size and design to the organ console, the Severance Hall switchboard provides flexible control of 110 lighting circuits, 36 flexibly connected dimming controls, and 4 additional controls which do not pass through the connecting mechanism. These latter are permanently connected to the down lights in the auditorium. The following items we have:

Remote controls enabling the switching of any one or seven of the 110 load circuits to any one of the 36 individual control drums.

Thirty-six individual control drums which remotely control the resistance dimming of whatever circuits may be connected to them by the switching under (a).

Nine sub-group foot pedals, each capable of electrically controlling any or all of the corresponding sub-group of four individual drums.

Four group masters, foot or motor operated, each capable of electrically controlling any combination of the 36 individual

individual drum controls which it may be desired to connect to them.

(e) One grand master, foot or motor operated, capable of controlling electrically any or all individual controls or group controls.

(f) One preset dimming device associated with each individual control drum, but with individual scene faders operated on a common gang shaft by motor or hand. Small sliders provide for four presets of dimming on each control unit.

(g) Four individual controls and one master for handling the house direct lighting.

(h) Remote individual control for 20 four-color boomerangs on spotlights.

(i) Remote individual "Joy Stick" control for direction and focusing of nine spotlights.

(j) Signals and remote iris diaphragm control to nine arc spot positions.

(k) Telephone to ten stations.

(l) Adequate illumination for cue sheet rack and all working faces of console, including pedal portion.

The console can be plugged in at two positions, one on the front orchestra lift and the other near the prompt position. It has a forty foot cable attached to it, containing in the neighborhood of 1,200 wires, encased in a vacuum cleaner hose. The weight of the console will probably not exceed half a ton.

In the console are located the potentiometers which control the grid bias on the small amplifier tubes mentioned earlier. Each individual control drum operates one of these resistance units. In turn these units can be cascaded through sub-group or through group master, each of which in turn can be fed from the variable voltage grand master bus or from direct feed. The individual unit, too, can operate direct from feed, independent of the mastering system. Lastly, any combination of individual controls can be fed from the grand master bus, without first going through group or sub-group masters.

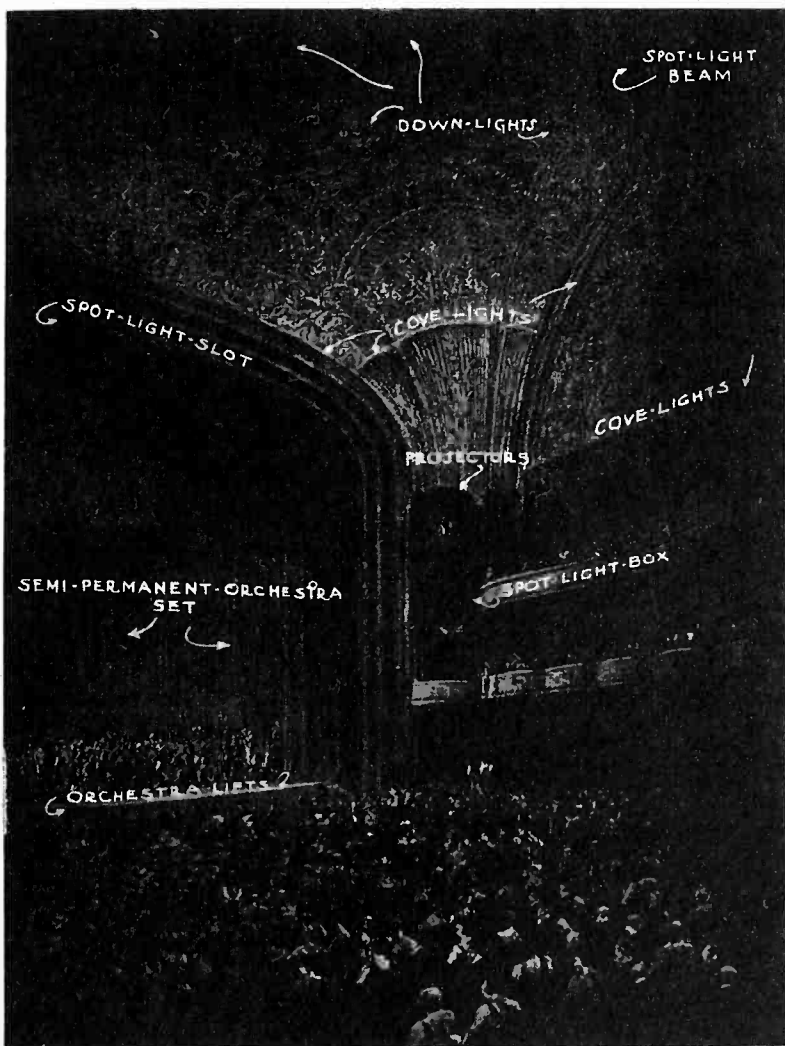

Location of light-sources in auditorium

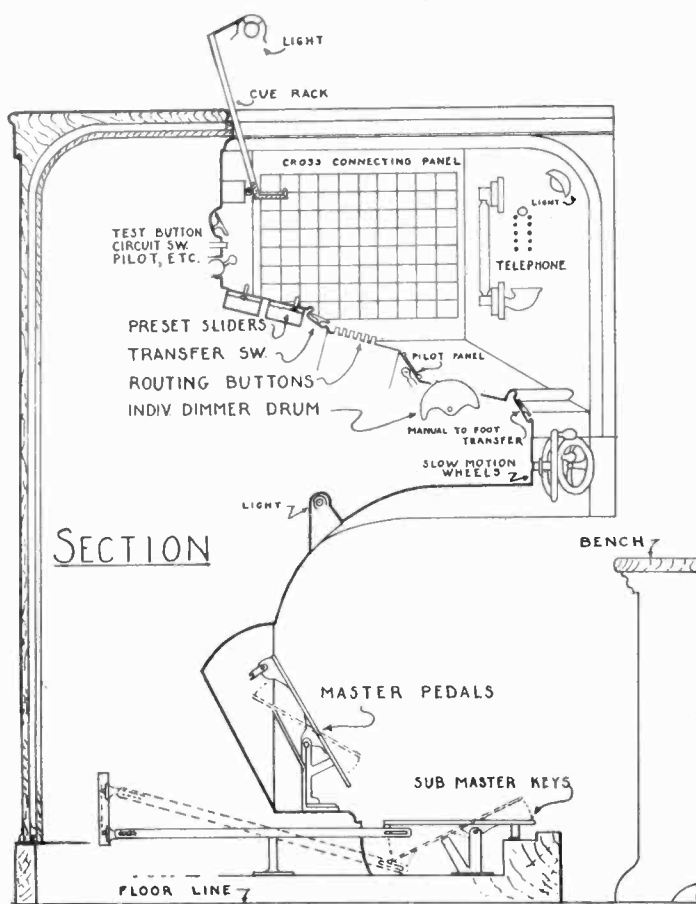

### Physical arrangement and function of controls

Beginning at the floor, there are inclined foot pedals comparable to the swells of an organ, one for each group master and one for the grand master. In front of these are nine broad foot keys. These operate the sub-master potentiometers.

Next above, and at the edge of the operating manual position are thirty-six tilt tablet switches, again of the usual organ type. Each of these is associated with one of the thirty-six individual control drums, and in turn, each group of four tablets is tied to one of the foot-pedal sub-group masters. These switches enable the operator to transfer control of all individual circuits to foot operation in a given sub-group of four dimmers, or any one singly, thus freeing his hands when necessary. Immediately above these on a sloping ledge are thirty-six individual drum controls.

These are six inches in diameter and protrude quarters of an inch above the panel face. The milled edges and a scale for definite recording. Like all controls on the board, they are fifteen sixteenths of an inch on centers, the spacing of piano and organ keys. Drum type was adopted because experiment proved it possible to operate several with one hand, some going others down simultaneously.

On the slope containing the preset, slider-type potentiometers, there are four of these to each of the six control circuits. They are crowded into only six inches high yet they are easy to work these sliders that are set to predetermined point up the brilliance of any circuit for four seconds advance. Associated with these, but behind them is a preset fader potentiometer. All of these are ganged on a common shaft and give smooth change of light from scene to scene whether one circuit is going up and another down, all moving in the same direction. Individual lights changing at various ratios. A single motion of a single drum, can completely change one lighting scheme into another, an achievement possible on any other board.

The last row at the top of the board has tilt tablet switches to throw a given control on or off and a test button which lights pilot. On lower switches, showing they are hooked to the particular control being examined.

A four-inch wide panel running from top to bottom through the center face of the console contains a series of controls. At the top is a clock, below, the master drum. The grand master drum follows. Below these are the four group master interlocks from foot pedal control. Lock and master switches and other miscellaneous items are worked into the spare space just above these. Scene pilot lights are provided which flash from scene to scene.

On the diagonal sides of the board in the side faces, are the 110 cross connecting switches as fifty-five on each side of the operator. On the left face at the left are the house light dimmers and on the right these are located the boomerang controls. In the center inclined panel are the "joy sticks" for directional spot control. They also are the scene signals and diaphragm controls.

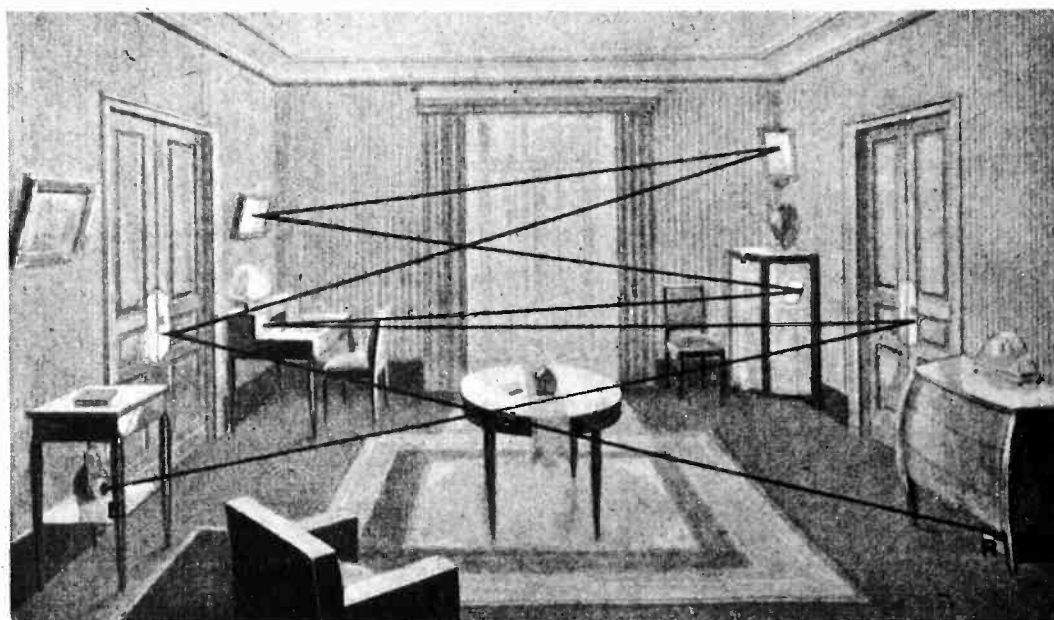

### Reflected infra-red-beam safeguards whole room

METHOD proposed by French inventor for protecting a room against burglars, utilizing an invisible infra-red-light. The beam reflector R is projected back and forth between successive reflective surfaces so that it criss-crosses the entire room before finally reaching the photo cell E. Interception of this beam at any point rings a bell.

# ound "tricks"

## picture roduction

CARL DREHER\*

THE making of a moving picture is essentially a composite process. Scenes which dovetail smoothly to produce comical or dramatic effects were originally made in disjointed form and in an order dictated by considerations of convenience and expense. The result as it is finally seen and heard from the screen, is a synthetic product in which many special and cleverly contrived processes play a part. Some of these fall within the domain of engineering, particularly those having to do with the recording of sound in conjunction with the photographing of action. This article describes some of the special devices in use, particularly as they affect the recording.

What is known as trick photography, or in more technical terms, special process photography, was of

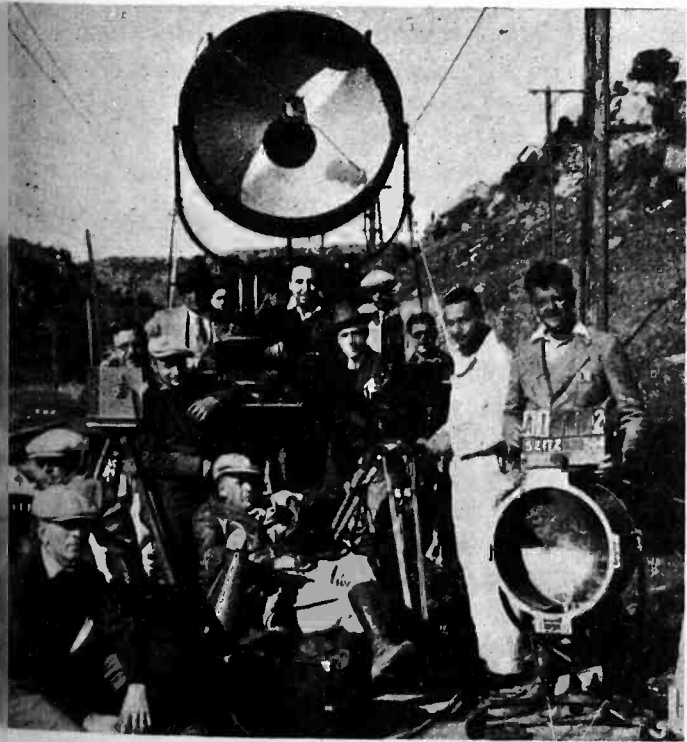

Microphone mounted on railway car to obtain long distance pick-up for outdoor scenes in sound recording

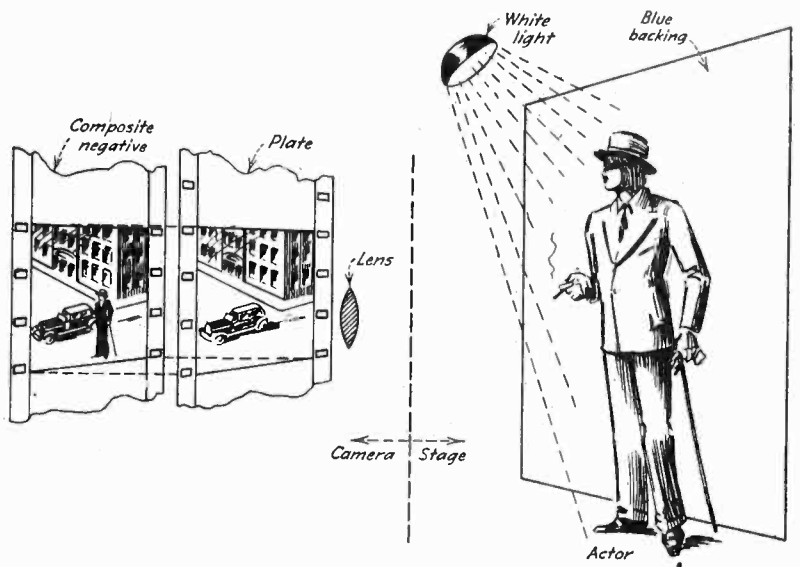

Fig. 1—Schematic diagram of composite photographic process to show an actor against a street background which could not be easily simulated by other processes

course well known in the art before the introduction of sound. Sound, in fact, was at first a severe handicap to the camera man and trick expert with creative ideas, and only recently have the two arts assumed a normal relationship in which each is an aid rather than an obstacle to the other.

The principal application of composite photography is in providing a background which is not actually available in the place where the foreground action is to be photographed. For example, an actor may be available for work in a Hollywood moving picture studio at a particular time, but it may be desired to show him against a Mississippi river background. Instead of taking the actor to the river, the river may be brought photographically to the actor. The means used will first be outlined in their purely optical aspects and later we will see how the problem is handled with the additional complication of sound.

Figure 1 shows the process schematically. An actor is represented on the stage where he is to be photographed. It is desired to show him against a street background with moving traffic and other features which could not be simulated by an ordinary painted backdrop. The street scene which is to provide the background is first photographed, if it is not already available. Usually all kinds of background scenes are on hand in the producer's library in negative form. From the negative of an appropriate scene a double image print is made. This double image print contains a superimposed positive image in color and a neutral negative image. The color (perhaps red) and the neutral or gray shade are selected by careful testing so that when interposed positive image in color and a neutral negative of white light, the two will give an equal fogging effect. Thus no image results as long as the printing light is white, since for white light the superimposed tones neutralize each other over the entire area. But if the light impinging on the double image transparency is suitably colored, some of it will pass through the transparency and a black and white image will result on the developed negative.

In Fig. 1, the actor is shown under white lighting against a blue backing. He may of course have around him any desired foreground props, which in the illustration have been omitted for the sake of simplicity.

\*Director of Sound, RKO Productions, Inc., Hollywood, Calif.

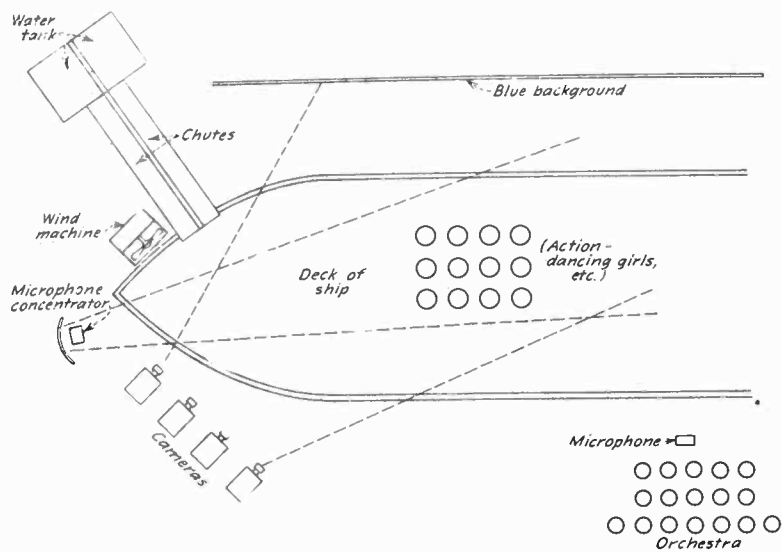

Fig. 2—Set-up of a ship scene for composite photography with sound pick-up

To the left of the figure is shown the camera lens, next the double image transparency or "plate" of the street scene, and finally, the negative on which the composite picture is to be photographed. In the special camera used in this technique, the transparency is unrolled from an intermediate magazine and threaded across the camera aperture in front of and in contact with the unexposed film stock. The light reflected from the actor is not affected by the "plate" except for a certain diminution in intensity. Hence, all that this light does is to produce an image of the actor on the raw stock. But the blue light reflected from the backing where it is not covered by the actor, does carry with it a print of the street scene, since the double image transparency is balanced or neutralized for white light but not for blue light. Blue objects in the foreground must of course be avoided since they will cause a phantom image of the street scene over the foreground image. But with this restriction it is readily possible to photograph persons and objects on a stage with the utmost convenience and at moderate expense, and then to represent them against a background which in the final released prints will appear just as real as if the work had been done in the actual setting. In up to date practice the blue background is generally illuminated by hard white light, while the foreground is under orange light, the double image transparency being balanced for the latter illumination.

Readers who are interested in composite photography will find further data in an article by C. Dodge Dunning: "Composite Photography," *Transactions S.M.P.E.* Vol. XII, No. 36, September, 1928. The Dunning Process Company does most of the work in this line in Hollywood.

Figure 2 shows a rather complicated case of composite photography with sound pick-up. The scene to be photographed is the forward deck of a ship. The ship is built outdoors against a background of deep blue curtain, several hundred feet long and about fifty feet high. The deck is arranged so that it may be swung or oscillated by a number of men to give the illusion of rolling. Everything on or above the deck, such as the railing, mast, halyards, and the part of the ship's superstructure included in the picture, is made very realistic, but of course at the point where the cameras cut, all pretense at reality is dispensed with. In this figure the cameras are shown taking in a part of the deck in which the

action takes place. Since the picture is a musical comedy, a large chorus of dancing girls goes through evolutions, using the deck as a stage. An orchestra is placed to one side off stage and picked up with a microphone close by. The footsteps of the dancing girls are picked up by an additional microphone out of the camera line, provided with a parabolic reflector. It will function efficiently at a distance of thirty feet from the sources of sound. During the action where it is desired to produce the effect of a rough sea, water is released from four large tanks erected on towers some fifty feet high. This water sweeps over the deck, to the discomfort of the performers in the action at that time. At the same time a wind machine, consisting of an electric motor and propeller, sweeps the spray before it. This parabolic action is shot silent, as the wind machine is too noisy to permit recording. Since there is no dialogue in this section, it is a simple matter to add a sound track containing synthetic wind and wave noises. A background of rolling waves and tilting horizon is photographed in by the composite process described above. When the picture is finished, we have to all intents and appearances a vessel rolling in the ocean with an occasional comber sweeping over the forward deck and this result has been secured at a far lower cost than would be entailed in taking a large composite picture on an ocean steamer and hoping for a storm to come up obligingly at the right time.

### Use of play-backs, pre-scoring and "dubbing"

Often it is expedient to shoot a scene silent, and to add a musical accompaniment at a later time. This is because the acoustic conditions may not be favorable for recording, or because of the camera shots required, it is impossible to place microphones for good pick-up without getting them in the camera field. Figure 3 shows a practical

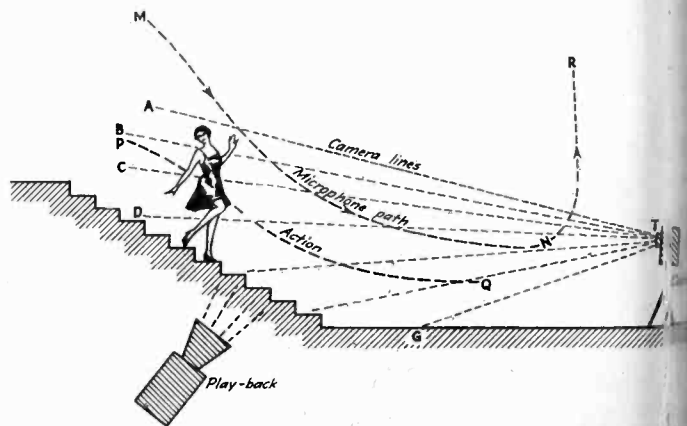

Fig. 3—Dancing scene requiring recording sound with playback to get proper effects for close-up and long picture shots

Here we have a grand staircase, at the top of which an actress begins a song and dance which takes her down the stairs and into a final rapid dance with a large number of performers at the foot. Both close-up and long picture shots are required in order to give the proper effect. The procedure in this case is as follows: the actress is shot with the camera following her down the stairs in a close-up shot, so that the upper limit of the camera field is represented successively by the lines A-M, B-N, C-O, D-P, E-Q, F-R, G-S, H-T, I-U, J-V, K-W, L-X, M-Y, N-Z, etc. The action follows the line PQ. Accompaniment is supplied by an orchestra off-stage, with a stationary microphone. The microphone for the

on a boom or other overhead suspension along the NR, always keeping just out of range of the

This gives us a close-up sound track of the long and a close-up picture only, since the microphone is too low to permit the taking of a long shot which includes the entire staircase and the landings and below it. This close-up sound take is rushed in the laboratory, developed and printed. The next day the sound track thus secured is played back on the set on a film phonograph in combination with a small address system, retaining, of course, the normal speed of ninety feet a minute at which the take was made. The girl is now photographed, dancing in time with this reproduction, in a long shot against the background of staircase and landings. Synchronism is readily maintained, since all that the girl has to do is to dance in time to the music and, if she falls out of time with her singing, it will not be noticeable in a long shot. Two complete picture films are available, one giving the close-up and the other the long shot. In a musical number it is generally possible to match a close-up sound track with a long shot of all the elements which facilitate a good job of editing are now available. However, the method is somewhat costly, since the cast must be brought back to the set day for the long shot.

It is also possible to make the entire musical take in a room separate from the stage. This room may be arranged to afford excellent characteristics for musical recording and pick-up. Here the orchestra plays and the girl goes through her song and dance for sound only, no photographing being involved. Later the sound record is played back and long shot and close-up photographs are made on the set. This is called the "dubbing" method.

The ordinary procedure, less expensive but also less convenient and artistic, could have been used. This would have involved starting the scene at the top of the staircase with a long shot and close-up cameras shooting simultaneously and with the microphone suspended high up out of range of even the long shot camera. As the girl begins, the microphone is moved down to the long shot which is thereupon terminated for cutting purposes and the close shooting for both sound and picture continues to the bottom of the staircase. The microphone is once more lifted out of camera range, and the long camera shot is again available for the dance. A second microphone remains with the orchestra off-stage. By this method there is no long shot available during the interval during which the girl is coming down the stairs, and likewise a close-up sound record has been made with in the beginning and end sections of the scene the cutter is therefore limited in his operations and the full effect of the scene may be lost. A question may be asked, "Why cannot one actress use the same procedure for the vocal portion of the scene and then another girl be put in her place for the close-up on the stage?" The answer is that it is possible there is no technical reason why one person's voice can be recorded and then another performer be used in the long shots, at any rate. However, even if the operation is feasible technically, it is not profitable for the reason that it would be bad business to make pictures on this basis. In the very early days of motion picture production, such illicit "dubbing" (or "doubling") was resorted to in a number of instances where the producer had a great deal of money invested in stars who could not sing or whose diction

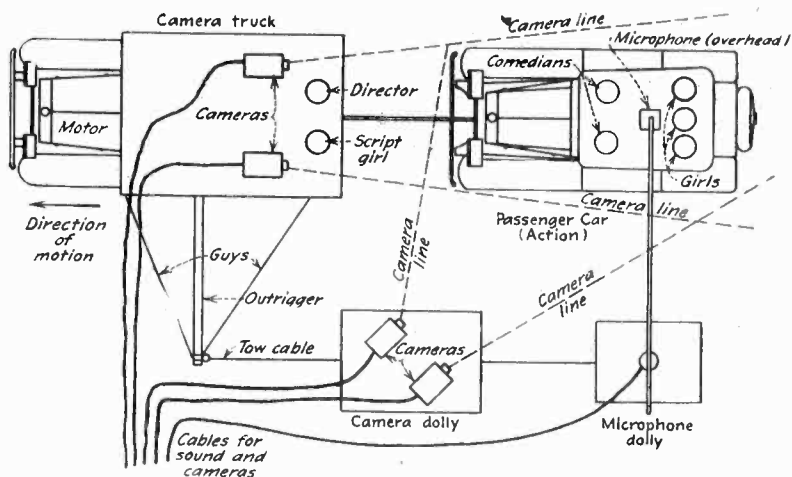

Fig. 4—Intricate set-up for sound recording requiring four moving units to obtain necessary action in special street scene

was not good, and before the dangers inherent in the practice were realized. When anything like this is done there is no possibility of keeping it secret, since a large number of technicians, actors, musicians, and other studio employees are necessarily aware of what is afoot. As soon as the public gets wind of the deception, and realizes that the captivating voice issuing from the loud speakers does not belong to the attractive face on the screen, the reaction is very adverse.

There is a legitimate form of "dubbing" which is used to some extent in the production of foreign dialogue versions to be added to pictures originally made in English. Here the picture is projected silently for a group of foreign players who talk into a microphone just as they would for the broadcasting of a play, the voices being recorded, however, on another sound negative, which is then synchronized with the original picture. The foreign voice "dubbers" watch the action on the screen and synchronize the words as closely as possible with the screen lip movements. Of course, it is necessary to make many modifications in the wording and idiom of the foreign dialogue in order to match it even approximately with the lip movements of the original English speech. Even after many trials, the result usually contains portions in which the synchronism leaves much to be desired. Accordingly, many Hollywood observers doubt whether this particular technical device has any future in the art. However, there is a compromise scheme which may develop into extensive use. This involves shooting the picture and sound with American actors and then getting the same actors to learn the foreign dialogue used in the close-up portions. These people are then re-photographed in silent close-ups, and then foreign players "dub" in the same lines by the method previously described. Under these conditions it is possible to get accurate synchronism in the close-ups, while for long and medium shots the ordinary foreign "dubbing" procedure is sufficient. The practicability of the method depends upon whether American stars with box office value abroad can become proficient enough in foreign languages to carry out their part of the enterprise.

### Traveling shots

With the advent of sound, the operation of "panning" the camera to afford a changing point of view became a more complicated process than in silent motion picture photography. Figure 4 shows an intricate moving shot.

{Continued on page 408}

# A simplified harmonic analyzer

By A. W. BARBER\*

**I**N THE development and manufacture of radio receivers it is often desirable to supplement the ordinary routine measurements of sensitivity, selectivity and fidelity by measurements of the distortion present, i.e. harmonics.

Prohibitive cost and complexity have prevented the general adoption of the apparatus hitherto available for such measurements. Indeed, if a range of frequencies is to be covered one may hardly hope to avoid such complexity in any device for analyzing electrical wave forms by means of tuned circuits.

Fortunately, one may go some distance on the road of harmonic analysis with a quite simple analyzer, adapted for work at a single frequency. The information so gained is sufficient to give a good general view of the performance of the radio set under investigation. This follows from the nature of the causes which generate harmonics within the set. They are dependent more on amplitude than on frequency.

Apparatus based on this simplified procedure has been devised at Radio Frequency Laboratories by P. O. Farnham, C. J. Franks and A. W. Barber, primarily for the study of some special audio amplifiers. The circuits are such as to make a considerable variety of uses possible. The general arrangement of a setup is shown in Fig. 1. In Case "A" the audio source must have a wave form which is nearly sinusoidal or at least whose harmonic content is known under all conditions of loading. Since the sources ordinarily available are not pure, it is a great convenience to have available the analyzer in its present form which permits investigation of the wave form at the input terminals of the set, as well as at the output terminals. One is thus certain what was fed to the set originally.

In Case "B" of Fig. 1 the source may be the usual standard signal generator, whose modulation is almost invariably at 400 cycles, of a known percentage, and of good wave form.

The analyzer consists of an input attenuator, a filter to remove the fundamental 400 cycle wave during the

investigation of a harmonic, a second attenuator, a tunable circuit across which appear voltages which be measured by means of the vacuum tube amplifier. The circuit diagram is shown in Fig. 2. A photograph of the completed instrument is shown in Fig. 3.

Since the analyzer is a voltage-operated device the input circuits must be of high impedance. The voltage divider  $R_1$  accordingly has a resistance of 18,000 ohms. Connected between the slider and the grounded end of  $R_1$  is a series of resistors totaling 1,000 ohms, of which 900 ohms lies in  $R_2$ . Thus only 10 per cent of the voltage picked off by the slider of  $R_1$  goes to the high-pass filter, which loss must be made up by the amplifier. The advantages of this arrangement are that the series resistor  $R_2$  prevents excessive loading of input impedance as the slider is moved up or down.

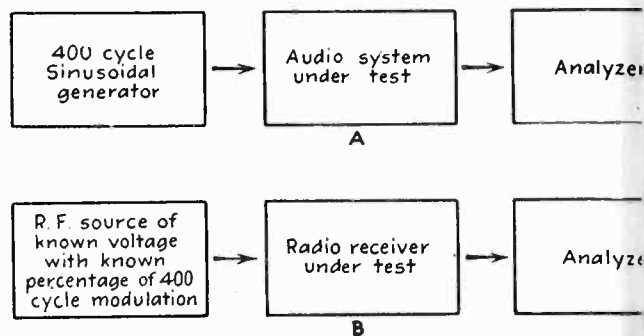

Fig. 1—Two methods by which the harmonic analyzer can be put to use

filter is fed from a source of the high impedance.

The filter has two high-pass sections with 600 cycle cutoff and is designed to work between 100 ohm impedances. When switched into the circuit it attenuates the fundamental 400 cycle frequency, making it possible to measure the relatively weak harmonics which pass through it almost undiminished. About 2 per cent of the fundamental 400 cycle wave passes through the filter, the transmission rising so rapidly at higher frequencies that even at the 2nd harmonic (800 cycles) 88 per cent transmission occurs. The coils of the filter are wound with No. 14 enameled copper wire and are so tuned as to give a low power factor (0.02 at 400 cycles). These coils are mounted at right angles to each other inside a heavy aluminum shield which also shields the filter condensers which are of the ordinary electrolytic and-foil bypass type.

The filter output is fed to the calibrated 10 dB attenuator. The construction of  $R_7$  and  $R_8$  is somewhat unusual. Two heavy insulated copper wires are wound on cores for a single-layer winding of double-cotton resistance wire. The two elements are then fitted to a bakelite drum and the cotton insulation partly removed so that a slider traveling around the drum may contact the two resistors together at any desired point. The filter and the calibrated attenuator can be bypassed when it is desired to work with the 400 cycle fundamental.

The filter is followed by a series-resonance circuit to select the frequency to be measured. This tuning system consists of the iron-core inductor  $L_3$  and the capacitors  $C_4$  to  $C_{11}$  inclusive. The latter are so connected to two rotary cam switches as to permit steps of 10 micro-microfarads from 500 to 30,000. The 500 micro-microfarad variable air condenser  $C_7$  makes the range continuous. One of the cam switches is so connected that when

\*Radio Frequency Laboratories, Boonton, N. J.

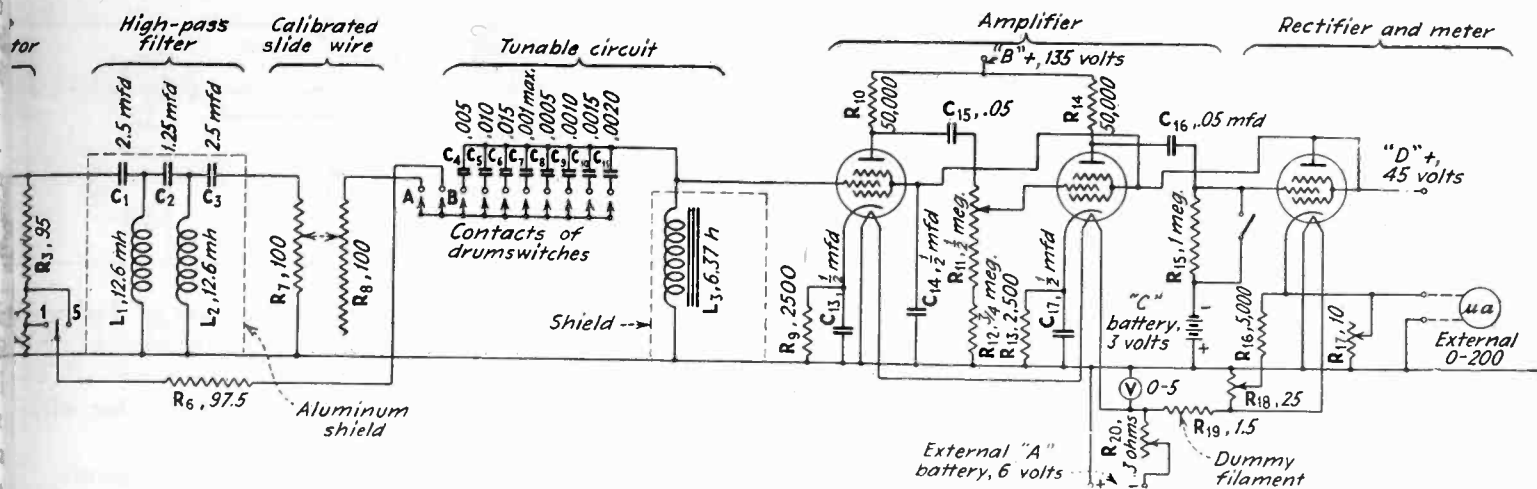

Fig. 2—Circuit diagram of the complete instrument

tune to 400 cycles the fundamental is shunted through the filter and the calibrated slide wire.

The purpose of the tuned circuit is to select a frequency it is important that this circuit be selective and that there be a known ratio between the voltage fed to the tuned circuit and the voltage which appears across  $L_3$  where it is applied to the amplifier. A very good coil is necessary to secure selectivity, good gain, and reasonable flatness of response against frequency. Of many coils tried, the one which gave the best gain has a 1,000 cycle inductance of 6.37

microhenries. It consisted of 10,000 turns of No. 28 enameled wire wound on an open core measuring  $3\frac{3}{8}$  in. x  $\frac{1}{8}$  in. x  $\frac{1}{8}$  in. To decrease pickup the coil is enclosed in a cubical aluminum can 10 in. on a side. A smaller can would decrease the efficiency greatly. With constant voltage at point "A" or "B" ( $L_3$  and tuning condensers) the voltage appearing across  $L_3$  varies as

Frequency	Per cent of 1,200 Cycle Voltage
400	81.3
800	95
1,200	100
1,600	96
2,000	86
2,400	73.6
2,800	68.7

it is desired to work with constant output-meter readings this variation necessitates a compensating adjustment beyond the tuned circuit. This is provided by the potentiometer  $R_{11}$ . As to the selectivity of the tuned circuit,

it is found that the 2 per cent of the 400 cycle fundamental which comes through the filter is so suppressed by the tuned circuit that it cannot be detected at the output meter at 800 cycles or above. No harmonic shows any reading when tuned to another unless the "unwanted" harmonic has the higher amplitude in a ratio of more than 20 to 1.

The resistance-coupled amplifier uses 224-type tubes. The first two tubes give a gain of 300 while the voltmeter tube shows a 100 microampere change in plate current when one volt is impressed on the grid. Over the 400-2,800 cycle range essentially flat amplification is obtained. The gain potentiometer  $R_{11}$  permits a one-third reduction in gain to provide the means of compensating for the variation with frequency of transmission through the filter and tuned circuit. Batteries are used on the heaters, as a.c. operation proved unsatisfactory because of magnetic field pickup in the tuned circuit and fluctuations in the line voltage. For economy, two heaters are placed in series in one circuit and the remaining heater is run in series with the dummy heater  $R_{19}$ .

The first adjustment to be made is that of "bucking" out the steady cathode current through the microammeter (output meter). Next it is necessary to set the fundamental at a convenient level. The tuned circuit is set to 400 cycles, whereby contact B is automatically closed, making available the "detour" via  $R_6$ . The tuned circuit now strongly suppresses any harmonics which may be present so that only 400 cycles is being fed to the amplifier. The slider of  $R_1$  is now turned up until a 100 micro-

(Continued on page 408)

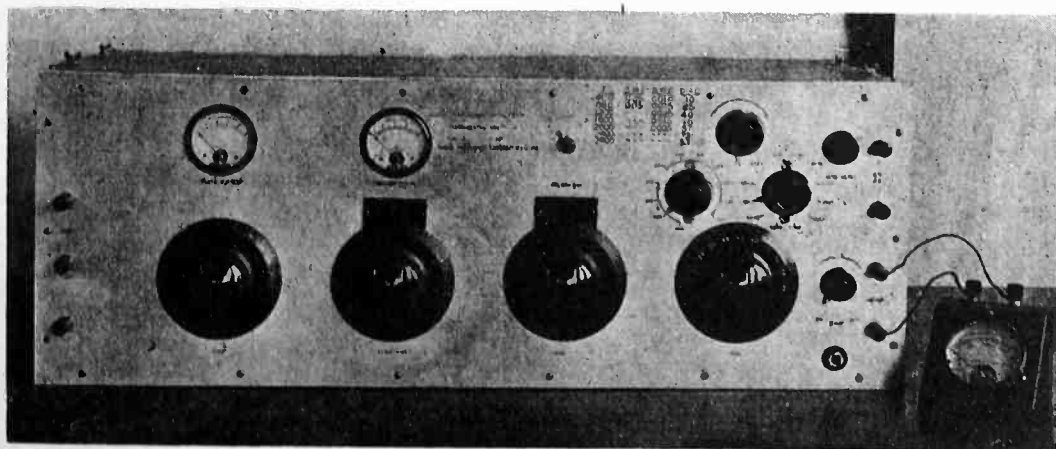

Fig. 3—Photograph of the analyzer as used at Radio Frequency Laboratories

# Developments in ultra-high frequency generation

By C. W. LOEBER

SINCE the use of short wave lengths for radio communication has become of great importance, radio engineers have been investigating the utility of the so-called ultra-short wave lengths, those lying in the electro-magnetic spectrum between five meters and the wave length of light. The various methods of generating these oscillations have all been developed in the past decade or so.

Whiddington<sup>1</sup>, in 1919, found that gassy triodes could be made to generate oscillations of very high frequency. In the same year Barkhausen and Kurz<sup>2</sup> described vacuum tube apparatus with which they were able to produce oscillations of a wave length below one meter.

## Barkhausen-Kurz effect

This effect was produced with a triode connected as shown in Fig. 1. It will be noted that a strong positive voltage was applied to the grid while a relatively weak negative voltage was applied to the plate. Variations of capacitance and inductance in the external circuit of the vacuum tube were found to have practically no effect upon the wave length, but when either grid or plate voltage was changed, the frequency also changed. Increasing the emission from the filament also affected the frequency. Oscillations could not be produced unless the vacuum tubes used had cylindrical concentric elements with the filament passing through the geometrical axis of the grid and plate. Grid voltages were varied from 80 to 200 volts positive while the plate was kept between 4 volts positive and 40 volts negative.

## Theory of operation

Since it was found that only changes in applied voltage affected the frequency of the oscillator, Barkhausen and Kurz believed that the oscillations existed within the

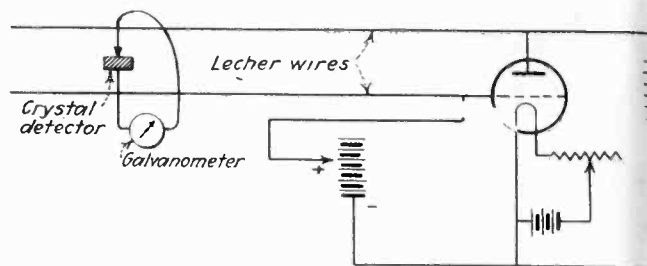

Fig. 1—Ultra-high frequency oscillator of Barkhausen and Kurz, in which the voltages determine the frequency. Wave length was measured by moving the crystal detector along the Lecher wire

tube and were caused by the motion of electrons. their theory was as follows: If a high positive potential is applied to the grid and a low negative potential to the plate, electrons emitted by the cathode will be attracted to the grid. Because of the construction of the tube and the speed with which the electrons are moving, many of these will pass through the grid to the field plate where they will be repelled. Upon returning to the grid, some will again pass through and reach the plate of the cathode where they originated. Thus an oscillation will be completed. The period of one oscillation will be very short because of the short distance between the electrodes of the tube and because of the velocity of the electrons.

The results of the Barkhausen-Kurz investigation

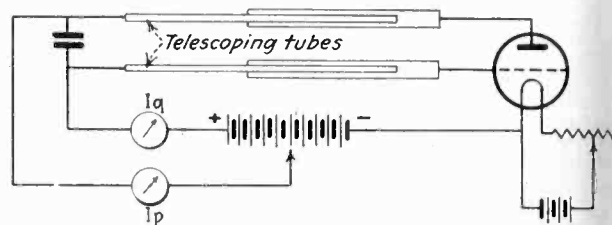

Fig. 2—Gill and Morrell's oscillating circuit. The frequency could be varied by the telescoping tube

were substantiated by Scheibe<sup>3</sup>, but he, as well as other investigators, discovered the existence of still other oscillations at these frequencies, and it is quite likely that these account for the irregularities which were observed by the early investigators. Gill and Morrell<sup>4</sup>, with apparatus as shown in Fig. 2, were able to vary the wave length of their oscillator by changing the constants of the external circuit. The Gill-Morrell oscillator differed from that of Barkhausen and Kurz in that a positive potential was applied to the plate. The theory was advanced that when the grid is arranged so that all electrons which pass the grid are absorbed by the plate where they cause secondary emission. The secondary electrons thus liberated pass to the grid where they in turn are absorbed. Thus the oscillation is not confined to the tube and exists in the external circuit as well as in the inter-electrode space.

At this time it is difficult to estimate the maximum transmission that may be obtained at ultra-high frequencies since little quantitative work has been done in measuring signal strength at appreciable distances.

## REFERENCES AND BIBLIOGRAPHY

- <sup>1</sup>Rad. Review, November, 1919.
- <sup>2</sup>Phy. Ztsft., 21, p. 1, 1920.
- <sup>3</sup>Ann. d. Phys., 73, p. 54, 1924.
- <sup>4</sup>Phil. Mag., 49, p. 369, 1925.
- Kohl, Ztsft. f. Tech. Phys., 9, p. 472, No. 12, 1928.
- Spitzer, Thesis for M.Sc., Mass. Inst. Tech., 1927.
- Gill & Morrell, Phil. Mag., 49, p. 369, 1925.
- W. Wechsung, Jahrb. d. Drahtl. Tel., 32, p. 15 and p. 16, 1925.
- A. Esau, Elektrotech. u. Machb., Part 2, 46, p. 78, 1925.
- H. E. Hollmann, Proc. I.R.E., 17, p. 229, February, 1929.
- H. E. Hollmann, Zettsft. f. Hochf. tek., 33, p. 128, 1929.



Electronics  
Diagnosis

# Measuring the heart's M F

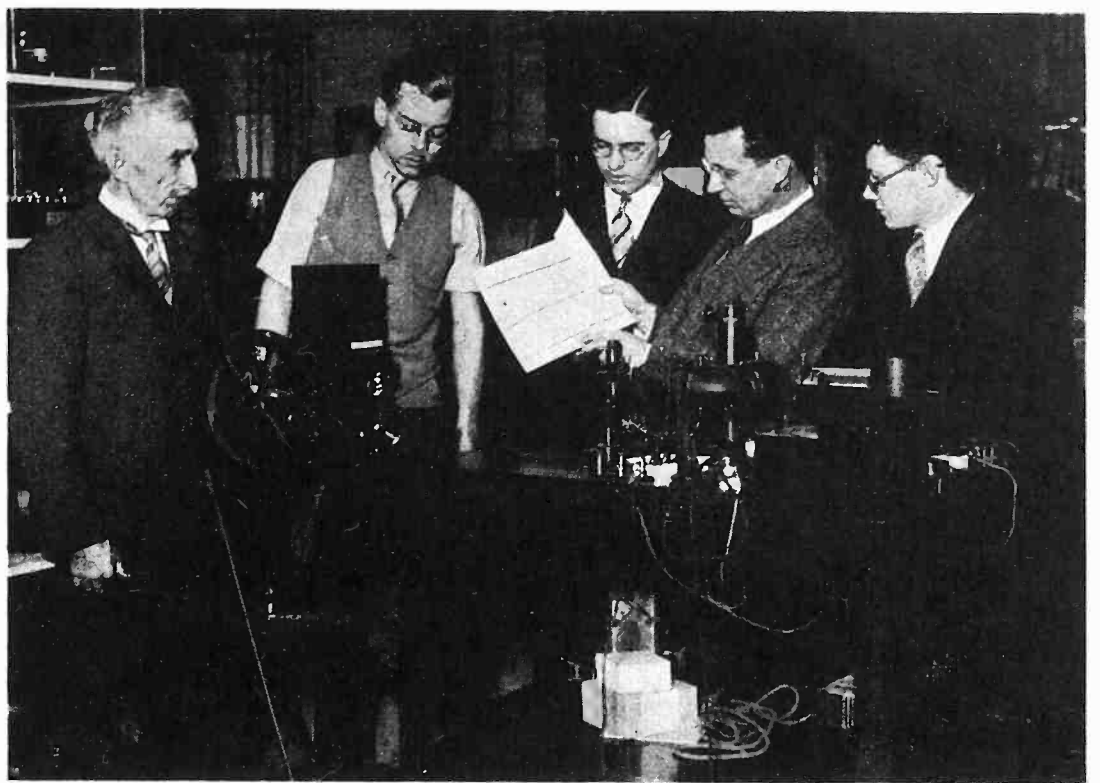

Every human being is an alternating-current generator, his output (mf being about one milli-volt (one-thousandth of a volt), and his frequency being that of his heartbeats. The "cardiograph," using this method of detecting and amplifying the heart's voltage, is widely employed by specialists to diagnose heart diseases

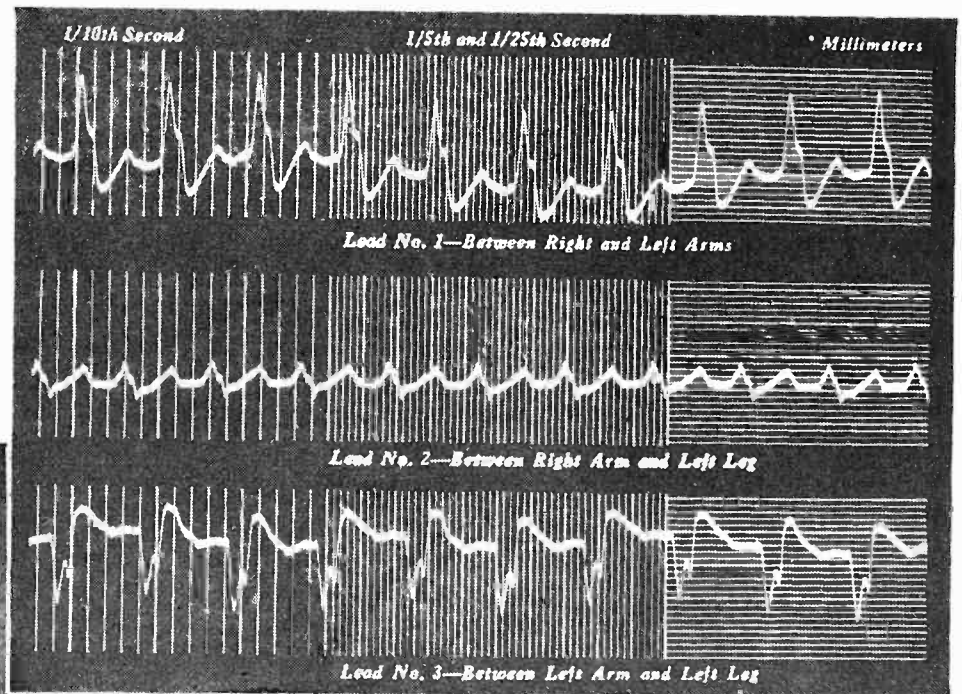

Three electrodes are employed, one on each wrist and one on the leg. This micro-voltage developed is multiplied by a group of amplifier tubes very much like an ordinary radio receiving set, and is recorded by an oscillograph, as above. The three sets of curves can be combined by vector analysis to show actual positions of the heart muscles

# The phototube in automatic weaving

By ARTHUR KORN\*



---

**W**EAVING is an art that has been practiced since the early days of history. It consists essentially in passing one series of threads called the shoots or wefts or woofs partly below and partly above a second series of threads called the warps. If the weft is white and the warp is black, the cloth will appear black when a weft passes below a warp, and white where a weft passes above the warp. To obtain the design wanted, the proper warps must be lifted for every weft and every weft must find the warp prepared for it.

In former times the lifting of the warps according to a given design was done entirely by hand. Automatic weaving was made possible by the invention of Jacquard (1728) which utilized a series of cards with holes punched in them to correspond with the design. Pins (one for each warp) entered the holes in the cards; this placed a small hook in position to be lifted; the raising of the hook prepared the corresponding warp for the shoot or weft. When the pin did not encounter a hole in the card, the warp remained unlifted and the weft passed over it. Thus hand labor was reduced to the task of preparing the cards according to given designs and to the attendance of the weaving machines.

In order to prevent the cards from becoming too long the holes of the Jacquard cards are arranged in a certain number of rows; when there are 400 warps, the holes are often arranged in eight lines; in other cases twelve lines, etc. The workman punching these cards uses a special punching machine provided with eight, twelve, or more punches according to the number of rows comprising a card.

The design serving as a basis for the work of punching has to be arranged in such a way as to allow the white and black spots of the weaving to be distinguished on a special design paper. In this design every line corresponds to one shoot. In every line each square corresponds to one warp; when the square is filled in (black or colored) on the design, this means that the

warp is to be lifted, and a hole must be punched corresponding spot in the card.

The punching is first done for the eight squares upper-left corner of the design. The workman has keys similar to those on a piano in the punching machine before him. He presses down these keys corresponding to the dark squares on the diagram, and brings into the punches on the card by means of a foot lever. The card is moved to the left, and the workman punches the next eight squares on the first line, and so on. When one line is finished a new card is put on the machine and the new card is punched according to the squares of the second line in the design; as many cards have to be prepared as there are lines in the design. To give you an idea of how difficult a work the punching of these cards is, I may explain that one to two thousand of such cards are generally required for one design and that it takes an expert laborer one to two weeks to finish one set of cards. The workmen used to do this as homework in the villages surrounding the big weaving centers, but now in their homes a simple kind of punching machine

▼

**PROFESSOR KORN** is internationally known for his work in transmission of photographs by wire and by radio. In 1907 he used light-sensitive cells in transmitting photographs between Munich, Berlin, Paris and London. His most recent work, described here, is an improvement in the art of weaving, again employing photoelectric cells.

▲

\*Professor in Technische Hochschule, Berlin, Germany.

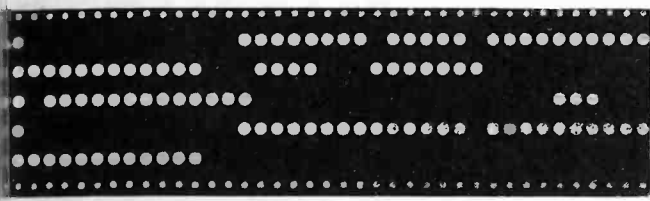
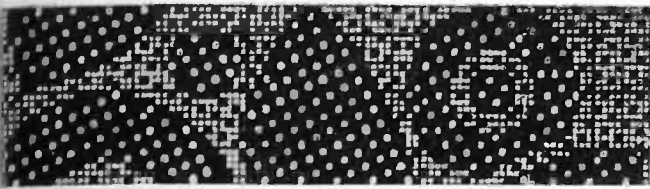

Patterns of design to be punched on card by phototube apparatus

progress which I am now going to demonstrate is based on the mechanical manufacture of the cards according to given designs by the aid of photoelectric apparatus so that this painstaking hand labor can be entirely done away with.

### Application of phototubes

In the new machine the design is wound upon a cylinder and rotated by an electric motor and shifting somewhat in the direction of the axis of the cylinder. The light from a lamp is concentrated upon one of the little squares by the aid of a lens, and the light reflected from the square falling upon a second lens is directed onto a photoelectric cell. As the illuminated square is white or black, the cell receives more or less light. After amplification of the current produced by the photo-cell, a relay is put into action which controls the punching of the Jacquard cards. When the cylinder rotates, one square after another is explored by the photo-cell, and the lever of the relay moves to one position or the other, closing one of two electric circuits.

### Operation of the improved system

Two sets "a" and "b" of eight polarized relays each (for 8-line cards) are controlled by these currents. A distributor turning with the cylinder sends current to each relay in turn as the squares are explored. For the first line the "a" relays are used, for the second the "b" relays, and for the third we begin again with the "a" relays.

While a piston driven by the same motor as the cylinder shifts up and down above a card fitted with a special carriage and would set into motion all the punches unless means are provided for putting out those punches corresponding to colored squares. In this the lower part of the piston is divided into

eight movable rods, individually rotatable around a horizontal axis and each provided with a protruding arm; these arms are stopped during the downward motion of the piston when the armature of a corresponding magnet is attracted by the latter, and will result in turning the corresponding rod in such a way as to prevent the punch from being struck. When the magnet is not energized, its armature will be withdrawn by a spring, and the rod will go down to its vertical position and punch the card. The armature is energized only by a corresponding white square on the design.

Before the piston shifts down for the first time, the magnets are connected with the first set of polarized relays. When the punching of the first row is finished and the piston begins its upward motion, the magnets return to their normal position. When the piston begins its second downward motion, the magnets will, by means of the distributor, be connected with the second set of polarized relays, so that the second row is punched; before the next upward motion of the piston the magnets

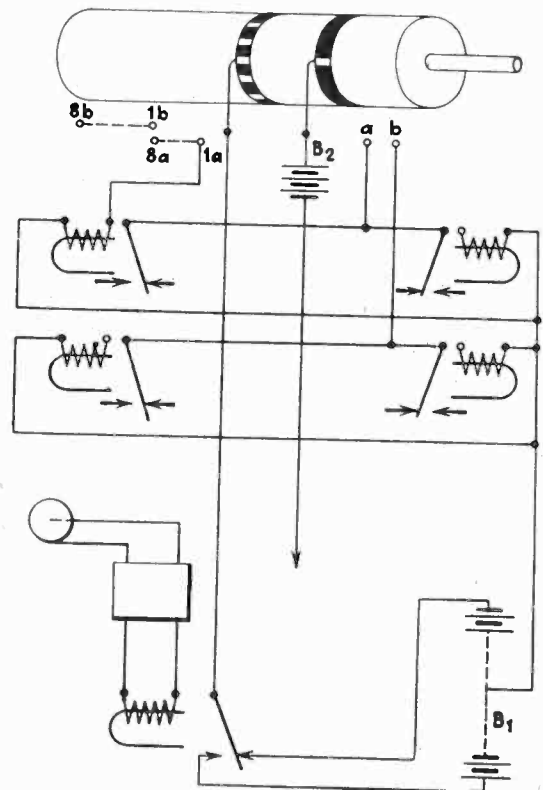

Phototube apparatus for punching design into Jacquard cards for weaving

will be again disconnected, and at the third downward motion of the piston they will be reconnected with the first set of relays for the third section of the line. After each action of punching, the carriage holding the card is shifted to the left to place the card in position for the next punching. When one card is complete it is automatically numbered and removed; the carriage runs back and takes up the next card.

For the time reserved for the exchanging of the cards the punches do not work. To obtain this a dead track is provided on the cylinder by making the technical design so that it does not cover the whole cylinder but leaves a small part of it blank, and when the exploring light runs upon this part of the cylinder, the punches are put out of operation while the machine takes up the new card.

All in all the application of photoelectric cells to a weaving industry seems not only to save time and labor but to effect savings in cost. It is but one more application of results of scientific research to the more practical pursuits of industry.



Enlargement of element of weaving pattern showing warp and weft

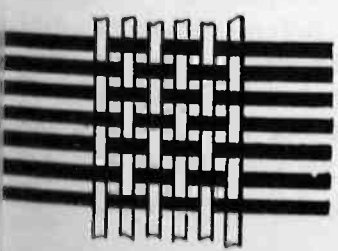

# Sound film reproduction without mechanical slit

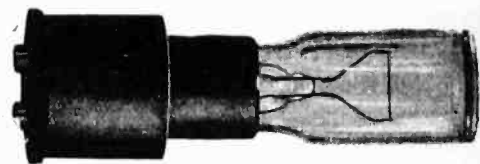

Exciter lamp with rectilinear filament and flat soldered window cut optically

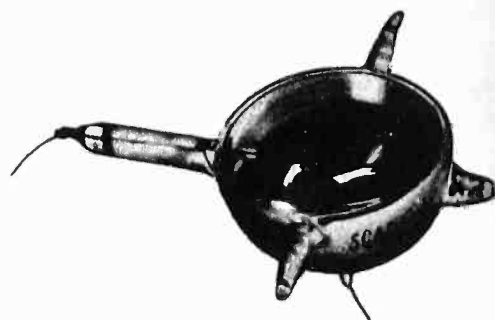

Hemispherical photoelectric cell of L. Dunoyer

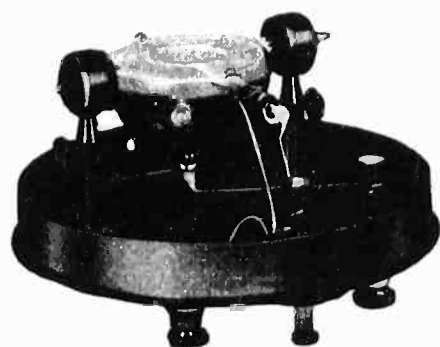

The photoelectric cell shown mounted in holder

PROFESSOR L. Dunoyer, of the Société de Construction d'Appareils de Laboratoire, Paris, France, has developed an optical system for reproduction of sound-on-film without the use of a mechanical slit.

Due to the normal speed of film in reproduction, the height available for the individual modulation, for the higher frequencies, is very small. The exploring beam of light will only pass through the film over a very small height. The greatest admissible height is at present 0.05 mm., and in fact, 0.02 mm. is generally used. The problem of illumination of the photoelectric cell through the film is similar to that in all recording microphotometers for the analysis of spectrograms.

The illuminating apparatus for sound films in general use is provided with a sound slit. In some equipments, this slit is in contact with the film, or is very close to it—in others, the image of the slit is formed upon the film. In the first case, the height of the slit must be equal to the height of the illumination required for the film, i.e., 0.02 mm. The distance between the film and the slit must be less than this value, or of the same order. Dust, which is usually present on the surface of the film, or the atmospheric dust, which it draws with it, will soon accumulate on the edges of the slit; this accumulation not only causes a diminution of the amplitude of the sound, but, as it is irregular, it also causes undesirable ground noise. This effect is not present in apparatus with a projected slit, but such apparatus is subject to other faults.

The apparatus shown in the accompanying illustrations has no slit. The illuminant is a straight filament lamp, especially designed so that it will not be affected by vibration. A parallel faced window is used to close the

end of the lamp and is soldered to the walls. The light falls upon a photographic lens of high quality and a wide opening, by which the image of the filament is formed upon the film. By the use of a parallel faced window of known thickness, it is possible to take account of the diffraction which this window causes in the calculation of the lens. Since the filament is only 0.1 mm. diameter, one can readily obtain an image of 0.01 mm. height, while maintaining a considerable focal distance between the lens and the film, which is often convenient.

It is easy to obtain an exploring image which is much narrower, enabling the higher harmonics to be reproduced. A wide opening of the lens provides a large quantity of light. The exciter lamp is fed by a transformer of 1.5 amperes at 3 volts. The apparatus, which is combined with a hemispherical photoelectric cell, will give a useful current of about 2 micro-amperes. The apparatus when operating, uses a moderate voltage and will last for several hundred hours.

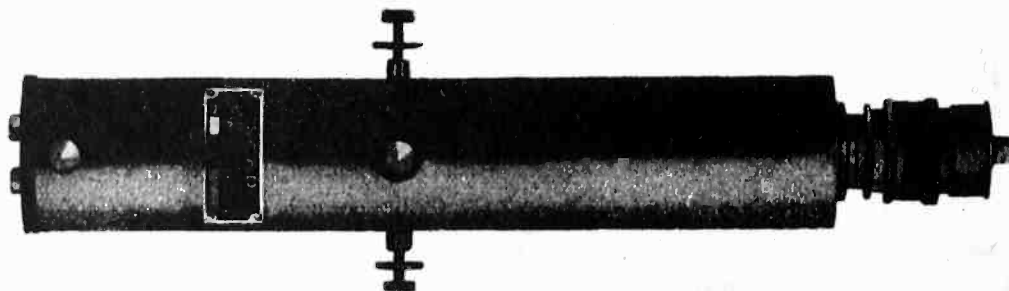

Complete assembly of exciter lamp and optical system for lighting sound track without slit

# Design of the output transformer

D. C. HITCHCOCK  
W. O. OSBON\*

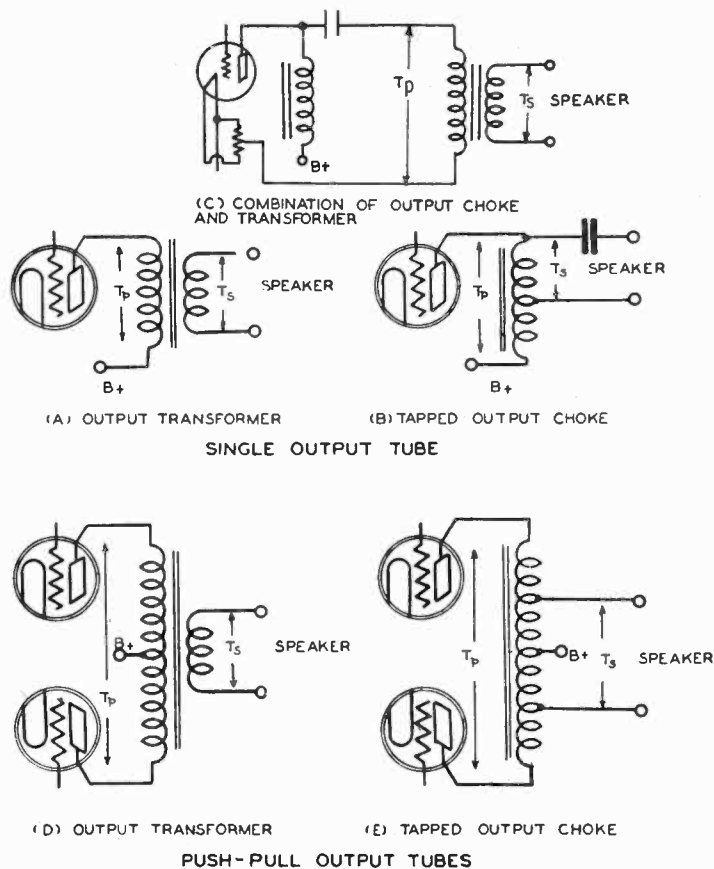

Fig. 1—Commonly used methods of connecting output tubes to loudspeaker

TO OPERATE the power stage of an audio-frequency amplifier under optimum conditions it is essential that the coupling unit between the tubes and loudspeaker be designed properly. This paper gives five commonly used circuits for single and push-pull audio-frequency tubes. In Fig. 1-B a condenser in series with the loudspeaker prevents the steady current from flowing through the loudspeaker. A condenser may be omitted and the loudspeaker

by the use of Fig. 4, as will be explained on another page.

Of the various types of coupling arrangements illustrated in Fig. 1 the transformer presents the greatest number of design problems, and a discussion of these problems will include solutions for other coupling devices. The authors know of no single article which discusses the effect of the various transformer constants on the quality of the transformer, and which at the same time presents data for designing transformers with predetermined constants. In this paper information gathered from various sources will be applied to the specific problem of output transformer design.

The three transformer constants which affect the efficiency of the output stage are the ratio of turns, primary inductance, and leakage inductance. The turns

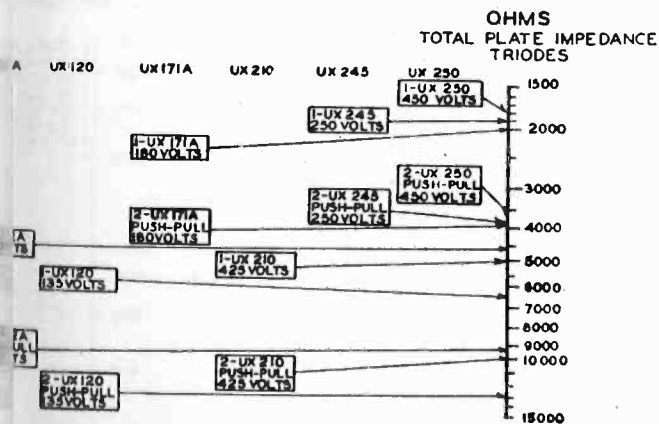

Fig. 2—Output impedance of commonly used tubes at maximum rated plate voltages

connected directly across the choke if the loudspeaker impedance is several times the choke d.c. resistance, which is usually the case. The tapped push-pull choke follows usual practice in spacing the loudspeaker turns on each side of the B-plus tap, so that the plate current does not flow in the loudspeaker circuit. The combination of choke and output transformer, as shown in 1-c, is frequently used, especially when an electrodynamic loudspeaker is a unit removed from the radio set. The correct ratio of  $T_p$  to  $T_s$  the terms used to indicate plate and speaker impedances respectively, in the diagrams of Fig. 1, is found

THE three important output transformer constants are the turns ratio, primary inductance, and leakage inductance. Each of these factors has some effect upon the transfer of power from an output tube to a loudspeaker, whether that speaker is part of a radio receiver, a public address system, or a sound-picture installation. These effects are discussed in this part; in Part 2 the authors will discuss the design of the transformer.

\*Research Department, Westinghouse Electric and Manufacturing Company.

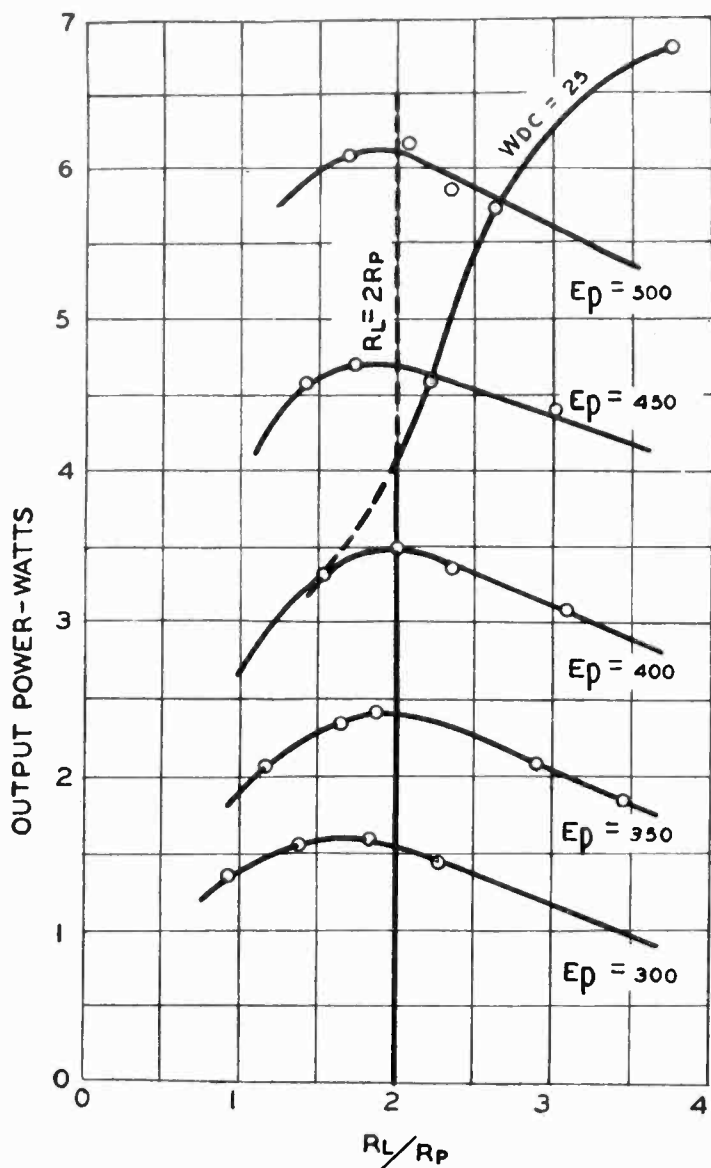

Fig. 3—Effect of load impedance on output power of UX-250

ratio determines the output of the power stage in the middle range of frequencies, that is, in the range where the response is uniform. The primary inductance determines the response at low frequencies, and the leakage inductance determines the response at high frequencies. The nature and magnitude of the effect of each of these constants, and the methods of designing a transformer when the correct constants are known will now be considered.

### Ratio of turns

Several writers<sup>1,2</sup> have found that the maximum undistorted power output of a tube will be obtained when the load impedance into which the tube works is twice the impedance of the tube. This condition is not very critical, however, as is indicated by Fig. 3 which shows the effect of load impedance on the output of UX-250 for various values of plate potential. This figure is taken from the paper by Messrs. Hanna, Sutherlin, and Upp.<sup>2</sup> At a plate voltage of 450 it is seen that for values of  $R_L/R_p$  between  $1\frac{1}{2}$  and 3 the greatest loss in power is only 7 per cent. Although the curves of Fig. 3 apply directly to the UX-250, the general conclusions drawn from them apply to all tubes. It should be noted in the case of the UX-250 that the ratio of load to plate impedance should be greater than 2 for high values of plate voltage in order not to exceed the maximum safe plate dissipation of 25 watts. Fig. 2 gives the plate impedances for output tubes now on the market.

The primary equivalent of the load on the sec is determined, then, by the foregoing consider The impedances of the various types of loudsp are well-known, so that the necessary transforme  $K$ , can be determined by the relation—

$$K = \frac{T_p}{T_s} = N \sqrt{\frac{R_L}{Z_s}} \quad \text{--- (1)}$$

where  $R_L$  = load impedance required by tul optimum power conditions

$Z_s$  = loudspeaker impedance.

Fig. 4 is an alignment chart for equation (1) ba the condition that  $R_L = 2R_p$ .

The fact that the value of  $R_L$  is not critica fortunate circumstance, because the impedance o types of loudspeakers varies with frequency t rather wide limits. In using the alignment ch equation (1) to determine the correct ratio, it i factory to use the nominal value of  $Z_s$ .

As an example, suppose two UX-250 tubes ar connected in push pull with a plate potentia volts. In Fig. 2 the impedance is found to b ohms. Using the nominal value of 3,000 ohms r representing the impedance of the usual magneti speaker, or the primary of the output transfor an electrodynamic loudspeaker, the turns ratio i is found to be 1.5 : 1. Similarly, using 12 ohms usual impedance of the moving coil of the louds the turns ratio is 25 : 1. These values are in by the dotted lines of Fig. 4.

The equivalent circuit of the output stage is in Fig. 5-A, where

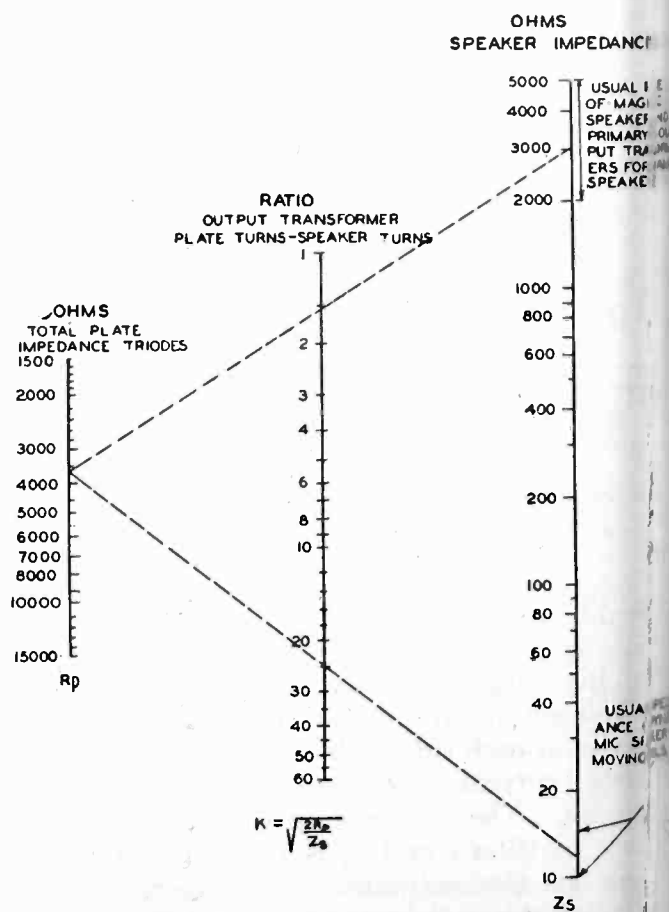

Fig. 4—Alignment chart correlating turns ratio transformer with resistance of tube and loudspeaker

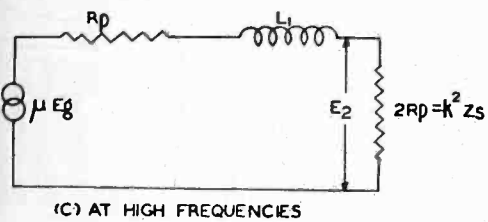
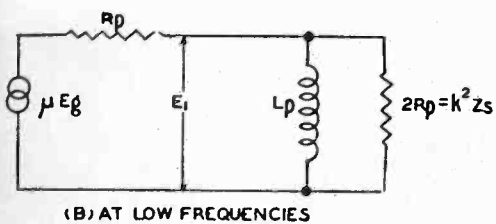
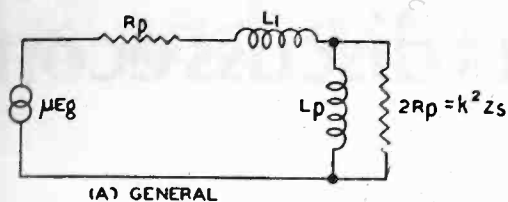

Fig. 5—Equivalent circuit of output stage

$E_g$  = voltage available in plate circuit  
 $R_p$  = plate resistance  
 $L_1$  = leakage inductance referred to the primary.  
 $L_p$  = primary inductance of transformer  
 $R_p$  = primary equivalent of secondary load  
 At high frequencies the leakage reactance is small compared to  $R_p$ , so that for these frequencies the circuit is as shown in Fig. 5-C. At low frequencies then, the voltage across the load is—

$$E = \frac{\mu E_g Z_L}{R_p + Z_L} \quad \text{--- (2)}$$

$$\text{WHERE } Z_L = \frac{1}{\frac{1}{2R_p} + \frac{1}{j\omega L_p}} = \frac{2j\omega L_p R_p}{2R_p + j\omega L_p} \quad \text{--- (3)}$$

$$E_1 = \frac{\mu E_g}{R_p + \frac{2j\omega L_p R_p}{2R_p + j\omega L_p}} = \frac{2j\omega L_p R_p}{2R_p + j\omega L_p}$$

$$= \mu E_g \frac{2j\omega L_p}{2R_p + j\omega L_p}$$

$$= \mu E_g \frac{2}{\sqrt{4\left\{\frac{R_p}{\omega L_p}\right\}^2 + 9}} \quad \text{--- (4)}$$

It is evident from (4) that the greatest possible voltage is obtained at high frequencies when  $\omega L_p/R_p$  is large, and that this maximum voltage is  $E_m = \frac{2}{3}\mu E_g$ . The actual voltage expressed as a percentage of the maximum is then given by—

$$\frac{E_1}{E_m} = \frac{1}{\sqrt{\frac{4}{9}\left\{\frac{R_p}{\omega L_p}\right\}^2 + 1}} \quad \text{--- (5)}$$

Using equation (5) the per cent of maximum voltage can be found for various values of  $\omega L_p/R_p$  and the results plotted as in Curve 1, Fig. 6. Since the power delivered to the load is proportional to the square of the voltage, the per cent of maximum undistorted power is given by the square of the ordinates of Curve 1, and is shown by Curve 2, Fig. 6.

The value of  $L_p$  to choose for a given tube depends upon the degree of uniformity desired in the low-frequency range. Curve 2 of Fig. 6 indicates that at the frequency at which the primary reactance equals the load impedance ( $\omega L_p/R_p = 2$ ), the loss in power is only 12 per cent, and that at the frequency where  $L_p$  equals the tube impedance ( $\omega L_p/R_p = 1$ ) the power

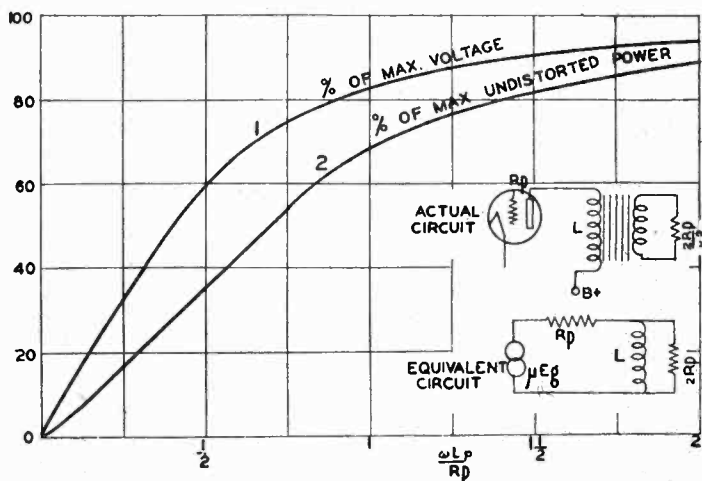

Fig. 6—Effect of primary inductance on power output of tube

has dropped to 69 per cent of the maximum. The actual design of the transformer will be given in Part 2.

<sup>1</sup>"Discussion, Symposium on Loud Speakers," *Proc. London Phys. Soc.*, 36, Part III; Apr. 1, 1924.  
<sup>2</sup>C. R. Hanna, L. Sutherland and C. B. Upp, "Development of a New Power Amplifier Tube," *Proceedings I.R.E.*, 16, 162; April, 1928.



## IN BIO-PHYSICS, SPECTROSCOPY AND GEO-PHYSICS

The electron tube has given physicists a new and wonderfully sensitive instrument with which minute currents and potentials may be almost incredibly magnified. The circuits are extremely sensitive to small changes in capacity and inductance.

One of the most recent developments is in the field of high-frequency oscillations, which have interesting possibilities not only in short-wave transmission but also in spectroscopy and biophysics. There are also possibilities in the application of vacuum-tube circuits to some of the important problems of geophysics.

HENRY G. GALE,  
 President, American Physical Society

# Sound-picture engineers discuss economic conditions



AT THE annual meeting of the Society of Motion Picture Engineers held in New York October 20-23, many interesting papers were given covering the advances in sound picture development, color films, and changing economic conditions in the industry. J. I. Crabtree, president of the society, presided. The high point of the convention was the banquet October 22, at which the leading motion picture producers were represented. Will H. Hays, one of the speakers on this evening's program, which also included Jesse B. Lasky, H. B. Charlesworth, Dr. A. N. Goldsmith and others, stated that an upward trend in business was at hand, and the future for the industry was bright. Serge Eisenstein, the Russian director, stated the American film industry has developed its mechanical and electrical art to a high state, but had neglected the background of training for its artistic side.

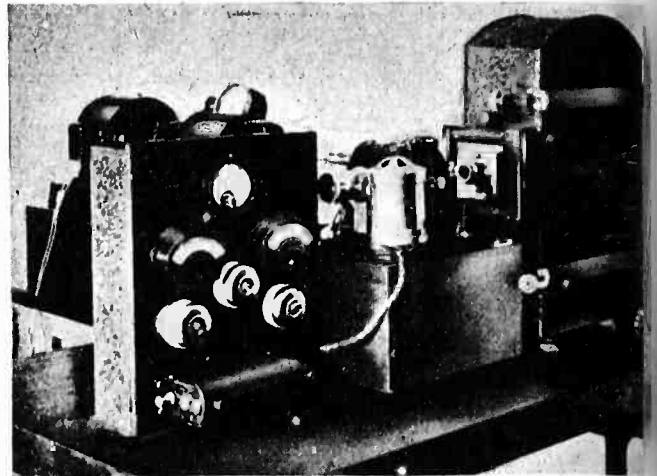

Sound-recording unit built in Russia employs an oscillograph with one ribbon suitable for either variable width or variable density recording

## Meeting sound picture competition abroad

C. J. NORTH and N. B. GOLDEN  
*Bureau of Foreign and Domestic Commerce*

The American film industry will continue to meet greater competition in non-English countries. European studios will probably supply not less than 300 feature sound pictures in their own language during the coming year. These studios are already achieving greater popularity with sound pictures recently released than formerly with silent films. This is attributed to the stage traditions of England, France and Germany, enabling these countries to adapt themselves more readily to the "talkies," which as an art form approaches more nearly the stage than did the silent films. In the latter two countries, likewise, the language barrier will undoubtedly cut down the American supply, and open play dates hitherto closed to the local product. This same barrier will have an important influence in other non-English speaking countries, heretofore large purchasers of American silent films.

American companies are going ahead vigorously with production of multi-lingual pictures, and will have close

to 175 such pictures on the European market coming season. These will be made either in Hollywood or in American studios abroad, and foreign cast directors will be used, as it has been proved that such as voice-doubling are not popular. There is no reason to believe, however, that while American revenues probably won't be as large from non-English speaking areas as in silent film days, they will, nevertheless, attain considerable volume.

Europe has gone sound, Mr. Golden stated, indicated by the fact that whereas only a year ago there were only about 650 theaters in Europe wired, the number has now increased to over 4,950, including all the theaters. Outside of Europe, about 1850 theaters installed sound equipment. As a result, the silent theater owner must choose between wiring or not wiring because he cannot compete with the sound theater. Furthermore, he will have increasing difficulty in showing suitable silent films. This means there is a wide market still open for installation of sound equipment of any type, for the smaller theaters throughout the world.



## Report of committee on progress

G. E. MATTHEWS, *Chairman, Eastman Kodak Company*

A system of recording being developed in the U. S. employs an oscillograph with one ribbon and is intended to be suitable for either variable width or variable density recording. Another sound-on-film process is being developed, a sound print having the record engraved in the film. A sapphire roller pick-up device is employed in the reproduction. A roll of clear celluloid is used in preparing the master record and this record is transferred to the sound print. No preliminary amplification are said to be necessary in reproduction.

A number of theaters throughout the United States have increased the size of their screens anticipating the advent of the wide-screen picture. Practically all theaters in one circuit on the Pacific Coast

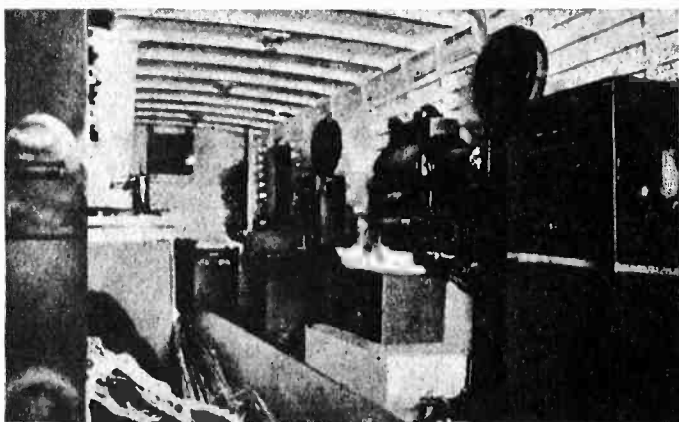

Motor truck containing two complete sound projectors brings sound pictures to French theaters not equipped with sound apparatus



# Progress and new problems of industry

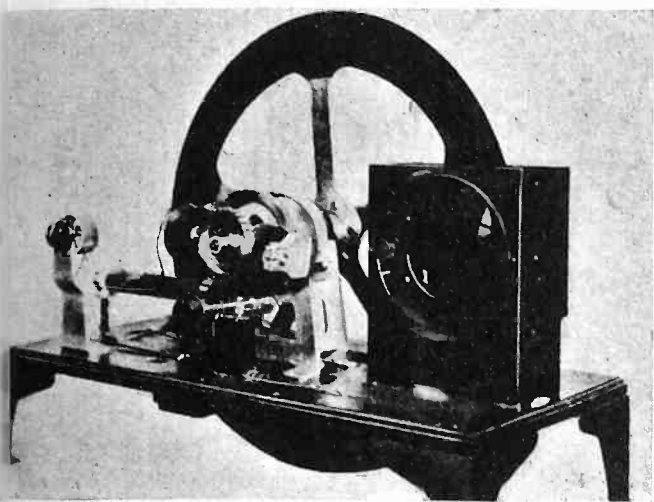

New form of television receiver developed by Baird Television, Ltd., London

To prevent resonance at this particular frequency the diaphragm is damped by attaching strips of balsa wood directly to it. By the proper arrangement of damping strips, adjustment of air gap and diaphragm tension, it is possible to tune the speaker so that it will have a rising characteristic as the frequency increases or a falling characteristic as may be most desirable under the conditions met with in its use.

The driving system is of the dynamic type employing a field coil consuming 0.75 amperes at 5 volts with 100 per cent safety factor. The voice coil wound with No. 36 aluminum wire 0.006 Bakelite enamel, has an impedance of 15 ohms and moves in a gap giving a clearance of 0.015 inches on each side. This large speaker requires no baffle but back stage treatment often is necessary to prevent undesirable echoes.



## Improvements in dynamic speakers

I. BOBROVSKY SERGE, *Consulting Engineer*  
*Utah Radio Products Corporation*

Acoustical problems are considered on the basis of a point source of sound. The number of sound sources leads to a number of technical problems. One unit is the ultimate solution, not yet reached, but necessity of fewer units is imperative. The ideal conditions may be approached by developing a cone type dynamic speaker which will have large power ratio. Problems of developing cone dynamic speakers for auditorium use are numerous of which some of the following are important.

1. Increase of output results in increased size of voice coil.
2. Maintaining as high flux density in the air gap to obtain highest ratio between mechanical watts radiated to electrical watts input.
3. Proper design of magnetic circuit which will develop maximum useful flux in the air gap for the total given flux. This results in selection of a set of dimensions to obtain minimum leakage flux. Substantial reduction of leakage is secured in design of new super dynamic speaker.
4. Increase of pole face to give a large and uniform density in the air gap. This will result in maintaining voice coil in uniform flux densities at all amplitudes to prevent subsequent variations in impedance that are detrimental to conversion efficiencies.

larger screens. A survey indicated, however, about 60 per cent of the theaters in this country space for screens of more than 24 ft. width. Sound prints by the Technicolor process are now with a silver image sound track having a contrast "gamma" of unity which is claimed to represent a real advance in the art of reproduction. The feature picture "Whoopee" was made with a sound track developed in this way. It is stated to be identical to control the gamma of the sound track as this on black and white prints. A power level indicator has been announced for reading signal amplitude in voice transmission circuits; from minus ten to plus thirty-six decibels can be read. A monitor has been developed to meet the need for accurate indication of volume levels from amplifiers in sound reproducing equipment. Sound film records made in England at the Wembley are identified by photographing at intervals on film, a lantern slide carrying the scene and shot numbers. Each half minute, figures up to 10, in Morse code are printed on the side of the film opposite the sound track. Corresponding figures are recorded on the negative in the space reserved for the sound



## Damped diaphragm reproducer

RULPH MIEHLING, *Universal Sound System, Inc.*

This paper deals with a new type of speaker recently developed which differs from both exponential and cone horns. It is termed the damped diaphragm reproducer because of the peculiar construction of this type of the instrument. It employs a large, metallic diaphragm rigidly attached to a heavy iron ring. The dynamic driving system is attached to the center of the diaphragm and serves to actuate the diaphragm. The diaphragm, which is made of duralumin, 0.002 of an inch thick, is not stretched on the ring to the extent its natural period of vibration is above audibility, its tension however is such as to place its resonance within the audible range.

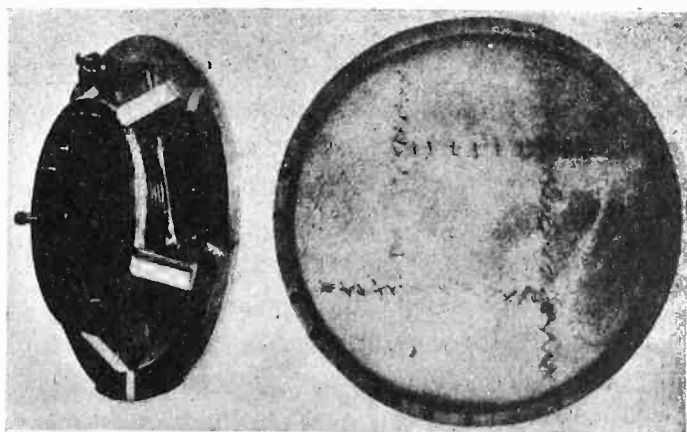

Loud speaker with a diaphragm three feet in diameter made of duralumin 0.002 in. thick

# Linear detection of heterodyne signals

By F. E. TERMAN\*

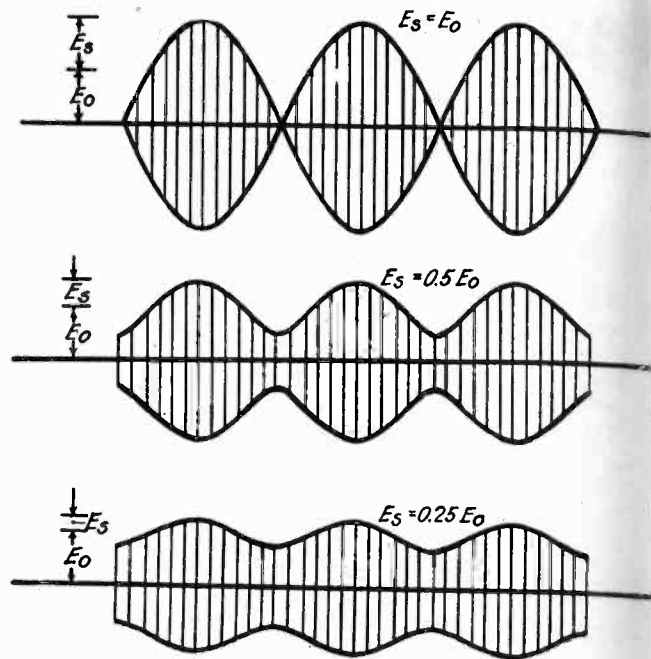

Fig. 1—Envelopes given by heterodyne signals having different values of  $E_s/E_0$ .

IN A radio broadcasting station the signals are modulated by causing the amplitude of the radiated waves to vary in accordance with the sound pressure that is to be transmitted. In reproducing the original signal without distortion it is therefore necessary that the detector in the receiving set give an output that is exactly proportional to the amplitude of the wave being rectified. Such a rectifier is known as a linear detector and will reproduce the ordinary modulated wave without distortion. Any other type of detector characteristic will introduce more or less distortion. Thus a rectifier developing an output proportional to the square of the amplitude of the wave will give proportionately more output when the amplitude is maximum than when it is minimum, with a resultant introduction of frequency components in the rectified output that were not present in the original signal modulated upon the transmitted wave.

In heterodyne signals, that is, in signals consisting of two superimposed waves of different frequencies, the object of detection is to obtain from the combination a rectified current that varies sinusoidally at a frequency that is the difference frequency of the two waves present in the signal. When this result is obtained the detection

of a heterodyne signal is distortionless, while if in addition, harmonics of this difference frequency are present the detector can be said to introduce distortion.

## Characteristics of heterodyne signal

In contrast with the situation existing in the detection of modulated waves, where a linear detector gives a distortionless output in the circuit, in the case of heterodyne signals a square law detector gives distortionless output while a linear detector will introduce distortion. This is because the amplitude of a heterodyne signal does not vary sinusoidally, with the result that a linear detector which gives an output proportional to the amplitude cannot be expected to give a sine wave output from a heterodyne signal. The way in which the amplitude of the heterodyne signal varies depends upon the relative amplitudes of the individual frequency components contained in the signal. The departure from the sine wave variation is maximum when the two waves have equal amplitude and becomes less as one of the components is made weaker with respect to the other. This effect is clearly brought out in Fig. 1, which shows envelopes that are obtained for a series of representative conditions. The exact way in which the amplitude is given by the following equation:

$$\left. \begin{array}{l} \text{Amplitude of} \\ \text{envelope heterodyne} \\ \text{signal} \end{array} \right\} = \sqrt{E_s^2 + E_o^2 + 2E_s E_o \sin \omega t}$$

in which  $E_o$  and  $E_s$  represent the amplitudes of the component frequencies contained in the heterodyne signal and  $\omega$  represents  $2\pi$  times the difference frequency of the two components. The method of deriving this equation is outlined in the appendix. It is apparent that a detector producing an output proportional to the square of the amplitude of the envelope will give distortionless detection of the heterodyne signal, since when Eq. (1) is squared, the right-hand member acquires a sinusoidal variation.

When the heterodyne signal given by Eq. (1) is detected by a linear detector the output varies in accordance with Eq. (1), which is plotted in Fig. 2 for several

PROFESSOR TERMAN points out an interesting phenomenon in connection with superheterodyne receivers. Linear detection produces distortion unless one of the component signals is strong compared to the other—as is usually the case in superheterodynes. On the other hand, detection of modulated carrier signals requires linear rectification if an undistorted product is desired.

\*Associate Professor, Electrical Engineering, Stanford University.

of  $\frac{E_s}{E_o}$ . The nature of the detector output of

can be most conveniently analyzed by expanding according to the Binomial Theorem and then a Fourier analysis to the result. When this is the following is obtained:

$$\begin{aligned}
 & E_o \sqrt{1+r^2} (1 - 0.0625k^2 - 0.0146k^4 - 0.0064k^6 - \dots) \\
 & + \frac{E_s \cos \omega t}{\sqrt{1+r^2}} (1 + 0.0938k^2 + 0.0341k^4 + \dots) \\
 & - \frac{E_s r \cos 2\omega t}{4(1+r^2)^{3/2}} (1 + 0.313k^2 + 0.1535k^4 + \dots) \\
 & + \frac{E_s r^2 \cos 3\omega t}{8(1+r^2)^{5/2}} (1 + 0.548k^2 + \dots) \\
 & - \dots \dots \dots (2)
 \end{aligned}$$

$E_s$  = weaker component of signal voltage  
 $E_o$  = larger component of signal voltage  
 $E_s/E_o$  = ratio of weak to strong signal components  
 $2r/(1+r^2)$

$2\pi$  times the difference frequency of  $E_s$  and  $E_o$ .  
 Inspecting these equations it is of assistance to note that the difference frequency output depends upon the ratio  $E_s/E_o$ , and reaches a maximum value of unity when  $E_s = E_o$  ( $r = 1$ ). For other conditions the equation of the envelope simplifies to

$$\begin{aligned}
 & E_s (1.274 + 0.851 \cos \omega t - 0.170 \cos 2\omega t \\
 & + 0.0729 \cos 3\omega t - 0.052 \cos 4\omega t + \dots) (3)
 \end{aligned}$$

The fundamental properties of linear detection of heterodyne signals are incorporated in equations (2) and (3). These equations show that the difference frequency output is largely independent of the amplitude of the stronger signal component  $E_o$  and is nearly proportional to the strength of the weaker component  $E_s$ . The magnitude of the deviations from these approximate relations is indicated by the fact that when the stronger signal component  $E_o$  from equation (2) is increased to a value many times  $E_s$ , while holding the amplitude of the latter constant, increases the difference frequency output 1.00/0.851 times or nearly 17 per cent.

The distortion frequencies produced in the linear detection of heterodyne signals are greatest when the two signal components have equal amplitudes, under these conditions the second harmonic of the difference frequency is seen from equation (3) to be 20 per cent of the difference frequency. This distortion is reduced when the signal component is much stronger than the other and is less than 2.5 per cent when the weaker component  $E_s$  is less than one-tenth the stronger  $E_o$ .

**Application to beat frequency oscillator**

The foregoing shows that distortionless rectification of heterodyne signals with linear detectors can be achieved only when the strong oscillation  $E_o$  (ordinarily the local oscillator) is much stronger than  $E_s$  (which is the signal). Under these conditions the rectified signal, in addition to being distortionless, will be proportional to  $E_s$  (i.e., the signal), and independent of the amplitude of  $E_o$  (i.e., the local oscillation).

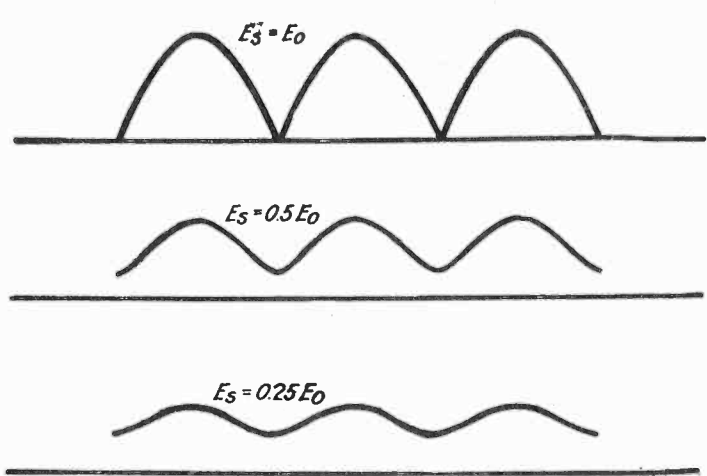

Fig. 2—Wave shapes obtained by linear detection of heterodyne signals. The detector output acquires a variation that is nearly sinusoidal if one of the components is small

heterodyne method of generating audio frequencies indicates the desirability of using linear rectification in the "mixer" tube, and making one of the oscillations much weaker than the other. This gives a distortionless difference frequency output that is proportional to the weaker oscillation and independent of the stronger

Straight line rectification is to be avoided in the first detector of the super-heterodyne receiver because of interference effects resulting from distortion components of the difference frequency. Thus a super-heterodyne receiver with a linear rectifier will respond to strong signals when the beat frequency is one-half, one-third, one-fourth, and so on, of the intermediate frequency. Inasmuch as the first detector is very likely to have a linear characteristic because of the large amplitude of the local oscillation, it is important that this point be carefully considered in the design of super-heterodyne receivers. The same effect can also produce cross-talk effects in the demodulation of single side band carrier current communication signals.

APPENDIX

Envelope equation of heterodyne signal

The problem is to find the envelope of a signal having the equation

$$e = E_o \sin \omega t + E_1 \sin [(\omega + \delta_1)t + \phi_1] + E_2 \sin (\omega + \delta_2)t + \phi_2 + \dots (4)$$

where  $\phi_1, \phi_2$ , etc., are phase angle constants, and  $\delta_1, \delta_2$ , etc., are  $2\pi$  times the frequency by which their respective terms differ from the  $E_o$  term's frequency. The envelope of equation (4) can be found in the usual manner,<sup>1</sup> which when applied to (4) consists in solving (4) for zero, equating to zero the partial derivative with respect to  $\omega$  of this transposed equation, and simultaneously solving the resultant equation with (4) to eliminate  $\omega$ . Carrying out these operations give the result

$$\begin{aligned}
 \text{Envelope} = & [E_o^2 + E_1^2 + E_2^2 + \dots (5) \\
 & + 2E_o E_1 \cos (\delta_1 t + \phi_1) \\
 & + 2E_o E_2 \cos (\delta_2 t + \phi_2) + \dots \\
 & + 2E_1 E_2 \cos (\delta_1 - \delta_2)t \\
 & + (\phi_1 - \phi_2) + \dots \dots \dots ]
 \end{aligned}$$

When only two components are present and  $\phi_1$  is taken as zero, this equation reduces to (1).

<sup>1</sup>For example, see *Mathematical Analysis*, by Goursat-Hedrick, Vol. I, page 426.

# HIGH LIGHTS ON ELECTRO

## Detecting adulteration with filtered ultra-violet or "black light"

"During a recent study of bootleg whiskey products it was possible to detect under the ultra-violet, or black, light the fluorescence of the adulterant of the industrial alcohol from which the bootleg whiskey was made, despite the fact that the original commercial alcohol had been distilled and that casual laboratory examinations for diethyl-phthalate had been reported negative," said Dr. Herman Goodman, in a recent talk before the Society of Medical Jurisprudence at New York. "By the judicious use of various colored fluorescing dyes it should be possible to determine the source of industrial alcohol used in the bootleg trade. The various districts could each have its individual dye and fluorescing signature."

One source of the near ultra-violet or black light shown by Dr. Goodman was a Cooper Hewitt low-pressure mercury-vapor lamp. Instead of the usual glass tube, used when the lamp is intended as a source of ordinary light, or the quartz tube used when the lamp is intended as a source of short, or far, ultra-violet radiation, the lamp used by Dr. Goodman was made of a dark blue-black glass. This glass, containing nickel and cobalt, is opaque to both the visible light to which glass is transparent and the far ultra-violet to which quartz is transparent. It is, however, transparent to the near ultra-violet, or longer wave-lengths than the middle ultra-violet, found in sunlight and produced

by health lamps, and the short or medial wave lengths. Since the light to which the human eye is sensitive is cut off by the blue-black nickel-cobalt glass, this emission has come to be known as black light. Such tubes have been used in spectacular theatrical illumination work, but have not been applied commercially otherwise.

Counterfeiting of bank notes and stock certificates, alteration of bank checks, and erasures in account books can be detected with black light, since papers, even from the same manufacturer, which seem alike under ordinary light are at once revealed as different by ultra-violet. Similarly, invisible inks which glow under ultra-violet can be used as a protection against forgers and check raisers. Such inks could also be used in marking cloth and other commodities as an invisible mark of ownership and protection against loss by theft.

Natural teeth fluoresce with a brilliant white light. False teeth, no matter how cleverly matched to the natural ones in ordinary light seem chocolate colored under black light if made by one manufacturer, or yellow if of another composition. A record of the fluorescence of the teeth could be added to identification charts.

An important place for black light in the cosmetic industry has to do with the substitution of cheap imitations for well known trade marked perfumes. By the addition of a tiny amount of a secret fluorescent dye it would be possible to detect substitution.



## Analyzing industry and traffic noises

Dr. E. E. Free, consulting engineer, New York City, who has made surveys of the noise conditions in several cities and industrial centers, reports on the results of the New York Noise Abatement Commission's work as follows:

"A necessary first step in organized attack on the noise problems of any city is the accurate measurement of the noises which actually exist, with the determination of their sources and the preparation of a 'noise map' of the city.

"All noise surveys which have been made indicate that the chief source of city noise is street traffic. In most instances, the noisiest points are also the points of greatest traffic concentration. Our New York City measurements indicate that the average sources of noise at a noisy street corner are approximately as follows:

Automobile trucks . . . . .40 per cent  
The elevated railway . . . . .25 per cent

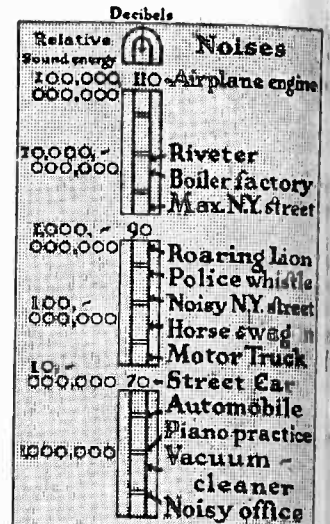

### Danger Line!

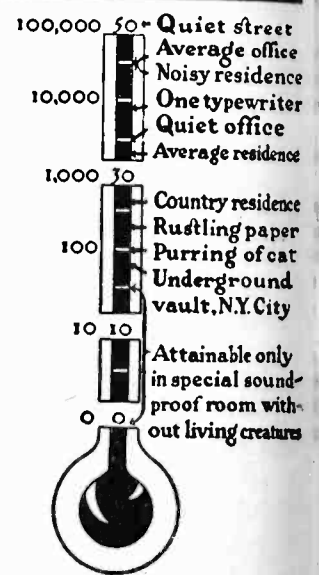

"Noise thermometer" showing sound levels existing under various conditions

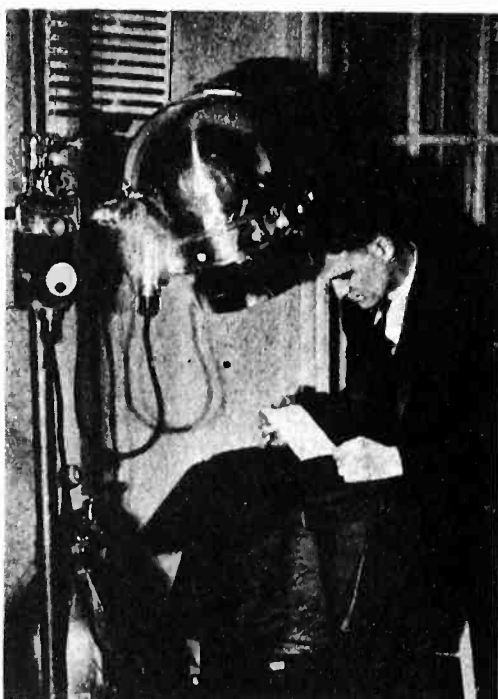

Scrutinizing bank checks for erasures, under ultra-violet light

Street-cars . . . . .20 per cent  
Other noise sources . . . . .15 per cent

"The reduction of total city noise will be expected from a successful car will range between 20 and 50 per cent."

"Noise surveys, recommended on the essential basis of such a noise commission's activities, are now usually by noise-measuring instruments called acoustimeters, which instrument consist essentially of a microphone connected to the microphones used in radio-casting, a vacuum-tube amplifier, and those used for radio-receivers, an electric-meter on which the output of this amplifier is measured.

"The microphone picks up the energy from the air and converts it into electric oscillations, just as in radio-broadcasting. The amplifier magnifies these electric oscillations several million times, keeping the amplified energy exactly proportional to the energy entering the microphone. The magnified energy then is measured by the meter."



## Cup under faucet; flows

Company diagram shows the employed in the "automatic cooler" which was exhibited at City by the Arcturus Radio Company. According to H. L. Mann, the amplifier used consisted of 124 tubes, resistance-coupled, worked a relay in the output whose secondary contacts were of passing five amperes at 110 the output of this relay was inected to a solenoid valve which hll the flow of water.

Placing a cup under the faucet was interrupted and the change in potential on the grid of the first tube caused by the photolytic-cell caused a change in the output circuit of the tube to function.



## Prevention methods. Tube starts blower

Methods of using the vacuum-tube prevent the production of smoke stacks are now available and in service.

One of these remarkable devices "see" smoke released by a care-man by day or night and in-apply correctives without the aid of a human hand. For ex-ample here is the electronic "smoke scanner" now installed in a number of plants. This device comprises an eye or photo-electric cell near the top of the smoke stack. Opposite the stack, is an ever-burning light. If a cloud of black smoke, from careless firing, starts up the photo-cell is eclipsed and it operates switches to start up blowers. These at once deliver an amount of fresh oxygen to the furnace and the smoke is burned up. All this is done automatically and is in full effect before the smoke gust has even reached the top of the chimney.

The photo-cell also can be arranged to give a sign indicating "smoking" and to ring an alarm bell in the boiler room to record occurrences of smoke on a twenty-four-hour recording tape on the desk of the big boss, either at the plant or elsewhere.

There is special significance in the fact that the electronic smoke warning remedies it applies are equally effective day or night.

Automatic detection of night smoke is especially important in doing away with the city's smoke pall. Despite human carelessness, many chimneys are now being equipped to pour forth great clouds of

Circuit of automatic water cooler. When cup is held under the faucet, intercepting the light beam, the photo cell operates the solenoid valve

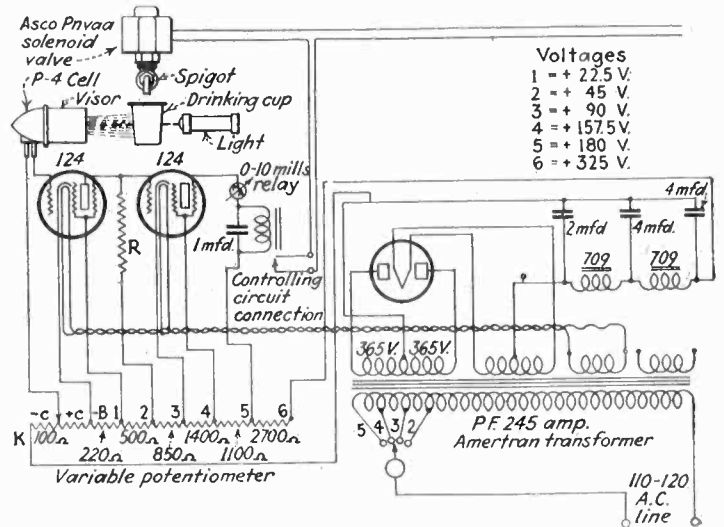

smoke under cover of darkness. Usually there is little wind in the early morning, therefore these smoke clouds settle on the community and produce the familiar black gloom which overhangs the city until nine or ten o'clock in the morning.

Electronic tubes are being used in other ways to suppress soot and dust. Electro-static smoke preventers now installed in plant chimneys have high-voltage plates charged with static electricity which attracts the soot and dust particles out of the flue gases in the same way that the static electricity in a comb attracts hair or paper particles on any frosty morning. Electron-tube rectifiers are used to produce high-tension direct current for charging these precipitator plates with static electricity.

## A mechanized "Army Band"

The Acting Secretary of War, Honorable F. Trubee Davison, has authorized the Quartermaster General to procure for service test one mechanical substitute for an army band. This device will be issued to Fort Washington, Maryland, for a test by the 3rd Battalion of the 12th Infantry.

This equipment is built into a three-fourths ton truck. The volume of music is equivalent to two large bands, and the volume may be controlled as desired. It is contemplated, if this apparatus is finally adopted for use by the army, to utilize it at stations which have no band, of which there are some sixteen such stations at present.



## SEARCHES OUT FIRES; EXTINGUISHES THEM

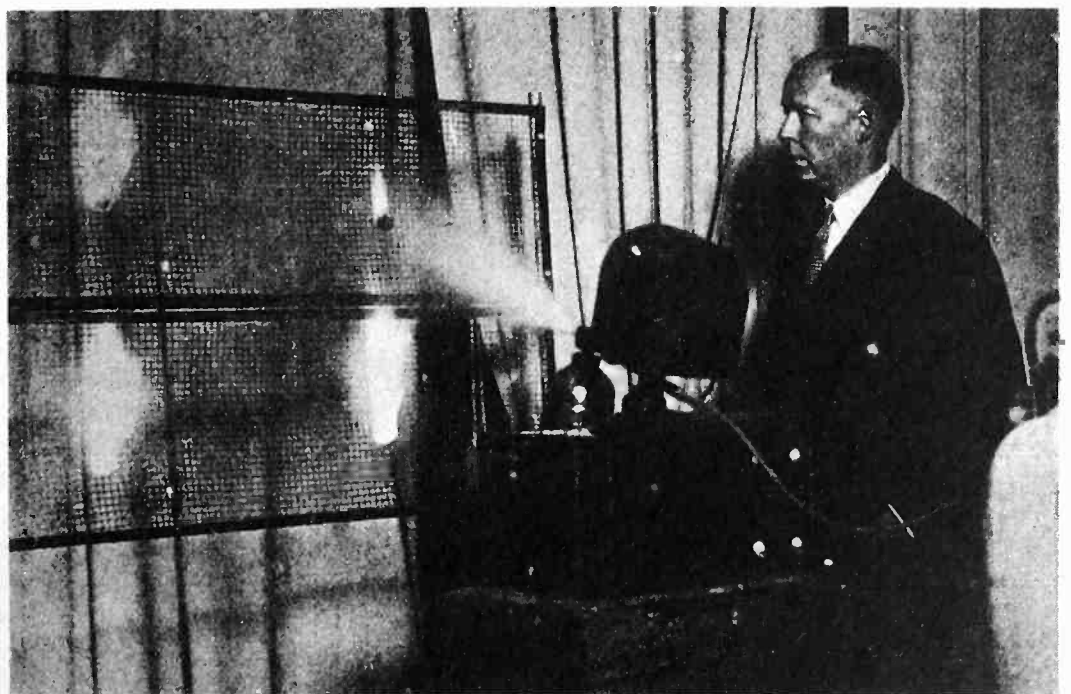

Before the A.I.E.E. at New York, Oct. 24. L. W. Chubb, Westinghouse director of research, demonstrated this "fire scanner." Four flames were lighted on the screen, the scanner was set in motion, and as it came in line with each fire, it stopped, aimed a stream of water, and then, the flame extinguished, went on to the next fire

# The role of barium in vacuum tubes

By J. A. BECKER\*

AMONG the filament characteristics most desired in the design of vacuum tubes are long life and low power for heating. The most desirable filament yet discovered for telephonic purposes consists of a platinum alloy whose surface is coated with a mixture of barium oxide and strontium oxide. A very minute amount of barium has been found to effect a vast increase in electron emission for each watt of power used to heat it—an obvious advantage when one considers that in the Bell Telephone system there are 250,000 tubes in use. Why the coated filament should liberate electrons more economically and how to increase these economies with added improvements in life and reliability have been important problems basic to tube development.

From the results of extensive research initiated by Dr. H. D. Arnold and followed by W. Wilson, J. E. Harris and M. J. Kelly certain facts have been established. An accompanying figure shows the remarkable effect that barium has upon the activity of a platinum filament. For filaments which are maintained at the same

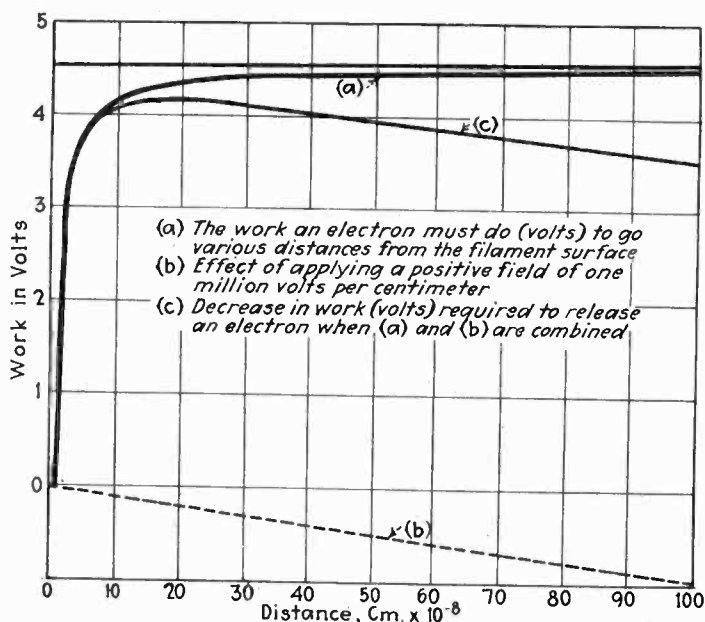

Barium supplies a positive field tending to pull the electrons from the filament

temperature, there is a very much greater emission in fact, more than a hundred million times as much for a clean platinum surface without barium—than for a filament surface is just completely covered with a thin layer of barium atoms. When the surface is only partially covered the electron emission is too small to be plotted on the scale used in plotting the figure. Emission increases rapidly as more and more of the surface is covered. When about 80 per cent is covered, when an enormous current is noted. When filaments were studied with enough barium to cover their surfaces, it was found that the current decreased and approached the value it would have for bulk barium.

The remarkable fact is that the electron current is possible at any heating temperature from 1000°C. A thin layer of barium atoms on a platinum wire is enough to give a current greater than the current which could be obtained from a filament of either substance alone.

In the filament of the standard repeater tube, the platinum core is covered by a thick layer of the oxide. In the course of the treatment of the tube some of this oxide is electrolyzed and barium is stored up in the core and in the oxide. While the tube is being used some of this barium is adsorbed on the surface of the oxide as an invisible monatomic film. This barium film is responsible for the high efficiency of the oxide coated filament.

Experiments have shown that barium on top of the oxide coating behaves qualitatively like barium on a clean platinum surface. Its characteristics are even more desirable. Apparently the forces brought into play between the barium and the oxide coating are essentially the same as those between a platinum core and a single layer of barium atoms deposited upon it.

These are the facts but to understand the rôle of barium atoms it is necessary to understand first how electron emission takes place from a clean filament surface. Electrons in the metal must have a certain speed in order to break away from the forces holding them to the surface and escape into the vacuum. Because of the heat of the metal, at any temperature a certain very small fraction of the electrons have enough speed to escape and some do so. As the temperature goes up, the agitation of the electrons increases and the fraction that escape increases rapidly. Therefore, the amount of electron current goes up with increasing temperature.

To make more electrons come out without raising the temperature, it is necessary to arrange matters to make it easier for them to get out. As the electrons escape from the surface, they must overcome the forces pulling them back. These forces might be like those acting on a ball which is started rolling up a hill. The heavy line (a) in the accompanying figure illustrates such an electrical hill for metallic tungsten. It shows the work an electron must do to go from the surface to various distances from the surface. For practical purposes if an electron ever gets out to a distance of  $10^{-8}$  cm., or one millionth of a centimeter, it permanently escapes from the filament and reaches the plate. At this distance it must have had at least 4.5 equivalent volt energy when it left the surface.

The electrons of the filament are continually trying to get out of this hill, but only a very small fraction can start with sufficient velocity to reach the top and escape. Of course, if the height of this hill can be reduced, more electrons can, at any given filament temperature,

\*Bell Telephone Laboratories, Inc.

it. One way of accomplishing this is to apply a positive electric field which pulls the electrons out. This can be produced by raising the plate of the tube to a positive potential. In the figure, the dotted line which slopes downward represents an applied field of a million volts per centimeter. By combining this field with the original field, we obtain a new potential hill whose height has been reduced. An electron can escape if it leaves the surface with 4.2 e.v. and reaches a distance of  $20 \times 10^{-8}$  centimeter. The barium atoms on the surface increase the height of the filament is a question. When the barium is on the surface, some of the atoms become ionized, and they give up one of their electrons to the surface and become positively charged.† These barium ions act in the same way as would a very fine-meshed positively-charged grid placed exceedingly close to the filament. This grid produces fields which, close to the surface, hinder electrons escape. Due to the fact that this ion is very close to the surface, the fields produced by it are tremendously great—several million volts per centimeter—and consequently the effect is proportionately greater the greater the number of ions on the surface. The greater the field and consequently the greater the electron emission.

This is true only so long as the surface is covered with less than one layer of barium atoms. Beyond this point additional barium atoms cover up the spaces between the atoms which the electrons come from the surface, and consequently the number of ions on the surface. Consequently the electron emission is reduced more and more until it reaches a value characteristic of a solid barium surface. This is the same picture of barium ions stuck to the surface which has been described from another set of experiments. It has been described a positive potential, applied to the end of a tube, increases the emission from its filament. From the careful analysis of such current-voltage curves one can deduce the exact value of the forces exerted on an electron while it escapes from the surface. This experiment discloses the interesting fact that at a distance of about ten atom diameters from the surface, the only forces which tend to pull the electron back are those induced by its own electrical field.

Near a clean metal filament there are thus no electrical fields excepting those produced by the escaping electrons. If, now, this clean surface is covered with a thin layer of barium ions, other fields are superposed on the original fields. These fields are presumably produced by the adsorbed barium and may be called adsorption fields. Very close to the surface these adsorption fields are tremendous and in a direction to pull electrons toward the surface. Further from the surface these fields decrease and actually reverse their direction; for a while they increase in magnitude, come to a maximum and then decrease. These characteristics of the adsorption fields, revealed by experiment, are just those which are expected from a non-uniform positively charged surface very close to the surface.

These adsorption fields have a marked effect on the voltage or saturation curves. It was long ago known that while clean tungsten yielded curves which saturated very well, the corresponding curves obtained from a barium coated filament saturated very poorly in comparison. The cause of this marked failure to saturate is due to the adsorbed barium atoms.

Of much value, the barium atoms must stick tenaciously to the surface even at high temperatures. It is therefore, becomes of interest to inquire what holds them

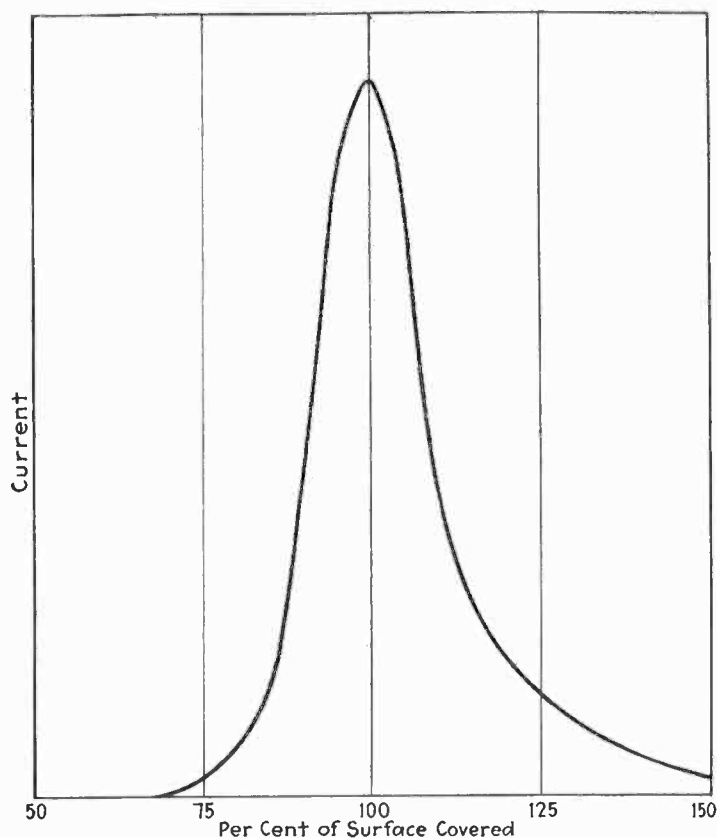

Effect of barium, expressed as per cent of surface covered, on electron current

to the surface. Here again our picture helps us out. Since some of the barium atoms are barium ions on the surface, they are positively charged and hence are held to the surface by the negative charge they induce on it. Furthermore, since the field produced by the ions helps to pull electrons from the surface, it hinders positive particles from leaving the surface. Consequently each ion helps to hold its neighbor to the surface even at temperatures at which solid barium would vaporize rapidly.

Still another prediction from our picture receives experimental verification. Since the electrical forces are chiefly toward and away from the surface rather than parallel to or along the surface, we should expect that each adsorbed ion would not be attached firmly to one particular spot on the surface but should be able to move about on the surface. This prediction was verified experimentally by putting barium atoms on one side of a flat ribbon. After this ribbon had been heated at a moderate temperature, barium atoms were detected on the other side. This surface creepage continued until only half the original deposit remained on one side.

We thus see how the simple picture of the ionic barium grid accounts for many of the observed emission characteristics of coated filaments. The economical side of the picture is just as remarkable.

In the ordinary telephone repeater tube the single layer of barium weighs about one-sixth of a microgram. For all the thousands of tubes in use in the Bell System the total amount of barium effective in the emission of electrons is not more than a twentieth of a gram.

Each barium coated filament requires only about 2.2 watts for heating as compared to about 35 for a clean tungsten filament. Multiplying this saving by the 250,000 tubes used in the Bell System gives an indication of the tremendous importance of barium to the vacuum tube.

†"The Life History of an Adsorbed Atom." *Bell Laboratories Record*, Vol. V, No. 1, p. 12.

†"On Electrical Fields Near Metallic Surfaces." J. A. Becker and D. W. Mueller, Bell Reprint B-300.

# electronics

McGraw-Hill Publishing Company, Inc.  
Tenth Avenue at 36th Street  
New York City

O. H. CALDWELL, *Editor*

Volume 1 — NOVEMBER, 1930 — Number 8

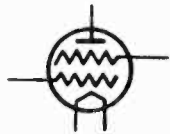

## Motion Picture Engineers look into future

AT THE annual convention of the Society of Motion Picture Engineers held in New York City, Oct. 20 to 23, nothing very new in the development of equipment was brought out. The standardization of wide film is one step nearer solution, however, with the definite recommendation of the standards committee for a picture area of 1.8 to 1 (ratio of width to height), with the possibility of 50-mm. overall width becoming standard.

One paper scheduled covering a 16-mm. sound-on-film home projector, was withdrawn and not presented. This was unfortunate as the device which was to have been described would have been at least a new step in the home entertainment field.

Serge Eisenstein speaking at the banquet of the society stated: "Mechanical and electrical developments in the industry are now far ahead of the artistic side of motion pictures." This may mean that some of the kind of effort spent on engineering might be turned to advantage on the program side in order that progress of the industry as a whole may go forward.

Much advance, however, yet remains to be made in sound pictures if the public's interest is to be held. Improvements throughout the sound recording and reproducing system, especially the loud speakers, should be looked for to more nearly approach the natural voice of the artist or the music from an orchestra. Acoustic treatment of the great majority of theaters is far from satisfactory; the owners apparently are merely hoping to ride the present wave of popularity of sound films as far as this tide will take them.

## Cold-cathode tubes

ELSEWHERE in this issue of *Electronics* given notice of a new tube produced in Germany, with a cold cathode. To do without the heating of cathodes has been the desire of tube engineers and users for a number of years and this is probably the first description of actual production and use of such tubes. In a particular case, the source of electrons is an electric surface which is illuminated by an arc lamp nearby. Other sources of electrons which have been suggested are radioactive substances. These tubes are not practical in present-day circuits, because of their very high internal impedance and low amplification and engineers will probably classify them as curiosities. It should be remembered, however, that the "audion" of de Forest was a curiosity for many years.



## Obstructing the farmers' use of radio—

EVERY man who has taken the oath as Federal Radio Commissioner has thereby obligated himself to exert all possible effort to bring radio reception to the people of the United States. The members of the Commission thus have a great personal responsibility—and an important opportunity—to enrich and brighten the lives of millions. It is their duty to so shape the channels with sufficient broadcasting power that strong, clear radio signals will be laid down every home in the United States,—so that the most modest farm dwelling with the simplest set, will enjoy the same priceless boon of entertainment as do people in the great cities and nearby communities.

High-power stations on every clear channel are the only answer to the demand for satisfactory broadcast reception on the farms and in towns remote from city centers.

There is now no reason why the farmers of the United States, the farmers' wives, and the boys and girls growing up on the farms and in towns should not receive a high standard of broadcasting—substantially the equal of the service supplied to cities and nearby communities.

The radio art, after costly research, is re-



broadcasting service of high technical quality to every home. The channels are cleared ready

Twenty-seven responsible broadcasters willing to invest several hundred thousand each, to bring city-quality to additional millions in their sections.

The Federal Radio Commission now blocks to better radio on the farm and in the towns of the nation.

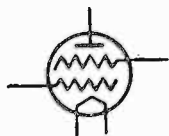

## Home recording devices may point new methods

WITH the addition of home disc-recording equipment to the latest designs of phonograph and radio combinations placed on the market, an interesting device has been made available for home entertainment. The simplified phonograph which is supplied as a part of the recording equipment, together with the six-inch disc on which the grooves are previously cut, is expected to furnish the same quality of recording as the elaborate recording equipment used in professional studios.

The ground noise level is quite high in such cases, resulting from the hard texture in which the cutting stylus has to operate. New materials have been developed that will furnish the necessary support for cutting, with low ground noise and still retain the desired wearing qualities. From the hands of users of such equipment, perhaps new ideas and methods may be advanced which will result in unlooked-for improvements in both home and professional use.



## Sic transit "photo-cell"

MEMBERS of the Vacuum Tube Technical Committee of the Institute of Radio Engineers recently decided to standardize the term "phototube" in place of "photo cell," a much longer word. On this committee are engineers from the large laboratories building and using phototubes, where the new designation is in common use.

The committee has arbitrarily limited itself to

the "Hallwachs" phenomenon in which a pure electron stream is liberated by the reception of light energy, or in which this electron stream—through the medium of a gas—produces a tube of increased sensitivity. The committee has not considered photo-conductive cells such as selenium or the photo-voltaic types which are now being made and sold, and which will probably be used in increasing quantities.

Shall the term "phototube" be applied to all light sensitive devices, or should the photo-conductive and photo-voltaic types of cells be called by other names? Since most of the definitions which will be agreed upon by the committee and written into the year's I.R.E. year book will apply to these other types of cells as well as to the so-called "photo-electric" type it appears that a decision regarding the terms by which the cells are called, is desirable.

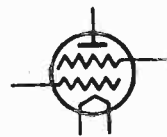

## Alongside "celestial mechanics," now comes "celestial electronics"

FOR hundreds of years men have viewed the solar system and the universe as a magnificent piece of mere mechanics—a superb machine of purely mechanical elements—until we had come to accept the term "celestial mechanics" to describe the whole vast system.

But within the last few years astronomers are finding that the heavenly bodies involve much more than the mechanistic considerations of the old-time astronomy. For now it is realized that the sun and other stars are huge and complex magnetic structures, that they radiate electrical vibrations of a wide range of frequencies, that space is threaded and cross-threaded by a maze of electromagnetic impulses of various wave lengths, that gravitation itself is perhaps electro-magnetic in nature, and that in the final analysis even the matter of which the stars and planets are made, is itself built up of countless minute "solar systems" of electrons or particles of electricity.

In the light of 1930, then, we must shape our ideas of astronomy around an *electro-magnetic universe*, and parallel to the old "celestial mechanics" we shall have to set up the new science of "celestial electronics" or "celestial electro-magnetics."

# REVIEW OF ELECTRONIC LITERATURE

## HERE AND ABROAD

### *Some measurements of optimum heterodyne*

[J. F. HERD.] By taking static characteristic curves and their rectification curves for a triode it may be shown that the rectification characteristics of a given set of tubes show less variation than do the static characteristics. Moreover a glance at these curves indicates the point where the mean plate current is most sensitive to a change in grid voltage and so indicates the point of optimum heterodyne. Starting from this optimum point measurements were made with the following:

- (a) a two stage choke coupled amplifier (as load on the detector tube)
- (b) a tuned audio frequency amplifier
- (c) an ordinary commercial transformer coupled amplifier.

All data showed: that the audio frequency output bore a linear relation to the input for small signals; that the point of optimum heterodyne corresponded to that obtained from the rectification characteristic; and that the gain in amplification of weak signals with optimum heterodyne was thousands of times that with equal heterodyne. — *Experimental Wireless*, September, 1930.

### *High frequency oscillator for general laboratory use*

[F. S. EVANS.] In connection with the discharge of electricity through gases need was felt for an ultra high frequency oscillator. The basis of the oscillator described is the Gill and Donaldson circuit which consists essentially of two parallel equal Lecher wires connecting grid and plate, with a variable condenser forming the junction between them. The circuit oscillates readily with all low impedance valves and may be readily adjusted to a frequency of about 30 megacycles. The energy is supplied to the discharge tube through a coupled circuit consisting of two Lecher wires closed at the end near the valve.—*Journal Scientific Instruments*, August, 1930, p. 261.

♦

### *Recent progress in the construction of photo-electric cells*

[ROY-POCHON.] Summary of the basic theories, details of construction (cathode, anode, gas, tube): with a bibliography.—*L'Onde Electrique*, Paris, August, 1930, published September 26.

♦ ♦ ♦

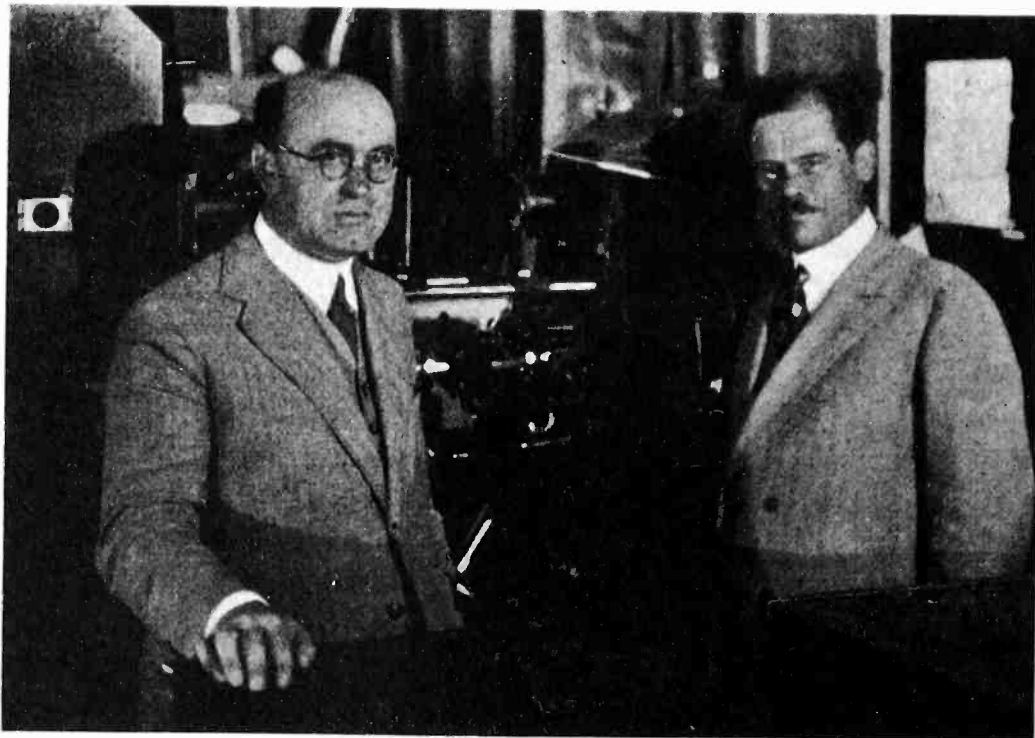

### **DR. KAROLUS AND DR. ALEXANDERSON**

Dr. Karolus, of Germany, inventor of the Karolus cell for modulating polarized light, used in the Alexanderson system of movie-screen television, visits Dr. E. F. W. Alexanderson in the latter's laboratory at Schenectady

### *Television glow lamps*

[H. W. WEINHART.] Development of the design of glow discharge lamps for television are recounted. The lamps for monochromatic television use flat plates for electrodes, cooled by radiation, so that the intensity of glow was limited by a current cap of only 50 milliamperes. Introduction of water-cooling permitted the currents as high as 500 milliamperes giving a very bright glow on cathode. For the more recent work on monochromatic television, the glow charge is confined to a flat square face by mica shielding; and the area is a metal strip fencing off this area. The cathode is clamped in contact with a glass tube through which the cooling water circulates. The recent tubes for color television employ the same scheme for water cooling. Mica is used on the cathode to provide a long insulating path and to prevent the glow from forming anywhere but the desired flat rectangular area.

Hydrogen which must be added to the gas within the bulb periodically is admitted from a separate glass chamber attached to the main bulb. Two plugs, one sealed in an extension of the lamp and one in the end of the hydrogen supply bulb, are normally sealed with mercury but when pressed together permit the passage of hydrogen into the tube. Lavite is used for the plugs and is heat treated until it is porous enough to pass hydrogen but not mercury.

The uniformity of the glow of the tubes and the sputtering from the surface depend on the use of the proper technique in preparing the cathode face. It has been found that beryllium deposited by the vaporization and condensation method sputters far less than other materials and so is used for final plating of the surface. For monochromatic television and for the blue component in color television neon is used as the discharge gas. For the red and green components argon is employed. Color filters are used with the lamps for color work.—*Bell Laboratories Record*, October, 1930.

♦

### *Customs regulations for travelers*

[UNSIGNER.] Very useful summary of the conditions governing the temporary import of radio receivers in to European countries.—*Radio B.F.f.A.*, Schenectady, October, 1930.

## of word "electron"

[McNICOL.] Although it was in 1896 that the electron as we know it today was identified and definitions made relative to its physical characteristics, it is history that the Greek poets called the sun and Homer repeatedly so terms (Z/513: T./398). "Electron" was used indefinitely by the Greek writers. In the minds of the ancients gold and the gold alloys were all of the sun "elector," and, in connection with these, amber, in Hellenic came to be called "electron." Through search of historical records might disclose that the word has been used long after the time it was used to refer to amber. That it was current and had some prominence in scientific circles is evidenced by the fact that in the electrical literature *The Telegrapher*, of December 1896, the word electron appears on the bottom of the first page.—*Radio Engineering*, New York, October, 1930.

## Frequency modulation distortion

[CKERSLEY.] Due to the difference in the path traveled by the direct and reflected waves the signal received at a receiver is composed of components of the transmitter sent out at different times. With frequency modulation means components of different frequencies so that in addition to the carrier tones between the carrier and the side bands for each of the components there will be beat notes between the two carriers and also between each carrier and the two side bands of the other component so that distortion results. Experiments with frequency stabilized transmitters show that this explanation is probably correct for the cause of distortion in short-wave radio-telephonic transmission on alleged amplitude modulation.—*Experimental Wireless*, New York, 1930.

## Inductive and capacitive coupling

[WILMOTTE.] An able presentation of an important but complex and difficult problem. The one objection our reviewer has is the convention employed for the sign of the mutual inductance, which leads, for instance, to the concept that the mutual inductance between adjacent wires on the same pole is negative. This is, however, the convention normally employed by the Physical Laboratory and so,

no doubt, much may be said in its favor.

After a preliminary explanation of the effects of impurities in condensers and mutual inductances the author presents two transformations, the first that of two self-inductances with mutual, connected at a common point, to a star arrangement of self inductances, and the second the star-delta conversions of Campbell (Kennelley?). By the aid of these transformations he shows how to convert capacitive coupling to its equivalent in magnetic coupling and vice versa. A means of measuring mutual inductance and its impurity is then disclosed and the paper ends with the comparison of the two types of coupling and a discussion of the limitations of the above mentioned transformations.—*Experimental Wireless*, September, 1930.

## Vacuum-tube voltage regulator for power alternators

[L. C. VERMAN AND L. A. RICHARDS.] Two novel features are incorporated in this vacuum-tube voltage regulator for a.c. power units. First, saturation current from the filament of a thermionic tube is used as the control element; and second, a feed-back stabilization system is employed which makes it possible to obtain stable regulated voltage conditions with high sensitivity. Operation of this regulator involves conversion of the a.c. line voltage fluctuations into d.c., amplifying these fluctuations, and applying them to the field of an exciter which supplies the main alternator field, thus controlling the line voltage. The exciter field winding is the only special piece of apparatus used in the system, all the other parts being standard and readily obtainable. The first tube (a UX 210) is operated at a low filament temperature and high plate voltage so as to obtain saturated plate current. Under these conditions the current through the coupling resistance  $R_2$  is nearly independent of the plate voltage but changes rapidly with the filament temperature and hence with the r.m.s. value of the line voltage. A UX 240 is resistance-coupled to the first tube, so that a decrease in the line voltage makes the grid of the 240 tube more negative, cutting down the current through  $R_3$ , making the grid of the third tube (210) more positive and building up its plate current. The almost instantaneous response of the vacuum-tube system to small line voltage fluctuations tends to cause hunting, because of the considerable time lags in the fields of the exciter and main alternator. This has been overcome by a feed-back coupling system with

condenser  $C$  and resistance  $R_1$  which reacts on the grid of the first tube, virtually delaying the response of the regulator. This arrangement gives voltage regulation of 1.5 per cent at full load unity power factor as compared to 45 per cent with fixed excitation. The regulator also functions as overload circuit breaker.—*Review of Scientific Instruments*, October, 1930.

## New radioelectrical instruments

[WEISS.] I. Radioelectric piano and organ, Givélet-Coupleux. Chiefly a general discussion of possible methods, with little details as to those actually used. II. Boreau "Radiotone." Full descriptions: the system is entirely new, a string in tension between a fixed support and the armature of a telephone receiver being "bowed" by a revolving wheel, and the currents induced in the receiver coils amplified. The critical positions of the bowing wheel for various pitches and its speed of rotation are discussed. Volume is controlled by a pedal. A system of filters controls the tone quality.—*La Nature*, Paris, September 15, 1930.

## Technical questions at the Vienna program convention

[UNSIGNED.] Descriptions of some of the demonstrations at this Convention of the German Radio Program Committee, more especially of: the ultramicroscope, using variation in condenser capacity and the heterodyne principle to measure changes in length of the order of one millionth of a centimeter; and the Scheminzky electro-stethoscope, in which a special arrangement of a semi-flexible cup is used to absorb the mechanical vibrations associated with heart-beats and with breathing. The same inventor also demonstrated the minute bioelectrical currents associated with muscular movements.—*Funk*, Berlin, October 10, 1930.

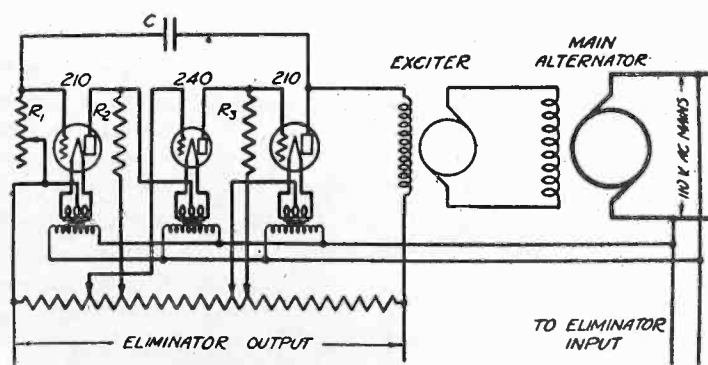

Circuit diagram of vacuum tube voltage regulator

## Distant control with very short waves

[BESSON.] Waves of 3 to 5 meters length are used (near La Rochelle) to start and stop the fog-signal, consisting of an acetylene-operated gun, at an isolated lighthouse without attendant distant 2.5 kilometers. The transmitter uses two tubes in a symmetrical arrangement (Mesny-Vallauri circuit) with a small dipole antenna. The receiver uses a similar antenna, and is itself of the super-regenerative type: it is switched on by a clock mechanism during seven seconds each 5 minutes only. The reception of a signal switches the gun into operation, the reception of a second signal switches it off: in order that a second impulse intended in reality to form part of the energizing signal may not de-energize, the receiver not only switches on the gun but simultaneously switches itself off, thus ensuring that the gun will actuate for at least five minutes. An anti-parasitic device is suggested, based on the saturation of a super-regenerative receiver by continuous wave signals. The system is to be extended on the Brittany coasts.—*L'Onde Electrique, Paris, August, 1930, published September 26.*

## A photo-electric cell with semi-conducting dielectric

[VON HARTEL.] Discussion of the theory of the new Lange cell as compared with the normal types: in these cells a copper-oxide layer replaces the vacuum, and separates a film of copper (cathode) so thin as to be transparent, from the anode which may also be of copper. The maximum sensitiveness occurs towards the red end of the spectrum, even with copper as the cathode, thus rendering the use of rare metals unnecessary. A striking advantage of these cells is that no auxiliary voltage is necessary: the sensitivity is also much greater than in the case of the normal cell (about ten times that of a vacuum cell). The internal resistance is of some hundred ohms only.—*Funk, Berlin, September 19, 1930.*

## Electrical musical instrument

[WEISS] Description of the "Ondium Péchadre," using the heterodyne beat-note. Pitch is controlled by a variable condenser, actuated by the right hand: the left hand controls the volume, by depressing a key to a greater or less extent, and also the tone-quality (no details of this are given).—*La Nature, Paris, July 15, 1930.*

## Cold cathode amplifiers

[M. VON ARDENNE.] Employing a cathode of photo-electric material, valves with an audio frequency voltage amplification of 30 in sunlight, and of as high as 17 under the illumination of a 50 cp., half-watt lamp have been successfully produced in Berlin. The greatest advantage of this method is the total absence of hum and line noises, although search for a cold-cathode tube was the original incentive. The effect of line voltage fluctuations can be entirely eliminated on either d.c. or a.c. by the proper choice of a light source. In addition, a whole series of receiving circuits in which the cathodes of the various valves do not have a common potential can quite easily be realized.

The valves for experimental work employed a potassium cathode of several square centimeters area, which was sensitized with hydrogen, and the valve filled with an inert gas. The ionic current due to the gas does not appreciably affect the operation of the valve as an amplifier, though it necessitates the use of different grid-bias voltages. The amplification factor of the valve itself is about 40, and its a.c. resistance is of the



Baron Manfred von Ardenne, German scientist and inventor, whose writings on radio and allied subjects have appeared in scientific journals throughout the world

order of two megohms. In the experiments described a plate resistance of ten megohms was used. The grid current curves have a shape which indicates that grid current will have no appreciable influence on amplification. A three-stage amplifier, resistance-coupled, with the three tubes grouped about a single motor-car headlamp, was found to work very satisfactorily. It was also found that a glow discharge in close proximity to the cathode, either in the same bulb or in a separate one, will provide as great a surface illumination as an ordinary electric lamp. This glow was energized from a battery eliminator. The results obtained are extremely interesting.—*Wireless World, September 3, 1930.*

## Equivalent circuit of the thermionic valve

[N. R. BLYTH.] Barkhausen and Pol have already shown that in any given equation, all voltages and currents are interchanged and ad-substituted for the corresponding impedances a new equation is which represents, as well as the equation, the phenomenon undergation. Applying this principle triode Mr. Blyth has derived conditions for various types of load: a simple circuit which is usually sent as a voltage  $\mu e_g$  working an internal impedance  $r_p$  and impedance  $Z$  is thus converted constant current generator  $G_n$  ing across an impedance consisting  $r_p$  and  $Z$  in parallel. Either for as the current through the load

$$i = \frac{\mu e_g}{R_p + Z}$$

The great advantage of the alternative method of representation is that external impedances in the anode are thrown in parallel with the impedance and the plate-filamentance so that the combination and shunt impedances is avoided.—*Experimental Wireless, September*

## A valve-operated coreless induction furnace

[FRANK ADCOCK.] The oscillator consists of two 2.5 kw. valves in parallel fed with raw a.c. The circuit is a tuned plate type with the coil the energy into the furnace. Various methods of applying grid bias to oscillating valves were tested. A combination of grid-leak and a denser in conjunction with a negative C bias of 36 volts was used. The grid-leak and condenser combination when used alone did not give efficient protection when the valve oscillating under inefficient conditions on the other hand a high plate bias unduly restricted the oscillation. Much trouble was experienced using magnetic materials due to change of their magnetic properties hence loading on the oscillator temperature. A solution was a specially designed condenser.—*Transactions of the Faraday Society, September, 1930.*

## Continuous-wave diathermy and its surgical applications

[COLOMBEER.] More complete description with diagrams and photographs of actual apparatus, based on the previously described (these details July, 1930).—*Radioelectricity, October, 1930.*

# and recording under difficulties

itions under which sound recording  
ment has to work. Illustrations taken  
*Recording Sound for Motion Pictures*,  
published by McGraw-Hill Book Com-  
this winter.



cameraman submerges for underseas sequences in  
mount's picture *The Sea God* with a water-proof  
connected by a motor to sound recording  
apparatus at the surface

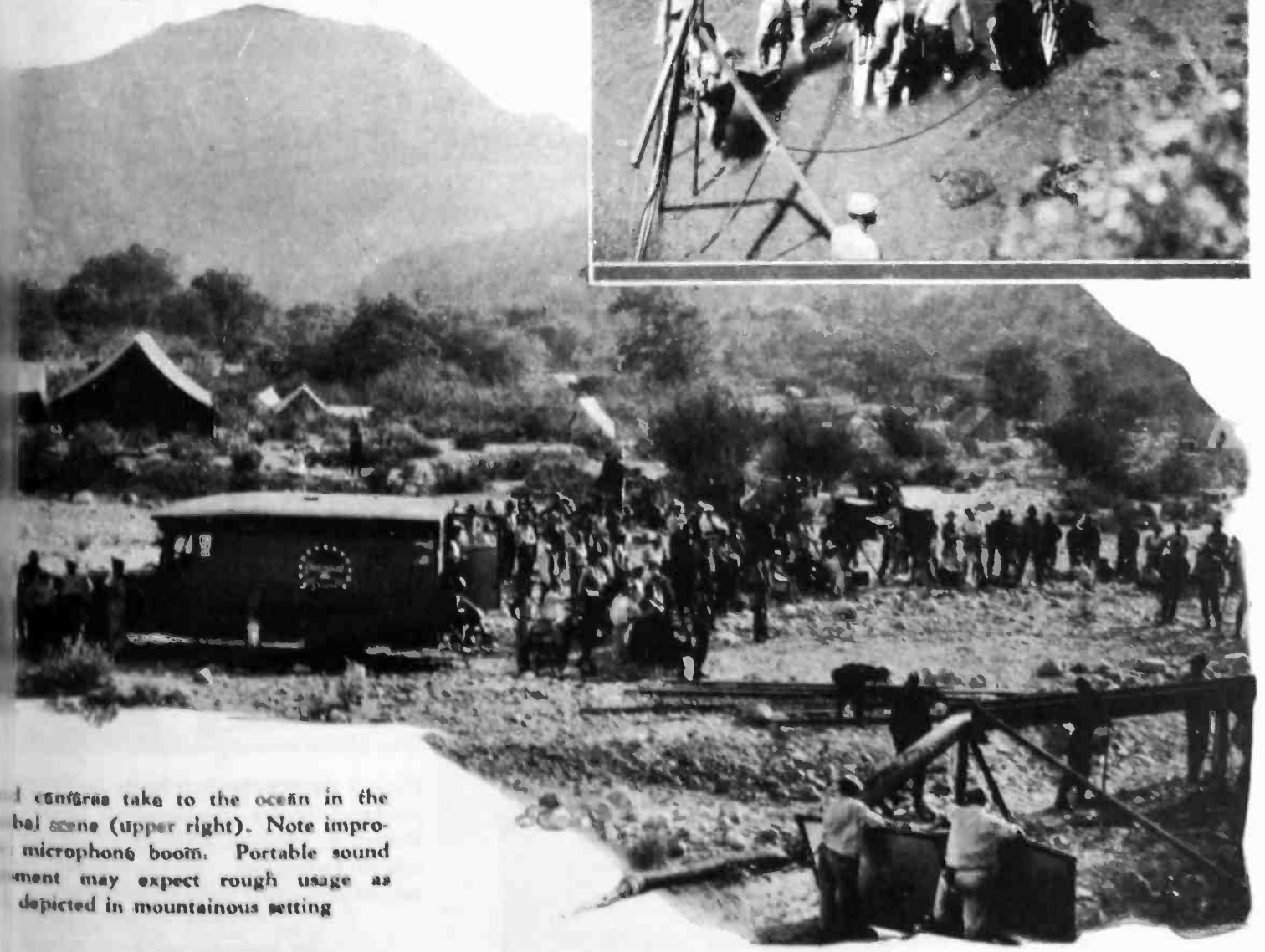
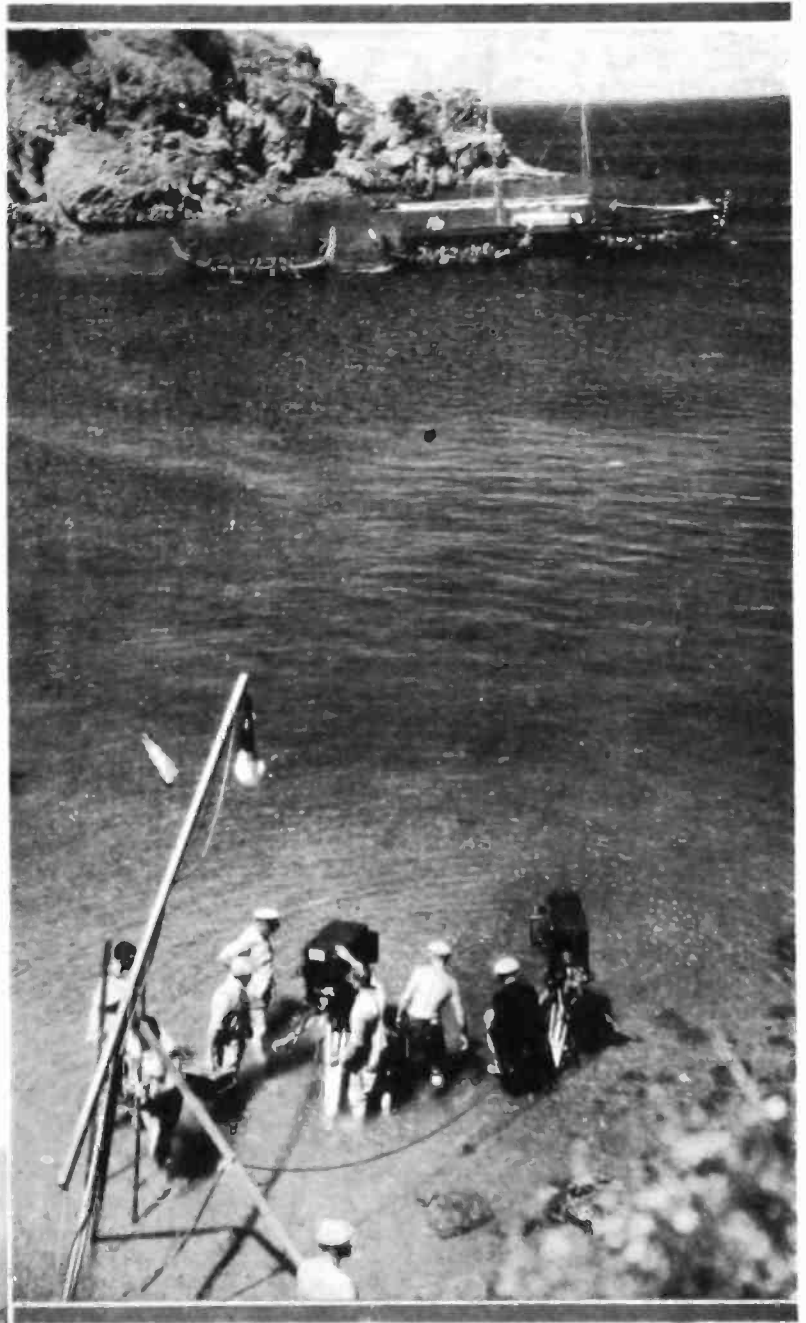

1 cameras take to the ocean in the  
bal scene (upper right). Note impro-  
microphone boom. Portable sound  
ment may expect rough usage as  
depicted in mountainous setting

# WITH ELECTRONICS'

## CAMERA

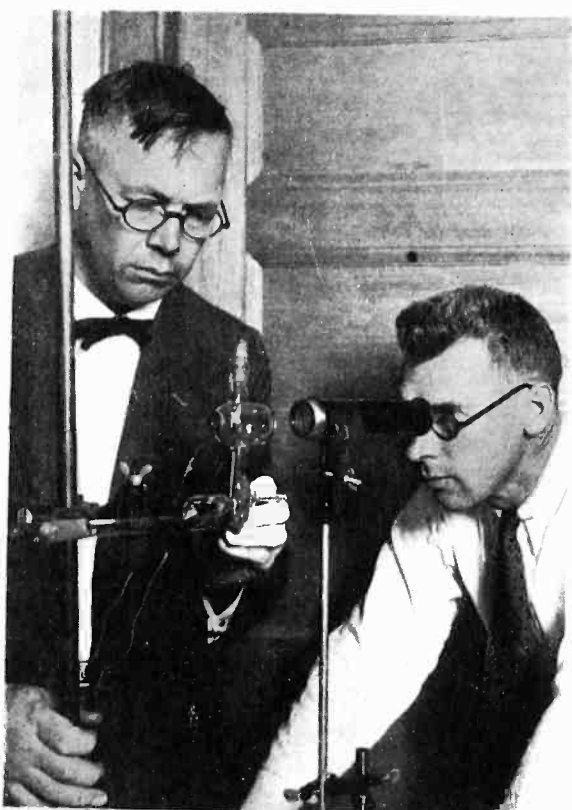

This thermo-couple, used with vacuum-tube amplifiers, will measure one-millionth degree, F. At Mt. Wilson, California, it detects heat rays of stars invisible to naked eye

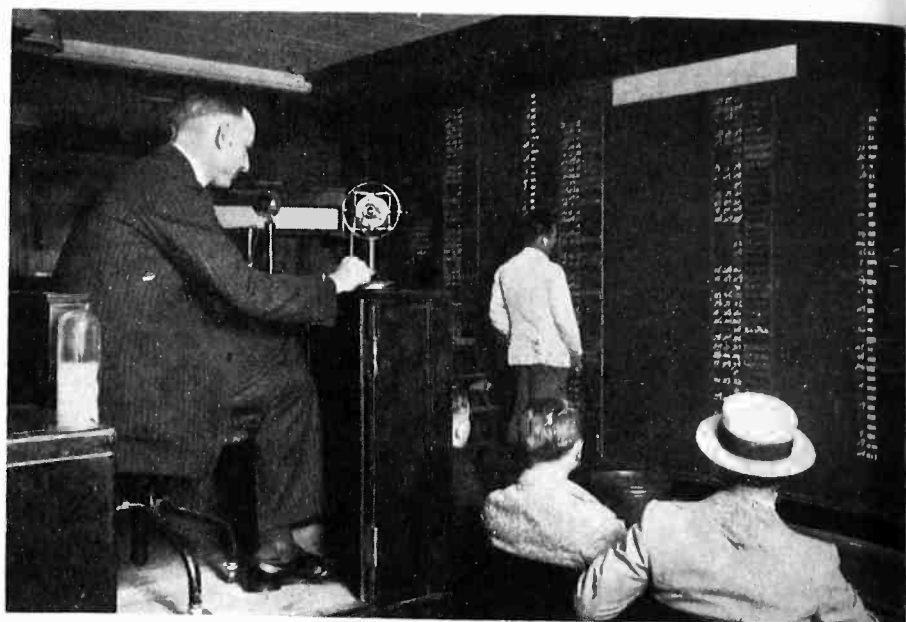

Chicago stock brokers are using microphones in their customers' rooms connecting to loudspeakers throughout their offices, so that every employee can be kept posted on stock movements

Ultra-violet light illuminates this Pittsburgh indoor golf course, assuring health and tan on darkest winter days

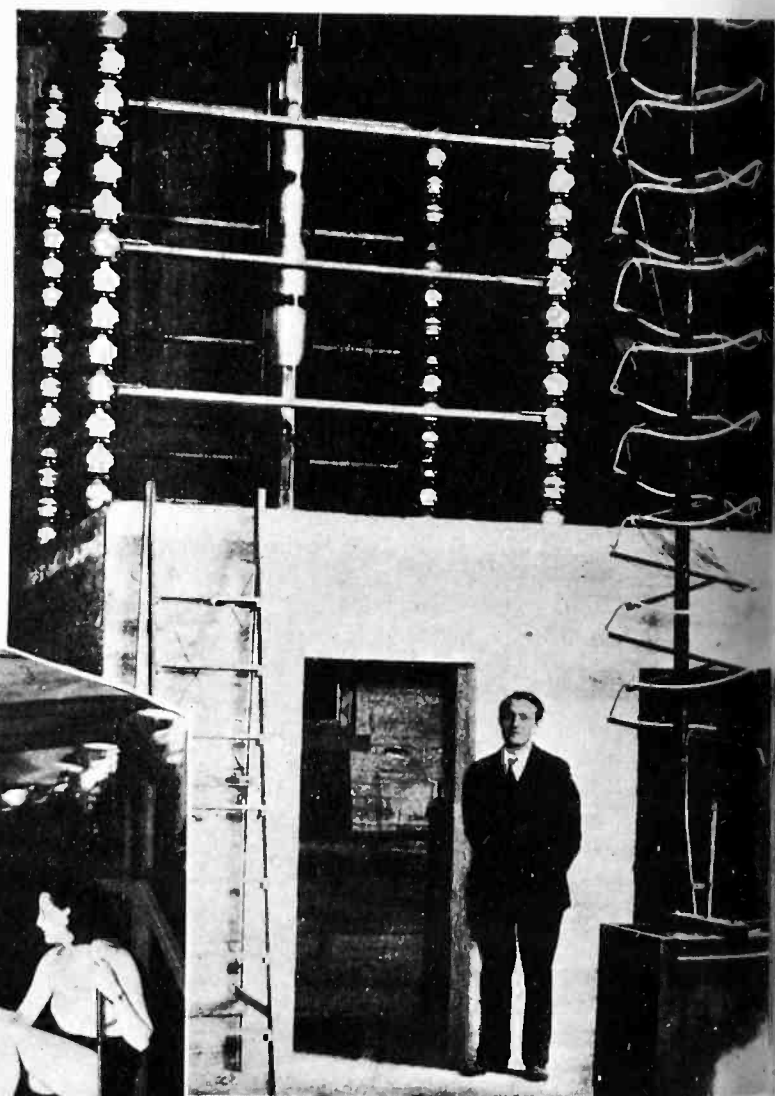
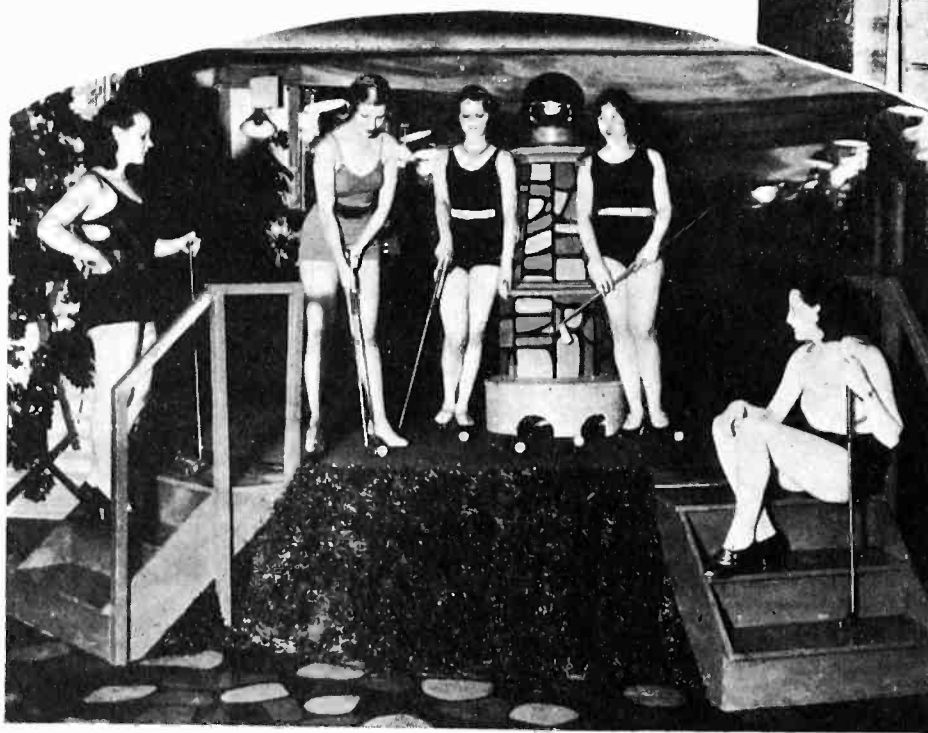

Here is the 600,000-volt X-ray outfit produced under direction of Dr. Robert A. Millikan, California Institute of Technology. For therapeutic use, its rays equal those from radium

# NEWS

## THE ELECTRON INDUSTRIES



### Radio sets at 13,478,600

Every family in the United States has a radio receiving set, according to a census estimate of Marshall T. Glavin, chief of the Electrical Division of the Department of Commerce. The number in use on July 1 is placed at 13,478,600, whereas the families in this country number approximately 28,000,000.

New York, doubtless because of its position in population, boasts the most radio sets. California and Illinois come second and third. Pennsylvania is fourth. These four States, with 29 per cent of the population, possess 39 per cent of the radios.

There were only 11,500,000 sets in this country in January and but 9,500,000 in July, 1929.

An increase was also reported in the value. The total for the first eight months of this year was \$11,904,171 for radio apparatus, an increase of \$15,000,000 over that of the same period in 1929. The industry continued to lead as the market for American radio products.

The estimated number of sets by State is given as follows:

87,700	Neb.	203,000
46,600	Nev.	23,000
90,500	N. H.	47,000
1,470,000	N. J.	453,000
172,000	N. Mex.	28,000
219,000	N. Y.	1,752,000
29,000	N. C.	92,000
105,000	N. D.	61,000
124,000	Ohio	845,000
111,000	Okla.	182,000
42,000	Ore.	219,000
1,060,000	Pa.	977,000
348,000	R. I.	111,000
310,000	S. C.	44,000
195,000	S. D.	77,000
92,000	Tenn.	104,000
121,000	Texas	364,000
80,000	Utah	72,000
115,000	Vt.	45,000
656,000	Va.	114,000
627,000	Wash.	351,000
239,000	W. Va.	86,000
48,000	Wis.	322,000
433,000	Wyo.	32,000
54,000		

Webster Electric Company reports increased foreign demand. Proof that electrical reproduction and amplification of sound is fast gaining favor in foreign countries, is shown by a greatly heightened demand for necessary equipment. This company, manufacturers of electric pick-ups and power amplifiers, is now shipping its products to over forty foreign markets. The volume of export sales of Webster pick-ups, for the first eight months of 1930, shows an increase of 130 per cent over the corresponding period in 1929. The sale of Webster power amplifiers, comparing similar months, has increased almost 350 per cent.

The Acme Electric and Manufacturing Company, 1444 Hamilton Ave., Cleveland, Ohio, has just issued an interesting bulletin (No. 121) which describes Acme step-down transformers for the export field where the voltage supply ranges from 200 to 240 volts.

Robert C. Sprague, President of the Sprague Specialties Company, electrical condenser manufacturer, Quincy, Mass., has announced the expansion of its group insurance program and the extension of its benefits to the workers in the North Adams, Mass., branch. To the \$130,000 of both life insurance and accidental death and dismemberment protection now in force, health and non-occupational accident insurance now rounds out the plan. The entire contract remains under the administration of the Metropolitan Life Insurance Company, and features the cooperative method of paying premiums, by which employer and employees jointly share the cost.

B. H. Noden, secretary Pacent Electric Company, New York City, sailed October 14 on the S. S. *Bremen* for Europe, where he will conduct important business for Pacent in the radio and talking picture fields. It was announced coincident with Mr. Noden's departure that both the Pacent Electric Company and the Pacent Reproducer Corporation have plans under way for the manufacture abroad of their radio, radio-phonograph and sound-reproducing products for the European market.

Howard W. Sams, general sales manager of Silver-Marshall, Inc., announces the appointment of Howard C. Briggs as assistant general sales manager. Mr. Briggs is a well known man in the radio industry in the middle west, having been five years with E. T. Cunningham, Inc., a year as district manager of Michigan for Grigsby-Grunow, and a year with the radio division of the Kellogg Switchboard & Supply Company before joining the sales organization of Silver-Marshall.

The Radio Corporation of America and others filed suits for patent infringement on October 17, 1930, in Brooklyn, New York, against DuoVac Radio Tube Corporation, because of the sale of DuoVac radio tubes, types 224, 227 and others, similar to RCA tubes, types 224, 227 and others. The plaintiffs claim that the unlicensed DuoVac tubes infringe their patents.

Goat Radio Tube Parts, Inc., 33 35th St., Bush Terminal Bldg., Brooklyn, N. Y., has published a comprehensive loose-leaf catalog, made up in the form of a handbook, with the idea of promoting standardization of tube parts. It is all in tabular form, classified under the types of tube, printed in large type, illustrated with many half-tones, and including specifications of various materials entering into tube parts. Engineers, purchasing agents and others connected with the manufacture of radio tubes will find this handbook of much assistance in ordering equipment.

Westinghouse Electric & Mfg. Company has issued in a new leaflet a description of the construction and uses for universal motors. Copies of this leaflet, No. L-20503, may be obtained from any district office or directly from the Advertising Department at East Pittsburgh, Pa.

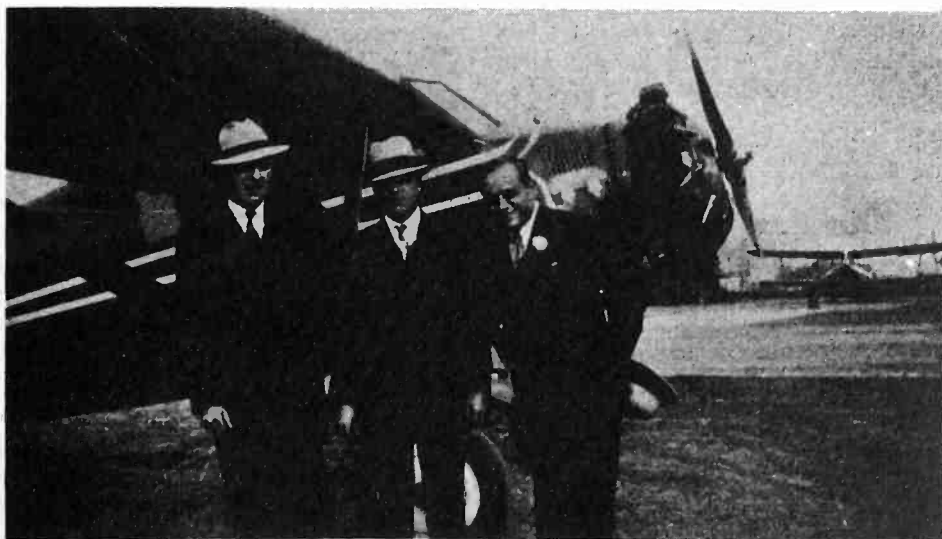

Henry S. Tenny, president of the Rola Company, Cleveland, Ohio, uses his own airplane to inspect company's plants in Cleveland and in Oakland, Calif. B. A. Engholm, vice-president, and Leon Golder, sales manager, are shown with Mr. Tenny

### Upcoming meetings

Institute of Radio Engineers—Philadelphia Section, Nov. 18.  
Institute of Radio Engineers—Fall Meeting, Nov. 21, Rochester, N. Y.  
American Physical Society—Chicago, Ill., Nov. 28-29.  
American Chemical Society—Richmond, Va., Dec. 12.  
Musical Society of America—Los Angeles, Calif., Dec. 12-13. Joint Meeting with American Physical Society.

# ★ NEW PRODUCTS

## THE MANUFACTURERS OF

### Constant voltage battery for two-volt radio tubes

ANNOUNCEMENT OF AN entirely new filament-supply battery for two-volt tubes has been made by the National Carbon Company, 30 East 42nd St., New York City. This Eveready air cell battery is expected to bring to the home not served by power lines the same quality of reception, ease of operation, and economical service as is enjoyed by the users of power sets. The battery, by virtue of its two special carbon electrodes,



is enabled to deliver a substantially constant voltage throughout its life. The carbon electrodes absorb oxygen directly from the air, eliminating the necessity for oxygen-evolving chemicals within the cell. Thus in the ordinary dry cell, as the oxygen becomes used up, the working voltage falls, but in the "air cell" a constant supply of oxygen insures constant voltage until the active electrode is consumed. The capacity of the battery is given as 600 ampere-hours, sufficient to run a seven tube two-volt set with a filament drain of 0.55 amp. for over 1,000 hours.—*Electronics, November, 1930.*

### Renewable high-voltage fuses

PROTECTION TO EQUIPMENT used in amateur and power broadcasting, sound pictures, television, and amplifiers of all kinds is provided in a series of new high-voltage fuses manufactured by the Littlefuse Laboratories, 1772 Wilson Ave., Chicago, Ill. Circuits with a voltage of from 1,000 to 10,000 volts and a current of 2 amperes or less may be protected inexpensively in this way. An unusual renewable design feature permits the return of a blown fuse for renewal at only  $\frac{1}{3}$  or  $\frac{1}{4}$  of the original cost of the fuse. Prices range from 35 cents to \$1, with renewals at 10 to 20 cents. A fuse rated at about 50 per cent higher than the normal plate current of a power tube will save the tube when it begins

This section is prepared by the editors of *Electronics* purely as a service to readers. Its aim is to present announcements of all new products, devices and materials of interest in the field of the paper. All items are published solely as news, and without any charge or any advertising consideration whatsoever.

to go "soft" or gassy. When power tubes are used as oscillators they will often overheat destructively unless protected by a proper fuse, if for any reason they cease to oscillate. A new catalogue describing these fuses in detail has been issued and will be sent to interested radio operators, amateurs, engineers, etc.—*Electronics, November, 1930.*

### Demountable microphones

TWO TYPES OF MICROPHONE, Models 29N and 30N, manufactured by the Ellis Electrical Laboratory, 337 West Madison St., Chicago, Ill., incorporate a new demountable feature. This permits the microphone button to be removed from

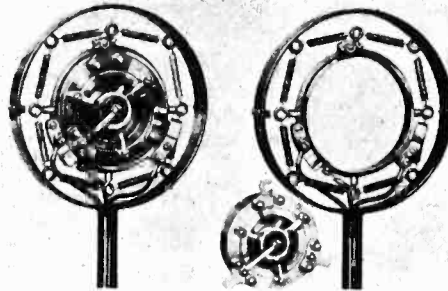

the stand by loosening a single wing nut. The contacts are made through the switch-blades attached to the microphone. Advantages claimed for this unusual feature include safety from theft and from exposure to the elements when not in use. There are many occasions when it proves to advantage to use the very sensitive Model 29N for the speaking voice and then change to the Model 30N for music. This is especially important in the production of talking films, both in the studio and in the field. In case of emergency the demountable feature permits a quick change to a reserve unit. The Ellis demountable microphone is shipped complete with all fittings, but does not include the desk stand and springs shown in the illustration. List price, including rim fittings, \$85.—*Electronics, November, 1930.*

### Self-contained ohmmeter

COMBINING CONVENIENCE, accuracy, sturdiness, a self-contained meter is being manufactured by Jewell Electrical Instrument, 1650 Walnut St., Chicago, Ill. Pattern 89 Ohmmeter uses flashlight cell within the case to supply its voltage, and is therefore independent of external voltage supply. A shunt corrects for variations in cell voltage. In operation the instrument can be adjusted to the cell emf. A series of tests is made, and the meter gives a high degree of accuracy. The instrument is protected and long life insured by the use of a bakelite case and shatterable glass in the scale.—*Electronics, November, 1930.*

### Power amplifier

SPECIALISTS IN AMPLIFIERS, Webster Company, Blackhawk St., Chicago, Ill., recently announced its Style 100 power amplifier. It is well adapted for centralized radio and public address systems, automatic musical instruments, sound picture recording and broadcasting, and many industrial uses. Webster catalogue has been issued which includes descriptions and

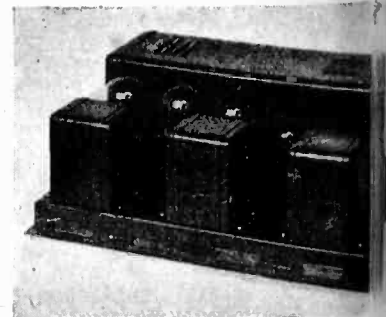

and descriptions of the many types of equipment manufactured. The catalogue is available to any who write the company.—*Electronics, November, 1930.*



## fitting condensers

SIZES OF stock condensers to demands for transmission are covered by the National Company, an St., Malden, Mass. These ng condensers are widely used broadcasting stations and transmitters, and are designed mechanically and electrically cor- TM type condensers are sup- either  $\frac{1}{8}$  or  $\frac{3}{8}$  in. spacing be- adjacent stator plates for high work. Standard insulation for M type condensers is crolite. acities range from 0.000035 to voltages, either 3,000 or 6,000, s from \$7 to \$22.50. These ude National Velvet Vernier ls. Prices on Navy type con- with ball bearing rotor shaft insulators for high voltage be quoted upon receipt of ons. — *Electronics, November,*

## Receiver Control

CONTROL IS now available for of radio set, according to an ment by the Clarostat Manu- Company, 285 North 6th St., n N. Y. This company has de- universal device applicable to i set in the form of a small felt bottom, for use on any n top of the set cabinet, to- th two long flexible leads

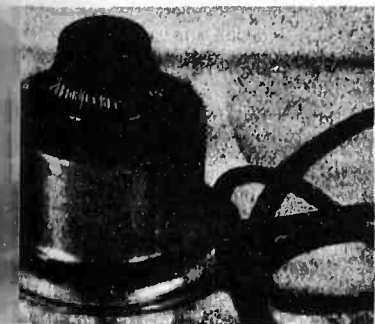

g in disk connectors. The ectors are fastened one to the the power tube and the other ound binding post, or, in the type of receiver, the con- e slipped around the prongs of er tubes. — *Electronics, No- 1930.*

## Control for Graph pick-up

OLYPHASE PICK-UP, a new in- of the Audak Company, 565 e., New York City, it is pos- vary the tone to suit the taste terner. Such an improvement eful in the reproduction of speech and music as in radio . With this method of tone ontrasted with the usual radio here is no loss of energy and

the tone quality is improved rather than vitiated, according to the manufacturer. There are three settings of a switch on the pick-up, permitting the emphasis of the low, the middle, or the upper ranges. By the change in the setting the desired frequencies are phased in, without disturbing the other frequencies. This instrument may be used in phonograph reproduction, in connection with home recording, and for other recording and reproducing purposes.—*Electronics, November, 1930.*

## Short wave coil sets

TWO TYPES OF short wave coil sets, each containing five coils, for tuning from as low as 14 meters to as high as 205 meters, have been placed on the market by the Hammarlund Manufacturing Company, 424 West 33d St., New York City. These plug-in coils, known as types LWI and LWT, are space-wound, supported by a thin film of strong dielectric material, affording low distributed capacity and minimum re-

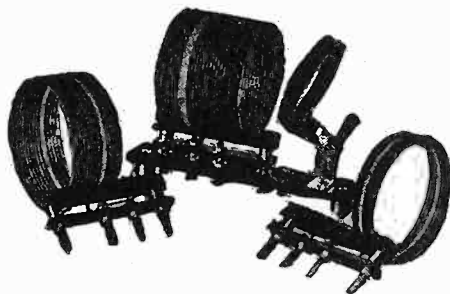

sistance. The LWT coil has both primary and secondary windings; while the LWI coil has only a secondary winding. Two types of base are also supplied for the LWT coils, one with a variable primary, and one without. The five coils forming each set have overlapping wave-bands so that all frequencies may be covered without a break.—*Electronics, November, 1930.*

## Wire-wound resistors of extreme accuracy

RESISTANCE UNITS FOR the precision required in attenuation pads, resistance bridges, and level indicators are being manufactured by the International Resistance Company, 2006 Chestnut St., Philadelphia, Pa. Special nickel alloy wire, with the practically negligible temperature coefficient of 0.00002 per degree Centigrade, is employed. The wire is wound in sections on a special ceramic form of close accuracy, high heat conductivity, minimum moisture absorption, and very high resistance. Special varnishing treatment applied to the resistors prevents atmospheric and temperature effects from altering their characteristics. These units are made with an accuracy of 1 per cent, or  $\frac{1}{2}$  or even  $\frac{1}{4}$  of 1 per cent.—*Electronics, November, 1930.*

## Portable amplifier

JENKINS & ADAIR, ENGINEERS, 3333 Belmont Ave., Chicago, Ill., have announced recently their Type B portable amplifier, primarily for broadcast station pick-up work. It consists of a three-stage amplifier, using standard tubes, together with a built-in level in-

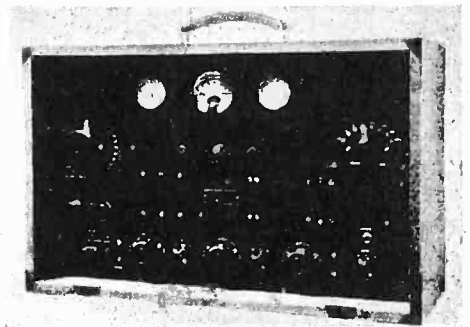

dicator. The two-position input is normally for either condenser transmitters or carbon microphones, but can also be built to accommodate wire lines or phonograph pick-up if desired. The input circuit switch, in addition to its normal duty, controls a relay in the output circuit, which prevents clicks from going out on the line. The maximum undistorted output level is approximately 6 db and the total variation between 50 and 6,000 cycles is approximately 1 db. The total gain is 70 db. List price \$425, less tubes and batteries. — *Electronics, November, 1930.*

## Movable single spool wire winding machine

SPOOLING MACHINES embodying new improvements are being manufactured by the Eisler Electric Corporation, 744 South 13th St., Newark, N. J. These machines have a distinct advantage over older types because of their moving spool feature. On the other types of machines when coated wire is being spooled the guides have a tendency because of their reciprocating motion to scrape off a small amount of coating. In order to avoid this, in the new machine the spool itself moves back and forth, the guide remaining fixed, thus permitting the wire to run straight and

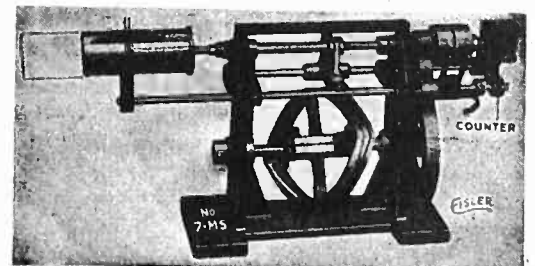

directly on the spool and preventing any scraping. The length of movement of the spool depends on a cam motion; this is readily made to suit requirements from 1 to 4 inches. The machine is also equipped with reset counter, indicating the number of revolutions of the spool. — *Electronics, November, 1930.*

## Control amplifier for broadcast use

FOR REMOTE CONTROL of broadcast station amplifier work, the Gates Radio & Supply Company, Quincy, Ill., has announced its Model 102C amplifier. The amplifier uses a three-stage combination capacity and transformer coupled circuit, a pair of UX 171A tubes being used in the final audio stage in a push-pull circuit giving a possible undistorted

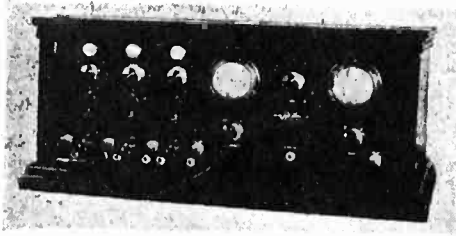

output of 1.4 watts with a gain of 80 db. overall. A microphone mixer is incorporated which has the ability to mix three carbon or condenser microphones. Each microphone circuit is controlled by a cam type anti-capacity switch. Signal lights designate which circuits are in operation. The mixer is featured with noiseless mixing and current controls and is designed for unrepulsive operation. A volume indicator is part of the equipment with separate indicator and monitor tubes employed. The output impedance is either 600 ohms for the input to a telephone line or 3800 ohms for the input of the final high stage amplifier where this equipment is used as a station amplifier. Price, F.O.B. Quincy, \$325.—*Electronics, November, 1930.*

## Simplified unit for remote tuning

REMOTE TUNING from any number of desired points is simplified by a new unit manufactured by the Pacent Electric Company, 91 Seventh Ave., New York City. The unit through which the set is remotely operated is smaller than a half-pound candy box, and, according to the inventor, it can be made even more compact in final manufactured form for radio manufacturers' use. On top of the single unit—combining remote tuning, automatic station selection when desired, remote control and on-off control, and calibrated station scale—are three small push buttons. By manipulation of one or more of them, the entire receiving range of the receiver is placed at the operator's command. The exact point of best reception of each station is before the eye on the graduated scale, above the tuning buttons. While the characteristic selectivity of a particular set is maintained, it is in no way made critical by the application of this system. Any one or number of programs may also be automatically tuned, as desired, with unwanted stations remaining silent during

the tuning process. On the front of the unit is built a combined volume and power supply control, which provides remote control of the volume level along with on-off control of current to be set. A red light indicates whether or not the receiver is operative.—*Electronics, November, 1930.*

## Rectifier type instruments

USEFUL IN THE measurement of alternating currents of such small magnitude that they cannot be measured readily by means of the ordinary types of a.c. instruments, dry rectifier type meters are now available from the Weston Electrical Instrument Corporation, Newark, N. J. This type of instrument is applicable also where accuracy is not of so much importance as ruggedness and ability to withstand heavy overloads without damage. It consists of a sensitive d.c. permanent

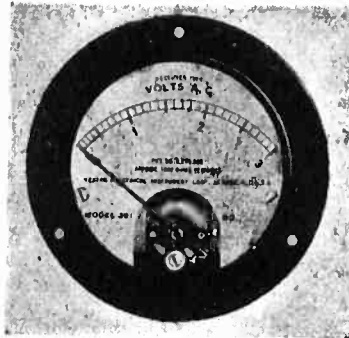

magnet movable coil instrument, similar to that illustrated, used in connection with a rectifier made of four sets of copper oxide disks arranged in the four arms of a Wheatstone bridge circuit. Instruments embodying such rectifiers are subject to errors from several sources, among which are temperature, frequency, wave form, and the fact that the resistance of the rectifier varies with the amount of current passing through the disks. The instrument is discussed together with its sources of error and their corrections, in a bulletin issued by the Weston Company.—*Electronics, November, 1930.*

## Dry electrolytic condensers

DRY, SELF-HEALING under overvoltage, and with a power factor better than the ordinary, an electrolytic condenser has been announced by the Concourse Electric Company, 294 East 137th St., New York City. This dry condenser, made in several types, is housed in either round or rectangular containers, and may be mounted in any position. It is designed for peak voltages of 500, or higher. Capacities range from 1 mfd. to 200 mfd. Samples and prices may be obtained from the company, who is also prepared to build its condensers to specifications.—*Electronics, November, 1930.*

## Power supply units for precision amplifiers

ONE OF THE LATEST developments in the American Transformer Company, 178 Emmet Street, Newark, the type P-77 power supply, capable of supplying filtered voltages to precision amplifiers, the slightest a.c. hum cannot be detected in the output. This unit is obtained directly from standard 110- or 220-volt a.c. circuits and supplies potentials of the order of 375 volts at 2 amperes as well as intermediate values. It has been designed for use with equipment using 250-volt tubes, but similar rectifiers with different output ratings are also available. The type P-77 power supply employs two 66-type mercury-vapor tubes in a full-wave rectifier circuit, and the equipment is so designed that if one tube fails while in operation, the other tube will provide full output until the failed tube has an opportunity to be replaced. This fact insures continuous operation without the necessity of changing the rectifier circuit. The unit is mounted on aluminum panels of standard 19-in. width and may be used on conventional mounting.—*Electronics, November, 1930.*

## High-voltage filter condensers

A LINE OF high-voltage filter condensers is announced by the Condenser Corporation, 342 Avenue C, New York City. These condensers are conservatively designed with a safety factor, thus eliminating the possibility of breakdown at rated voltage. They are available in a medium range, with 600, 1,000 and 2,000 volt units of wax-filled and oil-impregnated construction, and in a high range, of 3,500, 5,000, 6,000 and 10,000 volt units. The high-voltage condensers

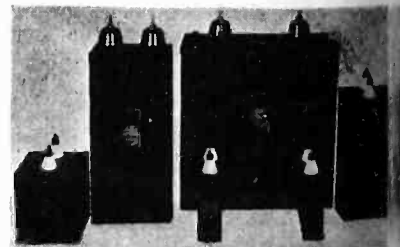

also employ paper dielectrics, oil impregnated and oil filled, and the internal construction is radically different from anything now employed in the construction of paper condensers. These units are also of the single-section type, conservatively rated, and provide a protective device.—*Electronics, November, 1930.*

# PATENTS

## IN THE FIELD OF ELECTRONICS

A list of patents (up to Oct. 28) granted by the United States Patent Office, chosen by the editors of *Electronics* for their interest to workers in the fields of the radio, visio, audio and industrial applications of the vacuum tube

### Automatic Rectification, Control

Automatic control. One of the two converters is connected between a.c. circuits and the other is connected to one of the circuits so that in various positions of the rotors of the converter automatically reverse the direction of the second converter. J. C. Crea, assigned to G. E. Co. No. 1,775,175.

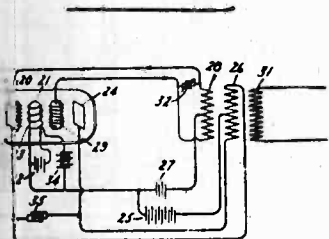

Harmonic generation. Two patents, Nos. 1,776,821 and 1,776,822, covering oscillating circuits with two grids and two other a triode. Irving Langmuir, assigned to G. E. Co. Filed Oct., 1927.

Rectifier circuit. In a full-wave rectifier, a solenoid is energized when it is delivering power, which is in series with the output. L. J. Buttolph, assigned to Vapor Lamp Co. Filed Dec., 1926. No. 1,778,416.

Rectifier. A selenium layer between electrodes, one a ferrous and the other of the tin group. J. C. Crea, assigned to Süddeutsche Kabel- und Drahtwerkzeugengesellschaft, Nuremberg, Germany. No. 1,778,645.

Regulator. In parallel with the winding of a generator is a vacuum tube with filament current supplied by the generator load. N. A. C. Crea and J. C. de Haas, assigned to Philips' Gloeilampenfabriek, Eindhoven, Netherlands. Filed Oct., 1927. No. 1,778,614.

Regulator. Full-wave rectifier with a unidirectional magnetomotive force of two coils for regulation of the supply. A. A. Oswald and E. J. Crea, assigned to W. E. Co. Filed Oct., 1927. No. 1,778,725.

Control of electrical variations. An apparatus with a resistance in the input circuit maintained at such a low temperature as to be independent of temperature changes. O. E. Buckner and B. Johnson, assigned to Bell Telephone Labs. No. 1,778,751.

Signalling. A high-frequency signal superimposed on a power distribution circuit with means for controlling the frequency. E. R. Evans, assigned to Westinghouse E. & M. Filed Oct., 1927. No. 1,778,827.

Harmonic generation. An arc converter tuned to a fundamental frequency with a coupled circuit tuned to a harmonic. H. O. Storm, assigned to Federal Telegraph Co. No. 1,779,198.

Oscillation generator. System employing conductive films exhibiting the Hall effect for generating electrical oscillations. P. H. Craig, Cincinnati, Ohio. No. 1,778,796.

Automatic volume control. Two patents, Nos. 1,776,821 and 1,776,822, utilizing a combination of neon tubes which break down in succession as the input voltage to the amplifier varies, thus controlling the gain of the amplifier. M. E. Strieby, assigned to A. T. & T.

### Sound Recording and Reproducing

Binaural sound recording and reproducing. Two differently-colored sound tracks are superimposed on a film, and separated by photo-cells sensitive to light of different wave lengths. See also patents Nos. 1,769,907 and 8, illustrated in *Electronics*, August, 1930. Lee de Forest, assigned to de Forest Phonofilm Corp. No. 1,777,037.

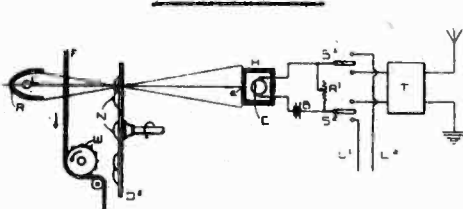

Motion picture transmission. Each elemental area of a moving film is magnified by the scanning disc. C. F. Jenkins, assigned to Jenkins Laboratories, Washington, D. C. No. 1,777,409.

Combined motion picture and sound camera. E. I. Sponable, assigned to Fox Case Corp. No. 1,777,682.

Sound recording. Apparatus for synchronizing simultaneous photography and recording of scene and sound. E. H. Foley, Astoria, L. I., 99 per cent assigned to Sound Films Corp., Tacoma, Wash. No. 1,776,969.

Sound reproduction. Two sets of film-controlled switches start and stop the turntable. H. W. Rogers, New York, N. Y. No. 1,777,418.

Sound picture photography. A plurality of cameras at different focal distances from the scene are driven in synchronism. Lee de Forest, assigned to General Talking Pictures Corp. Filed Nov., 1924. No. 1,777,828.

Song film synchronization. A method of determining the number of frames to carry song words in a song film so that the words will synchronize with the music of the song. W. J. Conkie, assigned to Alexander Industries, Inc., Englewood, Colo. No. 1,778,104.

Electro-static pick-up. W. D. Crozier, assigned to United Reproducers Patents Corp., St. Charles, Ill. No. 1,777,397.

Phonograph drive. A method for progressively reducing the speed of a phonograph turntable as the record is played. L. L. C. Jaffard, Paris, France. No. 1,777,973.

Acoustic device. Col n Kyle, San Jose, Calif., assigned to United Reproducers Patents Corp., St. Charles, Ill. No. 1,777,170.

Heterodyning horn. Conduit to which are attached two diaphragm assemblies whereby a superimposed vibratory effect is produced upon the air column within the conduit, not only by the two diaphragms, but also by the reaction of the sound waves against the conduit wall. Butler Ames, Lowell, Mass. No. 1,778,206.

Loud speaker. A conical sounding board is secured to a rigid conductor in the form of a loop. F. Cutting and I. G. Maloff, part assigned to United Reproducers Corp. No. 1,779,114.

### Radio Circuits and Apparatus

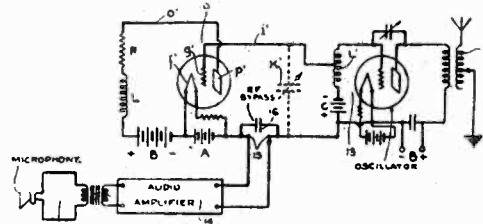

Demodulation. Demodulation system involving changes in condenser capacity. L. L. Jones, Oradell, N. J. No. 1,777,410.

Amplifying system. A series of vacuum tube push-pull stages, resistance-coupled, for distortionless amplification. Harry Nyquist, assigned to A. T. & T. Filed Nov., 1926. No. 1,778,085.

Amplifying system. Two-stage amplification system fed from a.c. mains. F. C. Barton, assigned to G. E. Co. Filed Nov. 1925. No. 1,778,058.

Receiving circuit. Detector and amplifier circuit using unipotential cathode tubes. Volume controlled by varying plate voltage. H. D. Currier, assigned to Kellogg Switchboard and Supply Co., Chicago. Filed Jan., 1926. No. 1,778,311.

Radio receiver. Tube filaments are connected in series, the d.c. voltage source being also used for plate supply. T. A. Willard, assigned to R.C.A. Filed Aug., 1922. No. 1,777,538.

Demodulation. System for demodulating radio signals by electrostatic means. G. W. Hale, London, England. Filed Oct., 1924. No. 1,777,433.

Wave antenna. A receiving circuit is connected to one end of the antenna, with an amplifier at the distant end. D. K. Martin, assigned to A. T. & T. Filed Nov., 1925. No. 1,777,374.

Demodulator. Heterodyne detector for telephone carrier circuits. E. Bruce, assigned to Bell Telephone Labs. Filed Dec., 1926. No. 1,778,750.

Negative impedance circuits. Three patents, all assigned to Bell Telephone Labs., No. 1,779,126 by F. H. Graham; No. 1,779,380 by H. W. Dudley; and No. 1,779,382 by R. C. Mathes; covering negative impedance circuits in telephone networks.

# PATENTS—

**Amplifying system.** Two triodes, two batteries, and a variable resistance form the elements of a bridge circuit. Andre Rio and Lucien Levy, Paris, France. No. 1,779,292.

**Modulation.** Circuit for the modulation of static frequency changer current utilizing saturated core. M. Osnos, assigned to Gesellschaft für Drahtlose Telegraphie, m.b.H., Berlin, Germany. Filed Dec., 1925. No. 1,778,724.

**Remote control.** Remote tuning control for radio receivers. R. A. Heising, assigned to W. E. Co. Filed March, 1924. No. 1,778,761.

**Radio relaying system.** A method of transforming a singly modulated carrier wave into a doubly modulated carrier wave of a lower frequency. E. E. Clement, assigned to E. F. Colladay, Washington, D. C. Filed Aug., 1925. No. 1,777,690.

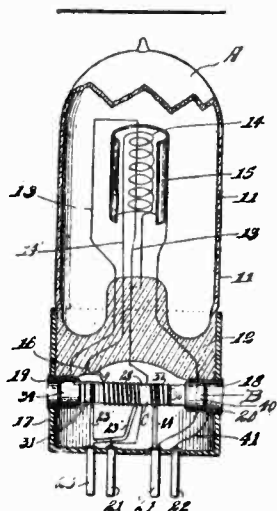

**Vacuum tube.** A three-element vacuum tube with means within the base for obtaining regeneration. E. G. Murphy, Chicago, Ill. No. 1,777,011.

**Amplifying system.** Automatic tuning, in which the frequency range is divided into portions and the circuit constants of the amplifying stages adjusted for automatic tuning in the different portions. L. L. Jones, Oradell, N. J. No. 1,779,881.

**Amplifying system.** An additional stage of amplification may be switched into the circuit between the initial stage and the output stage. H. I. Danziger, New York, N. Y., and L. L. Jones, Oradell, N. J. Filed August, 1924. No. 1,779,931.

## Television and Facsimile

**Television receiver.** Synchronization of the receiving disc by means of a stationary electromagnet and armatures revolving on the disc. R. D. Kell, assigned to G. E. Co. No. 1,778,674.

**Facsimile transmission.** The wave is phase-modulated in accordance with the tone values of the image scanned. R. K. Potter, assigned to A. T. & T. Co. No. 1,777,016.

**Television receiver.** A magnifying mirror reflects the picture from a slightly inclined scanning disc. C. D. Fahrney, Cambridge, Mass. No. 1,777,556.

**Colored facsimile system.** A method for reproducing transmitted pictures in color. F. G. Morehouse, assigned to R.C.A. No. 1,779,261.

**Television system.** Three patents covering the method and apparatus for high speed television utilizing a wire screen, the wires forming electrodes which cause glow discharges at predetermined points on the screen. A. M. Nicolson, New York, N. Y., assigned to Communication Patents, Inc. Filed Sept., 1927. Nos. 1,779,747 to 1,779,749.

**Scanning disc.** A. O. Tate, Toronto, Ontario, Canada. No. 1,779,518.

## Electron Tubes, Manufacture, Etc.

**Photo-electric cell.** The light-sensitive cathode has a high ohmic resistance, so that a moving light beam varies the voltage drop in the circuit. R. K. Potter, assigned to A. T. & T. Co. Filed Sept., 1926. No. 1,777,378.

**Vapor lamp.** Supplying a vapor lamp containing two anodes and two cathodes with d.c. voltage by means of a pair of diode rectifiers. L. J. Buttolph, assigned to G. E. Vapor Lamp Co. Filed Jan., 1927. No. 1,778,417.

**Oxide cathode.** An electron-emitting filament, comprising a metal wire helically wound on a core of refractory metal. J. Bruijnes, J. Vander Hoeven, and E. Oosterhuis, assigned to N. V. Philips' Gloeilampen-Fabrieken, Eindhoven, Netherlands. Filed Feb., 1927. No. 1,777,253.

**Tube evacuation.** A device for protecting the exhausting socket of vacuum tubes containing mercury. Erich Schott, Jena, Germany, assigned to Jenaer Glaswerk Schott & Gen., Jena, Germany. No. 1,777,861.

**Gaseous fluid switch.** Reception of radiant energy causes gas to expand and force a liquid conductor within the sealed tube to make or break contacts. I. E. McCabe, Chicago, Ill. Filed Apr., 1926. No. 1,777,887.

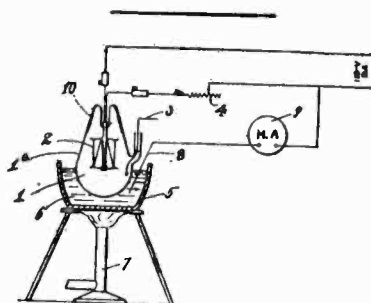

**Photo-cell manufacture.** The glass bulb is immersed in a molten alkali salt, and an electrical field set up between the salt and the bulb filament, whereby the alkali metal migrates through the glass, to serve as a cathode. R. C. Burt, assigned to California Institute of Technology. No. 1,776,993.

**Vacuum tube.** A triode in which the filament is held under tension. H. J. Nolte and W. I. Relyea, assigned to G. E. Co. Filed March, 1927. No. 1,780,033.

**Thermionic tube.** Several control grids, a space charge grid, and a cylindrical anode arranged concentrically. Siegmund Loewe, Berlin, Germany, assigned to R.C.A. Filed July, 1926. No. 1,779,550.

**Direct-reading photometer.** A portable instrument consisting of a light sensitive cell and a meter, mounted integrally. Samuel Wein, assigned to Radiovision Corp., New York. No. 1,779,574.

## Miscellaneous Applications

**Radiation meters.** Patents covering two methods of measuring the radiations by transforming the visible radiations and comparing with standard light. T. E. Foulke, assigned to G. E. Vapor Lamp Co. Filed Oct., 1926. Nos. 1,777,999 and 1,778,000.

**Telegraph repeater.** The input triode is made through an impedance high relative to the cathode-grid impedance of the tube, so as to attenuate all portions of the waves between the amplitude capable of saturating the tube and a predetermined lesser amplitude. E. T. Burton, assigned to Bell Telephone Labs. No. 1,778,377.

**Noise suppression device.** A wave filter for selectively suppressing the interfering speech currents in a phone line. W. P. Mason, assigned to Bell Telephone Labs. No. 1,778,000.

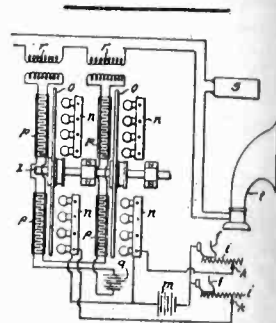

**Electric musical instrument.** Contacts controlled by keys vary the intensity of glow lamps, and photo-cells transmit the variations to a reproducer. Emerich Spielmann, Vienna, Austria. No. 1,778,374.

**Transmission-level control.** A device for maintaining constant the transmission equivalent of a line using a variable frequency carrier. C. H. Fette, assigned to A. T. & T. Filed Sept., 1926. No. 1,777,355.

**Vacuum measurement.** Gas pressure in the evacuation of incandescent lamps are measured by a bridge circuit containing resistance tubes, one a standard and the other connected to lamps being evacuated. J. S. Peoples, Oak Park, Ill. assigned to W. E. Co. Filed Oct., 1925. No. 1,778,508.

**Electrical measuring instrument.** A wattmeter with slotted squirrel-cage armature. P. H. Craig, Cincinnati, Ohio. No. 1,778,795.

**Measurement of hearing acuity.** Apparatus containing a mechanical vibrator and a vacuum-tube amplifier which may be switched to give a rectifying or an amplifying action for measurements of the acuteness of hearing. Helmut Sell, assigned to Siemens & Halske, Aktiengesellschaft, Siegen, Germany. No. 1,778,985.

**Photometric apparatus.** A device mounted to rotate about a light source which directs the light into a photo-electric cell during its complete movement. Long, Jr., assigned to G. E. Co. Filed Aug., 1926. No. 1,779,324.

**Liquid temperature regulator.** The resistance of an element immersed in a liquid varies with the temperature of the liquid, causing a galvanometer in a bridged circuit to deflect. Rays of light are reflected from the galvanometer mirror, striking one of two photo-cells, varying the heat supplied to the liquid. H. Essex, O. Gelormini, and Masterson, Syracuse, N. Y. No. 1,776,901.

# Simplified harmonic analyzer

[Continued from page 375]

reading is obtained on the output meter corresponding to about 3.2 millivolts on the first amplifier. It should be noted that the potential which is now applied to the tuned circuit is derived from  $R_5$ , but 1 ohm. Thus the tuned circuit receives but a fraction of the voltage across the filter input.

Harmonics may now be investigated. The tuned circuit is first set to 800 cycles. In this process contact B is closed automatically and contact A closed, thereby dropping the full drop (minus filter losses) across 100 ohms instead of that across 1 ohm only. If then we obtain the same reading of 100 microamperes it is evident that the harmonic (800 cycles) has 1 per cent the amplitude of the fundamental. If the meter reads more than 100 microamperes the calibrated slider  $R_7R_8$  is turned until the standard 100 microampere reading is

obtained. Unequal passage of different frequencies through the system is compensated with  $R_{11}$ . This adjustment is permanently calibrated by means of an audio oscillator and is thereafter adjusted as a routine part of the process of tuning to 400 cycles, 800 cycles, etc.

Coupling between the filter and the tuned circuit was avoided by very careful shielding and placement of parts. Further shielding was added to prevent feedback from the voltmeter tube to the amplifier input. If this is not done the higher harmonics will regenerate and produce exaggerated readings.

An obvious precaution is to check the purity of the wave form of the source before it has passed through the radio receiver or amplifier which is being investigated. In such cases as that of Fig. 1A the procedure is obvious. In the case of Fig. 1B the test signal must first be demodulated by a linear detector.

The sort of work that can be done with such a harmonic analyzer may be seen from the accompanying illustrations. Many problems relating to the production

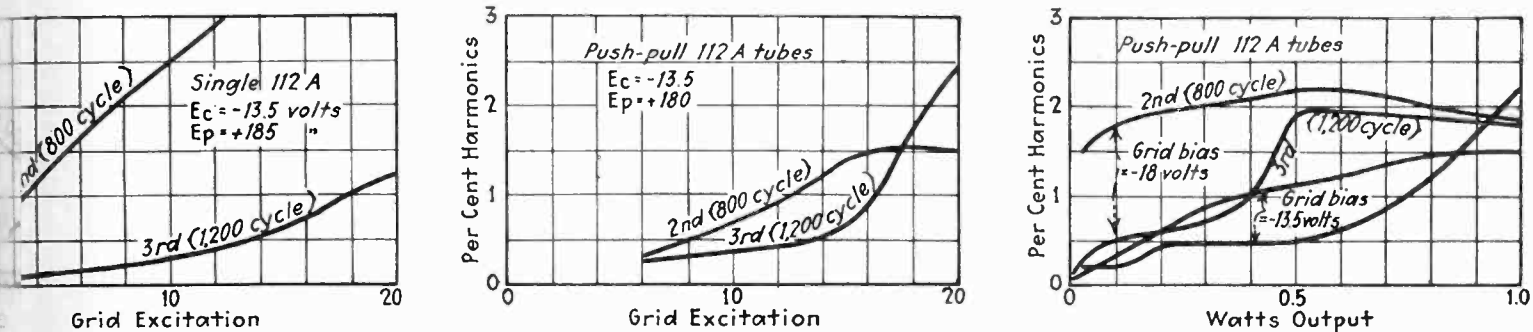

Fig. 4—Typical distortion analysis curves as made with the simplified harmonic analyzer

If the slider must be turned down half-way to 2 per cent of the harmonic, and so on. The scale, however, is an inconvenient one because percentages above 5 become very crowded. For this reason a switch provides an additional position which allows one to make a fresh start at 5 per cent of the fundamental, thus multiplying the readings by five.

of distortion in audio or modulated radio systems may be solved by having handy a fairly simple mechanism for determining the harmonics in the output of the device or system suspected of distortion.

The range of the device as described is from 400 cycles to 2,800 cycles with any fundamental input from 160 millivolts to 50 volts. Harmonics in the range of 1.0 per cent to 50 per cent may be measured.

# "tricks" in picture production

[Continued from page 373]

Action takes place in the passenger car, which does not have its own power but is drawn by a camera truck provided with a sufficiently powerful motor to carry the additional load. In the rear of the passenger car are three girls and in the front seat two male cameramen, one of whom pretends to be driving. The camera truck in the front carries two cameras shooting back to the passenger car where the action takes place. Besides the camera men, this truck carries the script girl sitting underneath the cameras and a camera operator in a position where they can hear the dialogue. The camera truck also tows, by means of the arrangement shown in the figure, a camera dolly which is in this case merely a platform on air-wheels, carrying two cameras which photograph the action in the passenger car from the side. This dolly in turn tows a microphone dolly carrying a microphone which is manipulated by a sound man riding on the dolly. The microphone is kept above the upper border of the camera field.

The grotesque procession moves around a large outdoor set representing a Parisian square. French taxi-

cabs, U. S. Army trucks and other vehicles (the time is 1918) move with it, supplying appropriate traffic noises, against a background of French restaurants, statues, public buildings, and walls plastered with war posters. With the caravan, behind the cameras, there moves a collection of assistant directors, sound supervisors, and "grips." The "grips" have the job of handling the various cables running to the camera motors and microphone so that they will not get into the picture nor into the way of the moving cars.

The task of the sound man in charge of the microphone boom, it may be imagined, is not easy. As the various cars move around the circle his unit swings through a curve which cannot be accurately forefold, but it is his business to keep the microphone at each instant over the head of the character that happens to be talking, and not to allow any erratic variations in the sound pick-up. At times it is necessary for the grips walking beside the microphone dolly to prevent it from tipping over as the sound man attempts to keep his microphone where it ought to be. Usually a shot like this must be gone through six or eight times in order to secure two good takes. It is well worth while if, after all the processing and cutting and editing, something mechanical, synthetic and artificial is transmuted into the vital elements of comedy or drama.