

Microprocessors: ICs with clout. They herald a new generation of improved logic designs. But to use these 'computers on a chip,' designers must think software as

well as hardware. And products come in many forms, running the gamut from chips to boards to minis. What other hurdles are there? See Focus on page 52.

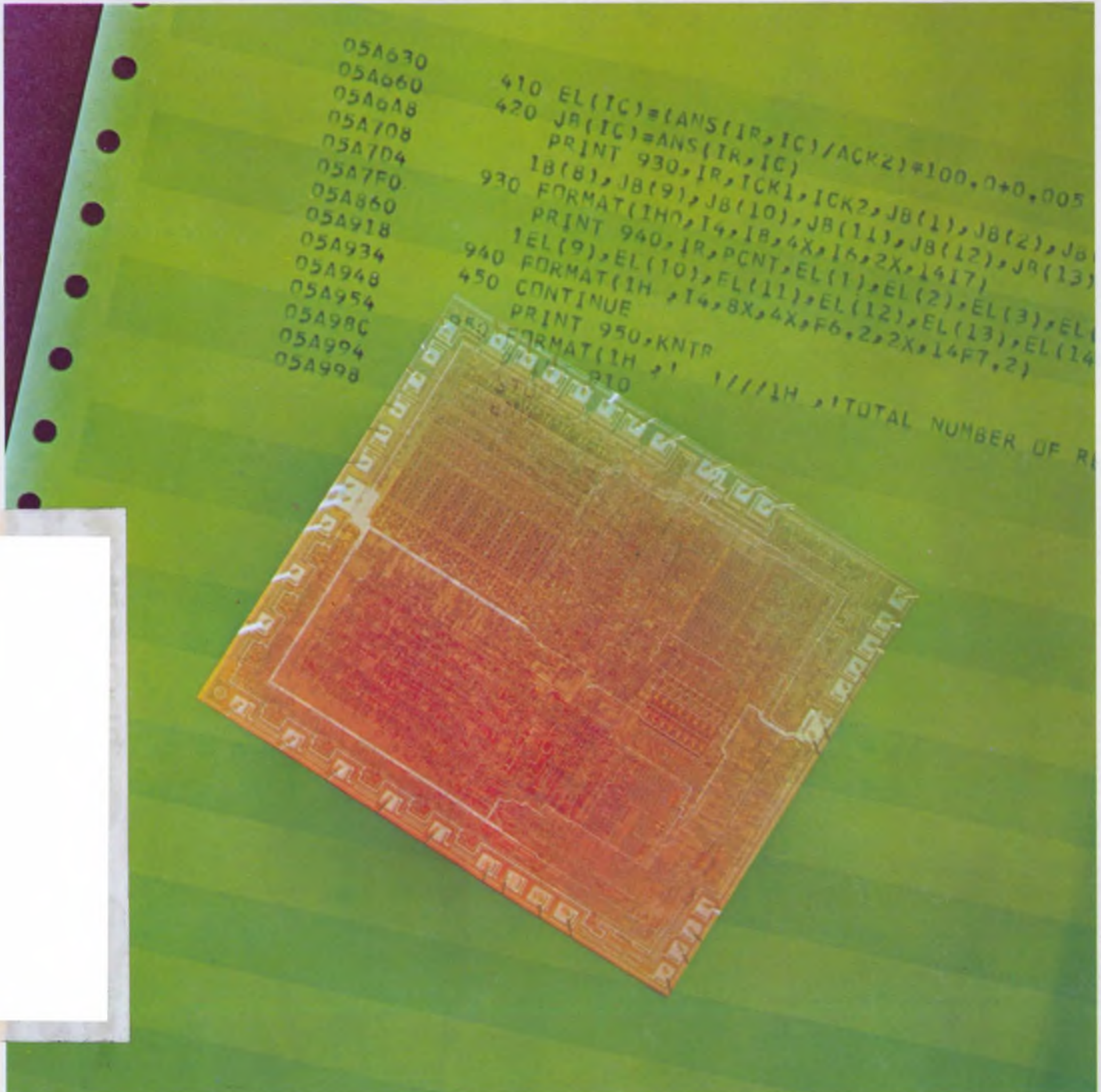



Ultra reliability in
ultra-miniature
transformers...

...and they're off the shelf!

PICO Electronics' patented construction combines mass production with the utmost in reliability to produce the smallest possible transformer.

These little giants handle up to 600 milliwatts at 1 KHz and 1.5 watts at 10KHz. They cover the frequency range of 300Hz to 250KHz. Primary or Secondary impedances of 3.2 ohms to 250K ohms. Pulse applications .05 μ s to

100 μ s. Construction can be TO-5 plug-in, insulated flexible leads or flat pack ribbon style.

Size variations from 1/4" dia. x 1/4" ht. to 1 1/2" dia. x 1/2" ht. Special designs with 1/4" dia. and .180" ht.

Pico Electronics is a Q.P.L. source. All transformers are hermetically sealed in a metal case and in strict compliance with MILT-27 specifications. Every Pico device has the added reliability feature of being

guaranteed for 25 cycles of thermal shock (MIL-STD-202D, method 107C).

Industrial and Commercial designs are also available for maximum economy.

Over 600 standard transformers to choose from... Delivery—stock to one week... specials take a little longer—9 days.

Send for free 36 page catalog.

PICO Electronics, Inc.

50 South MacQuesten Pkwy., Mt. Vernon, New York 10551 • Telephone 914-699-5514

THE FIRST OF THE BIG COUNT TIMERS

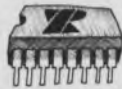
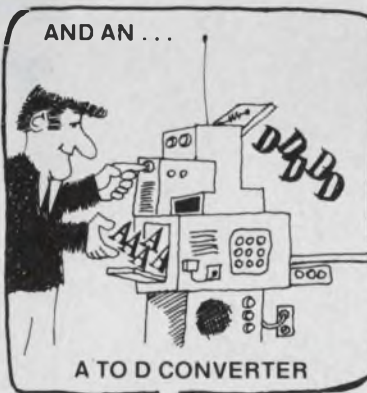
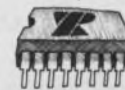
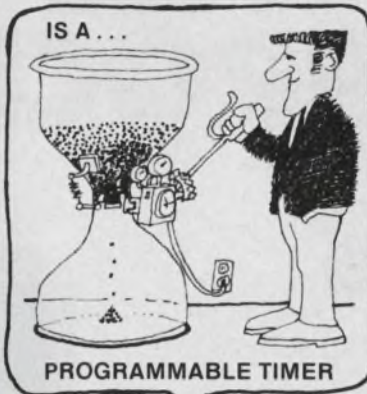
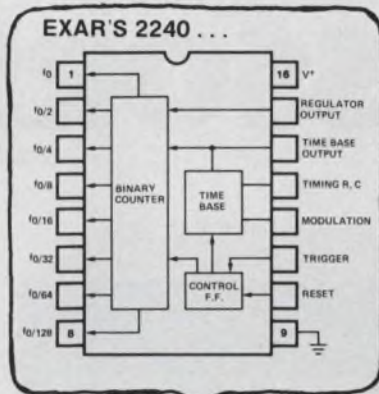

Exar's new XR-2240 counter/programmable timer solves so many tough problems that designers will unanimously agree that it's really the universal timer.

With its unique combination of analog and digital timing methods, you can now replace inadequate and complex assemblages of monolithic and electromechanical timers with the much simpler XR-2240. As a bonus, you get greater flexibility, precision operation, and a reduction in components and costs for most applications.

Because of built-in programmability, you can also use the XR-2240 for frequency synthesis, electronic music synthesis, digital sample and hold, A to D conversion, binary counting and pattern generation, and more.

With a single XR-2240 you can now generate

precision time delays programmable from 1RC to 255RC, a range of microseconds to 5 days. By cascading only two XR-2240 timers, you can extend the maximum delay by a factor of 2^N , where $N = 16$ bits, resulting in a total delay of 3 years!

The XR-2240 operates over a 4V to 15V supply range with an accuracy of 0.5% and an 80 ppm/°C temperature stability. It's available in either a 16-pin ceramic or plastic dual-in-line package for military or commercial applications. Prices start at \$4.50 in 100 piece quantities.

For the more conventional timing applications, look to our other timers: the XR-320 timing circuit and the XR-2556 dual timers. Call or write Exar, the timer leader, for complete information.

EXAR SPEAKS YOUR LANGUAGE

R-OHM CORPORATION
EXAR INTEGRATED SYSTEMS
P.O. BOX 4455, IRVINE CA 92664
TELEPHONE: (714) 546-8780
TWX: 910-595-1721

Rohm
QUALITY RELIABILITY

R-OHM ELECTRONICS GMBH
EXAR INTEGRATED SYSTEMS
MÜHLENSTRASSE 70
4051 KORSCHENBROICH
FEDERAL REPUBLIC OF WEST GERMANY

Members of the International R-OHM Group

INFORMATION RETRIEVAL NUMBER 2

THE MICROPROCESSORS

THE CHIPS

Microprocessors for do-it-yourselfers. On distributors' shelves now.

Two building blocks that can be assembled to form computer systems from 4-bits to 32-bits.

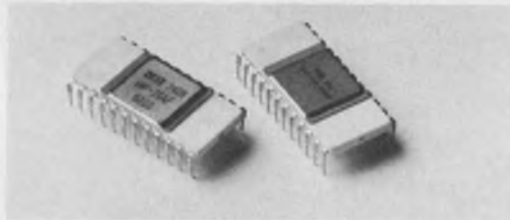

Chip #1, the one that does the work, is a Register and Arithmetic Logic Unit (RALU). And chip #2, the one that tells the RALUs what to do, is a Control and Read-Only Memory (CROM).

THE CARDS

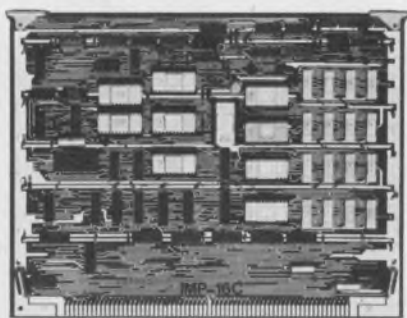

For people who want to save time, we offer our "ready-mades."

Complete, proven, fully-debugged 8 and 16-bit microprocessors on 8½ by 11 inch cards ready for your application program.



THE BOXES

The advantage of the whole microprocessor thing lies in the fact that it is standard hardware designed and built for you to *program* to your specific application.

Our boxes help you do that.

They're program debugging and prototyping systems, providing everything the engineer needs to develop and test both the interfaces and application programs.

Each box includes microprocessor card, programmers control panel and peripheral interface, memory, power supply and chassis.

National supplies it all.

Chips, cards, systems.

And we support our hardware with a wide array of software, firmware, and accessories that help make the whole thing easier to apply.

For further information write National Semiconductor Corporation, 2900 Semiconductor Drive, Santa Clara, California 95051. Attn.: Microprocessor Marketing.

NATIONAL

INFORMATION RETRIEVAL NUMBER 3

NEWS

- 19 **News Scope**
- 24 **A decade later, the bright promise predicted for undersea electronics** is becoming a reality.
- 38 **Laminar-flow gun cathode-ray tube** reported to have more brightness and improved resolution than standard CRT.
- 43 **Washington Report**

TECHNOLOGY

- 52 **FOCUS on microprocessors:** A report on the revolutionary ICs that promise to reshape logic systems. The story covers the microcomputer gamut from single chips to packaged systems.
- 72 **Give flexibility to memory systems** with an asynchronous design. You can use any type of memory chip, including the newer 4-k dynamic RAMs.
- 78 **Piezoelectric ceramic transducers:** Learn to use these energy transformers as a connecting link between mechanical equipment and electronic circuits.
- 86 **Shape foil into a magnetic shield** with scissors. Permeability, thickness and the layers needed are determined by simple formulas and measurements.
- 92 **When you have no choice but changeover,** good planning, the right technical talent and cooperation between hardware and software people can ensure success.
- 98 **Ideas for Design:** Accurate 10-MHz reference obtained from counter's 1-MHz internal standard . . . Programmable frequency multiplier uses octave scaler to simplify programming . . . Full and half-step motor operation obtained with 3-1/2-chip stepper circuit.
- 106 **International Technology**

PRODUCTS

- 109 **Integrated Circuits:** Bipolar/LSI processor races to the forefront.
- 110 **Integrated Circuits:** Redesigned 1-k NMOS RAM eliminates drive circuits.
- 114 **Integrated Circuits:** FET voltage comparators shrink input currents to pA.
- 123 **Power Sources:** Dc/dc converter needs less than 1/3 cubic in.
- 116 **Components**
- 130 **Modules & Subassemblies**
- 136 **Data Processing**
- 140 **Instrumentation**
- 141 **Discrete Semiconductors**

Departments

- 47 **Editorial:** The front-runner
- 7 **Across the Desk**
- 150 **Advertisers' Index**
- 152 **Product Index**
- 154 **Information Retrieval Card**

Cover: Photo by Harry Meier, courtesy of Intel, Santa Clara, Calif. The manufacturer's Model 8080 microprocessor chip appears against a background listing in Fortran. Though compilers accepting Fortran are not yet available for processor chips, the listing symbolizes some of the rapid advances that have marked the microprocessor field.

Anyway you 2105 is a better hi

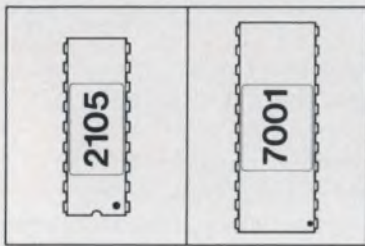

OURS

THEIRS

Before you spend much too much time and money building high performance memories, take a look at Intel's 2105 family of silicon gate n-channel 1K RAMs. The new invisible refresh 2105-2, for example,

can cut the cost of very fast memory systems by 25% to 50%.

From any system viewpoint, the 2105-2 is better than a metal gate quasi-static RAM. It approaches bipolar speed at the system level, offers the basic economies of Intel's 2105 design, is easier to refresh, drive and sense, eliminates the complications of hefty charge pumps and blow-out-prone inputs, and does a read modify write in one cycle.

The 2105-2 has a simple, invisible, planar refresh that doesn't increase the guaranteed maximum access time of 95 ns or the cycle time of 230 ns. Just apply a 100 KHz to 1 MHz digital signal to the system's planar refresh lines.

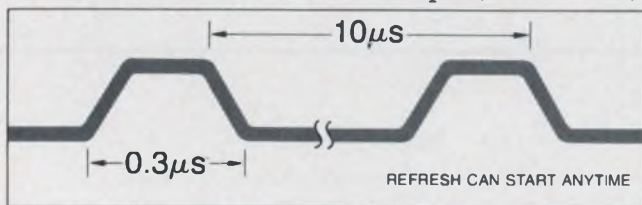

100 KHz TO 1 MHz INVISIBLE REFRESH SIGNAL

You can generate the signal with a one-shot and drive all the refresh pins on a board with one driver.

With this technique, system access can be less than 135 ns under worst case



look at it, the gh speed RAM.

conditions. Just take advantage of the extremely low capacitance (65 pF) low input level (4.0V) and high output current (1.2 mA) to minimize on-board delays. (For

even faster speed, use the 2105-1 in a dynamic mode.)

Quadrilevel supplies aren't needed either. A typical 4096 x 9-bit module with ECL interface operates on less than 5 watts from standard +5V, -5V, and +12V system supplies. Furthermore, you don't need special sense circuits since the output - 1.2 mA at ground reference - is easily biased for TTL or ECL sensing.

You save 30% to 40% on board area by using an 18-pin instead of a 22-pin package, and you save time and money by using standard supplies, 80% less drive and fewer support parts. Also, our smaller chip ensures volume availability and favorable pricing now and in the future. We even have economical interface circuits containing four

address drivers and one clock driver per package (3210 for TTL inputs, 3211 for ECL.)

The RAMs and support circuits are available now, at Intel distributors or in OEM quantities from the factory that produces most of the world's n-channel parts. So write or call for a new 2105 application note. It will show you how to build very fast memories at low cost.

Intel Corporation, 3065 Bowers Avenue, Santa Clara, California 95051.
(408) 246-7501.

intel® delivers.

2105 RAM FAMILY			
RAM	ACCESS TIME	CYCLE TIME	REFRESH MODE
2105	95 ns MAX	200 ns MIN	SYNCHRONOUS
2105-1	80 ns MAX	180 ns MIN	SYNCHRONOUS
2105-2	95 ns MAX	230 ns MIN	ASYNCHRONOUS

THINGS TO COMPARE	OUR 2105	THEIR 7001
VERY FAST ACCESS	✓	✓
QUASI-STATIC OPERATION	✓	✓
FEW SUPPORT CIRCUITS	✓	
LOW DRIVER LOADS	✓	
EASILY SENSED OUTPUTS	✓	
STANDARD SUPPLY LEVELS	✓	
ALL INPUTS PROTECTED	✓	
SMALLER CHIP SIZE	✓	
STANDARD 18-PIN PACKAGE	✓	
READ MODIFY WRITE CYCLE	✓	
REFRESH TESTED AT 70°C	✓	

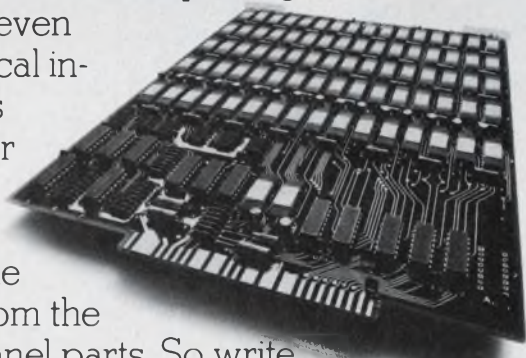

CABLE-BILITY WOVEN'S FLAT GOT IT!



Ribbon Cable IC Interconnects Custom Harnesses

A total source for flat interconnect systems, Woven Electronics offers unlimited design capabilities combining signal/power transmission with specialized functions. Independently insulated conductors give tighter transmission control, more protection, allow easy lead exposure.

Specify sizes, color coding, insulations, custom break-outs without restrictions of other cable forms.

Cable and ability. Get the best of both from one source.

WOVEN ELECTRONICS

P.O. Box 189 Mauldin, South Carolina 29622
803/963-5131

Vice President, Publisher
Peter Coley

Editors

Editorial Offices
50 Essex St.
Rochelle Park, N.J. 07662
(201) 843-0550
TWX: 710-990 5071
Cable: Haydenpubs Rochellepark

Editor-in-Chief George Rostky

Managing Editors:

Ralph Dobriner
Michael Elphick

Associate Editors:

Dave Bursky
Jules H. Gilder
Morris Grossman
Seymour T. Levine
John F. Mason
Stanley Runyon
Edward A. Torrero
Richard L. Turmail

Contributing Editors:

Peter N. Budzilovich
Alberto Socolovsky
Robert Wollins

Editorial Field Offices

East

Jim McDermott, Eastern Editor
P.O. Box 272
Easthampton, Mass. 01027
(413) 527-3632

West

David N. Kaye, Senior Western Editor
2930 West Imperial Highway
Inglewood, Calif. 90303
(213) 757-0183
Northe K. Osbrink, Western Editor
112 Coloma St.
Santa Cruz, Calif. 95060
(408) 426-3211

Editorial Production

Marjorie A. Duffy

Art

Art Director, William Kelly
Richard Luce
Anthony J. Fischetto

Production

Manager, Dollie S. Vieblg
Helen De Polo
Anne Molfetas
Christopher G. Hill

Circulation

Manager, Evan Phourides

Information Retrieval

Peggy Long

Promotion

Manager, Walter G. Salm
Karen Kerrigan (Reprints)

across the desk

Here are correct specs for LR171E IC timer

The table in the article "Which IC Timer to Buy?" (ED No. 3, Feb. 1, 1974, p. 62) contains some errors. The supply voltage for the LR171E, made by Electrical Remote Control, is stated as a +6 to 45 V, whereas the supply can be +6 to 450 V. Also figures are given for variation in timing to changes in the supply voltages for the IC timers, and the LR171E is "not specified." Yet the LR171E contains a 5-V shunt regulator and a 2.5-V regulator for the timing circuit. (The table does indicate that the LM122 is internally regulated.) The figure in the LR171E data sheet for timing accuracy to supply is given as timing to supply current; this is given as 0.1%/mA.

The accuracy of the XR2240 is stated as being 0.5% typical for a given RC. This figure is not specified for the LR171E because it has a calibration pin. A suitable trimming resistor can be used here to adjust the timing accuracy to any desired limit.

The LR171E has five TTL-compatible outputs, two of which are complementary. These two outputs can source or sink 20 mA, so they can drive loads without the need to interface. This seems to be a unique feature among the counter timers. Neither the XR2240 nor the Mostek MK5009 can source output current; the LR171E is the only counter timer at present that can. The two complementary outputs on the LR171E can be made to oscillate at a frequency independent of the timing oscillator and can be used to drive triacs and SCRs directly again; this is unique among IC timers.

I think that the only characteristic of the XR2240 that is unique is its high temperature stability compared with the MK5009 and

LR171E. The LR171E seems to be more versatile than the XR2240.

J. K. Chuchla

Electrical Remote Control Co., Ltd.
P.O. Box No. 10, Bush Fair,
Harlow, Essex, CM18 6LZ
England

Article on multipliers is rated impressive

I've just read the article "Get High Voltage With Low-Cost Multipliers," (ED No. 13, June 21, 1974, p. 64), and I'm impressed with the encapsulating information given on p. 68. This type of material discussion should really help the project engineer, who is deeply concerned with actual circuit performance, not just circuit diagrams. As the author of this article recognizes, circuit performance must consider the interaction of the circuit with its on-the-job environment and with the insulating and packaging materials that protect it from that environment.

*Philip K. Blumer, Supervisor
Marketing Communications*

Dow Corning Corp.
Midland, Mich. 48640

With piezo-crystals, the pressure counts

Regarding my article "Flints That Don't Wear Out" (ED No. 13, June 21, 1974, p. 88), I fear that the statement "It may then take as long as a minute or more to attain full voltage" may be misconstrued. Piezo materials are displacement-responsive rather than velocity-sensitive. Thus, in the subject application, the output voltage is directly dependent upon only the applied pressure.

Theoretically it doesn't matter how long it takes to get to the level

(continued on pg. 16)

Thin-Trim[®] capacitors



Tucked in the corner of this Pulsar Watch is a miniature capacitor which is used to trim the crystal. This Thin-Trim capacitor is one of our 9410 series, has an adjustment range of 7 to 45 pf., and is .200" x .200" x .050" thick. The Thin-Trim concept provides a variable device to replace fixed tuning techniques and cut-and-try methods of adjustment. Thin-Trim capacitors are available in a variety of lead configurations making them very easy to mount.

A smaller version of the 9410 is the 9402 series with a maximum capacitance value of 25 pf. These are perfect for applications in sub-miniature circuits such as ladies electronic wrist watches and phased array MIC's.

Johanson Manufacturing Corporation,
Rockaway Valley Road., Boonton, N.J.
07005. Phone (201) 334-2676, TWX 710-
987-8367.

Johanson

MANUFACTURING CORPORATION

Electronic Design welcomes the opinions of its readers on the issues raised in the magazine's editorial columns. Address letters to Managing Editor, Electronic Design, 50 Essex St. Rochelle Park, N.J. 07662. Try to keep letters under 200 words. Letters must be signed. Names will be withheld on request.

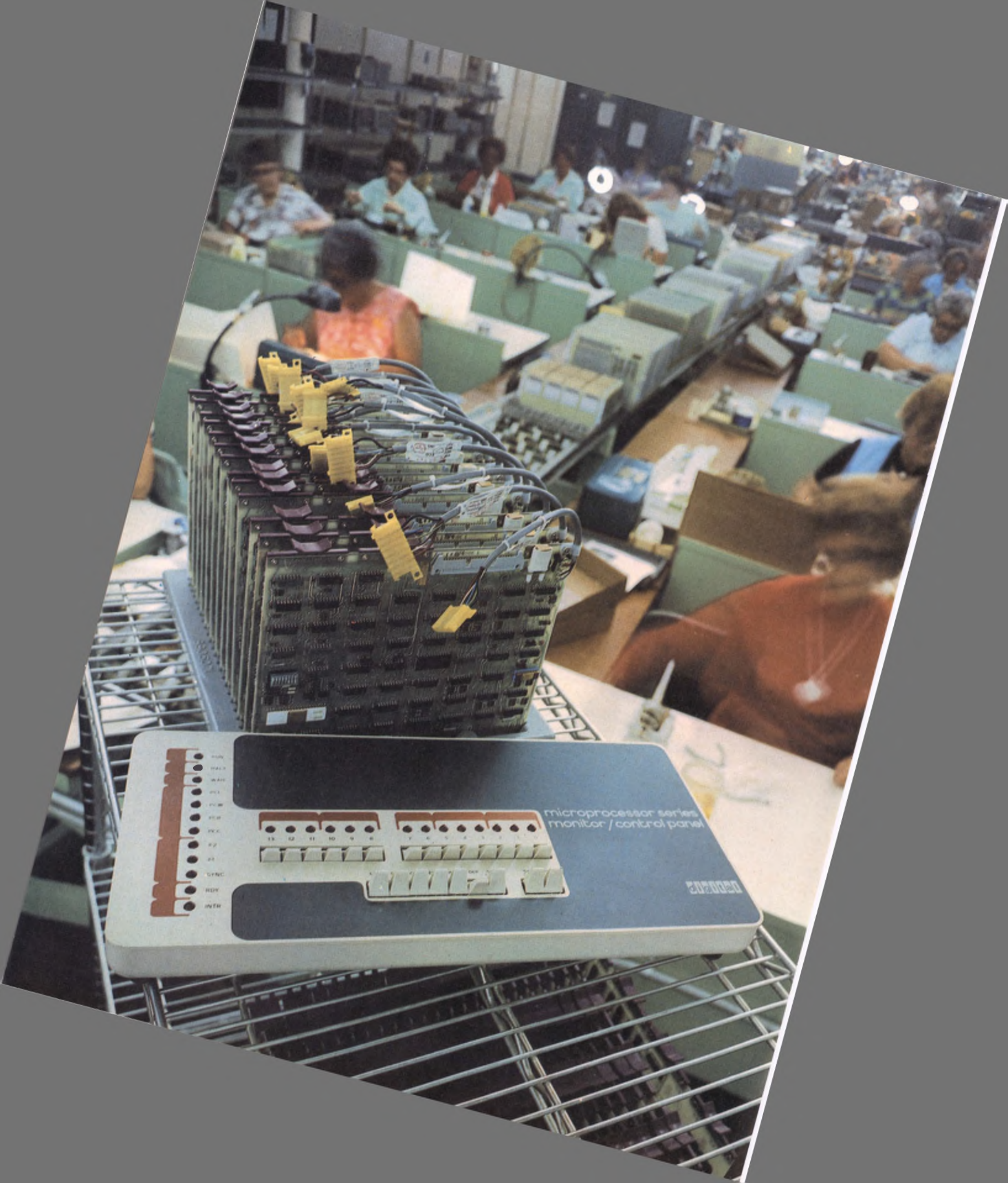

microprocessor series
monitor / control panel

EXPAND

DATA
HALL
WALK
PC1
PC2
PC3
PC4
PC5
PC6
PC7
PC8
PC9
PC10
PC11
PC12
PC13
PC14
PC15
PC16
PC17
PC18
PC19
PC20
PC21
PC22
PC23
PC24
PC25
PC26
PC27
PC28
PC29
PC30
PC31
PC32
PC33
PC34
PC35
PC36
PC37
PC38
PC39
PC40
PC41
PC42
PC43
PC44
PC45
PC46
PC47
PC48
PC49
PC50
PC51
PC52
PC53
PC54
PC55
PC56
PC57
PC58
PC59
PC60
PC61
PC62
PC63
PC64
PC65
PC66
PC67
PC68
PC69
PC70
PC71
PC72
PC73
PC74
PC75
PC76
PC77
PC78
PC79
PC80
PC81
PC82
PC83
PC84
PC85
PC86
PC87
PC88
PC89
PC90
PC91
PC92
PC93
PC94
PC95
PC96
PC97
PC98
PC99
PC100

The MPS microprocessor series: get it now and get it going. In volume from the Components Group.

The MPS microprocessor series of modules is available now. We designed it using only standardly available components with a proven track record. So we can make it and we can make it work.

Plus, the MPS is easy to get up and going. Its external circuitry is TTL-compatible, which means you can interface to your computer or controller using Digital's broad line of standard logic modules.



Software development is easier, too. Control programs are prepared on a small, low-cost PDP-8 minicomputer, using the MPS software development kit of six basic programs. And the modular construction of the MPS allows you to buy only what you need for your application.

Physically, the MPS is a series of four building-block modules and an optional control panel. A basic, fully-operational processor can be assembled from as few as two modules: the CPU and a memory module.

The CPU is an 8-bit parallel processor, employing reliable P-channel MOS/LSI technology. It will directly address up to 16K words of memory; cycle time is 12.5 μ sec. Reprogrammable memory (PROM) is available in 256-word increments. Read-write memory (RAM) is available in

1K-word increments.

An external-event-detection module implements nine levels of priority-arbitration. These include application-defined six-level priority interrupt schemes, AC and DC power-failure detection capacity, and the processor-controlled functions of Halt and Restart.

Volume buying will get you a very attractive discount. The MPS is priced at \$476 for CPU and 1K of RAM, in quantities of a hundred.

So pick up the phone and dial 800-225-9480. Toll-free from 8:30 AM to 5:00 PM your time. (US only. Massachusetts residents, please dial (617) 481-7400, extension 6656.)

We're the Components Group of Digital Equipment Corporation, One Iron Way, Marlborough, Massachusetts 01752.

In Canada: Digital Equipment of Canada Limited, P.O. Box 11500, Ottawa, Ontario, K2H8K8. (613) 592-5111, extension 154.

digital
COMPONENTS
GROUP

**Unbundling the world's
most popular minicomputers.**

Intersil P/ROMs with AIM* technology.

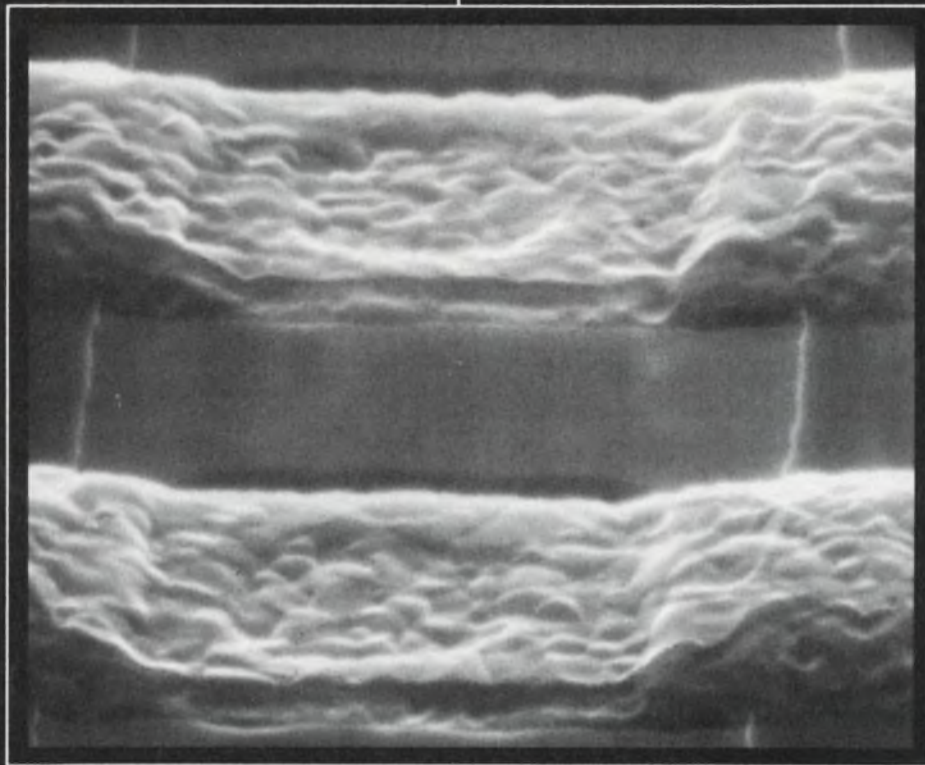

* AIM is Intersil's Avalanche-Induced Migration process. U.S. patent no. 3,742,592

AIM programming takes place entirely beneath the surface of the P/ROM. Compare the fully programmed diode junction (top) with an unprogrammed junction (bottom) in this unretouched 5000X photomicrograph of an Intersil IM5603A 1024-bit P/ROM. Note that there is no metal rupture or change of any kind in the appearance of the surface of the metal. Bit programming has taken place well below the surface, protected from any effect of environmental degradation.

100%
reliable
and faster to
program.

**Intersil
means
memory**

Programability

Intersil's Avalanche-Induced Migration technology gives superior reliability, faster programing and a better programing yield than fusible-link methods. AIM has been in use almost 4 years. It has created more than 1 billion memory bits without a single bit failure. And it lets you fully program a 2048-bit P/ROM in less than one second.

Technology

We apply a constant-current programing pulse to two back-to-back diodes. The reverse diode avalanches and shorts, leaving a single forward-biased diode. We then apply a sense pulse and determine the ohmic quality of the programed short; if it's not within specifications we immediately program it again until it is. Our pulse-sense programing sequence allows

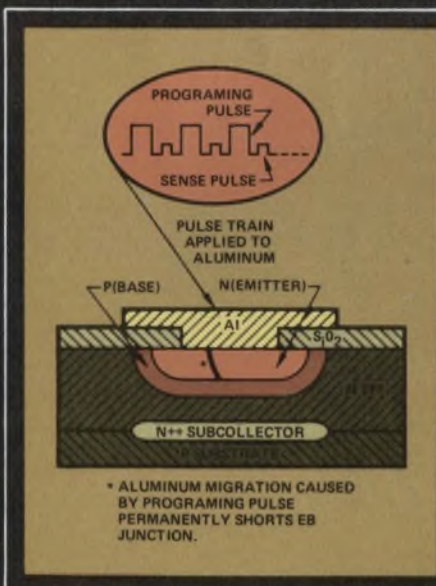

us to measure and control the quality of the programed short, whereas it's impossible to measure a programed "open" to a quality level that assures reliability.

Intersil P/ROMs in full volume production undergo a battery of static, dynamic and temperature checks before shipment to customers and distributors for off-the-shelf delivery.



Reliability

Once a short is formed, it's totally beneath the surface of the silicon, typically 1½ microns deep. It's covered by a natural passivation layer of silicon dioxide, aluminum and vapox — inherently hermetic and protected from any degrading effects of the environment. And there is no metallic debris to migrate or "grow back" with continued use of the memory at a later date.

Availability

Type	Capacity	Output	Access Time (Max)		Pd (mW)	Price (100-999)	
			Read (nSec)	C/S (nSec)		0 to +75 C	-55 to +125 C
IM5600	256 bit (32x8)	OC	50	50	350	\$ 6.00	\$ 9.50
IM5610	256 bit (32x8)	TS	50	50	350	6.00	9.50
IM5603A	1024 bit (256x4)	OC	60	30	450	22.00	44.00
IM5623A	1024 bit (256x4)	TS	60	30	450	22.00	44.00
IM5604	2048 bit (512x4)	OC	70	30	550	45.00	80.00
IM5624	2048 bit (512x4)	TS	70	30	550	45.00	80.00

Get immediate delivery on all Intersil P/ROMs, packaged in 16-pin DIPs. From Intersil, 10900 North Tantau Ave., Cupertino, CA 95014.

Get 'em here

Intersil stocking distributors.

Elmar/Liberty Electronics.
Schweber Electronics.
Semiconductor Specialists.
Weatherford.

Intersil area sales offices.

Boston (617) 273-2055.
Chicago (312) 371-1440.
Los Angeles (213) 532-3544.
Minneapolis (612) 925-1844.
New York (201) 567-5585.
San Francisco Bay Area.
(home office) (408) 257-5450.
Upstate New York
(315) 463-3368.

Representatives in major cities.





John Donohue's "blue line" turns out keyboard switches faster than you can say Oak.

John Donohue, Director of Manufacturing here at Oak, is mighty proud of his "blue line." He ought to be. It's the most sophisticated fully-automated keyboard switch assembly facility in the industry. It was designed with the customer in mind. We wanted to make sure we'd be able to meet his demands for huge quantities of our popular keyboard switches.

And popular they are. We build keyboard switches for everything from miniature calculators to data entry systems to point-of-sale terminals. You can buy them individually or in completely assembled custom keyboards.

If you need low-profile keyboard switches—we have 'em. Our Series 415 switches have a profile of less than $\frac{1}{2}$ inch. And they're available in either single or double "human engineered" keycaps that dress up any product design.

Series 400 and 475 keyboard switches are built with self-cleaning gold cross-bar wiping contacts. You're assured of trouble-free operation through millions of cycles. And our variety of contact arrangements gives you true design versatility.

We also offer a full selection of lighted and unlighted pushbutton switches plus almost any other type of switch you can put your finger on. Let us know your needs.

Write Lou Roels at Oak for product literature, helpful keyboard design tips and free samples of our keyboard switches.

Or if you prefer, dial 800-645-9200 (toll free) for the name of our local representative (In New York, dial collect 516-294-0990).

DAK Industries Inc.

SWITCH DIVISION / CRYSTAL LAKE, ILLINOIS 60014

TELEPHONE: 815-459-5000 • TWX: 910-634-3353 • TELEX: 72-2447

INFORMATION RETRIEVAL NUMBER 9

"Keep 'em coming, John"

Three new Jermyn logic checkers

Our original Jermyn Logic Checker was such a resounding success that we've now brought out a whole new range, with an even better basic design.

The contact mechanism is better, to give a firm grip on the IC at all board angles.

The internal circuitry is better.

The viewing screen is better, divided into 16 segments to make pin identification nice and easy.

And the body is stronger, in high-impact glass-filled nylon.

There are three versions.

1. TTL For positive logic TTL or DTL ICs, up to 16 pins, Vcc between +4.5V and +5.5V.
2. HTL For positive logic HTL ICs, up to 16 pins, Vcc between +11V and +18V.
3. CMOS. Sensitive microamp version for CMOS devices up to 16 pins, Vcc between +8V and +18V.

If you've ever tried a Jermyn logic checker, you'll know just how useful it is.

If you haven't yet, you're in for a treat.

Just clip it over the logic IC, and it shows you the state of each pin, instantly, on a 16 LED display.

Lamp on = logic state 1.
(Or open circuit, or Vcc supply, or unused pin.)

Lamp off = logic state 0.
(Or ground.)

It doesn't matter which way round you clip it, because the checker locates the supply pins, takes its own power from them (very little, actually) and then checks the other pins.

And it doesn't matter where you clip it, on devices with less than 16 pins (8 or 14 for example).

With a little practice, you'll soon be able to check ten or more ICs a minute.

Compare that with fiddling about with probes and a CRO.

Price TTL \$85, HTL \$120, and CMOS \$165. Plus 75¢ post and packing.

Please add California Sales tax where appropriate.

Orders in today, we post today. Or ask for the leaflet.

Jermyn

712 Montgomery Street
San Francisco CA94111
Telephone (415) 362-7431
or East Coast (914) 634-6151

Also at Sevenoaks (U.K.) (0732) 50144,
Paris 744 29-71, Munich (089) 39 88 01

INFORMATION RETRIEVAL NUMBER 10



Instant logic-state display for TTL, HTL or CMOS ICs

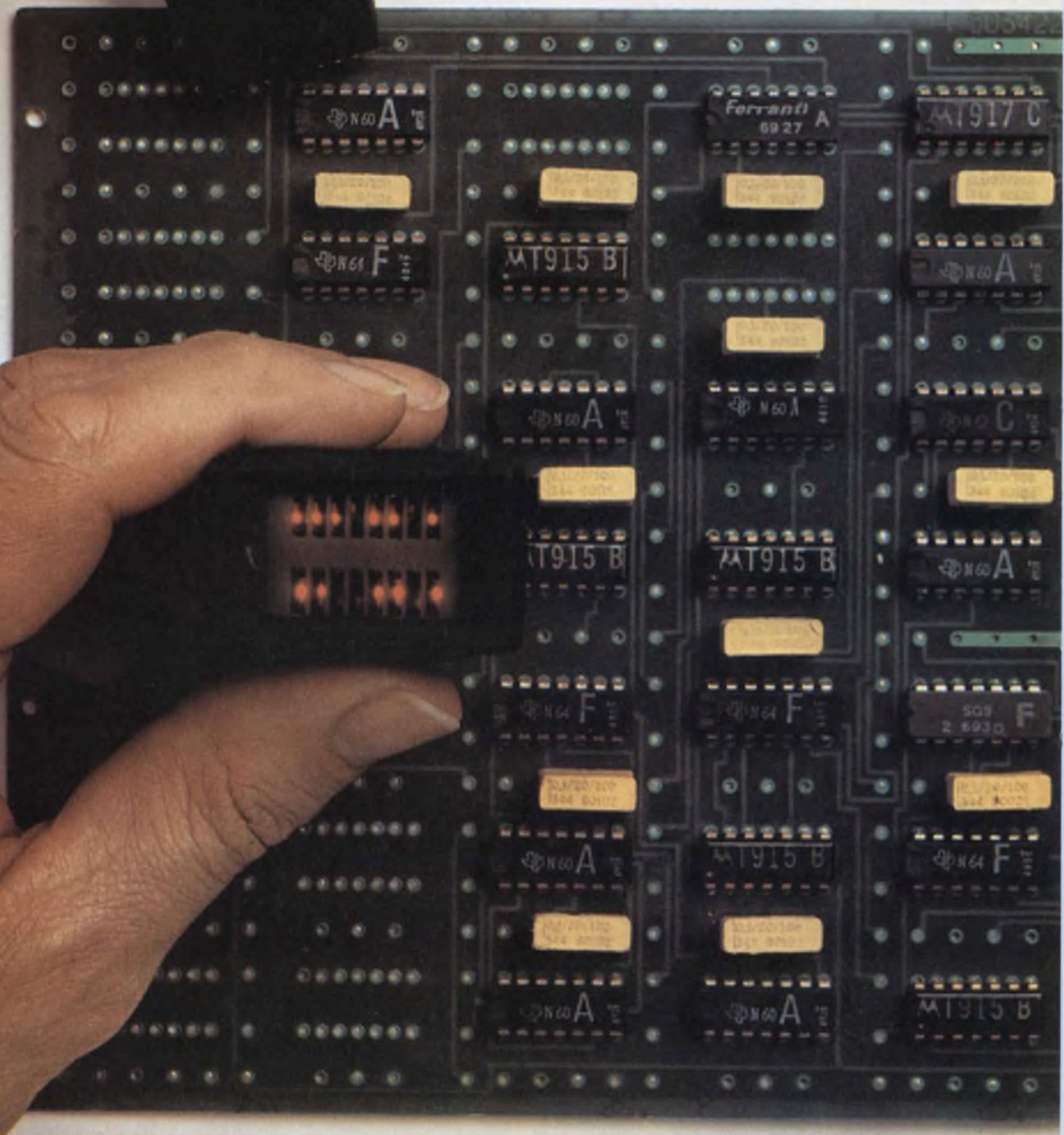

Another technical knockout

the first 900 MHz, 50 W RF chain

900 MHz radio is here now and Motorola is first with broadband devices for the entire range.

900 MHz TYPE	P _{out} W	G _{PE} (G _{PB})* dB Min	V _{cc} V
MRF816	0.75	10.0	12.5
MRF817	2.5	6.2	13.6
MRF818	8.0	5.05	13.6
MRF823	5.0	8.0	12.5
MRF824	12.0	5.0	12.5
MRF825	25.0	4.0*	12.5

*Common Base

Controlled Q[†] and mesh-overlay technologies are what did it. We combined all the best of land-mobile technology to develop the first lineup of common-emitter/common-base devices that meet the criteria of performance and cost.

†Trademark Motorola Inc.

A complete line of 50 ohm PC board demonstration amplifiers to aid you in building your radio is available through your Motorola representative. And a new Engineering Bulletin, EB-25, is waiting to start you in

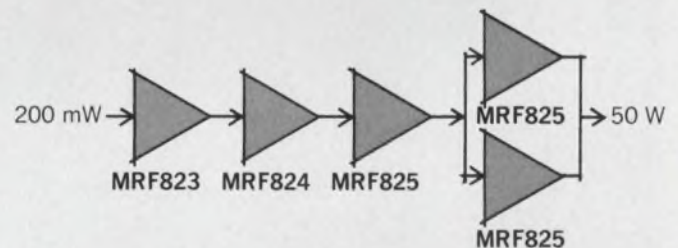

12.5 V, 806-821 MHz

the right design direction. Box 20912, Phoenix, AZ 85036. Be first with the first...

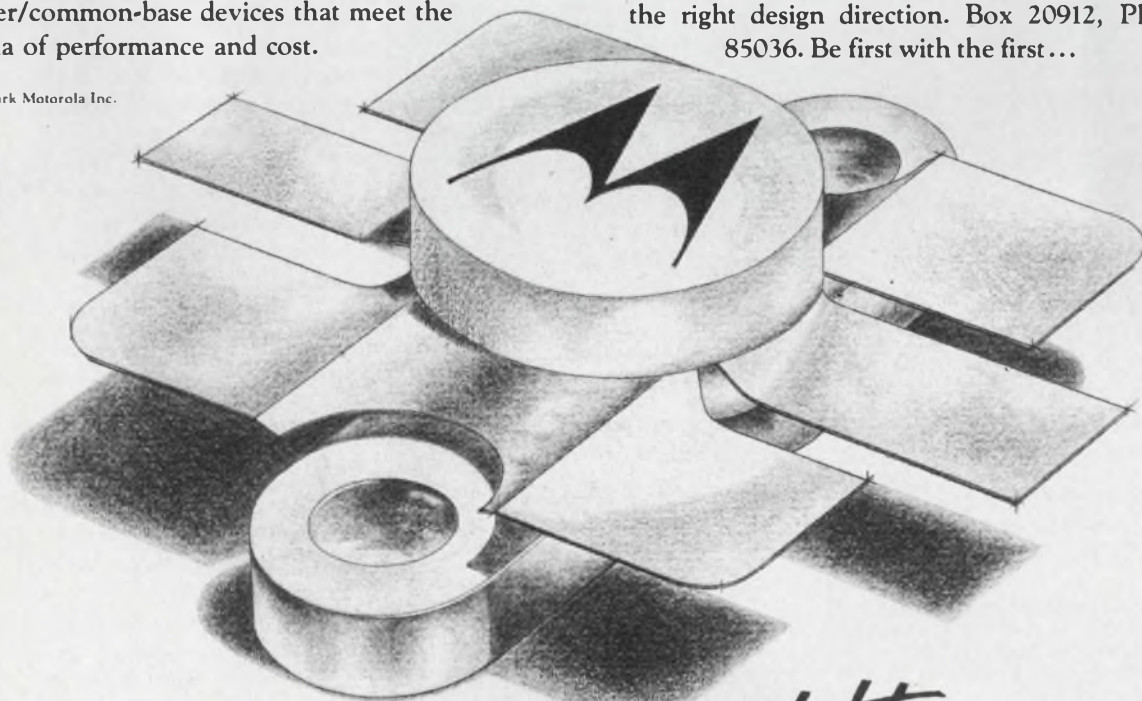

heavyweight
from Motorola, the RF producer.



No Offense

Non-PCB (polychlorinated biphenyl) . . . non-toxic . . . non-polluting. That's new Sprague ECCOL® A-C Capacitors . . . developed for today's ecology-conscious world.

Equipment manufacturers using capacitors with polychlorinated biphenyl impregnants are finding that some nations have prohibited the import of products containing PCB.

ECCOL® capacitors have been designed to meet industry needs for PCB-free capacitors. They exhibit essentially identical electrical performance characteristics to those of long-used askarel capacitors. Their operating life and reliability are also equivalent. Even the size of ECCOL® Capacitors is similar to previous designs, except for a slight increase in case height.

Drawn-case ECCOL® Capacitors are available in a wide range of capacitance values from 1 to 55 μ F, with four voltage ratings from 300 to 660 VAC.

For complete technical data, write for Engineering Bulletin 4550 to:
Technical Literature Service
Sprague Electric Company
347 Marshall Street
North Adams, Mass. 01247



THE BROAD-LINE PRODUCER OF ELECTRONIC PARTS

INFORMATION RETRIEVAL NUMBER 12

ACROSS THE DESK *(continued from pg. 7)*

of strain to generate the required gap breakdown level. This may occur in milliseconds or minutes. In the case of a slowly applied excitation, leakage may be a problem, and this was the only intended meaning of the aforementioned statement—not that squeeze type excitation is inherently slow.

C. P. Germano

Vernitron Piezoelectric Div.
 232 Forbes Rd.
 Bedford, Ohio 44146

It was a 'fine' Focus, but don't forget ILC

"Focus on Data-Acquisition Equipment" in the June 7 issue was fine. But ILC Data Device Corp. was omitted from the rather complete listing of manufacturers.

ILC was founded approximately 10 years ago to produce discrete operational amplifiers. As we progressed, we entered the areas of d/a, a/d, synchro-to-digital and digital-to-synchro converters, plus the associated sample-and-hold and multiplexer modules. We presently have a complete line of data-acquisition modules, which are manufactured in both thick-film hybrids and discrettes. These modules have been configured into many varied systems with our standard chassis configurations.

Jack R. Alford

Director of Product Planning

ILC Data Device Corp.
 Airport International Plaza
 Bohemia, N.Y. 11716

A call for ideas on acupuncture

I very much appreciated your circuit for alpha biofeedback (see "Simplified Biofeedback Circuit Detects Alpha-Wave Activity," ED No. 12, June 7, 1974, p. 154).

Do you intend to publish a circuit on the similar problem of acupuncture point locators?

Gerald W. Clarke

205 Driffill Blvd., #40
 Oxnard, Calif. 93030

Ed. Note: If someone has an Idea for Design on acupuncture, we'll consider publishing it.

From the voltmeter house...



Discover how these auto-multimeters keep you out of trouble.

On the surface they may look like any well-designed digital multimeters.

Now look closer. What else do you see?

There... the Fluke name!

That indicates unusual performance.

We designed both the Fluke 8600A and the 8800A with auto range, auto zero, and auto polarity. **And every parameter is fully protected.** This means you can accidentally overload the instrument with too much current... too much voltage... or too much resistance!!... and you're still okay.

Another way you stay out of trouble: MTBF on each instrument is a minimum of 10,000 hours.

Now, the specs.

The 26-range Fluke 8600A, \$599. We packed this 20,000 count multimeter with five

ranges of volts from 200 mV through 1200 V ac and dc. Five ranges of current, 200 μ A to 2 A ac and dc. And six ranges of resistance from 200 ohms to 20 megohms.

Basic dc accuracy is a fully credible 0.02%. Options include built-in automatic rechargeable battery pack for up to 8 hours off-line operation. Digital output is also offered.

The 0.005% Fluke 8800A, \$1099.

This digital multimeter features five ranges of dc volts from \pm 200 mV

to \pm 1200 V. Four ranges ac from 2 V to 1200 V. And six ranges of four terminal resistance from 200 ohms to 20 megohms. For complete isolation the input resistance is better than 1,000 megohms on lower ranges and 10 megohms on the higher ranges.

For critical resistance measurements the instrument provides completely isolated four terminal ohms with less than 4 volts open circuit from 200 ohms through 20 megohms.

So there are the specs.

Impressive? We think so. But

remember—specs are one thing. That name on the panel, however... It's what makes a Cadillac a Cadillac.

And a Fluke a Fluke.

For details, call your nearest Fluke sales engineer. Or simply dial our hot line.



For data out today, dial our toll-free hotline, 800-426-0361

In the continental U.S., dial our toll free number 800-426-0361 for the name and address of your nearest local source. Abroad and in Canada, call or write the office nearest you listed below, John Fluke Mfg. Co., Inc., P. O. Box 7428, Seattle, Washington 98133. Phone (206) 774-2211. TWX: 910-449-2850. In Europe, address Fluke Nederland (B.V.), P. O. Box 5053 Ledeborstraat 27, Tilburg, The Netherlands. Phone 013-67-3973. Telex: 844-52237. In the U.K., address Fluke International Corp., Garnett Close, Watford, WD2 4TT, England. Phone 0923-33066. Telex: 934583. In Canada, address ACA, Ltd., 6427 Northam Drive, Mississauga, Ontario. Phone 416-678-1500. TWX: 610-492-2119.



Our new 25 and 50 nsec Fast Recovery Rectifiers



are either 25% cheaper or 100% more expensive

We're not confused. Our new axial-leaded Fast and Ultra-Fast Recovery Rectifiers are cheaper—if you need the switching speed. But they're more expensive if you don't.

If you can get by with 100 nsec speeds in your power control and conversion circuits, go ahead. There's no need to pay for what you can't use.

But, if you're working with fast transistors, know this: at 25 and 50 nsec speeds, Fast Recovery Rectifiers protect your power transistors, operate with

greater efficiency, less power dissipation and heat. And that means less energy needed along with far simpler packaging.

Happily, at TRW, along with speed and efficiency, you get competitive savings. Our 50 nsec parts will generally cost out at 25% less than similar parts.

For complete specifications, write John Powers, TRW Power Semiconductors, an Electronic Components Division of TRW, Inc., 14520 Aviation Blvd., Lawndale, California 90260. Or call (213) 679-4561.

TRW POWER SEMICONDUCTORS

These products are available through the following authorized distributors:

Almo Electronics
Bell Industries
Cramer Electronics Inc.
De Mambro Electronics

Electronics Marketing Corp.
Elmar Electronics Inc.
Hall-Mark Electronics Corp.
Harvey-Michigan Inc.

Lake Engineering, Ltd.
Liberty Electronics
Pyttronic Industries Inc.
Rochester Radio

Semiconductor Concepts Inc.
Summit Distributor
R. V. Weatherford Co.
Westates Electronics Corp.
Wilshire Electronics

INFORMATION RETRIEVAL NUMBER 14

Voice-recognition computer responds to virtually anyone

A computer voice-recognition system that understands a simple vocabulary of numbers and key words spoken by virtually anyone may permit credit-card verification to the company's computer over the phone. Or it may allow policemen to talk directly with a central crime computer via radio link.

The system, developed by Dialog Systems, Inc., Cambridge, Mass., is advanced over others in use, says Stephen L. Moshier, technical director. It recognizes the same words spoken by a wide range of different voices—virtually anyone who pronounces the words clearly. This is in contrast with systems in which the computer answers only to operators whom the system has been "trained" to recognize.

A major portion of the Dialog system is its software package, which controls a PDP-11 computer and special peripheral hardware. Among the peripherals is an a/d converter that converts voice to digital signals, a correlator that generates short-term autocorrelation functions of the voice and a high-speed array processor.

The recognition system, Moisher explains, is based on linear predictive coding that provides a compact way of stating meaningful characteristics of voice signals. The voice sounds that are accepted by the system are transformed, and the data are fed to a "maximum likelihood" processor which operates on the statistical properties of the sound transform. This processor selects the word with the highest likelihood of being the right one. If the word has a low probability, the system rejects the inputs and verbally requests a repeat. Digital recordings of the vocabulary suitable for the system are stored on discs with the PDP-11 system.

According to Moisher, the present system accepts 1000 differ-

ent telephone messages with an average accuracy of 99%. A limitation of the system is that it cannot recognize words that are run into each other, as in normal speech. The machine only understands if the speaker pauses at the end of each word. This tells the system that one word is finished and the next is about to begin.

To increase recognition accuracy still further, the system repeats the message to the speaker and asks for verification. After the first message has been verified, the computer continually adjusts itself to understand the caller's voice quality better as it listens to subsequent messages.

Recycling gives U.S. copper self-sufficiency

Recycling of copper last year helped the United States push its self-sufficiency in the metal to a new high, reports the Copper Development Association, New York.

W. Stuart Lyman, the association's manager of technical and market services, points out that over the last 10 years the U.S. has been able to produce domestically over 91% of the copper and copper alloys it needs. The remainder is supplied principally by Canada.

The high point in copper self-sufficiency—95.1%—was reached last year principally because of a simple, low-cost copper recovery process. Recovery was responsible for 46% of the 1973 supply, or more than 1.6 million tons. This was close to the total U.S. mine production of copper; over 1.7 million tons, or 49% of the supply.

Consumption of copper and brass increased in the U.S. last year, with electrical and electronic products using 2.2 billion pounds

—record 30% of the output. This represents an increase of 13.1% over the 1972 total.

Total domestic shipments of copper and copper alloys also reached a record level of close to 7.4 billion pounds, an increase of 10.3% over 1972.

Lyman believes that copper demand has slowed this year because of reductions in gross national products, orders in durable goods and building construction in the last two quarters.

Tough Army survey simplified by software

Keeping track of equipment in an elaborate Army communications center can cost as much as \$20,000 and three months each time a survey is made. And surveys are needed frequently, because new equipment is constantly being added.

But with the help of a new computer program designated the Technical Control Facility Site Baseline Pilot Program, developed for the Army by Computer Sciences Corp. El Segundo, Calif., the time-consuming and expensive survey can be reduced to a routine operation. In addition the effects of changing different parts of the communications system can be simulated and studied beforehand.

This is important, a spokesman for Computer Sciences points out, because changing even one of the hundreds of message channels in one of these communications centers sets off a chain reaction of associated equipment changes that involve dozens of pieces of equipment in the center.

The new program, stored in an Army computer, records the effects of changes in circuits, message channels and new equipment. It also produces a list of circuit assignments that reflect the new layout of the facility. The detailed information provided by the computer makes it unnecessary for Army engineers to visit a facility to determine the changes required each time equipment is upgraded.

Communications personnel at each center log in a site-survey manual each month the changes in the center's operating configuration. The manual is returned to the

Army's Communications Electronics Engineering Installation Agency at Fort Huachuca, Ariz.

There the changes are entered into the computer, and each facility's status is updated automatically by the program. The computer then prints out a new set of current status records, which is sent to each site.

The data base developed for the program includes detailed engineering information on the communications circuits connected to each site, station equipment, power sources, air-conditioning and heating capacity, transmission interface equipment, signal conditioners, the location of cables and their connections, and a guide to the subscribers to receive service through the communications center.

Although complete records of only six communication centers are now stored in the computer, the data base for the program can handle all the records for every Army communications center in the world.

Although it was not designed for commercial applications, a Computer Sciences spokesman notes that the program can be used in civilian applications. He hastens to add, however, that these are limited to large companies, like Bell Telephone, or groups of communications companies.

Brain-wave system monitors meditation

An advanced electroencephalographic research system shows how "transcendental meditation causes the nervous system to become more flexible and stable," according to Paul Levine, chief scientist at Megatek Corp., of Point Loma, Calif., where the system was developed.

The core of the system is a 16-channel EEG Grass amplifier, which acquires signals from the brain. The 12-channel output of this amplifier is fed through an a/d converter to a Nova II mini-computer.

The computer takes the information, records it on magnetic tape and then does a real-time fast-Fourier transform on the brain-wave. The output is a frequency-

domain presentation that is displayed on a Megatek graphic interface. The interface provides a built-in memory with 50-Hz refresh to generate flicker-free displays.

The system reveals, Levine says, that transcendental meditation synchronizes electrical waves in the left and right cerebral hemisphere, bringing about concordance of phase.

"As a person meditates, his brain waves start out in the back with the Alpha rhythms, and these grow more intense as the meditation becomes deeper. Then these waves move forward toward the frontal lobes of the brain," explains Walter Foley, vice president at Megatek.

"By having the sensors in the 12 different positions, you can see on the screen in real-time the progress of the meditation; you can watch the synchrony between the halves of the brain."

The system can also be used for conventional brain-wave research.

Two OCR drawbacks reported overcome

Two basic drawbacks of computer optical character readers—the need to refer back to original documents to make error corrections and the rejection of all handwritten data or nonstandard OCR characters—have been circumvented in IBM's new low-cost optical character reader, the 3886.

According to an IBM spokesman letters, numbers and even signatures that are normally unreadable and rejected by optical-scanning devices can now be captured, stored and visually displayed. The display appears on a modified IBM 3277 CRT console. The operator can observe and correct directly OCR errors, or he can enter nonstandard OCR data by keyboard. Reference back to the original document—normally done as a batch operation—is not required.

The key to the new system is a "video-collect" capability obtained through microprogramming. It transforms the output of the 3866 LED character reader—which may be in the form of OCR or non-OCR characters, handwritten text or even sketches—into a visual dis-

play. This feature allows the operator to supplement input data with written information.

The video capture function also permits users to display and verify visually critical OCR information. An important use that IBM sees for the video capture function is the creation of signature files to permit banks to display and verify depositors' signatures.

The video-collected data can be transferred by user written programs from the 3886 directly to a computer; or the data can be sent to an IBM 3410 magnetic tape unit for storage and later display. The stand-alone video-collect display is obtained by connection of a modified 3277 to a 3886.

The 3886 operates with virtual storage models of the IBM System-370 under DOS/VS, OS/VS1 or OS/VS2 programming.

The 3886 video-collect capability requires added data and instruction storage, depending upon user requirements. For a 24-month period, monthly rental of the 3886 ranges from \$224 to \$324, with purchase prices at \$10,318 to \$14,918.

Beckman adds a line in process-control field

Introducing a new line of controllers, recorders, transmitters and computing modules, Beckman Instruments of Fullerton, Calif., has entered the process-control field.

Roy F. Brown, vice president and manager of the Process Instruments and Controls Group, says the new product line is the result of five years of research and development. Included is a pressure-sensitive-writing, dual-channel process indicator that can be read at up to 40 feet. Called the Model 8720, it uses two servo-driven tapes for each channel, to move the styli and provide a bar-like indicator of trend data.

All of the 8800 series feature an unusual "settling circuit" that eliminates the bumps—transients in the control signal—produced when control is transferred from automatic to manual, and remote to local, or when making gain or derivative changes.

RF switching to 500 MHz in a TO-5 package



RF circuit and packaging engineers are discovering that Teledyne TO-5 relays make excellent subminiature rf switches for frequency ranges up through UHF. Their reasons are: inherently low inter-contact capacitance and low loss contact circuit geometry. Typical rf performance: Isolation — 45db at 100 MHz, 35db at 500 MHz;

Insertion Loss — 0.2db at 100 MHz, 0.4db at 500 MHz.

And Teledyne Relays offer the widest possible selection: MIL relays in SPDT & DPDT standard, sensitive, and maglatch types, all available with internal diodes; commercial models in DPDT standard and sensitive types, also available with internal diodes. All Teledyne TO-5 relays feature hermetic sealing, gold plated contacts, and all welded construction for high reliability.

For Transmit/receive switching in hand-held transceivers or any low power remote band switching application, Teledyne TO-5 relays are an excellent choice. No other relay offers this combination of rf performance, low coil power dissipation, and small package size.

And they're **in stock** at your local Teledyne Relays distributor.



 **TELEDYNE RELAYS**

3155 West El Segundo Boulevard, Hawthorne, California 90250
Telephone (213) 973-4545

INFORMATION RETRIEVAL NUMBER 15

**Here's our
to holding down
of ceramic**

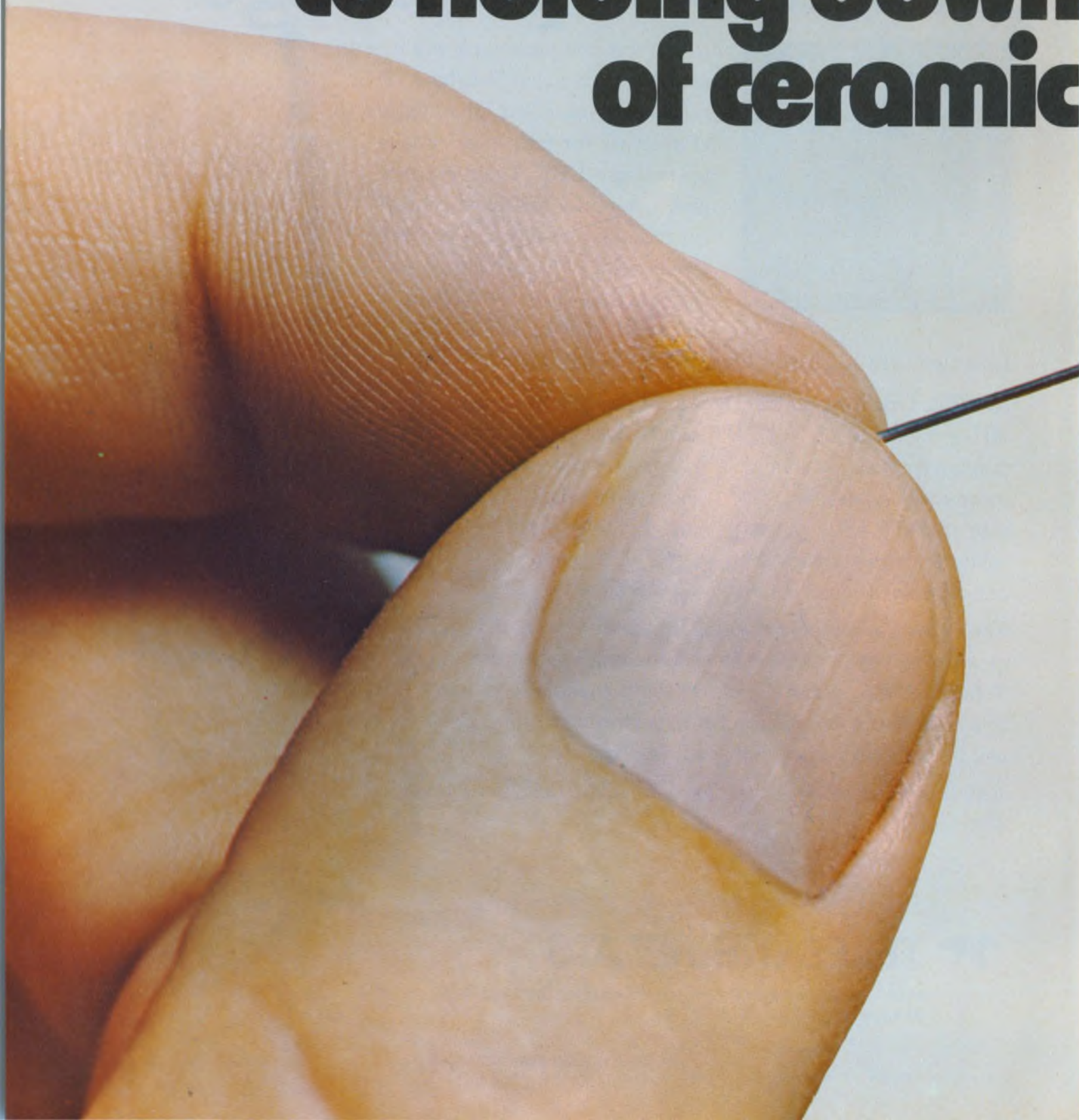

answer the cost capacitors.



Our new "spin-seal" conformal-coated axial may well be the industry's long-term answer to a truly low-cost, automatically-insertable ceramic capacitor.

"Spin-seal" uses techniques developed for and currently in use to produce hundreds of millions of metal film resistors. It permits us to manufacture axial ceramics at high speeds while closely controlling uniformity and handling characteristics necessary for automatic insertion. And at lower cost than molded case styles because more automated production techniques are used.

Right now, we're producing "spin-seal" capacitors in four case sizes with capacitance ranges of 0.027 μF to 0.47 μF

at 50 volts and 0.001 μF to 0.22 at 100 volts. Two tolerances are available: $\pm 20\%$ and $+80, -20\%$. "Spin-seal" capacitors are available with Z5U temperature characteristic. Capacitors with the X7R and NPO characteristics are nearing completion.

"Spin-seal" isn't the only new development we're working on in the area of low cost ceramic capacitors.

Watch for the announcement of our new line of dipped-radial ceramic capacitors. Another step in Corning's plan to serve your full ceramic capacitor needs.

CORNING
ELECTRONICS

ELECTRONICS TO HARVEST OCEAN WEALTH

A 1960s dream begins to come true under the seas

Remember back in the mid-1960s when there were predictions that people would one day be living in habitats on the ocean floor, raising fish, harvesting rich underwater crops and drilling for oil?

Why, providing the electronics for even one of those wet ventures would save an electronics company from the great defense budget drought that was looming.

And those minerals that were going to be scooped up—the ferromanganese, the copper and nickel. And the diamonds. Yes, there really were diamonds lying on the ocean floor, just off the South African coast. And they're still there.

In fact, *all* the attractions of "inner space," as we used to call it, hoping to make it the financial bonanza that outer space was, are still there. The only difference between the mid-60s and now is that now it makes economic sense to go after them.

Oil companies are spending hundreds of millions of dollars preparing electronically controlled sea-floor drilling and production facilities. They're moving to the sea floor because they have to: The untapped oil deposits are farther out, in water too deep for platforms.

And it's now economically

John F. Mason
Associate Editor

Divers operate out of the small submersibles, like this Perry PC-15, which oil companies are buying to inspect pipe lines and oil rigs.



The first modular instrumentation calculator.

Just \$5945 as shown.

It's our 31/53 Data Acquisition System with DM 501 and DC 503.

A powerful, yet inexpensive calculator combined with our 153 Instrumentation Interface and system software. You add the instrumentation modules you need. It's all there and it's portable. Now that's versatility!

With our 31 Calculator, you can read input from our DM 501 and/or DC 501, 502, 503 counters. You can log data selectively, calculate results and output data or trigger signals.

Programming? Little more than natural math. Go ahead, write your own. Also, our standard software gives you data logging (on the optional alphanumeric printer) and data capture on the 31 at operator selected intervals.

Dealing with complex variables? Then label 24 keys with personal functions on the user-definable overlay.

Energy monitoring. Quality control testing. Laboratory and production instrumentation. The applications go on, and so does our system's potential. Just add the main-

frames and modules you need. We have a graphic calculator system, too. Let our sales engineer fill you in. Pick up your phone and call our nearest center. Or write: IDD Calculators, P.O. Box 500, Beaverton, Oregon 97077.

Our programmable calculators. Natural. Powerful. Significantly less expensive.



feasible: In the late sixties, the price of oil just didn't warrant the tremendous expense of undersea facilities, and now it does.

The new "wet oil fields" call for a sizable amount of auxiliary equipment and services. They require divers, submersibles and a whole new line of electronic devices and systems. Some of this equipment is available and some isn't even designed.

There still won't be any habitat cities on the ocean floor, but there are habitats on board the surface ships that attend diving operations. Pressurized at sea-bottom pressure, the shipboard habitat is

home for the divers between trips in a transfer bell to the sea floor, where they swim out to work.

Scientific submersibles and surface ships will receive more emphasis as the need to exploit the oceans becomes more urgent.

Texas A & M's Oceanography Dept., for example, recently bought a submersible built by Perry Ocean Engineering, Riviera Beach, Fla., and now has a number of contracts with the Government and with industry. Among other studies, it is searching for natural gas bubbles in the Gulf of Mexico—an indicator of oil deposits below. The college is also studying

the effects of pollution on coral reefs.

And Alvin, the Navy's deep submersible operated by the Woods Hole Oceanographic Institution, is again in the news. This time, Alvin, along with two French counterparts, is being used off the coast of the Azores in the Atlantic to check out the Mid-Ocean Ridge System, or more specifically the tectonic plates on the ocean floor—the rocks that move apart, allowing lava to gush forth and islands to form.

The Navy has a number of undersea efforts in progress for search and location, rescue and recovery, salvage and recovery, survey, environmental prediction and underwater construction.

Automated data buoys are being given more jobs—monitoring the weather and ocean state, among them. And these call for innovative design for sensors, power supplies data processing and telemetry.

Ocean mining is also ready to come into its own—what with the scarcity and high cost of metals and other materials. Take those diamonds lying in relatively shallow water off South Africa, for example. Howard Hughes is building a sea-going vacuum cleaner to sail out and suck them up. The ship will undoubtedly also attempt to harvest some of the ferromanganese nodules that lie in rich patches on deeper ocean floors. Other companies, including Teneco's Deep Sea Ventures, Inc., and Kennecott, are also working toward the same end.

So electronics for ocean mining is also worth a realistic look. Ships need sea-bottom profiling equipment, sonar, underwater television, accurate depth measurement techniques, precise navigation systems and transducers to measure flow, pressure and the angle of the dredge pipe.

Oil fields on the ocean floor

Several subsea systems are being readied, some are wet and the

Diving bells serve as elevators to carry Taylor divers to work on the ocean floor. The large umbilical cord carries power and communication.



Photo by John F. Mason

*Here's a dependable, quick-delivery source
for Zero Defect*

High Voltage Silicon Rectifiers

- MEETS STRINGENT ENVIRONMENTAL REQUIREMENTS.
- HIGH TRANSIENT VOLTAGE RATINGS.
- EXTREMELY LOW LEAKAGE.
- WORKING VOLTAGE RANGE . . . 200V. THROUGH 50kV.

If you're looking for on-time delivery of miniature and micro-miniature High Voltage Silicon Rectifiers, look no further than ERIE. You simply can't beat our zero defect rectifiers since these units were first designed for high reliability night vision, lunar and aerospace applications. Their small size makes ERIE rectifiers ideal for thick film substrates, miniature power supplies, airborne displays, CRT displays, color TV, microwave ovens and other industrial and commercial applications where small size, reliability and superior performance are critical. All ERIE High Voltage Silicon Rectifiers feature conservative voltage ratings, fast recovery time, fast turn-on time, wide operating temperature range, high transient voltage ratings, low reverse leakage and unsurpassed reliability.

ERIE also offers double sealed, miniature Full Wave Bridge Rectifiers . . . perfect for P.C. use, with ratings up to 1000 volts per leg. So think ERIE for your High Voltage Silicon Rectifiers. Write TODAY for our new 24-page catalog . . . High Voltage Components and Devices.



ERIE

ERIE TECHNOLOGICAL PRODUCTS • Erie, Pennsylvania 16512

others are dry.

Two systems using the dry approach are being tested by Seal— or Sub-sea Equipment Associates Ltd.—in Houston, Tex. Seal is an international engineering services consortium jointly owned by Mobil Oil, Westinghouse Electric, British Petroleum, Compagnie Francaise de Petroles and Groupe Deep.

The dry approach means the entire control unit is housed in a pressure-tight container to maintain a sea-level environment, which enables normal oil-field electronic components to be used. Seal considers this an economy.

"We don't have to use the elaborate pressure-compensated devices that a wet system does," says the consortium's president A. T. Chatas in Houston.

The control unit must be installed by divers, but after that it can be repaired without manned intervention. A hook is lowered that picks up the entire control unit, brings it up and takes down a new one. This shouldn't be needed more than once every two years,



Electronic control unit for submerged well, by TRW, locks onto template, receives commands from surface via cable, decodes them and carries out the commands.

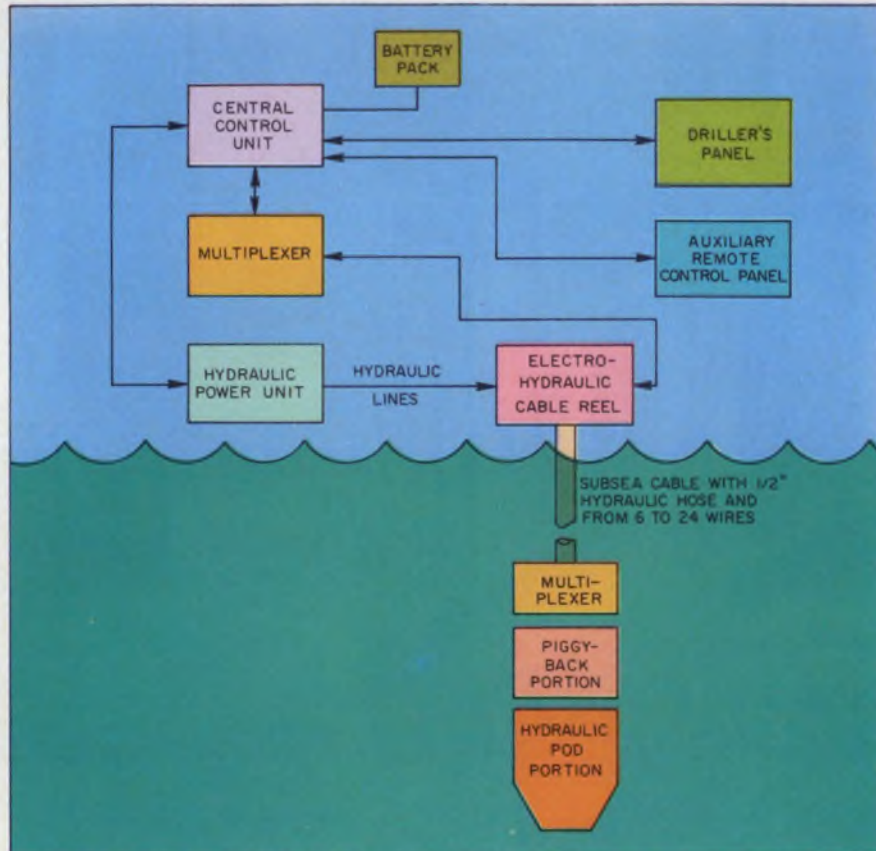

Koomey multiplex electro-hydraulic control system, by Stewart & Stevenson, is designed for deep producing wells. The multiplex cable sends signals to the underwater multiplexer, which instructs the hydraulic pod.

according to Seal's Chatas.

Transducers are installed on the oil well's template to measure pressure, temperature, flow rates, level of bilge and status of valves—and to set off an alarm if needed. Data are telemetered to the platform control panel by multiplexed hardwire.

A problem is the power source. Now, power is generated on the platform and sent down by cable. The Japanese have experimented with a diesel generator in the water, and though it hasn't gone beyond the drawing-board stage, submerged nuclear generators will undoubtedly be available one day.

Exxon has taken the wet approach to subsea oil and gas production. The company will soon test its Submerged Production System in 170 feet of water in the Gulf of Mexico. The system is designed to operate at depths of 2000 feet, with future systems planned for considerably deeper waters. Exxon's aim was to design a system that would need virtually no manned intervention on the sea floor.

The remotely controlled system is operated by a cable running from the surface to the sea-floor template. Command messages to open and shut valves are sent through the cable by binary code. A safety unit monitors the wells and automatically shuts them if leaks or other critical malfunctions are detected.

When modules or valves need to be changed, a remotely controlled manipulator performs the operation upon command from the surface. A guide buoy is released from the template, and the manipulator hauls itself down and lands on a special cogged track. It then proceeds to the faulty module, replaces it with a new one and takes the old one to the surface. The manipulator finds the right place by monitoring its position on the cogged track through a computer at the surface and seven television cameras it carries. A diving bell is incorporated into the manipulator to allow a man to inspect the sea-floor installation and assume control of the manipulator's operation, if necessary.

Lockheed Petroleum Services Ltd. in Canada and in Houston is working toward development of a

We stock more than 1,000 different types of coaxial connectors. From low-cost UHF types to the latest MIL-C-39012 designs. Sub-miniature SMA and SUB-Minax 27 Series, BNC, TNC and N Series.

But if that doesn't solve your problem, we've got more designs and options available than anyone else. Our vast file of engineering drawings and design variations



means that a call to us can literally put you in touch with as many as 90,000 different microwave interconnections. And if you still need something special, we'll custom-design it for you.

We mean business. Call your local Amphenol sales office, distributor or Amphenol RF division, Bunker Ramo Corporation, Danbury, Connecticut 06810. 203/743-9272.

**BUNKER
RAMO** AMPHENOL

**One call will put you in touch
with 90,000 different RF connectors.**





Welding habitats, such as Taylor's, are lowered to the ocean floor, where divers, monitored by transducers and TV, descend in bells to weld pipes.

complete ocean-floor oil field. To date, much of its work has been for Shell Oil and other oil companies in a large consortium, but Lockheed is also free to sell its system elsewhere.

Like Seal's, Lockheed's system is dry. But unlike Seal, which wishes to have as little manned intervention as possible, Lockheed is designing pressurized chambers where men, without divers' training, can work.

TRW Subsea Petroleum Systems in Houston, Tex., is producing subsea control units for a number of big oil companies. TRW's units are wet. All components operate at ambient pressure in an oil-filled, pressure-balanced package. Hydraulic systems are being left behind, because they're too slow, and multiplexed wire is moving in. Also, the number of functions that TRW's units can perform is growing. The present unit controls 126 functions, but one that will handle 256 is in the works.

TRW's systems have a unique



Pressurized "elevators" to take divers to sea-floor welding habitats and deck-mounted chambers are in big demand at Perry Engineering.

technique for supplying power from the surface to the subsurface unit. Inductive couplers are used instead of pin connectors to input power and signals to the remote module. Pin connectors corrode in water and hence are prone to failure, while inductive couplers operate magnetically and are less subject to corrosion.

Stewart & Stevenson is another big producer of control units. "Because of the move to deep water, business is booming," says the company's Leroy H. Cook, an electronics engineer. "And everyone wants multiplexed wire."

S&S's newest unit is a multiplex



Helium speech unscrambler by Helle Engineering is brought out of a Perry Ocean Engineering personnel transfer bell for inspection.

electro-hydraulic system. Signals that normally would be sent to solenoids in the electro-hydraulic system are interpreted, assigned a time slot and then sent down on a command to the submerged unit. The submerged multiplexer then fires the solenoid.

S&S recently developed an automatic current-sensing device that examines the wire pairs that fire solenoids for current draw. Should a short be detected, the unit cuts off the current and sounds an alarm.

S&S feels its multiplexer is a particularly good design. It operates and monitors subsea functions over an eight-wire cable. It time-shares six control wires and uses two wires for power. Four of the six control wires are used for command and two for analog read-back. The commands are sent, checked for authenticity and the solenoid is fired—all in less than a third of a second.

The multiplexer differs from



Environmental controls shack sits on top of Taylor's deck-mounted decompression chamber for divers. The men may stay in this chamber 30 days, leaving only for trips to the sea floor and back. The elaborate readouts in the control shack (above) are from transducers in the chamber that monitor the men.



**Put it all together
with Buchanan
Printed Circuit Board
Connectors – and
eliminate 4 connection
points per circuit!**

Here's a new solderless printed circuit connector that eliminates hybrid interfaces between electrical and electronic circuitry. It replaces costly interwiring between terminal blocks, barrier blocks, and internal electronics... saves you up to 4 or more separate connection points per circuit!

With only a screwdriver and this new Buchanan one-piece connector, you can quickly connect solid or stranded wires, #12 through #30 AWG, to standard .200" contact-spaced printed circuit boards. The connector block is available for 12, 18, 24, 30 and 36 circuits; provides 300V insulation spacing between circuits; can carry up to 5 amperes per circuit; and is flame-retardant.

A unique right-angle design provides mounting flexibility and increased density, and the block can be mounted against any two adjacent panel sides if desired, since wire entry is all on one side. You can even "daisy chain" two or more conductors!

For complete engineering, pricing and ordering information, write us at Dept. ED-4.



**CONTROL PRODUCTS
DIVISION**

Amerace Corporation
Control Products Division
2330 Vauxhall Road
Union, New Jersey 07083



Hyperbaric research and training complex at Taylor Diving takes divers and equipment down to 2200 feet. Control console (background) indicates the intricate instrumentation that monitors the men's condition.

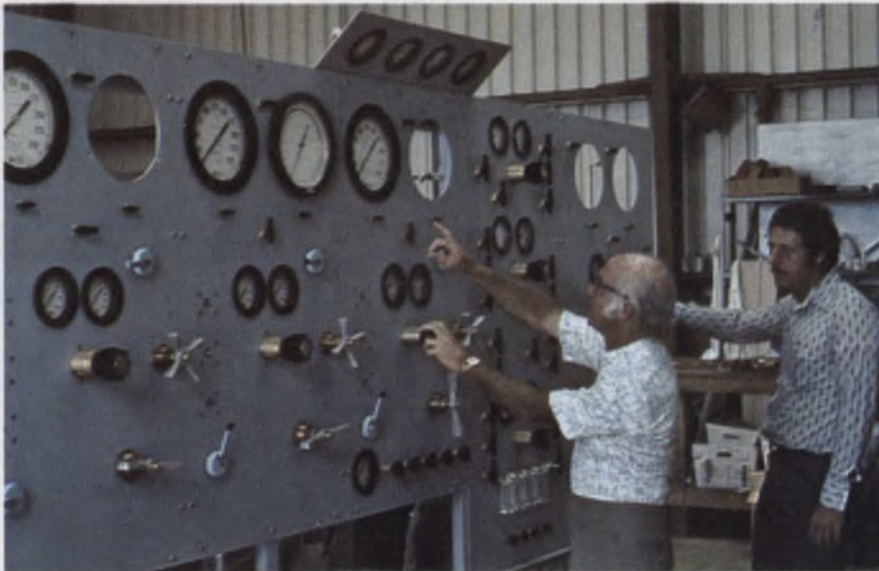

Control console, built by Perry, is used on the offshore platform or on board ship over a submerged well to monitor the diver saturation complex for diving bells and for the hyperbaric chamber on board ship.

our competitors use ordinary communication systems borrowed from the space program—a 10-bit-through-32-bit word serially sent through modems. We use a parallel command entry device; it is a true, synchronous multiplexer."

Divers are here to stay

In spite of the desire to fully automate submerged oil fields, divers are still needed and will be as fields move to deeper water, says Drew Michel, chief electrical engineer for Taylor Diving and Salvage

Co. in Belle Chasse, La., just across the river from New Orleans.

"Up until recently, television wasn't trusted," he explains. "Now it's destined to become one of the most popular aids a diver can have."

But there are problems: Visibility through the minute, light-reflecting organisms in water must be improved, the vidicon must be protected from direct contact with the sun's rays, and the units must be better packaged.

One TV camera built by Edo

Western, Salt Lake City, offers an automatic sun shutter that closes when the light gets too bright.

Building the minisubs

The small submersibles that the oil companies are now buying as fast, as they can be built are battery-powered and electronically controlled. Basically the minisubs carry sonar, a two-way sonar telephone, transponders on their outer walls for the mother ship to keep tabs on them, sensors for unhealthy air, and a pilot-control system. The buyer, of course, may further outfit them with television, seabottom survey equipment and a number of other devices.

"We're at the point now of trying to make maximum use of ICs, operational amplifiers and miniature parts," says Jon Newman, chief electrical engineer at Perry Ocean Engineering.

The big push at Perry is to get everything possible in epoxy and encapsulated. Solenoids that regulate motor speed have been successfully encased in plastic to protect them from hydrogen gas. The switch can be activated by simply moving a magnet over it.

A number of improvements have recently been made on submersible systems or are in the works:

- Plastic connectors deteriorate and permit leakage across the contacts. Perry has gone to rubber insert connectors.

- The sonar transducers fastened to the outside of the sub require a 2-1/2-in.-diameter penetration through the hull. Perry is working with Wesmar on a single coaxial multiplex system to reduce this opening.

- Sub-to-surface communication in the North Sea—where the action is nowadays—is difficult because of the sharp temperature gradient and the rough surface conditions. "The 27-kHz, upper-sideband system normally used doesn't penetrate too well," Newman reports. A dual-frequency system using military frequencies has worked better.

- The pilot's walk-around control box is too complicated. To prevent motor damage from a power drop when the submarine is suddenly switched from forward to reverse, the present system uses a multiplicity of cams and micro-

Dialight sees a need:

(**Need:** Single source supply for all indicator lights.)

See Dialight.



INCANDESCENT OR NEON MINIATURE AND LARGE INDICATORS

Designed to accommodate either incandescent (2-250V) or neon (105-250V) lamps for panel mounting in 11/16" or 1" clearance holes. Units meet or exceed MIL-L-3661 requirements; all are listed in Underwriter's Recognized Components Index. Wide selection of lens shapes, colors,

finishes and terminations. Many lenses may be hot stamped, engraved or offered with film legend discs. Oil-tight units with unique "O" ring construction make them oil, water and dust tight on the face of the panel. Available off the shelf for prompt delivery.



LED, INCANDESCENT OR NEON ULTRA-MINIATURE DATALITES®

Meet or exceed MIL-L-3661. Replaceable plug-in cartridges for 1.35-125V operation. Indicators mount as close as 1/2" centers; available with red, green, amber, blue, white translucent, light yellow or colorless lenses in wide range of lens shapes, legends and finishes. Off-the-shelf.



INCANDESCENT OR NEON SUB-MINIATURE INDICATORS

Meet or exceed MIL-L-3661. Mounts in 15/32", 1/2" or 17/32" clearance holes. Incandescent for 1.35-28V; neon has patented built-in current limiting resistor. Choice of cylindrical, faceted, convex, flat, square and round lens shapes, colors, finishes, legends. Off-the-shelf.

DIALIGHT

Dialight, A North American Philips Company
203 Harrison Place, Brooklyn, N. Y. 11237 (212) 497-7600

SEND ME FREE INDICATOR LIGHT PRODUCT SELECTOR GUIDE.



switches to cause a protective time delay. A new unit that is being designed will replace all the cams, switches and time delays with operational amplifiers and a single command-sensing potentiometer.

The scientific research submersible Alvin, now tooling around at the bottom of the Atlantic, only needs a few new items, according to its pilot, Lawrence A. Shumaner, who is also manager of the Deep Submergence Engineering and Operations Section at Woods Hole. He says: "We need a solid-state circuit breaker that will carry 200 amps at 600 V dc that I can put in an oil-filled can and pressurize at 6000 pounds per square inch without changing the values of the components. Maybe then my problems in arcing in oil would go away, and the size and cost would come down.

"We want to put as much equipment outside the crowded submarine as possible. I don't see why the telephone can't be put in an oil can and stuck outside."

Exploration ships are becoming more elaborate. Gulf Oil's new Hollis Hedberg research and exploration ship is the only one, the company says, that is equipped with a complete on-board seismic data-processing capability. Since it can also process gravity and magnetic data, the new vessel enables its crew to obtain, on-site, a complete geophysical interpretation of the area.

Texas A&M has developed a new concept in oceanographic ships. The instrumentation is packaged in modules that can be installed or removed, according to the ship's particular mission. This permits one ship to carry out the jobs of many.

And the Glomar Challenger research ship used by colleges and Government agencies has achieved a believe-it-or-not capability that will undoubtedly come in very handy for ships and semisubmersibles drilling oil in very deep water. Many people thought it would be impossible to find a 10-1/2-inch hole in water 13,000 feet deep after the drilling bit was pulled out and replaced. But Edo Western found it. And the whole thing is relatively simple. It's done with acoustic reflectors on the re-entry cone over the hole and a sonar transceiver in a pipe being lowered. The scene is transmitted to the



Alvin, the Navy's deep submersible operated by the Woods Hole Oceanographic Institution, is now diving in the mid-Atlantic to inspect rock formations.

surface ship and displayed on a PPI scope until the new bit is successfully guided into the old hole. Edo Western says the system will work in 20,000 feet of water.

The Navy is heavily engaged in underwater projects. Very advanced design has gone into the RUWS (remote unmanned work system), which will perform a variety of engineering and scientific work at depths of 20,000 feet.

The objective was to simulate man's senses in the cable-tethered system. A head-coupled TV camera on the vehicle follows the head motion of the operator some four miles above on a surface ship. Tension on the manipulator is fed up the cable to the operator so he can "feel" the weights and movements the claw is encountering. Integrated displays and controls allow the operator to control the remote vehicle with a minimum of

learning and conscious thought.

Also under Navy development: Snoopy, a remote-controlled swimming television camera; SCAT, a submersible, cable-actuated teleoperator designed for undersea inspection and work tasks; and a navigation system that uses natural gravity and magnetic fields as aids.

Three candidates for transmitting data and power through a pressurized hull without penetrating it physically are being studied: electromagnetic coupling (split transformer halves), acoustic coupling—theoretically, efficiencies of up to 65 per cent are possible—and light coupling. Light systems have the potential for transmitting extremely wide-bandwidth information, the Navy says. The circuitry is relatively inexpensive and uncomplicated. And the method is particularly adaptable to transmitting digital data. ■■

FAST RECOVERY POWER RECTIFIERS

Reverse Recovery (T_{rr}) 200ns and $2\mu s$

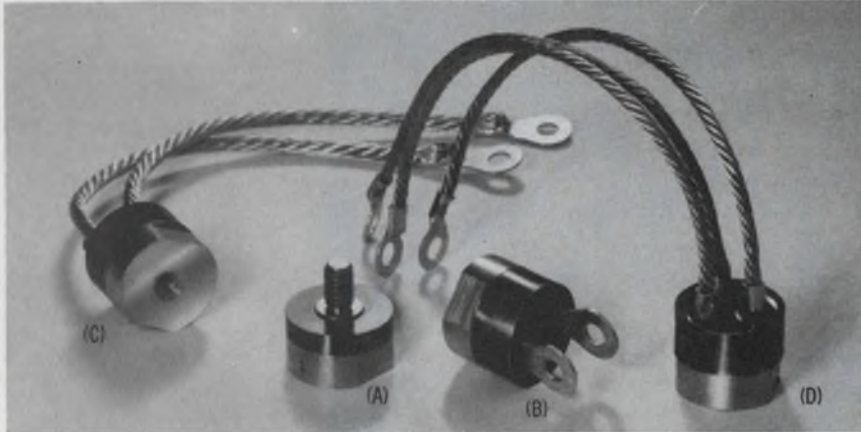

CUPAC 150

... the power house

CuPac 150 is specifically designed for high frequency-high power applications. CuPac 150 is capable of supplying up to 150 amperes with proper heat sinking. Available as half wave rectifier, doublers, center taps and three phase half wave bridge circuits.

Internally, CuPac 150 utilizes Semtech's Metoxilite rectifiers mounted on an (OFHC) oxygen-free hard copper insert base. Inherent rugged design and reliability enables the CuPac 150 to be used in stringent commercial, industrial, military and space applications.

Body Dimensions: 1.12" D x .70" H (+ stud)

FAST RECOVERY — (T_{rr}) 200ns. (Fig. A)
Peak Inverse Voltage: 50, 100, 200 & 400V.
 V_F (max.) (@ 100A): 1.40V, T_j @ 25°C;
1.35V, T_j @ 100°C.

Reverse Current (max.) @ PIV:
25 μA @ 25°C; 1 MA @ 100°C.

MEDIUM RECOVERY (T_{rr}) 2 μs .
PIV: 50, 100, 200, 400, & 600V.
 V_F (max.) (@ 100A): 1.22V, T_j @ 25°C;
1.17V, T_j @ 100°C.

Reverse Current (max.) @ PIV:
25 μA @ 25°C; 1mA @ 100°C.

CUPAC 150, LO- V_F

Peak Inverse Voltage: 30 & 50V.
Reverse Recovery: 85ns (typ.) & 100ns (max.)

• 1/2 WAVE RECTIFIER

	@ 25°C	@ 100°C	@ 150°C
V_F (typ.) @ 20A	.86V	.77V	.72V
V_F (typ.) @ 60A	.95V	.88V	.85V
V_F (typ.) @ 100A	1.02V	.97V	.93V

• DOUBLERS & CENTER TAPS Figs. (B) & (C)

Body Dimensions: 1.12" D x .9" H (+ leads).

FAST RECOVERY (T_{rr}) 200ns
PIV: 50, 100, 200 & 400V.
 V_F (max.) (@ 50A): 1.40V @ 25°C; 1.35V @ 100°C.
Reverse Current, per leg (max.):
13 μA @ 25°C; 500 μA @ 100°C.

MEDIUM RECOVERY (T_{rr}) 2 μs .
PIV: 50, 100, 200, 400 & 600V.
 V_F (max.) (@ 50A): 1.22V @ 25°C; 1.17V @ 100°C.
Reverse Current, per leg (max.):
13 μA @ 100°C; 500 μA @ 100°C.

• 3 PHASE 1/2 WAVE BRIDGE Fig. (D)

Body Dimensions: 1.12" D x .9" H (+ leads).

FAST RECOVERY (T_{rr}) 200ns
PIV, per leg : 50, 100, 200 & 400V.
 V_F (max.) @ 33A : 1.40V, T_j @ 25°C;
1.35V, T_j @ 100°C.

Reverse Current, Per Leg @ PIV:
10 μA @ 25°C; 350 μA @ 100°C.

MEDIUM RECOVERY (T_{rr}) 2 μs .
PIV, Per Leg : 50, 100, 200, 400 & 600V.
 V_F (max.) @ 33A : 1.22V, T_j @ 25°C;
1.17V, T_j @ 100°C.

Reverse Current, Per Leg @ PIV:
10 μA @ 25°C; 350 μA @ 100°C.

• DOUBLERS & CENTER TAPS

	@ 25°C	@ 100°C	@ 150°C
V_F (typ.) @ 10A	.86V	.77V	.72V
V_F (typ.) @ 30A	.95V	.88V	.85V
V_F (typ.) @ 50A	1.02V	.97V	.93V

• 3 PHASE 1/2 WAVE BRIDGE

	@ 25°C	@ 100°C	@ 150°C
V_F (typ.) @ 5A	.86V	.77V	.72V
V_F (typ.) @ 15A	.95V	.88V	.85V
V_F (typ.) @ 25A	1.02V	.97V	.93V

NEW "STUD"

... Super stud rectifier



Semtech Corporation introduces the DO-5 Stud, a new series of high current silicon stud rectifiers for high frequency applications. Capable of supplying up to 50 amperes with proper heat sinking, the DO-5 Stud has been specifically designed for industrial, military and space applications.

Metoxilite rectifiers are used internally, the base is a DO-5 configuration and terminals offer easy soldering properties.

Body Dimensions: .69" D x .45" H.

FAST RECOVERY (T_{rr}) 150ns
IR (@ PIV), Per Leg: 13 μA @ 25°C;
500 μA @ 100°C.
 V_F (max.) @ 50A : 1.40V @ 25°C;
1.35V @ 100°C.

MEDIUM RECOVERY (T_{rr}) 2 μs .
PIV: 100, 200, 300, 400, & 600V.
IR (@ PIV), Per Leg: 13 μA @ 25°C;
500 μA @ 100°C.
 V_F (max.) @ 50A : 1.22V @ 25°C;
1.17V @ 100°C.

LO- V_F "STUD"



... Low forward voltage drop.

LO- V_F stud rectifier is specifically designed for high frequency, high power applications.

VERY FAST RECOVERY (T_{rr}) 100 ns.

Peak Inverse Voltage: 30V.

	@ 25°C	@ 100°C	@ 150°C
V_F (typ.) @ 10A	.86V	.77V	.72V
V_F (typ.) @ 30A	.95V	.88V	.85V
V_F (typ.) @ 50A	1.02V	.97V	.93V

"We're number 1 because we try harder"



SEMTECH CORPORATION

652 Mitchell Road, Newbury Park, California 91320
(805) 498-2111, (213) 628-5392 / TWX: 910-336-1264

CHICAGO: (312) 352-3227
DALLAS: (214) 253-7644
FLORIDA: (305) 644-5404
NEW JERSEY: (201) 654-4884
SAN FRANCISCO: (415) 328-8025
EUROPEAN SALES: (Switzerland) (042) 232-242



3 1/2 x 3 1/2 x 76,000,000.

Unusual dimensions? It's an unusual tape cartridge. It stores up to 76 megabits, can transfer up to 100k bps per channel, and measures only 3 1/2" x 3 1/2" x 1/2". At the single cartridge price of \$19.95, the cost per megabit works out to 25¢. With OEM quantity discounts up to 50%, the cost per megabit can drop to 12 1/2¢!

It's our Datacord™ Tape Cartridge. It consists of a protective case, hub and tape. Inserted in our recorder, it becomes one end of a bi-directional quasi-zero loop system. Two read/write speeds, ranging from 7.5 to 125 ips, provide data transfer from communications rates to data processing rates. At 62.5 ips, with a recorded density of 1600 bpi, each cartridge stores 76 megabits and transfers them at 100k bps per channel.

Relatively high read/write speeds are well within the capability of the system because of the dynamics of the transport mechanism.

Compatible controller-interfaces supporting up to four Datacord recorders are available for most popular minicomputers. The system on the right uses four Model DI-112 Datacord Tape Memory Systems to put 304 megabits on line!

Send for complete specifications. Discover a new dimension of performance.



datacord™
Tape Memory Systems

AVE American Videonetics Corporation, 795 Kifer Road, Sunnyvale, California 94086 (408) 732-2000

INFORMATION RETRIEVAL NUMBER 24

ELECTRONIC DESIGN 18, September 1, 1974

What's going in... in mainframes?

MOSTEK's 16-pin 4K RAM.

Your mainframe memory system... MOSTEK's 16-pin 4K RAM. A perfect match. Because MOSTEK's 4K RAM gives you the performance, board density and ease of use your system demands. Plus it's available *now*.

Compare performance at the system level. MOSTEK's low capacitance, TTL compatible clocks, combined with superior output drive capability, provide the access time your system requires. Alternate 22-pin designs require high capacitance clocks and additional output buffering, causing system speeds to be lower. MOSTEK's 16-pin multiplexed design reduces the number

of address buffers required without affecting high speed access time. For small peripheral memory arrays the cost savings are substantial — even more so in the case of large mainframe arrays. So look to MOSTEK to meet the high speed requirements of your system.

Want board density? Of course. All memory users — from peripheral and minicomputer manufacturers to the big mainframe people — appreciate the increased density offered by MOSTEK's 16-pin design. (A 50% savings in memory board size over 22-pin alternates.) The result is a more compact, cost effective system.

Interested in ease of use? Again, compare the advantages of MOSTEK's MK4096. Readily available automatic insertion equipment can be used in

board assembly. Voltage pins are on the corners to simplify PCB layout. All inputs including clocks are directly TTL compatible with low capacitance. And the circuit is extremely tolerant of noisy system environments.

Your mainframe, minicomputer or peripheral memory and MOSTEK's 4K RAM. That's what's *going in*.

Want more details? Call your local MOSTEK distributor or representative or contact MOSTEK, 1215 West Crosby Road, Carrollton, Texas 75006, (214) 242-0444. In Europe contact MOSTEK GmbH, TALSTR. 172, 7024 Bernhausen, West Germany, Tel. 798038.

MOSTEK

INFORMATION RETRIEVAL NUMBER 25

MOSTEK moves forward...in memories.

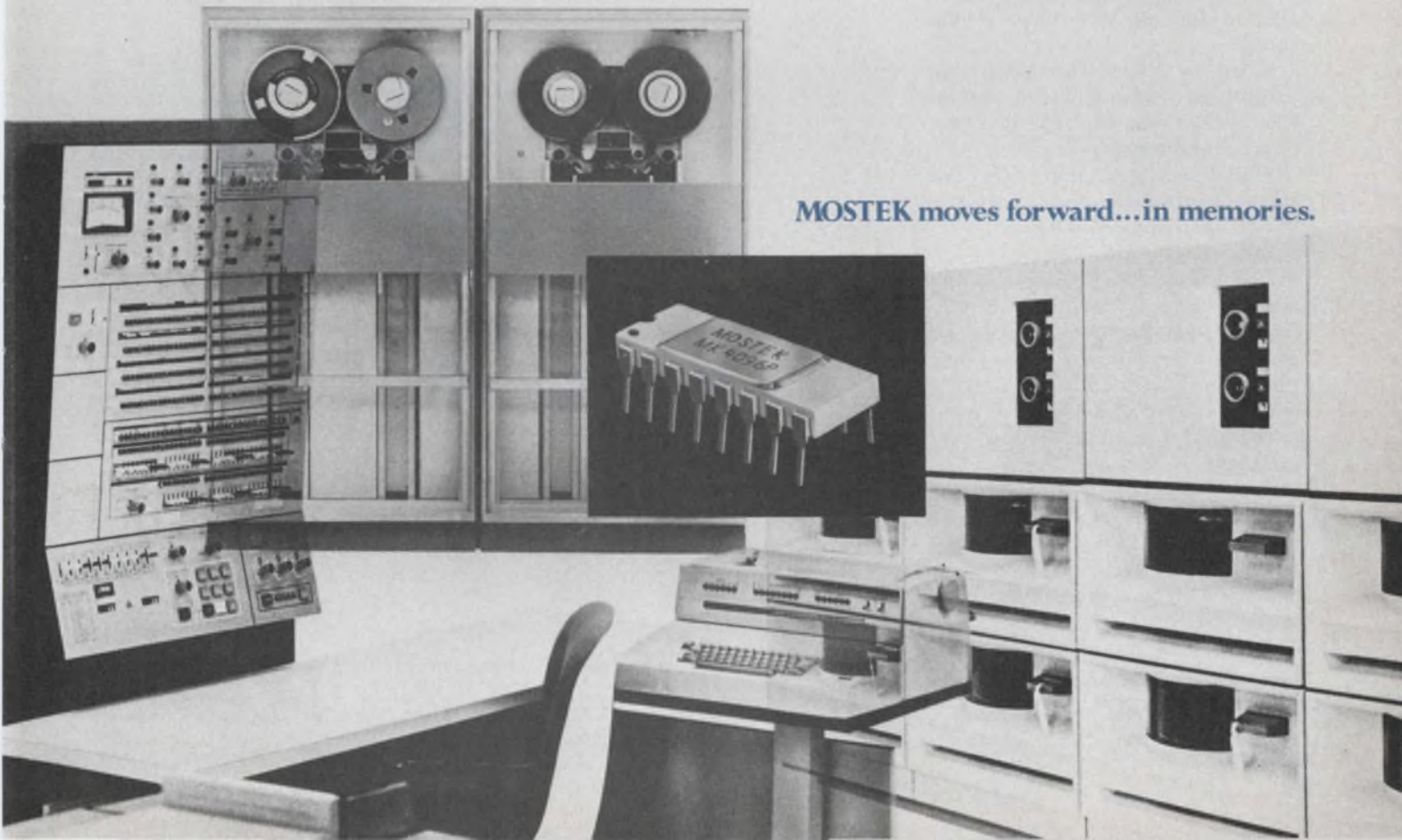

New laminar-flow electron gun promises brighter, better CRTs

Virtually every cathode-ray tube built since the 1930s—whether for oscilloscopes, television, radar or computer terminals—has used the same basic crossover electron gun. Watkins-Johnson Co. of Palo Alto, Calif., has developed an electron gun that uses a different operating principle—laminar flow.

The technique promises brighter CRT displays with smaller spot size, better resolution and lower drive requirements, the company says.

Although the superiority of the laminar-flow CRT has not yet been demonstrated in all applications, research indicates several theoretical advantages for tubes using the new gun:

- Up to a 30% reduction in spot size.
- Up to double the current density in the electron spot at the screen.
- Up to twice the peak line brightness without loss of resolution (when not limited by phosphor characteristics).
- Reduced grid drive for the same brightness, or a brighter image with the same signal.

By focusing the image of an intense source of electrons, any electron gun is designed to produce a small intense spot of controlled brightness on the phosphor screen of a CRT. The crossover electron gun can be compared to an optical system that produces a focused image of a small, bright point source. In the case of the crossover-gun CRT, the intense electron source is provided when the electric field in the gun is shaped so that the emitted electrons converge to a crossover almost immediately after leaving

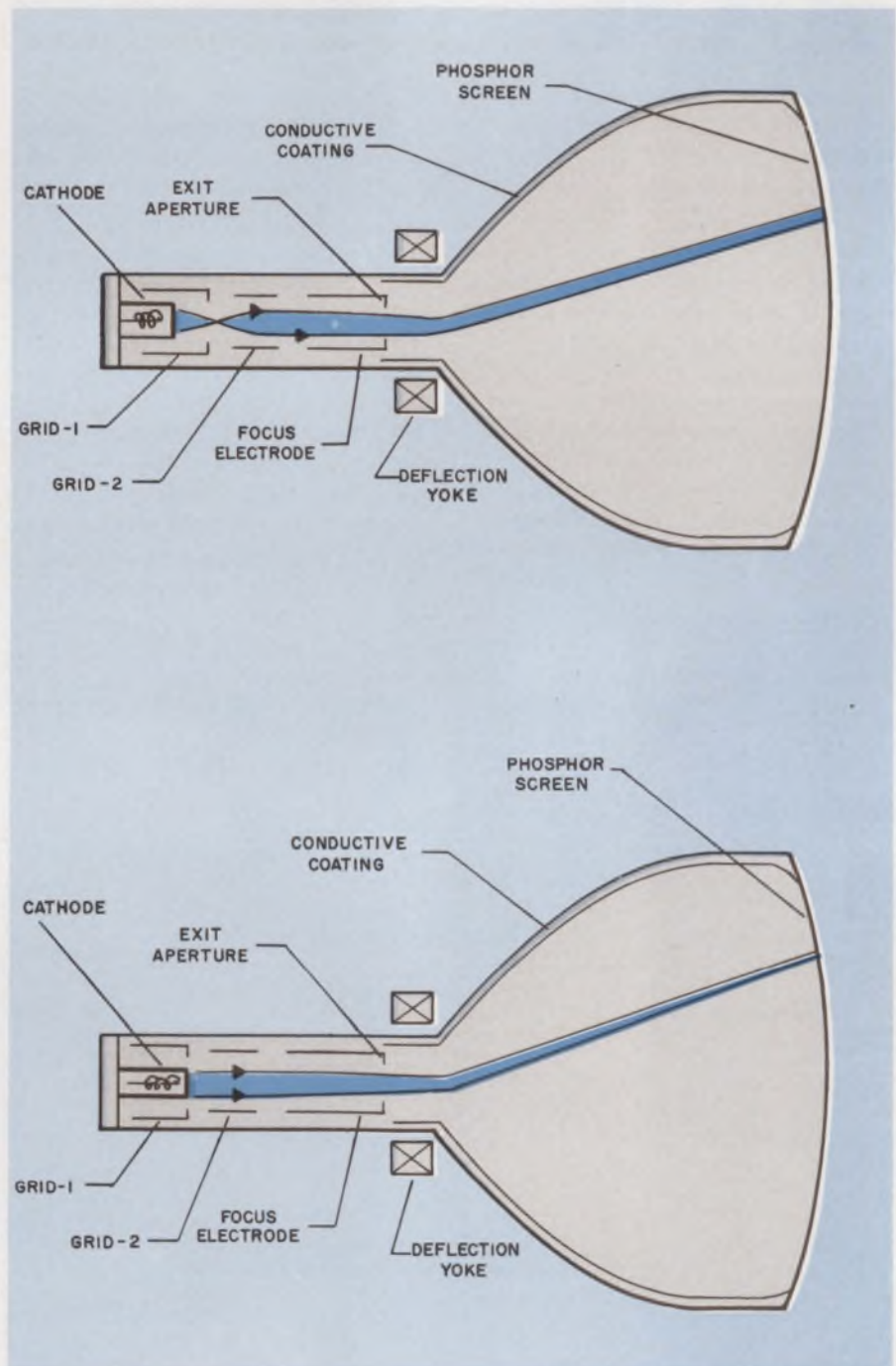

Electrons emitted from the cathode of the laminar flow gun (bottom) travel in a nearly parallel path beam until they converge to a focus at the viewing screen. This contrasts with the electron beam trajectory for the standard crossover type cathode-ray tube.

Northe K. Osbrink
Western Editor

The first color-capped industrial toggle.

Introducing our new heavy-duty Designer Line switches with up to 20 amp, 2 hp, A-c and D-c ratings. Now you can color-code almost any function or simply use color to improve overall equipment appearance.

Select from nine distinctive lever styles, nine standard colors, two bushing lengths, as well as eleven color-coordinated decorator facenuts in two types.

You also choose from five switch bases, screw or plug-in terminals, single and double poles, plus a variety of circuit configurations.

The first color-capped industrial toggle switch gives you the new colorful choice for your heavy-duty applications. Contact your Cutler-Hammer Sales Office or Switch Distributor.



Designer Line—the broadest line of commercial toggle switches, ratings up to 8 amps, A-c and D-c, and 15 amps A-c. A rainbow of colors! Virtually unlimited combinations of toggle styles, circuits, colors.



CUTLER-HAMMER

SPECIALTY PRODUCTS DIVISION, Milwaukee, Wis. 53201

INFORMATION RETRIEVAL NUMBER 26



the cathode. It is this crossover point that serves as the object that is projected onto the phosphor screen.

For a circular cathode, this crossover does not produce the ideal bright sphere, but approximates a cone. The electron distribution is highest at the center of the cone and is surrounded by a region of decreasing electron density. The resulting spot on the screen, therefore, has an intense center surrounded by a ring of decreasing intensity. Passing the electron beam through a circular aperture, which masks the outermost portion of the beam, improves the uniformity of the spot. Normally this requires more grid drive to the electron gun, to compensate for a loss in brightness.

Watkins-Johnson's laminar-flow electron gun can be compared to the magnifying glass that focuses parallel rays of light from the sun to a bright point. The electrons emitted from the cathode of the laminar-flow gun travel in a nearly parallel beam that is gradually compressed into a focal point at the CRT screen. Because the circular cathode has an even distribution of electrons emitted across its surface, the spot on the screen tends to have virtually a constant brightness.

There are a number of operational differences between the two types of electron guns. To produce the crossover, it's necessary to make the electric field of the crossover gun very strong at the center of the cathode. This field

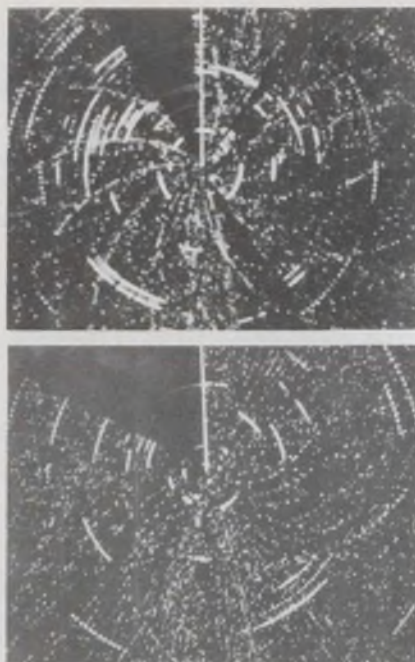

Improved resolution is evident in photo comparison of new laminar flow gun CRT display (bottom) and standard crossover CRT display in a PPI radar system. Actual size of each display is 10 in. in diameter.

strength falls off rapidly toward the edges. Conversely the electric field across the surface of the cathode in the laminar-flow gun is uniform. This provides more electrons from a given cathode configuration.

Another difference is that the optical analog of the crossover-gun CRT is a short-focal-length lens, which tends to exhibit more aberrations (failures to produce point-to-point correspondence between object and image) than the

longer-focal-length analog of the laminar-flow CRT.

Also, the high electron density at the crossover point in a crossover CRT produces a space charge that causes electrons in the beam to repel one another, thereby blurring the spot image—a problem not found in the laminar-flow CRT.

According to Norman Lehrer, staff scientist at Watkins-Johnson, tradeoffs are required to optimize each of the parameter advantages in the new tube, and they may not all be available in one CRT.

Lehrer feels that response to the new tubes has been very satisfactory. "In general, our customers have been impressed with the improved brightness and resolution evident in our laminar-flow CRTs," he reports, "In particular, designers of high-resolution CRT computer terminals are not only pleased with the improved clarity but find the reduced video drive requirements advantageous in simplifying circuitry and reducing production costs."

So far only a few laminar-flow CRTs have been produced, and for the foreseeable future production is to be limited to custom orders so the technology can be observed in critical applications.

Lehrer notes that electron guns using laminar flow can be applied to practically any CRT configuration, electromagnetic or electrostatic, and if produced in quantity, should not be significantly more expensive than crossover CRT counterparts. ■■

Plastic protects components at 800 F

Waveguides, circuit boards, structural members and heat-shield packages that can withstand 800 F are envisioned with a new plastic developed by Hughes Aircraft. The new class of polyimide, designated HR-600, is reported stable at 700 F and able to endure 800 F.

Dr. Norman Bilow, senior scientist at Hughes in Culver City, Calif., notes that although electronic components will not work at these temperature extremes, print-

ed circuit-boards sometimes are subjected to them, with resulting damage.

Bilow says that laminates of the new plastic with graphite fiber can be used to make a low-weight, strong waveguide for space applications. Such a waveguide could withstand better than twice the temperature extremes encountered by current epoxy-graphite waveguides.

HR-600 laminates with graphite

fiber even show an increase in flexural strength as the temperature increases, Bilow reports. ■■

ELECTRONIC DESIGN'S GOLD BOOK CONTEST

Want to win a \$5.00 certificate toward purchase of Hayden technical books plus a chance for a week's Windjammer cruise for two in the blue Caribbean? Turn to p. 134 this issue for details.



BOURNS®
New, Low-Cost
Cermet
Trimming
Potentiometer
outperforms
the other
"small-change"
models!

Bourns super cermet performance delivers again. Our new Model 3352 trimming potentiometer handles more power . . . takes more shock and vibration . . . has a lower CRV . . . and is easier to set than, for example, the "Model 91". Naturally, Bourns super cermet performance is comparably priced. You can depend on it.

The 3352 is a 3/8" diameter, single-turn device with an easy (but stable) three-way thumbwheel adjust. It can be wave-soldered, and withstands board washing processes with minimal (1%) TR shift. The 3352 is available TODAY in a variety of pin styles to suit your requirements.

Compare performance . . . specify Bourns Model 3352. For complete details, contact your local Bourns representative . . . or the factory direct.

COMPARE PERFORMANCE

	Model 3352	Beckman Model 91
Power	.75 watts at 40°C	.5 watts at 40°C
Electrical Angle	230°	180°
Adjustability	±0.05%	±0.05%
Torque	5 oz.-in. max.	6 oz.-in.
Shock	100G's max. ±2% VRS	50G's no VRS spec.
Vibration	30G's max. ±2% VRS	10G's no VRS spec.
Contact Resistance Var.	1%	2%
Rotational Life	200 cycles	200 cycles
Temp. Range	-55°C to +125°C	-55°C to +125°C



Nobody knows more about trimming potentiometers than we do



VACTEC Couplers

For putting it together, VACTEC is second only to RODIN*.

Vactec Optical Couplers (T.M. Vactrols) put together incandescent lamps, neon lamps or LEDs with photoconductors or phototransistors in a wide variety of packages and capabilities.

Couplers using photoconductive cells are useful for isolation where speed requirements are in the order of milliseconds. Applications include noiseless switching, noiseless potentiometers, signal modulators for audio, triac firing, and low cost RMS regulators.

Couplers using LEDs and phototransistors or photodarlington provide higher speed for output sensing, input driving, interfacing and coupling, solid state relays, and switching.

VACTEC really does put them together—we make our own photoconductive cells, phototransistors and photodarlington and do the assembly at our only factory near St. Louis. Write for all Vactrol bulletins.

*Reproduction of The Kiss by Rodin.



Vactec, Inc.
2423 Northline Industrial Blvd.
Maryland Heights, Mo. 63043 U.S.A.
(314) 872-8300



washington report

President Ford: A strong supporter of technology

Since becoming Vice President on December 6, 1973, Mr. Ford has walked a tightrope supporting the views and policies of President Nixon while carefully refraining from crossing swords with Congress. Then at high noon, August 9, 1974, it became a new ball game. Where does the new President stand on issues vital to the electronics industry?

Any changes from the Nixon administration's legislative programs, most observers believe, are likely to come in areas other than defense and space. President Ford has said he is a strong supporter of the space program, specifically because of the technological spinoffs, which he says have benefited the nation in national defense and the domestic economy. "These benefits justify the expenditures we have made," he said recently.

In 1973, for example, he voted against attempts to cut funds for the Space Shuttle. He supported the continuation of the supersonic transport program and the Lockheed loan guarantee.

While there may be trims, the defense budget will largely remain intact. President Ford said last spring he thought the nation was fully prepared to meet any challenge, but that the U.S. didn't have the military superiority it once enjoyed and it worried him. He's concerned about military sufficiency in the next five to ten years. "We cannot afford to neglect adequate procurement as well as adequate research and development." President Ford's first task, and a continuing one, will be dampening down inflation. At the same time he is expected to rebuild and modernize the defense forces, and he will probably give top priority to new technology for solving the energy situation. In summary, technology of all types and in all areas is likely to regain its old prominence. President Ford, by all accounts, has a better grasp and appreciation for science and technology than Mr. Nixon.

Pension protection for engineers nears reality

Highly mobile engineers appear likely to become eligible soon for a pension plan. After several years of legislative debate, many complications and disheartening delays, Senate and House conferees have finally agreed on a joint bill, and it is expected to be signed by the President. Nearly 35-million workers would be affected by this legislation.

One of the most important provisions is the mobility factor: Employees would be able to take vested pension benefits from employer to employer when changing jobs. Job-changing among engineers has become so prevalent that under present setups, many retired employees never get a penny in pensions.

The Federal bill would ensure against default in case of cessation of an employer's business. Self-employed engineers could deduct up to \$7500 for retirement, and employees of companies without pension plans could deduct up to \$1500. The bill places a \$45,000 ceiling on annual benefits and limits tax-deductible contributions in profit-sharing plans. The Government procurement clause for engineers is expected to be included in the final legislation. This requires companies that have Government contracts to participate in the pension plan to protect engineers.

The switch from inches to centimeters: Side-tracked

Legislation to convert to the metric system is dead this year, according to Congressional spokesmen. The reason: There's too much to do, and too little time. The House voted to kill the measure (H.R. 11035) when the proposal reached the floor under a rule preventing amendment. This legislation would have created a 21-member National Metric Conversion Board to plan and coordinate a 10-year voluntary conversion process in the nation. Labor forces and small-business interests wanted the bill changed to include provisions for Federal subsidies for worker retraining, tool replacement and conversion-cost assistance. But opponents, who favored "letting the chips fall where they may," insisted on a parliamentary procedure that insulated the measure against amendment during debate. Some observers feel that the decisive 240-153 vote against the bill reflected resentment over the "no-amendment" rule rather than the bill's merits.

Engineers call for better Federal use of technology

A strong case for Federal support of technology was made by some of the country's leading scientists and engineers at recent hearings on the subject by the House Science and Astronautics Committee.

Patrick Haggerty, chairman of the board of Texas Instruments, suggested a National Development Act of 1976 in conjunction with the celebration of the nation's Bicentennial. The act would foster growth in science and technology that are vital to continued economic and social growth in the U.S.

Senator Edward Kennedy (D-Mass.), who opened the hearings, pointed out that the Government's attitude and its support of science and technology had declined in recent years and that a re-examination of the role of science and technology in society was needed.

Commercial Avionics industry reports growth

Avionics systems executives have expressed optimism at the continuing growth of their industry. At a meeting of the Airline Electronic Engineering Committee more than 300 officials from the U.S. and overseas agreed that the avionics market for the air-transport industry and general aviation was very good. One boost to the growth of avionics is the Airport Development Aid Program of the Federal Aviation Administration. More than \$1-billion has been allocated under the program for airport development in the last four years. Funds have been approved for 1955 projects, of which 1355 were at airports serving airline users and 600 at airports handling general-aviation aircraft only. The FAA program operates on a matching fund basis with state and local sponsors contributing to over-all project costs.

The spec sheets tell you what should happen.

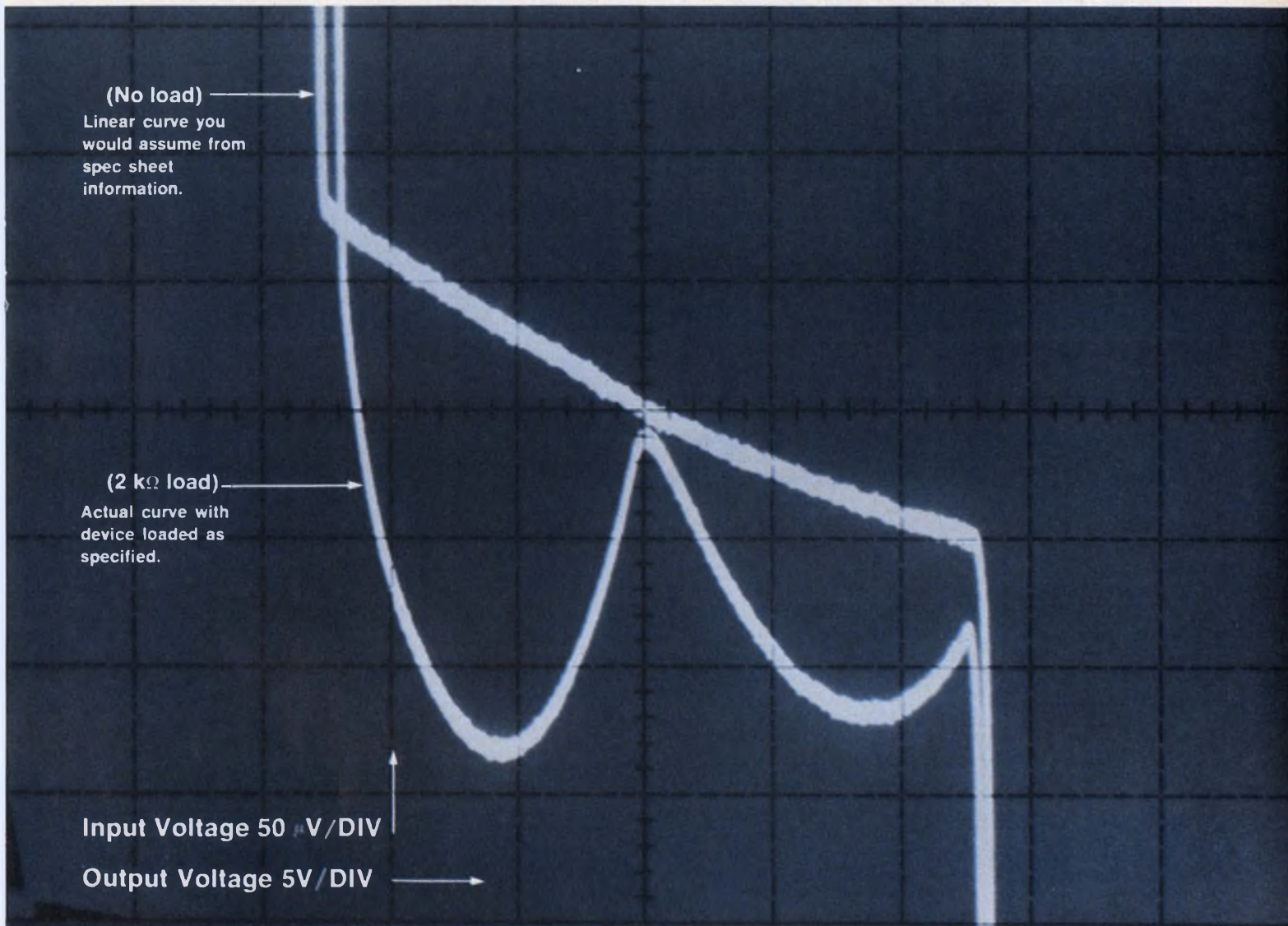

The 577 shows you what did.

When you're designing circuits using linear IC's, you count on spec sheets for the information you need. Generally, gain, CMRR and power supply rejection ratio are given as the ratios of voltage changes measured between discrete points. You assume a "linear" integrated circuit has a linear gain curve (a straight line) with no spurious excursions. But an actual device operating in real-life conditions isn't always linear. Often it produces very irregular curves that may make a big difference in your finished circuit.

These irregular curves are hidden from meters, digital read-outs and go no-go indicators. In fact, a Curve Tracer with its CRT display is the only way to see what is actually happening across the entire operating range of the device you're testing.

The Tektronix 577/178 Curve Tracer will measure and display gain. Offset voltage. Input bias current. Common-mode rejection ratio. And power supply rejection ratio. In addition, the 577/178 displays thermal effects. Popcorn (or flicker) noise. And parameter nonlinearities. And the 577/178 has a storage display to retain curves for comparison or detailed evaluation. Yet it costs only \$3100.

To learn about the pitfalls of linear IC performance and measurements write to Tektronix for pamphlet No. A3040, A3061. Tektronix, Inc., P.O. Box 500, Beaverton, Oregon 97005. Or call your local field engineer.

See You At WESCON — Booths 2206-2209



The last time someone announced 74C, it was a national campaign.

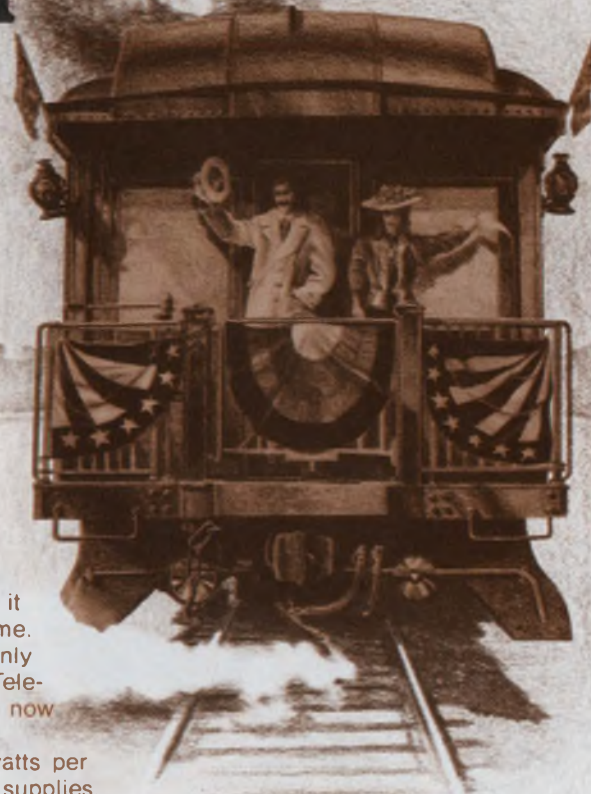

When we saw 74C coming down the tracks, we knew it would be the hottest and most logical CMOS line in a long time. Flags waved, bands played, and thousands of engineers suddenly found CMOS easier to design in. The only thing missing was Teledyne's big production volume and competitive pricing, and now you've got that too.

Here's what Teledyne 74C delivers: A mere 10 nanowatts per gate typical power dissipation. Operation on 3V to 15V power supplies. A big, guaranteed 1V noise margin. Typical noise immunity 45% of the supply voltage. Hefty outputs that drive MOS and bipolar logic (at least two LPTTL loads).

And 74C really simplifies design. 74C logic functions, pinouts and even numbers are identical to 7400 TTL, and every 74C device is compatible with every other 74C device. I/O specs are consistent (no interpreting a pile of data sheets to calculate what's compatible with what). Not to mention drastic cuts in the need for supply regulation, bypass capacitors and noise filtering.

The first batch is available now.

MM74C00	Quad 2-Input NAND Gate	MM74C107	Dual J-K Master-Slave Flip-Flop
MM74C04	Hex Inverter	MM74C160	Synchronous Decade Counter
MM74C20	Dual 4-Input NAND Gate	MM74C161	Synchronous 4-Bit Binary Counter
MM74C42	BCD-to-Decimal Decoder	MM74C192	Synchronous Up/Down Decade Counter
MM74C74	Dual D Flip-Flop	MM74C195	4-Bit Parallel-Access Shift Register

That's our national platform for 74C. But Teledyne's CMOS campaign has just begun. We'll soon be speaking softly about big values in proprietary devices compatible with 74C and custom CMOS for linear and digital applications. All with ultra-low power dissipation and high noise immunity.

 **TELEDYNE**
SEMICONDUCTOR

1300 Terra Bella Avenue Mountain View, California 94043
(415) 968-9241 TWX: 910-379-6494 Telex: 34-8416

INFORMATION RETRIEVAL NUMBER 29

The front-runner

Engineers throughout the world have traditionally viewed American engineers as the root of most progress in electronics. And with good cause. For, in fact, American engineers have been leaders in many areas of technology for a variety of historic and economic reasons.

I became particularly conscious of this on two separate recent occasions. First, I was studying comments from hundreds of readers polled for a "profile" study of ELECTRONIC DESIGN's 11,000 European subscribers, all of whom receive ELECTRONIC DESIGN's GOLD BOOK. Almost to a man these people stated, among other things, that they read ELECTRONIC DESIGN because it keeps them up to date on design techniques, products and technical developments in the United States.



Just a few days later, our circulation director showed me checks and purchase orders from an additional 2200 people outside the U.S.A. who wanted copies of ELECTRONIC DESIGN's GOLD BOOK. And that was just the beginning. I wasn't surprised to find additional orders from the major countries in Western Europe, where ELECTRONIC DESIGN has heavy circulation. But I was amazed to find that the list looked like an index to a World Atlas, with orders pouring in from every continent but Antarctica and almost every country you could name.

Since the products and manufacturers listed in the GOLD BOOK are predominately American and since the GOLD BOOK is the most extensive compilation of such products in the world, the message from these people is clear. Throughout the world engineers still feel that they must find out what's available in the United States. They still feel the U.S. is at the forefront.

Will such leadership continue forever? I suspect not. Engineers in Europe and Asia, particularly, see themselves in a race with American engineers. They see the American as a front-runner and they want to catch up and pass him. But the American engineer isn't looking back; he doesn't know he's being chased. He may be surprised one day to find himself watching the heels of a fellow he didn't know was following him.

A handwritten signature in dark ink, reading "George Rostky". The signature is written in a cursive, flowing style.

GEORGE ROSTKY
Editor-in-Chief

A low-cost scope offer more than a low



should price.



The new Heath/Schlumberger dual-trace SO-4510 has DC-15 MHz bandwidth, 1 mV sensitivity, post-deflection accelerated CRT, vertical amplifier delay lines & more ...for only \$750.*

The actual value of any oscilloscope is really how much it benefits the user in price, or performance, or both. Our SO-4510 offers a low price plus DC-15 MHz bandwidth, vertical sensitivity of 1 mV/cm, time base sweep to 100 nsec/cm and complete dual-trace capability. And it also offers many features that other manufacturers don't provide at anywhere near our low price.

Like post-deflection acceleration for a brighter trace and faster writing speeds. Many input signals that wouldn't be visible on a mono-accelerated CRT are presented in a sharp, bright trace on the SO-4510. Think of your applications for an oscilloscope. Can you really do without our additional brightness?

Trigger bandwidth—is it specified? The SO-4510 will typically trigger on signals up to 45 MHz and is guaranteed to 30 MHz. And there's no stability control needed with the digitally-controlled triggering circuits. In the automatic mode, a reference baseline is generated even when the trigger signal is absent. Complete triggering controls are provided with choice of AC or DC coupling, triggering at any point on the vertical signal. An AC fast coupling mode is provided to reject low-frequency components of the trigger waveform for accurate scope triggering. Choice of automatic or normal sweep uses any one of 22 time bases from 0.2 sec/cm to 0.1 μ sec/cm.

Vertical input sensitivity of 1 millivolt—over the full bandwidth. Think of this in terms of the way you're most likely to use an oscilloscope— with a X10 probe. With SO-4510 and a X10 probe, you can still read waveforms to 10 mV/cm, not the 50 or 100 mV/cm found on other scopes. We also offer a companion high impedance isolating probe with 10:1 attenuation for only \$23.95*.

Internal delay lines for the vertical amplifier insure start of the horizontal sweep prior to the beginning of the vertical signal. They allow display of at least 20 nanoseconds of the pretriggered waveform, insuring that the complete waveform will be displayed. Can you really do without this pulse analysis capability?

True X-Y capability. X-Y operation uses Channel 1 for horizontal deflection and Channel 2 for vertical deflection. Phase measurements can be made using the standard vertical inputs, not the horizontal input as other scopes require.

Dependable, rugged design with easy-to-service construction. The SO-4510 was designed by service-oriented engineers who have been designing low cost scopes for a long time. The SO-4510 is remarkable easy to service. All major circuitry is located on five circuit boards for easy trouble-shooting. Push-on connectors permit fast removal of any board. Even the CRT can be removed and replaced in a matter of minutes.

Most important, the SO-4510 is designed and built by Heath—specialists in high performance, low cost instrumentation. We know how to provide good instrument value for the money, not merely another low-price instrument. And we're not just entering the low-cost instrument market, we've been here for years. The SO-4510 was designed for a maximum of performance at the lowest possible cost. Compare our scope with the competition. You won't find a better value than the SO-4510 from Heath/Schlumberger.



The latest Heath/Schlumberger catalog describes a complete line of high performance, low cost instrumentation for industrial, R & D and educational applications. Mail the reply card or the coupon below for your free copy.

Heath/Schlumberger Instruments
Dept. 531-268
Benton Harbor, Michigan 49022

HEATH
Schlumberger

Please send the latest Heath/Schlumberger catalog.

Name _____
Title _____
Company/Institution _____
Street _____
City _____
State _____ Zip _____

*Mail order prices; F.O.B. factory. Prices & specifications subject to change without notice.

EK-432

FOCUS

on
Microprocessors

Digital designers faced with the many performance claims for new LSI microprocessors might conclude that one of these little, low-cost marvels could solve all their system problems. After all, if a small IC offers the processing of a computer, replaces scores of standard logic circuits and has a seemingly endless list of applications, who needs to design with anything else?

Closer examination of the burgeoning application literature for a "computer on a chip" reveals a different picture. A large-scale integration processor, for example, does perform many of the functions of the central processing unit in conventional computers. But to use the circuit, many more ICs may be needed to interface with peripheral devices, data-communication lines and even its own memory.

And that low price tag on the LSI processor—typically, well under \$100 for 4-bit word-length units and under \$400 for 8-bit units—is low compared with the thousands of dollars needed for a general-purpose minicomputer. However, to build a full-fledged microcomputer, you need memory, and the cost of that can easily exceed the price of the processor.

Moreover, if you add up the cost of all the necessary hardware components, you may find the total exceeding the less-than-\$1000 level of "stripped down" minicomputers available on PC boards.

Programming—unfamiliar demands

A decision to use an LSI processor opens up a whole new design ball game. Not only must a digital designer contend with the relatively familiar requirements of any logic system. The



Combine an LSI microprocessor with associated circuitry and memory, and you obtain a microcomputer. In the foreground are LSI circuits and prototype systems offered by Rockwell International. The manufacturer's line includes 4 and 8-bit microprocessor chip sets.

designer must also grapple with the relatively unfamiliar demands of programming. And software development, usually involving assembly language (only one step up from a computer's inherent machine language of ONEs and ZEROs), represents by far the major design effort and cost.

In addition microprocessors don't lend themselves to the traditional "learning curve" for new

Edward A. Torrero
Associate Editor

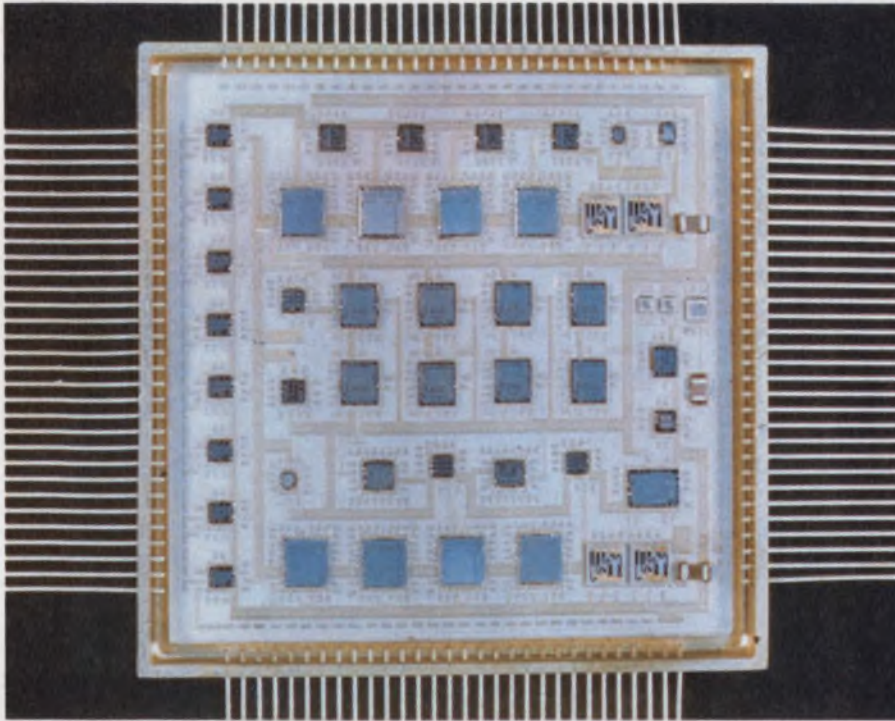

Dice mounted on a substrate form a microprocessor system. This unique packaging approach is used by Teledyne Semiconductor. Other vendors typically mount DIPs on PC boards.

components. Previously the experience gained in the use of one component could be transferred to a similar component from another manufacturer. But different microprocessors generally don't have alternate sources. And the chips come with different software capabilities, hardware requirements and design aids. Hence a completed design, using one LSI processor, might have to be scrapped totally if you decide to turn to another vendor's unit.

Still, there are major benefits. Microprocessors are unique among ICs in that they can be programmed like computers. As a result, they permit a tradeoff of software for hardware to achieve a dazzling increase in system capability and versatility.

They can be used economically to replace or upgrade random-logic designs, involving scores of standard ICs, when many functions must be performed. And they use less circuitry than hardwired logic in applications emphasizing random collection and routing of data.

Of course, for some applications microprocessors are not the sole LSI alternative. Complex logic decisions might be handled just as well with circuitry using programmable logic arrays. And arithmetic computations are performed by arithmetic logic units or by calculator chips—from which a number of microprocessors have evolved. Custom LSI chips provide yet another alternative.

Nevertheless microprocessors are filling the gap between special-purpose LSI circuits and conventional minicomputers. They are currently finding their greatest use as decentralized,

cheaper minis in remote, programmable controllers.

There's a wide product range

The many advantages of microprocessors are creating a demand that manufacturers are meeting in a variety of ways. Designers can choose from among single or multichip processors, chip sets or PC-board assemblies, and from among a wide range of technologies.

The most common technology is silicon-gate, p-channel MOS (PMOS). But manufacturers are also using n-channel MOS (NMOS) and silicon-on-sapphire MOS (SOS/MOS) to achieve speeds that are higher than those possible with PMOS. Bipolar processes are employed for the highest speeds—about 200-ns cycle vs 2 μ s for NMOS types. Complementary MOS (CMOS) is used for the lowest power dissipations—microwatt-range chip dissipation vs milliwatt range for other types.

Standard LSI-processor products in various configurations handle data in 4, 8 and 16-bit word lengths, and modular multichip microprocessors can be used to achieve even longer word-length processing. The available configurations, with their major features, consist of the following:

- Microprocessor chip sets, including special interface ICs and sometimes special memories, to simplify designs of minimum-hardware systems for specific applications.
- Microprocessor-based logic boards to eliminate the need to test, assemble and interconnect

processor chips, peripheral circuits and memory for a variety of applications.

- General-purpose—n o n d e d i c a t e d—microcomputers, on cards or in boxes, to permit system design, development and testing. These are offered by component manufacturers, as well as, a growing number of other vendors.

- Microprocessor-based minicomputers offering, as a result of their traditional mini features, maximum flexibility and capability when compared with MOS microcomputers. Offered by minicomputer manufacturers, these units generally use custom MOS processors.

The cost of each configuration increases with a unit's complexity. At the minicomputer level, hardware cost might be the highest. But available software support is the most extensive. Designers tend to feel that the number of units determines the major tradeoff in a choice between a micro and minicomputer. A small number of units—as for an end-user application—can best be served by a mini, which can minimize software development costs. But for large quantities—as for an OEM application—a microcomputer can minimize hardware costs.

Chip sets improve early versions

Due to increasing availability of special interface circuits and improvements in processor-chip architecture, fewer additional circuits are needed for the newest microprocessors than for earlier versions. First-generation 8-bit processors, for example, typically needed about 20 additional standard-TTL circuits to make them work.

The extra ICs include the following: registers to address memory, either ROM or RAM; decoders to interface with memories; other ICs to handle processor information and to synchronize the operation of the processor and circuits; clock circuits, and a variable amount of interface ICs, depending on the application. For example, in a multichannel data-communications application each channel requires an asynchronous receiver/transmitter and associated interface ICs.

But even with newer processors, applications still can require additional circuitry to obtain one or more of the following: clock generation and timing, memory and I/O control, data and address buffering, multiplexed inputs, interrupt control, refresh for dynamic memories and additional supply voltages.

And some microprocessors are offered only as part of complete chip sets or with the purchase of the associated memory from the same IC manufacturer. This may not be a problem if you plan to buy all your components from the same source, but it does stop you from shopping around for the lowest price and precludes the use of core memory—which most processors can ac-

cept just as well as semiconductor types. Also, if you purchase a chip set, you must design around the circuits offered.

Specs don't tell all

Unlike the less-complicated ICs, microprocessors cannot be completely characterized on a simple data sheet. Moreover different vendors use different parameters to measure a processor's capabilities. This makes any comparison of processors—not to mention selection of the best one—a difficult task. And there's no trend in sight toward standardization.

A microprocessor's computing speed is a case in point. Frequently manufacturers use a basic cycle time, or period—sometimes called a micro-cycle—to denote speed. But many microcomputer operations require several such cycles to be performed. This applies especially to the execution of the more powerful instructions. Hence a critical instruction may require more time than that indicated by the basic cycle.

In addition a microprocessor's maximum clock rate can be misleading, if taken for a measure of speed. It's possible for one microprocessor to perform basic operations—like register-to-register add—faster than a unit using a higher clock rate. Differences in microprocessor architecture and chip design tend to minimize the importance of the clock-rate spec.

Other specs given to indicate speed include minimum instruction time, interrupt response time, and time to add two numbers—which may already reside in the processor. Like cycle time and clock rate, these numbers don't measure such critical times as the over-all time needed to perform important routines. Excluded are additional delays, such as those needed to obtain data from memory. The solution is to use benchmark programs tailored to your application as a basis for selection of one microprocessor over another.

Use of benchmark programs can determine the power of the instruction set, thus circumventing one of the most abused specs—the number of instructions. Microprocessor comparisons based on this number abound, although such comparisons have serious flaws.

For example, a simple number doesn't reveal what instructions are available for data movement and manipulation, for decision and control and for input/output operations. Some microprocessors have far more I/O instructions than others; they are tailored for a specific class of applications. And missing instructions can always be performed by routines, although with a sacrifice in speed.

Also, the number of instructions claimed for the same microprocessor can increase from one page of a reference manual to another. One

reason is that instructions that move data have been multiplied by the number of addressing modes.

Common addressing modes include direct, immediate and indirect. In the immediate mode, the instruction includes data, while in the indirect mode, an address preloaded into a register increases the address bits in an instruction. Variations and extensions of these modes are also available, so a basic instruction can be multiplied several times.

Other factors that inflate the number of instructions may be the number of registers—in, say, a load-to-register operation—or the number of conditions—for example, those on which a branch may occur.

Of course, improved instruction sets are obtained with longer word-length microprocessors and advanced versions of smaller units. For example, 16-bit microprocessors have instructions for multiply and divide—functions that require

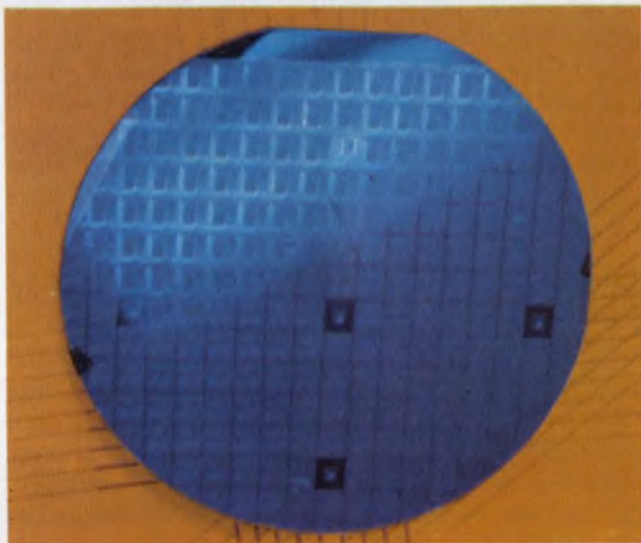

They're not "computers on a chip"—yet. But LSI microprocessors, symbolized by this wafer from Intel, perform many of the functions of central-processing units in conventional computers.

software routines in 8-bit models.

And advanced microprocessors feature more powerful instructions as well as the original set of a predecessor. However, this "software compatibility" doesn't allow routine upgrading of systems by chip replacement. In general, expect to redesign to employ the new hardware/software tradeoffs efficiently.

For virtually all models, data sheets claim TTL compatibility. But don't expect many MOS processors to drive TTL loads; most don't. The term primarily refers to the fact that both microprocessor and TTL circuit can use a common 5-V supply. Newer models list a maximum TTL-drive capability of only one standard load, and many

models require external components to achieve the interface levels needed for logic compatibility.

Watch architectural claims, too

Many computer-like features of microprocessors are frequently cited, including the number and function of registers, the type and depth of stack, interrupt capability and direct-memory access (DMA). However, there isn't as much architectural diversity as there is with minicomputers. IC manufacturers are constrained by technology limitations, so that comparable microprocessors tend to perform similarly. For example, preliminary benchmark programs run by several manufacturers for their 8-bit, single-chip NMOS processors often show comparable execution times.

Data sheets frequently boast several working registers. But only a single register, the accumulator, is essential. An accumulator, however, must have access to memory, and available instructions should permit immediate addressing and data manipulation between the accumulator and memory. If indirect addressing is available, even the function of special index registers can be accomplished with memory.

The major significance of additional registers lies in access time and the bit efficiency of instruction words. It takes far fewer bits to specify one of several previously defined working registers than a memory location. And a faster execution time can be obtained with registers that are separate from memory. They can be accessed without excessive memory-cycle delays. Otherwise it doesn't matter whether these registers are in an external memory or in the processor, so long as they can be referenced efficiently.

Some data sheets might seem to imply that the quantity of registers is more significant than their quality. It isn't. Not all registers can be incremented and tested for zero, even though they are described as "general-purpose." Those that can may be used for counting and program-loop control. In general, not all registers can be used for indexed addressing. Nor can they be loaded directly from memory—rather than only from the accumulator—or used as a source or destination for arithmetic logic operations.

Microprocessors employ stack-oriented registers that can be accessed only in a last-in-first-out basis—the so-called LIFO, or push-down, stack. These are used for subroutine nesting, interrupts and for temporary storage of data. They can be either on the chip (a hardware stack) or external to the processor in memory (a software, or pointer, stack). The hardware stack permits higher-speed operation, but it has limited size. The size of the software stack may be as large as available memory space permits, but the stack must be maintained by the program.

An interrupt capability is an absolute must for applications that involve asynchronous or unpredictable events. All microprocessors claim some type of interrupt handling ability, but the extent can vary from one unit to another. With older processors, you have to design the means to save the contents of the processor just prior to the interrupt, and then restore the information after the interrupt is serviced.

Those means may involve reservation of registers on the chip, use of external registers or use of another microprocessor. Any of these methods can store the essential contents of the processing unit. Software control, involving special routines, must also be provided to complete the design. The complexity of these techniques tends to discourage designers from attempting to handle even a single interrupt.

Newer microprocessors can accommodate single-line, multilevel and vectored interrupts, and they save essential registers automatically. A complete saving must be programmed. In one single-line interrupt system, device-interrupt requests are ORed together to form one request line. The program identifies the device and resolves priority. A multilevel scheme employs several single-level sense lines to handle additional interrupts. For very fast response, the vectored interrupt directly branches to a memory location that corresponds to a specific interrupt.

Another feature that depends on the unit is DMA capability. For some units, a "direct" access of memory must be performed indirectly through the microprocessor's usual word-by-word transfer procedure. This may not be a problem if you don't mind the processor's idle time, but it does limit data-transfer efficiency.

And don't expect I/O data throughput rates always to include the time needed to sense for a device or to respond to an interrupt. When these times are included, the actual throughput can be significantly less than expected.

Fixed instruction vs microprogram

Most microprocessors come with fixed instruction sets, around which software must be developed for an application. For some units, however, the option exists for microprogramming, the ability to alter or totally change the original instruction set. In essence, you program the microprocessor's internal microinstructions to obtain a macroinstruction set that is tailored to the application.

The advantages of microprogramming include increased speed, since microinstructions are executed considerably faster than macroinstructions are. Also, the technique allows a more detailed level of control that can be used to reduce hardware; the program controls more functions.

Because of the hardware savings, vendors expect microprogramming to find its greatest use in large-volume applications—in excess of tens of thousands of units. Alternatively, microprogramming represents the logical choice for an emulation of another computing system or for the speedy execution of critical, short routines.

The exceptional skills required for microprogramming constitute its major disadvantage. A microprogrammer must deal with the specific timing relationships of the internal architecture. And since each application requires a separate microprogram, each has its own instruction set that can't be transferred easily to another application. Nor can software design aids, geared toward the fixed instruction set, be applied to the changed set.

Design aids speed development

Much of the start-up, or development, effort in the design of a microcomputer system is linked to the coding phase. Coding converts system programs into instructions that can be loaded directly into the memory. However, the basic design-aid tools themselves are programs that generally require the use of time-sharing services or other computer facilities. And like the LSI processors they support, design-aid features can differ from vendor to vendor.

Assemblers are a case in point. All assemblers convert a program into the basic machine language in a process that usually involves several steps. Essentially the assembler reads a so-called source tape—with statements written in the mnemonic, or symbolic, assembly language—and produces a so-called object tape, with binary numbers suitable for the processor's memory. Errors due to misuse of the assembly language can be detected and pointed out by the assembler.

But some manufacturers offer single-pass assemblers, thereby reducing the steps needed to obtain the binary instructions for memory. Or they may provide the option of loading the assembler into ROMs and pROMs so that the microcomputer itself, rather than a host computer, executes the program. These are called hardware assemblers.

Another type, called a macro-assembler, simplifies coding when similar sections of code are used repeatedly, but variations preclude the use of conventional subroutine techniques. With a macro-assembler, a single instruction yields the necessary expansion.

Editors, available on time-sharing services, allow designers to prepare the original assembly-language programs and to change or correct them with simple commands. They can add documentation and store, combine and retrieve programs. And they can readily output programs onto paper

MICROPROCESSOR SCORECARD®

µP Scorecard®	Classification	Technology	Parts Family				Features				Word Size (Data/Program)	Address Capacity (Program Words)	Clock (KHz/Phases)	Register Add Time (µsec per Data Word)	Number of CPU Registers			Return-Stack Size (NR x Bits)	Voltages Required	Power Dissipation (Watts)	Operating Temperature Range (°C)	Package Sizes (DIP Pins)	Price Range (approx.: CPU only; quantity 100)	Status	Remarks	
			Clock Driver	I/O Interface	UART/USRT	RAM	ROM/PROM	Interface	Interrupts	Integrated CPU					Microprogrammed	Accessible Stack	DMA Ability									BCD Arithmetic
BURROUGHS MINI-D	One-chip CPU with ROM	PMOS										8/12	256	1000/1	9	3	—	1		-12, +5		0, +70	16	\$ 60	Custom	
FAIRCHILD PPS-25	Calculator-oriented	PMOS	✓		✓	✓						4x25/12		400/2	62.5	1	—	—	4x12	-10, +5	.6	0, +70	16, 18, 24, 40	\$ 60	Delivered	
INTEL MCS-4/4004	Calculator-oriented	PMOS	✓		✓	✓	✓					4/8	4K	740/2	10.8	1	—	16	4x12	-10, +5	1.0	0, +70	16	\$ 30	Stocked	
INTEL 4014	Calculator-oriented	PMOS	✓		✓	✓	✓	✓				4/8	8K	740/2	10.8	1	—	24	8x12	-10, +5	1.0	0, +70	16, 24		Rumored	
INTEL MCS-8/8008	One-chip CPU	PMOS										8/8	16K	500/2	20	1	—	6	8x14	-9, +5	1.0	0, +70	18	\$100	Stocked	
INTEL 8008-1	One-chip CPU	PMOS										8/8	16K	800/2	12.5	1	—	6	8x14	-9, +5	1.0	0, +70	18	\$130	Stocked	
INTEL 8080	One-chip CPU	NMOS	✓	✓	✓	✓	✓	✓	✓	✓	✓	8/8	64K	2083/2	2	1	—	6	(RAM)	-5, +5, +12	1.0	0, +70	40	\$200	Delivered	
INTERMIL ISD-8	One-chip CPU	CMOS										12/12	4K	2000/1	6	1	—	—	Modifies Program	5	.002	55, +125	40		Announced	DEC PDP-8 Code
MOTOROLA 6800	One-chip CPU	NMOS	✓	✓	✓	✓						8/8	64K	1000/2	2	2	1	—	(RAM)	5	.25	0, +70	24, 40	\$150	Samples	
NATIONAL GPC/P	4-bit Slice	PMOS										4N/23	100	715/4	1.4	8	—	—	16x4N	-12, +5	.7	0, +35	22, 24	\$150	Delivered	1 ≤ N ≤ 6
NATIONAL IMP-4	3-chip CPU	PMOS										4/4	64K	500/4	12	4	—	—	7x12	-12, +5	1.0	0, +70	22, 24	\$150	Samples	16x4 Data Stack
NATIONAL IMP-8	3-chip CPU	PMOS										8/8	64K	715/4	4.6	3	1	—	16x8	-12, +5	1.0	0, +70	22, 24	\$230	Delivered	
NATIONAL IMP-16	5-chip CPU	PMOS										16/16	64K	715/4	4.6	2	2	—	16x16	-12, +5	1.4	0, +70	22, 24	\$310	Delivered	
RAYTHEON RP-1600	4-bit Slice	Bipolar										4N, 48	64K	5000/1	1	j	k	—							Announced	(j + k) ≤ 8
RCA COSMAC	2-chip CPU	CMOS										8/8	64K	667/1	6	p	q	—	r x 16	12	.01	-55, +125	40		Announced	(p + r + 2q) ≤ 15
ROCKWELL PPS-4	Calculator-oriented	PMOS	✓	✓	✓	✓						4/8	4K	200/2	5	1	—	1	3x12	17	.225	0, +70	42	\$ 40	Delivered	
ROCKWELL PPS-8	One-chip CPU	PMOS	✓	✓	✓	✓	✓	✓	✓	✓	✓	8/8	16K	256/2	12	1	1	2	2x14	17	.3	0, +70	42		Announced	
SIGNETICS 2650	One-chip CPU	NMOS										8/8	32K	1200/1	4.8	s	t	—	8x15	5	.5	0, +70	40	\$100	Announced	(s + t) ≤ 6
TOSHIBA TLCS-12	One-chip CPU	NMOS	✓	✓	✓	✓	✓					12/12	4K	1000/3	13	1	—	—	(RAM)	-5, +5	.8	-20, +80	16, 24, 26, 42		Announced	Multiply Instruction

July 1, 1974

© Microcomputer Techniques, Inc.

A tabulation of representative LSI microprocessors reflects the product range: from calculator-oriented, 4-bit units using PMOS technology to newer 16-bit multichip bipolar processors. Note that the table, reprinted from "New Logic Notebook" by Microcomputer Techniques,

compares push-down stacks—called return stacks—in terms of number of registers (NR) and the bit size of each. Also processor registers are divided into accumulators (ALU), index registers (XR) and remaining registers (GP) for general use.

tape as well as printers.

A number of loaders are available to complete the coding process. With these, which can be stored in ROMs, assembled programs are loaded into read-only memory. They can also be loaded into RAMs, in which case a bootstrap type is used. A so-called relocating loader automatically adjusts program addresses and loads the resulting instructions. And some loaders have linking capability that lets you use routines with undefined labels. These types supply the missing cross-references between separate routines.

Several manufacturers also offer compilers, which allow programs to be written in a high-level language. The benefits are many: A short readable compiler statement corresponds to many symbolic assembly-language statements. Compilers eliminate the need to write detailed codes to control loops, to access complex data structures or to program formulas and functions. And since programming details are lessened, errors are reduced.

But while high-level language programs are compact, easy to read and much easier to write, the net result could be excessive storage space and slower execution, when compared with an assembly-language program. Generally a choice between the two approaches depends on the degree of optimization required and the design time allowable.

In addition to these design aids, test programs—such as simulators—are virtually mandatory to track down the various subtle errors that may remain. Similarly hardware prototype units are essential to the development of the final product. Prototype units generally involve expanded memory capability, teletypewriter or card-reader interface, power supply, chassis and control panel—in addition to a microcomputer.

Besides boosting initial development costs for the designer, the wide range of hardware/software support requires a major investment by the semiconductor manufacturers. This investment is in addition to that needed to produce the LSI chips. In fact, one indication of a vendor's seriousness in marketing a particular microprocessor is the availability of hardware/software support for the product.

Still, ever more manufacturers are entering the field because of the high potential payoff. Various sources predict that the microcomputer market—valued at under \$50-million last year—should reach at least \$500-million in four years. In the process, a sizable chunk of the TTL market could be replaced. Major microprocessor-chip vendors—such as Intel, National Semiconductor and Rockwell International—are meeting the challenge in a variety of ways.

The Components

By any standard, the recognized leader in microprocessors is Intel, which introduced the product in 1971. Benefiting from its early, one-to-two-year lead over competitors, Intel reportedly captured as much as three-quarters of last year's microcomputer market. Moreover each of its processor chips has been a first of its kind, beginning with a 4-bit unit, the 4004, and leading to an 8-bit PMOS model, the 8008, and the latest advance, an 8-bit NMOS microprocessor—the 8080.

Among the Intel products, the 8080 sets the pace for increased speed and improved instructions. The silicon-gate processor has a 2- μ s instruction cycle and 74 basic instructions, which include the 48 instructions of the earlier 8008. The additional 30 instructions and a 6:1 faster execution rate provide up to a 10:1 speed advantage over the 8008. Moreover the improved performance of the 8080 is obtained with a typical power dissipation of only 600 mW, the same as that of the 8008.

The 8080 can address up to 65-k bytes of memory without need for an external address register. This compares with 16-k bytes of memory and an external register for the 8008. The 8080 requires only six peripheral ICs, as contrasted with the 20 needed with the 8008. The NMOS 8080 comes in a 40-pin package and operates from +12 and ± 5 -V supplies.

A number of architectural differences account for the improved performance of the 8080. For example, it contains a 16-bit stack pointer (to operate the external LIFO stack) and a 16-bit program counter (to indicate the next instruction), instead of an address storage stack with eight 14-bit locations. A portion of the external memory can be used as a last-in, first-out stack, addressed by the stack pointer upon the execution of a Call, Return or Restart instruction.

Moreover not only the program counter but also the data register, the accumulator and the flags (bits that are set to indicate various conditions) can be saved in the external push-down stack. As a result, multiple interrupts can be handled more easily with the 8080.

The 8080 can perform BCD and binary arithmetic. It also has capability for double-precision arithmetic involving two 16-bit numbers. The NMOS processor can handle up to 256 input ports and a similar range of outputs.

Intel offers several hardware and software design aids for the development of microcomputer

systems with its processors. The aids include the Intellec series, consisting of expandable, modular systems that come complete with microprocessor, memory, power supplies and circuitry for teletypewriter interface and clock generation. Each Intellec system is housed in a compact cabinet that features a control and display panel for immediate system monitoring and debugging. All program storage can be accomplished with RAMs, rather than ROMs, for easier program loading and modification. After a program is firm, it can be loaded into ROM.

The standard software package for the Intellec

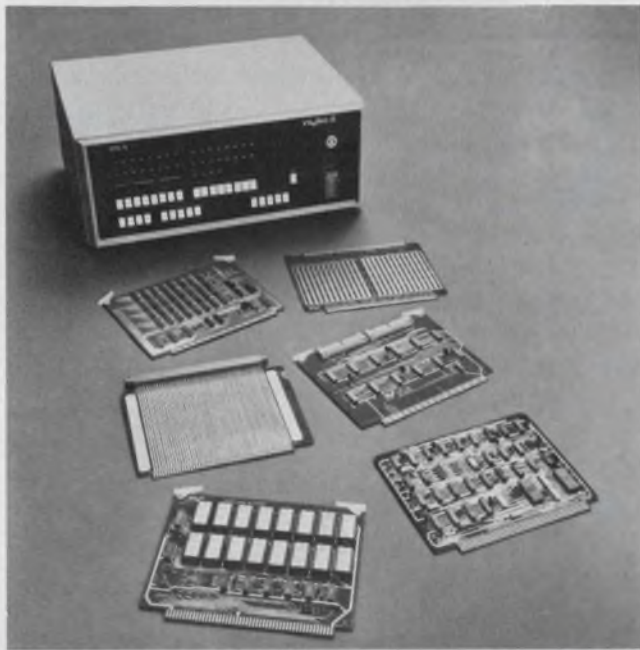

Most manufacturers offer design aids to simplify development of microcomputer systems. Intel's aids include the Intellec series, which comes complete with memory, supplies and clock and interface circuitry.

series includes a system monitor, contained in pROMs, resident assembler and text editor. A programming module provides the timing and level shifting to program pROMs. Additional support is provided by a cross-assembler and simulator written in Fortran IV and by a PL/M compiler available on time-sharing terminals.

The use of PL/M, derived from IBM's PL/1 language, permits sample programs to be written in a fraction of the time needed to write the same program in assembly language. PL/M offers a far simpler means of programming, compared with assembly language. And the debugging and checkout times of a PL/M program are less, because the structure of the language allows the compiler to detect error conditions that would not be spotted by an assembler.

Recent additions to the Intel product line include several ICs, intended to simplify system

design and expansion, and an advanced version of the company's 4-bit microprocessor. The additional circuits include a 4-k-bit dynamic RAM (the 8107), a 2048 × 8-bit ROM (the 8316), a 512 × 8-bit pROM (the 8604), and several peripheral circuits. The latter interface communications lines, handle increased loads and replace IC packages now required.

Intel's new 4-bit microprocessor, the 4014, features software compatibility with the earlier 4004. Additional instructions permit logic operations, such as AND and OR. The 4014 also allows storage capacity of 8-k bytes of memory, increased from the 4-k bytes for the 4004. Other capabilities include improved single-interrupt handling and a single-step mode of operation to simplify testing and debugging.

IMP series—chips, cards and 'boxes'

National Semiconductor offers a broad line of PMOS microprocessor products. They consist of 4, 8 and 16-bit parallel processors that are available in chip form, on card subsystems and in complete microcomputer boxes. Each microprocessor features downward software compatibility—it's compatible with a microprocessor having a shorter word length, but not one with a longer word length. And the fixed instruction set of each can be altered or changed through microprogramming techniques.

The National microprocessors are built around two building-block chips: a Register and Arithmetic Logic Unit (RALU) and a Control Read-Only Memory (CROM). The RALU is a 4-bit "slice"; four are used with one or two CROMs to obtain the 16-bit system, and eight RALUs with two CROMs can be used to form a 32-bit system. The CROM provides storage for the manufacturer's fixed instruction set and the control logic for up to eight RALUs.

The IMP-16C, National Semiconductor's 16-bit microprocessor system, comes on an 8-1/2 × 11-in. PC board. It consists of the processor, clock system, I/O bus drivers, 256 words of RAM and provisions for 512 words of ROM or pROM memory.

The IMP-16C uses a basic 43-instruction set and an expanded 17-instruction set provided by a second CROM. The additional 17 speed processing with instructions that include divide, multiply and double-precision add and subtract. The basic microcycle, or machine cycle, is 1.4 μs. Several microcycles are needed to execute a typical instruction. Two 16-bit numbers can be multiplied for a 32-bit result in a speedy 150 μs.

Each RALU supplies the IMP-16C with an accumulator and a push-down stack. A total of

four accumulators improve the bit efficiency of instruction words by cutting down memory-cycle delays. The hardware stack permits rapid nesting of subroutines and interrupts, and its limited depth can be extended—for, say, overflow conditions—by use of main memory.

The microprocessor also features vectored as well as slower, single-line interrupts. With a single-line interrupt, the total overhead time to get to the service routine can be as high as 34.85 μ s, since it depends on the number of peripheral devices, and these might number 16. But with a vectored interrupt, the total overhead is only 4.55 μ s, a figure that doesn't change with the number of devices.

Several software design aids are offered with each microprocessor. Programs are available for cross and self-assembling, source editing, debugging, and absolute and relocate loading. Also, driver/utility and diagnostic aids are offered. Hardware design aids using assembly language come as complete microcomputers and prototype systems. For the 16-bit system, these are the IMP-16L and 16P boxes. Both units contain a 16-bit microprocessor card.

The IMP-16L has a front-panel display, which provides access to memory and microprocessor registers. The box comes with 4-k, 16-bit words, expandable to 65-k words. Also, a high-speed asynchronous bus permits direct-memory access by peripheral devices without the need to go through the RALUs.

The IMP-16P can interface with a teletypewriter for application software development. This prototyping tool comes complete with chassis, control panel, power supplies and one or more 4-k, 16-bit-word read/write memory modules. National Semiconductor says the IMP-16P is the box to start with to begin a 16-bit design.

Recent additions to National Semiconductor's line are an advanced 4-bit microprocessor system and a microprogramming tool to help designers alter or change the fixed instruction set. The 4-bit system performs BCD arithmetic and uses one CROM, one RALU and a Four-bit Interface Logic Unit, called FILU. The interface unit combines the functions of a number of standard-TTL peripheral circuits.

The microprogramming tool, called Field-Alterable Control Element (FACE), makes use of the fact that a change of CROMs changes the fixed instruction set. FACE, which comes on a card, replaces the CROM on a microprocessor board to form what mainframe designers call writable-control store. Microprocessor control logic now becomes accessible to external ROM or RAM for development of a tailored microprogram. The final result can be stored in a custom-masked CROM or a bipolar pROM. The increased speed of the bipolar memory can reduce delays

incurred through connection of external, off-the-board circuitry.

PPS family provides chip sets

Aiming to reduce the number of additional components often needed with single-chip microprocessors, the Microelectronics Div. of Rockwell International offers chip sets for both 4 and 8-bit systems. The sets come complete with processor, clock circuit, memory and input/output ICs. For additional flexibility, you can get a combination ROM and RAM chip or you can select from a growing number of interface and peripheral circuits.

Rockwell estimates that up to 30 peripheral circuits can be eliminated by use of the PPS-4 or PPS-8 chip sets. These are 4 and 8-bit parallel processing systems, respectively. Moreover some of the special circuits in the Rockwell chip sets are not generally available with competing processors. For example, a nonvolatile RAM is being developed for the PPS-4 set. And a controller circuit, in an advanced development stage, for the PPS-8 will permit direct memory access. Rockwell is also developing other circuits for use with peripherals such as CRTs, printers and floppy discs.

The PPS-8 features over 90 instructions, with capabilities for decimal and binary arithmetic single-byte subroutine call and digit/byte manipulation. A complete instruction cycle can be executed in 4 μ s, and decimal addition or subtraction is performed at 12 μ s per digit. Among 4-bit microprocessors, the PPS-4 sets the pace for speed, with an instruction cycle of 5 μ s and a register-to-register add time of 2.5 μ s. The 50 instructions for the PPS-4 contain logic and conditional and unconditional data-transfer operations.

The PPS chip sets use a relatively slow clock, typically 200 kHz. However, signals internal to the system are handled at four times that rate. The clock generator provides the processor with two synchronized signals, which are then divided logically into four phases, thus boosting the speed.

Bus lines transfer data during the second and fourth time intervals. In the alternate intervals, address and data-bus lines are automatically cleared to zero. This interface timing scheme permits direct connection of an extensive number of circuits. For the PPS-4, up to 30 circuits can share the bus without need for additional buffering or drive circuitry.

Also, the control logic within the processor allows arithmetic or logic instructions to be carried out in one cycle time. Addition of two decimal digits requires six instructions, or six cycle times. Hence for the 5- μ s cycle of the PPS-4, two decimal

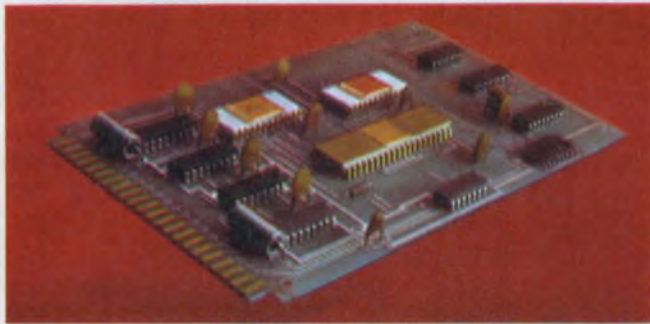
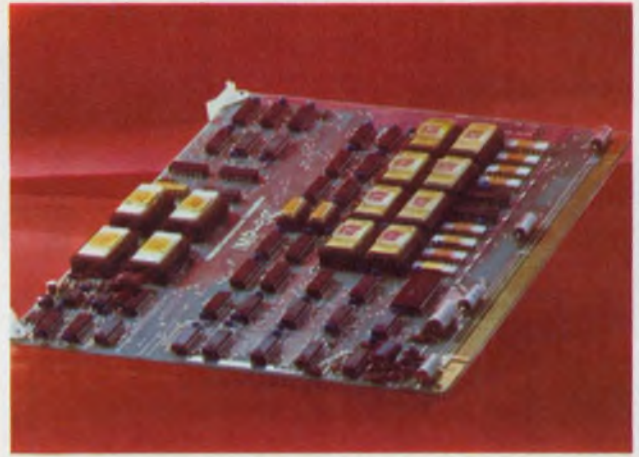
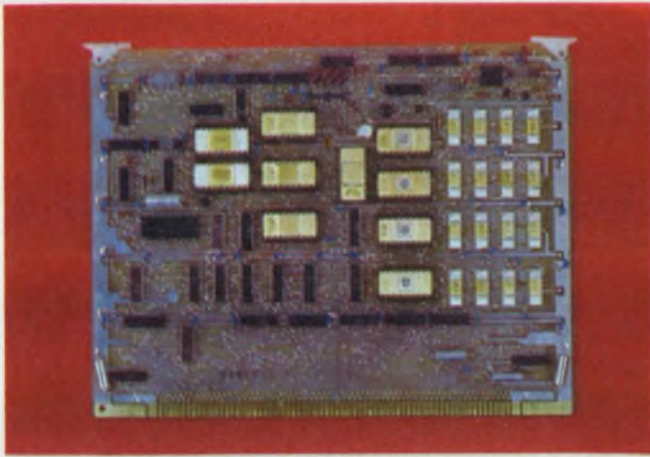

Processor cards provide an assembled and tested microprocessor system, complete with memory. Clockwise from the top left are National Semiconductor's 16, 8 and 4-bit models (the IMP-16C/300, 8C/200 and IMP-4, respectively). National units also feature a microprogramming option that can be used to alter or change the fixed instruction set.

digits can be added or subtracted in 30 μ s.

Software aids consist of cross-assemblers and simulators available on time-shared services. The aids may also be purchased for use on in-house computers. Hardware aids range from Assemblators (developed by Applied Computing Technology) to evaluation boards, containing microprocessors, RAMs, I/O circuits and clocks.

Micro Systems

Aiming to shorten the usual development time for a microcomputer design, some manufacturers are offering systems that constitute full-fledged microcomputers and complete prototype units. These vendors use chips supplied by Intel, National Semiconductor or Rockwell International.

Product forms range from consoles with circuitry on conventional PC boards to LSI dice mounted on a single substrate. Besides providing the necessary components for a host of applications, these products also feature additional circuitry that helps extend the capabilities of the internal LSI microprocessor.

An early microcomputer entry is the Micral series from R2E (Realisations Etudes Electroniques, based in France). Micral systems, built around Intel's 8-bit microprocessors, come

in three processing speeds: 12 μ s (basic model), 6 μ s (Micral G) and 2 μ s (Micral S).

Although Micral uses the 8008, it has several instructions beyond those available with the 8008. The additional instructions permit improved handling of interrupts and allow register saves. Interrupt-driven I/O channels can be operated at a maximum throughput of 56-Mbyte/sec. Also, the Micral G (and S) includes five added instructions for data manipulation.

Software support includes a two-pass assembler, keyboard editor and diagnostics for peripherals and I/O interfaces supplied with the microcomputer. In addition R2E offers a high-level control language to simplify prototype development.

Micral units have a memory capacity of 16-k bytes, and this can be increased to 64 k. The direct addressing capacity of peripherals is a hefty 1792 bytes at the input and 23 at the output. Up to seven I/O channels can be operated.

Applied Computing Technology provides a series of Assemblators—short for assemblers/simulators—for the Intel and Rockwell 4-bit processors. Assemblators, which can interface directly with a teletypewriter, reduce the development phase of microcomputer designs.

In a typical development phase, a designer specifies and interconnects the I/O circuitry, which is then interfaced to the Assembler. Programs are written and assembled in the Assembler, which holds the utility system in ROM

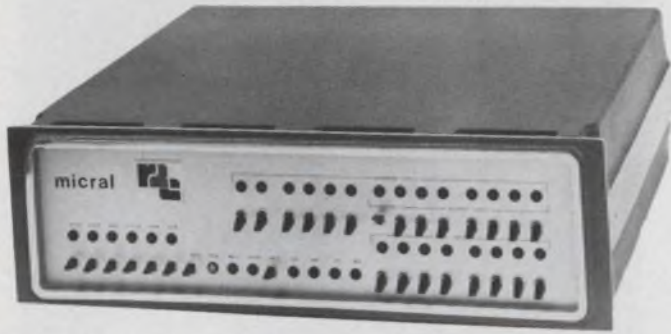

Complete microcomputers extend the capabilities of the basic microprocessor used. R2E's Micral system, for example, provides additional instructions for interrupt handling and data manipulation. R2E uses Intel chips.

and the assembled program in a special emulation ROM. As a result, testing of programs involves simple manipulation of Assembler console switches or the teletypewriter, so that program debugging can be reduced to a fraction of that normally required. And because the unit contains a resident assembler, costly time-sharing changes can be eliminated.

Both the CBC-4, the Assembler for the Intel chip, and the PPS-4MP, which is used for Rockwell's model, are similar. However, the CBC-4 features a single-pass assembler for simplified assembly. For both units, the corrected program can be recorded in pROMs, which are then inserted into the microcomputer to complete the design.

Pro-Log features the PLS-400 family of microcomputers on 4-1/2 × 6-1/2-in. PC cards. Built around Intel's 4-bit processor, the 4004, the PLS-400 also contains Intel's 4002 RAMs and 1702A erasable pROMs. A minimum system consists of a single card with 1024 bytes of memory and 32 TTL I/O lines. For expanded capability, a three-card system contains 4096 bytes of memory and 128 TTL I/O lines.

Also available from Pro-Log is the MPS-800 family of 8-bit microcomputers for data processing. The family consists of three-card and five-card systems. Both units come with 256 words of pROM and 1024 words of RAM data/instruction memory. The memory can be expanded to 16-k words.

Process Computer Systems offers a microcomputer built around Intel's 8080 microprocessor. Called the Series 2000 Micro CPU, the system aims for such industrial applications as torque monitoring and control and also engine testing.

Plug-in modules allow the Series 2000 to control a variety of processes. The I/O modules include a 12-bit a/d converter, 16-bit digital input interface and modules for relay outputs. These units communicate with the system's memory and microprocessor through a common back-

plane data bus. Moreover the microprocessor sees all I/O devices as memory locations, precluding the need for special—and possibly less efficient—I/O instructions.

Process Computer Systems also offers plug-in breadboard cards, which allow the development of special analog and digital I/O modules. In addition assembler, compiler, debugging and other programs are available.

Teledyne Systems takes a unique packaging approach for its microcomputers. Rather than mount DIPs on PC boards, it mounts IC dice on ceramic substrates. The hybrid approach results in reduced size and improved reliability at prices that are comparable with PC-board equivalents. A single package measures only 2 × 2 × 0.2-in.

Teledyne's microcomputers are the TDY-52A, which uses Intel's 4004 microprocessor, and the TDY-52B, which uses National Semiconductor's dice to form a 16-bit unit. Instructions for the TDY-52A can be tailored to an application by alteration of the control microprogram in ROMs mounted on the substrate.

The TDY-52A requires external power supplies and some I/O circuitry, as does the 16-bit unit. In addition the TDY-52B requires an external clock (5.7 MHz square wave) and memory (ROM, RAM or combinations of both). Memory configurations are available in hybrid packages identical to those of the microcomputers.

New LSI Processors

At various stages of introduction—from chip development to some product delivery—are a multitude of LSI processors, all of which are expected to be available in quantity by about the middle of next year. The great majority use NMOS technology, handle 8-bit word lengths and have a basic cycle of about 2 μs, as does Intel's 8080. And most of these are being offered with special peripheral circuits and memories to minimize the circuitry otherwise needed.

In addition to these circuits, manufacturers are developing 12-bit processors that employ CMOS technology and emulate popular minis. And bipolar/LSI processors, featuring high-density techniques, promise to close the speed gap between microcomputers and conventional minis.

Five ICs comprise the basic microcomputer chip set promised by Motorola in its M6800 family. The heart of the set is the microprocessing unit, or MPU—an 8-bit parallel processor. The MPU lists 72 instructions and seven ad-

dressing modes, with one mode reserved for two 8-bit accumulators on the chip. It also uses 16-bit memory addressing, allowing memory size up to 65-k addresses.

The MPU shares data and address buses with special byte-organized memories—1024 × 8-bit ROMs and static 128 × 8-bit RAMs—and two programmable I/O circuits, the Peripheral Interface Adapter (PIA) and the Asynchronous Communications Interface Adapter (ACIA). The special I/O circuits permit reduced interface circuitry.

All five silicon-gate NMOS chips operate from a single 5-V supply. A total of 10 circuits of the M6800 family can be interconnected on the bus without reduction of the maximum clock rate of 1 MHz, which must be supplied by an external clock.

The interface circuits look like memory locations to the MPU. Hence the MPU can use the same instructions for, say, peripherals, connected to the PIA that it uses with RAM; special I/O instructions are not needed. The PIA controls and transfers data and status information to and from peripheral devices or, possibly, other microprocessors.

Much of the control logic for peripherals can be handled by the PIA. In an application described by Motorola, for example, a PIA replaces the 16 to 20 standard MSI logic circuits usually required to control popular OEM printers. The complete interface consists of the PIA, peripheral drivers and comparators. The latter provide TTL-compatible logic levels in the face of inductive surges from the printer.

Similarly the ACIA performs all the functions of a standard universal asynchronous receiver/transmitter. It relieves the MPU of many of the timing and control functions of asynchronous data communications. And it can interface directly with standard modems, including a special modem IC planned for the M6800 family.

The MPU features decimal and binary arithmetic capabilities, variable-length instructions and double-byte operations. Addressing modes include extended, indexed, implied and relative, as well as immediate and direct. The minimum execution time, as for the Add instruction, is 2 μ s. The maximum time reaches 12 μ s in the case of a Software Interrupt instruction.

A special feature of Electronic Arrays' 8-bit NMOS parallel processor is string or series capability. Up to 16 bytes of data can be entered from memory or from an I/O device, and stored in the chip's multiregister accumulator for processing. And the 16-byte data transfer can be accomplished with a single instruction.

Moreover the chip contains a 24-byte RAM, called the Program-Address Storage (PAS). It can be used as a push-down stack, for interrupt

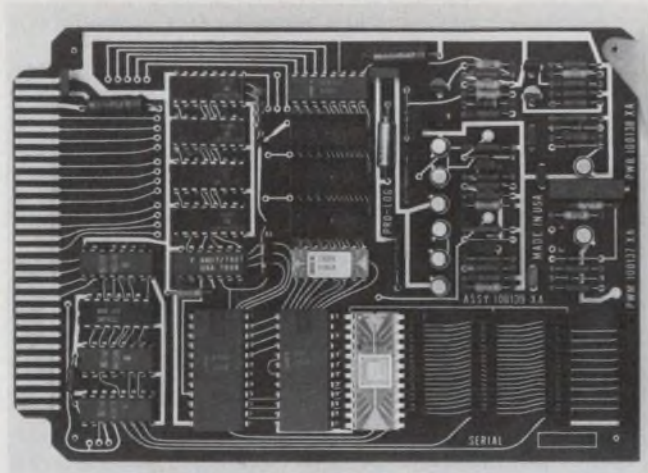

Microcomputers on PC boards are offered by Pro-Log. Models available include a 4-bit system for dedicated-controller applications and an 8-bit model for data processing. Both systems use Intel chips.

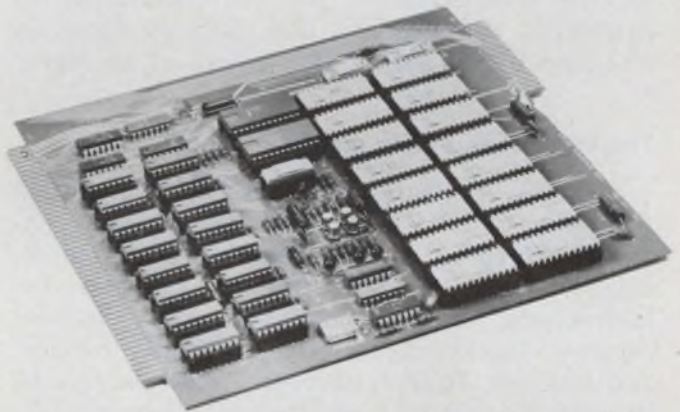

Prototype systems help cut development time. Applied Computing Technology calls its systems Assemblators, or combination assemblers/simulators. The vendor supplies prototype units for microprocessors offered by Intel and Rockwell International.

vectors, for program-call storage, or for a combination of these functions. For expanded capability, the PAS can be extended into external RAM.

The 8-bit processor has about 66 instructions and addresses up to 65-k bytes of memory. The four addressing modes are direct, immediate, indexed and extended. Memory can be ROMs or RAMs of various speeds in any combination.

Other circuits planned by Electronic Arrays for the microprocessor consist of the following: a 1024 × 8-bit ROM, 256 × 4-bit RAM and an I/O controller. The I/O chip is intended to be a general-purpose, programmable logic design for any interface.

Fairchild Semiconductor plans to offer the F8 chip set, consisting of an 8-bit NMOS Isoplanar microprocessor, a memory interface chip, an 8-k bit ROM and a custom RAM. The system features a basic cycle of 2 μ s and has internal clock and interface circuitry. Direct-drive capability exists

for standard peripherals, such as teletypewriters and printers.

Fairchild estimates that improvements in the F8 family can reduce the amount of peripheral circuits by 10 to 30%, compared with other 8-bit NMOS processors. Also, preliminary benchmark programs indicate speed improvements by a factor of 1-1/2 to 3.

Software support includes a compiler to accept the PL/M language and a special conversational utility system that requires an interface module. The system allows a program to proceed in slow motion, so designers can debug a program with paper tape or cassette. The utility system avoids the need to modify the contents of a pROM each time a correction is required.

An earlier microprocessor from Fairchild is the PPS-25 system, a 4-bit chip set. Intended for scientific calculators and control systems, the PPS-25 uses standard ICs for interfacing of keyboards and displays. The PPS-25 specs an add time of 125 μ s for two groups of 16 digits.

The PIP: 8 addressing modes

Signetics' upcoming Programmable Integrated Processor (PIP) allows the use of eight addressing modes, for increased flexibility and efficiency in programming. Operand addresses for instructions can be defined in these modes: register, immediate, relative, absolute, indirect and indexed. Branch addresses may be formed through the use of a relative or absolute mode, and each may be direct or indirect.

The PIP responds to over 64 instructions, the most complex of which are executed in less than 10 μ s. Instructions feature variable lengths for improved bit efficiency; they may be 1, 2 or 3 bytes long. Also each of the chip's four general-purpose registers may be used as an accumulator. Hence processing bottlenecks that result from having only a single accumulator are eliminated.

The Signetics' chip operates from a single 5-V supply. Its input clock frequency is variable down to dc; externally the PIP resembles a static IC. The processor's address lines allow direct addressing for up to 32-k bytes of memory. And PIP's vectored-interrupt capability allows indirect branching to any location in memory.

A full range of design aids is planned for the PIP, including a cross-assembler written in Fortran II rather than the more common but advanced Fortran IV. The use of the more basic language permits the assembler program to be run on a wide range of computers, from mainframes to minicomputers.

In a rare example of microprocessor alternate sourcing, Microsystems International Ltd. offers the 8008, the 8-bit PMOS processor introduced by Intel. MIL provides the microprocessor, as

well as the various components needed to make an 8-bit microcomputer, on seven basic boards. Each board measures 4-1/2 \times 6-in. and uses a standard dual 22-way edge connector.

On the MOD8-1 board, for example, are the microprocessor, clock generators and state-decoding and bus-switching control logic. An I/O board, the MOD8-2, contains teletypewriter interface and reader-control and system-restart logic. Other boards provide ROM, RAM, buffer and I/O circuitry.

MIL's design aids include the Monitor-8 software package, which allows interactive debugging of designers' programs entered in assembly language from a teletypewriter. In



Microcomputers aim for industrial applications such as engine testing and torque control. Process Computer System's Series 2000 Micro CPU features a common backplane data bus on which interface modules communicate with the microprocessor and memory.

addition the company offers a similar applications package for a series of boards that will use a proprietary 4-bit microprocessor expected shortly. The 4-bit system is called the MOD4 series.

Proving that PMOS is still around for 8-bit units, Mostek is sampling an 8-bit p-channel, parallel processor called the MK5065. Compared with first-generation units, the MK5065 expands the number of instructions and slashes the number of peripheral circuits. Also, the chip's architecture is three-leveled for rapid handling of interrupts. One or two of the chip's three program counters and three accumulators, for example, can be reserved for immediate servicing of interrupts.

Bipolar processors emerge

The first general-purpose bipolar/LSI microprocessor has just been announced by Raytheon

Semiconductor. A seven-chip processor called the RP16, the 16-bit unit surpasses MOS microprocessors in speed through the use of bipolar technology, increased addressing modes and an improved instruction set. Two versions of the RP16 are slated. Model A emphasizes arithmetic capabilities, while Model B stresses byte handling (see product feature; p. 109 this issue).

While most microprocessor chips are intended for random-logic designers, a Schottky-TTL processor from Monolithic Memories is aimed at the computer architect. The special-purpose microprocessor, dubbed the Model 6701 microcontroller, can be used to emulate conventional computers and replace scores of packages at reduced power. A single 6701 can perform the function of 25 TTL MSI packages while saving about 6 W.

The 6701 consists of four 4-bit controllers and associated ROMs and shift registers. None of the ROMs is used to decode the processor's 36 instructions, which are at the fundamental level of arithmetic logic units. As a result, microprogramming techniques can be employed to apply the IC.

A single cycle takes about 200 ns. But within this period the 6701 can execute such functions as subtract, shift and store. The bipolar speeds assure a precise emulation of conventional machines, which use standard-bipolar circuits. Moreover the 6701 can be expanded in increments of 4 bits, so that other than 16-bit systems can be designed without significant reductions in speed. Other applications foreseen for the 6701 include high-speed peripheral controllers and point-of-sale systems.

12-bit models fill a gap

Although much of the current microprocessor activity involves 8 and 16-bit units, two manufacturers—Intersil and Toshiba—are filling the gap with 12-bit models. The Intersil processor is designed to be a CMOS/LSI equivalent of Digital Equipment Corp.'s popular PDP-8 mini-computer. The Toshiba processor (the TLCS-12) is a proprietary PMOS design, with such component-saving features as a timing generator on the chip.

Preliminary data for the Toshiba chip indicate add and subtract times of about 10 μ s. And multiply and divide functions reportedly can be executed in 30 to 60 μ s. The chip operates from ± 5 -V supplies and dissipates 0.8 W.

Intersil's CMOS microprocessor benefits from the sizable software support that exists for the PDP-8. And the many designers familiar with the mini should be able to transfer that experience to the CMOS processor. However the unit's repertoire of eight basic memory-reference

instructions tends to limit the range of applications.

Still a multitude of applications uses the PDP-8. Noting this fact Intersil plans to develop a full set of circuitry and memory, all using CMOS, to operate with the processor. Conceivably, the end result could be a pocket-sized, portable PDP-8.

RCA, the leading CMOS manufacturer, also has a CMOS microprocessor. Called COSMAC, it is an 8-bit, two-chip set that emphasizes low-power dissipation and I/O interface capabilities in a proprietary design. Each chip dissipates only 100 μ W. And the I/O can be controlled

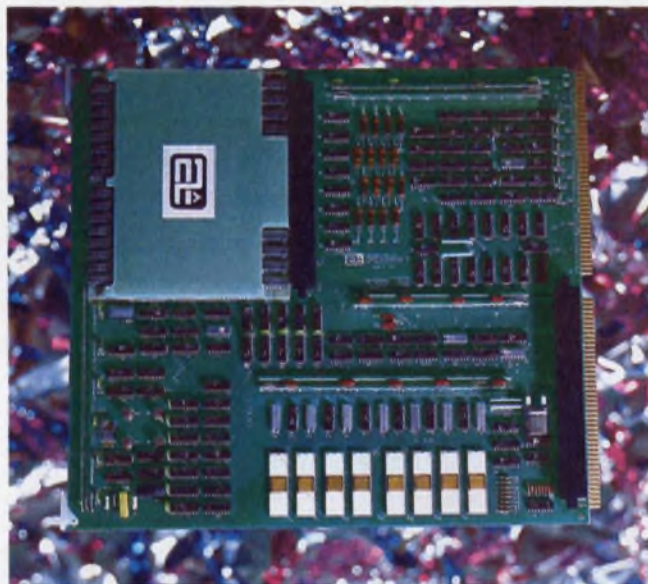

A complete mini, except for power supply, comes on this PC board. Computer Automation's Naked Mini/LSI-1 uses four custom LSI chips, each a 4-bit slice, and programmable logic arrays—rather than ROMs—to form the mini's central processing unit.

with up to 16 commands and a total of 23 lines, including a bidirectional data bus.

COSMAC is built around a 16 \times 16-bit scratch-pad register, from which references to memory are made. The microprocessor can address up to 65-k bytes of memory, and it uses a simple two-step fetch-and-execute sequence.

The processor cycle, consisting of eight clock pulses, ranges from 3 to 10 μ s. With the faster speed, and using a RAM with a 1- μ s cycle, a 6- μ s fetch-and-execute time can be obtained for any instruction. Response to interrupts, allowed only after complete instruction cycles, ranges from 3 to 9 μ s.

In the wings, RCA has a single-chip COSMAC. In addition the company is developing silicon-on-sapphire processors, with multichip units for military applications initially scheduled.

(continued on next page)

Micro-based Minis

Not to be undone by the emergence of component manufacturers into the microcomputer area, minicomputer makers have also embraced LSI microprocessors. Generally using custom MOS chips, they offer models aimed at high-volume applications—as are microcomputers—with large-quantity unit prices hovering about the \$500 level. This undercuts the price of many micros.

Micro-based minis are promoted as low-end



Custom silicon-on-sapphire LSI processors are the basis for General Automation's LSI 12/16, an 8-bit system. The mini maker also uses SOS chips for a 16-bit system, the LSI 16, that is a functional equivalent of the company's SPC-16 mini.

models complementing an established line. The new units benefit from the impressive software support—including extensive application programs—available with the rest of the line. Moreover the units offer traditional mini hardware/software features, which results in unique and versatile capability. At present Computer Automation, General Automation and DEC are incorporating microprocessors into their newer models. However, most industry observers expect that list to grow.

Computer Automation calls its microprocessor-based minicomputer the Naked Mini/LSI-1—an allusion to the fact that the mini comes complete, except for power supply, on a 15 × 17-in. PC board. The LSI-1 uses space-saving MOS

programmable logic arrays, rather than ROMs, to contain the unit's control logic. Four more MOS/LSI chips, each a 4-bit slice, make up the rest of the central processing unit for the 16-bit machine.

Standard features include direct-memory addressing and four other I/O systems. The unit also has hardware multiply and divide, multi-level indirect addressing, and up to 256 vectored priority interrupts. Memory can range from 1-k to 262-k 16-bit words, and may consist of core or semiconductor types in any combination. The basic processor cycle time is 1.6 μ s; an add-memory-to-register operation, involving 16 bits, takes 9.2 μ s.

A special feature of the machine's architecture is its ability to organize memory automatically. If memory modules of different size and type are mixed or rearranged on the bus, the computer assigns addresses without any reference to software.

The processor board contains slots for optional hardware functions. These include power-fail/restart, teletypewriter/CRT interface and real-time clock. In addition various plug-in options are available for additional buffers, drivers, interfaces and expanded memory.

Moreover the LSI-1 has an impressive 168 basic instructions. And most of these require only one memory location in contrast with the two or more locations usually needed in other minis.

The instruction set contains 29 memory-reference instructions—which simplify operations involving many pieces of data stored in memory. And conditional jumps can be performed with 63 instructions, each of which causes both the test and the jump. Other features of the instruction set include memory scan, three-way compare, word and byte addressing and full shift capability.

Among the various design aids available, Computer Automation offers several advanced software packages. These include Advanced BASIC, which can run with only 4 k of memory, Extended BASIC, using 8 k of memory, and FORTRAN. Standard packages include assemblers, loaders and debug and utility programs.

Mini turns to SOS

LSI processors employing silicon-on-sapphire techniques are used by General Automation in an 8-bit microcomputer—the LSI-12/16—and an expanded 16-bit model—the LSI 16. The SOS chips, developed for General Automation by Rockwell International, permit operation at speeds comparable with more conventional minis that use bipolar circuits.

The 8-bit unit, featuring 1 to 32-k words of

semiconductor memory and an instruction execution cycle of $2.64 \mu\text{s}$, comes with a low price tag of \$495 in 1000-unit quantities. It can be obtained on a $7\text{-}3/4 \times 10$ -in. PC board and in an enclosed system that contains power supply, battery backup for volatile memory and card slots for additional I/O boards.

For designers who want to retrofit new instructions in a ROM, the 8-bit LSI-12/16 provides a ROM "patch" system in addition to main memory. The patch eliminates the need to change ROMs when similar, but not identical, ROM programs are required. In addition the architecture of the LSI-12/16 has a shared-byte feature, allowing a two-byte instruction to be stored in a



A building-block approach to microcomputer designs is offered by Digital Equipment Corp. The modules, using Intel's 8008 PMOS processor, contain the peripheral circuitry usually needed to operate the microprocessor.

single-byte of memory. General Automation estimates that this architectural feature could reduce the amount of program memory otherwise required by about a third.

The LSI-12/16 uses 12-bit parallel addressing, which permits direct addressing of 4-k words of memory without paging techniques. It also provides eight 12-bit hardware registers, 52 basic commands, a processor-controlled priority-interrupt system and a teletypewriter interface. Standard control features include a relative time clock, external priority interrupt, 16-bit parallel I/O bus, integral console and a ROM-based console program. Several fail-safe features also protect against power transients and interruptions, component failures and program errors.

Software development can be minimized

through the use of a complete cross-program generation system on the company's SPC-16 minicomputer. The disc-based system provides assembly, editing and debugging. Other aids offered include a device-independent, real-time executive program and a conversational assembly system.

While the LSI-12/16 microcomputer can replace the company's somewhat slower SPC-12 minicomputer, General Automation's 16-bit unit is billed as the functional equivalent of the company's slightly faster SPC-16 mini. Furthermore the LSI-16 and expanded memory offers on two small boards the performance of the SPC-16 on six larger boards. The basic LSI-16 unit comes on a $7\text{-}3/4 \times 11$ -in. PC board, containing 1-k words of memory and an SOS microprocessor chip set. The two chips consist of an arithmetic logic unit and a control read-only memory, which stores the control logic for the ALU.

A second "micromemory" board of the same size provides a 32-k-word \times 18-bit (16 bits plus parity) memory system. The high density is achieved through the use of hybrid packaging. General Automation mounts eight 1103A (1-k bit RAM) memory chips onto a common ceramic substrate and plugs the substrates into vertical connectors on the board. A conventional approach, involving individual DIPs, would have resulted in a maximum board density of 16-k bits. In addition it will be possible to obtain a 120-k micromemory by replacement of the 1-k bit chips with 4-k bit RAMs, when they later become widely available.

Together with the micromemory board, the LSI-16 offers an average cycle time of $1.8 \mu\text{s}$. Standard features of the LSI-16 board include power-fail/restart capability, real-time clock, operation-monitor alarm, cold-start capability and an asynchronous memory interface. An additional PC board for options can be obtained with parity and hardware memory protection, teletypewriter controller, operator's console and a piggyback read-only memory board that can accommodate up to 4-k 16-bit words of memory.

MPS modules ease interfacing

A microprocessor module set is the initial entry into the microcomputer field by Digital Equipment Corp. The mini maker expects the modules, which use Intel's 8-bit PMOS processor, to be used as building blocks for dedicated controllers. Called MPS, the series can perform decision-making functions, add intelligence to data terminals and replace hard-wired logic systems. Moreover the units come complete with much of the peripheral circuitry usually needed to operate the microprocessor; hence interface

(continued on next page)

problems are reduced.

Five modules constitute the series. The CPU module contains the processor and complete instruction decode and control circuitry. Other modules provide 1-k to 4-k words of read/write memory and 256 to 4-k words of programmable read-only memory. A detection module can be used to obtain priority interrupts, while a monitor/control-panel unit can serve as a diagnostic checkout.

Software aids needed to program the MPS come in paper-tape format. The aids, offered in a special kit, consist of editors, assemblers, pROM programmer, debug software, duplicator and loader. Programs are prepared in conjunction with a PDP-8 with 4-k words of memory.

TTL/MSI processors are offered, too

Still other microprocessor products use medium-scale-integration (MSI) standard-TTL circuits. These TTL/MSI processors, like their LSI cousins, can be programmed for a host of high-volume applications.

Complete TTL/MSI processors come on PC boards or in compact modules, and they sell for about \$1000 in single-unit quantities. They operate at faster speeds than their MOS counterparts, and they are offered by established vendors in the minicomputer business.

For example, 12-bit TTL/MSI units have been introduced by DEC, Fabri-Tek and Microdata. The DEC model, called the PDP-8/A Miniprocessor, is a two-module, MSI version of the company's widely used PDP-8 mini.

Fabri-Tek's MP12 processor includes 4-k words of core memory in a 2 × 15 × 9.5-in. module, and it requires only one 5-V, 40-W supply. And Microdata's Micro-One unit, on a single 8-1/2 × 11-in. board, can be microprogrammed to emulate general or special-purpose computers.

The TTL/MSI processors use circuits that are widely alternate-sourced, in contrast with LSI units, which are virtually sole-sourced. But that picture could change dramatically in the next 12 months. Several manufacturers—Advanced Micro Devices, for example—are reportedly on the verge of following Microsystems International's

Need more information?

Readers may obtain more information on manufacturers' products and services by circling the appropriate information retrieval number. Organizations designated with a dagger (+) offer seminars or provide consultant services on the design or use of microcomputers.

Advanced Micro Devices, 901 Thompson Pl., Sunnyvale, Calif. 94086. (408) 732-2400. **Circle No. 400**

American Microsystems, 3800 Homestead Rd., Santa Clara, Calif. 95051. (408) 246-0330. (David L. Gellatly) **Circle No. 401**

+ Andy Hish Associates, 9710 Cozycroft Ave., Chatsworth, Calif. 91311. (213) 998-0222. **Circle No. 402**

Applied Computing Technology, 17961 Sky Park Circle, Irvine, Calif. 92707. (714) 557-9972. (Neil V. Gleason) **Circle No. 403**

+ Automata Systems, 592 Maude St., South Hempstead, N.Y. 11550. (516) 483-5185. (Ralph Sienna) **Circle No. 404**

Burroughs, P. O. Box 517, Paoli, Pa. 19301. (215) 648-2000. **Circle No. 405**

+ Compata, 1333 Lawrence Expy., Suite 220, Santa Clara, Calif. 95051. (408) 246-7575. **Circle No. 406**

Computer Automation, 895 W. 16th St., Newport Beach, Calif. 92660. (714) 833-8830. (Phil Kaufman) **Circle No. 407**

Datapoint, 9725 Datapoint Dr., San Antonio, Tex. 78284. (512) 696-4520. **Circle No. 408**

Digital Equipment Corp., 146 Main St., Maynard, Mass. 01754. (617) 897-5111. (Larry DeAngelo) **Circle No. 409**

Electronic Arrays, 550 Middlefield Rd., Mountain View, Calif. 94043. (415) 964-4321. (Richard M. Eiler) **Circle No. 410**

Fabri-Tek, 5901 S. County Rd. 18, Minneapolis, Minn. 55436. (612) 935-8811. (Gerald W. Larsen) **Circle No. 411**

Fairchild Semiconductor, 464 Ellis St., Mountain View, Calif. 94040. (415) 962-5011. (David Chung) **Circle No. 412**

General Automation, 1055 S. East St., Anaheim, Calif. 92805. (714) 778-4800. (Stephen D. Bowers) **Circle No. 413**

General Instrument, P.O. Box 600, Hicksville, N.Y. 11802. (516) 733-3000. **Circle No. 414**

+ iCOM, 21243 Ventura Blvd., Woodland Hills, Calif. 91364. (213) 340-0611. (David Callan) **Circle No. 415**

Intel, 3065 Bowers Ave., Santa Clara, Calif. 95051. (408) 246-7501 (Hal Feeney) **Circle No. 416**

Intersil, 10900 N. Tantau Ave., Cupertino, Calif. 95014. (408) 257-5450. (John Corser) **Circle No. 417**

+ Martin Research Ltd., 1825 S. Halsted St., Chicago, Ill. 60608. (312) 829-6932. (Kerry Berland) **Circle No. 418**

+ Microcomputer Associates, P.O. Box 304, Cupertino, Calif. 95014. (408) 226-3191. (Ray Holt) **Circle No. 419**

+ Microcomputer Techniques, 11227 Handlebar Rd., Reston, Va. 22091. (703) 620-9676. (Jerry L. Ogdin) **Circle No. 420**

Microdata, 17481 Red Hill Ave., Irvine, Calif. 92705. (714) 540-6730. **Circle No. 421**

Microsystems International Ltd., P.O. Box 3529, Station C., Ottawa, Canada K1Y 4J1. (John Freeman) **Circle No. 422**

Monolithic Memories, 1165 E. Arques Ave., Sunnyvale, Calif. 94086. (408) 739-3535. (Joseph J. McDowell) **Circle No. 423**

Mostek, 1215 W. Crosby Rd., Carrollton, Tex. 75006. (214) 242-0444. (Larry Sullivan) **Circle No. 424**

Motorola Semiconductor, P.O. Box 20912, 5005 E. McDowell Rd., Phoenix, Ariz. 85036. (602) 244-3465. (Link Young) **Circle No. 425**

+ National Electronics Conference, Oakbrook Executive Plaza #1, 1301 W. 22nd St., Oak Brook, Ill. 60521. (312) 325-5700. **INQUIRE DIRECT**

National Semiconductor, 2900 Semiconductor Dr., Santa Clara, Calif. 95051. (408) 732-5000. (Philip Roybal) **INQUIRE DIRECT**

Process Computer Systems, 5467 Hill 23 Dr., Flint, Mich. 48507. (313) 744-0225. (Dick Barnich) **Circle No. 426**

+ Pro-Log Corp., 852 Airport Rd., Monterey, Calif. 93940. (408) 372-4593. (Ed Lee) **Circle No. 427**

RCA Solid State Div., Route 202, Somerville, N.J. 08876. (201) 722-3200. (Lee Wu) **Circle No. 428**

Raytheon Semiconductor, 350 Ellis St., Mountain View, Calif. 94042. (Bruce G. Wenniger) **Circle No. 429**

Realisations Etudes Electroniques (R2E), 38 Garden Rd., Wellesley, Mass. 02181. (617) 235-3130. (Michael W. Rohrbach) **Circle No. 430**

Rockwell International, Microelectronic Device Div., P.O. Box 3669, Anaheim, Calif. 92803. (714) 632-2321. **Circle No. 431**

Signetics, 811 E. Arques Ave., Sunnyvale, Calif. 94086. (408) 739-7700. (Joe Kroeger) **INQUIRE DIRECT**

Teledyne Systems, 19601 Nordhoff St., Northridge, Calif. 91324. (213) 886-2211. (Russell E. Lewis) **Circle No. 432**

Texas Instruments, P.O. Box 5012, MS/84, Dallas, Tex. 75222. (214) 238-3741. **INQUIRE DIRECT**

Toshiba Transistor Works, 1-Komukai, Toshiba-Cho, Kawasaki-Chi, Japan. **Circle No. 433**

Transitron, 168 Albion St., Wakefield, Mass. 01880. (617) 245-4500. (Martin S. Gordon) **Circle No. 434**

Western Digital, Box 2180, 19242 Red Hill Ave., Newport Beach, Calif. 92663. (714) 557-3550. (Bill Roberts) **Circle No. 435**

Xerox Corp., Dept. 15-02, 701 S. Aviation Blvd., El Segundo, Calif. 90245. (213) 679-4511. **Circle 436**

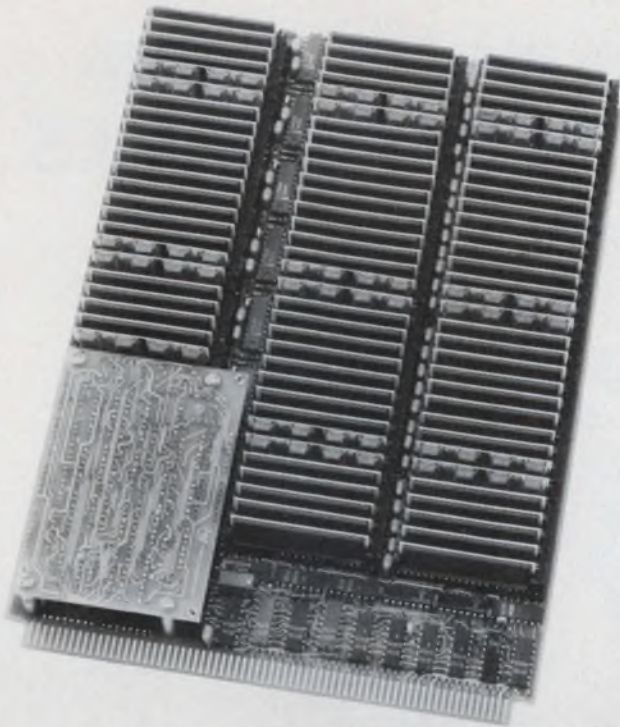

Hybrid packaging yields a 32-k × 18-bit 'micromemory' on a single board. General Automation offers the unit for use with the company's LSI-16 system.

lead in alternate-sourcing Intel's 8008 processor, or possibly producing Intel's 8080 chip. Aiming at more recent models, American Microsystems has plans to alternate-source Motorola's micro-processor chips. Furthermore a number of primary processor-chip suppliers are seeking other sources for their proprietary circuits.

Also expected are more bipolar/LSI micro-processors. For example, Texas Instruments—though tight-lipped officially—is said to be developing a bipolar unit that uses integrated-injection-logic (I²L) for increased density. I²L maintains the high speeds of bipolar circuits while achieving densities comparable with MOS (see "Integrated Injection Logic Shaping Up as Strong Bipolar Challenge to MOS," ED 6, March 15, 1974, p. 28). Most observers consider a high-density process, such as I²L, absolutely essential to achieve the high functions per chip needed for bipolar/LSI.

The strong emergence of bipolar/LSI micro-processors could have far-reaching effects. At present processor-chip vendors, who are the hardware experts, are increasing their software support, while mini makers, who excel in software, are stripping down to "bare-bones" models.

However, direct competition of products generally is limited because of the speed gap between most micros, which use MOS, and bipolar mini models. Bipolar/LSI processors could bridge the speed gap, thereby sparking a historic confrontation between chip vendors and mini makers. ■■

INFORMATION RETRIEVAL NUMBER 31 ►

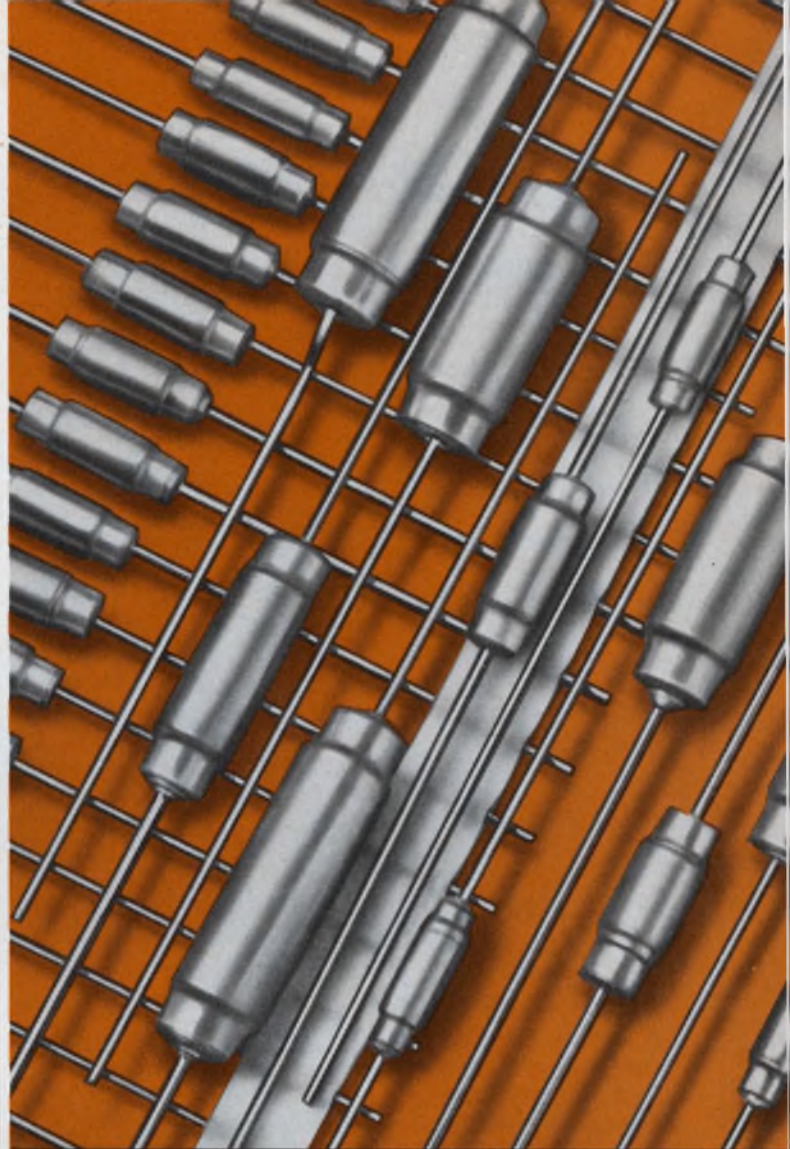

Last year these Paktron[®] film capacitors were revolutionary.

Now they are the standard.

And for good reasons. The Micromatic[®] capacitor, revolutionary for being wound on its own leads—and for its self-encased construction. Both polyester and polypropylene versions are widely accepted in industrial applications. Tape reeled for automatic insertion. Send for test samples and data.

PAKTRON, Division Illinois Tool Works Inc.,
900 Follin Lane, S. E., Vienna, Virginia 22180.
Phone (703) 281-2810. TWX 710-833-0682.



ITW PAKTRON[®]
innovators in film capacitors

The Innovative Electronic Group of ITW...
PAKTRON • LICON • EMCON

© ILLINOIS TOOL WORKS INC. 1974

The company that gave you the solution to memory testing... NOW INTRODUCES

“THE BIG M”

the first low-cost microprocessor tester.

Once semiconductor memories were “impossible” to test. Then Macrodata came up with the answer. Now, testing microprocessors is a whole new game. Even if you test all the logic on your chip with tens of thousands of test patterns, it does not guarantee that your microprocessor is a good device.

Classically, computers are tested through the simulation of instructions, so each and every individual instruction must be simulated. But experience has proven that even when each individual instruction works, it is no final guarantee of processor logic. Therefore, sequences of instructions must also be

tested—which implies the use of new test techniques.

That's where Macrodata's new Big “M” Microprocessor Tester comes in. With its processor-controlled buffer memory, the Big “M” provides the only low-cost solution to this testing problem. The Big “M” can do simulation on your microprocessor not only on an instructional basis but also on sequences of instructions.

Whether you're a manufacturer or a user of microprocessors, Macrodata's new Big “M” is your answer! For immediate action, call the marketing department, or send for more information.

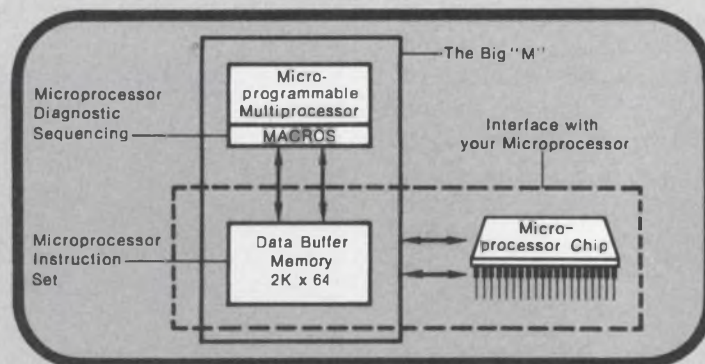

Macrodata



Macrodata Corporation, 6203 Variel Avenue, Woodland Hills, California 91364, Phone: (213) 887-5550, Telex: 65-1345
Sales Offices: Northern California Area Tel. (408) 735-9560 • Scottsdale Tel. (602) 966-2179 • Minneapolis Area Tel. (612) 454-2034 • Chicago Area Tel. (312) 297-8746 • Cleveland Area Tel. (216) 461-8333 • Dayton Area Tel. (513) 293-3145 • East Coast Tel. (516) 543-8600 International: West Germany — Munich Tel. (0811) 34 56 00 Telex: (841) 521-5969 • Milan, Italy Tel. 871-988/899-248 Telex: (843) 34314 • Sweden and Norway — Stockholm Tel. (08)-380-370 • Tel Aviv, Israel Tel. 25 55 69 • Tokyo, Japan Tel. (03) 985-5266 Telex: (781) 272-2171 • Buckinghamshire, England Tel. High Wycombe (0494) 36 3 81 Telex: (851) 837236

“See us at Wescon Booth No. 1160-1161.”

INFORMATION RETRIEVAL NUMBER 32

Microprocessors Are Old Hat.

To us.

But, when you learn about microprocessors, do it right.

Sure, you could talk to the salesmen from *all* the different semiconductor companies. Most of them have some important information to tell you.

But each of them has one thing in the back of his mind—to convince you to buy *his* microprocessors. That's what he's paid for.

However, we *don't* sell hardware. And no one's paying us to push their products. So we can afford to give you the straight facts. The good *and* the bad. No punches pulled.

In fact, that's what our business is all about. **Microcomputer Technique, Inc.** has been telling people about microprocessors and microcomputers from the first. Our seminar series has continuously sold out in major cities throughout the United States and Canada. Our papers have been presented to standing-room-only crowds at major meetings. And you've probably seen a variety of authoritative articles written by our staff in the trade press.

So what does all this mean to you?

Microcomputer Technique now offers you the monthly **NEW LOGIC NOTEBOOK**—the most in-depth analysis of how to select, apply and program microprocessors, microcomputers, and programmable logic arrays and all the other new alternatives to random logic available today!

We *don't* publish a collection of sales-oriented material pushed on us by other companies. We *don't* sell someone else's opinions—or a stranger's findings.

The **NEW LOGIC NOTEBOOK** is the direct result of our own staff's extensive experience and research. The documented experience of system designers we trust and know have used the products. Plus proven techniques that other respected users—just like you—have discovered. (Such as designs that incorporate two different microprocessors from different manufacturers, for example!)

Each and every month, the **NEW LOGIC NOTEBOOK** will feature topics scheduled for in-depth treatment in up-and-coming issues—

- Programmable Logic Arrays
 - PL/M versus Assembly Language
 - Application Techniques for Eight-bit μ P
 - Programming and Validating Math Routines
 - Multi-processor Configurations
- Your first issue will include a color-coded wall chart that brings into focus the essential features of every known microprocessor—with an accompanying detailed analysis of each processor's capabilities. It's The Microprocessor Scorecard[®], and it will be updated

quarterly *and* completely revised and re-issued every year (and included as a part of your subscription).

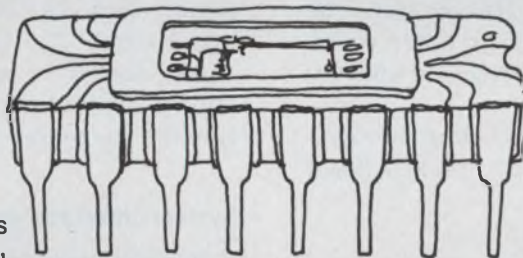

Get Your Free First Issue TODAY!

A full one-year subscription, 12 fascinating issues, costs only \$95. And your first issue is **TOTALLY FREE!** There's no obligation to buy anything. But, if you like it, subscribe. Less than eight dollars a month for this completely useful publication that's sure to help you make important money-saving decisions. You deserve this special opportunity to keep up to date on microprocessors—the right way. Call or write for your free issue today!

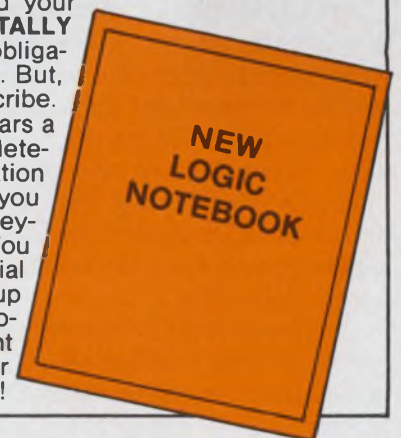

Microcomputer Technique, Inc.

11227 Handlebar Road
Reston, Virginia 22091
(703) 620-9676

INFORMATION RETRIEVAL NUMBER 33

Give flexibility to memory systems

with an asynchronous design. You can use any type of memory chip, including the newer 4-k dynamic RAMs.

Increasingly, asynchronous designs are being used in memory systems to boost versatility and capability. Among other benefits, an asynchronous system permits the use of virtually any speed memory element—up to certain processor limitations—and either dynamic or static types. The advantages result from the asynchronous method's well-defined, but flexible, interface.

Systems become flexible enough to be upgraded, as required, with larger, faster or cheaper memories. This flexibility is especially important, now that IC manufacturers are offering a variety of 4-k dynamic RAM chips. With an asynchronous system, designers need not be locked into one vendor's product. They can switch to other units, depending on the availability of alternate sources—or just plain availability.

Moreover the design of an asynchronous system need not be cumbersome if you break it down into these phases:

- Define the interface specifications.
- Select the memory chip.
- Design the control logic.
- Provide interface elements for compatibility.

What is an asynchronous system?

An asynchronous memory system operates independently of the processor timing. There are exceptions to this rule, but generally the memory system receives only a start command—to initiate a memory cycle—and the necessary address and data inputs from the processor. (The term "processor" indicates circuitry on the other side of the memory-system interface. It may be some other type of circuitry, such as a direct-memory-access controller.)

Communications between the memory and the processor are handled by a "hand-shaking" technique. The processor sends the address and data inputs with a request for a memory cycle. The memory system acknowledges the cycle request. If the cycle is an access from the memory, the memory system sends data back to the interface

along with a signal to indicate that data are available. When the memory can receive requests for a cycle from more than one source, the sources will have some sort of priority control of the memory. This priority circuitry is often contained in the control section of the memory system.

In addition to any priority logic, the control section contains the logic required to take the system interface commands and generate the signals for the internal operations of the memory system.

An asynchronous system also has two other major elements: interface circuitry and the storage matrix. The matrix consists of the memory chips, placed in a compact layout with power-supply decoupling, and any special signal conditioning elements—such as pull-up resistors.

System interface requirements

Several questions must be answered to determine the memory-system interface requirements. What is the timing for the control signals that the processor sends to the system interface? How are the data and address signals related to these control signals? Does the processor have any access or cycle-time limits?

To aid in the memory-circuit selection, the various cycle types—such as read, write, read-modify-write and write-verify-read—must be specified. This involves specification of control

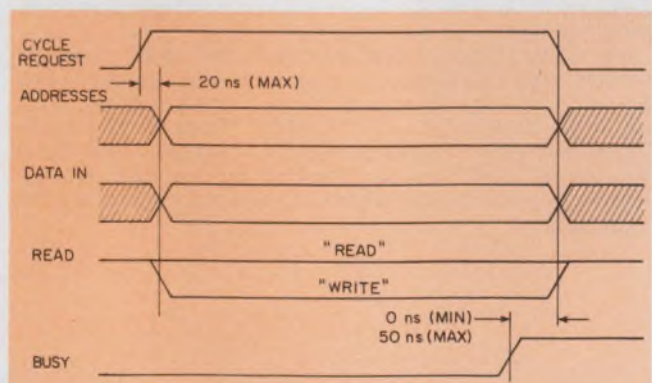

1. An asynchronous design begins with specification of the system interface signals to the memory system.

Bob Cook, Manager, MOS Memory Design, Mostek Corp., 1215 W. Crosby Rd., Carrollton, Tex. 75006.

signals from the processor and their timing.

For example, a typical memory cycle begins with a Cycle Request signal from the processor (Fig. 1). The cycle type—read or write—is determined by the Read signal. The diagram shows that the Address, Data In and cycle type signals must be available no later than 20 ns after Cycle Request.

The Busy signal comes from the memory system. From Fig. 1, information from the processor remains valid at the interface until 0 to 50 ns after Busy occurs.

Other questions relate to the control and data signals that the memory system sends back to the processor. How does the memory acknowledge the start of a cycle? How should valid output data be specified for memory access? How long should this output data be valid at the interface?

In a typical case—for a read cycle, for example—the Busy signal indicates that output data are at the interface (Fig. 2). The diagram shows that data must appear no sooner than 50 ns before Busy, but before the Busy signal fades. Data remain valid for 100 to 300 ns. A further interface requirement might be that no cycle requests can occur until after Busy returns to logic ZERO.

Save memory-system power

Another possible control signal at the interface indicates long periods of intended memory inactivity and permits lowered memory-system

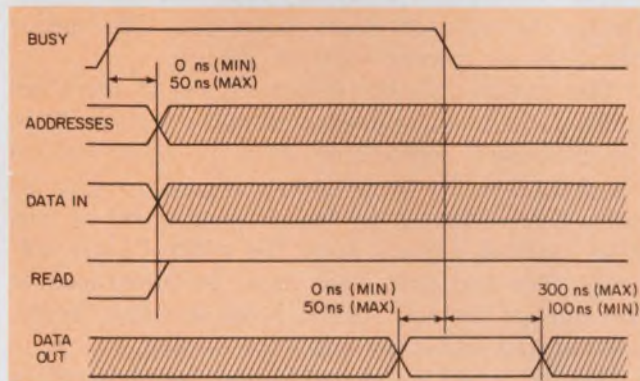

2. These control and data signals are sent back to the processor by the memory system.

4-k RAMs: New and efficient

The advance of memory chips to ever higher densities has culminated in 4096×1 -bit dynamic RAMs (see "4096-Bit RAMs Making the Scene as an Alternative to Core—Finally," ED No. 3, Feb. 1, 1974, p. 40). But these chips not only provide the largest storage density. Additional features on the chip allow increased efficiency for memory-system designs.

A 12-bit address selects one of 4096 memory locations, for which data are either read or written. Generally the RAM chips receive the 12 bits in parallel and latch them on the chip. One RAM comes in a package with only 16 pins. The 12 address bits multiplex into the chip on six address pins and in two steps, requiring two clocks. Other parallel-address RAMs use a single clock.

And 4-k RAMs usually include a chip-select input, allowing modules of greater than 4-k words to be built. All have read/write control circuitry, which determines whether data are written into or out of the IC.

Data into the chips are often latched, just like addresses. Output latches, a less common feature, are also available. For all of the new RAMs, inputs feature TTL-compatibility.

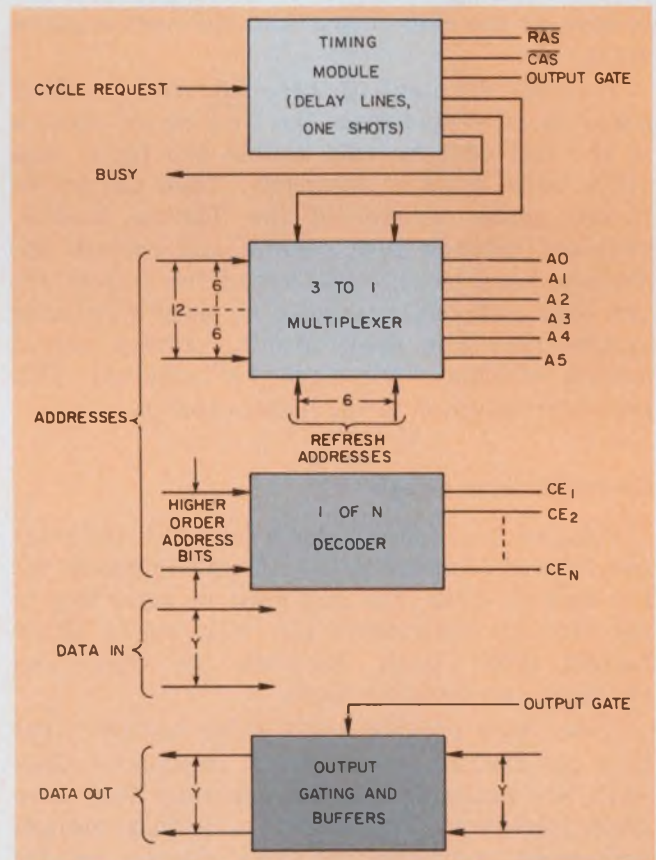

3. Interface circuitry for a memory system assumes the use of Mostek's 4-k dynamic RAM, the MK4096.

dissipation. This control signal is especially useful when memory systems are designed with circuits that have a standby mode or when system support circuitry must be powered down.

The memory circuits selected must, above all, be able to provide the timing and cycle types dictated by interface specifications. Further criteria are the memory's size and modularity, if any. For example, if a memory system has to be expanded in, say, 2-k-word sections, a 4-k-word-by-1-bit chip isn't the most efficient choice.

Price and availability are other important factors to consider in selection. And the easier a memory circuit is to design into a system, the shorter the development cycle and possibly the lower the system cost.

Newer memory chips offer several features that simplify their design into a system. These features include latches for addresses and input/output data, direct TTL compatibility, static operation and standby modes. The special features of Mostek's 4-k dynamic RAM (the MK4096), for example, allow use of the interface circuitry in Fig. 3. Buffering, needed to drive the memory array, is not shown.

The RAM, which comes in a 16-pin DIP, latches input addresses, chip enable and data as TTL signals. Two TTL clock signals (terminals $\overline{\text{RAS}}$ and $\overline{\text{CAS}}$) control the multiplexing of the 12-bit address onto the chip, which uses six pins for addressing. In addition the output data are latched at the chip output into the next memory cycle.

To take advantage of these features, the Busy signal is generated after the $\overline{\text{CAS}}$ signal strobes in the last address, chip enable and input data (if a write cycle is assumed). Then the multiplexer, under control of the Timing Module, switches between row, column and refresh addresses. As a result, data out of the system are not only buffered, but gated to meet maximum system hold-time specs. Again, on-chip output latches eliminate the need for external TTL latches in addition to the buffers shown.

Controller logic design

Some of the control signals from the processor can be used to generate the timing commands for the memory chip. The rest must be generated in the memory controller logic, with use of either tapped delay lines, one-shots or high-speed counters and decoding logic.

Delay lines provide reproducible accuracy, but they can require special circuit techniques. One-shots are easier to use, but generally they have delay tolerances from unit to unit that degrade high-speed performance. The counter-decoder scheme requires an accurate, high-frequency clock.

Generation of the memory-chip timing solves only part of the problem. The memory controller must also generate the output signals from the system. Here again, care must be taken to adhere to the system interface specs. The "output valid" signal has to be generated, and data from the memory must be supplied to the interface at the proper time. If an "end of cycle" command is required, it, too, must come from the memory controller.

The controller also contains priority logic to permit refresh cycles for dynamic memories. This logic provides the refresh interval, advances the refresh address counter and gains control of the system to perform the refresh.

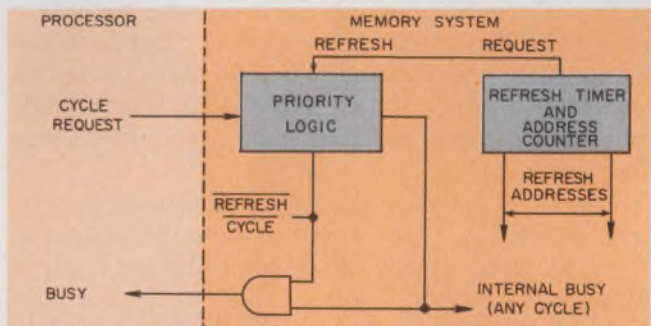

4. The controller section of an asynchronous design can include refresh-cycle interrupt logic needed for dynamic semiconductor memories.

The logic in Fig. 4 shows how a refresh cycle prevents the system from placing a Busy signal on the interface. If we assume still that Busy acknowledges Cycle Request, the priority logic must not interrupt a regular cycle once it has begun. But as soon as a normal cycle is completed, the refresh circuitry can take command of the system. If a regular cycle is requested during a refresh cycle, the priority logic ignores the request until the refresh cycle is completed.

Interface several processors

Also contained in some of the control logic might be the circuitry to achieve direct-memory access interfaces to more than one processor. Design of the controller represents the major challenge in memory-system design.

The last step in the design concerns interface elements. These are needed to make signals from the processor compatible with internal system requirements. Hence processor signals might require level shifting or demultiplexing off a bus. Also, internal signals from the control logic, address lines and data lines must be interfaced to the storage matrix. Again, level shifting, multiplexing and buffering might be needed.

Finally, interface elements may be required to achieve output voltage and current compatibility with other systems. ■■

Control Logic Programming

turn to CTS

for DIP set-up switches

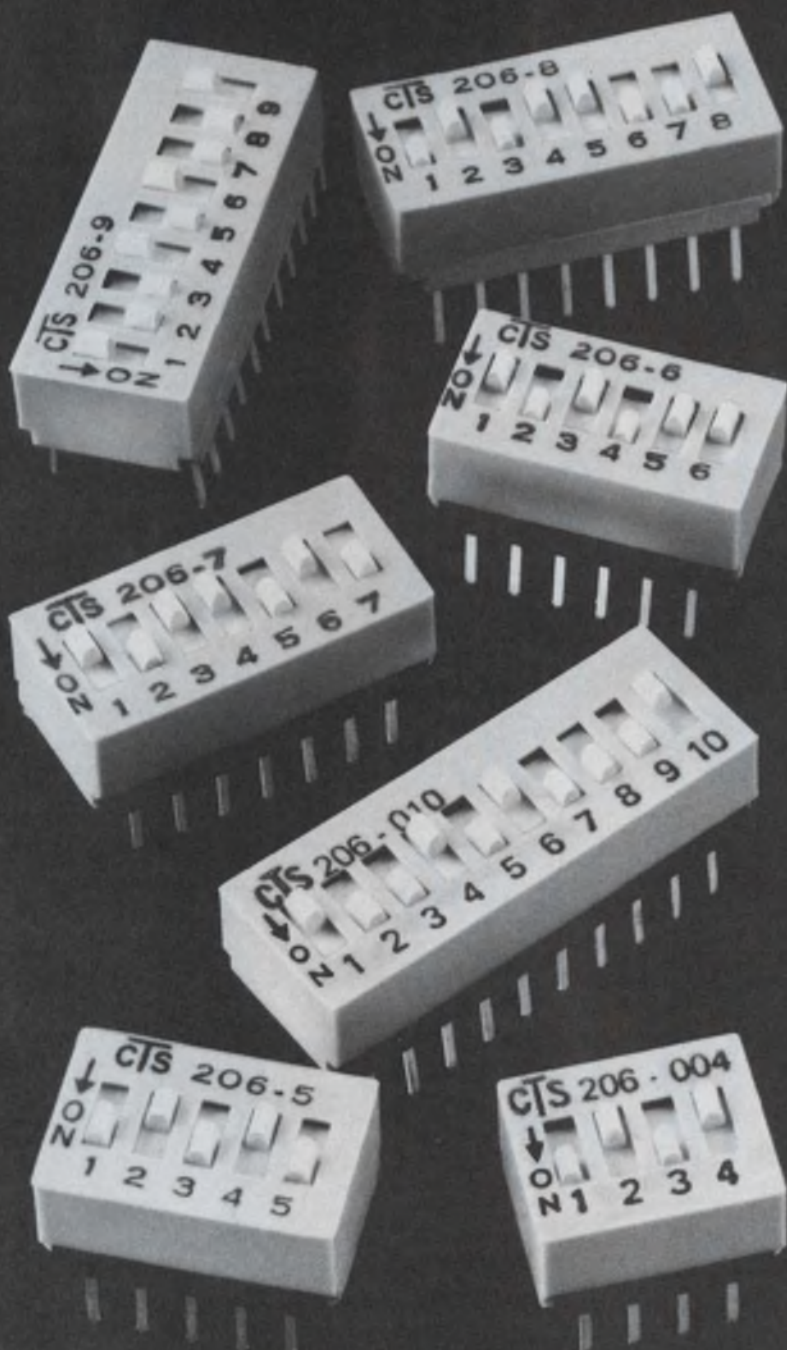

New CTS 206 Series switches will streamline your logic programming. These dual-in-line packages mount on the same PC board as other circuit components, eliminating the need for special mounting hardware/interconnection wiring. Program up to 10 different functions and/or signal levels with one compact switch.

CTS offers 7 different packages with 4 through 10 individual SPST slide switches per package. Automatic insertion saves you time and money. Units have .100" x .300" centers for inserting into either PC boards or standard IC sockets. Gold plated contacts that wipe on make and break assure low contact resistance over long life.

Designed for computer, computer peripheral, communication, test equipment and numerous other programming applications. Use good logic, turn to CTS. Find out more about our new, economical 206 series switch today. CTS Keene, Inc., 3230 Riverside Avenue, Paso Robles, California 93446. Phone: (805) 238-0350.

CTS CORPORATION
ELKHART, INDIANA



A world leader in cermet and variable resistor technology.

0000	0100	1000
0000	0100	1001
0000	0101	0000
0000	0101	0001
0000	0101	0010
0000	0101	0011
0000	0101	0100
0000	0101	0100
0000	0101	0110
0000	0101	0111
0000	0101	1000
0000	0101	1001
0000	0110	0000
0000	0110	0001
0000	0110	0010
0000	0110	0011



Can You Spot This Counter Problem?

With the new HP-1601L Logic Analyzer it's just as easy.

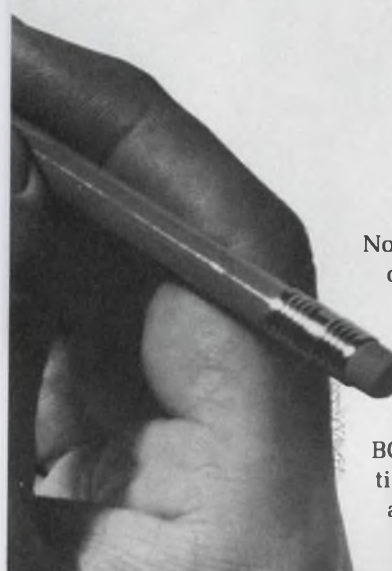

Now, watch your counters, or any other digital logic, dynamically step through their operations. Watch the display of "1's," and "0's" appear exactly as your logic calls for. Watch all this in hexadecimal, BCD or octal format, 16 words at a time, each 12 bits wide displayed as they actually occur in your design.



See negative time. Think of the time you can save with this breakthrough in performance capability. You can trigger the display on the first word or the sixteenth word to look ahead, or look back in time (negative time). **See dynamic data flow, much more.** Because the 1601L operates from your strobe signal (up to 10 MHz), delay can be conveniently dialed in up to 10^5 bits. Select positive or negative logic display depending on the type of circuitry you're working with, and adjust threshold over the $\pm 10V$ range provided. If a problem should occur, it's easy to select a window in time to help you diagnose the cause of your problem... quickly. And once the problem is isolated with the 1601L Logic Analyzer, your oscilloscope will help you to locate the component or circuit at fault. The 1601L provides a trigger for your scope making fault isolation even faster. **See things you've never seen before.** See those digital events you've always wanted to see. For all this capability the 1601L is priced at only \$2650*. Or consider the 5000A with LED display, two channels, thirty-two bits that sells for only \$1900*. Your local HP field engineer will be happy to arrange a "hands-on" demonstration in your office or lab.

*Domestic U.S. prices only.

HEWLETT  PACKARD

Sales, service and support in 172 centers in 65 countries
Palo Alto, California 94303 Offices in principal cities throughout the U.S.

083/9

Piezoelectric ceramic transducers:

Learn to use these energy transformers as a connecting link between mechanical equipment and electronic circuits.

Ceramic piezoelectric transducers—energy transformers—provide a sturdy bridge between mechanical processes and electronic circuits. The devices can work as linear translators, acoustic transmitters and receivers, dynamic strain gauges, storage devices, accelerometers and delay lines.

Ceramic transducers, of course, have both mechanical and electrical specifications. Electronics engineers recognize them as voltage generators; mechanical engineers see them as mechanical motors. In the last ten years, with the availability of more uniform materials, such as lead zirconate titanate instead of barium titanate, and with higher dielectric constants, applications have expanded from the simple phonograph cartridge to acoustic “X-ray” machines.

Making a piezoelectric transducer

Piezoelectric devices are composed of a high-dielectric-constant polycrystalline material, which can be formed into many shapes and sizes (Fig. 1). The piezoelectric ceramics don't exist in the free state. To produce piezoelectric properties, the dielectric material must be subjected to a process known as polarization. A strong electric field is placed across the dielectric (Fig. 2). This distorts the physical shape and electrical properties of the crystallites and creates a permanent, net electric polar moment. This process is similar to the creation of magnetic dipoles or the aligning of domains in magnetic materials.

Since the poling process distorts the piezoelectric material, the physical and electrical characteristics in the poling direction differ from the properties perpendicular to the poling axis—that is, the material becomes anisotropic.

To simplify the identification of the different ceramic parameters, the following standard notations are used: d_{ij} , g_{ij} , k_{ij} , y_{ij} and K_i . The “i” subscript identifies the direction of the electrical field associated with the applied voltage or charge



1. Piezoelectric ceramic materials are available in many shapes and sizes.

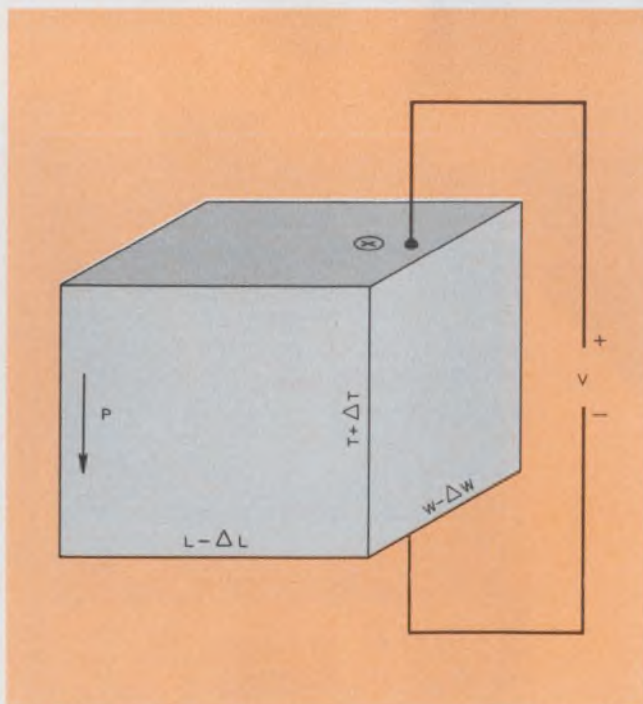

2. The electric fields required to pole the ceramic material are often as high as 100 V/mil.

Charles Edmiston, Field Engineering Manager, Gulton Industries, Piezo Products Div., P.O. Box 4300, Fullerton, Calif. 92634.

produced. The "j" subscript represents the direction of stress or strain. The numerical value of the subscript identifies the axis or direction in the ceramic material.

To identify directions in the ceramic, three axes are drawn on an imaginary unit cube of the material (Fig. 3). As shown in Fig. 3a, the 1 and 2 axes are perpendicular to the poling axis. The 3 axis is parallel to the poling axis. Since two of the axes are perpendicular to the poling direction, their properties are identical. Thus their subscripts (2) are usually omitted. When the mechanical stress or strain is shear in the mode, the applied stress is parallel to the direction of polarization and the mechanical subscript is designated as 5 (Fig. 3b).

Coefficients are important

The piezoelectric charge coefficient, designated d_{ij} , and the voltage coefficient, g_{ij} , describe the electrical and mechanical parameters of piezoelectric ceramics.

The coefficients d_{33} , d_{31} and d_{15} are the ratios of the electric charge generated per unit area to the force applied per unit area. The d_{33} term applies when the force is in the 3 direction (along the polarization axis, Fig. 4a), and the force is impressed on the same surface on which the charge is collected.

Coefficient d_{31} applies when the charge is collected on the same surface as before but with the force applied at right angles to the polarization axis (Fig. 4b). Subscript 15 indicates that the charge is collected on the electrodes that are at right angles to the original poling electrodes and that the applied mechanical stress is shear (Fig. 4c).

The units for the d_{ij} coefficients are commonly expressed as coulombs/meter² per newton/meter². When the area of the electrode on which the charge is collected equals the area on which the force is applied, the areas cancel and the coefficient is expressed as coulombs/newton.

The d_{ij} terms also represent the mechanical strain produced when the ceramic is used as a motor device. The units are then usually expressed as meters/volt.

Piezoelectric voltage coefficients g_{33} , g_{31} and g_{15} represent ratios of the electrical field produced to the applied mechanical stress in an open-circuited condition. Units are usually expressed in volt-meters/newton.

The ceramic materials are essentially dielectrics with unusually high relative dielectric constants. The constants have typical values that range from 500 to more than 3000. Ordinary dielectrics such as mica, glass or plastic have relative dielectric constants that might range from 2 to 10.

Relative dielectric constant is designated by the symbol K . Since no mechanical parameters are associated with K , the mechanical subscript is omitted. The symbol K_3 describes the relative dielectric constant in the direction of poling. And K_1 is the constant perpendicular to the poling axis.

The coefficients work together

At frequencies far below resonance, piezoelectric devices are fundamentally capacitors. There-

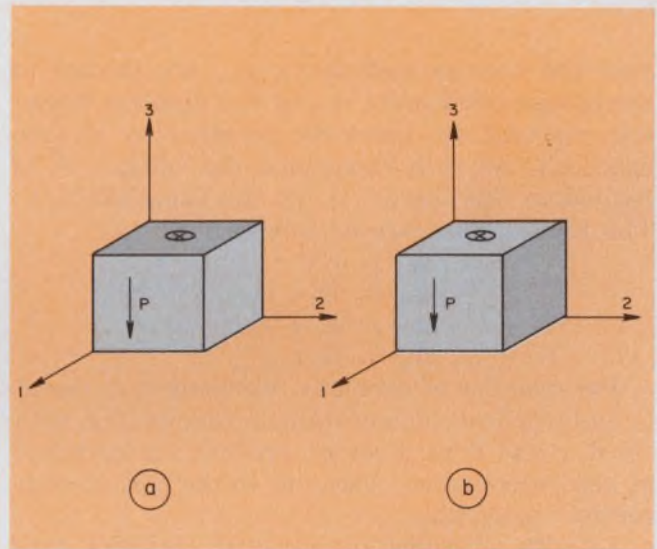

3. A unit cube of the ceramic material is set up as a three-dimensional solid for easy analysis.

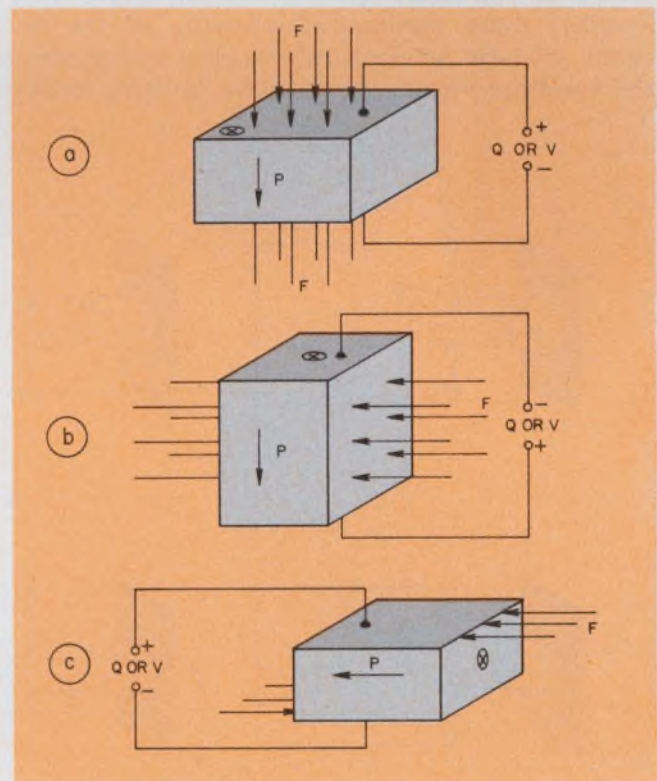

4. A polarized piece of ceramic has different characteristics when it is stressed in different directions.

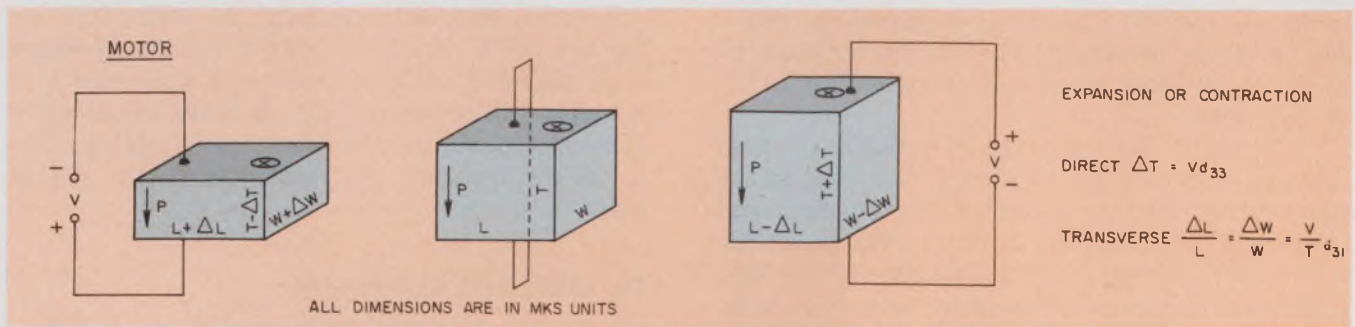

5. **Motor applications of the ceramic** let the material expand or contract when voltage is applied. Be careful

when you do computations—all dimensions should be in the MKS-units system.

fore the voltage coefficients, g_{ij} , are related to the charge coefficients, d_{ij} , by the absolute dielectric constant (K times the permittivity of free space ϵ_0). As with capacitors, the voltage, V , is related to the charge, Q , by the capacitance, C . The relationships are as follows:

$$Q = CV$$

$$d_{33} = K_3 \epsilon_0 g_{33}$$

$$d_{31} = K_3 \epsilon_0 g_{31}$$

$$d_{15} = K_1 \epsilon_0 g_{15}$$

The modulus of elasticity, mechanical Q , density and physical configuration, in combination with the d , g and K parameters, produce a wide range of electromechanical behavior in the piezoelectric ceramic materials.

As with all solids, piezoelectric ceramics have mechanical stiffness described in terms of Young's modulus—the ratio of stress (force per unit area) to strain (change in length per unit length). Since mechanical stressing of the ceramic produces an electrical response that opposes the resultant strain, the effective Young's modu-

lus with the electrodes shorted together is lower than with the electrodes open. Furthermore the stiffness is different in the 3 direction than in the 1 and 2 directions.

Thus when expressing such quantities, you must specify both direction and electrical or mechanical conditions. The term Y_{33}^E is the ratio of stress to strain in the 3 direction when the electric field is held constant (electrodes shorted). Y_{33}^D is the equivalent under a constant strain with the electrodes open. Y_{11}^D and Y_{11}^E are the moduli in the 1 and 2 directions, and Y_{55}^E and Y_{55}^D are the ratios of shear stress to shear strain. Units for the terms in Young's modulus are expressed as newtons/meter².

Since the ceramics are semimechanical devices, they have resonant frequencies—frequencies at which displacements (when driven electrically) or voltage outputs (when driven mechanically) will exhibit marked changes. The ratio of displacement or voltage output at resonance to the low frequency value is defined by the mechanical

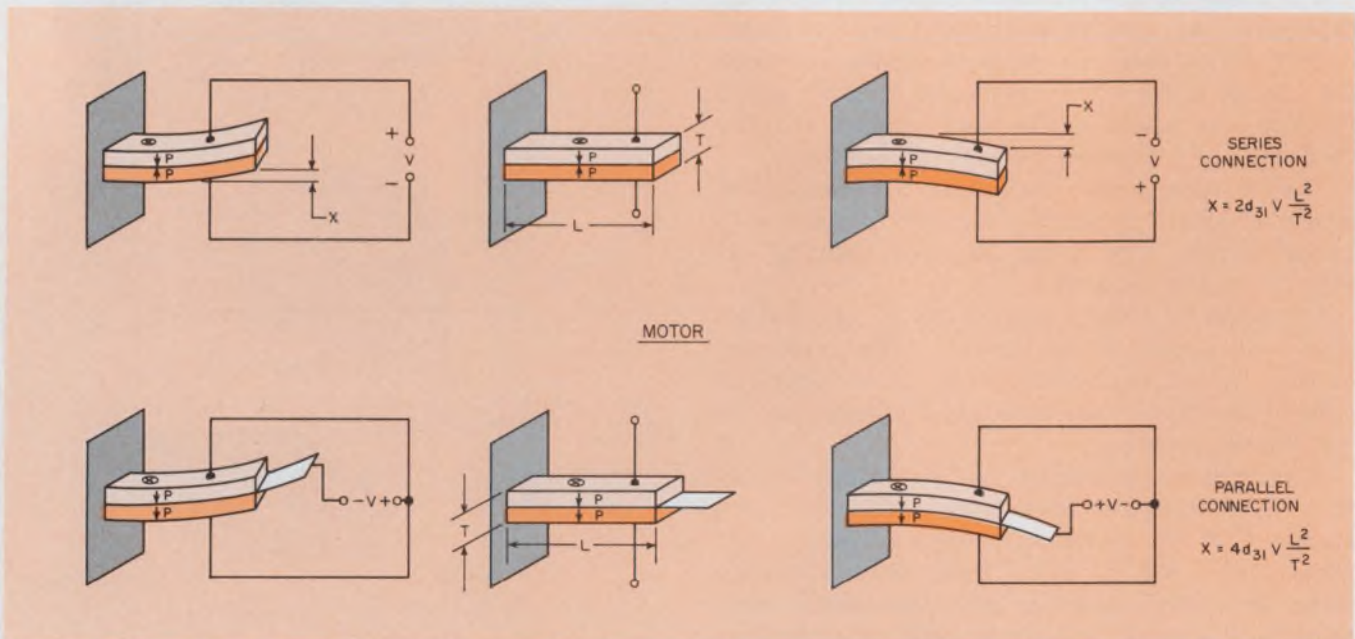

6. **Simple motor-bender applications** use a piezoelectric ceramic bonded to piezoceramic substrates.

quality factor Q_m . The finite value of Q_m results from internal losses or damping that is inherent in the material.

Electromechanical coupling coefficients combine all physical and electrical parameters at the same time. Somewhat analogous to the beta of a transistor—the conversion ratio for base current and collector current—electromechanical coupling coefficients k_{33} , k_{31} , k_{15} and k_p describe the conversion of energy by the piezoelectric ceramic from electrical to mechanical form, or vice versa.

The square of the coupling coefficient is the fraction of input energy of one kind stored in the piezoelectric ceramic. Subscripts denote the relative directions of electrical and mechanical quantities and the type of motion involved. The subscripts can be associated with the vibratory modes of certain ideal mechanical designs, and since they represent energy ratios, they are dimensionless.

Applying piezoelectric materials

Many applications require that the ceramic material be used with other materials that optimize a particular characteristic. In these cases mechanical amplifiers, mass loads, resonant horns and housings are usually part of the transducer. Let's look first at applications that use the motor properties below resonance.

The formula in Fig. 5 describes the displacement for the 33 orientation when a field is applied. Thus if 1 V is placed across the electrodes of a 2-mm-thick piece of ceramic, it will produce as much displacement as another transducer that is 2 cm thick. This motor characteristic, along with the fact that these materials can be connected in series mechanically and in parallel electrically, makes the transducers ideal for linear translators, micropositioners, wide-band, off-resonance acoustic projectors and many other applications.

When a voltage is applied across the electrodes in the 33 direction, the piezo material not only changes its physical dimension in the vertical direction but also in the length and depth (Fig. 5). In the formula that describes transverse movement, displacement is not only a function of the applied voltage but also of the physical dimensions of the transducer. This characteristic opens up applications in a different operating mode—known as bender or bimorph.

A piezoelectric ceramic bender takes advantage of the transverse expansion and contraction when voltages are applied in the 33 direction. If one of the electrode surfaces of a long thin piece of ceramic is bonded to a thin substrate so one surface is free and the other restricted, the transducer will bend when voltage is applied.

The bending motion is analogous to the curve

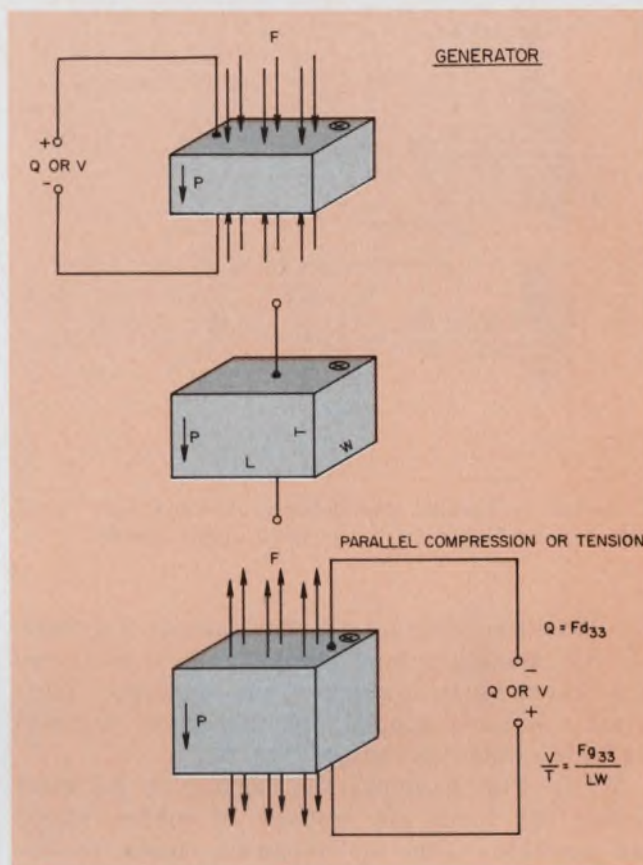

7. Direct generator applications make use of a charge output from the transducer under mechanical stress.

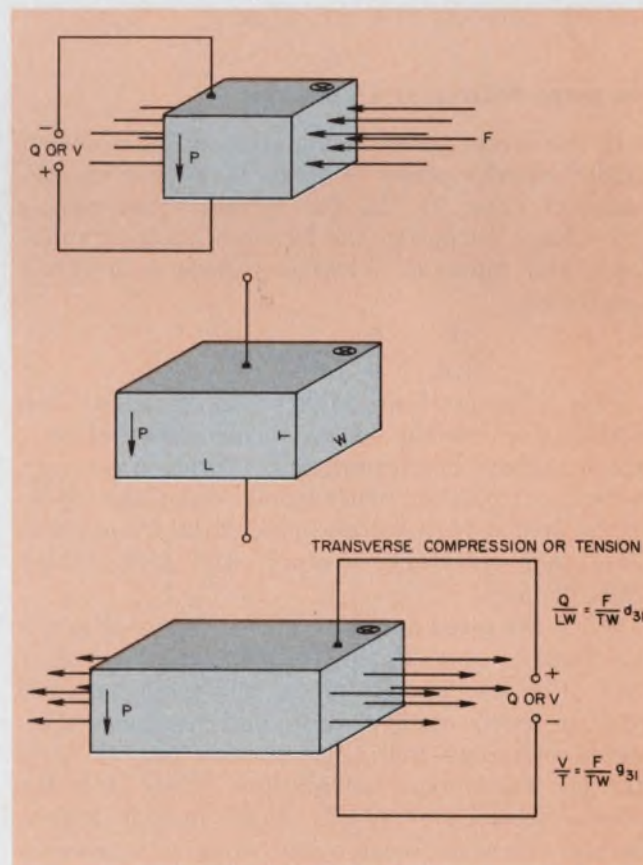

8. Forces applied perpendicular to the poling axis also produce usable electrical outputs.

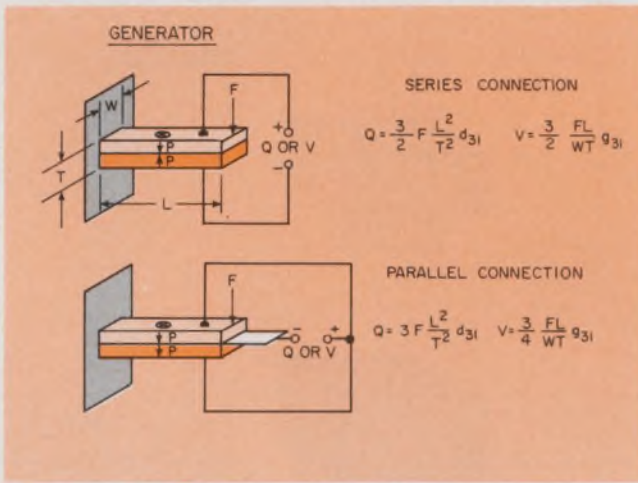

9. Series or parallel connections of transducer materials provide high outputs for small displacements.

in a bimetallic strip used in thermostats. To multiply the bending action, piezoceramic transducers are placed on both sides of the substrate. Thus when voltage is applied, one transducer expands while the other contracts (Fig. 6).

While Fig. 6 shows the bender in its most elementary form, any number of configurations are possible—from multifingered combs to circular discs. Motor benders are used where relatively large displacements and low forces are required—as in linear translators, micropositioners, clock-drive motors, tactile pressure sensors, acoustic tweeters and bell ringers.

The piezo material as a generator

In the direct piezoelectric application, a charge output results when a force is applied to the material (Fig. 7). In the formula that relates the voltage output in the 33 mode to the applied force and material thickness, there is a direct proportion:

$$\frac{F}{LW} = \frac{F}{a} = \text{pressure.}$$

This characteristic makes the configuration suitable for various forms of instrumentation—which include accelerometers, vibration sensors, mechanical position sensors, etc.—and also opens up the field of high-voltage generation for applications such as spark ignitors¹ and high-voltage transformers.

When the piezo material is used in the 31 mode, the force is applied perpendicular to the poling axis (Fig. 8). The 31 mode below resonance is used in such configurations as benders, thin-walled cylinders and spheres that provide substantial mechanical advantages. Uses for the below-resonance generator mode include hydrophones, vibration sensors and wide-band acoustic receivers.

The piezoelectric ceramic-generator bender

construction is identical to the motor bender described earlier (Fig. 9). But in this configuration the generator, or 31, mode provides substantial voltage outputs from small displacement inputs, because of the mechanical gain of the bending motion. Applications for these devices include phonograph cartridges, microphones, hydrophones and strain gauges.

Resonance has its uses, too

At frequencies far below resonance, the transducer responds in phase and proportionately to the applied input. A transducer will hold its mechanical displacement as long as the dc voltage is applied. However, the charge produced by the dc potential will leak off at a rate determined by the RC time constant of the transducer in combination with the external circuit. The leakage limits the frequency response of piezoelectric transducers that operate in the direct mode.

When the transducer is driven electrically, its motions are small at low frequencies. The material can be considered a reactive element (a capacitor).

As the resonant frequency is approached, the displacements are amplified, and the mechanical characteristics significantly affect the impedance seen by the electrical signal source (an oscillator).

In the vicinity of resonance the self-capacitance of the transducer is shunted by a series-resonant circuit that consists of the electrical equivalents of the effective mass, the compliance (stiffness) and the losses. At resonance, the shunting arm becomes resistive and acts as a low impedance in parallel with the self-capacitance.

By dipping to a minimum value, the impedance curve would show a marked change at the resonant frequency. At a frequency slightly above the resonant value, the series-resonant circuit becomes inductive. And a parallel resonance is created between the inductance and self-capacitance of the transducer. The parallel resonance represents a peak in the impedance-vs-frequency curve (anti-resonance).

Applications of the resonant properties include ultrasonic cleaners, fetal heart monitors, liquid atomizers, burglar alarms, delay lines and resonant audio speakers. ■■

Bibliography

- Mason, Warren P., "Physical Acoustics, Principles and Methods," Vol. I, Part A, Academic Press, 1964.
- Heuter, Theodor and Bolt, Richard, "Sonics," John Wiley and Sons, Inc., 1955.
- Glennite Catalog, Gulton Industries, Fullerton, Calif., February, 1974.

References

1. Germano, Carmen, "Flints That Don't Wear Out," *Electronic Design*, No. 13, June 21, 1974, pp. 88-90.

1974'S
BIGGEST
DESIGNER-IN
NUMBER.

THE 4136
QUAD OP AMP
REPLACES FOUR
AT 40% LESS.

741's.



If there ever was a linear IC destined to become the biggest volume commodity item since the 741, it's Raytheon Semiconductor's 4136 Quad Op Amp.

The 4136 is the only quad op amp that's electrically equivalent to four 741's. The only one that requires no design changes. And it's even better than the 741. Lower input noise, better input offset voltage matching, wider input common mode voltage range, greater gain, higher slew rate, and wider bandwidth.

The 4136 costs 40% less than four 741's. And that's just the beginning. Packaged in a standard commercial or military 14-pin DIP, it requires only one mechanical assembly step. So naturally it takes up less board space. Testing is simpler too. And inventory is less of a problem. This all adds up to greater cost savings.

There's more to the big 4136 design-in number story. Get all the facts on quads.

Raytheon Semiconductor
350 Ellis Street
Mountain View, California 94042

RAYTHEON



Send me all the facts on the 4136 Quad Op Amp and your other money-saving Linear Quads.

Name _____
Title _____
Company _____
Address _____
City _____
State _____ Zip _____

4136 Quad Op Amp • 324 Ground Sensing Quad Op Amp • 3900 Single Supply Current Quad Op Amp • 339 Quad Comparator

ED

RAYTHEON SEMICONDUCTOR

Shape foil into a magnetic shield

with scissors. Permeability, thickness and the layers needed are determined by simple formulas and measurements.

Many magnetic shielding problems can be solved with a pair of scissors and a sheet of magnetic foil. The thickness of the shield and the number of layers required are determined first by simple formulas. The foil is then hand-trimmed to the required outline and fitted around the structure to be shielded (Fig. 1). Measurements then tell whether refinements are needed.

If you have only a few shields to worry about, the job is done. If you have thousands to make, this is still a good initial design procedure.

Satisfactory ductile foil material, ranging from 0.002 to 0.01-in. thick, is available in a variety of permeabilities. It may be best to start with 0.004 or 0.006-in. thickness. Adhesive tape can hold the shield in place.

Low-permeability foils are usually 0.004-in. thick, and high-permeability foils can be obtained as thin as 0.002 in. Several widths are available.

Mathematical approach provides insights

What are the best materials to use, the most efficient geometries and the degree of shielding attainable? You can find out by trial and error, but that's time-consuming and imprecise. On the other hand, a purely mathematical approach can be very complex, and because of the many simplifications and assumptions that must be generally made to simplify calculations, the results can be unreliable unless the engineer makes some measurements. An approach that combines the insights of a mathematical analysis and practical trial and error, produces the best results.

The mathematical analysis of magnetic shielding is an ancient subject.¹ One of the first conclusions drawn by investigators was that multiple, concentric shields are more effective than increased thicknesses of a single magnetic material shell. Beyond a certain thickness, it has been found, much greater shielding can be obtained if the shell is divided into several layers of alternate magnetic and nonmagnetic material. For a



1. A pair of scissors and a roll or two of foil magnetic-alloy material are all you need to fabricate a practical magnetic shield.

sphere or long cylinder, when the radii of the layers are large compared with their thickness, best results are obtained when the alternate magnetic-nonmagnetic layers are approximately equally thick.

The general equations for calculating the degree of shielding in multilayer shells are complex; a calculator or computer is usually required to obtain solutions. But for a single-layer enclosure, an approximate solution is:

$$\begin{aligned} g_1 &= H_o/H_i = \frac{\text{field intensity outside the shield}}{\text{field intensity inside the shield}} \\ &= (\mu/4) (1 - r_i^2/r_o^2) \\ &= (\mu/4) [(t^2/r_o^2) - (2t/r_o)] \quad (1) \\ &\cong \mu t/2r_o, (t \ll r_o), \text{ when } (r_o - t) \text{ is substituted} \\ &\quad \text{for } r_i. \end{aligned}$$

In these equations,

- μ = permeability of the magnetic material,
- r_i = inner radius of the shield,
- r_o = outer radius of the shield,
- t = thickness of magnetic material.

Richard D. Vance, President, Ad-Vance Magnetics, Inc., Rochester, Ind. 46975.

These equations are valid for spherical shields or for cylindrical when the length-to-diameter ratio is 4 or more.

For multilayer shields, each additional magnetic-material layer around the first layer multiplies the attenuation by roughly

$$g_{ij} = \mu t^2 / r_o^2. \quad (2)$$

As an example, assume that a shield is in the form of a long cylinder with an OD of 2 in. and wall thickness of 0.02 in. and that the shield material has $\mu = 10^5$. Then the shield can produce attenuation of $0.02 \times 10^5 / 2 \times 1 = 1000$. Doubling the thickness of the material would only double the attenuation. But if a second 0.02-in.-thick magnetic layer, about 0.02-in. away, surrounds the first, the attenuation is 40 times greater, or 40,000. The space between the two magnetic layers must be occupied by nonmagnetic material, such as copper, aluminum or any dielectric material.

Magnetic materials saturate

Eqs. 1 and 2 are approximations. But even with use of a fully expanded equation,² the results are still approximate. This is because all mathematical analyses assume that the magnetic material behaves linearly—flux density is directly proportional to magnetomotive force—and that, thus, μ is a constant. This is far from true, especially with the high-permeability materials that are used for shielding (Fig. 2). In addition to nonlinearity, magnetic materials saturate. At saturation the permeability is very low, and the material has little shielding ability (see table).

Experience indicates therefore that the thickness of shield material should be selected to keep the flux density in the material in the range of 2500 to 3500 gauss, because generally the permeability is maximum in this region of flux density.

When the flux densities become larger than can be handled by a single sheet of foil material, multiple layers can be used. Or heavier-gauge sheets, to about 0.05 in., can be bent, stamped or drawn into the desired shape with shop tools. However, unlike foil, heavier-gauge material re-

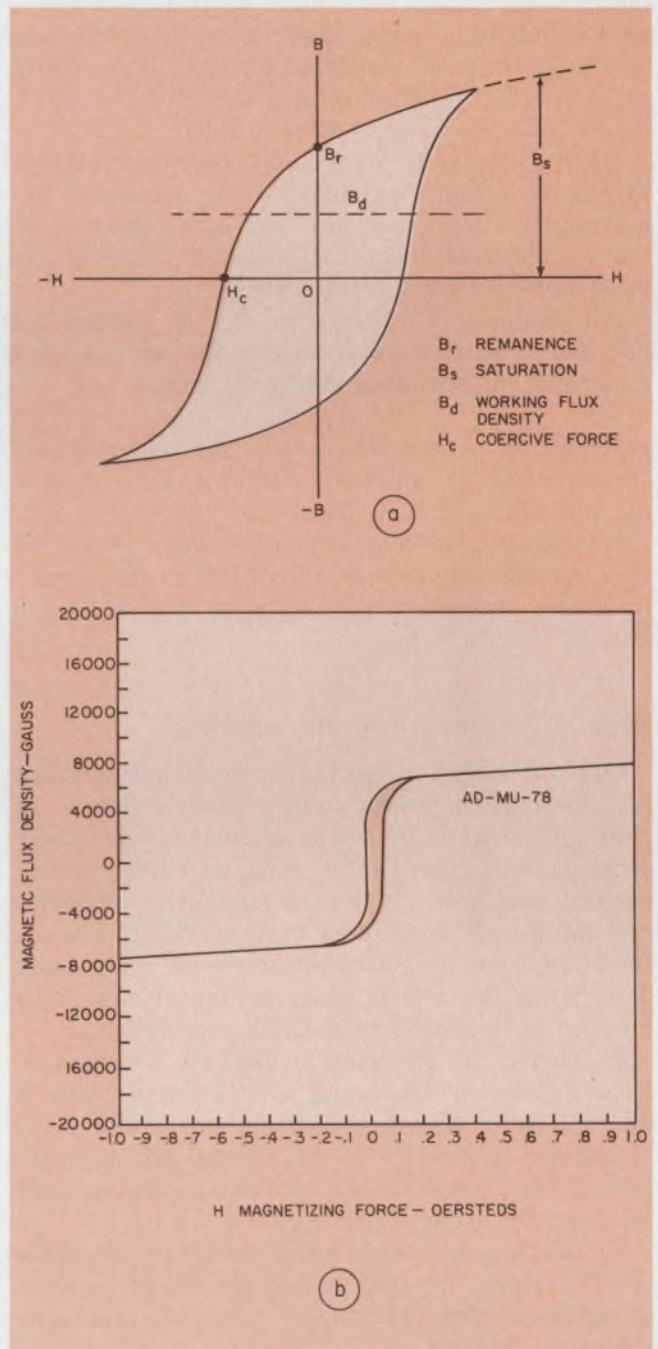

2. Permeability—the slope of a BH curve (a)—is not constant, contrary to the assumption in most mathematical analyses of magnetic systems. The BH curve of AD-MU-78, a high-permeability-alloy, is very steep, and it has an almost rectangular saturation point.

quires heat treatments after fabrication.

Obviously, it is desirable to use shield material with the highest possible μ . However, as the magnetic material table shows, high-permeability materials saturate at lower flux levels. Thus when multiple-layer shields are designed to provide high levels of attenuation, the outer layer—which is exposed to the highest intensity of flux density—should be selected from high-saturation-level, albeit lower- μ , material.

Shielding materials are classed as having low, medium or high permeability. Low-permeability materials, though, have high saturation levels—18,000 to 20,000 gauss. Medium-permeability materials saturate at somewhat lower levels—roughly 15,000 G. And the high-permeability materials saturate in the 7500-to-9000-G range.

Also, retentivity is related to permeability. Minimum retentivity may be an important requirement for assemblies that are sensitive to low dc magnetic fields. High-permeability materials have the lowest retentivities.

An example where theory can be misleading because of saturation occurs in the often-quoted criterion² for optimum shield thickness.

$$t = 3r_i/2\mu.$$

In this case it is better to use multilayered construction. In the previous example, with $r_i \approx 1$ in. and $\mu = 10^5$, $t = 1.5 \times 10^{-5}$ in.

However, most magnetic materials, when this thin, quickly saturate in a field of any reasonable intensity. Moreover the material would be too fragile to fabricate.

When do you need magnetic shielding?

Often it's hard to determine whether a problem is caused by magnetic fields. Many sources, including the earth, generate magnetic fields. Many other system components such as CRTs, photomultipliers, every coil and magnetic memories and tapes, can be affected by these fields. The effect can be a simple positioning error in a dc field. Or if the field is time-varying, it can cause hum or degradation of a CRT's resolution.

It used to be difficult to measure a magnetic field accurately. A small coil, excited with a distinctive ac signal, could serve as a source to determine if the circuit was susceptible to magnetic interference. Or the small coil could be used as a pickup probe to detect ac fields.

Though crude, these improvisations were often very effective, but they provided little in the way of accurate measurement of the field strengths that were present.

Today gaussmeters accurately cover the range from 0.02 to 50,000 G for frequencies from dc to 20 kHz and higher. They provide direct readings—as easily as a voltmeter does. The probes to detect the magnetic field are usually Hall-effect,

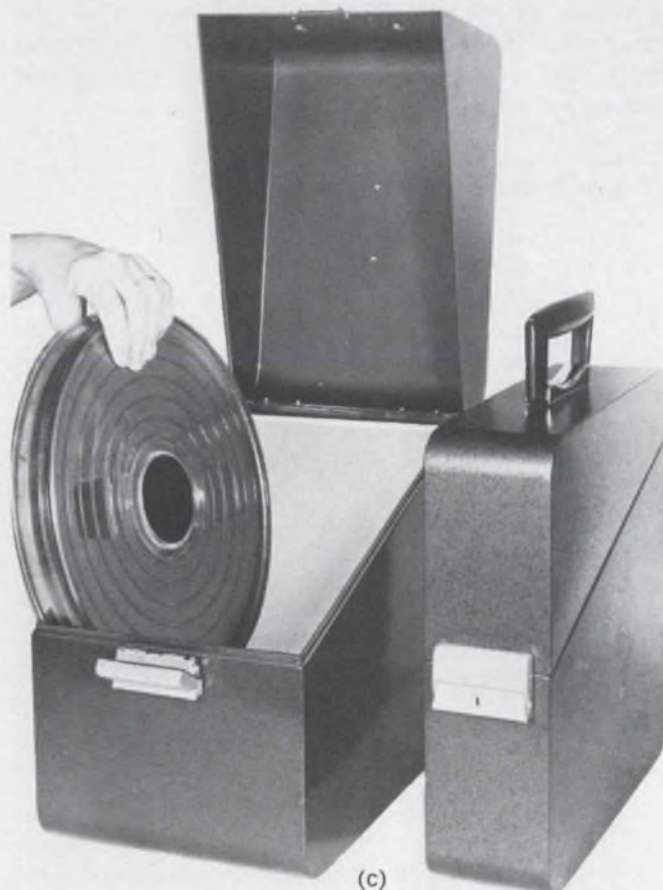
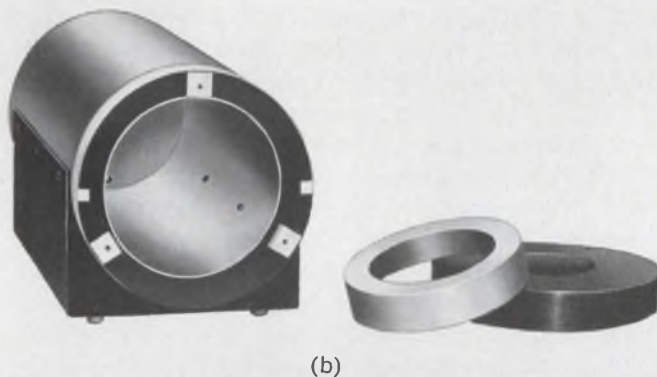

3. One of the many available custom-fabricated shields (a), or magnetic-isolation chambers (b), or perhaps a standard package such as a special protective case for magnetic tapes (c), might fill your need for shielding.

Typical dc magnetic properties for shielding alloys

	Material	Initial permeability at 40 gauss	Permeability at 100-200 gauss	Maximum permeability	Saturation induction gauss	Coercive force oersteds
High permeability	Carpenter HY-MU-80	50,000	60,000	350,000	7500	0.010
	Ad-Vance AD-MU-80	35,000	45,000	350,000	8200	0.015
	Ad-Vance AD-MU-78	20,000	30,000	300,000	7500	0.015
Med. permeability	Allegheny 4750	12,500	17,500	150,000	15,500	0.02
	Ad-Vance AD-MU-48	11,000	27,000	100,000	15,200	0.03
Low permeability	Millen Low Perm.	290	1000	9000	19,000	0.9
	Ad-Vance AD-MU-00	300	500	3000	22,000	1.0
	AISI M-36	280	600	5000	20,000	1.0

InAs elements. And for calibration of the meters, the National Bureau of Standards will certify the flux value of a simple permanent-magnet reference.

A well-stocked electronic laboratory should have a gaussmeter, and its probe can be used to hunt and measure interfering magnetic fields with ease.

After the offending field is detected and mapped, the accessibility and component layout in the region of the field will determine whether it is better to enclose the source or the pickup device, or perhaps both. A first-trial shield can be put together with the foil-and-scissors technique, and the results can be checked with a gaussmeter probe. Several adjacent foil layers can be applied to provide a simple, thick shield. Or a spirally wound foil, sandwiched with copper or aluminum foil, can produce a multilayer shield for greater shielding.

When the shape, thickness, number of layers and material types have been established by rough mathematics and measurements, more permanent designs can be undertaken, and companies that specialize in magnetic-shield fabrications can be called in. Now you can talk intelligently, with known facts and figures. Often a manufacturer may have a stock shield to suit your problem, or he may be able to modify one of his shields economically.

Note: The magnetic properties in the table are valid only if the material is properly annealed, especially after it has been stressed during fabrication of the shield. Even dropping or jarring the shield can, with some materials, substantially affect permeability. Thus it is wise to order by

specifying permeability and saturation—the vendor's material number is not enough.

The annealing process generally is not simply a heating process with slow cooling. It must be done under the proper atmosphere—sometimes in a vacuum—and with careful control of cooling rate at predetermined temperature levels.

And, of course, the shield material may require protective finishes, such as cadmium plating or painting.

Shields can also handle electrostatics

Since ferromagnetic shielding alloys are reasonably conductive, proper grounding of an electromagnetic shield can usually provide an adequate electric-field shield at low frequencies. Grounding is not necessary to obtain magnetic shielding, but it's good practice.

At increased frequencies, skin effect becomes a dominant factor, and the conductivity of the shield material should be greater than that of permeable alloys. For good conductivity, materials like aluminum or copper are needed. One way of combining magnetic and electrostatic capabilities in a single-layer shield is to copper-plate the magnetic shield with sufficient copper to satisfy skin-effect requirements. ■■

References

1. Giovanni Battista della Porta, *Magiae naturalis, sive de miraculis rerum naturalium . . . Libri VIII* (1589).
2. Wadey, W. G., "Magnetic Shielding with Multiple Cylindrical Shells," *The Review of Scientific Instruments*, Nov., 1956, pp. 910-916.
3. Kraichman, M. B., "Handbook of Electromagnetic Propagation in Conducting Media," NAVMATP-2302, available from Supt. of Documents, Gov't Printing Office, Washington, D. C. 20402.

MESA™* APR 1000 Responsibility check list



If you're responsible for:

- removing photoresist from silicon wafers or chrome masks; cleaning and drying silicon wafers, chrome masks or glass plates
- reducing chemical consumption
- reducing pollution
- improving yields and safety
- saving your company money

you should know about MESA™* APR 1000

MESA™* APR-1000 is the first in a series of automatic processing units from B&A. It has numerous advantages and safety features which you should know about. It can also save you money.

For additional information, call your nearest Allied Chemical Sales Office or write Allied Chemical Corporation, Specialty Chemicals Division, P.O. Box 1087R, Morristown, N.J. 07960. Attention: Advertising Department.



Another NOW Idea in Chemicals for Electronics

* Modular Equipment for Semiconductor Applications

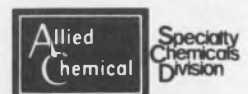

P. O. Box 1087R,
Morristown, N.J. 07960



There's more to microcomputer design than counting your chips.

Here is some new information to help you win at the product design game. *Microcomputer Design*, a new book by Martin Research, can show you how to cut the chip count on your 8008-based CPU by 20-50%. This is the first major source on cost-effective design with microprocessors. It shows you how to build increased performance and lower cost into your microprocessor system through the efficient use of your chips.

You'll find systems covered from theory to practice — from large to small. Plus important features on . . .

- **Designing for maximum flexibility and easy expansion.**
- **What should go into the peripheral, and what goes into the microcomputer.**
- **The most efficient bus-structured system for the 8008/8080 yet published.**
- **When an 8008 can do an 8080's job through efficient design.**
- **An OEM 8008 system for \$50.00.**
- **A complete communications controller with keyboard, only 19 chips. 8008, ROM, RAM, and interface.**
- **CRT interface added with only three more chips.**

- **Many design concepts applicable to any 8-bit microprocessor.**
- **Over 200 pages, dozens of schematics, and an easy-to-use lay-flat format.**

If you are working with microprocessors, you need *Microcomputer Design*. The book won't fit up your sleeve, but when you're designing for high stakes, it's like having an extra ace.

Fill out the coupon below to reserve your copy of *Microcomputer Design*. Do it before the Oct. 15th publication date, and you will receive one 8008 microprocessor *free* for the purchase price of the book alone.

You can't lose.



1825 S. Halsted St.
Chicago, IL 60608
(312) 829-6932

Send me ___ copies of *Microcomputer Design* at \$100.00 each, postpaid. Plus an 8008 microprocessor free with each book ordered before Oct. 15th.



- Check enclosed
- Purchase order enclosed.
- Bill my company.
- Send more information.

Name _____

Title _____

Company _____

Address _____

City _____ State _____ Zip _____

Phone _____

Signature _____

When you have no choice but changeover, good planning, the right technical talent and cooperation between hardware and software people can ensure success.

The challenge is this: to change over from making one electronics product to making a different one—and to do it without losing a beat. What's it like to try? And what does it take to succeed?

Four years ago we decided to make the shift from hardware to systems. Our company had been selling the old product line of hard-wired digitizers and had discovered, with the aid of the 1969-70 recession, that the market wasn't big enough for us to be successful. We decided to enter the interactive graphics market for automated drafting.

Our elements of success may seem obvious, but you have to work at them. They were these:

- Good planning. We were able to define a superior product, and it has become an industry standard.
- The right technical talent. We had to attract it.
- An extremely cooperative attitude between the hardware and software people. We developed it.

Designing for the future

The biggest challenge was to develop an operating system that was versatile and fast, so we could add new applications to the software. Initially we chose to pick a hole in the interactive graphics market; it was integrated circuits. We knew that we could sell there, and we knew there was a need.

We had to design the basic operating system, and the hardware that would make it work smoothly, in such a way that it could later accommodate automated mechanical drafting, schematics and PC boards. The challenge we faced was how to design the proper software operating system and how to drive those peripherals in a way they hadn't been driven before.

To define the product, we didn't use outside consultants because little was known about the new market we were entering. But we did rely

heavily on the opinions of our customers. In many cases these digitizer users were actually in applications that could be better served by an interactive system. We told them this was what we planned to do, and we asked them what they thought. Most thought we were right.

Our product line at the time of the changeover consisted of a series of hard-wired digitizers that were used to convert graphical information, such as maps, charts and other drawings, to computer-readable form. The result was then recorded on magnetic tape via an incremental recorder.

The company's new product line consists of a modularized series of interactive graphic systems that contain their own minicomputer, disc storage, magnetic-tape output, interactive digitizing and editing terminals, and on-line plotters operating in the background mode.

The new product line, the graphic data system, is used in the IC printed-circuit board, mechanical drafting and cartographing applications. It not only performs the graphical data-acquisition conversion and storage function, but sophisticated data-processing and art work generation functions as well. Only the data-acquisition and conversion functions were retained from our product line. The remainder were discarded in favor of more sophisticated technology.

Pricing considerations led us to abandon certain designs that could have been carried over from our old line. We thought that a system this size should be priced at 100k, to be competitive with other systems emerging on the market and to appeal to a larger segment of potential purchasers.

Another consideration was the availability of financial resources. We knew what had to be done, but because of the financial picture in 1970, we had to compromise in the area of packaging and esthetic appeal. We decided that performance was much more important than appearance. We did not redesign or repackage the input terminal, for instance, knowing that the option for doing that would always be available.

The cash-flow consideration also led us to retain in our new logic designs the concept of

Bob Benders, President, CALMA Company, Sunnyvale, Calif. 94086.

Robert Benders and CALMA Company



Three and a half years ago Bob Benders had risen from a research assistant to a company president. He was just over 33 and he'd taken only 11 years to reach the top. Today, at 37, he presides over CALMA, a company that makes, markets and supports minicomputer-based interactive graphics systems. Incorporated in 1964, CALMA Company develops and markets a line of high-quality digitizing equipment.

From that job as research assistant in airborne infrared scanners and coherent optical data processing at the University of Michigan Institute of Science and Technology, Benders went on to work as a senior research engineer on digital systems development, at both Boeing and Lockheed. He had received his BSEE at the University of Michigan. He's married and has four children.

As president and former chief engineer of CALMA, Benders directed the company change from hardware manufacturer to systems supplier. Applications for CALMA systems began with electronic circuit artwork generation and have expanded to encompass general drafting and various types of mapping. Continuing research and development activities consume approximately 10% of company revenues—the majority devoted to new and improved programming. Current programming staff members number 22.

CALMA sales have grown from \$1.5 million in Fiscal 1972 to \$5.4 million in Fiscal 1974 and are projected to reach \$20 million by 1977. A direct marketing force was established in 1974 with offices in eight U.S. cities and London.

packaging IC chips on large wire-wrapped boards. This resulted in lower over-all cost but more difficulty in maintenance, since repair was by the chip rather than by the board. We could do that kind of maintenance, however, because the company had a good maintenance group. But when the number of systems grew to over a hundred, we had to redesign and repackage the logic. We realized this at the beginning and built our plans around specific engineering talent.

Matching skills with needs

We couldn't keep every engineer when we switched over. We had to define carefully the design problem in terms of what could and could not be compromised. The most important prin-

ciple was to produce the most powerful and cost-effective system in its price range. In this area, we made no compromises. We defined the system in general terms and arrived at a basic configuration. Next we examined the availability of key components, such as minicomputer, CRT displays, disc and tape storage units, plotters and others. From these data, we made "buy and build" decisions and examined available designs.

We kept those engineers who were essential to design the configuration, as defined—about 30% of the staff. This decision was partly dictated by the economic conditions in 1970; we didn't really have much choice.

The most important hardware job titles we had to fill were:

- Logic design. We needed this expertise to

connect a minicomputer to various terminals, such as plotters, tape drives and inputs.

- Analog design. We were developing a CRT terminal base, and we were doing some work on the digitizing tables.

- Mechanical design. We had to improve the design of the digitizer. Formerly I had been chief engineer of the company and knew what our people could do. When it came time to match up people's skills with our needs, I had all the information I needed. We kept six engineers and used them throughout the changeover.

When I took over the company presidency, I also retained direct managerial responsibility for the engineering department and helped to preserve morale and to provide motivation. This direction gave the engineers a better feeling for what they were doing and quicker access to top management. Over-all, our engineers were dedicated professionals who wanted to see the company succeed.

We were never a large company, so little reorganization of personnel was needed. Senior engineers had to do additional tasks that formerly had been done by lower-level people; we also transferred some technicians to a manufacturing and field service unit.

Small talented groups are best

Later we needed software capabilities, which have to be continually enhanced to remain competitive. I don't want to minimize our hardware, which is in some ways superior to many competitive units on the market. But hardware, once developed, tends to remain stable for a time, whereas one can always think of new applications and programs to add to a software package.

I believe that most superior products are developed by small groups of extremely talented technical people, rather than large numbers of people. This is true for hardware and software. A company's return on investment is much greater from a small group of extremely capable people, although obviously they are more highly paid. This assumes, of course, that it's a job that lends itself to a small-group solution.

I also believe that, in programming, a person's basic ability is more important than specialized experience. When we were going into computer graphics, I felt that instead of getting computer programmers to build a system that was better, I needed instead the best possible engineering to build it. We found the proper people through the usual channels without having to make compromises.

We've been very liberal with stock options to engineers, which is meaningful because we're still a privately held operation. This company had always been managed by engineers, and we've always

tried to maintain a good working environment.

When we made the change, we anticipated some problems integrating the hardware people with the software people. To minimize these, I had all employees report to me. This not only gave them access to top management; it also helped them to be aware of one another's problems, thereby easing the transition. Later on, when the business grew and I could no longer meet personally with all of the employees, I put the software people under a software manager and the hardware people under a hardware manager, and now have those two managers report to me on an equal basis.

We didn't run across any technical design problems, because we defined exactly what could be built from the beginning and hired the people to do that task. Retraining wasn't necessary in engineering; the hardware people had been doing the same tasks on a different product. They all had the necessary skills to pick up and continue with a new product.

Company profitable since changeover

What about tooling and facilities? We didn't require a lot of new tooling, because we buy most of the complex components—like the minicomputer, the disc drive and the tape drive. We do have tooling for digitizers, but we already had this.

We needed some changes in the laboratory facilities, but the prime consideration in 1970 was to balance the requirement against the available financial resources. We needed some lab equipment to test IC chips and other components. But the biggest change was the additional requirement of a facility for the testing and debugging of computer programming. We decided that the most cost-effective method of providing this was to use the same product we ship to customers as a programming tool, with some additions.

But, over-all, we had no major facility problems. We had just moved into a new building in 1968, and when we changed over, we needed less space. For a time we actually decided to rent part of the building to a new startup operation. About two years ago we obtained some additional space to accommodate our own manufacturing operation. In our initial stages we were mostly designing and developing.

We made the change all at once, although we did continue marketing the old systems and gave them some engineering support. There was a slight business slump when we first started, but I think it could be related to the over-all slump at that time. We didn't start shipping our new system until July of 1971. And we have been continually profitable since the new product line was introduced. ■■

Ferrite power supplies are more efficient and cost less.

Inverter-Rated ferrites™ end the guesswork.

Replace metal laminations with ferrite components and get a lot of trade-offs going in your direction. Less weight. Higher efficiency. Smaller size. Better regulation. And lower system cost.

New applications

High frequency, low loss ferrites from Indiana General have improved the efficiency of inverters and power supplies in everything from computers to portable test equipment.

Whenever you need high efficiency power transfer, our Inverter-Rated components will also give you better regulation and vastly simplify your filter requirements.

Today's answer

Improved ferrite technology has made it economically feasible to operate inverter systems at 2KHz and beyond.

Inverter-Rated® ferrite components from Indiana General are designed and tested specifically for high frequency operation and feature low power loss to 150°C.

With our full line of components you can select the circuit characteristics you need in meeting your specific application requirements.

Ferrites for inverters

We specify and guarantee inductance and core loss under maximum and recommended conditions to end guesswork. By giving you circuit performance data instead of routine magnetic parameters, we make your design task easier and more precise.

Inverter-Rated components are tested under square wave drive so the performance you design in—stays in.

Free design guide

Our new design guide has all the

facts you need; component specifications, temperature characteristics and application data. The design procedure we outline in this guide and an afternoon of your time will tell you if higher frequency operation is the solution to your specific power supply requirements.

Circle the Bingo card for your copy or call (201) 825-5100 and ask us for specific answers to your requirements. Either way, if you're talking high efficiency power supplies, talk to the ferrite experts.

That's us.

Indiana General
Keasbey, N.J. 08832

National distribution through Permag locations in Atlanta, Boston, Chicago, Dallas, Detroit-Toledo, Los Angeles, New York and San Francisco.

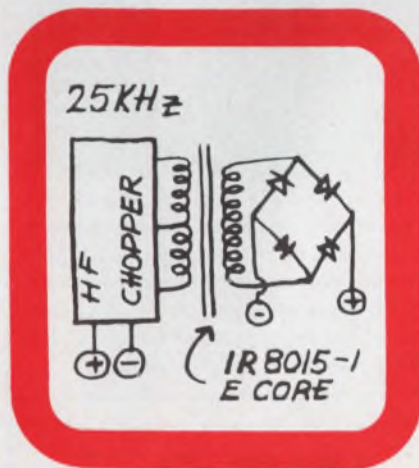

 **indiana general**

a division of Electronic Memories & Magnetics Corporation

INFORMATION RETRIEVAL NUMBER 36

These power semiconductor cooling ideas could get you out of a hot spot.

No. 12 of a Series

Semiconductor control of power means lots of heat generation in the semiconductor device. If the inherent power handling and switching capabilities of the device are to be taken advantage of, you've got to get rid

of that heat. But in power applications, the capabilities of discrete dissipators relying on natural convection or unchanneled air movement are soon outstripped. Here are some innovative ways power circuit de-

signers have used IERC liquid-cooled heat sinks, IERC heat dissipators in channeled air environments, and IERC heat dissipators in IERC forced air packages to get themselves out of big-power hot spots.



X-Y plotter designer put all his hot TO-3 power transistors in one basket to cope with heat problem. Utilizing existing chassis, he mounted devices in UP dissipators, wrapped a shroud around the assembly, and installed a blower. The UP's staggered fingers create turbulence in air stream for maximum efficiency of both the dissipator and air flow, and allowed the designer to meet his design goal of 80°C case rise maximum. He also had room within the shroud to cool his hot resistors.

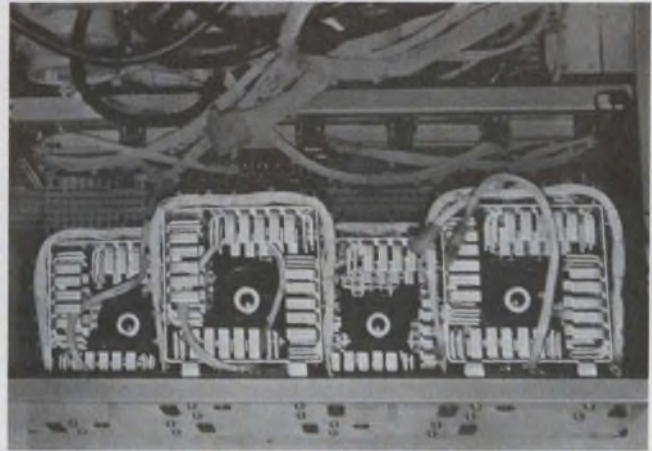

Dissipate 1280 watts in 530 cubic inches was the word given to designer of this power supply so he turned to our FAHP4 forced air packages. It took 4 units to do the job at a cost of \$26 (\$6.50 each/1000 pc qty.) plus \$40 for the fans. Average case rise of the 16 transistors was only 75°C.

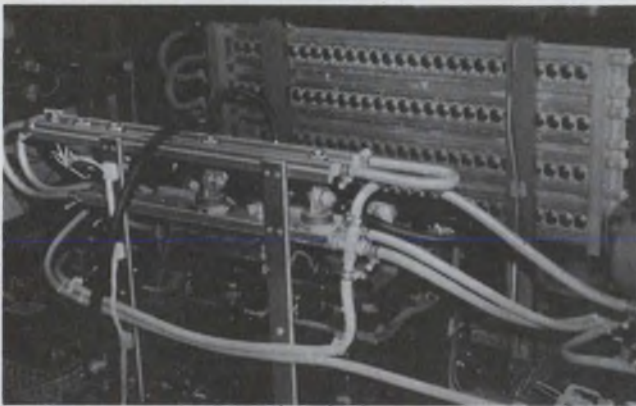

6000 watts of heat produced by 125 TO-3 case transistors in an industrial welding machine power supply was raw-power problem solved by IERC E4 liquid cooled sinks. Designer brazed together four standard E4's cut to 36 inches in length and tier stacked two other E4's to cool high power SCR's. Total area of heat sinks used only a fraction of the space required for a blower-cooled system of similar capacity.

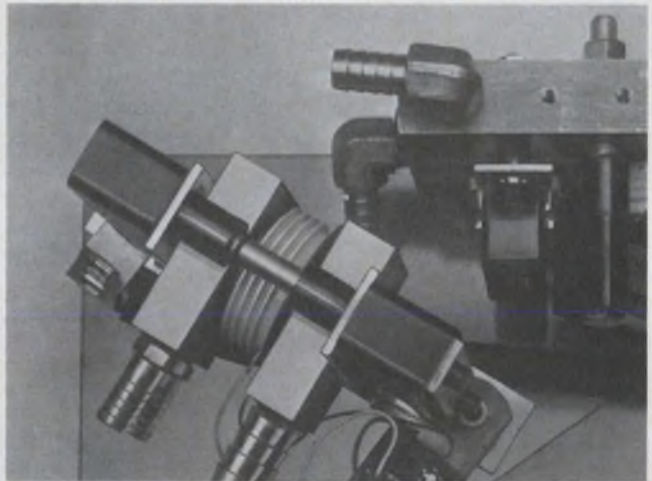

Fork-lift truck speed control used SCR's in hockey puck packages to handle thousands of watts in drive power. Big heat problem was solved with IERC liquid-cooled, double-side heat exchangers specially designed to let these big pressure-mount semiconductors dissipate on the order of 1000 watts each with just a 20°C case rise above ambient. Where did the designer get the coolant? He routed vehicle hydraulic fluid through the heat exchangers.



For more information

on heat sinks and dissipators for milliwatts to kilowatts, send for the IERC Short Form Catalog today. It covers the most complete line of thermal problem solving devices available anywhere.



Heat Sinks/Dissipators

INTERNATIONAL ELECTRONIC RESEARCH CORPORATION / A SUBSIDIARY OF DYNAMICS CORPORATION OF AMERICA / 135 WEST MAGNOLIA AVENUE, BURBANK, CALIFORNIA 91502

INFORMATION RETRIEVAL NUMBER 37

MICROCIRCUIT ELEMENTS

To obtain optimum L-value in microcircuits...
No better way than by ferrite core.

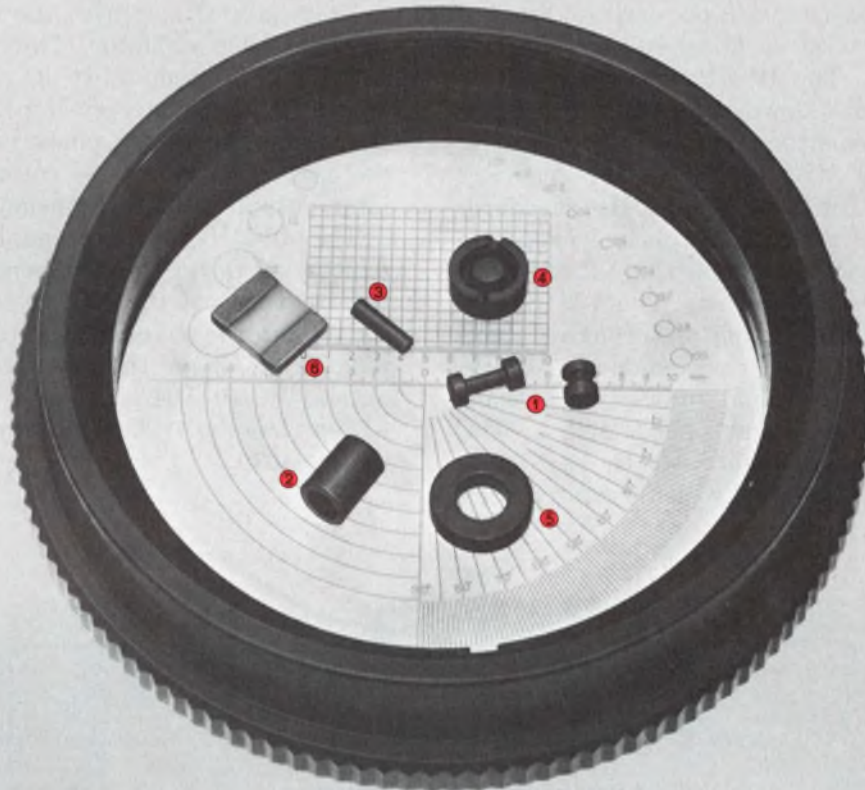

TDK's rich experience and proprietary technology in ferrite core production allows us to manufacture ultraminiature size ferrite cores for microcircuit applications.

As an inductance element for use in microcircuits required in such higher density type devices as

① **Bobbin cores**

The small bobbin core is 1.5mm (diameter) x 1.5mm (length) and the large one 1.3mm (d) x 2.75mm (l). Combination use with sleeves makes it possible to obtain a large inductance value together with high shielding effect.

② **Sleeves**

Their highly accurate dimensional tolerances enable minimization of characteristic discrepancy when used in combination with bobbin cores.

telecommunication equipment, measuring instruments, or computers, you can find no better element than ferrite cores. Ferrite cores are magnetically stable, produce larger inductance value, and can be manufactured to meet various shape criterion.

③ **Rod cores**

Rod cores are 0.78mm (d) x 2.79mm (l).

④ **Pot cores**

Pot cores can be as small as 3.2mm in diameter — ideal for use in electronic watches.

Our processing techniques ensure high dimensional accuracy thus eliminating concern about performance uniformity due to core size miniaturization. Please contact TDK about microcircuit elements. We will be pleased to assist you.

⑤ **Toroidal cores**

Toroidal cores with inside diameters of 2mm are available. We can also offer this core with slit processing according to your particular design requirement.

⑥ **Alumina chips**

TDK produces Alumina chips with solder-plated electrodes designed for combination use with ferrite cores. Substrate placement is very easy.



TDK CORPORATION OF AMERICA #31 South Douglas Str, El Segundo, Ca 90245 Phone: (213) 644-8625 CHICAGO BRANCH 2906 W West Peterson Av, Chicago, Ill 60659 Phone: (312) 973-1222
NEW YORK BRANCH 755 Eastgate Blvd, Garden City, N.Y. 11530 Phone: (516) 746-0880 EL PASO BRANCH Room 6, 8201 Montana Place, El Paso, TX 79925

TDK ELECTRONICS CO., LTD. 14-6-2 Chome, Uchikanda, Chiyoda-ku, Tokyo 101, Japan

Representative in U.S.A. & Canada for telecommunication and industrial use ferrites.

MH&W INTERNATIONAL CORPORATION 280 Midland Avenue, Saddle Brook N.J. 07662 Phone: N.J. (201) 791-6277 N.Y. (212) 244-0695 Telex: 134484, 134545

INFORMATION RETRIEVAL NUMBER 38

The 70-range circuit reader. 630-NA.

This versatile, general purpose V-O-M ideal for communications/computer circuits, Triplett Model 630-NA, is priced at just \$108.

The electronics equipment designer likes the 630-NA's 1½% DC accuracy, ease of operation, sensitivity, and reliability. So do the men who maintain communications equipment, computers, and satellite electronics. Still, it's no delicate flower. These strengths plus rugged dependability have put the 630-NA to work wherever a general purpose tester is needed: construction, electrical machinery, fabricated metal products, transportation systems, consumer electronic products, utilities, and radio, TV and appliance service.

You'll also like these features:

1. 70-range V-O-M with single range switch and DC polarity-reversing switch.
2. Accuracy 1½% DC and 3% AC; mirrored scale.
3. Diode overload-protected suspension movement with temperature compensation.

The 630-NA measures DC volts from 120 mV to 6,000 volts (10,000 or 20,000 ohms/volt). There are AC voltage ranges from 1.5 to 6,000 volts (5,000 or 10,000 ohms/volt). Six resistance ranges to 100 M Ω are provided.

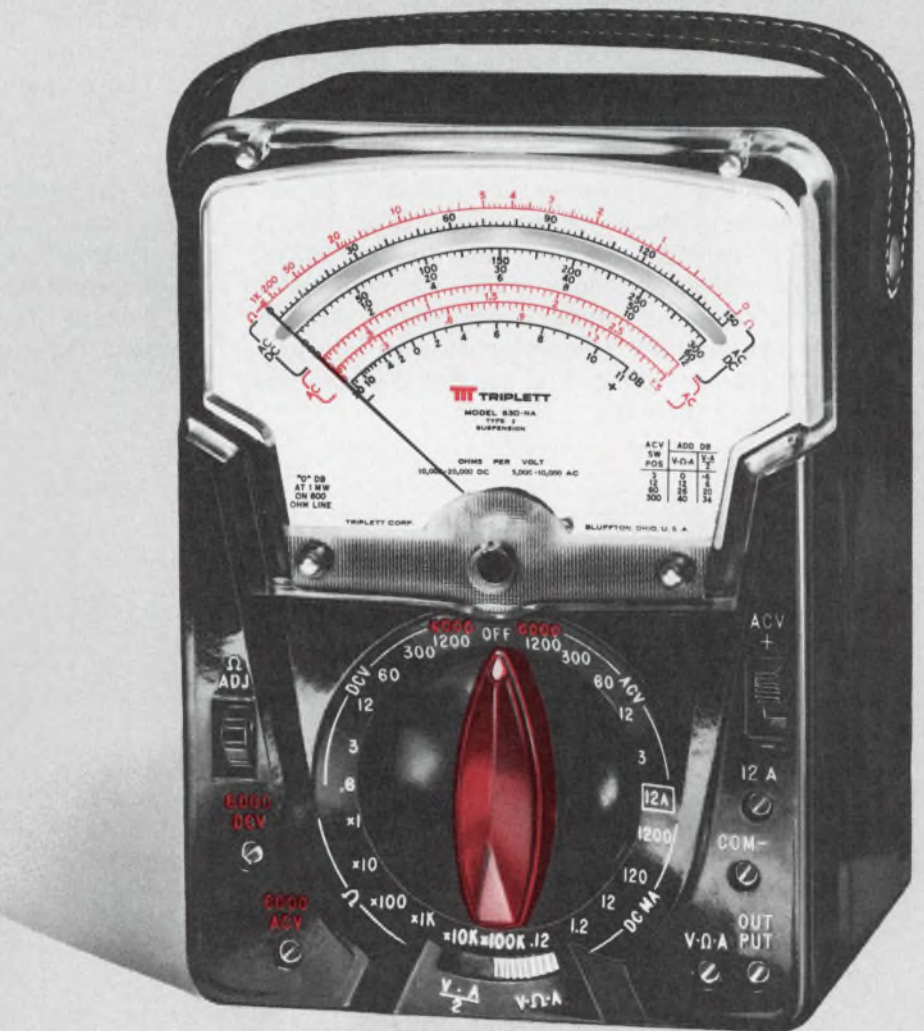

Need higher ohms per volt, greater sensitivity? Then you'll want Triplett's 630-NS at just \$128. Up to 200,000 ohms per volt DC and 20,000 ohms per volt AC; down to 150 mV at 60 microamperes.

For more information or a free demonstration, call your Triplett distributor or sales representative.

For the name of the representative nearest you, dial toll free (800) 645-9200. New York State, call collect (516) 294-0990. Triplett Corporation, Bluffton, Ohio 45817.

TRIPLETT
ALL YOU'LL EVER NEED IN V-O-M's.

Triplett. The easy readers.

Programmable frequency multiplier uses octave scaler to simplify programming

An improved frequency multiplier, built around a programmable octave scaler, is simpler to program than conventional systems that use two dividers. In addition the multiplier has the following features:

- Fairly constant lockup and settling time.
- Square-wave output at any selected frequency.
- Maximum VCO (voltage-controlled oscillator) tuning range of one octave.

The standard multiplier requires selection of preset values M and N in the two dividers to output the desired frequency (Fig. 1a). The new circuit uses a single input and tunes the VCO to the highest octave of the desired frequencies. The remaining frequencies are obtained by octave division of the VCO frequency (Fig. 1b). A cascaded priority encoder, such as the 74278, and toggle-mode flip-flops make up the scaler (Fig. 2). The most significant bit of the encoder enables the highest frequency (lowest divisor) output from the scaler. The flip-flop counter has one less stage than the $\div N$ counter.

The VCO frequency ranges from $F_r \times (N_{MAX}) / 2$ to $F_r \times N_{MAX}$. As N changes so that the next highest-order bit is ONE, the scaler divides F_{VCO} by one less octave.

For example, choose a five-bit multiplier so $N_{MAX} = 31$. With $N = 7$, the 2^2 bit is ONE, and the scaler divides by $2^{5-2} = 2^3$, or 8. The total loop division is $N \times S = 56$. For $N = 8$, the scaler divides by 2^{5-3} , since the 2^3 bit is ONE and the loop division is (8×4) or 32. Finally, when $N = 15$, $S = 4$ (the 2^3 bit is still ONE), and the loop divisor equals 60.

The output frequency is always NF_r , since

$$F_o = \frac{F_r \times (N \times S)}{S}$$

But the closed-loop gain, $N \times S$, varies by no more than a factor of two. This small variation in loop gain gives the system its fairly constant lockup and settling times.

Gary S. Vandeman, Associate Engineer, Burroughs Corp., 6300 Hollister Ave., Goleta, Calif. 93017.

CIRCLE NO. 312

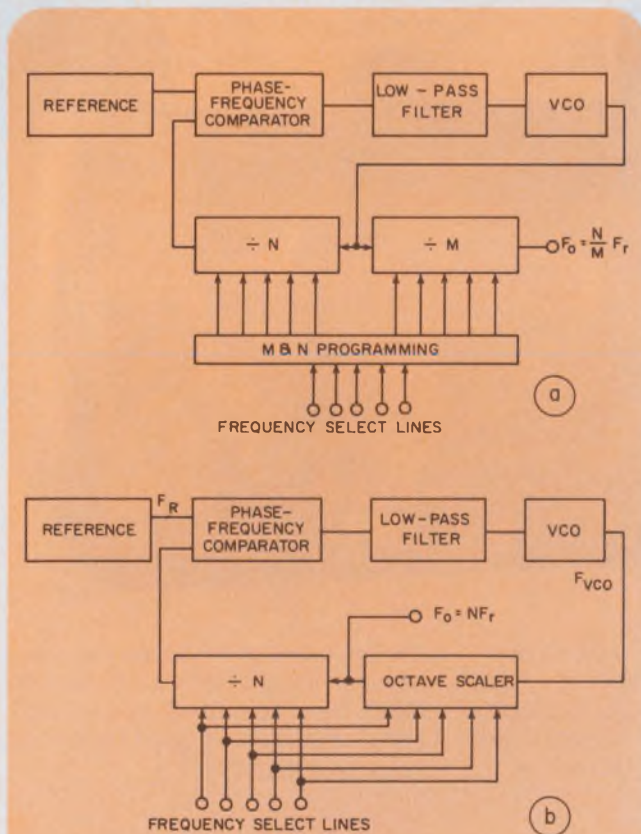

1. Conventional frequency multipliers (a) require selection of M and N. An improved version (b) requires selection of only N, and it reduces the VCO tuning range.

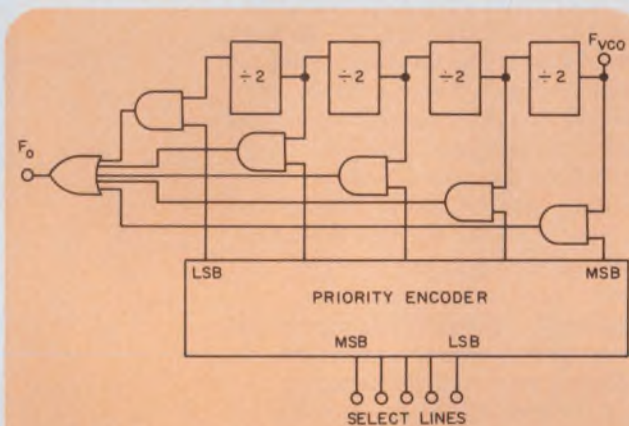

INPUT SELECT	DIVIDER (N)	SCALER (S)	F_{VCO} (N x S)	F_o (N x F_r)
N=1	1	16	$16 \times F_r$	$1 \times F_r$
2	2	8	16	2
3	3	8	24	3
4	4	4	16	4
5	5	4	20	5
6	6	4	24	6
7	7	4	28	7
8	8	2	16	8
10	10	2	20	10
11	11	2	22	11
12	12	2	24	12
13	13	2	26	13
14	14	2	28	14
15	15	2	30	15
17	17	1	17	17
18	18	1	18	18
19	19	1	19	19
20	20	1	20	20
21	21	1	21	21

2. The octave scaler uses a priority encoder to determine the octave submultiple of the VCO frequency. The maximum variation of F_{VCO} is one octave for the entire tuning range.

WORLD FAMOUS SIMPSON 260

OVER

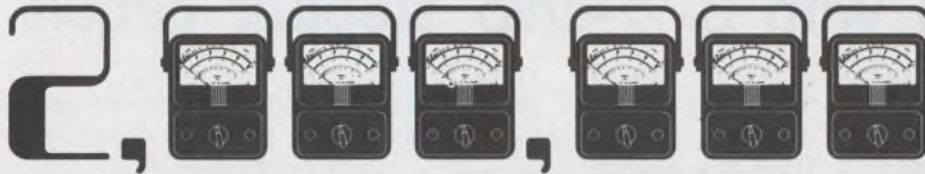

SOLD

The pace-setting VOM for over 30 years

The finest 260[®] SERIES 6

NOW... with
special Amp-Clamp dial ranges
for easy AC current
measurements up to 250 amps.



New Amp-Clamp, Model 150 Adaptor.

Measures AC current without breaking the circuit being tested. Plugs into the 260—reads directly on the new Amp-Clamp scales. Use with any 250, 260 (Series 3 thru 6) or 270.

Ranges: 0-5, 25, 50, 100, 250 amperes.



260-6, Complete with batteries, test leads and manual **\$74.50**

260-6P (overload protected), complete with batteries, test leads and manual **\$112.00**

260 CARRYING CASES:

Vinyl, DeLuxe #00805 **\$19.35**

Vinyl, standard #01818 **\$16.05**

AMP-CLAMP, Model 150 Adaptor with test lead **\$27.60**

Many other 260 models and accessories to choose from.

GET "OFF THE SHELF" DELIVERY FROM YOUR LOCAL ELECTRONIC DISTRIBUTOR . . . AND WRITE TODAY FOR CATALOG 4300.

KATY INDUSTRIES



ELECTRICAL EQUIPMENT GROUP

SIMPSON ELECTRIC COMPANY

853 Dundee Avenue, Elgin, Illinois 60120
(312) 695-1121 • Cable: SIMELCO • Telex: 72-2416

IN CANADA: Bach-Simpson, Ltd., London, Ontario

IN ENGLAND: Bach-Simpson (U.K.) Limited, Wadebridge, Cornwall

IN INDIA: Ruttonsha-Simpson Private, Ltd., Vikhroli, Bombay



INFORMATION RETRIEVAL NUMBER 40

Full and half-step motor operation obtained with 3-1/2-chip stepper circuit

A circuit built with 3-1/2 IC chips gives full or half-step operation of two-phase, permanent-magnet stepping motors. Half-step operation is often useful to provide additional resolution or to damp out rotor oscillations.

The stepping sequences generated cause incremental rotor advances of ϕ° or $\phi^\circ/2$ (full or half step) for each clock sequence.

The sequence for full-step motor drive (Fig. 1a) is a four-step cyclic rotation of A'_1, A'_2, A'_3 and A'_4 . The sequence for the half-step motor drive (Fig. 1b) is an eight-step cyclic rotation of A_1, A_2, A_3 and A_4 . The truth tables developed

from these sequences show that the driving functions for the half-step sequence are:

$$A_1 = Q_C Q_B + \overline{Q_C} \overline{Q_B} \overline{Q_A} \quad (1)$$

$$A_2 = \overline{Q_C} \overline{Q_B} + Q_C \overline{Q_B} \overline{Q_A} \quad (2)$$

$$A_3 = Q_C (\overline{Q_B} \overline{Q_A}) \quad (3)$$

$$A_4 = Q_C (\overline{Q_B} \overline{Q_A}) \quad (4)$$

As seen in Fig. 1, for every $\overline{Q_A}$ in the full-step sequence, there exists a Q_A in each driving function. Therefore driving functions A'_1, A'_2, A'_3 and A'_4 can be derived from Eqs. 1 through 4 when $\overline{Q_A}$ is forced to equal 1. Hence the logic for the full-step and half-step sequences

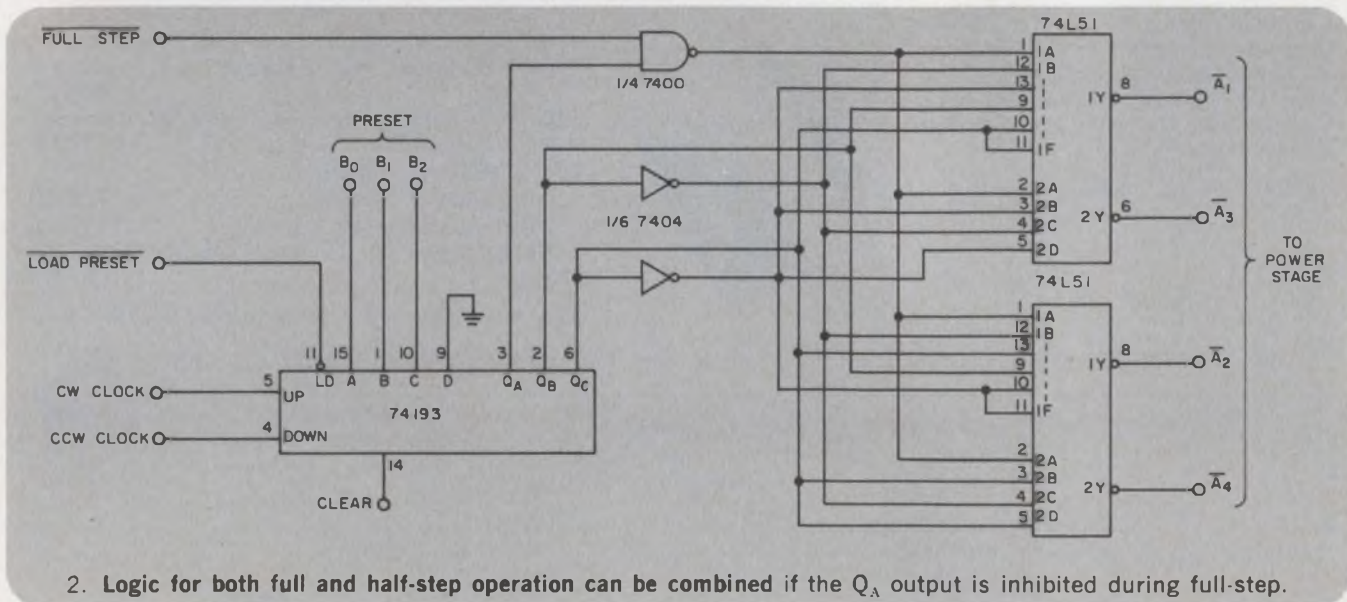
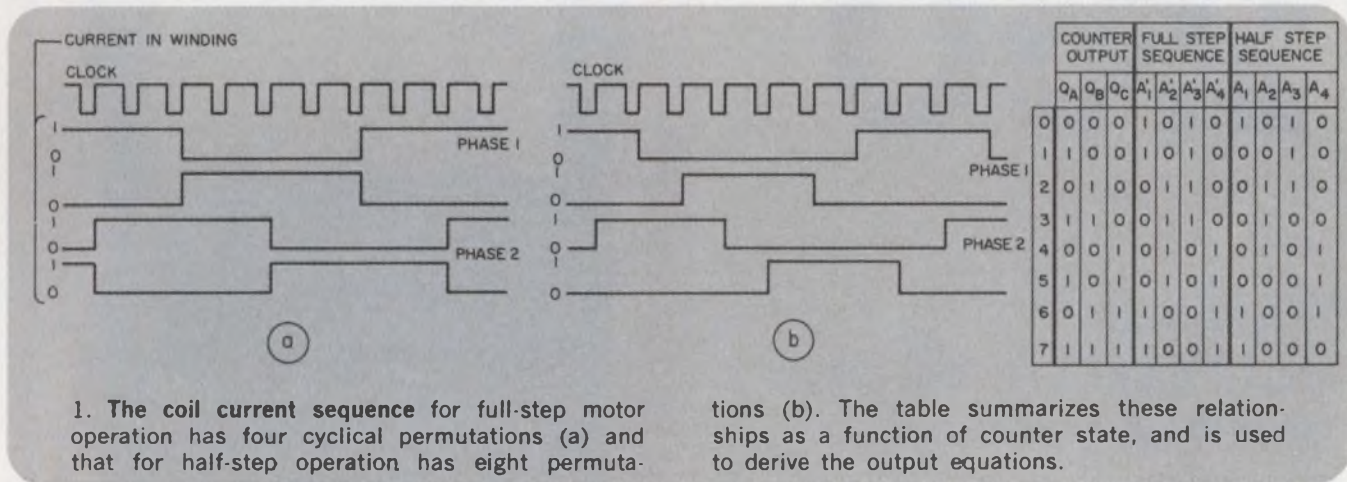

OUR 5V POWER MINI'S STACK UP LIKE THIS



OUTPUT VOLTAGE	OUTPUT CURRENT AMPS.	REGULATION LOAD $\pm\%$	REGULATION LINE $\pm\%$	RIPPLE MV RMS	PRICE	MODEL	SIZE INCHES
5	.250	.05	.05	0.5	\$39.00	5E25	2.3 x 1.8 x 1.00
5	.500	.1	.05	1	49.00	5E50A	3.5 x 2.5 x 1.00
5	1.0	.2	.05	1	69.00	5E100	3.5 x 2.5 x 1.25
5	1.5	.3	.1	1	98.00	5E150	3.5 x 2.5 x 1.25
5	2.0	.15	.05	1	110.00	5E200	3.5 x 2.5 x 2.00
5	2.5	.15	.05	1	125.00	5E250	3.5 x 2.5 x 2.00

... and the model you choose will be shipped 3 days after Acopian receives your order. With a 105-125 VAC input, use it at full rated load to 71° C. Short circuits won't damage it. These mini-modules can be mounted on a printed circuit

board in a space of only a few square inches. Generous quantity discounts are available. Or, if you're working with other voltages, choose from hundreds of other models. Single outputs from 1 to 75 volts.

Duals for op-amps with output currents from 25 to 500 ma. Even triple outputs. Complete details on these plus a comprehensive line of other power supplies and systems are included in the Acopian 73-74 catalog. Request a copy.



Corp., Easton, Pa. 18042. Telephone: (215) 258-5441.

INFORMATION RETRIEVAL NUMBER 41

can be combined by simple inhibition of the Q_A output during the full-step sequence.

The half-step/full-step sequence driver can be implemented as shown in Fig. 2. The 74193 up/down counter provides for the clockwise and counter-clockwise rotation of the A_1 , A_2 , A_3 and A_4 driving functions, depending upon whether the up or down clock inputs are pulsed. The counter also provides a preset input, thus allowing the drive sequence to be preset to any of the eight counter states. A clear input is also provided. The 74L51 AND-OR-INVERT gates decode the counter outputs into the $\overline{A_1}$, $\overline{A_2}$, $\overline{A_3}$ and $\overline{A_4}$ driving functions.

Outputs $\overline{A_1}$, $\overline{A_2}$, $\overline{A_3}$ and $\overline{A_4}$ can be used with

either unipolar or bipolar power stage drivers. For unipolar drive $\overline{A_1}$, $\overline{A_2}$, $\overline{A_3}$ and $\overline{A_4}$ each provide the drive to a single winding (Fig. 3a). For a bipolar drive, a positive voltage at $\overline{A_1}$ causes current to flow in the positive direction through the phase-1 winding pair, and a positive voltage at $\overline{A_2}$ causes current to flow in the negative direction through the pair. The same operation occurs with $\overline{A_3}$ and $\overline{A_4}$ with respect to the phase-2 winding pair (Fig. 3b).

Eugene Levine, Senior Engineer, Martin Marietta Aerospace, P.O. Box 5837, Orlando, Fla. 32805.

CIRCLE NO. 313

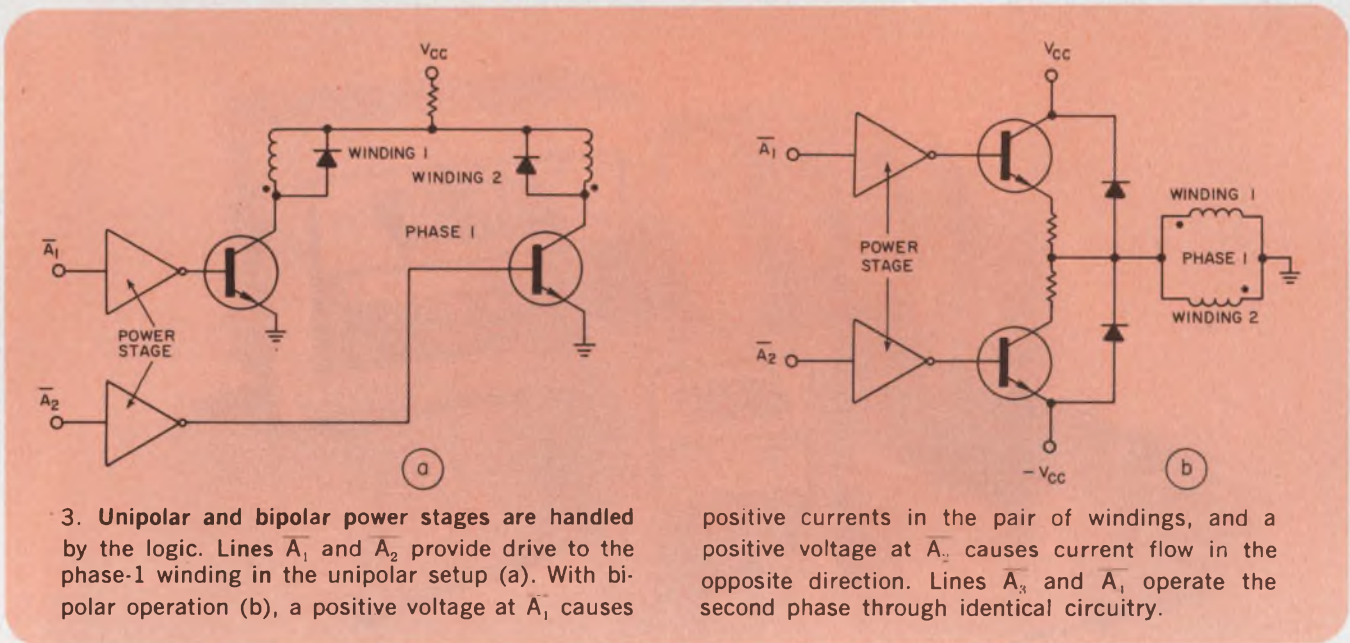

positive currents in the pair of windings, and a positive voltage at $\overline{A_2}$ causes current flow in the opposite direction. Lines $\overline{A_3}$ and $\overline{A_4}$ operate the second phase through identical circuitry.

IFD Winner of April 26, 1974

Surjan Dogra, Gull Airborne Instruments Inc., 55 Engineers Rd., Smithtown, N.Y. 11787. His idea "A Few Parts Convert 741 Op Amps for High-Voltage-Swing Applications" has been voted the Most Valuable of Issue Award.

Vote for the Best Idea in this issue by circling the number for your selection on the Information Retrieval Card at the back of this issue.

SEND US YOUR IDEAS FOR DESIGN. You may win a grand total of \$1050 (cash)! Here's how. Submit your IFD describing a new or important circuit or design technique, the clever use of a new component or test equipment, packaging tips, cost-saving ideas to our Ideas for Design editor. Ideas can only be considered for publication if they are submitted exclusively to ELECTRONIC DESIGN. You will receive \$20 for each published idea, \$30 more if it is voted best of issue by our readers. The best-of-issue winners become eligible for the Idea of the Year award of \$1000.

A CHECK



ON 3/4A AND 4A BRIDGE RECTIFIERS

	GENERAL INSTRUMENT	MOTOROLA	VARO	UNITRODE	SEMTECH	DIODES INC.
1—Who has a 4A rated bridge rectifier?.....	<input checked="" type="checkbox"/>	<input checked="" type="checkbox"/>	<input type="checkbox"/>	<input type="checkbox"/>	<input type="checkbox"/>	<input type="checkbox"/>
That does not require heatsinking?.....	<input checked="" type="checkbox"/>	<input type="checkbox"/>	<input type="checkbox"/>	<input type="checkbox"/>	<input type="checkbox"/>	<input type="checkbox"/>
At 85¢* each in 10K quantities?.....	<input checked="" type="checkbox"/>	<input type="checkbox"/>	<input type="checkbox"/>	<input type="checkbox"/>	<input type="checkbox"/>	<input type="checkbox"/>
2—Who has a 3/4A rated bridge rectifier?.....	<input checked="" type="checkbox"/>	<input type="checkbox"/>	<input checked="" type="checkbox"/>	<input type="checkbox"/>	<input type="checkbox"/>	<input type="checkbox"/>
Available in three case styles?.....	<input checked="" type="checkbox"/>	<input type="checkbox"/>	<input type="checkbox"/>	<input type="checkbox"/>	<input type="checkbox"/>	<input type="checkbox"/>
All at 20¢* each in 10K quantities?.....	<input checked="" type="checkbox"/>	<input type="checkbox"/>	<input type="checkbox"/>	<input type="checkbox"/>	<input type="checkbox"/>	<input type="checkbox"/>
3—Who has a bridge rectifier that can replace 4 rectifiers at no additional cost?	<input checked="" type="checkbox"/>	<input type="checkbox"/>	<input checked="" type="checkbox"/>	<input type="checkbox"/>	<input type="checkbox"/>	<input type="checkbox"/>
4—Which is the first and only company using flame-retarding materials (classified 94V-0) in the construction of its rectifiers and bridge rectifiers?	<input checked="" type="checkbox"/>	<input type="checkbox"/>	<input type="checkbox"/>	<input type="checkbox"/>	<input type="checkbox"/>	<input type="checkbox"/>
5—Which company should be checked for the lowest priced bridges, anywhere?	<input checked="" type="checkbox"/>	<input type="checkbox"/>	<input type="checkbox"/>	<input type="checkbox"/>	<input type="checkbox"/>	<input type="checkbox"/>

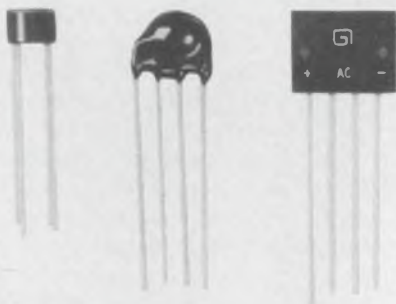

75WOM 75A 20¢* 75KBD 75A 20¢* 75KBP 75A 20¢*
WOM 1.5A 25¢* KBD 1.5A 25¢* KBP 1.5A 25¢*
KBL 4.0A 85¢*

*PRV @ 400V or lower, 10,000 units scheduled within 60 days.

GI'S GOT IT!

For complete information on GI's bridge rectifiers, call toll-free 800-645-1247 (In New York State call 516-733-3235) or write General Instrument Corporation, Semiconductor Components Division, 600 W. John St., Hicksville, N.Y. 11802.

**GENERAL INSTRUMENT CORPORATION
SEMICONDUCTOR COMPONENTS**



INFORMATION RETRIEVAL NUMBER 42

Flat-panel color TV explored in Britain

Thin panels that have sheets of birefringent plastic (Cellophane) in liquid-crystal, electro-optical shutters show promise for a flat-panel color TV system. The color of the sheets, developed at the Royal Radar Establishment in Britain, may be varied by application of 10 V ac.

A problem with liquid-crystal displays—their relatively slow response time—has been overcome, the Radar Establishment reports. The liquid-crystal cells can be switched at greater than 25 Hz, with rise and fall times of a few milliseconds.

With use of the new technique in a color panel mounted in front of a monochromatic cathode-ray tube, a sequential display of 50 frames a second can be obtained. Synchronization of different frames of information on the CRT

with the rapidly changing colors of the panel allows the eye to integrate the frames, giving two-color or multicolor displays.

Improvements in color purity are obtained by choice of CRT phosphors that give two or more emission lines. The panel switches between these peak phosphor wavelengths. The production of multicolor displays with these techniques is being investigated.

Simpler forms of the display may be produced without the fast switching technique. Two-color, four-digit numeric displays have been demonstrated, and multicolor-pattern displays have been produced that change their pattern and color continuously in response to an audio signal. These techniques will probably be applied in colorimetry and color printing.

Pulse-generator design simplified in Turkey

A two-step, recovery-diode pulse-generator circuit developed in Turkey eliminates the additional elements usually required as inductors, capacitors and biasing and matching networks. The Turkish design conceived at the Middle East University in Ankara, Turkey, consists simply of two matched step-recovery diodes (see illustration).

The simple circuit can be built in coaxial form, and it may be sine-wave or square-wave driven. When the input signal is positive, both diodes are forward-biased, and they store a charge, D_1 . This is slightly greater than charge D_2 , since some of the input current flows through the load.

During forward bias, the turn-on voltage of D_2 (about 0.7 V) ap-

pears across the load. On reversal of the input polarity within less than the minority-carrier lifetime of the diodes, the currents through the diodes reverse. The output voltage then remains almost constant until the stored charge in one of the diodes is completely recovered.

The charge in D_2 is recovered first, since the equivalent resistance seen across the terminals of

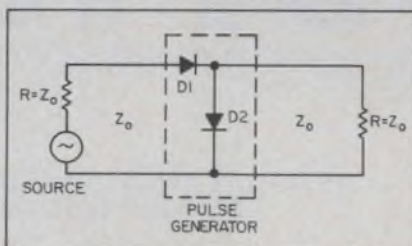

D_2 is less than that of D_1 . D_2 then ceases to conduct, and the output voltage rises towards the input-voltage level at a speed determined by the transition time of D_2 . As soon as the D_2 transition is complete, D_1 recovers and stops conducting, so that the output voltage falls to zero.

Since no external components are required, both diodes can be integrated on a single chip to form a pulse generator.

TV-telephone network to be tested by Dutch

An experimental video-telephone system will be set up by the Netherlands PTT (post office) for joint use with Philips over two years.

Philips Research Laboratories has tested a local network since 1972 and plans technical and operational evaluation of the new network. Changes in subscriber communication patterns will be watched, as well as the extent to which picture telephony reduces the need for travel.

Discussions are leading toward the setting up of international standards for video telephone systems. The Netherlands delegation is in favor of compatibility with broadcast television, so existing TV equipment can be used.

The total of subscribers on the PTT/Philips experimental system will be 65. Existing transmission and switching equipment will be used wherever possible, but the whole system will be separate from the public telephone network. Three hundred repeaters will be employed, and two picture telephone conversations will be possible simultaneously on a radio-relay link by use of a special modulator-demodulator developed by the post office.

The pictures will have 325 lines, with a bandwidth of 1.3 MHz sufficient to convey a head-and-shoulders picture. This bandwidth is about a quarter that required by European TV pictures with 625 lines per frame. Because compatibility with 625-line TV is required, the picture telephone will be developed to use 313 lines—the closest possible approximation to half the 625 lines of standard TV.

IR's new glass passivated, high voltage Power Transistors and Darlington...

Better performance where it really counts.*

The three other largest selling high voltage power transistor lines of today offer you good characteristics. But while a specific device may excel in specs for one parameter, it may be marginal in other equally important characteristics. Not so with IR's new high voltage power transistors. They easily meet or exceed all established specifications. Now you can design a better, more efficient circuit without compromising.

*** High Voltage and High Gain in the same transistor.**

Most others offer you either high voltage or high gain. They can't give you both in the same device. We can. For example: rated to 700V_{CBO} with an I_c from 7 to 10 Amps (pulse), we provide a gain of 30 - 90 at 1 Amp.

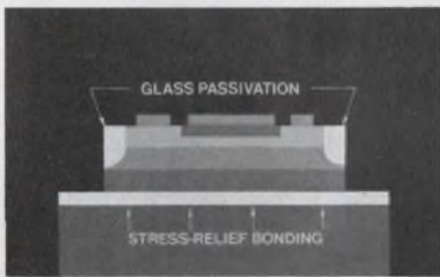

*** Glass Passivation for longer life, better stability.**

IR triple-diffused, NPN mesa structures are the first and only high voltage power transistors with glass passivated

junctions. You'll get longer life and a stability unequalled by the other brands.

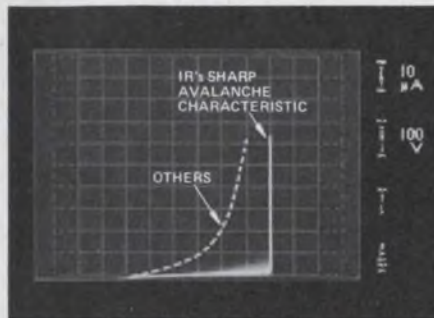

The avalanche curve pictured shows our "sharp" curve and the "soft" curve of the others. Convincing evidence of better junctions that you can operate at full rated specs without a worry.

*** Lower Saturation Voltage for better efficiency.**

IR saturation voltage is lower than the others. Higher efficiency, less power loss, reduced power consumption and system operation at lower power levels are your new advantages. And you won't have to sacrifice switching speeds or voltage capability.

*** "Stress-Relief" Bonding for better resistance to temperature cycling.**

IR's "Stress-Relief" bonding between the chip and mounting surface gives better protection from thermal cycling, gives you an extra margin of safety in thermal design considerations, with a broad safe-area that is more than adequate for any application.

Competitively Priced and Cross-Referenced to the 3 major lines.

IR high voltage power transistors are available in 12 models rated from 300 to 700V_{CBO} with an I_c from 7 to 10 Amps (pulse). Monolithic Darlington in 15 models are rated to 600V_{CBO} with an I_c from 15 to 25 Amps (pulse). All are in the standard TO-3 package.

Find IR's equivalent to the devices you're now using, then ask your local IR salesman, Rep or Distributor for complete specs and a test evaluation sample. When you've put it to the test, we think you'll agree. It's better — everywhere that counts.

IR P/N	Delco P/N	RCA P/N	Motorola P/N
IR401	DTS 401		MJ3026 MJ3027
IR402	DTS 402 2N3902		MJ3028 MJ3030 2N3788 2N3902
IR403	DTS 403		
IR409	DTS 409		
IR410	DTS 410	RCA410	MJ410
IR411	DTS 411	RCA411 2N5838 2N5839	MJ411 MJ1800 MJ3029 MJ3430
IR413	DTS 413	RCA413 2N5840	MJ413
IR423	DTS 423	RCA423	MJ423
IR424	DTS 424		MJ424
IR425	DTS 425		MJ425
IR430	DTS 430	2N5239 2N5240	MJ430
IR431	DTS 431	RCA431 2N5240	MJ431 2N5241

Monolithic Power Darlington

IR4040	DTS 4040	Ask for data on IR's 11 additional types.
IR4045	DTS 4045	
IR4060	DTS 4060	
IR4065	DTS 4065	

Prove our point on your curve tracer...

Get your test sample today.



International Rectifier

...the innovative power people

GATES - INS4000, INS4001, INS4002, INS4011, INS4012,
INS4019, INS4023, INS4025

BUFFERS - INS4007, INS4009, INS4010, INS4049, INS4050

FLIP FLOPS - INS4013, INS4027

COUNTERS - INS4017, INS4018, INS4020, INS4022, INS4024,
INS4029, INS4040, INS14510, INS14516

REGISTERS - INS4035, INS4042

SWITCHES - INS4016, INS4051, INS4052, INS4201

MEMORIES - INS4061, INS4200

**ARITHMETIC
FUNCTIONS** - INS4008, INS4030, INS14581, INS14582

DECODER - INS4028

HIGH SPEED CMOS

Our 4000 series SOS/CMOS are pin-for-pin compatible with the CD-4000 series, but ours are different. Different in that our 4000 series offer you the optimum balance between higher speed (three times faster than monolithic CMOS) and lower power dissipation (typically less than 10nW) than any other logic family. Different in eliminating SCR latch-up problems while the noise immunity remains 45% of supply voltage (3 to 15 volts).

Our INS4000 series is available in both military (-55°C to +125°C) and commercial (-40°C to +85°C) grades. Inselek also offers the INS4200 series of proprietary devices, including the INS4200 --- a 256 x 1 SOS/CMOS RAM, and the INS4201 --- a 4 x 4 cross point switch. Check the devices you want above and then contact one of our authorized sales representatives or distributors below.

Sometimes being different is better!



SALES OFFICES IN:
CONCORD, MASS. (617) 369-5298
LOS ANGELES, CALIF. (213) 889-2788
AUTHORIZED SALES REPRESENTATIVES
COAST TO COAST

DISTRIBUTORS:

CALIFORNIA, Westates Electronics, Chatsworth, (213) 341-4411 ● COLORADO, Electronic Parts Co., Denver, (303) 744-1992 ●
MASSACHUSETTS, Greene Shaw Co., Newtonville, (617) 969-8900 ● NEW JERSEY, Wilshire Electronics, Cinnaminson, (609) 786-8990
● NEW YORK, Summit Dist. Inc., Buffalo, (716) 884-3450 ● WASHINGTON, Sterling Electronics, Seattle, (206) 762-9100

new products

Bipolar/LSI processor races to the forefront

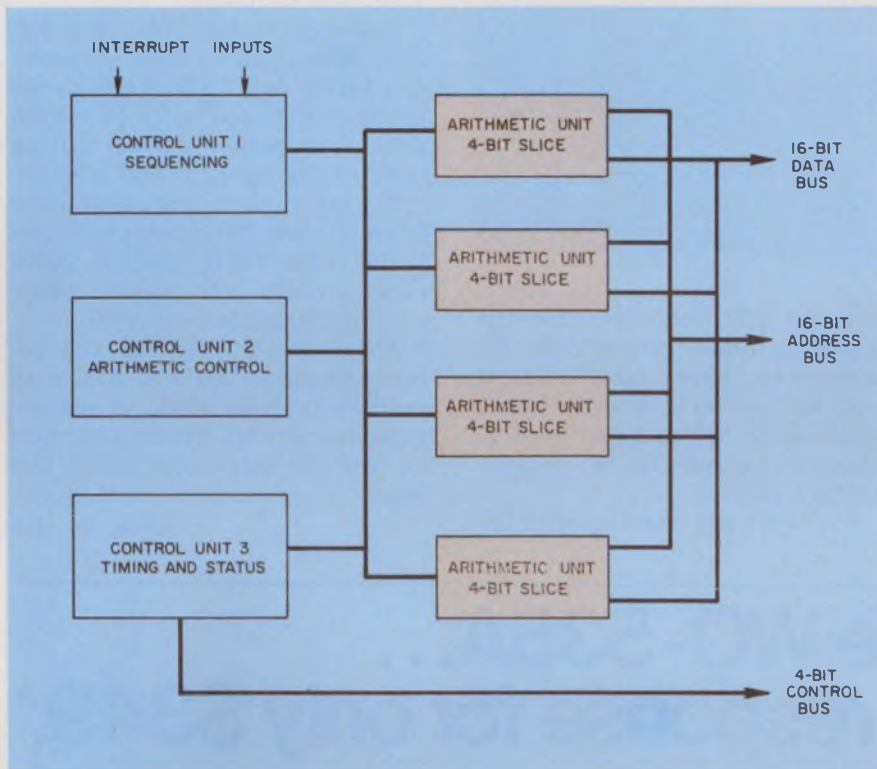

Raytheon Semiconductor, 350 Ellis St., Mountain View, Calif. 94042. (415) 968-9211. P&A: See below.

The first bipolar/LSI microprocessor, a 16-bit multichip parallel processor (Model RP16) announced by Raytheon Semiconductor, offers a 200-ns cycle and 1- μ s instruction time. These are the highest speeds available from general-purpose "computers on a chip" (see "Focus on Microprocessors," this issue, p. 52).

The only other LSI processor to use bipolar technology is a special-purpose, 16-bit unit from Monolithic Memories, Inc., 1165 E. Arques Ave., Sunnyvale, Calif. 94086. Called the Model 6701 microcontroller, this circuit is intended more for the computer architect rather than the random-logic designer. It requires microprogramming techniques and aims for applications such as the emulation of conventional computers.

Other microprocessors employ

MOS technology. One example is the IMP-16 (also a 16-bit unit) from National Semiconductor, 2900 Semiconductor Dr., Santa Clara, Calif. 95051. Architecturally the National and Raytheon units resemble each other. Both are multichip models built around two building-block chips—a 4-bit register and arithmetic logic unit (RALU) and a control read-only memory (CROM).

However, use of standard PMOS technology for the National IMP chips results in somewhat slower data processing, compared with Raytheon's RP16, which is manufactured using the company's high-density V-ATE process. For example, a basic register add time (per data word) for the IMP-16 is 1.4 μ s vs 1 μ s for the RP16.

Seven chips make up a complete Raytheon microprocessor (see diagram). Four RALUs—each containing eight registers, for 32 bits of storage—constitute the arithmetic

section. And three CROMs provide storage for the fixed instruction set and the control logic for the RALUs. For a complete processing unit, a delay line is also needed to obtain the required clocking. The RP16 can interface with low-power Schottky-TTL circuits (standard 54/74LS circuits).

The new bipolar microprocessor responds to 32 16-bit instructions. Although the number of instructions isn't as large as that for, say, 8-bit processors, the RP16 repertoire provides instructions that require routines in 8-bit units. For example, the RP16's 32 instructions include multiply and divide, add and subtract in single and double precision, and logic Inclusive and Exclusive-OR. Also in the set are seven conditional and unconditional jump commands, as well as five skip instructions that perform increment, decrement, compare or mask operations.

Data words can be 8 and 16-bits in length for fixed-point arithmetic, 16 bits for logic operation and 32 bits for double-precision arithmetic. In addition the RP16 has 11 address modes—seven basic and four extended—for increased flexibility and efficiency in programming.

The RP16 can address directly 64-k words of memory. An asynchronous timing scheme allows the use of virtually any speed or type of memory. However, Raytheon plans to offer a semiconductor memory card for the RP16.

Other features include a two-level interrupt scheme—direct or program controlled—that can be expanded to provide a multilevel priority network. Moreover the bipolar microprocessor requires only a single 5-V supply. And the processor operates over the MIL temperature range.

Two versions of the RP16 are planned. Model A emphasizes arithmetic capabilities, while Model B stresses byte handling. Both models are expected to be available early next year at an introductory price of well under \$300.

CIRCLE NO. 252

Redesigned 1-k NMOS RAM eliminates drive circuits

Advanced Memory Systems, 1276 Hammerwood Ave., Sunnyvale, Calif. 94086. (408) 734-4330. P&A: See text.

The unusual input level and drive requirements of the 1024-bit 7001 NMOS static RAM can be eliminated without loss of the circuit's high speed (60-ns access time and 180-ns cycle time). An improved version—the 7001I from Advanced Memory Systems—is much easier to use, and also adds some of the needed interface circuitry.

The new version uses standard TTL, 2.4 and 0.8-V, input levels. The old AMS memory required pullup resistors to change the 4 and 0.8-V input levels to a usable

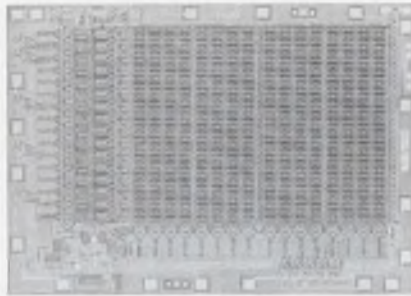

form for TTL interfaces. For the chip-select input, current-drive requirements have been reduced from 20 to 8 mA. And the select input can be driven by an emitter-follower instead of a complementary pair.

The 7001I can interface with the

Texas Instruments' or equivalent 75261 sense amplifier.

Redesign of the 7001 chip has also reduced the standby power dissipation to 0.5 μ W/bit from the previous 60 μ W/bit. Maximum power dissipation during cycling remains the same, at 640 μ W/bit.

All other operating characteristics of the 7001 have been retained in the 7001I. And the 7001I plugs directly into sockets originally designed for the 7001.

The 1-to-999 price of the ceramic-packaged 7001I is \$18, with availability from stock. A plastic-packaged version, priced 10% lower, will be introduced later this year.

CIRCLE NO. 251

RCA's versatile WO-535A... DC to 10MHz response for only \$349.*

1. Operates in either triggered or recurrent sweep mode.
2. Vertical sensitivity of 5.9 mV p-p/cm (15 mV/in).
3. Simplified calibration for p-p voltage measurements.
4. All solid state.
5. DC/AC input.
6. Preset TV, "V" and "H" frequencies for instant lock-in.
7. Flat-face 5-inch CRT.
8. Illuminated graph screen calibrated directly in volts.
9. Regulated power supply prevents trace bounce; excellent stability.
10. Return-trace blanking.

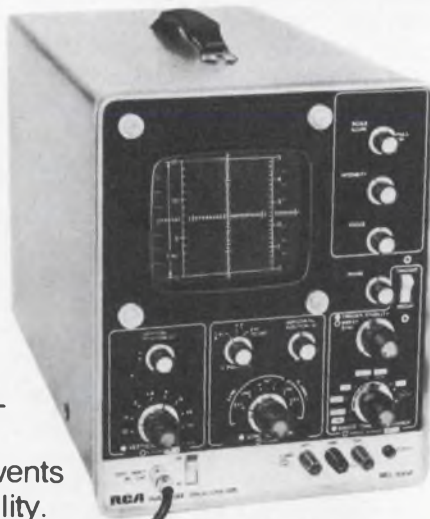

11. Terminals for direct connection to the CRT.
12. Camera mounting studs.
13. Phase control for sweep alignment.
14. Includes WG-400A shielded Direct/Low-Capacitance Probe and Cable.

For complete information and fast delivery on the versatile WO-535A, Dual Mode Oscilloscope, contact any one of the more than 1,000 RCA Distributors worldwide. Or write: RCA Electronic Instruments Headquarters, Harrison, N.J. 07029.

*Optional price including probe.



Specialists demand the best tools of their trade

RCA Electronic Instruments

INFORMATION RETRIEVAL NUMBER 45

4-package modem costs less than \$62

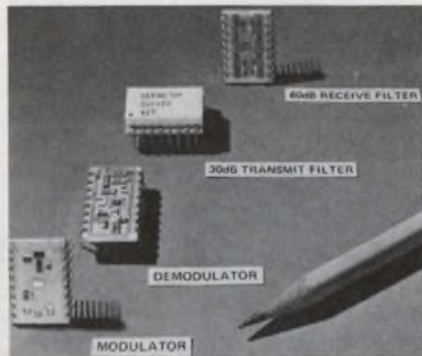

Cermetek, Inc., 660 National Ave., Mountain View, Calif. 94043. (415) 969-9433. P&A: See Below.

Four thick-film hybrid circuits can handle the great bulk of functions for a modem in 300-baud FSK applications. Called the mini-Modem, the quartet of hybrid circuits needs few additional components to create a Type 103/113 compatible modem—at a total parts cost of less than \$62, in 100-unit quantities. The circuits and their unit prices (100 up) are as follows: the CH1213 demodulator (\$19.50); the CH1214 modulator (\$10.65); the CH1252 dual frequency 30-dB transmit bandpass filter (\$12.70) and the CH1257 dual frequency 60-dB receive bandpass filter (\$16.45). All circuits are available from stock.

CIRCLE NO. 253

'Stik' family aims for calculator use

Western Digital Corp., 19242 Red Hill Ave., Box 2180, Newport Beach, Calif. 92663. (714) 557-3550.

Using MOS/LSI silicon-gate technology, the manufacturer offers an expanding line of single-chip calculator circuits, dubbed the Stik family. The units incorporate the following features: full floating-point entry and results, algebraic entry, automatic constant, chain calculations and reduced power consumption. One IC, the MC1532B, has a selectable 10 or 12-digit display for positive or negative numbers, permits user selection of arithmetic or algebraic entry and provides various fixed-point rounding options, such as roundup, rounddown and round-off.

CIRCLE NO. 254

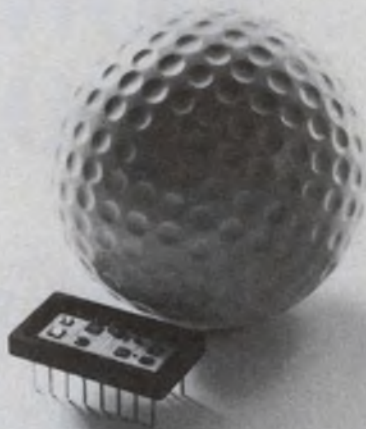

The 12 BIT IC DAC... from Hybrid Systems, naturally.

Why Naturally?

We offer the alternative to the cookie-cutter approach to converter fabrication. We laser-trim our own thin-film nichrome R-2R networks and combine them with matched monolithic quad switches... for complete control over accuracy.

IC SIZE: 16 pin DIP compatible. 12 BITS ACCURACY: A true 12 bits

LOW DRIFT: 1PPM/°C linearity. CODE: Inverted offset binary.

READY-TO-USE: Built-in reference, ladder, switches: pretrimmed output amplifier in the DAC346V-12-BP. RELIABLE: MIL-STD-883

hybrid μ circuit processing.

TEMPERATURE RANGE: 0°C to +70°C (Commercial)

HOW TO ORDER: DAC345I-12-BP, Current Out, 16 pin DIP . . \$69.

DAC346V-12-BP, Voltage Out, 18 pin DIP . . \$69. (Wide temperature range, hermetic, MIL versions available).

For Fast Action, Call:

In USA: (617) 272-1522 (or TWX 710-332-7584).

In Europe: Hybrid Systems GmbH, 61 Darmstadt, Luisenplatz 4, Germany Tel. 6151-291595.

Hybrid Systems Corporation
Burlington, Massachusetts 01803

Hybrid Systems
CORPORATION

Our paper tape punches and readers were built for comfort. Not for speed (max. — 50/60 cps). And, they're priced to barely budge your budget.

In fact, any self-respecting components savant would term these devices a real buy.

Why?

Because they're engineered to make your end-user happy. By practically eliminating I/O system down-time. By providing read stations sealed from dust, corrosion and contaminants. By not musing a hair on fuzziest tape. By functioning without continuous operator intervention . . . even under severe environmental extremes.

Besides being low-cost, they offer you the ultimate in flexibility. With bi-directional feed. With adjustable tape guides for standard tapes and edge punched cards (400 Series).

We offer a choice of 7 space-saver, basic, rack mounted or desktop punch and reader models.

If you want your customers to be happy with your total system installation, we suggest speed. Quick, contact any of our field representatives. Or, call OEM Products.

slow poke

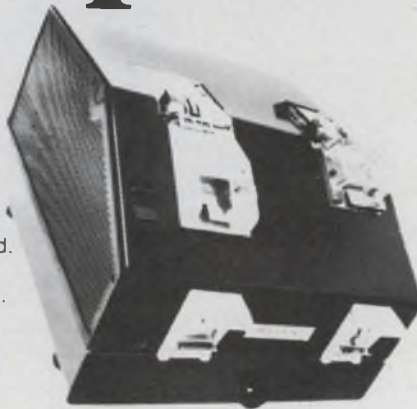

Model 5B2
Combination Reader Punch Station



OEM PRODUCTS DIVISION

LITTON ABS

Automated Business Systems

34 Maple Avenue, Pine Brook, N.J. 07058/(201) 575-8100

IN U.K. — LBS, 27 Goswell Road, E.C.1, London

IN FRANCE — LITTON ABS/OEM, 9/15 Avenue Paul Doumer, 92504 Rueil-Malmaison

INFORMATION RETRIEVAL NUMBER 47

Versatec does it again!

High-speed 20-inch plotters for \$12,300

We've done a lot with our Matrix electrostatic plotters in recent years. We made them quiet . . . fast . . . low cost . . . and high in resolution.

Now we're also making them WIDE.

The Matrix 2030 plotter offers a full 18.56-inch plotting width with an asynchronous paper speed of 3.0 ips. It also has a resolution of 100 dots per inch. The new Dual Array writing head improves contrast 250%.

Plotting is easy and fast with our unique Versaplot™ plotting software. But best of all, the Matrix 2030 is priced at only \$12,300.

For information on wide plotters with narrow prices, contact Versatec, Inc., 10100 Bubb Road, Cupertino, California 95014. (408) 257-9900, TWX 910-338-0243.



Specialists in hard copy information display

"See us at Wescon 2527 and INFO '74 4447"

INFORMATION RETRIEVAL NUMBER 48

INTEGRATED CIRCUITS

Two 555-type timers come on single IC

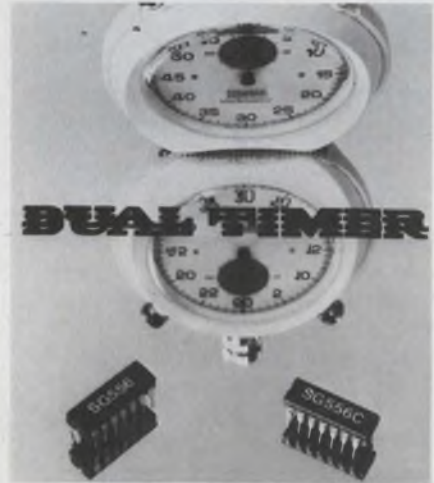

Silicon General Inc., 2712 McGaw Ave., Irvine, Calif. 92705. (714) 556-1600.

Two standard 555-type timers are available in one 14-pin DIP. Each section of the new dual timer (SG 556) can be used to produce accurate time delays ranging from microseconds to hours. Also, each timer has independent output and control terminals, and each can source or sink 200 mA and drive TTL. Timing accuracy (military grade) is typically 0.5%.

CIRCLE NO. 255

Interface ICs aid bussed-data designs

Signetics, 811 E. Arques Ave., Sunnyvale, Calif. 94086. (408) 739-7700.

A series of interface circuits, including transceivers, is available for bus-organized data systems. The two bus transceivers in the offering are the 8T34, which has three-state outputs, and the 8T38 with open-collector outputs. Each IC package contains four sets of drivers and receivers and they have a common two-input disable control for the drivers. Outputs can drive 100-Ω terminated busses. The drivers of the 8T38 can each sink 50 mA at 0.7 V, and those of the 8T34 sink the same amount of current at 2.4 V. In addition, each of the 8T34 drivers can serve as a source of 10.4 mA at 2.4 V.

INQUIRE DIRECT

FIFO measures 40-words x 9-bits

Fairchild Semiconductor, 464 Ellis St., Mountain View, Calif. 94042. (415) 962-3816. \$15.60 (100).

Problems associated with the interfacing of digital systems with different data rates can be solved through the use of a 40-word by 9-bit first-in, first-out (FIFO) memory called the 3351. The Isoplanar memory operates at data rates from dc up to 1.5 MHz, has independent asynchronous inputs and outputs and is compatible with TTL circuitry. It comes in a 28-pin DIP.

CIRCLE NO. 256

ECL 10,000 circuits include 200-MHz gate

Motorola Semiconductor Products, Inc., P.O. Box 20924, Phoenix, Ariz. 85036. (602) 244-3466. \$2.26 to \$5.10 (100-999).

Three new circuits in the MECL 10,000 series are offered in ceramic 16-lead packages for the -30 to +85 C temperature range. The circuits consist of a binary counter (the MC10178L), a negative-clock quad latch (the MC10153L) and a high-speed dual 2-NOR/1-OR gate (the MC10212L). The gate has minimum toggle frequencies of 200 MHz.

CIRCLE NO. 257

Analog switch has 3 SPDT circuits

Siliconix Inc., 2201 Laurelwood Rd., Santa Clara, Calif. 95054. (408) 246-8000. \$6.50 to \$26.25 (100); stock.

A triple SPDT analog MOS switch, the DG170, incorporates bipolar transistors, Schottky diodes and p-channel MOSFETs on a common substrate. The circuit is directly compatible with TTL, CMOS and DTL logic, and requires no external interface components. Features of the DG170 include 300-to-400-ns switching speeds and break-before-make switching action. ON resistance (DS) is 800 Ω , and analog signal range is -10 to +10 V. A level-shifting push-pull driver function enables low-level logic to control the ON/OFF state of the switch.

CIRCLE NO. 258

Audio amp works off 4-to-12-V supply

National Semiconductor Corp., 2900 Semiconductor Dr., Santa Clara, Calif. 95051. (408) 732-5000.

The LM386 audio amp, designed for use in battery-powered equipment, operates from 4-to-12-V supplies. It features a low quiescent current drain of 3 mA, and requires few external components. A com-

plete audio amplifier capable of delivering 500 mW into a 16- Ω load when operated from a 9-V supply consists of the LM386, an output coupling capacitor and a volume potentiometer. Gain is internally set at 20, but with the addition of an external RC, it can be set anywhere from 20 to 200. Another feature of the circuit, which comes in an 8-pin DIP, is a low total harmonic distortion of typically 0.2%.

INQUIRE DIRECT

Logic Level Power at Low Level Prices!



New Standard 5 Vdc, high-current power supplies. The "Blue Plus" Series from Standard Power, Inc!

"Standardize" your logic designs. Specify new Standard Power "Blue Plus" Series high-current 5 Vdc power supplies! Deliverable at low OEM prices now, off-the-shelf from 56 distributor locations nationwide. And delivering top performance for years! Check the specs:

Input: 115/230 Vac, $\pm 10\%$; 47 to 440 Hz
Line & Load Regulation: $\pm 0.1\%$
Ripple: $\pm 0.1\%$, 0.5-2.0mV rms

5 Vdc Output Open-Frame Models			5 Vdc Output Covered Models		
Amps	Model No.	1-9 Price*	Amps	Model No.	1-9 Price*
10	SPS 75-5	\$ 66.50	10	CPS 75-5	\$ 89.00
18	SPS 180-5	\$ 99.50	18	CPS 180-5	\$130.00
35	SPS 320-5	\$157.00	35	CPS 320-5	\$177.00
35	SPS 350-5†	\$180.00	35	CPS 350-5†	\$200.00

*OEM quantity discounts available of course! †Have built-in fan.

To find your nearest distributor, call toll free "Dial-A-Source": (800) 645-9200. (In N.Y. State, call (516) 294-0990.)

STANDARD POWER INCORPORATED

1400 So. Village Way, Santa Ana, CA 92705
Phone: (714) 558-8512 • TWX: 910-595-1760
Eastern Sales Office: 399 Conklin St., Farmingdale, N.Y. 11735 • Phone: (516) 420-0944
Export: Constantex, Inc., P.O. Box 64574, L.A., CA 90064
Canada: Wackid Radio & TV, 312 Parkdale, Ottawa • Phone: (613) 728-1821

**STANDARD
POWER
SUPPLIES**

See our Ads in EEM (Vol. 1, pp. 1-618 - 1-619) and Gold Book (Vol. 3, pp. 1118-1119).

INFORMATION RETRIEVAL NUMBER 49

The new 420L offers everything but the pedestal you'll want to put it on.

The pedestal's optional, but the broad frequency coverage of 100 kHz to 280 MHz and a power output up to 20 watts are standard in this state-of-the-art RF power amplifier.

Linear Class A circuitry will faithfully reproduce input modulations including AM, FM, SSB, TV and pulse with minimum distortion. Completely solid-state, the 420L will supply full power output into any load impedance (from an open to a short circuit).

Driven by any signal generator, frequency synthesizer or sweeper, the 420L is a flexible and versatile source of RF power for general laboratory work, RFI/EMI testing, signal distribution, RF transmission, laser modulation and ultrasonics.

The new 420L. Offering everything but the pedestal you'll want to put it on, at \$2950.

For further information or a demonstration contact ENI, 3000 Winton Road South, Rochester, New York 14623 (716) 473-6900 or TELEX 97-8283

ENI

The world's leader in solid state power amplifiers



INFORMATION RETRIEVAL NUMBER 50

FET voltage comparators shrink input currents to pA

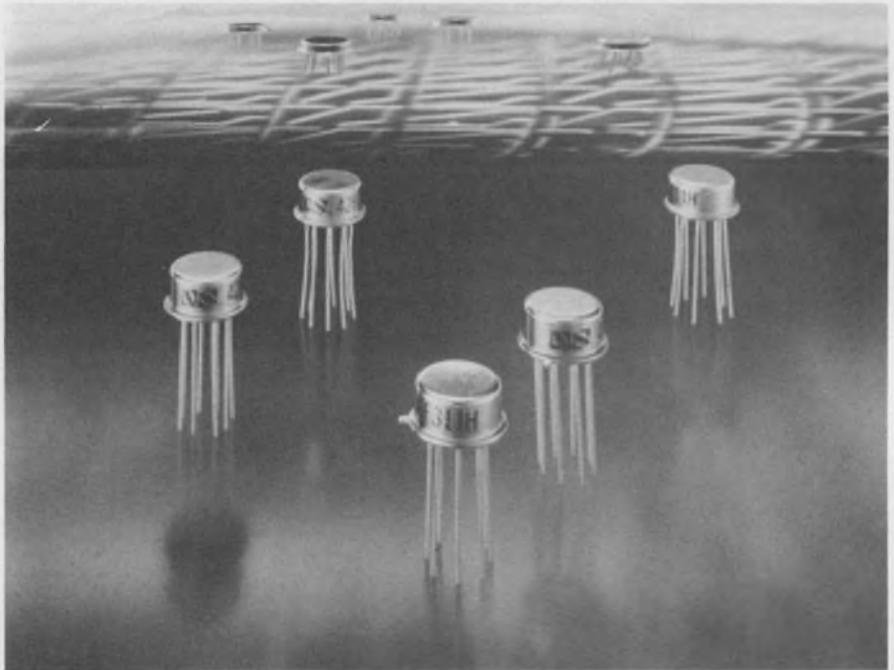

National Semiconductor, 2900 Semiconductor Dr., Santa Clara, Calif. 95051. (408) 732-5000. P&A: See text.

FET-input voltage comparators can eliminate source loading, and thus serious inaccuracies. The National Semiconductor LF series have input currents down in the picoamp region, to eliminate most input current-loading errors.

The LF111, LF211 and LF311 FET comparators can replace directly the older LM111, 211 and 311 bipolar-input models. Most of the basic comparator specifications have been maintained. The major change is an input offset current of 25 pA, max, and 5 pA, typical. The comparators' input bias current is 50 pA, max, and 20 pA, typical. By comparison, the older LM units have offset and bias currents of 10 and 100 nA, respectively.

Positive input voltages to the new series can be up to 30 V above the negative supply level. Negative input voltages can be equal to the negative supply or 30 V below the positive supply, whichever is less.

For ± 15 V supplies, this permits an input signal of ± 15 V. The relatively high input voltages are made possible without internal bootstrapping circuitry, because the input FET is a high-voltage (50-V), p-channel ion-implant device. National says it is the first use of such a transistor in a monolithic IC.

Some of the other comparator specifications include: maximum power dissipation of 500 mW; max differential voltage input of ± 30 V; typical voltage gain of 200 V/mV; output leakage current of 0.5 μ A, max; and a typical strobe ON current of 3 mA.

The LF series is available in metal TO-99 cans, flat packs, DIPs and miniDIPs, with both commercial and military temperature ratings.

The price of the least-expensive version, LF311H, with 0-to-70-C rating in a metal can is \$4.25 in 100 quantities, while the most expensive, LF111F, with -55-to-125-C rating in a flat pack is \$25 for 100 lots. Units are available from stock.

INQUIRE DIRECT

Our 4203 four-quadrant monolithic IC Analog Multiplier is not only tiny and priced to sell, but it is completely self-contained. It needs no external components to deliver a guaranteed untrimmed accuracy of up to 1%. And, if you need even less total error, it can be trimmed to just 0.6%.

What does it mean to you that it is self-contained? Less design time, and a lower installed cost, that's what. Also, because it doesn't need trimpots to adjust offset voltage and gain errors or external amplifiers, there are less circuit components to drift with time

and temperature, and less space needed. This hermetically sealed TO-100 unit is versatile, too. Its internal op amp allows you to use it as a highly accurate two-quadrant divider. Add a simple diode, and you have a neat little square rooter. You get high reliability, fully monolithic construction, versatility, and performance that equals some of the high cost modular units. You get a 25V/ μ sec slew rate, a 1 MHz bandwidth, and a settling time to 2% of final value of just 1 μ sec. And, you get a unit that is ideal for hundreds of medical, industrial, and

commercial applications. **The best part is that prices start at only \$17.00 in 100's. Write or call us for complete details.**

Burr-Brown, International Airport Industrial Park, Tucson, Arizona 85734. Telephone (602) 294-1431.



This MONOLITHIC 4 Quadrant Analog Multiplier shrinks your circuit size and your cost.

It's the best thing that's happened since sliced bread



*Another Analog IC
from Burr-Brown*

THE NO-FUSS VOLTAGE REFERENCE THAT RUNS OFF 5 VOLTS.

The Analog Devices AD580. Two bucks.

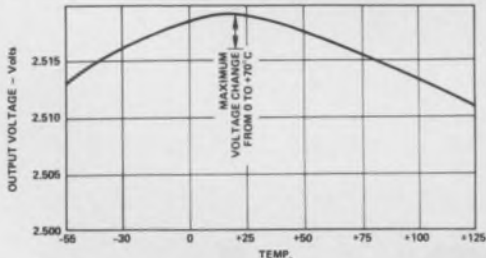

It's a three terminal, bandgap voltage reference that you just plug in—no external components. And it's the only one that works from the same power supply as your logic system—5 volts.

You get a fixed 2.5 volt output for inputs between

4.5 volts and 30 volts. With stability over temperature of 40ppm/°C, and over time of 25µV/month. Or 250µV forever.

The AD580 is an ideal external reference for 8 and 10 bit converters for digital panel meters and any low-power applications.

\$2.00 in hundreds. TO52 package or chip.

Call or write for our data sheet.

Analog Devices Semiconductor. Norwood, Mass. 02062.

East: (617) 329-4700; Midwest: (312) 297-8710;

West: (213) 595-1783.



**ANALOG
DEVICES**

INFORMATION RETRIEVAL NUMBER 52

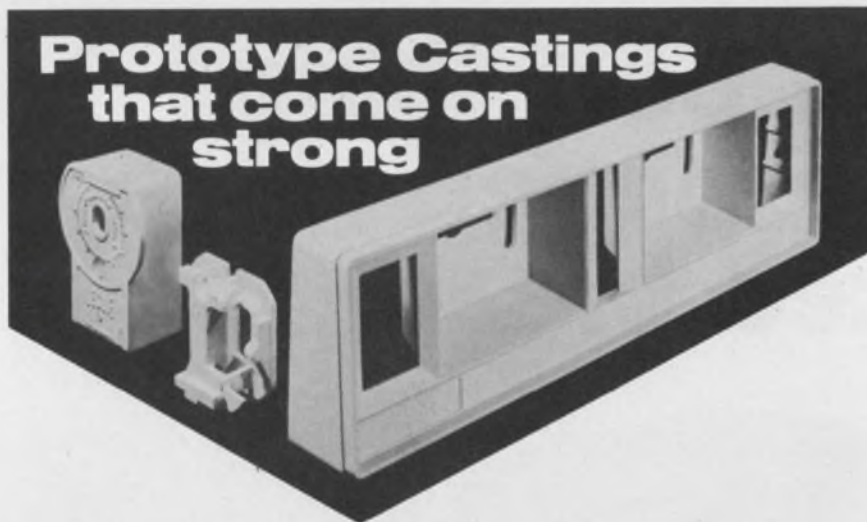

Prototype Castings that come on strong

If you're looking for metal casting processes that will give you prototype die cast or plastic injection type parts of almost any shape or size, then it's time for you to look to Atlantic.

You'll get Fast Turnaround—2 to 6 weeks from order to delivery. And your dimension control and surface finish retains all the virtues of die casting or plastic injection.

And in economy, Atlantic really comes on strong. If your volume requirements are low to medium, our prototype castings will give you a considerable cost saving and eliminate the need for a large investment in hardened tooling.

Write for our brochure on Atlantic's castings that come on strong.

Atlantic Casting

and Engineering Corporation

EIGHT TEN BLOOMFIELD AVENUE / CLIFTON, NEW JERSEY 07012
201 / 779-2450

INFORMATION RETRIEVAL NUMBER 53

COMPONENTS

Posistor protects semicons from overload

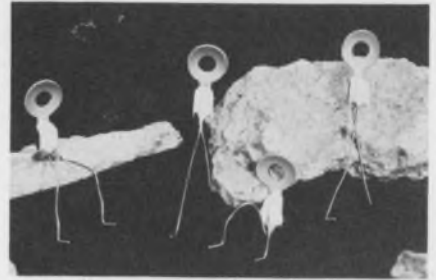

Murata Corporation of America, 2 Westchester Plaza, Elmsford, N.Y. 10523. (914) 592-9180.

A positive temperature-coefficient resistor can sense the case temperature of a high-power semiconductor and reduce its power dissipation when power limits are approached. This new Posistor, the PTH 487A, is mechanically affixed to the semiconductor device's case and electrically connected in series with its base-biasing circuit, in typical applications. The resistance of the unit, nominally 500 Ω at normal operating temperatures, increases rapidly once the protective temperature threshold is reached—2000 Ω at 176 F and 3000 Ω at 194 F. Maximum voltage and current ratings are 12.5 V dc and 0.1 A. Maximum external withstanding voltage is 15 V dc.

CIRCLE NO. 259

Ceramic chip capacitors take up to 4000 WV dc

Johanson/Monolithic Dielectrics Div., Box 6456, Burbank, Calif. 91505. (213) 848-4465. \$0.40 to \$4.11 (1000 up); stock to 8 wks.

HV series ceramic chip capacitors for operation up to 4000 WV dc are now available in a new group of monolithic ceramic construction. The capacitors are available in five standard sizes from 0.15 × 0.15 to 0.54 × 0.40 in. with a 0.12-in height. Each size includes units for 1000, 2000, 3000 and 4000 WV dc operation with standard RETMA capacitance values from 330 pF to 0.082 µF. Their small size and high voltage characteristics make them ideal for applications in high voltage power supplies and meter multiplier circuits.

CIRCLE NO. 260

Capacitors can store to 5000 joules at 20,000 V

Capacitor Specialists Inc., P.O. Box 2052, Escondido, Calif. 92025. (714) 747-4000.

Large energy-storage capacitors, designated Series ES, range from 1125 to 5000 joules at voltage ratings from 3000 to 20,000 V dc. They are all housed in cases with standard 7-1/4 x 14-in.-base sizes made of heavy-gauge heliarc-welded steel and have the latest paper/polyester-film dielectric construction. Of particular interest is the availability of two bushing styles in each rating: a standard low-profile bushing, where applications require under 40 nH inductance, high reversal and high peak currents; and a lower-cost, con-voluted, pillar-type bushing for flashlamp service.

CIRCLE NO. 261

Neon glow-lamp life increased with long bulb

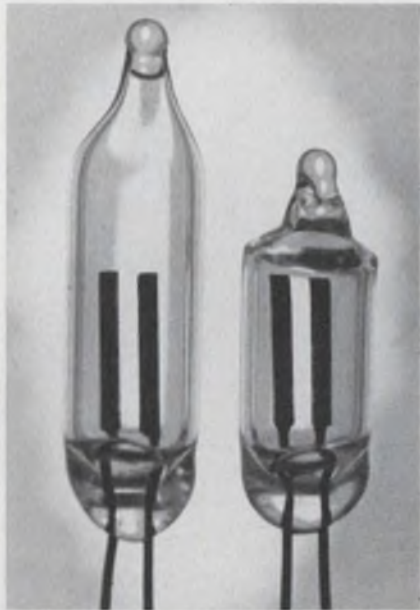

ELT Inc., Pauls Valley, Okla. 73075. (405) 238-5541.

Glow-Lite increases the photometric longevity of neon lamps by using longer glass envelopes than usual. In this way, disposition of sputtered material is confined to the lower two-thirds of the lamp, which leaves the tip clear. This is particularly important in photocell applications. However, the process can be adapted to suit any neon lamp, where end-on light output is critical.

CIRCLE NO. 262

Incandescent indicator guaranteed for 5 years

Data Display Products, 5428 W. 104th, Los Angeles, Calif. 90045. (213) 641-1232. \$2.32: lights; \$0.39; sockets (1000 up); stock to 4 wks.

Two types of long-life indicators are guaranteed for a period of five years when failure occurs during normal operation within specifications. Replacement will be made automatically, free of charge, upon

receipt of failed lights. Type A07 or D07 at 5 V, 30 mA is for low-current applications and type A1 or D1 at 5 V, 60 mA is for standard applications. And both have a built-in lamp driver with keep-alive lamp bias. Both types are in a miniature 1/4-in. dia. housing for use with inexpensive panel-mounting sockets. The socket mounts in a 5/16-in. dia. panel hole, and it may be mounted on 1/2-in. centers.

CIRCLE NO. 263

Here's HOW to choose the right ROTARY SWITCH for your needs!

FREE!
11" x 17" WALL CHART

With this handy new guide, you can cross-check over 50 basic specifications against each of our 15 switch "families". In just a few minutes, you can narrow your applications down to a few possibilities...save hours of catalog search and research! Covers our Rotary Switch lines from 10A-240V to 200A-600V. Send for your free copy today.



ELECTRO SWITCH
CORP.

Weymouth, Massachusetts 02188

Telephone: 617/335/5200 TWX: 710/388/0377

LOOKING FOR ICs AND SEMICONDUCTORS?

TRW SEMICONDUCTORS

intel®



MOTOROLA

RAYTHEON

Siliconix incorporated



**GENERAL INSTRUMENT CORPORATION
SEMICONDUCTOR COMPONENTS**



**ANALOG
DEVICES**

Beckman

AMI
AMERICAN MICROSYSTEMS INC.

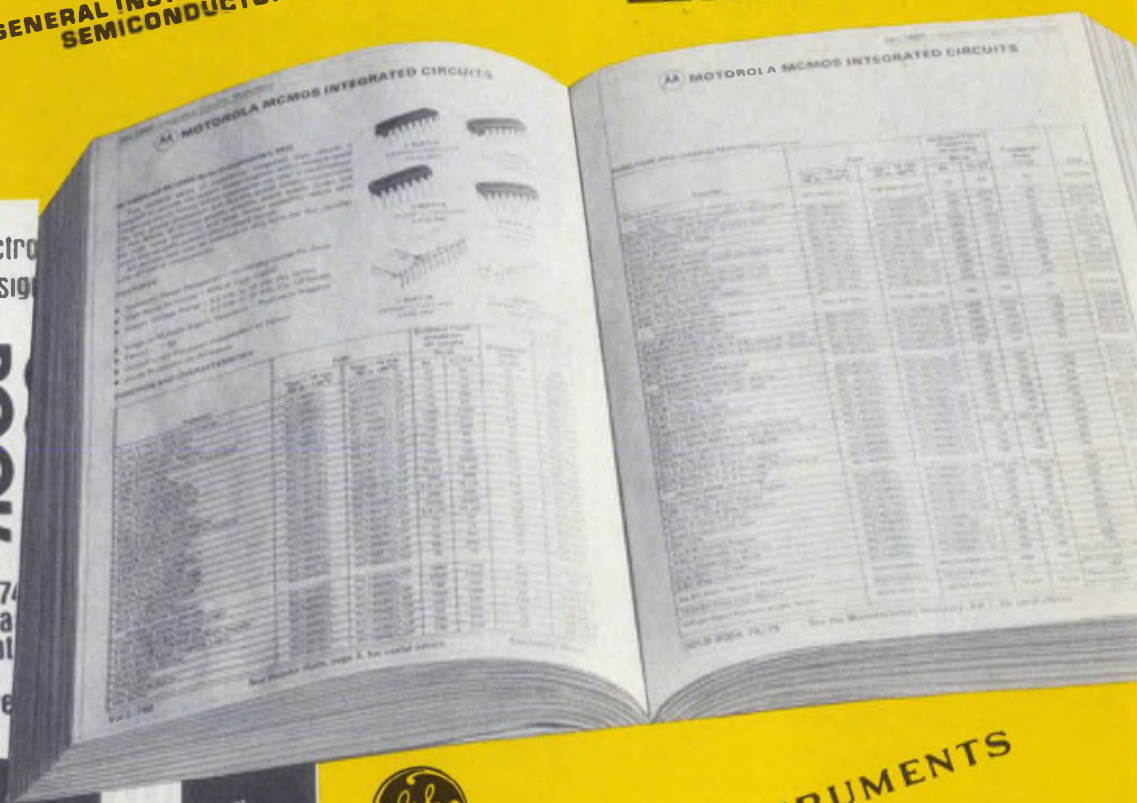

Electronic Design's

GOLD BOOK

1974-75 Master Catalog & Directory

Product Directory
Manufacturers Directory
Distributors Directory
Trade Name Directory

Vol. 1

Electronic Design's

GOLD BOOK

1974-75 Master Catalog & Directory

Components Materials

Vol. 2

Electronic Design's

GOLD BOOK

1974-75 Master Catalog & Directory

Equipment Hardware
Panel Components
Power Supplies
Tools & Production Equipment
Engineering Aids
Company Capabilities

Vol. 3



**TEXAS INSTRUMENTS
INCORPORATED**



RCA Solid State

MOSTEK

FAIRCHILD

Intersil

National Semiconductor Corporation

LOOK FIRST IN Electronic Design's GOLD BOOK

**MORE THAN 500 CATALOG PAGES DETAIL
ICs AND SEMICONDUCTOR PRODUCTS**

More than one-third of Vol. 2 of *Electronic Design's* GOLD BOOK is devoted to manufacturers' catalog pages on ICs and semiconductor products. There are separate sections on *Hybrid ICs*, *Monolithic ICs* and *Discrete Semiconductors*. LEDs are found in Vol. 3 as are products related to semiconductor use (such as IC sockets and other hardware). The catalog pages are filled with technical data you need to select and specify the right IC or semiconductor to suit your needs.

If you are interested in a particular manufacturer, move directly to the INDEX OF CATALOG PAGES to see what he has to offer. If you want to find new sources go to the PRODUCT DIRECTORY (Vol. 1) and check the roster. Boldface listings at the beginning of each product classification signal those companies who have placed catalog pages in *Electronic Design's* GOLD BOOK for your convenience.

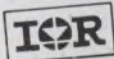

LOOKING FOR A DISTRIBUTOR?

Distributors are listed 3 ways in *Electronic Design's* GOLD BOOK.

1. **BY THE MANUFACTURERS THEY REPRESENT** U.S. distributors follow each manufacturer's listing in the MANUFACTURERS DIRECTORY (Vol. 1).
2. **ALPHABETICALLY BY NAME** 5,700 distributors are listed with complete addresses and phone numbers. When provided, you'll also find sales volume or net worth, year established and names of key officials.
3. **GEOGRAPHICALLY BY STATE** You can find a distributor near your town—or one nearby. Check the alphabetic section to learn more about them.

IT'S ALL THERE... IN ELECTRONIC DESIGN'S GOLD BOOK

Green, Yellow, Amber
or Red . . .



Our LED Panel Light Story is a Lot Brighter!

- LED panel lights brighter than incandescent lamps at 1/2 the current (2.5 mcd @ 10 mA).
- All four colors at the same low price as RED's (\$1.19 in 1000 quantities—includes built-in resistor and mounting hardware).
- Sub-miniature sizes with standard or low profile lens projections.
- Attractively styled and ruggedly built.
- Immediate availability of all colors.

TURN ON THE "LITTLE" LIGHT PEOPLE . . . phone or write for more information today!

DATA DISPLAY PRODUCTS

5428 W. 104th St., Los Angeles, Ca. 90045
(213) 641-1232

COMPONENTS

Current/voltage alarm repeats trip point 0.1%



Hades Manufacturing Corp., 151A Verdi St., Farmingdale, N.Y. 11735. (516) 249-4244. \$89 (unit qty); 4 wks.

Model NDA130 current/voltage alarm has a trip-point repeatability of 0.1%, is surge protected and has complete isolation between input, output and power. Multiple input ranges are available to accept a wide range of transducer voltage and current levels. Response time is 15 ms. Trip-level adjustments are made with a 20-turn potentiometer. Line voltage effect on trip point is 0.2% for line voltage changes of $\pm 10\%$. A built-in noise-rejector circuit reduces the effect of noise on the input lines. Output of the alarm is a heavy-duty DPDT relay with a 10-A resistive-load contact rating.

CIRCLE NO. 264

Resistor test unit has 1- Ω steps to 11 M Ω

Phipps & Bird, Inc., P.O. Box 2V, Richmond, Va. 23205. (804) 644-5401. \$48 (unit qty); stock.

Small enough to be easily hand held, a new aluminum-housed resistance-substitution unit provides a range from 1 to 11,111,110 Ω in 1- Ω steps with slide switches. The Model 236-A uses 1/2-W resistors with 1% accuracy and it has three binding posts—one to ground the case. Its aluminum case, finished in wrinkle blue, measures 4 x 6 x 1-3/16 in.

CIRCLE NO. 265

Thin-film resistor net uses nichrome elements

Analog Devices, Inc., P.O. Box 280, Norwood, Mass. 02062. (617) 329-4700. See text.

A family of seven discrete thin-film resistors in a single ceramic 14-pin DIP or Flatpak, the AD1830 series, can have resistances from 50 Ω to 500 k Ω . Ratio accuracies are to $\pm 0.01\%$; ratio TCR tracking is to ± 1 ppm/ $^{\circ}$ C max, noise to -50 dB; response time under 10 ns max; and long term ratio stability is $\pm 0.01\%$ per year at 25 C. Prices for a $\pm 0.1\%$ -ratio accuracy family with a 0-to-70-C temperature range, the AD1830J, are \$8 in small quantities, \$4.50 in hundreds. A $\pm 1\%$ version, the AD1830H, is priced at \$3 in hundreds. Nichrome thin-film resistive elements are used. The resistor series is also available in a chip version with optional certification to MIL-STD-883 and a -55 to 125 C temperature range.

CIRCLE NO. 266

Linear-motion pot measures displacement

Waters Manufacturing, Inc., Wayland, Mass. 01778. (617) 358-2777. \$100 to \$300; 8 wks.

Linear-motion potentiometers with plastic elements can measure mechanical displacement with an incremental sensitivity of 0.00005 in. Assemblies have anodized-aluminum housings, centerless-ground stainless-steel shafts, precision needle-roller bearings and a Delrin wiper carrier. Precious metal multifinger wipers, designed for minimum hysteresis (≤ 0.001 in.), are used on the measuring element and collector. The series of pots offers standard lengths in 6-in. intervals from 0.5 to 3.0 ft. with nonstandard stroke lengths and various mounting configurations available as special options. Also available are dual elements and through-shaft configurations. Standard resistance value is 10,000 $\pm 10\%$ Ω /ft. Linearity is $\pm 0.5\%$ standard, with an optional linearity of $\pm 0.1\%$ absolute available at extra cost. The nominal required operating force is 100 g, in the horizontal plane.

CIRCLE NO. 267

1.2 GHz

PLESSEY announces the world's fastest decade prescaler.

Now you can reach TACAN frequencies with integrated circuits. And greatly increase the reliability and cost-effectiveness of your design. The new high-frequency mobile communications market is yours now as well.

The revolutionary new Plessey SP8667 (1.2 GHz) prescaler is available for immediate delivery in the standard dual in-line package. Also available are the SP8666 (1.1 GHz) and SP8665 (1.0 GHz). All three of these new circuits feature a temperature range of 0-70°C, input sensitivity of 600 mv peak-to-peak, 600 mw of power dissipation, and enough output to drive MECL 10K.

High-frequency communications i.c.'s are not just talk with Plessey. We've offered a 1 GHz device for some time as part of our high speed divider family. Order your samples now of our new 1.2 GHz device and see how easy they are to use. Call or write today. **You'll find it pays to specify Plessey.**



PLESSEY SEMICONDUCTORS

1674 McGaw Avenue, Santa Ana, California 92705 • Tel: (714) 540-9945, TWX: 910-595-1930
Cheney Manor, Swindon Wiltshire, England • Tel: (0793) 6251, Telex: 449637

West Germany - Tel: 811 3516021, Telex: 5215322 • France - Tel: 727-4349, Telex: 62789 • Italy - Tel: 3491741, Telex: 34347 • Sweden - Tel: (08) 23 55 40, Telex: 10558

INFORMATION RETRIEVAL NUMBER 56

Add it all up...

- + Higher Operating Temperatures —**
Up to +275°C!



- + Higher Stability —**
Full power stability is typically better than 0.1% in 2000 hours!



- + Extra-Close Temperature Tracking —**
Matched resistor sets provide TC tracking as close as 2 ppm/°C!



- + Higher Voltage and Power Ratings In Smaller Sizes —**

Micronox power films handle more power over a wider resistance range with proven long-term stability!



- + Exclusive Non-Inductive Design —**
Serpentine film pattern produces axial-lead resistors with full voltage and power ratings!

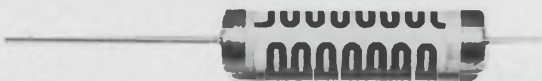

= Higher Performance in All of Your Circuits!

Caddock Power Film Resistors will help you up-grade your equipment...now!

Caddock has over 700 models of 12 standard resistor types to choose from, and our program of continuous testing proves the superior performance and stability that we claim!

Look into EEM for technical data, and write or call to Caddock Electronics, Inc., 3127 Chicago Ave., Riverside, Calif. 92507, Tel: (714) 683-5361 — TWX: 910-332-6108. We'll send you our 12 page catalog and the results of the full power stability tests that have been running continuously for over 5 years! Then you'll have positive proof of the performance you can expect from —



CADDOCK

INFORMATION RETRIEVAL NUMBER 57

Solder Clads for Electronics

TMI produces solder clads by pressure-bonding (cladding), re-flowing, and other proprietary methods. This enables us to offer a complete range of solder thicknesses and physical properties.

Advantages:

1. Reduced labor cost.
2. Increased flexibility in design.
3. Elimination of multiple handling and inspection of stamped parts.
4. Improved and consistent quality of the end-product.
5. Permanent solderability, providing increased shelf life.

Applications:

Among the major users of solder clads are the semiconductor and electronic industries. More recently, manufacturers of communication equipment, connectors for data processing equipment, jewelry, automotive, and computer parts have recognized the advantages offered by solder clads.

Availability:

Thin Solder Stripes (for protective coating)

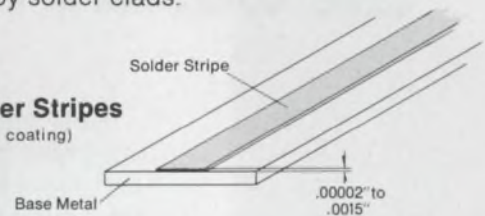

- To insure a solderable surface when subsequently soldering or brazing.
- To replace gold as a contact material.

Stripes can be on one or both sides. Complete overlay on one or both sides. All types of solder alloys.

Thick Solder Stripes (for replacing pre-forms or hand soldering)

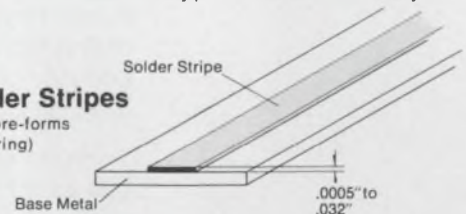

- Eliminates costly preform placement, applicable even to stainless and aluminum.

One or more stripes on one side only; however, complete overlays on one or both sides. All types of solder alloys. Base metals of any temper.

Write for our new "Design Aid for Solder Clads", showing all mill limits and tolerances, and a solder-alloy guide. Free on request.



TECHNICAL MATERIALS, INC.

25 Holden Street
Providence, Rhode Island 02908
Tel: (401) 272-4343

INFORMATION RETRIEVAL NUMBER 58

Industrial power module cuts price by 20%

Abbott Transistor Labs, 5200 W. Jefferson Blvd., Los Angeles, Calif. 90016. (213) 936-8185. \$121 to \$139; stock.

The RN5 family of industrial power modules provides 5.0 A at various voltages between 4.5 and 37 V dc. Line and load regulation are 0.1% and ripple is less than 0.02%. Standard features include short-circuit protection, input-transient protection and remote error sensing. Predicted MTBF is more than 75,000 h. Anodized aluminum-case permits sustained full-load operation at an ambient temperature of 71 C without heat sinks or forced air cooling. Tempco is 0.03%/°C.

CIRCLE NO. 268

Compact ac-to-dc unit delivers a big 100 W



Powercube Corp., 214 Calvary St., Waltham, Mass. 02154. (617) 891-1830. \$65 (100 up); 3-4 wks.

Series 300 Cirkitblock module is said to be the smallest known 100-W ac-to-dc isolated converter. The module measures 2 x 3 x 1 in., weighs 13-1/2 oz., and operates over the full "Mil" temperature range. The unit accepts a three-phase, 400-Hz input (120/208, MIL-STD-704A) and develops single or dual unregulated dc outputs. Typical ranges include 20 V at 5 A, 40 V at 2.5 A, or dual 20 V at 2.5 A each.

CIRCLE NO. 269

Dc/dc converter needs less than 1/3 cubic in.

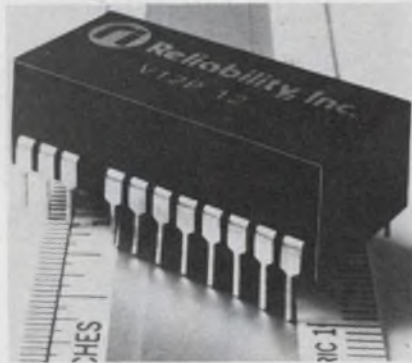

Reliability, Inc., P.O. Box 35733, Houston, Tex. 77035. (713) 729-4444. See text.

Small both in size and price, the V12 Series unregulated dc/dc converter, from Reliability, Inc., accepts a 12-V-dc input and delivers 1-W at a variety of isolated positive and negative dc voltages, from 5 to 15 V.

Forming part of the company's V-PAC Series, the V12's volume is less than 1/3 of a cubic inch—claimed by Reliability to be the smallest of competing converters. And its DIP-like package means you can mount the unit on the PC board along with the ICs to be powered. Mounting is on 0.6-in. centers and can be in standard sockets or flow soldered.

Seven different sources now comprise the V12 Series. Included are single-output units (5, 12 or 15 V), and dual-outputs—+12/-6, ±12 or ±15 V. Typical prices are \$17.60 each for the dual 12 or dual 15 units, in quantities of 100 to 199.

All of the Reliability, Inc., sources are hermetically sealed components and are short-circuit proof with automatic reset. And all are burned in and checked before shipment.

The V12 Series is rated to operate at temperatures between 0 and 70 C in free air. Minimum isolation from the driving source is 10 MΩ (at 50 V) and maximum input current at any load is 200 mA. All units exhibit an efficiency of 50% at full load. Noise of the series is a maximum of 50 mV rms but this figure can be reduced with an external capacitor.

Evaluation units are available from stock; production quantities take 30 days for delivery.

CIRCLE NO. 250

DOUBLE-BALANCED MIXERS

Great Value at

\$7⁹⁵

500 piece quantities.

\$9.95 in quantities of 1 to 49 pieces

DC-500MHz
6dB conversion loss
40dB isolation
EMI shielded case



A breakthrough in technology and high production volume enables Mini-Circuits Laboratory to offer these new products at an unprecedented low price.

In today's tough competitive market can you afford not to use these remarkably low priced and high performance units?

Ruggedness and durability are built in the SRA-1. These new units are packaged within an EMI shielded metal enclosure and hermetically sealed header. They use well matched hot-carrier diodes and uniquely designed transmission line transformers.

We invite you to convince yourself. Place your order now and check our delivery, product performance and reliability.

Mini-Circuits Laboratory

2913 Quentin Rd., Brooklyn, N.Y. 11229
(212) 252-5252, Int'l Telex 620156
A Division Scientific Components Corp.

*FRANCE: S.C.I.E., *31, rue George-Sand, Palaiseau 91, France *GERMANY, AUSTRIA, SWITZERLAND: Industrial Electronics GMBH, *Klüberstrasse 14, 6000 Frankfurt/Main, Germany *UNITS IN STOCK

ENGLAND: Dale Electronics: Dale House, Wharf Road, Frimley Green, Camberley, Surrey. JAPAN: Denisho Kaisha, Ltd.: Eguchi Building, 8-1, 1-Chrome, Hamamatsucho, Minato-Ku, Tokyo.

*UNIT IN STOCK.

INFORMATION RETRIEVAL NUMBER 59

IF YOU WANT DATA ON

POWER

IT'S ALL THERE

POWER SUPPLIES, A-C INPUT, 0 TO 100 VDC OUTPUT

Abbott Trnstr Labs, Dept G, 5200 W Jefferson Los Angeles CA 90016 Vol 3/853-858	(213)936-8185
ACDC Elecs Co Inc 401G Jones Rd Oceanside CA 92054 Vol 3/865-873	(714)757-1880
Acopian Corp 131G Loomis St Easton PA 18042 Vol 3/875,876,878-900	(215)258-5441
American Power Sys Corp 51 G Jackson St Worcester MA 01608 Vol 3/903-906	(617)753-8103
American Vector Inc, Dept G, 59H Brown Av Springfield NJ 07081 Vol 3/901	(201)379-7806
Amphenol Sis Div, Componants Group, Bunker Ramo Corp 2875G S 25 Av Broadview IL 60153 Vol 3/910,911	(312)345-4260
Analog Devices Inc, Dept G, PO Box 280 Norwood MA 02062 Vol 3/907	(617)329-4700
Berkeley Nucleonics Corp 1198G 10 St Berkeley CA 94710 Vol 3/567	(415)527-1121
Computer Prods, Dept G, Box 23849 Ft Lauderdale FL 33307 Vol 3/918,919	(305)974-5500
Dynage Inc 1331G Blue Hills Av Bloomfield CT 06002 Vol 3/922	(203)243-0315
Dynascan Corp, Dept G-B, 1801 W Belle Plaine Av Chicago IL 60613 Vol 3/574	(312)327-7270
ELDEC Corp 16700G 13 Av W PO Box 100 Lynnwood WA 98036 Vol 3/930	(206)743-1313
Elec Measurements Inc 405G Essex Rd Neptune NJ 07753 Vol 3/929	(201)922-9300
Electrostatics Inc, Dept G, 7718A Clairemont Mesa Blv San Diego CA 92111 Vol 3/943	(714)279-1414
Elpac Inc/Elexon Power Sys, Dept G, 3131 S Standard Av Santa Ana CA 92705 Vol 3/932-942	(714)979-4440
Fuji Electrochemical Co Ltd Hamagomu Bldg 5-36-11 Shinbashi Minato-ku Tokyo Japan Vol 3/1177	03-434-1271
Heath Co, Dept G, Benton Harbor MI 49022 Vol 3/664	(616)983-3961
Hewlett-Packard, NJ Div, Dept G, 1 Green Pond Rd Rockaway NJ 07866 Vol 3/950-980,982,987-1009	(201)627-6400
Hope Elecs Box 773 Clifton NJ 07013 Vol 3/1366	(201)777-3522
Instant Instrsr Inc 306G River St Haverhill MA 01830 Vol 3/948	(617)373-9260

An overview of electronic power supply manufacturers can be found in the **PRODUCT DIRECTORY** (Volume 1 of *Electronic Design's* GOLD BOOK). Complete street address, city, state, zip and phone numbers after each manufacturer's name make it easy for you or your secretary to contact many suppliers at one time—no need to leaf through other directory pages to find this basic information.

This symbol ■ before a manufacturer's name indicates he has submitted product literature to our editors, helps to verify the company as a serious entrant in the power supply field.

Boldface type at the beginning of each product section flags those manufacturers who have placed catalog pages for your further reference in Volume 3. If you want to know more about a specific company, its sales offices, reps, distributors, foreign agents & reps etc., simply turn to the **MANUFACTURERS DIRECTORY** in Volume 1.

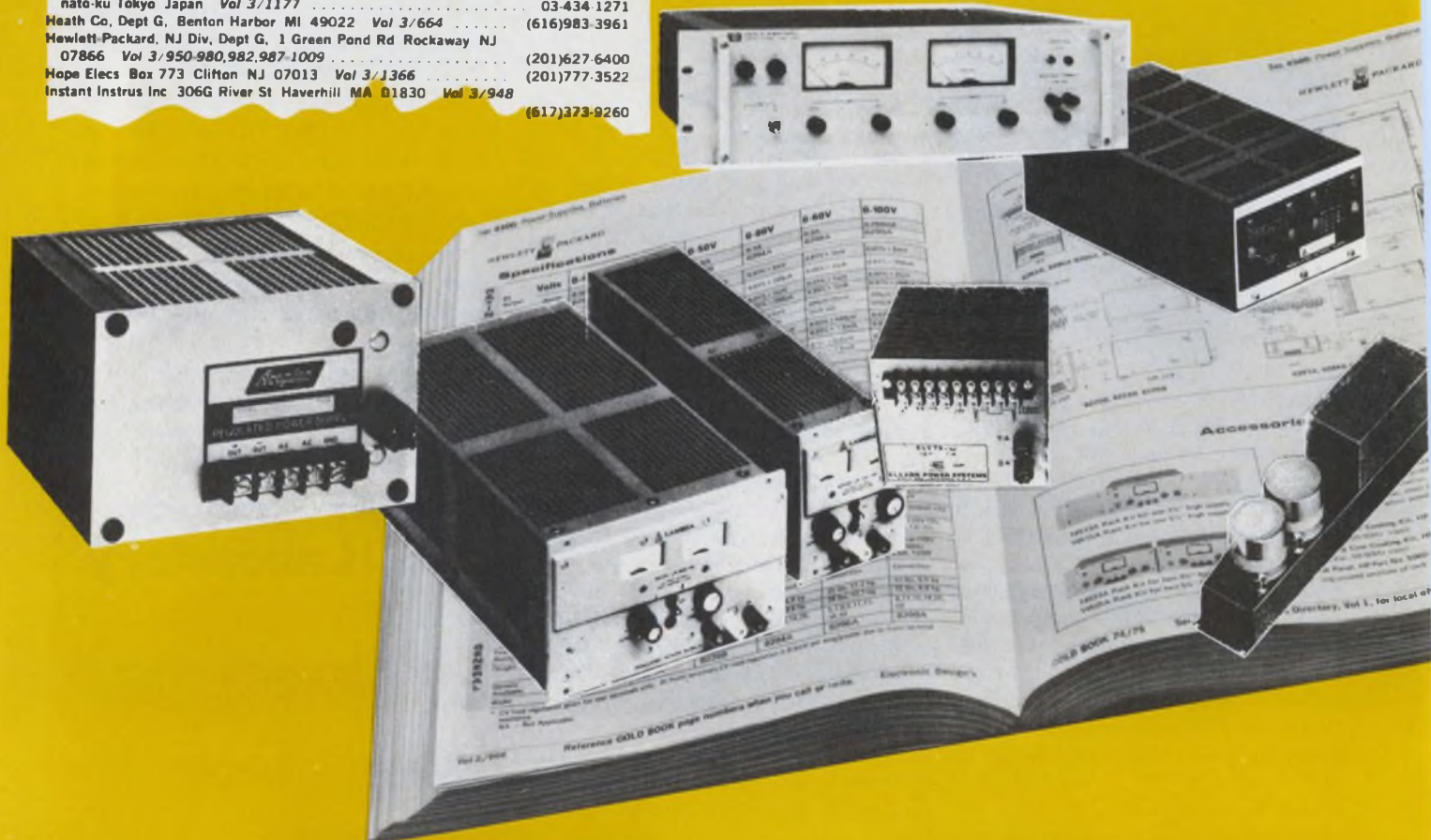

SUPPLIES

Electronic Design's

GOLD BOOK

IS THE PLACE TO LOOK

296 CATALOG PAGES DETAIL POWER SUPPLIES FROM 55 SUPPLIERS

Almost 300 catalog pages containing technical information, key parameters and specs on *power supplies* can be found beginning on page 852 of *Electronic Design's* GOLD BOOK (Volume 3). Fifty-five suppliers are represented. Hewlett-Packard alone gives you 68 pages of data including general information, features, descriptions, ratings, performance, price and ordering information. Lambda has 59 pages, Acopian has 26. AMP Incorporated offers a library of over 1,000 designs or will build to suit your needs. Amphenol stresses their "minis", Power/Mate Corp emphasizes same day shipment, Powercube Corporation talks about their modules . . . and so on.

Look over this section carefully, you may well find help in solving a design problem or even the exact product you're looking for. You can call the supplier with much of the details already covered, save time, or in some cases move directly from catalog page to purchase.

Get to know *Electronic Design's* GOLD BOOK and keep it handy. It will save you hours and hours of valuable time in the months ahead.



IF YOU'RE LOOKING FOR PRODUCT INFORMATION...
LOOK FIRST IN ELECTRONIC DESIGN'S GOLD BOOK

New Coaxial Switches For ATE



Systron-Donner's remotely programmable coaxial switches handle high-speed signal switching and multiplexing in 50 and 75 ohm systems. Choose from these 3 models:

Model Number	7714	7718	7732
Pole arrangement	1X4 (1P4T)	1X8 (1P8T)	3X2 (3P2T)
Rise time	< 500ps	< 1ns	< 350ps
Transient aberrations (Pk - Pk, 1 ns step)	2%	2%	1%
Price	\$130	\$185	\$165

For full details, call your Scientific Devices office or contact S-D at 10 Systron Drive, Concord, CA 94518. For immediate details, call our Quick Reaction line (415) 682-6471 collect.

SYSTRON  **DONNER**

INFORMATION RETRIEVAL NUMBER 60

apc

For Fast Delivery

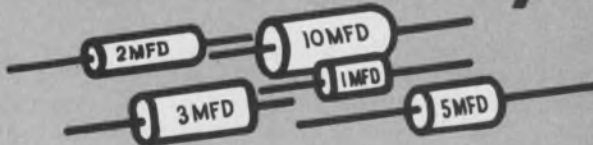

MICRO-MINIATURE

Metallized Film Capacitors

- ★ POLYCARBONATE ★ POLYSTYRENE
- ★ POLYPROPYLENE ★ MYLAR*
- ★ SPECIAL SIZES

MADE IN THE U.S.A. in large quantities and competitively priced.

Contact Larry Crane for fast quote at 516-433-5311.

ACTIVE & PASSIVE COMPONENTS, INC.
6 Ariel Way, Syosset, N.Y. 11791 • 516-433-5311

*DuPont Reg. TM

INFORMATION RETRIEVAL NUMBER 61

POWER SOURCES

Standby power system delivers 2 kVA

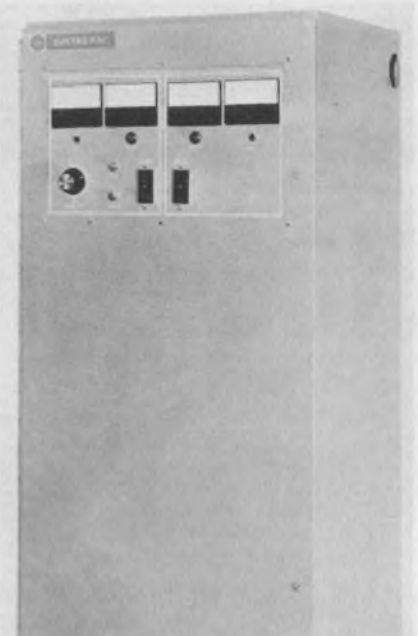

Electro Pac Div., Instrumentation & Control Systems, Inc., 129 Laura Dr., Addison, Ill. 60101. (312) 543-6200. \$4000; 2-4 wks.

Model UP20E 120-8-3A universal standby power system provides 2 kVA of power. Special line synchronization permits the inverter to be synchronized from 50 or 60 Hz or an external frequency source. Over and undervoltage sensors provide alarms when battery voltage drops below a predetermined level. Input can be 50 or 60 Hz, 120 or 240 V and output can be 50 or 60 Hz, 120 or 240 V.

CIRCLE NO. 270

Low-cost modular units deliver to 5 W

Dynasyn Corp., 77 Elm St., Amesbury, Mass. 01913. (617) 388-5187. 905A: \$28; 905B: \$24; 915: \$34.

Model 905A is rated at 5 V, 1000 mA; Model 905B delivers 5 V at 500 mA; and Model 915 outputs ± 15 V at 100 mA. Typical specs include better than 1% load-line regulation, less than 5-mV ripple for the 905 series and less than 10 mV for Model 915. All units are doubly protected, featuring thermal turn-off and current limiting. 900 series is intended for use in DPMs, MODEMs, test equipment, card-mounts, replacements and prototypes.

CIRCLE NO. 271

FOR PEOPLE WHO WANT TO READ ALL ABOUT IT!



We have nothing less than a fully illustrated, systematic, easy-to-use survey of the entire field of data management as it exists today. It covers it all, from A to Z, so it's for everybody. The programmer tightening up his files. The analyst working out a workable timesharing program. Top management needing industry-wide perspective on competitive system designs.

It's a rare publication that takes a unique "blueprint approach" to current know-how. Beginning with the single data item as the first building block in total system design. And progressing through specific techniques for data structures, streams, files . . . total hardware and operating system control . . . the latest advances in timesharing and multiprogramming . . . system modeling and simulation . . . complete

designs for various types of commercial accounting and document-oriented storage and retrieval systems. It all adds up to a vast and impressive "top to bottom" view.

And it does it all in fresh, jargon-free language, with scores of illustrations and diagrams for a rapid, visual grasp.

Whether you use it as an on-the-job manual, as a desk-top reference, or as a conference room companion with all the answers, it's an indispensable tool guaranteed to broaden your perspective and practical skill in a field that knows no limits to growth and progress. And generally give you the professional confidence that comes from knowing just about everything that's going on.

#5100-X, 6 x 9, 300 pages, cloth \$14.95

To Order:

Circle the **Information Retrieval Number** to order your 15-day free examination copy of **Data Management for On-Line Systems** by David Lefkowitz. At the end of that time please remit payment or return the book with no further obligation.



Hayden Book Company, Inc., 50 Essex Street, Rochelle Park, N. J. 07662

INFORMATION RETRIEVAL NUMBER 62

POWER SOURCES

Inverters work under rugged conditions



Topaz Electronics, 3855 Ruffin Rd., San Diego, Calif. 92123. (714) 279-0831. Start at \$675.

GP series inverters are designed for natural convection cooling under rugged environmental conditions. Protective circuitry prevents damage from reversed input polarity, low or high input voltage, overload, and short-circuits. Voltage regulation is less than ±5% for both line and load. Total harmonic distortion is less than 10% at full load and nominal line. Standard frequency stability is 1%. Ratings are 200, 250 and 500 VA, with outputs of 115 or 230 V ac, 50 or 60 Hz.

CIRCLE NO. 272

Compact switchers offer up to quad outputs

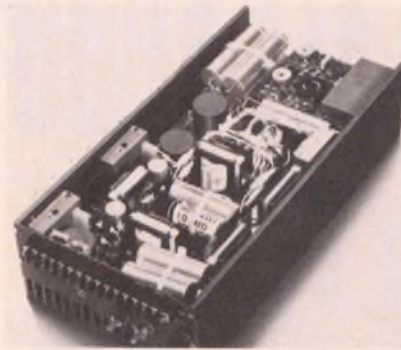

LH Research Inc., 2052 S. Grand Ave., Santa Ana, Calif. 92705. (714) 546-5279. \$493 (1000).

The 600 Series is a line of 600-W switching-regulated power supplies available in single, dual, triple, and quad-output models. Size is 3.9 × 7.5 × 16.12 in. and weight is 13 to 14 lbs. The complete line includes 85 standard models in six wattage ratings—250, 300, 500, 600 and 1000 W. A 1500-W series will be available in Sept., 1974. Efficiency of all single-output models is over 80%; multiple-output models average 75%.

CIRCLE NO. 273

Dc/dc converters deliver to 10 W



Semiconductor Circuits, Inc., 306 River St., Haverhill, Mass. 01830. (617) 373-9104. From \$45.95; stock to 10 wks.

This new series of regulated dc/dc converters consists of encapsulated modules that deliver from 0.9 to 10 W. Sizes range from 1.5 × 2 × 0.4-in. to 2.5 × 3.5 × 0.875 in. Standard output voltages are 5, ±12, ±15 and ±18 V, with standard input ranges of 5, 12, 24 or 28 V. Featured are regulation of 0.02% line and load, a Pi filter to minimize input reflected noise and no derating thru 71 C. All outputs are short-circuit protected and electrostatically shielded on five sides. The units come without input-polarity protection.

CIRCLE NO. 274

Whether you buy one's, two's...



or multitudes—



North delivers power reliability!

MODEL	11000	12000	13000	14000	15000	16000	17000	18000
VDC								
	5.0	3.9	5.3	11.3	13.0	20.0	32.5	49.0
	12.0	2.8	4.2	8.0	10.5	15.0	23.0	36.0
	15.0	2.4	3.7	7.5	9.5	14.0	20.5	27.0
	18.0	2.1	3.3	6.0	8.0	13.0	18.0	26.0
	24.0	1.5	2.8	4.2	7.0	11.0	15.0	21.0
	28.0	1.4	2.4	4.0	6.3	9.0	14.0	20.0
	36.0	1.2	2.2	3.1	5.6	8.0	11.0	14.0
	48.0	0.95	1.8	2.6	4.2	6.0	8.0	10.0

MODEL	10000
VDC	
	0-7.5
	0-16
	0-25
	0-33
AMPS	2.10
	1.25
	0.85
	0.68

DUAL OUTPUT SUPPLIES	
MODEL	N03052
VDC	
	±15
	±12
MODEL	N60052
VDC	
	±15
	±12
AMPS	1.0A

Listed here are the more popular models—many other voltages are available.

NORTH 
ELECTRIC COMPANY

North Electric Company / Galion, Ohio 44833 / A United Telecom Co

Many O.E.M.'s agree that it just doesn't make sense to risk the reputation of a major piece of equipment over a minor component—especially, when the cost difference is so little.

If you're one of them, we'd like to quote your next power supply order. Whether you need one unit—or one hundred, North has the product selection and the production capacity to deliver more standard power reliability for your dollar.

To back it up, we offer the industry's finest technical specialists and over 40 years experience as the leader in custom power supplies.

Send for a catalog today, or call 419/468-8874.

SP-16

Logs, roots and trig are your business.

Meet your partner.

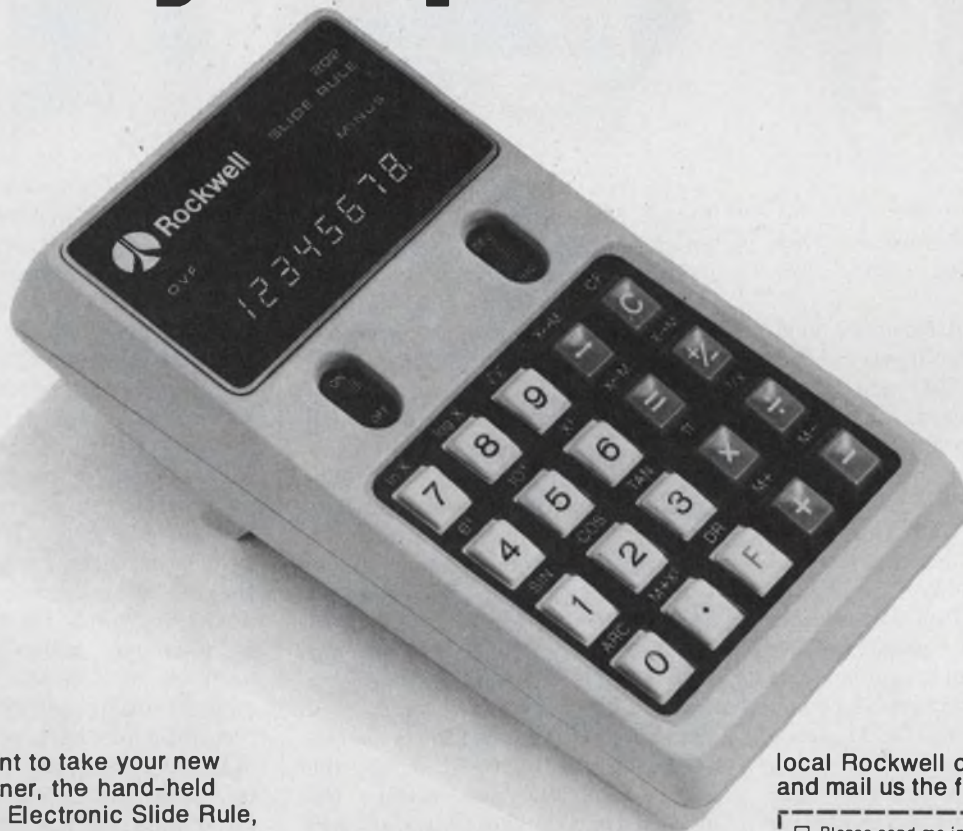

You'll want to take your new business partner, the hand-held Rockwell 202 Electronic Slide Rule, wherever and whenever there's work to be done. It's as portable as your old slide rule, but the similarity really ends there. For the 202 can perform a spectrum of scientific calculations with computer-like speed and accuracy—

ARITHMETIC FUNCTIONS

+ - × ÷

LOGARITHMIC FUNCTIONS

ln X log X e^x 10^x

TRIGONOMETRIC FUNCTIONS

sin X arc sin X degrees
cos X arc cos X radians
tan X arc tan X

OTHER FUNCTIONS

X^y √X 1/X +/- ↔

MEMORY FUNCTIONS

M+ M- X←M X→M
X↔M M+X²

The versatility of the 202 is enhanced by a fully-addressable memory. And a degree/radian selector. Underflow. A full-floating decimal system and automatic constants.

You'll agree, the 202's big, easy-to-read 8-column digitron display is a big improvement over your standard slide rule. And when you compare it with most other hand-held calculators, even more costly ones, you'll see just how much easier the 202 is to read.

Now that's the right kind of business partner.

For more information on the 202 Electronic Slide Rule or the entire family of Rockwell hand-held professional calculators, call your

local Rockwell dealer, or complete and mail us the following coupon.

Please send me information on the Rockwell 202. 8

Please have salesman call right away.

Name _____

Occupation _____

Company _____

Address _____

City _____ State _____

Zip _____ Phone _____

Mail to: Unicom Systems
Rockwell International, 950 DeGuigne Drive
Sunnyvale, California 94086

**Our family has
a mind for
business.**



**Unicom Systems
Rockwell International**

...where science gets down to business

INFORMATION RETRIEVAL NUMBER 64

Four-function controller is programmable

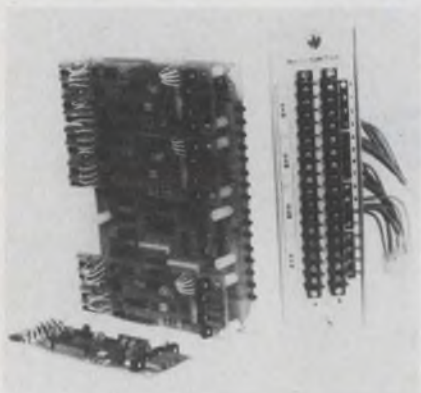

Eagle Signal, 736 Federal St., Davenport, Iowa 52803. (319) 326-8111.

The CP640 multifunction module combines input, output, random access memory (RAM) and timing functions on one card. The device includes these four functions on a card occupying the space of only one input/output (I/O) module in the company's CP600 programmable controller. The card is submodularized into four groups of four circuits (or functions) each. These submodules plug into a mother board. Input submodules are available for voltages of 24 and 120 V ac or 5, 10, 12, 15, 24, 48 or 120 V dc. Output submodules are available for 120 V ac, 1 A continuous, 5 to 48 V dc, 0.5 A continuous, or 120 V dc, 0.5 A continuous. Output submodules with a 10 VA reed relay output and special input and output voltages are also available. LEDs are used to indicate the logic status of each input/output circuit.

CIRCLE NO. 275

Digital control timer settable to 0.1 min



Alpha Components Corp., 115 Eucalyptus Dr., P.O. Box 947, El Segundo, Calif. 90245. (213) 322-7780. \$275 (unit qty).

Model 901 solid state digital timer can be front-panel programmed to a maximum of 99.9 min. in 0.1 min. increments. The start of the countdown timing cycle initiates a contact closure. A three-digit LED display continuously subtracts from the present time to zero while the decimal point pulsates every second. Upon completion of a cycle, an audible alarm is sounded and the control contact opened. The unit has an emergency stop switch that opens the relay contacts and stops the count until the switch is returned to its normal operating position. During the stop period, the unit retains the elapsed time. Subsequent start will continue the original programmed time. The timer operates on 117 V ac, 60 Hz and has its own internal regulated power supply. The stainless steel panel is standard DIN, 100 x 100 mm (4 x 4 in.) and has a depth of 4.75 in.

CIRCLE NO. 276

Amplifier-annunciator uses tri-mode LED



Consolidated Ohmic Devices, 115 Old Country Rd., Carle Place, N.Y. 11514. (516) 741-1500.

Model SCA 1460 dual point millivolt alarm incorporates an annunciator display which visually and continuously monitors operating condition. A tri-mode LED provides a visual off/normal/alarm indication for each trip point. The unit accepts millivolt or T/C signals without a separate amplifier. The input signal will automatically actuate an alarm when it exceeds the set safety limit. A choice of dual trip points for a single input is available allowing high-high, high-low, or low-low alarming. An analog output permits continuous recording of the process. T/C and millivolt inputs are field selectable in three different ranges with minimums as low as 6 mV and maximums up to 160 mV. Internal T/C ambient compensation is adjustable from 0 to 10% of input span. Alarm repeatability is less than 0.05% of input span at 75 F. Ambient operating temperature range is 15 to 140 F.

CIRCLE NO. 277

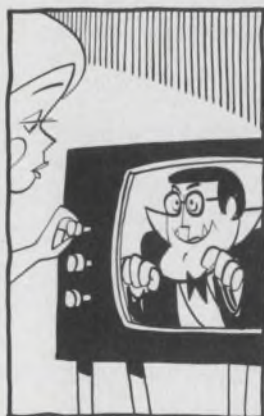
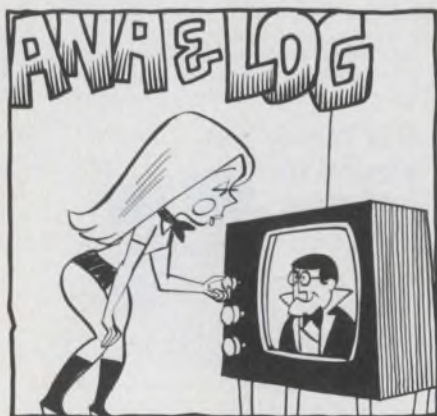

ANALOGY

BRING YOUR SYSTEM TO LIFE FAST WITH INTECH'S A-805 12-BIT MULTIPLYING D/A CONVERTER. SETTLES TO 0.1% IN 10μS IN A 2"X2"X0.4" PACKAGE.

intech INCORPORATED
(408) 244-0500
1220 COLEMAN, SANTA CLARA CA 95050



VOLTAGE TO FREQUENCY CONVERTERS

FROM THE WORLDS LEADING SUPPLIER OF MODULAR VFCs

27 ULTRA LINEAR MODELS
YOU CAN COUNT ON
FOR EVERY APPLICATION

- .005% Linear to Below 1mV
- Useable to 10 μ V
- Stability to 5PPM/ $^{\circ}$ C
- High CMRR Differential Input
- Programmable Voltage Range
- Current Input Option
- Low Power Consumption (26mW)
- Optically Isolated to 500V
- TTL and CMOS Compatible Output
- Transformer Isolated Output
- High Stability Internal Reference
- External Reference
- 0 to 1 KHz, 10KHz, 40KHz or 100KHz



FOR 14 PAGES OF DATA AND APPLICATIONS INFORMATION
CIRCLE THE NUMBER BELOW OR CONTACT

Dynamic Measurements Corp.

6 Lowell Avenue, Winchester, Massachusetts 01890 Tel: (617) 729-7870 Cable: DYMECO TWX (710) 348 6596

IN EUROPE DMC PRODUCTS ARE SOLD AND MANUFACTURED UNDER LICENSE BY



INDUSTRIES

CH-1211-GENEVE 8/SUISSE
Tel.: (022) 21 51 33
Telex: 22831 LANAT-CH



INDUSTRIES

B.P. 13
F-74240-GAILLARD FRANCE
Tel.: (50) 38 53 35

INFORMATION RETRIEVAL NUMBER 66

Digital delay module spans 10 to 1000 ns

Technitrol, 1952 E. Allegheny Ave., Philadelphia, Pa. 19134. (215) 426-9105.

A programmable dual delay module provides output pulses within 1 ns of digitally selected nominal times in a range of 10 to 1000 ns after trigger. It is ECL/TTL

compatible and PC-board mounted. The unit is designed to trigger on ECL/TTL positive or negative edges. Programming is accomplished by three decades of remotely generated BCD inputs for the control of each of two independently timed ECL/TTL outputs. The module occupies a 5 × 10 in. PC board, and is accessed through edge and high frequency connectors. Supply voltages required are ±5 V dc.

CIRCLE NO. 278

Motor speed controllers handle up to 250 hp

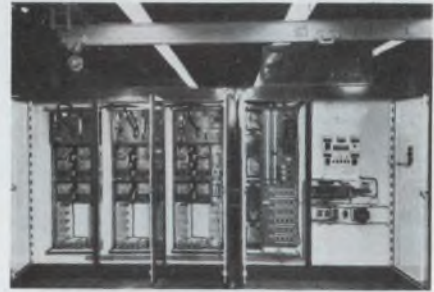

Ramsey Controls, 341 Rt. 17, Mahwah, N.J. 07430. (201) 529-4400. From \$30,000; 26 to 30 wk.

A 250 hp, ac motor speed control system offers an output frequency adjustment from 6 to 120 Hz with output voltages up to 440 V. This provides a motor speed range of 20:1. The system is enclosed in NEMA 12 TENV (totally enclosed nonventilated) housing, designed for installation in hostile environments. This system is cooled via natural convection—there are no fans, filters or pumps. All active system modules are mounted on aluminum heat sinks which protrude through the back of the system as cooling fins. Other systems include 1, 3, 5, 10, 15, 25, 50, 60, 75, 100 and 150 hp units. Most systems are available in NEMA 1 enclosures for normal factory conditions or the TENV NEMA 12 enclosure for wet, dusty and otherwise hostile environments.

CIRCLE NO. 279

Hybrid s/d converter accurate to ±3.9 min.

ILC Data Device Corp., 105 Wilbur Pl., Bohemia, N.Y. 11716. (516) 567-5600.

Thick-film hybrid versions of the company's MSDC series of multiplexed synchro converters are known as the HMSDC series. Accuracy is ±3.9 min. ±1 LSB, and resolution is 1.3 min. The HMSDC series uses successive approximation techniques and has simultaneous sampling to eliminate data skew, give fast (150 μs) conversion time and random access capability. The HMSDC units are available in SHP NAFI format, to fit on standard 1A cards. Processing to MIL-STD-883 level C is standard procedure, with processing to level B available

CIRCLE NO. 280

8 CASES FOR SWITCHING TO NATIONAL® SCRs



16-1600 Amperes rms
25-1700 Volts
Power and Inverter SCRs
Patented Regenerative Gate

Call or write for full details



NATIONAL ELECTRONICS

a varian division

geneva, illinois (312) 232-4300

Voltage sensors come in 3 or 10 A models

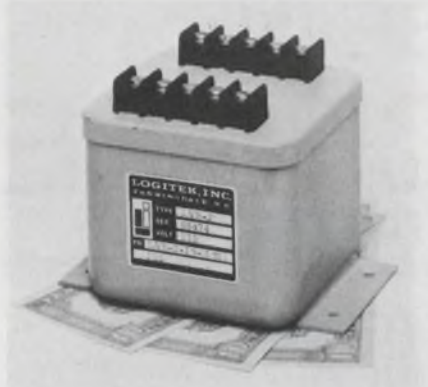

Logitek, 42 Central Ave., Farmingdale, N.Y. 11735. (516) 694-3080. \$30.

The type LVS low voltage monitor is available in adjustable or nonadjustable 3 and 10 A options. The Model LVS-2, single-phase unit for 115-V operation, contains a relay that deenergizes and automatically shuts down equipment when voltage drops to danger level. After voltage returns to normal, power is automatically reconnected. A built-in 5-s time delay prevents turn-off due to momentary voltage surges. The units are suitable for stand-alone mounting or installation in a standard NEMA enclosure.

CIRCLE NO. 281

Transient suppressor absorbs 120 j pulses

MCG Electronics, 279 Skidmore Rd., Deer Park, N.Y. 11729. (516) 586-5125. \$780; 4 to 6 wk.

The PTSA ac power transient suppressors can absorb high-energy transients of up to 120 joules. Damage from transients is prevented by the rapid switching of the PTSA unit from an open circuit to a clamping state, whenever the transient voltage exceeds the clamping threshold. Clamping occurs on overvoltages of either polarity and recovery is automatic when the transient passes. Some PTSA specs include: ac line voltage, 130 V ac rms (max); line frequency, 50/60 or 400 Hz; clamping voltage, 200 V peak $\pm 5\%$ (both polarities); clamping factor, 1.4 at 1 ms CF; response time, under 1 μ s (clamping), under 2 μ s (overload); and operating temperature range -40 to +175 C.

CIRCLE NO. 282

New low cost power converters



for portable instrumentation

Powercube® has now added high-reliability, low-cost DC to DC Converters to our menu of off-the-shelf Cirkitblock® modules.

Like all Powercube products, our new DC-DC Converters offer great flexibility in custom power module configurations with total output power up to 15 watts. You can specify up to four isolated, regulated, short circuit and overvoltage protected outputs and a DC-AC inverter input, all in one encapsulated 2" x 2" x 1" package weighing six ounces at most!

These Cirkitblock modules are ideal for powering railroad signaling equipment, automotive testing systems, computer-controlled heavy equipment, aircraft on-board electronic systems, oil and land surveying equipment, and other portable instrumentation. Ruggedly constructed, the modules assure unmatched reliability in hostile environments from -20 to +85°C.

Powercube can dish up a wide range of Cirkitblock pre-regulators, power generators, and output modules which offer the highest ratio of power/control density to unit cost of any micro-miniature power device. Outputs to meet your requirements available for all standard battery input voltages, all for less than it would cost you to make them yourselves. Request your free power module application handbook today.

Prices range from \$75-\$150 in small quantities.

Typical Powercube DC to DC Converter

± 15 V at ¼ amp*
+5 V at 1 amp
200 V at 10-15 mA
11-14 V input*
*Other input/output voltages available



POWERCUBE CORPORATION
214 CALVARY STREET, WALTHAM, MASS. 02154 (617) 891-1830
SUBSIDIARY OF UNITRODE CORPORATION

INFORMATION RETRIEVAL NUMBER 68

WIN A FREE CARIBBEAN WINDJAMMER CRUISE

PLUS ROUND-TRIP TRANSPORTATION FOR TWO

(OFFER LIMITED TO *Electronic Design's GOLD BOOK*
USERS IN U.S. AND EUROPE ONLY)

WE WANT TO LEARN HOW YOU USE **Electronic Design's GOLD BOOK**

Have you noticed this Diary and Quick Reference (see right)? It's on page 935, Volume 1, of *Electronic Design's GOLD BOOK*.

It's there to make the industry's most useful directory even more useful.

You can jot down frequently called numbers and suppliers' names, or keep a log of the progress of your contacts, negotiations, or purchases.

When you're contacting many suppliers it's often difficult to keep track of whom you've worked with, what you said, what they said. You can jot it down on this Diary or make copies of the Diary and keep one in each project file.

If you'll share your diary with us, we'll return the favor with a \$5.00 certificate toward book purchases plus a chance for a week's Windjammer Cruise in the blue Caribbean.



**PRIZE DRAWING
DEADLINE**

OCT. 15, 1974

SEND US A COPY OF YOUR DIARY & QUICK REFERENCE FORM (OR YOUR OWN LOG OF *Electronic Design's GOLD BOOK* USE) . . . IF YOU HAVEN'T BEEN KEEPING ONE, YOU CAN START NOW. USE THE FORM AT RIGHT

\$5⁰⁰

A \$5.00 CREDIT CERTIFICATE TOWARD PURCHASE OF HAYDEN TECHNICAL BOOKS FOR EVERY USER'S DIARY WE RECEIVE

To find out how you use *Electronic Design's GOLD BOOK*, we're offering a special incentive. If you'll send us a copy of your Diary (or a copy of your own record of dates, companies contacted, and action taken) we'll send you the \$5.00 book certificate described above. Then to make it even more worthwhile, we'll put all the replies in a hat and give a FREE WINDJAMMER CRUISE for two, plus air trans-

portation for two to the lucky winner. Be sure to indicate your complete name, title, company, and address.

SEND THE COPY OF YOUR DIARY OR PERSONAL LOG TO:

Marion Kerstner
Electronic Design's GOLD BOOK
50 Essex Street, Rochelle Park, N.J. 07662

DRAWING RULES

To be eligible, a copy of your Diary & Quick Reference sheet(s) or your own personal record of use of *Electronic Design's GOLD BOOK* must be mailed and post-marked on or before midnight Oct. 15. Diaries must cover at least a two-week span. No awards to any individual sending more than one entry (entry may be more than one page). No cash prizes or other substitutes will be made in lieu of any prize. Void where prohibited by law. Liability for any taxes on prizes is sole responsibility of winner. Employees (and their families) of Hayden Publishing Company, Inc. and its subsidiaries ineligible. Air transportation provided by regularly scheduled airlines to and from cruise point of departure. Cruise dates subject to advance booking requirements.

The PRD vector voltmeter measures nearly everything...



It goes all the way up to 2.4 GHz. It measures

- network parameters
- harmonic generators
- components
- radars
- crystals
- antennas
- parasitic effects
- amplifiers
- gain attenuation
- circuits
- group delay
- receivers
- phase shift
- crystals
- frequency response
- filters
- voltage/power ratio
- transistors
- voltage/power level
- mixers
- reflection
- isolators
- return loss
- attenuators
- complex impedance
- delay lines
- AM index
- cables
- s, h, y, z parameters
- and much, much more.

...on everything



Send for application notes on the 2020 Vector Voltmeter, and on the programmable P2020. Better yet, arrange for a demonstration. Call (516) 334-7810.

PRD Electronics, Inc.

A subsidiary of Harris Corporation
1200 Prospect Ave. / Westbury, L.I., N.Y. 11590



INFORMATION RETRIEVAL NUMBER 69

DATA PROCESSING

Microprocessor replaces 8-bit mini at low price

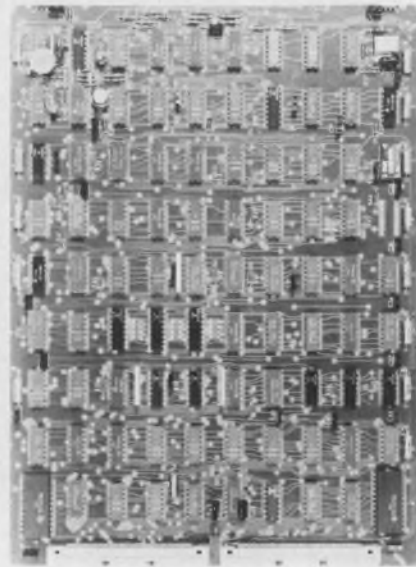

Microdata Corp., 17481 Red Hill Ave., Irvine, Calif. 92705. (714) 540-6730. Under \$1000.

A board-mounted, 8-bit microprocessor unit, the Micro-One, sells for less than \$1000 and replaces the manufacturer's 800/1600 Series mini. A unit with 1024 words of ROM and 1024 bytes of MOS memory occupies one 8.5-by-11 in. board. Operating characteristics include: bipolar CPU and circuitry, 1.2 μ s memory cycle and 8-bit arithmetic unit. The ROM provides the control logic for the CPU and microcommands are executed at a 200 ns rate. Additional features include 15 general-purpose registers and a real-time clock.

CIRCLE NO. 283

Budget calculator weighs 7.4 oz

Canon U.S.A., 10 Nevada Dr., Lake Success, N.Y. 11040. (516) 488-6701. \$44.95.

The Model LE-83 calculator weighs only 7.4 oz and has an eight-digit capacity. Features include a constant switch, floating decimal point, system, zero suppression, underflow and minus indication. The LE-83 adds, subtracts, multiplies, divides, performs mixed calculations, calculations with a constant and n-th power calculations.

CIRCLE NO. 284

Auto-answer modems on card are 103-compatible

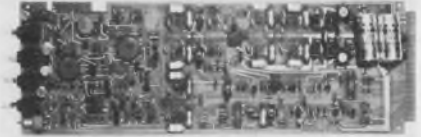

Tele-dynamics, 525 Virginia Dr., Fort Washington, Pa. 19034. (215) 643-3900. \$200.

Full duplex communications at 300 bit/s are available with type 7113B-LC-4 modem card. And you also get automatic answer-only operation. These units are intended for users with many lines such as time-sharing houses. Up to 16 modems can be housed in one 22 x 22 x 7-in enclosure. Test facilities include individual or group loop-back and a busy control that can be set by a switch or on command from a processor. The modems are end-to-end compatible with Bell 103A2, 103E, 103G and 103F Data Sets.

CIRCLE NO. 285

Low-speed PC modem is a second-source

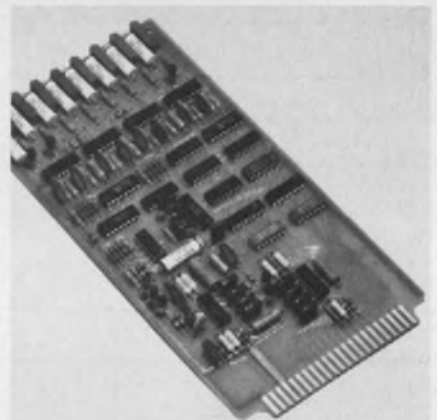

Advanced Terminal Systems, P.O. Box 90121, Los Angeles, Calif. 90009. (213) 644-5321. \$95 to \$105 (quan.).

Model M-2103F is a modem that gives full-duplex communications over two-wire voice grade lines. The unit is interchangeable with the Bell System 103F unit—also a 300-baud modem. In addition the unit is compatible with Intertel type 1038-9 modems. A TTY current loop interface is provided for receive and transmit lines. Design features include active filters, FET band-switching and crystal-controlled frequencies.

CIRCLE NO. 286

Pocket-sized calculator has dual role

Litton Monroe, 550 Central Ave., Orange, N.J. 07051. (201) 673-6600. \$139.95.

The Model 40 calculator has a 20-digit capacity and provides calculator as well as adding machine functions in a single unit. These functions operate independently, but alternately share the same 10-digit display. For example, a person can add a portion of a column of figures, perform separate calculations, then continue with the addition. Other features include positive and negative accumulation of results, constant multiplicand and divisor, and repeat addition and subtraction. The calculator also has a percentage key with add-on and discount capability. The unit is supplied with four disposable batteries and a converter/charger for ac operation. Rechargeable nickel-cadmium batteries are optional.

CIRCLE NO. 287

Calculator family aims at broad user base



Corvus, 13030 Branch View La., Dallas, Tex. 75234. (214) 620-2454. See text.

A family of three calculators provides something for consumer, engineer or businessman. Model 400 at \$39.95 provides eight-digits with floating point and features a percentage key and counts the number of entries. These are shown when the (N) key is depressed. The slide-rule calculator Model 411 uses scientific notation, does square root, reciprocals and memory-display exchanges. A 10-digit LED display shows a six-digit mantissa and two-digit exponent. The cost is \$89.95. The business calculator Model 415 (\$79.95) allows simultaneous operation on two calculation sequences via memory. An exchange key automatically reverses the role of multiplier and multiplicand or dividend and divisor.

CIRCLE NO. 288

Flexible-disc system includes controller

Tri-Data, 800 Maude Ave., Mountain View, Calif. 94040. (415) 969-3700. \$5200.

Called FlexiFile 52, this on-line memory includes two disc drives, a built-in controller with formatting electronics and a power supply. Storage capacity is 524-k bytes in a 16-sector, 64-track format with a data transfer rate of

31 kbytes/s. The unit accommodates an additional two-disc slave system which increases the total capacity to 1 Mbyte. Access time is 10 ms track-to-track. All assemblies and electronics, including the disc drives, operate in an extended position to simplify maintenance. Tri-Data plans to offer interfaces and cabling for most popular minicomputers. Immediately available is an interface for DEC PDP-11 minicomputers.

CIRCLE NO. 289

INTRODUCING THE UGLIES.™

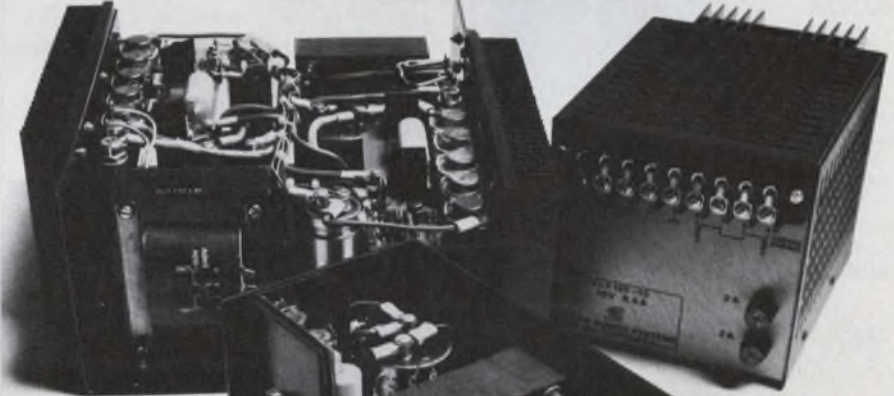

Okay, so they're not pretty. But that's only because we spent our time designing our OEM dc supplies, instead of styling them. And now we've got a complete family of dc power supplies that solve 90% of your computer, peripheral and instrumentation applications just as they come off the shelf:

With a choice of 16 voltages from 4-28V, adjustable $\pm 5\%$. Currents to 50 A, rated to $+55^\circ\text{C}$, $\pm 0.1\%$ regulation, ripple-and-noise. Remote sensing/programming, spike suppression and foldback current limiting. And 120/240 V, 50/60 Hz inputs.

All standard features for as little as 60¢/W (unit qty). Now what could be prettier than that?

For more info, use the bingo card or call 714/979-4440. Or call your local Cramer or Newark distributor and get UGLY today.

Elaxon Power Systems

Get UGLY wherever you are: New England: Coalley, Boyd & Abbott 617/444-5470 □ Upstate N.Y.: Kehoe Component Sales 315/524-2481 □ N.Y.: Metro, New Jersey: Ed Glass Assoc. 201/592-0200 □ Penn., Del., So. N.J.: T.O.E. Sales 215/348-2212 □ Va., S.C., Md., N.C.: Component Sales, Inc. 301/484-3647 □ Kentucky: Ohio, Ind.: Frank J. Campisano Co. 513/662-1616 □ Michigan: Villani-Pitcher, Inc. 313/271-4600 □ No. Carolina: Component Sales, Inc. 919/782-8433 □ Ga., Ala.: BJR Manufacturing Repts 205/881-3569 □ Florida: Orbe, Inc. 813/894-0687 □ Ill., Wisc., Iowa: Balhorn & Welch 312/889-5011 □ Minn., N. & S. Dakota: Lew Cahill & Assoc. 612/646-7217 □ Mo.: Kansas: K & M Sales Co. 816/471-2355 □ Colo., Utah: J. S. Heaton Co., Inc. 303/758-5130 □ Texas: La.: Carter Assoc., Inc. 214/276-7151 □ Okla., Ark.: Hugh J. Daly Co. 918/627-4159 □ Arizona: J. S. Heaton Co. 602/264-7887 □ New Mexico: J. S. Heaton Co. 505/293-3900 □ Wash., Ore.: Blum & Associates 206/782-1600 □ N. Calif.: J. S. Heaton Co. 415/369-4671 □ S. Calif.: RLS Associates 714/644-7497



© Copyright 1974 Elpac, Inc.

INFORMATION RETRIEVAL NUMBER 70

"off the shelf"

a rugged, well constructed, high quality switch from Capitol it has the same solid reputation as our custom ordered switches

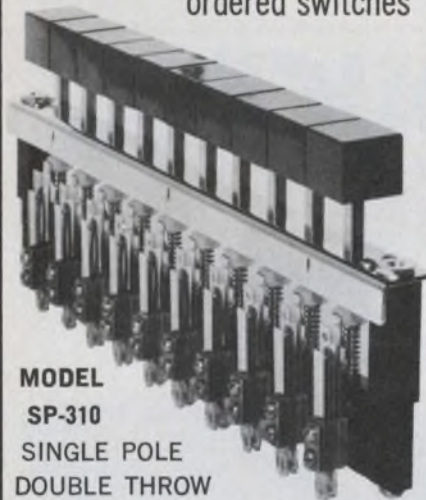

MODEL SP-310
SINGLE POLE
DOUBLE THROW
CONTACT
SQUARE BUTTON,
NON-ILLUMINATED

Contacts: Palladium
rated at 3 amp, 110VAC, non-inductive

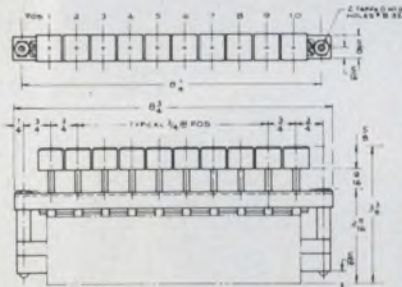

NOTES: 1. CONTACTS: 1 FORM C EACH FOR SNO 1
2. MECHANICAL ACTION: INTERLOCKING WITH POSITIVE LOCKOUT BETWEEN POS.
3. BUTTONS: 25.30 SQ.

We manufacture top quality push button and lever circuit selector switches single switches or banked assemblies. Write for our catalog.

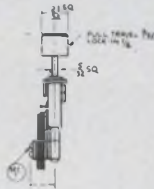

Representatives in principal cities.

CAPITOL SWITCHES

THE CAPITOL MACHINE & SWITCH CO.
87 NEWTOWN RD. DANBURY, CONN. 06810
(203) 744-3300

INFORMATION RETRIEVAL NUMBER 72

DATA PROCESSING

Printing calculator does cross-foot totals



Toshiba America, 280 Park Ave., New York, N.Y. 10017. (212) 682-8416.

An adding machine with multiplication and division, 10-column unit, Model BC-1003P, is designed for general figure work. Model BC-1003P has a basic adding machine keyboard and offers the added capability of "cross-footing," by means of total and grand-total keys. Individual totals can be produced for each of a number of columns. These totals are automatically transferred to the grand-total register, and the grand total is printed out by depressing the key. And you get the printed tape as with any office machine.

CIRCLE NO. 290

Peripheral accelerates mini's calculations

CSP Inc., 209 Middlesex Turnpike, Burlington, Mass. 01803. (617) 272-6020. From \$5000.

The use of array processors to boost a minicomputer's computation rate is advanced to a fine art by the MAP peripheral. This programmable Macro Arithmetic Processor has up to four fast arithmetic units, uses 32-bit floating point arithmetic and can, if so programmed, do a 1024-point FFT in 3.5 ms. The MAP can operate its own I/O devices through use of semi-independent processors called Scrolls. In such cases the MAP need only give one command to the Scroll and continue its computational tasks while output occurs concurrently. Data transfer rates to 32 Mbyte/s can be handled.

CIRCLE NO. 291

DO COLLEGES HELP BUSINESS AS MUCH AS BUSINESS HELPS COLLEGES?

Yes, they do. But not in the same proportion.

Business contributes about 15% of the total voluntary support received by colleges.

But today, business gets half the college-trained people who are employed. Tomorrow, it will need even more.

As a result, businessmen should think seriously about increasing the level of corporate giving to education. Can you, as a businessman, think of a better investment?

For the latest national figures on corporate giving to higher education, write on your letterhead for "CFAE Survey of Corporation Support of Higher Education," and enclose \$2.00 to help cover costs. Mail to: Council for Financial Aid to Education, 6 East 45th Street, New York, N.Y. 10017.

Give to the college of your choice. Now.



Advertising contributed for the public good.

Fixed-head disc unit stores 19.2 M bits

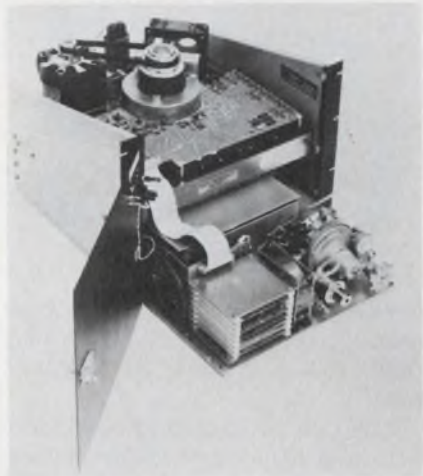

Pacific Micronetics, 5037 Ruffner St., San Diego, Calif. 92111. (714) 279-7500. Under \$10,000.

A 19.2 Mbit fixed head disc system offers an average access time of 8.3 ms with a data transfer rate of 9 MHz. The unit can be field-expanded in 16-track increments to a maximum of 128 tracks. System upgrade can therefore be provided with minimum impact on system design. The nonrecoverable error rate is said to be no more than one error in 10^{12} bits transferred. Available options include write lock-out, dc voltage margin sensing, a burst rate buffer and NRZ data format. The system mounts in a $14.75 \times 17 \times 19$ -in. rack space and is available for either 50 or 60 Hz operation at 120 V.

CIRCLE NO. 292

Machine controller uses programs, not relays

Barber Colman Co., 1300 Rock St., Rockford, Ill. 61101. (815) 877-0241.

A solid state machine controller, called the Machine Commander, duplicates relay logic functions under program control. The input section senses limit switch condition, the logic section evaluates the pattern and the output section energizes or de-energizes the appropriate machine functions. The programmer section can store up to 2048 program words in increments of 256. Execution times range from 7 to 20 ms. The overall equipment is designed to replace relay logic in injection molding machines for plastics.

CIRCLE NO. 293

Portable keypunch goes to data source



Varifab, 1700 E. Putnam Ave., Old Greenwich, Conn. 06870. (203) 637-

1434. \$1525.

Punchcards needn't wait for the keypunch room. Model 411, a portable electric punch, will let you do them at your desk. The unit provides a complete alphanumeric keyboard plus keys to space, backspace and manipulate the card. Fourteen special keys are available to program various formats. If desired, Model 412 (\$1645) will print numeric information as the cards are punched.

CIRCLE NO. 294

PLUG UGLY.™

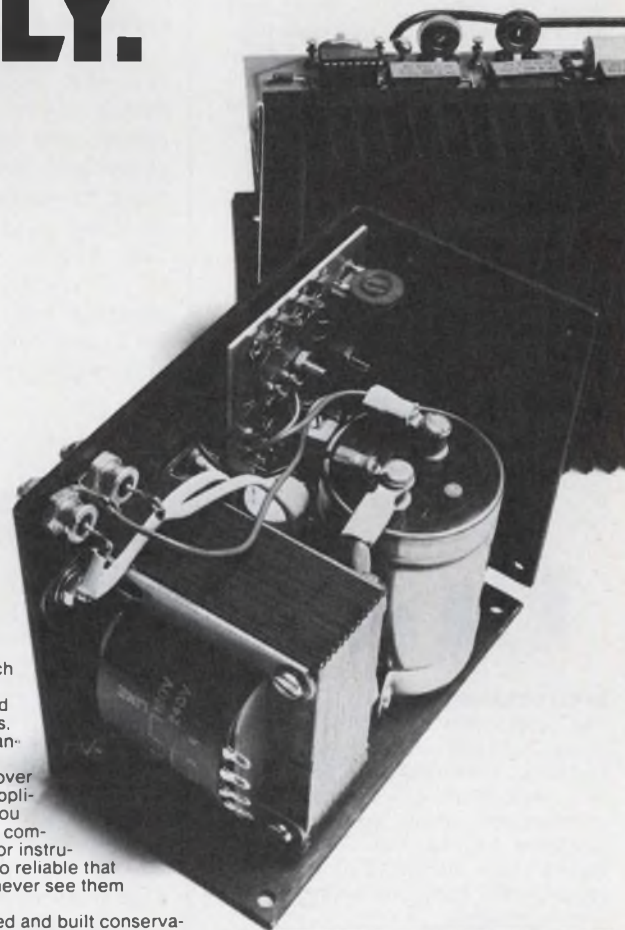

\$49 (unit qty)
5V, 6A

They're not much to look at.

Because instead of fancy front panels, we designed our standard open-frame dc power supplies to cover 90% of your OEM applications. And once you plug them into your computers, peripherals or instrumentation, they're so reliable that chances are you'll never see them again.

They're designed and built conservatively, so you get full rated power all the way up to +55°C. Regulation, ripple and noise are specified by the book. And with no expensive options, you can now get your dc power for as little as 60¢/W (unit qty).

If you've looked at the competition, we know that has to be a sight for sore eyes.

For more info, use the bingo card or call 714/979-4440. Or call your local Cramer or Newark distributor and get UGLY today.

OPEN-FRAME OLV SERIES 4-28 Vdc, 15-250 W

STANDARD FEATURES: Choice of 18 voltages, adjustable ±5%. Currents to 50A, no derating to +55°C ±0.1% (C regulation, ±0.1% ripple and noise. Remote sensing/programming. Spike suppression. Foldback current limiting 120/240 Vac. 50/60 Hz ripple.

OPTIONS: OVP crowbar. PRICES: \$28.00 to \$219 (unit qty)

Elexon Power Systems

Get UGLY wherever you are: New England: Coakley, Boyd & Abbott 617/444-5470 □ Upstate N.Y.: Kehoe Component Sales 315/524-2491 □ N.Y.-Metro, New Jersey: Ed Glass Assoc. 201/592-0200 □ Penn., Del., So. N.J.: T.O.E. Sales 215/348-2212 □ Va., S.C., Md., N.C.: Component Sales, Inc. 301/484-3647 □ Kentucky, Ohio, Ind.: Frank J. Campisano Co. 513/662-1818 □ Michigan: Villani-Pitcher, Inc. 313/271-4600 □ No. Carolina: Component Sales, Inc. 919/782-8493 □ Ga.: Aita BJR Manufacturing Reps 205/881-3569 □ Florida: Orbe, Inc. 813/894-0687 □ Ill., Wisc., Iowa: Bailhorn & Welch 312/889-5011 □ Minn., N. & S. Dakota: Lew Cahill & Assoc. 612/646-7217 □ Mo., Kansas: K & M Sales Co. 816/471-2355 □ Colo., Utah: J. S. Heaton Co., Inc. 303/758-5130 □ Texas: La. Carter Assoc., Inc. 214/276-7151 □ Okla.: Ark. Hugh J. Daly Co. 918/627-4159 206/782-1600 □ N. Calif.: J. S. Heaton Co. 415/369-4671 □ S. Calif.: RLS Associates 714/644-7497



ELPAC © Copyright 1974 Elpac, Inc.

Opto Products

- High Performance
- Immediate Availability

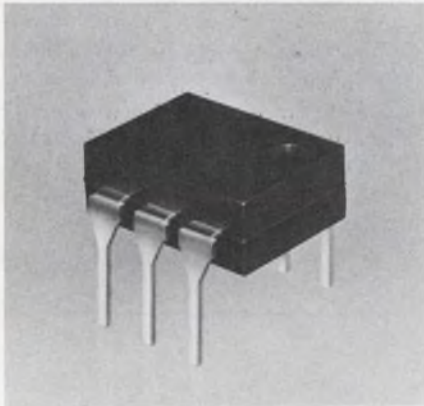

OPTICALLY COUPLED ISOLATORS

New isolators from Spectronics feature 6-pin, dual in-line packaging, high voltage electrical isolation (1.5 kV rating), high direct current transfer ratio and high-speed switching. SPX 2001 is a photo-transistor version; SPX 2002 is a photodarlington version. Both devices are completely interchangeable with standard industrial 6-pin isolators.



LIGHT EMITTING DIODES

Spectronics LEDs utilize the high efficiency of solution-grown epitaxial gallium arsenide, and range in power from 200 microwatts to 300 milliwatts. LED configurations such as SE1450, SE2450, and SE5455 are packaged with glass lenses, metal cans, and hermetic seals (where required).



PHOTOTRANSISTORS

The most complete choice of photodiodes, photodarlington, and phototransistors is available from Spectronics in a wide range of configurations as standard components. Spectronics photosensors (i.e. SD1440, SD2440, and SD5443) are manufactured with glass lenses, metal cans, and hermetic seals (where required).

Plus, Spectronics offers **SENSOR** and **EMITTER ASSEMBLIES** in both standard and custom configurations.

YOUR INTEREST AREA IS:

- RS 161 All Components and Assemblies
- RS 162 IR Emitters and Sensors
- RS 163 Visible Emitters Only



Spectronics
INCORPORATED
830 East Arapaho Road
Richardson, Texas 75080
(214) 234-4271

INFORMATION RETRIEVAL NUMBER 164

INSTRUMENTATION

Two automatic DMMs added to line



John Fluke Mfg. Co., P.O. Box 7428, Seattle, Wash. 98133. (206) 774-2211. 8600A, \$599; 8800A, \$1099; stock.

Models 8600A and 8800A are two new automatic DMMs. The 8600A offers 4-1/2 digits (20,000 counts), 26 ranges of dc V, ac V, ohms and dc/dc current, and a basic dc accuracy of 0.02%. Auto-zero and auto-range are standard. The 8800A is a 200,000-count (5-1/2 digits) unit, with 0.005% accuracy and 15 ranges of dc V, ac V and ohms. Auto-polarity and auto-range are also standard.

CIRCLE NO. 295

Unit measures distortion down to 0.001%

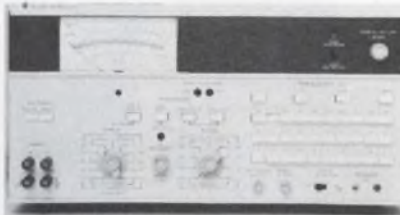

Sound Technology, 1601 S. Saratoga-Sunnyvale Rd., Cupertino, Calif. 95014. (408) 257-9171. \$1485; 90 days.

Model 1700A distortion analyzer measures distortions down to 0.001% with automatic nulling—no balancing controls are needed. The 0.001% figure is said to be about 25 dB better than existing equipment. The system includes the test oscillator which has an ultra-low distortion of only 0.001% and is tuned simultaneously with the analyzer. The unit operates from 10 Hz to 110 kHz.

CIRCLE NO. 296

Two counter-timers offer variable trigger



Berkeley Instruments, 1701 Reynolds, Santa Ana, Calif. 92705. (800) 854-3253. 6305: \$495; 6315: \$695.

Two counter-timers—Models 6315 and 6305—provide frequency measurements up to 150 MHz (50 MHz with Model 6305). Adjustable trigger level and trigger lamps allow convenient operation. Time measurements with up to 100-ns resolution are standard. With the Model 6315, resolution can be optionally increased to 10 ns. A TXCO provides accuracy and stability. Both models use the Beckman (formerly Sperry) display.

CIRCLE NO. 297

Meter measures laser output power to 30 mW



Liconix, 1400 Stierlin Rd., Mountain View, Calif. 94043. (415) 964-3062. \$595.

Model 35PM optical power meter measures laser power output from UV to near infrared. Each instrument is adjusted to provide direct readings at 325.0, 441.6, 530.5 and 632.8 nm. With an accuracy of 5%, the battery-operated Model 35PM can be used at other wavelengths with the supplied correction graph. Measurement range is from 10 μ W to 30 mW full scale. Zero suppression control on all ranges facilitates the measurement of small variations in the presence of high signal laser output. An output jack for remote indication or strip-chart recording is provided.

CIRCLE NO. 298

DISCRETE SEMICONDUCTORS

Varactor tuning diodes have Qs up to 2600



Varian, Beverly Div., Salem Rd., Beverly, Mass. 01915. (617) 922-6000. \$27 (100-up); 30 day.

The VAT series of tuning diodes is designed to minimize long term tuning drift in voltage controlled oscillators. The processing of the VAT-1000 series minimizes capacitance shifts and the PLESA passivation technique allows planar processing to be applied to surfaces containing silicon mesas. The VAT-1001 devices have a total capacitance of 2 to 3 pF, a minimum Q of 2600, a tuning ratio of 3.5:1 and a leakage current of 5 nA at 25 C. Similarly the VAT-1002, 1003 and 1004 have capacitances of 5 to 8, 2 to 3 and 5 to 8 pF, Qs of 2000, 2000 and 1500, tuning ratios of 4.75, 4 or 5.5:1 and leakage currents of 5, 3 and 5 nA, respectively.

CIRCLE NO. 299

Power transistors are glass passivated

International Rectifier, 233 Kansas St., El Segundo, Calif. 90245. (213) 678-6281. From \$2.83 to \$9.50 (1000-up); 8 to 10 wk.

The glass passivated transistor line includes devices rated from 400 to 700 V at collector currents up to 7.5 A. The IR401 transistor, for example, is rated for 400 V and a minimum gain of 20 at 0.5 A. The IR402 is rated for 700 V, also with a minimum gain of 20 at 0.5 A. The Darlington transistor line has devices rated up to 600 V and 20 A. The IR5000 Darlington, for example, is rated for 400 V with a gain of 140 at 5 A. The IR4060 is rated for 600 V with a gain of 250 at 3 A.

CIRCLE NO. 300

Alphanumeric display uses 16-segments

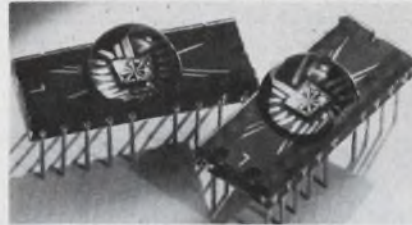

Litronix, 19000 Homestead Rd., Cupertino, Calif. 95014. (408) 257-7910. \$5.65 (1000-up); stock.

The Data-Lit 16 is a 16-segment display packaged in a 20-pin DIP. It creates 0.15 in. high numbers, letters and many special symbols in response to a standard ASCII code. The display draws only 1.5 mA per segment and has a total power dissipation of 510 mW. Luminance per segment at 10 mA is typically 0.82 mcd and guaranteed to be at least 0.44 mcd. Forward voltage per segment at 10 mA is typically 1.58 V and 2 V maximum.

CIRCLE NO. 301

MEAN AND UGLY.™



**\$79 (1-9)
3 outputs**

Our OEM dc supplies have always been stark, but now they're twice as ugly (also 3x).

Because instead of working up a new color scheme, we've combined two and three of them on a single chassis to make them an even better buy for your computers, peripherals and instruments.

We've taken out redundancies, but they still offer the widest range of voltages you can get in a modular dc supply. Still deliver all the power we promise across the full temperature range (even with 50 Hz inputs). And still include all the features you need as standards, not expensive options.

So that now if you check us out against the competition, they're liable to tell you that we're not just ugly.

We're downright mean.

For more info, use the bingo card or call 714/979-4440. Or call your local Cramer or Newark distributor and get UGLY today.

MULTIPLE OUTPUT DLV/TLV SERIES 1st output 5 V at 3-15 A. OVP standard. 2nd and/or 3rd outputs each 4-28 V @ 15 W. OVP optional. All outputs isolated, may be used as positive or negative supplies.

STANDARD FEATURES: Choice of 16 voltages, adjustable ±5%. Currents to 15 A, no derating to +55°C ±0.1% regulation ±0.1% ripple and noise. Remote sensing/programming. Spike suppression. Foldback current limiting 120/240 Vac. 50/60 Hz inputs.

OPTIONS: Enclosure. **PRICES:** \$29 to \$151 (1-9)

Elexon Power Systems

Get UGLY wherever you are: New England: Coakley, Boyd & Abbott 617/444-5470 □ Upstate N.Y.: Kehoe Component Sales 315/524-2491 □ N.Y.-Metro: New Jersey: Ed Glass Assoc. 201/592-0200 □ Penn.: Del.: So. N.J.: T.O.E. Sales 215/348-2212 □ Va.: S.C.: Md.: N.C.: Component Sales, Inc. 301/484-3647 □ Kentucky, Ohio, Ind.: Frank J. Campisano Co. 513/662-1616 □ Michigan: Villani-Pitcher, Inc. 313/271-4600 □ No. Carolina: Component Sales, Inc. 919/782-8433 □ Ga.: Ala.: BJR Manufacturing Reps 205/881-3569 □ Florida: Orbe, Inc. 813/894-0687 □ Ill.: Wisc.: Iowa: Balhorn & Welch 312/889-5011 □ Minn.: N. & S. Dakota: Lew Cahill & Assoc. 612/646-7217 □ Mo.: Kansas: K & M Sales Co. 816/471-2355 □ Colo.: Utah: J. S. Heaton Co., Inc. 303/758-5130 □ Texas: La.: Carter Assoc., Inc. 214/276-7151 □ Okla.: Ark.: Hugh J. Daly Co. 918/627-4159 □ Arizona: J. S. Heaton Co. 602/264-7887 □ New Mexico: J. S. Heaton Co. 505/293-3900 □ Wash.: Ore.: Blum & Associates 206/782-1600 □ N. Calif.: J. S. Heaton Co. 415/369-4671 □ S. Calif.: RLS Associates 714/644-7497

ELPAC © Copyright 1974 Elpac, Inc.

1%

AMERICAN

MADE

Tolerance **SCHAUER** 1-Watt **ZENERS**

Immediate Shipment Low Prices

ANY voltage from 2.0 to 16.0

Quantity	Price each
1-99	\$1.07
100-499	.97
500-999	.91
1000-4999	.86
5000 up	.82



All welded and
brazed assembly

No fragile
nail heads

Gold
plated
leads

Write for complete
rating data and other
tolerance prices.

Buy the kit- Save a lot



Kit contains a 51-piece assortment of SCHAUER 1% tolerance 1-watt zeners covering the voltage range of 2.7 to 16.0. Three diodes of each voltage packaged in reusable poly bags. Stored in a handy file box. Contact your distributor or order direct.

A \$54.57 value for
ONLY **\$24⁵⁰**

Semiconductor Division

SCHAUER

Manufacturing Corp.

4511 Alpine Ave. Cincinnati, Ohio 45242
Telephone: 513/791-3030

new literature



Data-acquisition module

A subminiature, high-accuracy high-speed data-acquisition system is described in a 16-page brochure. The brochure covers the theory of operation and provides application information for mini-computer, telemetry, spectrum analysis, communication systems and other uses. Data on design features, specifications, timing diagrams and setup and calibration procedures are included. Analogic, Wakefield, Mass.

CIRCLE NO. 302

ECG semi supplement

A supplement to the company's ECG semiconductor replacement guide adds 11,000 type numbers to the total number of units replaced by the ECG line. Transistors, ICs, diodes and rectifiers, special-purpose devices and transistor and IC accessories are included. GTE Sylvaia, Stamford, Conn.

CIRCLE NO. 303

Circuit breakers

Electrical parameters, mechanical characteristics and performance curves of 190 thermal and magnetic-hydraulic circuit breakers are contained in a 36-page catalog. A discussion on "How to Specify Circuit Breakers Properly" offers practical information on breaker selections. Potter & Brumfield, Princeton, Ind.

CIRCLE NO. 304

Temperature controllers

A two-page catalog features solid-state output relays to switch 2, 10, 25 and 40 A at 240 V ac with their Half-Size 100 and 100 series temperature controllers. Thermo Electric, Saddle Brook, N.J.

CIRCLE NO. 305

SCR power controllers

A two-color eight-page condensed bulletin covers SCR power controllers. General design features, connection diagrams and output waveforms are also included. Vectrol, Rockville, Md.

CIRCLE NO. 306

Opto-isolators

Axial opto-isolators are presented in a six-page brochure. Included are dimensional drawings and 41 graphs covering all parameters of the 36 single-element and 20 dual-element units. Vactec, Maryland Heights, Mo.

CIRCLE NO. 307

Photosensitive devices

Specifications on hundreds of photomultipliers, phototubes, photoconductive cells, light sources, memory tubes and video equipment are contained in a catalog. Hamamatsu, Middlesex, N.J.

CIRCLE NO. 308

Silicon-nitrided devices

Beam-leaded silicon-nitrided devices and improved solid-state diffusion beam-lead bonding machinery are described in a 12-page booklet. Radio Materials, Microcircuits Div., Indianapolis, Ind.

CIRCLE NO. 309

Thyristors/rectifiers

Over 500 thyristors and rectifiers are described in a 36-page catalog. Data are given for JEDEC (1N and 2N) types, commercial types and developmental types. Photographs and dimensional outlines are shown. RCA Solid State Div., Somerville, N.J.

CIRCLE NO. 310

SEMICONDUCTOR AND DIGITAL TECHNOLOGY SENIOR CORPORATE STAFF

Our rapid growth as a major force in digital LSI technology and application has generated a need for a senior staff engineer who can assume the broad responsibility of providing direction and guidance to our advanced development planning. You will work with various NCR Product Divisions concerned with microprocessor and MOS/LSI development to insure the maintenance of the leadership role we have gained.

To qualify, you should be well past the design stage of your career, with substantial depth of experience in digital design and MOS process technology. You will have a demonstrated ability to work with independent technical management and higher corporate management in a resultful manner. Successful past Project Leader experience is one possible qualifier.

This is an unusual opportunity to move forward in your career if you qualify. We will assist in relocation to our worldwide headquarters, in Dayton, Ohio.



Mrs. Marjorie Lyons Jones
NCR Worldwide Headquarters,
Dept. ED - 9-1
Corporate Executive &
Professional Recruitment
Dayton, Ohio 45479

INFORMATION RETRIEVAL NUMBER 901

The Ballantine 512 MHz DIGITAL COUNTER



The 5700A Frequency Counter. Range 10 Hz to more than 512 MHz. Nine digit display. Carrier measurements to 1 Hz resolution in 2 seconds of keyed transmitter time. Selective signal tone checks to 0.1 Hz resolution. Sensitivity 10 mV rms with AGC. Stability 3/10⁷/month. 3/10⁹/day optional.

- HIGHEST SENSITIVITY
- BEST RESOLUTION
- FASTEST COUNT RATE
- LOWEST PRICE **\$895**



Meets FCC Requirements
Ballantine Laboratories, Inc.
P.O. Box 97, Boonton, New Jersey 07005
201-335-0900, TWX 710-987-8380

INFORMATION RETRIEVAL NUMBER 78

THE COMPATIBLES

Spectrum Technology is your one source for frequency control devices that are compatible with the high technology logic of the Seventies. Standard, modified or custom designs include subminiature hybrid circuit crystal oscillators, dual in-line low profile hybrid circuit logic clocks, low cost crystal oscillator IC logic clocks, and TCXO's. Write or call for details.

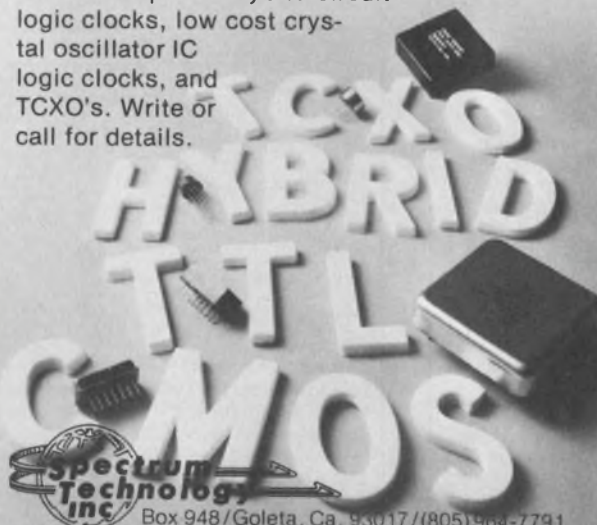

Frequency Control & Timing Systems Products
Crystal Oscillators • Logic Clocks • TCXO's.

INFORMATION RETRIEVAL NUMBER 77

ELECTRONIC DESIGN 18, September 1, 1974

BITE[®] SIZE INDICATORS



MINELCO[®] Magnetic Latching Indicators require only pulse power for operation. Resetting may be accomplished either manually or electrically.

Write for our full line catalog including MINELCO[®] Indicators, Switches and Trimmer Potentiometers.

*Built-In Test Equipment



MINELCO

Division General Time Corp.
A TALLEY INDUSTRIES COMPANY

135 SOUTH MAIN STREET • THOMASTON, CONN. 06787
PHONE: 203/283-8261 • TWX: 710/475-1091

INFORMATION RETRIEVAL NUMBER 79

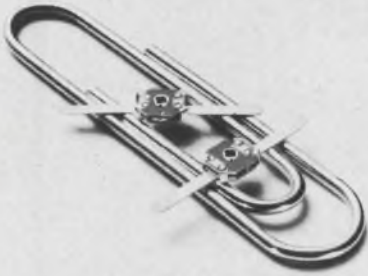

Thin-Trim variable capacitors provide a reliable means of adjusting capacitance without abrasive trimming or interchange of fixed capacitors. Series 9401 has high Q's and a range of capacitance values from 0.2-0.6 pf to 3.0-12.0 pf and 250 WVDC working voltage. Johanson Manufacturing Corporation, Boonton, New Jersey (201) 334-2676.

INFORMATION RETRIEVAL NUMBER 181



Receiver—VLF/MF. Sonic, Acoustic and rf applications. Direct digital frequency readout of 1 to 600 KHZ, 0.1/1/2.75/50 KHZ IF Bandwidth, Tuneable preselector, AM/FM/SSB and CW. Other receivers and active antennas also available. Bayshore Systems Corporation, Springfield, Virginia, (703) 321-9625.

INFORMATION RETRIEVAL NUMBER 184

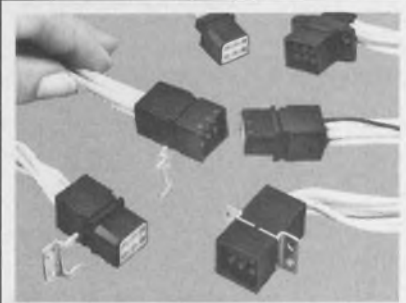

CAPITRON subminiature LGH high-voltage connectors. They're lightweight—a mated pair is less than 14 gr. And compact—requires less than .6 sq. in. of mounting surface. Operates up to 5 KVDC at 70,000 feet. And within a temperature range of -55°C to +125°C. AMP Incorporated, Capatron Division, Harrisburg, Pa. 17105. (717) 564-0100.

INFORMATION RETRIEVAL NUMBER 187

FREE 10 Ways To Use Conductive Paints



Our electrically conductive paints are solving "impossible" lab problems and reducing unit production costs. One customer saves a fortune each year PAINTING on four MILLION 1000 meg resistors. Think that over. Why not request "Ten Ways To Use Conductive Paints"? Micro Circuits Co., New Buffalo, Mich. 49117. (616) 469 2727.

INFORMATION RETRIEVAL NUMBER 182



Basic Engineering Sciences & Structural Engineering for E-I-T Exams. Sampling for test problems makes the best preparation yet for exams. #5712-1, 424 pp., \$14.95. Circle the Info Retrieval No. to order 15-day exam copy. When billed, remit or return book with no obligation. Hayden Book Co., 50 Essex St., Rochelle Pk., N.J. 07662

INFORMATION RETRIEVAL NUMBER 185



Datametrics offers a valuable handbook on the theory and application using the Model SP-465 WWVB Time Synchronizer providing an economical, simple method for disseminating time and frequency information in synchronization with NBS. Contact DATAMETRICS, INC., 340 Fordham Road, Wilmington, Massachusetts 01887. Phone (617) 658-5410.

INFORMATION RETRIEVAL NUMBER 188

Power Supply Catalog



POWER/MATE CORP

Free catalog of 34,500 power supplies from the worlds largest manufacturer of quality Power Supplies. New '74 catalog covers over 34,500 D.C. Power Supplies for every application. All units are UL approved, and meet most military and commercial specs for industrial and computer uses. Power Mate Corp. (201) 343-6294.

INFORMATION RETRIEVAL NUMBER 183

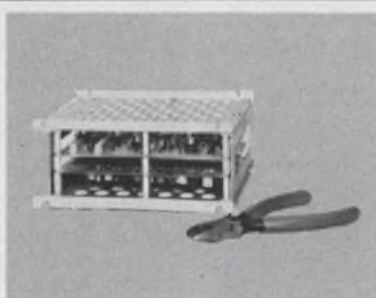

Model MOD-815 A/D Converter. Digital data with 8-bit resolution at any random or periodic word rate from DC through 15 MHz. Only 100 cu. in. Power dissipation approx. 20 watts. Computer Labs, 1109 S. Chapman St., Greensboro, N.C. 27403.

INFORMATION RETRIEVAL NUMBER 186



Introduction To Defense Radar Systems Engineering. Excellent introduction and practical reference to radar systems design and applications. #9194, 260 pp., \$20.00. Circle the Info Retrieval No. to order 15-day exam copy. When billed, remit or return book with no obligation. Hayden Book Co. 50 Essex St. Rochelle Park, N.J. 07662

INFORMATION RETRIEVAL NUMBER 189

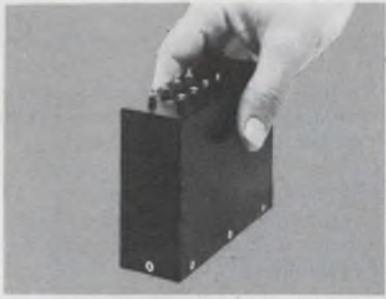

Big power supply for little spaces. 115 VAC, 50-500 Hz input. 1 to 6 isolated & regulated DC outputs. 120 W per output. 3.9 W delivered per cu. in. Modular construction lets you "Design-As-You-Order". Over 1200 configurations using off-the-shelf modules. Immediate deliveries! Arnold Magnetics Corp., Culver City, Ca. (213) 870-7014.

INFORMATION RETRIEVAL NUMBER 190



PC SERIES OFFERS CARD-MOUNTABLE, miniature, encapsulated DC power supplies in single and dual output models. Up to 24V, to 100mA in 12 different models. For linear and digital IC applications, digital displays, digital logic, and other uses. Rugged construction throughout. From \$25.00. Powertec, Inc. Chatsworth, CA. 213 882-0004.

INFORMATION RETRIEVAL NUMBER 193



The NEC VO21 is now available in the popular ML-3 100 mil-square package. The VO21M has an FT of 4.5 GHz and a maximum current of 70 mA. Noise figure at 2 GHz is 3.6 dB and less than 2 dB at 500 MHz providing an inexpensive transistor for low noise amplifiers. California Eastern Labs, Inc. One Edwards Ct., Burlingame, Ca. 415 342-7744.

INFORMATION RETRIEVAL NUMBER 191



Cut PC layout time 75% with PUPPETS™, Bishop's die-cut, transparent, reusable layout patterns in 2X or 4X scale that represent electronic components. Contain no adhesive yet adhere to any clear, non-matte drafting film. FREE Sample & technical bulletin. Bishop Graphics, Inc., 20450 Plummer Street, Chatsworth, CA 91311 (213) 993-1000.

INFORMATION RETRIEVAL NUMBER 194



Omega Navigational System Filters using stable ceramic elements are available at 10.2 kHz, 11.33 kHz, and 13.6 kHz. Consisting of 1 to 4 sections, these filters provide high selectivity, high stopband rejection and excellent phase stability. ANDEX CORP., 7076 Big Creek Pkwy., Middleburg Hgts., OH 44130 (216) 845-1953.

INFORMATION RETRIEVAL NUMBER 192



Electrical/Electronics Checklists. 22 detailed checklists to insure complete accuracy and efficiency for a broad array of designs. #9181, 190 pp., \$14.00. Circle the Info Retrieval No. to order 15-day exam copy. When billed, remit or return book with no obligation. Hayden Book Co. 50 Essex St., Rochelle Pk., N.J. 07660.

INFORMATION RETRIEVAL NUMBER 195

Advertisers wishing to reserve Quick Ad units should note the following mechanical requirements: Specs—Supply glossy photo of product and approximately 40 words which will set no more than 10 lines of 34 characters each. AFTER SUBMISSION NO COPY CHANGES CAN BE ACCEPTED. Quick Ads cost only \$300 per insertion, less for frequency advertisers.

RATES:

1x
\$300

7x
\$280

13x
\$255

19x
\$250

26x
\$245

39x
\$240

52x
\$235

104x
\$230

Design Data from Manufacturers

Advertisements of booklets, brochures, catalogs and data sheets. To order use Reader-Service Card
(Advertisement)

Electronic Design

ELECTRONIC DESIGN's function is:

- To aid progress in the electronics manufacturing industry by promoting good design.
- To give the electronic design engineer concepts and ideas that make his job easier and more productive.
- To provide a central source of timely electronics information.
- To promote communication among members of the electronics engineering community.

Want a subscription? ELECTRONIC DESIGN is sent free to qualified engineers and engineering managers doing design work, supervising design or setting standards in the United States and Western Europe. For a free subscription, use the application form bound in the magazine. If none is included, write to us direct for an application form.

If you do not qualify, you may take out a paid subscription for \$30 a year in the U.S.A., \$40 a year elsewhere. Single copies are \$1.50 each.

If you change your address, send us an old mailing label and your new address; there is generally a postcard for this bound in the magazine. You will have to requalify to continue receiving ELECTRONIC DESIGN free.

The accuracy policy of ELECTRONIC DESIGN is:

- To make diligent efforts to ensure the accuracy of editorial matter.
- To publish prompt corrections whenever inaccuracies are brought to our attention. Corrections appear in "Across the Desk."
- To encourage our readers as responsible members of our business community to report to us misleading or fraudulent advertising.
- To refuse any advertisement deemed to be misleading or fraudulent.

Microfilm copies are available of complete volumes of ELECTRONIC DESIGN at \$19 per volume, beginning with Volume 1, 1961 through Volume 20. Reprints of individual articles may be obtained for \$2.00 each, prepaid (\$3.50 for each additional copy of the same article) no matter how long the article. For further details and to place orders, contact the Customer Services Department, University Microfilms, 300 North Zeeb Road, Ann Arbor, Michigan 48106 telephone (313) 761-4700.

Want to contact us? If you have any comments or wish to submit a manuscript or article outline, address your correspondence to:

Editor
ELECTRONIC DESIGN
50 Essex Street
Rochelle Park, N.J. 07662

Dual Hi-Speed FFT Processor Easy to Operate



Conceived from the point of view of the operating engineer rather than the computer programmer, the new Omniferous™ FFT Analyzer operates like an instrument, calculates like a computer. This Series OF-400 Analyzer is a universal digital signal analysis system for real-time viewing of changing functions, a complete instrument with all signal conditioning and display calibration built-in. For the first time an operator can observe transfer function, cross-spectra or coherence as the signal is changing without waiting for the analyzer to perform successive laborious calculations.

Features include high speed of 68,000 samples/sec throughput, and high resolution with a 2048 transform size and extra-sharp input anti-aliasing filtering. Calculates FFT, IFFT, power spectra, auto-correlation, cross correlation, and signal enhancement (time averaging), as well as the averaging of any calculated function in sum, peak or exponential mode.

The system excels in high dynamic range, ease of use, display flexibility with two simultaneous display outputs, frequency coverage to 100 kHz, and reasonable cost. Designed by the originators of the famous Ubiquitous® family of real-time spectrum analyzers.

Nicolet Scientific Corp. (formerly Federal Scientific Corp.)

245 Livingston St., Northvale, New Jersey 07647
(201) 767-7100. TWX: 710-991-9619

Immediate, circle No. 170
Routine, circle No. 171

Giant Free Catalog! 4,500 Unusual Bargains



New 164-page catalog! Packed with 1,000's of hard-to-find buys in Optics, Science, Electronics. Loaded with optical, scientific, electronic equipment available from stock. Rare surplus buys. Many "one-of-a-kinds". Ingenious scientific tools. Components galore: lenses, prisms, wedges, mirrors, mounts, accessories. 100's of instruments: pollution test equipment, lasers, comparators, magnifiers, microscopes, projectors, telescopes, binoculars, photo attachments, unique lighting. Shop, save by mail! Request free Catalog "DA".

CIRCLE NO. 172

Edmund Scientific Co.

America's Largest Science-Optics-Electronics Mart
300 Edscorp Bldg., Barrington, New Jersey 08007 (609) 547-3488

Why Test Semi-Conductors For Noise?



The QUAN-TECH NOISE FILE contains technical reports on the nature and origin of electrical noise in semi-conductors.

The effects of noise in terms of impaired performance have been widely recognized, and the RELATIONSHIP BETWEEN NOISE AND COMPONENT RELIABILITY generally accepted in the electronic industry. Thus the analysis of electrical noise generated by components is not only vital to the development and production of low-noise circuits, but also is becoming of major importance in achieving maximum reliability of instrumentation.

Instruments are available for testing noise of transistors, and thin film circuits. Applications include Incoming Inspection, Laboratory Studies, and High-Speed Production Testing.

Quan-Tech

Randolph Park West, Route #10
Randolph Township, N.J. 07801, Phone #201-361-3100

CIRCLE NO. 173

recruitment and classified ads

SAME DAY SHIPMENT Minis & Peripherals PRINTERS

"BRAND NEW"

DATA PRODUCTS

2440- 700LPM

2470-1250LPM

MDS 4320-300LPM

ALSO

CENTRONICS, POTTER, CDC
A. B. DICK, IBM, HIS, UNIVAC
617/261-1100

Send for Free Report
"Maintenance of Computers"

AMERICAN USED COMPUTER CORP.

P.O. Box 68, Kenmore Sta., Boston MA 02215
member COMPUTER DEALERS ASSOCIATION

INFORMATION RETRIEVAL NUMBER 241

INDIAN ORGANIZATION HAS MFG. PROGRAMME FOR EXPORT OF ASSEMBLIES TO OEM. REQUIRES IN BULK, TRIACS, IC TIMERS, COMPONENTS FOR DPM & POWER SUPPLIES. MANUFACTURERS' OFFERS FOR REPRESENTATION IN INDIA INVITED.

INFORMATION RETRIEVAL NUMBER 242

SUBSCRIBER SERVICE For prompt service include the addressed label when writing about your subscription.

CHANGE OF ADDRESS

	NEW ADDRESS
city	name
company address	company
	division/department
state	
zip	

If you're moving, please let us know six weeks before changing your address. If you have a question, place your magazine address label here and clip this form to your letter.

MAIL TO: ELECTRONIC DESIGN Circulation Dept. Hayden Publishing Co., Inc., 50 Essex Street, Rochelle Park, NJ 07662

Electronic Design

Advertising Sales Staff

Tom W. Carr, Sales Director

Rochelle Park, N.J. 07662

Robert W. Gascoigne
Daniel J. Rowland
(Recruitment, Quick Ads, Classified)
50 Essex Street
(201) 843-0550
TWX: 710-990-5071

Philadelphia

Thomas P. Barth
50 Essex Street
Rochelle Park, N.J. 07662
(201) 843-0550

Boston 02178

Gene Pritchard
P.O. Box 379
Belmont, Mass. 02178
(617) 489-2340

Chicago 60611

Thomas P. Kavooras
Berry Conner, Jr.
200 East Ontario
(312) 337-0588

Cleveland

Thomas P. Kavooras
(Chicago)
(312) 337-0588

Los Angeles 90303

Stanley I. Ehrenclou
Burt Underwood
2930 Imperial Highway
Inglewood, Calif.
(213) 757-0183

San Francisco 94022

Jerry D. Latta
P.O. Box 1248
Los Altos, Calif.
(415) 965-2636

London, Amsterdam, Tokyo, Seoul

John Ashcraft
12, Bear St.
Leicester Square
London WC2H 7AS England
Phone: 01-930-0525

W. J. M. Sanders
John Ashcraft & Co.
Herengracht 365
Amsterdam C., Holland
Phone: 020-24-09-08

Haruki Hirayama
Electronic Media Service
5th Floor, Lila Bldg.,
4-9-8 Roppong
Minato-ku, Tokyo, Japan
Phone: 402-4556
Cable: Electronicmedia, Tokyo

Mr. O-kyn Park, President
Dongbo International
Corporation
1.P. O. Box 4010
Seoul, Korea
Phone: 28-1911
Cable: DONGBO SEOUL

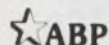

FROM
BREADBOARD
TO FINAL
PACKAGING
HARDWARE...

ALL AVAILABLE
FROM ONE SOURCE



★ ADHESIVE BACKED
CIRCUIT SUB-ELEMENTS
(Over 200 Pre-Drilled component mounting
patterns available "off-the-shelf.")

★ EPOXY GLASS BOARD MATERIALS

- 76 Standard "Off-the-Shelf" Boards.
- Including Unclad, Copper Clad, Cut & Peel Copper Clad, Pre-etched "X-Y" Pattern and Plated thru Hole Copper Clad.
- .100" Grid Hole Pattern or Undrilled.



★ GP CIRCUIT BOARDS and ACCESSORIES

- Highest Quality — Choose from 74 "Off-the-Shelf" Boards.
- Sockets — Low & Standard Profile, P.C. and Wire Wrap. • Highest Quality Gold Contacts.
- Adapter plugs • Connectors
- Card Pull Handles.



CIRCUIT-STIK'S
NEW CUT &
PEEL BOARDS

SEND FOR OUR NEW CATALOGS #502 & #801

circuIt-stik

P.O. BOX 3396 • Torrance, California 90510
Phone (213) 530-5530

INFORMATION RETRIEVAL NUMBER 86

LOOKING FOR INSTRUMENTS?

Electronic Design's
GOLD BOOK
1974-75 Master Catalog & Directory

Electronics Design's
BOOK

Directory

& Directory

Product Directory
Manufacturer Directory
Distributor Directory
Trade Name Directory

Component Materials

Equipment Hardware
Printed Components
Power Supplies
Tools & Production Equipment
Engineering Aids
Company Capabilities

Vol. 1

Vol. 2

Vol. 3

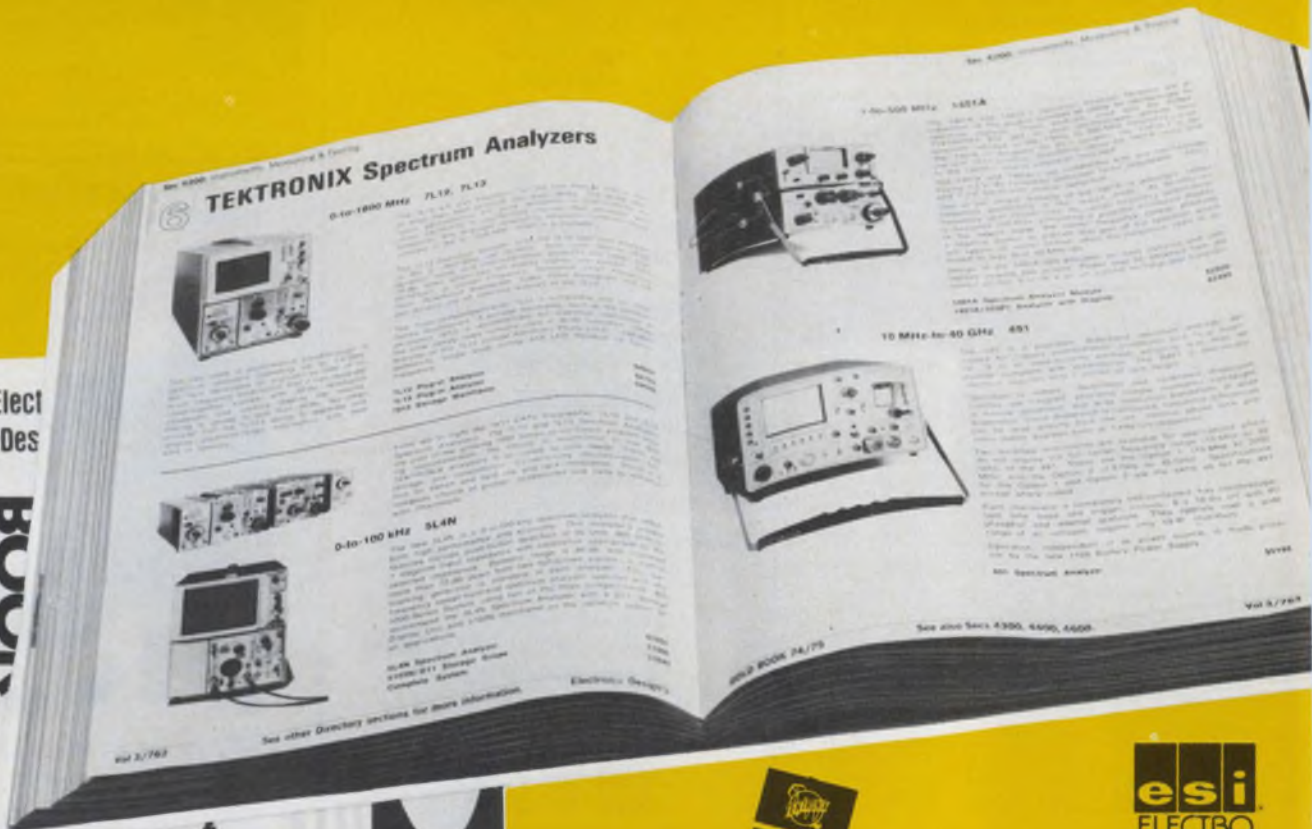

TEKTRONIX

esi
ELECTRO SCIENTIFIC

DANA

BOONTON

biomation

LOOK FIRST IN Electronic Design's GOLD BOOK

**YOU'LL FIND OVER 300 CATALOG PAGES ON
TEST, MEASURING & RECORDING INSTRUMENTS
AND SIGNAL SOURCES IN VOL. 3**

Here's a gold mine of technical catalog information for engineers requiring test, measuring and recording instruments and related equipment. The catalog pages start on page 545 of Volume 3 with "Environmental Testers and Chambers" and end over 300 pages later with "Signal Sources." In between you'll find specs and tech data on a wide range of instruments as detailed by more than 85 manufacturers. Tektronix provides 35 catalog pages divided into 8 product sections followed by price lists, terms of sale, warranty and order forms. Hewlett-Packard begins its 15 page catalog with hints on selecting oscilloscopes. Triplet, Fluke, Heath-Schlumberger, Wavetek all provide detailed ranges & specs in their multi-page sections, and so on. Check these catalog pages before you call your supplier, you may find the exact data you need.

 **TRIPLET**

elsytec

WESTON

federal scientific

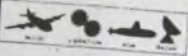

Simpson

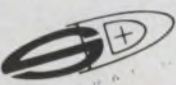
SYSTRON  **DONNER**

ELECTRONIC DESIGN'S GOLD BOOK

WILL SAVE YOU TIME

Electronic Design's GOLD BOOK is the most thorough industry directory ever produced and it's the easiest to use. Take the time to become familiar with its directories and check the useful information they contain. Take advantage of the TWX, TELEX, facsimile and toll-free numbers whenever listed. Examine the catalog pages on the products you normally specify. *Electronic Design's* GOLD BOOK can answer many of your questions about manufacturers and their products. Keep it handy to save valuable time when you contact suppliers or their distributors or reps.

IT'S ALL THERE...IN ELECTRONIC DESIGN'S GOLD BOOK

advertiser's index

Advertiser	Page	Advertiser	Page	Advertiser	Page
AMP, Incorporated	144	*Gold Book, The	22	Pico Electronics, Inc.	Cover II
Active & Passive Components, Inc.	126	Hayden Book Co., Inc.	127, 144, 145	Plessey Semiconductors	121
Acopian Corp.	103	Heath Company	48, 49, 50, 51	Power Cube Corporation	133
Allied Chemical	90	Hewlett-Packard	76, 77	Power/Mate Corp.	144
Amerace Corporation	31	Hybrid Systems Corp.	111	Powertec, Inc.	145
American Videonetics Inc.	36	Imperial Travel Service	151	Quan-Tech Division of Scientific Atlanta, Inc.	146
Amphenol RF Division, The Bunker-Ramo Corporation	29	Indiana General	95	RCA Electronic Instruments	110
Amplifier Research Corporation	154	Industrial Timer, A Unit of Esterline Corporation	153	RCA Solid State	Cover IV
Analog Devices, Inc.	116	Inselek, Inc.	108	Raytheon Semiconductor	83, 84, 85
Andex Corporation	145	Intech, Incorporated	130	Reader Service Card	154A, 154B
Angle Steel/Div. of Kewaunee Scientific Equipment Corp.	153	Intel Corporation	4, 5	Rockwell International	129
Arnold Magnetics Corp.	145	International Electronic Research Corporation	96	Schaer Manufacturing Corp.	142
Atlantic Casting and Engineering Corporation	116	International Rectifier	107	Semtech Corporation	35
Ballantine Laboratories, Inc.	143	Intersil	10, 11	Simpson Electric Company	101
Bayshore Systems	144	Jermyn Industries	14	Spectrum Technology Inc.	143
Bell Industries, Electronic Components Division	153	Johanson Manufacturing Corp.	7, 144	Spectronics, Incorporated	140
Bishop Graphics, Inc.	145	Litton OEM Products	112	Sprague Electric Company	16
Bourns, Inc., Trimpot Products Division	41	Magnecraft Electric Company	Cover III	Standard Power, Incorporated	113
Burr-Brown Research Corporation	115	Macrodata Corporation	70	Systron-Donner	126
CTS Corporation	75	Martin Research	91	TDK Electronics	97
Caddock Electronics	122	Micro Circuits Co.	144	TRW Semiconductors, an Electronic Components Division of TRW, Inc.	18
California Eastern Laboratories, Inc.	145	Microcomputer Technique Inc.	71	Technical Materials Inc.	122
Capitol Machine & Switch Corp., Inc., The	138	Minelco Division, General Time Corp.	143	Technical Wire Products, Inc.	154
Circuit Stik, Inc.	147	Mini-Circuits Laboratory	123	Tektronix, Inc.	25, 45
Computer Labs, Inc.	144	Mostek Corporation	37	Teledyne Semiconductor	46
Corning Glass Works, Electronic Products Division	22, 23	Motorola Semiconductor Products, Inc.	15	Teledyne Relays, A Teledyne Company	21
Custom Connector Corporation	153	NCR Corporation	143	Triplett Corporation	99
Cutler-Hammer, Specialty Products Division	39	National Electronics, A Varian Division	132	Vactec, Inc.	42
Data Display Products	120	National Semiconductor Corporation	2	Vernitron Control Components, A Division of Vernitron Corporation	154
Datametrix, Inc.	144	Nicolet Scientific Corp.	146	Versatec, Inc.	112
Dialight Corporation	33	North Electric Company	128	Woven Electronics	6
Digital Equipment Corporation	8, 9	Oak Industries, Inc.	12, 13	Yewtec Corporation	154
Dynamic Measurements Corporation	131	PRD Electronics, Inc.	136		
Edmund Scientific Company	146	Paktron, Division Illinois Tool Works, Inc.	69		
Electro Switch Corp.	117	*Philips Industries Electronic Components and Materials Division	127		
*Electronic Design	23				
Electronic Navigation Industries	114				
Elexon Power Systems	137, 139, 141				
Erie Technological Products, Inc.	27				
Exar Integrated Systems	1				
John Fluke Mfg. Co., Inc.	17				
General Instrument Corporation	105				
Gold Book, The	118, 119, 124, 125, 134, 135, 148, 149				

* Advertisers in non-U.S. edition.

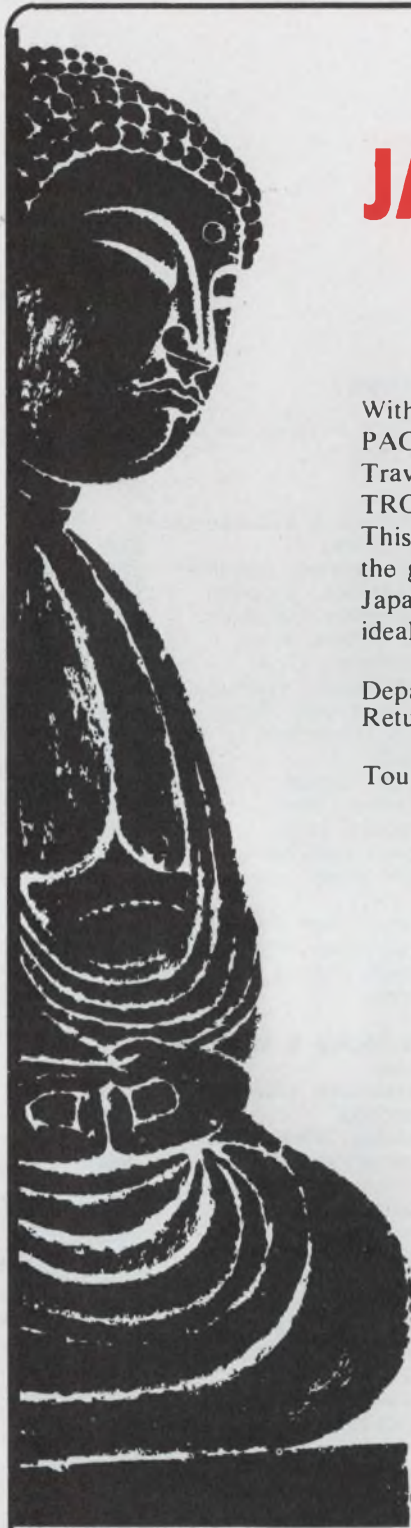

1974

JAPAN ELECTRONICS SHOW SPECIAL GROUP TOUR

With the cooperation of ELECTRONIC DESIGN and CP AIR (CANADIAN PACIFIC AIRLINES), a special tour program has been tailored by Imperial Travel Service of New York for exhibitors and visitors to the 1974 JAPAN ELECTRONICS SHOW to be held in Tokyo, Japan, September 18-24.

This program will offer you many unique opportunities to witness at first-hand the growing Japanese electronics industry and provide free time to do business in Japan and the Orient. If you are taking your wife along, you will find this tour ideal with its many side trips and excursions.

Departure from Vancouver: Sunday, September 15, 1974 via CP Air
Return to Vancouver: Sunday, September 29, 1974 via CP Air

Tour Fare: \$1,138 per person on sharing basis
\$175 per person for single supplement

The above includes:

Air transportation from West Coast to Tokyo, round trip,
Economy on GIT fare.

Accommodation for 15 days at first class hotels.

Full American breakfasts during the tour.

Transfers by chartered motorcoaches between airports and hotels.

Sightseeing tours in Tokyo, Nikko, Kyoto and Osaka.

Special plant tours designed for the participants.

Services of tour couriers and guides.

Features: Interpreter/Secretarial services will be available
upon request.

Extension trips to Taiwan, Korea, Hong Kong and
Singapore available.

For detailed information, complete and mail coupon below,
or call collect Area Code (212) 581-6350.



To: Imperial Travel Service
680 Fifth Ave., New York, N.Y. 10019
I am interested in your Special Group Tour to
the Japan Electronics Show, Sept. 18-24, 1974.
Please send me detailed information as soon as
possible.

Name _____

Title _____

Company
Address _____

product index

Information Retrieval Service. New Products, Evaluation Samples (ES), Design Aids (DA), Application Notes (AN), and New Literature (NL) in this issue are listed here with page and Information Retrieval numbers. Reader requests will be promptly processed by computer and mailed to the manufacturer within three days.

Category	Page	IRN	Category	Page	IRN	Category	Page	IRN
Components			Discrete Semiconductors			silicon nitrided devices (NL)	142	309
capacitors	7	6	diodes, varactor	141	299	timers	112	255
capacitors	16	12	display, alphanumeric	141	301			
capacitors	23	17	ECG semi supplement (NL)	142	303	Modules & Subassemblies		
capacitors	153	90	LED panel lights	55	120	amplifiers	154	91
capacitors, HV	117	261	opto-electronic equipment	146	172	annunciator, amplifier	130	277
capacitors, chip, HV	116	260	opto-isolators (NL)	142	307	controller, program	130	275
capacitors, metallized film	61	126	posistors	116	259	controller, sequence	139	293
circuit breakers (NL)	142	304	rectifiers, bridge	105	42	controllers, motor	132	279
current/volt alarm	120	264	rectifiers, fast recovery	18	14	converter, D/A	130	65
ferrite cores	97	38	rectifiers, silicon	27	19	converters, synchro	132	280
ferrites	96	36	SCRs	67	132	current/volt alarm	120	264
indicator, incandescent	117	263	SCRs	138	72	d/a converters	65	130
indicators	79	143	semiconductors	21	15	DACs	46	111
keypunch, portable	139	294	thyristor/rectifiers (NL)	142	310	delay, digital	132	278
motors, dc torque	154	92	transistors & Darlington	107	43	modem, data	136	285
neon lamp	117	262	transistors, power	141	300	modem, data	136	286
opto-electronic equipment	146	172	zeners	76	142	power amplifiers	50	114
paper punches	48	112				SCR power controller (NL)	142	306
photosensitive devices (NL)	142	308	Instrumentation			sensor, low voltage	133	281
posistors	116	259	amplifiers	154	91	suppressor, transient	133	282
potentiometer, linear	120	267	circuit readers	99	39	timer, control	130	276
potentiometers	41	26	counters	140	297	timers	153	88
relays, reed	111	244	DMMs	140	295			
resistors, thin film	120	266	digital counters	78	143	Packaging & Materials		
switches	39	26	distortion analyzer	140	296	cable	6	5
switches	75	34	dual mode oscilloscope	45	110	capacitors, chip, HV	116	260
switches	204	127	frequency-control devices	77	143	castings	53	116
switches, keyboard	13	9	logic analyzer	2	3	catalog, work station	153	89
tape cartridge	36	24	logic analyzers	76	35	connectors, rf	29	20
test unit, resistor	120	265	logic checker	14	10	connectors, PC board	31	21
timers	153	88	meters	154	94	ferrite cores	97	38
			microprocessor tester	70	32	ferrites	95	36
Data Processing			noise testers	146	173	relay sockets	153	87
calculator	136	284	optical power meter	140	298	resistors, thin film	120	266
calculator	136	287	oscilloscopes	48	30			
calculator	136	288	temperature controllers (NL)	142	305	Power Sources		
calculator	138	290	test unit, resistor	120	265	dc/dc converters	128	274
controller, program	130	275	VOMs	101	40	inverters	128	272
controller, sequence	139	290	vector voltmeters	69	136	miniature source	123	250
data-acquisition module (NL)	142	302				modular supplies	126	271
delay, digital	132	278	Integrated Circuits			module	123	269
FFT processor	146	170	analog multipliers	203	115	modules	123	268
frequency-control devices	77	143	analog switch	113	258	power supplies	49	113
keypunch, portable	139	294	CMOS	46	29	power supplies	63	128
logic analyzers	76	35	ECL 10-k circuits	113	257	power supplies	103	41
logic checker	14	10	FIFO memory	113	256	sensor, low voltage	133	281
memory, disc	139	292	high-speed CMOS	44	108	standby power	126	270
microprocessor	136	283	ICs, calculator	111	254	suppressor, transient	133	282
microprocessor tester	70	32	microprocessor	109	252	switchers	128	273
microprocessors	71	32	microprocessor	136	283			
modem, data	136	285	microprocessors	71	32	new literature		
modem, data	136	286	modem circuits	111	253	circuit breakers	142	304
paper punches	48	112	RAM, NMOS	110	251	data-acquisition module	142	302
processor, array	138	291	RAMs	37	25	ECG semi supplement	142	303
slide rule, electronic	129	64	RAMs	96	37	opto-isolators	142	307
switches, keyboard	13	9				photosensitive devices	142	308
tape cartridge	36	24				SCR power controller	142	306
						silicon nitrided devices	142	309
						temperature controllers	142	305
						thyristor/rectifiers	142	310

Custom Relay Sockets for every purpose



MODEL RB 08
Top Wired
Closed Back
Construction
10 AMPS.—
300 Volts



MR SERIES
Miniature
No retaining ring. Can be
pre-wired before installing.
Rated 5 AMPS. 4 PDT



MODEL RB 11
Top Wired
Closed Back
Construction
10 AMPS.—300 Volts



MODEL QC 11
Top Wired
Closed Back
Construction
10 AMPS.—
300 Volts



CM SERIES
Miniature
Square base. Chassis mount.
Solder or quick connect
terminals. Rated 10 AMPS.
2 PDT and 3 PDT.

Custom Connector Corporation

1738 EAST 30TH ST. • CLEVELAND, OHIO 44114 (216) 241-8064
INFORMATION RETRIEVAL NUMBER 87

FREE

...NEW STURDILITE CATALOG



TECHNICAL WORK STATIONS for:
*Research and Development • Quality Control
Production and Assembly*

This new catalog illustrates and describes the complete line of STURDILITE technical work stations, with special sections on *easy-to-order* functional groupings for RESEARCH and DEVELOPMENT, QUALITY CONTROL and PRODUCTION and ASSEMBLY work areas. STURDILITE components are detailed, allowing innumerable combinations for custom planning. STURDILITE SYSTEMS combine the look of quality furniture with the ruggedness of industrial equipment . . . to provide economical efficiency, no matter how large or small your work area may be (ask about our free planning service)!

ANGLE STEEL DIVISION
KEWAUNEE SCIENTIFIC EQUIPMENT CORP.
PLAINWELL, MICH. 49080 (616) 685-6831



INFORMATION RETRIEVAL NUMBER 89

FOR THE UTMOST IN RELIABILITY



INTERVAL TIMERS Series PAB.

This is an automatic reset interval timer with an extremely accurate timing mechanism built to stand up under hard usage in modern manufacturing processes. Due to the simplicity and reliability of its special clutch we can offer it in a range of time intervals from 1 second (1/60" dial divisions) to 3 hours (3' dial divisions), twelve in all. It is also available in a panel mount model PAF.

All of our timers are made to give you service far beyond what you'd reasonably expect. Our line consists of 17 basic types, each avail-

able in various mountings, voltages, cycles, circuits and load ratings . . . and with whatever special wrinkles you may need.

Bulletin #403 tells all about our line of reliable Interval Timers. Write for it or a catalogue of the entire line. If you have an immediate timer requirement, send us your specifications. Or for fastest service, give us a ring at (201) 887-2200.



INDUSTRIAL TIMER

A UNIT OF ESTERLINE CORPORATION

Industrial Timer Corporation, U.S. Highway 287, Parsippany, N. J. 07054

INFORMATION RETRIEVAL NUMBER 88

ELECTRONIC DESIGN 18, September 1, 1974

Now Mil Spec Capacitors

Radial/Axial Leads • All Values

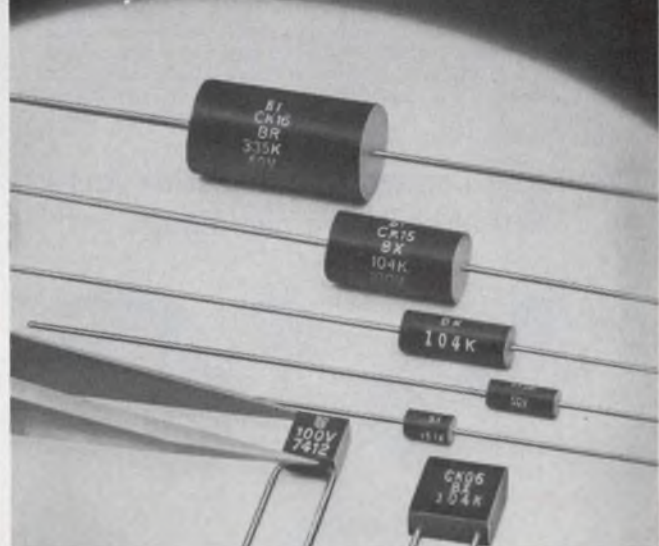

Many values off the shelf, other deliveries 6-8 weeks. CK05, CK06, CK12, CK13, CK14, CK15, CK16. Commercial versions available.

Write for full line ceramic capacitor catalog.



BELL INDUSTRIES / Electronic Components Division
150 WEST CYPRESS AVE. • BURBANK, CALIFORNIA 91505
(213) 846-9302 • TWX 910-498-2207

INFORMATION RETRIEVAL NUMBER 90

Our Amps Don't Quit in a Mismatch!

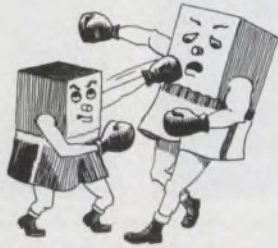

Amplifier Research has a tough line of broadband amplifiers -- all unconditionally stable and built to take on any mismatched load. These amplifiers sweep the spectrum from DC to 700 MHz and provide up to 5000 watts of RF power. Rugged design makes them perfect for antenna and component testing, equipment calibration and EMI susceptibility testing -- you'll never have to throw in the towel! Amplifier Research will also provide custom OEM packaging to meet your special requirements. Get the facts, contact:

Amplifier Research, 160 School House Road, Souderton, Pa. 18964 • Phone: 215-723-8181



INFORMATION RETRIEVAL NUMBER 91

Vernitorq long life motors should be used for any positioning requirement where continuous rotation is not essential. Infinite resolution and high linearity allow these motors to provide high accuracy in positioning, actuating, tensioning, measuring, and indicating applications. These motors provide smooth operation with no slot effect. They also offer high torque with low input power and high acceleration rates as well as no gears, no mechanical or electrical noise, no explosion hazard, no friction, and no ripple torque. Vernitorq brushless DC torque motors are available in two and four-pole designs, in a variety of sizes and outputs. Peak torque ratings range from 5 to 600 oz-in. Frameless or housed versions are available. Special designs to your requirements also supplied. Vernitron Control Components, A Division of Vernitron Corp., 2440 West Carson Street, Torrance, California 90501, Telephone (213) 328-2504.

Vernitron Limited Rotation Wide Angle Brushless DC Torque Motors

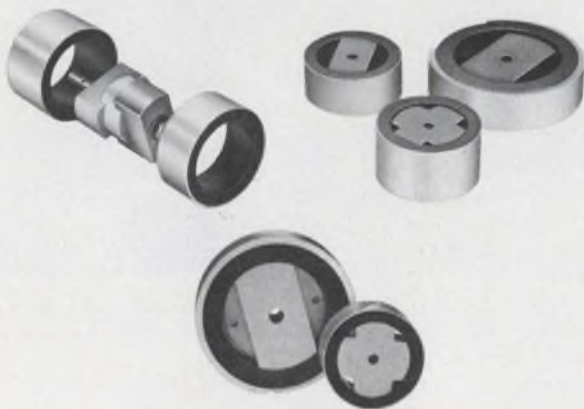

vernitorq

INFORMATION RETRIEVAL NUMBER 92

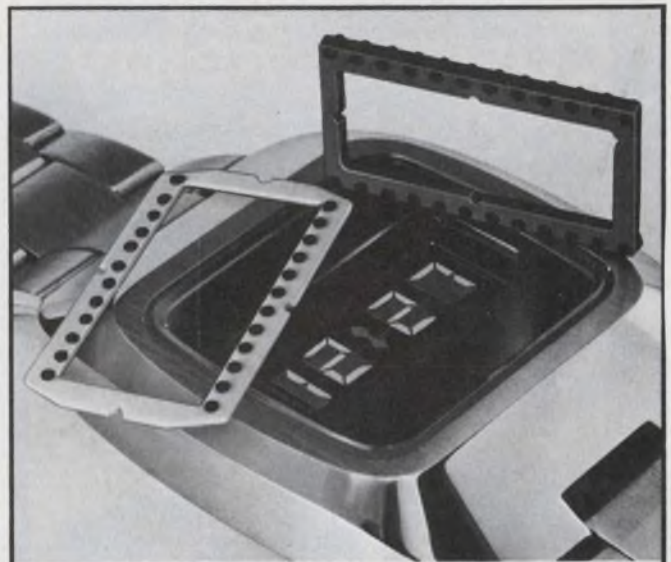

INTERCONNECTOR CONDUCTIVE ELASTOMERIC

- Conductive and resilient elastomeric contact elements retained and positioned in a dielectric carrier
 - Low cost
 - Reduces package volume
 - Seals contact surfaces
 - Isolates vibration
 - Speeds assembly
- U.S. Pat. 3,680,037

TECKNIT® Technical Wire Products, Inc.

Eastern Division • 129 Dermody St., Cranford, NJ 07016 (201) 272-5500
Western Division • 427 Olive St., Santa Barbara, CA 93101 (805) 963-1867

INFORMATION RETRIEVAL NUMBER 93

THE 25 YEAR METERS...



10/20/50/100 A AC: \$130.00

YEW's Precision Portables!

95% of all YEW precision portables that are returned for calibration certification are within original specifications, even after 25 years of use. We have even had instruments dating back 50 years within original specifications. *That is long term reliability* and that is why YEW is the world's largest manufacturer of precision portables.

Add taut band 0.5% accuracy, high quality and low cost, fast service, a vast selection of models and 25 years from now, you'll be glad that you tried a YEW portable. Prices start at \$120.00.

1% Portables also available. Prices start at \$50.



Yewtec Corporation

1995 Palmer Ave., Larchmont, N. Y. 10538
Telephone: 914 834-3550

60 Years of Measuring and Recording Instrumentation

INFORMATION RETRIEVAL NUMBER 94

ELECTRONIC DESIGN 18, September 1, 1974

Reed Relays in Stock with Long Life & Versatility

READY REEDS



The Ready Reeds are ready for you! Over 290 high quality types of reed relays are in stock for immediate delivery. A wide variety of hermetically sealed contact combinations and packaging techniques are available. Versions offered include; dry, mercury-wetted, sensitive, latching, power, high voltage, time delay, electro-statically shielded, and dual-inline-package DIP's.

Magnecraft's reed relays can provide almost everything that a designer would want in order to accomplish a high speed switching function. The versatility of the relay is so great that it can be custom-fitted to almost any application at a lower cost in dollars and power and in a smaller space than almost any other device, conventional or solid state.

The photo above portrays the reed relay packaging characteristics available: epoxy encapsulated, axial leads, plug-in, eight and fourteen pin dual-inline-package, open styles, and standard, miniature, and micro miniature printed circuit packages.

Our nationwide network of distributors and Chicago plant stand ready to serve your applications. But, if you don't find what you need in stock we will make it for you!



Free!
STOCK CATALOG

To help specify all your relay needs, ask for Magnecraft's new 1974 Stock Catalog with the most diversified line of over 1060 relays. A 68 page Designers Handbook and Catalog of Reed and Mercury Wetted Contact Relays with specific data drawings, and photos on all the various relays will accompany the Stock Catalog.

Find Magnecraft Relays in EEM sec. 4500.

Magnecraft ELECTRIC COMPANY

5575 NORTH LYNCH AVENUE • CHICAGO, ILLINOIS 60630 • 312 • 282-5500 • TWX 910 221 5221

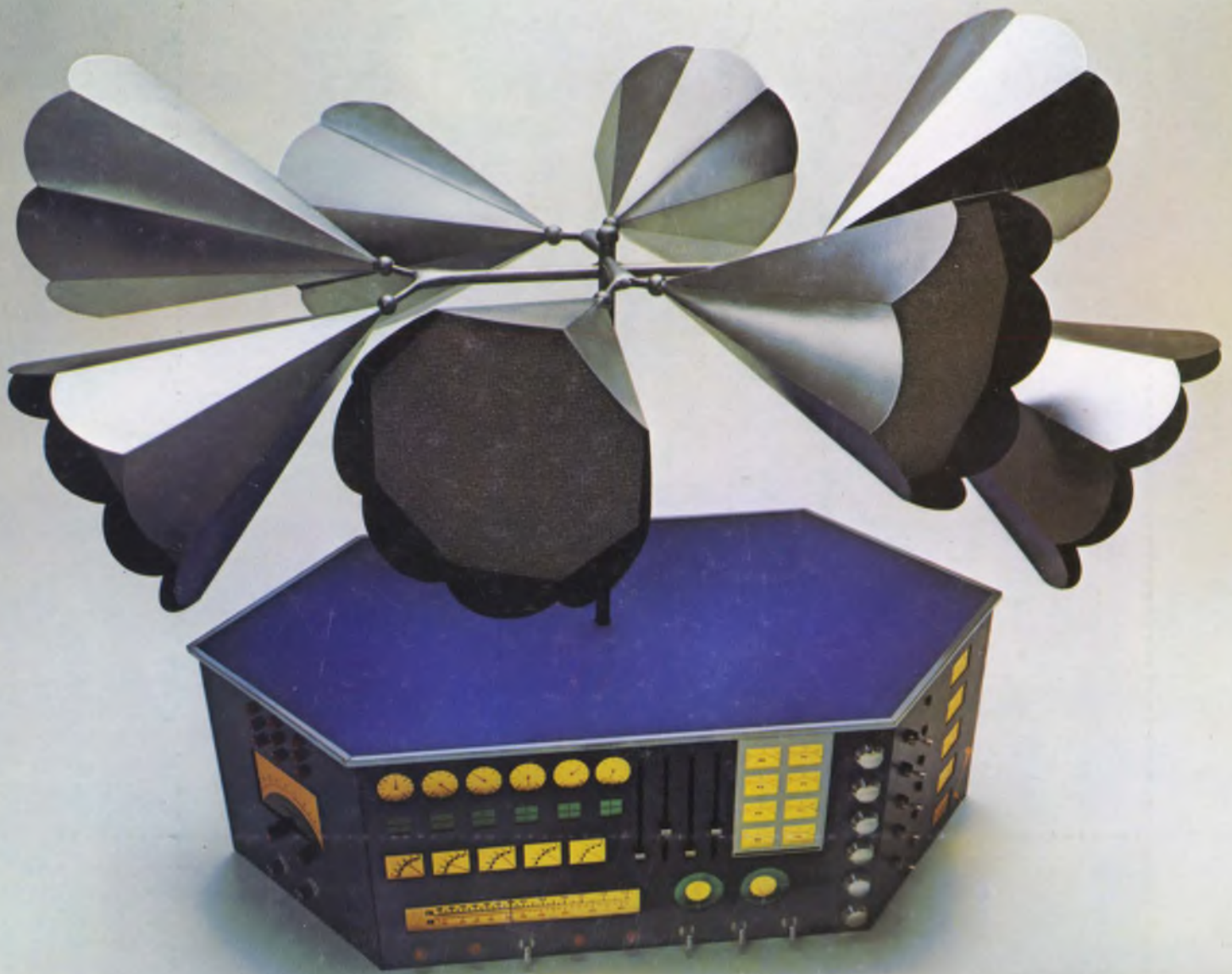

The octophonic amplifier. If you want to create one tomorrow, we're ready with your power transistors today.

No matter what product you want to design — from stereo amps to ignition systems to electronic ranges — there's one thing you want to remember. Nobody's design is any better than the devices that go into it.

And at RCA, we've got the devices that make the difference. Ready now to help your product perform the way you designed it. In numbers all the way from

one to one million and beyond.

We're a commodity supplier of power transistors; a recognized leader in CMOS building blocks; developers of liquid crystal displays; a leading producer of linear IC's; technology innovators of RF power components; and a major supplier of thyristors.

In addition to comprehensive technical product data, RCA also gives you professional and experi-

enced field engineering and applications support. As well as a commitment to excellence in everything from research to manufacturing.

So whatever you're into, and whatever you need, check with us first. Chances are one or more of our products anticipate your needs. A good place to start is to check our handy product line guide. Write: RCA Solid State, Section 5711 Box 3200, Somerville, N.J. 08876.

RCA Solid State