

# Electronic Design 6

VOL. 15 NO.

THE MAGAZINE OF ESSENTIAL NEWS, PRODUCTS AND TECHNOLOGY

MARCH 15, 1967

Here's an IEEE briefcase filled with news of this year's Big Show. From your desktop, no matter where you are, you can make the trip in the pages of IEEE USA. What's new in materials, plastic transistors or computer-aided design? What will speakers say about tomorrow's cities? The tour begins on p. U81.



*Put this new design window in your lab*

**New delayed sweep... magnifies... eliminates jitter for...**

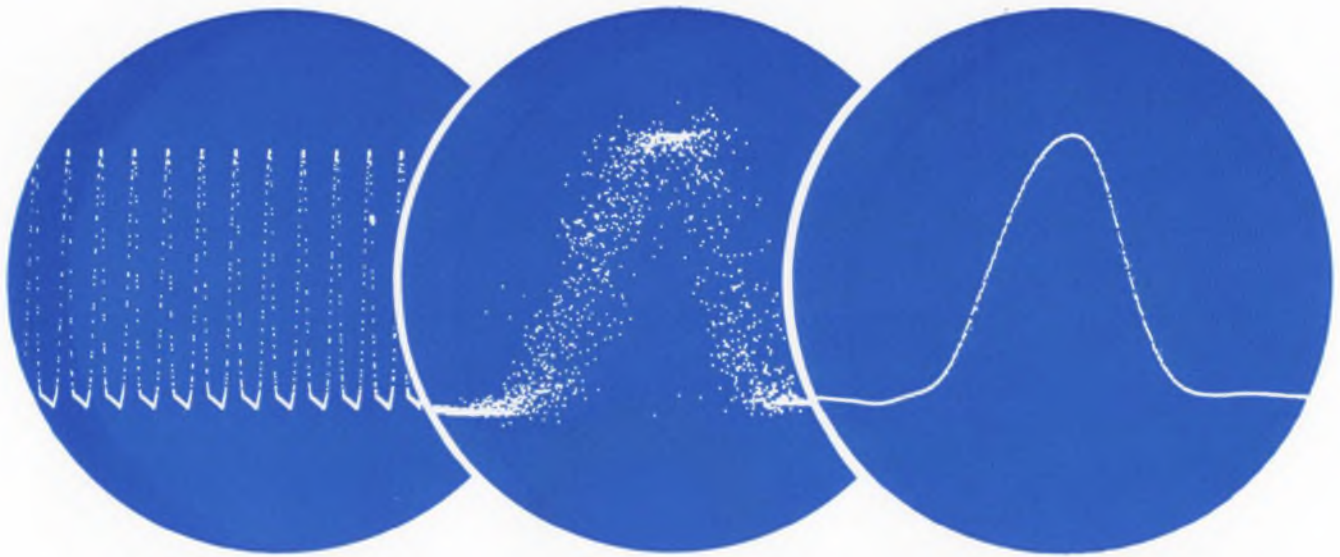

## CLEAR DISPLAYS TO 1 GHz & BEYOND

Here is an analytical window that sheds new light on the characteristics of computer and other fast logic circuitry—anywhere, in fact, where complex waveforms or pulse trains are involved. Notice how it pulls the picture into focus.

Mainframe of this step-ahead sampling system is the hp 140A with standard CRT. For low rep-rate waveforms (5 kHz and below or long delay times) you get clear, steady displays with the "stop-action" variable persistence and storage features of the hp 141A mainframe. Solid-state sampling plug-ins include:

**NEW 1425A TIME BASE & DELAY GENERATOR**— first delayed sweep in sampling. You get sweep speeds from 10 psec/cm to 500  $\mu$ sec/cm, triggering to 1 GHz, delay times as long as 5 ms, automatic triggering, and a movable intensified dot making it easy to set up point of magnification. \$1600.

**NEW 1410A DUAL-CHANNEL VERTICAL AMPLIFIER** with 1 mv/cm sensitivity at 1 GHz. This plug-in gives you the convenience of high-impedance probes for circuit measurements, plus internal triggering for measurements in 50-ohm systems. \$1600.

Mainframe prices: 140A, \$595; 141A, \$1275.

For sampling through X band, the 1411A Dual-Channel 1 mv/cm Vertical Amplifier (\$700) functions with any of three remote samplers: 1430A with 28 psec

rise time for clean pulse response (\$3000), 1431A with 12.4 GHz bandwidth and low VSWR (\$3000), and the 1432A with 4 GHz bandwidth and 90 psec rise time (\$1000). With the versatile hp 140 Scope System, you get *better performance in any direction*: 20 MHz wide-band • TDR • high sensitivity with no drift • variable persistence and storage—and *sampling*.

For data on the new hp sampling scopes, write or call Hewlett-Packard, Palo Alto, Calif., 94304. Phone (415) 326-7000. In Europe, 54 Route des Acacias, Geneva.



HEWLETT  PACKARD  
An extra measure of performance

087/20



## Introducing GR's new...

**Standard-Signal Generator** with a 9.5- to 500-MHz frequency range and 10-V, cw output behind  $50\ \Omega$ ; or 5 V, modulated, behind  $50\ \Omega$ . It has automatic output leveling *in all modes of operation* and true single-dial tuning (no trimmer adjustment needed). The generator frequency can be phase-locked to an external standard frequency. Modulation distortion is less than 3% at 80% AM. Type 1026-A Standard Signal Generator . . . \$6500.

**Sweep and Marker Generator** for use with GR Synthesizers. It has nine sweep speeds, from 0.02 to 60 seconds, and sweep excursion is adjustable from  $\pm .001$  Hz to  $\pm 1$  MHz. Generates scope markers for quick calibration of the swept output. The synthesized center-frequency marker and side markers are accurate, stable, and precisely settable. Type 1160-P2 Sweep and Marker Generator . . . \$495.

**General-Purpose Laboratory Oscillator** with its full 10-Hz to 50-kHz range covered by one turn of the dial. No range switch to wear out! This also means no range-switching transients and no ambiguous dial multipliers. Generates both sine and square waves, and can be synchronized to an external signal or can supply a sync signal. Has a calibrated 60-dB step attenuator and a 20-dB continuously adjustable attenuator. Type 1313-A Oscillator . . . \$325.

**Scanner System** to connect up to 100 capacitors sequentially to GR's 1680-A automatic capacitance bridge. Also useful for other scanning applications. Modular construction offers great versatility in the number of input channels, number of lines switched per channel, and line termination. Preserves the three-terminal, guarded connection between bridge and unknown. Digital readout and BCD output of channel identification. Automatic, manual, or externally programmed operating modes. Type 1770 Scanner System . . . \$3500 for a typical 50-channel guarded system.

**Precision Decade Transformer** with 0.2 PPM linearity and easily repeatable settings to  $1 \times 10^{-9}$ . Lever switches for easy, in-line readout plus infinite-resolution slide wire (that can be switched out of circuit for calibration). Type 1493 Precision Decade Transformer . . . \$1100.

Other new products include the Type 1406 Coaxial Capacitance Standards and several additions to the GR874 and GR900 lines of coaxial equipment. You can see these and many other new GR instruments at the New York IEEE Show, Booth No. 2E26-2E36.

For complete information, write General Radio Company, W. Concord, Massachusetts 01781; telephone (617) 369-4400; TWX 710 347-1051.

ON READER-SERVICE CARD CIRCLE 3

GENERAL RADIO

**You'll flip too!** A 16-bit data generator for only **\$680.00.**

The new Datapulse 201 offers **bit rates to 10MHz**, NRZ outputs to 10V, **variable baseline offset to  $\pm 10V$** , and continuous or command recycle. Multiple units can be sequenced for extended program lengths or paralleled for additional channels.

SHOWN FULL SIZE — two units require only 3½ inches of rack panel height.

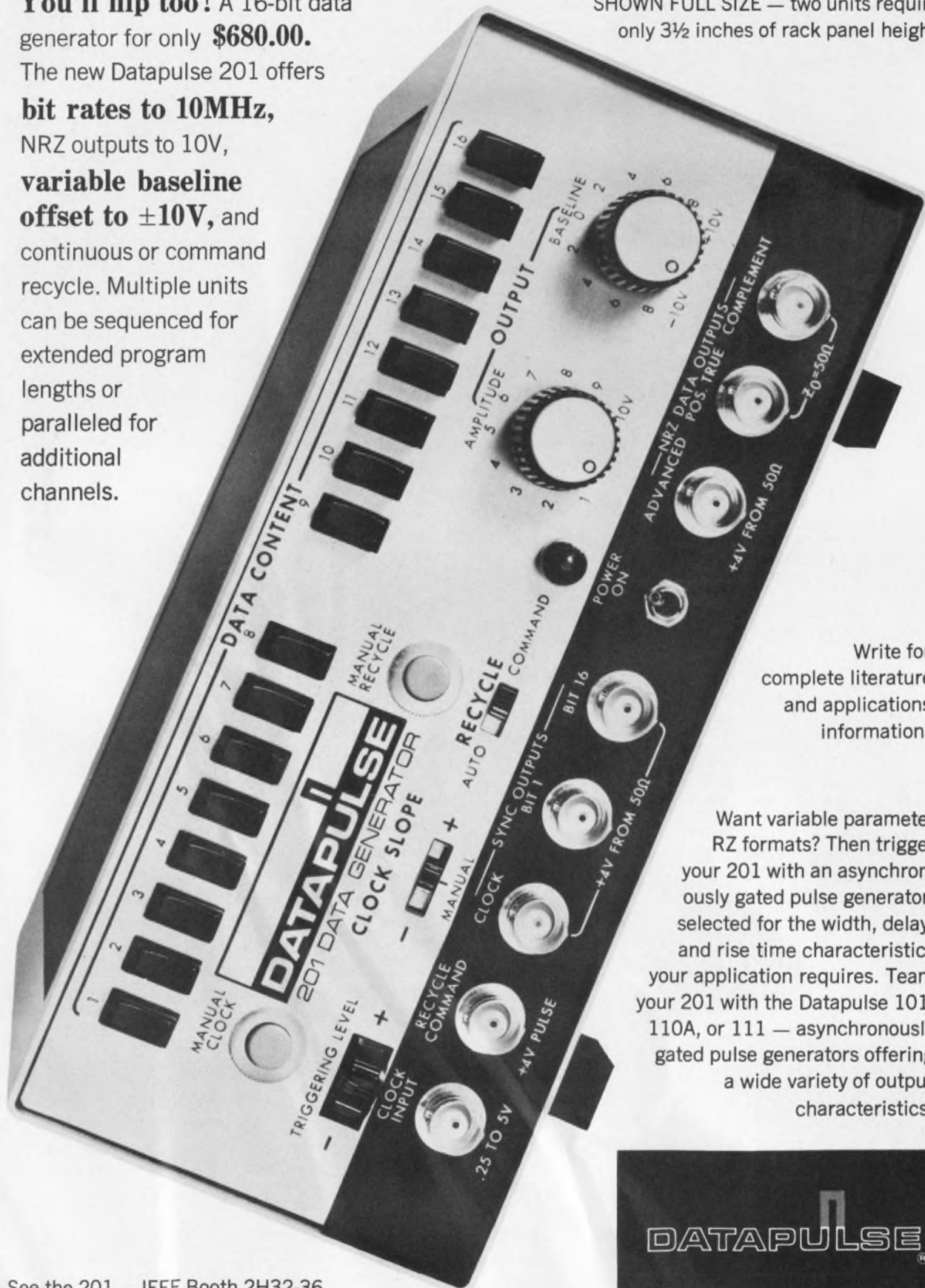

Write for complete literature and applications information.

Want variable parameter RZ formats? Then trigger your 201 with an asynchronously gated pulse generator, selected for the width, delay, and rise time characteristics your application requires. Team your 201 with the Datapulse 101, 110A, or 111 — asynchronously gated pulse generators offering a wide variety of output characteristics.

See the 201 — IEEE Booth 2H32-36.

DATAPULSE/Division of Datapulse Inc./10150 Jefferson Blvd., Culver City, Calif. 90230/(213) 671-4334, 678-4275/TWX: 910-328-6109/Cable DATAPULSE  
DATAPULSE • NESCO INSTRUMENTS • DE MORNAY-BONARDI • KRS INSTRUMENTS

---

## NEWS

- 13 News Scope
- 17 **Microwave semiconductors and LSI keynote Solid-State Circuits show.**
- 22 **Outlook for long-range weather forecasting: cloudy but clearing.**
- 31 Washington Report
- 42 **Computers and ICs to help physicists probe nature.**
- 72 Letters
- 227 **Editorial: What happens to your job if peace breaks out?**

---

IEEE USA—A special section

Pages U81-U224

---

## TECHNOLOGY

- 230 **SCEPTRE gives designers new power** to design and analyze electronic circuits accurately and rapidly. Versatile modeling capability is major feature.
- 238 **Get pnp Class-B stage efficiency** in all-npn transformerless integrated circuit with a flat frequency response from dc to 30 MHz.
- 244 **Inductor ups crystals' bandwidth to 2%** as substitute for conventional capacitive loading. Wider band and simple design offset slight stability loss.
- 250 **Pick the right hybrid technique** and you'll get the most suitable passive components for your circuit. Thick films and thin films, both have their place.
- 258 **Simplify capacitance measurements** with this handy nomograph. It allows you to correct for lead inductance quickly and easily.
- 261 **Variable-duty-cycle switching circuit** controls illumination intensity of a reticle within a crewman optical alignment sight.
- 266 **Capacitive voltages are found easily** with this simple nomograph which does away with the need for tricky calculations with log table or slide rule.
- 270 **Cut the 'noise' out of your next article** and editors will beat a path to your typewriter. A good manuscript distills the essence from your work.
- 274 NASA Tech Briefs
- 282 Ideas for Design

---

## PRODUCTS

- |                      |                          |
|----------------------|--------------------------|
| 292 Microelectronics | 322 Production Equipment |
| 294 Test Equipment   | 328 Microwaves           |
| 302 Semiconductors   | 332 Systems              |
| 306 Components       | 334 Power Equipment      |
| 320 Materials        |                          |

---

## Departments

- |                       |                         |
|-----------------------|-------------------------|
| 277 Book Reviews      | 340 New Literature      |
| 336 Design Aids       | 348 Advertisers' Index  |
| 338 Application Notes | 351 Designer's Datebook |

Reader Service card inside back cover

---

**Track down the  
broadest line of  
planar power  
transistors.**

**And you  
wind up at  
Bendix.**

IC	VCEO	hFE	VCE(sat)	PT	SWITCHING TIME			
					t <sub>on</sub> ns	t <sub>off</sub> ns	@ I <sub>C</sub> A	@ ± I <sub>B</sub> mA
3A	40 to 60V	25 min @ 2A, 10V	0.5V max @ 1A, 0.1A	5W	35	75	1.5	150
5A	40 to 80V	120 min @ 3A, 10V	0.75V max @ 3A, 0.3A		40	300	3.0	300
10A		40 min @ 5A, 10V	1V max @ 5A, 0.5A	25W to 50W	225	600	10	1000
15A	60 to 100V	1.5 min @ 10A, 5V	1.5V max @ 15A, 3A					
20A		20 min @ 10A, 5V	1.5V max @ 20A, 4A					

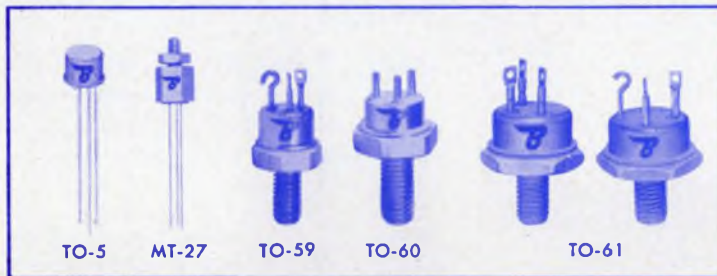

**SATURATED SWITCHING TEST CIRCUIT**

T1 TEKTRONIX PART # 015-041  
(5mV/mA)

**Maximum Switching Times:**  $t_d \leq 25$  ns;  
 $t_r \leq 200$  ns;  $t_s \leq 300$  ns;  $t_f \leq 300$  ns.  
**Test Conditions:**  $V_{in} = 70V$  when generator with  $50\Omega$  internal impedance is terminated in a  $50\Omega$  load.  $V_{BB} = -5V$ ;  $V_{CC} = 55V$ ;  $I_C \approx 10A$ ;  $I_{B1} \approx 1A$ ;  $I_{B2} \approx 1A$ ;  $t_p = 400$  ns;  $f = 720$  Hz.

You'll find over 100 types to choose from. With IC's of 3, 5, 10, 15 and 20 amps, and VCEO from 40 to 100 volts. Low saturation at high current, and low thermal resistance provides more useable power. There's sure to be one suited for your high current switching or amplifier application. Bendix silicon planar power NPN transistors come in six different package configurations, too.

You'll also find the top performance you're looking for—operating reliability from quality workmanship

in construction. There's another big benefit, too. SOAR. Clearly defined Safe Operating Areas for every transistor application. Second breakdown just doesn't occur when you operate within the SOAR specs. And SOAR saves design engineering time—lets you pick the right transistor for the right job.

So wind up your planar power needs the easy way. Just call our nearest office. We're all wound up to deliver. Bendix Semiconductor Division, Holmdel, New Jersey 07733.

**Stop at Bendix IEEE Booth 4C04**



Atlanta—Grady Duckett Sales Co., (404) 451-3529; Baltimore (Towson), Md.—(301) 828-6877; Chicago—(312) 637-6929; Dallas—(214) 357-1972; Detroit—(313) 548-2120; Greenwich, Conn.—(203) 869-7797; Holmdel, N. J.—(201) 946-9400; Los Angeles—(213) 776-4100; Minneapolis—(612) 926-4633; Los Altos, Calif.—W. W. Posey Co., (415) 948-7771; Seattle—Ray Johnston Co., Inc. (206) LA 4-5170; Syracuse, N. Y.—(315) 474-7531; Waltham, Mass.—(617) 899-0770; Export—Cable: "Bendixint," 605 Third Avenue, New York, (212) 973-2121; Ottawa, Ont.—Computing Devices of Canada, P.O. Box 508—(613) Talbot 8-2711.



# Why aren't all advanced computers designed with current-mode logic?

Here are some interesting insights into the merits of CML in logic designs

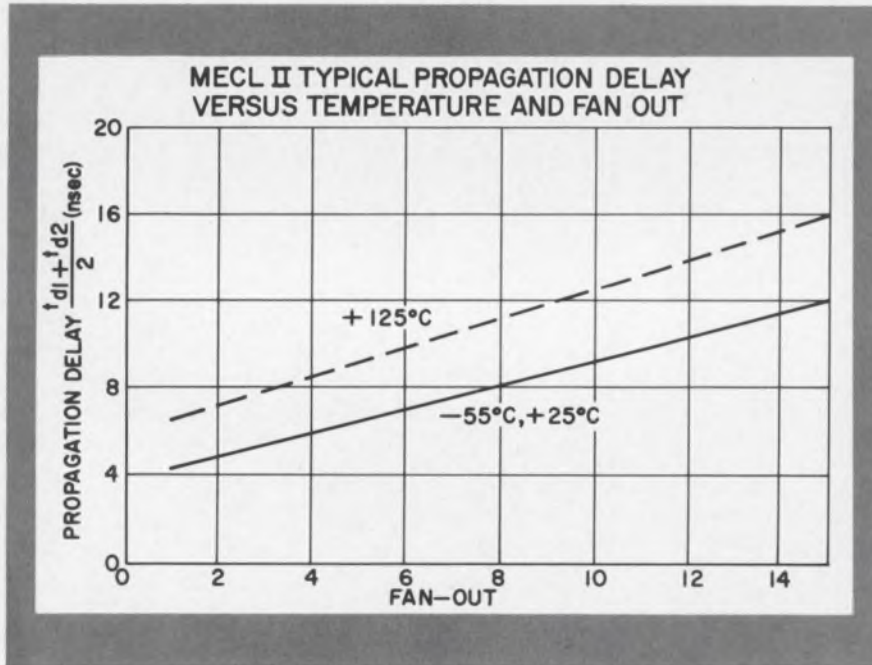

Fast speed even under heavy fan-out conditions typifies Motorola's MECL II type current-mode logic integrated circuits.

## Speed

Current-mode logic is practically and theoretically the fastest form of logic. That's because it isn't subject to transistor "storage time" which is a major speed limiting factor in every other form of logic. While we don't imply that either saturated or current-mode logic has yet reached its maximum theoretical limit, the fact is that present current-mode J-K flip-flops operate at a *minimum* toggle frequency of 70 MHz (Motorola MECL II\* type MC1013), while the fastest saturated logic flip-flops have a *typical* frequency of 50 MHz. And, while saturated-logic speeds are nearing the limits of their speed capability, current-mode logic speeds still have a long way to go.

## Noise Immunity

Inherently, current-mode logic is immune to state-changing transients

that are integral to all forms of saturated logic. That's because current drain in CML remains constant even during the switching interval whereas with saturated logic any slight difference in transistor characteristics (and there's always a slight difference in transistor characteristics) causes current and voltage spikes whenever a transistor is driven from cutoff to saturation or vice versa. Propagating down a line, these transients produce crosstalk and other forms of noise that can result in spurious or false triggering of succeeding stages. Consequently, the logic levels of saturated logic circuits must be considerably higher than those of CML for the same noise immunity. Since circuit speed is a function of logic levels, this requirement further increases the practical speed differential between CML and SL.

## Complementary Outputs

Because CML normally is designed with a differential input stage (consisting of a pair of transistors, one of which is turned off while the other is turned on), this logic form inherently provides a function and its complement without the need for a separate inverter. In many CML integrated circuits, these complementary signals are available at separate output terminals to simplify system design, reduce can-count and equipment cost.

## High Fan-Out, Fan-In

The normal CML gate is followed by a pair of emitter-follower stages (one for each of the complementary outputs) which are used as level translators to make the output voltage levels of a circuit compatible with input voltage level requirements of an identical circuit. These emitter followers, however, provide a very real additional functional benefit. Because of their very-low-output impedance, they can drive a relatively large number of succeeding stages without serious speed degradation. This high fan-out and fan-in capability is further enhanced by the high-input impedance of CML gates. A high-frequency fan-out of 15 is normally used, but even a fan-out of 25 at lower frequencies can be tolerated without excessive signal deterioration.

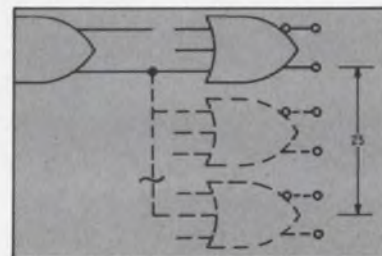

The capability of MECL II current-mode logic to fan-out up to 25 makes it superior in this category to all other available integrated circuit digital systems.





## SO, why aren't all advanced computers being designed with current-mode logic?

One reason might be that CML circuits, *in the past*, have been available with only a relatively simple logic function per package. As a result, it has been impossible to implement complex systems, in some instances, with "low can counts".

*But take another look now. With the introduction of Motorola's MECL II line, utilizing 14-pin flat ceramic and plastic packages, circuit complexity has been increased to include full adders as well as a variety of other multifunction units.*

A second reason might be that current-mode circuits in the past have operated at speeds that are approachable with a form of saturated logic so that high-speed requirements have been served by two IC lines.

*With the MECL II line, current-mode logic has significantly sur-*

*passed the high-speed capability of any saturated logic form. Flip-flop clock rates are two to three times those of the fastest saturated logic lines, and gate propagation delays, typically on the order of 5 ns, are well ahead of all other logic forms. And with a third line of current-mode logic (MECL III\*) presently in the prototype evaluation stage (speeds in the one nanosecond range and fully optimized to drive 50 ohm transmission lines), it is clearly predictable that, for high-speed computers, current-mode logic is the only logic form capable of meeting the needs of the most advanced systems.*

A third reason might be the misconception held over from the discrete circuit design era that current-mode is a relatively expensive form

of logic, due to the abundant use of transistors in place of diodes and resistors.

*Unquestionably, this has been true for circuits designed with discrete components—but it isn't with integrated circuits where transistors are no more expensive and are as easy to make as any other component. Motorola's pioneering efforts with current-mode integrated circuits have raised manufacturing yield to a level where these devices are price competitive (per function) with most other logic forms. And, though it is still possible to buy some logic circuits at a lower average per-package cost, it is quite likely that the systems oriented approach MECL\* design (complementary outputs, etc.) can reduce total system cost.*

MECL → MECL II → MECL III

Due to family-to-family compatibility between all MECL logic series, the designer can use highest speed forms where critical speed requirements exist, while using other types throughout balance of the system.

### And did you know

That Motorola's MECL lines are completely compatible? That is — MECL, MECL II, and the imminent MECL III lines have identical logic levels and power-supply requirements so that they can be judiciously mixed for optimized system needs. With this logic form, it is possible to customize each computer subsystem so that the total system will achieve the best possible speed-power product and the lowest cost.

### Therefore —

Do we recommend MECL for

all possible computer designs? Definitely not! There may always be special requirements where other logic forms may provide advantages in the form of system cost or simplicity, or where special performance requirements will stipulate another type of circuit. That's why we manufacture and supply virtually every other logic form in use today (T<sup>2</sup>L, DTL, RTL, VTL, HTL (High threshold), etc. We do maintain, however, that MECL should be carefully evaluated for every application, and we predict

that current-mode logic will become the predominant logic form in the years ahead.

(As a matter of fact, you might be surprised to learn the large number of advanced computer systems being designed today using MECL).

For a package of selected Application Notes describing the MECL line in use, write for Application Note Group #1. Send your request to Dept. TIC, Motorola Semiconductor Products Inc., Box 955, Phoenix, Arizona 85001.

\*Trademark of Motorola Inc.

# this is LSI...

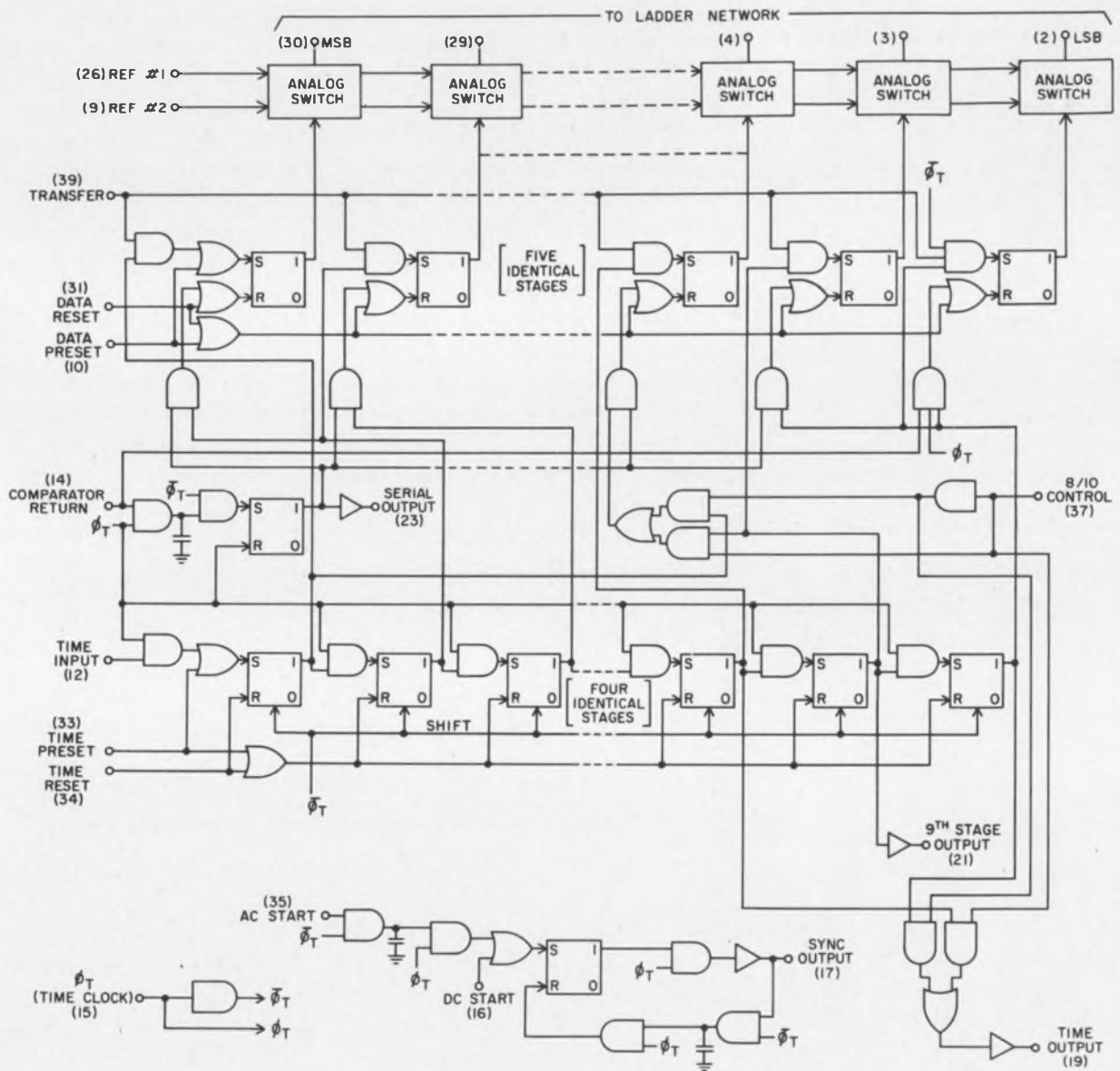

**Another MTOS First...** This Monolithic A/D-D/A Converter incorporates General Instrument's exclusive MTOS (Metal-Thick-Oxide-Silicon) process which provides Large Scale Integration without the need for high-cost discretionary wiring.

# the first available monolithic analog-to-digital digital-to-analog converter

And only General Instrument makes and delivers these advanced LSI devices...today!

See it in operation IEEE Booth 4D03-4D09.



Actual Size

## MEM 5014 A/D-D/A Converter..... \$268<sup>00</sup> each\*

General Instrument's MEM 5014 is a Monolithic MTOS Integrated Circuit containing 350 active components on a chip 62x104 mils. It performs all the logic and analog switching functions for 10-bit successive approximation analog-to-digital conversion. In addition, it operates in two other major modes—as a 10-bit digital-to-analog converter or a 10-channel analog multiplexer.

As an analog-to-digital converter, the MEM 5014 is used in conjunction with an external precision ladder network and voltage comparator. This mode provides both serial and parallel binary outputs. The MEM 5014 is packaged in a 40 lead hermetically sealed in-line package which can be soldered to a printed circuit board or used with a 40 pin socket. Write for complete data and application notes.

\*in quantities of 100



GENERAL INSTRUMENT CORPORATION • 600 WEST JOHN STREET, HICKSVILLE, L. I., NEW YORK  
ON READER-SERVICE CARD CIRCLE 7

**Only from Sprague!**

DIGITAL-TO-ANALOG

# HYBRID D to A CIRCUITS

with precision components not found in monolithic integrated microcircuits

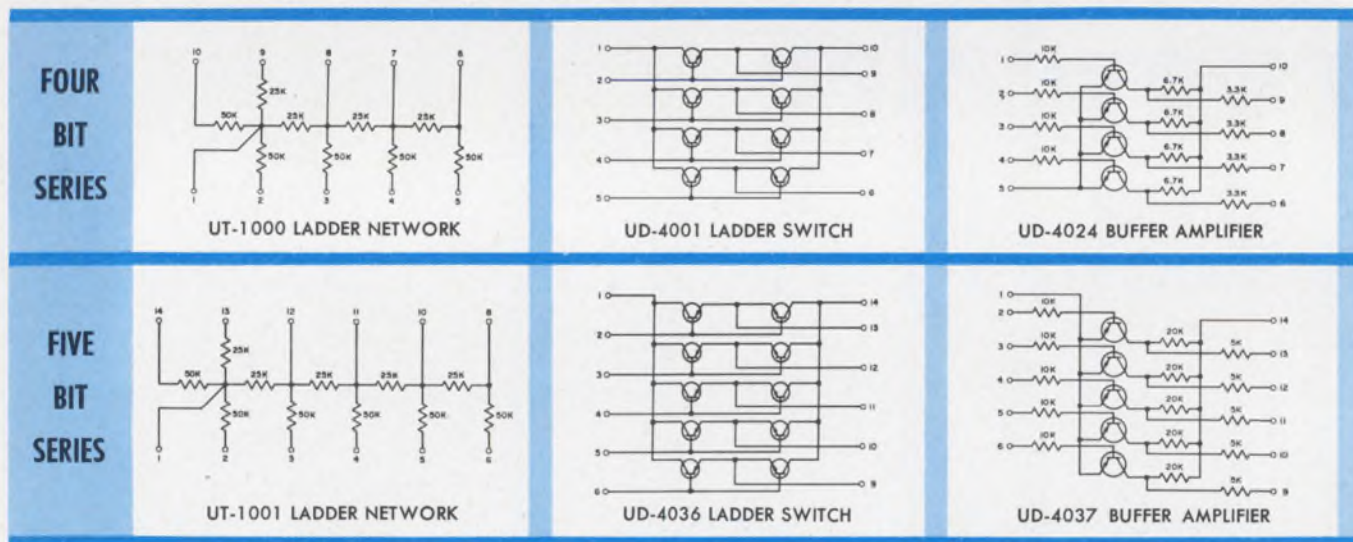

**Up to 12 bits with less than 1/2 bit error!**

- Silicon-base hybrid microcircuits in hermetically-sealed flat packs.
- 3 to 1 size reduction over conventional converters using discrete components.
- Improved tracking over temperature range of -55 C to +125 C.
- Reduced handling of components... fewer external connections... lower assembly costs.
- 4-bit series expandable to 8 or 12 bits... 5-bit series expandable to 10 bits.

- Combination of precision thin-film tantalum nitride resistors, nickel-chromium resistors, and active devices of planar construction.
- Packaged for compatibility with monolithic circuits.

.....

*For complete technical data on D-to-A microcircuits, write to Technical Literature Service, Sprague Electric Company, 347 Marshall Street, North Adams, Massachusetts 01247.*

**SPRAGUE COMPONENTS**

THIN-FILM MICROCIRCUITS  
INTEGRATED CIRCUITS  
TRANSISTORS  
CAPACITORS  
RESISTORS

PULSE TRANSFORMERS  
INTERFERENCE FILTERS  
PULSE-FORMING NETWORKS  
TOROIDAL INDUCTORS  
ELECTRIC WAVE FILTERS

CERAMIC-BASE PRINTED NETWORKS  
PACKAGED COMPONENT ASSEMBLIES  
BOBBIN and TAPE WOUND MAGNETIC CORES  
SILICON RECTIFIER GATE CONTROLS  
FUNCTIONAL DIGITAL CIRCUITS



'Sprague' and '®' are registered trademarks of the Sprague Electric Co.

# News



**Topics of liveliest discussion** at Philadelphia's International Solid-State Circuits Conference

were transistors as microwave power sources and LSI uses in computer equipment. Page 17

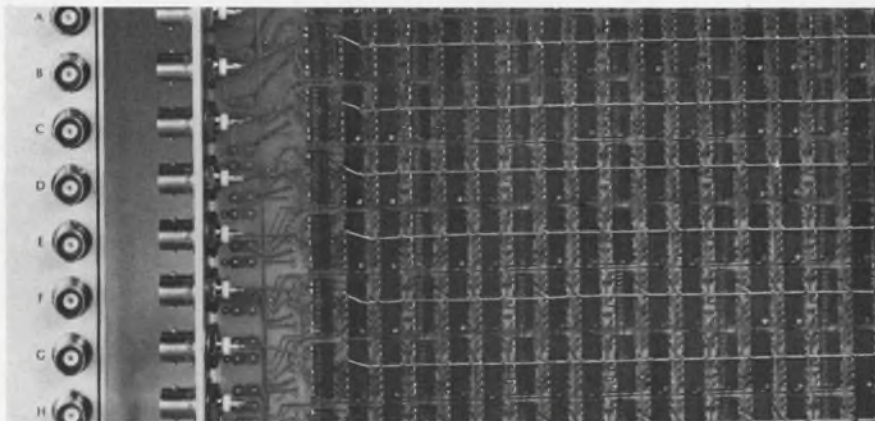

**Microcircuitry and computer compatibility** are the main trends apparent in the design of physics research equipment. Page 42



**Buoys yield data** for global weather forecasts. Page 22

## Also in this section:

**Army strengthens U.S. computer defenses** against bombers. Page 36

**'See-as-you-speak' telephones** to incorporate silicon image sensor. Page 60

**News Scope**, Page 13 . . . **Washington Report**, Page 31 . . . **Editorial**, Page 227

When it comes to high-voltage switching and control, nothing else comes close to the compact size, speed, and reliability of vacuum components. And ITT Jennings has a vacuum device for any switching or capacitor application where voltage is high, reliability is a must, and space is minimal.

Check these features: High voltage ratings • High rf current ratings • Long contact life • No contact maintenance • Impervious to environment • Faster operation • High capacity change ratios • Compact design . . . and many others.

ITT Jennings can help give you complete design freedom with such components as:

**VACUUM RELAYS** for high-voltage

switching applications in airborne, mobile, or marine communication systems — with new models available for almost any industrial or commercial application.

**VACUUM CAPACITORS** for the utmost in performance in rf generating devices such as high power transmitters and dielectric heating equipment.

**VACUUM CONTACTORS** for the most reliable means available for the remote control of high voltages from 60 cycle through rf and in applications ranging from antenna switching to motor controls.

**VACUUM INTERRUPTERS** for many applications in the utilities field including sectionalizing, underground dis-

tribution control, paralleling, capacitor bank switching, and others.

**VACUUM COAXIAL RELAYS** for automatic, remotely controlled coaxial switching in antenna and transmitter equipment for communication systems.

ITT Jennings has more experience in using the vacuum dielectric than anyone else in the world, and probably already has a vacuum device to meet your exact reliability and size requirements.

For information on any of the above components, or for our complete catalog, write to ITT Jennings, a division of International Telephone and Telegraph Corporation, 970 McLaughlin Avenue, San Jose, California 95108.



We've got  
plenty of  
nothing.

JENNINGS **ITT**

# News Scope

## FAA to test ground aids for supersonic flight

A combined program of the Federal Aviation Agency and the Air Force will determine whether present air-navigation aids, radio communications and ground radar in the United States are adequate to control supersonic traffic. Aircraft at both high and low altitudes will check out the systems in commercial air lanes.

The two-year program will begin in July. The FAA wants to know if present equipment is accurate enough for use in the navigation and control of supersonic aircraft at altitudes ranging between 40,000 and 70,000 feet.

An FAA spokesman said that about 100 transcontinental flights would be made as part of the program. An FAA C-135 jet will fly the routes at less than 40,000 feet, and an Air Force U-2 will fly at about 70,000 feet. Both aircraft will be equipped with the same instruments to check ground navigational aids.

The flights will be made together,

to rule out differences due to weather and atmospheric conditions. They will check such navigational aids as VORTAC (Vhf Omnidirectional-Range Tactical Air Navigation) DME (Distance Measuring Equipment) and radar. FAA plans do not include testing of collision-avoidance or other air-to-air electronic systems.

The agency will compare the accuracy of fixes obtained by each test aircraft with fixes obtained by ground radar.

Whenever a new navigational aid is installed in the system or an aid in service receives a major overhaul, it is checked immediately by an aircraft flyover, the FAA spokesman said. However, he added that checks were not usually made from altitudes over 40,000 feet.

The agency wants to know if the accuracy of navigational aids at all altitudes can be checked at the lower altitude. It will try to find out if there is any overlap of signals from stations about 100 miles apart. This

overlap would not affect planes flying at less than 40,000 feet, but might be confusing to pilots of high-flying supersonic jets, because the pattern dispersion increases with altitude. So far military pilots who regularly fly at those altitudes have reported no difficulties with present navigational aids. If the correlation of data from the forthcoming tests is not high, the FAA may have to conduct future routine checkouts at higher altitudes.

The FAA's concern with supersonic flight is reflected in its recent announcement of a \$44.8 million contract to the Raytheon Co., of Wayland, Mass., for development of a major part of a semiautomatic air-traffic system. Raytheon will build a Computer Display Channel for the agency's National Airspace System, which is intended to improve the capability of the FAA's air-traffic controllers.

The computer display will give the controllers a three-dimensional picture of aircraft in their control areas. Electronically produced alphanumeric tags will represent each aircraft on the radar scope.

### Texas power utility goes fully automatic

Automatic monitoring and control in the electric utility industry will take a giant step forward this summer when work begins on a new energy control center for the Houston Lighting and Power Co.

When completed, early in 1969, the center will control what is billed as the most advanced, fully integrated power system in the world. Two Sigma-5 digital computers from SDS Corp., of Pomona, Calif., will form the center's nucleus. One, called the energy dispatch computer, will govern the loading of the system's nine generating stations to exact optimum operation. It will also provide data for daily load forecasting as well as for scheduling energy interchange with neighboring electric utilities.

The other computer is the systems operation computer. It will control the high-voltage transmission facilities, up to a maximum of 300 distribution substations.

The two computers are coupled by common memory units that permit the transfer of data between them. Should one system fail, the other



U-2 takes the high route, C-135 the low, in FAA navigation aid check

# News Scope

CONTINUED

will automatically take over its functions while still performing its own operations. A small back-up analog computer will take over the essential functions of the two digital computers should both fail.

A variety of displays enables operation of the entire system to be monitored from the control center. The status of any substation can be displayed selectively on a CRT mounted on a control console. Appropriate lines and symbols on the CRT will represent various substation equipment and its status. With a special light-pen the operator can alter operations or conditions at a substation directly from the CRT.

A 20- by 30-foot wall-mounted dynamic display will also be installed in the control center to provide information on the dynamic status of the entire transmission system. An unusual feature of this display will be the use of electroluminescent strips to represent the transmission lines. Loss of power in any line will be indicated by illumination of the corresponding electroluminescent strip.

Prime contractor for the energy control center will be Leeds and Northrup Co. The visual displays and their programming will be handled by Philco-Ford.

## Laser system tracks 4000-mph rocket sleds

A laser system that will focus a camera on rocket sleds traveling at Mach 6 has been developed for the U.S. Air Force by Sylvania Electric Products, Inc.

The system, which will be installed 1000 feet from a test track at the Air Force Development Center, Holloman AFB, N. M., will permit scientists to follow and record photographically sleds moving as fast as 4000 mph.

The unit comprises a cw laser, an electronically controlled mirror, and a camera and accessories. Dr. James E. Storer, director of Sylvania's Applied Research Laboratory, explains that the tracker laser's high-intensity beam is aimed at a reflecting surface on the sled. The

mirror automatically rotates to keep the laser on target and simultaneously reflects an image of the moving sled into the camera equipment, which records the run.

Once aimed at the sled, the laser tracks the moving vehicle with an accuracy of 25  $\mu$ rads.

## Credit card may replace cash trading before 2000

A "money card," making possible the electronic transfer of money and credit, will be in use for almost all personal transactions within 25 years. Use of such a card, similar to today's credit cards, would drastically reduce the handling of cash and produce fundamental changes in the banking and monetary structure of the U.S. economy.

This was the opinion of 94% of respondents in a recent nationwide survey of top executives of banks, savings and loan associations, insurance companies and large firms.

A commentary on the survey, conducted by Diebold Group, Inc., of New York, described the technology involved in automatic money transfers. It said in part: "The relevant developments include vastly increased information storage capabilities and processing speeds, improved communication links, image storage and transfer devices, and easy man-machine relationships—all at greatly reduced costs."

Diebold has published the more than 2000 responses and their implications in *A Summary Report of the Survey on the Impact of Electronics on Money and Credit*.

## Computer data copier speeds distribution

A new, high-speed electrostatic duplicating machine that reproduces continuous computer output can now be housed in the same room as a computer. It uses Triac motor control and solid-state digital logic circuitry for RF suppression.

The copier designed and built by the Xerox Corp., Rochester, N. Y., is specifically made for use alongside computer printout equipment. Directly from continuous printer records it automatically reproduces and reduces to page size 40 copies of data a minute. Completed copies are collated and made ready for binding, thus speeding distribution



Continuous computer output is reproduced by high-speed Xerox copier that can be housed alongside the computer.

of data.

The Xerox 2400-IV can take 15-by-11-inch continuous fan-fold forms coming from a data-processing printer, and within a half hour turn them into as many as 20 collated sets of 60 pages on regular 11-by-8-1/2-inch paper.

Xerox engineers used solid-state components to eliminate objectionable RF interference. Printed-circuit module boards with discrete components perform the logic functions of control-timing, paper-feeding and copy-collating.

## Process transfers color from video tape to film

A process that permits broadcast-quality color films to be made directly from video tape has been announced by Technicolor Corp. of America, of Burbank, Calif.

Joseph E. Bluth, vice president and general manager of Technicolor's Vidronics Div., said the system combines "the economy and speed of video tape photography with the mass-production savings of color film duplication."

The transfer system basically involves breaking a video tape down into its red, green, and blue images and recording them separately. These images are specially enhanced electronically before processing. Technicolor then registers the separations to produce a quality composite print, integrating the components into a final film.

The process, according to the company, will transfer video tape onto 35-mm, 16-mm, 8-mm and the new Super-8-mm color film.



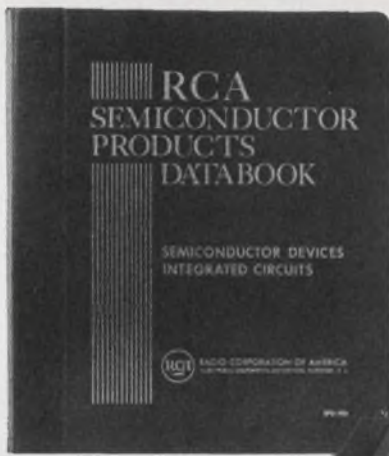

# The databook

The Industry's newest, fastest approach for finding the RCA Semiconductor Device or Integrated Circuit you want in the industry's most simplified filing system.

The new DATABOOK includes detailed engineering information in booklet form on RCA commercially available semiconductor devices, including silicon, germanium, and MOS transistors; thyristors (SCR's and Triacs); silicon rectifiers; tunnel diodes; photocells; and the new RCA integrated-circuit product line (both digital and linear types).

Frequent mailings serve as a "hot line" to RCA's new product announcements... and filing couldn't be easier. All you do is "drop in" the latest sheets on top.

Product selection is keyed to the circuit designer's real needs. A separate 44-page Product Guide allows the user to find his device easily and quickly by either type number or function.

Over 1000 data-packed pages... detailing more than 700 RCA solid-state devices with specifications and curves. Large-sheet format, the DATABOOK is designed throughout with today's busy engineer in mind.

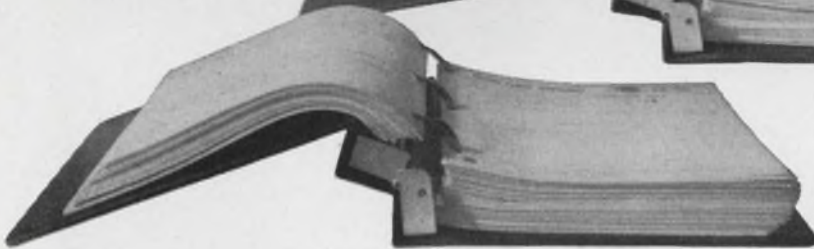
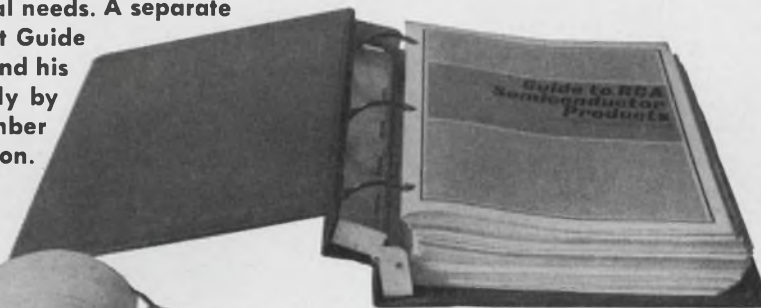
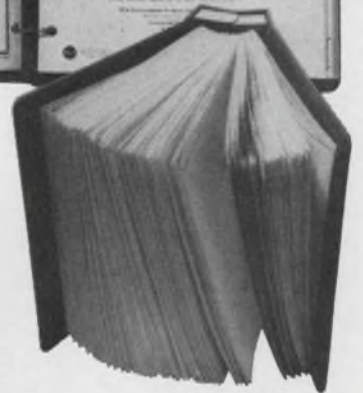
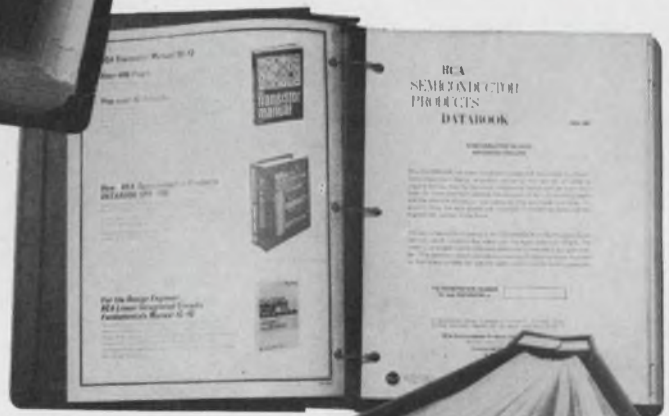

From front to back cover, the new RCA DATABOOK represents a true advance in technical data subscription services. To get your copy, fill out and mail the handy coupon today.



## SUBSCRIPTION ORDER FORM

RCA Electronic Components and Devices



The Most Trusted Name in Electronics

Commercial Engineering  
RADIO CORPORATION OF AMERICA  
Harrison, N. J. 07029

Date \_\_\_\_\_

Gentlemen: Enclosed is my remittance of \$ \_\_\_\_\_ (check or money order) for which please enter my subscription for \_\_\_\_\_ RCA Semiconductor Products DATABOOK, SPD-100 @ \$10.00\* each. \*Price shown includes service for one year. (Foreign \$15.00)

NAME \_\_\_\_\_  
(Please Print)

FIRM \_\_\_\_\_

ADDRESS \_\_\_\_\_ CITY \_\_\_\_\_

STATE \_\_\_\_\_ ZIP CODE \_\_\_\_\_

ON READER-SERVICE CARD CIRCLE 10

# A Family of Insulating Products...

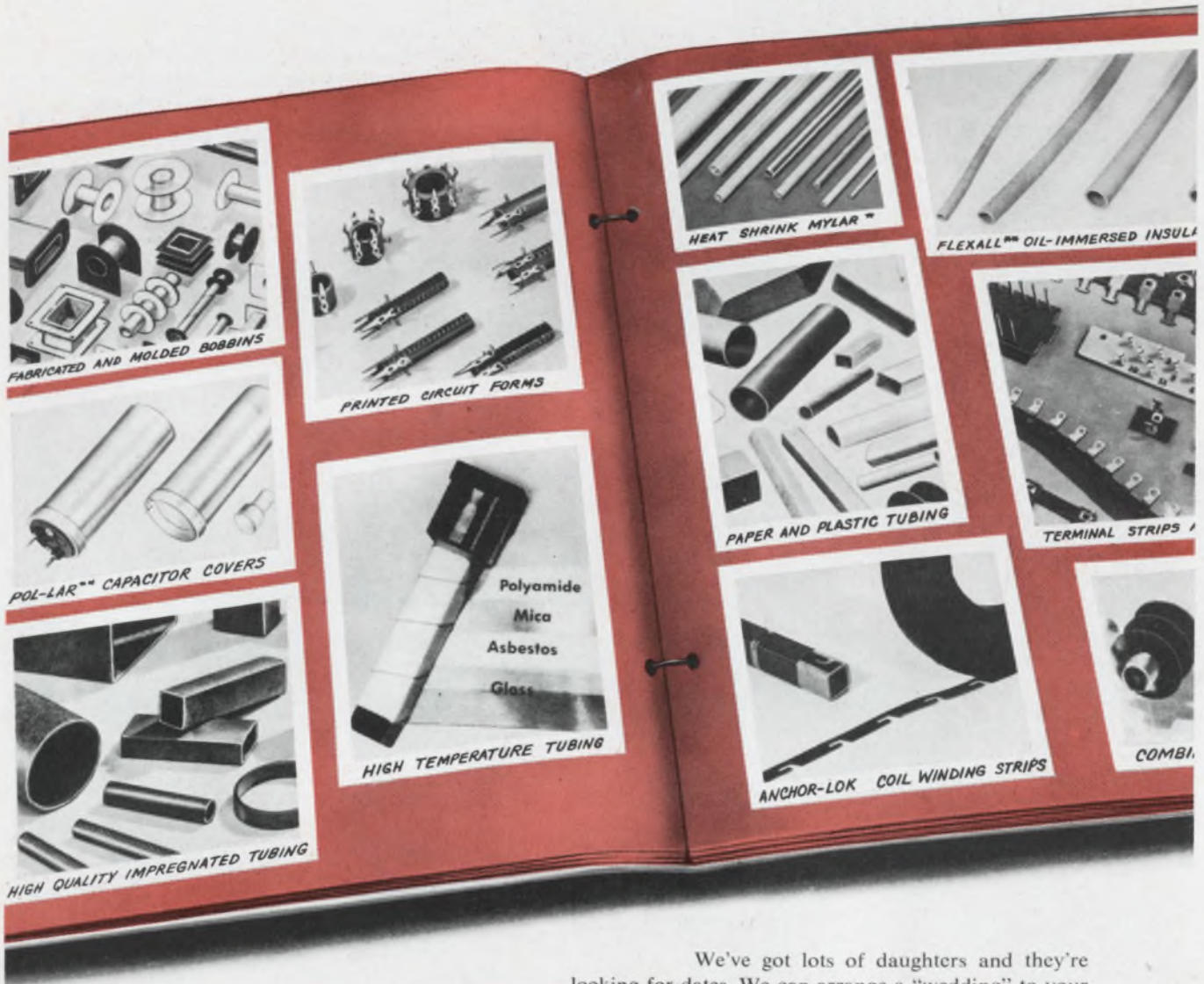

We've got lots of daughters and they're looking for dates. We can arrange a "wedding" to your specifications . . . quickly and with only a small dowry on your part. If you see a member of our family you'd like to know better . . . drop us a line or phone us at our "home" in Wheeling (Ill.). Let us know which one interests you the most and we'll send you full particulars.

\*Registered trademark—DuPont Co.  
 \*\*Registered trademark—Precision Paper Tube Co.



## Precision Paper Tube Company

Divisions: Resinite • Buckeye Bobbin • Automation Devices

1033 S. Noel Ave., Wheeling, Ill. Phones: Chicago: 631-1445 • Long Distance: 312-537-4250,

ON READER-SERVICE CARD CIRCLE 11

## Where LSI will really pack a wallop!

### Panel sees a future for those large-scale circuits in impending expansion of time-sharing terminals

**Roger Kenneth Field**  
Microelectronics Editor



The peripheral equipment in a time-sharing computer, said IBM's Paul Low, may contain four times as many circuits as the computer's main frame.

In a smoky room in the basement of Philadelphia's Sheraton Hotel last month, four men from different walks of computing life discussed the future of large-scale integration (LSI). The panel's subject: the peripheral equipment associated with time-sharing computers.

LSI is fraught with many uncertainties. Yet many fascinating speculations filled the air of this informal session. The panelists concluded tentatively that large-scale integration may do much to ease the maintenance and improve the reliability of peripheral equipment but that it won't cut costs significantly.

The first panelist to address the audience, Paul Low, is developing time-sharing terminals at IBM, Fishkill, N. Y.

"The terminals of a time-sharing computer are deceptively important," he said. "Though a fast computer might have 100,000 circuits in its main frame, it could well have four 100-circuit LSI arrays in each of its terminals. If the system were to have 1000 terminals, then these terminals would contain a total of 400,000 circuits."

Low pointed out that since the large-scale arrays in the terminals

are fed by a keyboard or graphic display tube, they don't have to be nearly as fast as the main frame logic circuitry. But they do have to be immune to ambient noise and capable of withstanding extreme temperature changes, since the terminals might be located anywhere from the basement of a power generating plant in Brooklyn to a loading dock in Vermont.

Power-supply requirements are an important consideration in the design of both the arrays and the terminals. It would be foolish, Low pointed out, to build a terminal with a \$125 keyboard, a few \$10 arrays and a \$350 power supply; it would be best to use large-scale arrays that didn't require extremely tight voltage regulation.

William Davidow of Hewlett-Packard agreed that the design of the terminals demanded much attention. "One Stanford professor dreams of a time-sharing terminal in every classroom," he noted, "and there are well over a million primary and secondary classrooms in the United States."

There are other problems besides the cost of the terminals. Costs for the use of lines that connect the terminals to the computing center can be considerable, Davidow observed. One professor associated with Project Mac at the Massachusetts Insti-



Users won't buy LSI just to improve terminal reliability, according to RCA's Richard Ahrons.



A terminal in every classroom is the dream of one professor, said William Davidow of Hewlett-Packard.

tute of Technology, whose broad goal is to develop a community "utility" that would supply computer "power" to customers, reportedly decided to solve a problem on the MIT computer in Cambridge, Mass., while he was traveling in Germany. He dialed the multiple-access computer and in a relatively short time solved the problem. He was startled when the total intercontinental phone charges reportedly amounted to over \$2000. One panelist suggested that information transmission was slow and costly because the lines were not designed for digital use but to carry signals in an extremely limited bandwidth, suitable for voice reproduction.

If communication lines for high-speed digital transmission become available, it will be desirable, from the standpoint of costs, to keep them fully loaded with information, noted Graham Tyson of Data Products Corp., Culver City, Calif., a manufacturer of peripheral equipment. "To keep the lines operating at full capacity," he said, "the terminals and print-out devices must buffer the data—store it and compress it before its transmission at high speed, and store it after reception prior to feeding it to electromechanical devices that run at their own [relatively slow] speed. Coding, too, can also be performed in



LSI will buffer, process and code data in the terminal, reported Graham Tyson of Data Products Corp.

the peripheral gear, which might even have built-in control logic and pre-programed instructions for the main computer."

The big question, Tyson feels, is: Will LSI help the maintenance problem? As the terminals move out of the building that contains the main frame, they move away from the personnel who stand by to service the computer.

"Many of the terminals may be located in pretty inaccessible spots, and it would be better if a secretary could unplug a faulty circuit and slip in a spare," Tyson said. "If she can't, it could take hours for a service man to reach the terminal and get it back into service."

Many potential users wonder if their hopes for LSI will ever come true. "They will!" panelist Gordon Moore assured the audience. His company, Fairchild Semiconductors of Palo Alto, Calif., is already marketing MOS large-scale arrays.

"It'll be hard to build factories fast enough to use up the LSI arrays that will be produced," he predicted. "The big arrays are really a marketing problem. They fall into three categories: relatively few types, such as shift registers and memories, are generally useful; many specialized units will be used extensively in long production runs of popular terminals and print-

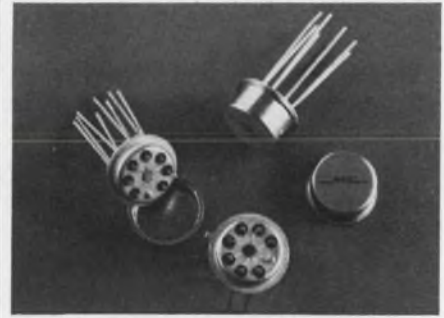

Available from your

**NSC**  
distributor

**WESTERN DISTRIBUTORS:**

Fortune Electronics  
695 Veterans Blvd.  
Redwood City, California 94063  
(415) 365-4000

Kierulff Electronics  
3969 East Bayshore Road  
Palo Alto, California 94303  
(415) 968-6292

Arco Pacific  
Bohamon Drive  
Menlo Park, Calif. 94025  
(415) 324-1356

Liberty Electronics Corp.  
339 South Isis Avenue  
Inglewood, California  
(213) 678-8111

Spectronics  
131 Garnet  
Ridgecrest, California 93555  
(714) 378-2831

Western Electronic Components  
4301 Birch St.  
Newport Beach, California  
(714) 540-1322  
(213) 631-6119

Newark-Denver Electronics Supply  
P. O. Box 22045  
Denver, Colorado  
(303) 757-3351

Pacific Electronics  
1336-4 Dillingham Blvd.  
Honolulu, Hawaii 96817  
817-118

Sterling Electronics, Inc.  
1712 Lomas Blvd., N.E.  
Albuquerque, New Mexico  
(505) 247-2486

Kierulff Electronics  
2585 Commerce Way  
Los Angeles, California 90022  
(213) 685-5511

Ballard Supply Company  
3109 Washington Blvd.  
Ogden, Utah 84400  
(801) 394-5541

Ballard Supply Company  
44 East 6th Street, South  
Salt Lake City, Utah 84100  
(801) 364-6541

Kierulff Electronics  
6133 Maynard Ave., S.  
Seattle, Wash. 98108  
(206) PA 5-1550

Kierulff Electronics  
8137 Engineer Road  
San Diego, California  
(714) 278-2112

ON READER-SERVICE CARD CIRCLE 13

# MONOLITHIC VOLTAGE REGULATOR

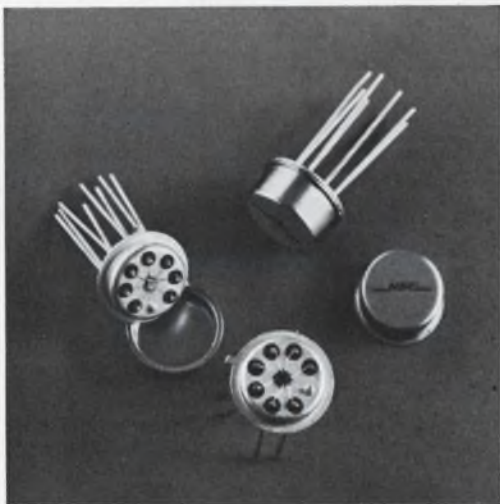

- Output adjustable from 2V to 30V.
- Output currents in excess of 5A using external power transistors.
- Can be used as either a linear or a high-efficiency switching regulator.

VISIT US AT THE IEEE SHOW  
BOOTH 4E19-21-23  
AND SEE OUR BROAD PRODUCT LINE

## The first of a new line of monolithic linear integrated circuits

This versatile regulator features regulation better than 1 percent for widely varying load and line conditions. Temperature stability is better than 1 percent over the full military temperature range. As a linear regulator, the LM100 provides current limiting, excellent transient response

and unconditional stability with any combination of resistive or reactive loads. As a switching regulator the circuit will operate at frequencies up to 100KHZ with efficiencies better than 85 percent.

The LM100 is immediately available from distributor stock..

**NSC**  
MICROCIRCUITS DIVISION  
NATIONAL SEMICONDUCTOR CORPORATION  
2950 SAN YSIDRO WAY, SANTA CLARA  
CALIFORNIA 95051 (408) 245-4320

ON READER-SERVICE CARD CIRCLE 16

# New from Sprague!

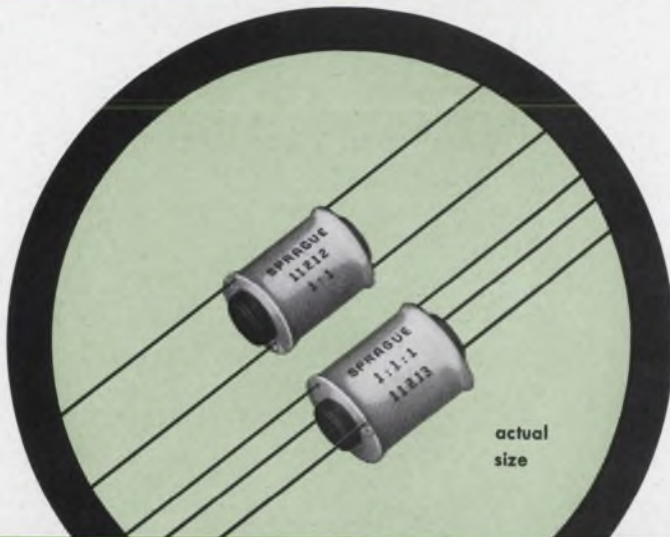

## TRIGATE\* PULSE TRANSFORMERS... the industry's lowest-cost SCR triggers!

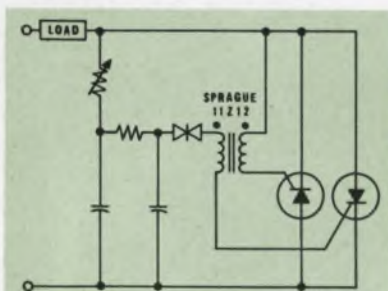

This breakdown-diode/transformer triggering circuit is a typical application for Type 11Z12 Trigate Pulse Transformers.

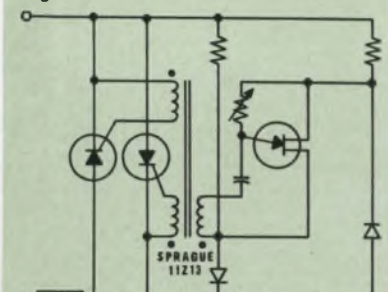

This unijunction-transistor/transformer triggering circuit is a typical application for Type 11Z13 Trigate Pulse Transformers.

### Dependable enough for industrial equipment, yet priced for high-volume commercial applications

Here's good news for designers of appliances; lighting controls; air-conditioning and heating controls; industrial controls. You can actually cut costs while upgrading your present method of SCR triggering!

Type 11Z Trigate\* Pulse Transformers offer these unique features:

1. Balanced pulse characteristics and energy transfer from primary to secondary and tertiary windings.
2. Minimum saturation effect to allow operation where increased pulse widths are required.
3. Fast pulse rise time and increased current capability to prevent SCR  $di/dt$  failure.
4. Increased energy transfer efficiency.

Temperature operating range,  $-10\text{ C}$  to  $+105\text{ C}$ . 2- and 3-winding designs for half- and full-wave applications. Turns ratios, 1:1, 1:1:1, 2:1, 2:1:1, 5:1. Available for use with line voltages up to 240 VAC or 550 VAC.

For complete information, write for Engineering Bulletin 40,003A to the Technical Literature Service, Sprague Electric Co., 347 Marshall St., North Adams, Mass. 01247

\*trademark

### SPRAGUE COMPONENTS

PULSE TRANSFORMERS  
CAPACITORS  
TRANSISTORS  
RESISTORS  
THIN-FILM MICROCIRCUITS  
INTEGRATED CIRCUITS

INTERFERENCE FILTERS  
PACKAGED COMPONENT ASSEMBLIES  
FUNCTIONAL DIGITAL CIRCUITS  
MAGNETIC COMPONENTS  
CERAMIC-BASE PRINTED NETWORKS  
PULSE-FORMING NETWORKS



\*Sprague and ® are registered trademarks of the Sprague Electric Co.

488C-6102R2

ON READER-SERVICE CARD CIRCLE 17

## NEWS



User dreams of LSI will come true! Fairchild's Director of Research, Gordon Moore, assured the audience.

outs; and some demand will exist for small runs of specialized circuits. It's this last category that will present a price problem."

Moore agreed that the large-scale arrays in most peripheral equipment did not have to be very fast. "MOS allows a high density of devices and circuits on a chip," he said. "They are more than fast enough to keep up with a mechanical keyboard."

One engineer in the audience rose to ask: "When will they get rid of the antiquated keyboard and develop better interfaces between operator and computer?"

The panel bandied the question about. One panelist pointed out that it was unlikely that \$5000 graphic consoles and still more expensive pattern-recognition equipment could be made cheap enough—even with the advent of LSI—to compete with the keyboard. The panel's general feeling was that LSI's main advantage was to increase system reliability.

At this an RCA representative in the audience, Richard Ahrons, stood up and said that "the reliability of today's integrated circuits is so high, compared with mechanical equipment, that it is pointless to use LSI just for the sake of improving reliability in peripheral equipment."

But Fairchild's Rex Rice, the moderator of the session, suggested that the reliability gains would result from the elimination of pins, connectors and soldered connections rather than from the circuits themselves. ■ ■

# Will LSA mode outmode Gunn oscillators?

## Transistors are still first as solid-state microwave sources, but new mode in GaAs may close gap

**Maria Dekany**  
Technical Editor

Transistors still lead the way as microwave solid-state power sources, but bulk oscillators and avalanche diodes are closing in.

In coming to this conclusion, a six-member panel on microwave power generation with solid-state devices at the International Solid-State Circuits Conference agreed on the following major points:

- The power and frequency limitations of transistors can be partly alleviated by better heat transfer through the packages and a reduction of the chips' parasitics.

- A new mode of operation, called limited space-charge accumulation, in gallium arsenide may make Gunn oscillators obsolete before they ever hit the market (see Figs. 1 and 2). But the lack of uniform and reliable gallium arsenide is preventing commercial marketing (see "Pace of Gunn-effect research quickens," ED

2, Jan. 18, 1966, p. 17).

- The major drawback of avalanche diodes is noise. Although their output is sufficient, they are too noisy for local oscillators and must be phase-locked, even in Doppler applications.

The six panel members were about evenly divided between transistor and bulk-device advocates. The transistor specialists were Harry Cooke, member, technical staff, Texas Instruments, Inc.; George Luettgenau, assistant plant manager, TRW Semiconductors, Inc.; and Ronald R. Carley, engineering leader, Radio Corp. of America.

The experts on bulk-effect and avalanche devices and on materials were Mark R. Barber, member, technical staff, Bell Telephone Laboratories, Inc.; Daniel G. Dow, manager, microwave semiconductor task force, Varian Associates; and B. Pistoulet, professor, Université de Montpellier, France.

### Transistors supply cleanest output

Transistors can now supply fundamental power up to about 6 GHz, said panel member Cooke, and do well with harmonics above this.

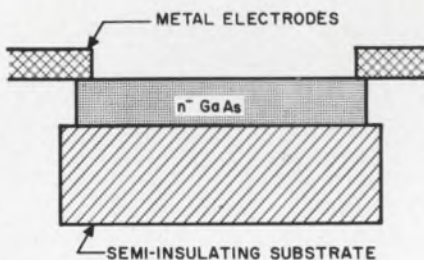

(a)

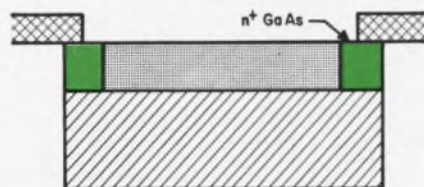

(b)

1. Fringing fields at the contacts of bulk oscillators, created by conventional mounting techniques (a), are eliminated by the deposition of n<sup>+</sup> type GaAs (b) that serves as a base for the contacts.

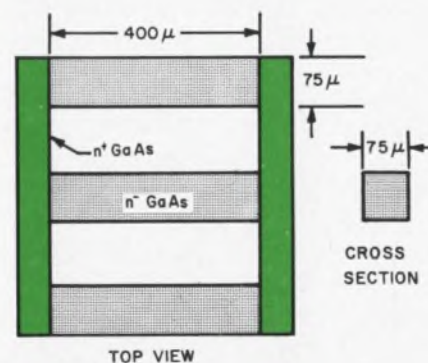

2. Schematic configuration of a GaAs oscillator shows dimensions for a unit that operates at 1 GHz in the LSA mode. Since in this mode the frequency does not depend on the length of the sample, it is shaped to obtain good heat transfer necessary for cw operation.

"Even at much higher frequencies, say, at 16 GHz, transistor-multipliers can yield a few hundred milliwatts' quiet power," he explained, "while the direct outputs of devices like the Gunn oscillator and the avalanche diode are very noisy."

Panelist Carley said that now there are transistors that can deliver 1 to 1.5 watts at 2 GHz with 30% to 40% efficiencies (input power is 300 mW). At 1 GHz, 10-dB gains are available, with output powers around 2.5 watts.

Outlining the limiting factors of transistors, Cooke pointed out the three major problem areas: the chip, the package and the circuit. The chip dictates the intrinsic capabilities of the device. Its parasitics and thermal resistance should be reduced for full realization of these inherent capabilities, he said.

The packaging of microwave transistors requires special care. From the thermal considerations, the ideal package should facilitate heat removal on two sides: through its top and bottom, said Cooke. The transistor specialists on the panel agreed that both stripline and coaxial approaches have their places. The critical factors in the package are the common-lead inductance and the input and output capacitances. Cooke offered a brief rundown of package types for systems engineers (see Fig. 3).

Large coaxial types are usually limited to about 2 GHz, while small coaxial ones have been operated up to about 8 GHz. The lead inductance of the former is about 0.3 nH, and of the latter, 0.08 nH.

Stripline packages come in several versions. For example, a stud-mount type is essentially a stripline package with a stud to remove heat. Its size (about 3/8 of an inch) prevents its use above 2 GHz. In general, the capacitances in the stripline package depend on the frequency. The rub is whether the tuning element should be considered a lumped or a distributed element when the device is inserted in a system.

The latest thing in packages is a

(microwave power, *continued*)

chip type. It is a 70-mil square of 20-mil-thick alumina. The transistor is mounted on the metal base and covered with epoxy. Texas Instruments reports operation up to about 6 GHz, with measured common-lead inductances of 0.15 nH.

Limitations due to circuit design usually appear in broad-band applications. The difficulty of matching to large admittances usually leads to losses and narrow bandwidths. In cases when more than one active device is needed to supply the required power, the complexity of the circuit imposes further restrictions on the bandwidth.

### Bulk devices near marketing

Bulk-effect devices can now operate in two modes: Gunn-oscillation, which is a transit-time effect and depends on the length of the sample, and LSA (limited space-charge accumulation), which does not depend on the length of the sample and promises substantial output (see "New technology keys Solid-State Circuits show," ED 5, March 1,

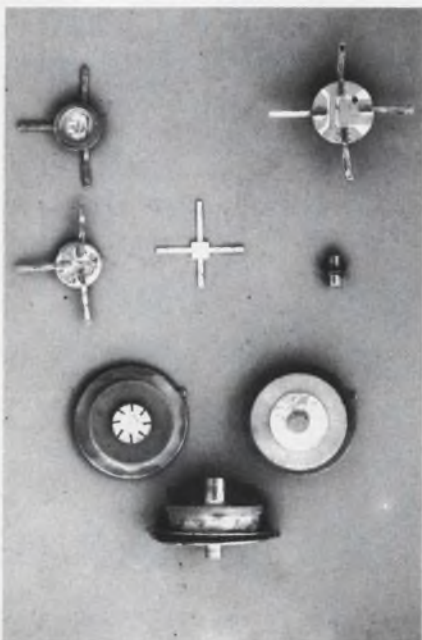

3. Package types affect frequency and power range. Both stud-mount stripline (upper right) and large coaxial packages (bottom) work up to about 2 GHz and dissipate about 5 watts. Small coaxial (right center), stripline (left) and pellet (center) types go up to and beyond 6 GHz and dissipate less than a watt.

1967, p. 17).

These devices, even though not yet marketed by U.S. companies, appear to hold great promise as practical microwave power sources. Some of the fundamental problems may soon be solved, as Barber pointed out.

The recently publicized LSA mode of operation strengthens the position of bulk devices at the low end of the microwave spectrum, said Barber. There is no need for very large dimensions, since the operating frequency does not depend on the length of the sample. "If LSA really works, the Gunn-type oscillator will cease to exist," said Harry Cooke.

Contact-mounting difficulties, long plaguing GaAs bulk devices, seem to be near solution, too. Figure 1 shows the approach taken at Bell Laboratories. The trouble with the contacts was the irregular fringing fields created at the point where the metal contacts were attached to the n-type GaAs (Fig. 1a). These fields are eliminated, Barber said, by the deposition of n<sup>+</sup>-type GaAs at the ends of the n-type (Fig. 1b) that serves as base for the contacts.

An L-band bulk oscillator, operating in the LSA mode, illustrates this approach (see Fig. 2). It has three 75-micron-wide and 400-micron-long active n-type strips, deposited on a semi-insulating substrate. The configuration looks very much like a transistor but it is obviously much larger. The comparable dimensions are the bulk oscillator's 75 microns versus about 1 micron for transistors, Barber noted.

The one remaining problem with bulk-effect devices is up to the material scientists: to produce gallium arsenide with the needed homogeneity in quantity. The problem is compounded with operation in the LSA mode; it requires more homogeneous materials than the Gunn oscillator. It will take at least another year for significant improvements to be made, according to Prof. Pistolet.

### English Gunn device for \$700

There is only one company, Standard Telephone Laboratories in England, that markets bulk oscillators, Barber commented when questioned about the availability of

these devices. The price of an X-band oscillator with a 5-mW output is \$700, excluding the cavity. That is \$28 extra. Obviously some efforts are still needed to make these devices commercially competitive with transistors and klystrons, the panel agreed.

The capabilities of these new power sources were summed up best by Dow. He uses the product of power and frequency squared ( $Pf^2$ ) to estimate the possibilities of the Gunn oscillator, the Impatt (impact avalanche and transit-time) diode and the LSA mode. (The complete expression is  $Pf^2Z$ , but  $Z$  may be assumed to be the same for all three cases.) In pulsed operation (in watts times GHz<sup>2</sup>) this product is 400 for the Gunn device, 4000 for the Impatt diode and already 3000 for the LSA mode. Dow believes that ultimately cw operation will follow the same  $Pf^2$  law.

Avalanche diodes received less than an equal share of the limelight during the panel discussion. The fact that they are the simplest solid-state source was briefly pointed out. Mark Barber mentioned some recent results: up to 3 watts pulsed power at 2 GHz is available from prototypes. Commercial devices deliver about 300 mW at the same frequency.

Curiously enough this apparent lack of interest did not extend outside the conference. For example, 16 companies are in the race for a contract to supply avalanche diodes for a Fort Monmouth, N. J., program.

The questions from the floor reflected some of the practical difficulties of the users. For example, a question on how to make good ground connections to the many types of striplines pointed up the lack of standards in striplines. The device designer does not know the thickness of the stripline the engineer will use with the active package. Therefore he cannot make the best-size flanges and the user must improvise. The panel suggested that the user can bring the flanges out and press them down to the stripline, or drill holes into the stripline for ground connection. But the panel agreed that this difficulty may soon be solved with the advent of beam leads (see "Integrated circuits shed their wires," ED 4, Feb. 15, 1967, p. 17). ■ ■



## HEWLETT-PACKARD MAGNETIC RECORDING SYSTEMS THRIVE ON ANYTHING YOU FEED THEM

Hewlett-Packard 3900 Magnetic Recording Systems are ideal for everything from storage of simple physical phenomena to applications in complex telemetry ground stations. You cannot buy better record, storage and playback performance for your money.



Hewlett-Packard's advanced tape transport design delivers reliable, maintenance-free operation. Three-mode recording — FM, Direct and Pulse — covers all your simple and complex data storage and playback needs. The HP 3900 Systems include 7- or 14-channel recorders in low or intermediate bandwidths. Low bandwidth direct mode is 50 Hz to 100 kHz and FM mode is DC to 10 kHz. Intermediate bandwidth direct mode frequency range is 50 Hz to 250 kHz and FM mode is DC to 20 kHz. Signal/noise ratio is 40 db or better and harmonic distortion is 1% typical 1 kHz per second at 60 ips with 0.2% peak-to-peak flutter. Six pushbutton-selected tape speeds range from 1<sup>7</sup>/<sub>8</sub> ips to 60 ips. HP tape systems are completely IRIG compatible.

Optional equipment includes: closed loop recording adapter, frequency-compensating plug-ins for FM and Direct mode record/reproduce circuits, remote control, voice commentary channel amplifier, input signal coupler, portable cases and rack adapter.



For complete information on the 3900 Systems, their variations and optional equipment, contact your local HP Field Office or write Hewlett-Packard Co., 175 Wyman Street, Waltham, Mass. 02154.

HEWLETT  PACKARD  
*measuring instruments  
for science and industry*

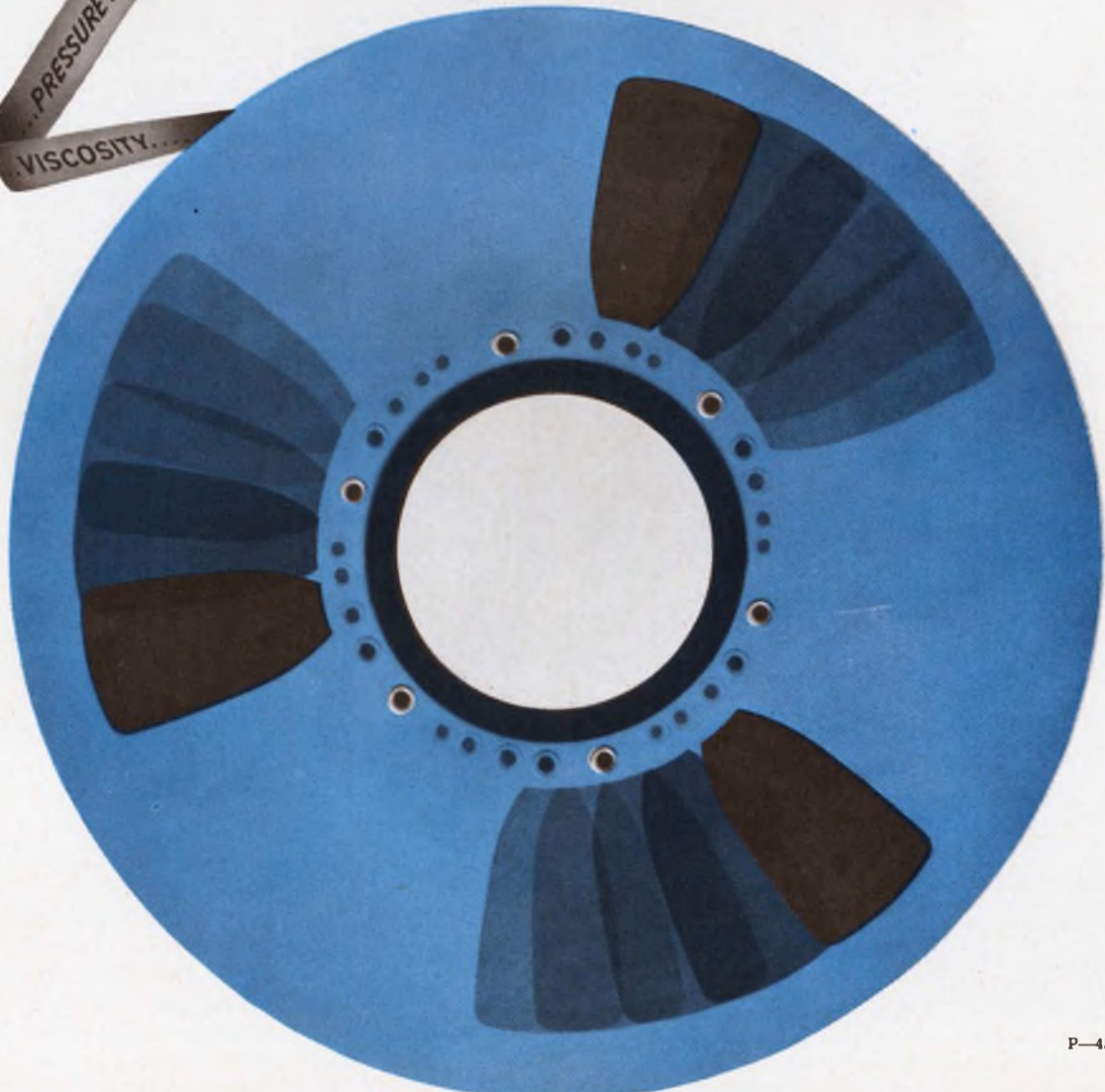

## THE OUTLOOK FOR LONG-RANGE WEATHER FORECASTING:

# Cloudy, probably followed by partial clearing

## Many electronic improvements being made, but accurate 2-week predictions still elude scientists

**Ron Gechman**  
West Coast Editor

From Biblical times, when weather worriers scanned the skies for telltale red, to the modern age of satellites, weather forecasters have pursued an elusive goal: long-range accuracy. In the Northern Hemisphere today, weather scientists use daily, besides the U.S. Tiros, Nimbus and Essa satellite systems, some 700 radiosonde balloons, 1000 aircraft and 7000 ships and land observation stations. But the goal of an accurate two-week forecast still escapes them.

The reason, it became clear anew last month at the IEEE Winter Convention on Aerospace and Electronic Systems in Los Angeles, is still basically simple and yet paradoxically complex: scientists still do not know enough about what causes weather. Once the weather is there, they can track it fairly successfully and predict reasonably accurately over a period of 36 hours where it will go.

A sprawling effort is under way

in the electronics industry to develop new equipment that will help fill the gaps in knowledge. Among the steps, sources at the Los Angeles convention and elsewhere report, are these:

- The updating of computer equipment.
- Improvements in transmitters.
- The use of rockets to supplement data from radiosonde weather balloons.
- Advances in wind-measuring instruments.
- The use of ocean buoys to relay meteorological information.
- The establishment of automated networks by the military to coordinate data from around the world.

### Present techniques limited

The present goal of two-week predictions, according to A. Wiin-Nielsen of the University of Michigan Dept. of Meteorology and Oceanography, stretches current scientific and mathematical techniques to their limits.

One specialist, however, looks to man's ability to overcome the "weather barrier." He is Glenn Cato, manager of atmospheric systems at Electro-Optical Systems, of Pasadena, Calif. He speculates that this country's proposed moon-landing program might lead to experiments that could open the way to weather control from space in 10 years, along with two-week predictions that would be 80 to 90 per cent accurate. Cato feels that after men are landed on the moon, the space vehicle and its service modules could be used for meteorological observations and might prove better suited for the task than unmanned satellites. With weather modification techniques, he looks for six-to-eight-week forecasts of weather in the next half century.

It has been estimated that weather-reporting stations today monitor only 10 to 20 per cent of the earth on a continuing and reliable basis. The areas lacking reporting stations include uninhabited land masses and vast regions of the oceans where much of the world's weather is born.

Nor are present weather satellites the ultimate in data-reporting, according to scientists. The spacecraft are unmanned, and thus restricted by their preselected orbits from following unexpected storm patterns. Moreover their viewing times in each geographic area are limited.

### Larger computers needed

But even with shortcomings, the weather satellites relay voluminous quantities of important data. The new technology has opened a need for larger computer systems to assimilate and interpret the deluge of data rapidly, before it is too old to be of value. One Weather Bureau spokesman is reported as saying: "Give me the largest computer you've got. My program is like a cylinder of gas; it will expand to fill it."

Harold Bedient, chief of the Na-



**Fosdic IV** enables the Weather Bureau to retrieve data from microfilm, shown being threaded onto a transport. The recorder is at left. Other racks contain logic, memory, scan control and film-advance circuitry.



# SCR SERIES POWER SUPPLIES



**NEW styling...**



**SMALLER size...**



**LESS ripple...**



Brand new design and a new concept and production of proprietary electronic filtering, all in the SCR from the oldest sole-manufacturer of power supplies, guarantees quality, highest performance and lowest cost.

Model No.	Voltage Range	Current Range	Voltage Regulation Line or Load
SCR 10-1000	0 to 10	0 to 1000	0.1% or 5MV
SCR 10-500	0 to 10	0 to 500	0.1% or 5MV
SCR 10-250	0 to 10	0 to 250	0.1% or 5MV
SCR 20-500	0 to 20	0 to 500	0.1% or 10MV
SCR 20-250	0 to 20	0 to 250	0.1% or 10MV
SCR 20-125	0 to 20	0 to 125	0.1% or 10MV
SCR 40-250	0 to 40	0 to 250	0.1% or 20MV
SCR 40-125	0 to 40	0 to 125	0.1% or 20MV
SCR 40-60	0 to 40	0 to 60	0.1% or 20MV
SCR 120-80	0 to 120	0 to 80	0.1% or 60MV
SCR 120-40	0 to 120	0 to 40	0.1% or 60MV
SCR 120-20	0 to 120	0 to 20	0.1% or 60MV
SCR 160-60	0 to 160	0 to 60	0.1% or 80MV
SCR 160-30	0 to 160	0 to 30	0.1% or 80MV
SCR 160-15	0 to 160	0 to 15	0.1% or 80MV
SCR 500-20	0 to 500	0 to 20	0.1% or 250MV
SCR 500-10	0 to 500	0 to 10	0.1% or 250MV
SCR 500-5	0 to 500	0 to 5	0.1% or 250MV

RMS Ripple: 10MV      Transient Resp: to within 2% in 50 M/S



*Write for more information.*

**THE ROWAN CONTROLLER COMPANY**

OCEANPORT, N. J. 07757

## NEWS

(*weather, continued*)

tional Meteorological Center's Data Automation Div. in Washington, D. C., sees the problem as twofold: computer systems must be improved to fit the thousands of inputs into a complete weather picture in a hurry and to predict changes in that picture, and the input network itself must be expanded to encompass the entire earth.

The Weather Bureau's most recent updating of equipment has been in a peripheral area. The bureau's Film Optical Sensing Device for Input to Computers (Fosdic), developed by the National Bureau of Standards for use with computers of the National Weather Records Center at Asheville, N. C., has come out in a new version. Designated Fosdic IV, the new machine reads data on past weather conditions from microfilms of punched cards, taken from the center's archives. Fosdic performs logical operations on the data it reads and selects some for recording on magnetic tape, to be used later as inputs to the center's computers. This permits comparisons of past weather conditions with more recently gathered data, so the center can study long-range patterns and improve its prediction services.

The machine reads the microfilms of punched cards at a rate of two million bits a minute, compared with the half-million rate of the earlier machine. The records center is in process of microfilming 400 million punched cards, to take advantage of the greater data density

of microfilm and the rapid access achieved by the new Fosdic. Each 100-foot reel of 16-millimeter microfilm can hold the images of up to 12,000 punched cards.

Data are read from the microfilm with the help of a flying-spot scanner. This technique allows examination of only certain areas of each frame, if desired. The punched holes on each photographed card appear as transparent rectangles surrounded by the opaque background of the card stock. A photoelectric cell senses light projected from a CRT beam through the holes. The data are passed from an 80-column storage register serially through a converter for translation from 12-bit logic (Hollerith) to six-bit-plus-parity or, binary coded decimal, whichever is compatible with the next computer operation. The results are then recorded on magnetic tape.

### New facsimile equipment

Map-transmission equipment is being updated, too. For years the Weather Bureau has struggled with equipment that, in some cases, is a decade or more old. Early in February, however, a new facsimile data-recording system went into 24-hour operation experimentally at the Weather Bureau center in Suitland, Md. There data from around the world are analyzed and weather maps are drawn up and transmitted to each local weather bureau in the United States. The new setup, a magnetic-tape system made by Consolidated Electrodynamics of Pasadena, Calif., is designed to record,

store, convert and transmit meteorological data throughout the entire country. It is being used in conjunction with new recording and scanning units in San Francisco, and it transmits, at higher speeds, maps of more detailed resolution.

With the new transmission and receiving equipment, an 18-by-24-inch weather map that formerly took 15 to 20 minutes to send and record can be processed in about a minute.

The transmission system uses well-known techniques to improve resolution:

- An input signal processor removes common-mode, or grounding, problems along the lines that might introduce noise.

- An input tracking filter with a narrow bandpass eliminates extraneous signal noise.

- The video information is first stripped from the carrier signal and recorded on tape. A new carrier is then generated from a highly stable oscillator, and it transmits the video information.

### Sensing equipment changing

A gradual change in ground-based data-collecting systems is also under way. To the familiar balloonborne radiosonde system, for example, has been added rocketsonde for collecting both low- and high-altitude data. The Missile Systems Div. of the Atlantic Research Corp., Costa Mesa, Calif., is developing a low-level meteorological sonde system that it calls Metarc. It consists of a solid-state instrumentation package that is lifted to an altitude of 5000 feet by a solid-fuel rocket. The package is ejected at the apogee, and it parachutes back to earth while an on-board transmitter relays data on wind direction and velocity, temperatures (including temperature differentials), humidity, dew point, pressure and density. The system's project engineer, Peter Anello, says it is designed for launching anywhere in the world from either land or sea, manually or automatically by remote control.

For high-altitude data gathering, other rocket systems such as one made by Metro Physics, Inc., of Santa Barbara, Calif., relay meteorological data starting at 200,000 feet. Metro calls its system Met-

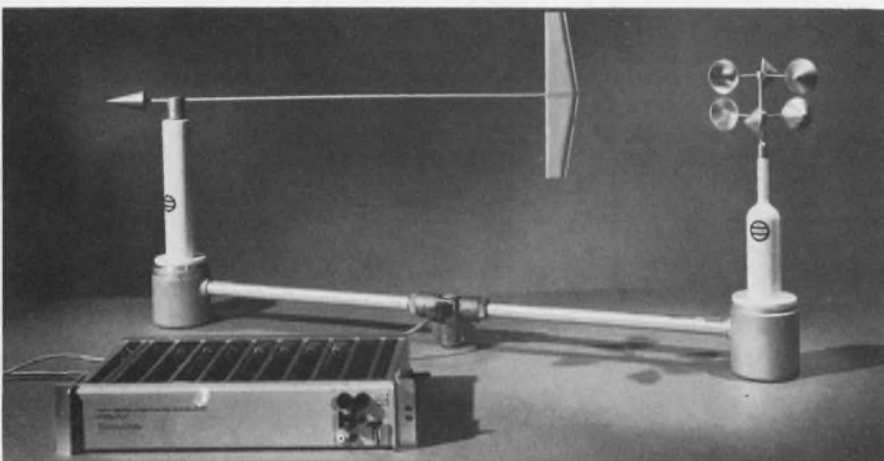

**Compact Meteorological package** built by Atlantic Research Corp. contains a solid-fuel rocket and a self-contained radar tracker. The rocket's instrumentation package is shown alongside the rocket.

# What's So Great About The Bourns Model 3438?

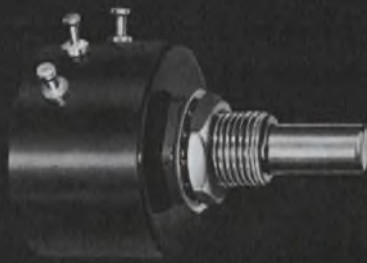

ACTUAL SIZE



\$ 8

## INFINITE RESOLUTION FOR ONLY EIGHT DOLLARS

Hard to believe, but here is an Industrial single-turn, precision potentiometer that uses the famous Bourns INFINITRON™ conductive plastic element, giving you infinite resolution for a list price of **only eight dollars**. The Model 3438 was designed for those control and instrumentation applications, where durability and resolution are the most important factors. Take a look at the outstanding specifications.

For further information and more detailed specifications on the Industrial Model 3438, contact your nearest Bourns representative, district office or the factory direct.



MODEL 3438

### Specifications

Resistance Range	100Ω to 50K ohms
Resistance Tolerance	± 20%
Linearity	± 1.0% max.
Power Rating	1 watt at 40°C
Operating Temperature Range	-15°C to +80°C
Vibration	10G
Shock	15G
Rotational Life	2,000,000 shaft revolutions
Weight	approx. 1 oz.
Dimensions	1 1/16" dia. x 3/4"
Terminals	Gold plated turrets



BOURNS, INC., TRIMPOT DIVISION • 1200 COLUMBIA AVE., RIVERSIDE, CALIF.  
TELEPHONE 714 684-1700 • TWX: 910 332-1252 • CABLE: BOURNSINC.

(*weather, continued*)

rodart. The Air Force Cambridge Research Laboratories has been developing its own systems to measure data in the 400,000-to-600,000-foot range.

Advances in more conventional meteorological equipment have been demonstrated by Beckman & Whitley of San Carlos, Calif. They have eliminated potentiometers and servos from their wind-speed and wind-direction instruments in favor of ac systems that employ capacitive transducers.

In their wind-speed sensor, an air-gap capacitive transducer rotates to produce an AM signal, which is demodulated to provide a sinusoidal output voltage that is proportional to the shaft rotation. The company's wind-direction sensor also employs an air-gap capacitive transducer, to phase-shift a 1-kHz sinusoidal signal proportional to the azimuth of the wind direction. The sensors have totally encapsulated solid-state circuitry and are designed to yield greater accuracy and high reliability with low maintenance.

### Weather buoys are launched

Meteorological buoys are being developed by a few companies, too. One buoy, called the Sea Environment Acquisition System, has been developed at Bissett-Berman's San Diego, Calif., plant. It consists of an instrumented subsurface buoy coupled to a surface buoy. The subsurface portion senses such oceanographic parameters as salinity, temperature, current speed and direction, and wave height. The surface buoy gathers meteorological data, such as wind speed and direction, barometric pressure and air temperature. An on-board tape recorder stores sensor input data in binary format until a readout interrogation signal is received from a shore station. The shore station normally reads out sensor data every six hours, but the buoy can be interrogated at any time. One such buoy is installed in the Pacific Missile Range, and the receiving station is at Point Magu, Calif.

General Dynamics has gone into buoy-making on a grand scale. Its Electric Boat Div. in Groton, Conn.,

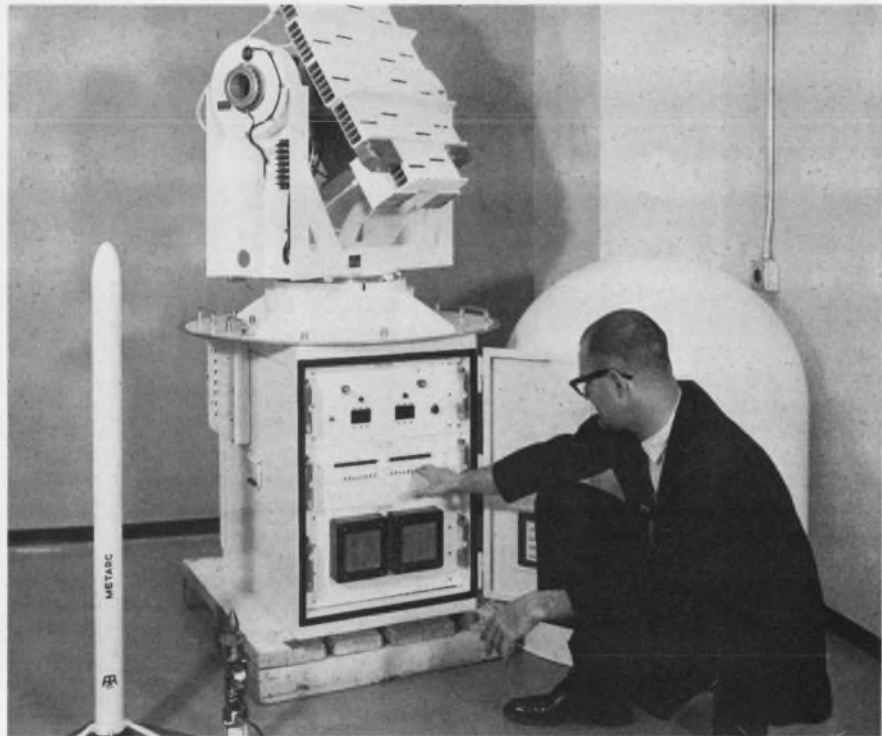

The latest in wind-sensing devices includes this Beckman & Whitley solid-state ac system, which measures speed and direction.

is making the hull for a monster buoy, 40 feet in diameter and weighing 50 tons, and its Convair Div. in San Diego, Calif., is instrumenting the buoy. The sensors measure the same basic information that Bissett-Berman's system does plus solar radiation, precipitation and humidity. A propane-driven generator provides power for operating the electrical systems. The buoy is designed to operate unattended for a year.

The monster-buoy data system can receive inputs from as many as 100 sensors. In normal operation the sensors are sampled once an hour, and the data are stored in two memories—a short-term and a long-term one. The short-term memory is used for telemetering data to shore; it reports all of the data collected in 24 hours. (A land-based receiving station interrogates the buoy every six hours to provide an 18-hour overlap in the received information.) The long-term memory stores all data collected in one year of unattended operation.

The data are telemetered in binary bits as a PCM signal on a FSK subcarrier. A single-sideband transmitter is used, with an average power of 100 watts.

General Dynamics is proposing a

network of its buoys scattered around all the oceans of the world.

### Military systems updated

The military weather services have been updating their equipment also. The Air Weather Service of the Air Force has placed in operation a computer-controlled, automated weather network to speed the flow of world data. The high-speed lines used in the system—some operating at up to 4500 words a minute—channel the data to the Global Weather Central at Offutt Air Force Base in Nebraska. Maj. William Roper of the Air Weather Service told last month's convention that since the system has gone into operation, the number of weather observations available for use within an hour and a half after transmission have increased 45 per cent. Upper-air data available within three hours after observation have increased by 67 per cent, he said.

Although the network has been in service only 18 months, the Air Weather Service has proposed to the Dept. of Defense that the automated setup be expanded and possibly tie in with satellites for the transmission of weather data. ■ ■

# REXOLITE<sup>®</sup> 2200 TAKES ON TOUGH ENVIRONMENTS

You can take a chip-on-the-shoulder attitude toward the cold, thermal shock and mechanical abuses that threaten microwave circuits — when you design with this laminate.

A glance at the physicals of Rexolite 2200 shows why. This copper-clad, glass-reinforced, cross-linked styrene copolymer has excellent strength, and a low coefficient of thermal expansion. With a 2.62 dielectric constant from 10 MHz to 10 GHz, it's no pushover in electricals, either.

If you're designing microwave circuits that have to "take it" in extreme environments, write for the specs on rugged Rexolite 2200.

One of the Brand-Rex microwave circuit laminates covering the broad spectrum of frequency and environment.

AMERICAN ENKA CORPORATION

BRAND-REX DIVISION

WILLIMANTIC, CONNECTICUT 06226  
PHONE 203 423-7771



# Tips on cooling off hot transistors

See how circuit designers use IERC heat dissipators to protect semiconductors...improve circuit performance and life.

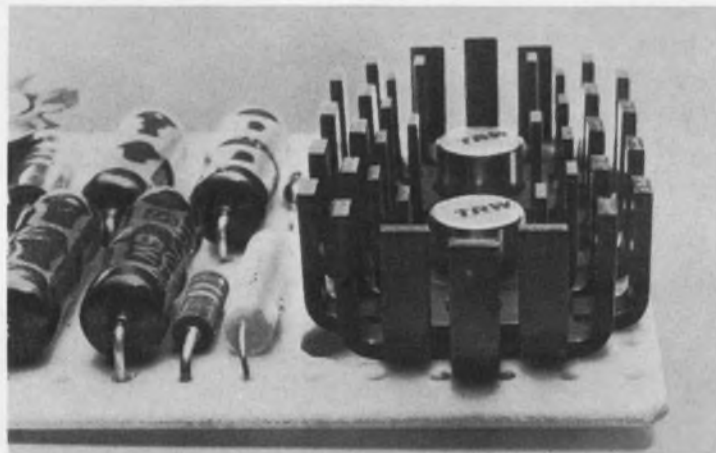
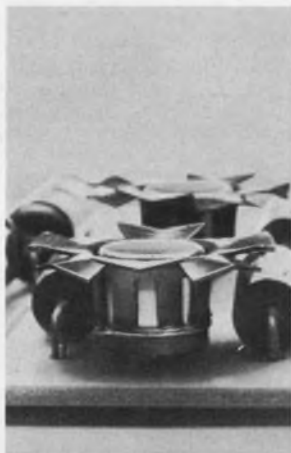
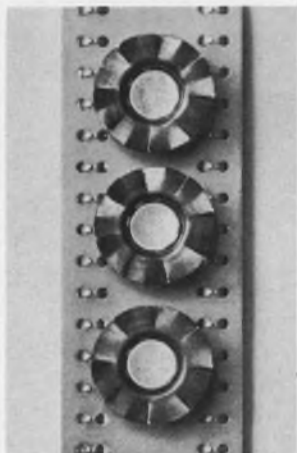

Fan-top dissipators for TO-5 and TO-18 cases drop temperatures dramatically; cost just pennies. T-shape adds almost nothing to board height; allows components to snuggle close to transistors. Spring fingers provide fast, press-on installation.

To cool off low-to-medium power transistors in TO-5 and TO-18 cases, use IERC's efficient LP's. Patented, staggered-finger design maximizes radiation and convection efficiency, radiates heat directly to ambient. Available in single or dual mounting for thermal mating of matched transistors.

IERC Thermo-Link Retainers provide efficient thermal links between transistors and chassis or heat sinks. (Also, excellent dissipation when used on p-c boards.) Integral BeO washers reduce capacitance up to 2/3. Fast, no-snap installation; transistors are firmly held.

New! Dissipators and retainers for plastic and epoxy transistors. 3 new series for RO-97A, RO-97 and X-20's. Permit a jump of 10% to 33% in operating power.

Free 8-page short form catalog discusses IERC's complete line of dissipators, retainers and tube shields. Gives specifications, prices, how to order. Send for your copy today.

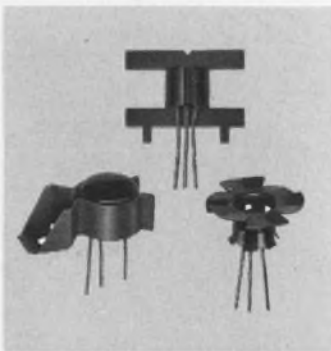
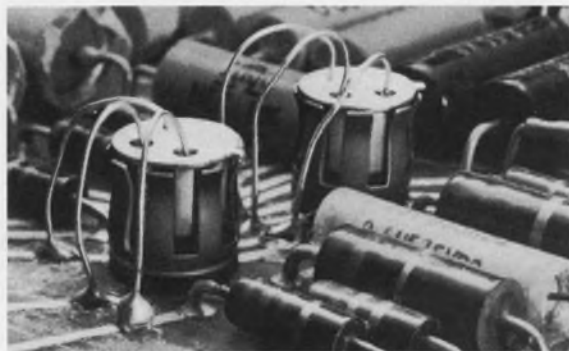

Special insulating coating — Insulube 448, a special non-hygroscopic finish developed by IERC, combines excellent dielectric properties, 50 K megs insulation resistance, and high heat emissivity. Also protects against salt spray, fungus, etc.

Tough heat dissipating problem? IERC engineers welcome your letter-head inquiry for specific information or assistance in selecting heat dissipators.

**ierc**  
SEMICONDUCTOR  
HEAT DISSIPATORS



Computerized-crime control in the office.



### Crime report gives electronics boost

The real significance of a recent report by the President's Commission on Law Enforcement and Administration of Justice is that Federal money for crime control may be channeled directly to industry, not only through cities and states.

It was predictable that the "Crime Commission" headed by Harvard law professor James Vorenberg should have urged a greater role for electronics in crime control. Computers, rapid communications systems, high-speed information retrieval, "systems-managed" deployment of police forces, new alarms—all have received greater publicity and financial support since the Justice Dept.'s Office of Law Enforcement Assistance was set up less than two years ago. Almost every chapter of the report spelled out in detail the parts that electronics should play.

Now, however, money for development may come straight to the industry. The report stressed the need for a massive program of RDT&E—a term borrowed from Pentagon parlance and meaning research, development, test and evaluation. A member of Vorenberg's staff commented that use of this term showed that the Government was envisioning not merely handing out grants and contracts but also going into crime control in a big way. And this, Washington would approach rather as the Pentagon does a new weapon system, laying out money for hardware and field testing. In fact, the commission itself specifically called for application of the systems approach already tried and proven by the Pentagon. "In other words," the informant said, "these things won't just be scholarly research grants; there are going to have to be some important production contracts after the development."

The report recommended establishment of Federal academies and institutions to guide the application of technology to crime control. Hitherto most of the Government's efforts along these lines have been channeled

# Washington Report

S. DAVID PURSGLOVE,  
WASHINGTON EDITOR

through the Office of Law Enforcement Assistance, which makes grants to states, metropolitan areas, cities and selected nonprofit organizations. If a hardware manufacturer or R&D firm wants support for a project, it must shop around for a cooperative city or police department that will ask for Federal aid. Now observers believe that contracts may go directly to industry, although the Office of Law Enforcement Assistance declines to comment on the suggestion. But then the office itself may shortly launch its own RDT&E program.

### Washington surveys the effect of peace

One of the big unanswered questions facing official Washington is where industry will be if the Vietnam war is settled. For all the studies by the Arms Control and Disarmament Agency, no one knows. Fearing what the effect of peace might be, President Johnson is trying to do something about it in advance. He has handed the job of assessing the impact of peace on present military contractors to Gardner Ackley, chairman of the Council of Economic Advisers. Ackley has to recommend which urban, social, transport and similar massive Federal programs should receive priorities in order to take up the slack.

During the talks between British Prime Minister Harold Wilson and Soviet Premier Aleksei Kosygin at the time of the Tet truce in Vietnam, the Economic Advisers, Commerce Dept. and Treasury Dept. rushed into the formation of peacetime conversion task forces. The nascent Transportation Dept. juggled continually with its plans for highway, high-speed ground transportation and vertical-take-off-and-landing aircraft programs, all of which could expect to receive increased funds if a peace settlement were reached. After months of talking of "peace just around the corner," the White House actually called in small groups of reporters to ask them to play down the

# Washington Report

CONTINUED

theme of an immediate cessation of hostilities because of its adverse effect on the stock market.

The outcome of all the excitement is that Ackley, the director of the Budget Bureau, and the secretaries of Defense, Commerce, the Treasury and Labor are to work out a conversion plan. During the course of the summer the outlines of that plan should become clear in the speeches of agency heads when they describe their future programs. They will begin to refer to what might be done in specific areas if Vietnam's demands were reduced, rather than to the damping effects of that war. Careful listening should reveal priorities that Ackley's group have set up.

## The FCC flutters the computer dovevote

Some of the firms asked by the Federal Communications Commission to provide data for the commission's look at the computer business feel that the FCC may be overstepping the authority that Congress gave it to regulate communications. An FCC spokesman says: "We've got plenty of grounds for this study, but if it should ever get down to the short rows, there's always this: The people in the business already have admitted that computers are now talking to other computers. That's communications." Some manufacturers have reservations about such a claim.

As a result of its inquiry, the FCC is caught between two fires. The common carriers want the commission to rule that any computer input or output fed over interstate lines puts that computer into interstate communications. They want the FCC to decide that the common carriers are responsible for all that goes on at either end of their interstate lines. This would give them control over all attachments to their lines and transfer to them from the computer industry a lucrative hardware sales and leasing business that runs to at least \$300 million a year. The computer makers and leasers, for their part, are vigorously opposing such a move.

## New source of funds for educational TV

A grant of \$61,365 to WOUB, an educational TV station run by Ohio University in Athens, Ohio, has set Washington abuzz. The Federal grant for WOUB to expand and improve its mobile services comes in the wake of President Johnson's pledge to extend support for educational television. But what has set the tongues wagging is the source of the grant. Over \$38,000 came from the Dept. of Health, Education and Welfare, which is usual enough. But a further \$23,000 came from the Commerce Dept.'s Economic Development Administration, and this is unprecedented.

The agency's main concern has been to help small towns and rural communities attract new business by support for the development of craft industries, industrial parks and tourist attractions. It is particularly linked with the Appalachia program. But in future it is going to be thought of also in connection with educational TV. Officials of the administration indicate that more such grants will be made if the television organization seeking funds can show that its activities will raise an area's general educational level and thus help the community to thrive.

WOUB's request had the backing of the Appalachia Regional Commission, which pointed out that the station's programming was seriously hampered because it had only one set of equipment to serve both its mobile unit and its campus broadcasting. The commission was eager for the mobile unit to be free to leave the campus and bring educational television programs to the people of the area. Ohio has 28 counties in the Appalachian region. The commission wants all of them to receive educational television services; at present just half get them.

## Medical television service proposed

Dr. James L. Goddard, director of the Food and Drug Administration, is apparently one of the few people who have not forgotten that the Federal Communications Commission has allotted a television band to medical education. He has proposed that a partnership of Federal and private interests should set up a medical television network to keep physicians up to date on the latest developments in their field.



**ELECTRONICS**

**SEMICONDUCTOR  
PRODUCTS  
&  
SOLID STATE  
OPERATIONAL  
AMPLIFIERS**

365 MIDDLEFIELD ROAD / MOUNTAIN VIEW, CALIFORNIA 94040 / TEL: (415) 961-3300 / TWX: 910-379-6942

March 1967



**ELECTRONICS**

**PNP TRANSISTORS/Silicon, Epitaxial Planar**

**ELECTRICAL CHARACTERISTICS**

TYPE	Package†	$h_{FE} @ 10 \mu A$		$h_{FE}$ -55°C 10 $\mu A$ Min	$h_{FE}$ 10 mA Max.	$BV_{CBO}$ Volt Min.	$BV_{EBO}$ Volt Min.	$V_{CE(sat)}$ Volt Min.	$V_{CE(sat)}$ Volt Max.	$V_{BE(sat)}$ Volt Max.	$I_{CBO}$ nA Max.	$C_{OB}$ pF Max.	NF dB Max.
<b>UC1100</b>	<b>†TO-46</b>	<b>200</b>	<b>500</b>	<b>30</b>	<b>800</b>	<b>45</b>	<b>6</b>	<b>45</b>	<b>0.5</b>	<b>0.9</b>	<b>0.5</b>	<b>6</b>	<b>2</b>
2N2604	†TO-46	40	120	10	350	60	6	45	0.5	0.9	10	6	4
2N2605	†TO-46	100	300	20	600	60	6	45	0.5	0.9	10	6	3
2N2605A	†TO-46	150	300	30	600	60	6	45	0.25	0.9	2	6	2

**NPN TRANSISTORS/Silicon, Planar**

**ELECTRICAL CHARACTERISTICS**

<b>UC900</b>	<b>†TO-18</b>	<b>400</b>	<b>1000</b>	<b>80</b>	<b>1200</b>	<b>45</b>	<b>7</b>	<b>45</b>	<b>0.5</b>	<b>0.9</b>	<b>0.25</b>	<b>7</b>	<b>3</b>
JAN 2N929	TO-18	40	120	10	350	60	6	45	1	1	10	8	3
2N929	†TO-18	40	120	10	350	60	6	45	1	1	10	8	4
2N929A	†TO-18	40	120	15	350	60	6	45	0.5	0.9	2	6	4
JAN 2N930	TO-18	100	300	20	600	60	6	45	1	1	10	8	3
2N930	†TO-18	100	300	20	600	60	6	45	1	1	10	8	3
2N930A	†TO-18	100	300	30	600	60	6	45	0.5	0.9	2	6	3
2N2483	†TO-18	40	120	10	500	60	6	60	0.35	0.7	10	6	3
2N2484	†TO-18	100	500	20	800	60	6	60	0.35	0.7	10	6	3
2N2509	†TO-18	25	—	—	—	125	7	80	1	0.9	5	6	7
2N2510	†TO-18	75	—	25	500	100	7	65	1	0.9	5	6	4
2N2511	†TO-18	120	—	40	750	80	7	50	1	0.9	5	6	4
2N2586	†TO-18	120	360	40	600	60	6	45	0.5	0.9	2	7	2
2N3117	†TO-18	250	500	50	—	60	6	60	0.35	0.7	10	4.5	1

**DUAL PNP TRANSISTORS/Silicon, Epitaxial Planar**

**ELECTRICAL CHARACTERISTICS**

TYPE	$\Delta V_{BE}$ $\mu V/^\circ C$ Max.	Package	$BV_{CBO}$ Volt Min.	$I_{CBO}$ Max. nA	$h_{FE}$ match %	$V_{BE(1-2)}$ mV Max.	$h_{FE}$ @ 10 $\mu A$ Min.	$h_{FE}$ @ 1 mA Max.	f, MHz Min.	NF dB Max.	$V_{CE(sat)}$ Volt Min.	$C_{OB}$ pF Max.	
2N2802	10	TO-78	25	10	10	5	15	—	20	60	4	20	8
2N2805	10	TO-78	25	10	10	5	30	—	40	60	4	20	8
2N3347	10	TO-78	60	10	10	5	40	300	60	60	4	45	6
2N3350	10	TO-78	60	10	10	5	100	300	150	60	4	45	6
2N2803	20	TO-78	25	10	20	10	15	—	20	60	4	20	8
2N2806	20	TO-78	25	10	20	10	30	—	40	60	4	20	8
2N3348	20	TO-78	60	10	20	10	40	300	60	60	4	45	6
2N3351	20	TO-78	60	10	20	10	100	300	150	60	4	45	6
2N3349	40	TO-78	60	10	40	20	40	300	60	60	4	45	6
2N3352	40	TO-78	60	10	40	20	100	300	150	60	4	45	6
2N2804	—	TO-78	25	10	—	—	30	—	20	60	4	20	6
2N2807	—	TO-78	25	10	—	—	15	—	40	60	4	20	6

**DUAL NPN TRANSISTORS/Silicon, Planar**

**ELECTRICAL CHARACTERISTICS**

TYPE	$\Delta V_{BE}$ $\mu V/^\circ C$ Max.	Package	$BV_{CBO}$ Volts Min.	$I_{CBO}$ nA Max.	$h_{FE}$ match %	$V_{BE(1-2)}$ mV Max.	$h_{FE}$ @ 10 $\mu A$ Min.	$h_{FE}$ @ 1 mA Max.	f, MHz Min.	$h_{FE}$ @ -55°C 10 $\mu A$ Max.	NF in dB $e_n \mu V/\sqrt{Hz}$ Max.	$V_{CE(sat)}$ Min.	$C_{OB}$ pF Max.
<b>2N4042</b>	<b>3</b>	<b>TO-70</b>	<b>60</b>	<b>0.1</b>	<b>10</b>	<b>3</b>	<b>200</b>	<b>600</b>	<b>200</b>	<b>75</b>	<b>2</b>	<b>60</b>	<b>0.8</b>
2N4044	3	TO-78	60	0.1	10	3	200	600	200	75	2	60	0.8
2N4878	3	TO-71	60	0.1	10	3	200	600	200	75	2	60	0.8
2N4099	5	TO-70	55	0.1	15	5	150	600	150	50	3	55	0.8
2N4100	5	TO-78	55	0.1	15	5	150	600	150	50	3	55	0.8
2N4879	5	TO-71	55	0.1	15	5	150	600	150	50	3	55	0.8
2N3680	5	TO-78	60	10	10	3	150	600	60	45	3	50	6
2N2453A	5	TO-78	80	5	10	3	150*	600*	60	40	4	50	4
2N2915A	5	TO-78	45	10	10	1.5	60	240	60	15	4	45	6
2N2916A	5	TO-78	45	10	10	1.5	150	600	60	40	3	60	6
2N2919A	5	TO-78	60	2	10	1.5	60	240	60	15	4	45	6

† Available in Union Carbide Micro-Package CC-3.



**ELECTRONICS**

**DUAL NPN TRANSISTORS/Silicon, Planar (Cont.)**

**ELECTRICAL CHARACTERISTICS**

TYPE	$\Delta V_{BE}$ $\mu V/^\circ C$ Max.	Package	$BV_{CBO}$ Volts Min.	$I_{CBO}$ nA Max.	$h_{FE}$ match %	$V_{BE1-2}$ mV Max.	$h_{FE}$ @ 10 $\mu A$ Min.	$h_{FE}$ @ 1 mA Max.	$f_t$ , MHz Min.	$h_{FE}$ @ -55°C 10 $\mu A$ Max.	NF in dB * $e_n$ $\mu V/\sqrt{\sim}$ Max.	$V_{CE}$ sus <sup>†</sup> Min.	$C_{OB}$ pF Max.
2N2920A	5	TO-78	60	2	10	1.5	150	600	60	40	3	60	6
2N4043	10	TO-70	45	0.1	20	5	80	—	150	30	3	45	0.8
2N4045	10	TO-78	45	0.1	20	5	80	—	150	30	3	45	0.8
2N4880	10	TO-71	45	0.1	20	5	80	—	150	30	3	45	0.8
2N3941	10	TO-78	60	0.25	10	3	400	1200	200	75	0.007*	45	6
2N3943	10	TO-71	60	0.25	10	3	400	1200	200	75	0.007*	45	6
2N2453	10	TO-78	60	5	10	3	150*	600*	60	40	7	30	8
2N2639	10	TO-78	45	10	10	5	50	300	—	10	4	45	8
2N2642	10	TO-78	45	10	10	5	100	300	—	20	4	45	8
2N2903A	10	TO-78	60	10	10	5	125*	625*	60	25	7	30	8
2N2915	10	TO-78	45	10	10	5	60	240	60	15	4	45	6
2N2916	10	TO-78	45	10	10	5	150	600	60	30	3	45	6
2N2919	10	TO-78	60	2	10	5	60	240	60	15	4	60	6
2N2920	10	TO-78	60	2	10	5	150	600	60	40	3	60	6
2N2974	10	TO-71	45	10	10	5	60	240	60	15	4	45	6
2N2975	10	TO-71	45	10	10	5	150	600	60	30	3	45	6
2N2978	10	TO-71	60	2	10	5	60	240	60	15	4	60	6
2N2979	10	TO-71	60	2	10	5	150	600	60	40	3	60	6
2N3942	20	TO-78	60	0.25	20	10	400	1200	200	75	0.007*	45	6
2N3944	20	TO-71	60	0.25	20	10	400	1200	200	75	0.007*	45	6
2N2640	20	TO-78	45	10	20	10	50	300	—	10	4	45	8
2N2643	20	TO-78	45	10	20	10	100	300	—	20	4	45	8
2N2903	20	TO-78	60	10	20	10	125*	625*	60	25	7	30	8
2N2917	20	TO-78	45	10	20	10	60	240	60	15	4	45	6
2N2918	20	TO-78	45	10	20	10	150	600	60	30	3	45	6
2N2976	20	TO-71	45	10	20	10	60	240	60	15	4	45	6
2N2977	20	TO-71	60	10	20	10	150	600	60	30	3	45	6
2N2641	—	TO-78	45	10	—	—	50	300	—	10	4	45	8
2N2644	—	TO-78	45	10	—	—	100	300	—	20	4	45	8
2N2913	—	TO-78	45	10	—	—	60	240	60	15	4	45	6
2N2914	—	TO-78	45	10	—	—	150	600	60	30	3	45	6
2N2972	—	TO-71	45	10	—	—	60	240	60	15	4	45	6
2N2973	—	TO-71	45	10	—	—	150	600	60	30	3	45	6

**MILITARY TRANSISTORS/Silicon, Planar**

Type	Military Specifications	Device Type
JAN 2N929	MIL-S-19500/253A	NPN Transistor
JAN 2N930	MIL-S-19500/253A	NPN Transistor
JAN 2N2607	MIL-S-19500/294	P-Channel FET
JAN 2N2608	MIL-S-19500/295	P-Channel FET

**FIELD EFFECT TRANSISTORS/Silicon, Epitaxial Planar**

**General Purpose**

**ELECTRICAL CHARACTERISTICS**

TYPE	Channel	Package	$BV_{DSS}$ * $BV_{DGO}$ Volts Min.	$I_{GSS}$ nA Max.	$I_{DSS}$ mA Min. Max.	$g_m$ $\mu Mhos$ Min. Max.	$V_p$ Volts Min. Max.	$C_{ISS}$ pF Max.	$C_{RSS}$ pF Max.	NF in dB * $e_n$ in $\mu V/\sqrt{\sim}$ Max.
2N4416	N	TO-72	30	0.1	5 15	4500 7500	— 6	4	0.8	2
2N4417	N	CC-3	30	0.1	5 15	4500 7500	— 6	3.5	0.8	2
2N3684	N	†TO-72	50	0.1	2.5 7.5	2000 3000	2 5	4	1.2	*0.15
2N3685	N	†TO-72	50	0.1	1 3.5	1500 2500	1 3.5	4	1.2	*0.15
2N3686	N	†TO-72	50	0.1	0.4 1.2	1000 2000	0.6 2	4	1.2	*0.15
2N3687	N	†TO-72	50	0.1	0.1 0.5	500 1500	0.3 1.2	4	1.2	*0.15

† Available in Union Carbide Micro-Package CC-3.



## FIELD EFFECT TRANSISTORS/Silicon, Epitaxial Planar (Cont.)

### General Purpose (Cont.)

#### ELECTRICAL CHARACTERISTICS

TYPE	Channel	Package	$BV_{GSS}$	$I_{GSS}$	$I_{DSS}$ mA		$g_m$ $\mu$ Mhos		$V_P$ Volts		$C_{ISS}$	$C_{RSS}$	$f_{\tau}$	NF in dB
			$BV_{DGO}$ Volts Min.	nA Max.	Min.	Max.	Min.	Max.	Min.	Max.	pF Max.	pF Max.	in $\mu$ V/ $\sqrt{V}$ Max.	
UC-20	N	†TO-72	30	0.01	0.4	2	300		2	5	2			
UC-21	N	†TO-72	30	0.01	0.12	0.6	200		1	2.5	2			
UC-22	N	CC-3	30	0.01	0.4	2	300		2	5	1.3			
UC-23	N	CC-3	30	0.01	0.12	0.6	200		1	2.5	1.3			
UC-200	N	†TO-72	50	0.1	10	30	6000			6	7			0.5
UC-210	N	†TO-72	50	0.1	4	12	4500			4	7			0.5
UC-220	N	†TO-72	50	0.1	1	5	3000			2.5	7			0.5
UC-240	N	†TO-18	50	0.1	1	10	1200			5	18			*0.02
UC-250	N	TO-18	30	1	50	150	20000		5	10	25			
UC-251	N	TO-18	30	1	7.5	75	12000		1	6	25			
2N3066	N	TO-18	*50	1	0.8	4	400	1000		10	10			3
2N3067	N	TO-18	*50	1	0.2	1	300	1000		5	10			3
2N3068	N	TO-18	*50	1	0.05	0.25	200	1000		2.5	10			3
2N3069	N	TO-18	*50	1	2	10	1000	2500		10	15			4
2N3070	N	TO-18	*50	1	0.5	2.5	750	2500		5	15			4
2N3071	N	TO-18	*50	1	0.1	0.6	500	2500		2.5	15			4
2N3365	N	TO-18	*40	5	0.8	4	400	2000		12	15			
2N3366	N	TO-18	*40	5	0.2	1	250	1000		7	15			
2N3367	N	TO-18	*40	5	0.05	0.25	100	1000		2.5	15			
2N3368	N	TO-18	*40	5	2	12	1000	4000		12	20			
2N3369	N	TO-18	*40	5	0.5	2.5	600	2500		7	20			
2N3370	N	TO-18	*40	5	0.1	0.6	300	2500		3.5	20			
2N3436	N	TO-72	*50	0.5	3	15	2500	10000		10	18			2
2N3437	N	TO-72	*50	0.5	0.8	4	1500	6000		5	18			2
2N3438	N	TO-72	*50	0.5	0.2	1	800	4500		2.5	18			2
2N3452	N	TO-72	*50	0.1	0.8	4	200	1200		10	6			2
2N3453	N	TO-72	*50	0.1	0.2	1	150	900		5	6			2
2N3454	N	TO-72	*50	0.1	0.05	0.25	100	600		2.5	6			2
2N3455	N	TO-72	*50	0.04	0.8	4	400	1200		10	5			1
2N3456	N	TO-72	*50	0.04	0.2	1	300	900		5	5			1
2N3457	N	TO-72	*50	0.04	0.05	0.25	150	600		2.5	5			1
2N3458	N	TO-18	*50	0.25	3	15	2500	10000		8	18			1
2N3459	N	TO-18	*50	0.25	0.8	4	1500	6000		4	18			1
2N3460	N	TO-18	*50	0.25	0.2	1	800	4500		2	18			1
2N3821	N	†TO-72	50	0.1	1	2.5	1500	4500		4	6	3		*0.2
2N3822	N	†TO-72	50	0.1	0.5	10	3000	6500		6	6	3		*0.2
2N3823	N	†TO-72	30	0.5	4	20	3500	6500		8	6	2		2.5
2N4117	N	TO-72	40	0.01	0.03	0.09	70	210	0.6	1.8	3	1.5		
2N4117A	N	TO-72	40	0.001	0.03	0.09	70	210	0.6	1.8	3	1.5		
2N4118	N	TO-72	40	0.01	0.08	0.24	80	250	1	3	3	1.5		
2N4118A	N	TO-72	40	0.001	0.08	0.24	80	250	1	3	3	1.5		
2N4119	N	TO-72	40	0.01	0.20	0.60	100	330	2	6	3	1.5		
2N4119A	N	TO-72	40	0.001	0.20	0.60	100	330	2	6	3	1.5		
2N4220	N	TO-72	30	0.1	0.5	3	1000	4000		4	6	2		
2N4220A	N	TO-72	30	0.1	0.5	3	1000	4000		4	6	2		2.5
2N4221	N	TO-72	30	0.1	0.2	6	2000	5000		6	6	2		
2N4221A	N	TO-72	30	0.1	0.2	6	2000	5000		6	6	2		2.5
2N4222	N	TO-72	30	0.1	0.5	15	2500	6000		8	6	2		
2N4222A	N	TO-72	30	0.1	0.5	15	2500	6000		8	6	2		2.5
2N4223	N	TO-72	30	0.25	3	18	3000	7000		8	6	2		5
2N4224	N	TO-72	30	0.5	2	20	2000	7500		8	6	2		
2N4338	N	TO-18	50	0.1	0.2	0.6	600	1800	0.3	1	6	2		1
2N4339	N	TO-18	50	0.1	0.5	1.5	800	2400	0.6	1.8	6	2		1

† Available in Union Carbide Micro-Package CC-3.

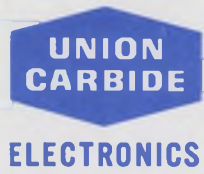

## FIELD EFFECT TRANSISTORS (Cont.)

### General Purpose (Cont.)

#### ELECTRICAL CHARACTERISTICS

TYPE	Channel	Package	$V_{DGO}$ Volts Min.	$I_{GSS}$ nA Max.	$I_{LOSS}$ mA		$g_m$ $\mu$ Mhos		$V_p$ Volts		$C_{ISS}$ pF Max.	$C_{RSS}$ pF Max.	$e_n$ in $\mu$ V/ $\sqrt{V}$ Max.	NF in dB
2N4340	N	TO-18	50	0.1	1.2	3.6	1300	3000	1	3	6	2	1	
2N4341	N	TO-18	50	0.1	3	9	2000	4000	2	6	6	2	1	
2N3695	P	†TO-72	30	0.1	1.25	3.75	1000	1750	2	5	5	1.2	*0.2	
2N3696	P	†TO-72	30	0.1	0.5	1.5	750	1250	1	3.5	5	1.2	*0.2	
2N3697	P	†TO-72	30	0.1	0.2	0.6	500	1000	0.6	2	5	1.2	*0.2	
2N3598	P	†TO-72	30	0.1	0.05	0.25	250	750	0.3	1.2	5	1.2	*0.2	
UC-40	P	†TO-72	30	0.01	0.2	1	150		2	5	2.5			
UC-41	P	†TO-72	30	0.01	0.06	0.3	100		1	2.5	2.5			
UC-42	P	CC-3	30	0.01	0.2	1	150		2	5	1.4			
UC-43	P	CC-3	30	0.01	0.06	0.3	100		1	2.5	1.4			
UC-400	P	†TO-72	30	0.1	5	15	3000		6	8			0.5	
UC-410	P	†TO-72	30	0.1	2	6	2250		4	8			0.5	
UC-420	P	†TO-72	30	0.1	0.5	2.5	1500		2.5	8			0.5	
UC-450	P	TO-18	25	0.25	25	75	10000		5	10	25			
UC-451	P	TO-18	25	0.25	3.75	37.5	6000		1	6	25			
2N2386	P	TO-5	*20	10	0.9	9	1000		8	50			2	
2N2497	P	TO-5	20	10	1	3	1000	2000	5	32			3	
2N2498	P	TO-5	20	10	2	6	1500	3000	6	32			3	
2N2499	P	TO-5	20	10	5	15	2000	4000	8	32			4	
2N2500	P	TO-5	20	10	1	6	1000	2200	6	32			1	
2N2606	P	TO-18	30	1	0.1	0.5	110		1	4	6		3	
2N2607	P	TO-18	30	3	0.3	1.5	330		1	4	10		3	
JAN2N2607	P	TO-18	30	3	0.3	1.5	330		1	4	10		3	
2N2608	P	TO-18	30	10	0.9	4.5	1000		1	4	17		3	
JAN2N2608	P	TO-18	30	10	0.9	4.5	1000		1	4	17		3	
2N2609	P	TO-18	30	30	2	10	2500		1	4	25		3	
2N2841	P	TO-18	30	1	0.025	0.125	60		1.7	6			3	
2N2842	P	TO-18	30	3	0.065	0.325	180		1.7	10			3	
2N2843	P	TO-18	30	10	0.200	1	540		1.7	17			3	
2N2844	P	TO-18	30	30	0.44	2.2	1400		1.7	25			3	
2N3329	P	TO-72	20	10	1	3	1000	2000	5	20			3	
2N3330	P	TO-72	20	10	2	6	1500	3000	6	20			3	
2N3331	P	TO-72	20	10	4	15	2000	4000	8	20			4	
2N3332	P	TO-72	20	10	1	6	1000	2200	6	20			1	
2N3376	P	TO-72	30	3	0.6	6	800	2300	1	5	5			
2N3573	P	TO-72	25	0.6	0.020	0.100	100	300	2	6	2		*0.15	
2N3574	P	TO-72	25	*0.6	0.075	0.375	200	600	2	6	2		*0.15	
2N3575	P	TO-72	25	0.6	0.200	1	300	900	4	6	2		*0.15	
2N3909	P	TO-72	20	10	0.3	15	1000	5000	8	32	16			

#### Low Noise

2N3684	N	†TO-72	50	0.1	2.5	7.5	2000	3000	2	5	4	1.2	*0.15
2N3685	N	†TO-72	50	0.1	1	3.5	1500	2500	1	3.5	4	1.2	*0.15
2N3686	N	†TO-72	50	0.1	0.4	1.2	1000	2000	0.6	2	4	1.2	*0.15
2N3687	N	†TO-72	50	0.1	0.1	0.5	500	1500	0.3	1.2	4	1.2	*0.15
UC-240	N	†TO-18	50	0.1	1	10	1200		5	18			*0.02
2N3695	P	†TO-72	30	0.1	1.25	3.75	1000	1750	2	5	5	1.2	*0.2
2N3696	P	†TO-72	30	0.1	0.5	1.5	750	1250	1	3.5	5	1.2	*0.2
2N3697	P	†TO-72	30	0.1	0.2	0.6	500	1000	0.6	2	5	1.2	*0.2
2N3698	P	†TO-72	30	0.1	0.05	0.25	250	750	0.3	1.2	5	1.2	*0.2



## FIELD EFFECT TRANSISTORS (Cont.)

### Amplifiers/DC Through UHF

#### ELECTRICAL CHARACTERISTICS

TYPE	Channel	Package	<sup>*</sup> BV <sub>GSS</sub> Volts Min.	I <sub>GSS</sub> nA Max.	I <sub>DSS</sub> mA Min.    Max.	Y <sub>fs</sub> μMhos Min.	V <sub>p</sub> Volts Max.	C <sub>ISS</sub> pF Max.	C <sub>RSS</sub> pF Max.	C <sub>OS</sub> pF Max.	G <sub>p</sub> dB Min.	NF dB Max.
2N4416	N	TO-72	30	0.1	5    15	4500	6	4	0.8	2	10 @ 400 MHz	4 @ 400 MHz
2N4417	N	CC-3	30	0.1	5    15	4500	6	3	0.8	1.3	10 @ 400 MHz	4 @ 400 MHz
2N3823	N	†TO-72	30	0.5	4    20	3500	8	6	2	—	—	2.5 @ 100 MHz
2N4223	N	†TO-72	30	0.25	3    18	3000	8	6	2	—	10 @ 200 MHz	5 @ 200 MHz
2N4224	N	†TO-72	30	0.5	2    20	2000	8	6	2	—	—	—

### Switching

#### ELECTRICAL CHARACTERISTICS

TYPE	Channel	Package	BV <sub>GSS</sub> Volts Min.	I <sub>DGO</sub> Max. nA	I <sub>Doff</sub> Max. nA	I <sub>DSS</sub> mA Min.    Max.	V <sub>p</sub> Volts Max.	C <sub>ISS</sub> Max. pF	C <sub>RSS</sub> Max. pF	*R <sub>on</sub> Max. Ohms	T <sub>on</sub> nsec	T <sub>off</sub> nsec	
2N3970	N	TO-18	40	0.25	0.25	50    150	10	25	6	30	20	30	
2N3971	N	TO-18	40	0.25	0.25	25    75	5	25	6	60	30	60	
2N3972	N	TO-18	40	0.25	0.25	5    30	3	25	6	100	80	100	
2N4391	N	TO-18	40	0.1	0.1	50    150	10	14	3.5	30	15	20	
2N4392	N	TO-18	40	0.1	0.1	25    75	5	14	3.5	60	15	35	
2N4393	N	TO-18	40	0.1	0.1	5    30	3	14	3.5	100	15	50	
UC155	N	TO-72	30	0.1	0.1	10	—	10	4	125	—	—	
UC155W	N	CC-3	30	0.1	0.1	10	—	10	3.5	125	—	—	
UC201	N	†TO-72	50	0.1	0.1	15	—	8	7	125	—	—	
UC250	N	TO-18	30	1	1	50    150	10	25	6	30	—	—	
US251	N	TO-18	30	1	1	7.5    75	6	25	6	75	—	—	
UC401	P	†TO-72	30	0.1	0.1	8	8	8	4	250	—	—	
UC450	P	TO-18	25	0.25	0.25	25    75	10	25	6	60	—	—	
UC451	P	TO-18	25	0.25	0.25	3.75    37.5	6	25	6	150	—	—	
2N3824	N	†TO-72	50	0.1	0.1	—	8	6	3	250	—	—	
2N4091	N	TO-18	40	0.2	0.2	30	—	10	16	5	30	15	40
2N4092	N	TO-18	40	0.2	0.2	15	—	7	16	5	50	15	60
2N4093	N	TO-18	40	0.2	0.2	8	—	5	16	5	80	20	80

### Industrial

#### ELECTRICAL CHARACTERISTICS

TYPE	Channel	Package	BV <sub>GSS</sub> *BV <sub>DGO</sub> Volts Min.	I <sub>GSS</sub> nA Max.	I <sub>DSS</sub> mA Min.    Max.	G <sub>m</sub> μMhos Min.    Max.	R <sub>on</sub> Ohms Max.	V <sub>p</sub> Volts Max.	C <sub>ISS</sub> pF Max.	C <sub>RSS</sub> pF Max.	NF dB Max.	Improved replace- ment for
UC701	N	TO-72	40	0.2	0.1    3	150    1500	—	6	3	—	4	—
UC703	N	TO-72	40	0.5	0.1    10	500    5000	2000	6	6	—	2	—
UC704	N	TO-72	40	0.5	0.2    24	1000    10000	1000	8	8	—	2	—
UC705	N	TO-72	40	1	0.5    50	2000    20000	500	8	12	—	2	—
UC707	N	TO-18	20	2	2.5    250	5000    50000	200	12	30	—	—	—
UC714	N	TO-72	30	1	2    20	2000    6500	500	8	8	4	2	2N3819
UC750	N	TO-18	30	2	0.05	120	—	6	6	—	—	—
UC751	N	TO-18	30	2	0.1	350	—	6	10	—	—	—
UC752	N	TO-18	30	6	0.3	1000	—	6	17	—	—	—
UC753	N	TO-18	30	10	0.9	2500	—	6	25	—	—	—
2N2386	P	TO-5	*20	10	0.9    9	1000	—	8	50	—	2	—
2N3909	P	TO-72	20	10	0.3    15	1000    5000	—	8	32	16	—	—
UC801	P	TO-72	25	0.2	0.05    1.5	75    750	—	6	3	—	4	—
UC803	P	TO-72	25	0.5	0.05    5	250    2500	—	6	6	—	2	—
UC804	P	TO-72	25	0.5	0.1    12	500    5000	2000	8	8	—	2	—
UC805	P	TO-72	25	1	0.3    25	1000    10000	1000	8	12	—	2	—





## FIELD EFFECT TRANSISTORS (Cont.)

### Industrial (Cont.)

#### ELECTRICAL CHARACTERISTICS

TYPE	Channel	Package	$BV_{GSS}$ $^{*}BV_{DGO}$ Volts Min.	$I_{GSS}$ nA Max.	$I_{DSS}$ mA Min.    Max.	$g_m$ $\mu$ Mhos Min.    Max.	$R_{on}$ Ohms Max.	$V_p$ Volts Max.	$C_{iss}$ pF Max.	$C_{RSS}$ pF Max.	NF dB Max.	Improved replace- ment for
UC807	P	TO-18	20	2	1    125	2500   25000	400	12	30			
UC814	P	TO-72	25	2	0.3   15	800   5000	1300	8	16	8	2	2N3820
UC850	P	TO-18	*20	2	0.1   1	110		6	6			U110
UC851	P	TO-18	*20	4	0.9   9	1000		6	17			U112
UC852	P	TO-18	25	2	0.025	60		6	6			U146
UC853	P	TO-18	25	4	0.065	180		6	10			U147
UC854	P	TO-18	25	15	0.2	540		6	17			U148
UC855	P	TO-18	25	50	0.44	1400		6	25			U149

## DUAL FIELD EFFECT TRANSISTORS N-CHANNEL

#### ELECTRICAL CHARACTERISTICS

TYPE	$\Delta V_{GS}$ $\mu$ V/ $^{\circ}$ C Max.	Package	$^{*}BV_{GSS}$ Volts Min.	$I_{GSS}$ pA Max.	$I_{DSS}$ mA Min.    Max.	$g_m$ $\mu$ Mhos Min.	$V_{GS1-2}$ mV Max.	$g_m$ match % Max.	$I_{DSS}$ match % Max.	$V_{GS(O)}$ Volts Max.	$C_{iss}$ pF	NF dB
2N3954	10	CO-71	50	100	0.5    5	1000	5	3	5	4	4	0.5
2N3955	25	CO-71	50	100	0.5    5	1000	10	5	5	4	4	0.5
2N3956	50	CO-71	50	100	0.5    5	1000	15	5	5	4	4	0.5
2N3957	75	CO-71	50	100	0.5    5	1000	20	10	10	4	4	0.5
2N3958	100	CO-71	50	100	0.5    5	1000	25	15	15	4	4	0.5
UC-2130	10	CO-71	50	100	0.5    4.5	1000	10	5	5	5	4	0.5
UC-2132	20	CO-71	50	100	0.5    4.5	1000	20	5	5	5	4	0.5
UC-2134	50	CO-71	50	100	0.5    4.5	1000	30	10	10	5	4	0.5
UC-2136	100	CO-71	50	100	0.5    4.5	1000	50	10	10	5	4	0.5
UC-2138	200	CO-71	50	100	0.5    4.5	1000	100	20	20	5	4	0.5
UC-2139		CO-71	30	200	0.2    6	750				6	5	2
UC-2149		CO-71	30	200	0.5    15	1000				6	6	2
2N3921	10	TO-71	50	250	1    10	1500	5	5		2.7	18	2
2N3922	25	TO-71	50	250	1    10	1500	5	5		2.7	18	2
2N3934	10	TO-71	50	100	0.25   1.3	300	5	5		2.7	7	2
2N3935	25	TO-71	50	100	0.25   1.3	300	5	5		2.7	7	2
2N4082	10	TO-71	50	100	0.25   1.3	300	15	5		2.7	7	2
2N4083	25	TO-71	50	100	0.25   1.3	300	15	5		2.7	7	2
2N4084	10	TO-71	50	250	1    10	1500	15	5		2.7	18	2
2N4085	25	TO-71	50	250	1    10	1500	15	5		2.7	18	2

## MONOLITHIC DUAL NPN TRANSISTORS/Silicon, Planar

#### ELECTRICAL CHARACTERISTICS

TYPE	$\Delta V_{BE}$ $\mu$ V/ $^{\circ}$ C Max.	Package	$BV_{CBO}$ Volts Min.	$I_{CBO}$ nA Max.	$h_{FE}$ match %	$V_{BE1-2}$ mV Max.	$h_{FE}$ @ 10 $\mu$ A Min.	$I_{C1}$ mA Max.	$f_t$ MHz Min.	$h_{FE}$ @ -55 $^{\circ}$ C 10 $\mu$ A Max.	NF in dB $^{*}e_n$ $\mu$ V/ $\sqrt{\sim}$ Max.	$V_{CE(sat)}$ Min.	$C_{OB}$ pF Max.
2N4042	3	TO-70	60	0.1	10	3	200	600	200	75	2	60	0.8
2N4044	3	TO-78	60	0.1	10	3	200	600	200	75	2	60	0.8
2N4878	3	TO-71	60	0.1	10	3	200	600	200	75	2	60	0.8
2N4099	5	TO-70	55	0.1	15	5	150	600	150	50	3	55	0.8
2N4100	5	TO-78	55	0.1	15	5	150	600	150	50	3	55	0.8
2N4879	5	TO-71	55	0.1	15	5	150	600	150	50	3	55	0.8
2N4043	10	TO-70	45	0.1	20	5	80		150	30	3	45	0.8
2N4045	10	TO-78	45	0.1	20	5	80		150	30	3	45	0.8
2N4880	10	TO-71	45	0.1	20	5	80		150	30	3	45	0.8



**ELECTRONICS**

**SILICON SOLID STATE OPERATIONAL AMPLIFIERS**

TYPE	MODEL	PKG	SERVICE	Operating Temperature Range		Open Loop DC Voltage Gain		Bandwidth	
				Min	Max	Min	Typ	Small Signal	Full Output
				°C	°C	dB	dB	MHz	kHz
<b>INTEGRATED CIRCUIT TYPES</b>	UC4000	TO-101	Any	-55	+125	86	92	2.0	15
	UC4001	TO-101	Any	-55	+125	86	92	2.0	15
	UC4002	TO-101	Any	-55	+125	86	92	2.0	15
<b>GENERAL PURPOSE TYPES</b>	H6000A	A	Military	-55	+125	90	97	4.5	25
	H6000	P							
	H6020C	C	Industrial	-40	+100	86	90	7.0	25
	H6020 <sup>(5)</sup>	P							
	H6010C	C	Commercial	-25	+85	86	90	7.0	25
	H6010 <sup>(5)</sup>	P							
<b>HIGH INPUT IMPEDANCE FET TYPES</b>	H7000A	AF	Military	-55	+125	86	92	2.5	20
	H7000	PF							
	H7020A	AF	Industrial	-40	+100	86	92	3.0	100*
	H7020B	BF							
	H7010A	AF	Commercial	-25	+85	86	92	3.0	100*
	H7010B	BF							
<b>WIDEBAND AND HIGH OUTPUT CURRENT TYPES</b>	H9000A	A	Military	-55	+125	95	100	20	200
	H9020A	A	Industrial	-40	+100	95	100	3.0	35
	H9020B	B							
	H9010A	A	Commercial	-25	+85	95	100	3.0	35
	H9010B	B							
<b>± 20 VOLT OUTPUT TYPES</b>	H7030A	AF	Industrial	-40	+100	90	97	3.0	45
	H7030B	BF							
	H9030A	A	Industrial	-40	+100	100	105	3.0	25
	H9030B	B							
<b>OUTPUT CURRENT BOOSTERS</b>	H6030C	CB	Military	-55	+125	-0.5	-0.2	22.0	—
	H6030	B							
	H6050	PB	Commercial	-40	+100	-1.0	-0.5	15.0	—
<b>DC COMPARATORS (Fast Slew-Rate Operational Amps., Uncompensated)</b>	H8000A	A	Military	-55	+125	90	97	—	—
	H8020A	AF	Industrial	-40	+100	90	95	—	—
	H8010C	C	Commercial	-25	+85	86	90	—	—

\* New improved specification. (1) Adjustable to Zero by ext potentiometer. (2) Input Offset Current doubles approximately every 11°C. (3) Plus output load current. (4) Adjustable to Zero by external rheostat. (5) Also available in "D" PKG upon request. (6) For -55°C < TA < +125°C only. (7) At rated load. (8) Typical value.

**UNION  
CARBIDE**  
**ELECTRONICS**

Input Impedance Open Loop		Input Voltage		Input Current			Input Noise Voltage	Common Mode Voltage Range	Rated DC Output		Power Requirements		Slew Rate	MODEL
Diff	CM	Offset	Drift	Bias	Offset	Drift	Max	Min	Min	Min	Nom	Nom	Typ	
Typ	Typ	Max	Max	Typ	Max	Max	Max	Min	Volts	mA	Volts	mA <sup>(2)</sup>	V/ $\mu$ sec	
M $\Omega$	M $\Omega$	mV	$\mu$ V/ $^{\circ}$ C	nA	nA	nA/ $^{\circ}$ C	$\mu$ V RMS	Volts	Volts	mA	Volts	mA <sup>(2)</sup>	V/ $\mu$ sec	
3.0	400	<sup>(1)</sup> Zero $\pm 5$	$\pm 10$	30	$\pm 15$	<sup>(6)</sup> $\pm 0.175$	<sup>(8)</sup> 0.2	$\pm 10$	$\pm 10$	$\pm 2.0$	$\pm 15$	$\pm 7$	1.0	UC4000
3.0	400	<sup>(1)</sup> Zero $\pm 10$	$\pm 20$	70	$\pm 30$	<sup>(6)</sup> $\pm 0.350$	<sup>(8)</sup> 0.2	$\pm 10$	$\pm 10$	$\pm 2.0$	$\pm 15$	$\pm 7$	1.0	UC4001
3.0	400	<sup>(1)</sup> Zero $\pm 15$	$\pm 40$	120	$\pm 50$	<sup>(6)</sup> $\pm 0.700$	<sup>(8)</sup> 0.2	$\pm 10$	$\pm 10$	$\pm 2.0$	$\pm 15$	$\pm 7$	1.0	UC4002
10	400	<sup>(4)</sup> Zero	$\pm 10$	15	$\pm 5.0$	$\pm 0.1$	2.0	$\pm 10$	$\pm 10$	$\pm 2.0$	$\pm 15$	$\pm 3.5$	1.6	H6000A H6000
1.0	500	<sup>(4)</sup> Zero	$\pm 5$	80	$\pm 25$	$\pm 0.5$	2.0	$\pm 10$	$\pm 10$	$\pm 3.0$	$\pm 15$	$\pm 6.5$	1.6	H6020C H6020
0.25	300	<sup>(4)</sup> Zero	$\pm 10$	100	$\pm 50$	$\pm 1.5$	5.0	$\pm 10$	$\pm 10$	$\pm 3.0$	$\pm 15$	$\pm 6.5$	1.6	H6010C H6010
10 <sup>6</sup>	10 <sup>6</sup>	<sup>(1)</sup> Zero	$\pm 25$	.015*	$\pm 0.05$	<sup>(2)</sup>	2.0	$\pm 10$	$\pm 10$	$\pm 2.0$	$\pm 15$	$\pm 4.2$	1.3	H7000A H7000
10 <sup>6</sup>	10 <sup>6</sup>	<sup>(1)</sup> Zero $\pm 1.0$	$\pm 25$	.04	$\pm 0.05$	<sup>(2)</sup>	2.0	$\pm 5$	$\pm 10$	$\pm 2.0$	$\pm 15$	$\pm 4.5$	6.5*	H7020A H7020B
10 <sup>5</sup>	10 <sup>5</sup>	<sup>(1)</sup> Zero $\pm 1.0$	$\pm 50$	.04	$\pm 0.1$	<sup>(2)</sup>	5.0	$\pm 5$	$\pm 10$	$\pm 2.0$	$\pm 15$	$\pm 4.5$	6.5*	H7010A H7010B
1.0	300	<sup>(4)</sup> Zero	$\pm 5$	75	$\pm 25$	$\pm 0.5$	2.0	$\pm 10$	$\pm 10$	$\pm 30$	$\pm 15$	$\pm 4.0$	13	H9000A
1.0	300	<sup>(4)</sup> Zero $\pm 0.5$	$\pm 5$	80	$\pm 25$	$\pm 0.5$	2.0	$\pm 10$	$\pm 10$	$\pm 30$	$\pm 15$	$\pm 4.2$	2.2	H9020A H9020B
0.25	300	<sup>(4)</sup> Zero $\pm 0.5$	$\pm 10$	165	$\pm 50$	$\pm 1.5$	5.0	$\pm 10$	$\pm 10$	$\pm 30$	$\pm 15$	$\pm 4.2$	2.2	H9010A H9010B
10 <sup>6</sup>	10 <sup>6</sup>	<sup>(4)</sup> Zero $\pm 1.0$	$\pm 25$	.04	$\pm 0.05$	<sup>(2)</sup>	2.0	$\pm 15$	$\pm 20$	$\pm 2.0$	$\pm 28$	$\pm 5.0$	5.5*	H7030A H7030B
0.5	400	<sup>(4)</sup> Zero $\pm 0.5$	$\pm 10$	250	$\pm 25$	$\pm 0.5$	2.0	$\pm 20$	$\pm 20$	$\pm 10$	$\pm 28$	$\pm 2.5$	3.2*	H9030A H9030B
—	<sup>(7)</sup> 4	$\pm 50$	—	2.5 $\times 10^3$	—	—	—	$\pm 10$	$\pm 10$	$\pm 20$	$\pm 15$	$\pm 2.0$	100	H6030C H6030
—	2	$\pm 50$	—	50 $\times 10^3$	—	—	—	$\pm 10$	$\pm 10$	$\pm 100$	$\pm 15$	$\pm 6.0$	150	H6050
10	400	<sup>(4)</sup> Zero	$\pm 10$	10	$\pm 5.0$	$\pm 0.1$	—	$\pm 10$	$\pm 10$	$\pm 2.0$	$\pm 15$	$\pm 3.5$	10	H8000A
10 <sup>6</sup>	10 <sup>6</sup>	<sup>(1)</sup> Zero	$\pm 20$	.05	$\pm 0.05$	<sup>(2)</sup>	—	$\pm 5$	$\pm 10$	$\pm 2.0$	$\pm 15$	$\pm 4.5$	20	H8020A
0.25	300	<sup>(4)</sup> Zero	$\pm 10$	100	$\pm 50$	$\pm 1.5$	—	$\pm 10$	$\pm 10$	$\pm 3.0$	$\pm 15$	$\pm 6.5$	11	H8010C

**TRANSISTOR PACKAGES**

All Dimensions Nominal in Inches Unless Otherwise Noted.

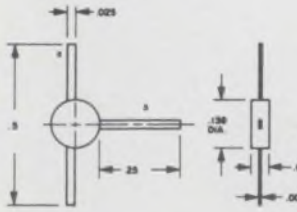

CC-3

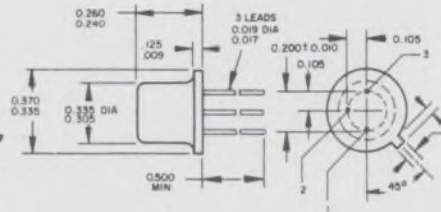

TO-5

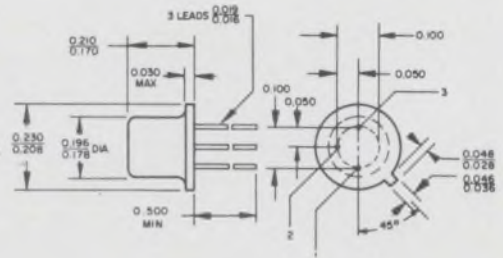

TO-18

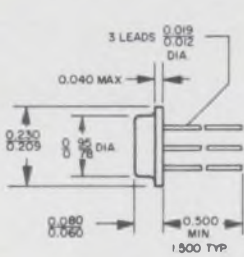

TO-46

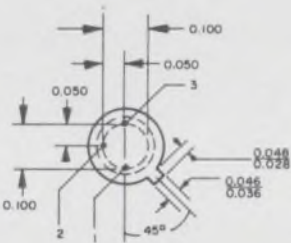

TO-72

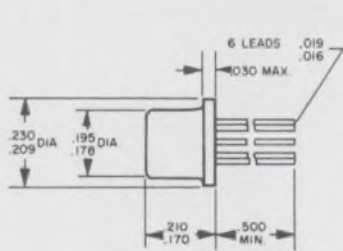
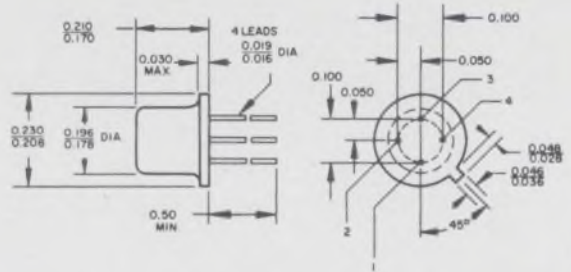

TO-71

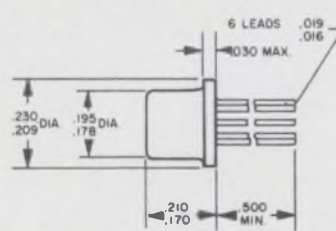
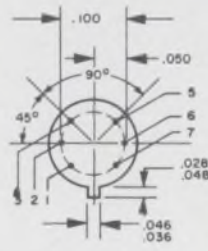

CO-71

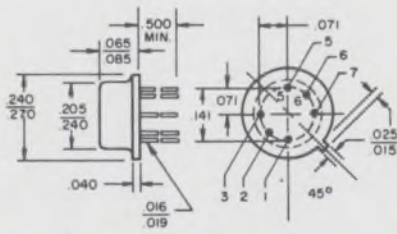
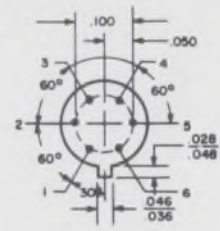

TO-70

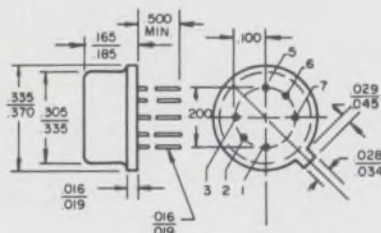

TO-78

NOTE: All base diagrams are bottom view.

DEVICE TYPE	HEADER																											
	TO-5/TO-18/TO-46			TO-72				CC-3			TO-70/TO-78					TO-71					CO-71							
PIN	1	2	3	1	2	3	4	1	2	3	1	2	3	5	6	7	1	2	3	5	6	7	1	2	3	4	5	6
NPN/PNP	E	B	C	---	---	---	---	E	B	C	C	B	E	E	B	C	---	---	---	---	---	---	---	---	---	---	---	---
2N2972-79	---	---	---	---	---	---	---	---	---	---	---	---	---	---	---	---	E	B	C	E	B	C	---	---	---	---	---	---
P-CHANNEL	S	G	D	S	G	D	Case	S	D	G	G	D	S	S	D	G	S	D	G	S	D	G	S	D	G	S	D	G
N-CHANNEL	S	D	G	S	D	G	Case	S	D	G	G	D	S	S	D	G	S	D	G	S	D	G	S	D	G	S	D	G
2N4878-80	---	---	---	---	---	---	---	---	---	---	---	---	---	---	---	---	C	B	E	E	B	C	---	---	---	---	---	---

**AMPLIFIER PACKAGES**

All Dimensions Nominal in Inches Unless Otherwise Noted.

**INTEGRATED CIRCUIT TYPES**

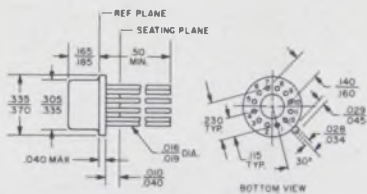

- (1) COMMON
- (2) NEGATIVE SUPPLY
- (3) OUTPUT COMPENSATION
- (4) INTERNAL CONNECTION
- (5) OUTPUT
- (6) POSITIVE SUPPLY
- (7) BALANCE POTENTIOMETER
- (8) INPUT COMPENSATION
- (9) INPUT (INVERTING)
- (10) INPUT (NON-INVERTING)
- (11) INPUT COMPENSATION
- (12) BALANCE POTENTIOMETER

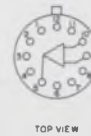

**SIDE VIEWS**

**BIPOLAR  
TRANSISTOR  
TYPES**

**FIELD EFFECT  
TRANSISTOR  
TYPES**

**BOOSTERS**

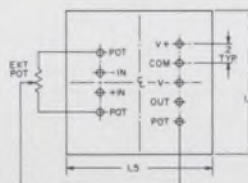
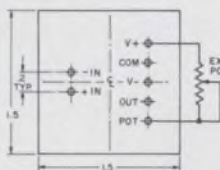
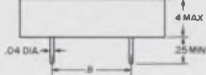

**"A" PACKAGE**

**"A" BASE**

**"AF" BASE**

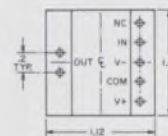
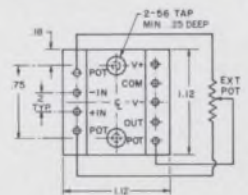
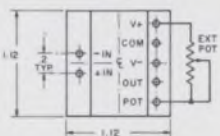
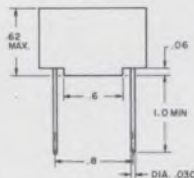

**"P" PACKAGE**

**"P" BASE**

**"PF" BASE**

**"PB" BASE**

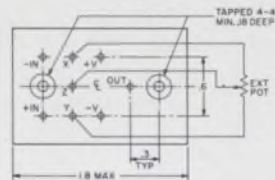
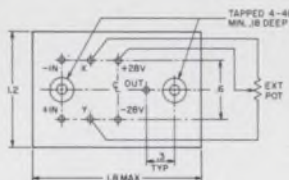
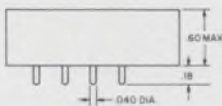

**"B" PACKAGE**

**"B" BASE**

**"BF" BASE**

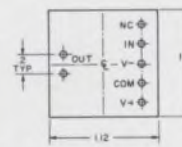
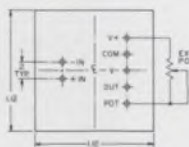
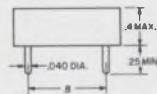

**"C" PACKAGE**

**"C" BASE**

**"CB" BASE**

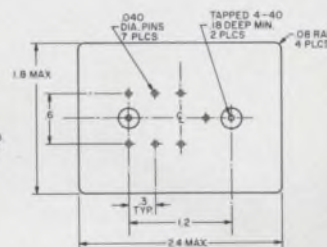
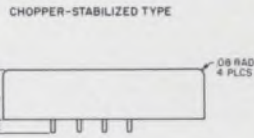
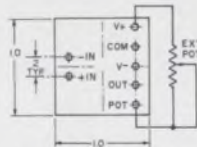
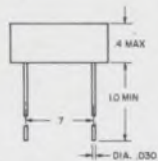

**"D" PACKAGE**

**"D" BASE**

**BL PACKAGE**

**BL BASE**

NOTE: All base diagrams are bottom view.

#### UNION CARBIDE SALES OFFICES

**CALIFORNIA 92633, Fullerton** • 2736 W. Orangethorpe  
Union Carbide Electronics • (213) 691-0958 • (714) 871-5073  
• TWX: 910-592-1255

**CALIFORNIA, Mtn. View** • 2680 Bayshore Frontage Road  
Union Carbide Electronics • (415) 969-9390 • TWX: 910-379-6444

**ILLINOIS 60068, Park Ridge** • 2 Talcott Road  
Union Carbide Electronics • (312) 825-7181 • TWX: 910-253-4081

**NEW JERSEY, Englewood Cliffs** • 320 Hudson Terrace  
Union Carbide Electronics • (201) 567-6730 • TWX: 710-991-9744

**MASSACHUSETTS, Needham** • 300 First Avenue  
Union Carbide Electronics • (617) 444-5400 • TWX: 710-325-1329

**TEXAS, Dallas** • Preston Forest Towers, 5925 Forest Ln.  
Union Carbide Electronics • (214) 239-0221 • TWX: 910-860-5000

#### REPRESENTATIVES / EASTERN:

**ALABAMA, Huntsville** • 2805 Governors Drive  
Bohman Associates • (205) 534-1355

**CONNECTICUT, Milford** • 662 Bridgeport  
Vector Sales, Inc. • (203) 874-2112

**FLORIDA, Orlando** • 7040 Lake Ellenor Drive  
Bohman Associates • (305) 855-0274

**MARYLAND, Towson** • 206 W. Washington Avenue  
Wm. I. Duncan Assoc., Inc. • (301) 823-2506

**MASSACHUSETTS, Belmont** • 774 Pleasant St.  
Vector Sales, Inc. • (617) 489-1400

**NEW JERSEY, Wayne** • 18 Sunny Ridge Road  
Unicomp • (201) 696-2888 • TWX: 201-835-5444

**NEW YORK, Ithaca** • 714 W. Clinton St.  
Bob Dean, Inc. • (601) 272-2187 • TWX: 510-255-5876

**NORTH CAROLINA, Bethania** •  
Candor Company • (919) 924-1480

**PENNSYLVANIA, Philadelphia** • 5452 Charles St.  
Wm. I. Duncan Assoc., Inc. • (215) 744-6110

#### CENTRAL:

**ILLINOIS, Chicago** • 7448 North Harlem Avenue  
Carlson Electronic Sales Co. • (312) 774-4812 • TWX: 910-221-5017

**INDIANA, Indianapolis** • 4010 Washington Blvd.  
Leslie M. Devoe Co. • (317) 283-1395 • TWX: 810-341-3284

**MICHIGAN, Detroit** • 16239 Wyoming Avenue  
Carter, McCormick and Peirce • (313) 863-4600 • TWX: 810-243-4067

**MINNESOTA, Minneapolis** • 7400 Lyndale Avenue South  
Stan Clothier Co., Inc. • (612) 869-3231 • TWX 910-576-3415

**MISSOURI, Kansas City** • 7916 Paseo St.  
Harris-Hanson Company • (816) 444-9494 • TWX: 910-771-2160

**MISSOURI, St. Louis** • 2814 So. Brentwood  
Harris-Hanson Company • (314) 647-4350 • TWX: 910-760-1650

**OHIO, Cleveland** • 3691 Lee Road  
Carter, McCormick and Peirce • (216) 921-1360

**OHIO, Dayton** • 3406 N. Main Street  
Carter, McCormick and Peirce • (513) 278-5873

**TEXAS, Garland** • 400 Forest Gate Lane, Suite 102 P. O. Box 87  
Carter Associates • (214) 276-7151

**TEXAS, Houston** • 1401 S. Post Oak Road, Suite 105  
Carter Associates • (713) 622-0844 • TWX: 910-881-2600

#### WESTERN:

**ARIZONA, Scottsdale** • 201 West 1st Street, P. O. Box 99  
Carter Associates • (602) 947-4355 • TWX: 910-950-0080

**CALIFORNIA, Costa Mesa** • 2956 Randolph  
Williams, Hedge and Martin • (714) 540-3244

**CALIFORNIA, Los Altos** • 175 So. Antonio Road  
W. W. Posey Co. • (415) 948-7771

**CALIFORNIA, Van Nuys** • 13615 Victory Blvd.  
Dorado Electronics, Inc. • (213) 873-4124

**COLORADO, Denver** • 2654 So. Krameria St.  
Lindberg Company • (303) 757-6489 • TWX: 910-931-2579

**OREGON, Beaverton** • 200 N.E. Canyon Road  
Arneson Associates • (503) 646-3416

**WASHINGTON, Seattle** • 5950 Sixth Avenue, So.  
Arneson Associates • (206) 762-7664

#### DISTRIBUTORS / EASTERN:

**ALABAMA, Huntsville** • 2805 Governors Drive  
Hall-Mark Electronics • (205) 536-9627

**ALABAMA, Huntsville** • Clinton Building, 2109 Clinton Ave.  
Schweber Electronics • (205) 539-2756

**FLORIDA, Orlando** • 7233 Lake Ellenor Drive  
Hall-Mark Electronics • (305) 855-4020 • TWX: 810-850-0183

**MARYLAND, Baltimore** • 5 North Howard Street  
Radio Electric Service Co. • (301) 539-3835 • TWX: 710-234-1050

**MARYLAND, Silver Springs** • 8720 Georgia Ave.  
Schweber Electronics • (310) 587-2900

**MASSACHUSETTS, Burlington** • 207 Cambridge Street  
Avnet Electronics • (617) 272-3060 • Telex: 94-6530

**MASSACHUSETTS, Waltham** • 400 Wyman Street  
Schweber Electronics • (617) 891-8484

**NEW JERSEY, Clifton** • 312 Clifton Avenue  
Eastern Radio • (201) 471-6600 • TWX: 710-484-4828

**NEW YORK, Buffalo** • 916 Main Street  
Summit Electronics • (716) 884-3450

**NEW YORK, New York** •  
Eastern Radio • (212) 244-8930

**NEW YORK, Westbury, L.I.** • Jericho Turnpike  
Schweber Electronics • (516) 334-7474 • TWX: 510-222-3660

**PENNSYLVANIA, Philadelphia** • 5908 Torresdale Ave.  
Buyers Electronic Distributors, Inc. • (215) 744-3242

#### CENTRAL:

**ILLINOIS, Elk Grove Village** • 75 Gaylord Street  
Arco Electronics • (312) 487-0500

**ILLINOIS, Franklin Park** • 10130 West Pacific  
Avnet Electronics • (312) 678-8160 • TWX: 910-227-0795

**KANSAS, Kansas City** • 2707 W. 43rd Street  
Precision Electronics Devices, Inc. • (913) 236-4343

**MINNESOTA, Minneapolis** • 4940 Viking Drive, Suite 208  
Avnet Electronics • (612) 920-5866

**MISSOURI, St. Louis** • 2605 S. Hanley Road  
Electronic Components for Industry • (313) 647-5505  
• TWX: 314-556-0584

**OHIO, Cleveland** • 20950 Center Ridge Road  
Schweber Electronics • (216) 333-7020

**OKLAHOMA, Tulsa** • P. O. Box 15565, Admiral Station  
Hall-Mark Electronics • (918) 8359-8458

**TEXAS, Dallas** • 9100 Markville Drive  
Hall-Mark Electronics • (214) 231-6111

**TEXAS, Houston** • 1616 McKinney  
Sterling Electronics • (713) 225-1321 • TWX: 713-571-3327

#### WESTERN:

**ARIZONA, Phoenix** • 1739 North 28th Avenue  
Avnet Electronics • (602) 272-6821 • Telex: 66-750

**CALIFORNIA, Culver City** • 10916 Washington Blvd.  
Avnet Electronics • (213) 870-6141 • TWX: 910-340-6753

**CALIFORNIA, Los Angeles** • 5645 E. Washington Blvd.  
K-Tronics • (213) 685-5888 • TWX: 910-580-3152

**CALIFORNIA, Mtn. View** • 344 Middlefield Road  
Avnet Electronics • (415) 961-7700

**CALIFORNIA, Newport Beach** • 4301 Birch Street  
Western Electronic Components • (714) 540-1322 (213) 631-6119

**CALIFORNIA, Palo Alto** • 3969 E. Bayshore  
Kierulff Electronics, Inc. • (415) 968-6292 • TWX: 910-379-6430

**CALIFORNIA, San Diego** • 7969 Engineer Road  
Avnet Electronics • (714) 279-1550 • Telex: 69-515

**CALIFORNIA, San Diego** • 8133 Engineer Road  
Kierulff Electronics • (714) 278-2112 • TWX: 910-335-1182

**COLORADO, Denver** • 2170 So. Grape Street  
Newark-Denver Electronics • (303) 757-3351 • TWX: 910-931-0479

**WASHINGTON, Seattle** • 2217 Third Avenue  
Washington Electronics, Inc. • (206) 682-8981

#### INTERNATIONAL SALES

**NEW YORK, New York** • 270 Park Avenue  
Union Carbide International

**AUSTRALIA, Sydney N.S.W.** • 167-187 Kent Street  
Union Carbide Australia Limited

**BELGIUM, Brussels 8** • 134 Boulevard Leopold II  
J. P. Lemaire

**CANADA, London Ontario** • 1255 Brydges St.  
Welwyn Canada Ltd. • (519) 451-9490

**CANADA, Montreal 11, Quebec** • 1505 Louvain St. W.  
Avnet Electronics of Canada • (514) 381-9126 • Telex: 01-20678

**CANADA, Toronto 19, Ontario** • 87 Wingold Avenue  
Avnet Electronics of Canada • (416) 789-1838 • Telex: 02-29195

**FRANCE, Clichy (Seine)** • 19-21 Rue Madame de Sanzillon  
Tranchant Electronique

**SWEDEN, Solna 3** • Gardsvagen 10B  
John C. Lagercrantz

**UNITED KINGDOM** • 31 Camden Road, London N.W. 1, Eng.  
Livingston Components Limited

**UNITED KINGDOM** • 8 Grafton Street, London W 1, Eng.  
Union Carbide Limited

**WEST GERMANY, Munich 19** • Nymphenburger Strasse 164  
Omni-Ray GmbH

**WEST GERMANY, Munich 90** • Chiemgaustrasse 109, 8000  
Sasco, GmbH



365 MIDDLEFIELD ROAD / MOUNTAIN VIEW, CALIFORNIA 94040 / TEL: (415) 961-3300 / TWX: 910-379-6942

## Temperature sensor has high stability

Attempts to use semiconductor diodes and transistors as temperature sensors have often been unsuccessful because of difficulties in obtaining measurement reproducibility and stability.

An ac-junction thermometer was described at the Solid-State Circuits Conference (see p. 17) in which improved performance was achieved by operating a transistor with ac to eliminate the contribution of saturation current in the device output.

According to D. W. Bargaen of Electro-Optical Systems, Inc., Pasadena, Calif., the transistor sensor is operated in such a way that the effects of recombination-generation currents and surface leakage are eliminated. As a result, stability of  $\pm 0.1^\circ\text{F}$  and interchangeability of  $\pm 1.0^\circ\text{F}$ , or better, may be obtained with transistors as temperature sensors, even though the transistor parameters vary by  $\pm 50\%$ , Bargaen said.

As shown in the illustration, a high-gain amplifier leads to low output impedance and essentially short-circuit operation of the collector base junction. Placing the transistor sensor in the amplifier feedback loop enables the collector current to be changed by switching between two fixed resistors. The emitter base voltage can then be read out as the dependent variable.

If the gain of the amplifier is high and the input current is negligible, the output of the circuit is:

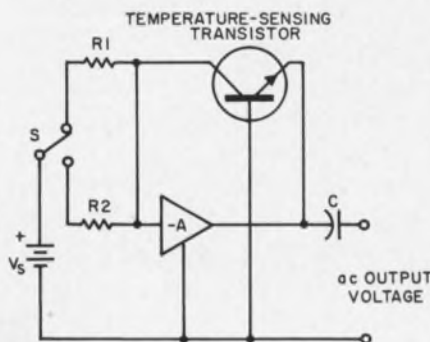
$$\Delta V_{BE} = V_{out} = T(k/8) \ln R1/R2. \quad \blacksquare$$

Transistor temperature transducer circuit eliminates the effects of recombination-generation current and surface leakages.

Eliminate Power Supply  
Obsolescence... Simplify  
Stocking Problems  
With These

# New Wide Range Compacts from ERA!



## Small Size, Wide Range DC Power Modules Permit Improved Design & Procurement Flexibility

The new Transpac® WR Series are ultra-compact, fully repairable,  $71^\circ\text{C}$  silicon power modules which provide regulated DC power over an extremely wide, adjustable voltage range.

Now you can use a single model for all your regulated power requirements... simplify your stocking requirements... eliminate power supply obsolescence... and enjoy significant purchasing economies.

### STANDARD MODELS

Output Voltage (DC)	Current ( $71^\circ\text{C}$ )	Size WxDxH (inches)	Weight (lbs.)	Model	Price
1-33	0-500 ma	$3\frac{1}{4} \times 3\frac{1}{4} \times 5\frac{1}{4}$	3.5	WR33P5	\$120.
1-33	0-1 amp	$3\frac{1}{4} \times 4 \times 5\frac{1}{4}$	5.1	WR331	\$155.
1-18	0-2 amps	$4 \times 4\frac{1}{8} \times 5\frac{1}{8}$	6.5	WR182	\$170.
1-33	0-2 amps	$4\frac{1}{4} \times 5 \times 6\frac{7}{8}$	7.8	WR332	\$185.
1-33	0-4 amps	$5\frac{1}{8} \times 7\frac{1}{4} \times 6\frac{1}{4}$	13.3	WR334	\$255.
1-33	0-8 amps	$8\frac{3}{4} \times 7\frac{3}{8} \times 6\frac{1}{8}$	22.5	WR338	\$305.

### SPECIFICATIONS

**Input:** 105-125 VAC, 50-400 cps  
**Ripple:** Less than 800 microvolts RMS or 0.005%, whichever is greater  
**Line Regulation:** Better than  $\pm 0.01\%$  or 5 mv for full input change  
**Load Regulation:** Better than 0.05% or 8 mv for 0-100% load change  
**Voltage Adjustment:** Continuous (Taps and screwdriver adjustment)  
**Short Circuit Protection:** Microseconds response, automatic recovery

**Vernier Voltage:** External provision  
**Transient Response:** Less than 50 microseconds  
**Maximum Case Temperature:**  $130^\circ\text{C}$   
**Operating Temperature:**  $-20^\circ\text{C}$  to  $+71^\circ\text{C}$  free air, full ratings  
**Temperature Coefficient:** Less than 0.01% per degrees C or 3 millivolts  
**Long-Term Stability:** Within 5 millivolts (8 hours reference)

WRITE TODAY FOR CATALOG #148



**ELECTRONIC RESEARCH ASSOCIATES, INC.**

Dept. ED-3, 67 Sand Park Road • Cedar Grove, N. J. 07009 • (201) 239-3000

Subsidiaries: ERA Electric Co. • ERA Acoustics Corp. • ERA Dynamics Corp. • ERA Pacific, Inc.





**We make our digital volt meters with integrated circuits. They do more and sell for less. We make a model for every price range. One is for you. Made to measure.**

**FAIRCHILD**  
INSTRUMENTATION

## Army strengthens U.S. computer defenses against bombers

While most public discussion about defense against air attack centers on antimissile-missile systems, the U. S. Army is quietly strengthening its potential to down any enemy bombers that might try to hit key cities. It is replacing its 10-year-old Missile Master system with a faster, more advanced electronic setup—Missile Mentor.

The new system employs high-speed, general-purpose computers and display consoles to give air defense commanders more data than they have ever had to make battle decisions, according to the Hughes Aircraft Co. of Fullerton, Calif., manufacturer of Missile Mentor.

The new system is housed in two vans that operate as a single com-

mand post. One van contains the display consoles and displays for defensive missile batteries, and the other houses the computer and a radar processor.

The general-purpose computer, built by Hughes, contains four core memories, each containing 8192 words of 18 bits each; eight buffered input-output channels, and 24 index registers. Parallel, synchronous operation is employed, with a 2.2-MHz clock rate.

Input to the system is from local radar installations or from other air defense systems, such as SAGE or BUIC. If desired, a remotely located third van, containing a computer and display consoles, can be used with a remote radar station to

enlarge defensive radar coverage.

Missile Mentor provides high-speed command and control facilities to coordinate the firing of the Army's Nike Hercules and Hawk surface-to-air missiles. Display and processing equipment in the vans provide surveillance, tracking, threat evaluation, battery-status monitoring, weapons assignment and damage-assessment data.

Missile Mentor systems are reported in operation in the air-defense areas of San Francisco, Los Angeles, Chicago-Milwaukee, Washington-Baltimore, Pittsburgh, New York-Philadelphia and Detroit-Cleveland. Sites at Boston and Miami are expected to be operational soon. ■ ■



Display console of Missile Mentor uses symbols and alphanumeric characters to identify targets.

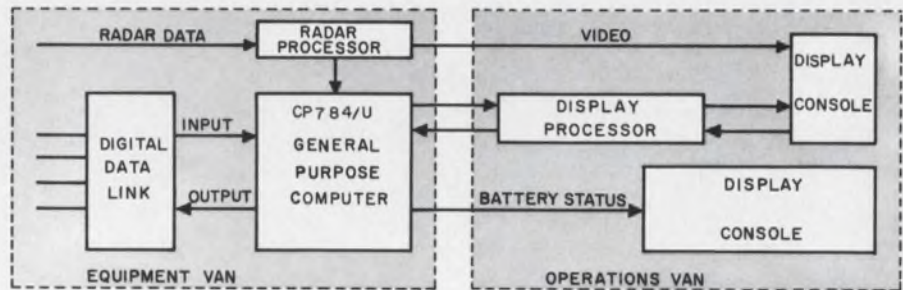

Missile Mentor block diagram, showing the data flow between the two vans that house the system.

## Compact, 3-W undersea nuclear generator makes bow

A small, self-contained three-watt nuclear generator for undersea use was unveiled by the Martin Marietta Corp. at the Offshore Exploration Conference in Long Beach, Calif.

The cylindrical unit, 30 inches high and 24 inches in diameter, operates at depths down to 3000 feet, and with modifications down to 15,000 feet. Two similar units generate 25 and 50 watts, respectively.

All three models, which contain no moving parts, are fueled with strontium 90. They generate power by converting the decay heat of the isotope fuel through a series of thermoelectric elements.

N. E. Felt, Jr., Martin Marietta's general manager of nuclear pro-

grams, says: "We can now offer long-lived electrical power from 3 to 50 W using single units, and we can meet higher power requirements by using more than one unit."

One of the three-watt units has been sold to the U.S. Navy for evaluation testing at the Naval Civil Engineering Laboratory, Point Hueneme, Calif. A 25-watt generator is already operating in the Bering Strait supplying electricity to a Navy oceanographic measuring station off the coast of Alaska.

Typical uses on land and at sea include offshore drilling equipment, navigation aids, and seismological and weather stations. ■ ■



Submersible nuclear generator, fueled with strontium 90, produces 3 watts.



**We make our digital volt meters with integrated circuits. They do more and sell for less. We make a model for every price range. One is for you. Made to measure.**

**FAIRCHILD**  
INSTRUMENTATION

FAIRCHILD INSTRUMENTATION, A Division of Fairchild Camera and Instrument Corporation • 475 Ellis, Mountain View, California 94040 • TEL: 962-2011 • TWX: 962-379-6944

## The DVM's:

### Fairchild 7200:

A full 5-digit meter made for precision measurements in the laboratory or on the production line. It operates to a high standard of accuracy, with  $10\mu\text{V}$  resolution, and excellent short and long term stability. The principle of operation is based on a new concept where high accuracy and long term stability are achieved by a digital time base memory (Pat. Pend.). The basic unit provides DC voltage measurements, DC ratio measurements, and counting functions to 1MHz. Optional plug-in cards or modules provide AC measurement, frequency measurement, resistance measurement, and other capabilities. Basic unit price is \$3500.00.

### Fairchild 7100A:

A full 4-digit meter with extensive capabilities for laboratory and production line measurements. The 7100A measures voltage, resistance and ratio, with AC capabilities optionally available in a plug-in unit. It features guarded construction,  $10\mu\text{V}$  resolution, 0.01% performance, and excellent stability. Price is \$2075.00.

### Fairchild 7000:

A small, half-rack size, portable, medium price 4-digit meter, the 7000 features 0.01% accuracy. The basic unit provides DC voltage measurements, with provisions for adding AC voltage, resistance and current measurements as well as autoranging and BCD output. The front panel of the instrument controls all measurement functions, so that capabilities may be added simply by plugging in a circuit board. Basic unit price is \$1150.00.

### Fairchild 7050:

This low-cost, accurate, 3-digit instrument is intended primarily as a replacement for analog-type meters and panel indicators in such applications as production testing, general testing, quality assurance, servicing and the like. Basic features include DC volts and resistance, full scale readout of 1500, input impedance greater than 1000 megohms, floating input, and readout storage (non-blinking display). Price is \$299.00.

**Where to get them:** For immediate assistance or for the name and address of the representative in your area, contact any of these Fairchild Instrumentation Field Sales Offices:

#### U. S. A.

4546 El Camino Real  
Los Altos, California 94022  
(415) 941-3111

5410 West Imperial Boulevard  
Los Angeles, California 90045  
(213) 678-3166  
TWX: 910-328-6177

50 Jericho Turnpike  
Jericho, L. I., New York 11753  
(516) 333-9311

TWX: 510-222-4479  
2105 Gulf-To-Bay Boulevard  
Suite #4  
Clearwater, Florida  
(813) 446-4619  
TWX: 810-866-0436

8517 39th Avenue, North  
New Hope, Minnesota  
(612) 544-5220

113 Gentry Road  
Hoffman Estates  
Roselle, Illinois 60172  
(312) 894-2060

#### EUROPE

FAIRCHILD INSTRUMENTATION LTD.  
Grove House, 551 London Road  
Isleworth, Middlesex, England

Tel: 560-0838  
TELEX: 24693  
Grunwalderstrasse 99  
Munich 90, West Germany  
Tel: 49 18 47  
Cable: FAIRINTA MUNICH

**FAIRCHILD**  
INSTRUMENTATION

FAIRCHILD INSTRUMENTATION / A Division of Fairchild Camera and Instrument Corporation • 475 Ellis, Mountain View, California 94040. (415) 962-2011 • TWX: 910-379-6944

ON READER-SERVICE CARD CIRCLE 26

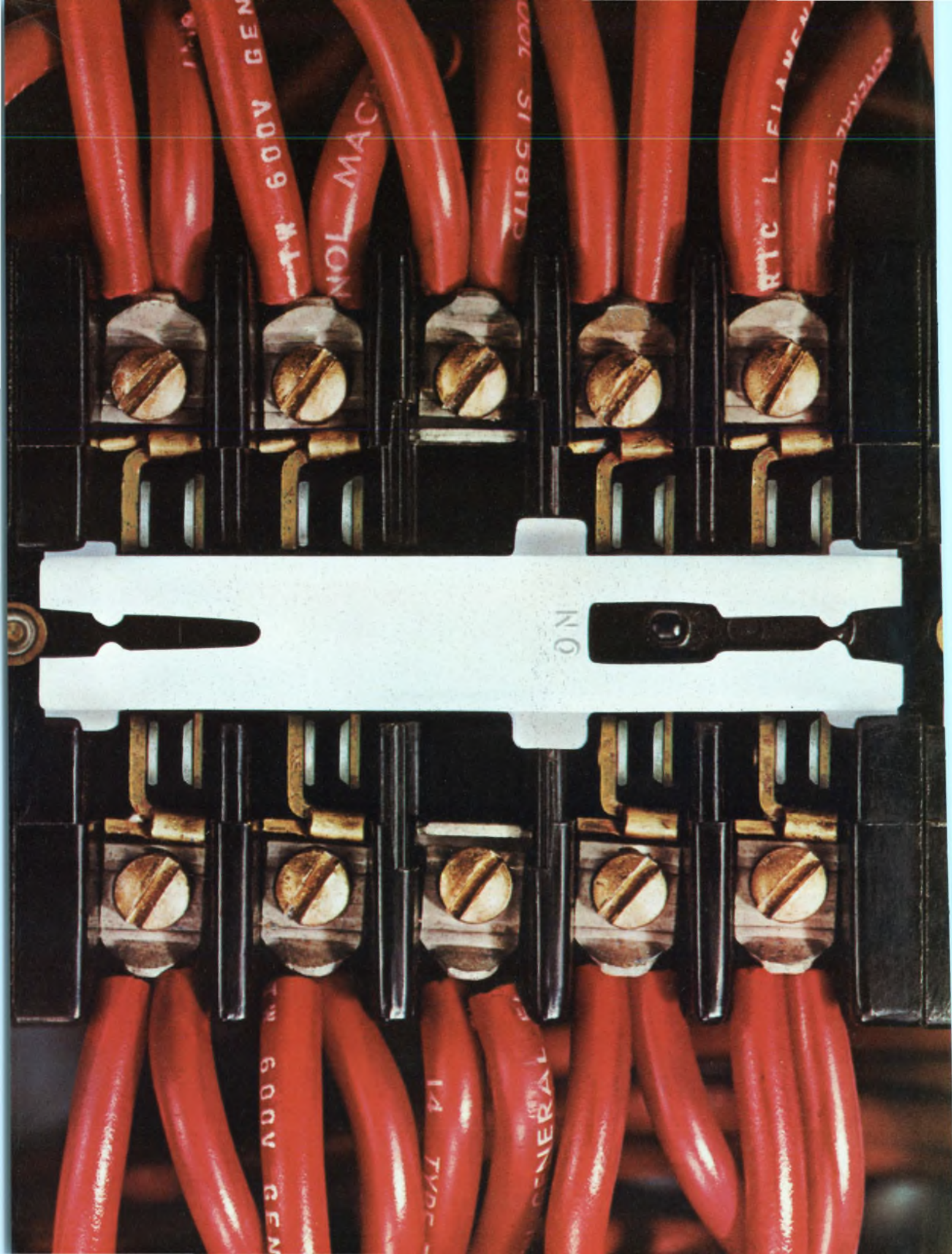

# You can't clean your relay contacts after every cycle...

## so we do it for you.

Or, more accurately, our contacts do. They clean themselves. Every time they open and close.

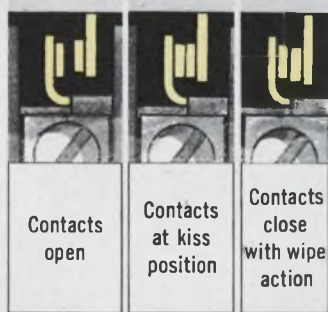

Here's how: As the contacts open and close with high tip pressure, they provide a scrubbing action that keeps the points clean—assures positive make and break for greater contact fidelity. Even after millions of operations. And under all kinds of operating conditions.

Every G-E 300-volt relay has these self-cleaning contact tips . . . a good tip to remember. Here are more:

G.E.'s open design of the contact structure exhausts dust particles. While, vertical contact tips further reduce dust accumulation. Result: cleaner tips, more positive action.

G-E 300-volt relays are available in 2-, 4-, 6-, 8-, 10- and 12-pole forms. Including latched, time-delay and d-c forms.

Need more poles? It's a snap. A unique building block design enables you to add them as the need arises. Quickly, easily.

### 2- & 4-pole adders available

Use 2-pole adders to continue an in-line relay approach without changing coils or disturbing wiring of existing relays.

Or, install 4-pole adders on the front of existing 4-pole relays. They snap right into place. Just the thing for saving panel space. Plus, the sides of the relay act as a wiring trough . . . more space saved.

And, 4-pole adders can be converted from normally open to normally closed. Quickly, without extra parts.

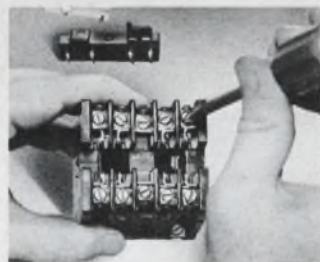

A specialized installation? No problem. A complete line of accessories is available.

Want to know more? Your G-E Sales Engineer or Control Distributor is the one to see. Just ask him for your free copy of "The General Electric Relay Selection/Application Guide."

Or write: Section 811-79, General Electric Company, Schenectady, New York and we'll rush one to you.

**GENERAL PURPOSE  
CONTROL DEPARTMENT,  
BLOOMINGTON, ILLINOIS.**

**LEADER IN CONTROL**



**GENERAL  
ELECTRIC**

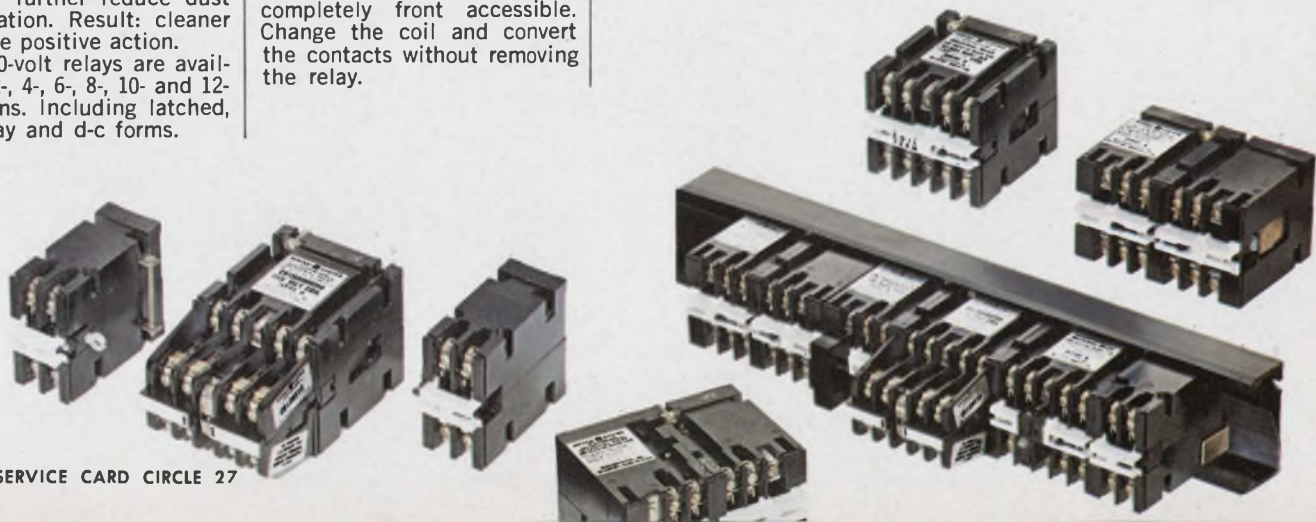

**NEW**



**SOLID STATE TIMER**

CA100

# **YOUR GREATEST CHOICE**

**NEW**



**ELECTROMECHANICAL DUAL-FUNCTION TIMER**

HG100

*The Man from E.A.G.L.E.\* presents two samples that show the range in his bag of timing tricks. The CA100 solid state timer provides split-second control of continuous, high-speed, "on-off" cycles from 3 to 2000 times a minute. Housed in Eagle's famous Cycl-Flex case, the CA100 can be plugged in and taken out in seconds. Solid state circuitry eliminates moving parts, makes this timer great for dusty, dirty locations. At the other extreme the HG100 electromechanical dual-function timer does the job of two ordinary timers. With a single, easily-set dial it provides adjustable "on" and "off" time periods for cycles ranging from 30 seconds to 60 hours. It gives you unmatched ease of adjustment without setting cams or changing gears.*

*For detailed descriptions of one or both of these timers, get our CA Series Bulletin 322 and our HG Series Bulletin 320. Write Eagle Signal Division, E. W. Bliss Company, 736 Federal Street, Davenport, Iowa 52808; or call (319) 324-1361.*

**BLISS**  **EAGLE SIGNAL**

A DIVISION OF THE E. W. BLISS COMPANY

\*E.A.G.L.E.—Engineering Assistance Given Locally—Effectively.

"Visit With the Man From E.A.G.L.E. at March IEEE Show, Booth 4G36-4G38"

"For information on CA100 Timer circle reader service card number 872"

"For information on HG100 Timer circle reader service card number 873"



## INSTANT EAGLE RELAYS

*Test Them Immediately...*

**Get Production Quantities in Two Weeks!**

That's right . . . Eagle challenges you to compare them with any relay on the market. NOW you can get immediate delivery on these general-purpose or medium-power relays. Test results prove they're the finest of their kind in the world. Eliminate your relay delivery problems. Call your "Man from E.A.G.L.E.". . . listed at the right. You'll find he has full details and specifications on Eagle relays.



A DIVISION OF THE E. W. BLISS COMPANY  
736 Federal Street, Davenport, Iowa

Visit With The Man From E.A.G.L.E. at March IEEE Show, Booth 4G36-4G38

ON READER-SERVICE CARD CIRCLE 29

## YOUR "MAN FROM E.A.G.L.E."

### Distributors

Burlingame, California  
415-697-6244  
Glendale, California  
213-245-1172  
Englewood, Colorado  
303-781-0912  
Hamden, Connecticut  
203-288-9276  
Orlando, Florida  
305-855-3964  
Baltimore, Maryland  
301-484-5400  
Newton Highlands, Massachusetts  
617-969-7140  
Minneapolis, Minnesota  
612-922-7011  
Clifton, New Jersey  
201-471-6090  
Haddonfield, New Jersey  
609-429-1526  
Albuquerque, New Mexico  
505-265-1020  
Albany, New York  
518-436-8536  
Depew, New York  
716-684-5731  
Endwell, New York  
607-723-8743  
Fairborn, Ohio  
513-878-2631  
Fairview Park, Ohio  
216-333-4120  
Dallas, Texas  
214-363-1526  
Houston, Texas  
713-649-5756  
Seattle, Washington  
206-725-7800

### Representatives

Scottsdale, Arizona  
602-947-4336  
Pasadena, California  
213-681-4421  
Jacksonville, Florida  
305-388-7656  
Orlando, Florida  
305-422-4295  
Roswell, Georgia  
404-993-6498  
Chicago, Illinois  
312-775-5300  
Chicago Illinois  
312-784-7314  
Baltimore, Maryland  
301-276-1505  
Norwood, Massachusetts  
617-769-3600  
Minneapolis, Minnesota  
612-922-0243  
St. Louis, Missouri  
314-428-5313  
Hackensack, New Jersey  
201-342-2602  
Latham, New York  
518-785-5032  
Rochester, New York  
716-436-4410  
Skaneateles, New York  
315-685-6172  
Fairfield, Ohio  
216-333-4120  
Havertown, Pennsylvania  
215-528-6640  
Dallas, Texas  
214-748-7788  
Houston, Texas  
713-224-9715  
Bellevue, Washington  
206-454-5200  
Charleston, West Virginia  
304-342-2211

# Computers, ICs to help physicists probe nature

## Designers are busy modifying research instruments to take advantage of new advances in electronics

Robert Haavind  
Managing Editor

Designers of instrumentation for physics research are heading rapidly into an era of microcircuitry and computer compatibility.

For years clever design has been necessary to cope with the nanoseconds, random events and angstroms that make up the world probed by the physicists. Some of these design techniques have found their way into other areas of electronics, such as high-speed computer circuits. A sampling of the design techniques used in recent instrumentation illustrates some of the latest trends. Of many new designs being developed, the following ones will serve to indicate the general directions:

- A microcircuit multiscaler suitable for eight count channels at rates up to 50 MHz.

- A 20-MHz scaler using miniature Nixie readouts, and containing a computer-addressable register, now under development.

- An active-filter amplifier used in counting instrumentation.

- An integrating-type signal averager for picking signals out of noise.

### Tight microcircuit packaging

Tight packaging of fast microcircuits leads to a compact 8-channel, 50-MHz multiscaler, designed by Carl Radmer of LeCroy Research Systems Corp.

The present package, an AEC-1 module, has signal wiring printed on the back of a circuit board, and supply buses on top of the microcircuit side (see photo). Multilayer boards may be used in future designs.

The model 150 multiscaler, shown in the photo, can collect counts in eight channels providing 24 parallel bit outputs suitable for computer interface. This unit sells for \$1950. A model 151 twelve-bit unit handles four channels and sells for \$750 to \$1090, depending on input and read-

out options.

Miniature Nixie tube readouts are provided in a scaler under development by Hamner Electronics, Inc., Princeton, N. J. This scaler, the model NS-20, will include a computer-addressable register. Thus, with proper interface circuitry, a computer can program the operation of a number of scalers. This unit will handle 20-MHz rates. Here again integrated circuits are used, this time as Nixie drivers, to keep the package compact. Total count capacity for the 7-digit scaler is  $10^7$ . Inputs of  $\pm 0.2$  volt or  $\pm 2$  volts can be accepted. The price will be under \$1500.

This scaler, which is scheduled to be marketed in the next couple of months, will be the start of a computer-addressable line of instrumentation available from Hamner.

### Pole-zero cancellation

The active-filter amplifier design includes a pole-zero cancellation technique to eliminate the long exponential tail on differentiated pulses. Essential details of the design are presented in the box (page 46). This amplifier is used for counting outputs of semiconductor detectors, scintillation counters or gas ionization chambers. It is important to eliminate the undershoot when making such measurements for two main reasons. First, high overloads may occasionally occur and thus saturate the amplifier long enough to miss subsequent counts. Second, "pile-up" may occur. That is, subsequent pulses may start somewhere along the overshoot rather than at the baseline after the exponential has decayed. If this happens sequentially, it can cause considerable errors.

Active filtering is used to eliminate the need for inductors. This results in simple networks which could be easily translated into microcircuit form in later designs.

This particular amplifier, the model 435, includes two integrated-circuit amplifying stages after the differential input preamplifier,

(continued on p. 46)

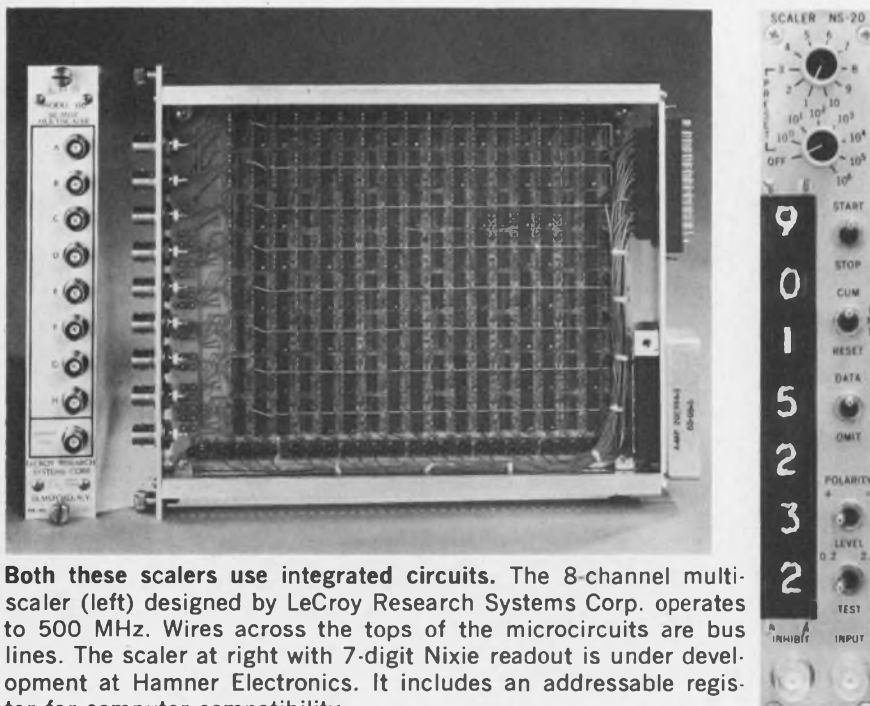

Both these scalers use integrated circuits. The 8-channel multiscaler (left) designed by LeCroy Research Systems Corp. operates to 500 MHz. Wires across the tops of the microcircuits are bus lines. The scaler at right with 7-digit Nixie readout is under development at Hamner Electronics. It includes an addressable register for computer compatibility.



# Tantalum A Go-Go

**KEMET C-Series Solid Tantalum Capacitors.** For the swinging new mood in consumer electronics.

You don't have to be rich to buy these low-leak tantalums. We've priced them in line with standard electrolytics. Yet they'll give you tantalum performance in transistor auto radios, portable phonographs, tape recorders—the mass-produced products that keep today's consumers turned on.

We make the KEMET C-Series in 0.1 to 220 microfarads, 6 to 50 vdc, for environments from  $-55^{\circ}$  to  $+85^{\circ}\text{C}$ . Catalog items are available for immediate or lightning-fast delivery, in any quantity from thousands to millions.

Shouldn't you go tantalum for today's go-go products?

For details, call our representative, or mail the coupon.

Clip, fill in name and title, attach to letterhead.

Union Carbide Corporation  
Components Department  
Dept. ED-33  
P. O. Box 5928  
Greenville, S. C.



**ELECTRONICS**

Please send details on "C" Series  
KEMET Solid Tantalum Capacitors

Name \_\_\_\_\_

Title \_\_\_\_\_

KEMET is a registered trade mark of Union Carbide Corporation.

**REGIONAL SALES OFFICES.** **New England:** T. J. Roper, 300 First Ave., Needham Heights, Mass. Phone: 617-444-5400. **Mid-Atlantic:** R. H. Robeck, 1341 Hamburg Turnpike, Wayne, New Jersey 07472. Phone: 201-696-2710. **Mid-West and South:** K. S. Collart, P. O. Box 6087, Cleveland, Ohio 44101. Phone: 216-221-0600. C. F. Fields, 2 Talcott Road, Park Ridge, Ill. 60068. Phone: 312-825-8189. **West Coast:** D. Purcell, 701 East Whittier Boulevard, Whittier, California 90605. Phone: 213-698-8077. C. E. Volpe, 2680 Bay Shore Frontage Road, Mountain View, California 94041. Phone: 415-969-9390. **For Overseas Inquiries contact:** J. G. Egan, 1341 Hamburg Turnpike, Wayne, New Jersey 07472. Phone: 201-696-2710.

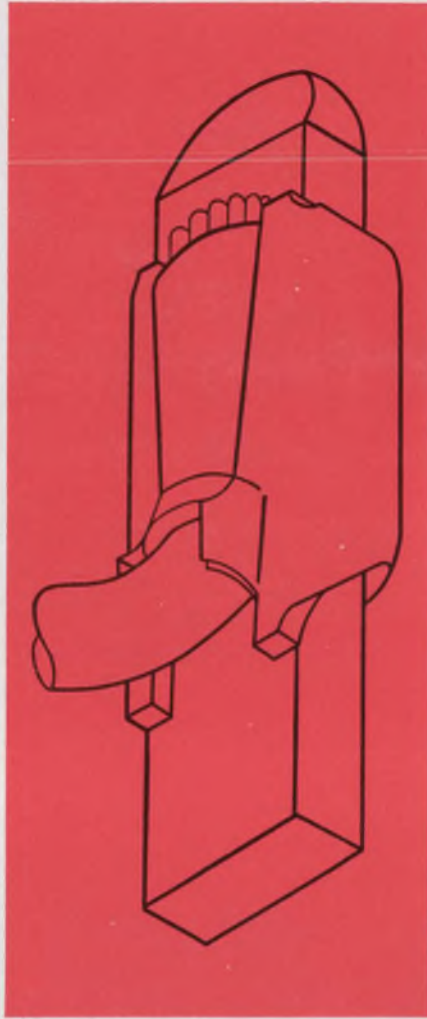

## Some pointed facts about wiring

**1. Ours is the only point-to-point wiring technique designed for both solid and stranded wire, bulk or pre-cut, and other types, such as enamel insulated wire. Production flexibility is further enhanced by the variety of TERMI-POINT tools which range from lightweight pneumatic and hand application devices to fully automated high-speed equipment. Since head-on insertion, not wrapping or twisting, is utilized in our technique, these tools require a minimum of working space, permitting grid densities to .100" . . . even tighter in future generation products!**

**2. TERMI-POINT wiring devices are fully compatible with other production methods . . . although our plated chamfered post was designed specifically for TERMI-POINT clips. These posts are available in several sizes, including the new miniature .022" x .036" rectangular post. Mating TERMI-POINT clips are applied over the mandrel and onto the post in a manner which "irons" the wire. Clips are made of fine grain phosphor bronze and incorporate integral springs. The combination of the ironed wire and the integral spring produces a gas-tight connection—without nicking either post or wire!**

**3. TERMI-POINT clip terminations are the easiest to service of any production wired devices. Individual connections may be tested non-destructively in the field using simple hand tools, without damage to the post involved or adjacent posts. Unlike wrapped connections that require a dozen or more steps to replace, the bottom TERMI-POINT clip on a 3-high post can be removed with a quick twist of the extraction tool. Upper clips slide into position on the post, and the new connection is applied on top. Posts can be used many times without deterioration.**

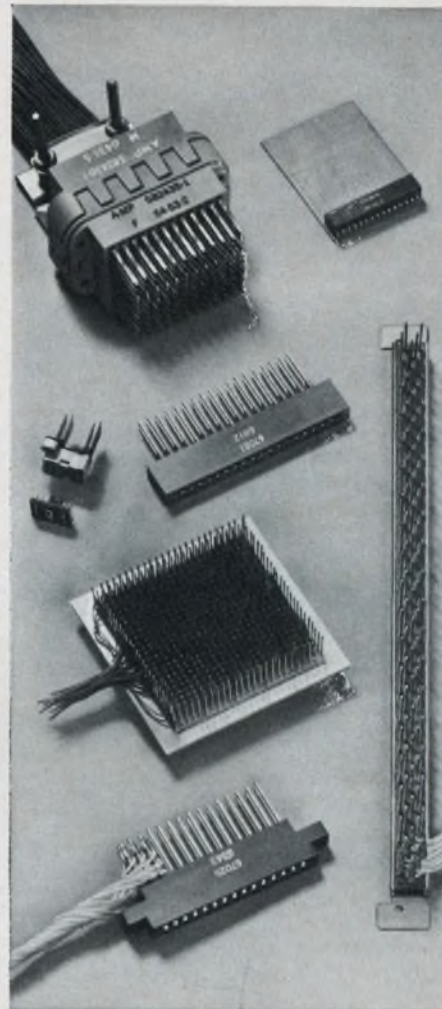

## with TERMI-POINT\* clips and tools

**4. Automated TERMI-POINT tooling offers the highest production speed in the industry.** Programmed by punched paper tape, our Automatic Wiring Machine can completely terminate a 10-inch lead in four seconds—faster than any other automated technique. In addition, it takes up one-third the space and weight\*, and provides the high efficiency of a moving applicator over a stationary work bed. High speed coupled with the ability to use bulk wire results in lowest applied cost of any point-to-point wiring method. (Customer panels can be produced on this machine at our Harrisburg plant, saving manufacturers capital investment. Ask for information on our pre-wired panel service.)

\*TERMI-POINT automatic wiring machine information:

Weight—approx. 4500 lbs.

Size—approx. 8' x 10'

Speed—over 1000 programmed wires in a one hour period

**5. We've developed the broadest line of products that have been made available for any automatic technique.** Associated products include one and two-piece printed circuit connectors, rack and panel connectors, flat pack receptacles, modular interconnection devices, transition and relay blocks, bus bars, and dual disconnects. Reliability is second to none in the industry. And AMP accepts total responsibility for its technique, its products and the performance of customer connections.

Write today for detailed literature on this advanced concept in point-to-point wiring and the family of products we've developed for it.

\*Trademark of AMP INCORPORATED

**AMP**  
**INCORPORATED**  
 Harrisburg, Pennsylvania

AMP\* products and engineering assistance are available through subsidiary companies in: Australia • Canada • England • France • Holland • Italy • Japan • Mexico • Spain • West Germany

ON READER-SERVICE CARD CIRCLE 31

(physics, continued)

which uses a pair of 2N3638s. The output stage is also not integrated, since to feed 100 ohms at about 10 volts requires an output current of 100 mA, a little too husky for today's ICs. The differential inputs are important in physics laboratories where lots of equipment is of-

ten humming away during an experiment. One cable carries the signal and the second acts as a dummy. This cuts common-mode noise by a factor of 200.

This amplifier, like most other equipment in this field, is designed according to AEC-recommended NIM (Nuclear Instrument Module) specifications. Design was handled

by Thomas Emmen, Ortec chief engineer.

Signal averagers are another type of instrument coming into wide use in physics research and also the medical field. Fabri-tek, Inc.'s Instrument Div. in Madison, Wis., is moving into this field with new microcircuit designs. The basic idea of such instruments is to sample a

### Pole-zero cancellation and active filtering

Pole-zero cancellation is a technique to eliminate the undershoot from the waveform  $e_1(t)$  in Fig. 1a. This pulse is obtained by putting the output of a preamplifier,  $e_0(t)$ , through a differentiator ( $R_1C_1$ ). The result, obtained by use of Laplace transforms, is:

$$e_1(t) = E_0 e^{-t/T_0} \times G_1(t),$$

$$e_1(s) = E_0 \left[ \frac{1}{s + (1/T_0)} \right] \times \left[ \frac{s}{s + (1/R_1C_1)} \right],$$

$$e_1(t) = \left[ E_0 / (T_0 - T_1) \right] \times \left[ T_0 e^{-t/T_1} - T_1 e^{-t/T_0} \right];$$

where  $T_1 = R_1C_1$ .

If the network of Fig. 1b is used instead, the undershoot is eliminated if the potentiometer ratio,  $K$ , is set correctly. This can be seen from the following expressions:

$$e_2(t) = E_0 e^{-t/T_0} \times G_2(t),$$

$$e_2(s) = E_0 \left[ \frac{1}{s + (1/T_0)} \right] \times \left[ \frac{s + (K/R_2C_1)}{s + (1/R_pC_1)} \right];$$

where  $R_p = R_1R_2 / (R_1 + R_2)$ . Thus, the condition for pole-zero cancellation is:

$$s + 1/T_0 = s + K/R_2C_1.$$

If this condition is met, the expression reduces to:

$$e_2(s) = E_0 \left[ \frac{1}{s + (1/R_pC_1)} \right],$$

$$e_2(t) = E_0 e^{-t/R_pC_1}.$$

Thus a single exponential with no undershoot results. A screw

adjustment in the side of the amplifier sets the potentiometer to determine the value of  $K$  between 0 and 1.

The amplifier also contains two integrated-circuit amplifier stages and an active filter. Active filtering is used to provide a waveshape that approaches a theoretical optimum for best signal-to-noise ratio. Such a point occurs, for a FET, when gate current and drain thermal noise are equal. The ideal waveform is a cusp (Fig. 2a) where:

$$e^{-t/RC}, t > 0;$$

$$e^{t/RC}, t < 0.$$

This could be simulated with a gaussian curve represented by the following transfer function:

$$\left[ \frac{1}{s + (1/RC)} \right] \left\{ \frac{1}{[s + (1/RC)]^n} \right\}$$

where  $n \rightarrow \infty$ .

A gaussian approximation for  $n = 2$  is shown in Fig. 2b. The first term of this function can be provided by an RC high-pass filter like the one of Fig. 1a. The circuit of Fig. 3 could provide this term if  $K = 1$ . However, an improved waveform, Fig. 2c, can

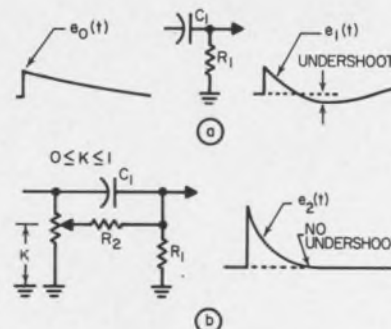

Fig. 1. Waveforms show results without pole-zero cancellation (a) and with it (b).

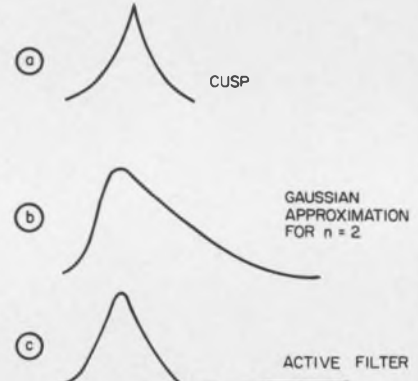

Fig. 2. Waveforms illustrate active filter concept.

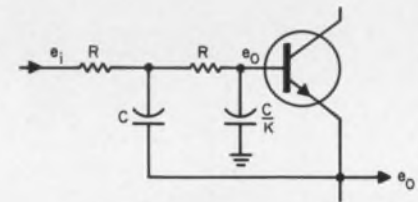

Fig. 3. Active filter circuit.

be achieved if a value of  $K = 4$  is used. The transfer function for this network is:

$$\frac{e_o}{e_i} = \frac{4/R^2C^2}{[s + (1 + j\sqrt{3}/RC)] \times [s + (1 - j\sqrt{3}/RC)]}$$

This can be combined with a differentiating (high-pass filter) stage to produce the waveform of Fig. 2c, represented by the following function:

$$\left( \frac{4}{R^2C^2} \right) \left[ \frac{s}{s + (1/RC)} \right] \times \left[ \frac{1}{s + (1 - j\sqrt{3}/RC)} \right] \times \left[ \frac{1}{s + (1 + j\sqrt{3}/RC)} \right].$$



## A post-graduate course in money-making

Some people think of Digital Equipment as a manufacturer of digital computers and modules for the university and scientific community exclusively. They're wrong.

Since the PDP-8/S was introduced in August of 1966, more than 300 such machines have been sold to be part of other people's money-making devices — blood analyzers, X-ray diffractometers, spectrum analyzers, batch controllers for cookie baking. One pipeline manufacturer ordered 25 PDP-8/S computers just to log data. (PDP-8/S is the world's first under-\$10,000 computer.)

For bigger, faster problems, the bigger, faster PDP-8

has been incorporated into money-making automatic transistor check out equipment, petroleum controllers, thickness testers for rolled steel. (PDP-8 costs \$18,000.) PDP-9 is bigger yet.

And modules. We sell more digital logic circuit modules to manufacturers who resell them as part of their instruments and systems than to all our university customers combined.

So we're very big in the universities. True.

But if you make instruments or systems (and particularly, if you sell these instruments to the scientific disciplines) maybe you should discover us. Before we get too well known.

**digital**  
COMPUTERS • MODULES

DIGITAL EQUIPMENT CORPORATION, Maynard, Massachusetts 01754. Telephone: (617) 897-8821 • Cambridge, Mass. • New Haven • Washington, D.C. • Parsippany, N.J. • Rochester, N.Y. • Philadelphia • Huntsville • Pittsburgh • Chicago • Denver • Ann Arbor • Houston • Los Angeles • Palo Alto • Seattle • Carleton Place and Toronto, Ont. • Reading, England • Paris, France • Munich and Cologne, Germany • Sydney and West Perth, Australia • Modules distributed also through Allied Radio

another  solution

## TEFLON\* SPACER/BUSHINGS FOR MOUNTING P.C. BOARDS TO METAL PANELS OR CHASSIS

Completely eliminate nuts, bolts, lockwashers, insulators, metal stand-offs and spacers, with Sealectro's new and unique Press-Fit® Teflon Spacer/Bushings. Simply drill or punch a hole in a chassis, panel, or other mounting area . . . pop in a spacer bushing . . . drill or punch a mating hole in the P.C. board . . . snap them together . . . that's all there is to it. They can't be shaken apart but can be unsnapped at will for service, test or modification

Press-Fit Spacer/Bushings are precision machined from pure Teflon. Stand-off heights from .125" to .750" with a standard diameter of  $\frac{3}{16}$ " are included in the complete line.

If you need a fast, reliable and inexpensive means to mount P.C. boards, consider Sealectro's new Spacer/Bushings. Sealectro is your No. 1 source for all types of electronic hardware. Complete information and drawings are yours for the asking.

\*Registered Trademark E. I. DuPont De Nemours & Co.

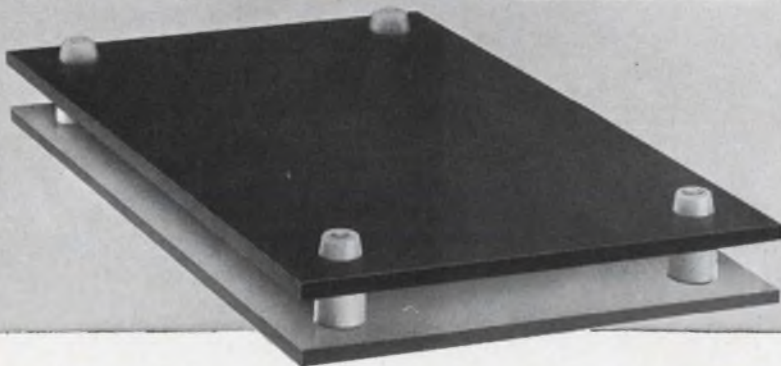
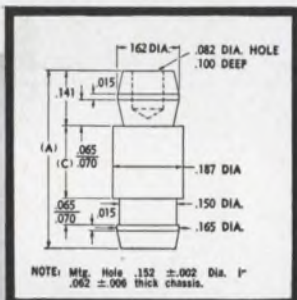

CIRCUIT HARDWARE DIVISION  
**SEAELECTRO**  
 CORPORATION  
 MAMARONECK • NEW YORK  
 PHONE: 914 698 - 5600 TWX: 710-566-1110  
 Sealectro Ltd., Portsmouth, Hants, England

See us at IEEE booths 4C-20, 22, 24.  
 ON READER-SERVICE CARD CIRCLE 33

## NEWS

(physics, continued)

voltage repeatedly at a number—typically 512 or 1024—of sampling times. An average value for each of the sampling time slots is built up. Since any noise superimposed on a periodic signal is just as likely to be positive as negative, the stored average values will eventually be almost noise-free.

An ideal averaging system of this type would do an integration over the total time of each sampling interval, and produce the average value for that interval. In Fabri-Tek's design (models FT-1051 and FT-1052 averagers), integration takes place over 97% of the sampling interval to produce an average value. The "growing" waveform that results from the averaging process is shown on a CRT. Digital output is also possible. One circuit board used in the averagers mounts 53 microcircuits.

Fabri-tek is now working with Federal Scientific Corp., New York, to apply the averaging process to a wave analyzer, thus giving a frequency-averaged signal analogous to the time-averaged signal being produced by the present instrument. ■ ■

## Helping hands tested



Mechanical hands could ease the task of astronauts clothed in bulky pressure suits or working in hostile space environments. Master-slave manipulators would enable the spacemen to repair spaceborne nuclear reactors, turn on tiny switches or even adjust dials. The experimenter above is performing a series of NASA tests with a pair of such manipulators at the Argonne National Laboratory.



RAY PROOF WAY

# BUT WHO KEEPS OUT RFI?

**Ray Proof** does. In labs, test centers and hospitals around the globe, **Ray Proof** has designed and built shielded rooms — small and not-so-small (55 feet high, 55 feet wide, and 165 feet handsome) — by the thousands. Our proven know-how in shielding techniques can eliminate your Radio Frequency Interference problems. To keep RFI out — Call Ray Proof in — Today.



**RAY PROOF**  
CORPORATION

50 Keeler Ave., Norwalk, Conn. 06856  
(203) 838-4555

Specialists in RFI-free rooms and components.

## YOUR 1967 TOUR GUIDE

OF

# BURLINGAME TERRITORY

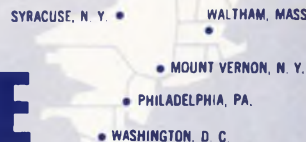

**Population:** 29 experienced instrumentation engineers

**Area:** Northeast U.S.A.

**Principal Resources:**  Allison Laboratories, Inc.  Brush Instruments Div. Clevite Corp.  Cimron Div. Lear Siegler, Inc.  Federal Scientific Corp.  Inland Controls, Subsid. of Kollmorgen  Lorch Electronics Corp.  Microdot, Inc.  National Company, Inc.  NJE Corp.  Ray Proof Corp.  Singer Co.—Metrics Div. (Empire, EMC, Panoramic, Sensitive Research)  SONY Corp. of America  Standard Controls, Inc.  Systron-Donner Corp. (Digital & Analog Instruments; Flight Systems)

**Climate:** Very hot, technically speaking

**Motto:** "GET THE BURLINGAME HABIT"... Your supplementary Instrumentation Engineering Department

**Points of Major Interest:**



Visit **BURLINGAME TERRITORY** (At IEEE 2nd Floor, Aisle B). See the newest instrumentation. Discuss applications with Burlingame and factory engineers.



Ask your Burlingame Field Engineer. He has up-to-the-minute application information.



Burlingame's factory-level Calibration and Maintenance Lab—your assurance of continuing, reliable performance.



Accurate, complete information... when you need it!

### BURLINGAME TERRITORY

A good place to visit at IEEE, 2nd floor Booths 2B25-2B42.



**BURLINGAME ASSOCIATES**

WRITE, WIRE OR PHONE:

**MAIN OFFICE**  
510 South Fulton Ave.  
Mount Vernon, N. Y.  
(914) Mount Vernon 4-7530  
N.Y.C. (212) Wellington 3-5555  
FAX: Mount Vernon, N. Y.  
TWX: 914 699-3671

**ASBURY PARK** (201) WX-2611  
**SYRACUSE** (315) 454-2408  
**WASHINGTON** (202) OLiver 4-6400  
**PHILADELPHIA** (215) Jackson 8-6080  
**BOSTON** (617) TWinbrook 4-1955

Ask operator for ENTERprise 9-6400  
Buffalo (716) Rochester (716)  
Baltimore (301) Binghamton (607)  
Poughkeepsie (914)



## Sure, DVM's have to be fixed

Cimron just makes it easy! We all know digital voltmeters are influenced by environment and the work demanded of them—and they do have to be calibrated at times. So Cimron makes it easy by etching this procedure on the guard shield. Lift 4 screws and you can do it in 15 minutes. That's Cimron's customer concern in action, a philosophy you'll see at work in everything from the way

the instruments operate to after-sales interest. Premium Line P9000B Series Instruments offer a 3-year warranty; 5 digits, automatic, programmable or manual ranging; 1 year stability of 0.001% F.S.+0.01% of reading; ratio, AC, low-level DC, resistance, true RMS available as options. Price: the P9200B DVM, \$3190. Write Cimron, Dept. A-102, 1152 Morena, San Diego, California 92110.

**CIMRON**  
A Division of  
Lear Siegler, Inc.





# Wide Dynamic Range Receiver

MODEL HR-240

2 to 32 MHz



A sensitive, wide dynamic range receiver with locally or remotely controlled all-electronic tuning, capable of practically instantaneous frequency programming.

#### APPLICATIONS

- General purpose communications, AM, SSB, CW.
- "Frequency Hop" communications where gain constancy and instantaneous frequency change are important.
- Search and electronic countermeasures.
- Spectrum surveillance.
- All uses requiring high sensitivity and virtual freedom from spurious responses to permit positive signal identification.

#### ENGINEERING DATA

Frequency Range: ..... 2 to 32 MHz  
 Tuning Time: ..... 5.0 milliseconds  
 Dynamic Range: ..... over 100 db  
 Spurious Response Rejection  
 (incl. Image and IF): ..... over 100 db  
 Sensitivity: ..... -130 dbm  
 (0.07 microvolts)  
 Gain Variation vs. Frequency  
 (2 to 32 MHz): .....  $\pm 1$  db  
 Size: ..... 17"W x 17"D x 3½"H



**LORCH ELECTRONICS CORP.**

105 Cedar Lane, Englewood, N.J. 07631 • 201-569-8282

SEE THIS RECEIVER AT BOOTH 2A40 AT THE IEEE SHOW

# Flaw-Less Power Supplies from NJE

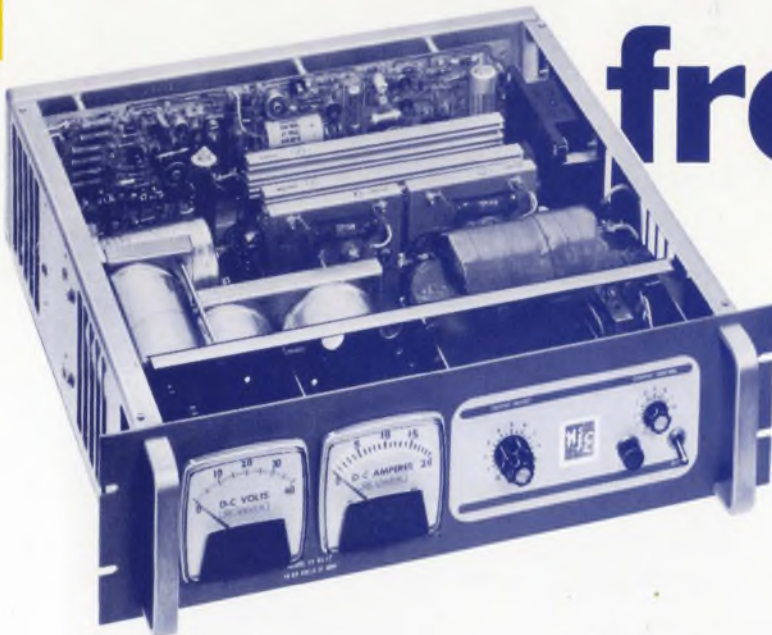

No doubt you've given up the search for high-quality power supplies. But here they are! Flaw-less, high-performance NJE "SY" series power supplies. They provide the regulation and ripple found only in high-cost laboratory equipment. We're so sure of their flaw-free performance, we're exhibiting them at the show without their dust covers. Here are some of their flaw-free features:

- Transformers and chokes with Mylar insulation and glass tape — MIL-T-27A grade
- Complete component symbolization for printed circuit cards
- Plug-in amplifier transistors
- High-quality commercial components

**"WIDE-SLOT" SYSTEM POWER SUPPLIES — "SY" SERIES**

**Widest Slot**

**Smallest Panel**

**Lowest Price**

Output		Model No.	Input Power		Max. Ripple RMS MV	Static Regulation		Dimensions H x W x D	Approx. Shipping Weight Lbs.	Prices
Volts	Amps*		Volts	Freq. (CPS)		Load	Line			
5-18	0-30	SY-18-30	105-125	55-65	1	±0.01%	±0.01%	5¼" x 19" x 16½"	80	\$580
10-36	0-10	SY-36-10	105-125	55-65	1	±0.01%	±0.01%	3½" x 19" x 16½"	65	\$370
10-36	0-20	SY-36-20	105-125	55-65	1	±0.01%	±0.01%	5¼" x 19" x 16½"	80	\$465
10-36	0-30	SY-36-30	105-125	55-65	1	±0.01%	±0.01%	7" x 19" x 16½"	105	\$625
10-60	0-6	SY-60-6	105-125	55-65	1	±0.01%	±0.01%	3½" x 19" x 16½"	65	\$400
10-60	0-12	SY-60-12	105-125	55-65	1	±0.01%	±0.01%	5¼" x 19" x 16½"	80	\$495
10-60	0-18	SY-60-18	105-125	55-65	1	±0.01%	±0.01%	7" x 19" x 16½"	105	\$645

\*Prices above are for unmetred models. For metred models, add suffix "M" to model designation, and \$20 to the price shown.

**VISIT BOOTH 2B31** and see flaw-less NJE power supplies — the ones that are on without their dust covers!



**NJE CORPORATION** Kenilworth, New Jersey • Tel. (201 Area Code) 272-6000  
Electronic Development & Manufacturing TELEFAX: FFP • TWX: (201 Area Code) 276-7630

# IC counters are here!



100 MHz counter-timer

Step into the future with the Thin Line – the sleek, ultra-reliable counters Systron-Donner now builds with integrated circuits. Nine different counters pack unprecedented range and utility into  $\frac{1}{4}$  inches of rack space.

Microwave counters measure frequency from 0.3 to 12.4 GHz, displaying final answer instantly and automatically. Other counters, with 5 MHz, 10 MHz or 100 MHz range, measure frequency, period, time interval, frequency ratio, and voltage. All Thin Line counters offer heretofore unavailable features – like 9-digit resolution, stability of 5 parts in  $10^{10}$  per day, and modern slide switches to reduce operator errors. And everything comes in a  $\frac{1}{4}$ "-high chassis that slips easily into a crowded system and operates under complete remote control.



100 MHz frequency counter



10 MHz counter-timer

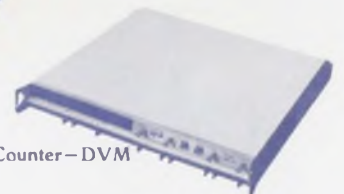

Counter-DVM



5 MHz frequency counter

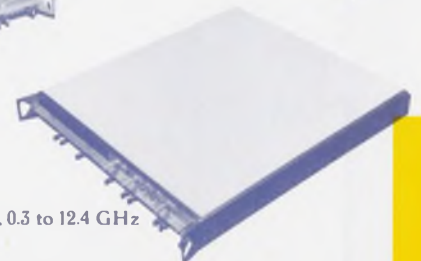

Microwave counters, 0.3 to 12.4 GHz

**See them at the IEEE Show. Second floor, Booths 2B32 to 36**

Systron-Donner Corporation, 888 Galindo Street, Concord, California, Phone: (415) 682-6161

SYSTRON  DONNER

ALLISON

CONTINUOUSLY  
VARIABLE FILTERS



HIGH CUTOFF • LOW CUTOFF  
BANDPASS • IN ONE UNIT

Allison continuously variable filters have long set an enviable standard of performance and dependability. In noise analysis applications, Allison Series 2 Filters may be set to pass bands as narrow as  $\frac{1}{2}$  octave while retaining their characteristic curves.

The Allison Series 2 Filters each consist of a two-section low-cutoff and a two-section high-cutoff passive network filter. Either filter may be used independently, or the two may be connected in series for bandpass operation. Each filter is tunable over a wide range of frequencies in overlapping octave steps by a patented variable inductor. Use of these highly efficient passive circuits guarantees negligible ringing and maintenance-free operation.

**ALLISON Series 2 Filters** • Wide dynamic range • No internal noise—negligible ringing • Flat pass bands • Steep continuous attenuation • Low loss in the pass band

**SPECIFICATIONS**

**Attenuation:** 30 db per octave  
**Impedance:** 600 ohms input and output. Special plug-in transformers available for 10,000 ohms input and 50,000 ohms output.

**Frequency Range:**  
2A—15 cps to 10,160 cps  
2AB—15 cps to 20 kcps  
2B—60 cps to 20 kcps  
2C—9 kcps to 672 kcps  
2D—240 cps to 80 kcps

**Size:**  $7\frac{1}{4} \times 17\frac{1}{2} \times 7\frac{1}{2}$  inches.  
Rack Mounted Models Available.

**Weight:** 17 to 23.5 pounds  
**Prices:** Start at \$365.00

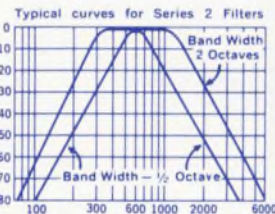

**Technical Data:** For free technical information clip the coupon, attach to company letterhead and mail.



NAME \_\_\_\_\_  
TITLE \_\_\_\_\_

**Allison LABORATORIES, INC.**  
11301 Ocean Avenue • La Habra, California  
Proved dependable in years of service



Ssssh!

The Ubiquitous<sup>TM</sup>  
Spectrum Analyzer  
is listening.

Real-time analysis of underwater sounds with accurate amplitude data requires an extraordinary instrument. The Ubiquitous<sup>TM</sup> Spectrum Analyzer produces high speed, real-time spectra, with bandwidths from 0.002 Hz to 20 Hz.

Bandwidth and frequency coverage are variable to match signal characteristics. Performance with respect to signal-to-noise enhancement, frequency resolution, and multiple signal discrimination, is as good as theory permits.

Spectral amplitude flatness and linearity plus an input dynamic range of over 48 dB make possible quantitative measurements. Stability is assured, since the final analysis is performed with only one filter, eliminating filter matching.

Extensive experience in producing the Ubiquitous<sup>TM</sup> and other high-speed analyzers for over 10 years allows Federal Scientific to assure reliability and closely specified performance. The Ubiquitous<sup>TM</sup> Spectrum Analyzer is compact and easy to operate, using the latest integrated circuits. The calculated MTBF is 4000 hours. Rugged construction makes possible airborne or shipboard use.

Optional equipment provides percentage bandwidth, increased dynamic range, multi-channel processing, and spectrum averaging. Please write us with details of your application so that we can recommend the most useful options.

**federal scientific**

FEDERAL SCIENTIFIC CORPORATION, 615 W.131 STREET, NEW YORK, NEW YORK 10027, 212-286-4400

# now..... a fully militarized primary cesium beam frequency standard

BY NATIONAL 

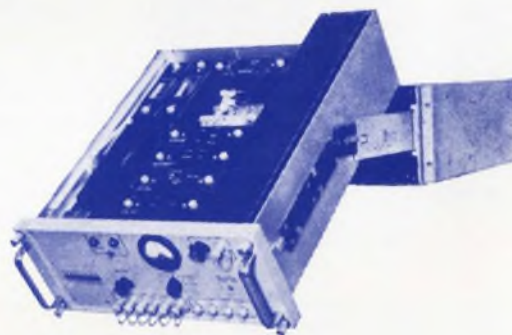

### NC 3501 SPECIFICATIONS

ACCURACY: . . . . .  $\pm 2 \times 10^{-11}$   
LONG TERM STABILITY: . . . . .  
 $\pm 2 \times 10^{-12}$  TYPICAL,  
 $\pm 4 \times 10^{-12}$  WORST CASE  
SHORT TERM STABILITY: . . . . .  
 $\pm 1 \times 10^{-11}$  TYPICAL  $5 \times 10^{-11}$  WORST CASE  
for 1 SEC AVERAGES  
OUTPUTS: 10MHZ, 5MHZ 1MHZ 0.1MHZ,  
14.591479MHZ (UT2 OR A.1)  
TIME SCALE  
INPUT POWER: . . . . . 115V/230V  $\pm 10\%$   
50 cps to 400 cps or 28VDC  $\pm 4$ VDC  
CESIUM BEAM RESONATOR LIFE: . . . . .  
10,000 hrs GUARANTEED  
SIZE: . . . . . 7" HIGH x 17" WIDE x 20" DEEP  
(RACK PROJECTION)  
STANDARD 19" RELAY RACK MOUNTING

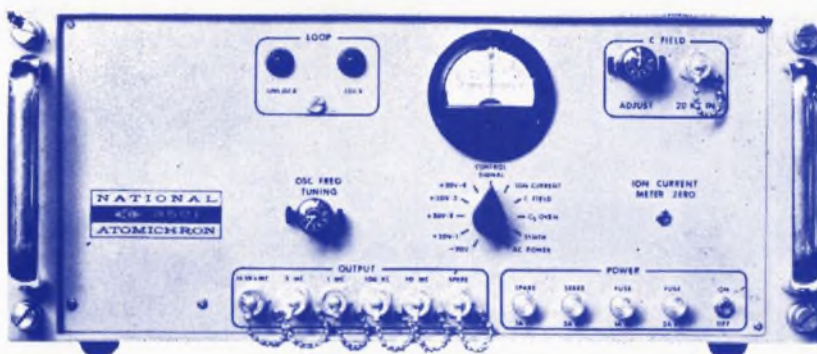

## THE ATOMICHRON

SEND NOW FOR COMPLETE DATA FILE ON NATIONAL'S ATOMICHRONS



NATIONAL COMPANY INC. 

**NEW** **SINGER**  
**INSTRUMENTATION**

**IN ACTION AT IEEE**

(BOOTHS 2B25-2B30)



EMA-910



20 Hz to 22 GHz

**Automatic EMI Instrumentation**

NEW automatic-scanning, solid-state NF-315A (20 Hz to 15 kHz); NEW automatic, solid-state EMA-910 System (1 to 22 GHz), with 10-channel frequency call-up unit, and digital data display unit; UNIVERSAL (14 kHz to 22 GHz) spectrum signature panadaptor, model PA-210.

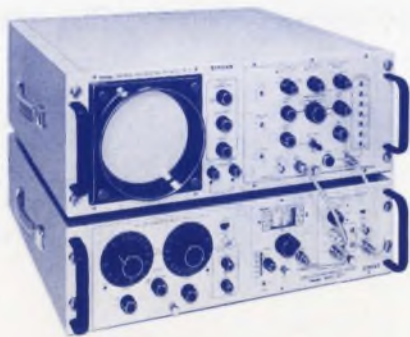

SSB-50



10 Hz to 40 GHz

**Spectrum Analyzers**

NEW modular, solid-state RTA-5 System (20 Hz to 27.5 MHz); VR-4 module features 0 to 25 MHz sweep width; NEW solid-state SSB-50 (10 Hz to 40 MHz) for single sideband communications analysis; NEW solid-state PSA-100 (0.01 to 40 GHz) microwave analyzer.



FLH-2



**DC to 1 GHz Electrical Measuring Instruments**

DC and TRUE RMS AC calibration systems (DC to 25 kHz); PRIMARY transfer standards (DC to 1 GHz); ELECTROSTATIC voltmeters (to 100 kV); HIGH VOLTAGE (DC to 200 kV) primary standard dividers.



\* A TRADEMARK OF THE SINGER COMPANY

**SINGER**  
**INSTRUMENTATION**

THE SINGER COMPANY, METRICS DIVISION • 915 Pembroke St., Bridgeport, Conn. 06608. U. S. A. • PHONE (203) 366-3201

## Cold-cathode operated over 6000 hours

A new type of cold-cathode, called a transverse-field semiconductor emitter, has now been operating successfully for more than 6000 hours.

The principle of the emitter has been known for years but first experimental results were announced only at last year's IEEE Tube Conference in New York City. Efforts to make the devices practical, however, have been hampered by major production difficulties.

The cathode is still considered a laboratory device and its future applications are not yet clear. However, according to Robert Dore and Don Geppert of SRI's Solid-State Research Div., it could eventually be used in conjunction with a photoconductor in a heat-sensing or infrared-imaging device. They also foresee its use in high-power microwave tubes, because the cathode can be pulsed on and off rapidly at low voltages.

The principle of the emitter, somewhat simplified, is that two electrical conductors are separated by a very thin gap—about 0.1 mils—and the gap is bridged by a thin film of semiconductor material. When a voltage is applied across the conductors, electrons will be drawn from one conductor to the opposite conductor, accelerating through the semiconductor and picking up energy in the process. Some of these "hot" electrons have sufficient energy to escape into the vacuum and are

then drawn to the anode as in an ordinary vacuum tube.

As shown in the illustration, one conductor side of the sandwich is a narrow slice of pure n-type silicon, the surface of which has been oxidized to a controlled thickness of about 1 micron. This layer of silicon dioxide is exposed to aluminum vapor in an evaporator, to form the top conducting layer of the "sandwich." This "sandwich" is broken into segments, exposing the edge of the "sandwich." A layer of semiconductor, barium oxide, is evaporated onto the segment, which is supported on a gold-plated base.

The result is two conducting layers separated by about 1 micron of insulator, but with a semiconducting layer bridging the one-micron gap all around the edge of the segment.

When a 50- to 100-volt dc potential is applied across the two conductors, electrons flow from the edge of the silicon through the barium oxide film.

Dore noted that a major hindrance to making a practical emitter has been the difficulty in defining the narrow gap between the two conductors. With IC technology, this is no longer a problem, he said.

Their laboratory device has an emitter current density of 10 mA/m<sup>2</sup>, but this, according to Dore, could be increased to as much as 100 mA per square centimeter. ■ ■

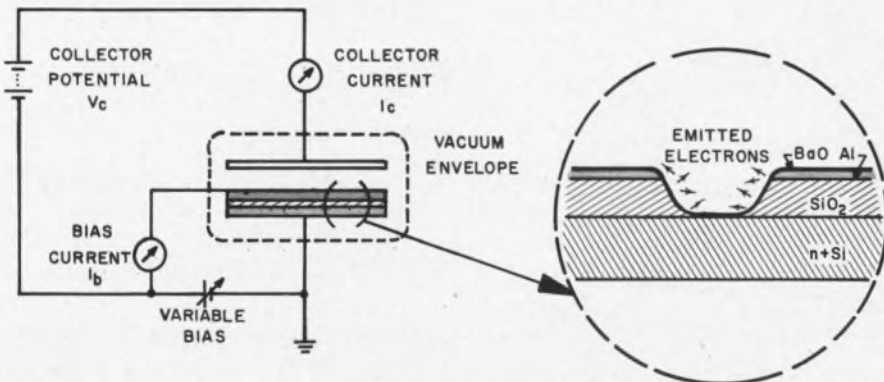

Transverse field semiconductor emitter in test circuit has been successfully operated for more than 6000 hours. Enlarged cross section shows cathode structure.

# MODEL CS-60 60 KHZ TIME CODE RECEIVER

### HIGH POWER • LOW CURRENT

A new, low current drain time code receiver, so sensitive that it will receive NBS signals from 2,000 or more miles away. Original and unique circuitry developed at the Seismological Laboratory in Pasadena, California. The unit will receive Radio Station WWVB signals, considered to be the most accurate time signals available. Intermediate frequency is 2kHz. It is designed for long term, remote, unattended operation as it requires power of only +12 vdc ± 1 vdc at 1.5 ma without audio (35 ma with audio).

PRICE: MODEL CS-60A \$540.00  
Battery powered portable field unit available.

Write, wire or phone for complete information.

**SPECIFIC PRODUCTS** P. O. Box 425 / 21051 Costanzo Street / Woodland Hills, California 91364 / Phone: (Area Code 213) Diamond 0-3131





New Insultape

New Insultite SR-350

Insultite FP-301

**Feed  
them  
your  
insulation  
problems.**

Here's a hungry family of heat-shrinkable polyolefins that will devour almost any subject. Quickly. And totally. The Insultites. From Electronized Chemicals Corporation.

**New Insultite SR-350.** This semi-rigid, mil-spec, heat-shrinkable tubing has been designed specifically for insulation and encapsulation of components that are subject to shock, strain, and vibration. It features superior puncture and abrasion resistance. New SR-350 is ideal for applications requiring a combination of excellent dielectric characteristics and high structural strength. It is available in a wide variety of sizes and colors.

**New Insultite SRT.** This commercial-grade, semi-rigid thin-wall tubing provides polyolefin protection for capacitors, connectors, semi-conductors, and other components requiring tough, clear, abrasion-resistant, thin-wall insulation. And it costs less than vinyl for many applications.

**New Exclusive Insultape.** This meltable inner-wall heat-shrinkable polyolefin tape reacts to heat just like all the other Insultites. It lets you wrap-up, encapsulate, and moisture-proof hard-to-get-at and complicated components. And it is an economic alternative to costly heat-shrinkable molded items.





New Insultite SRT

New Insulcaps

E. C. C. heat shrinkables are recognized under UL component file E39100.

**New Insultite SR Caps.** Here's a semi-rigid, rounded-end, heat-shrinkable end cap that features high abrasion and puncture resistance, excellent mechanical and electrical strength. Competitively priced with sealed and pinched end caps, Insultite SR caps eliminate worries about vibration-caused cut-throughs in adjacent wiring.

**Insultite FP-301.** This military-spec flexible heat-shrinkable tubing handles tough insulation problems as only an irradiated polyolefin can. Just apply heat, and like all Insultite products, FP-301 shrinks at a better than 2 to 1 shrink ratio. A commercial-

grade polyolefin version of FP-301, new Insultite CP-150 (not pictured) is ideal for computer, automotive, appliance and other commercial applications. It won't split or rupture even over the most irregular surfaces. And new CP-150 costs no more than vinyl. Think shrink with the Insultites. For additional information on the complete Insultite line and for free samples, write today (specify diameters, please).



**ELECTRONIZED CHEMICALS CORPORATION**

A subsidiary of High Voltage Engineering Corporation

Box 57, Burlington, Massachusetts, Area Code 617-272-2850

See us at the IEEE Show, Booth 1F32-34, New York Coliseum, March 20-23, 1967.

**We couldn't find these  
computer-quality relays on the market.  
So we had to design our own.**

**Here's what they offer you.**

**IBM Wire Contact Relays—200  
million operations at 45¢ per pole**

Solderless connections, multiple coils, compactness and standardized mountings give you lower manufacturing costs, lower initial product costs, lower product servicing costs.

Also high operate speed—as fast as 4 ms; fast release time—under 5 ms; versatile contact arrangements—4, 6 and



12 PDT, Form C, 4 and 6 PDT latch; maximum reliability—1 error per over 400 million contact closures at 48 VDC is attainable; variable coil voltages—up to 100 VDC.

IBM 12-pole wire contact relays start at \$5.40, 4-poles at \$2.90, latch relays at \$8.45 (even less in quantity).

**Permissive-Make Relays—high  
speed and virtually no bounce**

To design this kind of relay, we turned to a computer for help.

The result was a unique contact spring configuration as a basis for assembly — the "permissive-make". Its bounce is less than 50 microseconds. Its speed is as fast as 2.0 milliseconds. What's more,

Typical bounce characteristics of the IBM permissive-make relay appear at the right. Time base is 20 microseconds per centimeter—amplitude base is 0.5 volts per centimeter.

this relay has an exceptionally long, *adjustment-free* life—over 400 million operations.

Permissive-make relays are well worth considering for counting, logic switching, switch registers and timing circuits.

The cost: \$6.50 for 4-pole, Form C permissive-make relays; \$7.75 for the 6-poles. Incidentally, IBM permissive-make relays minimize maintenance time and costs. That's because they're pluggable—just like our wire contact relays.

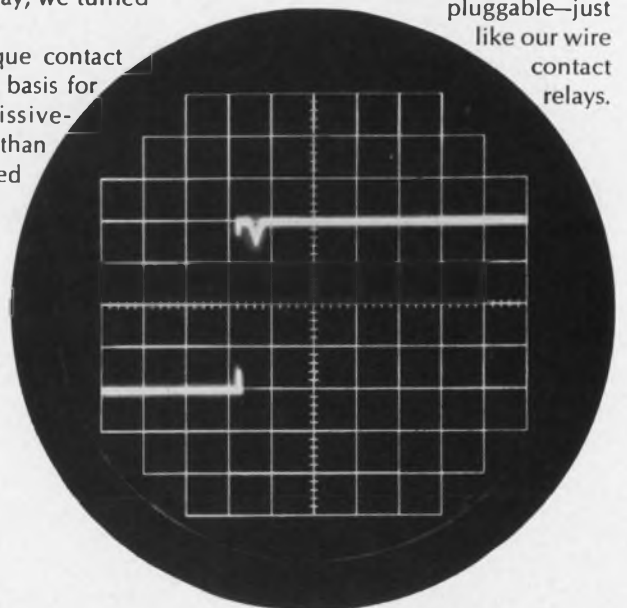

### Reed Relays—miniaturized and pluggable too

Newest of the IBM relays, the reed relays are especially suitable for interfacing relay logic and transistor circuitry.

They have an operate time of 1 ms or less, an operate time variation of 0.5 ms, a release time of 100 microseconds. And, every reed relay is electronically inspected *after* assembly to insure long, trouble-free life.

These miniature relays are available in 1, 2, 4 and 6-pole Form A and B configurations; plus various combinations with either single or double coils. Prices range from \$3.00 to \$8.55 for Form A packages (always lower in quantity).

The IBM miniature dry reed switch serves as the heart of the reed relays, and is now double plated, rhodium over gold, to give you low noise characteristics.

They provide long life (up to 125 million operations—mean time to first

error) and low contact resistance (less than 100 milliohms throughout life).

For highly consistent performance we *dynamically* set the air gap between

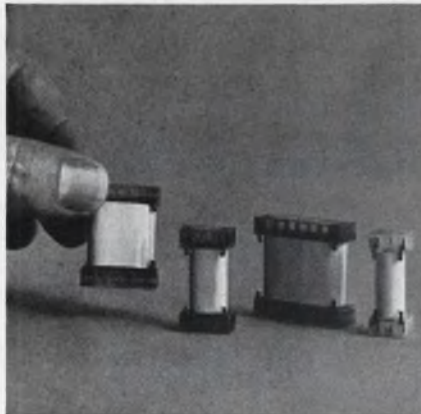

the reeds. This means a stable sensitivity of  $\pm 7$  NI (maximum) in every reed switch.

For illustrated literature on any of these products, write: IBM Industrial Products, 1000 Westchester Avenue, White Plains, New York 10604.

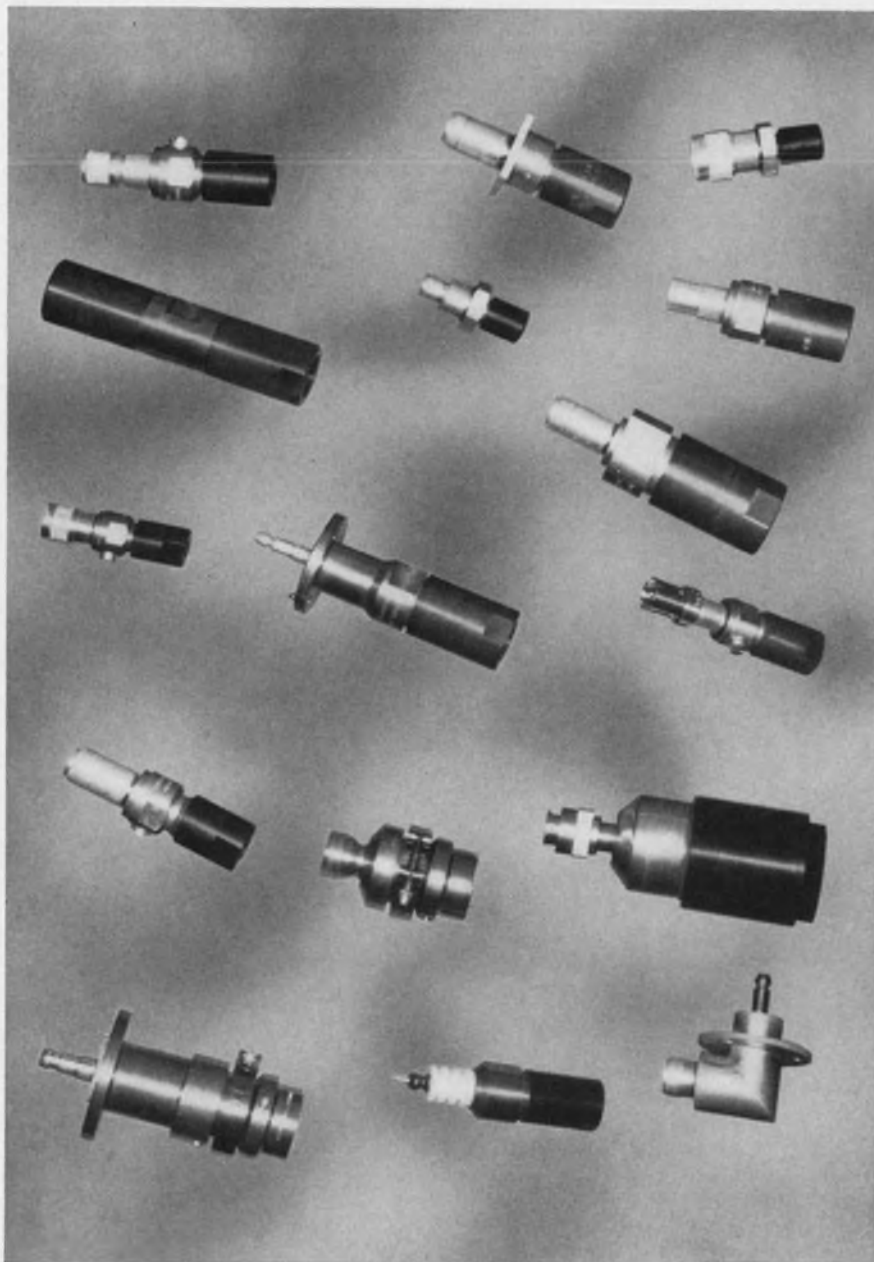

## Connectors for semi rigid coax? Yes. All sizes, all interfaces!

Here is an all new series of connectors ideal for Phelps Dodge or any other make of semi-rigid coaxial cable ready for delivery from stock.

This new design incorporates a captivated collet holding mechanism providing positive holding capability with best possible electrical contact. VSWR is low, and the maintenance of cable pressures up to 30 psi are guaranteed when properly installed. And, best of all, these new connectors are immediately available off-the-shelf

in all sizes, all interfaces, from  $\frac{1}{4}$ " to  $\frac{7}{8}$ " in Type N, HN, UHF, C, BNC, TNC, GR and Splice. Other interfaces and sizes are available on request.

Other important features include a  $\frac{1}{8}$ " NPT threaded gas port which is provided for the attachment of pressure lines or gages and a conventional "O" ring gasket gas and moisture seal. A special epoxy barrier around the base prevents electrolysis.

Can we tell you more? Write for Bulletin WH, Issue 4.

**PHELPS DODGE** ELECTRONIC PRODUCTS  
NORTH HAVEN, CONNECTICUT



ON READER-SERVICE CARD CIRCLE 39

### NEWS

## Picturephone to use silicon image sensor

A silicon optical sensor, which is many times more sensitive to light and lasts several times longer than a conventional vidicon, will convert light images into electrical signals in the Picturephone, the Bell System's video telephone. It is to be called the Dactron. The unit is seven inches long and one inch in diameter.

The sensor's working surface is a square of n-type silicon with a side that measures 0.8 in. An image, focused by a lens, falls on its matrix of 540 by 540 boron diffused p-type circles, each eight microns in diameter. The circles, spaced 20 microns apart, are scanned four at a time by an electron gun. Gold squares cover each p-type circle.

Although both the vidicon and the plumbicon use electron beams for scanning, neither uses a semiconductor for the photosensitive surface. They use antimony sulfide and lead oxide, respectively. The sil-

*(continued on p. 60)*



**New television tube**—called a Dactron—is held by M. H. Crowell of Bell Telephone Laboratories. It may be used in future models of the utility's Picturephone visual telephone.

# ARNOLD IS

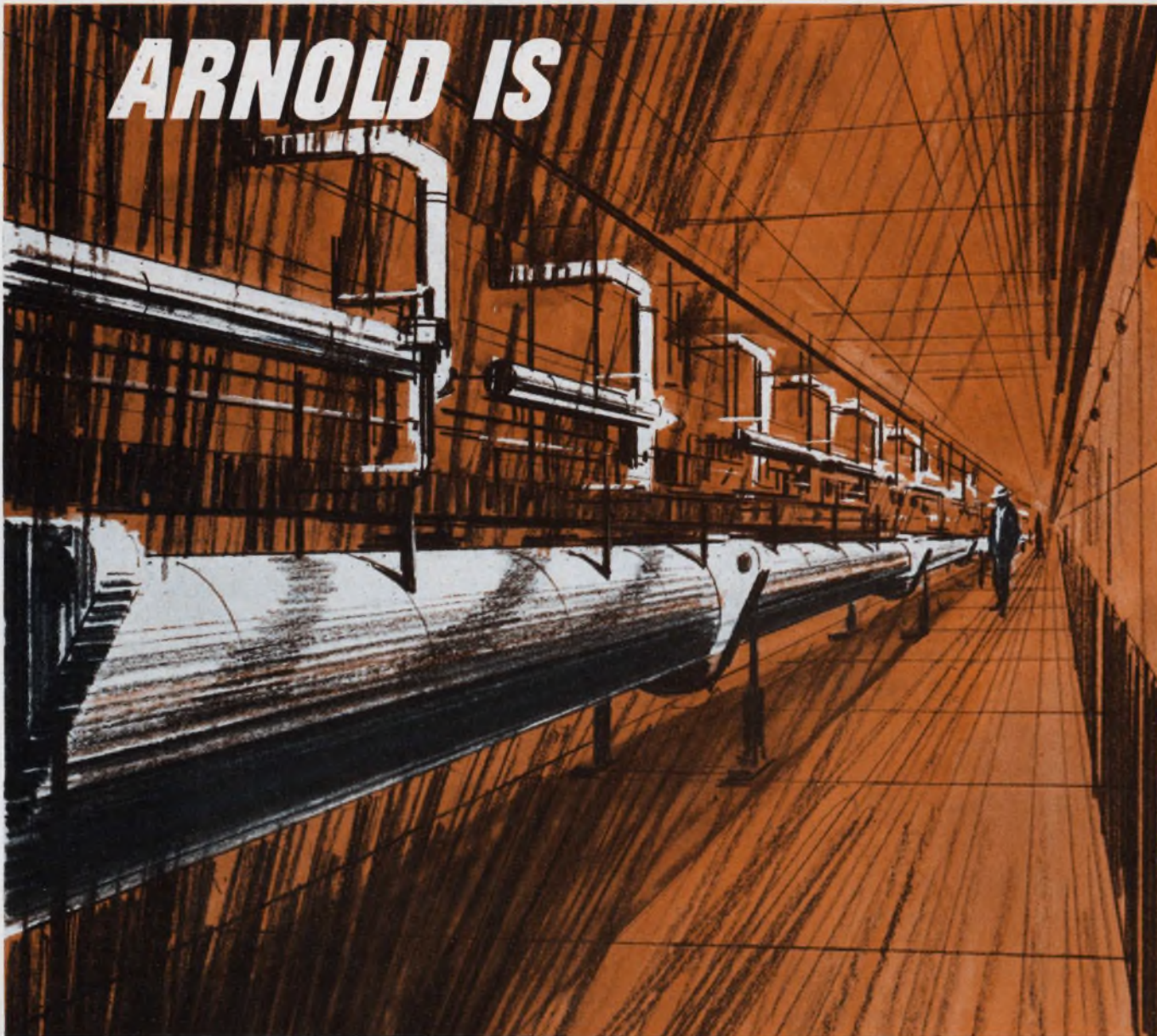

## MAGNETIC SHIELDING

### Two Miles of Shielding in the Stanford Linear Accelerator

Arnold can handle any magnetic shielding requirement . . . from CRT shields to shielding the full two mile length of the Stanford Linear Accelerator. Mumetal, 4750 and 4-79 Mo-Permalloy is stocked in quantity to meet any demand. Fabricating facilities include a high speed 750 ton hydropress and other capacity presses from 4 to 100 tons for high production work. Modern furnaces anneal shields in a dry hydrogen atmosphere to obtain maximum permeabilities for each material.

Arnold is also ■ Permanent Magnets ■ Tape Wound Cores ■ Bobbin Cores ■ MPP Cores ■ Iron Powder Cores ■ Electrical Alloy Transformer Laminations ■ Transformer Cans & Hardware ■ Silectron Cores ■ Special Magnetic Materials

Write for Catalog PD-122A

 **ARNOLD**  
SPECIALISTS in MAGNETIC MATERIALS

THE ARNOLD ENGINEERING COMPANY, Main Office MARENGO, ILL.  
BRANCH OFFICES and REPRESENTATIVES in PRINCIPAL CITIES

ON READER-SERVICE CARD CIRCLE 40

FOR PAGES 56 AND 57, ON READER SERVICE CARD CIRCLE 41 ➤

# IC counters

Step into the future with the Thin Line—the sleek, ultra-reliable counters Systron-Donner now builds with integrated circuits.



**Look, no knobs!** Sliding switches are easier to set, easier to read. Prevent errors in control settings. The modern touch on the outside that reflects the advanced design inside.

**9 digits for top resolution.** Thin Line counters give you readings with a resolution of 1 part in a billion.

**1. Microwave counter.** Reads frequency directly in gigacycles from 0.3 to 12.4 GHz. Displays final answer instantly and automatically by means of built-in automatic computing transfer oscillator. No tuning. No calculations. Phase lock for counter accuracy.

**2. 100 MHz Universal Counter-timer.** This Thin Line packs more utility in a smaller cabinet than any other instrument you've seen. Measures frequency, time interval, period, and frequency ratio — or just counts cycles under local or remote control.

**3. 100 MHz Frequency Counter.** A best buy for people who want to measure frequency and period only. Provides the wide range from dc to above 100 MHz.

**4. Counter-DVM.** A 5 MHz counter and an integrating DVM in one compact cabinet. DVM is referenced to an internal temperature-compensated Zener diode. It provides four ranges (1, 10, 100, & 1000v), 1 $\mu$ v resolution, automatic polarity indication, floating inputs, and selectable filters.

**5. 10 MHz Universal Counter-timer.** All the functions of the 100 MHz counter-timer at frequencies to 10 MHz and above.

**6. 5 MHz or 10 MHz Frequency Counter.** Frequency and period measurements only: dc to 5 MHz, or dc to above 10 MHz.



# are here!

They pack an unprecedented frequency range (to 12 GHz) or six different functions into 1 $\frac{3}{4}$  inches of rack space.

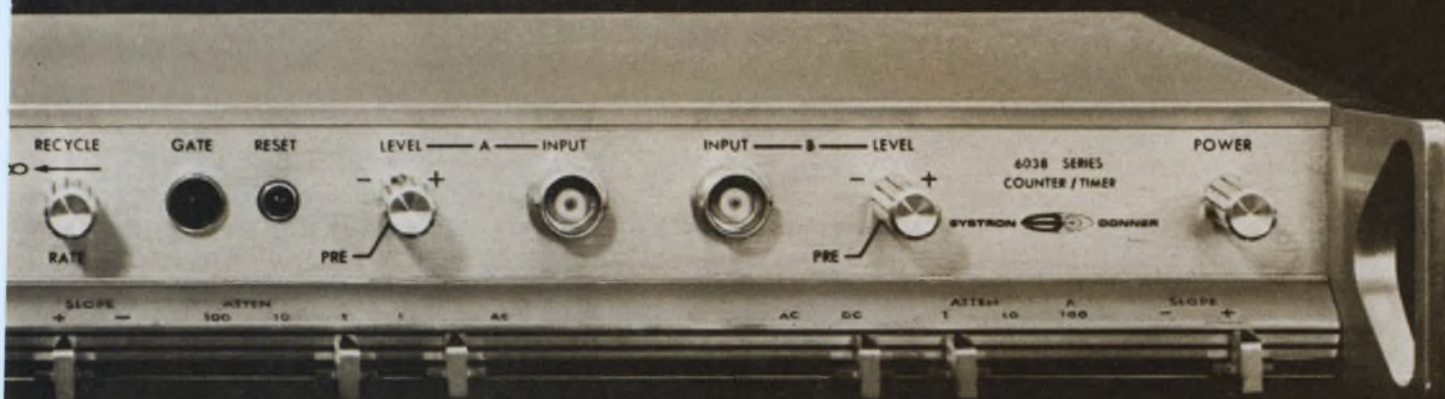

### Champion space saver.

Nothing could be less demanding of rack space – only 1 $\frac{3}{4}$  inches required. When there is “no room left,” a Thin Line counter may save the day.

### Breakthrough in accuracy.

A new high-stability oscillator with an aging rate of 5 parts in 10<sup>10</sup> per day – unmatched by any other counter manufacturer.

**Remote control.** Lets you plug Thin Line counters into a larger system and control all operations with electrical signals.



1.



4.



6.

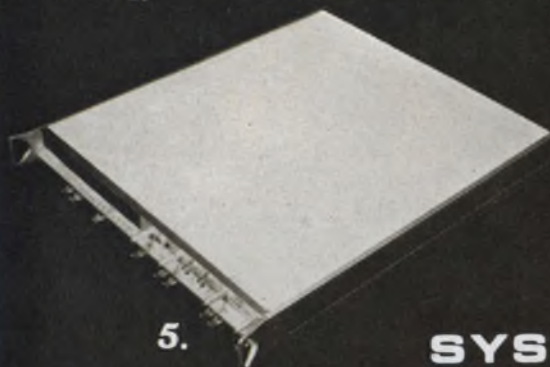

5.

### The Thin Line



Step into the future with IC counters from Systron-Donner

Send for free brochure

SYSTRON  DONNER

# EIMAC

## has advanced power amplifiers for low power UHF-TV transmitters

These power amplifier tubes are electrostatically focused klystrons (ESFK). They need no magnets. Our entire ESFK family offers you the best power-to-weight ratio of any power amplifiers. That means when you use one of our new ESFK's in your next design, your UHF-TV transmitter will be smaller—and easier to maintain. And since these tubes are air-cooled, they need less heat dissipation equipment, so your transmitter is less expensive to operate.

One example: the X-3068 amplifier. Note its 35 db gain with 36% beam power efficiency. At UHF frequencies, power outputs between 1 and 3 kilowatts are available.

For S-band transmitter designs, check our X-3065. It

offers 500 watts output yet weighs only 5 pounds and measures just 6 inches. And provides 30 to 40 db gain with efficiency between 35% and 45%; heat-sink or air-cooled.

We have spent more than ten years in advanced materials research, ceramic-to-metal technology, and beam focusing studies. To make an advanced power amplifier, it takes experience. You can count the number of experienced ESFK manufacturers on one finger.

**EIMAC**

Division of Varian

San Carlos, California 94070

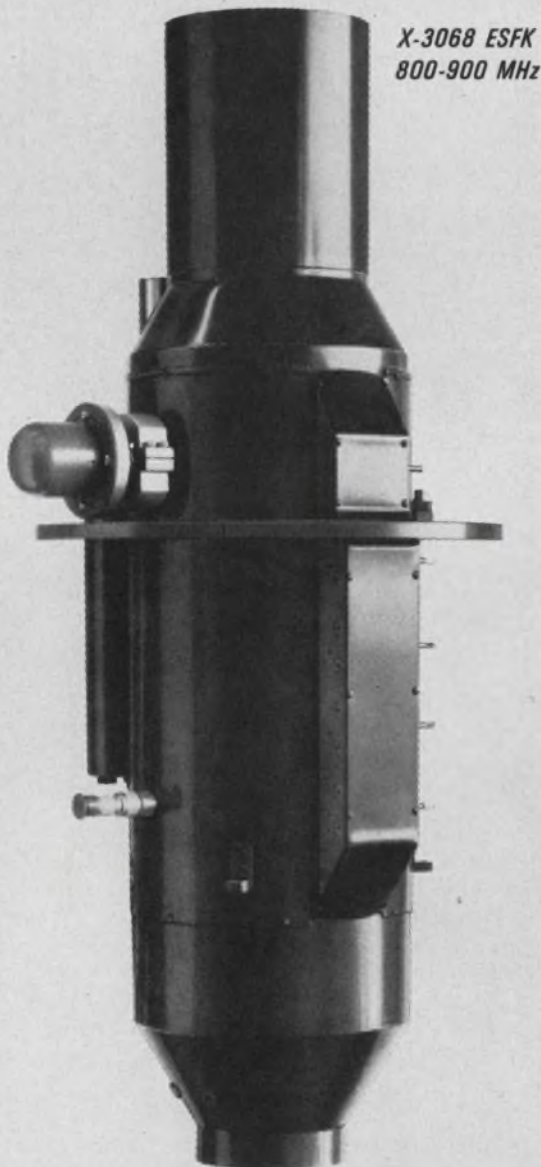

*X-3068 ESFK  
800-900 MHz*

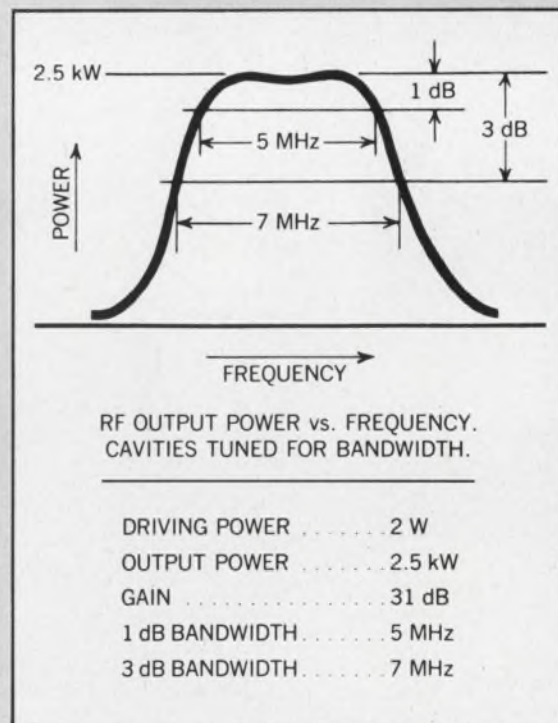



**Catalogs  
May Never  
Be the  
Same Again  
After This**

**NEW ELCO-WEBSTER  
CYLINDRICAL CONNECTOR  
CATALOG WITH *Prices!***

**Request  
A Personal  
Free Copy for  
Yourself!**

How many times have the words "How much" defeated you? Or caused endless delays until you found out? Or necessitated your starting all over when you did find out? Forget it from now on! Our new PW/EM Cylindrical Connector Catalog includes a Prototype Quantity Price Guide which allows you to "ball park" figures right from the start. (Large quantities are even lower priced.) So, since our prices are so competitive to begin with—and our cylindricals so commensurate with your requirements to end with, the Price Guide should be your "clincher" for specifying Elco-Webster from start to finish.



5 BRIDGE STREET, WATERTOWN, MASSACHUSETTS 02172  
617-926-2100 • TWX 710-326-0296

# NEW 5 MHz FUNDAMENTAL PRECISION CRYSTAL IN COLDWELD HOLDER

has time-frequency  
stability of better than  
 $1 \times 10^{-9}$  per day

This rugged, highly reliable, Reeves-Hoffman crystal is capable of withstanding temperature exposures in excess of 400° C without affecting stability or bond strength.

It is available in HC/6



or round C-type holders.

**See it at IEEE Booth 4B08**



**REEVES-  
HOFFMAN**  
DIVISION OF **DCA**



400 WEST NORTH STREET, CARLISLE, PENNSYLVANIA 17013

## NEWS

(optical sensor, cont'd from p. 54)

icon diode matrix, according to scientists at Bell Telephone Laboratories, is free from raster and image burn-in. Image burn-in occurs when a vidicon is focused on a very bright object such as the sun or a lighted bulb; the camera continues to transmit the image of the bright object for many seconds after the object has actually left its field of view. Raster burn-in is damage to the photosensitive surface caused by the scanning electron beam. The surface, under the intermittent bombardment of fast moving electrons, changes chemical structure and becomes insensitive.

The Dactron represents a viable intermediate image sensor between the bulky electron-beam scanning tubes and the beamless solid-state image sensors.

It has long been recognized that miniaturization of the television camera would require elimination of the bulky image orthicon tube and an even smaller sensor than the smaller vidicon. RCA, Westinghouse and Fairchild have been working on solid-state sensors. ■ ■

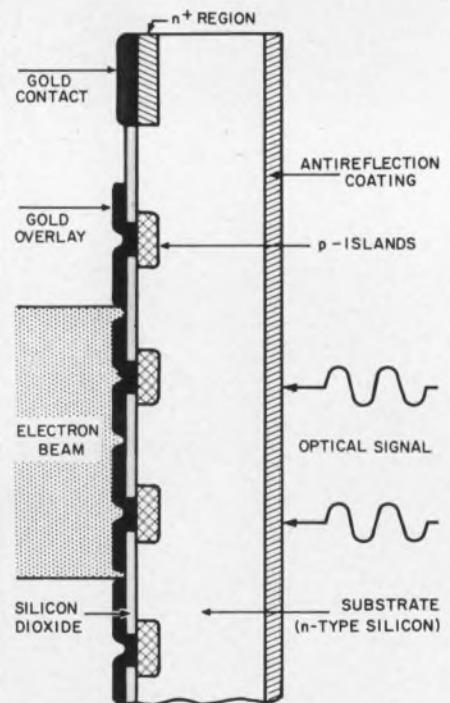

Main elements of Dactron's structure consists of p-type islands diffused into an n-type silicon substrate. The substrate is isolated from the scanning beam by a silicon dioxide coating. A gold overlay on each p-type island increases effective beam landing area of each diode.

# Now tunnel diodes cost as little as 50¢

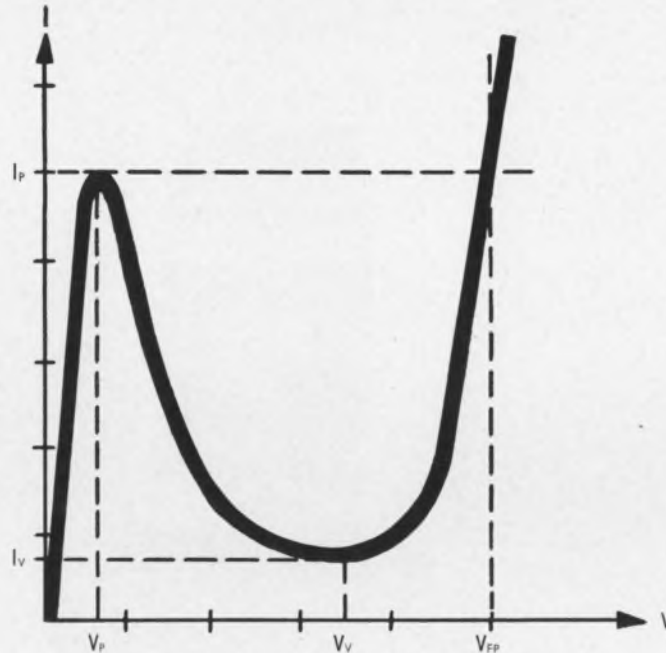

## Hadn't you better switch fast?

If tunnel diode performance at transistor prices sounds impossible, take another look at GE tunnel diodes.

Now you can get a typical switching speed of 1.5 nsec. or better in current ratings from 0.5 mA to 10 mA. Power dissipation is as low as 40 microwatts per unit.

All that performance can cost as little as 50¢.

And your circuits will benefit from greater packaging density, lower power consumption, and fewer components to perform a given function.

New General Electric tunnel diodes are available either in axial lead packages, or in pellet form for hybrid integrated circuits.

At the new low prices you can now

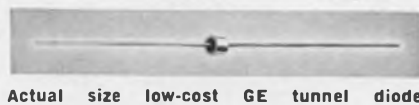

Actual size low-cost GE tunnel diode

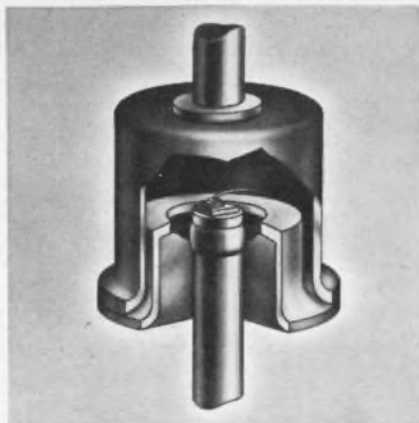

Planar and thin film fabrication techniques, used to form the germanium tunnel junction, make lower prices possible.

use GE diodes in many new applications. Why not try them for current or time delay thresholding, high-speed logic circuits, high-frequency oscillators or amplifiers, UHF mixers, or sense amplifiers?

This is just one more example of the low-cost semiconductor leadership and total electronic capability GE offers you.

For further details call your nearest GE engineer/salesman, or semiconductor distributor. Or write to Section 220-50, General Electric Company, Schenectady, N.Y. In Canada: Canadian General Electric, 189 Dufferin St., Toronto, Ont. Export: Electronic Components Sales, IGE Export Division, 159 Madison Ave., New York, N.Y.

SEMICONDUCTOR PRODUCTS DEPARTMENT

**GENERAL  ELECTRIC**

DON'T MISS GE'S TWO IEEE SEMICONDUCTOR APPLICATION SEMINARS MARCH 21 AT THE BARBIZON PLAZA HOTEL  
ON READER-SERVICE CARD CIRCLE 45

# Now Lambda offers the power supplies for test



1/4 RACK—LH SERIES

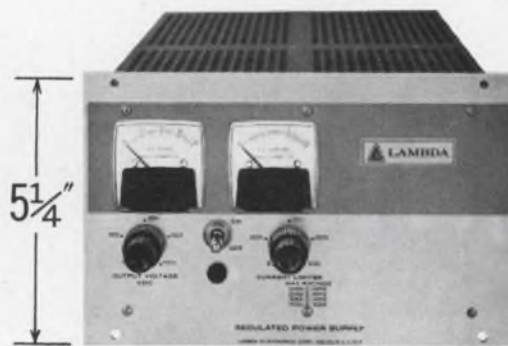

HALF RACK—LK SERIES  
LH SERIES

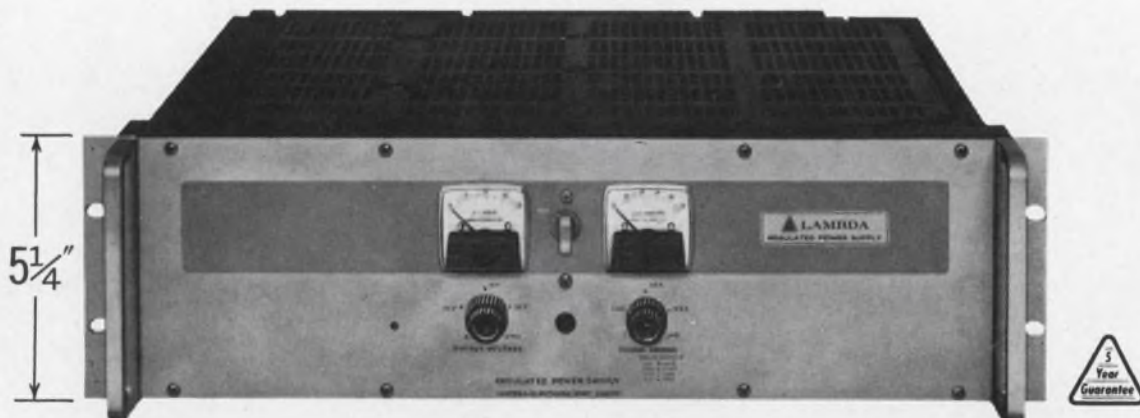

FULL RACK—LK SERIES

NEW AT IEEE SHOW—BOOTH 2A46

Be sure to see convection-cooled, 7" height LK Series • Up to 60 VDC • Up to 70 amps.

LA 177

# broadest line of all-silicon equipment and laboratory use.

For Rack or Bench Use—From 1/2 amp to 35 amps, 0-10, 0-20, 0-40, 0-60, 0-120 VDC—with full five year guarantee on materials and labor

## Features and Data

- Convection Cooled
- Remotely Programmable
- Remote Sensing
- Regulation—.015% or 1 MV (Line or Load)
- Temp. Coef. .015%/°C
- Transformer—designed to MIL-T-27 Grade 6
- Completely Protected—Short Circuit Proof—Continuously Adjustable Automatic Current Limiting
- Constant I./Constant V. by automatic crossover

- Series/Parallel Operation
- No Voltage Spikes or Overshoot on "turn on", "turn off" or power failure
- Meet Mil. Environment Specs. Vibration; MIL-T-4807A Shock: MIL-E-4970A
- Proc. 1 & 2 Humidity: MIL-STD-810
- Meth. 507 Temp. Shock: MIL-E-5272C
- (ASG) Proc. 1 Altitude: MIL-E-4970A
- (ASG) Proc. 1 Marking: MIL-STD-130 Quality: MIL-Q-9858

- Ripple—LK models—500  $\mu$ V RMS LH models—250  $\mu$ V RMS, 1 MV P-P
- Wide Input Voltage and Frequency Range—L K models—105-132 VAC, 47-63 cps LH models—105-135 VAC, 45-480 cps.
- LH models meet RFI Spec.—Mil-I-16910
- Rack Adapters LRA-1—5 1/4" Height x 16 1/2" Depth (For use with chassis slides) Price \$60.00 LRA-2—5 1/4" Height Price \$25.00

3 full-rack LK models—Size 5 1/4" x 19" x 16 1/2"

Model <sup>2</sup>	Voltage Range	CURRENT RANGE AT AMBIENT OF: <sup>1</sup>				Price <sup>2</sup>
		40°C	50°C	60°C	71°C	
LK 350	0-20VDC	0.35A	0.31A	0.26A	0.20A	\$675
LK 351	0-36VDC	0.25A	0.23A	0.20A	0.15A	640
LK 352	0-60VDC	0.15A	0.14A	0.12.5A	0.10A	650

6 half-rack LK models—Size 5 3/16" x 8 3/8" x 16 1/2"

Model <sup>2</sup>	Voltage Range	CURRENT RANGE AT AMBIENT OF: <sup>1</sup>				Price <sup>2</sup>
		40°C	50°C	60°C	71°C	
LK 340	0-20VDC	0-8.0A	0-7.0A	0-6.1A	0-4.9A	\$330
LK 341	0-20VDC	0-13.5A	0-11.0A	0-10.0A	0-7.7A	385
LK 342	0-36VDC	0-5.2A	0-5.0A	0-4.5A	0-3.7A	335
LK 343	0-36VDC	0-9.0A	0-8.5A	0-7.6A	0-6.1A	395
LK 344	0-60VDC	0-4.0A	0-3.5A	0-3.0A	0-2.5A	340
LK 345	0-60VDC	0-6.0A	0-5.2A	0-4.5A	0-4.0A	395

- <sup>1</sup> Current rating applies over entire voltage range.  
<sup>2</sup> Prices are for non-metered models. For metered models add suffix (FM) to model number and add \$30.00 to price.  
<sup>3</sup> Overvoltage Protection: Add suffix (OV) to model number and add \$70.00 to the price for half-rack models; \$90.00 for full-rack models.  
<sup>4</sup> Chassis Slides: Add suffix (CS) to model number and add \$60.00 to the price.

5 quarter-rack LH models—Size 5 3/16" x 4 3/16" x 15 1/2"

Model <sup>2</sup>	Voltage Range	CURRENT RANGE AT AMBIENT OF: <sup>1</sup>				Price <sup>2</sup>
		30°C	50°C	60°C	71°C	
LH 118	0-10VDC	0-4.0A	0-3.5A	0-2.9A	0-2.3A	\$175
LH 121	0-20VDC	0-2.4A	0-2.2A	0-1.8A	0-1.5A	159
LH 124	0-40VDC	0-1.3A	0-1.1A	0-0.9A	0-0.7A	154
LH 127	0-60VDC	0-0.9A	0-0.7A	0-0.6A	0-0.5A	184
LH 130	0-120VDC	0-0.50A	0-0.40A	0-0.35A	0-0.25A	225

5 half-rack LH models—Size 5 3/16" x 8 3/8" x 15 1/2"

Model <sup>2</sup>	Voltage Range	CURRENT RANGE AT AMBIENT OF: <sup>1</sup>				Price <sup>2</sup>
		30°C	50°C	60°C	71°C	
LH 119	0-10VDC	0-9.0A	0-8.0A	0-6.9A	0-5.8A	\$289
LH 122	0-20VDC	0-5.7A	0-4.7A	0-4.0A	0-3.3A	260
LH 125	0-40VDC	0-3.0A	0-2.7A	0-2.3A	0-1.9A	269
LH 128	0-60VDC	0-2.4A	0-2.1A	0-1.8A	0-1.5A	315
LH 131	0-120VDC	0-1.2A	0-0.9A	0-0.8A	0-0.6A	320

- <sup>1</sup> Current rating applies over entire voltage range.  
<sup>2</sup> Prices are for non-metered models. For metered models add suffix (FM) to model number and add \$25.00 to price. For non-metered chassis mounting models, add suffix (S) to model number and subtract \$5.00 from non-metered price.  
<sup>3</sup> Overvoltage Protection; Add suffix (OV) to model number and add \$60.00 to the price.

SEND FOR NEW  
LAMBDA CATALOG



LAMBDA ELECTRONICS CORP.

515 BROAD HOLLOW ROAD • MELVILLE, L. I., NEW YORK • 516 MYRTLE 4-4200

A  SUBSIDIARY

ON READER-SERVICE CARD CIRCLE 46

**Transistor  
Mounting  
Pads?  
Clips?  
Heat Sink  
Adapters?**

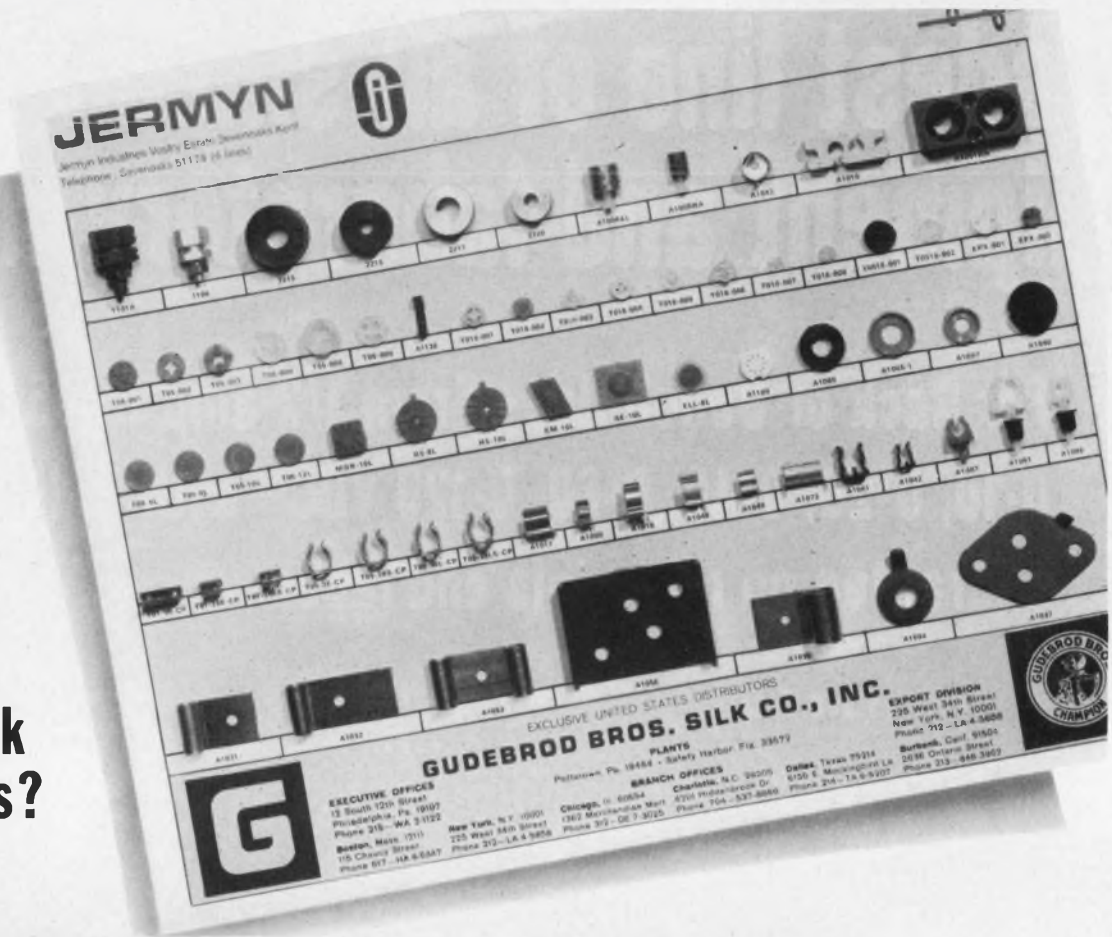

**GUDEBROD is your new, reliable source for this important circuit hardware.**

**Precision made with traditional English craftsmanship—by JERMYN Industries.**

**Stocked and sold exclusively in the United States by GUDEBROD.**

**You ought to know more about these products!**

**Send for catalog now!**

Gudebrod is now exclusive U.S. distributor for the electronic products manufactured by Jermyn Industries of Kent, England. Gudebrod feels it will be providing the industry with electronic hardware consistent with the high quality products manufactured by Gudebrod for nearly 100 years. Gudebrod will extend the same quality and depth of service it has become known for in lacing tapes. Write for the Catalog GJ100.



**GUDEBROD BROS. SILK CO., INC.**

FOUNDED IN 1870

*Electronics Division*

12 SOUTH 12th STREET, PHILADELPHIA, PENNSYLVANIA 19107

ON READER-SERVICE CARD CIRCLE 47

Area Code 215, WA 2-1122

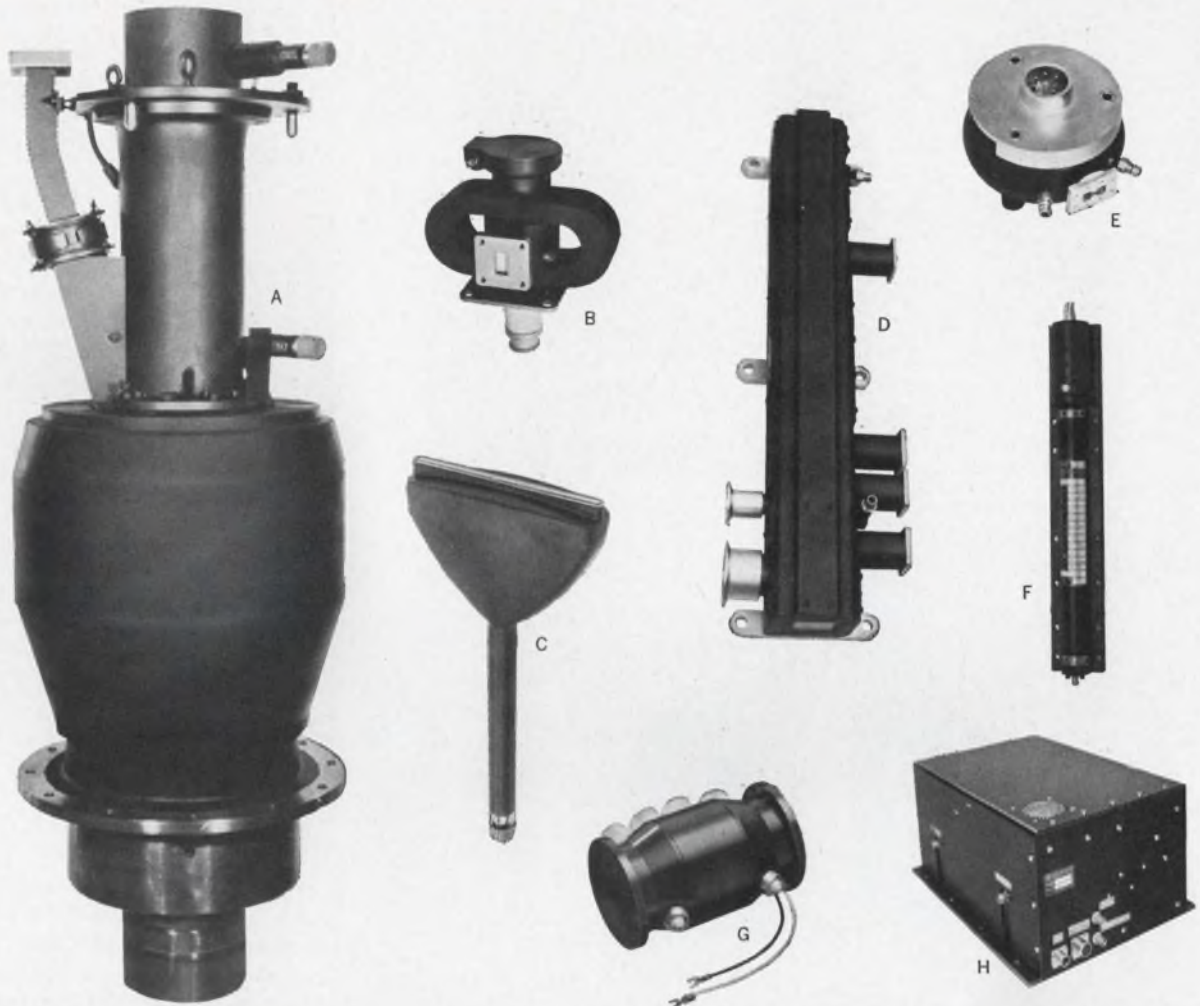

# Litton Electron Tubes

**Microwave Tubes  
Display Devices  
Integrated  
Sub-Systems**

*From 1 meter to  
4 millimeters;  
from milliwatts  
to megawatts.*

**MAGNETRONS** for radar, navigation and guidance, countermeasures, beacons, missile fuzes, fire control, transponders, IFF, and microwave heating & cooking. Litton magnetrons range in power from one watt CW to two megawatts pulse in frequency ranges from 406 to 34,900 Mc. Frequency agility & dither modes. Vane & strap and coaxial.

**M-TYPE BACKWARD WAVE OSCILLATORS** for high power sweep oscillators, FM or AM transmitters, and as electronic countermeasures power sources. Frequency ranges from 500 to 11,000 Mc. 100 to 500 watts. CW and Pulse modes.

**CROSSED FIELD FORWARD WAVE AMPLIFIERS** for electronic countermeasures, multi-channel wide band communications and CW & Pulse multi-mode radar.

**AMPLIFIER KLYSTRONS** for long-range search radar, missile and satellite tracking, linear accelerators, phased array radar and radar astronomy. Frequency ranges from 400 to 11,000 Mc. 20 kW to greater than 30 Mw, pulsed. 2 W to 75 kW. CW.

**TRAVELING WAVE TUBES** as drivers for high power microwave transmitters, missile guidance and control, electronic countermeasures, space communications, telemetry and phased array radar. Frequency ranges from 400 to 11,000 Mc. 10 mW to 10 kW. Small signal gains from 33 to 70 db. Pulse & CW. Low noise TWT's.

**CATHODE RAY TUBES** for airborne radar display, flying spot scanning, infra-red recording and photographic encoding. High resolution tubes, high brightness tubes, electrostatic printing tubes, fiber optic CRT's, and CRT operational accessories.

**INTEGRATED SUB-SYSTEMS AND TUBE-RELATED EQUIPMENT** to complement our tube line in many of the above applications. Microwave power sources, transitions, sockets, solid state TWT power supplies and solid state magnetron magnetic modulators.

**ADVANCED DEVICES.** Electrostatically focused klystrons, DEMATRON distributed emission crossed-field amplifier, BIMATRON<sup>®</sup> injected beam crossed-field amplifier, low noise research, solid-state devices, light amplifiers, etc.

**INFORMATION.** For information on the entire Electron Tube product line, send for the comprehensive 40-page brochure and catalog. Contact Electron Tube Division, 960 Industrial Road, San Carlos, California 94070.

Products illustrated: (A) L-3980 SLAC Klystron; (B) L-5049 Coaxial Pulse Magnetron; (C) L-4186 Fiber Optic CRT; (D) L-3765 CFA; (E) L-3726 M-BWO; (F) L-5088 Low-Noise TWT; (G) L-5044 Electrostatically Focused Klystron; (H) Model 393 Microwave Pulse Amplifier.

**ELECTRON TUBE DIVISION  
LITTON INDUSTRIES**

ON READER-SERVICE CARD CIRCLE 48

## Probe analyzes Semiconductors

A method for analyzing the performance of high-power semiconductor devices by measuring the potential along the surface has been devised and successfully tested at Bell Telephone Laboratories, Murray Hill, N. J.

The measuring technique is based on the following phenomenon:

When pulses of current are sent through a semiconductor, an electric field results. Device nonuniformities—the quality of contacts, doping gradients, etc.—contribute to unusual device performance and show up as variations in field strength. These variations are sensed by a resistive potential probe as voltage pulses and are amplified and displayed on an oscilloscope. They can also be recorded and analyzed.

The probe is a tungsten wire with a 2-micron-diameter point (which, incidentally, limits the use of this method to devices longer than 6 microns). In operation, the probe is mounted on a micromanipulator and observed through a microscope (see photo). The setup can define the measurement point to within  $\pm 1.5$  microns.

The probe is reported superior to such others as the Gunn capacitive probe in that it measures the potential directly.

The new method, Bell Labs says, can be used to analyze experimental semiconductor devices, being studied as sources of microwave and millimeter-wave power for communications systems. These devices include bulk gallium-arsenide diodes and avalanche diodes. The technique, however, is applicable to any type of semiconductor device.

The method can also be used to verify hypotheses relating to electron velocity as a function of field strength. And it can be used to measure the doping profile in bulk and epitaxial gallium arsenide.

As for future use, inspection tools could conceivably be built with the use of the new principle, and semiconductor manufacturers could use the tools in quality control. ■ ■

taking  
the  
heat  
off



Keeping the temperature of sensitive electronic circuits constant while the ambient temperature wanders all over the lot, helps take the heat off design engineers. And that's the job Eastern refrigeration-type cooling systems do best.

These refrigeration units are the vapor-cycle, closed-system type. Years of tough testing in actual operation prove they sail through government military "specs" with flying colors. The rugged heart of these systems is a semi-hermetically sealed compressor, piston type — powered by a 400 cycle motor.



Send for  
Series C Bulletin.



**EASTERN INDUSTRIES**

A DIVISION OF LABORATORY FOR ELECTRONICS, INC.

100 SKIFF STREET • HAMDEN 14, CONNECTICUT

BRANCH OFFICES: Nashua, N. H., Lyndhurst, N. J., Wilmington, Del., Chicago, Ill., Torrance, Calif. IN CANADA: ENTERPRISE AGENCIES, INC., Montreal, Quebec

ON READER-SERVICE CARD CIRCLE 49



# Does AE make the world's prettiest dry-reed switches?

Some of our customers think so. They go for the chic look of our PC Correeds on a printed circuit board.

Our designers are flattered. But they point out that the beauty of a PC Correed is more than skin-deep.

Take the contact leads. We keep them separate from the terminals—to eliminate strain. The terminals themselves have "I-beam" strength. They are longitudinally ribbed for extra rigidity—for easy insertion in PC boards.

The contact terminals are *welded*, not soldered. This makes a better electrical connection.

We filled the plastic bobbins with glass, to prevent moisture absorption. And to boost structural

strength. You can pack these smart-looking switches as densely as you like. Because of their low profiles, magnetic shielding, and standard PC terminal spacing (multiples of 0.200").

PC Correeds are available with 1, 2, 3 and 5 reedcapsules, in contact forms A, B, C and magnetic latching. You can get many of these modules right from stock. So it's easy to put a little beauty in your life.

Want some helpful new design information? Ask your nearest AE representative for Circular 1070-B. Or drop a line to the Director, Electronic Control Equipment Sales, Automatic Electric Company, Northlake, Illinois 60164.

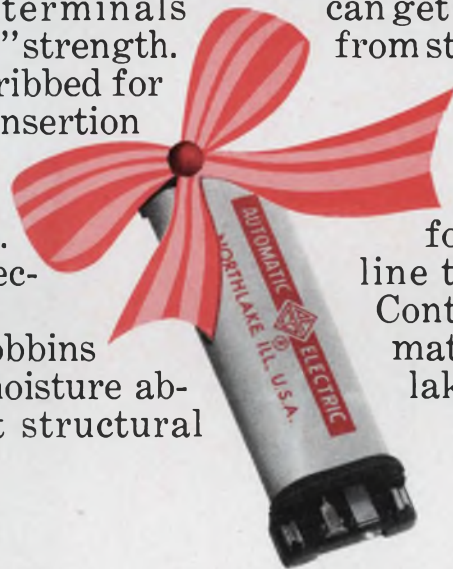

**AUTOMATIC ELECTRIC**

SUBSIDIARY OF  
GENERAL TELEPHONE & ELECTRONICS **GTE**

ON READER-SERVICE CARD CIRCLE 50

# State of the design art

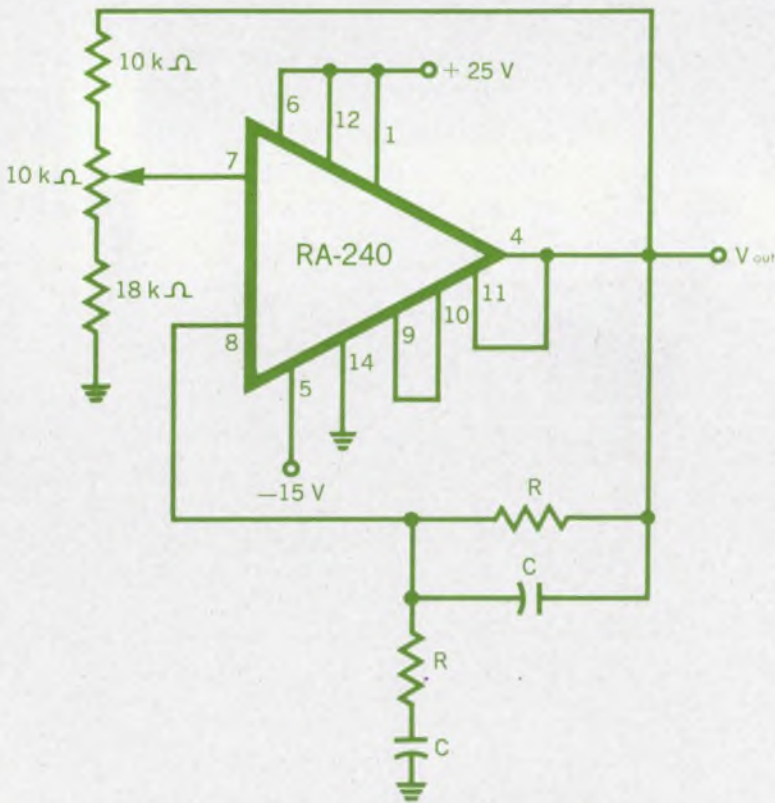

VISIT US AT THE IEEE SHOW . . . BOOTH 4G32, 4G34.

Radiation IC Amplifier  
simplifies design  
of highly stable  
Wien bridge oscillator

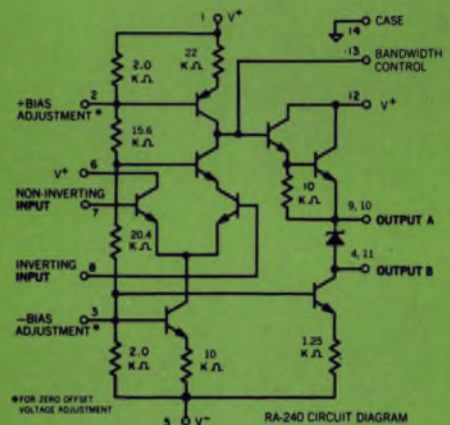

The flexibility of Radiation IC Operational Amplifiers is illustrated by the circuit at left. Here, the RA-240 is used in the design of a highly stable, uncompensated Wien bridge oscillator which is virtually unaffected by temperature variations.

Using the RA-240, engineers may select a wide range of RC combinations without regard to the active element of the circuit. Frequency of oscillation (up to 500 kHz) is defined by:

$$f_o = \frac{1}{2 \pi RC}$$

In this application, the amplifier offers the following typical performance characteristics:

@  $f_o = 10$  kHz; Undistorted  $E_{out} = 9.6$  V<sub>P-P</sub> with  $R_L = 2$  kΩ

@  $f_o = 150$  kHz; Undistorted  $E_{out} = 1.7$  V<sub>P-P</sub> with  $R_L = 2$  kΩ

The stability and versatility of Radiation Operational Amplifiers is made possible through advanced dielectric isolation and thin film over oxide technology.

# State of the monolithic art

A new line of universal building blocks for integrated analog circuitry is now available to design engineers. Radiation Incorporated supplies three different types of IC operational amplifiers to serve your individual requirements: general-purpose, broadband, and high-gain amplifiers.

These amplifiers provide outstanding performance. Parasitics are eliminated, thanks to our unique dielectric isolation technique. Tighter tolerances and improved temperature coefficients are achieved through use of precision thin film resistors over the oxide.

Thus, Radiation's technology simplifies system designs which

were hampered by limitations imposed by conventional integrated circuit fabrication techniques.

Only Radiation can provide production quantities of inherently stable IC operational amplifiers. These circuits are stocked for immediate shipment in TO-84 flat packages.

Write or phone for our data sheets which include *worst-case limits* as well as all information required by design engineers. We'll also be glad to send you a copy of our new manual entitled: Operational Amplifier Technical Information and Applications. For your copy, request publication number ROA-T01/A01 from our Melbourne, Florida office.



Radiation IC Operational Amplifiers\*

Typical characteristics ( $T_A = +25^\circ\text{C}$ )	GENERAL PURPOSE RA-238	BROADBAND RA-239	HIGH GAIN RA-240	UNIT
Phase margin	60	60	45	Degrees
Bandwidth (unity gain)	7	15	6	MHz
Slew rate	3.2	23	3.2	V/ $\mu\text{s}$
Voltage gain	2,700	2,700	33,000	
Offset voltage	2.0	2.0	2.0	mV
Offset current	80	400	80	nA
Thermal drift	$\pm 5$ $\pm 1$	$\pm 5$ $\pm 5$	$\pm 5$ $\pm 1$	$\mu\text{V}/^\circ\text{C}$ nA/ $^\circ\text{C}$
Undistorted output swing	21	21	9 (11.6) <sup>†</sup>	$V_{p-p}$
Power dissipation	90	160	90	mW
Common mode rejection	100	100	100	dB
Power supply rejection	100	100	100	dB
Input bias current	0.4	1.0	0.4	$\mu\text{A}$

\*Standard temperature range:  $-55^\circ\text{C}$  to  $+125^\circ\text{C}$ .  $V^+ = +25\text{V}$ ;  $V^- = -15\text{V}$ .  
<sup>†</sup> $V^+ = +20\text{V}$ ;  $V^- = -20\text{V}$ .

All Radiation integrated circuits are dielectrically isolated.



## RADIATION INCORPORATED

MICROELECTRONICS DIVISION

Sales offices: Suite 622, 650 North Sepulveda Blvd., El Segundo, Calif. (213) 772-6371—Suite 232, 600 Old Country Road, Garden City, N. Y. (516) 747-3730—Suite 201, 1725 Eye Street, N. W., Washington, D. C. (202) 337-4914—P.O. Box 37, Dept. ED-03, Melbourne, Florida (305) 723-1511, ext. 554

On Reader-Service Card Circle 245

Radiation Diode Matrices are ideally suited for design of high speed, low cost full adders. These circuits, using Radiation Matrices, offer three major benefits:

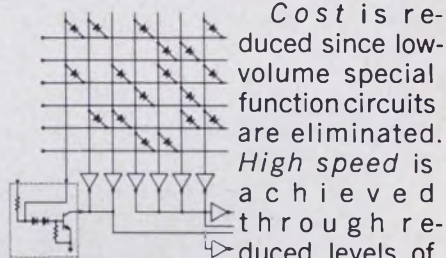

*Cost* is reduced since low-volume special function circuits are eliminated. *High speed* is achieved through reduced levels of active gating. *Flexibility* in matrix sizes, in conjunction with Radiation's unique fuse link technique for "customizing" patterns, permits design freedom in the organization of an adder.

The binary full adder, schematic above, requires only one Radiation RM-30 6 x 8 Monolithic Diode Matrix in addition to Radiation RD-220 Hex Inverters and RD-234 Interface Circuits. This adder provides both complementary SUM and CARRY output.

For detailed information, refer to our ELECTRONICS advertisement of March 6.

Our entire line of matrices contain all active devices within a single chip. A fusible link in series with each diode permits unlimited matrix patterns to be formed. Matrices can be combined to produce an infinite variety of size configurations.

We'll be glad to send data sheets which include *worst-case limits*. Our design manual, Monolithic Diode Matrix Technical Information and Applications, RDM-T01/A01, is also available. Write or call our Melbourne, Fla. office for your copy.



On Reader-Service Card Circle 246



# Balanced design makes Bodine N-1RD gearmotors last and last

...giving you After Delivery Economies (ADE)

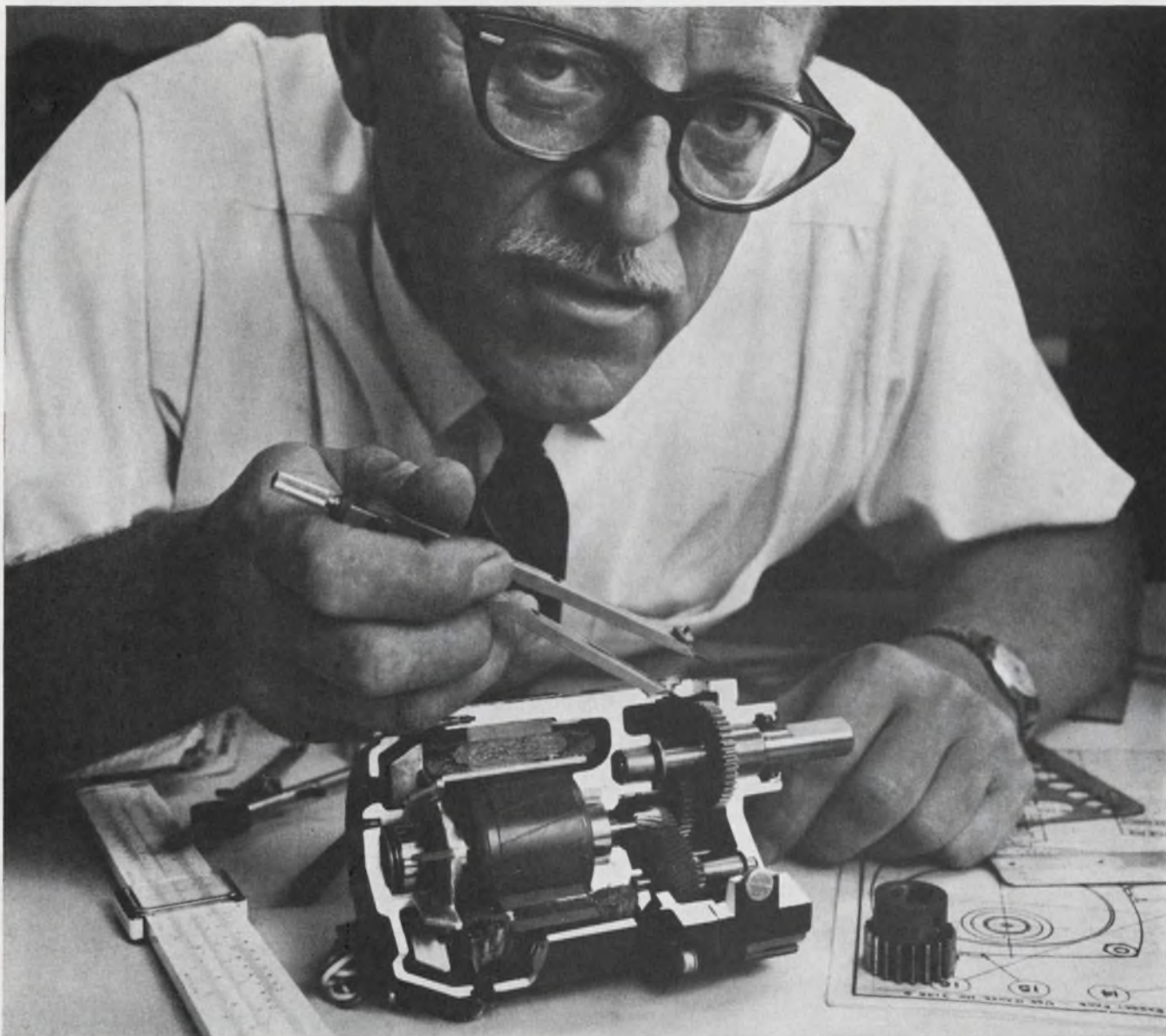

Each and every part used in Bodine's N-1RD speed reducer motor has been designed—and extensively tested—to assure approximately the same long life. This carefully balanced motor design results in lasting, rugged operation . . . consistent, reliable power.

Great overhung load capacity (needle bearings on output shaft). Remarkably high torque (25 in. lbs.) for its small size (5" long, 3 $\frac{3}{8}$ " square). Quality? . . . Check these *standard* features. Case hardened steel gearing with phenolic primary gear for quietness. Die cast construction. Ball bearings on rotor shaft. And modifications easily made at minimum extra cost.

Like all Bodine motors (over 3,500 standard specifications), the N-1RD gearmotor helps you cut end costs through After Delivery Economies (ADE):

1. Very, very few rejects in your receiving, production or final test stages.
2. Consistent performance in the field.
3. "Three-piece" design for easy servicing.
4. Reliability—few call-backs, low field service costs.
5. Enhancement of your product's quality, helping you earn customer satisfaction, repeat sales.

Write for Bulletin 1025—Bodine Electric Company, 2528 West Bradley Place, Chicago, Illinois 60618.

*Bodine motors wear out—  
it just takes longer*

**BODINE**  
fractional/horsepower  
**MOTORS**



*the power behind the leading products*

ON READER-SERVICE CARD CIRCLE 52

We  
have  
the  
only  
fully compatible  
family of  
high speed  
and  
low power  
TTL  
circuits.

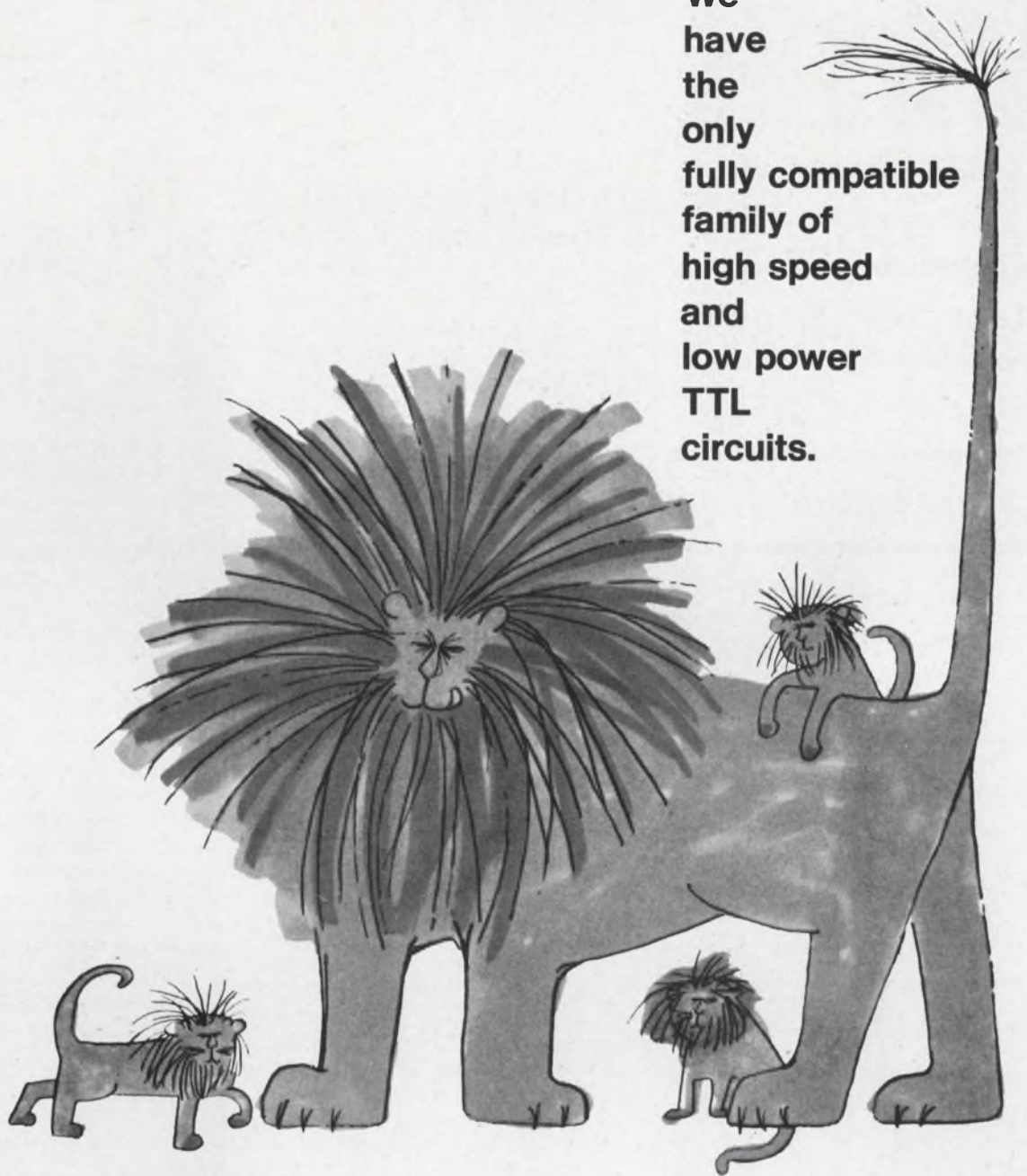

You can go wild with Signetics new Designer's Choice 8000 Series: it gives you the widest selection of design trade-offs in speed, power, noise immunity and price ever offered in a TTL family. The family consists of a very high speed set (the 8800's) and a fully compatible but slower low power set which offers very high AC noise immunity. Now TTL system designs can be optimized without laborious calculations, unusually expensive and time-consuming special ground-plane designs, or extensive use of outboard discrete components in areas where the highest possible speed is not required. All you do is follow the published S8000-series usage rules. All circuits are compatible over the full MIL temperature range of  $-55^{\circ}\text{C}$  to  $+125^{\circ}\text{C}$  and are available off-the-shelf in Signetics 14-lead glass-Kovar flat pack. Hunt up your local Signetics distributor. For further information on the Designer's Choice 8000 Series, write Signetics, at 811 E. Arques Avenue, Sunnyvale, California 94086. ■ At the IEEE Show, be sure to check into Rooms 3000A & B at the New York Coliseum, for latest Signetics news.

TYPE	DESCRIPTION		
S8416	Dual 4-Input Nand Gate	S8816	Dual 4-Input Nand Gate
S8417	Dual 3-Input Nand Gate	S8825	DC Clocked J-K Binary Element
S8424	Dual AC Binary Element	S8826	Dual J-K Binary Element
S8440	Dual Exclusive-Or Gate	S8840	Dual 4-Input Exclusive-Or Gate
S8455	Dual 4-Input Buffer/Drive	S8855	Dual 4-Input Power Gate
S8480	Quadruple 4-Input Expander	S8870	Triple 3-Input Nand Gate
S8806	Dual 4-Input Expander	S8880	Quadruple 2-Input Nand Gate
S8808	8-Input Nand Gate		

**SIGNETICS  
INTEGRATED  
CIRCUITS**   
A SUBSIDIARY OF CORNING GLASS WORKS

ON READER-SERVICE CARD CIRCLE 53

# MASKS

for

integrated circuitry

thin film devices

semiconductors

## PHOTOMASKS

NEW Perma-Chrome (metal film on glass).

High resolution photo emulsion.

## EVAPORATION MASKS

Electroformed nickel.

Etched molybdenum and stainless steel.

Bi-metal (electroformed nickel and copper).

Prompt quotations and deliveries.



Our new headquarters at  
ONE U.S. Highway 206, Somerville, N.J.



**TOWNE  
LABORATORIES, INC.**

SOMERVILLE, N.J. 08876 tel. 201-722-9500

ON READER-SERVICE CARD CIRCLE 54

## Letters

### DTL NAND gate circuit is open to improvement

Sir:

G. M. Ammon's use of integrated-circuit gates in monostable and astable multivibrator configurations ("DTL logic NAND gates bring versatility," ED 22, Sept. 27, 1966, pp. 74-79) brought to mind our own experience with a similar application. The basic timing circuit used by Ammon is shown in Fig. 1.

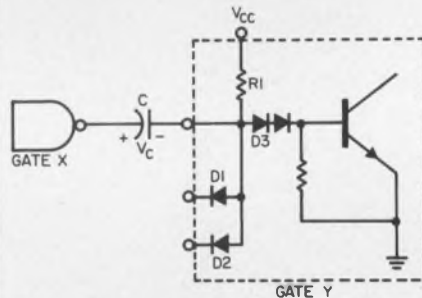

1. Basic timing circuit with IC.

When gate X in Fig. 1 goes low, approximately -3.5 volts is applied to the extender pin of gate Y. Ammon points out that the WM 226 DTL element has a reverse voltage rating at the extender pin of -7 volts. This is the key to the proper operation of his circuits. It should be noted that most, if not all, other manufacturers do not specify electrical ratings or characteristics for the extender pin. Therefore, a potentially dangerous situation occurs if this configuration is used with a DTL element other than the WM 226. An examination of the typical junction structure at the extender is given in Fig. 2.

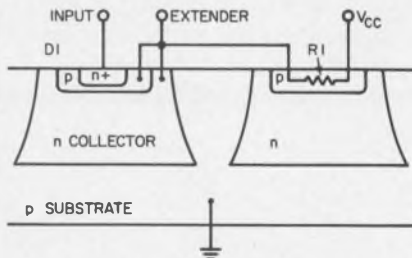

2. Junction structure at extender.

D1 is usually the base-emitter of a transistor with collector shorted to base; the n-doped collector region

forms a normally back-biased diode with the p substrate. In this application, however, the parasitic diode is forward-biased without the benefit of a known value of current-limiting resistance, as shown in Fig. 3.

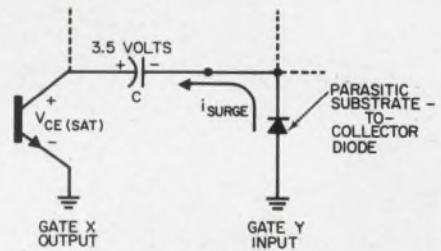

3. Forward bias of parasitic diode.

No problem exists if D1 and D2 do not have an n collector region common to the extender pin. However, the resulting so-called floating-collector diodes suffer from a higher forward voltage and a longer storage time delay than the diode in Fig. 2. R1 (Fig. 2) is normally p type; D3 (Fig. 1) can be a floating-collector diode since the properties of high forward voltage and long storage time are desirable in this diode. Since the extender pin connects only to p regions in this case, there is no danger of forward-biasing a normally reverse-biased junction by application of negative voltage to these p regions. Display of the extender-pin-to-ground-pin voltage-current characteristic on a curve tracer is a simple method of ascertaining the device's reverse voltage capability between these two points.

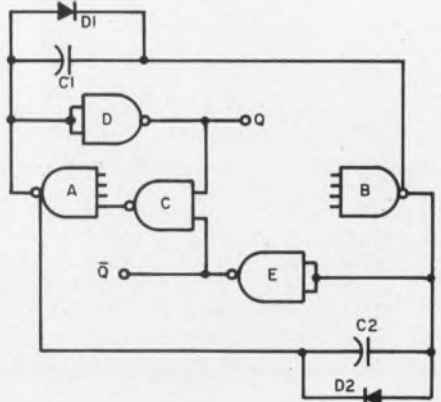

GATES A AND B MUST NOT BE "TOTEM-POLE" LINE DRIVER TYPE

4. Lock-up protection with 3 gates.

In order to extend this circuit's application for use with other manufacturers' DTL elements, the circuit of Fig. 4 is proposed. Gates  
(continued on p. 78)

Readout — bright, legible, IEE readout — makes the difference when the data must be accurately read at a glance, from any angle. That's the case with Lloyd Isaacs, Resident Manager of the Santa Monica office for Hornblower & Weeks — Hemphill, Noyes. On a busy trading day his clients start ringing for immediate quotations on New York prices. In 3/10 of a second, Isaacs gets and reads a crisp, brilliant figure from the IEE display on his electronic quoter. The client says *buy*. Done. He answers another line. Another client, and another quick-glance quotation goes out — accurately. IEE front-plane readouts assure that accuracy.

Whether *your* product is business machines, test equipment, or space instrumentation, your customers demand the best readout available. Give it to them with IEE rear-projection, front-plane readouts — your choice of sizes with an unlimited selection of characters and colors. Send now for your copy of the new IEE Readout Catalog.



Illustrated: IEE Series 120 Readout — 160° circular viewing angle; character boundaries 5/8" wide horizontal band drawn through .800" D circle. Brightness to 100 F. L.

"I double-E," the world's largest manufacturer of rear projection readouts. Industrial Electronic Engineers, Inc., 7720 Lemona Ave., Van Nuys, Calif. 91405. 

**When big money rides on a stock quotation,  
"readout" makes the difference!**

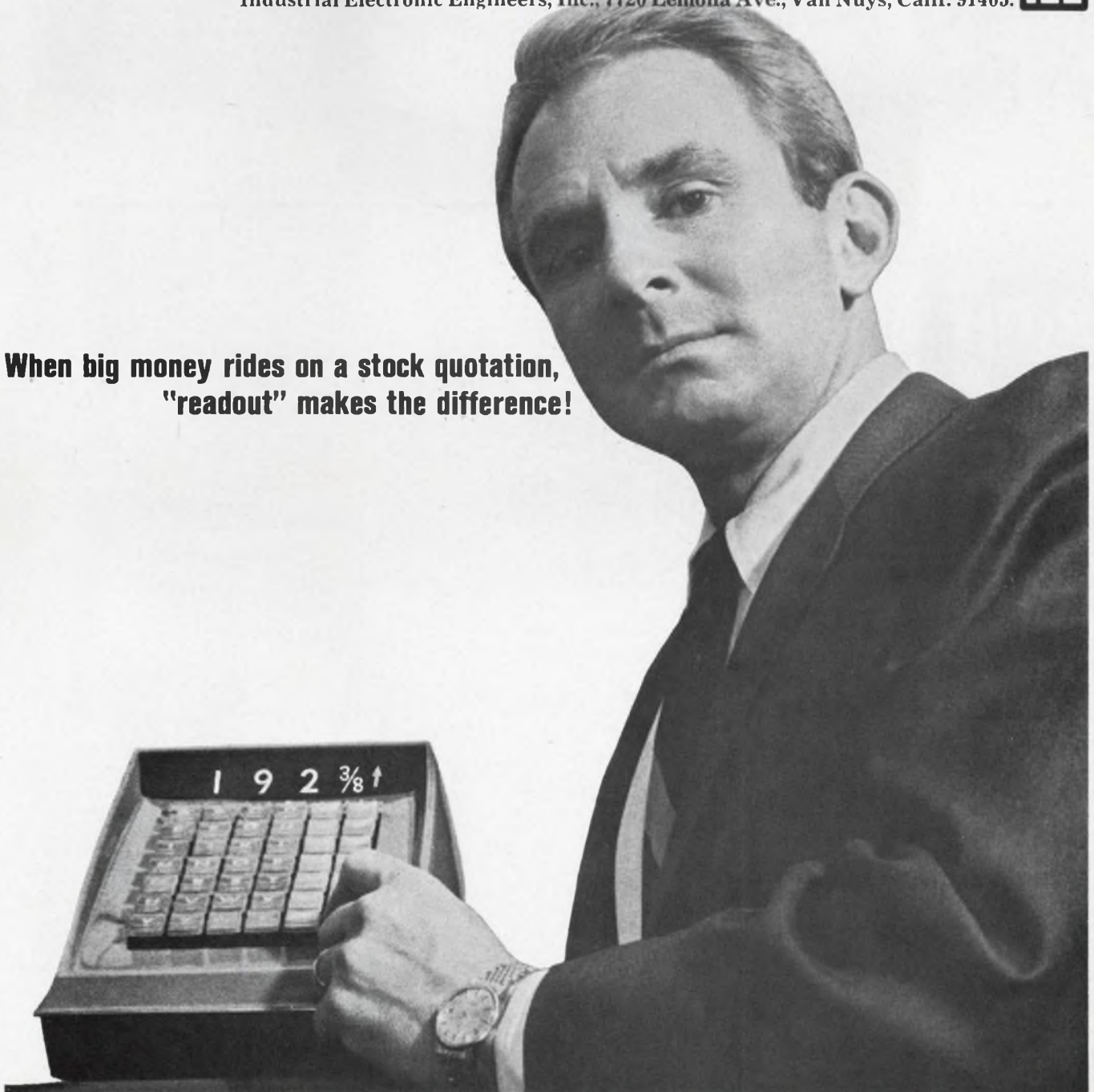

ON READER-SERVICE CARD CIRCLE 55

# select from the most complete line of relay rack panels on the market

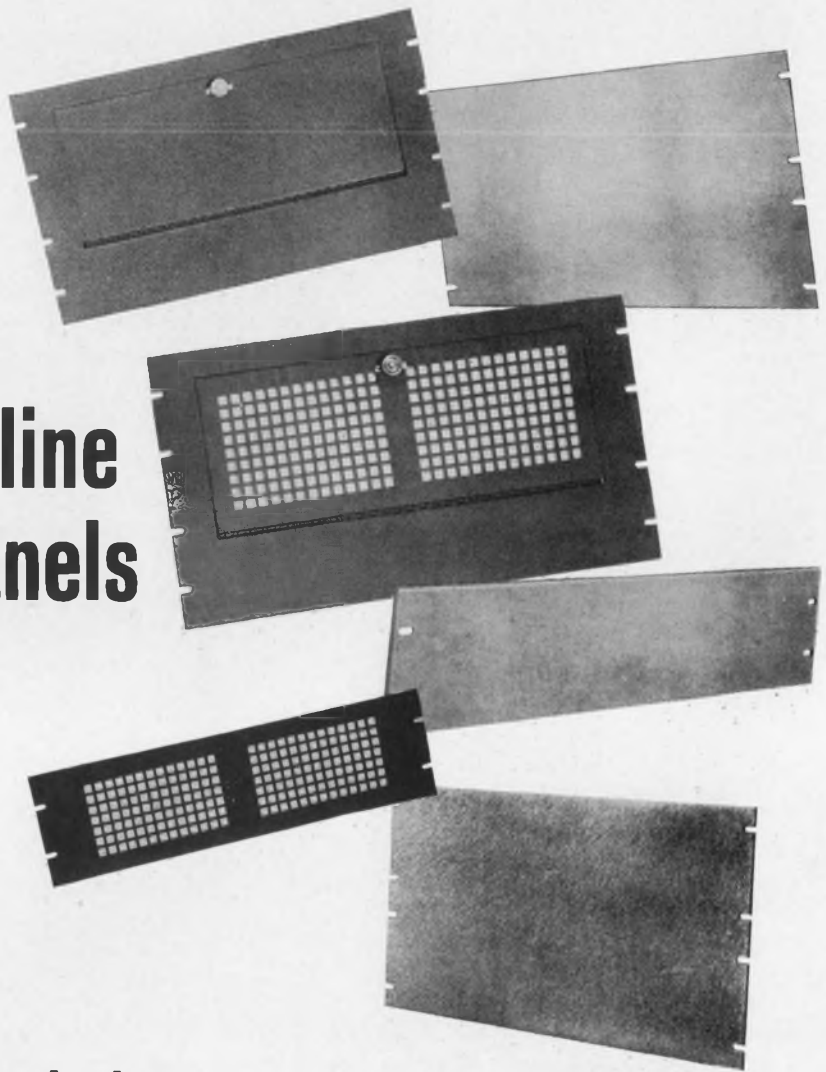

**BUD** makes

141 different types and sizes  
... in a choice of seven finishes  
... all delivered from stock

What do you look for in a relay rack panel . . . steel or aluminum . . . wide choice of sizes . . . good selection of finishes . . . immediate delivery!

Our huge production facilities enable us to meet your requirements promptly . . . smaller quantities from our distributors' stock — larger quantities from our plant.

If a stock panel doesn't exactly suit your needs, our special services include custom punching, color matching and silk screening.

See all the Bud relay rack panels at any one of 400 Authorized Bud Distributors.

Write us for Bulletin PA 67 which gives complete information about our complete line of relay rack panels.

We also make the most  
sizes and styles of standard  
racks and cabinets.

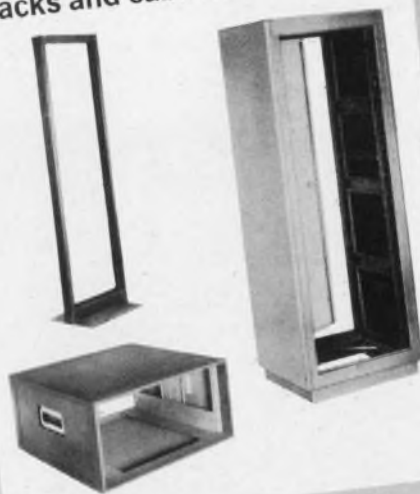

**BUD RADIO, INC.**

4621 E. 355th Street • Willoughby, Ohio 44094



# Tired of 4th digit bobble?



## Try the new X-2 (small, fast, integrating, DVM with multimeter capability: \$980)

Now you can get a low cost, small size integrating digital voltmeter with multimeter capabilities. With the new X-2 you can have AC, ohms, preamp and ratio functions in one compact package just by plugging in the appropriate circuit boards. And the X-2 has the exclusive NLS *anti-bobble* circuit. Unlike other low cost DVMs, the right hand (least significant) digit in the X-2 behaves as it would in a scan logic instrument . . . stays put, doesn't jump around.

Compare these features:

- Response—10 readings per second
- Resolution—4 digits with 5th digit (20% ) overranging
- Versatility—Functions include

AC, ohms, preamp and ratio—add functions as desired, and protect yourself against obsolescence

- Reliability—Integrated circuit construction meets Milspec standards
- Availability—Delivery 30 days
- Price—\$980 (basic DC instrument)

The X-2 also offers display storage and the space saving *half rack* size. It all adds up to a new capability at a price that will make the grimmest budget-watcher happy.

Take a closer look at the X-2. Fill out and mail the coupon, or write directly to Non-Linear Systems, Dept. 904, Del Mar, California 92014. For fast action, call us at (714) 755-1134.

I'd like more information on the X-2

Send me a data sheet

Have a representative call

Name \_\_\_\_\_

Title \_\_\_\_\_

Company \_\_\_\_\_

Address \_\_\_\_\_

State \_\_\_\_\_

Phone \_\_\_\_\_

Extension \_\_\_\_\_

Zip \_\_\_\_\_



Originator of the Digital Voltmeter

**non-linear systems, inc.**

DEL MAR, CALIFORNIA

ON READER-SERVICE CARD CIRCLE 57

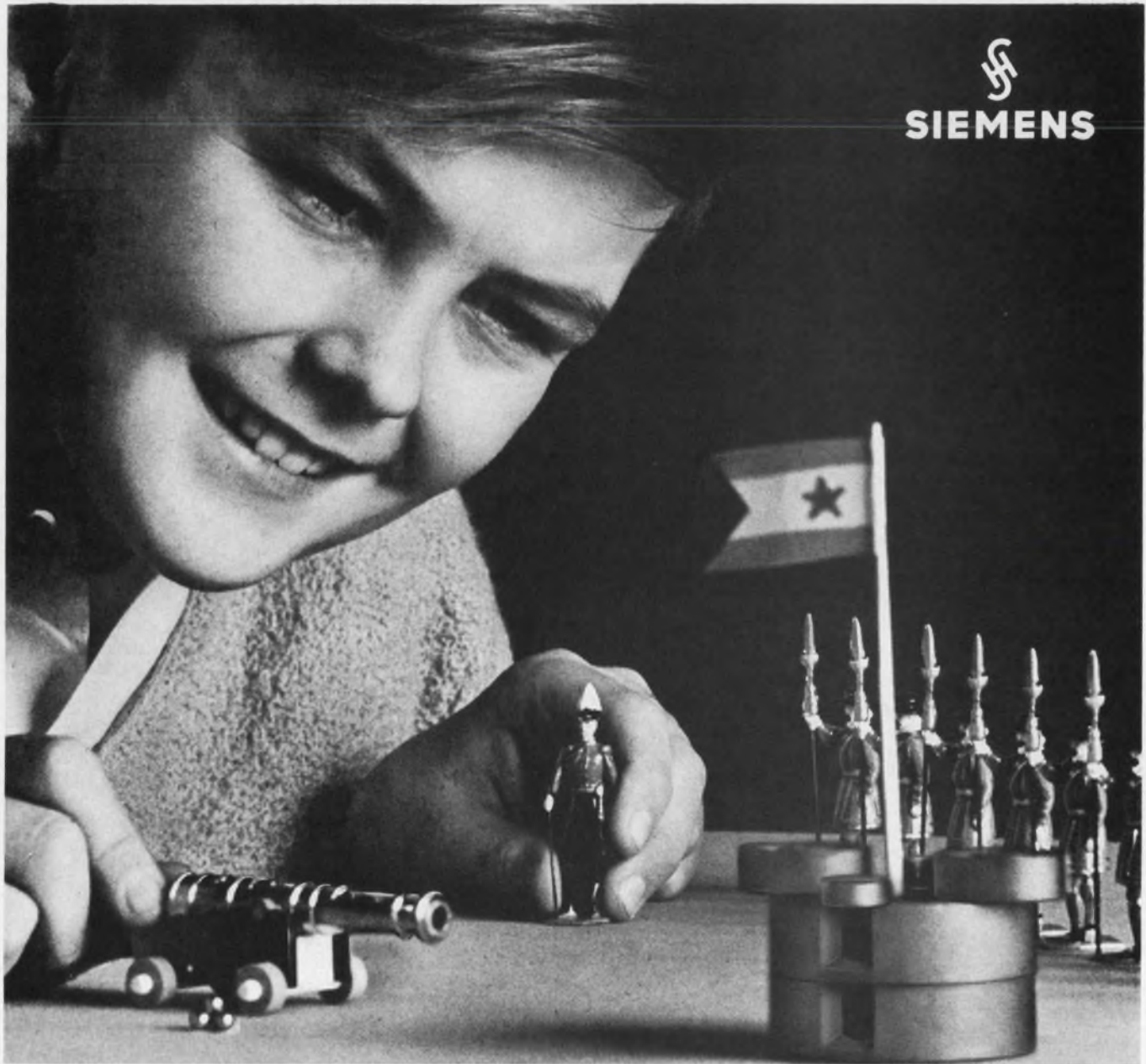

## uniformity

Month after month, the electrical characteristics of Siemens pot cores are consistent. Precision engineered for adjustable high stability, high-Q coils, they meet the most critical requirements for filters used in multiplex and other carrier-frequency applications. Low distortion and self-shielding are two important plus features. Available out of stock, too. Let a Siemens engineer show you how Siemens pot cores fit into your application. It's child's play.

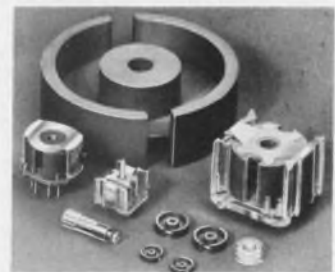

**SIEMENS FERRITE POT CORES**

8 different materials, 18 different sizes (.22 to 2.75 inches diameter) and more than 250 standard types afford optimum properties for all filter, oscillator and transformer applications. High Q value with high stability is typical: a 26 x 16 core of N22 or N28 material AL 315 at 100 kc/s shows a Q value of approx. 950. Siemens components include ferrite materials, metallized polyester and polystyrene capacitors, all electronic and microwave tubes, rectifiers and a complete line of semi-conductors.

### **SIEMENS AMERICA INCORPORATED**

VISIT BOOTH 4J 20-22 I.E.E.E. SHOW

Components Division • 230 Ferris Avenue, White Plains, N.Y. 10603  
ON READER-SERVICE CARD CIRCLE 58

# Why do conscientious engineers buy the X-1?



## Simple. To save \$540

Buy any other digital voltmeter at \$2450 and you're short changing yourself on features, functions and accuracy. Buy the *capabilities* of the X-1 in any other DVM and you'll pay at least \$540 more. *Only* the X-1 offers this combination of features and price:

- Response—Digitizing time 6 ms
- Resolution—5 digits with 6th digit (20% ) overranging
- Versatility—Functions include AC, ohms, preamp and ratio
- Reliability—All solid-state construction (no mechanical choppers)
- Availability—Delivery 2 weeks
- Price—\$2450 (basic DC instrument)

There are also features such as the active filter, floating input, isolated output and autoranging with all functions. And the capability of adding functions with additional or substitute circuit boards protects you against obsolescence. With the X-1 you can have the precise, versatile measuring instrument you need and still make the grimmest budget-watcher happy.

Take a closer look at the X-1. Fill out and mail the coupon, or write directly to Non-Linear Systems, Dept. 902, Del Mar, California 92014. For fast action call us at (714) 755-1134.

I'd like more information on the X-1

Send me a data sheet

Have a representative call

Name \_\_\_\_\_

Title \_\_\_\_\_

Company \_\_\_\_\_

Address \_\_\_\_\_

State \_\_\_\_\_

Phone \_\_\_\_\_

Ext. \_\_\_\_\_

Zip \_\_\_\_\_



Originator of the Digital Voltmeter

**non-linear systems, inc.**

DEL MAR, CALIFORNIA

ON READER-SERVICE CARD CIRCLE 59

# IC AIDS

**AUGAT offers easier, more efficient methods of Testing and Breadboarding Integrated Circuits**

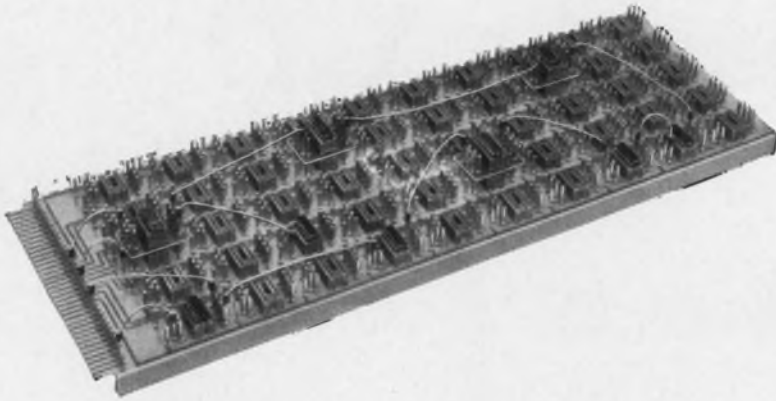

**Outstanding flexibility in Panels for simulated circuit construction, testing, and breadboarding.**

50 station panel illustrated; also available with fewer stations  
Solderless jumpers permit unlimited interconnections and fast change of circuitry

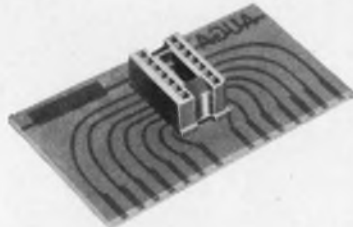

**TEST SOCKET**  
for rapid testing of IC's

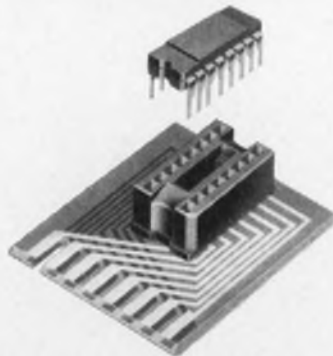

**SPACE-SAVING BOARD**  
printed both sides

All units illustrated are available for 14 and 16 lead plug-in IC's. Sockets have large contoured entry holes for easy, damage-free IC insertion; wiping gold-plated contacts assure low contact resistance.



**SINGLE BREADBOARD UNIT**

may be used as an individual unit or for "stacking" on multi-station panels



**EXTRACTOR TOOL**

A simple tool that assists removal of IC's. Speeds handling and minimizes IC lead damage.

Similar units are also available for Flat Pack and TO-5 integrated circuits.

Request Catalog 364 for complete line information

**AUGAT** INC.

31 Perry Ave., Attleboro, Mass. 02703

IEEE Booths 4H12-4H14

## LETTERS

(continued from p. 72)

C, D and E provide lock-up protection by driving gate A high if both gates A and B go low. The diodes clamp the timing capacitors, thereby preventing the development of a voltage destined to cause substrate current flow. Since the voltage swing at the extender pin is limited, some pulse width temperature stability is sacrificed; moreover, larger timing capacitors are required to achieve comparable pulse widths. Of course, if WM 226 gates are used, the diodes can be omitted.

Returning again to Ammon's article, the waveform labeled "PIN C TO GND" in his Fig. 2b [p. 75] should show that pin C starts in the 1 state. Even after the input trigger pulse has come and gone, pin C remains high, until capacitor  $C_T$  charges up to the gate threshold voltage. At this point, pin C goes low, causing the circuit output to return to its 1 state. When this output rise is coupled back through the circuit, pin C returns to the 1 state.

N. Panos and M. P. Trego  
Electronic Engineers  
General Dynamics/Convair Div.  
San Diego, Calif.

## Accuracy is our policy

In "Don't ignore thermal paths," ED 29, Dec. 20, 1966, pp. 76-80, the definition of  $\theta'_{ca}$  in Eq. 1 was omitted from the "Equivalent thermal circuits" box on p. 76.  $\theta'_{ca}$  is the series parallel equivalent to the combination of  $\theta_{cj}$ ,  $\theta_{ca}$ , and  $\theta_{ca}$ .

In "Will the machines eventually outwit man?" ED 1, Jan. 4, 1967, pp. 82-86, the author's affiliation was given as Project MAC, Massachusetts Institute of Technology. Mr. Jarnagin has been a consultant to Project MAC, but the views expressed in the article were his own and not those of the MIT project.

In "Submin EMI filters have low insertion loss," in the Components listing of the Products section of ED 2, Jan. 18, 1967, p. 98, the manufacturer, Sprague Electric Co., points out two errors. The filters have high (not low) insertion loss in order to reduce EMI, and operate up to 1000 MHz (not 100 MHz).

any  
other  
resistor  
would  
holler  
**UNCLE...**

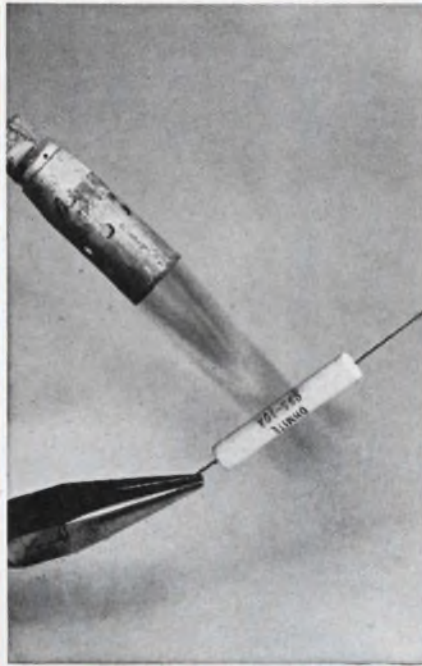

but not  
the "99"



**molded\*** in  
vitreous  
enamel

\*Patent No. 3,229,237



The Series 99 is the resistor that won't soften or deform at a cherry-red 1500°F... that clings to its markings like a leopard to its spots against the onslaught of solvents, abrasion, and extreme overloads. This is the resistor that laughs at abuse because of its tough, exclusive "molded" coating of vitreous enamel. This is the resistor of such uniform shape and size that metal clips can hold it securely and also provide a big increase in heat dissipation.

No wonder design engineers throughout industry are hollerin' for the resistor of incomparable performance

—the Series 99, molded in vitreous enamel.

Series 99 is supplied in commercial, MIL-R-26, and close tolerance types. *Commercial units are stocked in 5 sizes and 146 resistance values.*

**WATTAGES (COMMERCIAL):** 1.5, 2.25, 3.25, 5, 6.5, 9, 11 watts at 25°C.

**RESISTANCE RANGE:** 0.1 to 187K ohms.

**TOLERANCES:** 0.25% to 5%

**TEMPERATURE COEFFICIENT:**  $0 \pm 30$  ppm/°C at 25°C to +350°C for 10 ohms and above.

Write for Bulletin 103

**RHEOSTATS • POWER RESISTORS • PRECISION RESISTORS • VARIABLE TRANSFORMERS • RELAYS  
TAP SWITCHES • TANTALUM CAPACITORS • SEMICONDUCTOR CONTROLS • R.F. CHOKES**

**OHMITE** MANUFACTURING COMPANY  
3643 Howard Street • Skokie, Illinois 60076  
Phone: (312) ORchard 5-2600

ON READER-SERVICE CARD CIRCLE 61



# 10 GREAT THINGS YOU CAN DO WITH THE NEW SURMETIC "20" 1/2-WATT ZENER DIODE:



1. **Get 3/4 watts out of it.** Conservatively rated at 500 mW @  $T_L = 50^\circ\text{C}$  with  $\frac{3}{16}$ " heat-sinked leads, 1N5221-81 Surmetic<sup>®</sup> 20 units easily handle 750 mW with leads temperature maintained @  $50^\circ\text{C}$ ,  $\frac{1}{8}$ " from the device body.
2. **Design it into high-temperature environments.** Flame and distortion-proof silicone-polymer packaging plus a  $200^\circ\text{C}$  operating temperature ( $25^\circ\text{C}$  higher than other units) mean expanded application possibilities, less complex heat sink designs.
3. **Design it into high-humidity environments.** Surmetic 20 zener diodes consistently pass 50 day moisture-resistance tests . . . 5 times the exposure period required in standard MIL case integrity tests.
4. **Operate at low currents with excellent regulation.** Nanoampere reverse leakage current ratings indicate cleanliness of passivated junctions and ensure low power drain and sharp knees in all applications.
5. **Replace more than 450 older, more costly, less capable DO-7 devices** with just 61 Surmetic 20 units . . . "no-failure" zener diodes that have withstood overstressed, 1-watt, 1000-hour testing.
6. **Pay less for it.** Surmetic 20's cost as little as 36¢† each and are available from 2.4 to 200-volts from your franchised Motorola distributor.
7. **Use it in demanding industrial/military circuits.** 100% oscilloscope-tested and characterized at 4 critical points, including  $i_{z(\text{surge})}$ , the Surmetic 20 is completely spec'd to give you a total picture of its high-performance efficiency.
8. **Use it in non-critical commercial-type circuits.** Ultra-economical "non-suffix types" are available in standard 10% tolerances.
9. **Meet all your custom requirements** with Surmetic 20 non-standard voltages, double anode clippers, tight-tolerance units and matched sets.
10. **Apply practical, state-of-the-art knowledge** to your 1N5221-81 series circuits with the *all-new* Motorola Zener Diode Handbook . . . the industry-accepted, single-source zener diode reference guide.

Contact your distributor about evaluation units now . . . Write Box 955, Phoenix, Arizona 85001 for technical details!

*- where the priceless ingredient is care!*



## MOTOROLA Semiconductors

\*Trademark of Motorola Inc.  
† ± 10% Tolerance. 5000 up quantities.

# IEEE USA

For engineers all over the country, here's a preview of the world's biggest electronics show.



# Exploring the significant



It is 10 a.m. at Broadway and 60th Street in New York, March 20, 1967, and the doors of the city's Coliseum are opening for the annual IEEE show. Engineers who enter will find the four-story palace of electronics glittering with new features as well as many that are familiar.

New, advanced products fill the booths at the multimillion-dollar exhibition. Here are just a few highlights: gains in linear and digital integrated circuitry; plastic-encapsulated semi-conductors, cheaper and more reliable than ever; a man-made diamond temperature sensor with a fantastically wide environmental range.

For the first time, there is a movie theater, at which scientific, technical and educational films are being shown during the four days of the show.

On the first floor, exhibitors of production equipment and hardware are displaying their products. The second floor contains instruments and systems. The third and fourth floors feature components.

At the technical sessions, engineers may find some panel discussions in their specialties disappointing; few radical surprises are in store for the expert. But for the neophyte, or for those who seek to expand their interests to other fields of engineering, a broad choice of sessions and papers is available.

Come along on ELECTRONIC DESIGN's guided tour of the significant at the show.



# at the IEEE booths and sessions

**DESIGN TRENDS** in the major engineering disciplines, as reflected in new products on display and **TECHNICAL PAPERS**

Aerospace Engineer .....	U 90
Circuit Designer .....	U 92
"City of Tomorrow" Designers .....	U 93
Communications Engineer .....	U 94
Computer Engineer .....	U 96
Industrial Electronics Engineer .....	U 97
Materials Engineer .....	U 98
Medical Electronics Engineer .....	U 102
Microcircuit Systems Designer .....	U 103
Microwave Engineer .....	U 104
Oceanographic Engineer .....	U 105
Systems and Reliability Engineer .....	U 107

**THE ENGINEER AS A PROFESSIONAL —**

"The consumer industry wants YOU" ..... U 84

**WHEN, WHERE AND WHAT TO HEAR,**

listed by engineering specialty ..... U 110-122

**A CAMERA VIEW —** Touring the

exhibit areas ..... U 126-127

**OUTSTANDING NEW PRODUCTS**

Materials .....	U 128
Production and machinery equipment .....	U 132
Instruments .....	U 146
Systems .....	U 178
Components .....	U 188
	U 208



The world's oceans and the electronic engineer's efforts to tame them are featured in this year's IEEE Highlight Symposium.

# The consumer industry wants YOU

But educators, businessmen and engineering societies must first unite on a plan of action to attract recruits

**Maria Dekany**, Technical Editor



Many an engineer is at the threshold of a new career in consumer industry, but will he cross it?

“Engineering is becoming alienated from the productive civilian economy, which makes possible our good life and our expenditures on defense and space.”

This observation of Dr. John R. Pierce, an executive director of research at Bell Telephone Laboratories, has very valid foundation, according to prominent persons in industry and engineering education. They indicate, moreover, that the efforts of engineering societies—the IEEE show, for example—are failing to orient engineers sufficiently for careers in industrial and consumer electronics.

Space and military electronics attract most of the brightest engineers in the country, both the experienced and those fresh out of school, recruiters for the civilian electronics industry complain every year. “Glamour” and possibly better financial compensation have been cited as reasons for this trend.

However, some people, including Government officials are looking deeper into the problem and finding new answers: alienation starts, they say, during the educational process. The deep involvement of the Defense Dept. and military services in engineering education, especially at the graduate level, is blamed in part.

Civilian industry supports very few research projects in engineering colleges. About 80 per cent of graduate engineering education is supported by the Dept. of Defense, the National Aeronautics and Space Administration, and the Atomic Energy Commission, according to Dr. Herbert Holloman, Acting Under Secretary of Commerce and Assistant Secretary for Science and Technology. He feels that this support steers engineering education toward areas important for these agencies, and these areas do not necessarily coincide with the needs of civilian industry.

Engineering societies pay only lip service to the problem, civilian industry is either unwilling or unable to take a more active interest, and universities cannot fight it alone, Holloman and others conclude.

What is being done, and what could be done, to

change the situation?

### Societies need to widen outlook

Dr. Holloman says that the parochial interests of engineering societies prevent them from dealing effectively with broad engineering problems. What is needed is a forum in which engineers, the Government and industry can discuss problems of mutual concern. Holloman and others recommend the establishment of a first-class journal that would deal with broad national engineering problems and provide the open forum. So far there are no signs that his advice is being heeded.

Consider the potential role of engineering societies in offering technical guidance in areas of social significance. Wesley E. Gilbertson, chief of the Bureau of State Services in the U. S. Dept. of Health, Education and Welfare, says that engineering societies should exert a major influence in developing programs to deal with environmental pollution and effective exploitation of natural resources.

Do societies like the IEEE live up to such expectations? At this year's IEEE show the large majority of technical sessions relate to topics that deal with aerospace, deep-space and military systems. Not one session is devoted to consumer-product engineering. No paper explores the urgent technical problems of combating air pollution, for example.

No attempts are being made to acquaint engineers with the business ways of civilian industry; cost, profit and production appear to be outside the focus of the IEEE technical program. Some attention is being given to engineering education, but mainly to the effects of machines, visual displays and other tools of education and communication.

### What industry needs

Civilian industries are looking for specific qualities in engineers. Any engineer who is interested in such a career should appraise his capabilities along these guidelines:

- He should be well-versed in the fundamental disciplines of engineering, not formula-minded but capable of adapting to changing technology, according to Vaughn L. Beals Jr., vice president and general manager of engineering and research at the Cummins Engine Co., Columbus, Ind.

- He should be able to "devise, design and build engineering systems that work," adds Dr. Gordon S. Brown, dean of engineering at the Massachusetts Institute of Technology. He must develop abstract ideas into useful products. By seeking the useful rather than the unknown, he must top the work of the scientist. As Dr. Brown has put it: "The creative engineer is a scientist who complet-

ed his education."

- He must realize that time and money are integral parts of engineering. A perfect product may be largely a loss if it is delivered three weeks late at four times the originally planned cost.

- He must have enough background to become a useful, contributing member of the staff soon after being employed. "Companies are highly financially oriented," Beals points out, "and want people who don't have to undergo extensive training programs."

- He should have a reasonable understanding of how his specialty relates to others. Beals says: "Expanding this point, he should also understand the business as a whole, so that he can relate sensibly to marketing, manufacturing and other organic functions."

### What industry can do

What can industry do to encourage engineers to enter the civilian economy?



Public media, including television and radio, emphasize the technical challenges and personal satisfaction of the space age.



Most engineers plan to enter the space and defense industries upon graduation. This is almost inevitable, some authorities believe, since the graduate study of four out of five engineers is supported by the space and defense industries.

Public media, like TV and the press, emphasize the glamour and excitement of the space age. This, coupled with the vast outlay of Federal money for contracts and grants, makes the competition for engineers an uphill fight for civilian industries. To counter it, "industry just has to do a better sales job," Beals emphasizes.

Engineering educators and industry leaders agree that they should work closer together. And civilian industry must offer financial rewards to experienced engineers that are equal to those in the military and space fields.

Industry should take every opportunity to spell out the needs of the civilian economy and to point out the challenges of designing consumer products, Beals says. Drawing on his experience in both the glamorized space industry and the civilian economy (he's former director of research and technology at North American Aviation), he questions the claim that space electronics offers more technical challenge and personal satisfaction to the engineer. "After a short period, even on the most exciting space program," he says, "the engineer finds himself facing fundamental problems, like materials and component selection. He soon forgets that it is a moon project."

Mapping out a strategy for civilian industry, Beals outlines a six-point plan to attract engineers:

1. Give adequate financial support to universities.
2. Assist the universities by encouraging a steady flow of freshman students through active recruiting at the high-school level.
3. Let the universities and engineers know the qualifications needed in civilian industries.
4. Provide opportunities to students and faculty members for part-time employment.
5. Lend top industrial people to universities for better communication.

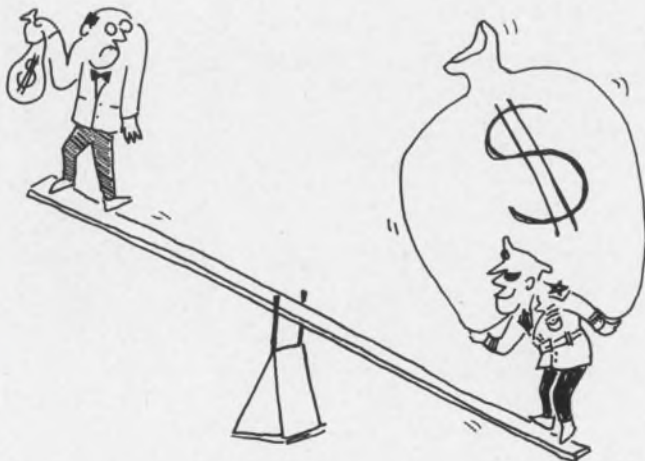

To keep talented engineers, the consumer industry should match the rewards awaiting engineers in the military and space fields.

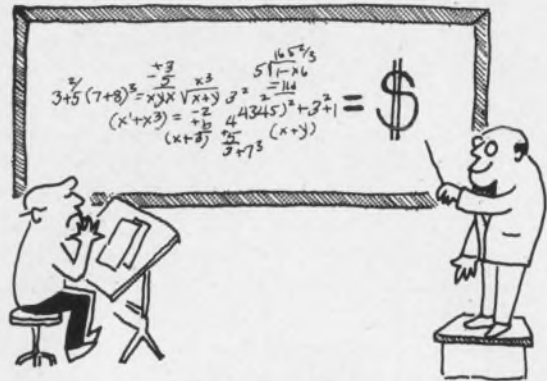

The profit-minded consumer industry is looking for engineers who can quickly become useful contributing members of the staff. Long training programs are usually not favored.

6. Learn how to use the engineers better and how to keep them.

Today only 5 per cent of all research and development funds spent in colleges and universities come from the consumer industry, Beals reports. This also effects the research projects that help support universities, he feels: "By default, we let DOD, NASA and others take over the financial support of most graduate engineering students."

#### Public education needed, too

Without the active support of such groups as engineering societies, the present picture does not seem destined to change rapidly. An executive spokesman for General Motors offers these comments:

"We give about \$2.5 million a year for graduate engineering education, with no strings attached. Admittedly it is but a small fraction of 1 per cent of our profits. But we have a hard time justifying even this to our shareholders. If we were to give more, we would have to pass it along to our customers, to those who buy our cars."

This view is echoed in other industrial quarters.

Dr. Holloman offers a suggestion that would not place undue financial burden on any one company. He recommends the establishment of a private agency, along the lines of the National Science Foundation, that would handle private and public donations and channel them to universities for research projects. This would help to lessen the dependence of universities on the Government, Beals agrees.

Some changes in college teaching seem called for, too. "Regrettably, engineering curricula don't stress engineering methodology," says A. Scheffer Lang, Deputy Under Secretary of Transportation and Research in the Dept. of Commerce. "I am appalled that modern engineers know so little about engineering economics, statistical decision theory, and economics of the firm or of public welfare." ■ ■

# The new concept in keyboards and control panels

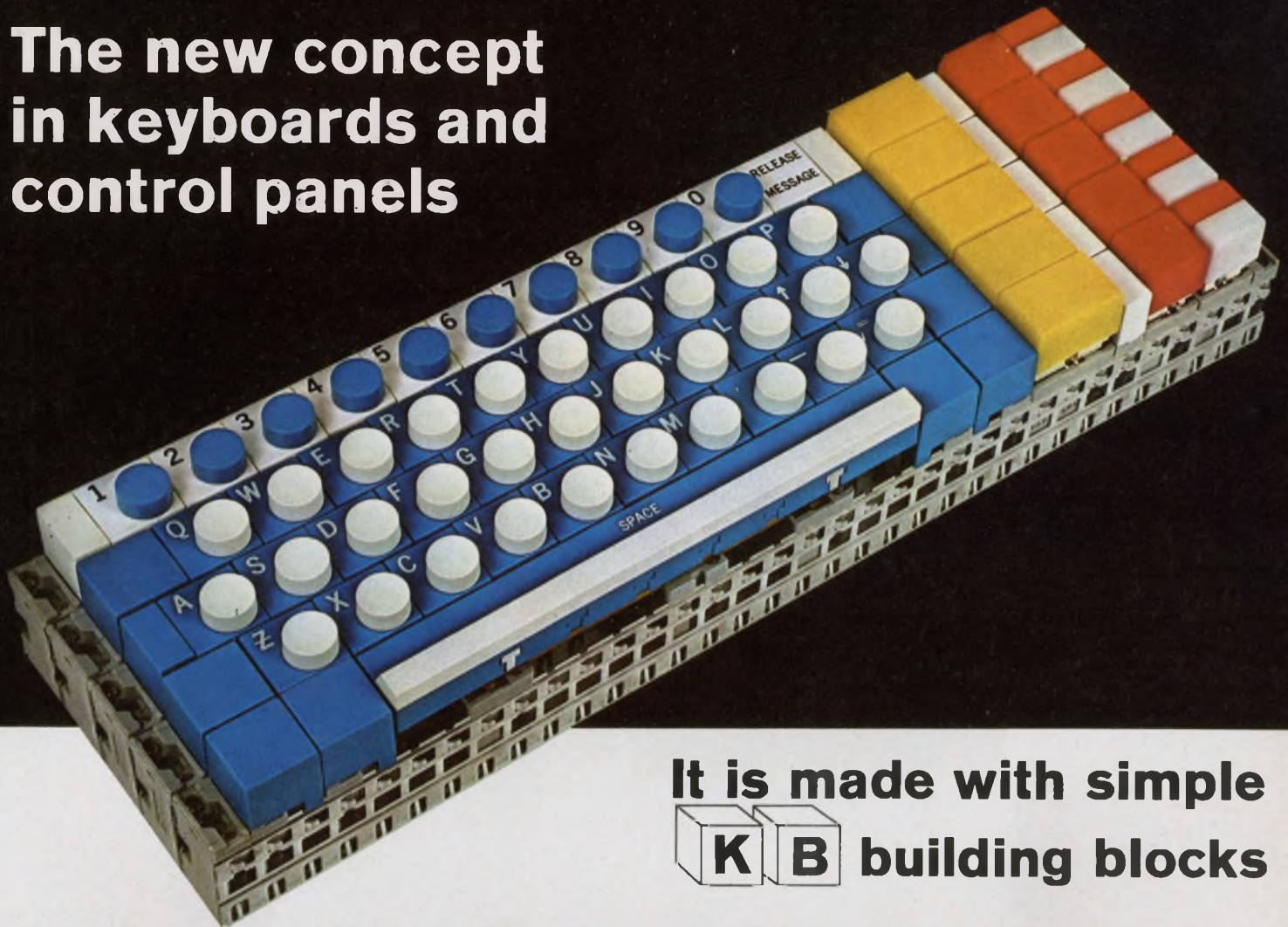

It is made with simple  
**KB** building blocks

**KB offers these exclusive advantages:**

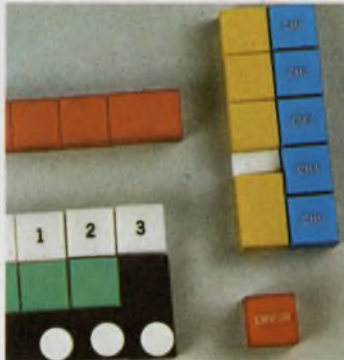

**KB allows new freedom of arrangement.** Modular construction makes it easy to customize your panels—economical, too.

Switches and indicators available in a wide variety of colors, shapes, sizes. Arrange in vertical columns, horizontal rows, compact rectangles, or individually—all, in a single cutout.

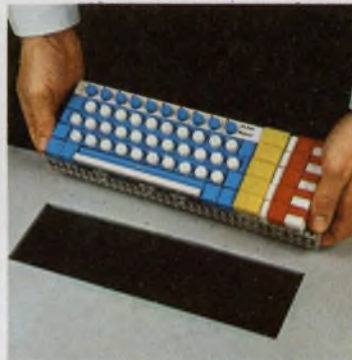

**KB allows bench assembly.** Assemble a complete keyboard matrix at the bench where the job is easier, faster. Even the wiring is done before the matrix is set into the console.

And only one panel cutout is required because KB forms its own self-supporting matrix—no additional support required.



**KB provides plug-in modularity.** With KB plug-in switches, simply loosen two screws, lift out the unit and plug-in a replacement—all from the front of the panel.

Store a reserve unit right in the board—or "borrow" one that is not as urgently needed elsewhere on the panel. Downtime is practically eliminated.

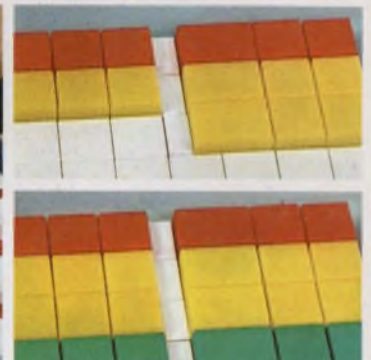

**KB simplifies expansion.** KB modular construction makes planned or unplanned expansion easy, economical. In many cases, you simply remove spacers and plug-in additional switch or indicator modules to up-date your panel. No additional cut-outs, no wiring, no soldering, no behind-the-panel work required.

**What is KB?** The KB system provides all the components necessary for a complete, self-supporting matrix, including: Power Switches and Indicators with lighted display, Encoding Switches with up to eight output bits, Mechanical Interlock Modules for a variety of sequential functions, and a unique Modular Framework System.

Find out what KB can save you in engineering time, tooling costs, assembly costs, panel space and weight—and how KB can put more sales appeal into your panels.

For a KB demonstration, call a MICRO SWITCH Branch Office (see Yellow Pages ). Or, write for literature.

**MICRO SWITCH**  
FREEPORT, ILLINOIS 61032  
A DIVISION OF HONEYWELL

# Now there's a "4th generation"



12 8 9 . 7 6 5 . 4 3 Hz

HERBERT FREQUENCY SYNTHESIZER MODEL 3100A

VARIABLE DECADE  
MEDIUM SELECT  
SAVE RELAY  
ATTENUATOR  
MODE  
D.C. OFFSET  
OUTPUT

# of signal instrumentation



This new Monsanto™ Model 3100A Digital Frequency Synthesizer has a computer-optimized design that creates new standards of stability, purity, precision and value for general purpose signal generators.

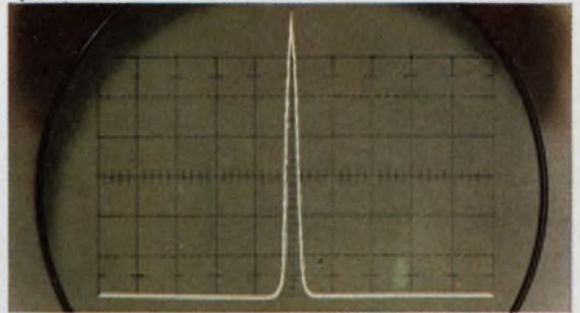

1 MHz OUTPUT SPECTRUM.

Gather 'round and look it over. From its clean, functional, prize-winning\* cabinet to its all-solid-state, I/C circuitry, this unique design is all new . . . the first of our "fourth generation" instruments.

The 3100A outperforms all other synthesizers. Select or program any frequency from 0.01 to 1.3 MHz (in 130 million steps). You've never had it so pure—from any signal source. Harmonics are down at least 50 db, and spurious components are down at least 80 db! Stability? 1 part in  $10^9$ /day, by an oven stabilized crystal oscillator.

The output is DC coupled with a  $\pm 2$  v offset bias control at a constant 50 ohms, through an accurate 90 db stepping attenuator. There is a flexible dual-frequency internal sweep and external AM, too. For maximum computer-system compatibility, the programming time is less than 20 microseconds. This versatile instrument has more of what you need in a signal source.

Here is the clincher. At \$3950, the Monsanto 3100A sells well below old-styled frequency synthesizers. (USA price f.o.b. New Jersey) Write or phone us for the full story. Monsanto Electronics Technical Center, 620 Passaic Avenue, West Caldwell, N.J. 07006 (201) 228-3800.

ON READER-SERVICE CARD CIRCLE 64

**Monsanto**  
**M**  
ELECTRONIC  
INSTRUMENTS

# The engineer's view of technology

Here's a summary of the significant papers and products arranged by engineering specialty at the IEEE show

## Aerospace Engineer

### 'Integrated avionics' is due for expansion

As the complexity of electronic equipment aboard an aircraft grows, one hears more and more about "integrated avionics." What is it?

Integrated avionics refers to the design and development of an over-all aircraft electronic system, as contrasted with many pieces developed independently of one another. The integrated approach matches the various subsystems to the over-all design, thereby assuring successful system performance.

Some of the major problems of integrated avionics include the following:

- Preparation of system and sub-system specifications.
- Coordination of system development, both hardware and software, when many design engineers and companies are involved.
- The need for a reliable display system.
- Managing, scheduling, and controlling the costs of design and development.

These and other problems facing the integrated-avionics engineer are discussed in Session 17. The scope of the papers ranges from the whys of integration ("Why Integrated Avionics?," by W. P. Beese, TRW Systems) to a "Status Report on Avionics System Integration," by L. S. Guarino, U.S. Naval Air Development Center.

Why should the average aerospace designer be interested in integrated avionics? For one thing, an understanding of the problems of integration will help him understand more clearly his own role in designing a small part of an aircraft or space system; the ultimate goal—reliable performance in an integrated system—must be his guide. Another point of interest: careers are opening up for a new classification in engineering—the integration specialist.

#### In-flight checkout systems

Recent combat experience in Vietnam with the Navy's E-2A Hawkeye airborne tactical control

system has proved that the checkout of electronic subsystems on aircraft can be performed nearly 100 per cent of the time while the plane is flying. A paper in Session 26, "Combat Experience With Automatic In-Flight Fault Isolation on the E-2A Hawkeye," discusses this time-saver in maintenance. The author is Henry C. Kline of the Grumman Aircraft Engineering Corp., Bethpage, N. Y.

An on-board checkout system consists of a number of strategically placed sensors whose outputs are fed into a computer. The computer is programmed to evaluate continuously the performance of replaceable assemblies. Deviations from the specified performance are stored in the computer, and, the minute the aircraft returns to its base, this information can be played back to maintenance personnel in the form of instructions as to which assemblies must be replaced. The checkout system also plays an important role in preventive maintenance, by sensing gradual deterioration in the performance of subsystems.

The on-board checkout concept is being adopted both for longer space flights and for commercial aircraft, particularly in the case of the proposed supersonic transport. For commercial airliners, in-flight checkout means more flying time for the aircraft. In the case of prolonged space travel, on-board checkout will help prevent sudden, catastrophic equipment failures, by continuously advising the crew of the operation of subsystems.

Session 26, devoted completely to on-board checkout systems, covers space vehicles, aircraft and even deep-sea submersibles. Design problems, such as sensor selection, signal processing and reliability requirements, are also covered.

#### Special helicopter problems

As more and more airports turn to helicopters to overcome city-to-airport traffic jams on the ground, the problems of helicopter traffic and airborne controls multiply. That such problems (and consequently the associated electronics) must be viewed apart from those of standard aircraft is amply evident in a paper, "Avionics for Rotary-Wing Aircraft," by L. G. Callahan Jr. of the Army Electronics Command, Fort Monmouth,



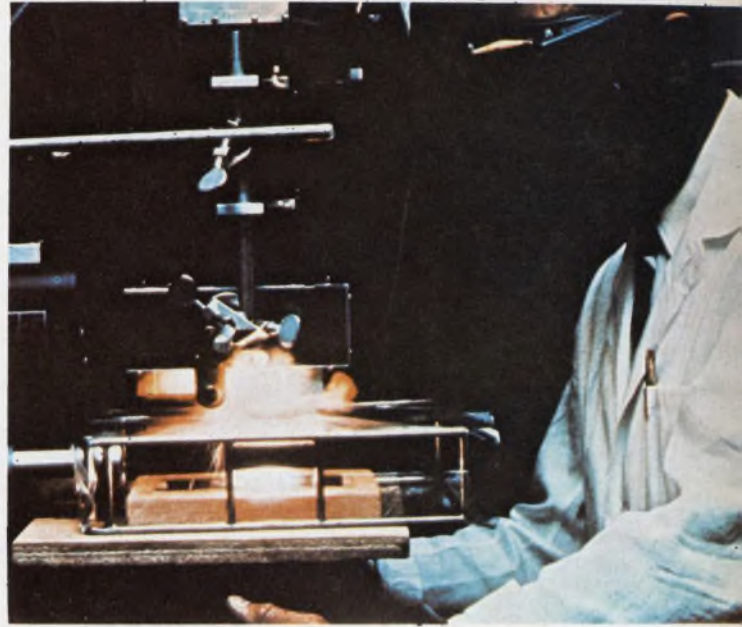

**Laser effects on living tissues** are determined in tests such as these conducted at the National Institutes of Health (Paper 18/1).

**Behavior pattern of monkeys** is controlled by means of implanted electronic stimulators that deliver pulses to defined portions of the animals' brain (Paper 27/4).



**Microvolt null detector** operated by Honeywell metrologist measures the potential difference between two standard cells (not shown) (Paper 59/2).

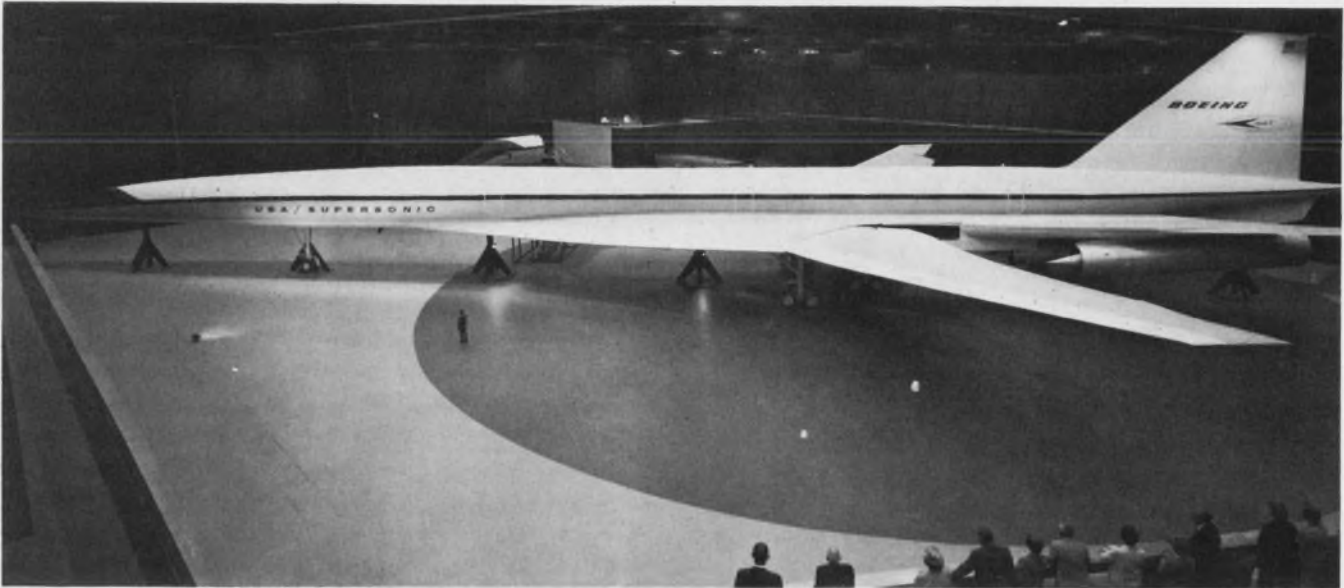

**Supersonic airliner** is expected to create problems in air traffic control. Each of the mammoth jets may carry

as much as 1900 pounds of airborne electronic equipment. Each aircraft may cost as much as \$35 million.

N. J. The paper is being given in Session 8.

The limited load capacity of helicopters implies a heavy reliance on microelectronics for on-board electronic equipment. And the unusual flying characteristics of helicopters place new demands on flight control, navigation, approach and landing systems. There is a possibility of utilizing the rotary wing as a part of the antenna system.

All these, and other problems, will be discussed in detail at the session.

#### **SST—a boon for electronics?**

With the U.S. aircraft industry committed to build eventually the world's fastest and largest supersonic airliner, the problem of traffic control becomes stickier than ever. Its importance is highlighted at the show by the IEEE decision to devote a complete session (No. 35) to the problem of controlling air traffic in the "super jet" age. The list of speakers includes Federal Aviation Agency and industry representatives and a guest from the French equivalent of the FAA, the Secretariat General a l'Aviation Civile et Commerciale.

—Peter Budzilovich

#### Circuit Designer

### **Plastic semiconductors: cost down, reliability up**

"The application era for plastic semiconductors has arrived."

These words by Glenn Patterson, marketing engineer for Texas Instruments' industrial plastic

silicon transistors, sum up the optimism of major semiconductor exhibitors at the show.

Last year was "the year of evaluation" for the plastic devices, Patterson says; this year will be "the year of utilization."

In the last three years an increasing number of manufacturers have been introducing "economy" lines of plastic semiconductors. The dime-a-dozen transistor is not here yet, but it may not be far off. Even today engineers can buy a 49-cent field-effect transistor, a 17-cent bipolar. IEEE showgoers are advised to check the booths of all semiconductor manufacturers for the latest information of new units, application hints and, possibly, free samples.

In the technical sessions, a circuit designer will find much practical and theoretical information, but little if any of it startlingly new. Almost every session can be construed to relate to circuit design. A few will deal directly with the subject: Sessions 15, 23, 24, 49, and 61.

Session 23 is devoted entirely to state- and N-variable realizations and filter design. Session 49 deals with ultrasonics in modern signal processing, and Session 61 summarizes infrared techniques used for nondestructive testing. Sessions 15 and 24 deal with the solid-state and vacuum-tube state of the art, respectively.

#### **Problems with plastic solved**

Two major problems have slowed the development of plastic semiconductors:

- Poor moisture and humidity resistance.
- Inability to operate at elevated temperatures.

These problems, according to a number of semiconductor manufacturers at the show, have

now been solved. Thus General Electric (Booth 3E01) has developed an epoxy compound capable of withstanding temperatures up to 200°C. Moreover it features high heat conductivity, a low coefficient of expansion and high moisture and humidity resistance (on a par with metal cans).

Texas Instruments (Booth 2F08) has completed a series of environmental tests that it started in early 1966 on its plastic units. These tests indicate conclusively, the company says, that the plastic semiconductors are on a par with metal ones, and they are available at bargain-basement cost.

Improvements in reliability and prices under 50 cents account for the glowing optimism in the semiconductor business. The Electronic Industries Association estimates that world use of the plastic devices will reach 1.8 billion units a year by 1971.

### **Military acceptance sought**

Since the most attractive feature of plastic semiconductors is their low price, manufacturers aimed originally at the consumer and industrial markets, which were largely inaccessible to the metal units. Today, however, a number of companies are nearing the finish line in the race to meet military standards. Cost-conscious Defense Dept. officials are eyeing the plastic reliability figures (such as a 2000-hour moisture life test performed by Texas Instruments on 52 planar UJTs) with great interest. The day when the military will specify plastic semiconductors seems near.

At this time plastic units are available in a variety of configurations, parameter values and types:

- Bipolars all—major manufacturers.
- Field-effect transistors—TI and GE.
- UJTs—TI, GE, and Motorola.
- SCRs—most SCR manufacturers.

At least one exhibitor will disclose at the show a voltage rating in excess of 1000 volts; it looks somewhat like a TO-3. High-frequency units (by TI, for example) will also be unveiled.

### **Environment checks a must**

In general, there is no difference between metal and plastic units with the same electrical characteristics. However, care must be taken in selecting plastic units for various environments. The user is strongly advised to get all the available test and reliability information that the manufacturer can provide. Such performance characteristics as power dissipation can be checked out quickly. For long-term performance (tied to the plastic unit's ability to soak up moisture) one has to rely on the manufacturer's figures and other users' reports.

As prices drop, it is obvious that many new markets will be opened or enlarged in the solid-state field. Here one can list home entertainment

(hi-fi, stereo, radio, TV), radio amateurs, the computer industry, small and large appliances, industrial controls. In some cases, equipment now using vacuum tubes will jump to plastic semiconductors.

Another important industrial effect of plastic semiconductors is that it is accelerating the diversification of military-oriented electronic firms into consumer and industrial markets. One of the big stumbling blocks has been the cost of semiconductors in consumer markets.

Luckily for electronic designers, the upcoming plastic semiconductor trend will not threaten engineers with obsolescence, as was predicted with the advent of computers and ICs. On the contrary, the demand for engineers should increase, as trails into new, stable consumer markets are blazed.

The greatest challenge to the designer will be the need for simple hardware to cut manufacturing costs further. Individual ingenuity and creativity will be taxed considerably more than they were in the development of military hardware, where more often than not the precision of components rather than their cost was the overriding consideration.

—Peter Budzilovich

### 'City of Tomorrow'

## **From pollution to trains, it's an electronic challenge**

Welcome to the Big City. Bumper-to-bumper traffic. Grime showering on people continuously. Fumes. People. More people. Noise. More noise.

Electronics can change all that. And it will, designers with foresight are saying. Not by eliminating people, but by helping to transform cities into pleasant places. This year Session 4 at the IEEE convention explores "The City of Tomorrow."

If it is to be a better place to live and work in than today's city, people must be able to move about swiftly and pleasantly; ways must be found to discard waste without contaminating the air and rivers; communications must be improved, and all improvements must be made without excessive disruption of the lives of inhabitants. Cities must be redesigned for people.

### **High-speed trains of future**

When it takes a man longer to drive 15 miles to an airport than to fly a thousand miles from one airport to another, something is wrong. High-speed electric ground transportation between cities could solve the problem. And it could do it

quietly and largely on existing rights-of-way. The route from Washington, D. C., to Boston, for example, is already under study. IEEE Session 58 presents papers that discuss such surface transportation systems—one by Ross McFarland and Howard Stoudt of Harvard University, and the other by Ezra Krende of the University of Pennsylvania.

The papers approach the problem from the point of view of the passenger. The transportation system must appeal to the public; it must be an attractive alternative to existing modes of conveyance. Electronics will play an important part in high-speed rail systems. Computers will keep the trains—which are to travel between 100 and 200 miles an hour—on schedule. Electronic controls are the natural interface between these computers and the trains' electric motors. Electronic sensors and ranging equipment will insure the safe passage of riders.

#### Traffic problems aloft

The jetliner has a lofty future for cross-country and intercontinental trips. The super jet is nearing production, and the supersonic transport is on

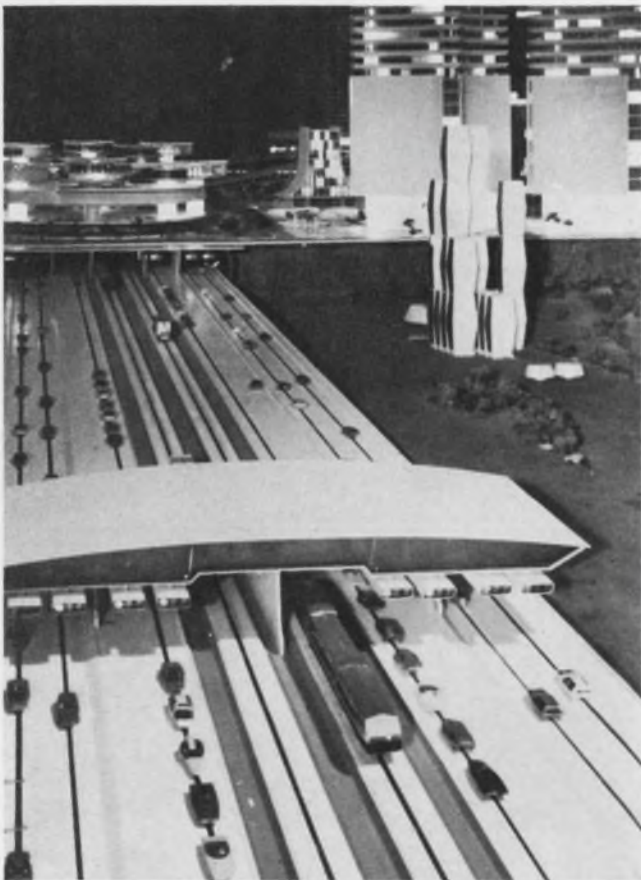

High-speed trains run alongside rail-guided autos in the General Motors' city of tomorrow. Almost every futuristic urban plan includes unusual geometrical configurations for housing and offices, such as those shown in the background. Two papers at session 4 will evaluate the effect of structural form on the urban environment.

the drawing boards. Session 35 will describe the progress being made in much-needed air-traffic controls. Papers on this topic are presented by R. J. Shamb of Airborne Instrument Laboratories and L. Lansalot-Basou, director of air navigation, Secretary General of Civil and Commercial Aviation, Paris, France.

#### What of the electric car?

For the last eight months there has been increasing talk in the press about the feasibility of the electric car. Yet each announcement is accompanied by a word of caution: the car can't make its reappearance for several years, perhaps as many as 10. A paper at Session 33B by Manfred Altman of University of Pennsylvania analyzes the credence of recent optimistic reports.

The main problem with electric cars is power—storing enough electricity to push the car far enough to make it practicable for the average motorist. A car that rides 20 miles on one battery charge is of little value. But one that can roll up to 200 miles might sell well.

The power systems that have recently been in the spotlight are silver-zinc and sodium-sulfur batteries and hydrazine fuel cells. Silver-zinc batteries are prohibitively expensive for automotive use. Sodium sulfur has other drawbacks: the batteries must be heated to 500 F, and sodium explodes in water. Hydrazine fuel-cell tests by the Army produced mileage roughly equal to that obtained with gasoline, but hydrazine is highly toxic. Session 33B considers the shortcomings and alternatives. ■ ■

—Roger Kenneth Field

#### Communications Engineer

### Bigger and faster systems leaning on digital control

The nation's largest communications network—the American Telephone and Telegraph Co.—is looking for electronic switching to replace electro-mechanical methods in virtually all telephone central offices in the U.S. by the year 2000. Two IEEE technical papers discuss the two largest electronic switching systems in use today.

The papers, which are being presented at Session 66, are "Early No. 1 ESS Field Experiences: Part I, Two-Wire System for Commercial Applications," by G. Haugk, and "Early No. 1 ESS Field Experiences: Part II, Four-Wire System for Government and Military Applications," by H. N. Seckler, both of Bell Telephone Laboratories.

Communications hardware is rather scarce at the Coliseum this year. Components and test instruments are plentiful, but systems and func-

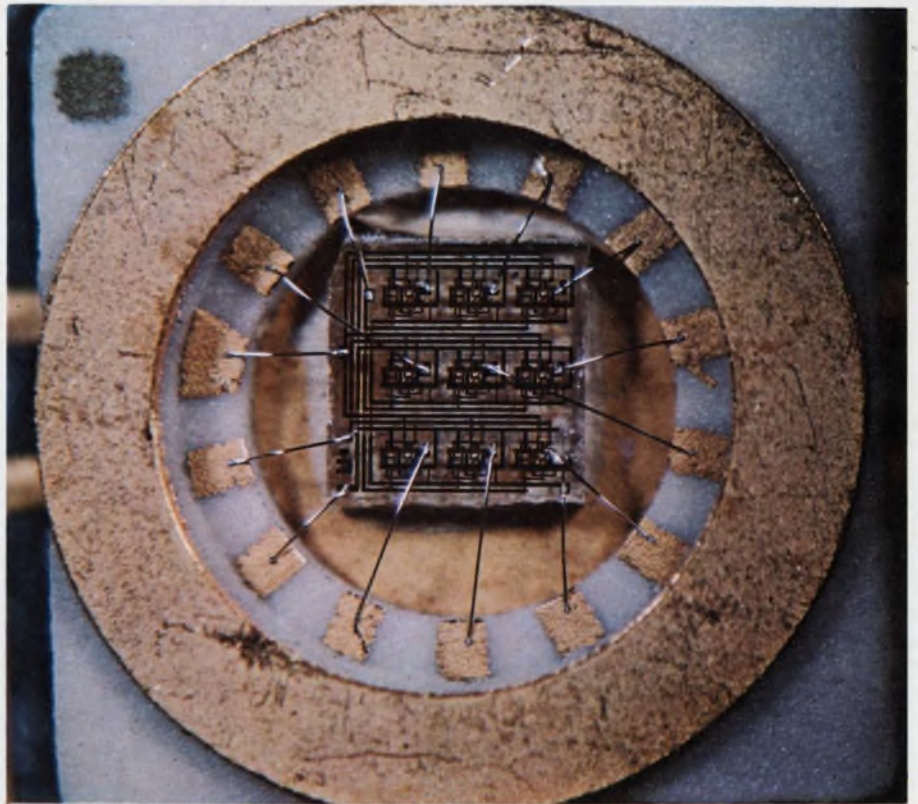

**Nine-bit NDRO computer memory** developed by RCA contains 90 silicon-on-sapphire MOS field-effect transistors (Session 15/2).

**Complex hybrid circuit** mounted in TO-5 can with top removed is made by Fairchild Semiconductor for commercial and military computers (Booth 4F03).

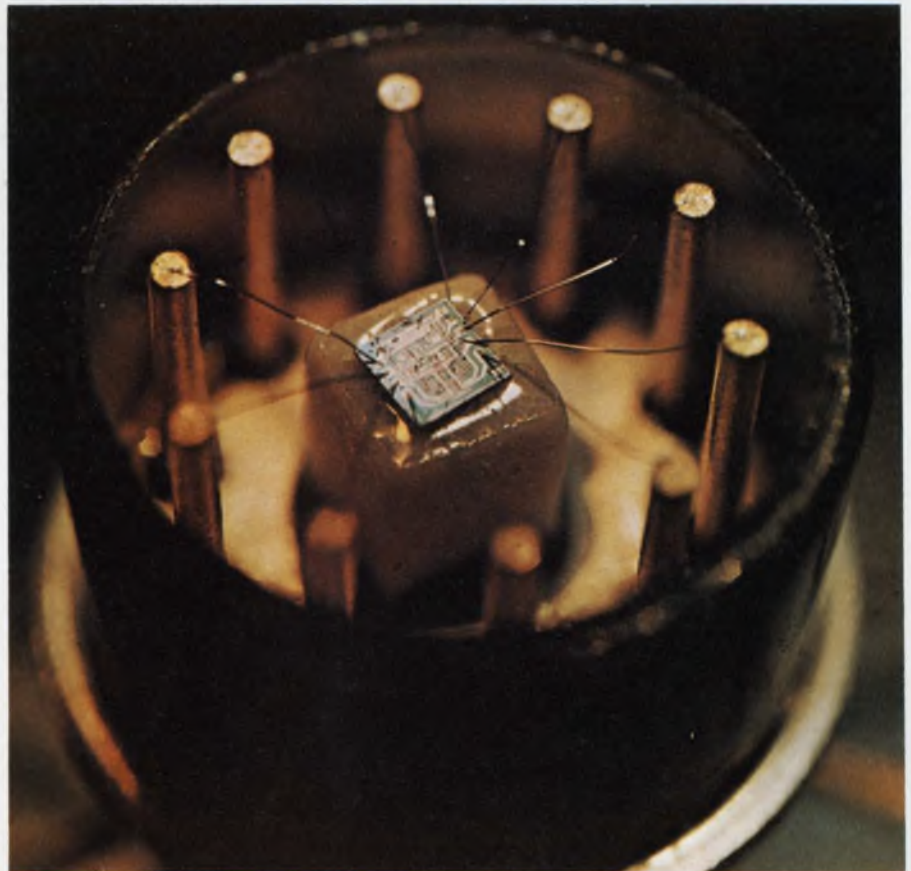

tional "block boxes" aren't too much in evidence.

Session 66 offers a fast, wide look at No. 1 ESS (Electronic Switching System), a large-scale electronic central office that uses stored program control, similar to the control system of a large-scale digital computer. Central offices of this type have been operating since the fall of 1964, and the papers by Haugk and Seckler describe the performance characteristics of these systems.

The electronic systems use parallel control and memory (both read-only and "scratch pad") to achieve the necessary reliability for maintenance of commercial and military telephone service.

No. 1 ESS is essentially a highly reliable computer communication system, an extension of the use of the digital computer to everyday life. The experiences obtained in its operation should prove helpful to both systems and circuit designers who are, or will be faced with, similar problems.

New opportunities for applications of telecommunications are outlined in "The Role of Telecommunications In Supporting Domestic Goals," a paper at Session 30. The authors, Harold R. Johnson and Charles E. Lathey of the Federal Office of the Director of Telecommunications Management, Office of the President, cite these potentials:

- Telecommunications can reduce costs dramatically and increase effectiveness in all areas of information exchange.
- Telecommunications can offer new concepts of education by providing visual and audio means for the transfer of information between teachers and students in different educational institutions.
- Telecommunications can help arrest the decay of cities by offering a practical way for people living outside the cities to communicate with the city in the conduct of social activities and commerce.
- Telecommunications can reduce costs and improve the effectiveness of travel by speeding reservation-making and providing safer patterns of flight.

Trends towards greatly increased cooperation between Federal, state and local governments may have an important impact in national telecommunications planning, the authors indicate.

Among the components on display, the Newport Beach Div. of Collins Radio (Booths 3B23-24) is showing a line of filters and other devices.

The Technical Materiel Corp. of Mamaroneck, N. Y. (Booths 2J03-07) is exhibiting a line of LF-MF-HF receivers and medium and high-power transmitters, along with antenna coupling units.

An interesting transmission measuring set that combines the functions of a selective voltmeter, tracking generator, spectrum display, attenuator and impedance matching panel is being shown by Sierra Electronic (Booth 2F07).

—Joseph J. Casazza

## Computer Engineer

# Role of data processing in daily life is explored

From the classroom to the courtroom, the digital computer's role is on the rise. The continuing expansion in applications is very much in evidence at the technical sessions of the IEEE convention.

The sessions stress computer applications rather than the machines' hardware—a trend that is likely to continue, at least until the next—the fourth—generation of digital computers appears. The next generation will probably take advantage of large-scale integration techniques to reduce the amount of "software" that is required in present-day computing systems.

Those interested in computer-aided learning should find Session 1 of great interest. The papers deal with the use of digital computers for education. Paul T. Shannon, Myron Tribus and Stanley Gembicki of Dartmouth College, in a paper entitled "Time-Shared Computers in Design Education," will report the college's experience in using a GE 265 time-shared computer system for three years. According to the authors, an educational environment has been created for the students in which the numerical answer to a problem becomes secondary to the problem's formulation. Also, the authors say, the use of the computer has made it possible to handle increasingly complex problems.

## Computers as judges debated

The widening role of computers in decision-making in modern society is being debated from an unusual standpoint at Session 22. Here the visitor can hear the pros and cons of using the computer as a replacement for the judge in both civil and criminal court cases. Among significant aspects of the question that the panelists will explore are the emotions and variability of a human judge; the constitutionality of using computers to decide cases; the process of legal reasoning and the effect that a computer judge might have on litigants.

According to a paper by Roy N. Freed, division counsel of Honeywell's Computer Control Div., while many aspects of present judicial procedure do not readily lend themselves to mechanization, efforts to achieve mechanization could produce important improvements in the judicial process.

## Design by computer draws attention

Computer-aided circuit design is the subject of two technical meetings. Sessions 42 and 51 examine the progress and promise, along with the problems, of this still young area of technology.

A paper by Dr. Allan F. Malmberg of the Los Alamos Scientific Laboratory describes the NET-2 Circuit Analysis Program. NET-2, an improved version of the classic NET-1, will give the electronic designer more powerful computational facilities along with more versatile device modeling capabilities.

The influence of the computer on network theory as well as on circuit design is being explored in a paper by Franklin H. Branin Jr. of IBM's System Development Div. Branin emphasizes the need for accurate statement of the problem to be solved, since the computer is capable of doing only what it has been explicitly instructed to do.

For maximum computational effectiveness, he continues, the computer also requires analysis techniques that differ from the methods used in the manual solution of network problems. Numerical methods, according to Branin, should at least supplement, if not supplant, Laplace transform techniques. One numerical method that he presents is said to give essentially all of the information that can be obtained through the use of Laplace transforms.

The matrix approach is used throughout the paper, as Branin considers this technique to be the most suitable for use with a digital computer.

—Joseph J. Casazza

#### Industrial Electronics Engineer

## Papers may disappoint, but new products abound

The designer in the large, ill-defined field of industrial electronics faces a mixed reception at this year's IEEE show. If he likes to listen to technical papers, he may be somewhat disappointed. But if he is looking for components, devices or instruments, he will find a wealth of products tailored to his needs.

Not too many design-oriented technical papers apply to industrial electronics. On the bright side, however, the product market is getting a large play from manufacturers, for a variety of reasons. Foremost is the fact that although military, aerospace and consumer business has been booming, there is no assurance that this will continue. Should business in these areas falter, the industrial market has the potential to take up the slack.

Typical of the efforts being made to woo industrial users are those of the semiconductor manufacturers, who this year are adding impressively to the galaxy of plastic-encapsulated devices already available. An 8-amp, 600-V SCR from Motorola (Booth 3A05), a line of planar unijunction transistors from Texas Instruments (Booth 2F08), and a variety of FETs are some of the new

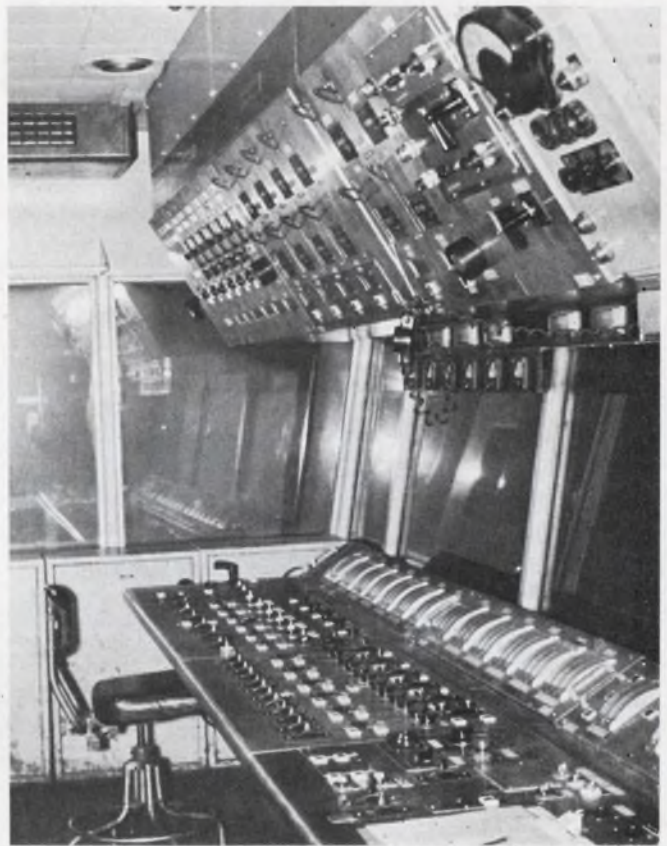

Control room in the largest steel plant in the U. S.—the Sparrows Point Plant in Maryland—is an example of the headway that solid-state equipment has made in the industrial-controls area.

plastic units that will interest the industrial user. All of the devices are bargain-priced and have specifications very close to their standard military counterparts. General Electric (Booth 3E01) expects to narrow the specification gap between plastic-encapsulated and hermetically sealed units even further with a new cast-epoxy that it is introducing at the show. The material reportedly has a 200°C capability as well as excellent moisture and humidity characteristics.

#### Simplified selection available

Ease of selection is another inducement being offered to industrial users by semiconductor manufacturers. This is particularly important to the user who has only a limited knowledge of the intricacies of semiconductor selection and application. An example is the plastic unijunction transistors being shown by Texas Instruments. The units are members of an applications-oriented family, with one tailored for thyristor triggering, another for low-frequency control circuits and a third for general bistable circuit use. This allows a purchaser to zero in easily on a suitable device with a minimum amount of spec-sheet searching and a limited knowledge of the trade-offs involved.

Another example of simplified selection and application is Fairchild Semiconductor's new

Compatible Current Sinking Logic integrated circuits, which are a highlight at Booth 4F03. Three types of digital logic—TTL, DTL and low-power DTL—are available in these circuits, and all are logically, electrically and mechanically compatible. This means that the designer need not use the same type of logic throughout his circuit; he can vary the logic from stage to stage, as requirements dictate. Here again, no intimate knowledge of the trade-offs is required to select one type of logic or another for an entire circuit.

### Analysis of drive equipment

On the technical program, designers interested in the control of electrical drive equipment, should find Session 50, "Drive Control Applications," interesting. Two of the papers cover speed control of ac induction motors, while a third analyzes the use of SCRs in controlling dc motors. The session may take on added meaning, and possibly produce a lively discussion period, as a result of the recent decision of the San Francisco Bay Area Rapid Transit District to employ dc motors for vehicle propulsion, despite their higher cost over ac units. The decision reportedly resulted from torque and speed deficiencies in the ac induction motors.

Another meeting of interest should be Session 61, covering various industrial applications of infrared. A particularly noteworthy paper of this session, by Dr. Riccardo Vanzetti and J. Fred Stoddard of The Raytheon Co, covers an automated infrared troubleshooter (the technique is described on page U107 of this section).

—Frank Egan

### Materials Engineer

## Uses instead of physics stressed at 'first' panel

For the first time, the IEEE convention will devote an entire session (No. 37) to materials for advanced electronic applications.

And on the Coliseum floor the unusual in products and technology will be evident. The products include:

- A laboratory-made semiconducting diamond thermistor, designed to operate from  $-325^{\circ}\text{F}$  to  $1200^{\circ}\text{F}$ .
- Continuous-length, flexible glass fiber optics.
- An electrogasdynamic technique for coating powdered conductive or nonconductive material on the inside of hollow tubes.

Gustave Shapiro, chief of the engineering electronics section of the National Bureau of Standards, is the organizer of the materials session. He terms it a "natural."

"Materials," he says, "are truly as important a

discipline in electronic engineering as any other specialty. For many years we have been publishing articles in our transactions on materials. It is natural that we should have an individual session for it—it just took a little longer to get started. Component considerations and materials considerations are part and parcel of one another."

Shapiro concedes that "the pendulum has swung all of the way over" from the components to the systems engineers, but he says emphatically that "one day it will have to swing back, at least part of the way."

### Problem-solving approach used

The co-chairmen of Session 37—Alex Javitz of Commonwealth Services, Inc., New York, and James Godfrey of Bell Telephone Laboratories, Allentown, Pa.—have given the meeting a problem-solving tone. Godfrey says that he and Javitz want to stress "the applications of materials rather than the materials themselves."

"What we do not want," he continues, "is a bunch of solid-state physicists discussing basic structure and properties and things of this sort; so we're strongly engineering-oriented rather than material-science oriented. We will stress the application of new materials or the novel application of well-known materials to the solution of important new problems. We are not restricting ourselves to commercially available materials either. For example, witness the session on optical devices [by L. A. D'Asaro of Bell Telephone Laboratories, Murray Hill, N. J.]. There are not really very many of these devices on the market today."

### Tomorrow's materials in today's R&D

Materials of the future are evident in the first two papers. In the first, J. E. Thomas of the General Instrument Co., Newark, N. J., concentrates on materials in integrated circuits, particularly problems of interconnection, insulation and environmental protection. Thomas feels that the IC revolution has been concerned with the physics and interior workings of the active devices. An IC evolution, he says, must solve the materials problems. He calls for a five-fold interdisciplinary attack involving electronics, chemistry, physics, optics and mechanics.

In the second paper, D'Asaro of Bell Labs covers bulk and junction semiconductor devices as applied to optical devices. Materials requirements for such devices as lasers, detectors and modulators are discussed. Some evidence of commercial activity in the area is evident in the exhibit areas. In Booth 4B15, TRG is demonstrating an accessory to increase the peak power and switching speed of any rotating-prism, Q-switched ruby laser in

(continued on p. U102)



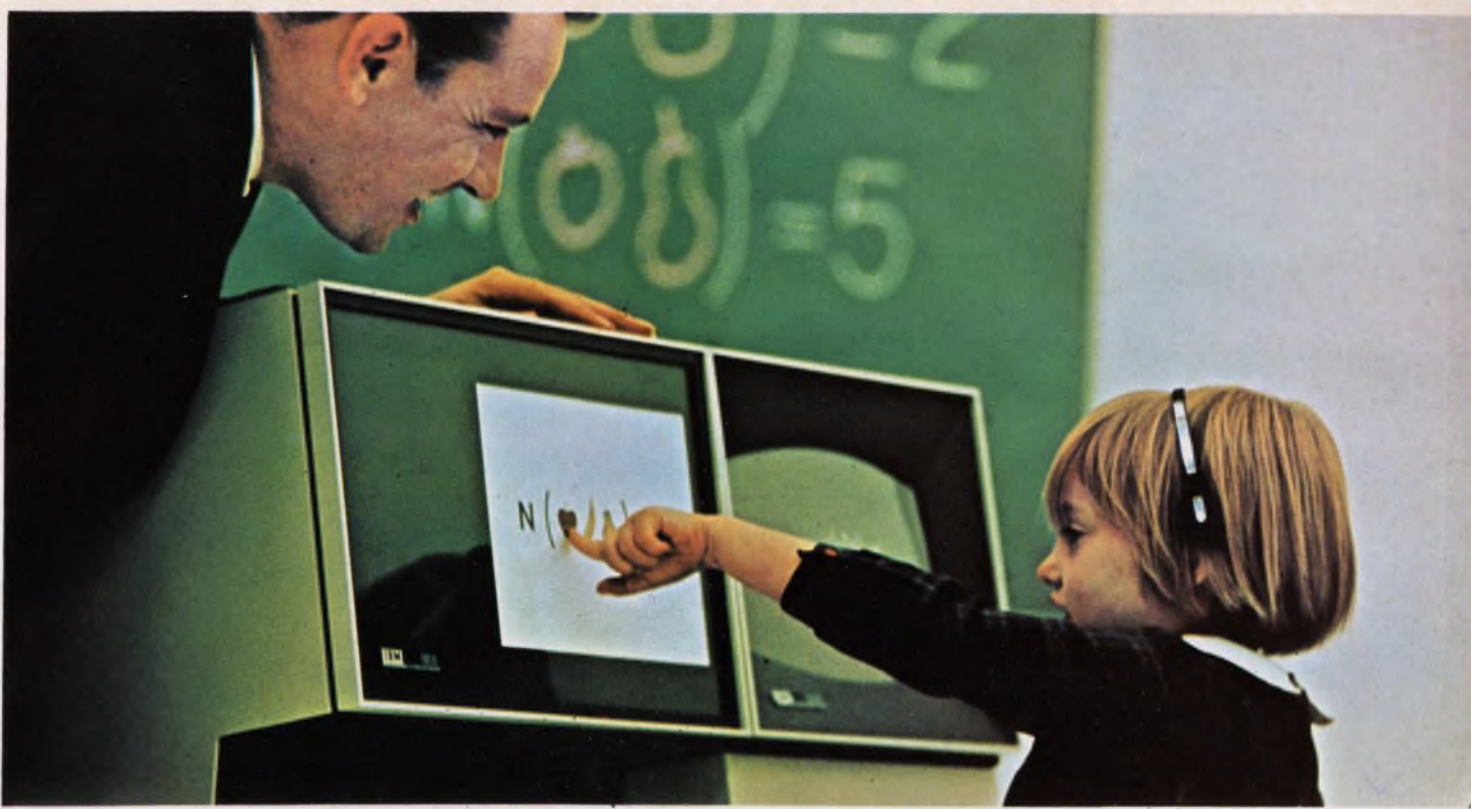

A little girl, using a computerized learning machine, not merely finds adding and subtracting fun, but also memorizes basic arithmetic processes faster and easier (Session 1).

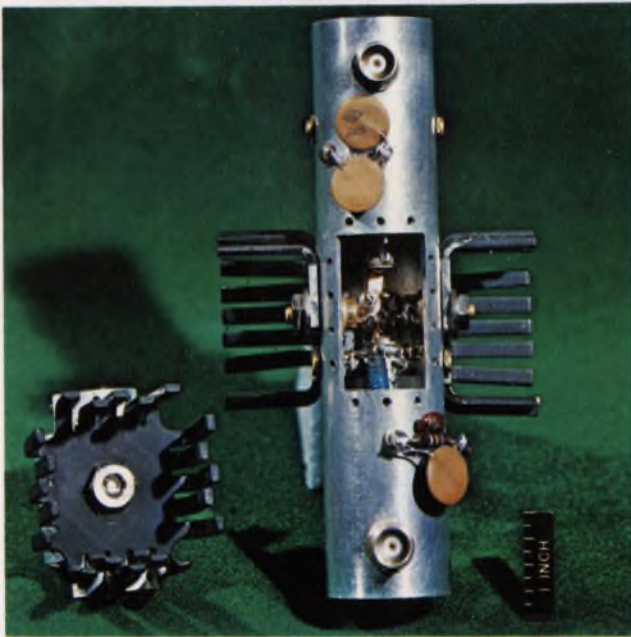

Coaxial transistor amplifier uses four overlay transistors in parallel. Developed at RCA's David Sarnoff Research Center, the amplifier has a saturated power output of about 90 watts at 370 MHz (Session 7).



Design engineer uses a light pen to feed data into a digital computer which performs the computations necessary to solve a mechanical engineering problem (Paper 24/4).



## The Kind of Knowledge that makes progress possible...

It was World War I. Man had already learned to fly, but he was an uneasy "bird" in flight. With the war came instrument flying. It gave man a new ability and confidence in the air, and galvanized his dream to conquer space. Now, in an age of electronic sophistication, man's dream beckons reality.

It took many minds of different skills to accomplish this dramatic progress in aviation. Mental perception of the highest order. Perseverance. Dedication in the face of setbacks. Step by step, a priceless knowledge of experience was stockpiled.



## IS THE KIND OF KNOWLEDGE YOU GET FROM KESTER

This knowledge of experience is the kind of knowledge you get from Kester. Back in 1899, years before the Wright Brothers' first flight, Kester Solder products and soldering knowledge were already contributing to the changing needs of industry. And as technology accelerated, Kester kept pace.

Today, after 67 years of working with development engineers in the technology of solders and fluxes and their applications, Kester's knowledge of experience stands ready to serve you. Write, phone or wire for specific information.



## KESTER SOLDER COMPANY

4216 Wrightwood Avenue, Chicago, Illinois 60639 • Newark, New Jersey 07105 • Anaheim, California 92805 • Brantford, Ontario, Canada

1899-1966—67 years manufacturing highest quality solders and fluxes

ON READER-SERVICE CARD CIRCLE 65

(continued from p. U99)

single-pulse operation. The accessory contains two optical cells filled with a saturable dye solution. Either of the two cells can be positioned so the dye be put into the laser cavity. Peak power is increased by suppressing multiple pulses and obtaining a single pulse.

### Down-to-earth capacitors

Capacitor dielectrics are probed in the third paper. David A. McLean, also of Bell Labs, explores dielectric materials and capacitors for thin-film devices and ICs. The effects of processing on dielectric materials properties will be discussed, while dozens of components manufacturers are displaying their wares on the exhibit floors. Capacitor chips, Mylar, paper, vacuum, air-variable and other types are being exhibited.

### Multi-signal cable flattens out

Jack Spergel and W. V. Lane of the Army Electronics Command at Fort Monmouth, N. J., complete the session with a two-part discussion of materials for conductive elements. Lane covers thin-film conductive materials, while Spergel examines aspects of flat-cable materials and techniques.

Spergel reviews in his paper the potential for flat or ribbon cable. Based on a NASA study of a Saturn rocket prototype, the author cites weight savings of 75 per cent, cost savings of 33 per cent and installation and assembly time savings of 75 per cent compared with round cable.

Applications, however, are not limited to the missile. In Booth 1G18, W. L. Gore & Associates are exhibiting their multiconductor (20-signal) ribbon cable. Gore says it has already sold a large quantity to "the largest computer manufacturer" to be used in computer backplanes in place of coaxial cable. The company cites space savings of 90 per cent for its Teflon-insulated, 1.15-by-0.026-inch cable. Visitors to the booth will have the opportunity to see the cable stripped, terminated and soldered. Free samples will be available.

The ACI Div. of the Kent Corp., Princeton, N. J. (Booth 4E26) is showing its Signaflo multiconductor transmission lines. ACI designs its systems, complete with terminations, strictly to specific customer requirements of impedance, propagation velocity, cross talk and capacitance.

### A diamond with unusual facets

Among the unusual products, General Electric is showing a thermistor of astonishing environmental range. The company's Magnetic Materials Section has successfully synthesized a semiconducting diamond, and GE engineers have designed the thermistor around the material. It can operate

over a range from  $-325^{\circ}\text{F}$  (where many gasses liquefy) to  $1200^{\circ}\text{F}$  (where metals glow red-hot). The material will be on display in Booth 3E13, and GE expects to deliver the first commercial diamonds by mid-summer. Incidentally, this is one of the few applications for diamonds that does not exploit the diamond's hardness.

Corning Glass is exhibiting the continuous-length, flexible, glass fiber-optics in Booth 4F20. The flexible, non-coherent bundles, jacketed in PVC, are said to be an industry first. They are available in single lengths up to 10,000 feet, priced at 10 cents a foot in lengths over 50,000 feet. They will be displayed along with fiber-optics faceplates and magnifiers.

An interesting exhibition is promised at Booth 2K29 by Jack McGruder, manager of product development for Gourdine Systems, Livingston, N. J. Gourdine has developed the electrogastodynamic technique for coating powdered conductive or nonconductive material on the inside surface of hollow tubes. The tubes may be of any inner geometry, and the coating is reported to be of almost perfect uniformity.

—David Surgan

### Medical Electronics Engineer

## New horizons are opening in surgery and prosthetics

To the biomedical design engineer, the IEEE show always poses a vexing problem, and this year it's no different. It is a general show and convention, and therefore must cater to all of the many areas of electrical and electronic technology. This naturally limits the number of technical papers and products for biomedical engineers to relatively few.

Two technical sessions are related directly to biomedical engineering: Session 18, "Engineering in Surgery," and Session 27, "The Design of Man: Man's Design." And no single booth at the show is devoted exclusively to biomedical electronics.

### A wide sweep needed

Biomedical engineering cuts across many disciplines. To find out what really is new in his field, the conscientious biomedical engineer must sift through the entire technical program, picking out the sidelights that might be of concern to him—computer papers, for example, if his immediate interest is in time-shared systems for medical data; microelectronic papers, if his interest is in implantable telemetry systems; or materials or ultrasonics papers, if these are applicable.

Similarly in his tour of the Coliseum, if he is interested in recorders with medical applications,

the biomedical engineer visits the booths of all major recorder manufacturers; if transducers are vital, he stops at the many points where transducers are on view.

The showgoer with a biomedical interest must ever be ready to bridge the gap between general electronic technology and its medical application.

The content of Technical Session 18 reflects the burgeoning interest in and use of electronics for surgical applications. In one of the papers, by Grant Riggle and Robert Hoye of the National Institutes of Health, the effects of laser power on living tissue are described. The findings are based on extensive tests conducted at the Government center. It is known that the effects of laser energy on living tissue depend on such factors as the laser's wavelength and power, as well as on the characteristics of the tissue. The aim of such tests is to make it possible to use lasers for selective tissue destruction—killing cancers, for example.

Electronics is also being widely used in an indirect way in surgical applications. This is in the area of patient monitoring during and after major surgery. With extensive measurement systems and displays, a wide variety of physiological conditions can be monitored for the physician. Such techniques are especially important in major heart surgery. Post-operative monitoring techniques are covered in Session 18 in a paper by John Lewis and John Jacobs of Northwestern University.

### Wide range of techniques

The broad scope of today's biomedical engineering is evident in Session 27. It contains papers on subjects as practical as the control of prosthetic devices and as esoteric as computer analysis of the brain's physiologic language. A paper of particular interest to the designer is "The Electrode Interface Between Man and a Prosthetic Stimulator," by Wilson Greatbatch of the State University of New York. The discussion should prove informative not only to the designer of prosthetic devices but to everyone involved in the measuring or recording of human physiological parameters.

Greatbatch covers the design of the electrode interface between man and such supplemental electronic devices as cardiac pacemakers and bladder stimulators. This interface has very complex electrical and chemical properties, which vary greatly with current density and duration, as well as with electrode material. In particular, electrochemical polarization of the electrodes has a significant effect on their operation, and it is this effect on various electrode materials—and the way that it influences the design of the prosthetic devices—that is emphasized in the paper.

Another interesting paper, pointing to new

directions for medical electronics, is "Man's Intervention in Intracerebral Functions," by J. Delgado of the Yale University School of Medicine. The author describes work that has been done with animals in direct electrical stimulation of the brain. Such techniques have been successful in eliciting a variety of behavioral and mental responses, such as walking, eating and sleeping. The techniques are limited, though, in that they only trigger physiological mechanisms that are already established in the neurons. They cannot, in effect, create new behavior. The paper also points out how research of this type will benefit significantly from impending developments in microminiaturization and new power sources.

—Frank Egan

### Microcircuit Systems Designer

## Two new trends pushing into consumer market

There are two discernible trends in the micro-electronic papers at this year's IEEE show: linear microcircuits are penetrating deep into consumer products, and large-scale integration is the present goal of digital-microelectronic-circuit manufacturers.

In the exhibition booths, a variety of interesting linear and digital ICs is available. Since cost is always a major consideration in acceptance of a component by commercial and industrial buyers, plastic ICs are receiving a big play; they've been around for some time, it's true, but only comparatively recently have they become truly reliable.

### Rise in linear circuitry

R. S. Pepper, director of integrated-circuit development at the Sprague Electric Co., North Adams, Mass., reports in Session 15 on linear microcircuit penetration into the consumer market. He says that linear microcircuits will account for half the dollar value of all ICs sold in the months ahead, but will represent only about a third of the total of IC units sold. This, he feels, is because the linear circuits will always have less general applicability than the more versatile, multifunctioned digital circuits. Large-volume, special-purpose linear circuits are expected to make their early appearances in automobiles and toys.

The linear ICs will also appear in telephones. The Bell System is planning to use a beam-leaded multitone oscillator in its pushbutton telephone. A paper in Session 69 by W. H. Orr, R. M. Rickert and D. M. Hill, all of Bell Telephone Laboratories, Inc., Murray Hill, N. J., describes this unusual RC oscillator.

## Complex arrays sought

Digital-integrated-circuit manufacturers and users are hoping to develop more and more complex arrays, but production yields hamper LSI progress. Three approaches can be used to overcome the yield fall-off: computer-generated masks for discretionary wiring of circuits; manual probe-testing and hand-wiring; and brute-force methods aimed at improving yield and restraining circuit complexity.

Session 60 concentrates on two of these approaches: discretionary wiring and restraining circuit complexity. J. S. Kilby of Texas Instruments, Inc., Dallas, and D. L. Critchlow of the IBM Watson Research Center, Yorktown Heights, N. Y., are reporting on the methods. Another paper in the same session—by Robert Seeds of Fairchild Semiconductor, Palo Alto, Calif.—concludes that reasonable yields can be attained with a 100-by-100-mil active chip area.

## Improvements in products

Among the linear and digital ICs on display at the booths are a five-amp integrated power switch by the Vector Co., a division of the United Aircraft Corp., Southampton, Pa. (Booth 4F26). Fairchild Instrumentation (Booth 4F03) is showing hybrid operational amplifiers that use field-effect transistors, integrated circuits and monolithic preamplifiers. A plastic operational amplifier and a complete, transformerless audio amplifier are being offered by the Radio Corp. of America (Booth 3C01-02). And Texas Instruments (Booth 2F08-20) has bolstered its popular TTL54 series with high-speed (54H) and low-power (54L) units.

Progress in plastic integrated circuitry is being eyed with interest by the makers of industrial controls, because it will enable them to shift from vacuum-tube equipment directly to microelectronics. The majority of IC manufacturers are displaying plastic devices.

—Roger Kenneth Field

## Microwave Engineer

# Solid-state applications emphasized at sessions

The systems engineer and the device man in microwave engineering are separated by an ever-widening gulf. Solid-state technology is the major cause; it has proliferated at an alarming rate. Hardly has the spec sheet on a new, high-frequency transistor reached the systems designer, when he hears of a new version that delivers more

power at higher frequency, or another device that will do the job better.

This year the IEEE microwave sessions are trying to bridge the gap. Authorities are discussing the state of the art in areas most influenced by solid-state developments. Emphasizing application, they offer designers a chance to catch up with the latest development and, at the same time, to get a comparative evaluation of these microwave building blocks, which are found in every system:

- Power sources.
- Receivers.
- Control circuits.
- Filters and duplexers.

Apart from systems applications, any new solid-state device must be considered a future candidate for integrated circuits. This thinking is also reflected in the technical program: the microwave semiconductor devices are being examined for both monolithic and hybrid circuits.

## Wide choice of power sources

Dr. Mark R. Barber of Bell Telephone Laboratories, Murray Hill, N. J. (Session 15) compares the performance of microwave oscillators that use avalanche diodes, bulk gallium-arsenide devices and transistors with the potential of reflex klystrons.

One of the latest advances in microwave-power generation in a commercially available device is illustrated by the Type 0320 X-band, step-recovery diode of Hewlett-Packard (Booth 2F25). It puts out 150 mW at 10 GHz when driven at 2 GHz with 2 watts. For lower frequencies, engineers may consider the Fairchild (Booth 4F03) MT1062 stripline transistor, which delivers a gain of 7 dB at 2 GHz and 3.5 dB at 3 GHz. It can oscillate up to 4.5 GHz.

Dr. Fred Sterzer of the Radio Corp. of America, Princeton, N. J., concentrates in Session 7 on the many ways transistors can be used in microwave and uhf power generation and amplification. Transistor-oscillator and amplifier multipliers, and transistor-driven harmonic generator chains, are two examples he includes.

One such transistorized amplifier uses four RCA TA2675 overlay transistors in parallel. The saturated output power of the device, on view at Booth 3C02, is about 90 watts at 370 MHz.

The continuous improvement of solid-state devices naturally leaves the design of systems that employ these—receivers, for example—in a state of change. Wesley G. Matthei of the Micro State Electronics Corp., Murray Hill, N. J., reviews in Session 7 the recent happenings in solid-state devices in the light of low-noise receiver design. He compares the new devices with competitive components, such as Schottky-barrier mixer diodes,

transistors and tunnel diodes, and also takes a look at receivers that use only microwave integrated circuits.

Characteristic of the new generation of mixer diodes is Fairchild's FH 1100 silicon diode, which uses the hot-carrier (or Schottky-barrier) principle. Its switching time is in the tenths-of-a-nano-second range, and, as a mixer, it has a maximum noise figure of 10 dB at 890 MHz.

Monolithic integrated versions of transistor amplifiers, oscillators, diode mixers and switches, bulk-effect devices and avalanche diodes are examined by Roger R. Webster of Texas Instruments, Inc., Dallas, in Session 16. The design and application of hybrid circuits is being discussed in the same session by James E. Dalley of Bell Telephone Laboratories, Reading, Pa.

### Ferrites catching up with diodes

The story in control circuits is the competition between ferrites and semiconductors in such devices as switches, phase shifters, attenuators, limiters and modulators. The boundary between diode and ferrite devices is becoming vague, as the performances of both are upgraded, concludes Donald H. Temme of the MIT Lincoln Laboratory, Lexington, Mass. His conclusion, being offered in Session 7, is based on a comparison of parameters, including insertion loss, isolation, control speed and power, bandwidth and power-handling ability.

An example of diode-switching capabilities is furnished by the broadband PIN diode switch of Hewlett-Packard (Booth 2F25) that operates from 12 to 18 GHz. The shunt-connected Model 3560 PIN diodes and the bias network are built into a 50-ohm microwave transmission-line structure to achieve the broad bandwidth.

Programmable coaxial switches, introduced by Marconi (Booth 2D04), operate from dc to 1 GHz, using reed dry reed relays mounted in striplines.

The rapid advancement of ferrite technology is being demonstrated by the appearance of planar ferrite devices. They can be built into integrated circuits with conventional photo-etch techniques, says Hugh A. Hair of the Syracuse University Research Corp. He reports on the progress of the development in Session 16.

—*Maria Dekany*

### Oceanographic Engineer

## Interest in the seas rising to new heights

Interest in oceanography is swelling so rapidly that the IEEE has made it the subject of its Highlight Symposium. In addition, three technical sessions are devoted exclusively to design and

engineering problems in exploiting the world's seas.

Last year two sessions were devoted to the field, and both were so well attended that Haig Manoojian, a prime organizer of this year's meetings, characterized them as "mob scenes." Standing-room audiences of more than 400 turned out for the single 1965 session.

The Highlight Symposium this year is entitled "Exploitation of the World's Oceans," and the keynote address, "Goals Being Developed by the National Council on Marine Resources and Engineering Development," is being given by Howard W. Johnson, president of the Massachusetts Institute of Technology.

The symposium is being held at 8 P.M. on March 21 in the New York Hilton grand ballroom. At a panel discussion, Dr. Thomas Kavanagh of the National Academy of Engineering will outline the engineer's role in oceanography, and Richard Fuller of the Bendix Corp. will give industry position. Robert W. Morse of the Case Institute of Technology will cover R&D in the field, while Dr. C. M. Herzfeld, director of the Advanced Research Projects Agency of the Defense Dept. will present the Government's view.

### Technical orientation offered

The technical sessions offer little that is new for the experienced in oceanography, but they are a



An acoustic transponder signals the location of an under-sea camera and helps to position it above the sea floor.

good introduction for newcomers, or for those who want to decide if their future lies in deep-sea electronics. Interest in the field is far out-pacing technical developments at present; the challenge to designers is virtually unlimited. Manoogian, an engineer with the Grumman Aircraft and Engineering Corp., Bethpage, N. Y., echoes a sentiment heard frequently in the field: most companies are waiting for the Federal Government to initiate large-scale projects and are reluctant to set up expensive projects with their own funds. In spite of the glowing promises, the market is not extensive. Aside from military antisubmarine equipment, most materiel is procured in small-lot quantities. This situation has led many companies to give oceanography a hard look—but to refrain from participation.

### **Exploitation: an in-depth view**

Session 44 is a continuation of the Highlight Symposium's panel discussion in greater depth. The impact of electronics on the fishing industry is being covered by Dayton Alverson of the U. S. Bureau of Fisheries. He reviews the strides in adapting electronic navigational and search devices to commercial fishing. He outlines the future role of electronics in four basic areas: communications, navigation, search, and extractive processes.

Dr. Alan Berman, director of Columbia University's Hudson Laboratories, is discussing electronics in underwater search, rescue and recovery. He relates radio direction finding, surface radar and radio navigation to their undersea equivalents—largely acoustic methods. The severe requirements imposed on electronic instrumentation in remote underwater sensors and manipulators is underscored.

The Navy's navigational satellite system and its application to ocean navigation and geodesy is outlined by R. B. Kershner of Johns Hopkins University's Applied Physics Laboratory. The system has other applications besides its principal one of supplying position data to Navy combat ships. Simplified lightweight receivers are being used to establish precise coordinates for oceanographic surveys and map-making, and even aircraft are using the satellite system experimentally for navigation.

Economic considerations that influence the choice of electronic systems and devices on deep submersibles are discussed by W. H. Scott of the Grumman Aircraft Engineering Corp.

### **Hardware challenges analyzed**

Session 55 is considering "The Deep Sea Challenge to Electronic Hardware Designers." Speakers are carrying the theme into such wide-ranging

areas as sonar, scientific undersea instrumentation, propulsion machinery and controls for deep submersibles, and equipment for divers. The electronic hardware designer is challenged primarily by the severe ocean environment.

The experience of the U. S. Navy in using sonar in a variety of operational situations is the basis for a paper by Capt. S. W. W. Shor on sonar engineering. He is stressing the urgent need for sonar design based on proven principles.

Instrumentation for deep submersibles is discussed by George Tajima, vice president for systems development at Bissett-Berman, Santa Monica, Calif. He reviews the problems of gathering oceanographic data with instrumented buoy systems, describes some of his company's current projects and states the needs in the field.

The propulsion and control of deep submersibles, especially small versions for two and three men, present some unusual problems. Capt. F. A. Hooper of the Navy's Marine Engineering Laboratory describes progress in designing electric motors and furnishing the necessary power.

Before man can enter the sea at great depths and safely carry out explorations or perform work, he must have effective life-support and communications equipment. Martin Harrell of the Navy's Deep Submergence Systems Project Office reports on individual navigation systems and a translator to improve speech in a helium-oxygen atmosphere. The need for lightweight, high-capacity power sources is also outlined.

### **Instrumentation directions outlined**

Session 65 describes new approaches to oceanographic instrumentation. Two University of Rhode Island oceanographers, for example, have found that underwater acoustic back-scattering from the ocean surface can be used to measure the roughness of the sea. Experiments in a model tank by R. F. Hill and L. O. Jacotin have demonstrated that the distortion of a back-scattered signal is directly proportional to the root mean square waveheight. The oceanographers are discussing the significance of their work at the session.

Digital hyperbolic chirp generators are being used by two oceanographers at Columbia University's Hudson Laboratories as signal sources in underwater research. M. Epstein and B. Harris are using the acoustic modulation scheme because the long-duration, wide-bandwidth signals are doppler invariant and acceleration intolerant. Their report to the session notes the high cross-correlation for signals on the order of 10 seconds long.

An "in situ" temperature-salinity depth recorder that transmits continuous records to the deck of a ship is discussed by T. M. Dauphinee of Canada's National Research Council. The instrument



can record data effectively when the measuring head is raised and lowered as rapidly as 2 to 4 meters a second.

Litton Industries' Amecom Div. has developed an oceanographic instrument system that includes modules for sensing conductivity, temperature, pressure, water speed and direction. Lawrence R. Murdock of the company describes how the system telemeters the data to an off-shore tower in a digital format by means of an inductive power link. A deck unit provides automatic programming on magnetic tape.

The long-awaited introduction to the laser as an oceanographic instrument will be made in session 65. Ronald L. Kirk of Electro-Optical Systems, Inc., Pasadena, Calif., will describe a practical laser instrumentation scheme that can be used to measure sea surface parameters from aircraft. Amplitude, length, and direction of waves as well as the direction and velocity of surface winds can be determined.

The laser technique is tested and evaluated with an indoor water tank and air-circulation system that can produce a variety of wind and wave conditions.

—Neil Sclater

#### Systems and Reliability Engineer

## Specialized reports limit interest for designers

The hardware-oriented atmosphere of much of the IEEE show has left its mark on the technical programs dealing with reliability. The practical, generalized viewpoint, based on test results, dominates the mathematical approach in papers. Engineers will have to interpret most of the conclusions to fit their own special problems.

Reliability-minded engineers can find discussions ranging from the evaluation of huge systems to the latest techniques in predicting performance. The reliability of electronic switching systems is under scrutiny in Session 66. Field reliability and maintenance data for electronic systems are compared with electromechanical ones. For example, the experience of Standard Elektrik Lorenz AG in Stuttgart, Germany, is reported by H. Willrett. He shows that a partly electronic system that combines electronic components with dry-reed contacts has excellent reliability. Figures for dry-reed contacts are compared with those of routing transistors to support his conclusion.

To predict the performance of subsystems, engineers can either apply statistical techniques or build a prototype and test it. In many instances it is more convenient to build the prototype; it is easier, for example, to put together a network and test it than to establish a mathematical model.

Infrared detection offers a nondestructive versatile technique that can solve many problems that evade more conventional methods. Session 61 demonstrates that infrared detection is finally making the transition from the laboratory to practical technique. It is being used to check and maintain a wide range of engineering products, from jet rotor blades to semiconductors, according to Dr. Riccardo Vanzetti of the Raytheon Co., Wayland, Mass.

The infrared profile of the device under test indicates the temperature distribution, Dr. Vanzetti notes, and this reveals physical conditions that pass undetected with other checking techniques. By pinpointing thermal conditions in a printed-circuit board, for example, temperature-sensitive semiconductors can be protected against early failure due to heat. Unexpected hot spots in a circuit may indicate an error in component selection, a wrong connection or a bad weld.

Dr. Vanzetti has developed a pushbutton troubleshooter that permits a quick look at the thermal interaction on a printed-circuit board. Such a board may contain hundreds of components, and the complex thermal interaction cannot be analyzed by the designer.

"Only a computer program can give the correct information," Dr. Vanzetti says. "The designer can only make assumptions."

The automatic troubleshooter can analyze a printed-circuit panel in 100 seconds.

Infrared techniques can also be used to check bonding between metals, according to Dr. E. W. Kutzscer of the Lockheed-California Co., Burbank (Session 61). The method described is especially useful in testing jet rotor blades and honeycomb structures. In both cases good bonding between metals is essential. Imperfect bonding can cause delamination, which may eventually lead to the complete destruction of the blade.

Infrared detection also allows very precise control of welding—essential in the interconnections of integrated circuits, for example. S. N. Bobo of the Raytheon Co., Waltham, Mass., has built a novel sensor with optical fibers and a silicon photodetector that looks at the weld while it is being done. He describes the setup in Session 61. The optical fibers transmit the temperature of the molten metal—in the gap between the two parallel electrodes of the welding gun—to the detector. A feedback loop connects the detector to the current control of the gun. Therefore it is possible to maintain the optimum temperature for the optimum time required for perfect welding. The temperature pulse of the weld is displayed on an oscilloscope, mainly to check the cooling process. Fast cooling means good thermal conductivity between the metals and a good weld. Slow cooling means high thermal resistivity and a poor weld.

—Maria Dekany

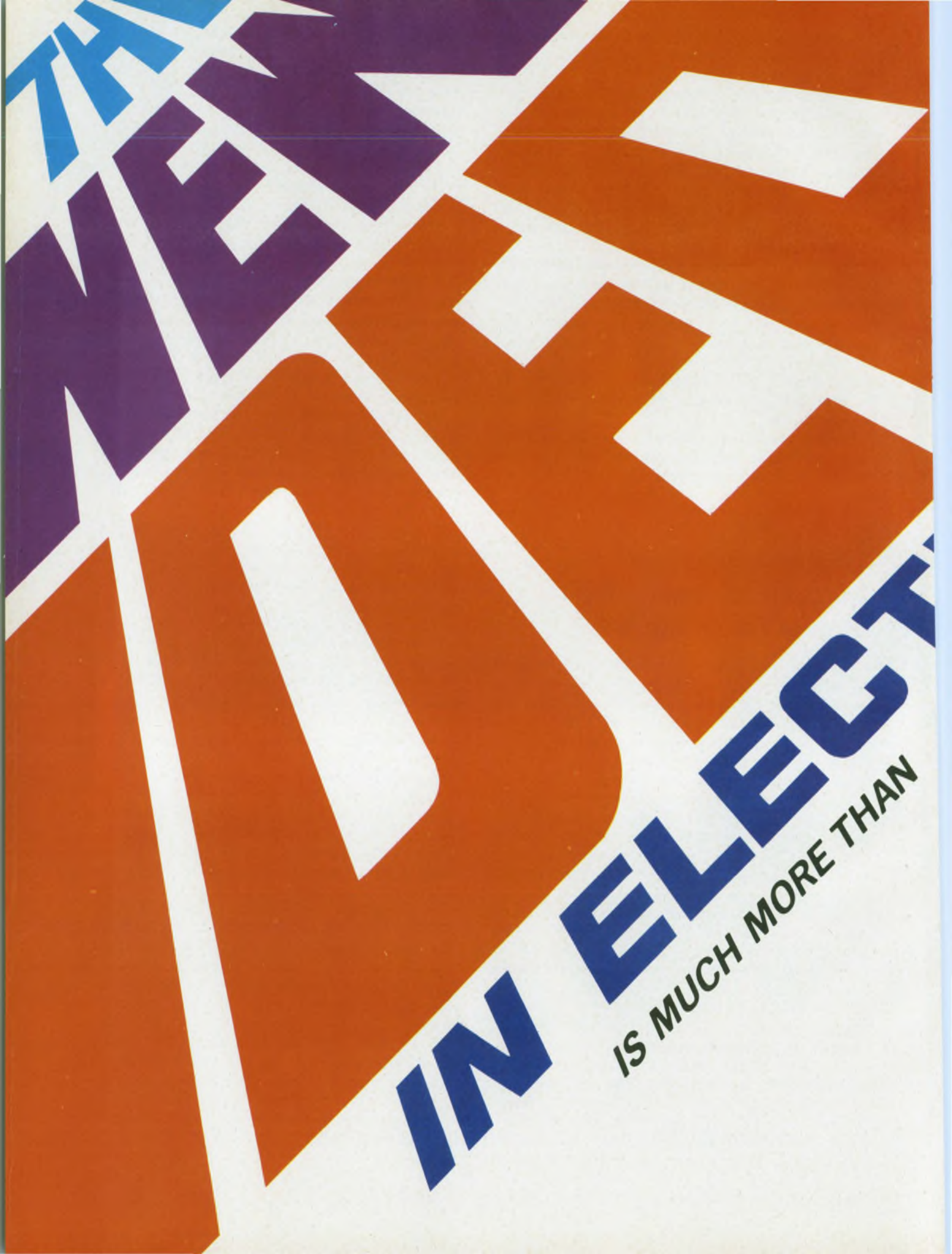

**THE**  
**NEW**

**IN ELECT**  
**IS MUCH MORE THAN**

# RONICS

THE PRODUCT YOU BUY...

## It's the right electronic component plus a trained and experienced marketing man working on your team

Straight talk! The new idea in electronics starts with a man—a man with a unique orientation to the special needs of your business.

He's more than a salesman. He's an expert oriented to your markets and to your business problems. He's not just looking for ways to replace the old with a new component; his responsibility is to find new ways electronically to do things for your business. He's business oriented. He's new idea oriented. He's new product oriented. He's customer oriented.

He's backed by General Electric's total electronic capability—in-depth technical backup assistance and the biggest (by far) product market basket in the world. You name it, and it's available through this one man. To mention just a few of the component types he offers:

- compactrons
- film and paper-oil capacitors
- epoxy transistors
- general purpose motors
- full line receiving tubes
- aluminum electrolytic capacitors
- silicon, selenium, germanium rectifiers and stacks
- Volt-Pac\* variable transformers
- microwave ceramic tubes
- foil and wet slug tantalum capacitors
- integrated circuits
- sealed relays
- five star military tubes
- signal diodes
- Alnico and Lodex\* magnets
- carbon brushes
- general purpose and reed relays—contactors
- current transformers

\*Reg. Trademark of General Electric Co.

He's your Electronic Components Sales Operation District Sales Manager—your single source for almost any electronic component requirements. He's located in every major market area.

Give him a call. Put the new idea in electronics to work for you. 285-21

ELECTRONIC COMPONENTS SALES OPERATION

GENERAL  ELECTRIC

## Technical Program

# When, where and what to hear at IEEE

Here's a complete guide to all the technical papers at the show.

The day, time and place for each paper are included.

### Technical papers are grouped in these categories:

Airborne Electronics	Industrial Electronics	Power Generation and Control
Antennas and Scattering Techniques	Lighting	Reliability
Circuits	Management	Sensing and Measuring
Circuit Theory	Materials	Signal Processing
Communications	Medical Electronics	Solid-State Devices and Theory
Components	Microelectronics	Space Electronics
Computer-Aided Design	Microwaves	System Engineering
Computers	Military Electronics	Television
Control Systems	Municipal Planning	Test Equipment and Techniques
Cybernetics	Nuclear Electronics	Transportation
Engineering Education	Oceanography and Underwater Systems	

## Airborne Electronics

The Application of Overstress Testing to Failure to Airborne Electronics, A Status Report—*J. J. Bussolini, Grumman Aircraft Engineering Corp. (9.1, Mon./a.m./SS)*

Trouble/Failure Reporting System for Surveyor Spacecraft—*F. A. Paul, Jet Propulsion Lab. (9.5, Mon./a.m./SS)*

National Airspace System Enroute—*F. K. Seward, IBM-NAFEC (14.4, Mon./p.m./R)*

Communication Transmission Requirements as Seen by Astronauts and Aquanauts—*Scott Carpenter, Manned Spacecraft Center (72.5, Thurs./p.m./SN)*

## Antennas and Scattering Techniques

The Use of Multi-Parameter Radar Imagery for the Discrimination of Terrain Characteristics—*R. D. Ellermeier, D. S. Simonett, L. F. Dellwig, Univ. of Kansas (70.1, Thurs./p.m./RS)*

Electromagnetic Scattering Phenomena Associated with Extended Surfaces—*J. J. Schindler, Air Force*

*Cambridge Research Lab. (70.2, Thurs./p.m./RS)*

Direct Backscatter of HF Radio Waves from Land, Sea, Water and Ice Surfaces—*G. H. Hagn, Stanford Research Institute (70.3, Thurs./p.m./RS)*

Generalized Surface Impedance Properties—*R. K. Ritt, K. M. Siegel, Conduction Corp. (70.4, Thurs./p.m./RS)*

Antenna Processing for High-Resolution Mapping—*A. A. Ksienski, Hughes Aircraft Co. (70.5 Thurs./p.m./RS)*

## Circuits

Microwave Control Circuits—*D. H. Temme, MIT Lincoln Lab. (7.4, Mon./a.m./RS)*

Design of Filters with Arbitrary Passband and Chebyshev Stopband Attenuation—*G. C. Temes, M. Gyi, Amper Corp. (23.1, Tues./a.m./R)*

F. E. T. Chopper Circuits for Low Level Signals—*J. J. Hitt, G. Mosley, Leeds and Northrup (59.3, Thurs./a.m./R)*

Amplifier Designs Using Repetitive Stabilized Gain Elements—*G. W. Haines, B. E. Amazeen, Sprague Electric Co. (69.1, Thurs./p.m./RN)*

Realization of Real Transmission Zeros Using Uniform Distributed RC Networks with Common Ground Connections—*J. J. Stein, Hughes Aircraft Co.; S. S. Shamis, J. H. Mulligan, Jr., City Univ. of New York (69.2, Thurs./p.m./RN)*

## Circuit Theory

Design of Filters with Arbitrary Passband and Chebyshev Stopband Attenuation—*G. C. Temes, M. Gyi, Amper Corp. (23.1, Tues./a.m./R)*

On the State Model Approach to the Realization of Portless RLC Networks—*Y. Tokad, J. C. Nordgren, Michigan State Univ. (23.2, Tues./a.m./R)*

Canonic and State Variable Characterization of Networks with Variable Elements—*N. DeClaris, R. Saeks, Cornell Univ. (23.3, Tues./a.m./R)*

Stable Realization of Impulse Response Matrices—*L. M. Silverman, Univ. of California (23.4, Tues./a.m./R)*

Multivariable Network Functions—*S. O. Scanlan, Leeds Univ., England (23.5, Tues./a.m./R)*

Computer Recognition of the Brain's Visual Perception Through Learn-

## Guide to abbreviations

Session locations in the New York Hilton are:

- G—Gramercy Suite
- MH—Murray Hill Suite
- N—Nassau Suite
- R—Regent Room
- SN—Sutton Ballroom North
- SS—Sutton Ballroom South
- RS—Rhineland Gallery South
- RN—Rhineland Gallery North

Numerals refer to sessions and to papers in a session—for example, 14.2 is paper 2 of session 14.

The schedule for the technical sessions is:

- Mon. 9:30 a.m.—12.00 noon  
2:00 p.m.—4.30 p.m.
- Tues. 9:00 a.m.—11:30 a.m.
- Wed. &
- Thurs. 2:00 p.m.—4:30 p.m.

ing the Brain's Physiologic Language—*Manfred Clynes, M. Kohn, J. Gradijan, Rockland State Hospital (29.5, Tues./p.m./MH)*

Numerical Methods of Network Analysis—*E. H. Branin, International Business Machines Corp. (42.1, Wed./a.m./RN)*

Network Analysis for Systems Applications: Present Capabilities of a Maintained Computer Program—*W. W. Happ, NASA (42.2, Wed./a.m./RN)*

A Program for Time-Shared Analysis of Nonlinear Electronic Circuits—*J. Katznelson, D. Evans, H. Lee, MIT (42.3, Wed./a.m./RN)*

NET-2 Circuit Analysis Program—*A. F. Malmberg, Los Alamos Scientific Lab. (42.4, Wed./a.m./RN)*

OLCA: AN On-Line Circuit Analysis System—*H. C. So, Bell Telephone Labs., Inc. (42.5, Wed./a.m./RN)*

Multilevel Design of Modern Networks: Summary—*J. D. Schoeffler, Case Institute of Technology; A. D. Waren, Cleveland State Univ. (51.1, Wed./p.m./RN)*

An Efficient Method for Numerical Laplace Transform Inversion Based on Error Control—*Michael Silverberg, Columbia Univ. (51.2, Wed./p.m./RN)*

Time-Domain Synthesis Using Linear and Quadratic Programming—*J. O. Bergholm, K. A. Fegley, Univ. of Pennsylvania (51.3, Wed./p.m./RN)*

One-Port Design for Prescribed Constant Phase Angle or Imaginary

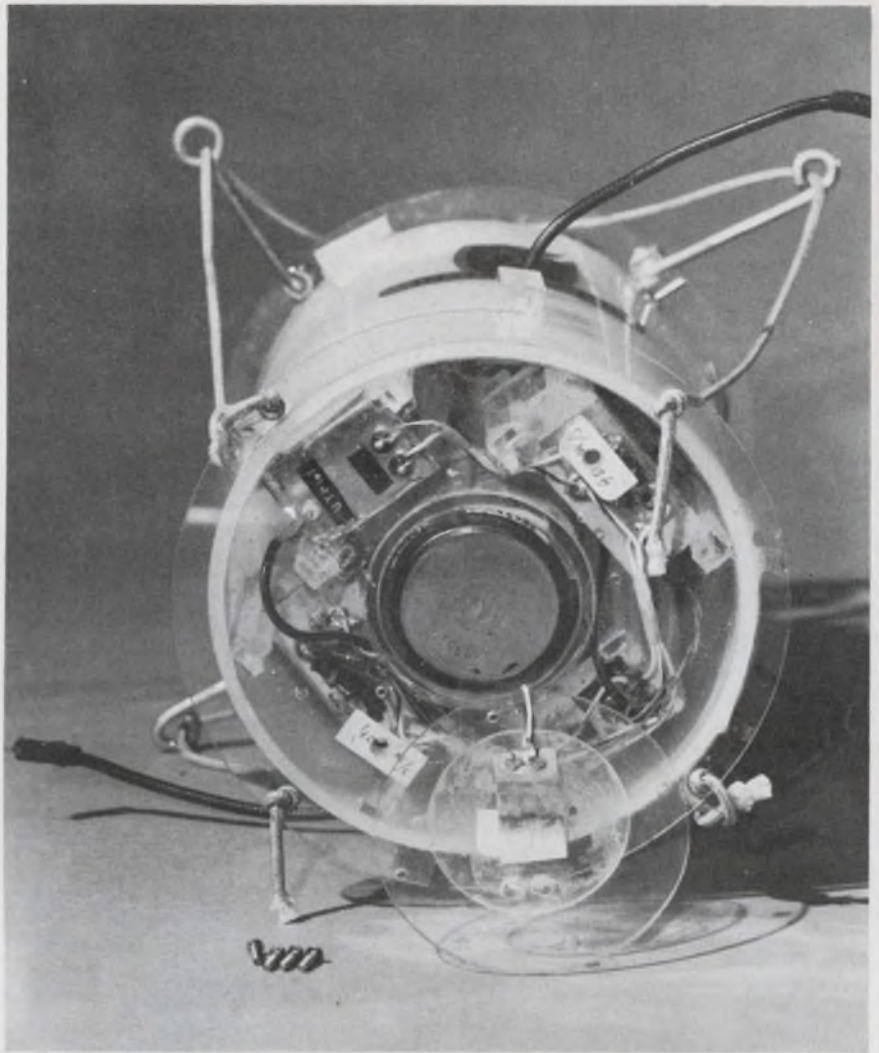

**Balloon-borne refractometer** measures radio propagation in the lower atmosphere. The unit contains two 400-MHz vhf transmitters, temperature and refraction sondes, and battery (Paper 3/1).

Part—*S. D. Bedrosian, D. B. Luber, Univ. of Pennsylvania (51.4, Wed./p.m./RN)*

A General-Purpose System of Digital Computer Codes for Linear/Non-linear Network and System Analysis—*C. T. Kleiner, E. D. Johnson, W. D. Ashcraft, North American Aviation, Inc. (51.5, Wed./p.m./RN)*

## Communications

An All-Solid-State Broadband 2-GHz Communication System—*K. Yamazaki, K. Takeda, M. Ogi, T. Sekizawa, J. Dodo, Fujitsu Labs. (3.2, Mon./a.m./MH)*

Design of Space Diversity Systems for Line-of Sight Microwave Links—*H. Makino, K. Morita, Nippon Telegraph and Telephone Co. (3.3, Mon./a.m./MH)*

Colorado River Storage Project Communication System—*A. H. Siniawsky, Stromberg-Carlson Co. (3.4, Mon./a.m./MH)*

Adaptive Control of Modulation Index in Tropo Scatter Communications—*R. T. Adams, J. Harvey, J. Craw-*

## Highlight symposium

**Exploitation of the World's Oceans** (Tues./8:00-10:30 p.m./Grand Ballroom)

Keynote address: Goals being Developed by the U.S. National Council on Marine Resources and Engineering Development

Panel discussion—*S.R. Keim, National Academy of Engineering; Richard Fuller, Bendix Corp.; R.W. Morse, Case Institute of Technology; Dr. C.M. Herzfeld, Director, Advanced Research Projects Agency, Dept. of Defense*

ford, *Communication Systems, Inc.* (3.5, Mon./a.m./MH)

Planning and Producing Better Visual Presentations—*J. T. McGarry, Eastman Kodak Co.* (6.1, Mon./a.m./RN)

Speech Compression in Theory and Practice: A Lecture-Demonstration—*S. F. Temmer, Gotham Audio Corp.* (6.2, Mon./a.m./RN)

The Implications of Speech Compression for Academic and Industrial Education—*Sam Duker, Brooklyn College* (6.3, Mon./a.m./RN)

Low-Noise Microwave Receivers—*W. G. Matthei, Micro State Electronics Corp.* (7.2, Mon./a.m./RS)

Coordination Activity Directed Toward Worldwide Standards—*C. R. Williamson, American Telephone & Telegraph Co.* (12.1, Mon./p.m./MH)

Military Global Networks—*Brig. Gen. J. B. James, Deputy Commanding General, U. S. Army Strategic Command* (12.2, Mon./p.m./MH)

Interface Between Global and Military Networks—*Robert Bright, Director Government Command Project, Western Electric Co.* (12.3, Mon./p.m./MH)

Civilian West European Fixed and Mobile Communications Related to Military Requirements—*General Edmond Combaux* (12.4, Mond./p.m./MH)

Data Rate and Reliability Requirements for Global Transfer in Terms of the Basic Properties of the Various Tandem Channels—*Steven Sussman, Adcom Inc.* (12.5, Mon./p.m./MG)

Satellite Communications in Global Networks, Including Mobile and Avionic Applications—*S. P. Brown, U. S. Army Satellite Command Agency* (12.6, Mon./p.m./MH)

Interconnecting Tactical and Strategic Networks—*Lorend Diedrickson, Office U. S. Project Manager, Project MALARD* (12.7, Mon./p.m./MH)

Testing the NORAD Command and Control System Man-Machine Interface—*R. T. Stevens, The Mitre Corp.* (14.2, Mon./p.m./R)

Design and Application of Multichannel Long-Haul Electronic Distribution System—*W. T. Smith, Superior Cable Corp.* (21.1, Tues./a.m./MH)

Field Evaluation of Cable Temperature Effects on Exchange Loop and Trunk Plant—*D. H. Potter, General Telephone Co. of Calif.* (21.2, Tues./a.m./MH)

Measurement of Unbalance Attenuation—*L. O. Olson, Western Electric Co., Inc.; J. C. Mau, General Telephone Co. of Florida* (21.3, Tues./a.m./MH)

Compact Solid-State Automatic Level Measuring Set—*C. B. Crane, Jr., Northeast Electronics Corp.* (21.4, Tues./a.m./MH)

A New System for Continuous Wide-Band Negative Impedance Coupling for Communication Facilities—*P. G. Lambidakis, Rural Electrification Administration* (30.1, Tues./p.m./MH)

The Role of Telecommunications in Supporting Domestic Goals—*H. R. Johnson, USAF Office of Telecommunications Management, Executive Office of the President* (30.2, Tues./p.m./MH)

Power Addition of Independent Random Variables Normally Distributed on a dB Scale—*Matthew Derzai, American Telephone & Telegraph Co.* (30.3, Tues./p.m./MH)

A New 25-MHz Transmission Measuring Set for High-Capacity Coaxial Carrier Systems—*H. H. Freytag, D. Seidel, Siemens America, Inc.* (30.4, Tues./p.m./MH)

Allocation of Multiple-Access Satellites to Multiantenna Terminals—*R. J. Hepps, A. L. Cohen, System Sciences Corp.* (36.1, Tues./p.m./SS)

A Frequency Time-Hopping Random Access Technique for Satellite Communications—*J. H. Wittman,sylvania Electronic Systems* (36.2, Tues./p.m./SS)

Experimental Determination of Intermodulation Distortion Produced in a Wideband Communications Repeater—*A. L. Berman, I. E. Podraczky, Communication Satellite Corp.* (36.3, Tues./p.m./SS)

Ranging the 1967 Mariner to Venus—*R. C. Tausworthe, Jet Propulsion Lab.* (36.4, Tues./p.m./SS)

Techniques for Altering the Proper-

ties of Re-entry Plasmas—*M. P. Bachynski, A. I. Carswell, B. W. Gibbs, RCA Victor Research Labs.* (36.5, Tues./p.m./SS)

Advances in the Facsimile Art during 1966—*W. H. Bliss, Radio Corp. of America* (39.1, Wed./a.m./MH)

Advances in Display Telegraphy—*C. R. Fisher, Stromberg-Carlson Co.* (39.2, Wed./a.m./MH)

Advances in Printing Telegraphy—*W. Y. Lang, Teleprinter & Data Apparatus* (39.3, Wed./a.m./MH)

The Touch-Tone Telephone Transmission of Digital Information—*J. H. Soderberg, R. R. Campbell, Bell Telephone Labs., Inc.* (39.4, Wed./a.m./MH)

Synchronous-Asynchronous Data Converter—*J. Deregnaucourt, Northern Electric Co., Ltd.* (48.4, Wed./a.m./MH)

New Horizons in Communications—*J. R. Pierce, Bell Telephone Labs., Inc.* (52.1, Wed./p.m./RS)

New Horizons in Television and Broadcasting—*G. H. Brown, Radio Corp. of America* (52.2, Wed./p.m./RS)

Analog Message Transmission: Bounds and System Performance Comparisons—*H. L. Van Trees, MIT* (54.1, Wed./p.m./SS)

Theoretical Ideals and Their Practical Attainment for Digital Communication on Telephone Channels—*R. W. Lucky, Bell Telephone Labs., Inc.* (54.2, Wed./p.m./SS)

Fading Radio Channels in Telecommunications—*B. B. Barrow,sylvania Electronic Systems* (54.3, Wed./p.m./SS)

A Study of Codes for Deep Space Telemetry—*D. R. Lumb, NASA* (54.4, Wed./p.m./SS)

The Atmosphere as an Optical Communication Channel—*E. V. Hoversten, MIT* (54.5, Wed./p.m./SS)

New Services for Residential Telephone Customers—*R. E. Fortenberry, American Telephone and Telegraph Co.* (57.1, Thurs./a.m./MH)

Implementation of New Services for Residential Customers—*W. Whitney, Bell Telephone Labs., Inc.* (57.2, Thurs./a.m./MH)

Custom Calling Services—*M. H. Bland, W. H. Stewart, Stromberg-Carlson Corp.* (57.3, Thurs./a.m./MH)

New Services in PBX and Centrex Systems—*V. W. Witkus, American Telephone and Telegraph Co.* (57.4, Thurs./a.m./MH)

Implementation of New Services in PBX and Centrex Systems—*D. L. Rodkin, Bell Telephone Labs., Inc.* (57.5, Thurs./a.m./MH)

Field Experience with Quasielectronic Telephone Switching Systems—*H. Willrett, Standard Elektrik Lorenz AG* (66.1, Thurs./p.m./MH)

Reliability and Field Experience of Electronic Switching Systems—*W. P. Karas, Stromberg-Carlson Co.* (66.2, Thurs./p.m./MH)

Early No. 1 ESS Field Experiences, Part I: Two-Wire System for Commercial Applications—*G. Haugk,*

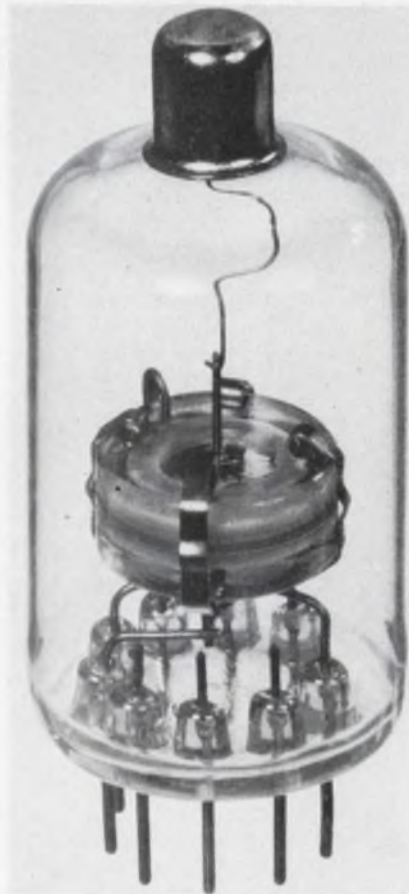

**Dynamic capacitor** housed in vacuum tube is part of electrometer that measures currents down to  $10^{-17}$  amps (Paper 59/4).

Bell Telephone Labs., Inc. (66.3, Thurs./p.m./MH)

Early No. 1 ESS Field Experiences, Part II: Four-Wire System for Government and Military Applications—H. N. Seckler, Bell Telephone Labs., Inc. (66.4, Thurs./p.m./MH)

Electronic Reliability in the Field—T. F. A. Urben, John Lawrence, British Post Office (66.5, Thurs./p.m./MH)

Communication Transmission Requirements as Seen by Astronauts and Aquanauts—Scott Carpenter, Manned Spacecraft Center (72.5, Thurs./p.m./SS)

## Components

Microwave Delay Lines—R. W. Damon, Sperry Rand Research Center (7.3, Mon./a.m./RS)

Microwave Filters—Leo Young, Stanford Research Institute (7.5, Mon./a.m./RS)

Design of Filters with Arbitrary Passband and Chebyshev Stopband Attenuation—G. C. Temes, M. Gyi, Ampex Corp. (23.1, Tues./a.m./R)

Comparison of Microwave Tubes for Phased Array Radar Transmitter Application—Laurence Clampitt, R. A. Handy, N. W. Huse, Raytheon Corp., (24.1, Tues./a.m./RN)

Modern Image Tubes and Their Applications—Jay Burns, Northwestern Univ. (24.3, Tues./a.m./RN)

Computer CRT Application and Future CRT Requirements—G. M. Krembs, International Business Machines Corp., (24.4, Tues./a.m./RN)

Advances in Gas Lasers—P. O. Clark, Hughes Research Labs. (33A.1, Tues./p.m./RN)

Dispersive and Nondispersive IF Ultrasonic Delay Lines—J. H. Eveleth, Anderson Labs., Inc. (49.1, Wed./p.m./N)

Delay Line Transducer Materials—D. A. Berlincourt, Clevite Corp. (49.2, Wed./p.m./N)

Monolithic Crystal Filters—R. A. Sykes, W. L. Smith, W. J. Spencer, Bell Telephone Labs., Inc. (49.4, Wed./p.m./N)

## Computer-Aided Design

Numerical Methods of Network Analysis—E. H. Branin, International Business Machines Corp. (42.1, Wed./a.m./RN)

Network Analysis for Systems Applications: Present Capabilities of a Maintained Computer Program—W. W. Happ, NASA (42.2, Wed./a.m./RN)

A Program for Time-Shared Analysis of Nonlinear Electronic Circuits—J. Katznelson, D. Evans, H. Lee, MIT (42.3, Wed./a.m./RN)

NET-2 Circuit Analysis Program—A. F. Malmberg, Los Alamos Scientific Lab. (42.4, Wed./a.m./RN)

OLCA: An On-Line Circuit Analysis System—H. C. So, Bell Telephone Labs., Inc. (42.5, Wed./a.m./RN)

Multilevel Design of Modern Net-

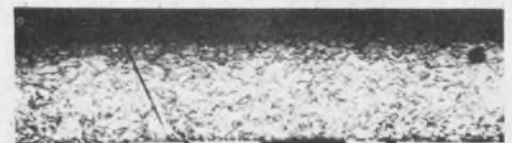
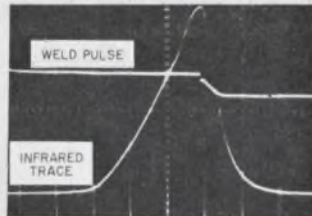
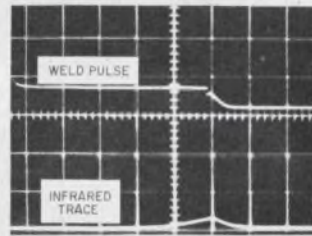

POOR MICROWELD

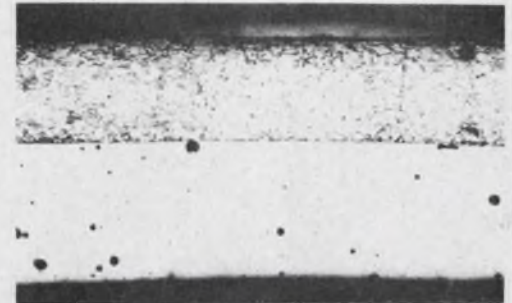

GOOD MICROWELD

Infrared detection picks out bad welds that would be passed by qualified visual inspection (top). On the oscilloscope (top left) the feeble thermal response calls attention to the large void in the joint (top right). A large response with exponential decay (bottom left) characterizes good thermal conductivity through the joint. Note that the void disappeared (bottom right) from the welded joint. (Session 61).

works: Summary—J. D. Schoeffler, Case Institute of Technology; A. D. Waren, Cleveland State Univ. (51.1, Wed./p.m./RN)

An Efficient Method for Numerical Laplace Transform Inversion Based on Error Control—Michael Silverberg, Columbia Univ. (51.2, Wed./p.m./RN)

Time Domain Synthesis Using Linear and Quadratic Programming—J. O. Bergholm, K. A. Fegley, Univ. of Pennsylvania (51.3, Wed./p.m./RN)

One-Port Design for Prescribed Constant Phase Angle or Imaginary Part—S. D. Bedrosian, D. B. Lubner, Univ. of Pennsylvania (51.4, Wed./p.m./RN)

A General-Purpose System of Digital Computer Codes for Linear Network and System Analysis—C. T. Kleiner, E. D. Johnson, W. D. Ashcraft, North American Aviation Inc. (51.5, Wed./p.m./RN)

An Application of Computer-Aided Design Methods to the Near Optimal Control of a Damped Second-Order System—W. L. Nelson, Bell Telephone Labs., Inc. (56.1, Thurs./a.m./MH)

## Computers

Time-Shared Computers in Design Education—P. T. Shannon, Myron Tribus, S. A. Gembicki, Dartmouth College (1.1, Mon./a.m./G)

Strategies for Design of Computer Aided Learning Exercises—K. L. Zinn, Univ. of Michigan (1.2, Mon./a.m./G)

The Eliza Program: Conversational Tutorial—E. F. Taylor, MIT (1.3, Mon./a.m./G)

Teaching by a Computer-base Instructional System—D. L. Bitzer, Univ. of Illinois (1.4, Mon./a.m./G)

Computational Aspects of Dynamic Programming—R. Larson, Stanford Research Institute (2.3, Mon./a.m./MH)

Rules for Applying Error Correcting Code to Computers—D. Goldman, Hofstra Univ. (9.2, Mon./a.m./SS)

DDC: Total Systems Approach—W. Brandt, S. Opie, General Electric Co. (14.1, Mon./p.m./R)

Integration of a Digital Computer into a Maneuvering Re-entry Vehicle—H. Most, General Electric Co. (14.3, Mon./p.m./R)

National Airspace System En Route—F. K. Seward, IBM-NAFEC (14.4, Mon./p.m./R)

Modern Image Tubes and Their Applications—J. Burns, Northwestern Univ. (24.3, Tues./a.m./RN)

Computer CRT Application and Future CRT Requirements—G. M. Krembs, International Business Machines Corp. (24.4, Tues./a.m./RN)

The Evolution of Computer Operating Systems—W. C. Lynch, Case Institute of Technology (25.1, Tues./a.m./RS)

Time-Sharing Systems: A Review—B. W. Arden, Univ. of Michigan (25.2, Tues./a.m./RS)

Computer Recognition of the Brain's Visual Perception Through Learning the Brain's Physiologic Language—M. Clynes, M. Kohn, J. Gra-

## Panel discussions

Electromagnetic Compatibility in System Design—*J. Cohen, J. Roman, R. W. Evans and W. D. McKerchar (5, Mon./a.m./R)*

Avionics Systems for Rotary Wing Aircraft—*L. G. Cullahan, Jr. and H. S. Oakes (8, Mon./a.m./SN)*

Integrated Avionics: Today and Tomorrow—*W. P. Beese, J. Cohen, W. H. Barnard, H. Davis, L. S. Guarino and A. J. Stanziano (17, Mon./p.m./SN)*

The Computer for Basic Research in the Humanities and Behavioral Science—*I. Kayton, R. N. Freed, S. P. Sims, L. E. Allen, A. A. Lebnun and F. Kort (22, Tues./a.m./N)*

On-Board Checkout for Aerospace Systems—*Dr. R. W. Lanzkron, R. A. Neilson, Col. R. Powell and S. K. Sezack (26, Tues./a.m./SN)*

Managerial Action and Organizational Effectiveness—*E. J. Tangerman, J. W. Haanstra, J. R. Ragazzine, R. R. Ritti, T. E. Woodruff and H. Zahl (31, Tues./p.m./N)*

How to Apply System Analysis Properly to Biological Systems—*G. Biernson, E. F. MacNichol, Jr., H. R. Blackwell, J. Lettvin and L. Stark (34, Tues./p.m./RS)*

The Impact of EDP on Engineers and Management—*J. P. Craven, A. G. Begeedov, J. W. Forrester and H. M. Sarasohn (41, Wed./a.m./R)*

Exploitation of the World's Oceans II—*D. Alverson, A. Berman, R. B. Kershner and W. H. Scott (44, Wed./a.m./SN)*

The Electronics Industry: An Outlook for Engineers and Management—*A. H. Hartman, G. Howick, E. D. Kenana, W. Davis, G. A. Lodge and J. Stegner (62, Thurs./a.m./SN)*

Speech: Man's Natural Communication—*J.C.R. Licklider, G. A. Miller, J. Bram, F. S. Cooper, J. Lotz and M. R. Schroeder (63, Thurs./a.m./SS)*

Electrical Corona—*E. R. Bunker, Jr., T. Dakin, L. J. Frisco, L. W. Kirkwood, R. Lee and J. R. Perkins (64, Thurs./p.m./G)*

*dijan, Rockland State Hospital (27.3, Tues./a.m./SS)*

Electromechanical Control of an Artificial Leg—*G. D. Summers, Fairchild Hiller Corp. (27.5, Tues./a.m./SS)*

An Application of Analog Computer to Solve the Two-Point Boundary-Value Problem for a Fourth-Order Optimal Control Problem—*V. J. Darcy, R. A. Hannen, Air Force Institute of Technology (29.1, Tues./p.m./MH)*

Numerical Methods of Network Analysis—*E. H. Branin, International Business Machines Corp. (42.1, Wed./a.m./RN)*

Network Analysis for Systems Applications: Present Capabilities of a Maintained Computer Program—*W. W. Happ, NASA (42.2, Wed./a.m./RN)*

A Program for Time-Shared Analysis of Nonlinear Electronic Circuits—*J. Katznelson, D. Evans, H. Lee, MIT (42.3, Wed./a.m./RN)*

NET-2 Circuit Analysis Program—*A. F. Malmberg, Los Alamos Scientific Lab. (42.4, Wed./a.m./RN)*

OLCA: An On-Line Circuit Analysis System—*H. C. So, Bell Telephone Labs., Inc. (42.5, Wed./a.m./RN)*

Measuring the Impact of Automation—*J. Duncan, Battelle Memorial Institute (47.1, Wed./p.m./MH)*

Impact of Automation in the Materials-Processing Industries—*H. R. Chope, Industrial Nucleonics Corp. (47.2, Wed./p.m./MH)*

Process Automation in the Petro-

Chemical Industries—*T. M. Stout, Profomatics, Inc. (47.3, Wed./p.m./MH)*

Automation in the Telephone Industry—*S. Washburn, Bell Telephone Labs., Inc. (47.4, Wed./p.m./MH)*

Social Aspects of Automation—*R. L. Cosgriff, The Ohio State Univ. (47.5, Wed./p.m./MH)*

New Horizons in Computers and Information Processing—*R. M. Fano, MIT (52.3, Wed./p.m./RS)*

Conversations with Computer in the Operation of Sea Traffic Control—*J. S. Elmaleh, J. S. Gustafarro, N. S. Prywes, Univ. of Pennsylvania (Thurs./p.m./N)*

Information Retrieval (71, Thurs./p.m./SN)

## Control Systems

Computational Algorithms in Optimal Control—*R. Kopp et al, Grumman Aircraft Engineering Corp. (2.2, Mon./a.m./MH)*

Microwave Control Circuits—*D. H. Temme, MIT Lincoln Lab. (7.4, Mon./a.m./RS)*

Identification for Control Purposes—*J. Eaton, International Business Machines Corp. (11.2, Mon./p.m./MH)*

DDC: Total Systems Approach—*W. Brandt, S. Opie, General Electric Co. (14.1, Mon./p.m./R)*

Speed Control of the Finishing Train of Hot Bar Mill—*R. M. Benza, Univ. of Pittsburgh (19.1, Tues./a.m./G)*

Direct Digital Control of a Reversing Slabbing Mill—*L. R. Berry, T. H. Bloodworth, Allis-Chalmers Mfg. Co. (19.2, Tues./a.m./G)*

Computerizing a Cold-Rolling Mill—*R. E. Slater, C. E. Trott, Jr., General Dynamics Corp. (19.3, Tues./a.m./G)*

A Steel Mill Engineer's Viewpoint of Solid-State Electrical Equipment—*G. C. Gingham, Bethlehem Steel Corp. (19.4, Tues./a.m./G)*

Minimum Norm Control of Discrete Systems—*C. H. Wells, Redstone Arsenal (20.1, Tues./a.m./MH)*

A Tunable Design Procedure for DDC—*R. W. Koepcke, W. G. Tuel, Jr., International Business Machines Corp. (20.2, Tues./a.m./MH)*

Maximum Likely Estimation of Rational Transfer Function Parameters—*A. E. Rogers, Univ. of Delaware (20.3, Tues./a.m./MH)*

CESSAM: Conversion Equipment System, Surface-to-Air Missile—*K. S. Bonwit, Johns Hopkins Univ. (20.4, Tues./a.m./MH)*

An Application of Optimal Control Theory to the Control of Color on the Paper Machine—*P. R. Belanger, Foxboro Co. (20.5, Tues./a.m./MH)*

An application of an Analog Computer to Solve the Two-Point Boundary-Value Problem for a Fourth-Order Optimal Control Problem—*V. J. Darcy, R. A. Hannen, Air Force Institute of Technology (29.3, Tues./p.m./MH)*

Design and Manufacture of Shipboard Centralized Engine-Room Control





# Our military switches are sweeping the country!

Quick now, what's the first thing you think of when you think of Cutler-Hammer military switches?

We thought so: airborne equipment.

Not surprising. We created the first line of switches for airborne use back in the roaring 20's. Today, nearly everything that flies—from helicopters to space vehicles—uses Cutler-Hammer switches.

So what's new? Just that designers are discovering that these same switches work as well in ground support equipment, ship-board electronics, and ordnance as they do in the air.

That's because of the painstaking care we take in design and manufacture. The exhaustive in-process inspection. And our rigorous final testing.

The result? Unquestionable reliability, performance, and long life—under extreme environmental conditions.

On your next project—ground, marine, or airborne—specify Cutler-Hammer military switches. Call your local stocking distributor, or write for new catalog E217.

Switch  
to No. 1

More than just switches:  
prompt availability,  
field help, innovation,  
quality assurance too.



A few of the thousands of military switches available from Cutler-Hammer: miniature, and standard-size positive-action toggle switches (MIL-S-8834), Shallcross rotary switches (MIL-S-3786).



**CUTLER-HAMMER**

Milwaukee, Wisconsin 53201

Systems—*W. I. Nagel, Westinghouse Electric Corp. (32.1, Tues./p.m./R)*

Achievements in Industrial Electronics and Control Instrumentation—*E. A. Weiss, Sun Oil Co. (38.1, Wed./a.m./MH)*

Representation and Identification of Nonlinear Systems—*R. L. Cosgriff, H. Hemami, Ohio State Univ. (56.2, Thurs./a.m./MH)*

Predicting the Nonlinear Operating Characteristics for a Two-Phase Servo Motor—*D. Springett, E. R. Corneil, Xerox Corp. (56.3, Thurs./a.m./MH)*

Evolution of Heuristics by Human Operators in Control Systems—*R. E. Thomas, J. T. Tou, Battelle Memorial Institute (67.1, Thurs./p.m./N)*

STSD: A Language for the Analysis of Military Command and Control Systems—*J. L. Bloom Franklin Institute Research Labs. (67.3, Thurs./p.m./N)*

## Cybernetics

The Brain of Yesterday and Today—*W. R. Ashby, Univ. of Illinois (13.1, Mon./p.m./N)*

Information Processing in Highly Damped Neural Nets—*E. M. Harth, Univ. of Syracuse (13.2, Mon./p.m./N)*

On the Applicability of Wiener's Canonical Expansion—*D. B. Brick, Information Research Associates (13.3, Mon./p.m./N)*

On the Complexity of Patterns—*L. N. Kanal, T. J. Harley, Jr., Philco-Ford Corp. (13.4, Mon./p.m./N)*

An Intelligent Automation—*C. A. Rosen, N. J. Nilsson, Stanford Research Institute (13.5, Mon./p.m./N)*

## Engineering Education

Education: Technology's Stepchild—*J. G. Truxal, Polytechnic Institute of Brooklyn (10.1, Mon./p.m./G)*

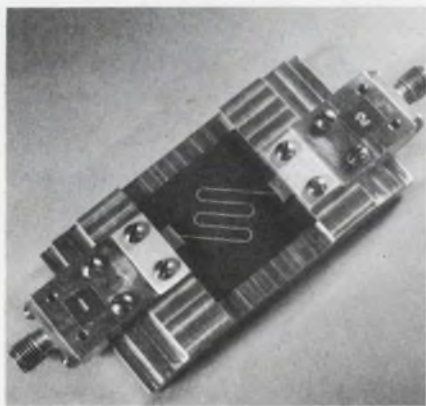

Reciprocal latching phase shifter from Syracuse University Research Corp. has digital and analog control of the insertion phase in S-band. The ferrite planar substrate is 20 mils thick (Paper 16/1).

The Student-Machine Interface in Instruction—*Robert Glaser, Univ. of Pittsburgh, W. W. Ramage, Westinghouse Research Labs., (10.2, Mon./p.m./G)*

The Key Educational Problems Posed by Advancing Technology—*W. B. Shockley, Stanford Univ. (10.3, Mon./p.m./G)*

Behavioral Engineering and Educational Technology—*Israel Goldiamond, Institute of Behavioral Research (10.4, Mon./p.m./G)*

A Basic Introduction to Reliability Engineering—*H. C. Jones, Westinghouse Aerospace Div. (38.2, Wed./a.m./MH)*

New Horizons in Physics—*R. F. Sproull, Cornell Univ. (43.1, Wed./a.m./RS)*

New Horizons in Quantum Electronics—*Nicolaas Bloembergen, Harvard Univ. (43.2, Wed./a.m./RS)*

New Horizons in Chemistry—*F. W. Westheimer, Harvard Univ. (43.3, Wed./a.m./RS)*

New Horizons in Bio-Medicine (43.4, Wed./a.m./RS)

## Industrial Electronics

DDC: Total Systems Approach—*W. Brandt, S. Opie, General Electric Co. (14.1, Mon./p.m./R)*

Achievements in Industrial Electronics and Control Instrumentation—*E. A. Weiss, Sun Oil Co. (38.1, Wed./a.m./MH)*

The Performance of the Two-Phase Induction Motor with Phase-Angle Control—*M. Ivison, Loughborough College of Technology, England (50.1, Wed./p.m./R)*

An Experimental Closed-Loop, Variable-Speed Drive Incorporating a Thyristor-Driven Induction Motor—*W. Shepherd, J. Stanway, Royal Military College of Science, England (50.2, Wed./p.m./R)*

Control and Protection of a dc Motor by Means of SCRs—*A. Alexandrovity, A. Emanuel-Eigles, Technion-Israel Institute of Technology (50.3, Wed./p.m./R)*

Test Circuit for Evaluation of Breaking Capacity of Motor Starters—*C. K. Eckels, L. H. Matthias, Allen-Bradley Co. (50.5, Wed./p.m./R)*

Overcurrent Protection Within the Motor Branch Circuit at Low Fault Currents—*R. E. Walters, Allen-Bradley Co. (50.5, Wed./p.m./O)*

A Direct Digital Control Stepping Motor Buffer—*K. J. Ayala, The Virginia Military Institute (56.4, Thurs./a.m./MH)*

## Lighting

Equipment for Measuring Inrush Currents into Magnetic Components—*G. M. Bell, General Electric Co. (40.1, Wed./a.m./N)*

Study of Lighting Equipment in Corrosive Atmospheres—*C. B. Kenty, F. A. Stein, Holophane Co. (40.2, Wed./a.m./N)*

What's New in Lighting?—*R. Harz, Owens-Corning Fiberglas Corp.*

(40.3, Wed./a.m./N)

## Management

Measuring the Impact of Automation—*J. Duncan, Battelle Memorial Institute (47.1, Wed./p.m./MH)*

Social Aspects of Automation—*R. L. Cosgriff, Ohio State Univ. (47.5, Wed./p.m./MH)*

Registration—*H. A. Moench, Rose Polytechnic Institute (53.1, Wed./p.m./SN)*

Ethics—*R. L. Benford, Itel Corp. (53.2, Wed./p.m./SN)*

Intersociety Relations with the Professional Societies—*G. A. Kiessling, Radio Corp. of America (53.3, Wed./p.m./SN)*

Legislative Activities Affecting Engineers—*M. F. Lunch, National Society of Professional Engineers (53.4, Wed./p.m./SN)*

## Materials

Introductory Remarks: The Materials/Design Interface—*A. E. Javitz, Commonwealth Services, Inc. (37.1, Wed./a.m./G)*

Materials Problems in Integrated Circuits—*J. E. Thomas, Jr., General Instrument Corp. (37.2, Wed./a.m./G)*

Semiconductor Materials for New Optical Devices—*L. A. D'Asro, Bell Telephone Labs., Inc. (37.3, Wed./a.m./G)*

Materials for Capacitor Dielectrics—*D. A. McLean, Bell Telephone Labs., Inc. (37.4, Wed./a.m./G)*

Materials for Conductive Elements, Part I and Part II—*J. Spergel, W. V. Lane, U. S. Army Electronics Command (37.5, Wed./a.m./G)*

Impact of Automation in the Materials-Processing Industries—*H. R. Chope, Industrial Nucleonics Corp. (47.2, Wed./p.m./MH)*

Delay Line Transducer Materials—*D. A. Berlincourt, Clevite Corp. (49.2, Wed./p.m./N)*

## Medical Electronics

Effects of Laser Power on Living Tissue—*G. Riggle, R. Hoye, National Institutes of Health (18.1, Wed./p.m./SS)*

An Electronic Heart Motion Tracking System—*W. Schuette, Biotronex; A. L. Simon, National Institutes of Health (18.2, Wed./p.m./SS)*

Post Operative Monitoring—*J. Lewis, J. Jacobs, Northwestern Univ. (18.3, Wed./p.m./SS)*

A Method for Identifying Brain Structures During Parkinson Surgery—*A. Saucers, Jr., S. J. Larson, Marquette Univ. (18.4, Wed./p.m./SS)*

The Electrode Interface Between Man and a Prosthetic Stimulator—*W. Greatbatch, State Univ. of New York (27.1, Tues./a.m./SS)*

Endocrine Control Systems and the Control of Them—*F. E. Yates, Stanford Univ. (27.2, Tues./a.m./SS)*

# Service beyond the call of duty

Those red and yellow ones at the left. They're for action, beyond the call of duty on a computer application. The little round one in the middle. Fighting at close quarters on a panel. The next two rows were on machine tools, office machines, guidance control and a few other items.

We put the whole Licon® lighted switch story in a book. **It looks like this.**



Request your copy

**Join forces with LICON...  
fastest growing full-line switch supplier**

**it LICON**  
DIVISION ILLINOIS TOOL WORKS INC.  
6615 WEST IRVING PARK ROAD — CHICAGO, ILLINOIS 60634

*\*Remember, you're never more than a few feet away from a product of ITW®*



ON READER-SERVICE CARD CIRCLE 68

- Man's Intervention in Intracerebral Functions—*J. M. R. Delgado, Yale Univ. School of Medicine (27.4, Tues./a.m./SS)*
- Electromechanical Control of an Artificial Leg—*G. D. Summers, Fairchild Hiller Corp. (27.5, Tues./a.m./SS)*
- The Organism Reorganized?—*N. S. Kline, Rockland State Hospital (27.6, Tues./a.m./SS)*

## Microelectronics

- X-Ray Vidicon Analysis of Microelectronics Devices—*H. F. Padden, Grumman Aircraft Engineering Corp. (9.4, Mon./a.m./SS)*
- Linear Integrated Circuits: Today and Tomorrow—*R. S. Pepper, Sprague Electric Co. (15.1, Mon./p.m./RN)*
- The Future Role of Field-Effect Devices in Electronics—*F. P. Heiman, Radio Corp. of America (15.2, Mon./p.m./RN)*
- Microwave Hybrid Integrated Circuits—*J. E. Dalley, Bell Telephone Co. (16.2, Mon./p.m./R)*
- Planar Ferrite Devices for Microwave Integrated Circuitry—*H. A. Hair, Syracuse Univ. Research Corp. (16.3, Mon./p.m./R)*
- Recent Advancements in Microwave Integrated Circuits Combining Semiconductor and Ferrimagnetic Elements—*J. C. Hoover, G. A. Foggia, R. W. Peter, L. B. Valdes, Watkins-Johnson Co. (16.4, Mon./p.m./R)*
- CESSAM: Conversion Equipment System, Surface-to-Air Missile—*K. S. Bonwit, Johns Hopkins Univ. (20.4, Tues./a.m./MH)*
- Materials Problems in Integrated Circuits—*J. E. Thomas, Jr., General Instrument Corp. (37.2, Wed./a.m./G)*
- Integrated Circuits: Their Current Technical and Economical Status—*E. F. Kvamme, Fairchild Semiconductor Co. (46.1, Wed./p.m./G)*
- Monolithic Analog Circuits—*J. E. Solomon, Motorola, Inc. (46.2, Wed./p.m./G)*
- MOS Devices and Arrays—*W. McKinley, Philco Microelectronics (46.3, Wed./p.m./G)*
- Microwave Integrated Circuits—*R. Webster, Texas Instruments (46.4, Wed./p.m./G)*
- Large-Scale Integration—*O. Baker, Signetics (46.5, Wed./p.m./G)*
- New Horizons in Microelectronic Circuits and Systems—*N. F. Parker, North American Aviation, Inc. (52.4, Wed./p.m./RS)*
- Functional Analysis of Integrated Digital Circuits—*J. J. Suran, General Electric Co. (60.1, Thurs./a.m./RN)*
- Yield, Economic and Logistic Models For Complex Digital Arrays—*R. B. Seeds, Fairchild Semiconductor Corp. (60.2, Thurs./a.m./RN)*
- Layout and Mask Generation in Large-Scale Integration—*D. L. Critchlow, International Business Machines Corp. (60.3, Thurs./a.m./RN)*
- Discretionary Wiring: An Approach to Large-Scale Integration—*J. S. Kilby, Texas Instruments Inc. (60.4, Thurs./a.m./RN)*
- Advanced Developments in Subnanosecond Integrated Logic Circuits—*J. A. Narud, Motorola Semiconductor Products Div. (60.5, Thurs./a.m./RN)*
- An Integrated-Circuit Helmet Radio Receiver—*T. B. Quaid, Motorola, Inc. (69.3, Thurs./p.m./RN)*
- The Application of Commercially Available Integrated Circuits in FM and AM Radio Receivers—*G. R. Madland, R. L. Hartley, Integrated*

*Circuit Engineering Co. (69.4, Thurs./p.m./RN)*

- An Integrated RC Oscillator for Touch Tone—*W. H. Orr, R. M. Rickert, D. M. Hill, Bell Telephone Labs., Inc. (69.5, Thurs./p.m./RN)*

## Microwaves

- Design of Space Diversity Systems for Line-of-Sight Microwave Links—*H. Makino, K. Morita, Nippon Telegraph and Telephone Co. (3.3, Mon./a.m./MH)*
- Solid-State Microwave Power Sources—*F. Sterzer, Radio Corp. of America (7.1, Mon./a.m./RS)*
- Low-Noise Microwave Receivers—*W. G. Matthei, Micro State Electronics Corp. (7.2, Mon./a.m./RS)*
- Microwave Delay Lines—*R. W. Damon, Sperry Rand Research Center (7.3, Mon./a.m./RS)*
- Microwave Control Circuits—*D. H. Temme, MIT Lincoln Lab. (7.4, Mon./a.m./RS)*
- Microwave Filters—*L. Young, Stanford Research Institute (7.5, Mon./a.m./RS)*
- New Solid-State Devices for Microwave Power Generation—*M. R. Barber, Bell Telephone Labs., Inc. (15.4, Mon./p.m./RN)*
- Microwave Semiconductor Devices—*R. R. Webster, Texas Instruments Inc. (16.1, Mon./p.m./R)*
- Microwave Hybrid Integrated Circuits—*J. E. Dalley, Bell Telephone Labs., Inc. (16.2, Mon./p.m./R)*
- Planar Ferrite Devices for Microwave Integrated Circuitry—*H. A. Hair, Syracuse Univ. Research Corp. (16.3, Mon./p.m./R)*
- Recent Advancements in Microwave Integrated Circuits Combining Semiconductor and Ferrimagnetic Elements—*J. C. Hoover, G. A. Foggia, R. W. Peter, L. B. Valdes, Watkins-Johnson Co. (16.4, Mon./p.m./R)*
- Effects of Laser Power on Living Tissue—*G. Riggle, R. Hoyer, National Institutes of Health (18.1, Mon./p.m./SS)*
- Comparison of Microwave Tubes for Phased Array Radar Transmitter Application—*L. Clampitt, R. A. Handy, M. W. Huse, Raytheon Corp. (24.1, Tues./a.m./RN)*
- Solid-State vs Gas Discharge Techniques for Microwave Duplexing—*G. Klein, Westinghouse Defense and Space Center (24.2, Tues./a.m./RN)*
- Microwave Scattering from Fluctuations in a Magnetoplasma—*R. F. Leheny, Y. G. Chen, T. C. Marshall, Columbia Univ. (28.3, Tues./p.m./G)*
- Microwave Integrated Circuits—*R. Webster, Texas Instruments (46.4, Wed./p.m./G)*

## Military Electronics

- Military Global Networks—*Brig. Gen. J. B. James, Deputy Commanding General, U. S. Army Strategic Command (12.2, Mon./p.m./MH)*
- Interface Between Global and Military

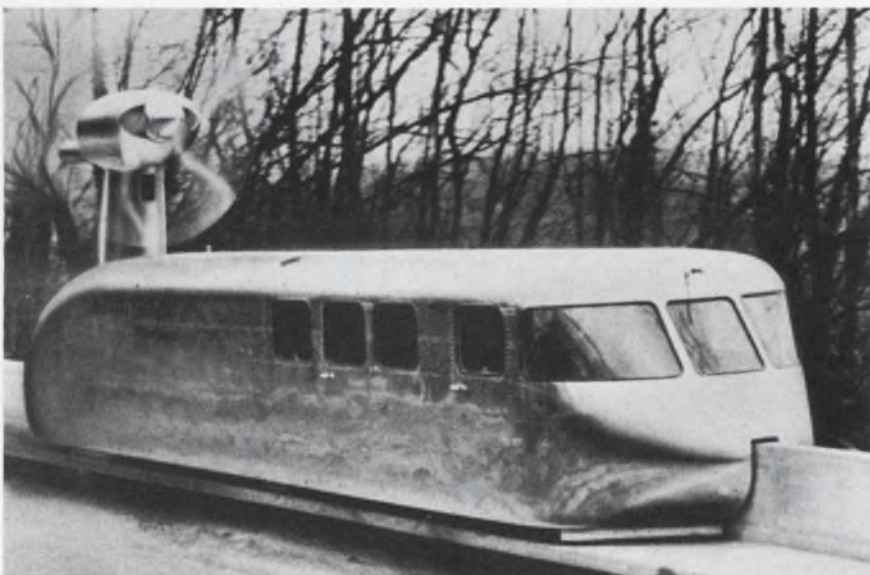

The French propeller-driven Aerotrain spins around its test track outside Paris. Clocked at 145 miles per hour, the French government and the French National Railroads are developing the Aerotrain for high-speed intercity passenger service (Session 58).

Networks—*R. Bright, Director Government Command Project, Western Electric Co. (12.3, Mon./p.m./MH)*

Civilian West European Fixed and Mobile Communications Related to Military Requirements—*General E. Combaux (12.4, Mon./p.m./MH)*

Data Rate and Reliability Requirements for Global Transfer in Terms of the Basic Properties of the Various Tandem Channels—*S. Sussman, Adcom Inc. (12.5, Mon./p.m./MH)*

Satellite Communications in Global Networks, Including Mobile and Avionic Applications—*S. P. Brown, U. S. Army Satellite Command Agency (12.6, Mon./p.m./MH)*

Interconnecting Tactical and Strategic Networks—*L. Diedrickson, Office U. S. Project Manager, Project MALARDA (12.7, Mon./p.m./MH)*

Testing the NORAD Command and Control System Man-Machine Interface—*R. T. Stevens, The Mitre Corp. (14.2, Mon./p.m./R)*

## Municipal Planning

Planners, Politicians and Popular Initiative: Squatter Settlements in Peru and Community Action in the U. S.—*W. Mangin, Univ. of Syracuse (4.1, Mon./a.m./N)*

Geometric Configurations: Their Systems and Social Implications—*W. A. Netsch, Skidmore, Owings and Merrill (4.2, Mon./a.m./N)*

Urban Structure—*C. Alexander, Univ. of California (4.3, Mon./a.m./N)*

The Urban Node in the Information Network—*P. Baran, Rand Corp; M. Greenberger, MIT (4.4, Mon./a.m./N)*

## Nuclear Electronics

Progress in Controlled Thermonuclear Research—*A. S. Bishop, U. S. Atomic Energy Commission (28.1, Tues./p.m./G)*

Production of Dense Plasmas by Laser Radiation—*A. F. Haught, United Aircraft Research Labs. (28.2, Tues./p.m./G)*

Microwave Scattering from Fluctuations in a Magnetoplasma—*R. F. Leheny, Y. G. Chen, T. C. Marshall, Columbia Univ. (28.3, Tues./p.m./G)*

## Oceanography and Underwater Systems

Design and Manufacture of Shipboard Centralized Engine-Room Control Systems—*W. I. Nagel, Westinghouse Electric Corp. (32.1, Tues./p.m./R)*

Shipboard Central Operation Systems: Design and Manufacture—*A. Nitsch, General Electric Co. (32.2, Tues./p.m./R)*

The Shipbuilder's Role in Shipboard Automation—*T. P. Campbell, W. E. Schmid, Sun Shipbuilding Co. (32.3, Tues./p.m./R)*

Operating Experience with Shipboard

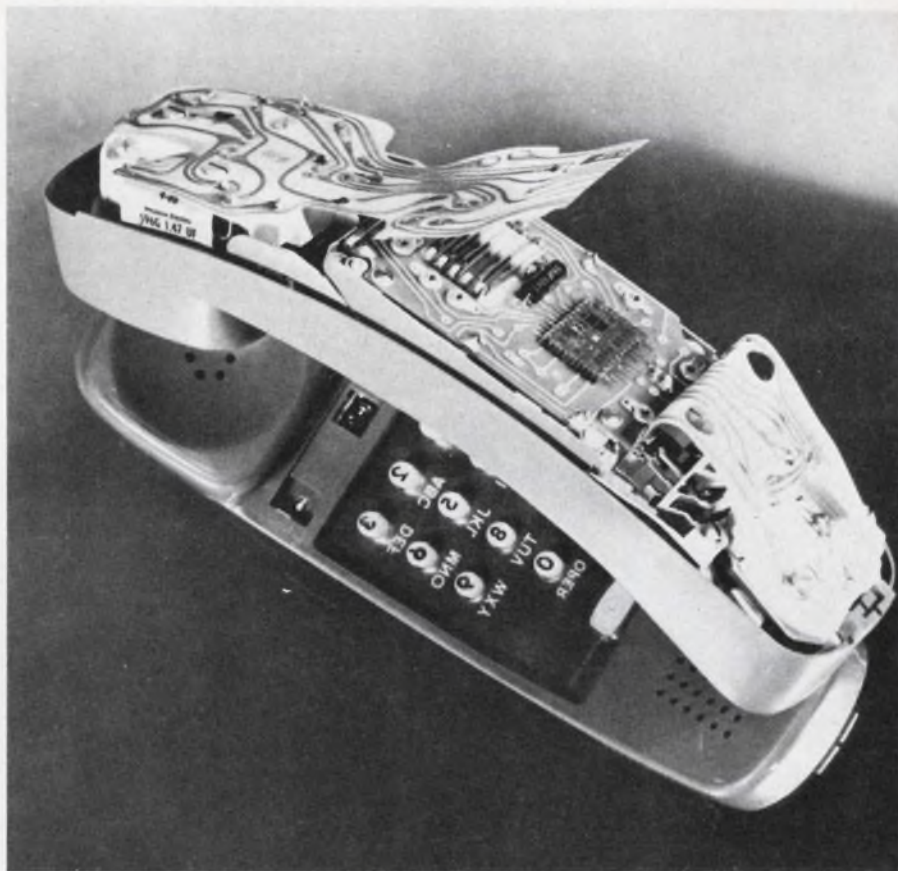

Integrated RC oscillators mounted in Touch-Tone telephone utilizes thin films and silicon beam leads. The microcircuits contain the equivalent of more than 50 discrete components (Paper 69/5).

Engine Room Automation—*N. Bachko, United States Lines (32.4, Tues./p.m./R)*

A Retrospect on Automation in Marine Engineering—*E. C. Mericas, Lykes Brothers Steamship Co. (32.5, Tues./p.m./R)*

Sonar Engineering for Submarines and Undersea Use—*S. W. W. Shor, Department of the Navy (55.1, Thurs./a.m./G)*

Research and Development in Undersea Instrumentation—*George Tajima, Bissett-Berman (55.2, Thurs./a.m./G)*

Deep-Submergence Power Machinery and Controls—*J. F. McCartney, T. D. Morrison, Marine Engineering Lab. (55.3, Thurs./a.m./G)*

Delay-Line Memory and Time Compression Systems—*P. S. Fuss, Bell Telephone Labs., Inc. (55.4, Thurs./a.m./G)*

Sea-State Observation with a Continuous Underwater Acoustic Signal—*R. F. Hill, R. O. Jacotin, Univ. of Rhode Island (65.1, Thurs./p.m./MH)*

A Digital Hyperbolic Chip Generator for Oceanographic Applications—*M. Epstein, B. Harris, Columbia Univ., (65.2, Thurs./p.m./MH)*

Ocean Surface Definition Utilizing Laser Techniques—*R. L. Kirk, Electro-Optical Systems, Inc. (65.3, Thurs./p.m./MH)*

An In Situ Temperature-Salinity-

Depth Recorder for Oceanographic Applications—*T. M. Dauphinee, National Research Council (65.4, Thurs./p.m./MH)*

Digital Oceanographic Data Collection System for Off-shore Towers—*Lawrence Murdock, Litton Industries (65.5, Thurs./p.m./MH)*

Conversations with Computer in the Operation of Sea Traffic Control—*J. S. Elmaleh, J. S. Gustafiero, N. S. Prywes, Univ. of Pennsylvania (67.4, Thurs./p.m./N)*

Communication Transmission Requirements as Seen by Astronauts and Aquanauts—*Scott Carpenter, Manned Spacecraft Center (72.5, Thurs./p.m./SS)*

## Power Generation and Control

Solid-State Microwave Power Sources—*Fred Sterzer, Radio Corp. of America (7.1, Mon./a.m./RS)*

New Solid-State Devices for Microwave Power Generation—*M. R. Barber, Bell Telephone Labs., Inc. (15.4, Mon./p.m./RN)*

Progress in Controlled Thermonuclear Research—*A. S. Bishop, U. S. Atomic Energy Commission (28.1, Tues./p.m./G)*

Status of Thermionic Energy Conversion—*Ned Rasor (33B.1, Tues./p.m./RN)*

## 1967 Convention Record Order Form and Price List

Part	Subjects, Session Numbers	Members	Nonmembers	Library
1	Wire & Data Communication 21, 30, 39, 48, 57, 66	\$ 2.00	\$ 4.50	\$ 6.00
2	Radio Communication; Broadcasting; Propagation; Plasma 3, 5, 12, 28, 36, 68, 70	2.50	5.75	7.50
3	Automatic Control 2, 11, 20, 29, 47, 56	2.00	4.50	6.00
4	Aerospace Systems 8, 17, 26, 35	2.00	4.50	6.00
5	Circuit Theory 23, 42, 51	1.50	3.50	4.50
6	Solid-State Circuit & Devices 15, 16, 46, 60, 69	2.00	4.50	6.00
7	Electron Devices, Materials, Microwave Components 7, 24, 33, 37, 64	2.00	4.50	6.00
8	Instrumentation; Ocean Electronics 44, 55, 59, 65	2.00	4.50	6.00
9	Bio-Medical Engineering; Human Factors; Systems Science & Cybernetics 4, 13, 14, 18, 27, 34, 58, 67	2.50	5.75	7.50
10	Computers; Education, Information Retrieval 1, 10, 22, 25, 71	2.00	4.50	6.00
11	Speech 6, 45, 49, 54, 63, 72	2.00	4.50	6.00
12	Engineering Management; Professional Relations 31, 41, 43, 52, 53, 62	2.00	4.50	6.00
13	Industry & General Applications 19, 32, 40, 50	2.00	4.50	6.00
14	Reliability; Industrial Electronics 9, 38, 61	1.50	3.50	4.50
<b>COMPLETE SET</b>		<b>\$28.00</b>	<b>\$63.50</b>	<b>\$84.00</b>

NOTE: For IEEE members, one set may be ordered at the Members' Rate, Additional sets will be charged at the Non-members' rate.

### ORDER FORM

### 1967 IEEE Convention Record

Part	1	2	3	4	5	6	7	8	9	10	11	Complete Set
Quantity												
Amount												

Total Amount Enclosed

\$

Name (Print) \_\_\_\_\_

IEEE No. \_\_\_\_\_

Address \_\_\_\_\_

Zip Code \_\_\_\_\_

Mail this form, with remittance, to IEEE, 345 East 47th St., New York, N.Y. 10017

## Reliability

- Application of Numerical Optimization Techniques to Aerospace Problems—*A. E. Bryson, Jr. Harvard Univ. (2.1, Mon./a.m./G)*
- The Application of Overstress Testing to Failure to Airborne Electronics: A Status Report—*J. J. Busolini, Grumman Aircraft Engineering Corp. (9.1, Mon/a.m./SS)*
- Rules for Applying Error Correcting Code to Computers—*D. Goldman, Hofstra Univ. (9.2, Mon./a.m./SS)*
- A Method for Predicting System Down Time—*E. J. Muth, General Electric Co. (9.3, Mon./a.m./SS)*
- X-Ray Vidicon Analysis of Microelectronics Devices—*H. F. Padden, Grumman Aircraft Engineering Corp. (9.4, Mon./a.m./SS)*
- Trouble/Failure Reporting System for Surveyor Spacecraft—*F. A. Paul, Jet Propulsion Lab. (9.5, Mon./a.m./SS)*
- Secondary Breakdowns in Power Transistors and Circuits—*W. C. Steffe, Fairchild Semiconductor Research & Development Labs. (15.3, Mon./p.m./RN)*

## Sensing and Measuring

- A New System for Continuous Wide-Band Negative Impedance Coupling for Communication Facilities—*P. G. Lambidakis, Rural Electrification Administration (30.1, Tues./p.m./MH)*
- An Application of Mode-Locked, Laser-Generated Picosecond Pulses to the Electrical Measurement Art—*H. A. Heynau, A. W. Penney, Jr. United Aircraft Research Labs. (33A.2, Tues./p.m./RN)*
- The Advantages of a Ten-Kilohm Transportable Resistance Standard—*R. M. Pailthorp, Electro Scientific Industries Inc. (59.1, Thurs./a.m./R)*
- The Problems of dc Null Detection and Their Solution—*John Parnell, Frank Brem, Honeywell Inc. (59.2, Thurs./a.m./R)*
- Measuring Currents Down to  $10^{-17}$  Amps with a Low Noise Level by Means of a Dynamic Capacitor Electrometer—*A. G. van Nie, N. V. Philips' Gloeilampenfabrieken (59.4, Thurs./a.m./R)*
- An Accurate, Semiautomatic Technique of Measuring High Resistances—*S. H. Tsao, National Research Council (59.5, Thurs./a.m./R)*
- An Impedance Meter for Automatic Test Systems—*W. A. Plice, Honeywell Inc. (59.6, Thurs./a.m./R)*

## Signal Processing

- Rules for Applying an Error-Correcting Code to Computers—*D. Goldman, Hofstra Univ. (9.2, Mon./a.m./SS)*
- Simplified Processing of Star Tracker Commands for Satellite Attitude Control—*R. D. Showman, Ames Research Center (29.4, Tues./p.m./G)*

- Power Addition of Independent Random Variables Normally Distributed on a dB Scale—*Mathew Derzai, American Telephone & Telegraph Co. (30.3, Tues./p.m./MH)*
- A Frequency Time-Hopping Random Access Technique for Satellite Communications—*J. H. Wittman, Sylvania Electronic Systems, (36.2, Tues./p.m./SS)*
- Techniques for Altering the Properties for Re-entry Plasmas—*M. P. Bachynski, A. I. Carswell, B. W. Gibbs, RCA Victor Research Labs. (36.5, Tues./p.m./SS)*
- An Adaptive Technique for Multiple Signal Detection and Identification—*J. W. Sammon, Rome Air Development Center (45.1, Wed./a.m./SS)*
- Suboptimum Rank Detection Procedures Using Rank Vector Codes—*E. D. Stoll, Bell Telephone Labs., Inc.; Ludwik Kurz, City Univ. of New York (45.2, Wed./a.m./SS)*
- Nonparametric Detection by Rank Statistics: A Unified View—*E. A. Feustel, L. D. Davisson, Princeton Univ. (45.3, Wed./a.m./SS)*
- A Linear Residue Recurrent Code—*David Mandelbaum, Communication Systems, Inc. (45.4, Wed./a.m./SS)*
- Digital Optimization of Exponential Representations of Signals—*R. W. Sears, Jr. (45.5, Wed./a.m./SS)*
- Ternary Phase Difference Modulation for Data Transmission in Telephone Networks—*H. V. Voss, Siemens A. G. Central Labs., Germany (48.2, Wed./p.m./MH)*
- Correlative Data Transmission with Coherent Recovery Using Absolute Reference—*Adam Lender, Lenkurt Electric Co., Inc. (48.3, Wed./p.m./MH)*
- The Prevention of Transmission Buffer Overflow in Telemetry Data Compressors—*J. E. Medlin, Lockheed Palo Alto Research Labs. (48.5, Wed./p.m./MH)*
- Dispersive and Nondispersive IF Ultrasonic Delay Lines—*J. H. Eveleth, Anderson Labs., Inc. (49.1, Wed./p.m./N)*
- Delay Line Transducer Materials—*D. A. Berlincourt, Clevite Corp. (49.2, Wed./p.m./N)*
- Ultrasonic Light Modulation and Deflection—*Robert Adler, Zenith Radio Corp. (49.3, Wed./p.m./N)*
- Delay Line Memory and Time Compression Systems—*P. S. Fuss, Bell Telephone Labs., Inc. (49.5, Wed./p.m./N)*
- Correlation and Pulse Compression—*L. J. Cutrona, Conduccion Corp. (49.6, Wed./p.m./N)*
- A New High-Sensitive Subminiature Condenser Microphone—*Yasuhiro Rikow, Matsushita Communication Industrial Co., Ltd., Japan (72.1, Thurs./p.m./SS)*
- Bandwidth Compression of Speech by Analytic-Signal Rooting—*M. R. Schroeder, J. L. Flanagan, E. A. Lundry, Bell Telephone Labs., Inc. (72.2, Thurs./p.m./SS)*
- Experimental, Limited-Vocabulary

- Speech Recognizer—*C. F. Teacher, H. Kellett, L. Focht, Philco-Ford Corp. (72.3, Thurs./p.m./SS)*
- Speech Processing Techniques and Applications—*H. F. Olson, H. Belar, E. S. Rogers, Radio Corp. of America (72.4, Thurs./p.m./SS)*
- Communication Transmission Requirements as Seen by Astronauts and Aquanauts—*Scott Carpenter, Manned Spacecraft Center (72.5, Thurs./p.m./SS)*

## Solid-State Devices and Theory

- Solid-State Microwave Power Sources—*Fred Sterzer, Radio Corp. of America (7.1, Mon./a.m./RS)*
- The Future Role of Field-Effect Devices in Electronics—*F. P. Heiman, Radio Corp. of America (15.2, Mon./p.m./RN)*
- Secondary Breakdowns in Power Transistors and Circuits—*W. C. Steffe, Fairchild Semiconductor Research & Development Labs. (15.3, Mon./p.m./RN)*
- New Solid-State Devices for Microwave Power Generation—*M. R. Barber, Bell Telephone Labs., Inc. (15.4, Mon./p.m./RN)*
- Microwave Semiconductor Devices—*R. R. Webster, Texas Instruments Inc. (16.1, Mon./p.m./R)*
- Microwave Hybrid Integrated Circuits—*J. E. Dalley, Bell Telephone Labs., Inc. (16.2, Mon./p.m./R)*
- Recent Advancements in Microwave Integrated Circuits Combining Semiconductor and Ferrimagnetic Elements—*J. C. Hoover, G. A. Foggia, R. W. Peter, L. B. Valdes, Watkins-Johnson Co. (16.4, Mon./p.m./R)*

## Space Electronics

- Satellite Communications in Global Networks, Including Mobile and Avionic Applications—*S. P. Brown, U. S. Army Satellite Command Agency (12.6, Mon./p.m./MH)*
- Integration of a Digital Computer into a Maneuvering Re-entry Vehicle—*Herb Most, General Electric Co. (14.3, Mon./p.m./R)*
- Interaction of the Solar Wind with the Magnetosphere—*W. I. Axford, Cornell Univ. (28.4, Tues./p.m./R)*
- Allocation of Multiple-Access Satellites to Multi-Antenna Terminals—*R. J. Heppe, A. L. Cohen, System Sciences Corp. (36.1, Tues./p.m./SS)*
- A Frequency Time-Hopping Random Access Technique for Satellite Communications—*J. H. Wittman, Sylvania Electronic Systems (36.2, Tues./p.m./SS)*
- Experimental Determination of Intermodulation Distortion Produced in a Wideband Communications Repeater—*A. L. Berman, I. L. Podraczky, Communications Satellite Corp. (36.3, Tues./p.m./SS)*
- Visual Sensors in Space—*J. J. Dishler, Radio Corp. of America (48.1,*

Wed./p.m./MH)

New Horizons in Space Technology—  
A. L. Kelly, NASA (52.5,  
Wed./p.m./RS).

## System Engineering

A Method for Predicting System Downtime—E. J. Muth, General Electric Co. (9.3, Mon./a.m./SS)

Trouble/Failure Reporting System for Surveyor Spacecraft—F. A. Paul, Jet Propulsion Lab. (9.5, Mon./a.m./SS)

Nonlinear Regression and Stochastic Approximation—Arthur Albert, ARCON (11.1, Mon./p.m./MH)

Identification for Control Purposes—James Eaton, International Business Machines Corp. (11.2, Mon./p.m./MH)

A Survey of Direct Optimization Techniques—Douglas Wilde, Stanford Univ. (11.3, Mon./p.m./MH)

The Evolution of Computer Operating Systems—W. C. Lynch, Case Institute of Technology (25.1, Tues./a.m./RS)

Time-Sharing Systems: A Review—B. W. Arden, Univ. of Michigan (25.2, Tues./a.m./RS)

The Digital Simulation of a Marine Gas Turbine and Its Controls Using MIMIC—J. C. Fistere, Jr., Westinghouse Electric Corp. (29.1, Tues./p.m./MH)

Simulation of a Large Central Station—R. G. Abraham, F. E. Wallace, Westinghouse Electric Corp. (29.2, Tues./p.m./MH)

An Application of an Analog Computer to Solve the Two-Point Boundary-Value Problem for a Fourth-Order Optimal Control Problem—V. J. Darcy, R. A. Hannen, Air Force Institute of Technology, Wright-Patterson Air Force Base (29.3, Tues./p.m./MH)

Process Automation in the Petrochemical Industries—T. M. Stout, Profitronics, Inc. (47.3, Wed./p.m./MH)

Systems Engineering in Surface Transportation Systems—R. M. Michaels, U. S. Department of Commerce (58.1, Thurs./a.m./N)

Field Experience with Quasi-Electronic Telephone Switching Systems—H. Willrett, Standard Elektrik Lorenz AG, Germany (66.1, Thurs./p.m./MH)

Human Communication in Complex Systems—R. L. Ackoff, Univ. of Pennsylvania (67.2, Thurs./p.m./N)

## Television

New Horizons in Television and Broadcasting—G. H. Brown, Radio Corp. of America (52.2, Wed./p.m./RS)

Practical Application of a High-Level CATV Transmission System—J. R. Palmer, C-Cor Electronics Inc. (68.1, Thurs./p.m./R)

Expanded Broadcast Coverage (TV) Through the Medium of CATV—L. Reinsch, Cox Broadcasting Corp. (68.2, Thurs./p.m./R)

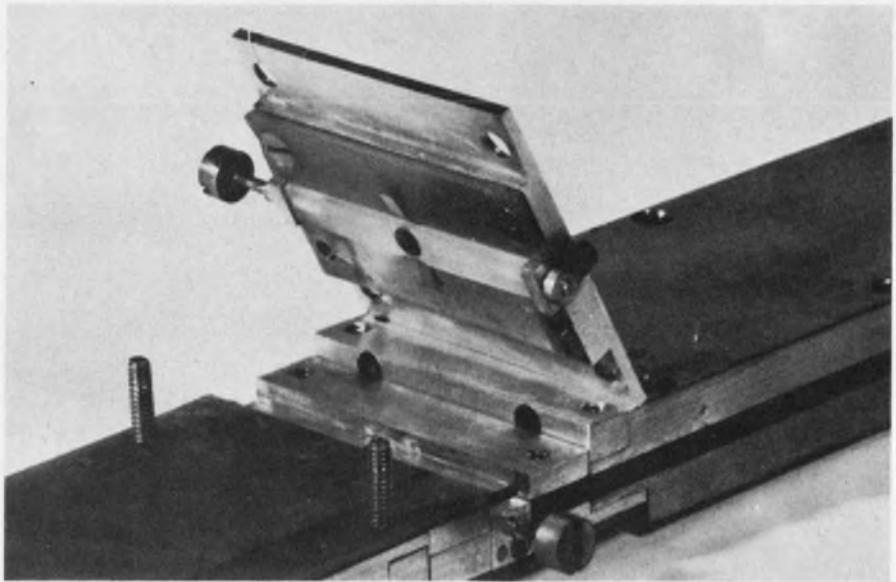

Pure YIG disk filter can resonate to below 2 GHz. It is tuned by adjusting the applied (static) magnetic field (Paper 7/5).

An 18-GHz CATV Distribution System: Propagation Tests—H. J. Schlasly, TelePrompter Corp. (68.3, Thurs./p.m./R)

## Test Equipment and Techniques

Measurement of Unbalance Attenuation—L. O. Olson, Western Electric Co., Inc.; J. C. Mau, General Telephone Co. of Florida (21.3, Tues./a.m./MH)

Compact Solid-State Automatic Level-Measuring Set—C. B. Crane, Jr., Northeast Electronics Corp. (21.4, Tues./a.m./MH)

The Advantages of a Ten-Kilohm Transportable Resistance Standard—R. M. Pailthorp, Electro Scientific Industries, Inc. (59.1, Thurs./a.m./R)

The Problem of dc Null Detection and Their Solution—John Parnell, Frank Brem, Honeywell Inc. (59.2, Thurs./a.m./R)

An Accurate, Semiautomatic Technique of Measuring High Resistances—S. H. Tsao, National Research Council (59.5, Thurs./a.m./R)

An Impedance Meter for Automatic Test Systems—W. A. Plice, Honeywell, Inc. (59.6, Thurs./a.m./R)

Thermal and Infrared Methods for Nondestructive Testing of Adhesive Bonded Structures—E. W. Kutzscher, K. H. Zimmerman, Lockheed-California Co. (61.1, Thurs./a.m./RS)

A Novel Sensor for Microelectronic Weld Quality Evaluation—S. N. Bobo, Jr., Raytheon Co. (61.2, Thurs./a.m./RS)

Automated Troubleshooter Works on Infrared Signatures—Riccardo Vanzetti, J. F. Stoddard, Raytheon Co. (61.3, Thurs./a.m./RS)

Infrared Radiometry of Semiconduc-

tor Devices—D. A. Peterman, Wilton Workman, Texas Instruments Inc. (61.4, Thurs./a.m./RS)

Infrared Pinpoints Second Breakdown Before Failure—N. F. Nowakowski, F. A. Laracuente, NASA (61.5, Thurs./a.m./RS)

## Transportation

Electric Automobile: Fact or Fiction—Manfred Altman, Univ. of Pennsylvania (33B.2, Tues./p.m./RN)

ATC in the "Super Jet" Age—R. J. Shank, Vice President Airborne Instruments Lab. (35.1, Tues./p.m./SN)

Anglo-French ATC Preparations for the Concorde—L. Lansalot-Basou, Director, Air Navigation, Secrétariat Général à l'Aviation Civile et Commerciale (35.2, Tues./p.m./SN)

The Airplane Manufacturer Looks at the Environment of the 1970's—A. F. Norwood, The Boeing Co. (35.3, Tues./p.m./SN)

Airline Preparations for SSTs and Jumbo Jets—N. E. Halaby, Pan American World Airways, Inc. (35.4, Tues./p.m./SN)

United States ATC preparations for the "Super Jet" Age—J. Blatt, Associate Administrator for Development, Federal Aviation Agency (35.5, Tues./p.m./SN)



Systems Engineering in Surface Transportation Systems—R. M. Michaels, U. S. Department of Commerce (58.1, Thurs./a.m./N)

Restraint Systems and Novel Human Packaging—Carl Clark, Martin Co. (58.2, Thurs./a.m./N)

Designing for Passenger Comfort in High-Speed Transportation—R. A. McFarland, H. W. Stoudt, Harvard School of Public Health (58.3, Thurs./a.m./N)

Human Decision-Making and High-Speed Transportation—T. B. Sheridan, MIT (58.4, Thurs./a.m./N)

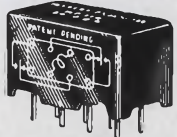

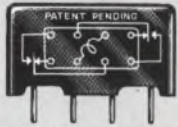
NEW! A commercial relay this  small with 2-ampere dpdt contacts. Printed circuit or socket terminals.  Has Lexan dust cover. This design bonus from our aero/space program is ideal for tape recorders, desk-top computers,  copying machines, television cameras, alarm systems, etc., etc., etc., etc., etc., etc.

High density relay packaging becomes a reality with the low profile HP Series. Only one-fifth of a cubic inch is required for each relay. Seated height in socket or printed circuit board is 0.49". Mechanical life is placed at 10 million operations.

The DPDT contacts are rated from low level to 2 amperes at 30V DC resistive or 0.5 ampere maximum at 120V AC. Coil voltages range from 6V to 48V DC . . . with 12- and 24-volt models available from authorized electronic parts distributors.

These microminiature relays are direct descendants of our military, aero/space designs and have been engineered to perform with singular reliability in modern commercial equipment.

#### HP SPECIFICATIONS

##### GENERAL:

**Temperature Range:** -45°C to +70°C.  
**Dimensions:** 0.49" x 0.88" x 0.48" max.

##### CONTACTS:

**Arrangement:** DPDT, 2 Form C.  
**Rating:** Low level to 2 amps @ 30V DC, resistive;  
 0.5 amps max. @120V AC.  
**Contact Resistance:** 50 milliohms before life measured at maximum rated load.

##### COILS:

**Power:** Approximately .662 watts nominal @ 25°C.  
 1.0 watts max. @ 25°C.  
**Duty:** Continuous.  
**Pick-up:** 75% of nominal @ 25°C.  
**Operate Time:** 5 milliseconds max. at nominal coil voltage and 25°C.

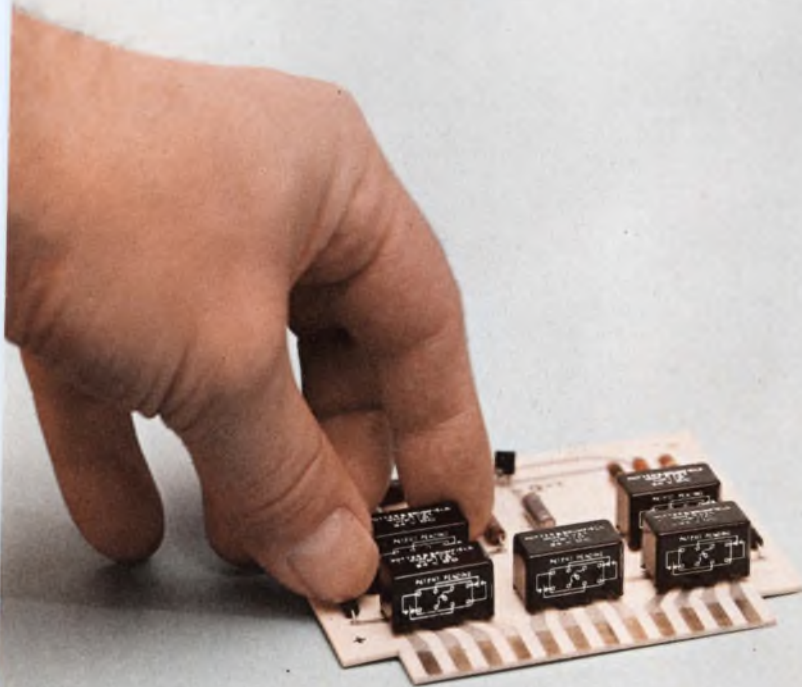

*Call your electronic parts distributor*



**POTTER & BRUMFIELD**  
 Division of American Machine & Foundry Co., Princeton, Ind. 47570  
 Export: AMF International, 261 Madison Ave., New York, N.Y. 10016



## **Reliable electrical connections**

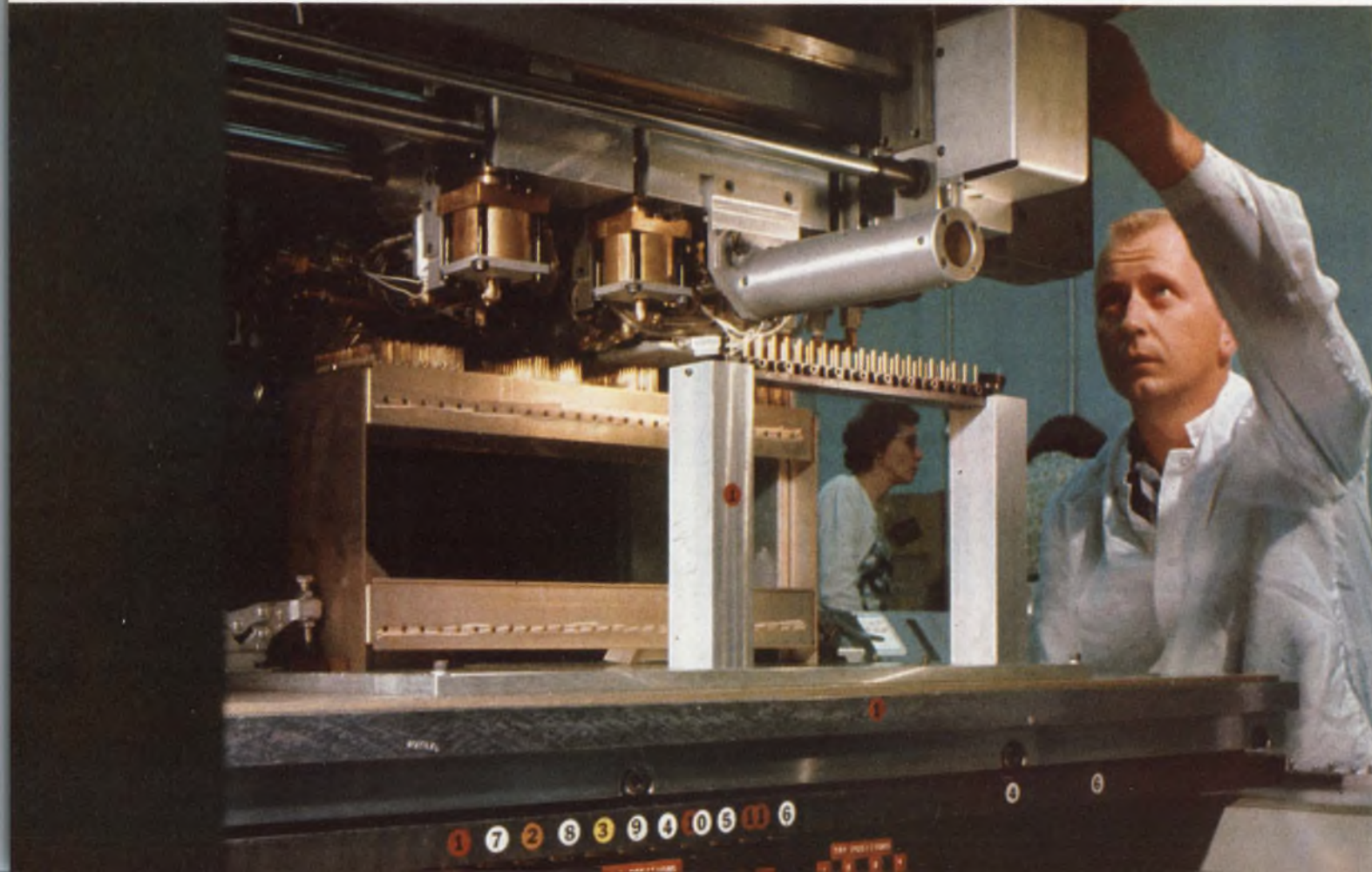

*See these machines running production...*

**GRID-  
DRILL™**

(A printed circuit board  
drilling machine)

**AUTOMATIC  
"WIRE-WRAP"®  
MACHINE**

*See them in action at the NEW YORK IEEE SHOW, March 20-23  
FIRST FLOOR BOOTH NUMBERS 1G12 - 1G14 - 1G16*

**in less than one second each**

Modular panels are quickly and securely wired on Gardner-Denver automatic "Wire-Wrap" machines, which are programmed with punched cards for maximum flexibility. Bulletin 14-121.

Reliable! More than 40 billion solderless wrapped connections have been made with "Wire-Wrap" equipment without a single reported electrical failure.



Film is scraped from wire and terminal at contact points. High pressure metal-to-metal contact invites solid state diffusion, maintaining low connection resistance.



Solderless wrapped connections remain gastight even when exposed to severe changes of temperature and humidity . . . so they're not affected by atmospheric corrosion.



Initial pressure may go as high as 100,000 psi. Pressure drops as wire relaxes, but stabilizes at a value greater than 29,000 psi.

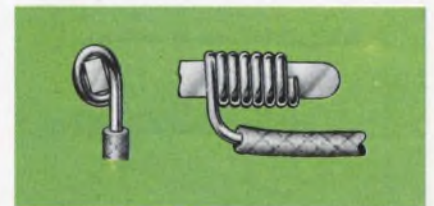

Flexible lead-off absorbs vibration and handling shocks . . . permits wrapped connection to stay tight and mechanically stable.



SEE WHAT AIR IS DOING NOW...SEE  
**GARDNER - DENVER**

# Touring the exhibit areas

From 75-ton encapsulating presses on the first floor to 75-mil integrators on the fourth, you'll find what's new here. Products are arranged in exhibition categories. Don't be a literature-lugger—use the Reader-Service card to “shop the show.”

Materials ..... P U128  
Production & Machinery ..... P U132  
Instruments ..... P U146  
Systems ..... P U178  
Components, 3rd floor ..... P U188  
Components, 4th floor ..... P U208

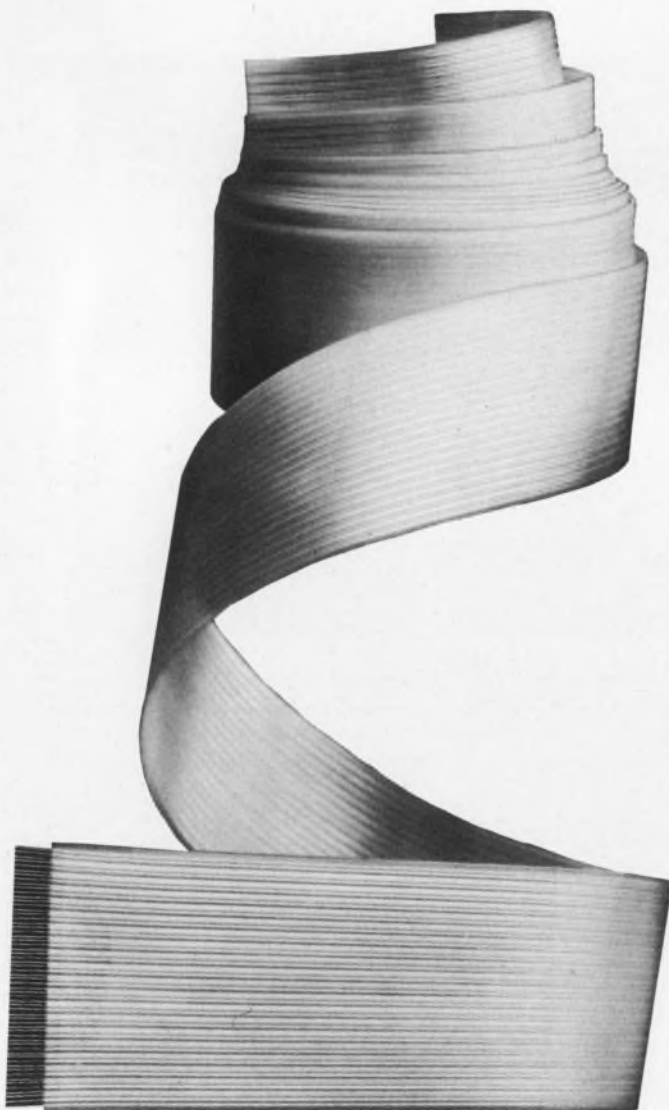

**Ribbon cable saves space.** Using Teflon TFE as the dielectric, 95- $\Omega$ , 20-signal transmission line can replace coaxial with a 90% space saving and easy assembly. Page U128.

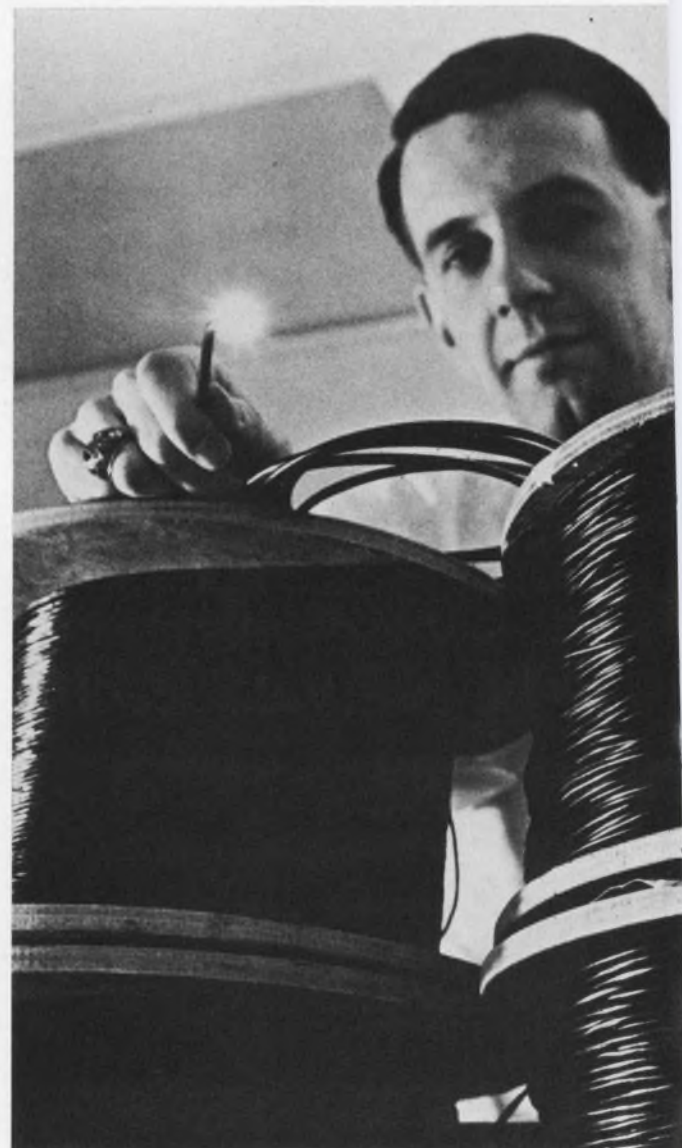

**Two miles of glass fiber optics.** Jacketed in PVC, the continuous-length noncoherent bundles are available in lengths to 10,000 feet. Page U219.

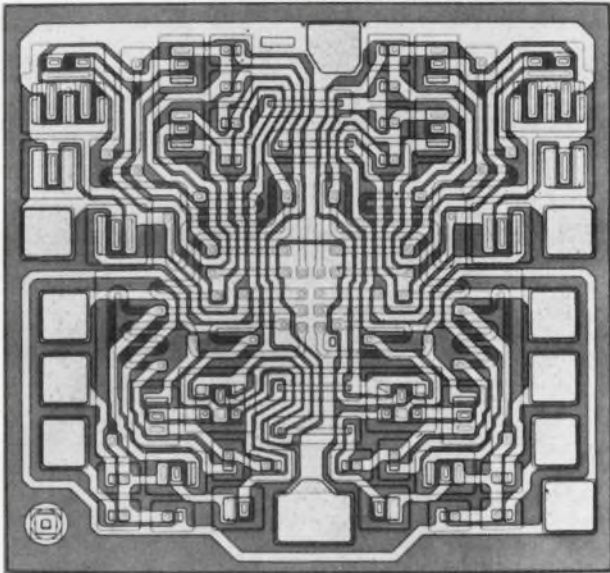

**Built-in avalanche emitter cuts noise** in logic ICs. A second emitter with avalanche breakdown characteristics is built into the output transistor of DTL circuits, such as this master-slave R-S flip-flop. Page U188.

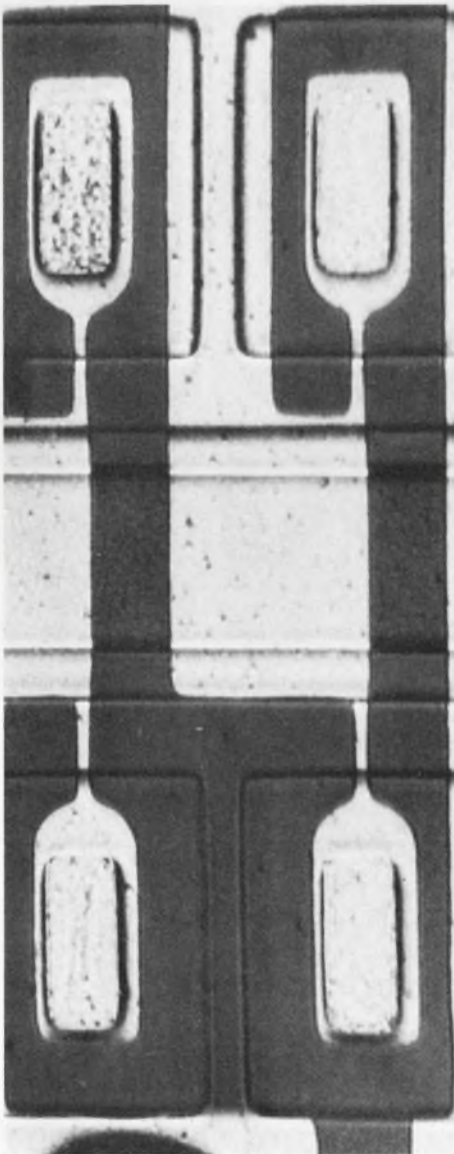

**Generate complex logic functions** with simple diode logic. Diode matrices and interface circuits team up. Page U208.

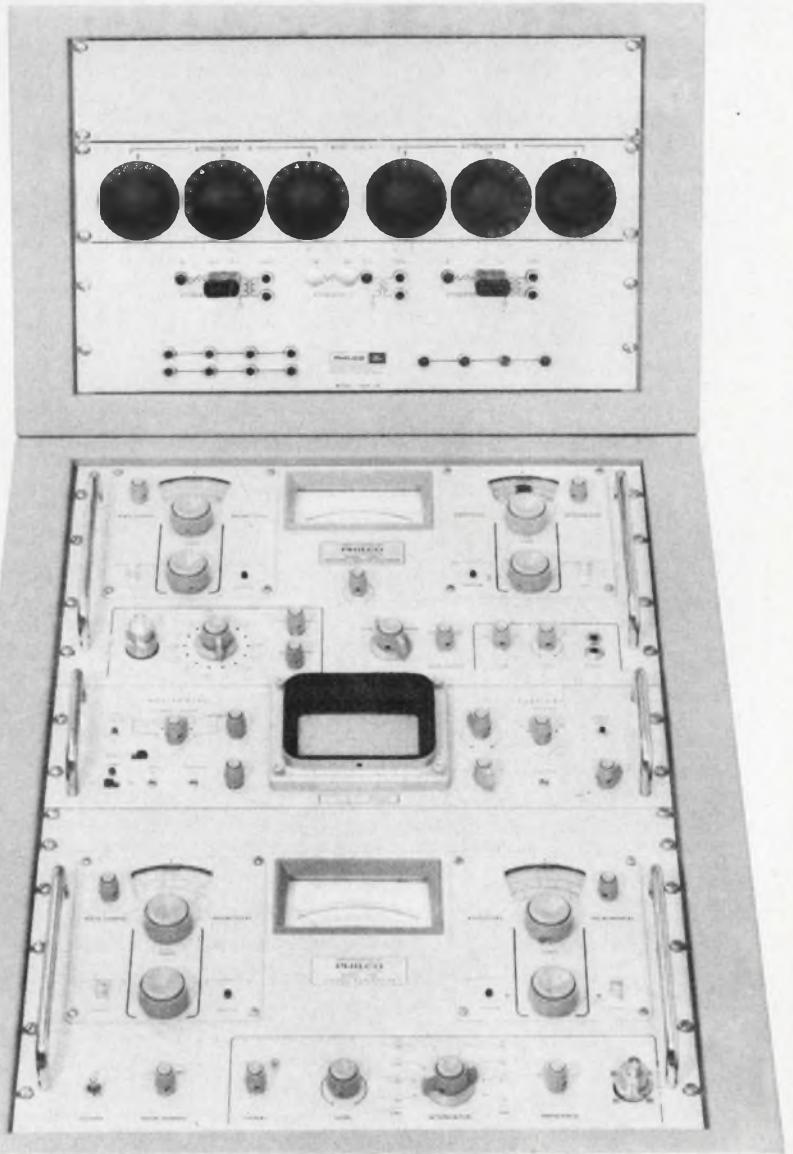

**Console contains complete transmission tester.** The set combines all the functions of a selective voltmeter, tracking generator, spectrum display, attenuator and impedance-matching panel in one. Page U178.

## PPO dielectric for microwave PC use

Polymer Corp., Reading, Pa. Phone: (215) 929-5858.

Z-Tron H, a modified PPO (polyphenylene oxide) base material with a dielectric constant of 2.72 is for use in stripline, microwave and high-frequency printed circuits. Available in copper-clad or unclad sheets, the material combines the strength, rigidity, thermal and dimensional stability of thermosets with the low, high-frequency electrical loss characteristics of thermoplastic olefins. The dielectric is designed for use in stripline circuitry and microwave printed circuits in missile ground support, general communications, warning systems, navigational and fire control systems, radar computers and other wide-temperature-range systems. Manufactured in 14 x 18 and 16 x 24-inch sheets, it can be obtained in larger or smaller sizes. Z-Tron H boards are operable over a wide temperature range (-270 to 375°F) and are produced to tolerances of ±0.001 inch.

Booth No. 1D26 Circle No. 288

## Accessory speeds harness tying

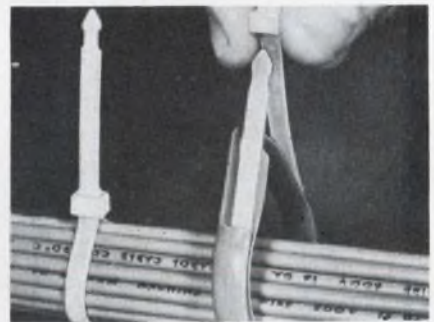

Panduit Corp., 17301 Ridgeland Ave., Tinley Park, Ill. Phone: (312) 532-1800.

Strap tying time on wiring harnesses can be reduced with a plastic Pan-Ring. Pan-Rings can be used on both point-to-point and harness board tying. They are available to tie bundles up to 1-1/4-inches in diameter.

Booth No. 1C16 Circle No. 291

It's time to renew your subscription to **ELECTRONIC DESIGN**. Return your renewal card today.

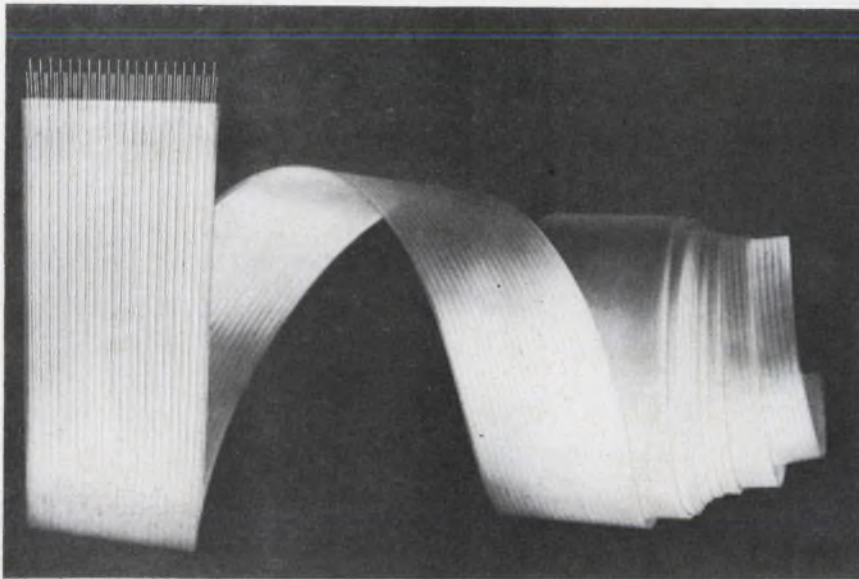

## Ribbon cable replaces coax in one-tenth the space

W. L. Gore & Associates, Inc., 555 Paper Mill Rd., Newark, Del. Phone: (302) 368-0651. P&A: \$1.20/ft (5000 to 25,000 ft), 90¢/ft (25,000 to 100,000 ft); 3 to 6 wks.

A 95-Ω ribbon cable transmission line is reported to take the place of coaxial cables at a 90% saving of space. The cable has already been used in the back plane of computers to carry signals from one section to the next. The over-all size of the 20-signal line is 1.15 by 0.026 inches.

Over-all size has been kept down by the parallel line geometry and the choice of insulation, Teflon TFE. TFE has the lowest dielectric constant (about 2.1) of any solid dielectric. This allows compact con-

ductor spacing for a required impedance and high propagation velocities. Attenuation losses are also held down since TFE's dissipation factor also is low (about 0.0002).

Crosstalk is effectively controlled through the use of a three-wire group; each signal lead is centered between ground wires. The basic three-wire unit is repeated 20 times across the cable for a total of 60 conductors. Stacking capability is good; since the geometry controls crosstalk, attenuation and impedance, these characteristics can be precisely defined.

A mechanical stripping tool prepares the cable for termination. When the cable is stripped, a small tab of Teflon is left on to permit easy separation of the signal leads. The signal leads are held by the tab. By bending the tab down, all of the ground leads are separated and are soldered to one side of a PC card. The card is flipped over so that the signal leads line up with termination points. They are then soldered.

The Teflon has almost universal chemical inertness. This inertness keeps cable properties stable regardless of exposure to ultraviolet radiation, high temperature, solvents or aging. The cables are very flexible and have a long flex life, dependent only on conductor fatigue. Booth No. 1G18 Circle No. 523

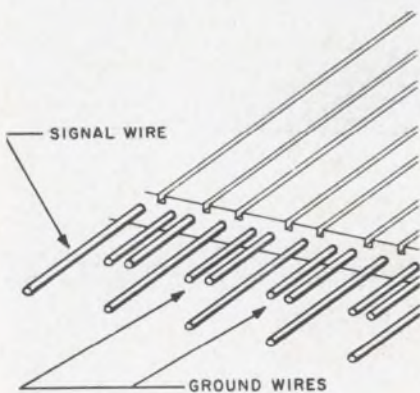

Signal wires are flanked by ground wires. This basic three-wire unit is repeated 20 times across the cable.



*explorer I*  
*explorer IV*  
*tiros*  
*telstar*  
*syncom*

*ranger VII*  
*ranger VIII*  
*ranger IX*  
*saturn I*  
*surveyor*



## the most honored resistor in the Space Program

■ Allen-Bradley hot molded resistors were chosen to participate in these many history-making space projects for only one vital reason—a history of proven performance that dates back for more than a quarter of a century! A record more conclusive than any testing program could possibly provide!

The superiority of Allen-Bradley resistors is found in the exclusive hot molding process. Through the use of completely automatic machines—developed and used *only* by Allen-Bradley—there is obtained such uniformity of characteristics from resistor to resistor, year after year, that the resistors' long term performance can be accurately predicted. Furthermore, no Allen-Bradley hot molded resistor has ever been found to have failed catastrophically.

The widespread use of the Allen-Bradley hot molded resistors in these space programs should convince you that to include this plus value in the equipment which you produce gives it the mark of "extra quality." Let us tell

you more about the complete line of Allen-Bradley electronic components. Please write for Publication 6024. Allen-Bradley Co., 222 W. Greenfield Ave., Milwaukee, Wis. 53204. In Canada: Allen-Bradley Canada Limited. Export Office: 630 Third Ave., N. Y., N. Y. U.S.A. 10017.



**HOT MOLDED FIXED RESISTORS** are available in all standard resistance values and tolerances, plus values above and below standard limits. Shown actual size.



**ALLEN - BRADLEY**

QUALITY ELECTRONIC COMPONENTS



# American Bosch

## uses Allen-Bradley Oriented Ceramic Permanent Magnets...

because of their uniformity in staying within specifications, and delivery schedules—though tight—are kept!

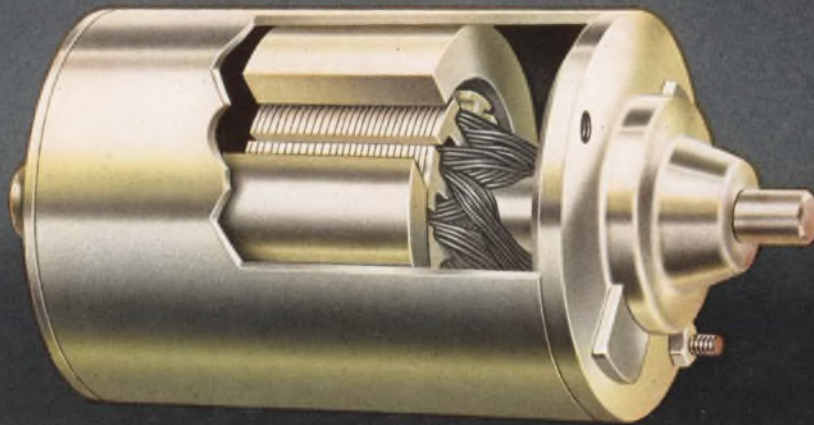

American Bosch permanent magnet motors are used for...

power windows

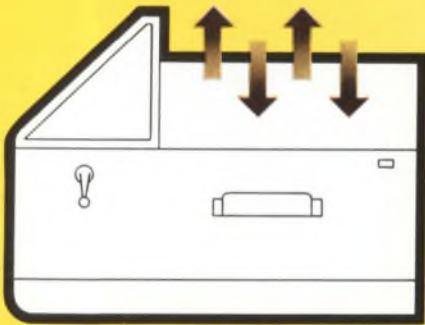

electric windshield wipers



power seats



Allen-Bradley's quality control procedures assure the continuously uniform properties—both electrical and physical—that are essential to profitable large volume motor production. The most modern manufacturing facilities in the hands of technically experienced craftsmen produce the highest quality, radially oriented ceramic permanent magnet segments that are presently available.

Allen-Bradley ceramic permanent magnets can be furnished for a wide range of motor sizes—from  $\frac{3}{4}$ " diameter up to a 10 hp motor rating. They are available in a variety of types—having different properties—to satisfy your specific requirements. A-B application engineers will be happy to consult with you in developing your dc motors for maximum motor performance. Allen-Bradley Co., 1316 S. Second St., Milwaukee, Wis. 53204. In Canada: Allen-Bradley Canada Limited. Export Office: 630 Third Ave., N.Y., N.Y., U.S.A. 10017.

Properties of typical Allen-Bradley ceramic permanent magnets

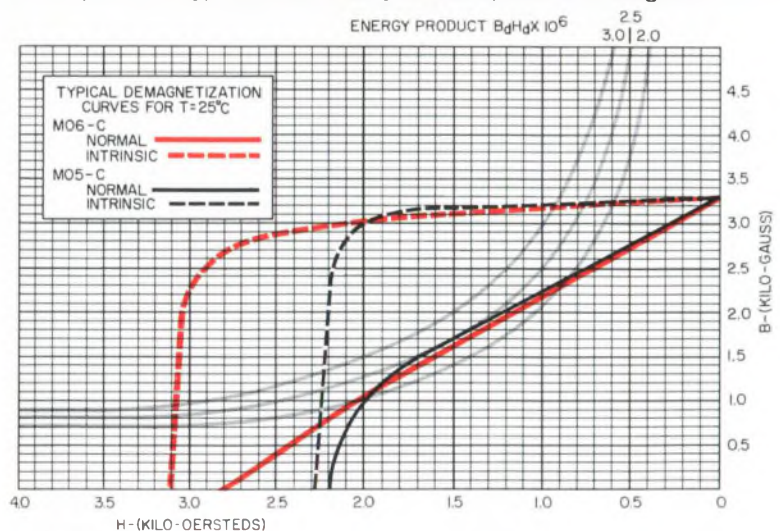

# ALLEN-BRADLEY

QUALITY MOTOR CONTROL  
QUALITY ELECTRONIC COMPONENTS



# Examine these outstanding new books for 10 days...with no obligation!

## EQUATIONS OF MATHEMATICAL PHYSICS

G. N. Polozhiy

This first English edition of Polozhiy's comprehensive text will prove an authoritative, time-saving aid for engineers and scientists faced with particularly difficult mathematical problems or interdisciplinary considerations. Exceptional in its scope and thoroughness, it is nonetheless compact and easily read. #5807, 556 pp., \$14.50

## MICROWAVE SYSTEMS PLANNING

Kenneth L. Dumas & Leo G. Sands

Providing a comprehensive view of the field, this book defines and explains the important criteria involved in the planning, engineering, and installation of microwave equipment used for communications purposes. Discussion is confined to point-to-point FM systems, with the use of terms, phrases, and symbols following telephone practice. #5696, 152 pp., Illustrated, \$8.00

## TRANSISTORS FOR AUDIOFREQUENCY

Guy Fontaine

This long-awaited companion volume to Fontaine's highly successful *Diodes and Transistors* gives special treatment to the practical aspects of semiconductors in the audio-frequency region (small signals, large signals, symmetric stages), in the radiofrequency range (behavior of the transistor in this range, amplification stages), and in the I.F. range. #5641, 384 pp., Illustrated, \$7.95

## ELECTRICITY ONE-SEVEN ELECTRONICS ONE-SEVEN

Prepared by a team of educational specialists under Harry Mileaf, Editor-in-Chief, and designed to meet all the requirements of modern technical education, these comprehensive and up-to-date courses are certain to become standards for fundamental preparation in electricity and electronics. Each course contains almost 1000 pages and over 900 two-color illustrations, and may be purchased in a single clothbound edition, as a set of 7 paperbound volumes, or in individual self-contained units. **ELECTRICITY 1-7**, Clothbound, #5551, \$12.76; Paper set, #5543, \$16.95. **ELECTRONICS 1-7**, Clothbound, #5560, \$14.96; Paper set, #5552, \$20.95

*Will you be at  
the IEEE Show?  
We will.*

**Booth #4G 37**

Examine these and many more  
invaluable books at the show.

**DON'T MISS OUR SHOW SPECIALS!**

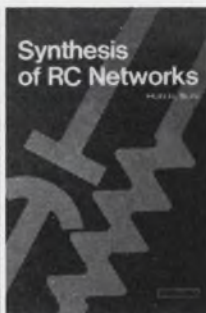
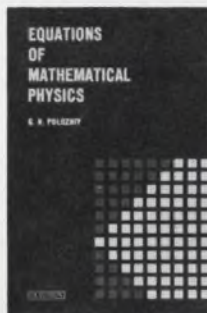

... and don't forget these  
top-notch recent titles:

## ENGINEERS' RELAY HANDBOOK

Nat'l Assn. of Relay Manufacturers

From terminology to testing procedures, here is the first complete roundup of objective relay information. Specifically prepared for the relay user, this invaluable reference has received international acclaim. ("A relay handbook to rely on"—*Product Engineering*.) #5665, 300 pp., Illustrated, \$11.95

## MICROELECTRONIC DESIGN

Edited by Howard Bierman

Almost 90 authoritative discussions of all aspects of microelectronics have been selected from *Electronic Design* and organized into a compact, convenient, and comprehensive reference. Each topic has been approached in practical and useful terms to provide a working overview of the field. #5762, 312 pp., Illustrated, \$11.50

## SYNTHESIS OF RC NETWORKS

Hun H. Sun

A complete and up-to-date text on the theory and practice of RC network synthesis. Includes all basic theory and practical design procedures needed for one-port and two-port synthesis, controlled-source devices, and general RC active network design. An added feature is the particularly thorough tutorial treatment of continued fractions, real roots of polynomials, and polynomial decomposition. #5676, 150 pp., Illustrated, \$7.50

## CIRCUIT PROBLEMS AND SOLUTIONS

Vol. 1: Elementary Methods Gerard Lippin

Here is a handy reference tool for technical training and a practical guide for the solution of electrical problems. Each chapter first briefly reviews a particular aspect of circuit theory and then applies it to numerous problems, showing their step-by-step solutions. Nearly 300 such problems extend from simple series circuits to series-parallel RLC circuits. #5754, 208 pp., Illustrated, \$3.95

## TRANSISTOR AND DIODE NETWORK PROBLEMS AND SOLUTIONS

Harry E. Stockman

This two-way reference demonstrates the practical application of theory and serves as sourcebook of step-by-step mathematical solutions to practical problems. With schematic situations covering the entire field of transistor and diode networks, the reader develops effective techniques by comparing his own solution methods with the author's. #5694, 332 pp., Illustrated, \$9.95

## TRANSISTOR BASICS: A SHORT COURSE

George C. Stanley, Jr.

For your own review, or for training technicians, here is a fast way to gain a practical understanding of transistors. Its simplified approach to transistor circuit analysis will enable the reader to determine desired values to an accuracy adequate for almost any practical situation. Includes material on working with and handling transistors and transistor troubleshooting techniques. #5819, 112 pp., Illustrated, \$2.75

HAYDEN BOOK COMPANY, INC., 116 W. 14 St., New York, N.Y. 10011

Send me the books circled below for a free ten-day examination. At the end of that time I will remit payment (plus postage) for those I wish to keep and return the rest.

5665	5762	5807	5696	5694	5819	5676
5754	5641	5551	5543	5560	5552	

Name \_\_\_\_\_

Title \_\_\_\_\_

Company \_\_\_\_\_

Address \_\_\_\_\_

City \_\_\_\_\_ State \_\_\_\_\_ Zip \_\_\_\_\_

Check here if payment enclosed. Publisher pays postage with same return guarantee. (On all foreign orders except Canada, payment in \$US must be enclosed.)

## Aerospace wire cuts weight

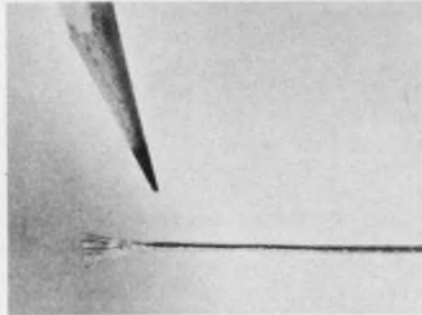

Rockbestos Wire & Cable Co., P. O. Box 1102, North Haven, Conn. Phone: (203) 787-1141.

Interzone X is constructed with a heat-sealed film insulation system over stranded silver-coated copper conductors. Maximum temperature rating is 200°C. The film insulated wire and cable claims weight savings of 22 to 36% and space savings of 35 to 50%. The insulation burns only in direct contact with flame, and there is no after-flame or melting.

Booth No. 1E29 Circle No. 290

## Tie anchor provides 'dual support'

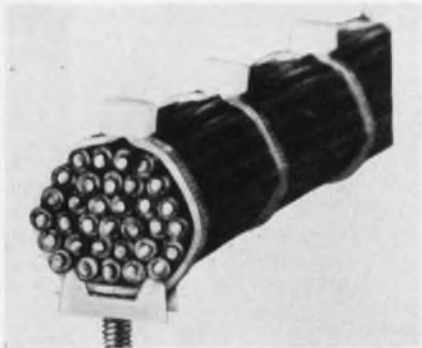

Panduit Corp., 17301 Ridgeland Ave., Tinley Park, Ill. Phone: (312) 532-1800.

A dual-support tie anchor secures wire harnesses more firmly. The nylon anchor is suitable for application in areas subject to vibration, high-G loads or shock. Two anchor points, instead of the usual one, form a platform to support the cable bundle, resulting in a more rigid mount with increased harness stability.

Booth No. 1C16 Circle No. 292

## Thread insert strengthens fasteners



Heli-Coil Corp., Danbury, Conn. Phone: (203) 743-7651.

Significant weight reduction as well as addition of strength to threaded assemblies are claimed for this thread insert. The #2-56 Heli-Coil insert is a spiral coil of stainless steel wire that clads the thread of a tapped hole. When installed in aluminum, magnesium or titanium it permits the use of a smaller, less bulky boss area with actual gain in thread strength.

Booth No. 1F27 Circle No. 293

## Plastic ball joints double as dielectric

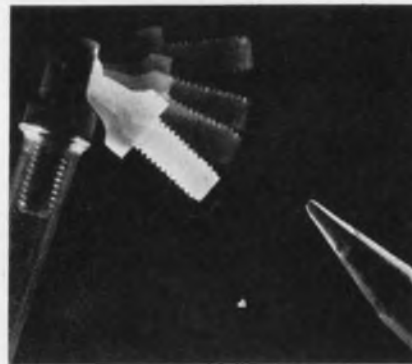

Gries Reproducer Co., New Rochelle, N. Y. Phone: (914) 633-8600.

Nylon-acetal ball joints are designed for light loads in push-pull linkages or for use in mechanisms where ability to compensate for misalignment during assembly or operation is necessary. Design of the ball joints permits up to 40° of angular motion on any axis. In electrical equipment, the dielectric strength provided enables the joints to link components mechanically, while isolating them electrically.

Booth No. 1G08 Circle No. 289

## Heat sink for fused glass diodes

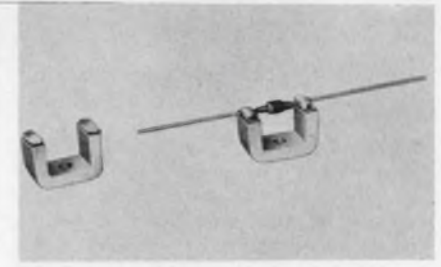

Wakefield Engineering, Inc., Wakefield, Mass. Phone: (617) 245-5900.

Type 258 thermal links heat sink fused glass diodes. Copper solder points are isolated from, but bonded to, the aluminum U-form. Dielectric coating extends down the legs to provide a long creepage path. All units are tested at 1000-V hipot. The unit is screw-mounted.

Booth No. 4B04 Circle No. 370

## Self-adhesive tabs indicate temperature



Tempil Corp., 132 W. 22nd St., New York. Phone: (212) 675-6610.

Self-adhesive temperature monitoring tabs combine the accuracy of a phase change (melting) with a color change. Each of the bull's eye spots within the indicator circles will transform from white (or near-white) to black at the temperature ratings specified on the Templabel. The change is irreversible and occurs at the stated temperature with an accuracy of ±1%. Transparent Mylar or mica windows protect the temperature indicating spots and minimize the possibility of contamination. Tempilabel singles are available in a choice of 47 single temperature ratings, spaced in the range of 100 to 500° F. The multiple type contain a sequence of 4 temperature ratings and are available in 49 temperature combinations.

Booth No. 4A06 Circle No. 372

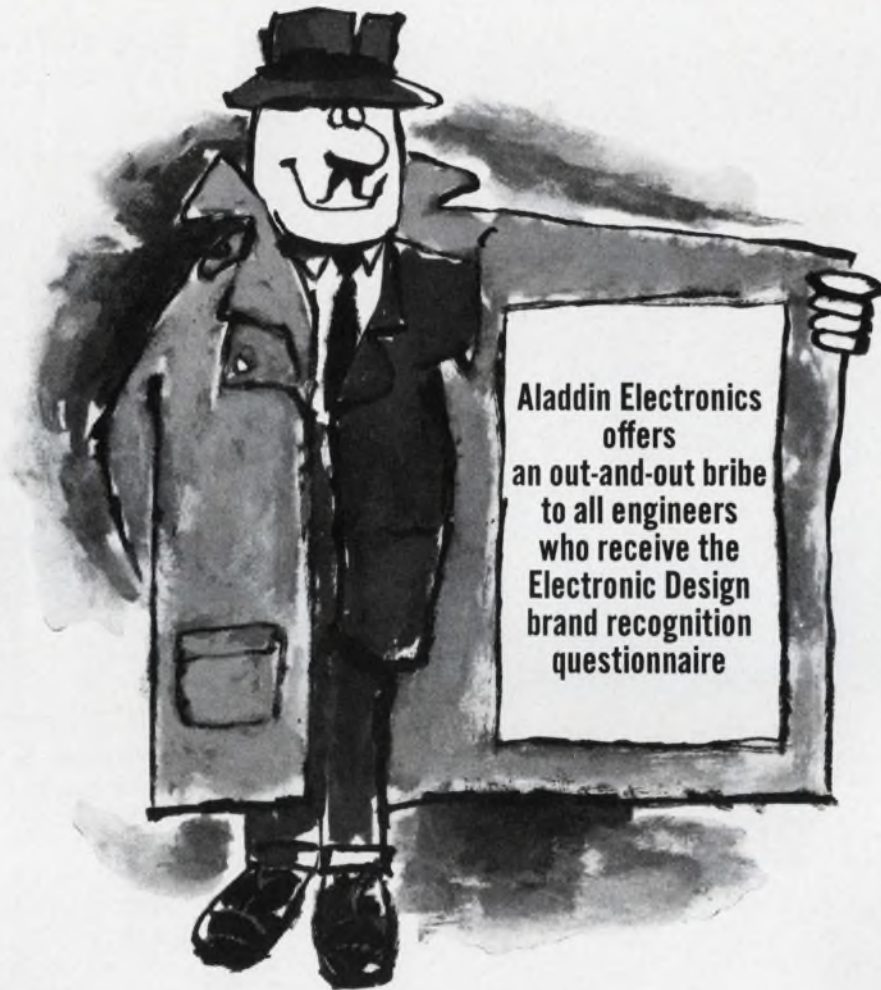

## here are the details of the offer:

Answer "Aladdin Electronics" to these questions in the Electronic Design brand recognition questionnaire:

"What manufacturers would you consider when planning purchase of: TRANSFORMERS & CHOKES; FILTERS; TOROIDAL COILS; REACTORS?"

Then write Aladdin and tell us you mentioned us. We will reward you with the following design aids: (1) A copy of the Aladdin Transformer Encyclopedia, (2) Three wall charts for selection of pulse transformers, inductors and frequency selective devices, (3) Numerous engineering bulletins including variable inductors, LC filters, delay lines, (4) (optional on your part) a personable, technically-oriented expert to discuss your projects, applications engineering problems, aspirations and even your hobbies, (5) A filter specification form with a universal curve that can be related to the characteristics of any filter, and finally (6) Our warmest thanks.

Your richest reward will be service! . . . Samples to your specifications, intelligent businesslike pricing, reliability of design and reliability in meeting delivery promises.

We will send you items 2, 4, and 6 if you will just circle the number below on the bingo card in the back of this publication. For the full treatment (items 1 through 6 inclusive) write to Aladdin Electronics, Nashville, Tennessee, and tell us you said "Aladdin Electronics" in answer to the Electronic Design Questionnaire.

★  
*where the magic of magnetics is a science...*

**Aladdin**<sup>®</sup>  
**electronics** /

703 Murfreesboro Road,  
Nashville, Tennessee

ON READER-SERVICE CARD CIRCLE 71

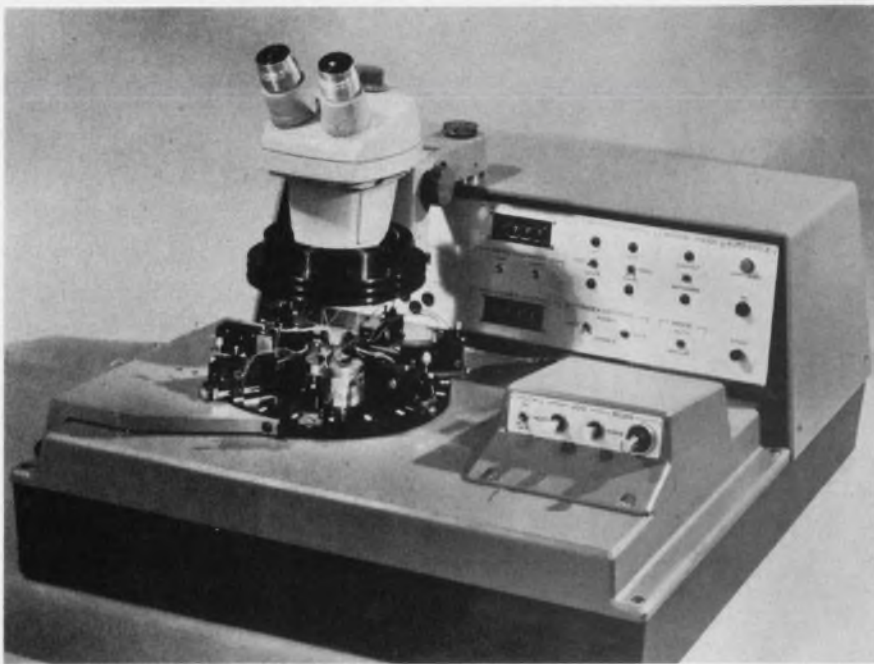

## Semiconductor wafers probed at rate of 20,000 per hour

*Electroglas, Inc., 150 Constitution Dr., Menlo Park, Calif. Phone: (415) 325-1536. P&A: \$12,700; April.*

A fully automated semiconductor wafer system is capable of operating rates of 19,700 devices per hour with inking or 27,000 devices per hour without inking. In addition, the model 900 prober, which is 92% ICs, has 100% electronic sequencing, edge-sensing circuitry and an inking reject system so that the probing rate is not affected unless inking actually occurs.

The manufacturer, Electroglas Inc., credits a proprietary technique for programming and control of X- and Y-axis stepping motors as responsible for the high acceleration and deceleration rates. Despite the high speeds, indexing accuracy is maintained at  $\pm 0.0001$  in./in. over an X- and Y-indexing range of 0.005 to 0.9995 inch.

All but 8% of the control electronics and logic circuitry of the unit are DTL ICs. All the transistors are silicon planar types, 50% derated. The electronics are housed on a swing-out card cage, using plug-in PC boards.

Edge-sensing circuitry (proprie-

tarily called Wafer Profiler) eliminates "waste" probing in areas beyond the periphery of the test wafer. Maximum wafer size capacity is 2-inch diameter. The sensing circuitry permits programming of reversal and row change delay from 0 to 9 steps of the wafer. This ensures testing of all devices—even those on partial or broken wafers. In all cases, the machine stops automatically 10 steps off the wafer. The Wafer Profiler also locks out the external test set when probers are in an off-wafer position. Thus, the counter only records the actual number of devices tested.

The unit's ring assembly has provision for mounting any combination of probes and inkers totaling twenty. The standard unit comes fitted with six inkers. Inking time (nominally 0.05 second) is automatically subtracted from the probing cycle when inking is not required or desired.

Utilities required are 110 to 125 Vac at 50 or 60 Hz, single-phase, 1.25 kW; 18 to 25 inch/minute Hg vacuum and 40 to 80 psi air pressure. The complete unit weighs 190 pounds and occupies 25 by 22 inches of bench space.

*Booth No. 1G26 Circle No. 522*

## Wire marker makes 175 imprints per minute



*Ackerman-Gould Co., Inc., 10 Neil Court, Oceanside, N. Y. Phone: (516) 678-4110.*

Wire can be marked at 175 imprints per minute with this automatic machine. Printing pressure and spacing between markings can be controlled during operation. For printing on insulated hookup wire, guide blocks are required. For printing on flexible tubing, an adjustable self-centering device is necessary. Each wheel has forty letters (or numbers) and one blank.

*Booth No. 1A07 Circle No. 378*

## Machine inserts wide variety of components

*United Shoe Machinery, 140 Federal St., Boston. Phone: (617) 542-9100.*

All kinds of axial-lead components from small diodes to large capacitors can be handled by this component inserting machine. Insertion units can be used interchangeably for different components, with a changeover time of less than 2 minutes by operators with little training. High product uniformity is claimed.

*Booth No. 1H07 Circle No. 379*

Remember to return your **ELECTRONIC DESIGN** renewal card. Don't miss any issues in '67.

Use the new Fluke 931A to measure virtually any waveform within 0.05% from 30 Hz to 50 KHz. Make these measurements without losing null sensitivity as the voltage decreases. For in the Fluke 931A, the null meter indicates percent deviation from the dialed voltage. Overall frequency response is 10 Hz to 1 MHz. Range is 0.01 to 1100 volts. Ten to one crest factor takes care of effects caused by voltage spikes and pulse trains. Other features include low capaci-

tance, high resistance input, inline digital readout with lighted decimal point, all solid state design, and linear recorder output. Meets MIL-SPEC shock and vibration requirements. Ten percent overranging cuts down range changing. Available with or without probe in both line and combination line rechargeable battery powered versions. Base price \$895. Call your full service Fluke sales engineer (see EEM) for a demonstration or write us for full information.

See us at the IEEE Booths 2C02-2C04



**When you use the probe  
to make true RMS measurements with  
the Fluke 931A AC differential voltmeter,  
you don't do a thing to the circuit  
or the meter. All you do is move the  
input 30 inches closer to the measurement  
without added loading or loss of  
sensitivity. That's just one more reason  
AC metrology isn't the same anymore.**

**FLUKE**

Fluke. Box 7428, Seattle, Washington 98133 • Phone: (206) 774-2211 • TWX: (910) 449-2950  
In Europe, address Fluke International Corporation • Suite D, Ambassador Hotel,  
Sophialaan 2, The Hague, The Netherlands • TELEX: 845-53239

# 48 circuits per foot

Actual  
Size



## ...no lugging!

## BUCHANAN<sup>®</sup> miniature terminal block.

- Snap-fit sections—no unused circuits.
- No hidden contacts or marking areas.
- Direct or channel mounting.

With 1/4" center-to-center spacing, Buchanan Miniature Terminal Block allows more circuits per space than any other 300V sectional block. Tubular contact with captive clamp eliminates lugging! Block handles up to #12 AWG. Rated 300V NEMA General Industrial Control Devices and 600V NEMA Limited Power Circuits. For Free Samples, write on your company letterhead.

FREE catalog  
available on  
request.



**BUCHANAN**  
ELECTRICAL PRODUCTS CORPORATION

1065 Floral Avenue • Union, New Jersey 07083  
(201) 289-8200 • Telex 1-25471

a subsidiary of Elastic Stop Nut Corporation of America

308

ON READER-SERVICE CARD CIRCLE 73

U134

## PRODUCTION & MACHINERY—1ST FLOOR

### Drag solderer is complete system



Zeva Electric Corp., 11 Park Pl.,  
New York. Phone: (212) 227-8288.  
Price: \$3304.

A complete soldering system features foam or rotating brush fluxer, pre-heating station and soldering station. It features independent and automatic speed control of the conveyor when the PC board enters and leaves the solder bath. The system is ready to operate within 40 minutes.

Booth No. 1G05 Circle No. 267

### Mark wire and cable to #26 AWG

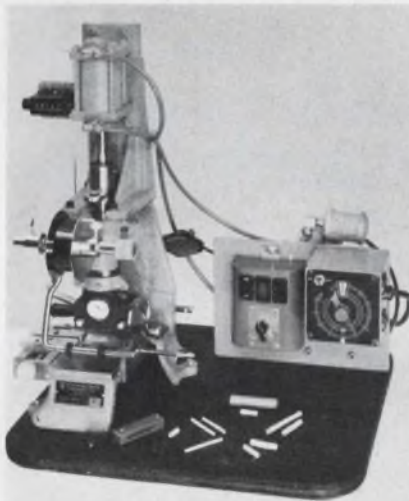

Ackerman Gould Co., Inc., 10 Neil  
Court, Oceanside, N. Y. Phone:  
(516) 678-4110.

An air/electric roll leaf imprinting machine for end marking and identification of insulated wire and cable works in conjunction with a wire stripper and cutoff machine. By use of a foot pedal, model KU-EM operates independently of the stripper and can be used to imprint insulated wire and/or cable. Imprints can be spaced up to four inches apart. All wire from 10 to 26 AWG can be printed and stripped.

Booth No. 1A07 Circle No. 252

### One cabling tool does the work of three

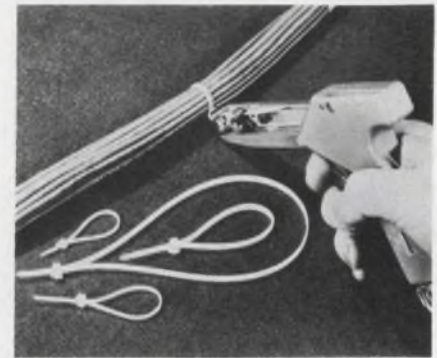

Panduit Corp., 17301 Ridgeland  
Ave., Tinley Park, Ill. Phone: (312)  
532-1800.

A universal cabling tool eliminates the need for three different tools to accommodate different sized cable ties. It incorporates a three-position knob that can be adjusted in two seconds to suit the precise cable tying job. An easy adjustment on the tool sets the tension so that every cable tie is tensioned precisely.

Booth No. 1C16 Circle No. 254

### Instrument cases made of formica

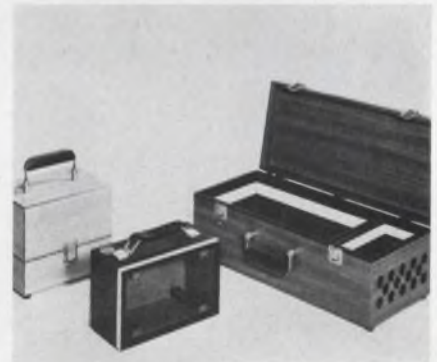

W.A. Miller Co., Oquossoc, Me.  
Phone: (207) 854-3344.

Ruggedized formica cases claim high strength. In manufacture, 1/16-inch formica is laminated to a mahogany core with waterproof epoxy resins and bonded under heat and pressure. Cases can be designed in any size or shape with any desired cutouts, partitions, panel seats, panel mounts or hardware. Light in weight, moisture and dust resistant, the cases have passed Navy shipboard requirements.

Booth No. 1C28 Circle No. 251

# UC

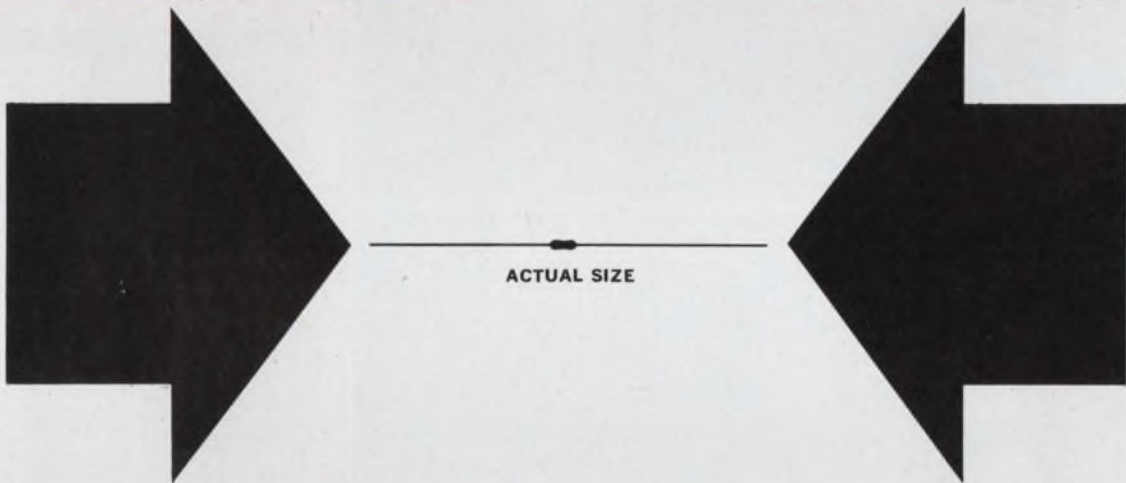

## New! Ultra-miniature metal film resistor

*offers precision, stability and reliability of higher-rated units*

IRC, leader in metal film technology, introduces a new ultra-miniature precision metal film unit that bridges the gap between available discrete resistors and microcircuitry.

Significantly smaller than style RN-50, the UC resistor provides the precision, stability and close tolerance not available with microcircuits. It meets or exceeds all of the performance and environmental requirements of MIL-R-10509.

These tiny resistors feature gold dumet leads and the same rugged termination as all IRC premium metal films. Not a "lab item" or "special," production quantities are immediately available. Write for data, prices and evaluation sample. IRC, Inc., 401 N. Broad St., Phila., Pa. 19108.

### CAPSULE SPECIFICATIONS

BODY SIZE	.125" long x .047" dia.
POWER	1/20 watt @ 100°C
TOLERANCES	±1, 2, 5%
TEMPERATURE COEFFICIENTS	±50, 100ppm/°C
RESISTANCE	50 ohms to 10K



\* Trademark of IRC, Inc.

ON READER-SERVICE CARD CIRCLE 74

# New FROM AD-YU ELECTRONICS INC.

249-259 TERHUNE AVENUE, PASSAIC, N. J.  
Phone (201) 472-5622 • CABLE: ADYU PASSAIC

## DIGITAL PHASE METER TYPE 524A3

±0.03 Degree Accuracy, 20 CPS to 500 KC



Type 524A3 with indicator. Computer alone (bottom panel) can produce analog output to drive recorder and d.c. digital voltmeter. Price \$999.

### FEATURES:

Phase reading directly in degrees in 5 digits (or 4 digits).  
No amplitude adjustment from 0.3v to 50v.  
No frequency adjustment up to 500 kc.  
Analog output available for recorder or programmable system.

### USES:

Plot phase vs. frequency curve of unknown network.  
Plot envelope delay curve with RF sweep oscillator.  
A standard phase meter with 5-digit readout.

## WIDEBAND PHASE STANDARD TYPE 209

0.015° Accuracy 50 CPS to 10 KC



Directly traceable to  
National Bureau of Standards.

### FEATURES:

Accuracy 0.015° resolution  
10 micro-degrees ( $10^{-5}$ ).  
Self-calibration, self-checking by means of fundamental bridge balancing without the use of an external standard.  
Phase shift can be set from 0° to 360° with 7-digit resolution.  
No error due to loading of both output signals.

### SPECIFICATIONS: FREQUENCY RANGE:

Continuous coverage from  
50 cps to 10 kc

### PHASE RANGE:

Can be set for any phase angle from 0° to 360° with 7-digit resolution.

### ACCURACY:

±0.015° for 50 cps to 1 kc; gradually increases to ±0.07° at 10 kc.

### RESOLUTION:

0.00001 degree (10 micro-degrees)

Measure phase between  
two antennas.

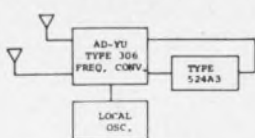

Measure signals from transducers,  
accelerometers, magnetic pickups,  
impedance heads, etc.

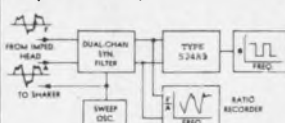

Measure phase shift of unknown  
network with accuracy better than  
0.02°.

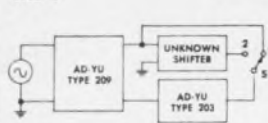

"See Our Booth Nos. 2J43-2J45 at The IEEE Show."

ON READER-SERVICE CARD CIRCLE 75

## PRODUCTION & MACHINERY

### ICs encapsulated with 75-ton press

Hull Corp., 7591-A Davisville Rd.,  
Hatboro, Pa. Phone: (215) 675-  
5000. Price: \$15,000.

A 75-ton semiautomatic encapsulating shuttle machine, model 359C, encapsulates integrated circuits with production molds. Parts too large for conventional loading frames can be unloaded and loaded in the bottom half of the production mold while the second half is in the molding cycle.

Booth No. 1H02 Circle No. 270

### Free-stand enclosures to NEMA specs

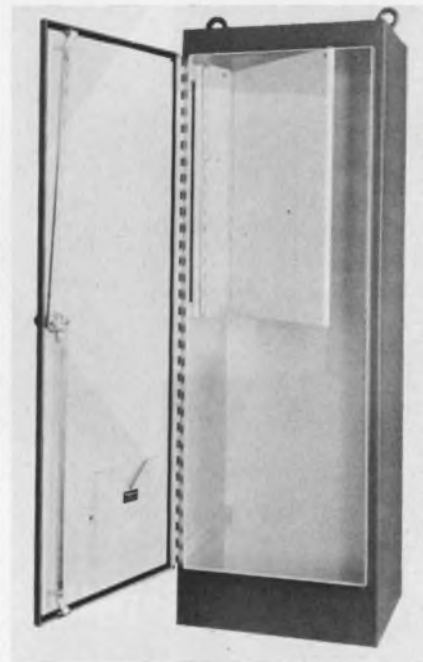

Hoffman Engineering Co., Anoka,  
Minn. Phone: (612) 421-2240.

Dual-access free-standing enclosures are made to NEMA 12 (industrial use) standards. The enclosures (gasketed doors front and rear) permit the use of 2 or more subpanels and are constructed of seam welded 12-gauge steel. Half and full-length relay rack angles are available for most models. Four dual-access and seven single-access stock sizes are available ranging from 72 x 24 x 18 to 90 x 36 x 24.

Booth No. 1E30 Circle No. 268

Don't risk missing any issues of  
**ELECTRONIC DESIGN**. Send in  
your renewal card today.



## Reel fast delivery of ceramic capacitors . . . the result of Mepco's automated production techniques

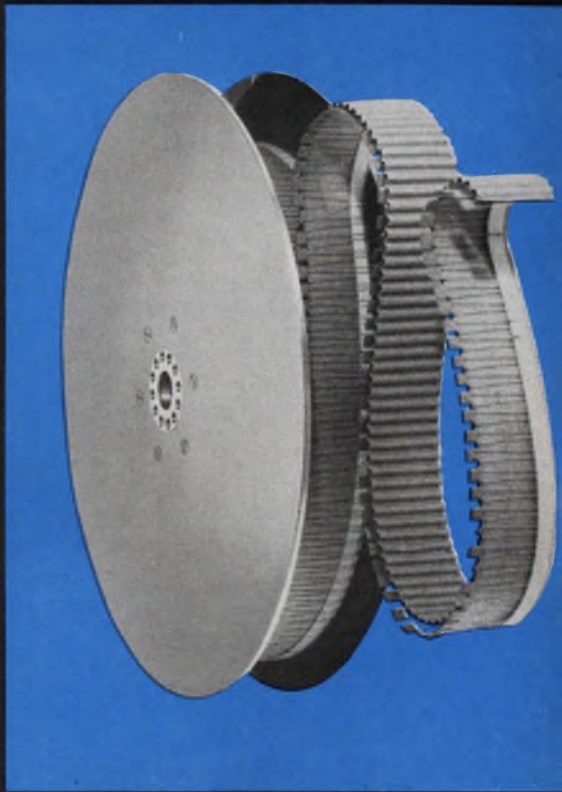

Mepco's subminiature Ceramic Capacitors meet the standards of military specifications, yet are designed and priced for high-volume industrial-commercial programs.

- Conformal epoxy enclosure offers excellent environmental protection and unusually high body insulation.
- Mepco's unique, non-migratory electrode system eliminates a major cause of ceramic capacitor failure.
- Delivery weeks ahead of usual industry standards.
- Dimensions as small as .100" x .100".
- Capacity ranges from 2.2 pF to 10,000 pF.

For complete details, call or write today  
Mepco, Inc., Morristown, New Jersey 07960  
(201) 539-2000 TWX: 201-538-6709

O.E.M. Sales Offices from Coast to Coast



MANUFACTURERS OF **PRECISION  
ELECTRONIC DEVICES**

*A Heritage of Reliability*

# The Spoiler.

## Sweep Generator Spoils Engineers

The lightweight, reliable VS-40 sweep signal generator covers the range of 1 MHz to 300 MHz with sweep width variable from 200 KHZ to 300 MHz. Its versatility provides for eight solid state single frequency or harmonic plug-in markers, supplies a 0 to 102 db attenuator and optional calibrated variable marker which covers the complete frequency range of the unit. A 0 to 6 db vernier control is included. The RF output is 0.5v rms into 50 ohms, flatness is  $\pm 0.25$  db at maximum sweep width. Four sweep rate modes are provided: variable from 5 HZ to 60 HZ, 50/60 HZ line rate, manual sweep and external. Price: \$895.00.



Specialists In Electronic Instrumentation

**Texscan**  
CORPORATION

**tc**

51 Koweba Lane  
Indianapolis, Indiana 46207  
Ph. (317) 632-7351

ON READER-SERVICE CARD CIRCLE 77

U138

## PRODUCTION & MACHINERY—1ST FLOOR

### Wavedipper offers flat solder surface

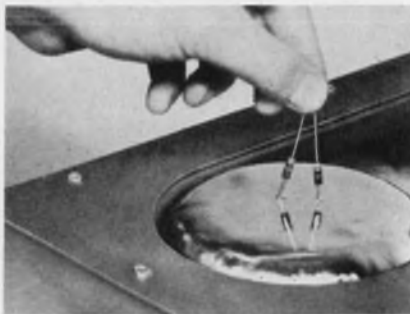

*Electrovert, Inc., 86 Hartford Ave., Mt. Vernon, N. Y. Phone: (914) 664-6090. P&A: \$750; stock.*

A flat 4-inch diameter, dross-free and constant-temperature molten solder surface for tinning component leads and dip-soldering small parts is provided by this wavedipper. By pumping the solder upwards from a reservoir through a circular nozzle, a mirror-like dipping surface is formed. Because the solder is constantly recirculated, there is no surface cooling and no dross contamination on the wave surface.

*Booth No. 1H22 Circle No. 269*

### Accurate grid drill has programable spindles



*Gardner Denver, Grand Haven, Mich. Phone: (217) 222-5400.*

A four-spindle grid drill is available with spindles arranged to suit customer requirements. Modular construction in spindle arrangement allows the user to add spindles to the machine as the work load increases. The control systems are standard for full spindle programmability for up to 16 spindles. The positioning system is accurate to 0.001 inch.

*Booth No. 1G12 Circle No. 253*

### Engraving machine enlarges and reduces

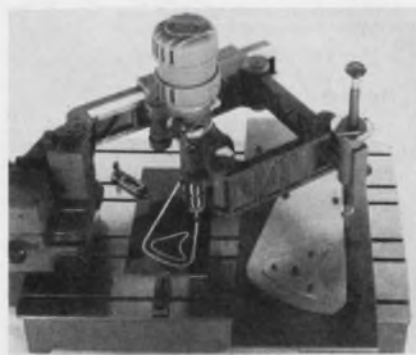

*Scripta Machine Tool Corp., 575 E. Linden Ave., Linden, N. J. Phone: (201) 925-1950. P&A: \$1060; stock.*

A bench-model pantograph engraving machine is applicable to instrument panels, engraving of stamps and cylindrical parts, copying, profiling, beveling, drilling, milling, and electromarking into hardened materials. The machine can reproduce a master template at 23 different reduction ratios and can also be used for enlarging. At its largest reduction ratio, it will cover an area of 4-3/4 by 9-1/4 inches in one setup.

*Booth No. 1J16 Circle No. 255*

### Embossed labels at your finger-tip



*W. H. Brady Co., 727 W. Glendale Ave., Milwaukee. Phone: (414) 332-8100. P&A: \$16.95 (3/8-in.), \$18.95 (1/2-in.); stock.*

Fast, finger-tip embossing of self-sticking labels is accomplished with this heavy-duty table-top machine. Tape labels can be embossed continually without squeezing, lifting or handling motions. The machine can deliver individually cut-and-tabbed labels, or multiple pre-cut labels on a continuous dispenser strip up to 36 feet long.

*Booth No. 1E12 Circle No. 319*

ON READER-SERVICE CARD CIRCLE 78 ➤



# GUARDIAN<sup>®</sup> SOLENOIDS

## You need this catalog

*THE WORLD'S MOST COMPLETE LINE OF SOLENOIDS* are here in one book . . . just off the press. It's packed with informative, detailed data and pictures: Operating temperatures, duty cycles, life expectancy, power requirements, pull charts and dimensions. In addition, there's a full description of how to select the proper solenoid for your particular application—from miniature to heavy duty—AC or DC—or custom engineered jobs.

## send for your copy today!

Be seeing you at the IEEE Show Booth 4E04 & 4E06

**GUARDIAN<sup>®</sup> ELECTRIC**

Guardian Electric Mfg. Co. • 1550 W. Carroll • Chicago, Ill. 60607

# THE FIRST

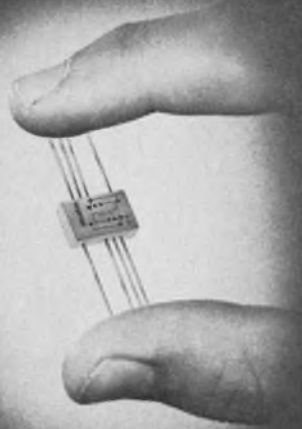

# FLAT PACK RELAY

PRODUCTION & MACHINERY

## Automatic testing for semiconductors

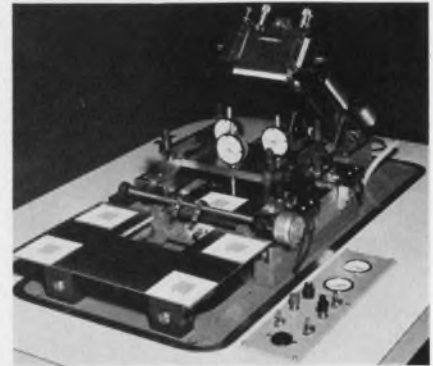

Affiliated Manufacturers Inc., Box 248, Whitehouse, N. J. Phone: (201) 534-2103.

A versatile machine for visual inspection or automatic test of diodes and other electronic parts requiring top and bottom probing permits simple conversion from one operating mode to the other. The parts are transferred one at a time via vibratory feeders to a stage mounted in front of the transfer device. At this point, the operator can inspect and sort the parts into four different categories by means of buttons.

Booth No. 1A01 Circle No. 337

## New sun throws light on spaceman's problems

Genarco, Inc., Jamaica, N. Y. Phone: (212) 658-5850.

A 120-kW carbon-arc light source is presented as the most powerful single-source solar radiation simulator developed to date. The highest power previously developed is 30 kW. The new unit will irradiate an area eight feet in diameter with one solar constant, the space of the sun's rays in the vicinity of the earth. This is considered large enough to cover an astronaut practicing a walk in space. Lamps used for this purpose have been unstable, noisy and even explosive. The new simulator is said to have overcome these defects.

Booth No. 1G30 Circle No. 338

Don't forget to return your **ELECTRONIC DESIGN** renewal card.

## NEW from BRANSON - TO-87 RELAY

This TO-87 size relay creates new design flexibility and capability in low profile applications including circuit boards, packaging with semiconductors, part of integrated circuits and hybrid devices, etc. The TO-87 DPDT relay, rated at 1/4 amp. at 28 volts, measures 3/8" x 1/4" x 1/10" and weighs 1 gram. It is hermetically sealed and exceeds all applicable MIL specifications.

Send For Complete Detailed Specifications

## OTHER BRANSON PRODUCTS...

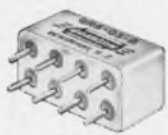

Solid State Time Delay Relay



4 Pole 1/6 Size Relay



6 Pole DT Crystal Can Relay



1/2 Crystal Can 4 PDT Relay

## Relays...Our Only Business

# BRANSON CORP.

VANDERHOOF AVENUE • DENVILLE, NEW JERSEY • 201-625-0600

SEE US AT IEEE BOOTH 3A41

ON READER-SERVICE CARD CIRCLE 79

# NO BURNS

LIKE THIS

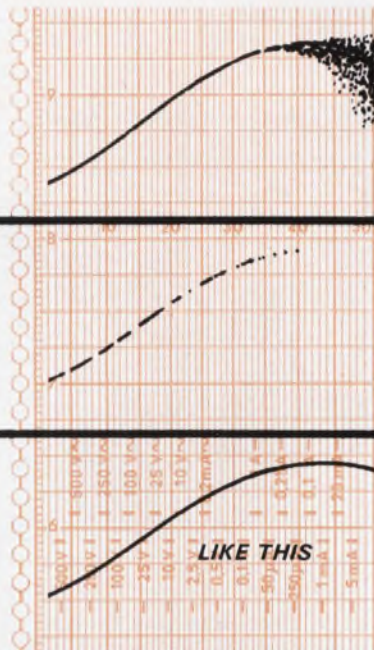

# NO BLANKS

LIKE THIS

# A PERFECT RECORD every time

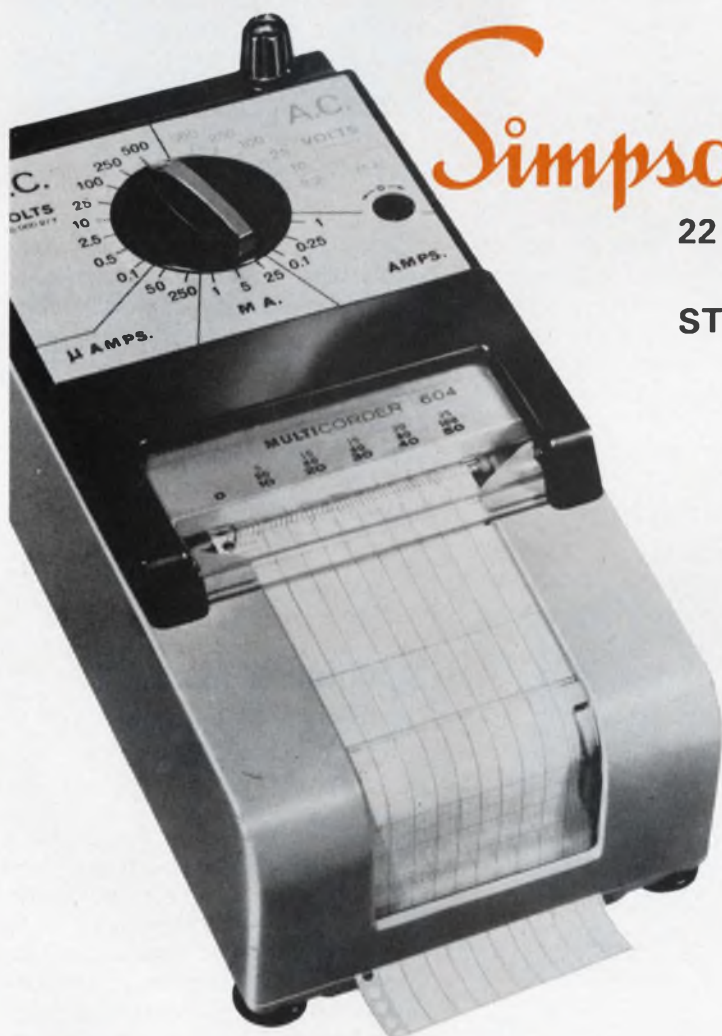

## Simpson Multicorder®

22 SINGLE ELECTRICAL RECORDERS  
WRAPPED IN ONE  
STANDARD 3 CHART SPEEDS  
1", 3", 12" PER HOUR

Impressions every 2 seconds. Additional speeds (30", 60", 90" per hour) with the optional gear unit Catalog #0682. This voltage-current recorder has a wide selection of ranges and functions to eliminate the need for separate recorders. The pressure-sensitive paper means that there is no conductive paper to burn, no ink to run dry. Meter movement features shock-proof **TAUT BAND SUSPENSION**. AC and DC indicating accuracy is  $\pm 1.5\%$  FS; recording accuracy  $\pm 2.5\%$  FS. These are just a few of the features that make the Simpson Model 604 Multicorder the most versatile and economical recorder on the market. For the full story, write for Bulletin 520.

### RANGES

DC VOLTS: 0-0.1, 0.5, 2.5, 10, 25, 100, 250, 500 @ 20,000  $\Omega/V$   
AC VOLTS: 0-10, 25, 100, 250, 500 @ 5,000  $\Omega/V$   
DC MICROAMPERES: 0-50, 250  
DC MILLIAMPERES: 0-1, 5, 25  
DC AMPERES: 0-0.1, 0.25, 1.0  
AC MILLIAMPERES: 0-0.2

Multicorder Model 604.....\$200.00

### ACCESSORIES

Gear Unit No. 6082 (30", 60", 90" per hour)..... 30.00  
Chart Paper No. 02612, Per Roll..... 2.50  
Ever-Redy Vinyl Carrying Case No. 02611..... 25.00

Representatives in Principal Cities  
... See Telephone Yellow Pages



### SIMPSON ELECTRIC COMPANY

5202 W. Kinzie Street, Chicago, Illinois 60644 • Phone: (312) 379-1121  
Export Dept: 400 W. Madison Street, Chicago, Illinois 60606, Cable, Simelco  
IN CANADA: Bach-Simpson Ltd., London, Ontario  
IN INDIA: Ruttonsha-Simpson Private Ltd., International House, Bombay-Agra Road, Vikhroli, Bombay



WORLD'S LARGEST MANUFACTURER OF ELECTRONIC TEST EQUIPMENT

ON READER-SERVICE CARD CIRCLE 80

### Holding device for quick adjustment



Hunter Tools, 9851 Alburtis Ave., Santa Fe Springs, Calif. Phone: (213) 692-7281. P&A: from \$6.65 to \$24.85; stock.

This unit is designed to meet the need for a fully positionable, holding device. It has a newly designed quick-adjust jaw, which allows one of the jaws to be changed from its widest opening to the center position instantly by the operator. The assembly is a combination of three separate units: vise, positioner and base.

Booth No. 1B08 Circle No. 375

### Laboratory oven for research and process

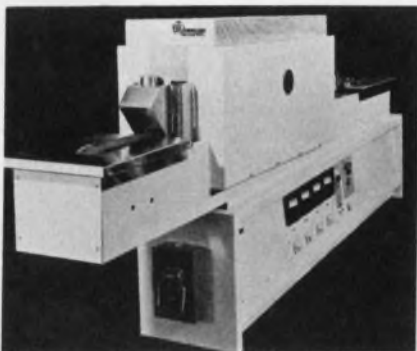

BTU Engineering Corp., Bear Hill, Waltham, Mass. Phone: (617) 894-6050. P&A: furnace, \$3657, dryer \$2700; 6 to 8 wks.

A versatile inclined laboratory furnace is offered for research and process development of hybrid circuits. It has an inclined quartz muffle, thermosensitive hearth, laminar flow of air, and uniform temperature profile from load to no-load. The dimensions are 76 by 18 by 51 inches. A dryer is optional.

Booth No. 1F18 Circle No. 374

### Wire color coder colors vinyl cotton

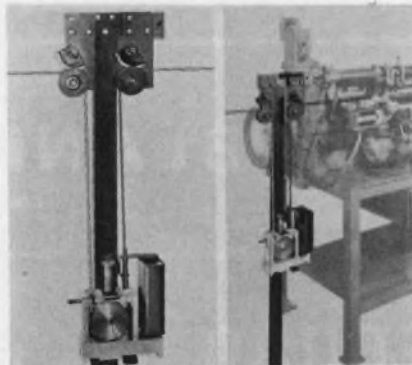

Artos Engineering Co., 15598 W. Lincoln Ave., New Berlin, Wis. Phone: (414) 782-3300. Price: \$85.

White insulated wire can be used to produce wire leads in all required colors by means of a new color coder unit. The machine handles vinyl-plastic and cotton-insulated wire, and will color two wires being processed simultaneously. It is mounted at the feed end of a stripping machine. The unit operates at the same speed as the machine.

Booth No. 1J22 Circle No. 376

### Soldering machine handles ICs

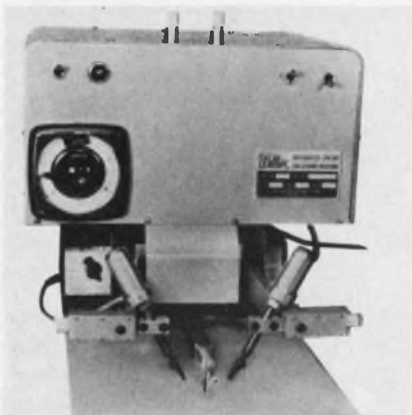

Weller Electric Corp., 100 Wellco Rd., Easton, Pa. Phone: (215) 258-5371.

Model C-700 integrated circuit soldering machine features dial-variable temperature control. Designed for production and lab use, the unit solders all leads, both sides in one operation, for prototype use as well as volume production.

Booth No. 1B12 Circle No. 258

### Machine prints on flat or irregular components

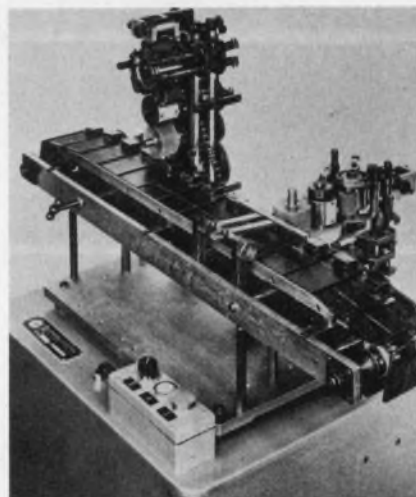

Eastern Marking Machine Corp., 30 Alabama Ave., Island Park, N. Y. Phone: (516) 889-9090.

A machine for high-speed printing on flat or irregular components or packages uses the dry-offset printing method. This ensures perfect prints even where there are variations or irregularities from piece to piece. Inexpensive photoengraving or foundry type is used, keeping the cost of printing to a minimum. Production rate is 6000 units per hour.

Booth No. 1H27 Circle No. 320

### Machine trims 3000 resistors per hour

S. S. White Co., Industrial Div., 201 E. 42nd St., New York. Phone: (212) 661-3320.

An automatic resistor trimmer can process 3000 resistors per hour. Resistors are brought within tolerance automatically, and a built-in memory system recognizes three categories and controls the machine accordingly. Resistors are monitored constantly to stop the machine within 0.5% of the desired value. The cutting and measuring sequence takes less than 2 seconds.

Booth No. 1D30 Circle No. 377

Don't forget to return your **ELECTRONIC DESIGN** renewal card.

# five new linear monolithic IC's

## each with its own claim to fame



**TAA320:** The 'BIFET,' world's first bipolar/mosfet IC amplifier. A new, basic, simple building block.

10,000 megs. input resistance, 40,000  $\mu$ mhos Gm. Takes 100 volt transients; will not burn out from static charge. We placed a mosfet and a silicon transistor on a single chip to give you an IC with high input impedance, high forward transadmittance and low noise. 3-lead, TO-18. Under \$1.25.



**TAA293:** Features accessibility to internal connections for wide design flexibility.

Ideal for audio and IF applications, and as an amplifier, oscillator or multivibrator in numerous low-frequency functions. Ten-lead, TO-5 package affords access to every internal component. Put two of them together—and you have an op amp! Priced at \$1.60 each in thousand lots.

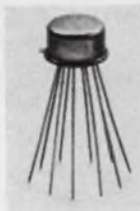

**TAA310:** The only IC designed specifically as a record/play-back preamp.

A single-ended Class A preamplifier with 100 db gain and less than 4 db noise. The ten-pin, TO-5 design allows external frequency compensation, gain control, etc. The TAA310 is an optimally-designed IC preamplifier priced at \$1.95 in production quantities.

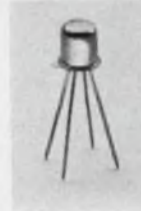

**TAA263:** Low cost, high gain transducer amplifier with a noise figure of only 2.7 db.

The TAA263 is an economical, low level amplifier, perfect for portable microphones, low-frequency IF's, microminiature receivers; as a preamp for infrared detectors, photocells, strain gauges, accelerometers, etc. In a four-lead, TO-18 envelope. \$1.25 in thousand lot quantities.

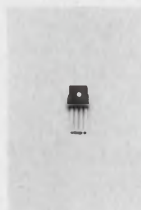

**TAA103:** Smallest integrated circuit amplifier in the business.

Packaged in a microminiature, plastic flat-pack measuring a scant .002 cubic inches, the TAA103 linear monolithic IC features 75 db gain and is ideally suited for amplifier applications from DC to 600 kHz. Buy as few as a hundred of them for well under \$2.00 each.

*These five new linear monolithic IC's from Amperex are products of industry's most advanced technology, most inventive thinking. They are available now at volume-production prices. For data and applications information, write: Amperex Electronic Corp., Semiconductor Division, Dept. 371, Slatersville, R. I. 02876.*

**Amperex**

TOMORROW'S THINKING IN TODAY'S PRODUCTS

# Wide and Narrow Sweeps with this

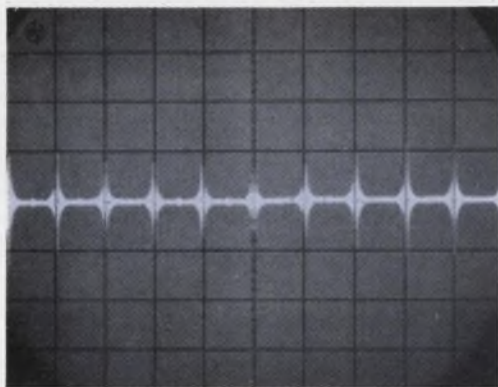

Oscillogram of a 10 to 110 MHz sweep with 10 MHz birdie markers added to show excellent sweep linearity. Specified 0.5% linearity and 1% frequency accuracy permit easy identification of intermediate sweep points, eliminating need for tedious pre-calibration.

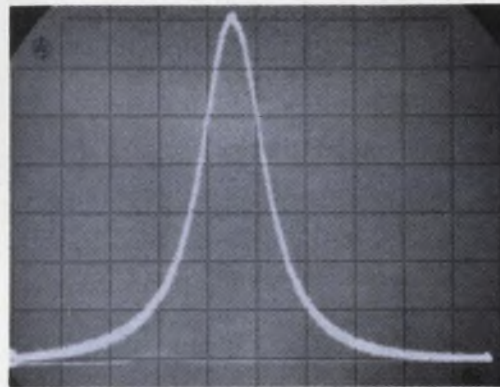

With low residual FM and very linear sweeps, you can measure narrow-band characteristics easily. Shown here is the response of a 20 MHz crystal filter over narrow 100 kHz sweep width (10 kHz/cm.); just read the 10 kHz pass band directly from oscilloscope.

The Hewlett-Packard 8690A/8698A Sweep Oscillator (0.1 to 110 MHz) offers all the performance and operating conveniences you've been looking for in an RF sweeper:

- Two independent broadband sweeps, each with 1% end-point frequency accuracy and 0.5% linearity.
- Calibrated  $\Delta F$  sweeps (sweeps 0 to 10% of frequency range) for narrow sweeps, maintaining 0.5% linearity.
- CW operation; external FM (DC to 2 kHz with full band deviation).
- Automatic, manual or triggered sweeps; sweep times from 0.01 to 100 seconds.

Frequency accuracy, frequency stability, sweep linearity, residual FM and spurious signal levels are all *specified* parameters (rarely done for RF sweepers).

The 8690A/8698A provides full band sweep capabilities and excellent narrowband performance, eliminating the need for two separate sweepers. Both high-Q and wide-band devices can be swept with just one instrument. In addition, the frequency stability, signal purity, calibrated

output power and precision output attenuator of the 8690A/8698A commend it for many applications calling for a precision signal generator.

And the 8690A Sweep Oscillator main unit accepts 17 other HP microwave sweeper units covering 1 to 40 GHz in octave- and waveguide-bands.

## Performance of 8698A RF Sweeper Generator (installed in 8690A Sweep Oscillator)

### FREQUENCY SPECIFICATIONS

#### Frequency Range:

0.1 to 11 MHz and 1 to 110 MHz, selected by front-panel switch.

#### Frequency Accuracy:

0.1 to 11 MHz,  $\pm 1\%$  or  $\pm 10$  kHz, whichever is greater;  
1 to 110 MHz,  $\pm 1\%$  or  $\pm 100$  kHz, whichever is greater.

#### Frequency Linearity:

$\pm 0.5\%$



# Linear RF Sweeper

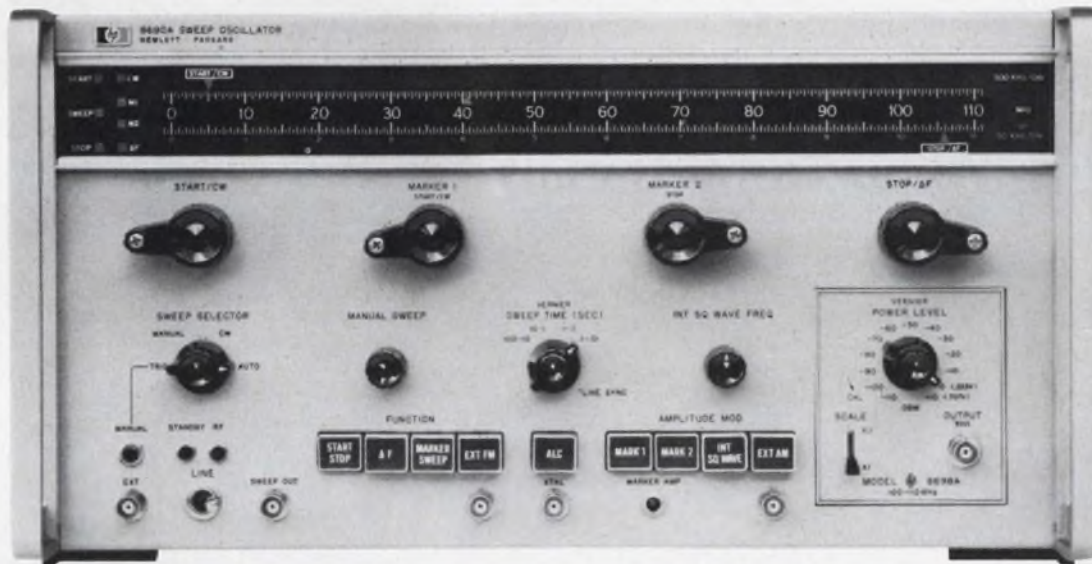

## Residual FM:

0.1 to 11 MHz < 150 Hz peak, 1 to 110 MHz < 500 Hz peak.

## Frequency Stability:

With temperature: 0.1 to 11 MHz,  $\pm 0.01\%$  / °C or  $\pm 200$  Hz / °C, whichever is greater; 1 to 110 MHz,  $\pm 0.01\%$  / °C or  $\pm 2$  kHz / °C, whichever is greater.

With 10% line voltage change: 0.1 to 11 MHz,  $\pm 5$  kHz; 1 to 110 MHz,  $\pm 50$  kHz.

## Spurious Signals:

Non-harmonics at least 40 dB below CW output. Harmonics at least 35 dB below +10 dBm CW output.

## POWER SPECIFICATIONS

### Power Output:

At least +20 dBm max. (2.23 VRMS into 50 ohms). Calibrated power output adjustable in 10 dB steps from +10 dBm to -110 dBm; 10 dB vernier permits continuous adjustment between steps. Source impedance is 50 ohms.

### Power Accuracy:

$\pm 1$  dB + attenuator accuracy (vernier in CAL position).

### Attenuator Accuracy:

$\pm 1$  dB to 70 dB attenuation;  $\pm 2$  dB to 120 dB attenuation.

### Output Flatness:

$\pm 0.25$  dB ( $\pm 0.1$  dB over any 10 MHz bandwidth).

Price: Model 8698A RF Sweeper Generator, \$950.  
(Model 8690A Sweep Oscillator, \$1550.)

For more information contact your local HP field engineer or write Hewlett-Packard, 1501 Page Mill Road, Palo Alto, California 94304, Tel: (415) 326-7000; Europe: 54 Route des Acacias, Geneva.

HEWLETT  PACKARD

See New Hewlett-Packard instrumentation  
at the IEEE Show, New York Coliseum, March 20-23

ON READER-SERVICE CARD CIRCLE 83

2470



## Angle position indicator employs inductive dividers for stability

North Atlantic Industries, Inc., Terminal Dr., Plainview, N. Y. Phone: (516) 681-8600. P&A: \$5900; 60 days.

An angle position indicator that gives direct reading of synchro or resolver shaft angle achieves long-term stability through the use of inductive dividers in the synchro bridge.

The input-to-output ratio of the inductive divider depends primarily on its turns ratio, which is inherently constant. The inductive divider also offers a high input impedance, about  $1/2 \text{ M}\Omega$ , to reduce loading of the resolver or synchro output. It also provides a low output impedance which reduces error due to loading by stray capacitance or low-impedance null detectors.

Figure 1 shows a simplified circuit of a manually operated bridge

on which the automatic version is based. One inductive divider has output taps arranged in a cosine relation, and the other in a sine relation. The two dividers are simultaneously switched by decade switches reading directly in synchro or resolver shaft angles. Here manual switches are used to alter the inductive dividers' ratios. The voltages across the dividers are proportional to the sine and cosine, respectively, of the shaft angle  $\theta$ . The ratio of the divider output,  $K_1/K_2$ , at null reading gives the tangent. One must go to the trig tables and look up  $\tan^{-1} K_1/K_2$  to find  $\theta$ .

In manual systems, as the switch positions are increased from one angle reading to the next, one divider output changes as the cosine of the angle, and the other as the sine. If the bridge dial reading is designated as angle  $\alpha$ , then the ratio of

the two divider outputs when both are excited by the same input voltage is  $\sin \alpha / \cos \alpha = \tan \alpha$ .

The divider tapped in sine relation is fed by the resolver's cosine winding, and the divider tapped in cosine relation, by the sine winding. At null, the ratio  $\sin \alpha / \cos \alpha$ , or tangent of the resolver shaft angle, is equal to  $\tan \alpha$ . This relationship involves a  $180^\circ$  ambiguity, since  $\tan \theta = \tan \pm \theta$ , but phase-sensitive null detection ensures that the correct value is chosen. In this way, direct reading of shaft angle is obtained.

The new automatic shaft angle indicator model 545 utilizes these methods with the added advantages outlined above, obtained by replacing the tapped resistive dividers with precision autotransformers and switching the autotransformers with solid-state switches.

The unit is an automated version of a direct-reading resolver or synchro bridge. In effect, it is a digital servo, in which the null detector's electrical output drives the semiconductor tap switches toward a null balance.

The converter operates in either the tracking or successive approximation mode. In the tracking mode, the divider taps are switched in smallest increment steps until null balance occurs.

In the successive approximation mode, the logic circuits switch the divider settings to  $180^\circ$  in order to interrogate the incoming data and decide whether the input angle is above or below  $180^\circ$ . If above, the most-coarse logic levels hold the dividers at the  $180^\circ$  setting, and the next stage of interrogation advances their setting toward balance at some, as yet unknown, angle between  $180^\circ$  and  $360^\circ$ . The second step chops the unknown angle in half again, and a succession of further steps carries the degree of approximation to the instrument's final 15-bit resolution.

At this point, the unknown angle has been halved many times, and the final logic step resolves the last 36 arc-second decision.

The logic circuits then turn on the display and transmit the angle in binary or other code to a computer data center. The readout is a 5-decimal Nixie display. Display resolution is  $0.01^\circ$  of arc.

Booth No. 2H19 Circle No. 521

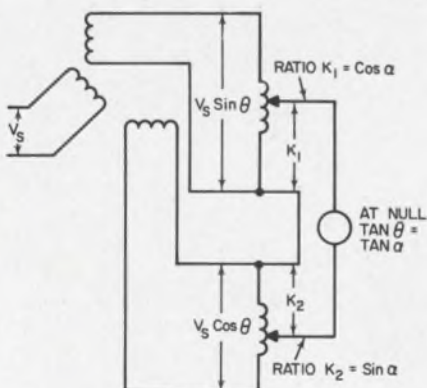

1. Simplified circuit of synchro or resolver bridge using inductive dividers for increased stability.

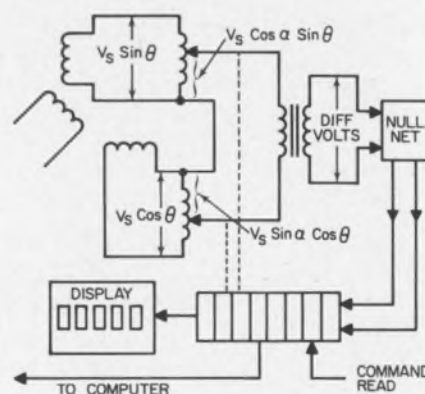

2. Over-all diagram. Up-down counter backtracks divider settings for correct angle.

Testing integrated circuits is a key step in their production. At the Molecular Electronics Division of Westinghouse Electric Corporation, Tally perforators are used to log data as each module is run through a series of parameter checks. Data logged on the tape is then analyzed by computer.

According to W. DeLauder, Foreman of the Instrumentation Section at Westinghouse, the five Tally Model 420 perforators worked extremely well

during a fifteen month period just ended. Fewer than eight calls per perforator were made to keep all five perforators on duty over the entire period. The average time per call was 2.23 hours with an average cost for parts of \$3.05.

During the fifteen month period, the five perforators punched with precision over 478 miles of tape. There are a lot of good solid engineering reasons why Tally perforators are extraordi-

narily reliable. For all of them, please address Ken Crawford, Tally Corporation, 1310 Mercer Street, Seattle, Washington 98109. In the U.K. and Europe, address Tally Europe, Ltd., Radnor House, 1272 London Road, London, S. W. 16, England.



**There are five hard working  
Tally perforators on the job  
around the clock at Westinghouse.  
During one 15 month period, these  
perforators were ready for work  
99.9% of the time...and work they  
did, knocking perfect chad out of  
2,520,000 feet of tape!**

**How's that for reliability?**

*Here is the latest Westinghouse integrated circuit test console  
with a new Tally P-120 Perforator which turns out twice the work of the Tally 420.*

*"See us at S.J.C.C."*

SHEAR DESIGNED FOR ISOLATION, 0.8 GRAMS WT.  
2MV/G OUTPUT, 70 kHz RESONANCE FREQUENCY

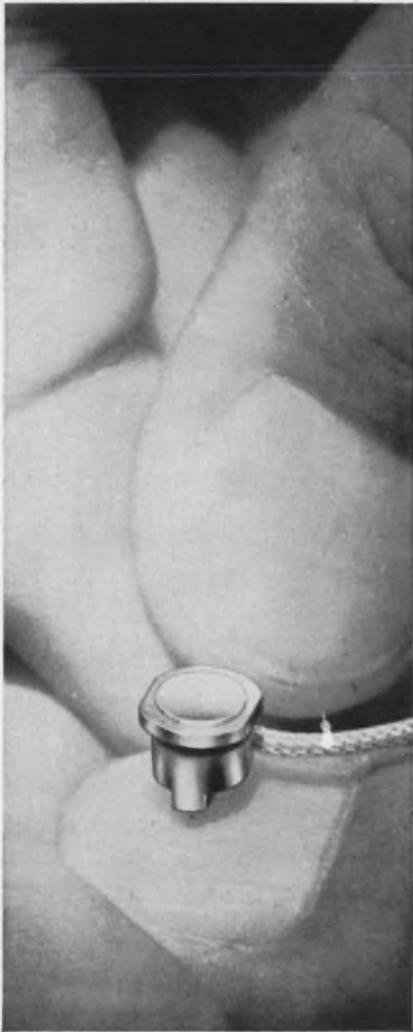

**This is the  
Unholtz-Dickie  
2E5 accelerometer**

*It may cost more, but  
we'd rather explain its price,  
than apologize for its quality*

If you are super-critical about an accelerometer for measuring vibration in one direction only — an accelerometer that is not sensitive to thermal shock, cable whip or base strain — we'd like you to try our 2E5 two weeks — for free. If it is not the best accelerometer you've ever worked with, send it back. No charge. If it is, we'll invoice you \$213. Ask for current data on our complete line.

manufacturers of vibration test systems,  
advanced instrumentation, accelerometers

**UNHOLTZ-DICKIE**  
CORPORATION  
3000 Whitney Ave./Hamden, Conn. 06518

See us at IEE Booth 2D02  
ON READER-SERVICE CARD CIRCLE 85

**INSTRUMENTS—2ND FLOOR**

**Frequency comparator  
reads 1 part in 10<sup>9</sup>**



*Vectron Laboratories, Inc., 146  
Selleck St., Stamford, Conn. Phone:  
(203) 324-9925.*

A frequency comparator accepts test and reference input signals of 1 MHz, 100 kHz and other sub-harmonics of 1 MHz with the optional added capability of accepting 5-MHz and 2.5-MHz test inputs. The comparator accepts a broad range of input levels at each of the frequencies without requiring any internal adjustments or front-panel switching. To further simplify operation, the test and reference inputs are each synthesized to 1 MHz in such a manner that the output is always referred to 1 MHz; this permits the output to be read as a percentage error without interpolation, independent of the input frequencies. If a 1-MHz test input were read directly on a frequency counter, the counter would provide a resolution of one part in 10<sup>6</sup> in one second. In order to improve the resolution, the two synthesized signals are processed through three tandem "times-ten frequency difference multiplier" circuits, each of which increases the resolution by a factor of ten. The resulting resolution with all three multiplier circuits switched into operation is one part in 10<sup>9</sup> in one second, and one part in 10<sup>10</sup> in ten seconds. A front panel switch allows selection of any one of four resolutions by connecting none, one, two or three of the multipliers into the system. The unit is applicable to measurement of the frequency difference between two oscillators, adjustment of two frequency sources to the same frequency, measure-mean of long-term stability (oscillator aging) and short-term stability analysis.

Booth No. 2J27 Circle No. 519

**Coaxial switches  
have low vswr**



*Marconi Instruments, 111 Cedar  
Lane, Englewood, N. J. Phone:  
(201) 567-0607.*

Low-vswr, high-isolation, single-pole two-, four- and eight-way programmable coaxial switches cover dc to 1 GHz. For routing high-frequency signals and for propagation of fast-rise-time pulses, the switches offer power handling of 10 W up to 250 V peak. Switching is performed by dry-reed relays mounted in strip line configuration. Isolation figures are typically 95 dB at 10 MHz, 80 dB at 30 MHz, 75 dB at 100 MHz and 55 dB at 1 GHz.

Booth No. 2D04 Circle No. 500

**Low-cost divider  
has 1-ppm resolution**

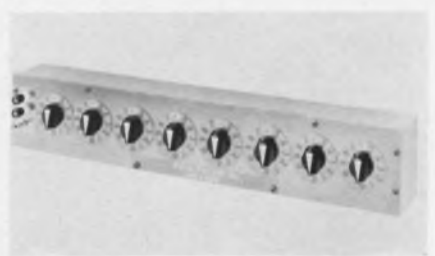

*General Resistance, Inc., 430 South-  
ern Blvd., Bronx, N. Y. Phone:  
(212) 292-1500. Price: \$339.*

A low-cost decade divider has eight dials and provides 0.01-ppm resolution. All dials are discrete-position decades since the unit contains no potentiometers. Features include accuracy (terminal linearity) for settings from 0.1 to full scale of ±1 ppm; for settings below 0.1 accuracy improves to 0.004 ppm.

Booth No. 2H44 Circle No. 512

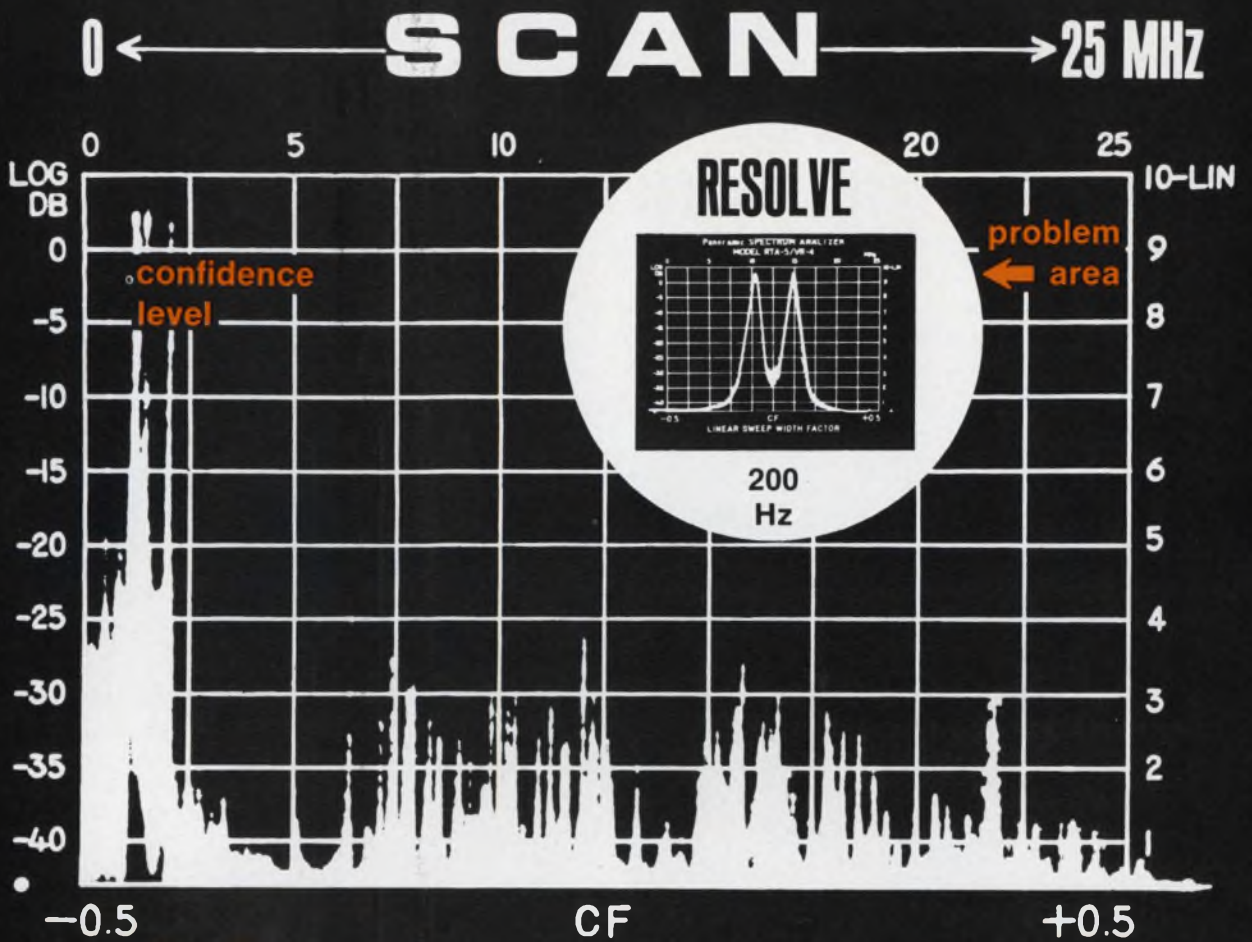

**MONITOR** COMMUNICATIONS SECURITY TELEPHONY TELEVISION **DIAGNOSE**

only with the **Panoramic<sup>®</sup> VR-4/RTA-5 modular<sup>†</sup> spectrum analyzer**



ON DISPLAY AT IEEE BOOTHS 2B25-2B30

**SPECIFICATION HIGHLIGHTS**

- Frequency range:** 1 kHz-27.5 MHz digital readout
- Scan widths:** 50 kHz-5 MHz, or 500 Hz-50 kHz phase locked, digital readout; preset 0-25 MHz full dispersion
- Resolution:** 200 Hz
- Sensitivity:** 30  $\mu$ v linear full scale
- Log display:** 40 db calibrated
- Display flatness:**  $\pm 1$  db
- Frequency calibration:**  $\pm 0.02\%$  internal crystal markers
- Main frames:** rack-mount or portable

<sup>†</sup> Currently-available interchangeable modules: sonic (AR-1), log-scan sonic (AL-2), ultrasonic (UR-3), and video (VR-4).



® Trademark of THE SINGER COMPANY

EMPIRE • EMC • GERTSCH • SENSITIVE RESEARCH

**SINGER**  
INSTRUMENTATION

THE SINGER COMPANY, METRICS DIVISION • 915 Pembroke St., Bridgeport, Conn. 06608, U. S. A. • PHONE (203) 366-3201

P-67-1

ON READER-SERVICE CARD CIRCLE 86

# 1/100<sup>TH</sup> SECOND STOP CLOCK!

RAPID • ACCURATE • DIGITAL READOUT

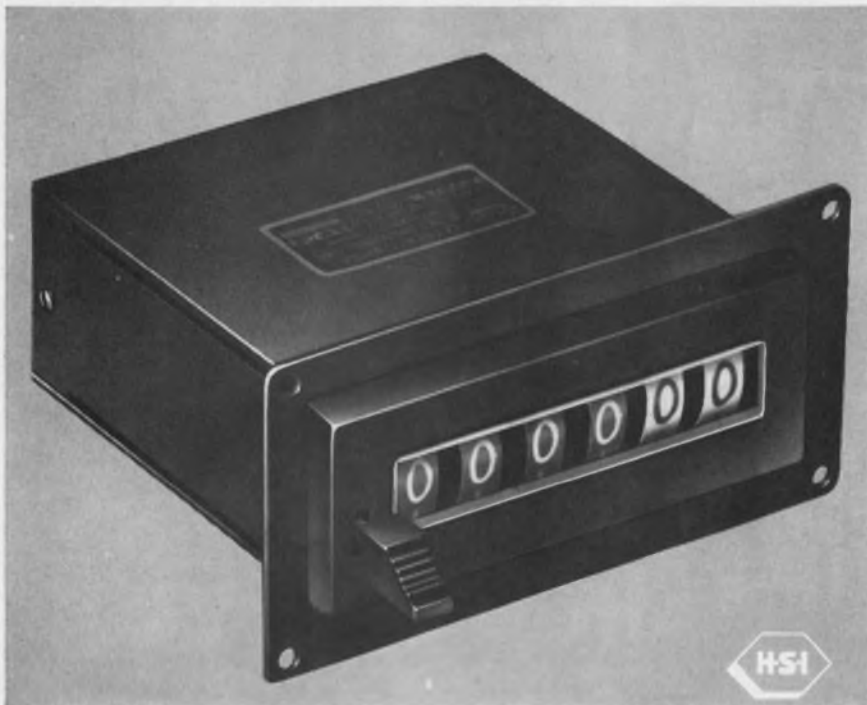

**THE HSI SERIES 42 PLANETGEAR<sup>®</sup> STOP CLOCK** makes it possible to measure, integrate or totalize with high accuracy and reliability. Average error over 10 or more readings is less than 5 ms. Well under this figure for integrating. Instant start-stop motor plus patented Planetgear low-torque transfer provide 5 exclusive features . . .

- No pre-start or stabilizing
- Memory lock for power loss
- No spurious counts due to line transients
- Quiet operation
- Extremely long life

Series 42 has large 5/16" high figures, 6 drum display, manual or electrical reset.

**HSI PLANETGEAR TRANSFER...  
YOUR BEST BET IN THE LONG RUN!**

Send for HSI Bulletin 42-3



**HAYDON SWITCH & INSTRUMENT, INC.**

*Where Optimum Performance Is Standard*

1500 Meriden Road, Waterbury, Conn. 06720/Area Code (203) 756-7441

ON READER-SERVICE CARD CIRCLE 87

INSTRUMENTS—2ND FLOOR

## Dividing head has continuous rotation

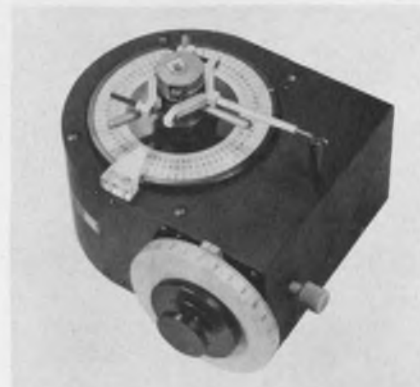

*Gertsch, Div. of Singer Co., 3211 S. La Cienega Blvd., Los Angeles. Phone: (213) 870-2761. Price: \$800.*

This dividing head features continuous rotation for testing pots and similar components for linearity. For rotary applications, an angular readout in 0.01° increments may be selected. The dividing head may also be used for field tests of synchros and resolvers.

*Booth No. 2B25 Circle No. 398*

## Transistor oscillator sweeps clean



*Wiltron Co., 930 E. Meadow Dr., Palo Alto, Calif. Phone: (415) 321-7428.*

High power output (1 V into 50 Ω) makes this sweeper useful for testing with large signals and thus minimizing noise and interference. The unit sweeps from 100 kHz to 2 GHz in four bands. Frequency calibration is made with a 1% accurate indicator dial and 0.01% accurate crystal-controlled markers.

Phase-locking provision is built in for locking to an external frequency standard. Provision is made for external programming of frequency, power output, sweep width and sweep repetition rates.

*Booth No. 2F43 Circle No. 503*

# Adlake Mercury Wetted Relay – Application Data

## Measurement of "Dynamic Contact Noise" for Low Level Signal Applications



**Adlake AWCS  
26000 Series Relay —  
2 Switch Form C**

In small signal applications, such as computers, telemetric systems, strain gauges, etc. generated emf. within the system's relays must be taken into account.

Dynamic Contact Noise is a "coined" phrase used to indicate an undesired generated emf. upon contact closure. It is the result of mechanical oscillation of the armature—caused by the impact of the armature on the stationary contacts — sweeping the coil flux.

Typical illustrations of this noise are shown in the oscillograms, with the relay being driven at nominal voltage in the test circuit shown below. The frequency and amplitude are integral functions of system bandwidth and coil drive conditions.

The slight ripple seen at the end of each trace is not noise, but due to resolution of test equipment and test circuit.\*

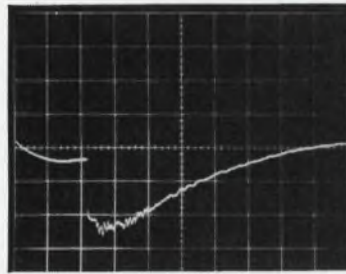

**FIGURE 1**

Horizontal Deflection 1.0 ms/cm  
Vertical Deflection 20  $\mu$ V/cm  
Systems Bandwidth .06–60 Hz.

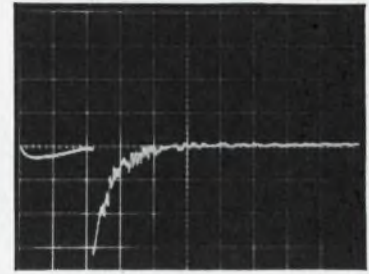

**FIGURE 2**

Horizontal Deflection 1.0 ms/cm  
Vertical Deflection 100  $\mu$ V/cm  
Systems Bandwidth .06–600 Hz.

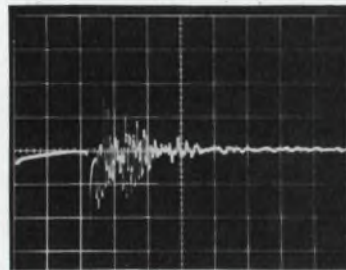

**FIGURE 3**

Horizontal Deflection 1.0 ms/cm  
Vertical Deflection 200  $\mu$ V/cm  
Systems Bandwidth .06–6K Hz.

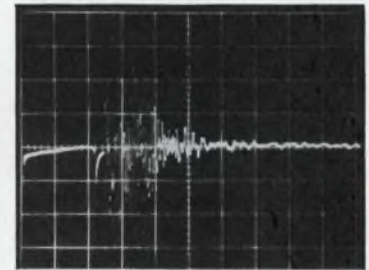

**FIGURE 4**

Horizontal Deflection 1.0 ms/cm  
Vertical Deflection 200  $\mu$ V/cm  
Systems Bandwidth .06–60K Hz.

### TEST CIRCUIT

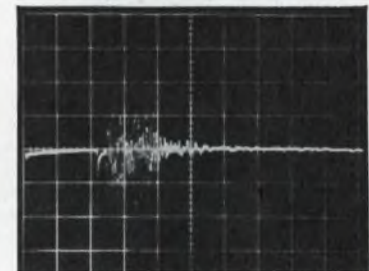
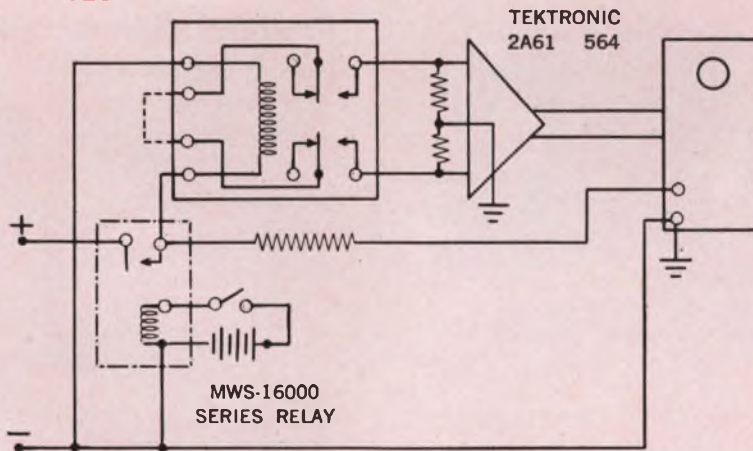

**FIGURE 5**

Horizontal Deflection 1.0 ms/cm  
Vertical Deflection 500  $\mu$ V/cm  
Systems Bandwidth .06–100K Hz.

\* If you have a problem regarding relay applications to a particular system our engineering staff is ready to help you. Contact Mr. Le Roy Carlson, Chief Project Engineer.

Backed by sound research and disciplined engineering, Adlake applies the industry's broadest line of mercury displacement and mercury wetted relays to the creative solution of design circuit problems. However unique or special your application, Adlake can assist you in

developing it. For prompt, personal and knowledgeable attention to your relay needs, contact the one source that is the complete source in the mercury relay field. Contact Adlake today for catalog and further information.



## THE ADAMS & WESTLAKE COMPANY

Dept. 1037 Elkhart, Indiana, U.S.A. 46514 • (AC 219) 264-1141

TRANSPORTATION EQUIPMENT • ARCHITECTURAL PRODUCTS • MERCURY RELAYS • DOORS AND ENTRANCES • CONTRACT MANUFACTURING

ON READER-SERVICE CARD CIRCLE 88

# DO YOU USE MAGNETS?

Save Time and Costs With RFL High-Quality Magnetics Equipment



## CHARGE

**MODEL 2470-350** magnetizes with variable energies of up to 440 watt-seconds. Handles a wide range of materials, including Alnico, Ticonal and Barium Ferrite, using wire-wound fixtures, easily fabricated for virtually any configuration.



## STABILIZE

**MODEL 889B** Magnetreater® demagnetizes and stabilizes almost any permanent magnet assembly, to specific flux levels, to within fractions of a per cent. Power level equivalent to 50 KVA.



## MEASURE

**MODEL 750** Gaussmeter—A wide-range Hall-effect gaussmeter capable of flux density measurements from .02 gauss to 50 kilogauss in 24 full-scale ranges. Measures permanent magnetic fields, DC and AC to 400 Hz.

Send for full details, or call Earle Seely



Units may be combined as a complete "SYSTEM" for charging, treating, and measuring, without removing material from fixture.

**RFL Industries, Inc.**

FORMERLY RADIO FREQUENCY LABORATORIES, INC.

Instrumentation Div. • Boonton, N. J. 07050  
Tel: 201-334-3100 / TWX: 710-987 8352 / CABLE RADAIRCO, N. J.

ON READER-SERVICE CARD CIRCLE 89

U152

## INSTRUMENTS—2ND FLOOR

### Peak detector reads 10-ms transients

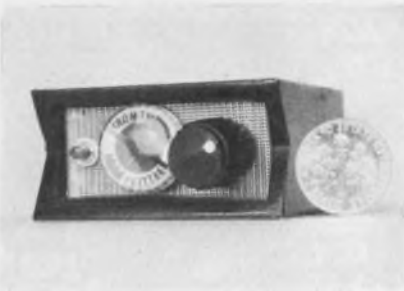

*Roveti Instruments, 1643 Forest Dr., Annapolis, Md. Phone: (301) 974-0876. P&A: \$44.50; 2 to 4 wks.*

Transients as short as 10 ms can be reliably detected and locked in with this unit to indicate the cause of failure in solid-state equipment. The unit has a floating input so it can monitor positive or negative levels from 50 millivolts to 50 volts at any point. An external resistor will increase the upper end of the range to hundreds or thousands of volts (sensitivity is 20,000  $\Omega/V$ ).

Booth No. 2A18 Circle No. 516

### RF load resistors rated 100, 225 W

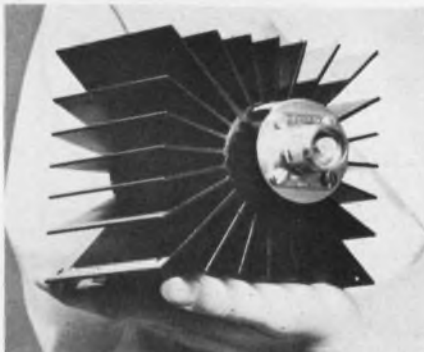

*Bird Electronic Corp., 30303 Aurora Rd., Cleveland. Phone: (216) 248-1200. P&A: \$125; stock.*

Dry high-power coaxial loads are designed for 50- $\Omega$  RF line and system termination in any position. The 100-W model 8160 is completely independent of extraneous heat sinks or cooling liquids. Mating it with an axial air-flow device in the model 8161, the "sun-burst" radiator permits a safe RF power dissipation of 225 watts. Maximum vswr limits are 1.1 from dc to 1 GHz, and 1.2 to 2.5 GHz.

Booth No. 2F39 Circle No. 390

### Wheatstone bridge accurate to 1 ppm



*General Resistance, Inc., 430 Southern Blvd., Bronx, N. Y. Phone: (212) 292-1500. P&A: \$3750; 60 to 90 days.*

A completely self-contained resistance measurement system consists of a wheatstone bridge, solid-state null detector, regulated power supply and automatic go, no-go per cent selector programmer. The go, no-go feature reads error in per cent or ppm of the component under test. Over 600 resistors per hour can be measured and sorted with 1-ppm relative or  $\pm 10$ -ppm absolute accuracy.

Booth No. 2H44 Circle No. 513

### Predetermining counter has 5-figure count



*Veeder-Root, Hartford, Conn. Phone: (203) 527-7201.*

The electronic predetermining sections of this counter are of modular design with sealed, plug-in relays for each preset level. The mechanical input shaft can accept up to 5000 counts a minute. The basic model has five-figure count capacity and accommodates up to four preset knock-off channels.

Booth No. 2D45 Circle No. 506



## Our new little stepping motor has two very interesting features:

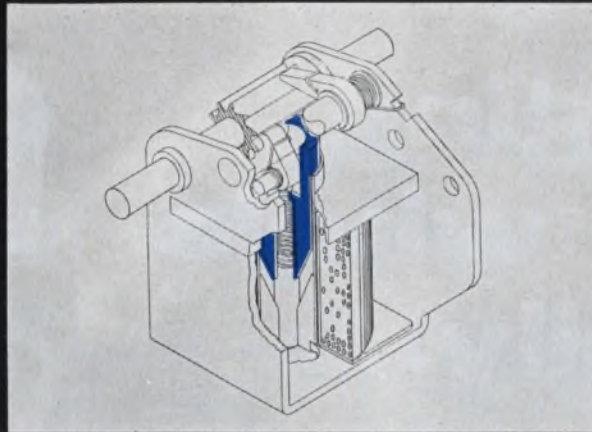

- 1. A linear-motion armature**
- 2. A price below ten dollars\***

Rotary-type stepping motors work pretty well, but as we see it, they're unnecessarily complicated (and expensive).

Consider rotor overshoot compensation. We don't need any. The linear, solenoid-and-plunger design of our Roto-Netic® stepping motor obviates the problem.

When the solenoid is de-energized, the armature moves straight upwards, under positive spring pressure, and directly drives the actuator that turns the starwheel. Neat and simple as that.

The plunger configuration also eliminates the need to compensate for lateral shaft movement. Because the output shaft turns on its own axis,

there is no axial thrust motion to worry about. (The output shaft, incidentally, is double-ended so that you have a built-in choice of either clockwise or counterclockwise rotation.)

Yet another advantage of our linear design is a relatively high torque output. The Model SC1 motor shown here will deliver a starting torque of 0.1 inch-pounds (1.6 inch-ounces). Pounds or ounces, that's good performance for a unit that is about the size of an ice cube and weighs a scant six ounces.

The SC1 provides a step increment of precisely 36°. The mathematically minded will immediately recognize that this works out to ten steps for one complete revolution. The motor should therefore be very attractive to

those of you working with decade functions.

At present, we're stocking 12VDC and 115VAC models. We can and will produce other voltage ratings to your order. At any rated voltage, the motor is capable of 600 operations per minute.

We'll be glad to send you a descriptive spec sheet. Just ask us for Bulletin 701. If you're inclined to be daring, you can send us ten bucks for a sample unit and investigate further on your own lab bench. Either way, let us hear from you. Heinemann Electric Company, 2616 Brunswick Pike, Trenton, N.J. 08602.



**HEINEMANN**

\*\$8.00 to be exact, for OEMs, in quantities of 100 to 499.

ON READER-SERVICE CARD CIRCLE 90

**we're  
bringing  
the whole  
family...**

**to the IEEE show**

**MAINE DIVISION**

manufacturers of  
MINITAN® and  
ECONOTAN® solid  
tantalum capacitors

**ARIZONA DIVISION**

manufacturers of  
MILITAN, DIPATAN,  
and WELTAN solid  
tantalum capacitors

**SEMCOR DIVISION**

manufacturers of  
ZENER DIODES and  
TEMPERATURE COMPENSATED  
REFERENCE ELEMENTS.

LET'S TALK ABOUT PRICE, DELIVERY,  
RELIABILITY, PRODUCT APPLICATION

**BOOTHS 4K08 - 4K10**



**COMPONENTS, INC.**

BIDDEFORD, MAINE / 207-284-5956  
PHOENIX, ARIZONA / 602-272-1341

INSTRUMENTS—2ND FLOOR

**Wire tester  
operates to 1500°F**

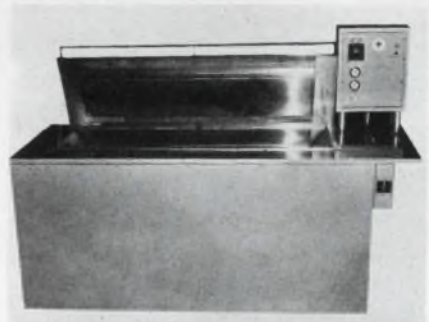

*Procedyne Corp, 221 Somerset St.,  
New Brunswick, N. J. Phone: (201)  
249-8347. P&A: \$6850; 8 to 10 wks.*

A constant temperature bath for wire and heat testing operates at temperatures up to 1500°F. The unit is designed for testing wire cable sheaths at their specification temperature. The tester permits putting about 30 cables into the air-fluidized solids for checking at specification temperature. The unit provides a temperature uniformity of  $\pm 0.5^\circ\text{F}$  and control of  $\pm 1^\circ\text{F}$ .

*Booth No. 2F44 Circle No. 389*

**Noise, field intensity  
by automatic scanning**



*Singer Co., Metrics Div., 915 Pembroke St., Bridgeport, Conn. Phone: (203) 366-3201.*

Automatic scanning within any portion of the 20-Hz-to-15-kHz range is possible with this noise and field intensity meter. Upper and lower limits of the sector to be scanned are selected remotely, or by means of a front panel scan limit control. This permits continuous spectrum scanning or single sweep, upward or downward in frequency. Three separate calibrated scales are provided: peak, average and rms.

*Booth No. 2B25 Circle No. 387*



**Now the  
industry-  
accepted TTL  
has a double,  
pin for pin...**

**Westinghouse TTL.  
Available now.**

The new direct replacement for industry-accepted SUHL II is here. Westinghouse TTL is a true mechanical and electrical replacement, pin for pin. Here's a second source TTL that can help keep your products competitive into the 1970's. □ Circuits now available in industry standard dual-in-line and flat packages include: 6G241 Dual NAND/NOR Gate; 6G221 Quadruple NAND/NOR Gate; 6F251 JK Flip-Flop, AND input; 6F261 JK Flip-Flop, OR input. □ For evaluation quantities, contact your Westinghouse Electronic salesman. Or phone Westinghouse at (301) 796-3666. Or write Westinghouse, Molecular Electronics Division, Box 7377, Elkridge, Maryland 21227.

**You can be sure if it's Westinghouse**



J-09141

NEW

# ALSiMAG<sup>®</sup>

## Compact Ceramic Capacitor

.020" sq 180 pf  
Photographed  
on the head  
of a pin.  
Enlarged 6¼ times.

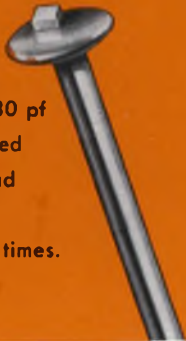

Is your Real Estate Expensive?

Are you Cramped for  
Capacitor Space?

Do you need Small Capacitors?

Is that your problem, Friend?

Then try our New  
"Compact Ceramic Capacitor"!

Of course it's no coincidence that this compact ceramic capacitor contains all the characteristics considered certain to certify its use in ceramic circuits. Coming in various colors, capacitances, and compositions, the compact ceramic capacitor can coexist with other components under conditions that would challenge a competitor's capacitor to be compatible.

Concise close control and cognizance of current circuit conditions were combined to create this new ceramic component.

For comprehensive information, call us, quick!

Bulletin 674 sent on request.

American Lava Corporation **3M**  
A SUBSIDIARY OF COMPANY

Titania Division

Chattanooga, Tennessee 37405  
Sixty-Fifth Year of Ceramic Leadership

### INSTRUMENTS—2ND FLOOR

## Six-figure counter to 2400 per minute

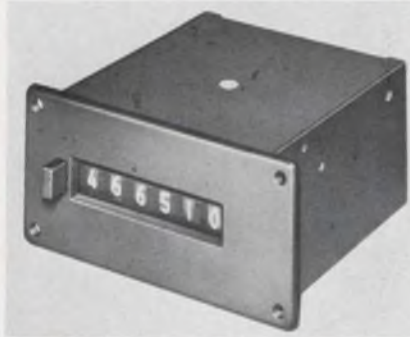

Durant Manufacturing Co., 622 N. Cass St., Milwaukee. Phone: (414) 271-9300.

High-speed six-figure counters panel or base mount, offer manual or electric reset options. They are said to be the only electrical reset counters with the entire mechanism housed within the case. Count speed is 2400 counts/minute dc and 1800 ac. Leads are accessible and provide for permanent installation without extraneous hardware.

Booth No. 2H48 Circle No. 518

## Variable filter covers 20 Hz to 2 MHz



Krohn-Hite Corp., 580 Massachusetts Ave., Cambridge, Mass. Phone: (617) 491-3211. P&A: \$695; 90 days.

Providing basic low-pass and high-pass modes, this unit can, by interconnecting its two independent channels, be operated as either a band-pass or band-reject filter. In addition, cascading the two channels can increase the basic 24-dB-per-octave attenuation slope to 48 dB per octave in the low-pass and high-pass modes. Each channel has response characteristics for frequency or time-domain applications.

Booth No. 2H11 Circle No. 514

## Vector voltmeter is battery-operated



Industrial Test Equipment Co., 20 Beechwood Ave., Port Washington, N. Y. Phone: (516) 767-9190.

A battery-operated portable vector voltmeter is available for operation over a range of 1 mV to 300 V full scale. It has a voltage accuracy of 2% of full scale, and a phase angle accuracy of ±1%. The frequency range is 50 Hz to 10 kHz. Noise and harmonic rejection is 40 dB.

Booth No. 2H02 Circle No. 515

## Programable attenuator ranges dc to 1 GHz



Marconi Instruments, Englewood, N. J. Phone: (201) 567-0607.

Programable attenuators for systems use cover dc to 1 GHz. They accept 1-2-4-8 BCD and have a range of 139 dB in 1-dB steps. Accuracy at 1 kHz is ±0.5%, ±0.1 dB to 120 dB; at 1 GHz it is ±1%, ±2 dB to 100 dB. Setting speed is less than 100 ms and at no time during switching is the attenuation less than the initial or final programmed value.

Booth No. 2D04 Circle No. 385

# Comar doesn't shy away from the tough one's



Anyone can handle the easy relay applications, but it takes a company with engineering knowhow, manufacturing superiority and just plain "guts" to take on the tough one's.

The engineers at Comar have an enviable record of rolling up their sleeves and burning the midnight oil to meet stringent relay specifications . . . shock, vibration, miss testing, humidity, special operating characteristics.

The next time someone tells you "it can't be done," call Comar. No miracles, just technical experience and the finest relay test laboratory in the world!



**Comar electric company**

3349 Addison Street  
Chicago, Illinois 60618

TELEPHONE TYPE RELAYS • SUBMINIATURE RELAYS •  
RELAY ASSEMBLIES • SOLENOIDS • SOLENOID ASSEMBLIES

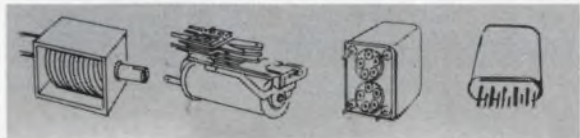

ON READER-SERVICE CARD CIRCLE 99

CHOPPERS • RELAYS • TRANSFORMERS • SWITCHES

# JAMES

## ISOLATES NOISE WITH SHIELDED TRANSFORMERS

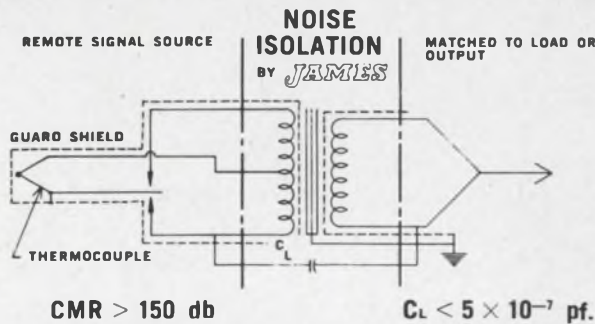

### 150 db COMMON MODE REJECTION

#### SIGNAL-GUARD TRANSFORMERS

Low and Medium Frequency (DC to 100KHz) response

Designed for use in analog acquisition and computation equipment. James Signal-Guard provides isolation, voltage comparison, impedance matching, and common mode rejection.

#### DATA-GUARD TRANSFORMERS

High Frequency Signal (1KHz — 40MHz)

Designed and shielded to isolate and terminate high frequency signal data in the form of pulses. AM and FM modulated carriers, multiplexed signals, and other low to high frequency data.

#### ELECTRO-GUARD TRANSFORMERS

Power (1 watt to 100VA)

Electrostatically shielded for use in signal conditioners, bridge supplies, and Zener reference supplies to isolate circuits from noise transients and undesirable common mode voltage commonly carried on power lines.

WRITE FOR FULL TECHNICAL DETAILS

# JAMES<sup>®</sup> ELECTRONICS INC.

4044 North Rockwell • Chicago, Illinois 60618  
Phone 312-463-6500 • FAX — JML

INSTRUMENTS—2ND FLOOR

### Solid-state ac voltmeter ranges 2 Hz to 6 MHz



Ballantine Labs., Inc., P. O. Box 97, Boonton, N. J. Phone: (201) 334-1432. P&A: \$320 (battery/line), \$290 (line only), \$62 (probe and cable); June.

Frequency range of this voltmeter is from 6 MHz down to 2 Hz. Its voltage range is 300  $\mu$ V to 350 V when used without model 1303 probe, or 1 mV to 1000 V when used with the probe. Accurate measurements may be made to as low as 100  $\mu$ V over the narrower range of 10 Hz to 1 MHz without the probe, or to 300  $\mu$ V with the probe.

Booth No. 2G26 Circle No. 392

### Squarewave generator has 5-ns rise time



Hewlett-Packard, 1501 Page Mill Rd., Palo Alto, Calif. Phone: (415) 326-7000. P&A: \$375; stock.

A solid-state squarewave generator covers 1 Hz to 10 MHz. Squarewave rise and fall times are less than 5 ns; overshoot, preshoot and ringing are less than 5%; and jitter is less than 0.2% of waveform period at any repetition rate. The generator takes only half the width of a 7-inch-high space when rack-mounted, and weighs 9 lbs.

Booth No. 2F25 Circle No. 501

# MATCH PROTECTOR TO HARDWARE

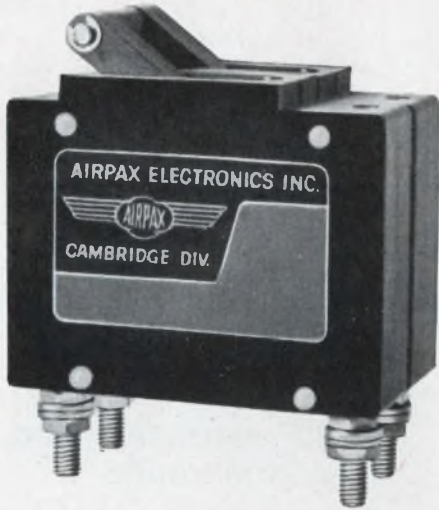

## An APL Circuit Protector—

will rupture a fault of 5,000 amperes at 240 volts!



provides a time delay for every demand!



is entirely magnetic — no heater elements!

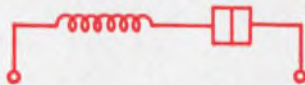

Tripping coils can be completely isolated!

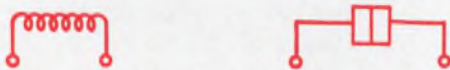

Gang every circuit together!

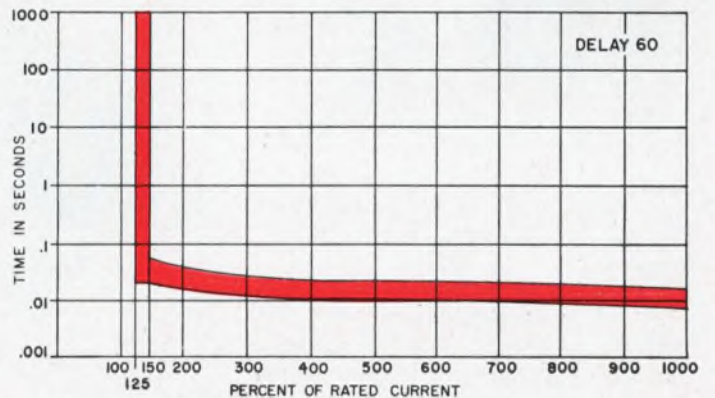
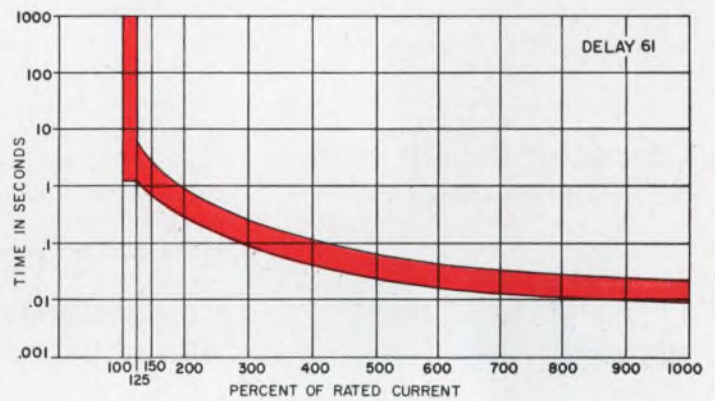
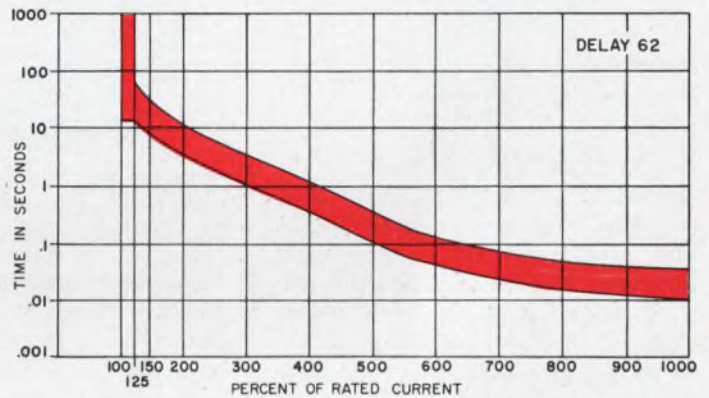
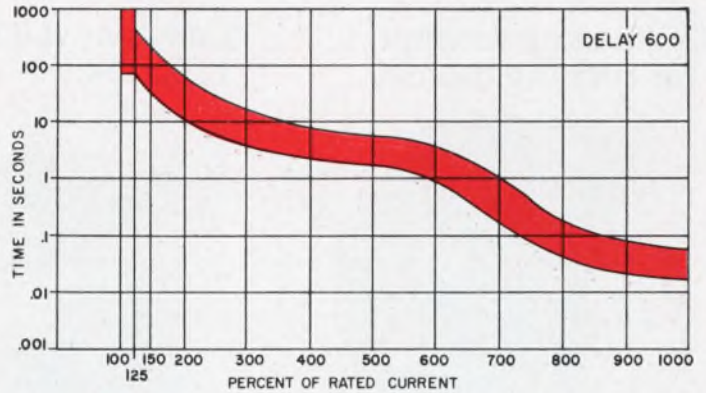
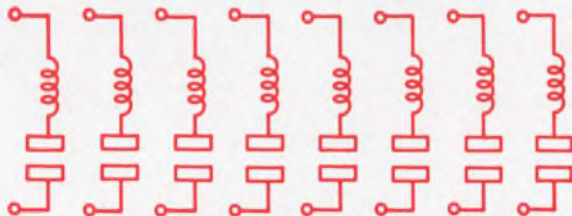

TYPICAL 60 CYCLE DELAYS

**AIRPAX ELECTRONICS**  
CAMBRIDGE, MARYLAND 301-228-4600

## Solid-state monitor for rotating devices



Himmelstein & Co., 2500 Estes Ave., Elk Grove Village, Ill. Phone: (312) 439-8181. Price: \$59.50.

A rotating switch monitor is offered for protection and control of rotating components, without slipping problems. It monitors contacts on rotating devices coupled through a 2-channel rotary transformer. Status lights indicate the condition of the rotating switch. A solid-state circuit drives an electromechanical relay with form C contacts.

Booth No. 2B46 Circle No. 396

## Connector design gives 50% more contacts



Winchester Electronics, Div. of Litton Industries, Main & Hillside, Oakville, Conn. Phone: (203) 274-8891.

A new arrangement of contacts is claimed to permit 50% more contacts in this connector than is usual for its size. Crimp contacts, 0.03 inch diameter, rated at 5 A, accommodate AWG 20 through 30 wire. The shell is of thermoplastic; the connector mounts with a single jackscrew and is polarized.

Booth No. 2K21 Circle No. 384

## Constant voltage supply replaces wet cells



Dynage, Inc., 390 Capitol St., Hartford, Conn. Phone: (203) 249-5654. P&A: \$125; stock to 2 wks.

Guarded constant voltage supplies are offered as replacements for dry or wet cells used to supply the standard current to laboratory potentiometers. The unit includes a guard feature that prevents leakage currents from passing from the positive output terminal to ground within the unit. Voltage regulation is 0.0005% for a  $\pm 10\%$  input change. The temperature coefficient is  $\pm 0.0005\%/^{\circ}\text{C}$  over a range of 15 to  $35^{\circ}\text{C}$ .

Booth No. 2F02 Circle No. 520

## Ku-band coax switching with shunted pin diodes



Hewlett-Packard, 1501 Page Mill Rd., Palo Alto, Calif. Phone: (415) 326-7000. P&A: \$325 (1 to 9), \$308.75 (10 to 24), \$292.50 (25 to 99); stock to 2 wks.

Two broadband solid-state switches achieve operation in the 12-to-18-GHz (Ku) band with insertion

loss of 1.5 dB, isolation of 50 dB and vswr of 1.6 in the on condition. Switching is accomplished by changing bias levels on two pin diodes that shunt the transmission line. The signal is passed when diode bias is zero or reverse, and hence diode resistance is high. When forward-biased, the matched diodes shunt the transmission path with a low impedance that reflects RF signals. The amount of forward bias current determines the magnitude of the shunt impedance and thus the amount of reflection. Full reflection is obtained with bias currents on the order of 50 mA.

Booth No. 2F25 Circle No. 399

## RF wattmeter/load is dual-range



Bird Electronic Corp., 30303 Aurora Rd., Cleveland. Phone: (216) 248-1200.

For design, service and maintenance of transmitters in the 2-to-30-MHz range when the system cannot be terminated in its antenna, model 6155 is an RF wattmeter and integral load. The wattmeter consists of a logarithmic coaxial-line load resistor, which serves as a 150-watt dummy load within a finned radiator, and a voltmeter circuit coupled to a direct-reading meter calibrated in watts. A slide-switch selects either the 50 or the 150-W scale. The load is a 50- $\Omega$  termination from dc to 1000 MHz with a vswr of less than 1.1.

Booth No. 2F39 Circle No. 391



CRTs

## How fiber-optic CRTs allow direct recording of 1 MHz signals

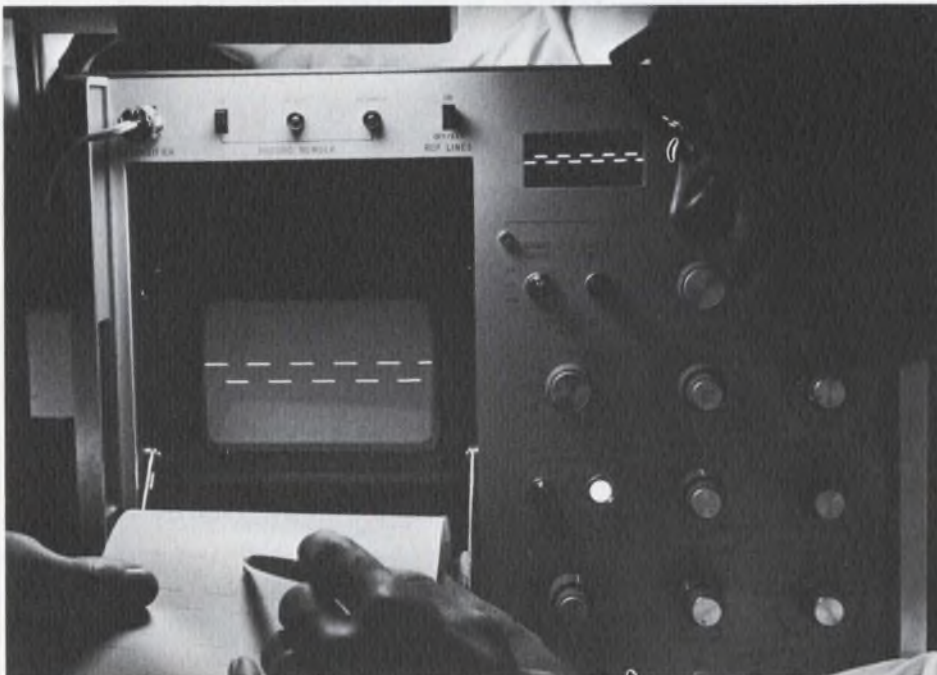

Honeywell's new Model 1806 CRT Visicorder

*How do you combine the direct-write features of oscillographs with the high-frequency measuring capabilities of modern oscilloscopes? Simple, if you use the electron beam of a specially designed Sylvania fiber-optic CRT to provide immediately available direct printout recordings of high frequency analog data and video signals.*

A special Sylvania fiber-optic CRT has helped engineers at Honeywell's Test Instruments Division to produce an instrument with recording speeds nearly 100 times greater than previously available oscillographs. Honeywell's Model 1806 Visicorder is a single-channel, 4-axis unit which employs the electron beam of the fiber-optic CRT to record continuous transient data directly on standard oscillo-

graphic paper.

The new instrument can record responses of from dc to 1 MHz on either the vertical or horizontal axis, or simultaneously on both, and has continuous or intermittent chart drive modes. In addition, video pictures can be recorded as a continuous series of individual 3 by 4 inch frames on the direct-record paper at the rate of 30 pictures per second.

The essential component in Model 1806 is the specially-designed Sylvania fiber-optic CRT. This new tube (SC-4082E) has an improved electron gun for initial fine spot resolution. Spots produced by the new gun have a diameter of 4-7 mils compared to 15-30 mils for typical laboratory scopes.

More than 35 million fibers, each 10

to 15 microns in diameter, insures that the initial small spot size is retained as it is conducted to the face of the CRT for recording. Here, signals are recorded by passing ultraviolet-sensitive paper over the 1/2-inch thick faceplate of the tube. Low-level ultraviolet light develops the paper as it comes out of the instrument to give a permanent record within seconds.

The SC-4082E, with its 3"x5" face, has the largest fiber-optic faceplate commercially available today. It uses a P16 phosphor and has electrostatic focus and deflection. Helical-resistor post-deflection acceleration is employed to get high writing rate, high deflection sensitivity, and freedom from pattern distortion.

In addition to the fiber-optic recording tube, the new oscillograph  
*(continued)*

---

## This issue in capsule

---

**Integrated Circuits** — How to step servo motors with SUHL/TTL circuits.

**Readouts** — Translator/drivers, like EL panels, can be customized to your specific needs.

**Diodes** — Low-leakage types included in silicon alloy junction DF-7 series.

**Photoconductors** — TO-18 50 mW cells added to extensive Sylvania PC line.

**Microwave Components** — Now an X-Band avalanche diode oscillator for parametric amplifier pumping.

**Integrated Circuits** — How to simplify noise and power problems in systems design.

**Television** — Broad monochrome picture tube line for 1967 set designs.

uses a conventional CRT, the Sylvania 3ASPI, to monitor the signal being recorded.

Sylvania has designed many other types of high resolution cathode ray tubes with fiber-optic faceplates as well as full faceplate arrays. Fiber size ranges from 4 microns up to 75 microns, depending on the specific tube and application. Basic characteristics on a few of these types are listed in the table.

CIRCLE NUMBER 300



Sylvania's SC-4082E fibre-optic CRT

BASIC CHARACTERISTICS OF TYPICAL FIBER OPTIC CRTS

Tube Type	Fiber Strip Size	Focus	Screen Size
SC-3304	2 3/4" x 1/4"	magnetic	3" x 1 1/4"
SC-3507	8 1/4" x 1/2"	magnetic	10" x 3 1/2"
SC-3800	8 1/4" x 1/2"	electrostatic	10" x 3 1/2"
SC-3850	4 1/2" x 1/2"	magnetic	5" dia.
SC-3876	8 1/4" x 1/2"	magnetic	10" x 3 1/2"

INTEGRATED CIRCUITS

# How to step servo motors with SUHL/TTL ICs

Until recently, discrete components were used exclusively to control the stepping of servo motors. Now, the same function can be done easily with Sylvania's versatile SUHL units. The only ICs you'll need are OR gates, AND gates, and J-K flip-flops. With SUHL, this can be done with as few as five packages.

Sylvania ICs can perform all the logic, counting, and decoding necessary to control the stepping of servo motors. The specific circuit described here can handle shift pulses of up to 28 volts while delivering 10 mA to the driver transistor of each of four motor windings.

Key elements in the control (see figure) are these Sylvania SUHL types: SF-60 J-K flip-flop, SG-90 exclusive

OR, and SG-280 dual AND gate or the SG-140 quad 2-input NAND/NOR gate. Whether you use the SG-280 or SG-140 series, the counting and decoding require only five IC packages.

In the circuit, pulling the direct set input to ground will set the Q outputs of both flip-flops to a "1." This corresponds to the unbarred letters A and B, and places both inputs to the #1 decoder gate high. Since the gate performs the AND function, the output will go high, turning on its transistor and activating the #1 winding. Now, should a shift right pulse be generated, the #2 winding will be activated. However, if instead a shift left occurs, the #4 winding is activated. Sequence for shift right pulses is: 1,

2, 3, 4, 1... For shift left it is: 1, 4, 3, 2, 1...

The 28 V shift pulses are dropped to approximately 3.5 V with the 7:1 ratio resistor network shown. When the pulse edges exceed a 1.0 μsec/volt slope it may be necessary to sharpen them with an SG-83 pulse shaping AND gate placed after the voltage divider.

The +28 V dc supply is cut to 4.5 to 6.0 V to provide dc for the ICs. This is done with a series dropping resistor. However, if the motor causes voltage spikes of considerable amplitude, a zener diode can be used for regulation.

The decoder gates perform the AND function. This can be accomplished with two SG-280 devices. Each SG-280 is a dual AND gate in a single package. However, two NAND gates in series will accomplish the same thing. By using the SG-140 quad two-input NAND gate, the function is provided with the same number of packages.

The transistor at the decoder gate output handles the motor's high voltage and coil current requirements. Value of the 500 to 1K resistor shown in the base will depend on the beta characteristics of the transistor. A 500-ohm resistor will supply a base drive of from 4 to 5 mA and 1K from 2 to 2.5 mA. If the resistor is dropped below 500 ohms for more current, SUHL II device SG-220 or SG-280 is recommended. Either can supply 10 mA or better with a 250-ohm resistor.

CIRCLE NUMBER 301

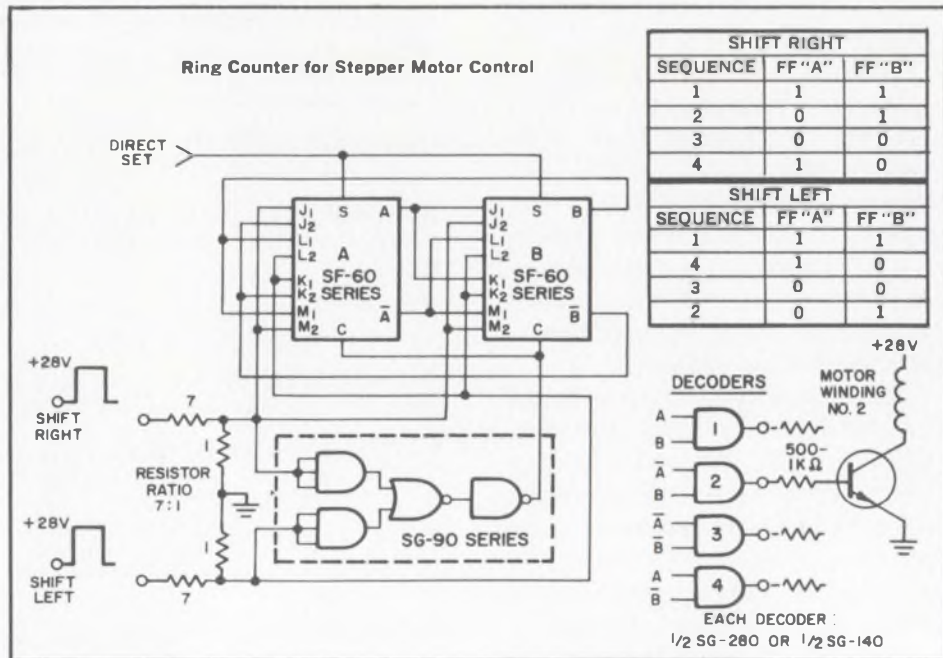

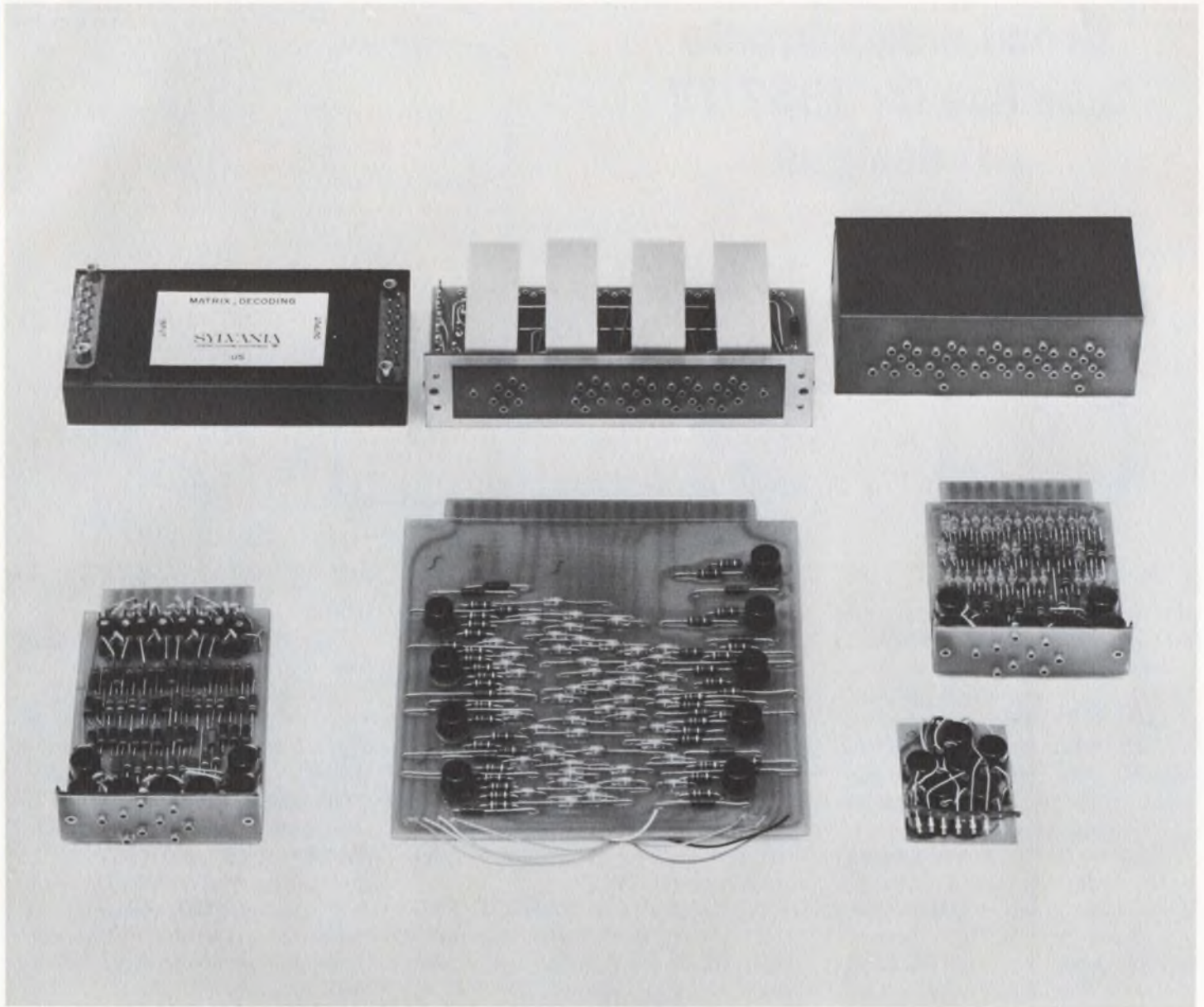

## Translators/Drivers, like EL panels, can be customized to specific needs

*It naturally figures that, whatever the electroluminescent display application, Sylvania engineering would provide the best interface between computers (or counter outputs) and EL panels. After all, experience gained as a prime producer as well as user of EL readouts gives us the custom-engineering capability which we apply over a wide application spectrum.*

The right translator or driver, singly or in combination, should be applied to your application—be it a relatively simple readout system for a non-critical environment or an advanced system for an aerospace application which may incorporate Sylvania's new

all-glass EL panel designs.

In all applications, translators and drivers combine to perform the double function of input translation and EL panel segment switching. They feature compact design, low-power requirements, fast switching, low-level logic input, long life, modular design and solid state reliability. In addition, they can be supplied with or without a memory capability.

Typically, in these Sylvania units, binary input codes are translated to numeric readout by diode logic circuits and EL readout panel power is switched by SCRs.

Translator power requirements are

a low 6 to 12 volts at a few milliamperes. Readout driver power depends on the size and type of the EL readout used. Units can have either positive or negative logic inputs of as low as 6 volts at 2 ma per data bit and pulse widths of 1  $\mu$ sec.

Sylvania has already developed units which encompass the needs of a wide variety of EL readouts requirements. We'll undertake custom designs which implement your special codes and fit your mechanical configurations. Sylvania design engineers use a computer program to determine the best translator circuitry for these customized devices.

## Broad monochrome tube line for 1967 TV set designs

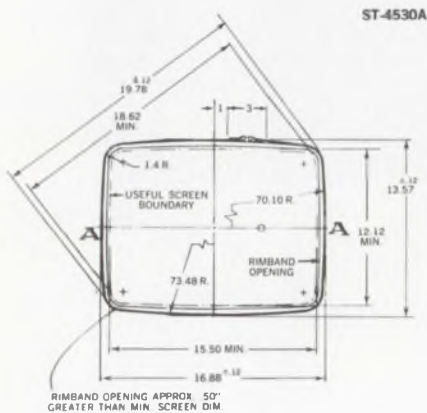

Already one of the most complete in the industry, Sylvania's monochrome picture tube line is still growing. Availability of production quantities of the new 20" tube, developed late last year, means designers are now choosing from even more tube sizes to find the specific picture tube to fulfill 1967 requirements.

Whatever the TV picture tube size needed today, chances are there's a Sylvania monochrome picture tube that size, today. That's because Sylvania produces a broad line of picture tubes that includes eleven standard sizes covering up to 26 inches.

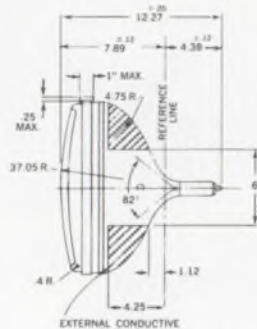

Tubes like the new 20" ST-4530A for building 19" sets to the new FTC labeling requirements. Or two recently announced 12-inch picture tubes to keep pace with the call for smaller, more portable TV sets.

The new 20" has a useful screen dimension of 18.625". This 114° dark bulb device gives 184 square inches of viewing area, yet has an overall length of only 12.27".

The 12CRP4 and 12CSP4 are 12" units of small-neck size, making them ideal for smaller portable set requirements. Overall lengths of these tubes are a short 9.021" (12CRP4) and

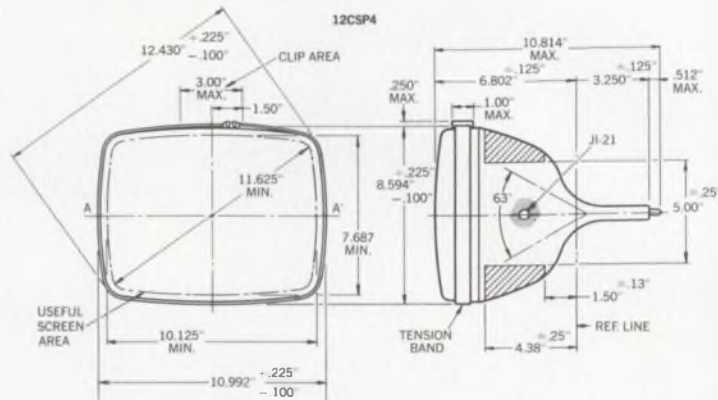
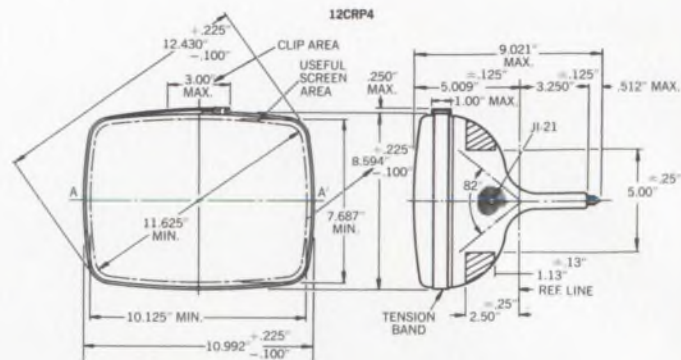

10.814" (12CSP4).

The 12CRP4 employs 110° magnetic deflection, the 12CSP4, 90° deflection. Both have aluminized screen with a useful area of 7.687" x 10.125" to give a minimum useful diagonal of 11.625".

Other sizes in the Sylvania line are also tailored to meet the specific need for present set production. All include the latest advancements in tube design, material and production techniques made available by Sylvania's continuing tube technology development program.

CIRCLE NUMBER 303

### MICROWAVE COMPONENTS

## Now an X-Band avalanche diode oscillator for parametric amplifier pumping

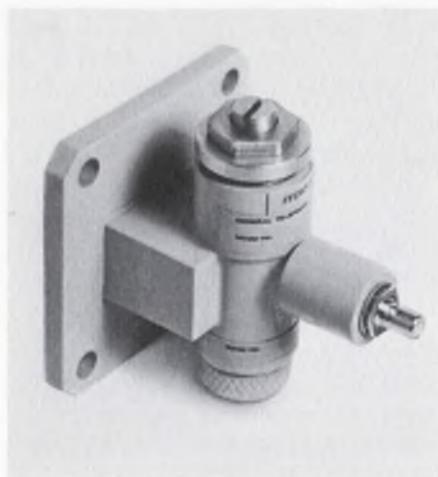

Use of parametric amplifiers in military systems has been limited because of the need for a pump source with a frequency much higher than the signal frequency. Traditionally klystrons provided this pump frequency. However, they require very large and expensive power supplies which usually weigh more than the rest of the solid state circuitry. More recently, varactor multiplier sources have been used, but this usually involves many semiconductors as well as complicated circuitry. Now a simple single device from Sylvania which converts dc to

rf directly at frequencies in X-band can be used to pump parametric amplifiers.

Sylvania's new SYA-3200 avalanche diode oscillator simplifies construction of parametric amplifiers by producing a minimum of 10 mW at any frequency in X-band (8.2 to 12.4 GHz). Requiring only a single dc power supply, the SYA-3200 is much more efficient and much lighter than any other solid state or tube pump currently in use.

This new source is mechanically tunable by means of a single screw

adjustment over a range of at least 200 MHz and has a temperature coefficient of frequency typically of 200 KHz/°C. This is comparable to that of the existing klystrons which it replaces.

Parametric amplifiers pumped by the SYA-3200 avalanche diode oscillator have exhibited performance which is indistinguishable from that obtained using conventional klystrons. A parametric amplifier operating in L-band was pumped at 11 GHz by a

SYA-3200. Result: a noise figure of 1.8 db, exactly what was obtained using a klystron. Saving in power supply, size, and weight reduced the overall weight and size of the amplifier by 50 percent. Gain, bandwidth, and stability were unchanged from the performance obtained from a klystron.

In addition to use as pumps, these oscillators function successfully as local oscillators in heterodyne receivers and as beacon transponder

sources. Of course, these represent only the first uses of this new device. We'll work with you in applying the full capabilities of an avalanche oscillator to your application.

The SYA-3200 is currently available in developmental quantities. Continued development over the next several months is expected to lead to improved devices with higher output power, electronic tuning, and additional frequency band coverage.

CIRCLE NUMBER 304

**ELECTRICAL CHARACTERISTICS OF SYA-3200**

Frequency .....	8.2-12.4 GHz*
Mechanical tunability .....	±100 MHz
Power output into matched load.....	10 mW min.
Efficiency .....	1-2% typical
Power variation over tuning range.....	1 db max.
Operating temperature range .....	-30 to +71°C
Temperature coefficient of frequency .....	-200 KHz/°C typical
DC bias voltage .....	-50 to -90 volts**
DC operating current .....	-10 to -25 ma**

\*To be specified within this range.

\*\*Required operating voltage and current will be specified with each unit. Constant current supply should be used.

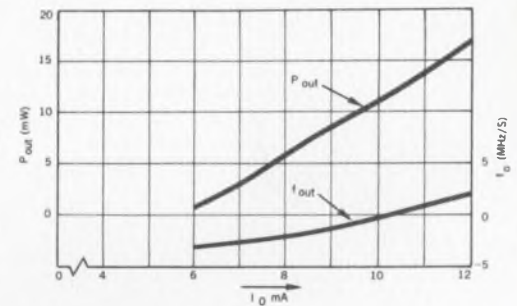
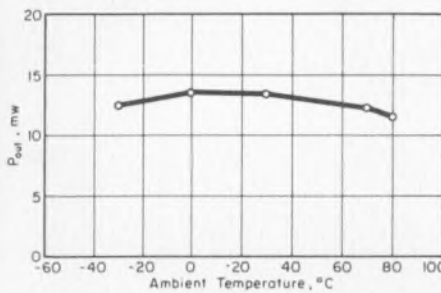

**MARKETING SERVICES MANAGER'S CORNER**

# "Trade shows are a waste of time"

"...and a waste of money too." How often have you heard this? You may have said it yourself. For a great many people it's true, shows are wasted efforts.

After all, too many exhibits are little more than 3-dimensional catalogs. Nothing's exciting in seeing cold lifeless products tacked to a back wall. We at Sylvania shudder to think of the dull repetition (and, possibly, repulsion) of 100 receiving tubes in a row.

And what if you just happen to see one product that interests you? Ask a reasonable question at the booth about it, and you usually find that the expert on the subject is out to lunch. (Would you believe this at 9:30 AM?)

But exhibitors are only partners in the crime of trade shows. Attendees share a large portion of the blame. Engineers are in New York during the IEEE show often for three or four days. But during that time they're seen in the Coliseum for as much as four hours! Ask them if they saw the show. Why, certainly they did! To have seen every exhibit in that period of time, they would have had to be Olympic track stars if only to go through all of the aisles.

After our sprinter does complete

his exhaustive survey, general comments run from "same old stuff" to "nothing really new." Anything less than the discovery of a new energy source seems to be a disappointment. Well, we could go on and on, but essentially our point of view is that, like most things, trade shows are valueless *unless* all exhibitors and attendees work at it.

Sylvania has made some innovations in presentation techniques—live presentations, information booth and telephone hot line. We hold no licenses on these methods and wish (in fact, strongly urge) other exhibitors would liven up their booths in a similar manner.

A better show benefits everyone. In fifteen minutes at the Sylvania booths, 3G01-3G12, we feel an engineer can be initially exposed to the full scope of Sylvania's manufacturing and engineering efforts. Included, of course, are new product developments, particularly those that are pertinent to today's designs and requirements. A few more minutes and we'll give detailed information on specific product types from our microfilm data file right at the booth.

Visitors also have the option of talking directly to our plant and engi-

neering locations anywhere in the country. Further, they can request that specific information be sent to them at the completion of the show on any product which we manufacture. It isn't necessary to ask ten people in order to receive this information. Our purpose at a trade show is not to take orders there on the floor, but rather to disseminate the maximum amount of information on our overall company capabilities.

We want people to know more of what Sylvania can do today and in the years to come.

For your company, trade shows can be a waste of time, but there is also the opportunity to learn a great deal at a relatively small cost. We sincerely hope you share our thoughts for maximizing the time and money devoted to the trade show concept. Sylvania wants to make good use of the time you give us.

*Bill Dixon*

W. R. DIXON

NOTE: Interest in this column, in IDEAS last year at IEEE Show time, was unusually high. We thought it deserving of a rerun. Mr. Dixon, Merchandising Manager a year ago, is now Marketing Services Manager of Sylvania's Electronic Components Group.

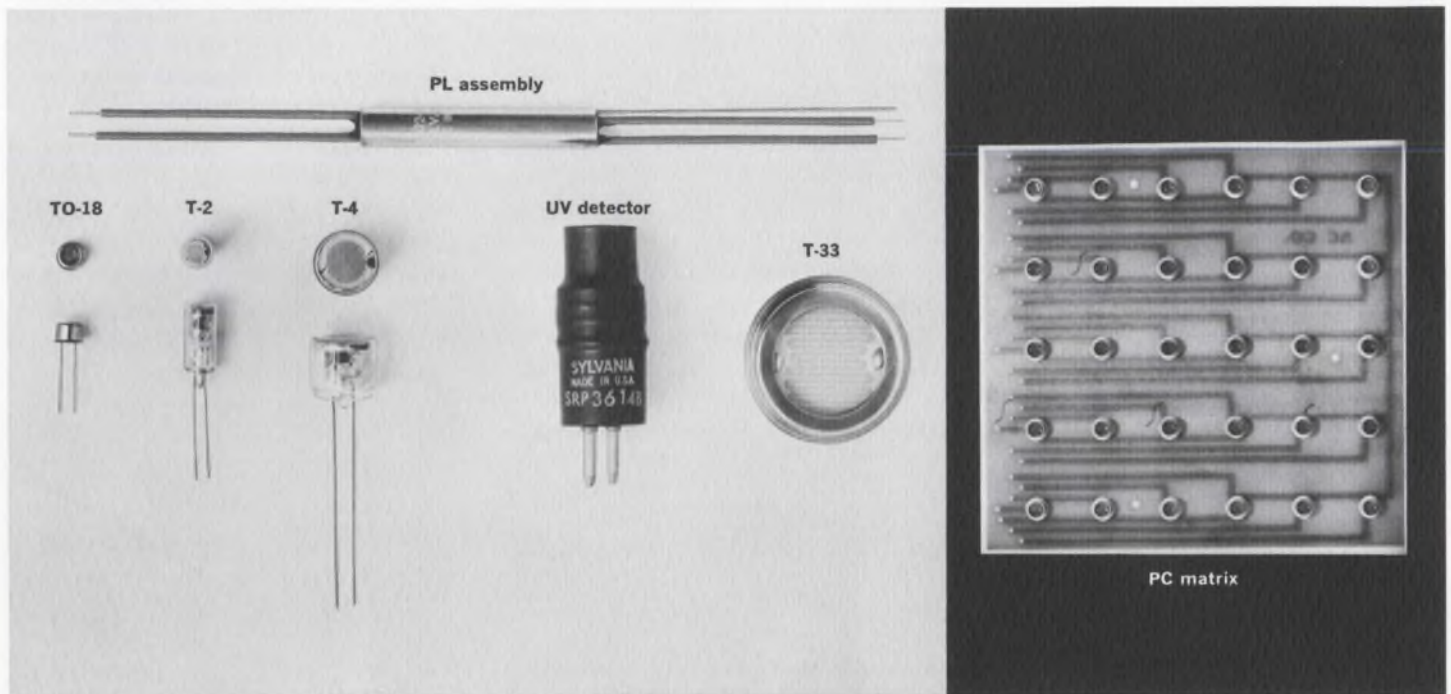

## Newest additions to an extensive PC line: TO-18 50-milliwatt cells

*How do you evaluate the completeness of a photoconductor line? By the range of power ratings? Sylvania has 50 mW and 500 mW units. By physical size? We now have photoconductors in TO-18 packages, in addition to the glass encapsulated T-2s and T-4s; also, the T-33 which is used for our street lighting cells. Specialty PC lines? Sylvania offers custom designed photoconductive matrices as well as both standard and customized photoconductor-lamp (PL) assemblies, and also ultraviolet types. Now with the introduction of the new TO-18 units, the line becomes even more functional. And more and more Sylvania becomes the logical source for all photoconductive devices.*

The TO-18s, latest additions to Sylvania's already varied line of photoconductors, are miniature, end-view packaged, cadmium sulfide cells. Because they are hermetically sealed, the new PCs are not affected by moisture. For the circuit designer, this means stable electrical characteristics and long term reliability.

The light and dark resistance characteristics of the new TO-18 units are similar to Sylvania's T-2 line. Power dissipation rating is 50 mW compared with 75 mW for the T-2 line.

Sylvania's T-2 cells are also minia-

ture photoconductors. With these rugged ¼-inch diameter units, the designer can select devices which have light resistance values in the range of 2000 to 128,000 ohms. Resistance change ratio of the T-2 PCs is better than 100.

The T-4 line consists of ruggedized photoconductors which can withstand 300-g impact shocks and 2.5-g vibrations for extended periods. These ½-inch diameter, end-view cells have high sensitivity and are rated at 400 volts. Light resistance values range from 750 ohms to 16 K ohms. Ratio of dark/light resistance is 100 to 1.

Sylvania's outdoor lighting control cell Type 7163 has a demand rating of 750 mW and a continuous rating of 500 mW. This cell easily operates relays directly in outdoor lighting control circuits. Orientated to north sky illumination, it detects the blue end of the spectrum. A response time faster than is found in the standard T-2 and T-4 photoconductor lines makes the 7163 one of the fastest cadmium sulfide cells and, therefore, a versatile vehicle for more industrial applications.

Because of its small size, the new TO-18 photocell is also an ideal choice for use in PC arrays. Any number of photoconductors can be im-

bedded in a printed circuit board, depending on the area available. Various pattern configurations and element sizes are possible to meet the demands of dissipation, resistance, and space requirements.

With Sylvania's PC type SRP-3614A, detection and measurement of ultraviolet radiation is simplified. Requiring only comparatively simple low voltage circuitry, a power handling capability of 300 mW enables this device to translate UV to signal levels which can operate a sensitive relay directly. This UV detector is supplied in a T-4 envelope.

In another specialty series, photoconductors and lamps are combined in light-proof housings to perform a wide variety of electronic functions. PL assemblies offer an economical and efficient approach to generating special musical effects. Other circuit applications of PL assemblies include: on-off switching, sequential switching, logic function, gain controls, linear amplification, delays, oscillators, filters, and regulators. These assemblies, like the other units in Sylvania's broad photoconductive devices line, are available in customized versions with a wide range of characteristics.

# SUHL circuits can simplify noise and power problems in systems design

*Sylvania's high-level TTL circuits are especially adaptable to systems applications. The inherent characteristics of SUHL units—high speed, low propagation delay time, high noise margin, low power, high fan-out and logic swing, high capacitance drive—can all be advantageously applied to systems design. SUHL is constantly solving designers problems where speed, low power and noise protection are considerations. Some of these aspects of SUHL are discussed below in a section excerpted from a forthcoming Sylvania brochure, "Optimum Design of Integrated Circuit Output Networks."*

In the design of high speed digital integrated circuits, special consideration must be given to circuit output networks.

In nearly all system wiring methods, circuit output loads include capacitance due to the driver loads and associated interconnection wires. This is particularly true in multilayer boards where the capacitance can reach 6 pf per inch. Driving such capacitance at high speeds requires

low impedances, with a resulting requirement for additional power dissipation.

Output networks with loadings approaching voltage sources in both the "1" and "0" state are desirable to reduce noise pickup and simplify loading rules.

With most saturated logic, output stage delay in going from the "0" or saturated state to the "1" or OFF state is primarily a function of the storage time of the output transistor. This storage time impairs circuit speed at room temperature and becomes progressively worse as the temperature increases. With proper design of the output portion of integrated circuits, transistor storage time variations can be reduced.

When the principles are examined, the desirability of this output network in a general-use high-speed monolithic circuit will be evident. By judicious use of transistor geometries as well as consideration of the associated life times and the stray capacitance of other components, effective networks such as those illustrated in

Figure 1 can be designed.

By using an output circuit shown in Figure 1, the pull-up network effectively removes the charge stored in the output transistor and virtually eliminates storage time as a factor in output characteristics. The result is a circuit having a propagation delay time which is constant over the full temperature range of  $-55$  to  $+125^{\circ}\text{C}$ . This is particularly evident when compared to high resistor pull-up networks.

The output networks shown in Figure 1 are coupled to a high speed TTL front end. To demonstrate the stability of this type circuit, typical propagation delays versus temperature, fan-out, and capacitance loading are shown in Figure 2.

In the circuit diagrams shown in Figure 1, both the "0" and the "1" output levels are obtained through low impedances. Aside from the drive capabilities, this also provides a stiff source which in turn provides a damping element for reflected signals and for noise pickup in a high speed system.

CIRCLE NUMBER 306

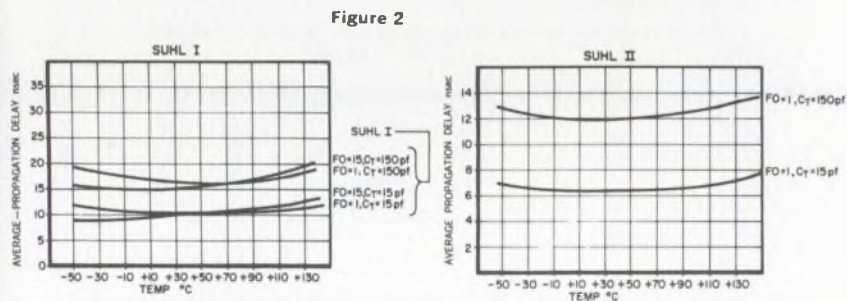
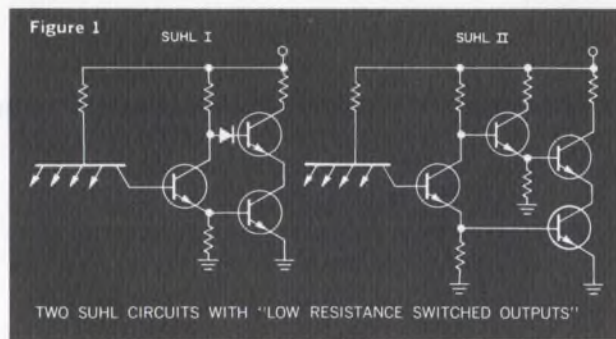

Use Sylvania's "Hot Line" inquiry service, especially if you require full particulars on any item in a hurry. It's easy and it's free. Circle the reader service number(s) you're most interested in; then fill in your name, title, company and address. We'll do the rest and see you get further information almost by return mail

**BUSINESS REPLY MAIL**  
No Postage Stamp Necessary if Mailed in the United States

POSTAGE WILL BE PAID BY  
**SYLVANIA ELECTRONIC COMPONENTS GROUP**  
Sylvania Electric Products Inc.  
1100 Main Street  
Buffalo, New York 14209

FIRST CLASS  
Permit No. 2833  
Buffalo, N. Y.

# Low-leakage types included in Sylvania's silicon alloy junction DF-7 series

*Sylvania's DF-7 series of high conductance silicon alloy junction diodes can solve a wide variety of your circuit design problems. In such applications as magnetic amplifiers, modulators, demodulators and power supplies these general purpose diodes combine excellent electrical characteristics, device uniformity and closely controlled manufacturing methods to give reliable operation.*

Device uniformity comes from Sylvania's alloy batch processing techniques with their emphasis on precise control of materials and manufactur-

ing procedure. The user gets uniformity from unit to unit as well as a product less prone to failure. Electrical characteristics of these diodes include high conductance, excellent stability and extremely low leakage. Stringent quality control procedures assure conformance to specification and reliability in operation.

With the DF-7 line, you're not limited to selecting from a narrow range of types. The line includes two general purpose JEDEC groupings (1N456A through 1N464A, and 1N482A/B through 1N488A/B), a series

of low leakage devices (D6623 through D6625), a stabistor (the 1N816) and several voltage variable capacitors (1N3182).

All units have a power rating of 250 mW, and a junction temperature range of  $-65^{\circ}\text{C}$  to  $+175^{\circ}\text{C}$ . Typical specifications show minimum forward currents of 100 ma at 1V, breakdown voltages of from 30 to 420 volts, and maximum reverse leakage currents of 2 to 50 nanoamps.

The large junction capacitance of these alloy junction diodes means they are less sensitive than epitaxial types to stray triggering pulse in many circuits. This makes these Sylvania DF-7 units ideal for slow speed industrial control circuits where the circuit may be exposed to ac switching transients.

The capacitance characteristic of these alloy units also makes them excellent voltage variable capacitors. Typical capacitance change over a voltage change of 10 volts is on the order of 4 to 1.

All diodes in the line are available in Sylvania's improved DO-7 package with assured hermeticity.

TYPICAL CAPACITANCE VS VOLTAGE DF-7

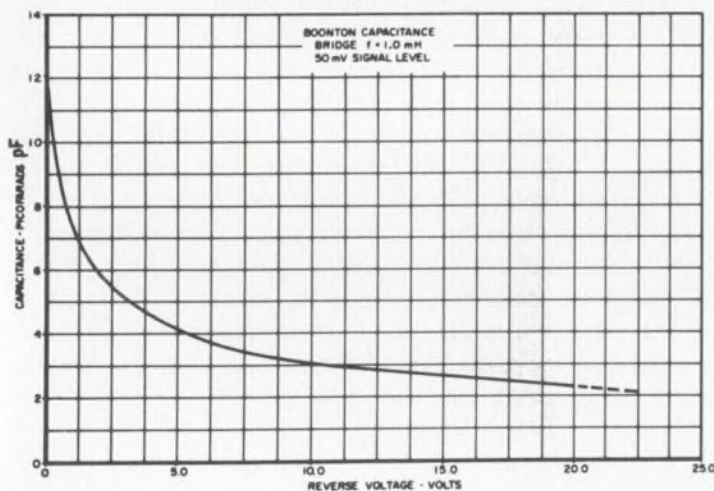

CIRCLE NUMBER 307

# SYLVANIA

SUBSIDIARY OF  
GENERAL TELEPHONE & ELECTRONICS GTE

NEW CAPABILITIES IN: ELECTRONIC TUBES • SEMICONDUCTORS • MICROWAVE DEVICES • SPECIAL COMPONENTS • DISPLAY DEVICES

This information in Sylvania Ideas is furnished without assuming any obligations.

NAME \_\_\_\_\_

TITLE \_\_\_\_\_

COMPANY \_\_\_\_\_

ADDRESS \_\_\_\_\_

CITY \_\_\_\_\_ STATE \_\_\_\_\_

Circle Numbers Corresponding to Product Item

300	301	302	303	304
305	306	307		

Please have a Sales Engineer call



## HOT LINE INQUIRY SERVICE

Need information in a hurry? Clip the card and mail it. Be sure to fill in all information requested. We'll rush you full particulars on any item indicated.

You can also get information using the publication's card elsewhere in this issue. Use of the card shown here will simplify handling and save time.



## True rms ammeter accurate, stable



*Greibach Instruments Corp., 315 New Ave., New Rochelle, N. Y. Phone: (914) 633-7900.*

True rms Transquare microammeters have a low full scale range of 50 microamperes. The instrument achieves an accuracy of  $\pm 0.5\%$  full scale for irregular wave forms with crest factors in excess of 8; also square waves up to several kHz. Exceptional stability, with repeatability of better than 0.1%, is reported since no amplifiers, power supplies, or other active electronic components are used in the meter design.

*Booth No. 2H45 Circle No. 386*

## Circuit breaker has wide threshold range

*Roveti Instruments, 1643 Forest Dr., Annapolis, Md. Phone: (301) 974-0876. P&A: \$39.50; 2 to 4 wks.*

Any dc power supply from 4 to 35 V will operate this circuit breaker and protect both power supply and load. The threshold value is adjustable from 1 to 100 mA with ranges of 0.1 to 10 mA, and 10 mA to 1 A optional. Units in the 1.5-to-200-V range are also available. Dimensions are 1 in. by 2 in.<sup>2</sup>.

*Booth No. 2A18 Circle No. 517*

Remember to return your **ELECTRONIC DESIGN** renewal card. Don't miss any issues in '67.

# gotta crazy curve?

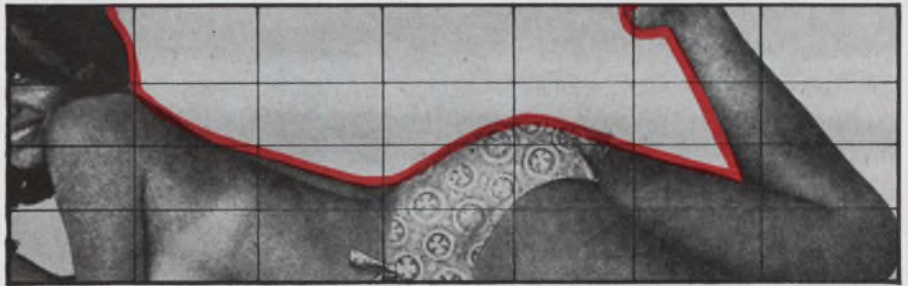

## A DUNCAN NON-LINEAR POT CAN MATCH IT!

Even if your non-linear function looks like the Playmate of the Month in profile, Duncan can build a pot to match it. All you have to do is use the new "DUNCAN DO-IT-YOURSELF NON-LINEAR FUNCTION KIT," which we'll send you without obligation if you'll fill out and mail the coupon below. The kit includes a fabulous French curve\* plus all other necessary ingredients and instructions. You supply us with the non-linear trace of your function and other supporting data. We'll feed it to our high-speed computer and analyze the data defining the pot's desired function. Then we'll enter the output tape into our servo-controlled machines to produce the variable-pitch winding to meet your function.

To be sure the output of the pot conforms to the specified tolerances, we'll compare it with the theoretical function on our unique conformity tester.

The result? A precision, accurate pot exactly to your specifications.

Our applications engineers can help solve your problems quickly and economically. In many cases they'll be able to match your function using pre-calculated data from our extensive tape library.

So forget about cams, differentials, and non-linear gears. For the direct approach to a complicated non-linear potentiometer problem — for airborne data computation or matching thermocouple curves — depend upon Duncan. You'll have more time to check out other interesting curves!

Send for your free Duncan "do-it-yourself" kit today. For literature only, circle the appropriate number and mail the inquiry card enclosed in this magazine.

### DUNCAN ELECTRONICS-INC.

Please send me my free "DUNCAN DO-IT-YOURSELF NON-LINEAR FUNCTION KIT" and complete technical literature on Duncan's family of non-linear potentiometers.

I understand that there is no obligation on my part.

Name \_\_\_\_\_ Title \_\_\_\_\_

Company \_\_\_\_\_

Address \_\_\_\_\_

City \_\_\_\_\_ State \_\_\_\_\_ zip \_\_\_\_\_

\*French curve ruler by Birule Co.



DUNCAN electronics, inc.

2865 Fairview Rd., Costa Mesa, California 92626 Tel.: (714) 545-8261 TWX: 910-595-1128

ON READER-SERVICE CARD CIRCLE 103

# Compare the All-New PAMOTOR Model 4500 with the miniature axial fan you're now using!



## POWERFUL MOTOR

Dependable shaded-pole motor operates with low internal heat rise. Efficient inside-out design.

## COMPACT SIZE

Only  $4\frac{1}{16}'' \times 4\frac{1}{16}'' \times 1\frac{1}{2}''$ . Weighs just  $1\frac{1}{4}$  lbs. Interchangeable with similar, less reliable  $4\frac{1}{16}''$  fans.

## EXCLUSIVE BROACHED BEARING SYSTEM

Hand-fitted proven broached dual-sleeve bearing system assures longer, more reliable operation.

## ALL-METAL CONSTRUCTION

Precision die cast housing, hub, impellers. Corrosion resistant. Natural heat sink. Warp-free, unlike conventional plastic fans.

# 115 CFM WITH LESS THAN 37.5 dB SIL\*

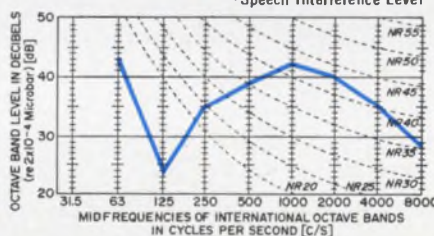
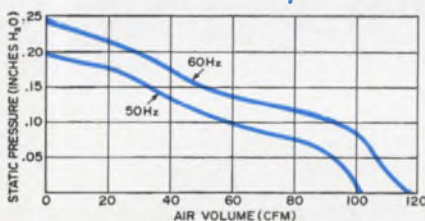

\*Speech Interference Level

- Lubrication-free life in excess of 20,000 operational hours, continuous duty at 55° C.
- Delivers more air at a lower noise level, yet priced under similar conventional plastic fans.
- Model 4500 designed for 117 V/50-60 Hz operation, while Model 4550 operates at 230 V/50-60 Hz.
- Now available for immediate delivery through leading electronic distributors or directly from factory stock.
- Has Underwriters' Laboratories Inc. Yellow Card Component Recognition Number E41168.

Write to PAMOTOR, INC., 312 Seventh Street, San Francisco, California 94103.

# PAMOTOR, INC.

Get the complete story at IEEE Booth 3K39.  
ON READER-SERVICE CARD CIRCLE 104

INSTRUMENTS—2ND FLOOR

## Hall-effect gaussmeter operates triple-mode



RFL Industries, Inc., Boonton, N. J. Phone: (201) 334-3100. P&A: \$1000; June.

A Hall-effect gaussmeter, model 3265, is useful for work with magnetron assemblies, TWTs, d'Arsonval meter gaps, accelerometers, mass spectrometers, loudspeaker gaps, motor fields, torque motors, magneto and alternator fields and any other device where a permanent or ac magnetic field is encountered. The unit performs three separate functions. It measures flux densities from 0.02 gauss to 50 kilogauss, dc and ac to 400 Hz. It measures incremental determinations of field variations to a resolution of 1 ppm when used as an expanded scale gaussmeter. In the differential mode it permits simultaneous measurement of two separate fields or single field gradients.

Booth No. 2A35 Circle No. 502

## Network analyzer sweeps 2 Hz to 30 MHz

Wiltron Co., 930 E. Meadow Dr., Palo Alto, Calif. Phone: (415) 321-7428. P&A: \$4925; 8 wks.

Swept frequency Smith chart plots can be made automatically with this network analyzer. It also plots phase vs frequency, level vs frequency and return loss vs frequency and can plot the transmission measurements in polar form. Swept frequency is performed in the 2-to-30-MHz range. Phase is measured with 0.1° resolution over a 360° range where amplitude variations are up to 60 dB. Amplitude is also measured over a 60-dB range for impedance plotting. The directivity of the internal coupler is 40 dB which permits the measurement of vswr as small as 1.02.

Booth No. 2F43 Circle No. 395

# NEW! ECONOMY + HIGH RELIABILITY

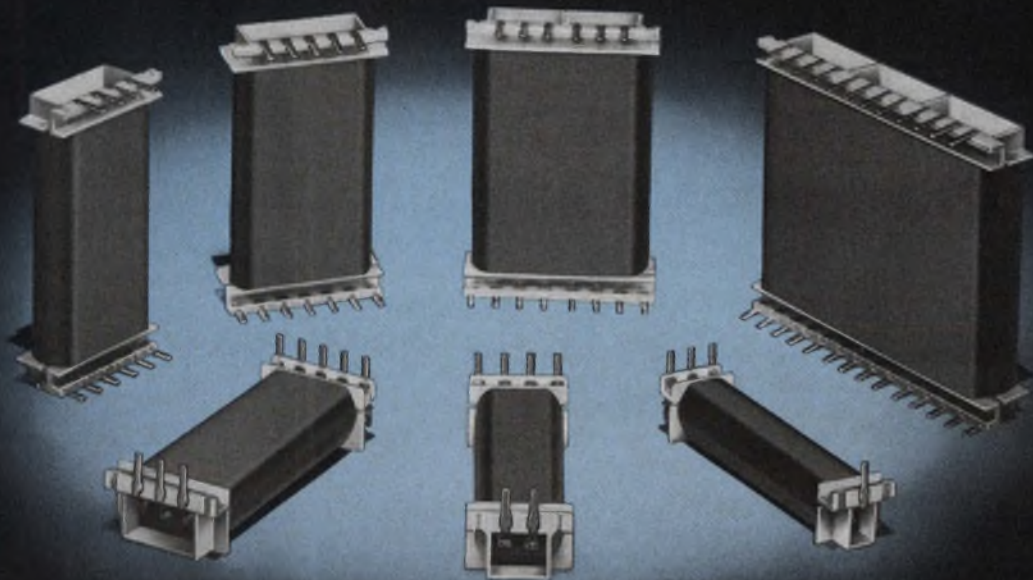

## Open Construction Bi-Reed Relays

This new family of standard size Bi-Reed relays offers true economy with RBM's industry-recognized high reliability. They feature straight, unstressed contact leads which prevent damage to capsule seals, and the contact terminals are welded (or soldered) to the printed circuit terminals which are on 2.5" centers with .218" terminal spacing. Standard 1 thru 6-pole and 12-pole forms are available with coil voltages thru 48 volts D.C.

Of course, RBM makes the complete unit . . . including the switch . . . with automatic equipment in "white room" facilities. This *single source responsibility* means consistent characteristics and total reliability in every RBM Bi-Reed you use! Call your local RBM Controls sales engineer or write for Technical Bulletin 2020.

**ESSEX**  
WIRE CORPORATION

CONTROLS DIVISION • 131 GODFREY STREET • LOGANSPORT, INDIANA

ON READER-SERVICE CARD CIRCLE 105

# DOES IT PAY ?

Does it really pay to go to the Hanover Fair? What is the Hanover Fair, anyway?

## This is Hanover:

- 9,600,000 sq. ft. of fair-grounds
- 2,385,000 sq. ft. of inside exhibition space
- 1,780,000 sq. ft. of outside exhibition space
- 24 manufacturing industries exhibiting
- 40,000 tons of exhibition goods from 292 product categories
- 6,031 exhibitors from 30 countries
- 511,663 visitors from 106 nations

Now, once again: Does it really pay to go to the Hanover Fair?

Be the 511,664th visitor to find out!

## HANOVER FAIR 1967



**April 29 - May 7  
Hanover, Germany**

For information, room reservation forms and tickets, phone 212—JU 2-7788 or write:

**GERMAN AMERICAN  
CHAMBER OF COMMERCE**  
New York: 666 Fifth Avenue  
Chicago: 77 East Monroe St.

ON READER-SERVICE CARD CIRCLE 106

U164

## INSTRUMENTS—2ND FLOOR

### Eddy current tester with new limit unit

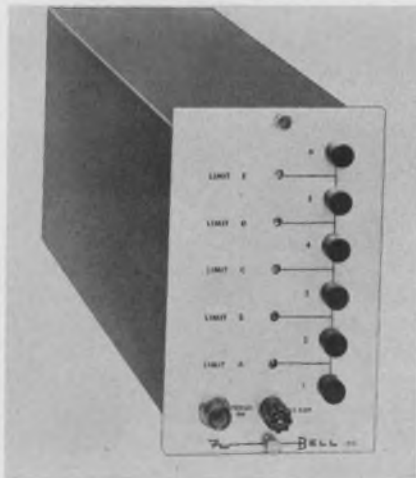

*F. W. Bell Inc., 1356 Norton Ave., Columbus, Ohio. Phone: (614) 294-4906. P&A: \$980; stock.*

A voltage-sensitive switching instrument, acting as a six-state electronic gate, will accept dc inputs of either positive or negative polarity. Any five dc signal levels between  $-2$  V and  $2$  V can be selected as switching levels. Upon selection of five levels within this range, six states are defined. When used in conjunction with a test application, these states may represent normal, marginal, and out-of-tolerance conditions for a test part. For use with an instrument that furnishes an output level range of  $0$  to  $2$  V, the switching levels (or limits) may be set at five different levels between  $0$  and  $2$  V.

*Booth No. 2B10 Circle No. 341*

### Delay distortion measured to 5 MHz

*Wiltron Co., 930 East Meadow Dr., Palo Alto, Calif. Phone: (415) 321-7428. P&A: \$6900; stock.*

The entire 30-kHz-to-5-MHz frequency range is covered in a unit designed for delay distortion measurements of carrier frequencies in the range. Crystal-controlled frequency and counter techniques are used for getting stable and accurate time delay measurement. The unit has crystal-controlled reference delays in 10-ms steps up to 200 ms for use in offsetting the time delay.

*Booth No. 2F43 Circle No. 537*

### Phase standard reads $0^\circ$ to $360^\circ$ in 7 digits

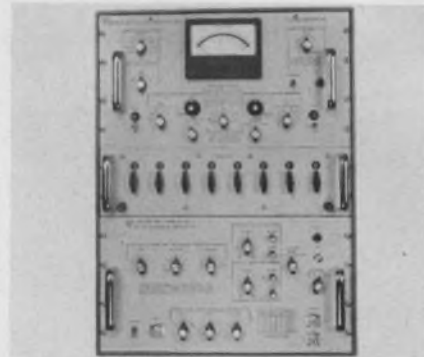

*Ad-Yu Electronics, Inc., 249-259 Terhune Ave., Passaic, N. J. Phone: (201) 472-5622. P&A: \$4365; 4 wks*

Self-calibration and self-checking by means of fundamental bridge balancing without the use of an external standard is featured in this phase standard. The instrument receives a signal from a sine wave generator with good frequency stability, then produces two output signed for serviceability, utilizing can be adjusted from  $0^\circ$  to  $360^\circ$  with 7-digit resolution.

*Booth No. 2J43 Circle No. 531*

### Digital voltmeter takes PC plug-ins



*United Systems Corp., 918 Woodley Rd., Dayton, Ohio. Phone: (513) 254-6251 P&A: \$585; stock.*

The basic unit of a series of solid-state digital voltmeters is designed for serviceability, utilizing plug-in PC boards and modular construction. The common circuitry—display drivers readout storage, control logic, and power supply—are packaged in the main frame.

*Booth No. 2B02 Circle No. 532*

DC DIGITAL VOLTMETER

9  
3 & A ranges: manual & automatic  
DC DIGITAL VOLTMETERS

Photo See Page	MANUFACTURER	MODEL	Number of Ranges	VOLTAGE			Polarity	Readout Type	Reading Mode	Speed Readings / sec	Input Imp. Ohms	AC Freq.	OUTPUT			RATIO MEASUREMENTS		
				Min	Max	Acc %							Type	Printer	Min	Max	Ref	
25	NON-LINEAR SYSTEMS	K25	3	0.001	999.99	0.1	auto	0	1	100	200 pF	100	0.0001	99.999	+10	-10	-10	-10
	NON-LINEAR SYSTEMS	V25B	3	0.001	999.999	0.1	auto	0	1	100	200 pF	100	0.0001	99.999	+10	-10	-10	-10
26	NON-LINEAR SYSTEMS	V25RB	3	0.001	999.999	0.1	auto	0	1	100	200 pF	100	0.0001	99.999	+10	-10	-10	-10
	DYNACOR	111	4	0.001	999.9	0.1	auto	0	1	100	200 pF	100	0.0001	99.999	+10	-10	-10	-10
	HARVEY DIVISION	3250	4	0.001	999.9	0.1	auto	0	1	100	200 pF	100	0.0001	99.999	+10	-10	-10	-10
	ELECTRONIC SINK LINES (S)	3000	4	0.001	999.9	0.1	auto	0	1	100	200 pF	100	0.0001	99.999	+10	-10	-10	-10
	FRANKLIN ELECTRONICS (S)	1811	4	0.001	999.9	0.1	manual	0	1	100	200 pF	100	0.0001	99.999	+10	-10	-10	-10
	HANMAN RANGE	24	4	0.001	1000	0.1	auto	0	1	100	200 pF	100	0.0001	99.999	+10	-10	-10	-10
	EPSON (S)	50-800	4	0.001	1000	0.1	auto	0	1	100	200 pF	100	0.0001	99.999	+10	-10	-10	-10
	SIPO (S)	50-813	4	0.001	1000	0.1	auto	0	1	100	200 pF	100	0.0001	99.999	+10	-10	-10	-10
	SYSTEM-CONER (S)	50-813-SC	4	0.001	1000	0.1	auto	0	1	100	200 pF	100	0.0001	99.999	+10	-10	-10	-10
	FRANKLIN ELECTRONICS (S)	856	4	0.001	1200	0.1	auto	0	1	100	200 pF	100	0.0001	99.999	+10	-10	-10	-10
	FRANKLIN ELECTRONICS (S)	1480-320	4	0.001	1200	0.1	auto	0	1	100	200 pF	100	0.0001	99.999	+10	-10	-10	-10
	FRANKLIN ELECTRONICS (S)	1330-3198A	4	0.001	1200	0.1	auto	0	1	100	200 pF	100	0.0001	99.999	+10	-10	-10	-10
	ELECTRONIC SINK LINES (S)	5100	4	0.001	300.3	0.1	auto	0	1	100	200 pF	100	0.0001	99.999	+10	-10	-10	-10

MECHANICAL Height	Depth	Weight Pounds	Price
10 1/2	10 1/4	16	5085.00
5.218	10 1/4	45	3282.00
5.218	15 1/4	45	3285.00
5 1/4	10 1/2	16	399.50
5 1/4	15	30	641.00
5 3/4	12	30	895.00
5 1/4	17 1/4	45	2550.00
5 1/4	17 1/4	30	2550.00
5 1/4	15	15	1375.00
5 1/2	16 3/8	20	395.00
6 1/2	13 1/8	15	1475.00
6 1/2	12 3/4	35	1975.00
6 1/2	12 1/8	35	1975.00
6 1/2	12 3/4	35	1975.00
6 1/2	17	35	1850.00
6 1/2	12 1/4	45	3350.00
6 1/2	21	55	3230.00
6 1/2	21	55	3230.00
6 1/4	17 1/4	45	3150.00
6 1/4	17 1/4	30	3150.00
6 1/4	19	30	3150.00

ti DIRECTORY OF TECHNICAL SPECIFICATIONS / ELECTRONIC TEST

If you are buying or selling **Digital Voltmeters, Signal Generators, Receivers, Microwave Equipment or Oscilloscopes**, a **Directory of Technical Specifications** will allow you comparative and current analysis of manufacturer's pertinent specifications... *at your fingertips.*

A one year subscription for \$300 contains 47 categories bound in 47 separate sections (includes six storage binders).



TECHNICAL INFORMATION CORP.

P.O. BOX 514 SMITHTOWN, N.Y. 11787 (516) 234-0100

See us at BOOTH 1A20/IEEE show

ON READER-SERVICE CARD CIRCLE 107

**ONLY THREE  
UNITIZED SUBASSEMBLIES**

... housing  
... rotor  
... element

fastened by a unique molding process that bonds the unit integrally without the use of adhesives for sealing or potting.

**HIGH-STRENGTH STOPS** designed to gear-theory principle to provide a minimum stop-strength of 15 oz.-in.

**HIGH PULL-STRENGTH PINS** totally encapsulated on their seats for a fail-safe pull-strength of 2 lbs.

**UNIQUE SEAMLESS CONSTRUCTION** for virtual elimination of any leakage problems.



Actual Size

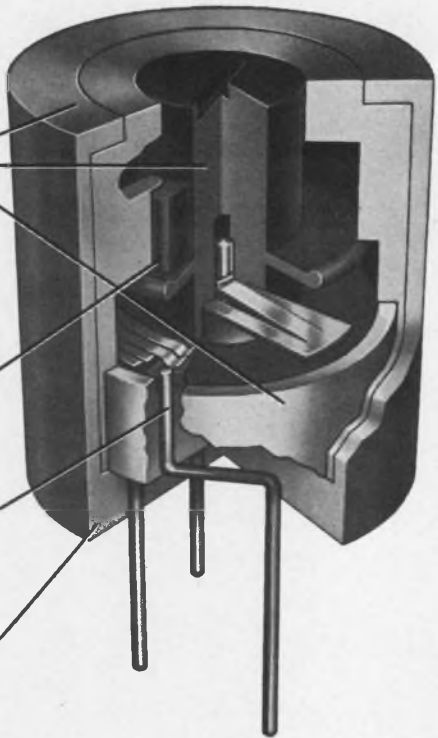

See us at IEEE Booth 4K04-4K06

## NEW! UNIQUE! A REVOLUTIONARY BREAKTHROUGH IN TRIMMER DESIGN!

(An exaggeration? Check the features!)

Look at the many quality features and outstanding performance characteristics we've packed into this tiny 11/32-inch-diameter industrial trimmer.

- A unique, molded, seamless housing that virtually eliminates leakage.
- A simplified design that greatly enhances reliability.
- A unit with only two electrical joints that minimize the possibility of catastrophic termination failure.
- An exclusive molded construction technique that provides a pin-pull-strength many times greater than that of comparable units.
- A multi-finger wiper that covers a large element area to provide "redundant" positive contact and reduced noise (CRV).
- A non-metallic housing that reduces the likelihood of voltage breakdown.
- Plus, exceptional product quality and uniformity that are consistently maintained through the

use of unique, semi-automatic final assembly equipment specially designed and developed by Spectrol.

All of these superior features are offered in Spectrol's highly reliable, industrial, cermet trimmer—the Model 53. Yet, this trimmer sells for less than comparable competitive units. This user-designed Model 53—developed in cooperation with one of the nation's largest computer manufacturers—is available in round top-adjust and cubic side-adjust versions. For complete specs, circle the reader service card.



Better Components  
for Better Systems

SPECTROL ELECTRONICS CORPORATION 17070 E. GALE AVE. CITY OF INDUSTRY, CALIF. 91745 PHONE: (213) 964-6565 TWX: (213) 686-6780

INSTRUMENTS—2ND FLOOR

### Microvoltmeter ignores noise

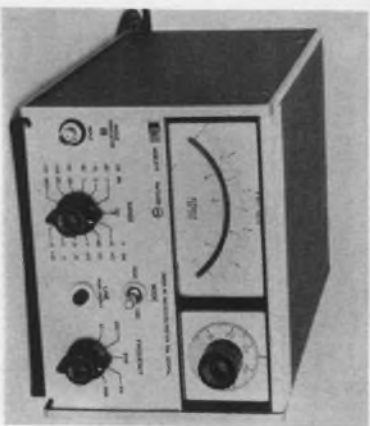

Hewlett-Packard, 1501 Page Mill Rd., Palo Alto, Calif. Phone: (415) 326-7000. P&A: \$800; 60 days.

Unlike conventional tuned voltmeters, this microvoltmeter uses a phase-locked synchronous detector rather than narrowband filters to separate the effects of noise from the signal. The detector is an electronic gate controlled by an oscillator phase-locked to the input signal. Alternate half cycles of the input signal are passed by the gate, and the output of the gate is smoothed by a low-pass filter to obtain a dc voltage proportional to the average value of the input waveform. Since both the positive and the negative excursions of noise and other randomly varying signals pass through the gate when open, these average to zero and do not affect the reading. Rms noise voltages up to 2 dB above full scale do not affect the accuracy of the reading, even for signal levels that are 1/10 of full scale. Booth No. 2F25 Circle No. 330

### Phase meter covers audio to 2 MHz

Wiltron Co., 980 East Meadow Dr., Palo Alto, Calif. Phone: (415) 321-7428 P&A: \$935; 10 weeks.

Calibrated offsets in 10° steps permit expansion around any phase angle in this 10-Hz-to-2-MHz phase meter. The instrument offers 0.1° resolution around any phase angle. Booth No. 2F43 Circle No. 536

Don't forget to return your  
**ELECTRONIC DESIGN** renewal  
card.

# DISCOVER HUDSON'S Electri-City

Looking for a quick way to solve your housing problem? Descend on one of our standard units built with a precision approach. With over 5000 varied shape enclosures to choose from, landing the right combination of design and material is a navigator's delight.

If you search our entire city without finding the desired accommodation, we'll alter the skyline — just for you!

**HUDSON** TOOL & DIE  
COMPANY, INC.

Enclosures, Stampings and Assemblies

NEWARK, NEW JERSEY — U.S.A.

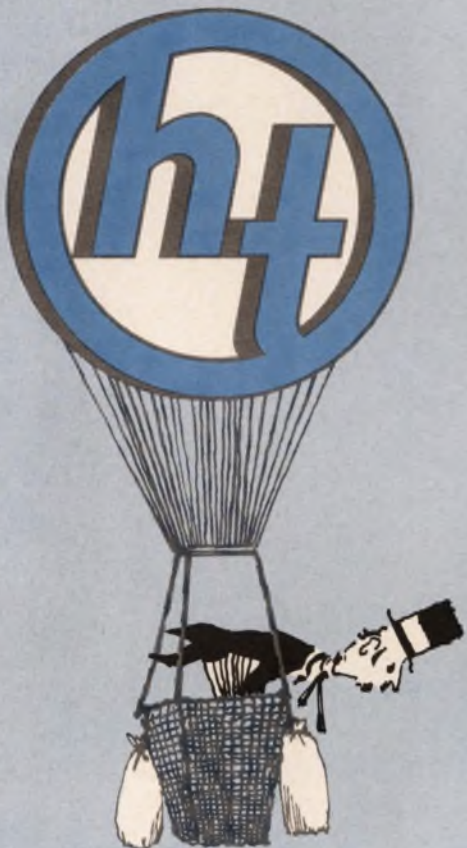

IEEE SHOW N.Y.C.—BOOTHS 1D07-1D11



ON READER-SERVICE CARD CIRCLE 122

# BOBBINS

...if you need them,  
**PERMACOR®**  
has them!



Name your size . . . select your shape . . . if it's Bobbins you want, we have them. As the world's largest maker of cores, we have the designers and production facilities to answer your every need, be it Bobbins or any other standard or special powdered iron cores.

IRON CORES... Plain, Hollow, Threaded, Insert, Tuning, Cup, and Toroidal Iron Cores, Iron Coil Forms, Sleeves, Flexible Magnetic Shielding, Bobbins and special shapes.

## PERMACOR®

A Division of Radio Cores, Inc.

9540 Tulley Ave., Oak Lawn, Ill. 60454  
Phone: 312-422-3353

## INSTRUMENTS—2ND FLOOR

### Temperature profiler reads 1/4° differences



Leeds & Northrup Co., 4901 Stenton Ave., Philadelphia. Phone: (215) 329-4900.

Temperature distribution differences on the order of 1/4 to 1/2°C (at ambients above 1000°C) can be found with this furnace temperature profiler. It offers complete line power operation, stable null detector, easily changeable automatic reference junction, Zener diode measuring current, and digital readout to two or three decimal points.

Booth No. 2A32 Circle No. 327

### Digital multimeter has pushbutton control



Cohu Electronics, Inc., Box 623, San Diego, Calif. Phone: (714) 277-6700. P&A: \$1495; 3 wks.

Bidirectional tracking logic used in this series offers a fast and accurate method of measuring parameters with small variations, such as those that occur when trimming or adjusting. A stable Zener-diode reference supply and a digital pot assure accuracy. The pushbutton instrument offers automatic ranging on the dc voltage function (1  $\mu$ V to 1000 V), resistance measurements from 0.1  $\Omega$  to 100 M $\Omega$ , ac voltages from 1 mV to 1 kV, dc-to-dc voltage ratios with 100- $\mu$ V sensitivity and dc currents from 0.1 nA to 100 mA.

Booth No. 2D13 Circle No. 322

### Dual-trace scope sits in 9-lb package

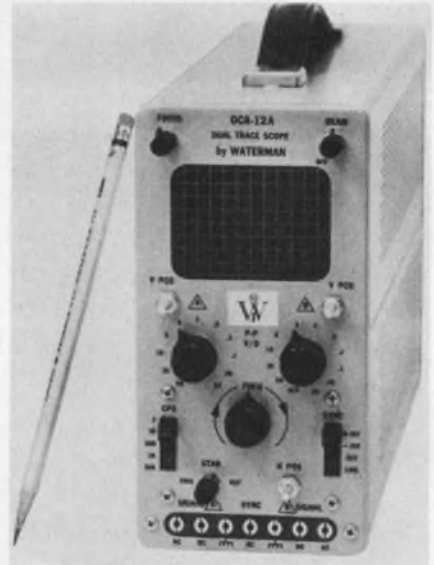

Waterman Instrument, 400 S. Warminster Rd., Hatboro, Pa. Phone: (215) 672-7400. P&A: \$325; stock.

A dual-trace oscilloscope set, 7-1/4-in. high, 3-1/2-in. wide and 13-5/32-in. deep, is offered as portable servicing equipment. It has a sensitivity of 20 mV p-p per division, and a bandwidth of dc to 200 kHz. The input impedance is 1 M $\Omega$  shunted by 30 pF. The unit weighs 9 lbs.

Booth No. 2A26 Circle No. 323

### Frequency meter counts to 3 GHz



Northeastern Engineering, Inc., 130 Silver St., Manchester, N. H. Phone: (603) 622-6485. P&A: \$1675; 30 days.

Frequency measurement to 50 MHz can be accomplished with a basic counter, which will accept plug-in converters to extend its range to 3 GHz. Seven-digit in-line display with automatic decimal point and legend are featured in addition to two switch-selectable input impedances of 50  $\Omega$  and 10 k $\Omega$ .

Booth No. 2B43 Circle No. 533



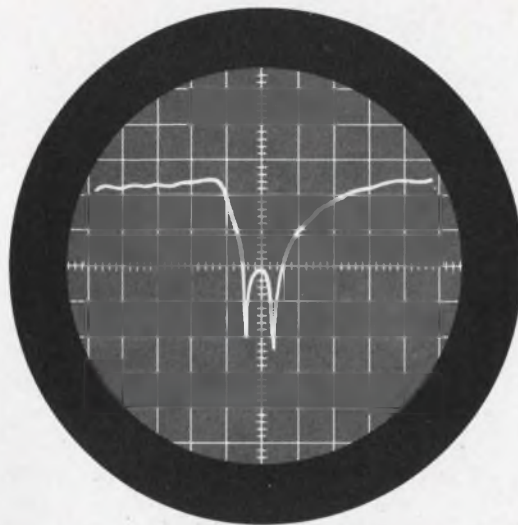

**First you look at the big picture\*...  
then...presto...zoom...**

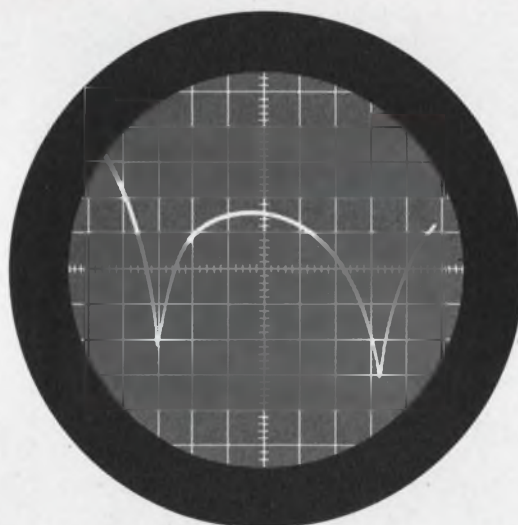

**see all the fine detail!**

Alfred Sweep Analyzers speed and simplify microwave measurements including insertion loss or gain, return loss (VSWR) or gain, and absolute or relative levels of CW power over a 60 db dynamic range with direct db or dbm readout.

It's not too much to say that Alfred Sweep Network Analyzers, Models 8000/7051 and 8000/7052, present a new dimension to microwave metrology. They take the agony out of designing and testing microwave instruments and components. Do in minutes what used to take hours.

The Model 8000/7051 Sweep Network Analyzer provides three signal channels to permit simultaneous, independent ratio measurements. It compares any two signal input levels with a common reference signal which eliminates the need for a leveled source. When the rf test loop is driven by a leveled sweeper, the lower cost single-chan-

nel Model 8000/7052 measures performance response directly.

Price of the Model 8000/7051 is \$1680. The Model 8000/7052 costs \$1250.

**New Catalog Ready**

For complete information ask your full service Alfred Sales Engineer for a copy of the Alfred '67 catalog just off the press. Or, if you prefer, you may address us at 3176 Porter Drive, Palo Alto, California 94304. Phone (415) 326-6496.

**ALFRED ELECTRONICS**

\*Upper and lower photos display, respectively, transmission characteristics of a passive microwave device examined by an Alfred Sweep Network Analyzer with wide sweep (10 db/div sensitivity) and then automatically zooming in with a narrow sweep (5 db/div).

Project responsibility opportunities exist for qualified engineers on our technical staff. An equal opportunity employer.

ON READER-SERVICE CARD CIRCLE 124

DISCRIMINATING  
ENGINEERS  
ARE  
AMAZED...

FIRST BY  
THEIR HIGH  
QUALITY  
&  
BROAD  
APPLICATION

...THEN BY  
THE  
LOW COST

**SWITCHCRAFT** *Preh*  
INC.

**2 TO 7 CONTACT LOW-LEVEL AUDIO CONNECTORS**

**FITS IN WITH TODAY'S TREND  
IN MINIATURIZATION**

Excellence throughout, low cost, wide variety of types and broad range of standard and optional features call-up practical and economical solutions to many design and cost-control problems in low level connections . . . particularly where miniaturization is a design consideration.

**OVER 90 CIRCUIT-TAILORED TYPES**

Includes male and female plugs and receptacles from 2 to 7 contacts, in nickel-plated shells, or snap-on plastic shells. 13 different receptacles offer some form of internal switching (SPST, SPDT in addition to mating of contact circuits . . . in some instances eliminating need for external switches! Silver plated pins for low contact resistance. Exclusive "automatic" grounding and fool-proof polarization provisions. Contact friction coupling for minimal mechanical interference noise; locking coupling for reliability where vibration is a factor. Ingenious 8-

position right-angle plug enables you to position cable entry in any of 8 different angles. Etc., etc. Rugged and versatile . . . yet they cost surprisingly little.

**APPLICATIONS LIMITED ONLY BY  
YOUR IMAGINATION!**

Virtually unlimited commercial, industrial, consumer and military applications in any type of low level circuitry: audio and test equipment, instruments, computers, cameras, control devices, communications equipment and business machines. Receptacles for flush, extended, P.C. board, screw and rivet type mounting; straight cord, 90° angle; control and switching plugs: many others.

**SEND FOR THE NEW COMPREHENSIVE  
ENGINEERING SPECIFICATION**

CATALOG NO. C-503 or see your local Switchcraft Authorized Industrial Distributor . . . he has units for your inspection, and can make immediate delivery at factory prices.



**SWITCHCRAFT**<sup>®</sup>

5529 No. Elston Ave., Chicago, Illinois 60630

\* Preh is a trademark of Preh Electromechanical Works, Bavaria, Germany

ON READER-SERVICE CARD CIRCLE 125

SEE IT  
AT IEEE —  
BOOTH  
2H29-2H31

**INSTRUMENTS—2ND FLOOR**

**Reflectometer couplers  
for L and S bands**



*Narda Microwave Corp., Plainview, N. Y. Phone: (516) 433-9000. Availability: 4 to 6 wks.*

Reflectometer couplers feature a precision 7-mm output connector, and minimum directivity of 40 dB in L and S bands, 35 dB in C band and 33 dB in X band. Resultant vswr measurement capability is less than 1.02, 1.035 and 1.05 respectively. In applications such as production line testing, they present a more convenient method of measuring reflection coefficient, vswr and impedance than slotted lines.

Booth No. 2F46 Circle No. 538

**Rotary transformers  
are multichannel**



*S. Himmelstein and Co., 2500 Estes Ave., Elk Grove Village, Ill. Phone: (312) 439-8181.*

Moderate-speed multi-channel rotary transformers are offered as instrumentation devices suitable for excitation and monitoring of resistive and reactive transducers. Standard windings are compatible with commercial carrier systems and wideband dynamic measuring techniques. The drive shaft itself can be strain-gaged.

Booth No. 2B46 Circle No. 527



## WE'LL JET THESE REEDS TO YOU TODAY!

Now ready for immediate air shipment, these six new Cook Electric relays bring you all the latest technical advances in reed relay design.

- Individually supported reed switches to eliminate glass breakage.
- All coils wrapped with magnetic foil to minimize flux leakage.
- Non-magnetic terminals assure stable operating characteristics.
- Highly weld-resistant rhodium plated contacts assure extra long life.

Order yours today, or for technical data write:



**COOK ELECTRIC**

AUTOMATIC CONTROLS DIVISION 2700 N. Southport Ave. • Chicago 60614 • Phone 312-348-6700

*See the new Cook Electric Jet-Reeds at Booth 4E-33 . . . IEEE, New York Coliseum, March 20-23*

ON READER-SERVICE CARD CIRCLE 126

# Now! TCXO's from Bulova!

Stability:  
±0.5 PPM!



Now you can get Temperature Compensated Crystal Oscillators from Bulova, with all the quality and dependability that have made Bulova the leader in frequency control products. Our new Model TCXO-5 is just four-cubic-inches, consumes only 50 mW, and employs a computer-selected-and-optimized compensation network designed to maintain frequency stability over wide temperature ranges without the need for an oven (±0.5 PPM from -40°C to +70°C). Perfect for aerospace and military applications where power, space and weight restrictions are severe.

## SPECIFICATIONS

Frequency Range:	2MHz to 5MHz
Frequency Stability:	±0.5 PPM from -40°C to +70°C
Output:	Sine Wave, 1VP-P into a 1000 OHM Resistive Load
Input:	50 mW
Size:	Just 4 cu. in.
Weight:	Only 5 oz.

Other frequencies, output wave shapes, output levels and load impedances can also be supplied.

Write today for more information about Bulova's new TCXO-5, or assistance with any Crystal Oscillator problem. Address: ED-27.

# Try Bulova First!

## FREQUENCY CONTROL PRODUCTS

ELECTRONICS DIVISION  
OF BULOVA WATCH COMPANY, INC.

61-20 WOODSIDE AVENUE  
WOODSIDE, N.Y. 11377, (212) DE 5-6000

ON READER-SERVICE CARD CIRCLE 127

U172

## INSTRUMENTS—2ND FLOOR

### Step-recovery diodes for microwave power

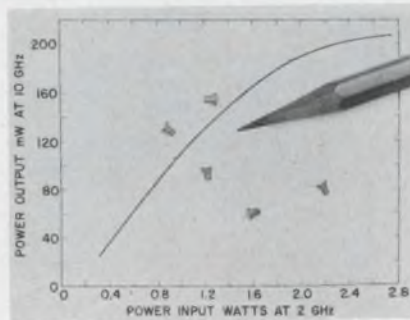

Hewlett-Packard, 1501 Page Mill Rd., Palo Alto, Calif. Phone: (415) 326-7000. P&A: \$92.50 (1-9), \$75 (10 to 99); stock.

A step-recovery diode claims increased power output as a high-order multiplier at microwave frequencies; X-band and above. Driven at 2 GHz with 2 W in a single stage X5 multiplier, the new diode provides 150 mW at 10 GHz. It is an epitaxial, surface-passivated silicon device with an abrupt junction gradient. The thermal resistance of the junction-to-mounting-stud path is 50°C/W and maximum permissible junction temperature, either operating or in storage, is 200°C. Device breakdown voltage is 20 V.  
Booth No. 2F25 Circle No. 340

### Wide-sweep generators and pulse markers



Kay Electric Co., Pine Brook, N. J. Phone: (201) 227-2000.

Wide-sweep and marker generators cover video, IF and vhf in a single frequency sweep. The additional features of continuously variable sweep width and continuously variable center frequency adapt these wide sweeps to stable narrow sweep generators. A multiturn center frequency control provides fine touch setting of narrow sweeps.  
Booth No. 2D25 Circle No. 530

### Edgewise panel meters RFI-shielded



International Instruments Incorporated, Marsh Hill Rd., Orange, Conn. Phone: (203) 795-4711. P&A: \$80, \$50, \$550.

Special-purpose edgewise panel meters are designated models 1124, 1125, and 1126. The 1124 meets MIL-M-17275 and MIL-STD-810 and incorporates a Lucite crystal. The 1125 and 1126 are designed to meet MIL-M-17275 and RFI-shielding requirements. Initial accuracy for dc meters is ±3% of full scale; for ac ±5%. Available models include 16 dc ranges from 0 to 100 μA to 0 to 3 A, 7 dc voltage ranges from 0 to 50 mV to 0 to 100 V and three rectifier-type ac voltmeter ranges.

Booth No. 2H12 Circle No. 325

### Thermal voltmeter spans 20 Hz to 1 MHz

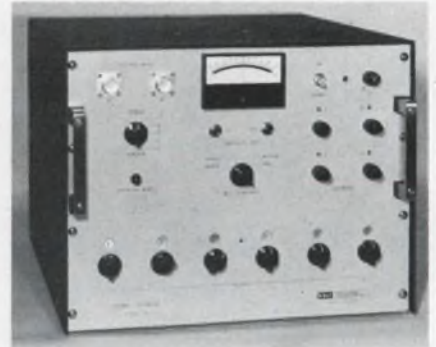

Holt Instrument Laboratories, P. O. Box 230, Oconto, Wis. Phone: (414) 834-2222.

A solid-state thermal voltmeter is an ac-dc standard with 1 to 1111 volts, 20 Hz to 1 MHz with dc reversal detector. Complete protection against overload, push-button reset and one-year recalibration are featured.

Booth No. 2A20 Circle No. 541

500  
to  
1,000 V.

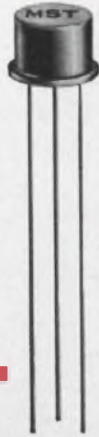

# VOLTAGE

## NPN SILICON TRANSISTORS

DESIGN LIMITS					
Type	BV <sub>CEO</sub> Volts		BV <sub>CER</sub> Volts	BV <sub>EO</sub> Volts	PT Watts
	I <sub>C</sub> = 0.1 MA	I <sub>C</sub> = 0.2 MA	I <sub>C</sub> = 0.2 MA R = I <sub>C</sub> <sup>2</sup>	I <sub>E</sub> = 50 μA	@100°C Case
	Min.		Min.	Min.	Max.
2N5010	500		500	5	2
2N5011	600		600	5	2
2N5012	700		700	5	2
2N5013		800	800	5	2
2N5014		900	900	5	2
2N5015		1000	1000	5	2

PERFORMANCE DATA						
Type	h <sub>FE</sub>		V <sub>BE</sub> Sat. Volts		V <sub>CE</sub> Sat. Volts	
	V <sub>CE</sub> = 10v		I <sub>B</sub> = 5 MA		I <sub>B</sub> = 5 MA	
	I <sub>C</sub> = 25 MA	I <sub>C</sub> = 20 MA	I <sub>C</sub> = 25 MA	I <sub>C</sub> = 20 MA	I <sub>C</sub> = 25 MA	I <sub>C</sub> = 20 MA
	Min.		Max.		Max.	
2N5010	30		1.0		1.4	
2N5011	30		1.0		1.5	
2N5012	30		1.0		1.6	
2N5013		30		1.0		1.6
2N5014		30		1.0		1.6
2N5015		30		1.0		1.8

Now in stock! A complete line of high voltage diffused npn silicon transistors. The 2N5010-2N5015 series has a voltage range of 500 to 1,000 volts. They are available in either a TO-5 or flanged package. These high voltage silicon transistors can extend many standard applications as well as open the door to new design capabilities (i.e., replacing vacuum tubes for driving CRTs). For complete information on these and our full range of intermediate and lower voltages, call or write today.

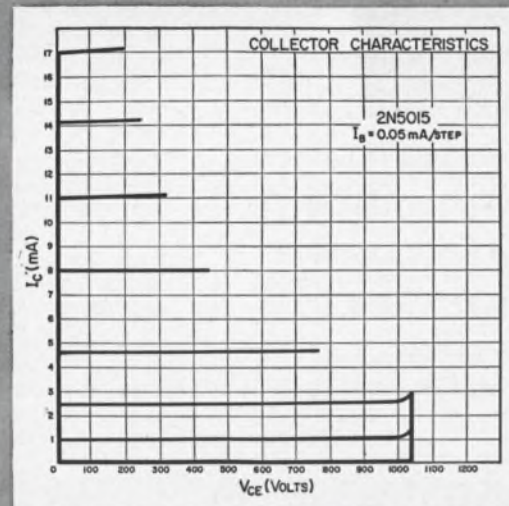

# M. S. TRANSISTOR CORPORATION

SUBSIDIARY OF SILICON TRANSISTOR CORPORATION

Executive offices and main plant: EAST GATE BLVD., GARDEN CITY, N. Y. 11530 (516) Pioneer 2-4100, TWX 510-222-8258

ON READER-SERVICE CARD CIRCLE 128



Juke Box

# THERMISTORS



Astronaut Power Pack



Computer

Micro-wave Instrumentation



Xerox 2400 Copier/Duplicator

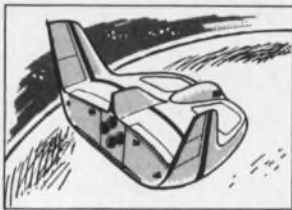

Martin Soft Landing Re-entry Vehicle



Digital Voltmeter

## for every application

BEADS • BULBS

DISKS • WASHERS

GLASS PROBES • RODS

CRYOGENIC THERMISTORS

SENSOR ASSEMBLIES

THERMISTOR CATHETERS

MILITARY GRADE

THINISTORS®

Thin film thermistors

From office business machines and juke boxes to computers and CATV distribution systems, engineers and designers have discovered that VECO thermistors can do the job better, with greater reliability and often at lower cost than conventional devices.

If your products require PRECISE temperature measurement, control or compensation with FAST RESPONSE it will pay for you to investigate VECO thermistors. VECO supplies a wide range of standard thermistors in various sizes, shapes, temperature coefficients and resistance values.

VECO's engineering staff is available to assist you in product application and circuit design. Write for Catalog MPG 681

VECO First in Progress • First in Service

J-7739



**VICTORY ENGINEERING CORP.**

136 Springfield Ave., Springfield, N. J. 07801  
Tel: 201-379-5900 TWX 710-983-440

ON READER-SERVICE CARD CIRCLE 129

INSTRUMENTS—2ND FLOOR

## Op-amp test set for many parameters

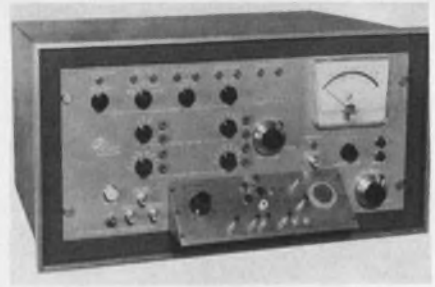

Optimized Devices, Inc., Pleasantville, N. Y. Phone: (914) 769-6100. P&A: about \$1950; 90 days.

Integrated circuit, hybrid and conventional operational amplifiers can be tested for dc open-loop gain, input currents, offset voltage, output swing and common-mode voltage. In addition to these tests, there are two extra test positions for specialized dynamic tests such as frequency for full output, and unity gain frequency. A self-balancing circuit eliminates the need for a manual balance of offset voltage prior to test.

Booth No. 2G35 Circle No. 529

## Modular synthesizers aid frequency resolution



Rohde & Schwarz, 111 Lexington Ave., Passaic, N. J. Phone: (201) 773-8010. P&A: \$4095 to \$6455; 30 days.

Modular construction of the manufacturer's frequency synthesizers has made possible expanded frequency resolution to satisfy special requirements. Units feature decade tuning, illuminated readouts, a metered output, spurious and noise suppression of over 80 dB and a built-in 1-MHz crystal in a temperature-controlled oven, with stability of  $5 \times 10^{-9}/^{\circ}\text{C}$ . Applications include bridge measurements, work with filters, networks and nuclear magnetic resonance.

Booth No. 2H03 Circle No. 342

# multiple choice

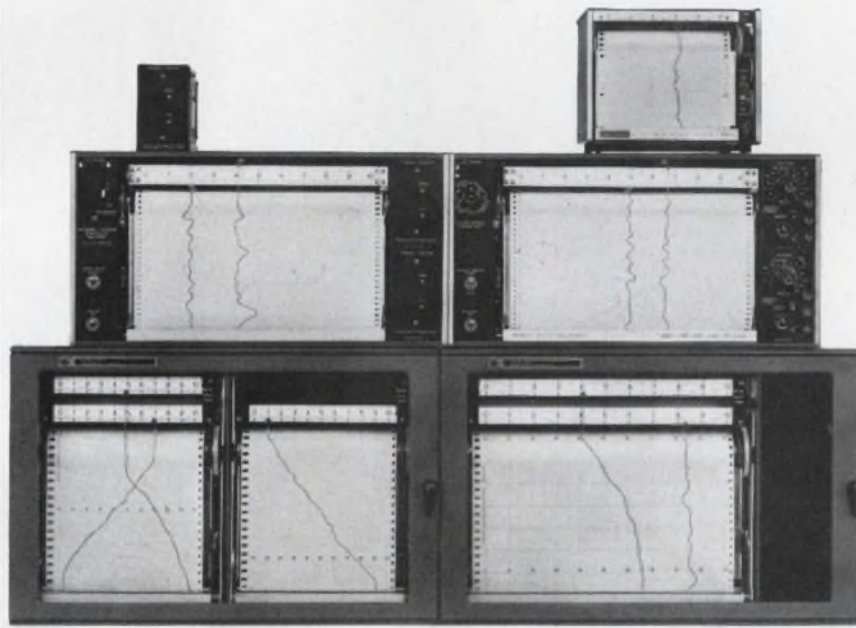

which of  
these  
strip-chart  
recorders  
is best for  
your needs?

With three highly flexible groups of recorders, Hewlett-Packard offers you a range of reliable models for the widest laboratory and industrial application. They feature modular solid-state construction, improved ink or inkless electric writing systems, and a choice of mechanical or optical slidewires.

The 680 is a general-purpose laboratory-type model that provides high accuracy and swift response in a 5" writing width. Important features are a 3-position tilting chart magazine, plus multi-range inputs and chart speeds. The Model 680 is priced at \$750.

In the 7100 Series, four recorders with plug-in modules provide customer-selected input level spans for versa-

tile, general-purpose 10" recording capability. Lower-cost models (7127 and 7128) are designed primarily for use with gas chromatographs. Recorders are priced from \$850 to \$1300, and plug-in modules are priced from \$200 to \$350.

The new 5700 Industrial Series of strip-chart recorders offers modular design for rapid interchange of modules on line and minimum down-time. Choose sensitivity and speed from a wide selection of low-cost recorders and match the recorder to your particular need; convert later if requirements change. One- and two-pen models, 6" and 11" recording. A choice of four models priced from \$825.

HEWLETT  
PACKARD  MOSELEY  
DIVISION

ON READER-SERVICE CARD CIRCLE 130



**ALFORD**



**HEWLETT-  
PACKARD**



**narda**

**ALFRED**  
ELECTRONICS

**PRD**  
ELECTRONICS, INC.

**We have connections  
with the leaders**





MAURY  
MICROWAVE



MICROLAB/FXR

VEINSCHEL  
ENGINEERING



When test equipment manufacturers select the Amphenol APC-7 precision connector for their equipment, there have to be good reasons.

There are.

With VSWR's less than 1.028 through X band, 1.037 at 17GHz and with the electrical length defined

within .002", their equipment can now perform coaxial microwave and short rise time pulse measurements with accuracies never achieved before.

When you have to make measurements you believe impossible, write to one of these leading manufacturers.

When you need APC-7 precision connectors for your test equipment, write to **Amphenol RF Division**, 33 E. Franklin St., Danbury, Conn. 06810.



**AMPHENOL**

Specify Amphenol . . . the leading name in cable, connectors, assemblies, RF switches, potentiometers, motors, microelectronics

ON READER-SERVICE CARD CIRCLE 132

## Console is complete transmission tester

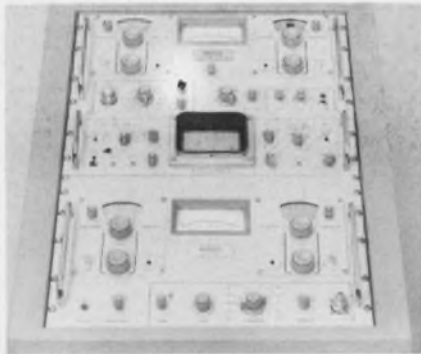

Sierra Electronic Operation, Philco Ford Corp., 3885 Bohannon Dr., Menlo Park, Calif. Phone: (415) 322-7222. P&A: \$10,695.

This transmission test set console combines all functions of selective voltmeter, tracking generator, spectrum display, attenuator and impedance-matching panel in one. The console is used for initial line-up and maintenance of carrier multiplex and high-frequency communications systems. It permits analysis of operating carrier systems showing levels of carrier signalling tone, carrier leak, crosstalk, noise, telegraph and telemetry subcarriers and rapid identification and isolation of circuits having out-of-limit signal, overload or noise condition. Frequency range is 4 kHz to 15 MHz and frequency measurement accuracy is 10 ppm.  $\pm$  300 Hz. Booth No. 2F07 Circle No. 275

## Digital printer uses IC modules



Clary Corp., San Gabriel, Calif. Phone: (213) 287-6111. P&A: \$1795; 90 days.

Model 7100 digital printer uses integrated circuit modules. Paper is loaded through the front panel,

eliminating the need for removal of the printer from its normal operational installation. Standard printing rate is 10 lines per second, maximum column capacity is 20 columns and maximum selection in each column is 12 characters. Printing occurs only when the typewheels are stationary.

Booth No. 2D52 Circle No. 281

## Recorder/reproducer has inertial damping

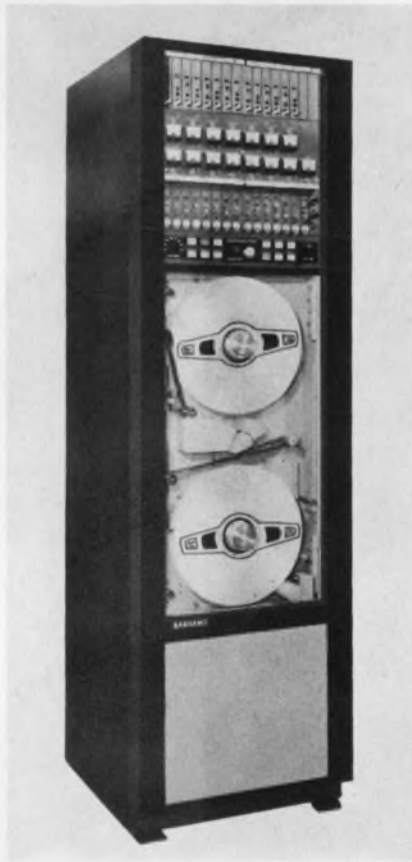

Sangamo Electric Co., P. O. Box 359, Springfield, Ill. Phone: (217) 544-6411.

Smoother tape handling, extreme flexibility, and data accuracy are claimed for this recorder/reproducer. The 4784 system includes a type path with variable inertial dampening roller, eliminating many flutter components. Other features such as vacuum tape tensioning, cleaning and guiding, a high-torque drive and low-mass capstan with 0.004% crystal-controlled servo are included.

Booth No. 2E07 Circle No. 283

## Print alphanumeric at a half-million per second

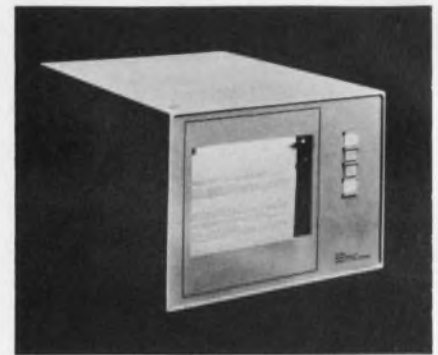

Datalog Div. of Litton Industries, 9370 Santa Monica Blvd., Beverly Hills, Calif. Phone: (213) 273-7500.

Alphanumeric page printers record over a half-million characters per minute on photosensitive paper. The MC 8800 Datalog is a CRT printer designed for compatibility with computers and communications equipment. It accepts data serially at a rate from zero to 8800 characters/second. The unit has an MTBF of over 8000 hours through the use of integrated circuits.

Booth No. 2K21 Circle No. 505

## Coordinatograph produces PC masters



Aero Service Div. of Litton Industries, 4219 Van Kirk St., Philadelphia. Phone: (215) 533-3900.

The Micro/Plotter is a high-precision coordinatograph to produce art master layouts for printed or integrated circuits or resolution targets for optical characteristic data. It is offered in three separate working area sizes and eight individual configurations ranging from 32 x 32 to 48 x 60 inches.

Booth No. 2K21 Circle No. 264

# 9 good reasons why Philco Epoxy Transistors (PET) are your best buy.



1. PET TO-18 is rated from 360 to 675 mW at 25°C (chip dependent).



2. PET TO-5 is rated from 550 mW to 1.2 W at 25°C (chip dependent).



3. PET packages have reliability factors equal to or exceeding that of metal cans.



4. PET's are immediately available in large volume production quantities.



5. PET's have a special deep-well interlock construction that insures hermeticity and reliability.



6. PET packages are permanently and legibly marked—lettered black on white.



7. PET's are packaged in our low-cost Taiwan production facility—to keep your cost low.



8. PET amplifiers operate on currents ranging from 10  $\mu$ A to 1 A; PET switches to speeds 8 ns turn on and 11 ns turn off.



9. PET's cover frequencies from 40 MHz to 1400 MHz.

Call or write: **Philco-Ford Corporation Microelectronics Division Sales Offices:** 2920 San Ysidro Way, Santa Clara, California (408-245-2966) / 999 North Sepulveda, El Segundo, California (213-772-6226) / Northwest Industrial Park, Second Avenue, Burlington, Mass. (617-272-1600) / Benson Manor, Suite 114B, Washington Lane, Jenkintown, Pa. (215-885-0430) / 1215 Drew St., Clearwater, Florida (813-446-0124) / 815 Connecticut Avenue, N.W., Washington, D.C. (202-298-7810) / Suite 208, 700-108th St., N.E., Bellevue, Washington (206-454-5061) / New York, N.Y. (212-244-1373).

**PHILCO**



**PHILCO-FORD CORPORATION**  
Microelectronics Division  
Santa Clara, California • 95051

ON READER-SERVICE CARD CIRCLE 133

# 13 MODELS



**WIDEST VOLT/AMPERE  
CHOICE IN LOW COST  
LABORATORY SUPPLIES**



### ALL-TRANSISTOR MODELS

MODEL	DC OUTPUT VOLTS	AMPS	PRICE (metered)
ABC 2-1M	0-2	0-1	\$125.00
ABC 7.5-2M	0-7.5	0-2	167.00
ABC 10-0.75M	0-10	0-0.75	125.00
ABC 15-1M	0-15	0-1	167.00
ABC 18-0.5M	0-18	0-0.5	125.00
ABC 30-0.3M	0-30	0-0.3	125.00
ABC 40-0.5M	0-40	0-0.5	167.00
ABC 100-0.2M	0-100	0-0.2	188.00

### HYBRID MODELS

MODEL	DC OUTPUT VOLTS	AMPS	PRICE
ABC 200M	0-200	0-0.1	210.00
ABC 425M	0-425	0-0.05	210.00
ABC 1000M	0-1000	0-0.02	295.00
ABC 1500M	0-1500	0-0.01	285.00
ABC 2500M	0-2500	0-0.002	365.00

- 0.05% REGULATION and STABILITY
- TEMPERATURE COMPENSATED ZENER REFERENCE
- TEN-TURN VOLTAGE CONTROL
- CURRENT LIMITED, CONVERTIBLE FOR CURRENT REGULATION
- OPERATIONALLY PROGRAMMABLE (Accepts modulation commands)



WRITE FOR  
NEW CATALOG  
CONTAINING COMPLETE  
SPECIFICATIONS  
AND  
APPLICATIONS NOTES



131-38 SANFORD AVE. • FLUSHING, N.Y. 11352  
(212) 461-7000 • TWX #710-582-2631

ON READER-SERVICE CARD CIRCLE 134

U180

## SYSTEMS—2ND FLOOR

### 'Call-up unit' tunes any of 10 frequencies

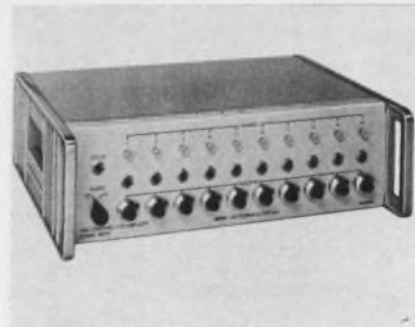

*Singer Co., 915 Pembroke St.,  
Bridgeport, Conn. Phone: (203)  
366-3201. P&A: \$880; 30 days.*

A frequency "call-up unit" permits any of ten discrete frequencies from 1 to 10 GHz to be tuned automatically on command. The unit is designed to work with Singer/Metrics' noise and field intensity analyzer for microwave surveillance, electromagnetic compatibility analysis, and noise and field intensity measurements. In operation, the user adjusts the frequency control (directly calibrated in GHz) for each channel and the corresponding vernier (calibrated in 100-MHz increments), permitting tuning with a precision of 0.01 GHz. Depressing the channel selection button "commands" the analyzer to automatically scan to the selected frequency.  
*Booth No. 2B25 Circle No. 279*

### Desk top computer stores 4000 bits



*Mathatronics, 241 Crescent St.,  
Waltham, Mass. Phone: (617) 893-  
1630. P&A: \$6990; 90 days.*

A desk-size computer/calculator is designed to solve complex mathe-

matical problems. With over 4000 bits of storage, this digital machine accepts standard algebraic and decimal numbers and includes automatic operators for square root, log, antilog, sine, arc-tangent and parenthesis. Up to 82 individually addressable storage registers are available with internal programable memory of 480 program steps. Master programs can automatically branch to sub-programs, execute them and then continue along the original path. Input/output devices include direct entry numeric keyboard, alphanumeric typewriter keyboard, punched paper tape, serial strip and page printers, and electronic interface.  
*Booth No. 2J50 Circle No. 256*

### Recorder/reproducer is cartridge-loading



*Sangamo Electric Co., P. O. Box  
359, Springfield, Ill. Phone (217)  
544-6411.*

Utilizing a standard 1/4-inch tape cartridge, the model D/C-1 magnetic tape data cartridge recorder/reproducer is available with either FM or direct electronics, with frequency responses to 5 kHz and 50 kHz respectively. Up to eight channels may be recorded and reproduced simultaneously.  
*Booth No. 2E07 Circle No. 282*

Don't risk missing any issues of **ELECTRONIC DESIGN**. Send in your renewal card today.

# To Those Of You Who Haven't Been Buying Pulse Generators:

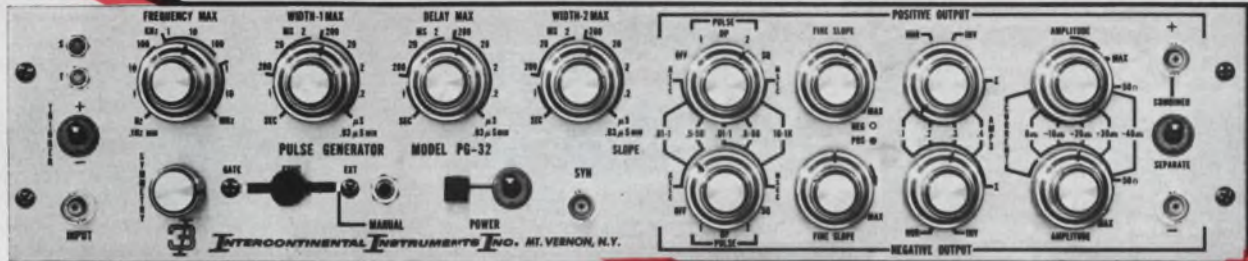

## CUT IT OUT!

Tell you why you should: **THREE-I** makes unusually versatile, high performance pulse generators and makes them much better. And they cost less. Two of them are shown here, our PG-2 and our PG-32. They aren't NEW! NEW! NEW! just GOOD, GOOD, GOOD. *Sophisticated, reliable and good.*

For example: The extremely versatile PG-32 gives you two fast rise time, independent output channels (+ and -). These can be combined to provide a bipolar output with pulses that can be slid across each other, adding, subtracting or forming complex waveshapes. A switch lets you select the normal output or its complement. The PG-32 can be used in an E-Mode (50 ohm source impedance) or an I-Mode (500 ohm source impedance, min.). In the I-Mode each channel can provide up to 400 mA. Outputs are DC-coupled. Rep rates are continuously variable up to 20 MHz (double pulse mode). You can get single pulses, double pulses or square waves plus a sync output. Rise times, fall times, output widths, delays, etc. are all continuously adjustable. You can gate it, trigger it or operate it as a manually controlled one-shot. You can get DC-offsets to 10 volts. It's 3-1/2" high, all silicon and costs \$1385.

The PG-2 is a single channel version of the PG-32. Same adjustability and performance: single or double pulses to 20 MHz (double pulse) plus sync pulse and square waves. I-Mode or E-Mode operation. Same solid-state, printed circuit, meticulous construction. Same 3-1/2" rack height. \$925. An ideal production test pulser.

There's a whole line of **THREE-I** pulse generators including three highly advanced new ones, among which is the most sophisticated 100 MHz, 2.5 ns rise time, 20 volt output instrument in the field.

So if you haven't been buying **THREE-I** pulse generators: **CUT IT OUT!**

Please?

Intercontinental Instruments Inc., an affiliate of **CHRONETICS**.



**U.S.A.:** 500 Nuber Avenue, Mt. Vernon, New York (914) 699-4400 TWX 710 560 0014  
**Europe:** 39 Rue Rothschild, Geneva, Switzerland (022) 31 81 80 TELEX 22266

IEEE Convention—Booth 2B48

ON READER-SERVICE CARD CIRCLE 135

# LET'S GET TECHNICAL!



## COMPLIANCE EXTENSION (for Current Regulators)

When a power supply is connected to control output current, the load is called "compliance voltage."

Sometimes, when a current regulator has insufficient compliance voltage range for a particular load, two units can be connected together as a means of relief. This is called appropriately enough, "compliance extension."

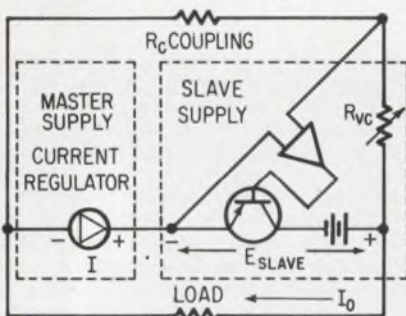

COMPLIANCE EXTENSION

In this circuit, the slaved power supply repeats the compliance voltage of the master supply current regulator itself, usually one-for-one, or in any ratio that may be desired. By then placing the supplies in series, the voltages are made to add across the load.

The repeater power supply may be diagrammed as one in which the conventional fixed (zener) reference has been replaced by the terminal voltage of the current regulator.

This connection is one of many master/slave circuits (complementary connection, parallel operation, series boost, voltage correction, etc.), that may be found in Chapter 7 of the *Kepeco Power Supply Handbook*.

For your personal copy of this handy Handbook, write on your company letterhead to:

**HANDBOOK, Dept. 1B**  
G.P.O. BOX 67 • FLUSHING, N.Y. 11352



ON READER-SERVICE CARD CIRCLE 136  
U182

## SYSTEMS—2ND FLOOR

### Xenon arc lamps rated to 6500 W



*Christie Electric Corp., 3410 W. 67th St., Los Angeles. Phone: (213) 750-1151.*

Complete illuminator systems for xenon, xenon-mercury, and mercury arc lamps produce a high intensity "point source" of light. Applications in photochemistry and semiconductor photoresist processes are cited. The systems include power supply, lamp housing with optics and igniter, and lamp. Systems are available in lamp ratings from 200 to 6500 watts.

Booth No. 2J16 Circle No. 276

### Serial entry printer lists 10 columns



*Victor Comptometer Corp., 3900 N. Rockwell St., Chicago. Phone: (312) 539-8210.*

Victor's serial entry digital printer features a 10-column list and 11-column total on accumulating models and 10-column list on listing models. The Digit-Matic operates on either 24- or 48-Vdc solenoid voltage. Standard features on listers and accumulators include 0 to 10 digits and print command and a choice of 24 Vdc at 0.98 A or 48 Vdc at 0.63 A solenoid voltage.

Booth No. 2B08 Circle No. 280

### SSB spectrum analyzer ranges 2 to 40 MHz



*Singer Co., 915 Pembroke St., Bridgeport, Conn. Phone: (203) 366-3201.*

A 2-to-40-MHz analyzer provides stable, high-resolution spectrum analysis for monitoring, and the low distortion two-tone generators needed for checkout of single-sideband transmitters and receivers. Applications include distortion, interference, spurious sideband, carrier level and noise measurement to better than -60 dB from the peak reference level.

Booth No. 2B25 Circle No. 278

### Strip printer fully buffered

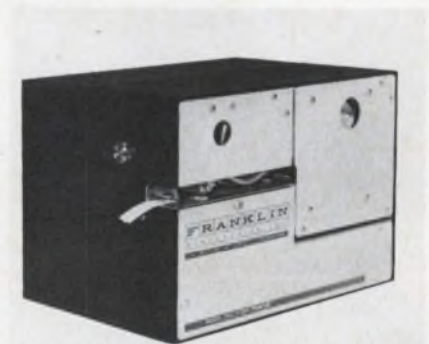

*Franklin Electronics, Inc., E. Fourth St., Bridgeport, Pa. Phone: (215) 272-4800.*

Model 120AX strip printer has a 64-character font and provides continuous printout along a 1/2-inch wide paper tape at a rate of 1200 characters per minute. The printer includes the electronics for operating and controlling. It is designed for systems manufacturers who prefer an operating printer complete with electronics.

Booth No. 2H33 Circle No. 274

# look into Optima

Prize-winning enclosure design, from stock —an unbeatable combination of style and function for instruments and systems of almost any size. Lightweight. Solid or perforated panels. Choose from 8 distinctive colors in one- or two-tone combinations. Vinyl finish throughout.

**CASES**—for 19" panels, 3½ to 28" high, stackable, recessed handles, matching front and rear panels, chassis slides, chassis handles.

**CONSOLES**—desk high, 5 standard sizes, with any number of OPTIMA cases simply set in place.

**RACKS**—for 19" or 24" panels, 22¾" to 77" high. Doors, slides, shelves, double bays, corner arrangements.

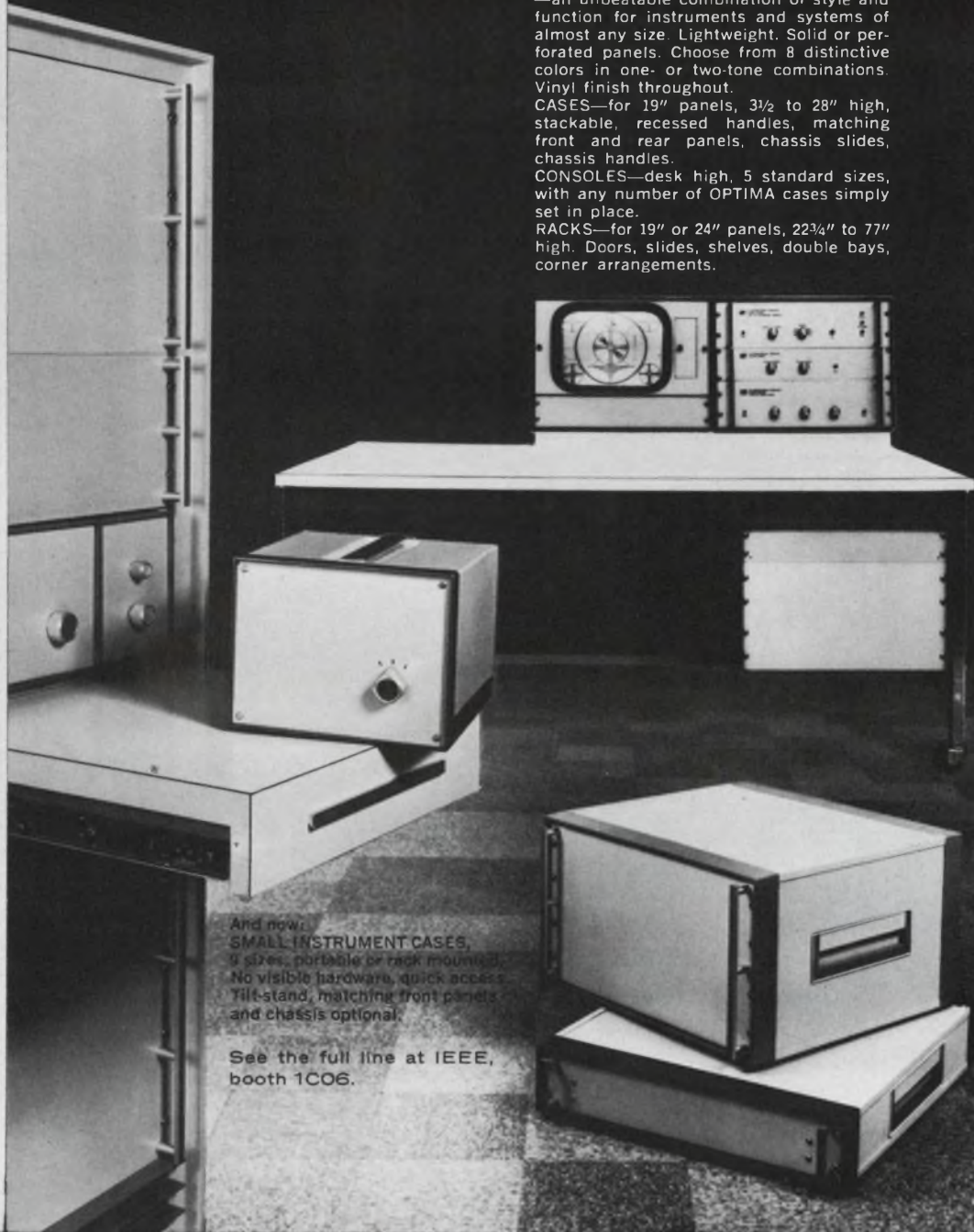

And now:  
**SMALL INSTRUMENT CASES**,  
5 sizes, portable or rack mounted.  
No visible hardware, quick access.  
Tilt-stand, matching front panels,  
and chassis optional.

See the full line at IEEE,  
booth 1C06.



## Optima<sup>®</sup> enclosures

made by Scientific-Atlanta, Inc.  
Box 13654, Atlanta, Ga. 30324  
Tel. 404-938-2930

ON READER-SERVICE CARD CIRCLE 137

### 2-pen recorder compares variables

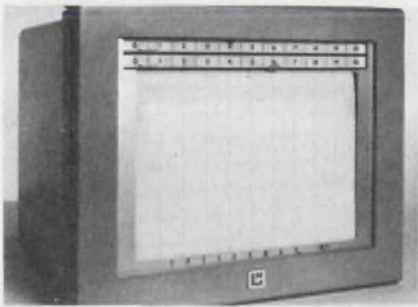

Leeds & Northrup Co., 4901 Stenton Ave., Philadelphia. Phone: (215) 329-4900.

Using the Speedmax 2-pen recorder, you can compare or contrast two related variables, using the same or different types of primary elements. Among the features are all-solid-state amplifiers which use all-silicon transistors, input filtering and shielded circuitry to maintain high common-mode and transverse rejection. An optional chart-drive selection of up to five chart speeds, ranging from 1 inch/hr to 6 inches/minute are available.

Booth No. 2A34 Circle No. 388

### Plug-in system for digital measurement



Hickok Electrical Instrument Co., 10514 Dupont Ave., Cleveland. Phone: (216) 541-8060. P&A: main frame, \$320, plug-ins, \$75 to \$240; stock.

Frequency or period, dc voltage, resistance and capacitance can be measured by a system consisting of a main frame that accepts only five plug-ins. Counting can also be performed. The main frame has a 3-digit Nixie display, automatic polarity indication and automatic decimal indication.

Booth No. 2C26 Circle No. 540

### Tape reader/spooler all solid-state

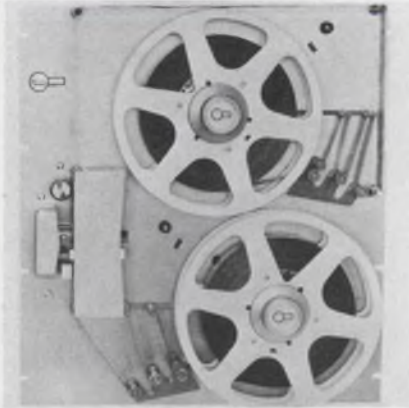

Remex Electronics, 5250 W. El Segundo Blvd., Hawthorne, Calif. Phone: (213) 772-5321. P&A: \$3435; 10 wks.

A high-speed photocell punched-tape reader/spooler features a 500-characters-per-second reader and a 50-inch-per-second spooler equipped with 10-1/2-inch reels. The electronics is all solid-state with a choice of output signals available. The reader/spooler operates at 500 characters per second in the continuous mode.

Booth No. 2G43 Circle No. 277

### 6-digit data printer is small package

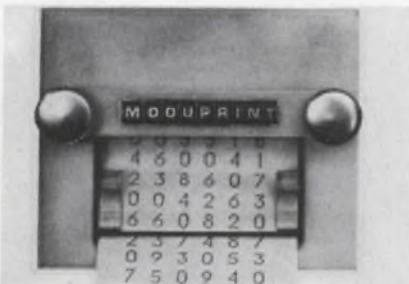

Presin Co., Inc., Trap Falls Rd., Shelton, Conn. Phone: (203) 929-1495.

With a capacity of 6 digits, this data printer measures only 3 inches high x 3-1/2 inches wide on the panel x 9 inches deep. Each digit may be individually energized to step to position (any of 10 or 12 per wheel), or count serially, cascaded as desired. A variety of printing wheels, normally 0.1 inch high, is available.

Booth No. 2J40 Circle No. 539

### Recorder prints quietly at 20 lines/second



Hewlett-Packard, 1501 Page Mill Rd., Palo Alto, Calif. Phone: (415) 326-7000. P&A: \$1750; May.

A digital recorder with 18-column capacity prints at rates up to 20 lines per second. The recorder has a photoelectric coding system in place of rotating electrical contacts, and there is no "start-stop" inked-ribbon mechanism. Formatting and coding are flexible, and are changed when required. Model 5050A converts binary-coded decimal data (BCD) into printed decimal form on paper similar to that used in adding machines.

Booth No. 2F25 Circle No. 265

### Detect leaks at production speeds

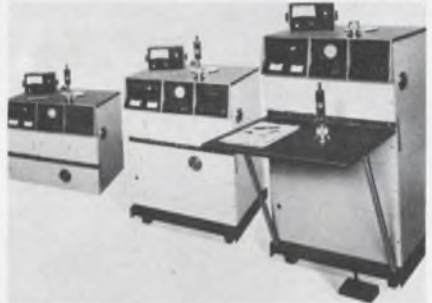

Veeco Instruments, Inc., Terminal Dr., Plainview, N. Y. Phone: (516) 681-8300.

Split-sector leak-test stations feature minimum detectable leak capability of  $5 \times 10^{-12}$  atm $\cdot$ cm $^3$ /second at production speeds with direct read-out. The MS-12 is available in three modular-convertible models. The bench model includes the basic automatic leak detector with the complete roughing station in a portable cabinet. The "roll-around" version features a mobile, completely enclosed housing. The high-speed, "sit-down" model is designed for production use.

Booth No. 2A46 Circle No. 271





# Others make promises...

# Nexus delivers

Why is it that NEXUS can usually deliver operational amplifiers, even when others can't? Mainly because we are set up — from teletype machine to shipping dock — to handle the extra-big orders . . . the special orders . . . the rush orders . . . the extra-small orders . . . as well as routine business. Here's how we do it —



**Computerized order processing** — An IBM system eliminates paperwork bottlenecks, slow-downs, and human error. Your order is normally processed and

in the works within minutes after we receive it.



**Automated production** — A completely automated line permits fast, error-free assembly of large production orders — fast change-over for special orders.



**Large stocks of standards** — Complete

inventories of standard Nexus models are maintained on the shelf for immediate shipment.

**Customer-first policy** — Small orders handled promptly . . . partial shipments made when you request it . . . air shipments routine . . .



**We stand on our heads to get you what you need, when you need it.**

**Send today for Nexus new short form catalog**



**NEXUS**  
RESEARCH LABORATORY, INC.  
480 NEPONSET STREET, CANTON, MASS 02021  
TEL. (617) 828-9000

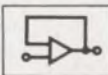

# Want to convert high energy at high efficiency?

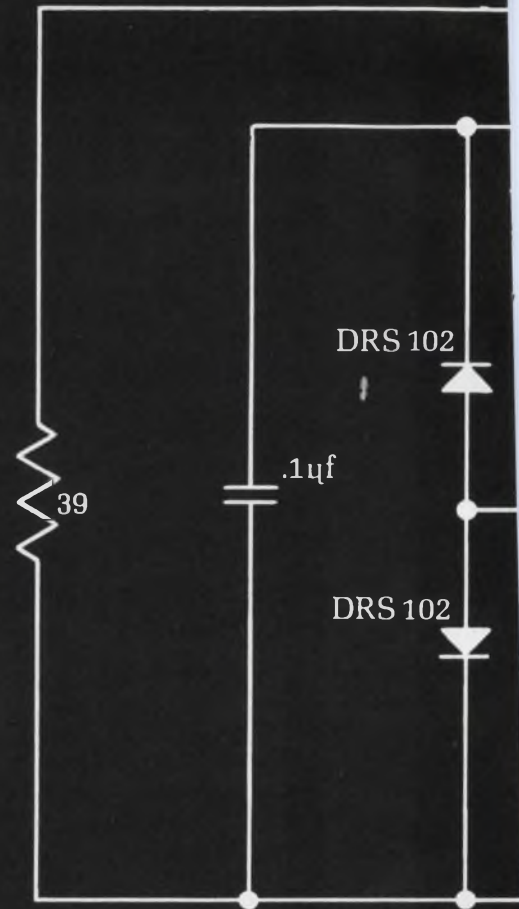

Convert to circuit designs using Delco high voltage silicon power.

The DC to DC converter above operates directly from a 150V DC source and delivers 180 watts to the load at an efficiency of over 94 percent. The 1.1 kHz circuit operates over a temperature range of  $-65^{\circ}\text{C}$  to  $100^{\circ}\text{C}$ . Frequencies of up to 25 kHz may be obtained with selected transformer core materials. And the switching job is handled easily by just two Delco NPN DTS-423 silicon transistors—priced at just \$4.95 each in 1,000 and up quantities.

Delco pioneered the development of high voltage silicon power transistors to provide you high energy capability at the lowest cost. Among the many circuit benefits you get are: high reliability, reduced assembly time, and a reduction in the number, weight and

complexity of the electronic components needed. Coupled with the low prices of the Delco silicon power line, these benefits mean real cost advantages to you.

Other applications? They've proven their capability in such high energy circuits as: DC and switching regulators, ultrasonic power supplies, VLF class C amplifiers, off-line class A audio output and CRT deflection (several major TV manufacturers use them for big screen horizontal and vertical deflection).

Availability? With Delco's lead in know-how and plant facilities it's no problem. Samples or production quantities can be shipped promptly. Contact one of our distributors or a Delco sales office right now and see.

For more details on the DC-DC converter circuit—ask for application note number 32.

# Application of Delco high voltage silicon power transistors: the DC to DC Converter.

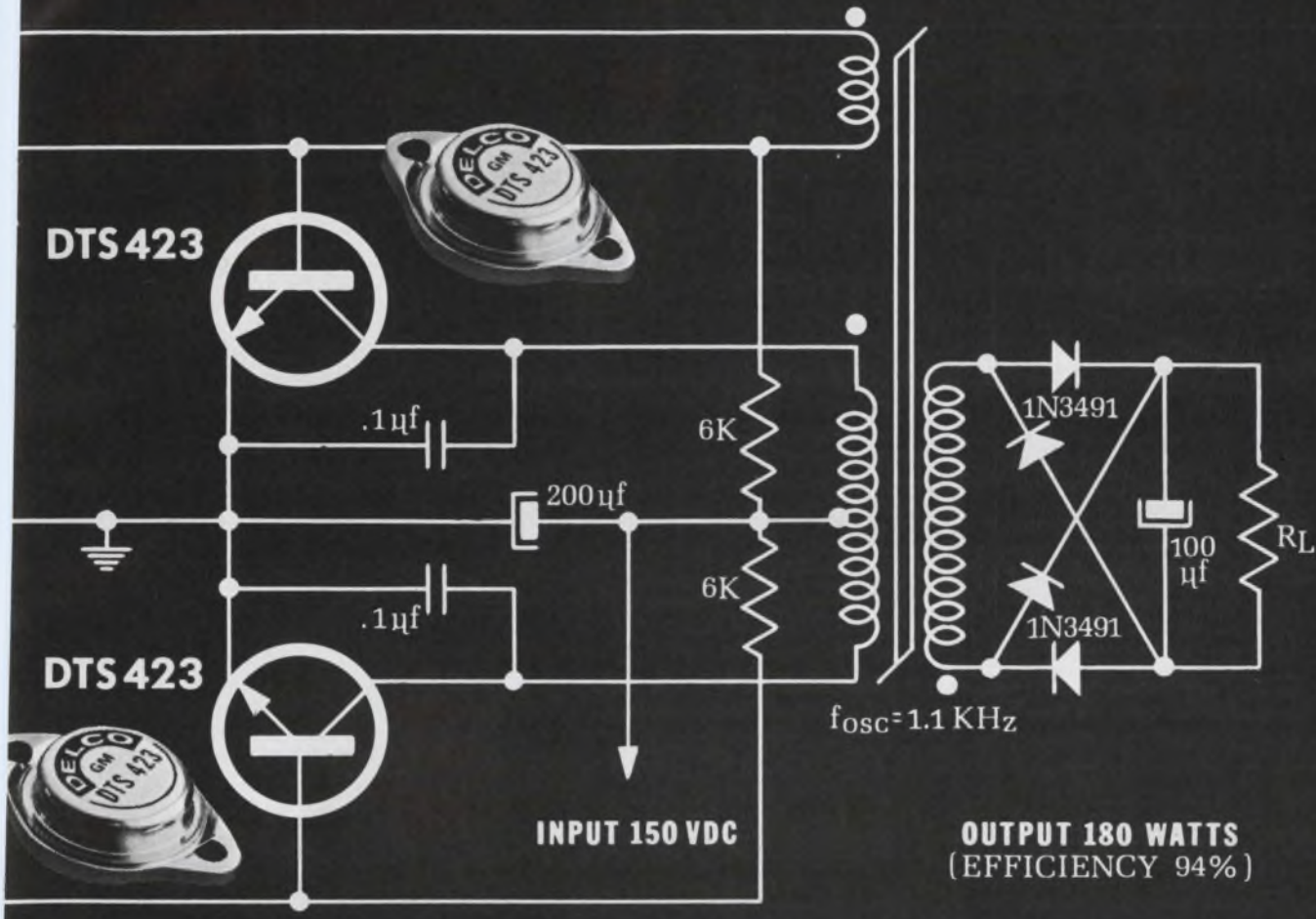

DEVICE TYPE	V <sub>CES</sub>	V <sub>CEO/SUS</sub> (min.)	h <sub>FE</sub> min. @ I <sub>C</sub> V <sub>CE</sub> = 5 V	I <sub>C</sub> max.	P <sub>D</sub> max.	
DTS-410	200	200	10	2.5A	3.5A	80W
DTS-411	300	300	10	2.5A	3.5A	100W
DTS-413	400	325	15	1.0A	2.0A	75W
DTS-423	400	325	10	2.5A	3.5A	100W
DTS-430	400	300	10	3.5A	5.0A	125W
DTS-431	400	325	10	3.5A	5.0A	125W

NPN silicon transistors packaged in solid copper TO-3 case.

See this and other circuits demonstrated at our High Energy Applications Lab at the IEEE, 4th Floor, Booths #4D-20-24.

Field Sales Offices:  
 Union, New Jersey\* 07083  
 Box 1018 Chestnut Station  
 (201) 687-3770  
 Syracuse, New York 13203  
 1054 James Street  
 (315) 472-2668  
 Detroit, Michigan 48202  
 57 Harper Avenue  
 (313) 873-6560  
 Chicago, Illinois\* 60656  
 5151 N. Harlem Avenue  
 (312) 775-5411  
 Santa Monica, Calif.\* 90401  
 726 Santa Monica Blvd.  
 (213) 393-1465  
 General Sales Office:  
 700 E. Firmin, Kokomo, Ind. 46901  
 (317) 459-2175

\*Office includes field lab and resident engineer for applications assistance.



**DELCO RADIO**  
 DIVISION OF GENERAL MOTORS • KOKOMO, INDIANA

ON READER-SERVICE CARD CIRCLE 140

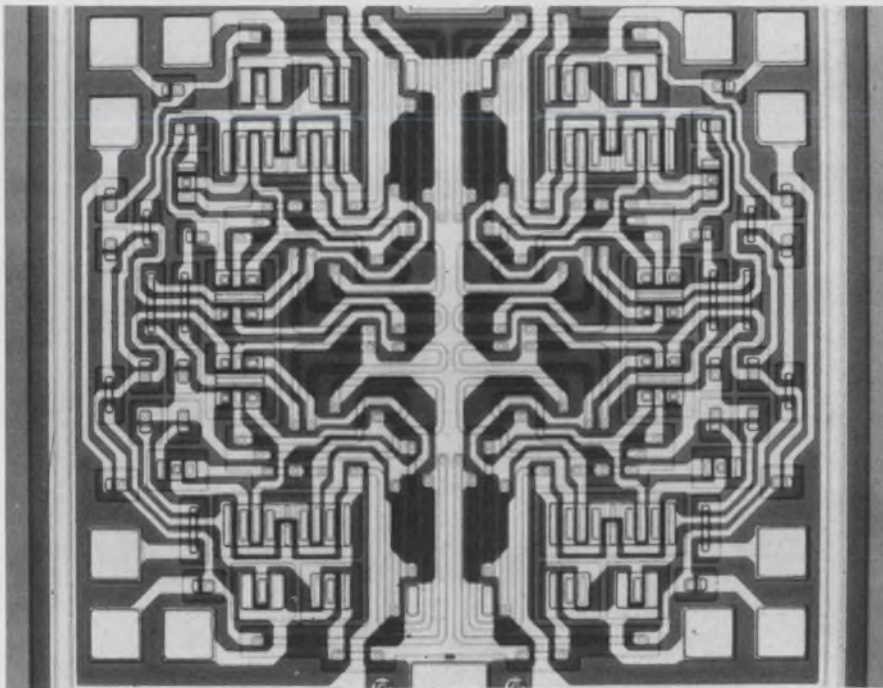

## Built-in avalanche emitter cuts noise in logic ICs

Motorola Semiconductor Products, Inc., P. O. Box 955, Phoenix. Phone: (602) 273-6900. P&A: \$3.50 (dual 4-input gate with active pull-up), \$3.50 (dual 4-input gate with conventional output transistor), \$6.10 (dual J-K flip-flop) \$4.05 (master-slave R-S flip-flop), (1000 to 4999); stock.

A new IC logic family features a high noise margin, obtained by building into the output transistor of a DTL circuit a second emitter, with an avalanche breakdown characteristic.

Currently popular modified DTL circuitry can provide noise margins

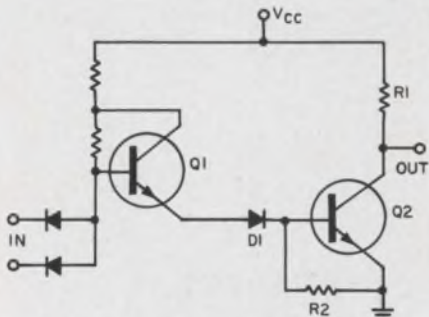

1. Modified DTL circuit. A critical input voltage swings the output high or low.

of the order of 0.7 V, adequate for general purposes. To satisfy the requirements of industrial applications, the new family of logic ICs, called MHTL, provide noise margins about seven times as high.

This can be best understood by first looking at a conventional DTL circuit, Fig. 1. The output is determined by the state of transistor  $Q_2$ . When  $Q_2$  is off, its base is held at ground potential through  $R_2$ . In order to turn  $Q_2$  on, its base must be raised from ground to 0.75 V. This

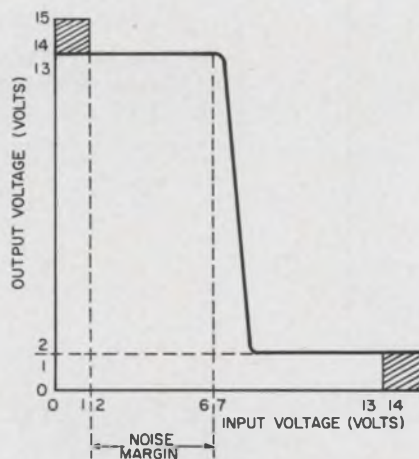

2. Transfer characteristics of the MHTL. Inputs from 1.1 to 1.9 volts swing output state.

requires a substantial current through  $Q_1$  and  $D_1$ . Since, for substantial conduction, the transistor base-emitter junction and the diode anode-cathode junction each introduce another 0.75-V drop, the minimum voltage on the base of  $Q_1$  that will cause the output to go low is 2.25. Because the input diodes are reversed relative to  $Q_1$ ,  $D_1$ , and  $Q_2$ , the input voltage corresponding to 2.25 V on the base of  $Q_1$  is 1.5 V. This is the transition voltage for a modified DTL circuit. Allowing for production variation, a transition region is usually more useful than a single voltage. In MDTL the transition region is between 1.1 and 1.9 volts at 25°C.

In the transfer characteristic of an MDTL, the difference between the normal output of a preceding stage and the edge of the transition region is the noise margin of the circuit. For MDTL, this noise margin is usually about 0.7 V. Figure 2 shows the transfer characteristic of the new circuit. The low output is just a saturation drop above ground, and the high state only a little below 15 V. The transition point is approximately 7.5 V.

The logic swing of almost 15 V is obtained by using the emitter-base breakdown of an additional emitter in the base of the transistor.

The transition region of the MHTL circuits is between 6.5 and 8.5 V. With the maximum low-state output voltage of 1.5 and the maximum high-state output voltage of 13.5, the MHTL circuits provide a noise margin of 5 V. This makes possible an IC logic line that can be operated in high noise environments.

An additional advantage of this design is improved temperature stability. In an ordinary modified DTL circuit, the offset diode and the base-emitter diode of  $Q_2$  are additive and introduce temperature instability. In the new device, the avalanche diode has a positive temperature coefficient that offsets the negative coefficient of the output transistors' base-emitter diode.

The initial circuits offered in the new series include dual 4-input gates with active pull-up, dual 4-input gates with a conventional single output transistor, a dual J-K flip-flop (shown above) and a master-slave R-S flip-flop.

Booth No. 3A05 Circle No. 524



## When your light specs seem impossible Monsanto's solid state lights shine

**Now you can get a new line of visible and infrared emitting diodes that feature long life, maximum reliability and fast switching speed . . . at low cost.**

These rugged light sources from Monsanto offer you design opportunities never before available in their price range. Just look at the following specifications and unit costs and see why they fit into your design for profit.

**MVE-100 Visible Light Emitter.** The MVE-100 gallium arsenide phosphide diode is suitable for use as an instrument signal light, panel indicator and for many computer uses. Price ranges from \$14.50 each in lots of one to nine, to \$8.00 each in lots of 1,000.

**MVE-101A Visible Light Emitter.** The MVE-101A gallium arsenide phosphide diode is packaged in a smaller coaxial package allowing high packing density for those applications where space is critical. Use the MVE-101A for film annotating, reticle illuminations and as indicators. Price ranges from \$16.50 each in lots of one to nine, to \$8.00 each in lots of 1,000.

**MVL-150 Visible Laser.** The MVL-150 is a gallium arsenide phosphide semiconductor laser which is available

with emission at any desirable wave length between 6,500 A and 8,300 A. This laser is designed for operation at 77 K. Price ranges from \$19.50 each in lots of one to nine, to \$13.00 each in lots of 1,000.

**MIE-200 Infrared Emitter.** An infrared radiation source consisting of a gallium arsenide mesa diode. It matches efficiency with silicon detectors, providing enough radiated power to work in common mode isolation, card reading, and chopping applications. Price ranges from \$9.85 each

in lots of one to nine, to \$6.00 each in lots of 1,000.

**MVA-300A Visible Light Emitter Array.** The MVA-300A 5x7 Array is a solid state read-out made with 35 MVE-101A diodes mounted on a metal heat sink. The display is used for visual read-out and film annotation applications. Price \$495.00 each.

For more information on low-cost Monsanto light sources, call (314) OXford 4-2136 or write: Monsanto Company, 800 N. Lindbergh Boulevard, St. Louis, Missouri 63166



**ELECTRONICS**

ON READER-SERVICE CARD CIRCLE 141

**when  
special  
cables**

**short-  
circuit  
your  
production**

**call  
Columbia  
Wire!**

When immediate delivery of special cables—any type up to 2" in diameter—will keep your production running smoothly and profitably, call Columbia Wire. Chances are we have the know-how and facilities for producing it for you . . . fast!

Try us and see.



Write for our fully illustrated catalog

**Columbia** 

**WIRE PRODUCTS COMPANY**  
2850 Irving Park Rd. • Chicago, Ill. 60618

ON READER-SERVICE CARD CIRCLE 142  
U190

COMPONENTS—3RD FLOOR

**Semiconductor diamond  
has many facets**



*General Electric Co., Edmore, Mich.  
Phone: (517) 427-5151. Availability: summer 1967.*

Semiconducting diamond, very rare in nature, is made synthetically in a high-temperature, high-pressure growing process. The starting material is graphite. It is transformed into diamond by the action of a molten metal catalyst under pressure of about one million pounds per square inch, and at a temperature above 9000°F.

Impurities such as boron, beryllium and aluminum are added in the growing process. The result is a diamond crystal weighing about 0.0004 carat.

A principal advantage is the wide temperature range. A temperature sensor built around this crystal operates from -325 to 1200°F. At this high temperature metals glow red-hot.

The diamond crystal has an electrical conductivity in the semiconductor range that decreases with temperature. Its wide temperature range makes it an ideal sensing element in thermistors designed for use in extreme temperatures.

In shape, the diamond approaches a cube, with a side of about 0.015 inches. Because of its small size and high thermal conductivity, it offers extremely fast response to temperature changes. The small size of the crystal also makes it useful in probes and permanent installations.

The thermistor offered has a diamond sensing element to which two wires are sealed by a tiny glass bead, which covers the whole diamond and the tips of the wires, resulting in a hermetically sealed, corrosion-resistant unit.

*Booth No. 3E13 Circle No. 257*

**Subcarrier oscillator  
for color TV**



*Bliley Electric Co., 200 Union Station Bldg., Erie, Pa. Phone: (814) 456-7561.*

For the color TV standard frequency of 3.579545 MHz this subcarrier oscillator is packaged as a plug-in module. It maintains the reference signal within 2 ppm over an ambient temperature range of 0 to 65°C. The solid-state oscillator provides a 1-V sine-wave output into 10 kΩ. Power requirements are 115 Vac for proportional control oven and 12 Vdc for the oscillator.

*Booth No. 3D03 Circle No. 394*

**High resolution from  
CRT displays**

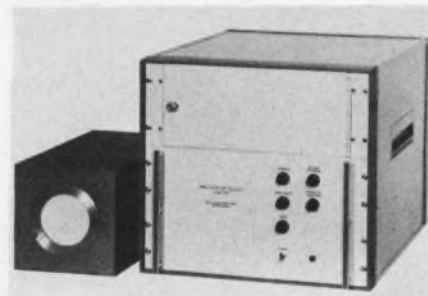

*Beta Instrument Corp., 377 Elliot St., Newton Upper Falls, Mass. Phone: (617) 969-6610.*

High-resolution CRT displays utilize all-solid-state circuitry. Applications are in film and hard-copy printing recorders, flying spot scanners, film readers, radar displays, computer output displays, TV monitors or any application requiring a precision programmable light source. The displays utilize 5-inch flat face magnetically deflected CRTs.

*Booth No. 3A09 Circle No. 507*

ON READER-SERVICE CARD CIRCLE 143 ➤

# new disciplines in DC



## take the models that give "EXTRA DIVIDENDS"

Medium power lab supplies  
designed for  
convenience, versatility, and compactness

Bonus features include: special circuitry for high speed programming; provision for remote programming of both the output voltage and current, using either resistance or voltage control. Silicon "Diff-Amps," packaged differential amplifiers, result in lower temperature coefficient and drift for both Constant Voltage and Constant Current operation. Meters are overload-proof for all range settings. All Supplies are short-circuit-proof. Model 6220B includes a front panel switch for rapid changeover between the two available output ranges.

DC OUTPUT	MODEL	PRICE
0-25V, 0-1A/0-50V, 0-0.5A Dual Range	6220B	\$250.
0-24V, 0-3A	6224B	\$325.
0-50V, 0-1.5A	6226B	\$325.

Regulation, Line or Load: Constant Voltage, 0.01% + 4 mV; Constant Current, 0.01% + 250  $\mu$ A • CV Ripple less than 500  $\mu$ V RMS/1 MV P-P; CC Ripple less than 500  $\mu$ A RMS/1 MA P-P • Input Power 115/230 V,  $\pm$ 10%, 50 or 60 Hz • No Overshoot on Turn-On, Turn-Off, or AC Power Removal • Optional 3-Digit, Front-Panel, Graduated Voltage and Current Controls available at additional cost • Size, 6 $\frac{1}{4}$ " (15.9 cm) H x 5 $\frac{1}{8}$ " (13 cm) W x 11" (28 cm) D.

Contact your nearest Hewlett-Packard Sales Office for full specifications.

**HEWLETT  
PACKARD**  **HARRISON  
DIVISION**

100 Locust Ave., Berkeley Heights, New Jersey 07922  
Telephone 201-464-1234 TWX 710-984-7972

H12A

All-Silicon Circuitry  
Remote Error Sensing  
Remote Programming  
Auto-Series, -Parallel, -Tracking

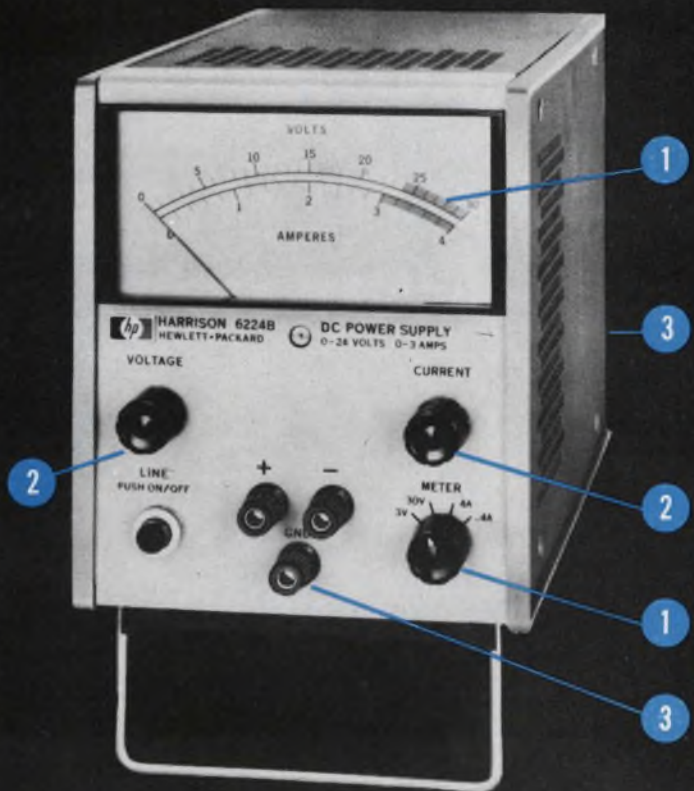

- 1 Large Easy-to-Read Meter  
x1 and x10 Sensitivity, Volts and Amps
- 2 Ten-Turn Output Controls  
Constant Voltage/Constant Current Operation  
with Automatic Crossover
- 3 Front and Rear Output Terminals with  
Automatic Error Sensing  
Floating Output, Ground Either + or -
- 4 Compact  $\frac{1}{3}$  Rack Width hp Module  
Convenient for Bench and Rack Use



4

## Plastic transistors for general applications

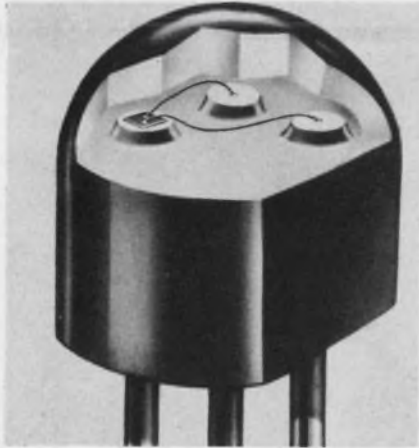

*Transitron Electronic Corp., 168 Albion St., Wakefield, Mass. Phone: (617) 245-4500. P&A: 17¢ to 41¢ (10,000 lots); stock.*

Thirteen families of silicon planar plastic packaged transistors are offered in both npn and pnp types for the following applications: high-gain, general-purpose amplifier, general-purpose high-frequency amplifier and driver; high-frequency logic and vhf and uhf units for high frequency oscillator and amplifier service. Each package has a locating flat, and leads which will fit the TO-18 standard socket without preforming.

*Booth No. 3K16 Circle No. 273*

## Aluminum heat sinks withstand 1 kV

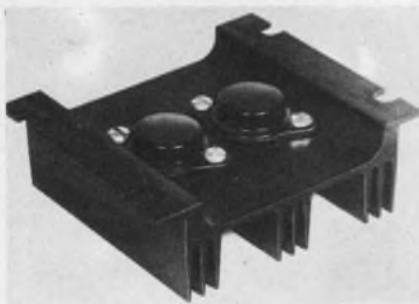

*Vemaline Products Co., Inc., Franklin Lakes, N. J. Phone: (201) 891-3200.*

Aluminum heat sinks are suitable for regular or stud-mounted semiconductor devices. They come in a black-anodized or a special hardcoat anodized finish that withstands 1 kV rms.

*Booth No. 3B18 Circle No. 263*

## Vacuum-variable cap takes high vibration

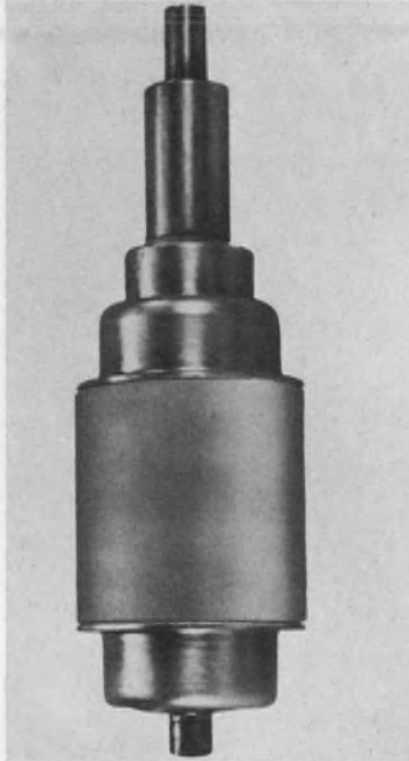

*ITT, P. O. Box 1278, San Jose, Calif. Phone: (408) 292-4025.*

Designed for communications systems in aircraft and other mobile applications, a line of vacuum-variable capacitors claims unusually high resistance to vibration. In the capacity range from 25 to 2500 pF, the average capacity shift is 1.5 pF at vibrations of 5 G from 55 to 500 Hz. Voltage rating is 5 kV peak; current rating is 70 A rms at 16 MHz.

*Booth No. 3B49 Circle No. 266*

## Flat-faced CRT for high frequencies



*General Atronics, 1200 E. Mermaid Lane, Philadelphia. Phone: (215) 248-3700.*

Designed for high-frequency operations, an all-electrostatic CRT

has a rectangular helix and a mesh deflection system to insure good high-frequency performance. It is flat-faced with a 4 x 5-inch viewing area and features high light output at good resolution. The M1252 is designed with an aluminized screen for maximum light output and minimum charging effects.

*Booth No. 3K02 Circle No. 510*

## Numerical controller has mirror-image capability



*Superior Electric Co., Bristol, Conn. Phone: (203) 582-9561. Price: \$4950.*

Several features previously available only as options are now incorporated as standard in this line of numerical tape controls. The units offer a choice of either two-axis models or models having two axes plus a time shared third axis. The X and Y axes can be operated simultaneously with the Z axis operated sequentially. Mirror-image capability, true 45° milling and tape-actuated rapid traverse during milling are also offered.

*Booth No. 3B03 Circle No. 261*

Don't risk missing any issues of **ELECTRONIC DESIGN**. Send in your renewal card today.





## The wrapped tubular explosion!

When you think of wrapped mylar capacitors, you naturally think of Cornell-Dubilier. Over the years, our type WMF has become an industry standard.

But our wrapped mylars are just a small part of the biggest selection of wrapped tubular capacitors made. The CDE line also includes type MFP pressed mylars, military grade type CTM mylars, type MMW metal-

lized mylars and two brand new types. WCR polycarbonates and MCR metallized polycarbonates.

All are SPRINT stock standards. All are available through CDE's Authorized Industrial Distributors.

**CDE** **CORNELL-DUBILIER**

# — STOCK STANDARDS — WRAPPED TUBULAR CAPACITORS —

## WMF — GENERAL PURPOSE MINIATURE

### STANDARD STOCK RATINGS

‡ Tolerance ±20% or ±10%

Cap. Mfd.	100V DCW		200V DCW		400V DCW		600V DCW		Cap. Mfd.	100V DCW		200V DCW		400V DCW		600V DCW	
	†Type WMF—	Size D x L (In.)	†Type WMF—	Size D x L (In.)	†Type WMF—	Size D x L (In.)	†Type WMF—	Size D x L (In.)		†Type WMF—	Size D x L (In.)	†Type WMF—	Size D x L (In.)	†Type WMF—	Size D x L (In.)	†Type WMF—	Size D x L (In.)
.001	1D1	.156 x 1/2	2D1	.156 x 1/2	4D1	.156 x 3/8	6D1	.170 x 3/8	.056	1S56	.265 x 3/8	—	—	—	—	—	
.0012	1D12	.156 x 1/2	—	—	—	—	—	—	.068	1S68	.280 x 3/8	2S68	.350 x 3/8	4S68	.390 x 1	6S68	.500 x 1
.0015	1D15	.156 x 1/2	2D15	.156 x 1/2	4D15	.156 x 3/8	6D15	.170 x 3/8	.082	1S82	.270 x 3/8	—	—	—	—	—	
.0018	1D18	.156 x 1/2	—	—	—	—	—	—	.1	1P1	.290 x 7/8	2P1	.410 x 7/8	4P1	.465 x 1	6P1	.520 x 1 1/8
.0022	1D22	.156 x 1/2	2D22	.156 x 1/2	4D22	.156 x 3/8	6D22	.187 x 3/8	.12	1P12	.315 x 7/8	—	—	—	—	—	
.0027	1D27	.156 x 1/2	—	—	—	—	—	—	.15	1P15	.335 x 7/8	2P15	.500 x 7/8	4P15	.515 x 1 1/4	6P15	.625 x 1 3/8
.0033	1D33	.156 x 1/2	2D33	.160 x 1/2	4D33	.190 x 3/8	6D33	.203 x 3/8	.18	1P18	.350 x 1	—	—	—	—	—	
.0039	1D39	.156 x 1/2	—	—	—	—	—	—	.22	1P22	.385 x 1	2P22	.500 x 1 1/8	4P22	.565 x 1 1/8	6P22	.660 x 1 3/8
.0047	1D47	.156 x 1/2	2D47	.170 x 1/2	4D47	.200 x 3/8	6D47	.234 x 3/8	.27	1P27	.380 x 1 1/8	—	—	—	—	—	
.0050	1D5	.156 x 1/2	—	—	—	—	—	—	.33	1P33	.415 x 1 1/8	2P33	.550 x 1 1/8	4P33	.600 x 1 3/8	6P33	.687 x 2
.0056	1D56	.156 x 1/2	—	—	—	—	—	—	.39	1P39	.460 x 1 1/8	—	—	—	—	—	
.0068	1D68	.175 x 1/2	2D68	.200 x 1/2	4D68	.250 x 3/8	6D68	.265 x 3/8	.47	1P47	.475 x 1 1/4	2P47	.600 x 1 1/4	4P47	.700 x 1 3/8	6P47	.855 x 2
.0082	1D82	.175 x 1/2	—	—	—	—	—	—	.50	1P5	.500 x 1 1/4	—	—	—	—	—	
.01	1S1	.200 x 1/2	2S1	.230 x 1/2	4S1	.300 x 3/8	6S1	.290 x 3/8	.56	1P56	.525 x 1 1/4	—	—	—	—	—	
.012	1S12	.215 x 1/2	—	—	—	—	—	—	.68	1P68	.570 x 1 1/4	2P68	.650 x 1 3/8	4P68	.790 x 1 3/4	6P68	.970 x 2
.015	1S15	.235 x 1/2	2S15	.290 x 1/2	4S15	.360 x 3/8	6S15	.312 x 7/8	.82	1P82	.585 x 1 3/8	—	—	—	—	—	
.018	1S18	.255 x 1/2	—	—	—	—	—	—	1.0	1W1	.625 x 1 1/2	2W1	.750 x 1 3/4	4W1	.875 x 2	6W1	1.165 x 2 1/2
.022	1S22	.275 x 3/8	2S22	.260 x 3/8	4S22	.320 x 3/4	6S22	.335 x 7/8	1.25	1W1P25	.690 x 1 1/2	2W1P25	.825 x 1 3/4	4W1P25	.950 x 2	6W1P25	1.340 x 2 1/2
.027	1S27	.300 x 3/8	—	—	—	—	—	—	1.5	1W1P5	.770 x 1 3/4	2W1P5	.900 x 1 3/4	4W1P5	.975 x 2 1/4	6W1P5	1.275 x 3
.033	1S33	.300 x 3/8	2S33	.270 x 3/8	4S33	.350 x 7/8	6S33	.350 x 1	2.0	1W2	.955 x 1 3/4	2W2	.980 x 1 3/8	4W2	1.250 x 2 1/4	6W2	1.460 x 3
.039	1S39	.245 x 3/8	—	—	—	—	—	—	3.0	1W3	1.100 x 2 1/8	—	—	—	—	—	
.047	1S47	.265 x 3/8	2S47	.320 x 3/8	4S47	.400 x 7/8	6S47	.415 x 1	4.0	1W4	1.250 x 2.500	—	—	—	—	—	
.050	1S5	.265 x 3/8	—	—	—	—	—	—	—	—	—	—	—	—	—	—	

† Order by complete type no.; e.g., WMF1D68 Type numbers listed are ±10%; Available to 1.0 mfd in ±20% tolerance. To specify ±20% add -20

## MFP — FLAT MYLAR<sup>®</sup> WRAP

### STANDARD STOCK RATINGS

‡ Tolerance ±20% or ±10%

Cap. Mfd.	100V DCW			200V DCW			400V DCW			600V DCW		
	†Type MFP—	L x W x T (Inches)		†Type MFP—	L x W x T (Inches)		†Type MFP—	L x W x T (Inches)		†Type MFP—	L x W x T (Inches)	
.01	★	—	—	★	—	—	★	—	—	★	.750 x .343 x .218	
.015	★	—	—	★	500 x .312 x .187		★	.625 x .437 x .312		★	.875 x .343 x .218	
.022	1S22	.625 x .343 x .218		2S22	.625 x .343 x .218		4S22	.750 x .375 x .250		6S22	.875 x .406 x .281	
.033	1S33	.625 x .312 x .187		2S33	.750 x .343 x .218		4S33	.875 x .406 x .281		6S33	1.000 x .468 x .312	
.047	1S47	.750 x .312 x .187		2S47	.750 x .375 x .250		4S47	.875 x .500 x .343		6S47	1.000 x .468 x .343	
.068	1S68	.750 x .343 x .218		2S68	.750 x .437 x .250		4S68	1.000 x .437 x .312		6S68	1.000 x .562 x .406	
.1	1P1	.875 x .343 x .218		2P1	.875 x .500 x .312		4P1	1.000 x .531 x .375		6P1	1.375 x .593 x .406	
.15	1P15	.875 x .406 x .250		2P15	.875 x .562 x .375		4P15	1.250 x .562 x .406		6P15	1.375 x .687 x .531	
.22	1P22	1.000 x .468 x .281		2P22	1.125 x .562 x .406		4P22	1.375 x .625 x .500		6P22	1.625 x .750 x .531	
.33	1P33	1.125 x .500 x .312		2P33	1.125 x .625 x .500		4P33	1.625 x .656 x .500		6P33	2.000 x .781 x .562	
.47	1P47	1.250 x .531 x .375		2P47	1.250 x .656 x .500		4P47	1.625 x .781 x .593		6P47	2.000 x .937 x .718	
.68	1P68	1.250 x .687 x .468		2P68	1.625 x .718 x .531		4P68	1.750 x .875 x .687		6P68	2.000 x 1.062 x .843	
1.0	1W1	1.500 x .718 x .500		2W1	1.750 x .812 x .625		4W1	2.000 x .937 x .750		6W1	2.500 x 1.250 x 1.062	
1.25	1W1P25	1.500 x .718 x .562		2W1P25	1.750 x .960 x .687		4W1P25	2.000 x 1.062 x .843		6W1P25	2.500 x 1.437 x 1.218	
1.50	1W1P5	1.750 x .843 x .656		2W1P5	1.750 x 1.000 x .781		4W1P5	2.250 x 1.062 x .843		6W1P5	3.000 x 1.406 x 1.093	
2.0	1W2	1.750 x 1.062 x .843		2W2	1.875 x 1.062 x .843		4W2	2.250 x 1.312 x 1.125		6W2	3.000 x 1.593 x 1.281	

★ Covered by Parent Case size. Use next higher voltage for same case size. † Order by complete type no.; e.g., MFP1S22. ‡ Type numbers listed are ±20%; to specify ±10% add -10 to type no.

## MMW — MINIATURE MYLAR WRAP — METALLIZED

### STANDARD STOCK RATINGS

Tolerance ±20%

Cap. Mfd.	200V DCW		400V DCW		600V DCW		Cap. Mfd.	200V DCW		400V DCW		600V DCW	
	†Type MMW—	D x L (Inches)	†Type MMW—	D x L (Inches)	†Type MMW—	D x L (Inches)		†Type MMW—	D x L (Inches)	†Type MMW—	D x L (Inches)	†Type MMW—	D x L (Inches)
.01	★	—	4S1	.180 x 3/16	6S1	.200 x 3/8	.22	2P22	.340 x 1 1/16	4P22	.400 x 1 1/4	6P22	.575 x 1 1/4
.015	★	—	4S15	.180 x 1/16	6S15	.250 x 3/8	.33	2P33	.390 x 1 1/16	4P33	.450 x 1 1/2	6P33	.560 x 1 3/4
.022	★	—	4S22	.210 x 1/16	6S22	.300 x 3/8	.47	2P47	.370 x 1	4P47	.520 x 1 1/2	6P47	.675 x 1 3/4
.033	2S33	.180 x 3/16	4S33	.250 x 1/16	6S33	.370 x 3/8	.68	2P68	.420 x 1	4P68	.625 x 1 1/2	6P68	.800 x 1 3/4
.047	2S47	.200 x 3/16	4S47	.300 x 1/16	6S47	.325 x 1 1/16	1.0	2W1	.500 x 1	4W1	.675 x 1 3/4	6W1	.950 x 1 3/4
.068	2S68	.200 x 1/16	4S68	.350 x 1/16	6S68	.400 x 1/16	1.5	2W1P5	.540 x 1 1/4	4W1P5	.825 x 1 3/8	—	—
.1	2P1	.240 x 1/16	4P1	.325 x 1	6P1	.450 x 1/16	2.0	2W2	.620 x 1 1/4	4W2	.950 x 1 3/8	—	—
.15	2P15	.280 x 1/16	4P15	.375 x 1	6P15	.475 x 1/4	—	—	—	—	—	—	—

★ Use next higher voltage rating. † Order by complete type number; e.g., MMW2S33.

## MCR — FILM WRAP METALLIZED POLYCARBONATE

### STANDARD STOCK RATINGS

Tolerance ±20%

Cap. Mfd.	200V DCW			400V DCW			600V DCW			Cap. Mfd.	200V DCW			400V DCW			600V DCW		
	†Type MCR—	Size D x L (In.)	Lead Size	†Type MCR—	Size D x L (In.)	Lead Size	†Type MCR—	Size D x L (In.)	Lead Size		†Type MCR—	Size D x L (In.)	Lead Size	†Type MCR—	Size D x L (In.)	Lead Size	†Type MCR—	Size D x L (In.)	Lead Size
.01	2S1	.150 x 3/16	24	4S1	.200 x 3/16	24	6S1	.245 x 3/8	24	.47	2P47	.370 x 1	22	4P47	.550 x 1 1/2	20	6P47	.775 x 1 3/4	18
.015	2S15	.175 x 3/16	24	4S15	.200 x 1/16	24	6S15	.295 x 3/8	24	.68	2P68	.450 x 1	22	4P68	.650 x 1 1/2	20	6P68	.925 x 1 3/4	18
.022	2S22	.185 x 3/16	24	4S22	.225 x 1/16	24	6S22	.350 x 3/8	24	1.0	2W1	.530 x 1	22	4W1	.725 x 1 3/4	18	6W1	1.125 x 1 3/4	18
.033	2S33	.215 x 3/16	24	4S33	.260 x 1/16	24	6S33	.420 x 3/8	24	1.5	2W1P5	.575 x 1 1/4	20	4W1P5	.865 x 1 3/8	18	—	—	—
.047	2S47	.240 x 3/16	24	4S47	.320 x 1/16	22	6S47	.375 x 1 1/16	22	2.0	2W2	.650 x 1 1/4	20	4W2	.990 x 1 3/4	18	—	—	—
.068	2S68	.215 x 1/16	24	4S68	.375 x 1/16	22	6S68	.435 x 1/16	22	3.0	2W3	.700 x 1 1/2	18	4W3	1.062 x 2 1/4	18	—	—	—
.1	2P1	.275 x 1/16	24	4P1	.345 x 1	22	6P1	.525 x 1/16	22	4.0	2W4	.745 x 1 3/4	18	—	—	—	—	—	—
.15	2P15	.310 x 1/16	22	4P15	.400 x 1	22	6P15	.565 x 1/4	22	5.0	2W5	.825 x 1 3/4	18	—	—	—	—	—	—
.22	2P22	.370 x 1/16	22	4P22	.425 x 1 1/4	22	6P22	.670 x 1/4	22	—	—	—	—	—	—	—	—	—	—
.33	2P33	.430 x 1/16	22	4P33	.465 x 1 1/2	22	6P33	.670 x 1 3/4	22	—	—	—	—	—	—	—	—	—	—

† Order by complete type number; e.g., MCR2S22

## WCR — FILM WRAP POLYCARBONATE

### STANDARD STOCK RATINGS

Tolerance ±10%

Cap. Mfd.	100V DCW			200V DCW			Cap. Mfd.	100V DCW			200V DCW		
	†Type WCR—	Size D x L (Inches)	Lead Size	†Type WCR—	Size D x L (Inches)	Lead Size		†Type WCR—	Size D x L (Inches)	Lead Size	†Type WCR—	Size D x L (Inches)	Lead Size
.001	1D1	.200 x 1 1/16	24	2D1	.200 x 1 1/16	24	.068	1S68	.415 x 7/8	22	2S68	.485 x 1 3/16	22
.0022	1D22	.220 x 1 1/16	24	2D22	.220 x 1 1/16	24	.1	1P1	.450 x 1	22	2P1	.585 x 1 1/16	20
.0033	1D33	.260 x 1 1/16	24	2D33	.260 x 1 1/16	22	.15	1P15	.525 x 1 1/8	20	2P15	.700 x 1 1/16	18
.0047	1D47	.290 x 1 1/16	24	2D47	.290 x 1 1/16	22	.22	1P22	.590 x 1 1/8	20	2P22	.675 x 1 1/8	18
.0068	1D68	.340 x 1 1/16	24	2D68	.290 x 1 1/16	22	.33	1P33	.645 x 1 3/8	20	2P33	.815 x 1 1/8	18
.01	1S1	.235 x 3/8	24	2S1	.290 x 1 1/16	22	.47	1P47	.735 x 1 3/8	18	2P47	.950 x 1 1/8	18
.015	1S15	.245 x 3/8	24	2S15	.320 x 1 1/16	22	.68	1P68	.765 x 1 3/8	18	2P68	1.000 x 2 3/8	18
.022	1S22	.295 x 3/8	22										

### Vacuum cap adjusts over wide range



ITT, 970 McLaughlin Ave., San Jose, Calif. Phone: (408) 292-4025.

For applications where a capacitance must be fine-tuned to a fixed value, this vacuum capacitor has a sufficient range of adjustment to eliminate stocking of a variety of fixed capacitors. It is applicable for tuning cavities in the vhf and uhf bands. It has a capacity range of 3 to 30 pF. Peak test voltage is 15 kV, and at 16 MHz the current rating is 40 A rms.

Booth No. 3B49      Circle No. 318

### Temperature controllers free from RFI



Harrel, Inc., 16 Fitch St., E. Norwalk, Conn. Phone: (203) 866-2573.

Temperature controllers said to be free from RFI are entirely solid-state. Circuitry is provided to ensure that power shall always be switched both on and off when the voltage of the power source is zero.

Booth No. 3K35      Circle No. 272



after all  
the **BIG**  
talk ...

**Who Makes & Delivers  
Metal Film Resistors  
In 20 Days ???????**



# PYROFILM

## PME-50 Metal Film Resistors

- Rating: 1/20 Watt
- Tolerance: .1% to 1%
- Ohms: 10 to 1M
- Temp. Coef: T-9, T-2, T-0
- Size: .060" x .150"

## PYROFILM RESISTOR COMPANY, INC.

3 SADDLE ROAD • CEDAR KNOLLS, NEW JERSEY • 201-539-7110

ON READER-SERVICE CARD CIRCLE 146

# This new machine could probe and ink 5000 semiconductor devices during her coffee break.

See us at IEEE Booths 1G26-1G28

She's using the all-new Electroglas Model 900 Automatic Wafer Prober—the industry's most sophisticated system for probing semiconductor devices in wafer form. The Model 900 vastly improves production efficiency by testing and classifying semiconductors at speeds of 10,000 to over 20,000 devices per hour\*—automatically and with minimal operator attention.

The remarkable speed and accuracy of the Model 900 have been achieved through a proprietary technique for programming and control of the machine's X and Y axis stepping motors. Other major advances include the use of integrated circuits in 92% of the unit's electronics, a reject inking system that affects the probing rate only when inking occurs, and many exclusive operator conveniences never before incorporated in a probing system.

Over six man-years have been devoted to developing the Model 900 since Electroglas invented automatic probing in 1964. If semiconductors are your business, you should know more about our business. Write, phone or wire today—for a demonstration or a data sheet.

\*DEPENDING ON DEVICE GEOMETRY AND TESTING INTERVALS

**electroglas, inc.** 150 Constitution Drive, Menlo Park, California 94025 • Phone (415) 325-1536



ON READER-SERVICE CARD CIRCLE 147

## COMPONENTS—3RD FLOOR

### Miniature axial fan has dual-sleeve bearings

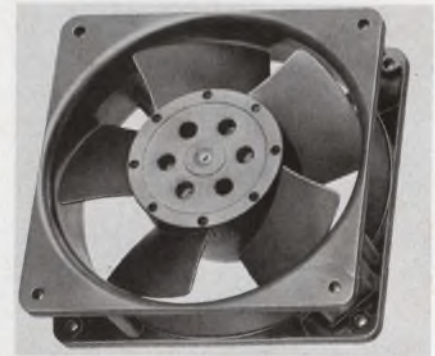

*Pamotor, Inc., 312 7th St., San Francisco, Calif. Phone: (415) 863-5440.*

Designed for 117 V, 50 to 60-Hz operation, this shaded-pole, miniature axial fan is of all-metal construction. It incorporates a broached dual-sleeve bearing system for longer and more reliable operation. In addition to having Underwriters Yellow Card Component Recognition, it offers a lubrication-free life expectancy of 20,000 operational hours, continuous duty at 55°C.

*Booth No. 3K39 Circle No. 339*

### Rheostat-potentiometers for 25- to 50-W control

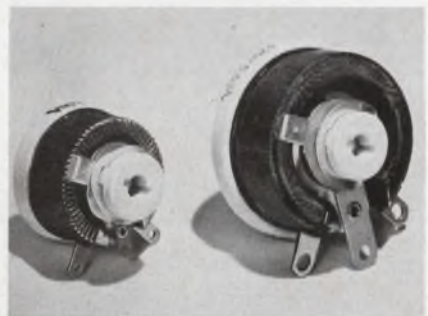

*Ward Leonard Electric Co., 87 South, Mt. Vernon, N. Y. Phone: (914) 664-1000.*

Available in 25 and 50-watt sizes, style MP, these rheostat-potentiometers feature all-ceramic construction (core, base, hub), vitreous enamel bonding, self-lubricating shoe, compact design and high-resolution action. Stocked in all popular resistance values to 5 and 10 k $\Omega$  for 25 and 50-W sizes respectively, the units are directly interchangeable with those of other manufacturers.

*Booth No. 3K04 Circle No. 360*

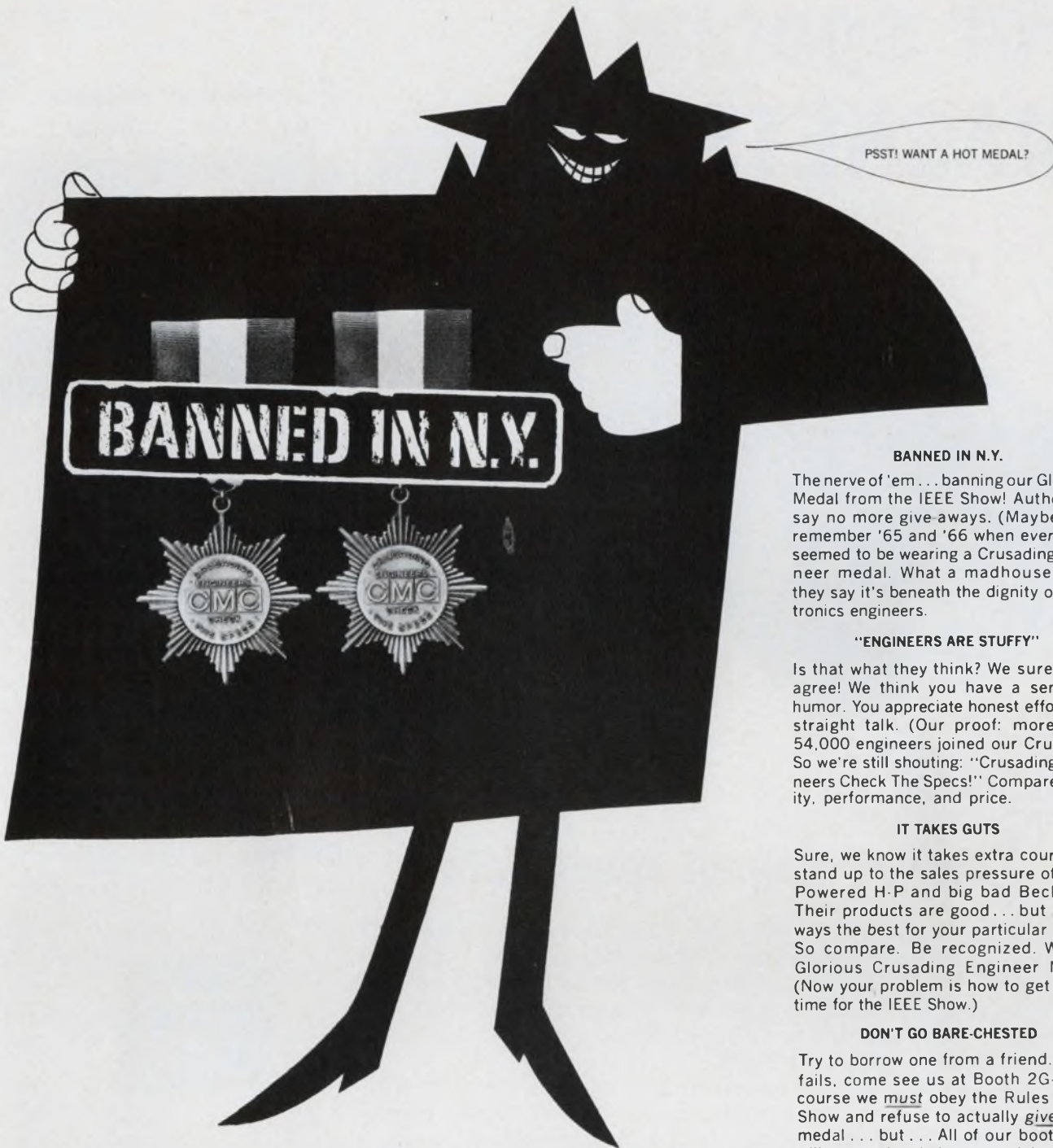

**BANNED IN N.Y.**

The nerve of 'em . . . banning our Glorious Medal from the IEEE Show! Authorities say no more give aways. (Maybe they remember '65 and '66 when everybody seemed to be wearing a Crusading Engineer medal. What a madhouse!) But they say it's beneath the dignity of electronics engineers.

**"ENGINEERS ARE STUFFY"**

Is that what they think? We sure don't agree! We think you have a sense of humor. You appreciate honest effort and straight talk. (Our proof: more than 54,000 engineers joined our Crusade.) So we're still shouting: "Crusading Engineers Check The Specs!" Compare quality, performance, and price.

**IT TAKES GUTS**

Sure, we know it takes extra courage to stand up to the sales pressure of High-Powered H-P and big bad Beckman. Their products are good . . . but not always the best for your particular needs. So compare. Be recognized. Wear a Glorious Crusading Engineer Medal. (Now your problem is how to get one in time for the IEEE Show.)

**DON'T GO BARE-CHESTED**

Try to borrow one from a friend. If that fails, come see us at Booth 2G-40. Of course we must obey the Rules of The Show and refuse to actually give you a medal . . . but . . . All of our booth staff will be wearing their own medals (loosely pinned). So if you snatch one, we won't exactly chase you down the aisles.

**NO-SHOW?**

Can't fly to New York this time? You still can get a medal. Just write us. We'll mail you a medal, and a new condensed catalog so you can earn your medal by checking specs.

Then, next time you talk to an H-P or Beckman salesman, wear your medal. You'll see grown men cry.

12982 Bradley/San Fernando, California  
Ph. (213) 367-2161/TWX 910-496-1487



VISIT BOOTH 2G-40: See counters, timers, printers, systems, Rutherford pulse and time delay generators, target simulators, surprises.  
COMPUTER MEASUREMENTS COMPANY IS A LEADING DESIGNER AND MANUFACTURER OF ELECTRONIC INSTRUMENTATION TO COUNT, MEASURE, AND CONTROL.

ON READER-SERVICE CARD CIRCLE 148

# For special MAGNETS

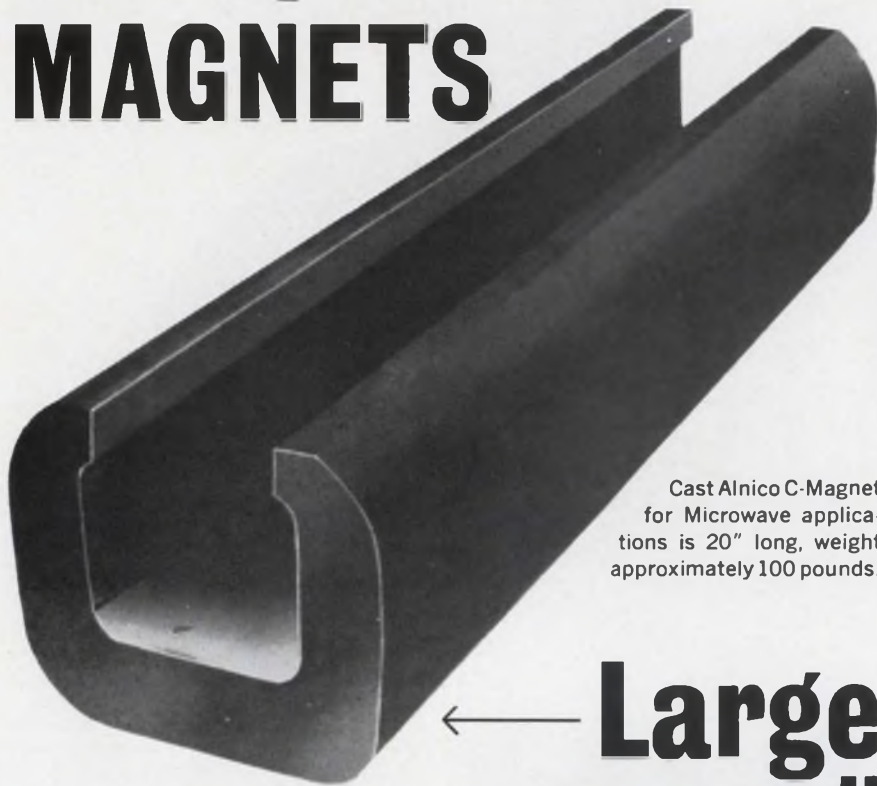

Cast Alnico C-Magnet for Microwave applications is 20" long, weight approximately 100 pounds.

**Large  
or small**

Actual size of cast Alnico magnet used for filter and reed switch applications . . .  $\frac{1}{2}$ " x  $\frac{1}{16}$ " x  $\frac{3}{16}$ " long.

*call on magnet specialists*

Magnetism has become a highly specialized field. New permanent magnet materials with precisely controlled magnetic properties are constantly being developed. Applications for permanent magnets are becoming more sophisticated. And design engineers are taking a long, hard look at permanent magnets from a value analysis standpoint. It takes a magnet specialist.

Thomas & Skinner has specialized in magnetic materials for over 60 years. T & S engineers have pioneered in developing many innovations in magnetic materials, shapes and applications. One of these, for example, is the recently-introduced Alnico 9. T & S engineering is available in design and development to suit any specific application.

Let Thomas & Skinner help solve your magnet problems, large or small, unique or ordinary.



Write for Bulletin M-304, Metallic Alloy Permanent Magnets, which gives characteristics and energy product curves for all Thomas & Skinner magnetic materials.

VISIT BOOTH 3K45, IEEE '67

Mr. Magnetician, symbol of over 60 years T & S experience in the field of magnetics.

**Thomas & Skinner, Inc.**

1120 East 23rd Street, Indianapolis, Indiana 46207

Phone 317-923-2501

ON READER-SERVICE CARD CIRCLE 149



COMPONENTS—3RD FLOOR

## PC transistor sockets only 1¢ per contact

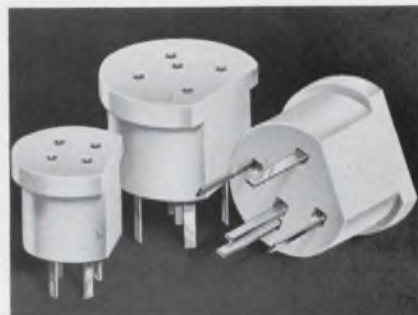

Industrial Electronic Hardware Corp., 109 Prince St., New York. Phone: (212) 677-1881. Price: 1¢ per contact.

PC transistor sockets are available for JEDEC transistor bases TO-5, TO-9, TO-11, TO-12, TO-33, TO-39 and TO-40. Another series will accept transistor bases TO-18, TO-46, TO-52, and TO-72. Both sockets feature restricted entry, which assures proper alignment and the elimination of damage to transistor leads.

Booth No. 3A32 Circle No. 373

## Differential amplifier accepts nanoamp input



Burr-Brown Research Corp., International Airport Industrial Pk., Tucson, Ariz. Phone: (602) 294-1431. P&A: \$125 (1 to 9); stock to 4 wks.

Input currents well down into the nanoamp range are feasible with this op-amp. Output currents range up to  $\pm 10$  mA (50 mA with optional booster). Maximum amplifier voltage is  $\pm 10$  V. Output current can be used to drive motor coils, galvanometers or deflection coils where the output is used for display or steering purposes. Gain is 100 dB and bandwidth is 1.5 MHz.

Booth No. 3A26 Circle No. 508

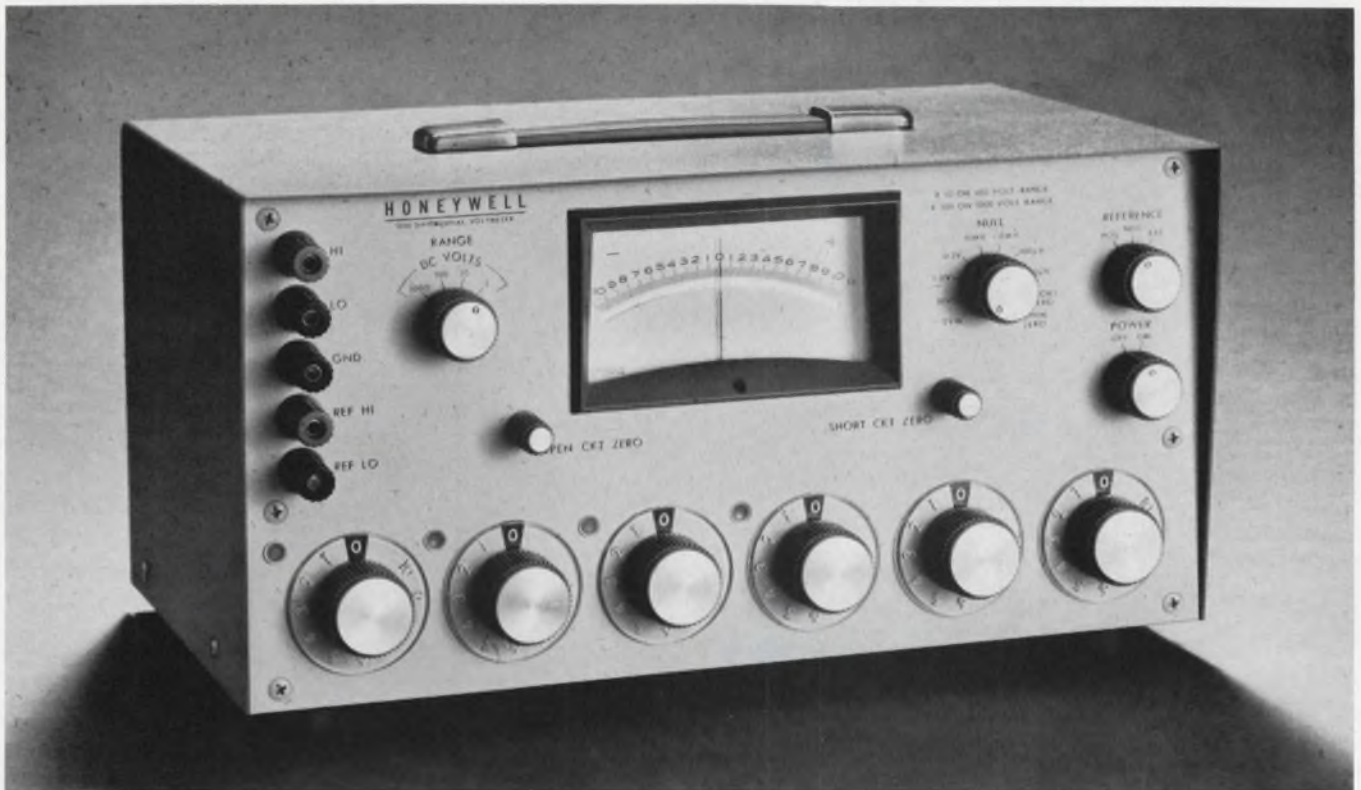

## Honeywell's new 5 in 1 Instrumentation Package:

own this Model 1000 Differential Voltmeter, and you also own a Differential Ratiometer, a Decade Voltage Divider, a Precision Voltage Reference Source, and an Electronic Null Detector!

Here's the most versatile single instrument any lab can own — five essential measuring functions combined in one neat, fully portable package! Let's look at the new Honeywell Model 1000, function by function.

As a **Precision Differential Voltmeter**, the Model 1000 provides  $\pm 0.0025\%$  accurate measurements to your DC signals. And you get 7 digit resolution from 6 decades with 10% overrange (also eliminates time consuming dial manipulation). Potentiometric input impedance to 11V provides errorless measurements to standard cells or high source impedance signals. Polarity is reversible from the front panel.

As a **Differential Ratiometer**, the 1000 gives you precise DC ratio measurements with  $\pm 0.001\%$  accuracy. External reference signal level may range up to

$\pm 100$  VDC. All Voltmeter mode convenience features are applicable when the 1000 is used as a Ratiometer.

As a **Decade Voltage Divider**, the 1000's precision, 6 decade Kelvin-Varley divider network gives accurate voltage level divisions to  $\pm 0.001\%$ . AC power not required in this mode.

As a **Precision Voltage Reference Source**, calibrated voltage levels of 6 digit resolution are provided at the 1000's rear panel. Output levels are selected by front panel dials. Levels vary from 0 to 11 VDC, and may be used for calibration of potentiometric instrumentation. Accuracy:  $\pm 0.0025\%$ .

As an **Electronic Null Detector**, the 1000 offers high sensitivity for use with balance type instrumentation or other circuitry. Silicon field effect transistors eliminate electro-mechanical choppers and assure drift-free operation. Changes as minute as 10 nanovolts or an input current of  $10^{-15}$  amperes may be detected.

**Other features** of this versatile instrument include: complete cancellation of common mode, standoff voltages; high superimposed noise rejection; Zener reference supply with 2-3 ppm stability; 4 full-scale ranges of 1, 10, 100, and 1000 VDC; ratio ranges of 1:1, 10:1, and 100:1; recorder outputs on rear panel, and silicon solid-state circuitry throughout. Ask your Honeywell Representative for a demonstration of the Model 1000, or mail coupon for literature.

Honeywell, Test Instruments Div.  
Denver, Colorado 80217

12-3

Please send Model 1000 Literature to:

Name \_\_\_\_\_  
Company \_\_\_\_\_  
Address \_\_\_\_\_  
City \_\_\_\_\_ State \_\_\_\_\_ Zip \_\_\_\_\_

LABORATORY STANDARDS  
**Honeywell**

HONEYWELL IS WORLDWIDE · Sales and service offices in all principal cities of the world. Manufacturing in Brazil, Canada, France, Germany, Japan, Mexico, Netherlands, United Kingdom, United States.

ON READER-SERVICE CARD CIRCLE 150

# 1 MHZ CAPACITANCE TESTER

COMPONENTS—3RD FLOOR



MODEL 1201DS \$1995

## ...with digital readout and bridge accuracy!

The Micro Instrument Model 1201DS Capacitance Tester measures capacitance values to 1000 picofarads with an absolute accuracy of  $1/2\%$  of reading and with a resolution of 0.01 picofarads. Coupled with this accuracy is an ease of operation that allows an untrained operator to test 1200 components per hour. And the Model 1201DS is fast — readout time is 0.5 seconds, as is the display time of the four-digit, in-line Nixie® readout.

Versatility is another feature of the 1201DS — its BCD output drives printers and other data loggers.

Other outstanding features of the Model 1201DS are:

- Signal level — less than 35mv rms
- Shunt resistance — no accuracy loss for 10K ohms or greater
- Bias — internal to 100v; external to 300v
- Optional transistor jig for Cob and Cib measurements
- Guarded front panel terminals for direct and 3-terminal measurements

**ADD THIS OPTION FOR PRODUCTION LINE TESTING:** The Model 6001 Go-No/Go Comparator allows selection of minimum and maximum limits, with no loss of basic instrument accuracy, by four-digit thumbwheel switches. Low, accept, and high readout lights are provided. Several Model 6001's may be stacked to allow simultaneous sorting to several tolerances. Price: \$695 each.



For capacitance testers from 120 Hz to 1 MHz, depend upon Micro Instrument Company. Write today for complete technical specifications on both the Model 1201DS and Model 6001. Also available is a four-page technical brochure — "The Theory and Applications of Capacitance Measurements."



12901 CRENSHAW BLVD., HAWTHORNE, CALIFORNIA 90250

TELEPHONES: (213) 679-8237 & 772-1275

"VISIT OUR BOOTH #2J11 AT IEEE"

ON READER-SERVICE CARD CIRCLE 151

## RF connectors field-serviceable



Star-tronics, Georgetown, Mass.  
Phone: (617) 352-2741.

Supplied as integral assemblies which cannot be disassembled, these RF connectors permit field repair of RF cables, being easily removed and reused many times. No special tools are required and cable preparation is reduced to a single operation, which is the same for both the plug and jack ends. Soldering is also eliminated, thus removing the cause of dielectric distortion common to solderable assemblies.

Booth No. 3B37 Circle No. 336

## Toroidal transformers mount PC boards

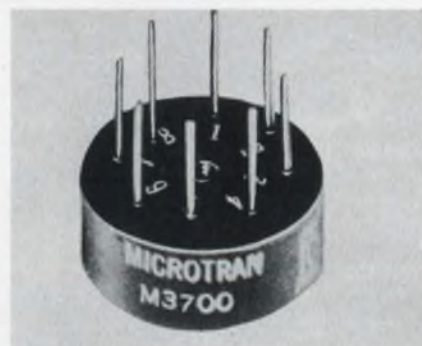

Microtran Co., Inc. 145 E. Mineola Ave., Valley Stream, N. Y. Phone: (516) 561-6050.

Toroidal power transformers (400 Hz) are designed for low-voltage silicon rectifier power supply and isolation applications for transistorized equipment. Stocked items are available with 28, 56 or 115-V secondary ratings with 115-V primaries in both 9 and 20-VA capacities. Units are of printed-circuit construction.

Booth No. 3B22 Circle No. 346



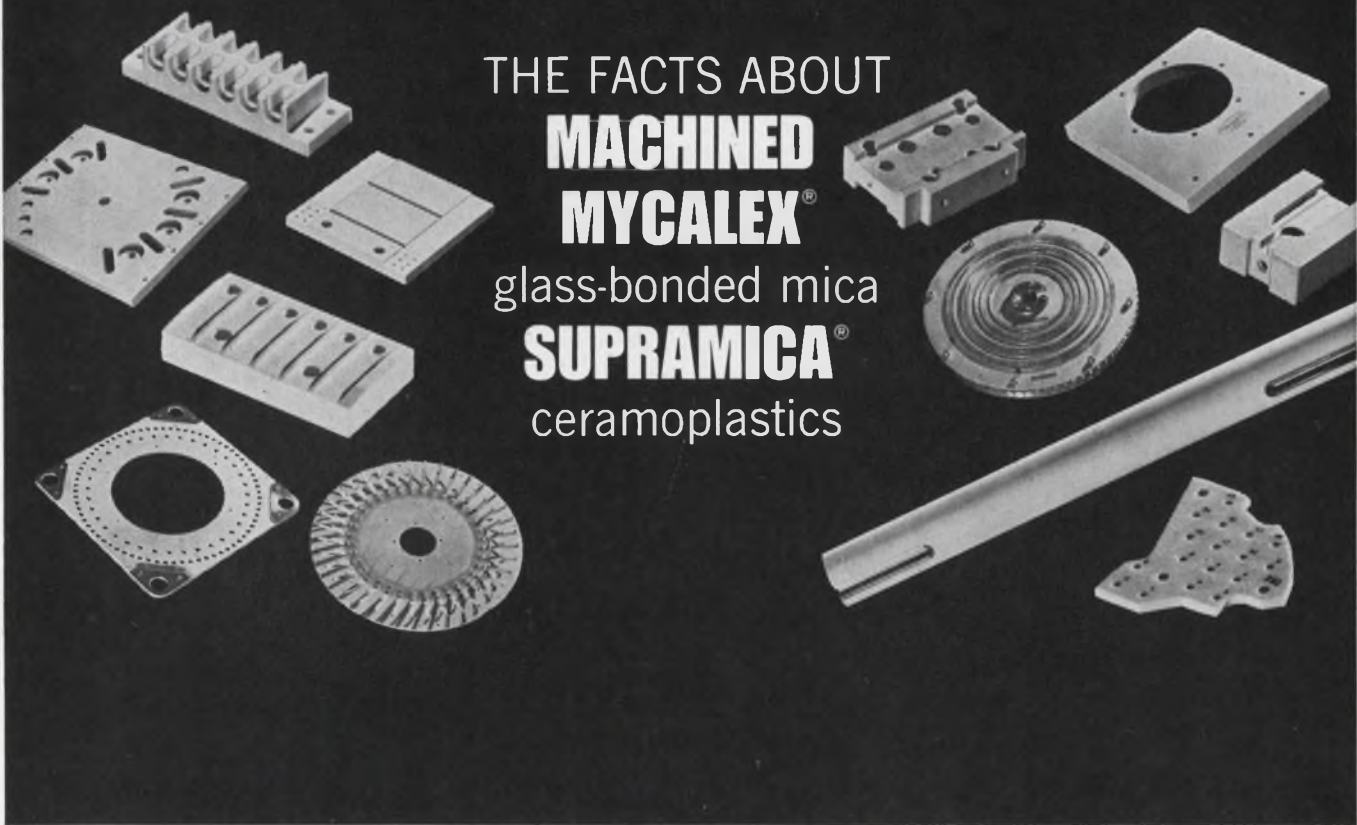
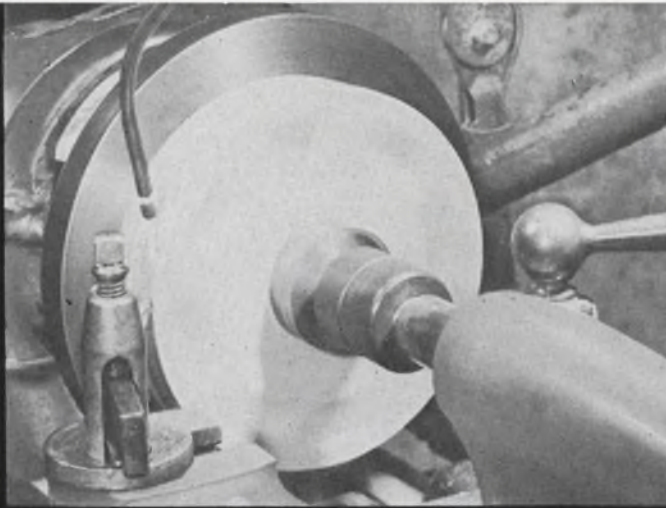

THE FACTS ABOUT  
**MACHINED**  
**MYCALEX<sup>®</sup>**  
 glass-bonded mica  
**SUPRAMICA<sup>®</sup>**  
 ceramoplastics

Precision-fabricated MYCALEX glass-bonded mica and SUPRAMICA ceramoplastics are exclusive products of the Mycalex Corporation of America. These materials are available in machined component form solely from Mycalex Corporation of America.

This insures the user of maximum quality, lowest cost and speediest deliveries. For nearly a half century we have been developing the skills and techniques for the manufacture of complex, close toleranced MYCALEX and SUPRAMICA components. These facts coupled with our intimate knowledge of our own formulations gives the application the ultimate in technical know how.

**MATERIAL CHARACTERISTICS**

The MYCALEX glass-bonded mica and SUPRAMICA ceramoplastics used in precision fabrication are formulated

for the most advantageous machining conditions as well as the electrical, mechanical and physical properties which are unique in these materials.

**FABRICATING FACILITIES AND SERVICES**

The combination of specialized equipment, proven techniques, and experienced personnel makes Mycalex Corporation of America your outstanding source for fabricated parts — on a production or experimental basis.

We are prepared to estimate, without cost or obligation, from your prints . . . or to offer suggestions for practical fabricating techniques which will meet your requirements.



**MYCALEX**  
 CORPORATION OF AMERICA  
 125 Clifton Boulevard, Clifton, New Jersey

ON READER-SERVICE CARD CIRCLE 152

# REED RELAYS

ENGINEERED FOR  
TROUBLE FREE, LONG LIFE

COMPETITIVELY PRICED

Computer Components manufactures from standard size thru micro-miniature size for every exacting application. Critical standards are maintained and complete testing procedures are utilized to insure a quality product. All standard relays can be supplied at an accelerated delivery schedule and if required, will meet all applicable portions of MIL-R-5757D.



#### PC SERIES — STANDARD

Available up to 6 pole normally open and 6 pole double throw.



#### MPC SERIES — MINIATURE

Available up to 4 pole normally open and double pole double throw.

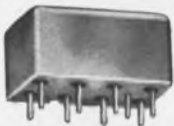

#### MG SERIES — MICRO MINIATURE

(1/2 size crystal can relay)  
Available up to 2 pole normally open and double pole double throw.

All relays are supplied magnetically shielded and epoxy filled. Optional features are as follows:

- Magnetic and Electromagnetic latching
- Bifilar Windings
- Electrostatic shielding
- Pin locations to match existing printed wiring boards

For additional information write for our detailed catalog or contact our Sales Engineering Representative in your area.



**COMPUTER COMPONENTS**  
INCORPORATED

88-06 Van Wyck Expressway  
Jamaica, New York  
212-AX 1-3500

## COMPONENTS—3RD FLOOR

### Microwave mixers with replaceable diodes



Sage Laboratories, Inc., 3 Huron Dr., Natick, Mass. Phone: (617) 653-0844. P&A: \$250 (dual-output), \$225 (single-output); stock to 30 days.

Eight models have been added to a line of miniature microwave balanced mixers. The line covers 1 to 4 GHz in two bands and has replaceable diodes in each band. Dual and single IF outputs are available with 1/4-36 connectors or solder lugs. Typical vswr is 1.3 and minimum isolation is 8 dB for all models. Noise figure is typically 8 dB from 1 to 2 GHz and 8.5 dB from 2 to 4 GHz with point contact diodes.

Booth No. 3K32 Circle No. 335

### Dual-in-line cards added to logic line

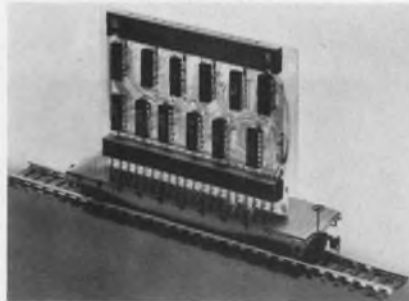

Monitor Systems Inc., Ft. Washington, Pa. Phone: (215) 646-8100.

Dual in-line diode-transistor logic and transistor-transistor logic IC circuit cards have top-mounted test points, and gold-plated spring-pin connectors. The cards are designed to fit into the manufacturer's Monipak files, which hold 16 to 32 cards each, depending on the model.

Booth No. 3A21 Circle No. 382

### Miniature relays for plug-in or PC board

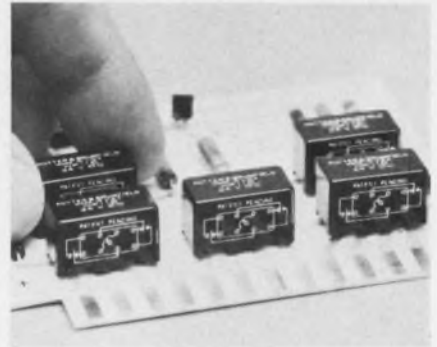

Potter & Brunfield, Div. of American Machine & Foundry Co., Princeton, Ind. Phone: (812) 385-5251. P&A: about \$10; stock.

Relays weighing only 0.3 oz fit into cases 1/2 the size used for small crystals. They have a high-impact dust cover, and are suitable for plug-in or PC board soldering, with terminals arranged on an 0.200-in. grid. The relays are intended for commercial applications, and have dpdt gold-plated silver contacts. Coils are rated for continuous duty with an operate time of 5 ms max, and a release time of 3 ms max. They are available at coil voltages of 6, 12, 24, 36 and 48 V.

Booth No. 3G14 Circle No. 328

### Ac power controller is solid-state, continuous



Semi-Elements, Inc., Saxonburg Blvd., Saxonburg, Pa. Phone: (412) 352-1548. Price: \$17.50.

Stepless control of ac power is achieved with a solid-state unit. The controller can replace the more expensive variable voltage transformers. Ac output voltage can be varied from 0 to 98% of input voltage. The brushless unit is operable at distances up to 50 feet by means of a flexible cord and control dial.

Booth No. 3J17 Circle No. 359

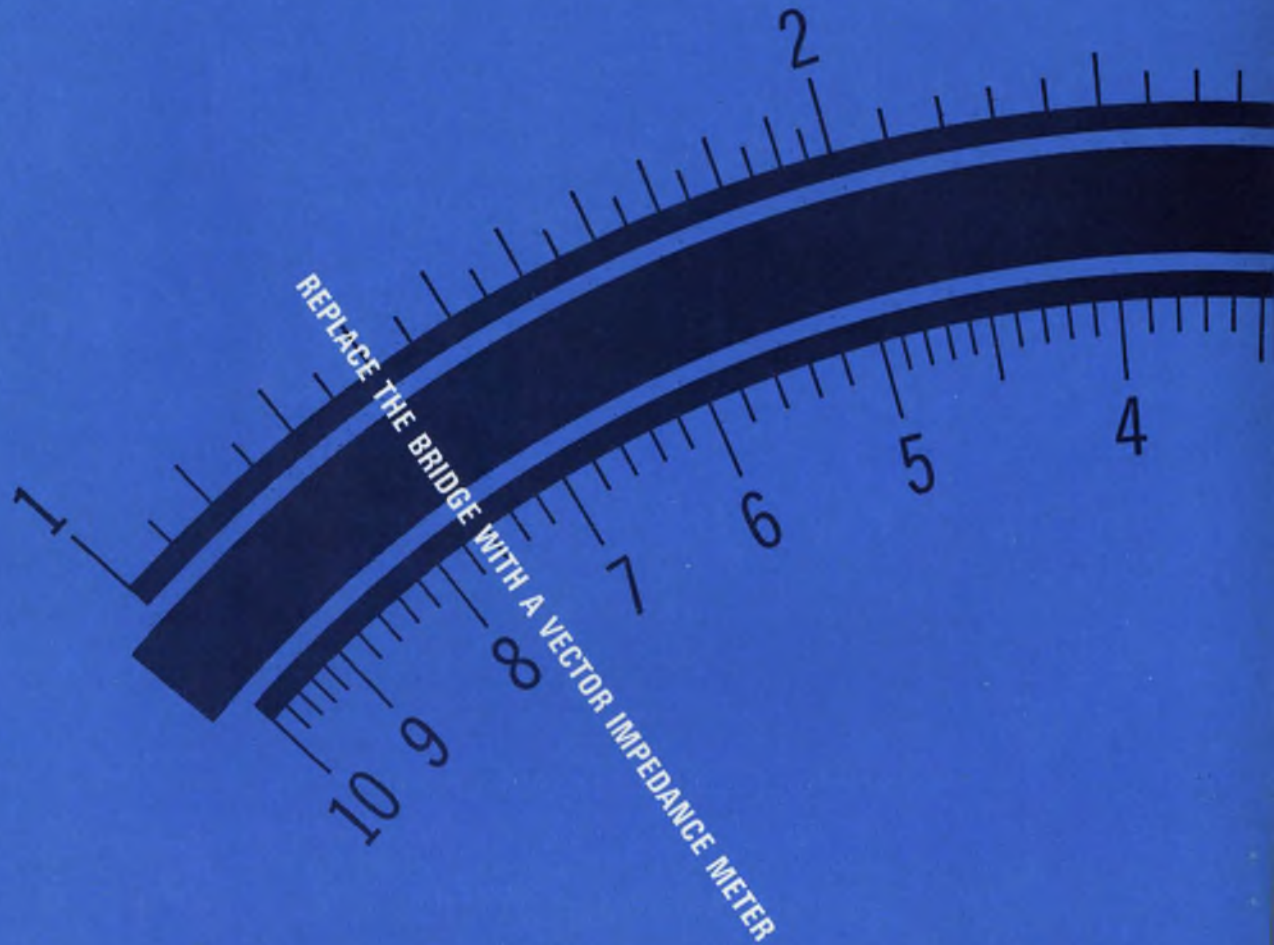

## *Vector Impedance Meter makes measurements in seconds*



### **MODEL 4815A OFFERS DIRECT READOUT OF HIGH FREQUENCIES IN OPERATING CIRCUITS**

The 4815A offers direct readout of impedance and phase angle measurements from 500 kHz to 108 MHz with continuous tuning. Probe on five-foot cable simplifies in-circuit measurements. Price: \$2,650.00. Complete specifications are yours on request.

Now there's no excuse for not making all the impedance measurements that previously have been too bothersome to make. The Hewlett-Packard 4800A Impedance Meter eliminates bridge balancing and nulling. It does for AC measurement what the ohmmeter does for DC testing. Just plug it in and read it. The 4800A may be mechanically swept to produce measurements over its full frequency range. You get direct readings of impedance and phase angle from 5 Hz to 500 kHz. Analog outputs of frequency, impedance and phase are available for X-Y recording.

The 4800A is an all solid-state integrated vector impedance *system* that reads out directly in  $Z$  and  $\theta$ . Low-level signal strength prevents overloading of the test component. Price: \$1,490.00. For complete specifications, contact your local Hewlett-Packard field engineer or write: Hewlett-Packard, Green Pond Road, Rockaway, N.J. 07866.

**HEWLETT**  **PACKARD**  
measuring instruments  
for science and industry

**off-  
-the-  
shelf**

**BERLOX®**

**TRANSISTOR  
HEAT SINKS**

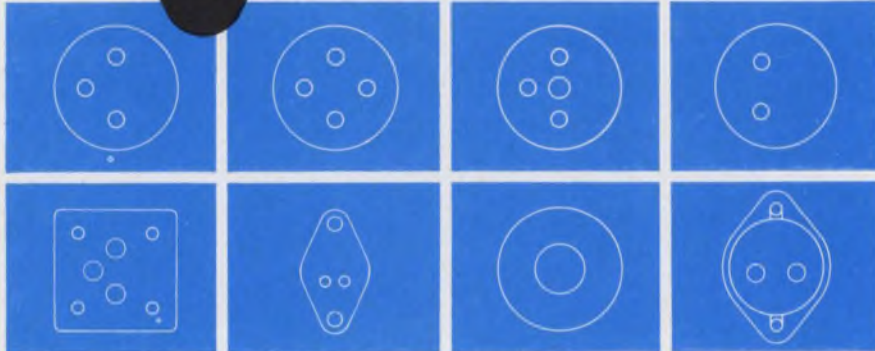

The standard "Off the Shelf" line of Berlox® beryllium oxide heat sinks are available in: Jeced-TO Numbers -3 through -66. DO Numbers -4 & -5. MT Numbers -1 through -14. Standard thicknesses 1/32" & 1/16"; others upon request. **Properties include:** Thermal conductivity equal to aluminum metals / High resistivity — low dielectric loss / Resists shock, vibration and moisture  
Send for new illustrated Heat Sink Brochure 267.  
See us at Booth 4J29 — IEEE Show

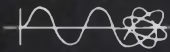

**NATIONAL BERYLLIA CORPORATION**

Haskell, New Jersey 07420

ON READER-SERVICE CARD CIRCLE 153

**SAMPLE AND  
HOLDHOLDHOLDHOLDHOLDHOLDHOLD  
HOLDHOLDHOLDHOLDHOLDHOLDHOLD  
HOLDHOLDHOLDHOLDHOLDHOLDHOLD  
HOLDHOLDHOLDHOLDHOLDHOLDHOLD  
HOLDHOLDHOLDHOLDHOLDHOLDHOLD  
HOLDHOLDHOLDHOLDHOLDHOLDHOLD  
HOLDHOLDHOLDHOLDHOLDHOLDHOLD  
HOLDHOLDHOLDHOLDHOLDHOLDHOLD  
HOLDHOLDHOLDHOLDHOLDHOLDHOLD  
HOLDHOLDHOLDHOLDHOLDHOLDHOLD**



**ANALOG CONTROL SIGNALS**

PD & C's new Model 102 Analog Memory Device makes continuous, trouble-free operation of process control a practical, economical reality. When a disruption of incoming data occurs, Model 102 retains the last valid signal to within 1% for over an hour, permitting service to be maintained until the input can be restored. Eliminates costly downtime and maintenance interruptions.

*Find out more today.*



**PACIFIC DATA  
& CONTROLS**

1476 Oddstadt Drive • Redwood City, California 94063

ON READER-SERVICE CARD CIRCLE 154

**Tantalum capacitor stacks up small**

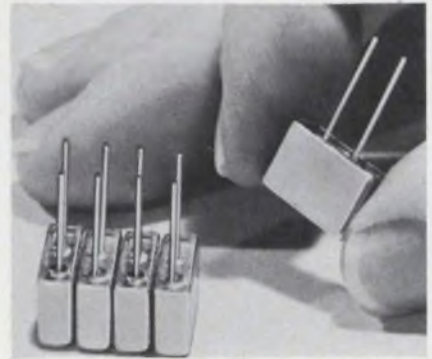

*Union Carbide Corp., Electronics Div., 270 Park Ave., New York. Phone: (212) 551-3105.*

Solid tantalum capacitors are so compact in shape that 14 of them can be stacked in less than 1 cubic inch. The F-Series polar capacitor starts as a high-purity slab (rectangular) anode, fitting tightly into a metal case that is hermetically sealed to an all-metal top. Working voltages are 6, 10, 15, 25, 35 and 50. Each capacitor has solder-coated Kovar wire leads spaced 0.2-in. apart to fit PC boards. The glass seal eliminates the problem of destroying hermeticity during wave-soldering.

*Booth No. 3J06 Circle No. 371*

**Cermet trimmer mounts vertical or horizontal**

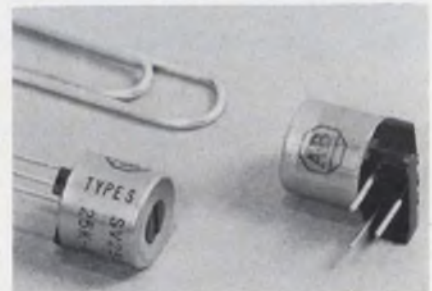

*Allen-Bradley Co., 1201 S. 2nd St., Milwaukee. Phone: (414) 671-2000.*

A cermet trimmer for vertical or horizontal mounting is rated at 1/2 W at 85 C, derated to 0 at 150°C. It has a continuous dc working voltage of 300. It is available in a range of resistance values from 50 Ω to 1 MΩ in tolerances of ±5%, ±10% and ±20%. It is designed to exceed requirements of MIL-R-23285A.

*Booth No. 3K42 Circle No. 334*

Think  
vertically.

Get your  
functional  
circuit  
designs  
stacked  
in a  
MicroCircuit  
Pack™...  
ready to  
mount.

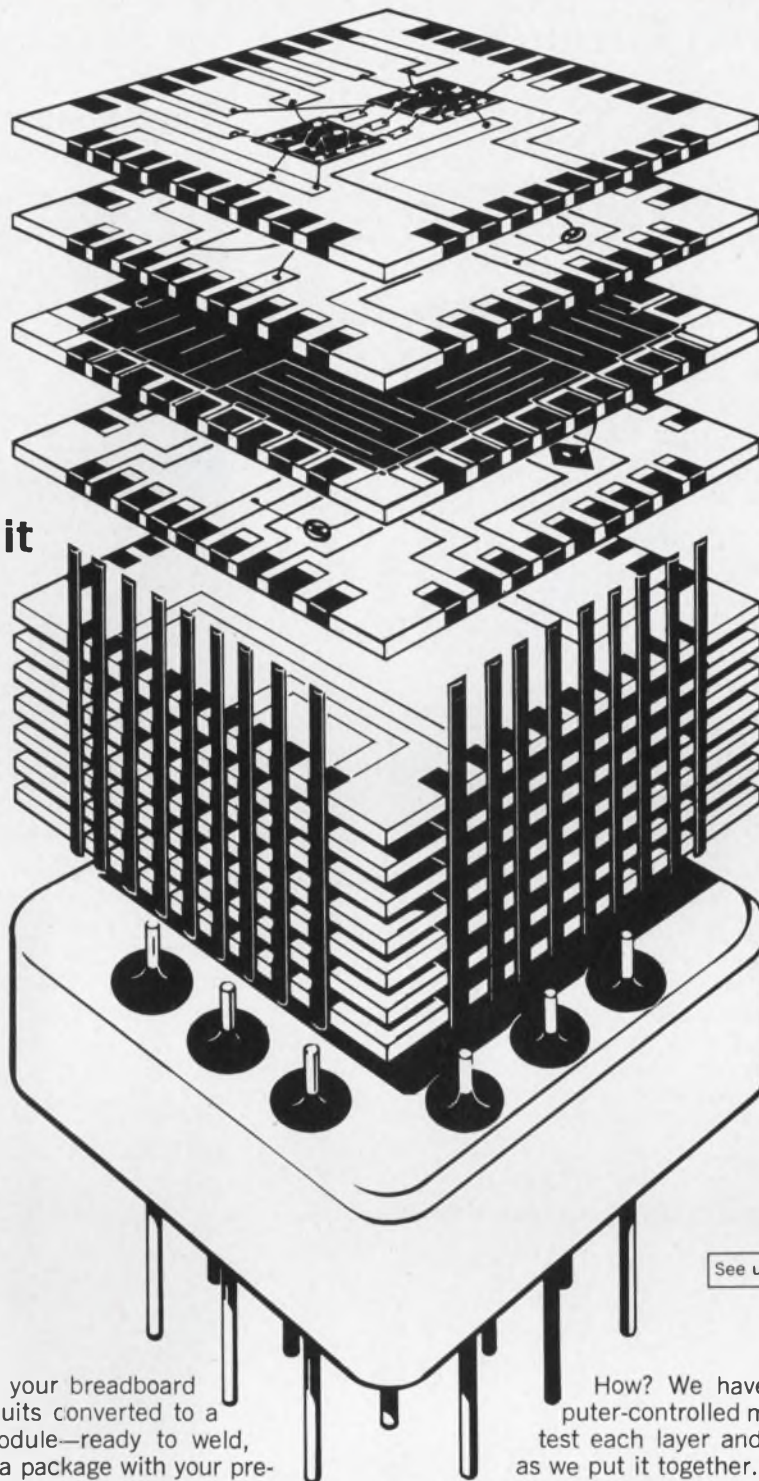

See us at IEEE Booths 4F26, 28 and 30

Wouldn't you like to see your breadboard model of functional circuits converted to a fully microelectronic module—ready to weld, solder, or plug in? Want a package with your preferred mix of semi-conductors, monolithic integrated circuits, thin-film and discrete devices ready to perform a number of system functions, either analog or digital—one that combines all the advantages of vertical, multilayer stacking, welded interconnections, hermetically-sealed enclosure, and uniform modular assembly?

That's no pipe dream with Hamilton Standard's MicroCircuit Pack technology. We can deliver a custom-built module of up to 15 ceramic wafers, pretested to meet your design, in either evaluation or production quantities. And it will cost far less than you would think.



Actual size

How? We have developed flexible, computer-controlled methods of manufacture. We test each layer and each module step-by-step as we put it together. And we use electron-beam scribing, welding and sealing under ultraclean vacuum conditions. Results? Your packaged module is strong and reliable, will resist moisture and radiation, and will operate over a wide temperature range.

Whatever your system requirements might be, investigate going to MicroCircuit Packs direct. Consider all the in-between expenses you can save. For more information, price quotations, or assistance in component selection and system layout, contact the Marketing Manager, Electronics Department, Hamilton Standard, Windsor Locks, Conn., 06096. Phone (203) 623-1621, ext. 2012. TWX 710-420-0586.

**Hamilton Standard** DIVISION OF UNITED AIRCRAFT CORPORATION  
WINDSOR LOCKS, CONNECTICUT

U  
A

ON READER-SERVICE CARD CIRCLE 155

ANOTHER FABRICATING SERVICE FROM



# ALL TYPES OF ALUMINUM ENCLOSURES

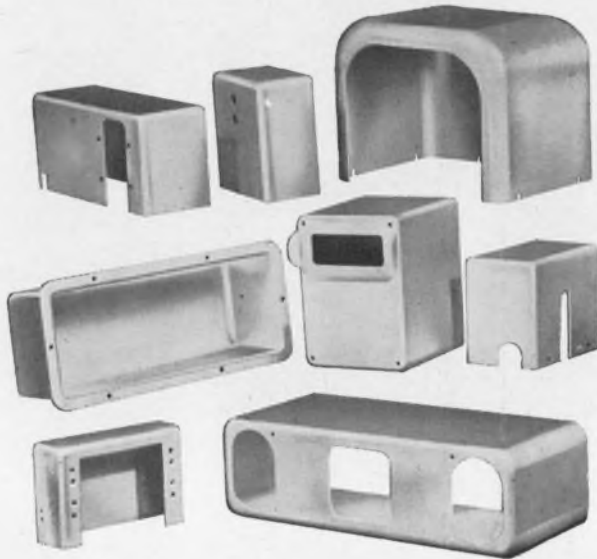

For over fifty years, American Aluminum Company has fabricated all types of aluminum enclosures for the electronics industry.

Today's need for lightweight enclosures are great and American Aluminum's vast facilities can provide many sizes and shapes to fill your specific requirements.

May we quote your next enclosure need? You'll find our services rapid, precise, and dependable. Immediate attention, with emphasis on quality and reliability will be given.

## OTHER PRODUCTS & SERVICES OF AMERICAN ALUMINUM

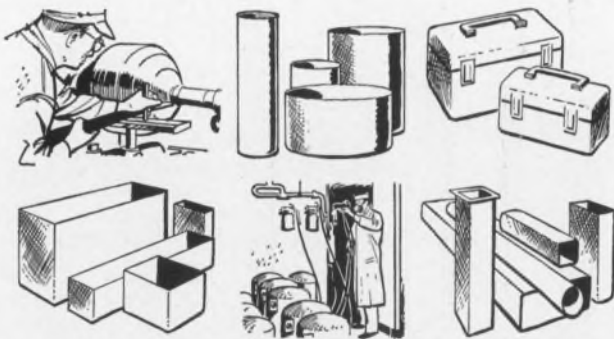

### SPECIALISTS IN CONTRACT MANUFACTURING OF ALUMINUM

COMPLETE FABRICATING FACILITIES FOR DEEP DRAWING, HEAT TREATING, SPINNING, ASSEMBLY, SHEET METAL, STAMPINGS, ANODIZING, WELDING, FINISHING.

Send for brochure "Aluminum Fabricating For Industry"



## AMERICAN ALUMINUM COMPANY

Manufacturers of Aluminum Products for Industry since 1910

230 Sheffield St. • Mountainside, N. J. • 201-233-3500

ON READER-SERVICE CARD CIRCLE 156

COMPONENTS—3RD FLOOR

## Ceramic planar triodes for TACAN and DME

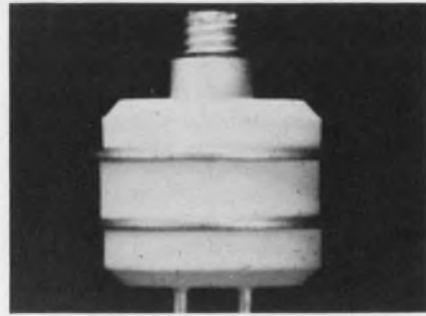

General Electric, 2100 Gardiner Lane, Louisville, Ky. Phone: (502) 459-4323.

Four new ceramic planar triodes for application in airborne micro-TACAN and DME equipments are available. The tubes are being designed into the amplifier chains of a new generation of TACAN and DME equipments. Three are intended for the low-level, high-gain stages, the intermediate driver, or output stage, the output stage, and one serves all of these functions in the lower powered commercial and private aircraft designs.

Booth No. 3E01 Circle No. 381

## Feed-thru terminal blocks for PC or wiring

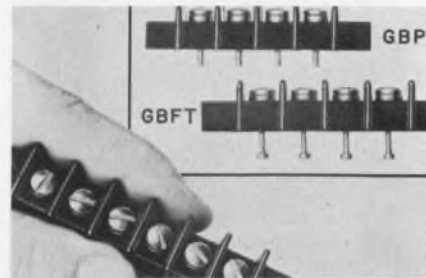

Curtis Development & Mfg. Co., 3250 N. 33rd St., Milwaukee. Phone: (414) 445-1817.

Flat-base, feed-thru terminal blocks, with a choice of printed circuit pins or turret-type solder terminals for internal connections are offered. The molded black thermoset phenolic blocks with 7/16-in. center-to-center terminal spacing are available with 1 to 18 terminals per block. The tinned screw machine inserts have #6-32 terminal screws for external connections of up to #12 AWG wire.

Booth No. 3K15 Circle No. 333

# IEC REDUCED THE CUSTOMER'S COST \$.87 PER BOARD



## ...ON THIS STEREO PREAMPLIFIER

We supplied 4 NPN Silicon planar transistors (2N3391A type), 4 miniature aluminum electrolytic capacitors, 6 sub-miniature polyester film capacitors and 2 metalized mylar capacitors at a cost of \$1.63 per board (production quantities). Our customer had been paying \$2.50 per board for these same components.

IEC's world-wide manufacturing facilities allow us to offer quality components of guaranteed reliability at extremely competitive prices. Let us quote on your circuit Board Component requirements.

IEC can supply complete printed circuit boards with components to meet your specifications.

*see IEC / BOOTH 4H24 / at the IEEE SHOW*

or write to components division:



**INTERNATIONAL ELECTRONICS CORPORATION**  
MELVILLE, L. I., N. Y., 11746 • TEL. 516-694-7700 • TWX 212-479-9410

Your most reliable source for components

ON READER-SERVICE CARD CIRCLE 157

# NEED A 3000 VOLT ZENER DIODE?

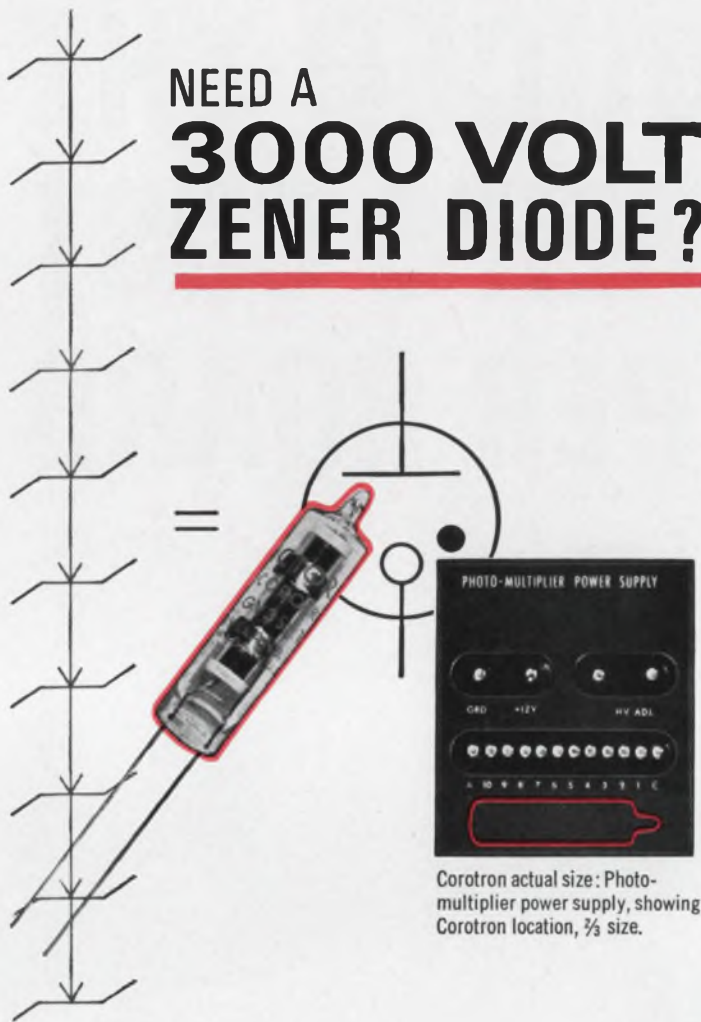

Corotron actual size: Photo-multiplier power supply, showing Corotron location,  $\frac{2}{3}$  size.

You could string together several hundred zeners. Or you could specify one Victoreen Corotron. It is the gaseous equivalent of the zener with all the advantages of an ideal HV zener diode.

For space research and other rugged applications requiring absolute power supply stability, GV3S Series, shown, provide the ideal reference voltage anywhere in the range of 400 to 3000 volts. They enable circuitry to maintain constant high voltage regardless of battery source voltage or load current variations. Cubage and weight (GV3S Corotron weighs only 4 gm.) are important considerations. So is temperature variation (Corotrons operate from 200°C down to -65°C). Ruggedized versions withstand shock to 2000 G, vibration 10 to 2000 cps.

If you're trying to simplify circuits . . . to cut cost, size and weight . . . to upgrade performance—you need Corotron high voltage regulators. Models are available now from 400 to 30,000 volts. A consultation with our Applications Engineering Dept. will speed up the countdown.

8501-A



**Components Division**

**THE VICTOREEN INSTRUMENT COMPANY**

**10101 WOODLAND AVENUE • CLEVELAND, OHIO 44104**

EUROPEAN SALES OFFICE: GROVE HOUSE, LONDON RD., ISLEWORTH, MIDDLESEX, ENGLAND  
ON READER-SERVICE CARD CIRCLE 179

## Pushbutton switches for low-current use

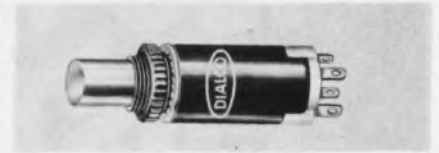

Dialight Corp., 60 Stewart Ave., Brooklyn, N.Y. Phone: (212) 497-7600. Price: from \$1.11 (1000).

Pushbutton switches designed for computer and data processing equipment claim a life rating of one million operations. They are useful for dry circuits or with low currents at higher voltages. Lighted switches use permanently mounted T-2 neon lamps with or without the current-limiting resistor.

Booth No. 3H14 Circle No. 380

## IC logic cards are voltage-decoupled

Datascan, Inc., 1111 Paulison Ave., Clifton, N. J. Phone: (201) 773-8803.

Complete voltage decoupling on IC logic cards is accomplished through the use of an emitter-follower driven by a highly regulated, low-ripple power supply. Capacitive decoupling on each board permits power supply bussing without detrimental power loss or noise generation. The logic cards have test points located at all convenient circuit nodes where oscilloscope display is required.

Booth No. 3A14 Circle No. 361

## X-Y positioner for welding and soldering

Hughes Aircraft Co., Welder Dept., 2020 Oceanside Blvd., Oceanside, Calif. Phone: (714) 722-2101.

Positioners, consisting of precision slide tables for positioning material in both X and Y axes, are designed for production welding and soldering. The systems are modular in design so that compatible subsystems can be combined into several standard configurations of complete working stations.

Booth No. 3A48 Circle No. 362



# The Unbeatable IC System:

**Your logic design and Raytheon Computer modules and hardware.**

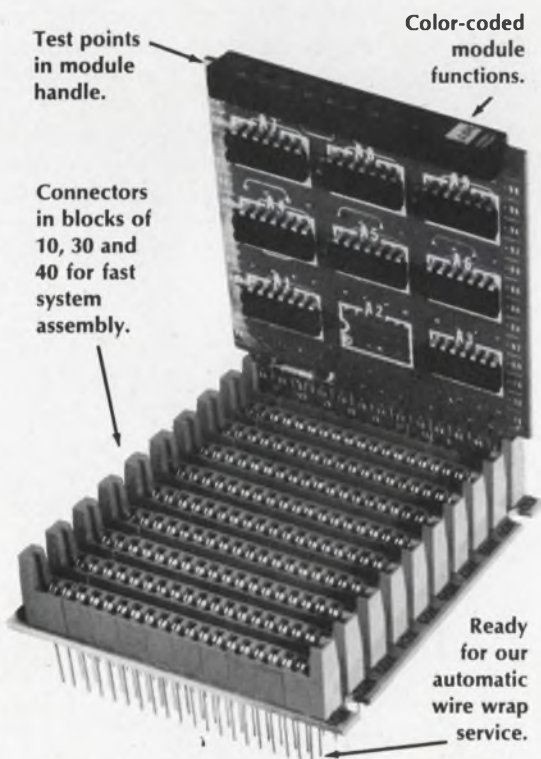

Laminated power bus bars installed and wired in each module case. Reduces noise, eliminates power inter-connections, cuts hours from assembly and test time.

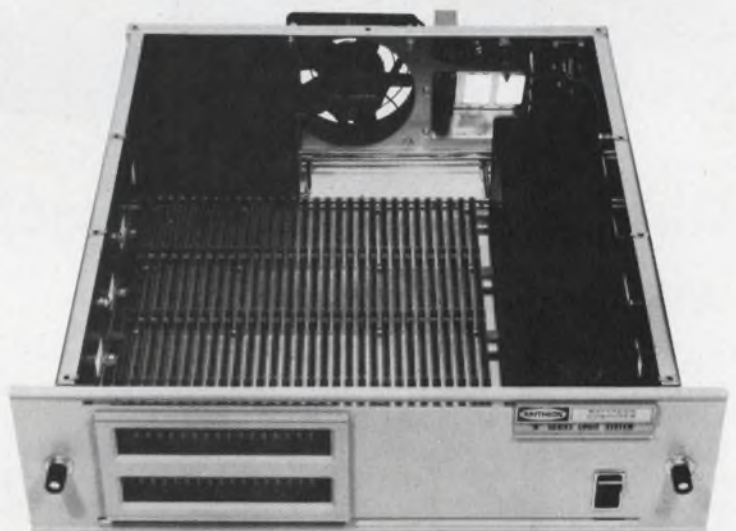

This case holds 120 modules. There's also one for 40; another for 400.

**Raytheon Computer's M-Series** — more than 30 modules—connectors, cases, power supplies and power distribution are so thoroughly engineered you can concentrate on logic and electronic design, not mechanical details. Every step—design, assembly, test, check-out, troubleshooting—is easier than you thought it could be.

**We'll even help you design your logic.** Call or write today for a visit from a helpful applications engineer or for the whole story in print. Ask for Data File M-136. Raytheon Computer, 2700 S. Fairview St., Santa Ana, Calif., 92705, Phone: (714) 546-7160.



ON READER-SERVICE CARD CIRCLE 180

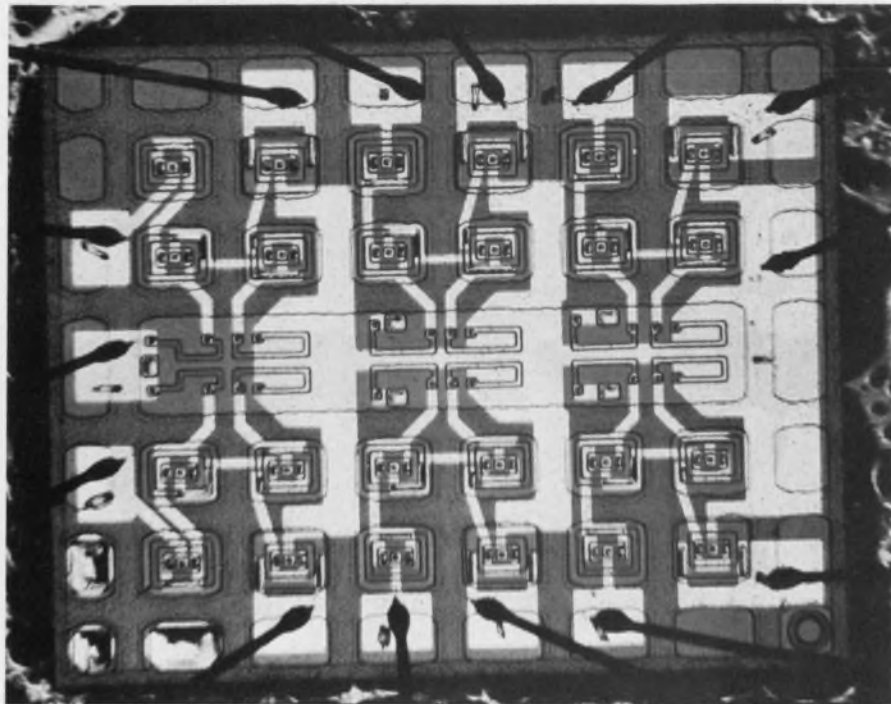

## Obtain complex logic functions with simple diode logic

Radiation, Inc., P. O. Box 220, Melbourne, Fla. Phone: (305) 723-1511. P&A: \$7 (MIL 5-V inverter), \$9 (MIL 35-V driver, \$3.50 (industrial 5-V inverter), \$4.50 (industrial 35-V driver); stock.

Input/output matrix interfaces can be integrated using monolithic interface circuits together with

monolithic diode matrices. Data processing systems, presently discrete, will be lighter, less complex and lower in cost according to the manufacturer, Radiation, Inc.

The new circuits include low-voltage hex interface inverters, high-voltage hex interface drivers and hex indicator drivers.

The inverters provide the neces-

sary low-voltage interface between standard 5-volt ICs and the diode matrices. The interface drivers adapt matrix input/output to high-voltage interfaces (up to 35 volts) while the indicator drivers (presently developmental) provide output drivers in excess of 50 volts.

The approach finds application in code conversions such as BCD to decimal. Speed of computation is claimed to exceed that of any other integrated logic circuitry.

A typical application is shown in Fig. 1. Here, two 6 x 8 diode matrices, an interface inverter and a DTL hex inverter generate a variety of logic functions. Typical logic transition times from input to output are in the 8 to 20 ns range.

In Fig. 2, two diode matrices, an interface inverter and a DTL hex inverter convert a 5-bit data input to a "custom-selected" modified 5-bit output.

A read-only memory may also be constructed with 260-ns cycle time and 150-ns access to data. Clear cycle is 70 ns and setup and clock address can be performed in 40 ns.

The hex indicator driver can be used in BCD decode networks to simplify control circuit design (such as Nixies). Other BCD decoders are limited to one weighted binary code, but these matrices can be "customized" to any weighted code due to the fusing technique used by Radiation for selection of coding patterns.

The circuits are available in TO-84 flat-packs or ceramic dual-in-lines in -55 to 125°C MIL units and 0 to 75°C industrial units.

Booth No. 4G32 Circle No. 383

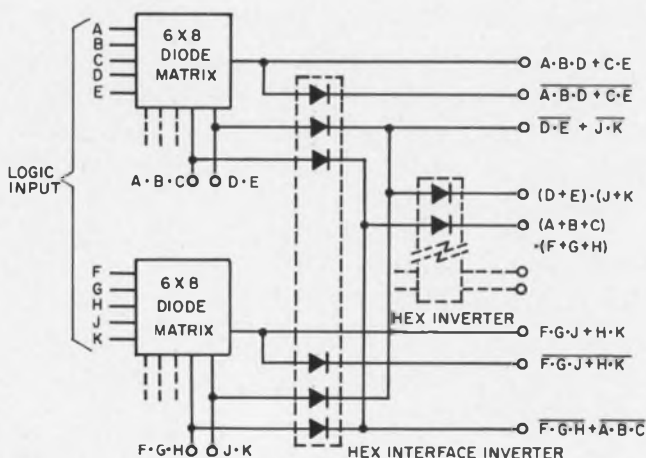

1. Generate a variety of logic functions with a few circuit packages. Here, two 6 x 8 diode matrices, a hex interface inverter and a DTL hex inverter are combined.

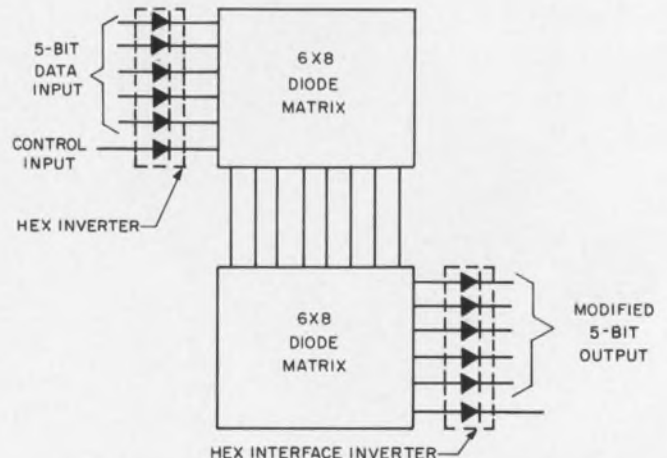

2. Use diode matrices and interface circuits to convert codes. A 5-bit data input is converted to a modified 5-bit output using the same 4 circuits as in Fig. 1.



## Don't be manipulated on SCR's—trust IR.

IR's Application Fact Book lets you select only specs that count.

SCR specifications take on a refreshing air of common sense when you read the new IR Application Fact Book. When do premium parameters really affect circuit performance? What do you give up to get a given parameter? What *combinations* of premium parameters are needed *and possible*...and at what price? You get the answers straight from IR, and you make your selection from quality SCR's rated from 4.7 amps to 550 amps RMS—25 to 1300 volts.

Specifying engineers are in the pivotal position today to smooth out production problems, to end delivery dilemmas, and protect performance. How? By writing specs around the parameters actually needed and

actually available...off-the-shelf, overnight. Most of the information needed to write such common sense specs can be found right in the book. If your application is farther out, call an IR sales engineer. We are pioneers, too, and know how to help you innovators.

APPLY YOURSELF TO THE FACTS OF SCR DESIGN. Write for IR's Application Fact Book. It's free, and it's packed with data to help you sidestep problems from design to delivery of: regulated power supplies, frequency converters, DC motor drives...*you name it!*

**IR** INTERNATIONAL RECTIFIER  
(213) OR 8-6281 • TELEX 6-74666 • EL SEGUNDO, CALIF.

## "BLUE CHIP" TRANSFORMERS NOW AVAILABLE IN CASE SIZE #7

IN STOCK—is the latest addition to the versatile family of Blue Chip transformers for printed circuit applications. This still smaller size; (Height .340 inch maximum, volume .060 cubic inches), transformer offers design engineers more flexibility for electrical and mechanical transistor circuit applications. The size #7 Blue Chip transformers provide a response of  $\pm 2$  db from 300 to 100,000 Hz in a number of impedance ranges and are designed to meet Mil-T-27B, Grade 5, Class S. Write for your copy of complete electrical and mechanical specifications.

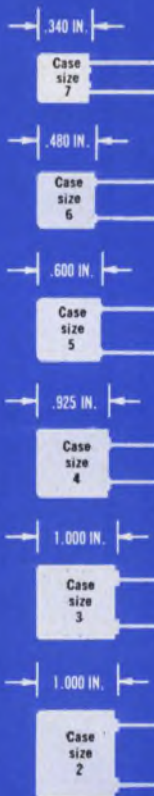
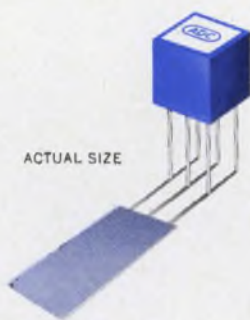

### ADC PRODUCTS

A DIVISION OF MAGNETIC CONTROLS CO.

6405 Cambridge Street • Minneapolis, Minnesota 55426

COMPONENTS—4TH FLOOR

## Monolithic preamp temperature-stable

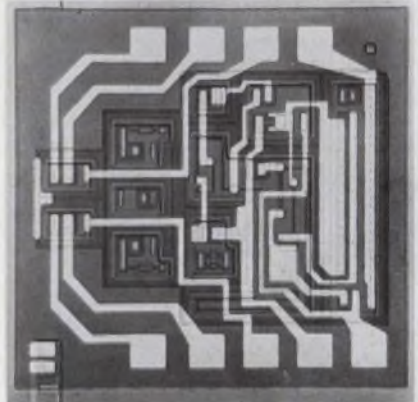

Fairchild Semiconductor, 313 Fairchild Dr., Mountain View, Calif. Phone: (415) 962-2530. P&A: \$12.50, \$25 (MIL), (100 to 999); stock.

A temperature-stable monolithic preamplifier operates with an offset voltage temperature coefficient of  $1 \mu\text{V}/^\circ\text{C}$ . Temperature tracking is typically  $30 \text{ pA}/^\circ\text{C}$ . The IC, constructed on a 45-mil square silicon die, is aimed at preamplifier, operational amplifier and instrumentation applications. Functionally, the  $\mu\text{A}-726$  consists of a matched differential transistor pair and a temperature control amplifier. Temperature is controlled by power dissipation on the chip. The sensing function is provided by two transistors whose emitter-base voltages are summed and applied across a resistor to produce a current which is approximately inversely proportional to the chip temperature. This current is amplified by the gain of the two transistors, one a high-power device. Dissipation at the collector-emitter occurs at 30 V with a maximum current of 50 mA. This gives 1.5-watts available power to heat the chip, which reaches a stabilization temperature in less than 1 second. As the chip temperature rises, the output stage current is reduced until the final chip temperature is reached. Quiescent power for most applications runs about 250 mW.

The circuit design and die layout are arranged so that the temperature-sensing elements are centrally located with the power dissipation device on one side and the differential pair on the other.

Booth No. 4F03 Circle No. 286

ON READER-SERVICE CARD CIRCLE 160

# OPTIONS GALORE for this 4 pole relay...

START WITH A  
BASIC RELAY

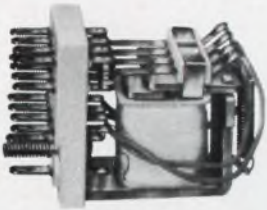

AEMCO type 156

WITH SOLDER TERMINALS



OR, TAPER TAB TERMINALS



OR, PRINTED CIRCUIT TERMINALS



OR, USE A PLUG

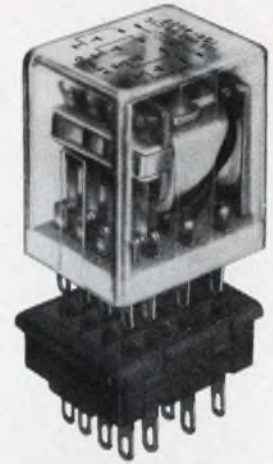

(actual size)  
SOCKET AVAILABLE WITH  
SOLDER OR PRINTED  
CIRCUIT TERMINALS

CHOOSE A  
TRANSPARENT COVER

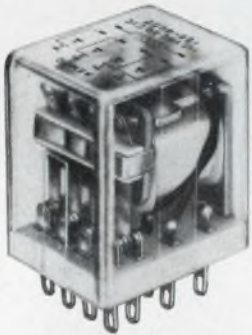

AN OPAQUE COVER



A COLORED COVER



SPECIFY CONTACTS

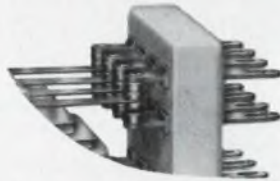

BUTTON  
TYPE



CROSSBAR  
TYPE

GOLD FLASHED SILVER  
SILVER CADMIUM OXIDE  
PALLADIUM  
GOLD ALLOY

SELECT FROM  
AC OR DC COILS

**ADD AEMCO QUALITY**

**AND YOU'LL HAVE...**

the **widest selection** of options available for this popular 4 pole relay—many types available from stock. **Directly interchangeable with similar relays** of other leading manufacturers. American made, too.

SWITCHES 3 A. per pole 200,000 times minimum (resistive load)—**TWICE THE RATED LIFE OF SIMILAR RELAYS**. Provides more than 100,000,000 mechanical operations.

**TEST THIS RELAY WITHOUT CHARGE!** Yes, we'll supply you the sample of your choice free. For selection, write for AEMCO catalog GC367. (Offer limited to OEM's having applications for relays in their products.)

**AEMCO DIVISION**

10 STATE STREET • MANKATO, MINNESOTA 56001 U.S.A

Telephone A/C 507 388-6286



**What's  
new  
in connectors?**



**VISIT**

**U.S. COMPONENTS, INC.  
BOOTH 3K33**

1320 ZEREGA AVE.  
BRONX, N. Y.

**AT THE 1967 IEEE EXHIBITION AND SEE!**

ON READER-SERVICE CARD CIRCLE 162

COMPONENTS—4TH FLOOR

**PC edge connector  
up to 80 contacts**



*Continental Connector Corp., Woodside, N. Y. Phone: (212) 899-4422.*

Printed-circuit card edge connectors are designed for commercial communications applications. The units are available with 80, 75, 52 or 30-contact terminations on 0.1-inch center-to-center spacing. Contact terminals can be supplied straight or with staggered right-angle configuration to permit wire-wrapping for up to three #24 AWG wires. All sizes are dual readout, and accept 1/16-inch PC boards.

*Booth No. 4D12 Circle No. 298*

**Silicon planars  
plastic-packaged**

*International Electronics Corp., Melville, N. Y. Phone: (516) 694-7700. P&A: 40¢ to 90¢; stock to 4 wks.*

Designated IE3011, an economy npn silicon planar unit is available in a solid encapsulated package with electrical characteristics and lead configurations similar to type 2N918. The transistor is suited to low-power, small-signal vhf and uhf oscillator and amplifier applications.

*Booth No. 4H24 Circle No. 311*

**ACHIEVEMENT**

**Monday  
through Thursday**

**MARCH  
20-23  
1967**



**In  
Electrical  
Electronics  
Engineering**

**IEEE '67 CONVENTION  
& EXHIBITION**

**EXHIBITS  
NEW YORK COLISEUM**

**TECHNICAL SESSIONS  
NEW YORK HILTON**

74 Technical Sessions at the New York Hilton. Hours: Mon. 9:30-12:00 a.m.; 2:00-4:30 p.m. — other days 9:00-11:30 a.m.; 2:00-4:30 p.m.

FOUR COMPLETE FLOORS OF EXHIBITS at the New York Coliseum including over 700 firms. Hours: 10 a.m.-8 p.m. 4 Days.

Gala Annual Banquet — Wednesday 7:15 p.m. New York Hilton Grand Ballroom — \$15.00

Free shuttle busses between the Hilton and the Coliseum — every few minutes.

Registration — IEEE Members \$2.00 Non-members \$5.00 Ladies \$1.00 High School Students \$2.00 if accompanied by an adult. One student per adult Monday through Wednesday. Thursday only — limit of 3 students per adult. Good for all days — Technical Sessions and exhibits. In and out privileges.

ON READER-SERVICE CARD CIRCLE 163

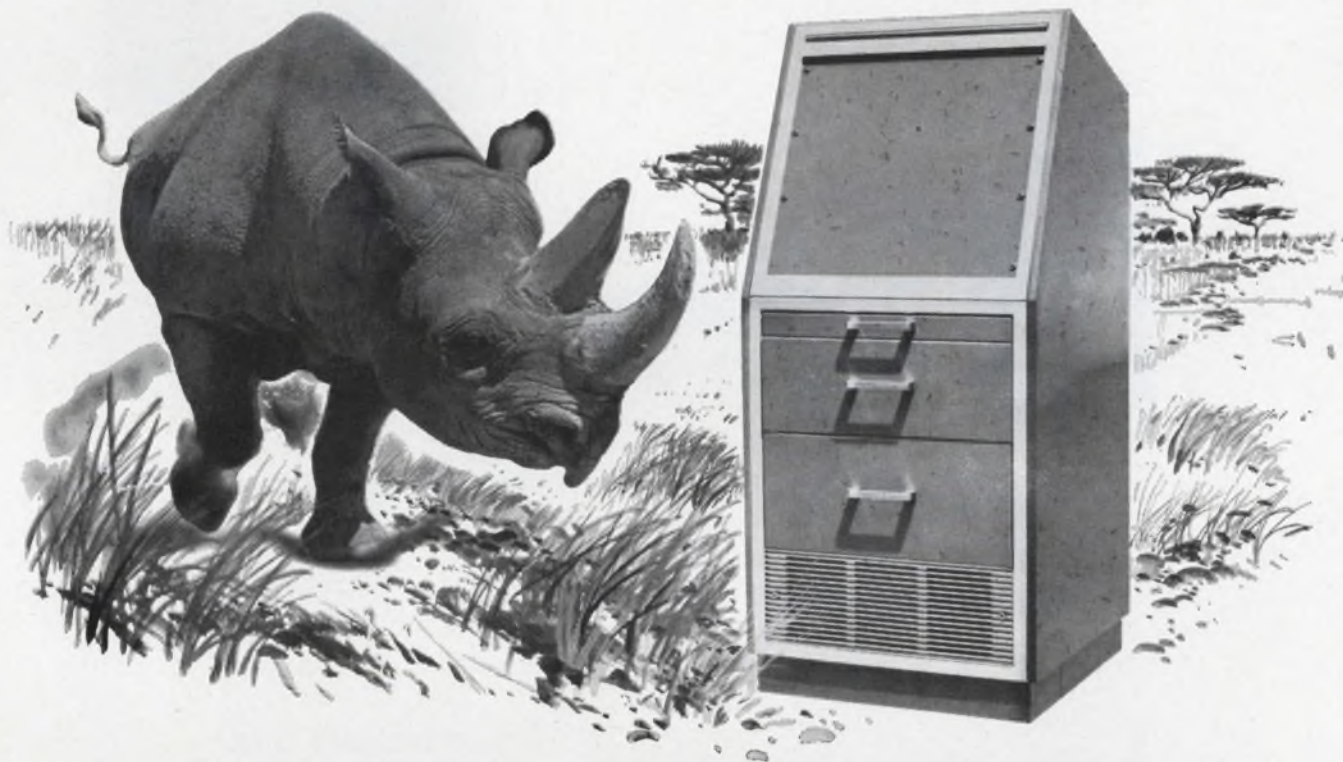

## EMCOR® II—tough, too—but more beautiful

You'll probably never have to pit your EMCOR II cabinet against a rhinoceros, but if you do, you'll find it's pretty tough, too.

EMCOR II cabinets are ruggedly made of steel, carefully welded and bolted for maximum strength and stability. They can bear heavy loads and take plenty of punishment . . . and look beautiful all the while.

*EMCOR/distinguished cabinetry*

Unique, too, in that you can customize EMCOR II to suit your particular preferences . . . with personalized nameplates and designs of your own making. EMCOR II gives you the "custom look."

When you're ready for strong, beautiful protection for your instrumentation, call your local EMCOR Sales and Service Engineer. Or write for our new EMCOR II catalog.

Albany: 436-9649; Albuquerque: 265-7766; Alexandria: 836-1800; Atlanta: 939-1674; Baltimore: 727-1999; Binghamton: 723-9661; Bridgeport: 368-4582; Buffalo: 632-2727; Chicago: 676-1100; Cleveland: 442-8080; Dallas: 631-7450; Dayton: 298-7573; Del Mar: 454-2191; Denver: 934-5505; Detroit: 357-3700; Fort Lauderdale: 564-8000; Ft. Lee (No. N. J.): 944-1600; Ft. Walton Beach: 243-6424; Houston: 526-2959; Huntsville: 539-6884; Indianapolis: 356-4249; Kansas City: 444-9494; Los Angeles: 938-2073; Minneapolis: 545-4481; Newport News: 245-8272; N.Y.C. area: 695-0082; Orlando: 425-5505; Palo Alto: 968-8304; Philadelphia: 242-0150; Pittsburgh: 884-5515; Phoenix: 273-1673; St. Louis: 647-4350; Seattle: 722-7800; Syracuse: 471-7274; Tulsa: 742-4657; Utica: 732-3775; Valley Forge (So. N. J.): 265-5800; Wilmington, Mass.: 944-3930; Winston-Salem: 725-5384. EMCOR Reg. U. S. Pat. Off. . . .

**Ingersoll Products** 1025 West 120th St., Chicago, Illinois 60643

DIVISION OF BORG-WARNER CORPORATION

**electronic  
equipment**



ON READER-SERVICE CARD CIRCLE 170

537  
~~414~~  
**STANDARD  
 MODELS...**

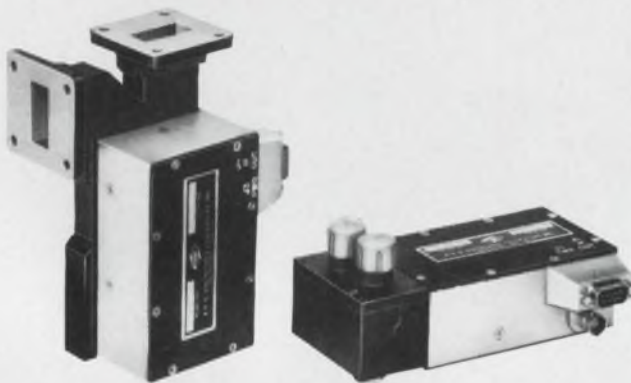

**RHG MIXER  
 PREAMPLIFIERS**

FEATURING

- SSB Noise figures to ~~7.6~~<sup>6.5</sup> db ▪ "G" Series, "hot carrier" and Schottky diodes ▪ MIL Grade ▪ RFI Protected
- Coaxial or Waveguide ▪ Ultraminature models

**RANGE OF SPECIFICATIONS**

RF Frequency:	250 MHz to 36 GHz
IF Frequency:	10 MHz to 300 MHz
IF Bandwidth:	2 MHz to 250 MHz
Gain:	20 db to 80 db
Price:	From \$495

Utilizing a complete complement of microwave test instrumentation backed by engineering know-how, an additional 346 CUSTOM DESIGNS have been produced. The solution to your problem may be on file in our library now.

For specials, test our ONE-DAY-QUOTE Service. For standards, see complete listing in EEM Section 3400.

**RHG**

**RHG ELECTRONICS LABORATORY, INC.**

94 Milbar Blvd., Farmingdale, L.I., N.Y. 11735 ▪ (516) 694-3100

MICROWAVE FM and AM RECEIVERS ▪ MICROWAVE MIXER PREAMPS  
 LINEAR and LOG IF AMPLIFIERS ▪ RF and OCTAVE AMPLIFIERS

ON READER-SERVICE CARD CIRCLE 164

COMPONENTS—4TH FLOOR

**General purpose op-amp  
 priced under \$10**

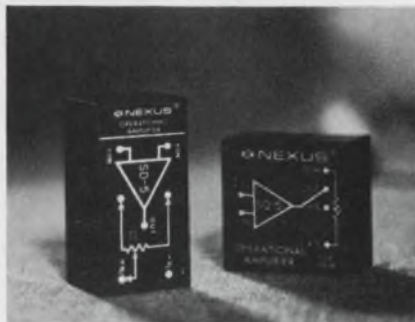

*Nexus Research Lab., Inc., 480 Neponset St., Canton, Mass. Phone: (617) 828-9000. P&A: \$9.75 (10 to 99); stock.*

This encapsulated low-cost unit is fully protected for input overdrive and indefinite short circuit to ground. To ensure stability with a variety of feedback elements, it is internally compensated for a controlled -6 dB/octave gain-bandwidth roll-off. Output is  $\pm 10$  V at 2.2 mA and open-loop gain at dc is 10,000. Common-mode input impedance is 20 M $\Omega$  and differential is 200 k $\Omega$ .

Booth No. 4D25 Circle No. 316

**Thermistors meet  
 tight tolerances**

*Yellow Springs Instrument Co., Inc., Box 279, Yellow Springs, Ohio. Phone: (513) 767-7242. P&A: \$6.90 (100 lots); stock.*

Thermistors match a common resistance temperature curve with an interchangeability of  $\pm 0.1^\circ\text{C}$  ( $\pm 0.5\%$  or better resistance tolerance) over a range from  $-10$  to  $75^\circ\text{C}$ . They are interchangeable to slightly looser tolerances from  $-50$  to  $-10^\circ\text{C}$  and from  $75$  to  $100^\circ\text{C}$ . The thermistors give the circuit designer great flexibility in temperature measuring circuits such as multiple-point monitoring with a single readout and in temperature compensation and temperature control.

Booth No. 4B23 Circle No. 314

It's time to renew your subscription to **ELECTRONIC DESIGN**. Return your renewal card today.



# Introducing 'the strong, silent one.'

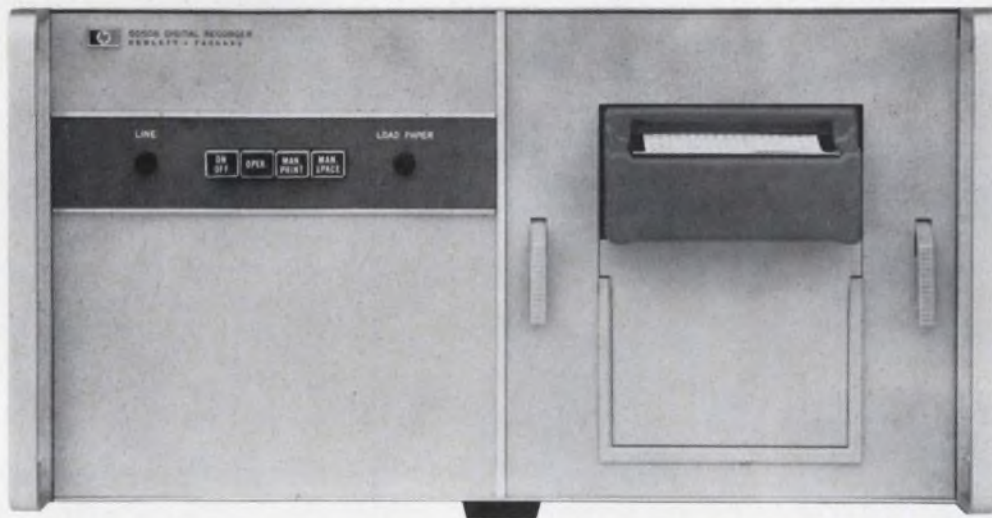

The HP 5050A Digital Recorder is no quitter. New mechanical techniques make this 20-line-per-second printer rugged, quiet, economical and simple. For example, there are no rotating electrical contacts for decoding, and no start-stop operation of printwheel and ink ribbon. Instead, photo-electric decoding is used, and the print drum rotates continually against an ink-impregnated roller. Fewer parts lead to increased reliability potential, which is necessary in printers with the 5050A's speed. Zero suppression is available.

The 5050A is quiet, too . . . measured noise is less than an electric typewriter, less than other printers in its speed class. It accepts 4-line BCD data from one or two sources, which can be in different BCD codes. For extra versatility, formats and codes are easily and economically changed by mechanical means without buying new circuitry for driving the printer.

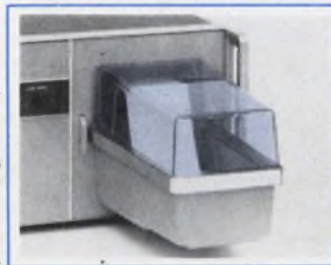

The 5050A can print up to 18 columns at rates to 20 lines per second . . . and without making a lot of noise about it.

Notice the unusual transparent hood. It muffles the sound. It lets you hear yourself think. It keeps your printed records in a neatly folded stack, instead of streaming over equipment, bench and floor. And it stores completely within the recorder when you're not using it.

The 5050A is, of course, fully compatible with other HP solid-state equipment. Price is favorable, too: \$1750 without the driving electronics (which are an additional \$35 per column).

For more information call your local Hewlett-Packard field engineer or write Hewlett-Packard, 1501 Page Mill Rd., Palo Alto, Calif. 94304; Europe: 54 Route des Acacias, Geneva.

## Brief Specifications

**Print Cycle Time:** 50 msec, asynchronous.  
**Maximum Capacity:** 18 columns, 16 characters each.  
**Data Input:** Parallel entry, BCD (1-2-2-4, 1-2-4-8 or 1-2-4-2); "1" must differ from "0" by 4.5 V min. to 75 V max.  
**Reference Voltage:**  $\pm 150$  V max.; both "0" and "1" states are required.

**Input Impedance:** Approximately two megohms.  
**Hold-off Signals:** Both polarities diode coupled, simultaneously available; 10 mA load max.  
 +15 V open circuit from 1 K source  
 -15 V open circuit from 1 K source  
**Print Command:** + or - pulse, 6 to 20 V amplitude, 1 V/ $\mu$ sec min. rise time, 20  $\mu$ sec or greater in width. AC coupled.

HEWLETT  PACKARD

ON READER-SERVICE CARD CIRCLE 165

# TIME/ FREQUENCY

is a unique dimension!

**WE MEASURE IT**  
(Frequency Standards)



**WE CONTROL IT**  
(Crystal Oscillators)

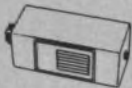

**WE CONTROL ITS ENVIRONMENT**  
(Proportional Ovens)



**WE PIPE IT**  
(Distribution Amplifiers)

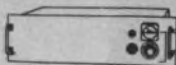

**WE COMPARE IT**  
(Phase Comparators)

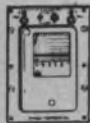

**WE EXERCISE IT**  
(Voltage Controlled Oscillators)



**WE COMPENSATE FOR ITS ENVIRONMENT**  
(Temperature Compensated Oscillators)



**WE CONTROL ITS ENVIRONMENT WITH MINIMAL ENERGY**  
(Low Power Oscillators)



**WE SOMETIMES CARRY IT**  
(High Stability Portable Clocks)



**WE EVEN CONVERT IT**  
(Linear Discriminators)



**SEE US  
AT BOOTH  
2A12  
IEEE**



SEND FOR OUR  
COMPLETE CATALOG ED

**FREQUENCY  
ELECTRONICS, INC.**

*No Compromise with Quality*

2335 New Hyde Park Road, New Hyde Park, New York 11043 (516) 328-0100

ON READER-SERVICE CARD CIRCLE 166

COMPONENTS—4TH FLOOR

## Planar silicon SCRs radiation resistant

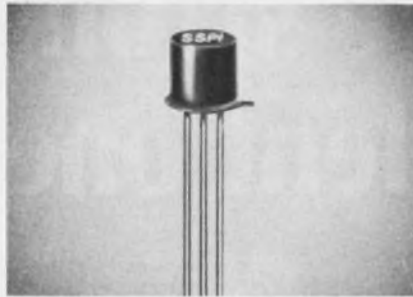

*Solid State Products, Inc., 1 Pingree St., Salem, Mass. Phone: (617) 745-2900. P&A: \$44 (100 lots); stock.*

Radiation-hard pnpn SCRs have design limits fully specified after exposure to  $3 \times 10^{14}$  nvt. Post-radiation specs are pulse currents to 30 A, max trigger current of 20 mA, max holding current of 30 mA and continuous dc forward current to 400 mA. They are in a JEDEC TO-18 case. The devices are for use in squib firing circuits, inverters and converters, pulse generators, relay drivers and modulator switches. They are free of "secondary breakdown" and can be operated in high-voltage circuits.

Booth No. 4D16 Circle No. 262

## 30-way power divider ranges 10 to 500 MHz

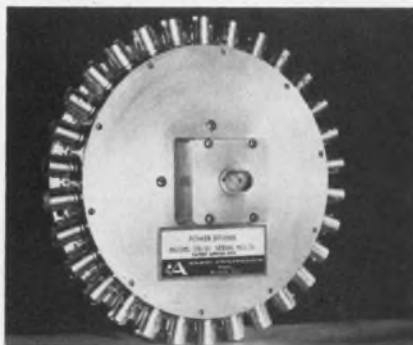

*Anzac Electronics, Inc., Moody's Lane, Norwalk, Conn. Phone: (203) 838-8451. P&A: \$590; 3 to 6 wks.*

Frequency range of this 30-way isolating power divider and summer is 10 to 500 MHz. Total power input is a max of 2.4 watts. Insertion loss is 18.5 dB from 10 to 300 MHz and 19.5 dB from 300 to 500 MHz. Vswr in 50-Ω systems is 1.25 at the output ports and 1.9 at the input port.

Booth No. 4C23 Circle No. 313

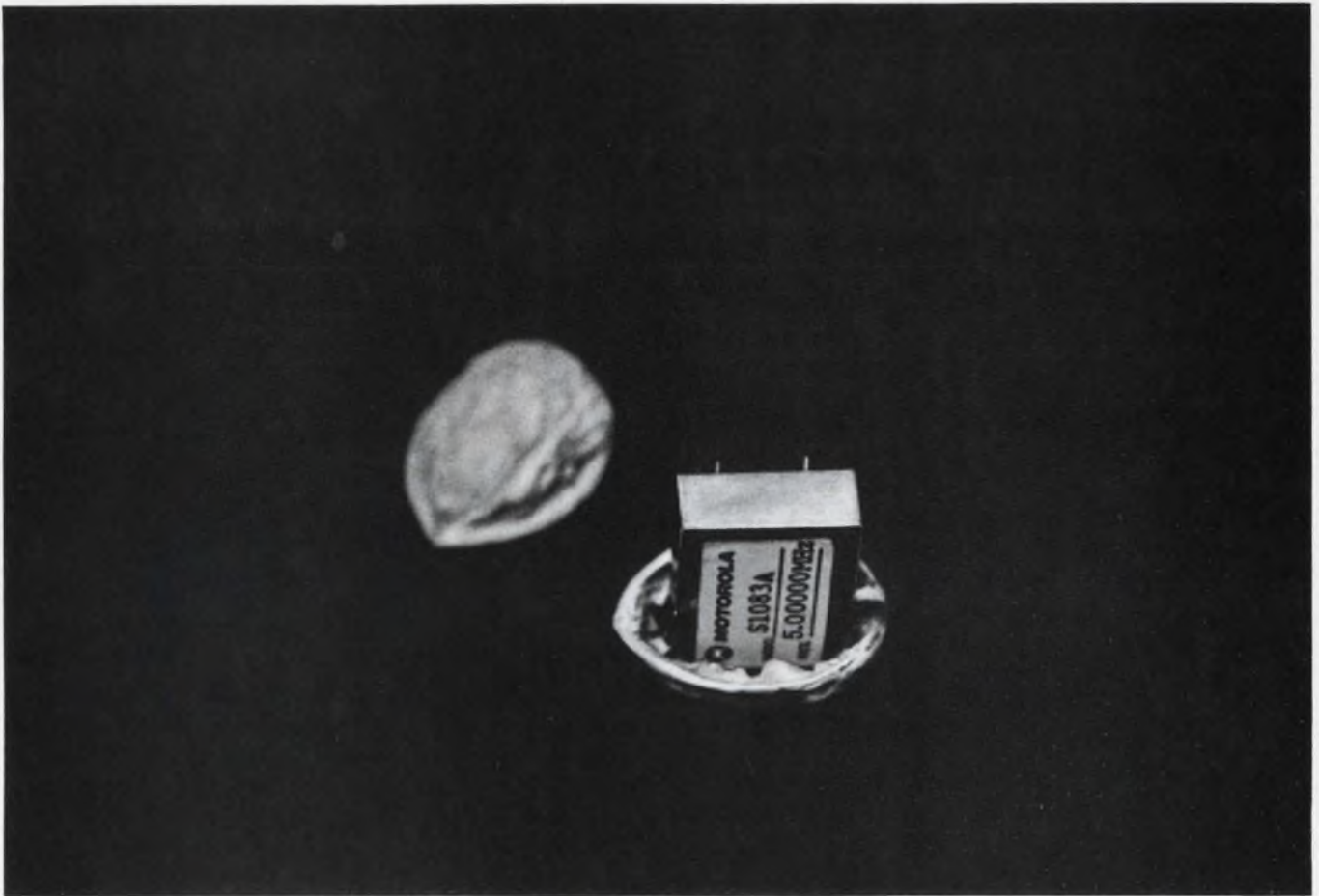

## a TCXO that fits almost anywhere

and offers exceptional frequency stability between  $-55^{\circ}\text{C}$  and  $+85^{\circ}\text{C}$

Only about  $\frac{1}{2}$  of a cubic inch in size, this TCXO (temperature compensated crystal oscillator) offers excellent frequency stability; 5 ppm over a temperature range of  $-55^{\circ}\text{C}$  to  $+85^{\circ}\text{C}$ . It's one of four new miniature TCXO's from Motorola. The slightly larger models offer stabilities as low as  $\pm 1$  ppm. Zener diode regulated compensating circuits provide on-frequency operation the instant they're turned on. All-silicon solid-state construction provides exceptional reliability. Take a look at these facts.

See it at Booth 3A05-6 at I.E.E.E.



**MOTOROLA**  
**PRECISION**  
**INSTRUMENT**  
**PRODUCTS**

**SMALL SIZE:** Sizes range from 0.58 cubic inch to 3.4 cubic inches.

**WIDE TEMPERATURE RANGE:** From  $-55^{\circ}\text{C}$  to  $+85^{\circ}\text{C}$ .

**HIGH FREQUENCY STABILITY:** Available as low as  $\pm 1$  ppm.

**WIDE FREQUENCY RANGE:** From 1 MHz to 30 MHz.

**LOW POWER CONSUMPTION:** As low as 100 milliwatts.

**NO WARM-UP TIME:** Adjusts instantly to temperature conditions.

FOR MORE INFORMATION contact your Motorola representative. Or write for bulletin TIC-3213.

**MOTOROLA COMMUNICATIONS AND ELECTRONICS INC.**  
 4900 West Flournoy Street  
 Chicago, Illinois 60644. A subsidiary of Motorola Inc.

ON READER-SERVICE CARD CIRCLE 167

# METALIZED MYLAR CAPACITORS



to your exact  
specifications...  
at stock prices

## METALIZED MYLAR CAPACITORS

Unique, self-healing units that remain in circuit during voltage surges with little or no loss of electrical properties. Use the M2W's where size and weight are limiting factors and long life and dependability are required. The units utilize metalized Mylar\* Dielectric with film wrap and custom formulated epoxy resin end fill. Available in round and flat styles.

\*Du Pont Trademark for Polyester Film

Samples available on your letterhead request



DEPT. ED-3, 1065 WEST ADDISON STREET, CHICAGO, ILLINOIS 60613

ON READER-SERVICE CARD CIRCLE 168

## COMPONENTS—4TH FLOOR

### Stud-mount rectifier recovers quickly

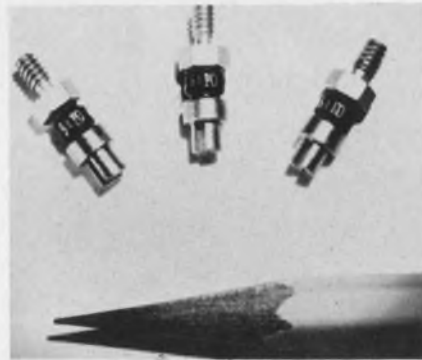

Unitrode Corp., 580 Pleasant St.,  
Watertown, Mass. Phone: (617)  
926-0404. P&A: \$8.50 to \$22; stock.

Miniature fast-recovery rectifiers offer a 9-A current rating and PIV up to 400 V with all models having controlled avalanche characteristics. Surge ratings are as high as 150 A for one cycle. Recovery times as low as 250 ns permit full power operation at frequencies as high as 40 kHz square-wave, or higher frequencies sine-wave.

Booth No. 4K19 Circle No. 294

### Patchboard programmer completely shielded

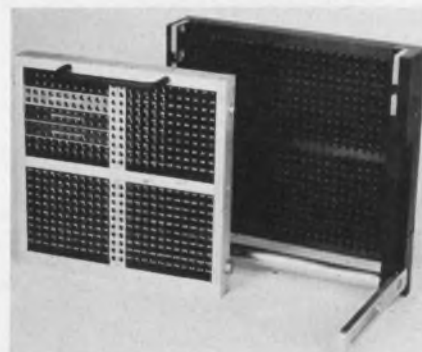

Virginia Panel Corp., 1400 New  
Hope Rd., Waynesboro, Va. Phone:  
(703) 924-8376.

Completely shielded programming systems utilize the locking concept in patchcords and a molded conductive-shielded board. The paddle contacts are completely isolated from each other by means of a metallic shielding around each contact. This reduces crosstalk and restricts outside interference. All contacts are on 3/8-inch centers. The systems are available with 120 to 4200 contacts.

Booth No. 4K14 Circle No. 315

## Glass fiber optics in continuous length



Corning Glass Works, Corning, N. Y. Phone: (607) 962-4444. P&A: about 10¢/foot (over 50,000 feet); stock.

Flexible non-coherent glass fiber optic bundles jacketed in PVC are available in single lengths up to 10,000 feet. The fibers can be twisted and flexed without degradation of light transmission. The jacketed fibers can be cut, terminated, end-finished and installed to light source and output devices. A 10-foot length of flexible glass fibers with polished ends will transmit 40% of input light. Light acceptance angle is 65° minimum.

Booth No. 4F20      Circle No. 284

## Silicon diode uses Schottky principle

Fairchild Semiconductor, 313 Fairchild Dr., Mountain View, Calif. Phone: (415) 962-2530. P&A: \$2 (100 to 1000); stock.

A new type of silicon diode uses the Schottky barrier or hot-carrier principle to provide higher performance in uhf mixer circuits and faster switching times. FH1000 hot carrier diodes are packaged in the DO-7 package with standard 20-mil axial leads. Maximum power dissipation rating is 100 mW. Maximum forward voltage is 0.55 V at  $I_F$  of 10 mA and leakage current is typically 50 nA at  $V_R$  of 1 volt. When employed as a mixer at 890 MHz, noise figure is 10 dB max. Switching time is in the "tenths of nano-seconds" range.

Booth No. 4F03      Circle No. 285

# 109 dB

is the upper range of a Telonic rotary attenuator that operates over a DC to 1000 MHz frequency spread, is adjustable in 1 dB steps from zero and shows the attenuation **digitally**. Internally, it is constructed with individual pi-pads and precision resistors for optimum accuracy, avoiding tolerance build-up and maintaining a constant, low insertion loss. This unit is the TA-109E. Other rotary models cover 0 to 50 dB in 10 dB steps, 0 to 10 dB in 1 dB steps, 0 to 59 dB in 1 dB steps, 0 to 1 dB in .1 dB steps and 0 to 10.9 in .1 dB steps.

But if you prefer a toggle switch type, there's the TG series in models ranging to 82.5 dB in

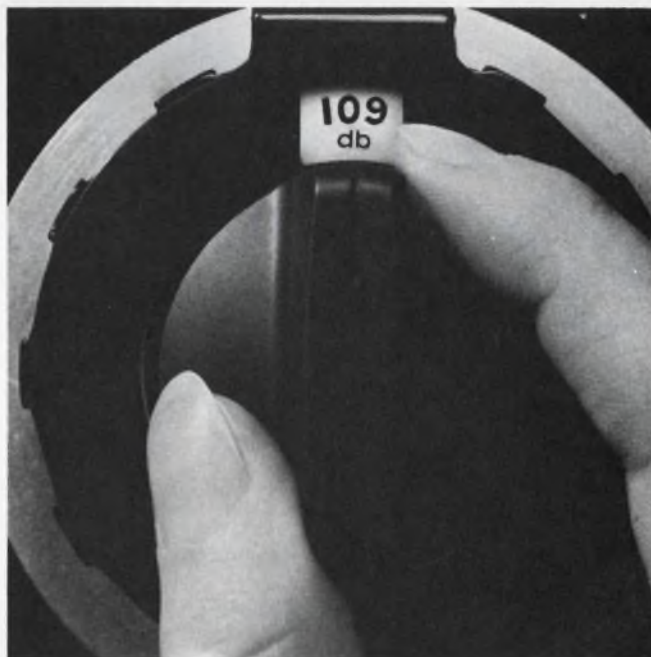

"See Telonic at IEEE, Booths 2G02-2G10"  
ON READER-SERVICE CARD CIRCLE 169

## Single pulse accessory ups laser power



TRG Control Data Corp., Route 110, Melville, N. Y. Phone: (516) 531-6464.

Model 104A-6 single pulse accessory is an optical device that increases peak power output of a rotating-prism, Q-switched ruby laser by introducing a saturable dye solution into the resonant cavity. This device can be used to effectively increase the switching speed of any rotating reflector Q-switch. The accessory contains two optical cells filled with a saturable dye solution. The cells are mounted in a disk that can be rotated to index either of the two cells or a clear aperture into the laser cavity. The second cell is provided as a convenience to alter the transmission characteristics of the dye solution for experimental purposes. The increase in peak power is obtained by suppressing multiple pulses common to rotating reflector Q-switches and obtaining a single narrow pulse, which contains essentially all the energy previously in the multiple pulses.

Booth No. 4B15 Circle No. 299

## 600-V relays measure 2-3/4 inches square

Struthers-Dunn, Inc., Pitman, N. J. Phone: (609) 922-2349.

For 600-V applications, the SC relay line requires a panel area of only 2-3/4 inches square. The units reportedly take no more space than most 300-V industrial relays. Available in 4-pole and 8-pole models with any combinations of NO and NC double-break contacts, the relays claim an operating life of 10 million operations at rated loads.

Booth No. 4J25 Circle No. 366

## Industrial SCRs have 0.2- $\mu$ s turn-on

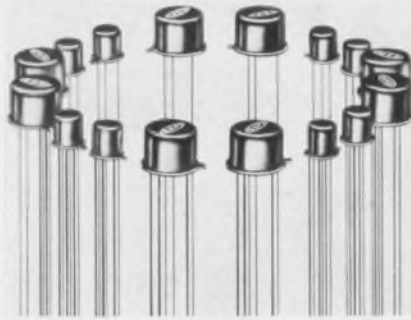

Solid State Products, Inc., 1 Pingree St., Salem, Mass. Phone: (617) 745-2900. P&A: under \$1 (100 lots); stock.

Silicon planar passivated SCRs combine low-level triggering, high pulse power, and fast switching. They are packaged in hermetically sealed metal cases and come in three sizes: TO-46, TO-18 and TO-5. The units are available in anode voltage ratings from 30 to 200 V and feature peak forward currents to 40 A, max trigger currents of 200  $\mu$ A, 8- $\mu$ s recovery times, and 0.2  $\mu$ s turn-on times.

Booth No. 4D16. Circle No. 259

## 'Doorbell' rectifier rated to 10 kV



Unitrode Corp., 580 Pleasant St., Watertown, Mass. Phone: (617) 926-0404.

Unitrode is offering a larger version of its high-voltage "doorbell" rectifier modules. Twelve new models offer ratings from 2.5 to 10 kV and are available in regular and fast recovery versions. Continuous current is 6 A in air or 15 A in oil. Surge rating is 200 A for 8.3 ms. They may be connected in stacks or in any of the usual bridge circuits using the integral threaded connections. Reverse transient ratings are as high as 20 joules.

Booth No. 4K19 Circle No. 369

## Dc torquer meets all drive requirements



Inland Motor Corp., 501 First St., Radford, Va. Phone: (703) 639-3973.

One dc direct-drive torque motor covers the drive requirements of all standard reel sizes, tape tensions and tape speeds. The NT-2922A torquer also provides extremely low ripple torque. The frameless design permits mounting directly on the shaft. Direct-drive with the elimination of gear trains provides servo stiffness and the complete absence of backlash.

Booth No. 4E32 Circle No. 349

## Heat exchanger cools cabinets

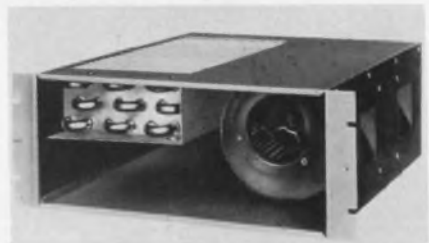

McLean Engineering Labs., Princeton Junction, N. J. Phone: (609) 799-0100. P&A: about \$175; 4 to 5 wks.

Rack-mounted, water-cooled heat exchangers maintain interior cabinet temperature at a maximum of 80°F with a 1-kW heat dissipation. They use chilled water within a temperature range of 66 to 70°F. Air is recirculated within the electronic enclosure and cooled by the heat-exchanger installed within the blower case. The system does not use room ambient air, nor does it exhaust warm inside cabinet air into the atmosphere.

Booth No. 4K12 Circle No. 368



The world's smallest fuse—Picofuse. 1/8 thru 5 amps . . . weight 1/5 gram each . . . 125 v. Standard or high reliability line.

# LITTELFUSE

DES PLAINES, ILLINOIS

ON READER-SERVICE CARD CIRCLE 863

## Control Knobs

by

# Rogan

*The Aristocrat of the Knob Industry*

Visit Booth  
1C08 IEEE Show



EXCLUSIVE DESIGNS  
AVAILABLE ONLY FROM ROGAN

World's finest knobs available from stock molds. Wide range of sizes, shapes and colors. No tool costs. Preferred by leading design engineers everywhere. Make Rogan your knob headquarters. Write for catalog.

**Rogan** 8031 N. MONTICELLO AVE.  
BROTHERS INC. SKOKIE, ILLINOIS 60076

*Specializing in Stock Molded Knobs Since 1939*

ON READER-SERVICE CARD CIRCLE 865

ELECTRONIC DESIGN 6, March 15, 1967

# 0.5 dB

steps, and to 42 and 102 dB in 1 dB steps. To assure long life and precise repeatability these Telonic toggle switch attenuators are heavy-duty type incorporating switch controls with a double knife edge and self-wiping action. Pads are shielded, individually, to prevent leakage, and to permit maximum range. The attenuators operate to 250-300 MHz, and can be furnished in 50 or 75-ohm versions. The unit shown below is a Model TG-9050A with additive steps of .5, 1, 2, 3, 6, 10, 20, 20, and 20 dB.

If you're using these attenuators (or other RF equipment) up to

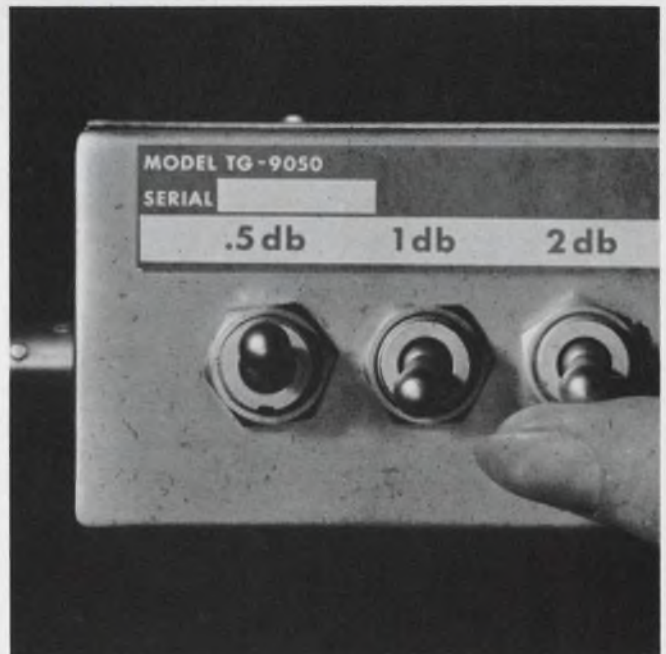

'See Telonic at IEEE, Booths 2G02-2G10'

ON READER-SERVICE CARD CIRCLE 864

## Firewall connector rises from the ashes



The Pyle-National Co., 1334 N. Kostner Ave., Chicago. Phone: (312) 342-6300.

Phoenix series firewall connectors incorporate the D-hole type receptacle mounting and bayonet coupling. The series meets Classes R and G requirements of MIL-C-26500B while exceeding Class K, MIL-C-5015D fireproof provisions. Environmental sealing provides 1000 hours of electrical continuity at 460°F and corrosive atmosphere resistance. Stainless steel shells are available in sizes 14, 16, 18 or 22. Contacts offered in 12, 16 and 20 sizes are rhodium- (or gold) plated. Booth No. 4G20 Circle No. 355

## Low-noise preamps cover uhf and vhf

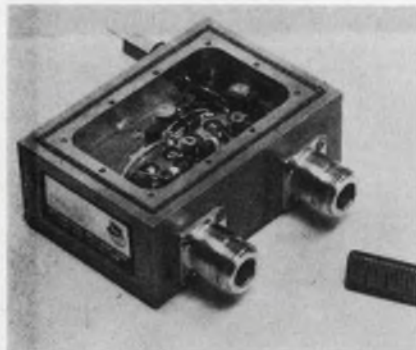

International Microwave Corp., River Rd., Cos Cob, Conn. Phone: (203) 661-6277.

Low-noise, solid-state broadband vhf-uhf preamps cover 200 to 550 MHz with a noise figure of 2.5 to 3.5 dB. Case and filter designs claim a high degree of protection against RFI. Gain is  $\pm 1$  dB, input and output impedance is 50  $\Omega$  and operating power is -24 Vdc at 17 mA. Booth No. 4E12 Circle No. 363

## Schottky diode quads processed 'bilithic'

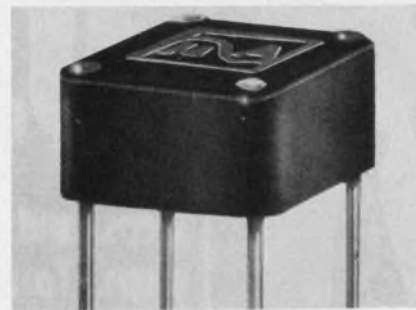

Microwave Associates, Burlington, Mass. Phone: (617) 272-3000.

Schottky-barrier junction diodes are closely matched for use as balanced modulators from low frequencies through the uhf range. They are also available as single units and matched pairs for detector and discriminator usage. The MA-4860 and MA-4878 series utilize a "bilithic" process which encapsulates the metal-silicon junction in a hermetic glass seal. This technique allows a large-area, low-loss top contact to the diode junction for improved reliability. Pulse burnout is rated at 5 ergs.

Booth No. 4E12 Circle No. 364

## Matrix assembly offers low capacitance

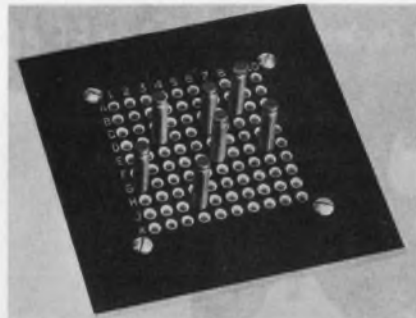

Taurus Corp., Academy Hill, Lambertville, N. J. Phone: (609) 397-2390.

Offering a new type of contact arrangement, this matrix-assembly is used in telemetry, monitoring, programing and automated functions. Its low capacitance insures good ac performance. Any combinations. Its low capacitance ensures the insertion of the appropriate number of terminals. The assembly features high insulation resistance between adjacent rows.

Booth No. 4K38 Circle No. 511

## PC card enclosure designed to stack

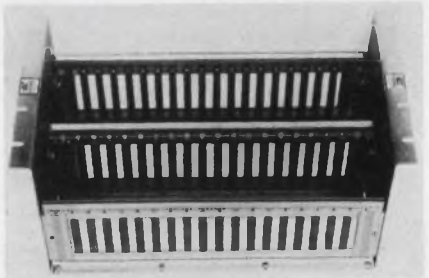

Elco Corp., Willow Grove, Pa. Phone: (215) 659-7300. P&A: \$20 to \$25; stock.

Double-tier Varipak printed-circuit card enclosures are designed for stacking. Available in 16 standard sizes and made completely of aluminum, the guides are easily insertable and removable without damage to guides or guide plates. The guides have sufficient "float" to allow for tolerance accumulation between card guides and connectors.

Booth No. 4F21 Circle No. 352

## Overlay transistors rated 20 W at 400 MHz



Vector Div. of United Aircraft Corp., Southampton, Pa. Phone: (215) 355-2700. P&A: \$63; stock.

Large-signal, high-power overlays are for application in class B and C RF power amplifiers for military and commercial communications equipment. The V-408 offers a power output of 15 W at 400 MHz and 22 W at 225 MHz. The V-410 has a minimum power output of 20 W at 400 MHz. Both use an overlay multiple-emitter geometry and perform with efficiencies on the order of 65%. Packaging is TO-60.

Booth No. 4F26 Circle No. 347



# ECCOMOLD® EPOXY MOLDING COMPOUNDS



**NEW FREE CHART NEW**

Comparative physical, electrical and processing properties of Eccomold transfer molding compounds are in colorful chart. Typical applications are indicated.

*This Valuable Chart Is Yours  
Write or Use Reader Service Card*



**Emerson & Cuming, Inc.**

CANTON, MASS.  
GARDENA, CALIF. • NORTHBROOK, ILL.  
*Sales Offices in Principal Cities*

EMERSON & CUMING EUROPE N.V., Oevel, Belgium

ON READER-SERVICE CARD CIRCLE 866

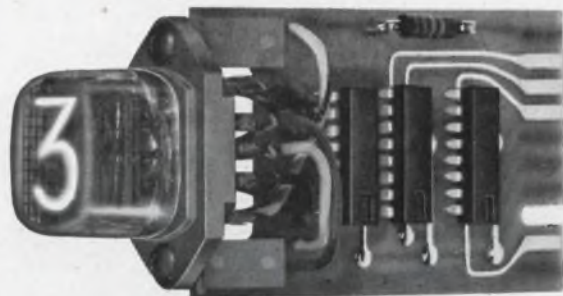

## TTL IC Drivers for NATIONAL® Readout Tubes

From stock: Decoder/Driver, Decimal Counter/Driver and Decimal Counter/Driver with Latching Memory.

■ 15 MHz Counting Rate ■ For all side and end view National readout tubes.

IEEE  
BOOTHS  
3F01-3F18

**NATIONAL**

REQUEST  
BULLETIN

**ELECTRONICS, INC.**  
a varian subsidiary

PHONE: (312) 232-4300 • GENEVA, ILLINOIS, U.S.A.

ON READER-SERVICE CARD CIRCLE 867

ELECTRONIC DESIGN 6, March 15, 1967

# 1 GHz

frequency, you will find Telonic's Coaxial Switches a boon in establishing test systems, checkout stations, or in any area of RF circuitry switching. Silver-plated with point-contact design, they give excellent service life and repeatability. The frequency range permits application to microwave, video, VHF and UHF systems. Two series and six models permit selection of 2 or 4 poles, 2 or 6 positions and an optional ganged wafer switch. Shown; the TS-103A, 4 pole, 2 position on both coax and wafer sections.



**INSTRUMENTS**  
Division of Telonic Industries Inc.

60 North First Avenue, Beech Grove, Indiana 46107  
TEL. (317) 787-3231 TWX: 810-341-3202

SALES REPRESENTATIVES THROUGHOUT THE WORLD. FACTORY OFFICES IN FRANKFURT, GERMANY AND MAIDENHEAD, ENGLAND.



Send for  
Catalog 70

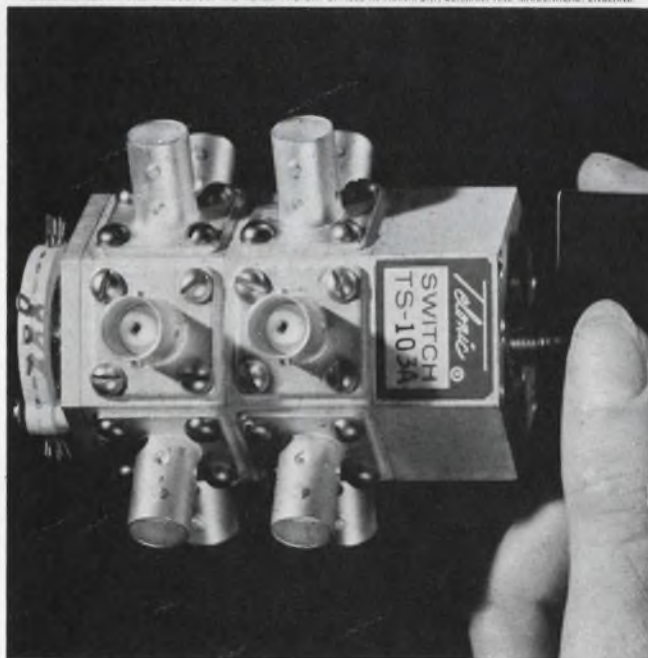

"See Telonic at IEEE, Booths 2G02-2G10"

ON READER-SERVICE CARD CIRCLE 868

U223

## Pushbutton reeds mount PC board

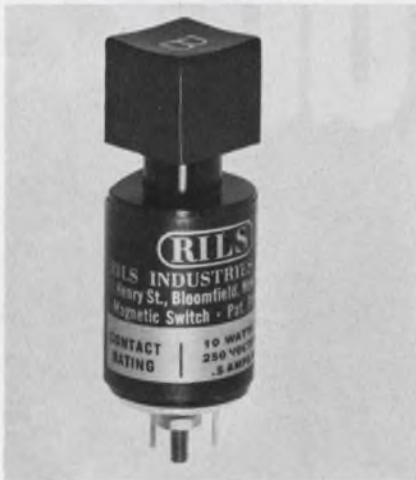

Gordos Corp., 250 Glenwood Ave., Bloomfield, N. J. Phone: (201) 743-6800.

Pushbutton reed switches for printed circuit mounting claim a life of over 20 million operations. Contact rating is 1/2 A at 10-W resistive load and minimum breakdown is 35 Vdc. Insulation resistance is  $5 \times 10^{10} \Omega$ . They are available spst, spdt or 3pst in flat or angled-base designs.

Booth No. 4K31 Circle No. 295

## Adjustable P-clips handle loops to 2 in.



Electrovert Inc., 86 Hartford Ave., Mt. Vernon, N. Y. Phone: (914) 664-6090. P&A: from \$24/1000; stock.

Only nine sizes of these adjustable P-clips will fit all loop diameters from 1/8 through 2 inches. Each of the sizes can be used with a wide range of bundles and the tension on each can be controlled. Typical applications include cables, bundles of wires, components, pipes and tubing where a clamp, strain-relief or strap is required.

Booth No. 4B27 Circle No. 350

## Stripline transistor oscillates at 4.5 GHz

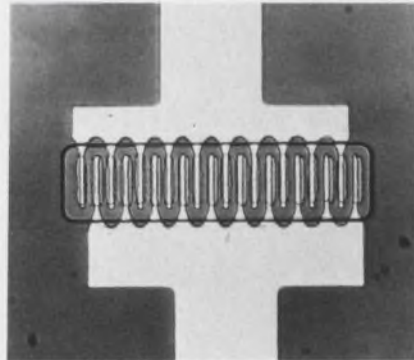

Fairchild Semiconductor, 313 Fairchild Dr., Mountain View, Calif. Phone: (415) 962-2530. P&A: \$42.50 (10 to 99); stock.

A microwave transistor, offering a maximum frequency of oscillation of 4.5 GHz, is intended for use in preamplifier and local oscillator applications through S-band. It is capable of delivering a maximum available gain (MAG) of 7 dB at 2 GHz and 3.5 dB at 3 GHz. The MT1062 is packaged in the TO-51 stripline package.

Booth No. 4F03 Circle No. 287

## Wirewound resistor slide-adjustable

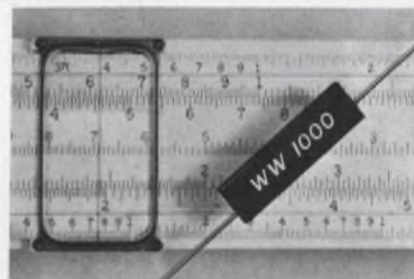

Radio Products International, 1501 S. Hill St., Los Angeles. Phone: (213) 746-0325.

Wirewound, variable resistors slide along the center lead to provide  $\pm 20\%$  variations in resistance. The center lead is attached to a multi-tang wiper and is insulated on one side. The resistance element consists of an extremely fine wire wound on a metal mandrel. Stability and temperature coefficient are in the range of 20 ppm/°C. Models are available in 1, 1/2 and 1/4-W ratings. Nominal resistance ranges are available from 10  $\Omega$  to 250 k $\Omega$ .

Booth No. 4E39 Circle No. 542

## Single-turn pot mounts PC boards

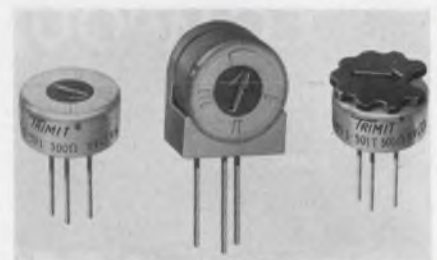

Bourns, Inc., Trimpot Div., 1200 Columbia Ave., Riverside, Calif. Phone: (714) 684-1700. P&A: \$2.30 (100 to 249); stock to 3 wks.

A low-cost, single-turn, industrial potentiometer measures 1/2 inch diameter by less than 1/4 inch long. It has a standard resistance range of 10  $\Omega$  and a power rating of 0.5 watt at 40°C. Model 3365 is housed in an all-plastic case, has sealed pins for printed circuit applications and stops at each end of adjustment. Each style is available with thumb adjustment knob.

Booth No. 4E11 Circle No. 326

## Rotary reeds in new configuration

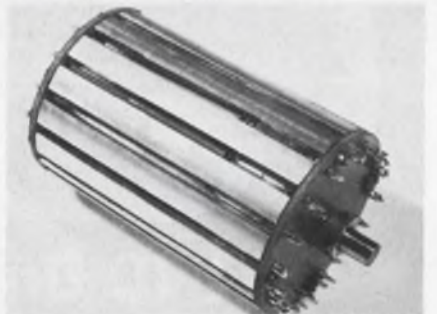

Arthur Ansley Mfg. Co., New Hope, Pa. Phone: (215) 297-5606.

A new rotary reed switch configuration consists of hermetically sealed reeds mounted around a drum-type support with the activating magnet rotating in the center. This results in a smaller diameter switch. In the version above, two sections are mounted on the same drum with a common shaft and ball bearings. One section consists of 16 evenly-spaced reeds with a break-before-make action. The other section has only two reeds, each of which is closed for just under 180°.

Booth No. 4C18 Circle No. 509



# Mix these signal, power and coax leads in any combination.

Burndy Trim Trio Connectors—available in many shapes—accept three contact styles, all crimp-removable, for signal and power leads #16 thru #24, twisted pair #24 and #26, and subminiature coaxial cables.

Changing conductors is fast and simple, whether for lower voltage drop or better shielding or mechanical reasons. This makes Trim Trio Connectors ideal for breadboard and prototype work as well as

production. For large production runs you can take advantage of the economies offered by the automatic Burndy Hyfematic™ with a crimp rate of up to 3000 contacts per hour.

Get more details on how you can take advantage of the Burndy Trim Trio System—THE ACCEPTED METHOD OF INTERMIXING CONTACTS.

 **BURNDY**  
Norwalk, Connecticut

INTERNATIONAL SALES HEADQUARTERS AND MANUFACTURING FACILITIES:

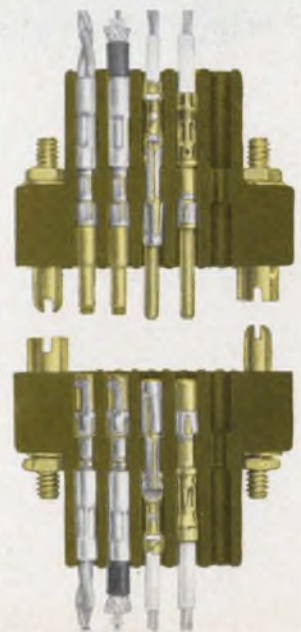



**...if you need transistors for mobile radio  
you should be talking to us!**

TRW will talk to you about RF output of 20 watts in the UHF Mobile Band...35 watts in the high band ...60 watts in the low band! And from what power source? From a 12 Volt automobile battery!

TRW will show you reliability—mobile transistors that keep on

going under the most extreme conditions of heat, cold, moisture, road shock. Improper tuning...even a broken antenna can't knock them out, and that spells reliability in any tough mobile service!

TRW is delivering now!

Contact TRW Semiconductors Inc., 14520 Aviation Blvd., Lawndale, Calif. 90260 Phone: (213) 679-4561 TWX: 910-325-6206. *TRW Semiconductors is a subsidiary of TRW INC.*

**TRW**

ON READER-SERVICE CARD CIRCLE 192

**Co-Publishers**  
James S. Mulholland, Jr.  
Robert E. Ahrens Dorf

**Editorial Director**  
Edward E. Grazda

**Editor**  
Howard Bierman

**Managing Editor**  
Robert C. Haavind

**Technical Editors**  
Peter N. Budzilovich  
Joseph J. Casazza  
Maria Dekany  
Frank Egan  
Roger K. Field

**News Chief**  
Ralph Dobriner

**East Coast Editor**  
Neil Sclater

**West Coast Editor**  
Ron Gechman

**Copy Editor**  
Peter Beales

**New Products Editors**  
David H. Surgan  
Daniel R. Butterly

**Washington Editor**  
S. David Pursglove

**Editorial Production**  
Dollie S. Viebig  
Karen L. Sherman

**Art Director**  
Clifford M. Gardiner

**Art Assistant**  
William Kelly

**Technical Illustrators**  
Cheh Nam Low  
Douglas Luna  
William Alvarez

**Production Manager**  
Thomas V. Sedita

**Asst. Production Manager**  
Helen De Polo

**Production Assistants**  
Bernard Wolinsky  
Robert B. Lichtig

**Circulation Manager**  
Nancy L. Merritt

**Reader Service**  
Diane Mandell

## EDITORIAL



# What happens to your job if peace breaks out?

We hear much talk these days about peace prospects in Vietnam, better relations with the Soviet Union, a possible détente in the development of costly antimissile defenses. Hopes for reduced military spending are riding high. At the same time there is excited discussion of the great part that the electronics industry can play in solving such peaceful problems as air and water pollution, urban development, transportation snarls on the ground and aloft, and unfilled demands for new and improved consumer and industrial products.

Where do you fit into this picture? If you're an average military-oriented engineer, one thing is clear: you are largely unemployable in the civilian sector of the economy. In any major swing toward the civilian market, your training as a "cost-plus-fixed-fee engineer" is largely useless. You are a highly skilled specialist; consumer and industrial-equipment concerns need engineers who can wear many hats—those fitted for design, development, production and even sales.

Since most engineers today are engaged in work for the military, it follows that a retraining program to equip them for civilian production would have to be big. Federal, state and local governments, industry officials, engineering societies and educators—all are involved. To date, none appears seriously concerned.

There is a story that former President Harry S. Truman once defined a recession as the loss of a job by your neighbor, and a depression as the loss of a job by yourself. If military spending ebbs drastically, will you face a depression?

If the answer is yes, try asking yourself these questions:

Shouldn't the engineering societies be devoting more time and effort to retraining programs?

Shouldn't government and industry officials begin meaningful discussions to pinpoint the urgent civilian problems that might be solved by "reborn" military engineers?

Shouldn't there be a formal program—sponsored by government or industry, or possibly both—to develop "specs" for detailed training and placement programs; for helping engineering schools to shape their curricula to match new demands?

Unless somebody starts moving soon, unless a workable plan is implemented, many perfectly capable engineers seem destined to join the army of the unemployed if peace should break out suddenly.

PETER N. BUDZILOVICH

# Galvanometer with brains



**ESI has combined the best features of the classic galvanometer and the modern electronic voltmeter in the new Model 900 Nanovolt Galvanometer.**

How do you create a galvanometer with true nanovolt sensitivity that is really *practical* to use... an instrument that doesn't require hours of delicate dial twiddling, trap-door adjustments or experimental hook-ups?

You give it brains. Brains in the form of feedback circuits that automatically control speed of response and damping for each of its 12 calibrated ranges. *It operates from any source resistance without changes in speed of response or damping characteristics.* Noise is less than 2 nanovolts regardless of the source impedance. With all this working for you, it's easy to make effective use of the extreme sensitivity of our Model 900 Nanovolt Galvanometer.

The instrument consists of *two* units—the control unit shown above, which is the brains of the outfit, and a galvanometer unit. The Model 900 is ideal for use with high-accuracy and high-resolution potentiometers and bridges; for the calibration of thermo-couples, strain gauges, thermopiles, standard cells and the like. It also has myriad applications in the measurement of tiny voltages or currents in experimental chemistry, physics, biology or medicine. A fixed input resistance of 1 kilohm allows calibrated ranges for *both* voltages and current.

Through solid state circuitry, we've been able to combine the best of two worlds in the Model 900. It has the

high sensitivity and ac rejection of mechanical galvanometers. But it also has the multiple calibrated ranges, meter readout, and operation simplicity of modern electronic voltmeters. It's an honest nanovoltmeter whose high sensitivity and complete guarding also simplify measurements in the microvolt area.

You'll have more time to use your own brains if your galvanometer has some of its own. ESI, 13900 NW Science Park Drive, Portland, Oregon 97229.

#### Model 900 Nanovolt Galvanometer

Ranges: 10nV (10pA) end scale to 3mV (3 $\mu$ A) end scale on zero-centered meter; 12 overlapping ranges in 1, 3, 10 sequence.

Accuracy: 2% of end scale for voltage and current.

Input Resistance: 1k $\Omega$  on all ranges.

Minimum Detectable Signal: Less than 2nV or 2pA.

Superimposed AC Rejection: Greater than 120 db (Infinite common mode rejection).

Noise: Less than 2nV or (2pA) peak-to-peak for all source resistances.

Damping: Slightly less than critically damped for all source resistances (adjustable).

Zero shift with source resistance change: None.

Price: \$1975.

# Technology

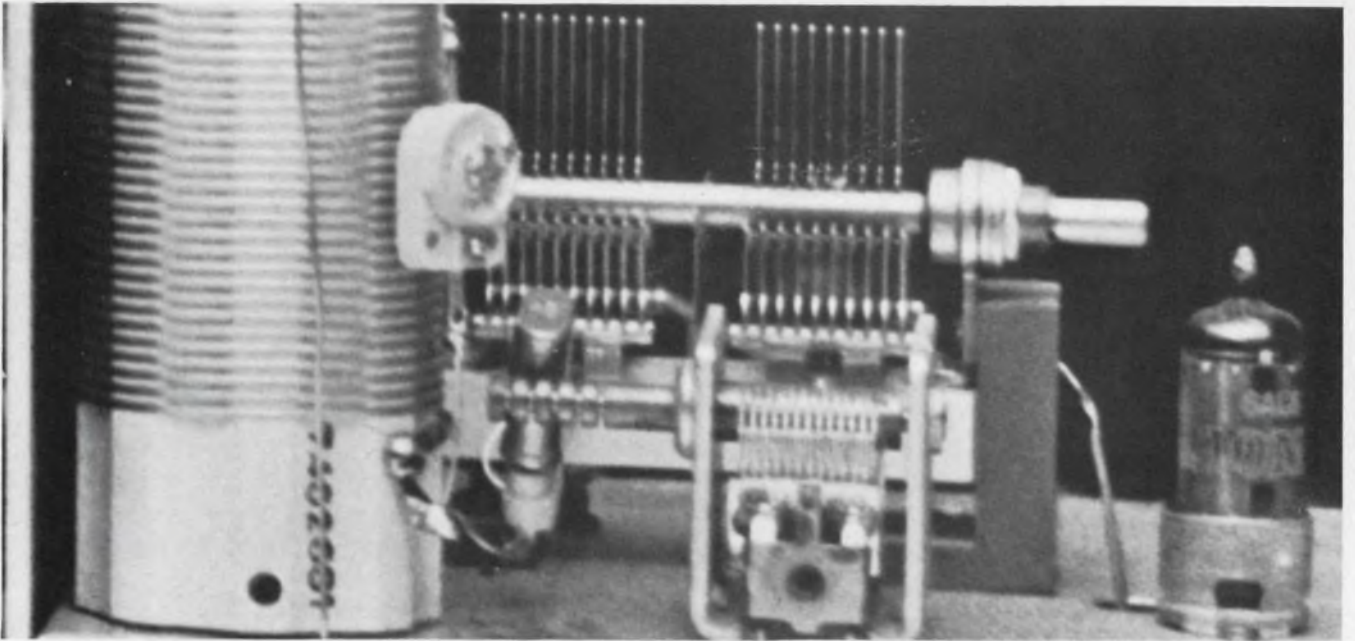

**Inductor increases the bandwidth of crystals to 2 per cent—20 times that of conventional**

oscillator designs. The wider band and simple design offset slight stability loss. Page 244

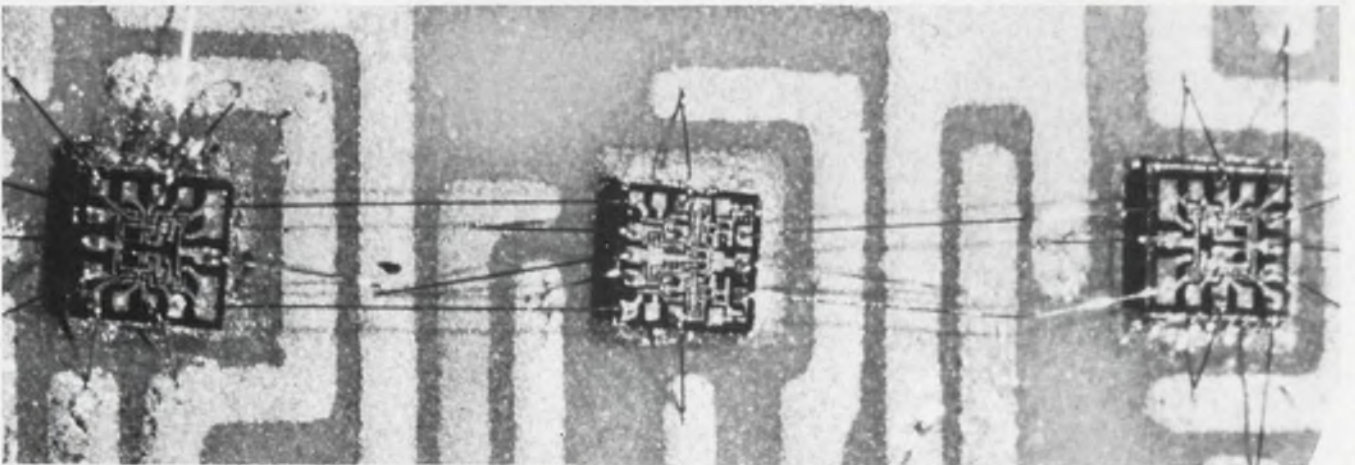

**Hybrid circuits combining ICs and transistors can improve on circuits that use either type of**

device alone. The key to success is selecting the right passive units for the job. Page 250

## Also in this section:

**SCEPTRE offers accuracy and speed in the design of electronic circuits.** Page 230

**All-npn transformerless IC gives pnp class-B stage efficiency.** Page 238

**Capacitance measurement is easy when a handy nomograph is used.** Page 258

**Variable-duty-cycle switching circuit controls retick illumination.** Page 261

# SCEPTRE gives designers new power

to design and analyze electronic circuits accurately and rapidly. Versatile modeling capability is a major feature.

SCEPTRE (Systems for Circuit Evaluation and Prediction of Transient Radiation Effects) is a newly designed circuit analysis program that is:

- Readily available to users (see the accompanying box).
- Relatively easy to adapt to a number of computers because it is written in FORTRAN IV language.

It is a system of IBM 7090/94 programs which supersedes PREDICT.\* In addition to everything that PREDICT can do, SCEPTRE incorporates these extra features:

- Higher computational efficiency.
- Optional stored models.
- Rerun capability.
- Automatic termination conditions.
- Dc capability.
- Flexibility.

## Engineer need not be a programmer

Both SCEPTRE and PREDICT are automatic circuit analysis programs. An automatic circuit analysis program can be described as one that does not require the user to write any circuit equations or to do any real programming. The circuit, including its topology and element values, is supplied to the program in a circuit description language which is easy to use and learn. All automatic programs can be categorized as either ac, dc or transient,<sup>1</sup> or any combination of these three. The basic operation of a transient analysis program such as SCEPTRE is reviewed with the aid of Fig. 1.

At the beginning of the  $n$ th solution interval, the vector of state variables  $\dot{Y}(n)$  is a known quantity. A pass through the equation solution process produces all of the desired output quanti-

\*The PREDICT program has been operational for about two years and is scheduled for replacement by SCEPTRE on or about February 1, 1967. Both programs have been sponsored by the United States Air Force Weapons Laboratory at Kirtland Air Force Base, N. M., and their dissemination is controlled by this agency. They were developed and are maintained by the IBM Electronics Systems Center at Owego, N. Y.

ties that are valid at that point in time, as well as the derivatives of the state variables  $\dot{Y}(n)$ . These derivatives together with the state variable values  $Y(n)$  are integrated into the state variables that are valid at the  $(n+1)$ th solution interval. From this point on, the process repeats itself until the end of the transient problem is reached. The importance of the highly simplified block diagram of Fig. 1 is that it helps to illustrate the primary factors involved in the amount of computer time required for the solution of any given problem. The numerical integration routine controls the size of the solution increments that can be taken and, therefore, the number of solution increments that are required. The efficiency with which the equation solution operations are carried out controls primarily the amount of computer time required per solution increment. It is thus important to make some effort to optimize the set of circuit equations that are used to compute the transient response of the circuit under investigation.

## New solution approach improves efficiency

Computational efficiency is improved by a new approach to the solution of circuit equations. While the mathematical formulation remains essentially the same as PREDICT's, the manipulation of topological and coefficient matrices in order to solve the equations has been greatly reduced. Instead, a set of actual circuit equations is created from a simple topological description of the circuit presented to the computer. These equations are similar to those that could be written by an experienced circuit analyst or engineer. To do so manually, however, would be an extremely tedious task and open to error.

Before the program generates the circuit equations, it conducts a very elaborate investigation of the circuit topology to determine how the equations should be written. This analysis establishes a set of equations which, when solved repeatedly, as indicated in Fig. 1, produces a significant reduction in computer time. A detailed description of the actual formulation of these circuit equations can be found elsewhere.<sup>2</sup>

As SCEPTRE proceeds with the creation of the



circuit equations, a FORTRAN subprogram is generated which contains these equations. This subprogram also contains the instructions required to control the computer's handling of circuit element and parameter values, equation solution and numerical integration as well as the output of computed results. After the subprogram has been completely generated, it is automatically compiled and executed. It is during execution of the subprogram that the circuit response is computed.

### Optional models can be stored

Storing a frequently used device model can save the designer considerable time. SCEPTRE allows the user to store and recall easily any equivalent circuit that he has a frequent need for. Most contemporary circuits include various types of diodes and transistors that require equivalent circuits of varying degrees of complexity. For example, a large-signal equivalent circuit for a transistor usually requires four to six passive elements and at least three or four current generators. If the computer program lacks a stored-model feature, the user has no alternative but to insert each component individually into the overall circuit. A partial remedy for this problem would be to provide an exclusive stored model of conventional form for diodes and transistors. The word exclusive is used in the sense that the user must use whatever topology is provided in the

stored model; little, if any, provision is made for flexibility.

A better solution, and the one used in SCEPTRE, is the optional stored-model feature. The user may himself store any equivalent circuit that is composed of resistors, capacitors, inductors (including mutual inductance), and voltage and current sources. This makes it possible to store frequently used subnetworks, such as biasing networks and filter sections, as well as equivalent circuits of active devices. Once stored, any of the models can be called out for use as many times as needed in a given circuit application.

### Effect of value changes is easier to calculate

It is often desirable to know how a given network would function if one or more of its components or forcing functions were varied in size. Of course, it is always possible to submit entirely new runs which contain the variations of interest, but there is a better way.

A master run is first described; this includes the nominal values of all components and forcing functions. The user appends to this description a list containing the number of reruns desired and the elements that are to be changed for each rerun. The FORTRAN program containing the circuit equations is then executed once for the original run and again for each rerun. Since it is only necessary to create the FORTRAN program once, less computer time is required than for



SCEPTRE print-out of design problem results is analyzed by authors Sents (l) and Sedore (r).

### SCEPTRE'S availability

SCEPTRE for the IBM 7094 computer is available to users who get clearance from:

Lt. Gary Pritchard, WLRET,  
U.S. Air Force Weapons Lab.,  
Kirtland Air Force Base,  
Albuquerque, N. M. 87118.

After receiving the necessary clearance, the user can arrange to obtain manuals and have his own tape magnetized at no charge by contacting:

Harry Mathers,  
IBM,  
Radiation Effects Department,  
Owego, N. Y. 13126.

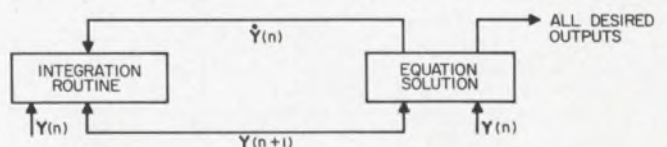

1. SCEPTRE operates by repetitive solution of circuit equations until the desired transient solution is obtained. The numerical integration routine determines the size of the solution increments that can be taken and, therefore, the number of solution increments required.

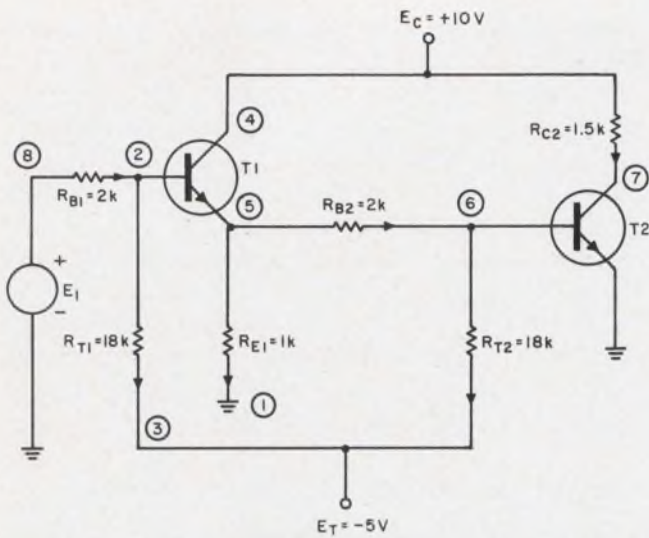

2. Performance of SCEPTRE can be demonstrated by using this circuit. The program is used to determine the effects of a noise spike at the two-stage circuit's input.

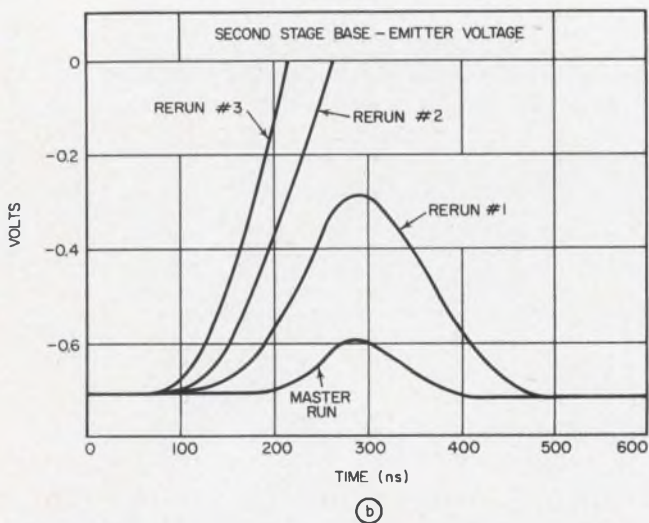
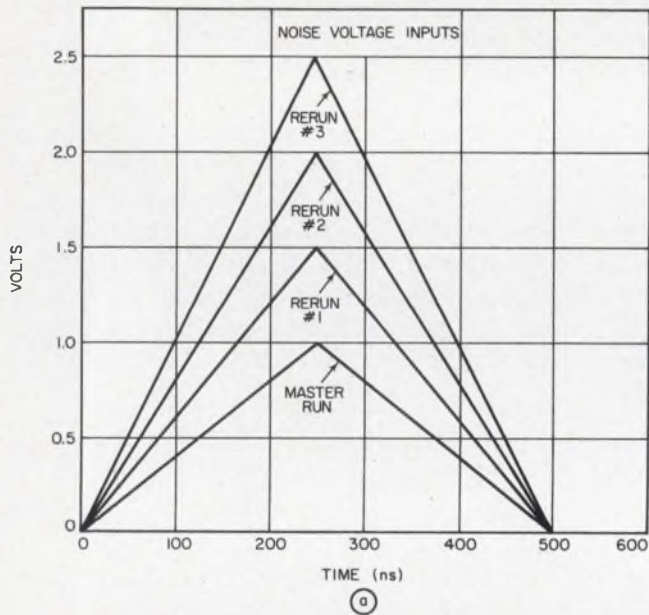

3. The spread of input pulses is applied to the circuit in four runs (one master and three succeeding runs) (a). Corresponding output plots of the base-emitter voltage for the second stage are shown in (b).

separately repeated runs.

The fact that SCEPTRE provides a rerun facility does not imply that anything like true statistical analysis is economically feasible. Solution times per run are still measured in minutes, so a large number of reruns can become an expensive proposition.

### Transient runs automatically stop at preset limits

In some instances the user will have no interest in carrying a transient run to completion, if it is known that some voltage or current has exceeded, equaled, or dropped below some other quantity or criterion. A single entry into the program can set up the logic necessary to monitor and automatically terminate a run.

The practical application of both the rerun and the automatic-termination features may be illustrated with the circuit shown in Fig. 2. The node numbers and reference current directions have been arbitrarily chosen. The aim is to determine the effects of a noise spike at the input of a two-stage logic circuit. Both stages are normally held in the off condition, so that no current flows in the load resistor,  $R_{L2}$ , of the inverter stage. It is assumed that the error criterion of this circuit is the turn-on of stage T2. This would be indicated by a positive voltage across the base-emitter capacitance of that stage. Once this occurs, the analyst has no further interest in the rest of the transient response. The spread of input pulses shown in Fig. 3a is to be applied to the circuit in four runs (one master and three reruns). The corresponding output plots for the base-emitter voltage of the second stage are given in Fig. 3b.

It can be seen that the results of the master run (with the 1-volt input) show little effect on the input to the second stage. The first rerun (with the 1.5-volt input) does indicate that a substantially larger signal reaches the second stage. Both these runs are carried through to the originally specified problem duration of 1000 nanoseconds. The second rerun (with the 2-volt input) shows that the effect of the input signal was sufficient to forward-bias the base of the second stage and therefore trigger the automatic-termination feature. This run was automatically stopped at a problem time of approximately 260 nanoseconds. The third rerun followed the same pattern, with the exception that the larger input signal turned the second stage on sooner, with the result that this run terminated at approximately 210 nanoseconds.

All four runs can be obtained with one submission of a single deck of cards. If the equivalent circuit for the transistors has been stored at some previous time as Model X1 (designation for a particular model), the only cards required for the solution of the master runs and the three runs

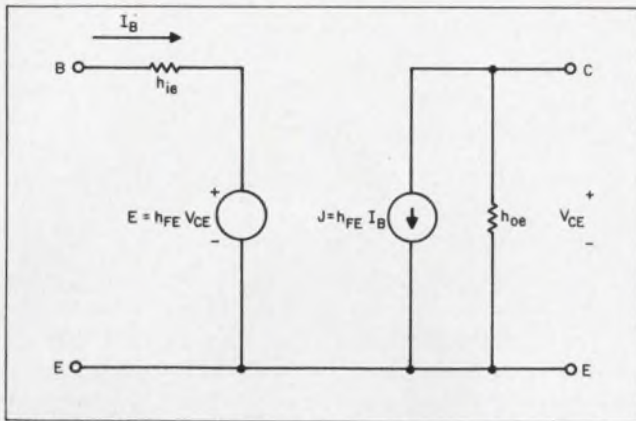

4. Though not as versatile as the Ebers-Moll equivalent, the low-frequency  $n$ -parameter model is often very useful because of its simplicity. Generally this type of model is not available in automatic transient programs because of the dependent sources. SCEPTRE, however, has provisions for accommodating this type of model.

(including initial conditions) are those containing the following FORTRAN statements (symbols used refer to quantities shown in Fig. 1):

#### CIRCUIT DESCRIPTION

##### ELEMENTS

EC, 1-4=0

ET, 3-1=5

E1, 1-8=TABLE 1 (TIME)

RB1, 8-2=2

RT1, 2-3=18

RE1, 5-1=1

RB2, 5-6=2

RT2, 6-3=18

RL2, 4-7=1.5

T1, 2-5-4 MODEL X1

T2, 6-1-7 MODEL X1

##### OUTPUTS

VCET1, VCET2, IRL2, IRE1, PLOT

##### FUNCTIONS

###### TABLE 1

0, 0, 250, 1, 500, 0, 600, 0

##### RUN CONTROLS

##### RUN INITIAL CONDITIONS

TERMINATE IF (VCET2, GT, 0)

STOP TIME 1000

RERUN DESCRIPTION (3)

##### FUNCTIONS

###### TABLE 1

0, 0, 0, 0,

250, 1.5, 2, 2.5

500, 0, 0, 0,

600, 0, 0, 0,

END

#### Iterative technique gives dc results

There are a great many situations in which the analyst is concerned with the steady-state dc status of a given network without regard to any transient. In many practical cases, these situa-

tions are merely the initial conditions that prevail in a circuit at the instant that transient forcing functions are applied. The correct initial conditions must be determined as a prerequisite to obtaining a correct transient solution. In other cases, the dc result itself is the objective and a transient solution is not even desired. Dc solutions can usually be obtained much more efficiently and economically than can transient solutions since a complete time history is not required. An iterative technique, which is entirely independent of the transient-problem formulation, yields the dc results.

PREDICT was not equipped with any special means for dc problem solution; SCEPTRE is. The capability can be used in conjunction with the transient program, or can operate quite independently with a great degree of flexibility.

#### SCEPTRE affords increased flexibility

Some idea of the trend toward flexibility has already been mentioned in connection with optional stored models, but there is considerably more to the subject. As an example, consider the use of a class of small-signal equivalent circuits in Fig. 4. This low-frequency  $h$ -parameter equivalent is not nearly as versatile as the large-signal Ebers-Moll equivalent, but applications do arise when its simplicity of form (as well as the comparative availability of parameters) makes its use desirable. Generally, models of this type are not available for use with automatic transient programs because of the source dependencies involved. It can be seen in the figure that the model contains a voltage source that is dependent on a resistor voltage, and a current source that is dependent on a resistor current. Neither of these independent variables is specifically provided in the general formulation<sup>3</sup> of the transient problem, since they are not state variables. Special provision is made in SCEPTRE's formulation to accommodate these types of sources and, therefore, this entire class of equivalent circuits.

Another example of the trend toward flexibility is the fact that the user may determine the power dissipation in any resistor, say R1, by simply defining a pseudo circuit parameter. This parameter would be defined in the circuit description language as  $PR1 = (R1 * IR1^{**} 2)$ . In FORTRAN IV, \* means multiply and \*\* means square, i.e.,  $P=IR^2$ . The user who is more computer-oriented may write subprograms in FORTRAN IV himself, which will work in conjunction with the main program to perform a great variety of tasks. In this respect, the only limitation is the user's own knowledge and imagination.

The program may also be used to solve systems of first-order differential equations that may or may not have any connection with the electrical

# Still using LC's? This might change your mind:

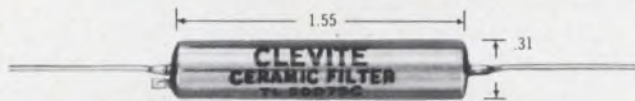

**Clevite's ceramic ladder filters deliver 80 db rejection in 0.1 cu.in.!**

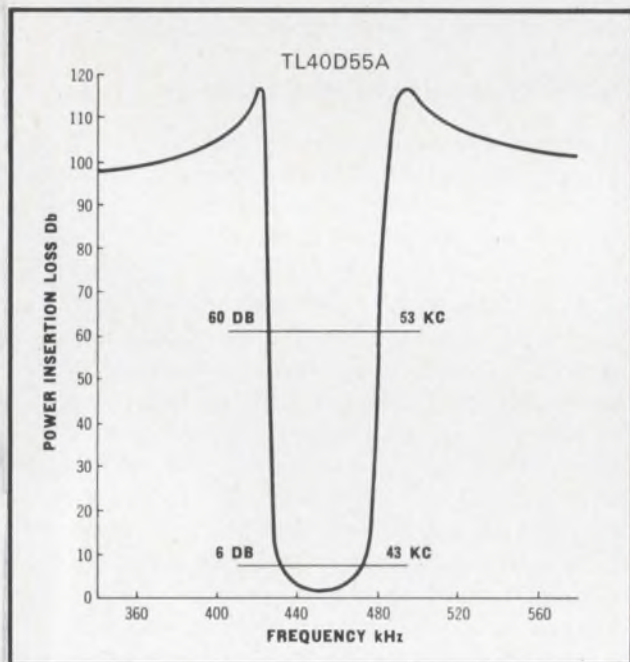

Here's a fixed-tuned filter that offers more selectivity for its size than any conventional i-f filter on the market! Clevite's non-magnetic, non-microphonic, 17-disc ceramic ladder filter is ideal for i-f stages of high quality superheterodyne radio receivers used in airborne or ground AM and FM communications equipment. Stop band rejection: 60 or 80 db. Center frequency tolerance:  $\pm 1$  kHz for 20 kHz B/W and below;  $\pm 2$  kHz for 30 kHz B/W and above. Stability: within  $+0.2\%$  for 5 years; within  $0.2\%$  from  $-40^{\circ}\text{C}$  to  $+85^{\circ}\text{C}$ . Impedance (in and out) 2500 ohms for 12 kHz bandwidth and below; 1500 ohms for 13 kHz to 29 kHz B/W; 1200 ohms for 30 kHz bandwidth and above.

Following models standard at 455 kHz (A) or 500 kHz (C) (custom models on special order):

Model Number	B/W Min. @ 6db	B/W Max. @ 60db	Model Number	B/W Min. @ 6db	B/W Max. @ 60db
TL-2D5 (A)	2 kHz	5 kHz	TL-20D32 (A)	20 kHz	32 kHz
TL-4D8 (A)	4 kHz	8 kHz	TL-30D45 (A)	30 kHz	45 kHz
TL-6D11 (A)	6 kHz	11 kHz	TL-40D55 (A)	40 kHz	55 kHz
TL-8D14 (A)	8 kHz	14 kHz	TL-45D65 (A)	45 kHz	65 kHz
TL-10D16 (A)	10 kHz	16 kHz	TL-50D75 (C)	50 kHz	75 kHz
TL-16D25 (A)	16 kHz	25 kHz			

**PRICES:** 1 — \$52.50; 25 — \$42.00 ea; 100 — \$36.75 ea; 500 — \$31.50 ea; 2000 — \$26.00 ea.

(Prices subject to change without notice.)

Send order or request for Bulletin 94017 to: Clevite Corporation, Piezoelectric Div., 232 Forbes Rd., Bedford, Ohio 44014, U.S.A. Or: Brush Clevite Company, Limited, Southampton, England.

## CLEVITE

ON READER-SERVICE CARD CIRCLE 194

network. Consider this system:

$$x = -6x + 5y + 10$$

$$y = 5x + 7y + 2z$$

$$z = 0.2y - 0.2z - 0.5$$

where  $x(t_0)$ ,  $y(t_0)$ ,  $z(t_0)$ , the initial conditions, are all known.

The complete transient response to this system can easily be obtained with just a few input data cards. Finally, as output, SCEPTRE will produce a listing of the results of the steady-state initial-conditions computation, if this type of analysis has been requested. For transient runs, a listing of the time histories of the computed results is produced along with machine-plotted graphs of these computed quantities, plotted against time or any other computed quantity. None of these examples of program flexibility is possible in PREDICT.

### SCEPTRE uses FORTRAN IV language

SCEPTRE is written entirely in FORTRAN IV programming language and it is run using a 7090/94 computer. An IBM System/360 conversion effort is also anticipated but no definite plans exist at this time.

Program modularity, program debugging aids, and the use of the less exotic or standard, FORTRAN statements were the major considerations in writing the program. The purpose of this approach was to enhance the convertibility of the program for use on computing systems other than the IBM 7090/94. Such an effort requires only a conversion from 7090/94 FORTRAN IV to the FORTRAN of computer X, rather than symbolic machine language for the 7090/94 to computer-X machine language. A secondary benefit is derived from a system programmed in FORTRAN if a user wishes to make modifications to the program to suit his specific needs, for changes in a FORTRAN program can normally be made more easily than in machine language versions. ■ ■

### Acknowledgement:

The authors wish to acknowledge the vital contributions that were made by Dr. Ralph M. Warten, IBM, Palo Alto, California.

The work described in this paper was sponsored by the U.S. Air Force Weapons Laboratory, a part of the Air Force Systems Command's Research and Technology Division, under contract AF 29 (601)-6852 with the Air Force Special Weapons Center, Kirtland AFB, N. M.

### References:

1. Stephen R. Sedore, "Computers Aid Circuit Design," *ELECTRONIC DESIGN*, XIV, No. 1 (Jan. 4, 1966), 96-99.
2. "Automated Digital Computer Program for Determining Responses of Electronic Systems to Transient Nuclear Radiation," Vol. II, IBM File No. 66-928-6II, Owego, N. Y., Sept., 1966.
3. T. R. Bashkow, "The A Matrix, New Network Description," *Trans. RE (Prof. Group on Circuit Theory)*, Vol. CT04, Sept., 1957, 117-119.
4. "Automated Digital Computer Programs for Determining Responses of Electronic Systems to Transient Nuclear Radiation," Vol. 1, IBM File No. 66-928-6II, Owego, N. Y., Sept., 1966.

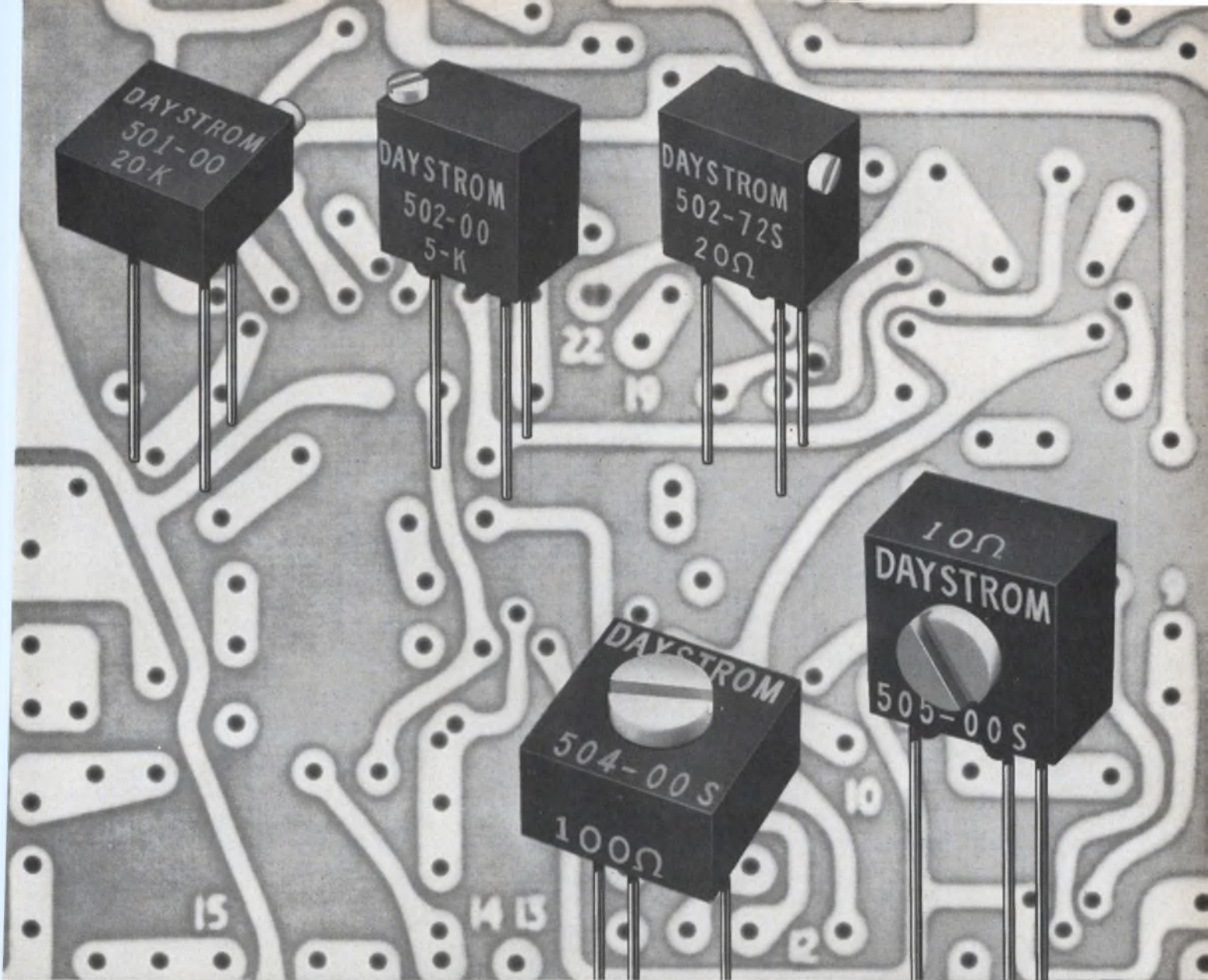

## Savings across the board just took a new turn

DAYSTROM Commercial Squaretrim® potentiometers now include single-turn types. New models 504 and 505 are fully adjustable with just one turn. Models 501 and 502 are 15-turn types. They all clear up to 80% more PC board space—at no extra cost. But the trim .02 cubic inch size is only one reason why these commercial 500 Series pots are proving so popular. They also feature Weston's exclusive wire-in-the-groove design, and all these performance extras:

Convenience 5 different configurations with adjusting screw on top, side or end • Tolerance  $\pm 5\%$  • Adjustability 15 turns or single turn • Slip Clutch eliminates wiper damage, cuts production delays • Suregard™ Terminations for better protection against vibration, shock and humidity—no pressure taps • Superior Resolution 0.125% or less • Wide Range  $10\Omega$  to  $20K$  (higher values on request) • High Power 0.6 watt in still air at  $70^\circ C$  • Wide Temperature Range  $-55^\circ C$  to  $150^\circ C$  • Low Temperature Coefficient 70 ppm max. • Low Noise  $100\Omega$  max. ENR • Small Size  $\frac{3}{16}'' \times \frac{3}{16}'' \times \frac{3}{16}''$  • Low Cost \$2.10 each for 501/502 in 500 lot quantity, \$1.95 each for 504/505 in 500 lot quantity.

Daystrom potentiometers are another product of:

**Weston Instruments, Inc. • Weston-Archbald Division • Archbald, Pa. 18403**

**WESTON®** prime source for precision... since 1888

ON READER-SERVICE CARD CIRCLE 195



# Five unique applications of FETs from

## 1. UHF tuner employs FET for low cross modulation

Here — for the first time — is a practical UHF tuner which offers considerable cross-modulation improvement in the RF stage. This circuit is made possible by the superior high-frequency performance of TI's 2N3823 N-channel silicon FET. In addition to its low cross-modulation characteristics, the circuit has a power gain of 12 to 15 dB from 400 to 900 MHz and a VSWR of less than 2 from 500 to 900 MHz with an input impedance of 50  $\Omega$ .

The accompanying graph shows the excellent cross-modulation performance of the tuner.

Circle 91 on the Reader Service card for application note on this tuner.

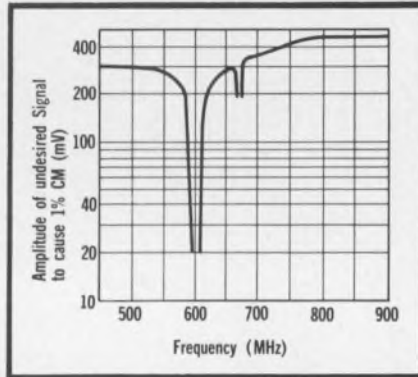
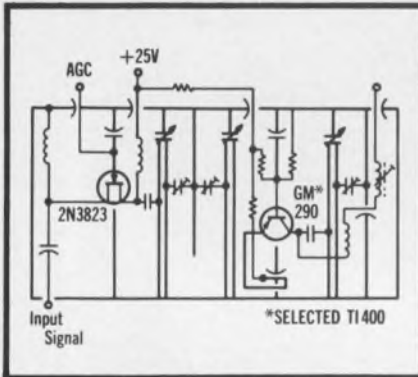

1. UHF tuner employs a TI 2N3823 N-channel silicon FET for improved cross modulation performance

## 2. Charge-sensitive preamplifier uses TI FET for lowest noise, highest resolution

This preamplifier, developed by Oak Ridge Technical Enterprises Corporation for nuclear detectors, limits noise to only 170 electrons rms when used with low-capacitance detectors. The extremely low noise level of field-effect transistors from TI permits detection and accurate measurement of low energy X-rays and gamma rays (less than 20 keV).

ORTEC determined that specially-selected 2N3823s resulted in superior amplifier performance. The graph at the left illustrates improvement in noise level compared with vacuum tubes, nuvistors and bipolar transistors.

Circle 92 on the Reader Service card for data sheet on the 2N3823.

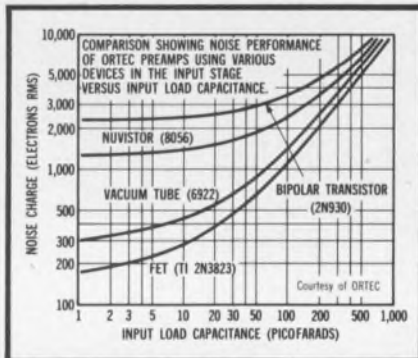
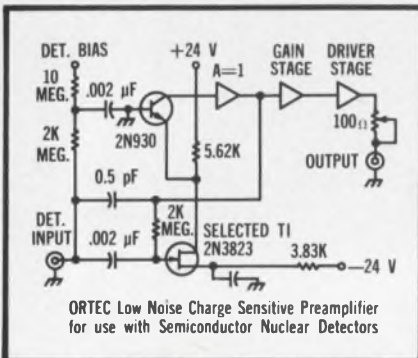

2. ORTEC charge-sensitive preamplifier uses FET for accurate measurement of low-energy radiation

## 3. 500 MHz FET oscillator achieves frequency stability without temperature compensation

This oscillator demonstrates the excellent high-frequency characteristics of the 2N4856 N-channel silicon FET from Texas Instruments. Power output, at 500 MHz with a  $V_{DD}$  of 20 V, is greater than 140 mW.

Frequency stability is a major advantage of FET oscillators. The graph at left compares frequency drift with temperature change for a 100 MHz FET oscillator versus a bipolar transistor. FET oscillators result in simpler biasing and possible elimination of AFC circuitry.

Circle 93 on Reader Service card for Silicon Technology Seminary paper on FET oscillators.

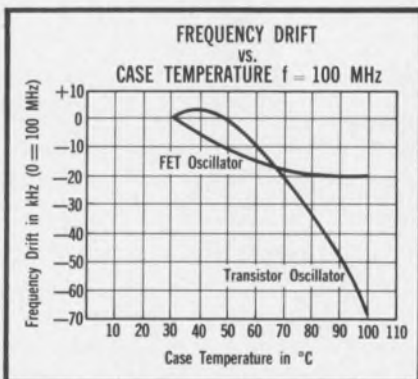
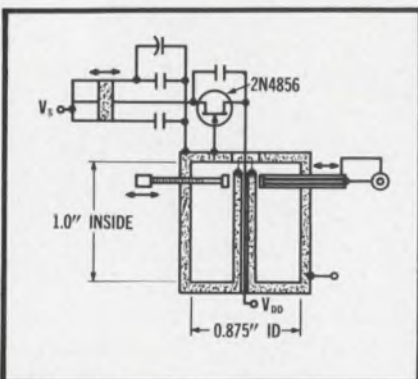

3. 500 MHz FET oscillator. Graph shows frequency stability over a temperature spread of 75 °F

*TI cannot assume any responsibility for any circuits shown or represent that they are free from patent infringement*



# Get pnp Class-B stage efficiency

in an all-npn transformerless integrated circuit that has a flat frequency response from dc to 30 MHz.

A long-standing problem in the design of efficient integrated-circuit (IC) output stages has been the inability to build IC facsimiles of the classic Class-B configuration. The problem stems from the fact that the quality of the required complementary pnp devices does not so far match that of the npn ones.

A novel circuit arrangement (patent applied for in the U.K.) using npn devices throughout can be constructed to yield a Class-B amplifier output stage with high efficiency, flat response from dc to well in excess of 30 MHz, and propagation delays of less than 5 ns.

Applications for the circuit include:

- Fast, nonsaturating digital push-pull stages.
- Audio and servo amplifiers.

## Why use the proposed circuit?

A general Class-B output stage that uses complementary (nnp and pnp) transistors is shown in Fig. 1. It has served as an audio amplifier output stage, a servomotor bidirectional drive, an analog operational amplifier output stage—in fact, anywhere where current has to be both driven into and taken out of a load.

The fundamental difficulty in producing an integrated circuit of the same configuration lies in the need for complementary transistors. The present IC processes result in pnp transistors that are of poor quality compared with npn ones. Specifically, their current gain and frequency response are inferior to those of discrete pnp transistors. The low current gain of these pnp transistors can be overcome by using npn-pnp pairs to simulate discrete pnp transistors. However, the poor frequency response which they exhibit remains a fundamental limitation to their performance at high frequencies.

## The pure npn approach solves the problem

The ideal solution to this problem is a circuit analogous to the simple npn-pnp complementary

emitter-follower but constructed only of npn transistors. This implies the use of two voltage-amplifying stages, one driving positive current into the load and the other drawing negative current from it. These two stages are easily designed, the first being an npn emitter-follower and the other an npn grounded-emitter stage with voltage feedback. However, when these stages are connected together to provide the required push-pull function, there arises the basic difficulty of preventing a large idling current from flowing between them. It is the prevention of this large idling current by a very simple arrangement that is the feature of the present circuit.

## The principle is simple

Figure 2 shows four transistors with shorted collector-to-base leads. This means, in effect, that they are connected as a diode quad. The current flowing in either arm of this quad will be dependent upon the voltage/current characteristics of the four base-emitter junctions. Herein lies the fundamental principle because, if the four transistors are constructed on a single integrated-circuit chip, they will all have base-emitter junctions with closely matched current/voltage relationships. Thus current ( $i_{D1}$ ) flowing through one pair of diodes ( $D1$  and  $D2$ ) will cause a voltage drop across  $D1$  and  $D2$ . This will define the current that

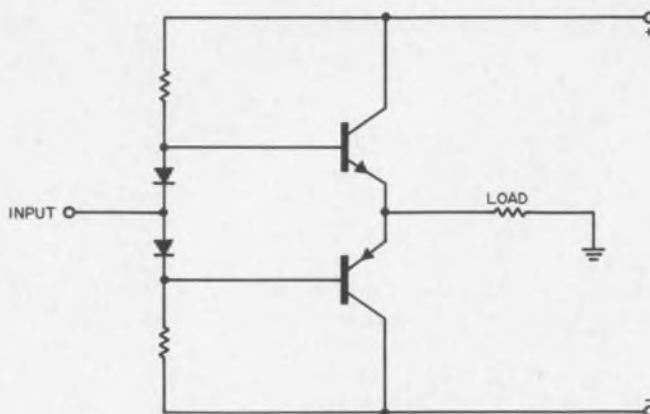

1. Classic Class-B stage configuration employing complementary pair of transistors is difficult to make with present IC techniques.

M. J. Teague, The Plessey Co., Ltd., Towcester, Northamptonshire, England.



must flow through the other pair of diodes ( $D3$  and  $D4$ ) as equal to  $i_{D1}$ . Consequently, if a current  $i_L$ , which is greater than  $i_{D1}$ , is made to flow in one diode ( $D3$ ) of a pair, then the current  $i_{D2}$  flowing through the other diode ( $D4$ ) of that pair must reduce to a value that is less than  $i_{D1}$ , in order to maintain the correct voltage drop defined by  $i_{D1}$ .

### Let's design a circuit

A practical Class-B circuit-coupled output stage employing the foregoing principle is shown in Fig. 3. The basic quad consists of  $D1$ ,  $D2$ ,  $D3$ , and the base-emitter junction of emitter-follower  $Q1$ . The resistor  $R_b$  is chosen to provide sufficient base current for  $Q1$  when the output voltage is positive, and consequently any current flowing through it will be small compared with the maximum load current.  $Q2$  is a grounded-emitter stage with voltage feedback through  $R_f$ ; it is driven by the collector current of  $Q3$ .  $D4$  and  $Q3$  are identical-geometry devices. Since they are on the same chip, the collector current of  $Q3$  is defined by input current  $i_s$  because of the close base-emitter voltage match of the two devices. Thus the output voltage is determined by signal current  $i_s$  flowing through the resistor  $R_f$ . Neglecting for the moment the action of the diode quad, it can be seen that this is the basic arrangement for a push-pull stage—that of two voltage amplifiers, one to drive

current into the load ( $Q1$ ) and the other to draw current from it ( $Q2$ ). It can also be seen that these two stages could have a large idling current flowing between them were it not for the diode quad. The operation of the quad to limit this idling current is as follows.

### The idling current is minimized

If the output voltage is positive, then load current will flow through  $Q1$  causing its base-emitter voltage to increase. The current taken by  $Q2$  through diode  $D3$  is consequently reduced to a value below that of  $i_{D1}$ . Similarly, if the output voltage is negative, then the voltage developed across  $D3$  due to load current will reduce the bias voltage available for  $Q1$  and lower its current to a value below  $i_{D1}$ . When the output voltage is zero, there is no load current and the idling current flowing through  $Q1$ ,  $D3$  and  $Q2$  will be defined by the current flowing through  $R_b$ ,  $D1$  and  $D2$ .

The diode quad has quite simply performed the feat of limiting the idling current of this output stage to a value that is small in comparison with the peak load current. Because of this, almost true Class-B efficiency can be obtained with a complete absence of crossover distortion. It should be noted that, in addition to limiting the idling current to an efficient value, the diode quad allows the output potential to be defined entirely by voltage

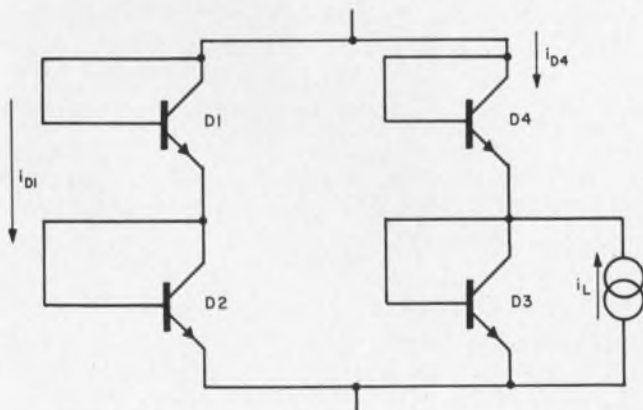

2. A diode quad of npn transistors on a single chip features very close current/voltage match between the transistors' base-emitter junctions.

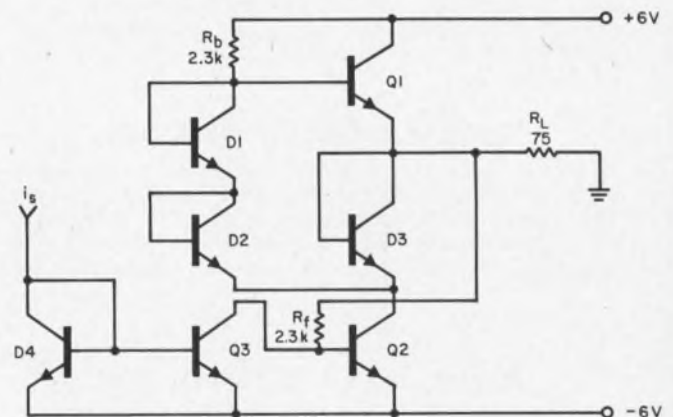

3. The complete all-npn Class-B stage built around the quad ( $D1$ ,  $D2$ ,  $D3$ ,  $Q1$ ) has very low idling current.

# New from Wiley

## THE TECHNICAL PROGRAM MANAGER'S GUIDE TO SURVIVAL

By MELVIN SILVERMAN, *General Precision, Inc.* Fully explains the mechanisms and philosophy of program management. A step-by-step description is provided of the design, development, and production of a product under the program management concept. 1967. Approx. 152 pages. \$6.95.

## SYSTEM ANALYSIS BY DIGITAL COMPUTER

Edited by FRANKLIN F. KUO, *University of Hawaii*, and JAMES F. KAISER, *Bell Telephone Laboratories, Inc.* A pioneering book on the computer techniques that will form much of the basis for system engineering design during the next few years. 1966. 438 pages. \$8.95.

## ELECTRONIC DIGITAL SYSTEMS

By R. K. RICHARDS, *Consulting Engineer.* Distills items of basic character from a mass of information, providing the reader with ready access to every important scheme devised to meet the requirements of digital systems. 1966. 637 pages. \$15.00.

## PHASELOCK TECHNIQUES

By FLOYD M. GARDNER, *Consulting Engineer.* The first book to gather together the journal literature on phaselocks and present it in a consistent, understandable way. 1966. 182 pages. \$8.95.

## FILTER DESIGN TABLES AND GRAPHS

By ERICH CHRISTIAN, *ITT Telecommunication Division*, and EGON EISENMANN, *Telefunken A. G., Germany.* A valuable aid to the network designer, arranged in three parts: 1) A concise introduction with numerical examples; 2) Tables; and 3) Nomographs. 1966. 310 pages. \$9.95.

## ANALYSIS AND SYNTHESIS OF TUNNEL DIODE CIRCUITS

By J. O. SCANLAN, *The University of Leeds, England.* A thorough, relatively advanced treatment of the basic mathematical approach to the analysis and synthesis of sinusoidal tunnel diode circuits. 1966. 274 pages. \$9.75.

## FEEDBACK CIRCUIT ANALYSIS

By S. S. HAKIM, *McMaster University, Hamilton, Ontario, Canada.* An excellent book for the practicing electronics engineer who seeks a sound understanding of the feedback problem and its various circuit implications. 1966. 392 pages. \$17.50.

Order from your bookseller or

**JOHN WILEY & SONS, Inc.**  
605 Third Avenue, New York, N. Y. 10016

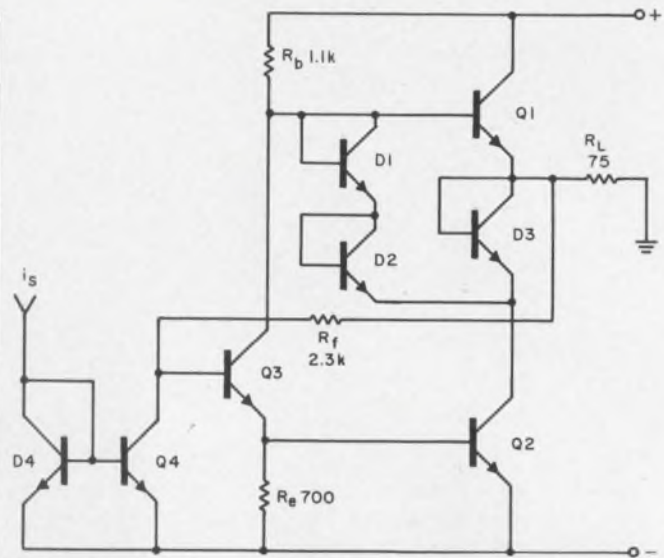

4. Even more efficient circuit than that of Fig. 3 can be made with only slight modifications. Its frequency response is flat from dc to well beyond 30 MHz; its propagation delay is less than 5 ns.

feedback stage  $Q2$  and  $R_f$ , forming the rather unusual arrangement of an emitter-follower without any direct drive to its base.

The values given in Fig. 3 are those for a video output stage which was designed to drive a  $\pm 3$ -volt signal into a 75-ohm load from a 6-volt supply. The design minimum  $h_{fe}$  of the transistors was 40.

An even more efficient arrangement is shown in Fig. 4 where the current flowing through  $R_b$  is used to provide base drive current for  $Q2$  when the output voltage is negative.  $Q3$  has an emitter resistor to keep its current at a level consistent with having a good  $f_T$ . The use of  $Q3$  also provides an input buffer that allows all the signal current to flow in the feedback resistor, instead of being shunted into the base of  $Q2$  when the output is negative, as in Fig. 3. This improves the linearity of output voltage to input current without impairing efficiency. The method of driving this stage presents no difficulty: current generator  $i_s$  is simply a resistor that is large compared with the dynamic impedance of diode  $D4$ . If this resistor is made equal to  $R_f$ , then the stage would have approximately unity voltage gain. Higher gain can be achieved by making  $Q4$  a larger-geometry device than  $D4$ .

The circuit shown in Fig. 4 has been made by the Plessey Company's silicon integrated-circuit process. It gives excellent results, with an efficiency previously associated only with pnp transistor stages, and a frequency response that is flat from dc to well beyond 30 MHz. This circuit is being considered for use as a fast, nonsaturating, digital push-pull drive stage. In this application measurements show that propagation delays less than 5 ns can easily be attained. ■ ■

# PUT YOUR FINGER ON REAL MINIATURIZATION



It's one thing to build small connectors. It's something else again to make them tiny *and reliable*. Like BRM, designed and developed by BENDIX/DAGE. BRM is one-fourth the size and weight of standard BNC and TNC, yet is loaded with quality features such as hermetic sealing, captive contacts, gold-over-silver plating . . . and low, *low* VSWR. That's *real* miniaturization. BENDIX/DAGE engineering contributes to the state of the art by helping *you* move forward to greater capabilities in *your* field.

Write for BRM/BRMM brochure and Engineering Qualification Test Reports. If you have a special problem, call. Call today!



**DAGE ELECTRIC COMPANY**

a subsidiary of the Bendix Corporation

Hurricane Road • Franklin, Ind. • Phone 317/736-6136

FIRST WITH IDEAS • FIRST WITH QUALITY • FIRST WITH SERVICE  
ON READER-SERVICE CARD CIRCLE 197

*this DIGI ▲ EC<sup>®</sup> ad is directed to...*

**USERS OF TRANSDUCERS WHO REQUIRE DIGITAL READOUT AND ORIGINAL EQUIPMENT MANUFACTURERS WHO REQUIRE DIGITAL INSTRUMENTATION**



**DIGITAL VOLTMETER**  
Model 201



**PRINTER**  
Model 611/620

**10 POINT SCANNER**  
Model 631



**DIGITAL CLOCK**  
Model 661



United Systems Corporation, manufacturers of

**DIGI ▲ EC**

low cost, high performance digital instrumentation, invites your inquiries to the above areas of interest

Our Senior Applications Engineer, Fred Pummill, Sales Manager, L. A. Lebowitz or Marketing Manager, Jack Paster will be happy to accept your call to discuss your requirements. (513) 254-6251



Stocking Representatives  
Throughout the World

For complete specifications,  
request new catalog D-67

Typical of our efforts to date include:

- Digital Readouts and Systems Interface for Color TV tube checkout
- Measurement and display of moisture content in tobacco and grain
- Measurement, display and control of liquid volume such as milk and oil
- Measurement, remote readout and control of bulk loading hoppers
- Measurement, presentation and recording of Exothermic reactions

**DIGI ▲ EC<sup>®</sup> by UNITED SYSTEMS CORPORATION**

918 Woodley Rd., Dayton, Ohio 45403



**We  
have  
a way  
with wire**

**(any way you want it)**

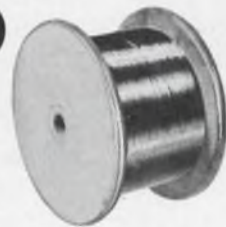

For example. Let's take a spool of wire. We can straighten it \_\_\_\_\_ and cut it. \_\_\_\_\_ (Diameters from .004 to .125, in lengths from .020" to 12 feet). And form it \_\_\_\_\_ into shapes \_\_\_\_\_ of all kinds. \_\_\_\_\_ Or \_\_\_\_\_ coil it. Head it \_\_\_\_\_ in sizes \_\_\_\_\_ as fine as .008". Upset it \_\_\_\_\_ even in multiples \_\_\_\_\_ as fine as .009". Or flatten it \_\_\_\_\_ wherever \_\_\_\_\_ you \_\_\_\_\_ want. Pierce it \_\_\_\_\_ to specs. \_\_\_\_\_ Swage it \_\_\_\_\_ in many \_\_\_\_\_ ways. Or chamfer \_\_\_\_\_ one end or both \_\_\_\_\_ ends—make a full radius on .025". And even give you \_\_\_\_\_ ? any combination \_\_\_\_\_ you may want. \_\_\_\_\_

Our range is from fine of .004" to heavy .125". Parts shown are subject to type of wire and temper. Send us your drawings and specs for an estimate. No obligation. And if you need small metal stampings, we do that too.

Write for free Bulletin 501  
**ART WIRE AND STAMPING CO.**  
17 Boyden Place, Newark, N. J. 07102

ON READER-SERVICE CARD CIRCLE 239

# Inductor ups crystals' bandwidth to 2%

as substitute for conventional capacitive loading. Wider band and simple design offset slight stability loss.

Inductive loading of crystal oscillators can increase their bandwidths to 2%—twenty times better than the range of conventional designs.

Bandwidths in excess of the usual 0.1% of capacitive-loaded oscillators are required in many applications, in particular in master oscillators for transmitters, RF test generators and local oscillators for receivers. These applications need a frequency stability that is better than LC oscillators' but not so high as that of conventional crystal oscillators.

Wider frequency range is achieved by operating the crystal below its resonant frequency and loading it with a variable inductance.<sup>1,2</sup> Some sacrifice of frequency stability ensues, but a well-designed unit will still hold stability to about two parts per million per hour at its least stable setting. The same unit without the variable inductance would have roughly one-seventh the frequency range and about ten times better stability.

The relationship between a crystal's characteristics and the load, and the effect of these on frequency range and stability, are shown by a simple analysis of the crystal's equivalent circuit.

The crystal should oscillate over a range from slightly above to about two percent below its resonant frequency. Since the crystal is capacitive below its resonant frequency, it must be inductively loaded if oscillation is to occur. Good variable inductors, however, are not readily available and are too bulky. A series combination of a fixed inductance and a variable capacitance does an equally good job and is much easier to handle. To examine the loading effects on the crystal, consider first its impedance in terms of its resonant frequency.

The negative value of the impedance of a lossless quartz resonator<sup>3</sup> is:

$$-Z_r = (\omega_r^3 - \omega^2) / \omega C_0 (\omega_n^2 - \omega^2) \text{ ohms, (1)}$$

where:

$$\omega = 2\pi f,$$

$$f = \text{frequency (Hz),}$$

$$\omega_r = \text{crystal resonant frequency,}$$

$\omega_a$  = crystal antiresonant frequency,

$C_0$  = crystal shunt capacitance.

Let:

$$\omega_r = \omega + \Delta\omega, \quad (2)$$

where  $\Delta\omega$  is a frequency change, which is small compared with  $\omega$ . Then:

$$\omega_r^2 \cong \omega^2 + 2\omega(\Delta\omega), \quad (3)$$

where the  $(\Delta\omega)^2$  term has been discarded as negligible. The square of the antiresonant frequency is:<sup>4</sup>

$$\omega_a^2 = \omega_r^2 (1 + C_1/C_0), \quad (4)$$

where  $C_1$  is the electrical equivalent of the mechanical compliance of the crystal. Substituting Eqs. 3 and 4 into Eq. 1 and simplifying yield:

$$-Z_r = 1/\omega C_0 [1 + (C_1/C_0) + (C_1 \omega / 2C_0 \Delta\omega)]; \quad (5)$$

$$-Z_r \cong 1/\omega_r C_0 [1 + C_1 f_r / 2C_0 \Delta f]. \quad (6)$$

For CR-18 crystals, in which  $C_0 = 7$  pF and  $C_1/C_0 = 1/250$ , the impedance becomes:

$$-Z_r \cong 22.7/f_r [1 + 2 f_r / \Delta f], \quad (7)$$

where

$Z_r$  = crystal impedance in  $k\Omega$ ,

$f_r$  = crystal resonant frequency in MHz,

$\Delta f$  = frequency change in kHz.

When the crystal is loaded with the series combination of a fixed inductance and a variable ca-

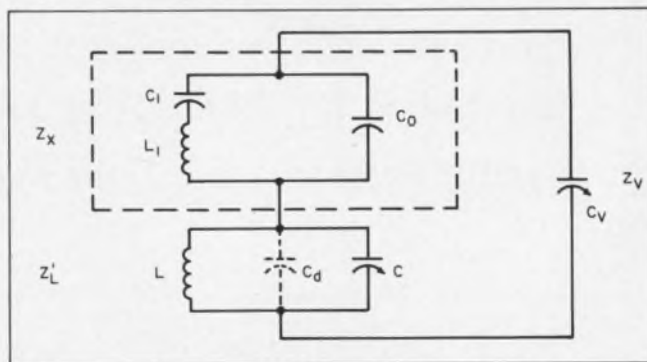

1. Equivalent circuit of an inductance-loaded crystal oscillator. The crystal has a capacitive impedance,  $Z_x$ . The parallel circuit of  $LC_1C$  has the inductive impedance,  $Z_L'$ . The tuning capacitance,  $C_v$ , has a capacitive impedance,  $Z_v$ .  $C_d$  is the distributed capacitance of the coil.

Frank W. Noble, Electronics Engineer, Laboratory of Technical Development, National Heart Institute, Bethesda, Md.

pacitor, a series circuit is formed, consisting of  $Z_r$ ,  $Z_v$  and  $Z_L'$ , where  $Z_v$  is the impedance of the variable capacitor and  $Z_L'$  is the impedance of the fixed inductor, as shown in Fig. 1.

The crystal will oscillate at a frequency for which the net circuit impedance is zero:

$$Z_r + Z_v = Z_L' \quad (8)$$

The easiest way to select the proper components and estimate stability is to plot the crystal's impedance variations with frequency. The curve for a CR-8 crystal is shown as a dashed line in Fig. 2. The curve actually represents the negative of the impedance, since that is more useful when  $Z_L'$  must be found (see Eq. 8).

The impedance-vs-frequency curve for any other type of crystal can be obtained by substituting the proper values of  $C_0$  and  $C_1$  into Eq. 6.

### Variable capacitor depends on practical factors

The extreme values of the variable capacitance ( $C_v$ ) are a function of the circuit configuration and manufacturing limitations (Fig. 3).

The minimum capacitance of a commercial air capacitor with large capacitance ratio tends to be in the range from 5 to 8 pF. In addition, the total minimum value of  $C_v$  cannot exceed the sum of stray capacitance to ground and that part of  $C_v$  which is in series with the crystal. Experience shows that a minimum value of about 7 pF is acceptable, provided that stray capacitances are kept low. The capacitor's impedance at its minimum value is denoted as  $Z_{v \max}$ .

The maximum value of  $C_v$  should be so chosen that the capacitor's impedance at its fully meshed state is small in comparison with the crystal's impedance, which depends on its capacitance,  $C_0$ . The maximum available value of  $C_v$  in commercial units is about  $8 C_0$ . It would be difficult to exceed this value with commercially available devices and still maintain the low minimum capacitance, the capacitance ratio and calibration linearity.

As an example, suppose a 7-MHz CR-18 crystal has to operate over a range of approximately 50 kHz. In Fig. 2, the lower dashed curve is a plot of the negative of the crystal impedance versus frequency. The value of the maximum capacitance of  $C_v$ , which will have an impedance  $Z_{r \min}$ , is  $8 C_0$ , or 56 pF. The negative of the sum of  $Z_r$  and  $Z_{r \min}$  is plotted as the solid line labeled  $8 C_0$ . A minimum value for  $C_v$  of about 7 pF is a reasonable assumption, on the basis of the previous discussion. The solid line labeled  $C_0$  is a plot of the negative of the sum of  $Z_r$  and  $Z_{v \max}$ .

To determine the required inductance, its impedance must equal the negative of the sum of the crystal impedance and the impedance of the variable capacitor, at any setting of the capacitor. Thus, when the capacitor is fully meshed, the in-

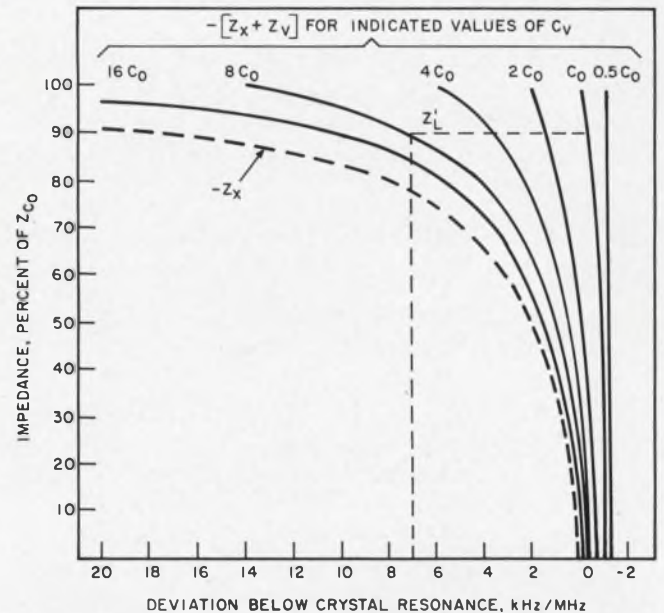

2. Impedance-vs-frequency deviation for inductive-loaded (LC) quartz resonator (VXO). The dashed line is the negative of a CR-18 crystal's impedance, the solid lines are the sum of the crystal's and the variable capacitor's impedances, as  $C_v$  is changed through its full range (from  $0.5 C_0$  to  $16 C_0$ ). The required operating range, 7 kHz/MHz, yields the value of the fixed inductor,  $0.903 Z_{c0}$ , or  $66.5 \mu\text{H}$  ( $Z_{c0} = 22.7/f_r$ , the first term in Eq. 7).

tersection of the 7 kHz/MHz line with the  $8-C_0$  curve yields an impedance of  $0.903 Z_{c0}$ , or about 2930 ohms for a 7-MHz crystal. This impedance will be supplied by an effective inductance,  $L'$ , of  $66.5 \mu\text{H}$ . If this value is used and the variable capacitor is set to its fully open position, the intersection of  $0.903 Z_{c0}$  with the  $C_0$  curve yields the maximum frequency,  $-0.2 \text{ kHz/MHz}$ , or about 1.4 kHz above the resonant frequency. This is shown by the dashed lines in Fig. 2.

A calibration of frequency deviation versus values of  $C_v$  may be obtained from the intersections of the dashed horizontal line with curves for various values of  $C_v$ . This calibration curve will be very nonlinear if semicircular plates are used. A reasonably linear calibration will result if mid-line plates are selected.

During the actual design of these oscillators, engineers will come across two difficulties. Fortunately, a single expedient solves both.

The first problem is that a very definite value of inductance is required to cover a particular frequency range. As stated earlier, good variable coils are not convenient, and coil pruning is a nuisance.

The second is that a change in the distributed capacitance of the coil will alter its effective inductance. The case of two mechanically different coils designed for the same inductance at low frequencies illustrates this effect: the coils' effective inductances become different as the operating frequency approaches the self-resonant frequency of

each coil.

The solution to both difficulties is to adjust the distributed capacitance by means of a small variable capacitor connected in parallel with the coil. This makes use of the fact that the effective inductance is:<sup>5</sup>

$$L' \cong L / [1 - \omega_r^2 L (C + C_d)] = L / [1 - (\omega_r / \omega_0)^2], \quad (9)$$

where

$L$  = coil inductance when  $(\omega / \omega_0) \ll 1$ ,

$C$  = capacitance of the variable capacitor,

$C_d$  = distributed capacitance of the coil,

$\omega_0^2 = 1 / L (C + C_d) =$  "adjusted" self-resonant frequency of the coil.

In the case illustrated in Fig. 2, a suitable value of  $L$  is about 30  $\mu\text{H}$ . Its effective value,  $L'$ , is set to the required 66.5  $\mu\text{H}$  by adjustment of capacitor  $C$ .

The advantages of the circuit in Fig. 3 are that the minimum capacitance is very low and stable,

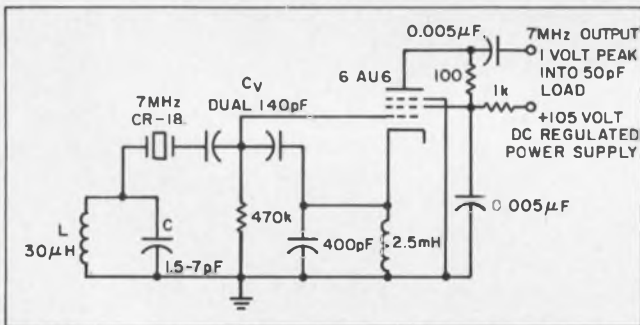

3. Typical oscillator circuit uses inductive loading.  $L$  is 34 turns of #18 tinned wire wound on a 2-inch-diameter ceramic form with a winding length of 3 inches. The output voltage is virtually independent of the position of  $C_v$ .

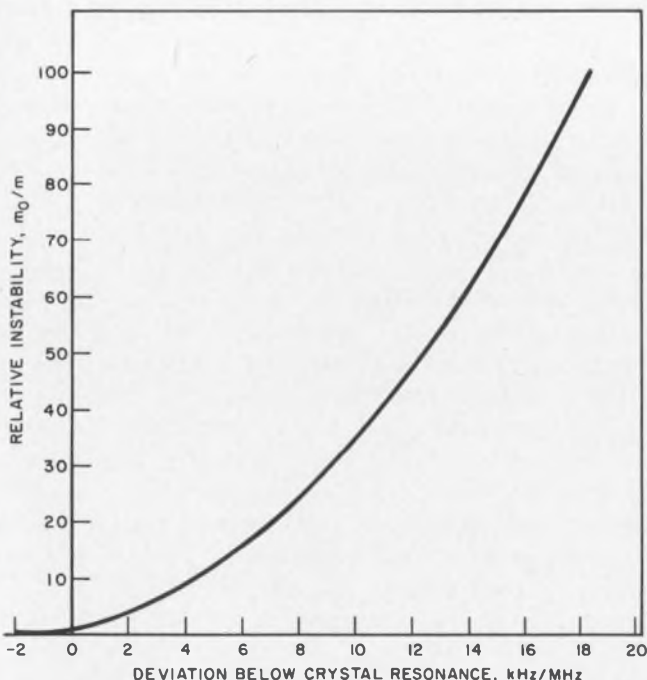

4. Stability-vs-frequency range for LC-loaded oscillator (VXO) shows rapid deterioration with large deviations. The crystal is a CR-18.

and the output voltage is virtually independent of the setting of  $C_v$ . Also, its range adjustment is extremely simple. The maximum frequency, occurring where  $C_v$  is a minimum, approximates the normal value for the crystal operating with a 32-pF capacitive load. This frequency is affected only slightly by variations in  $L'$ . The minimum frequency is set by adjusting  $C_v$  to its maximum value and then adjusting  $C$  to yield the proper value of  $L'$  for resonance at 49 kHz below the crystal's resonant frequency.

### What happens to stability?

The increased frequency range is obtained at the price of reduced frequency stability. If we make the reasonable assumption that the coil is the major contributor to instability, then variations in  $L'$  will shift the dashed horizontal line of Fig. 2 up and down. The frequency deviations thus produced depend on the slope of the particular  $-\{Z_r + Z_v\}$  line at the operating point. Since this slope is minimum where  $Z_v$  is minimum, it follows that the least stable point is always where the  $Z_L'$  line intersects the curve  $-\{Z_r + Z_{v \min}\}$ . It is also apparent that the stability at this poorest point decreases as the range is made larger by increasing  $Z_L'$ , i.e., by increasing  $C$ .

The variations in stability may be clearly appraised by examining Eq. 7, the impedance of the crystal. The first term is the impedance of  $C_0$  at the resonant frequency. The characteristic of the crystal cut (AT in this case) is given by the second term in the denominator. Rewritten, this term is:

$$y = 1 / (1 + 2/x) = x / (x + 2), \quad (10)$$

where  $x = \Delta f / f_r$  in kHz/MHz. Therefore:

$$dy/dx = m = 2 / (x + 2)^2. \quad (11)$$

The frequency stability of the resonator will be proportional to  $m$ . As normally used, the crystal operates close to its resonant frequency where  $x = 0$  and the slope,  $m_0 = 0.5$ . The stability at any other point will be related to the  $m/m_0$ . It is more convenient to plot the relative instability as:

$$m_0/m = (x + 2)^2/4, \quad (12)$$

as has been done in Fig. 4. It is clear that frequency stability decreases rapidly with deviation.

### Inductive loading compared with conventional design

To illustrate the change in stability caused by inductive loading, suppose that a given deviation,  $x$ , is required, where  $x$  is an integer.

One way to obtain this value of  $x$  is to use a stable capacitance-loaded oscillator, which will yield a deviation of approximately 1 kHz/MHz at the crystal's fundamental frequency, with a slope,  $m_0$ . If this frequency is multiplied by  $x$  in a fre-



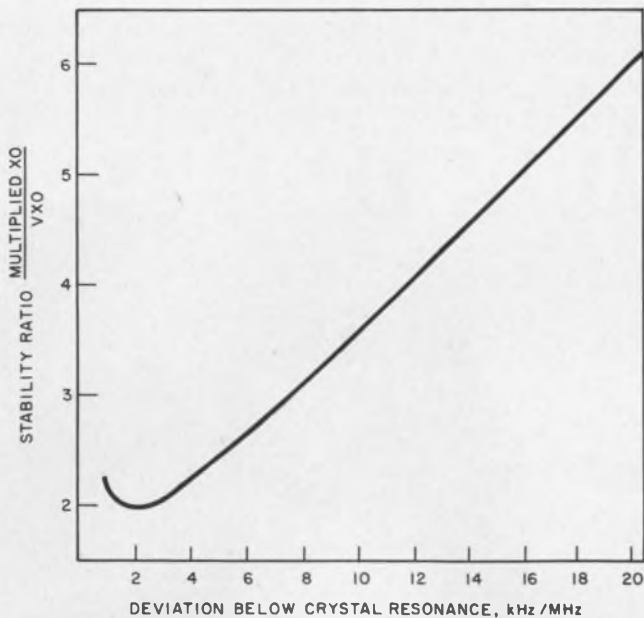

5. Plot of stability ratio offers a simple way to compare the stability of a frequency-multiplied capacitance-loaded oscillator (XO) with that of an LC-loaded oscillator (VXO) over the same frequency range. (Both oscillators use a CR-18 crystal.) As expected, the XO is more stable, but requires complex circuitry.

quency multiplier, the deviation will be the desired  $x$  kHz/MHz of the fundamental, while the effective slope will be reduced to  $m_0/x$ .

A second method of obtaining the deviation,  $x$ , is to use LC-loading directly on the crystal fundamental. The slope will be given by Eq. 11.

The ratio,  $G$ , of the stability of the multiplied, C-loaded crystal oscillator (XO) to that of the LC-loaded circuit (VXO) is the ratio of the slopes:

$$G = m_{xo}/m_{vx0} = (x + 2)^2/4x. \quad (13)$$

A plot of Eq. 13 is given in Fig. 5. Although the stability of the VXO is always less than that of a frequency-multiplied XO, the complexity and spurious signal generation, inherent in frequency multiplication, can be eliminated with the VXO.

It must be pointed out that Eqs. 12 and 13 and Figs. 4 and 5 are correct only if we assume that the loading impedances are of equivalent quality. Since the LC load is less stable than the capacitive load, it will be found in practice that the stability of the VXO is not as great as predicted above. Hence, Fig. 5 represents an ideal case which can be approximated by the use of the best possible components in the resonant circuit. ■ ■

#### References:

1. Frank W. Noble, "Variable-frequency crystal oscillators," *Proc. IEEE*, LIV, No. 12 (Dec., 1966), 1976-1978.
2. H. Shall, "VXO—A Variable Crystal Oscillator," *QST*, XLII, No. 1 (Jan., 1958), 11.
3. Landee *et al.*, *Electronic Designers' Handbook* (New York: McGraw-Hill Book Co., 1957), pp. 6-14 *et seq.*
4. *Ibid.*, Eq. 6.38.
5. *Reference Data for Radio Engineers* (3rd ed.; Federal Telephone and Radio Corp., 1949), p. 83.

## MIL-Spec'ed tuning fork oscillators and resonators available for evaluation-- from TRACOR



If you need a MIL-Spec'ed oscillator for current or anticipated programs . . . contact TRACOR. Chances are we've already got one to fit your requirements. We currently have MIL-Spec'ed oscillators being used in shipboard, ground station, airborne, space and tank installations.

For a catalog with complete information on MIL-Spec'ed low-frequency oscillators now available, write to TRACOR, Inc., 6500 Tracor Lane, Austin, Texas 78721. Phone (512) 926-2800.

**Component  
Products**   
by

REPRESENTATIVES IN PRINCIPAL CITIES

TFA-767

# CCSL is waiting for you.



**Fairchild  
Semiconductor  
Integrated  
Circuits**

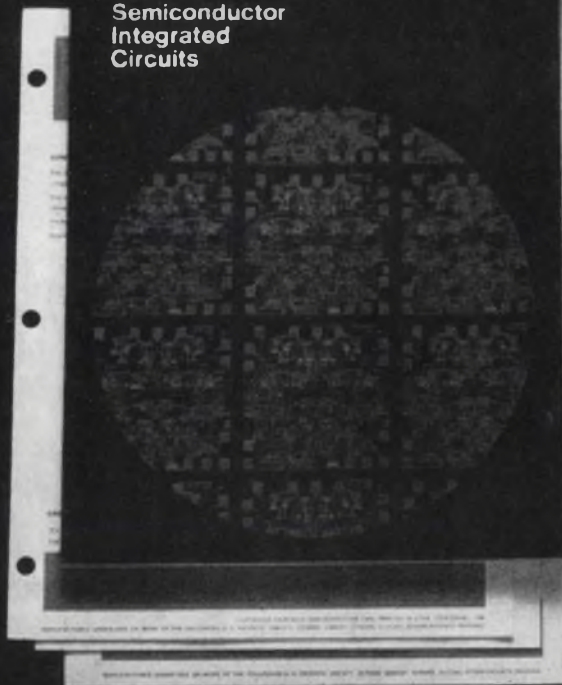

We have prepared a special product sampler to help you discover the advantages of designing with Fairchild's Compatible Current Sinking Logic. You can get it for less than you'd normally pay for the samples alone.

Integrated circuits are conventionally classified by family, and within each family by function. This method of classification restricts you to a single family within a system. Now Fairchild allows you to cross family boundaries and to design by function, selecting circuits from compatible logic families. This permits you to choose the best circuit for each function, and to optimize the system as a whole.

**What is compatible logic?** Fairchild classifies all digital integrated circuits into compatible logic groups: current sinking logic, current sourcing logic, and current mode logic. A current sinking logic gate (for example, a DTL gate) draws current into its output ("sinks" current) when in the low state, and draws virtually no current when in the high state. A current sourcing gate (for example, an RTL gate) drives current out of its output in the high state and, except for minor leakage, drives no current in the low state. Current mode logic can draw or drive current.

**Compatible current sinking logic:** There are three families within the Fairchild current sinking group:  $TT_{\mu L}$  (Transistor-Transistor Micrologic®),  $DT_{\mu L}$  (Diode-Transistor Micrologic) and  $LPDT_{\mu L}$  (Low-Power Diode-Transistor Micrologic) integrated circuits. By crossing family boundaries within the compatible logic group, you can optimize your system design. Here's how:

**How compatible logic helps you:**  $TT_{\mu L}$  is the fastest of the three families and also the one that dissipates the most power.  $LPDT_{\mu L}$  dissipates the least power, but is slower than the others.  $DT_{\mu L}$  is right in between, both in speed and in power dissipation. There are clearly some functions in your system that require all the speed you can get. There are other functions where the speed of  $TT_{\mu L}$ , for

example, is wasted, because it is waiting for slower system elements. So you can use a slower logic family and optimize your power dissipation without sacrificing overall system speed. When you design with Fairchild's current sinking logic group, you are assured that all the families within the group are fully compatible.

**What we mean by compatibility:** All three families use NAND logic, and all basic NAND logic functions are available in any of the three forms. All three families use a single 5V power supply, and all three are guaranteed to perform compatibly when the specified fan-out and fan-in rules for interconnecting between logic forms are observed. Pin configurations for the same functions are the same, and all three families come in the same two package configurations (maximum-density  $\frac{1}{4}'' \times \frac{1}{4}''$  Flatpak, and easy-to-handle Dual in-line). Finally, all three families are manufactured using the same technology, so that within the same working environment they will maintain a uniform stability over a period of time.

**Get our product sampler:** We want you to get acquainted with Fairchild's compatible current sinking logic group at first hand, so we have prepared a special product sampler you can get. The sampler contains a 90-page book describing Fairchild integrated circuits; a guide to current sinking logic; data sheets on individual products and families; and actual product samples (see listing). Our complete product sampler sells for \$51.00, which is the over-100 price of the samples alone. But quantities are limited, so act now.

**How to get it:** Simply return the attached coupon. Or call. For data-pack only, use reader service card No. 181.

**Fairchild Product Samples:**

4 ea.	9000	J-K flip-flop	1-99 price	\$ 5.10 ea.
2 ea.	9002	Quad 2-input gate	1-99 price	\$ 3.65 ea.
2 ea.	9946	Quad 2-input gate	1-99 price	\$ 3.65 ea.
2 ea.	9046	Quad 2-input gate	1-99 price	\$20.00 ea.

These products are in the industrial temperature range.

# What are you waiting for?



**FAIRCHILD**  
SEMICONDUCTOR

## Compatible Logic Can Optimize Your System. Send For Proof.

Please send me the Compatible Current Sinking Logic Product Sampler.

Name \_\_\_\_\_

Title \_\_\_\_\_

Company \_\_\_\_\_

Address \_\_\_\_\_

City \_\_\_\_\_

State \_\_\_\_\_ Zip \_\_\_\_\_

Check enclosed  Bill me

Bill my company. P.O. No. \_\_\_\_\_

Check here for data-pack only.

# Pick the right hybrid technique and you'll get the most suitable passive components for your circuit.

Thick films and thin films both have their place.

The hybrid circuit—one that contains two or more semiconductor chips on a substrate, with either thick- or thin-film resistors and capacitors—is a popular alternative to monolithic integrated and discrete-component circuits.

It is not plagued by the parasitics that may mar the performance of monolithics, and it requires far fewer masks and far less time to make the first unit. Moreover, it is a lot less bulky and more reliable than circuits that are made with discrete components.

But the designer must choose between thick films, alloy thin films and single-metal thin films. Regardless of whether the hybrid circuit contains integrated circuits alone (see Fig. 1) or a mixture of discrete transistors and ICs (Fig. 2), it will be a success only if the passive components are the best match for the job.

Depending on application, these factors will affect the choice: size, tolerance, power dissipation and processing problems. Examine them before you begin the design.

## Consider the size of the design

By a lengthy derivation based on skin and bulk resistance effects,<sup>1</sup> it can be shown that the resistance of a resistor (thick or thin) is related to its material through the following equations:

$$R = \rho L / WD,$$

where:

- $R$  = bulk resistance of the film,
- $\rho$  = resistivity of the material,
- $L, W, D$  = respective dimensions of the film (see Fig. 3).

Rearrangement of the equation shows that:

$$\begin{aligned} R &= (\rho/D) (L/W); \\ R &= KN; \\ K &= \rho/D; \\ N &= L/W; \end{aligned}$$

where the constant  $K$  is the ohms/square, and  $N$  is the number of square widths.

Consider this example: Given that the resistivity of nichrome is  $150 \Omega/\text{square}$ , the minimum width is  $0.25 \times 10^{-3}$  inches, and process tolerance is  $\pm 0.03 \times 10^{-3}$  inches, determine the length of the resistor. By rearrangement of the equation, it is known that:

$$L = WR/K.$$

If the width of the resistor is  $1/4$  mil, then:

$$\begin{aligned} L &= (3 \times 10^3 / 150) (1 \times 10^{-3} / 4) \\ &= 5 \times 10^{-3} \text{ inches.} \end{aligned}$$

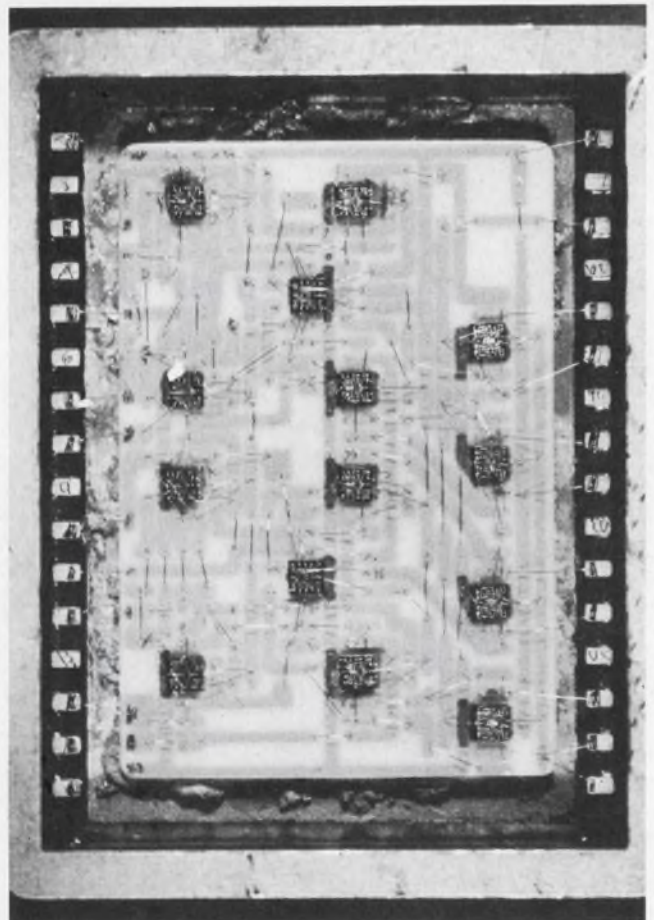

1. Fourteen integrated circuits nestle in one 1-by-0.8-inch package.

**Richard F. Bader**, Hybrid Circuit Product Manager, Fairchild Semiconductor Div., Fairchild Camera and Instrument Corp., Mountain View, Calif.

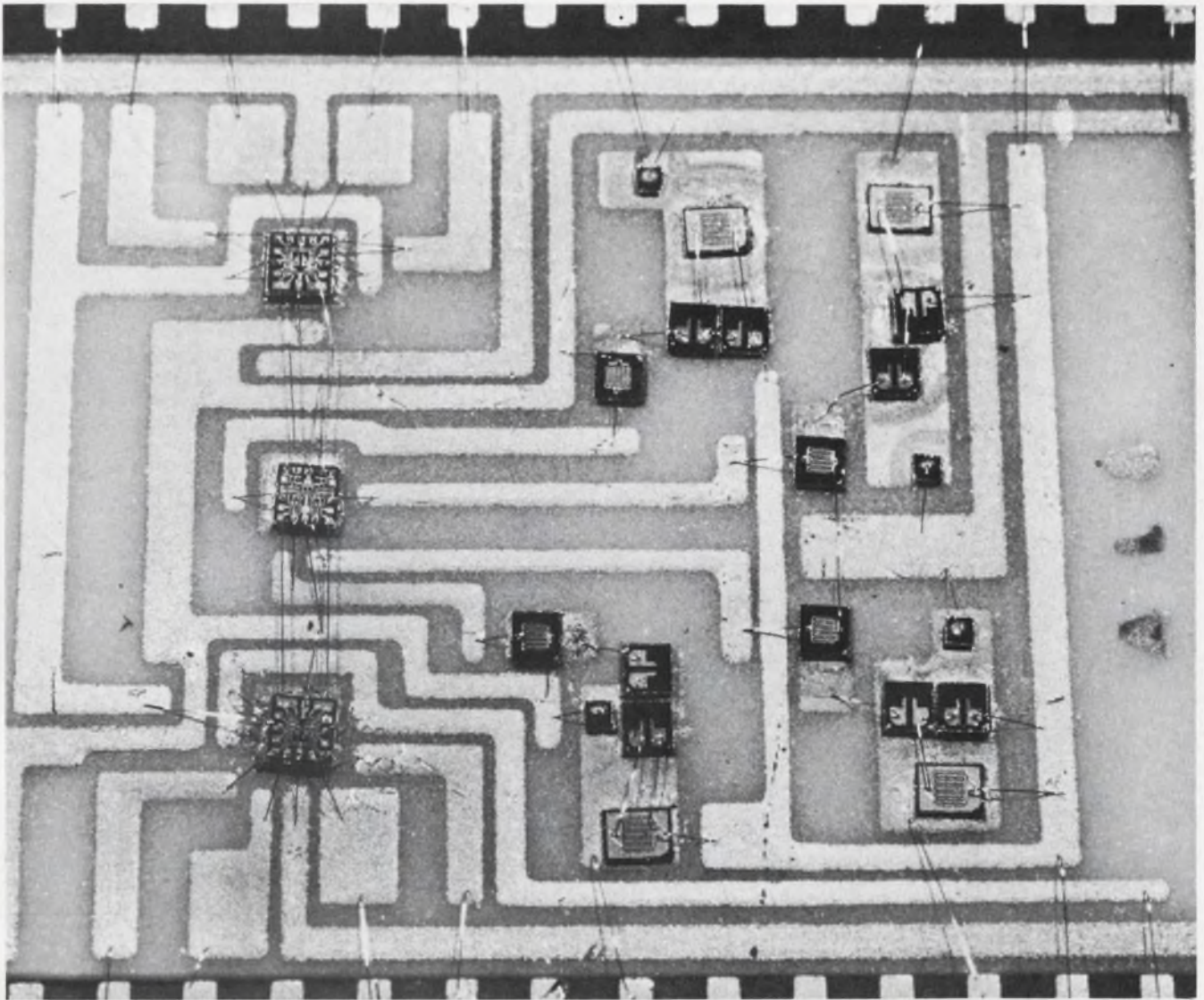

2. Transistors mix with integrated circuits in this 3/8-by-3/8-inch flat pack.

If the width of the resistor is 4 mils, then:

$$L = (3 \times 10^3 / 150) (4) (10^{-3}) \\ = 80 \times 10^{-3} \text{ inches.}$$

#### Check positive and negative tolerance

To determine which size to use, weigh the effect of the mechanical tolerance on the design. Since most mechanical deviations are in the same direction, it is necessary to investigate only the positive and negative tolerance changes:

$$R = N \left( \frac{L + \Delta l}{W + \Delta w} \right)$$

and

$$R = N \left( \frac{L - \Delta l}{W - \Delta w} \right).$$

If the line width of the resistor is 1/4 mil, then:

$$R = (150) \frac{5 \times 10^{-3} + 0.03 \times 10^{-3}}{0.25 \times 10^{-3} + 0.03 \times 10^{-3}} \\ = 2.7 \text{ k}\Omega$$

or

$$R = (150) \frac{5 \times 10^{-3} - 0.03 \times 10^{-3}}{0.25 \times 10^{-3} - 0.03 \times 10^{-3}} \\ = 3.4 \text{ k}\Omega.$$

Hence, with a resistor of 1/4-mil line width:

$$R = 3 \text{ k}\Omega \begin{matrix} + 13\% \\ - 10\% \end{matrix}.$$

By the same procedure, a like analysis shows that with a 4-mil line width:

$$R = 3 \text{ k}\Omega \begin{matrix} + 3.0\% \\ - 2.7\% \end{matrix}.$$

If space, then, is the prime consideration, the 1/4-mil-line-width resistor is the one to use. But the larger resistor exhibits better power dissipation and tighter tolerance.

It is important also to consider power in the design of resistors. An analysis of the thermal resistance between the resistor and the heat sink will yield the following equation (see Fig. 4):

$$\theta_T = \theta_{R/D} + \theta_{R/S} + \theta_{D/S} + \theta_S + \theta_{S/H/S},$$

where:

$\theta_T$  = thermal resistance (TR) between resistor and heat sink,

$\theta_{R/D}$  = TR between resistor and dielectric,

$\theta_D$  = TR between dielectric and substrate,

$\theta_S$  = TR of substrate,

$\theta_{S/HS}$  = TR between substrate and heat sink.

Normally  $\theta_{R/D}$  and  $\theta_{D/S}$  are small compared with the other terms in the equation. All bulk thermal resistance terms are available from a materials handbook<sup>2</sup> or from a ceramic manufacturer. Resistances are dependent on the area of the materials. Since power is the prime concern, the equation can be rewritten so that:

$$P = (T_{MAX} - T_{HS})/\theta_T,$$

where

$P$  = power,

$T_{MAX}$  = maximum allowable resistor temperature,

$T_{HS}$  = heat sink temperature.

Since  $T_{MAX}$  for most resistors is less than 200°C, and on the assumption that the heat sink is maintained at 25°C, then:

$$P_{MAX} = 175^\circ\text{C}/\theta_T.$$

For 96% alumina, the equation reduces to:

$$P_{MAX} = 15 \times 10^{-6} \text{ W/mil}^2 \text{ of resistor area.}$$

All the previous equations and examples were based upon a rectangular resistor. If, however, the resistor's size had to be larger than its substrate length, the resistor may be doubled back. To minimize hot spots due to abnormally high current densities forming at corners, all double-backs should be rounded. If the film's turns are separated by a spacing equal to the film's width, the entire rectangular area covered by the resistor may be used for the power calculation rather than just the area under resistor.

#### Definition of resistor cannot be hard and fast

There are a number of different definitions of what constitutes a thin-film resistor. These two are common:

- Any metal film deposited on a substrate by vacuum evaporating or sputtering techniques.
- A metal film 500 to 1000 Å thick.

Unfortunately there are exceptions to both definitions. Consequently a much safer, though less sophisticated, definition simply specifies the metals used. The most popular films are nickel-chromium alloys, chrome, tantalum and tin oxide.

#### Analyze two production techniques

Two techniques are commonly used for film

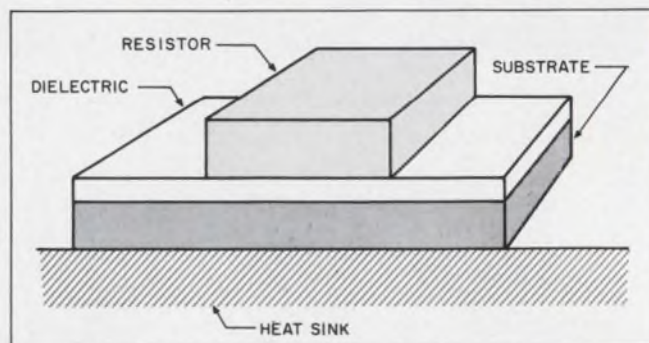

3. Calculate the thermal resistance between the resistor and the substrate to determine whether or not a particular configuration can handle the power that the circuit requires.

production: RF sputtering and vacuum deposition.

Both make use of vacuum chambers, which reduce the internal pressure. Typically, an evaporator produces pressures in the  $10^{-5}$ -to- $10^{-8}$  torr range (1 torr = 1 mmHg at 0°C at standard gravity = 1333.2 bars). Cathode sputtering takes place at a pressure of  $10^{-3}$  torr. In either case the time needed to load the systems and charge the evaporators is too long for mass production. Typically, 100 depositions a week can be performed with one system. Continuous process systems are under development but as yet are unreliable.

The actual resistor may be formed by evaporating through a mask inside the chamber or by etching after deposition over the whole substrate. There are many experts, though, who feel that the latter method permanently damages the crystal structure. Such damage affects long-term stability and reliability.

#### Nichrome and tantalum preferred

For thin films, nickel-chromium alloys and tantalum have been the preferred metals used. The major advantages of nickel-chromium alloys are:

- Line widths are narrow ( $0.25 \times 10^{-3}$  inches).
- $T_c$  is excellent (typically 100 ppm/°C but can be controlled to  $0 \pm 20$  ppm/°C).
- End-of-life (EOL) stability is excellent (0.1% after 10,000 hours).
- Initial tolerance depositions are good ( $0.05 \times 10^{-3}$  inches).
- Control during deposition is easy to achieve by a variety of methods.
- Adhesion qualities to glass or ceramic are good.

Nickel-chromium's disadvantages are:

- Oxides are formed by endothermic reactions when the alloys are heated above 380°C. This changes resistivity.
- Flexibility in resistivity selection is little

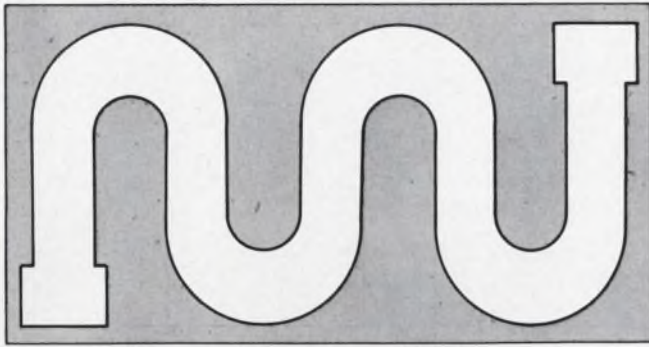

4. Heat spots won't occur at the bends, if the resistors have no sharp elbows and no constrictions. If the distance between the loops is equal to their width, include it in heat calculations.

(typically 50  $\Omega$ /square).

- Power handling capabilities are limited (typically 15 W/in<sup>2</sup>).
- Trimming is inconvenient and generally executed mechanically.
- A stabilization overcoating of silicon oxide or organic material is required.
- Production is costly.
- Resistance values are low (500 k $\Omega$ ).

There are two significant processing problems associated with nichrome:

- Awkward impurity problems arise with low-vacuum depositions. These impurities adversely affect the sheet resistivity and the temperature coefficient of resistance.
- It is difficult to maintain a uniform bulk composition of nichrome during deposition. This adversely affects long-term stability at high temperatures (200°C).

#### One metal deposits uniformly

The problems associated with nickel-chromium alloy during deposition have caused many thin-film manufacturers to prefer a one-metal system. Tantalum is by far the most popular one-metal system, although chromium and tin oxide resistors are also being used.

Tantalum is usually deposited by RF sputtering. Some of its major advantages are:

- Higher resistivities are available (150  $\Omega$ /square, 1 k $\Omega$ /square, 5 k $\Omega$ /square).
- Easily automatable trimming is usually accomplished by anodization: 0.1% resistors are possible. Tantalum can be trimmed by localized laser annealing.
- Good line widths are possible (1 mil).
- The temperature coefficient of resistance is controllable to a more predictable degree than with other films.
- The anodizing process automatically forms a stabilizing film over the resistor.
- Capacitors may be deposited with the same

material and equipment.

The disadvantages of tantalum films include the following:

- End-of-life tolerances are questionable at higher resistivities. There seems to be disagreement about the validity of some long-term stability data reported, especially at the high resistivity values.
- Stability of the films at die-attach temperature (420°C) is also questionable. Some authorities indicate the type of anodization used materially affects this property.
- To prevent oxidation during evaporation and to improve stability, it is necessary to evaporate a gold layer between the tantalum layers. This extra step makes more complex processing equipment necessary.
- The process does not lend itself to mass production techniques, thus adding to the expense of the resistor substrate.
- Resistance values are limited (up to one megohm).

Tantalum has some advantages over nichrome: it is easier to trim, and it allows a greater range of values. But there are many unknowns in tantalum processing, and the resistor values do not reproduce well. Nichrome, however, does possess reproducibility characteristics. It is the workhorse of the industry.

#### Thick films have come into production

If the electronics industry were subject to fads, one of the biggest today would be the thick film. This passive component technique has a number of advantages, but probably the biggest is that the process is commercially available. Thick films require no costly process development programs, and the equipment is cheap.

Thick films are generally either conductive inks or cermet (ceramic to metal). Four materials that are often found in commercially available thick films are gold-tungsten, platinum-tungsten, platinum-tantalum, or gold-tantalum. These conductive metals are usually combined with a dielectric compound.

Whatever the composition, essentially the same technique is used for mass fabrication. The resistors are deposited onto the substrate by an automatic wiper arm, which forces the ink through a silk screen. The arm is set for a particular speed and pressure, and it wipes the ink across the silk-screen pattern. The inked impression on the substrate is then dried and fused in an oxidizing atmosphere. This process is easily automatable and reproducible.

Here are the advantages to be gained by using thick films:

- Initial investment to buy equipment is low.

Masking costs are relatively inexpensive (\$75 to \$100 a mask).

- The process lends itself to the techniques of mass production.

- Many resistivities are available for flexibility in resistance tolerance (1Ω/square to 20 kΩ/square in decades).

- Trimming is easily automatable by the use of sand blasting or mechanical trim.

- Power ratings on resistors are high (50 W/in<sup>2</sup>).

- Capacitors are possible.

But thick films do have disadvantages, and among these are the following:

- Thick films tend to be unstable at high temperatures (380°C).

- End-of-life data are questionable.

- Thick films are noisy at high resistivities.

- Their lines are wide (10-15 mils).

- Each resistance change greater than a factor of 10 above the basic resistivity selection requires an additional screening.

- In mass production runs, more than two screenings seriously affect yields.

#### Examples show when to use which film

If size is the most important factor in design, the following examples should indicate when to

use thick and thin film:

#### Example 1: a 1-kΩ ±5% resistor

Assume that a 1-kΩ ±5% resistor has to be made. With a thin film of 150 Ω/square and a tolerance of ±0.05 mils, the resistor size can be determined as:

$$\begin{aligned} \text{Length} &= 5.35 \text{ mils,} \\ \text{Width} &= 0.80 \text{ mils,} \\ \text{Area} &= 4.27 \text{ mil}^2. \end{aligned}$$

If a thick film of 1 kΩ/square and a tolerance of ±2 mils is used, and the minimum width is 10 mils, the resistor size will be:

$$\begin{aligned} \text{Length} &= 10 \text{ mils,} \\ \text{Width} &= 10 \text{ mils,} \\ \text{Area} &= 100 \text{ mil}^2, \end{aligned}$$

and the resistor will have to be trimmed.

#### Example 2: a 500-kΩ ±5% resistor

When a 500-kΩ ±5% resistor has to be made, thin film must be trimmed in order to keep the size down:

$$\begin{aligned} \text{Length} &= 8.3 \text{ in.,} \\ \text{Width} &= 5.0 \text{ mils,} \\ \text{Area} &= 41.5 \times 10^3 \text{ mil}^2. \end{aligned}$$

Thick film of a 20-kΩ/square material has also to be trimmed:

$$\begin{aligned} \text{Length} &= 250 \text{ mils,} \\ \text{Width} &= 10 \text{ mils,} \\ \text{Area} &= 2.5 \times 10^3 \text{ mils}^2. \end{aligned}$$

These examples demonstrate that in situations where size is the most important factor, small-value resistors are handled better with thin film, and large-value resistors are handled better with thick film.

#### Breadboard the hybrid circuit

Unlike monolithic integrated circuits, hybrid circuits can be designed and breadboarded in the same way that discrete component circuits can. The circuit designer should consider both thick- and thin-film fabrication techniques before he executes his design. The table makes the trade-offs clear.

A relatively recent development that makes either of the film techniques attractive for production circuits is the proliferation of new inverted ceramic packages. These allow transistors to be bonded directly to either thick-film or thin-film substrates.<sup>3</sup> ■ ■

#### References:

1. E. Stern, "Precision Thin-Film Resistors," *Proc. Electronic Components Conference, Washington, D. C., 1966*.
2. *Bulletin No. 651* (Chattanooga, Tenn.: American Lava Corp.), p. 9.
3. "Mount transistors in topsy-turvy holders," *ELECTRONIC DESIGN*, XIV, No. 17 (July 19, 1966), 17.

**Table. Compare thick and thin films**

Circuit requirements	Thick film	Thin film
1. Mass producible	Lower cost	Higher cost
2. Close initial tolerance	±10% absolute ±1% match	±5% absolute ±0.1% match
3. Close trimming tolerance	±1% easily mass-producible	±0.1% mass-producible (using tantalum)
4. Temperature coefficient	±200 ppm/°C	0 ppm/°C
5. Power handling	50 W/in <sup>2</sup>	15 W/in <sup>2</sup>
6. Line width	10 mils ± 2 mils	0.25 mils ± 0.02 mils
7. Resistivities	1 Ω/sq to 20 kΩ/sq	0.1 Ω/sq to 1 kΩ/sq
8. EOL tolerance	±2%	±0.1%
9. Capacitance available	10,000 pF maximum	0.01 μF maximum



# Just a few of the hundreds of answers Aerovox has to your RFI problems



## MINIATURE CERAMIC LOW PASS RFI FILTERS



Present military specifications require that electronic equipment be kept free of interference from 150 KHz to 10 GHz. Aerovox type FC low pass, miniature ceramic RFI suppression filters will meet or exceed the applicable requirements of MIL-F-15733. These new units have been life tested for 250 hours at  $1\frac{1}{2}$  times the working voltage. After test, insulation resistance of units is greater than 50 megohms.

All FC units are hermetically-sealed in silver plated cases and have been tested for moisture resistance, temperature cycling and immersion and vibration under MIL-STD-202. Six standard ratings are available depending on minimum insertion loss, maximum DC resistance and maximum DC current or low frequency AC. Operating temperature is  $-55^{\circ}\text{C}$  to  $+125^{\circ}\text{C}$ . Our filter application engineering department will work with you to design and manufacture the exact filter for your specific application requirement.

## RFI FEED-THROUGH SUPPRESSION CAPACITORS



Designed for applications in aircraft, industrial and vehicular equipment these new Aerovox feed-through suppression capacitors will hold effective series inductance to an absolute minimum and effectively filter broadband interference. Series P340 and P341 units have been specifically engineered for through chassis or through panel mounting. Three terminal design — case serves as actual ground termination and the through input-output line for DC or low frequency AC appears at the remaining two terminals.

These capacitors are available in 5 DC voltage ratings from 100 to 600 VDC and 10 capacitance ranges from .001 to 2.0  $\mu\text{f}$ . They are hermetically sealed with glass-to-metal end seals for maximum performance in all environments. Aerovox types P340 and P341 meet or exceed the requirements of MIL-C-11693. Write today for complete descriptive literature.



**AEROVOX**  
CORPORATION  
OLEAN, NEW YORK  
NEW BEDFORD, MASS.

See AEROVOX IEEE Booths 3J-13 and 15.  
ON READER-SERVICE CARD CIRCLE 236

# OTHER 2, 4 AND 6 POLE 2 AMP RELAYS MIGHT BE AS GOOD AS THE NEW SIGMA SERIES 62.

If they were built as well.



Versatile, miniature Sigma Series 62 general purpose relays outperform their competitive counterparts because they are built better three ways:

**Larger Contacts For Longer Life:** The larger contacts (.093" & .058" dia.) used in the Series 62 assure superior thermal and electrical conductivity and a life expectancy of 1 million operations at rated load.

**Thicker Base For Greater Contact Stability:** The Series 62 base, in the terminal area, is twice as thick as competing types. This provides a much higher degree of mechanical support assuring long-term stability of the stationary contact members.

**More Durable Lifter For Better Contact Action:** The contact actuator of the Series 62 is made of

fabric-filled phenolic rather than paper-based phenolic. It is extremely durable, rigid, and not subject to cracking even after extended use.

**We'd like to give you a new Sigma Series 62**—or any of our other standard relays. Test and compare it against the brand you may now be using. It's the best way we know to prove what we say about Sigma relay performance. Just circle our reader service number on the reader service card. We'll send you the new Sigma relay catalog and a "free relay" request form. Return the form to us and your Sigma representative will see that you get the relay you need.

**Need fast delivery? The Series 62 is available off-the-shelf from your Sigma distributor.**

SIGMA DIVISION  SIGMA INSTRUMENTS INC  
Assured Reliability With Advanced Design / Braintree, Mass. 02185

ON READER-SERVICE CARD CIRCLE 235

# Tektronix Type 1S1

## DC-to-1 GHz

### Sampling Plug-in Unit

for your  oscilloscope  
that accepts letter and  
1-series plug-ins

Here's a new dc-1 GHz sampling unit with operation practically as simple as conventional plug-ins—as you can see by the front panel of the sampling plug-in. You need no pretriggers or external delay lines—the 1S1 unit has internal triggering with a built-in delay line.

Many other features add to the capabilities and operating ease of the Type 1S1, such as:  
A tunnel-diode trigger circuit that insures stable triggering through 1 GHz • A single control to select the sweep rate and magnify the display up to X100 when desired • Direct readout of the sweep rate even when magnified • A dc-offset control that permits observation of millivolt signals in the presence of up to  $\pm 1$  volt input levels • Less than 1 mV noise in the display, with a smoothing control for further reduction • Output signals available at the front panel for driving chart recorders—and for powering an auxiliary time domain reflectometer pulser unit.

#### BASIC CHARACTERISTICS

RISETIME  $\leq 0.35$  ns. SENSITIVITY from 2 mV/cm through 200 mV/cm, in 7 steps. DYNAMIC RANGE  $\pm 2$  V. Safe overload is  $\pm 5$  V. DC OFFSET range is greater than  $\pm 1$  V. SWEEP RATES from 100 ps/cm to 50  $\mu$ s/cm, with  $\pm 3\%$  accuracy normal or magnified. SAMPLES/CM continuously variable. TRIGGERING ac-coupled,  $\pm$  internal,  $\pm$  external, and free run. DISPLAY MODES are repetitive, single display, manual scan, or external scan. VERTICAL OUTPUT is 200 mV per displayed cm through 10 k. HORIZONTAL OUTPUT is 1 V per displayed cm through 10 k.

Type 1S1 Sampling Plug-In Unit . . . . . \$1100  
Type 281 TDR Pulser Unit . . . . . \$95

U.S. Sales Prices, f.o.b. Beaverton, Oregon

For a demonstration,  
call your Tektronix field engineer.

## Tektronix, Inc.

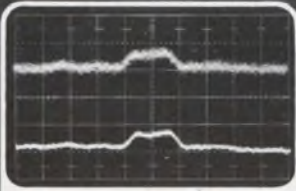
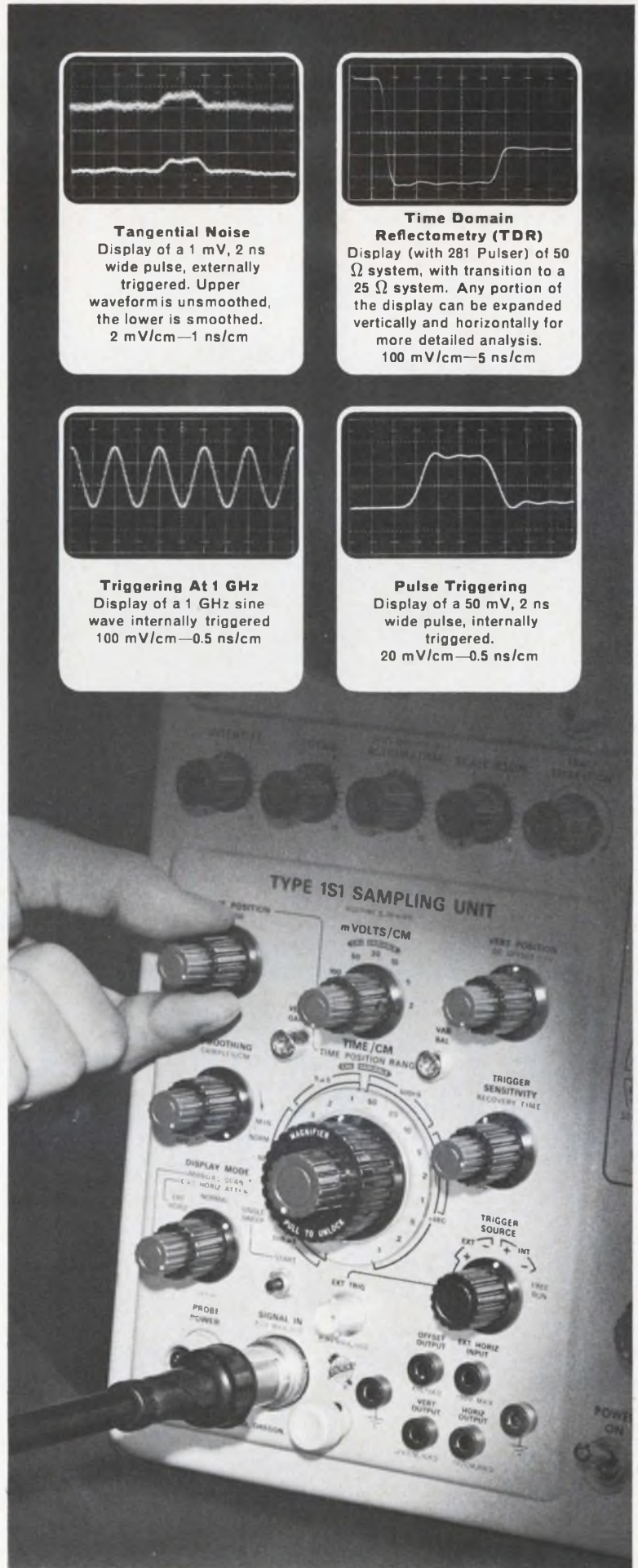

**Tangential Noise**  
Display of a 1 mV, 2 ns wide pulse, externally triggered. Upper waveform is unsmoothed, the lower is smoothed.  
2 mV/cm—1 ns/cm



**Time Domain Reflectometry (TDR)**  
Display (with 281 Pulser) of 50  $\Omega$  system, with transition to a 25  $\Omega$  system. Any portion of the display can be expanded vertically and horizontally for more detailed analysis.  
100 mV/cm—5 ns/cm

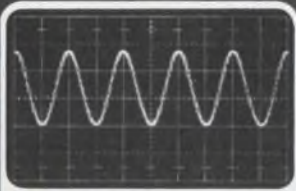

**Triggering At 1 GHz**  
Display of a 1 GHz sine wave internally triggered  
100 mV/cm—0.5 ns/cm

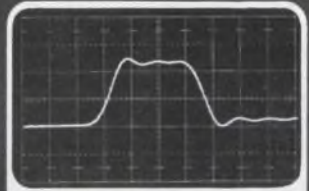

**Pulse Triggering**  
Display of a 50 mV, 2 ns wide pulse, internally triggered.  
20 mV/cm—0.5 ns/cm

# Simplify capacitance measurements

with this handy nomograph. It allows you to correct for lead inductance quickly and easily.

In capacitance measurements, the series inductance of component leads produces errors by causing an apparent increase in the capacitance. The effect of the series inductance becomes increasingly great as the capacitance, the test frequency, or the inductance increases. When low frequencies are involved, the resulting errors are negligible. However, with the advent of instruments capable of providing precise, high-resolution measurements of large values of capacitance at high frequencies, the influence of series inductance becomes significant.

A correction factor,  $C_{corr}$ , for the effect of series inductance can be calculated from the equation:

$$C_{corr} \approx \omega^2 C^2 L$$

where:

- $C$  = the measured capacitance,
- $L$  = the combined inductance of both leads of the component.

The computed correction factor is then subtracted from the measured value to obtain the true capacitance of the specimen.

The accompanying nomograph simplifies this calculation by defining the lead inductance in terms of lead-wire size (AWG) and the combined length of both leads.

Three lines laid off on the nomogram are required to arrive at the value of  $C_{corr}$ . These lines are as follows:

- From lead-wire size to total lead length, extended to turning line No. 1.
- From turning line No. 1 to measured capacitance value.
- From the intersection of the above line with turning line No. 2 to the measurement frequency.

This line then intersects the correction-factor capacitance.

Shown on the nomogram is an example of its use for the following measurement situation:

- Lead length =  $1/2 + 1/2 = 1$  inch
- Wire size = #22
- Measured capacitance = 10 pF
- Measurement frequency = 100 MHz
- Correction factor = 0.9 pF
- Actual capacitance =  $10.0 - 0.9 = 9.1$  pF

To extend the range of the nomograph, select appropriate decade multipliers for capacitance and frequency from the table, and multiply the capacitance correction by the indicated factor. For example, for a measured capacitance of 1 pF and a frequency of 100 MHz:

- $C = 1 \text{ pF} = 10 \text{ pF} \times 10^{-1}$  (decade multiplier is  $10^{-1}$ ).
- $f = 100 \text{ MHz}$  (decade multiplier is 1).

Since the two decade multipliers intersect at  $10^{-2}$  on the table, the correction factor,  $C_{corr}$ , is multiplied by  $10^{-2}$ .

Similarly, if the measured capacitance is 0.1  $\mu\text{F}$  and the measuring frequency is 100 kHz:

- $C = 0.1 \mu\text{F} = 10 \text{ pF} \times 10^4$  (decade multiplier is  $10^4$ ).
- $f = 100 \text{ kHz} = 1 \text{ MHz} \times 10^{-1}$  (decade multiplier is  $10^{-1}$ ).

Thus, according to the table, the correction factor is multiplied by  $10^6$ . ■■

Multiply correction by	Multiply frequency by			
	$10^{-2}$	$10^{-1}$	1	10
Multiply capacitance by $10^{-1}$	$10^{-6}$	$10^{-4}$	$10^{-2}$	1
Multiply capacitance by 1	$10^{-4}$	$10^{-2}$	1	$10^2$
Multiply capacitance by 10	$10^{-2}$	1	$10^2$	$10^4$
Multiply capacitance by $10^2$	1	$10^2$	$10^4$	$10^6$
Multiply capacitance by $10^3$	$10^2$	$10^3$	$10^6$	$10^8$
Multiply capacitance by $10^4$	$10^4$	$10^6$	$10^8$	$10^{10}$

Richard Lee, Development Engineer, Boonton Electronic Corp., Parsippany, N. J.

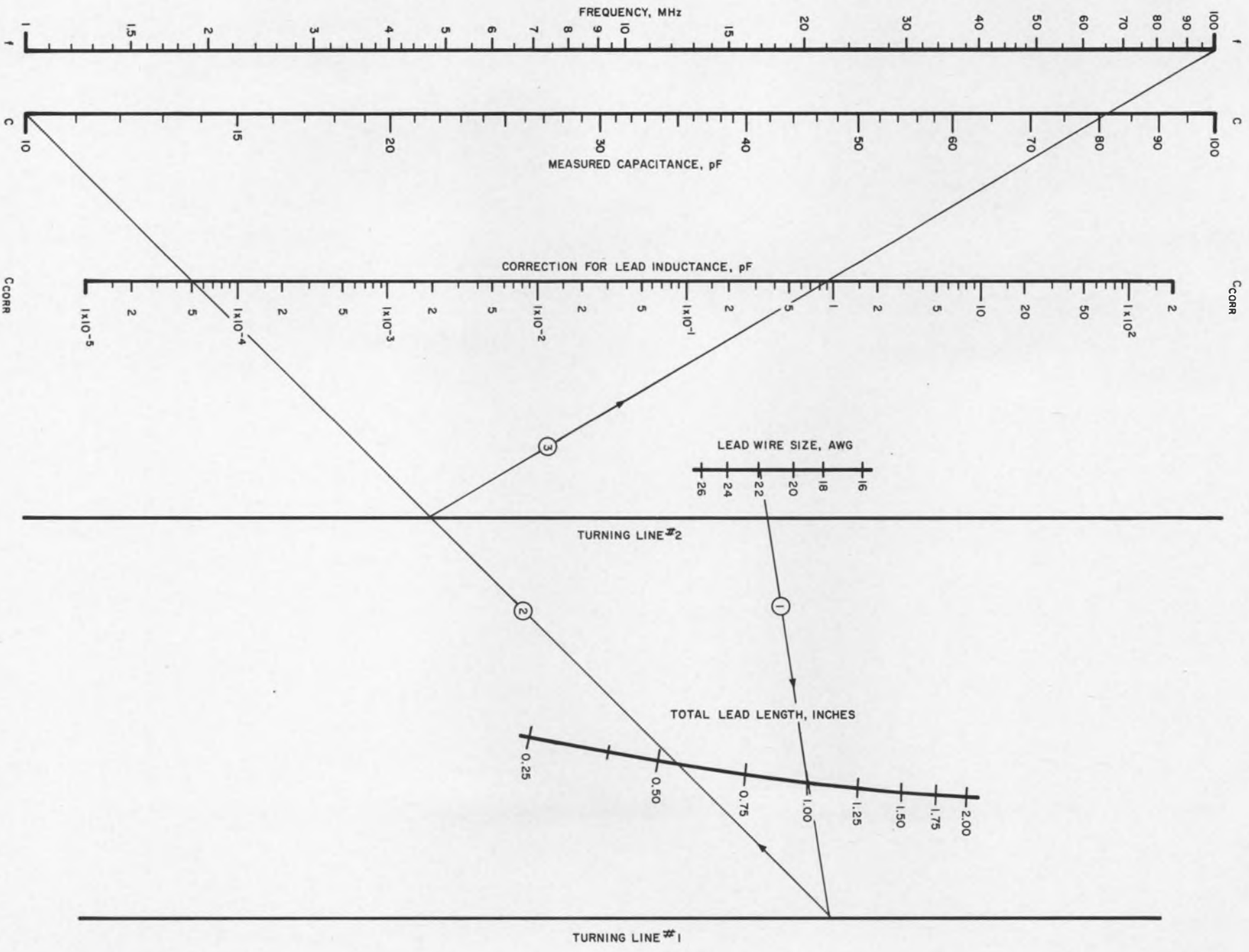

# THE NEW GENERATION



## **SILVERLINE**™

**a new, superior line of Clifton Synchros**

- Higher Accuracy. 5' standard
- Outstanding Repeatability of Calibration Pattern
- Stability of Calibration over Temp.
- 150°C Standard Operating Temp.

Keeping pace with the developing aerospace field, Clifton announces SILVERLINE, a new, superior line of standard synchros. □ These units, a natural evolution from our present line of quality synchros, embody certain new manufacturing techniques and space age materials. The result is a standard synchro which outperforms pres-

ent synchros in four distinct ways shown above. □ SILVERLINE synchros are in the field now. Call your local Clifton Sales Office for price, delivery and further information.

**cppe** **CLIFTON**   
DIVISION OF LITTON INDUSTRIES

# Variable-duty-cycle switching circuit

controls illumination intensity of a reticle within a crewman optical alignment sight.

Conservation of electrical power in manned space vehicles is of prime importance. Accordingly, all power control circuits are designed for the highest efficiency possible. A requirement for a continuous control of the illumination intensity of a reticle within a crewman optical alignment sight was thus met with a variable-duty-cycle power-switching circuit.

The advantages of this circuit, aside from its high efficiency, include:

- Versatility in providing illumination intensity patterns.
- High resolution for the illumination control.
- Circuit simplicity.
- Ease of analysis.

The circuit principles developed here can be used in most applications which require pulse width modulation and power switching. Such applications include motor controllers in servo systems, switching voltage regulators in power supplies, and information coding in logic circuits.

## Operator controls illumination intensity

A block diagram of the circuit is shown in Fig. 1. The operator adjusts the brilliance control knob for the desired illumination level from the lamp. The brilliance control determines the pulse duty cycle of the pulse generator. The pulse generator drives the power switch in accordance with the pulse duty cycle. The power switch applies the power supply voltage across the lamp in accordance with the power switch duty cycle, and thus fixes the lamp's brilliance.

## How the circuit works

The pulse generator is shown in Fig. 2. Transistors  $Q1$  and  $Q2$  form two constant current generators. Potentiometer  $R6$  adjusts their current distribution.

Power supply current through Zener diode  $CR2$  provides the voltage bias for the bases of  $Q1$  and

$Q2$ . Power supply current through Zener diode  $CR1$  in series with Zener diode  $CR2$  fixes the bias voltages for the bases of  $Q3$  and  $Q4$ .

The pulse generator circuit operates in the following manner. Initially, transistors  $Q3$  and  $Q4$  are forward-biased, but because of circuit imbalance only one transistor will switch on first. Assume that  $Q3$  switches on first. Current from  $Q1$  flows through resistor  $R4$ , causing the collector voltage of  $Q3$  to drop. This voltage drop is coupled through capacitor  $C1$  to the base of  $Q4$ , forcing transistor  $Q4$  off. While  $Q4$  is off, the current from  $Q2$  charges capacitor  $C2$ . Eventually, the base-emitter threshold voltage of  $Q4$  is exceeded and it begins to conduct. The conduction through  $Q4$  reduces the emitter current through  $Q3$ , thereby in-

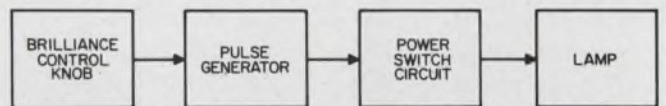

1. Simplicity of the lamp control circuit is demonstrated by the above block diagram. Circuit details are given in Figs. 2 and 3.

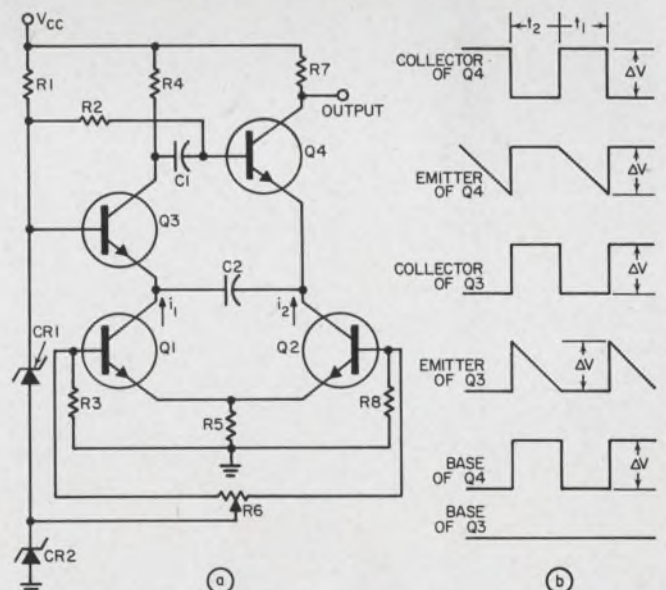

2. Pulse generator is controlled by  $Q1$  and  $Q2$  which, in turn, are controlled by the setting of  $R6$  (a). Voltage waveshapes at various points within the circuit are shown in (b).

George W. Candel, Research Engineer, Autonetics Div. of North American Aviation, Inc., Anaheim, Calif.

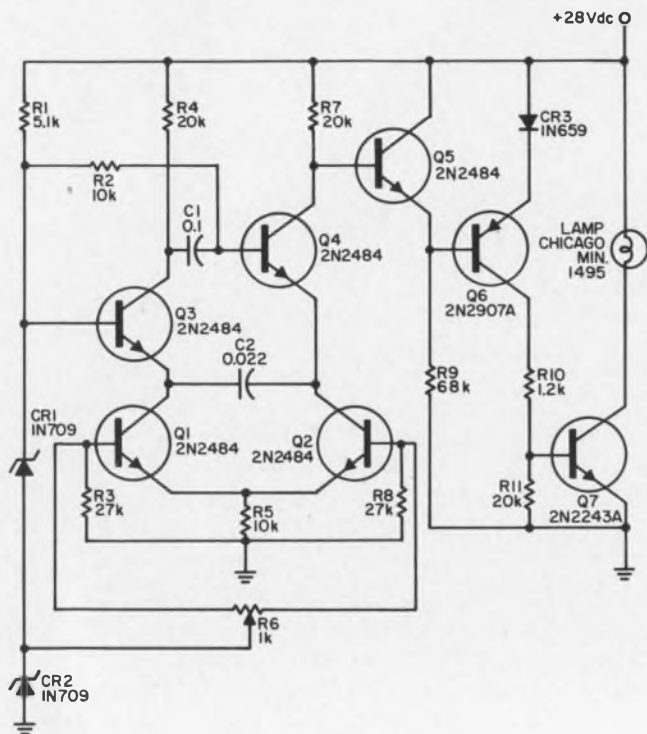

3. Addition of three transistors to the pulse generator of Fig. 2 completes the "lossless" lamp control circuit.

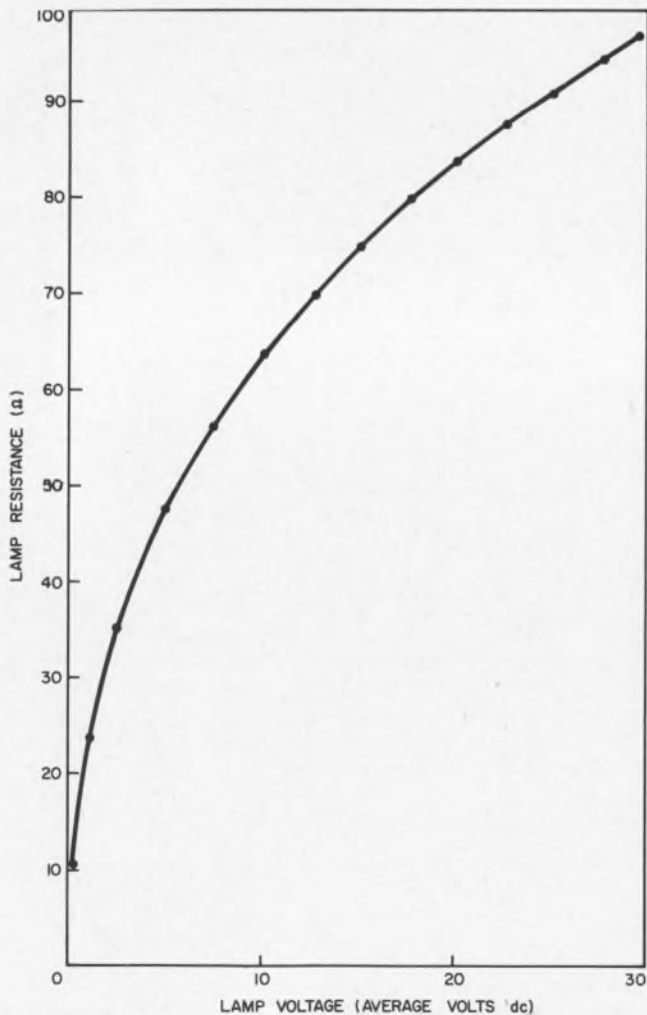

4. Lamp resistance vs voltage curve can be used to select the proper lamp.

creasing the collector voltage of  $Q3$ . The positive-going voltage at the collector of  $Q3$  is applied through capacitor  $C1$  to the base of  $Q4$ , forcing  $Q4$  into heavier conduction. Also, the emitter voltage of  $Q4$ , following its base drive, rises and is applied through capacitor  $C2$  to the emitter of  $Q3$ , forcing  $Q3$  into cutoff. These actions proceed rapidly until  $Q3$  is switched off and  $Q4$  is switched on. While  $Q3$  is off, the current from  $Q1$  charges capacitor  $C2$ . Eventually, the base emitter threshold voltage of  $Q3$  is exceeded and it begins to conduct. This reduces the emitter current through  $Q4$  and decreases the collector voltage of  $Q3$ . The negative-going voltage at the collector of  $Q3$  is coupled through capacitor  $C1$  to the base of  $Q4$ , forcing  $Q4$  toward cutoff. This action proceeds rapidly until  $Q4$  is switched off and  $Q3$  is switched on. The cycle then repeats itself. The waveforms of the circuit are shown in Fig. 2b.

### Circuit analysis is easy

The analysis of the pulse generator circuit (Fig. 2a) can be separated into two parts:  $Q3$  is on for time  $t_1$  and  $Q4$  is on for time  $t_2$ .

The approximate equation for the case of  $Q3$  on is:

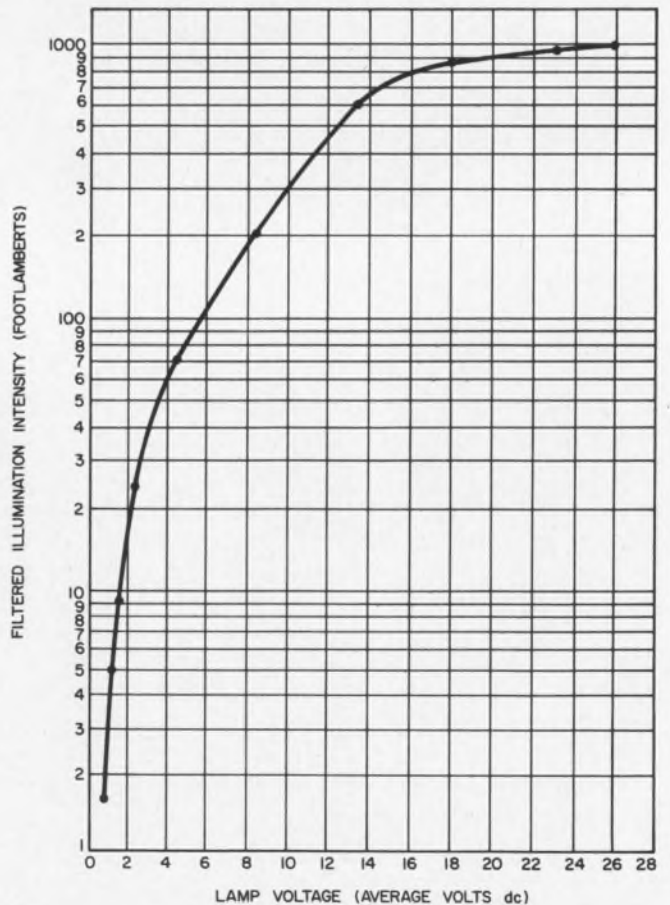

5. Illumination intensity as a function of average applied voltage combined with the curve of Fig. 4 narrows down the choice of the lamp.



$$\Delta V_1 = i_1 R_4 = i_2 t_1 / C_2,$$

where all symbols are those of Fig. 2. Therefore:

$$t_1 = R_4 C_2 (i_1 / i_2).$$

The approximate equation for the case of  $Q_4$  on is:

$$\Delta V_2 = i_2 R_7 = i_1 t_2 / C_2.$$

So that:

$$t_2 = R_7 C_2 (i_2 / i_1)$$

The period of oscillation equals  $t_1 + t_2$ .

The currents  $i_1$  and  $i_2$  are determined by the voltage across Zener diode  $CR1$  and the adjustment of the potentiometer  $R6$ .

When the potentiometer arm is set at the base of  $Q1$ ,  $i_1 = (V_{cr2} - V_{be1}) / R5$ . The voltage at the base of  $Q2$ ,  $V_{b2}$ , is given by:

$$V_{b2} = V_{cr2} [R8 / (R8 + R6)].$$

The resistor values are selected so that:

$$V_{cr2} [R8 / (R8 + R6)] < (V_{e2} + V_{be2}),$$

enough just to cut  $Q2$  off and make  $i_2 = 0$ .

When the potentiometer arm is set at the base of  $Q2$ ,  $i_2 = (V_{cr2} - V_{be2}) / R5$ . The voltage on the base of  $Q1$ ,  $V_{b1}$ , is given by:

$$V_{b1} = V_{cr2} [R3 / (R3 + R6)].$$

The resistor values are selected so that:

$$V_{cr2} [R3 / (R3 + R6)] < (V_{e1} + V_{be1})$$

enough just to cut  $Q1$  off and cause  $i_1 = 0$ .

As the potentiometer arm is moved from the base of  $Q1$  to the base of  $Q2$ ,  $i_1$  varies continuously from  $(V_{cr2} - V_{be1}) / R5$  to zero, while  $i_2$  varies continuously from zero to  $(V_{cr2} - V_{be2}) / R5$ . This, in effect, provides the required duty cycle variation from 0 to 100%.

### Power switch puts the finishing touch

The complete brilliance control circuit is shown in Fig. 3. The pulse generator output at the collector of  $Q4$  drives emitter-follower switching transistor  $Q5$ . During time  $t_1$ , the base voltage of  $Q5$  is slightly less than the power supply voltage by the forward bias voltage drop  $i_{b7} R_7$ . Since  $i_{b7} R_7 + V_{be5} < V_{cr3} + V_{eb6}$  transistor  $Q6$  is cut off. Therefore, transistor  $Q7$  is also cut off and the lamp is off. During time  $t_2$ , the collector voltage of  $Q4$  drops by  $\Delta V_2$  volts. The circuit resistance values are selected so that  $\Delta V_2 > V_{cr3} + V_{eb6}$ .

Since the emitter voltage of  $Q5$  is clamped to  $V_{cc} - V_{cr3} - V_{eb6}$ , transistor  $Q5$  is reverse-biased and so cut off. Resistor  $R9$  provides forward bias current to switch  $Q6$  on; this in turn switches  $Q7$  on, supplying power to the lamp.

The lamp illumination intensity is proportional to its dissipated average power. The average power,  $P_{AV}$ , is approximately:

$$P_{AV} = [t_2 / (t_1 + t_2)] (V_{cc})^2 / R_{lamp}.$$

Fig. 4 shows how the lamp resistance increases with the applied average voltage. Fig. 5 shows how the filtered lamp illumination intensity increases with the applied average voltage. ■ ■



## Cedar Standard Motor-Tachs give you

# TOP QUALITY FAST DELIVERY REAL ECONOMY

Nine out of ten of our size 8 or 10 motor-tachometers use identical housings, stacks, shaft and rotor assemblies, tuning plugs and bearings.

And yet, they still meet a wide variety of our customers' specifications. For, each unit has a different winding and pinion. Each unit performs in a different way—any way you prescribe. You still set the parameters. You still get the torque, speed, input voltages, pinions, tachometer gradients and other parameters you want.

What does this mean to you?

Standardization permits large volume manufacture . . . allows more intensive engineering and testing . . . and provides an on-hand inventory for immediate use.

This standard hardware approach has made Cedar the nation's largest manufacturer of size 8 and 10 motor-tachometers. We can deliver prototypes of standard size 8 or 10 motor-tachs in two weeks. Let's talk about it. Call or write Cedar today.

**CEDAR** **CONTROL DATA**  
ENGINEERING DIVISION CORPORATION

5806 West 36th Street, Minneapolis, Minn. 55416  
Phone (612) 929-1681

# When you measure operational amplifier value



## use the whole ruler!

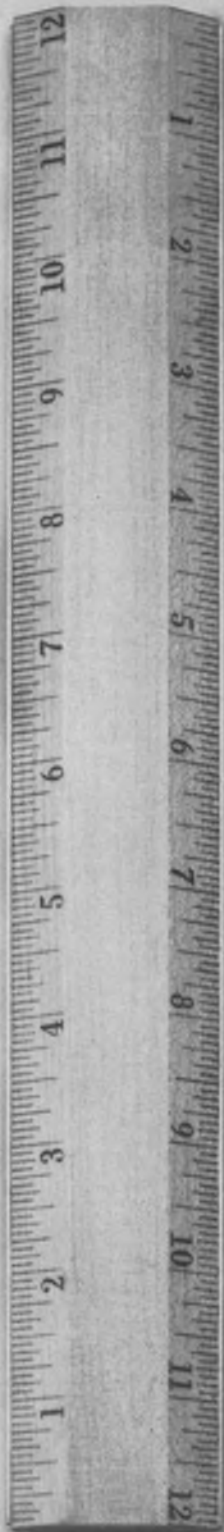

**The Right Amplifier** — You get the amplifier that's just right for your application from Burr-Brown's broad line. General purpose, FET, chopper stabilized, high voltage, low voltage, military, miniature and custom units are available in a wide range of configurations.

**The Right Circuit** — Burr-Brown wrote the book on operational amplifier applications. In addition to two popular handbooks, a large Applications Engineering staff is always at your service.

**The Right Accessories** — Burr-Brown has a complete line of support accessories including: power supplies, connectors, circuit simulators, adapters, and regulators.

**Immediate Delivery** — After all, "Dash" is our middle name. Exclusive Jet-Stock service puts most units in your hands within 24-hours. We have even designed, built and shipped custom demonstrator units in less than one day.

**Guaranteed Performance** — Every Burr-Brown unit is tested under a Quality Assurance program designed to meet the requirements of MIL-Q-9858A, MIL-I-45208A, MIL-C-45662A, and NASA NPC-200-3.

**Reliability** — Conservative component stress design, conservative ratings, and stringent process control procedures result in predicted MTF ratings in excess of 700,000 hours for most units.

**Satisfaction** — In ten years, we've built a reputation for customer satisfaction we don't intend to jeopardize.

**Guaranteed Source** — Burr-Brown is still supplying units introduced in 1956 despite averaging 200 new models a year.

**No-Cost Evaluation** — We currently have over 1,600 demonstrator units available at Field Offices. Which one would you like to evaluate?

**Local Service** — Over 80 domestic Burr-Brown Engineering Representatives are ready, willing and able to assist you.

**FOR CURRENT CATALOG**  
on Burr-Brown "maximum value" Operational Amplifiers and Accessories, contact your nearest Engineering Representative, write Burr-Brown, or use this publication's reader-service card.

**SEE US AT THE IEEE SHOW**  
BOOTH 3A26-27

## BURR-BROWN

RESEARCH CORPORATION

International Airport Industrial Park • Tucson, Arizona 85706  
TELEPHONE: 602-294-1431 • TWX: 910-952-1111 • CABLE: BBRCORP



*Operational Amplifiers  
Instrumentation Amplifiers  
Function Modules  
Analog Simulators  
Geophysical Instruments*

ENGINEERING REPRESENTATIVES: ALABAMA, HUNTSVILLE (205) 534-1648 / ALASKA, ANCHORAGE (907) 272-5231 / ARIZONA, PHOENIX (602) 254-6085 / CALIF., LOS ANGELES (213) 665-5181, SAN FRANCISCO (408) 245-3321 / COLO., DENVER (303) 388-4391 / CONN., MILFORD (203) 874-9222 / FLORIDA, ORLANDO (305) 425-2764 / ILLINOIS, CHICAGO (312) 286-6824 LA., NEW ORLEANS (504) 834-6598 / MD., SILVER SPRING (301) 588-8134 / MASS., BOSTON (617) 245-4870 / MICH., DETROIT (313) 353-3822 / MINN., MINNEAPOLIS (612) 781-1611 MD., ST. LOUIS (314) 524-4800 / N.C., GREENSBORO (919) 273-1918 / N.J., CAMDEN (609)

365-2450 / N.M., ALBUQUERQUE (505) 255-1638 / N.Y., ALBANY (518) 436-9649, BINGHAMTON (607) 723-9661, BUFFALO (716) 632-2727, MT. VERNON (914) 968-2200, NEW HARTFORD (315) 732-3775 / OHIO, CINCINNATI (513) 761-5432, CLEVELAND (216) 884-2001, DAYTON (513) 277-8911 / OKLA., TULSA (918) 835-2481 / OREGON, PORTLAND (503) 292-8762 / PENN., PITTSBURGH (412) 243-6655 / TEXAS, DALLAS (214) 363-1671, HOUSTON (713) 928-5251 UTAH, SALT LAKE CITY (801) 466-8709 / WASH., SEATTLE (206) 622-0177 / CANADA, TORONTO (416) 293-7011, VANCOUVER (604) 736-6377

# Adage makes the fastest A-to-D converter on the market

8 bits at 1 Mc, 1  $\mu$ s conversion time (Model VT7-AB)  
14 bits at 200 Kc, 4  $\mu$ s conversion time (Model VT13-AB)

Adage has been making solid-state analog-to-digital converters, and compatible sample-and-hold amplifiers, multiplexers, and D-to-A converters, since 1957 — longer than anyone else. We like to think our record of performance is also unmatched.

May we send you literature describing our products — or an applications engineer to help you with your problem? Write Leon Dall, Product Manager, Adage, Inc., 1079 Commonwealth Ave., Boston, Mass. 02215, (617) 783-1100.



*Adage*  
INC

ELECTRONIC DESIGN 6, March 15, 1967

ON READER-SERVICE CARD CIRCLE 203

## Capacitive voltages are found easily

with this simple nomograph which does away with the need for tricky calculations with log table or slide rule.

When performing a transient analysis of a digital circuit, the designer is often interested in knowing the instantaneous value of voltage  $V_c$ . This appears across a capacitance, connected across the circuit's output (see schematic), at some arbitrary time after switching begins. He may also want to know how much time is required for this voltage to reach a specified value.

The formula for the first case is:

$$V_c = E(1 - e^{-t/RC});$$

for the other case the formula is:

$$V_c = E e^{-t/RC}.$$

Evaluation of these expressions normally requires either a logarithm table or a good slide rule. The accompanying nomograph, however, eliminates the exponent. It then becomes a simple matter to calculate time constant  $T$  from the formula  $T = t/RC$ , and read out  $V_c$  as a percentage of maximum voltage  $E$  on the nomograph. Alternatively,  $t$  can be calculated if  $V_c$  is read into the nomograph as a percentage of  $E$  and time constants are read out and applied to the formula  $t = TRC$ .

### Two examples show how to use nomograph

**Example 1:** Suppose  $R$  to be 2 k $\Omega$  and  $C$  1000 pF, making sure that the driver gate  $Z_o$  and  $C_o$  are included in  $R$  and  $C$ . Assume that  $E_1$  is 5.25 volts and that  $V_{CE}(s)$  of the driver gate is 0.25 volt;  $E$  is then 5.0 volts. If you need to know the turn-off time required to reach 1.75 volts, subtract 0.25 volt from 1.75 volts. The difference, 1.5 volts, is 30% of 5.0 volts. From the nomograph, 30%  $E = 0.35T$ . From the formula  $t = TRC$ :

$$\begin{aligned} t &= 0.35 \times 2 \times 10^3 \times 10^{-9} \\ &= 0.7 \times 10^{-6} \text{ s.} \end{aligned}$$

**Example 2:** Assuming the same conditions as in the previous example, suppose you wish to calculate  $V_c$  at 18 ns after the driver output turns on.

In addition, assume that output impedance is 10 ohms. (For heavily loaded outputs, the effective resistance  $R = Z_o/(1 - Z_o/R_L)$ , but in this example  $R_L$  can be ignored.) From the formula  $T = t/RC$ :

$$\begin{aligned} T &= (18 \times 10^{-9}) / (10 \times 10^{-9}) \\ &= 1.8 \text{ s.} \end{aligned}$$

From the nomograph it can be seen that 1.8  $T = 16.5\%$   $E$  when  $V_c = 0.825$  volt. Be sure to return to ground reference by adding  $V_{CE}(s)$  to  $V_c$ . This gives 1.075 volts—the instantaneous output voltage after 18 ns.

Although this nomograph has been applied specifically to digital circuitry, its use is certainly not restricted to this type of circuitry alone. The nomograph will find capacitive voltages in a wide variety of other circuits. ■ ■

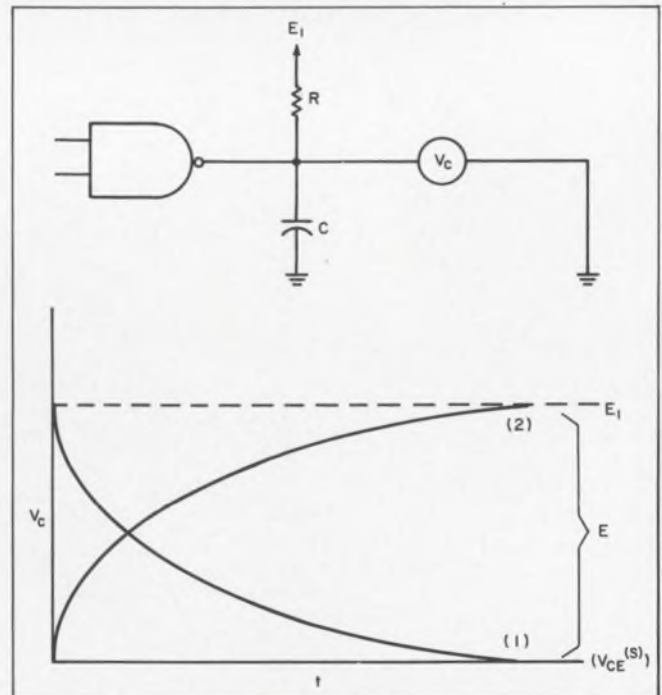

Finding the instantaneous voltage across  $C$  is simple with the accompanying nomograph. The steps involved are straightforward and avoid the need for error-prone manual calculations with slide rule or log tables.

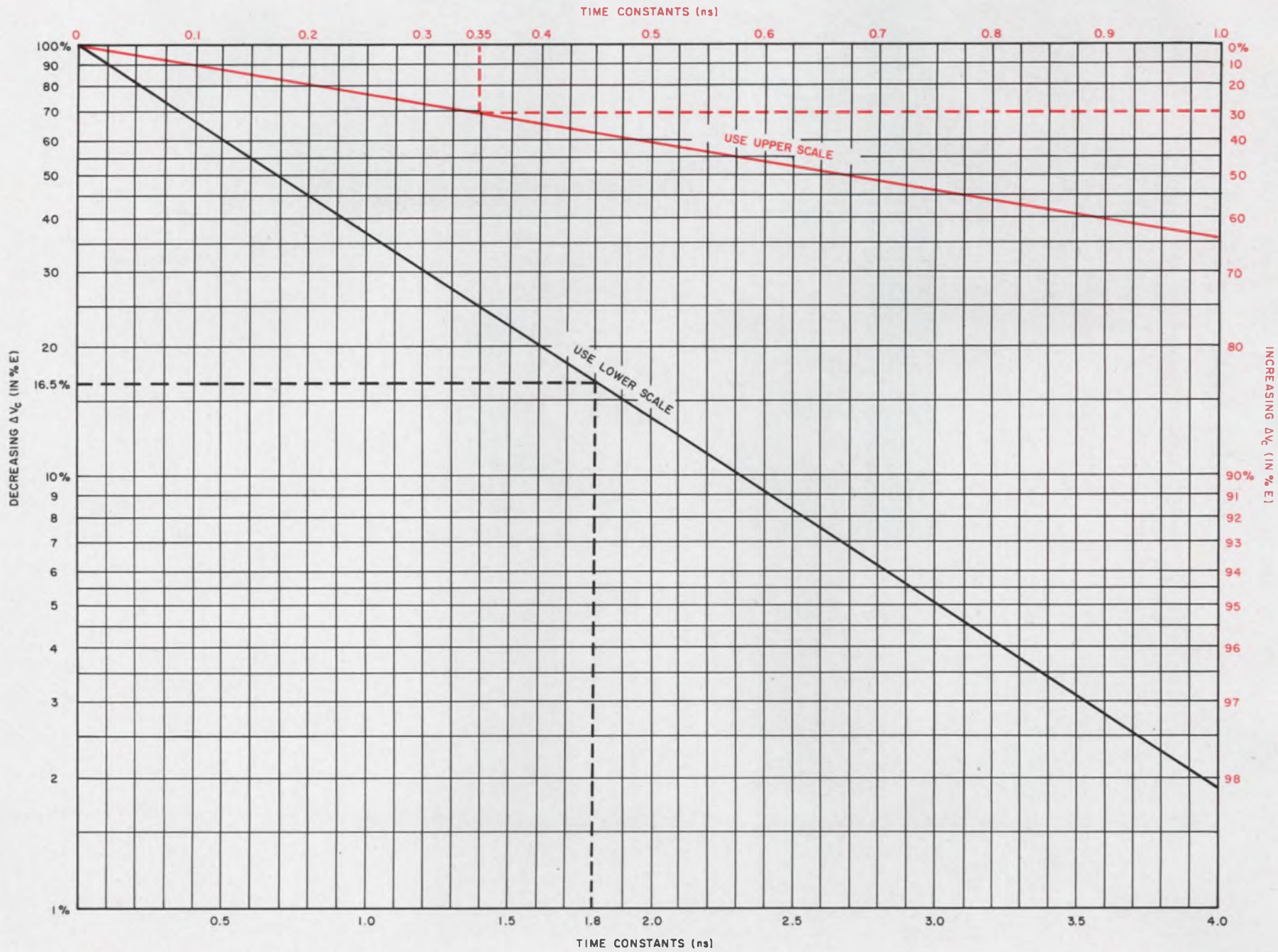

# Extra Value Reed Relays

*New Design provides Greater Reliability*

**PLUS Lowest Cost**

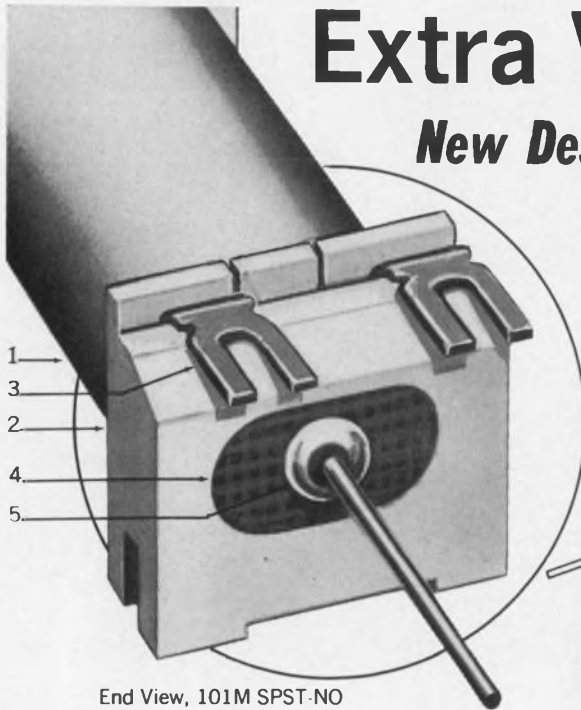

End View, 101M SPST-NO

Hermetically sealed reed capsules are completely enclosed and shielded by the bobbin.

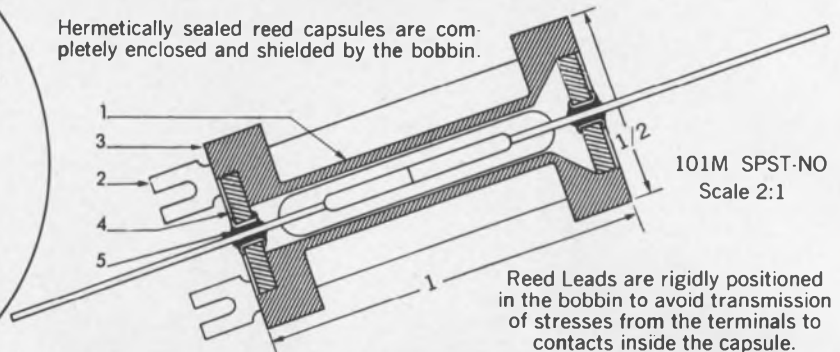

101M SPST-NO  
Scale 2:1

Reed Leads are rigidly positioned in the bobbin to avoid transmission of stresses from the terminals to contacts inside the capsule.

## *The new Design has been developed to provide maximum reliability in Axial Lead Reed Relays*

The coil bobbin (1) is integrally molded with square mounting supports (2) and tinned coil terminal inserts (3). With the reed capsule in place, ends of the bobbin are closed with insulating bushings (4). Rigid positioning of the contact leads in the insulating bushings (5) avoids transmission of stresses on the lead terminals to contacts inside the glass capsule and disturbance of relay adjustment.

This new design provides dust tight enclosure of the hermetically sealed glass capsule and increased protection against mechanical injury.

Configurations and contact combinations in which the new Axial Lead Relays are available are shown at the right.

## The New EXTRA value Reed Relays with Axial Leads adaptable to printed circuits

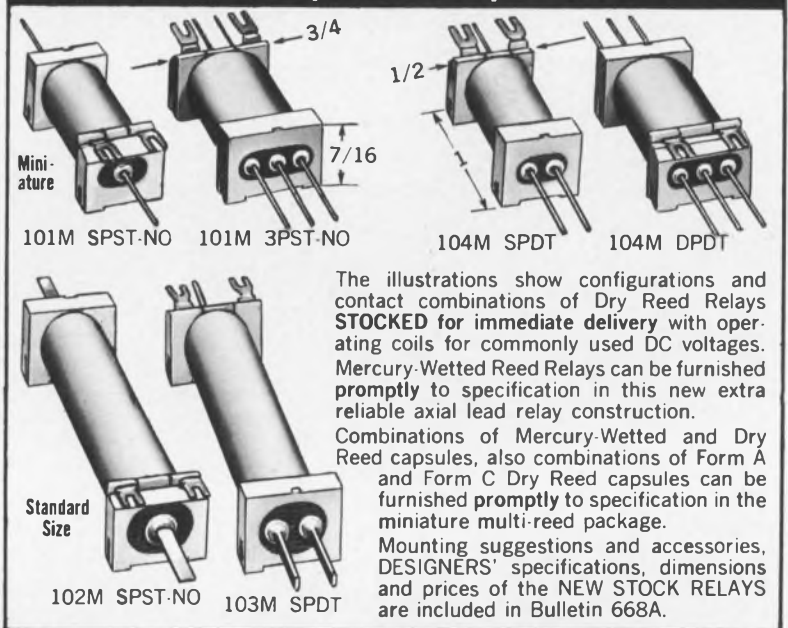

The illustrations show configurations and contact combinations of Dry Reed Relays **STOCKED** for immediate delivery with operating coils for commonly used DC voltages. Mercury-Wetted Reed Relays can be furnished promptly to specification in this new extra reliable axial lead relay construction.

Combinations of Mercury-Wetted and Dry Reed capsules, also combinations of Form A and Form C Dry Reed capsules can be furnished promptly to specification in the miniature multi-reed package.

Mounting suggestions and accessories, DESIGNERS' specifications, dimensions and prices of the NEW STOCK RELAYS are included in Bulletin 668A.

## Do YOU need Reed Relays, NOW

160 Mercury-Wetted and Dry Reed Relays including— • Axial Lead • Bi-Stable • Encapsulated • Enclosed • High Speed • High Voltage • Latching • Low Capacitance • Magnetically Shielded • Microminiature • Miniature • Multiple Coil • Multiple Contact • Open Style • Plug-in • Printed Circuit—are **STOCKED** for immediate delivery.

All the above Reed Relays plus 248 Telephone, General Purpose, Coaxial, Time Delay and other types in **STOCK** for immediate delivery and available through authorized distributors at low factory prices are described and priced in **STOCK RELAY CATALOG 267** and Bulletin 668A.

### Complete Reed Relay information in one cover

Complete DESIGNERS' data on the extensive line of **MAGNECRAFT** Reed Relays is provided in the **DESIGNERS' Handbook and Catalog**.

The **HANDBOOK** also includes complete information on Reed Relays—Principles of Operation • Styles and Characteristics • Application Information • Testing Procedures • How to Specify.

The two publications illustrated plus **Bul. 668A** are mailed promptly on request.

For prompt action contact the **MAGNECRAFT REPRESENTATIVE** in YOUR area, write or phone us.



See us at  
**IEEE**  
Booth  
**4G09**

# MAGNECRAFT Electric Co.

5575 North Lynch, Chicago, Ill. 60630  
Phone 312-282-5500

ON READER-SERVICE CARD CIRCLE 204

## COULD YOU SLICE THIS ANGLE INTO 300 EQUAL PARTS?

### M<sup>C</sup>COY DOES EVERY DAY!

That's the final step in cutting crystal blanks at M<sup>C</sup>Coy. Prior to this several cuts are made with diamond saws...and after each cut, blanks are X-rayed to assure proper angle.

X-ray inspection equipment is accurate to 1/300 of 1° of angle. Angle accuracy is vital because it influences crystal behavior under varying temperatures.

Blanks are then lapped—a few millionths of an inch at a time—to the desired thickness, accurate within 10

millionths of an inch. Crystals are then coated with metal films (in high vacuum evaporation platers) only a few millionths of an inch thick to provide the *exact* frequency required.

These are but a few of the precision operations that assure you of the highest quality available when you specify M<sup>C</sup>Coy crystals, oscillators and filters.

For full details on these precision components, write for our new product catalog.



**M<sup>C</sup>COY ELECTRONICS COMPANY**

A Subsidiary of OAK ELECTRO/NETICS CORP

Mt. Holly Springs, Pennsylvania 17065

ON READER-SERVICE CARD CIRCLE 205

# Cut the 'noise' out of your next article

and editors will beat a path to your typewriter. A good manuscript distills the essence from your work.

We are told that 90 per cent of all the scientists who have ever lived are living today—and writing! The technical information available more than doubles every 10 years; about 100,000 journals in more than 60 languages are published throughout the world, and the number doubles every 15 years. This plethora of paper has elicited from scientist Albert Szent-Györgyi this whimsical definition: "A drug is a substance which, if injected into an animal, produces a paper." As an engineer, you know the problem of keeping abreast of technology.

Accept your obligation to publish—in the most readable form—data that are useful, but bury forever the manuscript that only adds to the confusion.

Consider your writing job as you would any design task. A published article is one part of an information link. The information source is your storehouse of knowledge on the subject and the references you will use for your article. The transmitter is, of course, you, the author. The channel is the medium you select. The receiver of the signal you send is your reader and it is he who will apply the new knowledge you impart.

***"There is a great discovery still to be made in Literature, that of paying literary men by the quantity they do not write."***

**Thomas Carlyle**

To help the reader get the point, you must eliminate all interference, which is anything that hinders his understanding of the subject. Interference may be a missing signal: if you have not supplied the reader with all the details, he will be forced to supply the missing ones himself—and he may do so wrongly. Interference may be a term he does not understand, a formula or drawing that is not clear, or just plain involved writing. Your job is to design into your system the lowest possible interference level to ensure maximum signal reception.

Most poor technical writing suffers from the

same shortcoming—poor organization. You are familiar with the report or article that seems to have something to say, but even after reading it several times, you are not sure what. Organization is usually the problem. And often, the solution is simple. Ask yourself, "What point am I trying to make in my article?" Then organize your material in such a manner that the point is unmistakable.

***"The place for a writer to work is in his head."***

**Ernest Hemingway**

Good communication is a state of mind. You can communicate, if you put your mind to it. What is the purpose of your article? Why are you writing it in the first place? What is your main concept?

Put the most important points first. Do not back into the subject. Your busy reader may not have time to follow you. Take a direct approach. Do not go off on interesting but distracting side tracks. You can get back to them later if necessary. Before you put a word on paper, try to summarize your message in one succinct statement.

Organize your information by drafting a good outline—either in your head or preferably on paper. Then follow that outline when you write. Keep in mind the what, why, when, where, who, how, and so what of your thesis. The outline, which serves as the framework of your article, should be built carefully. These steps will help in its preparation:

- Jot down on paper each idea as it comes to mind, disregarding its importance in the final draft.
- Classify these ideas into major ideas or groups and subgroups.
- Arrange the subgroups into logical order under the main groups.
- Check the completed outline for sequence, importance, duplications, omissions, clarity.
- Rearrange and make changes as needed.

Begin your outline before you finish your project. Then you will be sure to have collected all the data necessary for a good paper. Spend as much time as possible organizing the article while it is in the outline stage; you will save a lot of time re-writing later.

Arrange your ideas so that your reader can

---

Dewey E. Olson, Manager of Engineering Publications, IBM Systems Development Div., Rochester, Minn.



easily follow the development of your message. Be sure to write ideas, not just verbiage. As you expand your outline into paragraphs, keep one idea to a paragraph and be sure that each paragraph has a topic sentence. If your organization is good, your article will flow smoothly. If it does not, go back and check the organization. Organize according to five steps to successful salesmanship:

- Gain attention with a succinct, informative and pertinent first sentence. For example, you may begin with: "A new approach to integrated-circuit design may halve the cost of your next logic system." You can be pretty sure that your reader will want to find out what your new approach is.

- Arouse interest by telling your reader how he will benefit from your article—and tell him early.

- Induce conviction by appealing to your reader's mind, not his emotions. He wants facts. Why is your approach better? Why should he use it? Do not just unload facts on an unsuspecting reader, though. Analyze them for him.

- Create desire by clearly showing your reader how he can use your idea to help him solve everyday problems. Tell him why your idea works.

- Get action by spelling out the steps that will produce the desired result. Do not present "obvious" conclusions that are not obvious to your reader. Do not insult his intelligence, but do not assume he is gifted with extrasensory perception.

***"A sentence should read as if the author, had he held a plow instead of a pen, could have drawn a furrow deep and straight to the end."***

#### **Henry David Thoreau**

When you are ready to write, be sure you start at the beginning. Someone outside your specialty may need an orientation; therefore, you must give him sufficient background in the introduction. You must walk the fine line between two extremes: do not give so little detail that your reader is readily lost or does not really grasp the significance of your paper, nor give so much detail that your reader is bored.

The main body of your paper tells your technical story—how the device works, the experimental setup, the method, the analysis. Use it to provide informative copy and to answer your reader's questions about your project. Most engineers have little trouble writing this section. You know more about how your circuit works than anyone else. You know why your design offers advantages.

#### **Good subheadings help the reader**

Use subheadings to break up your article. If you do not, the editor will, so you may as well express your preference. Subheadings indicate organiza-

tion to the reader who only scans the article. They emphasize the main points of what you have to say. They also help the busy reader find his place again if he is interrupted.

Organization of the main body of your article depends on your subject. An article describing a process, for example, takes a different shape from one describing a device or circuit. If, for instance, you are describing the operating theory of a circuit or device, state precisely how it works, what it can do well and why one method was chosen over others.

***"It has always been much like writing a check . . . It is easy to write a check if you have enough money in the bank, and writing comes more easily if you have something to say."***

#### **Sholem Asch**

Sometimes it will be necessary to describe the experimental or analytical setup you used to obtain your data, since the reader may evaluate your conclusion in the light of how you accumulated your data. For the same reason, you may be required to describe in detail how you actually performed the experiment or made the analysis. Present the necessary details, analyze the data, and explain how you reached your conclusions.

Unless your particular article calls for a special approach, try to emphasize the important findings rather than the techniques used. Try to make your article instructional rather than purely descriptive. One of the most telling ways to make a point is with an appropriate analogy. Do not be afraid to permit a conscious inaccuracy if it aids understanding. In other words, it may not be completely accurate to draw an analogy between water flowing through a pipe and electrons traveling along a conductor, but such an analogy may make the reader grasp your point more easily.

Be positive, be natural, be confident. To be a successful writer, you must develop a successful style. What is style? Jonathan Swift defined style as "proper words in proper places." Maybe it is just that simple.

When an engineer talks about his paper, he usually has no trouble expressing his complex idea in simple terms. Often, however, he clouds things as soon as he tries to put his thoughts on paper. The permanence of the written word makes him want everything to be just right. So it should be. But avoid being pompous or self-conscious on paper. And above all, do not complicate your treatment of your subject.

Study the styles that have made certain writers effective communicators. Consciously analyze the techniques that made a paper, magazine article, or other written communication memorable. When

you read something that you particularly like, go back to see how the writer stated his case.

The author E. B. White said, "Write in a way that comes naturally." For most people, it works. Do not try to impress, just say what you have to say. Keep in mind that your reason for writing is to inform. Write to be understood.

***"By being so long in the lowest form [at Harrow School] I gained an immense advantage over the cleverer boys. . . . I got into my bones the essential structure of the ordinary British sentence—which is a noble thing."***

### **Sir Winston Churchill**

There is no short cut to good writing. Writing is an art rather than a science. Considerable time and effort are required to learn to write well. But the simpler you keep it, the less trouble you will get into. Most engineers have an idea of good sentence construction, basic subject-verb-object order, agreement of verbs. Most engineers can spell (or have secretaries who can). Punctuation is important, but not the insurmountable problem your English teacher made it. What is the secret, then? Keep sentences simple and make them live.

One way to add vitality is to write in the active voice rather than the passive voice. Instead of saying "x is exceeded by y," say "y exceeds x." The sentence is not only shorter but also livelier.

Just as you should not back into your subject matter by starting your article with unimportant details, do not back into your sentences or paragraphs, either. For example, in this sentence the most important element is buried: "The continual need for minor adjustments is eliminated through pinpoint calibration of the power supply." Rather say, "Pinpoint calibration of the power supply eliminates minor adjustments."

Short, crisp, fresh words have impact. Make room for them by avoiding longer, more pedantic words. Concrete words rather than intangible concepts can enliven writing. They help you to have impact by telling your reader not merely the theory behind something, but also what happened, how it happened, and what made it happen.

***"'When I use a word,' Humpty-Dumpty said, 'it means just what I choose it to mean—neither more nor less.'"***

### **Lewis Carroll**

There exists no advice that will instantly transform an illiterate into a great writer. The road to good writing is strewn with discarded pages, paragraphs, sentences and words pruned from manuscripts. It is no exaggeration to say that one

of the writer's best friends is his wastepaper basket. There are, however, a number of simple procedures that will improve the presentation of a manuscript and, hence, its chances for publication.

Type it with a decent ribbon. Typing should be double-spaced on one side of each page. Leave wide margins so that there is room for an editor's changes. Proofread the manuscript carefully and keep a carbon copy.

Be sure that each page is numbered. Check your illustrations and make certain that your references to them are correct. Do not bind the pages, clip them together. Do not fold the manuscript. If you send photographs, type your caption on a sheet of paper and tape the sheet to the back of the photograph. Do not write on the back of the photograph and do not clip captions to it with staples. Most importantly, submit with the manuscript an outline that briefly describes its contents and explains your reason for writing it.

***"We are all apprentices in a craft where no one ever becomes a master."***

### **Ernest Hemingway**

We all have some communications faults. Do your best to eliminate whatever yours may be. The technologist is often accused of obscure writing because he packs too much message into too few words—his writing is too dense. The lawyer tries to make his meaning so exact that no one can misinterpret his writing—his writing is too precise. The doctor is accused of using so many complicated terms that only other doctors can read his writing—his writing is too specialized. The scientist is accused of hedging too much to ensure that his results will not be misinterpreted when they are applied to a similar experiment by another scientist—his writing is too qualified.

The engineer is accused of all these faults and others. But you can overcome most communications faults by carefully writing and rewriting your manuscript before you submit it. Let another engineer not connected with your group read your piece. Then find out if he really followed it by having him describe your main ideas back to you. If he can do this—you have communicated. If some points are fuzzy, sharpen up that portion of your explanation.

And remember, despite any suggestions or assistance you may receive from your colleagues or your manager, the paper is yours. Its contents reflect your technical ingenuity; its literary worth reflects your ability to communicate complex ideas. Put your best effort into making the paper accurate, exact, thorough, adequate, and readable. Do what you can to make your article convey your ideas in a manner that is completely intelligible. Then you are on the road to writing well. ■ ■



**LOOKING FOR  
GROWTH?**

**INVESTIGATE  
3C NOW!**

Net sales have increased an average of 50% each year over the past 10 years; personnel has grown from less than 200 people to 1700 in the same period.

3C offers, to its customers, a total digital capability; to our professional engineers we offer a dramatic, dynamic growth potential. Continued market acceptance of our new DDP-516, DDP-416 and DDP-124 computers, I/C logic modules and core memory systems has created key opportunities for professional design engineers with experience in integrated circuits, high speed switching circuits and A/D-D/A circuitry to work on our next generation of digital equipment.

If you want growth, in a challenging atmosphere, call collect, Mr. Martin Dorfman (617) 235-6220, or send your current resume to Honeywell, **COMPUTER CONTROL DIVISION**, Old Connecticut Path, Framingham, Massachusetts 01701.

**Honeywell**

To explore professional opportunities in other Honeywell locations, coast to coast, send your application in confidence to Mr. Fred G. Laing, Honeywell, Minneapolis 55408.

*An Equal Opportunity Employer*

# DO YOU MAKE THESE FIVE COMMON MISTAKES IN EVALUATING CAREER GROWTH OPPORTUNITIES?

1. Do you consider only the largest companies in your particular field? Size of opportunity is not necessarily proportional to size of company. Many medium size companies, such as ECI, offer faster achievement of professional recognition and personal satisfaction than do the "industry giants."
2. Do you fail to consider breadth of product/customer base? It's difficult to achieve career stability in a company that is closely tied to a narrow range of products and technologies and which sells them to a limited number of customers. You'll do better at ECI, where major projects in VHF/UHF communications, multiplex, space instrumentation, microelectronics, systems integration and advanced communications techniques are in progress simultaneously. ECI's broad customer base includes Army, Navy, Air Force, Marine Corps, NASA and foreign governments.
3. Do you consider joining a company which has insufficient R&D programs? Lack of aggressive R&D could mean future trouble for the company... and you. ECI has a wide range of Company and customer-funded development programs, particularly in the promising fields of microelectronics, telemetry, space instrumentation and digital switching systems.
4. Are you overly impressed with "boom" growth conditions? Growth that's too fast can point to future instability. Look for a record like ECI's, where years of stable, predictable growth demonstrate management's ability for both sound planning and successful execution.
5. Do you settle for less-than-optimum living conditions in the name of opportunity? You needn't! In addition to all the foregoing advantages, a career at ECI will let you and your family enjoy life to the fullest in St. Petersburg, Florida. This segment of Florida's Gulf Coast offers an unequalled combination of sunshine, beaches, golf, boating, and fishing plus cultural, educational and professional engineering opportunity.

## RF ENGINEERS SYSTEMS INTEGRATION ENGINEERS DIGITAL SWITCHING ENGINEERS

Make a new career evaluation today! Investigate the immediate and attractive opportunities at ECI by sending your resume, in confidence, to K. S. Nipper, Director of Professional Placement, Electronic Communications, Inc., Box 12248D, St. Petersburg, Florida 33733. (An equal opportunity employer.)



St. Petersburg Division  
Electronic Communications, Inc.

ON CAREER-INQUIRY FORM CIRCLE 902

## Threshold detector gives ns pulses

**Problem:** Generate fixed-duration output pulses in the nano-second range at input pulse repetition rates up to 5 MHz.

**Solution:** A solid-state device consisting of two tunnel diodes back-to-back in parallel, with an inductance driven by a constant-current generator. Input pulses of variable width in the nano-second range yield output pulses of fixed width. The circuit produces pulse repetition rates in the megacycle range and has low power drain.

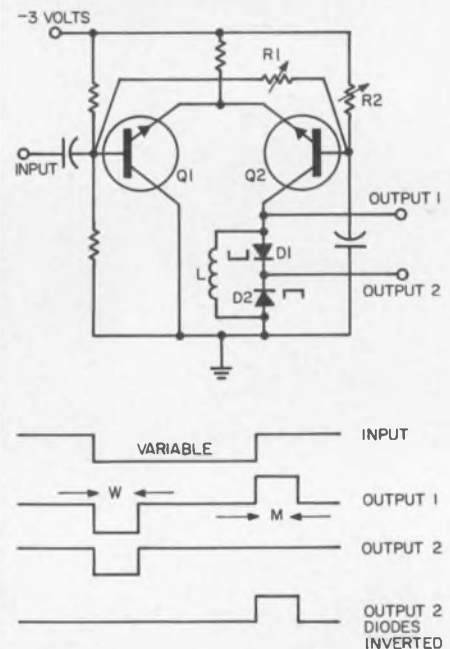

Stages  $Q_1$  and  $Q_2$ , together with tunnel diodes  $D_1$  and  $D_2$  form the threshold detector circuit. The voltage across  $D_1$  switches to its high-voltage state and produces the output pulse  $W$  whenever the input exceeds the threshold level. Diode  $D_2$  remains in its low-voltage state and presents a very low impedance. The current through inductance  $L$ , starting at zero, will increase with time, thereby decreasing current flow through  $D_1$  and  $D_2$ . The voltage across  $D_1$  will decrease to near zero and  $D_1$  will switch to its low-voltage state at a point in time when most of the current is flowing through  $L$ .

(continued on p. 276)

# CAREER INQUIRY – confidential

Respond to the career opportunities advertised in this issue. Fill out and send us this handy resume. **Electronic Design** will do the rest – neatly typed copies of this form will be mailed to the companies of your choice, indicated by the circled Career Inquiry Numbers at the bottom of this page.

6

Name Home Phone

Home Address (Street) City State ZIP Code

Age U.S. Citizen Security Clearance  
 Yes  No

Prime Experience	Secondary Experience

Desired Salary Availability Date

**Employment History – present and previous employers**

Company	City, State	Dates	Title
		to	
		to	
		to	

**Education – indicate major if degree is not self-explanatory**

Degree	College	City, State	Dates
			to
			to
			to

**Additional Training – non-degree, industry, military, etc.**

**Professional Societies**

**Published Articles**

**Career Inquiry Numbers:**

- 900 901 902 903 904 905 906 907 908 909
- 910 911 912 913 914 915 916 917 918 919

**ELECTRONIC DESIGN**  
 850 Third Avenue  
 New York, New York 10022

**Father  
proud  
ideas...  
like  
these**

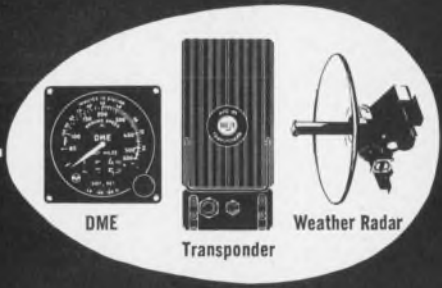

At RCA, we're continually developing new products for our expanding commercial avionics line. Help father them! Investigate these challenging opportunities:

**RF CIRCUIT ENGINEER** BSEE with 3 to 10 years experience in HF or VHF receiver and/or transmitter design. Recent experience with integrated circuits desired.

**RADAR ENGINEER** BSEE with 3 to 10 years experience in airborne radar design. Recent design experience in high power pulse modulators, magnetic components and video circuitry desired.

**MICROWAVE ENGINEER** BSEE with 3 to 5 years experience in design of microwave systems for X-Band and C-Band radar. Solid state design experience preferred.

**SERVOMECHANISMS ENGINEER** BSEE with 3 to 5 years design experience in servomechanisms for airborne electronic equipment.

Please send resume to: Mr. H. F. Dinnsen, Bldg. 1, RCA Aviation Division, 11819 W. Olympic Blvd., West Los Angeles, California.

*An Equal Opportunity Employer*



**The Most Trusted Name  
in Electronics**

ON CAREER-INQUIRY FORM CIRCLE 903

The output voltage will be approximately zero for the remainder of the input pulse.

As the input pulse reaches zero, current through  $L$  now flows through  $D_1$  and  $D_2$  in the opposite direction, causing  $D_2$  to switch to its high-voltage state and produce the output pulse  $M$  as  $D_1$  remains in its low-voltage state.

The threshold level in  $D_1$  and  $D_2$  is set with  $R_1$  and  $R_2$ . The value of  $L$  determines the output pulse width. The circuit configuration shown yielded 50-nsec pulses for an inductance of 56  $\mu\text{H}$ .

*For further information, contact: Technology Utilization Officer, Goddard Space Flight Center, Greenbelt, Md., 20771. (B65-10310).*

Remember to return your **ELECTRONIC DESIGN** renewal card. Don't miss any issues in '67.

Fold here, staple and Mail.

FIRST CLASS  
Permit No. 725  
New York, N. Y.

**BUSINESS REPLY MAIL**  
No Postage Stamp Necessary if Mailed in the United States

POSTAGE WILL BE PAID BY

**ELECTRONIC DESIGN**

**READER SERVICE**  
850 THIRD AVENUE  
NEW YORK, NEW YORK 10022

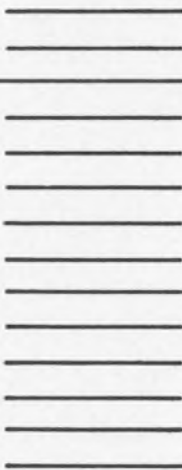

# Book Reviews

## communication systems and techniques

MISCHA SCHWARTZ  
WILLIAM R. BENNETT  
and SEYMOUR STEIN

McGraw-Hill Book Company

INTER-UNIVERSITY ELECTRONICS SERIES

### New communications reference is team effort

*Communications Systems and Techniques*, Mischa Schwartz, William R. Bennett and Seymour Stein (McGraw-Hill Book Company, New York, N. Y.), 618 pp. \$16.50.

Practicing communications engineers should find this new volume a useful reference source. Designed to serve as both a graduate text and a reference for the experienced engineer, the book provides an interesting mixture of both the theoretical and practical aspects of communications.

Each of the book's three authors prepared one section of the three-section volume.

Part I, by Schwartz, summarizes the fundamental aspects of modern communication theory and then develops applications to pulse and continuous wave systems. This section covers general tutorial material, statistical communication theory as applied to digital communications, cw communications, and a comparison of AM and FM.

Part II, by Bennett, develops in detail the technology of modern communications systems. This section covers amplitude modulation and related cw systems, angle modulation in cw systems, and pulse modulation.

(continued on p. 278)



# MOVE UP TO MELPAR WHERE PERFORMANCE COMES FIRST

Now celebrating our 21st year in space and defense, MELPAR brings new life to creative pioneering by continually expanding into new areas of R&D and further developing our broad capabilities. MELPAR, intimately associated with Apollo and other major space programs, has exciting opportunities in the following areas:

#### NASA Goddard Space Flight Center

Spacecraft and ground support systems with assignments in rf, television, microwave, computer, propulsion and instrumentation.

#### Applied Electronics Department

1. RF circuit design for automatic and remotely controlled HF receivers, HF, VHF and UHF Frequency Synthesizers.
2. Design of small special purpose digital computers and programming for real time and control applications, mathematical modelling.
3. Theoretical and experimental design of missile and ground-based microwave antennas and microwave receivers.
4. Advanced circuitry development and computer application related to information handling and processing.

#### Simulation & Training Department

Computer systems design, programming and analysis for advanced weapon systems and tactics trainers.

#### The Avionics Department

Radar, countermeasures and microminiature packaging techniques for high performance aircraft avionics systems.

#### Electronics Research Laboratory

R&D involving propagation of acoustic, seismic and electromagnetic signals in scattering media, such as earth, water and atmosphere to include data compression for long-distance communications.

#### Space Systems Laboratory

Space experiments, space chemistry and physics, interplanetary field and particles, electronic systems, mechanical systems, electro-optical systems, spacecraft structures, and control systems.

Write, in confidence, to: Clarence Endsley, Professional Placement

# WABCO MELPAR, INC

A SUBSIDIARY OF WESTINGHOUSE AIR BRAKE COMPANY

7745 ARLINGTON BOULEVARD, FALLS CHURCH, VA. 22046

(Suburb of Washington, D. C.)

An Equal Opportunity Employer M/F

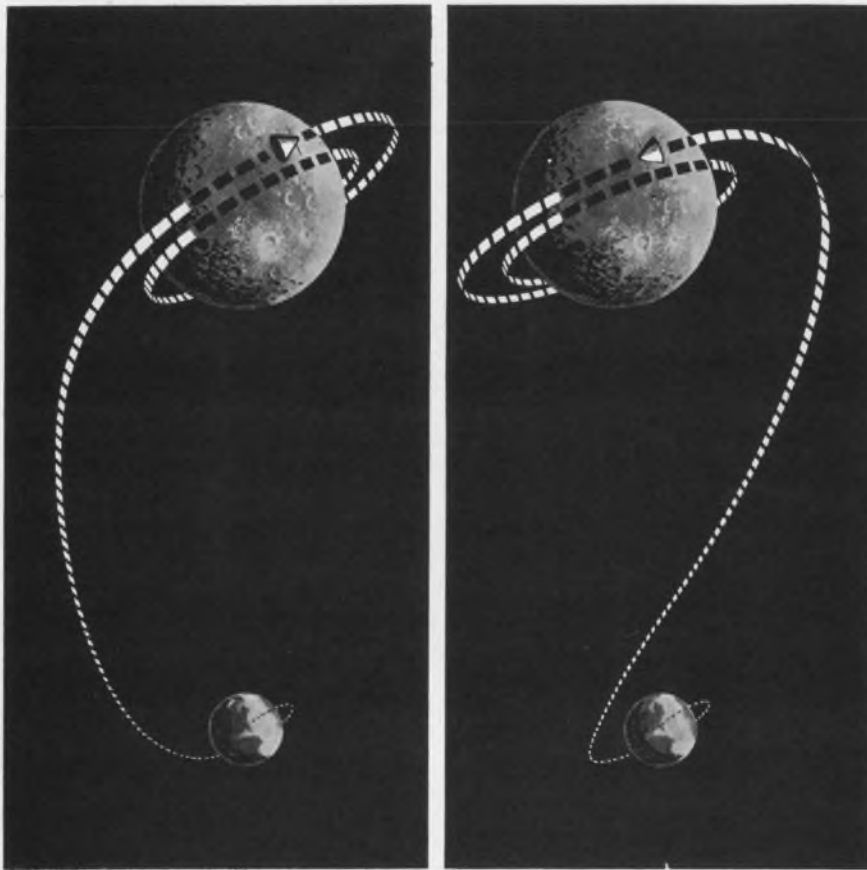

## Challenge: Which path would you take to the moon?

This question is easy compared to some of the problems of developing mission programs for Apollo. Yet—unless you are involved, you may not realize that the minimum energy trajectory is the one on the right. The flight computer programs to guide each Apollo mission will be developed, programmed, and certified beforehand. Typically, over seventy-two thousand sixteen-bit words and one computation, occurring every twelve microseconds, will be involved. It's another example of AC's guidance and navigation systems for the Command Module and the Lunar Module. Other AC projects: the navigator for Boeing's new 747 jet; a guidance/navigation system for SRAM, the Short-Range Attack Missile; also a new reentry system for missiles; the new Ship's Self-Contained Navigation System (SSCNS); navigation systems for low-level-attack aircraft; the guidance system for the Titan III; a computerized fire-control system for the new Main Battle Tank, a joint U.S.-Federal Republic of Germany program.

These are just a few of the challenging programs that await you at AC Electronics. Check the opportunities listed below. Then send your resumé, including salary requirements, to: Mr. M. D. Schroeder, Dir. of Professional Employment, Dept. 5753, AC Electronics Div., Milwaukee, Wis. 53201. Or call Mr. M. D. Schroeder collect at 414-762-7000 (Extension 412), Monday through Friday between 9:00 A.M. and 4:00 P.M. (C.S.T.)

CIRCUIT DESIGNERS  
MECHANICAL DESIGNERS  
DIGITAL COMPUTER DESIGN ENGINEERS  
SYSTEMS ANALYSIS ENGINEERS  
SYSTEMS MECHANIZATION ENGINEERS  
ELECTRONIC FAILURE ANALYSIS ENGINEERS  
DYNAMICISTS  
SEMICONDUCTOR PARTS ENGINEERS

ELECTROMECHANICAL PARTS ENGINEERS  
PRODUCTION ENGINEERS . . .  
• ENCAPSULATION  
• PRECIOUS METALS PLATING  
• PRINTED CIRCUIT BOARD  
MANUFACTURING DEVELOPMENT ENGINEERS  
• PRECISION MACHINING  
DIGITAL TEST EQUIPMENT DESIGN ENGINEERS

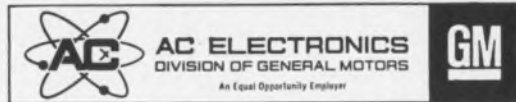

MARK OF EXCELLENCE

## BOOK REVIEWS

Part III, by Stein, discusses basic binary communication techniques, general analysis of single-channel binary systems in additive noise, fading communication media, linear diversity combining techniques, and decision-oriented diversity for digital transmission.

—Joseph J. Casazza

### Magnetolectric devices

*Magnetolectric Devices: Transducers, Transformers, and Machines*, Gordon R. Slemon (John Wiley & Sons, New York), 544 pp. \$11.50.

This introduction to magnetolectric devices is concerned with understanding, modeling, analyzing and designing those devices that are used to convert, transform and control electrical energy. Included are transducers, actuators, transformers, magnetic amplifiers and rotating machines. The book concentrates on an engineering rather than solely an applied-mathematics approach. A large part of the book is devoted to the development of analytical models for devices, usually in the form of equivalent circuits. A number of problems, some with answers, are given at the end of each chapter as an aid to study.

### Linear circuits

*Principles of Linear Circuits*, Eric A. Faulkner (Barnes & Noble, New York), 116 pp. \$4.50.

Here is a compact and logical presentation of the basic principles involved in the design and analysis of linear ac and dc circuits. Particular attention is paid to the properties of the linear amplifier and its use in feedback systems. Although no practical designs are described in detail, the discussion is oriented toward practical applications and includes an account of the characteristics of silicon junction transistors and the methods by which they are biased for use in linear circuits.



**We don't care how you do it,  
send us your resume.**

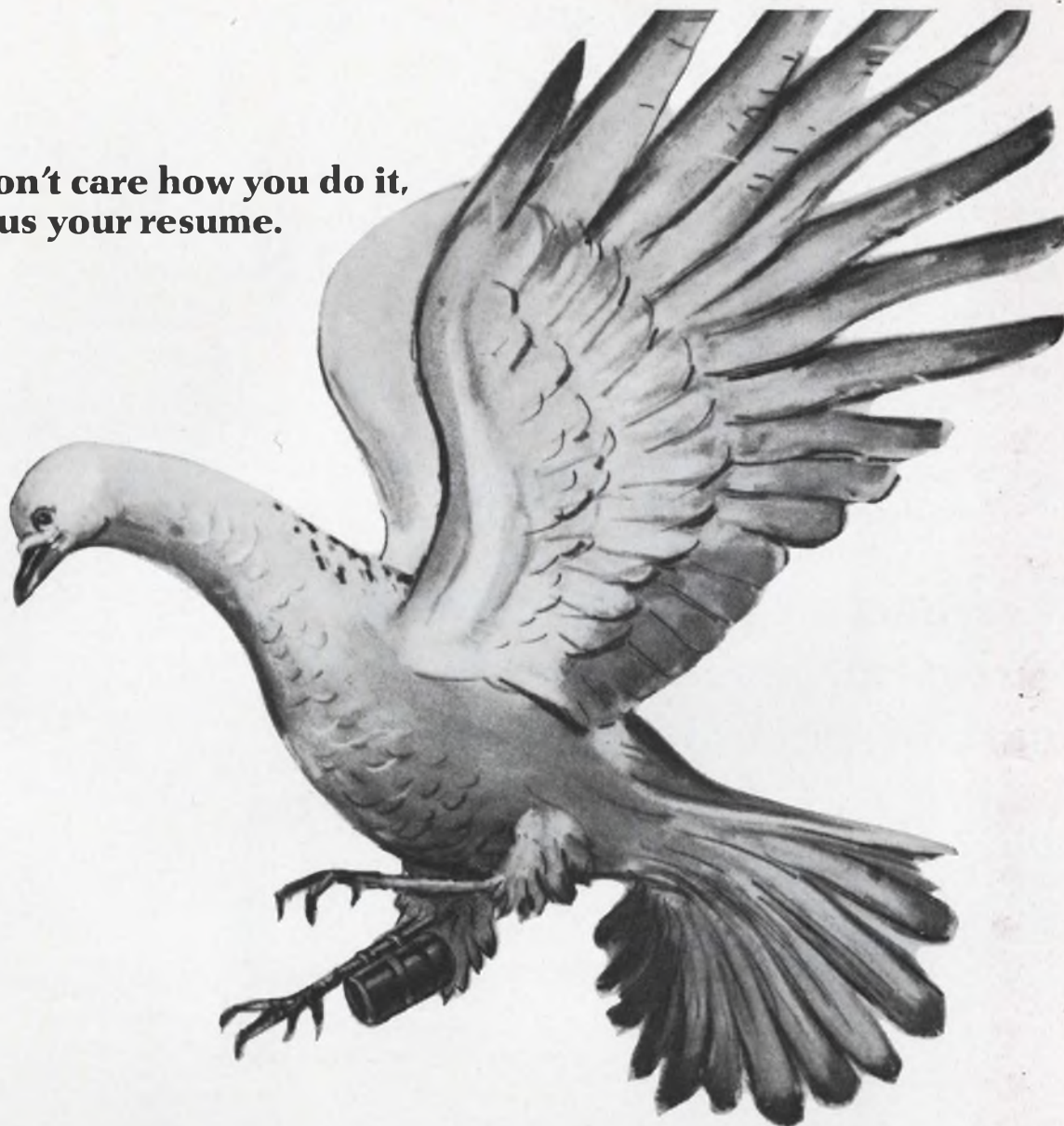

**Why put off any longer  
the challenge you could be  
enjoying right now?**

Your resume works harder for you at IBM Federal Systems Center in the Washington metropolitan area.

You see, right now you could work with us in any number of areas of the Center's prime responsibility: to develop, design, program and manage total, integrated systems for the Federal Government. Your task could involve you specifically with specialized data acquisition and display systems, tactical switching systems using advanced electronic

circuits or ASW signal-processing equipment.

Sound challenging? Our work is. And we need qualified engineers right now who are intrigued by tasks like these. Engineers who are concerned about our country's achievements—and their own. Who want to grow and thrive with a growing company.

There are immediate openings for Circuit Design Engineers, Logical

Design Engineers, Solid State Device Engineers, Solid State Circuit Designers, Display Circuit Engineers, Computer Systems Engineers.

Don't wait any longer for your chance to tackle a critical problem and grow as you help to solve it. Send your resume today to: Mr. J. B. Farrington, Dept. 555-C3, IBM Corporation, 18100 Frederick Pike, Gaithersburg, Md.

IBM is an Equal Opportunity Employer.



at the world's largest shipbuilding complex:

# career opportunities in nuclear power engineering

For nuclear power, electrical, chemical, general, marine and mechanical engineers.

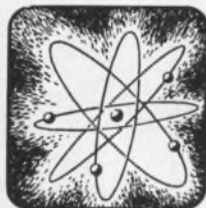

The San Francisco Bay Naval Shipyard offers both newly graduated and experienced engineers of many categories a chance to work today in what will be tomorrow's source of industrial power.

The Shipyard is engaged in important programs in all aspects of nuclear propulsion, including:

**Reactor Engineering**  
**Fluid Systems and Mechanical Engineering**  
**Control Engineering (Instrumentation)**

**Test Engineering**  
**Nuclear Quality Engineering**  
**Radiological Control**  
**Nuclear Refuelling**

Starting salaries are commensurate with academic achievement, experience and training.

Job locations: San Francisco Bay Naval Shipyard has two work sites located 40 miles apart: San Francisco and Vallejo, California. Each location has ready access to the full cultural advantages of San Francisco and the mild year-round climate of the Bay Area. All types of recreation from ocean surfing to skiing on the slopes of the Sierras are within easy driving distance.

Send your resume or Standard Form 57, Application for Federal Employment, to:

**Coordinator, Professional and Technical Recruitment (Code 174A13)**  
**Employment Division**  
**San Francisco Bay Naval Shipyard**  
**Vallejo, California 94592**

AN EQUAL OPPORTUNITY EMPLOYER

MUST BE A U.S. CITIZEN

ON CAREER-INQUIRY FORM CIRCLE 907

## BOOK REVIEWS

### Testing reference guide

*Electronic Testing*, compiled and edited by L. L. Farkas (McGraw-Hill, New York), 304 pp. \$12.00.

For the advanced engineer or technician as well as for the student, this is a practical guide to all major types of electronic equipment, their uses, and methods for aligning them and for testing their performance. It is written in clear and simple style, has numerous illustrations and employs a minimum of mathematics.

The 14 chapters are divided into three major parts: Receiving and Transmitting Equipment, Special Equipment, and Computers. Among the recent advances covered are digital-computer circuitry and troubleshooting techniques, display methods, and ordnance systems. Previously unpublished material is contained in chapters on such special topics as radio frequency interference, ordnance devices and systems, and digital-computer testing.

### Mathematics for engineers

*Matrices and Linear Transformations*, Charles G. Cullen (Addison-Wesley, Reading, Mass.), 227 pp. \$8.95.

The first five chapters of this book comprise a one-term text for science, engineering and mathematics students that covers those topics most frequently encountered in applications. The text approaches its subject from the matrix-theory point of view rather than from the more abstract approach using linear transformations. Vector spaces and linear transformations are nevertheless treated extensively, and carefully related to matrices. Key features include spectral theory and the Jordan form, the solution of the matrix equation  $AX=XB$ , matrix analysis and numerical methods, and numerous problems, many with answers.

It's time to renew your subscription to **ELECTRONIC DESIGN**. Return your renewal card today.

# RADAR TEST AND SIMULATION SYSTEMS

■ GROUND ■ SHIPBOARD ■ AIRBORNE ■ SPACE

Canoga offers a broad line of radar test and target simulation systems for military tactical use, aerospace operations support, radar systems design and operator training. These field proven systems have found wide applications in the Century Series Aircraft, Nth time around ground instrumentation radars and re-entry vehicle simulation. The units feature Integrated Circuit digital techniques and solid state circuitry. Video, IF and microwave test models are available. Write for catalog and complete capabilities.



**canoga**  
CANOGA DIVISION

**ELECTRONICS CORPORATION**  
8966 Comanche Avenue, Chatsworth, California 91311  
Telephone: (213) 341-3010 TWX (910) 494-1214

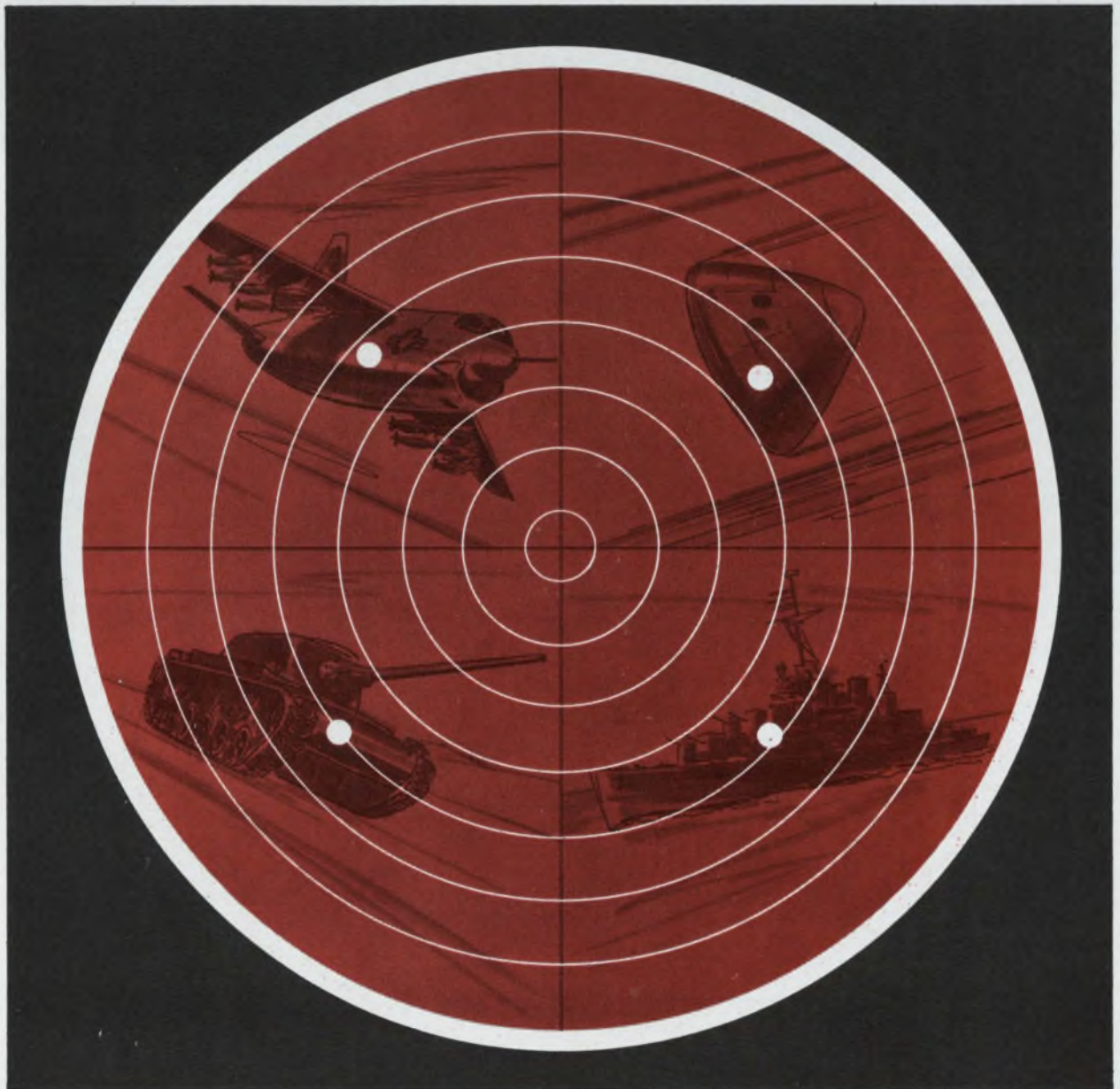

ON READER-SERVICE CARD CIRCLE 206

# Tunnel diode, shunted with a resistor, shapes pulses

A nanosecond, pulse-shaping circuit fulfills the need for a simple means of sharpening the leading edge of relatively slow rise-time pulses. It is a modification of the well-known technique of pulse-sharpening by shunting a tunnel diode from the switching-transistor base to the emitter. This latter technique requires a reasonable matching of tunnel diode and transistor characteristics. The addition of resistors  $R_2$  and  $R_3$ , however, makes this requirement considerably less exacting and allows greater freedom of component choice.

The circuit shown in Fig. 1a was capable of output pulse rise times of less than two nanoseconds when driven by a slower input pulse. The output voltage was limited approximately by the ratio of load resistance  $R_L$  to collector load resistance  $R_4$ , which in turn was limited by the current capabilities of the transistor.

The following design procedure is simple and allows construction of the circuit from a wide variety of components. Select  $R_4$  on the basis of transistor current specifications. Next choose a voltage drop across  $R_3$  and a tunnel diode such that the sum of this drop and the tunnel-diode valley voltage add up to the  $V_{BE(sat)}$  of the transistor, while this sum added to the tunnel diode peak voltage equals a value corresponding to a low state of transistor conduction. This choice ensures that the transistor will go into saturation from the cutoff condition when the tunnel diode changes state.

Now divide the voltage drop across  $R_3$  by the tunnel-diode peak current. This yields the value of  $R_3$ . It is assumed that the sum of currents through the tunnel diode and resistor  $R_2$  equals the tunnel-diode peak current and remains constant. This is an important condition which is explained in greater detail below. Resistor  $R_1$  is determined by the tunnel-diode peak current and voltage difference,  $V_{L,B} - V_{BE(sat)}$ . Since the tunnel diode is shunted by finite resistance  $R_2$ , the actual current through it is less than the peak value and

it normally remains in the low state.

Resistor  $R_2$  has a key role. It is selected to be approximately equal to the diode dynamic, negative resistance. It provides a current bypass so that, when the diode changes states, the sum of currents through the diode and resistor  $R_2$  remains constant. Consequently, the current through

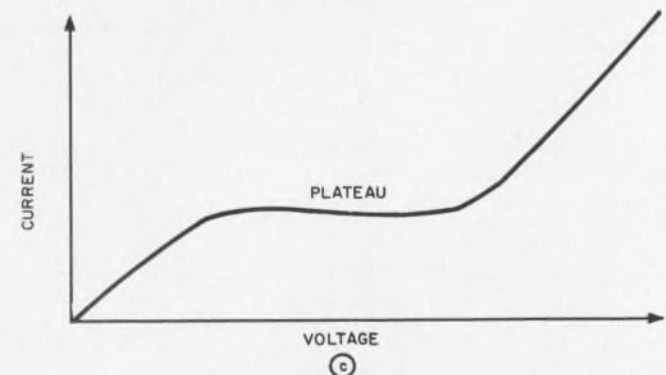
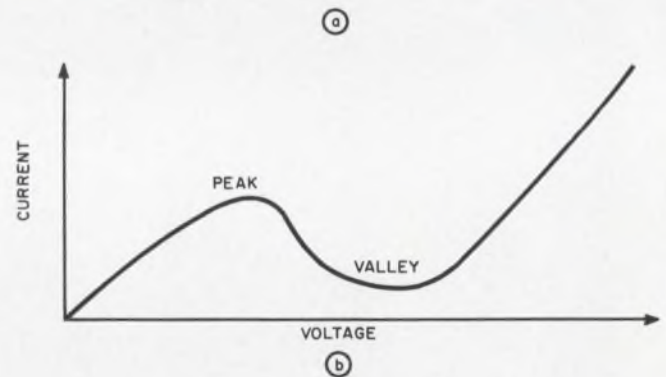
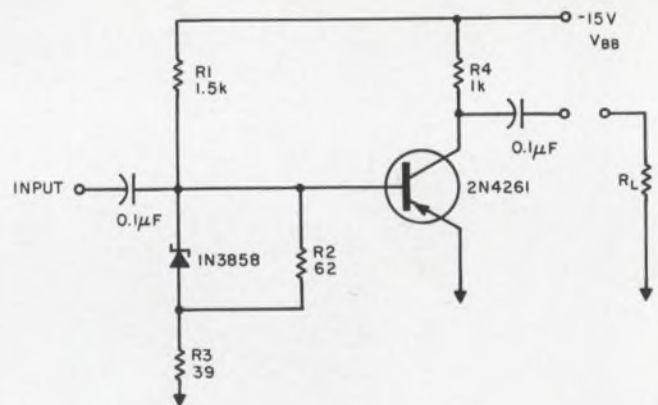

Nanosecond pulses are shaped with the circuit shown in (a).  $R_2$ , approximately equal to the dynamic negative resistance of the diode, changes the familiar tunnel-diode IV-curve (b) to the one with a constant-current plateau (c).

**VOTE!** Circle the Reader-Service-Card number corresponding to what you think is the best Idea-for-Design in this issue.

**SEND US YOUR IDEAS FOR DESIGN.** Submit your IFD describing a new or important circuit or design technique, the clever use of a new component, or a cost-saving design tip to our Ideas-for-Design editor. If your idea is published, you will receive \$20 and become eligible for an additional \$30 (awarded for the best-of-issue Idea) and the grand prize of \$1000 for the Idea of the Year.

# HST heat shrinkable tubing

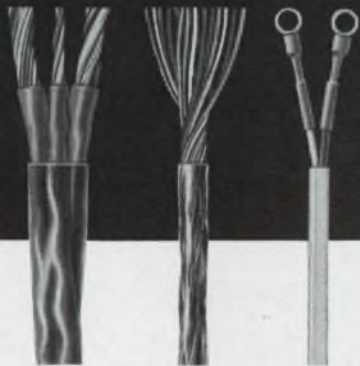

Have your Belden Electronic Distributor show you the types of "HST" heat shrinkable tubing now available from stock!

## THE BELDEN WAY

We stock the colors . . . the sizes . . . the lengths. Who else can take care of so many of your applications with immediate service from stock?

Yes, Belden inventories "HST" in a complete range of COLORS, SIZES, and LENGTHS in both polyolefin and vinyl in easy-to-use packages.

And "HST" meets the requirements of production line users because it is made to tight specifications in uniformity of diameters, shrink-down, and electrical properties.

**Belden**

**HST** HEAT SHRINKABLE TUBING

B-11-6

BELDEN MANUFACTURING COMPANY • P. O. Box 5070-A • Chicago, Illinois 60680

ON READER-SERVICE CARD CIRCLE 207

$R3$ , and hence the voltage drop, are constant. This is the condition initially assumed for circuit operation.

Bypassing the tunnel diode with this particular value of resistance  $R2$  changes its current-voltage characteristic from the familiar negative resistance shape (see Fig. 1b) to that shown in Fig. 1c. The negative resistance shape has degenerated into a constant-current "flat" in the characteristic. It is this constant-current plateau that makes  $V_{BE}$  step a predictable, known increment when the tunnel diode changes state.

The value of  $R2$  should be chosen to be slightly greater than the diode dynamic, negative resistance so that the constant-current plateau has enough negative slope to make the diode switch rapidly. Otherwise, no use is made of the fast switching property of the tunnel diode.

*Burton E. Dobratz, Designer, Aerospace Group, Hughes Aircraft Co., Culver City, Calif.*

VOTE FOR 110

## Motor has dynamic braking with a two-wire control

In *400 Ideas for Design*,<sup>1</sup> DeFir shows how two-wire control of a limit-switched motor can be accomplished by use of two diodes. His circuit is adequate provided that the motor does not coast after hitting the limit switch. If dynamic braking is required to ensure rapid deceleration after hitting a limit switch, two additional diodes,  $CR3$  and  $CR4$ , are needed, as shown in the accompanying figure. The limit switches must be of the spdt type.

Assuming the current directions shown, if *Terminal 1* is positive, the motor will run in a down direction until the down limit switch  $LS1$  is

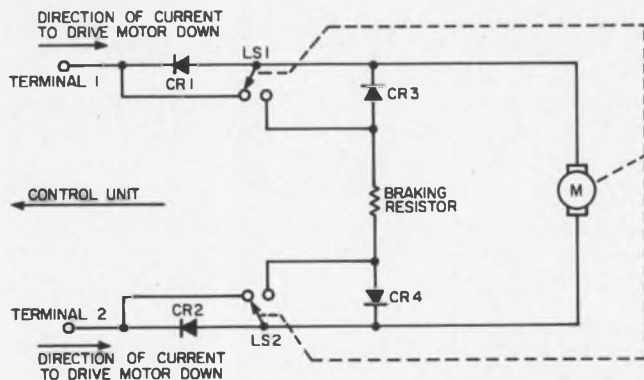

Four diodes and one resistor added to the two limit switches provide dynamic braking.

activated. When  $LS1$  is activated, current flow from the control unit is blocked by  $CR1$ ; dynamic braking is achieved by allowing braking current to flow through the NO contact of  $LS1$ , the braking resistor and  $CR4$ .

If *Terminal 2* is positive, current will flow through the NC contact of  $LS2$ , the motor armature and  $CR1$  back to the control unit. Thus the motor will run in the up direction. Current flow through the braking resistor is prevented by  $CR4$  until the up limit switch  $LS2$  is activated. When  $LS2$  is activated, current flow from the control unit is blocked by  $CR2$ , and dynamic braking is achieved by allowing braking current to flow through the NO contact of  $LS2$ , the braking resistor and  $CR4$ .

In this application, the motor coasted past the limit switch arms until  $CR3$ ,  $CR4$  and the braking resistor were added to the circuit.

### Reference:

1. Charles C. DeFir, "Diodes Allow Two-Wire Control of Limit-Switched Motor," *400 Ideas for Design* (New York: Hayden Book Co., Inc., 1964), p. 99.

*Dr. George E. Cook, Vice President, Merrick Engineering, Inc., Nashville, Tenn.*

VOTE FOR 111

## Probe spots shorted transistor in a parallel string

A current probe and a source of low-voltage ac are all that is needed to spot a shorted transistor in a parallel string.

Ordinarily, the transistors might be disconnected for individual testing—a time-consuming task. Instead, the string can be hooked up as shown to pass about 10 mA of ac. The current probe is then used to check for current flowing through the

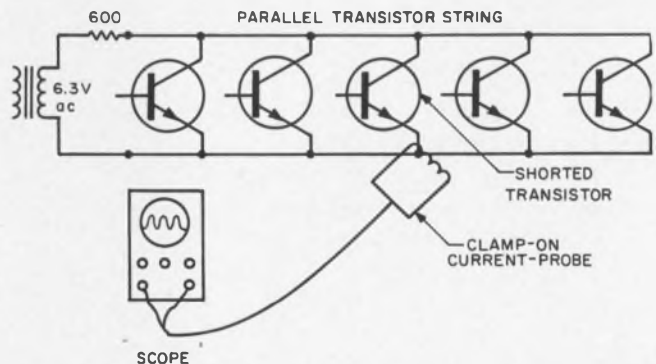

Current probe and a scope help to spot a shorted transistor in a parallel string. Note the use of an ac supply.



Electron Beam Gun.

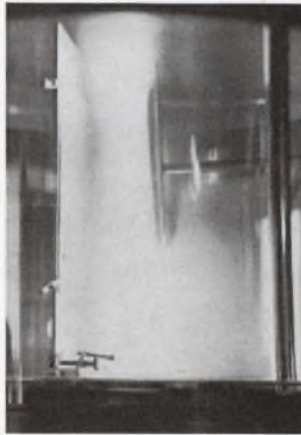

Plasma-Vac® low-energy sputtering with RF capability.



CV-type coaters.

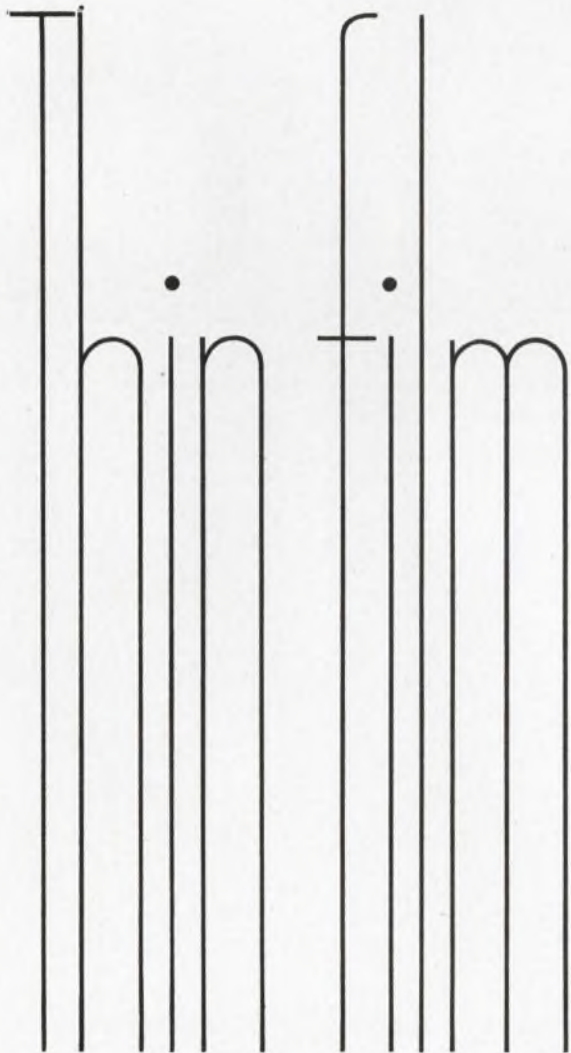

Here's all the equipment you need to put thin-film techniques to work on a research or production basis . . .

CVC's PlasmaVac® low-energy sputtering system gives you controlled deposition of metals, alloys, semi-conductors and insulators. Quality and yields are of a degree that make production-line operations a commercial reality.

Or, if your research or production application calls for resistance heating or electron beam gun evaporation, CVC has the equipment you need.

More important to you, we have the technological background and the applications laboratory to analyze your requirements and help you decide which thin-film deposition method will best handle your application.

Let us know how you would like to use thin-film deposition. We'll be glad to make recommendations. Consolidated Vacuum Corporation, 1775 Mt. Read Blvd., Rochester, N.Y. 14603. A subsidiary of Bell & Howell.



ON READER-SERVICE CARD CIRCLE 208

emitter or collector of each transistor. The majority of the current will be found in the leads of the shorted transistor, pinpointing the defect.

*J. A. Wisnia, Project Engineer, Comstock and Wescott, Inc., Cambridge, Mass.*

VOTE FOR 112

## 16-bit matrix built with four IC packages

X-Y matrices are utilized in any application where a two-register or any other dual information source is used to select a given point, as in

core memory schemes.

The conventional approach to implementing this function involves a total of 32 diodes and 16 resistors and has an offset of one diode drop. The four integrated-circuit packages needed to form the 16-bit matrix afford a great saving in component count and board space. The normal diode drop is also eliminated in the integrated-circuit version, since the matrix transistors are operated in the inverse saturation mode.

All X lines are strobed by a minus-3-to-5-volt level while ground is required to select the Y lines. The selected output is then the X-line strobe voltage minus the inverse transistor drop. All lines are terminated in a 640-ohm resistor.

*Robert Ricks, Application Engineer, Fairchild Semiconductor, Mountain View, Calif.*

VOTE FOR 113  
(continued on p. 288)

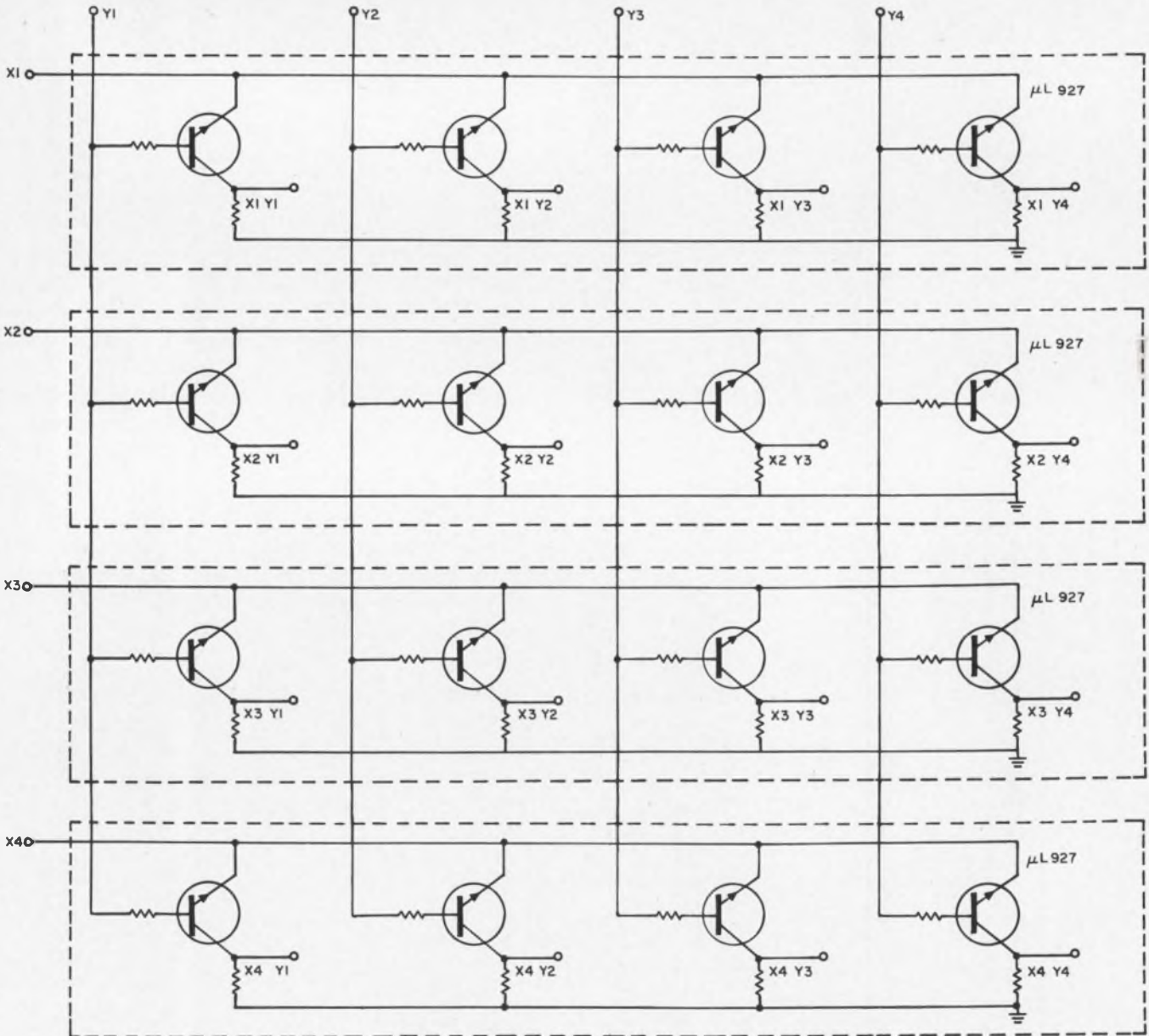

Integrated 16-bit matrix is built with four  $\mu$ L927 packages. This compares with 32 diodes and 16 resistors

which are used in a similar matrix built with discrete components.



When it comes  
to color-TV  
receiving tubes



...RCA  
Engineers  
are always  
one jump  
ahead...



LOOK AT HOW THEY'VE IMPROVED  
IF AMPLIFICATION—

**Higher gain** FOR  
YOUR IF STAGES FROM TWO NEW  
RCA FRAME-GRID TYPE TUBES  
—THE IMPROVED 'JC6A FAMILY  
OF SHARP-CUTOFF PENTODES  
AND THE NEW 'KT6 FAMILY OF  
SEMIREMOTE-CUTOFF PENTODES.



## Higher drive values

WITH CONSEQUENT IMPROVEMENTS  
IN **GAIN** AND  **$g_m$**  PERMITTED  
BY NEW PLATE STRUCTURE  
INCORPORATED IN EACH FAMILY.  
'KT6 FAMILY ALSO HAS AN  
EXCELLENT SEMIREMOTE-CUTOFF  
CHARACTERISTIC FOR BETTER  
AGC CONTROL.



## Features:

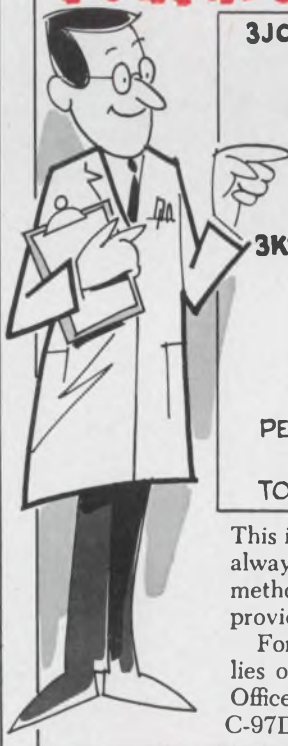

**3JC6A, 4JC6A AND 6JC6A** SHARP-CUTOFF PENTODES  
(9-PIN MINIATURES UNILATERALLY  
INTERCHANGEABLE WITH 'JC6 FAMILY)

- \*  $P_b = 3.1$  W
- \*  $P_{g2} = 0.7$  W
- \*  $g_m = 16,000 \mu\text{mho}$
- \* INTERNAL SHIELD

**3KT6, 4KT6 AND 6KT6** SEMIREMOTE-CUTOFF  
PENTODES (9-PIN MINIATURES)

- \*  $P_b = 3.1$  W
- \*  $g_m = 18,000 \mu\text{mho}$
- \* INTERNAL SHIELD
- \* SEPARATE BASE-PIN TERMINAL FOR  $G_3$ —  
PERMITS USE OF UNBYPASSED CATHODE RESISTOR
- \* TWO BASE-PIN TERMINALS FOR CATHODE  
TO REDUCE CATHODE LEAD INDUCTANCE

This is what you can expect from RCA Engineers. They are always on the alert for new ideas, new materials and new methods to give the color-TV circuit engineer tubes that will provide even better performance at the lowest possible cost.

For more information on the RCA 'JC6A and 'KT6 families of receiving tubes, contact your nearest RCA District Office, or write to RCA Commercial Engineering, Section C-97DE3 Harrison, N.J. 07029.

**RCA DISTRICT OFFICES—OEM SALES:** EAST, 2075 Millburn Ave., Maplewood, N.J. 07040, (201) 485-3900 • MID-ATLANTIC, 605 Marlton Pike, Haddonfield, N.J. 08034, (609) 428-4802 • MID-CENTRAL, 2511 East 46th St., Bldg. Q2, Atkinson Square, Indianapolis, Ind. 46205, (317) 546-4001 • CENTRAL, 446 East Howard Ave., Des Plaines, Ill. 60018, (312) 827-0033 • WEST, 6363 Sunset Blvd., Hollywood, Cal. 90028, (213) 461-9171 • INTERNATIONAL OPERATIONS, RCA International Division: Central and Terminal Aves., Clark, N.J. 07066, (201) 382-1000 • 118 Rue du Rhone, Geneva, Switzerland, 35 75 00.



RCA Electronic Components and Devices, Harrison, N.J.

The Most Trusted Name in Electronics

## Wiper-centering fixture allows easy alignment

When potentiometric instruments are designed to meet high shock and vibration requirements, it is frequently necessary to use a double-wiper configuration. This is particularly the case when small movements must be amplified through a

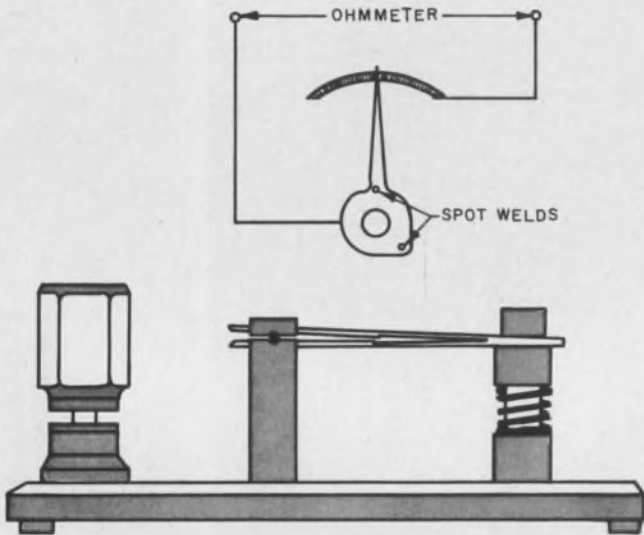

Double-wiper blades can be aligned electrically by use of this simple fixture.

lengthy wiper. Greater wiper travel gives higher resolution, and therefore allows more latitude for such things as linearity corrections. Where very small mechanical displacements are monitored, the designer is often limited to a choice between such a double-wiper configuration and an even less desirable mechanical linkage. The double-wiper potentiometer is useful when its torque level can be tolerated. The primary problem with this type of wiper is establishing and verifying that the two wipers are electrically centered.

This procedure is simplified by use of the fixture shown in the accompanying figure. Both wipers are placed on a spring-loaded post. The lower wiper is held captive in some position while the upper wiper is free to rotate. An ohmmeter is connected to the fixture through the binding posts and will read the average of the two wipers to coil-end resistances. When the wiper post is depressed, the lower wiper will leave the coil and only the upper wiper will be in contact. The difference in readings will indicate misalignment between the two wipers. Adjustment may be made and readings continued until both wipers are on the same turn of the wirewound coil. Then the wipers may be spot-welded to hold this orientation.

*Fred W. Kear, Production Engineer, Spartan Southwest, Inc., Albuquerque, N. M.*

VOTE FOR 114

## Block the sneak paths in a crossbar readout

Matrix or crossbar readouts built with neon lamps usually suffer from lack of brightness, particularly under high ambient illumination. If incandescent lamps (such as #44) are used instead, sneak paths occur (Fig. 1a). The addition of diodes in series with each lamp eliminates this

problem (Fig. 1b).

In the case of neon lamps, no sneak paths can occur, because each lamp requires some minimum breakdown and maintaining voltages.

The circuit of Fig. 1b can be built with almost any incandescent lamps, provided that the diodes can carry the required current.

*Ronald L. Ives, Palo Alto, Calif.*

VOTE FOR 115

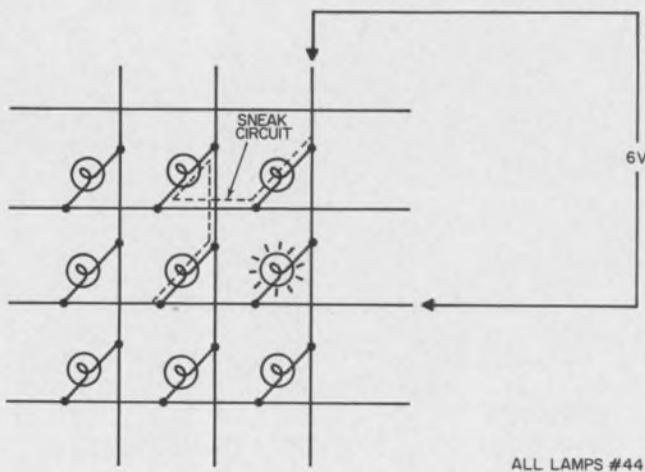

(a)

Sneak paths (a) are blocked by series diodes (b).

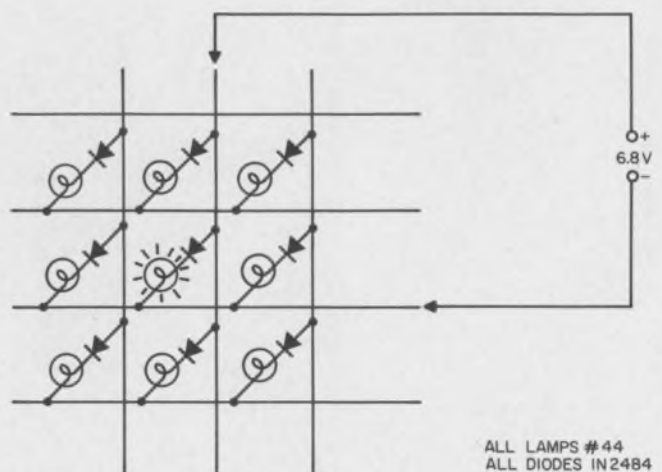

(b)

## Protect your panels from scratches and burrs

A persistent and annoying problem in assembly operations is the marring of panel surfaces or terminal lugs by the face of the nut-driver head when nuts are being tightened.

A simple and practical wrinkle to overcome this annoyance (see Figures) is to shrink a piece of shrink tubing over the nut-driver head. Select the proper size tubing and allow sufficient overlap beyond the front edge of the driving head for it to fit snugly round the face of the head when it is recovered. Then trim off the excess tubing overlapping into the interior of the driving head.

This will protect panel surfaces and terminal lugs from being grazed by the driver head.

Milton Dickfoss, Grumman Aircraft Engineering Corp., Bethpage, L. I., N. Y.

VOTE FOR 116

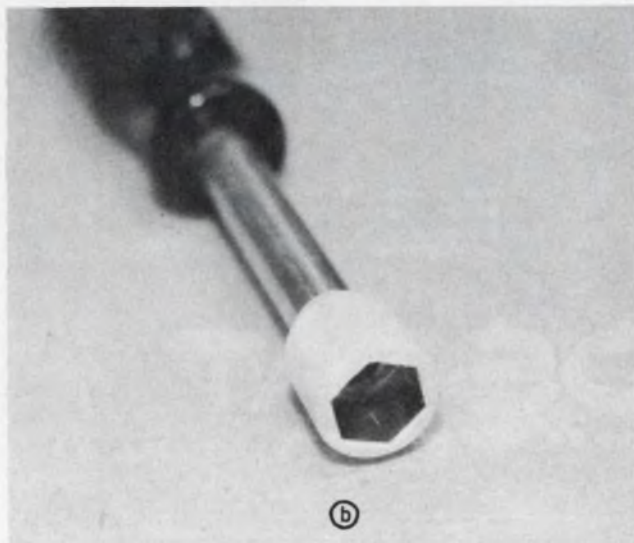
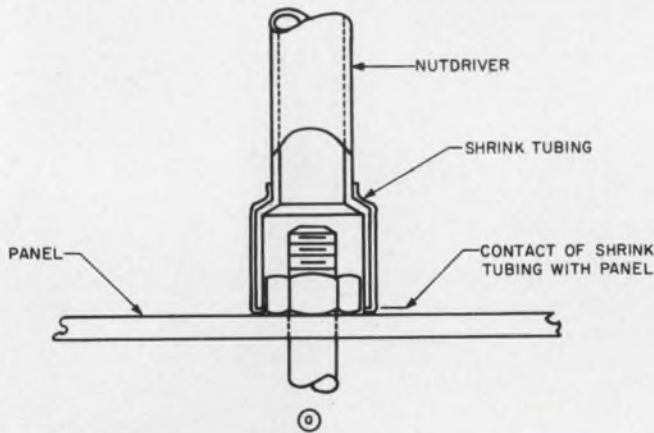

Piece of shrink tubing over the nut-driver head (a) gives the tool a "soft touch" (b).

## Standard recorder permits ratios to be read directly

Ratio recording provides a very convenient means for measuring electrical or nonelectrical quantities derived from a quotient of two variables, for example, resistance = voltage/current or heat conductivity = heat flow/temperature difference. The method can also be used to measure resistance changes by means of a bridge circuit, according to the relation  $V_o = kRV_i$ , where  $V_o$  = output voltage,  $V_i$  = bridge supply voltage,  $R$  = resistance change, and  $k$  = constant. If  $V_o/V_i = kR$  is recorded, fluctuations of the supply voltage are compensated for and do not influence the result.

The basic diagram of a ratio recorder is shown in Fig. 1. The motor will adjust the potentiometer

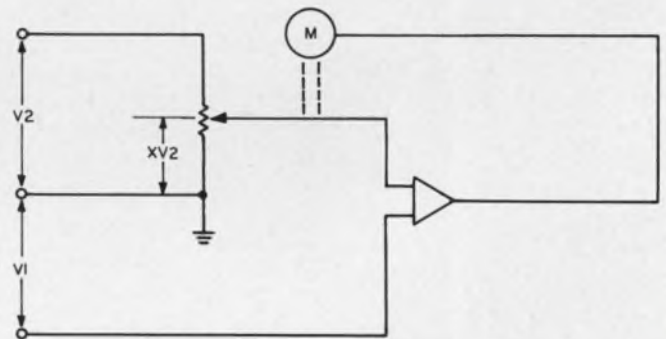

Ratio of two voltages can be read out directly by use of any of several commercially available recorders in the above configuration.

until the input voltage of the differential amplifier is zero. This condition is fulfilled when  $xV_2 - V_1 = 0$ , or  $x = V_1/V_2$ . Hence, the position of the potentiometer (and the pen of the recorder) is a direct measure of the quotient  $V_1/V_2$ .

Most potentiometer recorders can easily be converted into ratio recorders. For dc ratio recording, the reference voltage is disconnected and the denominator voltage  $V_2$  is applied to the potentiometer. The chopper has to be bypassed for ac (line frequency) ratio recording. Care must be taken that the voltages  $V_1$  and  $V_2$  are in phase with each other and with the line voltage feeding the two-phase motor.

The accuracy obtained is essentially that of the recorder. At low input levels, however, the accuracy is limited by the finite gain of the amplifier. Tests with a Speedomax-G recorder showed that, when the denominator voltage  $V_2$  was lowered from 1 V to 0.03 V, the error in the quotient remained less than 2%.

A. G. Engelter, Solid State Electronics Div., National Research Institute for Mathematical Sciences, Pretoria, Republic of South Africa.

VOTE FOR 117

# TRIMMED

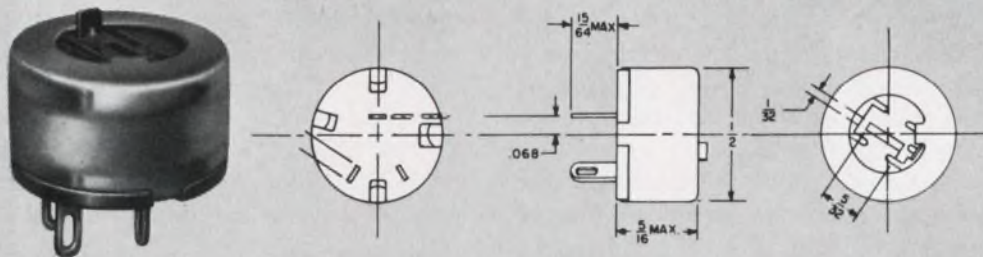

## CLOSER SPACING board-to-board SERIES 371 MOLDED CARBON POTENTIOMETER

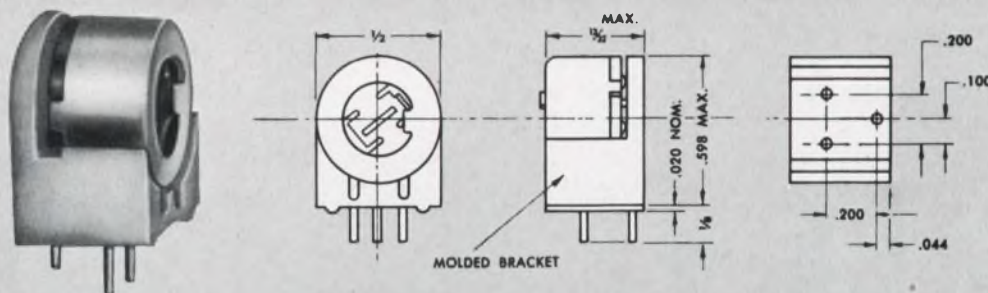

## EASIER ADJUSTMENTS at right angles... SERIES 371RA1 FOR PRINTED CIRCUIT BOARDS

When it comes to resolving big pot problems and confining them to a small space, Clarostat has the know-how. It brings them down to size.

In printed board applications where mounting is critical, the Clarostat 371 molded carbon trimming potentiometer provides maximum unit surface economy and permits closest board-to-board spacing. Elimination of the shaft and seal brings down costs as well as dimensions with the entire potentiometer limited to a minimum number of parts including a hot molded carbon element, carbon contact brush, pressure spring and cover.

Clarostat Series 371RA1 holder mounts are made of "Zytel 101" nylon with design rigidly encasing the leads at right angles to the pot even when mounted side-by-side on plug-in circuit cards. This permits easy adjustment of the trim pot body. Ends protrude from the mount on .1" grid centers. Since the Series 371RA1 is a bonded assembly, it should be specifically ordered.

### SPECIFICATIONS

#### Series 371 & 371RA1 Molded Carbon Potentiometers

Resistance Range: 100Ω to 1 Megohm.  
Resistance Tolerance: ±20% Standard, ±10% Special.  
Power Rating: .375 watt @ 70°C, derated to 0 watt @ 120°C.  
Taper: Linear.  
Dielectric Strength: Variable arm hot to case.

Working Voltage: 350 Vac maximum.  
Mechanical Rotation: 290° ±5°.  
Stop Torque: 20 oz.in.  
Operating Torque: 7.0 oz. in. maximum.

# CLAROSTAT

CLAROSTAT MFG. CO., INC. DOVER, NEW HAMPSHIRE

SEE US AT IEEE BOOTH 4H-32  
ON READER-SERVICE CARD CIRCLE 211

# Products

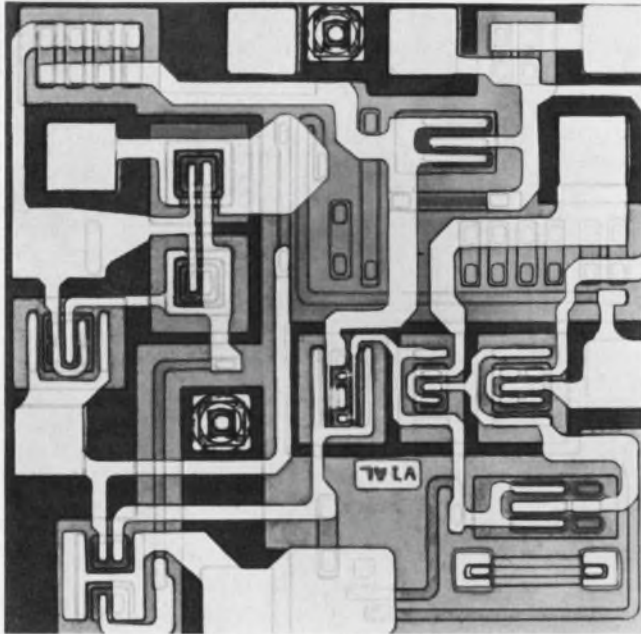

Gain-bandwidth products to 7 GHz are offered by this monolithic video amp. Page 292

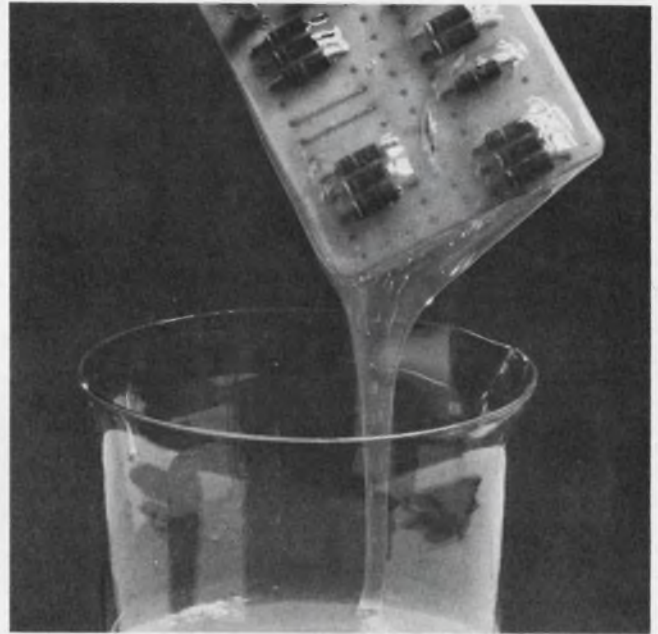

One-part silicones cure corrosion free. Acetic acid by-products are eliminated. Page 320

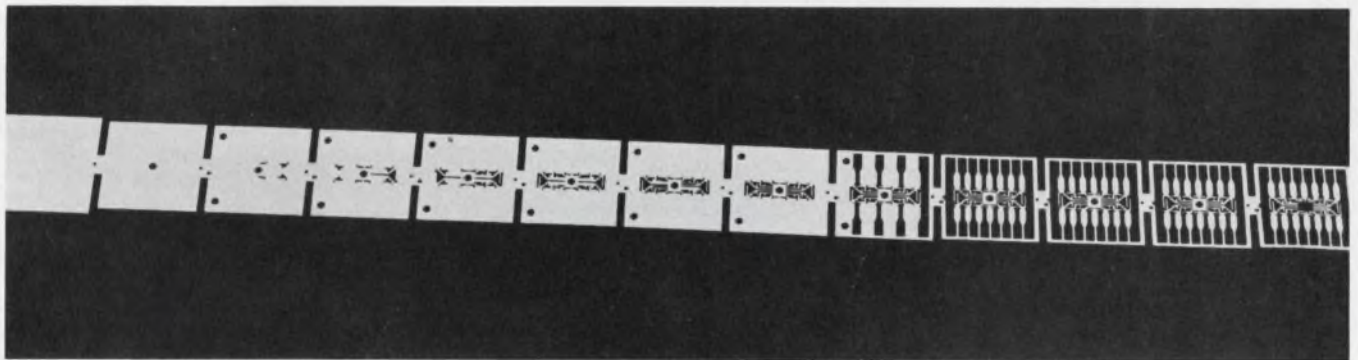

Subminiature Kovar IC frames are stamped by 13-stage progressive carbide dies. The

$\pm 0.00001$ -inch tolerance dies stamp at rates exceeding 200 per parts minute. Page 322

## Also in this section:

Rectifier modules can be series-strung for PRVs to 150 kV. Page 302

Analog module multiplies in all four quadrants. Page 306

Design Aids, Page 336 . . . . Application Notes, Page 338 . . . . New Literature, Page 340

## Video amplifier offers high gain

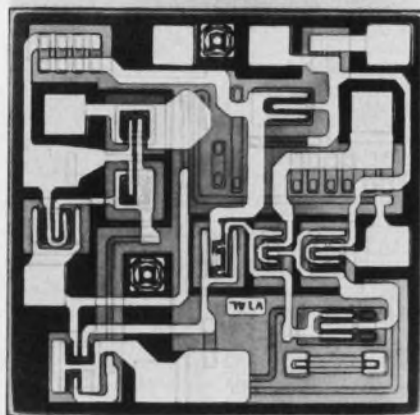

Motorola Semiconductor Products, Inc., P. O. Box 955, Phoenix. Phone: (602) 273-6900. P&A: \$8 (over 100); stock.

A pair of monolithic integrated video amplifiers offering high gain and wide bandwidth are designed for use as wideband linear or fast-rise pulse amplifiers. While basically the same structure, the pair are internally connected somewhat differently. In addition, each offers two gain-bandwidth combinations selectable by external pin connection. The MC1552G has a nominal gain of 50 or 100 and the MC1553G a choice of 200 or 400. Each gain level provides a different bandwidth (25, 21, 23 and 9 MHz.). The gain features for both devices are stable within  $\pm 1$  dB. The voltage gain variation with temperature is  $\pm 0.2$  dB across the range of  $-55$  to  $125^\circ\text{C}$ . The dc output voltage variation is  $\pm 0.05$  dB from  $-55$  to  $125^\circ\text{C}$ . Quiescent output voltage is 2.9 V with a  $\pm 6$  V supply.

The basic circuit is a three-stage direct-coupled common-emitter cascade, incorporating feedback from the third-stage emitter to the first-stage emitter. The output stage is an emitter-follower with a separate dc feedback path to the base of the input transistor. This sets the dc quiescent point so that approximately half the supply voltage appears at the output permitting a maximum output voltage swing for any supply voltage or temperature.

The common emitter configuration gives noise of 5 dB at 30 MHz and a 3-MHz bandwidth.

CIRCLE NO. 567

## Capacitor chips available to 180 pF

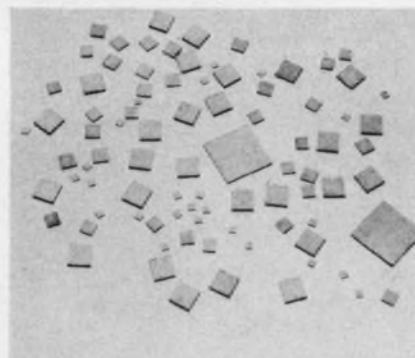

American Lava Corp., Titania Div., Chattanooga, Tenn. Phone: (615) 265-3411. P&A: about \$20 in large quantity; stock.

Small capacitor inserts for micro-miniature and integrated circuits can be supplied in sizes from 0.02 in.<sup>2</sup> in values to 180 pF. Available electrodes include palladium-gold, platinum-gold, gold and silver. The capacitors are produced from thin sections of high-K temperature-compensating ceramic materials. Dielectric constants range from 6 to 9000.

CIRCLE NO. 568

## Binary comparators handle 4 bits at once

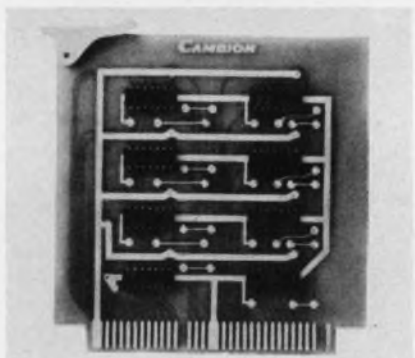

Cambridge Thermionic Corp., 445 Concord Ave., Cambridge, Mass. Phone: (617) 876-2800. P&A: \$38.50 (10 to 49); stock.

Designed to determine if one binary number is greater than, equal to, or less than another, this series of binary comparators can compare as many as four bits simultaneously with a single logic assembly, and can be cascaded to permit the comparison of long word lengths. Also available are a one-bit serial comparator and an equal-to comparator.

CIRCLE NO. 569

## Op-amp has 60,000 open-loop gain

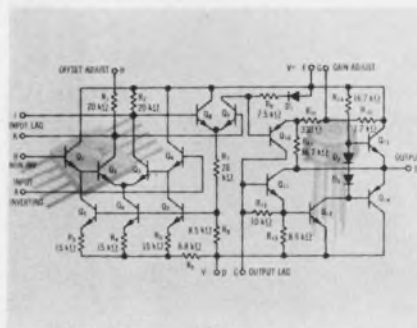

Motorola Semiconductor Prod., Inc., P. O. Box 955, Phoenix. Phone: (602) 273-6900. P&A: metal can, \$15; ceramic flatpack, \$19; stock.

Typical open-loop voltage gain of this IC op-amp is 60,000. The output voltage swing is typically  $\pm 13$  V with a power supply voltage of  $\pm 15$  V. This large output swing makes the voltage gain usable at higher input levels. The unit can be used as a summing amplifier, an integrator, or for any application requiring an amplifier with operating characteristics as a function of external feedback components. It is available in both the 10-pin metal can and the 1/4 x 1/4-inch ceramic flatpack.

CIRCLE NO. 570

## Five-amp power switch is integrated

Vector Div. of United Aircraft Corp., Southampton, Pa. Phone: (215) 355-2700. P&A: \$325; 6 wks.

V-1030 integrated power switches use a Darlington circuit with output diode protection. They have built-in thermal protection and are offered in a family of units switching up to 5 A with good  $LV_{CEO}$ . The monolithic unit is designed to meet military environments and features switching times of less than 1  $\mu\text{s}$ . Packaging is a standard TO-60. The switches are suited for use with digital power control for motor or servo systems in the military and commercial fields.

Booth No. 4F26 Circle No. 343

Don't forget to return your **ELECTRONIC DESIGN** renewal card.

# Air variables from JFD solve your high Q high frequency problems

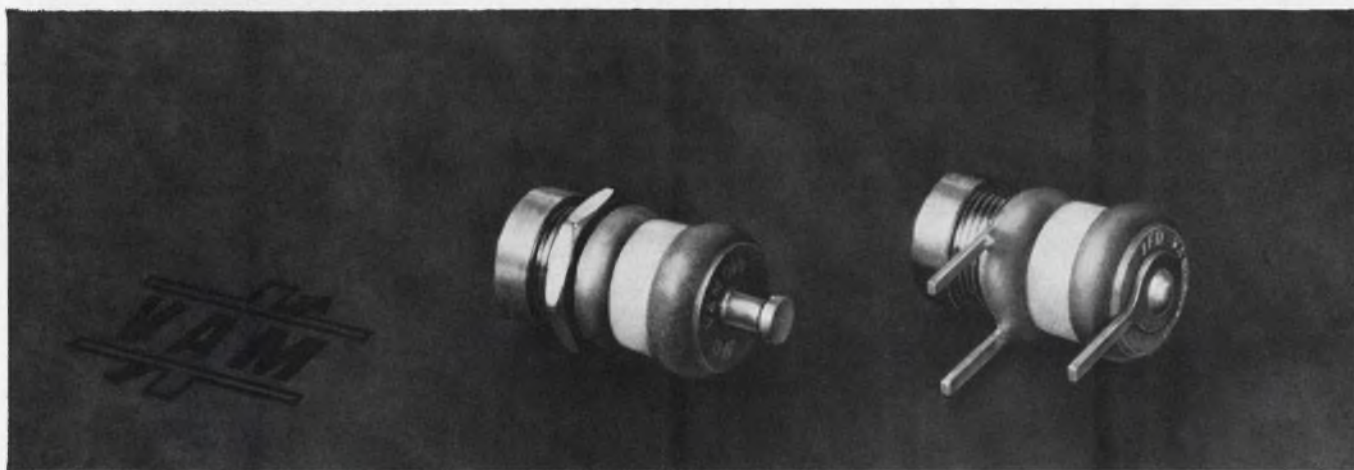

Capacitors shown enlarged 120%

These new JFD air variable capacitors are specially designed for high frequency applications that demand ultra stability, small size and high Q—greater than 2000 measured at 10 pf and 100 MC. These rugged, miniature units are offered in both printed circuit (VAM 010W) and panel mounting (VAM 010) models

with capacitance ranges from 0.8 through 10.0 pf measured at 1 MC.

These units which measure less than  $\frac{1}{2}$ " in length are completely interchangeable with competitive devices.

Internal air meshing shells are silver plated to provide good surface conductivity and to prevent corro-

sive effects. Internal contact springs assure positive electrical contact of rotor at all times. Leads on printed circuit model are tinned for ease in soldering . . . and these units are engineered to resist heat, won't come apart during soldering.

Bulletin VAM-65 gives more details. Write for your copy today.

## JFD

"TODAY'S COMPONENTS BUILT FOR TOMORROW'S CHALLENGES"

JFD ELECTRONICS CO. / COMPONENTS DIVISION • 15th Avenue at 62nd Street • Brooklyn, New York 11219 / Phone 212-331-1000  
Sales Offices — Arcadia, California / Chicago, Illinois / Baltimore, Maryland / Saxonville, Massachusetts / Brooklyn, New York  
New Hartford, New York / Cincinnati, Ohio / Philadelphia, Pennsylvania / Pittsburgh, Pennsylvania / Paris, France / Azor, Israel

SE US AT IEE BOOTH 4F25  
ON READER-SERVICE CARD CIRCLE 212

## Obsolete Hand Loading

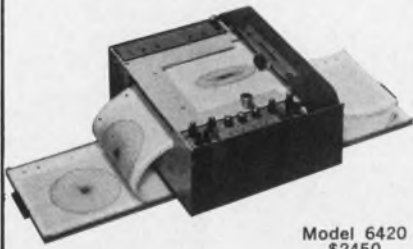

Model 6420  
\$2450

## Continuous Chart Supply

# X-Y Recording

- Bi-directional Chart Movement
- Z-Fold Paper
- 8½" x 11" Recording Surface (tears out for file use)
- Local or remote control of recording mechanism and pen lift
- English/Metric Scale
- 15 in./sec. slewing speed
- 18 calibrated voltage ranges for each axis—continuously variable in between
- ± .2% Accuracy
- ± .1% Repeatability

Model 6450 (same as above) offers 11" x 17" Recording Surface—\$2650.

Model 6452, X-Y-Y' (two pen)—\$3250.

**houston OMNIGRAPHIC corporation**

a subsidiary of houston instrument corporation  
4950 Terminal Ave. / Bellaire, Texas 77401  
(713) 667 7403 / cable HOINCO / TWX (713) 571 2063

## TEST EQUIPMENT

### Marker generators crystal controlled



*Jerrold Electronics, 401 Walnut St., P.O. Box 1467, Philadelphia. Phone: (215) 925-9870.*

Two marker generators for superimposing crystal-controlled ac or dc marks on scope displays of response curves can be programmed to provide any fundamental frequency between 2 and 100 MHz. Rack-mounted Model CM-10 has a frequency range of 100 kHz to 100 MHz. In the higher frequencies (20 to 100 MHz), up to the 20th harmonic will be visible.

CIRCLE NO. 571

### Timing system has high resolution



*Nanofast, 416 W. Erie, Chicago. Phone: (312) 943-4223.*

Model 535-7C continuous timing system measures the time between input start and stop pulses on a continuous basis. Features are 10-ns resolution and continuous timing with rep rate up to 50 kHz. Included is a 100-kHz preset counter which provides an output and optionally resets the unit when the measured time equals the preset value. Timing range is 10 ns to 0.1 s.

CIRCLE NO. 572

### Sweep measuring set ranges 10 kHz to 36 MHz

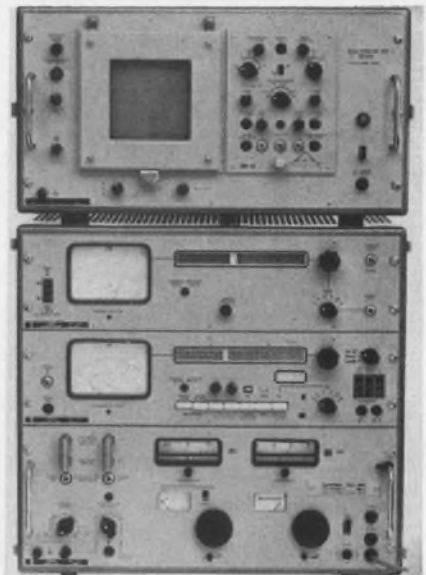

*Tel-Com Instruments, Inc., 17715 Chatsworth St., Granada Hills, Calif. Phone: (213) 360-2278.*

The manufacturer's level-measuring set and display unit are combined with a plug-in unit to form a sweep measuring set. Automatic level and attenuation measurements of active and passive 4-pole networks, and display of frequency response in the 10-kHz-to-36-MHz range are obtained with this combination. Wideband or narrowband (crystal) devices can be measured.

CIRCLE NO. 573

### Digital gaussmeter is stable and linear

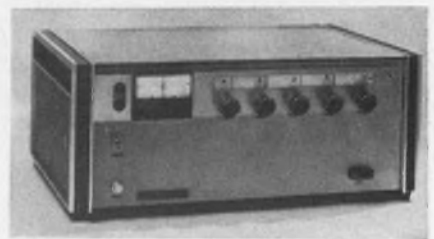

*Varian, 611 Hansen Way, Palo Alto, Calif. Phone: (415) 326-4000.*

A direct field reference, rather than indirect current reference of a power supply, eliminates difficult current cycling procedures in the use of this digital gaussmeter. Field settings up to 30 kilogauss can be repeated to within 50 megagauss with absolute field accuracy of ±0.1%. A temperature-controlled Hall-effect probe is employed.

CIRCLE NO. 574



# 200,000 OHMS PER VOLT



**Model 630-NS**  
VOLT-OHM-MICROAMMETER

### TRIPLET SUSPENSION MOVEMENT

*no pivots . . . no jewels . . .  
no hair springs . . . thus NO FRICTION.*

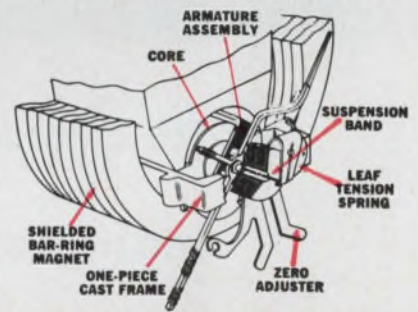

**\$10000**  
SUGGESTED  
U.S.A. USER NET

## FACTS MAKE FEATURES

- 1** 200,000 OHMS PER VOLT D.C. for greater accuracy on high resistance circuits. 20,000 OHMS PER VOLT A.C.
- 2** 5 $\mu$  SUSPENSION METER MOVEMENT. No pivots, bearings, hair-springs, or rolling friction. Extremely RUGGED. Greater sensitivity and repeatability.
- 3** 62 Ranges, usable with frequencies through 100 Kc. Temperature compensated. 1½% D.C. ACCURACY, 3% A.C.

Low voltage ranges and high input impedance make the 630-NS especially useful in transistor circuit measurement and testing. Input impedance, at 55 volts D.C. and above, is higher than most vacuum tube voltmeters.

The unit is designed to withstand overloads and offers greater reading accuracy. Reads from 0.1 $\mu$ a on 5 $\mu$ a range. Special resistors are rigidly mounted and directly connected to the switch to form a simplified unit. Carrying cases with stands are priced from \$11.00.

**TRIPLET ELECTRICAL INSTRUMENT COMPANY, BLUFFTON, OHIO**

### 62 RANGES

D.C. VOLTS	0-0.6-3-12-60-300-1200 at 100,000 Ohms/Volt. 0-0.3-1.5-6-30-150-600 at 200,000 Ohms/Volt. 0-0.150 at 60 $\mu$ a
A.C. VOLTS	0-3-12-60-300-1200 at 10,000 Ohms/Volt. 0-1.5-6-30-150-600 at 20,000 Ohms/Volt.
DB	-20 to 77 in 10 ranges.
D.C. MICRO-AMPERES	0-5 at 300 MV. 0-60-600 at 150 MV. 0-120 at 300 MV.
D.C. MILLI-AMPERES	0-6-60-600 at 150 MV. 0-1.2-12-120-1200 at 300 MV.
D.C. AMPERES	0-6 at 150 MV. 0-12 at 300 MV.
OHMS	0-1K-10K-100K (4.4-44-440 at center scale)
MEGOHMS	0-1-10-100 (4400-44,000-440,000 Ohms center scale)

OUTPUT: Condenser in series with A.C. Volt ranges.



THE WORLD'S MOST COMPLETE LINE OF V-O-M'S. AVAILABLE FROM YOUR TRIPLET DISTRIBUTOR'S STOCK.

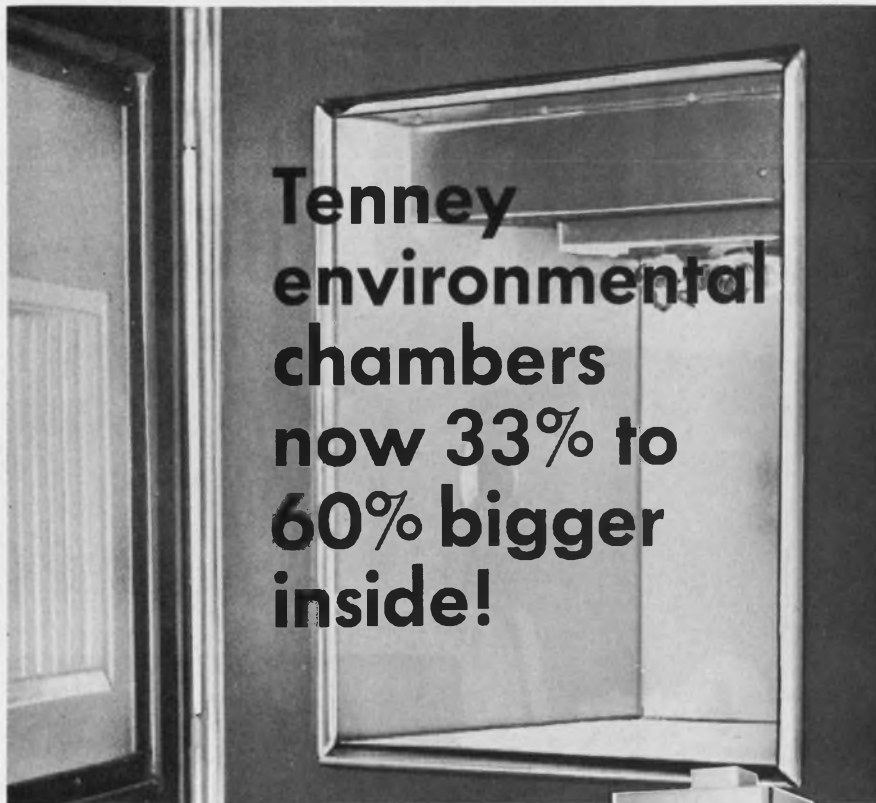

**same size outside**

**same prices**



**T**enney increased the work space of its new hi-low temperature environmental test chambers from 33% to up to 60%, without increasing overall dimensions! *You get more work space from the same floor space... and the price remains the same.* Improved systems and construction. All chambers have self-contained hermetic refrigeration and full-opening door... are available with optional humidity ranging from 20% to 95%. All are backed by a full year warranty. Low temperatures available:  $-40^{\circ}$  F,  $-100^{\circ}$  F, or  $-120^{\circ}$  F. High temperatures:  $+240^{\circ}$  F or  $+350^{\circ}$  F.

Check these dimensions.

	Interior	Exterior
TENNEY 5	21" W x 21" D x 20" H	2'6" W x 2'8" D x 6'0" H
TENNEY 14	28" W x 26" D x 34" H	3'2" W x 4'1" D x 6'1" H
TENNEY 40	40" W x 44" D x 40" H	4'2" W x 5'7" D x 6'10" H

Write today for complete information.



1090 Springfield Rd., Union, New Jersey 07083 • (201) 686-7870  
Western Division: 15700 S. Garfield Ave., Paramount, Calif. 90723

ON READER-SERVICE CARD CIRCLE 215

## TEST EQUIPMENT

### Resistance deviation in digital readout

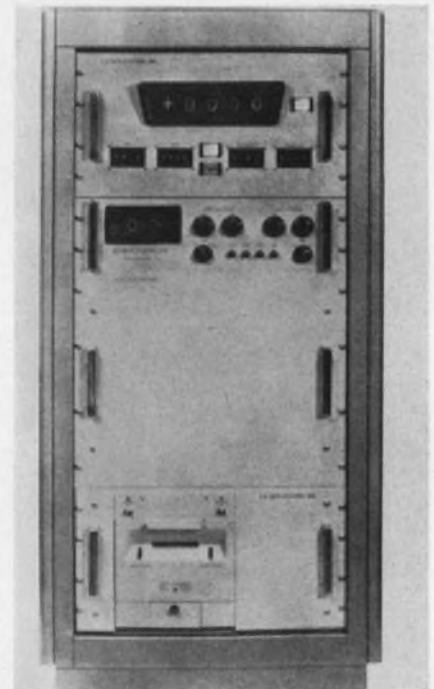

A. D. Data Systems, Inc., 830 Linden Ave., Rochester, N. Y. Phone: (716) 381-2370.

The resistance deviation checker gives a direct digital indication of the deviation between the standard resistor and the resistor under test. This approach eliminates the inherent inaccuracies which result from subtraction of two large numbers to obtain a small difference. These can be arranged to comply with MIL-R-11, MIL-R-22684 and MIL-R-39017 voltage requirement for lower test voltages at higher resistances.

CIRCLE NO. 575

### Bridge measures capacity, dissipation

Landis & Gyr, Inc., 45 W. 45th St., New York. Phone: (212) 586-4644.

For checking standard insulations and the newer liquid and solid insulations, this high-sensitivity bridge has operation contingent on 4 capacitors (not resistors) to insure large bridge independence. Measuring range is 0 to 2000 V, measuring frequency is 60 or 50 Hz, dissipation-factor measuring range is  $10^{-5}$  to 10 and capacitance range is 9 to 10,000 pF. Power supply is 110 to 220 V.

CIRCLE NO. 576

## A-to-D converter for nanosecond pulses

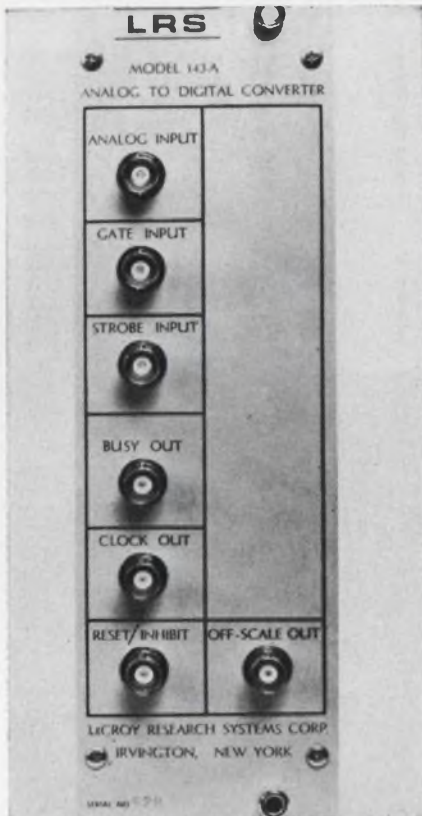

LeCroy Research Systems Corp., 1 Hayes St., Elmsford, N.Y. Phone: (914) 592-5010.

Designed to digitize nanosecond photomultiplier pulses directly, this A-to-D converter gives direct read-out onto magnetic tape or on-line computer, or into a multichannel analyzer memory. The unit combines a linear gate, stretcher amplifier, amplitude-to-time converter, clock, scaler and output multiplexer in one AEC standard module.

CIRCLE NO. 577

## Frequency scaler converts pulse rate

Fischer & Porter Co., 143 Jacksonville Rd., Warminster, Pa. Phone: (215) 675-6000.

You can convert the actual pulse rate from a transmitter or transducer to a more conveniently handled and decimally related pulse rate with this frequency scaler. Several input-output ratios are available. The unit also amplifies and shapes input signals to drive electromechanical counters, batch controllers and printers.

CIRCLE NO. 578

μsec/millisec delays

VIDEO

5 to 500MHz

MULTI-CHANNEL

TRIPLE TRAVEL

PROPORTIONAL CONTROL

analog

ISOTHERMAL

WIDEBAND

AMPLIFIERS

LOW LOSS

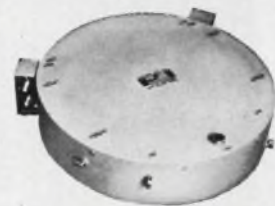
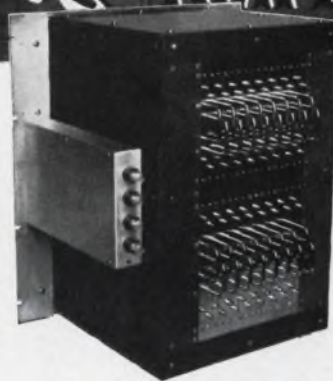

In a word, LFE

## for quartz or glass ultrasonic delay lines

You'll find the complete text — applications information — theory — technical data — specifying information for standard and custom delay lines for your application — in these authoritative LFE Catalog-Handbooks. Get them, now!



**ELECTRONICS DIVISION**

Laboratory For Electronics, Inc.  
WALTHAM, MASSACHUSETTS 02154  
Tel: 617-894-6600 • TWX: 710-324-0681

ON READER-SERVICE CARD CIRCLE 216

# Finally... a reasonably priced Taut- Band\* METER



... that meets  
your performance  
requirements.

- \* Will handle meters as large as 7"
- \* Excellent balance
- \* Good Damping and response
- \* No drift
- \* Tracking  $\pm 1\%$  or  $\pm 2\%$

Send for Data today

## BEEDA

ELECTRICAL INSTRUMENT CO., INC.  
PENACOOK, NEW HAMPSHIRE 03303  
Area Code: 603-753-6362

ON READER-SERVICE CARD CIRCLE 217

## TEST EQUIPMENT

### Video amplifier has 5 ranges



American Electronic Laboratories, Inc., P. O. Box 552, Lansdale, Pa. Phone: (215) 822-2929. Price: \$495.

This portable, low-noise video amplifier has 5 basic adjustable-bandwidth frequency ranges from 0.5 to 5 MHz. It features a gain of 65 dB at 10 kHz, and an input impedance at 1 MHz of greater than 350 k $\Omega$  and less than 10 pF  $\pm 10\%$ . A bias supply is built-in with a front panel meter covering 0 to 85  $\mu$ A in two ranges.

Booth No. 4K11 Circle No. 353

### Audio oscillator needs no bandswitching



General Radio Co., West Concord, Mass. Phone: (617) 369-4400. P&A: \$325; stock.

"Sync-able" RC oscillators cover the frequency range from 10 Hz to 50 KHz with both sine- and square-wave outputs. The entire frequency range is covered in one turn of the frequency dial, with no bandswitching required. Thus, there are no switching transients and no multipliers or decimal points.

CIRCLE NO. 579

### Differential preamp has remote gain control



Scientific-Atlanta, Inc., Box 13654, Atlanta. Phone: (404) 938-2930. P&A: \$2275; 90 days.

This remote differential preamplifier for high-impedance transducers has differential or single-ended FET input. Gain is -20 to 60 dB in 10-dB steps. Output is 1 V rms into 75  $\Omega$  and is flat to  $\pm 1$  dB over a max bandwidth of 20 Hz to 2 MHz. Selectable upper and lower cutoff-frequency filters have an 18-dB-per-octave attenuation slope.

CIRCLE NO. 580

### Insertion loss test with portable unit

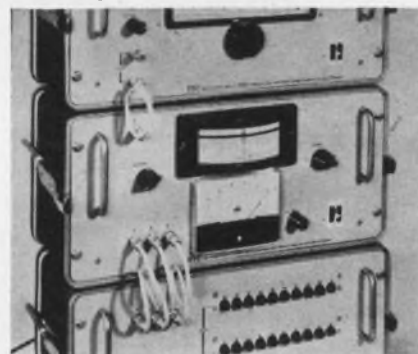

ITT Industrial Products Div., 15191 Bledsoe St., San Fernando, Calif. Phone: (213) 367-6161. Price: \$3940.

Equipment to measure the insertion loss of circuits and networks up to 60 dB (and up to 70 dB with lower accuracy) is available. A comparison method of measurement is used, so that the accuracy depends only on passive networks. Three portable units form the complete equipment: a sending unit and a measuring unit, both employing solid-state circuits, and a push-button attenuator.

CIRCLE NO. 581

# NOW... Break the "Dollar Barrier" with RF-IF Ampl CA3028 ...98¢ (1,000+)

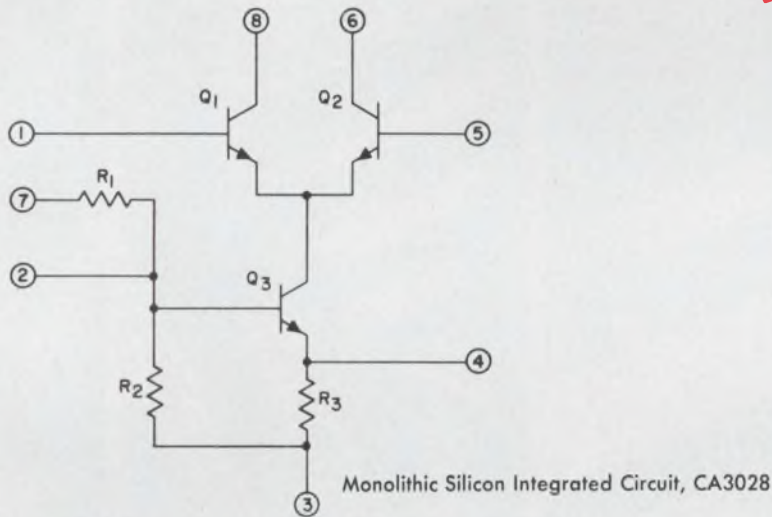

## TYPICAL SPECIFICATIONS

Power Gain @ 10.7 MHz	Cascode	39dB	Differential Ampl	32dB
@ 100 MHz	Cascode	20dB	Differential Ampl	17dB
Voltage Gain @ 10.7 MHz ( $R_L = 1K \Omega$ )	Cascode	98	Differential Ampl	32
AGC Range (Max. power output to full cut-off) @ 10.7 MHz				62dB

## APPLICATIONS

IF Ampl (differential or cascode)      Mixer  
 Converter in the Commercial FM band      Oscillator  
 Limiter

## AVAILABILITY FROM STOCK

Ask your RCA Representative about CA3028. Check your RCA Distributor for his price and availability schedule. Or send for complete data, including Application Note, ICAN-5337, to Commercial Engineering, RCA Electronic Components & Devices, Section 1GG3-3, Harrison, N.J. 07029

Check Your RCA Distributor for His Price and Delivery

RCA ELECTRONIC COMPONENTS AND DEVICES



The Most Trusted Name in Electronics

# What's our line?

We make rectangular connectors — MS, environmental and universal types.



... and high density, subminiature connectors.

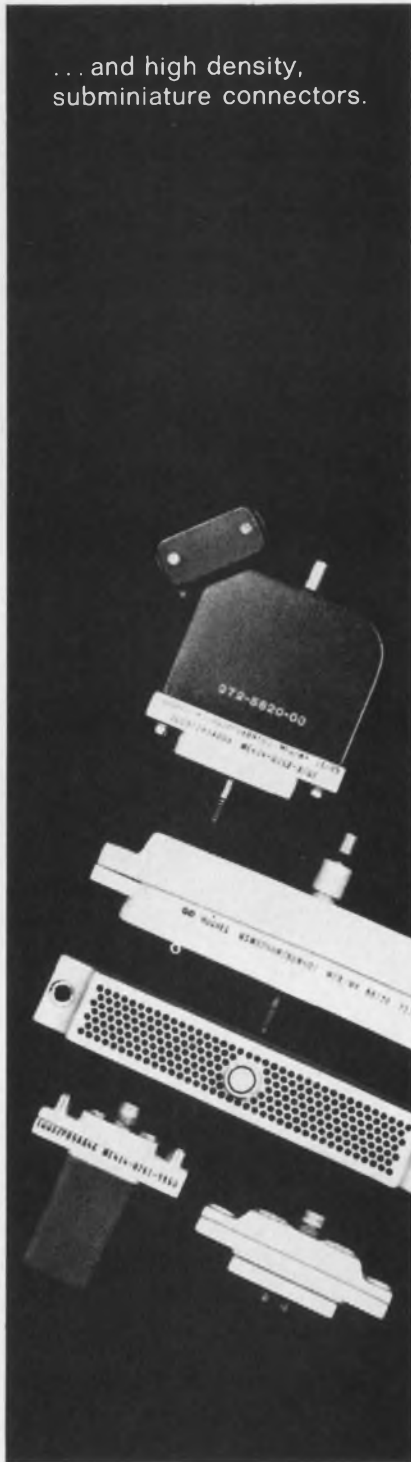

... and printed circuit and microminiature connectors.

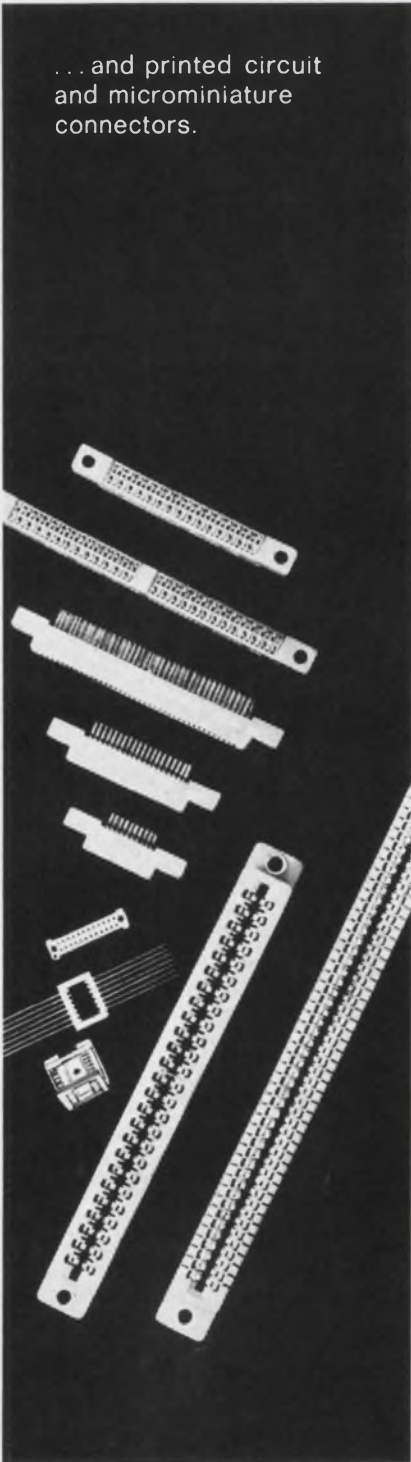

... and a brand new series of circular connectors — Mil-spec and subminiature types.



Our real line is solutions to tough interconnection problems. What we show above is just a cross section of the precision connecting devices we've developed to solve both standard and special problems. Chances are, we've already solved yours. If not; we'd welcome a crack at it. May we send you our descriptive literature? Or answer your questions about special types? You'll receive a prompt answer.



We'll also develop custom connectors, cabling and wiring harness assemblies, special devices and accessories to your own special requirements.

**CALL YOUR HUGHES  
CONNECTING DEVICES  
SALES REPRESENTATIVE**

He has specs, samples —  
and a hot line to our factory.

- CALIFORNIA (Northern)**  
The Woodworth Co.  
3639 Oak Knoll Drive  
Redwood City  
Phone 365-0252
- CALIFORNIA (Southern)**  
WEST, Inc.  
#1 Union Bank Square, Suite 512  
Orange, 547-0861
- CONNECTICUT**  
William McCoy Co.  
892 Main Street, Branford, 488-2012
- FLORIDA (Also Alabama)**  
John T. Brown, Inc.  
521 S.W. 31st Ave., Ft. Lauderdale  
583-4812
- GEORGIA (Also Miss., La., N.C., S.C., Tenn.)**  
John T. Brown, Inc.  
203 Cherokee Rd., Bldg. 7A  
Smyrna, 435-0873
- ILLINOIS**  
Technical Devices, Inc.  
6416 N. Central Ave., Chicago, 774-8252
- MARYLAND**  
Kraft Sales Engineering Co.  
510 Woodbine Ave., Towson, 828-5838
- MASSACHUSETTS**  
William McCoy Co.  
306 Water St., Clinton, 365-9254
- MINNESOTA**  
Fred B. Hill Co.  
6110 Excelsior Blvd., Minneapolis  
929-6727
- MISSOURI**  
Ridgewood Sales Co.  
P.O. Box 26, Webster Groves Station  
St. Louis, 961-0992
- N. JERSEY (North), N.Y.C. & LONG ISLAND**  
Robert Horne Assoc.  
2282 Hamburg Turnpike  
Pompton Lakes, 835-7400
- NEW JERSEY (Southern)**  
Thomas Mills Co.  
13-B Tanner St., Haddonfield, 429-1005
- NEW YORK**  
C. W. Floring & H. R. Murray, Inc.  
6585 Kinne Rd., Syracuse, 446-5555
- OHIO**  
Luebbe Sales Co.  
P.O. Box 8955, Cincinnati, 871-4211
- PENNSYLVANIA (Western)**  
Anderson Connector Corp.  
P. O. Box 237  
Wexford, 776-3211

- TEXAS**  
Space Electronics Corp.  
136 S. Main St., Irving, 631-0905
- WASHINGTON (Also Ore., Ida., Mont.)**  
J. J. Backer Company  
221 W. Galer St., Seattle, 283-6470
- For export:** Hughes International,  
5804 S. Centinela Ave., Culver City,  
California, 391-0711, ext. 6303



**TEST EQUIPMENT**

**Transient recorder for  
single events**



*E-H Research Labs., Inc., 163 Adeline St., Oakland, Calif. Phone: (415) 834-3030.*

Single-event recording and reproduction is accomplished by this transient recorder. The analog input signal is sampled up to as many as 1000 points along the X-axis (time axis.) At each time slot the signal amplitude is digitized at 10  $\mu$ s by an analog-to-digital converter, and stored in the Y-axis of the core memory. The reproduction mode is nondestructive so that the stored signal may be regenerated continuously as a repetitive waveform. The speed of generation ranges from one time slot per second to 100,000 time slots per second. This feature may be used to time compression or expansion of repetitive functions which have been recorded. In addition to the analog output of the recorded signal, 3-digit BCD is available at a rear-panel connector. *Booth No. 2H02 Circle No. 525*

**Multiscaler systems  
have central display**

*LeCroy Research Systems Corp., 1 Hayes St., Elmsford, N. Y. Phone: (914) 592-5010. P&A: \$1950 to \$2450 (24-bit); \$750 to \$1090 (12-bit).*

A modular counting technique provides more economical data readout by employing one centralized visual display to provide selective monitoring of any number of scalars. Strobed outputs fed into a common binary buss allow sequential interrogation into any of the manufacturers' data processors. *Booth No. 2D51 Circle No. 331*



## Cramped for space?

### Use Couch 1/7-size Relays

Space/weight problem? The new Couch 2X 1/7-size crystal can relay gives you tremendous savings in space and weight. 0.1" grid — plus many outstanding specs — all in micro-miniature. Thoroughly field-proven in electronics and space applications.

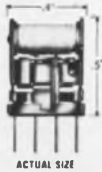

	2X (DPDT)	1X (SPDT)
Size	0.2" x 0.4" x 0.5"	same
Contacts	0.5 amp @ 30 VDC	same
Coil Operating Power	100 mw 150 mw	70 mw 100 mw
Coil Resistance	60 to 4000 ohms	125 to 4000 ohms
Temperature	-65°C to 125°C	same
Vibration	20 G	same
Shock	75 G	same

Broad choice of terminals, coil resistances, mounting styles. Write for detailed data sheets.

**RUGGED ROTARY RELAYS**  Dynamically and Statically Balanced

## COUCH ORDNANCE INC.

3 Arlington St., North Quincy, Mass. 02171, Area Code 617.  
CYPRESS 8-4147 • A subsidiary of S. H. COUCH COMPANY, INC.

ON READER-SERVICE CARD CIRCLE 220

## SEMICONDUCTORS

### Rectifier modules series-strung to 150 kV

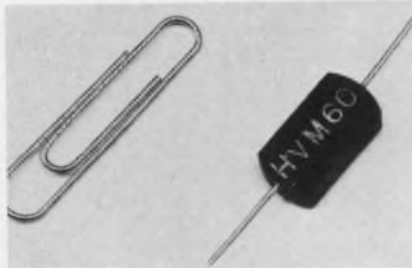

General Instrument Corp., Semiconductor Products Group, 600 W. John St., Hicksville, N. Y. Phone: (516) 681-8000. Price: 50¢/kV (production quantity).

High-voltage rectifier modules are designed for use in long series strings for high-voltage rectifier assemblies. The devices have PRV ratings from 2000 to 6000 volts at 250 mA; in typical non-compensated diode strings, PRV ratings to 150,000 volts are obtainable. Eight diode-diffused silicon cells are connected in series in the module, which is encapsulated in high thermal-conductivity epoxy. Applications include series strings for CRTs, photomultipliers, vidicon power supplies and other higher power applications.

CIRCLE NO. 582

### Avalanche diodes rated to 4 kV

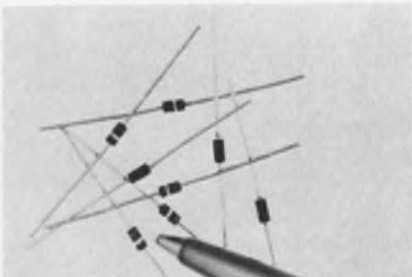

MicroSemiconductor Corp., 11250 Playa Ct., Culver City, Calif. Phone: (213) 391-8271. Price: 25¢/kV (100 lots).

High-voltage avalanche diodes and assemblies are rated to 4000 volts. Single silicon junctions are glass-sealed and have typical peak inverse ratings between 1000 to 1500 volts. Mechanical size of the 1000-to-4000-volt series is 0.1 by 0.3 inches, with 0.02-inch leads. Higher voltages are available.

CIRCLE NO. 583

### Current-limit diodes bias transistors

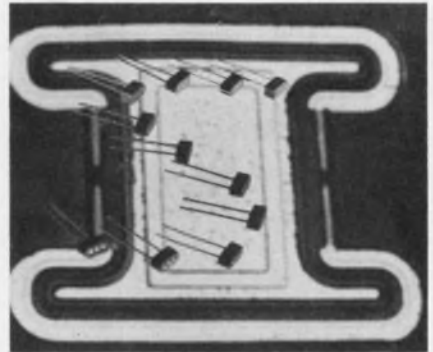

Siliconix Inc., 1140 W. Evelyn Ave., Sunnyvale, Calif. Phone: (408) 245-1000. P&A: \$3.15 to \$6.30 (100 lots); stock.

Nine current-limiter field-effect diodes are designed for constant-current biasing of transistors, FETs, differential amplifiers and Zener reference diodes. The current limiter is useful in place of a logic pull-up resistor for high-speed switching, as a high-impedance load with low supply voltage and as a current-limiting protecting device. The CL2010 series offers current values from 220 A to 4.7 mA.

CIRCLE NO. 584

### Npn power transistors leak like planars



Solitron Devices, Inc., 1177 Blue Heron Blvd., Riviera Beach, Fla. Phone: (305) 848-4311.

A transistor has been developed with the characteristics of low-leakage planar units, combined with resistance to secondary breakdown offered by homogenous devices. This Isoltaxial npn silicon power transistor is available in a TO-3 case. The devices feature low leakage currents, freedom from secondary breakdown, a flat gain curve and low saturation voltages.

CIRCLE NO. 585



Just push a button to select one of five different functions and make measurements in a total of 23 ranges.

Measure (1) dc voltage in 3 ranges from 0.0000 to  $\pm 999.99$  volts with automatic and manual ranging. Accuracy: .005%  $\pm 1$  digit. Sensitivity: 100 microvolts. Measure dc millivolts in 2 ranges from 00.000 to 100.00 millivolts. Accuracy: .02%  $\pm 1$  digit. Sensitivity: 1 microvolt. Stability: 30 days with 10°C temperature variation. Push a button for (2) DC/DC ratios in 3 ranges from .00000:1 to  $\pm 99.999:1$ . Standard feature: automatic polarity selection. Push a button to measure (3) ac in 3 ranges from 00.000 to 1000.0 volts rms; (4) dc current in 6 ranges from 0.0000 microamperes to  $\pm 100.00$  milliamperes; (5) resistance in 6 ranges from 0.0000 kilohms to 100.00 megohms.



Each button lights up for positive identification. And this versatile instrument takes up just 5¼ inches in a 19-inch rack. Model 533-4810, rackmount: \$2,750.

Also available: our new 530 Series DC DVM/Ratiometer, which measures dc voltage in 3 ranges from 0.0000 to  $\pm 999.99$  volts and DC/DC ratios in 3 ranges from .00000:1 to  $\pm 99.999:1$ . Accuracy: .005%  $\pm 1$  digit. Automatic ranging and pushbutton function selection are included in both cabinet (half-rack) Model 531-1000 and rackmounting Model 531-3000 at \$1,495.

Prices FOB San Diego. Additional export charge. Better get full details now from your nearest Cohu engineering representative. Or contact Ken Walker, Manager, Instruments and Systems. Phone 714-227-6700, or write Box 623, San Diego, California 92112.

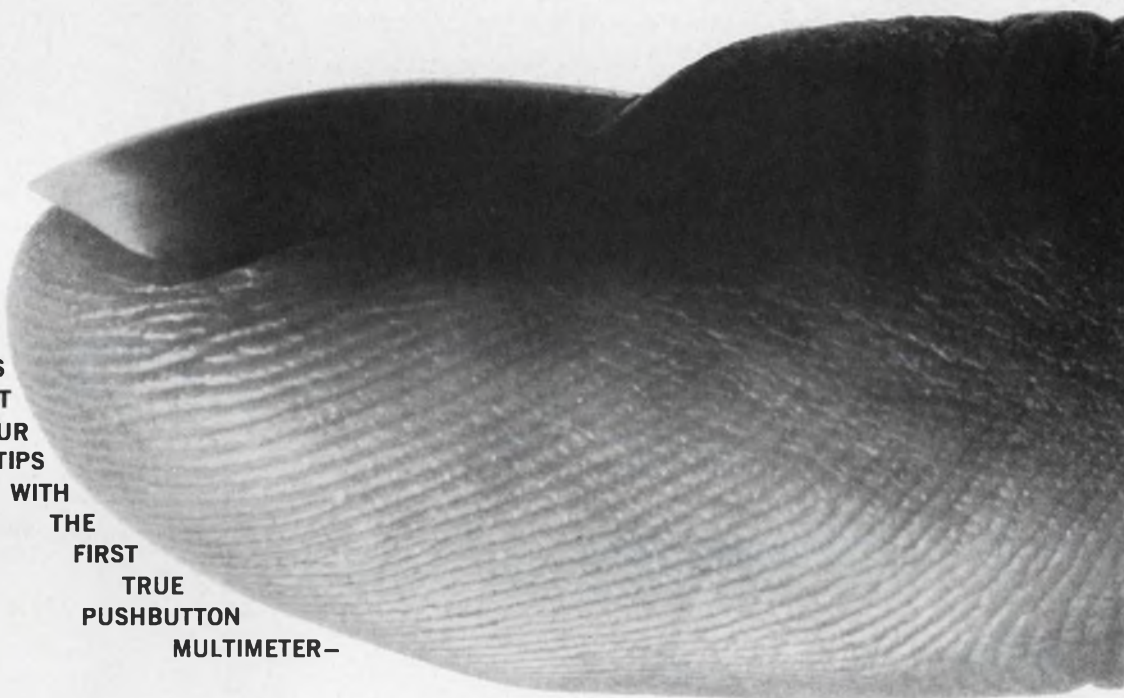

NOW  
FIVE  
FUNCTIONS  
AT  
YOUR  
FINGERTIPS  
WITH  
THE  
FIRST  
TRUE  
PUSHBUTTON  
MULTIMETER—

## COHU'S NEW 530 SERIES



# We can prove you can't afford HAND printed circuit board assembly!

Direct labor costs can be cut up to 94% by using Universal's N/C and pantograph operated insertion machines for discrete components and DIP module integrated circuits. And their labor savings include more than just direct labor. Overhead and floor space are reduced. Manufacturing cycle is shortened. Production control is simplified, with no in-process inventory. Inspection and rework are cut drastically.

Universal sales engineers have analyzed needs, prepared cost justifications, quoted and sold over 300 installations . . . many with pay-backs periods of less than 6 months. They've helped 3-man assembly groups, 3-shift departments, and almost every volume in between. They can prove the labor saving, profit making advantages of automatic printed circuit board assembly.

Now is the time to start this cost saving program. If an analysis of your requirements shows that pantograph machines give best cost justification, you can later add N/C or convert for integrated circuit insertion. Equipment can be leased; boards can be assembled by Universal on a contract manufacturing basis.

Call Us . . . Or Visit Us At N.Y.-IEEE Booths 1B19-1B23



**Universal** INSTRUMENTS CORPORATION  
East Frederick St., P.O. Box 825, Binghamton, N. Y. 13902 • 607-772-1710 • TWX: 607-772-0243

ON READER-SERVICE CARD CIRCLE 222

## SEMICONDUCTORS

### Plastic UJTs priced at 64¢



Motorola Semiconductor Products, Inc., P. O. Box 955, Phoenix. Phone: (602) 273-6900. P&A: 64¢ (over 100); stock.

A plastic unijunction transistor series, 2N4870 and 2N4871, are priced at 64¢ in quantities of 100 up. This series features the annular structure where the emitter junction and base contact areas are formed by diffusion rather than alloy techniques. The construction provides higher frequency capability, lower values of  $I_{E0}$  and  $I_P$  which are important in timing circuits.

CIRCLE NO. 586

### Monolithic diodes break down at 8 kV



Semicon Inc., Sweetwater Ave., Box 328, Bedford, Mass. Phone: (617) 275-8542. P&A: \$15 (1 to 99); stock.

High-voltage breakdowns from 1 to 8 kV are built into a single crystalline diode structure in a glass axial-lead package. Resulting properties of the diodes are  $I_R$  of 25 nA at 8 kV,  $C_j$  of 0.2 pF at 0 volts,  $T_{RR}$  of 200 ns and  $V_f$  of 10 volts at 15 mA. Designed specifically for voltage multipliers, the combination of low junction capacitance, low reverse current, low forward voltage and fast recovery makes the diodes ideal for laser and flash tube power supplies, fiber optic image amplifiers, ion pulse sources, radiation and pulse detection, deflection systems, solar plasma experimentation and infrared and RF power supplies.

CIRCLE NO. 587

# DC STANDARDS for

## Silicon rectifier stacks rated to 30 kV

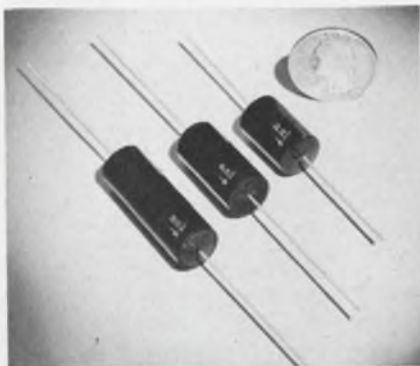

Atlantic Semiconductor, Inc., 905 Mattison, Asbury Park, N. J. Phone: (201) 775-1827. P&A: \$2 to \$12.50 (100 lots); stock.

High-voltage, high-current avalanche silicon rectifier stacks are capable of supplying 350 mA at ratings varying from 3000 to 30,000 volts. The type 35-ST stacks have built-in reverse avalanche voltage characteristic at a minimum of 20% or 2000 volts above the rated PIV. They have built-in short circuit surge of capacity of 15 A for 8 ms.

CIRCLE NO. 588

## Pnp integrated choppers have low 'on' resistance



Crystallonics Div. of Teledyne, Inc., 147 Sherman St., Cambridge, Mass. Phone: (617) 491-1670. P&A: \$7.50 (1 to 99); stock.

Pnp silicon integrated choppers feature  $R_{ON}$  of 15  $\Omega$ ,  $I_{OFF}$  of 0.1 nA,  $V_n$  of 25 mV and  $C_{ev}$  of 3.0 pF. The package is a 4-lead TO-72 common collector. Typical applications include digital-to-analog converters, multiplexers and chopper-stabilized amplifiers.

CIRCLE NO. 589

- Laboratory
- Production Line
- Field Service . . .



that is ■ portable laboratory calibration equipment designed for field environment ■ operational in 30 sec and ■ traceable to NBS.

All solid state . . . calibration and stability guaranteed for 1 year.

	Model MV-100-N	Model VS1000/007
Absolute Accuracy*	0.01% of reading	0.007% of reading
Output Voltage (fs)	$\pm 111.110$ mv dc and $\pm 11.1110$ vdc	$\pm 1111.110$ vdc
Stability (8 hrs)	0.001%	0.001%
Output Current	10 ma	10 ma
Weight	8 lbs	20 lbs
Price	\$745	\$1250

\*Calibration Accuracy (Basis for Absolute Accuracy statement): 20 PPM RSS of tolerance of primary calibration system, including 1000 volts.

OTHER FEATURES: Instant operation (30 sec), no zeroing, no balancing, short-circuit and overload protection (automatic recovery). Ideal for production line, laboratory and field service applications; for use as a voltage calibrator/source and a differential voltmeter.

Available for standard rack mounting . . . delivery from stock. Other standard models and ranges available from \$619.

• Instruments available for no charge evaluation. Contact local sales representative or factory direct.



**ELECTRONIC DEVELOPMENT CORPORATION**

423 WEST BROADWAY • BOSTON 27, MASSACHUSETTS  
Tel: 617 268-9696

ON READER-SERVICE CARD CIRCLE 224

WHEN  
POSITION MEASUREMENT  
IS IMPORTANT

**Digi-Point**<sup>T.M.</sup>  
BIDIRECTIONAL COUNTERS  
SHOULD BE INCLUDED  
IN YOUR N/C SYSTEM



This JANUS DIGI-POINT Three-Axis Position Measurement and Display System, for Westinghouse, is a typical application for Digi-Point Bidirectional Counter Displays.

Modern N/C machine tool and process control systems demand reliable high-speed digital electronics. Digi-Point Precise Position Measurement Indication and Control Bidirectional Counters have been developed by Janus Control Corporation to meet the specific needs of industrial control applications:

1. They accommodate virtually any sine or square wave signals from encoders, transducers and N/C systems.
2. Their high (3 MHz) counting and reversing speed eliminates lost counts and greatly improves measurement reliability.
3. Modern integrated circuits, plus exhaustive quality control, assure long-term, trouble-free operation.
4. Specialized application-oriented design and co-ordinated mass production techniques keep prices low.

Bidirectional Counters are just one aspect of the Digi-Point Precision Position Measurement, Indication and Control Technique. Full details on these and other units are available in the new Digi-Point Brochure. Write for a copy.



**JANUS CONTROL CORPORATION**  
296 Newton St., Waltham, Mass.  
Tel. 891-4700

ON READER-SERVICE CARD CIRCLE 223

COMPONENTS

Analog module multiplies  
in all four quadrants

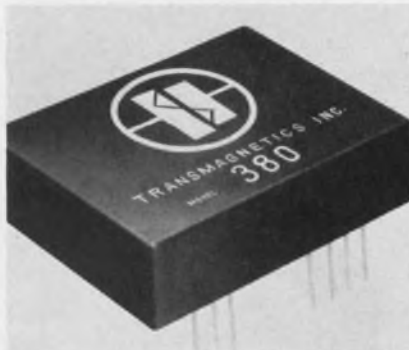

Transmagnetics, Inc., 134-25 Northern Blvd., Flushing, N. Y. Phone: (212) 539-2750. P&A: 258; stock to 6 wks.

True analog multiplication in all four quadrants with 0.5% full-scale product accuracy is performed by this module. Inputs range from dc to 30 kHz and output is  $\pm 10$  V into 10 k $\Omega$ . Applications are polar-to-rectangular transformation, trigonometric computation, dc-to-ac conversion servo modulation and variable gain control.

CIRCLE NO. 590

1/6 crystal can relay  
switches 1 A

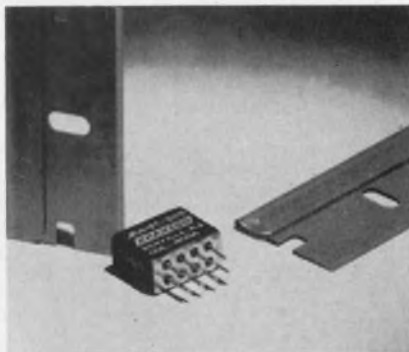

Branson Corp., Vanderhoof Ave., Denville, N. J. Phone: (201) 625-0600.

Dpdt 1/6 crystal can size relays are capable of switching 1 A. The JR relay meets MIL-R-5757/19 and is available in 6, 12 and 24 Vdc with corresponding coil resistance of 100, 400 and 1600  $\Omega$ . Minimum operating life is 150,000 operations, insulation resistance is 1000 M $\Omega$  at 25°C and volume is 0.04 in.<sup>3</sup>. Four case styles and three header styles are available.

CIRCLE NO. 591

2500-Vdc supply  
in 2-lb package

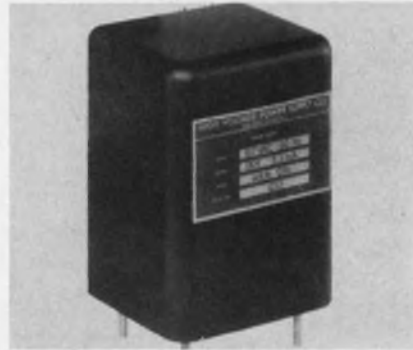

High Voltage Power Supply Co., 15820 Stagg Ave., Van Nuys, Calif. Phone: (213) 780-5526. Price: \$195 to \$238.

Small, light-weight, regulated power supply modules are available with 200- to 2500-Vdc output at 6 W for application with CRTs, photomultipliers, TWTs, BWOs and other general-purpose high-voltage sources. These 117-Vac, 60-Hz input modules are regulated to 0.05%, have ripple of less than 0.1% peak to-peak voltage, and output is adjustable  $\pm 80$  V. The modules weigh approximately 2 lbs.

CIRCLE NO. 592

Proportional controllers  
adjust from 60 to 70°C

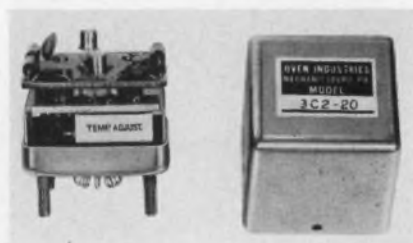

Oven Industries, Div. of Greenray Industries, Inc., 5235 E. Simpson Rd., Mechanicsburg, Pa. Phone: (717) 766-0721. P&A: \$59.50 (1 to 100 W); \$65 (1 to 20 W); 2 to 3 wks.

Ac and dc proportional controllers, when used in conjunction with a resistive load or heater, will accurately control temperature on any object which cannot be easily placed in an oven. Controlling temperature is 60 to 70°C. The 1-to-100-W units have 0.05°C resolution; the 1-to-20-W units, 0.01°C resolution.

CIRCLE NO. 593



# Think Uni-sel!

... for profits ...

Profit in space-saving with smaller physical sizes operating at higher current density ...

Profit in reduced costs with 45-volt quadruple density Uni-Sel ...

Profit with Higher Temperature Capability, 50% ratings at 70°C. ambients ...

Think Uni-Sel — and profit!

Send catalog data about  
Syntron Uni-Sel Rectifiers

283

Name/Title \_\_\_\_\_

Company \_\_\_\_\_

Street \_\_\_\_\_

City, State \_\_\_\_\_ Zip \_\_\_\_\_



Just out!  
New catalog with full  
information on Silicon  
Diodes and Assemblies.



**SYNTRON COMPANY**

283 LEXINGTON AVE. • HOMER CITY, PA. 15748

TELEPHONE 412-479-8011

Sales Representatives Coast-to-Coast

67R7

ON READER-SERVICE CARD CIRCLE 225

# NEWEST from ARNOLD

—a power supply  
designed specifically  
for users of  
INTEGRATED CIRCUITS

Here's a unit with 8 amps. output and a choice of 4 voltages— all continuously adjustable... housed in a small size, low weight package. All-silicon circuitry.

## MODEL PHU

Size: 1½" x 3½" x 3⅝". Designed to meet vibration and shock of MIL-E-5272C.

Weight: 27 oz.

Model No.	Output VDC	Output Current	Price Each
PHU-2WW	2	8 Amps	\$265.00
PHU-3WW	3	8 Amps	265.00
PHU-4.5WW	4.5	8 Amps	265.00
PHU-6WW	6	6.5 Amps	265.00

Input: 108-130 VAC @ 50-500 Hz.  
Output: adjustable +5 to -40%.  
Line Regulation: ±0.15% per volt.  
Load Regulation: less than 2.5%.  
Ripple: less than 1.5%.  
Operating Temp. Range: -55°C to +71°C.  
Delivery from stock. Ask for Art Heath.



## MODEL SHU

Size: 1½" x 3½" x 3⅝". Designed to meet vibration and shock of MIL-E-5272C.

Weight: 27 oz.

Model No.	Output VDC	Output Current	Price Each
SHU-2WW	2	8 Amps	\$265.00
SHU-3WW	3	8 Amps	265.00
SHU-4.5WW	4.5	8 Amps	265.00
SHU-6WW	6	6.5 Amps	265.00

Input: 28 ± 2 volts DC.  
Output: adjustable +5 to -40%.  
Line Regulation: ±0.06% per volt.  
Load Regulation: less than 2.5%.  
Ripple: less than 1.5%.  
Operating Temp. Range: -55°C to +71°C.  
Delivery from stock. Ask for Alan Schramm.



## 40 WATT DC-DC CONVERTER

8 MODELS—6.3V TO 5KVDC OUTPUT—ADJUSTABLE  
—senses overvoltage and current in MILLISECONDS!

Model No.	Output VDC	Output Current	Price Each
SHU-6.3	6.3	5.0 Amps	\$195.00
SHU-300	300	133 Ma.	200.00
SHU-1000	1000	40 Ma.	230.00
SHU-5000	5000	8 Ma.	390.00

SIZE: 3⅝" x 3½" x 1⅝" thick—Weight: 26 Oz.  
Input: 28 ± 2.0 volts DC. Load Regulation: 1%-4%. Typical Ripple: 0.2% (of E<sub>out</sub>) Max. Delivery from Stock—Special Voltages—2 Weeks ARO.  
\* Ask for Steve Lee.



"1400 MODELS IN STOCK"

ARNOLD / MAGNETICS

## ARNOLD MAGNETICS CORP.

6050 W. Jefferson Blvd., Los Angeles, Calif. 90016  
Telephone: 837-5313; 870-7014 (213)  
TWX: 910-340-6757

ON READER-SERVICE CARD CIRCLE 227

308

## COMPONENTS

### Module converts tach gen ac to dc

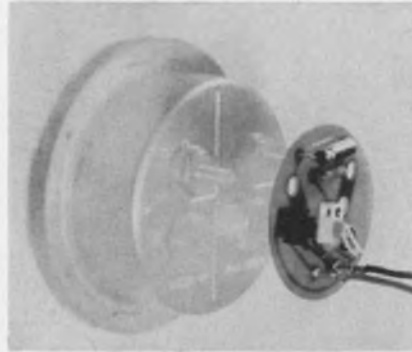

Vibrac Corp., Alpha Industrial Pk.,  
Chelmsford, Mass. Phone: (617)  
256-6581.

A "voltage responsive module" mounts directly on the rear of most 2-1/2, 3-1/2 and 4-1/2-inch panel meters. It converts the ac voltage from a tachometer generator to dc to drive the meter. A system consisting of a tach gen and module will give 1-mA output to drive a meter full scale at speeds as low as 300 rpm. A screwdriver adjustment permits the range to be set as high as 100,000 rpm for full-scale output.

CIRCLE NO. 594

### Signal conditioners for airborne use

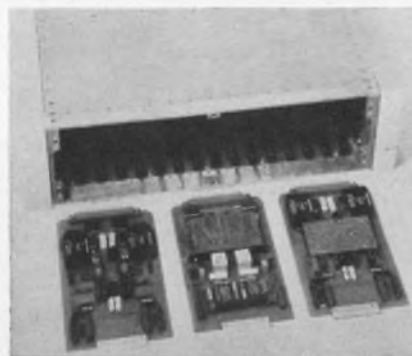

Aeroscience Electronics, Inc., 3181  
Roswell Rd. N. E., Atlanta, Ga.  
Phone: (404) 231-1278.

A versatile family of signal conditioners is offered for airborne use to prepare signals from various kinds of transducers for use with FM subcarrier oscillators, PAM-PDM-PCM multiplexers and other data-handling devices. The signal conditioners are constructed with two circuits per plug-in printed wiring card.

CIRCLE NO. 595

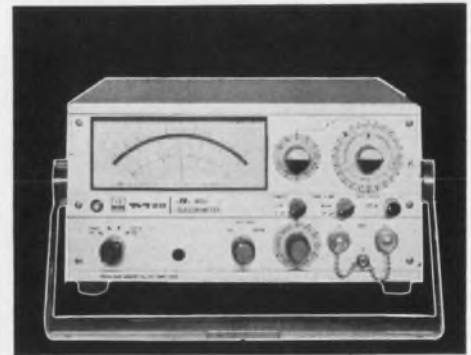

## UNANNOUNCED NEW ELECTROMETER -TR- 8651 FOR EASY AND HANDY MEASUREMENT

### FEATURES:

**-TR- 8651 ELECTROMETER** is conveniently used for:  
Measurements of ● Semiconductor resistivity ● Insulation ● Piezo-electric charge ● Photo-electric current

**-TR- 8651 ELECTROMETER** measures:

● **Voltage** from 1 mV to 100 V f.s. (11 range) with ±0.5% accuracy ● **Charge** from 10<sup>-12</sup> to 10<sup>-5</sup> coulomb f.s. ● **Current** from 10<sup>-14</sup> to 0.3 A f.s. ● **Resistance** from 100 to 10<sup>14</sup> Ω f.s.

### SPECIFICATIONS:

#### RANGE:

● **Voltage:** 1, 3, 10, 30mV, 0.1, 0.3, 1, 3, 10, 30 and 100V f.s. ● **Charge:** 10<sup>-12</sup> to 10<sup>-5</sup> coulomb f.s. (1× and 3× overlapping ranges) ● **Current:** 10<sup>-14</sup> to 0.3 A f.s. (1× and 3× overlapping ranges) ● **Resistance:** 10<sup>2</sup> to 10<sup>14</sup> Ω f.s. on linear 1× and 3× overlapping ranges.

For further details, write to:



## Takeda Riken Industry Co., Ltd.

285, Asahi-cho, Nerima-ku, Tokyo,  
Japan Cables: TRITRONICS TOKYO  
Phones: 930-4111

ON READER-SERVICE CARD CIRCLE 229  
ELECTRONIC DESIGN 6, March 15, 1967

## Transient arrester protects antennas



Joslyn Electronic Systems, P. O. Box 817, Goleta, Calif. Phone: (805) 968-3551.

Fast-responding antenna transient arresters feature low-clamping level and expanded signal operating range (10 kHz to 300 MHz). Installed in series with an external antenna (insertion loss is less than 0.5 dB at 300 MHz) as close to the receiver as possible, the arrester will attenuate an input transient before damage to active elements can occur. It can be used in single-element systems, or in multiple-element antenna arrays. A transient of 10-kV peak (1.5 x 40- $\mu$ s waveform) will be clamped to 50 V within 0.5  $\mu$ s.

CIRCLE NO. 596

## Miniature switch needs only 6 grams of force

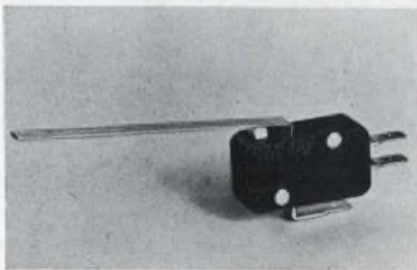

Cherry Electrical Products Corp., 1650 Old Deerfield Rd., Highland Pk, Ill. Phone: (312) 432-8182. Price: \$1.23; \$0.566 (2000).

Using the same coil spring mechanism as in the regular line of miniature switches, the manufacturer claims a record low operating force of 6 grams. This is ascribed to a special internal actuator. The ratings remain at 5 A, 1/4 hp, and 125 and 250 Vac.

CIRCLE NO. 597

*from Industro...*

# IMMEDIATE DELIVERY!

# NPN

HIGH VOLTAGE SILICON TRANSISTORS

*and*

# PNP

# COMPLEMENTS

INDUSTRO COMPLEMENTARY TYPES			
NPN	PNP	V <sub>CEO</sub>	Case Style
2N3439	TRSP-3504S	350V	TO-5
2N3440	TRSP-2504S	250V	TO-5
2N4063	TRSP-3515S	350V	MD-14
2N4064	TRSP-2505S	250V	MD-14

Write for full specifications.

watch...



**INDUSTRO TRANSISTOR CORPORATION**  
35-10 36th AVENUE/LONG ISLAND CITY, NEW YORK 11106/(212) EX 2-8000

Visit us at the Plaza (Fifth Ave. at 59th Street) during the IEEE Show.  
ON READER-SERVICE CARD CIRCLE 230



## NOW! An off-the-shelf systems amplifier with out-of-this-world performance.

Only the new standard Model C44A Amplexer Amplifier — for use in multi-amplifier systems — gives you **all** of these advantages:

- Three simultaneous outputs — filtered and commutated; filtered; wideband (55KHz).
- Six filter bandwidths — 5, 10, 100, 1K, 10K, 20KHz.
- Seven gains—1, 3, 10, 30, 100, 300, 1000.
- Gain accuracy —  $\pm 0.01\%$ .
- Gain stability and linearity —  $\pm 0.005\%$ .
- Output — 5 or 10v, 10 or 100ma.

The cost for this outstanding performance? A down-to-earth price of only \$590 per unit—with quantity discounts available.

For details contact:

**Beckman**

INSTRUMENTS, INC.  
ELECTRONIC INSTRUMENTS DIVISION  
FULLERTON, CALIFORNIA • 92634

INTERNATIONAL SUBSIDIARIES: GENEVA; MUNICH; GLENROTHES, SCOTLAND;  
TOKYO; PARIS; CAPE TOWN; LONDON; MEXICO CITY

ON READER-SERVICE CARD CIRCLE 231

## COMPONENTS

### Delay line memories store 16,660 bits

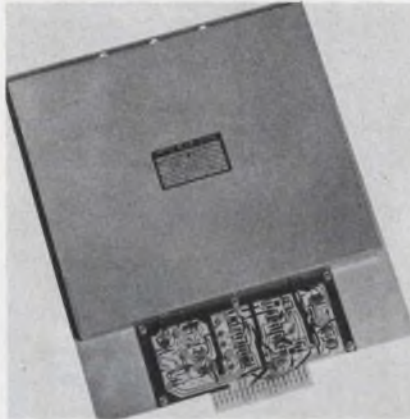

Computer Devices Corp., 63 Austin Blvd., Commack, N. Y. Phone: (516) 543-4220. P&A: under \$200 (100); 2 to 3 wks.

Model MS 2150 serial memory uses a magnetostrictive delay line with a delay of 8.33 ms as the storage element. It is supplied for operation in the return-to-zero and the bipolar mode at 1-MHz bit-rate or in the non-return-to-zero mode at 2 MHz, thus offering a storage of 8330 and 16,660 bits respectively.

CIRCLE NO. 598

### Cartridge heater has shaded heat gradient



Vulcan Electric, Danvers, Mass. Phone: (617) 774-1730.

Heat envelopes using a cartridge heater will have more heat loss at the ends than at the middle. This can be corrected by use of a shaded density which provides uniform heat curve over the entire surface. While the systems designer tries to minimize the effect of gradients by careful location of heaters and controls in the envelope, more even heating is easier to achieve by the use of heaters that incorporate gradient heat balance.

CIRCLE NO. 599

### Pushbutton series meets MIL-S-8805

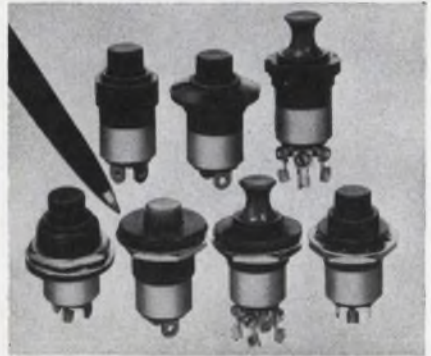

Controls Co. of America, Control Switch Div., 420 Delmar Dr., Folcroft, Pa. Phone: (215) 586-7500. P&A: From \$4.83; stock.

New military specifications MIL-S-8805 replaces MIL-S-6743 and the MS25089 drawing although the MS2508 part numbers have not been changed. This series is claimed to be the first meeting this MIL-spec. There are 110 moisture-proof push-button switches rated for loads of 10 A resistive, 5 A inductive, and 3 A lamp at 28 Vdc or 115 Vac, 60 and 400 Hz.

CIRCLE NO. 600

### Air velocity detector with sensing element

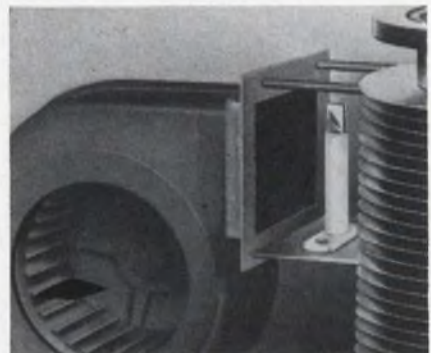

Fenwal Electronics, Inc., 63 Fountain St., Framingham, Mass. Phone: (617) 875-1351.

An air velocity detector that can be used in critical cooling and ventilating applications, utilizes a thermistor sensing element. Used with a simple relay circuit and mounted in the airstream of a cooling fan or blower, the detector will actuate a visible or audible alarm, and also shut down equipment when output velocity falls below a critical level.

CIRCLE NO. 601



In Making Masks for  
Electronic Components...  
...there's no  
Margin for Error!



With sharp blade, outline the areas to be masked. Do not cut through the backing sheet. The Ulano Swivel Knife does the job quickly, easily.



Now carefully peel off the film as outlined leaving a completed photo mask, positive or negative, that corresponds exactly to the desired pattern.

**THAT'S WHY EXPERIENCED DESIGNERS  
AND ENGINEERS ALWAYS INSIST ON...**



**RUBYLITH™**

HAND-CUT MASKING FILM FOR THE GRAPHIC ARTS

**THE KNIFE-CUT, LIGHT-SAFE MASKING FILM  
LAMINATED TO A STABLE POLYESTER BASE**

The most versatile line of hand-cut masking films, including

**.0075—RUBYLITH 75 DR\*    .005 RUBYLITH 5 DR  
.005 AMBERLITH 5 DA**

These new, thick Ulano films provide the positive answers where exact register assumes a critical importance.

*\* Available in sheets only, cut to your specifications.*

*by*

**Ulano™**

**ulano™**

610 DEAN STREET, BROOKLYN, N. Y. 11238

NEW YORK • CALIFORNIA • CHICAGO • ZURICH

In Europe: ULANO A. G., Untere Heslibachstrasse 22, Kusnacht 8700, Switzerland

*Write on your letterhead for special electronic test kit (no charge) No. 4127*

ON READER-SERVICE CARD CIRCLE 232

# INTRODUCING

A New Member of

The

Transformer Electronics Co.

Family of

Miniature Regulated

## POWER SUPPLIES

THE 6 WATT  
9589 SERIES  
(23 Models)

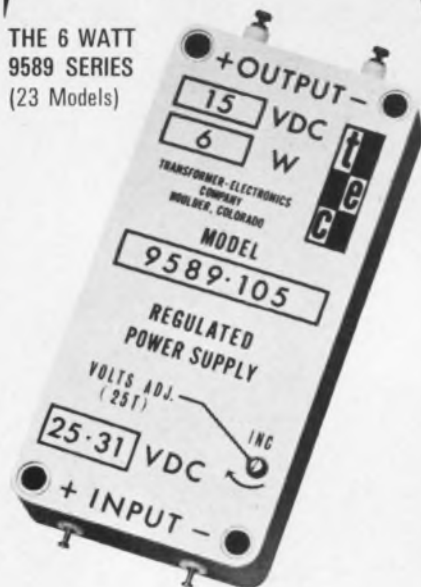

Output Power Capability: 6 watts  
Operating Temperature:  $-55^{\circ}\text{C}$  to  $+100^{\circ}\text{C}$   
Input Voltage: 25-31vdc  
Line Regulation: 0.1%  
Load Regulation:  $<3\%$  ( $\frac{1}{2}$  to full load)  
Output Ripple:  $<0.6\%$  p-p  
Efficiency:  $>46\%$   
No Load Current:  $<75$  ma  
Voltage Adjustability:  $\pm 10\%$   
Volume: 4.3 cu. in. (1.75" x 3.5" x .7")  
Weight: 7 oz.  
Voltage Range: 5 to 5000vdc;  
 $\pm 15, \pm 25, \pm 50, \pm 100$

Other T. E. C. Power Supplies—**1 WATT**, 9583 Series; **3 WATT**, 9567 Series; **10 WATT**, 9584 Series—Write or Call for complete details.

**TRANSFORMER  
ELECTRONICS  
COMPANY**

BOULDER INDUSTRIAL PARK  
BOULDER, COLORADO  
TWX 303 443-2881 PHONE (303) 442-3837

POWER SUPPLIES • INVERTERS  
CONVERTERS • TRANSFORMERS

ON READER-SERVICE CARD CIRCLE 750

## COMPONENTS

### Pressure cell weighs only 24 ounces



C-E Electronics, Inc., 363 W. Glenside Ave., Glenside, Pa. Phone: (215) 887-8900. P&A: \$230; stock.

This pressure cell is a precision electro-mechanical transducer for converting pneumatic signals into electrical equivalents of dc current or voltage. The unit features a frictionless floating core which provides infinite resolution, and a self-contained power package which permits easy conversion to a number of different output options. The unit is 3 in. diameter by 4 in. high and weighs 24 oz.

CIRCLE NO. 602

### Bellows contact springs mount diodes



Servometer Corp., 82 Industrial E., Clifton, N. J. Phone: (201) 773-0474.

Miniature bellows type contact springs for microwave applications are used for mounting diodes where compensation for environmental changes is required. They are non-inductive and have extremely low dc electrical resistance. Size range is from 0.066 to 0.25-inch OD. Force necessary for compression ranges down to 1 oz.

CIRCLE NO. 603

# Kulka

## TERMINAL BOARDS

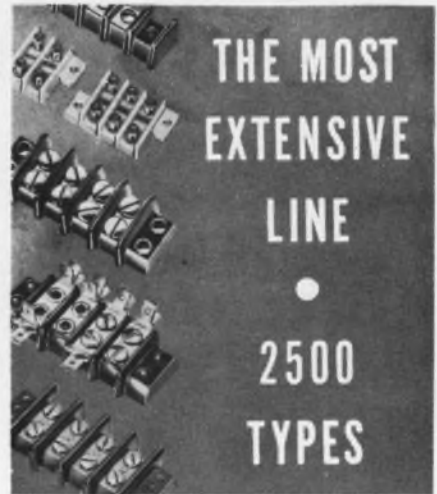

### MILITARY • COMMERCIAL

Kliptite • Pressure Contact  
High Heat • Standard Series  
Closed Back • Printed Circuit  
High Barrier • Stud & Turret  
Wire-Wrap (Solderless)  
Screw Clamp (Solderless)  
Military Terminal Boards

Available thru Nationwide Network of

**Kulka**

AUTHORIZED INDUSTRIAL DISTRIBUTORS

### NEWLY EXPANDED FACILITIES

New additional Plant more than doubles our previous capacity... excellent lead time on your orders for Kulka Catalog Items!

### NATIONAL SALES ORGANIZATION

There's a Kulka Sales Engineering Representative in your area, eager to help with your requirements for standard or custom terminal boards of every description!

New Complete 56-page Kulka Catalog #17A, available for Engineers and Purchasing Agents. This is an exhaustive Buying Guide on Terminal Boards, strips and associated hardware.



AT IEEE SHOW VISIT  
OUR BOOTH 4J04

**Kulka Electric Corporation**

520 South Fulton Ave., Mount Vernon, N.Y. 10551

ON READER-SERVICE CARD CIRCLE 751  
ELECTRONIC DESIGN 6, March 15, 1967

## Delay trimmers fixed or variable

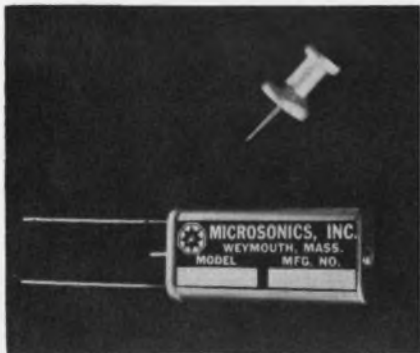

Microsonics, Inc., 60 Winter St., Weymouth, Mass. Phone: (617) 337-4200.

Ultraminiature wideband electromagnetic delay trimmers are for use in digital and RF applications. Designed for PC board mounting, the delay lines are supplied either as fixed or variable units. Delays range from 5 to 60 ns for the fixed series, and up to 30 ns for the variable units. Variable units are provided with a lead screw adjustment and feature delay resolution of 1% of total delay.

CIRCLE NO. 604

## 3-digit shaft encoder popularly priced

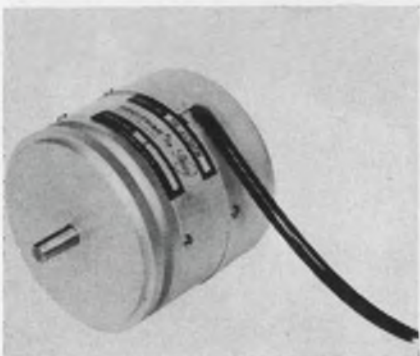

Theta Instrument Corp., Saddle Brook, N. J. Phone: (201) 843-6060.

A 3-digit shaft encoder features built-in logic and power drivers. Regardless of load characteristics, current and voltage through the brush structure remain controlled and a life of 50 million revolutions at max speed is claimed. Applications include remote digital readout of shaft position, data logging, and digital computer inputs.

CIRCLE NO. 605



## If you're old enough to play with blocks... you'll love CEC's DG 5000

Because, the DG 5000 is an assembly of standard product building blocks systematized into a *complete configuration*, thus providing overall capability from transducer to display. Furthermore, this is a completely operative system, fully wired and ready for use.

And since it comes from CEC, you are assured of single source responsibility for every unit involved.

Equally important, the DG 5000 is uniquely versatile in the *three ways* most important to every user.

**1.** CEC's building-block concept makes it possible to tailor-make the system to virtually *any* configuration. It will accept any of CEC's wide range of oscillographs, delivering up to 52 recording channels with light-beam galvanometers or 8 channels for thermal writing applications.

**2.** Maximum application flexibility can be provided for variations of system configuration through a programmable building-block interconnection.

**3.** This system may be *easily and economically* expanded to meet future configuration requirements.

The DG 5000 is the ideal answer for industry, aerospace and medical science. Or for anyone concerned with the acquisition and measurement of dynamic or quasi-static data.

For complete information, call your nearest CEC Field Office or write Consolidated Electroynamics, Pasadena, California 91109. A subsidiary of Bell & Howell. Bulletin 5000-X3.

**CEC**  
DATAGRAPH PRODUCTS

**BELL & HOWELL**

ON READER-SERVICE CARD CIRCLE 752

# NOW IN 4-POLE\*



THE HIGHLY RELIABLE, LOW COST

## Printact®

standard and latching  
magnetic relays

- NO SPRINGS ■ NO WIRING
- NO SOCKETS ■ NO SOLDERING
- NO MECHANICAL LINKAGE

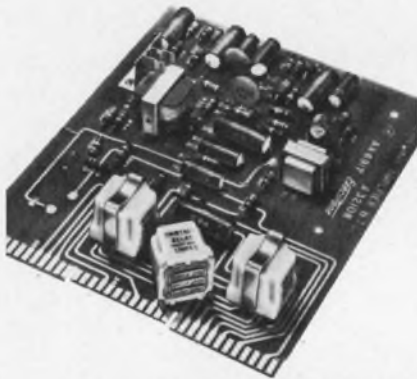

Plugs into your PC Board. Uses Plated Conductors as the fixed contacts.

Exclusive PRINTACT design saves space, weight, cost and installation time . . . with excellent reliability. 100 million cycles mechanical life, rated for up to 10,000,000 cycles depending on load from dry circuit to 2 amps, res. Coils available for 6, 12, 24 and 48 vdc. Time: 7 to 10 ms. Temperature: -30 to +95°C.

Quality features include: double-break contacts; balanced armature, enclosed housing, plug-in application; encapsulated coil; self-wiping contacts and inherent snap-action. Weight: 1 oz. in compact 7/8" cube.

\*Switches up to 4 form A plus B, or 4 form C.

For more data and prices, write:

### Executone

PRINTACT RELAY DIVISION

47-37 Austell Place

Long Island City, N.Y. 11101

ON READER-SERVICE CARD CIRCLE 753

## COMPONENTS

### Pulse transformers for SCR control circuits

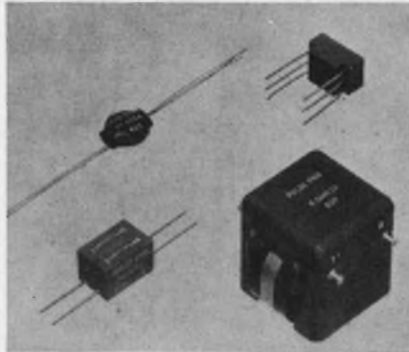

Pulse Engineering, Inc., 560 Robert Ave., Santa Clara, Calif. Phone: (408) 248-6040. P&A: under \$1; stock.

A series of miniature pulse transformers for use in SCR control circuits is offered. The units are tested to MIL-T-21038B, grade 7, class S, life X. The high-voltage unit is rated at 15 kVdc and provides a large safety factor in triggering high voltage SCRs or in cascade operation of SCRs.

CIRCLE NO. 606

### Flat-face CRT is all-glass



Thomas Electronics, Inc., 122 8th St., Passaic, N. J. Phone: (201) 473-4040. P&A: \$1200; 30 to 45 days.

A 24-in. all-glass flat-face cathode ray tube is designed for such large console displays as air-traffic control, military displays and computer-driven displays. Features include a flat face for wide-angle viewing, useful screen diameter of 22 inches, an all-glass tube, magnetic focusing and deflection and a 57° deflection angle for high-precision displays.

CIRCLE NO. 607

### Readers for 8 bits at 30-Hz speed

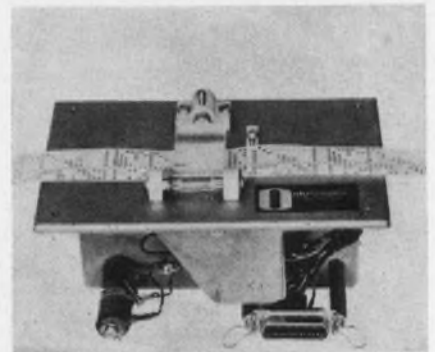

Ohr-Tronics, Inc., 305 W. Grand Ave., Montvale, N. J. Phone: (201) 391-7000. Price: \$345 to \$415.

Two readers are available, employing standard reading mechanism and reading up to 8 bits at speeds of 30 Hz serially. The flat-bed reader is designed for horizontal flush-mount, and the edge-punched card reader mounts on a 19-in. rack panel. Any edge-punched card having 8 channel paper tape codes along its edge can be fed through the latter model individually or in a fanfold series.

CIRCLE NO. 608

### Transformers convert synchro to resolver

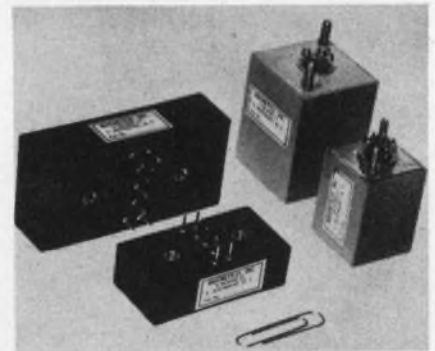

Magneto, Inc., 6 Richter Court, East Northport, N. Y. Phone: (516) 261-4502.

A line of precision miniature toroidal transformers has been designed for use in solid-state synchro-to-digital and digital-to-synchro converter systems. These units convert 3-wire synchro inputs to 4-wire resolver outputs, and resolver inputs to synchro outputs. Conversion accuracy of 30 seconds to 2 minutes of arc is standard.

CIRCLE NO. 609

# Plugboard programming systems? MAC ships off-the-shelf!

Compatibility is the difference between components and systems. Because we match plugboards, plugwires and receivers for such characteristics as conductivity, crosstalk, shielding and convenience, we can actually say that we ship simple systems off-the-shelf. But if you're thinking of a system that is really

different, that may take us a little longer . . . a matter of weeks, maybe. We are constantly exercising our ingenuity and engineering expertise in the creation of new systems, to order. If you're thinking now, and want delivery anytime soon, we should be talking. Or designing. Would tomorrow be too soon?

**MAC** O.E.M. DIVISION

MAC Panel Co., Box 5027, High Point, N. C. 27262



## the new magazine machine

this novel application of mechanism, to the purposes of periodical publications, is the invention of an ingenious literateur. the hoppers above being fed with subjects of all sorts, from "semiconductors" to "materials," the handle is turned, and the fountain-pens begin to write articles upon everything.

if you are wondering who fills

the hoppers, our editors do. they are engineering men who like to write. if you would like to be a news editor in this fast paced industry or, if you like to write about computer design or digital circuitry, we would like to talk with you. call howard bierman, electronic design's editor, new york (212) plaza 1-5530, or drop by booth-4G39/41 at the IEEE show.

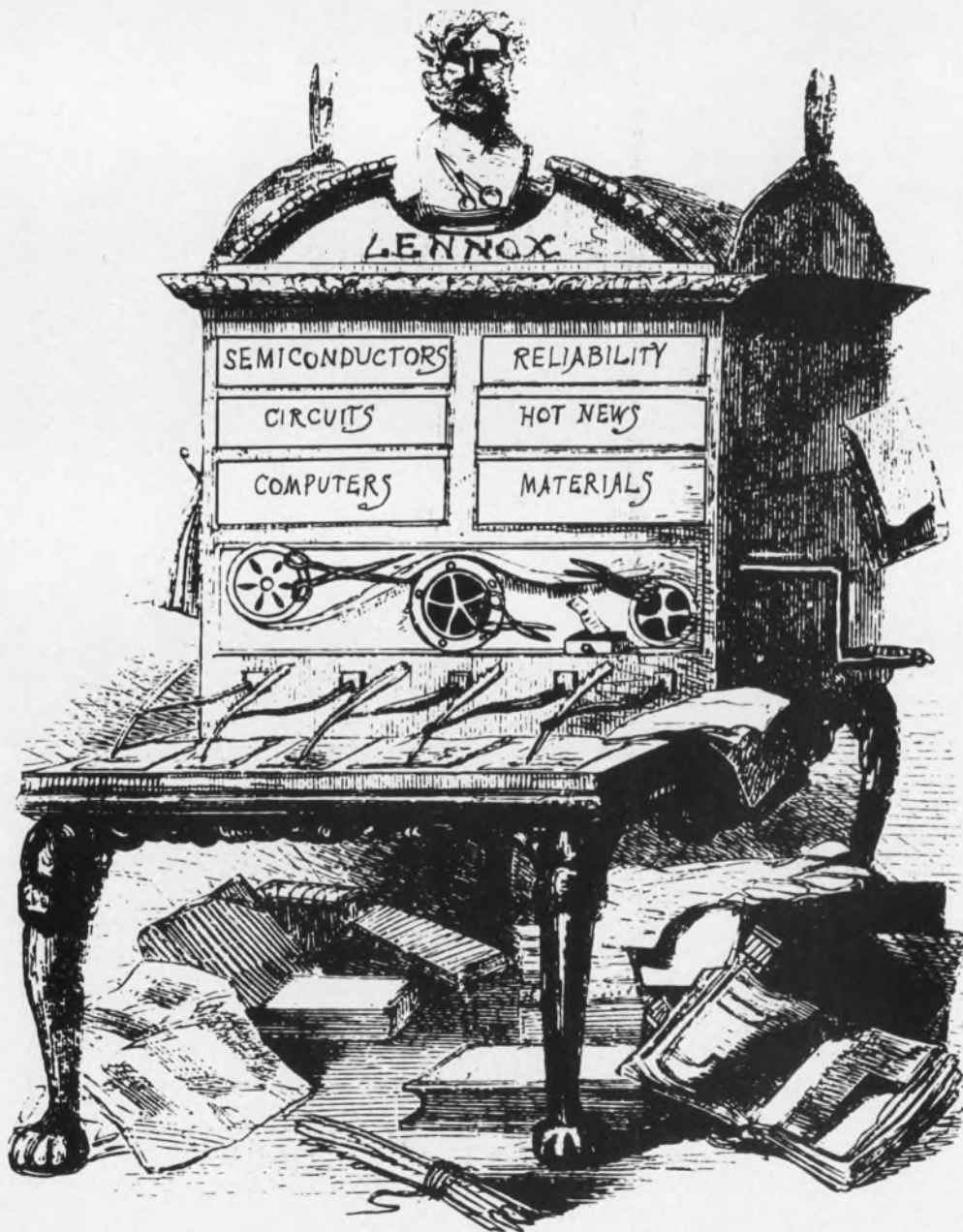

## Dual power supply for 1 to 18 V adjustable

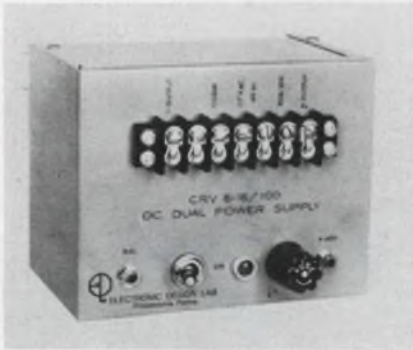

*Electronic Design Lab, P. O. Box 7837, Philadelphia. Phone: (215) 925-9500. P&A: \$99; stock to 2 wks.*

Two independent regulated power supplies with temperature-compensated Zener diode voltage reference, are offered in one 3-by-4-by-5-in. case. Positive and negative voltages are independently adjustable from 1 to 18 V by multiturn potentiometers, with 10-mV resolution. The current rating is 100 mA for each section. The unit is designed for reference voltage or power source for IC packages and solid-state operational amplifiers.

CIRCLE NO. 614

## Unit stabilizes klystron frequency

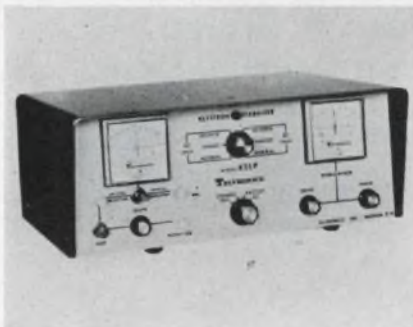

*Teltronics, Inc., 23 Main St., Nashua, N. H. Phone: (603) 889-6694.*

Klystron frequency can be stabilized by a unit that operates from line voltage or rechargeable battery. The unit generates a modulating signal, accepts a frequency error signal from a reference cavity detector, and develops a reflector correction voltage.

CIRCLE NO. 615

## Sophisticated!

... yet  
you  
just  
plug it  
in ...



Sophistication such as multi conductor transmission line systems with controlled values of impedance, capacitance, propagation, velocity and crosstalk! Each Signaflo system is engineered for your interconnection requirements. It's universally adaptable with exclusive aci "Spread-Pitch". High density cable conductors can be spread to match the pitch dimension of any hardware (p.c. boards, connectors, etc.).

See the  
latest  
ACHIEVEMENTS  
in flat wiring  
systems  
**IEEE**  
Booths  
**4E-26-28**

Your aci Signaflo signal or transmission line wiring system (shielded or unshielded) can be thin, flat, flexible, lightweight, and cost reducing. Let us plug in your requirements and come up with a highly sophisticated aci Signaflo wiring system you'll just plug in!

**SIGNAFLO**  
wiring systems

**aci** DIVISION OF KENT CORPORATION  
206 Industrial Center, Princeton, N. J. 08540  
Telephone 609-924-3800 TWX. 609-921-2077



"Acknowledged leader in flat cable systems."

ON READER-SERVICE CARD CIRCLE 756

# YOKE SPECIFYING PROBLEM?

**ASK AN  
EXPERT...**

**A SYNTRONIC  
DEFLECTION  
YOKE SPECIALIST**

Since we make more types of yokes than anyone else, it's natural enough for our team of experts to know more about yoke design, application engineering, and quality control.

Specifying can be a challenging problem, and with this in mind, we put our experience at your disposal. Don't hesitate to call or write us when you're puzzled as to the right deflection yoke for your display.



***syntronic***

**INSTRUMENTS, INC.**  
100 Industrial Road, Addison, Illinois  
Phone: Area 312, 543-6444

ON READER-SERVICE CARD CIRCLE 757

# Photocell Decay Problems?

*Typesetter  
lost a zero.  
This should be  
.0006*

Try Type 7H



Clairex Type 7H Photocells now offer decay times of .006 sec @ 100 ft-c. Couple this with 240 ohms @ 100 ft-c, CdS stability, and your problems are solved. Available in TO-18 and TO-5 cases. And 6 resistance ranges.

**CLAIREX**

"The LIGHT Touch in Automation and Control"  
1239 Broadway, New York, N.Y. 10001  
212 MU 4-0940

ON READER-SERVICE CARD CIRCLE 758

## COMPONENTS

### 'Caseless' commutator withstands high shock

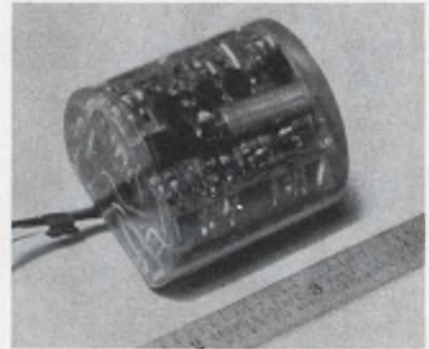

*Stellarmetrics, Inc., 416 E. Cota St., Santa Barbara, Calif. Phone: (805) 963-3566. P&A: under \$500; 30 days.*

A "caseless" telemetry commutator withstands 40,000-G shocks. The "caseless" package is rigid shock-proof epoxy with input-output terminals molded into the commutator body. The complete unit is less than 2 inches long and weighs about 60 grams. It is single-pole, high-level PAM RZ 18-channel unit with a channel rate of 450 samples per second. Input power is  $\pm 0.2$  Vdc at 30 mA, linearity is within  $\pm 0.1\%$  and crosstalk is less than 0.1% full scale. Input to output offset is less than  $\pm 25$  mV with a 200-k $\Omega$  load.

CIRCLE NO. 616

### AM-FM receiver has own signal monitor

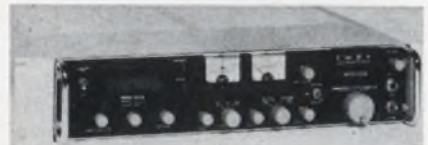

*Communication Electronics, Inc., 6006 Executive Blvd., Washington Science Center, Rockville, Md. Phone: (301) 933-2800. P&A: \$3,200; 60 days.*

This 20- to 70-MHz receiver, providing AM, FM and cw reception, has a built-in signal monitor with a max sweep width of 300 kHz and a resolution of 2.5 kHz, audio squelch and tunable BFO. Three IF bandwidths are provided: 4, 10 and 50 kHz. They are selectable by a front-panel switch.

CIRCLE NO. 617



## Set-point controller temp compensated

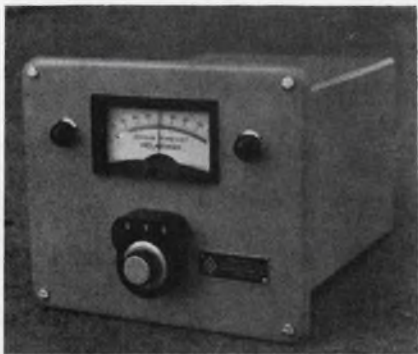

Helm Instrument Co., Inc., 4216 W. Alexis Rd., Toledo, Ohio. Phone: (419) 479-2951. P&A: from \$355; 30 to 60 days.

This solid-state unit features digital set-point, a calibrated deviation indicator and independently adjustable high and low alarms. Ambient temperature compensation and automatic time proportioning are also included. Plug-in accommodation is provided for accessory cards. It is available in either 2- or 3-position control.

CIRCLE NO. 618

## Counter-timer uses 90% ICs



Monsanto Electronic Instruments, 620 Passaic Ave., West Caldwell, N. J. Phone: (201) 228-3800.

Direct counting to over 100 MHz is obtained with these electronic counter-timers. Ninety per cent of the active circuit elements are microelectronic. With an eight-digit readout it has six modes of operation: manual, frequency, frequency ratio, period, time interval and time interval A-B.

CIRCLE NO. 619

Remember to return your **ELECTRONIC DESIGN** renewal card. Don't miss any issues in '67.

## Exclusive!

# New Wayne Kerr B331 Autobalance<sup>®</sup> Bridge Provides Automatic Measurement Lead Compensation for L, C, R, G

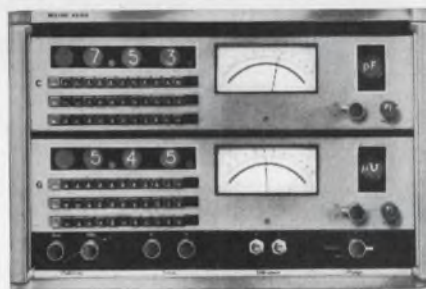

*...and it is accurate to  
0.01% at Point of Measurement*

Automatic Measurement Lead Compensation means you no longer have to measure lead capacity, lead resistance, and then subtract from your original reading . . . With Wayne Kerr's new B331 Autobalance Precision Bridge, this is accomplished by means of a six-wire system which automatically compensates the bridge for any lead capacity and resistance.

Equally important, 0.01% accuracy is maintained, not only at the measuring terminals as in other bridges, but at the point of measurement — the resistor or other component under test.

And, Autobalance — Wayne Kerr's electronic nulling process — is combined

with three decades of push-buttons for precise backing-off to provide a new simplicity of operation — even non-skilled personnel can achieve precise measurements in less than 30 seconds.

### SPECIFICATIONS

**Ranges for 0.01% Accuracy:** 1pF–10μF; 10nΩ–100mΩ (10Ω–100MΩ)

**Overall Measurement Ranges:** 100aF–0.25 Farad; 1pΩ–1kΩ; 1mΩ–1TΩ; 100nH–250MH. (100aF = 0.0001pF, 1TΩ = 1000kMΩ, max. L is 2.5×10<sup>8</sup>H)

**Frequency:** 1.00kHz (Internal); 50Hz–20kHz (External)

**Price:** \$2200. FOB Montclair, N. J.

For literature and detailed specifications, write:



## Wayne Kerr CORPORATION

18A Frink St., Montclair, N. J. 07042 • Phone (201) 746-2438

INNOVATIONS IN INSTRUMENTATION

Visit Wayne Kerr Exhibit at IEEE Show, Booths 2E06-2E08

ON READER-SERVICE CARD CIRCLE 759



**this  
DIMCO  
snapslide  
fastener...**

**holds assemblies  
securely...**

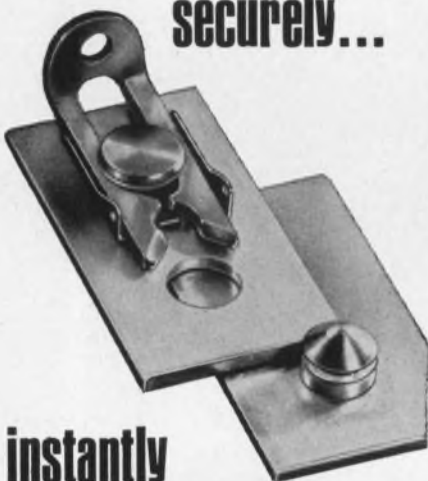

**instantly  
engages/releases...**



**write for  
new  
handbook**

Dimco-Gray Snapslide Fasteners hold assemblies firmly despite shock or vibration... never need adjustment, even with repeated use. Instant snap action engages or releases fastener... no tools required. Approved under Military Standards. Handbook illustrates typical applications, stimulates design ideas, describes attachment methods. Write for free copy today.

DIMCO-GRAY CO., 219 E. SIXTH ST., DAYTON, OHIO 45402

## MATERIALS

### One-part silicones cure corrosion-free

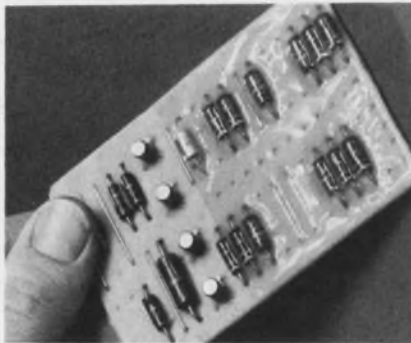

Dow Corning, Midland, Mich.  
Phone: (517) 636-8507. Price:  
\$11/lb. (40-lb. lots).

Two one-component silicone rubbers, a clear conformal coating and a high-strength sealant, feature a curing system which does not give off corrosive by-products. Previously available rubbers give off a small amount of acetic acid during the cure, and this acid by-product may cause corrosion of copper during the curing period under humid conditions. The conformal coating, designated 3140 RTV, is a clear, solventless, self-leveling, fluid material with a viscosity of 660 poises. It cures on exposure to moisture vapor in the air to form a tack-free surface in about two hours. Typical thickness of the clear rubber, when applied by a single dipping operation is about 25 mils. The non-corrosive elastomer, 3145 RTV adhesive/sealant, is a high-strength, grey material in a toothpaste-like consistency. It withstands long-term exposure at 200 to 250°C, and short-term use at 300°C. Tensile strength is about 800 psi; elongation, about 675%; and tear strength, 125 ppi.

CIRCLE NO. 620

### Platinum-gold coating bonds hybrid ICs

Electro-Science Labs., Inc., 1133-35 Arch St., Philadelphia. Phone: (215) 563-1360. P&A: \$72.25/oz.; stock.

Platinum-gold coating for electronic components and hybrid integrated circuit packages features good adhesion and scratch and peel

resistance on high-alumina surfaces. The fired deposit is dense, uniform and free from pinholes or cracking. It forms good ohmic contacts to resistive coatings. Conductivity of a 1-mil-thick film is 0.05 to 0.1  $\Omega$ /square. Because of the coating's ability to withstand acidic plating baths, conductivity can be increased by depositing a metallic overlay. The paste has a peak temperature firing-range from 850° to 1000°C, and may be soldered with normal or high temperature lead-tin alloy solders, using conventional techniques with resin fluxes.

CIRCLE NO. 621

### Copper foil plates PC finger contacts

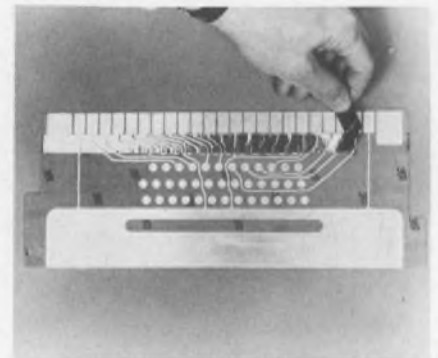

3M Company, 2501 Hudson Rd., St. Paul. Phone: (612) 733-4033. P&A: \$3.69 (36-yd., 1/4-in. roll, 3-in. ID core); stock.

Copper-foil plating tape aids in gold-plating the finger contacts on printed circuit boards. The tape is made with an electrically conductive, pressure-sensitive acrylic adhesive applied to a copper backing. This provides a means of conducting the plating circuit to the PC board finger contacts. The adhesive has a relatively high conductivity which is resistant to common etching and plating solutions without thermosetting, and will not corrode the copper circuitry. The tape comes with a removable paper liner to facilitate cutting to a precise length or shape with minimal wrinkling of the backing. Typical properties include 40 oz./inch adhesion, 20 lbs./inch tensile strength and 0.085  $\Omega$ /inch resistance. It is 2.5 mils thick.

CIRCLE NO. 622

**Nylon cable tie self-locking**

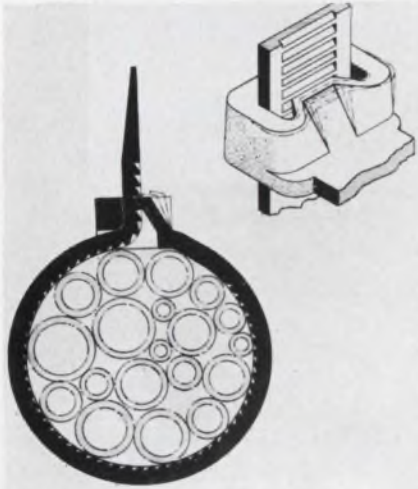

*Milton Ross Co., 511 Second St. Pike, Southampton, Pa. Phone: (215) 355-0200. P&A: \$24.50/1000; stock.*

A self-locking device is featured in this one-piece molded cable tie. Produced from lightweight nylon, the unit permits harnessing of wires and cables up to 1-3/4 inches in diameter. Installation is made without special tools and no extra fasteners are required. The locking device holds permanently and is an integral part of the molded one-piece unit. All ties are reusable, releasable and adjust to size.

*Booth No. 4K09 Circle No. 312*

**Electroless nickel plates silicon**

*Nitine, Inc., 45 S. Jefferson Rd., Whippany, N. J. Phone: (201) 887-6000.*

A solution for nickel-plating small parts without electrical plating equipment is formulated especially for silicon and other metals widely used in electronics. It is essentially non-corrosive, and can be used in any well-ventilated area. Plating occurs at a rate of 0.3 mil per hour at a temperature of 90°C. No special equipment is necessary. Glass-plating vessels are recommended, and provision must be made for maintaining a temperature of 90°C during plating.

**CIRCLE NO. 623**

**SCOTCH  
COOLER**

**by McLean**



**McLEAN "COMPUTER AGE" RACK-MOUNTED BLOWER**

**Thr...r...riffiest Blowers in America!**

The traditional key to economy is to make a little go a long way. But our problem at McLean is to make a great deal go by the shortest possible route.

In equipment cooling, this saves you money. By moving volumes of air through tight spaces — and doing it reliably, unfailingly, with miniaturized units — McLean protects millions of dollars worth of electronic installations each year. But whether it be in the rack-mounted blower shown here, or in tonnage-volume units for industry, McLean delivers more for less.

And you pay less for more.

See us at the I.E.E.E. Show, Booth 4K12.

SEND FOR  
NEW 1967  
CATALOG



**McLEAN ENGINEERING  
LABORATORIES**

Princeton Junction, N. J. 08550  
Phone 609-799-0100 • TELEX 083-4345



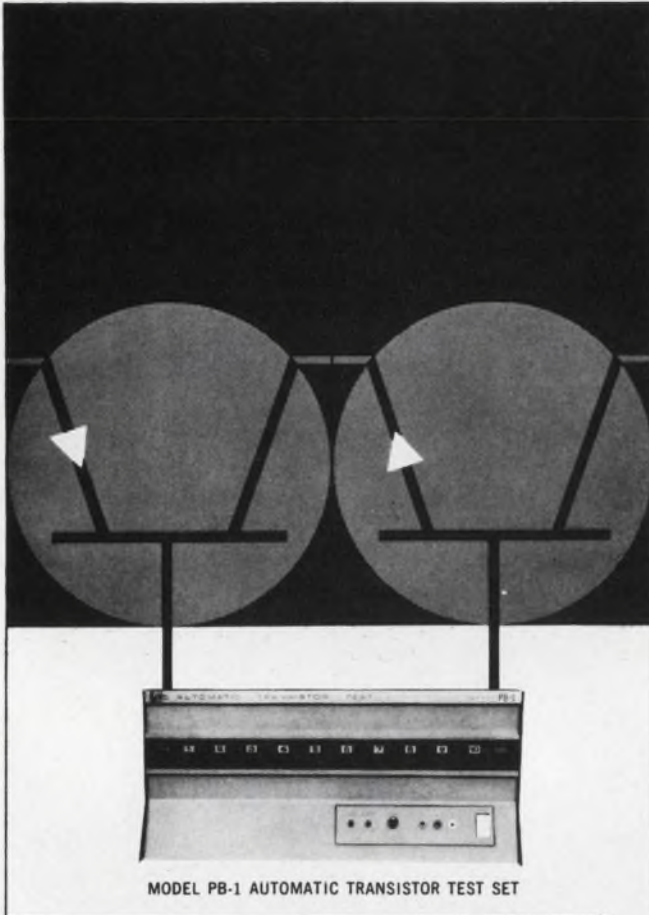

MODEL PB-1 AUTOMATIC TRANSISTOR TEST SET

## FOR FAST, AUTOMATIC TRANSISTOR TESTS!!!

**THE MODEL PB-1 PERFORMS UP TO 10 TESTS IN ANY SEQUENCE IN LESS THAN 1 SECOND!!**

For incoming inspection — in the lab — in production — the new Model PB-1 Automatic Transistor Test Set measures DC parameters of NPN and PNP transistors on a go/no-go basis at bias levels up to 250 volts, 300 ma!

Most important, the Model PB-1 can perform up to 10 tests in any sequence within 1 second — pulse drive techniques permit direct measurement of transistor DC parameters at far greater power levels than transistors could survive employing ordinary measurement techniques!

The versatile Model PB-1 can also test many types of diodes and SCR's on a go/no-go basis. Descriptive literature is immediately available — we cordially invite your inquiries!

SCIENTISTS: Investigate career opportunities at Baird-Atomic — an equal opportunity employer.

ATOMIC AND LABORATORY INSTRUMENTS DIVISION



# BAIRD-ATOMIC

33 UNIVERSITY RD., CAMBRIDGE, MASS. 02138. Tel: 617 864-7420  
OFFICES: ATLANTA BOSTON CHICAGO DALLAS DETROIT LOS ANGELES  
NEW YORK PHILADELPHIA PITTSBURGH SAN FRANCISCO WASHINGTON, D.C.  
EUROPE: BAIRD-ATOMIC (EUROPE) N.V. 26-27 VEENKADE, THE HAGUE, HOLLAND

Visit Baird-Atomic at the IEEE Show Booths 2C-18 and 2C-20

ON READER-SERVICE CARD CIRCLE 763

## PRODUCTION EQUIPMENT

### Carbide dies stamp IC frames

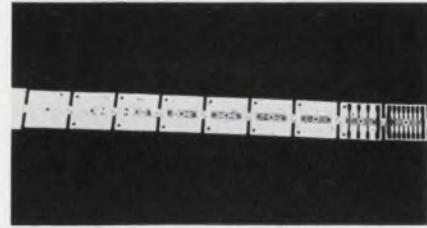

*Hydro-Cam Engineering Co., 1900 E. Maple Rd., Troy, Mich. Phone: (313) 588-2900.*

Frames for ICs produced by the stamping process of rate of up to 200/minute are possible with these carbide dies. The dies are a 13-stage progressive type with 72 tungsten-carbide inserts and a total of 129 different details. All die sections are ground to a tolerance of  $\pm 0.00001$  inch.

CIRCLE NO. 624

### 'Universal' test clamp grips fine wire



*Hunter Associates, 321 Highland Ave., Orange, N. J. Phone: (201) 672-0423. Price: \$1.50.*

The "universal" test clamp consists of a fine retractable spring clamp which is activated by light pressure on the head of the handle. The clamp will grip the finest wire and then retract into the insulating sleeve for use in high-density circuitry without any danger of short circuits. The head contains a standard banana plug jack.

CIRCLE NO. 625

## Diamond-plated tools work ceramics

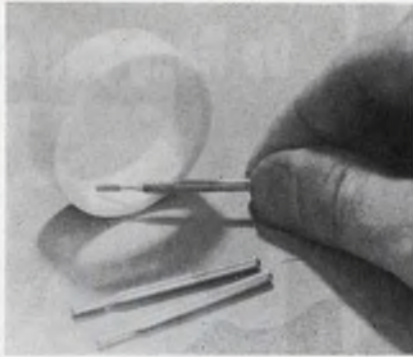

Aremco Products, Inc., P. O. Box 145, Briarcliff Manor, N. Y. Phone: (914) 762-0685. P&A: \$6.50 to \$6.90; 30 days.

The 113-series line of diamond plated mandrels are designed for grinding and polishing small holes in ultra-hard ceramics such as alumina and beryllia. The line includes 10 standard diamond "quills" ranging in diameter from 0.025 to 0.12 inch. The mandrels can make cuts of 0.0005 in. using water as a lubricant.

CIRCLE NO. 626

## Photoresist spinner controls coatings



Plat Engineering Co., 518 Ryers Ave., Cheltenham, Pa. Phone: (215) 379-4900. P&A: \$825; stock.

Model 102 photoresist spinner provides an accurate controlled coating of photoresist on semiconductor, thin- and thick-film and microelectronics devices. Features include dual acceleration to 10,000 rpm in either 30 ms or 1 second. Low vacuum safety prevents loss of work in case of vacuum failure. A timer and tach are built in. The unit handles devices to 3 x 3 inch.

CIRCLE NO. 627

## MSC Series 10E...the lighted pushbutton switch for reliable answers to your toughest control panel design problems!

The MSC Series 10E Twist-Lite® switch unit features four-lamp operation with individual color control for optimum visibility at any ambient light level, versatile lens configurations ranging from full to 4-way split display, internally bussed circuits to reduce wiring, and a positive hardmount without extra hardware. Add the optional features developed to solve critical electrical and environmental problems and the twist/lock design for safe relamping, legend or color filter change from the panel front... without tools... and you'll see why the Series 10E has become the preferred switch for the finest aerospace and industrial control systems. Write and ask for an operating demonstration in your office, or

**SEND FOR CATALOG 2000 TODAY!**

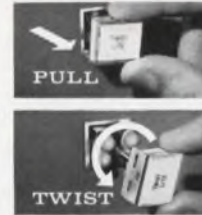

**RELAMP WITHOUT TOOLS!**  
Easily done without fear of accidental switch actuation.

**OPTIONAL DRIP-PROOF SEAL**  
blocks passage of foreign matter through panel cutout.

**OPTIONAL RFI SCREEN**  
inhibits radiated and conducted RFI passage through panel cutout.

**OPTIONAL SWITCH-GUARD**  
prevents accidental switch actuation.

**SNAP-ON MASTER TEST CONTROL CAPSULES**  
Permits lamp verification tests without external circuitry.

**INTERNALLY BUSSED COMMON GROUND LAMP CIRCUITS**  
reduces wiring time.

**SNAP-ON 2PDT or 4PDT SWITCH MODULES**  
Precision snap-action alternate or momentary modules rated to 5 amps/ 125 or 250VAC

**INTEGRATED MOUNTING SLEEVE**  
Produces a positive hardmount without brackets or hardware.

**FULL TO 4-WAY SPLIT LENS**  
4-Lamp projected color with individual lamp color control.

# Master MSC Specialties Company

25 YEARS IN INFORMATION DISPLAY AND CONTROL DEVICES

Master Specialties Company, 1640 Monrovia, Costa Mesa, Calif. 92627  
Telephone (714) 642-2427 • TELEX 6-78433 Offices in Principal Cities.

ON READER-SERVICE CARD CIRCLE 764

# Microsonics

## State of the Art Design in Filters Oscillators and Delay Lines



Continuously  
Variable Delay  
Systems  
Bulletins 4301 and 4302



Broad Bandwidth  
Highly Selective  
Crystal Filters  
Bulletin 6350

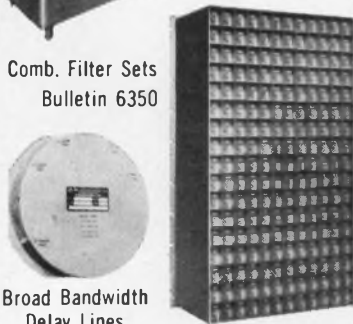

Comb. Filter Sets  
Bulletin 6350



Broad Bandwidth  
Delay Lines  
Bulletin 4300



Highly Stable  
Oscillators — Bulletin 6350



Voltage Controlled  
Crystal Oscillators  
Bulletin 6350



High Density  
Digital Storage  
Systems  
Bulletin  
5350

Send for literature.



A subsidiary of the Sangamo Electric Company

## PRODUCTION EQUIPMENT

### PC board retainers save space

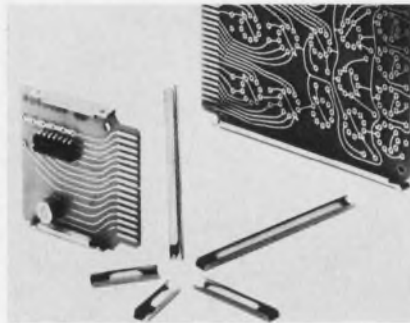

*The Birtcher Corp., 745 Monterey Pass Rd., Monterey Park, Calif. Phone: (213) 268-8584.*

Printed-circuit board retainers are designed for IC boards and for applications where space is at a premium. They use 1/8 inch of board height while providing the spring retention and shock protection qualities of standard-size retainers. Board spacing as close as 1/4 inch is possible. Retainers are available for 1/32- and 1/16-inch boards, in lengths from 1 to 6 inches in 1/2-inch increments.

CIRCLE NO. 628

### Aluminum cabinets in 3 rack widths

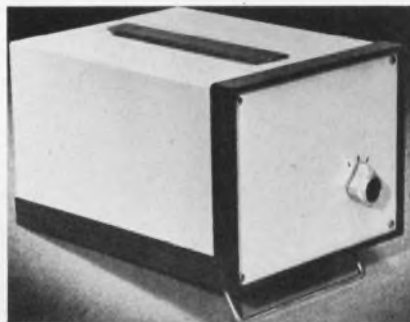

*Scientific-Atlanta, Inc., Box 3654, Atlanta. Phone: (404) 938-2930. P&A: \$22 to \$41; 4 wks.*

Small aluminum cabinets come in half, one-third and two-third rack width with optional rack adapters. Nine sizes are available. Heights range from 6-1/2 to 10 inches. Removal of two screws in the rear of the case allows the case body to be lifted from the front bezel and bottom pan. Front panel and chassis are held in place by two additional screws in the rear of the cabinet.

CIRCLE NO. 629

## The Guys in the Da Nang patrol



Now the time is near. Men in the chopper are counting the seconds. 17 of them. Dressed in green dungarees, soaked black in sweat. No wisecracks. No horseplay. They're the guys in the Da Nang patrol.

★ ★ ★

Ten thousand miles around the world, there are people who call them sucker. People who hope they'll give up. Quit. Go AWOL. But they won't. They care. Enough so 9 out of 10 men in the outfit put cash into U.S. Savings Bonds. To help pay the bill. They're the guys in the Da Nang patrol.

★ ★ ★

The next time they hit the landing zone, will you be with them? Make no mistake. These guys in the Da Nang patrol will hit the landing zone anyway. Maybe you'll stand a little straighter, walk a bit taller — knowing you're with them all the way.

## U. S. Savings Bonds



*The U. S. Government does not pay for this advertisement. It is presented as a public service in cooperation with the Treasury Department and The Advertising Council.*

## Acid-resistant tongs handle semiconductors

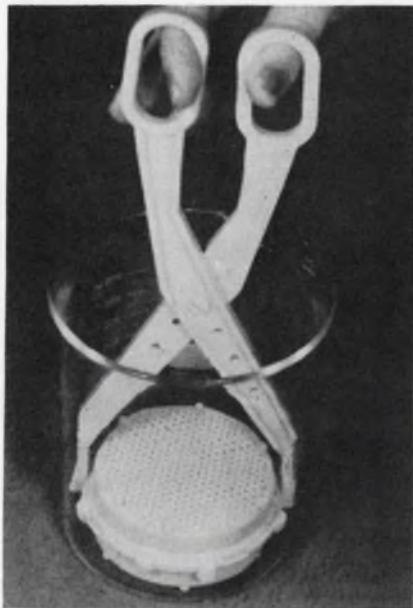

Fluoroware, Inc., County Rd. 17, Chaska Industrial Pk., Chaska, Minn. Phone: (612) 448-3131. P&A: \$5.50 (PVC), \$12.50 (FEP); stock.

Designed for use with strainer trays, acid-resistant tongs are 10 inches long and are made of natural teflon FEP. The material is corrosion-resistant for use in strong acids and is capable of withstanding temperatures up to 400°F. Model C40 tongs feature four-position adjustable jaws.

CIRCLE NO. 630

## Gold plater 100% uniform

Technic, Inc., P. O. Box 965, Providence, R. I. Phone: (401) 661-3400.

Virtual 100% uniformity is promised by the FP 100 gold plating system for IC flat packs. The system consists of a plating unit, an acid bright gold solution and a plating rack. The FP 100 system is said to reduce rejects through its ability to avoid edge buildup and overplating of the leads. Rate of the system is approximately 350 to 500 pieces in five minutes.

CIRCLE NO. 631

Don't risk missing any issues of **ELECTRONIC DESIGN**. Send in your renewal card today.

# It took Hughes engineers 3½ years to create the SYNCOM story.

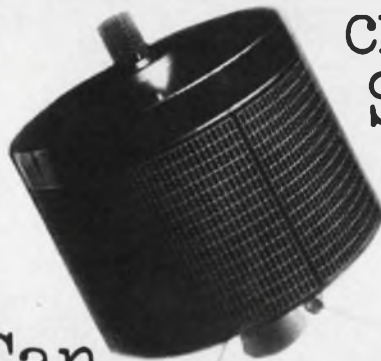

## Can you write it?

Hughes Field Service and Support is urgently seeking qualified E.E.'s for a dual challenge—to your engineering know-how and to your writing ability. You will be closely associated with the latest and most advanced aerospace projects. As a Systems Writing Engineer, your assignment will be to **communicate** your knowledge of these projects.

The Syncom series is just one example of the magnitude and significance of the projects involved. Other subjects include space vehicles, weapons systems, electronic computers, guided missiles, radar and communications, programmed instructional devices, and systems trainers.

You will research drawings, specifications, and reports; you will interview project engineers and make first-hand examinations and inspections. Then you'll interpret and analyze this data and write engineering publications for use by other engineers on allied projects.

This is a demanding position and an important one. If you wish to rapidly broaden your engineering knowledge and gain systems-oriented technical experience, if you have a B.S.E.E. or a B.S. in Physics—and if you can write—please send your resume at once to: Mr. B. P. Ramstack, Hughes Aircraft Company, P.O. Box 90515, Los Angeles, California 90009. U.S. citizenship required.

## HUGHES

HUGHES AIRCRAFT COMPANY  
FIELD SERVICE & SUPPORT DIV.

An equal opportunity employer



## NEW Microminiature "BITE"\* Indicators

**Continuously monitor circuit and system performance.**

**\*BITE . . . Built-In Test Equipment is now required by DOD on avionic equipment down to the module level where possible. These indicators give a visual indication if circuit or system performance falls below design parameters.**

Now you can design a microminiature indicator into any electrical or electronic circuit to alert operators if equipment performance is faulty or below desired operational levels. Even if the failure is transient, the indicator continues to register the fault by means of magnetic latching until a reset signal is applied to the terminals. Normal appearance of the case is black. If a fault develops, the windows show white in sharp contrast to the case.

#### TYPICAL APPLICATIONS

In-flight monitoring of 400 cycle alternators.

Voltage sensors to determine if voltage variations exceed an allowable excursion range.

Servo loop in aircraft control system. Indicator has a built-in time delay. When a control signal is applied to the system, the indicator detects any failure to respond within 10 milliseconds, after which the time delay triggers the BITE indicator to signal failure.

Ground-support computer equipment. Indicator continuously monitors the complement of the output code and signals if an erroneous code is generated.

#### GENERAL SPECIFICATIONS

These units measure only .7" x .2" x .4", a volume of only .056 cu. in. Operating range is 17-29 VDC. Response is to a pulse width as low as 15 milliseconds; special units will respond in 5 microseconds. They can be supplied with internal switching so power is used during indication transfer only. Several variations are available: Units utilizing a 4 volt fault signal; round types; pop-up indicators; and units with special interface circuitry. All meet the applicable requirements of MIL-E-5400H (ASG) Class 1-A Equipment.

#### SEND FOR TECHNICAL DATA

**AWH HAYDON**  
THE COMPANY

Timing & Stepper Motors • Electromechanical & Electronic Timing Devices & Systems

232 North Elm Street  
Waterbury, Conn. 06720  
4060 Ince Boulevard  
Culver City, Calif. 90231

ON READER-SERVICE CARD CIRCLE 767

## PRODUCTION EQUIPMENT

### Sequencer inserts PC components



*Universal Instruments Corp., E. Frederick St., Binghamton, N. Y. Phone: (607) 772-1710. P&A: \$19,000; 90 days.*

This machine sequences and inserts axial-lead components of different body diameters into PC boards at rates up to 3000 per hour. The unit is designed for PC board assembly applications where ten or less components are to be mounted. Components may be either reel-wound or magazine-loaded. Custom fabricated templates, master grid templates or an actual PC board can be used by the operator for stylus positioning.

CIRCLE NO. 632

### Eyelets fed, positioned, set in PC boards



*Edward Segal, Inc., 132 Lafayette St., New York. Phone: (212) 966-3935.*

An automatic eyelet attaching machine feeds eyelets as small as 0.02-inch ID. A carrier-type raceway feeds all types of eyelets used in PC boards, including funnel, flat or roll flange. Single bolt mounting provides quick change from one size eyelet to another. An oscillating agitator eliminates damage to plated eyelets. A limited travel spindle prevents tool damage.

CIRCLE NO. 633



## Printer stamps over 180 parts per minute

James H. Matthews & Co., 6516  
Penn Ave., Pittsburgh. Phone:  
(412) 362-6500.

Electronic component printers are offered that may be tooled with product feeding systems to suit the particular component, and used for axial-lead diode marking, flat-pack modules, TO-5 transistors and others. The units are also adaptable to printing two surfaces simultaneously, including round and flat surfaces. Standard operation is about 180 per minute, but the printers are capable of printing as fast as the components can be fed.

Booth No. 1J20 Circle No. 321

## Transistor test set fully automatic

Micro Tech Mfg. Inc., 703 Plantation St., Worcester, Mass. Phone: (617) 755-2515. P&A: \$2880, \$350 (optional counter); stock.

An automatic transistor probe test set features high testing speeds and simple programing. Model 8005 test set has a unique "first fail-end-of-test" mode which terminates testing of a device when the first failure is detected in a test series. The total time per individual test is 10 ms including switching delays. The test set is transient-free and has built-in current-limiting. All leads are automatically grounded between tests for device protection. Worst-case accuracy of the Model 8005 is  $\pm 2\%$ . Other features include probe continuity pretesting, IC logic circuitry, solid-state programing of function generators and limit comparators and dry-switching of reed-relay lead and range connections. Optional features and accessories include counters, sorting, punch-card programing, multiplexing and extended ranges. The testing capability can also be extended to ten tests.

Booth No. 1E08 Circle No. 324

It's time to renew your subscription to **ELECTRONIC DESIGN**. Return your renewal card today.

What are you buying...



PROBLEMS or



... PROFITS?

Why let printed circuit boards with faulty, unreliable solder joints cloud your production and profit picture? Trade those problems for profits by specifying Methode printed electronic circuits with exclusive new **\*SUPER-SOLDERABILITY**.

**SUPER-SOLDERABILITY**, Methode's outstanding contribution to the reliability of printed circuit assemblies, will increase your profits by decreasing your production problems. Put an end to time-consuming, work-stopping effects of such variables as touch-up, flux variables, solder bath, time and temperature variables.

**SUPER-SOLDERABILITY** assures 100% fine grain solder fillets around leads, fully-wetted pads that solder better, that eliminate void areas between leads and circuit paths. For space-age reliability, repeatability assured by improved quality control, joints free of surface imperfections, that look better and perform better than ever before, specify Methode printed circuit boards with exclusive **SUPER-SOLDERABILITY**.

Call, or write for sample board and complete information on Methode **SUPER-SOLDERABLE** printed circuits on your company letterhead. Do it today... you'll be glad you did!



Printed Circuit Division

**M**ethode Electronics, Inc.

7447 W. Wilson Ave.

Chicago, Illinois 60656 • 312 / 867-9600

\*Process Pat. App. For.

ON READER-SERVICE CARD CIRCLE 768

# Viscofilm

## CAPACITORS

### HOLD

### THEIR

### CHARGE!

1%  
VOLTAGE  
LOSS  
IN  
ONE HOUR

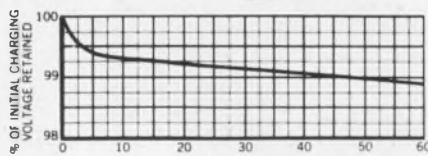

Self-time Constant at 25°C

VISCOFILM capacitors are impregnated with a unique plastic dielectric that remains permanently liquid. Its properties are such that it provides exceptionally high insulation resistance and, consequently, a long self-time constant for VISCOFILM capacitors.

This makes them especially suitable for applications requiring the storage or transfer of energy plus replacement of conventional oil filled capacitors.

- Excellent capacitance stability
- Temperature range  $-75^{\circ}\text{C}$  to  $+125^{\circ}\text{C}$
- Voltage ratings from 100 VDC to 6000 VDC
- Capacitance ratings from .004 MFD to 24 MFD

Write For  
VISCOFILM Catalog No. 1255

**INDUSTRIAL**  
CONDENSER CORPORATION

3243 No. California Ave.  
Chicago, Illinois 60618

ON READER-SERVICE CARD CIRCLE 769

## MICROWAVES

### Double-balanced mixer ranges dc to 500 MHz

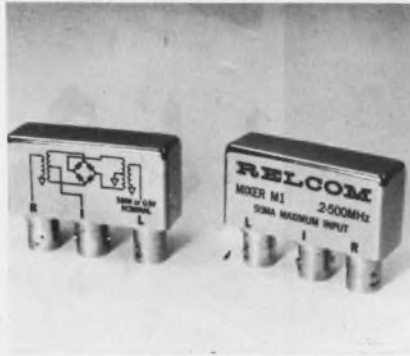

Relcom, 2164 E. Middlefield Rd., Mountain View, Calif. Phone: (415) 962-6265. P&A: \$126 to \$150; stock.

A double-balanced broad-band mixer is designed for frequency mixing, phase detection, amplitude and pulse modulation, current-controlled attenuation, or up or down frequency conversion. Frequency range is dc to 500 MHz. Noise level is typically 6 dB SSB at 50 MHz and isolation is 50 dB at 50 MHz. The mixer is designed for 50- $\Omega$  systems and comes with female BNC connectors.

CIRCLE NO. 634

### Coax circulators cover vhf region

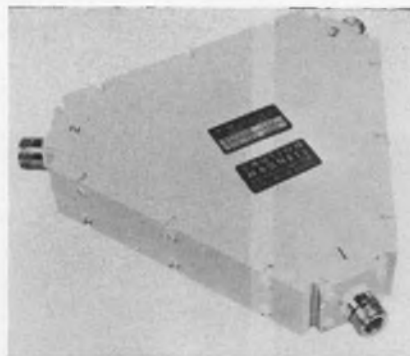

E&M Laboratories, 7419 Greenbush Ave., N. Hollywood, Calif. Phone: (213) 875-1484.

Vhf coaxial circulators feature bandwidths ranging from 10 to 30% in the 100-to-300-GHz region. The models have typical characteristics of 15-dB isolation, 0.7-dB insertion loss and 1.35 vswr. They are designed for system incorporation in common carrier, television, FM, aeronautical and military service.

CIRCLE NO. 635

### Bandpass filters range to 6 GHz

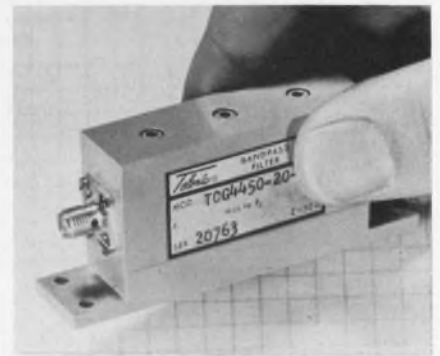

Telonic Engineering, Box 277, Laguna Beach, Calif. Phone: (714) 494-7581. P&A: \$215 to \$396; 6 to 8 wks.

Miniature bandpass filters operate at any center frequency from 2 to 6 GHz, with 3-dB bandwidths from 0.3 to 3%. They are available with 2, 3, 4, 5 or 6 sections, and exhibit vswr of 1.5 up to 4 GHz, and 2 from 4 to 6 GHz. Iris-coupled, capacity-loaded coax cavities, the filters use quarter-wavelength resonators for minimum size, maximum Q and low insertion loss.

CIRCLE NO. 636

### Coax diode switch handles 2.5 kW



Microwave Associates, Burlington, Mass. Phone: (617) 272-3000.

Coaxial spdt diode switches feature replaceable diodes. The MA-8306-2L24S is a lightweight unit which operates in the 1020-to-1100-MHz frequency range with a switching speed of 200 ns. Peak power is 2.5 kW; average power is 25 W. Isolation is 25 dB and insertion loss is 5 dB. The switch is suited for antenna lobing in military and commercial IFF systems.

CIRCLE NO. 637

# MAGNETIC SHIELDING

**TAILOR MADE...  
QUICKLY...BY YOU...**



Ideal for initial experimental evaluation. Also for production applications. Eliminate interference in your display or system by wrapping permanently effective Netic Co-Netic Magnetic Shielding Foils around offending components. Presto! No more interference. Easily shaped with ordinary scissors to your outline.

Co-Netic and Netic foils are not significantly affected by dropping, vibration or shock and do not require periodic annealing. High attenuation to weight ratio performance. Available in any required length in thickness from .004" in rolls 4", 15", and 19 3/8" wide.



Foil Performance Evaluation



Spiral Counter  
Spiral Cable  
Shielding



Adhesive  
backed Foil



## MAGNETIC SHIELD DIVISION

Perfection Mica Company

1322 N. ELSTON AVENUE, CHICAGO, ILLINOIS 60622

ORIGINATORS OF PERMANENTLY EFFECTIVE NETIC CO-NETIC MAGNETIC SHIELDING

# FREE TECHNICAL MICA MANUAL K-6

*gives electrical and physical data on all types of mica*

No tooling cost on numerous fabricated parts of natural and built-up mica.

Pre-punched insulating wafers to electrically isolate transistors, diodes, etc. from heat sinks.

Corrugated mica to reduce handling and fabrication costs for thermal elements.

All grades of mica offered.

Immediate delivery from stock on many items.

## PERFECTION MICA CO.

1322 No. Elston Ave.

Chicago, Illinois 60622

Phone: 312, EV 4-2122

ON READER-SERVICE CARD CIRCLE 770

## A MOST UNUSUAL RELAY

This ISOLATION RELAY has many applications for apparatus requiring a safe, shock-free remote control circuit. Consists of a transformer and low-voltage relay in a single laminated core construction. Operates on 95-125 VAC and handles 5 Amps by shorting the remote leads.

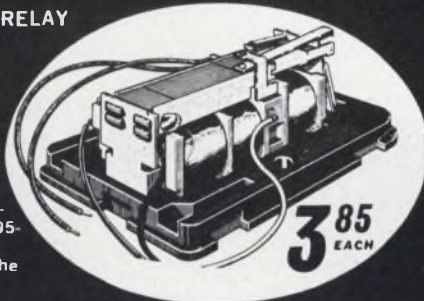

Send for  
28 Design  
IDEAS  
FREE!

**ALCO ELECTRONIC PRODUCTS, INC.**

LAWRENCE, MASSACHUSETTS

ON READER-SERVICE CARD CIRCLE 771

## THE WORLD'S FINEST MINIATURE SLIDE SWITCH With Positive Action



Exceptional quality, ultra-miniature switch with built-in computer grade reliability for integrated circuits, 'dry' circuits, moderate power handling. Smallest case size; incorporates new anti-tease design assuring positive 'snap' indexing. Goldplated terminals, contacts, and movable armature. Life 250,000 operations. 2 amps @ 120 VAC.

FREE  
PRODUCT  
PLANNING  
CATALOG

**ALCOSWITCH**

DIV. OF ALCO ELECTRONIC PRODUCTS INC. LAWRENCE, MASS.

ON READER-SERVICE CARD CIRCLE 772

## THE BEST DRY TRANSFER LETTERING COSTS LESS THAN ANY OTHER POPULAR BRAND

ONLY  
**\$1.25**  
per sheet

\$2.25/ two sheets

SPECIFY



Look in the Yellow Pages under Drafting Supplies or Art Supplies for your dealer's name.



That's the cost of a sheet of DECA-DRY Transfer Lettering. It's the lowest priced of all the popular brands of dry transfer lettering. But some people go right on paying more, and for less quality. It must be because they don't know DECA-DRY is the best transfer lettering you can buy. One way to find out is to try DECA-DRY. It's easy to use... all you do is rub it on for quick, reproduction quality lettering. We'll be glad to send you a sample, or better still, buy a sheet at your dealer today. People who have bought DECA-DRY have found better quality does cost less.

CHART-PAK, INC.

A Subsidiary of Avery Products Corp. @ 343 River Road, Leeds, Mass. 01053

Send free sample and catalog showing complete DECA-DRY line.

Name ..... Title .....

Company .....

Address .....

City ..... State ..... Zip .....

Application .....

ON READER-SERVICE CARD CIRCLE 773

## Requirement: How many antennas are needed to accomplish the functions of beacon tracking, command and voice communications during launch, flight and the critical reentry high temperature phase of the Apollo Mission?



**Solution:** One! Amecom's Unified S-Band Antenna that operates from 2100 MHz to 2300 MHz, provides circular polarization with a maximum ellipticity of 2 db and a gain of 6 db!

This antenna has been qualified to survive reentry heats of up to 3000°F.

It has been subjected to thermal inputs of 14,500 BTU/sq.<sup>2</sup> for over one-half hour with no performance deterioration.

The Apollo S-Band Antenna is similar to the Amecom C-Band models that are being used on Gemini and Apollo spacecraft and missile testing programs.

The Problem Solvers of Amecom's Antenna Systems Department will be pleased to review the hard-to-meet temperature requirements for antennas in your missile, rocket or space project.

Call or write: Amecom Division, 1140 East-West Highway, Silver Spring, Md. 20910. Tel: (301) 588-7273.

**AMECOM** 

DIVISION OF LITTON INDUSTRIES

ON READER-SERVICE CARD CIRCLE 774

## MICROWAVES

### Double-balanced mixer ranges 5 to 500 MHz

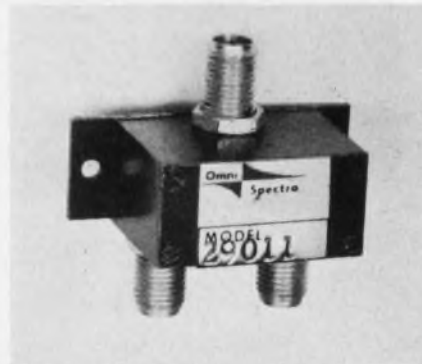

*Omni Spectra, Inc., 19800 W. Eight Mile Rd., Southfield, Mich. Phone: (313) 444-8890. P&A: \$160, \$100; 60 days.*

Typical conversion losses of 6.5 to 7 dB over the 5-to-500-MHz range are featured in these double-balanced mixers. Field-replaceable Schottky diodes are used. Model 29011 is a 3/8-in.<sup>3</sup> package weighing 1/2 ounce and using OSM jack connectors. Model 49011 is a 1/8 in.<sup>3</sup> package with 0.05-inch solder pins for application in stripline and printed circuit boards.

CIRCLE NO. 638

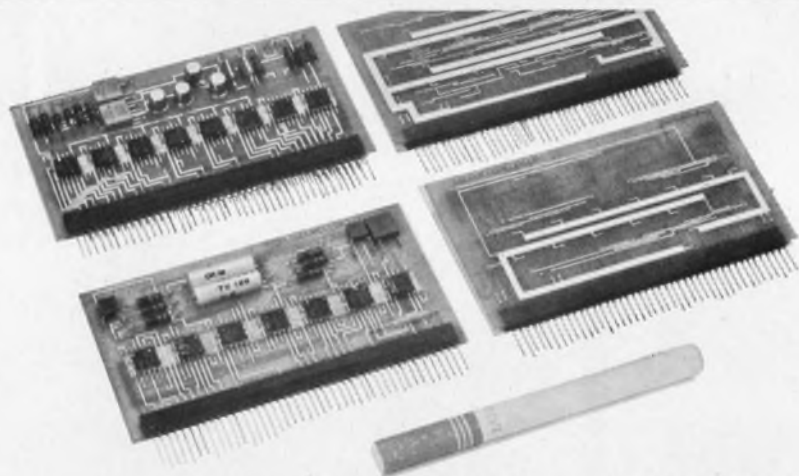

an Industry/Military/NASA  
**QUALIFIED SOURCE**



**For Engineering:** Concept. Analysis. Design (Circuitry, Interwiring, Structures, Heat Transfer, System Integration).

**For Manufacturing:** Volume Production. Prototype, Experimental Fabrication. Test.

Contact: William J. Laverty, Manager, Programs/Marketing Division, The Sippican Corporation, Marion, Mass. 02738, Telephone 617 748-1160.



Advanced Instrumentation  
Outer Space to  
Undersea Applications

**sippican**

ON READER-SERVICE CARD CIRCLE 775

### Crystal detectors range dc to 18 GHz



*Microlab/FXR, 10 Microlab Rd., Livingston, N. J. Phone: (201) 992-7700. P&A: \$35; stock.*

Miniaturized crystal detectors operate from dc to 18 GHz. Three models are available; all feature MFM connectors. Two units for use with crystals such as type IN23 and IN78 measure 2 inches long and weigh 6 ounces each. The third, for use with crystals such as type D5223, is 1 inch long and weighs 0.4 ounce.

CIRCLE NO. 639

**NEW! DIGITAL PANEL METERS**  
0.1% ACCURACY

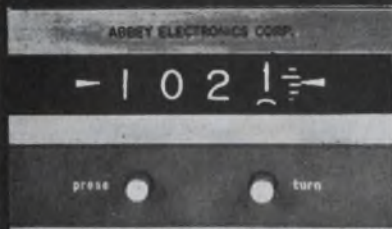

Shown 3/4 actual size

**DIGIMETER**

MODEL DM-25

**\$260**

OEM discounts available

For every application where a conventional panel meter is inadequate

- AC or DC measurements
- Single or multiple ranges
- 1  $\mu$ A to 1,000 A, full scale
- 10 mV to 10,000 V, full scale
- Other functions & ranges to order

Send for detailed literature



2 Sixth St., New Hyde Park, L. I., N. Y. 11044  
516 CH 8-8060

**UNIVERSAL CALIBRATOR**  
Model MC-10



Fast, accurate calibration of panel meters, multimeters, oscilloscopes, vtvm's, other measuring instruments. Full accuracy without correction curves. Meter indicates directly the % Error in device under test. All solid-state. Meets MIL specs for temperature, humidity, vibration, shock, RFI.

AC & DC VOLTAGE:  $\pm 0.2\%$ , 0-1000 volts in 1 millivolt steps, 0-20 mA load  
AC & DC CURRENT:  $\pm 0.2\%$ , 0-1 ampere in 1 microamp steps, 0-1 volt burden  
RESISTANCE:  $\pm 0.1\%$ , 0-1,000,000 ohms in 1 ohm steps

Send for detailed literature



2 Sixth St., New Hyde Park, L. I., N. Y. 11044  
516 CH 8-8060

**L-band oscillator has micrometer tuning**

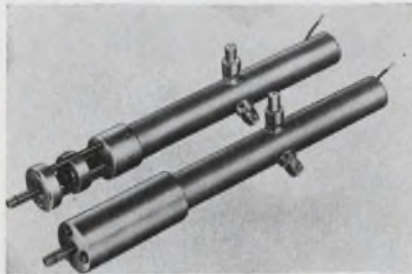

Trak Microwave Corp., 4726 Kennedy, Tampa, Fla. Phone: (813) 877-8341.

A low-noise master oscillator for L-band radar or microwave communications systems has a lead screw tuning mechanism with 12 oz-in. max torque, and frequency resolution of over 30 kHz. Frequency range is 1210 to 1330 MHz; RF power output, 17 dBm from two outputs (34 dBm total).

CIRCLE NO. 642

**Frequency doublers have low spurious signals**

Elpac Systems, 3760 Campus Dr., Newport Beach, Calif. Phone: (714) 546-8640.

Broad, instantaneous bandwidth is the feature of these solid-state frequency doublers. Each model is internally biased and fixed-tuned. Merely inserting the RF input provides twice the frequency at the output. Typical spurious signals are as low as -27 to -30 dB, assuming a clean input signal. The units are epoxy-finished. The band is 300 to 6000 MHz.

CIRCLE NO. 643

**Klystron output is 100 W in S-band**

Eimac Div. of Varian, 301 Industrial Way, San Carlos, Calif. Phone: (415) 592-1221.

An electrostatically-focused klystron designed for aerospace communication systems operates at output levels of 20 to 100 W. The S-band tube exhibits 3-dB electronic bandwidth in excess of 30 MHz, with 35% efficiency and 42-dB gain at the 100-W power level.

CIRCLE NO. 644

**Stays supple in continuous operation at very high temperatures**



**HYGRADE**

**THERMOFLEX**  
Fiberglass Sleeving

is designed for application where temperatures run as high as 1200°F. Constructed of closely woven 100% fiberglass, it provides maximum abrasion resistance and great flexibility. It is specially treated to remove all organic matter and to make it fray-resistant. Because dielectric strength is determined by the space factor, Thermoflex is available in regular, double or special construction in various wall thicknesses. Especially recommended where high flexibility is required. Write for samples, data and prices.



**L. FRANK MARKEL & SONS**  
Norristown, Pennsylvania 19404  
INSULATING TUBINGS AND SLEEVINGS  
HIGH TEMPERATURE WIRE AND CABLE

SYSTEMS

**Tape transport has speeds to 120 ips**

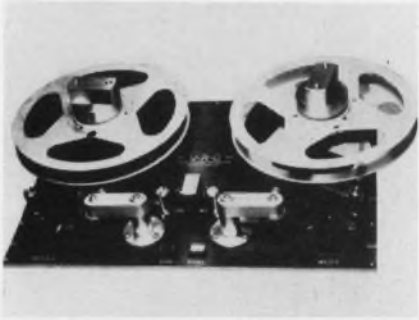

*Video Research Corp., 761 N. Washington St., Rockville, Md. Phone: (301) 762-5999.*

A flexible, high precision magnetic tape transport mechanism is supplied with a variety of options, including bidirectional capability, to satisfy most analog or digital performance requirements. Tape speeds are available from 15 or 16 ips to 120 ips, and the unit accommodates 10-1/2-in. standard NAB reels of 1/4-1/2-, or 1-in.-wide tape.

**CIRCLE NO. 645**

**Card reader accepts special symbols**

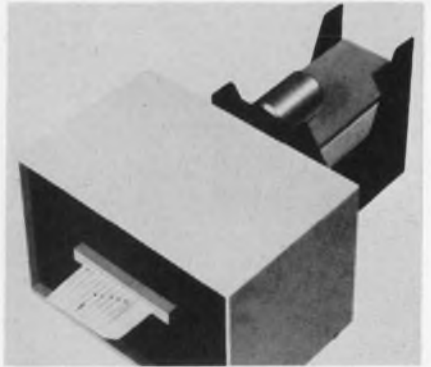

*Taurus Corp., Academy Hill, Lambertville, N. J. Phone: (609) 397-2390.*

Standard 80-column, 12-row cards are read serially, column by column, by this unit. Cards may be prepared in Hollerith or other coding systems. All alphanumeric or special symbols are accepted. It may be used on-line to a computer, interfaced with typewriter or adding machine, or used for card duplication or correction. Reading time is 10 or 40 columns per second.

*Booth No. 4K38 Circle No. 344*

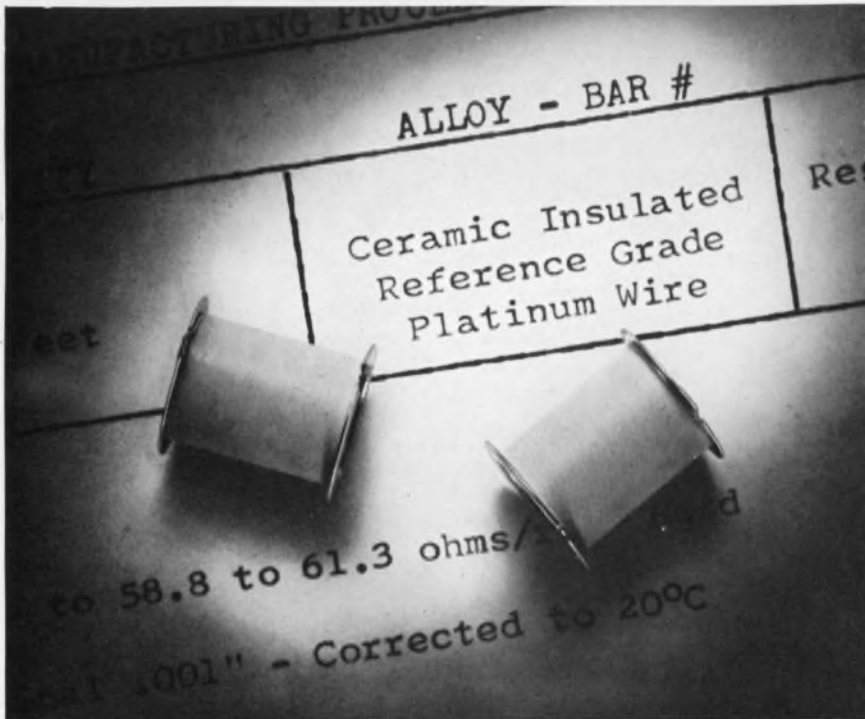

**EXCLUSIVE!**

*(you can't get it from anyone else!)*

Secon's way out front this time. This wire and insulation are designed for the resistance thermometer field.

We are the only producer of reference grade platinum that can supply it with a ceramic insulation, that allows the wire to be fully recrystallized without harm to the insulation. The ceramic insulated wire can be supplied as small as .0007". The ceramic insulation handles temperatures in excess of 1500°F. We also straight-draw bare reference grade platinum

wire to a diameter of .0005". Conventional insulations are also available.

If your requirements are for high quality, reference-grade platinum, bare or insulated, you will want a copy of our brochure on wire products for resistance thermometers. It lists the physical and electrical properties of available materials.

Please write on your letterhead; no obligation of course.



**SECON METALS CORPORATION**  
7 INTERVALE STREET, WHITE PLAINS, N.Y. 10606 ■ (914) WH 9-4757  
ON READER-SERVICE CARD CIRCLE 777

**Strip chart recorders in multiple, single-span**



*Varian, 611 Hansen Way, Palo Alto, Calif. Phone: (415) 326-4000. P&A: \$795, \$745; 30 to 45 days.*

Five-inch strip-chart recorders are offered in 2 models: the G-1010 multiple-span unit for general lab work and the G-1110 single-span unit for OEM applications. Sensitivity is 0.1% of the 5-inch span, accuracy is 0.25% and pen response is 0.35 second, full scale. The solid-state design and electronically regulated reference circuit ensure stability.

**CIRCLE NO. 646**

## Data set tolerates line distortion

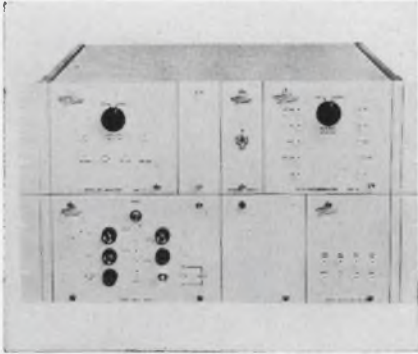

Rixon Electronics, Inc., 2120 Industrial Pkwy., Silver Spring, Md. Phone: (301) 622-2121.

Data can be transmitted over a type 3003 (4A) telephone circuit at 2400 bits per second without adjustment, due to high tolerance to delay and amplitude distortion of this data set. The 4-phase modulation technique which the unit employs makes it ideal for computer systems to poll remote stations for data.

CIRCLE NO. 647

## Modular keyboard for 12-bit words

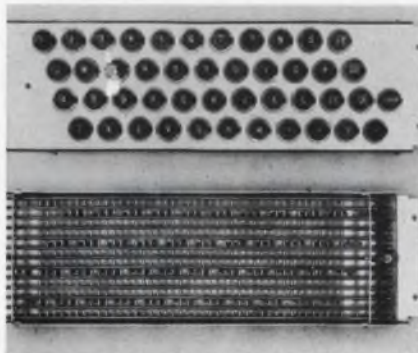

Computronics Engineering, Box 6606 Metropolitan Station, Los Angeles. Phone: (213) 876-1944. P&A: \$150; 2 to 3 wks.

A modular keyboard unit provides word length of 12 bits by means of a mechanical X-Y matrix. The method reduces switch contacts by as much as 15 to 1. Interface problems are eliminated by bounce-free action of the switch contact output. The module can generate either Morse, 3 BCDs, ASCII, IBM, EBCDIG or CCIT.

CIRCLE NO. 648

**PROVEN RELIABILITY—  
SOLID-STATE POWER INVERTERS,  
over 260,000 logged operational hours—  
voltage-regulated, frequency-controlled,  
for missile, telemeter, ground support,  
135°C all-silicon units available now—**

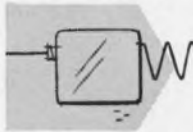

Interelectronics all-silicon thyatron-like gating elements and cubic-grain toroidal magnetic components convert DC to any desired number of AC or DC outputs from 1 to 10,000 watts.

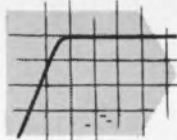

Ultra-reliable in operation (over 260,000 logged hours), no moving parts, unharmed by shorting output or reversing input polarity. High conversion efficiency (to 92%, including voltage regulation by Interelectronics patented reflex high-efficiency magnetic amplifier circuitry.)



Light weight (to 6 watts/oz.), compact (to 8 watts/cu. in.), low ripple (to 0.01 mv. p-p), excellent voltage regulation (to 0.1%), precise frequency control (to 0.2% with Interelectronics extreme environment magnetostrictive standards or to 0.0001% with fork or piezoelectric standards.)

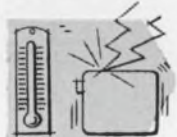

Complies with MIL specs. for shock (100G 11 msec.), acceleration (100G 15 min.), vibration (100G 5 to 5,000 cps.), temperature (to 150 degrees C), RF noise (1-26600).



AC single and polyphase units supply sine waveform output (to 2% harmonics), will deliver up to ten times rated line current into a short circuit or actuate MIL type magnetic circuit breakers or fuses, will start gyros and motors with starting current surges up to ten times normal operating line current.



Now in use in major missiles, powering telemeter transmitters, radar beacons, electronic equipment. Single and polyphase units now power airborne and marine missile gyros, synchros, servos, magnetic amplifiers.

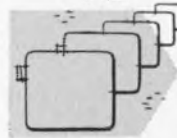

Interelectronics—first and most experienced in the solid-state power supply field produces its own all-silicon solid-state gating elements, all high flux density magnetic components, high temperature ultra-reliable film capacitors and components, has complete facilities and know how—has designed and delivered more working KVA than any other firm!

**INTERELECTRONICS CORPORATION  
550 U. S. Route 303, Congers, N. Y.  
Telephone: 914 ELmwood 8-8000**

ON READER-SERVICE CARD CIRCLE 778

**THE BIRTCHEER MODEL 70 SEMICONDUCTOR TEST SET... every important semiconductor test function in one test set:**

- Transistor Pulsed Beta
- Transistor Hybrid Parameters
- Transistor Saturation Voltage
- Low Leakage and Breakdown
- DC Parameters
- Transistor Pulsed Breakdown
- Zener Parameters
- Transistor Radio-Frequency  $h_{FE}$

It's done with plug-in modules—one module for each function. Buy as many or as few as you need, when you need them. As new needs come along, Birtcher develops new modules; your set is never obsolete.

Write for catalog and prices

**THE BIRTCHEER CORPORATION INSTRUMENT DIVISION**

1200 MONTEREY PASS ROAD / MONTEREY PARK, CALIFORNIA 91754 / TELEPHONE (213) 264-6610



ON READER-SERVICE CARD CIRCLE 779

**POWER EQUIPMENT**

**Modular supplies power klystrons and TWTs**

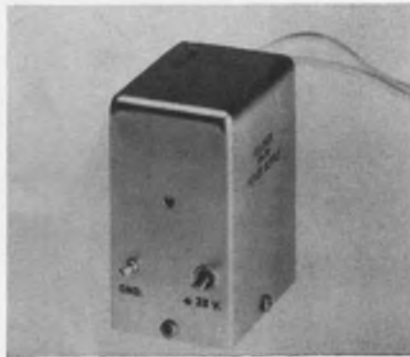

Velonex, 560 Robert Ave., Santa Clara, Calif. Phone: (408) 244-7370. P&A: \$400 to \$470; stock to 2 wks.

Ten-watt Pico-Pac power supplies measure approximately 6 in.<sup>3</sup>. The units are packaged to survive a wide range of operating environments common to aircraft, balloons, sounding rockets and satellites. The supplies are for use with CRTs, klystrons, TWTs, photomultiplier tubes and other high-voltage applications. Seven units span a variable range of 150 to 4000 V.

CIRCLE NO. 649

**Systems power supply has five outputs**

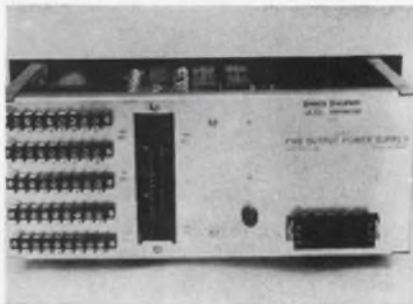

Advanced Development Corp., 137-24 S. Prairie, Hawthorne, Calif. Phone: (213) 679-1691.

A systems power supply produces five voltages from 20 to -20 Vdc at 1 to 7 A. The supply accepts inputs of 100 to 250 Vac at 47 to 63 Hz, and incorporates four series and one shunt regulator. Additional features include 1% envelope regulation, margin-checking, turn-on and turn-off sequencing, and remote sensing. Also provided are automatic current limiting, interlocks, and high pulse load capabilities.

CIRCLE NO. 650

PROVIDING FREQUENCY  
COVERAGE INTO THE  
**HF RANGES**  
AS WELL AS  
**VHF to 300 MHz**

**ACL**  
**SR-208**  
**RECEIVER**



This solid state unit uses printed circuit plug-in modular construction techniques. The 20-300 MHz frequency is accomplished by 3 RF tuners with fine tuning.

**SPECIFICATIONS**

- Tuning Range ..... 20-300 MHz
- Modes ..... AM, FM, CW
- Noise Figure ..... 4.0-6.5 db
- Image Rejection ..... 60-80 db
- Sensitivity ..... 2uv (20KHz BW)  
4uv (300 KHz BW)
- IF Bandwidths ..... 20-300 KHz  
(others available)

ACL INVITES YOUR INQUIRY

**ACL**

**ASTRO COMMUNICATION LABORATORY, INC.**

9125 GAITHER ROAD  
GAITHERSBURG, MD. 20760

Phone: (301) 948-5210 TWX 710-828-9706

RF Equipment for The Systems Engineer

ON READER-SERVICE CARD CIRCLE 780  
ELECTRONIC DESIGN 6, March 15, 1967



## High-voltage converter is programable

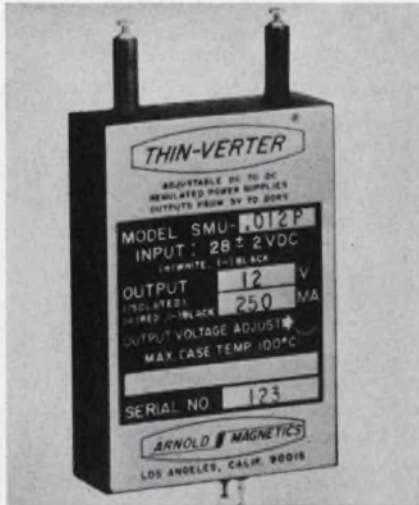

Arnold Magnetics Corp., 6050 W. Jefferson Blvd., Los Angeles. Phone: (213) 870-7014. P&A: \$285; 1 to 6 wks.

Designed for use as a control for transducers, VFOs and BWOs, model SMU-P is a 3-V static converter. Output voltage is directly variable by means of a  $9 \pm 4$ -Vdc control signal applied to a 2-k $\Omega$  input. Resulting output voltage ranges from 30% to 105% of rated output. Deviation from linearity is  $\pm 5\%$  of rated output.

CIRCLE NO. 651

## Line conditioner for 1-kVA power level



Elgar Corp., 8046 Engineer Rd., San Diego, Calif. Phone: (714) 279-0800.

Isolation of sensitive electronic equipment from all forms of power line disturbance is achieved with this line conditioner. Response times of less than 50  $\mu$ s, and input-output isolation of 100 dB are claimed, with max output distortion of 0.25% and regulation of  $\pm 0.05\%$ . Circuits are all-silicon solid-state. The unit operates at the 1-kVA power level.

CIRCLE NO. 652

# An X-Y Scope With Perfectly Matched Price

## \$575

○ Low Cost



○ Solid State Reliability

○ 10cm x 10cm Viewing Area

○ Matched, Calibrated Attenuators

○ 1° Phase Error at 2MHz

Are your amplifiers out of phase with your budget? Here's a scope that's matched in every way—Data Instruments S52. Two identical, eight stage, high gain amplifiers permit measurements and comparisons all the way to 2MHz with a phase error of only 1°. The calibrated input attenuators are also matched to assure accuracy. And the sophisticated 5 inch PDA tube operates at 2.4kv and provides a 10cm x 10cm display area. The S52 can also be used as a conventional single beam scope. A front panel control allows the Horizontal Amplifier to be switched out and the Time Base to be switched in. The Time Base is a miller type giving excellent linearity and starting time, and features automatic synchronization to 3MHz. Extensive use of solid state circuitry gives the instrument a high degree of reliability and is backed up with a full year warranty. Field and Factory Service are also provided by Data Instruments. The specifications:

X-Y AMPLIFIERS					
BANDWIDTH	SENSITIVITY/CM	ATTENUATORS	RISETIME	IMPEDANCE	
DC-3MHz DC-300kHz	100mv-50v 10mv-5v	9 position Matched	0.1 $\mu$ s	1M $\Omega$ + 3pf	
TIME BASE		CRT		PHYSICAL	
SPEED/CM	ACCURACY	DIA.	PHOSPHOR	VOLTS	DIM. & WEIGHT
1 $\mu$ s-0.5 sec. (18 cal. ranges)	$\pm 5\%$	5" PDA	P31 P7 optional	2.5kv	8½" x 9¼" x 15" 24 lbs.

Few other instruments have amplifiers so completely matched over such a broad bandwidth. Still, we're not perfect. We do have that 1° phase error in performance. But not in price. At \$575 the price is perfect. And it's unmatched.

Data Instruments Division • 7300 Crescent Blvd. • Pennsauken, N.J. 08110

ON READER-SERVICE CARD CIRCLE 781

Combined for Convenience!

# FREE!



## CAMBION<sup>®</sup> Catalog 700 and CAMBION Catalog 700 Supplement

Now — for your convenience, the industry's most complete file of technical data for quick, easy specifying. If you're currently without *both* CAMBION Catalog 700 and CAMBION Catalog 700 Supplement, now you can have them bound together under one convenient cover.

Filled with technical and performance data, specifications, outline drawings and dimensions, the new CAMBION publication offers a complete selection of battery holders, panel and chassis hardware, digital modules, solder terminals, swagers, terminal boards, insulated terminals, coil forms, shielded coil forms, coils, RF chokes, capacitors, connectors — plugs and jacks, component clips, handles, kollet knobs, thermoelectric modules and magnetic bearings.

For your free copy write Cambridge Thermionic Corporation, 410 Concord Ave., Cambridge, Mass. 02138. Tel: (617) 491-5400; or 8703 La Tijera Blvd., Los Angeles, Cal. 90045. Tel: (213) SP6-0472.



Standardize on CAMBION . . . the guaranteed electronic components

ON READER-SERVICE CARD CIRCLE 782

## new Harnessing Tool for HEAVY-DUTY PAN-RAP<sup>™</sup> Ties & Clamps

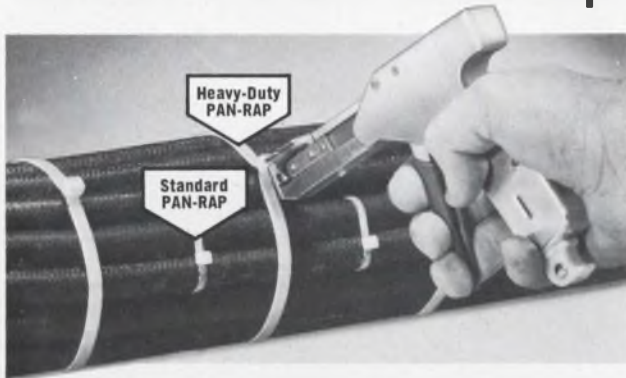

### Handles 10 Largest PAN-RAP Cable Ties

New Panduit GS4H Harnessing Tool handles ten different PAN-RAP Cable Ties from the Standard Tie to the Extra-Long Heavy-Duty Tie. Identification Markers and Clamps, too. Tool cuts nylon PAN-RAPS flush at preset tension, providing neater bundles, lower production costs.

At your Panduit distributor.

# PANDUIT<sup>®</sup> CORP.

Tinley Park, Ill. 60477 • Phone: 312-532-1800

FROM THE MANUFACTURERS OF  
PANDUCT<sup>®</sup> PLASTIC WIRING DUCT

Visit Panduit at IEEE Booths 1C16 & 1C18  
ON READER-SERVICE CARD CIRCLE 783

# Design Aids

**KULICKE and SOFFA** MANUFACTURING COMPANY  
Designers, Builders and Suppliers of Research and Production Equipment  
100 Commonwealth Avenue, Boston, Mass. 02116  
Phone 215-848-8800

CONVERSION CHART		English Decimal to Metric System		
Decimal Inch	Common Fractions	Milli-meters	Micro-meters	Milli-angstroms (Å)
0.0019		0.1900	19.00	
0.0025	+	0.2500	25.00	
0.0031		0.3100	31.00	
0.0037		0.3700	37.00	
0.0043		0.4300	43.00	
0.0049		0.4900	49.00	
0.0055		0.5500	55.00	
0.0061		0.6100	61.00	
0.0067		0.6700	67.00	
0.0073		0.7300	73.00	
0.0079		0.7900	79.00	
0.0085		0.8500	85.00	
0.0091		0.9100	91.00	
0.0097		0.9700	97.00	
0.0103		1.0300	103.00	
0.0109		1.0900	109.00	
0.0115		1.1500	115.00	
0.0121		1.2100	121.00	
0.0127		1.2700	127.00	
0.0133		1.3300	133.00	
0.0139		1.3900	139.00	
0.0145		1.4500	145.00	
0.0151		1.5100	151.00	
0.0157		1.5700	157.00	
0.0163		1.6300	163.00	
0.0169		1.6900	169.00	
0.0175		1.7500	175.00	
0.0181		1.8100	181.00	
0.0187		1.8700	187.00	
0.0193		1.9300	193.00	
0.0199		1.9900	199.00	
0.0205		2.0500	205.00	
0.0211		2.1100	211.00	
0.0217		2.1700	217.00	
0.0223		2.2300	223.00	
0.0229		2.2900	229.00	
0.0235		2.3500	235.00	
0.0241		2.4100	241.00	
0.0247		2.4700	247.00	
0.0253		2.5300	253.00	
0.0259		2.5900	259.00	
0.0265		2.6500	265.00	
0.0271		2.7100	271.00	
0.0277		2.7700	277.00	
0.0283		2.8300	283.00	
0.0289		2.8900	289.00	
0.0295		2.9500	295.00	
0.0301		3.0100	301.00	
0.0307		3.0700	307.00	
0.0313		3.1300	313.00	
0.0319		3.1900	319.00	
0.0325		3.2500	325.00	
0.0331		3.3100	331.00	
0.0337		3.3700	337.00	
0.0343		3.4300	343.00	
0.0349		3.4900	349.00	
0.0355		3.5500	355.00	
0.0361		3.6100	361.00	
0.0367		3.6700	367.00	
0.0373		3.7300	373.00	
0.0379		3.7900	379.00	
0.0385		3.8500	385.00	
0.0391		3.9100	391.00	
0.0397		3.9700	397.00	
0.0403		4.0300	403.00	
0.0409		4.0900	409.00	
0.0415		4.1500	415.00	
0.0421		4.2100	421.00	
0.0427		4.2700	427.00	
0.0433		4.3300	433.00	
0.0439		4.3900	439.00	
0.0445		4.4500	445.00	
0.0451		4.5100	451.00	
0.0457		4.5700	457.00	
0.0463		4.6300	463.00	
0.0469		4.6900	469.00	
0.0475		4.7500	475.00	
0.0481		4.8100	481.00	
0.0487		4.8700	487.00	
0.0493		4.9300	493.00	
0.0499		4.9900	499.00	
0.0505		5.0500	505.00	
0.0511		5.1100	511.00	
0.0517		5.1700	517.00	
0.0523		5.2300	523.00	
0.0529		5.2900	529.00	
0.0535		5.3500	535.00	
0.0541		5.4100	541.00	
0.0547		5.4700	547.00	
0.0553		5.5300	553.00	
0.0559		5.5900	559.00	
0.0565		5.6500	565.00	
0.0571		5.7100	571.00	
0.0577		5.7700	577.00	
0.0583		5.8300	583.00	
0.0589		5.8900	589.00	
0.0595		5.9500	595.00	
0.0601		6.0100	601.00	
0.0607		6.0700	607.00	
0.0613		6.1300	613.00	
0.0619		6.1900	619.00	
0.0625		6.2500	625.00	
0.0631		6.3100	631.00	
0.0637		6.3700	637.00	
0.0643		6.4300	643.00	
0.0649		6.4900	649.00	
0.0655		6.5500	655.00	
0.0661		6.6100	661.00	
0.0667		6.6700	667.00	
0.0673		6.7300	673.00	
0.0679		6.7900	679.00	
0.0685		6.8500	685.00	
0.0691		6.9100	691.00	
0.0697		6.9700	697.00	
0.0703		7.0300	703.00	
0.0709		7.0900	709.00	
0.0715		7.1500	715.00	
0.0721		7.2100	721.00	
0.0727		7.2700	727.00	
0.0733		7.3300	733.00	
0.0739		7.3900	739.00	
0.0745		7.4500	745.00	
0.0751		7.5100	751.00	
0.0757		7.5700	757.00	
0.0763		7.6300	763.00	
0.0769		7.6900	769.00	
0.0775		7.7500	775.00	
0.0781		7.8100	781.00	
0.0787		7.8700	787.00	
0.0793		7.9300	793.00	
0.0799		7.9900	799.00	
0.0805		8.0500	805.00	
0.0811		8.1100	811.00	
0.0817		8.1700	817.00	
0.0823		8.2300	823.00	
0.0829		8.2900	829.00	
0.0835		8.3500	835.00	
0.0841		8.4100	841.00	
0.0847		8.4700	847.00	
0.0853		8.5300	853.00	
0.0859		8.5900	859.00	
0.0865		8.6500	865.00	
0.0871		8.7100	871.00	
0.0877		8.7700	877.00	
0.0883		8.8300	883.00	
0.0889		8.8900	889.00	
0.0895		8.9500	895.00	
0.0901		9.0100	901.00	
0.0907		9.0700	907.00	
0.0913		9.1300	913.00	
0.0919		9.1900	919.00	
0.0925		9.2500	925.00	
0.0931		9.3100	931.00	
0.0937		9.3700	937.00	
0.0943		9.4300	943.00	
0.0949		9.4900	949.00	
0.0955		9.5500	955.00	
0.0961		9.6100	961.00	
0.0967		9.6700	967.00	
0.0973		9.7300	973.00	
0.0979		9.7900	979.00	
0.0985		9.8500	985.00	
0.0991		9.9100	991.00	
0.0997		9.9700	997.00	
0.1003		10.0300	1003.00	
0.1009		10.0900	1009.00	
0.1015		10.1500	1015.00	
0.1021		10.2100	1021.00	
0.1027		10.2700	1027.00	
0.1033		10.3300	1033.00	
0.1039		10.3900	1039.00	
0.1045		10.4500	1045.00	
0.1051		10.5100	1051.00	
0.1057		10.5700	1057.00	
0.1063		10.6300	1063.00	
0.1069		10.6900	1069.00	
0.1075		10.7500	1075.00	
0.1081		10.8100	1081.00	
0.1087		10.8700	1087.00	
0.1093		10.9300	1093.00	
0.1099		10.9900	1099.00	
0.1105		11.0500	1105.00	
0.1111		11.1100	1111.00	
0.1117		11.1700	1117.00	
0.1123		11.2300	1123.00	
0.1129		11.2900	1129.00	
0.1135		11.3500	1135.00	
0.1141		11.4100	1141.00	
0.1147		11.4700	1147.00	
0.1153		11.5300	1153.00	
0.1159		11.5900	1159.00	
0.1165		11.6500	1165.00	
0.1171		11.7100	1171.00	
0.1177		11.7700	1177.00	
0.1183		11.8300	1183.00	
0.1189		11.8900	1189.00	
0.1195		11.9500	1195.00	
0.1201		12.0100	1201.00	
0.1207		12.0700	1207.00	
0.1213		12.1300	1213.00	
0.1219		12.1900	1219.00	
0.1225		12.2500	1225.00	
0.1231		12.3100	1231.00	
0.1237		12.3700	1237.00	
0.1243		12.4300	1243.00	
0.1249		12.4900	1249.00	
0.1255		12.5500	1255.00	
0.1261		12.6100	1261.00	
0.1267		12.6700	1267.00	
0.1273		12.7300	1273.00	
0.1279		12.7900	1279.00	
0.1285		12.8500	1285.00	
0.1291		12.9100	1291.00	
0.1297		12.9700	1297.00	
0.1303		13.0300	1303.00	
0.1309		13.0900	1309.00	
0.1315		13.1500	1315.00	
0.1321		13.2100	1321.00	
0.1327		13.2700	1327.00	
0.1333		13.3300	1333.00	
0.1339		13.3900	1339.00	
0.1345		13.4500	1345.00	
0.1351		13.5100	1351.00	
0.1357		13.5700	1357.00	
0.1363		13.6300	1363.00	
0.1369		13.6900	1369.00	
0.1375		13.7500	1375.00	
0.1381		13.8100	1381.00	
0.1387		13.8700	1387.00	
0.1393		13.9300	1393.00	
0.1399		13.9900	1399.00	
0.1405		14.0500	1405.00	
0.1411		14.1100	1411.00	
0.1417		14.1700		

# Reed Relay Problems?

A special AND logic relay in the new "UF" configuration.



## Can We Solve Your Problem?

**Operating Inputs:** low as 1mA, and 15mW.  
**Standard Coil Voltages:** 6, 12, 24, 32, 48V in stock for immediate delivery.  
**Special Voltage or Resistance,** multiple windings for flip flop, memory and crosspoint selection applications — to customer specifications.  
**Relay Contacts** in Form A, B, C and latching. Also high vacuum type 5000V Form A.

Write for catalog and prices of our standard line of magnetic reed relays. For special requirements, give complete details for quotation.

# Coto-Coil

COMPANY INC.

59 Pavilion Ave.  
 Providence, R.I. 02905  
 Phone: (401) 941-3355

ON READER-SERVICE CARD CIRCLE 784

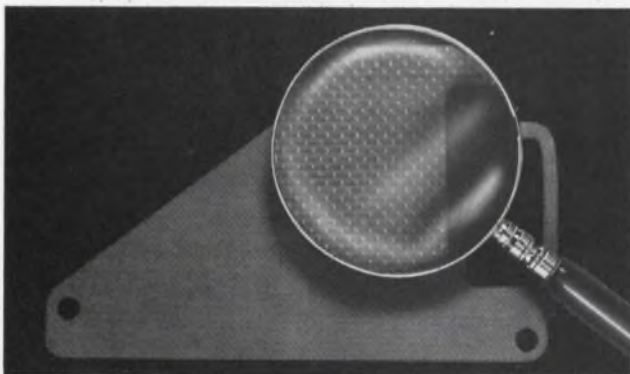

## Porcupine Metalastic™

### ...seals and shields with more RF pinch to the inch

Porcupine Metalastic is distorted solid monel sheeting in silicone rubber. Its great number of contact points give it more RF shielding pinch to the inch. Its compression characteristics make it excellent for vacuum, atmosphere or moisture seal. Porcupine

Metalastic is also available without the silicone rubber to withstand the highest temperature of any flat gasket. Standard width is 8" ... thickness .030". Other sizes also available. About 6¢ per sq. in. Write for free samples, prices and literature.

## METEX Corporation

Walnut Avenue • Clark, New Jersey 07066  
 (201) 381-7272 • TWX 710-744-4530

West Coast: 5057 W Washington Blvd., Los Angeles, Calif.



ON READER-SERVICE CARD CIRCLE 785

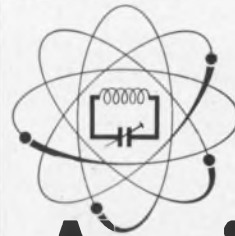

# April in Paris is electronic.

## Let Air France turn you on.

- April 5-10 International Exhibition of Electronic Components.
- April 10-15 International Conference on Electronics and Space.
- April 14-21 MESUCORA (Measurement and Automation).

We'll see you in the air and at the shows. We're happy to be the official carrier once again, and look forward to jetting you to Paris. At the shows, our Welcome Service will be on hand to give you any assistance you may need.

*Festival in the sky* stereo, and movies by In-Flight Motion Pictures, available at nominal cost.

For free brochures, mail the coupon to Air France, Overseas Trade Show Department, Box 707, New York, N.Y. 10011.

I am interested in:  International Exhibition of Electronic Components  International Conference on Electronics and Space  MESUCORA (Measurement and Automation).

Name \_\_\_\_\_

Company \_\_\_\_\_

Address \_\_\_\_\_

City \_\_\_\_\_ State \_\_\_\_\_ Zip \_\_\_\_\_

ED-4



ON READER-SERVICE CARD CIRCLE 786

# Application Notes

## Comparing heat sensors

Temperature sensing devices cannot be selected by comparison of manufacturers' data because of the different specifications used, according to this 5-page article. Three popular sensors are compared. A two-page application note is included. Harrel, Inc.

CIRCLE NO. 654

## Photochoppers

Four pages of descriptive matter and schematics describe the principal applications of the manufacturer's spst and spdt photochoppers. Applications to dc servo loops, power supplies, op-amps and voltage comparators are included. Leeds & Northrup Co.

CIRCLE NO. 655

## Semiconductor heat sinks

A twelve-page treatment of the application of heat sinks to semiconductor power devices includes charts, tables and explanatory text. Natural convection and forced-air sinks are discussed, and the computation methods of heat sink requirements are outlined. Westinghouse Electric Corp.

CIRCLE NO. 656

## Instrument notes

Nine data sheets and folders on the general subject of instrumentation and measurement are available. Capacitance and inductance, interference, tone-burst, two-port devices, and impedance of coax connectors are treated. General Radio Co.

CIRCLE NO. 657

## Saturable core reactors

The theory of saturable core reactors and their applications to high-power-factor loads are presented in six pages of text and diagrams. Their use in regulating power for large loads is discussed. Ordering information is supplied. Acme Electric Corp.

CIRCLE NO. 658

**If noise bothers you...**



**...San Fernando RFI filters can make your electronic life more pleasant**



**SAN FERNANDO ELECTRIC MFG. CO.**  
1509 FIRST STREET ■ SAN FERNANDO, CALIFORNIA 91341  
TELEPHONE: (213) 365-9411 ■ TWX: (213) 764-5963

ON READER-SERVICE CARD CIRCLE 787

**SMALLEST**  
**HIGH VOLTAGE POWER PACKS**

*Announcing Additions to the Widely-Used HV-M Series Power Packs  
New Ratings . . . Most Items Available From Stock  
Rated Output Voltages from 1000 to 75,000 Volts*



A welcome development in power packs — highest quality materials, smaller packaging, long life and high reliability — features commonly found only in power packs of much larger size and much higher cost.

Compact "M" Series Power Packs Give You:

- Choice of rated output voltages from 1000 to 75,000 DC
- Choice of rated output currents of 1.5, 5 and 10 milliamperes
- Choice of input voltages of 118, 220, 230 and 240 volts AC
- Input frequency range 50 to 500 CPS  
Output ripple 1% RMS at rated load and voltage with 60 CPS input
- Wide ambient temperature range
- Variable output from 0 to rated voltage
- Hermetically sealed

Write today for complete information, including technical data, on these amazing new compact power packs.

**Plastic Capacitors, Inc.**  
2620 N. Clybourn • Chicago, Ill. 60614  
DI 8-3735

Custom  Engineering at  
Production Prices

ON READER-SERVICE CARD CIRCLE 788

## Digital plotting systems

Two 4-page brochures describe automatic plotting systems for use with digital computers. One system performs on-line or off-line plotting from almost any standard computer output. The other plots from a remote teletypewriter using low-speed data transmission lines. California Computer Products, Inc.

CIRCLE NO. 659

## Electrical schematics

Symbols, circuits and text deal with the construction and interpretation of electrical schematic diagrams of power and control devices, in this 8-page informative article. Tables are included giving terms, functions and symbols of the most commonly used electrical components. The Clark Controller Co.

CIRCLE NO. 660

## Low-current SCRs

The low-current SCR, a 4-layer semiconductor switch with 3 layers accessible to the user, is the subject of a 40-page brochure. Text, schematics and formulas clarify the many applications of the device. GE Semiconductors Dept.

CIRCLE NO. 661

## Electrical isolation

Isolation by photon coupling permits the use of small, lightweight components. In a 4-page brochure, the manufacturer describes applications of a photon-coupled isolator to a number of circuits. Schematics and charts are included. hp Associates.

CIRCLE NO. 662

## IF and RF amplifier

Applications of a direct-coupled microcircuit amplifier designed for video, IF and RF are available in a 6-page brochure illustrated with charts and schematics. Philco-Ford Microelectronics Div.

CIRCLE NO. 663

# VACTEC

## Type O CdS Cells *Fastest at Low Light Levels*



The response time of any photocell slows proportionately as the light level decreases. But Vactec delivers a rapid response time even at low light levels.

At .01 ft. candles, for example, Vactec Type O material provides a rise time of 780 milliseconds with a delay time of only 90 milliseconds. And you also get the temperature stability provided only by CdS material. Even if yours is a higher light level application, isn't it reassuring to know there is a supplier whose cells are capable of such a high level of performance?

Five new materials ranging from Cadmium Sulfide to Cadmium Selenide are now available. Write for new Bulletin PCD-4 today!

**VACTEC**  
INC.

2423 Northline Industrial Blvd.  
Maryland Hts., Mo. 63042  
AC 314, HE 2-4200

See Vactec's listing in EBG under "Semiconductors," and in EEM, Sec. 3700.

ON READER-SERVICE CARD CIRCLE 789

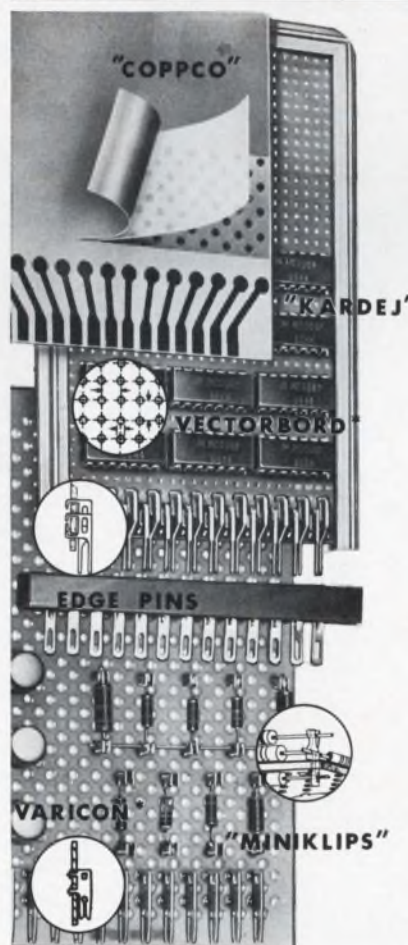

## VECTOR PLUGBORDS CUT CONSTRUCTION TIME

Why drill holes? Use prepunched Vector Plugboards to save time, work, and money.

- New "COPPCO"—Copper plus film plus Vectorbord\*. User "pokes" holes through.
- "KARDEJ"—Aluminum framing stiffens cards 1/32" to 1/16" thick.
- VECTORBORD: \* "P" Type—.042" holes, 0.1" grid for D.I.P.s; "M" Type—.025" holes on .050" grid for I.C.P.s; "G" Type—.062" holes, 0.2" x 0.1" grid for transistors and discrete components.
- EDGE PINS stake to card — fit New "VECTORCONN" receptacles.
- "MINIKLIPS"—Vector "Push Pins" and turned terminals for leads.
- ELCO VARICON\*, 12-47 contacts, or printed tabs.

\*Trademark

For complete information contact:

**Vector**

ELECTRONIC COMPANY, INCORPORATED  
1100 Flower Street, Glendale, California 91201

ON READER-SERVICE CARD CIRCLE 790

# NEW 1967 catalog

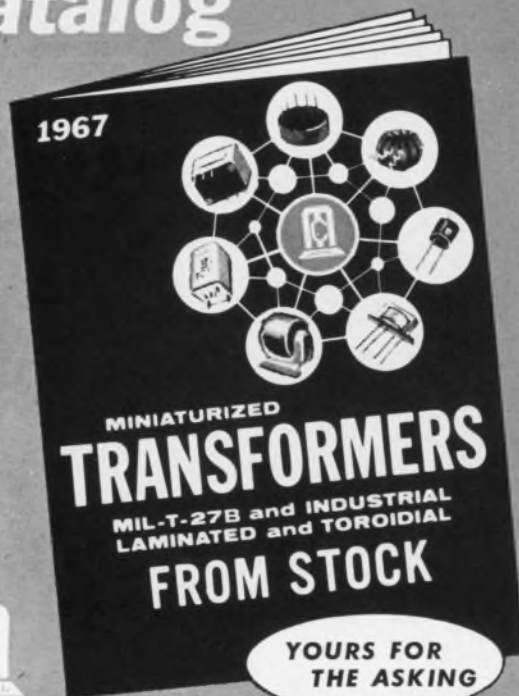

## MICROTRAN

145 E. Mineola Ave., Valley Stream, N. Y. 11582

ON READER-SERVICE CARD CIRCLE 791

### A NEW IDEA IN P-CLIPS!



## ADJUSTABLE P-CLIPS

Only nine (9) sizes of P-Clips will fit all loop diameters from  $\frac{1}{8}$ " through 2"; each size can be adjusted within a specified range. Does away with inventory problems, permits quantity purchases and controls the tension. Molded of non-corrosive, non-conductive, virgin nylon. Applications include: cables, bundles of wires, components, pipes, tubing—wherever a clamp, strain-relief or strap is required. Send for free samples.

**OTHER ELECTROVERT PRODUCTS:** Cradleclip; strapping; cable ties; spiroband; markers; grommet strip; wavesoldering systems.

Sold Coast-to-Coast through Authorized Distributors

**ELECTROVERT INC.**  
86 Hartford Ave., Mount Vernon, N. Y. 10553  
Burbank, California Milwaukee, Wisconsin

See us at IEEE Booth 4B27.

ON READER-SERVICE CARD CIRCLE 792

## New Literature

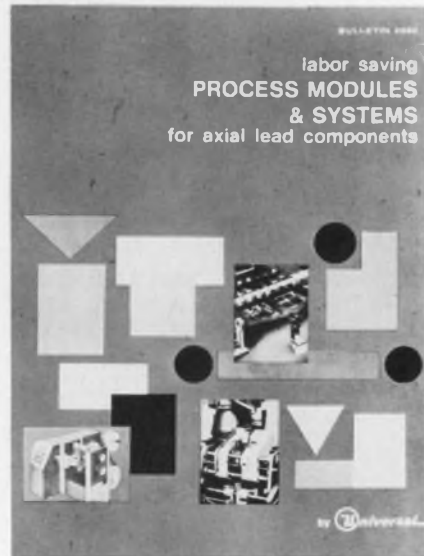

### PC assembly machines

Numerically controlled and pantograph-operated PC board assembly machines, component sequencers, axial-lead component reel packaging equipment, and axial and radial-lead component processing and production systems are described in a new 12-page catalog. Universal Instruments Corp.

CIRCLE NO. 664

### Molecules and microwaves

A new technical journal, to be called "Molecules and Microwaves," will be published on a periodic basis. Initially this journal will feature data on microwave spectroscopy applications. The first loose-leaf sheet shows that pertinent molecular structural information can be obtained from fast-scan, lower-resolution microwave spectroscopic data. Microwaves Div., Hewlett Packard Co.

CIRCLE NO. 665

### Switch uses

Eleven unusual switch operations for industrial and military installations are described in an 8-page illustrated brochure. Coordinated controls and switch consoles in current use in space, submarine and other operations are described with illustrations. Micro Switch, Div. of Honeywell.

CIRCLE NO. 666



### Adjustable speed drives

Covering drive ratings from 1/6 through 7-1/2 hp, a brochure fully describes and illustrates the design features, product selectability and options of adjustable-speed drives. It deals with special design measures to assure electrical, environmental and thermal protection, fully enclosed, solid-state controllers and design compatibility. U. S. Electrical Motors.

CIRCLE NO. 667

### ISA publications

The 20-page 1967 ISA Publications Catalog lists some 76 proceedings of ISA-sponsored and cosponsored conferences and symposia, standards books and 33 ISA Recommended Practices, and over 40 books, monographs and reference works. International Federation of Automatic Control publications, educational aids and periodicals that represent the most comprehensive and current data available in instrumentation are included. Instrument Society of America.

CIRCLE NO. 668

### Automatic speech

Educational and industrial uses of the company's line of speech generating equipment are described in this brochure. Telephone lines are identified by seven spoken digits with these devices. Cognitronics Corp.

CIRCLE NO. 669

## What's New With HEATH At IEEE

**Preview of New Heathkit®/ Thomas "Theatre" Organ**  
All solid-state; 19 voices; 2 amplifiers; 200 watts peak power; instant-play "Color-Glo"; horseshoe console; flip-type tabs; chimes; rotating Leslie plus main speaker systems; preassembled cabinet & bench.  
Kit TO-67 .....\$995



**Preview of New Heathkit Solid-State High Impedance Volt-Ohm-Milliammeter**  
Full scale ranges down to 150 mV & 15 uA; all-silicon plus FET's; AC and DC powered; 6" meter; new unitized construction.  
Kit IM-25 .....\$80  
Assembled IMW-25 .....\$115

**NEW Heathkit "180" Color TV**  
180 sq. in. viewing area; exclusive built-in self-servicing facilities so you can converge & maintain best color pictures; exclusive 3-way installation; rare earth phosphors; automatic degaussing, 25-hr. assembly.  
Kit GR-180 (less cab.) .....\$379.95

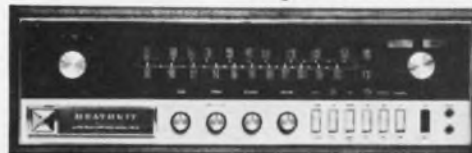

**Preview of New Heathkit AR-15 Solid-State 150-Watt AM/FM Stereo Receiver**  
Two integrated circuits and crystal filters in the IF section; preassembled FET FM tuner; positive circuit protection; 2 calibrated tuning meters; "black magic" panel lighting. All-silicon transistor circuitry.  
Kit AR-15 (less cabinet) .....\$329.95



**New Heathkit 60-Watt Transistor Guitar Amplifier**  
Cool, solid-state circuit; two 12" heavy-duty speakers; two channels & 4 inputs; tremolo & reverb; foot switches; line bypass reversing switch for hum reduction; preassembled cabinet.  
Kit TA-16 .....\$129.95

**New Heathkit Deluxe 80-10 Meter SSB Transceiver**  
Front panel switch-selection of standard USB/LSB 2.1 kHz SSB filter or optional 400 kHz CW filter; 180 watts P.E.P. — 170 watts CW on 5 bands; operates PTT or VOX.  
Kit SB-101 .....\$360



See 'em All At Japan Room & Booths 2C47, 2C48, 2C49 & 2C50.

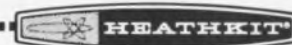

**HEATH COMPANY, Dept. 520-26**  
Benton Harbor, Michigan 49022

Please send FREE Heathkit Catalog

Name \_\_\_\_\_

Address \_\_\_\_\_

City \_\_\_\_\_ State \_\_\_\_\_ Zip \_\_\_\_\_

Prices & specifications subject to change without notice. CL-287

ON READER-SERVICE CARD CIRCLE 793

**FOR THE GUARANTEED ANSWER  
TO YOUR AIR MOVEMENT NEEDS  
ASK FOR THESE BULLETINS**



In the Howard CYCLOHM Fans and Blowers they describe, you get this unique combination of values:

**MORE AIR AT LESS COST**

For proof, see the performance data and price schedules in the Bulletins.

**GUARANTEED PERFORMANCE**

All CYCLOHM air movement units are Powered by the Howard Unit Bearing Motor, guaranteed for 5 years to require no maintenance or re-lubrication.

**IMMEDIATE DELIVERY**

of standard models. For availabilities contact Standard Motor Product Sales, 23 Broadway, Des Plaines, Ill. 60016 (TWX 910-233-1658).

3 Good Reasons for Requesting Bulletins 8-01 and 9-03 describing Fans and Blowers with Air To Spare.



**HOWARD INDUSTRIES**

MSL INDUSTRIES, INC./MOTOR GROUP  
1760 STATE STREET  
RACINE, WIS. 53404

ON READER-SERVICE CARD CIRCLE 794

**CALCULATOR  
BREAKTHRU**



**NOW 4 WANG electronic calculators  
cost less than 3 ordinary units**

New design permits simultaneous, independent operation of 4 keyboard/display consoles from a single, compact electronics package.

- Individual consoles as low as \$780.
- Performs +, -, ÷, ×, x<sup>2</sup>, v<sup>2</sup>, e<sup>x</sup>, log<sub>10</sub>x at a single keystroke
- Available with 4 additional storage registers
- 80-step plug-in programmer available
- Occupies only 8" x 10" desk space



Write today for complete information



DEPT. 1113, 836 NORTH ST., TEWKSBURY, MASS. 01876 ..... TEL. (617) 851-7311

ON READER-SERVICE CARD CIRCLE 795

**NEW LITERATURE**



**Flexible cables**

A brochure on applications and manufacturing techniques traces the history and manufacturing procedures in the development of flexible cables and circuitry. Photographs, diagrams, charts and descriptive copy outline the advantages, as well as the disadvantages of their use in military and commercial applications. Methode Electronics, Inc.

CIRCLE NO. 670

**Measuring instruments**

Potentiometers and voltage standards, dc resistance bridges, galvanometers and magnetic flux meters are a few of the electrical measuring instruments described in three pages of specs, photos and explanatory material. Yokagawa Electric Works.

CIRCLE NO. 671

**Permanent magnets**

Ten pages of charts, diagrams and text deal with the magnetization methods used in producing permanent magnets. Magnetic properties of several metals and alloys are tabulated. Permanent Magnet Association.

CIRCLE NO. 672

**DTL handbook**

Schematics and specs on the company's line of DTL-compatible ICs are offered in a 57-page catalog. Characteristic curves and test results are included. ITT Semiconductors.

CIRCLE NO. 673





**KEYSTONE**

DESIGNERS  
**K**  
MANUFACTURERS

STANDARDIZED  
**ELECTRONIC  
COMPONENTS**

KEYSTONE ELECTRONICS CORP  
40 BLEECKER ST., NEW YORK N.Y. 10012  
(212) 475-4600

CAT. NO. 678

### Components catalog

This 48-page catalog is a complete guide to the manufacturer's line of electronic components such as: battery holders, terminals, terminal boards, pre-punched boards, plug-in-housings, bushings, staking tools, and includes photographs and descriptions of each item. Keystone Electronics Corp.

CIRCLE NO. 674

### Servo motors

A pocket-size, 36-page stock list of gearhead servo-motors and generators is designed to serve as a reference manual for prototype and breadboard requirements. Electrical and mechanical specs, diagrams, tables and BuOrd listings are included. Vernitron Corp.

CIRCLE NO. 675

### Transformer catalog

Transformers and toroids in MIL-T-27B and industrial constructions are outlined in a 34-page catalog. Charts, graphs, applications, schematics and data for transformer specification are included. Microtran Co., Inc.

CIRCLE NO. 676

### Mass spectrometer

An eight-page brochure on a mass spectrometer gas analyzer with mass range to 300 AMU, unit resolution at 100 AMU and sensitivity in the  $10^{-12}$  torr range is available. Aero Vac Corp.

CIRCLE NO. 677



# High Q with Assured Reliability!



ACTUAL SIZE

## The Johanson 3955 Series Variable Air Capacitors are backed by these special RELIABILITY ASSURANCE PROVISIONS

1. Parts examined and assembled in accordance with special Johanson high reliability inspection and assembly procedures.
2. All sub-assemblies inspected under magnification to assure highest quality components prior to final assembly.
3. Final assemblies subjected to 100% burn-in and screening tests.
4. Samples taken from each lot and subjected to life tests.
5. Test data supplied on request.

#### SPECIFICATIONS

Capacity Range: 0-8 - 10 pf  
Working Voltage: 250 VDC  
Q >2000 @ 100 MC  
Temperature Coefficient:  $0 \pm 20.0$  ppm/°C

Write Today for Full Data

*Johanson*

**MANUFACTURING  
CORPORATION**

400 Rockaway Valley Road.  
Boonton, N. J. 07005 (201) 334-2676

ELECTRONIC ACCURACY THROUGH MECHANICAL PRECISION

ON READER-SERVICE CARD CIRCLE 796

**TOTALLY ENCLOSED ROTARY SWITCHES.  
TEMPERATURE TO 125 C. MULTI-POLE.  
30°, 36°, 45°, 60°, and 90° ANGLE of THROW.  
100,000 OPERATIONS.**



**Typical Specifications:**

- Explosion Proof
- Contact Resistance 10 Milliohms
- Make or Break 1/4 Amp. to 15 Amps., 115 VAC Resistive
- 1 to 6 Poles per Deck
- 1 to 12 Decks
- 2 to 12 Positions per Pole

Send for Engineering Catalog G304



565 Hillgrove Avenue  
LaGrange, Illinois 60525  
Area Code 312, Phone 354-1040

See us in Booth 4E03 — IEEE  
ON READER-SERVICE CARD CIRCLE 797

**GET THIS  
HANDBOOK/CATALOG**



**Dispensing Machines for  
Epoxy, Silicone, Urethane**

Descriptions, Specifications, Data,  
Uses, Prices . . . Write Today

**H. V. HARDMAN CO., INC.**  
600 Cortlandt Street, Belleville, N. J. 07109 • (201) 759-3700

ON READER-SERVICE CARD CIRCLE 798

NEW LITERATURE

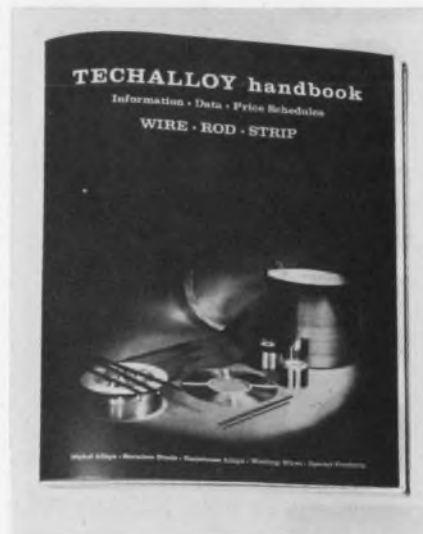

**Wire, strip and rods**

More than 100 different metals and alloys are discussed in a handbook on wire, strip and rods. Quick-reference tables give prices and mil limits with tolerances for the complete range of sizes. Techalloy Co., Inc.

CIRCLE NO. 678

**Firing circuits**

With over 50 diagrams, wave forms and other illustrations, this booklet presents a study of SCRs and their control by magnetic amplifiers. Single and 3-phase systems, high di/dt and high dv/dt conditions, protection of the firing circuit from failure, on-to-off ratio, sensitivity and gate pulses are discussed. Firing Circuits, Inc.

CIRCLE NO. 679

**Transfer molding**

Reprints of a 12-page article are available, describing: selection of plastic, its relation to good part design and molding method; liquid resin systems for molding and encapsulating; machine molding, compression, transfer, and injection methods. Hull Corp.

CIRCLE NO. 680

**Stock bobbins**

A 12-page folder gives charts and tables of a broad line of bobbins stocked by the manufacturer. Square and rectangular stacks and bobbins for cup cores and reed switches are included. Wilcox Products Co.

CIRCLE NO. 681



### Potentiometer catalog

A 32-page illustrated catalog of potentiometers, field-assembled controls, power rheostats and resistors includes photographs, engineering drawings and descriptions. A section describing potentiometers for military use is included. Clarostat Mfg. Co.

CIRCLE NO. 682

### MIL spec procurement

A 7-page data sheet gives part numbers under MIL specifications with a cross reference to the company's catalog listing. The purpose of the data sheet is to increase effectiveness in using the specification MIL-S-8805B, and to reduce delivery time for switches procured to the specification. Micro Switch, Div. of Honeywell.

CIRCLE NO. 683

### Deposition control film

An eight-minute, 16-mm color sound movie describes the latest techniques for automatically controlling multi-layered, multi-source depositions. It is available on a one-week loan basis. Sloan Instruments Corp.

CIRCLE NO. 684

### Guard circuits

A brochure offers 6 pages of text and schematics dealing with circuits for guarding measurement devices against loss of accuracy due to unwanted common-mode voltages. Hewlett-Packard, Moseley Div.

CIRCLE NO. 685

This  
is  
our

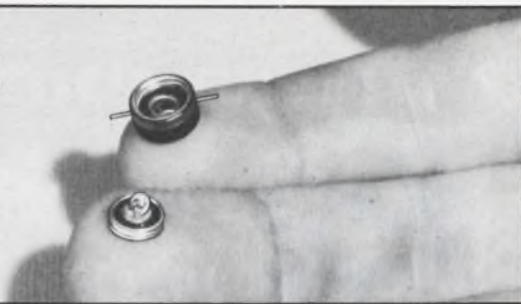

## FLYING SAUCER LAMP!

It doesn't fly, has no resemblance to a saucer and there's nothing "outer space" about it! "Flying Saucer" is just the designer's affectionate nickname for this completely new concept in panel lighting.

The "Flying Saucer" lamp has two parts—a clear or colored Tenite Filter with a threaded socket that can be permanently bonded into a plastic panel or mounted on a PC board, and an incandescent lamp with a threaded base. The overall height of the assembly is .175" so that it can easily be used in a .220" plastic panel leaving it flush front and back.

In operation, the lamp illuminates the panel legends clearly through edge lighting while it is itself invisible. It produces a clearly legible panel board, especially for viewing under low ambient light conditions. In addition, it has numerous other advantages in performance, in economy.

If your equipment includes an illuminated panel, investigate the "Flying Saucer"—it's the newest concept in panel illumination! Write for Catalog CMT-2.

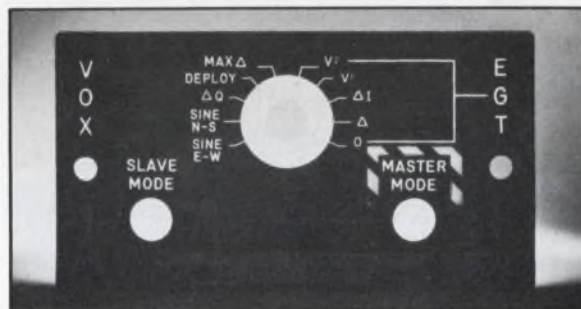

A "Flying Saucer" illuminated panel

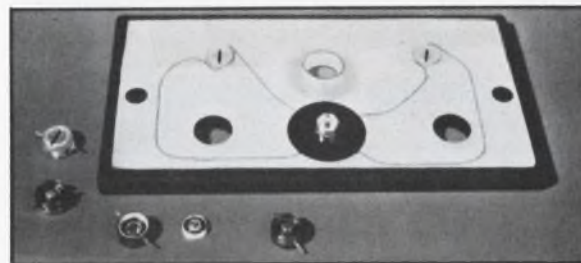

Lamp filter and leads are permanently bonded into the panel.

CHICAGO MINIATURE  LAMP WORKS

4433 RAVENSWOOD AVENUE • CHICAGO, ILLINOIS 60640

ON READER-SERVICE CARD CIRCLE 799

## DRAMATIC REDUCTION

formerly 77" h. x 33" w. x 33" d.

# now only

## 29" h x 17" w x 17" d

( 5 KW Audio Power Amplifier )



All other models similarly reduced... (but in size only!) For instance, 10 KW Model, formerly 78" h. x 78" w. x 36" d., now only 48" h. x 34" w. x 24" d. CML Audio Power Amplifiers produce tremendous power in the smallest packages. Wide frequency range. Low distortion. Ideal for CW and pulsed operation,

acoustic testing, vibration testing, plasma tubes, ion propulsion engines. Perfect for marine installations. All units with wide range of output impedance taps. Air-cooled and vapor-cooled units. Full power available into low power factor loads. Call or write today for details.

### CML, Inc.

A subsidiary of Tenney Engineering, Inc.  
350 Leland Avenue • Plainfield, New Jersey  
(201) 754-5502 • TWX: 201-756-2064



ON READER-SERVICE CARD CIRCLE 800

## ANOTHER WORLD'S SMALLEST Soshin's Dipped Mica Capacitors/DM05

Developed by SOSHIN ELECTRIC, the only mica capacitor maker in Japan with MIL-C-5C qualifications. This newest and its bigger brothers will meet all your requirements. Volume orders accepted.

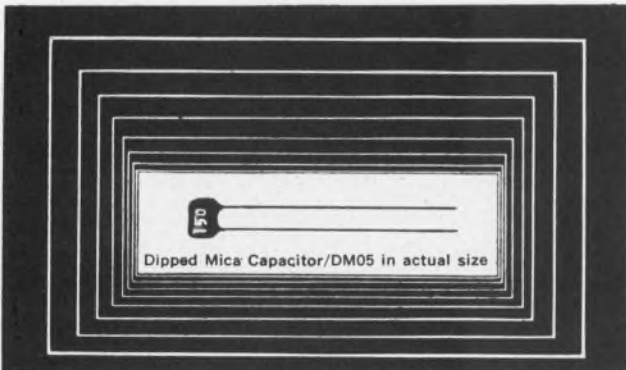

Types	Max Allowable Capacitance (pF)			Dimension (mm)								
	100 WV	300 WV	500 WV	100 WV			300 WV			500 WV		
				L Max	W Max	T Max	L Max	W Max	T Max	L Max	W Max	T Max
DM05	200	130	—	7.0	5.0	3.5	7.0	5.0	3.5	—	—	—
DM10	440	300	330	8.5	5.5	3.5	8.5	5.5	3.5	8.5	5.5	3.5
DM15 (CM05)	2000	1200	510	13.0	11.0	6.2	12.5	10.2	6.0	12.0	10.0	5.2
DM19 (CM06)	10000	6800	5100	18.0	15.0	8.5	18.0	15.0	8.0	17.5	15.0	7.5

For further information, write to

**SOSHIN SOSHINELECTRIC CO., LTD.**  
18-18, Nakamagome 1-chome, Ohta-ku, Tokyo, Japan  
Cables: SOSHINCAPACITOR TOKYO

ON READER-SERVICE CARD CIRCLE 801

## NEW LITERATURE



### Test equipment

A 16-page brochure contains a complete line of test instruments and adapters, VTMs, a recording VOM, general purpose micro-testers, scopes, temperature measuring instruments, carrying cases and other accessories. Simpson Electric Co.

CIRCLE NO. 686

### Nickel-cadmium cells

Characteristics and uses of nickel-cadmium batteries are discussed at length in a 24-page brochure with curves, photos, diagrams and tables. Battery principles, charging practices, idle storage and battery selection are among the subjects treated. International Nickel Co., Inc.

CIRCLE NO. 687

### Power supply aid

Prepared in flow chart form, this capsule guide presents four basic parameters of power supply operation, making it possible for the engineer to progressively narrow down his choices on the basis of output regulation, voltage output, programming speed, and power output. Hewlett-Packard, Harrison Division.

CIRCLE NO. 688

### Firing circuit modules

Schematics, specs and explanatory text describe a line of firing circuit modules designed to eliminate SCR failures due to di/dt and misfiring and interaction troubles. Crydom Labs., Inc.

CIRCLE NO. 689

## RTL line

An RTL integrated circuit line is covered in 18 loose-leaf pages. Product descriptions, logic diagrams, pin arrangements and schematics are included. Sperry Semiconductor.

CIRCLE NO. 690

## Reprints Available

The following reprints are available free and in limited quantities. To obtain single copies, circle the number of the article you want on the Reader-Service Card.

*Try solid-state regulators* (No. 691)

*Predict line regulation accurately* (No. 692)

*Evaluate thermal runaway point* (No. 693)

## Accuracy Policy

It is the policy of ELECTRONIC DESIGN:

To make reasonable efforts to insure accuracy of editorial matter.

To publish promptly corrections brought to our attention.

To reserve the right to refuse any advertisement deemed misleading or fraudulent.

All editorial correspondence should be sent to:

Howard Bierman, Editor  
ELECTRONIC DESIGN  
850 Third Avenue  
New York, N. Y. 10022

## Subscription Policy

ELECTRONIC DESIGN is circulated free of charge to qualified design engineers in the U.S., Western European Continent and Britain. To establish your qualifications, send ELECTRONIC DESIGN the following information on your company's letterhead: Your name, engineering title, description of your design duties and a list of your company's major products. The letter must be signed by you personally.

Subscription rates for nonqualified subscribers—\$25 a year in the U.S., \$35 in all other countries. Single copy, \$1.50.

## Change of Address

A subscriber's change of address requires a restatement of his qualifications. To expedite the change, and to avoid missing any issues, send along a label from a back copy.

## Microfilm Copies

Microfilm copies of all 1961, 1962, 1963, 1964, 1965 and 1966 issues of ELECTRONIC DESIGN are available through University Microfilms, Inc., 300 N. Zeeb Road, Ann Arbor, Mich. 48106

**CHOOSE DEL PRODUCTS FOR HIGH QUALITY PERFORMANCE & RELIABILITY**

## COMPACT HIGH VOLTAGE POWER SUPPLIES

APPLICATIONS: MISSILE GROUND SUPPORT EQUIPMENT • RADAR DISPLAYS  
• IMAGE INTENSIFIERS • STORAGE TUBES • ELECTRON OPTICAL DEVICES  
• NUCLEAR APPLICATIONS • CRT APPLICATIONS • ELECTROSTATIC PRECIPITATION EQUIPMENT

UNITS PERFORM TO MIL-E-16400



Regulated—Series "TRHV"  
Output: 1 KV to 30 KV  
up to 5 MA DC  
Input: 115V, AC—  
60/400 cycles  
From Stock



Unregulated—Series "S"  
Output: 1 KV to 60 KV up to  
10 MA DC  
Input: 115V, AC—60/400 cycles  
Regulation: 0.1% with  
DEL Line Regulator  
From Stock

Other instrumented  
power supplies available  
up to 250 KV ratings.

Write for bulletin



Del Electronics Corp.

Mt. Vernon, N.Y.

250 E. SANDFORD BLVD.

TEL: 914-699-2000

"See us at I.E.E.E. Booth Numbers 4H20-4H22"  
ON READER-SERVICE CARD CIRCLE 802

## New! Proportional temperature control module



Miniature, Repairable RFL Model 70  
Priced Competitively With  
Non-repairable, Fixed (on-off) Types.

### FEATURES

- Fully Repairable
- Controls to  $\pm 0.1^{\circ}\text{C}$
- Fifteen Probes Provide Range From  $-90^{\circ}\text{C}$  to  $355^{\circ}\text{C}$  ( $50^{\circ}$  to  $100^{\circ}\text{C}$  spans)
- Up to 30% Power Savings
- Adjustable Gain and Set Point
- Power Handling Up to 2 KW
- Low Cost for OEM Use

### APPLICATIONS

- Constant Temperature Baths
- Heaters and Humidifiers
- Environmental Chambers and Ovens
- Molding and Forming Equipment
- Copy Machine and Computer Enclosures
- And Many Others

Write for Complete Application and Technical Data  
or Free Evaluation Loan-or call John Carson



**RFL Industries, Inc.**

FORMERLY RADIO FREQUENCY LABORATORIES, INC.

Thermocontrol Div. • Boonton, N. J. 07005

Tel: (201) 334-3100/TWX: 710-987-8352 CABLE: RADAIRCO, N.J.  
ON READER-SERVICE CARD CIRCLE 803

# Advertisers' Index

Advertiser	Page	Advertiser	Page	Advertiser	Page
ACI Division, Kent Corporation	317	Electronized Chemicals Corporation	50, 51	Motorola Communications & Electronics, Inc.	U217
ADC Products, A Division of Magnetic Control Co.	U210	Electrovert, Inc.	340	Motorola Semiconductor Products, Inc.	6, 7, 80
AMP, Incorporated	44, 45	Emerson & Cuming, Inc.	U223	Mycalex Corporation of America	U199
Abbey Electronics Corp.	331	Executone, Inc.	314	National Beryllia Corp.	U202
Adage, Inc.	265	Fairchild Instrumentation, A Division of Fairchild Camera and Instrument Corporation	34, 35, 37	National Electronics, Inc.	U223
Adams & Westlake Company	U151	Fairchild Semiconductor, A Division of Fairchild Camera and Instrument Corporation	248, 249	National Semiconductor Corporation	18, 19
Ad-Yu Electronics, Inc.	U136	Fluke Mfg. Co., Inc., John	U133	Nexus Research Laboratory, Inc.	U185
Aemco Division, Midtek Corporation	U211	Frequency Electronics, Inc.	U216	Non-Linear Systems, Inc.	75, 77
Aerovox Corporation	255	Gardner-Denver Company	U124, U125	Nylomatic Corporation	350
Air France	337	General Electric Company, Electronic Components, Sales Operation	U108, U109	Oak Manufacturing Co.	288A-B
Airpax Electronics	U159	General Electric Company, General Purpose Control Department	38, 39	Ohmite Manufacturing Company	79
Aladdin Electronics, A Div. of Aladdin Industries, Inc.	U131	General Electric Company, Semiconductor Products Department	61	Pacific Data and Controls	U202
Alco Electronic Products, Inc.	329	General Instrument Corporation	8, 9	Famotor, Inc.	U162
Alfred Electronics	U169	General Radio	1	Fanduit Corp.	336
Allen-Bradley Co.	48A-B	German American Chamber of Commerce	U164	Phelps Dodge Electronic Products	54
Amecon Division, Litton Industries	330	Grayhill, Inc.	344	Philco-Ford Corporation	U179
American Aluminum Company	U204	Guardian Electric Manufacturing Co.	U139	Philips Electronic Measuring Instruments	15
American Lava Corporation	U156	Gudebrod Bros. Silk Co., Inc.	64	Plastic Capacitors, Inc.	338
Amperex Electronic Corporation	U143	Hamilton Standard, Division of United Aircraft Corporation	U203	Potter & Brumfield Division of American Machine & Foundry Company	U123
Amphenol R F Division, Amphenol Corporation	U176, U177	Hardman Co., Inc., H. V.	334	Precision Paper Tube Company	16
Arnold Engineering Company, The	55	Hayden Book Company, Inc.	U129, 350	Pyrofilm Resistor Co., Inc.	U193
Arnold Magnetics Corp.	308	Haydon Company, A. W.	326	RBM Controls Division	U163
Art Wire and Stamping Co.	243	Haydon Switch & Instrument Inc.	U150	RCA Aviation Division	276
Astro Communication Laboratories, Inc.	334	Heath Company	341	RCA Electronic Components and Devices	15, 287, 299, Cover IV
Augat, Inc.	78	Heinemann Electric Company	U153	RFL Industries, Inc.	U152, 347
Automatic Electric, A Subsidiary of General Telephone & Electronics	67	Hewlett-Packard, Sanborn Division	23	RHG Electronics Laboratory, Inc.	U214
Baird-Atomic, Inc.	322	Hewlett-Packard, Moseley Division	U175	Radiation, Incorporated	68, 69
Beckman Instruments, Inc.	310	Hewlett-Packard, Cover II	U144, U145, U191, U201, U215	Radio Cores, Inc.	U168
Beebe Electrical Instrument Co., Inc.	298	Honeywell, Computer Control Division	273	Raytheon Computer	U207
Belden Manufacturing Company	283	Honeywell, Test Instrument Division	U197	Reeves Hoffman Division of DCA	60
Bendix Corporation, The	4, 5	Houston Omnigraphic Corporation	294	Rogan Brothers, Inc.	U221
Birtcher Corporation, The	334	Howard Industries, Div. MSL Industries, Inc.	342	Rowan Controller Co., The	25
Bodine Electric Company	70	Hudson Tool & Die Company, Inc.	U167	San Francisco Bay Naval Shipyard	280
Bourns, Inc.	27	Hughes Aircraft Company, Connecting Devices	300, 301	San Fernando Electric Mfg. Co.	338
Brand Rex, Division of American Enka Corporation	29	IBM Corporation	279	Scientific Atlanta, Inc.	U183
Branson Corp.	U140	IBM Industrial Products	52, 53	Sealectro Corporation	48
Buchanan Electrical Products Corporation	U134	IEEE	U212	Secon Metals Corporation	332
Bud Radio, Inc.	74	IERC Division, International Electronic Research Corporation	30	Siemens America, Incorporated	76
Bulova Electronics Division of Bulova Watch Company	U172	IRC, Inc.	U135	Sierra Electronic Division of Philco	302
Burlingame Associates	48A-H	ITT Jennings	12	Sigma Division, Sigma Instruments, Inc.	256
Burndy Corporation	225	ITT Telephone and Telegraph Corporation	12	Signetics Integrated Circuits	71
Burr-Brown Research Corporation	264	ITT Semiconductors	352	Simpson Electric Company	U141
CML, Inc.	346	Industrial Condenser Corporation	328	Singer Company, The—Metrics Division	U149
Cambridge Thermionic Corporation	336	Industrial Electronic Engineers, Inc.	73	Sippican Corporation, The	330
Canoga Electronics Corporation	281	Industro Transistor Corporation	309	Soshin Electric Co., Ltd.	346
Cedar Engineering Division, Data Control Corporation	263	Ingersoll Products, Division of Borg Warner Corporation	U213	Specific Products	49
Chart-Pak, Inc.	329	International Instruments, Inc.	U181	Spectrol Electronics Corporation	U166
Chassis-Trak, Inc.	320A-F	International Electronics Corporation	U205	Sprague Electric Company	10, 20
Chicago Miniature Lamp Works	345	Interelectronics Corp.	333	Standard Condenser Corporation	U218
Clairex Corporation	318	International Rectifier	U209	Switchcraft, Inc.	U170
Clarostat Mfg. Co., Inc.	290	JFD Electronics Co./Components Division	293	Sylvania Electric Products, Inc.	U160A-H
Clevite Corporation, Piezoelectric Division	234	James Electronics, Inc.	U158	Syntron Company	31
Clifton, Division of Litton Industries	260	Janus Control Corporation	306	Syntron Instruments, Inc.	318
Cohu Electronics, Inc.	303	Johnson Manufacturing Corp.	343	Systron-Donner Corporation	56, 57
Columbia Wire & Supply Company	U190	Kepco, Inc.	U180, U182	TRW Electronics	226
Comar Electric Company	U157	Kester Solder Company	U100, U101	Takeda Riken Industry Co. Ltd.	308
Components, Inc.	U154	Kistler Instrument Corporation	351	Tally Corporation	U147
Computer Components, Inc.	U200	Kulka Electric Corporation	312	Technical Information Corp.	165
Computer Measurements Company	U195	LFE Electronics, Division of Laboratory of Electronics, Inc.	297	Tektronix, Inc., Oscilloscopes	257
Consolidated Electrodynamics	313	Lambda Electronics Corp.	62, 63	Telonic Instruments, A Division of Telonic Industries, Inc.	U219, U221, U223
Consolidated Vacuum Corporation	285	Licon, Division Illinois Tool Works, Inc.	U117	Tenney Engineering, Inc.	296
Cook Electric, Automatic Controls Division	U171	Littelfuse	U221	Texas Instruments Incorporated	236, 237
Cornell-Dubilier Electronics	U192A-B	Litton Industries, Electron Tube Division	65	Texscan Corporation	U138
Coto Coil Company, Inc.	337	M. S. Transistor Corporation, A Subsidiary of Silicon Transistor Corporation	U173	Thomas & Skinner, Inc.	U196
Couch Ordnance, Inc.	302	McCoy Electronics Co.	269	Towne Laboratories, Inc.	72
Curtis Development & Mfg. Co.	351	McLean Engineering Laboratories	321	Tracor, Inc.	247
Cutler-Hammer	U115	Mac Panel Company	315	Transistor Electronics Company	312
Dage Electric Company, Inc.	241	Magnecraft Electric Co.	268	Triplet Electrical Instrument Company	295
Dale Electronics, Inc.	Cover III	Magnetic Shield Division, Perfection Mica Company	329	Ulano	311
Data Instruments, Division	335	Markel & Sons, L. Frank	331	Unholtz-Dickie Corporation	U148
Datapulse Instruments Division, Datapulse, Incorporated	2	Master Specialties, Inc.	323	Union Carbide Corporation	32A-M, 43
Del Electronics Corporation	347	Mepar, Inc.	277	United Systems Corporation	242
Delco Radio, Division of General Motors	U186, U187	Mepeco, Inc.	U137	U.S. Components, Inc.	U212
Digital Equipment Corporation	47	Metex Corporation	337	Universal Instrument Corp.	304
Dimco Gray Co.	320	Methodo Electronics, Inc.	327	Vactec, Inc.	339
Duncan Electronics, Inc.	U161	Micro Instruments, Inc.	U198	Vector Electronic Co., Inc.	339
ESI/Electro Scientific Industries, Inc.	228	MicroSwitch, A Division of Honeywell	U87	Victoreen Instrument Company, The	U206
Eagle Signal, A Division E. W. Bliss Company	40, 41	Microsonics, Inc.	324	Victory Engineering Corporation	U174
Eastern Industries, A Division of Laboratory for Electronics, Inc.	66	Microtran	340	Wang Laboratories, Inc.	342
Eimac, A Division of Varian Associates	58	Monsanto	U88, U89, U189	Wayne Kerr Corporation	319
Elco Webster Corporation	59			Westinghouse Molecular Electronics Division	U155
Eldre Components, Inc.	351			Weston Instruments, Inc.	235
Electroglas, Inc.	U194			Wiley & Sons, Inc., John	240
Electronic Development Corporation	305				
Electronic Design	316, 349, 350				
Electronic Research Associates, Inc.	33				

## Career Advertising

A C Electronics	278
Electronic Communications, Inc.	274
Honeywell, Computer Control Division	273
Hughes Aircraft Company	325
IBM Corporation	279
Melpar, Inc.	277
RCA Aviation Division	276
San Francisco Bay Naval Shipyard	280

# SPECIAL TREATMENT FOR RECRUITMENT ADVERTISERS



## LATE CLOSE

To help recruitment advertisers meet urgent deadlines, ELECTRONIC DESIGN has established a special late close policy. The CAREERS & MANAGEMENT section closes ten full days after regular closing date. If necessary, you can phone in your copy and type will be set free of charge. For example, the June 7 issue closes May 8. Recruitment advertisers have until May 18 to furnish copy or plates. Sorry, late closing dates do not permit us time to show proofs for OK of publication-set ads.

Issue Date	Regular Closing Date	Late Closing Date for Recruitment Advertising	Issue Date	Regular Closing Date	Late Closing Date for Recruitment Advertising
Jan. 4	Dec. 5	Dec. 15	July 5	June 5	June 15
Jan. 18	Dec. 19	Dec. 29	July 19	June 19	June 29
Feb. 1	Jan. 3	Jan. 13	Aug. 2	July 3	July 13
Feb. 15	Jan. 16	Jan. 26	Aug. 16	July 17	July 27
March 1	Jan. 30	Feb. 9	Sept. 1	July 31	Aug. 10
March 15	Feb. 13	Feb. 23	Sept. 13	Aug. 14	Aug. 24
April 1	Feb. 27	March 9	Sept. 27	Aug. 28	Sept. 7
April 12	March 13	March 23	Oct. 11	Sept. 11	Sept. 21
April 26	March 27	April 6	Oct. 25	Sept. 25	Oct. 5
May 10	April 10	April 20	Nov. 8	Oct. 9	Oct. 19
May 24	April 24	May 4	Nov. 22	Oct. 23	Nov. 2
June 7	May 8	May 18	Dec. 6	Nov. 6	Nov. 16
June 21	May 22	June 1	Dec. 20	Nov. 20	Nov. 30

**Electronic Design**

To the attention of: Edward F. Clancy  
850 Third Avenue, New York, N. Y. 10022 • (212) PL 1-5530

### RECRUITMENT ADVERTISING INSERTION ORDER

We wish to place \_\_\_\_\_ page(s) in your CAREERS & MANAGEMENT SECTION on the following issue date(s)

Plates will be furnished

Copy to be set

Company \_\_\_\_\_

Address \_\_\_\_\_

City \_\_\_\_\_ State \_\_\_\_\_ Zip \_\_\_\_\_

By: \_\_\_\_\_ Title \_\_\_\_\_

## Advertising Representatives

### New York 10022

Robert W. Gascoigne  
Thomas P. Barth  
Samuel M. Deitch  
Richard W. Nielson  
850 Third Avenue  
(212) PLaza 1-5530  
TWX: 867-7866

### Philadelphia

Fred L. Mowlds, Jr.  
P. O. Box 206  
Merion Station, Pa. 19066  
(215) MO 4-1073

### Boston

Richard Parker  
7 Redstone Lane  
Marblehead, Mass. 01945  
(617) 742-0252

### Chicago 60611

Thomas P. Kavooras  
Berry Conner, Jr.  
720 N. Michigan  
(312) 337-0588

### Cleveland

Robert W. Patrick  
8410 Treetower Drive  
Chagrin Falls, Ohio 44107  
(216) 247-7670

### Los Angeles 90303

Stanley I. Ehrenclou  
Terrence D. Buckley  
W. James Bischof  
2930 W. Imperial Highway  
Inglewood, Calif.  
(213) 757-0183

### San Francisco

Ashley P. Hartman  
175 South San Antonio Rd.  
Ste. 243  
Los Altos, Calif. 94022  
(415) 941-3084

### Southwestern 75206

Tommy L. Wilson  
6200 North Central Express-  
way  
Dallas, Tex.  
(214) EMerson 1-2311

### London W. 1

Brayton C. Nichols  
44 Conduit Street

### Verviers, Belgium

Andre Jamar  
1, Rue Mallar, 1  
(087) 253.85

### Tokyo

Yoshihiro Takemura  
International Planning  
Service, Inc.  
Room 231 Tokyu-Mita Bldg.  
1, Shiba-Mita Koun-cho  
Minato-ku, Tokyo



# Design Data from

## Free: 2,500 Plastic Parts Catalog



New from Nylomatic, molders and fabricators of mechanical plastic components, a highly informative 48-page catalog of more than 2,500 standard parts. It can help you save time and money in design, test and production. Advantages of Nylomatic standard parts: no tooling charges, low unit costs, quick delivery, complete range of sizes. Nylomatic standard parts are made of Nylon, Delrin® and other thermoplastic materials. You'll find our new free catalog a real problem solver for designers, send for it today.

### Nylomatic Corporation

Dept. DE

Nolan Ave., Morrisville, Pa. 19067

# 171

## Engineers' Relay Handbook



A definitive work that is fast becoming a standard reference text for the relay user. Prepared and edited by the National Association of Relay Manufacturers, this book is a complete guide to the principles, properties, performance characteristics, application requirements, specifications, and testing of relays. Systems and product engineers will find the Handbook an indispensable help in determining the correct types of relays for their applications. For further information about this unique sourcebook, write Dept. ED

### Hayden Book Co., Inc.

116 W. 14th Street  
New York, N. Y. 10011

# 173

## How To Write Technical Articles



A guide for the engineer-author, "How to Write Technical Articles for Electronic Design" shows how easy it is to write for publication—once the engineer knows what to write and how to write it. The Author's Guide includes a complete run-down of the types of articles published by Electronic Design—plus detailed instructions on how to prepare technical articles and short special features. A MUST for every "would-be-writer" in the electronics industry. Send for your complimentary copy by circling the number to the right.

### Electronic Design

850 Third Avenue  
New York, N.Y. 10022

# 175



# Manufacturers

Advertisements of booklets, brochures, catalogs and data sheets. To order use Reader-ServiceCard.

## Electrostatic Instrumentation

...what to do  
when your son  
asks about ...



Six-page Bulletin No. 807116 presents in a humorous, question and answer form the basic facts about electrostatic instrumentation. It utilizes cartoon drawings and simple analogies with common household objects to clarify the operation of force measurement systems employing quartz sensors and charge amplifiers. Electron flow and measurement, leakage problems, and system calibration are covered.

**Kistler Instrument Corporation**  
8969 Sheridan Drive  
Clarence, N. Y. 14031

# 172

## Terminal Block Selector



A new 24-page, completely illustrated catalog contains photos, descriptions, ratings, engineering drawings, and prices of the complete line of Curtis terminal blocks. Included are printed circuit, insulated feed-thru, quick disconnect, track type, and high current terminal blocks. Handy selection chart quickly locates the perfect block for your particular requirements. Send today for your free copy. See us at Booth 3K15, IEEE Exhibition, New York City

**Curtis Development & Mfg. Co.**  
3236 North 33rd Street  
Milwaukee, Wisconsin 53216

# 174

## Laminated and Molded Bus Bars For Power Distribution



A 16 page Technical Bulletin is now available, describing a new concept in power distribution. Basic mechanical and electrical design principles, along with descriptive pictures and diagrams, are included in this bulletin. These compact buses can replace bulky cable harnesses and repetitive wiring for computer or modular application. This method of construction satisfies the demanding requirements of low inductance and resistance of high speed, solid state systems, while controlling electrical noises.

**Eldre Components, Inc.**  
1239 University Avenue  
Rochester, New York 14607

# 176

# Designer's Datebook

MARCH							APRIL						
S	M	T	W	T	F	S	S	M	T	W	T	F	S
			1	2	3	4							1
5	6	7	8	9	10	11	2	3	4	5	6	7	8
12	13	14	15	16	17	18	9	10	11	12	13	14	15
19	20	21	22	23	24	25	16	17	18	19	20	21	22
26	27	28	29	30	31		23	24	25	26	27	28	29

For further information on meetings, use Reader Service card.

### Mar. 20-23

IEEE International Convention (New York City) Sponsor: IEEE; The IEEE, 345 E. 47 St., New York, N. Y. 10017

CIRCLE NO. 694

### Mar. 22-24

International Symposium on Modern Optics (New York City) Sponsor: Polytechnic Institute of Brooklyn, AFOSR, NOR; Symposium Committee, Polytechnic Institute of Brooklyn, 333 Jay St., Brooklyn, N. Y. 11201

CIRCLE NO. 695

### Mar. 29-31

Symposium on Microwave Power (Stanford, Calif.) Sponsor: IMPI; Dr. Donald Dunn, IMPI, P. O. Box 2335, Stanford, Calif. 94305

CIRCLE NO. 696

### Apr. 5-10

International Exhibition of Electronic Components (Paris) Sponsors: Five specialized French professional societies under patronage of the Fédération Nationale des Industries Electroniques (EIA of France); J. Amiel, Air France, 1350 Sixth Ave., New York, N. Y. 10019.

CIRCLE NO. 697

### Apr. 10-15

International Conference on Electronics and Space (Paris) Sponsor: Two specialized French professional societies under patronage of the Fédération Nationale des Industries Electroniques (EIA of France); J. Amiel, Air France, 1350 Sixth Ave., New York, N. Y. 10019.

CIRCLE NO. 698

### Apr. 14-21

Mesucora 67 (International Exhibition and Congress on Measuring and Test Equipment and Automation) and Physics Exhibition (Paris) Sponsor: Société Française de Physique (French Physics Society); J. Amiel, Air France, 1350 Sixth Ave., New York, N. Y. 10019.

CIRCLE NO. 699

# Learn why

Please send me a FREE copy of "Transistor characteristics related to circuit performance," along with detailed specifications on ITT strip line transistors.

Name ..... Title .....

Company .....

Address .....

City ..... State ..... Zip .....

## ITT's exclusive strip line packaging makes VHF/UHF transistor circuits work better

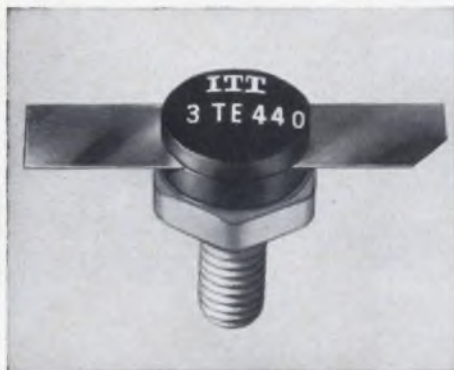

The strip line package reduces or eliminates many of the difficulties that were formerly inevitable when working with high-power VHF-UHF transistors.

Consider these advantages: strip line configuration simplifies final tune-up by virtually eliminating instability; low-inductance package means easier matching to driver stages and broad bandwidth. For 400 MHz application, you may select the 3TE440 (15 watts output) or the 3TE450 (4 watts output).

For full details fill in the coupon above. Or see for yourself — sample quantities are available off the shelf from your ITT distributor or factory representative.

**ITT**  
SEMICONDUCTORS

ITT SEMICONDUCTORS IS A DIVISION OF INTERNATIONAL TELEPHONE AND TELEGRAPH CORPORATION, 3301 ELECTRONICS WAY, WEST PALM BEACH, FLORIDA. FACTORIES IN WEST PALM BEACH, FLORIDA; PALO ALTO, CALIFORNIA; LAWRENCE, MASSACHUSETTS; HARLOW AND FOOTSCRAY, ENGLAND; FREIBURG AND NURENBERG, GERMANY

# Best sellers!



## When circuits need precision wirewounds, you can't beat **DALE RS RESISTORS**

When you need precision wirewounds—Dale's silicone-coated RS line offers the most for your money. For example: **Documented Reliability**—99.994% in tests patterned after Dale's famous Minuteman High Reliability Development Program (test report available). **Versatility**—There are 44 standard axial lead, radial lead and non-inductive styles plus 400 special RS variations already production engineered. **Competitive Price**—We invite you to match Dale RS wirewounds against any comparable part. Call or write us today for complete information.

### LATEST RS RELIABILITY REPORT

**Unit Test Hours:** 32,000,000 • **Reliability:** 99.994%

**Stability:** Units will not shift more than initial tolerance after 1,000 hours load life.

**Test Conditions:** 60% confidence level, 100% rated power, 25°C ambient, 1%  $\Delta R$  failure point.

### RS SPECIFICATIONS

- **Applicable Mil. Spec:** MIL-R-26D, MIL-R-26C & MIL-R-23379
- **Wattage Sizes:** .4, .75, 1, 1.1, 2.5, 3, 3.25, 4, 5, 7 and 10 watt
- **Tolerances:** 0.05%, 0.1%, 0.25%, .5%, 1%, 3%
- **Operating Temperature Range:** -55°C to 350°C
- **Resistance Range:** .1 ohm to 273K ohms
- **Load Life Stability:**
  - Char. U: .5% max.  $\Delta R$  after 2,000 hours at full rated power
  - Char. V: 3% max.  $\Delta R$  after 2,000 hours at full rated power
- **Moisture Resistance:** .2% max.  $\Delta R$
- **Thermal Shock:** .2% max.  $\Delta R$
- **Dielectric Strength:** 500 volts, RS-1/4 through RS-1B; 1000 volts RS-2 through RS-10
- **Insulation Resistance:** 1000 megohms minimum (dry)
- **Temperature Coefficient:** 20 ppm (high values); 30 ppm (intermediate values); 50 ppm (low values); 90 ppm (below 1 ohm).

Write for New Expanded Resistor  
Catalog A and RS Reliability Study



**DALE ELECTRONICS, INC.**

1328 28th Avenue, Columbus, Nebraska  
In Canada: Dale Electronics Canada, Ltd.





The new RCA **2N3839** for critical low-noise UHF applications in Military and Aerospace equipment is...

# directly interchangeable with the low-noise RCA 2N2857... **and has a 1.1 dB lower NF**

That's right! The famous, field-proved transistor family that brought you the low-noise RCA 2N2857, with types which meet requirements of MIL-S-19500/343 USAF, now gives you even lower noise capability in amplifier, oscillator and converter applications with the new RCA 2N3839.

Formerly known as developmental type TA2363, the new RCA 2N3839 silicon n-p-n epitaxial transistor offers the superior performance and reliability features of the 2N2857, with a substantially lower noise figure ... *only 3.4 dB max. at 450 MHz!* And power gain is 12.5 dB min. at 450 MHz. Furthermore, RCA can supply these new, high reliability UHF transistors in production quantities.

For complete pricing and delivery information on the new, low-noise 2N3839, call your RCA Field Representative. Ask him, too, about RCA developmental types which can meet even lower NF requirements, as well as information on ultra-reliable versions of the RCA 2N2857. For technical data sheets, write RCA Commercial Engineering, Section CG3-3, Harrison, N.J. 07029. Also available through your RCA distributor.

RCA Electronic Components & Devices



The Most Trusted Name in Electronics

ON READER-SERVICE CARD CIRCLE 244