

J 20 419 F



*A Publication  
for the Radio-Amateur  
Especially Covering VHF,  
UHF and Microwaves*

VHF

# *communications*

Volume No. 20 · Summer · 2/1988 · DM 7.50

1987 December 17 16:50  
from FD - 12  
1496 km over  
50.2 n 66.8 w

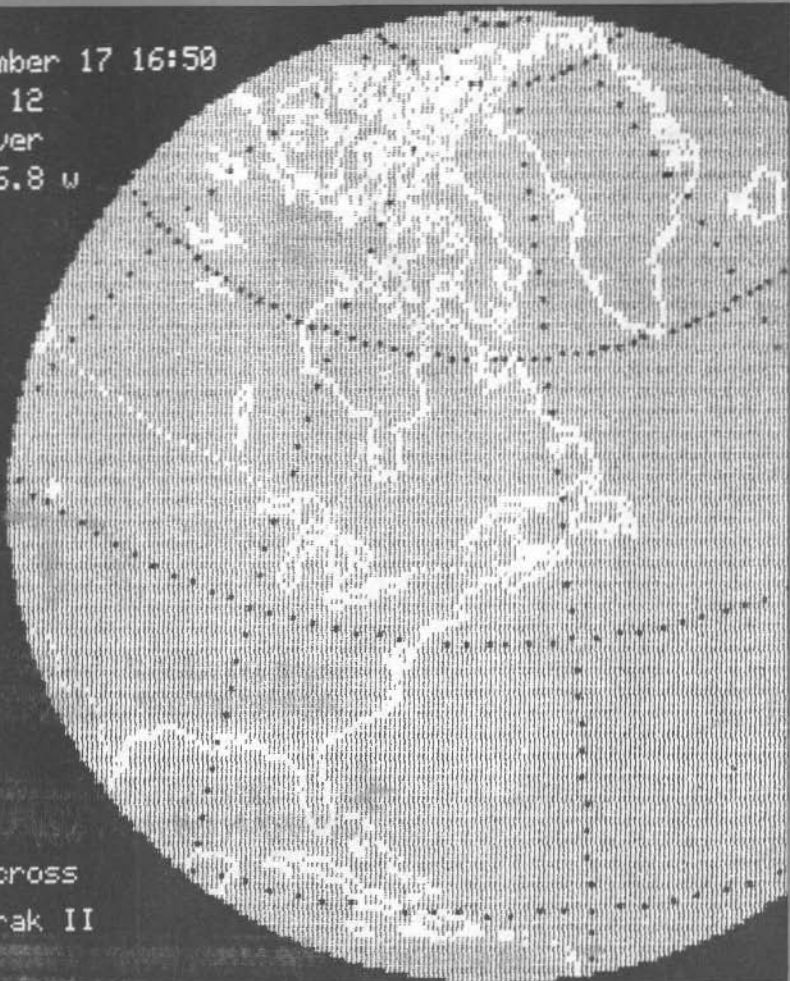

7993 km across  
SSI GrafTrak II



# VHF communications

A Publication for the Radio Amateur  
Especially Covering VHF, UHF, and Microwaves

Volume No. 20 · Summer · Edition 2/1988

**Published by:**

TERRY BITTAN OHG, P.O.Box 80,  
Jahnstraße 14, D-8523 BAIERSDORF  
Fed. Rep. of Germany  
Telephone (9133) 47-0 Telex 629 887  
Telefax 0 91 33-47 18  
Postgiro Nbg. 30455-858

**Publishers:**

TERRY BITTAN OHG

**Editors:**

Corrie Bittan  
Colin J. Brock (Assistant)

**Translator:**

Colin J. Brock, G 3 ISB / DJ Ø OK

**Advertising  
manager:**

Corrie Bittan

**VHF  
COMMUNICATIONS**

The international edition of the German publication UKW-BERICHTE is a quarterly amateur radio magazine especially catering for the VHF / UHF / SHF technology. It is published in Spring, Summer, Autumn and Winter. The 1988 subscription price is DM 25.00 or national equivalent per year. Individual copies are available at DM 7.50 or equivalent each. Subscriptions, orders of individual copies, purchase of PC-boards and advertised special components, advertisements and contributions to the magazine should be addressed to the national representative, or – if not possible – directly to the publishers.

©Verlag  
UKW-BERICHTE

All rights reserved. Reprints, translations, or extracts only with the written approval of the publisher.

Printed in the Fed. Rep. of Germany by R. Reichenbach KG  
Kreilingstr. 39 - 8500 Nuernberg.

We would be grateful if you would address your orders and queries to your representative.

**Representatives**

**Austria**

Verlag UKW-BERICHTE, Terry D. Bittan  
POB 80, D-8523 Baiersdorf / W. Germany  
PSchKto WIEN 1.169.146

**Australia**

W.I.A. P.O. Box 300, South Caulfield, 3162 VIC,  
Phone 5285962

**Belgium**

HAM INTERNATIONAL, Brusselssesteenweg 428,  
B-9218 GENT, PCR 000-1014257-25,  
Tel. 00-32-91-312111

**Denmark**

Halskov Electronic, ØZ 7 LX, Sigersted gamle Skole,  
DK-4100 RINGSTED, Tel. 03-616162, Giro 7 29 68 00

**France**

Christiane Michel, F 5 SM, SM Electronic,  
20 bis, Avenue des Clairions, F-89000 AUXERRE  
Tel. (86) 46 96 59

**Finland**

Peter Lytz, OH 2 AVP, Gesterbystingen 14 E 49  
SF-02410 Kyrkälätt, Tel. 358/0/2 98 17 61  
SRAT, PL 44  
SF-00441 Helsinki, Tel. 358/0/5625973

**Holland**

DOEVEN-ELEKTRONIKA, J. Doeven, Schutstraat 58,  
NL-7901 EE HOOGEVEEN, Tel. 05280-69679

**Israel**

Doron Jacobi 4Z4RG, P.O. Box 6382  
HAIFA, Israel 31063

**Italy**

Franco Armenghi, I 4 LCK, Via Sigonio 2,  
I-40137 BOLOGNA, Tel. (051) 34 56 97

**Luxembourg**

TELECO, Jos. Faber, LX 1 DE, 5 - 9, Rue de la fontaine,  
ESCH-SUR-ALZETTE, Tel. 53752

**New Zealand**

E. M. Zimmermann, ZL 1 AGG, P. O. Box 31-261  
Milford, AUCKLAND 9, Phone 492-744

**Norway**

Hanning Theg, LA 4 YG, Postboks 70,  
N-1324 LYSAKER, Postgirokonto 3 16 00 09

**South Africa**

HI-TECH BOOKS, P. O. Box 1142, RANDBURG,  
Transvaal 2125, Tel. (011) 886-2020

**Spain + Portugal**

Julio A. Prieto Alonso, EA 4 CJ, MADRID-15,  
Donoso Cortés 58 5<sup>a</sup>-B, Tel. 243.83.84

**Sweden**

Lars Pettersson, SM 4 IVE, Pl. 1254, Smögården Talby,  
S-71500 ODENSBACKEN, Tel. 19-50223, Pg. 914379-3

**Switzerland**

Terry Bittan, Schweiz, Kreditanstalt ZÜRICH,  
Kto. 469.253-41; PSchKto. ZÜRICH 80-54.849  
Leo Kälin, HB 9 CKL, Funktechnik  
Alte Landstr. 175, CH 8708 Männedorf  
Tel. 01-9203535

**USA**

Timekit  
P. O. Box 22277,  
Cleveland, Ohio 44122  
Phone: (216) 464-3820

ISSN 0177-7505



# Contents



|   |   |           |
|---|---|-----------|
| Klaus Eichel, DC 6 HY/<br>Hans-L. Rath, DL 6 KG | <b>GrafTrak and Mirage Interface (MTI) –<br/>Something Really Good for the Radio Amateur!</b> | 66 - 74   |
| Matjaž Vidmar,<br>YT 3 MV                       | <b>Digital Signal Processing Techniques<br/>for Radio Amateurs<br/>Theoretical Part</b>       | 76 - 97   |
| Dr. Eng. Jochen Jirmann,<br>DB 1 NV             | <b>A Thermal Power Mount</b>  | 98 - 102  |
| Matjaž Vidmar,<br>YT 3 MV                       | <b>Receiving Converter for 4-GHz-Band Satellite</b>   | 103 - 110 |
| Carsten Vieland,<br>DJ 4 GC                     | <b>50 Ω Wideband Detectors</b>  | 111 - 125 |

VHF COMMUNICATIONS cover illustration shows a portion of the earth as taken from FO 12 at a given point in time. A series of data information is superimposed in accordance with the programme offered by GrafTrak.

The Editor



**UKWberichte** Terry D. Bittan · Jahnstr. 14 · Postfach 80 · D-8523 Baiersdorf

Tel. West Germany 9133 47-0. For Representatives see cover page 2



*Klaus Eichel, DC 6 HY and Hans-L. Rath, DL 6 KG*

## GrafTrak and Mirage Tracking Interface (MTI) – Something Really Good for the Radio Amateur!

In the autumn of last year, UKW-TECHNIK took the agency for an antenna-control program, called **MIRAGE TRACKING INTERFACE (MTI)**, from the Californian firm of **MIRAGE/KLM**. The software used for this application came from the Texas firm **SILICON SOLUTIONS, Inc.** Its developers, **W 5 SXD** and **WB 5 CCJ** were honoured in 1986 by the **AMSAT-NA** in recognition of these outstanding programs which have been called "GrafTrak" and "Silicon Ephemeris". The latter program takes its name from the astronomical tables which indicate the pre-calculated position of a heavenly body at any given time.

Before dealing with the antenna control, which automatically tracks satellites, the Sun and the Moon, the complex software developed by Silicon Solutions will be described. This software is definitely not intended for the normal amateur who just requires a certain satellite to utilize in order to conduct QSOs. For the amateur, however, who has a fascination for all things satellite,

and is prepared to pay a lot of money for his interest, then this is **THE** program for him. Not all the possibilities of these programs can be dealt with here as the original manual for the MTI is covered by a good one hundred pages!

---

### 1. THE SILICON SOLUTIONS' PROGRAMS

---

In order to enable a radio link to be established via a satellite path, the time must be known during which the satellite is available together with information concerning the antenna's position in both the azimuth and elevation. The first satellite programs for computers were presented in the form of tables of time, azimuth and elevation which could be imparted manually to the antenna. The next step, entailed a graphical representation of the earth by the software which

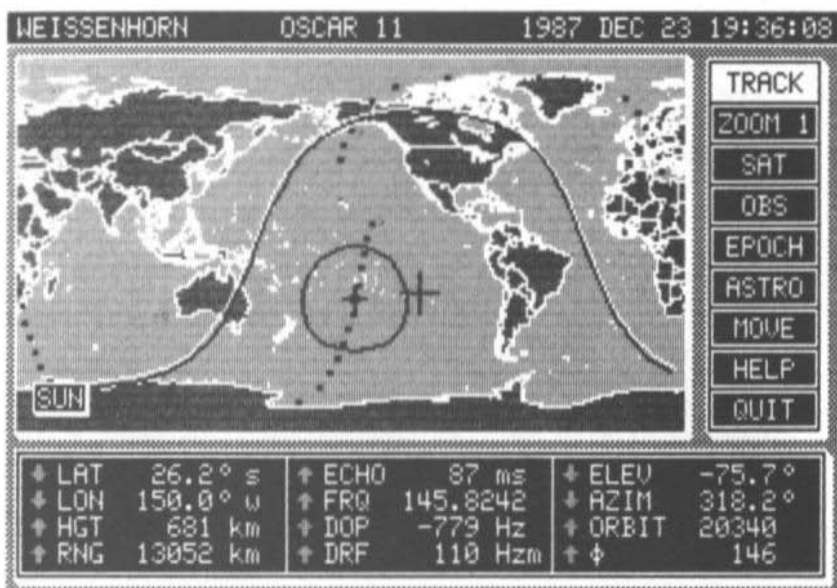

Fig. 1: GrafTrak presentation of OSCAR 11 over the Pacific Ocean. The dotted lines mark its path, the time between 2 dots being chosen as 2 minutes. This curve indicates the Sun's "movements", its momentary position is marked with a large cross.

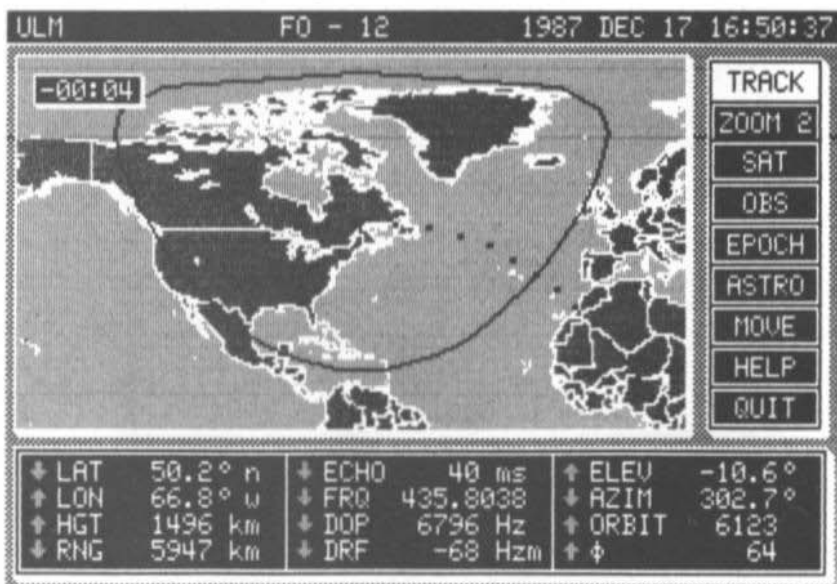

Fig. 2: GrafTrak presentation of Fugli-OSCAR 12 (FO-12) over North America with a twofold magnification (zoom 2). Four minutes are shown in the upper left insert, indicating the count-down time to the satellite's appearance.



showed the operator the various countries over which the satellite was passing at a given time (1). The development by Silicon Solutions combines a graphical representation with twelve digital functions which are updated every second (fig. 1), whereby the satellite's orbit and the radio communication range is displayed every 15 seconds.

## 1.1. The "GrafTrak" Program

### 1.1.1. Orbital Tracking

This program has been written for the IBM-PC or a compatible version of it. Furthermore, equipment requirements are: CGA, RGB or monochrome monitor, HD and one FD or two FD, 8087 or 80287 coprocessors, 512 kByte RAM. Hard-

disc operation is to be preferred but is not absolutely necessary.

The user can store up to a maximum of 16 satellites and 16 ground locations and decide which satellite of these is the most important and should appear first, together with one's own QTH. The changing over from one satellite to another or from one ground terminal to another is, however, quite simple. In the "autoswitch" mode, the computer gives several acoustical alarms before the satellite comes up and also the count-down time (given in a superimposed insert window, see fig. 2) until the satellite's appearance.

The earth's presentation uses the Mercator projection and the various country boundaries are surprisingly detailed and precise. A zoom facility enables the picture to be enlarged – ideal

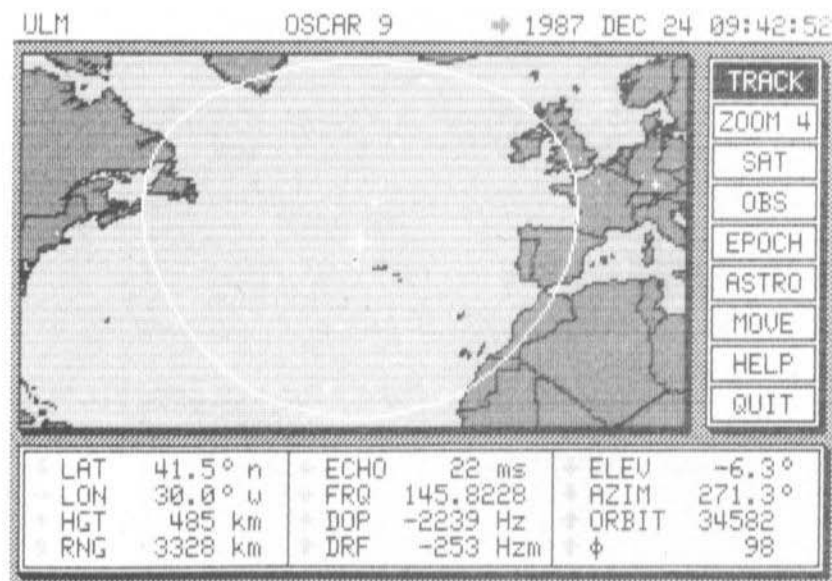

Fig. 3: GrafTrak presentation of OSCAR 9 over the Atlantic using a 4-fold magnification (zoom 4).

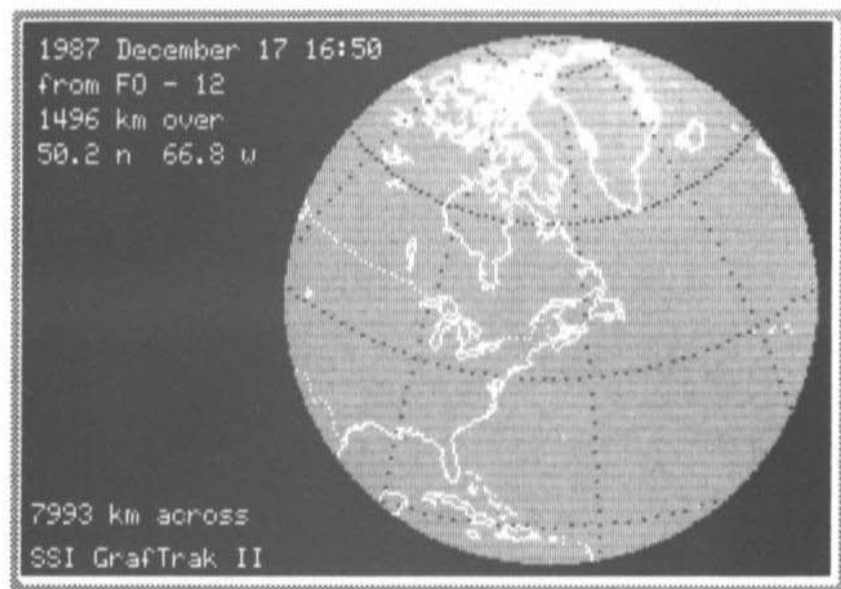

Fig. 4: GrafTrak with a global presentation shows FO-12 over North America. This fig. is associated with fig. 2.

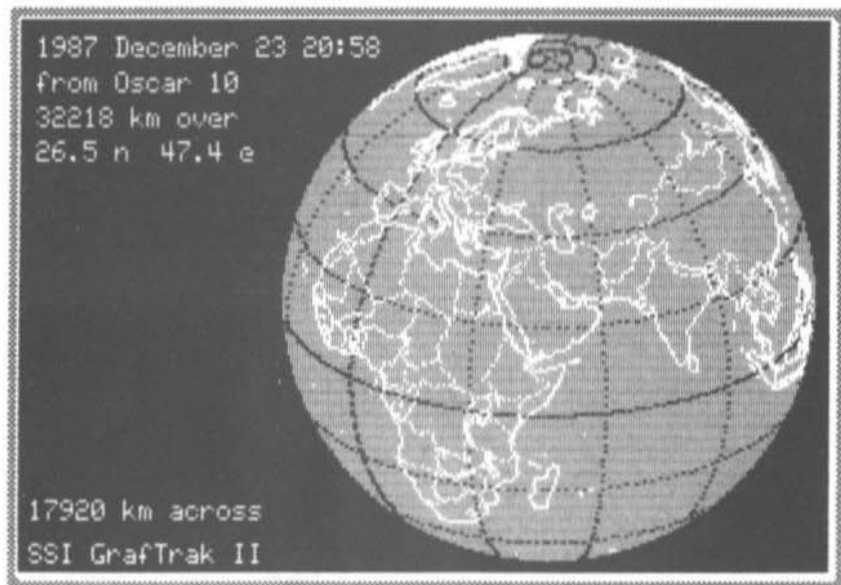

Fig. 5: GrafTrak with a global presentation showing OSCAR 10 over Saudi-Arabia. This fig. belongs to fig. 15.



if the rise and set of a satellite and its detectability are to be followed closely. Using the automatic zoom facility, the program selects a scale by which the chosen observation point will see the sub-satellite point at its maximal magnification (see fig. 3).

The Sun's illumination on the satellite, or lack of it, and also that of the earth itself, can be studied if the Sun's rays are superimposed. The dark curve represents the night side and the white side is the daylight zone. Also, the position on the earth at which the Sun is directly overhead is marked with a large cross (fig. 1). This particular presentation could be of interest for the low, HF-band DXers (Gray-Line DXing).

For satellite communication, the program runs in real-time but with the EPOCH mode, any chosen time, past or future, can be programmed in order that certain observations can be examined more closely or for the planning of future orbits. In addition, the program allows all satellites (reception only) to be prominently tagged. The great versatility that both program developers have incorporated into the commands and presentations, never fail to elicit surprise!

The graphical presentations are supplemented by a series of alpha-numerical entries (figs. 1,

2, 3). The top row shows the selected observation point, that is, in most cases, where the operator's QTH is located. The selected satellite is also indicated together with the date and time. If the computer is required to be used for other applications, local time may be programmed for Graf-Trak instead of GMT (UTC).

The information at the bottom of the display in the left-hand column gives the sub-satellite position (SSP) in longitude and latitude together with the satellite's height over the SSP and the point-to-point distance to the observer.

The middle column "ECHO" indicates the time a radio signal requires to traverse to and from the satellite. "FRQ" is the satellite's transponder frequency with an inbuilt correction for the Doppler shift effect. "DOP" represents the actual Doppler shift frequency and "DRFT" is the shift in Hertz per minute.

The right-hand column contains first, the two quantities required for the antenna guidance system, azimuth and elevation. "ORBIT" is the continuously updated orbit count of the satellite's trips around earth. Theta ( $\Phi$ ) is numbered from zero to 256 and, as far as OSCAR 10 is concerned (for Germany), is known as MA (middle anomaly)(2).

```
Silicon Ephemeris V2.0 Copyright (C) 1985, 1986, 1987
Silicon Solutions, Inc.
```

```
Mode 0 = exit to Operating System
```

```
Mode 1 = one observer to all satellites
```

```
Mode 2 = all observers to one satellite
```

```
Mode 3 = schedule for one observer to one satellite
```

```
Mode 4 = window between two observers and one satellite
```

```
Mode 5 = rise and set times for one satellite
```

```
Mode 6 = time ordered alerts for all satellites
```

```
Mode 7 = one observer to all satellites (astro)
```

```
Mode 8 = all observers to one satellite (astro)
```

```
Mode 9 = schedule for one observer to one satellite (astro)
```

```
Mode 10 = detailed ephemeris for Sun/Moon
```

```
Mode 11 = all observers to Sun/Moon
```

```
Mode 12 = schedule for one observer to Moon
```

```
Mode 13 = window between two observers and Moon
```

```
Mode 15 = schedule for one observer to Sun
```

```
Mode 18 = Sun/Satellite visibility
```

```
Mode 20 = select a new database file
```

```
Enter mode ( 1 ) : _____
```

Fig. 6:  
Silicon Ephemeris 15  
working possibilities





Silicon Ephemeris V2.0 Copyright (C) 1985, 1986, 1987 Silicon Solutions, Inc.  
observer(s): Weissenhorn object(s): Oscar 10

Wochenplan for Oscar 10

| rise        |       |       |        |       | set  |       |  |
|-------------|-------|-------|--------|-------|------|-------|--|
| utc         | azim  | orbit | length | utc   | azim | orbit |  |
| Sun 20Dec87 | 15:47 | 196.2 | 3400   | 10:34 |      |       |  |
| Mon 21Dec87 | 15:05 | 187.2 | 3402   | 10:31 |      |       |  |
| Tue 22Dec87 | 14:24 | 176.9 | 3404   | 10:27 |      |       |  |
| Wed 23Dec87 | 13:44 | 165.2 | 3406   | 10:21 |      |       |  |
| Thu 24Dec87 | 13:06 | 150.9 | 3408   | 10:11 |      |       |  |
| Fri 25Dec87 | 12:32 | 132.8 | 3410   | 09:57 |      |       |  |
| Sat 26Dec87 | 02:56 | 296.0 | 3411   | 02:01 |      |       |  |
| Sat 26Dec87 | 12:11 | 107.5 | 3412   | 09:27 |      |       |  |
| Sun 27Dec87 | 01:11 | 286.6 | 3413   | 05:05 |      |       |  |
| Sun 27Dec87 | 12:16 | 82.5  | 3414   | 08:28 |      |       |  |
| Mon 28Dec87 | 00:01 | 279.2 | 3415   | 06:58 |      |       |  |
| Mon 21Dec87 | 02:21 | 132.3 | 3400   |       |      |       |  |
| Tue 22Dec87 | 01:36 | 125.7 | 3402   |       |      |       |  |
| Wed 23Dec87 | 00:51 | 118.9 | 3404   |       |      |       |  |
| Thu 24Dec87 | 00:05 | 112.3 | 3406   |       |      |       |  |
| Thu 24Dec87 | 23:17 | 106.1 | 3408   |       |      |       |  |
| Fri 25Dec87 | 22:29 | 99.6  | 3410   |       |      |       |  |
| Sat 26Dec87 | 04:57 | 302.8 | 3411   |       |      |       |  |
| Sat 26Dec87 | 21:38 | 93.3  | 3412   |       |      |       |  |
| Sun 27Dec87 | 06:16 | 301.4 | 3413   |       |      |       |  |
| Sun 27Dec87 | 20:44 | 87.0  | 3414   |       |      |       |  |
| Mon 28Dec87 | 06:59 | 294.2 | 3415   |       |      |       |  |

Fig. 7:  
Silicon  
Ephemeris:  
Example of a  
week's schedule  
for OSCAR 10.

The arrow, accompanying every data item, indicates the trend of the on-going series of information.

The column on the right-hand edge of the display shows the various symbols of the selected program mode. "TRACK" is the output mode and is almost continuously in operation. "ZOOM"

indicates the magnification x 1, x 2 or x 4. With "SAT" and "OBS", the desired satellite or observation point can be selected from sixteen applications, in each case. "EPOCH" represents the desired time-frame. With "ASTRO", the Sun, Moon or a star may be selected. The "MOVE" facility shifts the map of the earth. The manual

Silicon Ephemeris V2.0 Copyright (C) 1985, 1986, 1987 Silicon Solutions, Inc.  
observer(s): ULM object(s): all

| date        | object   | beacon   | rise     | tca      | set   | elev | az  |
|-------------|----------|----------|----------|----------|-------|------|-----|
| Thu 17Dec87 | RS 10+11 | 29.3570  | 02:51:14 | 02:54:14 | 02:57 | 2    | 297 |
| Thu 17Dec87 | FD - 12  | 435.7970 | 06:48:47 | 06:59:00 | 07:09 | 23   | 126 |
| Thu 17Dec87 | FD - 12  | 435.7970 | 08:47:34 | 08:59:26 | 09:11 | 62   | 146 |
| Thu 17Dec87 | FD - 12  | 435.7970 | 10:49:03 | 11:01:11 | 11:13 | 84   | 352 |
| Thu 17Dec87 | RS 10+11 | 29.3570  | 11:09:30 | 11:16:48 | 11:24 | 17   | 78  |
| Thu 17Dec87 | FD - 12  | 435.7970 | 12:51:14 | 13:03:24 | 13:15 | 90   | 2   |
| Thu 17Dec87 | RS 10+11 | 29.3570  | 12:52:48 | 13:01:41 | 13:10 | 88   | 317 |
| Thu 17Dec87 | RS 10+11 | 29.3570  | 14:40:47 | 14:48:25 | 14:56 | 18   | 300 |
| Thu 17Dec87 | FD - 12  | 435.7970 | 14:53:06 | 15:04:50 | 15:16 | 49   | 220 |
| Thu 17Dec87 | RS 10+11 | 29.3570  | 16:35:25 | 16:37:29 | 16:39 | 1    | 327 |
| Thu 17Dec87 | FD - 12  | 435.7970 | 16:55:33 | 17:04:52 | 17:14 | 15   | 239 |
| Thu 17Dec87 | RS 10+11 | 29.3570  | 20:17:44 | 20:20:19 | 20:22 | 1    | 35  |
| Thu 17Dec87 | RS 10+11 | 29.3570  | 22:01:25 | 22:09:15 | 22:17 | 19   | 61  |
| Thu 17Dec87 | RS 10+11 | 29.3570  | 23:46:57 | 23:55:54 | 00:04 | 86   | 291 |

Thu 17Dec87 passes = 15

|             |          |          |          |          |       |    |     |
|-------------|----------|----------|----------|----------|-------|----|-----|
| Fri 18Dec87 | RS 10+11 | 29.3570  | 01:33:32 | 01:40:42 | 01:47 | 16 | 283 |
| Fri 18Dec87 | FD - 12  | 435.7970 | 05:56:38 | 06:05:39 | 06:14 | 14 | 121 |
| Fri 18Dec87 | FD - 12  | 435.7970 | 07:54:01 | 08:05:38 | 08:17 | 47 | 140 |
| Fri 18Dec87 | FD - 12  | 435.7970 | 09:54:55 | 10:07:01 | 10:19 | 89 | 8   |
| Fri 18Dec87 | RS 10+11 | 29.3570  | 09:59:46 | 10:03:13 | 10:06 | 2  | 64  |
| Fri 18Dec87 | RS 10+11 | 29.3570  | 11:38:41 | 11:46:54 | 11:55 | 32 | 84  |
| Fri 18Dec87 | FD - 12  | 435.7970 | 11:57:03 | 12:09:13 | 12:21 | 83 | 6   |
| Fri 18Dec87 | RS 10+11 | 29.3570  | 13:23:42 | 13:32:24 | 13:41 | 50 | 288 |
| Fri 18Dec87 | FD - 12  | 435.7970 | 13:59:01 | 14:11:00 | 14:22 | 63 | 213 |
| Fri 18Dec87 | RS 10+11 | 29.3570  | 15:13:30 | 15:19:53 | 15:26 | 10 | 309 |
| Fri 18Dec87 | FD - 12  | 435.7970 | 16:01:02 | 16:11:30 | 16:21 | 24 | 233 |
| Fri 18Dec87 | FD - 12  | 435.7970 | 18:08:38 | 18:10:29 | 18:12 | 0  | 251 |
| Fri 18Dec87 | RS 10+11 | 29.3570  | 20:47:04 | 20:52:20 | 20:57 | 5  | 45  |
| Fri 18Dec87 | RS 10+11 | 29.3570  | 22:31:53 | 22:40:24 | 22:48 | 33 | 68  |

Fri 18Dec87 passes = 14

Fig. 8:  
Silicon Ephemeris:  
Examples of all  
satellite's passings  
for 2 transponder  
satellites during  
two days and ordered  
according to time.  
(tca = time of  
closest approach)



Silicon Ephemeris V2.0 Copyright (C) 1985, 1986, 1987 Silicon Solutions, Inc.  
 observer(s): ULM object(s): Oscar 11

**Fig. 9:**  
**Silicon**  
**Ephemeris:**  
**Example of an**  
**OSCAR 11**  
**orbit with time**  
**increments of**  
**two minutes.**

| Bulletin-Empfang von Oscar 11 |      |       |       |      |       |        |          |           |     |
|-------------------------------|------|-------|-------|------|-------|--------|----------|-----------|-----|
| utc                           | elev | azim  | range | lat  | lon   | height | beacon   | orbit phi |     |
|                               | deg  | deg   | km    | deg  | deg   | km     | MHz      |           |     |
| Sat 19Dec87 19:34:00          | 7.6  | 126.2 | 2346  | 35.3 | 28.9  | 703    | 145.8279 | 20282     | 24  |
| Sat 19Dec87 19:36:00          | 17.9 | 110.8 | 1693  | 42.4 | 26.7  | 706    | 145.8273 | 20282     | 30  |
| Sat 19Dec87 19:38:00          | 28.2 | 77.6  | 1303  | 49.6 | 24.0  | 709    | 145.8257 | 20282     | 35  |
| Sat 19Dec87 19:40:00          | 24.6 | 34.4  | 1420  | 56.6 | 20.7  | 711    | 145.8235 | 20282     | 40  |
| Sat 19Dec87 19:42:00          | 13.4 | 10.2  | 1955  | 63.6 | 16.1  | 713    | 145.8224 | 20282     | 45  |
| Sat 19Dec87 19:44:00          | 4.3  | 358.9 | 2662  | 70.4 | 8.8   | 715    | 145.8220 | 20282     | 50  |
| ---                           |      |       |       |      |       |        |          |           |     |
| Sat 19Dec87 21:10:00          | 3.5  | 187.9 | 2702  | 26.1 | 6.6   | 699    | 145.8281 | 20283     | 18  |
| Sat 19Dec87 21:12:00          | 13.1 | 196.4 | 1950  | 33.3 | 4.8   | 702    | 145.8279 | 20283     | 23  |
| Sat 19Dec87 21:14:00          | 27.6 | 216.1 | 1313  | 40.5 | 2.7   | 705    | 145.8271 | 20283     | 28  |
| Sat 19Dec87 21:16:00          | 39.1 | 267.0 | 1048  | 47.6 | 0.2   | 708    | 145.8248 | 20283     | 33  |
| Sat 19Dec87 21:18:00          | 28.5 | 313.1 | 1390  | 54.7 | -2.9  | 711    | 145.8227 | 20283     | 39  |
| Sat 19Dec87 21:20:00          | 11.9 | 330.4 | 2051  | 61.7 | -7.1  | 713    | 145.8220 | 20283     | 44  |
| Sat 19Dec87 21:22:00          | 2.8  | 338.3 | 2807  | 68.6 | -13.5 | 715    | 145.8219 | 20283     | 49  |
| ---                           |      |       |       |      |       |        |          |           |     |
| Sat 19Dec87 22:52:00          | 1.2  | 258.2 | 2948  | 38.6 | -21.4 | 704    | 145.8262 | 20284     | 27  |
| Sat 19Dec87 22:54:00          | 3.0  | 276.0 | 2769  | 45.7 | -23.7 | 707    | 145.8253 | 20284     | 32  |
| Sat 19Dec87 22:56:00          | 2.6  | 294.7 | 2821  | 52.8 | -26.6 | 710    | 145.8243 | 20284     | 37  |
| Sat 19Dec87 22:58:00          | 0.1  | 311.4 | 3089  | 59.9 | -30.5 | 712    | 145.8235 | 20284     | 42  |
| ---                           |      |       |       |      |       |        |          |           |     |
| Sun 20Dec87 07:26:00          | 1.6  | 58.4  | 2904  | 55.6 | 48.0  | 705    | 145.8260 | 20289     | 87  |
| Sun 20Dec87 07:30:00          | 2.9  | 76.6  | 2762  | 48.5 | 44.8  | 701    | 145.8251 | 20289     | 93  |
| Sun 20Dec87 07:32:00          | 2.0  | 95.1  | 2852  | 41.3 | 42.2  | 697    | 145.8242 | 20289     | 98  |
| ---                           |      |       |       |      |       |        |          |           |     |
| Sun 20Dec87 09:04:00          | 7.8  | 25.9  | 2343  | 64.5 | 29.3  | 709    | 145.8281 | 20290     | 81  |
| Sun 20Dec87 09:06:00          | 19.2 | 38.2  | 1629  | 57.5 | 24.4  | 706    | 145.8277 | 20290     | 86  |
| Sun 20Dec87 09:08:00          | 33.1 | 70.1  | 1117  | 50.4 | 20.9  | 702    | 145.8262 | 20290     | 91  |
| Sun 20Dec87 09:10:00          | 33.8 | 128.5 | 1140  | 43.3 | 18.2  | 698    | 145.8236 | 20290     | 96  |
| Sun 20Dec87 09:12:00          | 17.7 | 157.9 | 1678  | 36.1 | 16.0  | 694    | 145.8223 | 20290     | 102 |
| Sun 20Dec87 09:14:00          | 6.5  | 169.3 | 2403  | 28.9 | 14.0  | 690    | 145.8219 | 20290     | 107 |
| ---                           |      |       |       |      |       |        |          |           |     |
| Sun 20Dec87 10:40:00          | 1.2  | 3.9   | 2961  | 72.9 | 15.4  | 712    | 145.8281 | 20291     | 74  |
| Sun 20Dec87 10:42:00          | 9.4  | 353.3 | 2221  | 66.3 | 6.3   | 710    | 145.8279 | 20291     | 79  |
| Sun 20Dec87 10:44:00          | 20.0 | 337.6 | 1594  | 59.4 | 0.9   | 706    | 145.8271 | 20291     | 85  |

doesn't always need to be consulted as there is a "HELP" facility which outlines the important commands and presents other information on the screen. With "QUIT", the computer leaves Graf-Trak and re-joins DOS.

### 1.1.2. Spherical Representation

The program contains a further surprising feature inasmuch that it can present a three-dimensional view of the earth as seen from the satellite. First, the longitude and latitude co-ordinates are drawn in, followed by coast lines and country borders.

Figures 4 and 5 show examples of this facility from the perspective of FO-12 and OSCAR 10 satellites showing clearly the gain in distance when the satellite moves out further from the earth in its orbit.

It is also possible to store these pictures or to print them out. Furthermore, these pictures may be presented for any desired altitude of the satellite and at any desired co-ordinate. Several of these 3-D presentations which have been stored can be re-played thus making a "movie". In order to ensure that these computer-intensive presentations occur in rapid order, a co-processor is necessary.



Silicon Ephemeris V2.0 Copyright (C) 1985, 1986, 1987 Silicon Solutions, Inc.  
observer:1 Weissenhorn/Honolulu object: Oscar 10

Verbindung mit Hawaii via Oscar 10

| utc                  | Primary |       |       | Alternate |       |       | orbit | phi |
|----------------------|---------|-------|-------|-----------|-------|-------|-------|-----|
|                      | elev    | azim  | range | elev      | azim  | range |       |     |
| Thu 10Dec87 05:00:00 | 12.1    | 288.5 | 39923 | 10.7      | 67.2  | 40065 | 3378  | 135 |
| Thu 10Dec87 05:30:00 | 10.7    | 289.9 | 39515 | 12.4      | 67.6  | 39332 | 3378  | 146 |
| Thu 10Dec87 06:00:00 | 9.1     | 291.0 | 38662 | 13.7      | 68.2  | 38175 | 3378  | 157 |
| Thu 10Dec87 06:30:00 | 7.5     | 291.6 | 37344 | 14.6      | 69.0  | 36591 | 3378  | 168 |
| Thu 10Dec87 07:00:00 | 5.8     | 291.7 | 35535 | 14.8      | 70.0  | 34577 | 3378  | 179 |
| Thu 10Dec87 07:30:00 | 4.0     | 291.1 | 33200 | 14.0      | 71.4  | 32128 | 3378  | 190 |
| Thu 10Dec87 08:00:00 | 2.1     | 289.2 | 30294 | 11.7      | 73.2  | 29251 | 3378  | 201 |
| ---                  |         |       |       |           |       |       |       |     |
| Thu 10Dec87 14:30:00 | 0.0     | 63.2  | 38406 | 0.9       | 292.7 | 38306 | 3379  | 88  |
| Thu 10Dec87 15:00:00 | 2.2     | 63.7  | 39593 | 0.0       | 294.2 | 39822 | 3379  | 99  |
| ---                  |         |       |       |           |       |       |       |     |
| Fri 11Dec87 04:00:00 | 19.2    | 281.2 | 39304 | 1.4       | 64.5  | 41197 | 3380  | 129 |
| Fri 11Dec87 04:30:00 | 17.8    | 282.7 | 39174 | 3.1       | 64.9  | 40732 | 3380  | 140 |
| Fri 11Dec87 05:00:00 | 16.3    | 284.0 | 38606 | 4.6       | 65.5  | 39844 | 3380  | 150 |

**Fig.10:**  
**Silicon Ephemeris:**  
**Example for a contact schedule between DL and Hawaii using OSCAR 10.**

## 1.2. The "Silicon Ephemeris" Program

As impressive as GrafTrak is, for planning a program of work which involves using the transponder of a certain satellite, a software is required which has the necessary wizardry for the display on the screen, printer or to store on a diskette. The Silicon Ephemeris program is extraordinarily versatile, which may be seen from a perusal of the 15 various methods of working, given in fig. 6.

Four examples should make this clear. **Figure 7** is a print-out for a weeks scheduled working using OSCAR 10 (mode 5 of fig. 6).

**Figure 8** shows a table of the two active satellites in a circular orbit with transponders, given as a function of time (mode 6 of fig. 6).

Finally, the table such as **fig. 9**, enables the antenna to be manually aligned, here for OSCAR 11, using a chosen time interval of two minutes (mode 3 of fig. 6).

Satellite Database Editor V 2.0 Copyright (C) 1985,86,87 Silicon Solutions  
file: DEMO edited: 21 Dec 1987 10:06  
title: Amateur satellites: 8 observer: 16

| observer name  | Weissenhorn | command:            |            |
|----------------|-------------|---------------------|------------|
| north latitude | 48.31       | degrees (- south)   | object: 13 |
| east longitude | 10.17       | degrees (- west)    |            |
| height         | 522         | meters              |            |
|                |             | E - edit            |            |
|                |             | S - satellite       |            |
|                |             | O - observer        |            |
|                |             | N - next            |            |
|                |             | P - previous        |            |
|                |             | .on - object 01-16  |            |
|                |             | C - clear entry     |            |
|                |             | R - read entry      |            |
|                |             | W - write entry     |            |
|                |             | G - get data        |            |
|                |             | U - roll up         |            |
|                |             | T - edit file title |            |
|                |             | X - exit            |            |
|                |             | Q - quit            |            |
|                |             | Esc - to this menu  |            |

**Fig. 11:**  
**Satellite editor:**  
**Table for the observer QTH.**



```

Satellite Database Editor V 2.0 Copyright (C) 1985,86,87 Silicon Solutions
file: DEMO edited: 21 Dec 1987 10:06
title: Amateur satellites: 8 observer: 16

satellite name Oscar 10 command:
element set desc Obj # 14129, Set # 311 object: 2
epoch year 1987
epoch day 284.74484093 E - edit
inclination 27.4620 degrees S - satellite
r. a. a. n. 357.8710 degrees D - observer
eccentricity 0.6026827 N - next
arg of perigee 247.3929 degrees P - previous
mean anomaly 40.3386 degrees ,nn - object 01-16
mean motion 2.05885112 orbits/day C - clear entry
decay (ndot2) -0.00000207 orbits/day/day R - read entry
use decay? 1 O=no, I=yes W - write entry
orbit number 3256 G - get data
orbit base 0 O=perigee, I=equator U - roll up
semi-major axis 0.0 km T - edit file title
beacon frequency 145.8100 MHz X - exit
uplink frequency 435.1 MHz Q - quit
offset frequency 0 MHz Esc - to this menu
doppler type 0 O=beacon, I=echo

```

**Fig. 12:**  
Satellite editor:  
Table for the  
Kepler orbital  
data

Figure 10 for example, shows a path between Weissenhorn and Hawaii via OSCAR 10 (mode 4 of fig. 6). A corresponding schedule for an EME contact is possible with mode 13 of fig. 6. There is no more space here to show any examples of its astronomical utilization.

### 1.3. The "Satellite Editor" Program

This program enables files from both GrafTrak and Silicon Ephemeris to be made available for satellites and observers. This enables the user to continuously express his requirements, for example, all active transponder satellites in one

file, weather satellites in another and the current active orbiting satellites FO-12 as well as RS-10/11 load into a third file. For the fixed locations, longitude and latitude together with altitude above sea-level should be given (fig. 11).

The satellite data corresponds to that of the Kepler orbital data (3.4), as they are used worldwide (fig. 12). Both entries can be changed easily with the editor program in order that the necessary updating of the Kepler values for the closer orbital satellites will be no problem. Provision was also made for this data to be transferred from one file to another.

The final part will follow at a later date.



We accept **VISA Credit Card, Eurocard** (Access/Master Card) and only require the order against your signature, card number and its expiry date.



VHF COMMUNICATIONS / UKW-BERICHTE

# SIEMENS

GaAs transistors, GaAs MMICs

## Giga speed in large numbers

**Giga:** from VHF to K band  
**Speed:** ex stock  
**Numbers:** on tape & reel, for cost-saving SMD assembly, in CERamic EConomy (CEREC) packages

**Product families:**

|                         |                |
|-------------------------|----------------|
| 0.5 $\mu\text{m}$ FETs: | CFY 18-xx      |
| 1 $\mu\text{m}$ FETs:   | CFY 19-xx      |
| dual-gate FETs:         | CFY 20, CFY 22 |
| GaAs MMICs:             | CGY 40         |



For your applications in the SHF range, an outstanding combination in performance: cascadable - low-noise - linear - fail-safe.

All GaAs components are offered in HiRel/MIL versions as well.

By the way, we are experts in silicon microwave devices, too.

If you'd like to hear more, just write Siemens AG, Infoservice 12/Z069e, quoting "GaAs microwave devices".

In USA:

Siemens Components Inc.  
Special Products Division  
186 Wood Ave. South  
Iselin, NJ 08830

**TopTech Components:**  
**Siemens**

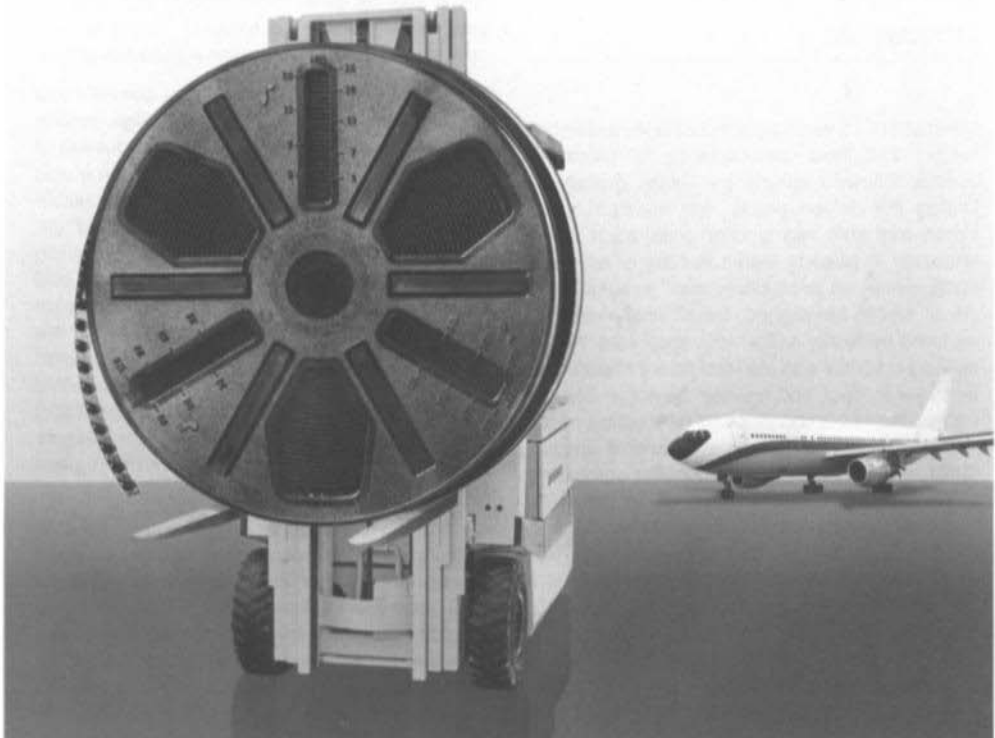



Matjaž Vidmar, YT3MV

# Digital Signal Processing Techniques for Radio Amateurs

## Theoretical Part

---

### 1. Introduction

---

Up to about 15 years ago, the design, assembly, testing and field maintenance of electronic circuits followed almost the same guidelines. During the design phase, the function of the circuit was split into smaller units, each corresponding to already tested circuits or available components. In production, after assembly the circuit had to be aligned, tested and eventually repaired by highly skilled test engineers. Highly skilled personnel was also required for field maintenance to spot and replace defective components. Due to the continuously decreasing prices and increasing complexity of available components, mainly integrated circuits, the complexity of the overall circuit became no longer limited by the cost of the components or assembly, but with the time and cost required to design, align, test and maintain a circuit. For instance, repairing a printed circuit board containing 100 TTL SSI function (gates, FFs, counters) ICs when the malfunction only appears at particular environment conditions (higher temperature or only from time to time) is an almost impossible task. Spotting the source of a problem in an analog

circuit can be even more difficult and requires expensive test equipment (oscilloscope, spectrum analyzer ...) besides a skilled engineer.

Easy to use 8 bit microprocessors solved many of the problems of digital circuit design, testing and maintenance, beside a further reduction of the cost of the hardware. The design time was shortened by introducing complex but reliable microprocessor and peripheral integrated circuits while test and / or debugging routines could be implemented at little if any additional cost in the final product. Although microprocessor technology created some new problems, like software design and maintenance, the overall effect was a great simplification over hardwired logic designs, either hardwired SSI TTL or CMOS logic or custom ICs. In fact, microprocessors replaced hardwired logic in all but the highest speed digital circuits.

Of course, continuous efforts were made to simplify the design and testing of the more difficult analog circuits. For example, a very successful innovation was the introduction of the operational amplifier: the design engineer could finally concentrate on the differential equations describing his problem instead of thinking how to bias his transistors ... Some analog problems could be solved more easily if electrical signals were re-



placed by other physical quantities. For instance, a long-delay line is easier to make with mechanical waves, and Surface Acoustic Wave (SAW) filters can now be found in almost all IF strips of domestic TV sets.

**The basic idea of Digital Signal Processing (DSP) is to replace an electrical circuit with its mathematical equivalent, solving the equations describing the circuit numerically in real time. The latter can be done either with hardwired logic or with computers. Of course DSP circuits do not require any tuning or alignment, since the tolerances of the components are only limited by the accuracy of the numerical models used. Production line testing and maintainance is limited to check the operation of a microprocessor.**

Beside cost advantages, DSP circuits allow the designer to use components that could hardly be implemented with analog electronic components: tuned circuits with arbitrary, even infinite but stable values of  $Q$ , easily variable component values during circuit operation (adaptive processing) or very complex algorithms that would require a very large number of high accuracy analog components (Fast Fourier Transform).

The main drawback of DSP is a limited bandwidth of all the signals present in the circuit: all the computations usually have to be performed at a rate of at least twice the signal bandwidth. DSP circuits are therefore limited to IF, audio and video applications. DSP circuits also require very fast logic or powerful microprocessors to provide useable results. This is the reason why DSP has only become popular with advanced 16 and 32 bit microprocessors and corresponding peripherals.

DSP has much to offer to radio-amateurs as well, especially since little if any alignment is necessary. DSP circuits will certainly replace expensive crystal filters within a few years. Some "forgotten" techniques like the phasing method for the generation of a SSB signal will again become popular due to the accuracy (and the ease with which it can be obtained) of DSP circuits. A microprocessor-based DSP hardware can be programmed for different circuits. For instance, the same hardware can generate all possible

modems for all known amateur modulation standards, including new experiments. DSP techniques can also improve weak-signal communications: narrowband CW filters can be built which ring much less than their analog counterparts and weak-signal detection and/or demodulation circuits can be built with performances beyond that of a human ear. Finally, some communication modes could become more popular thanks to DSP, especially image communications.

---

## 2. DSP CIRCUIT EXAMPLES

---

### 2.1. Principles of DSP circuits

A DSP circuit can generally be split into an interface part including A/D and D/A converters and related circuits to interface to the analog "environment" and a digital part performing some numerical operations on the digitalised analog signals (fig. 1). Of course, a DSP circuit may also include digital inputs or outputs, either when the signals are already available in digital format or when a conversion between an analog and a digital format is performed by the DSP circuit (DSP modems).

The input analog signal is first band limited essentially to prevent interferences called aliasing: a finite number of samples taken by the following sample-and-hold stage can only represent a limited bandwidth signal. The sample-and-hold circuit and following A/D converter are triggered periodically at regular intervals called the sampling period or its inverse, the sampling frequency. The latter should be at least twice the signal bandwidth: practical applications require a sampling frequency 2.5 to 3 times the signal bandwidth due to circuit imperfections.

The accuracy of the A/D and D/A conversions affects the available dynamic range of the DSP circuit: if the digital signal format is binary (as usual), then every additional bit increases the dynamic range by 6 dB. Finally, the output of the D/A converter again requires some analog

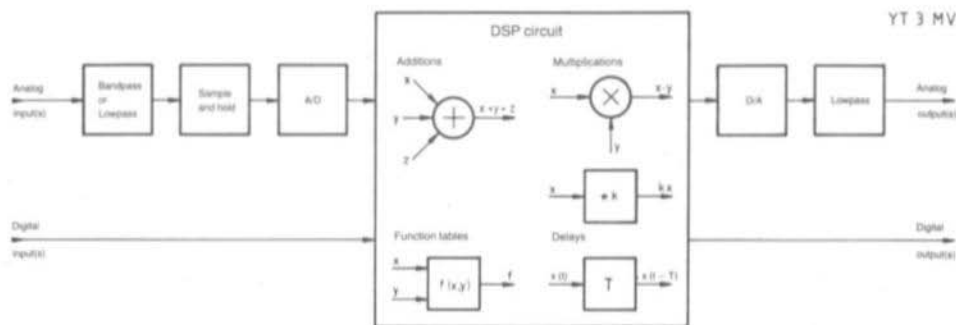

Fig. 1: DSP circuit principles

filtering to obtain the desired signal without spurious frequencies or distortions.

The following discussion will concentrate on the digital part of a DSP circuit and in particular on the various algorithms used to generate different circuit functions. The analog circuit designer has a number of different components available to generate the functions desired. The former could be grouped in three groups: linear amplifiers and attenuators to adjust signal levels, energy storing components like capacitors, inductors, delay lines and resonators to generate frequency dependent networks, and finally nonlinear components like rectifiers or multipliers (balanced mixers).

The DSP circuit designer has to replace all these components with mathematical algorithms that will be computed on each input signal sample coming from the A/D converter and will provide a regular stream of output signal samples to the D/A converter. Which algorithms are actually available to the DSP designer? Gains and attenuations can simply be performed by multiplying signal samples with a constant. Of course, a separate multiplication has to be performed on each signal sample. Although division could also be used, the hardware required for division is usually more complex (or, in other words, a microprocessor usually needs more time to

perform a division than a multiplication operation) and a multiplication with the inverse value is usually used.

Frequency dependent networks are usually built using delay lines. The delays are usually selected to be equal to or to be integer multiples of the signal sampling period: such delays can simply be implemented by using one or more previous signal samples in the computations on the actual signal sample. Circuits using delay lines and feedback can efficiently simulate capacitors, inductors and resonators.

Nonlinear components are represented by nonlinear functions. For instance, full wave rectification can simply be obtained by inverting the polarity of the signal subtracting the value from zero only when the sign is found negative. Multipliers or balanced mixers can be straightforwardly replaced by a multiplication operation. More complex functions, like the square root, trigonometric or other transcendent functions are very time consuming to be computed in real time on every signal sample. Therefore, function tables are prepared in advance and stored in memory. During real time processing, the operation is limited to retrieve the precomputed value from the lookup table memory (either ROM or RAM).





## 2.2. Simple linear circuits

Engineers usually describe the operation of linear analog circuits using linear differential equations (this is the reason why such equations were invented for...). The total number of independent energy storing components, like independent springs and masses in a mechanical problem or independent capacitors and inductors in an electrical circuit determines the order (and the complexity) of the resulting differential equation.

A DSP circuit will be a good replacement for an analog circuit if its operation can be described by a similar equation. Since DSP circuits work on a uniform stream of signal samples and not on continuous signals, there is no way to compute derivatives nor to obtain a differential equation. One can however compute differences between successive samples: if the sampling period is sufficiently short these can be con-

sidered a good approximation for derivatives. DSP circuits are therefore described with finite difference equations. Although the latter can be arranged in a form similar to the differential equations describing analog circuits to show the similarities, in practice it is usually simpler to solve the difference equation immediately!

A simple RC lowpass and its DSP equivalent are shown on **fig. 2**. The RC lowpass is described by a first-order differential equation since it contains a single capacitor. Its DSP equivalent includes a delay element and a feedback network. Rearranging the difference equation and considering that the difference between two successive signal samples divided by the time interval  $T$  between the two samples can be a good estimate for the first derivative, the difference equation becomes very similar to the differential equation of the analog circuit, except for a gain factor.

Simple (analog) low pass:

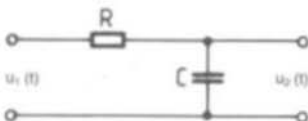

Corresponding differential equation:

$$\frac{d(u_2(t))}{dt} + \frac{u_2(t)}{RC} = \frac{u_1(t)}{RC}$$

Equivalent DSP circuit:

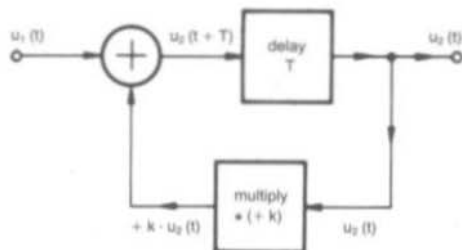

Finite difference equation:

$$u_2(t+T) - u_2(t) + k \cdot u_2(t) = u_1(t) \quad \text{or}$$

$$\frac{u_2(t+T) - u_2(t)}{T} + \frac{(1-k)}{T} \cdot u_2(t) = \frac{u_1(t)}{T}$$

Fig. 2: A simple analog lowpass and its DSP equivalent



LC-tuned circuit:

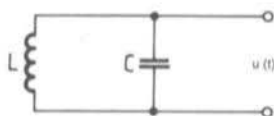

Corresponding differential equation:

$$\frac{d^2(u(t))}{(dt)^2} + \frac{u(t)}{LC} = 0$$

YT 3 MV

Equivalent DSP circuit:

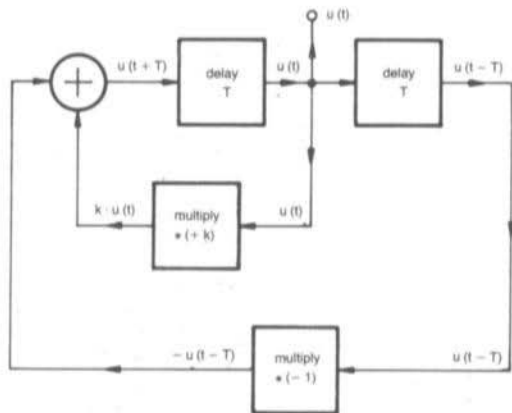

Finite difference equation:

$$u(t+T) = k \cdot u(t) - u(t-T) \quad \text{or}$$

$$\frac{u(t+T) - u(t)}{T} - \frac{u(t) - u(t-T)}{T} + \frac{(2-k)}{T^2} u(t) = 0$$

Fig. 3: An LC tuned circuit and its DSP equivalent

An LC-tuned resonant circuit contains two energy storing components and is described by a second order differential equation. Its DSP equivalent (**fig. 3**) must contain two independent delay elements. Again, the difference equation describing the DSP circuit can be re-arranged to become similar to the differential equation of the analog resonator: three successive signal samples are required to compute the approximation for the second derivative.

The analog LC circuit shown and its equation correspond to the ideal case of a lossless resonator. It is well known that such a resonator

can not be built in practice, since there are always some loss mechanisms. On the other hand, a lossless resonator (with infinite Q) can readily be built as a (stable!) DSP circuit. The loss (or gain) factor depends on the coefficient that multiplies the output of the second delay element:  $(-1)$  corresponds to a lossless resonator. Since the multiplication with  $(-1)$  only involves a sign change, it is always accurate: there is no truncation of the result. The output of such a circuit is a constant amplitude sine-wave, depending only on the initial conditions — energy stored in the two delay elements when the circuit was started.



YT 3 MV

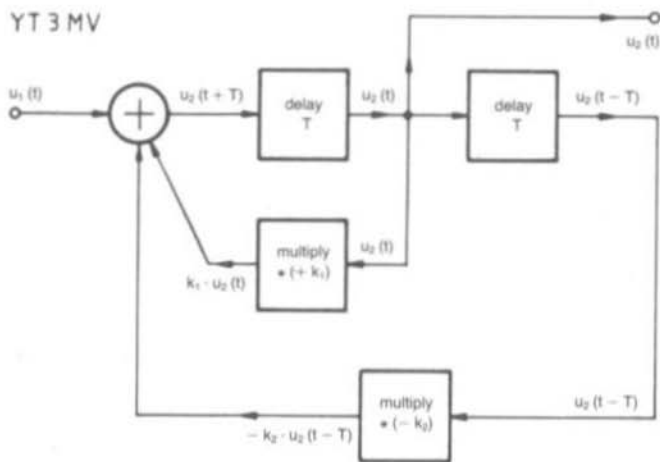

$$\text{Equation: } u_2(t+T) = u_1(t) + k_1 \cdot u_2(t) - k_2 \cdot u_2(t-T)$$

Fig. 4:  
A single "tuned circuit"  
band pass: Infinite  
impulse Response (IIR or  
recursive) filter

### 2.3. Infinite Impulse Response (IIR) or recursive filters

The DSP lowpass and resonator described above are just two members of a more general group of DSP circuits called Infinite Impulse Response (IIR) or recursive filters. These circuits always contain feedback networks and their response to a single input pulse always includes a form of exponential decay. In practice they are used as a DSP replacement for analog filters using discrete components like capacitors, inductors or resonators (quartz crystals).

Fig. 4 shows a simple recursive filter corresponding to a single LC damped resonant circuit. Compared to the lossless resonator, the output of the second delay element is multiplied by a negative constant ( $-k_2$ ) whose absolute value is less than one. The input signal is simply added to the feedback signals and fed into the delay elements. The overall transfer function is similar, except for a gain factor, to that of a loaded LC circuit.

More complex IIR filters can be obtained by a series connection of "single-tuned-circuit" filters or by designing a filter with more delay elements. Compared to analog filters, the series connection is simpler since there is no influence from the next filter back to the previous one: no separation amplifiers are required and the overall transfer function is simply a product of all the transfer functions of the single filters.

### 2.4. Finite Impulse Response (FIR) filters

Finite Impulse Response filters also include delay elements and multiplications with coefficients, but they do not include any feedback loops, as shown on fig. 5. Their impulse response is therefore limited in time to the sum of all the delay elements used. FIR filters are also built in analog technologies using tapped delay lines. The most popular analog implementation are Surface Acoustic Wave (SAW) filters.

The coefficients of a FIR filter have a straightforward influence on the impulse response of

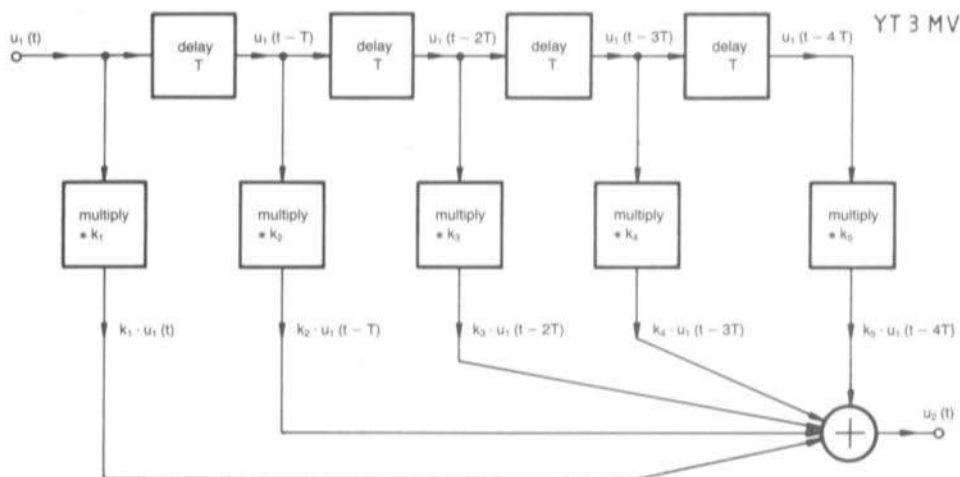

Fig. 5: A stage Finite Impulse Response (FIR or nonrecursive) filter

the filter, if one imagines a single pulse propagating along the delay line.

FIR filters require more stages and more computations for the same frequency response when compared to IIR filters. On the other hand, their time-domain response and group delay can be easily controlled. The differential group delay of a FIR filter becomes zero if symmetrical coefficients are selected: for example  $k_1$  equals  $k_5$  and  $k_2$  equals  $k_4$  in the filter on fig. 5.

FIR filters are therefore very useful where differential group delay is a problem, like with image or data transmissions, either to avoid distorting the signal or to correct distortions already present in the signal. SAW filters have therefore a definite advantage over conventional LC filters in television IF strips. DSP FIR filters will probably be used by radio-amateurs for CW reception, since they ring much less than discrete-component filters, which necessarily have an infinite impulse response.

A major application area of DSP is adaptive signal filtering to eliminate distortions: the actual

signal distortion is monitored continuously and the data obtained is used to update the coefficients of a distortion correcting FIR filter.

## 2.5. The discrete Fourier transform and the FFT algorithm

The Fourier transform is an algorithm that computes the spectrum of a signal from its waveform. It has the form of an integral with infinite bounds and the result is a function which is also defined over the interval from minus to plus infinity. Such a mathematical problem is very difficult to solve numerically for an arbitrary input function. The inverse Fourier transform, used to obtain back the original signal, is mathematically almost identical to the Fourier transform itself.

A limited bandwidth signal can be sampled without losing any information. On a limited number  $N$  of successive samples an approximate algorithm can be computed, called the discrete Fourier transform. The discrete Fourier transform is equivalent to a batch of FIR filters each tuned to



its own frequency. From  $N$  signal samples  $N$  different frequency components can be computed using  $N$  FIR filters each having  $N$  stages. Since the phases of the various spectral components are not known, all the computations are assumed to be done with complex numbers! The inverse operation, obtaining  $N$  signal samples from  $N$  frequencies, is very similar to the discrete Fourier transform too and requires the same number of mathematical operations.

The discrete Fourier transform is still a very time consuming computational task, since  $N^2$  complex multiplications and  $N^2$  complex additions have to be performed. The main idea of the Fast Fourier Transform (FFT) algorithm is to change the order of multiplications and additions to reduce the overall number of operations. FFT works on numbers of samples  $N$  that are integer powers of 2,  $N = 2^M$ , the number of operations required can be reduced to only  $N \cdot M$ !

The FFT algorithm has many applications, not limited to DSP and signal processing at all. The most obvious is a spectrum analyzer, unfortunately only for audio bandwidths or slightly above using available microprocessor technology.

The possibility to obtain the inverse transform in a similar way makes FFT-based filters and other circuits practical.

## 2.6. Nonlinear functions

Nonlinear functions can be computed either directly or, if the algorithm is too complex to be computed in real time on each sample, by using precomputed function tables. The following example shows the solution of an important practical problem using a precomputed function table.

The most widely used nonlinear function is certainly the fullwave rectifier, usually as an AM demodulator, which can be simply implemented. However, this is not the only way to build an AM demodulator. A major drawback of a full wave rectifier is that it requires to be followed by a low pass filter to eliminate any remainings of the carrier frequency. The low pass filter becomes quite complex if the carrier frequency is comparable to the modulation signal bandwidth.

A typical example is the demodulation of weather-satellite APT image transmissions. The signal

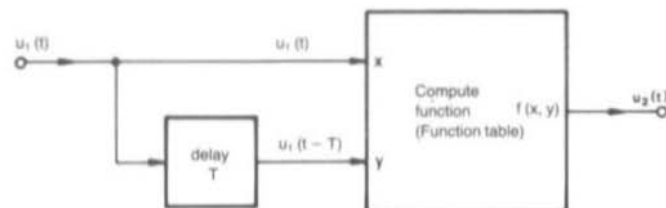

$$f(x, y) = k_1 \cdot \sqrt{x^2 + y^2} - k_2 xy$$

$$k_1 = \frac{1}{\sin \omega T} ; k_2 = 2 \cos \omega T$$

$$\text{If: } u_1(t) = A \cdot \cos(\omega t + \varphi)$$

$$\text{then: } u_2(t) = f(x, y) = A$$

**Special case:**

$$\omega T = \frac{\pi}{2} \text{ (90° degrees)}$$

$$f(x, y) = \sqrt{x^2 + y^2}$$

YT 3 MV

Fig. 6: A high performance AM demodulator



YT 3 MV

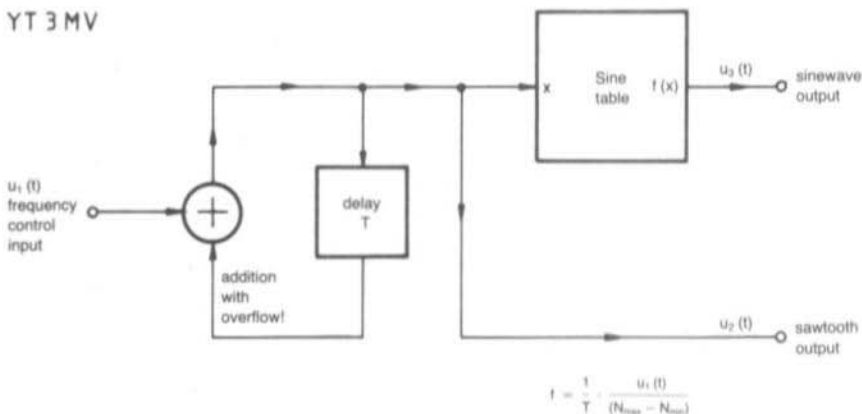

Fig. 7: A sawtooth/sinewave voltage controlled oscillator

obtained from a VHF FM receiver is an amplitude modulated 2400 Hz subcarrier with the video signal, which has a bandwidth in excess of 1600 Hz. Any residual carrier frequency will cause severe interference patterns on the image when the demodulated signal is sampled to obtain discrete pixels, if the pixel sampling frequency is not an exact submultiple of the carrier frequency.

An alternative, high-performance AM demodulator, that does not require any post-demodulation low-pass filtering, is shown on **fig. 6**. The amplitude of a sinewave can be computed from two successive samples, but this operation requires 4 multiplications, two additions and one square root to be computed for each sample. With the sampling frequency set to 4 times the carrier frequency, the formula becomes much simpler: only two multiplications, one addition and a square root are required. This is still not very practical, since the algorithm to compute the square root is time consuming: it requires a minimum of 5 division operations and as many additions and shifts.

A further speedup can be obtained by considering the actual data formats. The logarithmic A/D converter supplies samples coded to 8 bits:

one sign bit, 3 exponent bits and 4 mantissa bits. The sign bit can be discarded immediately, since only the square of the signal is used in computing the function. The desired result is a function of two 7 bit samples, totally 14 bits. These 14 bits are used to address a function table of the size of  $2^{14} = 16384$  memory locations containing all possible function results. The result is computed by a single access to the lookup ROM!

Function tables are therefore very practical as long as their size is affordable. In the above case, the size of the lookup table is multiplied by four for every additional bit supplied by the A/D converter! On the other hand, the direct computation of transcendent functions can be very time consuming, usually more than 10 multiplications and as many additions. Even some of the most powerful dedicated DSP microprocessors already have an on-chip lookup table ROM for the sine function!

## 2.7. Fixed-frequency oscillators and VCOs

Like their analog equivalents, DSP circuits need oscillators for carrier generation, frequency mixing or signal demodulation. Although models



of analog oscillators could also be built using DSP techniques, there are a number of simpler algorithms to generate oscillators in DSP. One was already mentioned: a lossless resonator circuit. Building oscillators can be even simpler if one considers the actual data formats.

For example, the circuit shown on **fig. 7** would generate a continuous slope if the addition were an ideal mathematical operation. However, at a certain time instant, overflow is reached. In the case of integer arithmetics, the value suddenly jumps from the most positive to the most negative number. The circuit generates a sawtooth waveform which is a slowly increasing slope from  $N_{\min}$  to  $N_{\max}$  and then a sudden jump back to  $N_{\min}$ . The amplitude of the oscillator is constant and equal to the maximum dynamic range that can be represented by a given data format.

The oscillator frequency is defined with the ratio of the number added each time compared to the available number range and of course multiplied with the sampling frequency. The number added each time can be a variable or the output of another DSP circuit. In this way a VCO can be built to form a phase-locked loop for example.

A sinewave output can be obtained from a sine-function table addressed by the original sawtooth. Triangular and square waves can be obtained by simple operations on the original sawtooth waveform. Harmonic frequencies, sometimes required in PLL carrier-recovery circuits, can be obtained by a simple multiplication (with overflow) of the sawtooth signal: due to the higher amplitude, overflows will occur more frequently.

## 2.8. A practical example: a 1200 bps PSK demodulator

Replacing a simple RC low pass with an expensive microprocessor is probably not worth the effort. DSP circuits become useful when more functions are performed by the same DSP hardware, like a complete demodulator or modem. The following example shows how different DSP algorithms can be combined into a useful circuit.

JAS1, renamed FUJI-OSCAR-12 after its successful launch in August 1986, is a radio-

amateur satellite receiving in the 145 MHz band and transmitting in the 435 band. Beside a linear, analog transponder it carries a digital transponder connected to the onboard computer. The latter is usually programmed to work as a multi-user mailbox to support store-and-forward type communications between radio amateurs. The downlink in the 435 MHz band is a 1200 bps PSK transmission and its bandwidth corresponds to that of available SSB receivers. PSK modulation was chosen since it efficiently uses the satellite transmitter output power and can be efficiently demodulated using coherent demodulators.

The signal at the output of a SSB receiver is suitable to be processed by a DSP circuit. In the actual circuit, the receiver audio output is sampled 9600 times per second with a 8 bit logarithmic A/D converter (telephone CODEC). Using a lookup table the samples are converted to a 16 bit linear format and sent to the circuit shown on **fig. 8**.

The signal path is straightforward: the incoming signal samples are multiplied by the locally regenerated carrier. This multiplication generates 32 bit products. This result is truncated so that only the most significant upper 16 bits are used for further processing. A two stage recursive low pass filter follows to eliminate any residual carrier signals. The output of the circuit is a NRZI data stream, which is simply limited and sent to the digital circuits for clock and data recovery (not shown on **fig. 8**).

The carrier recovery PLL is slightly more complex. The original PSK transmission does not contain any discrete spectral components at or around the carrier frequency. However, if the square of the signal is computed, a discrete spectral line appears at twice the carrier frequency. Squaring would require an elaborate AGC circuit to keep the PLL loop gain constant, so it was replaced with a simple search for zero crossing transitions in the original PSK signal: this rough approximation generates a discrete spectral line at twice the clock frequency as well.

The transition detector triggers a sampling phase detector operating on a double frequency sawtooth signal coming from the VCO. In fact, the

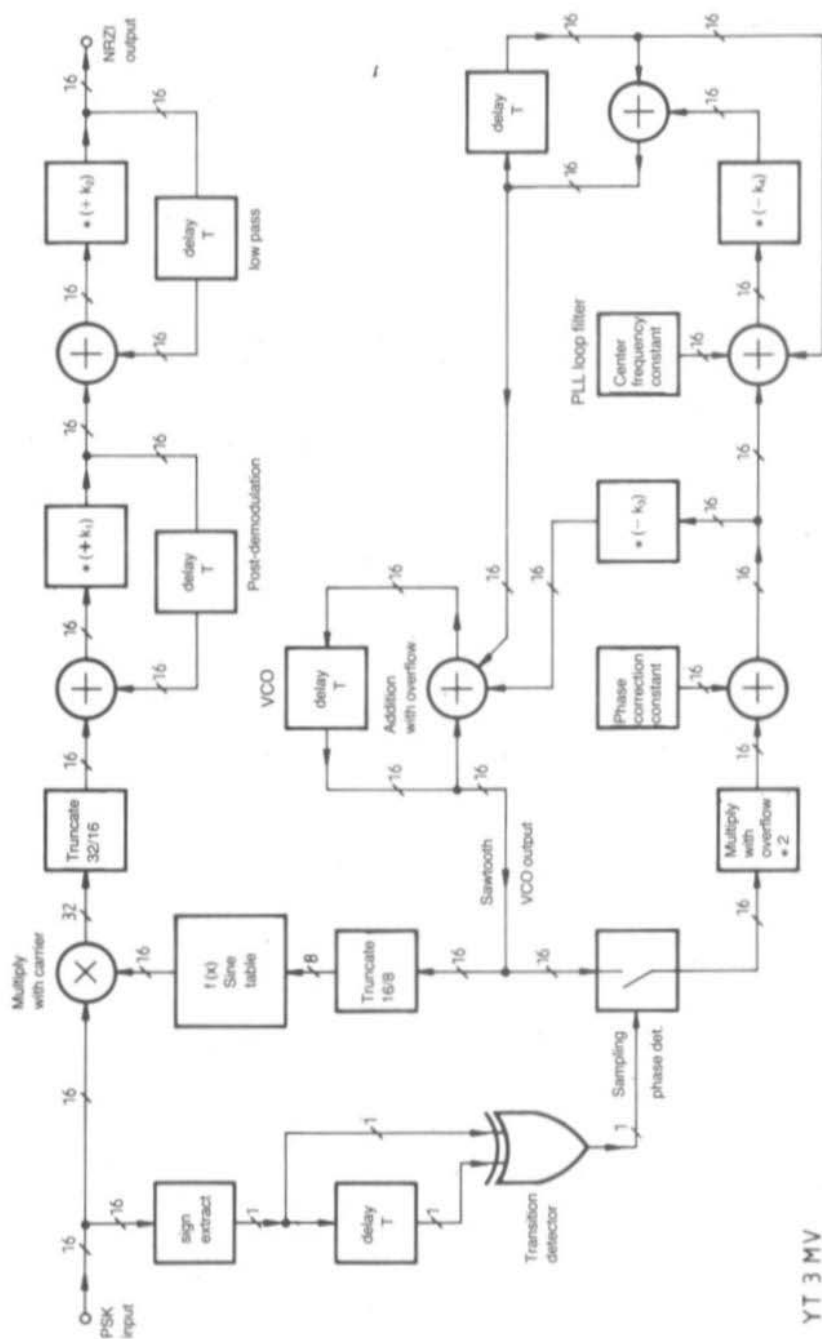

Fig. 8: 1200 bps PSK demodulator





frequency of the sawtooth is only doubled after the sampling detector to reduce the average number of mathematical operations. After adding a phase correction constant, the PLL error signal is passed through the loop filter. Since the PLL itself introduces a 90 degrees phase shift in the loop, the low-pass loop filter has to be designed to introduce an even smaller phase shift to avoid reaching instability at 180 degrees. The familiar resistor-capacitor network used in analog PLLs can be easily reproduced in DSP too: part of the feedback goes through  $(-k_3)$  directly to the VCO (resistor divider) while another part goes through a recursive filter (RC low pass).

The sawtooth generated by the VCO is transformed to a sinewave using a lookup table. Since a 16 bit accuracy is not required, only the most significant 8 bits are used to address the lookup table. The choice of the carrier frequency is arbitrary in theory. In practice, interferences with the bit rate frequency and passband limitations of SSB receivers limit the carrier frequency range to between 1500 and 1800 Hz for a 1200 bps PSK signal.

The circuit shown on fig. 8 was practically built in the form of a machine-code program for a MC68010 microprocessor (shown on fig. 9) and tested in real time on live satellite signals. Since the execution of this machine code routine only takes 31 microseconds or less for each signal sample, while samples are taken every 104 microseconds, the same microprocessor was also used for all data handling from the A/D converter to data demodulation and display, including an "all software" AX.25 controller (a detailed description is omitted for simplicity).

Practical results have shown that there is a considerable margin on the satellite signal, received with a 10-turn helix antenna and masthead pre-amp. Reception of error free AX.25 frames was still possible when the signal was more than 10 dB below normal (due to local obstructions), when noise was audible and contact with the satellite was already lost due to insufficient uplink performance. With such a high performance demodulator and a higher power transmitter (around 200 W), operation with the JAS1 mailbox using omnidirectional antennas should be possible.

### 3. HARDWARE FOR DSP

#### 3.1. A/D and D/A converters

Although not related directly to the DSP theory, A/D and D/A converters are important parts of a practical DSP system and may sometimes limit its performance. DSP systems require relatively fast A/D converters with sampling frequencies between 10 kHz and several tens MHz. D/A converters can more easily meet the specifications, since a simple R-2R network D/A can work at video frequencies and above.

Basically, two different types of A/D converters can be used: the "successive approximation" A/D converter and the "flash" A/D converter. "Successive approximation" A/D converters compute the digital result in steps, each additional bit taking one step. During all this time the input analog voltage must remain stable: "successive approximation" A/Ds require a high-performance sample-and-hold circuit for correct operation. Due to the internal step-by-step algorithm and the requirement for a high-performance sample-and-hold their operation is not particularly fast, up to about 100 kHz sampling frequency. They can however provide accuracies of up to 16 bits and beyond. Telephone CODECs are 12 bit "successive approximation" A/D converters, the format is however internally converted to 8 bits logarithmic (floating point).

"Flash" A/D converters include internally a large number of voltage comparators, one for each quantization step. Their outputs are connected to a priority encoder which supplies the digital result. "Flash" A/Ds usually don't need any sample-and-hold circuitry since the signal is sampled in an internal latch between the comparators and the priority encoder. Their operation is very fast: cheap types for video applications work up to 20 MHz, others can reach several hundred MHz. Their accuracy is however limited by the number of comparators that can be integrated into a single circuit to about 8 bits (which require 256 comparators, as many latches and a 256 input priority encoder).

\*\*\* 1200 bps PSK demodulator program for MC68010 \*\*\*

Input: D1.W  
 Output: D1.W  
 Address reference: A2  
 Other registers used: D0, D2

```

3401  MOVE.W D1,D2          ! Save input sample to D2
3012  MOVE.W (A2),D0       ! VCO output to D0
E048  LSR.W #8,D0        ! Truncate D0 content to 8 bits
E348  LSL.W #1,D0        ! Even address offset
0640  ADDI.W #0250,D0     ! Offset to start of sine table
0250                                     !
C3F2  MULS #00(A2,D0.W),D1 ! Multiply with carrier
0000                                     !
301A  MOVE.W (A2)+,D0     ! VCO output to D0
3212  MOVE.W (A2),D1     ! Previous sign to D1
0242  ANDI.W #8000,D2    ! Extract sign in D2
8000                                     !
34C2  MOVE.W D2,(A2)+    ! New sign to (A2)+
9441  SUB.W D1,D2        ! Any sign difference?
670E  BEQ #0E           ! Branch if signs equal >>-----\
3400  MOVE.W D0,D2      ! VCO output to D2
E34A  LSL.W #1,D2      ! Multiply by 2 (overflow!)
0442  SUBI.W #2000,D2   ! Phase correction
2000                                     !
3202  MOVE D2,D1        ! Phase difference to D1
E841  ASR.W #4,D1       ! Multiply by 1/16
9041  SUB.W D1,D0       ! Correction to VCO phase
321A  MOVE.W (A2)+,D1   ! VCO frequency to D1 <<-----/
D441  ADD.W D1,D2      ! Get new VCO frequency
945A  SUB.W (A2)+,D2    ! Add center frequency constant
E042  ASR.W #8,D2      ! Multiply by 1/256
9242  SUB.W D2,D1      ! Get new VCO frequency
3541  MOVE.W D1,#FFFC(A2) ! Save VCO frequency
FFFC                                     !
D041  ADD.W D1,D0      ! Get new VCO phase
3540  MOVE.W D0,#FF8(A2) ! Save VCO phase
FF8                                     !
4841  SWAP D1          ! Result to lower 16 bits
D252  ADD.W (A2),D1    ! Lowpass #1
E241  ASR.W #1,D1     ! Multiply by 1/2
34C1  MOVE.W D1,(A2)+  !
D252  ADD.W (A2),D1    ! Lowpass #2
E241  ASR.W #1,D1     ! Multiply by 1/2
34C1  MOVE.W D1,(A2)+  !

```

Fig. 9: PSK demodulator program example



D/A converters are usually driven to supply a constant output voltage during the time interval to the next sample. The output of a D/A converter should therefore be a step function, but due to the finite speed of its internal circuit the output needs some time to settle to the new value. During this settling time spikes may appear on the output due to the internal switching processes. These spikes may cause severe distortions, especially to video signals. The parameter that describes the magnitude of these spikes is called the glitch energy and should of course be minimized if possible.

The step function supplied by the D/A is not the best solution; ideally the D/A should provide very narrow pulses sent to an ideal low pass filter. The step function generates a low pass filter with a frequency function of the form  $\text{SIN}(X)/X$ . The D/A converter therefore requires at its output both an analog low pass filter to eliminate harmonics and an analog high pass to correct for the  $\text{SIN}(X)/X$  spectrum dependence.

### 3.2. Data formats

When designing a practical DSP system, a suitable digital data format has to be selected. The accuracy of the data format will limit the dynamic range of the system. Errors caused by data format inaccuracies are called quantisation noise. When selecting a data format it is not sufficient to find the corresponding A/D converter. The dynamic range may substantially increase in some DSP algorithms. For example, a recursive resonator filter may increase the signal magnitude by its Q factor, a FIR filter may increase the magnitude by the absolute sum of all its coefficients (usually many) and the FFT algorithm may increase the magnitude by a factor equal to the number of signal samples on which the FFT was computed.

A simple and widely used data format are binary integer numbers. The dynamic range of a binary integer is roughly equal to the number of bits multiplied by 6 dB (smaller deviations from this simple rule are caused by different methods of measuring the quantisation noise). Thus, an 8 bit binary integer will allow a dynamic range of

roughly 48 dB and a 16 bit binary integer format will allow a dynamic range of roughly 96 dB.

Binary integers can be signed or unsigned. Unsigned integers are always considered positive. A signed integer is considered negative if its most significant bit is a logical one. For example, the value of the binary number 1111 is considered 15 (fifteen) if it is an unsigned integer, but it is a -1 (minus one) if it is a signed integer. Microprocessors usually support both integer formats; addition and subtraction instructions are identical for both integer formats, there are only differences in the multiply and divide instructions.

The selection between signed and unsigned integers depends on the actual problem to be solved with the DSP circuit. Signed integers are suitable for signals that can have both polarities, like audio signals in general. Unsigned integers are suitable for single polarity signals, like video signals or image processing in general.

When the absolute magnitude of a signal is not known, the floating-point data format (also called real-number format) has to be used. The floating-point format includes a sign bit, a binary exponent and a mantissa. The exponent itself is a signed integer while the mantissa is an unsigned integer. Floating-point mathematical operations require more hardware and more time to be executed than integer operations, therefore they are not very popular in DSP.

A special case of the floating-point format is the telephone CODEC format: 1 sign bit, 3 exponent bits (chord bits) and 4 mantissa bits (step bits), for a total of only 8 bits. A/D and D/A converters for this particular format are available under the name CODEC and are inexpensive since they are widely used in telephone exchanges all over the world. Unfortunately there are two slightly different standards: the American mu-law and the European A-law. Although no mathematical operation can be performed directly on the 8 CODEC bits, the format is very suitable for lookup-table processing due to the very small size of lookup tables! Even some of the most powerful dedicated DSP microprocessors have ROM conversion tables for the CODEC formats.



### 3.3. Hardwired logic DSP circuits

The first real-time DSP circuits were implemented in hardwired TTL logic, since no suitable computers were available. Due to the high complexity and cost, DSP circuits were only used in places where there were no alternatives. Algorithms were simple due to the high cost of multipliers. The main function of DSP circuits was usually analog data storage for time expansion or contraction functions, like scan converters between different imaging systems.

Even today high-speed video DSP systems require hardwired logic, although integrated on a single chip. The new MAC television standard will probably use such decoders in domestic TV receivers. Another consumer video application is an adaptive FIR filter for automatic ghost elimination.

Hardwired logic DSP circuits are both complex and expensive. Once built they can not be re-programmed for another function and modifications are difficult. While custom-integrated circuits may reduce costs in volume industrial applications, these are out of reach for amateur experimenters. General purpose or dedicated DSP microprocessors are therefore used wherever possible in place of hardwired logic designs.

### 3.4. General purpose microprocessors

General purpose microprocessors can be used for DSP, but due to speed limitations their use is restricted to audio and lower frequencies. For example, a voice audio signal is usually sampled at 8 kHz, or every 125 microseconds. A typical 8 bit microprocessor takes about 200 microseconds to compute a single 16 bit by 16 bit product yielding a 32 bit result, using ADD and SHIFT instructions in a short machine code program. Therefore, an 8 bit microprocessor can not compute even the simplest DSP filter in real time. Some simple lookup table algorithms are however possible.

16 bit microprocessors offer an increase in the computing speed of about two orders of magnitude. The latter is not due much to the increased bus speed but rather to the much more powerful

instruction set, so that much less instructions are required for the same operation. A larger number of internal registers allows to decrease the number of data transfers on the bus even further. Multiply and divide operations are implemented as single instructions. A 16 by 16 bit multiply only takes about 4 microseconds in a modern 16 bit microprocessor, like the Intel 80286, NEC V30 or Motorola MC68010.

These components allow many useful DSP circuits to be built in software. If a sampling frequency of around 8 kHz is used (voice-bandwidth audio signal), filters of up to about 10th to 15th order can be built. This is sufficient for a complete FSK modem for RTTY, ASCII or PACKET up to 1200 bps and including all post-demodulation processing (UART or X.25 controller) and data display to be implemented in software on a single 16 bit microcomputer. A real-time 256 point FFT is also within range of 16 bit microprocessors.

Many actually available 32 bit microprocessors are merely 32-bit-bus copies of their 16 bit counterparts and are not significantly faster. Their processing power is limited by the same problems as 16 bit microprocessors: pipeline instruction decoding and relatively long execution times for some instructions.

Pipeline instruction decoding means that an instruction is not executed immediately after it has been fetched from the program memory but it is decoded sequentially and finally executed two or three instruction fetch cycles later. This process does not slow down the execution as long as the program does not contain jumps. After a program jump however, the content of the pipeline decoder is no longer usable and the execution only resumes after two or three instruction fetch cycles. This process slows down the execution of short program loops considerably.

16 bit microprocessors require a large number of clock cycles to execute complex instructions, like multiple shifts, multiply or divide instructions. The hardware used to execute the latter is usually a state machine with a microprogram ROM. Since hardware shifters, multipliers and dividers are at least an order of magnitude faster than a state machine, considerable improve-



ments in the computing speeds can be expected in future microprocessors.

Floating point coprocessors are usually of little use in DSP: their high computational accuracy (up to 64 bit mantissa) is actually not required in DSP, while low accuracy (16 bit) integer arithmetics is not faster than that of the master (general purpose) CPU.

### 3.5. Dedicated DSP microprocessors

As soon as microprocessor-based DSP became technically possible, the first dedicated DSP microprocessors appeared. Dedicated DSP microprocessors are optimized according to the specific requirements of DSP: very high speed arithmetic operations but (relatively) little memory both for data and program. High computation speeds are achieved both by using hardware adders, shifters and multipliers and by using separate buses for instructions and data.

Since separate buses require a very large number of connections, the memory is usually integrated on the same chip together with the microprocessor and only a few connections are taken out through the pins of the IC. The on-chip program memory is either ROM or RAM or both, since accessing external memory usually slows down the microprocessor.

One of the first and now most popular DSP microprocessors is the Texas Instruments TMS32010. Thanks to an on-chip hardware multiplier it is able to compute a 16 by a 16 bit product in just 200 nanoseconds, more than an order of magnitude faster than general-purpose 16 bit microprocessors. State of the art dedicated DSP microprocessors, both from the TMS320xx family and from other manufacturers are able to compute a product in less than 100 ns.

A disadvantage of dedicated DSP microprocessors is certainly their complex internal structure making them more difficult to program. Compared to general-purpose microprocessors they have a very small addressing range (for example: TMS32010 only 4 kilowords); this slows down the microprocessor when using large look-up tables or longer programs or when

processing large amounts of data, like images. Finally, a dedicated DSP microprocessor typically needs the support of a general-purpose microprocessor to work efficiently.

---

## 4. RADIO-AMATEUR APPLICATIONS OF DSP

---

### 4.1. Demodulators and modems

The first amateur applications of DSP techniques are certainly different demodulators and modems. These circuits are usually connected between an amateur receiver or transceiver and a home computer to receive and transmit in RTTY, ASCII, PACKET and other digital communications formats. Although amateur modems are usually not very complex, usually just a few operational amplifiers or other audio frequency components, the construction is made difficult due to the large number of transmission standards used.

For instance, FSK RTTY transmissions can have shifts of 170 Hz, 425 Hz or 850 Hz. 170 Hz shift transmissions can use low tones (1275/1445 Hz) or high tones (2125/2295 Hz). The transmission speed can be 45, 50, 75, 100 or 110 bps. Each of these combinations requires its own filters for best results since the bandwidth of the filters must match the transmission speed used. While changing the center frequency and the bandwidth of an analog filter at the same time is difficult at best, changing all of the parameters of a DSP filter is restricted to changing a few constants in the program!

Since amateurs usually only need a single modem at a given time, only one DSP processor is required. Changing from one standard to another is performed by simply changing the software running on the DSP processor. New standards, like satellite PSK transmissions, can be implemented quickly by writing new software, and most important of all, at little if any additional cost!

Modems working on voice-bandwidth audio signals, as provided or required by standard

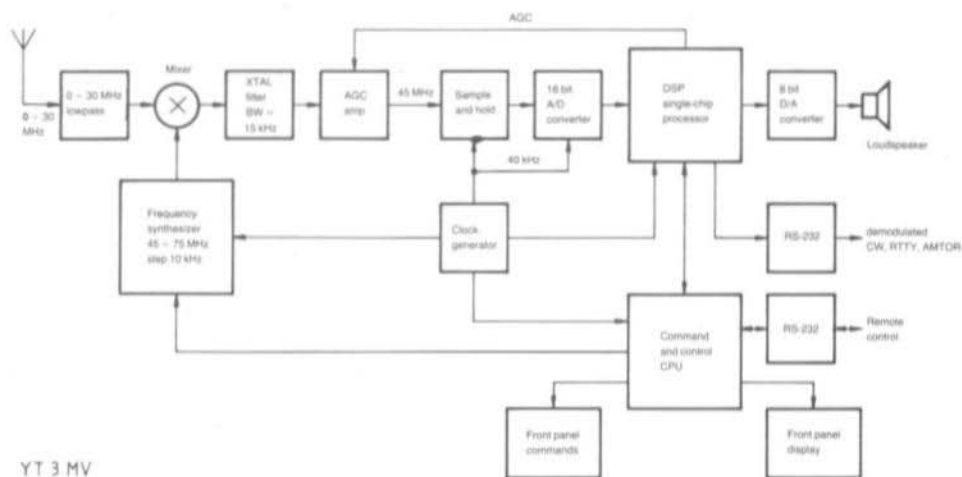

YT 3 MV

Fig. 10: An "all mode, general coverage" DSP oriented HF receiver

amateur transceivers, do not require very powerful DSP microprocessors. They can usually be implemented on general-purpose 16 bit microprocessors. The same microprocessor can be used for all data decoding, handling and display, since the latter require even less computing power than the DSP algorithm. A prototype RTTY, ASCII or PACKET terminal was built around a single 16 bit microprocessor (MC68010) including a DSP modem. Compared with analog modems built with operational amplifiers, the DSP modem performed much better in heavy QRM or poor signal-to-noise conditions thanks to the optimized filters for each transmission format.

#### 4.2. All-mode receivers and transceivers

State-of-art commercial amateur transceivers use microprocessors only for the front panel control and display functions. The signal processing part of the transceiver is a complex analog circuit including several conversions and intermediate frequencies and a complex multiple-loop PLL frequency synthesizer. Some of the analog components are very expensive,

like narrowband crystal filters. During production, the transceiver requires expensive test equipment and skilled technicians for alignment, further increasing the cost of the final product.

A DSP alternative for an "all mode, general coverage" HF receiver is shown on **fig. 10**. The front end is similar to analog receivers: a low-pass filter followed by a mixer and a first, wideband IF crystal filter around 45 MHz. After an AGC amplifier to optimize the level, the signal is sampled. The sample-and-hold circuit works as a harmonic mixer, translating the 15 kHz wide signal at 45 MHz down to frequencies acceptable for a dedicated DSP microprocessor. A 16 bit (or even more accurate) A/D converter has to be used to obtain the maximum possible dynamic range.

The DSP microprocessor generates the required filters and demodulates the signal. An 8 bit D/A provides sufficient dynamic range to drive the loudspeaker. Digital transmissions, like RTTY, can be demodulated directly and supplied in a digital format through an RS-232 port. The DSP processor also controls the AGC amplifier to optimize the useful dynamic range. Con-



sidering the amount of computations to be performed a dedicated DSP microprocessor has to be used. Practical receivers will probably use single-chip DSP microprocessors with an internal program ROM storing all the algorithms to receive all the modes (SSB, CW, RTTY...) with optimum-bandwidth filters.

A command and control microprocessor, similar to that used in "analog" transceivers, is also required in this DSP-oriented receiver. Another interesting detail is that a DSP-based receiver only requires a 10-kHz-step frequency synthesizer, which can be a single-loop PLL. "Analog" receivers require very fine-step (10 or 20 Hz) synthesizers with multiple-loop PLLs whose phase noise sidebands usually limit the receiver dynamic range.

Finally, a DSP-based "all mode, all features" HF receiver does only require little if any alignment! A companion transmitter can be built in a similar way. Considering all the above facts, the introduction of DSP technology means that the size and complexity of an HF receiver can be reduced to that of a VHF handie-talkie FM transceiver bringing at least a five fold reduction of the manufacturing costs! For a complete transceiver the simplification is slightly less spectacular since the transmitter output stage and corresponding power supply remain expensive, and a two to three fold reduction of prices can be expected.

The technology required to build DSP-based transceivers is available NOW. Since it brings substantial advantages, all the manufacturers will be forced either to accept it soon or to disappear from the market.

### 4.3. Weak-signal communications

Up to now weak-signal communications required a skilled operator with well trained ears, the final steps in the processing and decoding of weak CW or SSB signals being left to the human brain. Computer-aided communications were not used due to the poor performance of available modems and other problems, like interferences generated by the computer itself.

Improvements when receiving weak signals hidden in noise can only be obtained by reducing

the data rate: the significant quantity is the energy radiated by the transmitter per each bit of information. The main limitation of the human ear (and related part of human brain) is that the data rate can not be reduced indefinitely: below a certain speaking speed the probability of understanding a word decreases and below a certain keying speed CW characters become difficult to decode.

Radio operators therefore use redundancy: they repeat the same message (either CW or SSB) several times to be understood by their correspondent. Repeating is again limited by the memory available in the human brain...

DSP computers allow, at least in theory, almost unlimited filtering in front of the detector and averaging of the detected signal. The limit is of course defined by the usable data rate! The most interesting amateur application is certainly low-power EME (moonbounce) communication using (relatively) small antennas. DSP computers will certainly be advantageous at data rates below 1 bit per second. Some DSP experimenters already reported very enthusiastic results, like detecting their own signal echo using a single yagi antenna and a solid state TX. Maybe EME communications will no longer be a privilege for those having very large antenna systems, but one may still argue that the very low data rates that may result, like 1 bit per hour (!) can hardly be useful: DSP computers are not able to do miracles!

### 4.4. Image communications

Amateur image communications have never become very popular, probably due to the problems with transmission standards. Live image transmissions (ATV) have a very high information rate and thus a limited range compared to other communications modes. SSTV, FAX and other slow-scan standards require, each its own, incompatible hardware.

DSP microprocessors will essentially simplify the hardware required for slow-scan standards: just one microprocessor equipped with different software will be sufficient for all present and





future transmission standards. Of course, a TV monitor will be used as a display driven by the computer video board. The next step will be simple image processing: zooming, filtering, sharpening and contrast enhancement.

Digital image communications require even more bandwidth (or transmission time) but offer a much better image quality. Researchers all over the world are working on image data compression algorithms and hardware, which also requires high-speed DSP microprocessors. Hopefully these new techniques should some day allow a live image transmission at a limited data rate, maybe as low as 64 kbps.

---

## 5. A PROTOTYPE DSP COMPUTER

---

### 5.1. Hardware configuration

In the beginning of 1987 I started working on an image processing computer designed especially to demodulate, process and display weather-satellite APT pictures. At the beginning the project was intended as a state-of-art replacement for the now obsolete but famous "APT Scan Converter" developed more than six years ago. The design requirements were a high resolution video, a large memory to store images, and a fast bus to update the video as quickly as possible.

According to previous experiences, satellite APT pictures require at least 64 grey levels. 256 grey levels corresponding to 8 bits or one memory location per pixel were selected for convenience. To remain compatible with standard TV monitors a picture format of 256 useful lines out of 320 was selected with 512 pixels per line. The video board thus contains 128 kilobytes of special dual-port memory to avoid slowing down the microprocessor.

It was immediately clear that a 16 bit micro-processor was required already to move the data to the video board. After consulting various manufacturer's catalogues and distributor's price lists I decided to use a Motorola 680xx series microprocessor, and in particular the

MC68010. The MC68010 has a 16 Mbyte linear, non-segmented addressing space and 16 general-purpose 32-bit internal registers. Other available 16 bit microprocessors had the addressing space divided into 64 kbyte segments which makes it very difficult to handle large amounts of data like images or to write programs longer than 64 kbytes.

At first, a hardware demodulator like that in the APT scan converter was planned, except for using switched capacitor filters in place of op amps. After studying the problem it was found out that the MC68010 was not just able to generate a much higher performance DSP signal demodulator but it could automatically adjust the signal level, reliably extract sync pulses, process the demodulated video signal and display it on the TV monitor as well.

Once decided to do as much processing as possible in DSP with the microcomputer, only a band-pass filter was placed in front of the A/D converter. A telephone CODEC IC (MK5156) was selected as the A/D converter since its conversion speed and accuracy correspond to the bandwidth and dynamic range of the signals available at the output of a voice communications receiver (including the APT signal). The MK5156 already includes a sample-and-hold circuit and an almost independent D/A converter.

The block diagram of the prototype DSP computer is shown on **fig. 11**. The computer is built on several printed circuit boards connected with a mother board with 64 pole "eurocard" connectors. The computer actually includes the following printed circuit board modules:

- A) Processor board including the MC68010, 32 kbytes of EPROM (operating system), a keyboard interface and a real-time calendar/clock.
- B) Video board including 128 kbytes of dual-port dynamic video RAM, video D/A converter and all the timing circuitry.
- C) CMOS RAM boards carrying 256 kbytes of battery-backed RAM each. Usually four such boards are installed for a total 1 Mbyte of non-volatile RAM.



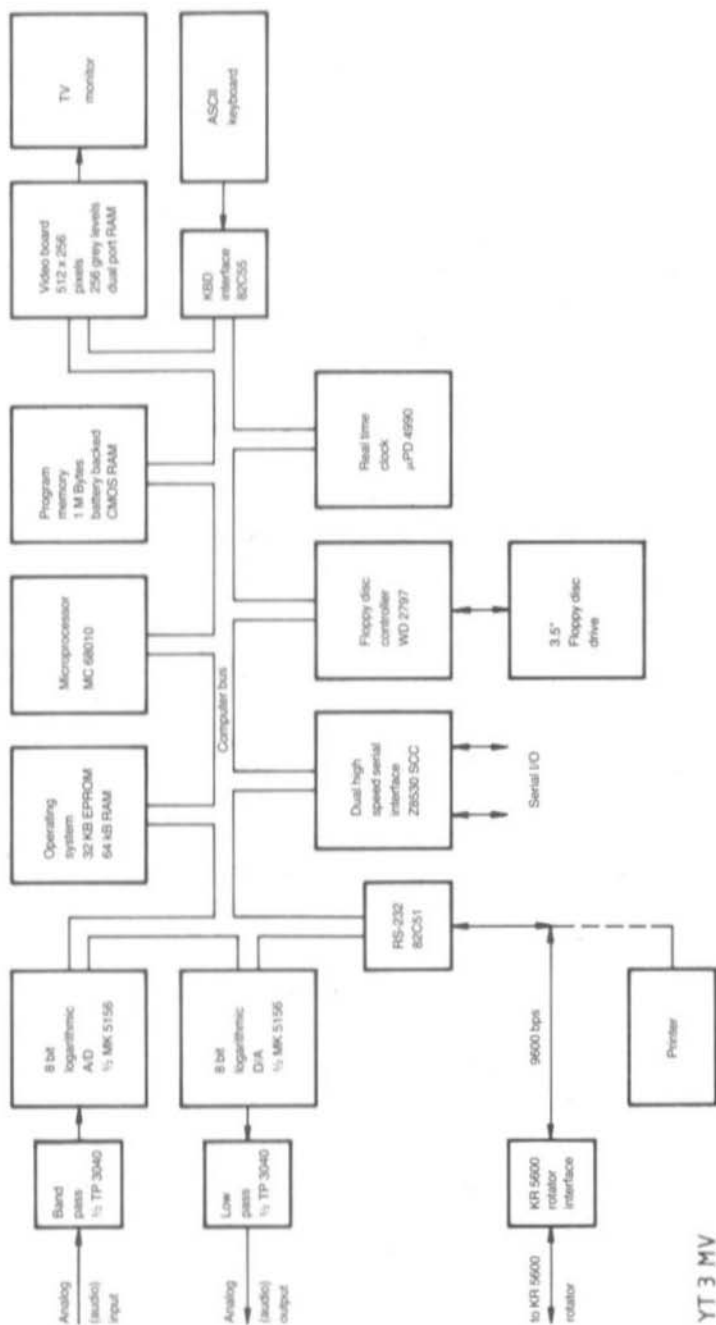

Fig. 11: Block diagram of the prototype DSP computer



- D) Analog I/O board carrying the CODEC A/D and D/A converter, a programmable timing generator and an RS-232 port.
- E) Floppy controller board including a WD2797 floppy controller, a high-speed dual serial port (Z8530 SCC) and corresponding support circuitry.
- F) Bus motherboard carrying 8 "eurocard" connectors.
- G) Switching power-regulator board including a NiCd RAM-backup battery and a very reliable RESET signal generator to protect the non-volatile RAM content regardless of the actual power-up or power-down timing.
- H) Rotator interface board designed to control a KR5600-type rotator through the RS-232 port.

Up to date 4 prototypes have been built and tested at different CPU clock frequencies. All the software developed requires a minimum clock frequency of about 9 MHz while reliable operation of the hardware can be obtained at clock frequencies up to 13 MHz.

## 5.2. Software developed and tested

The basic DSP routines are usually not very complex, up to 100 instructions using simple integer mathematics, but they are executed several thousand times per second. To use the available computer efficiently, programming directly in machine code (or assembly language) is required. This is especially important if a general-purpose microprocessor has to be used close to its theoretical speed limit. On the other hand, DSP support routines, like those computing the coefficients of the basic DSP routines or retrieving the final results, are not executed so frequently but may be quite complex and require floating point mathematics and transcendent functions.

In order to fulfill both the above requirements, a high-level language compiler that allows the insertion of arbitrary-size machine-code routines was written. The structure of the high-level language is similar to FORTRAN, allowing both single variables and multiple dimension arrays,

floating point mathematics, transcendent functions and conditional jumps or calls to labels. Most important of all, it allows a simple and efficient communication (data transfer) between the high-level language program and the machine code routines!

Since the economic advantages of using dynamic RAMs are declining, I decided to use CMOS static RAMs in my computer. The content of static RAMs can easily be made non-volatile with a small NiCd backup battery. This means that it is no longer necessary to base the operating system on floppy disks or other magnetic storage devices: all the software can remain in its place in the non-volatile computer RAM where it is actually executed. The floppy disk drive is only used for memory backup.

The software developed includes the operating system written directly in machine code and stored in an EPROM and various application programs written in high-level language and stored either in their original form or compiled in the non-volatile RAM or on floppy disks. The operating system includes a machine code monitor program (hardware debugging, data movements including the floppy disk), a screen-text editor program and a high-level language compiler. The operating system allows a simple interrupt-driven multitask, provided that the application programs use different peripherals with different interrupt vectors.

Up to date, the following application programs were developed and tested, not including various test and/or support programs and the software actually under development.

- A) Universal BAUDOT/ASCII receiving program. Allows to set the tones between 1000 and 2400 Hz, the speed between 45 and 1200 bps and all standard data formats. The received text is displayed on the TV screen and can be stored, on command, in the computer memory and handled later by other programs. Includes a tuning indicator. Tested both in heavy HF QRM and on satellite signals, it always performed equal or better than optimized analog modems built with operational-amplifier active filters.



- B) FSK PACKET RADIO (1200 bps, BELL-202) RX/TX program. Supports standard VHF terrestrial packet radio communications. Includes a terminal program. The received text can be stored, on command, in the computer memory for later use. Text files, prepared by other programs, can also be transmitted.
- C) Satellite tracking program. Computes the position of a selected satellite from its Keplerian Elements in real time once per second (using the real-time clock) and supplies the result to the antenna-rotator interface through the RS-232 port. It includes editing routines for the 40 satellite data sets stored. Different tracking procedures can be selected and during the tracking all the relevant parameters are displayed on the computer screen.
- D) Satellite APT-images receiving program. Designed especially to receive APT images from polar-orbiting weather satellites. Includes a menu of 12 user-defined picture formats including line rate and sync pulse data, pixel and line sampling ratios and display parameters. The display parameters include independent horizontal and vertical zooming in very fine steps and a sophisticated grey-scale enhancement function that does not saturate any part of the image. All the display parameters can be controlled interactively, without disturbing image reception or other tasks running on the computer.
- E) PSK PACKET READIO (1200 bps) program. Includes a PSK modem with a tuning indicator, but otherwise it is very similar to the FSK packet radio program. Specially designed to communicate with FUJI-OSCAR-12, it can be used for terrestrial PSK communications as well.

The satellite tracking program can be combined with any of the other four programs in a simple interrupt driven multitask so that only one computer is required to track a satellite and process the received data at the same time.

---

## 6. CONCLUSION

---

Digital Signal Processing will certainly bring many changes to the design and construction of electronic circuits, at least in the audio frequency range, where many problems can be solved efficiently using microprocessors. Engineers now have a whole group of new components to be considered in their new designs. Of course it was not possible to describe all possible applications of DSP techniques in this article: most applications of DSP probably have yet to be discovered! Similarly, some important DSP algorithms were merely mentioned to exist, like the Fast Fourier Transform.

DSP should be interesting for amateurs not just because it solves some problems but since it offers a much wider space for experiments than analog circuits can do. Beside improving existing communications modes it is hoped that DSP will make new communications modes possible, like QRP EME operation or live picture transmission over narrowband channels.

Finally, it is demonstrated that a general-purpose 16 bit microprocessor can generate many practical DSP circuits, provided it is not slowed down by inefficient hardware nor by a stupid operating system. Expecting that there is sufficient interest, a more detailed description of my prototype DSP computer is planned to follow.

Dr. Eng. Jochen Jirmann, DB 1 NV

## A Thermal Power Mount

The exact measurement of high-frequency power possesses, for most amateurs, an enormous problem. The most accurate results are provided by the so-called thermal power meters. These process the heat developed in an HF-mount resistor which has been subjected to the signal-under-test. The home construction of thermal power mounts has already been covered in VHF COMMUNICATIONS in (1), (2) and (3); they operate right up to 11 GHz but exhibit a very large inertia.

Another form of thermal mount will be described in this article which utilizes micro lamps as the measurement element. The electronic processing can be carried out by an easily modified power meter, indicator unit such as the Hewlett Packard 431 C. These items, without the thermal mounts, may be purchased at flea-markets etc, for a very favourable price.

---

### 1. A LITTLE POWER MEASUREMENT THEORY

---

The techniques involved in power measurements can be roughly divided according to (5), into two main categories, thermal and diode rectification. The thermal technique can be further divided into direct and substitution methods. The calorimeter techniques, also mentioned in (5), for the measurement of large powers will be ignored in this article.

When the radio amateur thinks about the subject of HF power measurement, he immediately calls to mind the circuit of **fig. 1**. This is a typical power instrument using rectified HF by means of a diode. The power to be measured is absorbed into a resistor (typically 50  $\Omega$ ) and thereby produces a potential difference across it, which is measured by a diode detector/voltmeter. This simple technique will yield accurate results only if two conditions are fulfilled. Firstly, the HF voltage to the diode rectifier must exceed a few volts in order that the diode barrier voltage becomes negligible in comparison. Secondly, the voltage to be measured must be sinusoidal, as the measurement circuit responds to the peak value of the voltage but the HF power is assessed from the root-mean-square of the input. Assuming a sinusoidal display, the peak value can be written down immediately as being  $\sqrt{2}$  x rms value and the indicator scale may be calibrated accordingly – directly in terms of power.

A diode rectifier can, in principle, detect high frequency voltage right down to a milli-volt (approx.) i.e. a power of  $-47$  dBm/50  $\Omega$ . At very

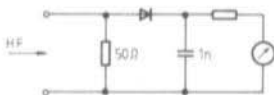

Fig. 1: Circuit of an HF power detector using diode rectification



low HF voltage inputs, however, the behaviour of the diode rectifier changes such that the output voltage is increasingly proportional to the input power, and not to the input voltage. If it is required only to measure very small powers, the rectifier characteristic has to be compensated for both linearity and temperature. Using this kind of attention to design detail, it is possible to construct a power meter which possesses a dynamic range which extends from  $-50$  dBm to  $+20$  dBm. The advantage of employing this complexity is that the end result is a responsive indicator system equally suited to sweep displays as well as for the momentary displays of transient signals. Commercial instruments, nowadays, carry the necessary information to correct the diode characteristic in an EPROM which is automatically called into service whenever a measurement is made.

As the complexity of the electronics is quite high, and the indication is still only true for sinusoidal signals, this type of realization for a precision HF power meter is not feasible.

The thermal method of power measurement is inherently capable of delivering an exact power value of the test signal quite irrespective of its form. The usual technique is to heat the load resistance with the test signal and then measure the heat expended by means of a thermistor. The advantage of this technique is that the resistor's physical form can be optimized to accommodate the frequency of interest, e.g. a chip resistor can be employed at very high frequencies. The indicator display's inertia, which is determined by the thermal mass of the resistor and its coupling to the temperature transducer, can be in the order of a few seconds.

A more responsive display is obtained when the measurement resistor and the temperature transducer are unified in one construction. The basic principle of the technique is the self-balancing bridge circuit of **fig. 2**. A temperature-dependent, measurement resistor is included in one arm of a Wheatstone bridge. The actual value of this resistor is dependent upon the converted power loss, and in consequence, upon the supply voltage to the bridge circuit. This implies that the bridge is only balanced at a certain bridge

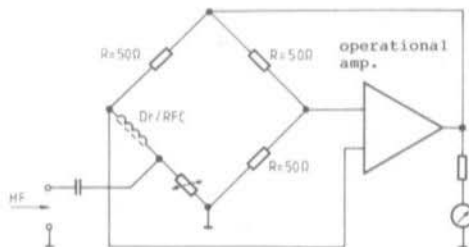

**Fig. 2: Self-balancing bridge for the measurement of RF power**

supply voltage, at which value, the measurement resistor is equal to the resistance of the other three arms of the bridge. An amplifier adjusts the bridge supply voltage to achieve this balance. If the HF power to be measured is increased, the measurement resistor heats up and the bridge unbalances. The operational amplifier reduces the DC supply current to the bridge until it again balances. The reduction in supply current is proportional to the increase in HF measurement power. This is a type of substitution measurement technique in which the DC power is substituting for HF power. Instead of a DC source, however, the bridge supply could work at a low, alternating frequency, say 10 kHz. The principle remains exactly the same but the advantage lies with the elimination of DC drift problems in the operational amplifier which would falsify the very small voltage changes involved.

This circuit cannot, however, distinguish between a temperature change which is due to the power to be measured and a change in the ambient temperature. For this reason, a practical measurement instrument contains two bridges, one for the actual measurement, and another which is influenced by the ambient temperature. The indicated reading is then the difference evaluation of the two bridge balances.

Thermal power meters from General Microwave and Hewlett-Packard (4) work according to this principle, and use bead thermistors as the measurement element. This type of instrument, together with its measurement mount, is exceedingly expensive but the instrument itself can be picked up quite cheaply. The author therefore



set himself the task of designing and constructing a replacement power mount which could be reproduced by the radio amateur.

## 2. MICRO LAMPS AS MEASUREMENT ELEMENTS

The first thoughts for the design of a power mount involved the use of a thermistor as the measurement element. Experiments with glass encapsulated bead thermistors resulted in a disappointing outcome.

An alternative is the use of a PTC resistor: in the beginning of the microwave technology, barretters were used for power measurements. These are thin tungsten filaments which are heated by HF power and thereby change their resistance. The resistance change per degree of temperature change is lower than with the thermistor and the temperature characteristic is opposite to the thermistor being positive with increasing temperature. In addition, the barretter is not so rugged and can easily be destroyed by an electrical overload. Barretters are therefore considered as being obsolete for professional purposes.

It suddenly became apparent, when watching the behavior of some micro lamps of the type used to illuminate LCDs. These lamps are tubular, wire ended, and extremely small, approx. 4 x 1 mm, the filament is not coiled, and the thermal resistance of the lamps is about 100  $\Omega$  to 200  $\Omega$ .

These lamps just had to be suitable for HF measurement elements! Accordingly, a test circuit was constructed as shown in **fig. 3**. It may be seen that it conforms exactly to the circuit of a normal coaxial thermister mount but the thermistors have been replaced by the micro lamps. A Hewlett Packard micro-wave power meter 431 C was employed as the display instrument. As this instrument was designed for operation with thermistors, the control sensing of the two self-balancing bridges had to be reversed. This is simply accomplished by merely changing over the bridge supply connections. The best way of doing this is to exchange the polarity of primary windings of the bridge transducer which is designated in the HP circuit diagram with T1A and T2A. A change-over switch may be inserted at this point, if operation with either a thermistor or a PTC mount is contemplated. This operation is easily accomplished if the circuit diagram is available.

The results of the test circuit with the modified power meter were so good that a reproducible RF mount was developed which will be described.

## 3. CONSTRUCTION OF THE RF MOUNT

An "N" panel plug forms the basic for the construction. This plug has on its rear side a metal

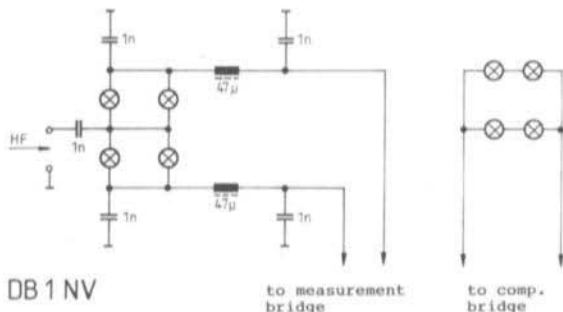

**Fig. 3:**  
Circuit diagram of micro-lamp  
RF-mount

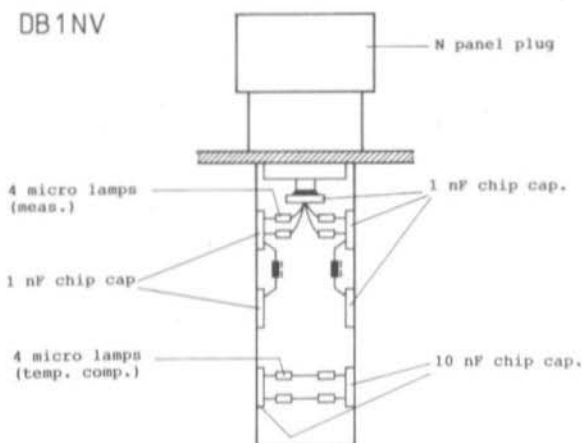

Fig. 4:  
Mechanical construction of  
RF mount

collar of approx. 11 mm diameter. From a 16 x 30 x 0.5 mm brass plate, a semi-circular (in cross-section) channel is fabricated which is then soldered on to the collar of the plug. The plug's inner connector is then shortened to 1.5 mm approx. The rest of the components may then be soldered on as shown in fig. 4.

First of all, a 1 nF disc capacitor of 5 mm diameter is soldered concentrically to the tip of the plug's (shortened) centre pin. Afterwards, four other 1 nF chip capacitors are soldered on to the inside lip of the brass channel. Four micro lamps are then soldered from the central chip capacitor, as directly as possible, to two adjacent 1 nF capacitors on the brass channel piece. Each leg carries two parallelled micro lamps as shown in fig. 4. Two small 47  $\mu$ H RF chokes are then extended to the second pair of 1 nF chip capacitors. These chokes, together with the 1 nF capacitors, form an additional filter which prevents low-frequency RF components of the test-signal from being carried along the cable mantle and directly to the instrument. The four other micro lamps are soldered on to stand-off insulators formed here by 10 pF chip capacitors. The given values should be used, as the indicator unit is adjusted for this value (4).

Now, the connections from the mount to the indicator unit may be made. The pin number, given in fig. 5, refer to the HP 431 C power meter. The connecting cable is a 6-way, screened, LF cable – the screening may be dispensed with if

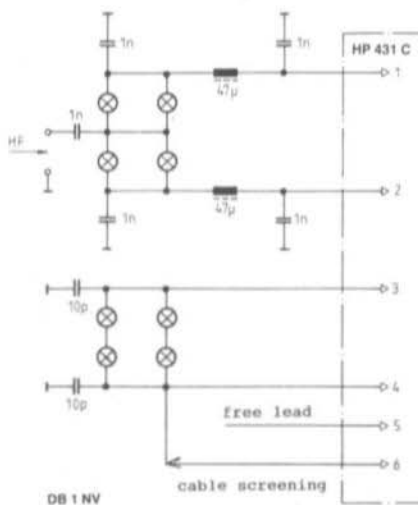

Fig. 5: Wiring diagram of RF mount connections to HP power meter



lengths under 1 meter are used. The lead to pin 5, apparently doing nothing, is in fact used for cable capacity compensation purposes. As the HP cable connectors cannot be obtained for a reasonable price (to buy the complete mount, cable assembly from HP will cost you more than you paid for the indicator unit!-G315B) it is advisable to put a 6-pole plug in the rear of the instrument and wire up the mount to a socket to suit it. The whole HF mount is then encapsulated fully by a metal housing which will prevent the movement of air from causing temperature differentials thereby unbalancing the bridge. A suitable enclosure is the "circuit box" by Greenpar or "sucobox" from Suhner.

### 3.1. RF-Mount Components

- 1 Piece 16 x 30 x 0.5 mm brass plate (see text)
- 8 micro lamps 1,5 V
- 4 x 1 mm: e.g. Conrad Electronics, Hirschau
- 1 "N" panel plug
- 5 1 nF chip capacitors
- 2 10 pF chip capacitors
- 2 micro chokes 47  $\mu$ H (Siemens, Jahre)
- 1 enclosure (Suhner, Greenpar)
- 1 length of 6-way screened cable
- 1 plug or socket to suit the one used in the instrument (see text)

## 4. ADJUSTMENT

The indicator unit is switched to the 10 mW range and the unit is switched on. All lamps will then glow weakly but not necessarily with the same intensity, due to manufacturing tolerances. The "zero" potentiometer on the front panel is then adjusted for a meter null reading. If this is not possible, it is due to the lamps being too dissimilar from each other in both measurement and temperature compensation bridges. The temporary inclusion of 10 - 20  $\Omega$  small, series resistors between the power meter and the bridges could be tried in order to effect a balance. When the null has been achieved, the capacitive symmetry is effected by the screw-driver adjustment on the

front panel - just as it is described in the HP instrument handbook. The RF mount is now ready for service.

## 5. RESULTS

No major differences could be detected between the manufacturers "power mount" and the RF mount described here, except perhaps, the drift in the lower measurement ranges is somewhat greater.

A network analyzer was employed to measure the RF mount's return-loss in the range 500 MHz - 18 GHz. It proved to be constant at about 14 dB ( $v_{swr} = 1.5$ ) to approx. 6 GHz, and deteriorating to 6 dB ( $v_{swr} = 3$ ) at 18 GHz. There were no spurious resonances. This result indicates that the RF mount may be used as a measurement instrument up to 6 GHz, and as an indicator up to 18 GHz.

## 6. REFERENCES

- (1) Frohsinn, O., DF 7 QF:  
A Home-Made UHF/SHF Power Meter  
VHF COMMUNICATIONS, Vol. 13,  
Ed. 4/1981, Pages 221 - 229
- (2) Vieland, C., DJ 4 GC:  
A Sensitive Thermal Power Meter  
VHF COMMUNICATIONS, Vol. 15,  
Ed. 4/1983, Pages 225 - 231
- (3) Vieland, C., DJ 4 GC:  
Thermal Power Measurement - yet another  
look  
VHF COMMUNICATIONS, Vol. 17,  
Ed. 2/1985, Pages 69 - 71
- (4) Manual zu Power Meter 431 C der Firma  
Hewlett-Packard
- (5) Osinga, J., Maaskant, J.:  
Handbuch der elektronischen Meßgeräte  
Franzsis-Verlag 1984, S. 236 - 251





Matjaž Vidmar, YT 3 MV

## Receiving Converter for 4 GHz-Band Satellite

In two previous articles (1) and (2), a complete receiving installation for Ku-band (11 to 12 GHz) television satellites was described. The present article describes an outside unit for the C-band thus extending the capability of the system into the 4 GHz range. The same "inside" unit (2) can be used with it, as the 4 GHz television transmissions possess similar modulation characteristics namely: wideband-FM with a spectrum interleaving signal and FM sound subcarrier.

---

### 1. TV RECEPTION IN THE 4 GHz-BAND

---

On the one hand, the technical demands made upon the microwave units, such as the profile accuracy of the parabolic reflector or the noise figure of the antenna pre-amplifier, are easier to fulfil at 4 GHz than at 11 GHz. On the other hand, however, only a few television programmes are to be received in the 4 GHz-band in Europe and even then, only with antenna diameters so large as to put them out of the question for most private people. The easiest to receive is certainly the Soviet satellite "GORISONT" (in English HORIZON) at 14 degrees latitude (west). Every HORIZON satellite has six transponders on

board each having an output of 40 W. One of them is connected to a spot-beam antenna and used for television broadcasting. This transmission may be received, noise-free, by antennas having only a 90 cm diameter dish. Unfortunately, the spot-beams of the other HORIZON satellites are positioned 53 degrees east and 70 degrees east covering the eastern part of the Soviet Union and can only be received with difficulty in Western Europe.

All the other European transmissions emanating from geostationary television satellites, such as the INTELSAT series, ARABSAT or TELECOM together with other transponders of HORIZON, use antennas with little directional gain and have a correspondingly large footprint – large enough to illuminate all areas bounded by the observable hemisphere from the satellite. These signals are 15 to 20 dB lower than those of the spot-beams from the HORIZON satellite and even antennas having a 3 m diameter yield very poor picture quality.

---

### 2. BLOCK DIAGRAM

---

All 4 GHz satellite signals, directed towards Europe, are circular polarized – either left or right handed. As most of the television signals,

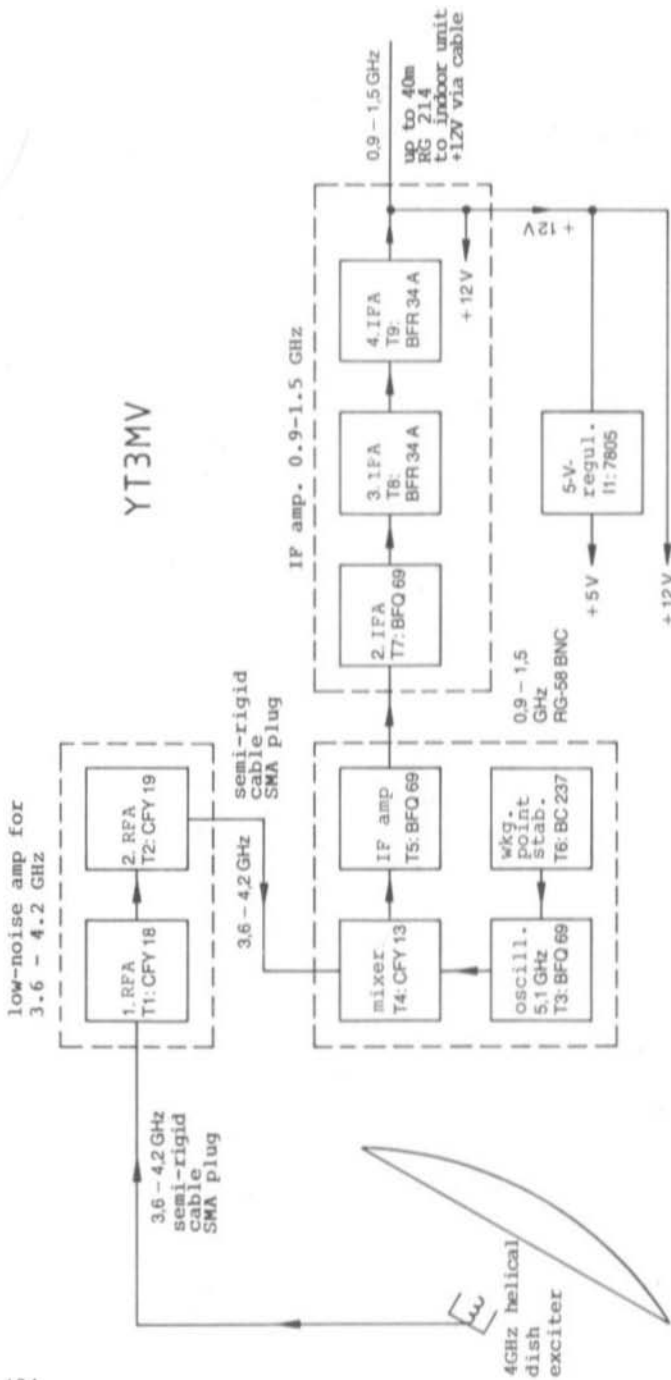

Fig. 1: Block Schematic of the 4 GHz Satellite installation's outdoor unit



including those from the powerful HORIZON, are right-handed, a short, helical, parabolic-mirror exciter element was installed.

The block diagram of **fig. 1** shows that the received signal is taken from the helical antenna on to a low-noise, two-stage pre-amplifier equipped with GaAs-FETs. The following converter possesses a 5.1 GHz fixed oscillator, this frequency being chosen in order that the image-frequency suppression is simplified and thereby facilitating the rejection of spurious signals. This oscillator enables the satellite band of 3.6 - 4.2 GHz to be translated to 900 - 1500 MHz. This corresponds to the frequency of the 'indoor' unit (the details of which have already been published) and is the range in most use in proprietary satellite receivers. It must be observed, however, that the polarity of the FM video signals is inverted with respect to the signals from the 11 GHz converter since the translating oscillator lies beneath this band at 5.1 GHz.

Following the mixer is an intermediate frequency amplifier in order to compensate for the connecting cable loss between outside and inside equipments. This IF amplifier is identical with the 11 GHz equipment described for the **YU 3 UMV 019** module and will therefore not be described again in these pages.

### 3. THE 4 GHz HELICAL PRIMARY RADIATOR

The sketch of **fig. 2** shows how the feed element can be realized in the form of a 4 GHz helical primary radiator. The two-turn helix, together with a pot-formed reflector, produces a suitable polar diagram which illuminates a paraboloid reflector of  $f/D$  at about 0.4. The helix consists of a brass or copper band which is supported on an insulated structure.

The author used the polyethylene dielectric from coaxial cables of the requisite diameter for both the boom and the helix, support pillars. Nylon screws were used to fix them together. The pot reflector was made from thin brass sheeting. Its diameter is 0.7 of a wavelength with a lip of 0.2 wavelength.

The helix has a relatively high feed-point impedance and the purpose of the quarter-wave transformer is to reduce it to a nominal 50  $\Omega$ . This match may be trimmed more finely — if found necessary — in the low-noise amplifier. The matching transformer is fabricated from a length of 50  $\Omega$  rigid coaxial cable. In order to bring its

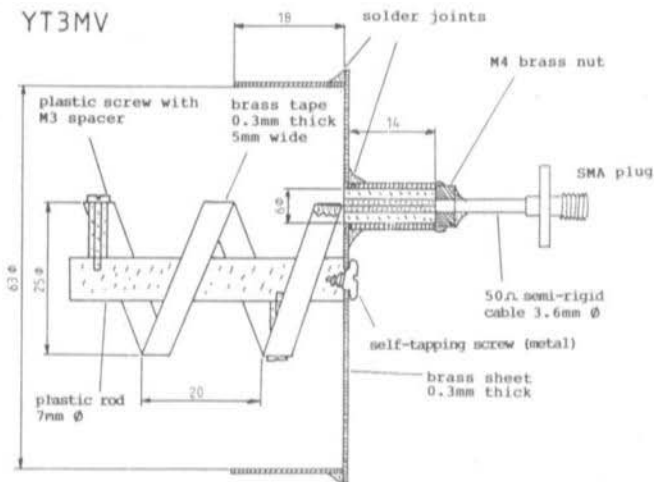

**Fig. 2:**  
The 4 GHz helical parabolic antenna exciter



impedance to a nominal  $80 \Omega$ , the original copper outer is removed. A tube of dielectric material is then slipped over the teflon inner of the rigid cable and the assembly pushed into a 6 mm internal diameter copper tube. One end of the copper tube is soldered to the reflector disc and the other end to a brass nut, which is in turn screwed on to the rigid coaxial cable.

Taking the velocity factor of the PTFE insulated cable into account, the length of the transformer is 14 mm. As it is quite difficult to find a PTFE (teflon) tube of the requisite internal and external diameters, a polyethylene tube was used instead, despite its somewhat higher dielectric constant. In practice, a piece of dielectric taken from RG-214 cable could be used.

The outer copper tube is heated to the melting temperature of the polyethylene with a soldering iron and the dielectric is then pressed into the copper tube. When the assembly has cooled to room temperature, the inner diameter is carefully drilled out by using increasingly larger drills at

low speed until the inner of the rigid coaxial cable can be slipped inside the polyethylene sleeve.

The parabolic reflector is a mirror and it reverses the sense of the circularly polarized wave. Therefore, if the satellite transmits a right-handed signal, the feed point must be left-handed to accommodate the sense reversal caused by the parabolic reflector. In general, the sense of a helical antenna can be related to that of screw threads; a right-handed helix is like a right-handed set-screw and vice-versa.

#### 4. LOW-NOISE AMPLIFIER FOR 3.6 - 4.2 GHz

If one were to consider the noise figures of proprietary mixers, the conclusion might be reached that at least 20 dB of pre-amplification

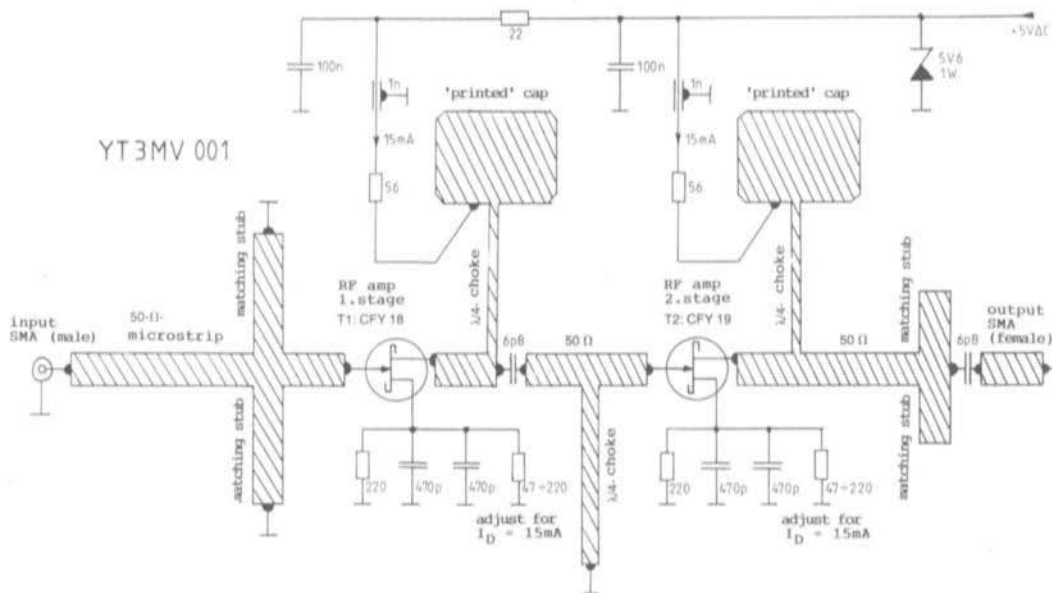

Fig. 3: The 3.6 to 4.2 GHz low-noise antenna amplifier



will be necessary in order to reduce the effects of second-stage noise. This degree of amplification is readily obtainable at 4 GHz by means of two GaAs-FET stages.

The circuit diagram of the low-noise, 4 GHz pre-amplifier is shown in **fig. 3**. The transistors are matched by means of a very simple method using two inductive stubs at the input and two capacitive stubs at the output. The matching between stages is achieved by the correct length of 50  $\Omega$  stripline. The data of the amplifier for a particular narrow band of frequencies can, of course, be improved by using additional matching lines which compensate for the spread in transistor tolerances or antenna mis-matches. This process is described in (1) for example.

With the exception of modifications, made necessary only by the differing frequency range, the bias feed arrangements are exactly the same as for the 11 GHz amplifier. Each of the two source leads of the FETs is decoupled to earth by a leadless ceramic disc capacitor and the drain current of each transistor is brought to the nominal value of 15 mA by a "trial and error" method involving changing the value of the source resistance.

The prototype version used a CFY 18-23 in the first stage and a CFY 19-18 in the second stage. At 4 GHz, the parameters of these two types are fairly similar. The cheap CFY 19 could be used in the first stage and the even cheaper CFY 13, CFY 19-22 or 27 in the second stage with only a marginal deterioration in the noise-figure specification.

The micro striplines are etched from glass-epoxy, reinforced PTFE (teflon), printed circuit board — the pattern details are shown in **fig. 4**. The board is 60 x 35 mm in dimension and 0.79 mm thick with a relative dielectric constant  $\epsilon_r$  of 2.6. The PCB (YT3MV 001) is soldered into a brass box, made to size. The cover of the box is dampened by a piece of microwave absorber foam in the same manner as the 11 GHz amplifier.

This amplifier does not require any tuning whatsoever. A component which might possibly cause trouble is the 6.8 pF coupling capacitors. The specimen module used the very smallest available structure (RM 2.5) and soldered in using the very shortest component leads.

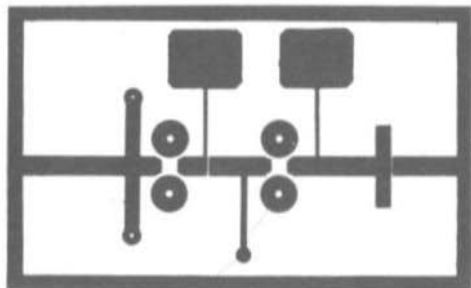

**Fig. 4:** Teflon printed circuit board for the amplifier of **fig. 3**

## 5. OSCILLATOR AND MIXER

The module shown in the circuit schematic of **figure 5** has an oscillator, the frequency of which, (5.1 GHz) lies above the received signal frequency. It also contains a GaAs-FET mixer and an IF pre-amplifier stage.

The mixer (T4) is built around a single GaAs-FET. Both the received signal and the local oscillator signal are fed to its gate. The signals are isolated from each other by a selective network, with quarter-wave traps, followed by a matching network to the gate of T4. The drain stub functions as a quarter-wave short circuit for the received signal and the oscillator frequency, and as a capacitive reactance at the IF frequency. This capacity, together with the inductance of L1, forms a matching-transformer, low-pass filter to match the pre-IF transistor T5.

A cheap bipolar transistor, type BFG 69, is used for the 5.1 GHz oscillator T3. Its frequency of oscillation is determined largely by the stubs in the emitter and base circuits. The collector stub serves to adjust the oscillator power output to the following mixer stage. When a bipolar transistor is used at microwaves, a working-point stabilizing circuit is required. This is supplied by T6 which holds a constant current, flow through the oscillator transistor and thereby also improving the phase-noise characteristics of the stage.

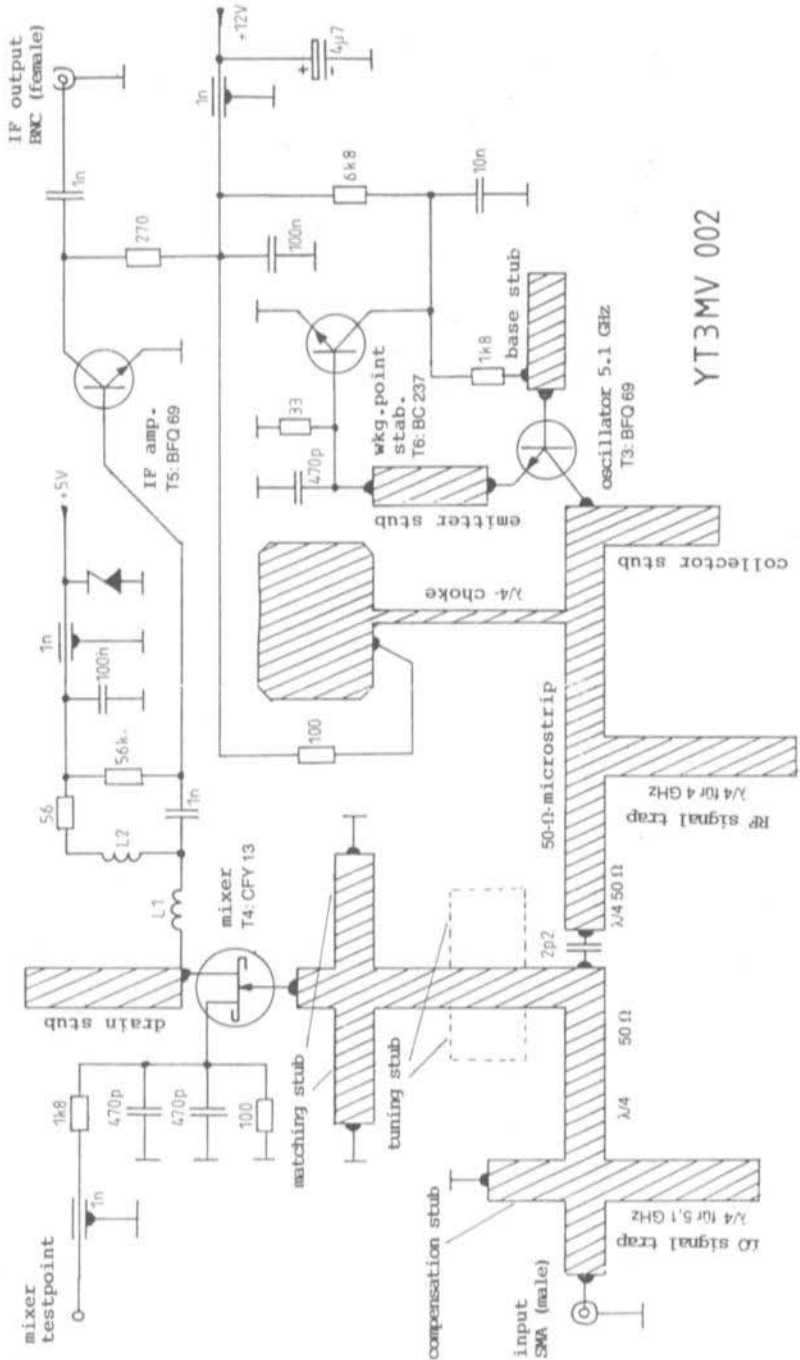

Fig. 5: Oscillator and mixer which translates 3.6 - 4.2 GHz to 0.9 - 1.5 GHz



The micro striplines of the oscillator and mixer are etched from the same material as that of the pre-amplifier. The track pattern and the component layout plan of the 60 x 60 mm board, YT3MV 002, is shown in **fig. 6**.

A 5 mm hole must be drilled in order to accommodate transistor T3 although there are no contacts to the ground plane to be made. The hole must therefore be covered with copper foil in order to provide a ground plane.

Three low-inductance, leadless, ceramic-disc capacitors, each of 470 pF, are required in this circuit: one in each of the source leads of T4 and another in the emitter circuit of T3. The 2.2 pF coupling capacitor is also somewhat special as it is made from a piece of 0.15 mm glass-fibre, teflon printed circuit board material. The inductance of L1 is identical to the equivalent inductance in the 11 GHz converter (1) and L2 is a quarter-wave at the IF frequency.

The printed circuit board YT3MV 002 for the converter is also soldered into a suitable housing (brass with an aluminium cover with absorber foam).

A few tuning adjustments must be made to the module. First the oscillator frequency must be checked. Its frequency is varied by altering the length of the tuning stub at its open end in the base circuit. The quarter-wave traps do not normally require any adjustment.

In order to effect a match to the input of T4, a tuning stub, in the form of a small piece of copper foil, is adhered onto the circuit, the position of which is varied until the maximum mixer gain is obtained. The output positions for this are shown dotted in **fig. 5**.

The mixer test-point can be used as an indirect indication of the oscillator's output power.

## 6. CONCLUDING REMARKS

The converter described was used mainly for the reception of the Russian satellite HORIZON, located at 14 degrees west. The Effective Iso-

tropic Radiated Power (EIRP) of this transmission is estimated to be about 46 dBW. Using a 1.2 m diameter parabolic dish antenna, many other television signals may be heard in the 4 GHz band, some having EIRP powers as low as 22 to 24 dBW. Of course, such low-level signals cannot be expected to produce a usable picture but the characteristic picture-change rumbling could be heard when an audio amplifier was connected to the video output.

The video monitor synchronizes to the received signal at EIRP powers of 30 to 33 dBW which, both the hemisphere beam of HORIZON and the zonal beam of INTELSAT radiate. These transmissions are usable – but not quite noise-free – with antenna-dish sizes of 2.4 to 3 m.

There are two problems worthy of note in the connection of the subject 4 GHz converter to the indoor unit described in the publication of (2).

The first one concerns the module YU3UMV 020, the tunable second converter. The local oscillator harmonics of this module fall into the receive frequency band and cause interference. This is no problem when it is used with the 11 GHz down converter, but at 4 GHz the harmonics are very much stronger. They can only be seen, however, when the "indoor" unit is brought into the vicinity

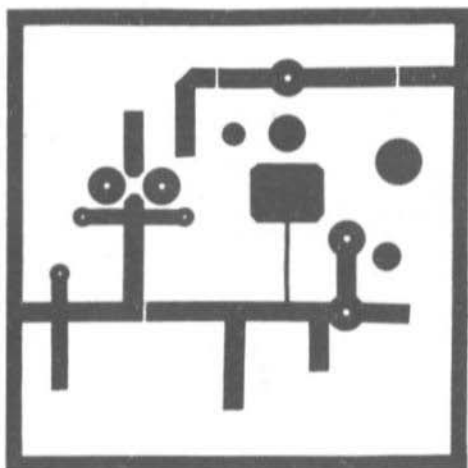

**Fig. 6:** Teflon printed circuit board for the converter of **fig. 5**



of the "outdoor" unit for test purposes etc. Normally, if the distance between indoor and outdoor units exceeds 10 m or if a metal screening object is strategically placed between them, the interference disappears to practically zero. The other alternative is, of course, to tackle the problem at its source and use more screening for the indoor module YU3UMV 020.

The second problem in connecting indoor to outdoor units, is manifest in the HORIZON transmission's FM sound-carrier deviation index which is much greater than that of most Ku-band television broadcasts. This causes distortion which can only be corrected by a modification to the sound demodulator. This, naturally, compromises the sound signal's quality of the Ku-band TV transmissions which must be amplified again to restore them if the highest fidelity is to be maintained.

It still remains a fact that the European 4 GHz band has much less to offer than the 11 GHz band. It is, highly interesting for the TV-DXer, especially if a large antenna dish is available.

There is yet another band waiting to be explored: the frequency range 2.5 to 2.69 GHz. This is

divided up according to the transmit powers of the various television satellites. There are satellites which have already been commissioned, such as INSAT or ARABSAT and there are a few third-world countries who are planning transmissions in this band. The ARABSAT has a 50 W transmitter in the 2.6 GHz band and its footprint covers the whole of southern Europe.

---

## 7. REFERENCES

---

- (1) M. Vidmar, YT 3 MV:  
TV Satellite Receive System;  
Part 1: Low-Noise 11 GHz Down-Converter  
VHF COMMUNICATIONS, Vol.18,  
Ed. 4/1986, Pages 194 - 213
- (2) M. Vidmar, YT 3 MV:  
TV Satellite Receive System;  
Part 2: Indoor Unit  
VHF COMMUNICATIONS, Vol. 19,  
Ed. 1/1987, Pages 35 - 56

---

## VHF COMMUNICATIONS – Selected Articles on a Common Topic

Each collection comprises 9 to 11 VHF COMMUNICATIONS articles in a blue binder. By ordering please quote the number of the desired collection.

1. Antennas: Fundamentals
2. Antennas for 2 m and 70 cm
3. Antennas for 23 cm and 13 cm
4. Microwave Antennas
5. Amateur Television (ATV)
6. Crystal Oscillators: XOs and VXOs
7. VFOs
8. Synthesizers
9. RF and AF filters
10. Frequency Counters and Dividers
11. Noise-Figure and Noise-Spectrum Measurements
12. Simple Test Equipment
13. HF Power Measurements
14. Shortwave and IF Circuits
15. Mini Radio Direction Finder for 2 m and 70 cm
16. Converters and Pre-amps for 2 m and 70 cm
17. Converters and Pre-amps, for 23 cm and 13 cm
18. Transverters and PAs for 2 m
19. Transverters and PAs for 70 cm
20. Transverters and PAs for 23 cm and 13 cm
21. Circuits for 9 cm and 6 cm
22. 10 GHz Technology Part 1
23. 10 GHz Technology Part 2
24. FM Equipment for 3 cm and 1.5 cm

Single-theme collection, including binder and postage, **only DM 29,50**



**UKWberichte** Terry D. Bittan · Jahnstr. 14 · Postfach 80 · D-8523 Baiersdorf  
Tel. West Germany 9133 47-0. For Representatives see cover page 2





Carsten Vieland, DJ 4 GC

## 50 $\Omega$ Wideband Detectors

Following a discussion about various measurement techniques and diode types, this article gives a description of a broadband detector and a logarithmic indicator amplifier (fig. 1).



Fig. 1: A dBm-meter with a 70 dB indicator dynamic range (scaled for low-barrier diodes)

### 1. MEASUREMENT TECHNIQUES

In high-frequency technology, there is a recurrent demand for signals to be registered in terms of their amplitudes. This is the case in every swept measurement which is used with a normalized impedance (invariably 50  $\Omega$ ) receiver (detector): the latter exhibiting no amplitude variations with frequency of its own. The difficulty in meeting adequate specifications increases sharply with increased sensitivity requirements, such as that presented by the assessment of return loss, by means of a wideband directional coupler. Although often, a relative indication will suffice (e.g. tuning for maximum); the power detector, or voltage detector, should satisfy the following demands: –

- 1) Voltage or power displayed accurately over a wide frequency range.
- 2) Good matching to the 50  $\Omega$  measurement system over a wide frequency range.
- 3) High measurement dynamic range together with an accurate as possible display over a wide range of input levels.
- 4) High basic sensitivity
- 5) High transit response for the measurement system in order that it may be used in a swept system.

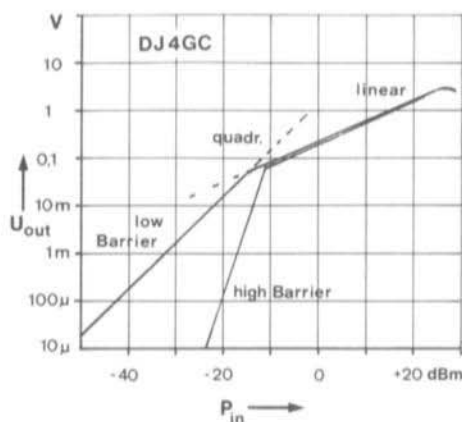

Fig. 2: Idealized characteristic of a Schottky diode

Between the requirements of 1) and 2), there is a certain common ground because an exact display is not possible in the absence of a good  $50 \Omega$  match. On the other hand, however, even with a good match, the absolute accuracy, under amateur construction limitations, is very much open to question. The requirements of 1) and 2), and with reservations 3), are easier to fulfil with a diode detector than with a thermal head. The high transit response requirement of 5) can only be accomplished thermally using highly demanding evaporation plating techniques (at threshold levels of approx.  $-50$  dBm). This demand is met, almost always, by the employment of a diode detecting head in self-made sweeper equipment.

The diode detector is very simple to effect when the demands upon a high absolute accuracy (i.e. relative indication), are not too great. Using careful constructional methods, a good basic accuracy and a high measurement dynamic range can be achieved. Some manufacturers have concentrated on this technique for their commercial wattmeters, e.g. HP: sensitive wideband milli wattmeter, Bird: wattmeter with changeable directional heads, and SSB-Elektronik: frequency-compensated power meter.

In order to achieve an even greater frequency range without sacrificing measurement dynamic

range and accuracy, a few criteria should be observed: —

- 1) The employment of a diode which has the most favourable high-frequency specifications.
- 2) The installation of this diode in a suitable detector circuit.
- 3) The employment of DC processing circuits which have high dynamic range, a very low intrinsic drift and equipped with an exact indicator.

## 2. FACTORS IN THE CHOICE OF THE DETECTOR DIODE

The rectification of high-frequency signals for measurement purposes may be undertaken by a variety of diodes. They are listed as follows: —

- 1) Germanium diodes (AA...)
- 2) High-barrier Schottky diodes (HP 2800)
- 3) Low-barrier Schottky diodes
- 4) Silicon point-contact diodes (1 N 23)
- 5) Planar-silicon diodes (1 N 4148)
- 6) Gallium-arsenide diodes (MFG 3000)

For each and every type of diode (fig. 2) there are many variants in relationship to the working frequency, the form of packaging (fig. 3), and other factors affecting both availability and price. If the exactly specified diode simply does not exist, the leading characteristics can be reviewed in order to arrive at a suitable choice for the particular application.

### 2.1. Germanium Diodes

The sometimes lowly-regarded germanium diode invariably displays, up to about 500 MHz, an optimal characteristic. The internal resistance of the germanium diode, which is important for matching purposes, is less dependent upon frequency than other types of diodes. The limit of detection lies under  $-50$  dBm (10 nanowatt) in a  $50 \Omega$  system. Now that this type of diode can be purchased by the kilo, it represents a very good choice right up to the 70 cm band.

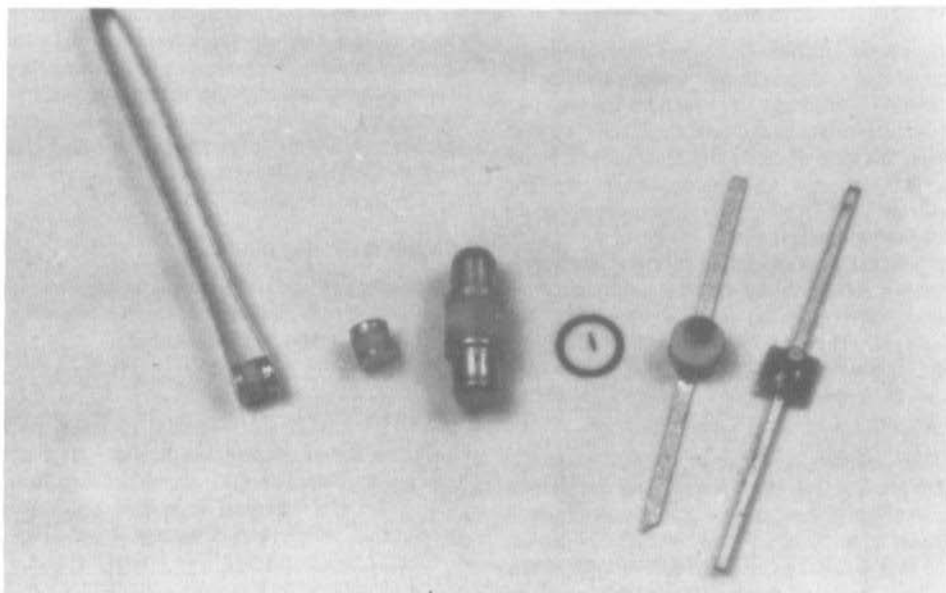

Fig. 3: Microwave diode forms from left to right:

- |                 |                                 |
|-----------------|---------------------------------|
| 1. BAT 14-094   | Siemens (with connecting leads) |
| 2. BAT 14-093   | Siemens (pill-box form)         |
| 3. MA 40203     | M/A-Conn. (small cartridge)     |
| 4. HP 5082-2778 | (beam-lead housing)             |
| 5. MGF 3000     | Mitsubishi                      |
| 6. DDB 6783     | Alpha Industries                |

Note: The beam lead-diode ring has a diameter of 2 mm

At higher frequencies, the rectification properties gradually diminish, and despite the impedance remaining constant, sets a system limit.

## 2.2. Schottky Diodes

Schottky diodes in glass packaging display no marked tendency to lose their rectification characteristics at high frequency in the same way that germanium diodes do. They are still rectifying efficiently at 23 cm. The series impedance (2), however, is low and very strongly dependent upon frequency. The impedance is very frequently under  $50 \Omega$  at frequencies around 1000 MHz.

The residual inductance, working in conjunction

with the barrier capacitance, causes a discontinuity in the impedance at high frequencies. This effect is common to all rectifiers and makes the measured value very inexact at high frequencies. In general, a step-up transformation is effected, which makes the detected voltage many times higher.

In addition, the voltage current characteristic of high-barrier diodes is very unfavourable. Although the so-called barrier voltage is similar to that of the germanium diode at approx. 0.3 V, the V-I-characteristic exhibits a much sharper transition, making it unsuitable for use at very low signal levels. The lower limit of detection for high-frequency signals in a measurement system, without a bias current, is in the order of  $-20$  to  $-30$  dBm in a  $50 \Omega$  system.



### 2.3. Low-Barrier Diodes

Low-barrier diodes (zero-bias-diodes) exhibit favourable voltage-current characteristics. The low-level threshold for high-frequency performance is extended down to  $-50$  or  $-60$  dBm using this type of diode in a  $50 \Omega$  measurement system. In order to compensate for the germanium diode's inherently good properties, the low-barrier has to resort to special constructional techniques. A whole range of favourably-priced, **low-barrier Schottky diodes** encapsulated in glass, have appeared on the market in the past few years. They are mainly intended as a substitute for germanium diodes (e.g. BAT 42, BAT 43 from CFS, the VALVO BAT 86 or the TOSHIBA 1 SS 99).

There are also low-inductive and low-capacitive microwave forms, having small dimensions, in the form of cartridges, pills or beam-lead housings. These types, however, are decidedly expensive (30 to 300 DM) but they do represent the almost optimal detector diode. This is the type that commercial manufacturers of wideband detector heads employ.

### 2.4. Silicon Point-Contact Diodes

At first sight, all the problems of the favourably-priced point-contact diodes, such as the 1N21, 1N23, 1N78, 1N26 etc, seem able to be remedied at one fell swoop. The low-barrier characteristic is associated with very favourable high-frequency characteristics. A more exacting study of the technical data reveals, however, an unsurmountable problem. It concerns those diodes possessing internal LC compensation and thereby having a relatively narrow range of frequencies. They are so constructed that their incorporation into a proprietary microwave waveguide is easily carried out. The semiconductor crystal is located in an optimum position in the high-frequency field in order to effect a suitable match. In a waveguide detector, these silicon point-contact diodes display good characteristics although the input VSWR can only be optimized over a 10 % frequency range. For coaxial wideband measurement, however, their large dimensions make them entirely unsuitable. Owing to the differing impedance relationship to the

mandatory  $50 \Omega$  system impedance, this type of diode is about 20 dB more sensitive than its coaxial relatives. The lower threshold limit of an X-band waveguide detector using an 1N23 is astounding  $-70$  dBm. Saturation effects occur at quite a low level. At 0 dBm the rectified DC no longer follows the increase in HF input power.

### 2.5. Silicon-Planar Diodes

Silicon-planar diodes for small signal applications have so many disadvantages for detector work that they will not be considered at all.

### 2.6. GaAs Diodes

Gallium-arsenide diodes are suitable for high levels and therefore find applications in low-intermodulation mixers at up to very high radio frequencies. As the barrier voltage is quite high (about 0.75 V), and well above that of the silicon diode, its application in a universal detector is not favourable as the result table indicates.

---

## 3.

### THE CONSTRUCTION OF A BROADBAND DETECTOR PROBE

---

The general experience in the dealings with microwave components seems to favour construction in a stripline technique with as little disturbance from stray inductance and capacitance as possible. On account of the very small current angle-of-flow, series inductance can be very disruptive (step-up transformation). For HF, VHF and UHF bands a printed circuit board was tried out which has already proved itself in attenuator pad construction. The mechanical construction details conform to those detailed in (6). A teflon board (RT-DUROID 5870) with an SMA plug (threaded, flanged plug) is used. The board housing can, of course, be tailored according to one's own mechanical possibilities.

The decoupling of the "cold" end of the diode requires a particularly lossless and low-inductive

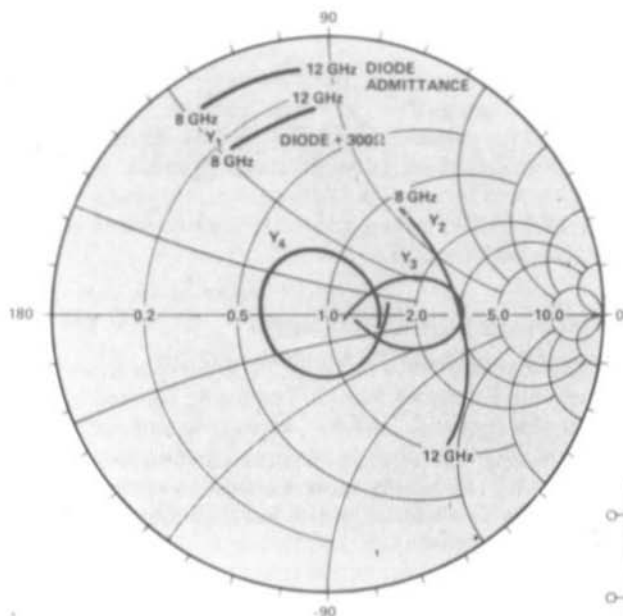
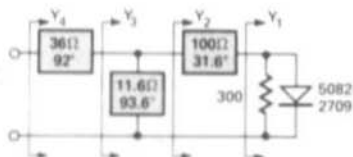

Fig. 4:  
An example of the matching  
of a detector diode with the aid  
of a transformation line (from  
HP application note)



filter. Normal disc and above all SMD capacitors are frequently not suitable as the whole spectrum, including harmonics produced in the process of rectification, should be provided with the same ground potential. The Fourier analysis of a half-wave rectifier output, reveals an unending series of harmonics of the input signal. If the basic frequency lies in the GHz region, the filter requirements must be effective right to the highest amateur band. Even an input at 500 MHz to a rectifier with a high-grade filter capacitor, has been observed to produce harmonics as high as 20 GHz – using a very expensive spectrum analyzer for the evaluation, of course!

As disc capacitors are not normally specified at high frequency with  $\tan \delta$ , the constructor must use a certain amount of intuition in order to search a suitable one out. In the author's experience, capacitors with a small capacity, of smallest thickness and a light dielectric, seem to fit the bill. High-quality chip capacitors (e.g. from ATC) can also be employed. The capacitor is so laid in the board that the copper removed by the drill can be replaced over it by thin sheet copper.

Unfortunately, however, the ever-decreasing diode impedance with frequency (even with high-grade microwave diodes) precludes a truly wide-band match without resort to some special measures. For the diode used here, chip resistors and capacitors did not yield the author the kind of root-locus that he was seeking. An HP application, however, suggested a solution. Using a computer, the matching in the entire X-band (8 to 12.4 GHz) was accomplished by selective transformer-line optimization. This measure resulted in a 4 dB gain in sensitivity, as a bonus. Outside the working frequency of the device, this form of compensation crashed. The design aim of a working spectrum extending into the X-band regions from the short-waves, was not realized by an experimentally optimized, wideband, match similar to that used in a diplexer (fig. 4).

In order that the total series impedance is not determined solely by that of the diode, a 27  $\Omega$  series resistor, in chip form, is included in the measurement head. This series circuit displays, according to the diode employed, a very good

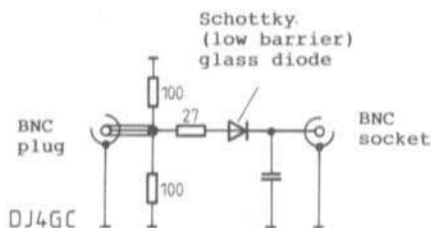

Fig. 5a: Detector circuit for diodes having glass encapsulation

match across the band, 3 to 5 GHz, even without other circuit refinements. The series resistor also dampens resonant effects in the diode and also the effects of the step-up transformation due to the stray LC components. The dependence of the detector head's output voltage with frequency is therefore reduced.

In the interests of a  $50\ \Omega$  input resistance, even at low frequencies, the present circuit contains a parallel resistance to earth (fig. 5a) which is countered by the effects of stray series inductance at high frequency (fig. 5b), that is, a part of an RL low-pass circuit. In a practical circuit, this inductance is formed by the lead wire to the chip resistor.

The soldered-board construction of this diplexer circuit has, due to this inductance, lost something of its functional elegance but does possess a good match and directional characteristics from

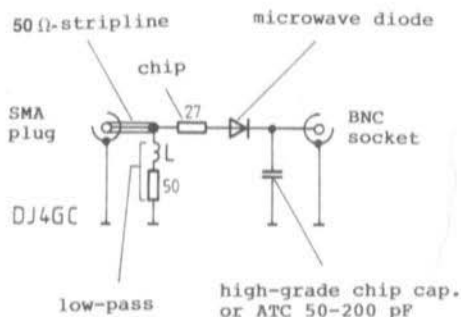

Fig. 5b: SHF detector circuit diagram

HF right into the X-band frequencies. This favourable result is obtained using a 2 to 6 mm length of 0.5 mm wire – length according to diode.

#### 4. MEASUREMENTS ON VARIOUS DIODE DETECTORS

Using a standard construction with a 3 mm long wire for the compensation inductance, many types of diodes were examined. As a screen presentation of the DC output voltage representing the return loss (indirectly the VSWR) over a trace width of 0 - 12 GHz surpasses the author's equipment capability, only representative bands in the total range have been given.



Fig. 6: HP detector with APC 3.5 plug

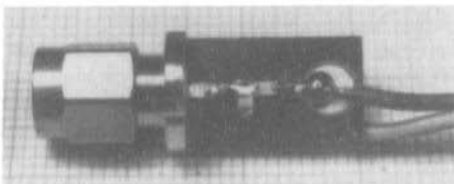

Fig. 7: Stripline construction for SHF using diode DDB 6783 and SMA plug, PCB material 0.5 mm RT-Duroid

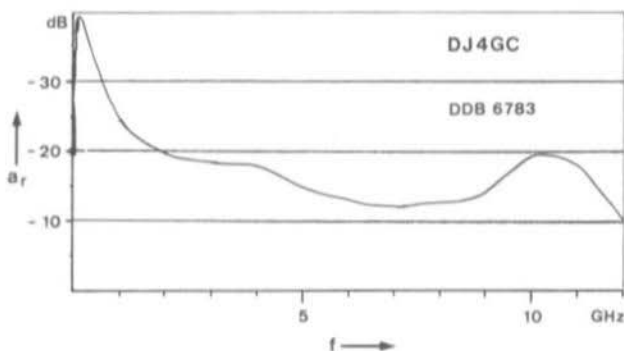

Fig. 8:  
Return loss from 0 to 12 GHz

The reference detector used in this survey was the HP 33330 B (fig. 6) for which the manufacturers specify a detected output voltage constancy over the 10 MHz to 12.4 GHz of  $\pm 0.3$  dB and 12.4 GHz to 18 GHz,  $\pm 0.6$  dB. The VSWR up to 8 GHz is better than 1.2 and from 8 to 18 GHz the VSWR does not exceed 1.5.

This kind of phenomenally-small, ripple specification in both input VSWR and output voltage is only achievable with computer optimized and miniaturized deposition techniques and is far removed from the soldering-iron techniques open to the amateur. But despite these limitations, reasonable results can be achieved even with the simple equipment to hand. A home-constructed detector using the diode DDB 6783 (fig. 7) by Alpha-Industries had an output ripple of  $\pm 1$  dB up

to 12 GHz relative to that of the highly expensive Hewlett Packard head (fig. 8), but with a somewhat higher output voltage.

At 12 GHz, the testing had to be curtailed owing to the lack of a suitable sweep generator. There was, however, a return-loss of less than 10 dB (VSWR 2 : 1) at this frequency – within the borders of serious measurement accuracy. The relatively small filter capacity of 50 to 200 pF determined the lower frequency limit at approx. 100 kHz.

The detector shown in fig. 9 has a low-barrier diode MA 40202 and possesses a still higher sensitivity, well into the X-band, but due to its larger diode geometry, displays a somewhat larger ripple over the spectrum for both detected output and matching.

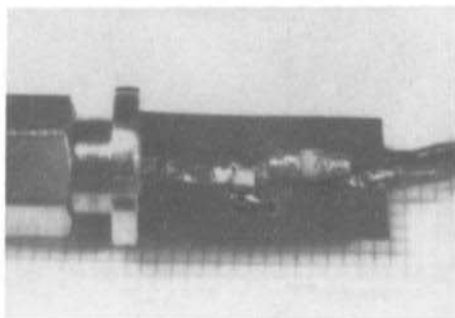

Fig. 9:  
Circuit as in fig. 7 but with ATC filter capacitor under the diode housed in a small cartridge

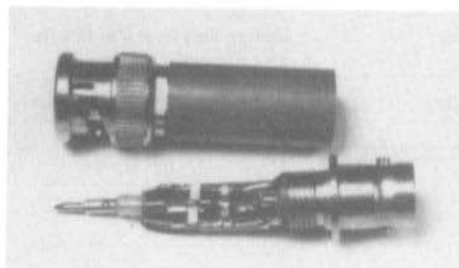

Fig. 10: Stripline construction to 2 GHz approx. for BNC connector



Fig. 11: The series inductor to the 50 Ω resistor is shown here

The BNC detector (for diodes having glass encapsulation, **fig. 10**) displays a practically constant output voltage extending from short-waves right up to 1.3 GHz. The characteristic then gradually rises by 2 dB at 2.3 GHz under the combined influence of the series inductance  $R_v$  and the diode. A similar characteristic is also apparent with the diode 1 SS 99 as regards the output voltage and input VSWR but the sensitivity, and thereby the dynamic range, is some 20 dB better.

Not all the diodes examined here are commonly available in every corner shop. The basic constructional details of **figs 11, 12 and 13** may be regarded as typical. In the search for a suitable semiconductor, properties such as: small form, high-limit frequency, low-barrier characteristic, price and availability are the deciding factors. An unknown flea-market type diode, implanted into a standard-constructed detector head, will nearly always produce results not too far short of the best available. The traces of **figures 14, 15, 16 and 17** show representative test results.

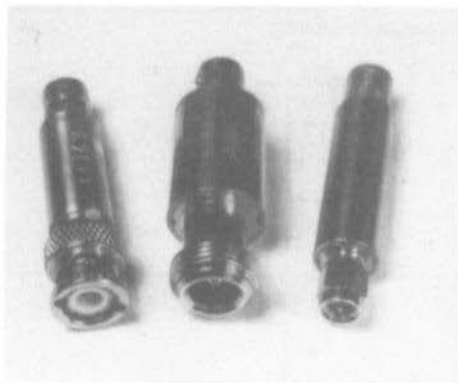

Fig. 12: Amateur-constructed detectors in three forms of construction. The housing with the SMA plug contains the circuit of fig. 7

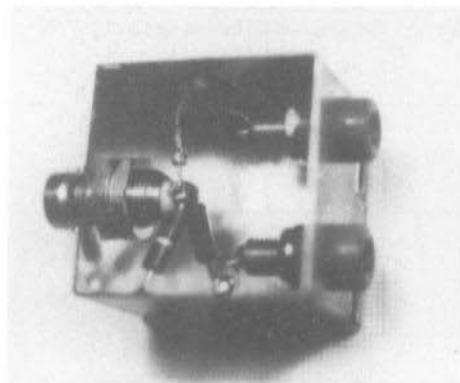

Fig. 13: This is also admissible – up to about 500 MHz!



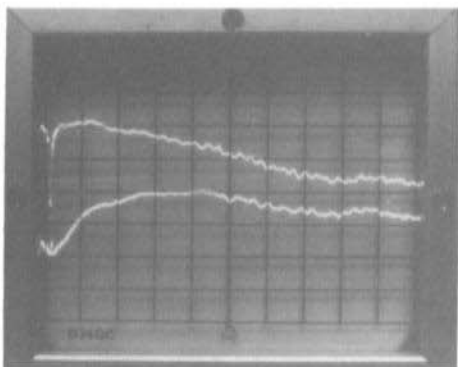

Fig. 14: Return loss of a circuit as in fig. 10 using diode BA 481 (Valvo) from 0 - 2 GHz  
 h: 200 MHz/box  
 v: 10 dB/box  
 Note: The reference line (upper) indicates 0 dB return loss

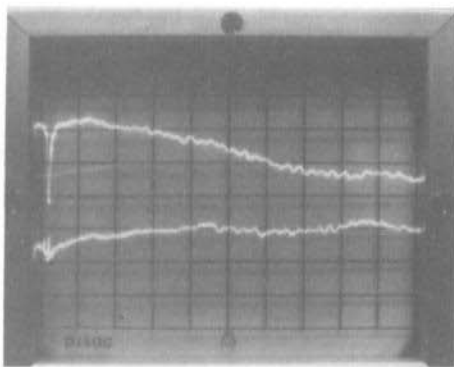

Fig. 15: Same circuit as in fig. 14 but with a 27  $\Omega$  diode series resistor

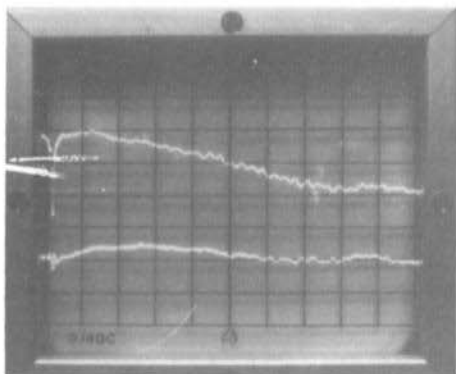

Fig. 16: Return loss of the SHF detector of fig. 7 (SHF detector)

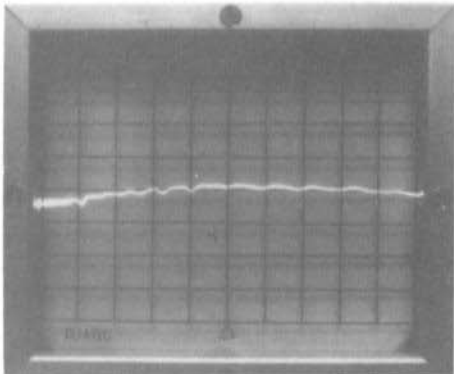

Fig. 17: Detected output of a BWO signal from 8 to 12 GHz using the detector of fig. 7  
 h: 400 MHz/box (approx.)  
 v: 10 dB/box

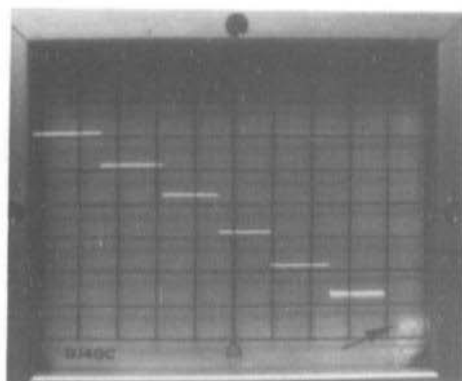

Fig. 18: The stepped attenuation of an HF signal in 10 dB steps to - 60 dB in a log-linear presentation. The lowest level is contaminated by noise (arrow)

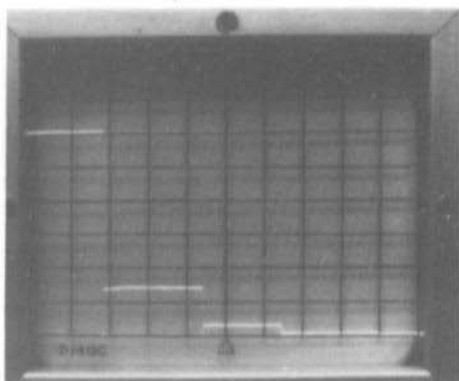

Fig. 19: The same range of attenuation using a linear system. The measurement range can be clearly seen to be several orders smaller

## 5. LOGARITHMIC DISPLAY AMPLIFIER

The detected output (voltage) of a diode detector, represents the measure of the high-frequency input signal. In the simplest form, a suitable indicator could be a voltmeter with a calibrated scale but only a very limited dynamic range would be available. The low-level region can only be readily detected with the aid of a low-drift DC amplifier. This must be capable of accepting input voltages of between about  $1 \mu\text{V}$  and  $5 \text{V}$  and handling them in exactly the same manner. Detector heads with low-barrier diodes can handle inputs with a range of 70 dB (figs. 18 and 19).

The author has developed a circuit which displays this high dynamic range linearly on a meter-scale (fig. 20). The heart of this unit is a logarithmic, operational amplifier, the output of which is proportional to the logarithm of its input. For circuit technical reasons, this analogue computer circuit is changed into a current converter as this type of circuit has a higher dynamic range with current drive (fig. 21). The input to this voltage/current converter may be reversed in polarity by means of the DPDT switch at its input. The log. amplifier's output voltage lies between  $-7 \text{V}$  and  $+2 \text{V}$  and must be offset to be referenced to ground potential.

An unfortunate trick of nature has given detector diodes a characteristic knee at about the  $-20 \text{ dBm}$  input level. Under this power, the input

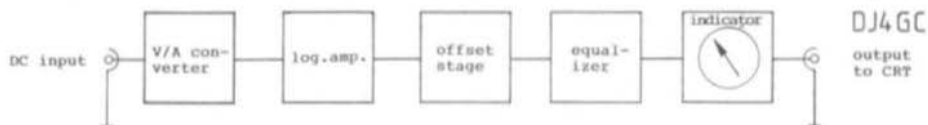

Fig. 20: Measurement amplifier block diagram

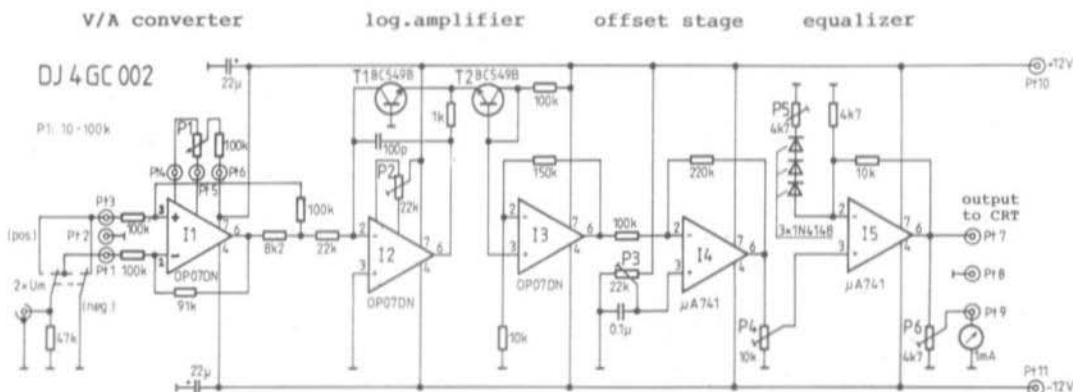

Fig. 21: Detailed circuit schematic of measurement amplifier

level is power-linear and above about 0 dBm a linear rectified voltage output is generated. In the transition region there is, of course, a mixture of both. This knee in the characteristics can, however, be largely compensated by the final equalizer stage.

As this circuit is intended to have a universal application, it was designed to work with various diodes of differing types and circuit dispositions and therefore the unit has been provided with the necessary means of adjustment to cope with this variety.

The operational amplifiers used in the first two stages are extremely low-noise and low-drift types such as the OP07, or better the OP77. Experiments with the integrated log. operational amplifier, Intersil ICL 8048, despite its high price, did not deliver the same good results as one made from discrete components. Although, at low levels, the operational frequency limit of the log. amplifier sharply decreases, it is still fast enough to fulfil the highest demands of sweep frequency measurement. At the threshold of detectability (under  $-50$  dBm), the few microvolts of DC signal

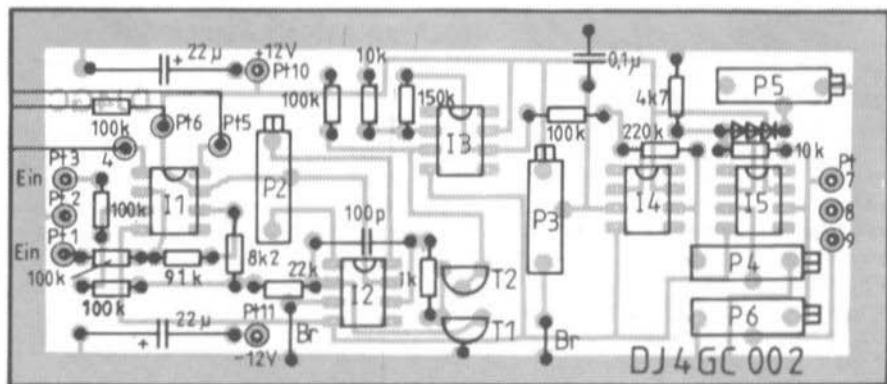

Fig. 22: Component layout plan of the PCB DJ 4 GC 002



**Fig. 23:**  
In the completed instrument, the cover has been removed to show the board. The small power supply unit is located behind it in a second tin-plate box

are overwhelmed by the thermal noise and residual hum. The output indicator then displays a certain nervous behaviour which disappears completely when the input is raised just 10 dB. This threshold noise limit may be seen in **fig. 18** at an attenuation of 60 dB. To compensate long-term temperature variations and thermal voltages generated in input connections, the offset adjustment of the first stage has been made variable from the front panel in order that the basic noise lies on the moving-coil indicator at  $-53$  dBm (approx.).

As commercial diode detector heads frequently have a negative output voltage, the voltage/current converter's input is fitted with a DPDT switch to accommodate this. This switch should be of the highest quality in order to avoid thermal voltages being generated at the contacts, voltages which can be as high as the input signal when working at low levels. The influence of temperature on the two low-noise transistors (e.g. BC 549 B or BC 550 B) is opposing and therefore to a large extent cancelling. It is advisable to bind these two transistors together with a metal band to make them thermally as one – they are deliberately located by each other for this purpose.

The printed circuit board of **fig. 22** is 116 x 48 mm, single-sided and designated DJ 4 GC 002. It is fitted into a tin-plate box together with a 10-turn potentiometer for the offset voltage adjustment and the polarity change-over switch (**fig. 23**). The box is totally sealed against the ingress of external electrical fields.

---

## 6. ADJUSTMENT OF THE MEASUREMENT AMPLIFIER

---

The multitude of adjustment points designed into the measurement amplifier will probably cause a few misgivings about the realization of the project. By a methodical and accurate adjustment, together with an exact adherence to the following procedure, an accuracy of  $\pm 1$  dB may be attained throughout the whole of the 70 dB dynamic range.

**The following test equipment is required:**

- 1) A signal source of exactly 100 mW ( $+20$  dBm) with an adjustable output. For example, a



handheld Tx/Rx set to "low power" and with a variable power supply.

- 2) A 0 - 70 dB attenuator, switchable in 10 dB steps. Fixed pads of 10, 20 and 40 dB are also usable but not so convenient.

**The adjustment procedure is as follows:**

- 1) Without an input signal, the front-panel potentiometer P1 is adjusted until the voltage to ground after the 8.2 k $\Omega$  resistor of the voltage/current converter is zero.
- 2) The point at which the voltage has been nulled in 1) i.e. the common of the 91 k $\Omega$ , 8.2 k $\Omega$  and 22 k $\Omega$  resistors, is then temporarily strapped to ground. Transistor T1 is then bridged with a 22 k $\Omega$  resistor. By means of I2's offset trimmer P2 (22 k $\Omega$ ), the output of I2 is also brought to zero voltage. The strap and the 22 k $\Omega$  resistor are then removed and the logarithmic amplifier is ready for service. Its output voltage, for a 70 dB dynamic range, varies between - 5 V and + 1 V.
- 3) The detector is then connected to the amplifier's input and a signal from the signal generator injected via the stepped attenuator. When the input signal to the detector is switched between - 20 dBm and - 50 dB, in 10 dB steps, the amplifier's output voltage should follow accordingly. If it does not, correct it with P1. Adjust trimmer P3 (22 k $\Omega$ ) of the offset-stage such that its output is - 50 dBm when its input is zero voltage. This step ensures that the output of this stage is always positive with respect to ground.

**Note:** This applies to Schottky low-barrier or Germanium diodes. "Normal" Schottky diodes cannot achieve the lowest levels and the instrument scale must be calibrated accordingly.

- 4) Set the HF input level to - 10 dBm with the stepped attenuator and then adjust the multi-turn pot P4 such that a flow of current through the diode chain is just detectable. The voltage at the input of the last stage is then around 1.4 V. P4 determines the position of the compensating characteristic knee in the amplifier.
- 5) The diode chain, together with multi-turn potentiometer P5, corrects the voltage linearity characteristic of the detector diode in

the "high-level" range. The trimmer is adjusted so that the rise in voltage at the output of the amplifier (i.e. the instrument) between 0 and + 10 dBm is exactly the same as that between, for example, - 30 dBm and - 20 dBm.

- 6) The multi-turn P6 for the instrument is adjusted so that the indicator calibration scale is in accordance with the input level.
- 7) The linearity and range of the indicator scale may also be optimised with controls P4, P5 and P6.

It must be admitted, that a simple equalizer such as this cannot be expected to match exactly every detector characteristic. The provision of four or five diodes in the compensating chain of the same low-barrier type that is used in the detector head, will normally yield a small improvement in the compensation. The inclusion of temperature compensation measures was also considered.

In more demanding applications, commercial instruments take the detector head output to an analog to digital converter. The digital output is then compared with a memory which holds information as to the exact characteristic of the detector head in use. Using high-speed converters, and very low access times for the memory, enable this approach to be used in a sweep frequency system. In order to ensure a high display accuracy, a new program is necessary each time the detector head is changed.

The application of a bias current to normal Schottky diodes for sensitivity enhancement, causes problems with temperature dependent offsets and thereby deformation of the amplified transfer characteristic. It is the author's experience that this measure, in spite of complex circuitry, is not as effective as the employment of low-barrier diodes.

---

## 7. APPLICATIONS FOR THE HF DETECTOR HEAD

---

The wide frequency range, the good match and the high-dynamic range of the subject diode

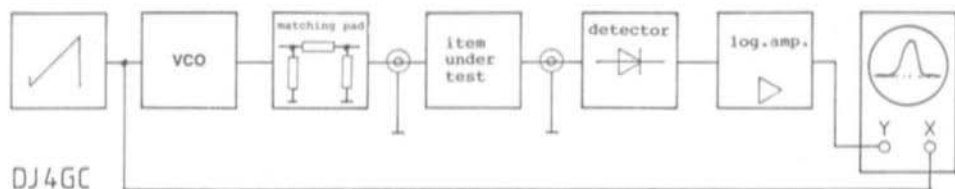

Fig. 24: The basic test set-up of a sweep measurement

detectors are favourable requirements for tuning work, for power and attenuation measurements as well as for applications in sweep techniques (fig. 24). The logarithmic indicator assists in the assessment of the test results. The cathode-ray tube used in the indicator oscilloscope should be of the long-persistence type. More practical still, is the employment of storage oscilloscopes which are making ever increasing inroads into the measurement scene. They will also allow a printed output of the displayed trace by means of a picture store output to a graphic printer.

The return loss is the quantity by which an impedance is adjudged to approach that of the system normalized impedance (mostly 50  $\Omega$ ). This may be carried out using a wideband sweep test set-up in order to detect discontinuities caused by spurious resonances etc. (fig. 25). The directional coupler, or RF bridge, must possess a uniform coupling factor over the whole of the test frequency range.

The one described by DJ 7 VY in (7) has a constant coupling factor extending from the short-

wave band right up to the 13 cm band – if it has been carefully constructed (I constructed a longer version of this RF bridge and the return loss was better than – 30 dB over a frequency range of 100 kHz to 1000 MHz – a highly recommended item of precision test equipment for the amateur constructor – G3ISB). Hewlett Packard has produced a wideband coupler with a – 22 dB coupling factor, constant and with high directivity, over the frequency range 2 to 18 GHz!

A reference line is established before the test object is introduced, by either open-circuiting the test-object port or terminating it with a precision pad of known impedance. By this means, any frequency dependent errors in the RF bridge, or in the detector, may be eliminated. The displays of fig. 14, 15 and 16 were produced using this technique.

High-dynamic range measurements are dependent for their accuracy upon the spectral purity of the signal- or sweep-generator employed. Both harmonic and non-harmonically

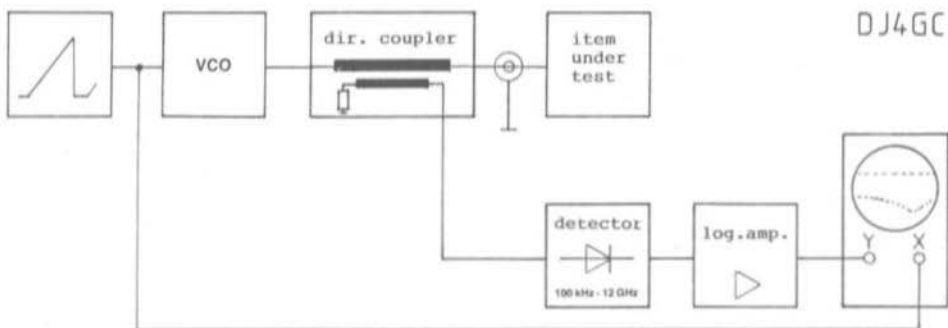

Fig. 25: The basic test set-up for a swept return-loss measurement



| Diode      | Manufacturer     | Threshold   | Type                        | Housing/<br>Limit frequency      |
|------------|------------------|-------------|-----------------------------|----------------------------------|
| AA 118     | ITT              | - 48 dBm    | Germanium-Diode             | Glass bead<br>to 500 MHz         |
| AA 143     | ITT              | - 52 dBm    | Germanium-Diode             |                                  |
| HP 2900    | HP               | - 28 dBm    | Schottky-Diode              | Glass bead<br>to 2 GHz           |
| BA 481     | Valvo            | - 31 dBm    | Schottky-Diode              |                                  |
| 1 SS 99    | Toshiba          | - 55 dBm    | Low-Barrier-Schottky-Diode  |                                  |
| MX 1435    | Metelix          | - 25 dBm    | High-Barrier-Schottky-Diode | Miniature SHF-diode<br>to 12 GHz |
| BAT 14-093 | Siemens          | - 18 dBm    | High-Barrier-Schottky-Diode |                                  |
| DDB 6783   | Alpha-Industries | - 40 dBm    | Low-Barrier-Schottky-Diode  |                                  |
| MA-40203   | M/A-COM          | - 55 dBm    | Low-Barrier-Schottky-Diode  |                                  |
| MGF 3000   | Mitsubishi       | - 8 dBm (!) | Gallium-Arsenide-Diode      |                                  |

**Table 1: Measured threshold limits of detector diodes**

related signals can easily present a very much worse measurement result than is actually the case. In particular, sweep-generators often have spurious output signals which are only - 20 dB with respect to the fundamental output. These harmonics must be kept out of the measurement system by means of low-pass filters when using wideband sweep techniques. The "exclusive" way to make a swept measurement is to use a spectrum analyzer with a tracking generator. The latter follows the received swept signal exactly over the whole of the measurement range. This technique allows measurements with a dynamic range of up to 100 dB.

Using a small Gunn oscillator, for example, the polar diagram of a directional antenna may be taken. This test set-up can be used for directional antennas of all frequencies and is characterized by the absence of measurement range-switching because of the high-dynamic range of the detector head.

In general, this technique is useful for all RF measurements involving voltage or power linear scales which require amplifier or attenuator-range switching. In particular, where range pads have to be inserted and removed, involving perhaps the use of connector adapters, the swept technique can avoid quite massive measurement errors.

## 8. REFERENCES

- (1) HP-Datenbuch:  
DIODE and TRANSISTOR DESIGNER'S CATALOG
- (2) Siemens-Datenbuch:  
Mikrowellenhalbleiter
- (3) Alexander Kraus:  
Einführung in die Hochfrequenz-Meßtechnik  
Pflaum Verlag - München
- (4) Tietze-Schenk:  
Halbleiter Schaltungstechnik  
Springer Verlag
- (5) Gerd Harms:  
Linearverstärker, Vogel-Verlag
- (6) Carsten Vieland, DJ 4 GC:  
Compact BNC Attenuators  
VHF COMMUNICATIONS Vol. 17,  
Ed. 1/1985, P. 2 - 7
- (7) Michael Martin, DJ 7 VY:  
Extremely Low-Noise Preamplifiers require  
Low-Loss Antenna Cables!  
Wideband Directional Coupler for VSWR  
Measurements on Receiver Systems  
VHF COMMUNICATIONS Vol. 15,  
Ed. 3/1983, P. 153 - 162



# MATERIAL PRICE LIST OF EQUIPMENT

described in edition 2/1988 of VHF COMMUNICATIONS

|  |   |                |                       |
|--|---|----------------|-----------------------|
| <b>YT3MV</b>                                       | <b>Receiving Converter for 4 GHz Satellites</b>   | <b>Art.No.</b> | <b>Ed.2/1988</b>      |
| PCB  | YT3MV 001 and 002   |                | upon request          |
| <b>DB1NV</b>                                       | <b>Thermal Power Mount</b>  |                | <b>Ed. 2/1988</b>     |
| Components   | DB1NV TLM 8 micro-lamp bulbs, 5 cer. chip<br>1 nF, 2 cer. chip 10 pF, 2 RFC<br>47 $\mu$ H   | 6994           | DM 13.-               |
| <b>Ready-made power mount</b>                      |   |                | <b>upon request</b>   |
| <b>DJ4GC</b>                                       | <b>50 <math>\Omega</math> Wideband Detectors</b>  |                | <b>Ed. 2/1988</b>     |
| PCB  | DJ4GC 002 for logarithmic amplifier   | 6986           | DM 26.-               |
| Components   | DJ4GC 002 1 tin-plate box, 5 op.amps,<br>2 transistors, 3 diodes, 5 multi-<br>turn pots, 15 0204 resistors, 2 foil<br>caps, 2 elkos                       | 6987           | DM 61.-               |
| <b>Kit</b>   | <b>DJ4GC 002 PCB and components</b>   | <b>6988</b>    | <b>DM 82.-</b>        |
| <b>Ready-made diode detector (BNC) 0 - 2.5 GHz</b> |   | <b>6989</b>    | <b>DM 89.-</b>        |
| ditto  | (N) 0 - 3.0 GHz   | 6990           | DM 112.-              |
| <b>DC1OP</b>                                       | <b>ATV-FM Driver for the 13 cm Band</b>   |                | <b>Ed. 1/1988</b>     |
| PCB  | DC1OP 001 double-sided, drilled   | 6074           | DM 45.-               |
| PCB  | DC1OP 002 double-sided, (one side etched)   | 6075           | DM 28.-               |
| <b>DB1NV Spectrum Analyser</b>                     |   |                | <b>Ed. 3 + 4/1987</b> |
| Ready-made unit                                    | with power supply and 0 to 70 dB<br>step-attenuator (10 dB steps).<br>Range: DC to 2 GHz, in a rugged<br>table-top housing, without display<br>circuitry. | <b>3303</b>    | <b>DM 6350.-</b>      |
|  | <b>Price per unit</b>   | (export price) | DM 5571.-)            |
| <b>Modules</b>                                     | Set consists of four ready-for-use<br>PCBs in tin-plate boxes   | <b>3302</b>    | <b>DM 2995.-</b>      |
|  | <b>Price per set</b>  | (export price) | DM 2628.-)            |





The ideal solution  
for the most  
discriminating  
satellite operator:

# Computer-Controlled Satellite Tracking

## MTI (Mirage Tracking Interface)

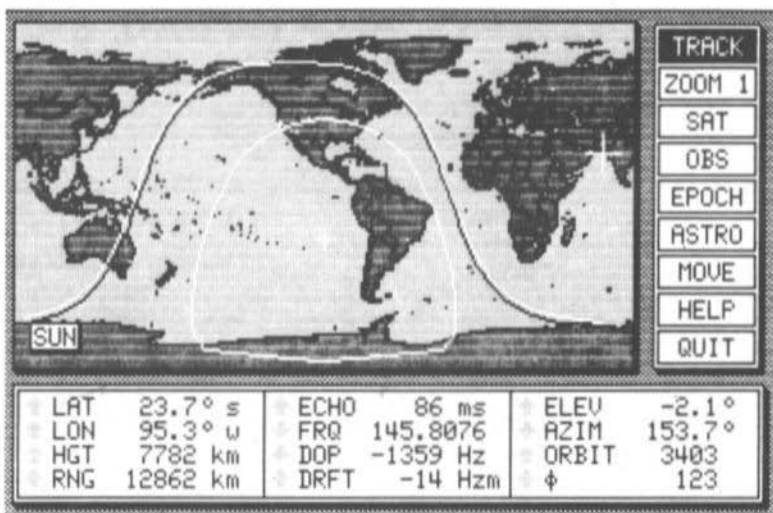

- Automatic tracking of any orbiting body
- Antennas stay aimed correctly at all times
- MTI works with Silicon Solutions software: GRAFTRAK, SILICON EPHEMERIS, SATELLITE EDITOR
- The computer controls the satellite rotators KR-5400 A / B, KR-5600 A / B via the Interface
- The user can change the current time and date forwards or backwards

### Features:

#### Switch selectable for:

Elevation 0° - 90° and 0° - 180°  
Elevation factor x 1 or x 2  
Northern or southern hemisphere  
Manual or automatic mode  
Baud rate 300 ... 2400

Detailed **manual** (in English)

**Cable** for rotators KR-5400 A / B and KR-5600 A / B

#### Required hardware:

PC / XT / AT or compatible

#### Required software:

MS-DOS

MTI consists of:

**Interface** with cable  
**Software** (3 floppies)  
**Manual** (106 pages)

Order nr.: 3400 (ex stock)  
Introductory price:  
DM

**1740.-**

(Export price)

Information and  
demonstration at:

 **UKW technik**  
**UKW berichte**

Telecommunications, VHF-Communications

UKW-Technik Terry D. Bittan oHG

Jahnstraße 14, D 8523 Baiersdorf

Tel. (0 91 33) 47-0, Tlx. 629887, Tfx. (0 91 33) 47 18

# EXTENSION OF OUR ANTENNA-ROTATOR PROGRAM

## Azimuth Rotators

|   |             | Art.Nr. | Export price |       |
|---|-------------|---------|--------------|-------|
| ● for large VHF / UHF or medium-sized shortwave-antenna installations     |             |         |              |       |
| ● rotation range of 450 degrees, with auto stop                           | KR-800 S    | 1024    | DM           | 658.— |
|   | KR-800 SDX  | 1025    | DM           | 780.— |
| ● pre-selection of the direction and variable speed for the ... SDX-types | KR-1000     | 1026    | DM           | 758.— |
|   | KR-1000 SDX | 1027    | DM           | 890.— |

## New Elevation Rotators

|   |          | Art.Nr. | Export price |       |
|---|----------|---------|--------------|-------|
| ● same dimensions as the KR-500                               |          |         |              |       |
| ● higher rotation torque: (100 Nm or 140 Nm instead of 40 Nm) | KR-500 A | 1017    | DM           | 460.— |
| ● higher brake torque, faster rotation                        | KR-500 B | 1018    | DM           | 600.— |

## Satellite Rotators

|  |           | Art.Nr. | Export price |        |
|--|-----------|---------|--------------|--------|
| ● including the enhanced dates of elevation rotator KR-500 A: (100 Nm / 200 Nm) and KR-500 B (140 Nm / 400 Nm) | KR-5400 A | 1013    | DM           | 710.—  |
|  | KR-5600 A | 1014    | DM           | 938.—  |
|  | KR-5400 B | 1015    | DM           | 947.—  |
| ● suitable for the tracking interface  | KR-5600 B | 1016    | DM           | 1120.— |

Available from:



Telecommunications, VHF-Communications  
 UKW-Technik Terry D. Bittan oHG  
 Jahnstraße 14, D 8523 Baiersdorf  
 Tel. (091 33) 47-0, Tlx. 629887, Tfx. (091 33) 47 18



## Plastic Binders for VHF COMMUNICATIONS

- Attractive plastic covered in VHF blue
- Accepts up to 12 editions (three volumes)
- Allows any required copy to be found easily
- Keeps the XYL happy and contented
- Will be sent anywhere in the world for DM 9.00 including surface mail

Order your binder via the national representative or directly from the publishers of VHF COMMUNICATIONS (see below)

## Reduced Prices for VHF COMMUNICATIONS !!!

|                                 | Volume          | Individual copy     |
|---------------------------------|-----------------|---------------------|
| <b>Subscription 1988</b>        | <b>DM 25.00</b> | <b>each DM 7.50</b> |
| VHF COMMUNICATIONS 1987         | DM 24.00        | each DM 7.00        |
| VHF COMMUNICATIONS 1986         | DM 24.00        | each DM 7.00        |
| VHF COMMUNICATIONS 1985         | DM 20.00        | each DM 6.00        |
| VHF COMMUNICATIONS 1980 to 1984 | DM 16.00        | each DM 4.50        |
| VHF COMMUNICATIONS 1975 to 1979 | DM 12.00        | each DM 3.50        |

Individual copies out of order, incomplete volumes, as long as stock lasts:

|   |              |
|---|--------------|
| 1/1970, 2/1971, 1/1972, 2/1972, 4/1972, | each DM 2.00 |
| 2/1973, 4/1973, 1/1974, 3/1974          | each DM 2.00 |
| Plastic binder for 3 volumes            | DM 9.00      |

All prices including surface mail.

When ordering 3 complete volumes, a free binder is included!



**UKW**berichte Terry D. Bittan · Jahnstr. 14 · Postfach 80 · D-8523 Baiersdorf

Tel. West Germany 9133 47-0. For Representatives see cover page 2

# You should know what's behind our sign

We are the only European manufacturers of these **Miniature TCXO's**

**CCO 102, CCO 103,  
CCO 104, CCO 152**  
**modulable table**

- higher stability than a quartz crystal:  
less than  $\pm 3$  ppm over the temperature range  $-30$  to  $+60^\circ\text{C}$ . (types B)
- low ageing rate:  
less than 1 ppm per year.
- wide frequency range:  
10 MHz to 80 MHz
- low supply voltage:  
 $+5$  V
- low current consumption:  
3 mA max. (series CCO 102)
- small outlines: CCO 104 =  $2,6 \text{ cm}^3$ , CCO 102/152 =  $3,3 \text{ cm}^3$ ,  
CCO 103 =  $4,0 \text{ cm}^3$
- widespread applications e.g. as channel elements or reference oscillators in UHF radios (450 and 900 MHz range)

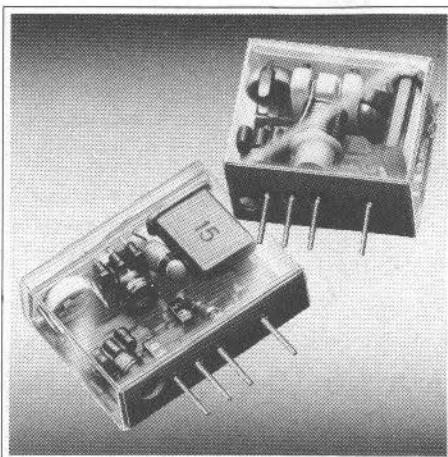

Our R + D engineers are constantly working with new technology to develop new products. We can offer technical advice for your new projects or manufacture against your specification.

**Quartz crystal units in the frequency range from 800 kHz to 360 MHz Microprocessor oscillators (TCXO's, VCXO's, OCXO's) crystal components according to customer's specifications**

| Types                    | CCO 102                      |   |   | CCO 103                      |   |   | CCO 104                      |   |   |
|--------------------------|------------------------------|---|---|------------------------------|---|---|------------------------------|---|---|
|                          | A                            | B | F | A                            | B | F | A                            | B | F |
| Freq. range              | 10 - 80 MHz                  |   |   | 6.4 - 25 MHz                 |   |   | 10 - 80 MHz                  |   |   |
| stability vs temp. range | $-30$ to $+60^\circ\text{C}$ |   |   | $-30$ to $+60^\circ\text{C}$ |   |   | $-30$ to $+60^\circ\text{C}$ |   |   |
| Current consumption      | max. 3 mA at UB = $+5$ V     |   |   | max. 10 mA at UB = $+5$ V    |   |   | max. 10 mA at UB = $+5$ V    |   |   |
| input signal             | $-10$ dB/50 Ohm              |   |   | TTL-compatible (Fan-out 2)   |   |   | 0 dB/50 Ohm                  |   |   |

**CCO 152 A + B**  
same size as CCO 102 A + B  
modulation input deviation: typ. 1 kHz/V  
mod. frequency: DC to 10 kHz  
impedance: 20 k Ohm

**TELE QUARZ**

... Your precise and reliable source

TELE-QUARZ GMBH · D-6924 Neckarbischofsheim 2  
Telefon 0 72 68/801-0 · Telex 782359 tq d · Telefax 07268/1435