

621.38
W 527

**WESTERN
UNION**

Technical Review

**High-Speed Facsimile:
A Direct-Scanning System
Transmitter
Recorder**

•

Chattanooga Works

•

Frequency Standard

•

Cable Transmission Spectrum

•

Toroid Coils

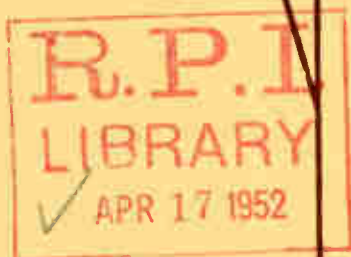

**VOL. 6
APRIL**

**NO. 2
1952**

WESTERN UNION

Technical Review

VOLUME 6
NUMBER 2

Presenting Developments in Record Com-
munications and Published Primarily for
Western Union's Supervisory, Main-
tenance and Engineering Personnel.

APRIL
1952

CONTENTS

	PAGE
A High-Speed Direct-Scanning Facsimile System	37
<i>C. R. Deibert, F. T. Turner and R. H. Snider</i>	
A High-Speed Telefax Recorder	48
<i>D. M. Zabriskie</i>	
A High-Speed Facsimile Transmitter	56
<i>L. G. Pollard</i>	
The Chattanooga Works	61
<i>E. J. Trent</i>	
Frequency Standard for Microwave Relay Systems	71
<i>L. W. Franklin</i>	
The Radio Spectrum—with Boost for the Low End	77
<i>I. S. Coggeshall</i>	
Toroid Coils for Miniaturization	82
<i>Clara U. Watts and F. L. Depperman</i>	
Telecommunications Literature	84

Published Quarterly by

THE WESTERN UNION TELEGRAPH COMPANY

COMMITTEE ON TECHNICAL PUBLICATION

F. B. BRAMHALL	Development and Research Dept., <i>Chairman</i>
I. S. COGGESHALL	Internat'l Communications Dept.
H. H. HAGLUND	Plant and Engineering Dept.
G. HOTCHKISS	Development and Research Dept.
G. P. OSLIN	Public Relations Department
M. J. REYNOLDS	Patent Department
H. M. SAUNDERS	Operating Department
NELL ORGAN, <i>Secretary</i>	

Address all communications to THE WESTERN UNION TELEGRAPH Co.,
COMMITTEE ON TECHNICAL PUBLICATION, 60 HUDSON ST., NEW YORK 13, N. Y.

Subscriptions \$1.50 per year

Printed in U.S.A.

(Copyright 1952 by The Western Union Telegraph Company)

A High-Speed Direct-Scanning Facsimile System

C. R. DEIBERT, F. T. TURNER and R. H. SNIDER

FACSIMILE, although almost as old as Morse telegraphy, did not come into widespread use as a communication device until after World War I. This is perhaps the result of a series of circumstances. In the first place, the Phoenicians are said to have developed the alphabet which is a cleverly contrived code making possible the recording of all of the sounds of spoken language by means of comparatively few symbols. Next must be added the work of Morse and Baudot who converted these symbols, the letters of the alphabet, into an even simpler code whereby the written language could be transmitted by wire using a series of electrical impulses. This makes possible the transmission by comparatively inexpensive and simple circuits, of any intelligence which can be expressed in language. Facsimile, on the other hand, scans the copy in terms of the elemental area, which in design can be varied to meet the definition requirements of any particular application. Anything which can be put on paper whether it be written, drawn, printed or painted can be transmitted with equal facility. This versatility does not, however, come free; it must be paid for either in terms of time or of spectrum bandwidth. If all languages had developed as did that of the Chinese, facsimile might today be a

more highly developed and common means of communication.

In time, so many channels were required for the simultaneous transmission of a large number of messages, that means were developed for stacking numbers of channels on a single facility. The ultimate to date is the development of the coaxial cable and the microwave relay system, where a very large quantity of terminal equipment is required for the combining and extracting of the large number of separate channels which can be handled.



Figure 1. A complete High-Speed Facsimile terminal

It is obvious at least where record copy is involved (that is, intelligence on a piece of paper), that were these copies to be sent in time sequence at high speed, less terminal equipment might be re-

A paper presented before the Winter General Meeting of the American Institute of Electrical Engineers in New York, N. Y., January 1952.

quired. Also, if the high-speed facility were simple enough to operate and maintain, although not as efficient of spectrum space as other means, it could conceivably be more economical to operate and maintain.

Thus, one must reach the conclusion that, where facsimile is used, it is and must be an economical solution to a communication problem rather than a scientific possibility, for systems have already been developed capable of sending full page letters at the rate of 15 per second and this is probably by no means the ultimate if circumstances require higher speeds. High speed is, therefore, a solution only so long as it creates no new problem of an economically serious character; namely, the problem of gathering and distributing the material at the terminals.

The Western Union facsimile terminal described in this paper (Figure 1) is believed to be the highest speed equipment announced to date employing direct scanning at both the transmitter and recorder. The original piece of copy, so long as it is a sheet of paper with dimensions no greater than 8 1/2 by 15 inches, is placed directly into the transmitting cylinder and is scanned directly through that cylinder by optical means. At the recorder, the copy is reproduced directly onto a sheet of Western Union "Teledeltos"* paper which is automatically ejected and is ready for delivery in a permanent dry form within a second or two after the last scanning line has been completed.

Terminal Components

A complete terminal consists of two transmitters operating alternately to keep the circuit in use continuously, a series of panels including amplifiers, power supplies and control equipment, and two recorders. The second recorder is a stand-by unit in the sense that one recorder is used continuously until its roll of paper is exhausted at which time operation is switched to the stand-by unit.

* Registered Trademark W.U.TEL.Co.

The speed is such that a series of 8 1/2 by 11 inch letters can be sent in their entirety at the rate of one every 45 seconds or 80 per hour. Copy is scanned at the rate of 2 1/8 square inches, or 1/4 lineal inch, per second. In the telegrapher's language, this corresponds to 1250 words per minute for pica type or 1500 words per minute for elite type. Definition is determined by an 8 1/3-mil diameter elemental area.

The facsimile or video signal developed at the transmitting photocell covers the spectrum from a fraction of a cycle per second to 15.5 kc for equal horizontal and vertical definition. When modulating the 25-kc carrier on a double sideband basis, the bandwidth required is 31 kc extending from 9.5 to 40.5 kc. To date, this equipment has been operating on a double-sideband basis; single-sideband operation is, however, envisioned for the future.

The functions of a facsimile system may be divided into three categories; namely, scanning, synchronizing and phasing. Scanning is the process of reading the original copy, point by point, at the transmitter, and laying down a copy of that original at the recorder. Synchronizing is the process of keeping the scanning motors at both ends of the system running at the same speed during a transmission so that the intelligence laid down at the recorder shall fall in the same relative position as it occupied on the original. Phasing, which may be called framing, is the process of setting up the equipment so that the reproduced copy shall be reasonably well centered on the sheet.

Transmitter Scans at 1800 rpm

Scanning at the transmitter is accomplished in the following manner (Figure 2). The copy is placed within a transparent cylinder which revolves at the rate of 1800 rpm. A carriage mounting a lamp, optical system, and photocell, travels along the length of the cylinder at a uniform rate thus scanning the inside surface of the cylinder in a continuous spiral. The area under an objective lens is floodlighted by means of an incan-

descent lamp and condenser lens. The objective lens images the lighted area onto an opaque plate with an 8 1/3-mil dissecting aperture at its center. The light passing through the aperture falls on the

pictorial copy with a continuous tone scale is to be sent, the original tone scale is preserved so long as the copy has a margin at least 1/4 inch wide. From the restorer, the signal is fed to a conventional

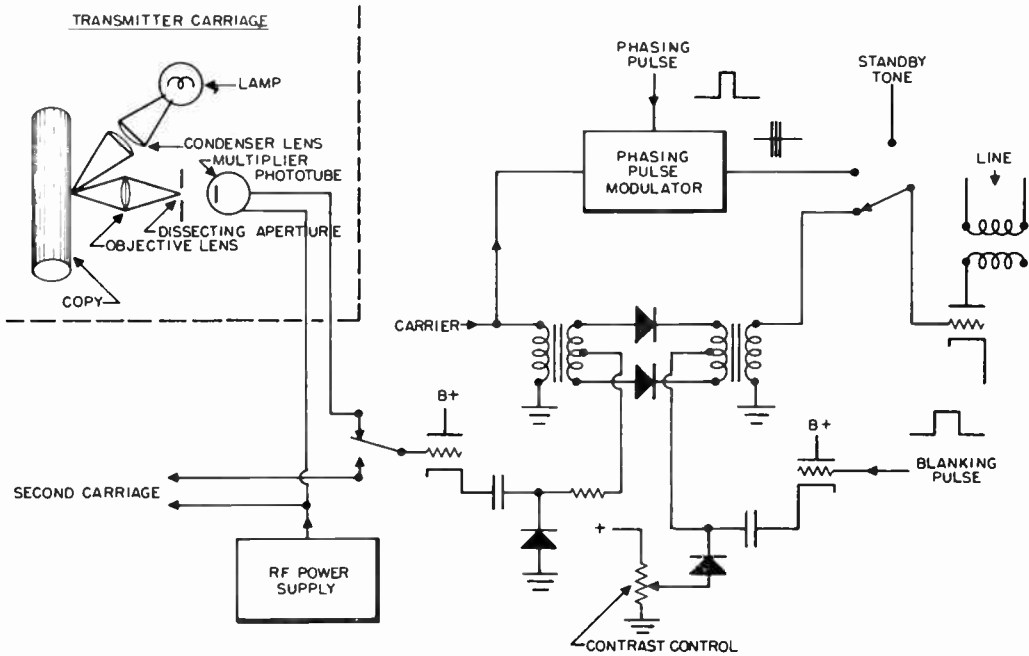

Figure 2. Transmitter scanning system

cathode of a multiplier phototube causing current emission proportional to the reflectivity of the area being scanned. By amplification within the phototube, the emission current is transformed to a peak voltage swing of up to 50 volts in amplitude. This voltage swings from a fixed positive value for black or no reflectivity, to a less positive value dependent upon the background reflectivity of the copy. Since the preponderance of written, printed, or drawn intelligence is in black or some dark color on a light background, it is desirable that the signal representing the background be held at a constant level just below the recording threshold. To achieve this end, a d-c restorer circuit has been added which always clamps the peak negative signal, regardless of its absolute value, to zero. The restorer was so designed that, when

balanced modulator and thence through amplifiers to the line.

Background Signal Reduced

In the modulator, two other functions are performed. First, a bias is applied to the modulator to eliminate that signal which is due to paper texture itself. It was found that there was a wide variation in the signal derived from the surface of various types of paper. Accordingly, a bias control was added to eliminate all but a trace of this signal which, insofar as the recorder is concerned, is actually little more than noise. This resulted in an apparent increase in signal-to-noise ratio especially for light marks.

The second additional function is to blank out the paper gap. The equipment is designed to handle variable widths of

copy up to 8-1/2 inches. The inside circumference of the cylinder is 8 5/8 inches so that there is always a paper gap of 1/8 inch or more. If not blanked out, it would be recorded as black. The blanking



*Original photograph by Eugene M. Hanson,
Los Angeles, Calif.*

Figure 3. High-Speed Facsimile reproduction of a photograph

is accomplished by biasing off the modulator completely during the time the paper gap is being scanned. This circuit too must include a d-c restorer because the signal is obtained from a plate circuit through a capacitor. Otherwise, the signal required to accomplish blanking would appear to vary with the length of the paper gap pulse.

At the recorder, scanning is accomplished by four styli mounted on a continuous belt recording on Western Union's direct recording "Teledeltos" paper. The distance between adjacent styli is equal to the inside circumference of the transmitter drum. The belt is driven by a motor identical to that used at the transmitting end. Here the styli continuously scan a fixed line, and paper is gradually fed past the scanning line at the same rate as the carriage is advanced to the transmitter.

The received signal is amplified and applied to the belt and styli. The current flowing from the styli through the "Teledeltos" paper to ground marks the paper, the density of the mark varying with the amplitude of the signal received from the transmitter. Although the recording characteristics of "Teledeltos" paper are not quite linear enough to give the best possible results insofar as the reproduction of photographs is concerned, no effort was made to minimize this defect in the first design. Figure 3 is an example of what can be accomplished.

The incoming modulated carrier is applied to a 75-watt recording amplifier. In early models of this equipment, the output was applied directly to the paper. Because it has since been found that positive polarity extended the recording range somewhat toward black, a full wave rectifier was included in the output to take advantage of this phenomenon (Figure 4).

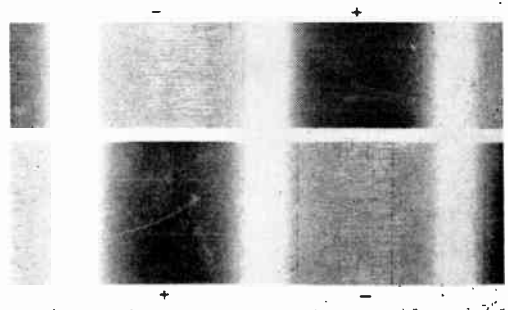

Figure 4. Effect of polarity on the density of recording

Precision of Synchronization

Synchronization has been defined as the process of keeping the scanning motors at both ends of the system running at the same speed. This identity must be maintained to a very high degree of precision, the exact degree depending somewhat on the nature of the disturbance. For instance, a disturbance at either the transmitter or recorder which shifts one with respect to the other by as little as 0.004 inch, is readily detected if it

occurs during the scanning of a single line of type or less, whereas a larger disturbance, if evenly distributed over say 5 or 10 lines of type, might go completely undetected.

The two important sources of disturbances are load changes and changes in motor power, be they voltage or frequency. Frequency differences and changes can be eliminated by driving the motors through amplifiers from frequency standards with accuracies of 4 parts per million or better. A relative difference between the two ends of the circuits of such an amplitude would result in a skew no greater than 1/16 inch for a transmission 14 inches long. Commercial frequency standards are readily available capable of giving such performance. From the curve of Figure 5 it will be noted that around 115 volts the deviation on the face of the facsimile copy is 0.008 inch for a change of one volt applied to the motor. Therefore, in order to maintain the equipment within the 0.004 inch previously mentioned, the output of the amplifiers at each end must remain relatively constant to within about 1/2 volt, or plus or minus 1/4 volt, for each amplifier. In order to achieve this requirement as nearly as possible, the plate and bias supplies associated with the motor amplifiers and the frequency standard are of the regulated type. This leaves the load variations which can be minimized, but not to the required extent, by careful design. Even in the transmitter, where the load consists entirely of windage and bearing friction, the variation in the ball-bearing load alone is enough to cause undesirable disturbances. In the recorder where, for good registration, stylus-restraining forces are required, variations in load become quite serious. The curve of Figure 5 indicates that in order to keep the system synchronous to 0.004 inch, the load variation of one terminal with respect to the other may be no greater than about 0.2 inch-ounces. If the tolerance is equally divided between the two ends of the system, each load must remain constant within 0.1 inch-ounce or within plus or minus 1 percent of the running torque.

One method of minimizing the effect of load variations is to add a constant load of such proportions as to render the variations inconsequential. Since we are after an improvement of the order of about 10 times, such an approach would

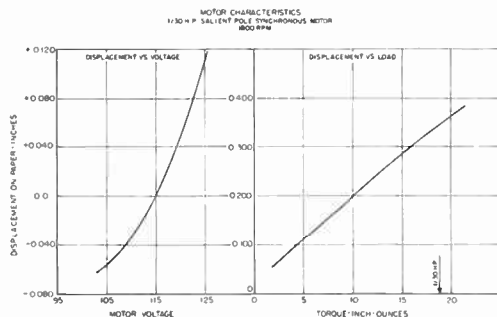

Figure 5. Motor voltage and load characteristics

require larger motors and larger amplifiers, and would result in an unwieldy, inefficient and uneconomical solution. Experience with other equipment indicated that some form of servo-loop was necessary to counteract those disturbances which could not economically be eliminated.

Flywheel Concept Applied

To fulfill this need, a device was developed which, in a sense, compares the instantaneous position of the rotating mass of the equipment with an ideal flywheel and develops from this comparison an error voltage proportional to the relative displacement of one with respect to the other. The error voltage is in turn applied in such a manner as to reduce the original displacement to negligible proportions.

In the equipment, the actual comparison is made between two a-c potentials (Figure 6). One, the ideal, is derived from the frequency standard, the other from a capacitive-type generator mounted on the motor shaft. A phase detector compares these two potentials and delivers an error signal which is proportional to the displacement of the rotor from its ideal position. The error voltage is applied to

a modulator which regulates the amplitude of the standard frequency applied to the amplifier and thus to the motor to compensate for the disturbing influence.

The heart of the frequency standard is a 240-cycle temperature-compensated fork. This frequency is divided to 60 cycles for the motor circuits and multiplied to 1440 cycles for the transmitter phase detector. These signals are fed through isolation amplifiers to the transmitter and recorder.

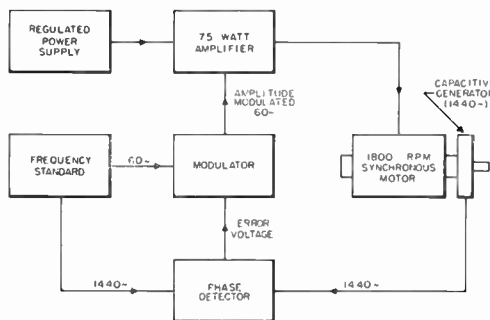

Figure 6. Transmitter drive system

The phase detector used is the conventional circuit consisting of two transformers feeding a double diode. The output is, within limits, proportional to the cosine of the phase difference between the two applied voltages and the amplitude of the smaller of the two voltages. In this equipment, a frequency of 1440 cycles was selected to apply to the phase detector in order to increase its sensitivity and eliminate the need for a stable d-c amplifier in its output. That the selection of a substantially higher frequency increases the sensitivity of the phase detector can be explained as follows: by designing the generator so that it develops 48 complete cycles per motor revolution, a displacement on the copy of 0.004 inch which corresponds to 1/6 of a degree on the motor shaft causes a phase shift of the generated tone of 8 degrees. Gain of this sort can be taken advantage of up to a point. If, during operation, disturbances are encountered which cause displacements just over 90 degrees of the generated tone, the motor and servo system will jump over to a new position which

is about one cycle of the reference tone away from the original position. A system of this sort tends to restore itself for disturbances which shift the tone between plus and minus 90 degrees. In the quadrants extending from plus and minus 90 to 180 degrees, the system is unstable and jumps to a new position. The tone generator itself is of the capacitive type because of its comparative simplicity. The error voltage from the phase detector is applied to the modulator in such a manner that, for an increase in load, the voltage applied to the motor through the amplifier is increased to compensate for the load change.

This system is of the positional-servo type with a loop-transfer function dependent upon the motor sensitivity, in degrees per volt, the phase detector sensitivity, in volts per degree, and the modulator and amplifier gain. All systems of this type tend to hunt or oscillate as the loop gain is increased. The insertion of a proportional-plus-derivative network between the phase detector and the modulator allowed the loop transfer function to be increased to the point where satisfactory operation was attained. The transfer function achieved results in a stability with respect to small load variations which is equivalent to a 15-times increase in the running torque of the motor.

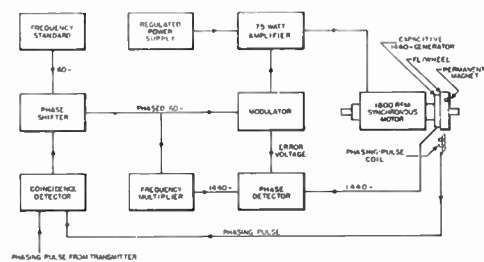

Figure 7. Recorder drive and phasing systems

The motor drive system (Figure 7) at the recorder differs somewhat from that at the transmitter because of the necessity of phasing the recorder motor. The standard 1440 cycles must be derived by multiplication from the phased 60 cycles, as the reference tone as well as the

motor must be properly phased to achieve satisfactory stabilization and accurate phasing.

Figure 8 is a photograph of transmissions of 9-point type with and without the servo-loops acting. The figure outline shows the extent of the displacement of

Phasing by Paper Gap Pulse

Phasing has been described as the process of setting up the equipment so that the received copy is reasonably well centered on its blank. To accomplish phasing, a signal which can be used to phase the scanning motors must be sent

Figure 3. Cross-section of parallel-plane resonator.

PLUNGER RESONANCES

The plunger used in the parallel-plane resonator of the Model 618A is a non-contacting type and therefore leaves a small gap between the periphery of the plunger and the inside surfaces of the outer conductor, as illustrated in Figure 3. This gap with its two flat conductors acts as a transmission line and, in the frequency range of the Model 618A, has a two-cycle and a four-cycle resonance; that is, the gap resonates at frequencies corresponding to one-half and one-fourth of the electrical length of the periphery of the plunger. These resonances are illustrated in Figure 4, where one-half of the peripheral transmission line is drawn as if it were unfolded. The methods used to control plunger resonances are described later.

A similar gap exists between the

The upper
is a plot of
At the low
hand, the
operated
point indi



Figure 4. Resonances.

Figure 3. Cross-section of parallel-plane resonator.

PLUNGER RESONANCES

The plunger used in the parallel-plane resonator of the Model 618A is a non-contacting type and therefore leaves a small gap between the periphery of the plunger and the inside surfaces of the outer conductor, as illustrated in Figure 4. This gap with its two flat conductors acts as a transmission line and, in the frequency range of the Model 618A, has a two-cycle and a four-cycle resonance; that is, the gap resonates at frequencies corresponding to one-half and one-fourth of the electrical length of the periphery of the plunger. These resonances are illustrated in Figure 4, where one-half of the peripheral transmission line is drawn as if it were unfolded. The methods used to control plunger resonances are described later.

A similar gap exists between the

The upper
is a plot of
At the low
hand, the
operated
point indi



Figure 4. Resonances.

Figure 8. Comparison of transmissions with and without motor stabilization

one terminal with respect to the other. The accompanying distortion in the text is quite obvious. Figure 9 shows on an amplified scale the variation of an uncontrolled and a controlled motor and indicates the effectiveness of the servo-loops.

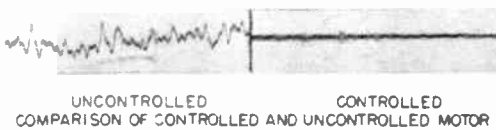

Figure 9. Comparison of stability of uncontrolled and controlled motors

from one terminal to the other. The system should be reliable, automatic and require no transmission path other than that used to send the message portion of the signal.

Because the two transmitters operate alternately and are designed primarily for ease of loading, the copy may be placed in the drum without any regard for its position circumferentially, and may have any phase relationship with respect to the drum. Such a situation requires that phasing precede every transmission.

The system used develops at the transmitter an 0.5-millisecond pulse from the paper gap, and with it modulates the facsimile carrier. The pulse-modulated carrier is automatically transmitted to the

recorder for a period of 3 seconds just preceding each transmission. At the recorder, while the equipment is phasing, the motor is running at 1830 rpm and a similar 0.5-millisecond pulse is developed. The transmitter pulse, after demodulation, and the recorder pulse are applied to a coincidence detector. Since the transmitter pulse occurs at a frequency of 30 pulses per second and the recorder at 30.5 pulses per second and they are each 0.5-millisecond wide, within a period of two seconds they will pass through coincidence. The pulse at coincidence will stop the phase-seeking device and change the recorder-motor speed from 1830 to 1800 rpm. The recorder is now running synchronously and in phase with the transmitter. The accuracy of phasing is dependent on the combined pulse widths. For two 0.5-millisecond pulses, 0.5 millisecond corresponding approximately to 1/8 inch on the copy, the theoretical maximum phasing variation is 1/4 inch. Wider phasing pulses would result in correspondingly larger phasing variations. It has been stated that the paper gap may vary from 1/8 inch up. It becomes obvious, therefore, that the paper-gap pulse itself should not be used as the phasing pulse, but rather a pulse of uniform width should be developed which has some definite relationship to an edge of the copy.

Figure 10 shows, in simplified form, the manner in which the phasing and blanking pulses are developed. An auxiliary photocell is installed on the outside of the scanning cylinder and a light source on the inside of the cylinder. Light is blocked off from the photocell by the copy except for that interval during which the paper gap passes by. A pulse is thus generated for each drum revolution. This pulse may be of variable amplitude, depending on photocell sensitivity, light brilliance and so forth, and is not entirely suitable for triggering purposes. To increase reliability,

the pulse is fed to an over-driven amplifier where the grid is swung from zero bias to cut-off, thus obtaining a pulse of more nearly uniform amplitude and requiring only a minimum sensitivity from the photocell. The pulse is next differentiated and the resultant negative-going pulse, developed from the trailing

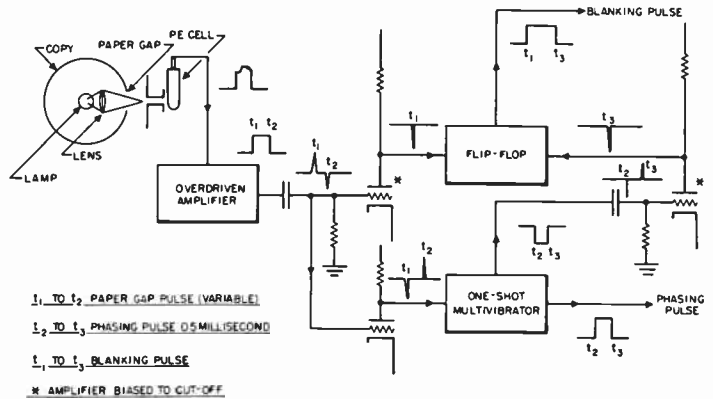

Figure 10. Transmitter pulse circuitry

edge of the gap, is caused to trigger off a one-shot or mono-stable multivibrator. The multivibrator time constants are adjusted so that the resultant pulse, the phasing pulse, is of 0.5-millisecond duration.

Blanking Pulse Cuts Out Modulator

These circuits also develop the blanking pulse. The auxiliary photocell is so located that it sees the paper gap 0.25 millisecond before the scanning photocell. The differentiated pulse, resulting from the leading edge of the paper gap pulse, is caused to trigger a flip-flop circuit and set up the beginning of the blanking pulse. The blanking pulse, in turn, biases off the facsimile modulator 0.25 millisecond before the paper gap actually reaches the scanning cell.

The end of the blanking time is marked by a pulse differentiated from the trailing edge of the phasing pulse. This pulse restores the flip-flop circuit to its original condition and removes the bias from the modulator. The blanking pulse is, therefore, a summation in time of the paper gap pulse and the phasing pulse. Because the phasing pulse is adjusted to be 0.5-

millisecond long and anticipates the paper gap by 0.25 millisecond, the signal is blanked out for a period extending from 0.25 millisecond before until 0.25 millisecond after the paper gap has passed by the scanning photocell. This results in blanking of the paper gap signal and allows for a slight misalignment of the copy in the drum.

Before describing the phasing process at the recorder it is necessary to explain some of the operations and their sequences in starting a recorder. The recorder is, in a sense, a complete slave of the transmitter, since all necessary opera-

Imbedded in a flywheel on the motor shaft is a small permanent magnet which causes a pulse to be generated in a coil which is mounted adjacent to the flywheel. The physical relationship between the permanent magnet, coil and styli is such that a stylus is always beginning the scanning of the left margin of the copy while the pulse is being generated.

Phasing Interval Fixed by Timer

Upon removal of the stand-by tone, the phase-detector circuit becomes sensitive to phasing pulses. This circuit causes a relay to operate when phasing pulses begin arriving and initiates the phasing interval timer at the recorder. This timer, theoretically, needs to be set for no more than 2 seconds; however, in order to be positive that a minimum 2-second period is always measured off, it is normally set for about 2.5 seconds.

Some time during the phasing period, pulse coincidence occurs, triggering the thyatron which removes the motive power from the clock motor driving the rotatable trans-

formers. At the end of the time measured off by the phasing interval timer, the recording amplifier and paper-feed motor are turned on and, a fraction of a second later, the facsimile signals begin to appear and actual message recording commences.

If the transmitters are operated alternately, the stand-by tone is applied to the line between messages for only about 1/10 second and is immediately followed by phasing pulses. The 1/10-second tone initiates not only the cut-off and delivery of the message but the complete recycling of the recorder with the exception of the initial motor starting period.

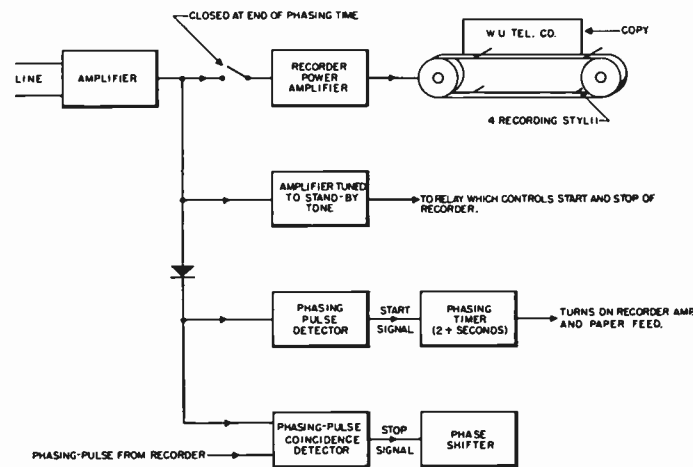

Figure 11. Recorder scanning and signal detection

tions are initiated and controlled from the transmitter (Figure 11). A signal, which is called stand-by tone, is sent from the transmitter at all times the equipment is idle. On initiating a transmission, the stand-by tone is removed and during a period of 7 seconds the recording motor is started on commercial a-c and transferred to run from the amplifier at 1830 rpm. This speed, which is called the phase-seeking speed, is obtained by applying the standard 60 cycles to a rotatable transformer which is continuously rotated at the rate of 1 rps by a small clock motor until the equipment is phased. In this way the standard 60 cycles is converted to 61 cycles before it is applied to the power amplifier and motor.

equipment is required. In the present instance, 13 relays and 3 timers are among the items required at the transmitting terminal. Their operation will not be described in detail but only insofar as it affects the apparent performance of the equipment.

12.5-kc Tone for Stand-by

As has been previously stated, the transmitter applies a stand-by tone of 12.5 kc to the line during idle periods. The selection of 12.5 kc was based on a number of reasons, dependent somewhat on the 25-kc carrier and the nature of facsimile signals. Frequency choice was based on the premise that, with a 25-kc carrier, 12.5 kc was the frequency of least incidence at appreciable amplitude either when considered as a direct component or when modulated onto the carrier. This fact, in addition to the sending of this one frequency at full power, makes possible a positive selectivity on an amplitude basis against signals which may result from facsimile copy. The absence or presence of this tone on the line determines whether the recorder runs or stands idle.

The tone is removed by a relay which operates when a transmitter door is opened and closed. Closure of the door also starts the transmitter. After the voltage across the motor comes up to a predetermined value indicating that the motor is reasonably close to synchronous speed, the motor is switched to the power amplifier, the servo-loop is applied and an additional fixed-time interval is measured off to assure that the recorder is ready to proceed. At the end of this time interval, a phasing timer is started and the phasing pulse amplifier is turned on. Transmission of phasing pulses continues for 3 seconds, because at the recorder the phasing-pulse detector must operate, a 2.5-second period must be measured off for phasing, and finally the platen must

bring the paper into contact with the styli. The time required is just a fraction under 3 seconds. At the end of the phasing time, scanning is initiated by turning on the facsimile amplifier and line-feed motor.

While the first transmitter is running, the second may be loaded and started. It will come up to speed and run idle until after the first message is completed when a switch is tripped causing the transmission of stand-by tone for about 1/10 second followed immediately by the transmission of phasing pulses from the second transmitter and in turn by the message. So long as the drums are kept loaded, only the 3 seconds of phasing time is lost between messages.

Two of these terminals have been in trial operation since September 26, 1951, handling live traffic between New York and Washington, D.C. Operating over a previously unused portion of Western Union's radio beam spectrum, about 77 percent of the total traffic between New York and Washington has been handled during the hours of facsimile operation. If available, up to 180 average size messages could be handled per hour.

Initially a few minor components were found unsuitable because of the manner in which they were used. After these situations were remedied, maintenance has consisted primarily of keeping the recorders in good repair including replacement of paper and styli and occasional replacement of vacuum tubes. For a time some difficulty was encountered with the phasing circuits; however, after satisfactory adjustment procedures were arrived at, misphases were reduced to the order of 1 percent.

The transmitter and recorder are described in detail in accompanying papers.

The authors acknowledge their indebtedness to Mr. R. J. Wise, Telefax Research Engineer, and his staff, for invaluable advice and assistance.



C. R. DEIBERT, a native of Pennsylvania, received his B.S. degree in Electrical Engineering from Northeastern University in June 1939. After graduation he was employed as a research assistant in the Physics Laboratories at M.I.T., where he was engaged in the development, operation and maintenance of equipment for measuring extremely small quantities of radio-active materials. In 1941 he joined the Engineering Department of Western Union and was almost immediately assigned to the Electronics Research Division at Water Mill. There he took part in the program to determine the feasibility of using electromagnetic radiation in the region including the visible spectrum for communication purposes. Mr. Deibert was co-inventor of the Concentrated-Arc Lamp and closely associated with its development until 1947 when he was made Assistant to the Electronics Research Engineer. His major effort since then has been his contribution to the program culminating in the high-speed facsimile terminal.

F. T. TURNER of the Electronics Research Division, Water Mill, L. I., entered the employ of the Telegraph Company in March 1946, from which time he has been engaged in the design of facsimile equipment. Prior to 1946, he had gained wide experience in the field of facsimile, having been employed by International News Photos for seven years in the design and production of facsimile apparatus. Following that period, he was instructor of facsimile operators with the USAAF Weather Wing HQ in Asheville, N. C., and then supervised installation, operation and maintenance of the Weather Map Facsimile Network of the 18th Weather Squadron ETO. in England, France and Germany. Mr. Turner has contributed substantially to the success of the high-speed facsimile system described in this paper. He is a Member of the IRE and served for two years on the IRE Technical Committee on Facsimile.



R. H. SNIDER was graduated from Cornell University in 1948 with the degree of Bachelor of Electrical Engineering. Immediately after graduation he joined the Telegraph Company on the staff of the Electronics Research Engineer at the Water Mill Laboratory on Long Island. He has been concerned mainly with facsimile development, including some work on the original design of the three-stylus hotel recorder. Mr. Snider has been associated with the high-speed facsimile program since its inception.

A High-Speed Telefax Recorder

D. M. ZABRISKIE

WESTERN UNION's High-Speed "Telefax" Recorder No. EM2074, shown in Figures 1 and 2, provides a means for fully automatic reception, on "Teledeltos" paper, of facsimile reproductions of graphic records at a speed ten times faster than equipment previously available. Pica type,

(1) to read the incoming message while being recorded; (2) to handle uniform sheet lengths of from 2 to 14½ inches and, alternately, to handle sheets of random lengths within the same range; and (3) to cut off and deliver the recorded message to a receptacle or conveyer belt with suffi-



Figure 1. High-Speed Recorder EM2074

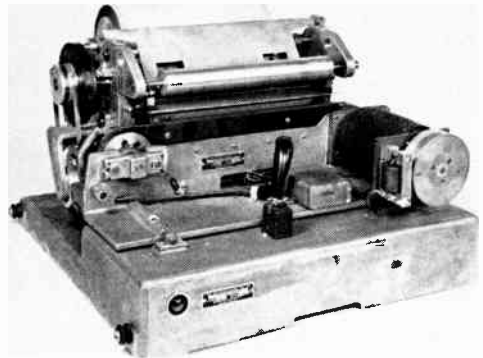

Figure 2. High-Speed Recorder—cover removed

single spaced, can be reproduced at the rate of 1300 words per minute.

The successful development of Western Union's High-Speed transparent horizontal-cylinder facsimile transmitter which, when used in pairs and operated alternately allowing an interval of two to three seconds between the end of one transmission and the beginning of the next, dictated the need for a single receiver which would operate with equal rapidity to handle the output of the two transmitters. The short interval between transmission ruled out the use of manual functions in the operation of receiving apparatus and the need for a fully automatic recorder was apparent.

Requirements

Features considered essential to permit simple operating procedure, along with automatic operation, included ability

cient rapidity so that a completed recording would not interfere with the succeeding one.

The first requirement, that of having copy visible while being recorded, suggested the use of a multistylus page-type continuous recorder similar to Western Union's No. 5616-A 3-stylus machine, which had been used quite successfully since late 1948 as the receiving element in the company's Desk-Fax tie-line concentrators.

A 3-stylus belt arrangement requires that, in order to lose no line time, scanning take place for the full length of the distance between pulley center lines. Operating at comparatively low speeds (180 lines per minute) this arrangement is entirely satisfactory because the belt can be guided to move along a straight line approximately tangent with the pulleys, without excessive frictional losses resulting from the belt guiding elements.

A paper presented before the Winter General Meeting of the American Institute of Electrical Engineers in New York, N. Y., January 1952.

At the speed required of the new recorder (1800 lines per minute), however, behavior of the belt due to centrifugal force made it necessary to elevate the scanning line somewhat above the pulley tangential line. Because of the natural curvature of the belt path leaving and approaching the pulleys, approximately 10 percent of the required straight line scanning is lost. Attempts to force the belt into a straight path by guiding obviously would create frictional load on the driving motor. To overcome these unfavorable conditions, the new design was based upon the use of four styli per belt which, because of the extra belt length, permits the pulleys to be spaced farther apart and consequently provides space, not needed for scanning, in which the belt may follow its natural curvature.

General Description

Telefax Recorder EM2074 is a 4-stylus page-type continuous recorder using Western Union "Teledeltos" recording paper 9¼ inches wide from rolls averaging 675 feet in length. A tabulation of pertinent data associated with the recorder follows:

- Recording Speed — 1800 lines per minute
- Length of Scanning line—8.639 inches
- Definition — 120 lines per inch
- Recording Rate — ¼ inch per second
= 2½ sq. in. per second
- Stylus Surface Speed — 1296 ft. per minute
- Stylus Diameter — 0.010 inch

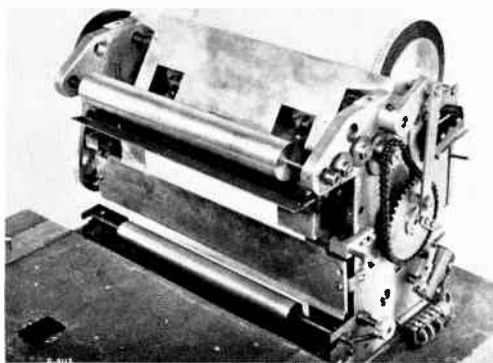

Figure 3. Paper-feed mechanism

The recorder is comprised of two major components: a paper-feed mechanism permanently attached to a cast aluminum base (Figure 3), and a detachable stylus drive mechanism (Figure 4), enclosed in a common cover 19 inches wide, 19½ inches deep and 14 inches high (Figure 1).



Figure 4. Stylus drive unit

Paper Feed

"Teledeltos" paper from a roll passes downward through a curved guide, then upward between a 2-speed motor-driven feed roll and a spring-tensioned pressure roll, through a vertical chute, into the channels of a pivoted, retractable platen, past the blades of a motor-driven cutter, then between the delivery rolls. (See Figure 5.) In passing through the platen the paper is yieldingly presented into the path of the moving styli. The paper is pulled off the roll and pushed upward through the platen by a motor-driven feed roll. When recording, a synchronous motor drives the feed roll at the rate of ¼ inch per second through a one-way clutch built into the end of the feed roll. After recording has been completed, the drive is taken over by the fast feed motor, also coupled through a one-way clutch, to feed out paper at the rate of 5 inches per second. Both motors are equipped with dynamic brakes to prevent overrunning.

Message Lengths Control

An electromechanical subassembly (Figure 6), mounted on the left side of the recorder and designated as the "feed meter", provides control for two methods of operation. First, the feed meter may be set so that after recording is completed,

only enough blank paper will be rapidly fed out to provide a margin of $\frac{1}{2}$ inch between the text of the recording and the bottom of the cut sheet. If sheets of uniform length are required, regardless of the length of recording, the feed meter may be set to handle any size from 2 inches to $14\frac{1}{2}$ inches of length. Means for setting the feed meter for either method of operation is provided by the engraved dial, the edge of which protrudes through the cover, conveniently accessible to the operator.

The feed meter assembly (Figure 6) consists of a stationary shaft supported between the frame and a bracket; the shaft carries the body and windings of a magnetic clutch to which direct current is supplied through slip rings and brushes. The clutch is compounded with a spur gear meshed with a pinion on the feed-roll shaft. The

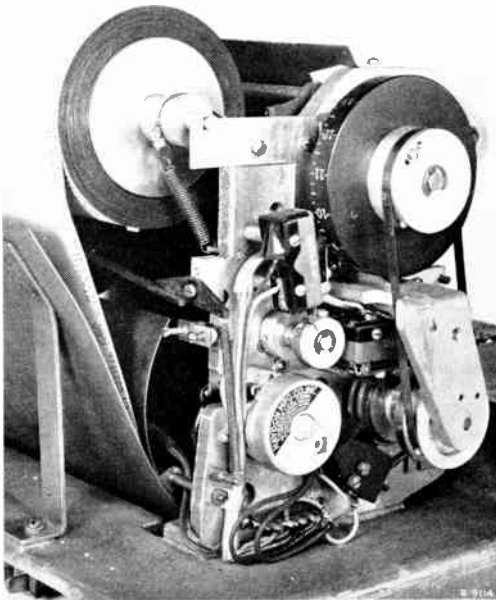

Figure 6. Feed meter mechanism

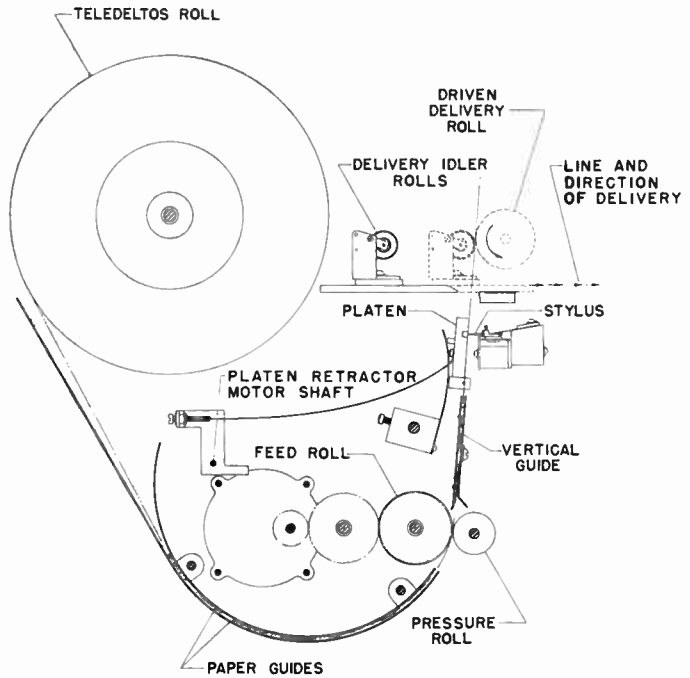

Figure 5. Paper course

clutch rotates whenever the feed roll turns. The armature of the clutch is a disk of Armco iron mounted on a sleeve, rotatable on the shaft. The sleeve carries a cam and an adjustable stop arm. The cam operates a twin switch and the stop arm limits the angle through which the cam may turn. The armature assembly is returned to a start position by a torsion spring. Stops for the armature sleeve are provided in an adjustable pulley which can be positioned by the dial protruding through the cover. The dial and stop pulley are coupled through a backlash-free drive consisting of two steel bands partially wrapped around the pulleys in opposite directions and anchored thereto.

A circuit selector switch, operated by the dial, is provided to set up the recorder control circuits to operate the meter for either "random" or uniform sheets. With the dial set at "random" the switch is closed, setting up the control circuits so that the end-of-message signal will stop the normal feed motor, retract the platen, start the fast feed motor, and energize the magnetic clutch which picks up the armature and its attached cam and rotates through an angle equal to $1\frac{1}{2}$ inches of

feed-roll surface, whereupon the cam operates the twin switch to stop the fast feed motor, start the cutter motor and release the magnetic clutch.

Operation of the feed meter for uniform length sheets is the same as described above for random length sheets except that by setting the dial for, say six inches, the circuit selector switch sets up the controls so that the magnetic clutch operates simultaneously with the start of the normal feed motor. The stops automatically are set to permit the cam to move through the greater angle required for six inches of paper.

Paper Cutter

Sheets are cut off and delivered by a combination of shears and delivery rolls driven from a common motor, equipped with a dynamic brake to prevent over-running. The cutter mechanism (Figure 3), is carried on a cross rail of the frame. A stationary blade of hardened tool steel is rigidly attached to the frame. The moving blade, the cutting edge of which is placed at an angle of $7\frac{1}{2}$ degrees to the stationary blade, is attached to guide bars. Parallel motion is imparted to the moving blade assembly through a rack and segment drive. The segments, carried on a rocker shaft, are reciprocated by a crank coupled directly to the cutter motor. Rolls, carried by spring-loaded levers, exert pressure on the moving blade to insure constant engagement of the shearing edges.

The crank pin is carried on a sprocket mounted directly to the motor shaft. The sprocket, chain and associated spur gears provide a stepped-up drive for the delivery roll which is located in front of the sheet to be delivered. Behind the sheet, and riding on the moving blade, is a pair of rolls carried in yieldable spring-loaded levers and adjusted to squeeze the paper against the driven delivery roll an instant after the sheet has been severed by the blades. A dwell in the engagement of these rolls, sufficient to permit the longest sheet to be delivered, is provided by a slot in the connecting link, where it is coupled to the crank pin.

One complete revolution of the crank is required for the cut-off and delivery cycle, which requires one second. Control for the cycle is provided by the feed meter to start, and by a self-operated switch to stop.

Retractable Platen

The platen, a solid magnesium bar equipped with pivots and paper guides, provides yielding support to the paper, holding it in a plane parallel to the path of the styli. A lateral groove directly behind the stylus path is provided in the platen to prevent any accumulation of deposit from the "Teledeltos" paper, which might otherwise result from constant recording over the same path. The platen is tilted at a slight angle with the vertical to permit contact of the styli on the scanning path and clearance for the return path. The left edge of the platen is shaped to place a slight curve in the paper to permit smooth engagement between the styli and the paper as each stylus in turn contacts the paper. Pressure is exerted against the platen, and consequently by the "Teledeltos" paper against the stylus, by an adjustable leaf spring.

The short interval between successive recordings makes it necessary to cut the paper while the styli are in motion; therefore, to prevent the paper from being torn by the styli because of the excessive pressure caused by the cutting action, it was necessary to provide a means to withdraw the paper from engagement with the styli during the cutting operation. It is also advantageous to ease the paper gradually into engagement with the styli after they are in motion rather than have them make a high-speed start while in pressure engagement with the paper.

For these reasons a platen retractor is provided, consisting of a 1-rpm clutched clock motor coupled to the platen through a lever and a flexible cord. The retractor motor is wired in parallel with the normal feed motor, therefore the platen engages the paper with the styli only when recording is required. When normal feed stops, the power to the stalled retractor motor is turned off and the platen is rapidly

withdrawn by a spring. Slackness in the cord, while recording, permits the platen to operate unhampered by its coupling to the retractor lever.

The diminishing paper roll is followed by a roller carried on a lever which, when the paper supply is nearly exhausted, operates a switch to light a signal lamp located at the front of the recorder base. Controls are arranged so that the recording in progress at the time the switch operates is completed before the recorder is rendered inoperative.

Stylus Drive

The detachable stylus drive assembly is fastened to the base with a shouldered pivot screw and a single cap screw. The essential components are shown in Figure 4. The unit consists of an aluminum sand casting supporting a 1/30-h.p. synchronous motor, coupled directly to a driving pulley. An endless flexible belt, propelled by the driving pulley, passes over an idler pulley running on sealed ball bearings. Four equally spaced removable styli are fastened to the belt, which is guided along the top run where scanning takes place. The styli engage the paper at a trailing angle of 75 degrees to the paper. Controlled by an adjusting screw (Figure 2) attached to the drive assembly and engaged with a slot in the base, the assembly can be swiveled about a shouldered pivot screw to place the plane of the stylus path in proper relation to the plane of the paper.

Stylus Belt

Belts are made of blue-tempered spring steel into which a line of holes, accurately spaced, is punched. The belt is joined into endless form with a spot-welded splice, Figure 7. Essential characteristics required for belt material are conductivity, dimensional stability, flexibility, fatigue resistance and machinability. Various materials were tried, including heat-treated beryllium copper and "Elgiloy", neither of which was found to be equal to spring steel for this particular application.

Roller, silent and block chains were considered but were rejected because of

excessive weight and the probability of dimensional variations, resulting from wear at the numerous pivot points. Toothed neoprene belts, with steel wire reinforcement were checked and, in their present state of manufacture, were found to be lacking in dimensional accuracy to the degree required for this application; however, further investigation is being

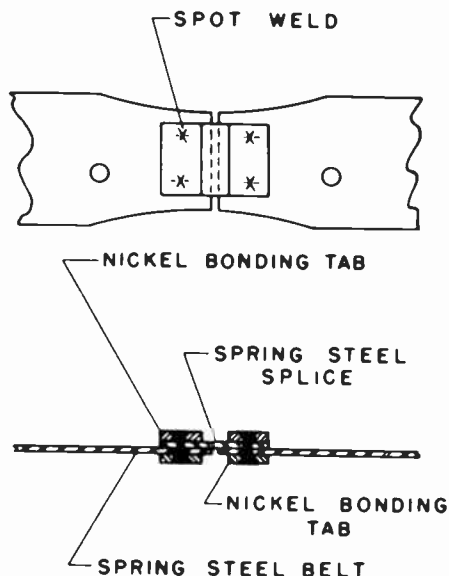

Figure 7. Welded splice—stylus belt

carried on, in recognition of the otherwise ideal qualities of such a belt.

Early belt models, based upon the original conception of pulley alignment, guiding and other details used successfully at lower speeds, broke down after periods of from three to four hours of continuous running at high speed. Fractures occurring at the sprocket holes due to excessive stresses exerted on the belt by the sprocket pins while guiding the belt on a straight path indicated the need for a more accurate alignment of the pulleys.

The accuracy of machining of the various components could not be depended upon to provide proper alignment; therefore an adjustment was provided for the idler pulley. Four adjusting screws, located in the idler mounting bracket, are used to tilt the pulley at any angle re-

quired for a proper alignment which, determined by trial, is a condition whereby an unguided belt will traverse rapidly at least 20 revolutions over pulleys from which the sprocket pins have been removed, without completely running off the pulleys.

Such improvement in alignment extended the life of belts up to approximately 100 hours, after which breaks then occurred at the stylus holder plates. A slight change in the shape of the holder plate washers, along with substitution of eyelets in place of rivets as the fastening medium, further increased the belt life to approximately 200 hours on bench tests.

Frictional load of the belt is inherently nonuniform because of the repetitive irregularities caused by the styli entering and leaving the guided path. Guiding the belt to drive the styli unerringly along the scanning line, without creating excessive friction or introducing stresses likely

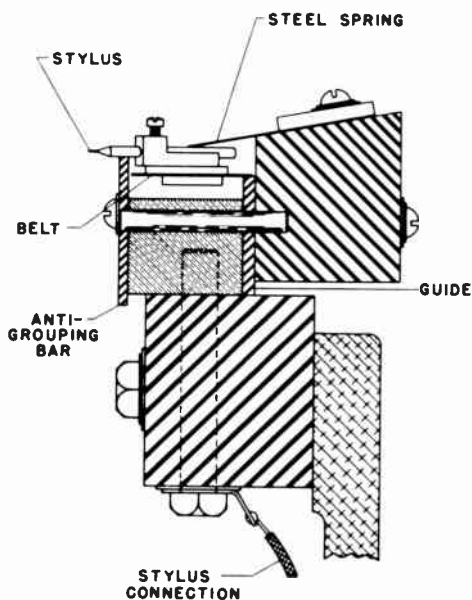

Figure 8. Cross-section of belt and guides

to fracture the belt, presented a problem not easily solved.

The guiding method found most satisfactory, shown in Figure 8, consists of a steel guide, hard chromium plated, supporting the rear bottom edge of the belt along with a hardened steel bar designated

as the "antigrouping" bar supporting the underside of the stylus. Midway between these two points of contact, a thin flexible steel spring exerts light pressure downward on the top of the stylus, guiding the styli to track uniformly without distorting the belt or overloading the motor.

Slight remaining irregularities of frictional load and variations in driving motor voltage, causing slight random jitters in recorded copy, are corrected with a flywheel containing a built-in tone generator, of the variable capacitor type, mounted on the front extension of the motor shaft, Figure 9.

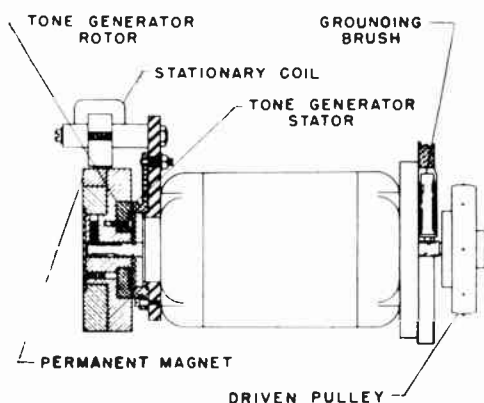

Figure 9. Stylus motor drive

Motor Stabilizer

A motor stabilizer circuit, controlled by the tone generator, consists of a phase detector, modulator, amplifier and corrective networks. It functions to compare a 1440-cps reference signal, derived from a frequency standard, with the signal derived from the tone generator, and to apply to the modulator an error signal which is proportional to the phase difference between the two signals. The modulator output signal is then either increased or decreased, in accordance with the sign and amplitude of the error voltage. The modulator output is fed to a synchronous power amplifier and in turn to the driving motor. An increase in friction load upon the belt which would cause a momentary reduction in motor speed causes an increase in voltage applied to the motor, to counteract the effect of the friction.

D. M. Zabriskie, Assistant to the Telefax Research Engineer, came to the Company with the Western Union-Postal merger. He had joined the Engineering Department of Postal in 1922, after two years in the U. S. Army, and in 1925 was appointed chief draftsman. From 1940 until the merger, as chief designer he directed the design of mechanical equipment for Postal's semiautomatic tape reperfector switching system which was installed in many cities and later adopted by the U. S. Signal Corps for their administrative network. Mr. Zabriskie continued in the same capacity with Western Union and worked on the Signal Corps project until its completion in 1945. He was then assigned to the Telefax Research Engineer's staff and subsequently placed in charge of machine design. His activities in Telefax recorder design have resulted in five patent applications.



The tone generator consists of two segmented rings, each with 48 teeth. The rotor, at ground potential, is attached to the flywheel and the stator mounts on an insulator carried on the motor frame. The stator is adjustable, which permits orientation of the generator with respect to the synchronous motor poles. A self-lubricated brush engages the motor shaft to provide a low resistance connection from the rotor to ground, not attainable through the ball bearings of the motor.

Phasing

“Framing” or phasing the recording between the margins of the paper is accom-

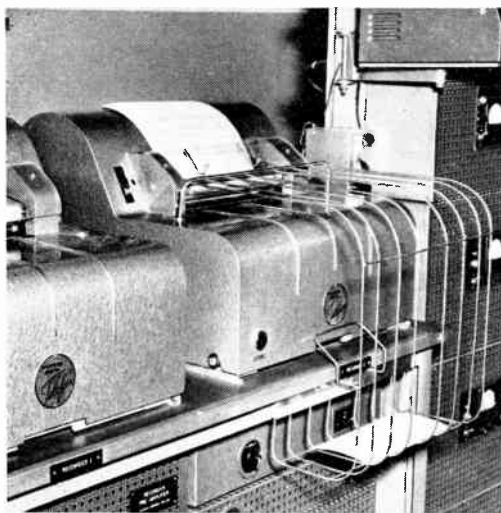

Figure 10. Receiving table

plished by maintaining a proper relation between the sprocket pins of the driving pulley and a permanent magnet, embedded in the flywheel, which generates a pulse in a stationary coil attached to the motor frame. The section of the flywheel carrying the phasing magnet is separated from and adjustable on the main body of the flywheel which is fastened to the motor shaft. The adjustment provides a convenient means of correcting phase without disturbing adjustments established on the tone generator.

During the interval of two seconds allowed for phasing, the recorder is driven at 61 cps, while the associated transmitter, similarly equipped with phasing magnet and coil, runs at 60 cps. When the pulses from the phasing coils coincide, the recorder drops back to 60 cps and is locked in phase with the transmitter.

A stylus setting gauge, integral with the detachable stylus drive assembly, is provided to establish the recording tips of the four styli in a uniform plane and at a proper depth with respect to the platen. A safety switch, controlled by the gauge, prevents the motor from running while the gauge is in proximity of the styli.

Application

In the present application of this recorder — Western Union's High-Speed Telefax Terminal WM136, Figure 10 — two recorders are slip-connected to a

receiving table which has facilities to switch either recorder into operating service, while the other is available for maintenance or as spare. The recorder bases are equipped with dampered ducts which connect them to a blower-filter system built into the table which absorbs any smoke generated in the recording process.

Renewal of "Teledeltos" paper rolls, expended styli and damaged belts, in that order, are maintenance functions most frequently encountered. Paper and styli can be installed without disturbing the recorder, other than removal of the cover. Replacement of belts requires the removal

of the stylus drive assembly from the base.

The recorder is now being used in field trials of the high-speed facsimile terminal, handling live telegraph traffic over a radio beam between New York and Washington.

The author wishes to acknowledge the full cooperation and valuable assistance rendered by Mr. Adolph Hofer, Western Union toolmaker at the Water Mill Laboratory, during the development of this recorder. Acknowledgement is also made to Mr. C. B. Rountree for the development of the welding techniques employed in the belt splice.

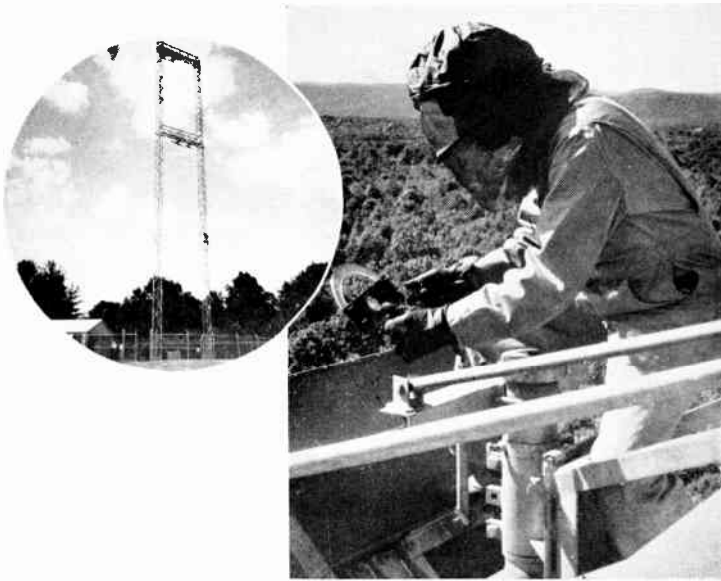

Engineer making azimuth angle adjustments on microwave reflector atop Western Union experimental radio beam mast (circle) wears insect hood, coveralls and heavy gloves to avoid sting of angry wasps.

A High-Speed Facsimile Transmitter

L. G. POLLARD

THE TRANSFER of intelligence from one point to another by any system requires time, and the amount of intelligence that can be transferred per unit of time is an indication of the efficiency of the system. What is known as "line time" is a critical factor that must be reduced to a minimum if production efficiency is to be kept high. A reduction in "line time" can be accomplished by two means, (a) by increasing the speed of transmission, and (b) by simplifying the operation of the equipment.

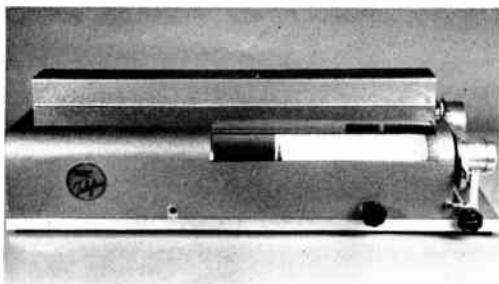

Figure 1. High-Speed Facsimile Transmitter

As the speed of transmission is increased the requirements for the transmitting medium become more exacting and a point is reached where it is not economical to carry the speed any higher, especially if the amount of traffic to be handled over the system does not necessitate higher speed. A point is also reached where some elaborate automatic devices may be required to allow operators who handle the equipment to keep the machines working at full capacity.

The Western Union high-speed facsimile telegraph system, operating at a speed of 1800 scanning lines per minute, appears to have as high a speed as can be justified economically, and such a system is applicable only to trunk circuits which have high quality transmission channels available.

This paper describes the transmitter which was designed for this high-speed

system. In the design of the transmitter it was necessary to consider the basic requirements of all facsimile systems, some of which assume greater importance only as the speed of transmission is increased. One of the main *mechanical* requirements that had to be met was a suitable method of handling the message blanks. In the majority of facsimile systems, the transmitter is equipped with a cylinder, around the outside of which the message to be transmitted is wrapped and held by means of spring garters or

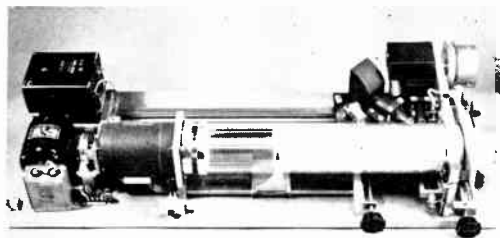

Figure 2. Facsimile transmitter with cover removed

some form of clamp. This method is quite satisfactory when operating at low speeds, but at high speeds the clamping method must be very complete in order adequately to hold the blank against the action of centrifugal force which tends to peel it from the cylinder.

Centrifugal Force Aids

This transmitter is a departure from the conventional design and centrifugal force is an aid rather than a hindrance. It consists of a horizontally mounted transparent cylinder, and the message to be transmitted is placed inside of the cylinder with the intelligence side of the message blank against the inside wall. Scanning of the message takes place through the cylinder wall, and when the cylinder is running at 1800 rpm centrifugal force presses the blank firmly

against the wall of the cylinder, thereby maintaining a constant plane of focus.

The transmitter is shown in Figures 1 and 2. A transparent cylinder 15½ inches long is mounted directly on the shaft of an 1800-rpm, 60-cycle, 1/30-hp, salient-pole type synchronous motor. The cylinder is made of Lucite supported at each end in suitable aluminum flanges. It is essential that this rotary unit be perfectly balanced about its axis, and to obtain such a unit it was necessary to machine and polish both the outside and inside surfaces of commercial tubing. Glass tubing made to accurate specifications has also been used successfully.

Provision is made for opening the right end of the cylinder for the insertion of message copy, after which a swing gate, equipped with suitable bearings, engages the end of the cylinder. A travelling carriage supporting the photo pickup system is fed along a track parallel to the axis of the cylinder to scan the copy in the conventional manner.

Figure 3 shows the open end of the cylinder with the bearing gate swung back to permit loading. Figure 4 shows the gate in closed position. The gate supports a housing which contains two large ball bearings. A hollow shaft through these bearings carries a tapered spring-mounted flange which engages a mating tapered flange on the end of the cylinder. When at rest, with the gate open, the right end of the cylinder is supported in a large clearance hole in the right-hand vertical supporting member of the ma-

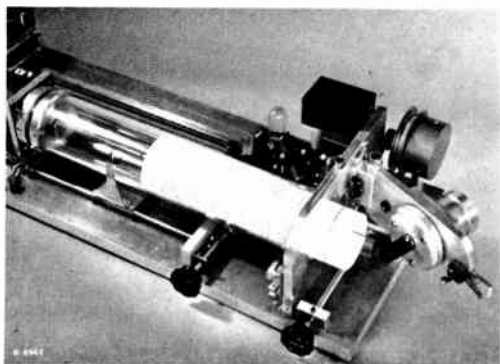

Figure 3. Facsimile transmitter showing insertion of copy

chine, but when the end of the cylinder is picked up by the gate bearings, it revolves freely, supported at one end on the motor shaft and at the other by the gate bearings.

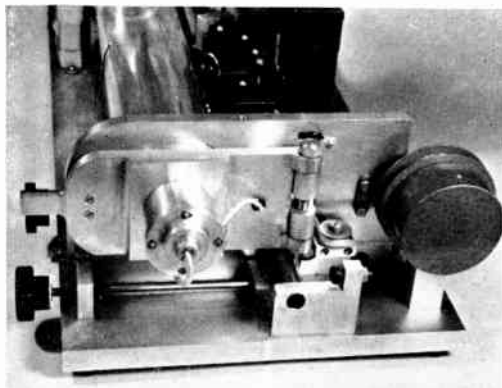

Figure 4. End view showing bearing housing

1440-Cycle Tone Corrects Speed

Mounted at the motor end of the cylinder, between the cylinder and the motor, is a tone generator. This is a variable capacity type unit, the rotor being integral with the cylinder assembly and the stator mounted on an insulating plate on the face of the motor support. The generator consists of two annular rings each having 48 equally-spaced teeth, as can be seen in Figure 5, which shows the two parts in a separated position. In the assembled condition there is approximately 0.010 inch clearance between the stator and the rotor. A polarizing voltage is applied to the stator section of the generator and the rotor is at ground potential. At the synchronous speed of 1800 rpm, this generator develops a frequency of 1440 cps. As described in an accompanying paper, this generated frequency is compared with a 1440-cps reference derived from a frequency standard, and the resulting phase difference between these two frequencies is used to correct the motor driving voltage to maintain a steady nonvarying cylinder rotation.

The cylinder-driving motor has a double-ended shaft and the opposite end from the cylinder is fitted with a brake drum. A solenoid-operated brake arm

bears against this drum to bring the message cylinder to a quick stop at the termination of each transmission. The solenoid is actuated at the same time that power is applied to the cylinder motor, and the brake arm is retracted to allow free rotation of the cylinder. A spring exerts pressure on the brake arm when power is removed from the solenoid.

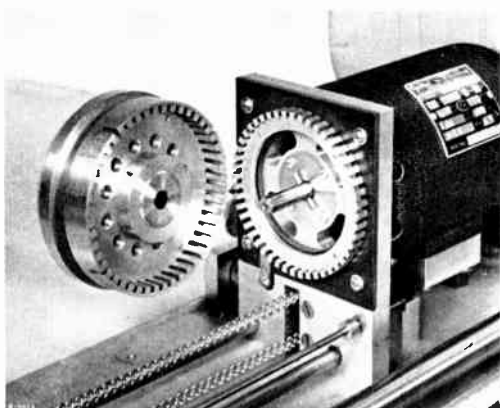

Figure 5. Tone generator

The scanning carriage travels parallel to the cylinder axis along two rails mounted to the rear of the cylinder and close to the base of the machine. It is essential that the path of the carriage be exactly parallel to the cylinder axis throughout the entire length of its travel in order that accurate focus be maintained from the top to the bottom of a message. In this transmitter the front carriage rail is round and the rear rail is flat. Mounted along the front under-side of the carriage are two pairs of ball bearings, two bearings of each pair being mounted at right angles with each other to form two inverted "V's", as can be seen in Figure 6 showing the under-side of the carriage. These bearings engage the round rail and maintain the carriage parallel with the cylinder. A single ball bearing at the rear of the carriage rides the flat rail.

Lead Screw Moves Carriage

Mounted midway between the carriage rails is a long lead screw supported in ball bearings and driven through gearing

by a second 1800-rpm synchronous motor. The lead screw is provided with a buttress thread with a pitch of 20 threads per inch. Engagement of the carriage with the lead screw is accomplished by means of a half-nut mounted on a retracting arm beneath the base of the carriage. A solenoid magnet, mounted on top of the carriage, is coupled to the retracting arm to disengage the half-nut at the end of each transmission. Return of the carriage to its starting position is accomplished by means of a typewriter carriage-return spring coupled to the carriage with a canvas belt. To eliminate the severe jolt which would result with the free return of the carriage to the start position, a small governor is coupled directly to the coil spring mechanism.

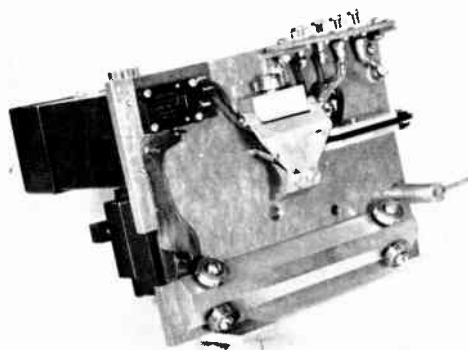

Figure 6. Carriage—bottom view

The carriage, shown in Figure 7, carries the complete photoelectric scanning system. A prefocused type of projection lamp beams light through a condenser lens onto the inside surface of the message cylinder at an angle of 45 degrees, thus floodlighting the area of the copy that is being scanned. An objective lens system images the lighted portion of the copy onto a plate fastened to the end of the objective-lens barrel. A small 8 1/3-mil hole in the center of this plate dissects the copy as the drum revolves and the carriage advances. Light passing through this aperture falls on the cathode of a multiplier type phototube mounted in a housing at the rear of the carriage. Asso-

ciated with the phototube is a one-stage amplifier of the cathode-follower type for impedance transformation. Mounted at the front of the carriage can be seen a small metal plate. This carries about 100 micrograms of radium bromide which, by ionizing the air in its vicinity, inhibits the tendency of dust to cling to the outside surface of the Lucite cylinder.

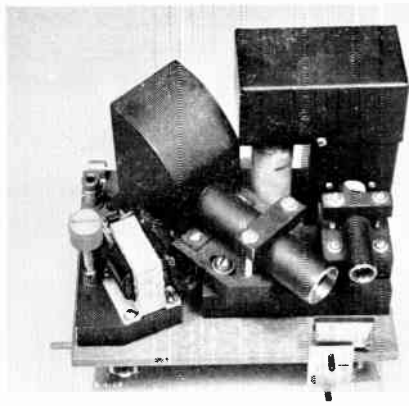

Figure 7. Carriage—top view

Phasing Is Described

The function of phasing in this transmitter is accomplished as follows: Mounted on a column extending through the hollow shaft of the gate bearing is a lamp housing as seen in Figure 3. When the gate is closed, this lamp housing extends inside the cylinder. The cap on this lamp housing is fitted with a small projection lens to focus a beam of light through the cylinder wall onto a photocell mounted just to the rear of the cylinder. The photocell is a miniature type contained within a suitable housing supported on the vertical end plate of the machine. Light is admitted to the cell through a small hole adjacent to the cylinder wall.

Messages to be transmitted by this machine must have a width of not more than 8 1/2 inches. The inside circumference of the message cylinder is 8 5/8 inches, which leaves a 1/8-inch gap between the edges of the blank after the blank has been rolled up and placed within the cylinder and the cylinder is up to speed. A wider gap is also accept-

able, but not a narrower one. Around the circumference of the cylinder, one inch in from the right-hand end, is a black scribed line to which the top of the message blank must be positioned when it is inserted in the cylinder. Scanning of the message begins at a point one-half inch from this line. Between this point and the top of the blank, at a point 1/8 inch from the scribed line around the cylinder, the phasing beam passes through the cylinder wall to the phasing photocell. Light can reach the cell only during the short interval of the gap between the edges of the message blank, resulting in one short pulse for each revolution of the cylinder, or 30 pulses per second when the cylinder is running at synchronous speed.

These phasing pulses are fed to electronic units where they are compared with pulses originating from the recorder at the opposite end of the circuit. During the starting cycle, the recorder is run at a slightly increased speed, and at some point within two seconds pulses from the transmitter and recorder will coincide, at which time the recorder will be locked in on the 60-cycle driving frequency and the recorder will be in phase with the transmitter. At this time scanning of the message copy begins, and pulses from the phasing photocell are then used to disable the transmitter momentarily as the paper gap is scanned.

Variable Start and Stop Controls

The point at which the start of scanning of a message takes place is controllable by a knob located at the right end of the transmitter. Many messages to be transmitted will have the same heading, such as Western Union telegraph blanks, and it is not desirable to transmit this heading for each message. Start of scanning may be set at varying distances up to 2 inches from the top of the blank adjustable in 1/2-inch steps. The action of this control knob is to adjust the location of the rubber-covered bumper against which the scanning carriage comes to rest at the end of each transmission.

The transmitter is equipped with a variable end-of-message stop controlled by a

knob located at the front of the base. Although the message cylinder will accommodate blanks up to 15 inches long, most messages are shorter than this, and it is desirable to stop the transmitter as soon as all intelligence on the blank has

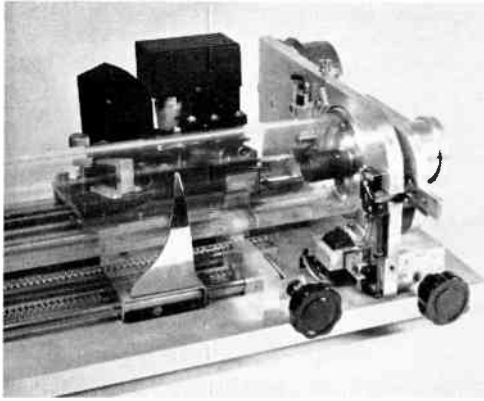

Figure 8. Solenoid-operated lock, and positioning controls

been transmitted. The control knob adjusts the position of a small carriage along two rails located beneath the message cylinder. On the rear face of this carriage is a movable plate supporting two cams with protruding arms. Between the cam faces is a long push rod which, when

moved slightly to the left, actuates a microswitch to shut down the transmitter. A pair of trip pins mounted on the front face of the scanning carriage engages the cam arms at the proper time, causing the cams to turn in opposite directions and pinch the push rod between them. A slight additional movement of the carriage then causes the push rod to move and actuate the switch. The point at which transmission will cease is indicated by a pointer attached to the end-of-message carriage.

Operation of the transmitter is made as nearly automatic as possible. Incorporated with the bearing gate are two microswitches. When the message has been inserted in the cylinder and oriented in correct position, the gate is manually closed. Closing the gate actuates the two switches and puts the transmitter in operation. A solenoid-operated lock, Figure 8, holds the gate in the closed position until the completion of transmission, when the actuation of the end-of-message switch by the carriage stops the transmitter and unlocks the gate. A reject button, at the front of the transmitter, enables the operator to stop transmission at any time after scanning of the message has started, should this be necessary.

L. G. Pollard, recently appointed Electronics Research Engineer, in charge of the Water Mill Laboratories, joined Western Union in 1922 after graduating from the University of Vermont. After three years of research work under the Transmission Engineer, he was transferred to Water Mill to assist in the organization of the laboratory. In this undertaking, his ability in every phase of the Laboratory's work was soon demonstrated. During the war Mr. Pollard was put in charge of the model shop, where he was responsible for final designs and production of specialized devices for the Army and Navy, and in 1943 he became Assistant Electronics Research Engineer. He has contributed many new developments to facsimile design and directed the construction of new facsimile equipment, of which the high-speed facsimile terminal is the most recent.



The Chattanooga Works

E. J. TRENT

"THE CHATTANOOGA WORKS" has been a phrase used and known throughout Western Union for over 40 years, but beyond the personnel directly connected with the plant, few realize its scope of operation or the "backstage" part it has played in the chronological development from KOB (Key on Board) to our present high-speed telegraph system. The following article will outline briefly the historical background of the plant and detail a few of the major functions performed. Due to the wide variety and specialized character of the facilities, other major functions not covered in this article are to be described in subsequent issues of this publication.

General

To keep a communications system operating with economical efficiency and to maintain leadership in its field by constant research and development, and by application of the newly developed techniques to operating use, varied shop facilities under the direct control of the



Figure 1. Main shop building —
Chattanooga Works

system become a necessity. Units not commercially available because of their very individual requirements must be provided. Development models demand metal and wood framework, cabinets or special details only a diversified assortment of shop operations could supply.

The Chattanooga Works, known to the "old timers" in Chattanooga, Tennessee, as the "Western Union Pole Yard" or just plain "Car Shop", is a part of the Telegraph Company's great system. Varied shop facilities available are applied exclusively for the assembly of specific Western Union telegraph equipment. The 13.7-acre plant is located on Cumberland Street and Cleveland Avenue, approximately two miles northeast of the shopping and business sections of Chattanooga. The main lines of two large railroads parallel the west boundary of the Works, and switching tracks with rail sidings connect directly into the yard to provide excellent transportation facilities.

An observer in the yard of the plant looking directly south can recognize the bold characteristic outlines of Lookout Mountain. Encircling the horizon, the distant Cumberland ranges combine to present a rugged panoramic background. Directly east about a mile is the famous Civil War battleground "Missionary Ridge". Chickamauga Dam, located seven miles north of the Works on the Tennessee River, impounds the 59-mile-long Chickamauga Lake, providing a reliable source of water power from which electricity for home and industry is generated.

The country surrounding Chattanooga is fertile farm land. Many of the employees of the plant live in the rural areas and drive cars to and from work daily. Adequate parking space is available for over 100 employees' cars each day.

Although the annual average temperature of the surrounding country is 60.8 degrees F., the reported seasonal extremes range from over 100 degrees F. to -10 degrees F., for quite a variety of weather. During the winter, snowfalls of two to three inches are not uncommon.

A study of the past history of the Chattanooga Works will reflect eloquently the progress and change in telegraph techniques during the past 40 years.

Historical

On August 23, 1909, approximately 11 acres of land were purchased at the site of what is now the Chattanooga Works. At that time pole yard operations and very limited car repair work were being done at Boyce, a suburb of Chattanooga about three miles north of the present location. The Boyce yard was a rented, 5-acre tract of land and employed a total force of six workers. Poles were loaded and unloaded from railroad cars with the aid of wooden derricks. Motive power for the derricks was mules—plus man power. Mule-drawn wagons supplied the local transportation of the yard. Warehousing and office functions were carried on at 202 Carver Street in Chattanooga.

Early in 1910, the Boyce yard was discontinued and all operations were moved to the new location. This was the starting point for the present Chattanooga Works. The new yard at that time consisted of one small office building and numerous railroad sidings. The total force numbered 12 employees. A locomotive crane replaced the wooden derricks for handling poles in 1920.

From 1910 to 1915 operations at the new yard involved only the storage and distribution of poles. Late in 1914 an open construction type car repair shed was built. The shed consisted only of a roof supported by poles, with all sides open, but outside car repair work could be performed, fairly well protected from the elements except in very extreme weather conditions. Car repair work increased rapidly and car construction work developed until in 1920 the Chattanooga Works had produced 65 camp car outfits which were in use throughout the country. In addition to the construction and repair work, crews of men travelled out of Chattanooga maintaining camp car outfits in the field. The force in 1920 had grown to 50 employees. With a capacity of four cars, the car repair shed became inadequate to meet the increased demands for camp car outfits, so in the later part of 1920 plans were made to build a modern, well-equipped car repair shop.

Early in 1921, two parcels of land totaling 3.2 acres, adjoining the southwest edge of the yard, were purchased and construction work on the car repair shop was begun. At this time the first pole-

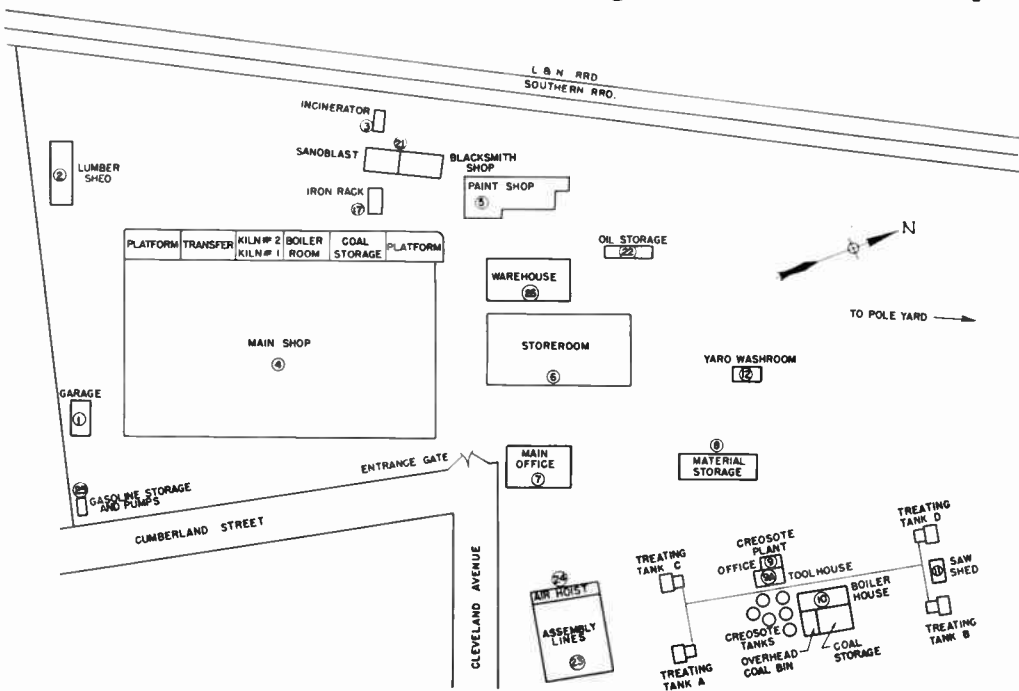

Figure 2. Layout of Chattanooga Works

treating plant was installed. The plant consisted of two small open tanks into which creosote was poured and the poles inserted therein. An open fire under the tanks developed the heat required for treating but later in the year a small steam boiler replaced the open fire method. A larger and improved pole creosoting plant was completed in 1923. This plant had four cold-storage tanks with a total capacity of 50,246 gallons, two creosote preheating tanks with a total capacity of 15,490 gallons, a new complete steam boiler system, four open treatment tanks, and a creosote pipe-line circulating system connecting all tanks.

The car repair shop, constructed of steel framing with reinforced concrete floor and walls, a large part of the exterior wall, panel sections of glass set in steel sash, the roof, saw-tooth sky-light construction of reinforced concrete covered with cemented tiles, was completed in 1923. It was 280 feet long, 160 feet wide and 22 feet high. The unusually high ceiling was required to accommodate cars. Figure 1 shows the present Main Shop Building, which was first constructed for car repair work and later applied to other functions of the Chattanooga Works. Equipment for practically every car repair function and a comprehensive woodworking shop was installed. Two types of moulding machines, a rip saw, cut-off saw, tenoning machine and a jointing machine were added to a planer, rip saw and band saw already in use. Larger compressors were installed to supply air for pneumatic tools, paint sprays, and testing of air lines and brakes on the cars. The shop building had a capacity of 16 cars or four complete camp car outfits.

Local transportation and deliveries from the plant were made by horse-drawn wagons from 1910 until 1923, when all horse-drawn vehicles were replaced by a Pierce Arrow 2-1/2-ton, stake body, solid-tired truck.

The period from 1923 to 1927 saw another tremendous increase in camp car repair and car construction work. The new shop building with complete facilities coupled with precision workmanship earned for the plant a fine reputation with

the railroads for car repair work. In 1927 the woodworking section began producing table tops, tune stamp stands, ticker pedestals, cable boxes and reels. During the late twenties (1925-1929) the Chattanooga Works was a beehive of activity. Line construction work increased the pole yard activities, more camp car outfits were needed and new office installations required tables, counters and customers' equipment. There were now 105 camp car outfits in the field being maintained by the Chattanooga Works. The outfits were scattered all over the country and additional travelling repair crews were required. The force averaged 175 employees during this period; then late in 1929 came a lull in the nation's business activities. That national calamity, often referred to as "The Depression", had arrived. The beehive at the Chattanooga Works gradually "buzzed out" until in 1934 there were 23 employees at the Works engaged in plant maintenance and pole yard work. General business conditions improved from this point on and in 1937 a need for wood products and car repair work reactivated the plant.

In 1940, metal working became a function of the Works and the first fabricated metal units of consequence turned out were some custom-built varioplex racks. These were followed by the metal work for the Atlanta, Dallas, St. Louis and Oakland reperforator installations. The woodwork for the Richmond reperforator installation was a product of the woodworking section at Chattanooga.

A power brake, power punch press, angle iron shear, foot shear, baking oven, arc welder, heavy duty lathe, and a water wash spray booth were installed between 1940 and 1942. A second water wash spray booth, baking oven, power punch press, two additional arc welders and a larger replacing metal shear were added in 1945.

Plans for an Assembly and Wiring section were formulated in 1945 and it was organized and put into operation in 1946. The first completely wired units shipped to the field from the new section were the reperforator racks and tables for the Philadelphia and Cincinnati reperforator installations. A large assembly line and

various smaller assembly lines were constructed and put into operation. During the period from 1946 through 1948, completely wired reperforator units were being supplied to eight reperforator center installations in varying quantities at the same time. The plant's total force reached an all-time high of 593 employees by the middle of 1948.

In 1950, a 50-ton power punch press and a milling machine were added to the metal working section, and a wire measuring and cutting machine was installed in the assembly and wiring section. A new small unit assembly line was constructed; a testing room was built and modern electronic test equipment added to the testing facilities already on hand. Early in 1951 a group of testers qualified to perform operating tests on completely wired units or components was organized to work as a part of the assembly and wiring sections.

The historical past now becomes the present with the Chattanooga Works, at the end of the year 1951, as a modern industrial plant, assembling specific equipment exclusively for the telegraph sys-

tem, and performing the following major functions:

- Assembly and wiring
- Metal working
- Woodworking
- Painting
- Camp car repair
- Pole yard operations
- Pole treating

The buildings, large devices, and special storage vehicles at the plant bear designating numerals as shown in Figure 2. The total average force is 250 employees. The 1950 value of shipments from Chattanooga was \$1,113,804.00. The 1951 value of such shipments was \$1,125,000.00.

Assembly Line Methods

Any manufacturing organization producing in quantity develops an assembly line as a means of turning out a uniform, controlled quality product at a competitive cost. The success of such an organization is often determined by how well the assembly line operates. Each automobile, refrigerator, radio, television set,



Figure 3. Large unit assembly line carrying printer-perforator tables

or even box of candy purchased was at one time on an assembly line of some sort. The assembly line is the focal point where all the pieces go together to form a finished product.

Assembly line techniques vary widely, and with justification. The method best applied and the scope of the production problems involved start with the quantity of an identical unit to be assembled. Interruptions on an assembly line cannot be tolerated and an entire production run, to be successful, must be made in unmolested sequence. In cases where from a hundred thousand to millions of an identical unit are required, a timed moving belt for small units or an overhead monorail carriage for heavier units, designed especially for the units, is the almost universally applied method. The engineering time, construction material, and production planning time is costly, but the method is very effective. When huge quantities are to be produced, the costs preliminary to actual production on the assembly line are prorated to each unit, and when considered on the large quantity basis are a negligible factor. For smaller quantities the planning cost makes the timed belt procedure prohibitive and a less elaborate but economically feasible method is applied.

In the assembly of smaller quantities (smaller quantities, from a production standpoint, are normally from three or four hundred to a few thousand) the generally accepted practice is to provide stationary operating positions and manually pass or slide the unit from one position to the next. Preliminary planning is a necessity for this procedure, as the success of any assembly line is dependent in a large measure on how well the advance planning has been done. The stationary position assembly line has the facility of being easily applied to production runs of varying types of equipment with minor changes, and the construction cost is far less than that required for the timed belt method.

In using either of the above methods it is necessary to time and divide the

work carefully so that the time used at each position is practically the same. A timed belt automatically takes care of the position time element in moving past an operating position. Where the unit is slid or passed from one position to the next, the operator sets the time element and thus the whole assembly line progress is based on the slowest worker on the line and averaged times are of little value in planning.

The human characteristic of mechanically performing a small number of repetitive motions after a few days experience is put to good use on an assembly line. If the number of operations at a position are so numerous that continued reference must be made to a chart or print, progress will be slow. Psychological studies have indicated that the average person can learn and retain three words or motions at a glance, and by repetitive performance will learn and retain for daily use the knowledge for approximately 25 motions or actions. To meet this psychological characteristic, an operating position is limited to from 15 to 25 physical motions, the actual number allotted being determined by this limit plus the position time element.

The ultimate aim of any multiple position assembly line is to start a foundation component (usually the chassis) at one end of the line, pass it through all operating positions, and have it reach the other end of the line as a completed unit.

Another assembly method occasionally applied is to allow one operator to completely wire and assemble a unit at one position. When this method is used on quantity production runs the operators must, of necessity, have long experience at this type of work and possess assembly and wiring skills far beyond the average. Quickly replacing or adding assemblers and wirers possessing these skills presents a near impossibility. Supplying assembly components to one position is a problem which usually is solved by re-designing a unit into numerous subassemblies and assembling them elsewhere for application to the operating position.

CHATTANOOGA ASSEMBLY AND WIRING

There are two main types of assembly lines and a variety of assembly positions used at the Chattanooga Works. All lines are not in constant use. Each line is flexible and can be applied to the demands of the current job. This is essential because the total quantities to be produced, in most cases, are not very large; also the physical size and general character of the units is quite varied.

Large Unit Assembly Lines

A portion of the large unit assembly line in operation at Chattanooga is shown in Figure 3. This is the first main type of assembly line used and is designated as the "Large Unit Assembly Line." There are three lines involved in assembly of large units—the first 220 feet long, the second 30 feet long, and the third 100 feet long. They are made of 24-inch narrow gauge track embedded in the concrete floor of the main shop building. Turntables strategically located on each line and cross-connecting tracks between each line form a network of track upon which low flat trucks are manually moved. Large metal frameworks ready for the assembly and wiring section are placed on the trucks and rolled out on one of the lines. All preformed cable forms are wired in, components mounted and connecting wiring done while the unit is on the truck; the unit is removed only after it has passed inspection and is ready for crating. This is easy to understand when the physical size and weight of one of the Send Circuit Cabinets used in a Plan 51 Patron's Switching Center is considered. Measurements of the unit are: 5 feet long, 30 inches wide and 73 inches high. The weight when completed is approximately 1,700 pounds. The preformed cable form that is wired into the unit weighs about 85 pounds and the entire unit requires 32,000 feet of wire for completion. Assembling and wiring units of such proportions one at a time would provide for few and only occasional installation jobs. On the assembly line basis, the metal frameworks are rolled out on the line in numbers, and crews of

two or three men assigned to each cabinet. The installation of a new switching center usually requires three of these units, hence all three are planned to reach completion on the line at the same time.

Other units assembled on the large unit lines are telefax central office cabinets and tables, reperforator racks, cabinets and tables, carrier test boards, and patrons' switching system receiving and sending tables, all of which weigh from 400 to 1,000 lbs. when completed.

Small Unit Assembly Lines

A second type of assembly line used at the Chattanooga Works is the "Small Unit Assembly Line" which handles such units as Desk-Fax, carrier control panels, way-station selectors and wiring cabinets. The line is constructed of 30-inch high operating table frameworks, with a highly polished and waxed fibre board table top, and is laid out in the form of a horseshoe. The curved portion of the line can be removed if necessary to provide two shorter assembly lines.

Figure 4 pictures a production run of Desk-Fax units. The assemblers are seated on the inner side of the line to permit easier passage of the unit on the curve and allow plenty of room for hand trucks to supply assembly materials to the positions from the outer side of the line without interference to the operators. A specially designed removable rack for holding various shapes and sizes of bins is used at each position. (A day's supply of transformers, chokes, etc., requires a stronger and larger bin than, for instance, a day's supply of terminal lugs.) Each individual item has its own container and is placed in the sequence of use. Special attention was given to positions where soldering was done. At a position where hand tools such as screwdrivers, pliers or wrenches were used, soldering was not allotted as a function. A rail and angle detail is mounted along the front edge of the table top to guide the unit as it progresses on the line; the angle detail also supports a well-insulated soldering

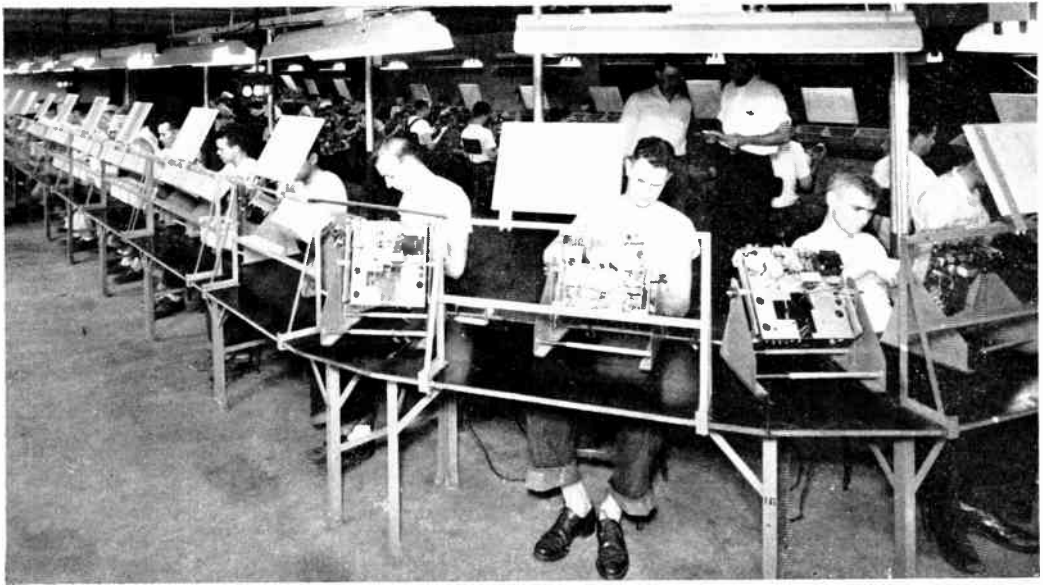

Figure 4. Small unit assembly line carrying Desk-Fax units

iron holder. Two power receptacles, each supplied from a different power source, are available at all positions. Subassemblies were assembled at auxiliary positions set up on the outer side of the line at points where they were required.

As an example, a production run of Desk-Fax units required extensive preliminary planning for the timing and allotting of functions to keep a smooth running and economically operated line. The production planning group at the Chattanooga Works had to compile certain pertinent data before any assembly line went into action. The required daily output was 25 Desk-Fax units. Some of the major questions to be answered were: How many operations were involved? What subdivision of operations was required for correct timing? What sequence of assembly would prevent assembling interference? Where should subassemblies be applied and what comprised a subassembly?

After actual timed experiments were conducted a plan of action was developed as follows:

Daily delivery demands.....	25 units
Daily planned output.....	27.5 units
Number of operating positions	27

Time at each position.....	16.3 minutes
Number of subassemblies..	6
Man hours to assemble and wire and test each unit....	14.3
Number of wires not in form	38
Number of wires in cable form	56

The cable form was made as a subassembly. Each wire in the form and all wires required for wiring were accurately measured and each wire numbered. A multiple pigeonhole type container was made and all wires for the entire assembly were cut and skinned on a wire cutting and measuring machine. This type of machine cuts wire to any predetermined length between 2 inches and 97 inches, and skins the wires to any predetermined skinning length (on both ends) between $\frac{1}{8}$ inch and $1\frac{1}{2}$ inches. The measuring function of the machine before cutting is done in 15-inch multiples, and the full capacity of the machine using the first multiple is approximately 3,000 pieces per hour, and using the last multiple 500 pieces per hour. An automatic wire cutter is the heart of the wiring portion of an assembly line working on a quantity production run, and from an operational viewpoint merely

requires installing the correct cutters for the type of wire to be cut, setting the cutting and skinning lengths, threading a spool of wire in place and applying power, then carting away the cut and skinned pieces of wire until they are required.

After the planning has been completed, the real action on the assembly line starts. A painted and silk-screen process marked chassis, mounted on an assembly cradle, enters the line at one end and moves progressively through 27 assembling and wiring positions, emerging on the other end as a complete Desk-Fax unit ready for testing. The unit is not removed from its cradle until all tests have been completed.



Figure 5. Test room

The completed units are immediately given a short manual and circuit operating test. The test room is shown in the photographs, Figures 5 and 6. Immediate tests give a good indication of accuracy in the assembly line. Satisfactory tests show the line is functioning correctly, but if the tests show failures, the trouble is located and that portion of the line involved is indicated.

A group of testers performing the immediate circuit tests on Desk-Fax units just off the small unit assembly line is shown in Figure 6. A signal box mounted on the wall above the test benches and appearing in the upper left-hand portion of the picture is the remote control signal system for the assembly line control lights.

Referring to the picture of the small

unit assembly line, Figure 4, it will be noted that clusters of three lights, suspended from the ceiling, appear at regular intervals above the assembly line. These are known as the assembly line control lights. The three lights are colored respectively green, yellow and red. The green light remains on as long as no line fault appears and means "Continue, all is well." When a defect in line operation is indicated to the tester, the section of the line involved is located and the yellow light in that section is switched on. This means "Trouble—check your section." An operating assistant assembly foreman, responsible for that section of the assembly line, is placed at each of the signal light locations. He immediately investigates his section and if unable to locate the trouble quickly has the red light (which means stop) switched on at any desired section or for the whole line, stopping production until the trouble is cleared. It is a pleasure to burn out green lights from too much use.

After the immediate tests are performed, the units are given a thorough check, serial numbered and released for inspection. During inspection two copies of the Desk-Fax units' operation, one received copy and one transmitted copy produced by the unit, are attached to the completed unit and it is sent to the shipping department for immediate packing.

The small unit assembly line is very flexible and is used for quite an assortment of small units assembled at the Chattanooga Works.

In addition to the production records



Figure 6. Testers at work on Desk-Fax units

kept on file for the Desk-Fax units, other files are currently on hand and maintained for future application on carrier control panels, way-station selectors, wiring cabinets, polar press repeaters, potential cabinets, test sets, network repeaters, duplex panels and variable voltage rectifiers.

Various Assembly Positions

For that one cabinet, table or set required to be assembled and wired on a rush order to meet an emergency, or for items required in very small amounts, assembly line procedures are not applicable. To handle such cases, individual assembly positions have been constructed. They are in most cases obsolete telegraph operating tables modified to hold assembly components. The tables are not rigidly installed so they can be easily moved into convenient operating space. Various small subassemblies associated with the larger assembly lines are also a product of these positions.

Cable Forming

A cable form is composed of a varying number of wires placed in a form to fit

the physical layout of a specific unit of equipment and provide component connecting wires according to the circuitry of the unit. The wires, using similar paths, parallel each other until reaching their breaking-out point or termination, and are held into the form desired by a specialized manner of sewing with waxed twine, stay binding, tape or special devices. Cable forming is the practical way to avoid a tangled mass of interconnecting wires, and to assure that all wired circuits have been completed as a unit. Assembly line practices make good use of preformed cables to control assembly costs.

The production planning group at the Chattanooga Works applies or redesigns, from a production viewpoint, the templates and wire running charts for the hand forming of cables. The physical spacing between components, the factor of the shortest wire path through the form between components, the sequence of laying in the wires, and the breaking-out points to produce an economical and professional appearing form are given consideration.

Full size scale blueprints are made of

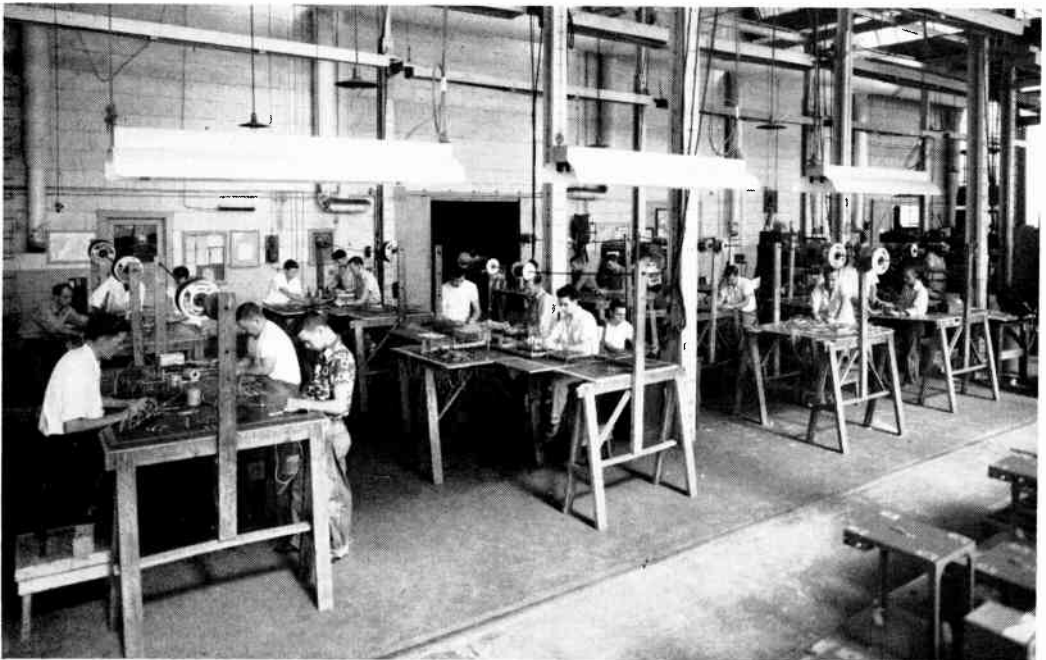

Figure 7. Cable forming group

the final plans and cemented or tacked to plywood panels. Suitable pins or nails are placed, and in some cases holes are drilled in the panels at terminating or turning points of the cable. Each wire termination on the template bears a wire number identical to its corresponding wire identification on the wire running chart. The plywood panel with its accessories then becomes the cable forming board and is used horizontally placed across wooden horses, or vertically in easels. The wires of a type specified are laid on the forming board in the sequence listed on the running chart.

Figure 7 shows a group of assembly and wiremen at work forming cables for various purposes. It will be noted that overhead racks hold the spools of wire required for the form being made. This method affords easy access to the wire and supplies quickly each type of wire specified. After all the wires have been placed on the board, they are tightly

sewed into a form. Sewing is usually started at the largest part of the form and extended out to the smaller branches. When completely sewed, the wired form is removed from the cable forming board, ready for installation in the unit for which it was produced.

Cable forming boards and wire running charts can be used indefinitely for further production of identical forms. Forming boards made at the Chattanooga Works are stored for future use until the unit for which it was designed becomes obsolete.

The functions of the Chattanooga Works described in this issue are those connected exclusively with the Assembly and Wiring Section. This section is the largest at the Works and employs 110 of the total force. It was one of the later sections organized but has developed rapidly and is now a very important part of the plant's production processes.

E. J. TRENT, Installation Equipment Engineer in the Plant and Engineering Department, joined Western Union's Lake Division Plant Equipment force early in 1924 from the Circuit Layout Engineering branch of Western Electric. In 1926 he was transferred to the Lake Division Plant Maintenance Department as Tickerman and Switchboard Attendant. In 1934, he went to the Metropolitan Chicago Plant Maintenance Department, where he served progressively as Field Maintainer, Maintenance School Instructor, and City Foreman. He was detailed to the Eastern Division Plant Engineers as Field Engineer in 1942, and to New York General Headquarters in 1943 as Equipment Supervisor in the Carrier Section. During 1947 and 1948 he was General Headquarters Field Supervisor for the installation of inside equipment on the Radio Relay Systems, and in 1950 was appointed Group Head of the P. & E. Installation Section. He became Installation Equipment Engineer in 1951. Mr. Trent attended Wisconsin University and Schurz College; he is a registered Professional Engineer and a member of the Western Society of Engineers.



Frequency Standard for Microwave Relay Systems

L. W. FRANKLIN

THE MAINTENANCE of highly accurate frequencies is necessary in many kinds of Western Union operations, for instance in the multiplex for operating the distributors, and in the carrier telegraph for keeping the multiple channels in proper relative positions in the transmission band. But frequency deviations in these operations may affect only Western Union services. In radio systems, where Telegraph Company channels must share the frequency spectrum with many other licensees of the Federal Communications Commission, maintenance of the assigned frequencies is mandatory, infractions being punished, not only by disturbance to the flow of traffic, but by cancellation of licenses and consequent loss of use of the radio medium.

In the microwave radio relay systems the necessity for maintaining accurate frequencies is complicated by the character of the frequencies themselves. Several thousand million cycles is so high a frequency that the apparatus commonly associated with frequency standards; i.e. pendulums, tuning forks, and vibrating crystals, are far too low in frequency to produce the desired standards directly. Resonant cavities used as wavemeters, calibrated by harmonics of extremely accurately maintained standards of more conventional frequencies, are so far the most practical means of testing the emission from the radio relay transmitters. Thus the fixed standard must have an accuracy higher than the portable wavemeters, which must in turn have an accuracy higher than the frequency tolerance permitted in microwave transmission. The laboratory standard, of course, also serves in calibrating signal generators and oscillators used in adjusting other frequency sensitive parts of the radio apparatus in order to insure optimum performance.

Since the maintenance of accurate frequency, in cycles per second, includes the concept of accurate time measurement, further complications arise due to the

change in rotational speed of the planet Earth. What is known as frequency-measurement might more correctly be called frequency-comparison, as what is done is to compare the unknown frequency in cycles-per-second with a standard frequency, also in cycles-per-second. In our system of time, there are 86,400 seconds in a day. One thinks of a day as having a very definite length, of the earth as an infinitely large flywheel. It is large, but not infinitely so. Our time is so corrected that the length of the day is the average of the length of the day for the past year. The astronomers use what is known as Newtonian Time, which is based upon the average length of the day for the year 1900 A.D. The earth's rotation is slowing down, which means that the days are longer now than they used to be.¹ Most of this is accounted for by the energy lost in the friction of the ocean tides. Other variations occur, the effects of which are not predictable. The cause of these may be some of the following: For the next 400 years, the Northern Hemisphere will average somewhat warmer. This will result in more of the polar ice melting, which will raise the level of the seas, thus increasing the moment-of-inertia of the earth. Signs of this are that vegetable life is growing further north each year, certain tropical marine life is also moving north, and the ocean level is rising slightly.² The position of the North Pole is said to wander as much as 30 feet erratically.¹ Any changes in the earth's surface, whether caused by nature, or man-made, will alter the speed of the earth's rotation.

Correct time and standard frequencies accredited by the U. S. A. are based upon observations of the U. S. Naval Observatory and disseminated by the National Bureau of Standards in broadcasts over a number of radio frequencies from Radio Station WWV located in Beltsville, Maryland.

The signal from WWV useful most of the time at New York is that broadcast

at 5 megacycles. This emission is modulated with a "seconds beat" consisting of 5 cycles of 1000 cps at the end of each second, and with audio tones of 440 cps (A above middle C in the musical scale) and 600 cps alternately for four minutes out of each 5-minute interval. In the relatively quiet one minute out of each five, the end-of-interval Greenwich Mean Time is transmitted in Continental Code, and the Eastern Standard Time is given by a voice which also identifies the station. At

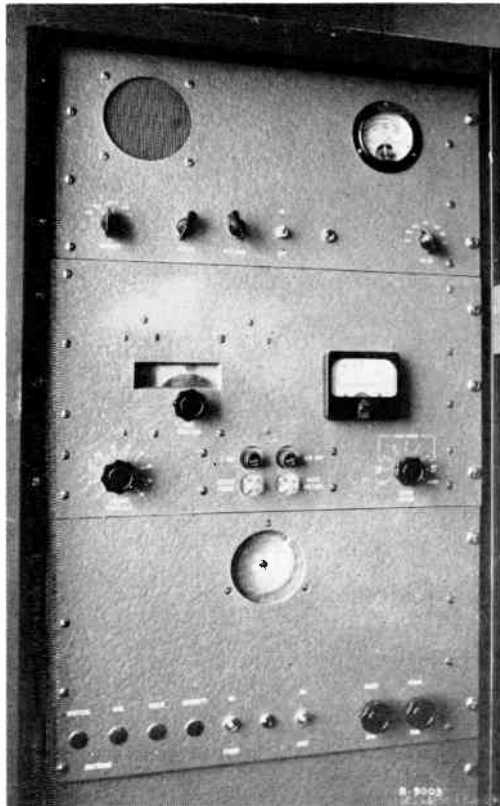

Figure 1. Standard Frequency Comparator

20 minutes past the hour and 10 minutes of the hour, an additional code signal describes the radio transmission over the North Atlantic route to Europe. This WWV emission is a very busy channel from which a large amount of information may be obtained.

The several frequencies broadcast as standards by Station WWV are correct to about two parts in 100 million as *transmitted*, as accurate as a clock that is

within one second of correct time over nearly two years. The signals *received* in New York from the station by radio waves do not have this accuracy, however, since the transmission between antennas is a skywave which is reflected from an ionized layer in the stratosphere. Since this layer is in motion a large part of the time, the received signals appear slightly lower in frequency when the layer is moving upwards and slightly higher in frequency when the layer is moving downwards, the change being in the order of 1 to 4 parts in ten million.³ The morning signals are usually affected by a rising layer and the afternoon signals may show the effect of a falling layer, but luckily between the hours of noon and about 3:00 p.m. E.S.T. each day the ionized layers appear to become stabilized and the received signals are constant and steady. By averaging observations taken during this period for several days, it is possible to compare a standard in New York with the Station WWV standards to an accuracy of three to four parts in 100 million.

Where less extreme accuracies are required, say only one or two parts in one million, a simple comparison method may suffice. For audio-frequency standards a 100-kc crystal with reducing multivibrators is often used. Some of the 100-kc output may be passed through a diode rectifier to obtain a rich harmonic content and fed into the antenna circuit of a radio receiver tuned to five megacycles. The 50th harmonic of the 100-kc source will fall near the 5-mc standard frequency, producing a beat note in the radio-receiver detector. Since with a good standard source of 100 kc this beat-note will be quite low in frequency, it would be almost inaudible of itself. While the audio frequency modulations are being transmitted on Station WWV, however, this beat-note can be heard as a waxing and waning of the audio frequencies of the 5-mc carrier and the rate may be set very nearly to zero audibly. It is also practicable to produce an audio beat-note during the one minute quiet periods by using a second local oscillator.

The audible method of frequency comparison not only does not indicate which

of the frequencies is too fast or too slow, but also may be rendered entirely inoperative when certain faulty radio signals are involved. Sometimes fading due to multipath reception may cause the radio-signal modulation to rise and fall rapidly

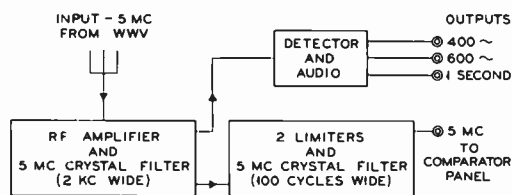

Figure 2. Block diagram of the radio receiver

in amplitude in a manner very similar to the beat-note, thus masking the effects of the compared frequency on the signal. These rapid fading phenomena also render very difficult the application of conventional cathode-ray oscilloscope methods to frequency comparisons involving received radio signals.

The standard frequency comparator devised for the Radio Research Laboratory operates with its special standard frequency source in unconventional manner, by a scheme arranged to obtain the best available accuracy from the radio signals. Figure 1 is a photograph of the apparatus assembly showing the three parts of the equipment, the radio receiver at the top, the 100-kc standard oscillator below it, and the special comparator at the bottom.

Figure 2 shows a block diagram of the radio receiver. This 5-mc receiver is of the tuned-radio-frequency type, the detector being followed by a 2-stage limiter and a crystal-filter with a pass-band of about 100 cycles. The combination of the limiters and the narrow crystal-filter permits the recovery of the 5-mc signal essentially unmodulated. In the comparator panel, shown in Figure 3, a signal from the 100-kc frequency standard is raised to ten times frequency, fed into a phase-splitting network, and applied to the deflecting plates of a special cathode-ray oscilloscope, producing a 1-mc circular trace controlled by the frequency standard. The 5-mc signal from the WWV receiver, freed of its modulation, is applied

to the center pin on the face of the cathode-ray tube, providing radial deflection in response to the received WWV signal. A 5-toothed star-wheel pattern is obtained from the interaction of the 1-mc and 5-mc signals as can be seen in Figure 1. Rotation of the pattern counterclockwise shows that the local standard oscillator is too fast, rotation clockwise indicates that the local standard is too slow. Rotation of the pattern, in either direction, of one tooth in ten seconds indicates a frequency discrepancy of one part in 50 million, or the accuracy of the WWV transmitted signal. Fading of the signal from WWV changes the size of the pattern, but does not cause it to rotate. Strong interference or noise may at times blank out the pattern instantaneously, but any movement of the pattern or the rate of movement can easily and surely be determined, even under adverse conditions. Occasionally the pattern disappears for a fraction of a second, being replaced by a pattern displaced one-half a tooth or less from the

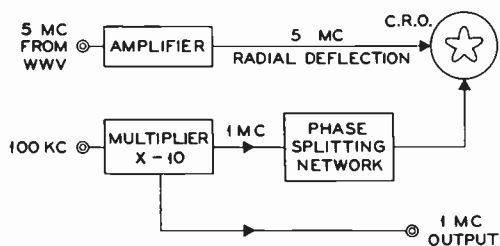

Figure 3. Comparator panel

original pattern. A short time later the original pattern reappears. Sometimes both can be seen at the same time. This phenomenon is caused by the strongest signal being reflected from a different height in the ionosphere, or perhaps from the Sporadic E Layer that is blamed for most of the unexplainable radio propagation troubles.

In Figure 4 is shown the circuit arrangement of the frequency standard oscillator panel, similar to those now in use by the National Bureau of Standards. The frequency-determining element is a plated, glass-enveloped, wire-mounted, GT type 100-kc crystal, connected in one arm of a resistance bridge circuit. This bridge is balanced at the series-resonant frequency

of the crystal, when the crystal arm of the bridge is also a pure resistance of the proper magnitude. A two-stage amplifier connected between the output and input terminals of the bridge oscillates when the gain of the amplifier slightly exceeds the loss, or balance, of the bridge. The bridge arm opposite to the crystal arm is a

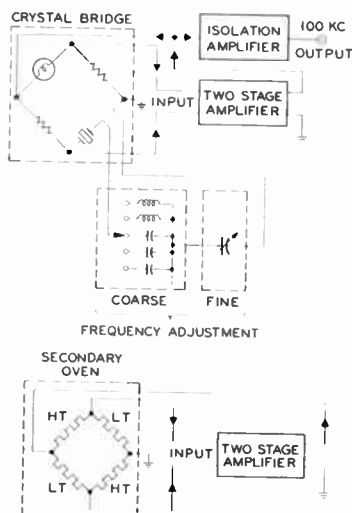

Figure 4. Circuit arrangement of frequency standard oscillator panel

tungsten lamp bulb, its resistance increasing rapidly with increasing current. This current-sensitive resistance adjusts the bridge off-balance at the desired current so that the amplitude of oscillation will be sustained at this level, the frequency being determined by the resonant frequency of the crystal arm of the bridge. In series with the crystal arm, a coarse-frequency switch can connect either capacity or inductance into the circuit, altering the resonant frequency in steps of four parts per million. A fine-frequency control, a variable condenser with a 5000-division dial covering five parts per million, is also included, each dial division equaling one part in one billion. The fine-frequency condenser is made of invar, with fused quartz insulation. It is enclosed to keep it dust-free, and to prevent drafts of air from changing its temperature. The inductance and capacitors associated with the coarse-frequency adjustment switch are enclosed in an insulated box, with a thermostatically-operated heater.

The standard crystal is kept in an oven about 6 inches in diameter and about 15 inches long. Inside this, insulated by glass-wool from the case, is the primary oven heater, controlled by a mercury thermostat to about one-tenth of a degree Centigrade. Inside the primary oven is a one-quart size Thermos-jar. Inside this is the fine heater, wound on a brass tube about 2 inches in diameter and 10 inches long. This heater is shown at the bottom of Figure 4, and consists of four resistances in a bridge circuit. This bridge has its input and output terminals also connected to a two-stage amplifier, similar to that of the crystal bridge circuit. This heater amplifier is tuned to around 800 cycles. Two of the heater bridge arms are made of zero temperature-coefficient wire, while the other two arms are made of high temperature-coefficient wire. This bridge balances at a fixed temperature, not turning the heat on and off, but gradually turning it up or down slightly as required. The crystal is placed inside a heavy brass block mounted at the far end of the fine-heater tube.

To obtain a frequency stability of the same order as the stability of WWV's

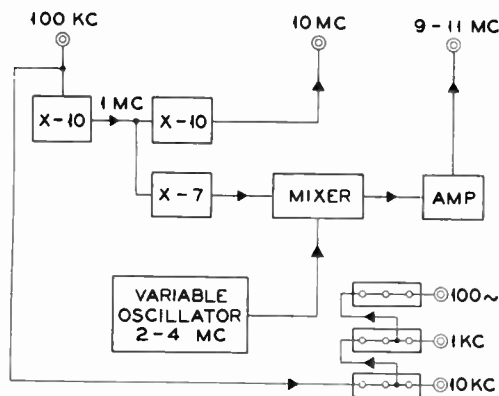

Figure 5. Frequency divider panel

transmitted signal it has been necessary to control everything controllable. The two-staged crystal oven, with the fine-heater temperature held to around 0.01 degree Centigrade is backed up by a long heat-conducting path to the crystal, and the thermal inertia of the large block of metal in which the crystal is mounted,

even though the GT type crystal has a temperature-frequency coefficient of one part in 100 million per degree Centigrade. The main power supply furnishes regulated heater power, and has two regulated plate power output circuits, similar to the one developed by A. A. Steinmetz,⁴ as well as unregulated outputs for frequency-multiplier stages.

The above description covers the basic frequency standard from which outputs of 100 kc and 1 mc are available. Adjuncts which extend the coverage are shown schematically in Figure 5. Three regenerative modulator type frequency-dividers provide output frequencies of 10 kc, 1 kc and 100 cycles. Also the 1-mc signal is

multiplied to 7 mc and to 10 mc. The 7-mc output is mixed with a 2- to 4-mc signal from a variable oscillator to provide an output over the frequency range of 9 to 11 mc. Additional multiplier chains cover the range between 10 mc and 4000 mc in suitable steps.

References

1. HIGH-PRECISION FREQUENCY AND TIME STANDARDS, JOHN M. SHAULL, *Proceedings of the IRE*, January, 1950.
2. THE SEA AROUND U.S. RACHEL CARSON, Oxford Univ. Press, 1951.
3. A STANDARD OF FREQUENCY AND ITS APPLICATION, BOOTH and LAVER, *Journal IEE*, July, 1946.
4. A PRECISION VOLTAGE STABILIZER FOR DIRECT CURRENT POWER SUPPLY, A. A. STEINMETZ, *Western Union Technical Review*, Vol. 3, No. 4, October, 1949.

L. W. FRANKLIN graduated from Purdue University in June 1924, and then started with Western Union as an Engineering Apprentice with the Traffic Department in Pittsburgh, Pa. In 1927 he was transferred to the Engineering Department at New York, and worked for several years in the office of the Engineer of Automatics, during which time he was granted about 20 patents. He also supervised the design and installation of the public address systems for the reperforator offices at St. Louis, Dallas and Oakland, Cal., and a special PA system between Oakland and San Francisco. He developed the Fork Control Banks first used with the Navy Multiplex System, and installed them on the multiplex sets in the Oakland office. In 1949 he was transferred to the staff of the Radio Research Engineer, D. & R. Department. Mr. Franklin is a member of Eta Kappa Nu, Electrical Engineering honorary fraternity, a Senior Member of IRE, holds First Class Radio-Telephone and Advance Class Amateur radio operator's licenses. Since 1940, he has won three of the first four clocks given as prizes for the highest accuracy in frequency-measuring contests run by the American Radio Relay League.



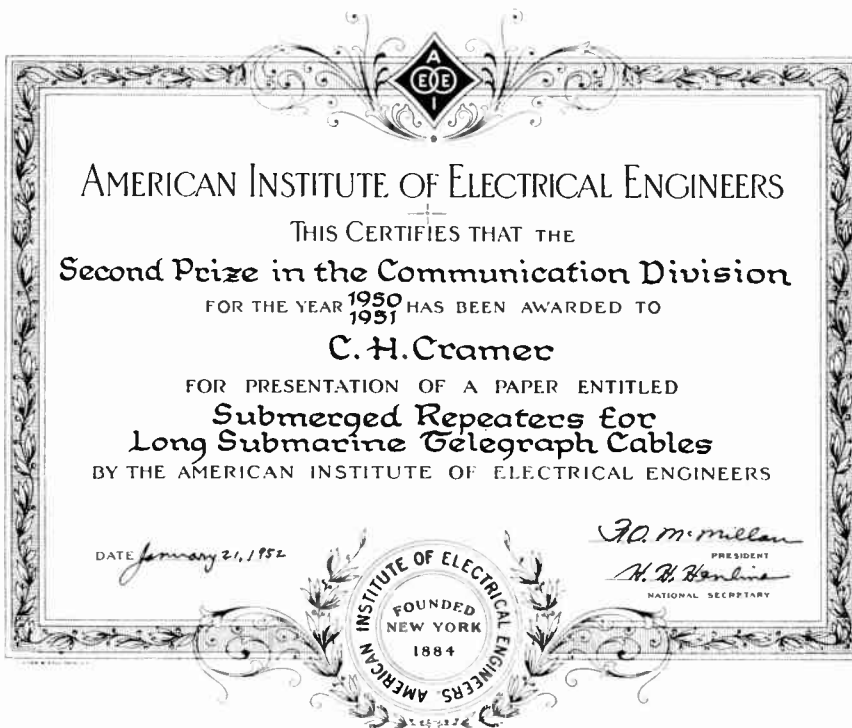

CLIFFORD H. CRAMER, Member, AIEE, Assistant Transmission Research Engineer in the Development and Research Department of Western Union at New York, received the 1950-51 Certificate Award of the American Institute of Electrical Engineers communication division in recognition of the excellence of his paper on "Submerged Repeaters for Long Submarine Telegraph Cables".

Mr. Cramer's paper was published in *ELECTRICAL ENGINEERING* for July 1951, and in the July 1951 issue of the *Western Union TECHNICAL REVIEW*, and has been abstracted by a number of other publications. The Western Union submerged repeater also has been the subject of talks by the author before groups of Naval officers and radio engineers.

The award to Mr. Cramer which was made at the AIEE Winter General Meeting in New York, was one of a number of Institute honors distributed at that time and announced to more than 20,000 members throughout the world. Award of the Edison Medal established in 1904 in commemoration of the activities of Thomas A. Edison, a pioneer in the art of telegraphy as well as in other fields of science, was made at the same time.

Mr. Cramer, a graduate of the University of Michigan, came to the Telegraph Company's Research Department in 1919 following service in the Signal Corps and the Radio Section of the Air Service. His research activities have been chiefly concerned with submarine cable and interference problems, and he has contributed to the application of permalloy loaded cables and to subsequent cable system improvements involving amplification, shaping, balancing and interference elimination. Mr. Cramer represented the Company at the Pan-American Radio Conference at Rio de Janeiro, in 1945. His contribution to technical literature has been substantial.



The Radio Spectrum—With Boost for the Low End

I. S. COGGESHALL

"Information is the life-blood of science, and the more freely and effectively it can be exchanged, the greater will be the gain to all concerned. In my opinion, one of the most important solutions of the problem is that of expediting the exchange of information in basic research. Here there is and should be a minimum of security and proprietary barriers".
—Dr. Alan T. Waterman, *Director of the National Science Foundation.*

Back in 1912 when the Institute of Radio Engineers was founded, the frequency-band denoting the electrical industry took on the superficial aspects of the spectrum of potassium, displaying two bright lines at zero and 60 cycles per second, and above them a faint continuum standing for the crude transmission of speech over wires. To only a few was vouchsafed at that time a prophetic glimpse of the amazing flash of rainbow extending from C below the bass clef to some 30-thousand-million cycles per second, whose colors represent dispersion from the incandescent crucible which is the radio industry today. To the members of this Institute, more than to any other one intellectual group on earth, this vast domain belongs by right of discovery and conquest. They have never ceased rolling back frontiers—frontiers in lateral expanse; frontiers in exploited depth.

No one man's mind can encompass this terrain. Only by free exchange of information can its horizons be discerned. An author may therefore be forgiven if he puts pre-emphasis on some portion of the continuum which he wishes, for the purposes of examination, to stand out. "Boost for the Low End" is thus obviously directed toward the author's specialty—submarine cable telegraphy.

While the Telegraph Company's field of experimentation runs the gamut of spectrum width from frequencies lower than a cycle per second, important to the proper shaping of submarine cable signals, up to 10,000 megacycles on an experimental radio beam, my particular concern is at the lower end. A cable man has to take an elevator to reach his telegraph engineering associates who are concerning themselves with the problems of intercity TV program beaming!

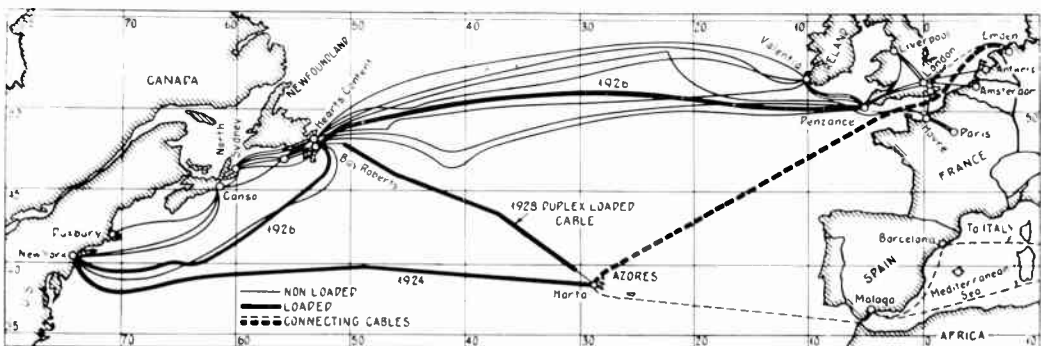

Western Union cable system in the North Atlantic, showing loaded cables

Essential substance of a paper presented by Dr. I. S. Coggeshall, then President of the Institute of Radio Engineers, before the Washington Section at its Annual Meeting, December 1951.

To show how, in contrast to conditions in the radio-frequency realm, everything is in the cable end of the business, the following facts are striking. There are three transatlantic cables which earn their keep, each of which has a maximum bandwidth of 6 1/4 cycles per second! Into each of these cables 5-unit printer signals are transmitted at the maximum rate of 12 1/2 cycles. Single impulses and reversals sent at that double rate are completely attenuated as they cross the ocean, but their very attenuation acts as a control for artificially filling in, at the receiving end, the pulses which never arrive. So a perfectly useable 50-words-per-minute teleprinter facility is obtained from only 6 1/4 cycles of bandwidth. Overseas radio likes about 2 kc for a circuit which ambles along at 50 or 60 words per minute; and in addition, radio insists upon a portfolio of about four frequencies that wide to maintain the circuit under all transmission conditions or, in all, say 8000 cycles to match the cable's six-and-a-quarter.

Here's another: The premier telegraph circuit across the Atlantic is an inductively loaded cable which for 15 years and with very few stops, has run at 400 words per minute, 24 hours each day, month in, month out, stable enough to carry the most exacting forms of teleprinter operations, including direct connection to the landline reperforator switching system; automatic enciphering and deciphering machines; the varioplex, with thirty pairs of connected subscribers; a half-dozen leases with extensions from New York to Washington, Philadelphia, Boston, and Halifax, and other extensions from London to Liverpool, Paris, and Amsterdam—the band pass on this cable is 50 cycles per second!

And if one takes *all* the eastbound transatlantic cables of *all* the companies and combines their spectra, one gets the prodigious total bandwidth of 270 cycles per second. On this capacity, which is divided among 18 one-way time-division-multiplex channels, about 60 percent of the entire load to the transatlantic countries of Europe, Africa, and the Near East, where most of America's community of

interest lies, is handled, radio getting the other 40 percent.

Now you can appreciate what a tiny bit of the vast continuum which was mentioned has been carved out for cable transmission, and how carefully it is being husbanded. Perhaps it can also be appreciated with what glee plans are being pursued to sink shore-powered vacuum-tube repeaters in the ocean bottom, after the initial one so installed in late 1950 tripled the speed of the cable it was inserted in; for if it were in the radiotelegraph end of the business it would have been like finding scores of new cleared channels.

To understand the significance of submerged repeaters, attention is directed to a very simple formula

$$S=K/CRL^2$$

showing that the speed of a cable, expressed in letters or words per minute or cycles per second, is equal to a constant divided by the product of the unit-length resistance of the copper core, the unit-length capacitance of the dielectric, and the square of the length of the cable. Since speed is thus in inverse-square relationship to cable length, the desirability of cutting a cable into short, electrically segregated sections by means of repeaters or amplifiers is self-evident. Cutting a 2000-mile cable into two halves will quadruple its speed. Dividing it into eight 250-mile sections, as is done on open-wire transcontinental landlines, should multiply its speed by 64.

The problem of furnishing 125 volts of battery at 1/3 ampere to a repeater sunk in mid-ocean, over a distance of 1000 miles of older-type cable, was a stumbling block to any earlier achievement of a successful sea-bottom repeater for transatlantic employment. It was not until the engineers had shifted their objective to increasing the speed by operating on the signal-to-noise ratio of the received transoceanic impulses, that the solution came to hand. Even then they had to contend with some only partially understood factors, such as the shielding effect of various depths of sea water on atmospheric disturbances; the extremes and

rates of variation of earth potentials to be encountered between an undersea amplifier and the shore; the ability of submarine cable to withstand the additive strain on the dielectric caused by superimposing signal voltages, power-supply voltages, and earth potentials; the problems associated with the hydrostatic



Jute and steel wire wrappings make up most of diameter of undersea cables

pressure difference between vacuum within the tubes and the ambient sea-water pressure on the ocean floor; the functioning of components, like condensers and resistors, at extreme pressures; the sealing of repeater casings against leakage; and such practical operating problems as cutting of the repeater in and out of circuit for testing the cable or reversing its direction of operation; and substitution of spare sets of tubes for those which might burn out.

Preceding Western Union's submerged repeater development, which has already been described in the *WESTERN UNION TECHNICAL REVIEW*,¹ and consummated a few months previously, the Bell Telephone Laboratories developed, and the Cuban-American Telephone and Telegraph Company, a jointly owned A. T. & T.-I. T. & T. subsidiary, with the aid of

Western Union's Cable Ship *Lord Kelvin*, laid a pair of coaxial cables between Key West, Florida, and Havana, Cuba, about 120 miles in length, each containing three submerged repeaters in series, about 36 nautical miles apart, for complementary unidirectional, telephone-telegraph use.² These repeaters effectively divide the cables into discrete sections for speed advantage under the inverse-square-of-distance formula which has been mentioned previously. In addition, the final repeater in each cable is located so as to strengthen the signal before it enters shallow water, and so operates on the signal-to-noise ratio in a manner similar to Western Union's repeater. However, the cable length and repeater spacings, plus the fact that the cables are of coaxial design with copper return and polyethylene insulation, afford an entirely different range of frequencies, namely, from 12 to 108 kc. The 96-kc band is broken down by conventional telephone band filters into 24 voice circuits, each 4000 cycles wide, any of which is amenable to further subdivision for telegraph tone channels.

The long-life tubes used were developed by Bell Laboratories especially for this amplifier. The telephone job, while 3-stage, is not push-pull; the power stage contains one tube instead of four; the tubes are not interchangeable by switching from the shore stations. The B-drop per repeater is 40 to 60 volts. The six repeaters in the two cables are joined in series through a grounded juncture between the cables at Havana and fed plus-and-minus 250 volts at Key West. Constant-current correction for earth currents is provided, as in the case of the Western Union repeater; the current is 1/4 ampere.

The Western Union repeater, as has been said, tripled the one-way speed of the capacitance-nonloaded transoceanic cable in which it was inserted. It is only reasonable to anticipate a question as to plans for the general employment of such repeaters in the future. The present objective is, as quickly as materials can be obtained, individual repeater designs completed, and ship-time allocated around the usual steady calls for cable repair

work, to place repeaters in both ends of each of the main Atlantic crossings; plus a sufficient number in the Newfoundland-Nova Scotia and Newfoundland-New York feeder cables to provide the necessary number of channels to feed the main sections.

It is estimated that this program when fully carried out has the potentiality of about doubling the total capacity of the plant as a whole between the British Isles and North America. The reasons why one does not look for a tripling of capacity of the total cable plant are: (1) the unwarranted expense of applying repeaters effectively to loaded cables; (2) a relatively small net traffic capacity loss occasioned by the removal of the duplexing features of nonloaded cables before insertion of the repeaters; and (3) the increased protection reserve which must be set aside to protect the multiplicity of newly derived channels.

The attempt has been made, of course, to "make-do" with the cables which Western Union has. The further question is often raised, what could be done if one started with a cable of a new design? Perhaps it might not be too bold a stand to take that a coaxial polyethylene telegraph cable might be designed upon the basis of present knowledge, to be laid, say, between New York and Newfoundland, having five or six repeaters in series, with sufficient bandwidth for carrier operation of one fairly wide voice band in both directions, capable of being broken down by a combination of filtering and time-division multiplex into more than 50 duplexed teleprinter channels. Such a cable would be expensive; it would have serious aspects of placing many eggs in one basket even when backed up by available fallback facilities; but it would point the way to making the somewhat longer jump from Newfoundland to Ireland or England.

If transistors of the junction type become available, the power requirements and applied-potential gradients may be greatly reduced. The question then arises whether the Key West-Havana pair of telephone cables will become prototypes of transatlantic sections, somewhat similar

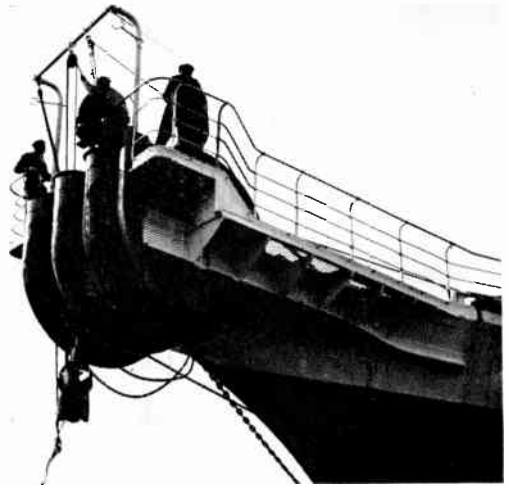

Distinctive bow sheaves provide unusual figurehead for Cable Ship Lord Kelvin

in bandwidth and design to the Caribbean type but containing 50 to 60 repeaters in series? Perhaps that question is better left for some Bell System engineer to answer. The observation might be made that marginal dependability of operation of a large number of repeaters in circuit can conceivably become the determinant as to whether a very wide band should be sacrificed, so far as telegraphy is concerned, for a narrower band requiring relatively few repeaters. In other words, the design of transatlantic cables, depending, of course, on their purpose, would have to be closely engineered; and at the moment it is a question of whether the type of repeater chosen would more closely resemble those recently laid by the Telephone Company or by the Telegraph Company.

Another question arises and is rather easily disposed of: Is a transatlantic cable, capable of transmitting a television program, in prospect? In the author's opinion, not without new invention. Land-line coaxial cable with air-and-wafer dielectric has such high attenuation at megacycle frequencies as to require repeaters to lift the gain every 8 miles or less. Substitution of solid polyethylene for the dielectric, to withstand hydrostatic pressures of three tons to the square inch or more, would tend to narrow the physical spacing to a distance only par-

tially to be offset by the larger mechanical construction warranted by the nature of submarine cable investment. If one assumes 5-mile repeater spacing (and it might be three), more than 400 amplifiers would have to work in series; the applied voltages at the terminals would be excessive by present-day criteria; and the continuity prognosis would be poor indeed. On the basis of present knowledge and designs, the risk would be too great to be undertaken. But in this business knowledge is increasing all the time.

Let me next anticipate and attempt to answer a final question: Will the new submerged repeater techniques have any effect upon the question of merger of international cable and radio companies? One conclusion drawn by the President's Communications Policy Board was that technological developments might dictate the kind and the timing of merger, and be the conclusive factor in determining the future of radio and cable carriers. The sea-bottom repeaters appear to represent a technological development of sufficient moment to have a determining influence upon the design of transoceanic communications systems of the future.

If the pattern of competition, voice versus record communications, long distance telephone versus telegraph, now prevailing internally within the United States, is to be projected on a world-wide scale, new cables incorporating electronic repeaters in their structure for the derivation of multiple communication paths may economically appear in the picture. Admittedly the rather narrow portion of the radio spectrum useful for intercontinental connections is congested and demands for facilities are bound to outstrip any now foreseen efficiencies of the radio spectrum utilization. Under conditions of a happier world, the community of interest in news, commerce, finance, and social culture between the United States and the rest of the world will grow apace, with a consequent new level of demand for communication facilities. Somewhere new utilities have got to be provided, and if not in radiotelegraphic communications, then where else than through the laying of new cables and

the further refurbishing of older ones?

To cultivate friendship and amity among the nations, the lines of communication must be kept open. Each nation—any nation, *THIS* nation — must insist upon an opportunity to learn about all others; upon its own initiative it must inform all other countries about itself. To



Cable Ship staff keep accurate charts of undersea locations of every strand of the submarine telegraph systems

withdraw into isolation, to let down an iron curtain, breeds doubt, leads to suspicion and distrust, puts an end to progress, and makes impossible the achievement of world peace.

Progress toward the desirable ends of political peace and freer economic trading points to the provision of more and better communication facilities. To those ends the sea-bottom amplifier may prove to be a potential major contribution.

References

1. SUBMERGED REPEATERS FOR LONG SUBMARINE TELEGRAPH CABLE, C. H. CRAMER, *Western Union Technical Review*, Vol. 5, No. 3, July 1951.
2. A SUBMARINE TELEPHONE CABLE WITH SUBMERGED REPEATERS, J. J. GILBERT, *Bell System Technical Journal*, Vol. 30, No. 2, January 1951.

Dr. Coggeshall's picture and biography appeared in *TECHNICAL REVIEW*, Vol. 5, No. 1, January 1951.

Toroid Coils for Miniaturization

IN COMMON with the entire communications industry Western Union is engaged in a program of miniaturization of equipment. This program has four purposes: first, lowered operating and maintenance costs; second, improvement in the efficiency of equipment; third, reduction in the amount of critical material needed with its attendant reduction in initial cost; and fourth, the saving of valuable floor space required by large apparatus.

The need for more compact and efficient equipment becomes apparent during a survey of the Telegraph Company's Testing and Regulating or "T&R" department where row on row of carrier telegraph terminals are being installed. Available space is diminishing rapidly. Moreover, each new terminal installed adds to the problem of adequate ventilation as the heat generated therein must be dissipated.

The use of miniature vacuum tubes in all new carrier equipment is a step in the right direction, but the major problem still exists in connection with the frequency separation units or, as they are commonly termed, filters. There are a great many of these filters needed to select or reject the numerous frequencies which make up a modern carrier telegraph system. Each of these filters has between *three* and *seven* coils which at present are large and must be shielded from each

other or separated to prevent interaction between them.

According to Webster a "toroid" is a surface generated by the rotation of a plane closed curve about an axis lying in its plane. The popular ring-style cruller or doughnut with center hole is representative of a toroid form.

Great progress in reducing the size of filters has been made possible through

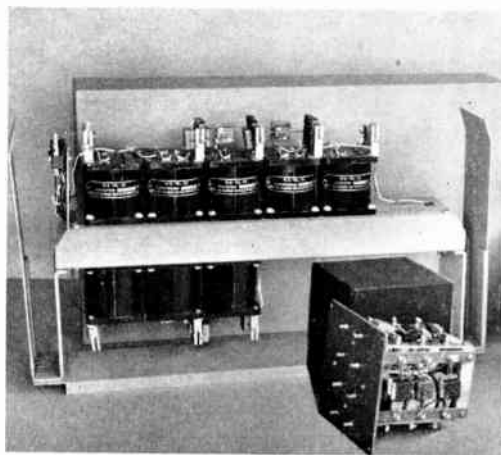

Figure 2. Widely-used filter assemblies and smaller toroid coil assembly (in front) which may replace it

the use of inductance coils having toroidal or ring-shaped cores of powdered magnetic material. The toroid-shaped core is the most practical shape into which powdered permalloy, one of the best available magnetic materials, can be readily moulded. In addition, the finished coils need no shielding because all the flux remains within the winding, and they may therefore be placed close together in the filter. Figure 1 is a comparison of the size of old and new type cores, while Figure 2 shows the reduction in size for one filter made possible by the use of the new coils.

But winding a coil on a closed ring core is not simple and the advantages inherent in the toroid coil are somewhat offset by the difficulty in winding. The problem of winding a modern toroid core one inch in diameter with wire from a spool six times

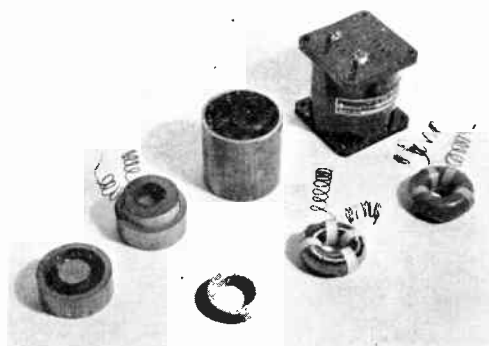

Figure 1. Comparison of filter coil having two-piece molded core, copper tube shield and case (above) with toroid-core coil (below, right) shows size reduction

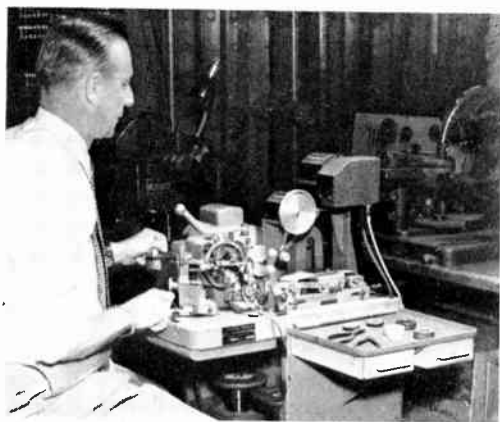

Figure 3. Toroidal winder in Western Union research laboratory

larger might seem insurmountable, and the toroid coil could have remained only of academic interest if inventive genius had not developed a machine capable of doing the winding. This problem resolved itself into the same one which faced grandma when she wished to tat. That is, there must be provided a shuttle upon which or in which the wire or thread can be stored and from which it is removed and wound on the surface of the toroid as the shuttle rotates through the core.

Pictured here (Figure 3) is one of the most modern of the toroid coil winding machines, in use in the Telegraph Company's Transmission Research laboratory for the production of model coils.

The machine operates as follows: Shuttle "B", Figure 4, is a deeply grooved split ring which may be sprung apart to permit insertion of the toroid core which is firmly clamped in mount "E". The shuttle has a large diameter to permit storage of enough wire to wind the coil while keeping the shuttle cross-section small enough to thread the finished winding. After inserting the core, the required length of wire is wound into the shuttle.

To wind the coil the wire is led through a slot in slider "C" (Figure 4), enough wire being pulled through to make one complete turn around core "A". As the machine operates, the slider "C" lifts the wire from the rotating shuttle and guides it over the side to be wound on the core "A". As the slider "C" moves upward

past the center of the core, the wire is firmly held between two polished steel shoes "D" which hold the wire taut until the slider "C" has been carried around the shuttle to a point where more wire is needed. Then the wire is pulled through the shoes and against the core to complete the turn.

As the wire for each turn is pulled through, an electric circuit is broken thereby actuating a turn counter. As the winding progresses, the clamping pillar "E" is automatically swung back and forth, rotating the core about its center through the arc upon which the winding is being placed. Usually this is a semi-circle. When that sector of the winding is complete, the core is turned in its clamp so the unwound portion is in the winding position inside the shuttle. At this time, additional wire may be placed in the shuttle if needed to complete the coil.

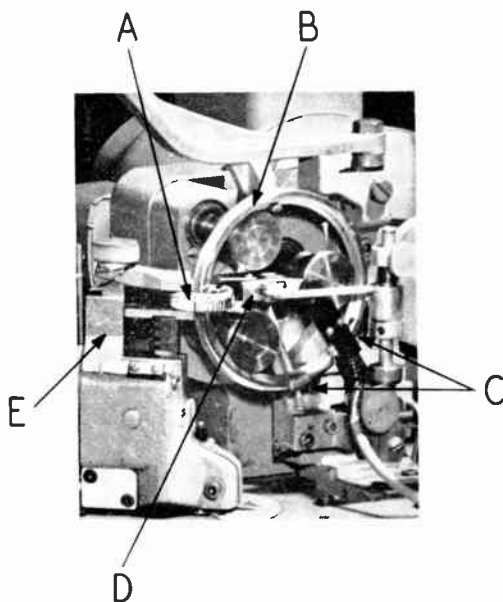

Figure 4. Coil clamp and shuttle of toroid winder

As ingenious machines such as this coil-winding mechanism become available, more and more of the many research laboratory developments that bring increased efficiency to the telegraph industry can be put to practical use.

CLARA U. WATTS and F. L. DEPPERMAN.

Telecommunications Literature

THE DESIGN OF SWITCHING CIRCUITS — WILLIAM KEISTER, ALISTAIR E. RITCHIE and SETH H. WASHBURN—D. Van Nostrand Co. Inc., N. Y., 1951. 556 pp., \$6.00. This excellent text is unique in its field. The literature in the past covering switching has consisted of a few texts describing large telephone switching systems, and some articles describing specific switching principles and circuit arrangements. The authors of this book have started from the fundamentals of the subject and continued through various classes of basic circuits to a discussion of the principles underlying the development of multifunctional circuits. The idea of logic as applied to such two-valued devices as the relay is developed in one of the first chapters. The theory of switching algebra is covered and numerous examples given of its use. Although the authors have devoted most of their attention to circuits for relays, they have provided sufficient information on circuits for rotary switches, gas tubes, vacuum tubes, varistors, and other switching devices to indicate the theoretical possibilities, if not always the practical limitations, of these elements.

The text is made more valuable for the student, and more interesting for the experienced, by the problems that conclude most chapters. They have been chosen to give practice on the subjects considered, and in most cases include a statement by which the correctness of a solution may be checked from an economic point of view. This work is highly recommended to all those interested in the growing switching field.—W. S. W. EDGAR, JR., Ass't to Systems Development Engineer.

MICROWAVE DUPLEXERS, MIT Series Vol. 14—LOUIS D. SMULLIN and C. G. MONTGOMERY—McGraw-Hill Book Co., Inc., N. Y., 1948. 437 pp., \$6.50. Microwave duplexers are microwave switches that allow the same antenna to be used for transmission and reception in radar. The radar du-

plexer is thus the microwave equivalent of a fast double-pole double-throw switch with low loss. This book is an up-to-date report of the development, theory, and problems of duplexing as thus designed. The subject material is broad and covers many problems that are of interest to the microwave design engineer not necessarily interested in duplexing. The measuring techniques and circuit designs given may be used for other microwave transmission designs. After an introductory chapter on the background of the subject and an explanation of the terms used in the book, the authors give theoretical considerations and results of many duplexer designs. These include band-pass TR tubes, linear theory of high "Q" TR tubes, and the characteristics of TR tubes at low and high power level. Practical designs and principles of balanced and branched duplexers are illustrated and compared to reveal their properties.—H. E. STINEHELPER, SR., Engineer, Radio Research Division.

RADIO AND TELEVISION RECEIVER TROUBLESHOOTING AND REPAIR — GHIRARDI and JOHNSON—Rinehart Books, Inc., N. Y., 1952. 822 pp., \$6.75. An excellent and complete textbook on television-radio trouble clearance and servicing, written in a straightforward nonmathematical style easily understandable by student technicians with high school or equivalent education. Systematic testing procedures, short cuts, alignment methods, problems encountered in connection with the replacement of defective components, etc., are covered in considerable detail. Theory, operation, and design of the types of equipment and their component parts are treated on a secondary basis and only where essential to aid the main purpose of the book—fault location, repair and servicing. Some of the methods and principles described can be applied directly to the maintenance of communication equipment.—E. F. JAEGER, General Operations Supervisor.

