



# SYLVANIA NEWS

Copyright 1947, Sylvania Electric Products, Inc.



MARCH, 1947

EMPORIUM, PENNA.

VOL. 14, NO. 3

## WHO IS THIS MAN?

He's a great guy! A solid citizen!  
 In fact, he's aces! The kind of a  
 fellow people like to do business with  
 . . . capable, trustworthy, skillful.  
 He uses good tools, dependable  
 equipment . . . does an expert  
 job at a price that's right. Who is  
 he? You . . . the radio service-  
 man. This, your story, is now being  
 told to a gigantic audience in a  
 different, dramatic way . . . as it  
 has never been told before.

See the Merchandising  
 Section.

Also in this issue:

**NEWS**  
 Sylvania Announces New  
 Transmitting Tube

**TECHNICAL**  
 Simplified Amplifier  
 Design

## SYLVANIA COMMENTATOR ... IN THE MID-WEST

As business gets nearer to normal (by prewar standards) there is a great need for promotion and extra sales efforts to sell merchandise and service—just the opposite from the period we have just gone through. Many radio service dealers in the central states are already noting the return of competition to the field. But while the war years were tough, they taught some radio men new ways to meet this problem and increase their sales.

One dealer in Chicago is a particularly good example of this. Prior to the war he placed little emphasis on his service department, a lot on his appliance and radio sales departments. When shortages developed he found, like hundreds of others, that he was beginning to lose money. Astutely analyzing the situation, he decided that if he was to remain in business there were two courses open to him: (1) to get better deliveries by fair means or foul; or (2) to develop sales in a new direction.

The choice was an easy one for him. He already had his service department; the wheezy sets his new customers brought in had to be repaired, since they couldn't be replaced. Although it hurt to use scraps and poor materials, he built the best-looking service bench he could manage in plain sight at the back of his store. He placed radio service signs in his window and combed his files for the names and addresses of his old customers to launch a post-card campaign pushing the new service department.

The service business boomed. He added two servicemen to his staff. He was amazed, he said afterward, that so many people were surprised to learn he could also repair sets, not just sell them. He was still plagued by the shortage of parts, but his deliveries were sufficient to repair a great many and show a considerable profit on the department. Better still, he said, his inquiries and potential sales of new radios and appliances were increased by an estimated 50%.

Do you think this dealer will go back to his prewar style of doing business? Not by a long shot!

ROBERT F. HENDERSON

## REVISED RETAIL PRICE SCHEDULE ISSUED

Lists Both Current  
and Obsolete Types

Enclosed with this issue of Sylvania News you will find a revised Retail Price List. No major changes have been made in the retail price structure since the OPA revision of October 28, 1946. The enclosed schedule does reflect a few changes since the last printing, and it has been brought up to date as of April 1, 1947.

For your convenience in checking we are listing the revisions below:

		Revisions		
1C8		6AQ5	12AT6	
1Q6		6AQ6	12BA6	
1U4		6AT6	12BE6	
1V5		6AU6	35W4	
1W5		6BA6	50B5	
6AC7/1852		6BE6	70L7GT	
6AK6		6C4	117Z3	
6AL5		6J8G		
		Additions		
XXB	6AL7GT	7AF7	12AW6	
1U5	6S8GT	7AH7	14F8	
1X1	6X4	7C8	100-77	
5AZ4	7AD7	12AU7	100-79	

## New Transmitting Tube Announced

Sylvania has announced the first in a new line of transmitting tubes, the 3D24. This tube is a four-electrode amplifier and oscillator with 45 watt anode dissipation. Most outstanding in the development of the 3D24 is the electronic graphite anode which allows high plate dissipation for a small area and maintains constant interelectrode relationship and uniform anode characteristics.

The 3D24 may be used at full input up to 125 Mc. The maximum permissible frequency will be announced later, upon completion of tests. Interesting potentialities of the 3D24 include amateur, police, mobile and marine radio.

Other features of this new transmitting tube are the top cap which provides for a short path, greater cooling by radiation and convection, resulting in a cooler seal. The thoriated tungsten filament gives a high power output per watt of filament power. The #1 grid is supplied with two leads for better high frequency performance and the #2 grid provides for a heat resisting

In preparing this price schedule we have attempted to include all types. Obviously, a large number listed are obsolete. As new types are released or when changes are made, an announcement will be given in Sylvania News and a revised schedule issued. Extra copies of the enclosed latest schedule may be obtained from Sylvania Distributors or by writing us.

### MODMETER X7018

Price schedule for the Sylvania Modulation Meter, Type X7018 (SYLVANIA NEWS, Sept. 1946) has been announced. The price will be \$34.75. The unit is intended primarily for use by amateurs operating on radio telephone, although it is applicable to police, forestry, marine and other services operating up through the region of 54 megacycles.

shield for greater dissipation and low grid plate capacity. The low interelectrode capacity requires no neutralizing with proper circuit arrangements. High power for small size is provided in the hard glass envelope. The lock-in base allows short leads with no welded or soldered joints.

Further information on the 3D24 will be provided in future issues of the SYLVANIA NEWS.





# SYLVANIA NEWS TECHNICAL SECTION

Copyright 1947, Sylvania Electric Products Inc.

A. V. BALDWIN, Technical Editor

These data have been compiled from information which we believe to be accurate. No responsibility can be assumed in the application thereof or for patent infringement.

MARCH, 1947

EMPORIUM, PENNA.

VOL. 14, NO. 3

## SIMPLIFIED AMPLIFIER DESIGN

*Editor's Note: There are many servicemen to whom the design of amplifiers is a cut-and-try process. In order to correct this and illustrate the use of the data in the new Sylvania Manual we asked Roy McNaughton supervisor of our Test Equipment Design Section to write an article suitable for beginners explaining the procedure. To do this requires almost four full pages and there was no logical place to divide it for continuation in the next issue. We hope those who have "passed this course" or who are not interested in amplifier design at present will forgive us.*

Recently Sylvania Electric Products Inc. announced the publication of a new Technical Manual containing a wealth of information not previously published in the Sylvania Manuals.

The new issue includes the important characteristic curves for all Lock-In tubes and resistance-capacity coupled amplifier data for many of the tubes used as audio voltage amplifiers. This information supplements the typical operating data listed for each tube and thereby gives the designer of electronic equipment nearly all the information concerning tubes necessary for successful design.

As an illustration of the use of the information available the following article on the design of an audio amplifier was prepared.

In order to use a concrete example we will assign the following arbitrary conditions for the amplifier to be designed: Operate from a 110 volt, single phase, 60 cycle line; give 10 watts audio output to an 8 ohm P.M. speaker with not more than 10% total distortion; have sufficient gain to give full output with a crystal microphone input; and to have approximately flat response to all frequencies from 100 to 5000 cycles per second.

Before selecting any tubes for our amplifiers we should review the characteristics of the different classes of power amplifiers and decide which best meets our requirements from an economic and performance viewpoint.

### Amplifier Classification

For audio work the most generally used amplifiers are Class A1, AB1, AB2, or B. The class of amplifier used depends greatly on the range of signal levels, permissible distortion, and output power required.

A class A1 amplifier is one in which the grid bias is set at approximately the center of the linear portion of the plate current-grid voltage curve for a constant plate voltage and the signal is restricted to a value which will not drive the grid into the positive region or into the sharp bend near cut-off. Such an amplifier may be either a single tube or tubes in push-pull. Its important characteristics are low power, low distortion, and high average current which does not change appreciably with signal level thus permitting the use of a poorly regulated power supply.

A class AB1 amplifier is one in which the grid bias voltage is set at a point between the center of the linear portion and the sharp bend near cut-off on the plate current-grid voltage curve. Operating at low signal voltages this type of amplifier gives Class A1 performance but approaches Class B performance at high signals. For this reason it generally uses two tubes in push-pull to minimize distortion at high signal level. Its advantage lies in its ability to give higher output per tube at slightly better plate circuit efficiency than possible in Class A1 operation. Its disadvantages are slightly higher distortion at high signals and it requires better regulation in the power supply.

In Class AB2 amplifiers the grid bias is set at a point near cut-off and the signal is allowed to drive the grid into the positive region thus requiring some driving power from the preceding amplifier. For these reasons push-pull operation is always employed to reduce distortion. This type of amplifier gives high power output at high plate

circuit efficiency but requires careful design to reduce distortion and obtain good regulation in the power supply. Because of the power required to drive the grids it is usually transformer coupled to the preceding stage but by careful design may be used with resistance-capacity coupling.

The Class B amplifier is one in which the grid bias is set at cut-off so that plate current flows during the positive half cycle only. To minimize distortion in an audio system Class B amplifiers are always used in push-pull. They are used generally for high level output systems such as plate modulators and outdoor public address systems. Their greatest disadvantages for general use are high distortion at low signal level and the need for a well-regulated power supply.

It may be noted from the above amplifier descriptions that the no- or low-signal B+ current required is highest for Class A1 and lowest for Class B while AB1 and AB2 are intermediate and that the power supply regulation requirement ranges from poor for Class A1 to very good for Class B. This directly influences the cost of the power unit and should be considered when economy is a factor in design.

Now that we have a general description of the power amplifiers and the tube characteristics we can start selecting the tubes and operating conditions for our system. For the economy involved we decide to use resistance-capacity coupling between stages and limit the amplifier to Class A1 or AB1 operation.

Looking over the typical operating conditions for the power output amplifier tubes we find a large number which will give us 10 watts output with less than 10% total distortion under Class A1 or AB1 conditions. We note also that the beam power amplifier tubes will meet our requirements for power output and distortion at a lower

## SYLVANIA COMMENTATOR ... IN THE MID-WEST

As business gets nearer to normal (by prewar standards) there is a great need for promotion and extra sales efforts to sell merchandise and service—just the opposite from the period we have just gone through. Many radio service dealers in the central states are already noting the return of competition to the field. But while the war years were tough, they taught some radio men new ways to meet this problem and increase their sales.

One dealer in Chicago is a particularly good example of this. Prior to the war he placed little emphasis on his service department, a lot on his appliance and radio sales departments. When shortages developed he found, like hundreds of others, that he was beginning to lose money. Astutely analyzing the situation, he decided that if he was to remain in business there were two courses open to him: (1) to get better deliveries by fair means or foul; or (2) to develop sales in a new direction.

The choice was an easy one for him. He already had his service department; the wheezy sets his new customers brought in had to be repaired, since they couldn't be replaced. Although it hurt to use scraps and poor materials, he built the best-looking service bench he could manage in plain sight at the back of his store. He placed radio service signs in his window and combed his files for the names and addresses of his old customers to launch a post-card campaign pushing the new service department.

The service business boomed. He added two servicemen to his staff. He was amazed, he said afterward, that so many people were surprised to learn he could also repair sets, not just sell them. He was still plagued by the shortage of parts, but his deliveries were sufficient to repair a great many and show a considerable profit on the department. Better still, he said, his inquiries and potential sales of new radios and appliances were increased by an estimated 50%.

Do you think this dealer will go back to his prewar style of doing business? Not by a long shot!

ROBERT F. HENDERSON

## REVISED RETAIL PRICE SCHEDULE ISSUED

Lists Both Current  
and Obsolete Types

Enclosed with this issue of Sylvania News you will find a revised Retail Price List. No major changes have been made in the retail price structure since the OPA revision of October 28, 1946. The enclosed schedule does reflect a few changes since the last printing, and it has been brought up to date as of April 1, 1947.

For your convenience in checking we are listing the revisions below:

Revisions			
1C8	6AQ5	12AT6	
1Q6	6AQ6	12BA6	
1U4	6AT6	12BE6	
1V5	6AU6	35W4	
1W5	6BA6	50B5	
6AC7/1852	6BE6	70L7GT	
6AK6	6C4	117Z3	
6AL5	6J8G		
Additions			
XXB	6AL7GT	7AF7	12AW6
1U5	6S8GT	7AH7	14F8
1X1	6X4	7C8	100-77
5AZ4	7AD7	12AU7	100-79

In preparing this price schedule we have attempted to include all types. Obviously, a large number listed are obsolete. As new types are released or when changes are made, an announcement will be given in Sylvania News and a revised schedule issued. Extra copies of the enclosed latest schedule may be obtained from Sylvania Distributors or by writing us.

## MODMETER X7018

Price schedule for the Sylvania Modulation Meter, Type X7018 (SYLVANIA NEWS, Sept. 1946) has been announced. The price will be \$34.75. The unit is intended primarily for use by amateurs operating on radio telephone, although it is applicable to police, forestry, marine and other services operating up through the region of 54 megacycles.

## New Transmitting Tube Announced

Sylvania has announced the first in a new line of transmitting tubes, the 3D24. This tube is a four-electrode amplifier and oscillator with 45 watt anode dissipation. Most outstanding in the development of the 3D24 is the electronic graphite anode which allows high plate dissipation for a small area and maintains constant interelectrode relationship and uniform anode characteristics.

The 3D24 may be used at full input up to 125 Mc. The maximum permissible frequency will be announced later, upon completion of tests. Interesting potentialities of the 3D24 include amateur, police, mobile and marine radio.

Other features of this new transmitting tube are the top cap which provides for a short path, greater cooling by radiation and convection, resulting in a cooler seal. The thoriated tungsten filament gives a high power output per watt of filament power. The #1 grid is supplied with two leads for better high frequency performance and the #2 grid provides for a heat resisting

shield for greater dissipation and low grid plate capacity. The low interelectrode capacity requires no neutralizing with proper circuit arrangements. High power for small size is provided in the hard glass envelope. The lock-in base allows short leads with no welded or soldered joints.

Further information on the 3D24 will be provided in future issues of the SYLVANIA NEWS.

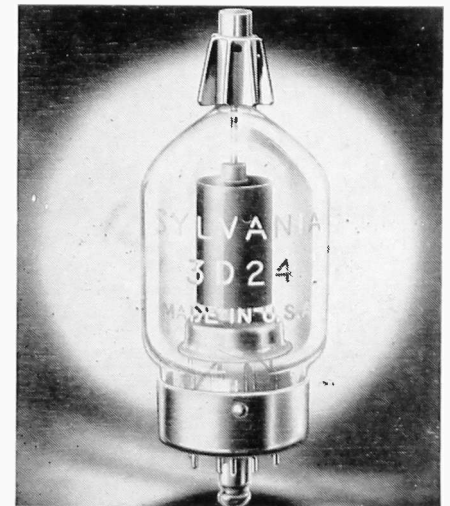



## SIMPLIFIED AMPLIFIER DESIGN (Continued)

signal voltage than either triodes or suppressor grid type pentodes. Therefore, should we use beam power tubes in our output stage we would require less voltage amplification in the preceding stages and thus give us the possibilities of reducing the number of stages or of operating on them to improve frequency response, distortion, and stability. With our search narrowed to the beam power tubes we note that the type 7C5 tube operated at 250 volts on the plate and screen and 15 volts bias will give us 10 watts output at 5% total distortion. Type 6V6GT is the octal equivalent of the type 7C5 and may be used. Since we have selected our output tubes we may proceed with the complete design of our amplifier. The ratings for the type 7C5 show that we need an output transformer which when properly matched to the speaker will reflect a load of 10,000 ohms from plate to plate of the output tubes and that we need a 200 ohm self-bias resistor to develop the required 15 volts bias. Also in the application notes for the type 7C5 tube we note that the grid resistor for self-bias operation should not exceed 0.5 megohm. This is important since the statements in the notes are included by the tube manufacturers to aid in establishing the best conditions for good performance and life of the tubes. We will be conservative and use 0.27 megohm for the grid resistors. This completes the design of the output stage which, summarized, includes the appropriate output transformer, two type 7C5 Beam Power Output tubes in push-pull, a 200 ohm self-bias resistor, and 0.27 megohm grid leak resistors.

### Selecting the Phase Inverter Circuit

The next step in the design of our amplifier is to determine the type of phase inverter. Here again we have a variety from which to choose.

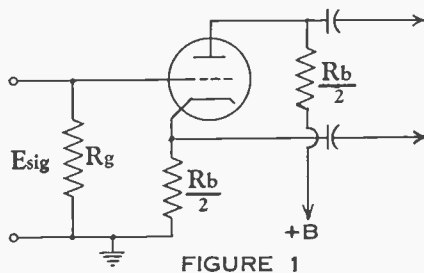

FIGURE 1

The simplest circuit is shown in Figure 1 and uses a single tube with

its plate load divided, half of it being in the plate circuit and the other half between the cathode and ground or B—. This type of circuit has the disadvantage that the part of the plate load in the cathode circuit is also in the grid circuit and results in degeneration of the input signal which reduces the gain of the tube so that the output voltage from either the plate or cathode to ground is less than the applied signal input. Thus this type of phase inverter contributes very little to the overall gain of the amplifier. Also it has the disadvantage of being very difficult to keep balanced at high frequencies because of the difference in the stray capacities between plate and ground and cathode and ground.

Another type of phase inverter, Figure 2, uses two tubes or one dual tube. In this circuit the signal from the preceding stage is fed to the grid of one tube, amplified by the tube and coupled to one grid of the push-pull stage. A voltage divider at

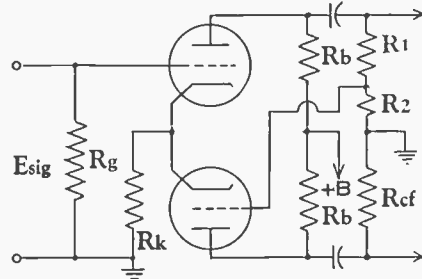

FIGURE 2

this point picks off a portion of the output equal to  $E_o$  divided by the gain of the tube and feeds it to the grid of the second tube where it is amplified, shifted in phase by  $180^\circ$ , and fed to the grid of the other output tube.

This circuit is balanced (equal voltage output from each tube) when the gain of the second tube or section is the same as that of the first section. If not it may be balanced experimentally by adjusting the voltage divider.

The two cathodes of the phase inverter stage may be tied together and connected to ground through an unbypassed bias resistor. By omitting the cathode by-pass condenser the bias resistor aids slightly in balancing the stage, should the gain of the second section be slightly different than the first.

This type of phase inverter has the advantage that it utilizes the full gain of one of the tubes and gives a plate to plate output equal to twice that of one tube.

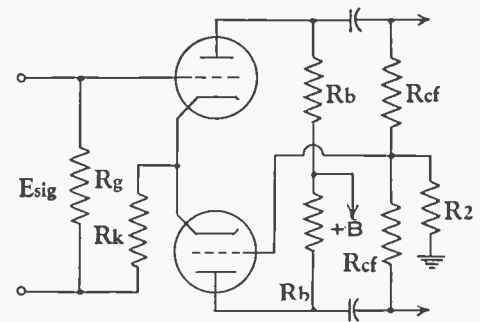

FIGURE 3

Another type of phase inverter which operates on the same principle as that above is the self-balancing inverter shown in Figure 3. In this circuit the signal for the grid of the second tube is obtained across a resistor which is common to the output of both halves of the phase inverter. Since this resistor is common to both sections whose output is  $180^\circ$  out of phase, the signal to the grid of the second section can never exceed that value which when amplified will produce an out of phase voltage across the resistor equal to that voltage across the resistor due to the output of the first section.

There are other methods for obtaining phase inversion but those named and the center tapped secondary transformer are the most commonly used types.

For our amplifier we will use the circuit of Figure 2. The selection of circuit values and tube or tubes depend on the output voltage required and the frequency response desired.

### Circuit Constants

Knowing the maximum frequency desired we can proceed to set up the circuit constants for the output side of the phase inverter circuit. It is usually good practice to keep the ratio of AC load to DC load impedance for an amplifier as high as possible. This requires that the grid resistor for the following stage should be large compared to the DC plate load resistor. Also the following grid resistor should be large in order to decrease the size of coupling condenser required to maintain low frequency response. The AC load impedance consists of the plate load resistor paralleled by the plate to cathode capacity of the tube, the following grid resistor, and the total effective input capacity of the following stage, i.e.  $C_g - k + C_g - p$  (gain of stage + 1). The coupling condenser is neglected since its reactance in series with the following grid resistance and input capacity

# OVER 150 MILLION MESSAGES SELLING TO APPEAR IN WORLD'S MOST W

EYE-CATCHING ADS LIKE THESE TO MAKE PEOPLE STOP, LOOK, READ!



A skillful fellow who takes pride in his work is your local radio service dealer. His trained hands will keep your set going strong. Leave it to him to do the job you need—to do it well and at a fair price. Chances are he will recommend Sylvania radio tubes, because it's his business to know and use the best equipment. There are no finer tubes made!



**SYLVANIA  
RADIO  
TUBES**

Product of Sylvania  
Electric Products Inc.



**SOLID  
CITIZEN!**

He's the fellow who keeps your radio on the beam — your local radio service dealer. His motto is excellent service at a moderate price. Does he live up to it? Give him a try. You'll find that he prefers Sylvania testing equipment and Sylvania radio tubes. They enable him to do the very best job for you!

**SYLVANIA  
RADIO TUBES**

Product of Sylvania  
Electric Products Inc.



Imagine these ads on the pages of your favorite magazine. They just don't lie there. They pop off the page . . . command your attention . . . arouse your curiosity. You want to read about the fellow they talk about. That fellow is YOU!

They tell a convincing story because they're based on fact. They sell you, your products and your service. They sell hard and often, appearing in the three most popular national weekly magazines—LIFE, SATURDAY EVENING POST and COLLIER'S.

## NEVER BEFORE HAVE RADIO SERVICEMEN RE

# YOU, YOUR SERVICES, YOUR PRODUCTS WIDELY-READ MAGAZINES THIS YEAR

IN LIFE, COLLIERS AND THE SATURDAY  
EVENING POST WITH A COMBINED WEEKLY  
CIRCULATION CLOSE TO 12,000,000

Yes, your ads will appear in the most widely-read weekly publications in the entire world. LIFE Magazine alone has 5,200,000 readers a week. Sylvania will run thirteen ads in this magazine throughout the year. In other words, 67,600,000 messages about you.

SATURDAY EVENING POST weekly circulation is 3,800,000. Twelve different issues will carry your ads. Another 45,600,000!

Each week, 2,900,000 people read COLLIER'S in which you'll have thirteen insertions . . . an additional 37,700,000 sales messages.

The circulation of each of these highly popular national magazines is expected to increase during the year. So you will actually benefit from the additional power of many more sales stimulators than the 150,000,000 now scheduled.

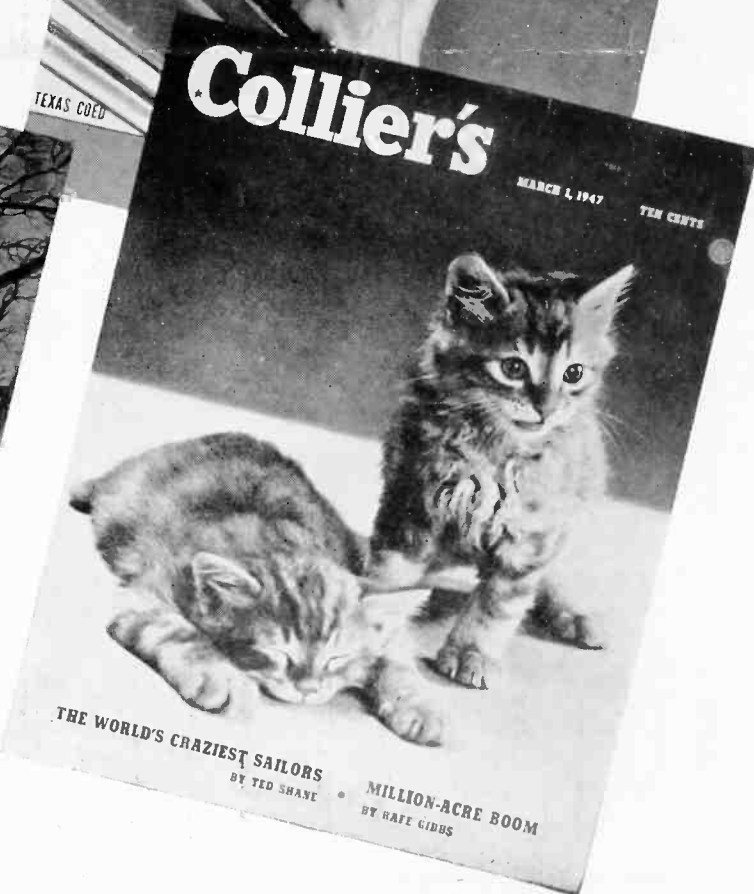

RECEIVED SUCH OVERWHELMING SALES SUPPORT!



## SIMPLIFIED AMPLIFIER DESIGN

(Continued)

has a very small effect on the total impedance. The total shunt capacity will have a negligible effect on the gain of an amplifier if its reactance at the high frequency end of the desired pass band is approximately five to ten times the resistance of the DC plate load and following grid resistor in parallel.

If we estimate the total shunt capacity including strays on the output of the phase inverter to be 40 micromicrofarads, it will have a reactance of 800,000 ohms at 5000 c.p.s. Dividing this by ten we get 80,000 ohms which should be the resistive plate load for the stage. Since we have already set 0.27 megohm as the value of grid resistor for the output stage we may calculate the DC plate load resistor as 114,000 ohms. This is the maximum value which should be used to maintain the desired high frequency response. Any value lower than this will extend the high frequency end of the pass band.

So far we have the following information on the phase inverter stage for our amplifier:

1. The plate load resistor for each section of the inverter must not exceed 114,000 ohms.

2. The following grid resistors are each 0.27 megohm.

3. The bias on the output tubes is 15 volts so we need 15 volts peak or 10.5 volts R.M.S., signal from each section of the phase inverter to drive the output stage to full power output.

### Selecting the Inverter Tube

This is sufficient data to enable us to select our tubes for the phase inverter. From the R-C Data in the front section of the new Technical Manual we note that a number of the duo triodes such as the type 7N7 and 7F7 will give us the required output voltage with low distortion when operating self-bias from a 250 volt plate supply. Since the type 7F7 gives higher gain and requires less filament power we will use this tube for our phase inverter.

From the R-C Data we note that each section of this tube will give us a gain of 40 when operated with a 100 megohm DC plate load, 0.27 megohm following grid resistor, 1800 ohm cathode resistor, and a 250 volt supply. Therefore, the 0.27 megohm grid resistor for one output tube should be made up of

two resistors in series from which 1/40 of the voltage across them may be fed to the grid of the second section of the phase inverter. The divider would consist of 263,250 and 6750 ohm resistors in series with the junction connected to the second grid of the phase inverter and the opposite end of the 6750 ohm section to ground.

The cathode resistor ( $R_k$ ) is given as 1800 ohms for one tube or section and since we intend to parallel the cathodes of both sections we must divide this by 2 which gives 900 ohms. Since this is an odd value of resistor we can use 1000 ohms without difficulty. The grid resistor for the input section of the phase inverter is not critical and should be selected to meet the requirements for maintaining the desired frequency response from the preceding stage.

Since the output required to drive each grid of the final stage is 15 volts peak or 10.5 volts RMS and the gain of each section of the phase inverter is 40 we will require 10.5/40 or 0.263 volts RMS input signal to the phase inverter.

### Design of Input Stage

We are now ready to design our input stage. The output voltage from a crystal microphone may vary from a fraction of a millivolt to several millivolts depending on the sound pressure driving it. Therefore, our input stage must have sufficient gain to give us 0.263 volts output with less than 10 millivolts input. Assuming a value of 5 millivolts signal our input stage must have a minimum gain of 53 to be capable of driving our system to full output.

Again referring to the R-C Data in the manual we find that pentode tubes such as the Type 7C7 should meet our requirements. To keep our tube line-up consistent we will use the type 7C7 providing we can get sufficient gain and still maintain our frequency response.

The approximate total capacity shunting the plate load must be calculated and its reactance at 5000 c.p.s. determined. From the ratio of this reactance to the plate load (AC) resistance for the various conditions we can determine the approximate percentage of the 400 c.p.s. gain remaining for the stage at 5000 c.p.s.

Our total capacity shunting the output of this stage will consist of the type 7C7 output capacity,

effective input capacity of the one section of the type 7F7, and the stray wiring capacity. Referring to the manual and remembering that we have a gain of 40 in the type 7F7 we note that these capacities will be  $6.5 + 2.4 + (1.6 \times 41) + 7.5$  (strays) or 80 micromicrofarads. This will have a reactance of approximately 400,000 ohms at 5000 c.p.s. Since the gain of a type 7C7 tube operating with a plate load (AC) of 73,000 will be 106 and the ratio of  $X_c$  to  $R_L$  will be approximately 5.5 we can use the tube and still have very little loss (approximately 2%) in gain at the high frequency. Should this loss in gain be undesirable it would be necessary to reduce the plate load or to add another stage of amplification.

The conditions for a gain of 106 from the type 7C7 tube are .1 megohm DC plate load, 0.27 megohm following grid resistor, 0.47 megohm screen grid resistor, 470 ohm cathode resistor, and a 250 volt plate and screen supply. These constants determine the output circuit for the input stage including the grid resistor for the input to the phase inverter.

We now have to determine the values for the cathode and screen bypass condensers, the plate to grid coupling condensers, and the input grid resistor.

The cathode and screen bypass and the coupling condensers all affect the low frequency response and must be determined, using proper formulae, to give the desired response.

On Page 32 of the new Manual the formulae for determining the various condensers are given.

Our low frequency is 100 c.p.s. and by use of the formulae:  $C_k$  for the type 7C7 should be  $34 \mu\text{f.}$ ,  $C_{c2} = .034 \mu\text{f.}$ , and  $C_c = .06 \mu\text{f.}$  for 0.27 megohm following grid resistors. These are odd values of condensers so we decide to use 50  $\mu\text{f.}$  25 volts, .05  $\mu\text{f.}$  400 volt, and 0.1  $\mu\text{f.}$  400 volt for  $C_k$ ,  $C_{c2}$ , and  $C_c$  respectively.

The input grid resistor should have sufficiently high resistance to prevent excessive loading of the microphone or pick-up. A value of 1 megohm will be satisfactory for many applications. So far we do not have a volume control and by using a good grade of potentiometer we can make the input grid resistor a 1 megohm volume control. Care

## SIMPLIFIED AMPLIFIER DESIGN

(Continued)

must be used when placing the volume control on the input of a high gain amplifier because any pick-up on or noise in the control will be amplified by the full gain of the system.

### Decoupling and Filtering

At this point we have completed the design of the amplifier proper and all that remains is to de-couple the stages to prevent feedback, provide additional filtering for the voltage supplying the input stage, and design the power supply. Both de-coupling and filtering may be accomplished by resistance-capacity sections in the B+ line between stages.

In the R-C Data for the types 7F7 and 7C7 the total currents are given as 1.834 ma. and 2.17 ma. respectively for the operating conditions chosen. Therefore, our de-coupling resistor between the output and phase inverter stages will carry 4 ma. current and that between the phase inverter and input stage 2.17 ma. Normally de-coupling between the output and inverter stages is not necessary but we will insert a resistor R14 and condenser C8 of Figure 4 at this point to aid in filtering the supply to the input stage. Since we do not want too great a reduction in supply voltage to the phase inverter we will make this resistor 5000 ohms.

To adequately de-couple the input stage the de-coupling resistor R9 should be at least one-tenth the plate load resistor or 10,000 ohms. To filter the supply line and by-pass the signal from each stage to ground we will use a dual 8 $\mu$ f. 450 volt condenser C7, C8 with the negative terminal or terminals on ground, one positive terminal connected to the junction of the 10,000 ohm resistor and the plate and screen grid resistors of the type 7C7 tube, and the other positive terminal to the junction of the 10,000 and 5000 ohm resistors and the plate loads of the type 7F7 tube.

### Power Supply

Adding the total currents of the amplifier tubes gives us a total B+ current drain of 96 ma. at full output and 79 ma. at zero output. Therefore, our power supply must be capable of delivering 265 volts DC at 96 ma. current and should not give a large change in voltage when the current drops to 79 ma.

We need the 265 volts output to supply the 250 volts between plate and screen and cathode of the type 7C5 and the 15 volts bias from cathode to ground.

Since many of the lower priced power transformers have both 5.0 and 6.3 volt filament windings and for best operation we should keep the filament supplies for the rectifier and amplifier tubes separate we will use one of the 5.0 volt filament type rectifiers for the power supply. Again referring to the tube manual we find that the type 5Y3GT tube will meet our requirements for voltage and current output.

In view of the 96 ma. current requirement we should use a 110 ma. or 120 ma. rated transformer and filter choke. The choke should be selected to give adequate filtering with a minimum DC resistance since this influences the regulation of the supply. Without going into the details of filter design let us assume that it should have a minimum of 10 henries inductance at rated current. Such chokes usually have a resistance of approximately 230 ohms which at 96 ma. will cause a 22 volt drop in voltage to the output of the filter. Therefore, the

DC voltage from the rectifier must be 265 + 22 or 287 volts at the input to the filter. Referring to the curves for the type 5Y3GT\* we find that this voltage can be secured at 96 ma. load with approximately 300 volts RMS applied to each plate of the tube when operated with condenser input to the filter. For our filter condensers we will use an 8  $\mu$ f. 450 volt and 16  $\mu$ f. 450 volt respectively on the input and output of the pi filter. The power transformer should also supply 5.0 volts at 2.0 amperes and 6.3 volts at 1.35 amperes for the filaments.

This completes the design of our amplifier which will give us approximately 10 watts output at less than 10% distortion and full output with a signal input of 3 millivolts. The final circuit design is shown in Figure 4 but we will leave the constructional details to the builder with a warning that the circuit for the input tube should be box shielded from the balance of the unit.

\*NOTE: A misprint in the new manual resulted in printing the curve for type 5Y3G with choke input twice and omitting the condenser input curve. We suggest that the condenser input curve on page 65 of the old manual be pasted in the new manual.

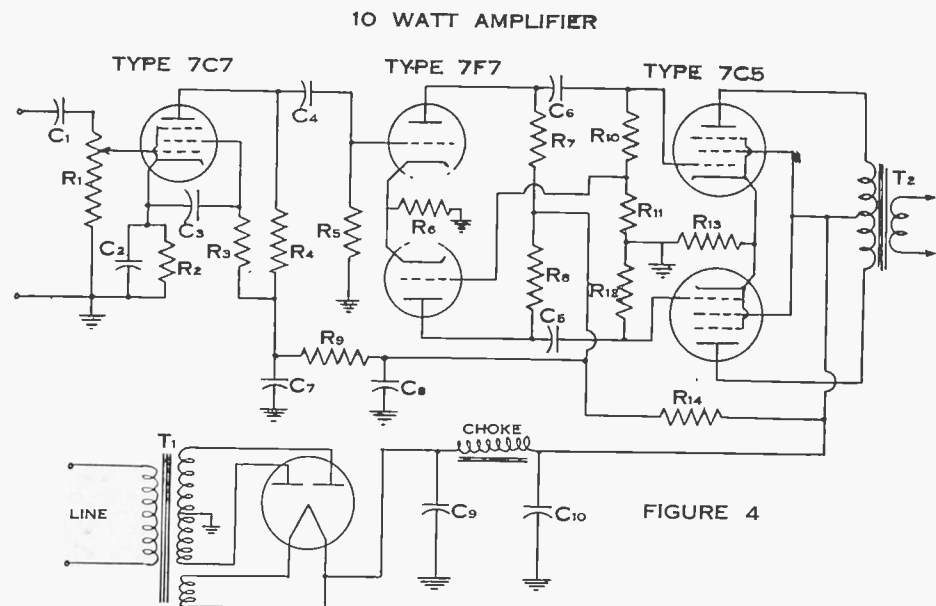

## PARTS LISTS

RESISTORS		CONDENSERS	
R1	1 Meg. Volume Control	C1	.05 mfd.
R2	470 Ohms	C2	50 mfd. 25 Volt
R3	470,000 Ohms	C3	.05 mfd. 400 Volt
R4	100,000 Ohms	C4	0.1 mfd.
R5	270,000 Ohms	C5	.01 mfd.
R6	1,000 Ohms	C6	0.1 mfd.
R7	100,000 Ohms	C7	8.0 mfd. 450 Volt
R8	100,000 Ohms	C8	8.0 mfd. 450 Volt
R9	10,000 Ohms	C9	8.0 mfd. 450 Volt
R10	263,250 Ohms	C10	16.0 mfd. 450 Volt
R11	6,750 Ohms	T1	Power Transformer
R12	270,000 Ohms		300-0-300 @ 110 ma.
R13	200 Ohms		5 Volts @ 2 amps.
R14	5,000 Ohms		6.3 Volts @ 1.35 amps.
Choke	10 henry 110 ma.	T2	Output Transformer
			10,000 Ohms to 8 Ohm Voice Coil.

# — SHOP O' THE MONTH —

## GOOD SERVICE BRINGS MORE WORK



Northwest Electronics has drive-in service for two cars. Smaller test board for pre-installation testing is located in auto installation department.

Test board at Northwest Electronics has everything at finger tips. Board is self-contained with only one 110 volt A.C. cord to supply.

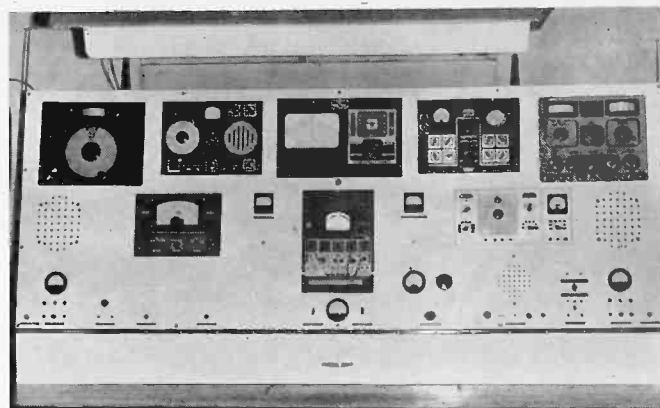

Maurice E. Yoes, Manager of the Northwest Electronic Service in Seattle, Wash., is another serviceman whose goal is to raise the service industry from, as he terms it, "the screwdriver and voltmeter" class to a higher professional level. Much of Mr. Yoes business is auto radio work, but in the four years that he has been in business he has repaired about 14,000 sets of all types.

The shop is equipped with drive-in facilities for two cars with a small test board for pre-installation testing of sets. The main panel is 8' by 4' finished with a white lacquer in dural finish. The frame is wood,

finished in white lacquer.

The main board consists of duplex battery outlets with individual meters; antennas and speakers at each end of the board for auto radios; variac and voltmeter for checking intermittent portables; "A" eliminator, loaded for voltage regulation; universal field and output transformer connections for AC receivers. The board incorporates a high gain audio amplifier for testing phonograph changers, pickups and microphones. The conveniently located center drawer holds all leads and prods. The antenna connections are panel amphonal mountings.

In addition, the board incorporates the following pieces of test

equipment: condenser analyzer; vedolyzer comprising scope and vacuum tube voltmeter; large scale multimeter; audio oscillator; mutual conductance tube tester; audolyzer; AM signal generator; AM and FM signal generator; constant line voltage check. The bench carries a duplex 100-watt fluorescent fixture above for perfect shadowless lighting.

Northwest Electronic employs three technicians, one salesman and one office girl. The business has no time for the "something for nothing" type of advertising, since their record bears out the statement that "good work will bring customers' friends' work."

## SPECIALTY DISTRIBUTING SALES FORCE

On the right is the sales force of the Specialty Distributing Co. of Atlanta, Georgia. Specialty is an exclusive parts house and sells no major appliances or radio sets. It has one of the largest sales organizations of any electronic parts distributor in the Southeastern territory. In addition to the Atlanta office, Specialty has branches in Macon, Savannah, and Chattanooga.

Seated L. to R.: "Bull" Durham, Judson Myers, J. E. Kelly, Chattanooga; "Stumpy" Eaton, Macon; Bob Morris, Atlanta; Wade McCurry, "Hutch" Hutchison, Macon; "Ted" Cape, Billy Blount, Jimmy Morris, Atlanta.  
 Standing L. to R.: Alex Sterk, Chattanooga, "Honk" Honiker, "Gus" Barron, John Tucker, Atlanta; Monroe Hutto, Ben Team, Martin Boyd, Savannah; Fred Morris, Atlanta, owner of the company, W. H. Nilsson, Savannah; Bill Hutchison, Marcus Warren, Kirby Baker, Atlanta. Absent: Herman Edison, Charlie Olive, Macon; Smith Padgett, Chattanooga; "Bubber" Adams, Vernon Check, Atlanta.





## COMMENTATOR

# Sylvania

KANSAS CITY

During the war and in recent post war months, most independent radio servicemen made little or no attempt to stimulate or create new business. They already had more repair work than they were able to handle with shortages of parts, tubes and labor.

Now that labor has become more plentiful and tubes and parts have just about reached a pre-war level of supply, the serviceman is faced with the situation of a decrease in business. The great number of new sets now available has put servicing in the background, at least until the regular warranty period has expired and maintenance must be started again. New shops have added to the burden too by providing more competition.

If the older service dealers are to continue to prosper, they must give full consideration to two things. First, they should dress up their shops so that they will be more inviting to the public. They must impress the public with signs of prosperity—a sign of success in business.

Second, servicemen should plan a well organized advertising program. One of the most effective vehicles in a program of this type is direct mail. This is done inexpensively through the use of post cards. A well selected list of prospects is important and mailings should be made regularly throughout the year.

Ted Combs Radio Service Co. of Wichita, Kan. has been in business for 22 years. Mr. Combs has been most successful. His success has been attributed to two things; one, he has always turned out good work; two, he has used the direct mail system to stimulate his volume of business.

Ted Combs operates a very attractive, neat appearing service shop in residential Wichita. His work speaks well for him since much of his business comes from satisfied customers who are willing to give him a boost when they hear of a radio in need of repair.

President of the thirty member RSA Mr. Combs does much to promote better dealer relations and bring better technical information to the service men of Wichita.

D. C. Patrick

## NEW GERMANIUM VARISTOR FOR COMMUNICATIONS AND RADAR

A new four-element germanium varistor designed for service in telephone, telegraph, and other communication applications has been announced by the Electronics Division of Sylvania.

Features of the varistor include improved stability, long life, and low shunt capacity permitting high frequency operation. A virtual elimination of contact potential is another important consideration. Also of value in many applications is the characteristic of these germanium varistors which enables lower impedance circuit operation with attendant efficiencies.

These new products of Sylvania germanium research are valuable as modulators or demodulators, ring modulators and in circuits of the carrier transmission or carrier suppression type.

The varistors are available in two mechanical mountings; electrical characteristics are the same. The plug-in unit, type V-301, contains four carefully selected and balanced germanium crystal diodes



and is mounted in a compact metal shell with an octal tube base. The lug type, V-307, comes in a metal can adapted for top or sub-panel mounting and is recommended for circuit designers who may prefer to use solder type terminals.

Further information on these germanium varistors can be secured by writing to the Electronics Division, 500 Fifth Avenue, New York.

## ENGINEER CALLS LONDON FAMILY

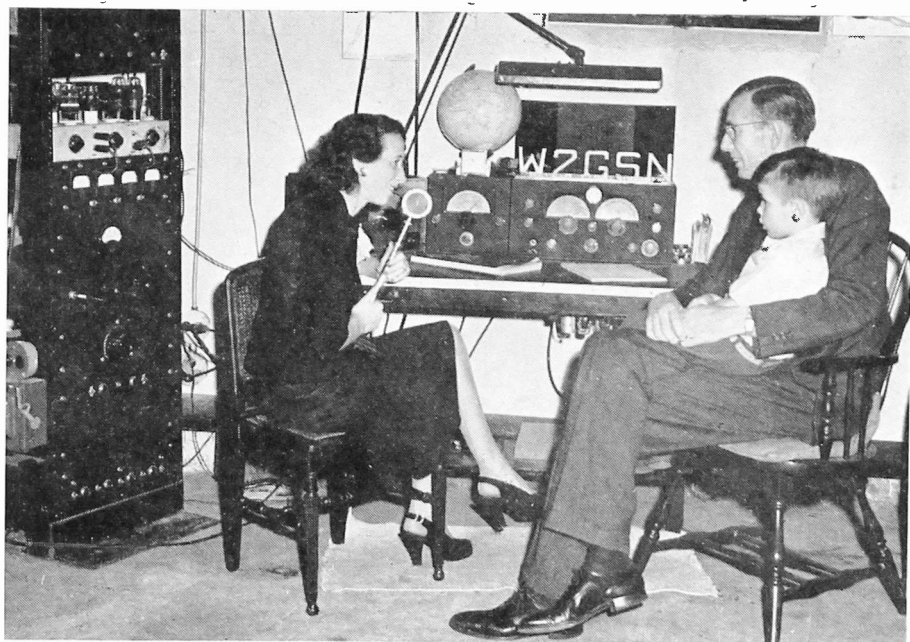

Bob Palmer, key engineer in the development of the 3D24 transmitting tube is an avid amateur radio fan. His activities on the ten meter band over W2GSN paid off recently when he was able to contact Mrs. Palmer's parents in London. The process took about

a year before he was able to locate a British amateur who lived near enough to their residence to permit them to take part in the transatlantic call. Above is Mrs. Palmer, Mr. Palmer and four-year-old Bobby Palmer who has never seen his grandparents and spoke to them for the first time.

### SERVICEMEN, PUBLIC AIDED BY NRIAA

The National Radio Institute Alumni Association, established in 1929, is another organization which is vitally interested in a plan for placing the radio serviceman in a position above reproach. More efficient service at fair prices, contrasted to price gouging and customer cheating, is the aim of the organization.

The NRIAA has now grown to a membership of about 6,000 with chapters located in New York, Baltimore, Philadelphia, Camden, Detroit and Chicago. The Detroit Chapter (21 Henry St., Detroit, Mich.) holds meetings on the first and third Friday of each month at the Electronics Institute in Detroit. This chapter is looking for helpful suggestions which will aid them in bringing about more cooperative action in licensing, service charges and dealer discounts to legitimate servicemen. The group is making an effort to develop national interest in the program to promote similar cooperation throughout the country.

### ENGINEERS APPOINTED TO NEW RESEARCH POSTS AT SYLVANIA

Appointment of three scientists to important engineering posts was announced by Sylvania in January. Stuart L. Parsons was named chief engineer for the Tungsten and Chemical Division at Towanda, Pa. Dr. George C. Kuczynski and Dr. Igor N. Zaverine were appointed to the research staff of the Metallurgical Laboratory at Sylvania Center, Bayside, L. I., N. Y.

Parsons will direct divisional engineering, including research and equipment design for the production of tungsten salts and fluorescent powders for fluorescent lamps and cathode ray tubes. He joined Sylvania's Physical Research Department September 1, 1939 and

has specialized in design and development of spectrographic equipment; mechanical components for radar; microwave tubes and equipment; wire drawing machines; and special instruments for measuring the light output of fluorescent lamps and cathode ray tubes. Parsons received his B.S. degree in 1938 and a M.S. degree in 1939 from the University of Michigan.

Dr. Kuczynski will do basic research work in studies of the electron theory of metals at the Sylvania Center Laboratory. Prior to joining the company's Research Staff he was a special instructor in the application of quantum mechanics to the electron theory of metals at M. I. T. He has been associated with the Hilger interests in Great Britian where he worked on developments in spectrographic and similar types of metallurgical analyses. During 1943-44 he participated in a special research project at Washington State College where corrosion of magnesium alloys was being studied.

Dr. Kuczynski received a M.A. degree from the University of Cracow in 1936; a B.S. degree from the University of Wales in 1942 and a Ph.D. in science from M. I. T. in 1946. He was the 1945-46 recipient of the Baldwin-Southwark Fellowship Award for fundamental work on strain gage wires.

Dr. Zaverine is an expert in studies relating to the working properties of metals and alloys. He was professor of physical metallurgy at M. I. T. from 1930 to 1940 and received his Master's Degree in mechanical engineering and Ph.D. in metallurgy from M.I.T.

#### NEW PRICE SCHEDULE

Increased production and material costs necessitate the advance in price of service jackets and shop coats. Effective immediately, the price of the jackets will be \$3.10 and the coat price \$4.00.

SYLVANIA NEWS

Published By  
SYLVANIA ELECTRIC PRODUCTS INC.  
Manufacturers of Sylvania Radio Tubes and Electronic Devices, Sylvania Incandescent Lamp Bulbs, Fluorescent Lamps and Equipment

MARCH, 1947  
Vol. 14, No. 3

RETURN POSTAGE GUARANTEED

For:

Mr. T. Laranowicz  
81 Chestnut St.  
Shickshinny, Pa.

A

POSTMASTER: If Addressee has moved, notify sender on Form 3547, postage for which is guaranteed. When Form 3547 is sent abandon this mailing. Return only if no correct address is available.



Sec. 562, P. L. & R.  
U. S. POSTAGE  
PAID  
Emporium, Pa.  
Permit No. 1

Emporium, Pennsylvania  
P. O. Box 431

#### BOOK MATCH PRICE

Prices for book matches have been increased. Accordingly, we are compelled to increase prices on Sylvania book matches, effective immediately. The new price schedule on both regular and serviceman styles in any quantity will be \$3.85 per 1000 plus 40c per thousand Federal tax. Shipments of less than 10,000 books will be made F.O.B. shipping point. On shipments of 10,000 or more, F.O.B. destination.





# SYLVANIA NEWS

Copyright 1947, Sylvania Electric Products Inc.

APRIL, 1947

EMPORIUM, PENNA.

VOL. 14, NO. 4

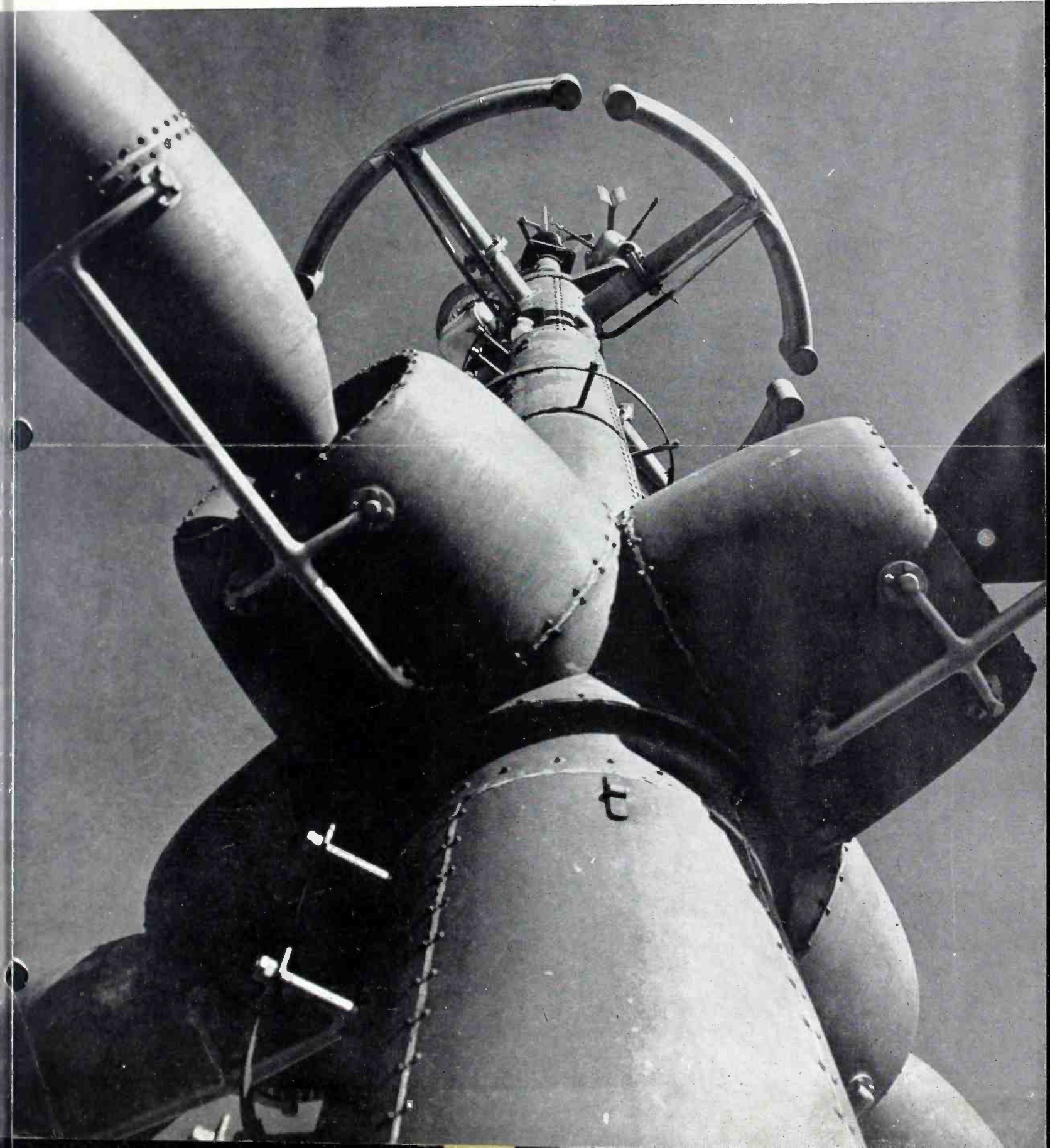



# SYLVANIA NEWS MERCHANDISING SECTION

Copyright 1947, Sylvania Electric Products Inc.

APRIL, 1947

EMPORIUM, PENNA.

VOL. 14, NO. 4

## EMPLOYEES VITAL TO SUCCESSFUL BUSINESS OPERATION

Yes, Sir, there are a lot of angles to this business of selling. It's a tough racket, even in times like these. The customers may come to you, but YOU have to do a little work before they will buy.

You can advertise to your heart's content, but if you don't do a good face to face selling job, you're lost. Personal sales contact is an art. You've got to be good to make it work.

### Personnel Important

No matter how large or how small a shop you have, your personnel has to be tops to bring you the results you want and need. Selecting good personnel for your shop is the most important thing you can do to stimulate your sales. Efficient organization will bring you maximum profits. With a good working organization, you will be ready to handle your business in a way that will bring you more profits.

Selection of your employees is not an easy matter. Not every man or woman will fit into your particular

situation, therefore it is essential that you use the utmost care in selecting your employees.

### Select Employees Wisely

In selecting an applicant for a position, first investigate his record to see what it reveals about him as an employee. If he passes this screening, consider his fitness for the particular job you have in mind. Be selective about your employees. No matter what the position, remember that he is your representative and as such casts a reflection on you in whatever he does.

Once you have selected an employee for a specific job, give him all the freedom possible. You can, perhaps do his job better, but he must learn, and the easiest way is to let him make mistakes. Constant interruption from you when he is making a sale or performing a job, will only discourage him.

### Praise Frequently

When an employee has done a good job, see that he is properly praised. Public praise is the best,

but should not be overdone. If it is necessary to reprimand an employee, do it in private. There is nothing so brutal as to criticize in public.

Criticism should be given in such a way that the employee will not feel resentment. Before you deliver a criticism, say something nice to him. "Jim, you've really done a swell job here. We think it is grand, but I happened to notice the other day . . ." This type of criticism will strike a more receptive chord and the employee, will feel less ill-will.

### Employee Part of Business

One of the best ways to get along with your employees is to let them feel a part of your business. They are a vital part of your organization and should be treated as such.

Your personnel, no matter who he is or what his job, is as important to you as the business which keeps your shop running. If you lose business, your employees are affected; if you lose employees regularly, your business is affected.

## PERSONAL LETTERS STIMULATE SERVICE BUSINESS

Mike Waxman of Los Angeles, Calif. is an energetic fellow who likes to keep his name before his customers. It pays off too, because Mike has a busy life. When Mike gets a new customer, he lets them know how much he appreciates their work by writing a personal letter to thank them for their business.

That is a good way to keep friends but Mike doesn't stop here. About three months after he has gone over a set and put it into tip-top condition, Mike writes another letter to let them know that he is still around, and that they might let

their friends know what kind of work he does.

The same process is repeated at regular intervals because, as all good servicemen know, you have to remind people that radios need attention. This can be over-done we will admit, but good planning will make it effective.

Mike thinks of his friends too. If a customer sends him some business, Mike lets them know how much he appreciates it with a short note. This type of thing takes time, of course, but if it has a return in \$\$ then it must be of value.

Here are some examples of the letters Mike sends to his customers.

### For New Customers

Dear Sir:

I am taking the liberty of writing you, because I have been established in the radio business in this district since 1925.

As you know in this day and age, businesses come and go. If they don't give satisfaction to their customers, they cannot last long and naturally they have to close up. Giving customer satisfaction is the

(Continued on page M-15)

## SYLVANIA POLYMER IN PLASTIC CASE

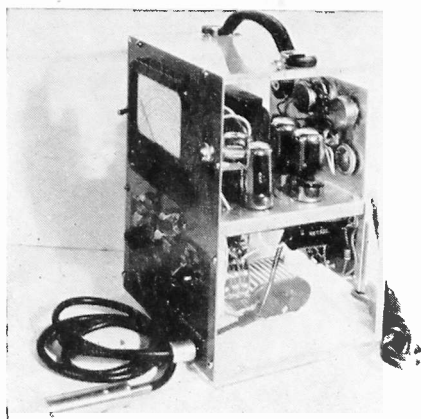

You can now see what makes the Sylvania Polymer tick. Sylvania's salesmen and distributors have been supplied with polymeters in a plastic case. The case gives you a maximum advantage in looking over the works with a clear view at the interior. See the Plastic Case Polymer at your Sylvania distributor or ask your distributor salesmen to show it to you.

## SERVICEMEN PLAN STATE MEETING

The Federation of Radio Servicemen's Association of Pennsylvania are projecting plans for a statewide meeting. This type of meeting is one of the first that has ever been sponsored by servicemen themselves.

These men are interested in any suggestions from individuals or groups on such a meeting. Correspondence concerning the meeting should be directed to A. R. Guild, Secretary, 410 Campbell Street, Williamsport 11, Pa.

## WANTA' BE IN PRINT?

Are you proud of your shop? We hope you are. And what's more, we would like to let others know about it. Our SHOP O' THE MONTH column is for you. Let us have some pictures and some details and we will be happy to publish them in future issues of the SYLVANIA NEWS. Send your stories to the Editor, SYLVANIA NEWS, 500 Fifth Avenue, New York, N. Y.

## NEW PROMOTION ITEMS FOR SHOP AND WINDOW

Sylvania has announced a new promotion item which can serve a great many purposes. The Sylvania Electric Clock is now available for shop window or store service.

Built by Telechron, one of the country's finest manufacturers of electric clocks, it will stand out in any location. The 15" face has large, well defined figures which stand out on the white background. The lettering is in black and green with the red second hand pointing to the message as it rotates. The clock is well lighted with two 15-watt lamps. It is designed to use a minimum of current.

The New Sylvania Electric Clock is available for delivery immediately. The price is \$8.50, including federal tax and shipping charges.



The Sylvania Electric Flasher Sign display is another attention-getter which will catch the eye of people on the street. This display is an inexpensive item which will help put your shop in the public eye.

Attractively styled in dark blue cardboard, the seven color lettering and attractive Miss give color and life to your store window. The sign is equipped with an electric flasher which plugs into an ordinary 110-120 volt current.

Your distributor can take your order now for immediate delivery. The price is \$2.00 (bulb not included).



## SYLVANIA GIRL FEATURED ON APRIL RADIO NEWS COVER

Patricia A. Greene, an inspector in the Test Instrument Assembly Department of Sylvania's Williamsport plant, appears in full color on the cover of this month's RADIO NEWS Magazine. The black and white version of the cover photograph shown here illustrates Miss Greene's unusual photogenic qualities. She is making a final check on one of Sylvania's newest products for radio servicemen, an improved tube tester. In the background are other Sylvania testing instruments, three inch oscilloscopes and polymeters.





# SYLVANIA NEWS TECHNICAL SECTION

Copyright 1947, Sylvania Electric Products Inc.

A. V. BALDWIN, Technical Editor

These data have been compiled from information which we believe to be accurate. No responsibility can be assumed in the application thereof or for patent infringement.

APRIL, 1947

EMPORIUM, PENNA.

VOL. 14, NO. 4

## NEW SYLVANIA TRANSMITTER TUBE TYPE 3D24 HAS 140 WATTS OUTPUT



Sylvania Type 3D24 is a newly announced beam power tetrode for use as a medium power oscillator or amplifier. The illustration shows the actual size of the new tube. In order to get such an efficient and compact tube several new and interesting features have been combined to give characteristics suitable for use in police, fire department, forestry, marine and aircraft applications.

The anode material is "electronic" graphite which may be run red hot without causing frequency shift due to dimensional changes. Safe dissipation is approximately four times that permissible for a metal anode of the same dimensions. The high frequency performance is obtained by use of a number of features including:

- (a) Short direct leads to the lock-in base.
- (b) Special shield to provide low grid-plate capacitance.
- (c) Two grid terminals on opposite sides of the base.

- (d) Small bulb size permitting a very short plate lead.
- (e) Use of Zirconium getter prevents loss of radiation area due to formation of a mirror.

The high power rating is obtained in this small bulb by the following additional features.

- (a) Top cap threaded to plate lead to get larger heat conducting area.
- (b) Heat radiation shield to keep base cooler.
- (c) Use of a top cap with heat radiating fins.
- (d) Use of a hard glass bulb.
- (e) An efficient carburized Thoriated Tungsten filament.

Technical data is provided on an inside page of this issue of the News for inclusion in your Technical Manual. The plate characteristic curve is available on request but is not shown here because it requires more room than we can spare in the News.

## HANDY OHMMETER PROBE

The illustration shows a new handy gadget which you can carry in your pocket. It is built in a plastic case  $5\frac{1}{2}$  inches long. The meter movement is quite sensitive for such a small meter being 667 ohms per volt or full scale deflection on  $1\frac{1}{2}$  milliamperes. It is operated by one of the small "penlite" batteries.

Servicemen will find this to be a useful continuity meter and medium range ohmmeter, for indication of resistances from 500 to 10,000 ohms.

The battery is removable for replacement by pressing on the plastic case at right angles to the studs just back of the probe point.

This unit is available only from your Sylvania dealer and its price is \$7.50.

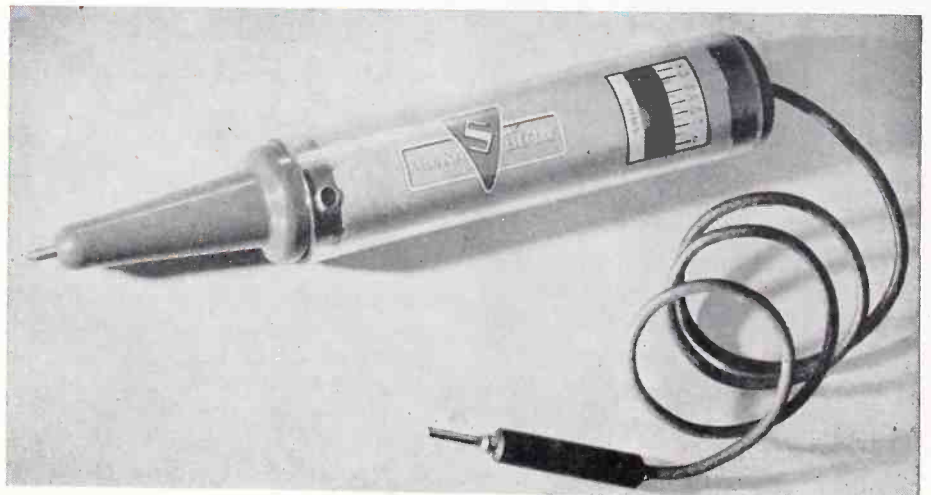



## PHOTOCELL RELAY CONTROL

Sylvania engineers sometimes dream up interesting uses for tubes and here is one that A. J. Schultz of our Commercial Engineering Department worked out for use as a foul line indicator for the local bowling alley. Of course it may be adapted for other purposes or the principles explained may help you in repairing the many types of phototube burglar alarms, door openers and safety devices that might come to you for servicing.

In order to make a simple low-cost device and since more than 90 volts is not recommended for use on the type 918 phototube the power supply may be obtained from a simple half-wave rectifier circuit using either a type 117Z3 or the NC-5 Selenium rectifier. A small filament transformer supplies voltage for the light source and the 2A4G filament.

The time constants determined by the resistances and capacitances used in the grid and photocell circuit are important for the bowling application but may not matter so much for other uses. The .015 mfd. condenser C1 and the 4.7 meg resistor R5 give just enough delay to allow the bowling ball to break the light beam without tripping the relay but a player's foot placed on the foul line momentarily will be detected. One tenth of a second is the approximate delay. Both C1 and C4 should have low leakage.

### Operation

In order to make manual resetting unnecessary the 4 mfd. condenser C4 connected to the relay was added. When this has been charged through the 4.7 meg resistor R5 to a high enough potential the type 2A4G grid regains control and the relay will fall back to normal again. The 1 meg resistor R8 is to discharge C4 so that it will be ready for the next indication.

### Light Source

The light source used should be small and carefully focused on the phototube. A reflector assembly from a small flashlight, the common size about 1½ inches diameter, was used with a panel lamp.

It is quite necessary that good alignment be obtained since the total light available is quite small.

The indicator light may be a 25 or 40 watt lamp in a box with a glass front painted "FOUL" in large red letters and located in a prominent place.

### Adjustments

The values of resistance specified should be followed closely but condensers C1 and C4 may be selected to meet your own requirements as explained below. The variations most likely to be encountered by other experimenters are due to the varying strength of the light source, efficiency of the reflector, sensitivity of the phototube, alignment, and leakages in the phototube and grid circuits. Condenser C1 may be any value which gives delay adequate for the purpose intended and the suggested value is about right to allow a ball to cross the light path without tripping the relay with the light source used here. Larger values will give a longer delay period. The value of C4 is selected to hold the indicator lamp on for the required time, about 6 to 10 seconds in this application. Changes in any resistor value will affect both of the circuits making it difficult to get both time delays at the desired values.

### Precautions

Since this circuit is similar to many AC-DC sets the polarity of the line should be watched so that any exposed metal chassis parts are at ground potential. The ground side of the line is indicated but does not mean that the chassis should be grounded elsewhere as a short could occur. The relay listed was selected because the operating coil current is within the current rating of the thyatron tube used but any other make of relay having a similar rating could be used and for other purposes single contact relays or no relay at all may do. This circuit could be used with other thyatrons such as 884, 885, or 2050 with slight changes in the condensers to get the desired time delay characteristics. The same fundamental circuit could be used also for ultra-violet or infra-red sources with the proper phototube but we have no similar data on the light sources required for such purposes.

BOWLING ALLEY FOUL INDICATOR

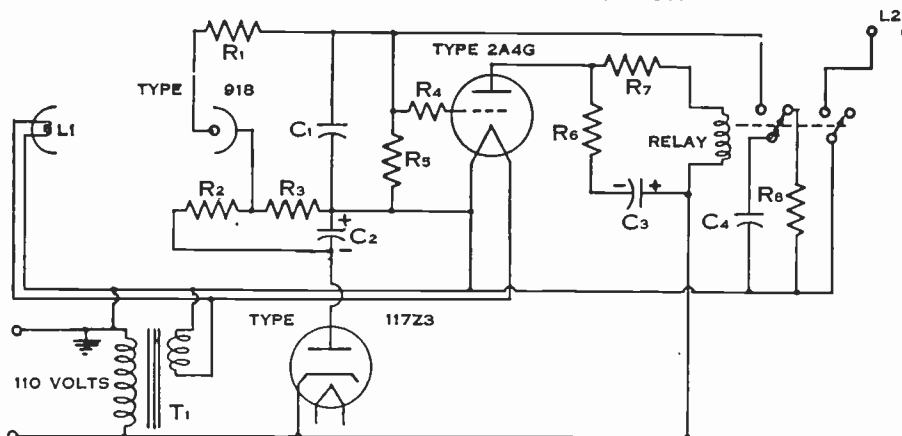

### PARTS LIST

Resistors	
R1—2.2 megohm	
R2—33,000 ohms	1 watt
R3—44,000 ohms	1 watt
R4—1.0 megohm	
R5—4.7 megohm	
R6—150 ohm	1 watt
R7—2500 ohm	10 watt
R8—1.0 megohm	

Condensers	
C1—.015 mfd.	400 volt bypass. See article.
C2—8.0 mfd.	150 volt electrolytic
C3—16.0 mfd.	150 volt electrolytic
C4—4 mfd.	paper or Dykanol. See article.

### Miscellaneous Parts

L1—Flashlight bulb in reflector
L2—Red signal lamp
T1—Filament transformer
Relay—Potter Brumfield MRA-4 or equivalent

## New Roller Chart For Sylvania Tube Checkers

The Sylvania policy of providing up-to-date information for owners of Sylvania test equipment is well exemplified this month by our making available a new roller chart for the Type 139 and 140 Tube Checkers.

This first new chart will be supplied free to all owners of these Sylvania tube checkers on request

to the Advertising Dept. at Emporium. Just send a post card or letter and state the serial number of your checker.

No assurance is given that later revisions will also be free as it is quite probable that a nominal charge to cover actual cost will be necessary.

(Continued on page T-15)

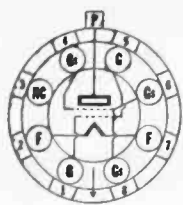

**Sylvania Type 3D24**  
VHF TRANSMITTING TETRODE

**PHYSICAL SPECIFICATIONS:**

Base.....	Lock-In 8 Pin
Bulb.....	T-12
Top Cap.....	1/4" Diameter + Radiator
Maximum Overall Length.....	4.3"
Maximum Seated Height.....	3.8"
Mounting Position.....	Vertical

**TENTATIVE RATINGS AND CHARACTERISTICS**

Filament Voltage.....	6.3 Volts
Filament Current.....	3.0 Ampere
Maximum Plate Voltage DC.....	2000 Volts
Maximum Screen Voltage.....	400 Volts
Maximum Control Grid Voltage.....	350 Volts
Maximum Plate Current DC.....	100 Ma.
Maximum Screen Current.....	25 Ma.
Maximum Control Grid Current DC.....	20 Ma.
Maximum Plate Dissipation.....	45 Watts
Maximum Screen Dissipation.....	10 Watts
Maximum Plate Input.....	180 Watts
<b>Direct Interelectrode Capacitances:*</b>	
Grid to Plate.....	0.20 $\mu$ f. Max.
Input.....	6.5 $\mu$ f.
Output.....	2.4 $\mu$ f.

\*Unshielded, but with base shell and unconnected pin grounded.

**TYPICAL OPERATING CONDITIONS AND CHARACTERISTICS**

**RF POWER AMPLIFIER AND OSCILLATOR—CLASS C TELEGRAPHY**

	cca	cca
Filament Voltage.....	6.3	6.3 Volts
Filament Current.....	3.0	3.0 Ampere
Plate Voltage DC.....	1500	2000 Volts
Screen Grid Voltage.....	375	375 Volts
Control Grid Voltage.....	-300	-300 Volts
Plate Current DC.....	90	90 Ma.
Screen Grid Current DC.....	22	20 Ma.
Control Grid Current DC.....	10	10 Ma.
Peak RF Input Signal (Approx.).....	400	400 Volts
Total Grid Driving Power**.....	4.0	4.0 Watts
Power Output.....	105	140 Watts
Amplification Factor.....	50	50

\*\*With a grid resistor of 30,000 ohms, the grid requires 1 watt driving power and there is a loss of 3.0 watts in the grid resistor.

**CIRCUIT APPLICATION**

Sylvania Type 3D24 is a high-efficiency, air cooled tetrode designed for use in small compact transmitters where space and weight saving are important. The use of a short T12 bulb on a Lock-In header gives short leads and improved high-frequency performance.

In order to get such a high rating in this small size, great care has been used in the choice of materials. The plate is graphite with a coating of zirconium to make a getter deposit on the bulb unnecessary. A special top cap which includes an external radiator connected directly to the plate is used. The emitter is thoriated tungsten requiring good regulation of the supply voltage. High frequency performance is obtained by the use of vertical bar type grids, the Lock-In construction and high-conductivity Kovar leads. Full ratings may be used up to 125 mc.

There are a few precautions to be observed in designing equipment to use the Sylvania Type 3D24; a ceramic socket is essential as the high operating temperature will soften the usual socket materials. Do not try to solder to the tube pins or remove the top cap.

When adjusting equipment, it is suggested that the plate voltage be reduced as the high output is based on use in carefully adjusted circuits. An improperly adjusted circuit would increase the plate dissipation greatly and soon cause damage to the tube.

**SYLVANIA RADIO TUBES**

We have printed the above data in the size and style required for insertion in your new Sylvania Technical Manual. We suggest that these two data sheets be pasted on the blank pages at the back of the manual.

Type 1273 should interest those who have public address equipment as the selection of a quiet input tube is sometimes quite a problem.

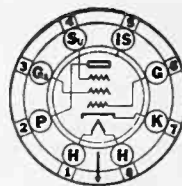

**Sylvania Type 1273**  
NON-MICROPHONIC PENTODE  
AMPLIFIER  
SIMILAR TO TYPE 7C7

8V-L-5

**PHYSICAL SPECIFICATIONS:**

Base.....	Lock-In 8 Pin
Bulb.....	T-9
Maximum Overall Length.....	2 1/8"
Maximum Seated Height.....	2 1/4"
Mounting Position.....	Any

**RATINGS AND CHARACTERISTICS**

Heater Voltage (Nominal) AC or DC.....	7.0 Volts
Heater Current (Nominal).....	0.320 Ampere
Maximum Plate Voltage.....	300 Volts
Maximum Screen Voltage.....	100 Volts
Maximum Screen Supply Voltage.....	300 Volts
Maximum Plate Dissipation.....	1.0 Watt
Maximum Screen Dissipation.....	0.1 Watt
Minimum External Grid Bias.....	0 Volt
Maximum Heater-Cathode Voltage.....	90 Volts
<b>Direct Interelectrode Capacitances:*</b>	
Grid to Plate.....	.007 $\mu$ f. Max.
Input.....	6.0 $\mu$ f.
Output.....	6.5 $\mu$ f.

\*With 1 1/4" diameter shield (RMA Std. M8-308) connected to cathode.

**TYPICAL OPERATING CONDITIONS AND CHARACTERISTICS**  
**CLASS A<sub>1</sub> AMPLIFIER**

Heater Voltage (AC or DC).....	6.3	6.3 Volts
Heater Current.....	0.300	0.300 Ampere
Plate Voltage.....	100	250 Volts
Screen Voltage.....	100	100 Volts
Control Grid Voltage.....	-1.0	-3.0 Volts
Self Bias Resistor.....	130	100 Ohms
Suppressor Grid and Pin No. 5.....	Connected to Cathode	
Plate Current.....	5.7	2.2 Ma.
Screen Current.....	1.8	0.7 Ma.
Plate Resistance (Approx.).....	.400	1.0 Megohm
Mutual Conductance.....	2275	1575 $\mu$ mhos
Grid Bias for Approx. Cathode Current Cut-Off.....	-7	-7 Volts

**CIRCUIT APPLICATION**

Sylvania Type 1273 is a triple grid amplifier designed specially for use in the first stages of high gain amplifiers where low microphonism and absence of tube noise is essential. The electrical characteristics are identical with those of Sylvania Type 14C7 except for the heater rating. Reference should be made to the Sylvania Type 14C7 data sheet for curves and to the Type 7C7 data sheet for resistance coupled amplifier data.

(Continued from page T-14)

The instructions for installing the new chart are printed at one end as a simple ten step procedure that will take the average serviceman 20 to 30 minutes altogether.

In order to provide this service for Sylvania tube checker owners it has been necessary for us to build up what we call a "tube library." In it we have a few tubes of each type it is possible to obtain—not just Sylvania types but many other manufacturers too. The settings are determined by actual comparison of these tubes in the tester and in our laboratory equipment.

The new chart is quite an improvement over the original, not only in the increased number of types included but because we were able to get these printed in one piece which, if carefully installed, will operate more smoothly than the original.

This information presented in the Sylvania Service Exchange is contributed by servicemen as the result of practical experience. It is very carefully considered before being accepted, and we believe it to be correct and authentic. However, we assume no responsibility for results. Please do not send routine or generally known information. Each hint accepted entitles the writer to his choice of one Sylvania receiving tube. Please specify tube choice when submitting hints.

THE

# Service Exchange

**Crosley Model 56TJO:** If the customer complains of weak or no reception check the avc voltage. If it is found abnormally high, and pin No. 2 on the 35W4 rectifier socket is used as an avc tie point, remove the leads from this terminal and use a separate tie point to anchor them. Electronic leakage to unconnected pins within the 35W4 has been found to develop sufficient voltage in the avc circuit to severely limit the sensitivity of the receiver.—Robert T. Nagler, Prairie Du Sac, Wisconsin.

\* \* \*

**Hum in Philco 37-641.** While repairing a Philco Model 37-641, I encountered an unusual amount of tunable hum and distortion which was caused by the grid lead of the second I. F. 6Q7. Simply by dressing the lead away from the 6K7 R. F. the trouble disappeared entirely. Hope this experience will be of some use to other service men.—S. Fuchs, New York City.

\* \* \*

**Substitute Majestic and Stewart-Warner Ballasts:** Excellent emergency or even permanent replacements can easily be made by screwing a cone shaped heater element into the two pin base of an Edison standard socket (screw) adapter and plugging the assembly into the ballast socket. The 660 watt type coil strikes a very good average for all of the following set models:

Majestic.....70, 71, 7P6, 1928  
Majestic.....180, 181, 8P6  
Majestic.....90, 91, 92, 100  
Stewart-Warner.....900-61816  
Stewart-Warner.....950-62152  
Stewart-Warner.....R100-66756

If power transformer primary voltage is materially below the specified 80 to 90 volts when using the above specified heater element, remove nichrome wire from the coil a little at a time until the desired voltage is obtained. Naturally the element will get hot. So will the original ballast.—J. E. Milton Snyder, Columbus, Indiana.

**Hum on Zenith Portables:** In a number of models it will be noted that certain leads are shielded (with a coiled spring type of shield) and that this shield is insulated from the chassis by means of a spaghetti sleeve. The shield is connected to the filament circuit and not to chassis. It was discovered that a high resistance leakage had developed between the shielding and chassis, through the insulating sleeve. Upon removal of several of these sleeves it was found that resistance readings of various values could be obtained through numerous parts of this supposed insulating material. Replacing with new spaghetti tubing cleared up the hum.—Harold Fread, Irvington, N. J.

\* \* \*

**Substitute for Type 25AC5GT.** Many sets use a Type 25AC5GT as a final audio with a Type 6AC5 first audio. The cathode of the Type 6AC5 is connected to the Type 25AC5 control grid. A number of Emerson Sets employ this system, the rather acute shortage of the Type 25AC5 has proven a problem. I have successfully circumvented this by substituting a Type 25L6GT, tying screen grid and control grid together and grounding to chassis direct. The bias is sufficient to bring the set to a remarkably well operating point. Realignment is necessary for a complete job.

Number 4 pin of the Octal Socket in the Model C5-320 is used as a connecting lug for voltage distribution to the second I. F. Remove the connections when replacement is made with the Type 25L6.—Edward Nareski, Wilkes-Barre, Pa.

\* \* \*

**Pontiac Auto Radio Model 983679:** Intermittent reception may be caused by an open .05 paper condenser inside the antenna coil shield. This is rather hard to find as all voltages check OK and you can hardly see this condenser due to leads covering it at the bottom of the coil. When this condenser opens up the radio will play weak at the high end of the dial.—Henry J. Hudnall, Putney, West Virginia.

**Repairing the Remote Control Switch on Stromberg-Carlson Models 65 and 66—**On these models and others having the dial and controls in a small armchair box, but connected to the main part of the set by a long flexible cable, trouble is often encountered with the "on" and "off" switch. This small switch in the control box is just a low voltage unit which operates a relay which is located in the main set and carries the 110 volt contacts. With age this relay often sticks due to residual magnetism in the cores and armature of the relay. To restore to perfect operating condition carefully unsolder and unbolt one operating coil at a time and file the core so that there will be a  $\frac{1}{32}$  to  $\frac{1}{16}$  inch air gap between the core and the relay armature which will then rest against the insulating washer of the coil and will not stick to the core. File cores so that the air gap is parallel to the armature, as this does not change the length of the cores too much.—William Ford, Chicago 40, Illinois.

\* \* \*

**Neat Termination for Cable:** At a point about one inch from the end of the shielded wire, double it back sharply. At the "knee" of the bend, take a sharp-point instrument and work a hole through the woven shield, being careful not to break any of the individual strands of the shield. After this hole in the shield (made by displacing the strands) is sufficiently large, insert a small screwdriver between the exposed inner wire and the shield and pull the inner lead out through the hole. Flatten out the remaining piece of empty shielding, and for connection you will have the convenient equivalent of two wires. This method has the advantages of being neat, sturdy, and of eliminating the necessity of soldering a wire to the end of the shield for making this connection, which sometimes results in breaking down the insulation of the inner lead.—Max McKahan, Buchanan, Michigan.



# — SHOP O' THE MONTH —

## SIGHT SELLS SERVICE

Barnes Brothers Radio and Electronics Service of Little Rock, Ark. take advantage of their new location to publicize their business. The shop is located in downtown Little Rock, just opposite a large theater. At night the store is well lighted so the people waiting in line have a good view of the salesroom and shop. The shop is separated from the salesroom by a soundproof window so it is always in view, but has the advantages of another room.

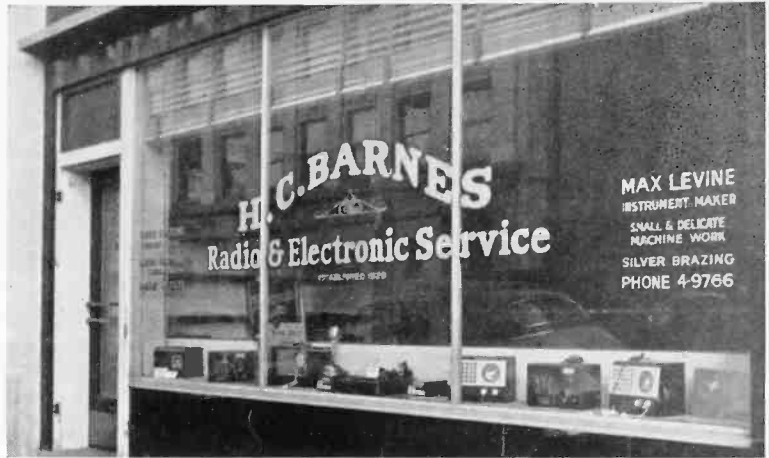

Most of the panel equipment has been designed and built in the Barnes Bros. own shop. At present the plan is to change the work bench over to a 19" panel in order to gain all the advantages of such standardization.

Though Barnes Brothers have lost drive-in facilities for eight cars since they moved to their new location, they are still doing a booming business. Their service calls for sound and radio take them all over the state.

### PERSONAL LETTERS

(Continued from page M-13)

reason why I am still doing business in this district.

A business to succeed in its particular line, must have the necessary equipment and data to service any kind of job in the quickest possible time, that means we charge less for our time.

No matter how old or how new your radio is, we have the latest testing equipment, diagrams and quality parts to quickly and efficiently service and guarantee our workmanship and parts.

Even as you brush your teeth every day; see your doctor every year; change oil every 1000 miles; so too, your RADIO needs attention and care. It's a good habit and good insurance to have your radio inspected every six months. Our expert, economical service will keep

your radio performing like new.

We recommend Sylvania Set Tested Radio Tubes.

Phone us today ARdmore 8-2232.

Cordially yours,

Mike's Radio Service,  
Michael Waxman.

One Year After Repair

Dear Sir:

Time certainly flies, for it has been over a year since we have had the pleasure of serving you in the repair of your radio receiver. Although your radio may appear to be working correctly, there are many parts which deteriorate with age, such as tubes, filter condensers and speaker cones.

We have found from our experience that a check-over once a year will often find some defect which a minor repair will remedy, eliminating a costly repair at a later date.

You know that if you have a cavity in a tooth, your dentist can fill it and save the tooth, but if you let this cavity grow, you may finally lose the tooth. You know that a periodical check-up of the performance of your car often eliminates large repair bills later on.

The same applies to your radio receiver and, after all, your radio receiver gives you more for your money than any other commodity you can buy today.

Let us give your radio a check-up now—our charge is, as you know, most reasonable for the high quality of our workmanship.

We recommend Sylvania Set Tested Tubes.

Phone us today.

Cordially yours,

Mike's Radio Service,  
Michael Waxman.



## SUCCESS OF FM CHALLENGE TO RADIO SERVICEMAN

FM radio is rapidly becoming a reality. With 191 FM stations now operating in the U. S. and 500 construction permits granted by the FCC, listening audiences in every major community will soon have an opportunity to enjoy the benefits which this type of broadcasting allows.

Along with FM, however, comes many problems for servicemen and radio retail salesmen. Set installation and service must be top-notch if the customer is to gain the full benefits from FM. AM radio will give some kind of results under most any conditions. FM, on the other hand, gives performance which is either all or nothing.

Ultra-high frequency used in FM, television and facsimile broadcasting is of a different characteristic than the low frequency AM. The use of a higher frequency band in short wave FM broadcasting necessitates a change in circuit design and new forms of transmitter and receiver designs.

Antenna requirements are of the utmost importance if the fullest satisfaction is to be gained from FM. In many cases the built in FM antenna may do a satisfactory job, but generally, the use of an additional dipole antenna will increase the efficiency of the receiver by a great deal. Perfect reception cannot be guaranteed unless a good antenna is available.

The type of receiver is another important factor in the success of good reception in FM. Different makes vary widely in performance. Quality of sets vary from excellent to poor. The price is not necessarily

a criterion of FM results.

Salesmen who attempt to sell FM should be thoroughly familiar with its intricacies. Lack of proper information, or misinformation will go a long way in discouraging the public about the greater advantages of FM.

When a customer buys an FM receiver, he will expect: freedom from static and background noise; freedom from fading; freedom from squeals and interstation cross talk; signals of constant strength day and night; life-like natural tone quality. If the dealer can satisfy these things in an FM customer, the price of the set or the installation of an adequate antenna will be minor considerations.

### INTERFERENCE IS PROBLEM IN FM

FM is presently bucking another of its many problems. Reports from Syracuse, N. Y. have indicated that interference is being encountered causing the constant retuning of home receivers.

The trouble arises from stations WSYR and WFBL being separated by only one channel. In this case receivers have drifted from one station to another causing reception to be jumbled. When this occurs, retuning of sets is required, but it is found that many receivers are not satisfactory in adjustment.

Probably the biggest headache which comes out of this problem is for set manufacturers. With increased production and promotion of FM under way, the manufacturers may be faced with extensive change in design and loss of public sympathy toward this improved type of broadcasting.

The problem has been squarely faced by Major Edwin H. Armstrong, inventor of frequency modulation, who has indicated that the problem can be solved by simply separating stations by two channels instead of the present one. If this is the answer, then FM will not really suffer too great a blow. If on the other hand, the answer lies in a complete revamping of the frequency system, as hinted by the FCC, the problem will be more acute.

## RMA LAUNCHES RADIO PROMOTION PROGRAM

Formal launching of the \$50,000 radio set promotion campaign of the Radio Manufacturers Association took place on March 25. This campaign, labeled "A Radio in Every Room—A Radio for Every Purpose," is designed to stimulate radio set sales by suggesting benefits and values that can be obtained by the individual family members through ownership of his or her own radio.

The campaign will push the basic market of the console as a "family radio" and the other models as suitable for the individual members both in the home and outside the home. Obsolescence of pre-war radios will be stressed along with minimizing the problem of trade-ins.

All promotional activities in the campaign will be keyed toward the family and to the interest of individual members of the family. The American family will be dramatized with its need for enjoyment of a family radio, and console radio phonograph combinations will be promoted to serve the purpose.

Extensive publicity will appear in newspapers, magazines, trade papers and on radio broadcasts. To benefit the distributors and retail dealers, special promotion material will be prepared for their use. Other retail trade associations will be contacted to participate in the campaign.

Servicemen will be a vital part of this program, as it will eventually be of value to them. Dealers will benefit and each member of their organization should be keyed to the program.

### ON THE COVER

No, it's not from Buck Rogers! This futuristic looking bit of equipment is the football type television antenna of station WNBT in New York. Until a short time ago it stood atop the Empire State Building. This antenna was 35 feet high and was designed to send out sound and sight transmissions. It has been replaced by a new 61 foot antenna which sends out sight, sound and FM signals.

### TUBE COMPLEMENT BOOK DISCONTINUED

In view of the rapidly changing technical picture in radio, the well-known Sylvania Tube Complement Book will be discontinued. New service organizations in the radio industry are preparing such data on a commercial basis so it is no longer practical to continue publication.

# TELEVISION DEVELOPMENTS

## PHILCO ANNOUNCES VIDEO RECEIVER

Philco Corporation has announced that it will introduce a complete line of direct view and projection television receivers in the near future. The receivers which are now in production will incorporate the latest research and engineering developments of the Philco Laboratories.

John Ballantyne, president of Philco announced that one of the most important achievements in the research and engineering developments was the design of a new projection-type receiver providing a 15 by 20 inch picture with four times the brilliance and far greater contrast than any other projection television receiver. The picture can be viewed in daylight or with normal room lighting.

## FCC REJECTS CBS BID FOR COLOR TELEVISION

Color television is destined to remain in the experimental stage for another few years. The FCC has denied the petition of CBS for their color television on the ground that it is still in the experimental stage and that "many of the fundamentals of a color television system have not been adequately field tested."

One of the main points of the fourteen page FCC report is the fact that the frequencies available for color television do not allow room for more than one system. "In television the receiver and transmitter are effective components of one integrated system, or, expressed in another manner, the receiver and transmitter are related to each other as a lock and key.

"Before approving proposed standards, the Commission must be

satisfied not only that the system proposed will work, but also that the system is as good as can be expected within any reasonable time in the foreseeable future."

It was pointed out that the objective of television is to bring news, education, culture, and entertainment to the public and such objectives can not be carried out unless television receivers can be manufactured and sold at a price which the general public can afford.

If television is to be put on a truly nation-wide competitive basis, 27 channels (those allowed under CBS's proposed sequential system) would not ultimately be enough to provide for such competition.

Television has been just around the corner for twenty years, but with only 10,000 receivers (all black and white) in use today, it looks as though the general public will have to wait a few more years until they can find in television the satisfaction of radio.

## RADIO FAN MUSTERS AID FOR SNOW-BOUND COMMUNITY

When it snows in Upstate New York, you can expect to do a lot of shoveling. Snow also causes some people trouble too, just as it did Stanley Conklin of Cobleskill, a town of 2300 population located about 40 miles west of Albany.

Telephone lines went down and power was shut off. Contact with the outside world was nil until Mr. Conklin put his amateur station, W2DBX, on the air and contacted the Army Signal Corps station at Fort Monmouth, N. J. to ask for help in restoring phone lines.

The N. Y. papers made quite a play of the incident, but Mr. Conklin modestly declares that conditions were not as critical as reported and he was glad that he could be of some help in restoring service to his community.

Conklin has been operating his station since 1929 and says that he used about 75 watts input current to feed a pair of Sylvania 10's in

push pull circuit amplifier of his transmitter during this operation.



Stanley Conklin, W2DBX, seated at his transmitter making contact with outside world after Cobleskill, N. Y. was snowed in. Photographer Harold Toles used Wabash-Sylvania flash bulbs when taking this picture.

## VIDEO RECEIVER OUTPUT SPURRED

Rejection of CBS proposal for color television has been a signal for increased production of black and white television receivers. RCA has announced that it will soon introduce its first post war console television set and has completed extensive production changes designed to increase the output of all types of television receivers.

Capacity for television receivers has been estimated at 250,000 units of which RCA should be able to produce 160,000. The long delay in Commission hearings has set back production for the first quarter. However, it is reasonable to expect that 100,000 sets should be produced before the close of 1947.

So far no producer has attempted to make a receiver retailing for less than \$250. Industry leaders have agreed that this cannot be accomplished until a larger market is available.

# DALE DISTRIBUTING SALESMEN HEAR TEST EQUIPMENT TALK



Sales features of Sylvania test equipment was discussed at a recent sales meeting of Dale Distributing Co. in New York. Sylvania presentation was managed by Sam McDonald, distributor tube salesman for the metropolitan New York area. Above, standing left to right: R. M. Jacobs, Vice President, Dale Distributing Co.; R. W. Andrews; S. J. McDonald, Sylvania Distributor Tube Sales; W. Pringle, Manager, N. J. Branch, Dale Distributing Co.; R. A. Penfield and R. E. Lamar, Advertising Department, Sylvania. Seated, left to right: L. Vogel; N. Savage; S. Gordon; W. Haberman; P. Smith; G. Brandwin; A. Land; H. Appelbaum; C. Fox; M. Saper; C. Joseph.

# FACTS AND FIGURES...

## Radio Ownership Report

Data released by the Sales Research Department of Sylvania shows that there were approximately 61 million radio sets in use in the United States at the beginning of 1947. Radios are owned by 34.8 million families or about 91% of the families in the U. S.

## 1946 Production Report

Radio set production in the U. S. was set at 15,034, 417 sets of all types in 1946. Greatest production was in table models with 9,344,760 sets produced.

Television sets manufactured in 1946 numbered 5,367.

## February Production

February production of radio sets was reported by RMA to be 1,379,966. Included in this number is 6,243 television receivers—a number greater than the entire production in 1946.

## FM Swings Into Mass Production

FCC records indicate that 191 FM broadcasting stations are now in operation in the U. S. Construction permits have been granted for an additional 500 stations. Production of FM-AM sets of all types was reported by RMA at 52,594 for February.

## Radio Sales Increase Over Year Ago

Independent radio household appliance dealers showed a sales increase in January of 71% over January 1946. This figure is 29% below the December sales figure, however. Dollar sales of the 562 dealers reporting in this Bureau of Census report totaled \$7,211,745.

## Price Adjustment Predicted in 1947

Department of Commerce publication, Survey of Current Business for March concludes in a price study of 31 commodity groups that there is reason to expect a considerable adjustment in the price structure in 1947.

The analysis shows that many prices have increased by extraordinary amounts since June 1946; that prices of many groups of commodities have not increased or have increased only by small amounts; and in limited segments prices are considerably out of line with the general movement of all prices.

SYLVANIA NEWS

Published By  
**SYLVANIA ELECTRIC PRODUCTS INC.**  
Manufacturers of Sylvania Radio Tubes and Electronic Devices, Sylvania Incandescent Lamp Bulbs, Fluorescent Lamps and Equipment

Vol. 14, No. 4

APRIL, 1947

RETURN POSTAGE GUARANTEED

For:

Mr. T. Laranowicz  
81 Chestnut St.  
Shickshinny, Pa.

A

Sec. 562, P. L. & R  
U. S. POSTAGE  
PAID  
Emporium, Pa.  
Permit No. 1

POSTMASTER: If Addressee has moved, notify sender on Form 3547, postage for which is guaranteed. When Form 3547 is sent abandon this mailing. Return only if no correct address is available.



P. O. Box 431

Emporium, Pennsylvania





# SYLVANIA NEWS

Copyright 1947, Sylvania Electric Products Inc.

MAY, 1947

EMPORIUM, PENNA.

VOL. 14, NO. 5

## In This Issue:

### NEWS

CHICAGO PARTS SHOW  
ATTRACTS MANY IN  
RADIO INDUSTRY

### MERCHANDISING

CARTOON ADS TO PLUG  
RADIO SERVICE

### TECHNICAL

GEIGER-MULLER  
COUNTER HIGH  
VOLTAGE VOLTMETER





## COMMENTATOR *Sylvania* ... BALTIMORE

Sixteen years ago John E. Minor opened a radio service shop in a busy suburban shopping center of Baltimore. He was qualified to do a good job since he had studied radio and worked successfully for a time in a large radio store. The beginning was modest but business got under way quickly through a direct mail campaign.

Today the shop occupies two full store fronts at the same location. It is more than just a radio repair business. Mr. Minor has the agency for Scott Radios, a large record sales department and a first class repair shop equipped with the latest and best test equipment.

The glass enclosed service department is its own advertisement since its well organized appearance is in the full view of the customers in the shop. Three top-flight technicians spend full time turning out repair jobs which are first class.

Organizations like this are not built over night. It takes good hard work and lots of planning. Mr. Minor has done all of this. From his small beginning, he expanded slowly. Improvements came when funds were available, but service has always been kept at a high level.

Careful and exact reconditioning of sets has brought in plenty of business. All work carries a guarantee and is doubly checked before delivery. Customer satisfaction and word of mouth praise has been a great business builder.

The clean, efficient layout of both store and shop creates an atmosphere which invites customers to return with more work. Modest prices and high calibre work do their own selling and business still continues to grow.

Mr. Minor served in the Navy for three years during World War II. During his absence, the wheels continued to turn and the same quality of work was maintained. Although hampered by shortages, his customers remain understanding and loyal. This type of business is a credit to the servicing industry and speaks well for those who are with it. The best advertisement for a growing business that would be successful is a *satisfied customer*.

G. R. Wannan

## CHICAGO PARTS SHOW ATTRACTS MANY IN RADIO INDUSTRY



Sylvania sales and promotion executives discuss test equipment at the Stevens Hotel during the Chicago show. Left to right: R. W. Andrews, G. C. Isham, S. J. McDonald, J. T. Mallen, R. F. Henderson, H. H. Rainier, G. R. Wannan.

Sylvania's booth at the 1947 Radio Parts and Electronic Equipment Show held this week at the Hotel Stevens in Chicago is a busy place. About thirty-five members of the Sylvania sales and advertising staffs will be kept busy answering questions and demonstrating the equipment on display.

One of the unique features of Sylvania's booth is an exhibition of the R4330 flash tube demonstrating a stroboscopic application in stopping motion. A complete line

of Sylvania tubes and electronic equipment is on display in the booth.

Registration figures indicate that well over 8,000 radiomen from all parts of the country are in attendance at the show. More than 900 exhibitors are registered to display their products.

Principal speaker at the keynote dinner, held on May 12, is Benjamin Bills, Northwestern University Faculty Member, and authority on salesmanship.

## SYLVANIA SALES REACH NEW PEACETIME PEAK IN 1946

Sylvania attained a peacetime record volume of business in the year ending December 31, 1946, according to the company's annual report issued recently. Consolidated net sales were \$69,313,128 compared with \$125,750,512 in 1945 when approximately 86 per cent of sales represented war production. For 1941, last peacetime year, the company's sales were approximately \$20,000,000.

Consolidated net income for 1946 after all charges was \$2,384,017. The income statement reflects an estimated federal carryback tax credit of \$1,580,000. For 1945 the company reported net income of

\$2,136,279.

### Radio Sales 60% of Income

In summarizing the report Walter E. Poor, Chairman of the Board, states that lighting products including photoflash bulbs accounted for approximately 40 per cent of the 1946 sales, and about 60 per cent comes from radio and electronic products.

"In appraising 1946 results and the position of the company at the beginning of 1947," states Mr. Poor, "the management finds much that is encouraging. Results for the year show that Sylvania has attained a more important position in both the

(Continued on page G-20)

# SYLVANIA NEWS MERCHANDISING SECTION

Copyright 1947, Sylvania Electric Products Inc.

MAY, 1947

EMPORIUM, PENNA.

VOL. 14, NO. 5

## CARTOON ADS TO PLUG RADIO SERVICE

Part of Sylvania's hard-hitting national ad campaign will be in the form of cartoon ads. These ads, designed to command attention through their humor, will be seasonal and deal with current interests of the public. The ads will use sports in their subjective matter and will be head-lined with popular phrases of baseball and football.

The first of these ads pictured here will appear this month in the three top magazines of the country, LIFE, COLLIERS' and SATURDAY EVENING POST. LIFE will carry the ad on May 19 and COLLIERS' and the POST will carry it on May 31. The ads are designed to focus attention on radio repairmen and will plug their services as being tops in quality.

Reproduction of future ads and dates of publication will be made in the SYLVANIA NEWS previous to their appearance in other magazines. Watch for them in these three popular publications and point them out to your customers. They will get a kick out of them and remember you when their radio misbehaves.

## WHO'S ON FIRST?



Does your radio bobble its own words? Does it sound as though a catcher's mitt might be stuffed in the speaker? Listen, that's a sign of bigger trouble coming... trouble you'll dodge by having your local radio service dealer inspect your set now. Let him go over your radio with his "fine-tooth-comb" Sylvania equipment. He will do the job you need at a price that's fair. If he suggests Sylvania radio tubes, be assured you're getting the best. There are no finer tubes made.

Product of  
Sylvania Electric  
Products Inc.

## SYLVANIA RADIO TUBES

## PENNSYLVANIA SERVICEMEN PLAN STATEWIDE MEETING

Pennsylvania's FEDERATION OF RADIO SERVICEMEN'S ASSOCIATIONS will sponsor a Radio Serviceman's convention in Philadelphia on June 14 and 15.

This meeting, one of the first of its type, will bring to the radio servicemen all types of current information pertinent to the radio servicing field. There will be a large exhibition of the latest in test equipment, service accessories and components.

Numerous eastern parts distributors are cooperating to display the equipment and it is expected that this will be one of the largest exhibits ever shown at one time to radio servicemen. A unique feature of the meeting will be the absence of any radios. Since the program is essentially a technical meeting it has been felt that emphasis should be placed on modern servicing.

Included in the program of the two-day convention will be talks by

well known figures in the radio servicing field covering matters of importance to members of the profession.

The program is designed to have matters of interest for all radio servicemen. Distributors in the area have been contacted and are well acquainted with the program. Servicemen in the eastern U. S. are invited to attend the meeting and should contact their local parts jobber for further information.

## RADIO INSTITUTE TO USE SYLVANIA EQUIPMENT

Sylvania has announced its entrance into a participation with Howard W. Sams & Co. Inc. in connection with Photofact Folders and the Radio Servicing Institute.

Servicing information given in the Photofact Folders will include mention of Sylvania Radio Tubes. Test Equipment, including Sylvania Tube Testers, Polymeter and Oscilloscope will be employed in clinical service work in the Howard Sams Radio Institute.

The Howard Sams Company will also publish important information on the proper use of test equipment and aids in rapid radio trouble shooting. Circulation of Photofact Folders today is something in excess of 28,000.

## DO YOU KNOW?

An avalanche of requests for display material is pouring in to Sylvania's advertising department. Alert merchants are ordering signs and display pieces, welcoming the variety of selling aids available. Never before has such interest been displayed in these dealer helps. Order yours today!

## RADIO A BUSINESS SUCCESS BUT NOT YET PERFECT

Clifford J. Durr, member of the FCC, stated recently that radio in this country has been an outstanding business success but still has not measured up to its potentialities.

Mr. Durr was one of four participants in a radio forum discussing the question, "Is Our System of Broadcasting a Success?" Carl Haverlin, president of Broadcast Music, Inc., agreed that radio has made great strides in the last twenty-five years but that all aspects of current broadcasting are not perfect. They attributed its success to the encouragement of free competition among broadcasters with Government regulation only when necessary.

Freedom of the people was stressed by Mr. Durr when he said "we should concern ourselves with the freedom of 150,000,000 American people rather than with the freedom of broadcasters arbitrarily

## COLONIAL RADIO CORPORATION OPENS NEW CALIFORNIA PLANT



Colonial Radio Corporation, a wholly-owned subsidiary of Sylvania, began production of private brand radio sets at their new Riverside, Calif. plant on April 12. Formal opening of the plant was attended by Don G. Mitchell, President of Sylvania, Allen H. Gardner, President of Colonial, local civic leaders, Colonial employees, and officials of Sears, Roebuck & Co.

The Riverside plant, established for production of radios for west

coast distribution, is the second branch plant recently built by the company. Parent plant of Colonial is located in Buffalo, N. Y. The company was established in 1924, became a wholly-owned subsidiary of Sylvania in 1944.

During the war, the entire production of Colonial was devoted to war products, including automatic airborne communication equipment, walkie-talkies and proximity fuzes. Employment at Riverside is expected to reach 400.

## TUBE SUPPLY REPORTED TO BE AMPLE

M. F. Balcom, Vice President and Treasurer of Sylvania and Chairman of the Tube Division of the RMA reported at the joint conference of Canadian-U. S. RMA directors at Absecon, N. J. that the shortage of receiving tubes which slowed radio set production in 1946 has been overcome in the first quarter of 1947 and sufficient tubes are now being produced to meet all domestic demands and also provide a reasonable supply for export.

As Chairman of the Surplus Disposal Committee, Mr. Balcom stated that the government handling of surplus radio and electronic products continues unsatisfactory. The W.A.A. is embarking on a new program for disposal of electronic components and equipment and if this plan is carried through, it will constitute "dumping" and may have unfortunate repercussions on the industry.

to run their own stations in any way they see fit without regard to listeners and their needs."

The commissioner said that by free radio he meant the freest possible outlet for the widest possible range of ideas, opinion and talent and that we should strive for just that. It was pointed out that only one group of people—the listeners—can improve radio. Advertisers are sensitive to criticism and urge listeners to complain to the manufacturer as well as to the station when dissatisfied.

Radio conditions have improved since issuance of the FCC Blue Book in 1946 and more attention is being paid to programs of public service nature. Stations are more willing to make their facilities available to civic groups and to carry some of the fine network sustaining programs previously rejected for local programs of questionable value.



# SYLVANIA NEWS TECHNICAL SECTION

Copyright 1947, Sylvania Electric Products Inc.

A. V. BALDWIN, Technical Editor

These data have been compiled from information which we believe to be accurate. No responsibility can be assumed in the application thereof or for patent infringement.

MAY, 1947

EMPORIUM, PENNA.

VOL. 14, NO. 5

## GEIGER-MULLER TUBES AND COUNTERS



FIGURE 1

Probably the best place to start an article on Geiger-Muller tubes and their use is to review the characteristics of the various rays and particles they are designed to detect.

Alpha particles are positively charged helium atoms. They are emitted by many of the radio-active elements such as Actinium, Polonium, Radium, Thorium and Uranium and have a velocity of about 9300 miles per second. They are dangerous but since their penetrating power is the lowest of all these radiations (being only about three inches in air at atmospheric pressure) they can readily be avoided. The effect of these particles on the body is to prevent the formation of red blood cells, thus causing anemia.

Beta particles are actually electrons produced in the disintegration of all the elements listed above except Polonium. Their velocity is approximately that of the speed of light. These are relatively harmless, as developed by ordinary sources and, in fact, are the foundation of the new science of tracer chemistry that will be familiar to all who have read about the civilian benefits we are obtaining from atomic research. The efficiency of ionization of a Beta particle is very much less than that of an Alpha particle. They do not have much penetrating power, as about  $\frac{1}{16}$ " of aluminum will effectively stop half of those emitted by the strongest source.

Gamma rays (note that these are not particles) are similar to X-Rays, but shorter and like them may be of long or short wavelength depending on the source. They are emitted by practically all the radio-active elements with Radium and Thorium being particularly strong emitters. These are the rays from which we really need protection. Several layers of lead or other heavy material provide the best shielding.

Cosmic rays are much higher energy radiations than Gamma rays and so far have not been made on earth. They originate somewhere in space and are greatly reduced in strength by passing through the upper atmosphere. Small quantities of these exist about us all the time, except perhaps at the bottom of the deepest mines. They are of research interest only at present.

### Detection

There are several different classes of instruments used for detection and measurement of these radiations, the ionization chamber, the cloud chamber, the electroscope and counters of which the Geiger-Muller Counter is the latest development. All of these depend on the ionization of the air or gas by collision. Other methods of detection sometimes used employ the fogging effect on a photographic film or the production of induced radio-activity. The safety precaution observed by laboratory workers of carrying a piece of film in their pockets is an example of such use, but is not measurement as thought of by people in the radio industry. (See Note 1)

The actual structure of a Geiger-Muller Counter is not too complicated, but calibration and the proper interpretation of the readings requires more knowledge of atomic physics than is possessed by the average experimenter and certainly more than we can explain in this article.

### Sylvania Geiger-Muller Tubes

Sylvania Type GB302 is the short tube shown in Figure 1, and is used for detection of Beta rays. The

light-colored disc on the top is the special alloy "window" through which the radiation must pass in order to ionize the gas. This "window" is very thin and the cap shown alongside is used to protect it when not actually in use. It is necessary to pack this tube in a special air-tight container as the changes in air pressure that might be encountered in shipping by airmail, for example, might rupture the window. Great stability and a long useful life are obtained by use of a special gas. This type tube is the one employed in the new radio-active tracer chemistry technique. (Note 2)

The Sylvania Type GG-304 is the long tube in the illustration and is used to indicate Gamma ray radiation, especially in radiological safety surveys where detection of Gamma radiation harmful to personnel is imperative. It can also be used to detect Cosmic rays. The maximum seated height of this tube is 8".

Both tubes are furnished with standard medium 4 pin radio tube bases which is an advantage over tubes available for similar service.

### Theory of Operation

The operation of both types is dependent upon the ionization of the gas and the resulting change in the potential of the pentode grid to which the anode is connected. In the GB-302 the Beta rays ionize the gas directly while in the GG-304 the rays striking the activated surface of the metal cylinder cause it to emit electrons which ionize the gas after sufficient acceleration. The

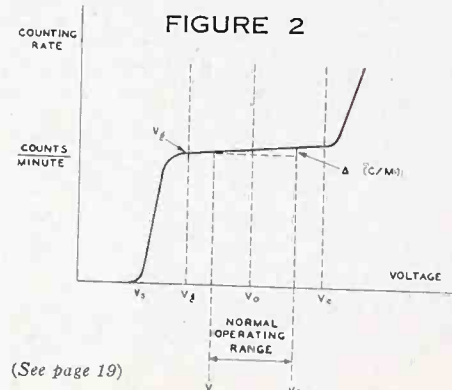

(See page 19)

*Servicemen who have only occasional use or a meter to read very high voltages will be interested in a simply-made voltmeter made by the engineers in our Television Application section.*

Constructional details are given below for a H. V. meter that can be used to measure the high potentials in television receivers featuring extreme portability with low cost, and a high degree of accuracy.

The completed instrument is shown in Figure 1.

The important thing in selecting the meter for this tester is to consider its loading effect on the circuit. In H. V. television systems such as R. F. power supplies and flyback type supplies, only a limited amount of current is available. Therefore, only a meter with a full scale sensitivity of 40 or 50 ua should be considered. A Weston panel type meter model 301 is used in the unit described. If the meter is to be mounted on a metal panel an insulated case should be used to minimize leakage.

Having selected the meter, the next thing to consider is the voltage range required so the voltage multipliers may be selected. The resistance required for any desired range will be equal to the maximum voltage to be measured divided by the maximum current of the meter.

### HIGH VOLTAGE VOLTMETER

By Arthur Faust

(Meter resistance is negligible in a highly sensitive meter and can be disregarded.)

Example:

Range desired 12,000 volts max.  
Meter sensitivity 50 microamperes.

Equation:

$$R = \frac{E \text{ max. } 12,000v}{I \text{ max. } .000050} =$$

240,000,000 ohms or 240 megohms

The resistors selected for the multiplier should have moisture-proof protection and should be of the insulated type. I. R. C. type BTA 1 watt resistors have the above characteristics and were selected. The resistance must be divided so there is no more drop across each individual unit than the manufacturer's rating. Type BTA have a maximum drop of 500 volts.

We have a total of 240 megohms to be divided; 5.1 meg resistors would have a drop of 255 volts across each unit which would be well within the manufacturer's rating. Forty-seven 5.1 meg and one .3 meg resistors would equal 240 megohms. Therefore, we have a total of 48 resistors to mount. Type BTA resistors are  $\frac{23}{32}$ " long x  $\frac{1}{4}$ " diameter.

Polystyrene B was selected for its fine dielectric properties and low leakage loss under varying condi-

tions of humidity. A piece 5" x 8" is adequate to use as a support for both resistors and meter.

Holes are drilled in the polystyrene as shown in Figure 2. When soldering, sharp projections should be avoided. When all resistors are mounted they should be given a coat of coil dope with a polystyrene base. This will prevent moisture from affecting the resistors and changing their values.

If a metal panel is used  $1\frac{3}{8}$ " holes are cut into it. A polystyrene panel is attached behind and banana type jacks are centered in the polystyrene for the terminals. The positive terminal goes to the resistor string and then through the meter; the negative terminal goes to the negative terminal of the meter. A piece of H. V. cable such as ignition cable should be used.

Multiplier resistors should be strung out in such a manner that there will not be too great a difference in potential between any two points.

The entire unit is housed in a metal cabinet 6" x 9" x 5" deep.

#### Accuracy

Owing to the fact that so many resistors are used, the accuracy of each resistor is not important. Resistors with an individual accuracy of 10% will probably give an overall accuracy of about 2% because all the resistors are unlikely to be off in the same direction.



FIG. 1

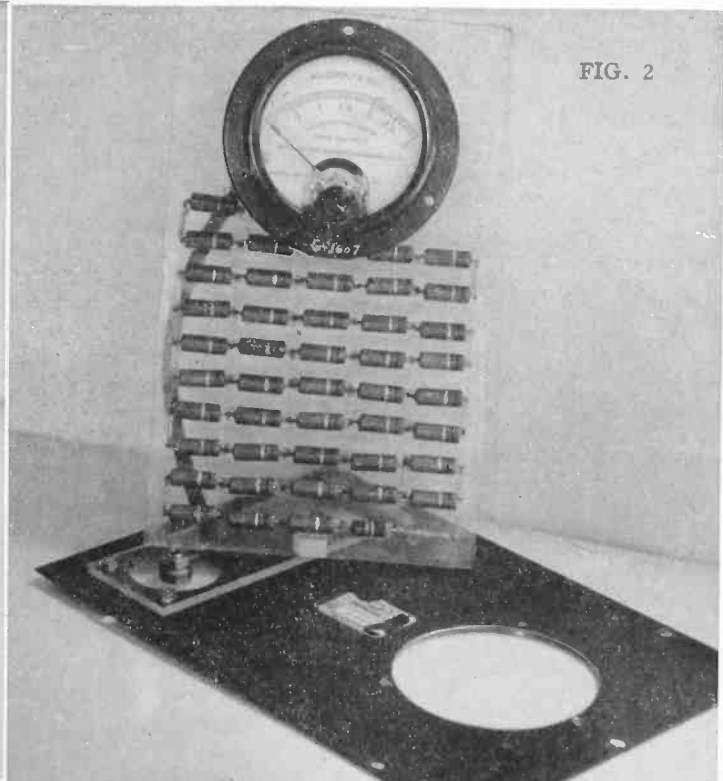

FIG. 2



# GEIGER-MULLER TUBES AND COUNTERS

## TENTATIVE RATINGS

### SYLVANIA TYPE GB-302—Beta Particle Detector Tube

Window	5.8 milligrams per sq. cm.
Operating Voltage	Approx. 1500 v with usual amplifiers
Background Counting Rate	40 per minute—maximum
Capacitance at Pins	4.0 $\mu\text{f}$ .—maximum

### SYLVANIA TYPE GG-304—Gamma Ray Detector Tube

Operating Voltage	Approx. 1400 v with usual amplifiers
Plateau Slope ( $\Delta C/M$ ) (Change in counting rate)	7/10% per volt over operating range
Background Counting Rate	100 per minute—maximum
Sensitivity	Approx. 3700 counts per minute with 5 microgram radium at 3' from center of effective area of cathode.

(Continued from page 17)

characteristic curve of these tubes is shown in Figure 2. Assuming a constant amount of radiation while varying the voltage across the tube from zero to a maximum, the rate of counting will be shown by the heavy line. The voltage  $V_s$  is the lowest voltage across the tube at which a very few radiated particles will possess enough energy to cause the gas to ionize and indicate their presence. If the voltage is raised above  $V_e$  the gas is subjected to such a strong ionizing field that it becomes unstable and not suitable for use as a counter tube. This region is close to the arcing voltage of the tube. Between  $V_g$  and  $V_e$ , however, there is a straight, almost flat portion called the plateau over which the tube will operate satisfactorily. This is reduced a little at each end to get the recommended normal operating range  $V_1$  to  $V_2$ . We can consider the Geiger-Muller tube as a gas tube with enough D. C. voltage applied to bring it almost to the firing point. A single ionizing particle is then all that is needed to start the discharge.

### Nehrer-Pickering Circuit

Like all gas tubes a discharge once started tends to continue, so these tubes are recommended for use in what are called externally quenched circuits, such as the modified Nehrer-Pickering circuit. A typical counter circuit is shown in Figure 3.

Special circuits have been developed to meet many requirements such as integrating the total exposure over an elapsed time and indicating it on a meter, but such circuits and applications will not be considered here. (See Note 3)

The operation of this circuit is as follows:

The type 6C6 is operating with the grid floating except for the bias provided by the 10 megohm grid resistor. Assuming no radiation the grid will go positive enough to allow the tube to conduct a large

current making the voltage drop across the pentode very low. Most of the high voltage will therefore appear across  $R_2$  putting about 800 volts or more across the G. M. tube to keep it in a sensitive operating condition. As soon as ionization starts, negative charges which can leak off only through the 10 megohm resistor, will collect on the anode making the grid more negative with respect to the cathode. Owing to the trigger-like action of gas tubes, this charge will tend to build up rapidly and the grid voltage will reach the cut-off point. When this occurs, the voltage drop across the pentode will become very high, leaving only a low voltage across the G. M. tube which will immediately become insensitive. As soon as the charge leaks off the original sensitive condition will be restored and the circuit will be ready for another operation. Each pulse through the pentode causes the type 885 tube to conduct momentarily and operate the counter. This cycle can repeat

itself quite rapidly as there are no condensers in the circuit to give a time delay. Actual counters operate at 600 per minute. Special circuits which permit scaling down so as to operate a mechanical counter enable faster counting rates to be handled.

Since the original announcement of these tubes we have had a few requests for information, but in many cases the proposed use was not stated. The Geiger-Muller Counter was a research tool when nuclear physics was primarily a research field. Now, however, with the many startling and practical applications of nuclear physics, such as the diagnosis and treatment of thyroid and other disorders, this counter will have a large number of medical, industrial, and other uses outside the research field. In fact, the practical uses of nuclear physics, and the Geiger-Muller tubes with which it is inseparably identified, have just begun to be explored. Research applications are expanding too, of course.

These tubes have been so recently announced that plans for general distribution through renewal sales have not been completed. Delivery and price can only be supplied by our Electronics Division, 500 Fifth Avenue, New York, N. Y.

Note 1: For a discussion of these various methods, reference may be made to any of the newer college text books such as "Procedures in Experimental Physics" by Strong or "Treatise on Physical Chemistry" by Taylor.

Note 2: Some examples of the use of tracer chemistry are mentioned in Science News Letter, February 8, 1947; December 7, 1946; December 21, 1946.

Note 3: Electronics, January, 1947.

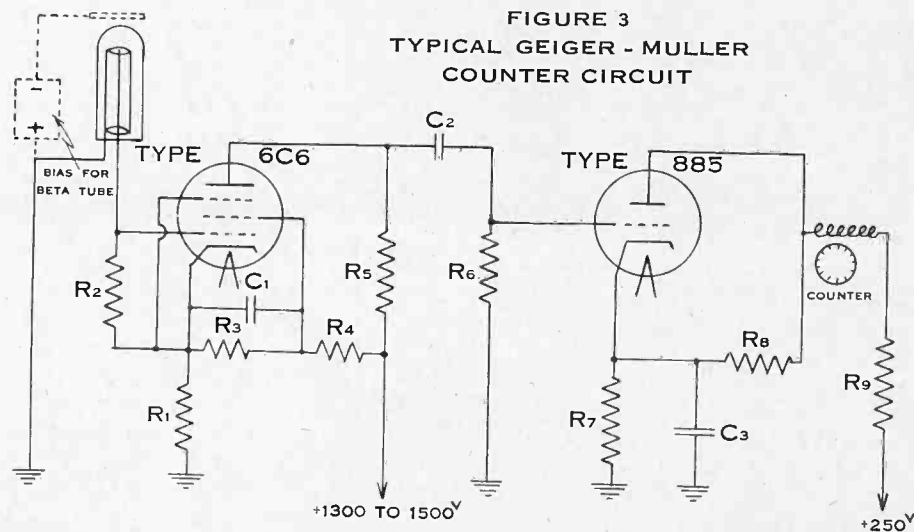

### Parts List

R1	1 Megohm	R7	10,000 Ohms
R2	(about 5 separate resistors)	R8	80,000 Ohms
R3	5 Megohms	R9	1000 Ohms
R4	1/2 Megohm	C1	0.1 $\mu\text{f}$
R5	1/2 Megohm	C2	50 $\mu\text{f}$
R6	1/2 Megohm	C3	0.2 $\mu\text{f}$



THE information presented in the Sylvania Service Exchange is contributed by servicemen as the result of practical experience. It is very carefully considered before being accepted, and we believe it to be correct and authentic. However, we assume no responsibility for results. Please do not send routine or generally known information. Each hint accepted entitles the writer to his choice of one Sylvania receiving tube. Please specify tube choice when submitting hints.

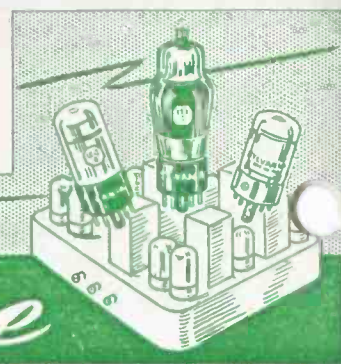

# THE Service Exchange

**Handy Test Speaker:** I fastened a universal output transformer to a 100 ma. choke, bottom to bottom by bolts. The center tap of the transformer primary, i.e. the B+ tap is connected to one side of the choke. Insulated leads about three feet long are connected at one end to each terminal of the choke and to the plate leads of the output transformer. The other ends of the leads are provided with alligator clips. I use a PM speaker having leads with alligator clips with this arrangement while working on any chassis when the regular speaker is not available. In fact, I rarely remove the customer's speaker when I am confident the speaker is OK.

**NOTE:** There are, of course, some sets where this should not be used; sets with a total drain of more than 100 ma; those having chokes with much more than 200 ohms resistance and those having considerably different circuits.

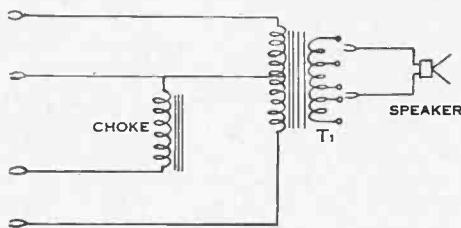

**Parts Required:** Choke, 8 to 10 henry 100 ma, 200 ohms; T1, Standard Multitap Output Transformer; Speaker, P.M. Type on Baffle.—Henry Heyman, Washington, D. C.

\* \* \*

**RCA 5M Auto Radio:** A complaint of intermittent howls and oscillations was caused by an intermittent A.V.C. capacitor C-40, 0.007 mfd. To gain access to C-40 requires unsoldering one end of C-18, 0.05 mfd., I.F. cathode bypass.

To avoid the probability of C-18 becoming intermittent due to handling, it is advisable to replace it also. (Reference Riders Volume 7, RCA 7-10).—Joseph S. Napora, Dayton 3. Ohio.

**Silvertone Radio Phonograph—Burnout of Series Filament Resistor:** In the models employing the following tubes, 35Z5, 35L6, 12SA7, 12SK7 and 12SQ7 there is 90 ohm 2 watt filament dropping resistor. After being in use for some time this resistor will have burned off the fabric coating and then the heat will cause some of the turns to short out. Eventually there will be enough shorted out that the type 35Z3 will fail on line surges. The remedy I have found for this is to remove the resistor entirely and substitute type 50L6GT for the 35L6GT. The sum of the heater voltages add up correctly to the line voltage and there will be no loss of volume.—Abe Vilensky, New York, N. Y.

\* \* \*

**Lamp Shade for Short Test Lamp:** I just bought a Sylvania Type 140 tube tester and like it very much. Of course as with all tube testers, the neon short indicator is difficult to see under a bench light. To correct this I used an aerial insulator (Cowl type) ground it flat on the bottom and cemented it over the neon bulb to shade it. The upper Cowl insulator was bakelite and I cemented with the slant toward center of the instrument. Being shiny black it blends nicely with the other test sockets.—Russ Walters, Wausau, Wisconsin.

\* \* \*

**Philco 46-480, 46-1201, 46-1203 46-1209, 46-1213, and 46-1226. Noise at Minimum Volume:** We have repaired several of the Philco models above and the main complaint has been a slight crackling noise in the speaker at low volume. The noise is not loud, but very annoying in a quiet room.

After checking several components in the first audio amplifier circuit it was found that the plate resistor, .22 meg., 1/2 watt, was the sole source of interference. This resistor has been replaced in each instance and completely eliminated the noise.—Byron A. Neal, Mansfield, Pennsylvania.

**Substitution for Type 15:** I have had many calls for type 15 tubes and have been unable to supply them. However, a fellow serviceman accidentally broke one the other day out of a customer's radio and it was just about absolutely necessary to find a substitute. The radio was a 6 volt Zenith, Model 4V-31. This radio used two type 15 tubes which were hooked in series with a voltage dropping resistor to cut the filament voltage to 4 volts for the two tubes. It occurred to me that this resistor could be removed and the filaments wired in parallel for six volts so that standard type 36 and type 39 tubes could be used in plate of the type 15. The 36 tube is used in the autodyne detector socket. Some change in the value of the detector cathode resistor is necessary to make the tube oscillate. The radio worked perfectly after the change. This same circuit change can be used on numerous other 6 volt Zenith radios which use type 15 tubes.—Donald Slattery, Chadron, Nebraska.

\* \* \*

**RCA Model 87K1:** I have had considerable trouble with this and similar Console models. The set sometimes fades intermittently and the tubes check OK. Connections, resistors, voltages and condensers will also prove in good order upon test. After much trouble I have found the cause of this to be a loosened mechanical connection on the outside of the chassis where there are screws for the connection of a phonograph. The metal lug connected across these screws makes the electrical connection when the phonograph is not being used. These screws may come loose in time and thereby cause the contact to loosen and cause the set to fade. The best repair is to use a lock washer under each screw. Besides this I always let the customer know what the trouble is so that if it reoccurs he will not think it is due to faulty servicing.—Allan Lyons, New York, N. Y.

NEW ADVERTISING HEAD



TERRY P. CUNNINGHAM

Terry P. Cunningham has been appointed to assume the duties of Henry C. L. Johnson, Advertising Manager, radio, electronics and international, who has resigned from Sylvania.

Mr. Cunningham is not new in this capacity since he held the job for 1½ years while Henry Johnson was in the service. In 1945, Mr. Cunningham was transferred to Colonial Radio Corp. where he was company representative for the Sears, Roebuck & Co. account.

With twenty years experience in the advertising field, Mr. Cunningham is well qualified to handle Sylvania's radio tube advertising. He has, during this period, written advertising for three major radio set manufacturers. Most of his previous experience has been with the distributor - dealer type of product.

FM SERVICING REQUIRES LATEST IN TEST EQUIPMENT

During 1947 FM radio will become of age. Set production is expected to reach new peaks and this will mean more repair jobs.

Up to the present, many retailers and servicemen have avoided FM service jobs, and many have even sidestepped thinking about the matter, others have not yet been bothered. The problem must now be squarely faced. FM servicing, properly handled, will be a good business builder, improperly handled will be a big blackeye to radiomen.

The general public is not conscious of FM. It is not familiar with its capabilities; many do not know the advantages offered by FM over AM. The job of educating the public is a big one which must be conquered by the people who sell.

Salesmen must be familiar with the problems connected with FM. If they do not do a satisfactory job of selling and installation they will be faced with loss of reputation and a drop in their business.

The serviceman who is on his toes will make plans for a complete FM service. This will require expert technical knowledge and up-to-date test equipment, designed to do the job. Every repair man should make it his business to familiarize his organization with the problems of FM sales and service.

Test equipment problems should not be considered too lightly. The best in test equipment will be

necessary if a complete job of servicing FM sets is to be accomplished. The forward looking serviceman who sees servicing as one of his major stocks in trade, will find that up-to-date equipment, built with FM and television servicing in mind, will be an asset which can be used to turn out better work in a shorter time.

The good repairman will also take advantage of his acquisition of new equipment by letting the public know that he is equipped to do the finest job possible in servicing the newest in radio receivers. Investment in up-to-date equipment is an assurance of a better place in the radio service business.



The Sylvania Polymeter is an excellent test instrument for convenient and accurate measuring of wide-range voltage, current and resistance values found in home radio receivers, FM, television sets and many types of electronic apparatus. It is indispensable in servicing FM receivers.

"TAKE ME OUT TO THE BALL GAME"

"Take me out to the ole ball game" looks like it may someday be an obsolete expression. With television stations springing up in many localities where the big leagues swat the ball around, many people can soon expect to see their favorite team play ball in their own living room.

In New York and other cities, all big league games are broadcast via television. The office boy whose deaths in the family used to reach astronomical figures during baseball season can now tuck a video receiver in a dark corner of the office and relax—the boss may never get wise.

Here is one of the season's early games being televised in New York's Yankee Stadium.



## SURVEY REVEALS LARGE OUTPUT OF FM RECEIVERS IN 1947

Output of FM receivers in 1947 has been estimated to be between 1,800,000 and 2,100,000, according to a production survey by a special committee of the RMA.

The study indicated that the industry plans to turn out 2,600,000 sets with FM facilities in 1947 with the majority being AM-FM consoles. The committee, however, took a more cautious view after a thorough analysis of all factors. The lower estimate was made because of anticipated production difficulties.

### Growth Must Be Gradual

The committee indicated that it is most encouraged by the outlook, but warned that the growth of this new broadcasting service will be gradual and would be hampered rather than aided by the production of cheap FM sets which would not realize the full advantages of FM.

"Under the right conditions, FM supplies certain advantages to the consumer. As far as the public is concerned, these advantages will be realized when stations of sufficient power are broadcasting and their radio set is of such character as to allow them to receive the transmission with the lack of noise and the added fidelity that are inherent in FM."

The committee pointed out that it has taken approximately 25 years to make possible the present AM radio program service and to provide the public with 60 million receiving sets. "It is obvious that the creation of such an audience for FM, even at enormous production levels, will take some time."

### Cheap FM Sets Impractical

Added service in the nature of FM is perhaps best presented first in sets of the more expensive class, since it is easier to more readily absorb the increased cost without greatly affect-

ing the retail price. As the production progresses, engineering and production costs can more readily be absorbed in offering low priced merchandise to the public.

It would be a mistake to produce a cheap FM set at the present time. Such a set would, with today's knowledge, be low in sensitivity and have poor selectivity in relation to the established standards of AM. Such performance would do irreparable harm to FM before it had a chance to prove itself a service.

Volume production of FM receivers takes plenty of know-how. While the set manufacturer is integrating FM into his overall program, he must maintain volume production in his plants to be able to afford to maintain an organization which can acquire mass production techniques of FM manufacturing. Without this volume production, the cost of sets would be prohibitive.

In 1946 manufacturers lost a great deal of money in an effort to produce a large volume of FM receivers. Shortages of radio components and skilled labor along with the problem inherent in making operative new engineering designs all resulted in hampering the manufacture of FM receivers. As a consequence, only 1.4% of the total production of radio sets last year included FM reception facilities. Already this year the percentage of FM receivers being manufactured is  $4\frac{1}{2}$  to 5%.

## HOME WORK A CINCH WITH MERCURY TANK MEMORY

Parents faced with embarrassing questions while trying to solve junior's homework will soon find relief in the EDVAC. This super calculator, now being constructed at the University of Pennsylvania, is a magic brain which will figure out answers to tough mathematical problems in an instant.

The EDVAC (electronic discrete variable computer) is being built for the Ordnance Department of the Army. One of its most distinct features is the so-called "mercury tank memory." This device is capable of memorizing eight 10-digit numbers and referring to any one of them in an average time of 1/5000 of a second.

Another distinctive feature of the

## VIDEO NEEDS BETTER PROGRAMS

Need in television for more and better video programs to cope with the growing acceptance of the naturally attractive sports items as video subjects was stressed in a meeting of the Television Institute in New York recently.

David P. Lewis, New York advertising executive, charged that the industry has been too busy turning out its promised millions of new receivers and has done far too little toward preparing something good to show on their screens to keep them sold and operating continuously in the home.

He asserted that not enough good television directors have been developed, and skilled persons to do the necessary television writing were too few. The drama, he pointed out, is especially lagging in television.

Harvey Marlowe, executive director of programs for ABC asserted that television may be in for a shock soon when the owners of music unauthorized for television find some of the video impresarios have been inadvertently using it on the air. Such music has been authorized for normal use in theatres, but not for television.

Importance of televised sports was emphasized when more than 75% of those in attendance flocked to video receivers to see the opening baseball games over Manhattan's television stations.

### ON THE COVER

The lovely lady on the cover is Angelyn Orr, versatile radio actress whose roles range from ingenue to gun moll. She is heard in one of the former characterizations over MBS on the Monday through Friday broadcasts of "Captain Midnight."



### F. W. MANSFIELD HEADS RMA COMMITTEE

Frank W. Mansfield, Director of Sales Research for Sylvania has been appointed Chairman of the RMA Industry Statistics Committee, a committee for improvement and expansion of radio statistics.

The committee plans to cooperate with various RMA divisions toward development of improved and increased data for RMA members and many other interests requiring adequate industry statistics.

A meeting of the Industry Statistics Committee will be held at Chicago during the RMA annual convention on June 10-12 to outline immediate and long range plans including presentation of systematic industry data.

### APARTMENT OWNERS BAN ERECTION OF TELEVISION ANTENNAS

Current headache among television manufacturers, listeners and broadcasters is the prohibition against erection of individual antennas by management of more than 100 New York apartments. The problem has long been recognized, but not faced in view of more pressing problems.

Television engineers have long been aware that erection of several antennas within an area of a few square wave lengths would permit interaction between receivers generally injurious to reception. Work on master television antenna systems which would provide multiple signal sources has already begun.

The problem was brought more actively to light in February when notice was served on several thousand tenants that apartment owners would not permit installation of television sets until some scientific method is developed for a master television antenna. The reason for such action was pointed out to be the danger and unsightliness which would result if a great number of tenants in a large apartment were to erect individual antennas.

#### TBA Proposes Two Plans

Relief in the situation, proposed by the Television Broadcasters Association, was outlined recently in two plans. The first, a long range plan, covers the design, production and eventual installation of master systems so that any tenant in the building could hook up his receiver and get pictures from any station.

The second proposal, which is an interim plan, involves the use of a temporary system now which will protect the landlords from expense and liability resulting from its use. The system would allow thirty or forty set owners in one building to hook up and use their receivers in their homes pending creation of the permanent system.

#### Reality Board Rejects Plan

Both proposals have, in effect, been rejected by representatives of more than 700 apartment owners in New York. It was reported that the real estate board considered the proposals "inadequate—does not go far enough to be of any great benefit."

It is felt that more antenna development is necessary and that a usable master antenna is paramount because, in time, everybody in the building might use it. It was also pointed out that there should be a way to relieve the landlords of the burden of costs for installation and upkeep.

The problem is not only applicable to the New York area, but will eventually be of importance in nearly all metropolitan areas where television is a growing industry.

### SYLVANIA EXECUTIVES SPEAK ON MARKET RESEARCH



Above are the four Sylvania executives who conducted the forum before the New York IAA. Left to right are Paul S. Ellison, Director of Public Relations, John P. Waters, Advertising Manager Lighting, A Davis, Master of Ceremonies, New York, IAA, H. C. L. Johnson, Advertising Manager Radio Division, Frank W. Mansfield, Manager of Sales Research.

Sylvania's use of market research in advertising was the subject of a forum at the regular monthly meeting of the New York Industrial Advertisers Association recently. The program outlined the purpose of market research and what Sylvania has done to put it to work in advertising.

Slides and slide films were used

to present the program which showed how Sylvania had discovered that the majority of people think the radio serviceman is doing a bang-up job, and have confidence in him.

The material is now being put to work in Sylvania's big advertising campaign announced in the March issue of the SYLVANIA NEWS.

### SALES EXCEED PREVIOUS PEACETIME LEVEL

(Continued from page G-18)

radio and lighting fields than it occupied before the war.

"It is satisfying to report that in a year of so much labor-management controversy throughout the country, the good relations between the management and workers of Sylvania were maintained." Employment, which had dropped from a V-J Day peak of 29,500 to 13,500 by the first of 1946, rose gradually to 17,300 at the end of the year.

#### Shortages Affect Profits

The company was able to meet the requirements of most customers in 1946 despite a greater than anticipated demand for its products, and in spite of material and labor shortages and generally unsettled national conditions.

Results for the last quarter of the year were much improved compared with the preceding three quarters, reflecting some improvement in production efficiency and the fact that price adjustments had been made where necessary.

#### Engineering Activities Expand

Sales effort in 1947 will be reinforced by the largest advertising

program in the company's history. (Announcement of the campaign was made in the March issue of SYLVANIA NEWS. Additional information appears on Page M-17 of this issue.)

The report discloses that the management has budgeted approximately \$6,500,000 for its engineering and research activities in 1947 in the belief that engineering "will be of great importance" to the company's growth.

"At the beginning of 1947, deliveries on many other items were beginning to be more satisfactory. The management believes that a more competitive market is imminent and that Sylvania is equipped to maintain its position as one of the leaders in the lighting and radio fields."

Plans developed during the war years for new products and merchandising methods to increase the sale of the company's other products became effective at the beginning of 1946, states the report. Radio sets, photoflash lamps, tungsten and chemical products, electronic and other products had been added to Sylvania's prewar lines.

### FACTS AND FIGURES...

#### First Quarter Production

Production of radio receivers in the first quarter of 1947 was 4,231,415 according to an announcement made recently by the RMA set manufacturers. Television receivers manufactured in this period totaled 18,329 and AM-FM sets 172,176. During this period 53% of the total or 2,220,986 sets were table models. Consoles produced came to 11% or 465,931.

#### March Production

RMA tabulations show that radio set production for March paralleled that of February. The March output was 1,377,269. Television receivers numbered 6,639, while AM-FM sets numbered 56,150.

#### FM Stations Increasing Rapidly

FCC records indicate that 204 FM stations are now on the air and construction permits have been issued for 589 others. In addition, 220 conditional grants have been authorized while 111 applications are pending and 110 other applications are in hearing.

#### Educational Networks Proposed

Two state legislative bodies are considering measures proposing establishment of FM educational broadcasting systems. The states are California and Pennsylvania. The states together would appropriate over \$1,500,000 for construction and operation of their systems.

#### Inventories-Shipments Improve

Department of Commerce reports that manufacturers' inventories increased \$300 million during February to a total of \$21 billion. Manufacturers' deliveries were up 6% above the January rate and were 2% above the previous peak of February 1945.

#### Sales Increase 16.9 Per Cent

The last quarter of 1946 revealed an increase of 16.9 per cent over third quarter sales for 1,270 American corporations. Twenty-seven electrical supplies and equipment showed a jump of 34.6 per cent during this period.

**SYLVANIA NEWS**  
 Published By  
**SYLVANIA ELECTRIC PRODUCTS INC.**  
 Manufacturers of Sylvania Radio Tubes and Electronic Devices, Sylvania Incandescent Lamp Bulbs, Fluorescent Lamps and Equipment  
 Vol. 14, No. 5  
 MAY, 1947

RETURN POSTAGE GUARANTEED

For:

Renville Radio & Washer Serv.  
 196 Main Street  
 Luzerne, Pa.

Sec. 562, P. L. & R.  
 U. S. POSTAGE  
**PAID**  
 Emporium, Pa.  
 Permit No. 1

POSTMASTER: If Address has moved, notify sender on Form 3547, postage for which is guaranteed. When Form 3547 is sent abandon this mailing. Return only if no correct address is available.



Emporium, Pennsylvania  
 P. O. Box 431





# SYLVANIA NEWS

Copyright 1947, Sylvania Electric Products Inc.

R. A. PENFIELD, Editor

JUNE-JULY, 1947

EMPORIUM, PENNA.

VOL. 14, NO. 6

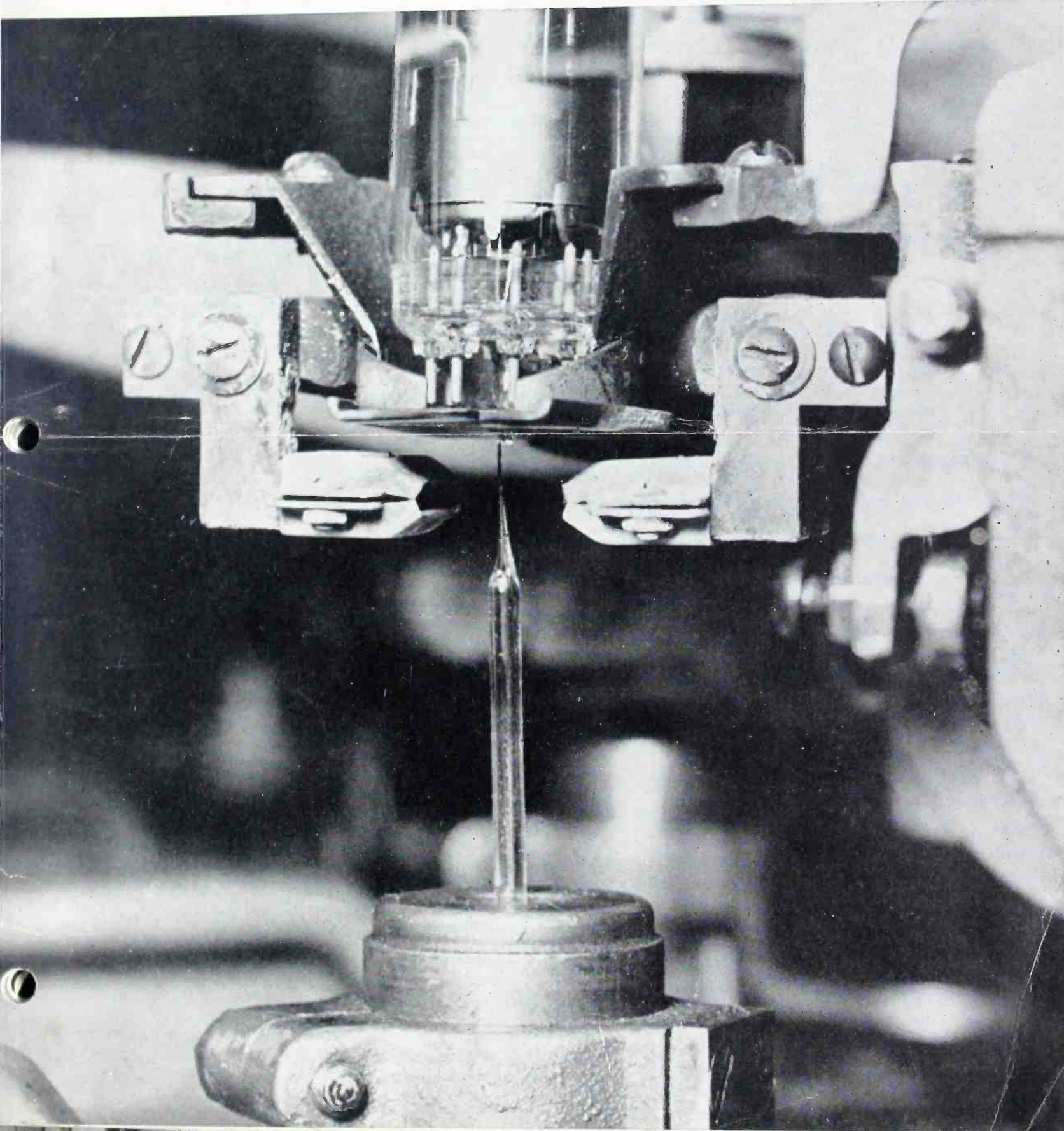



# Sylvania Commentator . . . NEW YORK

In the fall of 1945 Mike Stolfi of Stamford, Conn. felt the need of a larger radio sales and service store in order to better accommodate his many customers. He had been in business for six years and had done all right for himself. He found a new site that answered his requirements. It had 5000 square feet of floor space and ample parking and drive-in facilities for auto radio repairs.

First on Mike's program in his new location was a novel way to bring his shop to the attention of the people of Stamford and surrounding communities. Toward the end of the year he put his plan into effect and began a campaign of advertising on two billboards in the Stamford area.

Billboard advertising pays off, but Mike doesn't let it get stale. Each month he switches his advertisements to two other locations in the area. In this way he not only

changes his copy frequently, but his advertisements pop up in different places every month. Altogether, Mr. Stolfi has six billboards which carry his ads.

In the beginning Mike featured nothing on the billboards but his sales and service of radios, television, refrigerators, washing machines and other appliances. On June 1 he began to feature, along with his other service, Sylvania tubes and test equipment. This is the first experience he has had with featuring a manufacturer, and Sylvania is pleased to know that this serviceman feels its product worthy of his advertising program.

Mr. Stolfi is justly proud of the Sylvania name and has been a loyal Sylvania dealer for the entire eight years he has been in business. His endorsement of Sylvania products is attributed to two important reasons: 1. Sylvania quality; 2. Sylvania price maintenance. He knows

that when he uses a Sylvania tube in a repair job the customer will not be back in a few days to say the tube is defective, nor will he see the same Sylvania tube advertised by some other concern at a cut price.



SAM McDONALD

Mike has been a true pioneer in the sale, installation and repair of television and FM and has been equally farsighted in opening up this new means of advertising. His old and new customers are generous with their compliments, because they know his well-placed billboard advertising is backed by good service. Mike Stolfi has developed here a novel and profitable means of successful sales promotion.

Sam McDonald

## WHO SAID RADIOS ARE HIGH PRICED?

### SURVEY SHOWS SETS CHEAPER THAN 10 YEARS AGO

#### What Does a Radio Cost?

Frank W. Mansfield, Director of Sales Research for Sylvania spends a lot of time playing with figures and has just recently come to the conclusion that, in spite of the present day trend toward higher prices, people paid less for a radio in 1946 than they did ten years ago!

Looking at the matter from one viewpoint, in 1936 it was necessary to work 2.56 weeks in order to have enough money to buy the average priced radio, that is, provided you saved all your pay for that purpose. Last year, the average worker could get a new radio after working only 1.25 weeks.

Getting down to more pertinent facts, the average retail price of a radio in 1936 was \$55.70. Mr. Average Workingman was getting \$21.78 per week then. Last year, Mr. A.

Workingman's earnings increased to \$43.71 while the average radio price declined to \$54.52. Boiling it down to basic facts, Mr. A. W. had to work less than half the time to get the equivalent radio of ten years ago, pricewise speaking.

#### Cheapest in 1940

Looking back over the years, Mr. Mansfield tells us that the low point in radio retail prices came in 1940 when the average was \$29.70. In that year weekly wage averages hung at \$25.20, so it took only 1.18 weeks to get a new set. Back in 1929 the cost of radios was high, \$135.50 to be exact. At that time A. Workingman was only making \$25.03 a week, so it took 5.41 weeks to buy a new set.

With a little more figuring, we find that the average radio costs about \$1.25 a week—but that was only for last year. It has been shown that the average life of a radio is seven years, so actually, all that a radio costs is about 15 cents a week

over the seven year period.

Suppose now that we assume that the radio was bought by an average family, whose members, it is reported, is about 3.8 people. That means it costs each individual 4 cents a week to get that new radio. Or if you want to get down to finer points, the average listening time per family is about 5 hours a day, or 35 hours a week, which simply means that the new radio in the living room actually cost you less than one-half a cent an hour for every hour you listened to it!

#### Movies More Than Radio

In case these figures aren't very convincing on the price of a radio, we have compared them with the money spent for movies last year. It figures out that Mr. A. Workingman spent \$36.35 to go to the movies last year. With that money he went about 76 times during the year. When you consider that the average price of admission is 48 cents, it

(Continued on page G-23)

# SYLVANIA NEWS MERCHANDISING SECTION

Copyright 1947, Sylvania Electric Products Inc.

JUNE-JULY, 1947

EMPORIUM, PENNA.

VOL. 14, NO. 6

## A RADIO IN EVERY ROOM . . .

RMA's "Radio in Every Room" campaign is now swinging into high gear. Support of the program has been pledged by organized broadcasters and several national magazines have prepared feature stories for publication in the near future.

Through the National Association of Broadcasters, spot announcements, scripts and promotion items will be sent to local stations. These promotion ideas will emphasize the great advantage of "A Radio For Everyone."

One of the main points of promotion will be emphasis on the fact that only  $\frac{1}{3}$  of the nation's families now have two or more radios in their homes. When it is considered that the average family is 3.8 persons, the radio potential might fairly be estimated at 100,000,000 radios of all types.

### Film To Aid Dealers

To enlist the aid of dealers in this program, a slide film entitled, "Let's Get Personal" has been prepared by the RMA. This film will be distributed to member companies for use in sales meetings and talks to distributors and dealers. The main subject of the film will be centered around the theme that radios, like clothes, are personal possessions and that every member of a family should have his own.

Magazines which will feature stories on the campaign will include **THE AMERICAN WEEKLY**, which boasts a circulation of nine and one-half million readers; **GOOD HOUSEKEEPING** with a reading audience of nearly four million will feature a two page spread telling the public that there is "a radio for every room, for every purpose."

Readers of **AMERICAN HOME**, circulation two and one-half million, will find in the October and November issues that the radio is an integral part of the kitchen.

**HOUSE & GARDEN**, influential

in the decorating and home furnishing habits of two and one-half thousand women in the upper income brackets, will also emphasize the importance of the radio in the model kitchen in the November issue.

Servicemen and service dealers

will be directly affected by the program. The increased business will mean more repair business, more radio sales, bigger profits. Tie-in with their own advertising programs will stimulate business for themselves.

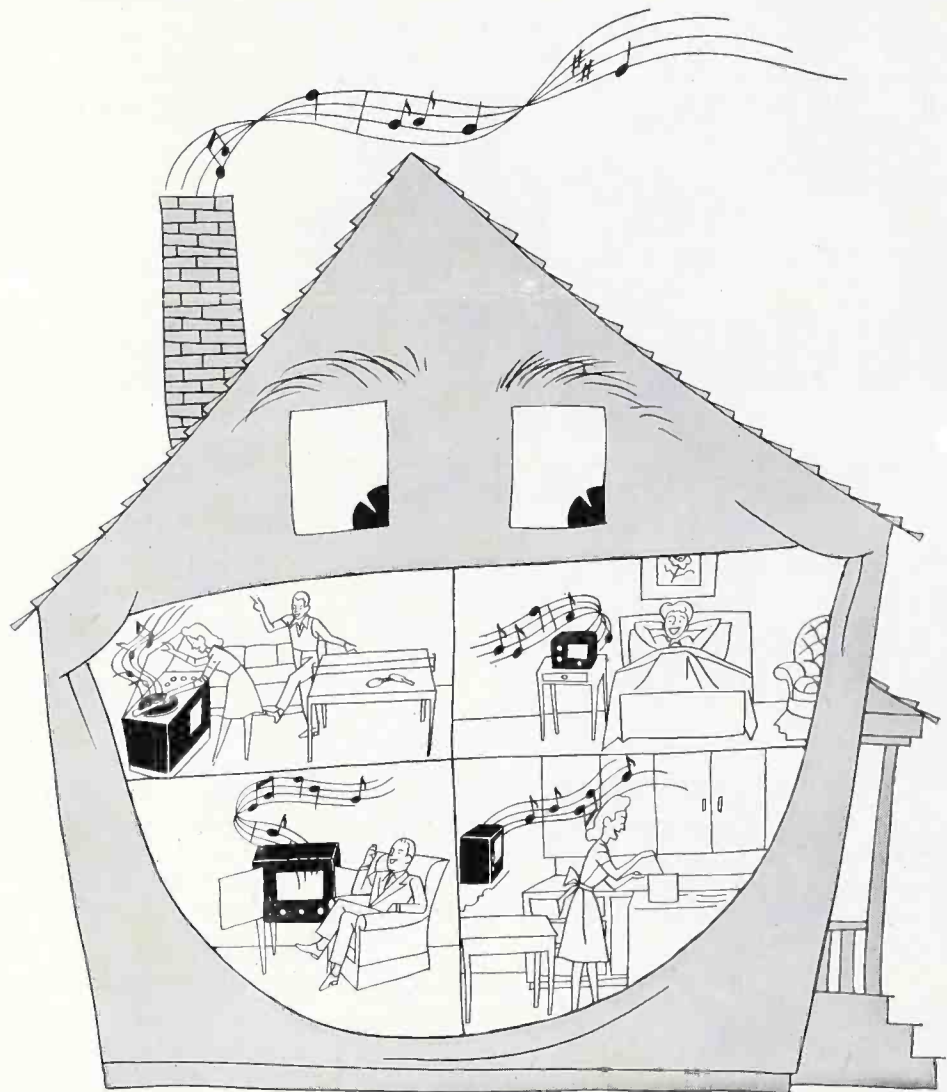

## . . . MEANS A HAPPY HOME

# BABY SQUAWKS, PAPA WALKS . . .



## TO THE NEAREST RADIO SERVICE SHOP

Here is the second in the series of Sylvania's cartoon ads which will appear during June and July in the nation's three top magazines. (Announcement of the series was made in the May issue of SYLVANIA NEWS.)

☑ This particular ad should appeal to parents who have their hands full with new arrivals and dread duplications of baby's squawks in their radio too. Reminders like this will bring customers to your door. They know your service is tops—you're a "Great Guy!"

You can be sure too that there will be plenty of prospects in your town because this ad, in quarter page size, will appear in LIFE on June 30, COLLIERS' and SATURDAY EVENING POST on July 12.

Smart dealers will use Sylvania service aids and point of sales helps to identify themselves with the campaign. This is an opportunity no one can afford to miss. See your Sylvania distributor for his list of sales helps and use them in your windows and on your counters.

## IS YOUR RADIO SQUAWKING, TOO?

You won't have a single "squawk" coming if you have your radio looked over every six months. Then you'll be sure to hear your favorite programs clearly all the time. And how this check-up saves big repair bills! Let your local radio service dealer keep your radio in shape. His work is good, his prices fair. His Sylvania equipment and Sylvania Radio Tubes help him give you maximum radio enjoyment. There are no finer radio tubes made.

Product of Sylvania Electric Products Inc.

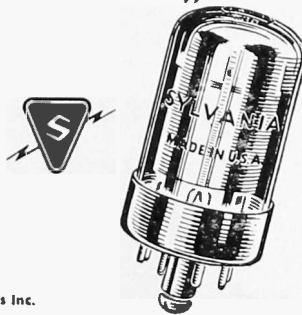

# SYLVANIA RADIO TUBES

## HUGE RADIO MARKET IN STORE THIS YEAR

Service dealers can look forward to a big market for radios this year, according to a recent survey made by COLLIERS'. It was found that over 1,341,000 COLLIERS' families will buy about 1,530,000 radios next year at a cash outlay of \$193,000,000.

Pre-war buying tastes were found to have changed and the consumer has switched to preference for radio-phonograph combinations. Buying demand for this type of radio will be about 983,000 sets.

The survey was made in a carefully selected cross-section of COLLIERS' readers who revealed that nearly half (48%) would buy a new set in 1947; 49.3% will buy a console type radio-phono, and 19% will buy table combinations.

### Many Sets Not Working

The report shows that 99.3% of the homes polled have at least one

set, however, 8% of these sets were reported out of order. The average number of receivers in working condition was found to be 1.8 sets per home, which, compared to a similar survey made in 1939, shows a steady increase in the number of families owning two or more radios.

Over half of the radios in use today are plain table radios; a third are consoles; and only slightly more than one out of ten are of the combination radio-phono type.

### FM Sets Wanted

About 1,078,000 families expressed interest in having a set with FM, and, what is more, they are willing to pay more than the ordinary price to get it. A third of the families interviewed frankly admitted that they don't really know what FM means. It was revealed that four out of five persons

polled are willing to pay an average of about \$30 or more for an ordinary set.

297,000 COLLIERS' enthusiasts would include television receivers among their present buying plans. However, most families have the notion that home video sets are in combination with radio sets which might indicate difficulty in selling problems on separate television receivers.

Over half the families (56.9%) admitted having no idea of the value of a television set; those who thought they did know figured that the price should be about \$215.

The survey results should indicate to servicemen that a large potential market exists in radio. The figures themselves are convincing, but it should be borne in mind that the audience polled is only a small cross-section of the buying public.



# SYLVANIA NEWS TECHNICAL SECTION

Copyright 1947, Sylvania Electric Products Inc.

A. V. BALDWIN, Technical Editor

These data have been compiled from information which we believe to be accurate. No responsibility can be assumed in the application thereof or for patent infringement.

JUNE-JULY, 1947

EMPORIUM, PENNA.

VOL. 14, NO. 6

## SERVICING WIRE RECORDERS

THEODORE WROBLEWSKI, Engineering Department Colonial Radio Corporation

*Wire recorders are becoming quite popular and we believe many of you will be getting service calls on them soon. This article by an engineer who has done considerable design work on wire recorders will give you confidence in working on any of these that come in for repair.*

The art of magnetic recording is approximately fifty years old. However, it took the recent war to add enough impetus to make the present home recorders possible.

A wire recorder consists basically of two units, one is the mechanical part which spools the wire from the reel to reel, and the second is the electrical part which consists of the recording head and its associate amplifiers. In treating the subject, we will first review the "drive" or mechanism and then discuss the amplifier and recording head.

Several methods of spooling wire have been devised but in any system there are certain basic requirements. Some of these are as follows:

1. The wire must pass over the recording head at a uniform speed free from erratic or sudden changes.
2. The wire must pass over the play-back head at the same speed at which the recording was made.
3. The wire must be under uniform tension.
4. The wire must be wound onto the spools and uniformly spaced with the turns side by side to allow it to unwind properly without snarling.
5. A method for rewinding the wire is required.

In addition to the above, the system must include a method for stopping the spools at high rates of rewind speed without breaking the wire and an automatic stop must be provided to stop the machine when the wire comes to the end of the spool.

Several home-type wire recorders have recently been placed on the market, but this discussion will mainly deal with the model recently

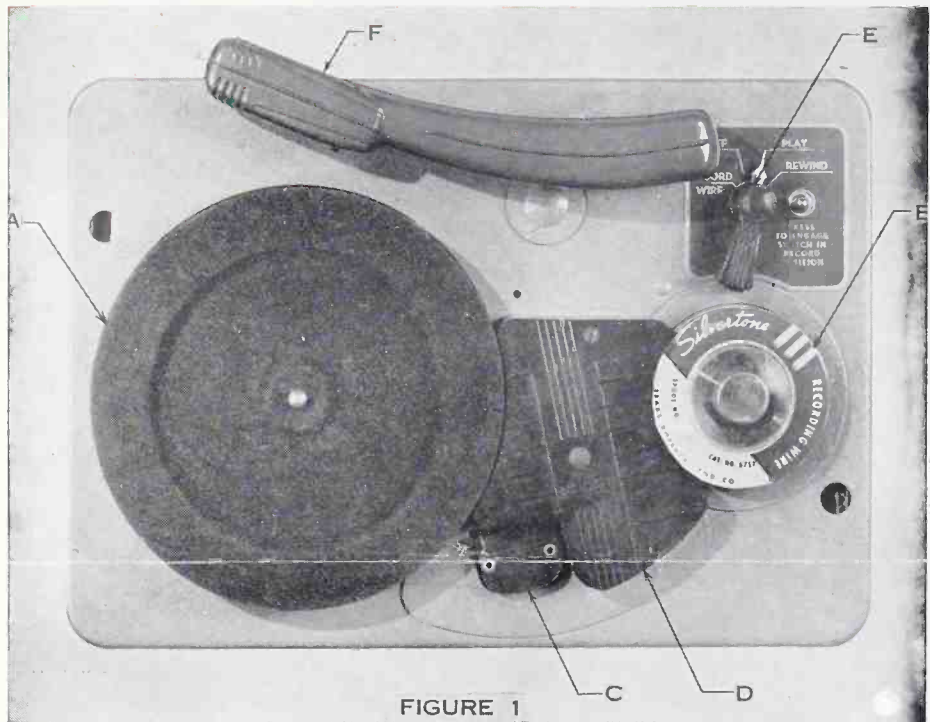

FIGURE 1

introduced by Sears Roebuck & Company.

### Mechanical Features

Figure 1 is a top view of the mechanism. This consists of (a) a large spool (turntable) which has an inside groove diameter of approximately  $5\frac{13}{16}$ " (b) a supply spool (c) head (d) automatic switch (e) main control (f) tone arm. Turntable B diameter was chosen such that it turns 78 RPM in order to permit the user to have the additional feature of a record player. The supply spool is a band type of spool which presses onto the hub. The recording head oscillates up and down to level wind the wire on the take-up and supply spools. The automatic switch shuts the machine off when the wire comes to the end of the spool. The main control switch has four positions: (1) record, (2) play-back, (3) rewind, and (4) off. Tone arm is used for playing records.

Figure 2 is the bottom view of the mechanism. As can be seen from the pulley arrangement, the motor drives a pulley which in turn drives a pulley on the rim of the turntable similar to a record player. When the mechanism is switched to "off" or "playing" the idler (a) engages between the motor shaft and turntable thus acting as a brake in going from rewind to stop or play, the springs (1) and (2) provide proper tension during the play or rewind to give proper winding onto the spool and tension as the wire passes over the head. Idlers b, c, and d engage drum, (e) in the rewind process. Item (f) is the level wind mechanism which is geared from the supply spool. This oscillates the head up and down to give the required number of turns of wire per layer onto the supply spool. The above description covers the basic mechanism. Naturally there will be varia-

(Continued on next page)

## SERVICING WIRE RECORDERS (Continued)

## RECORD AND PLAY BACK HEAD

tions of the parts from time to time. Other mechanisms are on the market which have other types of drives but the problems are quite similar.

## The Play-Back Head

The heart of a wire recorder perhaps is the magnetic recording and play-back head. This consists of two coils which can be wound on separate laminations or on a common one as shown in Figure 3. The functions of these coils are: 1. Erase coil to provide enough energy to erase a signal on the wire, and provide the proper supersonic bias for proper recording. The bias is primarily used to raise the recording head to a linear portion of the wire hysteresis curve. 2. The record coil provides the required magnetization which is impressed onto the wire. For play-back the record coil is generally used to pick up the signal from the wire. Essentially, in recording, the varying input signal varies the amount of magnetization on the wire. This variation of magnetization of the wire in play-back induces voltage in the play-back coil which in turn is amplified and provides the necessary signal for listening. As shown in Figure 3, when the wire passes over the erase or record coil it passes over a small gap. The wire effectively short circuits the magnetic circuit and is thus magnetized in the process. In general, the erase gap is on the order of five to ten times as great as the record gap. The gap

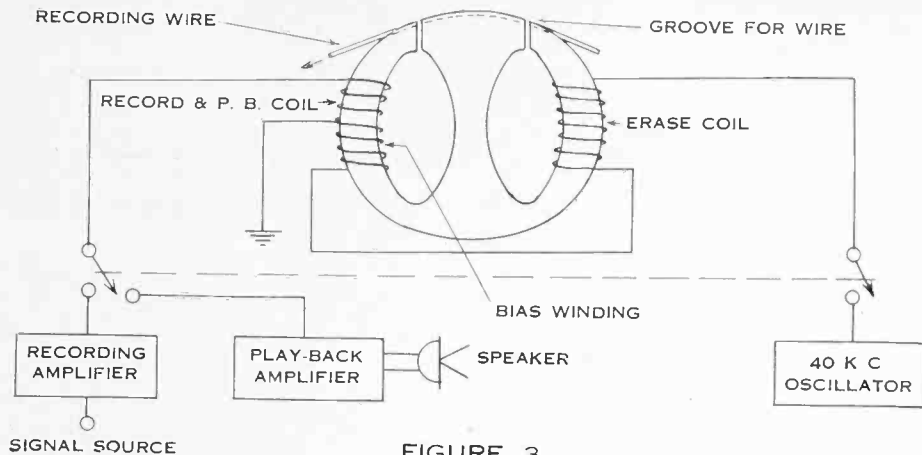

FIGURE 3

distance for the record circuit is approximately one to two mills (.001"—.002").

The gap width in the record coil determines the frequency response for the head and wire. Generally speaking, a larger gap gives more lows but less highs, therefore, an optimum value is generally picked.

## Response Curves

If proper bias is applied to the recording head and the head is connected to an amplifier which has a flat response and a constant current signal source is used, the play-back voltage will look as in Figure 4A. It will be observed that the response curve as shown is lacking in "lows" and "highs". As a result it is necessary to emphasize the "lows" and "highs" in either the record

process or play-back process, or both. A common method is to emphasize on record so that the record amplifier has a response curve as shown by Figure 4B. Combining the two curves the result is shown in overall response curve in Figure 4C. This final response curve is that which is required for good listening. The overall response curve in play-back can be varied by conventional methods of boosting the highs or lows as desired.

The wire used for recording on a Sears recorder is a stainless steel wire with a .004" diameter. It passes over the head during the record and play-back process at approximately 2' per second. The wire, if broken, can be tied together with a square knot and the loose ends trimmed off with an ordinary pair of scissors. A knot will pass over the head without any trouble.

## Servicing Suggestions

In servicing wire recorders of any type several simple points should be checked which we will list as follows:

## A. Mechanical

1. No loose parts.
2. No varying friction or "drag" in the mechanism to make the wire tension change.
3. All adjustments set so that no loose windings develop and the wire is properly wound.
4. Brakes set properly.
5. Head oscillates to wind the wire uniformly.

## B. Electrical

1. No opens or shorts in the recording head.
2. Check bias for frequency and voltage.

(Continued on page 24)

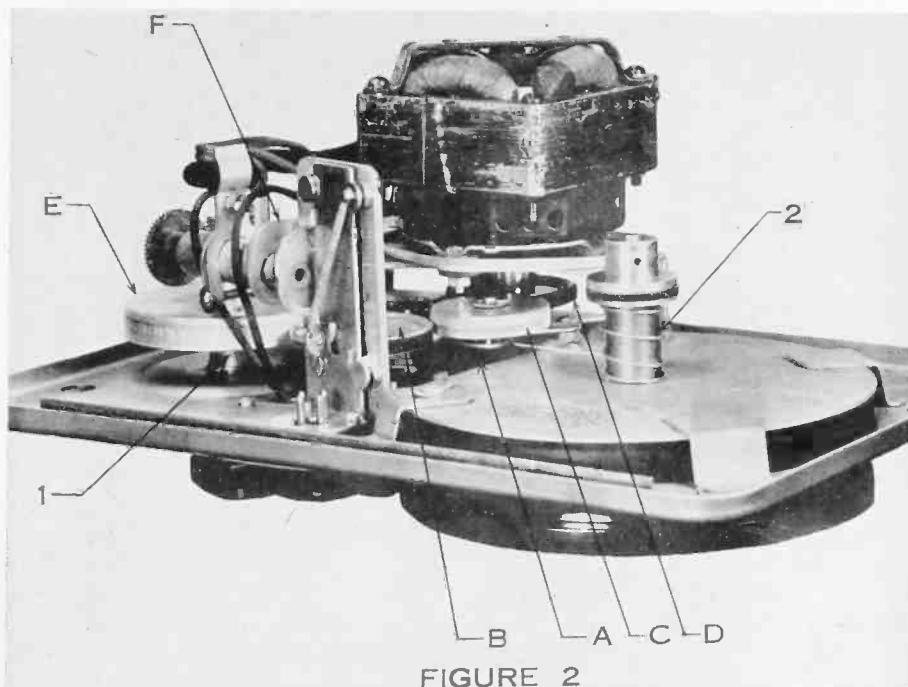

FIGURE 2

# 3,000 VOLT POWER SUPPLY FOR CATHODE RAY TUBES

3000 VOLT CATHODE RAY TUBE POWER SUPPLY

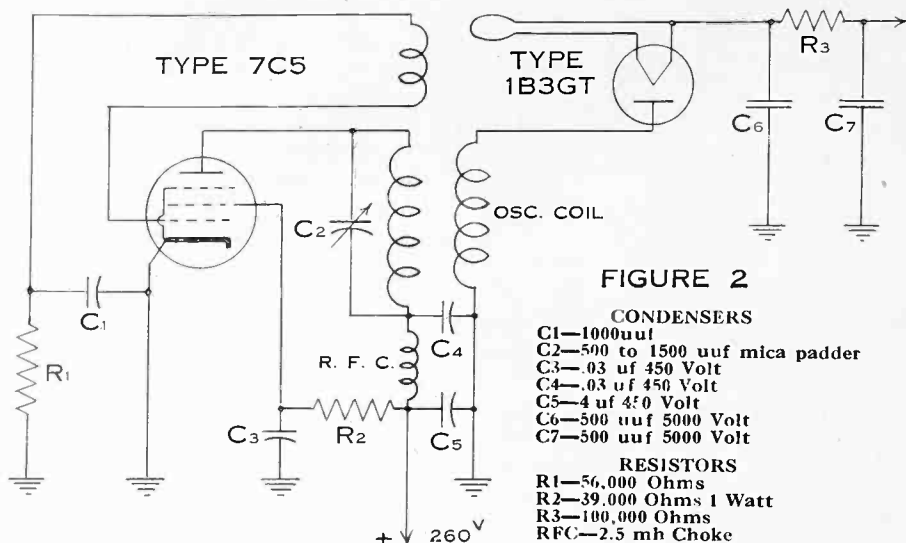

FIGURE 2

- CONDENSERS**  
 C1—1000uuf  
 C2—500 to 1500 uuf mica padder  
 C3—.03 uf 450 Volt  
 C4—.03 uf 450 Volt  
 C5—4 uf 450 Volt  
 C6—500 uuf 5000 Volt  
 C7—500 uuf 5000 Volt
- RESISTORS**  
 R1—56,000 Ohms  
 R2—39,000 Ohms 1 Watt  
 R3—100,000 Ohms  
 RFC—2.5 mh Choke  
 Osc. Coil—Essex #A662

Basing for  
Type 1B3GT  
(Also Known As  
Type 8016)



inserting the ends in tight-fitting holes in the panel. Be sure to provide wide spacing between the 1B3GT filament circuit and all other components. The whole unit should be completely enclosed in a shield can having copper screen over the necessary ventilating holes.

The high-voltage lead between the oscillator coil and the rectifier plate should be short, of large diameter and without sharp bends in order to reduce corona loss. Poor construction here could greatly reduce the output obtainable.

### Adjustments

The coil assembly is factory adjusted for proper coupling, so the only two adjustments are the tank condenser C2 of Figure 2 and the filament heating loop. The tank circuit is adjusted to maximum before the rectifier tube is inserted by use of a small loop and a neon lamp. The coil is designed for use at approximately 270 kc but since the unit is completely shielded this is

(Continued on next page)

Some time ago, in the January, 1944 issue of SYLVANIA NEWS, we described a method of obtaining small quantities of DC power at high voltage by stepping up and rectifying the voltage of an R. F. oscillator using a Sylvania Type 28D7.

We believe this method has a number of advantages such as compactness, light weight, and safety. Coils are now available for use with this system to get the high voltage necessary to operate cathode ray tubes for either oscilloscope or television service.

### Construction

A polystyrene panel about 5" x 7" x 1/4" is used as the base in order to get good insulation. The illustration Figure 1 shows the approximate location of the parts. The coil and the two tubes are mounted above the panel, bypass condensers, resistors and choke underneath with the plate tank tuning condenser wherever convenient for adjustment. Note however that this model was made for use in a laboratory set where reduction in size was important so the nearest equivalent miniature types 6AQ5 and 1Z2 were used. The coil will dissipate heat better if mounted with the axis horizontal, but we have had no trouble with heating when mounted vertically as shown. The filament heating loop is made from bare or enameled No. 12 copper wire formed to about 2" diameter and mounted rigidly by

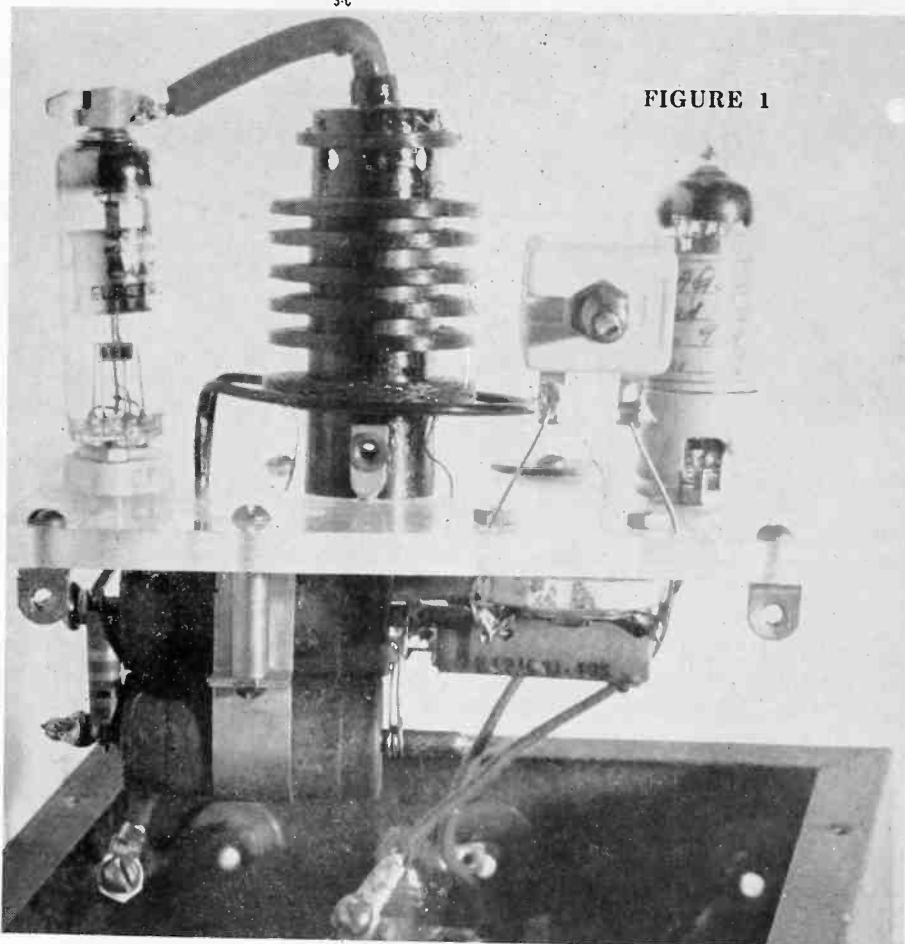
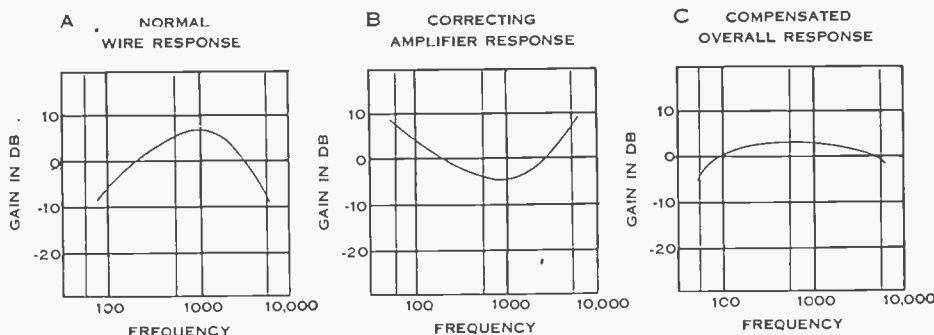

FIGURE 1



## WIRE RECORDERS *(Continued)*

FIGURE 4



3. Check recording current.
4. Check rest of amplifier in normal way.
5. Make sure the wire rests properly in the groove of the recording hand.

It is impractical here to give recording currents and bias voltage because there are so many different heads available and in use. The same is true for bias frequency although this is generally between 25 and 40 Kc.

In recording on wire normal recording precautions common to all types of recording must be followed, such as, microphone placement, acoustics, monitoring for proper level. One of the things to watch in wire

recording is not to overload the wire, that is, to make sure your recording level is properly adjusted. If too much signal is impressed on the wire, it will sound distorted at play-back and it will be difficult to erase the wire completely. Incomplete erasure will have a signal in the background which will be noticeable on subsequent recordings, especially on soft passages. This will sound similar to an interfering distant radio station on the same band in an ordinary home radio. Often times several passages of the wire over the erase head will completely erase even an over-recorded signal. In most wire recorders erasing is accomplished while recording. The wire passes

over the erase head first and is prepared for recording so it is possible to record right over a previous recording. In order to erase a portion of a recording simply turn the input signal control to zero (0) and record. This will automatically erase without recording.

In magnetic recordings it is also important to get enough signal on the wire because the output of the play-back head is on the order of one (1) millivolt for normal recording unless enough signal is available a very high gain amplifier will be necessary. In some cases enough level will not be available with present recorders if the recorded signal is too low.

A wire recording may be kept and played back thousands of times without any increase in noise or loss in signal level. Also, the number of new recordings on the same piece of wire is unlimited.

In handling a wire recorder, normal precautions must be followed and for "live" recordings proper microphone placement and room acoustics are essential. If simple precautions are followed, it is possible to attain a very high quality of recording on these simple devices known as wire recorders.

## 3000 VOLT POWER SUPPLY *(Continued)*

not critical. After this adjustment for maximum output voltage the rectifier tube should be inserted but before connection is made to the top cap the loop should be adjusted to give the proper filament voltage. This is done best with a Sylvania Polymeter or similar vacuum-tube voltmeter, but if a suitable instrument is not available the temperature of the filament should be compared visually with a similar

filament operating from a metered source. After connecting the top cap the load voltage may be read with a DC meter like the one described last month. **WARNING.** Do not try to read the filament voltage with a vacuum-tube voltmeter after the top cap has been connected as most meter insulation is not designed for such high voltage above ground.

The output voltage may be varied

either by changing the load or by adjusting the plate voltage of the oscillator tube. The unit as made here has an output of 3300 volts at 230 ua which increases to 5000 volts at 20 ua. Intermediate loads will give output voltages almost exactly in linear proportion between these points but would drop off rapidly if much higher currents were drawn.

In a later issue we hope to give similar information on an 8 to 10,000 volt unit. At the higher voltages some additional precautions are necessary.

## SERVICE HINTS

**Silvertone R5501:** Many servicemen repaired this set, that is, replaced the dial cord and it either jumped off or broke, but they didn't find out **WHY**.

The condenser gang rotor is suspended in a special pair of brackets that revolve with it, in fact, are soldered in place at each end. If this gang breaks loose at one end, the rotor plates hit the binding rod that holds plates to-

gether and stops at about 80 on dial. If the owner has pushed a push button to say 1210 something has to give and the cord is weakest.

This is a difficult repair to make unless two soldering irons are available. One using a  $\frac{3}{8}$ " tip was filed flat  $\frac{3}{32}$ " so it will go into narrow space, end of tip is also filed flat, giving a flat face about  $\frac{3}{32}$ " x  $\frac{3}{16}$ " and tinned. This iron is inserted in space to make contact with joint

and 1" tip iron or larger, laid against the upper part of tip of smaller iron to give extra heat. This resolders joint like original condition.—David V. Chambers, Upper Darby, Pa.

**Speaker Cone Repair:** To patch holes in speaker cones I cut a piece from any old cone. You can select from your old cone a piece that has the proper contour.—Tracy's Radio Shop, Danville, Ohio.

# LIST PRICES INCREASED JUNE 2 ON 37 TYPES OF SYLVANIA RECEIVING TUBES

Effective June 2, the following revisions in retail selling prices were announced by Sylvania.

Type	RETAIL PRICE	
	June 2	Prior to June 2
	REVISIONS	
1A6	\$2.65	\$1.80
1C6	2.65	1.80
1C7G	2.65	1.80
1D7G	2.65	2.20
1F4	2.20	1.80
1F5G	2.20	1.80
1G4GT	2.20	1.80
1H4G	1.80	1.35
1J6G	2.65	1.80
2A5	1.80	1.35
2A6	2.20	1.35
2A7	2.20	1.50
2E5	2.20	1.80
6AC5GT	1.80	1.50
6D8G	2.65	2.20
6L7G	2.65	2.20
6P5GT	1.80	1.10
6R7GT	1.80	1.25
6S7G	2.65	2.20
6SF5GT	1.80	1.35
6T7G	2.65	1.80
12Z3	2.20	1.35
19	2.65	1.80
30	1.80	1.35
32	2.65	1.80
32L7GT	3.20	2.65

## RETAIL PRICE

Type	June 2	Prior to June 2
	REVISIONS (Continued)	
33	2.65	1.80
36	2.20	1.35
46	2.20	1.50
56	1.50	1.10
57	1.80	1.25
58	1.80	1.25
71A	1.80	1.25
76	1.50	1.25
77	1.50	1.25
85	1.50	1.25
117L7GT	3.90	3.20

## ADDITIONS

FM-1000	\$3.20	—
1273	2.20	—
1280	2.20	—

A new price schedule incorporating these changes has been prepared. As a matter of service to the trade, we have followed our regular practice of listing not only current types but also a number which are obsolete.

All Sylvania Distributors have been supplied with quantities of the revised Retail Price Lists. If you have not obtained a copy please see your Sylvania Distributor or write to Sylvania Electric Products Inc., Emporium, Pennsylvania.

## MANUFACTURERS' SHIPMENTS INCREASE

Shipments by manufacturers increased by \$1 billion over the February level to a total of \$13.8 billion, but the rise was entirely accounted for by the difference in the number of working days in the two months. The daily average indicated the value of shipments declined about 2%. Durable goods industries, however, increased their daily average rate of shipments along with their increase in inventories.

## WINDOW DECAL NEW ADVERTISING AID

It's good business to let your customers know that you are part of the Sylvania family, and even if you have told him before, frequent reminders are still in order.

Newest of Sylvania dealer helps which informs the public that you are in the radio business, with finest parts and the best of service, is the window decal pictured below.

It is in three colors with bright Sylvania green and bold black lettering on a white background. The bright lettering stands out to tell your friends that you are in the service business.



The new decal measures 5 inches by 7 1/2 inches and can easily be applied to your window or door. Simple instructions on the back tell you how to fix it permanently where you want it. You can put it in place in nothing flat.

Sylvania decals are now available FREE from your distributor. Order one from him the next time he visits you. It is the mark of quality in radio tubes.

## WHOSE MAGAZINE IS THIS ANYWAY?

That's just what we asked ourselves the other day. Thought we'd see if we could get a good answer, so we asked the boss. He was quite surprised.

"It belongs to all those men and women who are the backbone of the radio repair business," he said. "They are the guys that come first with the NEWS."

That was enough to convince us. And it should be enough to convince you. So here it is, all yours. Yours to do what you want. We

are only the clearing house. Now, it's up to you. If you want to read the best about your job, send us your ideas and suggestions, you'll get others in return.

If you have a good idea for getting business or doing a better job, why not pass it along to some other guy who might not know about it?

Take some time soon and send your stories to THE EDITOR, SYLVANIA NEWS, 500 Fifth Avenue, New York 18, N. Y.

THE EDITOR

# GOT AN IDEA?

## \$5 REWARD \$5 In Merchandising Aids

What's an idea worth?

Have you any tricks of the trade that save you time and money? Well, if you do, we'd like to give you five bucks for it. Yes, sir, we said \$5! It's as easy as falling off a log, and the five bucks won't just be some dough in your pocket for an evening's fun, but better than that, we're going to give you the equivalent of that sum in advertising material, Sylvania advertising material. So really, it's more than just five, because that advertising material will be something that will put more dollars into your pocket.

### Have You a Money Maker?

All this is well and good, but naturally you want to know just what you have to do. Well it's simple. Just relax a minute. What have you done to make your business run better? Have you a novel advertising scheme? Do you have some homemade gadgets in your shop to speed up your work? What is the best way you keep your customers coming back and the new ones flocking into your store? They probably don't get there by chance.

Well, these are just some of the ideas you might work on. Maybe you have plenty of ideas for running your business that other guys don't know about. Let them in on it and cut yourself in for \$5 worth of loot from the "Pennies" folder.

### Paper, Pencil, Stamp

If you're game to try it, here's all you do. Write us a letter about your brainstorm. (You don't have to be a genius at writing, because we can read most anything.) Put the idea on paper and, if you can, draw us a picture. (You don't have to be an artist either.) We will look the thing over, and if it's good we will put it in the NEWS and send you a certificate for \$5. Easy isn't it?

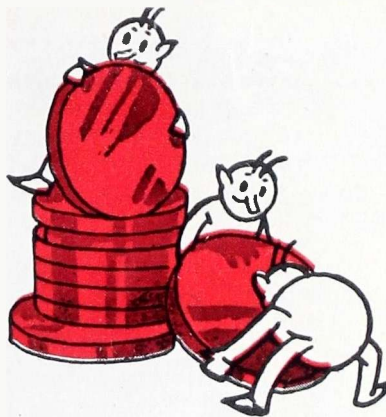

### Must Be Serviceman

Of course, you must be a radio serviceman to compete and your idea must be tested. If it has worked successfully for you, that is all that matters.

Don't worry about something world shaking. No matter how small a thing is, it probably has merit. And in case you won some money before, don't worry about that either. You can win as many times as you have a good idea. We're not too fussy about receiving a couple of ideas along the same line

from different people, and we'll send along a \$5 certificate to all concerned if the duplicate idea is used. That means you won't lose out if someone sends in an idea like yours at the same time you do. If your idea is published, we will give you full credit for it in the NEWS.

That's the deal in a nutshell. Sit down and write us a letter with an idea and sit back. Your \$5 certificate will be in the mail in a few days. Our address is, The Editor, SYLVANIA NEWS, 500 Fifth Avenue, New York 18, N. Y.



# TELEVISION DEVELOPMENTS

## TELEVISION ANTENNA PLAN ACCEPTED

Acceptance of the much-disputed apartment house television antenna plan of the T.B.A. has been announced by one of New York's largest realty concerns. The plan was originally rejected as "inadequate" by owners of 700 multiple dwellings in the New York area.

In statement made jointly with the broadcasters, Robert W. Dowling, President of City Investing Co., said his concern had accepted the T.B.A. "interim plan" which provides for the erection and use of temporary video antennas until permanent ones can be developed and installed.

The action affects more than 2,000 tenants in 13 apartment buildings who may now apply for antennas and buy receivers for installation.

Mr. Dowling pointed out that it is futile for apartment owners to blind themselves to the fact that television is now a reality. "It would be equally futile to attempt to deprive tenants of a television service if they desire to have one," he said.

In the "interim plan", a limited number of dipoles will be installed until such time as a master system, capable of feeding all receivers in one building, can be fully developed, tested and installed.

## WHO SAID RADIOS ARE HIGH PRICED?

*(Continued from page G-22)*

means that the cost is about 24 cents an hour to see a movie compared with 1/2 cent an hour to listen to the radio. Then too, 93 per cent of the people probably didn't go to the movies last year while they still had their radios.

What does all this mean? Well you might look at it this way. For 0.43 cents an hour, 93% of our country's population was able to get entertainment of any variety 24 hours a day, seven days a week. All of which goes to prove that radio is the cheapest form of entertainment a person can purchase with his money today, in fact, any day.

## NEW YORK TELEVISION DEALERS VOICE GRIPES IN SURVEY

Television dealers in the metropolitan New York area where video is a growing child have tossed some brickbats at the industry in a survey published by THE TELEVISER, a television trade publication.

Biggest gripes were about prices and program quality. The dealers expressed the belief that drastic price cuts in video receivers and considerable improvement in programs will be necessary to make television the early success expected.

The survey revealed that the public is prepared to spend \$500 for a video receiver, providing the instrument includes AM, FM and a phonograph. Such receivers are now selling in the \$800 to \$2,500 range.

More than half the 800 dealers polled felt that table models, biggest seller today, should be dropped in price to \$200 to \$300 per set. Present standard makes of this type are selling for \$250 to \$400. Console prices, stated the dealers, should range from \$500 to \$750, with the top price giving an all purpose receiver in return.

At the present time, the dealers indicated receivers are selling on a cash basis with very few customers asking for time-payments.

Biggest obstacles to present day selling of video receivers is the ban by apartment owners for erection of antennas. Installation costs and poor quality of programs follow in customer reluctance to buy.

## COLOR VIDEO SYSTEM DEMONSTRATED FOR THEATER USE

Television images 7 1/2 feet high and 10 feet wide were demonstrated at a recent showing of a new color television system at the Franklin Institute in Philadelphia. The images were in good color and were projected on a large theater size screen.

The system used was the RCA all-electronic "simultaneous" system. Kodachrome slides and films were used as a source for transmission. The images produced were excellent in clarity and of unusual intensity, although they lacked somewhat in the delicate color gradations seen in nature.

Engineers report that the system is still in the laboratory stage, but that it is probable that in two years it might be developed for use in theaters. Five years will be required to perfect the system for home use.

One of the features of the system is its ability to utilize either black and white or color in its transmissions. Either system can be had by only flipping a switch.

In color transmission a system called the "flying spot" is used to

scan the original scene, producing three identical images. These are passed through the film or transparency to be sent to a "beam splitting" device, thence to pick-up tubes for each primary color. The result is three colors corresponding closely with the original, which are greatly amplified and broadcast.

The reverse process, essentially, takes place at the receiver. The three colors finally emerge from three separate small high-power cathode tubes, operated at high voltages to project the images, and these emerge through special optical lenses to form the final view.

Work is now under way to adapt the system for outdoor pickups. Field tests are to be made in the metropolitan area during the summer.

## ON THE COVER

Precision equipment melts off the excess glass exhaust stem sealing the vacuum. This is one of the many processes involved in making the famous Sylvania Lock-In Tube.

# WATERBURY SERVICEMEN MEET FOR VIDEO DISCUSSION



The Independent Radiomen's Association, Inc. of Waterbury, Conn. is shown above at a recent meeting on the fundamentals of television. One of the most progressive groups of its kind, the organization holds regular meetings for discussion and instruction in current topics of radio servicing. Speakers at the meetings include many prominent men in the radio field. Pictured above are: Andrew Battaglia; Walter Carrington; Sal Catuccio; Connie Faro; Pat Canelli, Vice President; Arthur Andrus, Secretary; Mike Barrachine; Louis Cipriano; Joseph Smith; Howard Kemp; Miro Ferri; Joseph Hildebrand; Anthony Rolli; Gene Blower, Financial Secretary; Al Kylloman; Eddie Bellemore; Walter Scappini; Gaysie Stokes; Angelo Stanco; Joseph Ruggiero; Leo Phelan, President; Raymond Fulliero; Elias Sterling; Henry Posila.

# FACTS AND FIGURES...

## Radio Ownership Increases

One in every three U. S. families has more than one radio, and one out of every five bought a new radio in 1946 according to a recent CBS survey. Total home sets bought in 1946 was 8,500,000, 30% of which were purchased by prosperous families; 40% by average families; 30% by poor families. In urban areas 18% of the families bought single sets; 21% in rural non-farm areas; 22% in rural farm communities. 1% of all families bought 2 or more sets in 1946. Total public outlay for new home radios was \$330,000,000.

## Set Output Rises in April

FM-AM receiver production took a sharp upturn during April. RMA member-companies reported producing 112,256 FM-AM sets and a total of 1,759,723 of all types of receivers for the five week period ending May 2. The period included the last working day in March and the first two days in May. April FM-AM set production represented a substantial increase over March and was well ahead of the 23% monthly average rise between Oct. 1 and Feb. 28. The rise over March was 48%.

## New FM Station Grants

Conditional grants for 7 new FM stations and construction permits for 9 other FM outlets were authorized by the FCC on May 22. At the same time, FCC records showed 223 FM stations in operation.

## March Appliance Sales Up

Sales of appliance and specialty dealers in March were 115% above the level for the same month last year and 15% higher than February 1947, states the Office of Business Economics. Findings were based on reports of 102 selected appliance and specialty dealers who reported a \$10 million business during the month of March. The same concerns showed only 1% increase in the cost value of their inventories compared with February.

## Tube Production Declines

Production of radio receiving tubes totalled 16,181,672 in April compared with 19,048,950 in March, according to a report by RMA member-companies.

**SYLVANIA NEWS**

SYLVANIA ELECTRIC PRODUCTS INC.  
P. O. BOX 431  
EMPORIUM, PENNA.

RETURN POSTAGE GUARANTEED

Sec. 562. P. L. & R.  
U. S. POSTAGE  
PAID  
Emporium, Pa.  
Permit No. 1

Mr. T. Laranowicz  
81 Chestnut St.  
Shickshinny, Pa.

For:

POSTMASTER: If Addressee has moved, notify sender on Form 3547, postage for which is guaranteed. When Form 3547 is sent abandon this mailing. Return only if no correct address is available.

Vol. 14, No. 6

JUNE-JULY, 1947

Published By  
**SYLVANIA ELECTRIC PRODUCTS INC.**  
Manufacturers of Sylvania Radio Tubes and Electronic Devices, Sylvania Incandescent Lamp Bulbs, Fluorescent Lamps and Equipment





# SYLVANIA NEWS

Copyright 1947, Sylvania Electric Products Inc.

R. A. PENFIELD, Editor

AUGUST, 1947

EMPORIUM, PENNA.

VOL 14, NO. 7

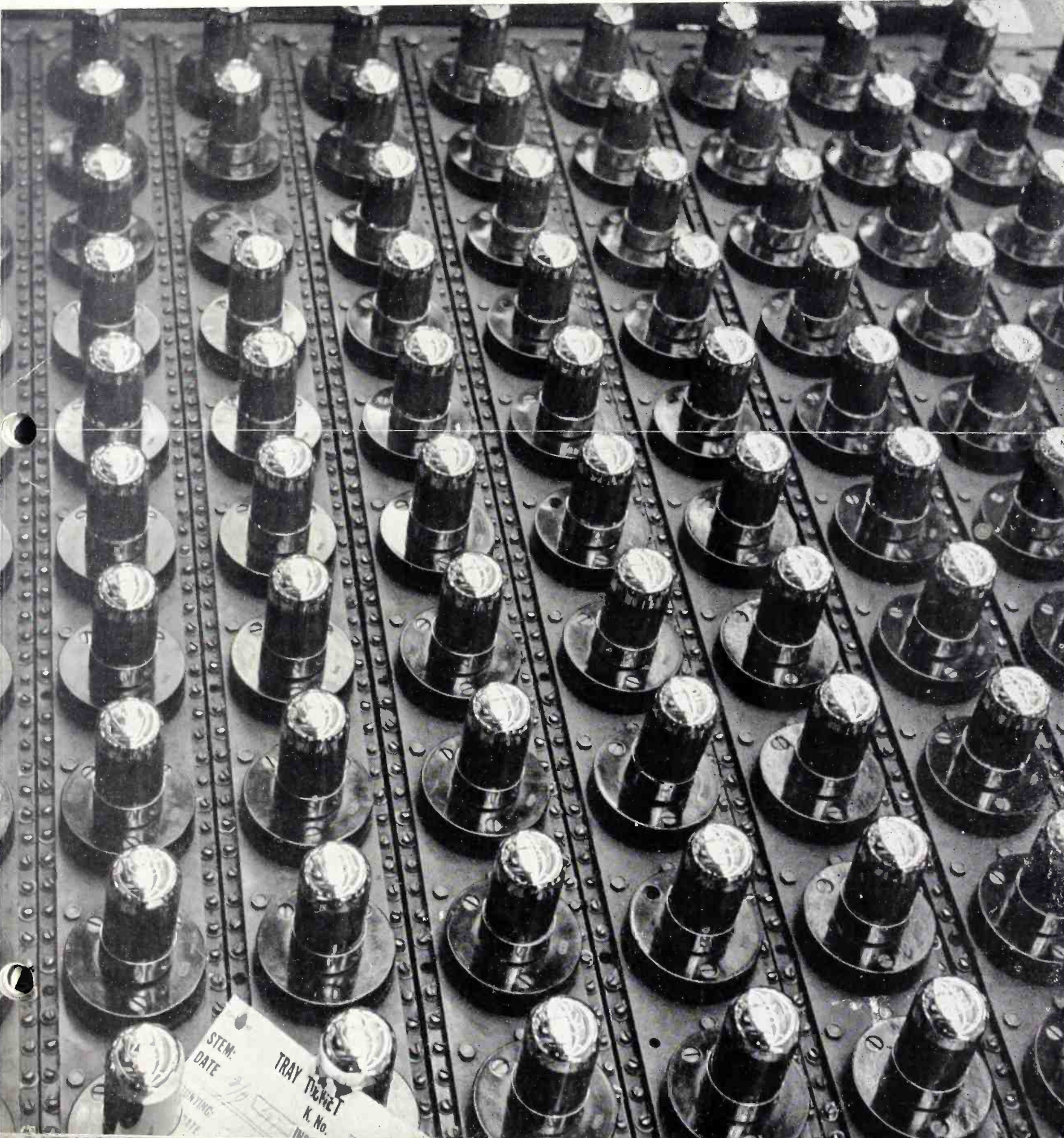



## SYLVANIA SERVICE MEETINGS BACK, TALKS BEGIN THIS MONTH



**JIM CANNING**

Prior to the war one of the most popular means employed by Sylvania for keeping radio servicemen up-to-date on the latest developments in radio was the Sylvania Service Meeting. Sylvania is pleased to announce that this service will soon be available again on a similar basis.

Old timers in the servicing business will recall with pleasure the

interesting technical discussions presented by Walter Jones, George Conner and Frank Langstroth in past years. Newcomers can look forward to an excellent opportunity to keep abreast of the technical developments.

Mr. J. H. Canning, Sylvania Commercial Engineering Department has been selected to carry on the work of addressing radio service and similar technical groups throughout the country. Jim is well qualified for this work. An interesting speaker, he holds a B.S. degree in Com. Eng. from Carnegie Tech, and carried on his own radio service business for two years prior to the war. He served as a Lieutenant Commander in the Navy during the war and was assigned to communications duty.

Jim has already spoken before service groups in the northeast and middle west. His schedule, when completed, will take him to all parts of the U. S. Your Sylvania distributor will inform you when Jim is to speak in your locality.

## WHO'S WHO AT SYLVANIA



**MEET BILL SHAW**

C. W. Shaw, genial sales manager of Sylvania's Radio Tube Division joined the company in 1931 to handle methods work; transferred into the sales department, going on the road selling lamps and tubes as assistant to the sales manager covering New England. Later spent considerable time in the New York area handling equipment tube sales. 1933 transferred to New York to work on equipment tube sales under B. G. Erskine, former president of Sylvania. In 1935 he was appointed manager of equipment sales. January 1, 1937 took over sales on renewal tubes as well as equipment tube sales, later becoming general sales manager of the Radio Tube Division, handling all domestic tube business.

Bill joined the Manufacturers National Bank of Lynn, Mass. in 1907 as a messenger boy and was head bookkeeper in 1912 when he left to join Central National Bank as teller and head bookkeeper. Following navy service in the First World War he joined Brophy Brothers Shoe Co. in 1920 as an accountant, later becoming assistant to the president; junior partner in 1924; assistant treasurer in charge of sales, then general manager of the business for several years.

Worked in leather factories and ran paper routes as a boy. Bill has risen through the ranks. He knows his business well, and under his guidance, Sylvania's feeling for the serviceman has become more sincere. Men like Bill Shaw are a credit to Sylvania and the industry.

## WANT A "WRIST RADIO"? FCC SAYS OKAY

Regular consumer use of Dick Tracy's "wrist radio" may not be too far in the future. FCC has now proposed technical requirements and procedure for obtaining type approval of equipment to be used in the contemplated new service.

Designated by the FCC as the "Citizens Radio Service," the system has been approved for operation in the 460-470 megacycle field. Technical standards for the equipment have been worked out by the FCC engineering staff and manufacturers. Efforts have been made to keep the requirements at a minimum consistency. The apparatus will be reasonable low priced and

will not require technical skill to operate.

The Citizens Radio Service will provide an opportunity for adapting short-range radio communication equipment, including pocket-size sets now under development, to varied personal needs. The possibilities for size utilizing this type of radio are unlimited with the use of printed circuits and subminiature tubes.

No licenses, except on an experimental basis, are being issued to the general public pending establishment of the Citizens Radio Service. The public will be notified as soon as approved equipment is available for operation in the assigned band and the Commission has drafted rules and regulations governing the system.

It has been pointed out that war surplus "walkie-talkies" will not operate in the assigned frequency. This equipment was designed for use in frequencies overseas, but would interfere with police, fire and marine if used in this country.

### ON THE COVER

Ageing is an important process in making radio tubes. The process involves life tests from a few minutes to several hours. Bad tubes are weeded out and good tubes are put into shape to take a beating.

# SYLVANIA NEWS MERCHANDISING SECTION

Copyright 1947, Sylvania Electric Products Inc.

AUGUST, 1947

EMPORIUM, PENNA.

VOL. 14, NO. 7

## DOES YOUR MAILING LIST WORK?

Whom do you know who needs his radio repaired? That's a pretty good question, and many radio servicemen often ask themselves just that. The worst part about it is, even if you do ask it, have YOU the answer?

When it comes to getting more business, it takes a wide awake guy to know just where. A lot of people depend on the customers coming to them, but the guys who are on their toes don't wait for that. They find the business and make it come to them.

The best darn business getter we know is a direct mail campaign. It



brings plenty of results, and fast—if you know the right people to put on the mailing list.

### Phone Book? Danger!

If you want to get some new customers, you've got to know where to find them. A lot of people use the old routine of looking in the phone book for names, but take it from us, this isn't the best place to look. You can get a lot of names for a starter, but you can build a better prospect list by other means.

Well then, what is another way that's better? One of the best suggestions to come along is one that you will find very effective. Take a few bucks from your pocket



and make a deal with a high school girl to work for you. For a small fee per name, let your new employee go out after school and call on people in your neighborhood. Make a list of questions for her to follow and soon you'll have some good names that will bring in a pile of business. You might call this "systematic money making."

### Research All Your Own

When you make up the questions include questions that will mean something to you. For instance (and these are good leads):

Name, address; Have you a radio? Is your radio in good working condition? How long has it been since it was last checked? How old is your radio?

With these questions you'll get a



good idea of your potential market, and a darn good prospect list. From the list you will be able to tell where there is new business and where your postcard campaign might be wasted. For those who have new radios, the reminder need only be after long intervals. You can work on the people with the ancient sets for all you are worth.

### Uncle Sam Can Help

Another way you might run a direct mail campaign is to get friendly with the mailman. He usually has a lot of hot tips on new faces in the neighborhood and can let you in on a lot of secrets of the new families.

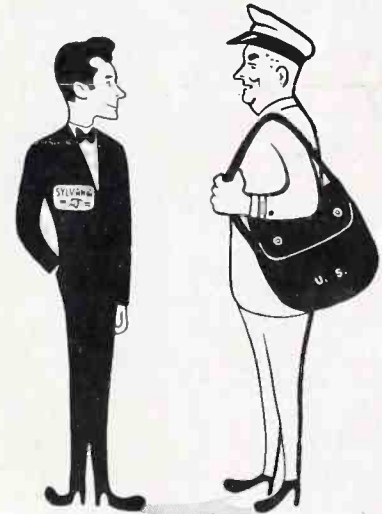

If you live near a hotel, there is another good bet for using your postcards. Most every hotel now has radio service for its patrons, and those radios are just as hard on tubes and parts as any other. Even if you make personal calls on these places, a postcard to the manager every month will keep you on his mind, and he will remember when his radios start acting up.

### Customers Know Too

Don't forget too, that your old customers may have some tips on radios that need repairs. You know,

(Continued on page M-26)

## FM BROADCASTERS TO COVER U. S. BY END OF 1948

Spokesmen for the FM Association predicted recently that by the end of 1947 there will be well over 700 FM stations servicing 80% of the population in the U. S. This information has spurred radio manufacturers to switch more output to FM receivers and has brought many newcomers to the set making field.

Arthur Freed, treasurer of the FM Association ruled out any immediate price reductions on FM sets because of costly materials required in components. He indicated, however, that reductions are "in the cards" in the not-too-distant future. Great need today in FM receivers is for reduced prices on table models now retailing between \$50 and \$100. The industry and broadcasters would like to bring prices down below the \$50 figure.

In spite of the trend toward FM it is generally agreed that the price gap makes a continued market for straight AM receivers assured for a long period. Large stocks of console combination radio-phonograph-

AM-FM sets are available, but mostly at prices out of reach for the average buyer. Many people are unwilling to pay the high prices asked for these sets. With the increase of FM broadcasters in the nation, production can be increased with the ultimate outcome in price reductions. Perhaps in a few months the situation will ease, but meanwhile, dealers must stew in an unstable market.

### DOES YOUR MAILING LIST WORK?

*(Continued from page M-25)*

the Jones' they visited last night and their radio didn't work just about time for Fibber Magee. They'll want their friends to get the good service they got and will be glad to give you some good tips on the radio situation in their neighborhood.

#### Firstus With Mostus

There is one thing about this mail campaign. Your postcards are your salesmen. Look at it this way. When you want to buy more insurance whom do you think of first? The guy who called on you last year, or the fellow who was in to see you yesterday? The one who was there yesterday, of course. It is the guy who is fresh in your mind that you think of first. That is just how a mail campaign works.

When the radio in the living room conks out, Dad looks in the phone book for the first name. But if you have the jump on the other folks with your Sylvania postcards, he'll certainly think of you. That is a

### LOOK !! MR. SECRETARY

It's a tough assignment trying to keep up with late technical developments in radio servicing. You have to read a lot and try a lot of experiments before you get many of the answers. Sylvania is anxious to help keep radio servicemen informed on new developments and that is why we maintain many engineers for research.

If you want your organization to keep abreast of the technical developments, Sylvania will be glad to keep you informed through the SYLVANIA NEWS and other technical publications. If your secretary or president is not on our mailing list, write us a letter about your organization and we will be happy to add your service organization to our list to receive all the latest technical information we have available. Address your requests to Advertising Dept., Sylvania Electric Products Inc., Emporium, Pa.

### SERVICE KITS

Sylvania Service Kits, a popular item with servicemen for a number of years, have been discontinued. Prices are high, quality is low and available supplies are extremely limited so that we are unable to meet the demand.

We have had no kits in stock for over a year and a half. All orders received, had to be placed on back order, until this condition, beyond our control, caused considerable dissatisfaction.

Kits could be purchased now in limited quantities but these kits are of inferior quality and priced out of the market. Rather than offer such kits to our customers, we believe it advisable to temporarily discontinue merchandising Sylvania Service Kits.

All orders for service kits from distributors are being cancelled and servicemen who have ordered direct will be reimbursed. Announcement of new kits will be made in the SYLVANIA NEWS when they are available at prices reasonable and quality good.

good bet to keep in mind.

There are plenty of possibilities for building up a mailing and prospect list. There are many not covered here, probably some we never heard about, but just keep in mind that when a radio squeals and squawks, it is the guy who has been there latest in person or in the form of an eye-catching postcard that gets the business.

### WHAT'S ON YOUR MIND, MR. SERVICEMAN?

It isn't easy to tell servicemen everything they want to know, but we're willing to try. The toughest thing about it is that we need suggestions, or, if you want to put it another way, criticisms.

SYLVANIA NEWS is for servicemen. It is just what they want it to be (at least we would like to have it that way) and we're willing to do anything to make their job easier. So if you have any brickbats, or

bouquets, won't you let us hear about them? We're willing to listen to anyone.

When you get a spare moment in that busy life of yours, why don't you sit down and drop us a letter or a postcard telling us about your gripes. You can be sure your letter won't go unanswered. Our address is SYLVANIA NEWS, 500 Fifth Ave., New York 18, N. Y.

THE EDITOR



# SYLVANIA NEWS TECHNICAL SECTION

Copyright 1947, Sylvania Electric Products Inc.

A. V. BALDWIN, Technical Editor

These data have been compiled from information which we believe to be accurate. No responsibility can be assumed in the application thereof or for patent infringement.

AUGUST, 1947

EMPORIUM, PENNA.

VOL. 14, NO. 7

## SERVICING WITH A MODERN OSCILLOSCOPE PART 1

By FRED DALASTA, Sylvania Sales Engineer

Many servicemen would like to become more familiar with the use of the cathode ray oscilloscope in modern servicing. A few years ago there was a flurry of interest in oscilloscopes, but this interest died out partially due to the high cost of the instrument at that time. However, in the quest for more expert servicing, and with the advent of FM and television an oscilloscope is becoming a "must" to the progressive service engineer. This is the first of a series of articles which it is hoped will aid our readers to fully appreciate the real possibilities of the oscilloscope which is becoming more widely used in AM, FM, television, audio circuits, etc.

In this issue we will consider the action of the electron beam in the cathode ray tube, the operation of the new Sylvania Oscilloscope, and its application in the analysis of a typical superheterodyne receiver.

### The Cathode Ray Tube

The cathode ray tube is quite similar to the common receiving tube in many respects, but instead of the electron beam accelerating in space toward the plate, as in the receiving tube, the cathode ray tube provides that the electron beam be accelerated and guided (focussed) so that the beam passes beyond the accelerating anodes and strikes the specially prepared screen located within the tube. Wherever the beam strikes the screen a luminous spot appears which is caused by the fluorescent property of the screen. The brightness of this spot (magnitude of beam current) is varied with a change in potential of the control grid much as the plate current is varied by the control grid voltage in a receiving tube. The spot will move on the screen when the electron beam is subjected to an electrostatic or magnetic field. Electrostatic deflection, as used in the

Sylvania Oscilloscope, is accomplished by passing the electron beam between a pair of electrodes called deflecting plates. When a voltage difference is applied between the plates, the electron beam is bent or deflected toward the more positive plate. With two pair of deflecting plates placed at right angles, the beam can be deflected in two mutually perpendicular directions simultaneously and the luminous spot observed over a wide useful area on the screen of the tube.

The outstanding feature of the oscilloscope is its ability to show a picture of a wave form or a combination of two or more wave forms whose amplitude is directly proportional to the actual voltage of the signal. The oscilloscope circuit supplies a sawtooth sweep voltage to the horizontal plates to cause the spot on the screen to move from the left side to the right side of the screen leaving a succession of luminous traces. When the spot reaches the right side of the screen, it returns with such speed that no objectionable trace is seen because it does not remain in any one spot long enough to cause sufficient fluorescence.

Now, when an alternating voltage is applied to the vertical plate in

addition to this sweeping action applied to the horizontal plate, this line will be drawn up and down by the variations in applied AC voltage. We see indicated on the screen a continuous picture of these variations. Actually, we see only the variations which take place in the time taken by the spot to be moved across the screen by the horizontal sweep. (Figure 1). Thus, if the spot moves across the screen in  $\frac{1}{60}$  of a second and a 60 cycle sine wave is applied to the vertical plates, we will see but one complete cycle. If the spot takes a little more or less than  $\frac{1}{60}$  of a second to get across, each sweep will show a different portion of the wave and a confused pattern will result.

### Using the Oscilloscope

Let us now place an oscilloscope, such as the Sylvania Type 131, in operation. First, check the AC power source for correct line voltage and frequency before plugging in the instrument. Set the VERTICAL and HORIZONTAL CENTERING and FOCUS pointers at the midpoint of their rotation. Set the INTENSITY (also Power Switch) control to  $\frac{1}{2}$  clockwise rotation. Set the HORIZONTAL GAIN between 2 and 4 and the COARSE FREQUENCY to 15-90 position.

After the tubes have warmed up, a horizontal trace will appear on the screen. Adjust the VERTICAL and HORIZONTAL CENTERING to position the trace on the screen. Readjust the FOCUS and INTENSITY to obtain the desired trace with respect to brightness and width. Adjust the HORIZONTAL GAIN for about a  $2\frac{1}{2}$ " trace. With a little practice one can readily remember the function of each control. The only precaution necessary is to avoid the maximum clockwise position of the INTENSITY control. A small bright

(Continued on next page)

FIGURE 1  
VOLTAGES APPLIED TO PLATES

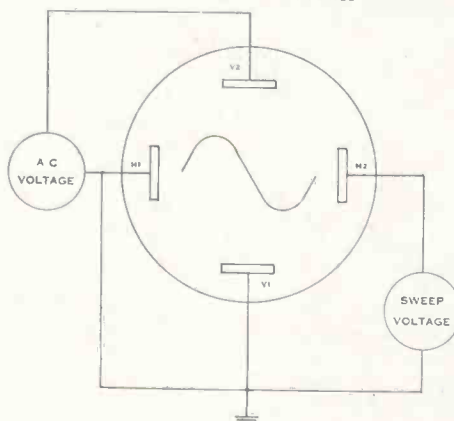

## SERVICING WITH A MODERN OSCILLOSCOPE *(Continued)*

spot on the screen will tend to burn the screen particularly if it is left on a long time. The other controls may be rotated without harm to the instrument.

To observe a 60 cycle sine wave, set the SYNC SELECTOR at LINE FREQUENCY. Connect the 6.3V AC terminal to the VERTICAL INPUT terminal and adjust VERTICAL GAIN for the desired pattern height on the screen. Turn the FINE FREQUENCY control to obtain 2 or 3 sine waves on the screen then adjust the SYNC AMPLITUDE to give a steady pattern. Do not advance the SYNC AMPLITUDE further than is necessary because the wave form may become distorted.

For frequencies other than 60 cycles, set the SYNC SELECTOR at the INTENSITY position and connect the signal to be observed between VERTICAL INPUT and GROUND. Set the COARSE FREQUENCY so that the desired number of complete cycles can be obtained. For example, if a 400 cycle signal is connected between VERTICAL INPUT and Ground, set the COARSE FREQUENCY at 90-500 position. Then by varying the FINE FREQUENCY, one to four complete sine waves may be obtained on the screen.

### Analysis of a Typical Superheterodyne Receiver

In the analysis of a typical receiver the first step is to check the tubes and tube voltages. If these are found to be satisfactory, it is recommended to begin from the speaker and work toward the antenna to test for defects.

A modulated variable frequency generator and an audio signal generator are both required for use in conjunction with the oscilloscopes but both functions may be combined in one instrument.

NOTE: Whenever possible follow the receiver manufacturer's instructions. The following are general instructions:

1. Assuming the receiver is not working, the first step is to connect the VERTICAL INPUT and GROUND terminals of the Oscilloscope across the voice coil of the speaker. (If the receiver is in operating condition, use the part of the instructions which apply in the particular case.) Set the SYNC SELECTOR to INTENSITY and use the 90-500 COARSE FREQUENCY range. Set the AF signal generator for 400 cycle out through a .02 to .5 uf condenser to the input grid of the last stage and the ground lead to the chassis. (Use a series condenser of .01 uf 400v if the set is an AC-DC unit.) Set the output of the AF signal generator no higher than is necessary to obtain an audible tone from the speaker. Adjust the VERTICAL GAIN to give the desired pattern height. Set the FINE FREQUENCY and the SYNC AMPLITUDE control to obtain two cycles and a steady pattern, respectively.

2. A symmetrical sine wave should be obtained on the screen of the Oscilloscope. If the wave form is distorted as in Figure 2, the stage may be overloaded (improper bias on), the tube may not have the proper bias caused by a defective cathode resistor or a leaky cathode by-pass condenser. Figure 3 shows the effect of too high a bias. A combination of Figures 2 and 3 would indicate the overloading of the tube.

- Hum and noise may be detected in a trace as shown in Figure 4, which is sometimes caused by a defective filter condenser or tube. A ripple voltage (60 cycle or 120 cycle) is indicated by this undulating wave form caused by insufficient

filtering. Distortion in the wave form also may indicate trouble in the screen or plate by-pass condenser, coupling condensers, or output transformer. An irregular wave form may be obtained showing second harmonic content (Figure 5), or a picture may be obscured by a strong high frequency signal (parasitic oscillation). Practice will enable the operator to recognize these and other symptoms rapidly and apply the standard cures.

Proceed to the next stage and connect the 400 cycle signal to the input of the first audio stage and observe the wave form as indicated above.

3. The next step is to align the IF stage, which requires that the signal be at the IF frequency with audio modulation. Connect the modulated signal through a .05 ufd condenser to the input grid of the IF amplifier tube. Turn the receiver tuning condenser fully closed and set the receiver volume control at maximum. Adjust the output of the signal generator to obtain a low audible signal from the speaker and set the VERTICAL GAIN to obtain the desired trace height on the screen. Adjust the FINE FREQUENCY control to present 2 or 3 cycles on the screen and keep the SYNC AMPLITUDE control as far counterclockwise as possible consistent with keeping the pattern stationary on the screen. Then adjust the trimmers of the last IF transformer for maximum deflection on the screen of the Oscilloscope.

4. If there is more than one IF stage, connect the signal generator successively to the grid of each IF amplifier tube and finally to the grid of the converter tube, adjusting for maximum output in each case. With the signal at the converter grid, all IF trimmers should be

*(Continued on page T-28)*

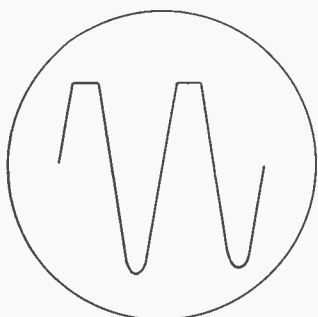

FIGURE 2

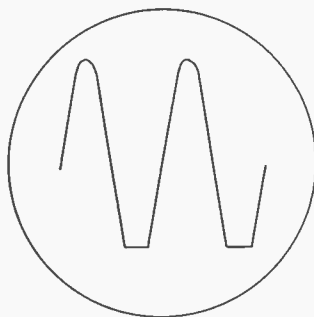

FIGURE 3

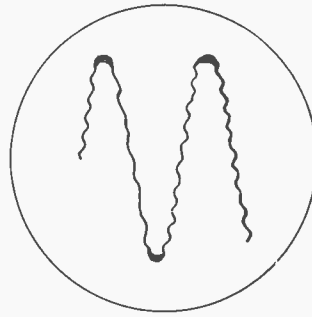

FIGURE 4

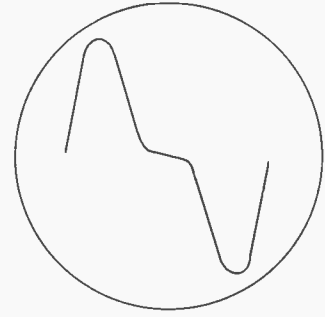

FIGURE 5

# MEASURING CAPACITANCE WITH THE SYLVANIA POLYMER

Contributed by FRANCIS W. SWANTZ

**EDITOR'S NOTE:** Mr. Swantz is now with one of our distributors in St. Louis. He says, "Since many servicemen must watch their budgets carefully, it is imperative that they wisely invest their spare change in the most essential and necessary test equipment. My twenty-five years of radio service experience, including ten years of instrumentation, lead me to believe that the Polymer is the most necessary and versatile of all instruments. With it the radio man can test tubes, align radios, trace a signal through the set, make impedance measurements, as well as measure any values of current, voltage or ohms. The Polymer is limited only by the user's fundamental knowledge and initiative."

We hope he will send us some more suggestions.

It is very simple to hook up a circuit using the Polymer and a potentiometer, a spare transformer and a few standard condensers so as to read capacitance values with considerable accuracy. The simplest circuit is shown in Figure 1. The transformer is any radio transformer having enough low voltage secondary windings to add in series to a little over 10 volts. R1 is a potentiometer having any convenient value between 50 and 500 ohms. Adjust the slider until the output voltage is 10 volts, as measured by the Polymer on the 10 volt AC scale. Then place the unknown condenser

in series and read the voltage again on the same scale. Curve "A" of Figure 1 is used to find the capacitance. Divide the capacitance scale values by ten when using curve "A".

This method is very satisfactory for values between .0001 and .001 but should not be relied on for higher values since this circuit uses the input impedance of the meter

itself as the reference standard and some variation should be expected between meters. If you have 3 known values, between .0001 and .001 mfd you can check your meter against the one used for the curve and draw a similar curve through your experimental points. On these low values it is best to use short

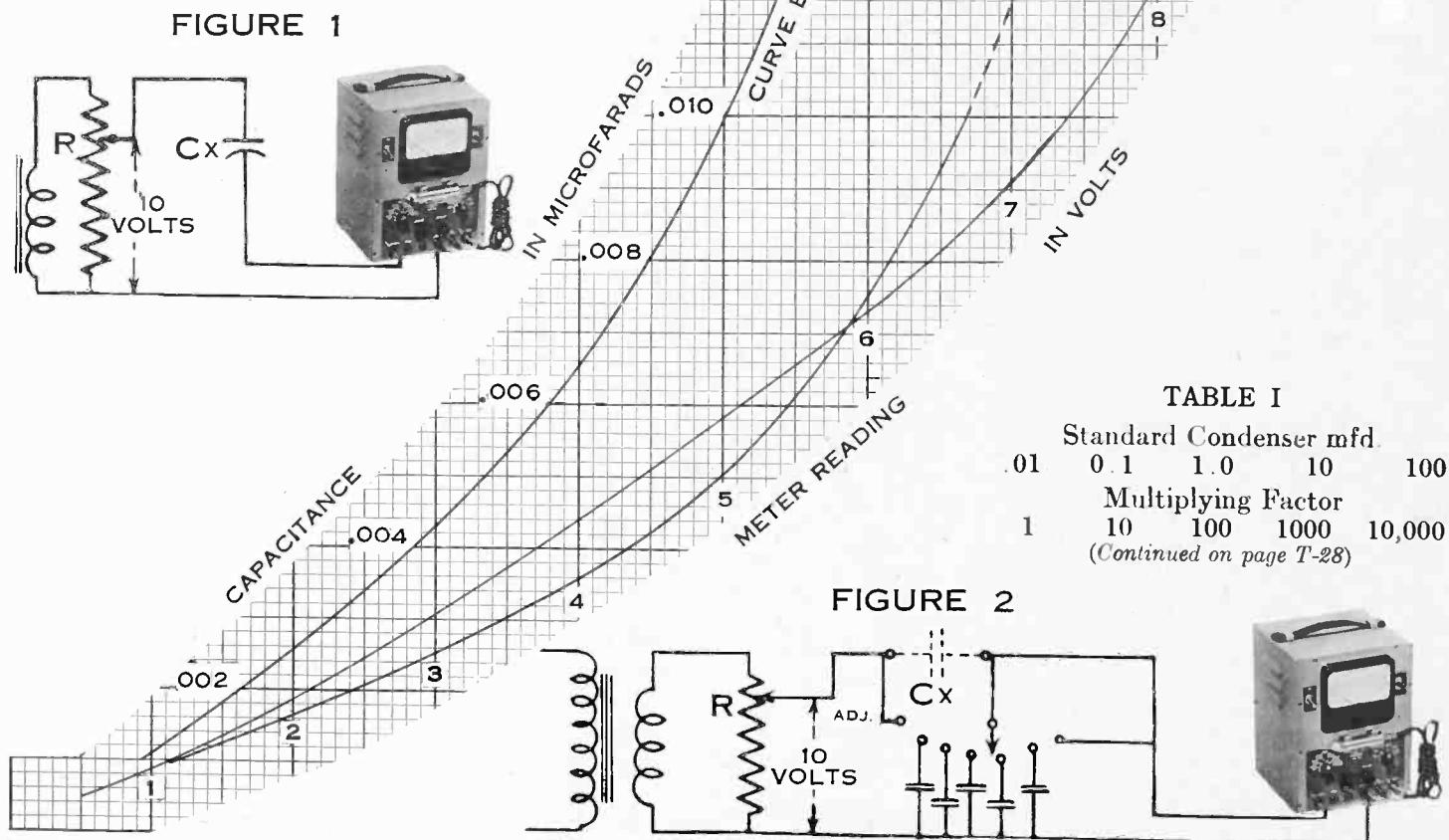

FIGURE 3

FIGURE 1

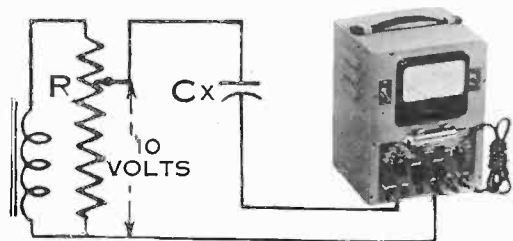
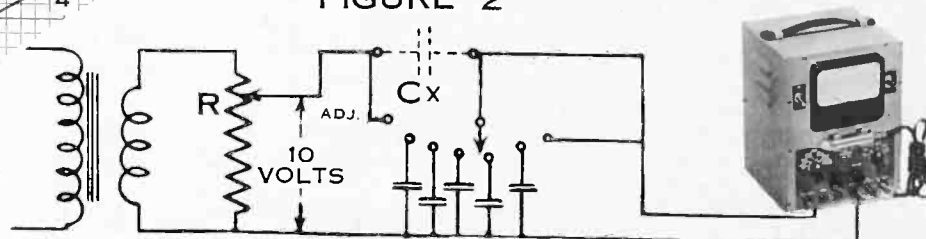

TABLE I

	Standard Condenser mfd			
	0.1	1.0	10	100
Multiplying Factor				
1	10	100	1000	10,000

(Continued on page T-28)

FIGURE 2





## Servicing With A Modern Oscilloscope (Cont'd)

re-checked for final alignment. Decrease the output of the signal generator when necessary to maintain pattern height on the screen.

5. Set the signal generator to 1400 KC and connect the output through a 200 uuf condenser to the antenna terminal of the receiver. Tune the receiver dial to 1400 KC and adjust the shunt oscillator trimmer for maximum output on the screen.

6. (If the receiver has one or more RF stages, perform the following next. If not perform step 7.) With the receiver adjusted as in step 5, do not move the receiver dial but adjust the antenna trimmer (and any RF grid shunt trimmers in case of more than one RF stages) for maximum output as shown by maximum vertical deflection. At this point, the signal generator output may be so low as to give

considerable noise indication on the screen. If so, reduce the setting of the volume control on the receiver, and increase the output of the signal generator.

7. Set the signal generator to 600 KC, leaving it connected to the antenna and ground terminals of the receiver. Tune the receiver to the signal generator frequency and adjust the series padder of the receiver oscillator for maximum output while rocking the receiver dial. Repeat the 600 KC and 1400 KC oscillator adjustments (steps 5 and 7) so that little or no change in either adjustment is needed when the other adjustment is made.

This completes the analysis of receiver alignment using an AM signal generator and the Oscilloscope. For the alignment of the IF and RF stages, a vacuum tube voltmeter such as the Sylvania

Polymer Type 134 would suffice as an output indicator.



Sylvania Type 131  
A Typical Modern Oscilloscope

In the next article of this series, the procedure for aligning a FM receiver will be outlined. Since new FM broadcast stations are being put into operation weekly, and the number of receivers manufactured is rapidly increasing, we feel the FM alignment with an oscilloscope should be of considerable interest.

## Measuring Capacitance With the Sylvania Polymer (Cont'd)

direct wiring so as not to add too much wiring capacity. No twisted pair for this job.

To check higher values of capacitance the circuit of Figure 2 is used. In this the Polymer is shunted by a known condenser and voltage readings obtained are transferred to capacitance values by use of curve "B". In this case the shunting condensers are so large in comparison with the possible variation

in Polymer capacitance that the accuracy obtainable is dependent only on the accuracy of the standard and the accuracy of reading the meter.

By using 5 standards which are simple multiples of 10 the range of measurement can readily cover the range of values used in service work. If these standards are built into a box with a selector switch an extra point on the switch can be used for

reading the calibrating voltage and another to include the circuit of Figure 1. Table 1 shows the multiplying factors for the suggested values of standards.

*EDITOR'S NOTE: This will be fine if paper or oil condensers are used, but we cannot recommend the use of electrolytic condensers for standards as we believe that they may soon require reforming if used on AC. We recommend instead the use of a 270 ohm resistor for the 10 mfd and 27 ohms for the 100 mfd range. This gives a different shape of curve which we have marked curve "C". However, electrolytic condensers can be measured quite satisfactorily.*

# SERVICE HINTS

**RCA Model 110K—Oscillation and Tube Failures:** This set has given me considerable trouble. A year ago I put in all new filters and four new 6K6G output tubes. The set oscillated and made an awful racket maybe once a day or it might be good for a week. Today it came in again with the 6K6G cathode resistor burned out, shorted 6K6G tubes and one side of the output transformer open. I installed new ones but the tone was not right and the current drawn by the output tubes was too high. I got suspicious of the two .007 mfd. condensers connected to the 6K6G plates and found them to be open. This proved to be the cause of all the trouble as these are to prevent the stage from oscillating. If the line voltage is

low the set might perform OK but every once in a while it would act up and eventually something had to burn out.—P. J. Carrelle, Cliffside Park, New Jersey.

\* \* \*

**Zenith Models 6D413, 6D414, D426, 6D427, 6D446, 6D455, (Chassis 5660):** The original tube complement included a type 12Q7-G. When replacing this tube with a metal 12Q7 or a metal-based 12Q7GT place some spaghetti insulation over the shielded control-grid lead. This will eliminate the probability of a short from the shield to the tube.

The reason for this precaution is that the shield over the grid lead connects to chassis and the tube is

grounded through pin #1 to the AC line. The chassis is isolated from the AC line by Condenser C2 (0.1 mfd.) and Resistor R-12 (220 K) and a short between the shield and tube places the chassis at line potential as R-12 and C2 are shorted out.—Joseph S. Napora, Dayton 3, Ohio.

\* \* \*

**New Zenith Changer (Cobra Tone Arm):** In this model the pick-up hops from groove to groove after playing about half-way through a record. This is caused by a small burr left on the corrugated piece of metal the arm plays across in rejection process. I smooth this off with a small flat file.—W. H. Colvin, Lancaster, Ohio.

# KEEP THE BUSINESS GROWING

## SELL SERVICE WITH SERVICE

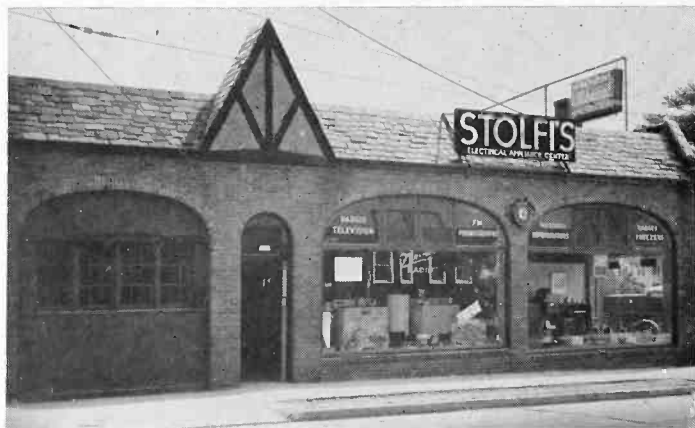

Left is the attractive shop of the Stolfi Radio and Appliance Shop. One large showroom is reserved for television set exhibition and demonstration.



Above: At work at the busy service bench is Gordon Stanys, on television; John Geriah, on a home receiver; Angelo Pellicciari, autoradio; and Nicholas Amenti, checking tubes on a Sylvania Tube Tester. Sylvania Tubes are used as replacements in the sets repaired in the Stolfi shop.

Right: Two service trucks are used by Stolfi to handle the call for and deliver end of the business. The full force in the picture are, Mike Stolfi; Katy Filmer; Dave Stolfi; John Geriah; Gordon Stanys; Anthony Obizud; John Frattaroli; Nicholas Amenti; Angelo Pellicciari.



Mike Stolfi of Stamford, Conn. started a radio business in 1939. That wasn't so long ago, but Mike has made those years count. His business has expanded rapidly. The old shop was found to be too small, so about a year and a half ago he moved into a new spot where he could properly display his wares and service sets.

of the leaders in the field in the Stamford area. Men like Mike Stolfi are good examples of the spirit of free enterprise.

It has taken a lot of hard work to make a business like Mike Stolfi's, but his shop is proof that hard work pays off. Today the volume of his business is big enough to give nine people full time jobs. That is a good example of what can be done with the radio sales and service business.

Below: Billboards like this keep the Stolfi name before the people of Stamford. Sylvania is the first manufacturer to be features on these billboards.

One of the big things in Mike's favor has been his constant plugging of his shop. No method of advertising has escaped him and each has brought successful results. His customers too, are staunch supporters of the quality of work that is done in Mike Stolfi's shop. When they keep coming back, you know the work is good.

One of the first to take the ball when FM and television became practical. Mike has remained one



# YOUR IDEA MAY GET YOU



How far can you get on five dollars? A long way if it's in Sylvania sales and business helps. And to make the way even easier, we will give you five dollars worth for a starter. Yep, we said we'd give you five bucks.

"Well now," you say, "there must be some catch to that." Could be, but it isn't anything tough. In fact, it's probably easy for you, if you are a serviceman. Okay, Okay, so there is a catch, but just wait a minute and we will tell you our proposition.

There isn't anybody, yes, we said anybody who doesn't have some good angle for getting more business or improving the efficiency of their



## WHICH COULD GET YOU

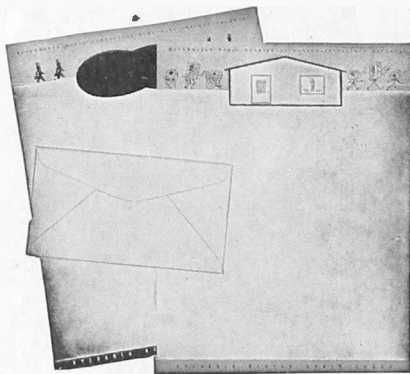

THIS . . . .

shop. You have some neat tricks that you use to get business and keep it, so we'd like to know about them. Then we'll pass them along to some other guys who will want to know if they can't do something about it too.

After all fellows, this game is like being a doctor. If you have a good reputation the business keeps coming in, but first you had to sell your customers. Just like a doc. First folks are a little afraid to go to him, but later on when they get to know him, nothing stops them. Same way with you. And good doctors depend on other fellows for ideas.

It's just natural that one guy can't know everything.

So if you are interested in making the five bucks we offer, drop us a line and tell us about a pet idea of yours. If we use it for publication in the NEWS we will send you a



OR THIS . . . .

certificate worth \$5 in merchandising aids, and with that you can make more money. The only thing we require is that you be a serviceman and when you write us don't forget to print your name and address so we can send you that certificate.

Your idea does not have to be world shaking. Just any little scheme you might have for making your shop run more smoothly. It can be something mechanical, or something in line with business. Since service is your business, you must have many ideas which have improved your service.

Our address is, The Editor, SYLVANIA NEWS, Sylvania Electric Products Inc., 500 Fifth Ave., New York 18, N. Y.

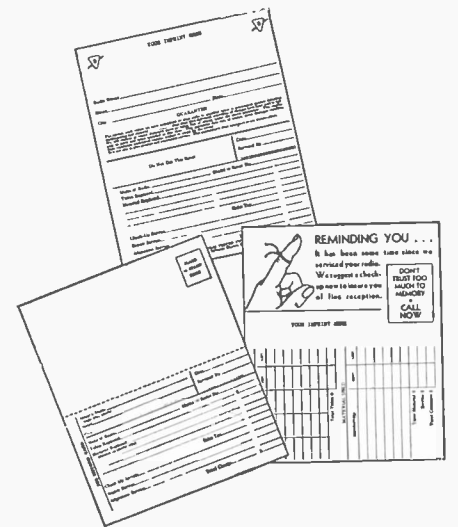

OR THIS



## SYLVANIA EXECUTIVE HEADS RMA



M. F. BALCOM

Max F. Balcom, vice-president and treasurer of Sylvania has been elected president of the Radio Manufacturers' Association. Mr. Balcom has been active in the RMA for many years, and was formerly chairman of the RMA Tube Committee. He has also served as a member of the executive committee.

## ELECTRONIC TRAFFIC COP TO WORRY SPEEDERS

Wartime promises of future electronic devices were almost unbelievable, but we have seen some good ones since the war. Latest among the "miracle" gadgets is a new device known as the "electromagnetic speed meter" which is capable of clocking automobile speeds.

This new device, which utilizes radar, has been perfected by engineers at the Eastern Industries' Automatic Signal Division plant in South Norwalk, Conn. To prove its effectiveness, it will be put to work on the main highways of Connecticut and other states in the near future.

Main use of the device will be for a survey of road traffic and highway safety trends. At the same time, however, it will be clocking the cars that exceed the speed limits.

The engineers who perfected the speed meter explain its operation as simply as follows; a constant microwave is sent out by the meter and a moving car reflects the waves, causing a shift in wave length propor-

Latest idea for putting television broadcasting on a paying basis may be in the "pay as you see" video set. This set is designed to receive programs over telephone wires, and for the service, listeners would pay a monthly fee to the broadcaster.

The new set plugs into the subscribers telephone. Most programs are received via frequencies just like the ordinary set, however, a few key frequencies would be transmitted into the users home by means of telephone wires. Without the key images, the pictures on the tube are blurred. To get clear pictures, the user need only pick up his telephone and ask the operator for "phone-vision." "Phone-vision" in turn takes his call and completes the picture by feeding the missing frequencies over the telephone lines.

The "pay-as-you-see" television set would put the video broadcasting on a paying basis and programs of a higher type could be seen. Under present standards, the best radio

tional to the speed of the car. The direct signal from the transmitter and the reflected signal from the moving car are compared in the meter and the difference is translated into miles an hour.

The only visible portion of the speed meter is a small transmitter box that can be placed in a bush, on a bridge railing, or on the running board of a parked car.

Our first reaction to this gadget is that it might encourage our guardians of the law to become a little less vigilant in patrolling the highways. There could undoubtedly be a great temptation to recline in a shady spot along the road and check the readings at scattered intervals when ambition would permit. However, when we think about it a little, we are less reluctant than before, since we see no provision made for the machine to record license numbers. We can still speed merrily along and if the cop is tired, we'll be plenty safe.

## TELEVISION BY TELEPHONE MAY BE THE ANSWER

entertainment would cost about \$10,000,000 a year to produce on television, a price which commercial sponsors could not afford. "Phone-vision" would eliminate commercials and sponsors and provide top-flight shows by charging the user. Price of a movie over this type of video broadcasting would be about the same as a person pays at the box-office. The set-up provides an end-of-the-month billing by the broadcasters for services performed.

One hitch in the "pay-as-you-see" plan has been noted by the Telephone Company which asserts that there is at present a law which prohibits the attachment of a "foreign" device to the telephone. There would be no interference with regular phone operation during the process and Zenith Radio Corp. officials, (founder of the system) assert that they have been transmitting experimental images through Chicago switchboards for months. The operators did not know the difference. It is predicted that the system will be ready for operation in about six months.

## DO YOU KNOW . . .

There are 13,500,000 more homes with radios than with telephones in the United States, and 7,500,000 American homes have radios and don't own automobiles. If there are any radio servicemen around who are considering a change to the plumbing profession, it will be well for them to know that there are 5,800,000 homes with radios which don't have bathtubs!

## RADIO DEALER SURVEY SHOWS HIGH PROFITS

The Office of Temporary Controls has released a "Survey of Electrical Appliance Dealers" which shows combined income statements by this type of store for the years 1939, 1941 and 1944. Net profit before income taxes of radio stores whose reports were tabulated are: corporations, 0.4% in 1939, 3.1% in 1941 and 5.5% in 1944; partnerships 8.1% in 1939, 11.6% in 1941 and 16.8% in 1944.

## NEW SYLVANIA DISTRIBUTOR HEARS TALK ON TEST EQUIPMENT



Above is the personnel of Radio Electric Service Co., new Sylvania distributor in the Eastern Pennsylvania-New Jersey area. The picture was taken at a recent sales meeting on Sylvania products conducted by George Isham, Sylvania Div. Mgr., and Salesman Sam MacDonald. Jim Canning of the Sylvania Commercial Engineering Department was chief speaker of the evening with a talk on test equipment and special electronic tubes. Those in the picture are first row seated left to right: Sid Klaos, Len Steinberg, Aaron Berkowitz, Harry Brown, Mort Cohen, Irving Sanborn, Carmen Salvucci, Ed Fettinger, Tony Bronca, Milt Reese, Jim Foti. Second row, left to right: Charles Bowman, Dave Fineberg, Bruno Haake, Norm Steedle, Mgr. Allentown store, James Weaver, Vic Kopnitzky, Jack Goldstein, Mgr. West Philadelphia store. Standing, left to right: Ted Feinstein, Industrial and Government Order Dept.; Al Kass, Treasurer and Sales Mgr., Sol Furman, Mgr. Wilmington store, Al Steinberg, General Mgr. and Purchasing Agent, Carmen Linsalata, Assistant Purchasing Agent, Arch Campbell, John Gallagher, Howard Kull, Herb Amesburg, Ray DeCourcelle, Roland Levinson, Oscar Mackles, Sam McDonald, Distributor Tube Sales, Sylvania, Herb Levinson, Ray Keifer, George Isham, Aldo Ciprianai, Ed Pond, Mgr. Easton store; Paul Steiner, Jim Canning, Joe Berman.

## FACTS & FIGURES

### Television Set Output Rises

Production of television receivers continued to climb during May, while radio set production fell below the high level that had been maintained during the first four months of 1947. May production of all types of receivers dropped to 1,316,373 as compared to 1,759,723 for the five-week April period. Output of television receivers in May was 8,690 bringing the years total to 34,895 sets. Total sets produced this year is 7,397,502.

### May Tube Production Declines

Production of radio receiving tubes totaled 14,475,237 in May, a decrease of more than a million and a half from April, according to a tabulation of RMA member-companies. The May output reflects the anticipated seasonal decline and brings the years total of tubes produced to 88,305,323.

### FM Moves Ahead

Latest look at FCC records show that a total of 242 FM stations are now in operation; 659 others have been authorized and 164 applications are still pending. This makes a total of 1,065 FM stations in store for the U. S.

### May Business at High Level

Business activity during May continued relatively steady and on a high level according to the Department of Commerce. Unemployment in the month was cut back to 2,000,000, the lowest level since last fall and there was an increase of 1,500,000 in employment.

### Export Market Booms

Department of Commerce reports that a new high volume of over \$60,000,000 in radios will be exported this year. Exports during the first four months are reported at five times that of the corresponding months last year.

### Radio to Locate Oil

More than 500 "geological radio stations" have been licensed to probe the earth's surface for new sources of oil, the FCC announced recently. The announcement also said that geological radio stations may someday be employed to ferret out new mineral and metal deposits.

SYLVANIA NEWS

SYLVANIA ELECTRIC PRODUCTS INC.  
P. O. BOX 431  
EMPORIUM, PENNA.

RETURN POSTAGE GUARANTEED

Sec 562, P. L. & R  
U. S. POSTAGE  
PAID  
Emporium Pa.  
Permit No. 1

For:

Mr. J. Kenneth Bowman  
Rt. 4  
Rocky Mount, Va.

POSTMASTER: If Addressee has moved, notify sender on Form 3547, postage for which is guaranteed. When Form 3547 is sent abandon this mailing. Return only if no correct address is available.

Vol. 14, No. 7

AUGUST, 1947

Published By  
SYLVANIA ELECTRIC PRODUCTS INC.  
Manufacturers of Sylvania Radio Tubes and Electronic Devices, Sylvania Incandescent Lamp Bulbs, Fluorescent Lamps and Equipment





# SYLVANIA NEWS

Copyright 1947, Sylvania Electric Products Inc.

R. A. PENFIELD, Editor

SEPTEMBER, 1947

EMPORIUM, PENNA.

VOL. 14, NO. 8





## SYLVANIA INTRODUCES NEW 7-INCH OSCILLOSCOPE



OSCILLOSCOPE 132

This month Sylvania joins with its distributors in announcing the startlingly NEW 7-Inch Oscilloscope Type 132. First of the new service instruments that we will announce this season, the new oscilloscope has

unusual versatility in modern radio servicing, school, industrial and laboratory applications. It will be widely used in receiver alignment, audio circuit analysis, filter and vibrator waveform checking, transmitter monitoring and many other applications too numerous to mention here.

The new oscilloscope was thoroughly field tested by selected service dealers, laboratories and broadcast stations before our designers would permit production to start. Many helpful suggestions were received and have been incorporated in the design of the new instrument. Months of painstaking development make the new 'scope an unusual instrument—especially at its moderate price of \$124.50. See THE NEWS Technical Section for circuit details, and ask your Sylvania distributor for further particulars. Initial shipments are now being made.

## ENGINEER FROM INDIA VISITS SYLVANIA

Mr. Amarjit Singh of Punjab Province, India visited the Flushing laboratories of Sylvania recently. Mr. Singh said that he expects to apply some of the things he saw at Sylvania to aid him in setting up an electronic research laboratory in his native country upon his return there. Mr. Singh is, at present, studying for his Ph. D. at Harvard University under the auspices of the Indian Government.

According to Mr. Singh, India is sixth among the nations of the world in industrial production, and intensive plans are under way to improve this record. He said that India is looking to the United States in its program of industrial expansion.

*(Continued on page G-31)*



Mr. Amarjit Singh, Punjab, India on a recent visit to Sylvania's Flushing, N. Y. Laboratory. With him on his right is R. K. McClintock, Field Engineer, International Division, and on his left, Dr. R. M. Bowie, Manager of the Research Laboratory.

## WHO'S WHO AT SYLVANIA



THIS IS BOB ALMY

R.P. Almy, assistant general sales manager of Sylvania's Radio Tube Division, is responsible for all distributor tube sales. At present the oldest man, in years service, in the Sylvania sales force, he recently began his twentieth year with the company.

A native of Randolph, N.Y., Bob's past experiences embrace many fields. Before becoming associated with Sylvania he engaged in retail selling, managed a speciality mail order sales business, did construction work, did a turn at railroading and worked as a private secretary. He modestly declares that he too delivered papers and did many odd jobs as a boy. "Every kid did it", he says.

Bob's service with Sylvania dates way back to the Nilco Lamp Works. He was originally hired by them as a private secretary to the late B.G. Erskine, but when he showed up to go to work there was an opening in the sales force, so he was put to work selling lamps. When that company merged with Hygrade and Sylvania, Bob went along to the Salem plant. From there he transferred back to equipment sales at at Emporium in 1932, followed up by joining the distributor sales department as sales supervisor. Next he became sales manager of the western division with offices in Chicago. After a time as sales manager of the Eastern Division in New York, he became assistant sales manager, sales manager and finally his present position.

*(Continued on page G-31)*

### NEW PRICE CHANGES ANNOUNCED

Effective September 2, 1947 Sylvania revised prices on a number of receiving type tubes in the Sylvania line. Some were increased—some decreased.

Enclosed with this issue of SYLVANIA NEWS is a new retail price list. As heretofore, we have listed practically all types including obsolete types and the newer types which have recently been announced. Additional copies of this retail price list are available from your Sylvania distributor.

# SYLVANIA NEWS

## MERCHANDISING SECTION

Copyright 1947, Sylvania Electric Products Inc.

SEPTEMBER, 1947

EMPORIUM, PENNA.

VOL. 14, NO. 8

### HAS YOUR SHOP EYE APPEAL? DRESS UP WITH A SYLVANIA SERVICE BENCH

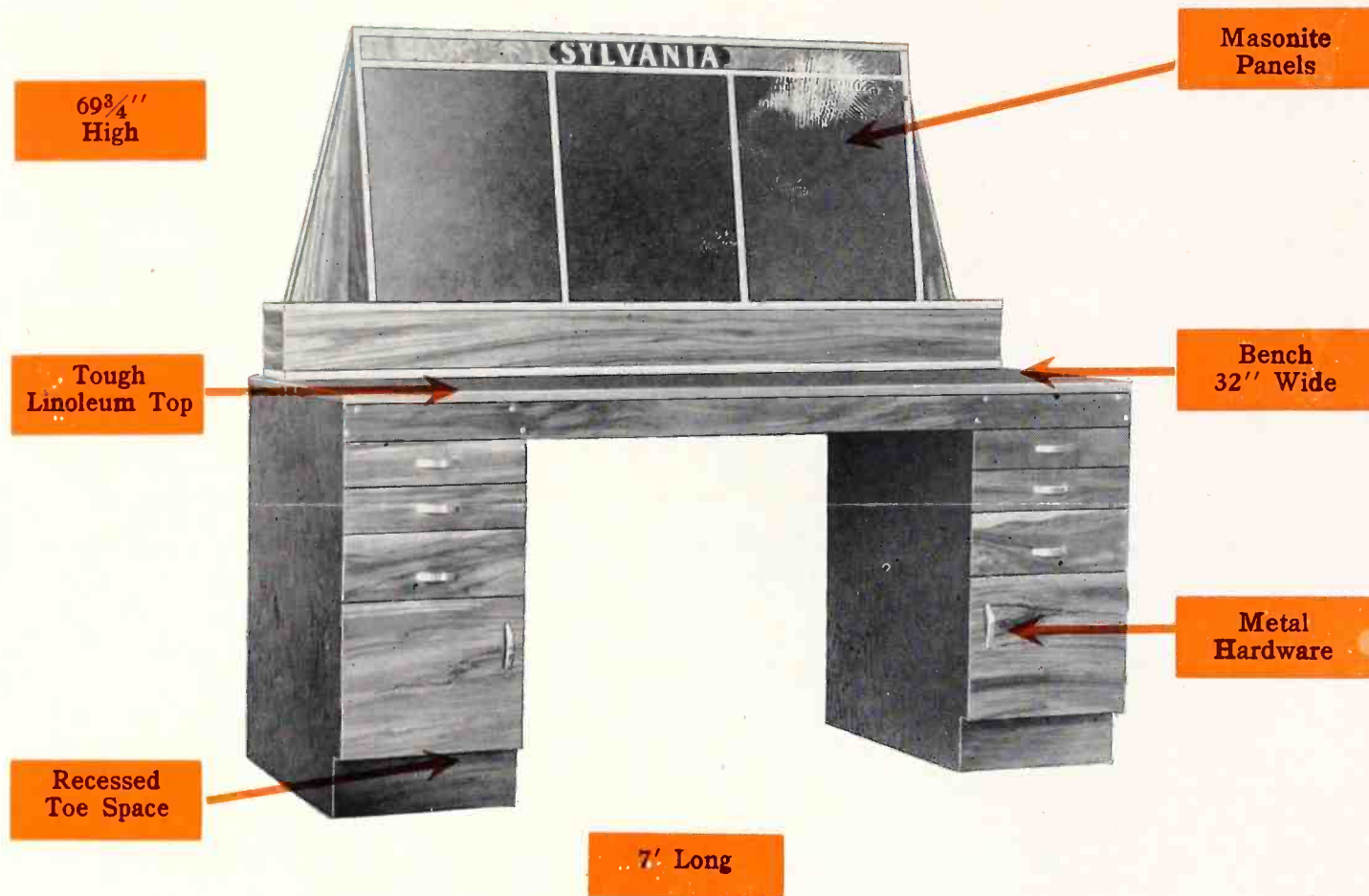

Do you suffer from clutteritus? Does your service bench look drab and messy? If it does, here is **BIG NEWS** for you. Sylvania announces with pride its new Service Bench for the 1948 service shop. It's the best answer in years for giving your shop, customer eye-appeal.

Make way for the Sylvania Service Bench. This new bench is designed for maximum efficiency, beauty and ruggedness. It is a honey of a place to work and a credit to any serviceman.

Built from sturdy lumber (gum-wood front, <sup>5</sup>/<sub>8</sub>" plywood sides) its got everything a guy can ask for. The spacious 7' long, 32" wide

work bench will give you plenty of room for giving a tired radio a workout. The 33" panel is constructed of wood and masonite and its sectional design is made for simplification of instrument installation and rigidity. It's built to have "plenty of room for everything" with six drawers, two large storage cabinets and a recessed toe space.

Top of the bench is heavy tough linoleum. To save shipping costs it comes knocked down. Follow the complete instructions for easy assembly and paint or stain it (it comes unpainted) to fit your shop's color scheme and you'll be the envy

of the servicemen in your town.

We just haven't space to give you all the favorable comments on our new service bench, but you can well imagine the Ohs and Ahs we get when people see it. What gets 'em more than anything is the price. Can you imagine, only \$139.50! (F.O.B. Grand Rapids, Michigan.)

We're not saying you can't get along without this service bench, but it will be a mighty swell addition to your shop and a good salesman for your service. For complete details on delivery and how to get your Sylvania Service Bench, see your Sylvania distributor today.



## TIE-IN FOR NATIONAL AD CAMPAIGN AVAILABLE TO SERVICEMEN

What magazines do most people read? Why LIFE, COLLIERS' and THE SATURDAY EVENING POST, of course. And when people read those magazines they pay a lot of attention to the ads. It's just the natural thing to do, because our public knows that the material advertised there is good. That's why Sylvania places ads for you in these magazines.

But beyond that, servicemen need to identify themselves as the guys we portray them to be. That is just good business. If people know you are one of these people who do a good job fixing radios, they too, will count on you to do a good job.

Here we have a good sales promotion item which will help you sell more service. It identifies you with your manufacturer and lets people know that you can do a swell job. The ad pictured here is the one which will appear in LIFE, COLLIERS' and POST this month in quarter page size. To help you, we have prepared newspaper mats for your own use in your local paper. They come in one and two column size and are available "for free" from our Advertising Department at Emporium, Pa.

They are timely and eye-catching and your own tie-in with Sylvania's national ad campaign will help make more business for you.

## A HANDY GADGET FOR SPOT TESTS

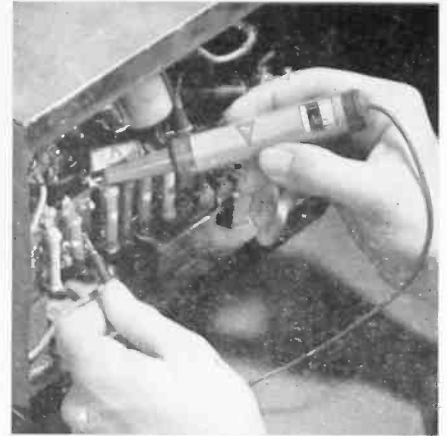

Servicemen, engineers, teachers, hams and just plain tinkerers have found the Sylvania Pocket Test Prod Ohmmeter (Continuity Meter) a natural for trouble shooting. This little gadget, which fits into your vest pocket, has a thousand uses. Whether it be checking a radio circuit or just tinkering with electricity, the Test Prod Ohmmeter is ready instantly for use.

Small size, self-contained power supply, and full scale deflection on 1.5 millamperes makes the Pocket Ohmmeter a desirable instrument for service bench or service kit. Available now from your Sylvania distributor or from the Advertising Department, Sylvania Electric Products Inc., Emporium, Pa. The price? \$7.50.

## WILL YOUR RADIO



Play fair with your set and it won't go foul on you. Let us check it regularly. You'll avoid big repair bills and you'll hear all your favorite broadcasts better, enjoy them more. Our work is dependable, our charges are reasonable. We use and recommend Sylvania radio tubes to assure top results.

**SYLVANIA  
RADIO TUBES**



**DEALER'S NAME  
ADDRESS**



Another tie-in is the new post-card, pictured here. It follows the same idea and will get your message across. These are available at the usual cost of \$1.00 per 100 from our Advertising Department at Emporium, Pa.

For better business and more dollars in your pocket, use these sales promotion aids. They are the framework of the foundation we lay in our national campaign.

## NOW IN THREE VOLUMES!

SYLVANIA NEWS Technical Sections are now available in three volumes.

Volume I contains all issues of the Technical Section from May 1935 to January 1941. Volume II is composed of back issues dating from January 1941 to January 1946. Both of these volumes are sewed bound books. Volume III, which contains Technical Sections from January 1946 to the present, is a loose leaf book which permits addition of subsequent issues. The price of each volume is \$1.00.

Servicemen who would like complete files of the Technical Section may order them direct from the

Advertising Department, Sylvania Electric Products Inc., Emporium, Pa.

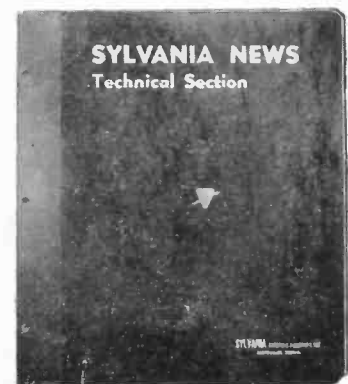



# SYLVANIA NEWS TECHNICAL SECTION

Copyright 1947, Sylvania Electric Products Inc.

A. V. BALDWIN, Technical Editor

These data have been compiled from information which we believe to be accurate. No responsibility can be assumed in the application thereof or for patent infringement.

SEPTEMBER, 1947

EMPORIUM, PENNA.

VOL. 14, NO. 8

## SERVICING WITH A MODERN OSCILLOSCOPE

### PART 2 F. M. SET ALIGNMENT

By FRED DALASTA and W. P. MUELLER

This is the second in a series of articles to aid the radio service engineer with the use of the oscilloscope in his daily work. After the 'first wave' of portable and table radios reached the postwar market, AM-FM receivers arrived in quantity sufficient to impress the alert servicemen with the fact that FM was really here. With the coming of FM receivers the problem of FM servicing naturally became important. The eventual scope of the problem is apparent if we realize that in October, 1946 only 6 FM broadcast stations were reported in operation, over 200 are now operating (Aug. 1947), and by the end of 1948 over 1000 are expected to be on the air.

In the first article on servicing with a modern oscilloscope, we considered the general theory of the cathode-ray tube, the operation of a typical oscilloscope (Sylvania Type 131) and its application in the analysis and alignment of an AM receiver. In continuing this series of articles, we will consider next the alignment of an FM receiver, when no FM modulated signal generator is available.

It is recommended that you follow the manufacturer's instructions in the alignment of AM-FM receivers where possible but satisfactory results can be obtained with general instructions which follow, when more specific instructions are not available. Usually in a combination AM-FM set the general rule is to align as many tuned circuits as possible in the proper sequence with one signal generator setting. (Refer to the previous article for AM receivers and alignment.) The order of alignment may be as follows: IF of AM section, IF of FM section, discriminator of FM section, RF and oscillator of AM section, RF and oscillator of short wave band, and RF

and oscillator sections of FM band or bands.

#### Equipment for Alignment

The method of aligning an FM set usually described in technical and service magazines uses an FM modulated signal or sweep generator

together with a cathode ray oscilloscope. The oscilloscope is indispensable when this method is used. However, the FM signal generator method will be treated at a later date, and the method outlined in this article will be confined to the

### NEW SYLVANIA 7" SCOPE

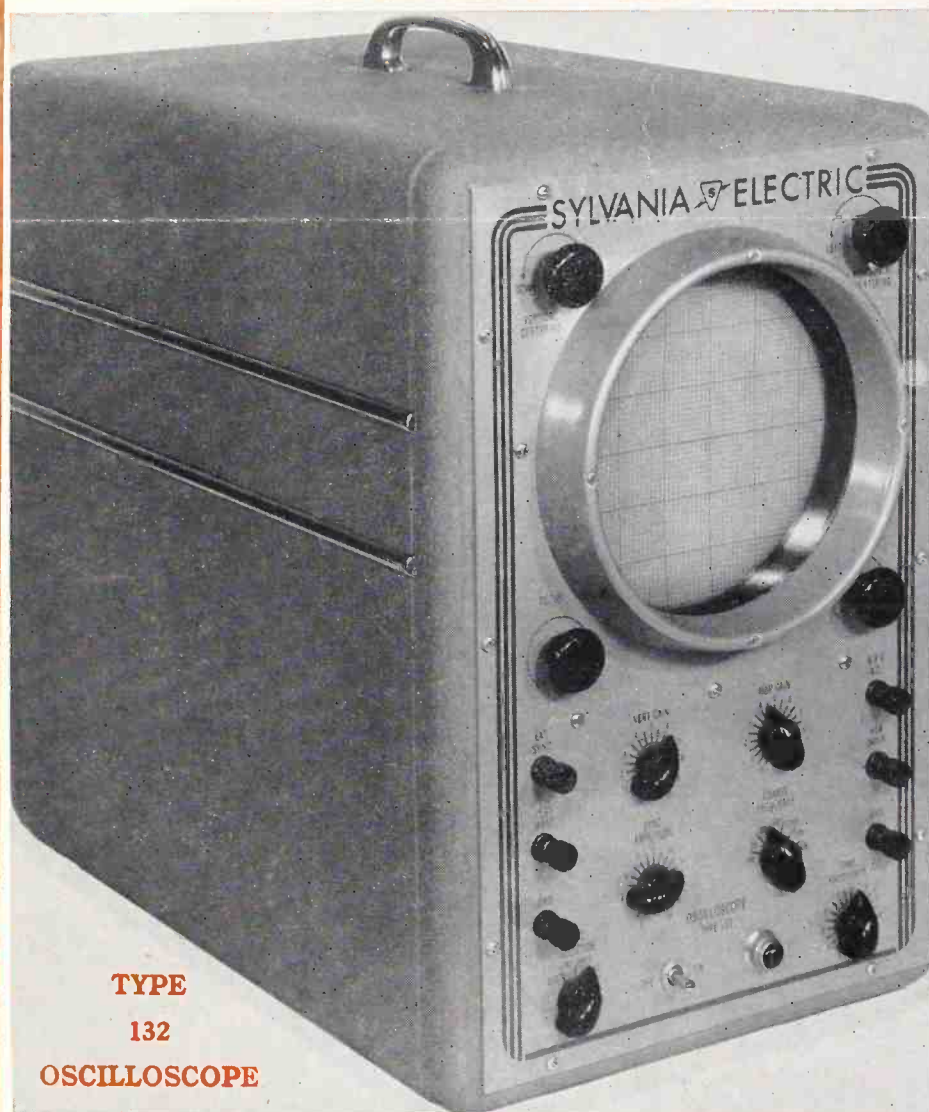

TYPE

132

OSCILLOSCOPE

Latest addition to Sylvania line of test equipment now available through Sylvania distributors. For further details see pages T-32 and G-30.

## SERVICING WITH A MODERN OSCILLOSCOPE

alignment of an FM set when only a conventional AM modulated signal generator is available.

Essential equipment required is:

1. AM Modulated Signal Generator which covers the frequency range to 108 mc.

2. Vacuum Tube Voltmeter such as the Sylvania Polymer Type 134.

Alternate equipment in place of the VTVM:

1. DC Microammeter in series with a 100,000 ohm resistor and a double pole double throw switch to reverse the meter connections.

2. Cathode Ray Oscilloscope such as the Sylvania Type 131 or the new Sylvania 7-inch Oscilloscope Type 132.

### Alignment of the FM Receiver IF

1. First determine the FM-IF frequency of the receiver. This is usually marked on the chassis or transformer can. The RMA standard is 10.7 mc., but 4.3 mc., 9.1 mc., and others may be encountered in some sets. The AM-IF frequency is usually 455 kc. In many cases the AM and FM-IF transformers are housed in the same shield can and it is necessary to determine which of the trimmers are FM and which AM.

2. Connect the DC voltage lead of the Polymer to the grid side of the first limiter tube grid resistor and the common lead to ground. The negative DC voltage developed when signal is applied will serve as the output indicator during the alignment. Alternately, the DC microammeter and 100,000 ohms combination or an Oscilloscope may be used instead of the Polymer. Connect the vertical input of the Oscilloscope through an isolating resistor of about 100,000 ohms to the limiter tube grid resistor. The

isolating resistor must be connected directly at the set and a shielded lead should be used from it to the Oscilloscope, to prevent oscillation of the IF stages due to feedback caused by the added leads. In some "hot" sets it is also necessary to ground the Oscilloscope and the signal generator to the same point on the set chassis to prevent oscillation. See Figure 1.

This method employs the limiter as an AM detector and the IF alignment can be made as in an AM set.

3. Connect the signal generator to the set. The preferred connection is to connect the signal generator through a condenser of about .05 mfd to the grid of the last IF tube, and align the transformer feeding the limiter stage. Then shift the signal generator to the proceeding stage and align the next transformer working backwards stage by stage to the grid of the converter. See Figure 1. It is sometimes possible or even necessary due to inadequate output from the signal generator, to connect the signal generator to the converter grid at the start, and align the set starting from the back, but the stage by stage connection is the safest, particularly when over-coupled stages are encountered.

If the Polymer is used as the output indicator the signal generator need not be modulated. If the Oscilloscope is used, modulation must be used.

4. Adjust the trimmers of the IF transformer for maximum Polymer or Oscilloscope deflection. Note whether the setting of one trimmer has an effect upon the setting of the other. If there is little interaction of the trimmers, the stage is not over-coupled and the alignment is as straight forward as

the usual AM alignment. The higher IF frequencies make over-coupled transformers less necessary and simplify the alignment. If the IF transformers are of the flat topped or over-coupled type, two maximum responses will be observed as the frequency of the signal generator is tuned through the IF frequency from about 100 kc. above and below the center value. For over-coupled transformers, align the trimmers for equal response of the two peaks equally spaced on each side of the center frequency and the response in the center not less than 90% of the peak response. Align each stage in succession, back to the converter.

### Alignment of the Discriminator

1. Connect the DC lead of the Polymer to the high side of the discriminator load resistors, and the common lead to the receiver chassis. A 0-100 DC. microammeter in series with 100,000 ohms may be used instead of the Polymer. Connect the signal generator to the grid of the last IF amplifier tube, through an .05 mfd condenser. No modulation of the signal generator is required. See Figure 2.

2. Vary the frequency of the signal generator about 100 kc. about the center frequency of the IF. A plus and minus voltage should be developed on the Polymer by the action of the frequency sensitive discriminator circuit. With the signal generator set at center frequency, adjust the secondary of the discriminator transformer until the output voltage is nearly zero. Then adjust the primary trimmer for maximum voltage. Readjust the secondary trimmer so that the output voltage is exactly zero.

3. Swing the frequency of the generator above and below center frequency and note the output voltage developed. The positive vol-

FIGURE 1

STAGE BY STAGE ALIGNMENT OF IF AMPLIFIER

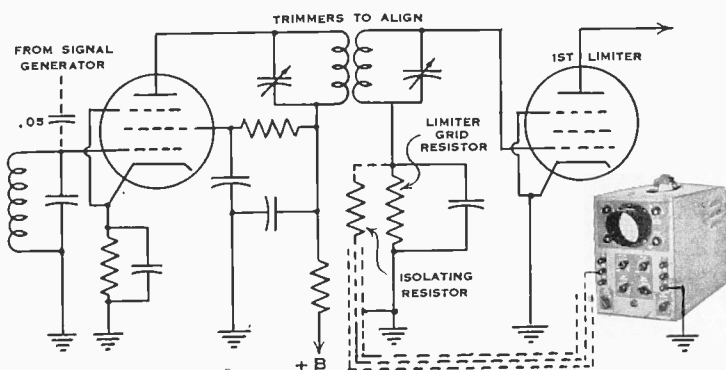
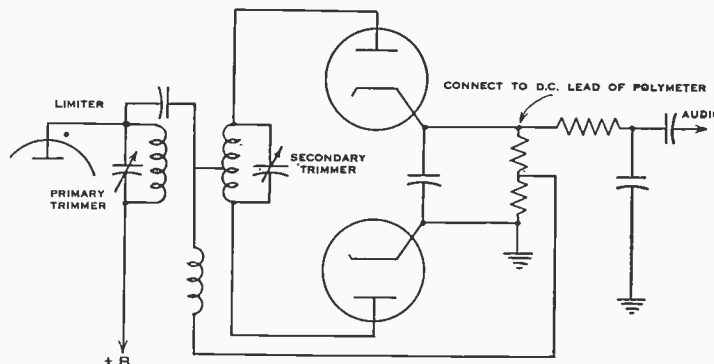

FIGURE 2

DISCRIMINATOR ALIGNMENT



# SERVICING WITH A MODERN OSCILLOSCOPE

tage should nearly equal the negative and these maxima should occur at equal frequency intervals on either side of the center frequency. See Figure 3. Repeat the alignment if required.

FIGURE 3  
DISCRIMINATOR CHARACTERISTIC

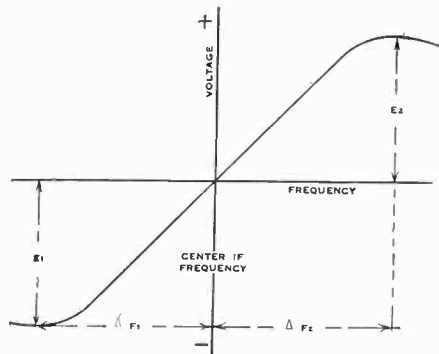

4. It is possible to use the Oscilloscope in place of the Polymeter for discriminator alignment. The vertical amplifier of the Oscilloscope should be connected to the high side of the discriminator load resistors through 100,000 ohm isolating resistor. The signal generator must be AM modulated. The process of AM modulation of the signal generator must not produce any appreciable amount of FM modulation of the generator. Connect the signal generator as before and carefully adjust the output of the generator for maximum output as shown on the oscilloscope. As the frequency of the signal generator is varied, this output will go through zero sharply at one particular frequency. Set the frequency of the generator to center IF frequency and adjust the secondary of the discriminator for zero output on the oscilloscope. With the secondary slightly detuned, adjust the primary for maximum output. Readjust the secondary for zero output. Tune the signal generator about 100 kc. above and below the center frequency. Equal outputs should be

FIGURE 4  
ALIGNMENT OF RATIO DETECTOR

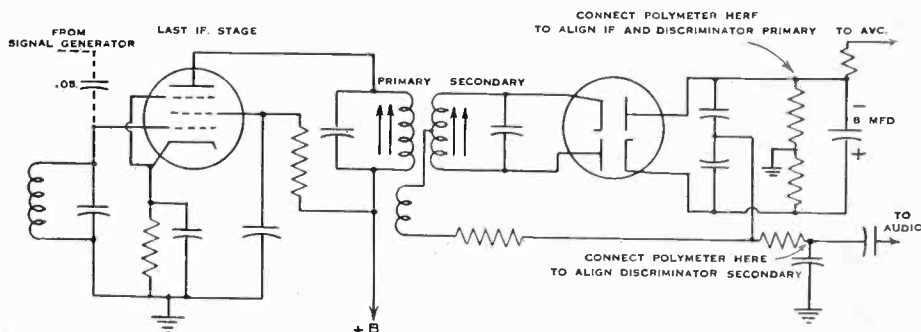
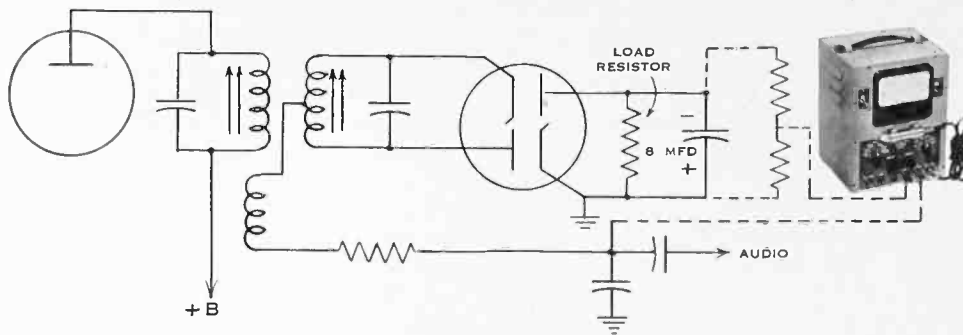

FIGURE 5

ALIGNMENT OF ALTERNATE CIRCUIT OF RATIO DETECTOR



obtained on the Oscilloscope at equal frequency intervals from center frequency.

### Alignment of Receivers Using "Ratio Detector"

Some post-war sets use a ratio detector in place of the conventional discriminator and may not have a limiter stage. The modifications to the aligning procedure given above required to align sets of this type are as follows:

1. In place of the limiter grid resistor connect the Polymeter from the negative end of the load resistor to ground, as shown in Figure 4, and align the IF's for maximum output.
2. To align the discriminator tune the primary for maximum output of the Polymeter with the signal generator at center frequency.

To align the secondary of the discriminator disconnect the Polymeter from the load resistor and connect it to the audio output. Adjust the secondary for zero DC voltage on the Polymeter.

If the center tap of the load resistor is not grounded, but one end is grounded instead as shown in Figure 5, it is expedient to connect two equal resistors across the load resistor, and connect the common point of the Polymeter to the center

tap of these resistors when aligning the discriminator secondary for zero output at center frequency. The added resistors should be about ten times the sum of the load resistors in the set.

### Alignment of Receivers Using Locked in Quadrature Circuits

The locked in oscillator-quadrature detector circuit is characterized by the absence of the conventional limiter, discriminator, and diode detectors, whose functions are combined in a single tube, a special heptode, Type FM1000. The first and second grids of this tube are used as grid and anode of an oscillator which nominally operates at the intermediate frequency. The output of the I.F. amplifier is fed into the injection grid of the Type FM1000 tube. The plate is reactively coupled to the oscillator circuit and causes the oscillator to lock in and follow the variations in frequency of the I.F. signal. This in turn causes variations in the plate current which are linear with respect to frequency deviation and the audio signal is obtained from the plate circuit.

To align sets using this circuit, connect the oscilloscope to the voice coil of the receiver or some other convenient point in the audio amplifier. (An AC range of the Polymeter could be used instead if desired). Connect a jumper from the first grid (pin #2) of the FM1000 tube to ground. This shorts the oscillator and the tube functions as an AM detector. Align the I.F. amplifier for maximum audio output.

To align the FM detector, apply an unmodulated signal of center intermediate frequency to the grid of the last I.F. stage. Remove the



## SERVICING WITH A MODERN OSCILLOSCOPE (Cont'd)

jumper from grid one to ground and connect a jumper across the tuned circuit in the plate of the Type FM1000 tube. Adjust the trimmer across the oscillator circuit for zero beat of the oscillator frequency with the applied I.F. signal. This is the point at which the audio output drops sharply to zero. Remove the jumper across the tuned circuit in the plate of the Type FM1000 tube. Keep the output of the signal generator low, below the level which causes the oscillator to lock in, and adjust the trimmer in the plate circuit for zero beat. A single very sharp zero beat point should be obtained.

### Alignment of RF Circuits

The RF section may contain provisions for both the old 42-50 mc. and the new 88 to 108 mc. bands. The following procedure is appli-

cable to both bands:

1. Connect the signal generator high terminal to the antenna terminal of the receiver through a 300 ohm carbon resistor and connect the low side to the receiver chassis. If the antenna winding is balanced to ground, it may be desirable to connect the antenna terminals to the signal generator terminals through two 15<sup>0</sup> ohm resistors. Connect the Polymeter to the limited grid resistor as the output indicator.

2. With the signal generator unmodulated, and tuned near the high end of the band, set the dial of the receiver to the signal generator frequency adjusting the oscillator trimmer if required. Adjust the antenna and RF trimmers for maximum output.

3. Tune the signal generator and receiver to near the low end of the

band and adjust the oscillator pad-der if one is provided, or adjust the oscillator inductance by spacing the coil turns closer or farther apart until the receiver dial coincides with the signal generator. Adjust the inductance of the antenna and RF coils for maximum output. Repeat (2) and (3).

For receivers having both old and new FM bands, repeat the complete RF alignment procedures for the second band.

This completes the alignment of the FM channel of the radio. The Oscilloscope can be used to align and analyze the AM and audio sections of the receiver, as described in the previous article. The alignment of AM and FM receivers with an FM signal generator will be considered at a later date.

In the next article some additional applications of the Oscilloscope in the service shop will be described.

## NEW SYLVANIA TYPE 132 OSCILLOSCOPE LARGE 7" SCREEN HAS MANY APPLICATIONS

The illustration on a previous page shows the latest addition to the line of Sylvania service equipment.

The Sylvania Oscilloscope Type 132 is intended for servicemen who need a larger screen for investigating wave forms or for television servicing than is afforded by the 3" tube in the Oscilloscope Type 131. You may wonder why this model does not use a 5" tube but an examination of the tube prices and characteristics will show that with very little more cost in either tube, power supply or amplifier the screen

area can be almost doubled.

The schematic will be shown in a later issue. In addition to the features of the smaller instrument, two switches have been provided so that direct connections may be made to the deflecting plates. This permits the observation of D.C. components as would be required in checking the waveform of the pulse generator in a television receiver, and any frequency too low to pass through the amplifier may be observed providing the synchronizing or scanning can also be provided from the source. Higher frequencies may

also be observed providing amplification is not required. The use of the instrument for this purpose and other standard procedures is explained in the instruction book.

In order to make full use of the separate connections to the deflection plates a push-pull amplifier is provided. This uses two 7C7's for each amplifier and has a gain of about twice that of the smaller instrument as well as the phase inversion required.

An additional feature is the provision for an intensity modulation connection which permits the accentuation of the positive part of a complex wave form when desired.

## WE NEED YOUR HELP

The usual procedure is for us to give you technical information, but here is an opportunity for you to give us some.

There is a trend in the industry to change the terminology used in describing tube connections by dropping the functional descriptive terms such as control grid, screen grid, suppressor, oscillator grid, etc. and substitute for them the terms grid No. 1, grid No. 2, etc. If this is progress we want to adopt it, but do not want to confuse Servicemen using our Characteristics Chart where information is given in very condensed form. Eventually all the base diagrams would be changed, for

example, the information given on the base diagram for 1A7GT would be as follows:

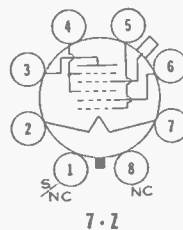

The tabulation in the chart would probably be the same as at present, but in manual or similar descriptions the voltages would be given as:

Plate Voltage.....	90 Volts
Grids #3 and #5 Voltage.....	45 Volts
Grid #2 Voltage.....	90 Volts
Grid #4 Voltage.....	0 Volts
Grid #1 Resistor.....	20,000 Ohms etc.

We realize that many servicemen will understand either system, but those who are not too familiar with the functions of the various grids may be confused. If you feel strongly about this please send us a card or a letter stating your opinion. We hope to get too many to acknowledge individually, but we will report the "votes" in THE NEWS and try to be governed by the majority decision. Send your "vote" to the attention of the Technical Editor, Box 431, Emporium, Pennsylvania.

# SMALL TOWN SERVICE IN BIG STYLE

Big stuff can sell radio service in small towns too. O. K. Radio Service of Cutbank, Mont. is a good

example of this. Business is good and the shop well equipped.

To make servicing better with

more and finer test equipment, Mr. Orin E. Knutson, proprietor, has combined his shop with The Perry Motor Co. in Cutbank. Overhead costs come down and more business is at hand in auto radio servicing. It's an effective arrangement for a small town.

Perry Motors in Cutbank, Montana is an effective arrangement for good radio servicing by O. K. Radio Service.

The test panel of O. K. Radio Service is a homemade one with a professional look. The panel is white masonite and contains complete equipment for testing sets. Mounted in the panel is a signal generator, oscilloscope, tube tester, volt-ohmmeter, condenser tester and signal tracer.

Also contained in the test board is a phono-amplifier for testing record changers. The panel has four 110 volt AC outlets, one six volt DC outlet for testing car radios. Two test speakers are also on the panel. Antenna connections are included for auto and outside connection. Under the bench is a loop antenna.

The bench is amply provided with drawers for storage of components. Fluorescent lighting makes the bench a pleasant place to work and a complete line of Sylvania tubes is on the shelves.

Mr. Knutson's O. K. Radio Service proves that big stuff goes in small towns too.

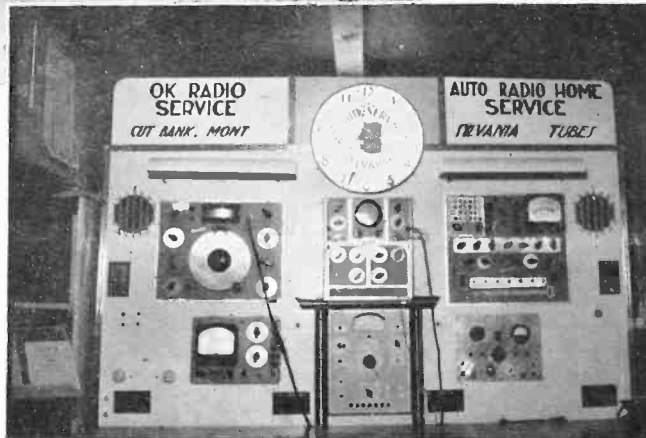
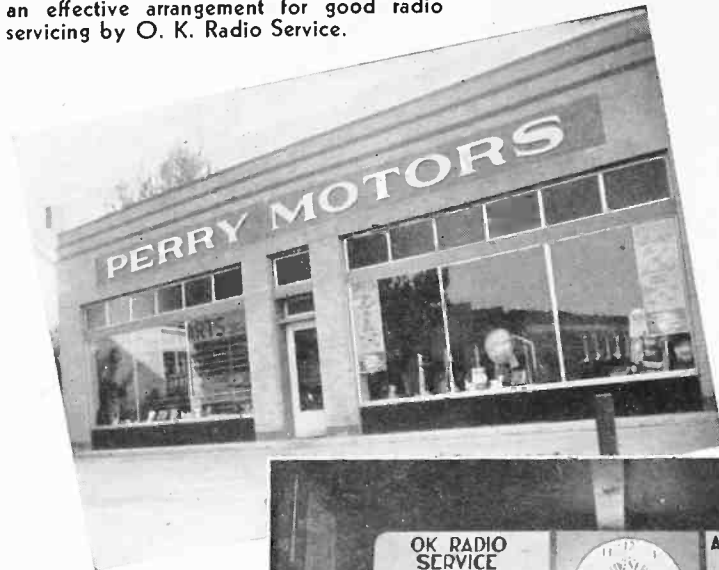

Test Board at O. K. Radio speaks for itself. New Sylvania Clock commands a prominent position in the test panel.

## A TIP-TOP SALESMAN

## ... FOR A TINY SALARY

It's a funny thing about pretty girls. They can do most anything, if you'll give them a chance. You know the old saying, "You can't get along with 'em and you can't get along without 'em." It's true too, 'cause we found out a lot about those things.

Well, if you're still not convinced, just feast your eyes on that new Sylvania Flasher Sign. It's a honey (so is the little girl) and will go a long way toward hauling new customers into your store. It must be the wink in the flash, but then again, it doesn't always take a wink.



She is a lovely lady all done up in seven brilliant colors. What's more she lights up!

If you're still not convinced, just give our little working girl a chance. Selling is her business, and she knows all the ropes, besides she's an inexpensive salesman. Only \$2.00 at your Sylvania Distributor, or a letter with your two bucks to the Advertising Department, Sylvania Electric Products Inc., Emporium, Pa. will bring her to your shop, (postage prepaid) and she'll be working for you in a jiffy.

# IDEA DEPARTMENT

## HERE ARE THREE \$5 WINNERS

Ideas! Ideas! They keep pouring into the editor's desk. We're swamped, but we love it. From all over the country have come ideas for merchandising, speedup of service work and improvement of shop efficiency. The tough part about it is that we don't have enough space to publish all the swell ideas we get.

Don't be too disappointed if your idea isn't on this page. We'll hold it for possible publication later. Remember, you have had to compete with a lot of others, and the ones here are those which we thought best. Perhaps a lot of servicemen can get some good pointers from them, so even if you don't win the \$5.00 certificate with your suggestion this month, you've got some good ideas here which might bring you more business.

Meanwhile don't forget to send in your idea. Remember a five dollar certificate will go a long way toward putting dollars in your pocket. Send your ideas to the Editor, SYLVANIA NEWS, 500 Fifth Ave., New York 18, N. Y.

### FIVE CENTS BUYS NEW BUSINESS

One of the best ideas submitted came from Mr. James C. Day of Day's Radio Service, Gallipolis, Ohio. This unique idea can probably be put to work in a lot of communities.

Gallipolis is another town which uses parking meters, and parking meters, which we all know, seem to tick faster than watches, putting us in the unhappy situation of having to pay a fine now and then. Well, Mr. Day's answer for that is simple. When he makes a trip along the streets, he carries with him a pocket full of nickels and a few of his job record cards. When he comes to a meter which is in the violation zone, he sticks in a nickel and puts the card under the windshield of the car in the space where a cop would put a ticket. Written on the back of the card is this little message,

Your meter has been paid for one hour to save your having to pay a fine.

Courtesy of  
**DAY'S RADIO SERVICE**  
59½ Court St.

"You'd be surprised at the number of people that thank me for paying their meter when they bring their radios to my shop for repair" says Mr. Day.

### PEOPLE'S VANITY USED TO MERCHANDISE

Another good idea for getting your name spread around comes from Mr. E. E. Baldwin of Harvard, Nebraska. This idea involves little expense and does a lot to bring in the sets to be repaired.

Mr. Baldwin has bought some dime store mirrors and fixed them up with decal letters to advertise his service. These mirrors are then placed in rest rooms in tavern, bars, hotels and other public places where the proprietor is willing. Since the mirror costs them nothing and is a necessary piece of furniture for any establishment they go over in a big way. Mr. Baldwin is enthusiastic when he says, "... the effect is pleasing, both to the customers and to my pocketbook." And the cost for the whole project is less than \$1.00 each.

### THOUGHTFULNESS SELLS MORE SERVICE

Clyde D. Kiebach, of Washington, D. C. doesn't let his customers forget about him either. Below are several copies of letters which he sends out to old and new customers to remind them of the expert work which his shop puts out. The system works wonders and Mr. Kiebach sums up the practice by saying, "Thoughtfulness works, and the word gets around when one is trying constantly to improve his work and gain additional customers."

Dear Neighbor,

Ordinarily, your dentist requests your presence in his office for an examination twice each year—and rightly so—irreparable damage often results from negligence in not answering his urgent plea.

And—so—we also want to save you from extra added worries and headaches by keeping your radio repair bills at a minimum and your set always in tip-top order. As in dentistry, let us repair now before the damage has gone too far!

May we call on you now for a semi-annual examination?

Dial EXecutive 4700 at once.

Clyde D. Kiebach  
Certified Radio-Trician

Dear Neighbor,

Your radio set has been very carefully inspected and several defective parts have been located.

One of these parts, the \_\_\_\_\_ must be secured direct from the factory, which will mean a delay of a period of time before I can deliver your radio set to you.

You can rest assured that your radio set will be returned to you as soon as this radio part has been received and properly installed.

Clyde D. Kiebach  
Certified Radio-Trician

Dear Neighbor,

Your radio set has been thoroughly checked, cleaned, balanced and reconditioned with the use of modern laboratory instruments especially designed for radio servicing.

Bad tubes were replaced with the famous Sylvania Set-Tested Radio Tubes; and since your set is now ready for your use, it will be delivered to you on \_\_\_\_\_.

If the above stated time is not convenient for you, please dial 3-6925 on your telephone to arrange for a more suitable time.

Clyde D. Kiebach  
Certified Radio-Trician

P.S. Are you well supplied with household electric light bulbs?

Dear Neighbor,

Last week, your radio set was returned in excellent condition; and since you have had an opportunity to test the mechanical workings of this wonderful invention, we trust that you are as pleased with it as we are to receive your patronage.

We aim to please, so keep us informed about your radio's clarity of reception and performance.

Thank you. Our number, as listed in the telephone book, is 3-6925.

Clyde D. Kiebach  
Certified Radio-Trician



## MEET BOB ALMY

(Continued from page G-30)

Well known in the radio parts industry, Bob has seen service on many committees and organizations associated with the industry. Among his activities are included such things as one time chairman of the Radio Parts Manufacturers Sales Managers Club, member of RMA committees, director of the Radio Trade Show Corporation and one of the original members of the Radio Parts Industry Coordinating Committee. His travels throughout the U.S. have made him well known to radio servicemen, radio parts distributors, and the radio parts industry.

During his years of service in the sales department, Bob Almy has, more than any other person, guided the policies and merchandising of Sylvania Radio Tubes in the replacement field. For several years his "Comments" column in THE NEWS kept retailers and distributors posted on the current items of interest in the tube picture.

Servicemen as well as Sylvania can be proud of the job Bob Almy has done for them. His tireless efforts on the part of the servicemen have made them partners of Sylvania instead of hard nosed customers. "No matter who's doing the selling, it's building for the future that really counts", commented Bob.

## ENGINEER FROM INDIA VISITS SYLVANIA

(Continued from page G-30)

sion and for the extension of its higher educational system. The Indian government has sent several hundred students to the United States to partake of courses that will enable them to play a major part in expanding the educational program in India.

In addition to his recent visit to the Flushing laboratories, Mr. Singh has visited many other Sylvania laboratories and plants. These visits were arranged by Dr. D. L. Benedict of the Cruft Laboratory of Harvard. Dr. Benedict was a member of the Flushing Research Laboratory during the war.

Mr. Singh said that he was grateful for this excellent opportunity to view at first hand the industrial methods and electronic production as carried out at Sylvania.

## SYLVANIA SALES DEPARTMENT MAKES PERSONNEL CHANGES



BILL MAGUIRE

The transfer of Wm. M. Maguire from the Salem, Mass. plant to the Distributor Sales Department of the Radio Tube Division of Sylvania has been announced by C. W. Shaw, general sales manager. He will serve as products specialty salesman in cooperation with Sylvania sales division managers and distributors in the eastern half of the United States.

He joined the Company in 1930, having previously been associated with the radio tube division of the Consolidated Lamp Works. Before the war he specialized in the development of electrical equipment for vacuum tube manufacture in the company's plants at Clifton, New Jersey, and Salem, Mass. During the war he was active in proximity fuze tube production and also served as a member of the test equipment standardizing committee.

A native of Peabody, Mass., he has been an active radio amateur since 1924. He is a member of the A.R.R.L. and the Institute of Radio Engineers.

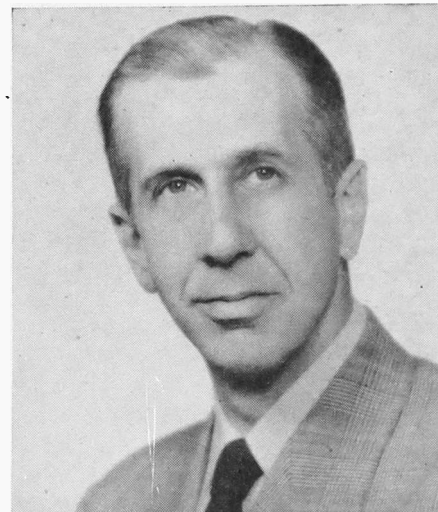

GEORGE ISHAM

George C. Isham, manager of distributor sales in the Northeast Division for Sylvania, will also be responsible for distributor tube sales in the Metropolitan Division covering Eastern New York, New Jersey and Eastern Pennsylvania.

His appointment was announced by C. W. Shaw, general sales manager of Sylvania's Radio Tube Division. He will be assisted by S. J. McDonald, sales representative for Sylvania's Metropolitan Division distributors.

Since 1928 Isham has been actively engaged in radio parts sales through distributors and brings a wealth of experience to benefit radio men in the new territory.

He is a native of Jefferson County, Rodman, New York, where his home has been occupied by members of his family for more than a century. He also operates two dairy farms in upstate New York. He is president of the Alumni Association of St. Lawrence University and is currently running for the office of Alumni Trustee.

## JULY SET PRODUCTION DECLINES

Radio and television receiver production showed a decrease in July as a result of a seasonal decline plus many plant vacation shut-downs, according to a recent report of the RMA. July production of all types of receivers by RMA member - companies dropped to 1,155,456 against a total of 1,213,142 for the preceeding month.

A sharp increase was noted in the last week of July. In the work week ending August 1 a total of 357,240 radio receivers were produced.

July television receiver production was reported at 10,007, slightly below the 11,484 chalked up for the month of June. This total was well above the other months reported this year.

# SYLVANIA EXECUTIVE ON SECOND EUROPEAN TOUR

Walter A. Coogan, Managing Director of the International Division of Sylvania, sailed for Europe recently on the S. S. "Queen Elizabeth," seven months after a previous continental trip lasting two-and-a-half months. His plans include the study of rapidly changing political and monetary conditions in countries in which Sylvania maintains distributorships.

Mr. Coogan expects to cover ten countries, traveling on the continent entirely by plane. His itinerary includes England, Ireland, Sweden, Norway, Denmark, Belgium, Holland, France, Switzerland and Italy.

He is particularly interested in determining whether shortages of food and coal, many of which he predicted right after the cessation of hostilities in Europe, have been remedied or whether there is prospect of shortages being overcome in the immediate future. The availability of both of these commodities has a strong influence on



WALTER COOGAN

the buying habits of the customers of Sylvania.

### ON THE COVER

Careful inspection of even the smallest parts that go into Sylvania Tubes, insures the user that the performance of Sylvania Tubes is superior.

# FACTS & FIGURES

## Mid Year Tally of Broadcasters

AM station licensees totaled 1806 in the U. S. and its possessions on July 1. Of these 535 are still in the construction permit stage. There are more than 750 applications for new AM stations pending. FM tallies show 48 licensees, 622 construction permits, 251 conditional grants and 174 applications pending. Of the 1095 prospective stations, 263 are now on the air.

## First Half Tube Production

Radio tubes produced during the first half of 1947 totaled 103,362,432 despite a recent decline from the record output earlier this year, according to the RMA. The output of the first six months included 66,371,204 for new sets, 23,920,166 for replacements, 12,804,197 for export and 266,865 for government agencies.

## Personal Income at Peak

Personal income reached an all time high in the U. S. during June when it rose to an annual rate of \$193 billion, or \$1.2 billion more than the previous peak reached in March of this year, according to a report of the Department of Commerce. The June rise was primarily due to increased wage and salary receipts and higher agricultural net income.

## Inventories Increased in June

The dollar volume of all manufacturers shipments in June is estimated at \$13.6 billion, slightly below that in May. Inventories held by manufacturers advanced another \$300 million in book value during June to \$22.7 billion. The increase was about the same as for May and was accounted for entirely by the durable goods industries.

## General Mobile Licenses

The FCC has extended to Nov. 1, 1948 the license term of all General Mobile Class 2 Experimental licenses which would normally expire Nov. 1, 1947. The new order relieves the licensees of taxicab dispatching systems and other general mobile experimental radio-telephone systems of the requirement that they apply for renewal of their experimental licenses this year.

SYLVANIA NEWS

SYLVANIA ELECTRIC PRODUCTS INC.  
P. O. BOX 431  
EMPORIUM, PENNA.

RETURN POSTAGE GUARANTEED

Sec. 562, P. L. & R.  
U. S. POSTAGE  
PAID  
Emporium, Pa.  
Permit No. 1

For:

Mr. J. Kenneth Bowran  
Rt. 4  
Rocky Mount, Va.

A

POSTMASTER: If addressee has moved, notify sender on Form 3547, postage for which is guaranteed. When Form 3547 is sent abandon this mailing. Return only if no correct address is available.

Vol. 14, No. 8

SEPTEMBER, 1947

Published By  
SYLVANIA ELECTRIC PRODUCTS INC.  
Manufacturers of Sylvania Radio Tubes and Electronic Devices, Sylvania Incandescent Lamp Bulbs, Fluorescent Lamps and Equipment





# SYLVANIA NEWS

Copyright 1947, Sylvania Electric Products Inc.

R. A. PENFIELD, Editor

OCTOBER, 1947

EMPORIUM, PENNA.

VOL. 14, NO. 9

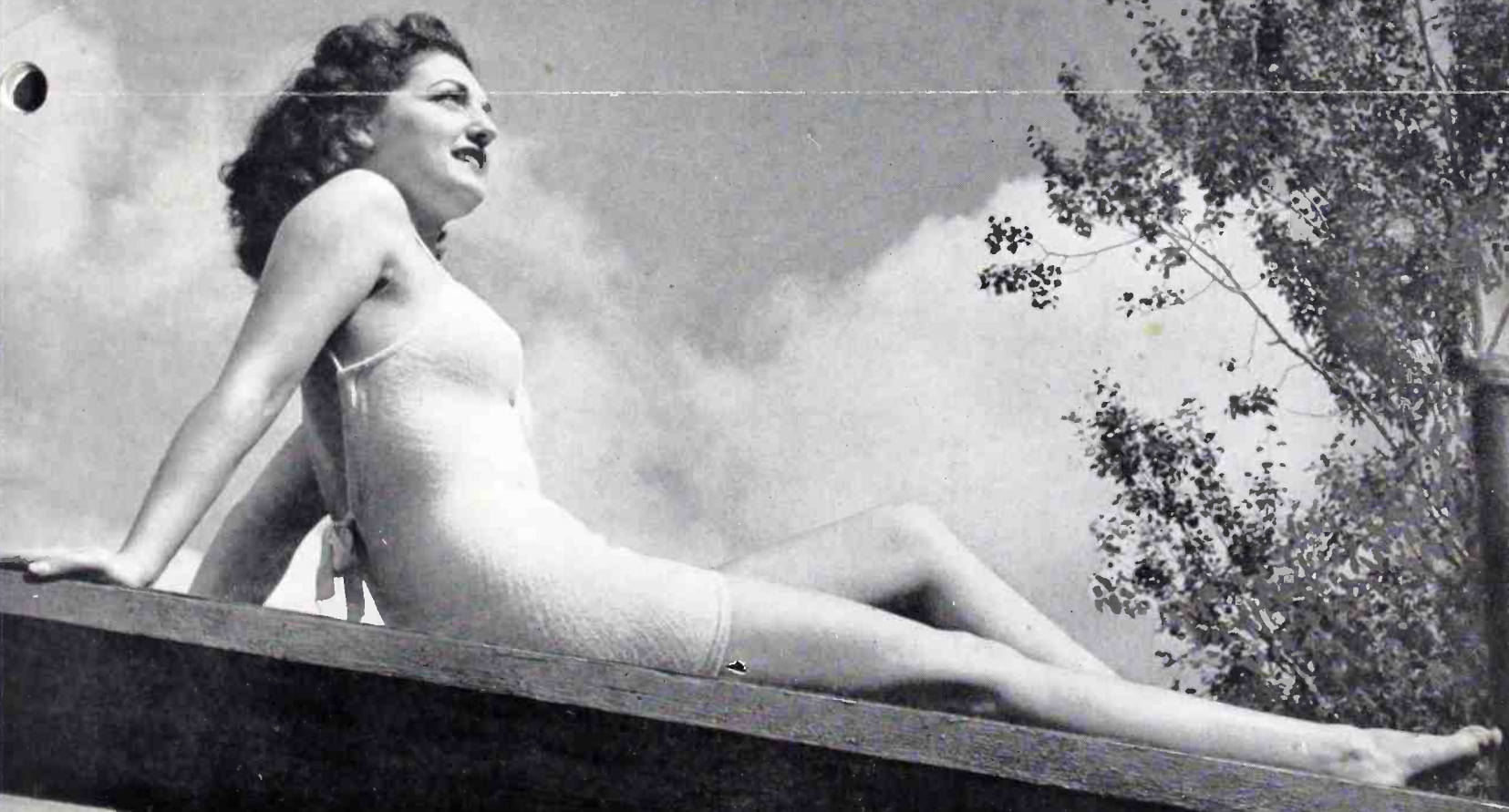

**OUR OWN COVER GIRL**  
See Page G-34



## SYLVANIA EXECUTIVE TELLS FM FUTURE AT FIRST ASSOCIATION MEETING



MAX BALCOM

Max F. Balcom, vice president and treasurer of Sylvania and president of the RMA was one of the chief speakers at the first convention of the FM Association in New York recently.

Speaking at the banquet of the association, Mr. Balcom reviewed the part manufacturers have played in making FM a success. He pointed out that manufacturers had lost money in the manufacture of FM sets, and had millions invested in

equipment to make FM receivers. In a review of production figures, Mr. Balcom pointed out that FM sets were gradually gaining a good share of the manufacturers production. With the increase of FM-AM table models being put on the market, the production of 2,000,000 FM receivers may easily be exceeded this year, according to Mr. Balcom.

It was pointed out that new engineering designs and extra components have added to the cost of FM receivers, but the history of radio set prices in the past 25 years shows, "there is no reason to doubt that the same will be true in the field of FM."

RMA's promotion program this year has been geared to be a boon to FM. The very theme of the program will be a great influence on the sale of FM receivers because the "family is more likely to choose a new receiver with the newest reception facilities—FM", he said.

Mr. Balcom warned that FM broadcasters should not be too optimistic because, "Despite the best possible production records the

*(Continued on page G-36)*

## WHO'S WHO AT SYLVANIA



HAROLD RAINIER

Perhaps the best known member of the Sylvania sales staff is Harold Rainier. As manager of distributor sales, he oversees Sylvania's ten major territories throughout the United States. His time is spent in traveling about the country, visiting servicemen and distributors, listening to their problems, helping when he can and tossing the gripes of larger dimension into the lap of the sales department to find a cure.

Harold is an Illinoisian by heart and heritage, but most of his time is spent looking after national distributor sales for Sylvania. When at home he holds down a desk in Sylvania's Chicago office and lives on the Windy City's South Shore.

Behind Harold Rainier is twenty consecutive years in radio tube sales, probably longer than anyone in the industry. Until 1940 he held down a sales managers position with a competitive company where he did much of the organization of the distributor set-up.

Since coming with Sylvania, Harold has done much to carry out the Sylvania policies and trade relationships set up by Sylvania management. Objective of the policy he has tried to effect is to bring about a closer relationship between the retailer, distributor and manufacturer.

"A close knowledge of each others problems brings about complete teamwork which can't fail to be reflected in more SALES for everyone," is Harold's way of summing up his job.

## THIS IS "OUR" COVER GIRL

Just to prove a point, all beautiful women don't come from big cities. And to prove another, beauty helps to get SYLVANIA NEWS in the mail each month.

On the cover is Miss Marion A. Gulnac. This attractive young lady is an employee of Sylvania's Advertising Department in Emporium. But, that's not all. Last month Miss Gulnac was chosen to represent Cameron County, in the Pennsylvania state beauty pageant, with hopes of going to Atlantic City for the Miss America Contest. Well, she didn't go to Atlantic City, but in our hearts she is still our choice for Miss America, if not that, she makes a darn good Miss Sylvania.

Miss Gulnac is a native of Emporium, but has spent a few years in Buffalo. We, of course, do not count that too much, even though she did go to school there and work in the city for a time. Miss Gulnac belongs to Emporium, Cameron County, and Sylvania. Life long

ambition of our beauty queen has been to be a nurse. Things just haven't worked that way, but we selfishly admit that we aren't sorry. She is a swell addition to our office.



Pretty Marion Gulnac sorts the stacks of SYLVANIA NEWS just before they are ready for mailing. Patty Stroll and Doris Krug are in the background.

# SYLVANIA NEWS MERCHANDISING SECTION

Copyright 1947, Sylvania Electric Products Inc.

OCTOBER, 1947

EMPORIUM, PENNA.

VOL. 14, NO. 9

## HOW IS YOUR SALES APPEAL?

S.A. means sex appeal to most of us, but it also means **Sales Appeal**. Now we might ask, "What does sales appeal have to do with selling service?" In plain ordinary terms, "A helluva lot!"

From whom do you like to buy your supplies? The guy who gives you a lot of guff and tells you stuff that isn't true, or the square-shooting, good guy who gives you a lot of help and tells you what's cooking in the best circles? The latter guy, of course. Well the same is true of your customers. They are human too. They like to know you're doing a good job and that you are playing fair with them.

### Things Are Different Now

Sure, sure, we know you know all this. But sometimes we just forget, so we need to think about it a little. War time servicing was a tough business. Most of the time we had more work than we could handle, and what work we did have we had a tough time getting the proper parts. Then we could afford

## DISTRIBUTOR CELEBRATES 15 YEARS IN PARTS BUSINESS

Wilkinson Bros., Sylvania distributors in Dallas, Tex., recently celebrated their fifteenth anniversary in the radio parts business. That fact alone is distinction enough, but the growth of Wilkinson Bros. is still more distinctive.

From their tiny first location where 800 square feet seemed like plenty of room, and two employees were adequate, they have grown into a major distributor, employing 21 people and occupying 8,000 square feet. The four top employees of Wilkinson Bros. represent an aggregate of over 100 years experi-

to be a little choosy. Matter of fact, we almost had to be.

But things are different now. We've got to do some good stepping to sell ourselves. Not only that, but being nice to people always pays off in the end.

It's just human nature to do business where you are treated the best. For example, how would you like it if you went into a place and they told you, "Naw, we don't have that. What do you want that for?" We like the guy who tells us that he is very sorry; he doesn't have it in stock right now; but he will see what he can do for us.

### Let's Treat 'Em Nice

Just for the records, we recalled a few ideas which will work well in keeping your customers happy and help a lot to bring in new ones.

If a customer only wants his tubes checked, treat him with respect. Your confidence and politeness will go a long way toward making a friend. Besides, maybe his tubes are alright and his radio

ence working together in the radio parts business.

Highlight of the anniversary celebration was a contest to determine which of their customers had in his possession the oldest invoice or packing slip of a shipment from the firm. The winner, who turned up with a slip dated July 19, 1932, only two months after the business was established, was awarded a Sylvania Portable Tube Tester, Type 140. Fourteen other prizes were awarded to holders of slips showing that they were early friends of Wilkinson Bros.

has more trouble. That will give you a foot in the door to look it over, and maybe mean a big service job.

Don't let a customer go out of your shop without wishing him **GOOD BYE** and giving him a pleasant **THANK YOU**. It will make him feel good about coming in, even if he didn't want much.

Lots of times you get tied up and have to make a service call which doesn't bring any returns. Don't worry about it and don't complain. The day will come when you will make a call to the same place that will pay dividends.

When you are asked about competitors, don't run them down. Remember you may be talking to a friend.

### Show Off Your Shop

People are funny. They love to see gadgets work even if they don't understand them. You can do a lot for your customers by having your test equipment out where they can watch you. Then too, letting people see you test things makes them respect you more. If you take it out of their sight they may become suspicious.

Never misrepresent. Somebody will always tell your customer the truth, and then you've lost a friend. Explain to him about everything you do for him. Honesty, it seems, never fails to be the best policy.

### Most Of All, Keep Smiling

Maybe we've said too much, but maybe it has been too little. Just remember, with the customer, it's Sales Appeal that counts, and you might talk yourself blue in the face, but nine times out of ten the customer will believe he is right, and what's more, you've got to keep him thinking so, if you want him to be your customer.

# NOW THEY'RE BACK IN SYLVANIA GREEN

Things are looking up! Now you can get Sylvania Service Jackets



Shop Coat \$4.00

and Shop Coats in that snappy green material like we had before

the war. Yes, things are looking up. Now you can dress yourself as well as your shop.

Sylvania Coats and Jackets will do the trick every time. When you are kneeling on a dirty floor, or climbing under a car, the shop coat offers you plenty of protection, so that when you have finished your job, you'll be neat as a pin. There are roomy pockets, too, that can handle all the little gadgets that you'll need.

The service jacket too, will be a blessing to you. Well cut, with three buttons, it will keep you in shape to meet your customers. For outside service calls the service jacket is a winner. Plenty of room in the three pockets for your gadgets that won't go in your kit.

If you want to be trim, follow the style set by tip-top radio servicemen. Wear a Sylvania Shop Coat or Service Jacket. Both are available from your Sylvania distributor, or from the Advertising De-

partment in Emporium, Pa. The four bucks invested for the shop



Service Jacket \$3.10

coat or the \$3.10 for the service jacket is well worth the money.

# CHINATOWN DEALER HAS BIG BUSINESS



Shown just before a broadcast over KSAN is, left to right, W. G. "Pat" Patterson, Western division manager, H. W. Zimmer, vice president of Sylvania Radio Tube Division, and Tommy Tong. Mr. Zimmer, on a combined vacation and business trip, discusses the merits of Sylvania Tubes with Mr. Tong.

Thomas Tong, Golden Star Radio, San Francisco, Calif, is another proud Sylvania dealer. Radio servicemen, radio dealer and exporter to China where he has his own distributorship, are only a few of Mr. Tong's activities. In addition to his retail radio business, Tommy Tong operates radio station KSAN and publishes the local Chinese newspaper in San Francisco's Chinatown.

Over broadcast station KSAN Mrs. Tong, Tommy's wife, broadcasts news and other information nightly in seven different Chinese dialects. During the United Nations Conference in San Francisco in 1945, station KSAN figured prominently in the broadcasts to the Chinese people by prominent members of the Chinese Delegation.

Golden Star Radio has handled Sylvania Tubes for ten years. During the war years, Tommy Tong utilized Sylvania Tubes on his sound truck from which he broadcast Chinese war news in the streets of San Francisco's Chinatown.



# SYLVANIA NEWS TECHNICAL SECTION

Copyright 1947, Sylvania Electric Products Inc.

A. V. BALDWIN, Technical Editor

These data have been compiled from information which we believe to be accurate. No responsibility can be assumed in the application thereof or for patent infringement.

OCTOBER, 1947

EMPORIUM, PENNA.

VOL. 14, NO. 9

## SERVICING WITH A MODERN OSCILLOSCOPE

### PART 3

By FRED DALASTA

In this article on the application of an oscilloscope in servicing we will consider some additional uses to which the radio service engineer may apply this instrument in his shop. The two previous articles of this series discussed the application of the oscilloscope (Sylvania Types 131 and 132) in servicing AM and FM receivers. An oscilloscope in the service shop becomes a more worthwhile investment if the instrument is used wherever practicable to give complete information and reduce time spent in locating defects.

The applications we will discuss are: amplifier power output testing, checking amplifier frequency response, frequency determination by comparison, filter characteristics, vibrator testing, and transmitter modulation checking.

#### Amplifier Power Output Testing

When testing for undistorted power output of an audio amplifier, it is necessary to use an audio oscillator (having a good sine wave output) covering the audio range, and an output meter or a VTVM such as the Sylvania Type 134 Polymeter to measure the voltage developed across the output load. The test may be performed to check the maximum undistorted output at standard audio frequencies, i.e. 400 or 1000 cps. or the undistorted output over the entire audio range. In the latter case the maximum undistorted output vs. frequency response of the amplifier can be plotted.

1. To make this test, connect the audio oscillator to the input of the first audio amplifier stage with the oscilloscope and an output meter across the normal output load. Set the frequency of the audio oscillator to 1000 cps. and increase its output to as high a point as possible without visible distortion of the wave as seen on the oscilloscope. When testing high gain

amplifiers, it may be necessary to connect a voltage divider across the output of the audio oscillator to obtain a stable oscillator output at low voltage. Record the output voltage. The power output of the amplifier may be calculated by

the well known formula  $P = \frac{E^2}{R}$ ,

where E is the output voltage in volts and R the output load resistance in ohms.

2. Repeat the above procedure for each desired frequency and plot the values if a curve is desired.

#### Amplifier Frequency Response

1. Connect the audio oscillator, output meter and oscilloscope, as described above, and set the audio oscillator at 1000 cps. Adjust the output level of the audio oscillator so that the amplifier output wave will not indicate distortion on the oscilloscope screen.

2. With the 1000 cycle signal connected adjust the input signal strength to get a value of output which will not overload the amplifier at frequencies where the gain is

highest. In amplifiers having bass or treble boost circuits use an input which will give maximum output at the point where the boost is highest. It is customary to show a curve for each of the controls in maximum and minimum positions.

3. Typical frequencies for a response curve would be 20, 40, 70, 100, 200, 400, 700, 1000, 2000, 4000, 7000 and 10,000 cps. Additional intermediate frequencies may be used where there are sharp changes in amplifier response. With a constant input voltage to the amplifier record the output voltage of the amplifier at each frequency. A curve may be plotted directly by referring to the 1000 cps. output as the reference level and plotting the response in percentage or decibels for each frequency above or below the 1000 cps. value.

#### Frequency Determination by Comparison

With the use of a known oscillator frequency and the oscilloscope the frequency of an unknown oscillator may be determined. Figure 1 shows the basic circuit used for producing Lissajous figures which may be used in the comparison of the two frequencies for calibration.

1. Connect the oscillator of known frequency to the vertical input and the oscillator of unknown frequency to the horizontal input of the oscilloscope. Turn off the internal sweep generator of the oscilloscope. If the frequencies of the two oscillators are identical, the patterns shown in Figure 2a will be observed on the cathode ray tube.

On account of phase differences the different patterns shown above may be obtained, generally shifting slowly from one to another unless the two frequencies are exact multiples. By counting the points of tangency to two perpendicular lines, as shown dotted in Figure 2b, the ratio (2 to 1) of the oscillator

FIGURE 1

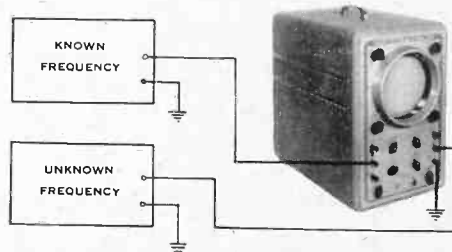

#### Type 132 Oscilloscope

As promised last month we are showing in this issue the circuit diagram and parts list for the new Sylvania 7" Oscilloscope.

Delivery of this model started early in September and your distributor should be able to fill orders from stock.

# SCHEMATIC CIRCUIT

## SYLVANIA TYPE 132 OSCILLOSCOPE

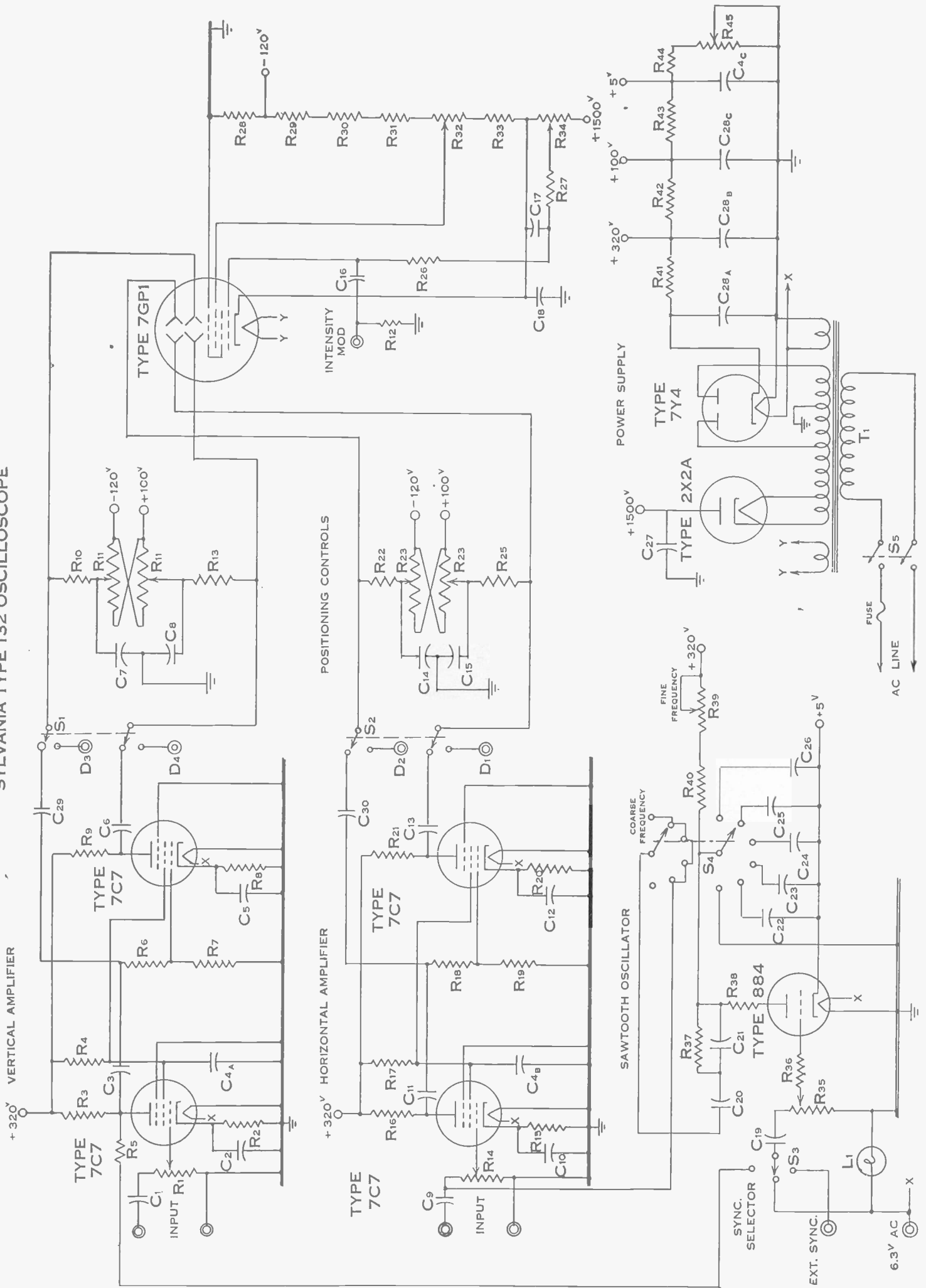

PARTS LIST FOR TYPE 132 OSCILLOSCOPE

CONDENSER	TYPE	VOLTAGE	CAPACITY	RESISTOR	TYPE	OHMS	WATTS
C1	Paper	1000	.25 mf.	R14	Same as R1		
C2	Paper	400	.005 mf.	R15	Same as R2		
C3	Paper	400	.50 mf.	R16	Same as R3		
C4	Electrolytic	450-25	10-10-20 mf.	R17	Same as R4		
C5	Same as C2			R18	Same as R5		
C6	Paper	400	0.1 mf.	R19	Same as R7		
C7	Paper	400	.01 mf.	R20	Same as R2		
C8	Same as C7			R21	Same as R3		
C9	Same as C1			R22	Same as R10		
C10	Same as C2			R23	Same as R11		
C11	Same as C3			R25	Same as R10		
C12	Same as C2			R26	Same as R5		
C13	Same as C6			R27	Carbon	47,000	1/2
C14	Same as C7			R28	Carbon	.22 Meg.	1/2
C15	Same as C7			R29	Carbon	.18 Meg.	1/2
C16	Paper	2000	.05 mf.	R30	Same as R28		
C17	Paper	200	1.0 mf.	R31	Same as R28		
C18	Paper	1500	1.0 mf.	R32	Linear Control	.4 Meg.	2
C19	Paper	600	0.1 mf.	R33	Carbon	.3 Meg.	1/2
C20	Paper	400	.25 mf.	R34	Linear Control	50,000	1/2
C21	Ceramic	500	5 mmf.	R35	Linear Control	50,000	1/2
C22	Paper	400	.25 mf.	R36	Carbon	27,000	1/2
C23	Paper	400	.045 mf.	R37	Carbon	1.8 Meg.	1/2
C24	Paper	400	.008 mf.	R38	Carbon	390	1/2
C25	Mica	500	.001 mf.	R39	Linear Control	4.0 Meg.	1/2
C26	Mica	500	220 mmf.	R40	Carbon	.51 Meg.	1/2
C27	Paper	2000	.5 mf.	R41	Wire Wound	3000	10
C28	Electrolytic	450	10-10-10 mf.	R42	Carbon	33,000	2
C29	Same as C6			R43	Carbon	15,000	1
C30	Same as C6			R44	Carbon	750	1/2
				R45	Linear Control	400	1

RESISTOR	TYPE	OHMS	WATTS	SWITCH	TYPE
R1	Linear Volume Control	1/2 Meg.	1/2	S1	D.P.D.T. Slide
R2	Carbon	820	1/2	S2	Same as S1
R3	Carbon	68,000	1/2	S3	Rotary S.P. 3-Point Non-Shorting
R4	Carbon	.27 Meg.	1/2	S4	Rotary D.P. 6-Point Non-Shorting
R5	Carbon	1.0	1/2	S5	Toggle D.P.S.T.
R6	Same as R5				
R7	Carbon	36,000	1/2		
R8	Same as R2				
R9	Same as R3				
R10	Carbon	3.9 Meg.	1/2		
R11	Linear Dual Control	4.0 Meg.	1/2		
R12	Carbon	1.0 Meg.	1		
R13	Same as R10				

TRANSFORMER	TYPE
T1	Special 1140 v. -300-0-300 volts 6.3 volts @ 1.5 amps 6.3 volts @ 1.0 amps 2.5 volts @ 2.0 amps Pilot Lamp 6-8 volt bayonet
L1	

SERVICING WITH A MODERN OSCILLOSCOPE (Cont'd)

frequencies can be found; thus a number of calibration points may be found on an unknown oscillator. This method may also be used for checking audio oscillator frequencies against power frequencies. A ratio of about 10 to 1 is about the maximum that can be readily distinguished by this method.

FIGURE 2



Vibrator Testing

The oscilloscope is indispensable when testing for defects in a vibrator. Since most vibrators encountered by the radio serviceman are used in auto radios, we will describe the testing of them, although other vibrators may be checked in the same general manner. It is recommended that a DC supply variable from 5 to 8 volts be used so that the vibrators may be tested under voltage ranges encountered in normal automotive use.

**EDITOR'S NOTE:** We believe it is good practice to check the buffer condensers to be sure they are neither open nor shorted before making any tests on vibrators and particularly before installing a new one.

1. Connect the vertical input of

the oscilloscope across the entire primary of the transformer, then turn on the receiver. The correct wave-form of a synchronous vibrator (the type which requires no rectifier tube) operating under load and properly adjusted is shown in Figure 3. It is necessary that the capacity of the buffer condenser be of correct value for proper operation. In some instances the value of the buffer condenser should be changed when a replacement vibrator of a different frequency is installed in place of the original.

2. Figure 4a shows the effect of too small a capacity of the buffer condenser with the vibrator operating under load, while Figure 4b shows the wave-form under the same conditions except that the load is removed. Both wave-forms are from the non-synchronous vibrator. In the case of a synchronous vibrator, the high peak voltages shown in Figure 4b will be rounded off somewhat.

FIGURE 3

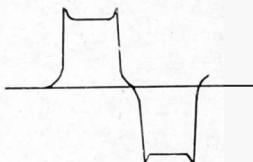
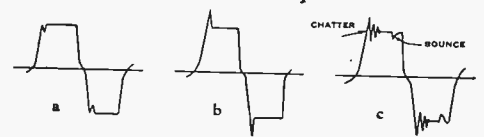

FIGURE 4



3. Bouncing or chattering vibrator contacts will show a transient in place of the rounded peak, as shown in Figure 4c.

Manufacturers recommend replacing defective vibrators instead of attempting to repair them. Usually the buffer condenser can be quickly isolated as a source of trouble and replaced if necessary.

Filter Characteristics

In most instances a defective filter circuit is easily recognized but occasionally the oscilloscope is an aid to rapid isolation of the cause. Connect the vertical input of the oscilloscope across the first filter condenser. (If the B+ voltage exceeds the maximum input rating of the oscilloscope, add a series .5 mfd. capacitor of adequate voltage rating.) The usual wave-form at the condenser input section of a full-wave rectifier is a ripple of twice the line frequency. Next, connect the oscilloscope input across the output condenser. If the action of



## SERVICING WITH A MODERN OSCILLOSCOPE

(Continued)

the filter is normal, the ripple voltage will be much lower.

### Transmitter Modulation Checking

Since many servicemen are also licensed radio amateurs, we will describe a method of checking modulation of a transmitter showing the actual modulation envelope.

1. Connect a dummy antenna to the output of the transmitter and tune up the transmitter for regular operation. (The dummy antenna is not necessary if the oscilloscope is used for monitoring actual transmissions.) Set the vertical input of the oscilloscope for direct input and connect a pickup loop to the oscilloscope. Next, loosely couple the loop

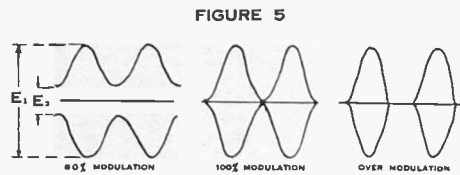

to the modulated amplifier tank coil. It is necessary to obtain enough RF voltage to give a satisfactory deflection on the oscilloscope.

2. Connect an audio signal generator to the modulator input. Next, connect a lead from the External Sync terminal of the oscilloscope to a point on the audio circuit to obtain a stationary pattern. Figure 5 shows the sample modulation patterns that may be

obtained.

The modulation percentage may be obtained by direct measurements on the cathode ray tube using the following equation:

$$\% \text{ Modulation} = \frac{E_1 - E_2}{E_1 + E_2} \times 100$$

where  $E_1$  and  $E_2$  are voltages, as shown in Figure 5.

A quick modulation check with speech input may also be accomplished by direct monitoring with the oscilloscope.

Frequent use of the oscilloscope is a good practice. As you become more familiar with the oscilloscope, you will find it speedy, thorough and easy to use. Make its use a habit. As your skill increases, so will your profits.

## SERVICE HINTS

**Chrysler Mopar 600:** I have found that failure of this set to align properly is often due to the change in value of the .00035 ceramic temperature compensating condenser in the oscillator circuit. It has a habit of losing capacity with age and you will probably find that it measures considerably less than its rated value.—Reid B. Thatcher, Nampa, Idaho.

**Halicrafters S-20R:** Distortion and poor volume are caused by a blocked 6SQ7 audio amplifier and detector tube. The voltage of the cathode with respect to ground of this tube should be approximately 1.3 volt. Larger voltages than this are caused by excessive currents flowing through the bleeder resistors of which the cathode resistor of the 6SQ7 tube is a part. Resistors R31

and R32 are responsible for this. They normally are 10,000 and 12,000 ohms but drop to values as low as 2000 ohms. There is no change in color in these resistances and other voltages measure normally, consequently the trouble is not easily detected. However, replacement of these resistors restores normal operation.—Donald Slattery, Chadron, Nebraska.

## NEW LOOSE LEAF MANUAL SHEETS

Where can servicemen get a good loose leaf tube manual with free additional pages on the very newest types? Sylvania, of course. Here's how.

With this issue we are enclosing an extra sheet giving data on the new types 1B3GT, 1C8, 1V5 and 1W5. These are already punched for insertion in your Sylvania Technical Manual (1946 edition). All you have to do is separate them

on the dotted line and make the gadget shown below for inserting in the manual.

A piece of  $\frac{1}{16}$ " thick aluminum, bakelite or hard fibre would be just the thing. The cut is shown full size so it will be easy for you to trace the shape of the ends and cut it out. Round the edges so as not to scratch the plastic "comb" (that is the trade name for the white binder.)

### To Insert New Sheets

—Lay the manual on a flat surface open at the place where insertion is to be made. Put the point of the tool into the comb and shove it carefully the full length of the book. All the sheets on the right side will now be loose and the new sheets can be placed in position. Then line up all the holes and withdraw the tool slowly being sure that the first plastic ribbon catches all the sheets, after which you can withdraw the tool more rapidly.

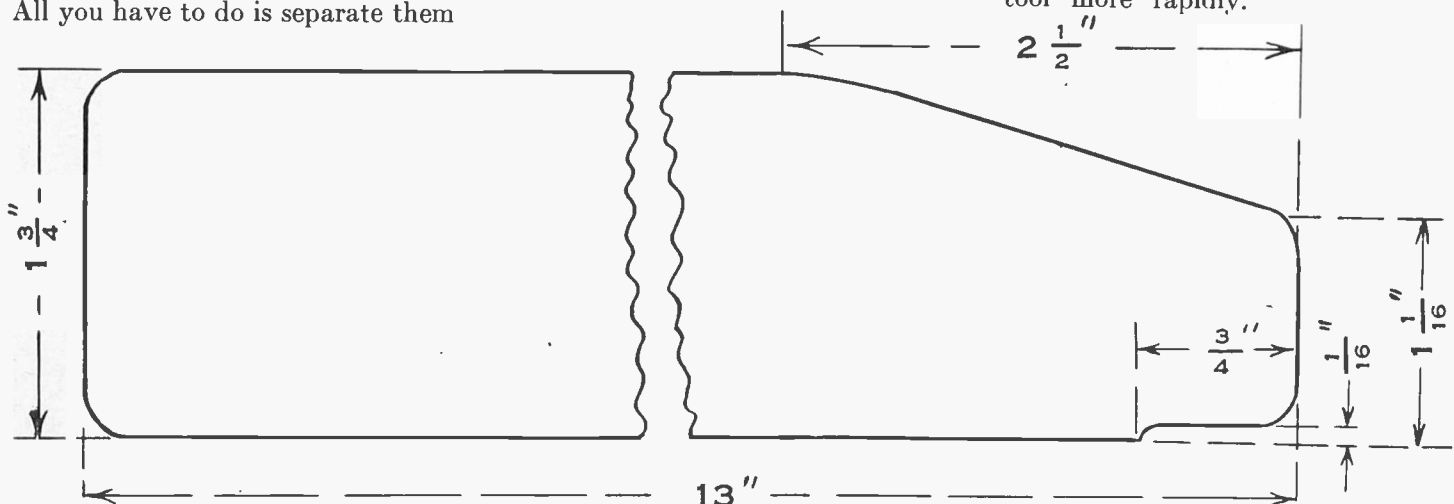

# "RADIO WAS MY HOBBY"

"Radio was my hobby, then I started into the business for myself. That was 17 years ago," said Mr. Carmel Umina of 630 Wyoming St., Dayton, Ohio. "Altogether, I've been in radio for about 27 years. Guess I've seen it grow up."

Mr. Umina's business has become of age along with radio. At first, his shop was not too pretentious, just the front room of his home. But the kind of work put out in his shop wouldn't let him stay that way. In 1941 an addition was added to the house for the business. Last year he felt the squeeze again and another part was added. Now the Umina shop is the pride and joy of its owner.

Not only does Mr. Umina take pride in his shop, but in his knowledge of radio as well. In the years spent in the radio repair business, Mr. Umina has built much of his own test equipment. "It's my hobby, too," he repeated again. "That's why I like to build these things." Stepping across the room he



Umina's Radio Sales and Service is an attractive shop in Dayton, Ohio. Drive-in for auto radios is in rear of bldg.



Mr. Carmel Umina at his modern test bench. Much of the work that went into the bench is a product of his own labor.

unveiled the prize piece of work—a homemade tube tester which he calls a "Universal Switching Eye Tube Checker." "This one is getting a little old fashioned now," he said. "I'm building a new one with an audio system. It takes a lot of work, but it will be something when I get it completed."

Business is adequate in the Umina shop, but they still continue to advertise through the phone book and in the local paper. "You have to keep reminding people if you want to get their business."

Sylvania Tubes are prominently displayed on the shelves in the Umina service shop. "I've been using them for seven years, and they are darn good tubes," declared Mr. Umina.

Business comes into this shop from the neighborhood and the city. A parking area in the back gives the added facility for car radio servicing. All in all, Mr. Umina and his brother Joe, are kept busy repairing sets and turning out the best work their years of experience know how to deliver.

## IN ONLY TWO HOURS

You'll never believe it! For only \$139.50 (F.O.B. Grand Rapids, Mich.) you can get the big new Sylvania Service Bench. There's

nothing on the market to match it, and you get it through Sylvania Distributors ONLY.

What's more, it comes all knocked down (to save shipping costs). But that is little worry, from the box of material you get, you can put it together yourself in two and a half hours. That is the claim of our own boys, and they are usually a little slow. With directions and all, you can do it quicker than that.

Give your shop a break and give it a new look with the Sylvania Service Bench.

Call or write to your Sylvania Distributor today. We aren't kidding when we say the Sylvania Service Bench is the biggest buy today.

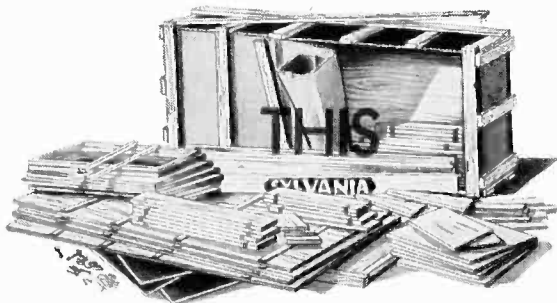



# DEPARTMENT

HAVE YOU SENT US YOURS?

Yes, we are still in the market for ideas. Ideas on merchandising. Ideas on home made gadgets in your shop. Ideas on how to promote your service. They are all good. We may not print your idea, or send you a \$5.00 Merchandising Certificate, but we want ideas on the kind of things servicemen like and use.



and which will put more dollars in your pocket.

Sure as shootin' you've got a good idea which is home made that helps you get more out of your business. Anyway, if you have a good idea, send it along to The EDITOR, SYLVANIA NEWS, 500 Fifth Avenue, New York 18, N. Y.

This month we have a couple of good ideas for helping out in your service shop. They are

For the ideas we use for publication in SYLVANIA NEWS we'll send along a certificate worth \$5.00 in merchandising aids. Something you can use,

simple little things, which cost practically nothing to make, but they mean a lot in return.

## SIMPLE RACK FOR SERVICING AUTOMATIC RECORD CHANGERS

Here is an idea which came from four different servicemen. Their ideas varied slightly, but the idea behind them all is the same. For illustration we have used the simplest to construct and the cheapest to make.

The sketch and idea below was submitted by J. W. Sneed Jr., Menefee Radio Sales & Service, Orange, Tex. It is a simple rack for checking

automatic record changers. Both top and bottom of the motor board are visible under this arrangement.

The four chains hook under the motor board of the changer. The chains should be of proper length so that the changer is on eye level. When not in use, the chains may be hooked near the top to keep them out of the way. Mr. Sneed reports that the total cost for a record changer rack of this type, which will fit all record changers, is only 50c!

Three other variations of the record changer rack were submitted. These are not illustrated here, but the servicemen who submitted them will also receive a \$5.00 certificate.

These men are:

Mr. L. H. Harry,  
Harrys Radio Service  
Star Route  
Kellogg, Idaho

Mr. W. E. Daugherty  
5020 Hohen Street  
Dallas, Tex.

F. Laughlin  
Fred's Radio Service  
1040 Persia Avenue  
San Francisco, Calif.

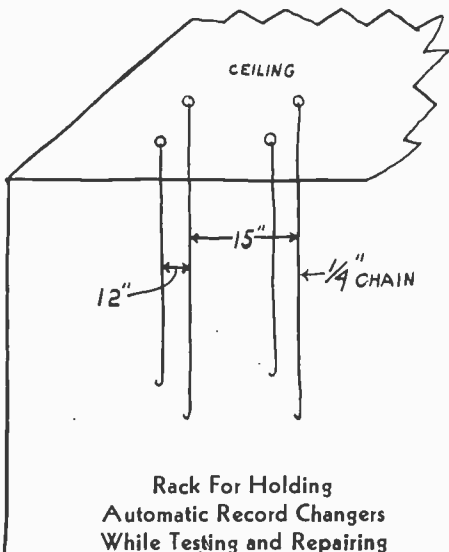

Rack For Holding Automatic Record Changers While Testing and Repairing

## PROTECTION AGAINST HOT SOLDERING IRONS

From Mr. A. L. deLong, 3838 Plumstead Ave., Drexel Hill, Pa. comes an idea for protection against a hot soldering iron. "My idea is along the idea of safety. It is a permanently installed soldering iron holder and guard to prevent burned hands, cords, etc. It can be constructed of scraps of sheet iron for nearly nothing," writes Mr. deLong.

Below is a simple sketch of Mr. deLong's arrangement. The cover

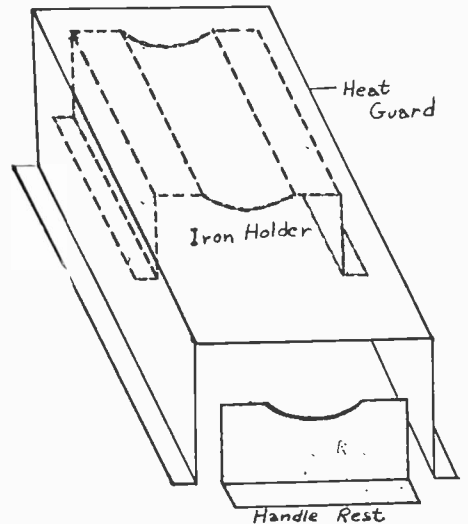

Soldering Iron Stand For Safety In Your Shop

can be constructed of either 1/4" hardware cloth or metal cane. This arrangement will keep your hot soldering iron out of the way, but always within reach.

To Mr. deLong goes a \$5.00 Certificate for merchandising material.

**WE CAN'T HELP IT**

Increased production costs make it necessary that the price of the Sylvania Electric Clock be increased. The new price, which is effective immediately, is \$9.50 including Federal tax and prepaid transportation.

The electric clock is still a good buy at \$9.50. It is an attractive, eye-catching salesman that passes its message along day and night.



# CHIEF ENGINEER SPEAKS AT PRSMA MEETING

Walter Jones, chief engineer of Sylvania's Radio Tube Division was the speaker at the regular meeting of the Philadelphia Radio Servicemen's Association on September 2. The meeting, which was held at the Benjamin Franklin Institute in Philadelphia, was sponsored jointly by Radio Electric Service Co., new Sylvania Distributor in the area, and Sylvania.

The meeting was attended by several hundred radio servicemen from the Philadelphia area. Topic of discussion by Mr. Jones was "New Problems Confronting the Radio Servicemen in Connection with FM and Television," a subject of particular interest to Philadelphia servicemen where two video stations are now operating and one other has obtained a conditional grant.

Sam McDonald, Sylvania sales representative in the area, made the arrangements with PRSMA and RESCO for the appearance of Mr. Jones at the meeting.



September meeting of the PRSMA at Franklin Institute in Philadelphia. Servicemen from Eastern Pennsylvania, New Jersey, Delaware and Maryland heard Walter Jones, (inset) chief engineer of Sylvania Tube Division talk on new problems facing servicemen in FM and Television.

# DALE SALESMEN VISIT EMPORIUM PLANT

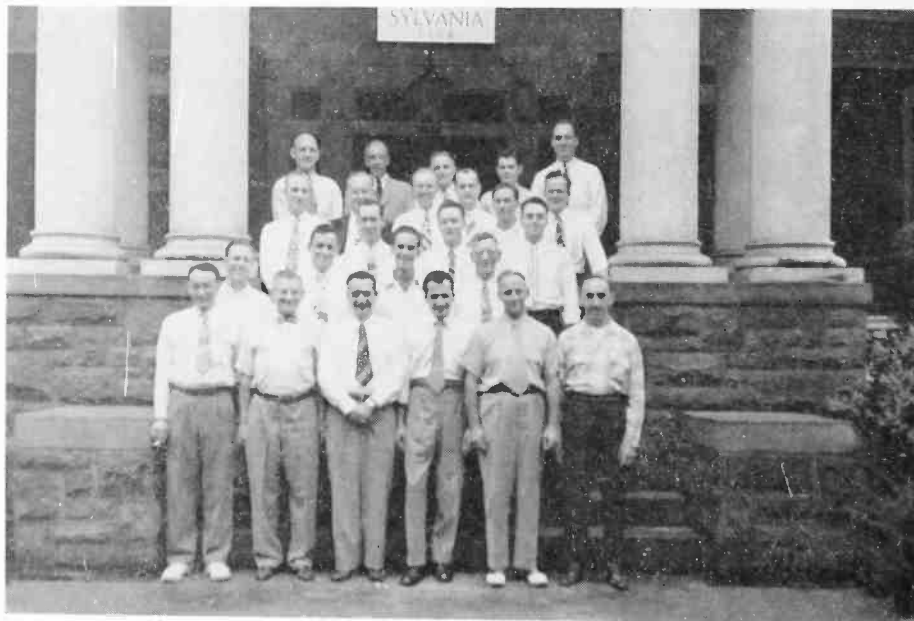

Dale Distributing Co. salesmen and Sylvania officials posed on the steps of the Sylvania Club during a recent visit to the Emporium plant. First row, left to right, Howard Borson, Johnny Klein, Cy Joseph, Gerry Brandwin, Rene Jacobs, Dale Sales Manager, Sid Berliner. Second row, left to right, Dick Stamm, Max Natowitz, Harvey Appelbaum, Jack Unger. Third row, left to right, Paul Smith, Leonard Gladstone, Milton Saper. Fourth row, left to right, Warren Pringle, Bob Almy, Maurice Wolf, Ray Andrews, C. Fox, Jim Ritter. Top row, left to right, John Hauser, George Isham, Bob Kronenwetter, Bob Penfield, Sam McDonald.

Salesmen for Sylvania's metropolitan New York distributor, Dale Distributing Co. paid a three day visit to the main tube plant in Emporium recently. Purpose of the visit was to get acquainted with tube manufacturing and obtain information of other Sylvania products.

During meetings of the Dale men and Sylvania factory and sales officials, the new Seven Inch Oscilloscope was shown for the first time. Ray Andrews, Sylvania merchandising manager, pointed out the features of the scope and discussed other Sylvania test equipment.

Some of the history of Sylvania was given by John Hauser, sales supervisor. Bob Almy, assistant general sales manager, pointed out some major points of Sylvania's program for helping the servicemen.

Information on Sylvania's advertising and sales promotion helps was outlined by Bob Kronenwetter, who emphasized the help Dale salesmen could be to servicemen and dealers.

# EQUIPMENT TUBE SALESMEN LAY PLANS FOR FALL AND WINTER

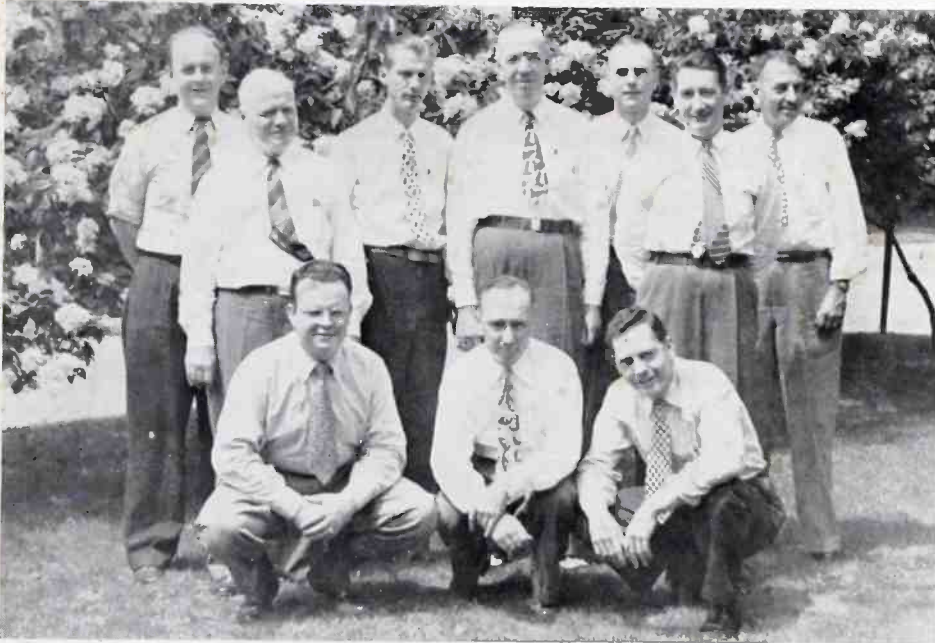

Salesmen for Sylvania's Equipment Tube Sales Department met in Emporium recently to discuss plans for the fall and winter. The boys took time out from business to pose for the above photograph. Standing, left to right, Dick Bachhuber, Les Raynor, Phil Pritchard, H. P. Gilpin, manager of Equipment Sales, Dr. Ben Kievit, Ben Gunn, Lou Wheelock. Kneeling, left to right, Bruce McEvoy, Charlie Marshall, Ray Burnett.

# FACTS & FIGURES

## August Set Production

Production of radio and television receivers in August totaled 1,265,855, according to RMA statistics. This brought output of RMA member-companies for the first eight months of 1947 to 11,031,935, and registered the first increase in monthly production since the peak was reached last April.

Television receiver production in August showed a gain over July and established a new record for the year, reaching 12,283 sets against 10,007 for the five-week period in July. The previous monthly record was set in June when 11,484 television sets were produced. Of the August output, 7,984 were table models, 2,181 direct viewing radio consoles, 92 projection-type radio consoles, 2,008 direct viewing radio-phonograph combinations, and 18 projection-type radio phonograph combinations.

August production of RMA member-companies of FM-AM receivers totaled 72,014 against 70,649 in the previous month. Of the August output 8,653 were table models, 178 consoles, and 63,183 radio-phonograph combinations.

# TELLS FM FUTURE AT ASSOCIATION MEETING

(Continued from page G-34)

industry cannot possibly turn out FM receivers and the public cannot be expected to buy them as rapidly" as some people believe. "it would take four or five years to saturate the U. S. with as many FM sets as there are AM sets" if the industry were to switch to 100% FM production, stated Mr. Balcom.

"Actually, together with television, FM offers the greatest incentive to radio set production today and the best prospective market for our war expanded industry . . . the manufacturer has a new product

The listener . . . knows he is getting something new," pointed out Mr. Balcom.

Cooperation throughout the entire industry including manufacturers, broadcasters, and radio dealers and servicemen has much in its favor. These groups will continue to work together with the same objective in mind "A radio for everyone—everywhere."

SYLVANIA NEWS

SYLVANIA ELECTRIC PRODUCTS INC.  
P. O. BOX 431  
EMPORIUM, PENNA.

RETURN POSTAGE GUARANTEED

Sec. 562, P. L. & R.  
U. S. POSTAGE  
PAID  
Emporium, Pa.  
Permit No. 1

For:

Mr. J. Kenneth Bowran  
Rt. 4  
Rocky Mount, Va.

A

POSTMASTER: If addressee has moved, notify sender on Form 3547, postage for which is guaranteed. When Form 3547 is sent abandon this mailing. Return only if no correct address is available.

Vol. 14, No. 9

OCTOBER, 1947

Published By  
SYLVANIA ELECTRIC PRODUCTS INC.  
Manufacturers of Sylvania Radio Tubes and Electronic Devices, Sylvania Incandescent Lamp Bulbs, Fluorescent Lamps and Equipment





# SYLVANIA NEWS

Copyright 1947, Sylvania Electric Products Inc.

R. A. PENFIELD, Editor

NOVEMBER-DECEMBER, 1947

EMPORIUM, PENNA.

VOL. 14, NO. 10





## IMPROVED AUDIO OSCILLATOR NOW IN SYLVANIA TEST EQUIPMENT LINE

Latest addition to Sylvania's growing list of test instruments for radio servicing is the Audio Oscillator Type 145. A great advancement over the conventional beat frequency oscillator, the Sylvania Audio Oscillator is an ideal instrument for testing AM-FM receivers to insure maximum audio quality.

Features offered in this new instrument include a greater degree of stability, output more than sufficient to drive a speaker direct and low distortion. The extraordinary degree of inverse feedback reduces distortion tremendously.



AUDIO OSCILLATOR TYPE 145

Designed for use at frequencies from 20 to 20,000 cycles the Audio Oscillator Type 145 is excellent for testing audio amplifiers and public address systems. It is also a great aid to broadcasting stations, police radio systems, physical laboratories and is indispensable for wired music and juke box servicing.

The Sylvania Audio Oscillator is available now at your Sylvania Distributor. Call or write for further details.

For more information on the Audio Oscillator Type 145, see page T-37 of the Technical Section in this issue.

## RMA ACTS ON NEW YORK PROPOSAL TO LICENSE RADIO SERVICEMEN

Proposal of an ordinance by the New York City council to license radio servicemen and technicians has prompted the RMA to develop an industry plan to improve servicing of radio sets through "authorized" servicemen in the radio trade. The program is being developed by the RMA Service Committee for submission to set manufacturers and the RMA Board of Directors at their next meeting in January.

Action on the New York City ordinance has been deferred pending the RMA industry action designed to stabilize and improve radio service and prevent over charges to the public through the designation of "authorized" servicemen by radio dealers and distributors. Councilman Stanley Issacs, author of the ordinance, indicated willingness to defer action on his licensing proposal pending the industry action.

The RMA stand on such an ordinance was clearly defined at a public hearing when W. L. Parkinson, head of the RMA Service Committee

declared that such action would be undesirable as well as ineffectual. The RMA Board of Directors has adopted a resolution formally opposing any such action.

The proposal for "authorized" servicemen contemplates that set manufacturers request their distributors and dealers to advertise and recommend to radio set owners that they have their radios serviced by experienced and competent servicemen who are recognized by the radio manufacturing trade.

### WHAT DO YOU THINK?

What do SYLVANIA NEWS readers think about licensing? Is it good or is it bad? We are interested to hear your comments. Send them to the Editor, SYLVANIA NEWS, Sylvania Electric Products Inc., 500 Fifth Ave., New York 18, N. Y.

## WE LOOK AT THE OLD AND NEW

The end of another year is just around the corner, and new hope for better living lights the horizon on the dawn of 1948. Nature shows little response to the new year, but humans find happiness in the passing of the old and the coming of the new. For many, the new year is hope of greater things. For others, 1948 means a new beginning in life.

A quick glance over the past year reveals many interesting things. We can see them clearly in retrospect. Great things happened in radio in 1947. We have seen two new forms of broadcasting emerge from childhood into adolescence. FM has grown by leaps and bounds and now is squarely faced with the growing pains of youth.

Television, too, has thrown off the blanket of the cradle and walked its first step. It has been the industry of 'firsts' in 1947. First broadcasts of the World Series have spiraled it to success. It has made its first entry into the intersanctum of our White House to catch our president in an historic appeal for food conservation. More and more, electronics of every sort have taken an adult ticket to the passing show.

Business in general has remained at a high level, and, in spite of higher prices, we all have managed to pull through. We look to a brighter sky in 1948 to iron out all the difficulties created by now aged 1947. Most of the predictions made in 1947 have been fulfilled, some have even exceeded their promise, while others have fallen a little short of their mark.

As a whole, 1947 hasn't been such a bad year. We have had our troubles, but nothing too great for most of us to handle. We are now reaching sight of solid ground after the tempest of war and its aftermath and we all look to 1948 as the year of peace and prosperity. For all of us it means working together for better things for a more pleasant life. No part is too small. Each niche of life has its part to play in building a better life for everyone all over the world.

To one and all the people of Sylvania wish health, happiness and prosperity in the year to come.

# SYLVANIA NEWS MERCHANDISING SECTION

Copyright 1947, Sylvania Electric Products Inc.

## IT'S THE JINGLE OF THE CASH BOX THAT SPELLS SUCCESS IN BUSINESS



Perhaps the most pleasant sound in any business man's ear is the jingle of the cash register. The more frequently it rings, the happier we are. The radio serviceman is no exception when it comes to the pleasantries of a ringing cash box. Just what makes it ring now and what will make it ring in the future is a good subject for conjecture. Let's look over the situation and see if we can find what to look for in the future as well as review some of the things that happened in the past year.

One thing is sure. The radio tube market is an expanding one, and what does that mean? Well, the more tubes in equipment now, means more tubes for replacement in the future and more dollars in the serviceman's pocket. Let's see what has happened so far this year.

### 1947 Production to Date

The first eight months of 1947, saw a jump from 51,318 AM-FM and straight FM receivers in January to 90,546 in September. Television sets delivered increased by six times the volume with 5,437 in January to 32,719 in September.

These figures may not look very convincing at first glance, but the tubes required in this new type of receivers has increased over AM. This means that it is a new and very promising market for radio tubes. While the straight AM set averages only about five tubes per set, AM-FM sets require an average of 8 tubes and television 18.

Another thought we might consider in this situation is the trend of deliveries. While the AM sets have just about caught up with the

demand, FM and television sets have hardly begun to fill the market. In addition the growing FM industry will soon spread itself throughout the entire country, and demand will increase even more.

### Set Delivery Estimate

In estimating the total delivery of AM-FM and television sets for this year, we can conservatively say that, under present production rates, about 1,000,000 AM-FM sets will be produced and about 110,000 television sets will be in consumers' hands by January 1.

Now we can get a pretty definite picture of the expanding tube market. The 1,000,000 AM-FM sets means a potential market of approximately 8,000,000 tubes, while the television sets would call for about 1,280,000. Add all this to the tubes in the 60,000,000 receivers now in service and the renewal tube business looks pretty good for the serviceman. Of course, not all these tubes will need to be replaced in the near future, but the average set calls for about one tube each year, so the market still remains a big one.

Not only that, but with the flood of FM-AM and television receivers, the renewal tube market should greatly expand in the years to come. There is no doubt about it now, television and FM seem to be here to stay, and servicemen can look forward to a larger tube business in the future.

### Lower Priced Sets Will Help

Many new manufacturers are entering the television field. Practically all are on the FM bandwagon.

Although the actual number of radios manufactured next year is expected to be lower than the preceding years, (see page G-39 of the General Section) these radios and video sets will be of a larger size containing more tubes and their eventual worth will be greater to the servicemen in replacement tubes and net repair profits.

Prices of initial equipment are now on the down grade so a mass market of the larger sets can be expected before too long. One producer now has a television set on the market to sell for \$169.50. This set contains 22 tubes, a nice potential market for replacement tubes for any man's money. Other producers will follow suit when they can place their production in the "higher end" merchandise. This will mean to the serviceman that eventually the larger set, the FM and television set, will be a big part of their business and mean more tubes to sell for replacement.

### More Shoes For Baby

What the expanding business will mean in dollars, is a hard question to answer. Most servicemen make a profit of about 90c per tube, which means that healthy promotion of this item, will put more money in the cash box. Translate that dough into shoes for junior or rent on your store and it goes a long way toward making your business a success. Just keep in mind, radio tubes



are good business. They are profitable, and more than ever, they are necessary in the American Home. In replacing tubes, any tubes are good, but Sylvania tubes are better.

# HOW IS YOUR FINANCIAL STANDING?

## TELL AT A GLANCE WITH A SYLVANIA BUSINESS RECORD



Does the first of the year scare you? Worried about the slice Uncle Sam is going to take from you when you figure out your income tax re-

port? Are you planning to spend a few nights burning the midnight oil? If you are, you have our sympathies. It's hard to think about income tax when you have so many other things on your mind.

Here's a cure that will help you next year. Too late to do anything about this year, but boy! how it saves the gray hair. If you haven't heard about it, here's a chance to save you time and trouble next year.

The Sylvania Business Record Book is a trouble shooter when it comes to money worries. Designed especially for radio servicemen at

Sylvania's request by a former Collector of Internal Revenue it is

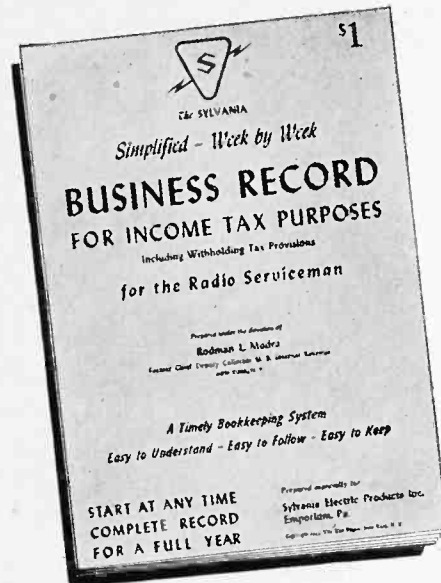

the most complete and simple bookkeeping system yet devised. No trouble at all to keep and it

provides daily, weekly and monthly records of your receipts, expenses, taxes, overhead, etc.

The Sylvania Business Record Book also contains a simple profit and loss statement for the year. In it you have a record of bad debts and a schedule of depreciation. Income taxes, pay-as-you-go withholding taxes and social security are made easy for you with the instructions in the book.

This book is published by Sylvania to help you be a better business man and relieve you from the worries of financial tangles. With this book you can measure your progress and keep close tab on losses before they plow you under.

Available from your Sylvania distributor for only one buck (\$1.00), the Business Record Book is the best investment you can make with your hard earned money. The time is ripe for keeping records, so start out the new year on the right foot.

# YOU THINK WE'RE KIDDING WHEN WE SAY IT'S BIG!!!



"You mean the Sylvania Service Bench really is that big?" questioned a recent correspondent. "Gosh, I thought it was just a little thing. It certainly is a beauty. I can make my shop look like new with that."

Yes, when we said the Sylvania Service Bench was BIG, we meant it! There's room for everything. The large instrument panel has plenty of room for permanent installation of your test equipment. Holes in the shelf below the panel are swell places for putting those screwdrivers and pliers that never seem to be around when you need them.

You'll find the 7 foot long, 32 inch wide work bench big enough to hold most any set you will repair. Knee room and drawer space are just as plentiful in the Sylvania Service Bench. You'll marvel at what this new piece of furniture will do to give your shop "the new look."

Best of all, the Sylvania Service Bench is priced just right for even the smallest budget. We have done everything we could to bring you a good test bench at low cost. When you see it, you'll agree that it is a steal for \$139.50 (F.O.B. Grand Rapids, Mich.).

Drop around to your Sylvania Distributor soon and get the complete story of this big Service Bench.



# SYLVANIA NEWS

## TECHNICAL SECTION

Copyright 1948, Sylvania Electric Products Inc.

A. V. BALDWIN, Technical Editor

These data have been compiled from information which we believe to be accurate. No responsibility can be assumed in the application thereof or for patent infringement.

### SYLVANIA AUDIO OSCILLATOR FOR SERVICEMEN

Continuing the line of Sylvania service equipment, we are announcing the new Sylvania Type 145 Audio Oscillator. Those of you who do considerable sound work will find this a very useful instrument.

The circuit is shown in Figure 2. In this the Type 7C7 and the Type 7B5 are used in a Wein-bridge-stabilized multivibrator circuit with the Types 7A4, 7N7 and 7C5 following as voltage and power

amplifiers. The tuning control is a 4 gang variable condenser C3, C4, C5 and C6 in the diagram. The wave form obtained is very nearly a pure sine wave due both to the Wein bridge control in the grid circuit of the Type 7C7 and to the feedback used. After the proper wave form is obtained from the oscillator distortion is prevented by use of a push-pull driver amplifier and push-pull output stage with a

large amount of negative feedback.

The use of this circuit enables us to manufacture an instrument with the following ratings:

Frequency Range: 20 to 20,000 cycles directly readable on a dial having 3 ranges with multiplying factors of 1, 10 and 100.

Output Impedance: 8, 15 and 500 ohms selected by a switch on the panel.

Power Output: 1 watt at 500 ohms load; slightly less at the lower impedances, particularly at the higher frequencies, due to transformer loss.

Distortion:

20 to 30 cycles per second,  
less than 15%.

30 to 150 cycles per second,  
less than 4%.

150 to 20,000 cycles per second,  
less than 2%.

Hum Level: Better than 60 db below full output.

Output Variation with Frequency: On the 500 ohm output the variation (over the frequency range) is within  $\pm 2$  db (of the 1000 cycle response).

The illustration, Figure 1, shows the convenient control arrangement of the panel. Note the new modern cabinet design with the rounded corners similar to the Type 132 7" Oscilloscope. The size is  $11\frac{3}{8}$ " x  $9\frac{9}{16}$ " x  $17\frac{1}{6}$ " and the total weight is  $27\frac{1}{2}$  lbs.

Circuit and Parts List given on page T-39.



Figure 1

### REPORT ON TUBE BASING POLL

In our September issue we described a proposed simplified system of showing tube basing connections and asked for comments from servicemen. We were disappointed in the number of comments received, less than 100, although the general opinion was

about as expected. The opinions were 10 to 1 in favor of continuing the present Sylvania system. No one threatened to stop buying Sylvania tubes if we changed, but there were a number of very interesting and well-thought-out letters. Some we would like to print but we don't believe that we

should take space in the technical section for this purpose.

It is not too late to send your comment. The larger the number of replies to a poll of this nature, the more weight it has with those who have to approve expenditures for the Sylvania technical literature you receive.

# AN 8000 VOLT POWER SUPPLY FOR CATHODE RAY OR TELEVISION USE

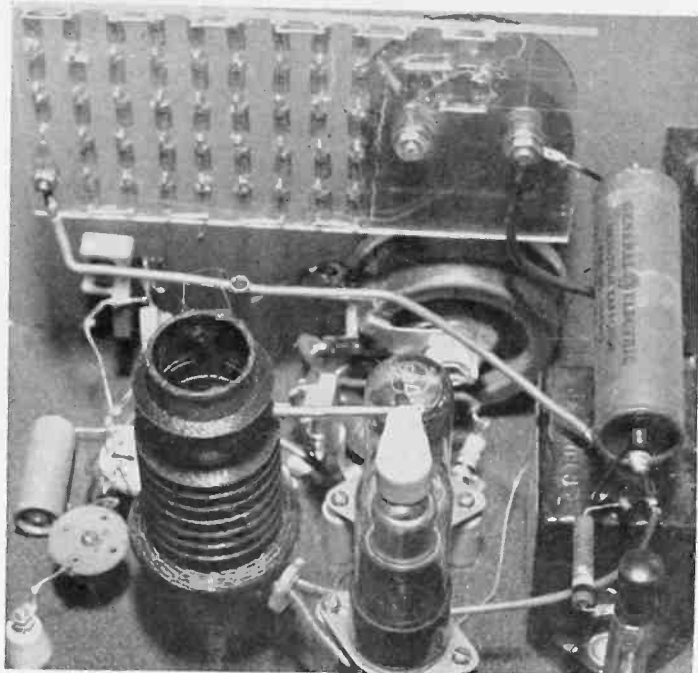

In our June-July issue we promised to describe in a later issue an oscillator type high voltage power supply that would deliver 8000 volts. Figure 1 shows the layout and Figure 2 the circuit diagram as made for use in one of our cathode-ray tests.

### Construction

This particular piece of equipment is built into a relay-rack which explains the metal panel and the use of stand-off insulators. Most home constructors will probably prefer to use a polystyrene panel as it is a little easier to obtain adequate insulation and large spacings from the high voltage circuits to ground. This is particularly necessary since the 8000 volts will act like the high voltage DC used in Precipitrons and attract a layer of dust. A minimum spacing of 1" is suggested for all the parts connected to the Type 1B3GT rectifier tube.

As explained in the previous article precautions must be taken to reduce corona loss. The lead to the Type 1B3GT top cap is most important. This should be short and straight if possible. Any bends should have a long radius and the wire itself should be of large diameter. Plastic insulation on the wire is unsatisfactory at this voltage and frequency as the losses would cause

it to heat. A suggested lead is either a tightly coiled spring (having adjacent turns touching and not insulated) or a piece of large diameter shielded wire using the shield as the connection. It is necessary in this case to solder all the strands at the ends and get them smoothly rounded.

The filament loop is a single turn of heavy insulated wire at the lower end of the oscillator coil assembly. A piece of polystyrene insulated co-ax. with the outer braid removed was found to be very satisfactory as the insulation helps in preventing arcs to other parts of the circuit. Adjustment of the coil to obtain the correct operating temperature should be done with the top cap disconnected and if a good R.F. voltmeter, such as the Sylvania Polymeter, is not available it may be set by comparing the filament temperature with that of a tube operating on a power source you can measure. After the top cap is connected the filament will be at such a high voltage above ground that it is not safe to measure it with any standard instrument.

Note the meter and multiplier in the background used for measuring the output voltage. This was described in the May, 1947 issue of the "News."

8000 VOLT POWER SUPPLY

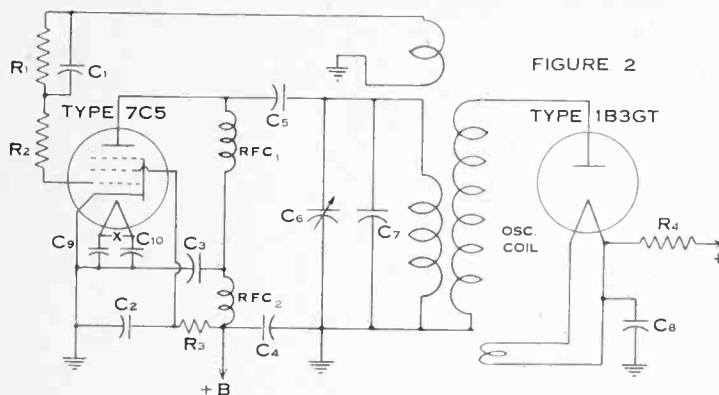

FIGURE 2

PARTS LIST		
RESISTOR	OHMS	WATTS RATING
R1	56,000	1/2
R2	1000	1/2
R3	56,000	1
R4	100,000	1
CONDENSER	CAP	RATING
C1	2200 $\mu$ f.	
C2	.25 $\mu$ f.	450 V.
C3	4 $\mu$ f.	
C4	4 $\mu$ f.	450 V.
C5	2200 $\mu$ f.	
C6	600 to 1600 $\mu$ f.	mica padder
C7	1000 $\mu$ f.	mica
C8	500 $\mu$ f.	150,000 V.
C9	.25 $\mu$ f.	450 V.
C10	.25 $\mu$ f.	450 V.
RFC1	2.5 mh.	
RFC2	15 mh.	
Osc. Coil	Essex Coil No. A596	

### Adjustment

The frequency of the oscillator is about 270 kc. and the only adjustment other than the filament is the tuning condenser C6. Adjust this for maximum oscillation strength using a neon lamp as the indicator. Output voltage may be varied by adjustment of the supply voltage or by changing the load. With 50 ua. the voltage is 11,000 volts and at 350 ua. 8000 volts. These values are obtained with 350 volts on the plate and a current of about 43 ma.

### Shielding

To prevent the R.F. from getting into other equipment, good shielding and filtering are necessary. Shielding consists of completely surrounding the unit in a metal box. Ventilation is provided by fastening copper screen over some 1" to 2" holes near the top and bottom. The filtering consists of the bypass condensers shown on the input and output leads. These should be connected as close as possible to the point where the lead enters the enclosure. If the 6.3 volts for the heater is used elsewhere this becomes equally important for these leads also.

# COMPLETE CIRCUIT OF TYPE 145 AUDIO OSCILLATOR

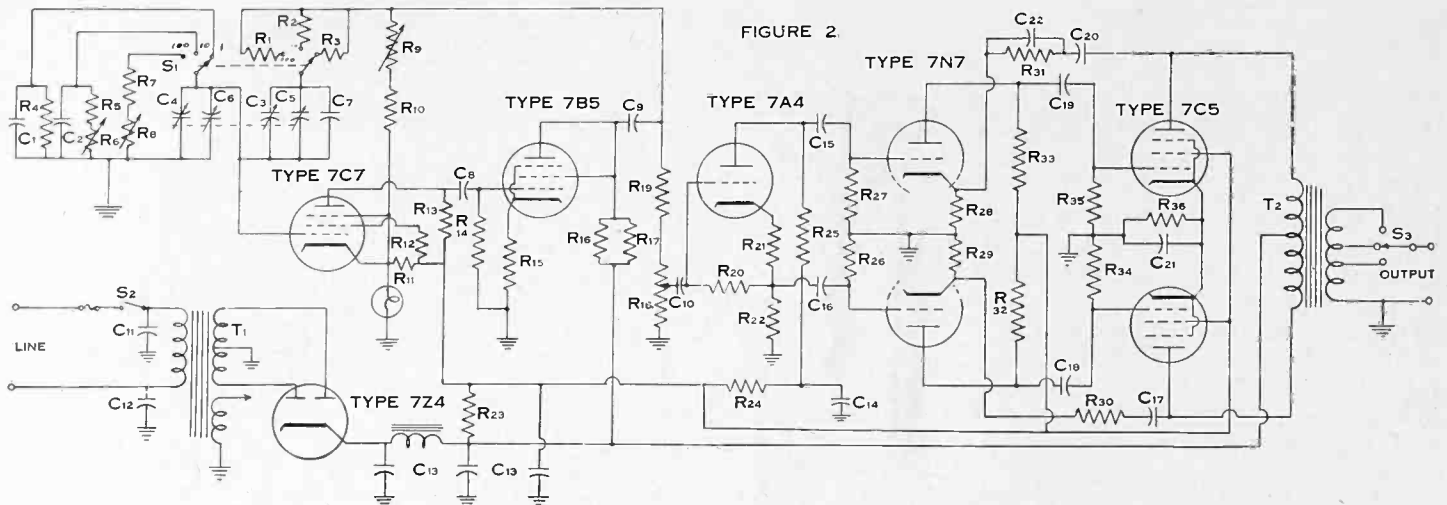

CONDENSER	TYPE	VOLTAGE	CAPACITY	RESISTOR	TYPE	OHMS	WATTS
C1	Variable	Mica	2-15 mmf	R12	Carbon	0.1 Meg.	2
C2	Same as C1		2-15 mmf	R13	Carbon	47,000	1
C3	Variable	Ai-	603 mmf per section	R14	Carbon	.39 Meg	1/2
C4	Same as C3			R15	Carbon	3300	1/2
C5	Variable	Mica	2-40 mmf	R16	Carbon	47,000	2
C6	Same as C5			R17	Carbon	Same as R16	
C7	Ceramic		50 mmf	R18	Carbon	0.1 Meg	1/2
C8	Paper	400 V.	0.5 mmf	R19	Carbon	56,000	1/2
C9	Electrolytic	450 V.	4.0 mf	R20	Carbon	.22 Meg	1/2
C10	Paper	400 V.	.01 mf	R21	Carbon	2700	1/2
C11	Paper	800 V.	.008 mf	R22	Carbon	33,000	1/2
C12	Same as C11			R23	Carbon	5600	1/2
C13	Electrolytic	450 V.	15-15-15 mf	R24	Carbon	27,000	2
C14	Electrolytic	450 V.	8 mf	R25	Carbon	Same as R24	2
C15	Paper	400 V.	0.1 mf	R26	Carbon	.47 Meg	1/2
C16	Same as C15			R27	Carbon	Same as R26	
C17	Same as C9			R28	Carbon	1500	1/2
C18	Paper	400 V.	.05 mf	R29	Carbon	Same as R28	
C19	Same as C18			R30	Carbon	27,000	1
C20	Same as C9			R31	Carbon	Same as R30	
C21	Electrolytic	50 V.	50 mf	R32	Carbon	Same as R19	
C22	Mica		240 mmf	R33	Carbon	Same as R19	
R1	Carbon	68,000	1	R34	Carbon	Same as R14	
R2	Carbon	.69 Meg	1	R35	Carbon	Same as R14	
R3	Carbon	6.9 Meg	1	R36	Wire Wound	300	4
R4	Carbon	Same as R3					
R5	Carbon	.62 Meg	1				
R6	Variable	.1 Meg	1/2				
R7	Carbon	56,000	1				
R8	Variable	20,000	1/2				
R9	Wire Variable	2000	1				
R10	Carbon	2400	1/2				
R11	Carbon	47,000	1/2				

RESISTOR	TYPE	OHMS	WATTS	MISCELLANEOUS	ITEM	RATING
L1	Lamp	115 V., 3 Watt				
T1	Line Transformer	10 h, 110 Ma. 390-0-390				
T2	Audio Output Transformer	6.3 @ 3.3 amps 10,000 P-P 500-15-8				
S1	Rotary Switch	2 Circuit 3 Position				
S2	Toggle Switch					
S3	Rotary Switch	2 Circuit 3 Position				

## ADDITIONAL CHART SETTINGS FOR SYLVANIA TYPE 139-140 TUBE CHECKERS

TYPE	A	B	C	D	E	F	G	TEST	TYPE	A	B	C	D	E	F	G	TEST
FM1000	6.3	0	..	0	3	05	23	V	12AW6	12.6	0	..	0	4	06	86	X
1Z2	1.4	4	123456	0	4	06	74	T	14F8	12.6	1	7	1	2	8	45	U
2C4	2.5	2	48	4	4	..	70	T	26A6	25	0	..	0	5	1	45	U
3C6/XXB	1.4	7	17	1	2	4	56	T	26C6	25	0	..	0	3	06	63	U
5AZ4	5.0	0	7	1	5	5	56	T					4	3	63	X	
			2	6	3	..	23	Y					5	4	58	T	
			..	5	5	..	23	Y	26D6	25	0	..	0	5	58	T	
6N4	6.3	0	46	0	4	3	45	U					4	46	19	V	
7AD7	6.3	0	..	0	1	03	72	Y					5	5	52	X	
7AH7	6.3	0	..	0	1	036	35	W	35B5	35	0	4	0	4	36	25	Y
12AU6	12.6	0	..	0	4	36	47	U	1273	6.3	0	..	0	1	036	56	T
			..	0	4	36	47	U	1280	12.6	0	..	0	1	036	56	U

Signal Tracer: Recently I needed an indicating device to use in "signal tracing" a set I was working on. I happened to think of my R-C Bridge I made following instruction in Technical Section Volume 11 Number 5 of October, 1944. I

connected the Bridge chassis to set chassis and using a blocking condenser in series with a test lead connected to common post of the three R and C posts on Bridge panel, thus utilizing the 7F7 amp and diode rectifier of the Bridge I was able to

check the progress of a signal through the set very readily. I used the RX 1 meg position on Range Sw and found the eye adjust control enabled me to find a satisfactory operating point for the 6E5.— W. I. McCann, Cincinnati 5, Ohio.



**T**HE information presented in the Sylvania Service Exchange is contributed by servicemen as the result of practical experience. It is very carefully considered before being accepted, and we believe it to be correct and authentic. However, we assume no responsibility for results. Please do not send routine or generally known information. Each hint accepted entitles the writer to his choice of one Sylvania receiving tube. Please specify tube choice when submitting hints.

THE

# Service Exchange

The sketch below while it looks a lot like an ice pick is a very convenient form in which to make a crystal probe. This unusual arrangement was sent to us by Mr. V. R. Krause of Johannesburg, South Africa, who says it is worth its weight in gold for testing sets, as it will work on either R.F. or audio and requires no batteries.

## SIGNAL TRACER PROBE

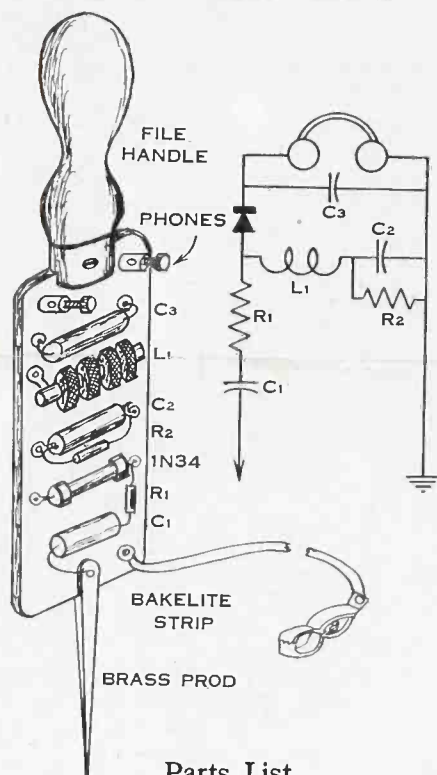

### Parts List

R1.....	50,000 Ohms
R2.....	100,000 Ohms
C1.....	.01 uf.
C2.....	.001 uf.
C3.....	.002 uf.
L1.....	2.5 mh.

In operation with R.F. applied, L1 is the load as R2 is bypassed, while on AF the resistance of L1 is relatively high and R2 becomes the load.

**RCA Model RE45 Noisy:** Crackling and frying noises in this model can be caused by a defective push-pull input transformer. This is difficult to find particularly if it is intermittent. I use a standard 3 to 1 ratio replacement transformer.—W. H. Colvin, Lancaster, Ohio.

**Severe Hum in Philco Model 46-350:** One of the most difficult defects to locate I have encountered in some time is found in Philco Model 46-350. It is a defect which may develop in a considerable number of others in this particular model. The defect was a severe tunable hum when the radio is operated on AC current. The hum is continuous but becomes slightly worse when a station is tuned in. Symptoms are exactly like a defective filter condenser but that isn't the cause. This receiver contains a resistor (Part number 33-3431) which serves as a filament supply resistor as well as a filter resistor. A high resistance leak between this resistor and the metal shell which it is housed in is sufficient as that places the B plus voltage on the chassis. Ordinarily the defect cannot be found when the receiver is cold as the resistor does not short but can be readily detected by the fact that the chassis is 100 volts plus with respect to the B minus.—Donald Slattery, Chadron, Nebraska.

**Use for Old Electrolytic Condensers:** To prevent the caps of glue, shellac, cements and similar bottles from sticking to the bottle, insert a disc of aluminum foil between the bottle top and the usual cardboard insert in the cap. This disc may be cut from the smooth polished foil of a "blown" electrolytic condenser after washing off the electrolyte. The threads of the cap and bottle must, of course, be clean.—T. LeBaron, Oak Park, Illinois.

**Crosley Model 56TJO:** If the customer complains of weak or no reception check the avc voltage. If it is found abnormally high, and pin No. 2 on the 35W4 rectifier socket is used as an avc tie point, remove the leads from this terminal and use a separate tie point to anchor them. Electronic leakage to unused pins within the 35W4 has been found to develop sufficient voltage in the avc circuit to severely limit the sensitivity of the receiver.—Robert T. Nagler, Prairie Du Sac, Wisconsin.

**Convenient Dummy Antenna Connection:** I find that most signal generators come with a single shield cable for output with alligator clips on ends (one on shield or one on hot wire that carries signal) and when using a dummy antenna as described in the instructions you have to add a condenser or a resistor in series and it is very inconvenient. So if you take a metal tube and drill a hole in the side of the tube near each end bringing out the hot wire and put on two alligator clips, then solder shield to tube at both ends, you can change dummy antennas very fast and not have a lot of parts in your way and no long leads which we don't want on high frequency work.—Bud's Radio Service, St. Louis, Missouri.

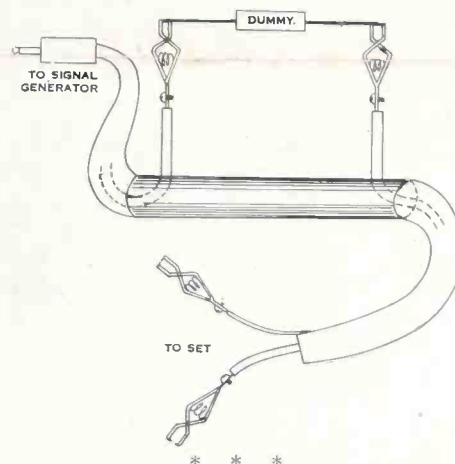

**Intermittent Noisy Reception:** One of my customers located next door to an industrial plant complained of noisy reception at 15 minute intervals during the day. The cause was found to be an air compressor which had a defective motor causing noise under maximum load. The plant engineer did not realize the motor was defective so readily agreed to decrease the load temporarily until it could be replaced.

I could hardly charge my customer for this service but I didn't lose on the deal because I got two other sets to repair from the plant manager and the engineer.—Raymond A. Patzke, Milwaukee, Wisc.

# SHOP OF THE MONTH



Spaciousness of Ace Radio's shop is clearly defined in the above photograph. Drive-in for a dozen automobiles makes car radio servicing a big business with Ace. From sight alone, customers know they can expect the best service.

## *For Ace It's Aces*

### CUSTOMERS HELP DEVELOP NEW BUSINESS THAT PAYS OFF

Success stories are always popular and this one is no exception. It is different only in the road traveled to attain that success. As true in many cases, James R. Wilson, Ace Radio Co., 214 E. Gay Street, Columbus, Ohio reached the top over a road he hadn't expected.

Like many radio servicemen, Mr. Wilson followed radio as a hobby. After twenty years his hobby became his business. His shop was not pretentious at the start, in fact, not much bigger than a good sized living room. That was in 1940.

In 1945 he became cramped, so a move was made to a new store with 10,000 square feet of space. Today you will find this one of the busiest places in Columbus. Last year, for instance, he repaired 13,000 sets with about 25% of this number being automobile radios.

That too, was a departure from the road he intended to climb, but his customers virtually forced him into the business. "I guess all this comes from just giving a good honest dollar in work for the dollar received," says Jim when asked for

his magic formula.

Servicing is the business of Ace Radio. Good servicing draws many new customers and servicing backed by good advertising and promotion is proof to the customer that Ace Radio does the best job. When customers themselves help to open a new part of any business, you can be sure that the business is a good one. Experience is the best teacher for both customer and serviceman, and if the experience is a good one, then both can feel that a satisfactory job has been done for both.

Five servicemen are employed by Ace Radio. They all share Jim's opinion on success and are ready to believe that a satisfied customer is the best bet in any business. It doesn't take a sales talk either to have all five servicemen tell you that the best tube for replacement in a service job is a Sylvania tube. "We can use everyone we get our hands on."

Up to date servicing equipment, including Sylvania test instruments, is important too for doing a good job. With good test equipment you cut down the time on a job and give the customer the best kind of a repair job possible.

Ace Radio is a good example of how one man attained success in the radio servicing business.

# IDEA DEPARTMENT

Have you looked into your idea box recently? Or perhaps you don't have a file on your homemade shop and business helps. We're darn sure you have some little tricks though, and we'd like to hear about them. A lot of servicemen have already sent in their ideas to this department of THE NEWS but we'd like to hear from more of you.

If you send us an idea, we'll make a deal with you if we can publish it in THE NEWS. Yep, for publishing your trick we

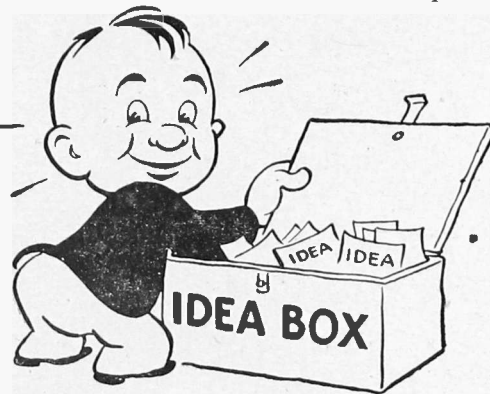

will send you a \$5.00 Merchandising Certificate. With that certificate you can get yourself five bucks worth of shop helps and promotion

items from the "Multiplying Pennies" folder. That is a sure way to make money and help your business grow and grow.

Just pen a short note telling us about your little shop help and we'll give it our fullest

attention. Address your letter to the EDITOR, SYLVANIA NEWS, 500 Fifth Ave., New York 18, N. Y.

## SELL YOUR SERVICE WITH BAD TUBES

Anyone can tell you that a good way to stimulate your own business is to make a comparison of the performance of your service to that of some other well known service. J. Clifton Shears, Cresaptown, Md. has used just that idea to promote his own service business.

From his local radio station he secured five large transmitting tubes. These he placed in his shop window along with five small receiving tubes. In his window display he cited the fact that radio stations checked their tubes every hour and therefore the radio listener should have his tubes checked at least twice a year.

"Let us check your tubes," is the sales appeal," says Mr. Shears. "If the tubes are weak or bad, the customer is sure to want them replaced. If the tubes check good, there is still a chance for a sale of some other item or appliance to make the radio work top notch."

## MOVIE AUDIENCES GET A LAUGH FROM COMIC ADVERTISEMENTS

Mr. R. E. Kellison, Kellison's Radio Shop, Granby, Mo., has sent us an idea which is a good one for small towns. All that is needed is a good theater with the proper equipment and a few bucks to have a slide made. The idea uses the national ads put in the large magazines by Sylvania and the Sylvania ad mats which are available free to radio servicemen.

Mr. Kellison's example of his advertising is like the accompanying picture. This he has made into a slide and it is projected on the screen of his local theater between features. Reports received from Mr. Kellison indicate that he gets good results from this type of advertising. "They give the crowd a laugh, and don't think it doesn't bring results. This will give you a lot of help. If you don't know whether the people will notice it or not, just drop around to Mathier's Theater in Granby, Mo."

We might point out that servicemen interested in this type of promotion should check with their theater to see if equipment and facilities are available before going to the expense of making up such a slide for their own use.

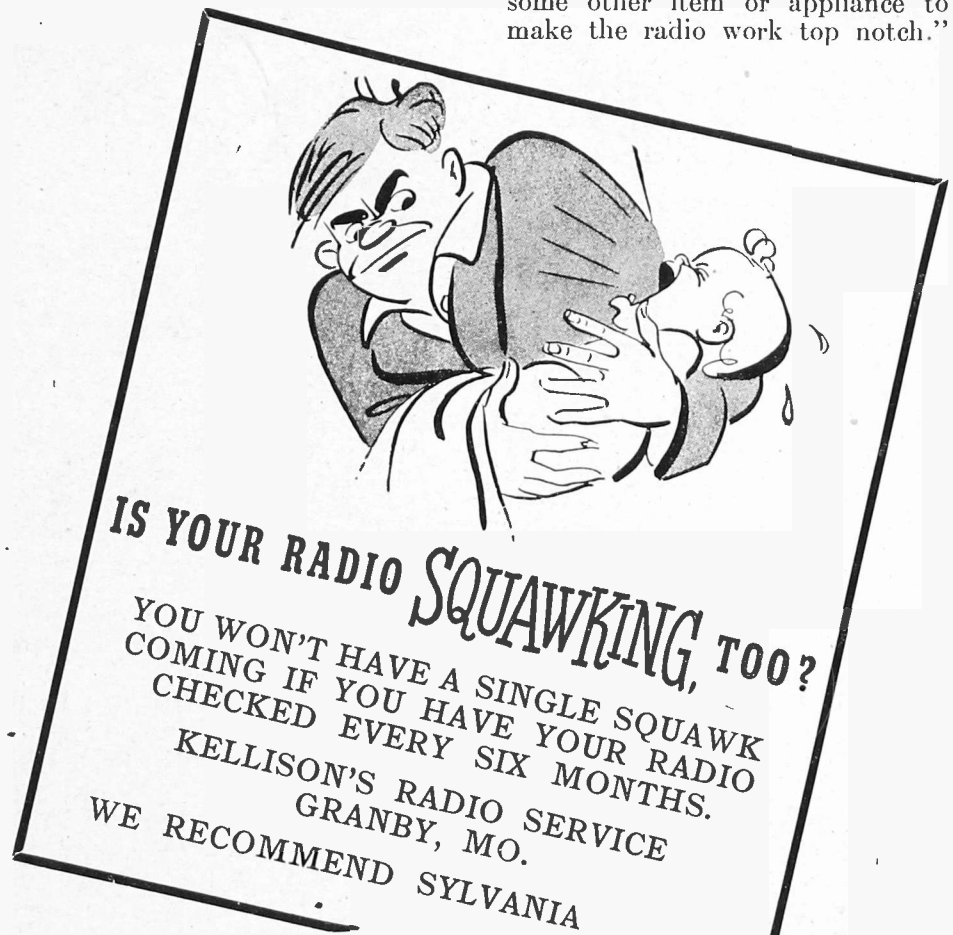



## BUREAU OF STANDARDS CLAIMS WORLD'S SMALLEST TUBE

In an announcement recently released by the Bureau of Standards it was stated that they now have developed a radio tube only a trifle larger than a grain of rice. The Bureau stated that as far as is known this is the smallest tube ever to be developed.

The new tube, the release stated, is just a product of the evolution of the radio tube in recent years. Design simplifications over the famous wartime T-1 have made reduction in size possible. Since this tube has various military applications the Bureau remains mum on further details. Main function of the Bureau's tube laboratory has been the development of special purpose tubes and work in the field of subminiatures.

## SET MAKERS PREDICT FEWER SETS: SAME DOLLARS IN 1948

Total 1948 production of all types of radio and television receivers will range between 12,900,000 and 15,300,000 units, a definite drop compared with the estimated 1947 output of 16,000,000, according to a consensus of leading producers attending the RMA fall meeting in New York recently.

The prediction was based on an informal poll taken at the session of the set division. No producer gave any reason for the anticipated production decline.

Although unit production will be down next year, members of the group do not look for a corresponding decrease in dollar volume. It was pointed out that much of this year's production was devoted to low-end table models, while the bulk of 1948 output will be in

television, combination consoles, FM units and other high-end electronic merchandise.

Report on a spot survey of New England retail markets was given by Frank Mansfield, director of research for Sylvania. The survey, which took in a few representative samples in large, medium and small urban markets and some rural ones, established no national trends, he emphasized. It did establish that dealers in the few areas covered are selling sets faster than they are purchasing from distributors and are "living off inventories," for the most part.

The survey also showed that straight consoles are "practically disappearing" as a factor in retail sales. Finally, the survey indicated that a healthy demand for FM receivers exists. In this connection, Mr. Mansfield's report stated that dealers are also "living off inventories," but held that present inadequate production is responsible for the situation.

## RALEIGH SERVICEMEN HEAR CANNING TALK ON SERVICING FM RECEIVERS



Jim Canning, Sylvania commercial engineer and lecturer for Service Schools, shows his plastic demonstration radio to servicemen at Raleigh, N. C. after a recent meeting.

Radio Servicemen of the Raleigh, N. C. area met recently to hear James H. Canning, Sylvania commercial engineer, speak on servicing FM receivers. The meeting, which was held in the Woman's Club of Raleigh, was attended by nearly a hundred servicemen from the area.

Jim Canning is currently touring the country making similar lectures to radio servicemen. Because of the large area to be covered, his appearances are limited. Your Sylvania distributor will keep you informed when Jim will be in your locality to speak on current topics.

## VIDEO GIVES DOCS BOX SEAT FOR OPERATION

Educational uses of video were demonstrated recently before the annual clinical congress of the American College of Surgeons when they met in New York. The demonstrations literally transported operating rooms from the New York Hospital to the meeting rooms where the convening surgeons viewed operations over television.

The program was experimental in nature and was presented to the surgeons to indicate the possibilities of television in surgical education. The telecasts were accompanied by commentaries of the operating physician and were viewed by some 5000 surgeons. The experiment registered a view for each person comparable to that seen by the operating physician.

High praise of the effectiveness of such education was given by Dr. Arthur W. Allen, president of the College when he declared, "This is a teaching medium that surpasses anything we have had in the past. I never imagined that television could be so effective until I actually saw it demonstrated here."

# PENNSYLVANIA SERVICEMEN TO MEET FOR CLINIC AND SHOW

C. F. Bogdan, publicity director of the Federation of Radio Servicemen's Association of Pennsylvania, has announced that plans are now being completed for the statewide convention of radio servicemen to be held in Philadelphia on January 11, 12, 13. The convention, which is the first of its kind, will be held in the Bellevue-Stratford Hotel.

Made possible through the close cooperation of the Federation, NEDA and the RMA, the meeting will feature displays, lectures and movies of technical nature of interest to radio servicemen. Although the Pennsylvania group is sponsoring the meeting, servicemen and technicians from all over the country are invited to attend. The Philadelphia Radio Servicemen's Association will play host at the convention.

### RMA To Sponsor Clinic

Also scheduled during the three day convention is the serviceman's clinic sponsored by the RMA.

This clinic is to be an experiment by the RMA and its success at the Philadelphia meeting will be a big factor in their decision to present similar clinics in other cities.

The Philadelphia clinic is under the local sponsorship of Philadelphia distributors and has the backing of the PRSMA, radio stations and others. It will open on Sunday evening, January 11 following a meeting of the Pennsylvania servicemen and will continue through Monday and Tuesday. These sessions will also be held at the Bellevue-Stratford.

Member Associations of the Pennsylvania group are currently developing a code of ethics for servicemen which will be circulated and publicized in that state. Recent reports from one Better Business Bureau in Pennsylvania indicated that complaints concerning radio servicemen have fallen off as much as 50% since the formation of the service organization.

# REPRESENTS SYLVANIA IN SOUTHWEST



J. ARDEN STILL

The appointment of J. Arden Still as manager of the Southwestern Division for Distributor Tube Sales, Sylvania, was announced recently by C. W. Shaw, general sales manager of the Radio Tube Division. Mr. Still succeeds Ray Carson, representative in the Southwestern Division for the past 11 years, who has resigned to establish his own business as manufacturer's agent in San Antonio, Texas.

Active as an amateur operator for the past 33 years, Mr. Still's previous positions include two years with the Davis Russ Company, purchasing and managing for the Radio Department, and 13 years as manager of the Radio Department of Strauss Frank Company. He was a member of the Naval Reserve from 1938 to 1941. Mr. Still will make his headquarters in Houston, Texas.

SYLVANIA NEWS

SYLVANIA ELECTRIC PRODUCTS INC.  
P. O. BOX 431  
EMPORIUM, PENNA.

RETURN POSTAGE GUARANTEED

For:

Sec. 562, P. L. & R.  
U. S. POSTAGE  
**PAID**  
Emporium, Pa.  
Permit No. 1

Mr. J. Kenneth Bowman  
Rt. 4  
Rocky Mount, Va.

POSTMASTER: If addressee has moved, notify sender on Form 3547, postage for which is guaranteed. When Form 3547 is sent abandon this mailing. Return only if no correct address is available.

Vol. 14, No. 10

NOVEMBER-DECEMBER, 1947

Published By  
**SYLVANIA ELECTRIC PRODUCTS INC.**  
Manufacturers of Sylvania Radio Tubes and Electronic Devices, Sylvania Incandescent Lamp Bulbs, Fluorescent Lamps and Equipment

**In This Issue**

**NEWS**  
NEW AUDIO OSCILLATOR  
RMA ACTS IN SERVICEMEN LICENSING ISSUE

**MERCHANDISING**  
TO HELP THE CASH BOX RING  
IDEA DEPARTMENT

**TECHNICAL**  
8000 VOLT POWER SUPPLY  
ADDITIONAL CHART SETTINGS  
FOR SYLVANIA TUBE CHECKERS  
SERVICE HINTS