

PHILCO

TECHREP DIVISION BULLETIN

Volume 8 March-April, 1958

No. 2

In This Issue...

Editorial	<i>John E. Remich</i>	1
The Magnetic Core as a Storage Device	<i>Harold Small</i>	3
"What's Your Answer?"		6
Radar Receiver Evaluation	<i>Clifford L. Abel</i>	7
Solution to January-February "What's Your Answer?"		11
Microwave Tropospheric Scatter Link		12
BULLETIN Binders Now Available		13
Logarithmic I-F Amplifiers (Part 2)	<i>Donald R. Taylor, Jr.</i>	14
Biasing the Transistor		24
A Tube Aging Rack	<i>Russell B. Martin</i>	27
Radar Systems Correspondence Course		31
Reduction of CPN-4 Magnetron Failures	<i>T/Sgt. Lee R. Bishop</i>	32
An Introduction to Analog Computers		33

PHILCO®
TECHREP DIVISION
BULLETIN

Published bimonthly by
The TechRep Division of Philco Corporation
Philadelphia, Pennsylvania

Editor John E. Remich
Managing Editor Francis R. Sherman
Technical Editors Harvey W. Mertz
James R. Spencer

Editorial Office:

Technical Information Section
Philco TechRep Division
22nd St. and Lehigh Avenue
Philadelphia 32, Penna.

If any information contained herein conflicts with a technical order, manual, or other official publication of the U.S. Armed Forces, the information in the official publication should be used. Views expressed in this publication are the opinions of the authors and do not necessarily represent those of Philco Corporation. All technical information and circuits are presented without responsibility as to patent infringement.

Editorial

by John E. Remich
Manager, Technical Department

NEW FRONTIERS IN ELECTRONICS

The birth of the space age in 1957 brought with it new problems and new horizons in the design and engineering of electronic systems. Although a considerable research effort is being concentrated on the solution of problems already known, much remains to be accomplished, and many new problems will become evident only with the advent of manned space flight.

The impact of the space age is already apparent to those engaged in research and development in the field of electronics. To the field engineer, however, such developments as micro-miniature electronic systems, solar batteries, and components built to withstand temperatures higher than 1500 degrees may seem remote and far in the future. Past experience has shown that field engineers should be prepared well in advance for the introduction of new concepts and equipments. This is particularly true in the case of the space age developments. Micro-miniaturization, for example, will require new techniques in troubleshooting and maintenance. The tools required for repair of such equipment must also be miniaturized, and the use of such tools will require new techniques. New components such as solar batteries must be studied and understood before troubleshooting can start, and the checking of components under the environmental conditions encountered in actual operation will be essential.

These are only a few of the problems that the field engineer can expect to encounter in the future, problems peculiar to equipments developed to meet the challenge of the space age. Now is the time when we must prepare for these problems — not after operating equipment has been introduced.

In this, the infancy of the space age, all indications point to an ever increasing demand for the conscientious field engineer to follow the trend of new development and techniques at an early stage.

MAGNETIC MEMORIES

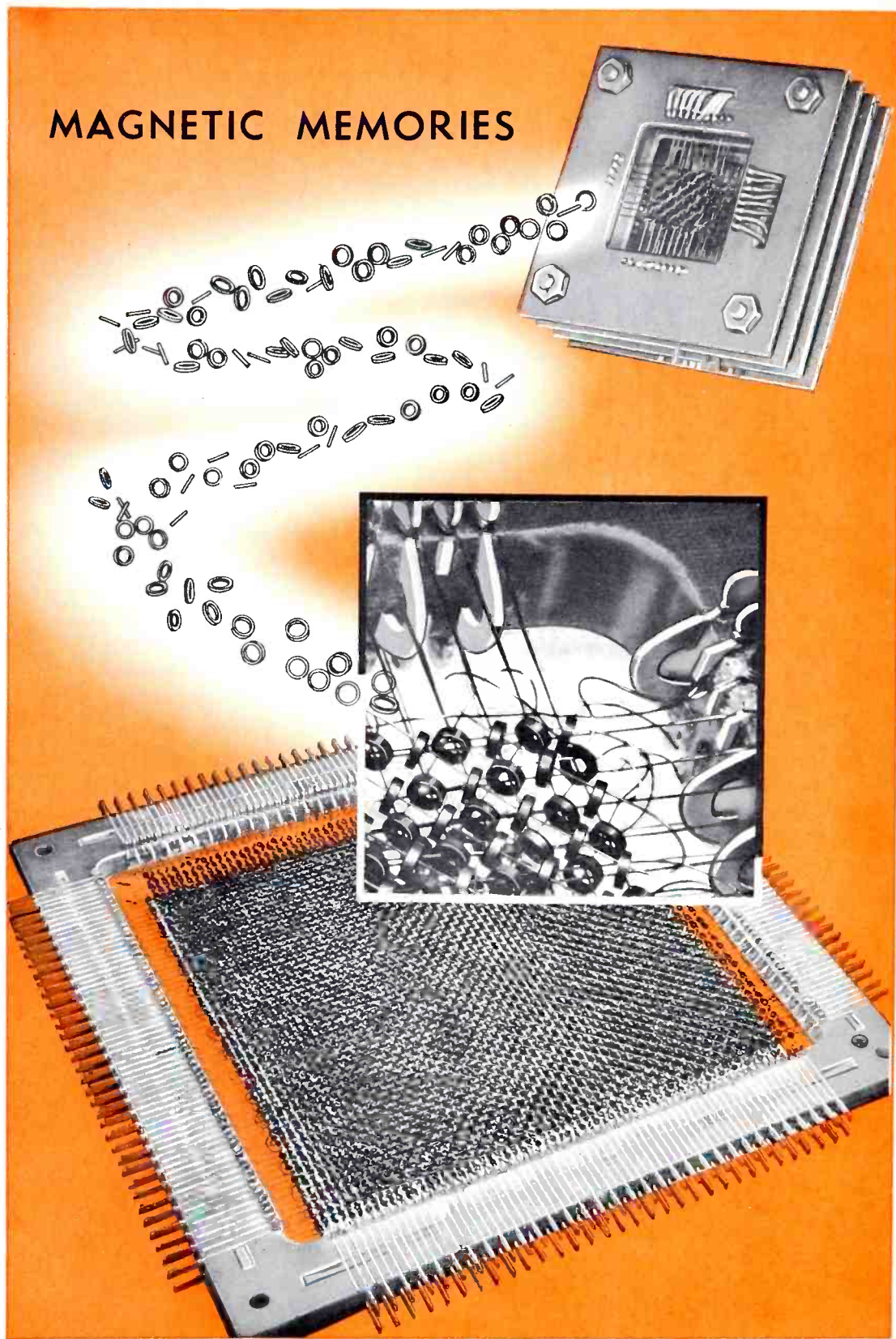

A four-plane 8 x 8 magnetic core memory and a 64 x 64 core matrix. The enlarged view shows the magnetic cores and indicates wiring details.

THE MAGNETIC CORE AS A STORAGE DEVICE

By Harold Small
Philco G & I Division

This article describes a present-day magnetic, or ferrite, core of the type used as a memory element in many modern digital computers. An explanation of the important core properties is given, together with an example of the use of such cores in a simple memory device.

THE MAGNETIC CORE has played a prominent role as a memory element in the development of large-scale digital computers. In keeping with the miniaturization trend, the magnetic core has been miniaturized with the development of new ferrite materials and techniques.

Physically, the magnetic core is a small ring (similar to a doughnut, or toroid) with an inner diameter of 0.050 inch, and an outer diameter of 0.080 inch. It is made of a ferrite material which has a somewhat square hysteresis loop. It is this hysteresis loop that provides a working explanation of the core's storing ability. Figure 1 shows an idealized loop with flux change Φ plotted against current (I). The loop has been labeled N (north) and S (south), or 1 and 0. These designations are entirely arbitrary, and merely serve to illustrate the explanation.

Since a starting point is necessary, assume initially that the core has no magnetism. This is represented by point X (the origin) in figure 1. If enough current is now passed in the N direction, the magnetic flux increases along the dotted line A and eventually reaches saturation at point B. (The core is said to be saturated when an increase in current does not result in an increase in magnetic flux.) If the current is then removed, a slight decrease in magnetism occurs, causing the magnetic flux point to move from B to C, where it is held by the residual magnetism. It should be made clear at this

point that a pulse of current which is capable of saturating the core in any one direction is known as a *full pulse*, and that a pulse of current extending only to the knee of the curve is known as a *half pulse*. For the type S1 core described in this article, a full pulse is approximately 800 ma and a half pulse is approximately 400 ma.

If the core is magnetized in the N direction (refer to point C on the curve of figure 1), then a full current pulse passed through the core in the S direction, will cause the magnetic flux to traverse around the knee of the loop

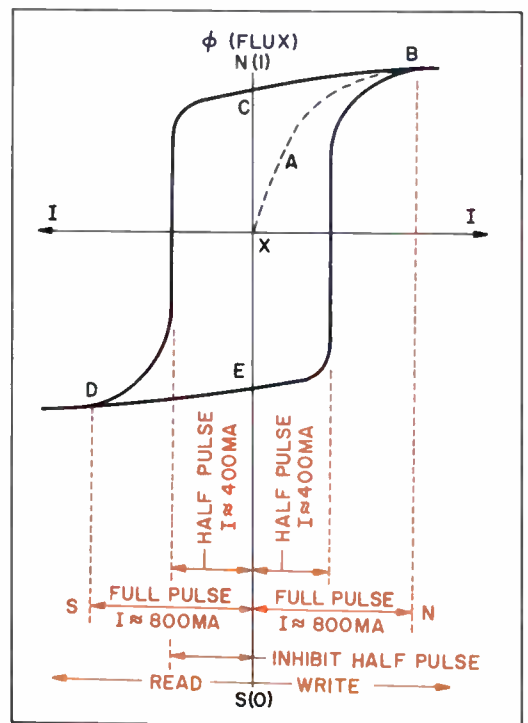

Figure 1. Idealized Hysteresis Loop

and down to point D. This point corresponds to saturation in the S direction. When the pulse is removed, the point on the loop will change to E, which represents the residual magnetism. From here on, when the magnetism is switched (reversed) in either direction, the change in flux will follow the path E, B, C, D.

A core to be used as a storage device in a coincident current memory will have two drive wires through it. For convenience, these drive wires are designated as X and Y, and each drive line must supply half the current to create a full pulse. To switch the magnetism of a core, both X and Y lines must be energized, and thus supply a field of sufficient magnitude to reverse the magnetization of the core. (The average switching time for an S1 type core is approximately 1.0 microsecond.) Two other windings are usually employed, one for "sense" (or reading), and one for "inhibit."

The voltage induced in the sense winding as the magnetic flux point traverses the loop (see figure 1) is used in the following way to extract stored information. Consider the case of the core magnetized in the N, or 1, direction, and at point C on the loop. A half pulse each on the X and Y lines in the S direction will cause a voltage to be induced in the sense winding. If the same core has already been magnetized in the S direction a full pulse in the S direction would have resulted in no flux change and, therefore, in no induced voltage.

If the S direction is now considered to be the read direction, as indicated in figure 1, then it is true to say that an induced voltage implies that the core held a 1, or an N, and that no induced voltage implies that the core held a 0, or S. This method of reading is termed *destructive reading*, and requires that if the information is to be retained it must be rewritten in the core after reading.

An explanation of the binary system of counting is beyond the scope of this article. However, it should be noted that the basic philosophy used in computers is the changing of states or conditions such as on/off, present/absent, yes/no, or 1/0. Computer logic is built on this simple basis. The basic 1/0, or binary type, information is the type of intelligence that can be sensed in the magnetic core. If the south, or 0, direction is considered to be the "read" direction, then it is reasonable to consider the north, or 1, direction to be the "write" direction.

The following description of the "write" function assumes that the "read" function has just taken place, and that the flux position on the curve of figure 1 is E. Two half-amplitude pulses in the N direction will drive the point to B or saturation, and the core will subsequently be magnetized in the N, or 1, direction. (When the pulses have been removed, point C will be the point of residual magnetism on the curve which the flux will assume.)

At this point, the reader might logically ask, "How can a zero be written in a core if the N direction is the write direction, and this direction writes a one?" The answer is simply the addition of one more winding, known as the *inhibit* winding (see figure 2).

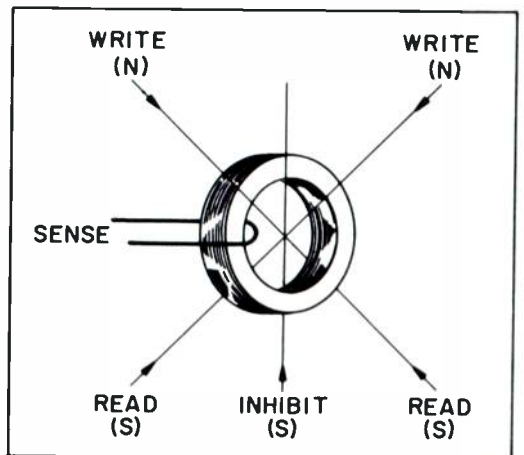

Figure 2. Wiring of a Typical Memory Core

Current is passed through this winding in a direction opposing that of the write current. Thus at the end of a read function, if it is desired to write a zero in the core, a full write pulse of current is passed through the write wires, as if to write a one. But at the same time, a half-amplitude current pulse is passed through the inhibit winding in the opposite direction to the write pulse.

The net result is a half pulse in the write direction, which is insufficient to switch the magnetization from the S, or 0, end of the loop, and thereby leaves the core holding a 0 (see figure 1).

The cores are assembled into planes or matrices. The size of a plane is determined by the number of words or units of information the memory is required to store. Figure 3 illustrates a 4 x 4 core matrix with a storage capacity of 16 words. To interrogate any core in the plane, a half pulse is passed in the read direction on one X coordinate and on one Y coordinate. At the point of intersection, these pulses add, so that the core receives a full read pulse. In the case shown in figure 3, pulses applied to Y coordinate 2 and X coordinate 2 result in selecting the dark-shaded core, while all other cores on the respective X and Y lines (indicated by light shading) are subjected to half pulses. By referring to figure

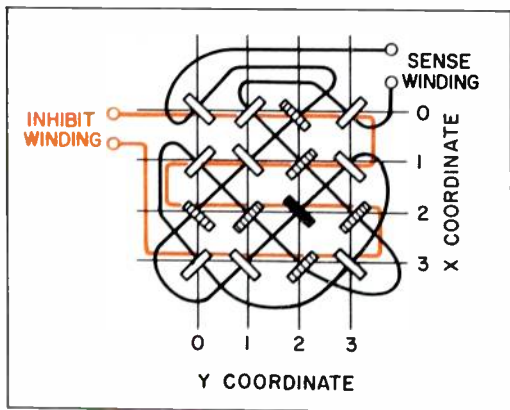

Figure 3. Small 4 x 4 Core Plane or Matrix, with Eight Possible Inputs Selecting Any One of 16 Cores

1, it can be seen that the application of half pulses does not change the state of these cores. However, these pulses do disturb the position of the magnetic flux point on the hysteresis curve; for this reason they are sometimes called *disturb pulses*. As shown in figure 4, a disturb pulse will cause the degree of magnetism to change slightly, and, when continuous disturb pulses are applied in each direction, the magnetic flux point will traverse a small loop called a *minor loop*. But the information content will remain the same.

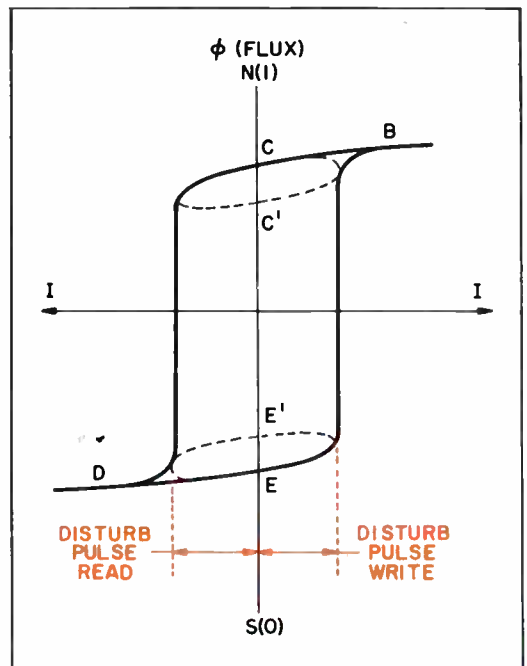

Figure 4. Hysteresis Loop, Showing a Minor Loop at Each End Caused by Disturb Pulses

After the matrix size has been determined, only the number of digits per word remains to be selected. Since each core represents only one digit of a word, the number of planes required will be equal to the number of digits per word. Figure 5 shows that, with four planes wired together, the same core in each plane is selected by coordinates $Y=2$ and $X=2$, and thus one four-digit word is extracted from the 16 four-digit word memory.

Although a core plane can be made

with almost any number of X and Y coordinates, it is usually simpler and more economical to select a number which is used in the binary system of counting (i.e., 2, 4, 8, 16, 32, etc). Thus, circuitry handling the memory address can be more efficiently used. Any number, which is not a binary number (such as 9) would require circuitry capable of handling the next higher binary number, and would therefore be wasteful.

A common memory size currently in use is the 64 x 64 matrix. This matrix contains 4096 words or units, and the number of digits or core planes varies

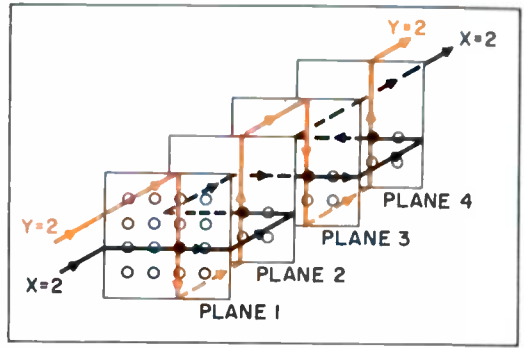

Figure 5. Four-Plane Memory, Showing How a Complete Four-Digit Word Is Selected with One Pair of X and Y Coordinates

from 24 to 48, depending on the particular requirements.

"What's Your Answer?"

The problem below is somewhat different from the recent problems which have appeared in this column. Two views — from the side and the front — of a solid object are shown below. Following the standard drafting practice of showing all visible edges as solid lines and all edges not directly visible as dashed lines, draw the top view of the object shown.

FRONT VIEW

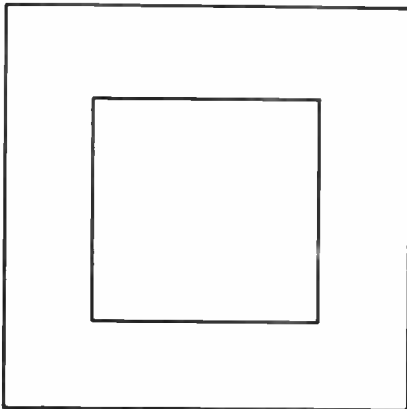

SIDE VIEW

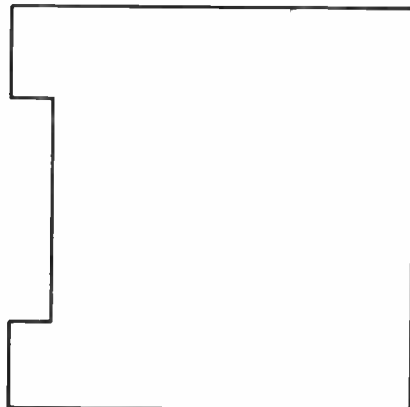

NOW DRAW TOP VIEW

RADAR RECEIVER EVALUATION

By Clifford L. Abel
Philco TechRep Field Engineer

This article states the problems involved in accurate radar receiver evaluation in the field, and describes a method of evaluation which holds an important advantage over the normally used MDS (minimum discernible signal) method. Tests conducted on an AN/FPS-3 are described and used as a basis for the following discussion.

IN ORDER TO EVALUATE radar receiver performance, a noise-figure measurement or an MDS measurement may be made. Although a noise-figure measurement has the advantages of excellent quantitative accuracy and repeatability, the following objections to it have been raised.

1. On existing radar sets, the test is difficult to perform because it involves replacement of waveguide sections and requires cumbersome equipment. This results in excessive "off-the-air" time.

2. The test equipment used is costly and could not be made available to the using agency in quantity for a considerable period of time.

The radar sets involved are mainly interim equipments which will be replaced by types utilizing built-in devices for noise-figure measurement.

The MDS measurement has also been criticized for two basic reasons:

1. There are subjective operator er-

rors in determining when the minimum discernible signal point has been reached.

2. Reliability of the calibration of the signal-generator output attenuator is questionable.

The latter error can be minimized by a good test equipment recalibration program and by maintaining (as is generally being done at present) at least two signal generators at each radar site. However, the necessity for the operator's arbitrary interpretation of the A-scope presentation remains a problem.

To circumvent the difficulties listed above, it has been proposed that the noise figures of the radars be measured by utilizing a CW signal source in place of a conventional noise source and associated test equipment. This method has been used successfully on other equipments in the past, and its validity is discussed in various standard reference works.*

* MIT Radiation Laboratory Series, Vol. 18, Chap. 14.

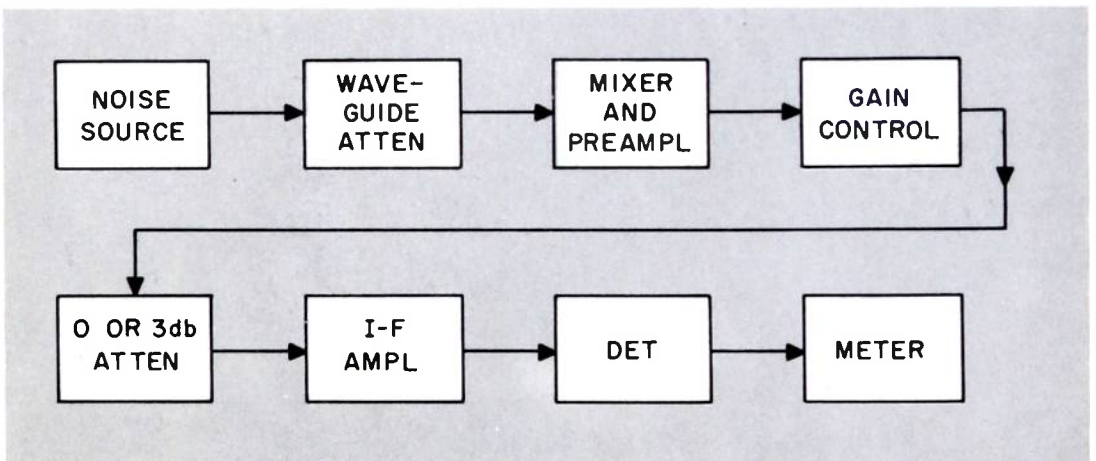

Figure 1. Block Diagram Showing Connections for Conventional Noise-Figure Measurement

CONVENTIONAL NOISE-FIGURE MEASUREMENT (AN/FPS-3)

To perform a conventional noise-figure measurement on an AN/FPS-3, the various equipments are connected as shown on the block diagram in figure 1. After maximum attenuation has been introduced in the waveguide attenuator, the gain control is adjusted for nominal receiver detector current. The 3-db attenuator is then inserted between the preamplifier and receiver and the waveguide attenuation decreased until the detector current rises to its original value. Noise figure is then determined from the equation

$$NF_{db} = 15.8 - A - 0.05 (T - 32)$$

where A = reading of waveguide attenuator
 T = temperature in degrees centigrade

MDS MEASUREMENT

In the MDS measurement (illustrated in figure 2), the pulsed r-f output from the signal generator is tuned to the receiver frequency, adjusted to the proper pulse width, and then attenuated until it reaches the minimum level at which it is still discernible to the operator on an A-scope. The MDS (in dbm) is then equal to the sum of all attenuations in the signal path (attenuation of signal-generator attenuator,

loss in interconnecting cables and cable adapters, plus directional coupler attenuation). The signal-generator output attenuator should be calibrated directly in dbm.

CW NOISE-FIGURE MEASUREMENT (AN/FPS-3)

The CW noise-figure measurement may be made by two methods. In the first method (illustrated in figure 3), the equipments are connected in exactly the same manner as for the MDS test except that a gain control is inserted in the line between the preamplifier and the receiver. A schematic diagram of the gain-control circuit is given in figure 4. With maximum signal-generator attenuation inserted, the gain is adjusted for a nominal detector current level (150-250 microamperes), and the 3-db pad is then inserted in the line. The pad, of course, decreases the detector current reading. The signal-generator output is then increased until the original detector current reading is restored. The CW power added (W) is then determined in the same manner as in the case of the MDS measurement. The receiver bandwidth (between 3-db response points) also must be determined by use of an i-f signal generator, such as the TS-497, and a detector current meter. Once this is done, the

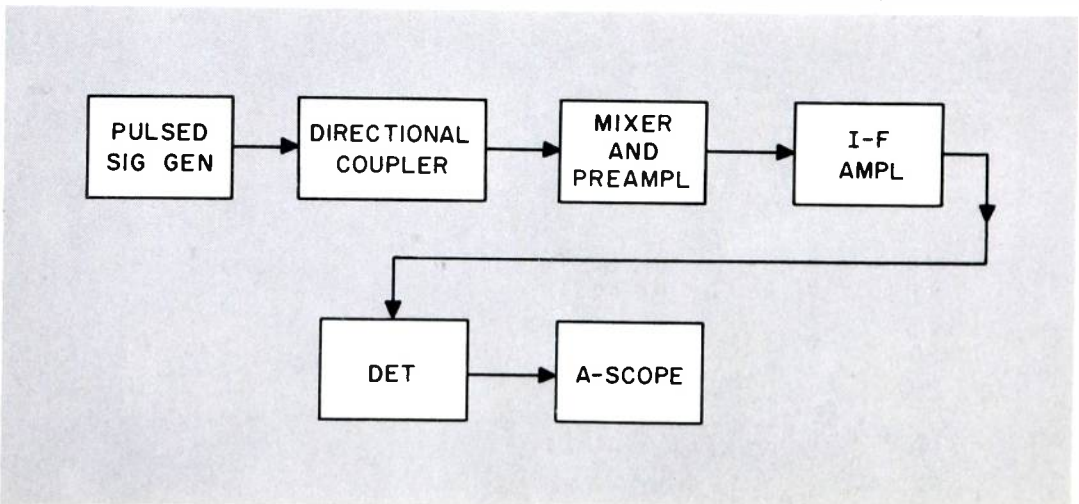

Figure 2. Block Diagram Showing Connections for MDS Measurement

noise figure of the receiver may be determined from the formula:

$$NF_{db} = 10 \log (W/KTB)$$

where:

K = Boltzmann's constant

B = receiver bandwidth

T = temperature in degrees Kelvin

This measurement, although much simpler to perform than the conventional noise-figure tests, suffers from several inherent errors. The absolute accuracy of calibration of the r-f signal-generator output attenuator is involved, the relative accuracy of the i-f signal-generator frequency calibration is a factor, the use of the half-power receiver response points to determine noise bandwidth (B) is only a close approximation, and all amplifiers do not necessarily amplify noise and CW signals equally.

In the second CW noise-figure method, the 3-db attenuator and gain-control box are not used. The procedure is as above except that the r-f signal-generator output is simply increased to the point where detector power output is doubled (1.41 times the original detector current). This method suffers from an additional disadvantage of a possible non-linear receiver detection characteristic.

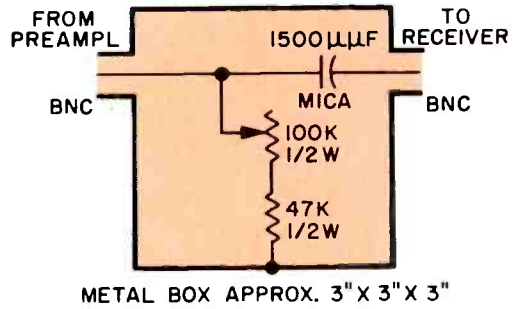

Figure 4. Schematic Diagram of Gain-Control Box

Despite the known possible sources of error in the CW noise-figure method of receiver evaluation, because of its relative simplicity it was decided that an investigation of its merit should be conducted. It was desired to determine the degree of repeatability of the measurement and to establish correlation between the two CW noise-figure methods and the conventional noise-figure method, under field conditions.

TEST RESULTS

Three separate runs were made on an AN/FPS-3, using three different receiver mixer crystals in order to obtain a spread in the actual noise figures involved. In each case, three separate comparative measurements were made

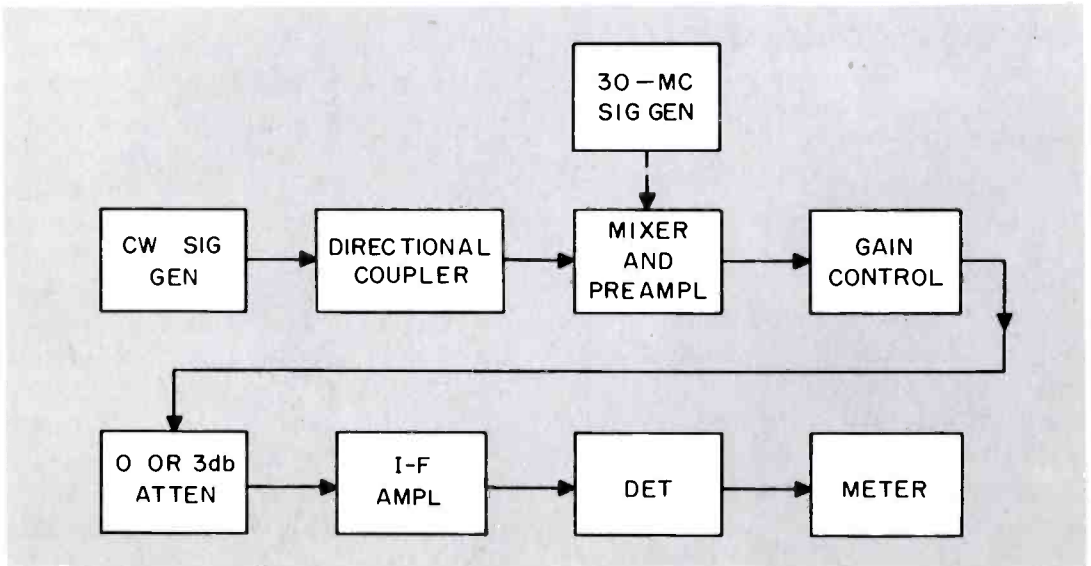

Figure 3. Block Diagram Showing Connections for CW Noise-Figure Measurement

using initial detector current values of 150, 200, and 250 microamperes. The 150-microampere setting was found to most closely approximate the normal condition where A-scope "grass" is equal to one third of the limiting video level.

Using crystal No. 1, the conventional noise-figure test yielded a result of 8.8 db. The average of the three CW noise-figure tests gave a resultant noise figure of 6.94 db, for a difference in results between the two methods of 1.86 db. The results of the CW method which does not utilize the 3-db pad were not recorded, as it became apparent early in the tests that results varied widely, depending upon the detector current level at which the test was made. Results using the 3-db pad varied only over a total range of 0.4 db, and the three conventional noise-figure measurement results varied by only 0.1 db. The receiver bandwidth was found to be 0.4 mc.

Using crystal No. 2, the conventional noise figure was found to be 9.7 db, and the CW noise figure was 7.54 db, for a difference of 2.16 db. The spreads at the individual detector current values were the same as above.

With crystal No. 3 in the mixer circuit, the conventional and the CW measurements yielded results of 9.7 db and 7.44 db, respectively, for a difference of 2.26 db.

Using the conventional noise-figure results as the standard, the CW results are then in error by an average of 2.09 db over a range of 0.4 db. The major portion of this error is believed to be due to the calibration of the signal-generator output attenuator. The attenuator was originally calibrated at room temperatures, while temperature on the antenna tower during the tests was approximately 5°C.

The carefully conducted MDS measurements, performed coincidentally with the other tests, revealed that the

pulsed power output from the r-f signal generator at the minimum discernible signal condition was equal to the CW output power from the generator when the CW noise-figure measurement was made.

This was to be expected since the minimum discernible signal condition exists at the point where the signal is approximately equal to the receiver noise level.

CONCLUSIONS

While the conventional noise-figure method of receiver evaluation is presently impractical for use in the field, the two other evaluation methods (MDS and CW noise figure) may be criticized for the reasons stated previously. Of the two, however, the CW method appears to be superior because of the fact that the subjective operator errors are largely eliminated. Using this method, a number of operators should be able to perform several successive measurements, with all results being very nearly the same.

Without too great difficulty, a family of curves could be prepared for a radar set, showing the relationship between noise figure, CW power output required from the signal generator, receiver bandwidth, and temperature. Actually however, once the bandwidth has been determined to be within specifications, the important parameter is the amount of CW power input to the receiver which is required to return the detector current to normal after the 3-db pad has been inserted. This power is determined in exactly the same manner as in the presently used MDS measurement; that is, the attenuations of the connecting cable and directional coupler (in db) are added to the signal-generator output (in db) to give the resultant receiver noise power. Therefore, the measurement is equivalent to an MDS measurement except that the subjective error has been eliminated. The effects of temperature, signal-generator cali-

bration, and bandwidth should influence both the MDS measurement and the receiver CW noise power measurement equally.

Because this CW noise power test is superior to the MDS measurement, it has been recommended that it be used

for the evaluation of radars which do not incorporate built-in noise-figure test equipment. The gain-control box can be built from service stock parts at an estimated cost of \$3.00. Attenuators, such as Daven spec. 2722, are available for approximately \$26.00.

Solution to January-February "What's Your Answer?"

The values of the two unknown resistors may be found by first considering the two cases separately, as shown in the figure below. With the voltmeter across R_1 , the circuit is as shown in part A of the figure. Under these conditions, since the meter reading is 30 volts, the current through the 20,000-ohm voltmeter is 1.5 ma. Therefore:

$$I_1 = I_{R_1} + 1.5 \text{ ma} \quad (1)$$

and, using Ohm's Law and considering R_1 and R_2 to be in kilohms:

$$\frac{90}{R_2} = \frac{30}{R_1} + 1.5$$

Solving for R_2 results in:

$$R_2 = \frac{90 R_1}{30 + 1.5 R_1} \quad (2)$$

For the second measurement, the voltmeter is placed across R_2 , resulting in the circuit shown in part B of the figure. In this case, the meter current is 2.5 ma; hence:

$$I_2 = I_{R_2} + 2.5 \text{ ma} \quad (3)$$

Again using Ohm's Law and considering R_1 and R_2 to be in kilohms:

$$\frac{70}{R_1} = \frac{50}{R_2} + 2.5$$

Solving for R_2 gives:

$$R_2 = \frac{50 R_1}{70 - 2.5 R_1} \quad (4)$$

Since the value of R_2 is constant, the two expressions can be equated, giving:

$$\frac{90 R_1}{30 + 1.5 R_1} = \frac{50 R_1}{70 - 2.5 R_1} \quad (5)$$

This can now be solved for R_1 , giving a value of 16K for R_1 . This value can then be substituted in either equation (2) or equation (4) to give a value of 26.7K for R_2 .

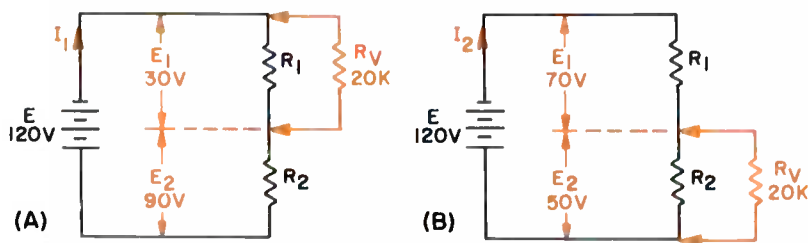

MICROWAVE TROPOSPHERIC SCATTER LINK

Philco G & I Division

A MICROWAVE-RELAY SYSTEM and a tropospheric scatter system will be mated in the new 295-mile communications system to be built for the Air Force's Eglin Gulf Test Range for transmission of timing, telemetering, and radar data as well as for voice communications.

As shown in figure 1, the microwave relay system will consist of five hops, originating at Eglin Air Force Base and connecting to one of the tropo-

spheric scatter sites at Cape San Blas. A four-frequency microwave system will be used to carry over 100 voice channels, and will be expandable to 240 channels when the need arises. The back-to-back terminals to be used at every station will provide independent circuits in each direction, thus giving maximum flexibility.

The tropospheric scatter system will span the 180 miles of the Gulf of Mexico between Cape San Blas and Anclote

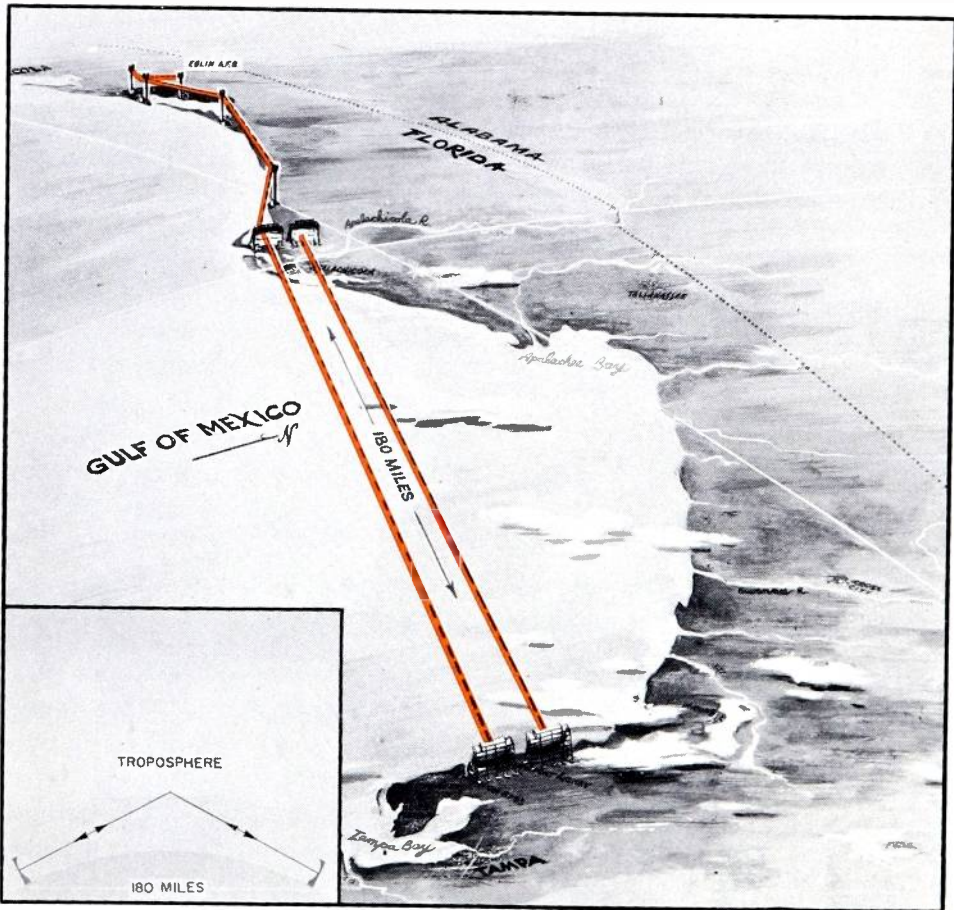

Figure 1. Artist's Drawing of the New Eglin Gulf Test Range Communications System. The Insert Shows the Operation of Tropospheric Scatter.

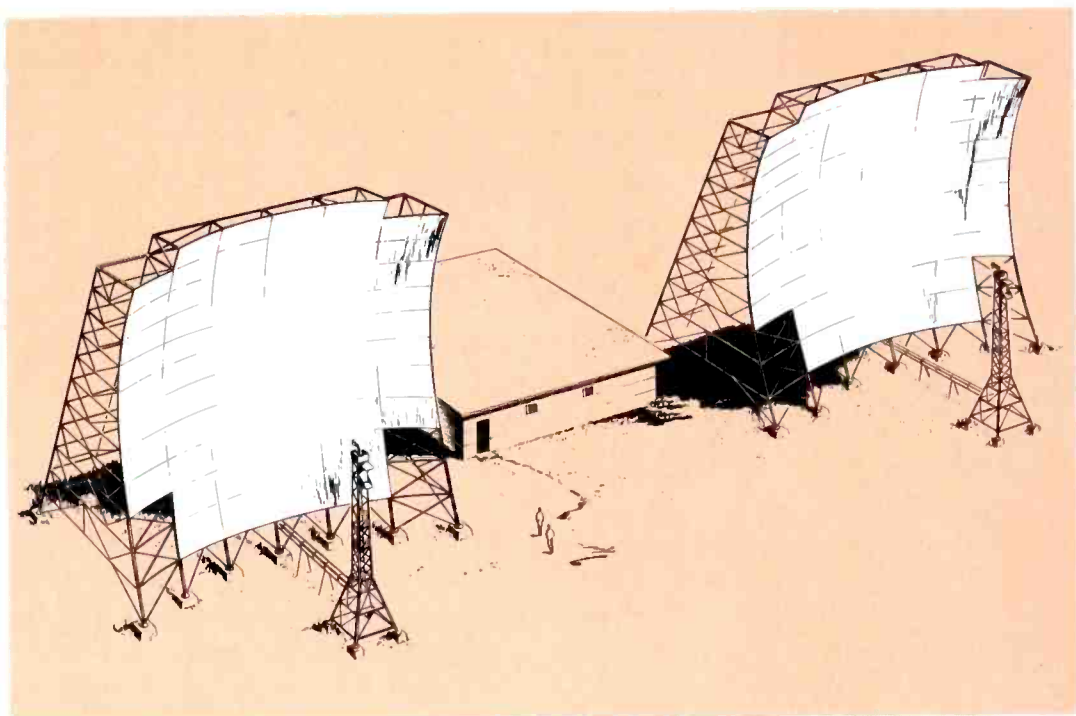

Figure 2. Tropospheric Scatter Site, Showing the 60-Foot Parabolic Antennas

Point in a single hop. Over-the-horizon scatter systems such as this operate by virtue of the scattering of radio waves by the troposphere (as shown in the insert of figure 1), and require extremely high transmitter power and large, highly directional antennas. Figure 2 is a drawing of one of the scatter sites showing the two 60-foot parabolic antennas to be used at each end of the 180-mile hop.

In order to meet the required performance and reliability standards, a recently developed wideband, frequency-diversity communications system

will be used, with the microwave relay operating in the 7000-mc range and the tropospheric scatter link in the 2000-mc range. The use of frequency-diversity equipment will provide for the necessary continuity in the transmission of the microwave signals, since information is simultaneously transmitted over two parallel paths.

Loss of signal at one of the frequencies caused by fading or over-water reflection will, in general, not be apparent at the second frequency, thus insuring an uninterrupted flow of information.

BULLETIN BINDERS NOW AVAILABLE

The binders cost \$1.50 each and will hold 12 issues of the PHILCO TechRep Division BULLETIN.

Make check or money order out to Philco Corporation, and send it to:

**PHILCO TECHNICAL PUBLICATIONS DEPT.
18th and Courtland Sts., Philadelphia 40, Pa.**

LOGARITHMIC I-F AMPLIFIERS

PART 2

By Donald R. Taylor, Jr.

Philco Research Division

This is the second and concluding article on the subject, and deals with the various factors which must be considered in the design of an amplifier having logarithmic output. The design of the i-f stage, the selection of tube type, delay line considerations, the effects of circuit parameters, and methods of compressing the dynamic output range are discussed in detail, and a summary of the results is given.

I-F DESIGN

In considering the use of an i-f amplifier which provides both logarithmic and linear operation, it should be remembered that certain design factors have an important effect on logarithmic operation. These factors are discussed below. With the aid of the theory of operation given in PART 1, the relationship of each factor to the over-all i-f performance can be easily seen.

Gain Per Stage

From the manner in which the over-all curve is obtained by the addition of the individual contributions, it can be seen that the stage gains must be the same if irregularities are to be avoided. In addition, the gain per stage must be of the proper value to overlap the individual curves correctly and give a smooth, continuous curve. The effects of inequality of stage gains and improper overlap are illustrated in figures 1 and 2.

In cases where the gain per stage is low and the individual curves overlap

excessively, it may be possible to take the output from only every other stage and obtain the proper overlap to produce a well-shaped over-all curve.

After giving the pole pattern (which will be discussed presently) special attention, it is usually convenient to use the same type tube throughout the main body of the amplifier, and to operate all tubes at the same d-c operating potentials. The gain control should not be inserted in the log stages because of its disturbing effect on the gain distribution and the resultant log curve. The most logical position for the gain control is ahead of the logarithmic detectors, where the signal is small and the log curve is not affected. However, noise considerations require that it should not be placed in either of the first two stages.

The absolute value of gain per stage used in the amplifier will be determined by the stage loading and the char-

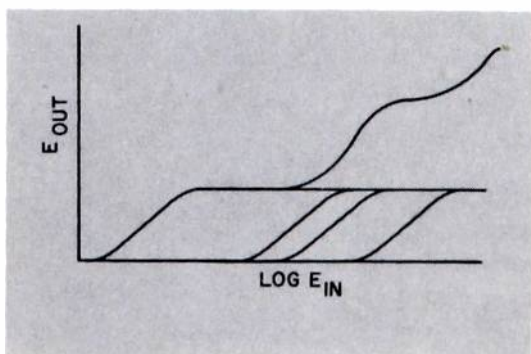

Figure 1. Effect of Unequal Stage Gains

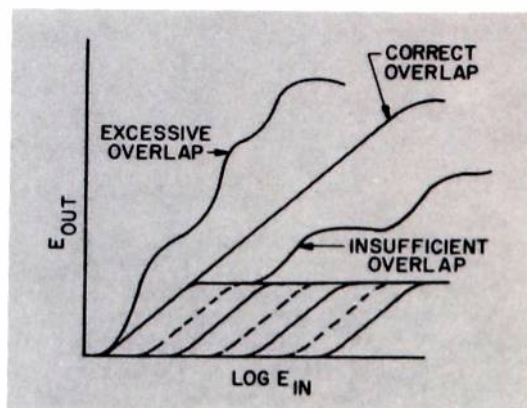

Figure 2. Effect of Improper Overlap

acteristics of the tube. Once the pole pattern has been obtained, any change in stage gain that may be necessary for the correct overlap of the individual curves can be effected by altering the g_m of all the stages simultaneously.

Pole Pattern

With identical tube characteristics and operating points, equality of gain per stage will be determined by the pole pattern. Synchronously tuned, equally damped stages or double-tuned stages of the same gain and bandwidth are satisfactory. Non-identically tuned or damped stages, such as those used in a stagger-tuned amplifier, can be made to fulfill the requirement at only one point in the bandpass. For a symmetrical bandpass, this point will be the center frequency. Stagger-tuned pole diagrams yielding equal stage gain at center frequency are arranged on a semicircle, the Butterworth distribution being the best solution for a good response. Experience has shown such stagger-tuned arrangements to be satisfactory. Curves taken at the 3-db points of the bandpass for bandwidths of 5 megacycles indicate that the departure from the log curve obtained at the center fre-

quency is small enough to be entirely acceptable for most purposes (see figure 3).

Number of Stages (Total Gain)

The number of stages, or total gain of the log detecting stages, is determined by the desired logarithmic range.* The maximum range over which no saturation of output occurs is given by the total gain between the first and last i-f stages contributing to the logarithmic output. Examination of the formation of the over-all curve from the smaller ones shows this clearly. The position of the noise level on the curve fixes the lower limit of the range, while the upper limit remains the saturation level of the earliest contributing stage. Changing the position of the noise level on the curve (by means of the i-f gain control) alters the logarithmic range.

Cathode Detection

Since the cathode is the point of video signal removal and is also a part of the r-f circuit, the bypassing of the

* Except for the indicator limitations, a log range extending from the noise level to the maximum amplitude signal returned would be desirable.

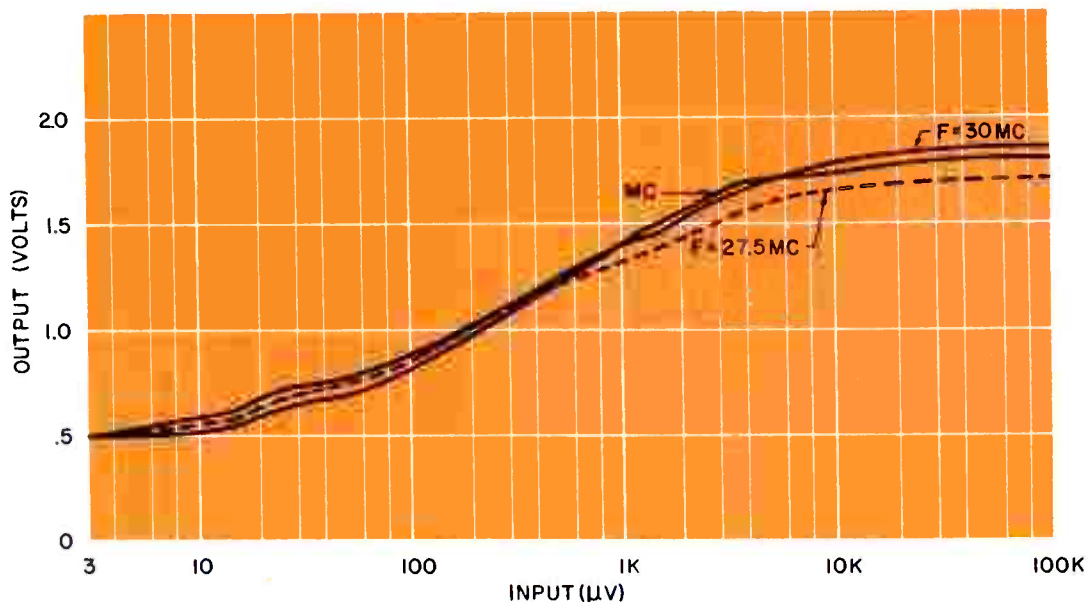

Figure 3. Logarithmic Characteristics at Center Frequency and at 3-db Points

cathode resistor must be a compromise between two separate and distinct requirements. For good pulse reproduction, the 3-db point at the cathode resistor-capacitor combination should be at least one-half the i-f bandwidth, and should preferably be equal to it. On the other hand, the bypassing at rf must be sufficient to prevent degeneration or instability. The lower the i-f center frequency, the more difficult it becomes to find a good compromise between the two requirements. In general, it is desirable to use as low a resistance as possible consistent with good detector operation, so that a larger capacitance may be used for the same video 3-db point, and thus provide a lower total r-f impedance to ground.

The detection occurring at large signal levels causes large video signals to be present in the plate and screen circuits of the i-f stage. In order to prevent the detected video from reaching the following grid and remodulating the signal, the video impedance from grid to ground must be low, and the i-f coupling circuit from plate to grid should present a high impedance to video and a low impedance to rf. Bifilar or mutually coupled circuits fulfill this function well. R-C coupling

is not too well suited to this function, but, by keeping the coupling capacitor small and introducing an r-f choke from grid to ground, it is possible to reduce the transmission of video to a satisfactory level.

The plate supply circuit should be reasonably well bypassed and free from ringing. Where practicable, an effort should be made to approximately terminate the B+ filter line even though cathode detection is relatively insensitive to plate circuit disturbances.

Grid Detection

In the grid detection stage shown in figure 4, the signal is removed from across the diode load resistor and its bypass capacitor. The bypass capacitance must be large enough to bypass rf, and small enough to give a good 3-db video response. Where the i-f damping resistor is in the grid circuit, an r-f choke should be used around it to prevent division of the detected video voltage before reaching the video load resistor. The cathode resistance should be kept small, to reduce the portion of the detected signal dropped across it. With these precautions, the cathode bypass capacitor can be made as large as desired.

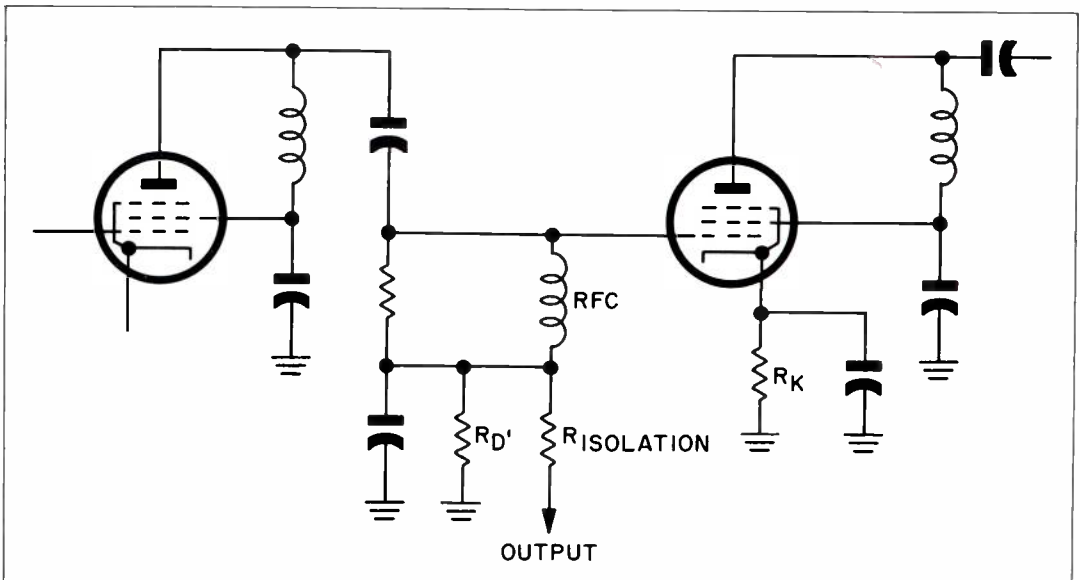

Figure 4. Typical Grid Detection Stage

Video signals from the B+ filter and from the preceding plate circuit show more tendency to appear with the desired signal than is the case with cathode detection. While the video impedance is necessary in the grid circuit, coupling of the undesired video to the grid circuit can be reduced by using a smaller coupling capacitor or bifilar or double-tuned coupling arrangements. Termination of the plate filter line should be included to eliminate ringing effects.

Plate Detection

Removal of the demodulated signal component at the plate circuit yields a large pulse voltage and eliminates any need for amplification. The plate supply filter is normally used as the delay line and thus serves a dual purpose. Bifilar or mutually coupled circuits are good interstage devices, although r-c coupling may be employed if care is taken to minimize coupling of video into the succeeding grid circuit.

Power-supply noise, ripple, and ringing are the most serious drawbacks to the use of plate detection. The B+ line must be very carefully filtered,

since any noise or ripple entering the receiver appears directly with the signal at the log output. Experience has shown that this problem is sufficiently troublesome to favor either grid or cathode detection in preference to plate detection. In addition, it should be noted that, in the absence of the isolation resistors used in grid and cathode detection, the amount of signal contributed by each stage is not directly controllable.

Selection of Tube Type

Choice of tube type should be made with both the i-f amplification and the detection properties of the tube in mind. Any tube type normally used as an i-f amplifier can be made to yield a reasonable logarithmic curve. A cursory investigation was made of five tube types commonly used as i-f amplifiers, to determine the characteristics for use in a cathode detection strip. The detection curves of one stage operating in a strip cascading the same type tubes are shown in figure 5.

It should be noted that when such curves are taken, say for the 6AG5, all

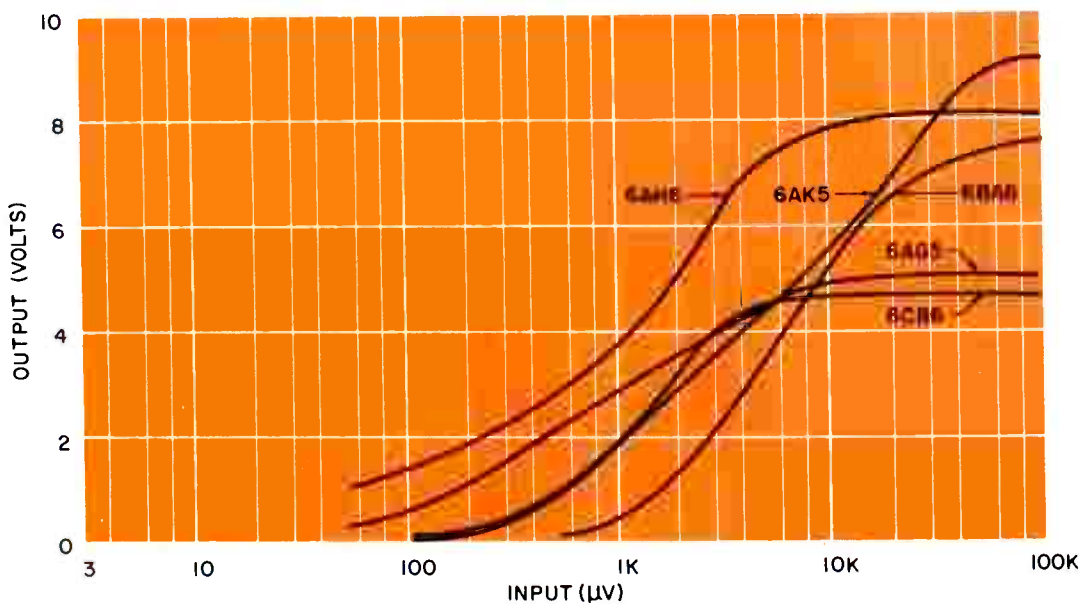

Figure 5. Detection Characteristics of Various Type Tubes. In each case, the output of each stage is taken from the cathode, and all stages use the same type tube.

the stages, or at least several preceding stages, should incorporate the same tube type. This is necessary because the performance of the preceding tubes greatly affects the character of the detection curve of the tube under investigation. Two tube types whose e_g-i_p curves show great similarity may give quite different results when several of them are cascaded in the amplifier.

In general, if several tube types are satisfactory (as the i-f amplifiers), the one giving the largest detected signal with good linearity should be chosen. Of the five curves shown, the 6AK5 was chosen because it provided a large detection signal at the cathode, showed good linearity of the detection curve, and performed well as an i-f amplifier tube. As has been pointed out before, the larger the signal developed, the smaller the cathode resistance may be made for the same output. Decreasing the cathode resistance permits better r-f bypassing while preserving the video response. An equally satisfactory log characteristic is obtainable with the type 6CB6, but a larger cathode resistance is required for a substantial output.

Over-all curves for the 6CB6 and 6AK5 are shown in figure 6. Note that for similar curves, the 6AK5 requires only 100 ohms cathode resistance.

The Delay Line

Since the signal in the i-f amplifier undergoes an envelope delay in passing from stage to stage, the detected signals at the tube elements are displaced from each other in time. To bring the signals into coincidence, a delay equal to the envelope delay is inserted between stages before adding the outputs together. For synchronously tuned and damped stages, the delay is the same per stage.

For stagger-tuned amplifiers, the delay varies from stage to stage. Since the time delay varies considerably with frequency, the selection of the point on the individual phase curve for delay calculation is rather arbitrary. It is also inconvenient to adjust each delay individually. To avoid these complications, it is customary to take the average delay per stage from the over-all amplifier phase characteristic as obtained from the pole pattern. For most good pole patterns, the over-all phase char-

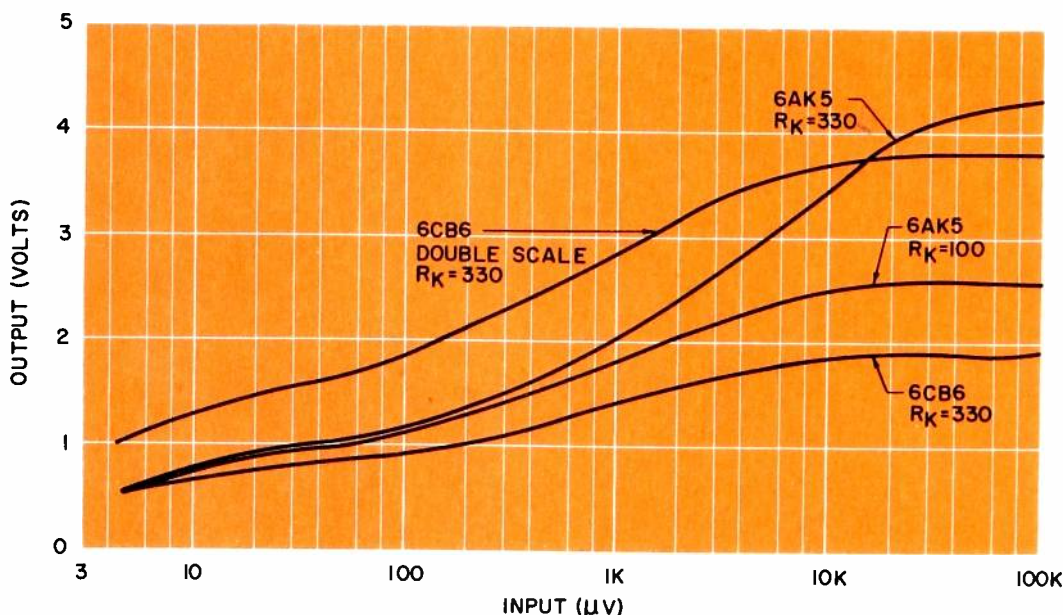

Figure 6. Log Characteristics of the 6AK5 and 6CB6 (Characteristic Impedance = 1500 Ohms, Isolation Resistance = 1500 Ohms)

acteristic will be fairly straight, and selection of the 3-db point will therefore yield a good figure. This procedure has been found to be satisfactory for most cases, since the delays involved are relatively small compared with the pulse widths commonly encountered.

An approximation of δ /stage

$$\frac{0.2}{\text{i-f bandwidth in mc}}$$

for single-tuned stages, and

$$\frac{0.4}{\text{i-f bandwidth in mc}}$$

for double-tuned stages yields a fairly close figure as a check. For a Butterworth distribution the average delay per stage is approximately

$$\frac{0.20}{\text{i-f bandwidth in mc}}$$

to

$$\frac{0.25}{\text{i-f bandwidth in mc}}$$

for single-tuned stages.

Effects of Circuit Parameters (Cathode Detection)

Investigation was made on a cathode detection strip to determine the effects of circuit parameters on the over-all

characteristic. The particular amplifier involved was a 5-mc stagger-tuned amplifier centered at 30 mc. The design was such as to give the most stable operation possible, in order to eliminate the possibility of confusion between component and regeneration effects.

The major effect of varying the cathode resistance is to change the amplitude of the video output. Within the limits of normal amplifier operating points, increasing the resistance at the cathode increases the slope of the over-all curve. Linearity may be affected to some extent because of the change of gain per stage. When a fixed contribution from a diode detector at the end of the amplifier is added to the log stage outputs in an effort to reduce the dynamic output range, decreasing the cathode resistance of the log stages helps to decrease the output dynamic range. Figure 7 shows two curves taken for 100-ohm and 330-ohm cathode resistors with all other parameters fixed and no diode contribution. Figure 8 shows the curves taken with the diode contributing the same amount in each case. The value of resistance for best performance is determined mainly by

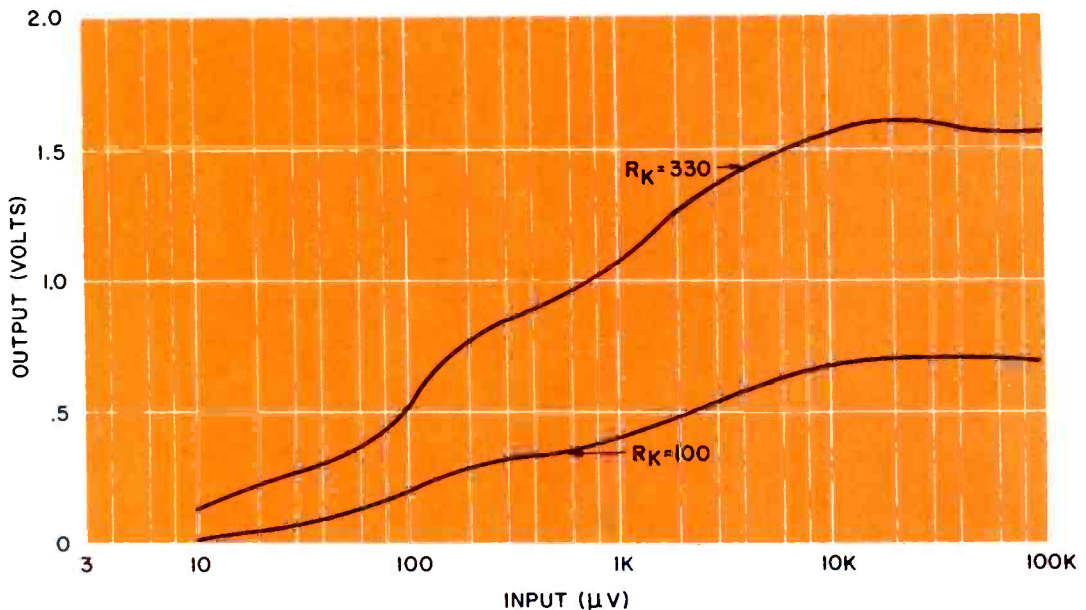

Figure 7. Effect of Cathode Resistance on Log Characteristic for Four 6CB6's with No Diode Contribution (Characteristic Impedance = 1500 Ohms, Isolation Resistance = 1500 Ohms)

the type tube employed. Curves for the 6CB6 and 6AK5 are given in figure 6. Note that the curve obtained with 100 ohms and the 6AK5 is very similar to that obtained with 330 ohms and the 6CB6.

Isolation Resistance

The value of isolation resistance depends mainly on the characteristic impedance of the delay line, which forms a common load for the output of all stages. The resistor serves to isolate each stage from the others. Although such isolation is mainly for dc and video, it also attenuates any i-f signal as well. Figure 9 shows the effects of changing the isolation resistance from 1000 ohms to 100 ohms. For an isolation resistance of 100 ohms, the curve is very bumpy and irregular. Little increase in output has been realized over that of the 1000-ohm curve, and linearity has been greatly impaired. Figure 10 shows curves of 1500 ohms and 15,000 ohms. Less output is obtained with the 15,000-ohm isolation resistance, but the linearity is better still. Ordinarily, the linearity obtained with the 1500-ohm resistance would be

acceptable and give substantial output. If an extremely high degree of linearity is desired, it may be worth the drop in output to go to the higher values. Reduction of isolation resistance to such a value as to produce a definite loading on the delay line makes the line essentially a lossy one. This may be desirable as a means of reducing the output dynamic range when it is required. However, heavy loading on the line will result in distortion of the pulse and the appearance of "dog-ears" (see figure 11).

In general, therefore, raising the value of isolation resistance reduces the output but gives better linearity while decreasing the isolation resistance increases the output up to a certain point and tends to make a less even curve. The actual value selected will be a compromise dictated by the requirements of the particular case.

The characteristic impedance of the delay line should be kept high enough so that this impedance, in series with the isolation resistance, does not load the cathode circuit of the stage too heavily. Too high a value of char-

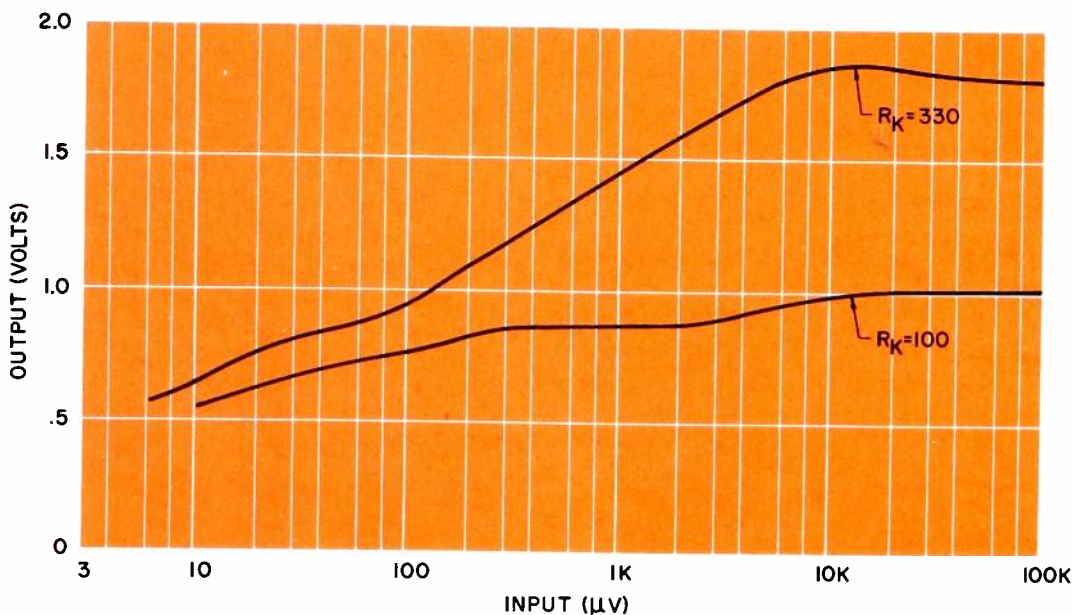

Figure 8. Effect of Cathode Resistance on Log Characteristic for Four 6CB6's with Diode Contributing (Characteristic Impedance = 1500 Ohms, Isolation Resistance = 1500 Ohms)

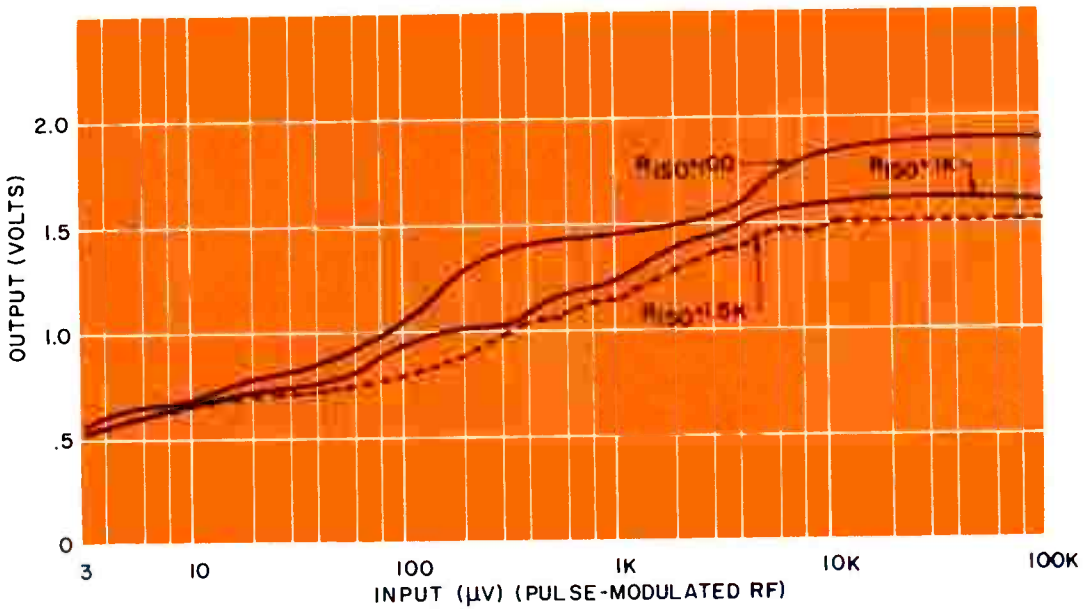

Figure 9. Characteristic of Log I-F Strip with Cathode Detection

acteristic impedance may cause i-f feedback problems, and too low a value will substantially reduce the output. With a fairly stable amplifier, an impedance on the order of 1000 ohms is quite satisfactory.

Compression of Output Dynamic Range

A log i-f of the type under consideration normally yields an output dynamic range that is quite large. Un-

fortunately, present PPI indicators are able to handle only a very limited swing of signals before blooming occurs. Unless the method of display can be made to accommodate a larger dynamic range, the log i-f must be restricted. The problem is quite important, since failure to meet the restrictions of the PPI results in a reduction of the log range by the blooming of the scope.

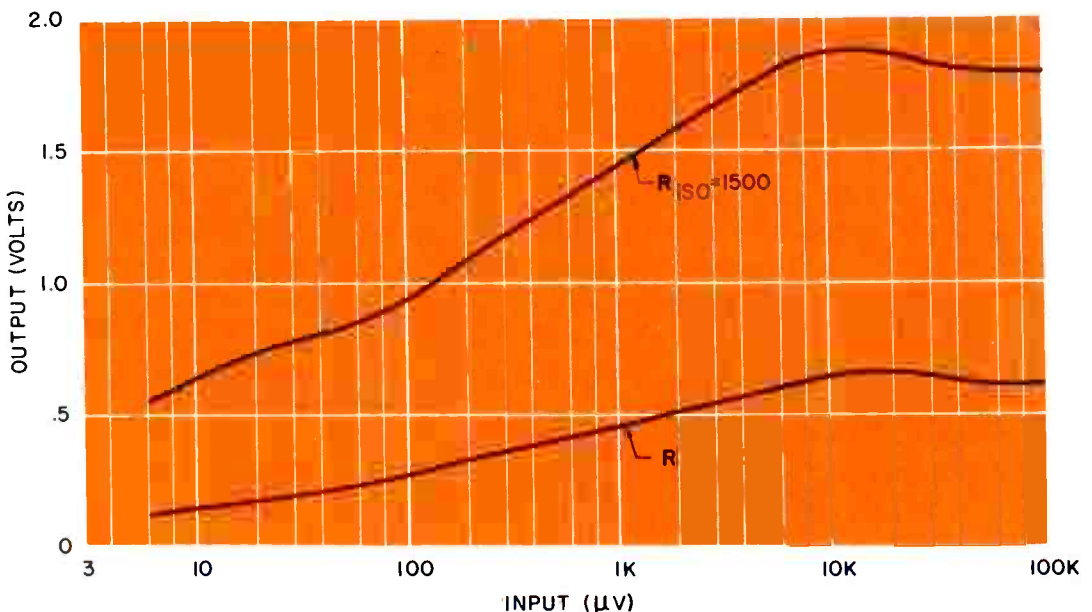

Figure 10. Effect of Isolation Resistance on Log Characteristic for Four 6CB6's with Diode Contributing (Cathode Resistance = 330 Ohms, Characteristic Impedance = 1500 Ohms)

The most practical method of decreasing the output range is to add a contribution from a diode detector at the end of the strip and at the same time reduce the slope of the log curve somewhat. A judicious amount of diode contribution brings up the lower end of the curve in the region of the weakest signals, and a decreased slope of the log stages (obtained by decreasing R_k) cuts down the slope of the remainder of the curve. Some distortion of the curve takes place at the lower end, and, if the diode contribution is made too large in proportion to the other stage outputs, a badly distorted curve will result.

A means of decreasing the dynamic range is to vary the resistance of the isolation resistors. The contribution of each stage to the total output can be changed by varying the size of this parameter. Increasing the resistance in steps going toward the input of the amplifier will reduce the output range, with a small amount of irregularity in the log curve. If the bumpiness that may result is acceptable, it may also be possible to omit entirely the contributions from alternate stages and thus reduce the dynamic output range.

A different technique which produces essentially the same effect is to decrease the isolation resistance to the point where a definite loading of the delay line is produced. The delay line then introduces attenuation to signals traveling from one end to the other. Since the output is taken from the line at the output end of the amplifier, the outputs of the earlier stages undergo an increasing attenuation as they pass along the delay line, with the result that the over-all curve is compressed. The disadvantage of loading the line in this way, as was pointed out previously, is that it may result in a "dog-eared" pulse (see figure 11).

In summary, compression of the dynamic output range to the approximate

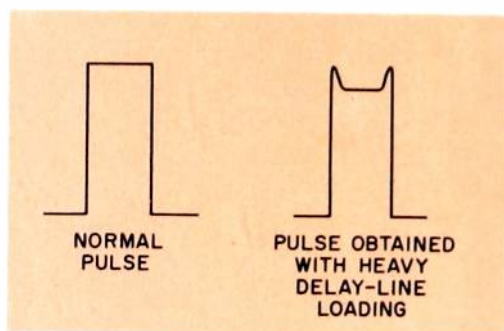

Figure 11. Illustration of "Dog-Ears" Caused by Heavy Loading of Delay Line

12db required by the indicator can be accomplished by the following methods:

1. Grading isolation resistance along the line or omitting alternate stages.
2. Decreasing the ratio of isolation resistance to delay-line impedance.
3. Adding a portion of the linear diode output and reducing cathode resistance.

Satisfactory output level, dynamic range, and linearity can be obtained by a combination of these methods.

CONCLUSIONS

Theoretically and practically, it is possible to use either grid, cathode, or plate detection and obtain a satisfactory logarithmic response. However, each type has its own particular problems. A comparison of the different types of log detection and their associated characteristics and problems is of value and is therefore given below.

In the early parts of the investigation of the log if, plate detection was found to be the least desirable of the three because of the problems of power filtering to eliminate transients and ripple, and the provision of adequate plate line termination.

Of the grid and cathode types, comparison of operating strips yielded the following important points:

1. A spike appearing at the leading edge of the pulse, due to feedthrough of video from the preceding plate, was never completely eliminated in the grid

detection strip, while in the cathode detection strip this problem was negligible. An explanation of the effect can be obtained by examination of the relative signal magnitudes. When grid detection is employed, the driving stage produces video in its plate circuit both before and during rectification by the following grid. Therefore, at the time when an output is obtained from the rectification action of the grid circuit, the amount of video existing at the preceding plate is very large. Coupled with lower output from grid detection this makes the video feedthrough more apparent.

In cathode detection, however, the output signal from the stage is already of large magnitude before sufficient video has been developed in the preceding plate to be observable. Cathode detection therefore shows superiority in this respect.

2. Effects of ringing in the plate supply were found to be less pronounced with the cathode strip. Again the explanation is found by consideration of the relative signal magnitudes.

3. Because a much larger driving signal is necessary to produce detected output at the grid of the i-f stage than at the cathode, removal of signal from the cathode can be considered more efficient. In addition, since the g_m of the detecting stage is involved in the cathode circuit, more signal is developed there than in the grid circuit, for the same video load.

4. Comparison of grid and cathode detection circuitry shows the advantage of cathode removal of signal in the relative number of additional components necessary.

5. Because the cathode circuit is near ground potential, fewer problems of isolation and stability are encountered.

Summarizing, the relative advantages of each type of log detection are as follows:

Plate — High output; power supply problems; fewest number of components; fair linearity.

Grid — Low output; greatest number of components; video feedthrough problems; stage outputs more independently adjustable.

Cathode — Medium output; median number of components; fewer feedthrough, power supply, and isolation problems.

By careful attention to the design of the receiver and the use of a few additional parts, it is a relatively uncomplicated problem to supply logarithmic output as a simultaneous alternate to the normal linear operation in a radar system. As was pointed out earlier, other methods of obtaining log response can be used, but for an alternate video presentation of a non-saturating character, the lin-log strip utilizing the non-linearities of the i-f amplifiers offers the designer the least expensive and simplest way of adding the advantages of logarithmic operation to the receiver.

BIBLIOGRAPHY

- R. V. Alred and A. Reiss, "An Anti-clutter Radar Receiver", *Journ. IEE* (London), Vol. 95, Pt. 3; November 1948.
- S. N. Van Voorhis, "Microwave Receivers", *Radiation Laboratory Series*, Vol. 23, pp 583-606. McGraw-Hill Book Co., Inc., N. Y., 1948.
- J. Croney, "A Simple Logarithmic Receiver", *Proc. IRE*, Vol 39, No. 7, July 1951.
- F. E. Terman, *Radio Engineering*, Third Edition. McGraw-Hill Book Co., Inc., N.Y., 1947.
- Philco Engineering Department, Final Report on Research Model Log I-F ASW Evaluation, Navy Department, BuAer Contract NOa(s)-9993.
- Philco Research Division, "I-F Amplifier Coupling".
- Philco Research Division, Progress Report No. 1, Navy AN/APS-30 Task Contract N55a-13638, 1946.
- Philco Research Division, Report No. 58.

BIASING THE TRANSISTOR

Reprinted from
"Philco Electronic Supervisor"
Philco Service Division

SINCE THE METHODS of biasing transistors are standard, a technician can readily memorize the polarity of the applied bias voltages to the emitter and collector sections of either PNP or NPN transistors. However, in some cases the technician may not have an understanding of what is being accomplished or know the reasons for the application of the bias voltages.

For competent service of transistor equipment and in order to understand transistor biasing methods, the technician should be familiar with the internal structure of the transistor and the formation of the barrier area, since the bias will either reduce or increase the barrier area effect on current flow.

THE BARRIER AREA

In general the P and N sections of a transistor are created by the addition of minute quantities of impurity elements to intrinsic (pure) germanium or silicon. The sections become either P type with an excess of positive holes or N type with an excess of negative electrons, depending upon the type of impurity element which is added to the

crystal. The barrier area which forms between the P and N sections because of the action of the electrons, holes, and the atomic structure of the sections represents resistance to current flow. The resistance of the barrier area can be reinforced or decreased by the application of external potentials or bias voltages.

APPLICATION OF FORWARD BIAS — PNP

In order to promote current flow for normal operation of the transistor, the barrier resistance between the base and emitter sections must be reduced. The applied voltage or bias, therefore, must be of the proper polarity to cause the current carriers to cross the barrier area from the emitter to the base. In figure 1, the application of the bias voltage to a PNP transistor is illustrated. The positive pole of the battery is connected to the emitter P section, and the negative pole is connected to the base N section. This is called forward bias. Forward bias reduces barrier resistance and promotes current flow. The positive battery terminal causes the positive

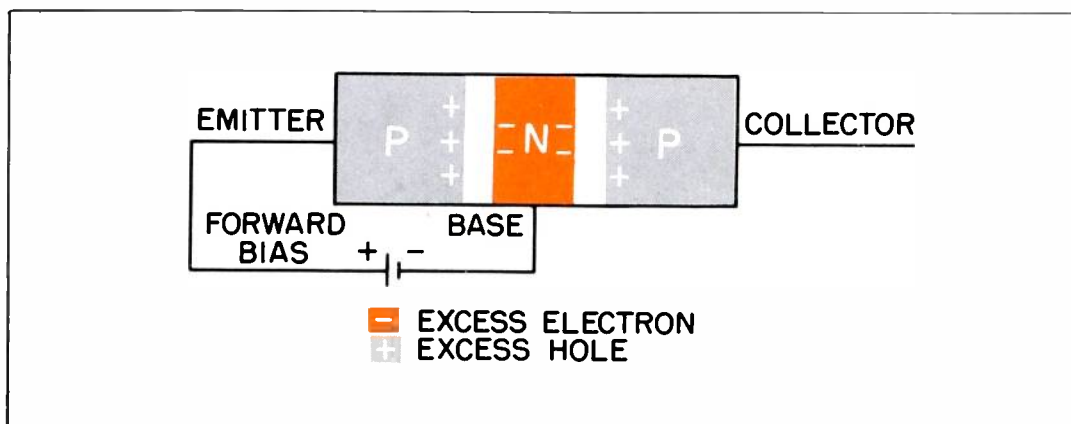

Figure 1. Forward Bias — PNP Transistor

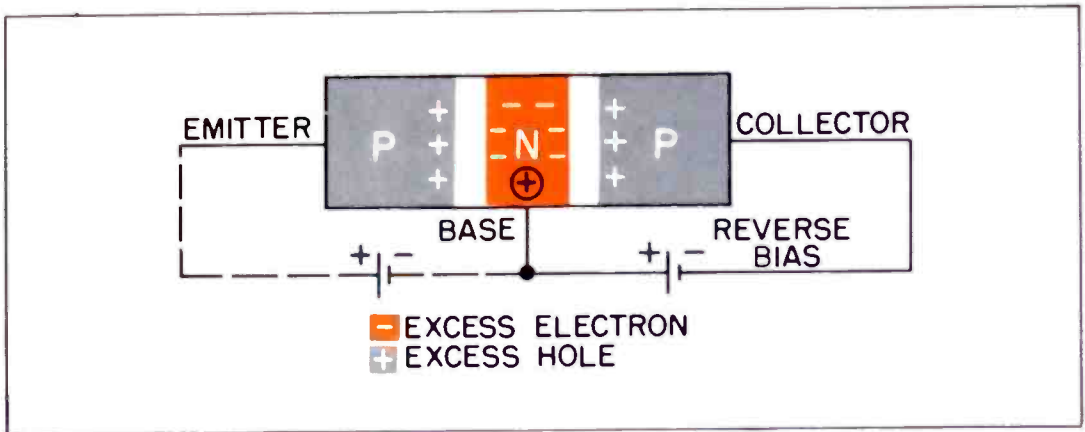

Figure 2. Reverse Bias — PNP Transistor

holes of the emitter section to cross the barrier area into the base section. The N base section is purposely made very thin so that the holes diffuse through this section to the collector barrier area with very few combining with base section electrons. Thus only a small current flows in the base-emitter circuit, while the major current reaches the collector barrier.

APPLICATION OF REVERSE BIAS — PNP

In figure 2, the collector-base bias is illustrated. The battery negative terminal is connected to the collector section of the transistor, and the positive terminal is connected to the transistor base. The polarity of the connections insofar as the P and N sections are concerned is opposite to that employed for the emitter-base bias. This method is called

reverse bias. Reverse bias increases the barrier resistance between the collector and base. The emitter holes, however, will cross the barrier because of the attraction of the negative collector potential. The increase in resistance of the collector over that of the base, while maintaining the hole current flow with only a small loss to base section electrons, enables the transistor to achieve power gains.

APPLICATION OF FORWARD BIAS — NPN

The application of forward bias to an NPN transistor (see figure 3) is essentially the same in principle as for a PNP transistor. The polarity of the applied bias potential is such that the barrier area resistance between the emitter and base is neutralized to permit current flow. Electrons from the emit-

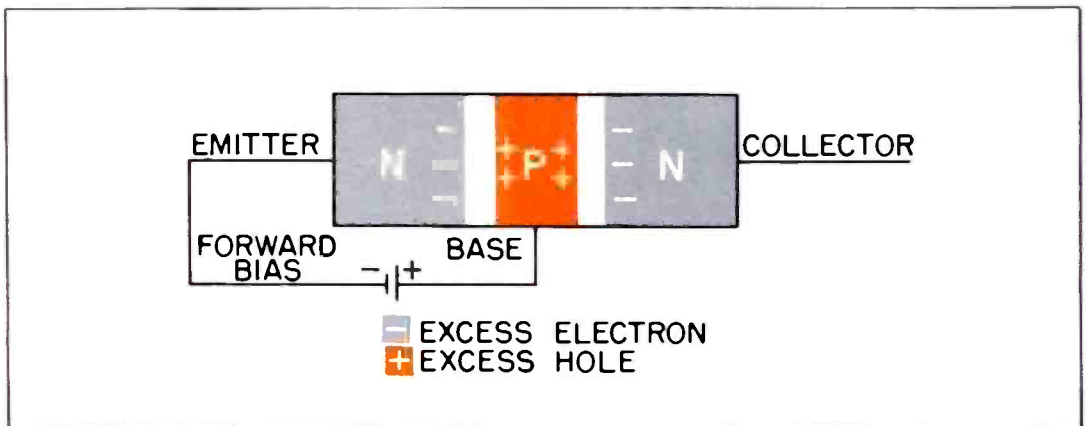

Figure 3. Forward Bias — NPN Transistor

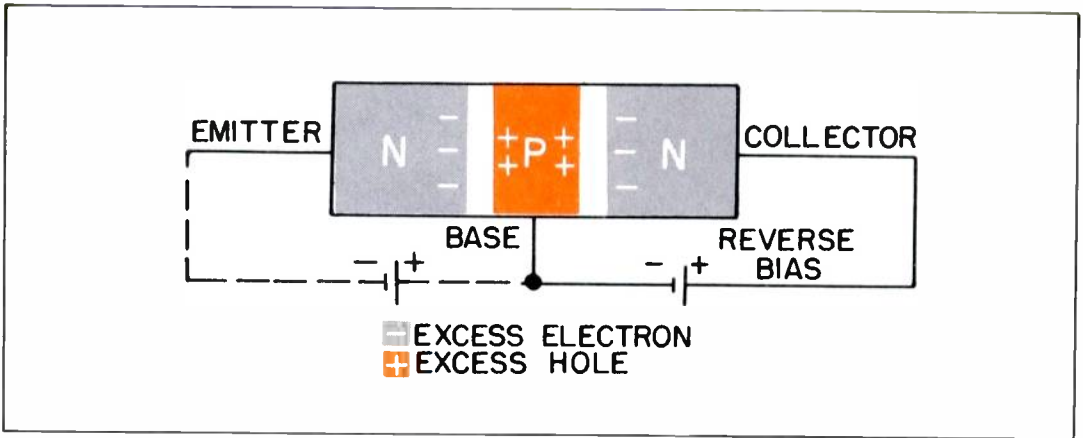

Figure 4. Reverse Bias — NPN Transistor

ter N section are moved across the barrier into the base P section by the repelling action of the negative battery terminal, where they move through the thin base section to the collector barrier. Only a few electrons are lost in combining with base section holes. The polarity of the bias voltage coincides with the polarity of the emitter and base sections of the transistor for forward bias in either the PNP or NPN transistors, the negative battery terminal being connected to the N section and positive battery terminal to the P section.

APPLICATION OF REVERSE BIAS — NPN

The application of reverse bias to the collector-base sections of the NPN transistor is illustrated in figure 4. Again the action is fundamentally the same as for reverse bias of the PNP transistor, with the exception that the battery polarity is opposite to that of the PNP transistor because of the different polarities of the transistor collector and base sections. The collector of an NPN transistor is N-type crystal while the base is P-type. Therefore, to increase the barrier resistance between the base and collector, the negative battery pole is connected to the base, and the positive pole to the collector. Electrons from the emitter reaching the collector barrier are drawn to the positive potential of the collector.

CONCLUSIONS

In summarizing forward bias, the bias voltage is applied between the emitter and base of either PNP or NPN transistors in the proper polarity to reduce barrier resistance and promote the flow of current. Forward bias voltage polarity coincides with the polarity of emitter and base sections for either PNP or NPN transistors. Forward bias results in a small emitter-base current with a large current flow to the collector.

Reverse bias of the collector and base means that the bias voltage is applied in the proper polarity to increase the barrier resistance. Emitter current reaches the collector in spite of the increased barrier resistance because of the collector potential which attracts the emitter current carriers. The resistance gain of the collector over that of the emitter with only a slight decrease in the current reaching the collector enables the transistor to provide a power gain.

The current to the collector is controlled by the base-to-emitter bias and the base-emitter current. As we have noted, this current is relatively small. Small changes in the base-emitter current will produce relatively large changes in the collector current, and in this manner the transistor is capable also of current and voltage gains.

A TUBE AGING RACK

By Russell B. Martin
Philco TechRep Field Engineer

This article describes the construction of a device for properly aging a group of vacuum tubes before using them in an equipment. Such a process makes it possible to reduce equipment failures resulting from tube malfunctions by eliminating tubes which would otherwise fail after a short period of use.

AS FAR BACK AS 1955 the desirability of aging tubes was recognized. Certain type tubes are known to have a high mortality rate during their early period of use, and tube parameters often change during the life of the tube. Accordingly, an effort was directed toward the development of an aging unit for giving a 50-hour aging to all tubes not previously aged. It was believed that this amount of aging would eliminate the greatest percentage of potential tube malfunctions and would stabilize tube parameters. Stabilization is essential for tubes used in highly critical applications such as master timer or frequency control circuits.

At this location, it was felt that the aging unit design should incorporate the following features:

1. Regulated plate supply capable of supplying maximum required plate current.
2. Bias supply protected from indi-

vidual tube failures involving grid shorts.

3. Maximum flexibility and reliability.

Figure 1 shows an illustration of the resulting device, and figure 2 shows the schematic diagram.

In figure 2, T1, the plate-supply transformer, is capable of supplying 400 volts, a.c., either side of center tap at approximately 350 ma. This a-c voltage is rectified by a pair of 5R4's and fed to an 8- μ f electrolytic filter capacitor. Four 6AQ5's in parallel are utilized as a series-regulator element, the grid-to-cathode potential of the series regulators being controlled by a 1-megohm resistor acting as a plate load for a fifth 6AQ5, which is connected as a conventional amplifier. A reference bias for the control amplifier is obtained from a voltage-divider network consisting of a 470K resistor in series with an NE2 bulb. The drop across the bulb is constant, and thus maintains the cathode of

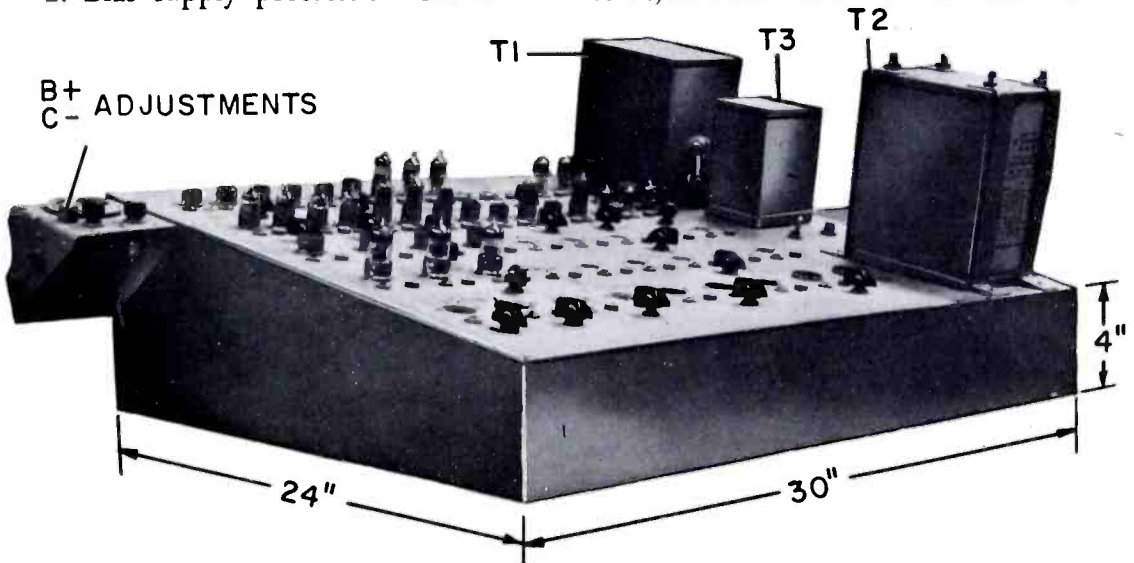

Figure 1. The Tube Aging Rack, Showing Dimensions and Locations of Adjustments

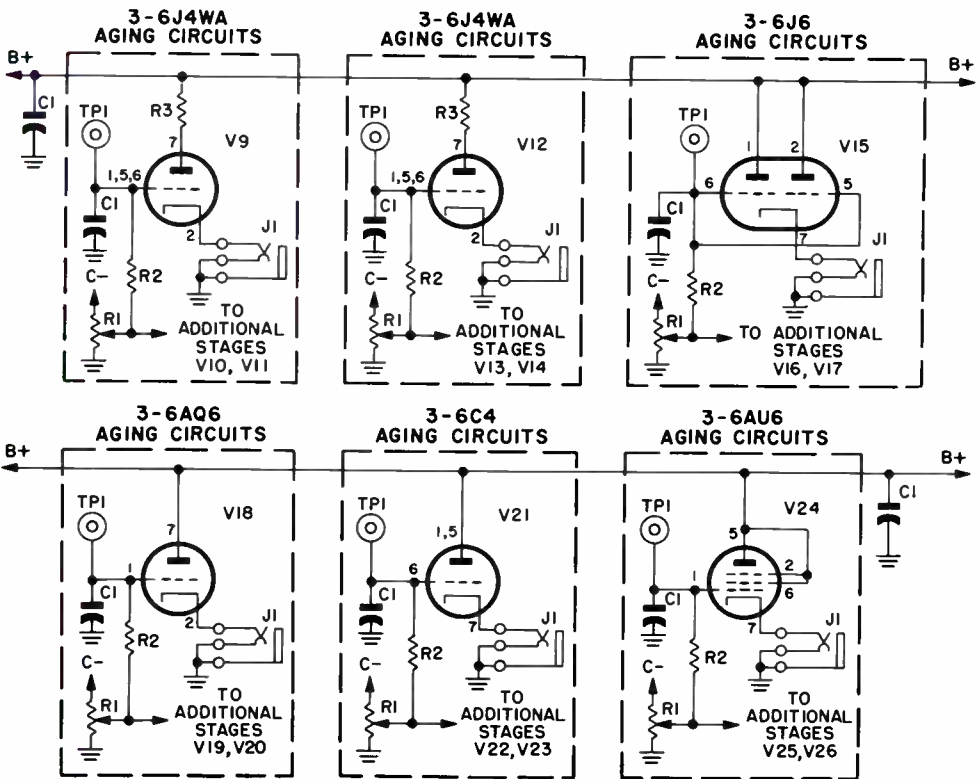
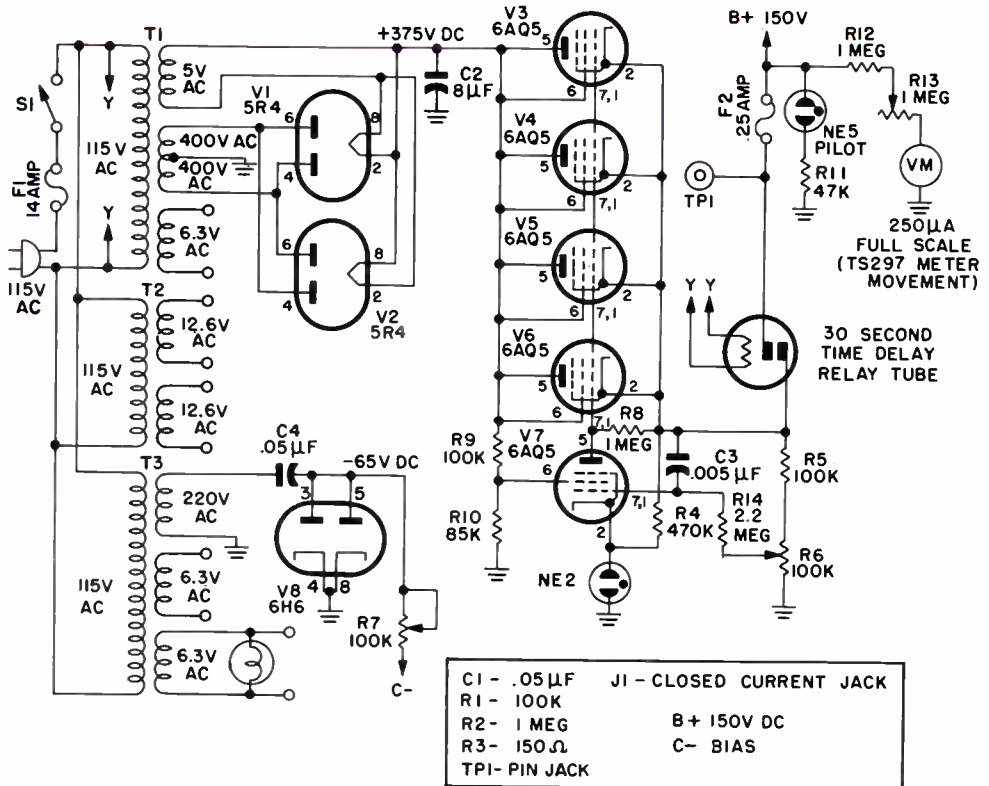
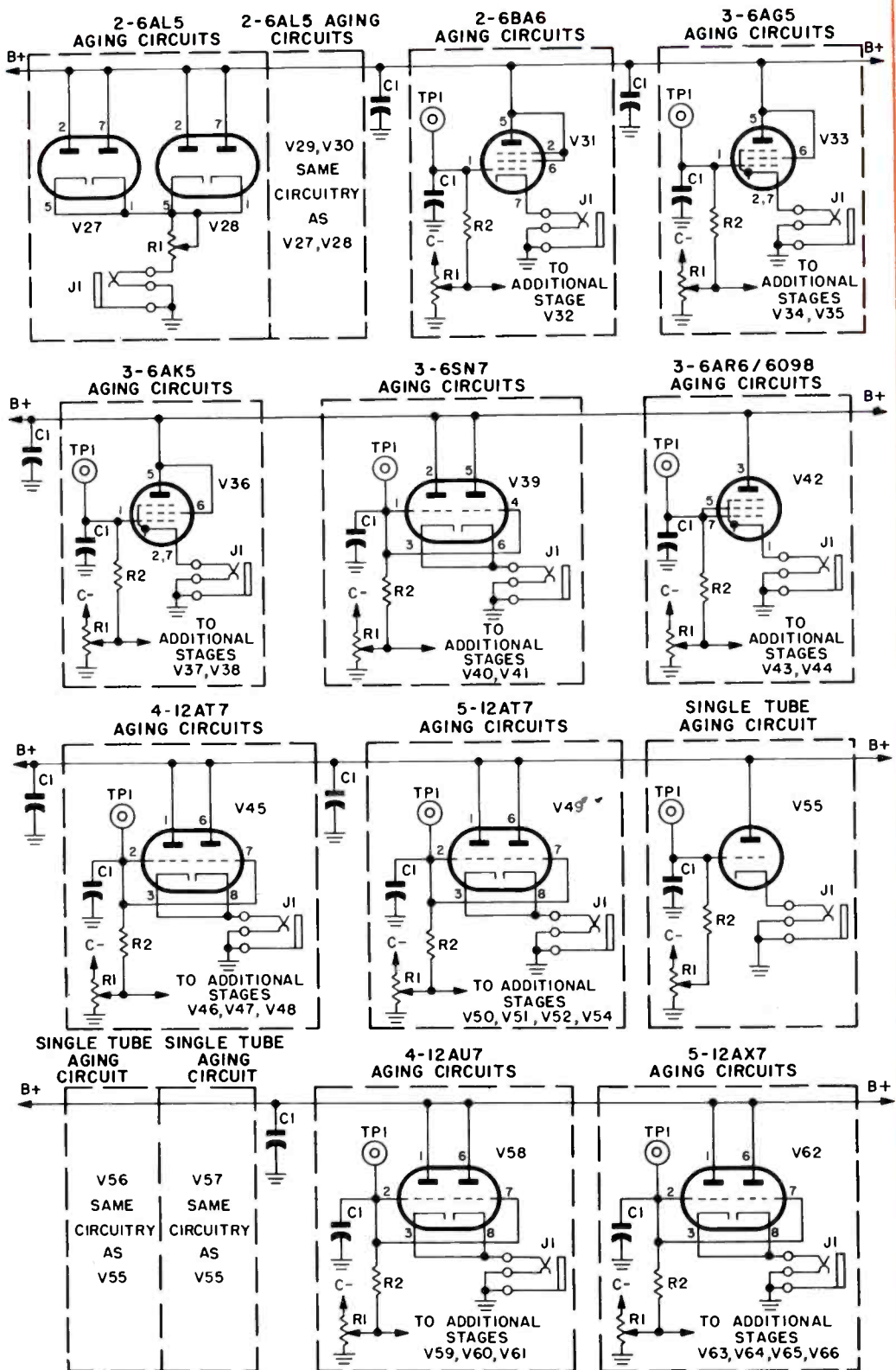

Figure 2. Schematic Diagram of Tube Aging Rack



the control amplifier at a constant potential with respect to ground. A positive voltage with respect to ground is applied to the grid of the control amplifier from a voltage divider on the load side of the series regulators. Since the cathode is held at a reference which is positive with respect to ground, the potential at the grid with respect to the cathode can be varied sufficiently by the 100K potentiometer (R6) to effect full control.

As the conductivity of the control amplifier is varied, the voltage developed across its plate load resistor also varies. Since this resistor is common between the grids and cathodes of the series regulators, any potential developed across it is applied between the grid and cathode of the regulators. This condition has the desired effect of varying the internal resistance of the regulators and, hence, the percentage of d-c voltage across them. Through the use of this type control system, any change in the potential between the cathodes of the series regulators and ground will be reflected as a change in the series resistance of the regulators.

A similar principle is involved in the use of the .005- μ f capacitor (C3) and 2.2-megohm isolation resistor. Ripple components are fed back to the series regulators out of phase and thus maintain a very low ripple percentage.

Bias is supplied from a clamp circuit in series with the 220-volt, a.c. secondary winding of T3. The .05- μ f coupling capacitor (C4) is used as a series reactance to reduce the potential of the pulsating d.c. appearing across the variable 100K coarse bias adjustment potentiometer (R7) in series with the 100K fine bias adjustment potentiometers (R1). This capacitor also provides the necessary load for the 220-volt, a.c. winding during the positive swing of the cycle. Each time the cycle swings positive and makes the plate of the 6H6 diode posi-

tive with respect to ground, the diode conducts and clamps that portion of the swing to ground. During the negative half of the cycle, the potential at the plate of the diode is negative with respect to ground, and the diode does not conduct. Hence, a pulsating negative bias of the proper voltage level is applied to the grids of the tubes to be aged. The pulsations are purposely retained in order to provide a measure of dynamic aging. It will be noted that all bias potentiometers are connected in parallel. Since there are 18 potentiometers in the ager being used, the parallel connection reduces the equivalent resistance to approximately 5555 ohms. In the original design, twenty 100K potentiometers with an equivalent resistance of 5K were incorporated; however, in the interest of flexibility, the 100K variable resistor was added as a coarse adjustment, and two of the original 20 potentiometers were connected as variable resistors in the cathode circuits of the 6AL5's.

Test points are provided at the grid of each aging socket for use in the measurement of grid potential. It is recommended that a vacuum-tube voltmeter be used for this check. A closed-circuit jack is provided in the cathode of each socket, to serve as a convenient point for the measurement of plate current. A PSM-6 is very suitable for this application.

When the ager was first constructed, it was noted that the 6J4's would break into oscillation during the initial operating period. This condition was quickly rectified by inserting a 150-ohm resistor (R3) in series with the plate lead at each tube socket. These resistors, in conjunction with several .05- μ f capacitors (C1), decouple the stages and damp out any possible oscillation.

As an operating convenience, an NE-51 in series with a 47K resistor is connected from regulated B-plus to ground. If B-plus should fail, this pilot lamp

will be extinguished. Actually, the NE-2 used in the regulated supply would have served the same function; however, since construction and design more or less paralleled each other, it was more expedient to add the NE51. A voltmeter was also added as a convenience.

The purpose of the 1-megohm grid resistors (R2) and the (C1) .05- μ f capacitors from grid to ground is to provide decoupling, and at the same

time prevent grounding of the bias supply in the event of a grid-to-cathode short at one of the aging sockets.

Figure 1 indicates major chassis dimensions and layout of the unit as used at this location. One-eighth-inch sheet aluminum and aluminum angle with rivet construction was employed. The resulting unit is sufficiently rugged to withstand all normal usage.



Course No. 101 — Radar Systems Principles and Practices — is now available through the Philco Technological Center. This is an advanced course designed to meet the needs of those who wish to acquire a broader knowledge of radar systems engineering. Such topics as operational requirements, recognition and correlation of radar targets, microwave propagation, CW radar, examples of radar system design, modern a-f-c systems, cathode-ray tubes and displays, moving target indication, and radar power sources are discussed in detail in the 23 lessons which constitute the course. In addition to the two textbooks which are used, each lesson contains detailed discussions of topics which are not found in present-day textbooks.

When the work assignment in each lesson is completed and returned by the student, it is carefully reviewed by experienced instructors. Comments are added by these instructors and the lesson returned to the student for his file. In addition to the work assignments, two intermediate examinations and a comprehensive final examination provide a means of gauging the student's progress.

Further information regarding this course may be obtained by writing to the Editors of the BULLETIN.

REDUCTION OF CPN-4 MAGNETRON FAILURES

By T/Sgt. Lee R. Bishop

(Editor's Note: The modification described below is simple to accomplish and should increase magnetron life in the CPN-4. However, it should be remembered that proper authorization must be obtained before making this modification.)

PREMATURE REPLACEMENT of 2J51 magnetrons in several AN/CPN-4 ground control approach radars has been observed by the writer to be caused by failure of K-1302 (the filament current relay) in the T-273. The purpose of this article is to describe the manner in which this failure can occur and to suggest a simple modification that will monitor the operation of K-1302, thereby protecting the magnetron. In view of the high cost of the 2J51, the cost and time involved in the following described modification to conserve the magnetron is easily justified.

In normal operation at a PRF of 1833 PPS with an average magnetron current of 4 ma, the magnetron should have filament voltage applied. Upon switching to a PRF of 5500 PPS (average magnetron current of 12 ma), the ion bombardment of the cathode will supply sufficient heat, and under these conditions relay K-1302 (figure 1) is energized to remove filament voltage and thus prevent overheating.

Although filament voltage is necessary for proper magnetron operation at a PRF of 1833 pps, it has been found that the magnetron will start and operate in an apparently satisfactory manner at this PRF with no filament voltage. Under this condition of no filament voltage, the magnetron current will build up slowly and reach a stable value which is 25 to 50 percent lower than normal. The initial heating is supplied by arcing and the resultant

positive ion bombardment of the negatively charged cathode. The actual value at which the magnetron current stabilizes will depend on the condition of both the keyer and the magnetron itself, and in most cases the spectrum will be satisfactory. However, the average life expectancy under these conditions is approximately 2 weeks, and this

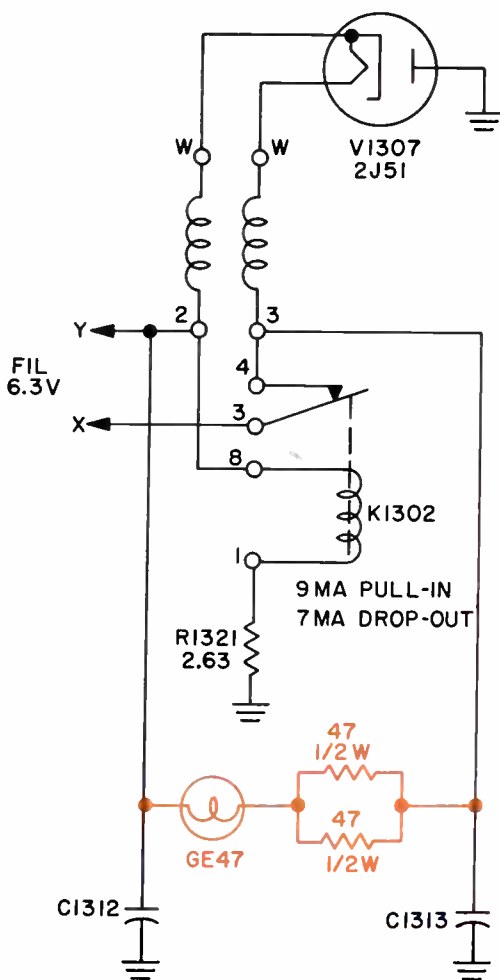

Figure 1.

may be further decreased by excessive starting and stopping.

A pilot light to indicate the presence of magnetron filament voltage is now in use at this station. The necessary connections are shown by the orange lines in figure 1. A hole to mount the necessary socket can be drilled under the name plate on the transmitter, and a wire from each lug of the easily accessible terminals on equalizing capacitors C-1312 and C-1313 run to the lamp socket. Although the filament voltage is 6.3 volts, the life of the bulb

can be considerably increased by the use of the two 47-ohm resistors in parallel. A white jewel cover will give more than adequate brilliance.

About 15 minutes is required to make this modification. At the first failure of relay K-1302, this simple device will have paid for itself, as well as similar modifications at quite a few other stations. In addition, the modification quickly eliminates one more possibility for a mechanic tracing the cause of low magnetron current.



AN INTRODUCTION TO ANALOG COMPUTERS

Correspondence Course No. 104 — Introduction to Analog Computers — is now available from the Philco Technological Center. Designed for the experienced electronics man who desires to enter the analog computer field, this course provides an introduction to analog computers and detailed discussions of the various devices which make up these computers. The course consists of nine lessons which contain detailed discussions of such topics as general computer concepts, mathematical concepts, adders, multipliers, dividers, function generators, and coordinate transformation. Both mechanical and electronic devices are discussed, and all text material is included in the lesson plans. When the work assignment contained in each lesson is completed and returned by the student, it is reviewed by an experienced staff. The assignment is then returned with comments and suggestions. In addition, a comprehensive examination provides a further means of gauging the student's progress.

Detailed information on this course may be obtained by writing to the Editors of the BULLETIN.

**CONSULTING, PROJECT, AND FIELD ENGINEERING
CONTRACT AUGMENTATION**

**ELECTRONICS • COMMUNICATIONS
POWER PLANT • REFRIGERATION
ELECTROMECHANICAL AND SPECIAL SYSTEMS**

STANDARDIZED TRAINING

**COURSES • TRAINING DEVICES
INSTRUCTORS
for
EDUCATIONAL INSTITUTIONS
ARMED FORCES • INDUSTRY**

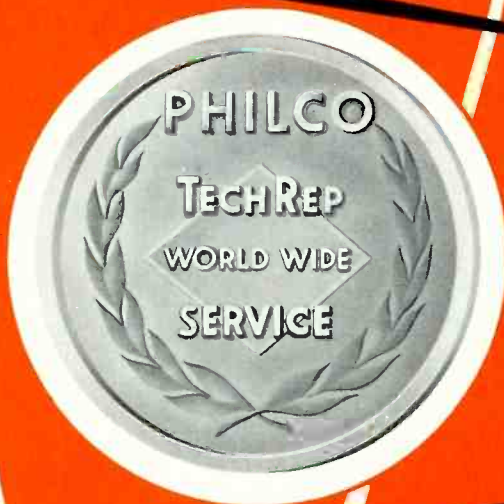

**COMPLETE PUBLICATIONS FACILITY FOR PREPARATION
OF TECHNICAL MANUALS *such as—***

**MAINTENANCE HANDBOOKS • OPERATIONAL HANDBOOKS
ILLUSTRATED PARTS BREAKDOWNS • CATALOGS
ENGINEERING REPORTS • SPECIAL PROJECTS**