

PHILCO

TECHREP DIVISION BULLETIN

Volume 5 January and February, 1955

No. 1

In This Issue...

Editorial	<i>John E. Remich</i>	1
Noise	<i>Murray Elson</i>	2
A Codan Unit for the BC-779 Receiver.....	<i>George C. Apostolakis</i>	8
High Stability 1-Megacycle Frequency Standard.....		12
Electronic Collision Course Computer.....	<i>Russell Wolfram</i>	15
Design of Junction Transistor Audio Amplifiers.....	<i>James B. Angell and Edwin J. Podell</i>	18
Solution to November-December "What's Your Answer?".....		28
"What's Your Answer?"		29
A New Philco Technical Publication.....		29

PHILCO
TECHREP DIVISION
BULLETIN

Published bimonthly by

The TechRep Division of Philco Corporation
Philadelphia, Pennsylvania

Editor John E. Remich

Managing Editor Gail W. Woodward

Technical Editors Francis R. Sherman
John W. Adams
Baldwin G. Sullivan

Editorial Office:

Technical Information Section
Philco TechRep Division
22nd St. and Lehigh Avenue
Philadelphia 32, Penna.

If any information contained herein conflicts with a technical order, manual, or other official publication of the U.S. Armed Forces, the information in the official publication should be used. Views expressed in this publication are the opinions of the authors and do not necessarily represent those of Philco Corporation. All technical information and circuits are presented without responsibility as to patent infringement.

Editorial . . .

TECHNICAL MANPOWER

by John E. Remich

Manager, Technical Department

In recent months a number of articles have appeared in newspapers and technical magazines disclosing some alarming facts concerning technical manpower. All of these articles, written by experts on the subject, reveal that the U.S.A. is not replenishing its technical manpower reservoir in keeping with present day needs. In fact, with increased technical manpower requirements, the rate at which men are being trained for technical positions is less than half that of five years ago. The present situation will no doubt surprise many people, in view of the fact that the technical supremacy of America has always been taken for granted. In the past, America not only has had greater numbers of technically trained people but also has had people of superior skill.

The TechRep Field Engineer, in his role of training specialist for on-the-job and formal training, is a key man in the solution of the technical manpower shortage, especially since new developments in training courses and techniques make his efforts more effective than ever before. We are confident every TechRep Field Engineer will realize the urgency of the training mission and will redouble his efforts to increase the quantity and skill level of electronics personnel.

NOISE

by Murray Elson

Philco Field Engineer

A discussion of communication circuit noise, and how it can be measured.

NOISE IS ALWAYS PRESENT in all circuits. The degree to which noise exists determines the grade of the circuit. It is frequently required that the field engineer reduce or abate the noise which exists within the metallic or carrier portions of a radiotelephone system, to improve the performance of the circuit.

It is the intent of this article to present a readily available method and a measurement technique that may be used by a field engineer to evaluate the condition of an individual circuit.

The following definitions are offered for consideration:

1. Noise. That group of undesirable random voltages, either generated within a communications system, or received from an outside source.
2. Signal. The desired intelligence, message, or effect conveyed by the electronic circuit.
3. RN. The term RN (reference noise) is used as the reference for noise voltages and is taken to be -90 dbm (1 micromicrowatt).

During the normal course of events, the field engineer is often forced to face the fact that a specific circuit is not performing well. In the search for an answer to the problem, the field engineer is led into the consideration of circuit noise as the discrepancy within the circuit. Procedures from that point vary almost as widely as the number of field engineers.

Attention is invited to the opening statement of this article, "Noise is always present in all circuits." Since this statement is obviously true, it is possible that the noise observed may be perfectly normal to the circuit under consideration. The first problem facing the field engineer is to decide the degree or level of the noise in relationship to the known effects of noise.

It is rather obvious that, with the presence of both noise and signal, the degree of interference by noise to the reception of the signal is the most important factor. Since the type of signal transmitted varies from circuit to circuit, or from time to time within the same circuit, while the noise remains substantially constant, the type of signal being used will limit the signal-to-noise ratio. This effect is illustrated in TABLE 1.

The information listed in TABLE 1 shows the following: in a c-w telegraph circuit, a minimum of 1 microvolt per meter will be necessary for satisfactory reception *if* the average noise level is 6 db below the signal level; in a single-sideband circuit, a signal of 5 microvolts per meter will be satisfactory *if* the average noise level is 20 db below the signal level.

It then becomes a question of what "satisfactory" communications means. According to the various references quoted in the bibliography following this article, "satisfactory" communications is defined as those communications which progress in a normal manner and

TABLE 1*

Minimum Field Strengths and Signal-to-Noise Ratio for Satisfactory Reception		
Class of Service	Minimum Signal Field Strength ($\mu\text{V}/\text{m}$)	Minimum Signal- to-Noise Ratio (db)
Manual C-W Telegraph (30 w.p.m.)	1	6
High-Speed Printer Telegraphy, 1-kc. Bandwidth	2	14
Double-Sideband Telephony	10	26
Single-Sideband Telephony	5	20
Broadcasting (Standard)	40	40

* From *Radio Installations*, W. E. Pannett, Chapman and Hall, Limited, publisher.

are completely intelligible with no repetition. It should be noted that if, in the case of double-sideband telephony, the noise level is raised so that only 15 db difference between the signal and noise exists, communications will not necessarily be halted, but will be greatly impeded. The speed of communications will then drop. Many experiments involving hundreds of listeners have established the fact that, for ordinary speech, a noise level 6 db below that of the received signal will render the circuit unusable. Noise levels less than this value will allow service, but not necessarily of good grade. It is estimated that an average value of 13 db for the signal-to-noise ratio is approximately the minimum figure that should be permitted as an engineering basis of design.

The field engineer is faced with the problem of deciding what limits of noise will be tolerable in the circuit under examination. The writer suggests that the field engineer adopt the figure of 56 db above RN (-34 dbm) as an acceptable figure. This figure is selected because the more commonly found test equipment will readily measure such a level. It is fully realized that this figure will not always be obtainable, but it has been the writer's experience that working toward it results in satisfactory improvements.

Atmospheric noise is most difficult to reduce. Yet, with considered selection of frequencies, a fair amount of transmitted power, and well-tuned directional antennas, the effects of atmospheric noise may be reduced to a minimum. The noise produced in the components of the system frequently exceeds the atmospheric noise and, in all cases, this noise may be reduced to a satisfactory level. It is this noise, hum, and crosstalk that this article is primarily concerned with.

A radiotelephone system which utilizes transmitters and receivers remote from the operating site usually follows the plan indicated in figure 1. In such a system, there is opportunity for generation of noise, and for the appearance of hum and crosstalk, especially where several systems are in use. The field engineer must reduce or hold this noise to a minimum.

The first step in reducing noise in a system is to find a satisfactory means of measuring the noise. The writer once had the experience of instituting procedures that he fondly hoped would improve a circuit, with the embarrassing result that nearly a week's work was spent without producing any significant improvement. Without an accurate yardstick, it is almost impossible to effect circuit improvement.

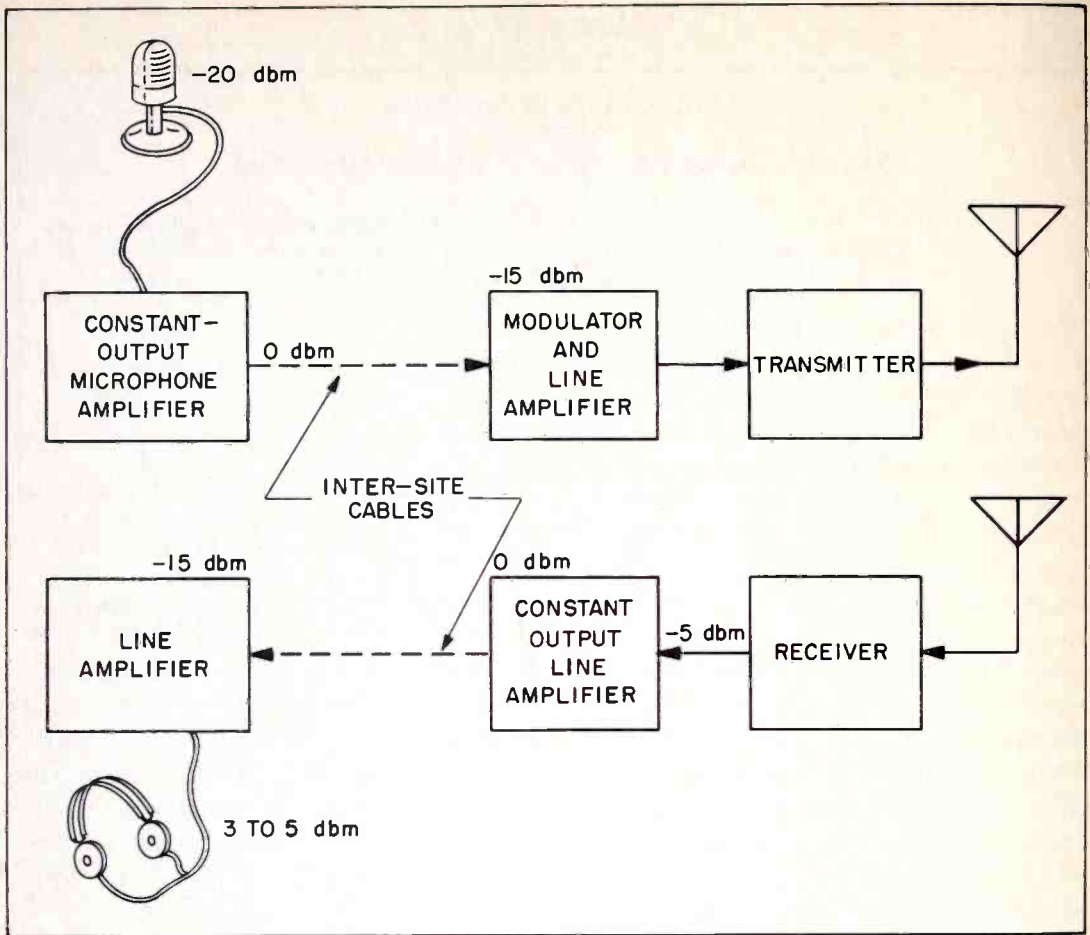

Figure 1. Typical Radiotelephone System

There are several instruments which will measure noise directly. In most cases, however, these instruments are inaccessible to the field engineer. Nevertheless, with a small amount of effort, adequate results may be obtained using a receiver, an audio oscillator, a pair of headphones (or speaker), and (most important) an oscilloscope.

To illustrate the writer's method of measuring noise, the following procedures are offered — due consideration will probably suggest many variations of these procedures to the field engineer.

To check a transmitter system for noise, hum, and crosstalk, proceed as follows:

1. Connect the receiver and oscilloscope as illustrated in figure 2, part A, and key the transmitter.

2. Tune the receiver, with the b.f.o. and a.v.c. on, to the transmitter frequency. Use a short antenna which will not result in receiver blocking.
3. Adjust the b.f.o. to produce about a 1-kc. beat note.
4. Turn the a.v.c. off, and release the transmitter key.
5. Turn the receiver audio and r-f gain controls to zero. Adjust the vertical gain of the oscilloscope to near maximum.
6. Slowly increase the audio gain of the receiver until noise from the receiver begins to appear on the oscilloscope trace. Then decrease the audio gain until the noise barely disappears.

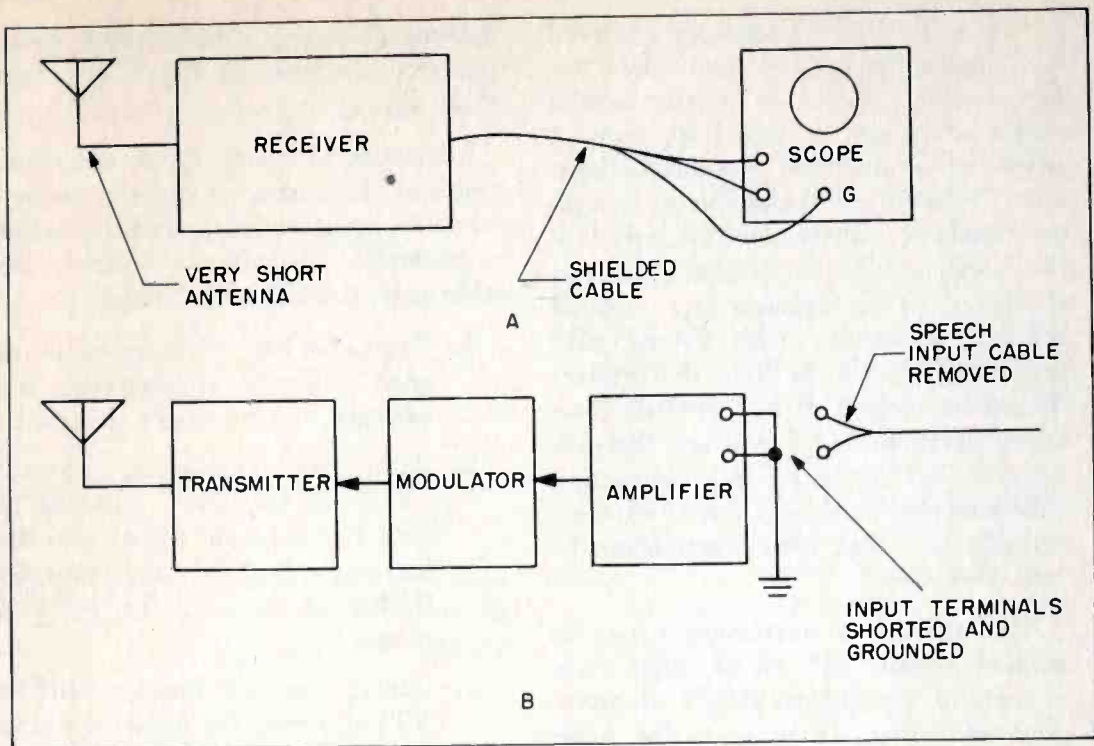

Figure 2. Equipment Connection for Noise Determination

7. Repeat step 6 using the r-f gain control of the receiver.
8. Disconnect the speech input line as shown, place a short across the input terminals, and GROUND THE SHORT.
9. Key the transmitter.
10. Adjust the resulting trace on the oscilloscope for a convenient size. Adjust the sweep frequency of the oscilloscope until one or more sine waves appear on the screen. DO NOT ADJUST ANY CONTROL OF THE RECEIVER.

Appearing on the face of the oscilloscope at this time will be the resultant signal from the receiver of the transmitter output. If the receiver was carefully adjusted, any noise which now appears will be noise from the transmitter and/or modulator-amplifier. Since the amplitude of the resultant signal is determined by the transmitter power output, any noise appearing on the scope

will be proportional to the signal-to-noise ratio of the transmitted signal. Thus, the noise voltages which may now appear, when measured in terms of percentage of the carrier (which is indicated by the beat-note output), will give a voltage ratio which may be converted into decibels of relative noise. It is estimated that the minimum percentage of noise-to-carrier voltage that may be read accurately is 2 percent. This gives a 50-to-1 voltage ratio, which is equivalent to 34 db.

EXAMPLE: Assume that the sine wave appearing on the screen has an amplitude of 40 squares, and that the noise amplitude is 2 squares, giving a signal-to-noise voltage ratio of 20 to 1. Then,

$$\begin{aligned} \text{db} &= 20 \log \frac{E_1}{E_2} = 20 \log 20 \\ &= 20 \times 1.3 = 26 \text{ db} \end{aligned}$$

In this case, the noise level is 26 db below the signal level.

A few precautions must be observed when using the method outlined above. The receiver should be stable, have a stable b.f.o., and be free from hum. A small battery-operated portable is desirable. If it is found impossible to contain the resultant pattern on the screen of the oscilloscope, the antenna can be shortened, or the receiver gain may be reduced, preferably with the r-f gain control. When this is done, the receiver should be rechecked for freedom from noise. It is highly important that the receiver, oscilloscope, and connecting cables be well shielded from all external voltages and that both instruments be well grounded.

This method of measurement may be applied equally well to all other components of the system. It will be necessary, of course, to measure the noise output of the audio oscillator, since it is used as a signal source for measurement of all noise other than the r-f noise. When measuring noise in the audio transmission portions of the system, it is important that no amplifier be operated above or below its normal level unless it is desired to determine the maximum noise figure of that amplifier. When making noise measurements in cable pairs, it is necessary to terminate both ends of the line under test in the line's characteristic impedance. This may be accomplished by the use of high quality noninductive resistors which are known to have a low thermal-noise characteristic.

When adding or subtracting noise levels of various system units, it should be kept in mind that it is *not* correct to add or subtract db values of noise directly. It is necessary to convert to power levels before manipulation. For example, 30 db RN (-60 dbm) corresponds to a power ratio of 1000, which means that the level is 1000 times that of the reference level. Similarly, 36 db RN (-54 dbm) corresponds to 4000 times the reference level. Thus, the sum

of these powers is equal to 5000 times the reference level, or 37 db RN (not 66 db RN).

Returning to figure 1, the other elements of the system may be measured for noise by using the procedures below as examples. To measure noise in the cable pair, proceed as follows:

1. Terminate the transmission line at each end in its characteristic impedance, as previously described.
2. At one end of the circuit, connect an audio oscillator, adjusted to feed a 1000-cycle signal into the line at a level of approximately 0 dbm, as read on a VU or DBM meter.
3. Connect an oscilloscope and a VTVM across the terminal end of the circuit.
4. Measure the signal voltage on the VTVM. (Note: It may be necessary to increase the output of the audio oscillator in order to obtain a satisfactory reading.)
5. With the oscilloscope, measure the noise in percentage of the 1000-cycle tone present, as in the previous example.
6. Both noise and VTVM voltages may now be converted to dbm if desired. (It should be noted that a noise voltage of -30 dbm is equal to 60 db RN. Use whichever value seems the most convenient.)

EXAMPLE: Assume that the measurement circuit is set up as described above, and that the characteristic impedance of the transmission line is 600 ohms. A level of 0 dbm is fed to the line from the audio oscillator, and the VTVM and oscilloscope are connected to the other end of the line, as described. The VTVM reads 0.137 volt. The pattern on the oscilloscope screen shows that the noise amplitude is 10 percent of the signal amplitude, which means a signal-to-

noise ratio of 20 db. It also means that the noise voltage is 0.0137 volt. Using the formula to convert both voltages to dbm:

$$\text{dbm} = 10 \log \frac{\frac{E^2}{Z}}{0.001}$$

or, in this case,

$$-\text{dbm} = 10 \log \frac{0.001}{\frac{E^2}{Z}}$$

where E = measured r-m-s voltage and Z = characteristic impedance of line

Calculating the expression E^2/Z , and dividing the result into 0.001, gives 31 for the signal value and 3100 for the noise. Therefore,

$$\begin{aligned} \text{dbm (signal)} &= 10 \log 31 = \\ 10 \times 1.4914 &= -15 \text{ dbm} \\ (75 \text{ db RN}) \end{aligned}$$

$$\begin{aligned} \text{and, dbm (noise)} &= 10 \log 3100 = \\ 10 \times 3.4914 &= -35 \text{ dbm} \\ (55 \text{ db RN}) \end{aligned}$$

To measure noise in the speech system, proceed as follows:

1. Reconnect the transmission line to the amplifier.
2. Feed the 1000-cycle audio oscillator output to a speaker. The speaker is placed so that it supplies the audio for the microphone pickup.

3. Using a VU or DBM meter, adjust the output of the microphone amplifier so as to feed the desired signal level into the line (usually 0 dbm).
4. Follow steps 3, 4, 5, and 6 of the preceding procedure.
5. The measured noise at the transmitter location will be the speech equipment noise *plus* the line noise. Since the latter is already known, the noise figure of the speech equipment may be calculated by subtracting the powers and then converting to db RN, as explained in a previous paragraph.

BIBLIOGRAPHY

1. *Electrical Communications Systems Engineering* (TM-11-486), 1945.
2. *Reference Data For Radio Engineers* (3rd Edition), Federal Telephone and Radio Corporation, 1949.
3. *Radio Installations, Their Design and Maintenance*, by W. E. Pannett, Chapman and Hall Limited.
4. *Radio Engineering* (3rd Edition), F. E. Terman, McGraw-Hill Book Company, 1947.

A CODAN UNIT FOR THE BC-779 RECEIVER

by George C. Apostolakis

Philco Field Engineer

An effective and easily constructed squelch unit which has been employed successfully by certain AACS Wings for voice reception on the BC-779 receiver.

REALIZING THE DELETERIOUS EFFECT of noise upon operator efficiency, certain AACS Wings have made use of a codan unit (carrier-operated device, anti-noise) in conjunction with the BC-779 receiver, to mute the audio output of the receiver during stand-by periods. This unit, which is relatively simple to construct, operates very satisfactorily, and its use has been valuable in reducing operator fatigue.

The codan unit, shown schematically in figure 1, incorporates a 6J5 audio tube and a 6SJ7 squelch tube; it is designed to connect to the receiver, by means of a plug which replaces the 6C5 first audio tube. Its use requires no major circuit changes in the BC-779, and it can be disconnected very quickly, and normal receiver operation restored by simply returning the 6C5 tube to its socket.

When the codan is in use, the 6J5 functions as the first audio tube for the BC-779. The 6SJ7 squelch tube, the conduction of which is controlled by the receiver a-v-c voltage, controls the bias applied to the 6J5 so that the 6J5 is permitted to operate only when a carrier is present at the receiver input. Thus the receiver output is heard when a signal is received, and is muted when no signal is present.

Referring to figure 1, it will be noted that the grid of the 6SJ7 is connected to the a-v-c line of the receiver. The ad-

justment of the codan is made under no-signal conditions, for which there is only a low value of a-v-c voltage on the 6SJ7 grid. With no signal, the 10K screen voltage potentiometer is adjusted so that the noise output of the receiver is just cut off. The noise silencing takes place because the 6SJ7 plate current, flowing through the 50K load resistor, produces a voltage drop across the resistor which is sufficient to bias the 6J5 audio tube below cutoff. Thus the first audio stage is rendered inoperative. Upon reception of a carrier signal, the a-v-c voltage rises to a value which biases the 6SJ7 squelch tube to cutoff, reducing its plate current to zero. This removes the high negative bias from the 6J5, allowing the stage to operate in the normal manner.

Since the successful operation of the unit depends upon proper a-v-c operation, it is essential that the BC-779 receiver be correctly aligned so as to ensure the required a-v-c action. If this condition is not fulfilled, adjustment of the codan will be very difficult, if not impossible. With the 6C5 (V13) in its socket and the AVC-MANUAL switch turned to AVC, the a-v-c operation should be checked, using the following procedure:

1. Apply a 5-microvolt, 30-percent modulated, 400-cycle signal to the antenna of the receiver.
2. Connect an output meter to the re-

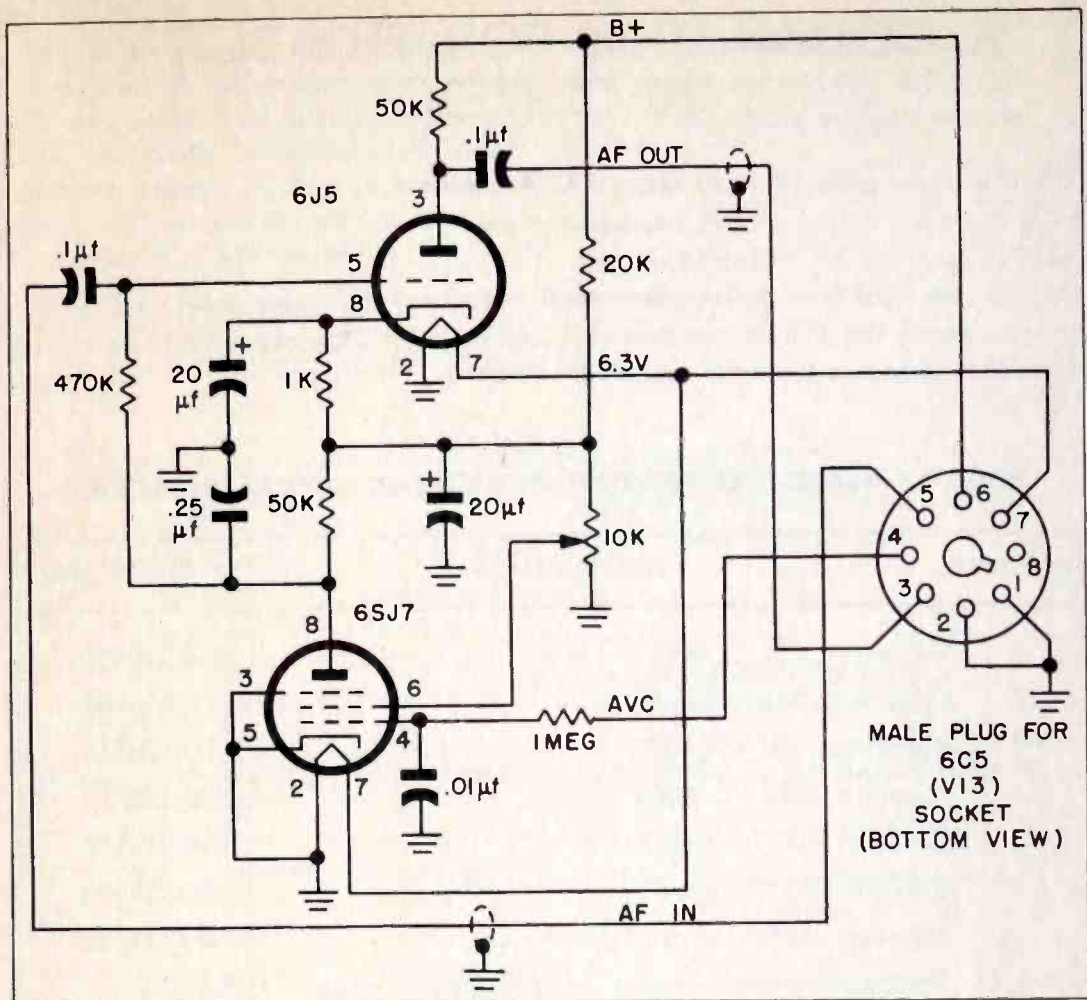

Figure 1. Schematic Diagram of Codan Unit

ceiver, and adjust the audio gain control until the meter reads 10 volts.

3. Increase the input signal from 5 to 50,000 microvolts. The output voltage should remain less than 50 volts if the a.v.c. is functioning properly.

As shown in figure 1, the signal and operating voltages to the codan unit are supplied from an octal plug which is inserted in the 6C5 (V13) socket of the BC-779. In adapting the unit to the receiver, a few minor wiring changes must be made in the BC-779. However, it is important to emphasize the fact that these changes are merely wiring rearrangements and do not alter the original circuitry. Because of this fact, the

BC-779 may be restored to its original status at any time simply by replacing the codan plug with the original 6C5 first audio tube. As shown in figure 2, the following changes must be made:

1. Remove the wire and resistor from pin No. 6 of the 6C5, which is a blank pin, and re-terminate them on a blank lug on the E23 terminal strip, as shown.
2. Wire pin No. 6 of the 6C5 to the third terminal of E23, as indicated. This places the B+ voltage on pin No. 6.
3. Connect a wire from pin No. 4 (also a blank pin) of the 6C5 socket to the lug on the E22 ter-

minal strip, as shown in the drawing. This connection places the a-v-c voltage on pin No. 4.

Figure 3 illustrates the mounting of the codan unit. If the receiver has been modified with the MC-531 crystal oscillator kit, the unit may be mounted to the chassis of the CY-161 console in which the receiver is normally mounted.

The potentiometer adjustment is purposely made inaccessible to the operator, since it should be handled only by qualified maintenance personnel. The adjustment should be checked periodically during the day since the noise level at the receiver site may change.

A list of the materials needed for the fabrication of the codan unit is given in table 1.

TABLE 1. MATERIALS REQUIRED FOR CODAN UNIT FABRICATION

QUANTITY	DESCRIPTION	STOCK NO.
2	Capacitor, 0.1 μ f., 400v	8800-124470
2	Capacitor, 20 μ f., 250v	8800-125264
1	Capacitor, 0.25 μ f., 400v	8800-124316
1	Capacitor, 0.01 μ f., 400v	8800-124210
2	Resistor, 50,000 ohms, 1 watt	8800-711111
1	Resistor, 20,000 ohms, 1 watt	8800-711105
1	Resistor, 470,000 ohms, 1/2 watt	8800-711122
1	Potentiometer, wire-wound, 10,000 ohms, 5 watts	NSN
1	Resistor, 1 megohm, 1/2 watt	3RC20BE105M
1	Resistor, 1000 ohms, 1 watt	8800-711091
1	6J5 vacuum tube	2J6J5
1	6SJ7 vacuum tube	2J6SJ7
2	Octal tube socket	2Z8678.326
1	Octal male plug	8850-325225
4	Lug, 4 terminals	8800-796549
1	Aluminum sheet, 0.051" x 12" x 12"	8800-141860
2	Insulated grommet	8800-379000
1	Wire, two No. 22 AWG solid conductors (1 red, 1 black), 6 ft. long	8800-959797
1	Shielded cable, one No. 22 conductor, 3 ft. long	8800-086862-222
12	Machine screw, No. 6-32, 1/2"	6L6032-8.1S
12	Brass nut, No. 6-32	6L3106-32
12	Lock washer, steel, No. 6	6L70006-1
7	Self-tapping sheet metal screw, No. 6, R.H.	NSN

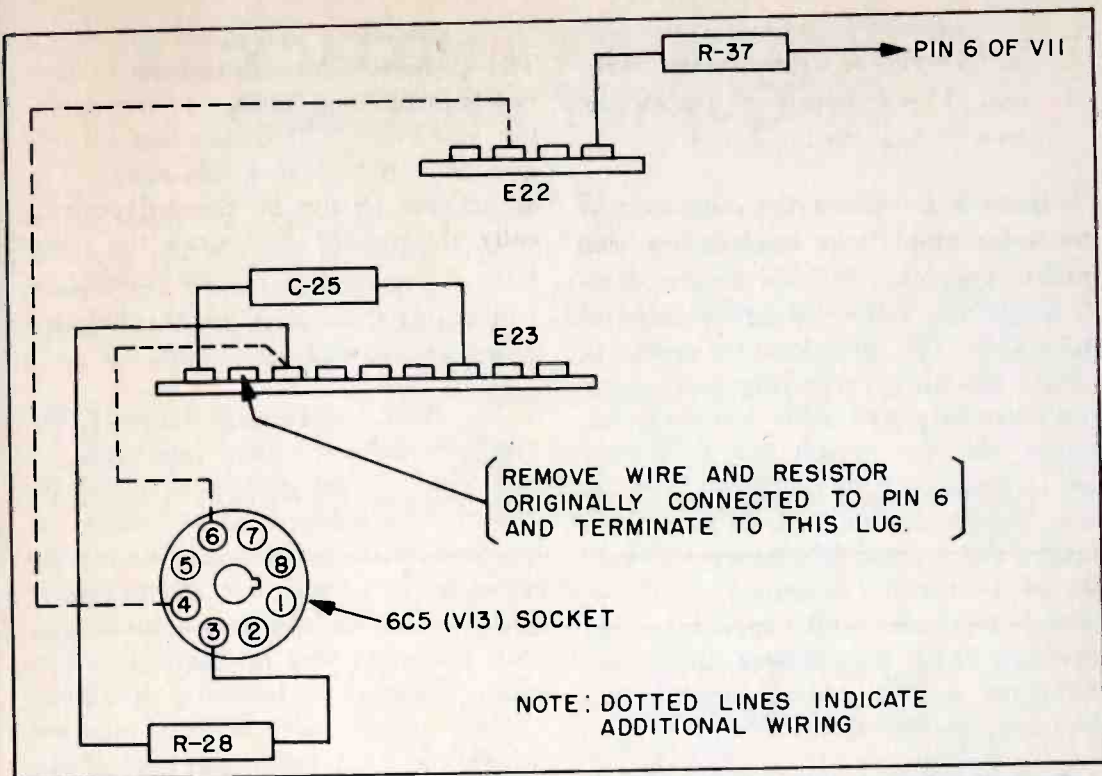

Figure 2. Wiring Changes Required for the 6C5 Socket To Permit Codan Operation

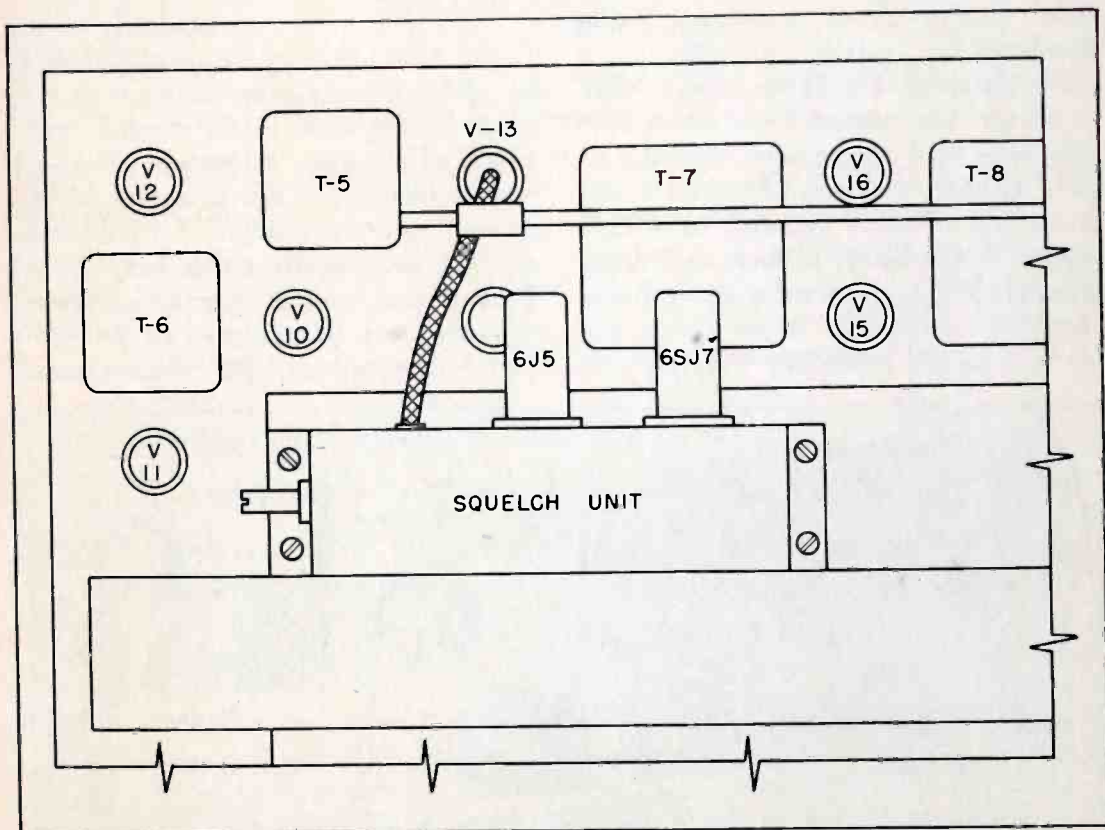

Figure 3. Mounting Position of Codan Unit in the BC-779

HIGH-STABILITY 1-MEGACYCLE FREQUENCY STANDARD

A PORTABLE 1-MEGACYCLE FREQUENCY STANDARD, stable to a few parts in 100 million per day, has been developed by P. G. Sulzer of the National Bureau of Standards. The compact and relatively simple assembly, employing inexpensive commercially available components, makes use of a crystal unit to control the frequency of an oscillator. The device, shown in figure 1, is sufficiently rugged for general laboratory and field use as a working standard. It is expected to have wide application in checking radio transmitters and measurements, and in various other industrial and research fields.

As custodian of the national standards of physical measurement, the Bureau develops and maintains basic standards for electrical quantities at all radio frequencies. From these basic standards are obtained the secondary standards used by research laboratories and the radio industry. As science and technology advance, research must constantly be conducted to meet increasing demands for more precise and reliable secondary standards. In its search for more accurate secondary standards of

frequency, the Bureau has made a continuous effort to improve the performance of crystal-controlled oscillators, which appear to offer the best solution in the present state of the art.

The NBS 1-megacycle standard, like other crystal-controlled oscillators of this type, consists of three elements: the crystal unit proper, an amplifier or negative-resistance device to supply the losses in the crystal unit and to deliver power to a load, and an amplitude control. However, this oscillator was specially designed to minimize frequency changes caused by tube or component instability. As a result, the over-all stability of the unit is nearly that of the crystal itself.

Any phase shift in the amplifier must be offset by a corresponding but opposite phase shift in the crystal unit, which will produce a frequency change. Such a phase shift can be caused by an actual reactance change or by a variation in the reactive component of the input impedance of the tube. Phase shifts can also be produced by the electronic component of the input capaci-

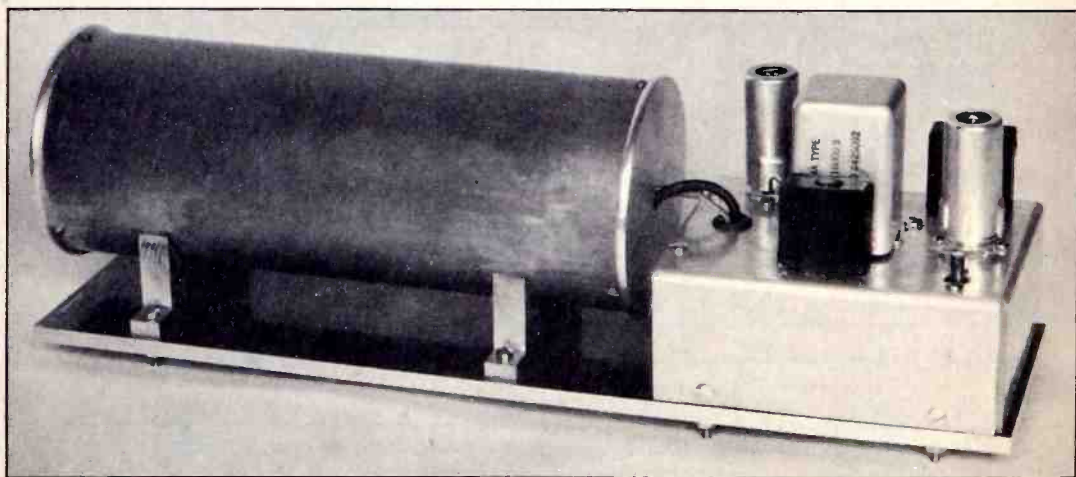

Figure 1. *The NBS 1-Megacycle Frequency Standard, Showing Crystal Oven (Left) and Accompanying Electronic Equipment (Right)*

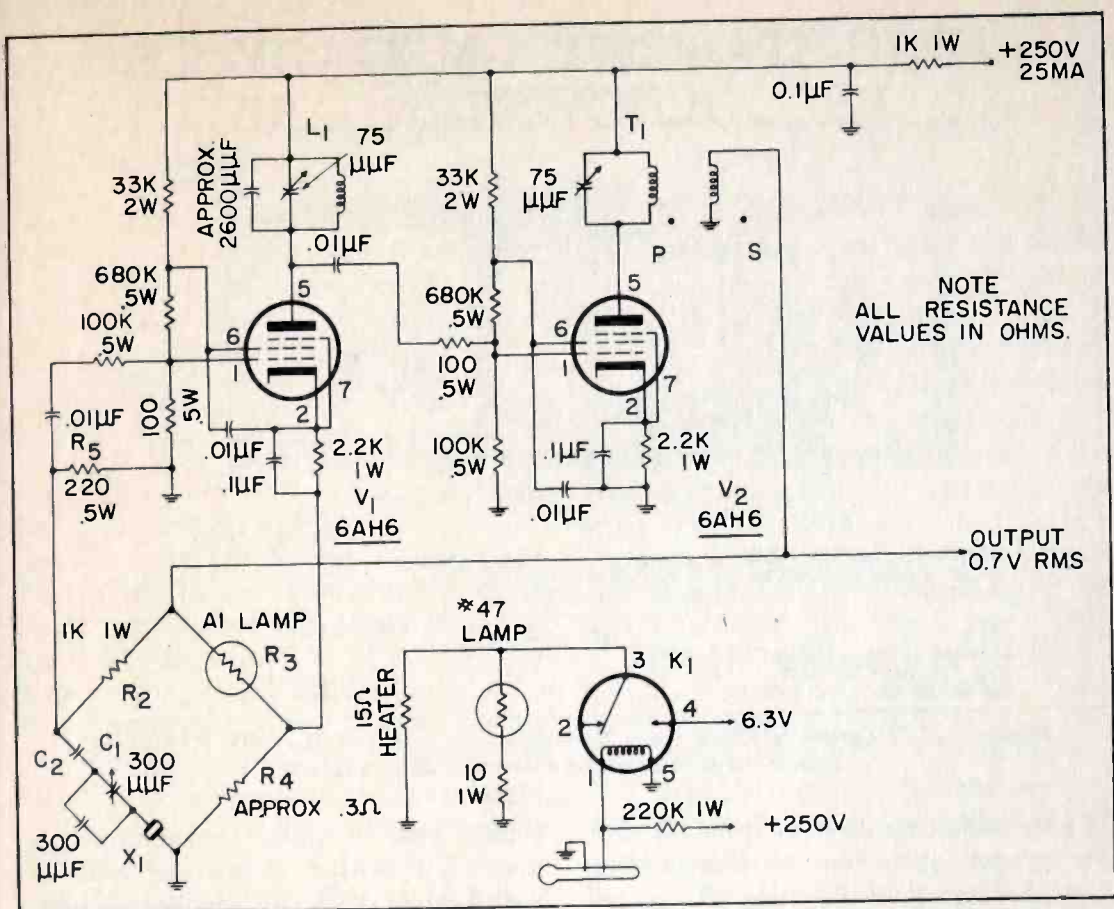

Figure 2. Schematic Diagram of the NBS 1-Megacycle Frequency Standard (Meacham-Bridge Circuit Shown at Lower Left)

tance of a tube, by transit time, and by the effects of nonlinearity.

In the NBS oscillator, the effects of these amplifier variations are decreased by the use of inverse feedback. The familiar Meacham bridge oscillator, as shown in figure 2, is utilized because it gives excellent results with comparatively simple circuitry.

The Meacham bridge consists basically of a crystal, X_1 , a pair of resistors, R_2 and R_4 , and a lamp resistance, R_3 . These components are so arranged that negative feedback occurs through X_1 and R_2 , while positive feedback occurs through lamp R_3 and resistor R_4 . The capacitors in the crystal leg of the bridge permit a precision adjustment to cancel the reactive component of the circuit. If the amplifier has sufficient gain, oscillation will start at the frequency of minimum degeneration,

which is nearly the series-resonant frequency of the crystal, and the lamp resistance will increase with the amplitude of oscillation until the bridge is nearly balanced. When equilibrium is reached, the bridge attenuation must equal the amplifier gain.

Good phase stability of the amplifier requires a large voltage gain (A) and a maximum transmission (β) through the negative-feedback path. However, certain practical considerations limit the increase of transmission. With a given amplifier, the product of A and β cannot be increased without increasing the crystal current or decreasing the lamp voltage, both of which are undesirable. The 20-ohm, glass-enclosed, contoured AT-cut crystal chosen for the present oscillator has a Q of 5×10^5 and a maximum current limitation of 1 ma. The A1 switchboard lamp, R_3 , used

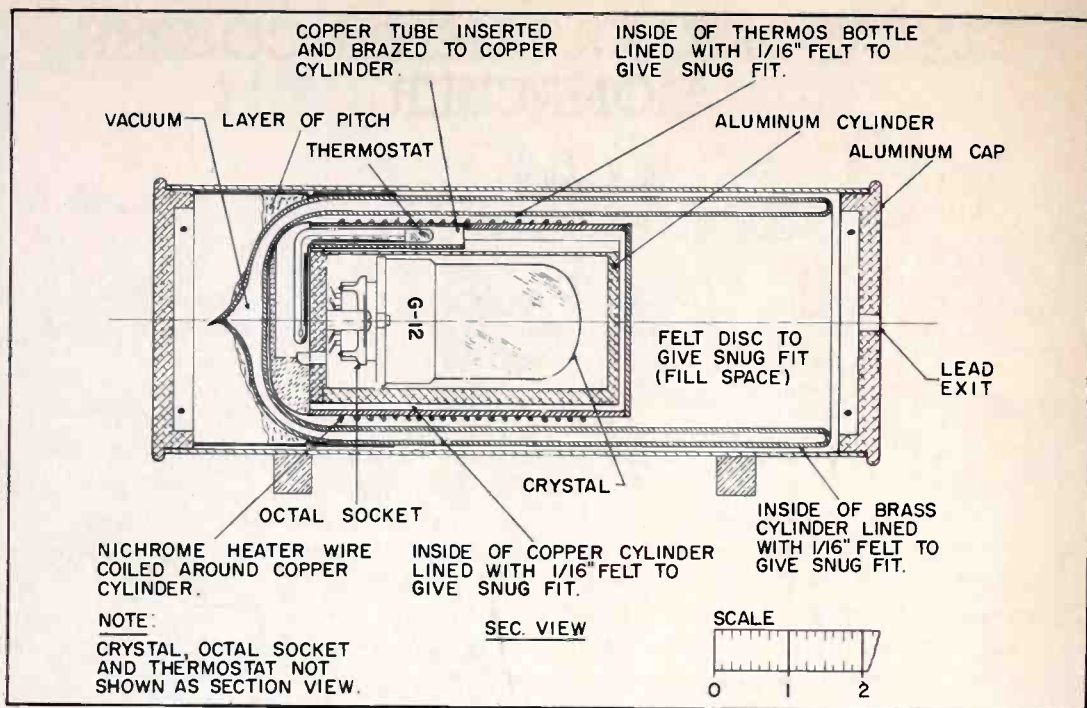

Figure 3. Diagram of Oven Used To Maintain Crystal of the NBS 1-Megacycle Standard at a Specific Constant Temperature

in the bridge requires at least 0.7 volt for proper operation, so that with a crystal current of 0.7 ma., R_2 is approximately 1000 ohms, and the transmission through the degenerative branch is approximately 1/50. If the gain equals 1000, then the product A times β is approximately 20, and a 20-fold reduction in effective phase shift is obtained.

Sufficient voltage gain for good amplitude stability requires the use of two amplifier stages. The crystal current must be kept constant because the resonant frequency is a function of current. With two similar stages the voltage gain is squared, while the shift is at most doubled, permitting sufficient gain without greatly increased phase shift.

A two-stage amplifier with a voltage gain of 1000 exhibits a maximum phase shift of ± 10 degrees over a 2:1 supply-voltage range. Thus, when the Meacham bridge is used, the maximum expected phase change with feedback becomes ± 0.5 degree. The crystal must experience the same phase shift, and its fre-

quency will be pulled accordingly. A simple calculation shows that with Q approximately 5×10^5 , the corresponding fractional frequency change is $\pm 1 \times 10^{-8}$ c.p.s. Thus, with reasonably constant supply voltages, the short-term frequency stability can be expected to be somewhat better than this. The long-term stability, however, will depend on these and other factors, including the drift of the crystal resonator itself.

To obtain the best frequency stability, the AT-cut crystal used is kept in an oven at a specified, constant temperature. The oven, as shown in figure 3, is of a single-stage type, with temperature control provided by a 50° mercury thermostat. A Dewar flask is used to isolate the controlled oven chamber from outside temperature changes. Consequently, the average power requirement is only 0.4 watt at a temperature difference of 25°C . Frequency changes in the crystal due to oven cycling are less than 10^{-9} c.p.s., and normal laboratory temperature changes are apparently not reflected in the temperature of the crystal.

ELECTRONIC COLLISION COURSE COMPUTER

by Russell Wolfram

Philco Field Engineer

(Editor's Note: This article was submitted by the author as an idea for an easily constructed computer for GCI—Ground-Controlled Intercept. The computer has not been constructed and therefore its practicability is not known; however, it should prove to be a useful addition as a training aid for directors and as such it was deemed desirable for BULLETIN publication.)

THE COMPUTER described in this article was designed primarily as an aid for the determination of the fighter-interceptor course required to intercept an unknown or hostile aircraft. In figure 1, T represents the target, F the fighter, while line b is the target course, and line a is the fighter course. If the collision point is at X, then b/a is proportional to S_t/S_f , where S_t is target speed and S_f is fighter speed. According to the law of sines:

$$\frac{\sin \theta_2}{b} = \frac{\sin \theta_1}{a}$$

or: $\sin \theta_2 = \frac{b}{a} \sin \theta_1 = \frac{S_t}{S_f} \sin \theta_1$

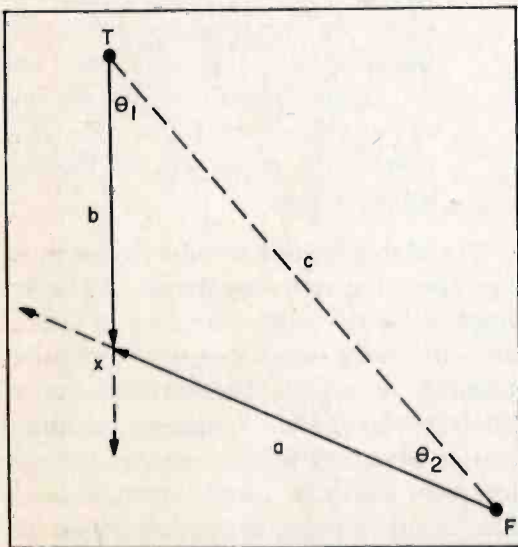

Figure 1. Graphic Collision Course Solution

Angle θ_1 and the two speeds can be determined from the radar PPI scope presentation at GCI stations. Angle θ_2 can then be solved using one of the above relationships. Since the positions of T and F, the speeds of T and F, and the target heading are known, the collision course can be determined by using θ_2 .

A balanced bridge circuit, as shown in figure 2, can be used to solve electronically the collision course problem. When the bridge is balanced, $a/c = b/d$ or $a = bc/d$. If resistors b and d are calibrated in speeds for target and fighter, and a and c are calibrated in terms of $\sin \theta_1$ and $\sin \theta_2$, then by setting the bridge arm with the known

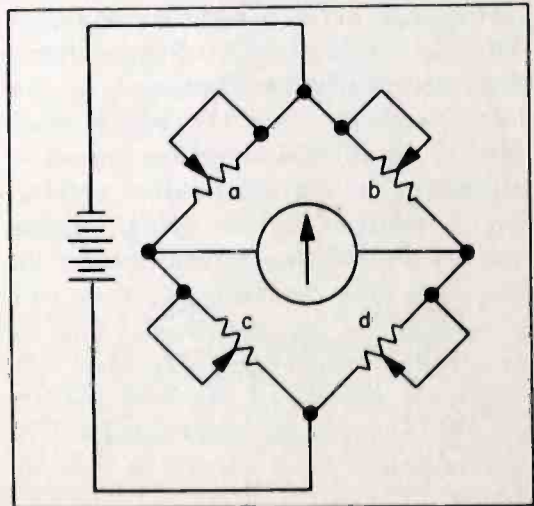

Figure 2. Basic Bridge Circuit Used in Computer

variable factors and balancing the bridge with the resistor representing the unknown variable (in this case $\sin \Theta_2$) the unknown variable can be read from the calibrated dial on that resistor.

The schematic diagram of the complete computer is shown in figure 3, and the dial calibrations of the bridge components are shown in figure 4. The angle controls are calibrated directly in degrees instead of sine values, so the angles can be set or obtained directly.

An electron-ray tube is used as the null indicator, and bridge balance is indicated by maximum opening of the eye. Each angle control has two ranges in order that more accurate settings can be obtained. The angle control is a 10K precision potentiometer which accounts for one half of the total bridge arm resistance. The other half of the arm is a 10K precision resistor. The angle control is calibrated from 0 to 30 degrees, with the resistor of the arm shorted by switch S1 or S2 (refer to the schematic), and from 30 to 90 degrees with the switch open and the entire arm resistance in the circuit. This calibration is possible because $\sin 30^\circ = .50$. Fourteen degrees represents .242 of the total arm resistance of the circuit; 45 degrees, .707 of the total resistance; etc. The relationship between the resistance of the angle controls and $\sin \Theta$ is linear. The dial calibrations in degrees, therefore, are non-linear. Because it is possible to short-circuit the bridge when two of the variable resistors are set at minimum, a current-limiting resistor, R_1 , is required in the bridge circuit. Use of the limiting resistor causes the voltage across the bridge to vary with the settings of the controls and thus decreases the bridge sensitivity when low-resistance settings are required, but this should not prove too objectionable. The null-indicator tube circuit is conventional.

The computer can be used in the fol-

lowing manner to solve a collision course problem:

1. Draw a line on the PPI scope face from the target position to the fighter position.
2. Draw a line from the target in the direction of the target heading.
3. Using a protractor, preferably an adjustable self-indicating type, measure the angle between the two lines. This is angle Θ_1 .
4. Set this angle on the Θ_1 angle control on the computer. If angle Θ_1 is greater than 90 degrees use 180 degrees minus angle Θ_1 as the angle. Be sure the switch in the angle Θ_1 arm is in the correct position.
5. Determine the target speed and set the proper computer control to the value obtained.
6. Set the fighter speed on the proper control.
7. Balance the bridge by adjusting the angle Θ_2 control for maximum eye opening. If the bridge will not balance, use the other range.
8. Read angle Θ_2 from the control and transfer this angle to the PPI with the protractor, using the fighter position as the vertex and the target-fighter connecting line as one side of the angle. The other side of the angle will be the collision course.

The fighter speed should be the average speed between scramble and interception for the particular type of fighter aircraft being used and the particular altitude at which the interception is likely to be made. A change of target course or speed will, of course, necessitate new settings on the computer. If the bridge cannot be balanced at all, there is no possible collision course for the particular set of conditions.

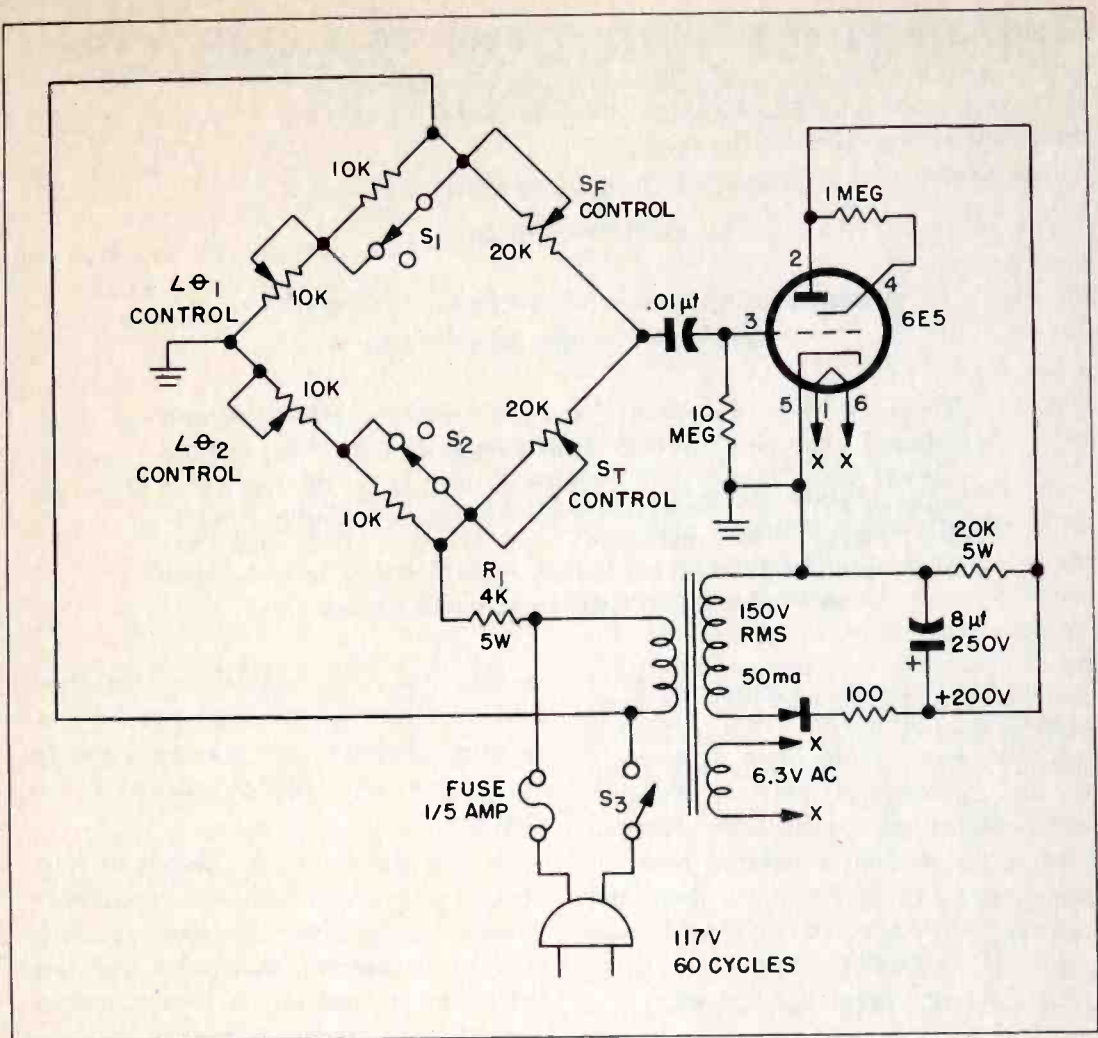

Figure 3. Schematic Diagram of Computer

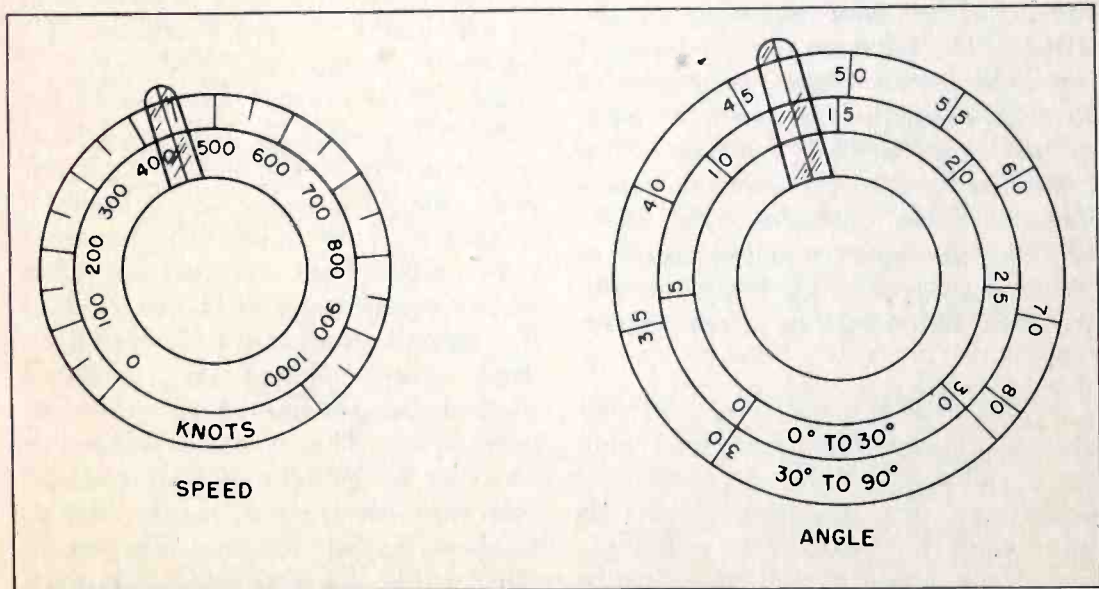

Figure 4. Speed and Angle Control Dial Calibrations

DESIGN OF JUNCTION TRANSISTOR AUDIO AMPLIFIERS

by James B. Angell and Edwin J. Podell

Philco Research Division

A practical approach to the design of low-level transistor audio amplifiers.

(Editor's Note: In view of the increasing availability and reduced cost of junction transistors, this article is considered quite timely. At present Philco is producing three types of PNP transistors in addition to the Surface Barrier line. These PNP units, 2N47, 2N49, and 2N62, are currently available, and technical specifications will be sent to Philco Field Engineers upon request.)

IN RECENT MONTHS, various types of transistors, heretofore not generally available, have made their appearance on the commercial market. Furthermore, improved production methods have made possible a reduced price on many types. As a result of these two factors, it is expected that field engineers will engage in increased experimental activity involving transistor circuitry.

From time to time, a number of transistor articles have appeared in the BULLETIN, and from the standpoint of transistor circuit design, these articles have discussed the resistance (r) parameters. An example of this type of discussion is found in "Transistors Versus Vacuum Tubes" (August, 1953, BULLETIN), in which the author compares the r parameters of the transistor with the static characteristics of the vacuum tube.

In this article, a somewhat different approach is used, since it is based upon the so-called hybrid (h) parameters. It is believed that this type of analysis lends itself to considerable simplification in the design of transistor circuits. Since this discussion is concerned with the application of junction transistors

to low-level audio amplifiers, distortion and operation limits need not be considered; therefore, the transistor can be represented by a linear equivalent circuit.

Before going into the details of transistor audio amplifiers, the mechanism by which a junction transistor amplifies will be considered briefly. A junction transistor is basically a device consisting of two diodes connected back-to-back in a rather unorthodox manner. In part A of figure 1, a block of germanium is split into P, N, and P regions. The left-hand junction is biased in a forward (low-resistance) direction by the battery V_{ee} , while the right-hand junction is reverse-biased by V_{cc} . An equivalent circuit for such a device is shown in part B of the figure. The transistor device differs from a similar connection of two separate diodes in that most of the current flowing in the left-hand diode passes through the right-hand diode despite the ground connection between them. This is explained by the fact that the collector is more negative than the base in respect to the emitter, as shown in the schematic diagram. In other words, if a small signal is injected into the left-hand loop by means of generator V_G , most of the current from

the generator flows into the right-hand diode and thence into the load. Consequently, it can be seen that the transistor transforms a signal current from a low-impedance circuit to a high-impedance circuit without decreasing the magnitude of the current. This impedance transformation, without loss of current magnitude, is the basis for amplification in a common-base junction transistor. It will be shown later that more gain can be obtained with other transistor connections, but this additional gain is realized by taking advantage of the feedback characteristics of the transistor.

With this introduction to the amplification characteristics of the transistor, a more rigorous study of transistor circuits will follow. A linear circuit for a transistor and the equations that describe the circuit will be considered first. Then, a set of useful gain and impedance expressions will be derived. Next, these expressions will be applied to the equivalent circuit of the transistor in its three basic connections.

EQUIVALENT CIRCUIT

Consider the common-base connection of a transistor, as shown in figure 1. The circuit in part C of the figure shows the symbol normally used to denote a transistor, together with the voltage and current designations. A set of collector characteristics, such as that shown in part D of figure 1, can be obtained for this connection, where the collector terminal is the lead from the reversed-biased diode. These characteristics show how collector voltage and current vary for different fixed values of emitter current. Note that for the PNP transistor being considered, the collector voltage and current, as defined, are negative, while the emitter current is positive. If an operating point is established by means of the supply voltages, a load line can be drawn on the collector characteristics, as shown.

For linear operation about the chosen operating point, the transistor may be considered as a two-terminal-pair device. The black-box representation (figure 2) for a two-terminal-pair network

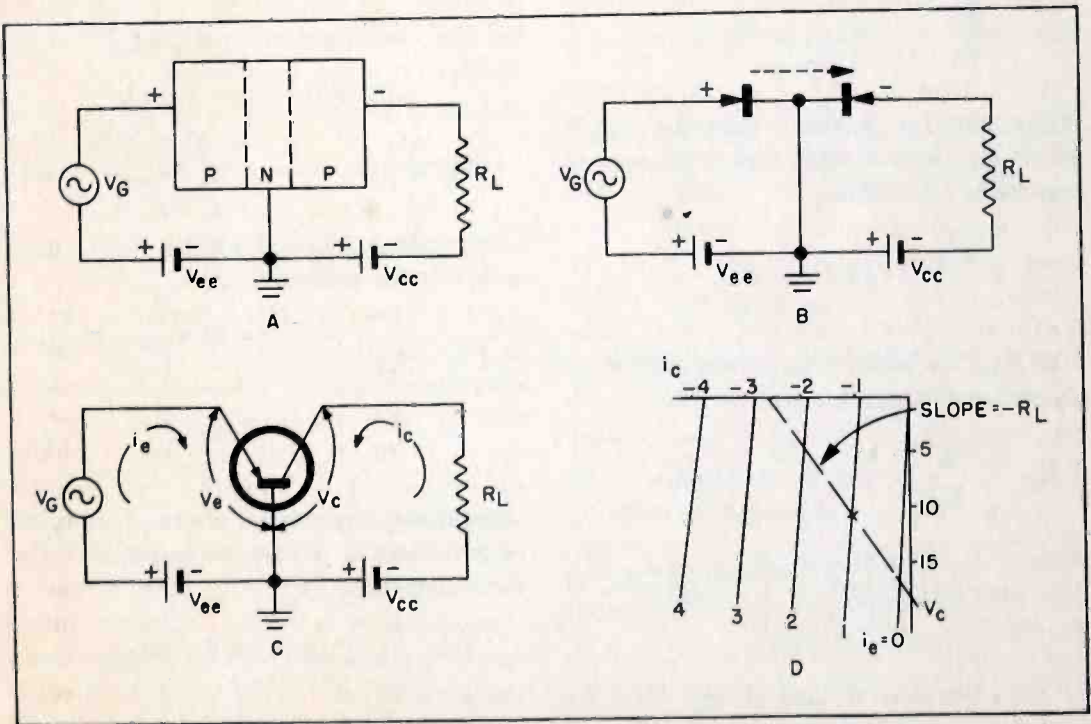

Figure 1. Analysis of PNP Junction Transistor Operation (Common-Base Connection Shown)

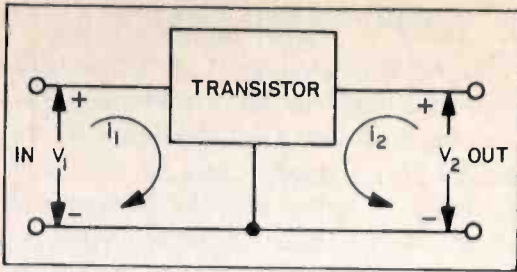

Figure 2. Black-Box Representation of Transistor

can be described completely by the h parameters. These are defined by the equations:

$$V_1 = h_{11}i_1 + h_{12}V_2 \quad (1)$$

$$i_2 = h_{21}i_1 + h_{22}V_2 \quad (2)$$

Parameter h_{11} is taken with the output considered short-circuited. Thus, V_2 is zero in equation (1) and

$$h_{11} = \frac{V_1}{i_1} = \text{input impedance} \quad (3)$$

— ohms units

Parameter h_{12} is taken with an open input circuit. Thus, i_1 is zero in equation (1) and

$$h_{12} = \frac{V_1}{V_2} = \text{voltage feedback ratio} \quad (4)$$

— no units

Parameter h_{21} is taken with the output short-circuited, which makes V_2 zero in equation (2). Thus,

$$h_{21} = \frac{i_2}{i_1} = \text{current gain} \quad (5)$$

— no units

For h_{22} , the input is open-circuited, and i_1 becomes zero in equation (2).

$$h_{22} = \frac{i_2}{V_2} = \text{output admittance} \quad (6)$$

— conductance units

It will be noted that these parameters are not expressed in the same units; hence the term, "hybrid."

The various h parameters can be written for the three usual transistor connections — common base, common

emitter, and common collector. These relations are illustrated in figure 3, 4, and 5, respectively, with part A of the figures showing the transistor connections, and part B the equivalent circuits. The items of special interest in these relationships are the comparatively low open-circuit output impedance ($1/h_{22}$) in the common-emitter and common-collector circuits, and the low short-circuit input impedance (h_{11}) of the common base.

SIMPLIFIED POWER-GAIN EXPRESSIONS

A set of three power-gain equations, based upon the h parameters, may now be derived. The first of these relates the power delivered to the load to the actual input power into the transistor, in terms of impedance and circuit current gain.

The advantage of dealing with these simple relationships, rather than the more complicated single expressions for gain, is that one does not lose the intuition gained from such expressions because of their complexity.

$$\text{input power} = R_{in} \times i_1^2$$

$$\text{output power} = R_L \times i_2^2$$

$$\text{power gain} = G_p = \frac{R_L}{R_{in}} \left(\frac{i_2}{i_1} \right)^2 \quad (7)$$

The second relation shows the current gain. From equation (2),

$$i_2 = h_{21}i_1 - h_{22}R_L i_2$$

therefore,

$$A_i = \frac{i_2}{i_1} = \frac{h_{21}}{1 + h_{22}R_L} \quad (8)$$

The third expression shows the input impedance in terms of current gain. From equation (1),

$$V_1 = h_{11}i_1 - h_{12}R_L i_2$$

therefore,

$$R_{in} = h_{11} - h_{12}R_L \left(\frac{i_2}{i_1} \right) \quad (9)$$

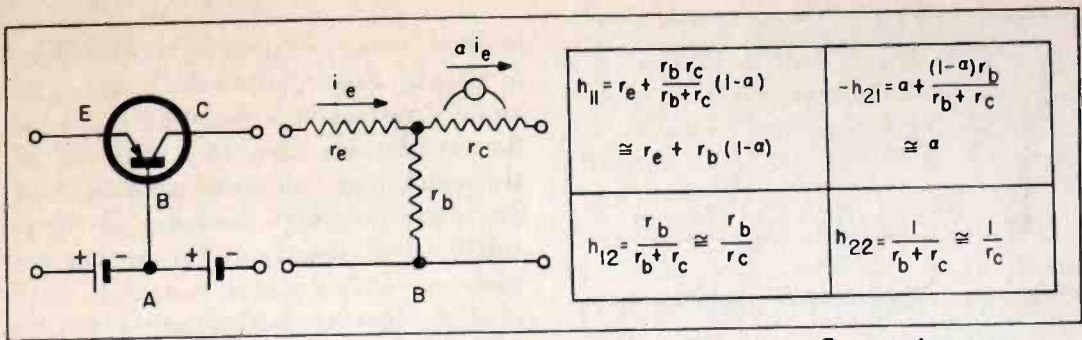

Figure 3. H Parameters for Common-Base Transistor Connection

The question of what value to make the load impedance in order to obtain the maximum power gain is not easily answered by these expressions. However, if R_{in} and i_2/i_1 are eliminated from equation 7, then with the aid of equations 8 and 9, the expression of the optimum load impedance may be obtained by differentiating equation 7 with respect to R_L in the usual manner. This load resistance is shown by

$$R_L = \frac{1}{h_{22} \sqrt{1 - \frac{h_{12} h_{21}}{h_{11} h_{22}}}} \quad (10)$$

All the basic relationships have been derived. It is now a matter of applying these equations to the different transistor connections.

COMMON-BASE AMPLIFIER

If the common-base impedance expressions of figure 3 are substituted in the current-gain and input-impedance equations (8) and (9), the results shown below are obtained.

$$A_1 = \frac{i_2}{i_1} = \frac{-\alpha}{1 + \frac{R_L}{r_c}} \quad (11)$$

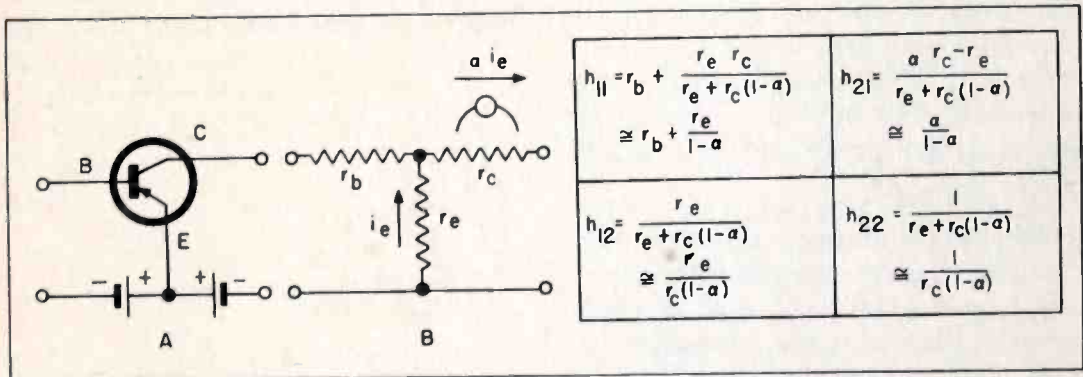

Figure 4. H Parameters for Common-Emitter Transistor Connection

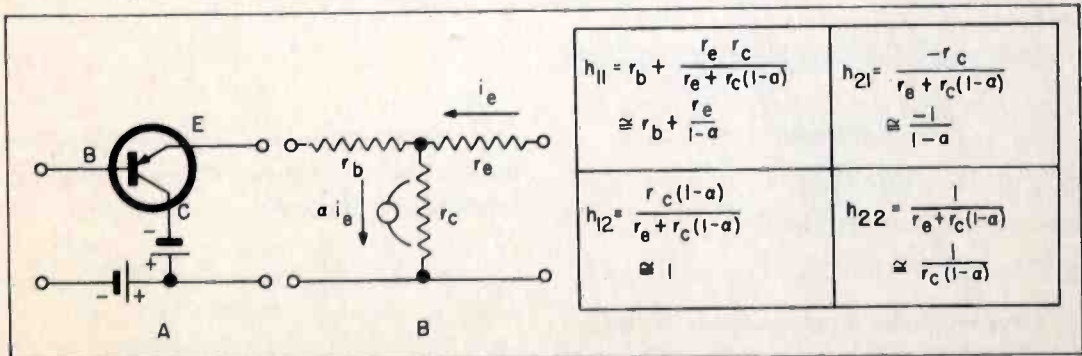

Figure 5. H Parameters for Common-Collector Transistor Connection

$$R_{in} = r_e + r_b (1 - \alpha) - \frac{r_b}{r_c} R_L \left(\frac{i_2}{i_1} \right)$$

$$= r_e + r_b \left(1 + \frac{i_2}{i_1} \right) \quad (12)$$

$$G_p = \frac{R_L}{R_{in}} \left(\frac{i_2}{i_1} \right)^2 \quad (7)$$

where α = current amplification factor of transistor

$$\frac{i_2}{i_1} = \text{current gain}$$

In cases where $R_L \ll r_c$, equations (11), (12), and (7) may be modified as follows:

$$A_i = \frac{i_2}{i_1} = -\alpha \quad (11a)$$

$$R_{in} = r_e + r_b (1 - \alpha) \quad (12a)$$

$$G_p = \frac{R_L}{R_{in}} \times \alpha^2 \quad (7a)$$

Normally r_c is large, on the order of a megohm; therefore, the assumption that the load impedance is small compared with r_c is often valid. This condition is equivalent to the case of the pentode vacuum tube, which is seldom matched to its load. With negligibly large r_c , the expressions for input impedance, current gain, and power gain become very simple, as shown.

An example of the maximum possible gain that can be obtained with a common-base transistor will now be given. Consider that a typical transistor has been selected and has the following characteristics:

$$\alpha = 0.975 = \text{current amplification factor}$$

$$r_c = 1 \text{ megohm}$$

$$r_e = 25 \text{ ohms}$$

$$r_b = 600 \text{ ohms}$$

$$r_b(1 - \alpha) = 15 \text{ ohms}$$

In applying the above values to equation (10) in order to find the value for R_L for maximum possible gain, it will

be found that a factor of $r_c/4$ for R_L is a good compromise which is usually close. Consequently, equation (13) can be used for equation (10) in most instances. In the calculations below, note the great difference between the input and load impedances. This makes the problem of impedance matching (particularly in cascaded stages) a difficult one. In the example under discussion, for maximum gain,

$$R_L = r_c/4 = 250,000 \text{ ohms} \quad (13)$$

$$A_i = \frac{i_2}{i_1} = \frac{-0.975}{1 + 0.25} = -0.78 \quad (11)$$

$$R_{in} = 25 + 600(1 - 0.78) = 157 \text{ ohms} \quad (12)$$

$$G_p = \frac{2.5 \times 10^5}{157} \times 0.78^2 = 970 = 29.9 \text{ db} \quad (7)$$

COMMON-EMITTER AMPLIFIER

Formulas for current gain, input impedance, and power gain for a common-emitter transistor amplifier, as shown in figure 4, are given as follows:

$$A_i = \frac{i_2}{i_1} = \frac{\alpha}{1 - \alpha} \times \frac{1}{1 + \frac{R_L}{r_c(1 - \alpha)}} \quad (14)$$

$$R_{in} = r_b + \frac{r_e}{1 - \alpha} - \frac{r_e R_L}{r_c(1 - \alpha)} \left(\frac{i_2}{i_1} \right)$$

$$= r_b + r_e \left(1 + \frac{i_2}{i_1} \right) \quad (12)$$

$$G_p = \frac{R_L}{R_{in}} \left(\frac{i_2}{i_1} \right)^2 \quad (7)$$

In cases where $R_L \ll r_c(1 - \alpha)$, equations (14), (12), and (7) may be modified as follows:

$$A_i = \frac{i_2}{i_1} = \frac{\alpha}{1 - \alpha} \quad (14a)$$

$$R_{in} = r_b + \frac{r_e}{1 - \alpha} \quad (12b)$$

$$G_p = \frac{R_L}{R_{in}} \times \left(\frac{\alpha}{1 - \alpha} \right)^2 \quad (7b)$$

Where $R_L = R_{in}$ (direct cascade),

$$G_p = \left(\frac{\alpha}{1 - \alpha} \right)^2 = 1520 = 31.8 \text{ db} \quad (7c)$$

In applying the typical transistor values to equation (10), it will be found that the maximum available gain from the common-emitter stage is obtained with a load resistance of approximately twice the open-circuit output resistance. It is known that the power gain obtained from an amplifier is not a critical function of load impedance for values of load resistance in the vicinity of the output impedance. In fact, a 2 to 1 resistance mismatch results in a loss of only 1 db. Consequently, the specification for R_L in equation (15) will, in general, give a gain of within 1 db of the maximum possible gain. A similar degree of accuracy is realized from equation (13) with respect to load impedance in the common-base connection. Thus, for maximum gain, for the typical transistor considered,

$$R_L = 2r_c(1 - \alpha) = 50,000 \text{ ohms} \quad (15)$$

$$A_1 = \frac{i_2}{i_1} = \frac{39}{3} = 13 \quad (14)$$

$$R_{in} = 600 + (25 \times 14) = 950 \text{ ohms} \quad (12)$$

$$G_p = \frac{5 \times 10^4}{950} \times 13^2 = 8900 = 39.5 \text{ db} \quad (7)$$

Equation (14) shows that the current gain is appreciably greater than unity, for alpha near unity, and that the current gain is positive. This latter condition is similar to that in a grounded-cathode vacuum-tube amplifier; i.e., the connections give a 180-degree phase reversal between input and output voltage signals.

From the input impedance equation, it may be seen that the input impedance of the common-emitter amplifier is equal to that of the common-base amplifier when their outputs are open-circuited. However, it is important to note that the input impedance of the common-emitter stage increases as the load impedance is decreased, whereas the common-base input impedance decreases with decreasing load impedance. This fact, together with the fact that the output impedance of the common-emitter amplifier is an order of magnitude or more lower than that of the common-base amplifier, makes the problem of matching between successive stages of amplification much easier with the common-emitter connection.

From the expression for power gain, it can be seen that appreciable gain is obtained even with a direct cascading of common-emitter stages. In fact, the low-frequency gain of 31.8 db, shown for the typical transistor under consideration, is slightly greater than the maximum available gain from the common-base stage. In the example, the maximum available gain of 39.5 db is about 10 db higher than that of the common-base amplifier. This additional gain is obtained at the expense of stability (change in operating point with change in temperature); the common-emitter amplifier has a gain which is a very sensitive function of alpha. Finally, in the example given, the impedance ratio works out to only 50, whereas in the common-base example, the ratio was about 1600.

COMMON-COLLECTOR AMPLIFIER

The expressions for current gain, input impedance, and power gain in a common-collector amplifier, as shown in figure 5, are as follows:

$$A_1 = \frac{i_2}{i_1} = \frac{-1}{1 - \alpha} \times \frac{1}{1 + \frac{R_L}{r_c(1 - \alpha)}} \quad (16)$$

$$\begin{aligned}
 R_{in} &= r_b + \frac{r_e}{1 - \alpha} - R_L \left(\frac{i_2}{i_1} \right) \\
 &= r_b + \frac{r_e}{1 - \alpha} + \frac{\frac{R_L}{1 - \alpha} r_c}{\frac{R_L}{1 - \alpha} + r_c} \\
 &= \frac{\frac{R_L}{1 - \alpha} r_c}{\frac{R_L}{1 - \alpha} + r_c} \quad (17)
 \end{aligned}$$

$$G_p = \frac{R_L}{R_{in}} \left(\frac{i_2}{i_1} \right)^2 \quad (7)$$

For $R_L \ll r_c (1 - \alpha)$, the above formulas may be taken as,

$$A_i = \frac{i_2}{i_1} = \frac{-1}{1 - \alpha} \quad (16a)$$

$$R_{in} = \frac{R_L}{1 - \alpha} \quad (17a)$$

$$G_p = \frac{1}{1 - \alpha} \quad (7d)$$

The expression for the current gain is identical to that of the common-emitter amplifier with the exception of the factor -1 in the numerator in place of the factor α . The input impedance looks like a parallel combination of r_c and $R_L/1 - \alpha$. Therefore, the input impedance of this connection is appreciably higher than the load impedance. For load resistances which are small compared with the output impedance of the transistor, the input impedance is just $1/1 - \alpha$ times the load impedance. This condition is based on the assumption that r_b and r_e are negligibly small; obviously, R_L cannot be as low as these parameters and still have the above-mentioned impedance relations hold.

Using the values for the typical transistor in the examples, the h parameters in figure 4 are found to be,

$$h_{11} = 1600$$

$$h_{12} = 1$$

$$h_{21} = 40$$

$$h_{22} = 4 \times 10^{-5}$$

Applying these values to formula (10) in order to find R_L for maximum gain,

$$\begin{aligned}
 R_L &= \frac{1}{4 \times 10^{-5} \sqrt{1 - \frac{40}{1600 \times 4 \times 10^{-5}}}} \\
 &= \frac{10^5}{100} = 1000 \text{ ohms} \quad (10)
 \end{aligned}$$

$$A_i = \frac{i_2}{i_1} = \frac{-1}{1 - \alpha} = -40 \quad (16a)$$

$$R_{in} = \frac{1000}{.025} = 40,000 \text{ ohms} \quad (17a)$$

For design considerations where $r_b(1 - \alpha) + r_e \ll R_L \ll r_c(1 - \alpha)$,

$$R_{in} = 40R_L$$

$$G_p = 40 = 16 \text{ db} \quad (7d)$$

The condition for maximum available gain is that the load resistance be small compared with the open circuit output impedance ($1/h_{22}$). This maximum gain is small, and is obtained by a circuit that does not throw away gain in a direct trade for stability. It can be seen that the transistor device is similar to a vacuum-tube cathode follower. For current gain, note that the common-collector circuit is just as sensitive to changes in alpha as is the common-emitter circuit. In the example given, $r_b(1 - \alpha) + r_e = 40$ and $r_c(1 - \alpha) = 25,000$. For these conditions, then, the specification that $R_{in} = 40R_L$ will hold for any value of R_L between 400 and 2500 ohms. Thus R_{in} may be chosen and R_L taken as $1/40$ of R_{in} , providing the figure lies within the 400—2500 ohm range.

Because of the factors of small gain and alpha sensitivity, the common-collector amplifier has a limited usefulness; there are other more satisfactory circuits possessing the desirable features of the common-collector amplifier.

LOW-POWER OPERATION

Among electronic amplifiers, transistors have the unique property of being able to function with extremely small bias voltages. Vacuum tubes cannot be operated at very low voltages because of the curvature of the characteristics in the region near the origin. Similarly,

point-contact transistors have characteristics which lose their identity at very low values of voltage and current. However, the junction transistor has a set of characteristics (figure 6) which permit operation even at extremely low bias levels. For instance, in part A of figure 6, the common-base and common-

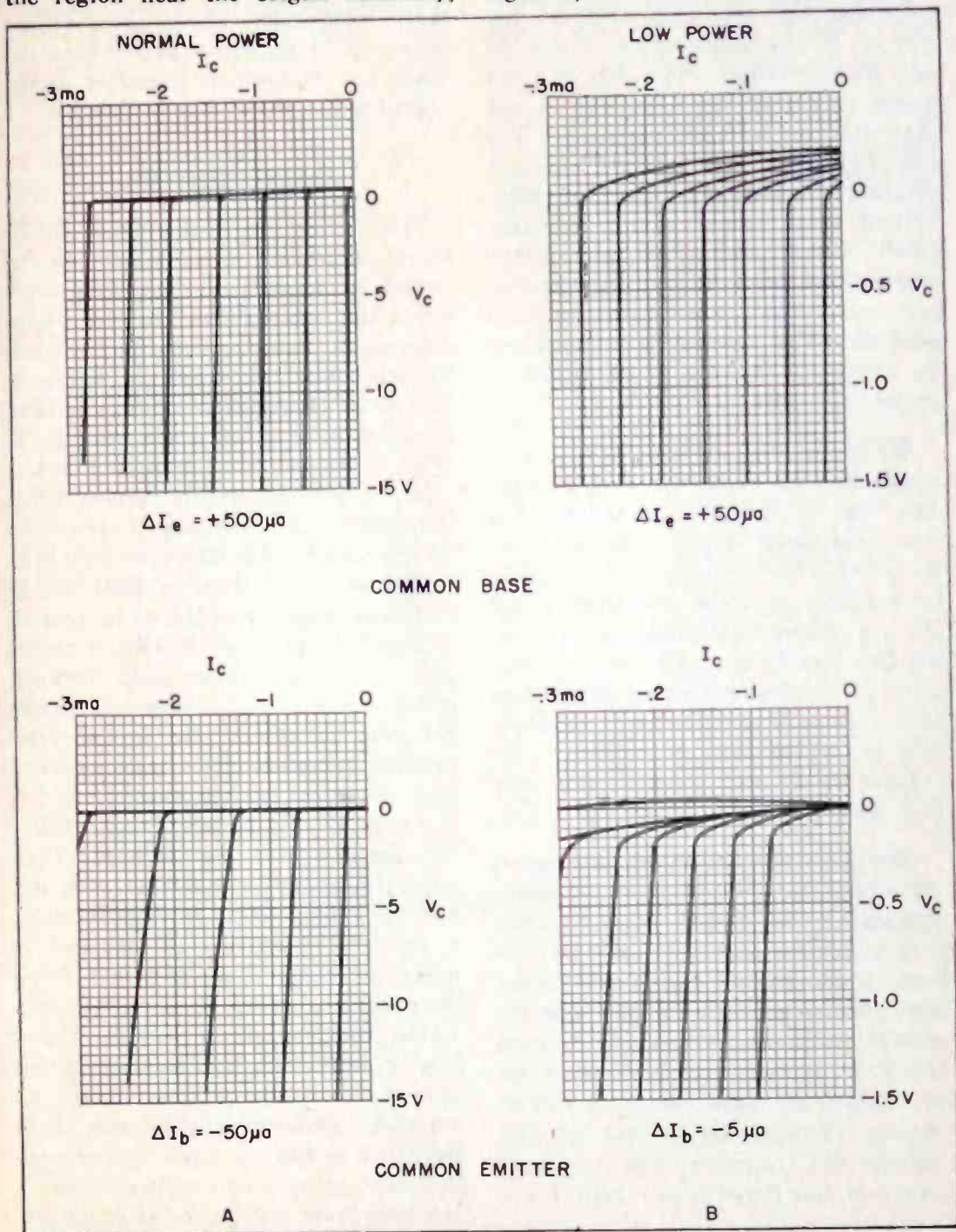

Figure 6. Transistor Collector Characteristics for Common-Base and Common-Emitter Connections

emitter collector characteristics are shown for normal voltage and current ranges. In part B, the same characteristics are shown with both scales expanded by a factor of 10. It can be seen that the common-base characteristics are almost identical at low level even though the full-scale voltage is only 1.5 volts and the maximum current only 300 μ a. From these curves, it can be seen that operation with a bias of a few tenths of a volt and a current of less than 100 μ a. is entirely feasible. The low-power, common-emitter curves are displaced horizontally from the zero-current axis because of I_{co} (collector cutoff current), which is the collector current that flows with zero emitter current and a finite, normal collector-base potential. This current is exaggerated by a factor, $1/1 - \alpha$, in the common-emitter amplifier.

While on the subject of I_{co} , it is worthwhile to point out that extreme care must be taken in the design of a common-emitter amplifier to minimize its effect. This current is extremely temperature sensitive, changing about 9% per degree centigrade. In view of the fact that I_{co} is much more troublesome in a common-emitter circuit than in a common-base circuit, it is desirable to operate with very low d-c resistance in the base circuit and a very high d-c resistance in the emitter circuit.

The characteristics shown in figure 6 do not tell the whole story of low-power operation. One feature that becomes very important with very low bias currents is the emitter resistance. Theory states, and experiment verifies, that the emitter resistance is inversely proportional to the emitter current, being approximately 20 ohms with 1-ma. emitter current. Consequently, at very low bias currents, the transistor input impedance increases and the available gain drops.

One other feature of junction transistors which makes possible their opera-

tion at extremely low levels is their low noise. For normal bias currents, of the order of 1 ma., common-base or common-emitter amplifiers can be built having a noise figure of approximately 15 db at 1 kc. The noise in a transistor decreases with increasing frequency, so that better figures can be obtained at radio frequencies. The common-collector circuit is somewhat noisier than the other two connections, another factor opposing the use of this connection.

GAIN CONTROL

The problem of building a small-signal amplifier whose gain can be varied by changing the operating point seems to be a difficult one when considering the extreme linearity displayed by transistors, as shown in figure 6. With such characteristics, the amplifier is either full-on, distorting, or full-off. What is needed is the transistor equivalent of a remote-cutoff vacuum tube. Fortunately, the nonlinear characteristic required for this condition does exist in transistors, because of their highly nonlinear input impedance. In part A of figure 6, the upper family of curves shows a linear relationship between emitter current and collector current. However, because of the inverse relationship between emitter resistance and emitter current (as illustrated in part A of figure 7), the emitter voltage-collector current curves are not linear. Consequently, if the input current is varied, and the input voltage is held constant, a new set of curves, as indicated in part B of figure 7, would result. From these curves, it can be seen that uniformly varying gain is possible. Therefore, in order to take advantage of this nonlinear characteristic to obtain an automatic gain-controllable stage, it is necessary to run the input (either common-base or common-emitter) from a low-impedance source, so far as the signal is concerned. Of course, it makes no difference how the bias for the transis-

tor is obtained, provided the bias supply is bypassed at signal frequencies.

Two circuits for such a gain-controlled stage are shown in figure 7. Part C shows a simple common-base stage, having a generator impedance of less than 100 ohms. This circuit requires considerable power from the bias supply. The common-emitter stage, shown in part D, requires much less bias power. If the emitter is directly grounded, the problem of varying I_{co} is acute. Consequently, a bypassed resistor is included in the emitter circuit to stabilize the operating point. This

component is similar to a bypassed cathode resistor for vacuum tubes; its value should be chosen as a compromise between circuit stability and ease of gain control.

SUMMARY

The common-base amplifier has a low input impedance and a current gain of less than unity. It is useful in specialized low-level audio circuits, such as a preamplifier stage for a dynamic microphone, etc. Common-emitter amplifiers, with a 180-degree phase reversal, have the greatest gain, and a flexibility which

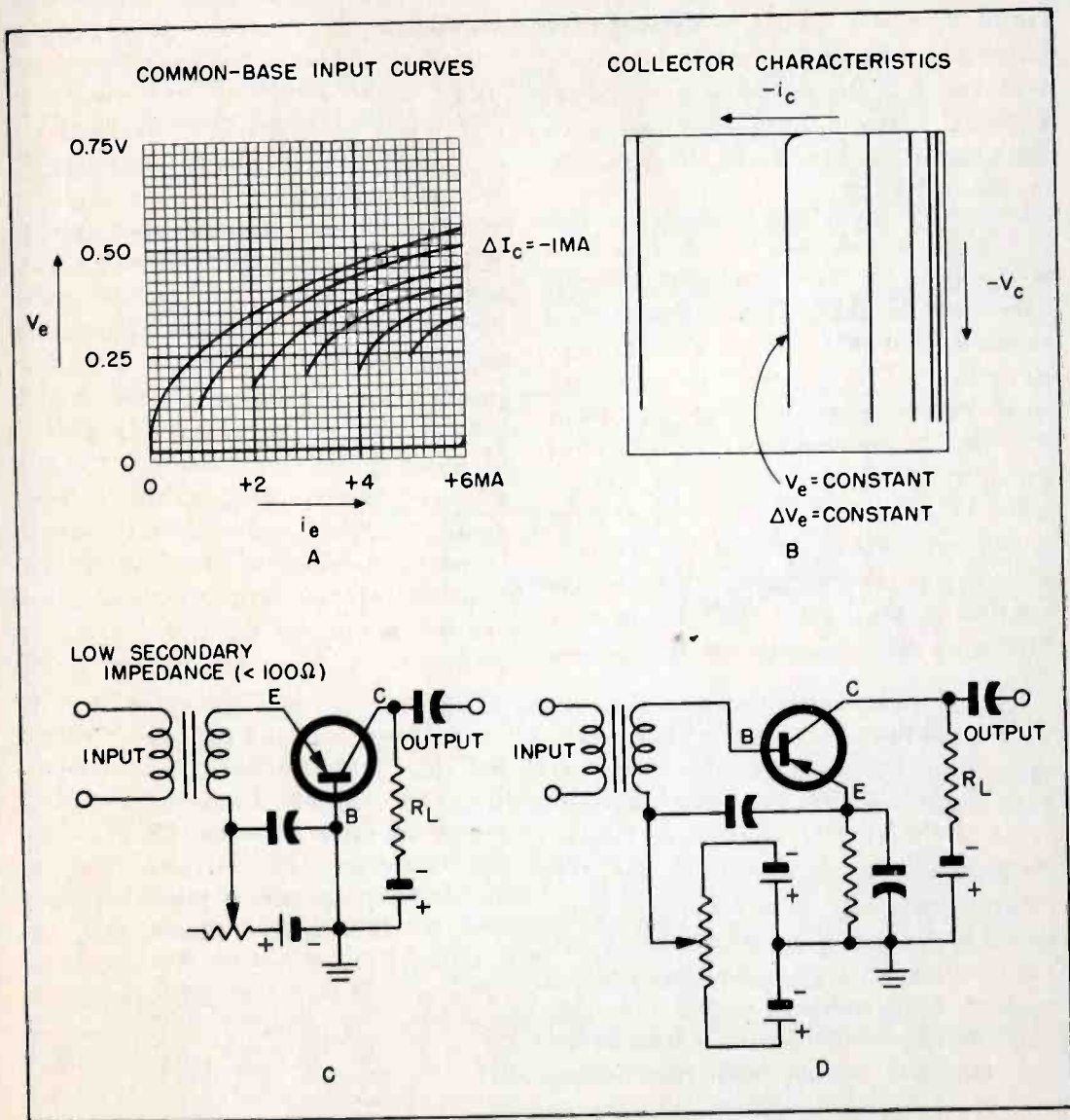

Figure 7. Typical Common-Base and Common-Emitter Transistor Audio Amplifiers, Showing Gain-Control Circuits

CONSULTING, PROJECT, AND FIELD ENGINEERING

- ELECTRONICS • COMMUNICATIONS**
- POWER PLANT • REFRIGERATION**
- SPECIAL SYSTEMS**

"3-D" TRAINING

- COURSE MATERIAL**
- TRAINING DEVICES**
- INSTRUCTORS**



**WRITING, PROCESSING, AND PUBLISHING
OF TECHNICAL LITERATURE**

- TECHNICAL MANUALS • INSTRUCTION BOOKS**
- CATALOGING • TECHNICAL REPORTS**
- DESCRIPTIONS OF MANUFACTURE**