

PHILCO

TECHREP DIVISION BULLETIN



NOVEMBER
and
DECEMBER
1953

S. ZOSSA FCS



GGZ HFFRGC

A. HENRICH

PHILCO

TECHREP DIVISION

BULLETIN

Published monthly by
The TechRep Division of Philco Corporation
 Philadelphia, Pennsylvania

Volume 3

NOVEMBER-DECEMBER, 1953

Number 11

CONTENTS

Editorial	2
<i>By John E. Remich</i>	
The Philco Method of Surveying Microwave Systems by Means of the Precision Surveying Altimeter	3
Electronic Computers—Part V Memory Systems	25
<i>By Warren M. Kitter</i>	
Solution to "What's Your Answer?"	29
The NBS Microwave Frequency Standard	30
An Electric Gun Charger Tester	39
<i>By Ray A. Martin</i>	
Radioactive Cleaning	42
Field-Strength Indicator Attachment for Test Set TS-352/U	43
<i>By Robert E. Jones</i>	
Storage Cabinet for Chassis of MK-113/6SQ Trainer Kit	46
Index for Volume 3	48

Editor
John E. Remich

Managing Editor
Gail W. Woodward

Technical Editors
Francis R. Sherman
John W. Adams

EDITORIAL OFFICE:
Technical Information Section
Philco TechRep Division
22nd St. and Lehigh Avenue
Philadelphia 32, Penna.

If any information contained herein conflicts with a technical order, manual, or other official publication of the U.S. Armed Forces, the information in the official publication should be used. Views expressed in this publication are the opinions of the authors and do not necessarily represent those of Philco Corporation. All technical information and circuits are presented without responsibility as to patent infringement.

Editorial

1953

By John E. Remich

This issue marks the end of the third year of BULLETIN publication. As in previous years we find ourselves looking back upon another series of remarkable advances in the electronics industry. Many new devices, some of which have been in development since 1946, have appeared in field service, and they markedly add to an already complex technology.

No discussion would be complete without mentioning transistors, which are now found in widespread production. Most common electronics catalogs now list at least three manufacturers representing about nine models. Components manufacturers' lines also reflect the transistor age in terms of complementary items such as microminiature transformers, capacitors, resistors, and batteries. A major contribution to the transistor art, in the form of the Surface-Barrier transistor, was announced by Philco Corporation early in December. This new transistor operates on remarkably low power, and has an outstanding gain-bandwidth factor. Most important, the new fabrication process is subject to unheard of precision in transistor manufacture.

Probably one of the most interesting developments to be announced was Project Tinker Toy, an operating automatic manufacturing device produced for the Navy Bureau of Aeronautics and based on National Bureau of Standards developments. According to announcements, several items have been designed for automatic production, including a drone radio control receiver, a radio altimeter, and the electronic portion of a sonobuoy. Mass production was actually carried out on the sonobuoys. It may be that we are entering a new era—the era of automatic production.

In terms of the immediate future, Color TV was probably the biggest item of the year. A great deal of effort has been directed toward getting Color TV into use, and the close of the year finds most of the obstacles overcome. Standards were agreed upon and production should be under way in a relatively short time.

1953 has been an outstanding year in electronics, but recent developments indicate that we are just getting started.

THE PHILCO METHOD OF SURVEYING MICROWAVE SYSTEMS BY MEANS OF THE PRECISION SURVEYING ALTIMETER

The latest method for accurately surveying a microwave radio relay path.

(Editor's Note: The following procedures represent a supplement to the "Philco Handbook of Microwave Systems Planning," Section 3-D, "Detailed Description of the Final Field Survey." The material published in this article is based in part upon data submitted by the American Paulin System, 1524 South Flower Street, Los Angeles 15, California.)

THE ART of microwave-system surveying has progressed to the point where optical and line-of-sight methods of checking grazing points are no longer completely satisfactory. It is not to be inferred that optical methods are necessarily rendered obsolete, but rather that they are limited in dependability and expediency to short hops and to situations where topographical features provide considerable terrain clearance. The altimeter method is currently being employed for microwave surveying, and it has proved to be economical, reliable, and expedient when carried out by properly qualified personnel.

BRIEF DESCRIPTION OF METHODS USED

The altimeter method of microwave-system surveying revolves around the effective use of a precision surveying altimeter of the barometric-leveling type.* (See figure 1.) Barometric leveling, the method of determining altitude by measuring differences in air pressure, is based on the fact that air pressure varies inversely with altitude. The altimeter is carried to selected points along the terrain to be traversed by the micro-

wave beam, to determine the elevations of these points above sea level. These elevation data are used to plot a profile of the terrain on an earth-curvature chart. (See figure 2.) Then, the required tower heights are established directly on the chart, by graphical methods.

Since barometric leveling is dependent on the measurement of air pressure, conditions other than changes in elevation that affect the density of air introduce errors for which corrections must be applied. One such condition is the temperature of the air—the density of air varies inversely with its absolute temperature. Therefore, when the air temperature differs from that for which the altimeter is calibrated, a temperature correction must be applied. (See figure 3.)

* The precision surveying altimeter is not to be confused with an ordinary aneroid altimeter. Friction and lag are practically eliminated in the precision instrument, by using a "zero-gauging" type of mechanism. The precision instrument measures altitude indirectly, by gauging the force necessary to balance its corrugated disks, while in the ordinary aneroid type a pointer is moved directly across a scale, by mechanical linkage to the disks. Careful use of the precision altimeter will yield elevation data with a probable error on the order of 5 feet.

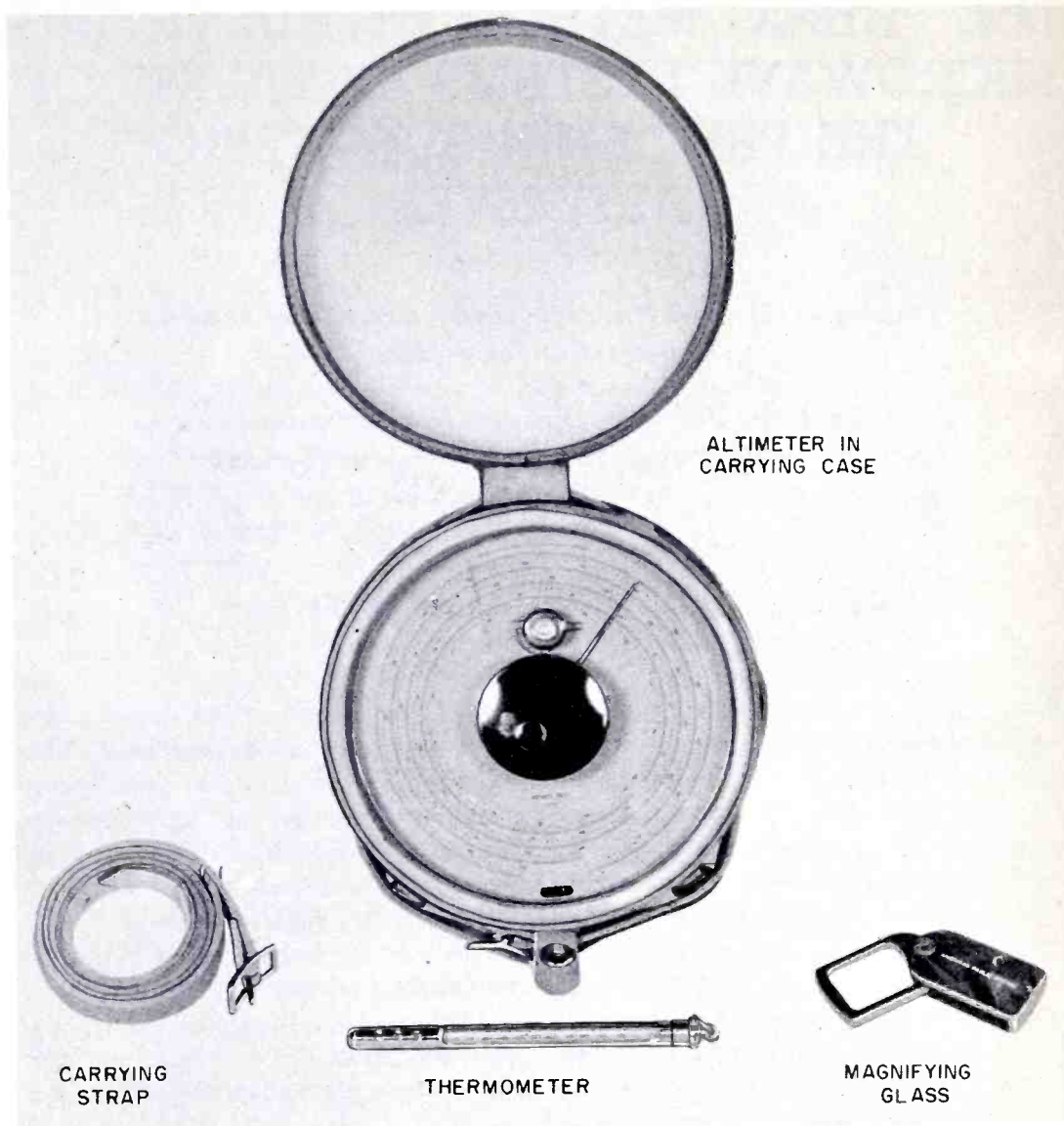

Figure 1. Precision Surveying Altimeter, with Accessories

Another condition which affects the density of air is the variation in barometric pressure caused by a change in local weather conditions, such as the approach of a storm. It is impracticable to attempt barometric leveling when thunderstorms are occurring or when whirlwinds are forming in the locality. However, the variations in pressure caused by the relatively slow movement of major storms (high- and low-pressure centers) and the normal pressure variation due to the sun can be ascertained and a barometric correction applied.

Either of two basic techniques, which

are to be described, may be employed in the altimeter survey. The choice of technique depends upon the density of distribution of vertical control levels (bench marks) in the vicinity of the microwave path. If there are one or more bench marks located near each 5-mile segment of path, the first procedure is used. If there are few or no bench marks located near the microwave path, the second procedure is used. The first procedure requires one man and one altimeter, while the second procedure requires two men and two altimeters.

PHILCO MICROWAVE SYSTEM

EARTH CURVATURE AND PROFILE CHART

DRAWN BY R.H.W. DATE 4-14-53
 SHEET NO. 1 OF 1 SHEETS

FOR WEBSTER & SOUTHERN RAILROAD TO HOLMESVILLE, MISSOURI
 SIGNAL PATH BRASS HILL
 DISTANCE IN MILES 27.6

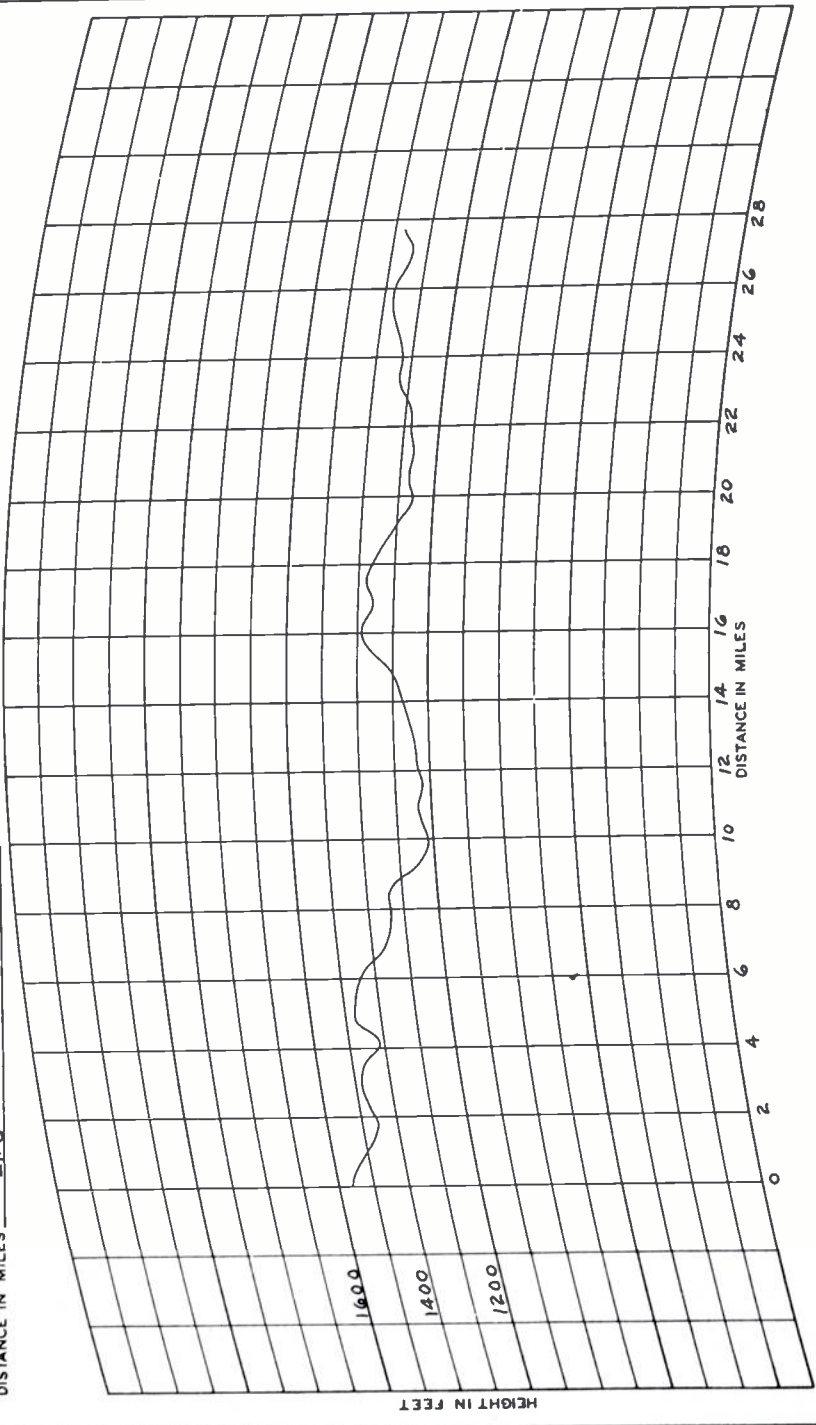

	20 MILE SCALE	40 MILE SCALE	60 MILE SCALE
DISTANCE	1" = 2 MILES	1" = 4 MILES	1" = 6 MILES
HEIGHT	1" = 100 FEET	1" = 400 FEET	1" = 1600 FEET

IFE 101

Figure 2. Typical Earth Curvature and Profile Chart

Average Air Temperature Correction in Feet

For temperatures above 50° F. the values are to be added
 For temperatures below 50° F. the values are to be subtracted

Average air temp. °F.		Difference of readings in feet													Average air temp. °F.		
		0	20	40	60	80	100	120	140	160	180	200	220	240			260
	+50°	0	0	0	0	0	0	0	0	0	0	0	0	0	0	+50°	
+48°	+52°	0	0.1	0.2	0.2	0.3	0.4	0.5	0.5	0.6	0.7	0.8	0.9	0.9	1.0	+52°	+48°
+46°	+54°	0	0.2	0.3	0.5	0.6	0.8	0.9	1.1	1.3	1.4	1.6	1.7	1.9	2.0	+54°	+46°
+44°	+56°	0	0.2	0.5	0.7	0.9	1.2	1.4	1.6	1.9	2.1	2.4	2.6	2.8	3.1	+56°	+44°
+42°	+58°	0	0.3	0.6	0.9	1.3	1.6	1.9	2.2	2.5	2.8	3.1	3.5	3.8	4.1	+58°	+42°
+40°	+60°	0	0.4	0.8	1.2	1.6	2.0	2.4	2.7	3.1	3.5	3.9	4.3	4.7	5.1	+60°	+40°
+38°	+62°	0	0.5	0.9	1.4	1.9	2.4	2.8	3.3	3.8	4.2	4.7	5.2	5.7	6.1	+62°	+38°
+36°	+64°	0	0.5	1.1	1.6	2.2	2.7	3.3	3.8	4.4	4.9	5.5	6.0	6.6	7.1	+64°	+36°
+34°	+66°	0	0.6	1.3	1.9	2.5	3.1	3.8	4.4	5.0	5.7	6.3	6.9	7.5	8.2	+66°	+34°
+32°	+68°	0	0.7	1.4	2.1	2.8	3.5	4.2	4.9	5.7	6.4	7.1	7.8	8.5	9.2	+68°	+32°
+30°	+70°	0	0.8	1.6	2.4	3.1	3.9	4.7	5.5	6.3	7.1	7.9	8.6	9.4	10.2	+70°	+30°
+28°	+72°	0	0.9	1.7	2.6	3.5	4.3	5.2	6.0	6.9	7.8	8.6	9.5	10.4	11.2	+72°	+28°
+26°	+74°	0	0.9	1.9	2.8	3.8	4.7	5.7	6.6	7.5	8.5	9.4	10.4	11.3	12.3	+74°	+26°
+24°	+76°	0	1.0	2.0	3.1	4.1	5.1	6.1	7.1	8.2	9.2	10.2	11.2	12.2	13.3	+76°	+24°
+22°	+78°	0	1.1	2.2	3.3	4.4	5.5	6.6	7.7	8.8	9.9	11.0	12.1	13.2	14.3	+78°	+22°
+20°	+80°	0	1.2	2.4	3.5	4.7	5.9	7.1	8.2	9.4	10.6	11.8	13.0	14.1	15.3	+80°	+20°

+18°	+82°	0	1.3	2.5	3.8	5.0	6.3	7.5	8.8	10.0	11.3	12.6	13.8	15.1	16.3	+82°	+18°
+16°	+84°	0	1.3	2.7	4.0	5.3	6.7	8.0	9.4	10.7	12.0	13.4	14.7	16.0	17.4	+84°	+16°
+14°	+86°	0	1.4	2.8	4.2	5.7	7.1	8.5	9.9	11.3	12.7	14.1	15.6	17.0	18.4	+86°	+14°
+12°	+88°	0	1.5	3.0	4.5	6.0	7.5	9.0	10.4	11.9	13.4	14.9	16.4	17.9	19.4	+88°	+12°
+10°	+90°	0	1.6	3.1	4.7	6.3	7.9	9.4	11.0	12.6	14.1	15.7	17.3	18.9	20.4	+90°	+10°
+8°	+92°	0	1.6	3.3	4.9	6.6	8.2	9.9	11.5	13.2	14.8	16.5	18.1	19.8	21.4	+92°	+8°
+6°	+94°	0	1.7	3.5	5.2	6.9	8.6	10.4	12.1	13.8	15.6	17.3	19.0	20.7	22.5	+94°	+6°
+4°	+96°	0	1.8	3.6	5.4	7.2	9.0	10.8	12.6	14.5	16.3	18.1	19.9	21.7	23.5	+96°	+4°
+2°	+98°	0	1.9	3.8	5.7	7.5	9.4	11.3	13.2	15.1	17.0	18.9	20.7	22.6	24.5	+98°	+2°
0°	+100°	0	2.0	3.9	5.9	7.9	9.8	11.8	13.7	15.7	17.7	19.6	21.6	23.6	25.5	+100°	0°
-2°	+102°	0	2.0	4.1	6.1	8.2	10.2	12.3	14.3	16.3	18.4	20.4	22.5	24.5	26.6	+102°	-2°
-4°	+104°	0	2.1	4.2	6.4	8.5	10.6	12.7	14.8	17.0	19.1	21.2	23.3	25.5	27.6	+104°	-4°
-6°	+106°	0	2.2	4.4	6.6	8.8	11.0	13.2	15.4	17.6	19.8	22.0	24.2	26.4	28.6	+106°	-6°
-8°	+108°	0	2.3	4.6	6.8	9.1	11.4	13.7	15.9	18.2	20.5	22.8	25.1	27.3	29.6	+108°	-8°
-10°	+110°	0	2.4	4.7	7.1	9.4	11.8	14.1	16.5	18.9	21.2	23.6	25.9	28.3	30.6	+110°	-10°
-12°	+112°	0	2.4	4.9	7.3	9.7	12.2	14.6	17.0	19.5	21.9	24.4	26.8	29.2	31.7	+112°	-12°
-14°	+114°	0	2.5	5.0	7.5	10.1	12.6	15.1	17.6	20.1	22.6	25.1	27.7	30.2	32.7	+114°	-14°
-16°	+116°	0	2.6	5.2	7.8	10.4	13.0	15.6	18.1	20.7	23.3	25.9	28.5	31.1	33.7	+116°	-16°
-18°	+118°	0	2.7	5.3	8.0	10.7	13.4	16.0	18.7	21.4	24.0	26.7	29.4	32.1	34.7	+118°	-18°
-20°	+120°	0	2.7	5.5	8.2	11.0	13.7	16.5	19.2	22.0	24.7	27.5	30.2	33.0	35.7	+120°	-20°
-22°	+122°	0	2.8	5.7	8.5	11.3	14.1	17.0	19.8	22.6	25.4	28.3	31.1	33.9	36.8	+122°	-22°
-24°	+124°	0	2.9	5.8	8.7	11.6	14.5	17.4	20.3	23.3	26.2	29.1	32.0	34.9	37.8	+124°	-24°
-26°	+126°	0	3.0	6.0	9.0	11.9	14.9	17.9	20.9	23.9	26.9	29.9	32.8	35.8	38.8	+126°	-26°

Figure 3. Air Temperature Correction Chart

SURVEY TECHNIQUE FOR DENSELY DISTRIBUTED CONTROL LEVELS

This technique may be employed only when one or more bench marks are located near each 5-mile segment of microwave path.

Equipment Required

1. One Precision Surveying Altimeter, 4.)

American Paulin System, Micro Series, complete with thermometer, magnifier, and field book. (See figure 1.)

2. One wrist or pocket chronometer, one 100-foot steel tape, one pair of field glasses, and one pocket transit combining the features of a sighting compass, hand level, and clinometer. (See figure 4.)

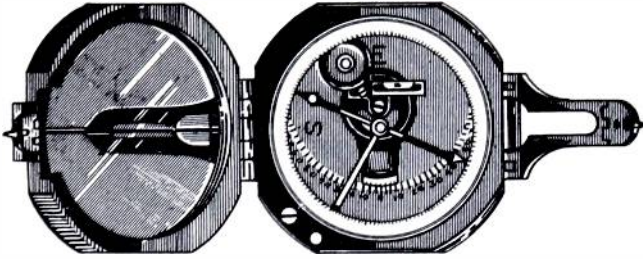

POCKET TRANSIT

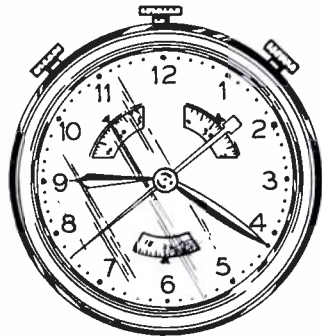

POCKET
CHRONOMETER



FIELD GLASSES

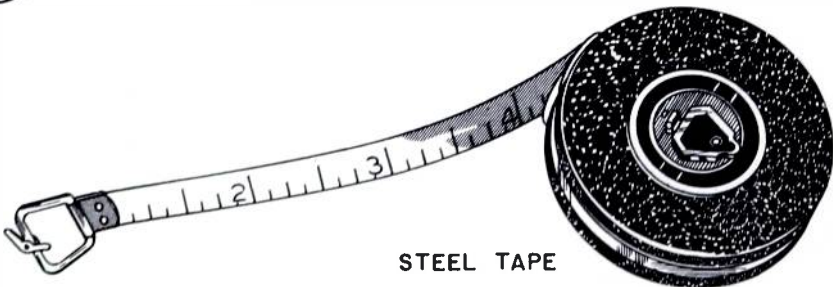

STEEL TAPE

Figure 4. Additional Equipment for the Survey

3. Topographic map data of area to be surveyed, such as U.S.G.S.* quadrangle maps (see figure 5), U.S. Engineers and Air Force maps published by the Army Map Service (see figure 6), U.S.C.&G.S.† control-level-line listings and index maps, CAA Sectional Aeronautical Charts (see figure 7), county general highway maps, U.S. Forestry Service maps, up-to-date road maps, and pertinent strip and profile maps when available from such customers as railroad, oil, and power companies. In the accomplishment of foreign surveys, equivalent map coverage should be obtained whenever possible.

Personnel Required

One man, adequately trained and experienced in altimeter surveying, and equipped with means for expedient movement along the microwave path, is required, and suitable assistance must be available when needed.

Planning the Survey Itinerary

In order to ensure a high order of accuracy and reliability of elevation data, the various readings must be taken over the shortest possible period of time. Therefore, it is necessary to make the proper preparations prior to starting the actual reading of elevations, to eliminate lost time during the actual run. These preparations are made by utilizing the topographic-map data described under Equipment Required. (See figures 5, 6, and 7.) In cases where difficulties are anticipated on the actual run, it is advisable to make a preliminary run over the area. On this run, valuable information is obtained concerning the best routes to follow on the actual run, and an acquaintance is made with bench-mark locations and pertinent landmarks.

* United States Geological Survey.

† United States Coast and Geodetic Survey.

1. Making use of the topographic maps (see figures 5, 6, and 7), a rectangle is laid out which encloses the area for $\frac{1}{4}$ mile on each side of the microwave path for the proposed hop. This long, narrow rectangle is divided into a series of segments, by lines drawn perpendicular to the path at intervals of approximately 5 miles, as shown in figure 8. The area enclosed in the large rectangle is surveyed, to determine the positions and elevations of the terrain and obstructions of highest elevations along the path.

2. A circle of $\frac{1}{4}$ -mile radius is laid out on the maps, using each proposed tower site as a center, as shown in figure 9. The areas enclosed by these two circles are surveyed, to determine the positions and elevations of all practicable tower sites. The reason for this procedure is that it may be necessary to select an actual tower site at some location other than that of the proposed site, in order to circumvent adverse propagation effects resulting from such conditions as obstructions on the microwave path or multipath interference from reflecting surfaces. Movement of the tower to a site of different elevation will naturally result in a change of tower-height requirement.

3. All bench marks that exist near and within the areas enclosed by the 5-mile segments of the large rectangle and the two tower-site circles laid out on the maps are located, as shown in figure 10. There must be at least one bench mark near or within each 5-mile segment, to ensure reliability of the data obtained by using this single-instrument procedure. These bench marks are used as control points, to establish the variation in barometric pressure with time in the area, so that accurate corrections may be applied to the altimeter readings. In the event that all of the bench marks were not determined by the same surveying agency (such as U.S.C.&G.S.),

the applicable control-level listings must be consulted to determine whether there are any discrepancies among the reference levels utilized to set the benchmark elevations. All bench marks are then referenced to the same level, and the resultant values are used in the survey.

Following are three examples of descriptions of bench-mark locations in a control-level listing:

G 164—At Holmesville, Brown County, on the Webster & Southern Railroad, at the Carlton Electric Co. power dam, 40 feet north of power building, 40 feet south of a highway bridge, in a concrete walk on the east side of the dam, and 15 feet west of the center line of the track. A standard disk, stamped "G 164 1934."

Chiseled Cross—About 1.6 miles south along the Webster & Southern

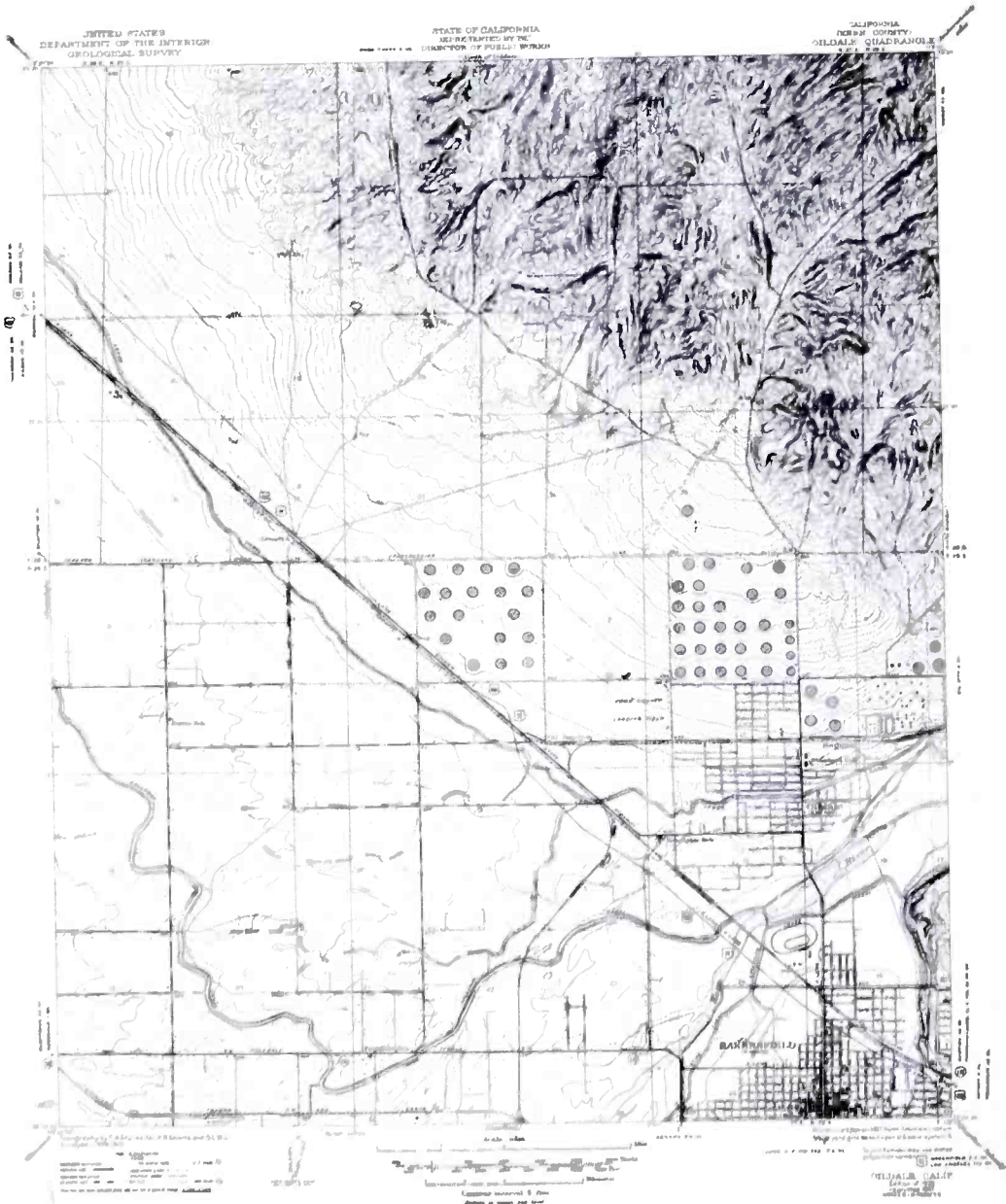

Figure 5. Typical U.S.G.S. Quadrangle Map



4 W 3, 1922

Copyright under the authority of the War Department, by the Army Map Service, for the use of the War Department, in the form of a map, is hereby granted to the public for non-commercial purposes in the United States and its possessions, territories and possessions, and in all other countries where copyright is secured, on the condition that the recipient thereof shall not, without the express written permission of the War Department, make any further copies or reproductions, or in any way use the same for profit or other commercial purposes.

LEGEND
Scale 1:24,000

Symbol	Description	Symbol	Description
(Solid black)	Water	(Dashed line)	Proposed road
(Thick black line)	Major road	(Thin solid line)	Minor road
(Thin solid line)	Minor road	(Dotted line)	Proposed minor road
(Thin solid line)	Minor road	(Dotted line)	Proposed minor road
(Thin solid line)	Minor road	(Dotted line)	Proposed minor road

Scale 1:24,000

(ON FOUR-INCH PRINTS)
POLYCONIC PROJECTION

AND MAPS BY U.S. GEOLOGICAL SURVEY, WASHINGTON, D. C.

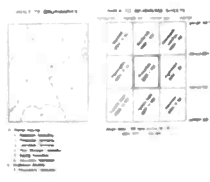

PRINCETON, NEW JERSEY
6064-I-SW

Figure 6. Typical U.S. Engineers and Air Force Map

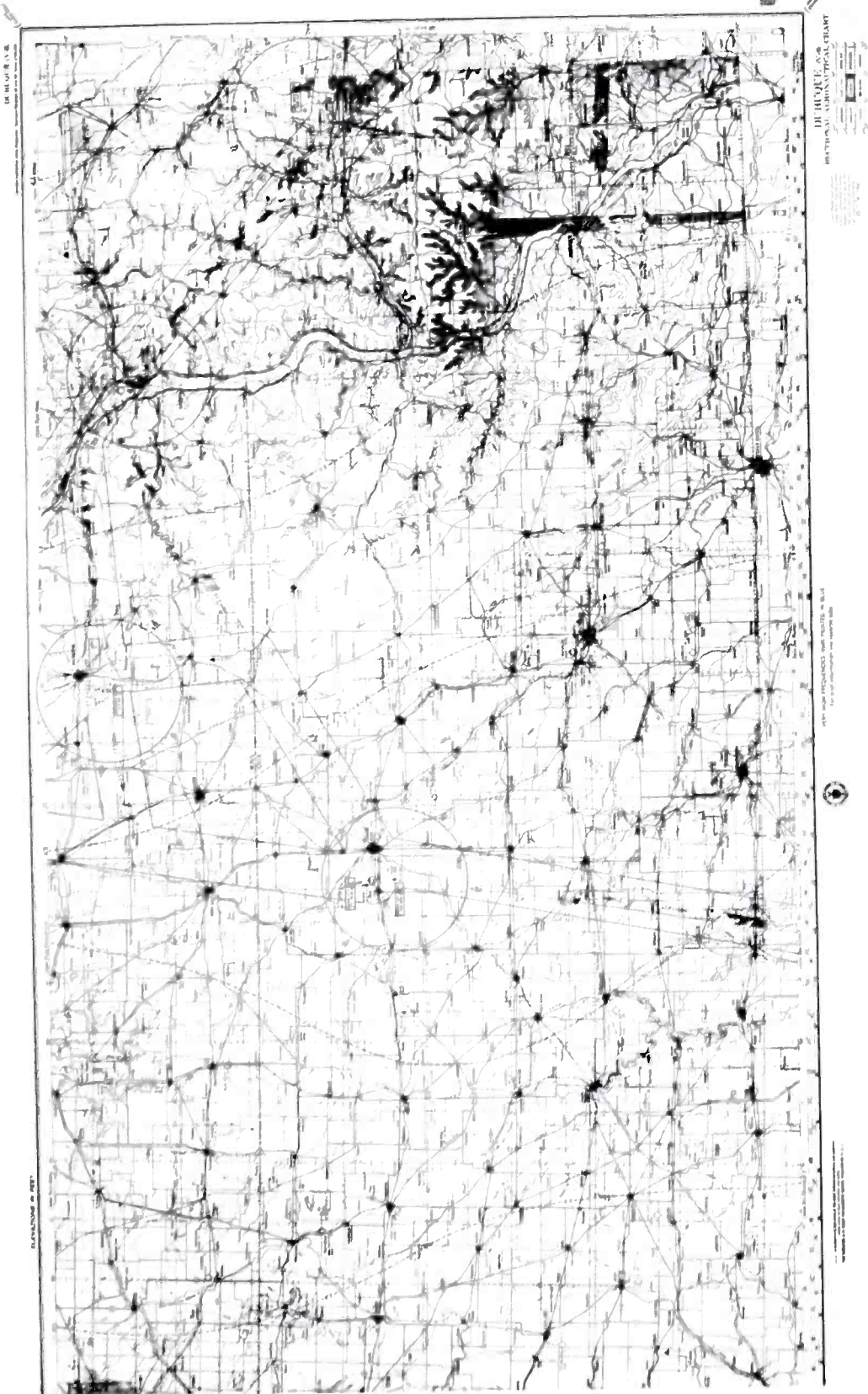

Figure 7. Typical CAA Sectional Aeronautical Chart

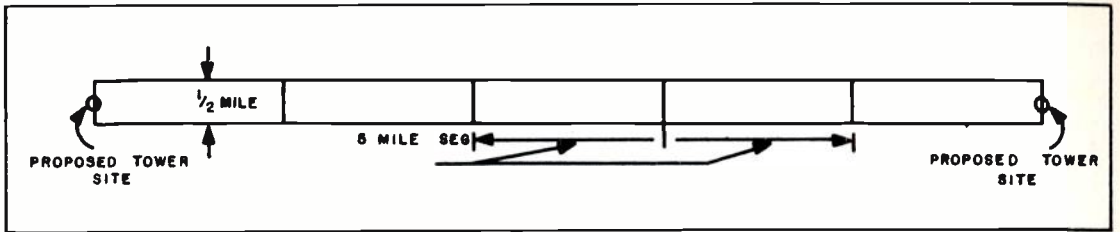

Figure 8. Method of Dividing the Microwave Path into Segments

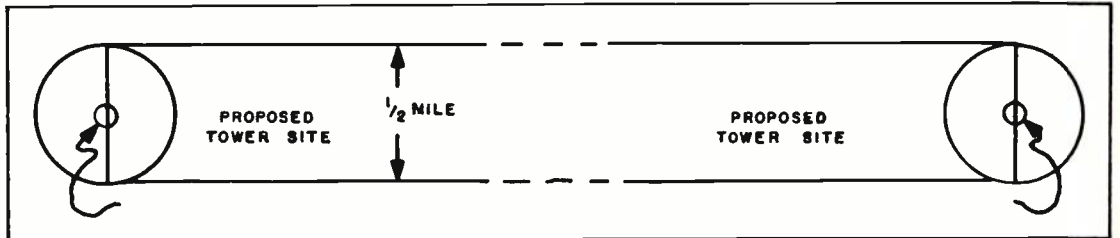

Figure 9. Method of Laying Out the Proposed Tower Site Areas

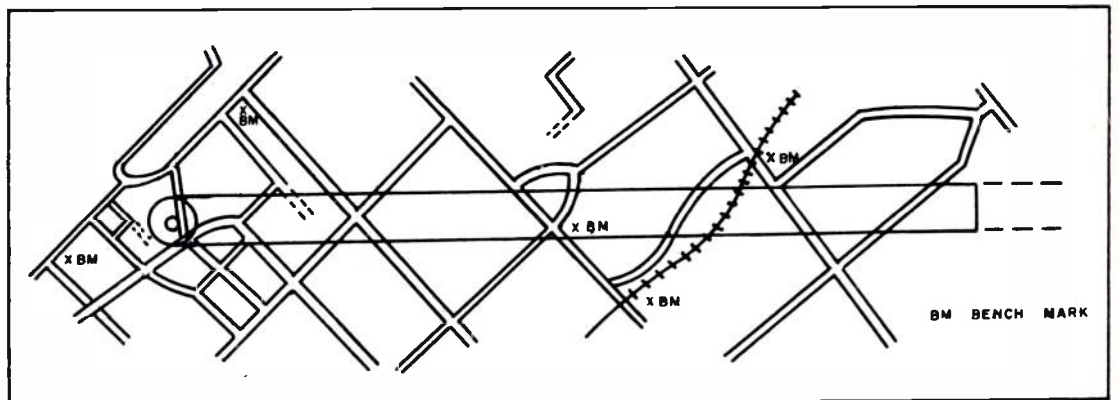

Figure 10. Method of Locating the Bench-Marks in Proximity to the Microwave Path

Railroad from the Carlton Electric Co. power dam at Holmesville, Brown County, at the north end of bridge 105.70 over Mud Creek, between the rails, and on the center of a steel cross beam. A chiseled cross.

Holmesville, top of east rail opposite the Webster & Southern Railroad ticket office.

Following are three examples of the tabulation of bench-mark elevations in a control-level listing:

B.M.	Adjusted Elevation	
	meters	feet
G 164	372.585	1222.389
Chiseled Cross	373.457	1225.250
Holmesville, E. Rail		1221.1

4. Making use of the topographic map data, a preliminary route and schedule are planned by estimating times of arrival at the various places where readings are to be taken, based upon satisfying the following conditions:

a. Each 5-mile segment of the path is explored as a separate area, within

which elevation readings are taken as rapidly as possible. The route is planned so that a reading is taken at a bench mark (also called a control point) at least every 45 minutes. This frequency of control-point readings is necessary in order that the fluctuations of barometric pressure in the locality during the time the various elevation readings are taken may be accurately determined. If only one bench mark is located near a given segment, it is necessary to return to this mark each time a control-point reading is needed. If more than one bench mark is located near a given path segment, a reading at the nearest bench mark will suffice each time a control-point reading is needed. For the purpose of establishing the route for each segment, the $\frac{1}{2}$ -mile circular area at each tower site is considered as a part of the adjacent segment.

b. Although the survey may be started at a bench mark near any convenient path segment, it is usually simpler to begin at the bench mark closest to one of the tower sites. The first and last of the series of readings taken for a given path segment, or tower-site area and adjacent segment combined, are taken at a bench mark. Readings are taken at all practicable alternate tower sites within $\frac{1}{4}$ mile of each proposed tower site. It is particularly important to determine the elevations of the lowest possible tower positions within each tower-site area.

c. Readings are normally taken at $\frac{1}{2}$ -mile intervals along the microwave path. These intervals may be increased to 1 mile or more if the terrain is relatively flat, but must be reduced to $\frac{1}{4}$ mile or less when steep slopes are traversed. Time must be allowed for additional readings in towns and in heavily wooded areas, because it is more difficult to determine the points of highest elevation when the view of surrounding terrain is limited. Also, additional time is needed for determining obstruction

heights. Each reading will usually require about 3 minutes. The time required to travel the distance between points where readings are taken will depend on the accessibility of roads and their condition, and on the type of terrain that must be traversed afoot. The taking of elevation readings, including a control-point reading every 45 minutes, is continued until the survey of a given path segment is complete. The procedure is repeated for each path segment, until the opposite tower site is reached. The survey itinerary is planned so that stops for lunch and at the end of the work day are made between surveys of individual path segments. This practice prevents excessive error due to failure to maintain the proper frequency of control-point readings.

Taking the Elevation Readings

1. Although the altimeter is temperature-compensated, it is necessary to allow sufficient time for the instrument to become uniformly heated or cooled to the outdoor air temperature before readings are taken. At least 1 hour must be allowed for the instrument temperature to equalize after it is taken through a marked temperature change, such as from a heated building or vehicle to outdoor air at low temperature. If possible, it is advisable to store the instrument in an unheated building or vehicle during the night preceding the day of use. This practice minimizes lost time on the following day. When in use, the altimeter must be shaded from the direct rays of strong sunlight, to prevent heating of parts to temperatures above that of the outdoor air.

2. When taking the first reading for each 5-mile segment, the altimeter is positioned on the bench mark and leveled by tilting until the level indicator bubble is centered. The instrument is then balanced by rotating the pointer knob until the balance indicator, its

image in the mirror, and the balance mark are exactly in line. The magnifier aids in making this adjustment. The altimeter is calibrated by holding the pointer knob stationary at the balance point and adjusting the reset control to indicate the same altitude as that of the bench mark. The magnifier is used to recheck the instrument balance and to note the reading of the pointer on the scale; this reading is then recorded. It is not necessary that the reading of the altimeter agree exactly with the elevation of the bench mark, since a correction will automatically be applied later to eliminate the error. Finally, the time of day and the air temperature are recorded. When taking subsequent readings for each 5-mile segment, the technique used is the same except that the instrument calibration is not changed; that is, the reset control is not disturbed. A sample record of readings is shown in figure 11.

3. By the use of the techniques described in the paragraph above, the survey itinerary is followed and readings are taken at the proper points. Deviations from the survey itinerary are made as warranted by conditions encountered on the actual run. The proper point to take an elevation reading within each path element ($\frac{1}{4}$ to 1-mile segment) is on the terrain of highest elevation. The pocket transit is used as a hand level to determine this point by sighting about the path element area.

4. Where objects extend above the terrain of highest elevation in a path element, the heights of the objects are determined by vertical triangulation, using the pocket transit as a clinometer in conjunction with the 100-foot steel tape. The locations of these objects relative to the microwave path are determined by horizontal triangulation to nearby landmarks which appear on the maps, using the pocket transit as a sighting compass. The elevations of the tops of the objects and their plan posi-

tions are recorded, so that their locations may be pinpointed on the maps. This is important because in some cases it may be more practicable to relocate a tower so that the microwave path bypasses an obstruction, rather than to increase the tower height to provide vertical clearance.

5. As the microwave path is surveyed, the surrounding countryside is subjected to close examination with the field glasses. The presence of any objects which may adversely affect propagation on the path are noted. A complete description of the location and nature of these objects is recorded. Examples of such objects are: any smooth surface of large area, such as a body of water, wide highway, or large building wall or roof, oriented in such a way that multipath interference may be caused by reflection; any radio broadcast or radar transmitter antenna operating in the vicinity of a tower site; and airports located near the microwave path.

Correcting the Elevation Readings

The pressure exerted by a column of air is dependent upon the temperature of the air, since the density of air varies inversely with its absolute temperature. The American Paulin System altimeter is calibrated to indicate true differences in altitude for an air temperature of $+50^{\circ}$ F. Therefore, an adjustment must be made in the elevation readings when the average air temperature for two successive readings differs from $+50^{\circ}$ F.

The density of a true gas is inversely proportional to its temperature on the absolute scale. Since the altimeter is calibrated for 50° F., which is 510° above absolute zero, the pressure varies by $1/510$, or 0.196 percent, for each degree of temperature change. Since air is not a true gas, the pressure change is actually 0.204 percent per degree variation from $+50^{\circ}$ F. When the mean air temperature exceeds $+50^{\circ}$ F., the alti-

PHILCO MICROWAVE SYSTEM
ALTIMETER SURVEY

System WEBSTER & SOUTHERN RAILROAD
Hop Designation BRASS HILL TO
HOLMESVILLE, MISSOURI
Signal Path Surveyed FIRST 10 MILES OF
HOP FROM BRASS HILL NORTH

ALTIMETER OBSERVATIONS
OF SURVEYING OBSERVER
Observer A. D. Williamson
Date APRIL 14 19 53
Sheet No. 1 of 3 Sheets

Weather Conditions SLIGHT BREEZE. SKY CLEAR BECOMING PARTLY
CLOUDY BY LATE MORNING. SUN ROSE AT 5:50 A.M.

I	II	III	IV	V
Loc. No.	Description of Location	Hour	Reading	Temp.
1	U.S.G.S. BM. 0 141 1/2 MILE SE OF BRASS HILL	8:51	1517	35
2	PROPOSED TOWER SITE AT BRASS HILL	9:02	1561	37
3	ALTERNATE SITE, 2 MILES N. & W. OF BRASS HILL	9:07	1502	39
4	1.7 MILES N OF BRASS HILL ALONG PATH	9:20	1459	40
5	3 " " " " " " " "	9:26	1484	43
6	U.S.G.S. BM 171 AT CEDAR SCHOOL	9:30	1470	46
7	4.1 MILES N. OF BRASS HILL ALONG PATH	9:39	1410	45
8	4.8 " " " " " " " "	9:45	1481	49
9	SAME AS LOC. #6	10:08	1481	51
10	U.S.G.S. BM TYS. 61K 6 MILES NNE OF BRASS HILL	10:20	1404	55
11	6 MILES N OF BRASS HILL ALONG PATH	10:29	1452	58
12	6.6 " " " " " " " "	10:37	1381	60
13	7.5 " " " " " " " "	10:51	1354	63
14	TOP OF W. RAIL OPPOSITE W & S RR MP 79	10:58	1318	64
15	8.4 MILES N. OF BRASS HILL ALONG PATH	11:05	1361	65
16	9 " " " " " " " "	11:15	1300	67
17	9.9 " " " " " " " "	11:22	1244	69
18	U.S.G.S. TBM 9 11 MILES N. OF BRASS HILL	11:33	1116	70

Figure 11. Sample Record of Observer Using a Single Instrument

meter indicates a difference in elevation between two points which is less than the actual difference in elevation. Conversely, a mean air temperature of less than +50° F., will cause the altimeter to indicate an elevation difference which is greater than the actual difference.

The adjustment for temperature is calculated and made on a suitable chart, as shown in figure 12. The computations shown in figure 12 are based on the data listed in figure 11. The easiest way to compute percent adjustment is by means of the formula:

$$\% \text{ adjustment} = (T_1 + T_2 - 100) 0.102$$
where T_1 is the air temperature at a given reading in ° F., and T_2 is the air temperature at the following reading in ° F. The sum of the temperatures, $T_1 + T_2$, is tabulated in column VIII. Notice that the percent adjustment (column IX) is positive when $T_1 + T_2$ exceeds 100° F., and negative when $T_1 + T_2$ is less than 100° F. The appropriate polarity sign is prefixed to each percent-adjustment value tabulated in the chart, as shown in figure 12.

The differences in elevation readings (column VII) are obtained by subtracting any given reading from the following reading. The difference in readings is positive when ascending, and negative when descending. The appropriate polarity sign is prefixed to each difference-in-readings value tabulated in the chart, as shown in figure 12.

The actual temperature adjustment in feet (column X) is obtained by algebraic multiplication of the percent adjustment by the difference in readings (observing polarity signs). A running total is tabulated in column XI, by algebraic addition of each figure in column X and the figure just above and to the right in column XI, rounding out the values to the nearest foot.

The adjusted readings (column XII) are obtained by adding, algebraically,

each figure in column XI in figure 12 to the corresponding elevation reading (column IV) in figure 11.

In addition to temperature changes, variations in barometric pressure in a locality during the time that elevation readings are being taken introduce an error for which a correction must be applied. A pressure change of 1/100th of an inch of mercury changes the altimeter rating by about 10 feet. These variations in pressure are caused by the movement of high- and low-pressure centers, local storms and atmospheric disturbances, and the effect of sunshine on the atmosphere. The normal pressure variation due to the sun amounts to about 1/10th of an inch of mercury (equivalent to a 100-foot difference in elevation) in latitude 30°. This normal daily variation is known as the "diurnal range." There is a high barometric pressure about 3 hours after sunrise and a low pressure about 6 hours later, a secondary high during the night, and a secondary low about sunrise. The diurnal variation is more pronounced in the tropics than in high latitudes.

Errors due to variations in barometric pressure are readily corrected by using the data obtained at the control points (bench-mark readings). The barometric correction, C_B (column XIII of figure 12), is computed by subtracting the adjusted reading (column XII) from the actual elevation as obtained from the control-level listings, and is tabulated in column XIV for each bench-mark location. The barometric-correction figures thus obtained are plotted against their corresponding times of reading on linear graph paper, as shown in figure 13, and a smooth curve is drawn connecting these control points. The correction for each intermediate elevation reading is then determined by reading the value of C_B on the curve for the time corresponding to the reading, and the correction is tabulated in column XIII (figure 12). Finally, the actual elevations (column

XIV) are determined by algebraic addition of the adjusted readings (column XII) and their respective C_B values (column XIII).

or no bench marks are located near the microwave path.

Equipment Required

- Two Precision Surveying Altimeters, American Paulin System, Micro Series, each complete with thermometer, magnifier, and field book.

SURVEY TECHNIQUE FOR SPARSELY DISTRIBUTED CONTROL LEVELS

This technique is employed when few

PHILCO MICROWAVE SYSTEM ALTIMETER SURVEY

System WEBSTER & SOUTHERN RAILROAD
Hop Designation BRASS HILL TO
HOLMESVILLE, MISSOURI
Signal Path Surveyed FIRST 10 MILES
OF HOP FROM BRASS HILL NORTH

ALTIMETER CORRECTIONS FOR SINGLE INSTRUMENT

Computer R. H. Williams
Date APRIL 14 53
Sheet No. 1 of 5 Sheets

VI Loc. No.	VII Difference in Readings	VIII Sum of Temps.	IX Temperature Adjustment			XII Adjusted Reading	XIII C_B	XIV Actual Elev.	XV Loc. No.
			Percent	Actual	Total				
1					0	1517	+2	1519	*1
2	+44	72	-2.9	-1.3	-1	1560	+2	1562	2
3	-59	76	-2.5	+1.5	+1	1503	+1	1504	3
4	-43	79	-2.1	+9	+2	1461	-1	1460	4
5	+25	83	-1.7	-.3	+2	1486	-2	1484	5
6	-14	88	-1.2	+2	+2	1472	-3	1469	*6
7	-60	91	-.9	+5	+3	1413	-5	1408	7
8	+71	95	-.5	-.4	+3	1484	-7	1477	8
9	0	100	0	0	+3	1484	-15	1469	*9
10	-77	106	+6	-.5	+2	1406	-5	1401	*10
11	+48	113	+1.3	+6	+3	1455	-8	1447	11
12	-61	118	+1.8	-1.1	+2	1393	-11	1382	12
13	-37	123	+2.3	-.9	+1	1355	-16	1339	13
14	-36	127	+2.8	-1.1	0	1318	-20	1298	*14
15	+43	129	+3.0	+1.3	+1	1362	-23	1339	15
16	-61	132	+3.3	-2.0	-1	1299	-27	1272	16
17	-56	136	+3.7	-2.1	-3	1241	-29	1212	17
18	-128	139	+4.0	-5.1	-8	1108	-34	1074	*18

Figure 12. Sample Computations From Single Instrument Data

BAROMETRIC CORRECTION FOR SINGLE INSTRUMENT



WEBSTER & SOUTHERN RAILROAD - FIRST 10 MILES OF HOP NORTH FROM BRASS HILL TO HOLMESVILLE, MO.
R. H. WILLIAMSON 4-14-53
SHEET 1 OF 3 SHEETS

Figure 13. Sample Graph of Barometric Corrections

2. Two wrist or pocket chronometers, one 100-foot steel tape, one pair of field glasses, and one pocket transit combining the features of a sighting compass, hand level, and clinometer.

3. Topographic map data of area to be surveyed, such as U.S.G.S. quadrangle maps, U.S. Engineers and Air Force maps published by the Army Map Service, U.S.C. & G.S. control-level-line listings and index maps, CAA Sectional Aeronautical Charts, county general highway maps, U.S. Forestry Service maps, up-to-date road maps, and pertinent strip and profile maps when available from such customers as railroads, and oil and power companies. In the accomplishment of foreign surveys, equivalent map coverage should be obtained whenever possible.

Personnel Required

Two men, adequately trained and experienced in altimeter surveying, equipped with means of transportation for expedient movement along the microwave path.

Planning the Survey Itinerary

1. Making use of the topographic maps, lay out a rectangle which encloses the area for $\frac{1}{4}$ mile on each side of the microwave path, divide this rectangle into a series of five-mile segments, lay out the $\frac{1}{2}$ -mile tower site circles, and locate any bench-marks which may exist near the microwave path, as described in Planning the Survey Itinerary, under SURVEY TECHNIQUE FOR DENSELY DISTRIBUTED CONTROL LEVELS.

2. Making use of the topographic map data, plan a preliminary route and schedule by estimating times of arrival at various places where readings are to be taken, based upon satisfying the following conditions:

a. Each five-mile segment of path is

explored as a separate area by one man (called the surveying observer), while the other man (called the stationary observer) takes readings at five-minute intervals at a point selected near the center of each path segment, which is readily accessible by road.

b. After the stationary observer has reached his position at the selected point, the surveying observer begins taking readings at a tower site or path-segment junction. Readings are taken at all practical alternate tower sites within $\frac{1}{4}$ mile of each proposed tower site. Readings are then taken at half-mile intervals along the microwave path. These intervals may be increased to one mile or more if the terrain is relatively flat, but must be reduced to $\frac{1}{4}$ mile or less when traversing steep slopes. Time must be allowed for additional readings in towns and heavily wooded areas, because it is more difficult to determine the points of highest elevation when the view of surrounding terrain is limited. Also, additional time is needed for determining obstruction heights. Each reading will usually require about three minutes. The time required to travel the distance between points where readings are to be taken will depend upon road accessibility and condition, and the type of ground to be traversed by foot.

c. The surveying observer continues taking readings along the microwave path until the survey of a given path segment is complete. The last reading is taken at a point near the junction of the next path segment. When a bench mark is located near a given path segment, a reading is also taken at the mark. When the surveying observer completes his readings for a given path segment, the stationary observer moves to the point in the next path segment, and again takes readings at five-minute intervals. The surveying observer begins the survey of this next path segment by taking a reading at the same point

where the last reading was taken for the preceding path segment. It is absolutely necessary to take two readings at a common point near the junction of two path segments, when bench-mark readings are not included in both segments, to determine the variation in barometric pressure during the time that the stationary observer is changing positions. One reading is taken when the stationary observer is at his position in a given path segment, and the second reading is taken when the stationary observer is at his position in the adjacent path segment. The above procedure is repeated until the opposite tower site is reached. The survey itinerary is planned so that stops for lunch and at the end of the work day are made between surveys of individual path segments.

Taking the Elevation Readings

1. Proper allowances are made to ascertain that the altimeters have equalized to the outdoor air temperature, as described in Taking the Elevation Readings, under SURVEY TECHNIQUE FOR DENSELY DISTRIBUTED CONTROL LEVELS.

2. Both altimeters are set at the selected stationary position, and each instrument is leveled by tilting until the level indicator bubble is centered. Each instrument is then balanced by rotating the pointer knob until the balance indicator, its image in the mirror, and the balance mark are exactly in line. The magnifier aids in making this adjustment. The altimeters are calibrated by holding the pointer knob of one instrument stationary at the balance point and adjusting the reset control to indicate the same altitude as that indicated by the other instrument. The magnifier is used to recheck instrument balance and to note the reading of the pointer on the scale. It is not necessary that the readings of the two altimeters agree exactly, since a correction will automatically be applied later to eliminate the

discrepancy. The reset controls on the altimeters are not disturbed after they have been set at the beginning of the survey for a given hop.

3. The stationary observer remains at his position, noting and recording the time of day, air temperature, and altimeter reading every five minutes until notified by the surveying observer that the survey of the path segment is complete. A sample record of readings taken by a stationary observer is shown in figure 14. The surveying observer takes his first set of readings at the stationary position and proceeds to survey the path segment as described in Taking the Elevation Readings, under SURVEY TECHNIQUE FOR DENSELY DISTRIBUTED CONTROL LEVELS. The surveying observer makes certain to include a reading at a point near the path junction where a reading was also taken for the preceding path segment. A sample record of readings taken by a surveying observer is shown in figure 15. When the survey of a given path segment is complete, the surveying observer notifies the stationary observer. The stationary observer then takes up his position in the next path segment, and the survey is continued until the opposite tower site is reached.

Correcting the Elevation Readings

The elevation readings are subject to errors caused by temperature and barometric changes as discussed in Correcting the Elevation Readings, under SURVEY TECHNIQUE FOR DENSELY DISTRIBUTED CONTROL LEVELS. The corrections for these errors are calculated and made on a suitable chart, as shown in figure 16. The computations shown in figure 16 are based on the data listed in figures 14 and 15.

The figures listed in columns I, III, IV and V of figure 15 are transcribed directly into columns IV through VII of figure 16. For each time listed in col-

PHILCO MICROWAVE SYSTEM
ALTIMETER SURVEY

System WEBSTER & SOUTHERN RAILROAD

Hop Designation HOLMESVILLE TO
CONCORD, MISSOURI

Signal Path Surveyed FIRST 10 MILES OF
HOP FROM HOLMESVILLE NORTH

ALTIMETER OBSERVATIONS
OF STATIONARY OBSERVER

Observer J. T. Cotton

Date APRIL 15 19 53

Sheet No. 1 of 4 Sheets

Location No. <u>1</u> of Surveying Observer's Record		
Hour	Reading	Temp.
8:20	2010	37
8:25	2010	37
8:30	2009	38
8:35	2009	38
8:40	2008	38
8:45	2008	39
8:50	2008	39
8:55	2008	40
9:00	2008	40
9:05	2009	40
9:10	2009	41
9:15	2010	42
9:20	2010	42
9:25	2012	43
9:30	2013	45
9:35	2015	46
9:40	2016	46
9:45	2017	46

Location No. <u>9</u> Surveying Observer's Record		
Hour	Reading	Temp.
10:00	1640	49
10:05	1642	49
10:10	1644	49
10:15	1646	50
10:20	1648	50
10:25	1649	51
10:30	1652	50
10:35	1653	51
10:40	1655	52
10:45	1658	52
10:50	1659	54
10:55	1661	55
11:00	1664	57
11:05	1666	58
11:10	1667	59
11:15	1670	59
11:20	1672	60
11:25	1674	61

Figure 14. Sample Record of Stationary Observer

umn V of figure 16, the corresponding altimeter reading and temperature are interpolated from the data listed in figure 14, and tabulated in columns II and III of figure 16. Column I of figure 16 indicates the location of the stationary observer by the applicable location number described in the surveying observer's record (figure 15).

In figure 16, for each set of altimeter

readings, the difference in readings (column VIII) is established by algebraically subtracting the reading of the stationary observer (column II) from the reading of the surveying observer (column VI). The sum of the temperatures (column III plus column VII) are listed in column IX. The percent adjustment is computed by the formula,

$$\% \text{ adjustment} = (T_1 + T_2 - 100) .102$$

PHILCO MICROWAVE SYSTEM
ALTIMETER SURVEY

System WEBSTER & SOUTHERN RAILROAD ALTIMETER OBSERVATIONS
OF SURVEYING OBSERVER
Hop Designation HOLMESVILLE TO
CONCORD, MISSOURI Observer W.O. White
Date APRIL 15 19 53
Signal Path Surveyed FIRST 10 MILES
OF HOP FROM HOLMESVILLE NORTH Sheet No. 1 of 4 Sheets
Weather Conditions CLOUDY SKY - WIND CALM
SUN ROSE AT 5:50 AM

I	II	III	IV	V
Loc. No.	Description of Location	Hour	Reading	Temp.
1	2.9 MILES NORTH OF HOLMESVILLE ALONG PATH	8:20	2014	37
2	PROPOSED TOWER SITE AT HOLMESVILLE	8:34	2204	38
3	ALTERNATE SITE 1 MILE S OF HOLMESVILLE SITE	8:40	2191	39
4	1/2 MILES N OF HOLMESVILLE ALONG PATH	8:52	2014	39
5	2.1 " " " " " "	9:01	1956	40
6	3 " " " " " "	9:12	2028	41
7	3.7 " " " " " "	9:21	1908	41
8	4.8 " " " " " "	9:33	1852	43
9	7.7 " " " " " "	10:00	1644	49
10	SAME AS LOC. #8	10:14	1779	51
11	6.3 MILES N OF HOLMESVILLE ALONG PATH	10:28	1761	52
12	7.6 " " " " " "	10:37	1710	52
13	8.6 " " " " " "	10:49	1702	53
14	USGS. B.M. G 170 9 MILES N.W. OF HOLMESVILLE	11:06	1610	57
15	10 MILES N OF HOLMESVILLE ALONG PATH	11:16	1594	59

Figure 15. Sample Record of Surveying Observer

where, T_1 is the air temperature at a given survey location in °F., and T_2 is the air temperature at the stationary position at the same time. The percent adjustment, with the proper polarity sign prefixed, is listed in column X. The actual temperature adjustment in feet (column XI) is obtained by algebraic multiplication of the percent adjustment (column X) by the difference in read-

ings (column VIII). The adjusted elevation differences (column XII) are obtained by algebraic addition of the column VIII and column XI figures.

If the series of readings for a given hop includes a reading at a benchmark, the actual elevations of all points on the path may be determined. Determine the calibration figure by algebra-

PHILCO MICROWAVE SYSTEM ALTIMETER SURVEY

System WEBSTER & SOUTHERN RAILROAD

ALTIMETER CORRECTIONS FOR TWO INSTRUMENTS

Hop Designation HOLMESVILLE TO CONCORD, Mo.

Computer J.F. Caulton Date APRIL 15, 53

Signal Path Surveyed FIRST 10 MILES OF HOP FROM HOLMESVILLE N.

Sheet No. 1 of 4 Sheets

Stationary Altimeter			Surveying Altimeter				Diff. in Rdgs.	Sum of Temps.	Temp. Adjust.		Adj. Elev. Diff.	Calibration Figure	Actual Elev.	Loc. No.
Loc. No.	Reading	Air Temp.	Loc. No.	Hour	Reading	Air Temp.			Percent	Actual				
1	2010	37	1	8:20	2014	37	+4	74	-2.7	0	+4	1871	1875	1
1	2009	38	2	8:34	2204	38	+195	76	-2.5	-5	+190	1871	2061	2
1	2008	38	3	8:40	2191	39	+183	77	-2.4	-4	+179	1871	2050	3
1	2008	39	4	8:52	2014	39	+6	78	-2.2	0	+6	1871	1877	4
1	2008	40	5	9:01	1956	40	-62	80	-2.0	+1	-61	1871	1810	5
1	2009	41	6	9:12	2028	41	+19	82	-1.8	0	+19	1871	1890	6
1	2010	42	7	9:21	1908	41	-102	83	-1.7	+1	-101	1871	1770	7
1	2014	45	8	9:33	1852	43	-162	88	-1.2	+2	-160	1871	1711	8
9	1640	49	9	10:00	1644	49	+4	98	-2.2	0	+4	1578	1582	9
9	1646	50	10	10:14	1779	51	+133	101	+1	0	+133	1578	1711	10
9	1651	50	11	10:28	1761	52	+100	102	+2	0	+100	1578	1678	11
9	1654	51	12	10:37	1710	52	+56	103	+3	0	+56	1578	1634	12
9	1659	54	13	10:49	1702	53	+43	107	+7	0	+43	1578	1621	13
9	1666	58	14	11:06	1610	57	-56	115	+1.5	-1	-57	1578	1521	14
9	1670	59	15	11:16	1694	59	+24	118	+1.8	0	+24	1578	1602	15

Figure 16. Sample Computations From Two-Instrument Data

ically subtracting the adjusted elevation difference for the bench-mark location from the actual elevation of the bench mark. This calibration figure is tabulated in column XIII for each location of the path segment in which the bench-mark reading occurs. The actual elevations (column XIV) for all points in this path segment are then determined by adding the column XII and column XIII figures. The actual elevation of the common point in each of the adjacent path segments is transcribed into its proper space in column XIV. The calibration figure is then computed by algebraically subtracting the column XII figure from the column XIV figure for the common point location in each adjacent path segment. The actual elevations for the adjacent path segments are then determined as before. This procedure is repeated in both directions, to establish the actual elevations of all points for the hop. In the event that the series of readings for a given path segment does not

include a reading at a bench mark, the surveying of the microwave system is continued with subsequent hops until a bench mark is obtained. Then, the actual elevations of all points in the system are determined by the same procedure described above.

CONCLUSIONS

In addition to the two techniques described above, there are several other procedures that may be employed to survey microwave systems. These alternate techniques, however, are limited in practical application to special situations.

For example, a single instrument may be used to survey a microwave hop with few bench marks located nearby by substituting multiple readings at a number of locations for bench-mark readings. By comparing two or more altimeter readings taken at the same point, but

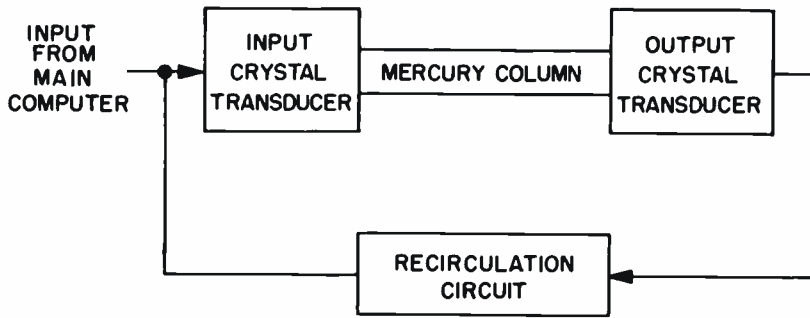

Figure 1. Simplified Block Diagram of Delay Line Memory System

the electrical impulse is reproduced across this crystal. The length of the mercury column determines the amount of delay that will take place.

The memory function of a sonic delay line is developed by causing the impulses to recirculate through the line. After the impulses arrive at the second crystal, they are fed back to the input crystal, through the recirculation circuit. (See figure 1.) The process is continuous as long as power is applied to the circuit, and the memory impulses are available at any time for gating into other computer circuits, as required.

The operation of the mercury delay-line memory system shown in figure 2 is as follows:

The information that is to be stored is applied to the AND (1) circuit, together with pulses from the computer's master-oscillator circuit. (The AND and NOT circuits mentioned in this discussion were explained in the January, 1953, issue of the BULLETIN.) When coincidence exists between these two inputs, the AND (1) circuit gates pulses through to the delay-line driver circuit. This stage amplifies the pulses and applies them to the input crystal transducer of the mercury delay line. The pulses obtained from the output crystal transducer are reduced in amplitude and distorted in shape because of the action of the delay line upon them.

They must, therefore, be restored in amplitude and shape, or recirculation through the delay line will cause them to be lost completely after a short time. The output of the delay line is applied to an amplifier and then to the AND (2) circuit. The AND (2) circuit, like the AND (1) circuit, also has applied to it pulses from the master oscillator. When coincidence occurs between the two inputs, the AND (2) circuit gates through pulses to the NOT circuit. The pulses which are gated through are not those from the amplifier, but those from the master-oscillator circuit. The reason for this is that the master-oscillator circuit provides pulses which are undistorted. In effect, then, the amplifier output is required only to gate the AND (2) circuit. The output of the AND (2) circuit is applied to the NOT circuit and, when permitted, passes on to the input of the delay-line driver, after which the process is repeated. In this manner, information once applied to the memory circuit circulates continuously until the memory circuit is cleared.

To "read out" the stored information, it is only necessary to continuously pulse the AND (3) circuit, thus gating through the pulses from the AND (2) circuit. When the stored information is no longer needed, the circulation of the pulses through the NOT circuit is blocked, so as to clear the memory circuit.

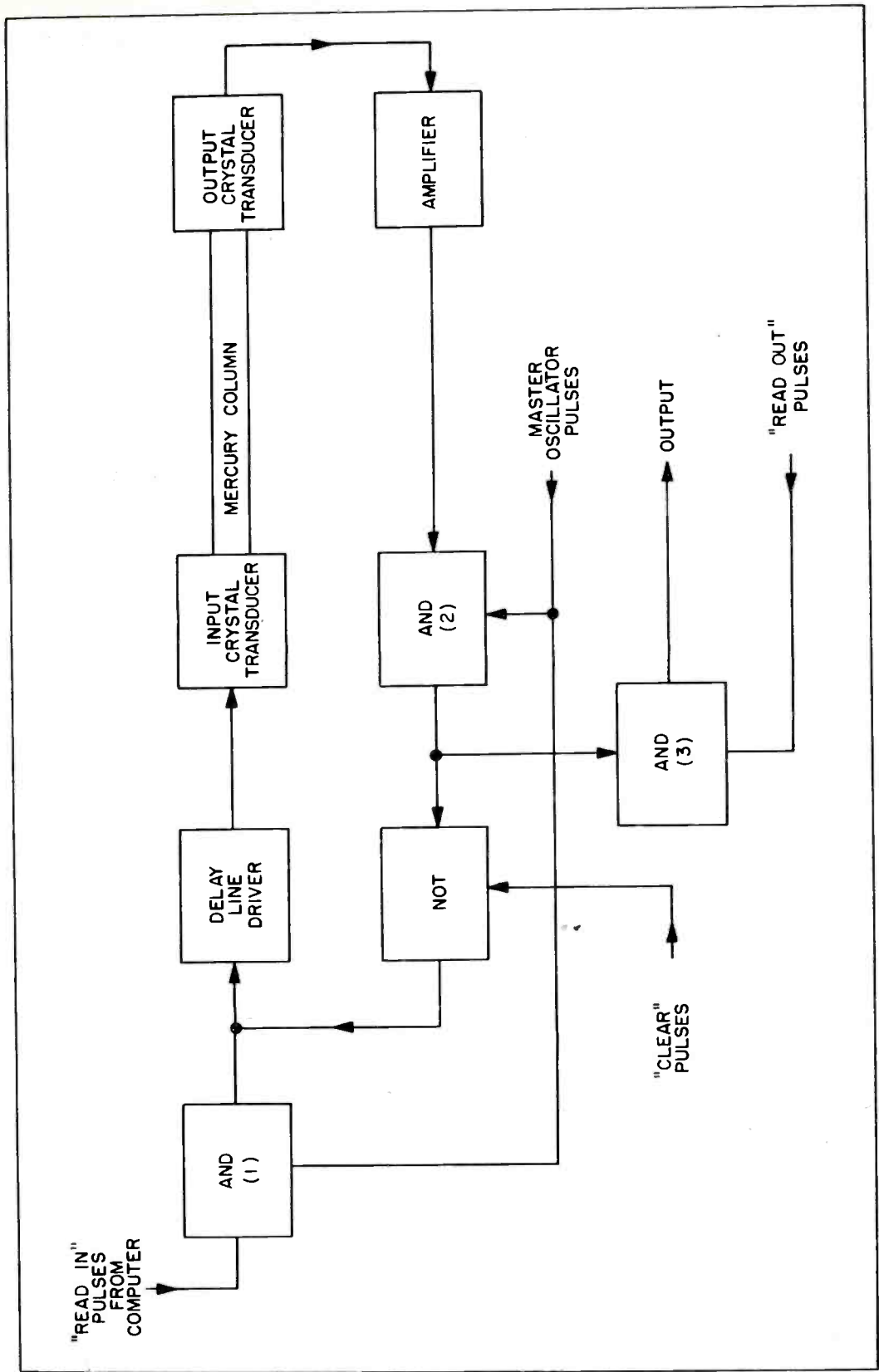

Figure 2. Detailed Block Diagram of Delay Line Memory System, Showing Recirculation System

If the "read out" information is to be valid, the pulse-chain output of the AND (3) circuit must occur in the same sequence that it entered the memory "tank"; therefore, the "read out" pulses applied to the AND (3) circuit are synchronized to occur at the exact moment when the lead pulse of the circulating pulse train arrives at the output of the AND (2) circuit.

One difficulty encountered in the sonic type of memory circuit results from the fact that the velocity of sonic waves in any medium varies with the temperature of that medium. Thus, if there is any variation in the temperature of the mercury column the velocity of the pulses will vary, and synchronization between the input to the delay line and the output to the computer will be impossible to maintain. Therefore, the temperature of the mercury column is very accurately controlled by heating coils which are acted upon by extremely sensitive thermal control circuits, or alternatively, the computer is synchronized by sync pulses circulated through the memory system.

The velocity of sound in mercury is approximately 5.7×10^4 inches per second. Therefore, if a 20-inch mercury column is used, it will take approximately $\frac{20}{5.7 \times 10^4}$ or 350 microseconds for an impulse to reach the end of the column. If the pulse rate of the computer is 1 microsecond, 350 binary digits can be stored in a 20-inch mercury column. In order to increase the storage capacity, either the column must be lengthened or the pulse rate of the computer must be increased. Modern computers can easily operate at four times the pulse rate given above, and thus they can store four times this number of digits in a 20-inch column.

As the length of the column is increased, it becomes increasingly difficult to stabilize the temperature of the mer-

cury, and, in addition, the time required to obtain the stored information becomes greater, thus slowing down the calculating speed of the computer. A mercury delay line, therefore, is suitable for only a few thousand binary digits at most; however, mercury columns may be used in parallel, to increase this number. The main disadvantage of the sonic type of memory circuit is that if the input power is removed or varied momentarily, the digits stored in the tank will either be "forgotten" or rendered invalid.

Magnetic-Drum Type

The magnetic-drum type of memory system will not forget even if the primary power is turned off for long intervals. In this type of memory system, a cylindrical drum coated with a magnetic substance is rotated at a comparatively high speed, so that the surface of the magnetic material moves past a given point at a rate of over 100 inches per second. Spaced along the surface of the drum are magnetic recording heads, called "read in" heads, arranged so that they provide parallel channels throughout the length of the drum. As the drum rotates past the heads, magnetized spots representing the information to be stored are produced by the pulses applied to the heads. The absence of a magnetized spot indicates binary 0. With modern techniques it is possible, by using parallel heads, to have over 400 magnetized spots, or binary digits, per square inch of drum surface. If the drum has an area of 250 square inches, over 100,000 binary digits may be stored.

A series of "read out" magnetic heads scan the parallel channels so that the access time for any particular digit is never greater than the time of one revolution of the drum. The "read in" and "read out" circuits are much the same as those used in the mercury memory system, except that a number

of channels are used, and each is capable of storing a separate train of binary-digit information.

There are many other types of memory systems besides the two discussed in this article. Their use in computer equipments greatly increases the scope of the operations that can be performed,

because, in addition to their ability to maintain in a state of continuous and instantaneous availability various portions of a solution, they store information on numerical methods or routines which, when followed by the computer, facilitate the solution of large classes of problems.

Solution to

Last Month's "What's Your Answer?"

The black box described in the problem contained a hybrid junction with matched loads on the E and H arms. Therefore, any power inserted into one opening would divide equally between the E and H arms with practically no transmission to the other open end. Since the system can be broad banded, no pronounced resonance effects would be noted. (An ordinary radar duplexer system could produce the required conditions, but only at one frequency.)

THE NBS MICROWAVE FREQUENCY STANDARD

IN AN EFFORT to keep pace with the growing utilization of an ever-expanding radio-frequency spectrum, the National Bureau of Standards maintains a program of research and development aimed to make available, to science and industry, accurate standards of frequency measurement. Research in microwave principles and techniques and the development of microwave frequency standards are the responsibility of the NBS Microwave Frequency Standards group, under the direction of Dr. Harold Lyons and L. J. Rueger. The laboratory used by this group is equipped to operate between 300 and 40,000 mc. with completely standardized equipment*, and up to 75,000 mc. with instruments currently in the final stages of development. In addition to its broad research and development program, the group also calibrates the secondary microwave frequency standards used in science and industry. (See the note at the end of this article.)

The vast spectrum of radio frequencies above 300 mc. is presently employed in such military applications as radar, navigation systems, blind bombing, and guided missiles. Research in microwaves has been responsible for better FM and television relay systems presently in operation and under construction. It is equally important to medicine and to those industries utilizing electronic equipment, as in dielectric heating for case-hardening of metals, rubber curing, plastic molding, food processing, textile fabrication, and radio-frequency therapy. Extended use of the millimeter bands (above 30,000 mc.) is important to work in microwave spectroscopy and microwave optics, and in applications

requiring sharp microwave beams of high resolution, such as short-range target-seeking equipment for rockets and guided missiles. However, to fully exploit the far reaches of the microwave region it is necessary to have national standards and measurement methods which provide the necessary tools for the design, development, and production engineering of practical electronic equipment, as well as for basic research.

The microwave frequencies used by the National Bureau of Standards for calibration are derived directly from one of the stable 100-kc. oscillators maintained by the Bureau for time and frequency standards. The frequency of the driving oscillator is determined to better than 1 part in 10^9 by reference to the other NBS standard oscillators and to astronomical observations made by the Naval Observatory. The standard oscillators also control the operating frequencies of the NBS radio broadcasting station WWV (Beltsville, Md.). Since the 100-kc. signal must be multiplied up to thousands of megacycles, some difficulties arise because of noise and other small effects which tend to create a phase modulation in the frequency-multiplier chain. In all, the frequency and phase modulation produced is less than 1 part in 10^8 at 300 mc., less than 1 part in 10^7 at 24,000 mc., and less than 1 part in 10^5 at 54,000 mc. The increase in bandwidth at the highest frequency arises primarily as a result of the low signal strength of the generating equipment at these levels. In special setups, bandwidths of less than one part in 10^{10} have been achieved. By comparison, resonant cavities and other secondary frequency standards are rarely dependable to better than 1 part in 10^4 ; some cavities have been constructed that

* "Microwave Measurements Standards," *NBS Tech. News Bulletin*, 32, 12 (Dec. 1948).

will consistently function within 1 part in 10^5 , but only if the temperature, humidity, and pressure are carefully controlled.

GENERATION OF STANDARD MICROWAVE FREQUENCY SIGNALS

The 100-kc. standard signals, from which the microwave frequencies are

multiplied, are developed in a Meacham bridge oscillator circuit and a carefully, hand-tailored 100-kc. crystal. They have a short-time stability (10 minutes) of 1 part in 10^{10} and a long-time stability (1 week) of 1 part in 10^9 . Two distinctly separate multiplier chains are employed in the NBS microwave frequency standard: one a fixed-frequency system, and the other an adjustable-frequency sys-

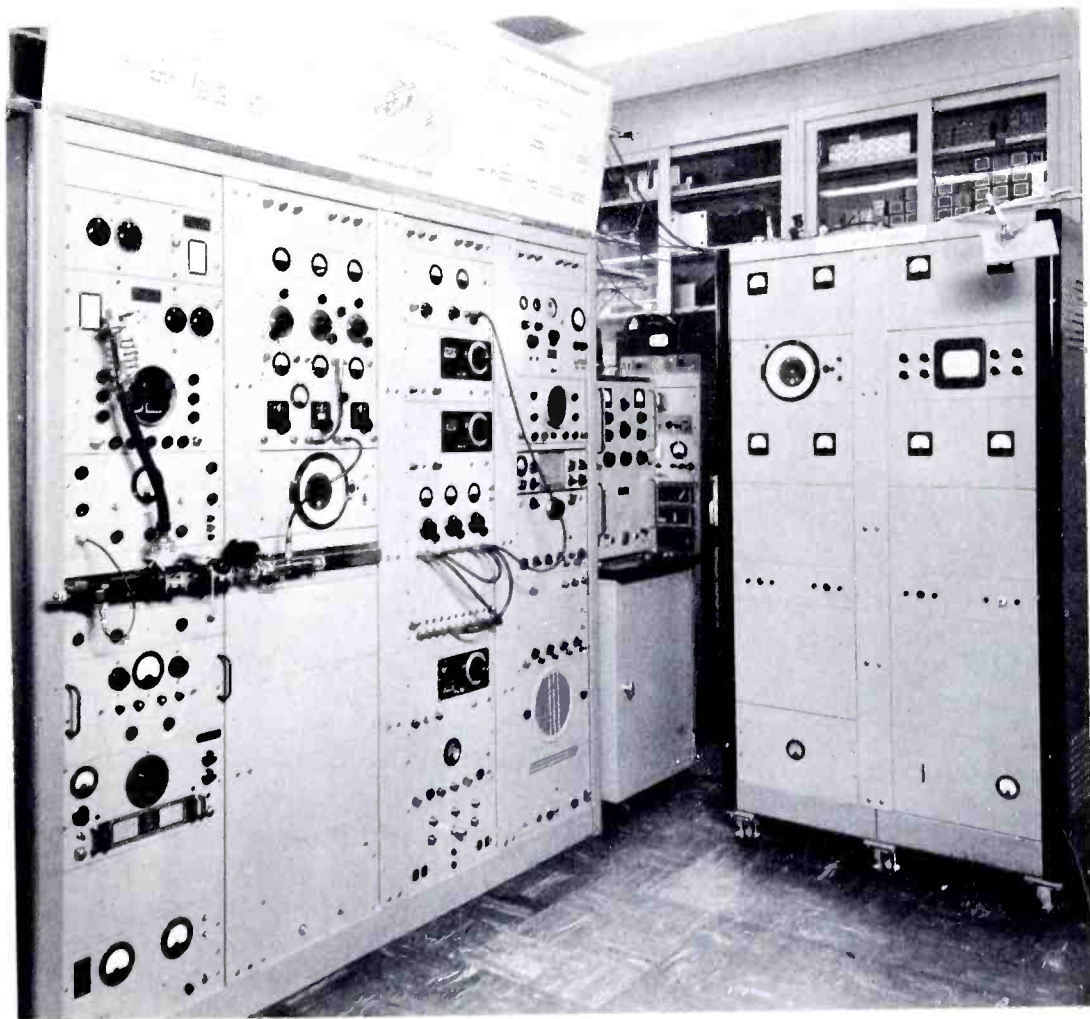

Figure 1. The microwave adjustable-frequency standard with which the National Bureau of Standards calibrates secondary frequency standards for Government agencies and defense activities, as well as science and industry. The four-rack system includes frequency multipliers, adjustable-frequency oscillators, and the necessary metering and monitoring equipment. The adjustable-frequency standard occupies the two center racks. Two transmission-type wavemeters are shown mounted for a calibration; the meter to the left has been sent to the Bureau to be calibrated against the standard. Variations in output with change in meter setting are monitored on the visual analyzer mounted in the first rack. The system of panel jacks permits the mixing of many standard frequencies. The pair of dolly-mounted racks to the right contain the electronic components of the Model II ammonia clock.

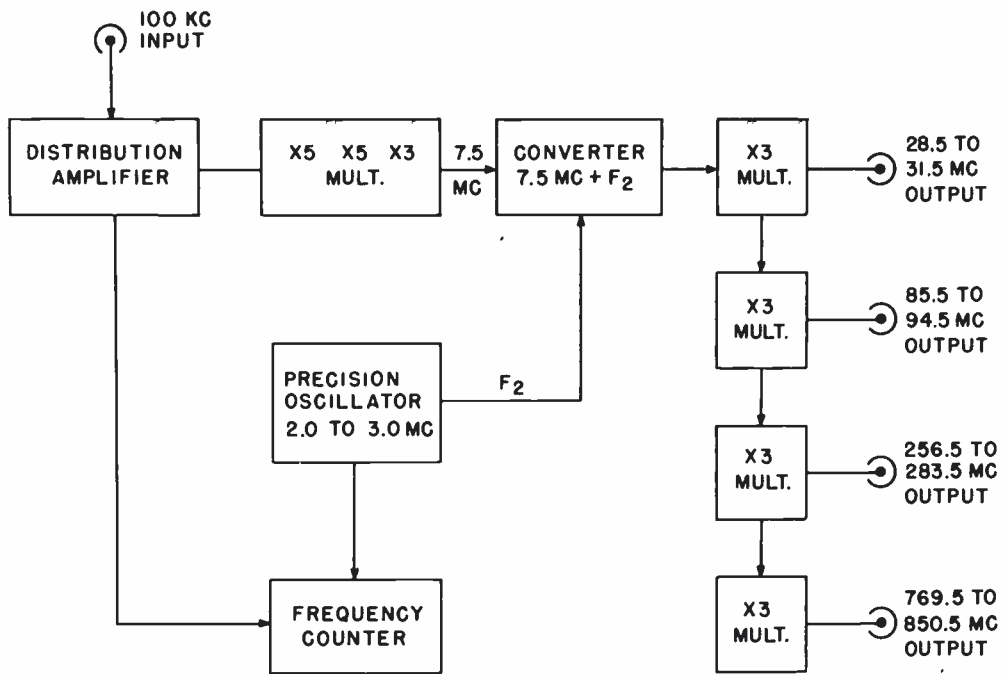

Figure 2. Block diagram of the microwave adjustable-frequency standard maintained by the National Bureau of Standards. The diagram shows the 100-kc. reference signal entering a distribution amplifier, from which it goes to the frequency multipliers, mixers, converters, and output terminals. A wide range of frequencies is derived from this standard by combining a fixed multiplier of the 100-kc. source with the signal from a precision adjustable oscillator. Complete coverage begins at 300 mc. and extends up to 25,000 mc.

tem. (See figures 1 and 3.) In both systems, unwanted sidebands or harmonics are suppressed 60 db at each stage of the chain. Conventional grid-controlled vacuum tubes multiply the frequencies up to several hundred megacycles, while fixed-frequency klystron multipliers yield frequencies up to 25,000 mc. Frequencies above this range are obtained from crystal rectifiers employed as harmonic generators, the working frequencies of which are selected by a transmission cavity filter.

The NBS fixed-frequency system has higher outputs than the variable system, but is not as versatile. Frequency-mixing is accomplished at the end of the chain (high-frequency mixing), the outputs

of which permit a coverage of the spectrum at very closely spaced intervals. The strongest signals are obtained from the following mixing combinations: 10-mc. intervals through 5000 mc.; 50-mc. intervals through 25,000 mc.; and 250-mc. intervals through 40,000 mc. Errors in transcribing and plotting data are minimized because the signals occur at evenly spaced round numbers. Power outputs are: at the 10 and 50-mc. outputs, 5 watts; at the 250 and 3000-mc. outputs, 1 watt; and at the 9000-mc. output, 20 milliwatts. Power stability and long life are achieved in the klystron amplifiers and multipliers by immersing them in a temperature-controlled oil bath, and operating them well below their maximum ratings.

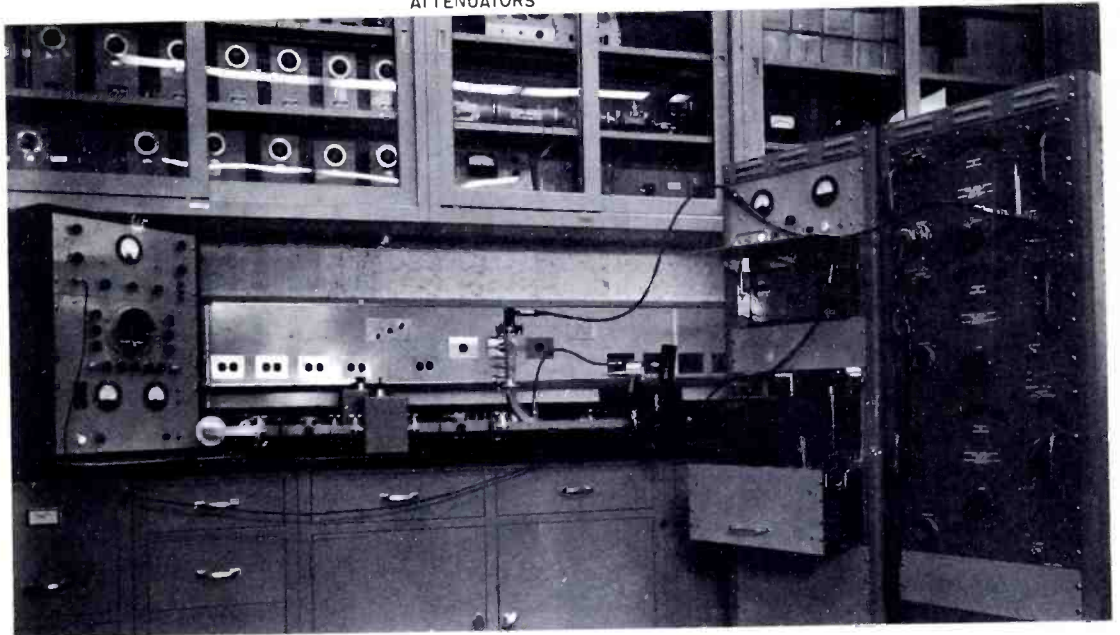
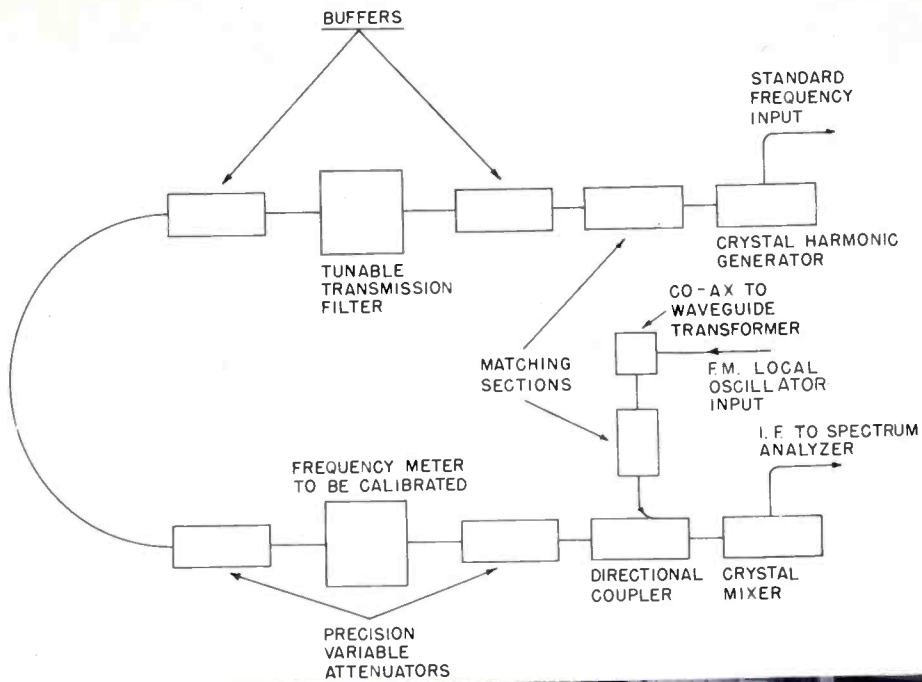

Figure 3. *Calibrating a frequency meter with the NBS microwave fixed-frequency standard. The rack to the far right contains the local oscillator and associated power supplies; the rack to the left of the first contains the fixed standard. The r-f components on the bench include (in a clockwise direction): directional coupler, matching section, and coaxial-to-waveguide transformer; variable attenuator; the frequency meter to be calibrated (similar to those in the shelves above); another attenuator; buffer; tunable transmission filter; another buffer and matching section; crystal harmonic generator; connector for the standard; and mixer (black box and cylinder) for mixing the standard signals. The output of the system (an intermediate frequency) is fed to the spectrum analyzer at the far left. The accompanying block diagram shows the relative positions of the r-f components used in the calibration.*

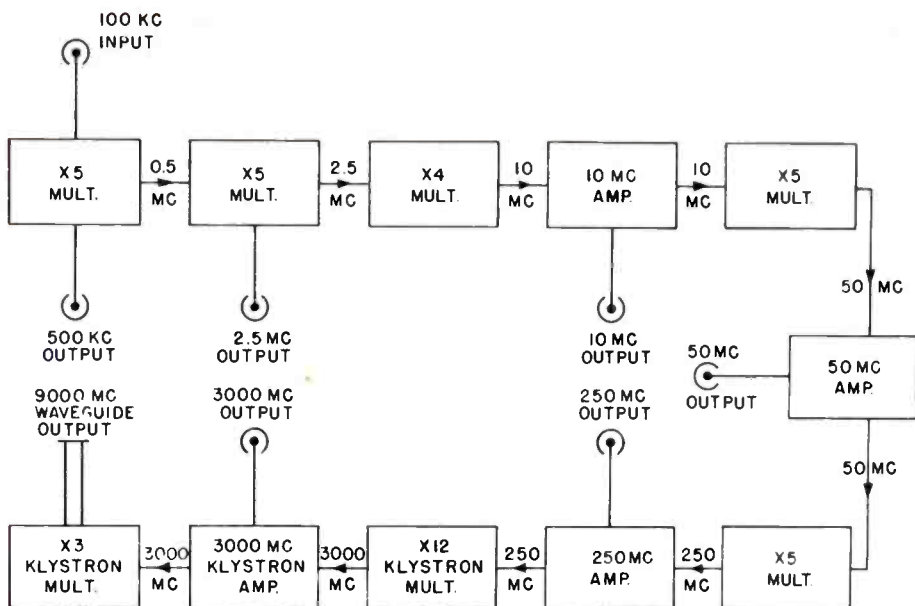

Figure 4. Block diagram of the NBS microwave fixed-frequency standard. The 100-kc. reference source is multiplied in evenly spaced intervals. Strongest signals are obtained at 10-mc. steps through 5000 mc.; 50-mc. steps through 25,000 mc., and 250-mc. steps through 40,000 mc. Conventional vacuum tubes are used for frequencies up to 250 mc., and klystron amplifiers and multipliers provide the higher frequencies. The klystrons are immersed in a temperature-controlled oil bath to stabilize their power output.

Signals are generated in the adjustable-frequency standard by combining a fixed multiple of the 100-kc. source with the signal from a precision oscillator that is continuously adjustable between 2 and 3 mc. The combination frequency passes through tunable multipliers with a range of 10 percent. The adjustable range may be expanded to 100 percent by using the 10th harmonic of any output from the multiplier chain. The radio-frequency power available to the harmonic generators is at least 2 watts at each output of the multiplier chain. Excellent efficiency in the generator and the detector systems permits the use of harmonics as high as the 30th for calibration purposes, and extends the range of the standard through 25,000 mc. Frequency-mixing is accomplished near the beginning (low-frequency mixing) of the multiplier chain, which has the advantage of wide separation between adjacent harmonics. A major disadvantage of the system lies in the fact

that the very-low-difference intermodulation frequencies are multiplied in the chain together with the desired signal, and, therefore, create unwanted sidebands.

When relatively high standard-frequency power (about one milliwatt) is required, a frequency-transfer process can be used with the normal loss of overall precision. Here, CW klystron oscillators are synchronized to a standard oscillator, and frequency-modulation of the oscillators is minimized by using battery power and by stabilizing the klystron temperature in a temperature-controlled oil bath.

In those locations that are isolated from direct connection to the NBS standard oscillators, calibration of secondary frequency standards is possible by using one of the standard frequencies broadcast by radio station WWV (2.5, 5, 10, 15, 20, and 25 mc.) as a reference for synchronizing harmonics of an

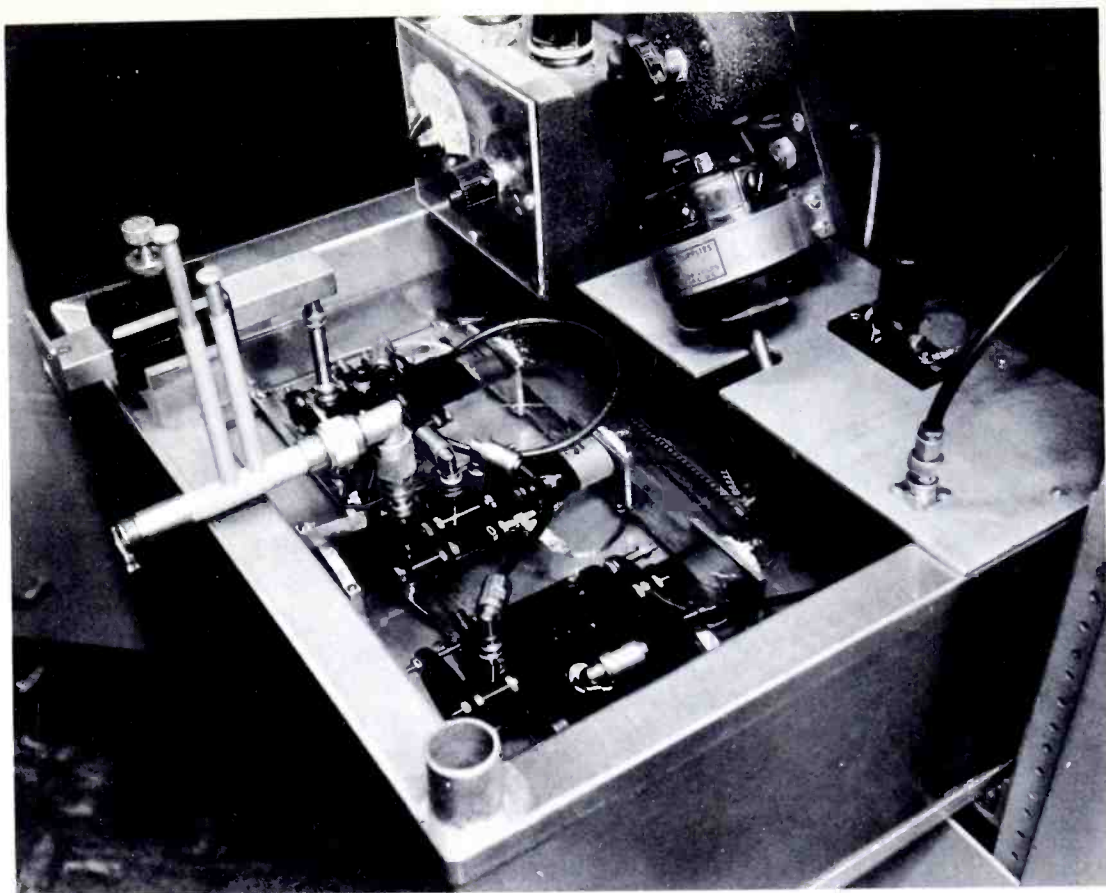

Figure 5. Temperature-controlled oil bath for the klystron multipliers and amplifiers used in the NBS microwave fixed-frequency standard. The klystrons are completely immersed in the oil, which is kept gently agitated by a stirring motor. A sensitive control maintains the bath temperature to $\pm 0.01^\circ \text{C}$. The outputs of the klystrons are fed into the calibrating system through matching sections of waveguide (left).

auxiliary 100-kc. oscillator. Precisions of about 1 part in 10^7 are attainable if reception is limited to sky-wave propagation, or 1 part in 10^8 if groundwave reception is possible. The National Bureau of Standards' ammonia clock* has been used as a reference for absolute calibration to 1 part in 10^7 , and to a relative frequency constancy of 2 parts in 10^8 .

CALIBRATION OF SECONDARY STANDARDS

Frequency meters sent to the Bureau are calibrated, when possible, under

* "The Atomic Clock," *NBS Tech. News Bulletin*, 33, 2 (Feb. 1949).

normal operating conditions. For instance, if the meter has a built-in detector and indicator, sufficient power is used to operate the complete indicating system. Or, if the meter can be employed either as a transmission or a reaction device, the calibration includes both methods, and checks are made for any existing discrepancies between the two. The ambient room temperature of the calibration laboratory is maintained at $23^\circ \pm 2^\circ \text{C}$, and the relative humidity at 50 percent ± 2 percent. Meters are permitted to reach equilibrium with the room conditions before a calibration is made.

In the calibration procedure, the

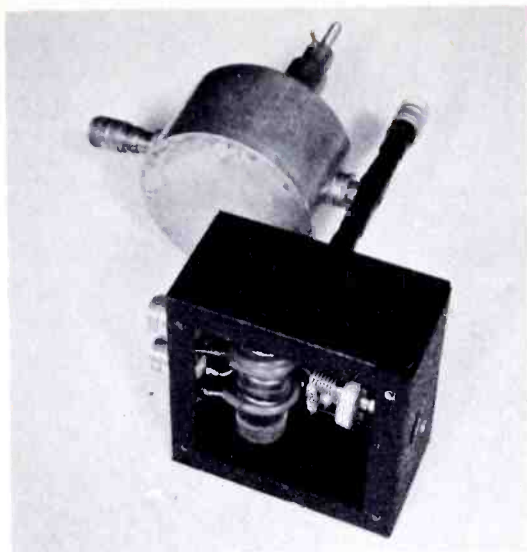

Figure 6. *Crystal mixer for combining frequencies generated by the NBS microwave fixed-frequency standard. By means of resonant circuits in series, three standard signals—50, 250, and 3000 mc.—are applied simultaneously to the crystal converter. By extending these methods, additional frequencies may be added. The small box contains tuned circuits for the 50-mc. and 250-mc. signals. The cylinder is a cavity tuned to 3000 mc.*

standard frequencies are applied to a crystal diode mixer, a non-linear device that generates all of the sum and difference combinations of the signal present. The desired signal is selected and all others are rejected by a tunable transmission filter, which has been previously calibrated. The output of a frequency-modulated local oscillator is admitted to the converter crystal through a directional coupler, where it is mixed with the standard signal.

The intermediate frequency from the converter is fed to a spectrum analyzer, and the matching sections are adjusted for maximum signal strength. Attenuators placed on either side of the meter to be calibrated are set to 10 db each, which effectively isolates the calibrating equipment and prevents reactive "pulling" of the meter.

The frequency meter to be calibrated is set to resonance at each calibration frequency at least 10 times. The divergence or spread of the readings at a given frequency is then a measure of the backlash or other mechanical defects of the drive and indicating mechanism. This spread is included in the calibration report as the tolerance to which the readings are reproducible.

Although not included in a normal calibration, it is possible to measure the cavity temperature coefficient of frequency, near room temperature, and the approximate "Q" of the cavity. The temperature coefficient is determined by observing the shift of resonant frequency at a fixed setting of the meter while the temperature is changed. Changes in cavity are monitored by a thermocouple junction attached to the meter. The Q of the cavity is determined by observing the half-power points on the response curve of the cavity for a signal which is frequency-modulated through the resonance frequency.

DETECTION OF MICROWAVE SIGNALS

The power of the harmonics used as standard-frequency signals is often as low as 1 microwatt; therefore, direct detection by means of a crystal diode and a sensitive current meter is usually impracticable. In addition, the useful power at the detector is further reduced by a nominal insertion loss of 10 db for the transmission filter, and 10 db each for the padding attenuators. The power available at the detector is then about 0.001 microwatt. Therefore, when a frequency meter with a built-in crystal detector is to be calibrated, a higher-power CW oscillator is used, and is adjusted to the frequency of the standard signal. Amplification of the beat note between the standard signal and a small portion of the oscillator output is sufficiently high to permit the adjustment of the oscillator to the same frequency as the

standard-frequency signal. The accompanying precision is decreased approximately one order of magnitude. The remainder of the oscillator power is sufficient to permit the crystal current from the detector to be monitored with a microammeter.

When the type of calibration is such that the standard-frequency signal can be passed through the meter to be calibrated, a sensitive receiver is used to detect the signal. In the frequency range from 300 to 750 mc., a double-superheterodyne panoramic receiver is employed; above 750 mc., a sensitive spectrum analyzer detects the signal.

Direct-reading local oscillators of the external-cavity reflex-klystron type generate the signals from 750 to 11,000 mc. Above 11,000 mc. internal-cavity reflex klystrons, mounted directly on the waveguide connecting the meter to the standard, provide local-oscillator power. Since the power of the local oscillator is much greater than that of the standard signal, the height of the pulse displayed is directly proportional to the power of the standard signal. The frequency meter being calibrated is tuned to resonance by observing the relative pulse height on the cathode-ray tube of the analyzer. Voltage gains of 160 db are possible

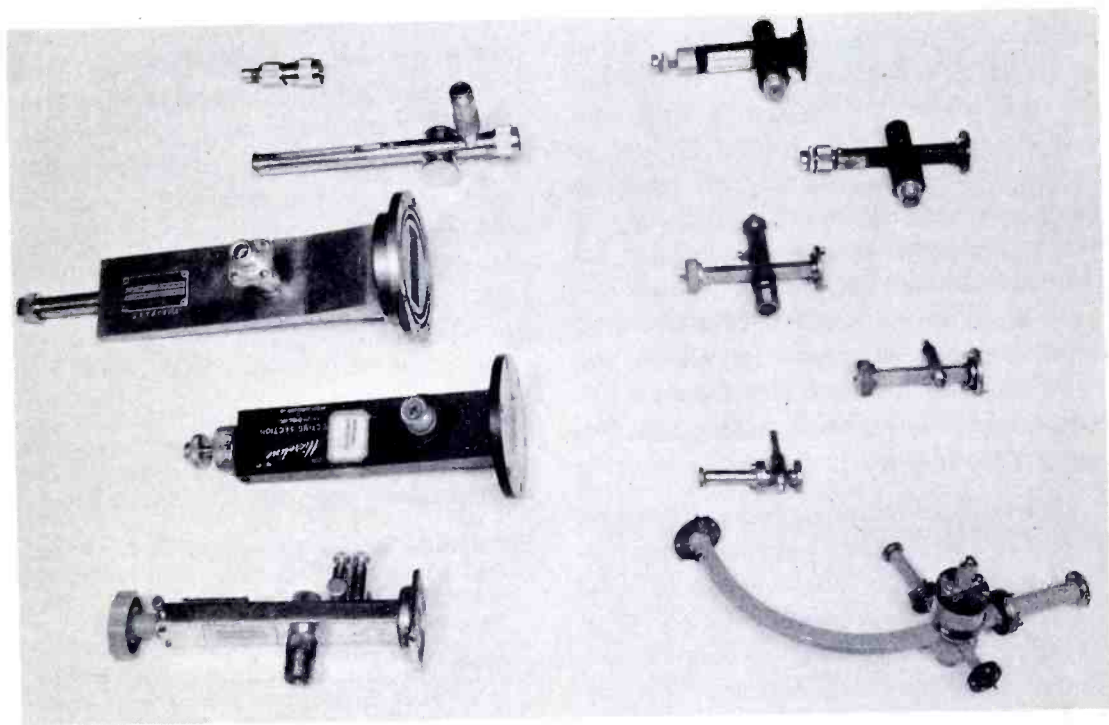

Figure 7. Harmonic generators used in the NBS microwave frequency standard to provide frequencies from 300 to 75,000 mc. The generators are arranged according to increasing frequency, the column on the left ranging from 300 mc. (top) to 10,000 mc. (bottom). The mounts on the right (top to bottom) start at about 10,000 and increase to 75,000 mc. Some of the harmonic generators are modified crystal detectors used in the reverse direction. The shorting capacitances are removed; the signals are inserted into the low-frequency side of the generator, and the harmonics are recovered from the high-frequency side. The smallest unit (right column, second from bottom) generates signals as high as 75,000 mc. The unit below it is a frequency doubler capable of doubling frequencies in the range of 26,000—40,000 mc.

with the spectrum analyzer, which can then detect microwave signals as low as 0.1 micromicrowatt.

DEVELOPMENTAL COMPONENTS AND TECHNIQUES

An important phase of the development work in progress in the NBS Microwave Frequency Standards laboratory is aimed to improve the calibration techniques at frequencies above 40,000 mc. Many of the components can be scaled down from the designs employed in lower-frequency equipment, but the harmonic generators and crystal detectors normally used at the lower frequencies are about as small as manufacturing techniques will permit. Thus some other technique must be utilized in order to develop similar equipment for the higher microwaves. The engineering effort at the Bureau is concentrated on three major research projects for frequencies about 40,000 mc.: (1) crystal harmonic generators; (2) crystal detector (mixer crystals in which the local-oscillator power is adequate) and crystal video detectors in which the local-oscillator power is less than 1 milliwatt; and (3) reliable secondary frequency standards.

A technique is now under investigation for mixing an interpolation-oscillator signal with the outputs of the fixed microwave frequency standard, to improve the continuous frequency coverage. Amplitude modulation of a standard-frequency signal in a magnetic attenuator offers certain possibilities. Since only small power levels are available at frequencies above 40,000 mc., it is necessary that a passive secondary standard of frequency require very little power. A waveguide-contained interferometer design currently under consider-

ation shows promise as a reliable secondary standard of frequency.

The future program of the NBS Microwave Frequency Standards laboratory includes expansion of the calibration facilities to permit the extension of the present 300-mc. to 75,000-mc. range upward to 100,000 mc. and higher. Attempts are being made to simplify high-precision frequency measurements by providing higher power in the standard signals at the microwave frequencies. Clocks using ammonia and oxygen, and employing gas-absorption techniques, are under development; they promise accuracies equal to or better than those obtained by astronomical methods. Recent research has indicated that the ammonia clock as a standard is several orders of magnitude better than current secondary standards, and approximately equal to the precision of long-distance radio links to the standard signals of station WWV. Even greater absolute accuracies are possible from a standard based on atomic-beam techniques, as in the NBS cesium clock.

For additional details see, "The Microwave Frequency Standard," by L. J. Rueger and A. E. Wilson, *Radio and Television News*, 49, 3 (March 1953).

For details on atomic standards see "Spectral Lines as Frequency Standards," by Harold Lyons, *Annals N. Y. Acad. Sciences*, 55, 831 (Nov. 1952).

NOTE: The fee schedule for NBS calibration of microwave frequency equipment is as follows: \$33.00 to \$42.00 for the first frequency calibration point and \$5.00 to \$8.00 for each additional frequency calibration point, depending on the type of secondary standard. More complete information may be obtained from NBS Circular 483, for sale by the Superintendent of Documents, U. S. Government Printing Office, Washington 25, D. C. (price 25¢).

AN ELECTRIC GUN CHARGER TESTER

An easily constructed test unit that will rapidly test the electrical portions of 20-mm. guns.

by Ray A. Martin
Philco Field Engineer

WHenever a wing changes to a newer type aircraft, the maintenance technician is presented with many equipments of new design to service and maintain. For the servicing of most of this equipment the technician can readily adapt standard test equipment and procedures. However, there are usually a few equipments of unique design for which the technician must develop special test equipment, for use in the interim before the necessary test instruments become available through regular supply channels. This was the case with the 20-mm. electric gun chargers when they were first introduced. A satisfactory means of testing them had to be devised.

As first conceived, the tester to be developed was to incorporate only those features necessary for testing the electric charger portion of the gun. Hence, it was given the name, "Electric Gun Charger Tester," by which it is still known. A thorough study of the gun, however, revealed the need for additional features that would permit the tester to be used for checking all of the electrical circuits of the gun.

The tester that was built is shown in schematic form in figure 1. With the aid of this tester, the technician can check all of the following on the test bench:

1. Charging
2. Hold back
3. Firing circuit
4. Rounds counter
5. Feeder
6. Feeder heater
7. Gun heater
8. Feeder winder (if used)

In addition, the tester is sufficiently versatile to permit its use with guns employing any one of three different types of electric gun chargers: Rhodes Lewis, Johnson Fairbox, and General Electric. At the time the schematic was drawn no provision had been made for the testing of General Electric rounds counters. The addition of this feature to the tester is simple, however, and will be discussed in the latter portion of this article.

A description of the procedures for the use of the tester is given below. Since the Rhodes Lewis and Johnson Fairbox chargers are identical, the same procedure is applicable to guns employing either type of charger. Guns with General Electric chargers are tested in the same manner except for the charger and the rounds counter. A separate procedure is given for testing those components.

RHODES LEWIS OR JOHNSON FAIRBOX CHARGER

After the completely assembled 20-mm. weapon is placed on the test bench, the first step is to connect the ground clip and turn on the power. (When a group of 20-mm. weapons is to be checked, the POWER switch is left ON continuously.) With power applied to the tester and all other switches in the OFF position, make the following connections to the weapon: Connect the power and control plug to the cannon plug on the charger. At this point, determine whether the weapon is a right- or left-hand gun, and connect the corresponding firing lead from the firing control box to the firing plug. Also, connect the feeder and gun-heater

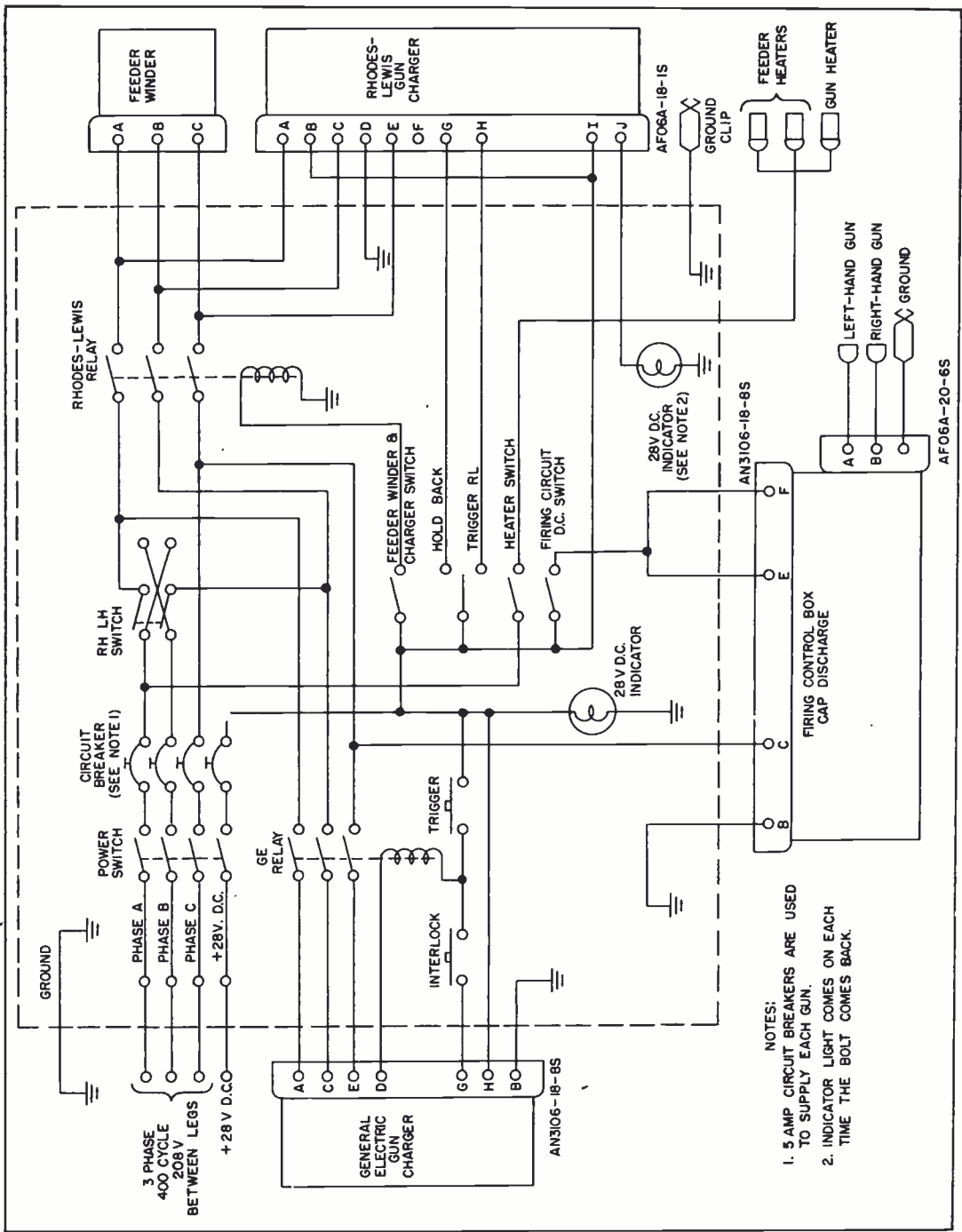

- NOTES:
1. 5 AMP CIRCUIT BREAKERS ARE USED TO SUPPLY EACH GUN.
 2. INDICATOR LIGHT COMES ON EACH TIME THE BOLT COMES BACK.

Figure 1. Diagram of Electric Gun Charger Tester

leads to their respective plugs. If the weapon has a feeder winder, connect this to the cannon plug.

With the weapon completely connected, place the R.H.-L.H. switch in a position corresponding to the weapon. Turn ON the HEATER switch and FIRING CIRCUIT d-c switch. Then insert a magic wand into the tube (barrel) of the weapon until steady contact is made with the firing pin. A magic wand is a metal tube with an insulated contact inserted in one end with a wire extending through the center to one contact of a lamp (the lamp may be a 28-v., 1—3-amp. incandescent lamp or a 28-v. neon lamp). The other contact of the lamp is connected to the tube (effectively ground). The firing contact is a conical-shaped piece of metal, which is spring-held through a circular hole. The wand must be carefully inserted to the exact position, so that the firing pin is pressed out of the hole to a position where the firing pin makes contact with nothing but the center contact of the wand. When the firing pin is in this position, the lamp should flicker. This indicates that the firing circuit of the weapon is good. Turn the FIRING CIRCUIT d-c switch OFF and disconnect the firing lead. At intervals the heaters are touched with the hand to determine whether or not they are heating, then the HEATER switch is turned OFF.

Turn the FEEDER WINDER CHARGER switch ON. This energizes the Rhodes Lewis relay, thus applying 208-volt, 3-phase, 400-cycle power to the charger. The disposition of this power is then controlled by the HOLD BACK-TRIGGER switch on the tester and the CHARGE-HOLD BACK switch on the charger. Operate the TRIGGER switch (spring-loaded) on the tester. The weapon should charge continuously until the TRIGGER is released. Turn the HOLD BACK switch on the tester to ON. The bolt should come to the rear and stop. When the HOLD BACK switch is turned

OFF, the bolt should release and go forward. The same procedure is repeated for the CHARGE-HOLD BACK switch on the charger. When the weapon is being charged with the TRIGGER on the tester, the 28-volt indicator lamp connected to pin J should light each time the bolt comes to the rear. This indicates that the rounds counter circuit is operating. Lock the feeder into position on the weapon, and then insert dummy rounds into the feeder. If the weapon has a feeder winder, it will automatically torque the feeder; otherwise, the feeder must be torqued manually. When the TRIGGER on the tester is operated, the dummy rounds should be fed into the chamber and then ejected. Turn the FEEDER WINDER CHARGER switch OFF and disconnect the weapon. This completes the check.

GENERAL ELECTRIC CHARGER

As was previously stated, the checking of a 20-mm. weapon using the General Electric charger is the same except for the charger and the rounds counter.

To check the charger, connect the power and control plug to the plug on the charger. Press the TRIGGER button on the tester; the weapon should charge continuously. Simultaneously press the INTER LOCK switch on the tester and the HOLD BACK button on the charger until the weapon starts to charge, then release both switches. The bolt should stop and remain in a fixed position. The charging cycle should continue when the INTER LOCK switch only is pressed. The cycle can be stopped at any point until the bolt reaches the rear.

The rounds counter on the General Electric charger has a separate cannon plug and is merely a switch to complete a 28-volt d-c circuit. As mentioned previously, no provision is shown in the schematic for testing the rounds counter. However, a 28-volt indicator lamp can be installed for this purpose.

GENERAL CONSIDERATIONS

The optimum rating of the circuit breakers has been found to be 5 amperes. In case of an overload, circuit breakers with this rating will open before the 5-amp. slow-blow fuses in the charger have time to blow out. This saves fuses as well as a lot of trouble in changing them.

The relays should have contacts designed to stand current surges up to 20 amps. None of the components should be rated less than 5 amps.—a higher rating is preferable.

The R.H.-L.H. switch is used to switch two phases of a three-phase system to the charger motors of Rhodes Lewis chargers where the motor runs in opposite directions for right-hand and left-hand chargers. The motor on the General Electric charger runs in the same direction at all times; therefore, the R.H.-L.H. switch is set to the RIGHT HAND position.

The firing control box is the same type as that used in the aircraft for firing the 20-mm. weapon. This item is classified and will not be discussed here.

Radioactive Cleaning

The Geiger counter may soon become standard equipment at dairies, assuring clean and germ-free areas in which to process milk, butter, and other dairy foods. This product of the atomic age is being used at the New Jersey Agricultural Experiment Station to test the effectiveness of standard methods of cleaning. The tests work like this: Radioactive isotopes of phosphorus are mixed with known bacteria. This mixture, in a solution, is then applied to the area of the dairy to be cleaned. After the area has been cleaned it is checked carefully by the Geiger counter. If the counter registers activity it means there are still some radioactive bacteria left in the area, that the cleaning method in use is a faulty one, and that a more efficient cleaning method must be developed.

FIELD-STRENGTH INDICATOR ATTACHMENT FOR TEST SET TS-352/U

A handy field-strength meter that can be constructed with very little difficulty, using readily available components.

by Robert E. Jones
Philco Field Engineer

A FIELD-STRENGTH indicator is often needed by personnel responsible for maintaining vehicular and aircraft radio sets in tactical units. Such a device is invaluable for making transmitter and antenna tuning adjustments, as well as for routine trouble shooting. At the present time, no field-strength indicating equipment is issued at battalion level. However, with a minimum of materials it is possible to construct a simple device that, when used with Test Set TS-352/U (or equivalent multimeter), will give a relative indication of transmitter field strength.

The device to be described has been used as a field-strength indicator in making tests with radio transmitters having power outputs ranging from 0.25 to 600 watts and frequency ranges from 1.8 to 150 megacycles. No tuning or adjustment of the attachment is required. The device can be constructed by personnel having a limited knowledge of radio maintenance. No modification of Test Set TS-352/U is necessary.

THEORY OF OPERATION

The schematic diagram of the device is shown in figure 1, the mechanical construction is illustrated in figure 2, and figure 3 is a sketch showing the device connected to Test Set TS-352/U.

The presence of a field radiated from a nearby radio transmitter causes a voltage to be induced in the pickup antenna. The resulting current flow produces a voltage across inductor L. This

voltage is rectified by the crystal diode, and a direct current flows through the meter movement. The meter reading observed is roughly proportional to the strength of the radiated field.

CONSTRUCTION

With the exception of the crystal diode, most of the materials needed for constructing the attachment can be found in various sections of any tactical unit.

A 6-inch length of 1 $\frac{1}{4}$ -inch phenolic tubing makes the ideal combination coil form and foundation unit. However, many of these attachments have been successfully constructed using lengths of broom handle, and wooden or plastic rods. The pickup antenna and connecting pins are lengths of 1/16 or 3/32-inch brass welding rod. Any other similar material can be used for these parts. One unit was built using coat-hanger wire for this purpose. Insulated copper wire size 16 to 26 may be used for wind-

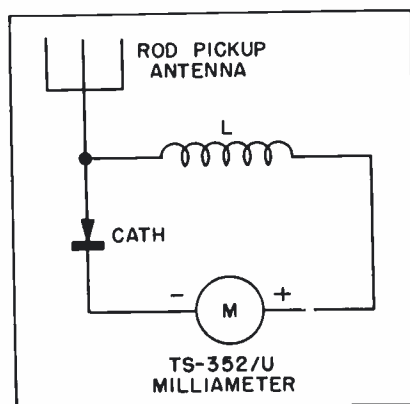

Figure 1. Schematic Diagram of Field Strength Meter

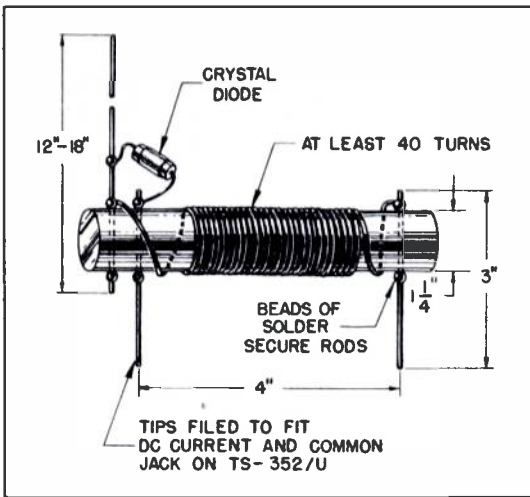

Figure 2. Sketch of Field Strength Attachment

ing the coil. The number of turns on the coil is not critical, but at least 40 turns should be wound on the form for best

over-all results. Any readily available crystal diode having an average current rating of over 10 milliamperes may be used. A 1N34 is recommended from the standpoint of economy, if it is necessary to purchase the unit.

Figure 2 gives the construction details. The holes through the foundation unit should be slightly smaller than the diameter of the material used for the connecting pins and pickup antenna. The pins and antenna are forced through the holes, as indicated in figure 2, and secured in place, by means of a bead of solder, at the points where they enter and emerge from the foundation unit. The coil is wound on the foundation unit between the connecting pins. One end of the coil is connected to the far

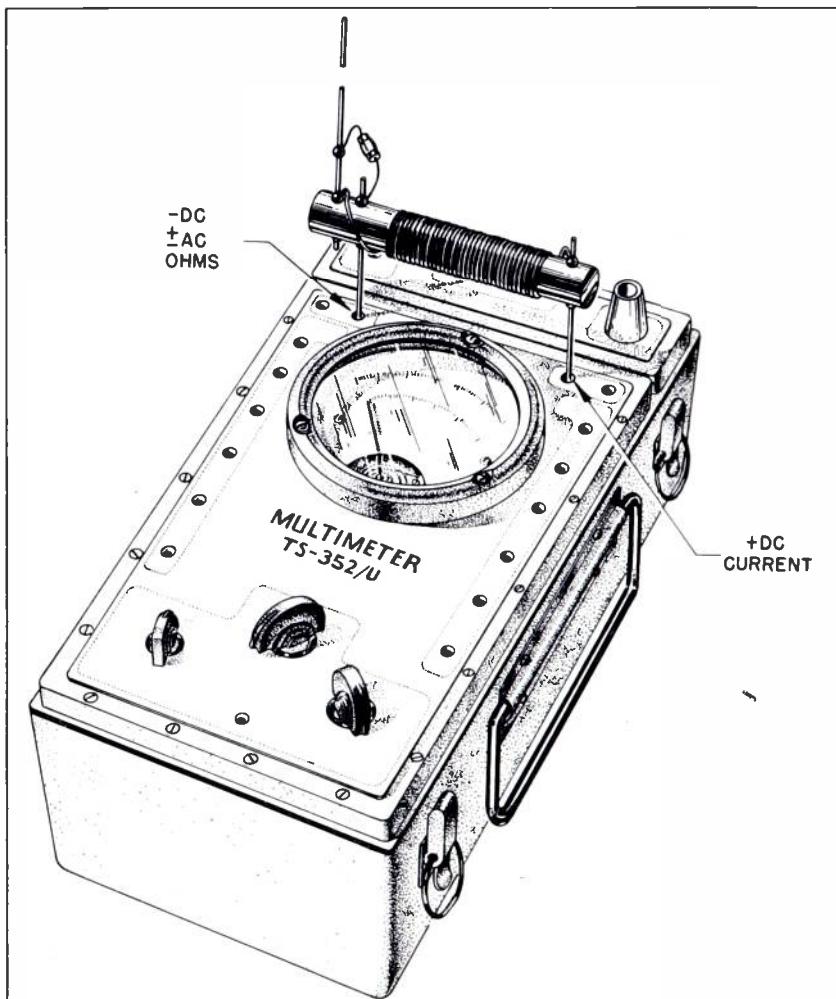

Figure 3. Sketch of Multimeter Showing Field Strength Attachment in Place

pin, and the other end is connected to the pickup antenna. The crystal diode is connected between the pickup antenna and the pin nearest to it.

If the pins are too large to fit into the COMMON and D.C. CURRENT jacks on the multimeter, file the tips to the proper shape and size.

OPERATING INSTRUCTIONS

Plug the attachment into the multimeter (Test Set TS-352/U or equivalent). Set the multimeter to 2.5-ma. d-c range. Place the meter with attachment near the antenna of a radio transmitter, and key the transmitter. If the meter reads down scale, remove and reverse the attachment connection to the multimeter. If the meter deflection is slight, switch to the 250-microampere scale. If the meter reads full scale, either switch the meter to a higher scale or move the

meter and attachment back from the transmitter antenna.

It has been found that the attachment shows resonant characteristics at various frequencies. For this reason the device should not be relied upon for checking relative power output over a range of frequencies.

Increased output may be obtained at frequencies above 25 megacycles, by connecting a jumper wire between the tip of the pickup antenna and the pin farthest from it.

CAUTION: To prevent damage to the meter through accidental exposure to the radiation fields of high-powered transmitting equipment, remove the field-strength indicator attachment from the multimeter immediately after the field-strength measurements have been completed.



STORAGE CABINET FOR CHASSIS OF MK-113/GSQ TRAINER KIT

The MK-113/GSQ Trainer Kit, as supplied, provides no means for storage and protection of the individual chassis, other than leaving them mounted on the rack. It is desirable to provide a better means of storing and protecting the chassis, and of issuing only those required to perform the experiment being conducted.

The cabinet illustrated in the accompanying photograph and drawing provides a convenient means of protecting the components and tubes from damage, and it can be locked if desired. The plans are for a cabinet, two of which will provide adequate storage space for the chassis from four MK-113/GSQ Trainer Kits; however, the cabinet depth may be changed to provide space for more or fewer chassis, as required.

The individual compartments of the cabinet are numbered in accordance with the Trainer Kit chassis numbers, and a convenient reference list containing the chassis name and number is attached to the inside of the cabinet door. Note that some of the larger chassis, such as the oscilloscope, occupy more than one compartment in the vertical direction, and that some spare space is provided to take care of additional chassis that may be locally fabricated, or for spare parts and tubes.

The depth of the cabinet illustrated permits the storage of four standard-width chassis of each type; thus four double-width chassis require two compartments, both of which are labeled with the same chassis number. To provide storage space for a different num-

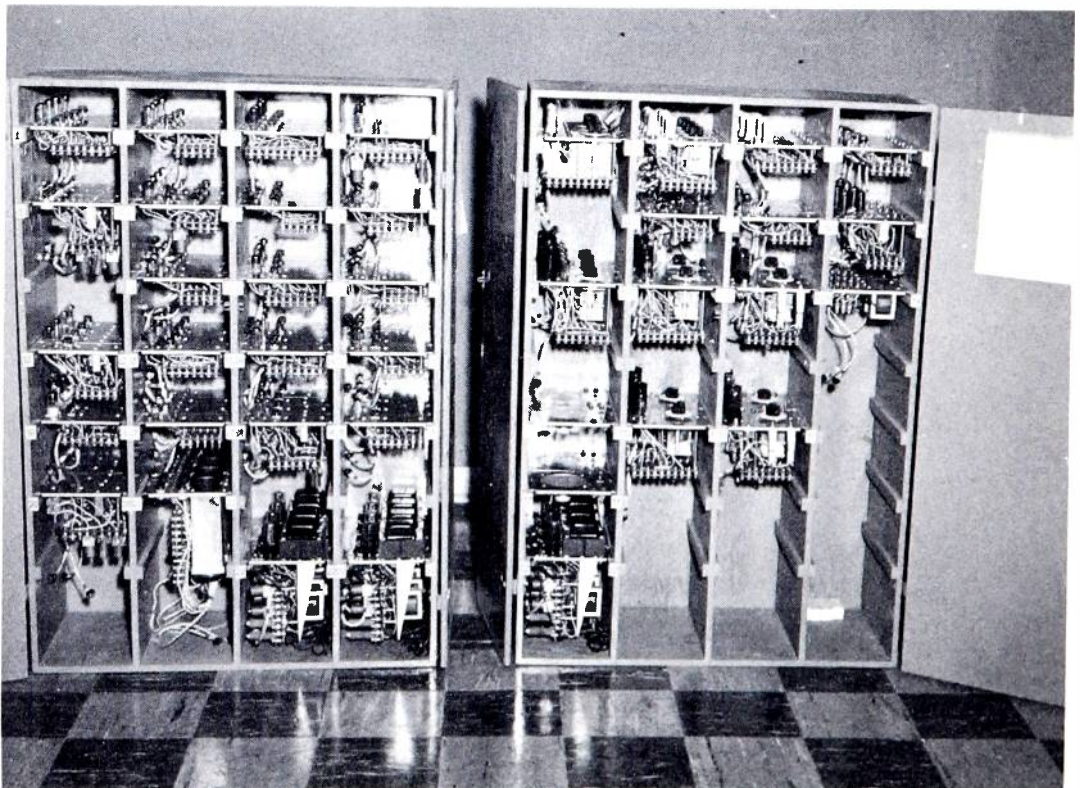

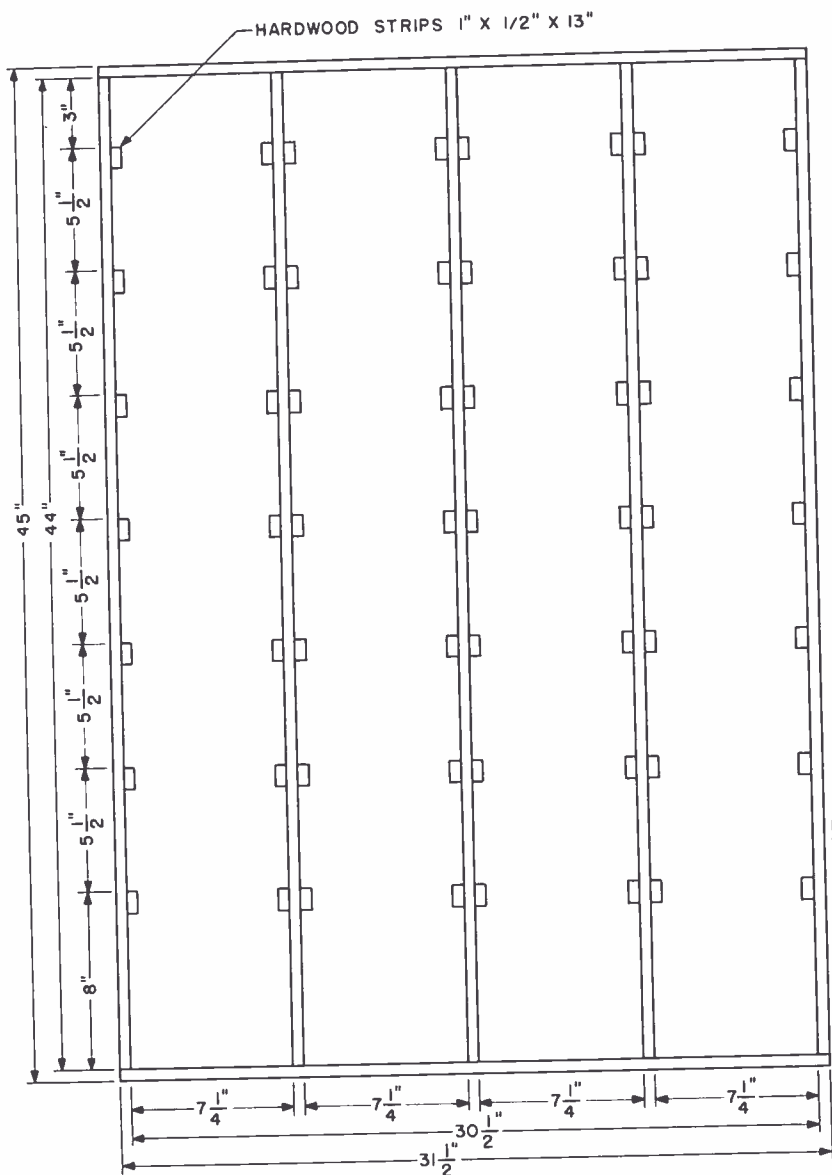

ber of chassis, the inside cabinet depth, in inches, should be made equal to three times the number of chassis of each type, plus one inch for clearance.

This storage cabinet has been in use for several months in conjunction with a training course, and has been found to be satisfactory in every respect.

Lloyd M. Boutwell,
Philco Field Engineer

Index for Vol. III Philco TechRep Division BULLETIN

Month Page

A

AN/APQ-13 Computer Attachment for CP-7.....	January	3
AN/ARC-27 Auxiliary Power Supply.....	July	7
AN/MPN-1, Test Equipment for.....	March	3
Accidental Firing of Electric Blasting Caps by Means of Radio Frequency Energy.....	March	7
Antennas:		
Antenna Pattern Plots.....	February	3
Simultaneous Transmission Systems—Part I.....	May	21
Simultaneous Transmission Systems—Part II.....	July	19
Arithmetical Techniques, A Rediscovery of Long-Standing..	January	23

B

BC-221 (SCR-211) Frequency Meter, An Emergency Power Source for the.....	April	44
Bulletin Binders.....	June	22

C

Carrier:		
Eliminating Interference in Carrier—VHF Systems.....	February	42
“Levels” and “Powers” in a Carrier System.....	April	12
Cellular Electronic Construction.....	September	33
Computers:		
Circuitry “Packages” for Electronic Computers.....	June	31
Computer Attachment for CP-7/APQ-13.....	January	3
Electronic Computers—Part III.....	January	6
Electronic Computers—Part IV.....	April	6
Electronic Computers—Part V.....	Nov.-Dec.	25
Crystals:		
Emergency Repair of Crystal 1N21.....	April	19
The Piezoelectric Effect—Part I.....	September	13
The Piezoelectric Effect—Part II.....	October	3
Short Cuts to Crystal Frequency Determination.....	September	11

D

Declassification Notice.....	October	36
------------------------------	---------	----

E

Editorials:

Navy Emphasizes Need for Accelerated OJT Program.....	January	2
Safety	February	2
Walking that Extra Mile.....	March	2
Electronic Computers	April	2
The Important Job.....	May	2
A New Challenge to The Field Engineer.....	June	2
Field Reports	July	2
Modification of Equipment.....	August	2
Transportable Communications	September	3
Technical Writing	October	2
1953	Nov.-Dec.	2
Electromechanical—A Recording Analytical Balance.....	October	30
Electronic Construction, Cellular.....	September	33
Electronics and Pain.....	October	29
Engine Timing.....	August	4

F

Facsimile Signals, A Device for Improving.....	August	11
FCC Licenses, Renewal of Commercial.....	August	8
Field-Strength Indicator Attachment for Test Set TS-352/U	Nov.-Dec.	43
Frequency:		
An Emergency Power Source for the SCR-211 (BC-221) Frequency Meter.....	April	44
High Frequency Sound Waves (Ultrasonic Brain Surgery)	August	31
Improvements in the NBS Primary Standard of Frequency	January	11
Short Cuts to Crystal Frequency Determination.....	September	11
The NBS Microwave Frequency Standard.....	Nov.-Dec.	30

I

Intercoms:

A Six-Channel Intra-Facility Intercom (Microwave).....	October	16
Engineering Channel Intercom Unit for Use in Microwave Radio Relay Systems.....	July	31
Telephone Handset Intercom System.....	June	34
Interference, The TV Receiver as a Source of Low-Frequency Communications	October	33

Index (Cont.)

	Month	Page
M		
Magnetic Pump, The.....	April	3
Magnetron Operation, Basic.....	May	3
MARS Station Accessory, A.....	August	14
Microwave:		
A Six-Channel Intra-Facility Intercom.....	October	16
Engineering Microwave Radio Relay Systems.....	July	31
Philco Transportable Microwave Communications System	September	4
The NBS Microwave Frequency Standard	Nov.-Dec.	30
The Philco Method of Surveying Microwave Systems By Means of the Precision Surveying Altimeter.....	Nov.-Dec.	3
Missiles, Guided	January	16
MK-113/GSQ Trainer Kit, Storage Cabinet for Chassis of	Nov.-Dec.	46
Monitor, Transmitter	May	38

N

NBS:		
Cellular Electronic Construction.....	September	33
Improvements in the NBS Primary Standard of Frequency	January	11
The NBS Microwave Frequency Standard.....	Nov.-Dec.	30

O

Oscillator, A Precision Transistor.....	March	14
---	-------	----

P

PE-108, Power Unit, Modification of Exhaust System of.....	Nov.-Dec.	43
PE-215A, Low-Voltage Operation of the.....	June	37
Piezoelectric Effect, The—Part I.....	September	13
Piezoelectric Effect, The—Part II.....	October	3
Power Supply, AN/ARC-27 Auxiliary.....	July	7
Power, Transformation from Three-Phase to Two-Phase.....	March	10
Publications:		
Declassification Notice.....	October	36
Philco TechRep Division Publications.....	July	15

Index (Cont.)

Month Page

R

Radar-Scope Display Unit, Transistorized.....	July	3
Regulated Voltage Source, A.....	September	30
Resistors:		
Measurement of Multimegohm Resistors.....	July	11
The Overheating of Miniature Resistors During Soldering	March	14
Rocket and Rocket Circuit Testing.....	February	37

S

SCR-211 (BC-221) Frequency Meter, An Emergency Power Source for the.....	April	44
Switchboard-Ringing Interference in Carrier-VHF Systems, Eliminating.....	February	42

T

Telephone Handset Intercom System.....	June	34
Teletype:		
An Emergency Teletype Relay System.....	May	43
Radio Teletype Frequency-Shift Measurements at Receiving Stations	August	9
Teletype Training Aid.....	January	32
Transformation from Three-Phase to Two-Phase Power...March		10
Transmitter Monitor	May	38
Test Equipment:		
An Electric Gun Charger Tester.....	Nov.-Dec.	39
Test Equipment for AN/MPN-1.....	March	3
Transistor:		
The Transistor	June	2
Introduction to Transistor Electronics—		
Installment IV	February	7
Introduction to Transistor Electronics—		
Installment V	April	20
A Precision Transistor Oscillator.....	March	14
Transistors Versus Vacuum Tubes.....	August	21
Transistorized Radar-Scope Display Unit.....	July	3
TV Receiver As a Source of Low-Frequency Communications Interference, The.....	October	33

Index (Cont.)

Month Page

U

Ultrasonic Brain Surgery.....August 31

W

What's Your Answer?

Solution to the "Great Joule Robbery" Problem.....	January	30
"Power Transformer Winding" Problem.....	January	22
Solution	February	41
"A-F Voltage Amplifier Bias" Problem.....	February	6
Solution	March	6
"Resonant Frequency" Problem.....	March	9
Solution	April	11
"Rectifier Switch" Problem.....	April	5
Solution	May	37
"Capacitor" Problem.....	May	18
Solution	June	44
"Black Box" Problem.....	June	36
Solution	July	36
"Selsyn System" Problem.....	July	9
Solution	August	13
"Capacitor" Problem.....	August	32
Solution	September	Inside Back Cover
"Resistor" Problem.....	September	32
Solution	October	14
"Black Box" Problem.....	October	13
Solution	Nov.-Dec.	29
Writing, Technical	March	25

A NEW PHILCO TRAINING MANUAL

As we go to press, availability of the PHILCO TRAINING MANUAL—ELECTRONIC CIRCUIT DIRECTORY has been announced. We are confident that this manual will prove to be a valuable aid to the electronics field engineer, and that it will take its place along with the other Philco publications that have been so well received in the field.

It is the purpose of the Philco Electronic Circuit Directory to provide a straight line between two points—from the engineer's question to the directory's answer. The circuit explanations are expressed in terms easily understood by the electronics field engineer, and are, for the most part, short and to the point. With an eye toward maximum flexibility in training, the directory has been designed to dovetail into the Philco Standardized Training Program.

In this directory, circuits which are used in communications, radar, and other specialized fields are grouped into sections by classification of their functions. Most of the sections deal with circuit discussions, which include applications, characteristics, and basic operation. However, special sections are also provided to supply general circuit information, as well as typical combinations of circuits found in electronic equipments. A cross-reference index is included at the back of the directory as a further aid in locating a specific circuit.



