

PHILCO

TECHREP DIVISION BULLETIN



DECEMBER

1951

PHILCO TECHREP DIVISION BULLETIN

Published Monthly by
The TechRep Division of Philco Corporation
Philadelphia, Pennsylvania

Volume I

DECEMBER, 1951

Number 8

CONTENTS

Letters to the Editor	2
Editorial	3
<i>By John E. Remich</i>	
Slide Rule Techniques for Engineers	4
<i>By Lt. Col. William B. Wrigley</i>	
Telephone Patching	10
<i>By Lyle A. Gallegos</i>	
The Platte Story	12
<i>By Spencer Ross</i>	
What's Your Answer?	18
Cable Practices for the Radio Station	19
<i>By M. M. Elson</i>	
Reception of Facsimile Signals Without a Converter	27
Modifying the CF-2-B Carrier Bay for Additional Printers	28
<i>By Harrison J. Smith</i>	
Solution to Last Month's "What's Your Answer?"	29
Index for Volume I	30
New Training Manual for Radar Set AN/APN-9	<i>Inside back cover</i>

Editor
John E. Remich

Managing Editor
Robert L. Gish

Technical Editors
Frederick S. Mohr
Francis R. Sherman
Gail W. Woodward

**EDITORIAL OFFICE:
PHILCO CORPORATION
TECHREP DIVISION
22nd and LEHIGH AVENUE
PHILADELPHIA 32, PA.**

If any information contained herein conflicts with a technical order, manual, or other official publication of the U.S. Armed Forces, the information in the official publication should be used.

Letters to the Editor

Recently we wrote to certain field supervisory personnel, asking for the names of members of the Armed Forces who wanted personal copies of the BULLETIN. We received long lists, as we expected, and we also received a number of comments which reflect what non-Philco readers think of our magazine. With what we hope is pardonable pride, we decided to print some of these comments:

●

"Most of our field engineers have circulated their own copies of the BULLETIN among the personnel of their respective organizations. It would be impossible to list all of the favorable comments; it suffices to say that the publication is a success, and that its circulation among the military is one of the best ideas to come out of the TechRep Division."

Robert T. Temmerman
Philco Team Leader
Clark AFB, P.I.

●

"Needless to say, the BULLETIN is overwhelmingly accepted with genuine interest and pleasure by the military at Fort Bliss."

Andrew Murnick, Jr.
Philco Group Supervisor
Fort Bliss, Texas

●

"I received your latest (October) BULLETIN about three days ago, but so far I've not been able to get it back from the

borrowers long enough to read it myself. In order that I may read my copy of the BULLETIN, will you please add to your mailing list the following names . . . (9 names)."

M. M. Elson
Philco Field Engineer
Kwajalein Island

(We've added them, Murray; now you may read your own copy.)

●

"Congratulations on the BULLETIN, and on the high level of interest it inspires in the people who have a chance to read it. I particularly enjoy the articles concerning special applications of test equipment. The rest of the BULLETIN is tops too, and I look forward to each issue."

Julius Weichbrodt
Philco Field Engineer
MAAG, Belgium

●

"The people, other than Philco Field Engineers, who read this monthly book like it very much because of its coherent content. That goes for me also."

George H. Booth
Philco Field Engineer
APO 994, San Francisco

●

"I have read all of the many fine issues of the Philco TechRep Division BULLETIN, and find them a limitless source of information and good references. Many of the articles have inspired favorable comment from members of the 7th Radar Calibration Squadron."

Emol L. Blackburn
Philco Field Engineer
EADF



Editorial

LOOKING BACK ON VOLUME I

By John E. Remich, Manager, Technical Department

Just ten months ago, the Philco TechRep Division BULLETIN was officially born. Since that time, eight issues have been produced (the first appeared in February), and with this December issue we close Volume I.

Looking over the index of articles published in the first eight issues (see page 30), we were quite surprised to discover how many articles we have released, and how many subjects we have covered. It is only when the total is added up that the large volume of data becomes apparent.

During this same period, we have expanded our circulation. Almost all of the circulation of the February issue was within Philco. Now we have a much wider circulation. Furthermore, our list of readers is growing at a very rapid rate on an unsolicited, personal-request basis. There is every reason to believe that the number of our readers will increase even more rapidly in future months, as the BULLETIN becomes more widely circulated throughout the field.

Our readers now represent Philco's entire technical and engineering staffs (both domestic and foreign), many hundreds of military electronics personnel, and nearly a thousand members of other companies in the electronics aircraft and allied industries. The BULLETIN is now in the reference libraries of nearly all the major American universities, as well as several foreign centers of learning such as the Institution of Electrical Engineers, in London. In some universities almost the entire staffs of certain technological departments have become part of our reading audience.

We are pleased, and more than a little proud, that our magazine has been so quickly and so widely accepted. Needless to say, we plan to continue producing a top-quality journal of practical technically accurate, electronic information.

Naturally, as with any new publication, we have encountered certain "growing pains" in preparation and production during the past year. However, we are gradually overcoming these problems, and with continued cooperation from our readers, in the form of articles suitable for BULLETIN publication, we will achieve a continual improvement in the magazine.

SLIDE-RULE TECHNIQUES FOR ENGINEERS

By Lt. Col. William B. Wrigley

154th A.C.&W. Group

Sewart A.F.B., Tennessee

A group of little-known but very useful time-saving applications of the slide rule.

SEVERAL years ago, the author attended an "out-of-hours" course given by Mr. R. W. Harrelson, of the RCA Engineering Department, at Camden, New Jersey. One session of this course was devoted to slide-rule "tricks" which the instructor had collected during his engineering practice.

These "tricks" are extremely useful timesavers, but unfortunately, most engineers are not aware of their existence. If you will get out your slide rule and follow the instructions below, you are sure to be pleasantly surprised.

SIMPLE ADDITION

To show how addition can be accomplished on a slide rule, a simple equation is derived in the following manner:

Let a and b represent two numbers to be added, with a the smaller of the two.

Let $\frac{1}{a} = \frac{n}{b}$, where n is that number which expresses the ratio between b and a .

Since $n = \frac{b}{a}$, it can be shown that:

$$\frac{1}{a} = \frac{n}{b} = \frac{n+1}{a+b}$$

It can be seen that we now have a simple proportion which can be set up on the C and D scales of the slide rule so that the sum, $a + b$, appears in the proportion as a function of $n + 1$.

BASIC FORMULA:

$$\frac{1}{a} = \frac{n}{b} = \frac{n+1}{a+b}$$

Slide-rule arrangement:

Scale	Step 1	Step 2	Step 3
C	set 1	read n	opposite $(n + 1)$
D	opposite a	opposite b	read $(a + b)$

Example 1:

$$2.5 + 3.2 = 5.7$$

Scale	Step 1	Step 2	Step 3
C	set 1	read 1.28	opposite 2.28
D	opposite 2.5	opposite 3.2	read 5.7

Always set the C-scale index on the smaller given number, using the index which allows the C scale to extend over the larger given number.

Example 2:

$$35 + 112 = 147$$

Scale	Step 1	Step 2	Step 3
C	set 1 (right index)	read 3.20	opposite 4.20
D	opposite 35	opposite 112	read 147

From the basic formula, n is the ratio of the two given numbers; therefore, if one number is more than ten times the other, n is larger than 10.

Example 3:

$$2.5 + 32.0 = 34.5$$

Scale	Step 1	Step 2	Step 3
C	set 1	read 12.8	opposite 13.8
D	opposite 2.5	opposite 32.0	read 34.5

QUADRATURE ADDITION

By bringing the A and B scales into play, quadrature addition can be performed. Typical uses might be solution for resistance and reactance in series, or resistive and reactive currents in parallel. Since the algebraic sum of two quantities (a and b) in time or space quadrature is equal to the square root of $a^2 + b^2$, we first locate a and b on the D scale, then find their squares on the A scale. Next, we add a^2 and b^2 (using the A and B scales in the same manner as the C and D scales were used above), after which the square root of the sum is found on the D scale.

Slide-rule arrangement:

Scale	Step 1	Step 2	Step 3
A	read a^2	b^2	read $(a^2 + b^2)$
B	set 1	read n^2	opposite $(n^2 + 1)$
C	set 1	n	
D	opposite a	opposite b	read $\sqrt{a^2 + b^2}$

Example 4:

$$\sqrt{3^2 + 4^2} = 5$$

Scale	Step 1	Step 2	Step 3
B	set 1	read 1.78	opposite 2.78
D	opposite 3	opposite 4	read 5

(Remember that the B scale goes from 1 to 100.)

Example 5:



$$Z = \sqrt{5^2 + 18^2} = 18.7$$

Scale	Step 1	Step 2	Step 3
B	set 1 (right index)	read 13	opposite 14
D	opposite 5	opposite 18	read 18.7

SERIES-TO-PARALLEL TRANSFORMATION

BASIC FORMULA:

$$R_s R_p = X_s X_p = Z^2$$

When the hairline is at $(n^2 + 1)$ in the previous operation, it is also at $(a^2 + b^2) = Z^2$, on A. Using A and B scales, divide Z^2 by R_s to find R_p , and by X_s to find X_p .

Example 6:

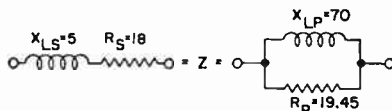

First:

Scale	Step 1	Step 2	Step 3
A			read 350
B	set 1 (right index)	read 13	opposite 14
D	opposite 5	opposite 18	

$$\text{Second: } \frac{350}{18} = 19.45 = R_p$$

$$\text{Third: } \frac{350}{5} = 70 = X_{LP}$$

RESISTORS IN PARALLEL OR CAPACITORS IN SERIES

BASIC FORMULA:

$$R = \frac{R_1 R_2}{R_1 + R_2} = \frac{R_2}{\frac{R_2}{R_1} + 1}$$

where $R_1 < R_2$

Slide-rule arrangement:

First:

Scale	Step 1	Step 2
C	set 1	read $n = \frac{R_2}{R_1}$
D	opposite R_1	opposite R_2

Second:

Scale	Step 1	Step 2
C	set $n + 1$	opposite 1
D	opposite R_2	read R

Example 7:

2 ohms in parallel with 3 ohms gives 1.2 ohms.

First:

Scale	Step 1	Step 2
C	set 1	read 1.5
D	opposite 2	opposite 3

Second:

Scale	Step 1	Step 2
C	set 2.5	opposite 1
D	opposite 3	read 1.2

If more than two paralleled resistors (or series capacitors) are to be combined, first combine two, then combine that result with the third, etc. By starting with the smallest and working up to the largest, it will usually not be necessary to reset the index.

Example 8:

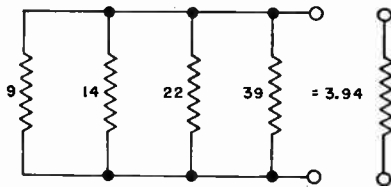

First:

Scale	Step 1	Step 2
C	set 1 (right index)	read 1.555
D	opposite 9	opposite 14

Second:

Scale	Step 1	Step 2
C	set 2.555	read 4.02
D	opposite 14	opposite 22

Third:

Scale	Step 1	Step 2
C	set 5.02	read 8.9
D	opposite 22	opposite 39

Fourth:

Scale	Step 1	Step 2
C	set 9.9	opposite 1
D	opposite 39	read 3.94

NOTE: Resetting the index after a combination may be avoided by use of the folded (CF and DF) scales.

Example 9:

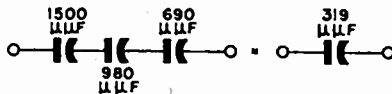

First:

Scale	Step 1	Step 2
C	set 1	read 1.42
D	opposite 690	opposite 980

Second:

Scale	Step 1
C	set 2.42
D	opposite 980
DF	opposite 1500
CF	read 3.7

Third:

Scale	Step 1
CF	set 4.7
DF	opposite 1500
C	opposite 1
D	read 319

SIMILAR REACTANCES IN PARALLEL

Add inductances or similar reactances in parallel like resistances.

Example 10: (See examples 1, 2, and 3.)



LT. COL. WILLIAM B. WRIGLEY

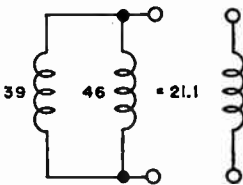

First:

Scale	Step 1	Step 2
C	set 1	read 1.18
D	opposite 39	opposite 46

Second:

Scale	Step 1	Step 2
C	set 2.18	opposite 1
D	opposite 46	read 21.1

OPPOSITE REACTANCES IN PARALLEL

With opposite reactances in parallel, the one of smaller magnitude may be considered as composed of two parts, one part equal in magnitude and in anti-resonance with the opposite reactance, and the other part unknown.

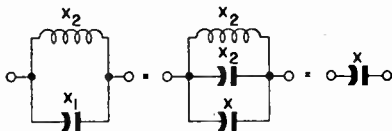

BASIC FORMULA:

$$X = \frac{X \cdot X_2}{X_2 - X_1} = \frac{X_2}{\frac{X_2}{X_1} - 1}$$

This slide-rule operation is the reverse of solving resistances in parallel, in that the C scale is slid to the right to place $(n - 1)$ under the hairline instead of to the left as when $(n + 1)$ is in the denominator of the formula.

Slide-rule arrangement:

First:

Scale	Step 1	Step 2
C	opposite 1	read $n = \frac{X_2}{X_1}$
D	set X_1	opposite X_2

Second:

Scale	Step 1	Step 2
C	set $n - 1$	opposite 1
D	opposite X_2	read X

Example 11:

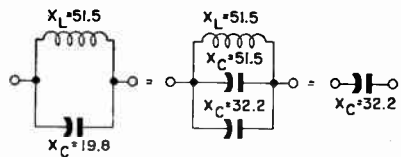

First:

Scale	Step 1	Step 2
C D	set 1 opposite 19.8	read 2.6 opposite 51.5

Second:

Scale	Step 1	Step 2
C D	set 1.6 opposite 51.5	opposite 1 read 32.2

When X_L is nearly equal to X_C , $(n - 1)$ is very small.

Example 12:

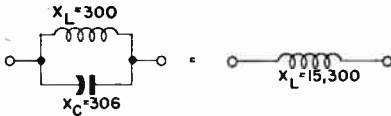

First:

Scale	Step 1	Step 2
C D	set 1 opposite 300	read 1.02 opposite 306

Second:

Scale	Step 1	Step 2
C D	set 0.02 opposite 306	opposite 1 read 15300

REACTANCE AND RESISTANCE IN PARALLEL

BASIC FORMULA:

$$Z = \sqrt{\frac{R^2 X^2}{R^2 + X^2}} = \sqrt{\frac{R^2}{\left(\frac{R}{X}\right)^2 + 1}}$$

Slide-rule arrangement:

First:

Scale	Step 1	Step 2
A	X^2	R^2
B	1	read $n^2 = \left(\frac{R}{X}\right)^2$
C	set 1	n
D	opposite X	opposite R

Second:

Scale	Step 1	Step 2
A B D	set $n^2 + 1$ opposite R	Z^2 opposite 1 read Z

Example 13:

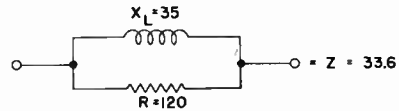

First:

Scale	Step 1	Step 2
B D	set right index opposite 35	read 11.75 opposite 120

Second:

Scale	Step 1	Step 2
B D	set 12.75 opposite 120	opposite right index read 33.6

PARALLEL-TO-SERIES TRANSFORMATION

BASIC FORMULA:

$$R_s R_p = X_s X_p = Z^2$$

In the second step of the previous example, the B- or C-scale index is at Z^2 on the A scale. Therefore, R_s and X_s can be found by dividing Z^2 by R_p and X_p , respectively, directly on the A and B scales.

Example 14:

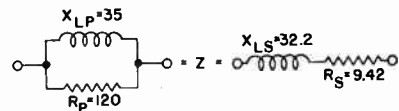

First:

Scale	Step 1	Step 2
B C	set right index opposite 35	read 11.75 opposite 120

Second:

Scale	Step 1	Step 2
A		
B	set 12.75	read 1130 opposite right index
D	opposite 120	

Third: $\frac{1130}{35} = 32.2 = X_{L8}$

Fourth: $\frac{1130}{120} = 9.42 = R_8$

NETWORK SOLUTION

All of these operations may be cascaded in a network problem. The concluding example illustrates a step-by-step breakdown of a typical network.

Example 15:

Solve for Z:

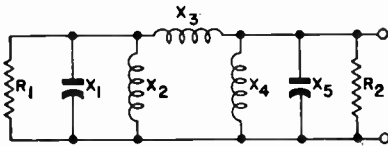

First (reactances in parallel):
 $X_1, X_2 \rightarrow X_6$

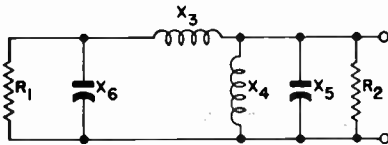

Second (parallel-to-series transformation):

$R_1, X_6 \rightarrow R_3, X_7$

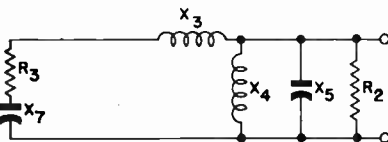

Third (reactances in series):

$X_7 - X_3 = X_8$

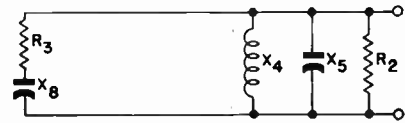

Fourth (series-to-parallel transformation):

$R_3, X_8 \rightarrow R_4, X_9$

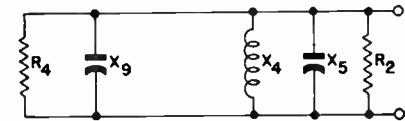

Fifth (resistances in parallel):

$R_4, R_2 \rightarrow R_5$

(reactances in parallel):

$X_9, X_5 \rightarrow X_{10}$

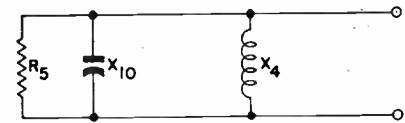

Sixth (reactances in parallel):

$X_4, X_{10} \rightarrow X_{11}$

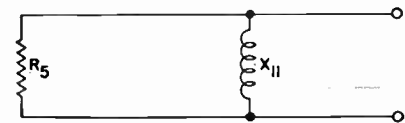

Seventh (reactance and resistance in parallel):

$R_5, X_{11} \rightarrow Z$
or

(parallel-to-series transformation):

$R_5, X_{11} \rightarrow R_6, X_{12}$

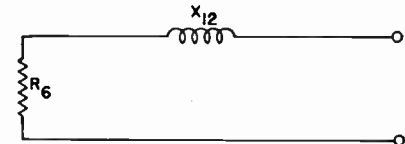

Eighth (reactance and resistance in series):

$R_6, X_{12} \rightarrow Z$

Telephone Patching

By Lyle A. Gallegos

Philca Field Engineer

A simple, reliable method of patching a telephone conversation into a radio-communications system.

(Editor's Note: This "phone patch" has been used and tested by the author in his own station, W4PWF. The circuit was first used when a local call from a Naval Hospital was relayed to another station. Less than a half hour was required to place the circuit in operation.)

The phone-patch circuit shown in the figure consists of nine 570-ohm, carbon, half-watt resistors. An 8-terminal, barrier-type terminal strip can be used both as a mechanical support for the resistors and as a connector strip. For convenience, a d-p-s-t toggle switch is used to make or break connection to the telephone line.

This circuit, which consists of a balanced bridge floated across the telephone line, is hybrid in that separate "send" and "receive" paths are provided from the common 2-wire telephone line. The impedance of the network, as seen from the telephone line, is a match of the impedance of the average telephone line.

The insertion loss through the network is approximately 11 db; however, the attenuation between TX IN and RX OUT is approximately 41 db. The 11-db insertion loss is no disadvantage, because the output from any communications receiver is sufficient to provide the proper level for the receive circuit, and the phono-input circuit of a typical speech amplifier provides more than enough gain to overcome the insertion loss in the transmit circuit. If the speech input to the transmitter is of the high-impedance type, it will be necessary to provide a 500-ohm line-to-grid transformer.

The main advantages of this type of circuit are: (1) no special transformer or hybrid coils are necessary, and (2) after switch S_1 is closed, no other switching is required until the circuit is secured. The reason for S_1 is obvious. It should remain open until the last digit has been dialed, to avoid transmitting

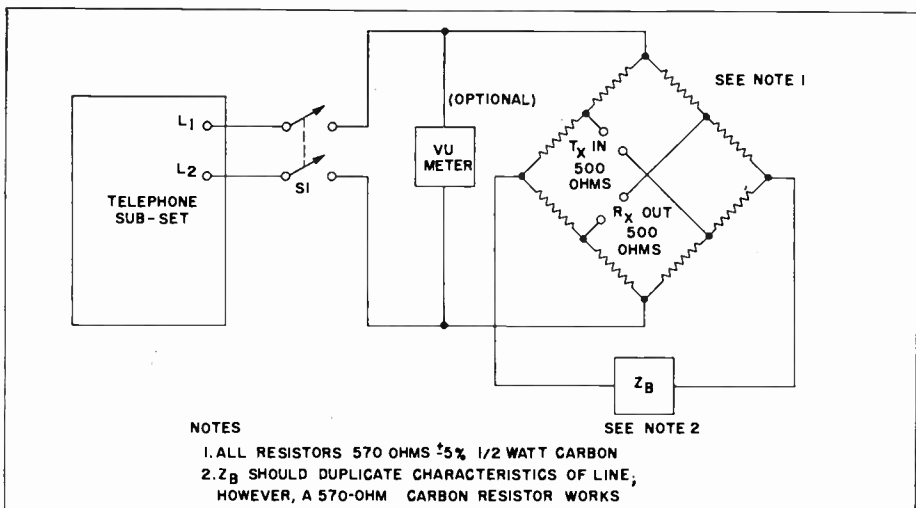

Phone-Patch Circuit

the dial pulses; also, the switch should be opened as soon as the QSO is finished, to avoid feeding receiver audio into the telephone line.

A word of caution is in order. All telephone lines are loaded with 60-cycle hum. This is not objectionable in the telephone handset because the handset receiver is designed to cut off at approximately 200 c.p.s., and accordingly, the low-frequency response of the trans-

mitter speech amplifier should be limited to frequencies above 200 c.p.s. to avoid transmitting any 60- or 120-cycle hum which might be present on the line. The ideal way, of course, is to insert a band-pass filter between the line and the speech-amplifier input, but satisfactory results can be obtained by inserting a .001- μ f. capacitor between the line transformer and the grid of the stage concerned.

Emergency Teletype-Converter Circuits

Two simple teletype-converter circuits that will work satisfactorily in an emergency are shown in the accompanying schematics. The only special requirements for their operation are that the noise level should not be too high, and that the relay must be properly adjusted. Circuit A uses two 50L6's to rectify the audio voltage and operate the teletype relay. The filaments are connected in series with a dropping resistor. Func-

tionally, circuit B is the same, except that two 1N43 crystals replace the tubes used in the other circuit. In operation, the receiver is tuned for zero beat on the space signal. A mark signal then produces an 850-cycle tone to operate the relay.

Raymond H. Rathjen
Philco Field Engineer
U.S.S. Estes

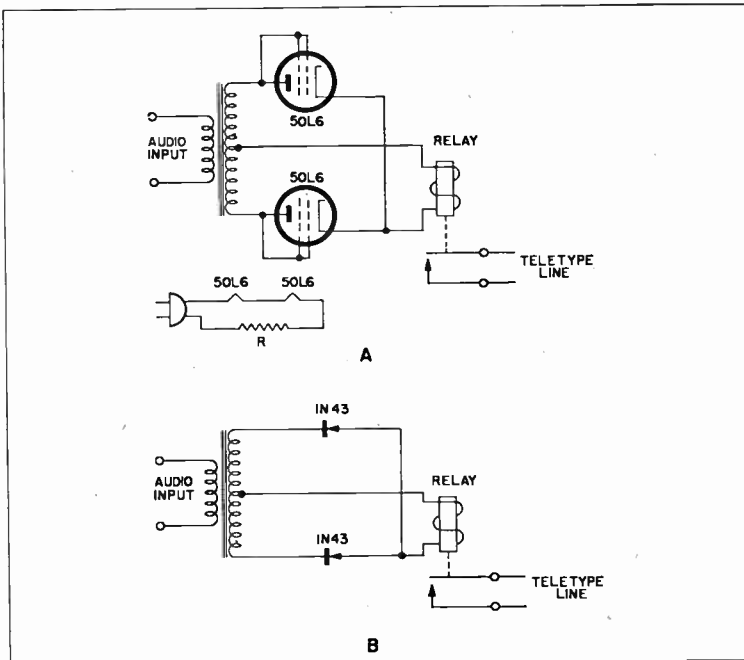

Two Forms of Converter Circuit for Emergency Use

The Platte Story

By Spencer Ross

Systems Engineering Group

A description of the new thousand-mile microwave communication and control system designed and now being installed for the Platte Pipe Line Company by Philco Corporation.



SPENCER ROSS

IT WAS nearly a century ago when Colonel Edwin Drake and "Uncle Billy" Smith brought in the first oil well at Titusville, Pennsylvania. That thin shaft, which they drilled on August 27, 1859, freed from a million years of imprisonment the "giant in the earth" that is oil. The tremendous and continuing growth of the petroleum industry has resulted, as would be expected, in communications requirements that far exceed those of the early days.

A small part of the vast pipeline network which covers the United States was laid as far back as 50 years ago. Since that time, the long-distance wire line has been providing yeoman service for pipeline-communications purposes. The wire line, however, is not the ultimate answer for this type of communications, because of high installation costs, high maintenance costs, and frequent outages, caused by the vagaries of the weather.

At Titusville it would have been a simple matter for Uncle Billy's 15-year-old son to climb to the top of the well house and "wave" to the men in the

nearby refinery, informing them that a cartload of oil was on its way. Now, a hundred years later, the oil industry is looking for its communications toward a new type of "wave" that has appeared on the scene—MICROWAVE.

The term "microwave" refers to that portion of the radio spectrum in which the wavelengths range between approximately 1 centimeter and 1 meter in length. This corresponds to frequencies between 300,000 and 30,000,000 kilocycles.

Two decades ago, the late Guglielmo Marconi, father of wireless, predicted in a lecture before the Royal Institution of Great Britain—"The permanent and practical use of microwaves will be, in my opinion, a new and economical means of reliable radio communication. . . ." As a result of Wartime developments in high-frequency techniques, Marconi's prediction has now become an accomplished fact.

ADVANTAGES OF MICROWAVE EQUIPMENT

Even a cursory examination of the characteristics of microwave equipment will reveal why it is a "natural" for application to the pipeline communications problem. Microwave communications equipment can perform any service which a wire line can perform, and, in addition, has the following advantages:

1. It is virtually impregnable to the ravages of the elements.
2. It can be installed and operated for much less than can a wire line that furnishes comparable communications facilities.
3. It can be installed in many locations where a telephone line is pro-

hibitive in cost. (A geographic barrier is just another "hop" to a microwave system.)

4. Operation at microwave frequencies provides freedom from natural and man-made electrical interference, and thus results in very-high-quality communications.

Microwaves, closely approaching the behavior of light, may easily be focused into a narrow, high-intensity beam. (Hence the evolution of the parabolic antenna, which has become the symbol of the microwave era.) It is this beam, a shaft of energy that "can be heard but not seen," which links one microwave station with the next.

Exemplifying the utmost in versatility and practicability is the microwave communications system which is being installed for the Platte Pipe Line Company, by the Philco Corporation. This system, paralleling the pipeline itself, stretches from Casper, Wyoming, to Wood River, Illinois—a distance of nearly a thousand miles. Representing a total investment of over a million dollars, the system is functionally the most complex yet devised in the industry. In inverse proportion to its functional complexity, it will materially simplify pipeline communications and control operations.

The Platte system, operating in the 7000-megacycle range, will use a total of 41 microwave stations. These stations, spaced from 11 to 30 miles apart, form a path down which the intelligence-laden microwave beam will race (see figure 1). The system is Philco-engineered from its head to its toes—from the microwave relay equipment itself to the last door hinge on the microwave shelters. The utmost in dependability will be provided by the inclusion of standby microwave equipment at all stations.

Figure 2 illustrates how the microwave beam projects upward to a reflecting surface mounted at a 45° angle on a tower, shoots across space to the next station, and ricochets off another reflector into the receiving antenna. The same paraboloid which is used to focus the microwave beam and transmit it toward a particular station is used to collect another beam coming from that station.

SYSTEM FACILITIES

The Platte microwave system will offer the following facilities along its route:

1. Voice communication.
2. Supervisory control of numerous operations.
3. Continuous telemetering of pressure, gravity, and flow.

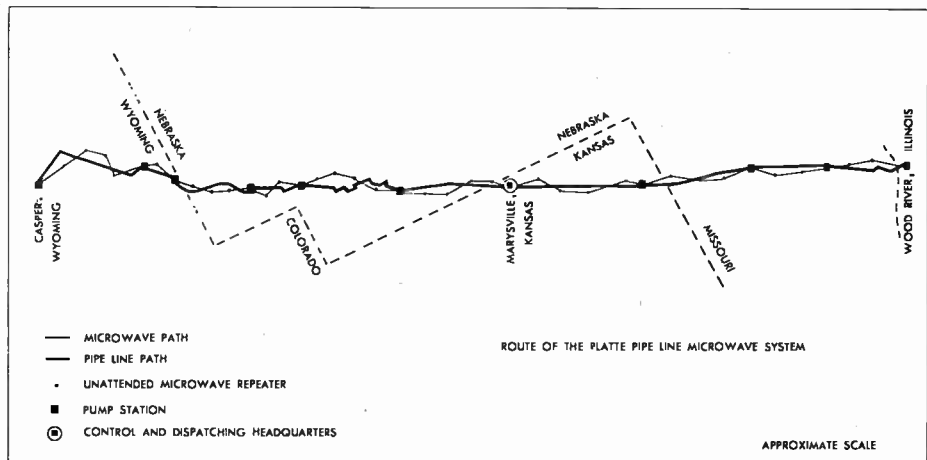

Figure 1. Map of Pipeline and Microwave System

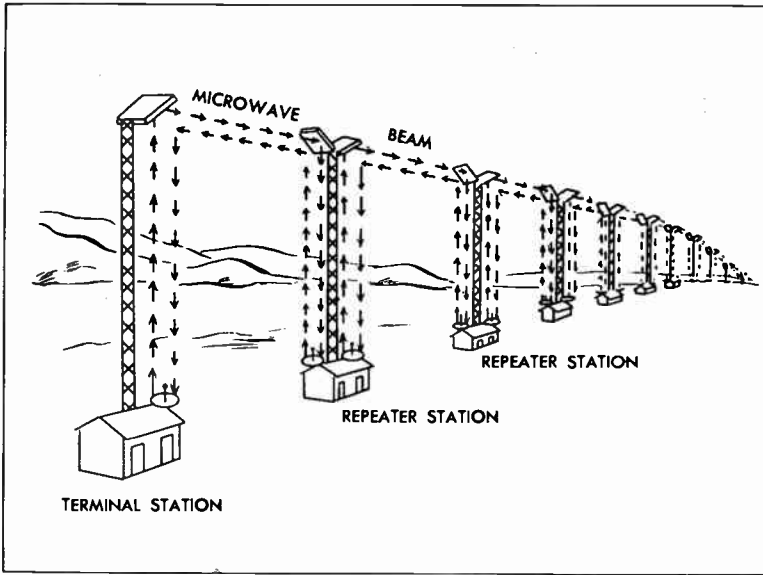

Figure 2. Path of the Microwave Beam

4. Selective telemetering (as called for) of pressure.
5. Remote control and operation of v-h-f transmitters for communication with distant mobile units.
6. Fault alarm.
7. Teletype.
8. Channel-expansion space for many future additional functions.
9. Servicing channel for maintenance.

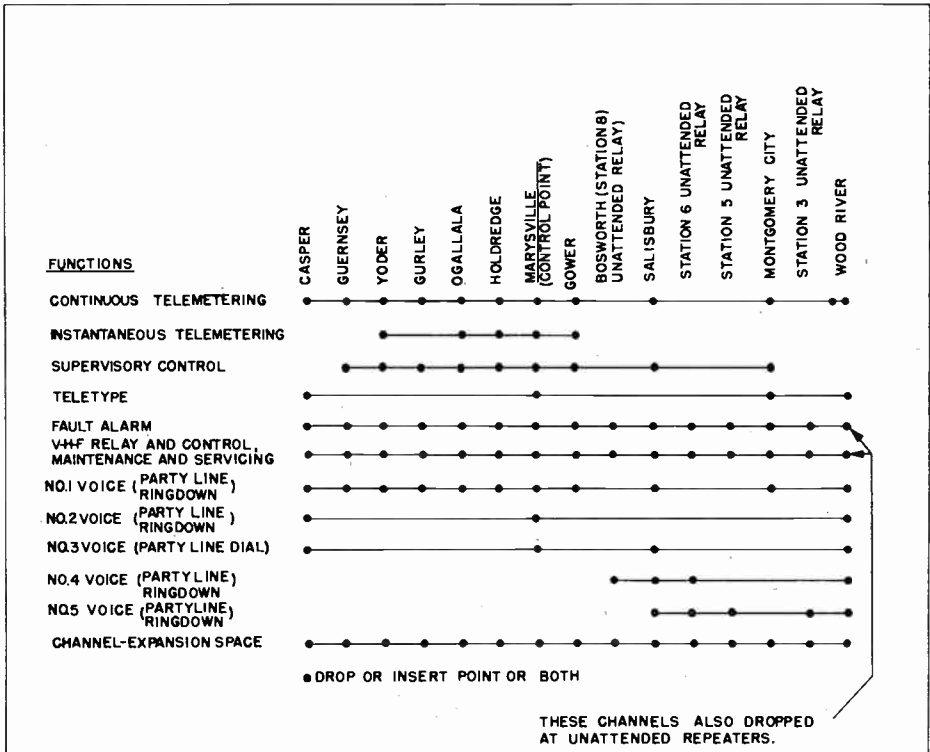

Figure 3. Channelizing Diagram

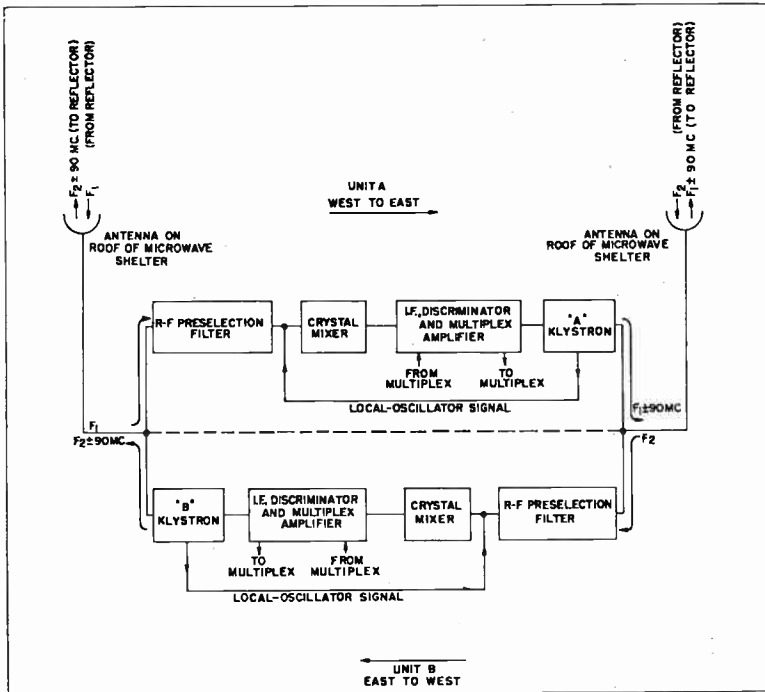

Figure 4. CLR-6 Functional Block Diagram

The channelizing diagram (figure 3) illustrates the functions which will be performed at each of the pump stations. It is possible to perform all these functions (with still more functions to be added in the future) because of the basic design of the Philco CLR-6 microwave relay equipment.

The CLR-6 will accept for transmission (at any station) a band of frequencies which ranges from 50 to 300,000 cycles. (These frequencies, after entering the CLR-6, are converted to the actual FM microwave signal.)

Platte will use Philco's CMT-5 frequency-division multiplex equipment to carve from this available 300-kc. spectrum the individual channels required to perform specific functions. One channel will slice only about 5000 cycles from the 300,000-cycle "loaf" of frequencies. Many functions, such as fault alarm, on the other hand, will require but a single frequency plus a small

guard band. Such individual tones may either be fed "raw" into the CLR-6, or may be submultiplexed onto an already-derived voice channel. For the block-diagram fan, figure 4 illustrates the principles of operation of the CLR-6.

The dotted line separates the east-to-west section (unit A) of the microwave repeater from the west-to-east section (unit B). Both sections are housed in the same cabinet, and perform identical functions except for the direction of operation. Note that both sections share the same antenna paraboloids; this is an economical feature of the design.

FUNCTIONAL EXPLANATION

For a functional explanation, consider the east-to-west section (figure 4):

The incoming signal, F_1 , passes through the entire CLR-6, and emerges as a frequency 90 mc. removed from its original value. During F_1 's travel through unit A, it first passes through the preselection filter, which keeps the

output of unit B from interfering with the operation of unit A. At the input of the crystal mixer, F_1 is then mixed with a small portion of the output of the unit-A klystron, which is oscillating at a frequency 90 mc. removed from F_1 . The difference frequency of 90 mc. is fed into the i.f., discriminator, and multiplex amplifier assembly, where it is detected and amplified. The detected and amplified signal then modulates the reflector of the unit-A klystron, and thereby determines its operating frequency. If the incoming r-f signal (F_1) does not vary, the unit-A klystron remains at a frequency 90 mc. removed from F_1 . Thus the klystron acts both as a local oscillator and as a transmitting tube.

Fundamentally, the terminal unit functions in the same fashion, except that the input and output circuits associated with one of the antennas in figure 4 are not required, since continuation of a "through" signal is unnecessary.

MULTIPLEX EQUIPMENT

Signals from the associated multiplex equipment are fed into, and extracted from, the i.f., discriminator, and multiplex amplifier assembly. Both frequency-division and time-division multiplexing systems may be used in conjunction with the CLR-6.

Platte's voice communication will proceed on a duplex basis, and will utilize frequency-division multiplexing, of the single-sideband, suppressed-carrier type. Both ringdown and dial-signalling will be provided.

Fault-alarm facilities are of the "fail-safe" type, which will indicate that a trouble has occurred at a particular station by interruption of a tone. Interruption of the tone will cause blinking of a lamp and sounding of a buzzer at the dispatcher's console at Marysville. Typical troubles which can be indicated are:

1. Failure of primary microwave equipment, and changeover to standby microwave equipment.

2. Failure of primary power, and changeover to auxiliary gasoline motor-generator.

3. Failure of tower lighting.

V-H-F Control and Relay

A total of 17 v-h-f transmitters for communication with mobile units will be spaced at intervals along the Platte microwave system. The dispatcher at Marysville will be able to select any one of the transmitters for use, and will hear messages transmitted to him from any mobile unit along the system. Operationally, the system will function as follows:

When a mobile unit calls in from the field (in this case the field may be rather distant, as much as 600 miles or more away), the dispatcher will be notified by a monitor speaker that he is being called. The dispatcher will then select a particular transmitter for operation, by sending out a train of coded pulses actuated by a dial mechanism. After the particular transmitter has been selected, conversation will proceed on a normal push-to-talk basis.

Telemetry and Supervisory Control

Pressure, gravity, and flow values from 10 points along the system will be continuously transmitted into Marysville, where they will be chart-recorded. In addition to the continuous telemetering facility, it will be possible for the dispatcher to select a particular station for return telemetering of pressures. The selective telemetering values will be indicated on a dial-type indicator at Marysville.

Teletype

Teletype facilities, which will be provided on a party-line basis, will involve the transmission of tones generated by AM telegraph carriers. At each station where the facility is provided, these carriers will be keyed on and off in accord-

ance with the impulses received from the associated teletype unit.

System Reliability

The Platte system is designed for the utmost in reliability. Several of the factors which contribute to this reliability are:

1. Complete primary and standby r-f equipment at every station. In the event of failure of the primary microwave equipment, the standby equipment will automatically switch in.

2. Standby power provision — Gasoline-driven standby motor-generators located at each microwave station will automatically take over the load in the event of failure of the primary power source. In general, units of 5-kw. capacity are sufficient for unattended microwave stations, while microwave stations at the pump stations (where most of the control and communications functions are performed) require units of 10-kw. capacity.

3. 30-db fading margin — During their travel through the troposphere (atmosphere which directly blankets the earth), microwave signals are subject to fading. There are a number of "propagation pixies" waiting to beset the unwary microwave beam. Researchers in the field have coined a horde of new terms such as "ducting," "stratification," "multipath," "sub-standard M curve," "temperature inversion," and "cellular structure of the atmosphere." These terms assist in describing the possible causes of bending, cancellation, or cleavage of the beam.

In 1948, Western Union completed a series of tests which showed that, in spite of fading, propagation reliability of the order of 99.99% could be achieved when using a 27-db fading margin. Having a 27-db fading margin means that the signal may degrade in strength 500 times below normal from transmitter to receiver before communication becomes unacceptable. The Platte

system is designed with a minimum fading margin of 30 db, representing a possible signal attenuation of 1000 to 1 below normal without interruption of communication. It is standard Philco practice to design this extra fading margin into microwave systems so as to provide super-reliability.

Because no effort has been spared to design a system that is the last word in reliability, the most extreme test conditions have been imposed upon Philco microwave installations in a deliberate effort to cause communication interruption. At one Philco installation, located in the proximity of an airfield, it was decided to conduct a number of tests to determine the effect on communication when airplanes intercept the microwave beam. The results of these tests were extremely gratifying. *In spite of the fact that a large airplane was flown across and along the microwave beam many times, at no time was communication disturbed even the slightest.*

The microwave towers which Platte will use at each station will range in height from 60 to 280 feet, with an average height of 180 feet. They are of triangular construction, and are designed to prevent extreme twist and sway, which would deflect the beam beyond reasonable limits. In general, the towers are taller in the eastern part of the system, where the land is flat. In the western part, it was often possible to take advantage of high points for tower locations, with consequent reduction in the required height of the towers.

The shelters which will house the microwave equipment will be of four sizes — 8' x 12' x 8', 12' x 12' x 8', 12' x 18' x 8', and 12' x 20' x 8'. These houses are of precast-concrete construction, and are divided into two compartments by a fireproof separating wall. One compartment will house the microwave and multiplex equipment, while the other will house the standby generator.

The following quotation is from Mr. Ralph Slough, superintendent of communications at Platte:

“The Philco Corporation has designed the Platte system in accordance with the latest engineering thinking.

“It would be inconceivable to use 2-wheel brakes instead of 4-wheel brakes on a modern automobile. It would be, similarly, inconceivable to use anything

but microwave for Platte’s control and communications functions.”

Today, an observer of the petroleum industry’s growth truly has a panorama of progress spread before him in all directions. He can look *down* to the establishment of new wells, *ahead* toward the building of new pipelines, and *up* to the microwave towers that will keep their vigil over the highways of communication.

WHAT’S YOUR ANSWER?

Here is an interesting theory problem which has recently come to our attention. The solution is a bit surprising, and would be rather difficult to check in practice.

Assume that the capacitors shown in the figure are all equal in value and have no leakage. Perform the following steps:

1. Move S_1 to position 2 and allow sufficient time for the capacitors to charge.
2. Close S_2 and allow sufficient time for C_2 to discharge.
3. Open S_2 .
4. Move S_1 to position 3.

The problem is the determination of the charge upon each capacitor at the end of step 4.

(Solution next month)

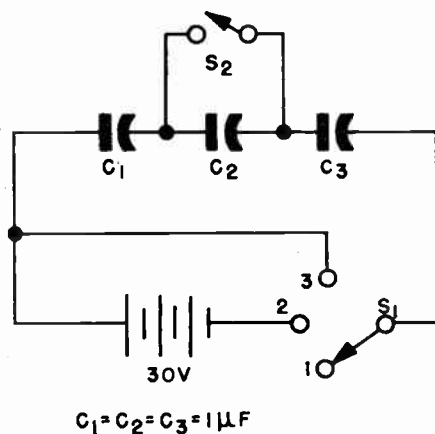

CABLE PRACTICES FOR THE RADIO STATION

By M. M. Elson

Philco Field Engineer

A discussion of standard procedures used in the installation and maintenance of cables in a radio-communication system.

IN THE average military radio station, equipments must be interconnected with one or more wires. The larger the station, the more wires required. In the majority of cases, the interconnecting wires are not more than about 20 miles in length. In some installations, however, the distance between the equipments is so great that the handling of the interconnecting wires constitutes a major problem. Once the wires are installed, the field engineer would like to forget them, but troubles do arise in this part of the installation, and, in spite of the difficulties involved, must be corrected quickly. The standard procedures developed by the various telephone companies should be used when trouble develops; these procedures will not only aid in finding existing troubles, but will prevent the recurrence of these troubles in the future.

CABLES

The interconnecting wires are often grouped together into cables, and given names, such as "remote control cable." A cable may be defined as "wires of extended length, used to interconnect equipments, and grouped together for purposes of ready identification." Unless otherwise specified, the term *cable*



M. M. ELSON

as used in this article refers to a lead-sheathed, paper-insulated non-quadded cable containing more than two pairs (four wires).

In most cases, cable identification is accomplished by the use of a numbering system. The number assigned to a cable (No. 5, for example) should come to mean that this particular cable ex-

tends between the receiver site and the transmitter site. This, of course, comes with familiarity with the installation.

When using such a cable, the necessity for identifying a pair within the cable frequently arises. Identification of proper pairs should be accomplished with minimum delay and maximum accuracy. Pairs may be identified by numbering the pairs at both ends of the cable, but the numbering of pairs should proceed in an orderly fashion (usually based on the color coding of the insulation). It is all too possible that a pair may be identified at one end as pair 5-15 (meaning, of course, cable 5, pair 15), but reappear as pair 5-29 at the other end. This information is of somewhat dubious value unless the personnel at both ends are fully aware of the change in pair numbers.

CABLE RECORDS

A cable terminal may be defined as "a type of installation located at a con-

venient point along a cable, arranged so that connection to and identification of pairs within the cable are readily accomplished." If properly designed terminals are provided, it is a simple matter to make all pairs follow some logical sequence, and to prepare adequate records of cable data. These records are probably the most important source of information available concerning the cables in use, and must be prepared locally for each station. Examples are shown in figures 1, 2, 3, 4, 5, and 6.

Figure 1 illustrates a very simple communications station. Three sites are shown, interconnected by a telephone-type cable. In this case, two simple terminal charts, such as the one illustrated in figure 2, are adequate for the installation. It is suggested that a terminal chart similar to that illustrated in figure 2 be prepared, and that a block diagram similar to that in figure 1 be included in the cable-data book.

Figure 3 illustrates a more complex station. Note that cable 1 is divided into sections A, B, and C, for record purposes. (This division is necessitated by the branched, or "tipped off," cable to the radio range.) Further, a main distribution rack is installed at the control point. Adequate records for the cable terminals are considerably more complex than the cable records, since they include both cable-identification data and distribution-rack tie-point data.

CABLE RECORD		
CABLE #1 - CONTROL POINT TO RECEIVER SITE - 1.3 MI 52 PAIRS, LEAD COVERED, TAPLE ARMORED, JUTHS COVERED, STRUNG AERIALLY CONTROL POINT TO DUCT ENTRANCE (0.5 MILES). UNDERGROUND FROM THAT POINT.		
PAIR NUMBERS		USAGE
CONTROL POINT	RECEIVER SITE	
1	1	RECEIVER SITE TELEPHONE
2	2	FR-3A CONTROL LINE "2" MACHINE
3	3	FR-3A CONTROL LINE "1" MACHINE
* 4	17	BC-779 AVAILABLE FREQUENCIES
5	5	NOT USED

NOTES: ALL ENTRIES IN CABLE-DATA BOOK SHOULD BE MADE IN PENCIL, TO ALLOW FOR CHANGES.
* SWITCH IN PAIR NUMBERS TO BE AVOIDED WHEREVER POSSIBLE.

Figure 2. Terminal Chart for Simple Communications Station

Note that the general form of the cable-record sheets follows that used in the simpler installations. The only rule that must be observed is that the originating point of all cables must be the distribution rack, and that all cables must be numbered from that point. Where another distribution rack is employed at some point other than the control point (the receiver site, for example), the cables extending beyond the second distribution rack, but not to the control point, should be numbered from the second rack.

In figure 3, cable 1 extends from the control point to the receiver site and to the radio range. At the control point, this is a 104-pair cable. At the splicing point, the cable becomes two 52-pair cables, one extending to the receiver

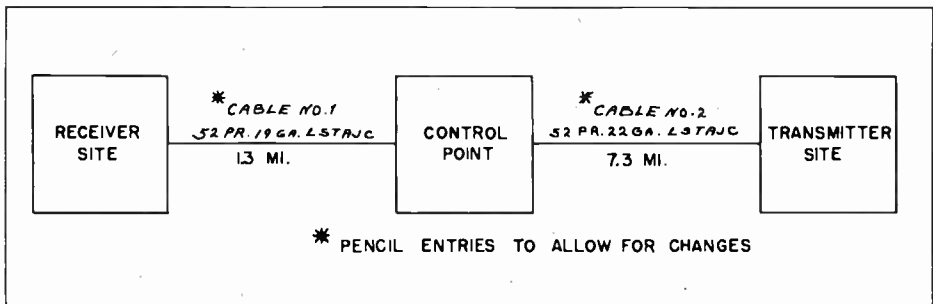

Figure 1. Block Diagram of Simple Communications Station

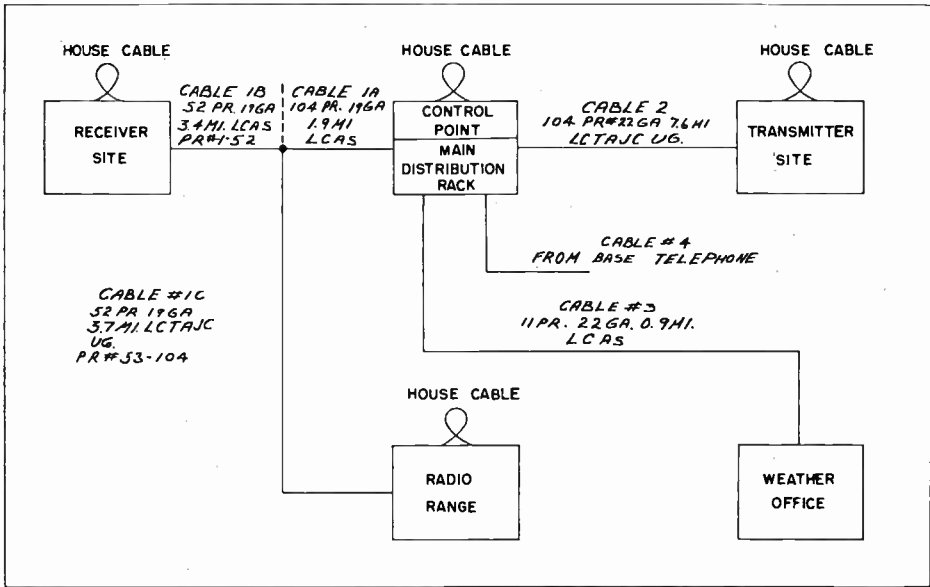

Figure 3. Block Diagram for Large Communications Station, Showing Line and House Cables

site, and the other to the radio range, Since cable 1 originates at the control point, it is labeled 1A from that point to the splice, and from the splicing point, 1B and 1C, respectively. Because of the necessity for keeping the pair

numbers straight, the pairs are arbitrarily divided between the terminals, with pair numbers 1 through 52 assigned to the receiver-site cable, and pair numbers 53 through 104 assigned to the radio-range cable. Figure 4 illustrates this method of notation on the cable-record sheets.

PAGE 1 OF 3 PAGES		CABLE RECORD	CABLE #1 A,B,C
CABLE #1 - A-104 PR. 196A, LEAD COVERED, AERIALLY SUSPENDED, TIPPED OFF 32 PR. - 32 PR. @ 1.9 MI. AERIAL SPICLE; B-32 PR. 196A, LEAD COVERED, AERIAL SUSPENDED; PAIR NOS. 1-52, CONTROL POINT TO RECEIVER SITE 3.4 MI. C-32 PR. 196A, LEAD COVERED, TAPE ARMORED, JUSE COVERED, TRUNK BURIED FROM TIP OFF 3' DEEP, PAIR NOS. 53-104 CONTROL POINT TO RADIO RANGE - 3.7 MI.			
PAIR NUMBERS		USAGE	
RECEIVER SITE	CONTROL POINT		
1	1	RECEIVER SITE TELEPHONE	
2	2	FBC-S OUTPUT LINE "1"	
3	3	" " LINE "2"	
4	4	" " LINE "3"	
5	5	" " LINE "4"	
<hr/>			
50	50		
51	51		
52	52		
RADIO RANGE	CONTROL POINT		
53	53	TOZ CONTROL LINE "1"	
54	54	" " LINE "2"	
55	55	" " LINE "3"	
56	56	" " LINE "4"	
57	57	" " LINE "5"	

Figure 4. Cable-Record Chart, Showing Method of Notation for a Complex Cable

In figure 3, several items of information are shown at the control point. The most important is that a main distribution rack exists at that point. A distribution rack is a point from which cables originate. Physically, it generally consists of some arrangement whereby it is possible to connect equipments to cables, or cables to cables. The most common form is an iron rack, mounting a sufficient number of solder-type insulated terminals to provide for all necessary connections. The rack sometimes contains all of the station protective devices, such as protector blocks, heat coils, and fuses, but its main function is to serve as the originating point of all cables.

DISTRIBUTION-RACK CHARTS

Distribution-rack charts are vitally necessary for "unconfused" operations. A suggested form is shown in figures 5 and 6. Distribution-rack tie points are numbered consecutively, and each cable is tied to a consecutive series of these tie points. In figure 5, cable 3 is shown tied to tie points 1 through 11. Tie point 1 is also permanently tied to tie point 212, as shown by the cross-connection note on the chart. Tie point 212, according to the cross-connection note, is connected to tie point 1, and is the originating point of pair 3 in cable 1. Thus, cable pairs 3-1 and 1-3 are common to each other. Examination of the block diagram (figure 3) reveals that the receiver site and the weather office are interconnected by this arrangement. Inspection of the cable record for cable 1 (figure 4) reveals that this is the line connecting from FGC-5, line No. 2. If the cable chart were shown for cable 3, it would reveal that a teletype printer was on the other end of the line, in the weather office.

HOUSE CABLES

House cables are shown in four of the five locations in figure 3. Again, some arrangement which is the equivalent of the distribution rack must be provided to facilitate the interconnection between the house cable and line cables. This is most conveniently done by terminating the cables in separate terminals, known as *house-cable terminals* and *line-cable terminals*, which are then interconnected, as required. A large amount of work may be expected at this point; therefore, special provisions should be made for inspection and testing of the circuits. These functions can be accomplished by the use of a patch field.* Every effort should be made to keep this installation down to a minimum, yet

* (See "Patch Fields," August-September, 1951 BULLETIN.)

POST DAILY /		DISTRIBUTION RACK			PAGE OF PAGES	
IDENTIFICATION			CROSS CONNECTION			
TIE POINT	CABLE PAIR NUMBER	STATUS	REMARKS	TIE POINT	OUT CABLE	
1	3-1	PER	REC SITE	212	1-3	
2	-2	PER		213	-4	
3	-3	PER		214	-5	
4	-4	PER		215	-6	
5	-5	TEMP	CONTROL TOWER	209	1-52	
6	-6	TEMP		217	4-23	
7	-7		HOLD FOR PRCL. OF STANCE CORR. 2227			
8	-8					
9	-9					
10	-10					
11	11		TELEPHONE	HOUSE	HOUSE	
209	1-52	TEMP	CONTROL TOWER	4	3-2	
210	2-1	PER	TELEPHONE	HOUSE	E.C.	
211	-2	PER	TELEPHONE	HOUSE	CO	
212	-3	PER	WEATHER OFFICE	1	3-1	
213	-4	PER		2	-2	
214	-5	PER		3	-3	
215	-6	PER		4	-4	
216	-7	PER	BASE TELEPHONE	HOUSE	4-51	
217	-8				4-2	
218	-9				-2	
219	-10				-3	

TEMPORARY CONNECTIONS—USE PENCIL TO ALLOW FOR CHANGES

Figure 5. Chart for Main Distribution Rack

provide sufficient equipment for the job required.

Continual changes will occur in house-cable circuits as a result of changes in modes of operation, and the installation of different equipments; therefore, it is desirable to provide for these changes. Figure 7 shows one type of installation which eliminates the masses of wires commonly found. Each equipment rack is equipped with a series of terminal strips, to which all input and output signals (except a-c power or antenna circuits) are connected. These terminal strips are, in turn, connected to a house-cable terminal through a normalised patch field, which provides for testing, monitoring, and switching.

The house-cable is fabricated locally, and provides one pair of wires for each pair of terminals on the terminal strips. Another separate cable, also fabricated locally, is used to connect the patch

POST DAILY!	DISTRIBUTION RACK		PAGE OF PAGES		
IDENTIFICATION			CROSS CONNECTION		
TIE POINT	CABLE PAIR NUMBER	STATUS	REMARKS	TIE POINT	OUT CABLE
100	HOUSE #1	PER	THRU JACK #1	100	H.1-1
101	-2	PER	2	101	-2
102	-3	PER	3	102	-3
103	-4	PER	4	103	-4
104	-5	PER	5	104	-5
105	-6	PER	6	105	-6
106	-7	PER	7	106	-7
107	-8	PER	8	107	-8
108	-9	PER	9	108	-9
109	-10	TEMP	10	109	-10

110	HOUSE #2-1	PER	FRR-1 TO FSC-1	100	H.1-1
111	-2	PER	FSC-2 TO FSC-2	101	-2
112	-3	PER	FRR-2 TO FSC-2	102	-3
113	-4	PER	FRR-3 TO FSC-3	103	-4
114	-5	PER	CO AMP BC 774 #1 TO #1	104	-5
115	-6	PER	CO AMP BC 774 #2 TO #2	105	-6
116	-7	TEMP	CO AMP BC 774 #3 TO #4	106	-7
117	-8	PER	CO AMP BC 774 #4 TO #4	107	-8
118	-9	PER	FSC-9 TO FSC-9	108	-9
119	-10	TEMP	FSC-10 TO #1	109	-10

Figure 6. Distribution Rack Chart for House-Cable Terminal

field to the house-cable terminal. The house cable is not tied directly to the line-cable terminal, since not all pairs in the house cable are connected to

pairs in the line cable. In fact, a large number of the house-cable pairs are usually interconnected in the house-cable terminal, to provide the functional operation between separate equipments within the house. The house-cable terminal should be mounted as close as is practicable to the line-cable terminal, preferably within the same cabinet or rack. It is then a very simple matter to tie such house-cable pairs as are necessary to the line-cable terminal.

Adequate records should be prepared for house cables, in the same manner as for the line cables. The same types of record forms should be used wherever possible. House cables are subject to cross-talk and hum pick-up, as are line cables; therefore, the house cable should be spaced well away from any open a-c power wiring. Levels of input to the cable should be kept as low as possible, to avoid cross-talk. If, for instance, a BC-774 receiver and a constant-output amplifier are to be used in conjunction with each other, they should be mounted in the same rack, and the connection from the receiver to the amplifier should

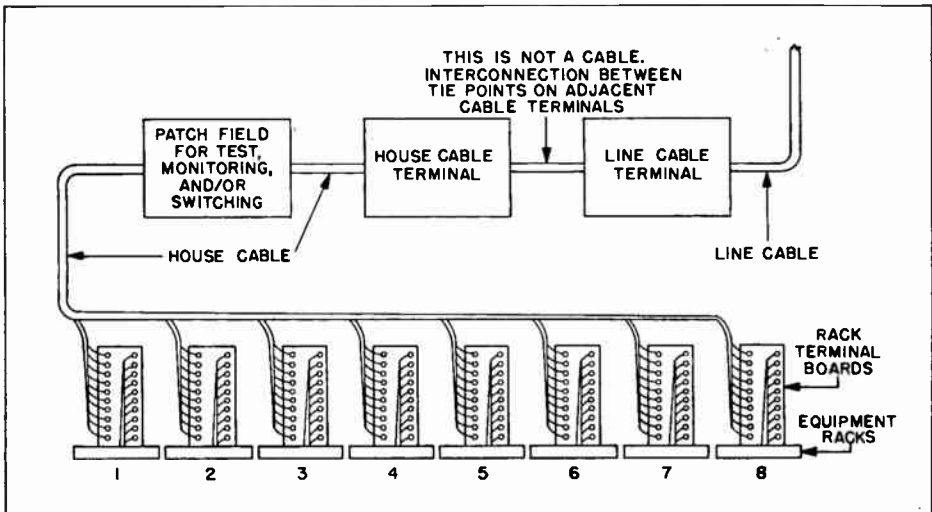

Figure 7. Interconnection of Equipment to Line Cable by Means of House Cable, Patch Field, and Two Terminals

be made within the rack. Only the output from the constant-output amplifier should be fed through the house cable.

EXTRA LINE PAIRS

When intelligently employed, house cables very seldom give the field engineer very much trouble. In a house cable extra pairs may be included with comparative ease, but in a line cable the inclusion of extra pairs is not practicable. When extra circuits are needed over a line cable, employment of the standard practices of pair utilization (simplexing, duplexing, compositing, and phantoming) will usually solve the problem.

Fortunately for the radio station, line cables are very seldom over 20 miles long, and even an average of 10 miles is probably quite high. Thus, the practice of phantoming a line is quite simple in any type of cable. If the lines are

longer than about 17 to 20 miles, the line unbalance and line resistance will become so great that phantoming becomes impracticable, unless very costly, low-resistance types of cable installations were originally made. However, over the shorter distances normally involved, ordinary equipment will yield satisfactory results.

SIMPLEXING AND COMPOSITING

Most field engineers divide the pairs in a line cable into two different classes: those pairs whose operating current is essentially d.c., and those pairs whose operating current is essentially a.c. Simplexing or compositing these pairs will yield a large number of additional circuits, which may be used for other functions of the station.

When using equipments such as the AN/FGC-5, which has multiple d-c signal outputs, compositing of the circuits

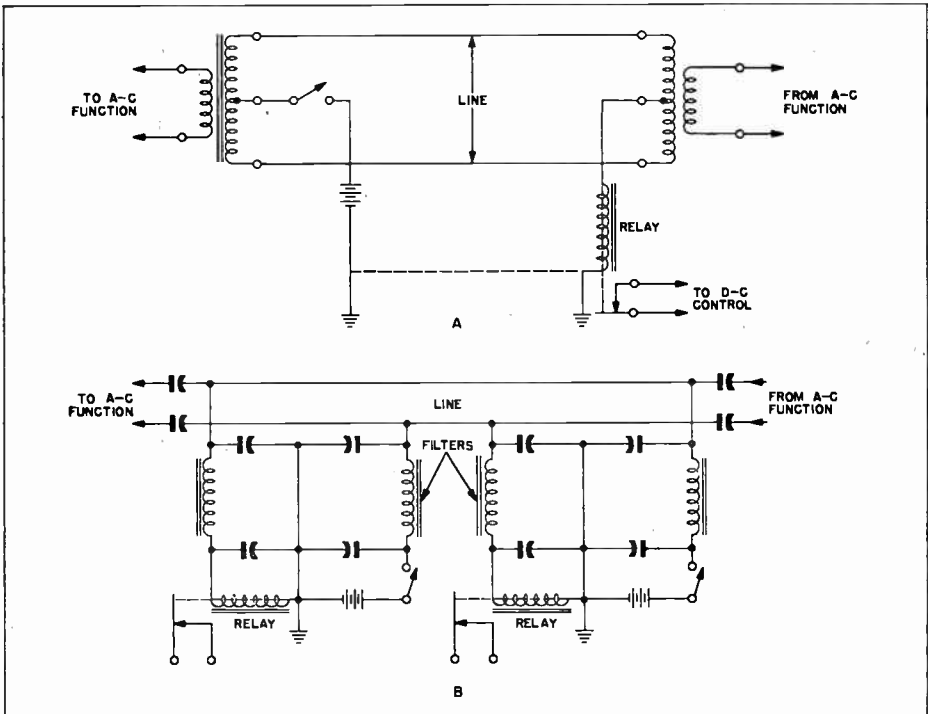

**Figure 8. A. Simplex Circuit Operation on A-C Line
 B. Composite Circuit Operation on A-C Line**

(Note that two independent circuits exist—one over each wire of a-c pair.)

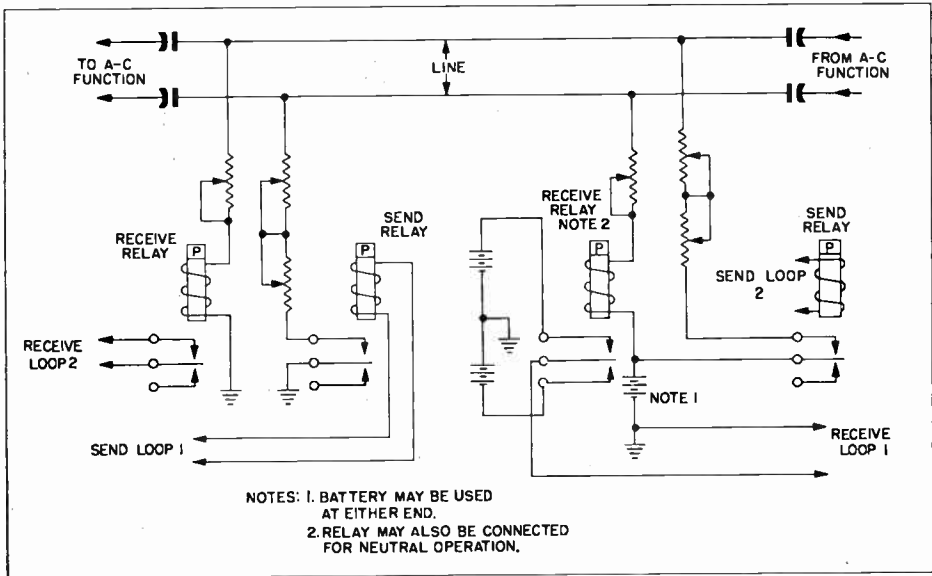

Figure 9. Compositing an A-C Metallic Circuit To Provide Two Additional D-C Teletype Circuits

affords a great saving in pair count. This is illustrated in figure 9, which shows one transmit circuit and one receive circuit in each direction. One receive relay is connected for neutral

operation, and the other for polar operation. Of course, any combination necessary may be used. Both circuits may be receive circuits or transmit circuits; the choice is dependent upon the particular requirements.

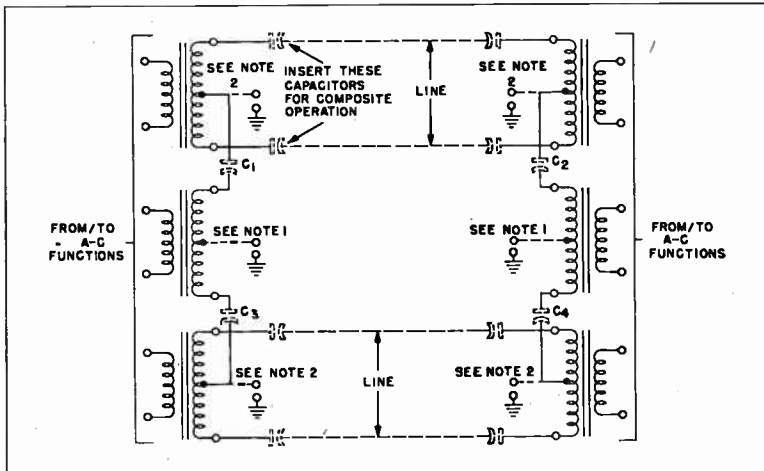

Figure 10. Method of Phantoming a Circuit, with Provisions for Simplex or Composite Operation

- NOTE 1. Simplex operation at reduced resistance from this point to corresponding point at other terminal, if all blocking capacitors are omitted from circuit.
- NOTE 2. Normal-resistance simplex operation from this point to corresponding point at other terminal, if C_1 and C_2 , or C_3 and C_4 are inserted.

PHANTOM CIRCUITS

The composited circuits illustrated in figures 8 and 9 may be phantomed, but not simplexed. In this case, four d-c circuits and three a-c circuits are available from each two pairs of metallic circuits so connected.

Figure 10 illustrates the method of phantoming a circuit. Several special requirements should be considered before phantom-type operation is attempted. Phantom circuits, for any appreciable distance, require the use of open wire or quadded cable. For best operation of the a-c portions of the phantom circuit, the circuit must be balanced; that is, the resistance of the two side pairs (the two physical pairs) must be made equal, by adding resistance as required. Figure 11 illustrates a test method for balancing the resistance in pairs of wires. The resistance in each wire is measured, with the balancing resistor out of the circuit, to determine which wire has the greatest resistance. Then, to each remaining wire a balancing resistor is added and adjusted until all wires have the same resistance. For

satisfactory operation, it is necessary to balance the circuit within very close tolerances.

INPUT LEVELS

Frequently, cross-talk becomes a considerable problem. Proper adjustment of all a-c input levels will usually cure this trouble. In most cases equipment which is designed to operate with a non-quadded cable will operate satisfactorily when the a-c input is 0 dbm. However, if satisfactory operation cannot be obtained at this level of input, the use of an amplifier at the receiving end is recommended. In the case of receivers similar to the BC-779, levels vary so widely because of noise, fading, and the changes in intensity of transmitted intelligence, that establishing a satisfactory input level is very difficult. In such cases, a constant-output amplifier (one which employs negative feedback) should be inserted between the receiver and the line. Cross-talk levels will be very high if the cable has split pairs within it. Wherever possible, avoid the use of split pairs for any a-c function. If a 0-dbm level is insufficient to satis-

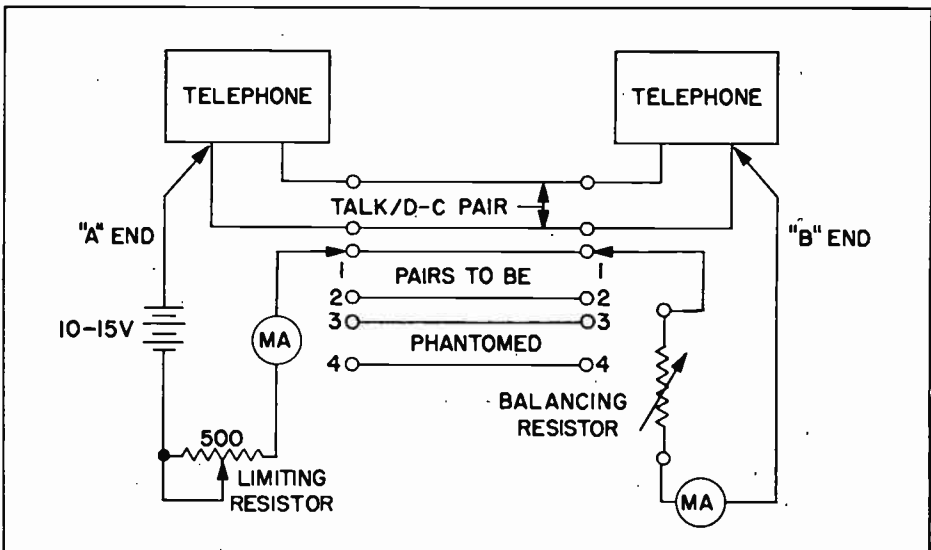

Figure 11. Method for Balancing Line Pairs (If battery and limiting resistor are placed at end "B", only one milliammeter is required.)

factorily operate the equipment at the other end of the pair, it is sometimes desirable to place this input on a phantom circuit, which will improve the operation because of the decreased resistance losses of the phantom circuit, as compared with the losses in a single metallic pair.

CARRIER OPERATION

Unless loaded quadded cables are available, voice-frequency carrier operation is not advisable. However, for short distances, this type of operation may be used without the more expensive installations. For carrier operation, the use of equalized cable is almost mandatory. It is beyond the scope of this article to go into the design of equalizers, but, in most cases, equipment designed for carrier operation has an equalizer included in the input stages. Adjustment of this built-in equalizer is all that is necessary. If the equalization of pairs is

required, the following books will be helpful:

Principles of Electricity Applied to Telephone and Telegraph Work (AT&T Publication)

Electrical Communications Engineering (War Dept. TM 11-486)

Principles of Long Distance Telephone and Telegraph Transmission (War Dept. TM 11-475)

Communications Engineering, Everitt, McGraw-Hill.

CONCLUSION

When a station engineering survey is initiated, the cable system of the station is a convenient place to start the engineering considerations. No matter how well designed the individual component parts of the station are, the cable system which integrates the components into a station will determine the ease and stability of operation. It is hoped that this article will provide sufficient information to enable the design engineer or field engineer to evaluate the requirements of the system with beneficial results.

Reception of Facsimile Signals Without a Converter

In an emergency, frequency-shift and subcarrier-frequency-shift facsimile signals can be copied without a converter, by use of an RBC or similar type of receiver switched to the "sharp i.f." position, with the audio fed directly into the transceiver. When the tuning is properly adjusted, high-contrast illustrations, such as maps or line drawings, are easily copied with this arrangement.

Raymond H. Rathjen
Philco Field Engineer
U.S.S. Estes

Modifying the CF-2-B Carrier Bay for Additional Printers

By Harrison J. Smith
Philco Field Engineer

A simple modification of the CF-2-B carrier bay to permit the operation of additional teletype printers without the use of a carrier bay at each location.

AT TIMES, when using a CF-2-B tone-carrier system, it is desirable to operate one or more teletype printers on receive loops (in addition to the tone-carrier circuit) without installing a carrier bay at each receiver location. The modification described in this article allows this type of operation; it requires no changes in the wiring of the carrier bay, and no additional parts. The system can be used only on full-duplex, neutral to positive or negative, or full-duplex, two-path-polar operation of the loop circuit.

In full-duplex operation, the only function of the break relay in the CF-2-B is to key the bias-measuring circuit; once the bias is set on a repeated space

signal, the break relay has served its purpose, and can then be removed from the circuit.

Taking advantage of this fact, remove the break relay from its socket, and place it in a spare-relay socket at the bottom of the bay. Run external connections from the mark- and space-winding contacts of the break-relay socket to the corresponding contacts on the spare-relay socket. Then make external connections from the mark, space, and armature contacts on the spare-relay socket to the corresponding contacts of any receive-relay socket of the same bay, or any other CF-2-B bay that has an idle receive-loop circuit on full-duplex operation. These connections are

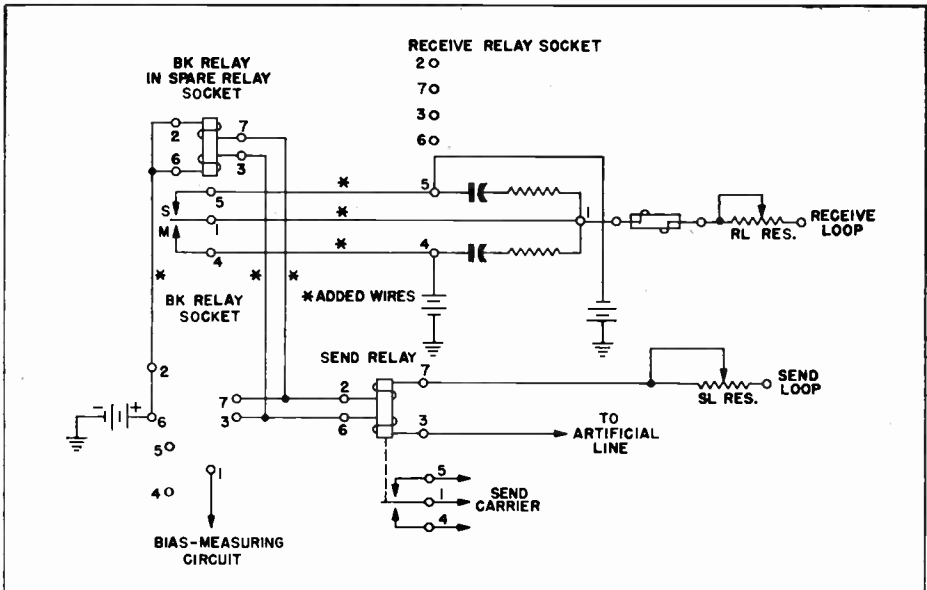

Figure 1. Simplified Schematic, Showing Modification

best made by using bases of old relays (or Sigma model "D" relays) as plugs.

Once these connections are made, the send-loop circuit is still the same electrically, except that the break relay now keys a receive loop from which an additional printer can be operated. Send bias may be set by removing the relay-base plug from the break socket, inserting a relay, setting the bias, and then removing the relay and reinserting the plug.

In the case of duplex neutral loop circuits, three connections are made from the break-relay socket to the spare-relay socket. Only two connections need be made in two-path polar duplex loop circuits. If necessary, several more relays can be added in series with the break relay, each one keying a separate

receive loop. If this is done, slight compensating adjustments of the send-loop and send-bias rheostats should be made because of the added resistance of the send-loop and artificial-line circuits. These compensating adjustments need not be made in two-path polar loops, since there is no artificial-line circuit, and battery voltage is supplied at the distant station.

The use of this system eliminates the expending of an entire bay for the operation of an additional printer. The system does not require any special parts, and the bay can be returned to its original condition in a matter of seconds simply by removing the relay-base plugs from the sockets and inserting the break relay in its proper socket.

Solution to...

Last Month's "What's Your Answer?"

The output waveform in the problem should look like the one shown in the figure. Of course, the R-C circuit will pass the leading edge of the input wave,

The charge will leak off much more slowly than it was formed, because the input wave is changing much more slowly.

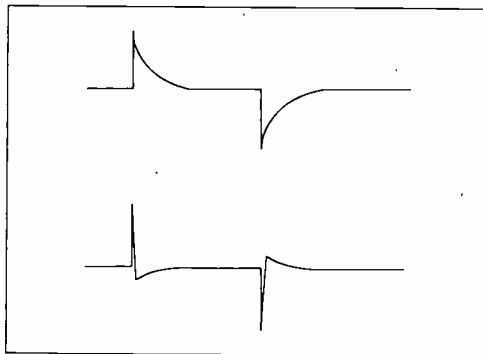

and the capacitor will develop a slight charge during the peak portion. As soon as the input voltage drops below the value of charge assumed, the capacitor will start to discharge, thus forming the negative-going part of the output wave.

The important factor to observe is the formation of the negative overshoot on the positive input peak, and the positive overshoot on the negative input peak.

Index for Vol. I—Philco TechRep Division BULLETIN

	MONTH	PAGE
Air Transportable AN/MPN-1, An	November	14
Antennas:		
Antenna Construction Handbook, New	October	29 <small><i>Inside back cover</i></small>
Beverage Antenna Theory	June	29
Construction of the Beverage Antenna	February	4
Dummy Antenna for T-14/TRC	November	4
High Gain U-H-F TV Antenna, A New	November	18
Orienting Microwave Antennas	June	6
SCR-527 Receiving Antenna Modification	November	25
AN/TRC:		
Dummy Antenna for T-14/TRC	November	4
Improved Tuning Procedure for the 5-Mc. Stages of Receiver R-19(*)/TRC-1	August-September	40
Modification of TS-32(*)/TRC-1 to Provide 5-Mc. Output	July	31
Correction of Dead Spot in TS-32(*)/TRC-1 Output	July	31 <small><i>Inside back cover</i></small>
Balitron Amplifier, Background of the	October	18
Book Reviews	October	30
Cable:		
Cable Practices for the Radio Station	December	19
Misuse of Paper-Insulated Lead-Covered Cable	June	19
Patch Fields	August-September	30
"Carl's Comments"	February	14
Circuits:		
Correction of Dead Spot in TS-32(*)/TRC-1 Output	July	31 <small><i>Inside back cover</i></small>
Electrical Deflection System for A-1C Gunsight	August-September	43
Unusual Receiver Mixer Circuit	February	26
Wide-Band Input Circuits for Oscilloscopes	October	13
Crystals:		
Crystal Grinding	July	20
Quartz Crystals	May	4
C-R-T Screen Characteristics	May	14
Editorials:		
Equipment Complexity and the Repair Problem	February	3
The Growing Importance of Field Engineering	May	3
Human Engineering	June	3
Selection of Manuscripts for Publication	July	3
Publication of Classified Material	August-September	3
Keeping Pace	October	3
There Is a Future in Field Engineering	November	3
Looking Back on Volume I	December	3
Electrical Deflection System for A-1C Gunsight ..	August-September	43
Electricity Used 20 Centuries Ago	February	19
Engineering of Military Electronics Installations ..	October	11
Facsimile Signals Without a Converter, Reception of ...	December	27
Handling of Radio-Active Tubes	February	22

Index for Vol. I—Philco TechRep Division BULLETIN (Continued)

	MONTH	PAGE
Maintenance:		
Line Maintenance of Airborne V-H-F Transmitters.....	February	15
Preventive Maintenance of Rotating Electrical Machinery.....	May	23
Testing Amplidynes	October	32
Measurement, High-Frequency Power	November	6
Microwave:		
Microwave Propagation	August-September	35
Microwave Radio-Invisible Pole Lines.....	July	14
Microwave Wave Guides and Components.....	August-September	9
Orienting Microwave Antennas.....	June	6
S-Band Propagation	October	4
Platte Story, The.....	December	12
Training Manual on CLR-6, New.....	July	36
Modification of AN/FGC-1 for "Make-and-Break"		
Operation	October	24
Modifying the CF-2-B Carrier Bay for Additional		
Printers	December	28
MTI:		
An Interference Blanking System for MTI-Modified		
Radars	August-September	4
Theory of a Moving Target Indicator System.....	July	7
Navigation, "R-Theta"	October	26
Nomography	June	10
Oscilloscopes:		
Improvising a Spectrum Analyzer.....	May	8
Large-Screen Oscilloscope Adapters.....	May	29
Simplified Electronic Switch for Oscilloscopes.....	June	9
Wide-Band Input Circuits for Oscilloscopes.....	October	13
Polar Relays:		
Adjusting Polar Relays Without a Test Set.....	October	16
Polar Relays	May	11
Power Measurement, High-Frequency	November	6
Preparing a Good Technical Report	July	34
Preventive Maintenance of Rotating Electrical Machinery	May	23
Processing Your Article	June	20
Radar:		
Interference Blanking System for MTI-		
Modified Radars	August-September	4
Standardized Radar Local Oscillator Tuning Procedure.....	May	25
S-Band Propagation	October	4
Theory of a Moving Target Indicator System.....	July	7
Trigger-Delay Unit for Radar Range-Zero Adjustment.....	July	4
Training Manual for Radar Set AN/APN-9, New.....	December	4
Training Manual on Radar System Measurement.....	June	4
Radio-Active Tubes, Handling of	February	22
Reception of Facsimile Signals Without a Converter	December	27
"R-Theta" Navigation	October	26
Slide-Rule Techniques for the Engineer	December	4

*Inside
back cover*

*Inside
back cover*

Index for Vol. I—Philco TechRep Division BULLETIN (Continued)

	MONTH	PAGE
Sound, The Power of	November	24
Spectrum Analyzer, Improving a	May	8
Standard Frequencies and Time Signals, WWV and WWVH	August-September	37
Technical Report, Preparing a Good	July	34
Telepathic Communication	November	8 <small>Inside back cover</small>
Telephone Patching	December	10
Television:		
High Gain U-H-F TV Antenna, A New	November	18
Philco "Balanced Beam" Television	February	7
Training Aids:		
Block System, The	May	27
Electronic Countermeasures Training Aid, An	June	4
Improvised Training Aids	June	21
Tubes:		
Background of the Balitron Amplifier	October	18
C-R-T Screen Characteristics	May	14
Extending Tube Life of 12GLX-2A Transmitter	June	36
Handling of Radio-Active Tubes	February	22
Tuning:		
Improved Tuning Procedure for the 5-Mc. Stages of Receiver R-19(*)/TRC-1	August-September	40
Standardized Radar Local Oscillator Tuning Procedure	May	25
Unusual Receiver Mixer Circuit	February	26
'You Name It' Contest Winner Chosen	May	8 <small>Inside front cover</small>
Wave Guides and Components, Microwave	August-September	9
"What's Your Answer?":		
Phase-Splitter Problem	May	36
Solution	June	26
Ohm's Law Problem	June	34
Solution	July	13
Black-Box Problem	July	28
Solution	August-September	42
Power-Supply Problem	August-September	41
Solution	October	35
Resistor-Cube Problem	October	36
Solution	November	28
Differentiator-Action Problem	November	27
Solution	December	29
Capacitor-Charge Problem	December	18
Writing Hints for Field Contributors	February	20

New
TRAINING MANUAL
for Radar Set AN/APN-9

The newest addition to our current series of training manuals is now nearing completion—the “Philco Training Manual for Radar Set AN/APN-9.”

For a time, we debated whether such a manual was seriously needed, since the AN/APN-9 is not a new equipment. However, as a result of the current military expansion program, this airborne LORAN unit is being installed in nearly all new bombers and cargo aircraft, and will apparently continue to be in wide use for a number of years. Therefore, the training of technicians to maintain these units will continue to be a requirement for an indefinite period.

The new manual will be similar in style and format to the recently released “Training Manual on Philco Microwave Radio Relay Equipment (CLR-6),” and will include three wall charts to facilitate classroom training: an overall circuit schematic, an equipment block diagram, and a series of typical waveforms found at test points throughout the equipment.



