

HEWLETT-PACKARD JOURNAL

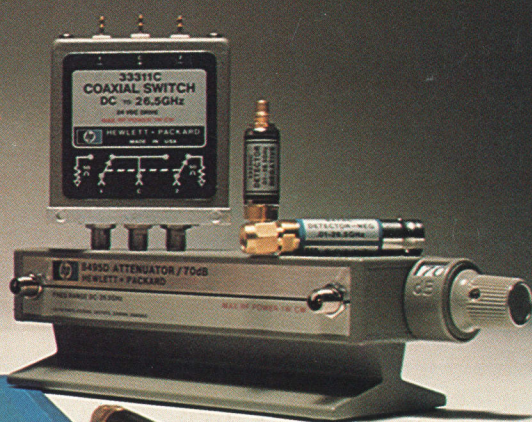

A Wide-Ranging Power Supply of Compact Dimensions

Its output ranging from 0 to 50 volts and 0 to 10 amperes, this 200W, series-regulated, laboratory power supply spans a range that would normally require three power supplies, and it can be programmed by way of the HP interface bus.

by Paul W. Bailey, John W. Hyde, and William T. Walker

LAB SECTION MANAGERS, production engineers, and materials engineers often face a difficult choice when specifying the purchase of a power supply for their operations. The immediate need may be, say, for 5 volts at 7.3 amperes for a prototype TTL circuit, or 48 volts at 1 ampere for production test of an analog circuit board, or 24 volts at 0.6 ampere for a stepper motor controller, or 10 through 18 volts to life-test a batch of CMOS integrated circuits. But what of future requirements? Will other voltages or other currents be needed? Estimates of future needs are seldom clear at the time a purchase order is drawn.

As one solution to this problem, a new power supply, Model 6002A, uses electronic tap switching to achieve an extremely wide range of output voltage and current ratings within its 200W power capability. As shown by the power output curve of Fig. 1, it is equivalent to three power supplies: a 50V-4A supply, a 20V-10A supply, and a third that provides in-between voltage-current ratings within the 200W limit. This one compact supply (Fig. 2), operating either in the constant-voltage mode with an adjustable crowbar protection circuit or in the constant-current mode, may thus fulfill a wide range of present and future power supply requirements where the good regulation and low-noise output of a series-regulated power supply are needed.

Besides service on the lab bench, the new power supply is well adapted to systems work, being programmable by analog voltages or resistances, and it can be equipped for digital programming through the HP interface bus* (the method of implementing interface bus control is described on page 6). System speed is improved by circuits that enable the output to slew up or down to a new voltage level quickly (<400 ms) in response to programming commands.

Alternatives

Before explaining electronic tap switching, let's explore some alternative techniques for obtaining

ranges of 0 to 50 volts and 0 to 10 amperes in a series-regulated power supply. One way would simply be to design a 500W supply, but that is not a very practical solution since the series regulator could be called upon to dissipate as much as 650 watts at low output voltage settings with high output currents.

A second approach would be to use three 200W power supplies with overlapping ranges. Besides being an expensive solution, this would require some

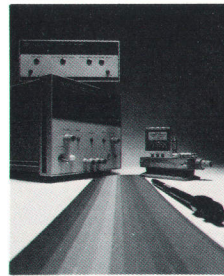

Cover: *Technical developments described in this issue occupy widely spaced positions in the frequency spectrum (symbolized here by the visible spectrum)—at the low, low end, a dc power supply and power supply programmer, and at the high end, coaxial microwave accessories. But most of these devices share one common characteristic: they can be equipped to work on the HP interface bus.*

In this Issue:

A Wide-Ranging Power Supply of Compact Dimensions, by Paul W. Bailey, John W. Hyde, and William T. Walker **page 2**

Remote Programming of Power Supplies Through the HP Interface Bus, by Emery Salesky and Kent Luehman, page 6.

Coaxial Components and Accessories for Broadband Operations to 26.5 GHz, by George R. Kirkpatrick, Ronald E. Pratt, and Donald R. Chambers **page 10**

Personal Calculator Algorithms II: Trigonometric Functions, by William E. Egbert **page 17**

*Hewlett-Packard's implementation of IEEE Standard 488-1975.

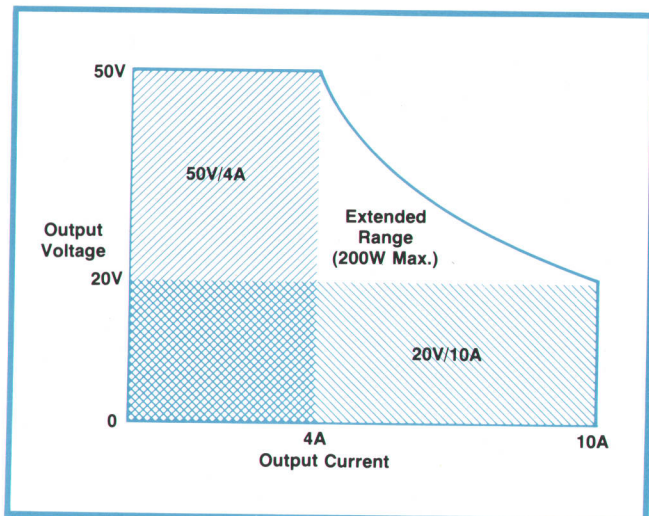

Fig. 1. Maximum output capability of Model 6002A DC Power Supply is bounded by 50 volts, 10 amperes, and 200 watts. At least three traditional 200W series-regulated power supplies would be required to cover the same range of output voltage-current combinations.

sort of switching arrangement to enable an arbitrary device to be powered throughout the entire range.

Pre-regulation—using phase-controlled silicon-controlled rectifiers ahead of the series regulator for coarse regulation—is the usual way to obtain a wide-ranging power supply. However, pre-regulated power supplies do not respond very quickly to remote programming. This is because the series regulator, which in the steady state operates with a V_{ce} of only a few volts, is not designed with enough heat-sink capability to absorb the extra energy dissipated when

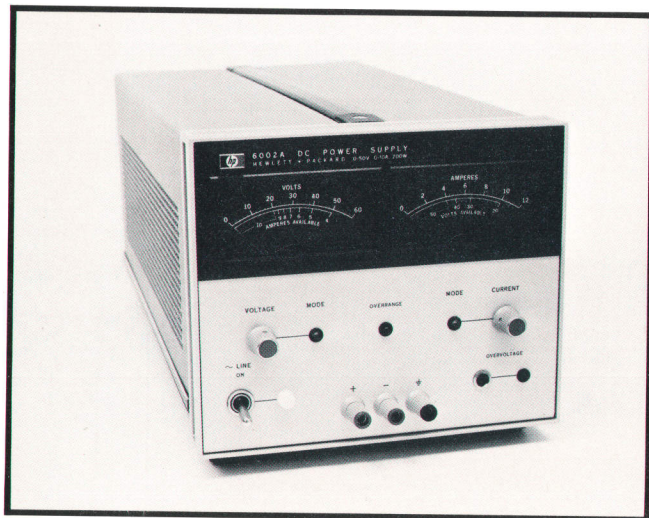

Fig. 2. Model 6002A is a 200W series-regulated dc power supply that works in either the constant-voltage or constant-current modes of operation. The lower scales on the meters show the maximum current available for any voltage setting or the maximum voltage available for any current setting within the 200W limit.

discharging the input filter capacitor during down-programming, so it is turned off under these conditions. Since several seconds may be required to discharge the capacitor, the power supply becomes the limiting factor on system speed when the application calls for frequent down-programming.

Electronic Tap Switching

The new Model 6002A uses electronic tap switching to charge the input capacitor to one of four discrete voltage levels, depending on the output voltage and current required. With these four levels, the voltage drop across the series regulators at high current levels never exceeds 25 volts, so the regulators are never required to dissipate more than 250W in steady-state operation. A wide range of output voltage and current levels may thus be provided by a compact lab bench supply.

A diagram of the power mesh in the 6002A Power Supply is shown in Fig. 3. The main secondary winding of the power transformer has three sections, each of which has a different turns ratio with respect to the primary winding. Two triacs, T_A and T_B , connect the taps on the secondary winding to the augmented rectifier bridge

At the beginning of each half cycle of the line voltage, the control logic selects which triac is to be fired. If neither triac is fired, the input capacitor is charged to the voltage determined by N_1 turns. If triac T_B is fired, the capacitor charges to a voltage determined by $N_1 + N_2$ turns. Likewise, if T_A is fired, the capacitor is charged by $N_1 + N_3$. Finally, both triacs can be fired at the same time, charging the capacitor to its highest level ($N_1 + N_2 + N_3$).

These four voltage levels map into four partitions on the output power plot, as shown in Fig. 4. The boundaries between the partitions, which are "invisible" to the user, are determined electronically. These are named V_{OD} , for the output voltage decision line, and I_{OD1} and I_{OD2} for output current decisions one and two. If the selected output voltage falls below the sloping V_{OD} line, both triacs are inhibited and the input capacitor charges to the voltage determined by winding N_1 . When the output is programmed above the V_{OD} line, the control logic looks at the output current level to decide which triac should be fired. The diagram indicates the windings connected as a result of these decisions.

I_{OD1} and I_{OD2} are not fixed levels of current but are modified by the level of the input line voltage (I_{OD} decreases as the line voltage increases). This assures an adequate voltage drop across the series regulator during periods of low line voltage without causing excessive regulator dissipation during periods of high line voltage.

The control logic continuously monitors the output

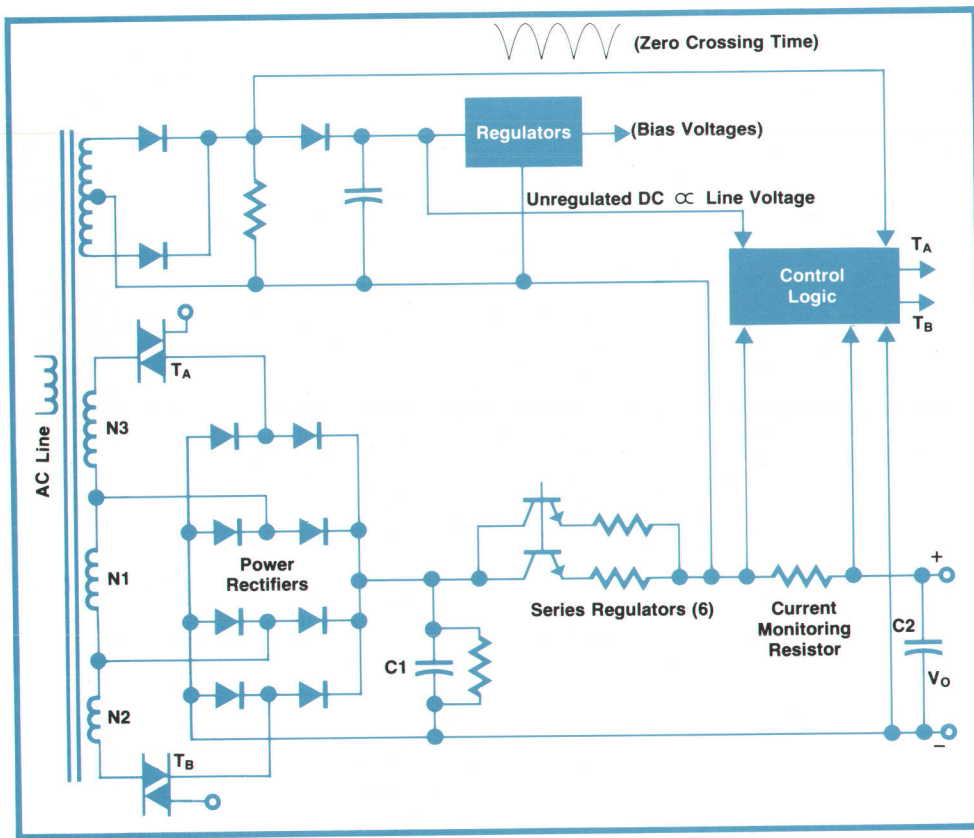

Fig. 3. Simplified diagram of Model 6002A's power circuits. The control logic monitors the output voltage, output current, and the line voltage level to decide which triacs (T_A and T_B) should or should not be fired to connect the appropriate transformer taps to the power rectifiers (triacs are bipolar switches that conduct current in either direction if a gate pulse is properly applied and continue to conduct until the current from the source goes to zero).

load current, the output load voltage, and the input line voltage. These inputs are applied to a resistor network that derives control signals applied to comparators along with internally derived references for V_{OD} , I_{OD1} , and I_{OD2} .

As shown in Fig. 5, the comparator outputs are applied to flip-flops clocked by pulses that coincide with the zero-crossover of the ac line voltage. The comparator outputs are thus latched into the flip-flops at the start of each half cycle of the input line voltage and retained there for the full half cycle.

The triacs are fired by 18-kHz pulses. If the output voltage falls below the sloping V_{OD} line, the V_{OD} latch inhibits the generation of 18-kHz pulses and neither triac is fired. If the voltage is above V_{OD} , then the logic steers the 18-kHz pulses to the appropriate triac (or to both) according to the output current level.

Noise Minimization

Triacs are capable of generating a considerable amount of electromagnetic interference. This interference is proportional to the turn-on dv/dt so it can be minimized by firing a triac only when the voltage is low. The current through a triac, on the other hand, must be greater than a certain minimum, known as the latching current, if conduction is to be sustained. There thus exists an optimum time for firing a triac—late enough in the ac cycle for the current to be above the latching level but not so late that the dv/dt would

generate excessive EMI.

Since the triac load in the new power supply is the input filter capacitor, current flows only when the transformer secondary tap voltage exceeds the capacitor voltage by some minimum. The time in the powerline cycle when the triac cut-in should occur thus varies widely as the power supply load is changed, so it is quite unpredictable.

The solution adopted in the Model 6002A was to use an 18-kHz train of 8- μ s pulses to trigger the triacs.

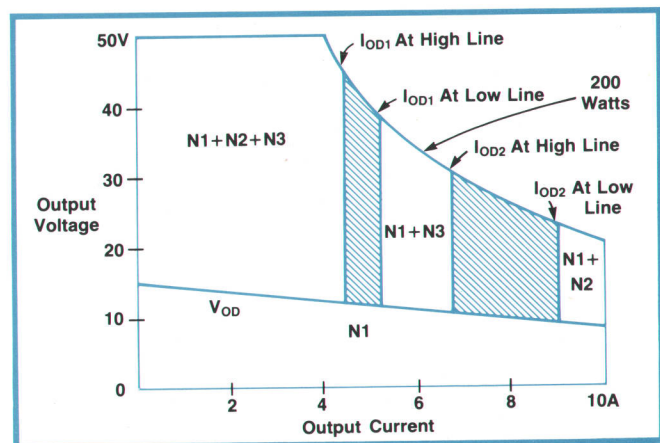

Fig. 4. Plot shows which transformer taps are connected for any voltage-current output. The boundaries established by output current levels (I_{OD1} and I_{OD2} decision lines) shift in response to the input line voltage level.

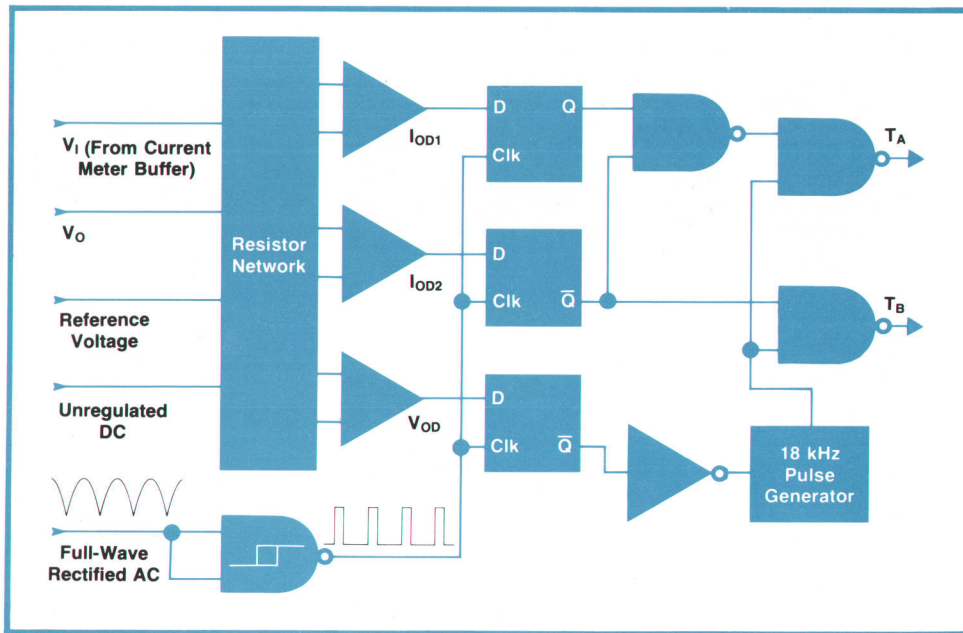

Fig. 5. Triac control circuits react to the output voltage level, the output current level, and the input voltage level.

The triacs are turned on by the first pulse to occur after the load conditions are proper. Because the pulse period is relatively short with respect to the line voltage period, the triac voltage will not have risen very far when this first effective pulse occurs. Also, latching the comparator outputs for the whole of each half cycle prevents changing load conditions from initiating triac firing at a time when the instantaneous line voltage may be above the optimum low level.

As a result of these techniques, EMI generated by the triacs is below that contributed by the triac driving circuits. This in turn was reduced by decreasing the interwinding capacitance of the pulse transformers used to couple the pulse trains to the triac gates. Only light filtering across the secondary windings was then required to meet target specifications.

Implications of Extended Range

The series regulator and related circuits in the Model 6002A are conventional in concept except that the outputs of the constant-voltage and constant-current comparison amplifiers are fed to the regulator-driver circuits by way of a diode OR gate. If the load should cause the supply to exceed its 200W limit, say it were programmed to 40V while supplying a 6Ω load, both diodes would become reverse biased and neither comparison amplifier would have control. Internal biasing in the driver circuits then causes the regulators to conduct heavily. The supply is not damaged by such operation but regulation is poor and ripple is higher. A front-panel indicator warns the operator when the supply is in this over-range condition.

The extended range of this supply presented many other new circuit and component requirements. The

input filter capacitor (C1 in Fig. 6), for example, must have the high storage capacity with the low series resistance needed to handle the higher ripple current that occurs when the supply is operating at full current capability. At the same time, the capacitor must be able to sustain the high voltage present when supplied by the maximum input voltage ($N1 + N2 + N3$). This required the use of two 7800-μF, 100V aluminum electrolytic capacitors in parallel.

The large amount of energy stored in these capacitors must be dealt with carefully during such transients as power up or down, tap switching, switchover from constant-voltage to constant-current operation, down programming, load transients, sudden shorts or opens at the output and overvoltage tripping of the crowbar circuit. For example, consider a situation where the supply is operating at 50V constant voltage with a load drawing 3 amperes. Depending on input line conditions, the input capacitor (C1) would be charged to about 60V so the series regulator would have about 10V across it with a resulting power dissipation of 30W.

If a short circuit should suddenly occur in the load, the regulator would have 60V across it and 10A through it until the control circuitry can react and reduce the voltage supplied to C1. Thus the series regulator transistors must have voltage ratings greater than 60V as well as a 10A steady-state current capability. In addition, the heat sink must not only be able to cool the transistors under worst-case steady-state conditions, but must have the additional thermal capacitance needed to protect the transistors from transient overpower conditions.

The above example also brings up another problem: transient overcurrent in the series regulators. As the

Remote Programming of Power Supplies through the HP Interface Bus

The Model 6002A Power Supply described in the main text can be programmed remotely by way of the HP Interface Bus (HP-IB) when equipped with the appropriate option (opt 001). The same circuits have been designed into a separate unit, Model 59501A Power Supply Programmer (Fig. 1), that provides a convenient means of interfacing a wide variety of power supplies (71 from HP) to HP-IB-controlled systems. It can also serve as a general-purpose, isolated digital-to-analog converter.



Fig. 1.

Two techniques are commonly used for controlling power supplies remotely: (1) resistance programming; and (2) voltage programming. To illustrate, the basics of a typical series-regulated power supply are shown in Fig. 2. It can be shown that:

$$V_o = \frac{V_R}{R_p} R_c$$

where V_o is the output voltage and V_R is a reference voltage.

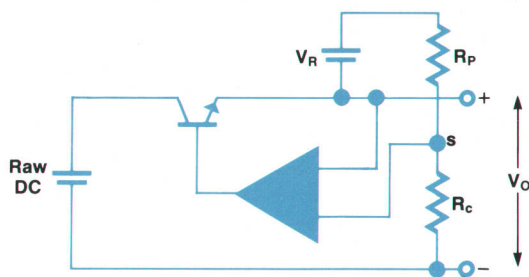

Fig. 2.

To control this supply by resistance programming, one adjusts the value of R_c , typically by using some sort of switching device to switch in various resistors. The output voltage V_o is linearly proportional to R_c when the other parameters are fixed.

To control the supply by voltage programming with unity gain, R_c is disconnected and a variable voltage is connected to point s. The output voltage V_o then equals the variable voltage V_R .

Each of these methods has drawbacks. With resistance programming, switching speeds tend to be slow, especially if large voltages are involved, and the switching arrangement becomes cumbersome if many different voltages are needed.

Voltage programming of the type just described requires high voltages to obtain high voltage output. In addition, voltage programming can become quite complex when a digital controller is used, especially if electrical isolation between the power supply and the rest of the system is required.

The 59501A Approach

The approach taken with the Model 59501A Power Supply Programmer (and option 001 for Model 6002A) is to use an isolated digital-to-analog converter that takes the place of V_R in the power supply, and a resistor scaling network that takes the place of R_p and R_c . Referring to the equation above, it can be seen that the power supply output is a linear function of V_R in proportion to the ratio R_c/R_p . The scaling network thus provides a means for setting the range of voltages that the power supply will output while the D-A converter subdivides this range into 999 steps (e.g., a range of 0 to +99.9V in 100-mV steps for a 100V power supply).

Applying this programmer is much simpler than previous methods of configuring power supplies into automatic systems which often compromised versatility, response time, and electrical isolation. Access to the internal connections needed within the power supply is usually provided at a barrier strip on the power supply's rear panel so connections to the programmer are easily made. The programmer's HP-IB "listen" address is set on a rear-panel switch bank (it's a listen-only device). The power supply is set for the maximum output desired by adjusting R_c in the programmer with a front-panel control (POWER SUPPLY FULL SCALE ADJUST). Voltage values may then be sent to the power supply programmer over the HP-IB where the numbers sent represent a percentage of full scale, e.g., sending 900, which represents 90.0%, obtains 540V from a 600V supply.

Actually, four digits are transmitted, with the first digit, transmitted as a 1 or a 2, selecting one of two 10:1 output ranges, the lower range giving a 10 \times increase in resolution. Hence, 2900 would be sent to obtain 540V in the example above; 1900 would obtain 54.0V.

A rear-panel UNIPOLAR/BIPOLAR switch adds a full-scale negative offset to V_R and doubles the size of the D-A converter steps so the power supply programmer can program a bipolar dc power supply through its entire negative-to-positive range. In this case, a programming input of 2000 programs the bipolar power supply to its maximum negative voltage and 2999 gives the maximum positive output. Zero volts out is obtained with a programming code of 2500 (or 1500).

Although this discussion has centered on programming the output voltage of a dc supply, the output current can be programmed just as easily. Programming both the voltage and current, however, requires two power supply programmers.

The output of the power supply programmer itself is 0 to 9.99V in 10-mV steps (0 to 0.999V in 1 mV steps on the low range). In the bipolar mode, the output is -10V to +9.98V in 20-mV steps (or -1V to +0.998V in 2-mV steps). Wherever the current demand does not exceed 10 mA, the programmer itself can serve as a power supply or D-A converter over these voltage ranges.

Inside

A simplified block diagram of the Model 59501A Power

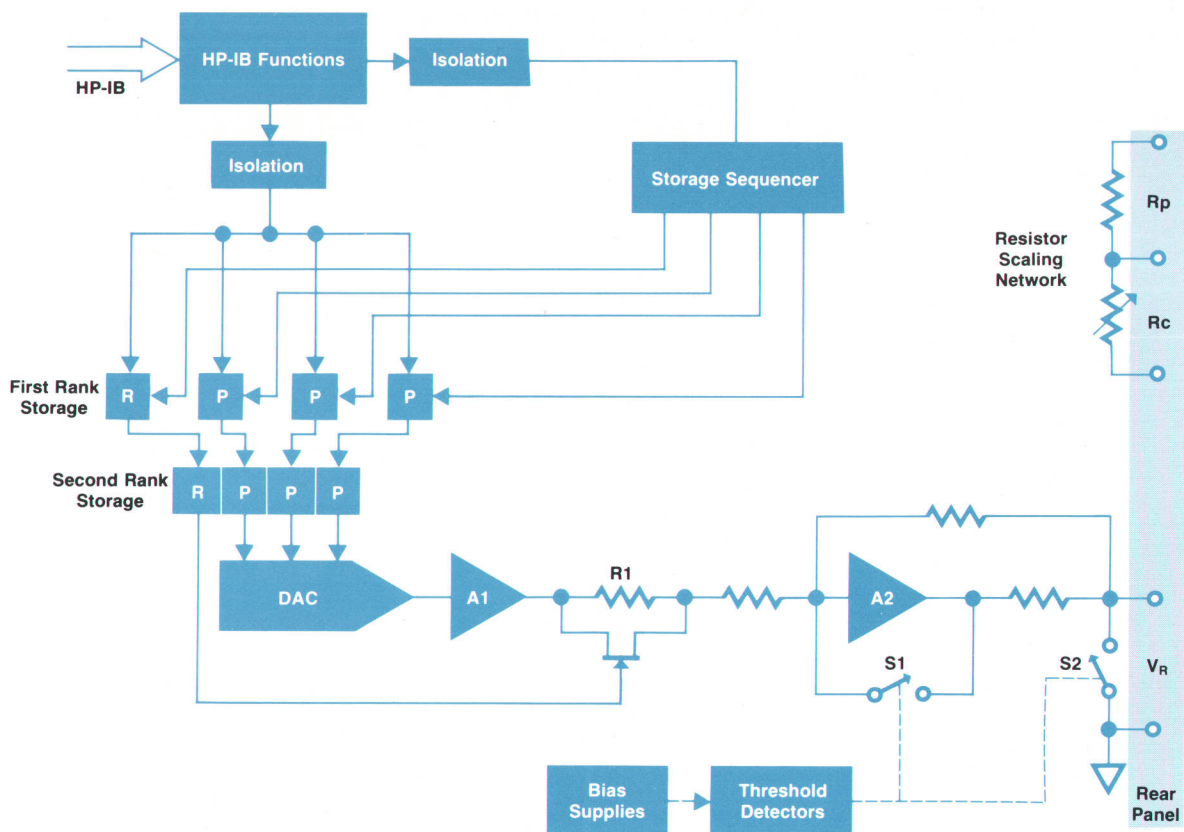

Fig. 3.

Supply Programmer is shown in Fig. 3. The four characters representing the programming code are transmitted one at a time in 7-line ASCII code on the interface bus. The handshake signals used by the bus circuits in accepting data into the instrument are used as a clock signal by the storage sequencer to place each character in a separate latch in the first rank of storage. When all four characters have been stored, they are clocked simultaneously into the second rank of storage. The D-A converter and the range circuit then change to the new value. The use of two ranks of storage prevents the occurrence of undefined output voltages during the time the programming codes are being accepted.

Once it has been addressed, the power supply programmer can respond to a new program code in about 250 μs (80 μs to handshake the four digits across the HP-IB and 170 μs to slew to the new value). The speed of response of the programmer-power supply combination thus is usually limited by the slew rate of the power supply.

The range digit (R) controls the gain of amplifier A2 by shorting out resistor R1 to obtain 10 \times greater gain. The switches shown as S1 and S2 in Fig. 3 are actually FETs that were installed at key locations to clamp the V_R output at zero during turn-on, holding it there until the instrument's internal power supplies have stabilized at their normal operating level. Without this clamping, V_R would tend to change erratically while the bias supplies stabilize, which could cause some problems with sensitive loads connected to the driven power supply. They also clamp the output to zero during turn-off.

The optical isolators provide electrical isolation (up to 600V) between the programmed supply and earth ground. Isolation is

particularly important in situations where objectionably large ground-loop currents would otherwise flow between the programmed supply and ground. It also allows the programmed supply to be floated with respect to the other devices connected to the HP-IB.

In the 6002A

The circuits just described function in essentially the same manner when installed in the 6002A Extended Range Power Supply except that no provision is made for bipolar operation nor is there any provision for selecting the operating range other than that provided by the first digit of the programming code. Thus the programmable voltage range is 49.95 volts in 50-mV steps in the high range, or 1 to 9.99 volts in 10-mV steps on the low range. In constant current operation the ranges are 0 to 9.99 amperes in 10-mA steps and 0 to 1.998 amperes in 2 mA steps.

The choice of programmed constant-voltage (CV) or constant-current (CC) operation, but not both at the same time, is made manually with rear-panel switches. When both switches are OFF, control reverts to the front panel and there is no interaction with the interface bus.

Acknowledgments

The authors would like to share design credit with Rick DeRick and Bill Darcy who did the printed circuit board and mechanical designs.

—Emery Salesky
—Kent Luehman

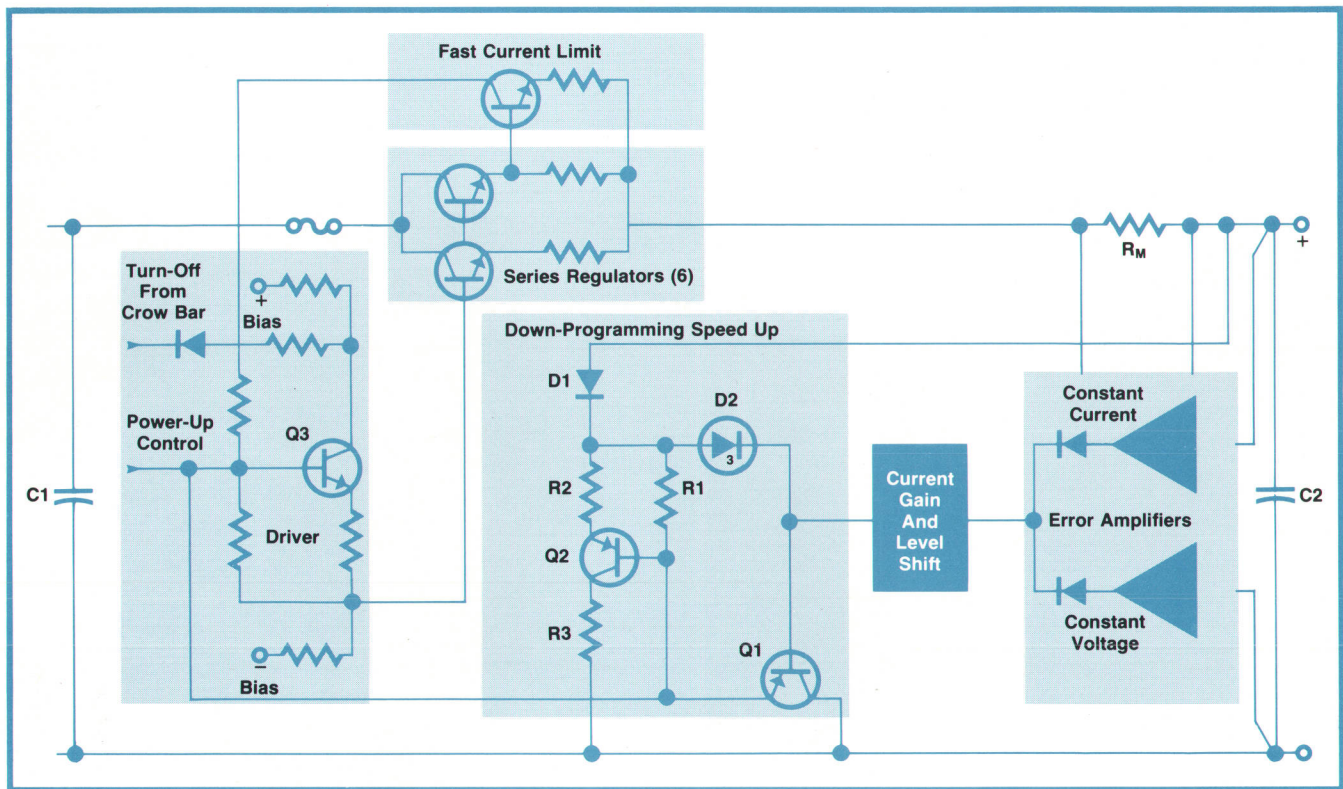

Fig. 6. Simplified diagram of the series-pass regulator circuit in Model 6002A DC Power Supply.

supply makes the transition from 50V constant voltage to 10A constant current, excessive current could flow during the time needed for the constant-current amplifier to take control. Excessive transient current flow is prevented by the "fast current limit" circuit (Fig. 6) which responds to high currents through the regulators by inhibiting the regulator driver circuit, holding the regulator current to a value about 120% of maximum rating.

A power-up control circuit prevents output overshoots during power up or down. This circuit, which is powered by the unregulated dc, inhibits base drive to the regulators whenever the internal regulated bias supplies are below a certain minimum voltage.

Fast Down-Programming

A major design objective was to obtain a considerable improvement in programming speed over that available in existing power supplies capable of this power level—a must if this supply is to be useful in automatic systems. The enhanced transient capability of the series regulator removed many restrictions to programming speed but the rate at which the output capacitor (C2 in Fig. 6) can be discharged remained a limiting factor. Circuits were added to speed up this discharge.

During down-programming, the negative-going signal from the error amplifiers turns on transistor Q1

more fully, causing it to turn off the regulator driver and the series regulators, thereby stopping charge transfer from C1 to C2. At the same time, diode D1 becomes forward biased, opening a discharge path for C2 through resistor R1 and transistor Q1. Stabistor diode D2 establishes a bias that holds the current through Q1 at a safe level.

An additional current path is provided by transistor Q2. During down-programming, the voltage drop across resistor R1 turns on Q2. Resistor R3 limits the voltage drop across Q2 to allow greater current without excessive power dissipation in Q2, but R2 limits



Paul W. Bailey

A native of Possum Trot, Kentucky, Paul Bailey obtained his BSEE at the Massachusetts Institute of Technology (1973) and MSEE at the University of California at Berkeley (1974). He then joined Hewlett-Packard's New Jersey Division. At NJD, Paul did studies of the thermal impedance of power semiconductors before joining the design team on the 6002A Power Supply. Paul enjoys tennis, basketball, volleyball and gardening. He and his wife are presently moving into a house in Roxbury, New Jersey.

this current to a safe level. Altogether, this arrangement enables the output to drop from 50V to 0.05V in 400 ms. Smaller voltage drops and/or the existence of load current result in shorter down-programming

Acknowledgments

The authors wish to acknowledge the contributions

of Engineering Manager Jim Gallo to early concepts of the power supply design and of Ed Coffin to the compact mechanical design. Other major contributors to the mechanical design were Sui Wong, Rick DeRick, Ken Woolley, and Nick Greendyke, who also performed most of the electrical evaluation. 

HP Model 6002A DC Power Supply		SPECIFICATIONS		HP-IB Options	
DC OUTPUT: Voltage: 0-50V (200 maximum watts output from 20V to 50V). Current: 0-10A.		WEIGHT: 14.5 kg. (32 lb)		DRIFT (change in output over 8-hour interval following 30-minute warm-up):	
LOAD EFFECT (Load Regulation): VOLTAGE: 0.01% + 1 mV. CURRENT: 0.01% + 1 mA.		PROGRAMMABLE RANGE		RANGE High Low	
SOURCE EFFECT: VOLTAGE: 0.01% + 1 mV. CURRENT: 0.01% + 1 mA.		HI RANGE: 0-50V or 0-10A.		UNIPOLAR: .04% + .5mV .04% + .1mV	
PARD (Ripple and Noise), 20 Hz to 20 MHz: VOLTAGE: 1 mV rms/10 mV p-p. CURRENT: 5 mA rms.		LO RANGE: 0-10V or 0-2A.		BIPOLAR: .04% + 1mV .04% + 2mV	
TEMPERATURE COEFFICIENT ($\Delta\%$ /C after 30 minute warmup): VOLTAGE: 0.02% + 200 μ V. CURRENT: .02% + 5 mA.		ACCURACY (25 \pm 5°C after 30-minute warmup):		TEMPERATURE COEFFICIENT:	
DRIFT (change in output over 8-hour interval after 30-minute warmup). VOLTAGE: .05% + 1 mV. CURRENT: .05% + 5 mA.		HI RANGE 0.2% + 25mV 0.2% + 25mA		RANGE High Low	
OUTPUT IMPEDANCE: Typically 0.5 m Ω in series with 1 μ H.		LO RANGE 0.2% + 10mV 0.2% + 25mA		UNIPOLAR: .01%/C + .5mV/C .01%/C + .1mV/C	
LOAD EFFECT TRANSIENT RECOVERY: 100 μ s for output voltage to return to within 15 mV of nominal output voltage setting following load current change from 50% to 100% or 100% to 50% of full load current.		RESOLUTION CV CC		BIPOLAR: .01%/C + .5mV/C .01%/C + .1mV/C	
REMOTE CONTROL (Analog Programming): RESISTANCE CONTROL COEFFICIENT: VOLTAGE: 1k Ω /V \pm 7%. CURRENT: 100 Ω /A \pm 7%.		HI RANGE 50mV 10mA		ZERO ADJUST: \pm 250mV.	
VOLTAGE CONTROL COEFFICIENT: VOLTAGE: 1V/ \pm 20 mV (50 mV positive offset required)		LO RANGE 10mV 2mA		D/A FULL SCALE ADJUST: \pm 5%	
CURRENT: 50 mA/A \pm 10%		ISOLATION: 250 Volts dc from Bus data lines to power supply.		PROGRAMMING SPEED: time required for output to go from zero to 99% of programmed output change is 250 μ s.	
RESPONSE TIME (maximum time for output voltage to change between 0 to 99.9% or 100% to 0.1% of maximum rated output voltage): UP: No Load - 100 ms. Full Load - 100 ms. DOWN: No Load - 400 ms. Full Load - 200 ms.		PRICE IN U.S.A.: 6002A, \$800; Opt 001 (HP-IB Interface), \$350.		Power Supply Programming	
DC OUTPUT ISOLATION: 150V DC.		HP Model 59501A Isolated D/A/Power Supply Programmer		Programming Network Specifications: M represents calibrated full scale value of supply being programmed and P represents actual programmed output. Full scale value (M) can be any value within supply's output range and is calibrated with 59501A programmed to its maximum high range output.	
OVERVOLTAGE PROTECTION: Trip voltage adjustable from 2.5V to 60V.		Digital to Analog Converter		ACCURACY (23°C \pm 5°C):	
TEMPERATURE RATING: 0 to 55°C operating; -40 to +75°C storage. Fan cooled.		DC OUTPUT VOLTAGE		High Low	
POWER: 100, 120, 220, or 240Vac (-13%, +6%), 48-63 Hz.		RANGE UNIPOLAR: 0 to +9.99 Volts 0 to .999 Volts		UNIPOLAR: .05% M + 25% P .01% M + 25% P	
DIMENSIONS: 212 mm W x 177 mm H x 422 mm D (8 1/4 x 7 x 16 1/2 in).		BIPOLAR: -10 to +9.98 Volts -1 to +.998 Volts		BIPOLAR: 0.1% M + 25% P .02% M + 25% P	

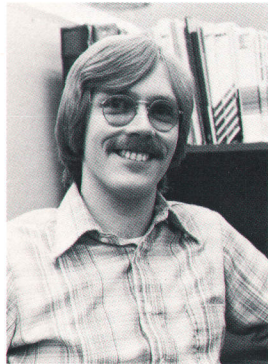

John W. Hyde

John Hyde started designing power supplies with the Hewlett-Packard New Jersey Division after graduating with an MSEE from Rutgers University where he also received a BSEE in 1973. Now that his work on the 6002A is completed, he is involved with power supply investigative projects. John keeps active in his spare time playing tennis, improving his guitar technique, and dabbling in photography.

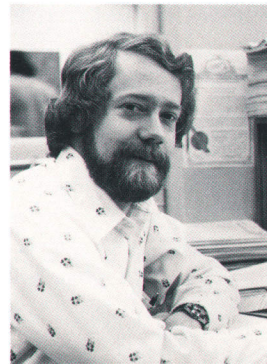

Kent Luehman

Kent Luehman joined Hewlett-Packard in 1975 upon graduating from Stevens Institute of Technology where he earned his BE degree and is currently working on his ME. After working on the HP-IB Interface for the 6002A Power Supply and the 59501A Programmer, he became involved in new product investigations. Kent does some biking and enjoys photography along with hiking. He and his wife live in Parsippany, New Jersey.



Emery Salesky

Prior to graduation in 1970 from Polytechnic Institute of Brooklyn with a BSEE degree, Emery Salesky designed magnetic components for a New York firm. Following graduation, he designed military-electronic production test equipment. Since joining HP in 1972, he designed the 6236A/7A Triple Output power supplies and was project engineer for the 59501A Programmer and the HP-IB interface for the 6002A.

Emery and his wife have two sons, 2 years and 2 months. He is presently working toward an MSEE at the New Jersey Institute of Technology. Any spare time available is taken up with wood-working and tennis.

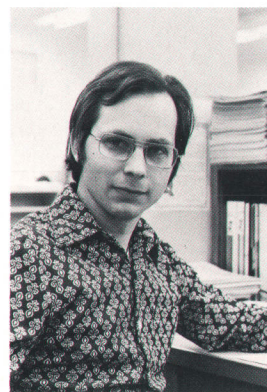

William T. Walker

A graduate of Lehigh University (BSEE, 1969), Bill Walker completed a two-year ROTC commission with the U.S. Army, then joined Hewlett-Packard. Initially he worked on the 62000 series of modular power supplies (HP Journal, February 1973). Bill originated the power-mesh circuitry and control philosophy for the 6002A Power Supply, then left the project to become a production engineer. He is currently production engineering manager for the New Jersey Division. Bill is a computer hobbyist and also enjoys reading novels and assembling an occasional furniture kit. Bill and wife and two children (1 and 2 1/2) live in Summit, New Jersey.

Coaxial Components and Accessories for Broadband Operation to 26.5 GHz

The new APC-3.5 coaxial connector makes it possible to design detectors, attenuators, sliding loads, and switches for broadband operation to 26.5 GHz.

by George R. Kirkpatrick, Ronald E. Pratt, and Donald R. Chambers

WHERE FEASIBLE, COAXIAL CABLE has always been preferred to waveguide for the transmission of microwaves because of its broader bandwidth, flexibility, and lower cost. This is especially true of microwave measurements where the general convenience of working with coaxial cables far outweighs the disadvantages of higher signal losses and slightly poorer electrical performance.

The development of a new 3.5-mm connector^{1,2} now allows practical application of coaxial components at frequencies from dc to well above 18 GHz, the practical upper limit in recent years. The new connector is used on several new microwave components (Fig. 1), that operate to 26.5 GHz with instrument-quality performance. The convenience of working with coaxial systems thus becomes available for design and test of a broader range of microwave systems,

such as those involved with telecommunications.

Mechanical details of the 3.5-mm connector, available commercially as the APC-3.5, are shown in Fig. 2. The salient features of the new connector are:

- Entirely mode free up to 34 GHz.
- Optimized cost/performance. Reflection coefficient is typically 0.05 for random mated pairs operating to 34 GHz while cost is much less than precision connectors previously available.
- Mechanically rugged and electrically repeatable. It is not readily deformed so performance is maintained over hundreds of insertions.
- Compatible with the proposed IEC standard 3.5-mm connector mounting. Mechanically and electrically compatible with the SMA connector system presently used for frequencies up to 18 GHz.
- Male and female connectors are electrically inter-

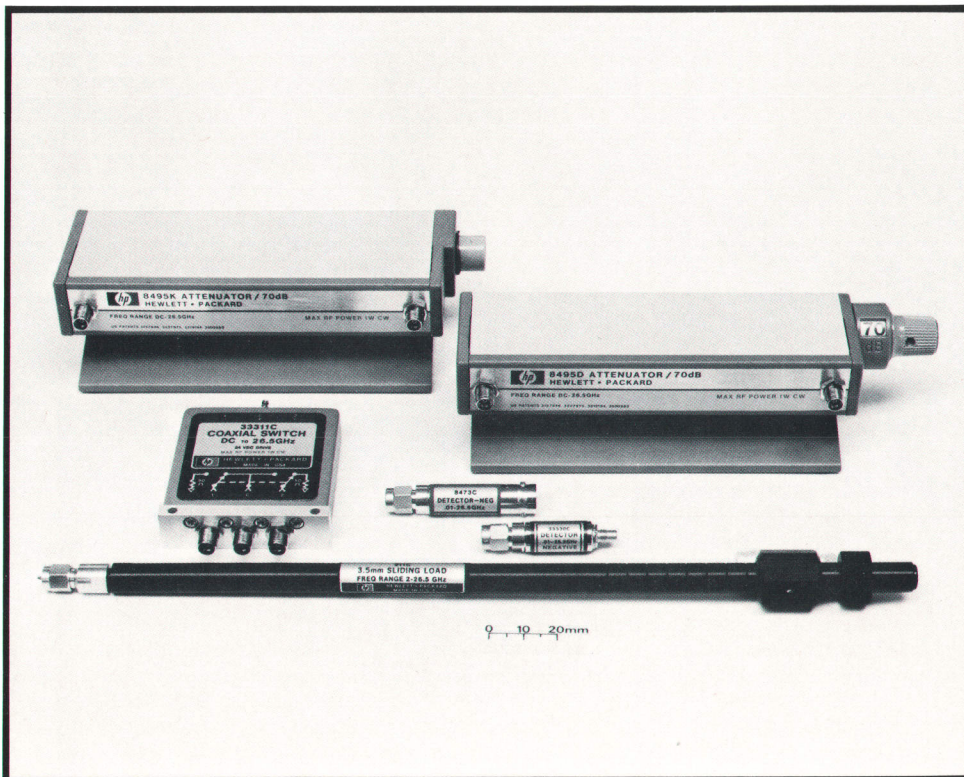

Fig. 1. Broadband performance to 26.5 GHz is achieved by new microwave components and accessories equipped with the APC-3.5 connector system.

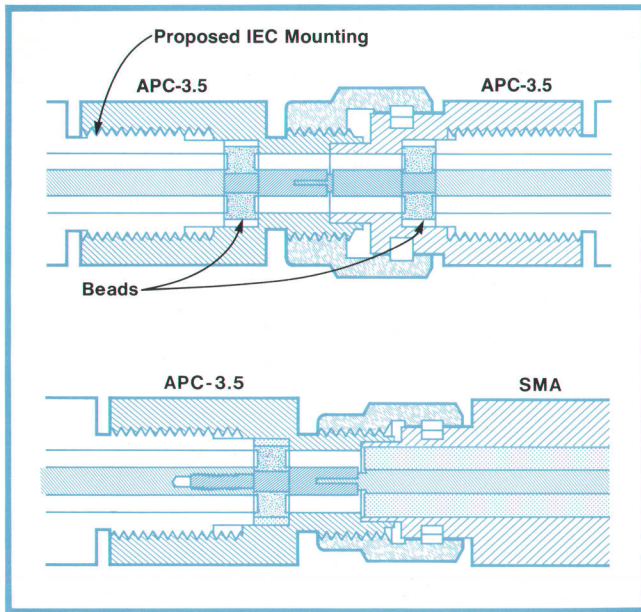

Fig. 2. A cross-section of mated male and female APC-3.5 connectors is shown in the upper drawing. The structure at the mating surface is an air-dielectric line with only the dimensions of the center and outer connectors controlling the impedance. The lower drawing shows how the APC-3.5 interfaces with the widely-used SMA connector.

changeable. The mating interface of the inner and outer conductors are in the same plane and the electrical distance from the mating interface to the IEC mounting interface is identical for the male and female connectors.

- The plane of the mating interface is separated from the center conductor support insulator sufficiently to minimize the effects of variations in mechanical tolerances and temperature on the SWR of mated connectors.
- The female connector provides a mode-free connection directly to 0.141-inch (3.5-mm) diameter semirigid coaxial cable fitted with the standard male cable terminator, allowing easy integration of the new components into microwave systems.

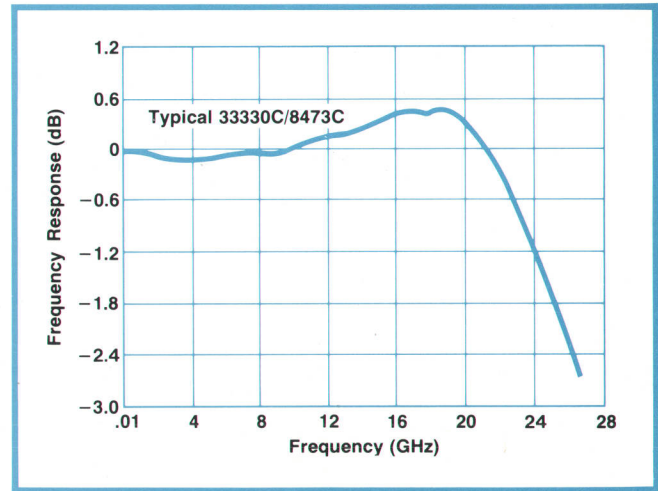

Fig. 3. Frequency response of a typical 8473C detector. Matched pairs track within ± 0.5 dB over the entire frequency range.

26.5-GHz Detectors

The new connector allows the frequency range of HP's low-barrier Schottky-diode detectors (LBSD)* to be extended to 26.5 GHz. As shown in Fig. 3, detector response is flat within ± 0.6 dB up to 20 GHz and then rolls off monotonically at about 0.51 dB/GHz. This response results from the interaction of the diode parasitics and the thin-film matching network (Fig. 4) but because of the close control that can be exercised over the circuit parameters, the response of a pair of detectors can be matched within ± 0.5 dB up to 26.5 GHz.

In certain applications, airborne radar for example, the detector might be exposed to extreme temperature variations. The LBSD may be operated over a temperature range of -65 to 100°C and unlike fragile point-contact devices, it is not damaged by repeated temperature cycling. There may be some changes in per-

*Low-barrier Schottky diodes are rugged mesa devices designed for low impedance at the origin of the I/V curve so no bias is required for low-level detection applications. Included with the diode in the detector is a thin-film resistor network that matches the diode to 50Ω transmission lines.³

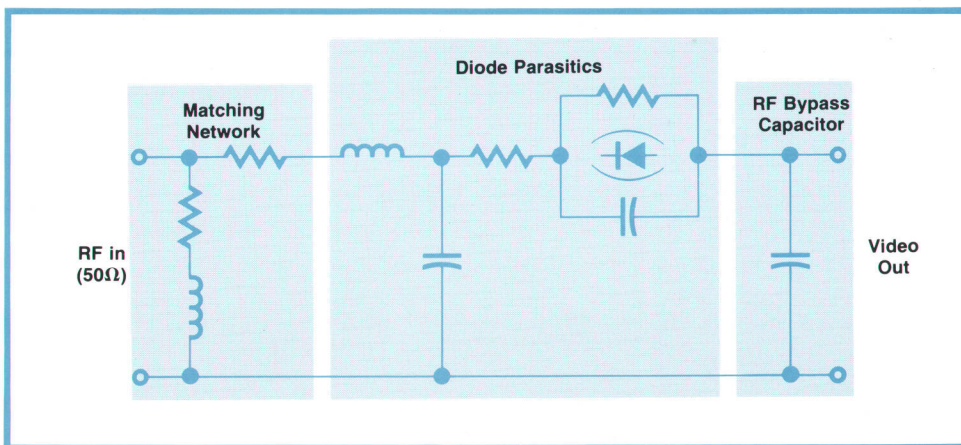

Fig. 4. Schematic representation of a low-barrier Schottky-diode detector.

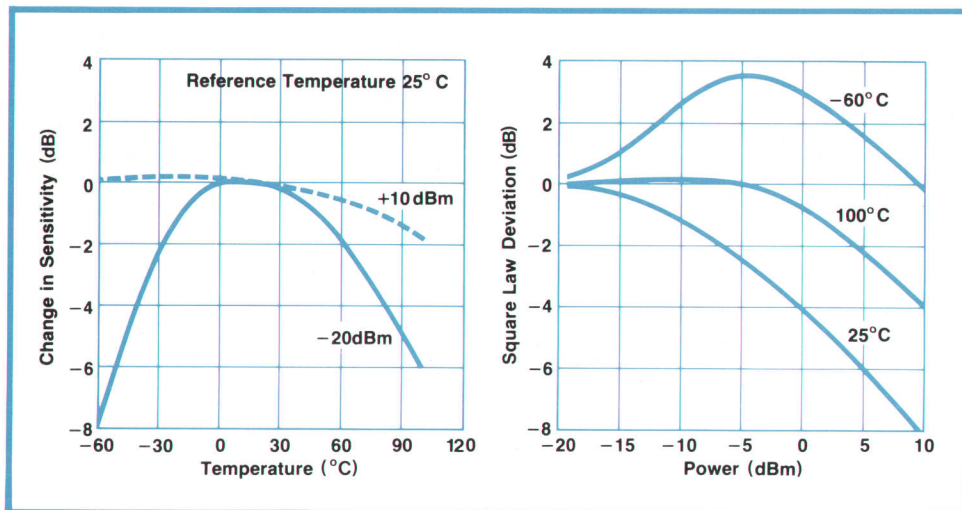

Fig. 5. The effects of temperature on the performance of a low-barrier Schottky-diode detector (Model 33330C) when operating with a 10-k Ω video load. Detector performance is affected by the video load and the power level so for a given operating point, the effects of temperature can be minimized by the choice of load.

formance at the extremes of the temperature range, as shown by the curves of Fig. 5. The temperature-induced changes in performance are strongly affected by both the video load and the power level so over a limited temperature range (30—50°C) there exists an optimum load that will minimize the effects of temperature. This is best determined experimentally.

The new detector is available in two basic configurations (Fig. 1). Model 8473C has a BNC video output connector and is intended for use in laboratory, production, and field measurement setups where the convenience of the BNC connector is an important factor. Model 33330C has an SMC video output connector that meets the size restrictions of many OEM applications. The APC-3.5 RF input connector in both detectors provides a mode-free, well-matched, and mechanically rugged interface to the detector over a bandwidth of 10 MHz to 26.5 GHz.

Two additional products, the 8473B and 33330B, offer the advantages of the new connector in lower-cost detectors for use up to 18 GHz.

Miniature Coaxial Sliding Load

A reflectionless termination is a basic requirement in many measurements, such as that required at the output of a 2-port network when its s-parameters are being measured. Since reflectionless terminations are unattainable, a sliding load is used. Observation of the resultant signal as the sliding load is moved enables the operator to identify load element reflections with respect to the fixed reflections existing in the measurement setup so corrections can be made to the measurement results.

Sliding loads generally consist of a tapered load element in an air-dielectric line that has a precisely controlled geometry. Nevertheless, three general sources of reflection exist: the connector, impedance errors in the line itself, and the sliding element. The first two are fixed and can be measured, and the com-

bined SWR is specified for HP sliding loads. The third is determined during a measurement by moving the sliding element.

As frequencies go higher and transmission-line dimensions become smaller, variations in line geometry have a greater effect on measurement accuracy, thus requiring more care to protect parts that can be bent or otherwise damaged. Consequently, a new sliding load (Model 911C, Fig. 6) was designed with minimum length and weight to reduce stress on the mated connector pairs. Since it has the new APC-3.5 connector, it can be used over a frequency range of 2.0 to 26.5 GHz.

The design also minimizes the exposure of the center conductor to accidental damage by bending. Because the center conductor in air-dielectric sliding loads has no supporting beads so as not to introduce additional impedance discontinuities, it is supported by the mating connector at the front and two Teflon

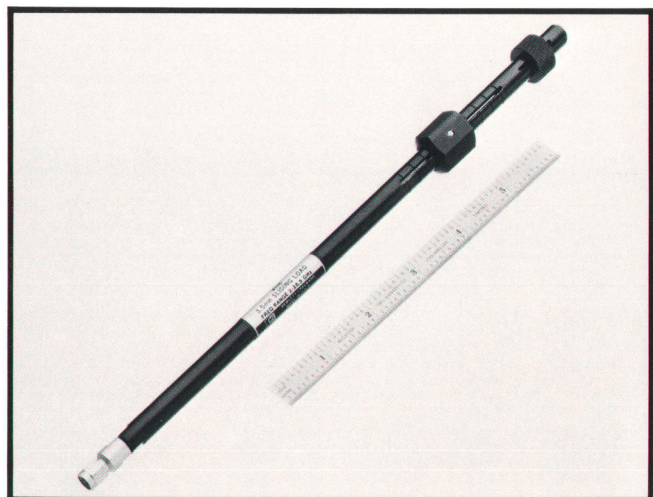

Fig. 6. Model 911C sliding load fully protects the center conductor against accidental bending. The range of the load element travel is $3/8\lambda$ at 2 GHz.

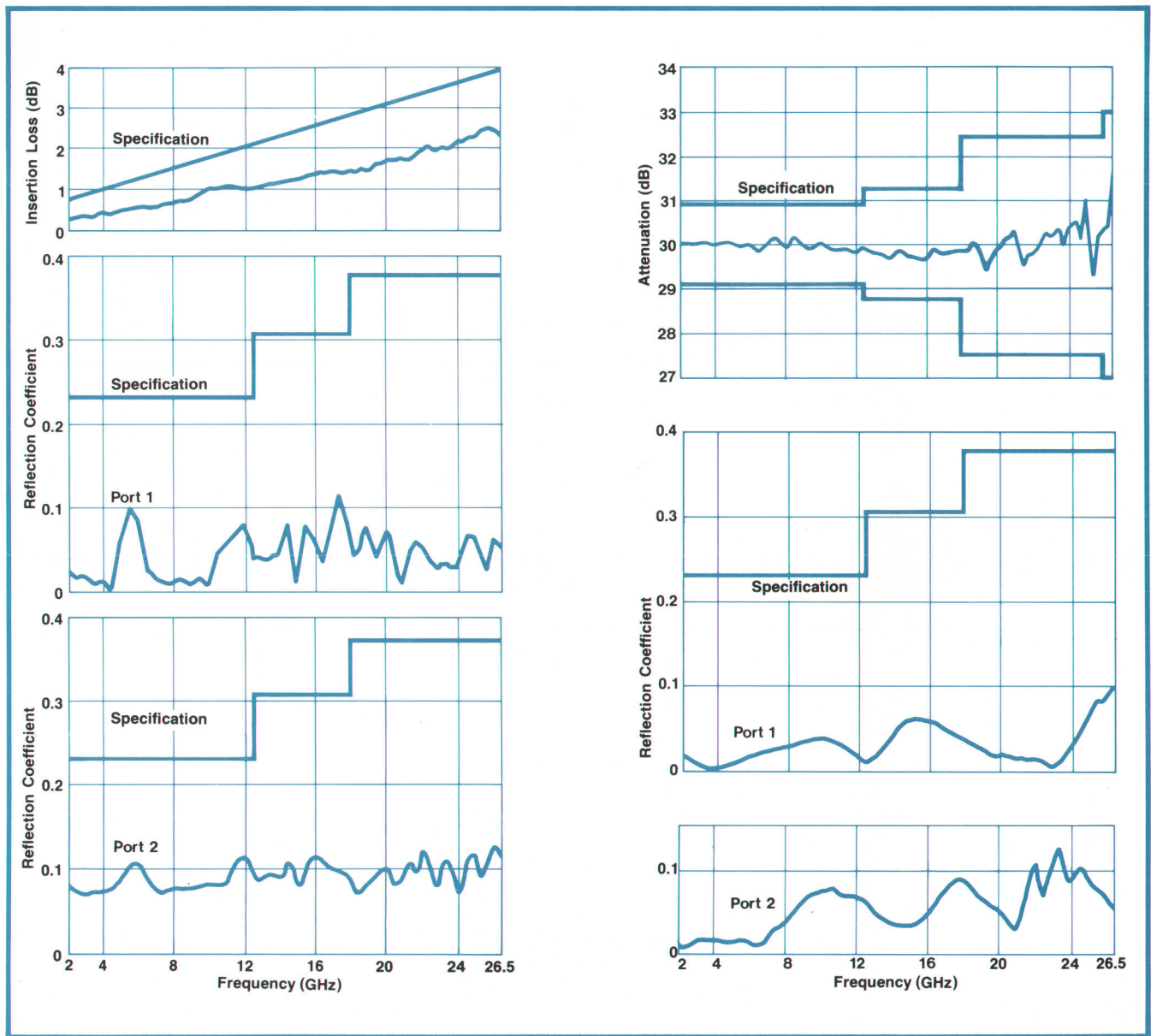

Fig.7. The plots at left show insertion loss and reflection coefficients for both ports of a typical 8495D step attenuator at the 0-dB setting. The plots at right show attenuation and reflection coefficients for the 30-dB setting. Typical step-to-step accuracy is ± 2 dB at 26.5 GHz. The reflection coefficients are similar for the other attenuation levels.

bearings within the tapered load at the rear. Although the center conductor is allowed a small amount of lengthwise travel to facilitate its insertion into the mating connector, the amount of forward travel in the new Model 911C is limited to the minimum required for convenience in making the RF connection and at no time does it protrude from the back, as in earlier designs. Its exposure to accidental bending forces is thus minimized.

The connector parts are replaceable so either male or female APC-3.5 connectors can be installed. With the female connector, SWR of the fixed discontinuities is less than 1.07 to 14 GHz and less than 1.10

to 26.5 GHz. For the male connector version, SWR is less than 1.04 for the entire 2—26.5 GHz range. The load element itself has an SWR of less than 1.22 at 10 GHz and less than 1.07 to 26.5 GHz.

Dc—26.5 GHz Precision Step Attenuators

Precision attenuators serve various purposes in microwave measurements, primarily in reducing RF power levels to a suitable range for a detector or power meter or providing calibration points for insertion loss or reflection measurements when a substitution technique is used.

Attenuator operation over a frequency range ex-

tending from dc to 26.5 GHz is now provided by a new coaxial step attenuator that has an attenuation range of 0 to 70 dB in 10-dB steps. Frequency response is shown in Fig. 7.

The new attenuator is similar to the 8494/5 series of dc-18-GHz attenuators⁴ but the design was modified to eliminate moding at frequencies above 18 GHz by using female APC-3.5 connectors. Like the 8494/5 series, the new attenuator uses the edgeline transmission system⁵ to obtain reliability and repeatability.

The edgeline transmission system consists of a flexible, flat ribbon center conductor suspended at right angles between two ground planes. Since the center conductor can be flexed without changing its spacing with respect to the ground planes, it can be bent to one side to contact an attenuator card and to the other side to contact a bypass section of transmission line, thereby producing a switchable attenuator that maintains constant characteristic impedance.

The attenuator elements are passivated tantalum-nitride thin-film distributed resistor-conductor patterns established on sapphire substrates by a high-resolution photolithographic process. The center conductor makes contact with a small wiping action, thus avoiding problems with contact contamination and ensuring good electrical contact each time. Repeatability of settings is typically within 0.05 dB at 26.5 GHz.

The new attenuator is available in two bench-top versions, the manually switched Model 8495D and the programmable Model 8495K, and two OEM versions, Models 33321D (manual) and 33321K (programmable). The programmable versions are switched by internal self-latching 24V solenoids that draw 110 mA during switching (30 ms), then automatically disconnect themselves. They can be incorporated into HP interface bus systems by use of the Model 59306A Relay Actuator and a 20–30V power supply.

A Mechanical Microwave Switch

The fundamental purpose of any switch is to separate and direct signals. In the case of microwaves, obtaining adequate signal separation between the common and “off” ports can be a problem, as in systems for measuring the s-parameters of 2-port networks where there is a requirement for a high degree of separation. Another special requirement for microwave switches, again as in s-parameter measurements, is that a well-matched termination, not an open circuit, must be maintained on the unconnected line.

To fulfill these requirements, the 33311-series of single-pole, double-throw switches was developed. This design has now been adapted to use the APC-3.5 connector to give a switch (Model 33311C) that can work with signals over a range of dc to 26.5 GHz.

The basic approach to the design was to dimension the area surrounding the contact mechanism so it functions as a waveguide beyond cut-off. The rapid reduction in coupling with respect to distance between ports achieved by this construction allowed close spacing of the connectors while still achieving at least 85 dB isolation between the common port and the “off” port up to 18 GHz (50 dB at 26.5 GHz). This made short conductors possible so insertion loss, even at high frequencies, is quite low, as shown in Fig. 8.

The circuit between the common port and the connected port is completed by an edgeline conductor that is moved into position to contact the port-connector center conductors, as shown in Fig. 9.

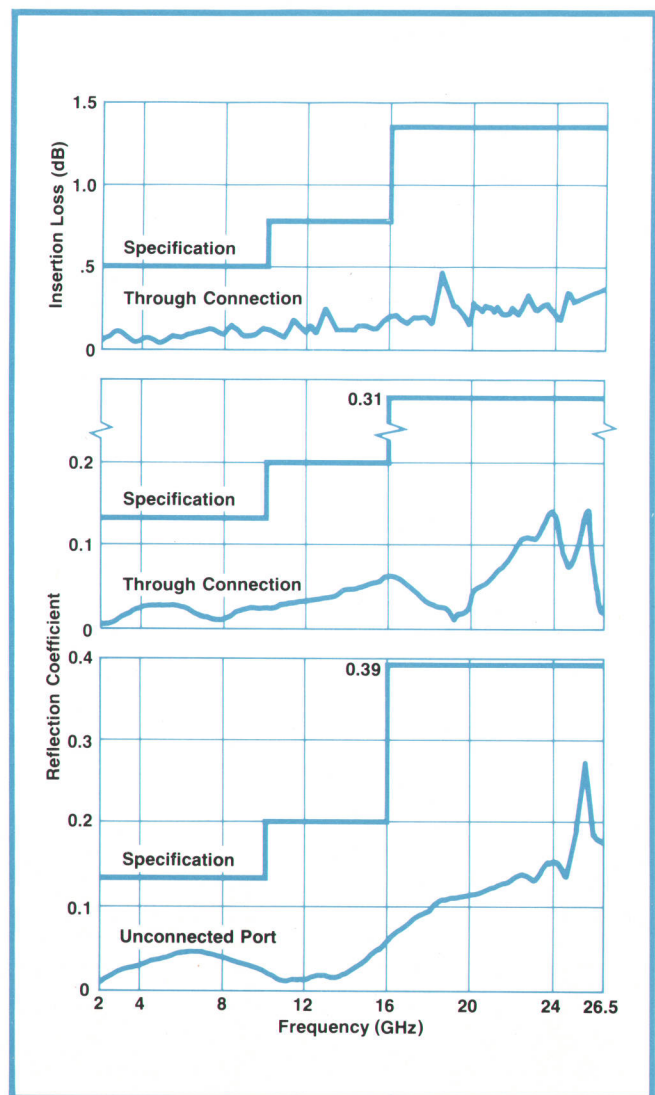

Fig. 8. Plot at top shows the insertion loss through the connected port of a 33311C switch at microwave frequencies. The center plot shows the reflection coefficient of the input port when the connected port is terminated in a well-matched load. At bottom is the reflection coefficient looking into the unconnected port (terminated internally).

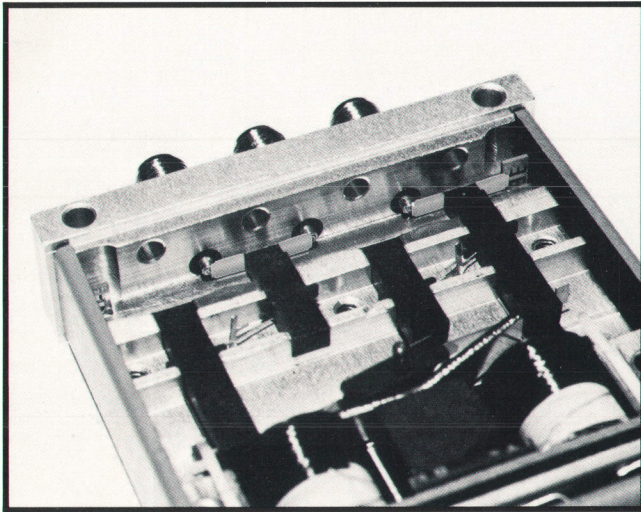

Fig. 9. Internal view of the Model 33311C microwave switch.

Another section of edgeline connects the unconnected port to a 50 Ω thin-film resistor. Two other sections of edgeline make the connection for the other condition.

The conductors are slightly bowed to provide a slight wiping action when contact is made, achieving very good repeatability and long life. By the nature of edgeline construction, SWR is not appreciably affected by slight flexing of the conductors when making contact. Typical SWR is also shown in Fig. 8.

Switching is effected by a magnetic circuit using two 24V coils and permanent-magnet latches. Separate contacts remove power from the activated coil when the switching action is completed so power is consumed only while the mechanism is switching (30 ms). Besides reducing power consumption and related heat buildup, this arrangement allows external circuits to sense the switch position since one of the two solenoid coils will be open. Like the attenuators, the switch can be incorporated into an HP interface bus system by use of the Model 59306A Relay actuator and an appropriate power supply.

Acknowledgments

Many people were involved with the successful completion of these new 3.5-mm connector products. Of particular note are the following: Lawrence B. Renihan, for the sliding load and also for the original design on the APC-3.5 connector; Norbert J. Sladek, Saverio T. Bruno and Pasquale Petté, all of Bunker Ramo, Amphenol Division, who brought the APC-3.5 connector design to production status; David R. Veteran, who did the original design for the attenuators; Robert Jacobsen for the switch design; Pedro Szente, Jerry Burgess, and Lee Colby for valuable help on the detectors, and Elmer Lorence, Norm Royce, Mike Norton, and Wayne Frederick who helped the authors design an extended-range Automatic Network

George R. Kirkpatrick



A frequent contributor to the HP Journal and other publications, Bob Kirkpatrick has designed coaxial components since joining HP in 1956, including much of the coaxial hardware and test sets needed by the HP network analyzer systems. Now a project manager for coaxial devices, Bob has a BSEE degree from the California State Polytechnic College and an MSEE degree from Santa Clara University. Bob's a member of the HP Easy Speakers Club, an in-house version of

Toastmasters, but nowadays, to cope with the current drought, much of his spare time goes into redoing the plantings around his home in Los Altos Hills, with help from his wife and four children, ages 14 to 20, and a 39-year-old Caterpillar tractor.

Ronald E. Pratt



Ron Pratt earned his BSEE degree by attending the Newark College of Engineering (New Jersey) at night while working at Bell Labs by day. He came west when he got his degree (1967) and joined HP where he has been designing hybrid microcircuits, such as the 8484A Power Sensor for the 436A Power Meter, and a number of devices for the HP sweepers and network analyzers. Spare time activities include teaching microwave electronics at Foothill Junior College, keeping an aging

Porsche in operation, and making cabinets and furniture for the new home in San Jose that he and his wife occupy with their two daughters, 3 and 5.

Donald R. Chambers

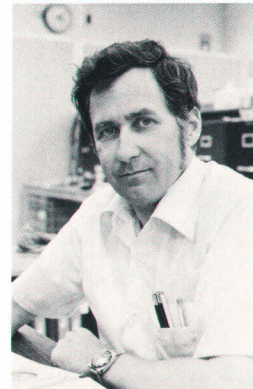

On getting his BSEE degree from Oregon State University in 1954, Don Chambers went to work for a midwest firm designing electric motors. He subsequently returned to OSU for an MSEE degree (1961) and then became involved in microwave and millimeter-wave components research with emphasis on broadband applications and systems. He also did extensive post-graduate work at Stanford University. Don joined HP in 1974 and is now a project manager on coaxial devices. Married, and with

one grown son, Don lives in Mountain View, California, and bicycles the five miles to work. His spare time activities include Toastmasters International and dingy racing on San Francisco Bay.

Analyzer that quickly and accurately characterizes each production unit over its entire frequency range of operation. Special thanks are due to Stephen F. Adam for guidance and encouragement. 

References

1. S.F. Adam, G.R. Kirkpatrick, N.J. Sladek, and S.T. Bruno, "A New 34-GHz 3.5-mm Low-Cost Utility Coaxial Connector Featuring Low Leakage, Low Standing-Wave Ratio, and Long Life," IEEE Transactions on Microwave Theory and Techniques, Volume MTT-24, Number 12, December 1976.

2. S.F. Adam, G.R. Kirkpatrick, N.J. Sladek, S.T. Bruno, "A High Performance 3.5-mm Connector to 34 GHz," Microwave Journal, July 1976.

3. P.A. Szente, S.F. Adam, and R.B. Riley, "Low Barrier Schottky Diode Detectors," Microwave Journal, February 1976.

4. G.R. Kirkpatrick and D.R. Veteran, "Economical Precision Step Attenuators for RF and Microwaves," Hewlett-Packard Journal, May 1974.

5. S.F. Adam, G.R. Kirkpatrick, and R.A. Lyon, "Broadband Passive Components for Microwave Network Analysis," Hewlett-Packard Journal, January 1969.

SPECIFICATIONS

HP Models 8473C and 33330C Coaxial Detectors (Models 8473B and 33330B have identical specifications to 18 GHz.)

FREQUENCY RESPONSE:

OCTAVE BAND FLATNESS: ± 0.2 dB over any octave to 8 GHz.
BROADBAND FLATNESS: 0.01 to 12.4 GHz: ± 0.3 dB
0.01 to 20 GHz: ± 0.6 dB
20 to 26.5 GHz: ± 1.5 dB from a -3.3 dB linear slope.

SWR (50 Ω characteristic impedance): 0.01 to 4 GHz: < 1.2

4 to 18 GHz: < 1.5
18 to 26.5 GHz: < 2.2

LOW LEVEL SENSITIVITY (< -20 dBm): 0.01 to 18 GHz, > 0.5 mV/ μ W;
18 to 26.5 GHz, > 0.18 mV/ μ W.

MAXIMUM OPERATING INPUT (peak or average): 200 mW

SHORT-TERM MAXIMUM INPUT (less than 1 minute): 1 watt (typical)

NOISE (μ V peak-to-peak with CW power applied to produce 100 mV output, 400 kHz BW): < 50 μ V.

OUTPUT POLARITY: negative.

RF CONNECTOR: APC-3.5 male (SMA compatible)

OUTPUT CONNECTOR: BNC female (8473B/C); SMC with male center conductor (33330B/C).

DIMENSIONS (length x diameter): 48.4 x 9.9 mm (1.89 x 0.39 in)

PRICES IN U.S.A.: 8473C, \$275; 8473B, \$235; 33330C, \$260; 33330B, \$205.

Opt 001, matched pair: add \$20 per unit; Opt 003, positive polarity output: add \$30 per unit.

HP Models 8495D/K and 33321D/K Step Attenuators

ATTENUATION ACCURACY (\pm dB referenced from 0 dB setting):

Frequency Range	Attenuation Setting (dB)*						
	10	20	30	40	50	60	70
DC-12.4 GHz	0.6	0.7	0.9	1.8	2.0	2.2	2.3
12.4-18.0 GHz	0.7	0.9	1.2	2.0	2.3	2.5	2.8
18.0-24.0 GHz	0.9	1.5	2.5	3.0	3.2	3.3	3.5
24.0-26.5 GHz	1.0	2.5	3.0	4.2	4.4	4.6	4.8

*Typical Step-to-Step Accuracy: ± 1 dB to 18 GHz; ± 2 dB to 26.5 GHz.

SWR (characteristic impedance, 50 Ω): dc to 12.4 GHz, 1.6;

12.4 to 18 GHz, 1.9;
18 to 26.5 GHz, 2.2

INSERTION LOSS: (0.5 + 0.13f) dB where f is frequency in GHz.

LIFE (minimum): 1 million steps or switchings per section.

REPEATABILITY: 0.03 dB typical after 1 million steps, to 18 GHz; 0.05 dB typical after 1 million steps, to 26.5 GHz.

RF INPUT POWER (max): 1 watt average, 100 watts peak (10 μ s pulse width).

POWER SENSITIVITY: < 0.001 dB/dB/watt.

ATTENUATION TEMPERATURE COEFFICIENT: < 0.0001 dB/dB/ $^{\circ}$ C.

RF CONNECTOR: APC-3.5 female (SMA compatible).

WEIGHT: Manual versions, 425 grams (15 oz); programmable versions, 454 grams (16 oz).

DIMENSIONS: 159 mm L x 52 mm W x 43 mm H (6.2 x 2.1 x 1.7 inches).

PROGRAMMABLE VERSIONS

SWITCHING SPEED: 20 ms max.

COIL VOLTAGE: (20-30V).

SWITCHING CURRENT: 110 mA at 24 V.

COIL IMPEDANCE: 220 ohms, 70 mH.

PRICES IN U.S.A.: 8495D (manual), \$700; 8495K (programmable), \$1060; 33321D, \$690; 33321K, \$1050.

HP Model 911C Sliding Load

FREQUENCY RANGE: 2.0 to 26.5 GHz.

IMPEDANCE: 50 Ω nominal.

REFLECTION COEFFICIENT:

MOVABLE LOAD ELEMENT: < 0.1 , 2.0 to 10.0 GHz; < 0.035 , 10.0 to 26.5 GHz.
CONNECTOR AND TRANSMISSION LINE: < 0.02 , 2.0 to 26.5 GHz for male APC-3.5; for female APC-3.5, $< 0.02 + 0.001 f$ (where f is frequency in GHz), 2.0 to 26.5 GHz.

POWER RATING: 1 watt average, 5 kW peak.

LOAD ELEMENT TRAVEL: Three-eighths of a wavelength at 2.0 GHz (5.6 cm minimum).

CONNECTORS SUPPLIED: Interchangeable connector bodies and center conductor pins for use with male and female APC-3.5 connectors.

LENGTH: 266 mm (10.5 in).

WEIGHT: 71 g (2.5 ounces).

ACCESSORIES FURNISHED: Carrying case and two wrenches.

PRICE IN U.S.A.: \$720.00.

HP Model 33311C Microwave Switch

TYPE: Single-pole, double-throw, break-before-make; self-latching solenoids with automatic solenoid disconnect after switching.

INSERTION LOSS: DC-2 GHz, < 0.25 dB;

2-10 GHz, < 0.50 dB;

10-16 GHz, < 0.80 dB;

16-26.5 GHz, < 1.40 dB (typ. < 0.6 dB).

ISOLATION: DC-12.4 GHz, > 90 dB;

12.4-18 GHz, > 85 dB;

18-26.5 GHz, > 50 dB.

SWR (characteristic impedance: 50 Ω)

THRU LINE: DC-2 GHz, < 1.15 ;

2-10 GHz, < 1.30 ;

10-16 GHz, < 1.50 ;

16-26.5 GHz, < 1.90 .

50 Ω INTERNAL LOAD: DC-2 GHz, < 1.15 ;

2-10 GHz, < 1.30 ;

10-16 GHz, < 1.50 ;

16-26.5 GHz, < 2.30 .

INPUT POWER RATING: 1 watt average, 100 watts peak for 10 μ s. (Also less than ± 7 Vdc).

RF CONNECTOR: APC-3.5 female (SMA compatible).

LIFE: $> 1\ 000\ 000$ switchings

REPEATABILITY: 0.03 dB typical to 26.5 GHz after 1 000 000 switchings.

SWITCHING SPEED: 30 milliseconds max.

SOLENOIDS

COIL VOLTAGE: 20-30V.

SWITCHING CURRENT: 120 mA at 24V (coils disconnect after switching).

COIL IMPEDANCE: 200 Ω , 127 mH.

ENVIRONMENTAL

OPERATING TEMPERATURE: -25° C to $+75^{\circ}$ C

HUMIDITY: 95% RH, 40 $^{\circ}$ C, 5 days

VIBRATION: .3", 10-55 Hz

SHOCK: 50 g's, 3 ms

WEIGHT: 88 gm (3.1 oz)

DIMENSIONS: 53 mm W x 14 mm D x 35 mm H (not including connectors). (2 x 1/2 x 2 inches).

PRICE IN U.S.A.: \$395.

MANUFACTURING DIVISION: STANFORD PARK DIVISION
1501 Page Mill Road
Palo Alto, California 94304 U.S.A.

Personal Calculator Algorithms II: Trigonometric Functions

A detailed explanation of the algorithms used by HP hand-held calculators to compute sine, cosine, and tangent.

by William E. Egbert

BEGINNING WITH THE HP-35,^{1,2} all HP personal calculators have used essentially the same algorithms for computing complex mathematical functions in their BCD (binary-coded decimal) microprocessors. While improvements have been made in newer calculators,³ the changes have affected primarily special cases and not the fundamental algorithms.

This article is the second of a series that examines these algorithms and their implementation. Each article will present in detail the methods used to implement a common mathematical function. For simplicity, rigorous proofs will not be given, and special cases other than those of particular interest will be omitted.

Although tailored for efficiency within the environment of a special-purpose BCD microprocessor, the basic mathematical equations and the techniques used to transform and implement them are applicable to a wide range of computing problems and devices.

The Trigonometric Function Algorithm

This article will discuss the method of generating sine, cosine, and tangent. To minimize program length, a single function, $\tan \theta$, is generated first. Once $\tan \theta$ is calculated, $\sin \theta$ is found by the formula

$$\sin \theta = \frac{\pm \tan \theta}{\sqrt{1 + \tan^2 \theta}}.$$

It turns out (as will be explained later) that $\cot \theta$ can easily be generated while generating $\tan \theta$. Then $\cos \theta$ is calculated using the formula

$$\cos \theta = \frac{\pm \cot \theta}{\sqrt{1 + \cot^2 \theta}}.$$

It can be seen that these formulas are identical, except for the cotangent replacing the tangent. Thus the same routine can solve for either sine or cosine depending on whether the argument is tangent or cotangent.

Scaling

Since θ and $\theta + n(360^\circ)$ yield identical trigonometric functions, every angular argument is resolved to a positive angle between 0° and 360° . For reasons to be explained later, all calculations assume angles expressed in radians. An angle in degrees is first converted to radians by:

$$\theta_{\text{rad}} = \theta_{\text{deg}} \times \pi/180.$$

Angles expressed in grads are also converted using the appropriate scale factor.

Once θ is in radians, 2π is subtracted repeatedly from $|\theta|$ until the absolute remainder is between 0 and 2π . For large angles this would take a long time. In such cases $2\pi \times 10^n$ can be subtracted in a process similar to division. Suppose an angle θ is expressed in scientific notation (e.g., 8.5×10^5). $2\pi \times 10^n$, or $6.28... \times 10^n$, is then repeatedly subtracted from θ until the result becomes negative (underflow). Thus $6.28... \times 10^5$ is subtracted from 8.5×10^5 twice and underflow occurs. $6.28... \times 10^5$ is then added to the negative remainder to give a number between 0 and $2\pi \times 10^5$, in this case 2.2×10^5 . The remainder is expressed now as 22×10^4 and the process is repeated, this time subtracting $2\pi \times 10^4$. With this method, large angles are quickly resolved.

The problem with this scaling process is that in current computers numbers can be expressed only to a limited number of digits, so 2π and therefore $2\pi \times 10^n$ cannot be expressed exactly. Error creeps in with each shift of the remainder. Thus, the larger the angle, the fewer significant digits remain in the scaled result. A rule of thumb for rough estimates is that for each count in the exponent, one digit of accuracy will be lost. For example, 5×10^5 when scaled will lose five digits of accuracy.

A negative argument is treated the same as a positive number until the end, when the scaling routine returns a number between 0 and -2π . Then 2π is added to the negative result, giving again a number between 0 and 2π . This addition of 2π causes a digit

to be lost, which results in asymmetry such as $\cos(86^\circ) \neq \cos(-86^\circ)$. Newer calculators obviate this problem by scaling to a number between 0 and $\pi/4$.

Vector Rotation

An angle can be expressed as a vector having X and Y components and a resultant **R** (see Fig. 1). If **R** is the unit vector, then $X=\cos \theta$ and $Y=\sin \theta$. However, regardless of the length of **R**, $Y/X=\tan \theta$ and $X/Y=\cot \theta$. This holds true for all values of θ from 0 to 2π . Thus, if some way could be found to generate X and Y for a given θ , all the trigonometric functions could be found.

In vector geometry a useful formula results when one rotates a vector through a given angle. Let us suppose we have a vector whose angle is θ_1 , and we know its components X_1 and Y_1 (see Fig. 2). The X_2 and Y_2 that result when the vector is rotated an additional angle θ_2 are given by:

$$X_2 = X_1 \cos \theta_2 - Y_1 \sin \theta_2$$

$$Y_2 = Y_1 \cos \theta_2 + X_1 \sin \theta_2$$

Dividing both sides of these equations by $\cos \theta_2$ gives:

$$\frac{X_2}{\cos \theta_2} = X_1 - Y_1 \tan \theta_2 = X_2' \quad (1)$$

$$\frac{Y_2}{\cos \theta_2} = Y_1 + X_1 \tan \theta_2 = Y_2'$$

Note that X_2' and Y_2' , while not the true values of X_2 and Y_2 , both differ by the same factor, $\cos \theta_2$. Thus $Y_2'/X_2' = Y_2/X_2$. From Fig. 2 it is plain that the quotient Y_2'/X_2' is equal to $\tan(\theta_1 + \theta_2)$. Thus the tangent of a large angle can be found by manipulating smaller angles whose sum equals the large one. Returning to equation 1 above, it can be seen that to generate X_2' and Y_2' , X_1 and Y_1 need to be multiplied

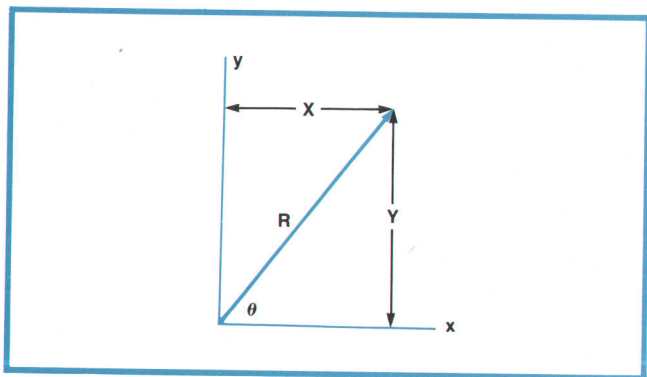

Fig. 1.

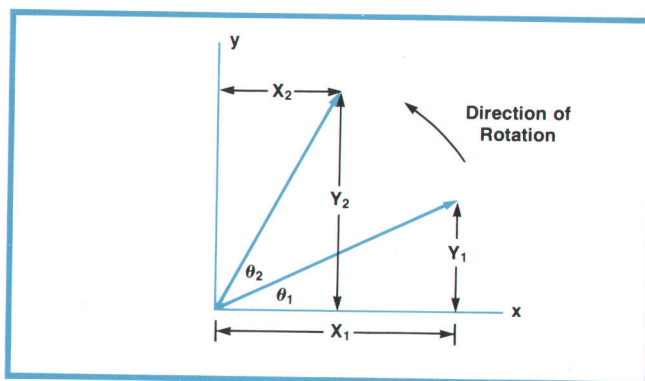

Fig. 2.

by $\tan \theta_2$ and added or subtracted as needed. If θ_2 is chosen so that $\tan \theta_2$ is a simple power of 10 (i.e., 1, 0.1, 0.01,...) then the multiplications simply amount to shifting X_1 and Y_1 . Thus to generate X_2' and Y_2' , only a shift and an add or subtract are needed.

Pseudo-Division

The tangent of θ is found as follows. First θ is divided into a sum of smaller angles whose tangents are powers of 10. The angles are $\tan^{-1}(1) = 45^\circ$, $\tan^{-1}(0.1) \approx 5.7^\circ$, $\tan^{-1}(0.01) \approx 0.57^\circ$, $\tan^{-1}(0.001) \approx 0.057^\circ$, $\tan^{-1}(0.0001) \approx 0.0057^\circ$, and so on.

This process is called pseudo-division. First, 45° is subtracted from θ until overdrift, keeping track of the number of subtractions. The remainder is restored by adding 45° . Then 5.7° is repeatedly subtracted, again keeping track of the number of subtractions. This process is repeated with smaller and smaller angles. Thus:

$$\theta = q_0 \tan^{-1}(1) + q_1 \tan^{-1}(0.1) + q_2 \tan^{-1}(0.01) \dots + r$$

The coefficients q_i refer to the number of subtractions possible in each decade. Each q_i is equal to or less than 10, so it can be stored in a single four-bit digit.

This process of pseudo-division is one reason that all the trigonometric functions are done in radians. For accuracy, $\tan^{-1}(10^{-i})$ needs to be expressed to ten digits. In degrees, these constants are random digits and require considerable ROM (read-only memory) space to store. However, in radians, they become, for the most part, nines followed by sixes. Because of this, they can be generated arithmetically, thus using fewer ROM states. Also, in radians, $\tan^{-1}(1) = \pi/4$, which is needed anyway to generate π . The problem with using radians is that since π is an irrational number, scaling errors occur as discussed earlier. This means cardinal points do not give exact answers. For example, $\sin(720^\circ) \neq 0$ when calculated this way but rather 4×10^{-9} . See reference 3 for a discussion of this point.

So far, a pseudo-quotient has been generated that represents the division of the given angle θ into smaller angles whose tangents are powers of 10. In many HP calculators the pseudo-quotient is five hexadecimal digits long. Each digit represents one series of subtractions and is a number from 0 to 10. For example, if θ were 359.9999° , the pseudo-quotient would be 77877, representing $\theta = 7\tan^{-1}(1) + 7\tan^{-1}(0.1) + 8\tan^{-1}(0.01) + 7\tan^{-1}(0.001) + 7\tan^{-1}(0.0001)$. There may also be a remainder r , which is the angle remaining after the previous partial quotient subtractions have taken place.

$\tan \theta$ can now be found using the vector rotation process discussed earlier.

Pseudo-Multiplication

To use equation 1 we need an initial X_1 and Y_1 . These correspond to the X and Y of the residual angle r discussed previously. This angle is small (less than 0.001°), and for small angles in radians, $\sin \theta = \theta$ (another reason to use radians instead of degrees). Thus, to good accuracy, the initial Y_1 can be set to the residual angle, and the initial X_1 set to 1. Equation 1 can now be repeatedly applied, where θ_2 is the angle whose tangent is 10^{-j} . Each time equation 1 is applied, a new X_1 and Y_1 are generated, i.e., X_2' and Y_2' . The number of times equation 1 is applied is determined by the count in the pseudo-quotient digit for that θ . Thus if the original angle had a 3 in the pseudo-quotient digit corresponding to $\tan^{-1}0.1$, or 5.7° , equation 1 would be applied three times with X_1 and Y_1 being shifted one place right for $\tan^{-1}0.1$ before the addition or subtraction. In this manner, new X_1 and Y_1 are formed as the vector is rotated the amount corresponding to the count in the pseudo-quotient digits which, of course, sum to the original angle θ .

Equation 1 shows that to generate X_2 requires a shift of Y_1 and a subtraction from X_1 . Likewise Y_2 requires a shift of X_1 and an addition to Y_1 . To implement this would require either two extra registers to hold the shifted values of X_1 and Y_1 , or else shifting one register twice and the other once. It would be desirable to shift only one register once. Happily, this is possible. Consider the following: Let $Y = 123$ and $X = 456$. Suppose we want $Y + (X \times 0.01)$. This can be obtained by keeping the decimal points in the same places and shifting X two places right.

$$\begin{array}{r} 123 \\ + 4.56 \\ \hline 127.56 \end{array}$$

Now suppose instead of shifting X two places right, we multiply Y by 100, shifting it two places left. What happens?

$$\begin{array}{r} 12300 \\ 456 \\ \hline 12756 \end{array}$$

The digits in both answers are exactly the same. The only difference between the two is that the second answer is 100 times the correct value, which is the same value by which Y was multiplied before the addition. Thus to avoid shifting X, Y must be multiplied by 10^j .

Expanding this method to the problem at hand also helps us solve another problem, that of accuracy. During pseudo-division, the angle θ is resolved until a small angle r is left as the original Y value. Since this is done in fixed point arithmetic, zero digits are generated following the decimal point (e.g., .00123).

Since zero digits do not convey information except to indicate the decimal point, the remainder is shifted left one place (multiplied by 10) during each decade of pseudo-division. This preserves an extra digit of accuracy with each decade. The final remainder is equal to $r \times 10^4$ if the pseudo-quotient is five digits long.

To demonstrate mathematically the implementation that requires only a single register shift, return to equation 1 and replace $\tan \theta_2$ by 10^{-j} . This substitution is legal because $\theta_2 = \tan^{-1}(10^{-j})$, where j is the decade digit.

$$\begin{aligned} X_2' &= X_1 - Y_1 \times 10^{-j} \\ Y_2' &= Y_1 + X_1 \times 10^{-j} \end{aligned} \quad (2)$$

Now let $Z = Y_1 \times 10^j$, or $Y_1 = Z \times 10^{-j}$. Substituting in equation 2,

$$\begin{aligned} X_1' &= X_1 - Z \times 10^{-2j} \\ Y_2' &= Z \times 10^{-j} + X_1 \times 10^{-j} \end{aligned}$$

Multiplying the second equation by 10^j gives:

$$Y_2' \times 10^j = Z + X_1$$

The left-hand side ($Y_2' \times 10^j$) is in the correct form to be the new Z for the next iteration. Thus for each iteration within a decade:

$$\begin{aligned} X_2' &= X_1 - Z \times 10^{-2j} \\ Y_2' \times 10^j &= Z + X_1 \end{aligned} \quad (3)$$

X_2' becomes the new X_1

$Y_2' \times 10^j$ becomes the new Z

Since the shifted remainder ($r \times 10^4$) is desired as Z for the first iteration, the original j is 4.

To implement equation 3, X_1 and Z are stored in two registers. $Z \times 10^{-2j}$ is formed and stored in a third register. X_1 is added to Z to form the new Z. This leaves X_1 undisturbed so that $Z \times 10^{-2j}$ can be subtracted from it to form the new X_2' .

This implementation saves extra shifts and increases accuracy by removing leading zeros in Z. The only register shifted is Z.

After equation 3 has been applied the number of times indicated by one pseudo-quotient digit, Z is shifted right one place, and a new pseudo-quotient digit is fetched. This in effect creates $Y_1 \times 10^j$, where j is one less than before. Again equation 3 is applied, and the process is repeated until all five pseudo-quotient digits have been exhausted. The result is an X and a Y that are proportional to the cosine and sine of the angle θ . Because the final j is zero, the final Y ($=Z$) is correctly normalized with respect to X .

So far, then, an X and a Y have been generated by a pseudo-multiply operation consisting of shifts and additions. If $\tan \theta$ is required, Y/X is generated, which is the correct answer. For $\sin \theta$, Y/X is calculated, and for $\cos \theta$, X/Y is calculated. Then either X/Y or Y/X is operated on by the routine described at the beginning of this article. The only difference between the computation for $\sin \theta$ and that for $\cos \theta$ is whether X and Y are exchanged.

In summary, the computation of trigonometric functions proceeds as follows:

1. Scale the input angle to a number in radians between 0 and 2π .
2. Using the pseudo-division process divide the scaled number into groups of selected smaller angles.
3. With the pseudo-multiply process of equation 3 applied once for each angle resulting from the division of the input argument, generate an X and a Y that are proportional to the sine and co-

sine of the input angle.

4. With X and Y , compute the required function using elementary operations.
5. Round and display the answer.

The calculator is now ready for another operation. 

References

1. T.M. Whitney, F. Rodé, and C.C. Tung, "The 'Powerful Pocketful': An Electronic Calculator Challenges the Slide Rule," Hewlett-Packard Journal, June 1972.
2. D.S. Cochran, "Algorithms and Accuracy in the HP-35," Hewlett-Packard Journal, June 1972.
3. D.W. Harms, "The New Accuracy: Making $2^3=8$," Hewlett-Packard Journal, November 1976.

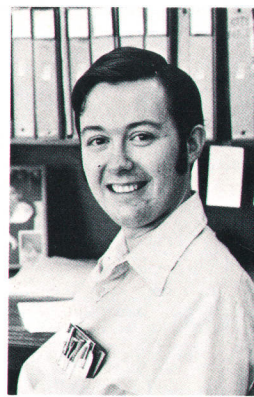

William E. Egbert

Bill Egbert is a project leader at HP's Corvallis, Oregon Division. He produced this series of algorithm articles as part of his work on the HP-67 and HP-97 Programmable Calculators. He was project leader for the HP-67 and did micro-programming for both calculators. Bill received his BSEE degree from Brigham Young University in 1973 and his MSEE from Stanford University in 1976. He's been with HP since 1973. Born in Fallon, Nevada, he's married, has two small children, and lives in Corvallis.

Hewlett-Packard Company, 1501 Page Mill Road, Palo Alto, California 94304

HEWLETT-PACKARD JOURNAL

JUNE 1977 Volume 28 • Number 10

Technical information from the Laboratories of
Hewlett-Packard Company

Hewlett-Packard Central Mailing Department
Van Heuven Goedhartlaan 121
Amstelveen-1134 The Netherlands
Yokogawa-Hewlett-Packard Ltd., Shibuya-Ku
Tokyo 151 Japan

Editorial Director • Howard L. Roberts
Managing Editor • Richard P. Dolan
Art Director, Photographer • Arvid A. Danielson
Illustrator • Susan E. Wright
Administrative Services, Typography • Anne S. LoPresti
European Production Manager • Dick Leeksma

Bulk Rate
U.S. Postage
Paid
Hewlett-Packard
Company

CHANGE OF ADDRESS . To change your address or delete your name from our mailing list please send us your old address label (it peels off).
Send changes to Hewlett-Packard Journal, 1501 Page Mill Road, Palo Alto, California 94304 U.S.A. Allow 60 days.