



DIRECTOR'S CORNER

BY

Harold J. Schulman

It seems only fitting and proper that we close 1953 with a sincere tribute to the men (and women) in the Television Service industry.

The serviceman today is a member of a large group of people, who, by their combined efforts, bring to the average American something that only a short 10 years ago even a millionaire couldn't have.

I am talking, of course, about Television—and all the good things it adds to our lives.

Home wouldn't be as sweet without the television set in the corner, to keep the children busy while Mom prepares supper. Mom and Dad have also become used to the plays and movies and wrestling and quiz shows. We are all a little richer for the pleasure and stimulation television brings right smack into our homes.

But it's the dealers and servicemen, going about their daily work, fixing Mrs. Jones set, installing Mrs. Smith's, and explaining to Mrs. Doe for the tenth time how to tune in a picture, who we would like to honor.

When the factory's Final Inspector cuts the umbilical cord, and the newly born TV receiver goes out to face the world, it's the television technician who is entrusted with its welfare.

With more than 25,000,000 sets in operation and survey after survey showing increased customer satisfaction, who can deny that a tremendous job has been done—and done well.

So, to the servicemen, who as a part of the team which makes this miracle possible, may we extend our heartfelt thanks and congratulations. All of us at Du Mont extend to you the Season's Greetings and wish you a Happy, Healthy and Prosperous New Year.

TROUBLESHOOTING DU MONT UHF TUNERS

The Du Mont UHF tuner has proven itself to be an extremely reliable and troublefree unit. However, you will occasionally encounter a tuner which is in need of repair or adjustment.

No difficulty in working on UHF tuners should be encountered if you follow the usual precautions which apply to the handling of UHF circuits. Briefly, these precautions are as follows:

1. Do not disturb parts and lead positioning.
2. Use exact replacement parts.
3. When making replacements, duplicate the original part positioning and lead dress.
4. Do not make adjustments unless

you are familiar with the proper procedure and have the necessary test equipment available.

A faulty UHF tuner may produce any of the following symptoms; weak picture and sound, no picture or sound, weak sound, loss of video gain, microphonics, and intermittent noise.

When a receiver equipped with a UHF tuner is not operating properly on UHF signals, don't assume that the UHF tuner is at fault until the other receiver circuits have been checked. If possible, check the receiver's performance on a VHF signal. If it is not as good as it should be the trouble probably is not in the UHF tuner.

When the trouble has been localized

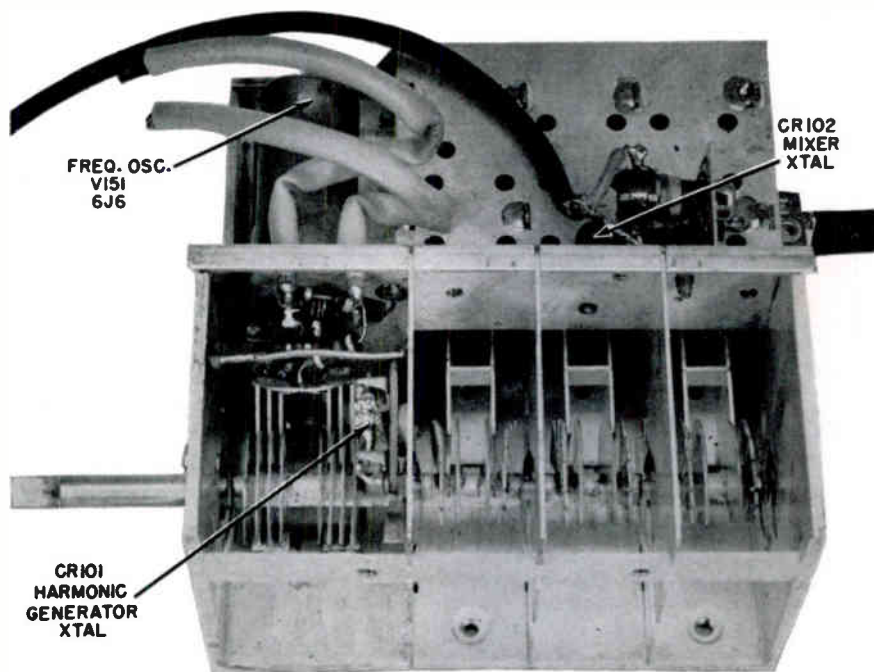

Figure A-1. Du Mont UHF tuner with shields removed, showing the location of the mixer and harmonic-generator crystals.

to the UHF tuner, the following procedure may be used:

1. Check the oscillator tube by substitution.
2. Remove the oscillator tube and check for the presence of filament and B+ voltages at the socket. With the tube removed the B+ voltage will not agree with that shown in the chart below the schematic, however its presence or absence will be determined.
3. Check the harmonic generator and mixer crystals by substitution. The crystal locations are shown in figure A-1. If a faulty crystal is found, try several crystals and use the one which gives the best results. The crystal which gives the most output can be found by connecting a VTVM between the AGC test point and ground, and noting the a-g-c voltage as each crystal is inserted. The one giving the

highest a-g-c voltage should be selected.

4. Inspect the oscillator circuit for signs of shorted or burnt components.
5. Measure the resistances between the oscillator socket pins and ground.
6. Check the resistances of suspected components.

Table I lists possible tuner faults and their causes.

UHF Tuner Alignment

To align Du Mont UHF tuners, the following items are required:

Two VTVMs.

An AGC bias source. This bias source may be a 7.5-volt battery, shunted by a potentiometer, or the a-g-c bias supply described on page 72 of August issue of the Service News.

UHF signals off the air, or from the UHF signal source described on page 86 of the October issue of the Service News.

An insulated alignment screwdriver.

The alignment procedure is as follows:

1. Remove the UHF tuner bottom cover.
2. Tune in a UHF station between channels 66 and 76.
3. Connect the a-g-c bias source to the receiver's a-g-c test point, and adjust the bias source for best picture.
4. Connect one VTVM to the receiver's video test point, and connect the other VTVM to one side of the 5-mf electrolytic capacitor in the ratio-detector circuit.
5. Adjust the trimmer capacitors, A in figure A-2, using an insulated align-

TABLE I

Symptom	Procedure
No sound, no picture	<ol style="list-style-type: none"> 1. Check 6J6 by substitution. 2. Check oscillator socket pins for shorts to ground. 3. Check for short between oscillator tuning capacitor rotor and stator plates. 4. Check mixer and harmonic generator crystals by substitution. 5. Check R152, 470 ohm B+ resistor. 6. Check C153, 800 mmf B+ feed through capacitor. 7. Check C156, C157, 4.7 mmf oscillator tank coil capacitors. 8. Check VHF tuner 40 mc i-f strip by substitution. 9. Check cam position on VHF tuner drum shaft for correct S101 switching action.
Weak sound, snowy picture	<ol style="list-style-type: none"> 1. Check 6J6 is firmly seated in its socket. 2. Check 6J6 by substitution. 3. Check harmonic generator and mixer crystals by substitution. 4. Check for short between case and antenna coupling loops. 5. Check the VHF tuner r-f amplifier (6BK7) by substitution. 6. Check the VHF tuner 40 mc i-f strip by substitution. 7. Check the UHF tuner alignment.
Microphonics	<ol style="list-style-type: none"> 1. Make sure the 6J6 is firmly seated in its socket. 2. Make sure the 6J6 tube shield is firmly mounted. 3. Check the 6J6 by substitution.
Intermittent picture	<ol style="list-style-type: none"> 1. Make sure the 6J6 is firmly seated in its socket. 2. Make sure the 6J6 tube shield is firmly mounted. 3. Check the 6J6 by substitution. 4. Make sure the mixer and harmonic generator crystals are firmly seated in their holders.
Normal picture, weak sound or Normal sound, weak picture	<ol style="list-style-type: none"> 1. Check the tuner alignment and tracking.

ment screwdriver. Bend the tabs nearer to and farther from the tuned lines, until maximum readings are obtained on the VTVMs. The video detector output may be favored slightly, if the sound output does not show appreciable drop.

6. Tune in a UHF station between channels 20 and 24. Adjust the a-g-c bias source for best picture.

7. Using long nosed pliers (or a soldering aid) adjust the rotor plates, B in figure A-2. Bend only the outer, split, rotor plates, to obtain maximum reading on both meters. Bend only the plate ends that mesh at or near maximum capacity. The video output may be favored slightly over the sound output providing only a slight loss of sound occurs.

CAUTION: Do not touch the tuning capacitor sections in the oscillator compartment.

8. Tune to a high frequency channel and repeat step 5 if necessary.

9. If the UHF tuner does not tune in channel 14, substitute one or more oscillator tubes. If this does not help, adjust the oscillator trimmer capacitor (C152), located on the top side of the tuner next to the oscillator, to correct the oscillator frequency.

Using the above procedure it is possible to favor the reception from a particular UHF fringe station. This should not be attempted, however, until all other possibilities of improving the station's reception have been exhausted.

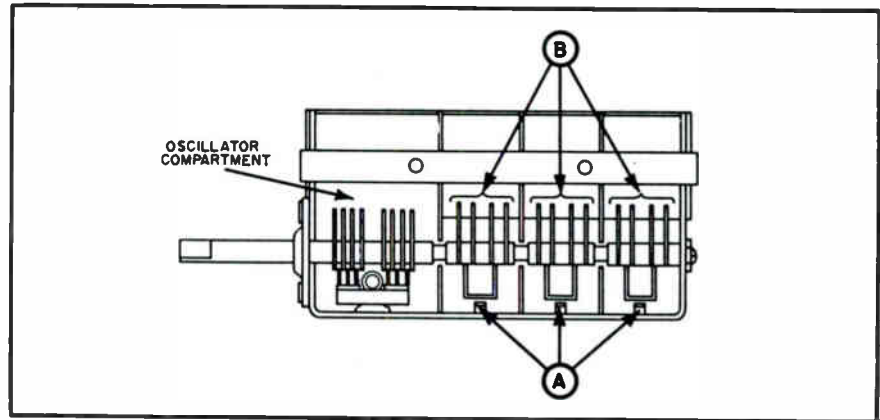

Figure A-2.

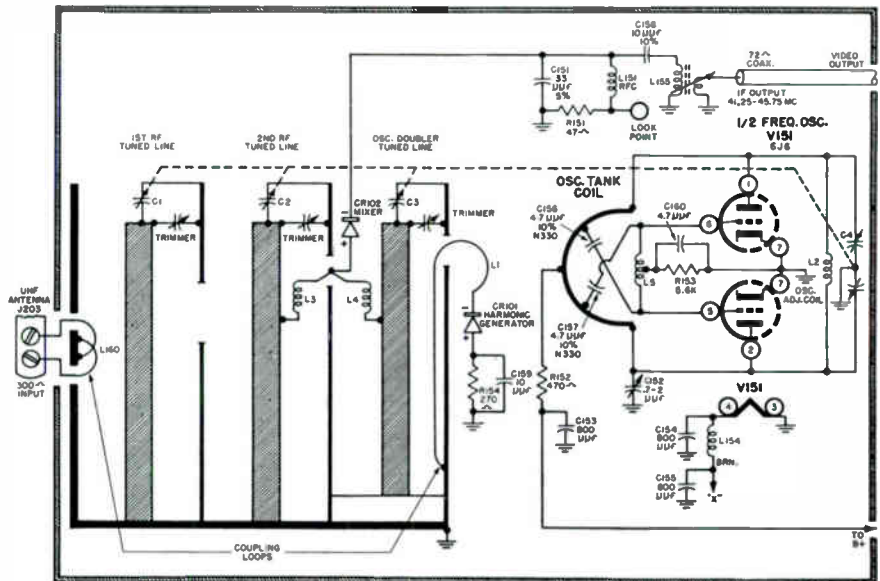

Figure A-3. Schematic diagram of the UHF tuner. The tuner voltage readings are shown below.

	VOLTAGE						
	1	2	3	4	5	6	7
RA-171 UHF Tuner	+125	+125	0	6.3AC	-8	-8	0
RA-307 UHF Tuner	+130	+130	0	6.3AC	-5.4	-5.4	0

Installing CASCODE TURRET TUNERS

In weak signal areas the performance of RA-112/113, 117, 109, 120, 130, 133, and 147 chassis can often be improved by the installation of a turret-type cascode tuner. Current cascode tuners provide a lower noise figure which results in a reduction in snow, when receiving weak signals. No improvement will be obtained if snow-free pictures are received using the original tuner.

Installation of a turret tuner in any

one of the receivers mentioned above results in loss of FM broadcast reception. In addition the dial mechanism on RA-112/113, 109, 120, 130, and 133 chassis is rendered inoperative. In view of the above the installation of turret tuners in these receivers is worthwhile only in very weak signal areas, where the primary problem is to obtain a satisfactory picture.

RA-112/113 and 120

To install turret tuners in RA-

112/113 and RA-120 chassis the following procedure should be used:

1. Remove the original tuner, noting all lead connections.
2. Enlarge the tuner mounting holes to 1/4 inch, as shown in figure B-1A.
3. Remove the dial mechanism from the old tuner and cut out the sections of the dial plate and bracket shown in figure B-1B and D.
4. Drill three holes in the dial-plate bracket and the front of the chassis

as shown in figure B-1B and C. Use a #18 or slightly larger drill.

5. Check the part number of the old tuner. If it is 89 003 901, 3902 or 3911, replace the first i-f transformer (Z204) with part number 20 005 351. If L213, a slug tuned coil mounted next to Z204, is used, remove it. Rewire the circuit as shown in figure B-2. It may be necessary to add an 8-50 mmf ceramic trimmer capacitor between the first i-f transformer and ground. Some chassis have this capacitor already mounted on a standoff. If not, it may be mounted by soldering one terminal to pin 3 of Z204. If a 2.7K, 1/2W, resistor is not connected in grid circuit of the first vif, it must be added.

6. Install the new tuner, as shown in figure B-3. The lead connections are shown in figure B-2. A 3K, 5W, and a 2.7K, 2W, resistor must be added in the tuner B+ lines. The tuner ends of each resistor should be bypassed to ground with a .005 mf, ceramic disc capacitor.

7. Connect an insulated lead from the output tab of the tuner to terminal 3 of Z204.

RA-117 and RA-147

To install a cascode tuner in an RA-117 or RA-147 Teleset proceed as follows:

1. Remove the CRT and front CRT support.
2. Remove the original tuner, noting the points in the chassis to which the tuner leads were connected.
3. Mount the new tuner in the chassis. It may be necessary to enlarge the chassis holes (see figure B-1A) with a 1/4 inch drill, to obtain a fit.
4. Connect all tuner leads as shown in figure B-2. The 3K, 5W, and 2.7K, 2W, resistors must be added. The tuner side of each resistor should be bypassed to ground with a .005 mf ceramic disc capacitor.
5. Connect an insulated lead from the tuner output tab to the junction of the 8-50 mmf trimmer and the first video i-f transformer.

RA-109, 130 and 133 Telesets

To install a cascode tuner in an

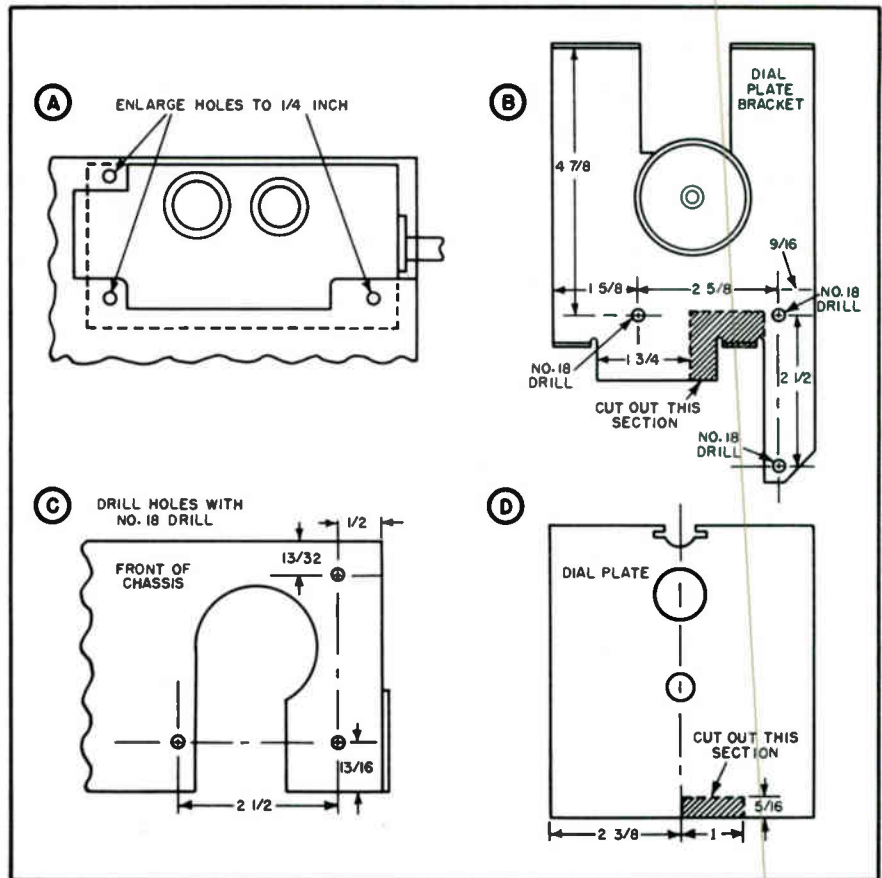

Figure B-1. Mounting modifications required in RA-112/113 and RA-120 chassis. A—Enlarge tuner mounting holes. B—Drill three holes in dial plate bracket and cut out shaded portion. C—Drill holes in chassis to match those in bracket. D—Cut out shaded portion of dial plate.

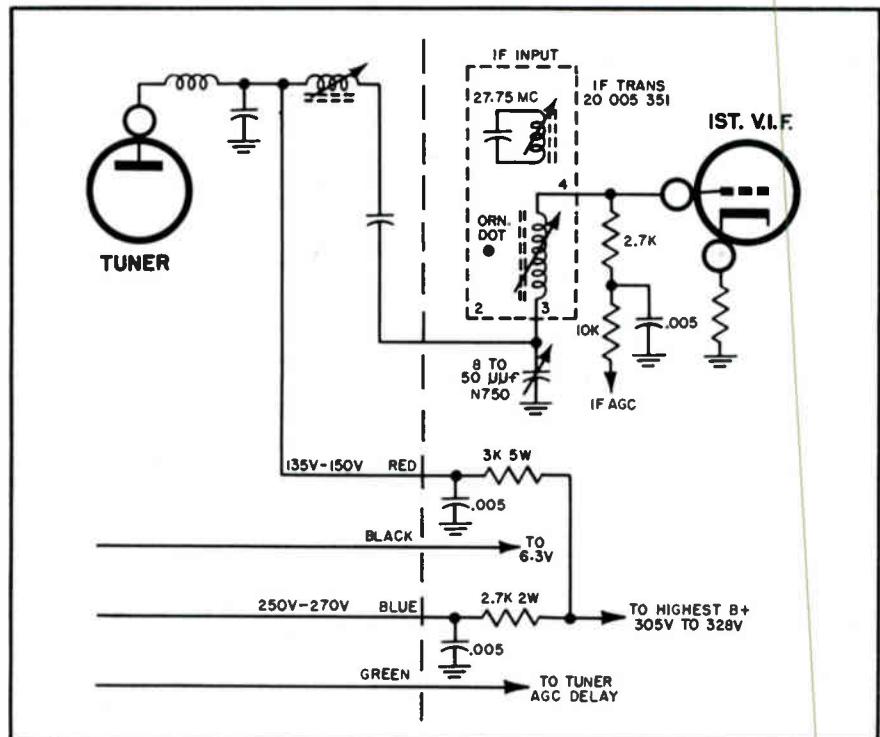

Figure B-2. Partial schematic showing cascode tuner connections to receiver chassis.

RA-109, 130 or 133 chassis proceed as follows:

1. Remove the original tuner and mounting bracket. Unfasten the terminal strip from the underside of the mounting bracket.
2. Make up three brackets as shown in figure B-4A. Fasten the brackets to the new tuner, as shown in figure B-4B.
3. Drill three holes in the chassis for the three mounting brackets. To locate the holes, place the tuner in proper position and mark the holes. The rear of the tuner turret shaft should not project beyond the chassis cutout.
4. Mount the tuner in the chassis cutout.
5. Fasten the terminal strip, mentioned in step 1, to the front of the chassis, under the tuner, using one of the holes already available. Lengthen the leads where necessary.
6. Mount a four-lug terminal strip in the hole already available near the rear of the tuner cutout, as shown in figure B-4C.

7. Connect the tuner leads, as shown in the schematic of figure B-2. The 3.3K, 5W, and 2.7K, 2W resistors, should be mounted on the terminal strip mentioned in step 6 (see figure B-4C). Bypass the tuner end of each resistor to ground with a .005 mf ceramic disc capacitor.

8. Remove Z205, the first video i-f transformer, and replace it with part number 20 005 351. Remove L215, a slug tuned coil mounted next to Z205, if it is present. Connect Z205 as shown in figure B-2. The 8-50 mmf ceramic trimmer may be mounted by soldering one of its terminals to terminal 3 of Z205.

NOTE: Some chassis do not have the 2.7 K resistor, in the grid circuit of the first vif, and it must be added.

9. Cut out the sections of the dial plate and bracket shown in figure B-5. Bend the dial bracket 90°, at the point shown, and mount the dial and bracket as shown in figure B-6.

Alignment

After installing the new tuner, the mixer output and first i-f coils, and the trimmer capacitor connected between

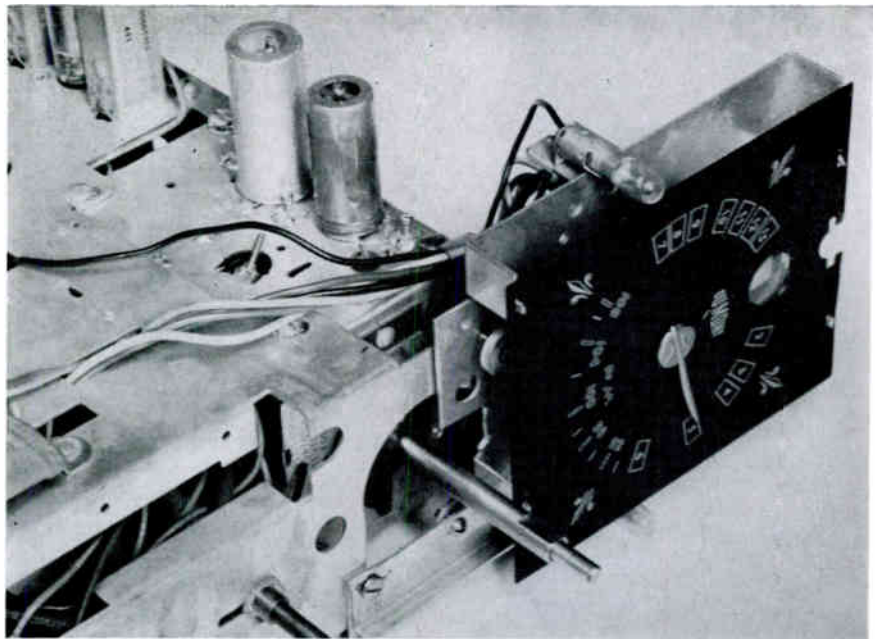

Figure B-3. RA-112/113 chassis modified for use with cascode turret tuner. Note cut outs in dial plate and bracket to provide clearance for the tuner shaft. The dial plate bracket is fastened to the chassis by means of three screws.

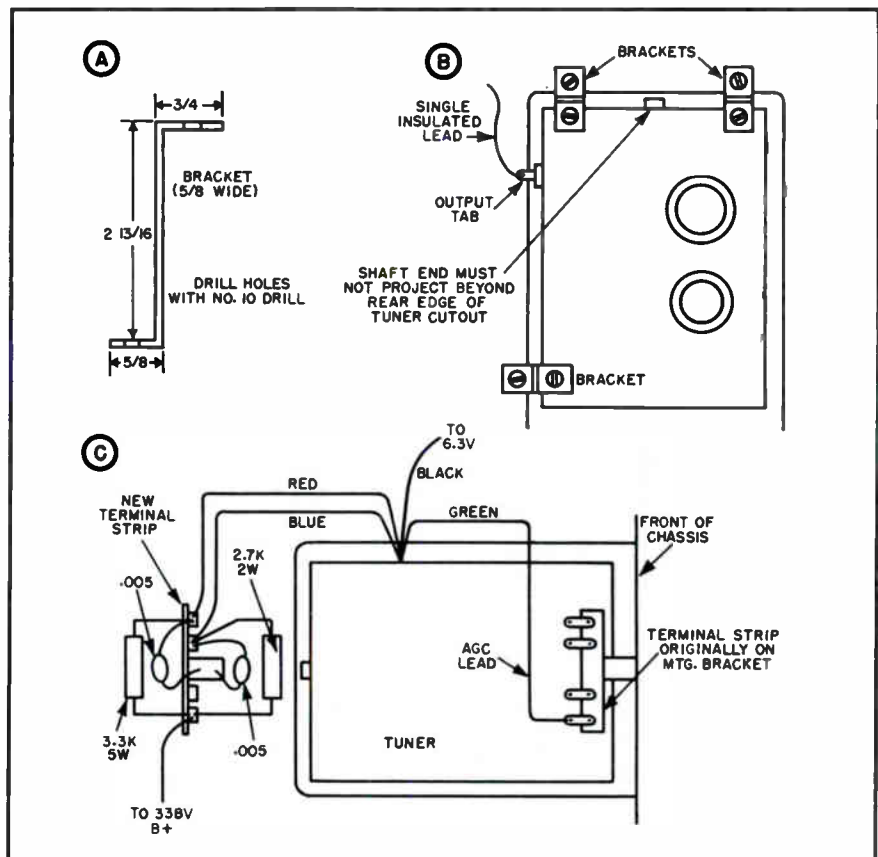

Figure B-4. Illustration of mounting and wiring modifications required to incorporate a cascode tuner in an RA-109 chassis. A—Mounting brackets. B—Tuner mounted on chassis. C—Wiring modification.

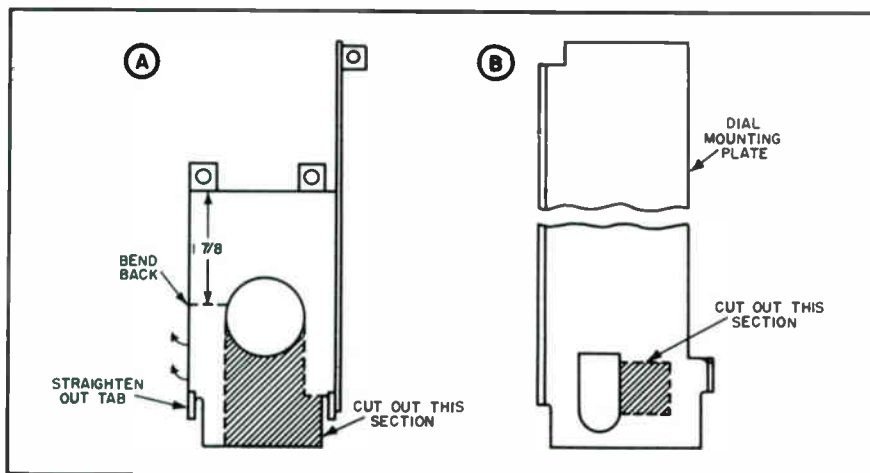

Figure B-5. RA-109 dial mounting plate modification.

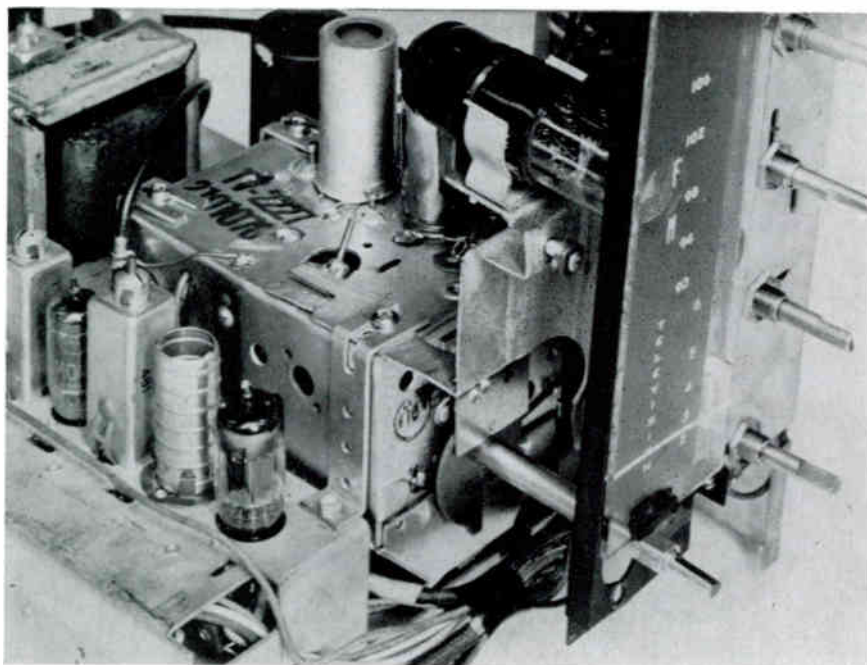

Figure B-6. RA-109 chassis modified for use with a cascode turret tuner.

the i-f coil and ground, must be adjusted.

Follow the regular alignment procedure, injecting the signal at the grid of the mixer and connecting the scope at the plate of the first video i-f tube. Adjust the trimmer capacitor for proper bandwidth. The top slug of the first i-f can should be adjusted for minimum lower adjacent-channel-sound-carrier (27.75 mc or 27.9 mc, whichever is used in the chassis in question) response. The tuner mixer plate coil and the bottom slug of the i-f can must also be adjusted. The proper bandpass curve is shown in figure B-7.

The tuner oscillator slugs should

be adjusted to provide proper fine tuning range on each channel.

Turret Tuners

Several different Standard Coil tuners can be used. The most important requirement is a 21 mc i-f output. Du Mont part number 21 010 783 is satisfactory. Standard Coil model TV-2232, which can be obtained from your local parts jobber, may also be used.

In most cases it will be necessary to cut the tuner shaft to proper length. The shaft dimensions are shown in figure B-8. A shows the dimensions for RA-112, 113, 117, 120, and 147 chassis. In the case of the

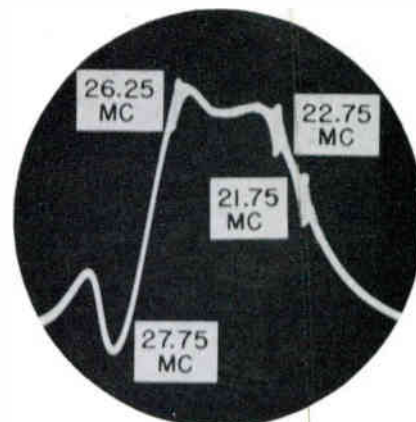

Figure B-7. Bandpass of tuner output and i-f input circuits.

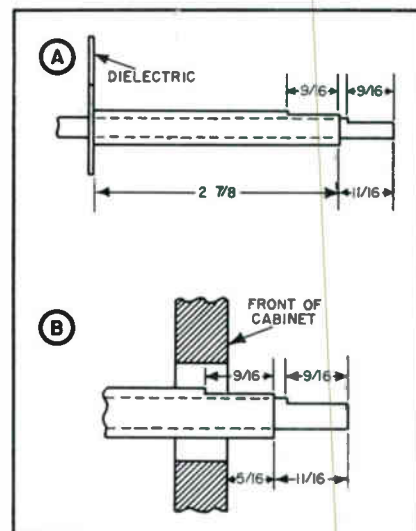

Figure B-8. Turret-tuner shaft lengths and shaft flat dimensions. A—RA-112/113, 117, 120 and 147 chassis. B—RA-109, 130 and 133 chassis.

RA-109, 130, and 133 chassis the shaft length should be determined by mounting the chassis in the cabinet and marking the proper length, as shown in figure B-8B.

If tuner 21 010 783 is used, new flats must be filed on the fine tuning and channel selector shafts. The proper dimensions are shown in the figure. The position of the flat on the selector shaft must be the same as the original one, otherwise the knob will not indicate the correct channel.

On RA-112,113, and 120 chassis all of the tuner strips must be moved three turret positions counter-clockwise, so that the channel will be indicated at the top of the channel selector knob, since in these receivers the chassis and tuner mount on their sides.

SERVICE NEWS INDEX

January - December, 1953

- AGC,
 adjustment procedure, RA-166/171, Jan. 13
 adjustment procedure, RA-306/307, Nov. 92
 circuits, explanation of, Jan. 7, July 57, Nov. 89
 curves, July 60 - Nov. 91
 delay circuits, Jan. 7, July 57, Nov. 89
 excessive, July 61
 faults, symptoms of, July 59
 noise immunity, July 58
 oscillation, July 62
 troubleshooting, July 57
 bias supply for, July 60 - Aug. 72
- Antennas,
 crossover networks, April 36
 installing UHF, May 45
 UHF, April 33
 Bias supply, a-g-c, July 60 - Aug. 72
 Blooming, causes of, Aug. 66 - Sept. 77
 Cabinets, ordering parts for, March 25
 Contrast, explanation of, Aug. 67
 Crossover networks, antenna, April 36
 Converters, UHF, June 55
 Fuse blowing, causes of, Sept. 76
 Gamma, explanation of, Aug. 67
 Gray Range, explanation of, Aug. 67
 Headphones, connecting to TV receiver, July 63
 High voltage circuits,
 operation and explanation of, Sept. 73
 measurements in, Sept. 74
 troubleshooting, Sept. 73
 blooming, Sept. 77
 fuse blowing, Sept. 76, 80
 high voltage, loss of, Sept. 75
 width, insufficient, Sept. 78
 symptoms of defective components in, Sept. 79
 waveforms, correct and incorrect, Sept. 76
 Horizontal hold, critical, July 61
 Horizontal size, loss of, Sept. 78
 Hum,
 locating source of, June 49
 symptoms, June 49
 Ion-trap magnet, adjustment of, Jan. 12
 Measurements in high voltage circuit, Sept. 74
 Modulation depth, explanation of, Aug. 67, 68
 Noise figure, explanation of, Oct. 83
 Noise immunity, July 58
 Noise, picture, Oct. 81
 Oscillation, a-g-c, July 62
 Overloading, causes of, July 60
 Overshoot, cause of, Aug. 69
 Picture quality,
 analysis of, Aug. 65
 contrast, Aug. 67
 gray range, Aug. 67
 horizontal resolution, Aug. 68
 modulation depth, Aug. 67
 overshoot, Aug. 69
 ringing, Aug. 69
 smear, Aug. 70
 spot size, Aug. 65
 Production changes,
 RA-162B, May 47
 RA-166/171, June 52
 RA-306/307, Nov. 95
 Resolution,
 horizontal, Aug. 68
 vertical, Aug. 68
 Return-trace blanking modification, Nov. 93
 Ringing, explanation of, Aug. 69
 Scanning, non-uniform, cause of, Aug. 66
 Sensitivity, explanation of, Oct. 82
 Smear, causes of, Aug. 70
 Spot size, importance of, Aug. 65
 Station changes, service problems due to, Feb. 24
 Strips,
 VHF, coding of, April 39
 part numbers of, April 39
 replacement of, Feb. 17
 UHF, circuit explanation of, May 41
 coding of, April 39
 installation of, March 25 - May 42
 servicing, May 41
 Telesets,
 names and descriptions of, May 43
 model numbers, May 45
 Tone-control, interaction with volume in RA-105, Sept. 80
 Troubleshooting,
 a-g-c circuits, July 57
 high voltage circuits, Sept. 73
 hum problems, June 49
 tuner, r-f turret, March 26
 Tuner, r-f turret,
 alignment, Feb. 19
 contacts, adjustments of, Feb. 17
 part numbers, Feb. 18
 interchanging, Feb. 19 - Dec. 99
 low gain in, Oct. 87
 servicing of, Feb. 17, March 26, Aug. 71, Oct. 87
 strips, replacement of, Feb. 17
 troubleshooting, March 26
 schematics, March 27, 28 and 30
 Tuner, UHF
 alignment, Dec. 98
 troubleshooting, Dec. 97
 schematic, Dec. 99
 servicing of, April 37, Nov. 96, Dec. 97
 symptoms and procedures, Dec. 98
 voltages, Dec. 99
 UHF,
 antennas, April 33
 antenna installation, May 45
 converters, June 55
 signal source, Oct. 86
 strips, identification of, May 41
 servicing of, May 41
 installation of, Feb. 24, March 25, May 42
 tuners, April 37, Nov. 96, Dec. 97
RA-103D, 104 110A
 Overload, picture, Sept. 80
 Horizontal size, loss of, Sept. 80
RA-109, 116, 130, 133
 Cascade tuner, installation of, Dec. 99
 Sound, loss of, Oct. 87
 Return-trace blanking, adding, Nov. 93
RA-112, 113, 120
 Cascade tuner, installation of, Dec. 99
 Brightness control, improper operation of, Sept. 80
 Return-trace blanking, adding, Nov. 93
 Power rectifier, failure of, Oct. 87
RA-117
 Cascade tuner, installation of, Dec. 99
 Power rectifier, failure of, Oct. 87
 Return-trace blanking, adding, Nov. 93
RA-164/165
 Audio buzz, Feb. 23
 Bright lines in picture, March 32
 Brightness, insufficient, Oct. 88
 loss of, Oct. 87
 Contrast, gradual increase, June 54
 poor, March 32 - April 40
 Fuse blowing, high voltage, Sept. 80
 High voltage, loss of, March 32 - May 48
 Horizontal hold, poor, March 32, Aug. 71
 Horizontal line in picture, July 63
 Hum,
 in raster, June 54
 in sound, March 32
 intermittent, June 54
 Horizontal sync,
 intermittent loss of, June 54
 poor, April 40
 Inoperative, March 32
 Noise in picture, March 32 - Oct. 88
 Overload, April 40 - June 54
 Production changes, Feb. 22
 Return-trace blanking, loss of, Sept. 80
 Smear, picture, Sept. 80
 Snow, picture, April 38
 Sound and picture,
 loss of, July 62
 loss of high channel, July 63
 Tuner, weak or inoperative, March 32
 Tube failure, horizontal amp., Sept. 80
 Vertical size, loss of, Oct. 88
 Vertical sync, drift, Aug. 71
RA-166/171
 AGC circuits, explanation of, Jan. 7
 Audio howl, July 63
 Bars, horizontal picture, July 63
 Brightness,
 insufficient, Oct. 88
 loss of, Oct. 87
 Contrast, poor, April 40
 Fuse,
 repeated blowing of, Aug. 71 - Sept. 80
 High-channels, loss of, July 63
 High voltage, loss of, May 48
 Horizontal hold, unstable, Nov. 96
 Horizontal line in picture, July 63
 Horizontal pull, Feb. 24
 Horizontal sync,
 intermittent loss of, June 54
 poor, April 40
 Hum in raster, June 54
 Models, Jan. 1
 Noise in picture, Oct. 88
 Noise-inverter circuit, Jan. 9
 Overload, picture, April 40 - Oct. 87
 Picture, distorted sound and loss of, July 63
 Production changes, June 52
 Return-trace blanking, loss of, Sept. 80
 Safety glass, removal of, Feb. 24
 Size, insufficient, Oct. 87
 Smear, picture, Sept. 80
 Sync, loss of, Sept. 80
 Sync circuits, explanation of, Jan. 9
 Troubleshooting, Jan. 14
 Tube failure, horizontal amp., Sept. 80
 Vertical hold, critical, Oct. 87
 Vertical lines in picture, Aug. 71
 Vertical sync,
 gradual loss of, Aug. 71
 unstable, Aug. 71 - Nov. 96
 White compression, Nov. 96
RA-306/307
 AGC delay, Oct. 88
 Focus, uneven, Nov. 96
 Horizontal wobble, Oct. 88
 Production changes, Nov. 95
 Regeneration, Nov. 96
 Sound bars in picture, Nov. 96
 Sync, critical, Oct. 88

THE TV SCREEN - A tube process requiring chemical precision and manufacturing thoroughness

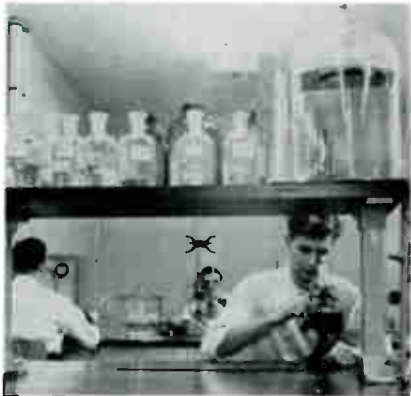

Thoroughness and constant diligence in the screen process is an important function of the Chemistry Lab.



This machine, used in the medical industry to measure critical chemicals, doles out a precise quantity of phosphor material for each tube screen.

DISTRIBUTED BY:

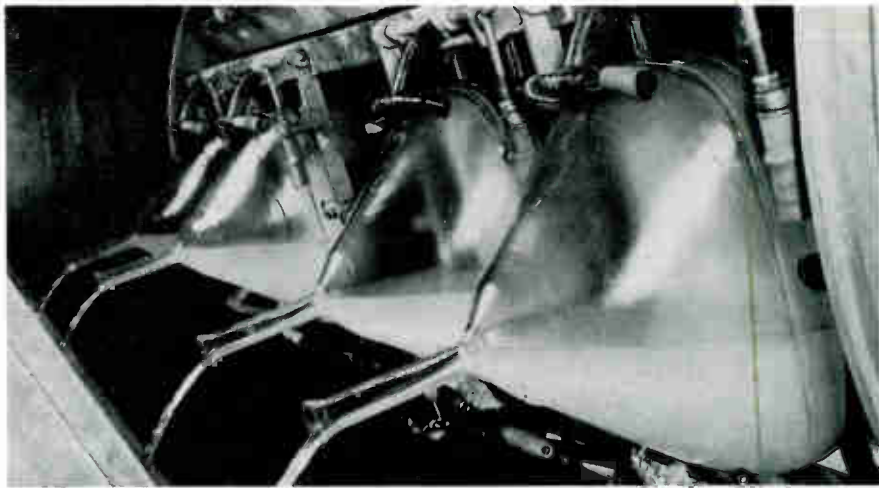

After the phosphor screen has been deposited on the tube face, the settling belt automatically pours off the liquid remaining and dries the screen before it is baked.

The bottle marked "shake well before using" is a typical example involving the basic theory used in settling the picture tube screen. The contents of such a bottle is usually a liquid solution in which a solid is suspended. Between uses, the solid settles to the bottom and the liquid remains on top. This is how the phosphor screen is deposited on the face of the picture tube, only it's not quite so simple. Very costly equipment is required and many controls, too numerous to mention in this space, must be kept to insure proper screen thickness and uniformity.

Extensive preparations must be made to obtain the right solution in which to suspend the screen material. This consists of purifying water by electro-chemical means and mixing the de-ionized water with an agent to speed up the necessary chemical actions.

The solution is mixed in huge stainless steel tanks and pumped through stainless steel pipes to guard its purity, since a single foreign particle of metal in fifty million particles of phosphor material can seriously contaminate and discolor the screen.

The screens are settled in a specially air-conditioned room on large, intricate settling belts. These machines are completely automatic and are specially installed on huge concrete slabs, isolated from the rest of the room by a cork lining. This reduces undesirable vibration to an amazing degree. The water solution is poured into the glass blank and an exact amount of phosphor mixed in water glass is added. This creates an immediate chemical action which forms a gel solution in

which the screen material becomes suspended. This Du Mont patented screen process greatly shortens the time required for screening and represents one of the greatest contributions to the tube making industry.

When the screen has been deposited fully, the remaining liquid must be poured off without damaging the delicate screen material. (If you've ever tried to pour off a liquid without disturbing bottom sediment, you'll have an idea of the care with which the liquid must be poured off the settled screen.) The tube must be tipped very slowly and gently for even the slightest agitation would ruin the screen. When the solution has been poured off, the screen is dried and baked.

Much attention is paid to screen thickness and uniformity because they have a great influence on brightness and color of the TV picture. If the screen is too thick, only the inside layer is activated by the electron beam and the light produced is filtered by the remaining thickness. If the screen is too thin, many of the electrons pass through to the glass. The thick screen appears too yellow in color and the thin screen appears too blue.

Uniformity of screen color is also controlled by the mixture of phosphor salts used. Samples are received from the supplier and placed into production to be tested by electronic and visual standards. Regular production is sampled in the same manner.

Through such diligence, Du Mont has gained a reputation among receiver manufacturers for screen quality and color uniformity of which we are justly proud.

ALLEN B. DU MONT LABORATORIES INC.

REPLACEMENT SALES

CATHODE-RAY TUBE DIVISION