

THE
OSCILLOGRAPHER

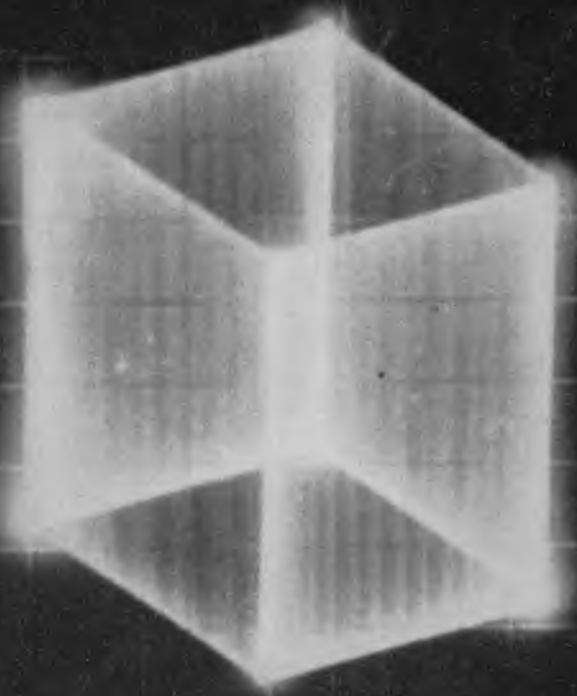

Vol. 13, No. 4

AUGUST-DEC., 1952



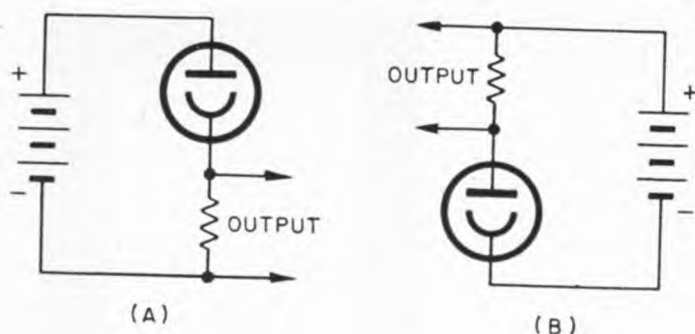

Figure 33a and b.
Common meth-
ods of connecting
phototubes

length of wire. The cathode is usually made of an inert material, coated with some appropriate substance, which, after proper treatment, enables it to emit electrons after absorbing energy of the appropriate wave length. These electrons are drawn to the anode wire since this electrode is maintained at a positive potential with respect to the cathode.

The sensitivity of the cathode surface depends upon its composition, and, to some extent, upon the treatment which it has undergone in manufacture. The sensitivity of the tube as a whole does not depend entirely upon the sensitivity of the cathode surface unless the glass envelope is equally transparent to all radiation to which the surface is sensitive. As the spectral transmission of glass is usually poor in the ultraviolet region of the spectrum, it is necessary to employ tubes with special glasses or quartz envelopes which pass radiation in this region.

Phototubes are current operated devices. The flow of current will be relatively unaffected by increasing the voltage once the voltage is raised to a sufficiently high value to operate the phototube properly. The current which flows is entirely determined by the amount of light which falls upon the cathode, except for a small current arising from the thermal effect on the cathode which is called the dark current. The dark current will decrease as the temperature of the phototube is lowered. For many applications the dark current can be ignored.

The total current which flows through a phototube is generally quite small; therefore, it can rarely be made to oper-

ate a current sensitive device. In practice a resistor of comparatively large value is connected in series with one of the electrodes and the voltages impressed across the other electrode and the free terminal of the resistor, as shown in Figure 33a and b. (The large straight line represents the anode and the curved line the cathode in these figures.) The output signal, taken across the resistor, is a voltage which varies with the current.

The output operates a voltage sensitive device of a type which draws negligible current and whose impedance is large compared to the resistor across which the signal is developed. The usual method of operation is to feed the output signal into the grid of a vacuum tube. The vacuum tube may be employed either as a cathode-follower or as an amplifier depending upon the application. It should be a type which does not draw much grid current when the grid is connected directly to the output.

Wherever low luminous flux intensities are to be measured, the phototube should always be operated into the grid of an electrometer tube. A phototube with a non-hygroscopic base and/or with a special low leakage coating between the electrodes may be employed advantageously. When the electrodes are well separated, some reduction in the leakage current may be effected by wrapping a fine wire around the tube between electrodes and grounding it. Leakage current appears as an additional dark current and should always be minimized to reduce masking.

Phototubes are presently manufactured in a multitude of shapes and sizes, as can

be seen in Figure 34. Phototubes vary in size from $1\frac{1}{4}$ inches long and $\frac{1}{4}$ inch wide to greater than $1\frac{1}{2}$ inches wide and 4 inches long.

A distinction between "standard" and "end" types can be made. The "standard" tube is characterized by having its cathode parallel to the axis of the tube, while the "end" type is characterized by having its cathode parallel to the base of the tube and the sensitized surface on the side away from the tube base. The "end" types are manufactured with a round face such as the 1P42 and a flat face such as the CE 25.

A further subdivision can be distinguished between tubes having standard bases and those with the electrodes brought out at the opposite ends of the tube such as the 931 and 926, respectively.

The spectral response can be altered to suit the application within the tube's ability to respond by inserting optical filters in the light path. Various textbooks give the method of calculating the response when optical filters are employed. A word of warning — the response curves given

by most manufacturers are an approximation. For exacting work the individual tube must be measured to determine its response and sensitivity and the calibration repeated occasionally to assure that the characteristics have not changed with age or use.

The high vacuum phototube response is almost perfectly proportional to the light flux falling on it after the dark current is subtracted. Therefore, linear operation can be expected. When the frequencies of the light flux become high, however, some care is necessary in designing the circuits if linearity is to be maintained. The value of the resistance chosen should be lower than the reactance of the capacity (the phototube electrode and wiring) that shunts it. It should operate into a cathode-follower amplifier because this device will reflect the minimum amount of capacity. When the frequencies are comparatively low and the signal variation small, it may be found advantageous to connect the amplifier tube in the usual manner. Where the frequency response extends from d-c to reasonably high frequencies, the circuit shown in



Figure 34. Various phototubes available. (Courtesy of the Radio Corporation of America)



SELLING AGENTS
of
ALLEN B. DU MONT
LABORATORIES, INC.

TECHNICAL SALES
CLIFTON, NEW JERSEY

- | | | | |
|----------------------------------------------------------------------------------------------------------------------------------------------------------------------------------------------------------------------------------------------------------------------------------------------------------------------------------------------------------------------------------------------------------------------------------------------------------------------------------------------------------|----------------------------------------------------------------------------------------------------------------------------------------------------------------------------------------------------------------------------------------------------------------------------------------------------------------------------------------------------------------------------------------------------------------------------------------------------------------------------------------------------|----------------------------------------------------------------------------------------------------------------------------------------------------------------------------------------------------------------------------------------------------------------------------------------------------------------------------------------------------------------------------------------------------------------------------------------------------------------------------------------------|------------------------------------------------------------------------------------------------------------------------------------------|
| <p>1 Merritt, Ron
217 Ninth Avenue North
Seattle 9, Washington
Seneca 4948</p> <p>*2 Hill, J. T. Sales Co.
800 W. 11th Street
Los Angeles 15, California
Richmond 7-5384</p> <p>J. T. Hill Sales Co.
625 Laurel Ave.
Menlo Park, Calif.
Davenport 5-4983</p> <p>3 Gates, Franklin Y.
200 South Main Street
Salt Lake City, Utah
Salt Lake City 9-1101</p> <p>Gates, Franklin Y.
110 Harvard Drive, S.E.
Albuquerque, N. Mex.
Alb. 3-8010</p> | <p>4 Birch-Jones and Co.
119 Pender St. W.
Vancouver, B. C., Canada
Marine 2048</p> <p>5 Pinkney and Hine
562 Plymouth Bldg.
Minneapolis 3, Minn.
Lincoln 0523</p> <p>6 Harris-Hanson Co.
5506 S. Kingshighway
St. Louis 9, Mo.
Sweetbriar 5584</p> <p>*7 Earl Lipscomb Associates
P. O. Box 8042
Dallas 5, Texas
Elmhurst 5345</p> <p>*8 Alfred Crossley and Associates
4501 N. Ravenswood Ave.
Chicago 40, Illinois
Upton 8-1141</p> | <p>Alfred Crossley and Associates 14
11 W. Monument Ave.
Dayton 2, Ohio
Mich. 8721</p> <p>10 Murphy and Cota
1409 Peachtree St. N.E.
Atlanta, Georgia
Elgin 3020</p> <p>*11 Bayly Engineering, Ltd.
5 First Street
Ajax, Ontario, Canada
Waverly 6866</p> <p>*12 Sterling, S., Company
15310 W. McNichols Rd.
Detroit 35, Mich.
Broadway 3-2900</p> <p>13 Ransford Co., H. E.
Grant Building
Pittsburgh 19, Pa.
Grant 1-1880</p> | <p>14
1
P
C</p> <p>1
G
9
S
J</p> <p>1
G
4
W
O
L</p> <p>15
C</p> <p>3
R
C</p> |
|----------------------------------------------------------------------------------------------------------------------------------------------------------------------------------------------------------------------------------------------------------------------------------------------------------------------------------------------------------------------------------------------------------------------------------------------------------------------------------------------------------|----------------------------------------------------------------------------------------------------------------------------------------------------------------------------------------------------------------------------------------------------------------------------------------------------------------------------------------------------------------------------------------------------------------------------------------------------------------------------------------------------|----------------------------------------------------------------------------------------------------------------------------------------------------------------------------------------------------------------------------------------------------------------------------------------------------------------------------------------------------------------------------------------------------------------------------------------------------------------------------------------------|------------------------------------------------------------------------------------------------------------------------------------------|



Wahler-Knoop Co.
8 Eagle Rock Ave.
Deland, N. J.
Tel. 6-4545

Wash., D. C., Va. & Md.
Wahler-Knoop Co.
104 Second Ave.
Silver Spring, Md.
Tel. 5-7550

Philadelphia, Pa. & Vicinity
Wahler-Knoop Co.
17 Greenwood Ave.
Plymouth, Pa.
Tel. 8-5480

Ossmann, Edward A. &
Assoc. Inc.
1 Juniper St.
Rochester 10, New York
Tel. 7640

Ossmann, Edward A. &
Assoc. Inc.
RFD #1, Delanson, N. Y.
Delanson 2319

*16 Waters, Robert A., Inc.
4 Gordon Street
Waltham, Mass.
Waltham 5-6900
Waters, Robert A., Inc.
1150 Whalley Ave.
New Haven 15, Conn.
Fulton 7-6760

*17 Allen B. Du Mont Laboratories,
Inc.
Instrument Division
1500 Main Avenue
Clifton, New Jersey
Mulberry 4-7400

International Division
Allen B. Du Mont Laboratories, Inc.
Empire State Bldg., Room 8201
New York 1, N. Y.
Murray Hill 8-2600
Cable Albeedu, E. Paterson, N. J.

*These Du Mont Selling Agents also
operate Du Mont-authorized service and
repair facilities. In addition, the follow-
ing service organizations have been
authorized to service and repair Du Mont
instruments.

Barfield Industries, Inc. Missouri Electronics
P. O. Box 435 6058 Maple Ave.
Miami Springs, Florida St. Louis 12, Mo.
Delmar 0043

Industrial Radioelectric Enterprise Ltd.
1356 Seymour St.
Vancouver 2, B. C., Canada

Moto Radio Distributing Co., Inc.
5732 Baum Blvd.
Pittsburgh 6, Pa.

Mohawk Electronics Laboratories
3 Juniper St.
Rochester 10, New York
Culver 7640

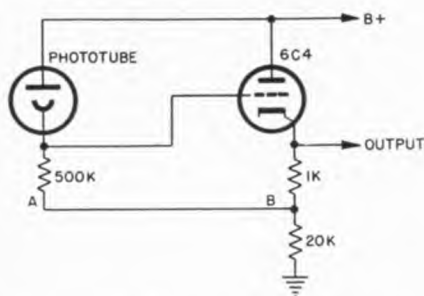

Figure 35. Vacuum phototube with cathode-follower amplifier for small signal variation and with a frequency response from d-c to reasonably high frequencies

Figure 35 may be employed. This circuit is a compromise between a cathode-follower and conventional amplifier. The plate load resistor "A" has been put into the cathode circuit. This circuit is similar to the cathode-follower inasmuch as the polarity of the output is the same as the input. The resistor "B" causes the circuit to act as a partial cathode-follower. The output obtained is at low potential and can therefore be employed to operate a second amplifier.

The gas phototube differs from the high vacuum type in two respects. The electrons emitted from the cathode are accelerated toward the anode wire. As this occurs in the presence of a gaseous atmosphere, the electrons strike the gas, thereby ionizing it, which releases more electrons to travel towards the anode and some ions to travel towards the cathode. This causes an amplification, known as gas amplification, to occur. The ionization time affects the frequency response of the tube, causing gas tubes to show a decreasing response with increasing frequency. The degree to which this occurs is determined by the gas pressure and the tube geometry. Some types show a response of less than 50 per cent at 10,000 cycles when compared to the response at 800 cycles. Above 10,000 cycles the response, in general, can be expected to fall off rapidly as the frequency is increased.

Some care must be exercised when using gas phototubes. The potential across the tube should be maintained low

enough to prevent a glow discharge from occurring as this discharge can damage the tube. The exact potential which can be applied must be determined from the characteristics of the tube type under consideration and the maximum illumination permitted to fall on the tube. Generally, the voltage should be maintained at less than 90 volts for normal usage. If the intensity of the radiant flux causes a glow discharge at this potential, a vacuum tube should be used. Where the maximum intensity is low, the potential may sometimes be raised to a value considerably higher than the above mentioned value, with a consequent gain in gas amplification. There is a definite limit above which the anode-to-cathode potential cannot be raised.

The dark current in the gas tube is usually higher than the vacuum phototube. Where low light levels are to be measured, a high ratio of dark current to signal current may mask the signal and become the limiting factor. The vacuum type with its lower dark current should then be employed. If the dark current still masks the signal, the tube should be refrigerated.

PHOTOMULTIPLIERS

The photomultiplier tube has a series of electrode surfaces called dynodes which serve to amplify the cathode current. Electrons emitted from the cathode are attracted to the positive potential on the first dynode. The electrons, on striking this electrode, cause many additional electrons to be emitted from the electrode surface; a phenomenon known as secondary emission. These electrons are then drawn to the second dynode where this is repeated and so on. After leaving the last dynode, the current flows to the plate.

There are generally nine dynodes in a photomultiplier, each maintained at a potential of 50 to 75 volts higher than the next. Dynode No. 1 is usually maintained at a potential of 50 to 75 volts more positive than the cathode. This value increases stepwise from Dynode No. 1 to Dynode No. 9 which is usually maintained not

more than 50 volts more negative than the plate. (See circuit in Figure 36.)

The dynodes are held at constant potential by means of a bleeder resistor. The current through the bleeder should be considerably more than the maximum expected dynode current. If the tube is to be used to measure high frequencies, the dynodes should be bypassed with suitable condensers, as shown in Figure 36, or to ground.

The multiplier tube is operated with a potential of 500 to 1200 volts across it. To avoid obtaining the signal output at high potential, the tube is commonly operated from a source which has its positive polarity grounded. The plate is then returned to ground through a resistor, across which the signal appears.

The currents which can be caused to flow can become high enough to heat the electrodes to red heat and thereby ruin the tube. The light intensity falling on the cathode should be limited to a safe value. As the tube is a very sensitive light detector, this should cause no hardship.

The amplification factor of a photomultiplier varies almost exponentially with the applied voltage. Amplification of a million and more may be readily obtained.

Because of the exponential characteristic of the amplification factor with vari-

ations in supply voltage, it is desirable to maintain the supply voltage for this device at a constant value. While the voltage required is high, the current drain is low and a regulated source can be readily constructed which will give satisfactory operation.

The dark current of the photomultiplier is considerably higher than that of a simple phototube. The masking which this current produces can become serious at low light levels. The photomultiplier can be refrigerated when it is desirable to reduce this current to a minimum.

The signal obtained from a photomultiplier is great enough to operate many devices without further amplification. Peak currents in the order of $\frac{1}{2}$ ampere may be obtained from light pulses of short duration — one or two microseconds, if these do not occur too frequently.

The photomultiplier tube, which is currently used for measuring scintillations, is both a simple and stable device for research and industrial applications. It can be used readily by industry because it is trouble free, and, when employed without refrigeration as it is in most applications, requires neither critical maintenance nor operating conditions for reliable operation.

With photo-sensitive devices as the ac-

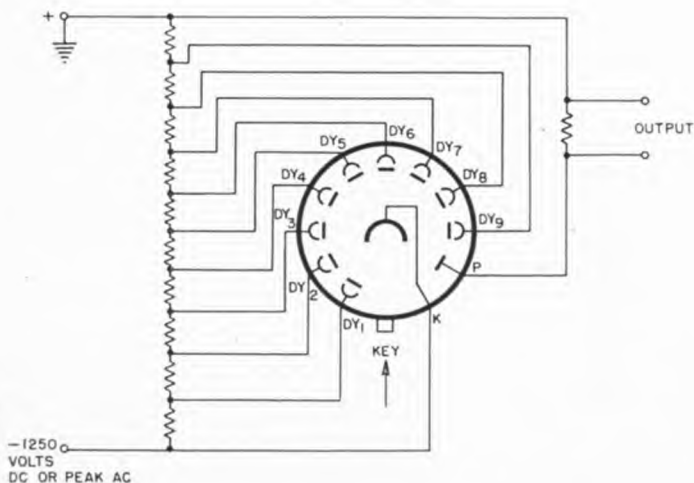

Figure 36. Photomultiplier circuit

tive element large numbers of transducers designed to measure the most diverse quantities can be built. A list of quantities measurable by this device, properly used as a transducer, would contain half of the physical qualities which are measured daily.

LEAD SULFIDE CELLS

The lead sulfide cell consists of a semi-transparent coating on the inner surface of an evacuated glass container. This coating is contacted by two electrodes, two parallel surfaces painted or sprayed on, which are slightly separated from each other. The semi-transparent coating of lead sulfide between the electrodes is the light sensitive surface of the cell.

These cells are made in a variety of physical sizes as can be seen from Figure 37. The smallest of these has a glass envelope and is approximately $\frac{1}{4}$ inch wide and $\frac{3}{8}$ inch long.

The spectral sensitivity peak is in the infrared region. The peak of the sensitivity curve varies with the preparation of the cell and the glass used. Since its sensitivity to infrared is greater than the phototube, the spectral response of the cell makes it useful for many applications where it is undesirable or impossible to use a phototube.

There are occasions when it is desired to determine the percentage of light transmitted or absorbed by a partially opaque body intercepting a beam of collimated light. Under this condition the lead sul-

fide cell and the incandescent lamp make an excellent combination, as they both show peak performance in approximately the same region.

The lead sulfide cell is essentially a resistor which possesses the property of varying its resistance in accordance with the amount of radiation received on its sensitive surface. It may logically be classified in the same group as thermistors, thyrite and transistors: the semi-conductors.

The circuits and operating conditions for the lead sulfide cells are essentially those required for the gas phototube. The main difference from the applications viewpoint is the spectral response, as can be seen from the curves shown in Figure 38.

THERMISTOR FLAKES

The thermistor flake, a thin flake of thermistor material, has physical and electrical properties chosen to make it suitable for radiation detection. The flakes are obtainable in pairs for use in a bridge circuit.

The radiation permitted to fall on one of these flakes causes it to heat, changing its resistance and unbalancing the bridge. Alternatively, radiation from two sources may be employed, each being permitted to fall on one of the flakes. When the radiation causes an equal change in both flakes, the bridge will return to balance. If the intensity of radiation reaching one of the flakes is known, the intensity of radiation on the other may be determined from this value and the spectral response of the flakes.

Thermistor flakes may show a wide range of sensitivity, depending as they do on the conversion of radiation into heat. They are in reality heat detectors, and are being employed in infrared-spectral analysis using the flakes as detectors and a cathode-ray oscillograph as an indicator.

The characteristics of these flakes are interesting. One of the commercially available types has the following dimensions: length 2.5-mm by 0.2-mm, and thickness of 0.010-mm. The resistance at 25°C is approximately 3 megohms. The

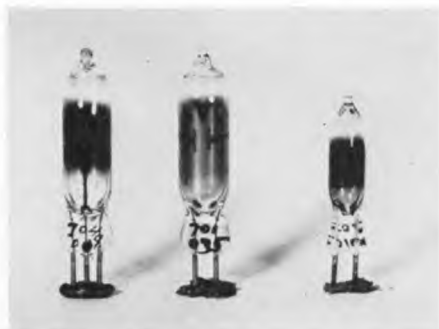

Figure 37. Lead sulfide cells (Courtesy of the Continental Electric Company)

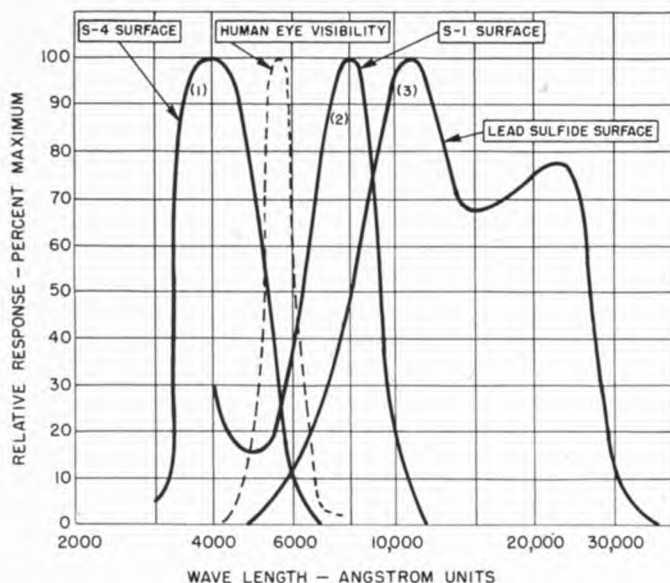

Figure 38. Spectral response of three lead sulfide cells and human eye. (Courtesy of the Continental Electric Company)

flakes may be obtained with either a quartz, glass or metal backing. In the case of the metal backing, the flake is separated from the backing by a few microns. The sensitivity may be as high as 300 volts per watt with time constants as small as 3 milliseconds.

As originally intended, these devices were meant to work into a d-c amplifier. However, with the radiation falling upon them interrupted periodically by mechanical means (15 or 20 times per second), they can operate into an a-c amplifier.

While these devices were designed for spectographic use, they are not necessarily limited to this type of employment. Their wide spectral response, especially in the infrared region, and their short time constant make them eminently suited to investigation of problems where other devices fail in some respects.

PHOTOCELLS

The barrier layer photocell (sometimes called a photovoltaic or photonic cell) is a sheet of metal with another metal deposited on it. A semi-transparent layer or sensitive surface is deposited upon this. An electrode is sprayed, painted or de-

posited on the edge of the semi-transparent layer. Contact is made to this electrode and to the back of the plate.

Two types of photocells are available: the back-effect and front-effect barrier layer cells. In the back-effect cell the light passes through the semi-transparent layer to the underlying metal. The boundary between the semi-transparent layer and the underlying layer is the region where the photoelectrical action occurs. Electrons flow from the semi-transparent layer to the underlying metal. In the front-effect barrier layer cell the light passes through the film to the underlying surface and electrons are emitted from both surfaces. The emission from the transparent surface is greater than that of the underlying surface and current flows in the reverse direction to that of the back-effect type.

If the front and back layers are connected to a low-impedance current-sensitive device, the current will flow when the photovoltaic surface is exposed to radiation to which it is sensitive. Figure 39 shows the linearity which may be obtained between current and radiation with current sensitive devices of various internal impedances. It will be observed that

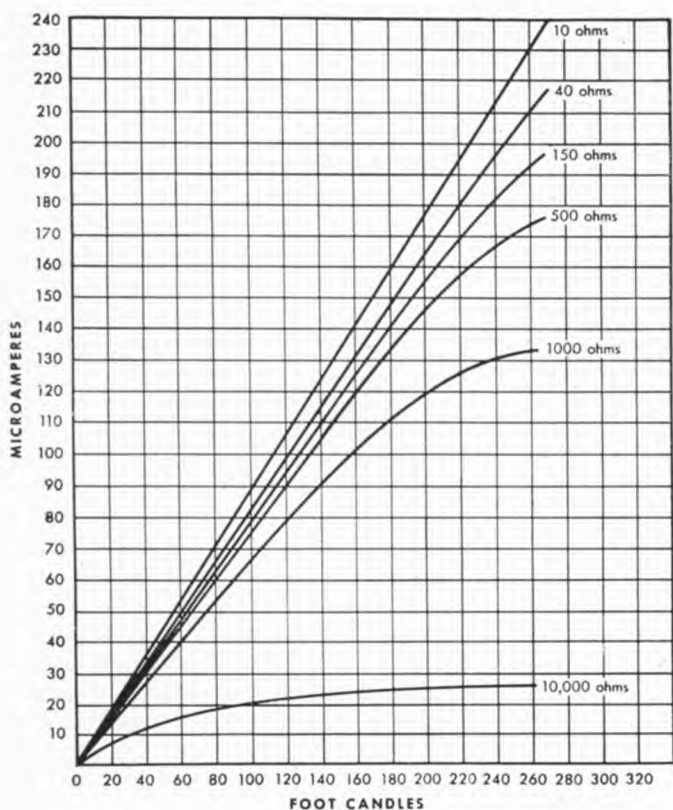

Figure 39. Current versus radiation at various values of external resistance for typical barrier layer photocell. (Courtesy of Vickers Inc.)

for small internal impedances, the radiation and current are directly proportional.

Peak spectral response of the barrier layer cell is in the visible region, shown in Figure 40. It may be observed that the response extends further on both sides

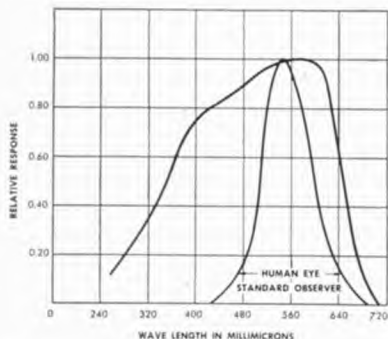

Figure 40. Spectral response of typical photocell (Courtesy of Vickers, Inc.)

of the spectrum than does the human eye. The cell may be made to approximate the eye by covering it with the appropriate optical filters.

The response of a barrier layer cell is not constant, varying with the time that it is exposed to radiation. (See Figure 41.) This limitation must be borne in mind when designing equipment employing this device for quantitative measurements.

Because of the large capacitance existing between electrodes of the photovoltaic cell the frequency response is relatively poor. Its response will vary considerably with load impedance in the external circuit; as the impedance is reduced, the frequency response will increase. A typical response curve for this device is shown in Figure 42.

When the photocell has a low impedance placed in its external circuit, the ratio between light input and current out-

put is fairly linear and the frequency response is reasonably flat to 2000 cycles. These conditions no longer hold when a cell is open circuited. Under open circuit conditions the voltage output increases logarithmically with the light output. The frequency response falls considerably and is determined by the time constant of the cell.

The available output voltage under any condition does not exceed a few millivolts even though light intensity reaches an exceedingly high value. The photocell current may reach a few milliamperes but its voltage will always be either in the microvolt or the lower end of the millivolt region. For this reason the photo-voltaic cell is not generally employed in conjunction with an oscillograph, although it has numerous applications when used with current sensitive devices. Recent developments in magnetic amplifiers may make this device a useful tool for oscillography.

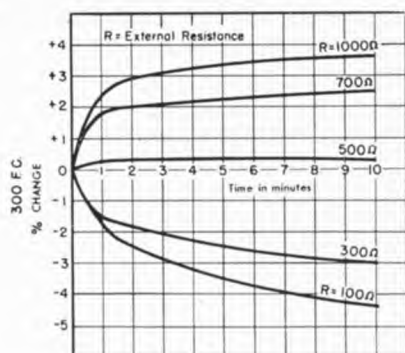
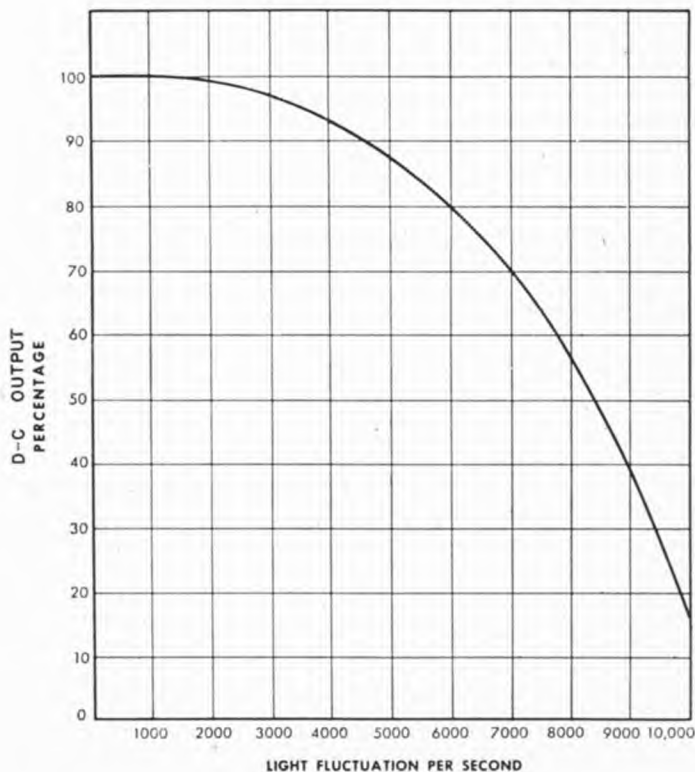

Figure 41. Temporary fatigue curves of barrier layer photocell showing percentage change in current output and external cell resistance. (Courtesy of General Electric Company)

THERMOCOUPLES AND THERMOPILES

All radiant energy appears as heat upon being absorbed by a body. The thermocouple and thermopile are both heat sen-

Figure 42. Frequency response of typical photocell. (Courtesy of Vickers, Inc.)



The New Du Mont Type 2602 Movable Table

A new movable table, designated the Du Mont Type 2602, for mounting cathode-ray oscillographs in a convenient tilted position has been announced by the Instrument Division, Allen B. Du Mont Laboratories, Inc.

The top of the new table can be tilted from the horizontal plane to angles up to 20 degrees. This provides for convenient viewing of the oscillograph from either a sitting or standing position. Provision is also made to allow the oscillograph to be placed at varying depths on the tilted top by means of an adjustable bar which supports the instrument.

The Type 2602 also contains a lower

(Continued on Page 20)



THE OSCILLOGRAPHER

A publication devoted exclusively to the cathode-ray oscillograph, providing the latest information on developments in equipment, applications, and techniques. Permission for reprinting any material contained herein may be obtained by writing to the Editor at address below.

Published quarterly & Copyright 1953 by
Allen B. Du Mont Laboratories, Inc.
Instrument Division
1500 Main Ave.
Clifton, N. J.

PRINTED IN U.S.A. Editors: R. J. Ross and Neil Uptegrove

ON THE COVER

Shown on the cover is a cubical oscillogram, taken from the face of a Du Mont Type 304-A Cathode ray Oscillograph. In the parlance, this oscillogram is a function of three variables, displayed with fixed limits. To learn under what conditions this oscillogram was obtained, see the forthcoming article on three-dimensional oscillography in a future issue. Those interested may also consult the article, "Three-dimensional Representations of Cathode-ray Tubes," Carl Berkley, Proc. I.R.E., Vol. 36, No. 12, Dec., 1948.

Du Mont Agents

A complete list of Du Mont agents and service organizations, together with a map of their individual territories, is presented in this issue on Pages 12 and 13. As a result of the efforts of these men, working in close cooperation with the Instrument Division, many industrial and laboratory problems have been solved by the application of the proper oscillographic techniques. Please feel free to call upon them for aid at any time.

TABLE OF CONTENTS

The New Du Mont Type 2602 Movable Table	2
The Function and Design of Transducers for Oscillography	3
Du Mont Agents and Service Centers	12
Correction	20
A Simplified Phase-Shift Test	21
Production Line Hardness Testing with the Cathode-ray Oscillograph	22

sitive devices and are extensively employed for measurement of radiation.

When two dissimilar metal wires are joined at both ends, a current will flow when the temperature of one of these junctions is raised or lowered with respect to the other junction. This device is known as a thermocouple. A commonly used combination is iron and constantin, but it is by no means the only one.

When thermocouples are joined together, in series, the device is known as a thermopile. Dissimilar metals are always joined. For measuring radiation, the thermopile is generally designed on the circular plan with alternate junctions diametrically opposed. Central junctions are brought as close together as possible and blackened with a material having

good radiation absorbing properties (such as soot). Alternate ends of the junctions are shielded from radiation. Wire used for this purpose is usually the thinnest available to avoid conducting the heat from junction to junction. When measuring low light levels, the whole unit should be enclosed in a vacuum to prevent air from dissipating the heat.

The voltage output of the thermocouple is very low, in the order of a few microvolts. The current may be quite high depending on the temperature difference between junctions. The relationship between current and temperature is generally non-linear and varies considerably with the temperature region and the metals employed.

As in the case of the photocell, the thermocouple is not generally used in oscillography without preamplifiers.

(To be concluded)

Correction

It has been called to our attention that the writing-rate capabilities of the Du Mont Type 297 Oscillograph-record Camera, published in the July-Sept., 1950, issue of the Oscillographer (Vol. 12, No. 3), do not correspond to the specifications of this camera in the Du Mont Cathode-ray Equipment Catalog. The writing-rate capabilities of the Type 297 in the Oscillographer were, "With a Du Mont Wollensak f/2.8 lens, 3.5 in/sec from a cathode-ray tube with a P11 screen and 12,000 volts acceleration; with a Du Mont Wollensak f/1.9 lens, 7 in/sec." These figures do not agree with those given in the Du Mont Catalog

which are, "With a f/2.8 lens, 1 in/sec; for a f/1.9 lens, 2 in/sec, both with a P11 screen and 12,000 volts acceleration." The discrepancy is explained by the fact that the higher writing-rates in the Oscillographer were for Polaroid-Land Film, Type 40 (sepia) while the figures given in the Catalog were for Polaroid-Land Film, Type 41 (black and white).

Since only the Type 41 film is available at present, writing-rate capabilities for this film are properly specified in the current Catalog.

We sincerely hope that this seeming inconsistency in specifications did not inconvenience any of our readers.

Type 2602 Movable Table (Cont'd)

shelf and a large drawer in which tools, auxiliary instruments and components may be stored.

Although ruggedly constructed of cold-rolled steel, the Type 2602 moves effortlessly on large, rubber-tired swivel casters. It is attractively designed in gray-

wrinkle finish, identical to all Du Mont instruments, with chrome supporting members.

The Type 2602 is 19 inches wide, 31 inches deep, 36-5/8 inches in height and weighs 57 pounds. Cat. No. 1637-E. Price, \$95.

A Simplified Phase-Shift Test

William F. Eaton, assistant chief engineer of the Bower Roller Bearing Company, Detroit, Mich., recently sent the following description to the Oscillographer of an interesting phase-shift test on amplifiers used by his concern in which a Du Mont Type 304-H Cathode-ray Oscillograph* plays a key part:

"Periodically, we must check the electronic circuit of a number of gages used in our plant. One step in calibration of these units requires that its amplifier output be adjusted to zero phase shift with respect to its oscillator. The frequency involved is approximately 100,000 cycles.

"We investigated the possibility of correcting the phase shift existing between the vertical and horizontal amplifiers of the Du Mont Type 304-H Cathode-ray Oscillograph, and found this possible if the horizontal amplifier output was shunted with a condenser. We, of course, used what was available from our junk box and came up with a 20 *mf*d condenser fixed in parallel with a 10-30 *mf*d variable condenser. The variable condenser enables adjusting the correction for all frequencies from 4000 cycles, where the phase shift is first observable, to over 100,000 cycles. Although we did not have a true straight line at 100,000 cycles, we obtained a pattern which we believed to be superior for our purpose.

"By applying the same signal to both vertical and horizontal inputs, the condenser is adjusted to obtain the pattern illustrated by the solid line in the accompanying sketch (exaggerated slightly). A phase displacement of the signal into one input with respect to the other will cause

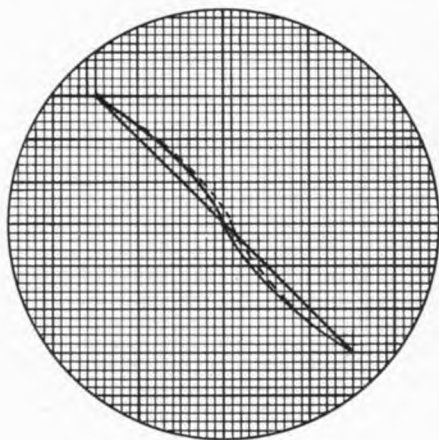

the 'S' portion of the pattern to shift up or down as illustrated by the dashed line. A small change in phase will cause a relatively large movement of the 'cross-over' point.

"Undoubtedly, it may be possible to design an R-C network to be inserted at either the input or the output of the horizontal amplifier to completely correct the pattern to a straight line at the higher frequencies. However, we found the 'S' pattern to be adequate for our needs and believe that it is much easier to observe than the opening and closing of an ellipse."

We are much indebted to Mr. Eaton and the Bower Roller Bearing Company for their interesting application of the Type 304-H Oscillograph. However, while the setup as described is obviously satisfactory in this application, and doubtless in many others, it should be pointed out that a continuous check of frequency is not obtained for each setting of the variable condenser. It must be readjusted for every new frequency setting

*Now succeeded by the Type 304-A.

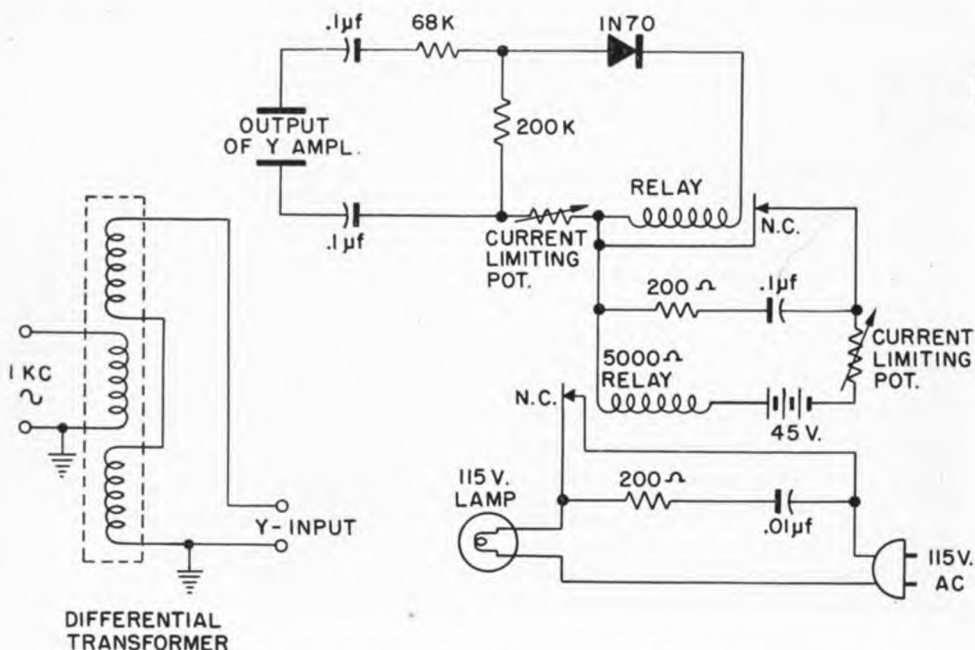

Figure 1. Schematic diagram of the automatic hardness tester

Production Line Hardness Testing with the Cathode-ray Oscillograph

The Problem

A manufacturer of twist drills was encountering difficulty in his manufacturing process. The unhardened ends of some of the drill blanks were being machined into finished drills. Damage to his stamping machinery dies was caused when the hardened ends of the drill blanks were stamped with the size numerals, and furthermore, he was receiving complaints from his customers that his drills were "mushrooming." A simple method to check the hardness of the drill blanks within specified limits before the grinding operation was needed. This method should fit into an automatic production line.

Solution

A test setup was devised which chiefly employed a Du Mont Type 304-H Cath-

ode-ray Oscillograph*, a differential transformer, an audio oscillator, a crystal diode and a sensitive relay used in conjunction

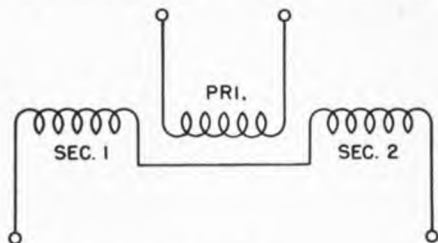

WIRE SIZE - #40 DCC
CORE DIA. - 1/2" O.D
WINDING LENGTH EACH COIL - 1"
WINDING DEPTH EACH COIL - 3/16"

Figure 2. Details of the differential transformer

*Now succeeded by the Du Mont Type 304-A Cathode-ray Oscillograph.



Figure 3. Unhardened drill blank being inserted into differential transformer. Result: deflection on oscillograph, light remains on

Figure 4. Hardened drill blank being inserted into differential transformer. Result: no deflection, light goes out



with an indicating lamp. A schematic diagram of the setup is shown in Figure 1.

The differential transformer was utilized to detect differences in reluctance of a standard heat-treated drill blank from that of a sample under test. This hollow-

core transformer, the schematic diagram of which is shown in Figure 2, was wound longitudinally with a primary coil in the center and two secondary windings, one on each end of the primary coil. The latter were matched as closely as possible in

wire size, winding dimensions, d-c resistances and other electrical characteristics, and wired in series.

The standard drill blank was placed correctly in one end of the core of the differential transformer, and fixed permanently in that position. Samples were checked merely by inserting and withdrawing them from the other end of the core. When a sample with the same hardness as the standard drill blank was placed in the core, no signal output was present across the secondary. Care had to be taken that each sample butted flush against the end of the standard drill blank.

The output of the differential transformer was displayed on the screen of a Type 304-H. The output of the vertical amplifier was used to actuate an external circuit which consisted chiefly of a crystal diode and a sensitive relay. The relay was adjusted to stay closed when the output was a certain level and, thus, keep an indicating lamp extinguished.

In the case of an unhardened drill blank being inserted in the differential transformer, the deflection on the cathode-ray screen would increase greatly, the relay would open and the light would be lit. This is shown in Figure 3. In Figure 4 a hardened drill blank is being tested.

Through experimentation it was found that the best differentiation between samples, in view of the particular transformer and the $\frac{1}{4}$ " samples used, was obtained at a frequency of approximately 1 kc. The Y-axis sensitivity of the Type 304-H was adjusted to actuate the relay with the signal levels obtained. With the circuit values indicated in Figure 1, a peak-to-peak value of less than $\frac{1}{4}$ " on the cathode-ray screen closed the relay, while a signal value of more than $\frac{1}{2}$ " opened it. The external circuit loading reduced the gain approximately 50%.

The advantages of using a cathode-ray oscillograph in this application as opposed to a center-zero milliammeter, for ex-

ample, are manifold. To cite one instance, too high a signal voltage from the audio oscillator might saturate the differential transformer, with the result that the meter reading might be interpreted erroneously as a high signal voltage from the differential transformer. On the other hand, the oscillograph will show a distortion from the pure sinewave being fed to the differential transformer when the transformer is saturated.

Also, a meter would require the addition in the circuit of amplifiers, to attain the necessary signal voltage to deflect the needle. These amplifiers, moreover, would have to possess a fairly wide bandpass, depending upon the materials in the drill blanks. The test setup might conceivably be used, at some future date, for testing the core of case-hardened materials, for example. In this event, frequency selection would play an important part in the validity of the test because of "skin effect." These problems would be minimized with the use of the oscillograph, which possesses its own wideband amplifiers.

One final consideration concerns 60-cycle pickup. If a meter were employed in this application, poor shielding might result in 60-cycle hum being picked up and deflecting the needle. This might easily be interpreted as the output of the differential transformer. However, the oscillograph, with its inherent monitoring ability, would show clearly the modulating effect of this 60-cycle interference, and thus, make possible its correction.

Through the method described in this article the drill manufacturer was given the means of obtaining both qualitative and quantitative analyses of his product. Besides increasing the life of his stamping machinery, the new test method made higher quality and more uniform drills possible.

In addition, the method described shows how by the addition of a simple circuit the cathode-ray oscillograph can be converted from a strictly indicating device to an automatic actuator.



The Function and Design of Transducers for Oscillography

By Mark T. Nadir

(Part 2 of a continued article. In this issue Mr. Nadir describes electro-magnetic and optical transducer elements.)

In Table 2 a partial list of electro-magnetic elements is given. These elements when properly employed can be used to construct a large variety of transducers. These elements find their widest use in transducers designed to measure or control displacement (both radial and linear), acceleration, velocity, vibration and distance. This is by no means a complete list; pressure, for example, can be determined as a function of displacement.

All means of inducing a voltage in a

conductor are included under the heading of electro-magnetic elements. The magnetic field required may be derived either from a permanent magnet or an induction coil. This coil may be either in and/or around a ferro-magnetic body or air wound. Either alternating or direct current is supplied to the coil.

The voltage generated is determined wholly by the change of magnetic flux with time. Mathematically stated, $E = d\phi/dt$. Since the flux decreases rapidly with distance from its source and the magnitude of the induced voltage is dependent on the change of flux per unit time, we cannot increase or decrease the flux steadily by positioning the conductor at varying distances from the flux source, nor can we increase or decrease the flux through a coil indefinitely by varying the current. Therefore, we cannot usually generate a d-c voltage. It is usually necessary in practice to obtain the change of flux by supplying either alternating current to

TABLE 2

Electro-magnetic Transducer Elements

1. Steady-field Generator
2. Variable-field Generator
3. Variable Reluctance
4. Variable Coupling
5. Variable Inductance
6. Magnetostrictive
7. Non-linear

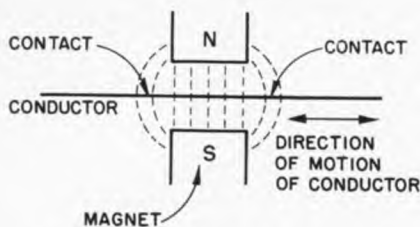

Figure 24. Steady-field transducer

the induction coil or by varying the distance between the conductor and the flux source. As a result, most electro-magnetic elements generate alternating current.

The voltage generated in a conductor from a flux source which is either a permanent magnet or a coil energized by direct current is dependent on the rate of change of flux. This change of flux must be obtained by moving either the flux source or the conductor. If this motion is slow, the rate of change of flux is slow and the voltage obtained is small. This type of element is, therefore, impractical for measuring slow displacements unless very sensitive detectors or meters are to be employed. This restriction does not apply to elements energized by alternating current.

STEADY-FIELD GENERATORS

A conductor placed between the poles of a magnet so that its length is at right angles to an imaginary line connecting the magnetic poles will generate a voltage when it is displaced in the direction of its length. (See Figure 24.) A pair of contacts, facing each side of the magnet and preferably inside of the magnetic field, pick up the generated potential.

The conductor may be either a metallic wire or a fluid which conducts electricity. In the event that the conductor is a fluid, two methods of construction are possible.

In the first case the magnet (preferably a powerful permanent magnet) is submerged in the fluid as are the contacts or probes. (See Figure 25.) The probes should be of some metal which is not corroded by the liquid; the usual choice is some noble metal such as platinum or

gold. A sixteenth inch or less of contact area is all that is required. The probes are surrounded by glass or some other insulator which will not be affected by the solution. It is important that the probes be small as practicable and be located as to offer minimum impedance to the flow of the liquid. Where the rate of flow is great and/or turbulent, probes and magnet must be firmly anchored and not permitted to vibrate. The magnet usually must be covered with a protective coating to prevent its being etched or corroded.

In the second case the fluid flows through the magnetic field inside a tube or pipe made of some insulating material such as glass. (See Figure 26.) The contacts are brought through the wall of the tube. As mentioned previously, these contacts should be of some metal which will not be corroded by the contents of the tube. As the rate of flow is most rapid in the center of the tube and slowest near the walls, it is important that the contact area be properly positioned in the tube. The entrance to the tube should be designed to minimize turbulent flow inside.

Making good electrical contact to a metallic conductor, such as a wire, may become difficult if the conductor is moved for a long distance in one direction as would be the case for wire being spooled. Dirt, oil, grease or an uneven surface, all can cause lack of contact which will appear as noise when viewed on an oscillograph.

The steady-field generator is the only electro-magnetic transducer which can generate pure d-c. The voltage generated

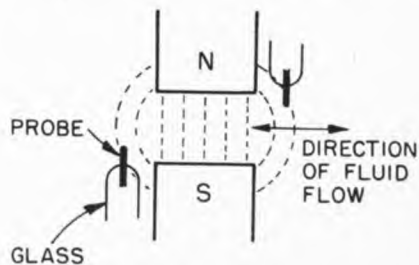

Figure 25. Steady-field transducer for total submergence

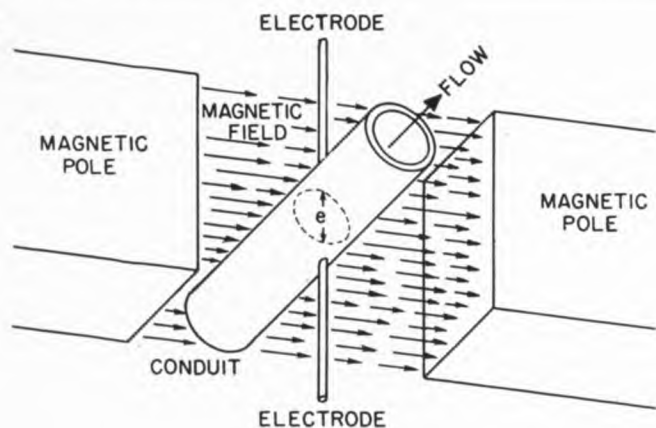

Figure 26. Steady-field transducer for fluid flow through tube

is directly proportional to the rate of displacement of the conductor. Exceptions to the above statement only occur when the resistance of the conductor is non-linear.

The calibration of this type of transducer element is simple, if the conductor's resistance is linear. The voltage as read on a meter or by the displacement of the spot on a cathode-ray oscillograph must be obtained from a known rate of displacement under only one condition. The voltage or spot displacement will be twice as great when the rate of flow is made twice as great, etc. On the other hand, the resistance of a chemical solution whose concentration varies may not be linear. The variation in resistance may be small enough in many instances to ignore, but this must be determined from measurements.

The steady-field transducer element has not been employed much in the past. Its chief advantages should be recognized — sturdiness, simplicity, and linearity of calibration. When large displacements such as large vibration amplitudes must be measured, no other element is so well suited for the job.

The chief disadvantage of this type of transducer element is its low voltage output when the displacement is slow. However, with the steady increase in sensitivity occurring in modern instruments, this is no longer the great disadvantage it once was.

VARIABLE-FIELD GENERATORS

A conductor, usually wound into the form of a coil, is placed in a magnetic field. The field strength about the conductor is made to vary by either moving the conductor or the source of the field. This arrangement forms one of the most commonly used transducer elements.

The voltage generated by such a device depends on the rate of change of flux, which in turn depends on the amplitude and rate of change of displacement imposed on the movable element. As the magnetic field strength varies in inverse proportion to the square of the distance from its source (if the source is effectively a point), the voltage generated will show this square law effect if magnetic poles widely separated are used and the displacement is large compared to the source. To minimize this effect, the coil is usually placed between the magnetic poles and the allowable displacement made relatively small.

Inasmuch as the voltage generated depends on the rate of change, such a device will not be linear with frequency. If two displacements of the same magnitude but of different frequency are imparted to the movable element, the voltage generated by the higher frequency will be greater because the rate of change is greater for the higher frequency than it is for the lower frequency.

The most common construction of this type of element generally employs a small

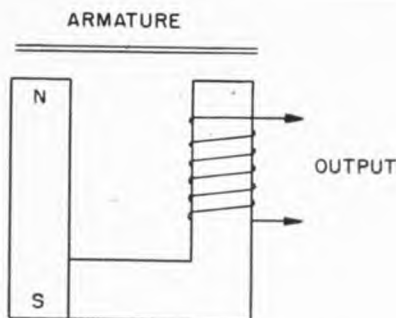

Figure 27. Generator type of variable reluctance element

movable coil and a powerful permanent magnet. (Alnico is a good choice.) The coil can be made small and light and consequently of little inertia — a highly desirable quality. However, there is no reason why the magnet cannot be made small and light (in the form of a needle) and the coil made large. In this latter form the magnet may be easily coupled to the device which will motivate it, and the body containing the coil held rigid and stationary.

Any inexpensive and easily available d-c milliammeter or microammeter can be converted into a transducer element. The springs used to restore the pointer to zero should be removed unless this restoring force is desirable. The pointer is set into motion by the force which is to be measured, and the output voltage taken from the meter terminals. Such an element is quite satisfactory for some purposes.

As all electromagnetic elements are generators, they derive their power from some external source. When this source is mechanical, the electromagnetic element may tend to damp the source. If the mechanical source is a large, heavy body or a large power-driven device, this damping is not important, but when the source is small and light, its performance may be altered materially by the damping or by the energy removed from the system. This effect can be minimized by making the movable element as light as possible and by drawing as little current as possible from the transducer element. The

transducer should operate into a voltage sensitive device.

All mechanical systems have a natural resonant frequency. This resonance is determined by the mass and compliance of the system. To make the resonant frequency as high as possible, the mass should be as small and the springs as stiff as possible.

Because reliable measurements can most easily be obtained only below the self-resonant frequency, it is desirable to make the frequency response of the system as high as possible. At frequencies higher than one-half the self-resonant frequency, the readings obtained can be quite misleading and care should be exercised in interpretation of such data. This is equally true when applied to harmonic components of lower frequencies when these harmonics approach one-half the self-resonant frequency of the system.

VARIABLE RELUCTANCE

The variable reluctance transducer element can be arranged in many ways — that is, the arrangement and number of coils employed are capable of considerable variety. Basically, this element is characterized by the fact that all variable reluctance elements operate by the variation of an air gap in the magnetic circuit. Any arrangement which accomplishes this is acceptable.

A ferro-magnetic body whose length is long compared to its width is folded, usually, so that the ends are separated from each other by a small space, the air gap. It is energized by either a coil or a permanent magnet. A coil wrapped around the core develops the output signal. The gap is mechanically varied by moving a light ferro-magnetic body in or near it in such a manner that the magnetic path through the moving element and through the air is made shorter or longer. This displacement causes a signal to be induced in the coils.

Figure 27 shows a common type of variable reluctance element, essentially a generator. The output of this device is dependent on the rate of change of flux which depends on the rate of change of displacement and the displacement dis-

tance itself of the armature with respect to the gap. As mechanical energy is being converted into electrical energy, it is often desirable to minimize the required input energy. This can be done by making the core, the gap and the armature displacement small, and by using a core made of low-loss magnetic material. Also, the electrical load on the output coil should be as small as possible.

When a high-frequency response is required, the above precautions should always be observed. In addition, a light armature, plus a coil wound with few turns and in a manner to reduce stray capacitance will help raise the frequency response.

VARIABLE COUPLING

Another arrangement frequently used is shown in Figure 28. The coil may or may not be center-tapped. If this is done as shown in the figure, the center-tap may be used to build an electron-coupled Hartley oscillator using the coil as the oscillator tank. If so desired, the end terminals may be connected to an inductance bridge. In this type of reluctance element the variation in the flux path at the gap resulting from displacements of the armature causes the inductance of the coil to vary. An inductance bridge measures the armature displacement as a change in inductance, while the Hartley oscillator converts the inductive change in a frequency shift.

The element shown in Figure 28 is useful where the armature motion is slow or static. Such an element is sensitive to small displacements and can be used as a microammeter. When the coil is used as

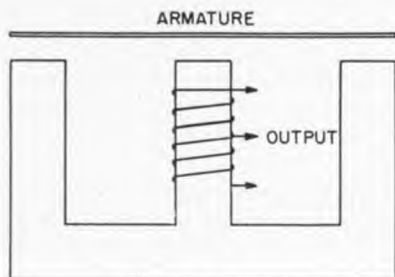

Figure 28. Variable inductance reluctance element

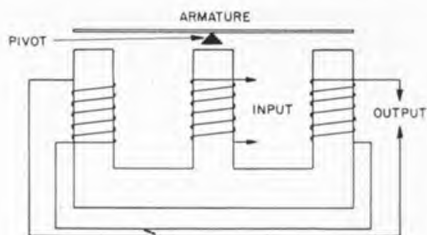

Figure 29. Balanced coil arrangement

the tank of an oscillator, the resulting frequency variation can be transmitted over wires for remote measurements.

A commonly used arrangement employs coils connected in series as shown in Figure 29. The element is of the type shown in Figure 27 where d-c current is the input. If a-c current is used, the amplitude of the output signal will be a function of the armature displacement. If, however, the coils are connected in series so their fields oppose, at some position of the armature (when it is pivoted about its center) the output signal will fall to zero. The phase and amplitude of the output signal will vary as the armature is rotated about this zero position. Such a signal, when fed into a lock-in amplifier, can be converted into a d-c signal whose amplitude is a function of the amplitude of input signal and whose polarity is a function of the phase of the input signal.

VARIABLE INDUCTANCE — DIFFERENTIAL TRANSFORMER

The differential transformer, a device which has become popular in recent years, is manufactured by many companies and possesses wide variations and characteristics. This element is capable of measuring linear displacements from less than .0001 inch to several inches with good accuracy and reproducibility. The schematic arrangement is shown in Figure 30. Physically, it consists of three coils wound longitudinally on a hollow form, the two outer coils of which are spaced an equal distance from the center coil and wound with an equal number of turns. They are externally connected in series so that their fields oppose, and are energized from an alternating current source. The center coil

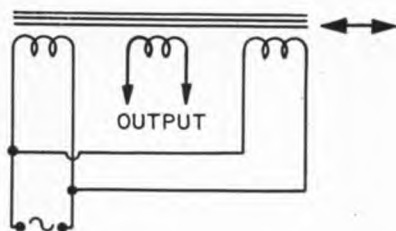

Figure 30. Differential transformer

forms the output loop. A rod of ferro-magnetic material inserted into the form, but not physically connected to it, is the variable electrical and mechanical element.

When the output of the center coil is connected to some measuring device, such as a cathode-ray oscillograph, a position of the rod will be found where the output current and voltage falls to a minimum. This usually occurs when the rod is located with its center aligned approximately with the center of the output loop. A true zero is not always obtained due to generation of the third harmonic component in the ferro-magnetic rod when saturated.

It is advisable to excite the field from an audio oscillator using the highest possible frequency commensurate with the requirements of the rate of displacement and the winding of the differential transformer. The operating voltage should be maintained as low as feasible to avoid generation of third harmonics.

The ferro-magnetic rod acts as a coupling between the outer coils and the center coil. When the flux induced from either of the outer coils to the center coil is equal, the output is zero because their fields are equal and opposite. Any displacement of the rod from this neutral position will cause a voltage to be induced in the center coil. The phase of the output signal will vary with the direction of displacement and the amplitude will vary with the distance of displacement.

This device makes an excellent microammeter and displacement pickup. When used with an oscillograph, without intervening devices, the output appears as an envelope, which varies at twice the rate

of displacement. Inasmuch as the magnitude of the displacement and not the direction is indicated, it will sometimes be found convenient to have the null appear at some point that does not correspond to zero displacement so that the direction may be obtained in the unequal traces which appear under this condition. (See Figure 31.) The trace shown in this oscillogram shows part of the envelope to be of greater magnitude than the succeeding envelope cycle. The large displacement is in the positive direction as the null was adjusted to occur at a negative value. When the differential transformer is operated into a lock-in amplifier, the output is the displacement actually obtained both in direction and distance.

MAGNETOSTRICTIVE

A ferro-magnetic body will alter its length when brought into a magnetic field. If this body is weakly magnetized and is of low permeability, it will induce a current into a coil wound around it when it is compressed or elongated. This property has been utilized occasionally in magnetostrictive transducers. This type of element is suited for measurements where large forces are involved and a high amount of energy may be taken from the system without affecting it materially.

NON-LINEAR DEVICES

In recent years a group of alloys has been developed which possesses the property of saturating abruptly under the in-

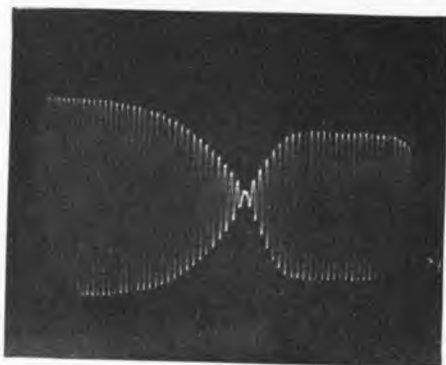

Figure 31. Envelope obtained from differential transformer. Null is not in center of displacement

fluence of strong magnetic fields. These materials can be used for the development of instruments which will act as limiting devices. Moreover and probably more important at this time, is the use that can be made of these materials to linearize the above transducers or to extend their operating ranges. The author knows of no transducer which utilizes this unique property.

TABLE 3

Optical Transducer Elements

1. Phototubes
2. Photomultipliers
3. Lead Sulfide Cells
4. Thermistor Flakes
5. Photocell
6. Thermocouples and Thermopiles
7. Phosphors

The optical elements or radiation detectors are not uniformly sensitive, necessarily, to radiation of varying frequency. Most types depart widely from uniformity of sensitivity; indeed, some do not even possess a range of sensitivity extending over a full octave.

Such devices as phototubes are rated in microamperes per lumen (average sensitivity at a given wave length). Departures of over 50 per cent in this value may be expected of any given phototube. The sensitivity curves shown in Figure 32 show the sensitivity of typical phototubes to various wave lengths when the maximum sensitivity to a given wave length is assumed to be unity.

Most phototube ratings are given in lumens. A lumen is the unit of luminous flux and is measured by means of physical devices. This rating does not always apply to all types of photo-sensitive devices. Where the energy lies outside the visible spectrum, radiation sensitive devices are occasionally rated in microamperes per watt.

Radiation detectors are frequently called upon to measure transient phenomena. The ability of a device to respond varies considerably with the type of transducer employed. Some, the thermocouple for example, have considerable time lag, while

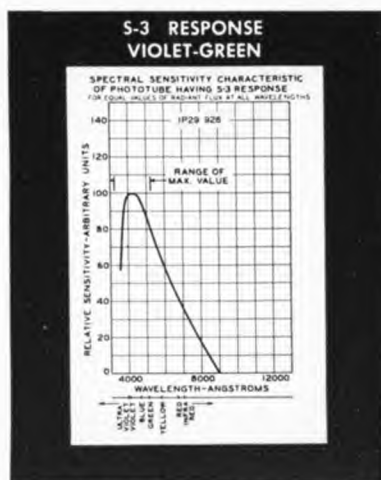

Figure 32. Spectral response of typical phototube. (Courtesy of the Radio Corporation of America)

others, such as the vacuum phototube, have a time lag so small that it is normally neglected. For this reason, it is not unusual to find these devices rated for various response times. Usually this rating is the ability of the device to respond to a light beam being turned on and off at the rated frequency.

All types of radiation detectors are more or less thermo-sensitive. Some, such as phototubes and photocells, are not sufficiently thermo-sensitive to appreciably affect their properties for many applications. On the other hand, thermocouples and other radiation detectors are heat sensing devices and consequently must be employed under carefully regulated conditions and/or must be compensated.

PHOTOTUBES

There are three distinct types of phototubes; the gas, the high vacuum, and the photomultiplier types. The gas and vacuum types are both diodes, differing only in the extent to which they are evacuated and the type of gas which is permitted to remain. The photomultiplier has a series of built-in electrodes called dynodes which serve to amplify the original current.

The high-vacuum phototube possesses a large cathode and an anode, usually a