

# N° 9-A Speech Input Equipment



*Western Electric*

The cover illustrates the No. 9-A Speech Input Equipment and the No. 12-A (100 Watt) Radio Transmitter being used together at a studio location. Behind the observation window may be seen a floor type Moving Coil Microphone

Copyright, 1931, by  
WESTERN ELECTRIC COMPANY, INC.



# *Western Electric* No. 9-A Speech Input Equipment

A development of Bell Telephone Laboratories, Incorporated,  
the research laboratories of the American Telephone and  
Telegraph Company and the Western Electric Company

**D**ESIGNED primarily for studio use with the Western Electric No. 12-A (100-watt) Radio Transmitter, the Western Electric No. 9-A Speech Input Equipment can be used also for other purposes.

It meets the very definite need for a flexible speech input equipment at important remote pick-up points—a need due to the expansion and progress in radio broadcasting.

It can be used also with other transmitters where a compact, simply designed and inexpensive speech input equipment fulfills the requirements.

## APPLICATIONS

When used with the No. 12-A Radio Transmitter, the No. 9-A Speech Input Equipment forms an integral part of a very compact broadcasting outfit. It not only provides facilities for switching several microphones together with the necessary mixing apparatus, but, also, is capable of furnishing power for two monitoring loud speaking telephones, one in the control room and the other in the studio.

While pick-up points remote from the transmitter such as theatres, concert halls, ballrooms and large restaurants, do not require elaborate input facilities, they do require handling facilities better than those which heretofore have been available. For these purposes the Western Electric No. 9-A Speech Input Equipment performs a distinct service.

{ T H R E E }

## No. 9-A SPEECH INPUT EQUIPMENT

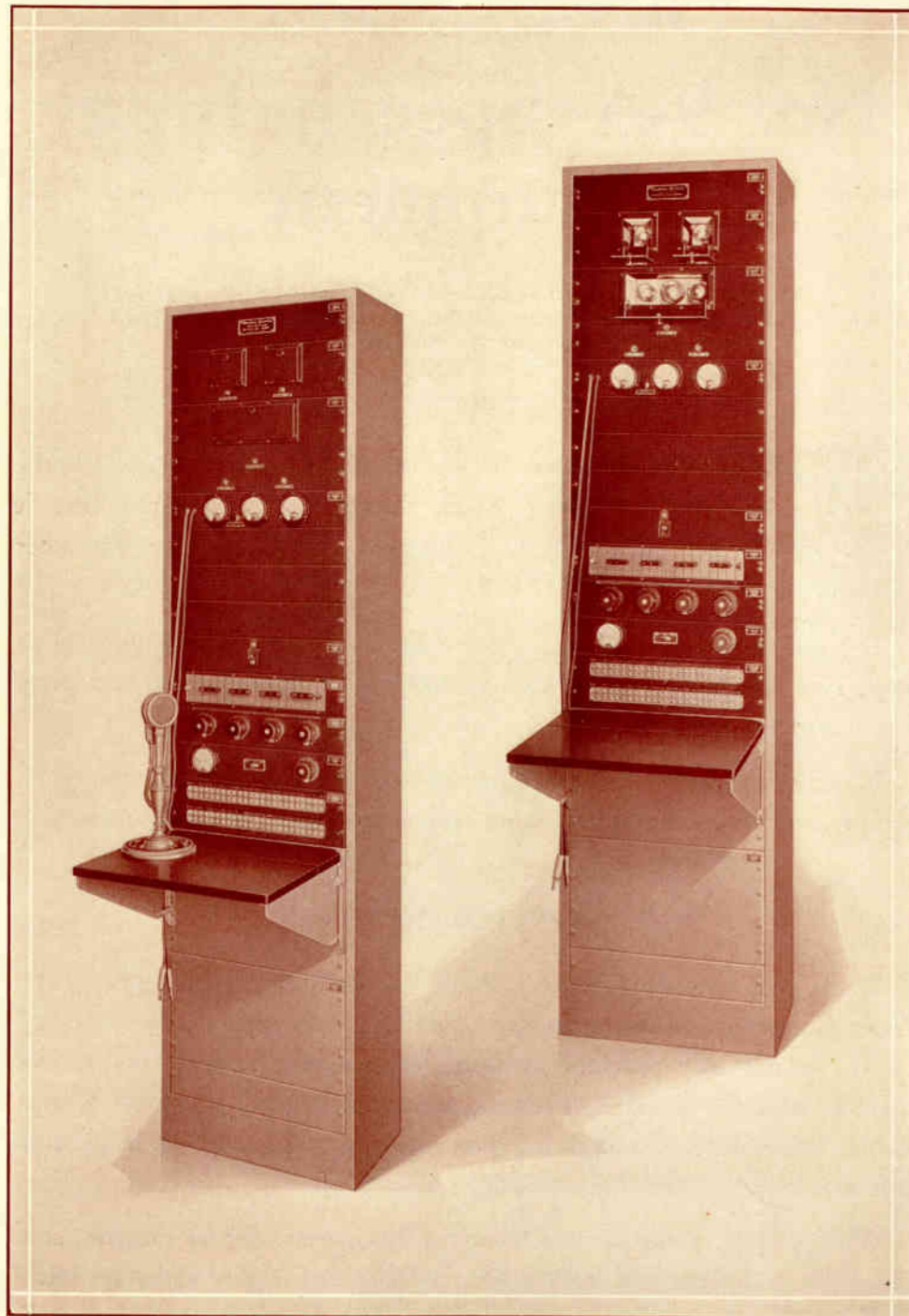

Front views of the No. 9-A Speech Input Equipment Panel. Tube covers opened and closed shown at right and left respectively. Desk type Moving Coil Microphone shown with panel at left

[ F O U R ]

*Western Electric*

## I M P O R T A N T F E A T U R E S

In a large building which contains a number of pick-up locations such as assembly hall, ballroom and several committee rooms, each pick-up point can be controlled from a centrally located No. 9-A Equipment. This eliminates the necessity of moving a portable amplifier from one place to another, and is of great advantage at large trade shows and expositions where programs originate in a number of booths.

### IMPORTANT FEATURES

A few of the outstanding features of the Western Electric No. 9-A Speech Input Equipment are:

1. All A.C. operation.
2. Moving coil microphones.
3. Single panel mounting.
4. Factory wiring.
5. Complete monitoring facilities.
6. Microphone mixing equipment.
7. Microphone switching facilities.
8. Master gain control.
9. Up-to-date power supply equipment.
  - a. Mercury vapor rectifiers for all plate supply.
  - b. Filters for rectified current.
  - c. Automatic line voltage regulation.
  - d. Provision for use in D.C. areas.
10. Possibility of adding carbon or condenser microphones, if desired.

### ALL A. C. OPERATION

The 9-A Speech Input Equipment is entirely A.C. operated. The use of batteries in the standard equipment has been eliminated. The moving coil microphones also make any outside microphone power supply unnecessary.

### ADVANTAGES OF THE MOVING COIL MICROPHONE

Aside from possessing superior transmission characteristics and faithfulness in sound pick-up, the construction of the moving coil microphone is

*Western Electric*

[ F I V E ]

## N O . 9 - A S P E E C H I N P U T E Q U I P M E N T

unusually rugged. This microphone is unaffected by changes in temperature and barometric pressure and is less affected by dust and moisture than other types of microphones.

It requires no external power supply and consequently no microphone control panels are needed in this speech input equipment. This not only decreases the complexity of the equipment but also results in reduced operating and maintenance costs.

Another advantage of this microphone is the fact that it may be located at a distance of 200 to 300 feet from an amplifier, without reduced efficiency.

### DESCRIPTION OF EQUIPMENT

The No. 9-A Speech Input Equipment consists chiefly of a single panel assembly. The overall dimensions are: 83 inches high, 20 inches wide and 12 inches deep. On this panel are mounted the amplifier, power supply, amplification controls, switching keys, mixing potentiometers and jack strips. All apparatus is mounted flush with the exception of the switching keys and the potentiometer control dials.

Attached to the front of the panel, at table height, is a removable shelf which serves as a writing surface and as a convenient arm support when the operator is adjusting the controls. The rear and sides of the panel are enclosed in a neat, strong, steel cabinet, which protects the equipment from dust and mechanical injury, yet permits easy access to the apparatus. The cabinet has a hinged door provided with a lock and switch. The switch cuts off the current as soon as the door is opened. Thus adjustments can be made with safety.

When the No. 9-A Equipment is used with the Western Electric No. 12-A (100-watt) Radio Transmitter (also a single unit) the entire broadcasting system occupies less than 10 square feet of floor space. The saving in space is most desirable in small stations.

When used at remote pick-up points the fact that this speech input equipment is confined entirely to a single panel eliminates the extra space usually required for power supply apparatus.

[ S I X ]

*Western Electric*

## D E S C R I P T I O N O F E Q U I P M E N T

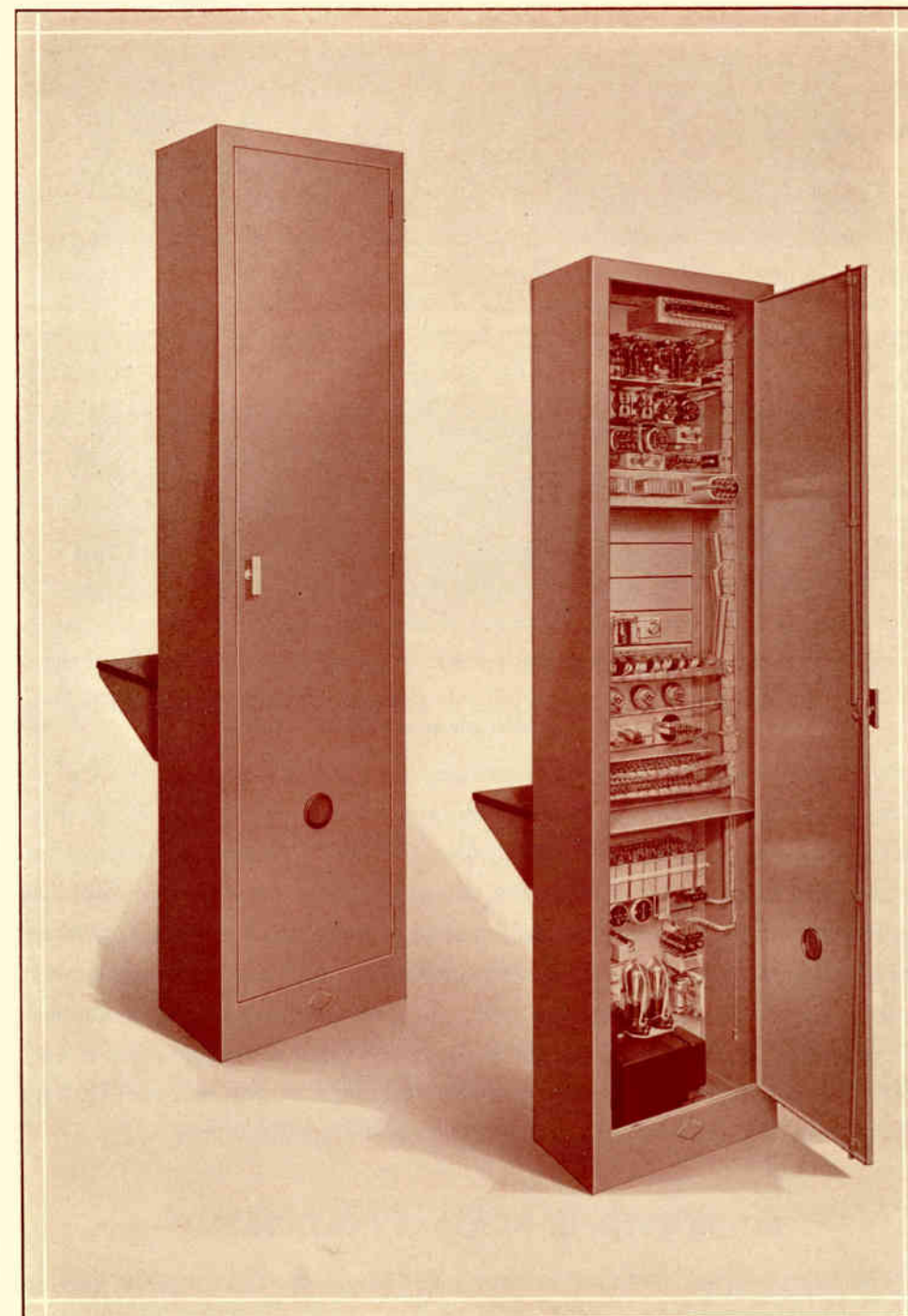

Closed and open views of the No. 9-A Speech Input Equipment Panels. The open view shows compact arrangement of apparatus in a neatly designed metal cabinet.

*Western Electric*

[ S E V E N ]

## No. 9 - A SPEECH INPUT EQUIPMENT

### **ALL WIRING DONE AT WESTERN ELECTRIC PLANT**

The panel assembly is factory wired and then after rigid inspection is shipped as a unit. This assures superior workmanship and minimum installation time and expense.

Terminal blocks provide connections for the local power source and microphones, the radio transmitter input, monitoring loud speakers, lines from pick-up points and order wire lines.



No. 217-A Panel for controlling the power to condenser microphone amplifiers, when this type of microphone is used.

### **MICROPHONE CIRCUITS**

Standard equipment provides for the use of three of the new Western Electric moving coil microphones. Mounting space and wiring are provided for microphone control panels if either carbon or condenser microphones are desired instead of the moving coil type. Where condenser type microphones are preferred space is provided for a panel on which a voltage divider and filter are mounted to supply the 200 volts required by one or two Western Electric condenser microphones and their associated amplifiers.

### **MICROPHONE MIXING EQUIPMENT**

The mixing panel, mounted at convenient height for the operator, carries four mixing potentiometers of the latest design. These provide noiseless control in each of four program channels. Each potentiometer has 18 steps of approximately 2 db. attenuation each as well as an "OFF" position.

[ E I G H T ]

*Western Electric*

## FLEXIBLE SWITCHING FACILITIES

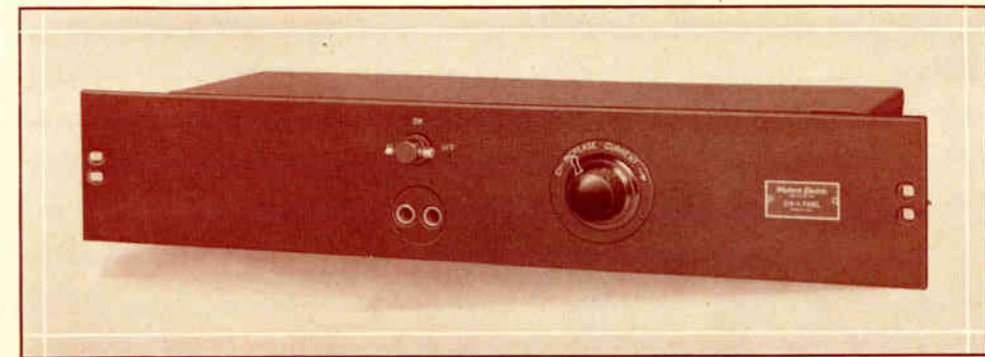

No. 218-A Panel for controlling the power to carbon microphones, when this type of microphone is used.

### **FLEXIBLE SWITCHING FACILITIES**

Jacks and patching cords are provided to connect any one of four program circuits from remote pick-up points, to any of the four switching circuits, through an artificial line and a balanced repeating coil. This arrangement provides maximum flexibility for switching programs outside the studio so that they may follow each other in uninterrupted succession.

Jacks are also provided for terminating four order wire circuits associated with the program line circuits. By this means it is possible in an emergency to interchange any order wire and its program line circuit by a simple patching operation. Four two-way keys are provided, arranged so that any four of eight possible program circuits may be connected to the four mixing potentiometers.

Telephone sets for use with the order wire circuits are not provided as part of the No. 9-A Speech Input Equipment. These should be procured from the local telephone company.

### **HIGH QUALITY AMPLIFIERS**

Two amplifiers are used: one, a low level amplifier, having a maximum gain of approximately 58 db, and the other, a high level amplifier, having a maximum gain of 54 db. Both represent the latest developments in apparatus of this type.

*Western Electric*

[ N I N E ]

## N O . 9 - A S P E E C H I N P U T E Q U I P M E N T

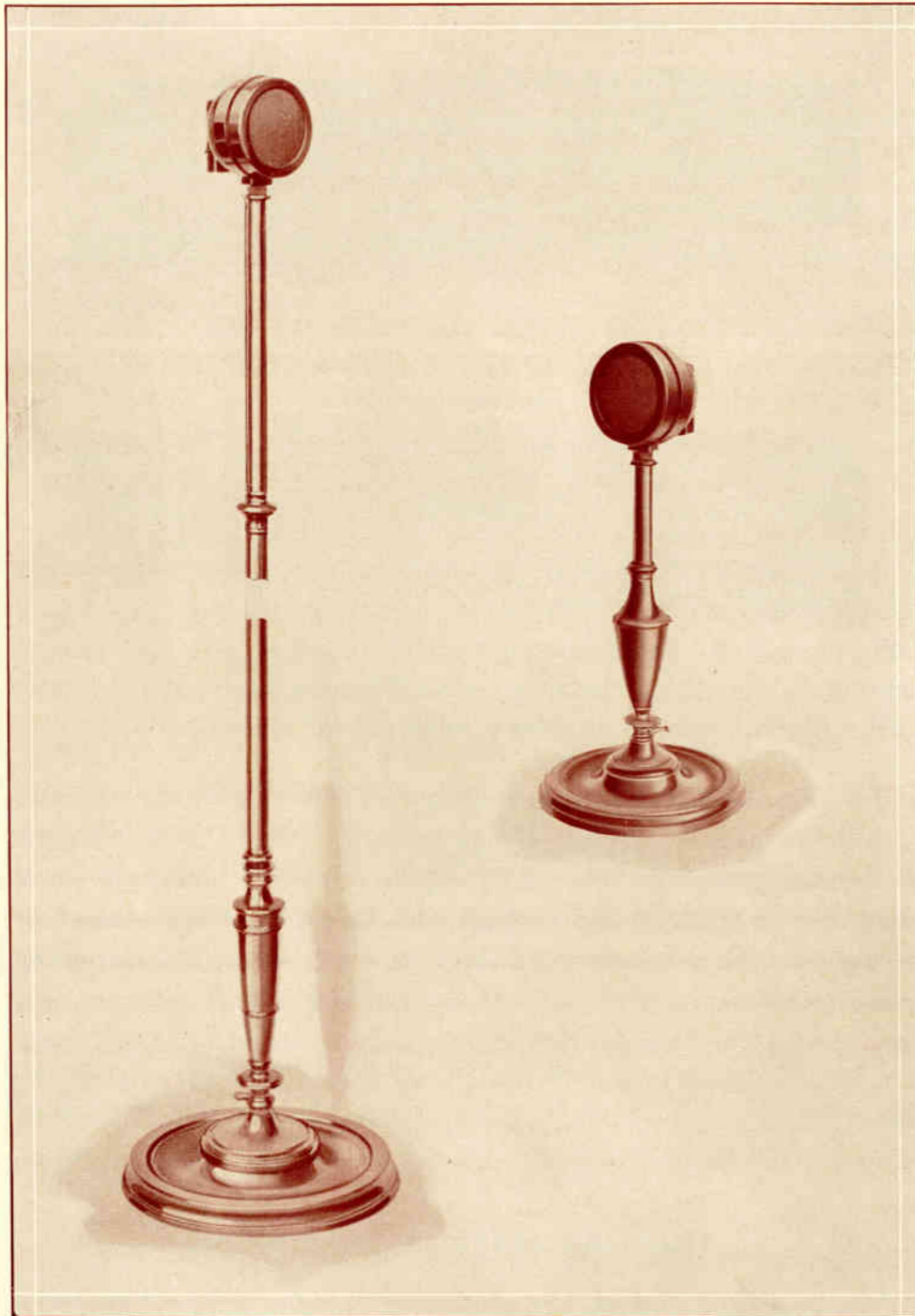

The Western Electric Moving Coil Microphone used with the standard 9-A Speech Input Equipment represents a distinct advance over other pick-up equipment in use at the present time. Illustrations above show the floor and the table mountings.

[ T E N ]

*Western Electric*

## M A S T E R G A I N C O N T R O L

The overall frequency characteristic of the amplifier system is uniform to within 1 db. from 30 to 10,000 cycles. The output stage of the high level amplifier consists of two vacuum tubes connected in push-pull. This gives ample undistorted output power for feeding either a telephone line or a radio transmitter, besides furnishing enough power for the two monitoring loud speaking telephones.

The gain of the amplifier system can be reduced in small steps to approximately 34 db. If it is desired, it is possible to use only the high level amplifier for amplifying programs coming in at a relatively high level from remote pick-up points.

### MASTER GAIN CONTROL

A low impedance potentiometer, connected between the two amplifiers, is used as a master gain control. This master control with a level indicator is mounted on the panel at convenient height. It provides 18 steps of approximately 2 db attenuation each as well as an "OFF" position.

The level indicator associated with the amplifier system is provided with a key for setting at the desired operating range.

### POWER SUPPLY

The power source is 110-volt, 50 to 60-cycle A.C. The plate voltage for the amplifiers is supplied by a full wave rectifier employing two mercury vapor tubes. Filters provide adequate smoothness of the rectified current so as to insure quiet operation in the amplifier system. Transformers are used to supply the low voltage A.C. current to the filaments of the amplifier tubes and an automatic voltage regulator is provided for the line voltage. This simplifies the operation of the equipment by relieving the operator of the responsibility for checking the line voltage and regulating it manually.

A 12-volt battery is required for the carbon microphones or the filaments of the amplifiers of the condenser microphones when these are used instead of the moving coil microphones.

A small motor-generator set is available when the 9-A Speech Input Equipment is desired for use in D.C. districts.

*Western Electric*

[ E L E V E N ]

METER PANEL

A panel is provided on which three meters are mounted. These meters, an ammeter and two milliammeters, are provided with cords and plugs for inserting in the current measuring jacks of the amplifiers and microphone control panels.

MONITORING FACILITIES

For monitoring purposes, two of the latest type of loud speaking telephones are furnished. One is intended for use in the control room and the other in the studio. The speech energy for the loud speaking telephones is controlled by keys mechanically linked to the microphone switching keys. Thus when a microphone is turned on, the loud speaking telephone at that point will be automatically disconnected. This avoids "singing." A key is provided for switching the monitoring loud speaker in the control room from the output of the speech input equipment to the output of a radio monitoring circuit.

Developed by Bell Telephone Laboratories and manufactured by Western Electric, the 9-A Speech Input Equipment conforms to Bell System standards of high quality. Here, again, simplicity is attained without the sacrifice of utility or dependability.

ADDITIONAL INFORMATION AVAILABLE

For further information and advice in regard to this or other Western Electric Speech Input Equipments you are invited to address the nearest distributor whose name and address will be found on Page 14 of this bulletin.

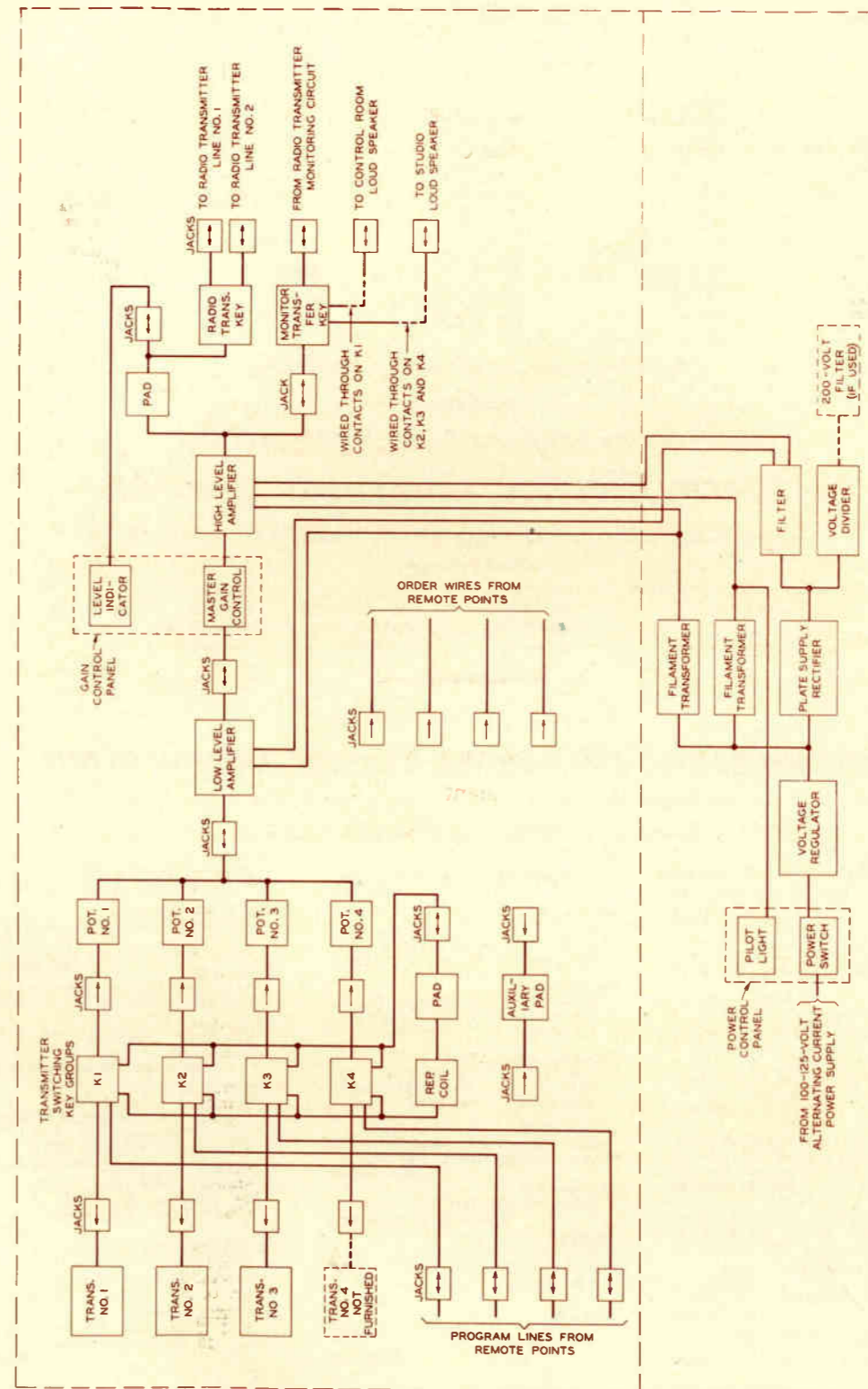

Block schematic of the 9-A Speech Input Equipment.

DISTRIBUTOR IN THE UNITED STATES

# Graybar

ELECTRIC COMPANY

Akron	Dallas	Indianapolis	Norfolk	Salt Lake City
Albany	Davenport	Jacksonville	Oakland	San Antonio
Asheville	Dayton	Kansas City	Oklahoma City	San Francisco
Atlanta	Denver	Knoxville	Omaha	Savannah
Baltimore	Detroit	Los Angeles	Peoria	Seattle
Beaumont	Duluth	Louisville	Philadelphia	Spokane
Birmingham	Durham	Memphis	Pittsburgh	Syracuse
Boston	Flint	Miami	Portland	Tacoma
Brooklyn	Fort Wayne	Milwaukee	Providence	Tampa
Buffalo	Fort Worth	Minneapolis	Reading	Toledo
Charlotte	Grand Rapids	Mount Vernon	Richmond	Trenton
Chicago	Hammond	Nashville	Roanoke	Washington
Cincinnati	Harrisburg	Newark	Rochester	Wichita
Cleveland	Hartford	New Haven	St. Louis	Worcester
Columbus	Houston	New Orleans	St. Paul	Youngstown

A NATIONAL ELECTRICAL SERVICE

DISTRIBUTOR FOR CANADA AND NEWFOUNDLAND

## Northern Electric Company Limited

General Sales Offices: 637 Craig Street, West, Montreal, P. Q.

Branch Houses

Saint John, N. B.	Ottawa	Windsor	Regina
Halifax	Toronto	New Liskeard	Calgary
Quebec	Hamilton	Sudbury	Edmonton
Montreal	London	Winnipeg	Vancouver

FOREIGN DISTRIBUTORS

## International Standard Electric Corporation

67 Broad Street New York, U.S.A.

Associated, Allied or Affiliated Companies

<b>ARGENTINA</b> Cla Standard Electric Argentina, Casilla de Correo 49, (Street Address, Paseo Colon 185), Buenos Aires	<b>ESTONIA</b> Tehnika Büroo (Standard Electric), Vene tänav 11a, Tallinn	<b>JAPAN</b> Nippon Electric Co., Ltd., 2 Mita Shikokumachi, Shiba-Ku, Tokyo
<b>AUSTRALIA</b> Standard Telephones and Cables (Australasia) Ltd., 71 York Street (P. O. Box 525-B), Sydney, N. S. W.	<b>FRANCE</b> Le Materiel Telephonique, 46-47 Quai de Boulogne, Boulogne-Billancourt, Paris	<b>NEW ZEALAND</b> Standard Telephones & Cables (Australasia) Ltd., 24-26 Balance Street, P. O. Box 638, Wellington
<b>AUSTRIA</b> United Telephone and Telegraph Works, Ltd., Dresdner Strasse No. 75, Vienna, XX/2	<b>GERMANY</b> Standard Elektrizitäts Gesellschaft A. G., Schinkelplatz No. 1 and 2, Berlin, W. 56	<b>NORWAY</b> Standard Electric Aktieselskap, Drammensveien 20, Oslo
<b>BELGIUM</b> Bell Telephone Manufacturing Co., 18 Rue Boudewyns, P. O. Box 526, Antwerp	<b>GREAT BRITAIN</b> Standard Telephones and Cables, Ltd., Columbia House, Aldwych, London, W. C. 2	<b>POLAND</b> Standard Electric Co., W. Polsce, Sp. z.o.o., Warsaw, Stenklewicza 10
<b>BRAZIL</b> International Standard Electric Corp., Caixa Postal 430, (Street Address, Rua Visconde de Inhauma, 64), Rio de Janeiro	<b>HOLLAND</b> Bell Telephone Manufacturing Co., Scheidestraat 160-162, The Hague	<b>SOUTH AFRICA</b> Standard Telephones and Cables, Ltd., Exploration Buildings, Commissioner and Fox Streets, (P. O. Box 1571), Johannesburg
<b>CHINA</b> China Electric Co., Ltd., Kin-cheng Bank Bldg., 212 Kiangse Road (P. O. Box 289), Shanghai	<b>HUNGARY</b> Standard Electric Co., Ltd., Ujpest 4, n. Budapest	<b>SPAIN</b> Standard Electrica, S/A, Calle de Ramirez de Prado 3 y 5, (Post Office Box 7040), Madrid
<b>CZECHOSLOVAKIA</b> Standard Electric Doms a Spolecnost, Samova, U 1. 664, Prague	<b>INDIA</b> Standard Telephones and Cables, Ltd., Block C2, Clive Buildings, 8 Clive Street, Calcutta	<b>STRAITS SETTLEMENTS</b> Standard Telephones and Cables, Ltd., 57 Robinson Road, (P. O. Box 553), Singapore
<b>EGYPT</b> Standard Telephones and Cables, Ltd., Cozzika Buildings, Sharia Soliman Pasha, Cairo	<b>ITALY</b> Standard Elettrica Italiana, Via Vittoria Colonna No. 9, Milan, 125	<b>SWITZERLAND</b> Bell Telephone Manufacturing Co., 10 Bubenbergplatz, Berne