



DATA AND CIRCUITS TELEVISION RECEIVER VALVES

BY
J. JAGER

PHILIPS' TECHNICAL LIBRARY

+485V 0B
+10kV
64358

SERIES OF BOOKS
ON
ELECTRONIC VALVES

The series of books on Electronic Valves includes:

- Book I Fundamentals of Radio Valve Technique, 547 pages, 6'' × 9'',
384 illustrations.
- Book II Data and Circuits of Radio Receiver and Amplifier Valves,
424 pages, 6'' × 9'', 531 illustrations (1933/39).
- Book III Idem, 220 pages, 6'' × 9'', 267 illustrations (1940/41).
- Book IIIA Idem, 487 pages, 505 illustrations (1945/50).
- Book IIIB Idem, 1951/53 (in preparation).
- Book IIIC Idem, of Television Receiving Valves.
- Book IV Application of the Electronic Valve in Radio Receivers and
Amplifiers
(Part 1).
(1) R.F. and I.F. amplification. (2) Frequency changing.
(3) Determination of the tracking curve. (4) Interference and
distortion due to curvature in characteristics of the receiver
valves. (5) Detection.
440 pages, 6'' × 9'', 256 illustrations.
- Book V Application of the Electronic Valve in Radio Receivers and
Amplifiers
(Part 2).
(6) A. F. amplification. (7) Output stage. (8) Power supply.
434 pages, 6'' × 9'', 343 illustrations.
- Book VI Application of the Electronic Valve in Radio Receivers and
Amplifiers
(Part 3) (in preparation):
(9) Inverse feedback. (10) Control devices. (11) Stability and
instability of circuits. (12) Parasitic feedback. (13) Interference
phenomena (hum, noise and microphony). (14) Calculation of
receivers and amplifiers.
- Book VII Transmitting Valves, 284 pages, 6'' × 9'', 256 illustrations.
- Book VIIIA Television Receiver Design — monograph 1.
I.F. Stages, 180 pages, 123 illustrations.
- Book VIIIB Television Receiver Design — monograph 2.
Flywheel Synchronization of Saw-Tooth Generators, 165 pages,
118 illustrations.

BOOK III C

DATA AND CIRCUITS

OF

TELEVISION RECEIVING VALVES

DATA AND CIRCUITS

OF

TELEVISION RECEIVING VALVES

U.D.C.
621.385:621.397.62

BY

J. JAGER

This publication deals with a complete series of modern valves for television receivers. In the first chapter complete data and characteristic curves are given for each type of valve, accompanied by circuit descriptions of the most usual applications. The second chapter discusses a few important aspects of modern receiver technique (intercarrier sound and flywheel synchronization) followed by a description of the circuit of a complete receiver.



PHILIPS TECHNICAL LIBRARY

The English translation of this book is by:
J. Jager, Eindhoven and Harley Carter, London

Publisher's note:

This book has been published in: Dutch, English, French and German

All rights reserved by N.V. Philips' Gloeilampenfabrieken, Eindhoven
(Netherlands)

All information in this book is given without prejudice to patent rights
of the above company

English edition first published in 1953
Printed in the Netherlands

Foreword

It is well known that the valves in a television receiver must satisfy requirements which are very different from those in a normal radio receiver. Although conventional radio and amplifying valves were used in the experimental stage of television, the production of very large numbers of television receivers has created the need for valves specially designed for this purpose. In 1951 a complete range of television receiving valves was therefore introduced by Philips a range which has been extended from time to time, to keep pace with the rapid development of television throughout world.

The first chapter of this book gives complete data and characteristic curves for these valves and also of two picture tubes. For each valve, typical circuits are described. The second chapter discusses intercarrier sound and flywheel synchronization of the line deflection. Then follows a description of a complete television receiver circuit. The matter dealt with in this book has been kept on an entirely practical basis. For a fundamental treatise on television the reader is referred to "Television", by F. Kerkhof and Ir. W. Werner, also published in the Philips Technical Library.

In preparing this book use has been made of the wealth of information available at the Application Laboratories of the Electronic Tube Division. Thanks are finally due to Mr. J. Haantjes and Dr. B. G. Dammers for their many valuable suggestions and the reading of the manuscript and to Mr. Harley Carter for scrutinizing the English translation.

J. JAGER

TABLE OF CONTENTS

Foreword.	07
Chapter I <i>Data and circuits</i>	1
Introduction.	1
The double triode ECC 81	6
Description	6
Application	6
1. The ECC 81 as R.F. amplifier in a grounded-cathode circuit	7
2. The ECC 81 as R.F. amplifier in a grounded-grid circuit	8
3. The ECC 81 as R.F. amplifier in a cascode circuit	8
4. The ECC 81 as frequency changer	9
Data of the ECC 81	10
The R.F. pentode EF 80	18
Description.	18
Application.	18
1. The EF 80 as I.F. amplifier	18
2. The EF 80 as R.F. amplifier	25
3. The EF 80 as frequency changer	25
4. The EF 80 as video amplifier	26
Data of the EF 80	28
The double diode EB 91	39
Description	39
Application.	39
Data of the EB 91	42
The video output pentode PL 83	46
Description.	46
Application.	46
1. The PL 83 as video amplifier with cathode compensation	46
2. The PL 83 as video amplifier with anode compensation	47
Data of the PL 83	48
The direct-viewing picture tube MW 36-44	52
Description.	52
Application	56
Data of the MW 36-44	60
The direct viewing picture tube MW 36-24	65
The direct viewing picture tube MW 43-43	66
Description	66
Provisional data of the MW 43-43	67

The output pentode PL 82	74
Description	74
Application	75
1. The PL 82 as sound output valve	75
2. The PL 82 as frame output valve	75
Data of the PL 82	80
The triode pentode ECL 80	88
Description	88
Application	89
1. Triode as blocking oscillator (frame frequency)	
Pentode as frame output valve	89
2. The ECL 80 as synchronizing pulse amplifier and separator	91
3. Triode as A.F. voltage amplifier	
Pentode as sound output valve	92
Data of the ECL 80	93
The line-output pentode PL 81	108
Description	108
Application	109
1. General introduction	109
2. A circuit for line deflection and an E.H.T. of 10 kV	115
3. Standard components for the line deflection circuit	123
Data of the PL 81	127
The booster diode PY 80	134
Data of the PY 80	135
The booster diode PY 81	137
Data of the PY 81	138
The mains rectifier PY 82	141
Data of the PY 82	141
The E.H.T. rectifier EY 51	144
Data of the EY 51	145
Chapter II <i>Circuit descriptions</i>	147
Intercarrier sound	147
Introduction	147
Circuit description	150
Flywheel synchronization	164
Circuit with the ECL 80 triode pentode	164
Circuit with the EQ 80 enneode	171
Description of a television receiver employing the picture tube	
MW 43-43	177
Introduction	177
1. Picture channel	179
2. Sound channel	185

3. Line deflection and synchronization	186
4. Frame deflection and synchronization	193
5. Power supply	200
6. Voltages and currents	200
7. List of parts	202

DATA AND CIRCUITS

Introduction

Before describing in detail each of the valves it will be advantageous to review them as a whole and to classify them according to their functions in a television receiver. For this purpose a block diagram showing the main stages of a typical television receiver is reproduced in Fig. 1. In this diagram the appropriate valve types are indicated for each function and it is seen that often more than one type is available for a specific application. This is further explained in the following notes.

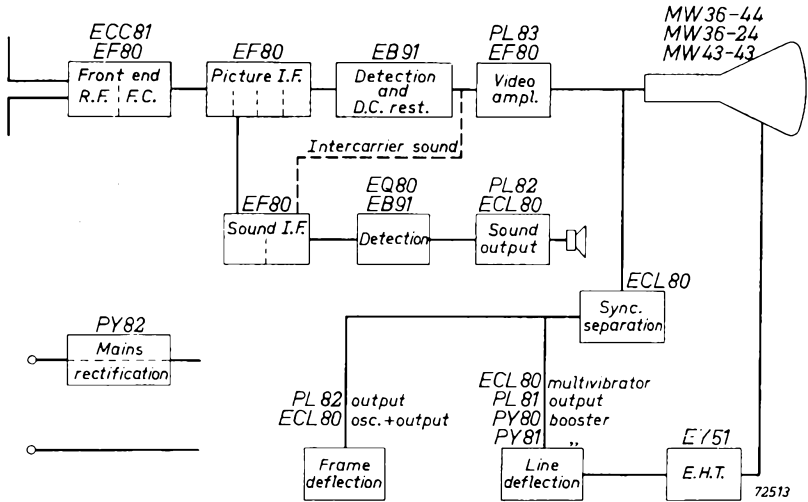

Fig. 1
Block diagram of a typical television receiver.

R.F. amplification

In the so-called low band from 40 to 70 Mc/s the EF 80 can be used for R.F. amplification. This is a pentode with high mutual conductance and low input and output capacitances. In the high band from 174 to 216 Mc/s the application of the double triode ECC 81 has advantages owing to the lower noise level that can be obtained with this valve, but the EF 80 is also suitable at these frequencies, especially in the simpler receivers where a very high sensitivity is not required.

Frequency changing

Because of the wide bandwidths and the consequently low circuit impedances used in television receivers, the conventional multiplicative frequency changer valves are less suitable, because of their high noise level and comparatively low conversion conductance. Additive mixer circuits, in which a high-slope triode or pentode is used with either self excitation or separate excitation, are much more favourable in these respects. In such circuits an ECC 81 double triode or an EF 80 pentode can be used.

Picture I.F.

According to the sensitivity aimed at in the design, four or three stages of picture I.F. amplification preceding the video detector will normally be used. The valve for this application is the EF 80.

Video detection and D.C. restoration

For this application the double diode EB 91 is available. The two sections of this valve have separate cathodes, so that one section may be used as the video detector and the other as D.C. restorer.

Video amplification

Two types, the PL 83 and the EF 80, are indicated for this application. In receivers with a single video stage the EF 80 can be used but the PL 83 is capable of providing a higher undistorted output voltage at a given bandwidth or, alternatively, a larger bandwidth at a given maximum output voltage. For systems with the higher definition the PL 83 is therefore to be preferred. When two stages of video amplification are used the EF 80 may serve as the pre-amplifier followed by a PL 83. It should be borne in mind, however, that, in view of the possibility of microphony, the gain between the input of the EF 80 and the control electrode of the picture tube should be kept below 25.

The picture tube

The all-glass picture tubes MW 36-44 and MW 36-24 have a rectangular screen (dimensions 30 cm \times 23 cm), corresponding to the C.C.I.R. standards. The tubes employ wide-angle deflection, so that the total length is reduced to 42 cm. A larger type is the MW 43-43, also having a rectangular screen (36.5 cm \times 27 cm), but a metal cone. The types MW 36-44 and MW 43-43 are provided with a special gun giving improved average resolution over the entire screen area.

Sound I.F.

In the conventional arrangement where the sound I.F. is abstracted from the picture I.F. amplifier, two stages of amplification using EF 80

pentodes will normally be required preceding the F.M. detector. In a receiver with intercarrier sound one stage of sound I.F. using the EF 80 will be sufficient.

Sound detection

For this application the special F.M. detector and limiter valve, Type EQ 80, is available. In other detector systems operating with a double diode, the EB 91 may be used.

Sound output

Two valves are available for this application. The pentode section of the ECL 80 can provide an output of 1.75 W at a supply voltage of 200 V. With certain types of F.M. detector giving a low A.F. output some pre-amplification preceding the output stage is required. The use of the ECL 80 has the advantage that its triode section can be used as pre-amplifier. If a higher output is required the pentode PL 82 can be used. This valve is capable of giving an output of about 4 W. With the EQ 80 as F.M. detector, giving a high output voltage, pre-amplification between the detector and the PL 82 is not required.

Synchronizing pulse separation and amplification

Owing to its short grid base, when the pentode section of the ECL 80 is operated with a low screen-grid voltage, this valve is eminently suitable as a synchronizing pulse separator. The triode section may then be used for further clipping and amplification of the synchronizing signal.

Frame deflection

In this section of the receiver the ECL 80 can serve for two functions, viz. the triode as blocking oscillator and the pentode as frame output valve. If a H.T. line voltage of 200 V is available, the pentode section of an ECL 80 can provide sufficient peak anode current for deflection in a picture tube with narrow deflection angle and a comparatively low anode voltage. For deflection in a wide-angle picture tube operating at an anode voltage of 10 kV or more, it will normally be necessary to feed the anode of the pentode section from the boosted H.T. voltage, which is available in the line-output stage when this operates with a booster diode. Alternatively, the PL 82 pentode may be used for frame deflection. This valve can provide a much higher peak anode current than the pentode section of the ECL 80, so that its anode can be supplied from the normal (unboosted) H.T. line.

Line deflection

In the oscillator section of the line timebase generator the ECL 80 can again be used, either with the pentode or the triode section as blocking oscillator or with both sections in a multivibrator arrangement.

A special line output pentode having high anode insulation and capable of delivering a high peak anode current is the PL 81. This pentode will normally be used in combination with one of the booster diodes PY 80 or PY 81, the latter having special insulation between cathode and heater, thus simplifying the design of the line-output transformer.

E.H.T. rectifier

In modern television receivers the E.H.T. potential is normally obtained by rectifying the flyback pulses in the line circuit. A special diode of the wire-in type for this application is Type EY 51. The heater wattage of the EY 51 is very small, so that it is possible to feed the heater from a separate winding on the line-output transformer.

Mains rectifier

For the power supply section of the receiver the PY 82 is available. This half-wave rectifier can deliver a rectified output current of 180 mA, so that in most television receivers two of these valves must be used in parallel.

From the above notes it may be seen that the range of television valves covers all the functions likely to be encountered in a receiver. For several functions more than one type is available, so that a suitable valve complement can always be found for any television standard now in use.

During recent years the size, cost and weight of television receivers has been considerably reduced. This is to a large extent attributable to the widespread adoption of the transformerless technique, in which the mains transformer is dispensed with. The heaters of the valves are then connected in a series chain across the mains supply, the H.T. line voltage being obtained by direct rectification from the mains. For this reason, with the exception of the EQ 80 and the EY 51, the range of valves described here has been designed for series operation of the heaters, the heater current being 0.3 A. The heater wattage of the EY 51 has been kept small (6.3 V, 90 mA), to permit supply from a separate winding on the line-output transformer. The heater current of the EQ 80 valve is 0.2 A at 6.3 V, so that when it is used in a receiver in which the valve heaters are operated in series, the EQ 80 heater must be shunted by a resistor of 63 Ω .

Some of the valves in the range are suitable for either series or parallel operation of the heaters. With the EF 80 and the ECL 80, for example, the heater voltage is 6.3 V at 0.3 A. Of most of the P-types, such as PL 81 and PL 83, having a heater voltage greater than 6.3 V, equivalent E-types are also available. The type numbers are then EL 81, EL 83 etc.; the heater voltage is 6.3 V, but the heater current is, of course, greater than 0.3 A. The adoption of a heater current of 0.3 A is a deviation from the conventional practice with radio valves, where, for series operation, a heater current of 0.1 A is used. There are, however, good reasons for this. In the first place, in a television receiver one heater chain would be impossible with 0.1 A heaters, so that several chains would be needed in parallel, each with its

own series resistor, and this, of course, would be a more expensive arrangement. With valves having a heater current of 0.3 A, in the majority of cases one single heater chain suffices and consequently this is the cheapest solution. Secondly, the adoption of a heater current of 0.3 A has made it possible to design some of the valves in this range for a heater voltage of 6.3 V, so that these types are suitable for either series and parallel operation.

There are many possible arrangements of the supply system of a receiver. The arrangement in a receiver with parallel operation of the heaters needs no special comment. In a receiver designed for series operation of the heaters, one heater chain will be employed at the higher mains voltages, whilst the required high-tension supply is obtained by direct rectification from the mains. At the lower mains voltages two heater chains will normally be required, and the high tension may be obtained either by direct rectification from the mains or by the inclusion of a comparatively small auto-transformer between rectifier and mains.

Care has been taken in the design of the valves to ensure good heater-cathode insulation. Some capacitance between the heater and the other electrodes, particularly the cathode, is, however, inevitable and this may result in objectionable hum interference if the position in the heater chain of the particular valve in which the interference might be caused is not judiciously chosen. One end of the heater chain is normally connected to the receiver chassis, to which most of the cathodes are also connected. It is therefore advisable to choose the position in the heater chain of, for example, the frequency changer and the picture tube in such a way that the potential between heater and cathode is a minimum. The heaters of other valves not likely to cause hum interference, such as the mains rectifier, should then be included in the other end of the heater chain. It is also possible that undesirable coupling effects arise between the various stages of the receiver via the heater chain. It is then necessary to use by-pass capacitors of about 1500 pF between the heater terminal on the socket and the chassis, this applying especially to the picture channel of the receiver.

Finally, due precautions should always be taken to avoid temporary overheating of some of the valves. When the set is switched on the heater voltage of those valves having the lowest heater wattage — which implies a low thermal inertia — will temporarily exceed the rated value, and this tends to reduce the useful life of these valves. This can be avoided by using a series resistor having a high negative temperature coefficient (NTC resistor), so that the heater current is initially low and the warming up time is governed by the thermal inertia of the NTC resistor.

The double triode ECC 81

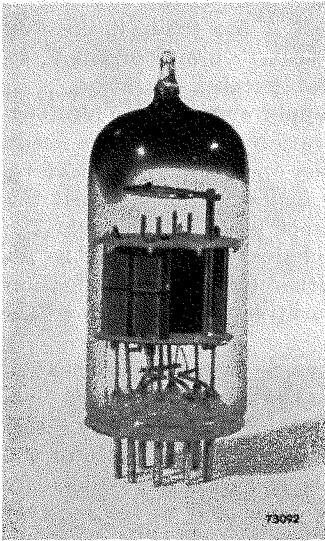

Fig. 1
The double triode ECC 81
(about actual size).

Description

The ECC 81 is a double triode in noval envelope, specially designed for use as R.F. amplifier or frequency changer at high frequencies (100-300 Mc/s). When used as a frequency changer one triode section may serve as mixer and the other as local oscillator.

In the design of the valve special attention has been paid to the performance at high frequencies. The electron transit time between cathode and grid is short, resulting in a reduction of noise and input conductance. The triode sections are mounted side by side in order to keep all leads to the base pins as short as possible. This is especially important in respect of the cathode lead, where a high inductance would result in a high input conductance. Owing to the high mutual conductance and the low input capacitance of each system a high gain can be obtained at large bandwidths.

When the ECC 81 is used as a combined mixer and local oscillator, the two triode sections operate under very different conditions.

It is then often convenient to be able to choose the cathode bias of each triode independently. This has been made possible by connecting the cathodes of the two systems to separate base pins.

Application

For amplification at high frequencies a triode is often preferred to a pentode. While it is true, that "shot" noise occurs in both the pentode and the triode, the pentode has an additional source of noise, caused by random variations in the distribution of electron current between anode and screen grid.

An R.F. stage equipped with a pentode will therefore be noisier than a similar stage with a triode of comparable mutual conductance, but this will only be noticeable when the external noise caused by the impedance of the input circuit and the noise received by the aerial is small compared with that caused in the valve.

In the 41 to 68 Mc/s television band the noise received via the aerial normally exceeds the noise generated in a high slope pentode, so that no appreciable improvement can be obtained by using a triode. In the 74 to 216 Mc/s band, however, both the equivalent circuit noise and the noise received via the aerial are much smaller, so that an improvement in noise level can be obtained by using a triode instead of a pentode in the R.F. stage. This, of

course, applies especially to a receiver of very high sensitivity. In a receiver of lower sensitivity, where the minimum useful signal largely exceeds the equivalent noise voltage of the R.F. valve, there is no appreciable difference between a pentode and a triode.

The internal resistance of a triode is much smaller than that of a pentode, but this is no great disadvantage, because at high frequencies where a triode would be used the circuit impedances are several times smaller than the internal resistance of the valve. A real disadvantage of the triode is the relatively large capacitance between anode and grid, which, in a normal circuit with grounded cathode, must be neutralised to prevent instability. In the grounded-grid circuit, however, the grid shields the input from the output, so that neutralisation is not required. It is also possible to combine the grounded-cathode and the grounded-grid circuits (cascode circuit), in which one section of the ECC 81 operates as grounded-cathode amplifier working into the other section connected as a grounded-grid amplifier. The gain of the first section is then practically unity, so that instability as a result of anode-to-grid capacitance cannot occur.

1. The ECC 81 as R.F. amplifier in a grounded-cathode circuit

A circuit diagram of an R.F. stage in which the two sections of an ECC 81 valve are connected in push-pull is represented in Fig. 2. This circuit has the advantage that the input resistances and the capacitances of each triode are effectively in series across the tuned circuits. Compared with a single stage this results in the valve capacitances across the tuned circuits being halved and the valve resistances doubled. It is therefore possible to obtain a high L/C ratio and a high quality factor.

It is necessary to neutralise the anode-to-grid capacitance of each triode section. The capacitors used for this purpose must have a value from 1 to 2 pF, and can most conveniently be obtained by twisting together two short lengths of insulated copper wire. Optimum compensation can be obtained by varying the twisted length.

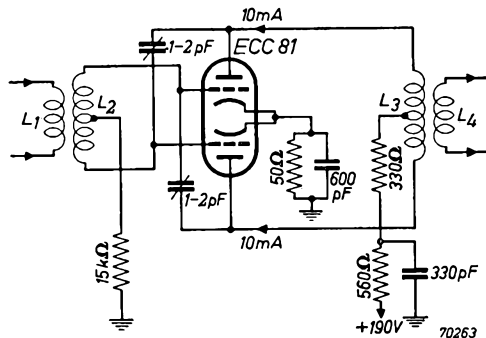

Fig. 2
The ECC 81 as R.F. amplifier with the two sections in push-pull.

ECC 81

The inductances L_2 and L_3 are tuned to the required frequency by the valve and wiring capacitances. Since the bandwidth is fairly large, variable tuning can often be dispensed with. At a frequency of 200 Mc/s the input resistance of each triode section is approximately $2\text{ k}\Omega$ and the equivalent noise resistance approximately $500\ \Omega$.

2. The ECC 81 as R.F. amplifier in a grounded-grid circuit

The circuit diagram reproduced in Fig. 3 differs from that of Fig. 2 in that the signal is applied to the cathodes of the triodes instead of to the grids. The grids shield the input circuit from the anodes, so that it is no longer necessary to apply neutralisation, which simplifies the circuit.

In the grounded-grid arrangement the input resistance of each system is much smaller than in the grounded cathode circuit. The input resistance is the reciprocal value of the mutual conductance, i.e. for one section of the ECC 81 it is approximately $180\ \Omega$. The low input resistance results in a low voltage gain in the input circuit. On the other hand the bandwidth becomes so large that several channels can be received without retuning the R.F. stage. Variable tuning of the local oscillator therefore suffices. The intermediate frequency should be chosen so high that image frequencies fall outside the television band.

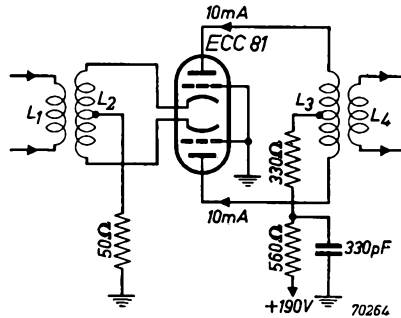

Fig. 3
The ECC 81 as R.F. amplifier in a grounded-grid circuit, with the two sections in push-pull.

3. The ECC 81 as R.F. amplifier in a cascode circuit

It is possible to combine the advantages of the grounded-cathode with that of the grounded-grid circuit. Using the two sections of an ECC 81 valve in cascade with the first section in a grounded cathode and the second section in a grounded-grid circuit gives the combined circuit the high input resistance of the grounded-cathode arrangement and the favourable shielding between input and output of the grounded-grid circuit. The complete circuit is given in Fig. 4.

Since the input resistance of the second stage is $1/S$, the voltage gain of

the first stage is unity. Neutralisation by means of L_3 is therefore not used to prevent instability, but to reduce noise. The noise decreases with decreasing feedback from anode to grid. The inductance of L_3 is so chosen that it resonates with the anode-to-grid capacitance at the signal frequency, so that the impedance between anode and grid becomes very high.

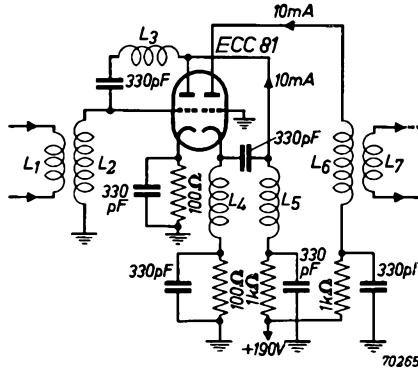

Fig. 4
The ECC 81 as cascode amplifier.

The inductor L_5 is tuned to the signal frequency with the valve and wiring capacitances, whilst L_4 serves as an R.F. choke in the cathode lead of the second stage. For alternating currents the triode sections are connected in series, so that the alternating anode current of the first stage flows through the second stage. The voltage gain between the grid of the first stage and the anode of the second is therefore SR_a , where S is the mutual conductance of one triode and R_a the load measured across L_6 .

Owing to the current feedback in the grounded-grid stage the load of the first stage is practically noise-free. The noise is therefore determined by the first triode, so that the combination has the low noise of a triode amplifier and the shielding between input and output of a pentode. The gain is also identical to that of a pentode with mutual conductance S .

4. The ECC 81 as frequency changer

If the R.F. stage in a television receiver is designed to have a large bandwidth, and consequently a low gain, an appreciable reduction in noise can be obtained by using a triode for frequency conversion. A circuit diagram in which one triode section of an ECC 81 valve is used as mixer and the other as local oscillator is given in Fig. 5.

The oscillator voltage is applied to the mixer grid via a small capacitor of 1 to 2 pF, which again can be obtained by twisting together two short lengths of insulated wire. Adjustment of this capacitor to such a value that a grid current of slightly less than 1 μ A flows in the grid leak of 1 M Ω gives optimum conversion conductance. The oscillator voltage at the grid is then

ECC 81

between 2 and 2.5 V_{rms} , and the conversion conductance 2 mA/V. Automatic bias is obtained for the mixer section by means of the cathode resistor of 500 Ω , which prevents overloading of the triode if the oscillator voltage should fail.

With a combination of the circuits represented in Figs. 2 and 5 at a signal frequency of 200 Mc/s a voltage gain of approximately 15 R_a can be obtained, where R_a is the impedance in the anode circuit of the mixer. This figure refers to an aerial impedance of 70 Ω . With a total receiver bandwidth of 5 Mc/s and an aerial E.M.F. of 6.6 μV the signal-to-noise ratio measured at the output is then unity. With optimum matching of the input this signal corresponds to 3.3 μV at the input terminals of the receiver.

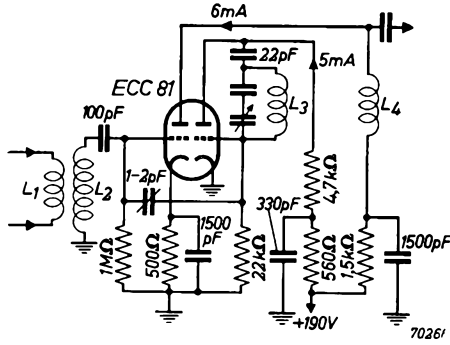

Fig. 5
Frequency changer circuit using the ECC 81, in which one section serves as mixer and the other as local oscillator.

DATA OF THE ECC 81

Heater data

Heating: indirect by A.C. or D.C.; series or parallel supply

Heater voltage $V_f = 6.3$ 12.6 V

Heater current $I_f = 0.3$ 0.15 A

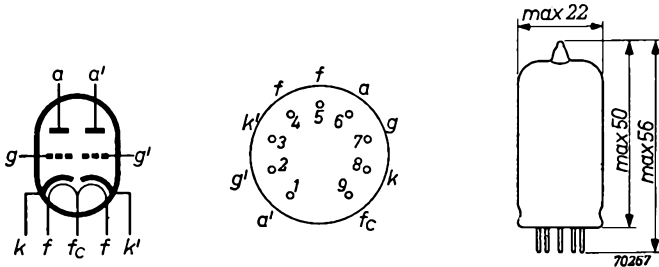

Fig. 6
Base connections and dimensions of the ECC 81.

Capacitances (measured on the cold valve)

		Section 1	Section 2
Input capacitance	C_g	= 2.3	2.3 pF
Output capacitance	C_a	= 0.4	0.35 pF
Capacitance between anode and grid	C_{ag}	= 1.6	1.6 pF
Capacitance between anode and cathode	C_{ak}	= 0.18	0.18 pF
Capacitance between heater and cathode.	C_{fk}	= 2.5	2.5 pF
Capacitance between cathode and grid + heater	$C_{k(g+f)}$	= 4.8	4.8 pF
Capacitance between anode and grid + heater	$C_{a(g+f)}$	= 1.9	1.8 pF
Capacitance between the two grids	$C_{gg'}$		< 0.005 pF
Capacitance between the two anodes	$C_{aa'}$		< 0.4 pF

Typical characteristics (for each section)

Anode voltage	V_a	= 100	170	200	250 V
Grid voltage	V_g	= -1*)	-1*)	-1*)	-2 V
Anode current	I_a	= 3.0	8.5	11.5	10 mA
Mutual conductance	S	= 3.5	5.5	6.4	5.0 mA/V
Amplification factor	μ	= 58	66	66	60

Limiting values (each section)

Anode voltage at zero anode current	V_{a_0}	=	max. 550 V
Anode voltage	V_a	=	max. 300 V
Anode dissipation	W_a	=	max. 2.5 W
Cathode current	I_k	=	max. 15 mA
Heater voltage during warming up period (for V_f normal = 6.3 V)			max. 9.5 V**)
(for V_f normal = 12.6 V)			max. 19 V**)
Voltage between heater and cathode	V_{fk}	=	max. 90 V
Negative grid voltage	$-V_g$	=	max. 50 V
External resistance between control grid and cathode, with automatic bias	R_g	=	max. 1 MΩ
External resistance between heater and cathode.	R_{fk}	=	max. 20 kΩ

*) At this adjustment grid current may occur. In cases where this is inadmissible it is advisable to adjust the bias to -1.5 V.

***) When the ECC 81 is used in a receiver or any other circuit with series-connected heaters it is necessary to use a device limiting the initial current after switching on. This may be an NTC resistor in series with the heater chain.

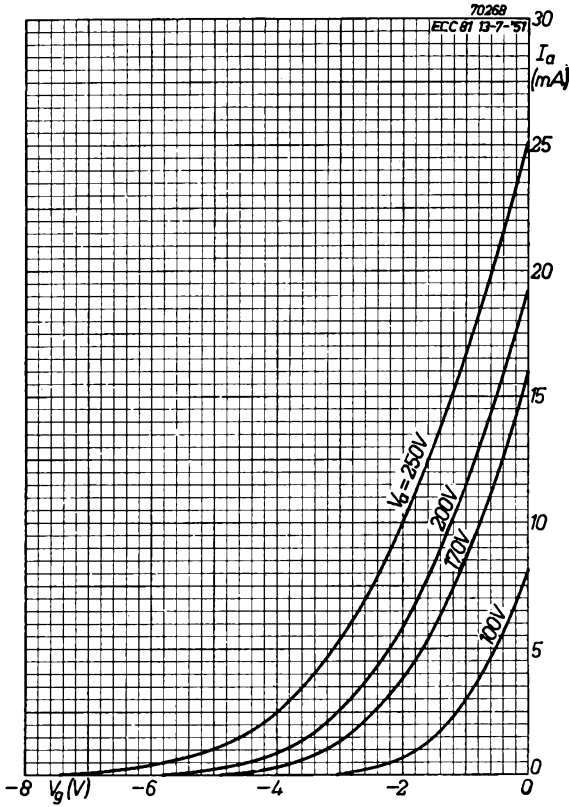
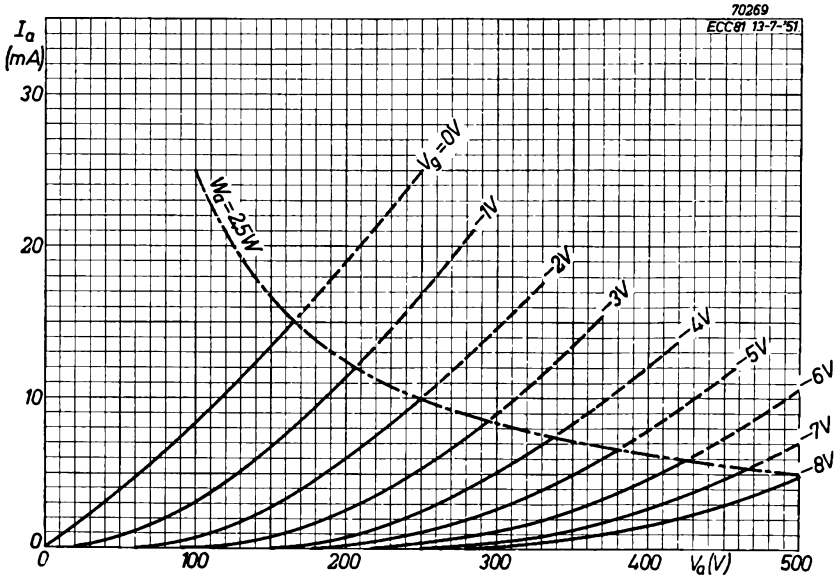

Fig. 7
Anode current plotted against grid voltage, with anode voltage as parameter (one section).

Fig. 8
Anode current plotted against anode voltage, with grid voltage as parameter (one section).



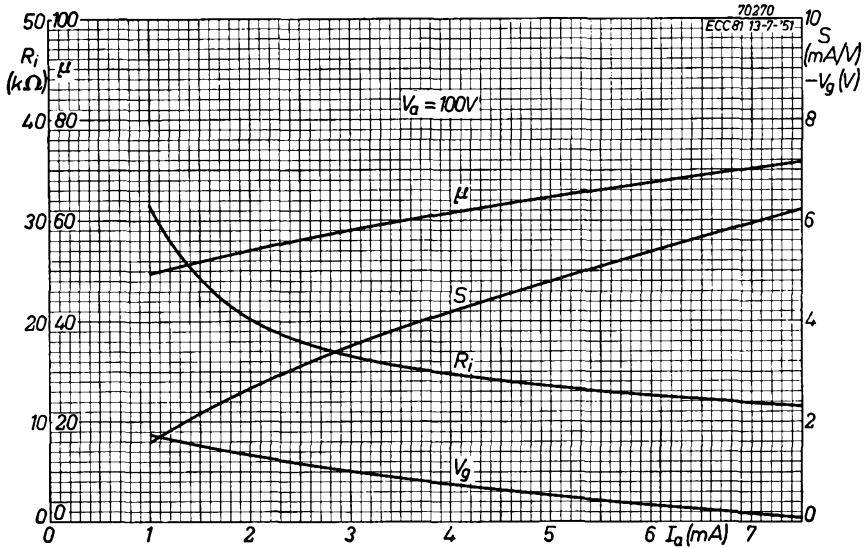

Fig. 9

Mutual conductance, amplification factor, internal resistance and grid voltage plotted against anode current, for anode voltage of 100 V (one section).

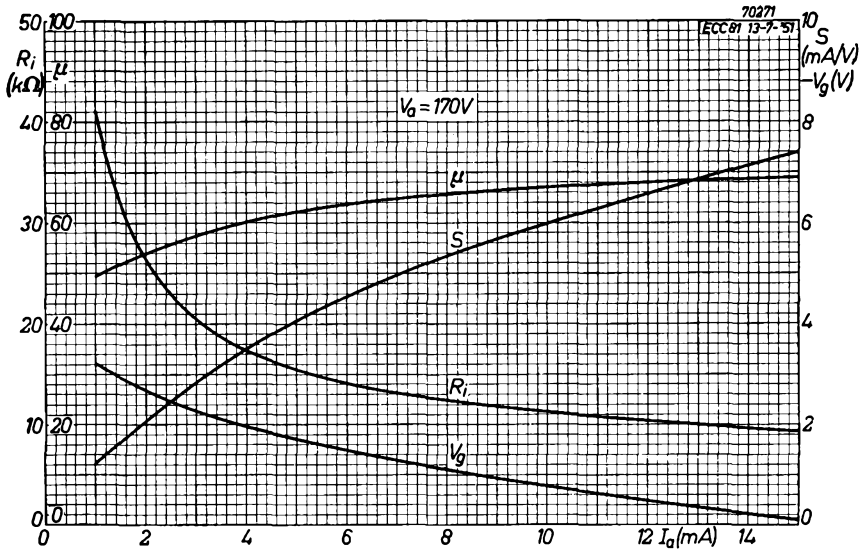

Fig. 10

As fig. 9, but for an anode voltage of 170 V.

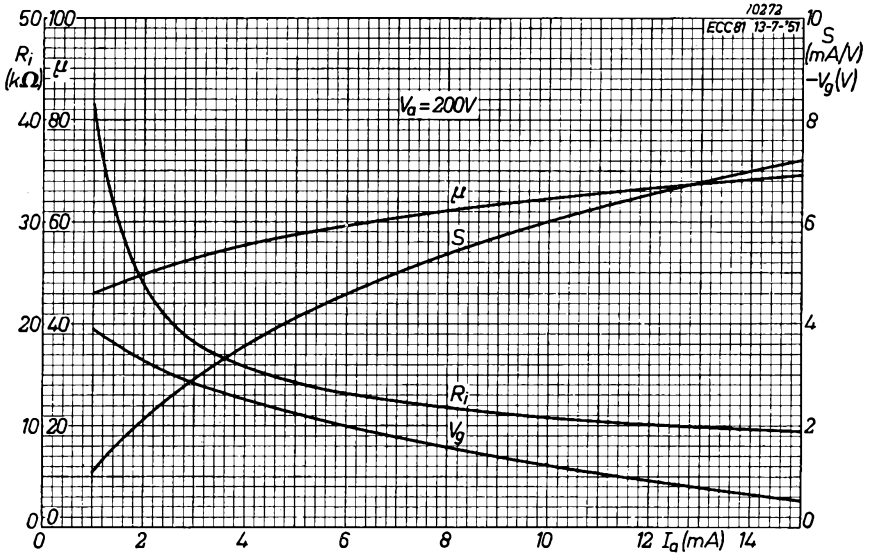

Fig. 11
As fig. 9, but for an anode voltage of 200 V.

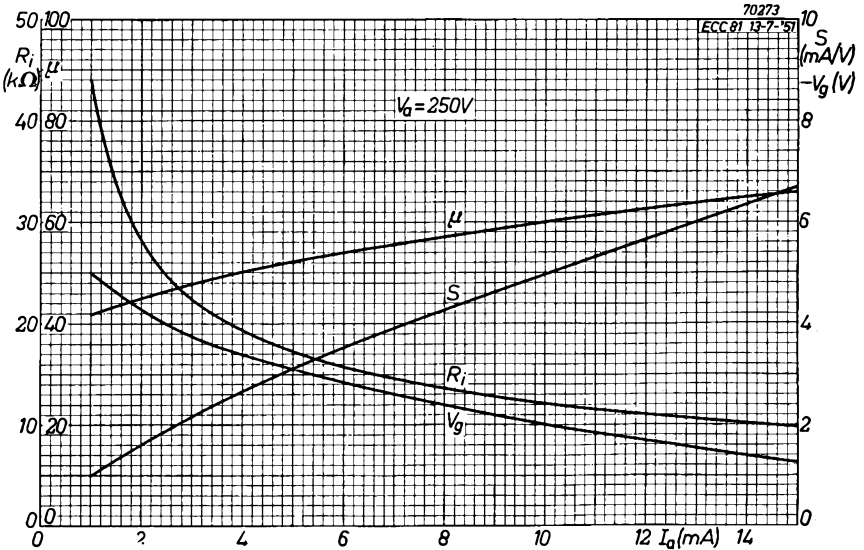

Fig. 12
As fig. 9, but for an anode voltage of 250 V.

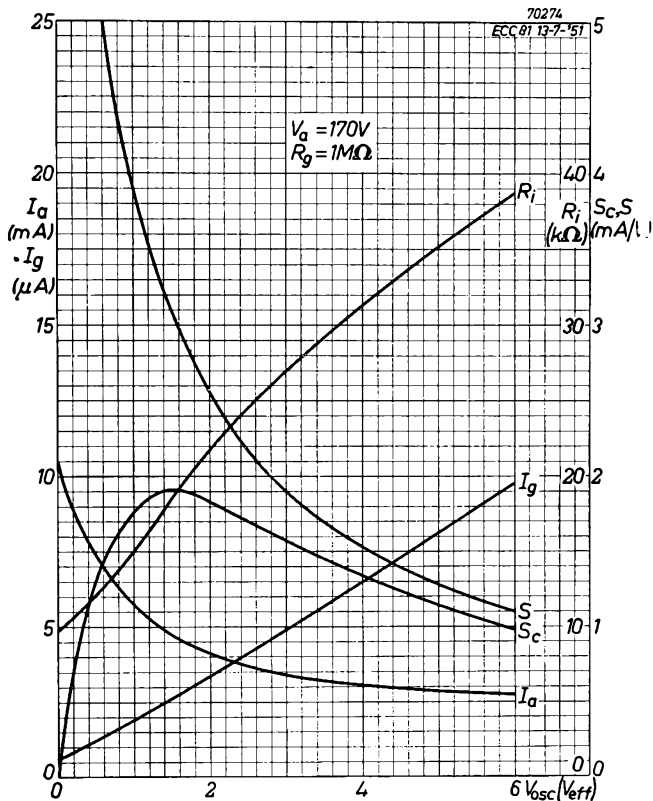

Fig. 13

Performance curves of the ECC 81 as mixer operating at an anode voltage of 170 V, without cathode bias resistor. S is the effective mutual conductance for a signal of 100 mV at intermediate frequency.

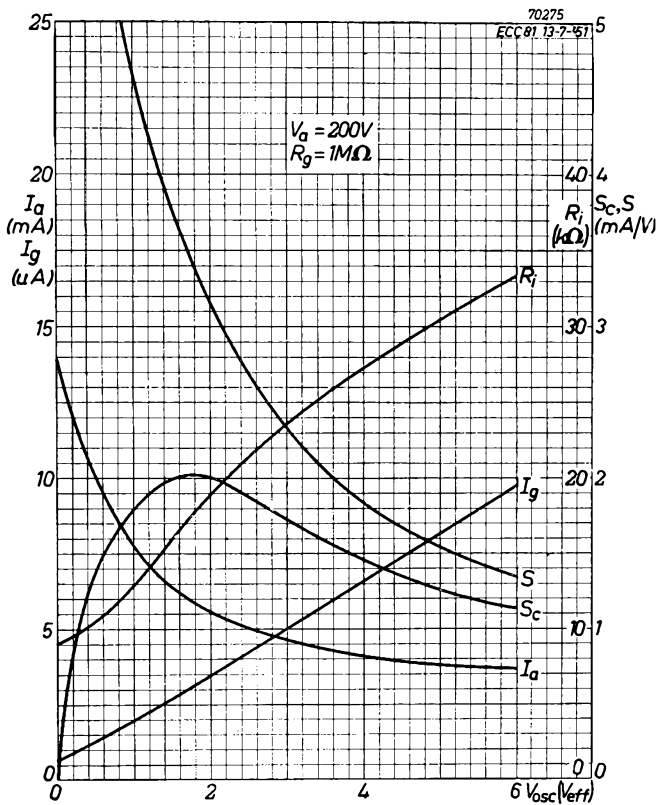

Fig. 14

As fig. 13, but for an anode voltage of 200 V.

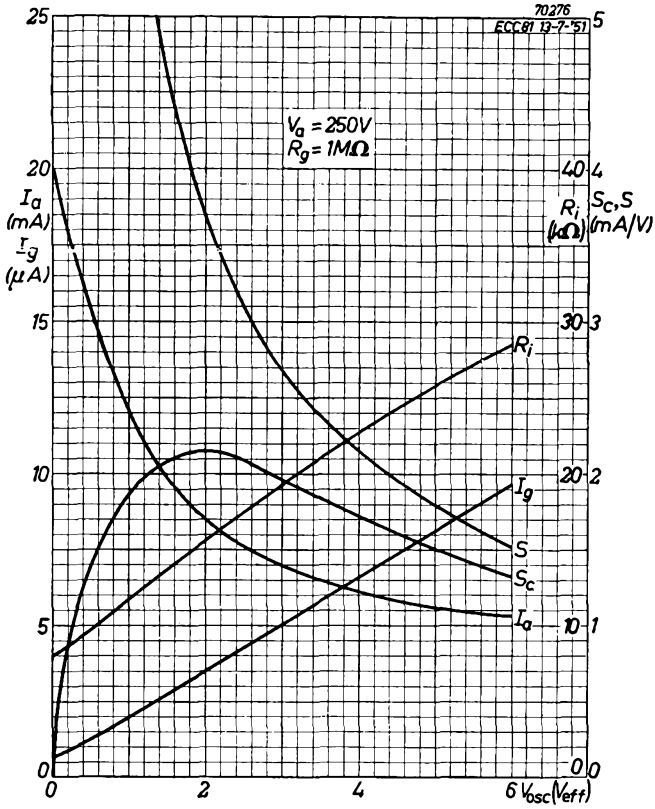

Fig. 15
As fig. 13, but for an anode voltage of 250 V.

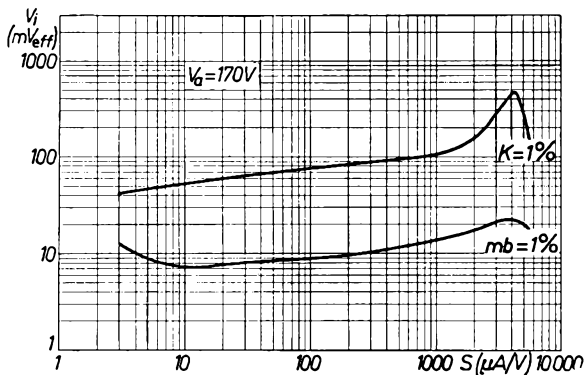
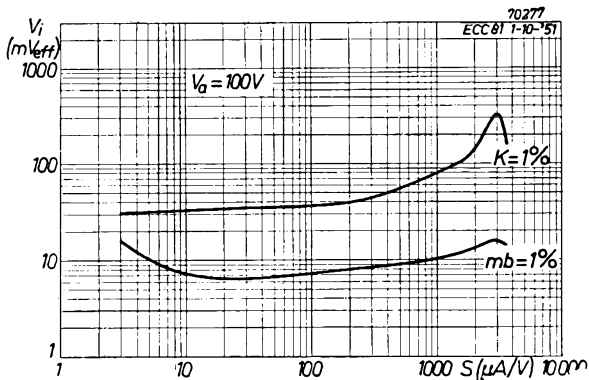

Fig. 16

R.m.s. value of an interfering signal which results in a cross modulation of $K = 1\%$, and hum voltage giving a modulation hum of 1% , plotted against the mutual conductance, for anode voltages of 100 and 170 V respectively.

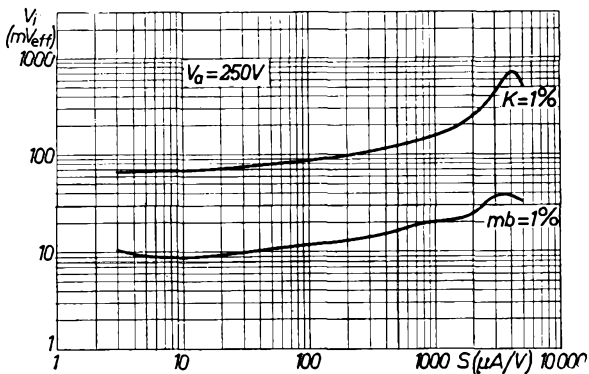
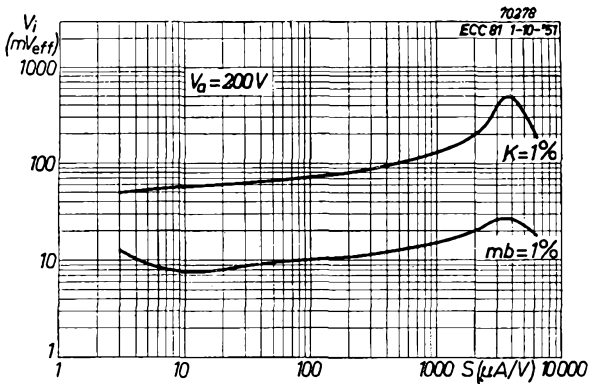

Fig. 17
As fig. 16, but for anode voltages of 200 and 250 V respectively.

The RF pentode EF 80

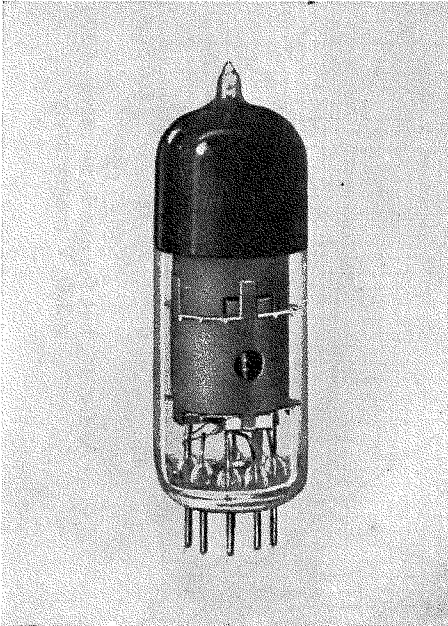

Fig. 1
The R.F. pentode EF 80 (about actual size).

Description

The EF 80 is a high-slope R.F. pentode on the Noval base, designed primarily for wide-band R.F. and I.F. amplification in television receivers. Its characteristics render the valve suitable for use also as a video amplifier, as a frequency changer, and in some forms of synchronizing-pulse separator circuits. As with other valves in the range, the EF 80 can be used with an H.T. line voltage of 170 V without sacrificing performance. A line voltage of about 170 V is commonly encountered in television receivers with a transformerless supply system when the mains voltage is 220 V. Due to the provision of two cathode leads, the input conductance has been reduced, and this is of particular importance at the higher frequencies in the television bands.

Application

1. The EF 80 as I.F. amplifier

The carrier frequencies of the low television band for channels I to IV of the 625 line system lie between about 40 and 70 Mc/s. Two possible circuit arrangements are available for the amplification of these signals to a level suitable for video detection. In receivers intended for the reception of one channel only a T.R.F. amplifier can be used but, owing to the high carrier frequencies, efficient screening is required, whilst it is also difficult to adapt such a receiver for the reception of more than one channel. A superhet arrangement is therefore often preferred and most of the gain is then provided by the I.F. amplifier, the preceding stages mainly serving for frequency conversion and some pre-selection. Moreover, the frequency response of the R.F. stage of the receiver is usually very flat, so that the shape of the response curve of the receiver is almost entirely determined by the I.F. circuits.

A normal figure for the required I.F. signal at the video detector for average

picture contrast with a direct-viewing picture tube and one stage of video amplification is 2 V. Assuming that one stage of R.F. amplification and a frequency changer are employed, giving a total gain of 20 between the aerial terminals and the grid of the first I.F. tube, a total I.F. gain of 10 000 is required when the sensitivity at the centre frequency of the pass band has to be 10 μ V, and one of 1000 when a sensitivity of 100 μ V is considered sufficient. A convenient figure for the 3 db bandwidth with the 625 line system is 5 Mc/s and, in order to keep image frequencies outside the television band and to minimize feedback of harmonics of the detected I.F. signal into the first stages of the receiver, the centre of the I.F. band should be chosen at about 21 Mc/s. In the high band from 174 to 216 Mc/s a higher intermediate frequency is often used.

A basic diagram for a four-stage stagger-tuned I.F. amplifier is given in Fig. 2. A very useful characteristic quantity of a valve is the product of gain and bandwidth, GB , which is equal to $S/2\pi(C_i + C_o)$, in which S is

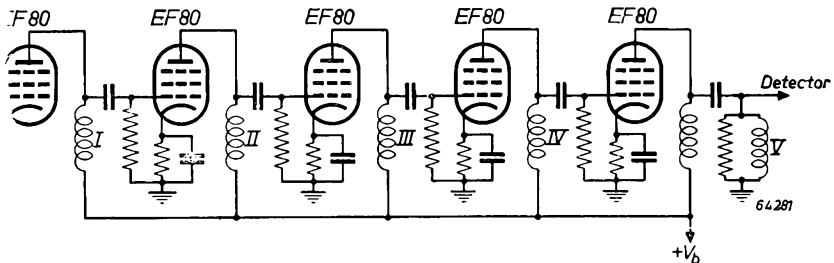

Fig. 2

Simplified diagram of a four-stage I.F. amplifier with staggered tuning.

the static mutual conductance and C_i and C_o are the input and output capacitances respectively. With the EF 80 this figure is 110 and this would imply that a voltage gain of 22 could be achieved when the 3 db bandwidth of the anode circuit is 5 Mc/s. However, the GB figure is purely a valve characteristic and therefore does not take into account the unavoidable increase in total capacitance of the anode circuit caused by the wiring and the distributed capacitance of the coil. Moreover, the GB figure is given for the cold capacitance of the valve and for a valve in operation the actual capacitances are somewhat greater. A practical figure for the product GB of the EF 80 is 55 when the capacitance in the anode circuit is not intentionally increased, which implies tuning of the circuits by means of slugs of powdered iron. A stage gain of 11 can therefore be obtained when the bandwidth is 5 Mc/s. This method of calculation may also be applied to a stagger-tuned amplifier when the circuits are mutually detuned and damped according to the method of flat staggering.

A four-stage amplifier with EF 80 will therefore provide a total I.F. gain of 10,000 and one with three stages a total gain of 1000. With these figures allowance is made for some decrease in gain due to the inclusion of trap circuits for the suppression of sound, adjacent sound and adjacent picture

signals. Also the inclusion of small non-bypassed cathode resistors, for compensating the variation of the input capacitance of the valves caused by the contrast control, will result in a somewhat lower gain. A simple method for determining the tuning frequencies of each of the five tuned circuits of the four-stage amplifier of Fig. 2 and the required bandwidths of each circuit will now be given.

From a semi-circle, subdivided into 5 equal parts, a perpendicular is dropped to the diameter from the centre of each part (see Fig. 3). The scale of this

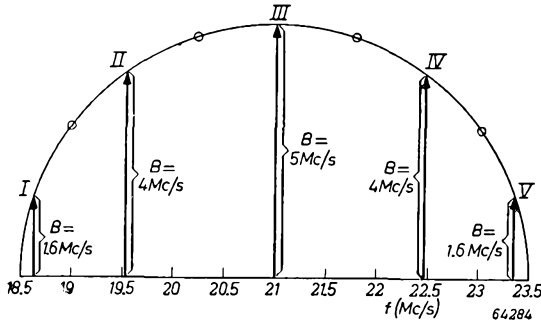

Fig. 3
Stagger diagram for a four-stage I.F. amplifier
centred at 21 Mc/s.

figure should be so chosen that the diameter represents the required 3 db bandwidth of the whole amplifier, which in the present case is 5 Mc/s. The base of the central perpendicular now represents the centre of the I.F. band and the horizontal distances of the other perpendiculars represent the detuning of the other circuits with respect to this centre. Moreover, the length of each perpendicular gives half the required bandwidth of each circuit. The tuning frequencies and bandwidths of the circuits of Fig. 2 may now be tabulated as follows:

Circuit No.	Tuning frequency	Bandwidth
I	18.6 Mc/s	1.6 Mc/s
II	19.5 Mc/s	4 Mc/s
III	21 Mc/s	5 Mc/s
IV	22.5 Mc/s	4 Mc/s
V	23.4 Mc/s	1.6 Mc/s

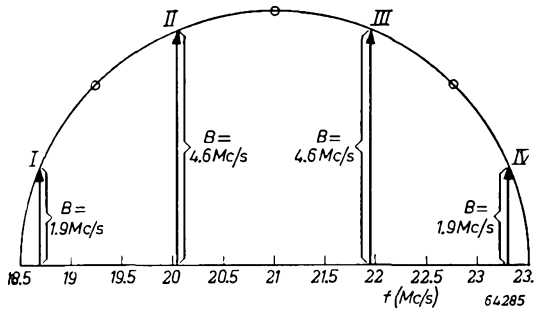

Fig. 4
Stagger diagram for a three-stage I.F. amplifier
centred at 21 Mc/s.

The staggering scheme for a three-stage I.F. amplifier, also with a bandwidth of 5 Mc/s and a centre frequency of 21 Mc/s is shown in Fig. 4. Such an amplifier with three EF 80 valves provides a gain of 1000 and the stagger frequencies and bandwidths are:

Circuit No.	Tuning frequency	Bandwidth
I	18.7 Mc/s	1.9 Mc/s
II	20.05 Mc/s	4.6 Mc/s
III	21.95 Mc/s	4.6 Mc/s
IV	23.8 Mc/s	1.9 Mc/s

From this stagger diagram it appears that it is not always necessary to have a circuit tuned to the centre frequency. In fact such a circuit will only occur in an amplifier having an uneven number of tuned circuits. The required bandwidth of each individual circuit is usually obtained in the following way. All coils of the amplifier are given equal Q 's and the bandwidth of each circuit is adjusted to the desired value by choosing a suitable value for the grid leak resistor (Fig. 2). In determining the value of this resistor it is not necessary to take the input damping of the EF 80 into account, this damping having a very small value. The damping on the last I.F. circuit caused by the detector diode, however, may be quite considerable, its value being approximately equal to the diode load. When the smallest bandwidth of the circuits is obtained from the stagger diagram the minimum Q of the coils may be calculated with the aid of the following formula:

$$Q = \frac{f_0}{B}$$

EF 80

in which f_0 is the tuning frequency of the circuit in question and B the bandwidth. For instance, the minimum Q of circuit No. I in the stagger diagram of Fig. 3 is $Q = 18.6/1.6 = 11.6$. In the examples given above the total tuning capacitances have been assumed to be 22 pF, which is about twice the sum of the input and output capacitances of the valve. The total parallel resistance of the circuit is now:

$$R = \frac{Q}{2\pi f_0 C} = \frac{11.6}{2\pi \times 18.6 \times 10^6 \times 2.2 \times 10^{-11}} = 4500 \Omega.$$

Assuming the actual coil Q to be 25, this being a value which can easily be attained in practice, the parallel resistance of the circuit would be:

$$\frac{25}{11.6} \times 4500 = 9700 \Omega.$$

In order to arrive at the required total parallel resistance of 4500 Ω , a grid leak of 8400 Ω should be chosen in this case. The grid leaks of the other stages can now be calculated in a similar way.

Referring once more to Fig. 3, it will be clear that in the case of large numbers of mutually detuned circuits the bandwidths of the outermost circuits in the stagger diagram may become inconveniently small. This difficulty can be avoided by using two or more identical staggered groups in cascade, but this involves some loss of total gain. According to this method a five-stage amplifier, i.e. with six tuned circuits, can be composed of 2 identical groups of 3 circuits or of 3 groups of 2 circuits. If, however, the 3 db bandwidth of each group is again chosen equal to the required total bandwidth of the amplifier, the drop at the limits of the total pass band will be 6 db when two identical groups are employed, and 9 db in the case of three groups in cascade. It is therefore necessary to give each group a bandwidth greater than the total bandwidth of the amplifier. The factors with which the required total bandwidth of the whole amplifier must be multiplied to obtain the bandwidth of each group can be found in the following table.

Number of staggered circuits in each group	Number of identical groups				
	1	2	3	4	5
1	1	1.56	1.96	2.27	2.56
2	1	1.25	1.41	1.54	1.61
3	1	1.16	1.25	1.32	1.37
4	1	1.11	1.19	1.23	
5	1	1.09	1.15		
6	1	1.075	1.11		
7	1	1.05			

From this table it appears that the required bandwidth of each group increases with the number of groups employed. In an amplifier with six tuned circuits, for example, the factor is 1 in the case of one staggered group, 1.16 for two identical groups of three circuits and 1.41 for three groups of two staggered circuits. In the latter case when the total bandwidth of the amplifier has to be 5 Mc/s each group must have a bandwidth of 7 Mc/s and, since the product of gain and bandwidth is constant for a given type of tube, the result will be a smaller gain.

It is interesting to note the difference in performance with regard to gain between an amplifier employing circuits all tuned to the same frequency and a stagger-tuned amplifier. The four-stage stagger-tuned amplifier of Fig. 2 gives a gain of 10,000. In another four-stage amplifier, however, in which the five circuits are all tuned to the same frequency, the bandwidth of each individual circuit would have to be 2.56 times the required total bandwidth. Whilst the gain per stage of the stagger-tuned amplifier was 10, in the latter case this would be reduced to about 4, giving a total gain of $4^4 = 256$.

The inclusion of traps for the suppression of the sound carrier and for adjacent sound and picture signals will influence the shape of the response curve of the I.F. amplifier. This will usually necessitate small corrections of the tuning frequencies and dampings of the I.F. circuits when these are determined according to the method represented in Figs. 3 and 4.

Also the sequence of the circuits will often be chosen differently, for various reasons, although this does not influence the shape of the response curve. The first stages of the picture I.F. amplifier are often also used to amplify the I.F. sound signal, which is usually tapped off after the second I.F. stage. Economies may then be effected in the design of the sound I.F. amplifier by choosing the most favourable stagger frequencies with regard to sound I.F. amplification for the first stages of the picture I.F. amplifier. This, however, often conflicts with the requirements of picture contrast control and a compromise must then be sought.

The contrast of the television picture is normally adjusted by varying the bias of the valves in the first stages of the receiver. Owing to unavoidable oscillator-frequency shift the bias of the mixer stage must not be varied and contrast control must therefore be achieved by varying the bias of the R.F. stage and of the first two I.F. stages. Variation of the bias, however, results in a variation ΔC_i of the input capacitances of the valves and this may upset the total response curve of the receiver. Therefore, those I.F. circuits from the stagger diagram having the largest bandwidths should be used to precede those valves of which the grid bias is varied, as this keeps the influence of the contrast control upon the total response curve as small as possible. As may be seen from the curves given in Fig. 18, when the slope of the valve is varied between 7.4 and 0.74 mA/V the variation in input capacitance of the EF 80 is 1.95 pF. This variation may be inadmissible and special methods are available to reduce this variation. A simple and efficient form of ΔC_i compensation is briefly described below.

Compensation of input capacitance and resistance variation

To give a complete explanation of this method it would be necessary to consider many effects, including those of lead inductances, stray capacitances and transit time. The practical value of such an analysis is, however, limited, as lead inductances and stray capacitances occurring in production cannot be accurately predicted. The most favourable values of the components for compensating the variation in input capacitance and resistance are therefore normally determined by experiment, but the main principles should, of course, be understood.

In the basic circuit of Fig. 5 a non-bypassed resistor is included in the cathode lead, C representing the capacitance between grid and cathode of the valve. Due to electronic effects this capacitance varies with the bias. In the cut-off condition C has a value of 7.2 pF, this gradually increasing to about 9.8 pF when the grid bias is reduced to -2 V. In the first case the effective capacitance measured across the input terminals is practically 7.2 pF, R having a low value compared with the reactance of C . In normal operation, however, a voltage V_R occurs across the cathode resistor, so that the voltage across C is reduced by the factor $1/(1 + SR)$, in which S is the static mutual conductance of the valve. The object now is to keep the charging current of C constant, so that the effective input capacitance of C is also kept constant. In the above example the factor $1 + SR$ should therefore have a value $9.8/7.2 = 1.36$, so that, since S is 7.4 mA/V, the cathode resistor must have a value of $0.36/S = 49 \Omega$.

This resistor would indeed be required for optimum compensation of the input capacitance variation, but the result would be that the effective mutual conductance of the valve is reduced by a factor $1/1.36 = 0.74$. A lower value of R still giving adequate compensation is therefore normally used, a practical value for the EF 80 being 27 Ω .

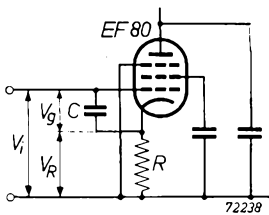

Fig. 5
Basic circuit for the compensation of input capacitance variation.

The variation in effective input resistance is also reduced by the inclusion of a non-bypassed cathode resistor. At cut-off, when the input resistance of the tube is very high, the input damping caused by the current flowing through C and R prevents the effective input resistance from reaching a very high value. However, this additional damping is also present in normal operation, so that, although the effective input resistance of the valve is somewhat increased by the effect of the negative feedback, the total effective input resistance measured across the input terminals will usually be slightly lower than that which would be obtained without a non-bypassed cathode resistor. This may be improved upon by shunting the cathode resistor by a small capacitor having a value of 5 to 10 pF.

2. The EF 80 as R.F. amplifier

As in all R.F. amplifiers, the connecting leads should be kept as short as possible in order to minimize stray capacitance and self-inductance. The lay-out should be such as to reduce the risk of feedback, a centre screen on the valve holder connected to the chassis being an advantage.

Normally, common decoupling may be employed for anode and screen. If trouble is experienced due to feedback through the anode-to-grid capacitance, it may be profitable to use separate decoupling for anode and screen, as this results in a lower effective feedback capacitance. At frequencies of 50 Mc/s and higher the effect of the input resistance of the valve becomes noticeable. In order to obtain the highest value of input resistance the cathode pins 1 and 3 should be interconnected.

In the frequency range from 100 Mc/s to 300 Mc/s the noise level due to static and cosmic noise is very low. The use of a triode may therefore be preferred at these frequencies.

3. The EF 80 as frequency changer

Fig. 6 shows a typical circuit for operation at the lower television carrier frequencies, in which one EF 80 pentode is used as R.F. amplifier and the other as self oscillating frequency changer.

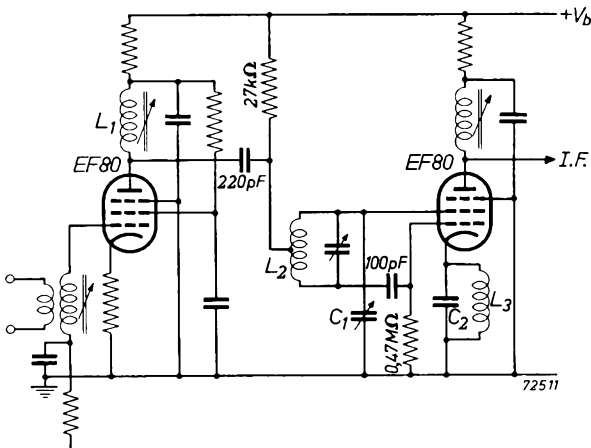

Fig. 6
Front end for a television receiver with one EF 80 as R.F. amplifier and the other as self-oscillating frequency changer.

The circuit of the R.F. stage is conventional in all respects. In this stage the grid and anode circuits are tuned by means of iron-dust slugs in the inductors, the tuning capacitances being formed by the valve and wiring capacitances. A variable bias for gain control is applied to the bottom of the

grid circuit, a non-bypassed resistor, which may have a value of 27Ω , being included in the cathode lead to reduce variations in input capacitance as a result of the gain control. The bypass capacitors for the anode circuit and the screen grid may have values of 1500 pF and should be of a type with low inductance, for example ceramic capacitors. A suitable value for the resistors in series with the H.T. supply is $1 \text{ k}\Omega$.

The signal at the anode of the R.F. valve is applied via a coupling capacitor to a tap on the oscillator circuit. Since the oscillator circuit is so adjusted that the oscillator voltage at the tap is a minimum, coupling between the oscillator and the R.F. input is negligible, so that there is no "pulling" of oscillator frequency when tuning the R.F. circuit.

The oscillator coil L_2 is tapped at the centre, and the oscillator voltage at this point is made a minimum by adjusting the capacitor C_1 connected between the screen grid and earth. In practice it is possible to use a capacitor of fixed value for C_1 .

The inductance of the oscillator coil should be small compared with that of the R.F. coil L_1 , and this can be achieved by using a high Q , high C oscillator circuit, and choosing the oscillator frequency higher than the signal frequency.

The amplitude of the oscillation should be that which gives a direct voltage in the order of 2.5 V across the oscillator grid resistor. This voltage can be determined by measuring the oscillator grid current, which should be approximately $5 \mu\text{A}$.

The input impedance of the frequency changer at carrier frequency is inherently low, mainly because the control grid is coupled to the screen. Owing to the large bandwidth employed in television this is no disadvantage. In receivers for F.M. broadcast reception, however, the required bandwidth is much smaller and the input impedance may then be increased by using a cathode capacitor C_2 , which will produce a negative component of input resistance. The value of this capacitor can best be determined experimentally by starting with, for example, 500 pF and reducing this progressively. The shunt coil L_3 , which is required for connecting the cathode to the chassis for D.C., should have a value of about one microhenry.

4. The EF 80 as video amplifier

The normal direct-view picture tube requires a maximum drive voltage of about 60 V peak-to-peak, including the synchronizing signal, derived from the video stage. This drive voltage can be delivered by an EF 80 operating with cathode compensation, when the required bandwidth is not too large. In the case of a projection tube, however, which requires a drive voltage of about 100 V peak-to-peak, a considerably greater anode current swing is required with the same anode load. A large bandwidth, normally involving a low value for the load, also requires a greater anode current swing. It is then advisable to use the PL 83 as video amplifier.

A suitable circuit with the EF 80 for driving a picture tube of the direct-viewing type is given in Fig. 7. Under quiescent conditions the valve is operated at an anode current of 6.5 mA and a screen-grid current of 1.8

mA. For 60 V peak-to-peak output voltage an anode current swing of 9.4 mA is required. The gain of the stage is 12.

A series peaking coil of $145\ \mu\text{H}$ shunted by $3.3\ \text{k}\Omega$ resonates with the input capacitance of the EF 80 at about 5 Mc/s, thus improving the response at the high video frequencies. Moreover, I.F. frequencies are attenuated by this series circuit. The shunt resistor is included to prevent overshoot. It is assumed that the black level of the input signal is at chassis potential. In this stage cathode compensation has been applied by shunting the cathode resistor with a capacitor of 470 pF. At high frequencies the negative feedback caused by the cathode resistor decreases as a result of the by-passing effect of the capacitor, thus compensating the loss in gain due to parasitic capacitances in the anode circuit. This compensation is effective up to 3.5 Mc/s.

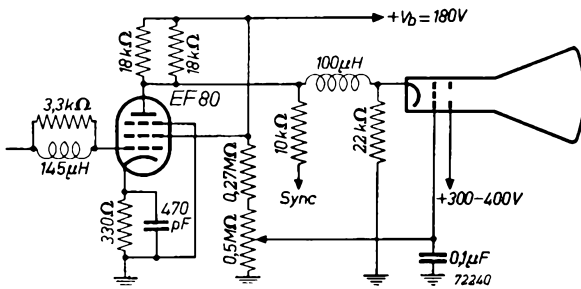

Fig. 7

The EF 80 as a video amplifier with cathode compensation.

A series peaking coil of $100\ \mu\text{H}$ between the anode of the EF 80 and the cathode of the picture tube extends the frequency characteristic to about 4.5 Mc/s. The self-capacitances of the compensating coils should be small, and wave winding is therefore recommended.

The output signal of the video stage is applied to the synchronizing pulse separator via a resistor of $10\ \text{k}\Omega$, thus preventing an increase in the capacitance of the anode circuit. Since direct coupling is used between the EF 80 and the cathode of the picture tube, a positive variable potential can be applied to the grid of the brightness control ($0.5\ \text{M}\Omega$ potentiometer). A direct voltage of 300-400 V with respect to the chassis is required for the second grid of the picture tube. In a receiver with a high-tension line voltage of about 180 V, this voltage may be taken from the booster capacitor in the line-output circuit.

DATA OF THE EF 80

Heater data

Heating: indirect by A.C. or D.C.; series or parallel supply

Heater voltage	V_f	=	6.3 V
Heater current	I_f	=	0.3 A

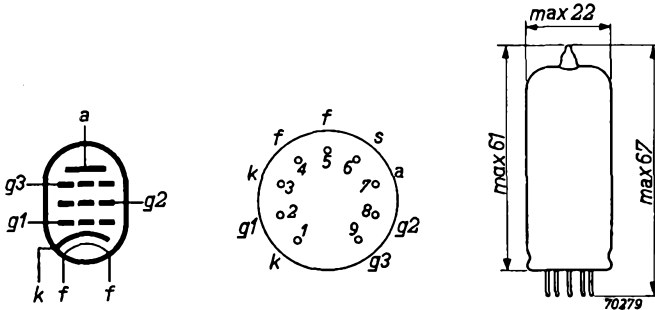

Fig. 8

Base connections and dimensions of the EF 80 pentode.

Capacitances (measured on the cold valve)

Input capacitance	C_{g1}	=	7.5 pF
Output capacitance	C_a	=	3.3 pF
Capacitance between anode and control grid	C_{ag1}	<	0.007 pF
Capacitance between anode and cathode	C_{ak}	<	0.012 pF
Screen-grid capacitance	C_{g2}	=	5.4 pF
Capacitance between screen grid and control grid	C_{g2g1}	=	2.6 pF
Capacitance between control grid and heater	C_{g1f}	<	0.15 pF
Capacitance between heater and cathode	C_{fk}	=	5.0 pF

Operating characteristics as R.F. or I.F. amplifier

Anode voltage	V_a	=	170	200	250 V
Suppressor-grid voltage	V_{g3}	=	0	0	0 V
Screen-grid voltage	V_{g2}	=	170	200	250 V
Control-grid voltage	V_{g1}	=	-2	-2.55	-3.5 V
Anode current	I_a	=	10	10	10 mA
Screen-grid current	I_{g2}	=	2.5	2.6	2.8 mA
Mutual conductance	S	=	7.4	7.1	6.8 mA/V
Internal resistance	R_i	=	0.4	0.55	0.65 MΩ

Amplification factor between screen grid and control grid	μ_{g2g1}	=	50	50	50
Equivalent noise resistance . .	R_{eq}	=	1	1.1	1.2 k Ω
Input damping at 50 Mc/s (socket pins 1 and 3 interconnected)	r_{g1}	=	10	12	15 k Ω

Limiting values

Anode voltage at zero anode current	V_{ao}	=	max.	550 V
Anode voltage	V_a	=	max.	300 V
Screen-grid voltage at zero screen-grid current.	V_{g2o}	=	max.	550 V
Screen-grid voltage	V_{g2}	=	max.	300 V
Control-grid current starting point (grid current + 0.3 μ A)	V_{g1}	=	max.	-1.3 V
Heater voltage during the warming-up period			max.	9.5 V
Voltage between heater and cathode	V_{fk}	=	max.	150 V
Cathode current	I_k	=	max.	15 mA
Anode dissipation	W_a	=	max.	2.5 W
Screen-grid dissipation	W_{g2}	=	max.	0.7 W
External resistance between control grid and cathode, with self bias	R_{g1}	=	max.	1 M Ω
with fixed bias	R_{g1}	=	max.	0.5 M Ω
External resistance between heater and cathode	R_{fk}	=	max.	20 k Ω

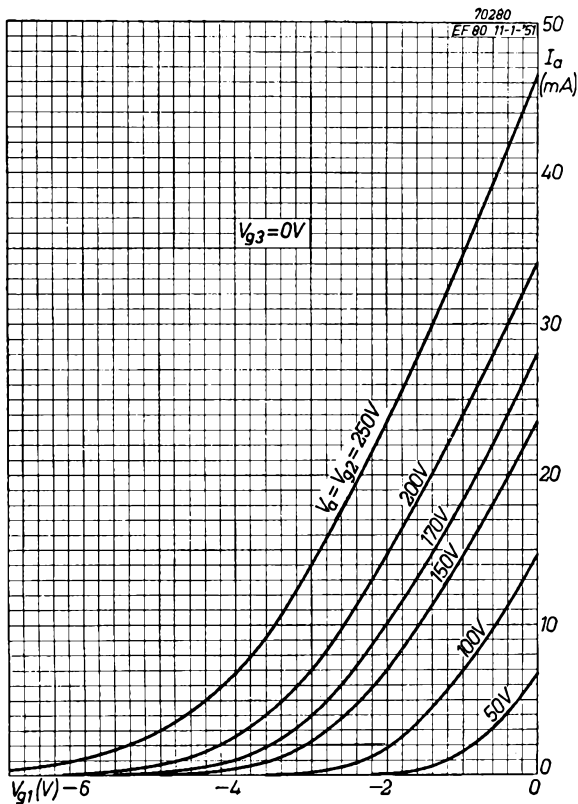

Fig. 9
Anode current plotted against control-grid voltage for anode and screen-grid voltages between 50 V and 250 V.

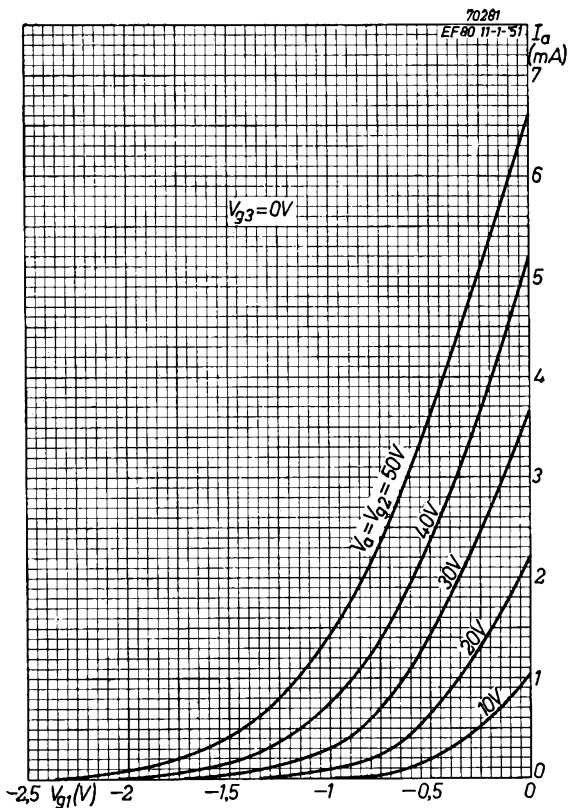

Fig. 10
Anode current plotted against control-grid voltage for anode and screen-grid voltages between 10 V and 50 V.

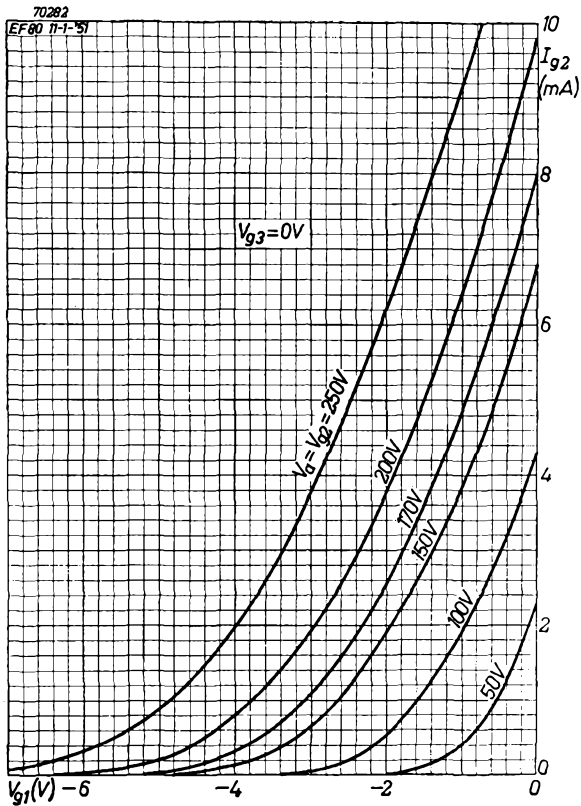

Fig. 11
Screen-grid current plotted against control-grid voltage for anode and screen-grid voltages between 50 V and 250 V.

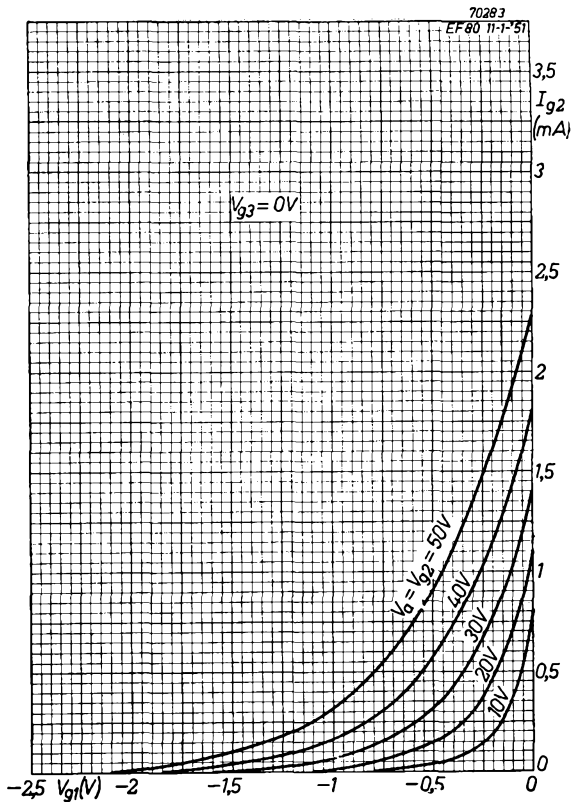

Fig. 12
Screen-grid current plotted against control-grid voltage for anode and screen-grid voltages between 10 V and 50 V.

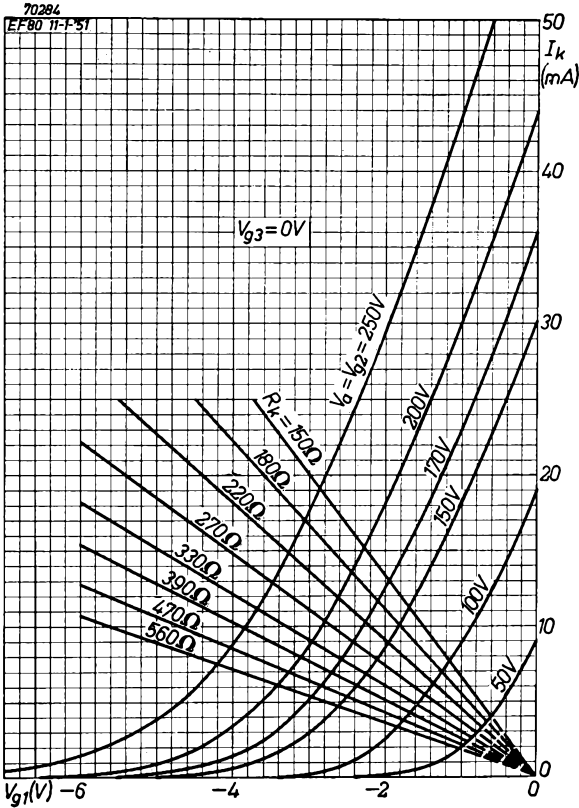

Fig. 13
Cathode current plotted against control-grid voltage, with anode and screen-grid voltage as parameter.

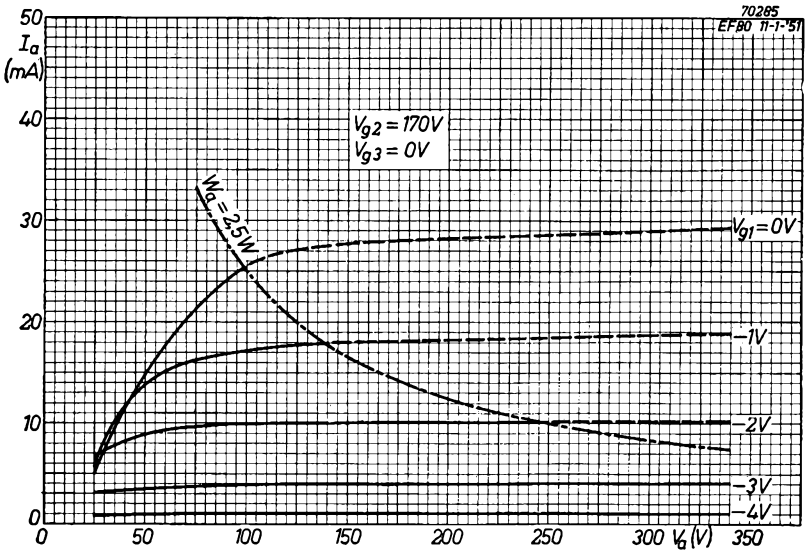

Fig. 14
Anode current plotted against anode voltage for screen-grid voltage of 170 V, with control-grid voltage as parameter.

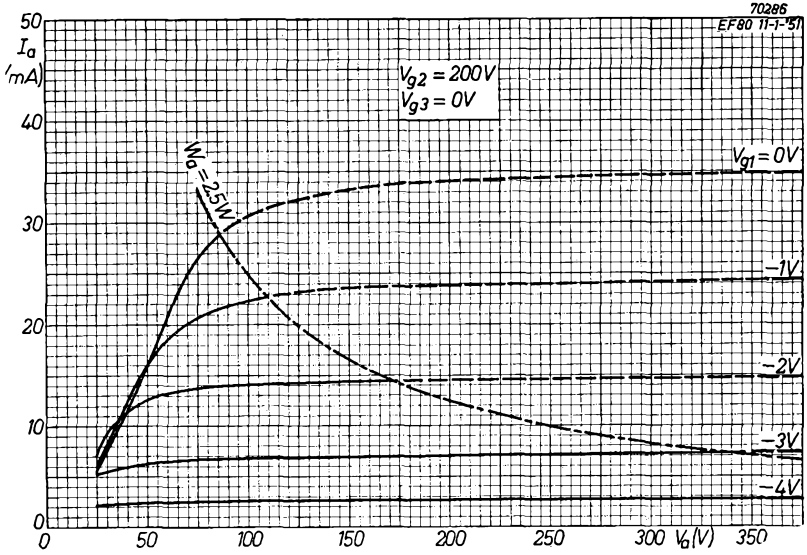

Fig. 15

Anode current plotted against anode voltage for screen-grid voltage of 200 V, with control-grid voltage as parameter.

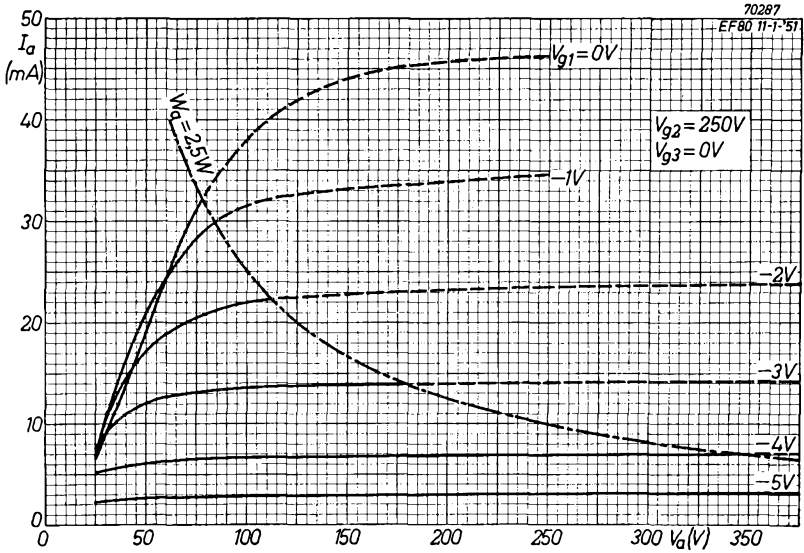

Fig. 16

Anode current plotted against anode voltage for screen-grid voltage of 250 V, with control-grid voltage as parameter.

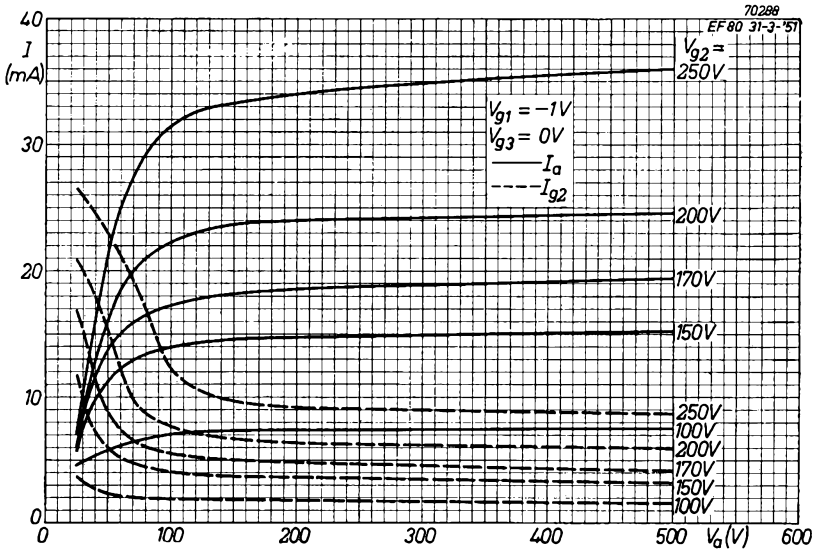

Fig. 17
Anode current and screen-grid current plotted against anode voltage for control-grid voltage of $-1V$, with screen-grid voltage as parameter.

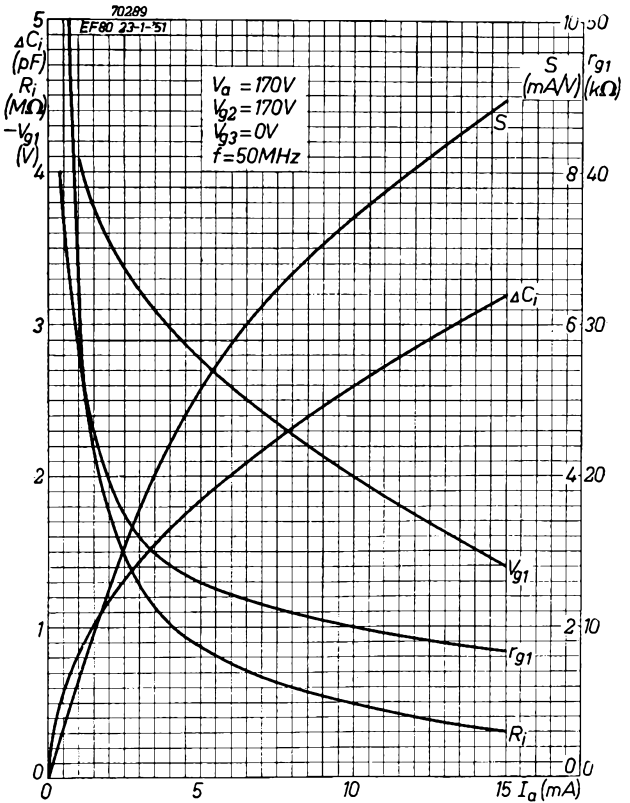

Fig. 18
Control-grid voltage, mutual conductance, internal resistance, input capacitance and input damping (at 50 Mc/s) plotted against anode current for anode and screen-grid voltage of 170 V.

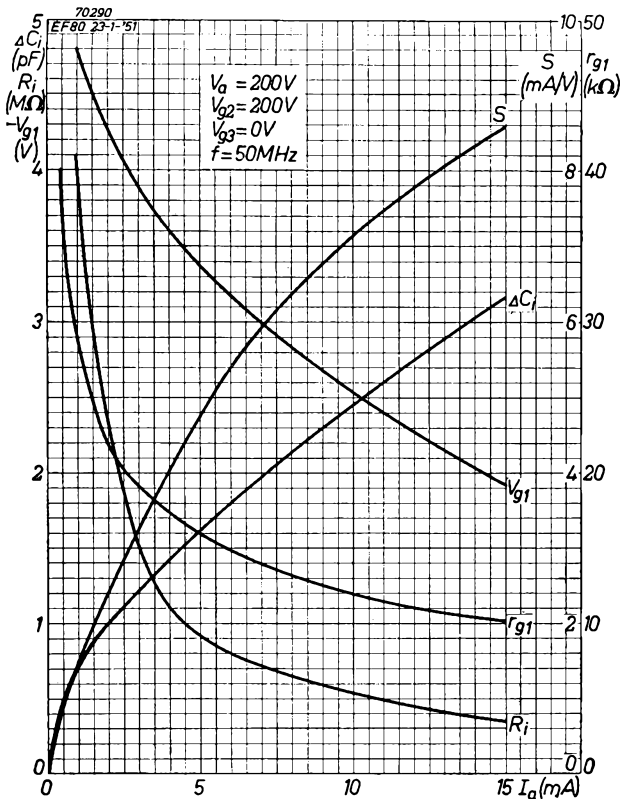

Fig. 19

Control-grid voltage, mutual conductance, internal resistance, input capacitance variation and input damping (at 50 Mc/s) plotted against anode current for anode and screen-grid voltage of 200 V.

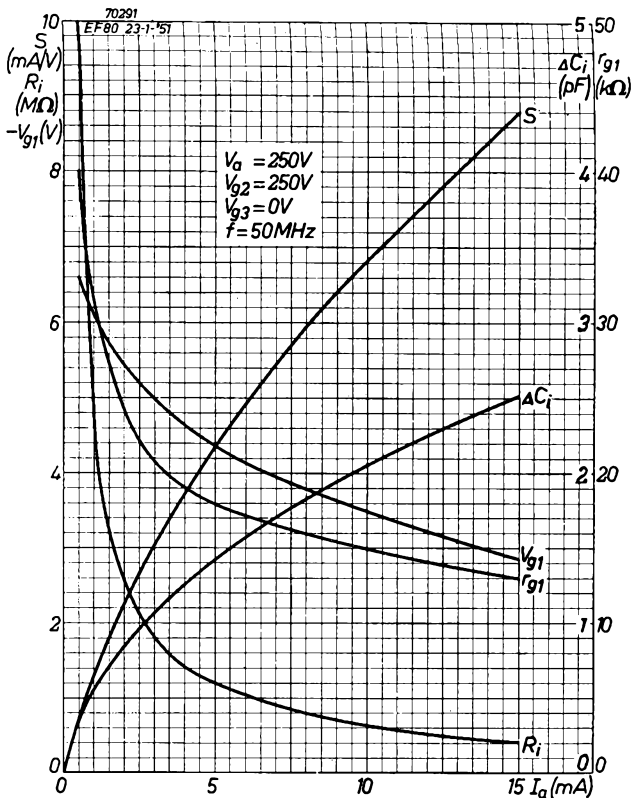

Fig. 20

Control-grid voltage, mutual conductance, internal resistance, input capacitance variation and input damping (at 50 Mc/s) plotted against anode current for anode and screen-grid voltage of 250 V.

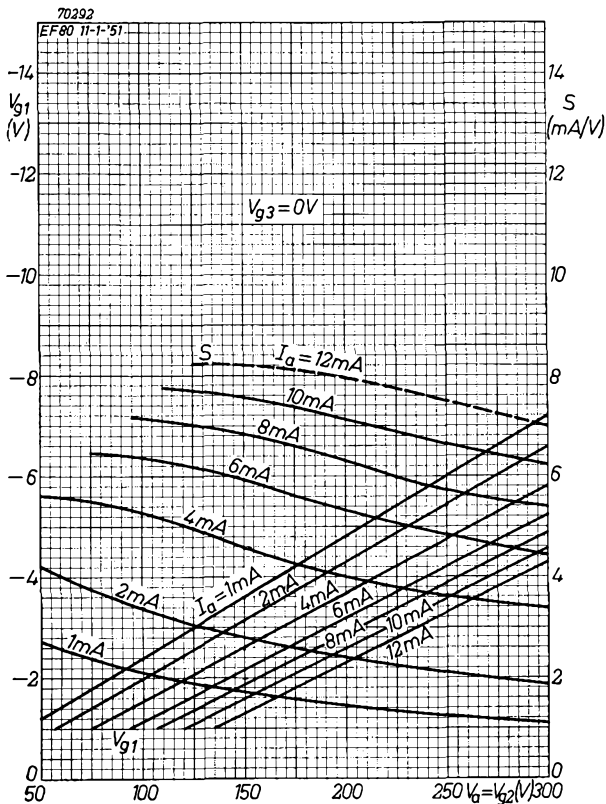

Fig. 21

Relation between control-grid voltage and mutual conductance and anode and screen-grid voltage, with anode current as parameter.

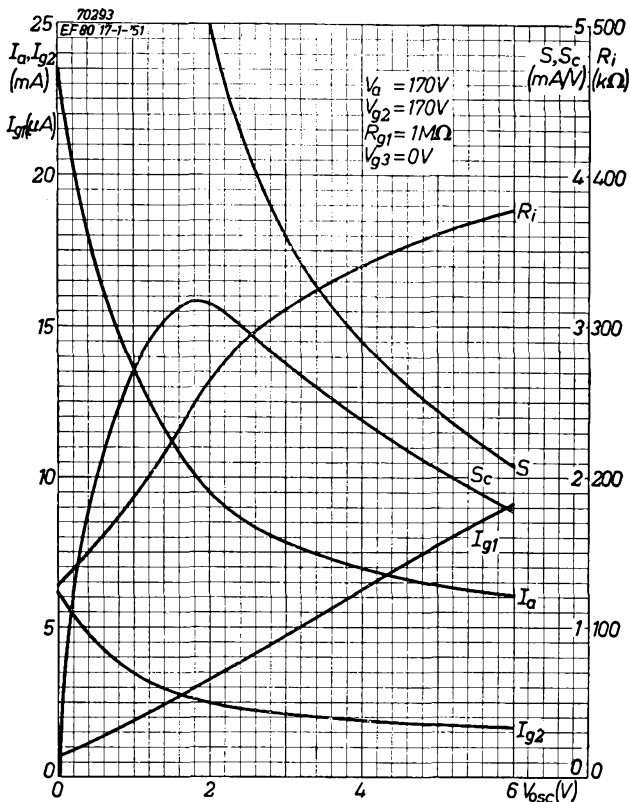

Fig. 22

Internal resistance, mutual conductance at a signal voltage of 100 mV, conversion conductance, control-grid current, anode current and screen-grid current, plotted against the oscillator voltage at the control grid, for anode and screen-grid voltages of 170 V.

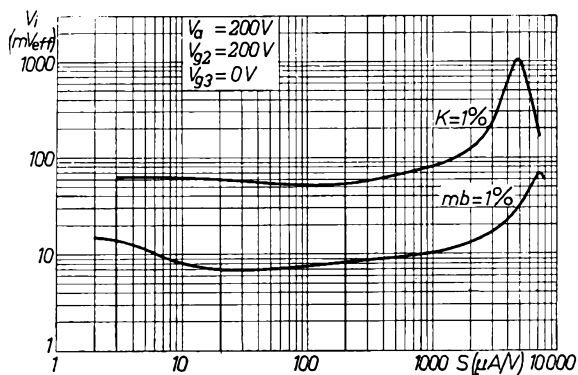
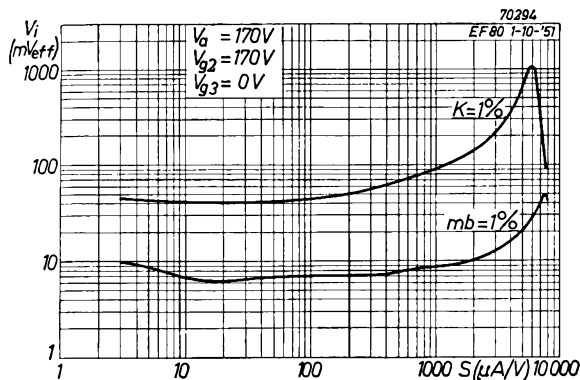

Fig. 23

R.m.s. value of an interfering signal which results in a cross modulation of $K = 1\%$, and hum voltage giving a modulation hum of 1% , plotted against the mutual conductance, for anode and screen-grid voltages of 170 V and 200 V respectively.

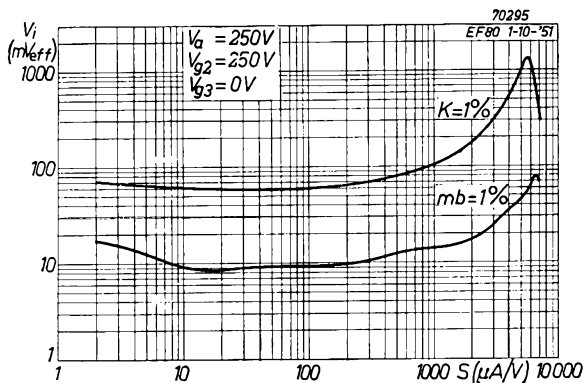

Fig. 24

As fig. 23 but for anode and screen-grid voltages of 250 V.

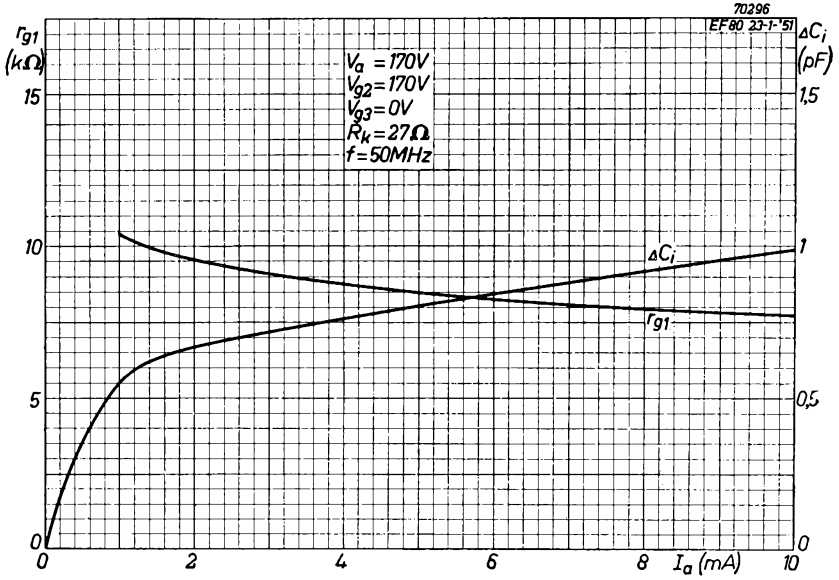

Fig. 25

Input capacitance variation and input damping at 50 Mc/s plotted against anode current in a cathode-compensated circuit ($R_k = 27 \Omega$).

The double diode EB 91

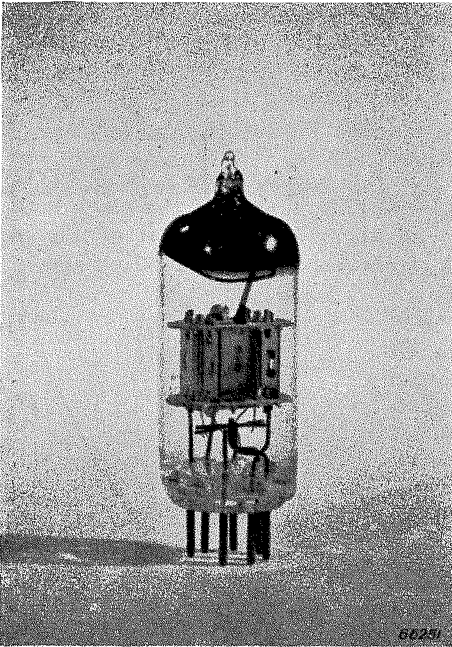

Fig. 1
The double diode EB 91 (about actual size).

Description

The EB 91 is a 7-pin miniature double diode with low internal resistances, so that it is suitable for use in circuits with low load resistances. Each section has an independent cathode, and an electrostatic screen is provided between sections.

One diode section may be used as vision demodulator, and the other section for such functions as D.C. restoration. In the sound channel of a receiver the EB 91 may also be used as an F.M. demodulator, for example in a ratio-detector circuit.

Application

The most important application of the EB 91 in a television receiver is in the vision demodulator stage. Only one diode section is required for this purpose and the other section can therefore be used as a D.C. restorer. The polarity of the diode used for demodulation depends upon

a number of factors, such as the type of transmission (either positive or negative modulation may be used in the transmitter), the method of modulating the spot brightness of the picture tube (the video signal may be applied either to the cathode or to the grid of the picture tube) and the number of stages used for video amplification. Cathode modulation of the picture tube is now almost exclusively employed and, in the case of a direct-viewing tube, one stage of video amplification will usually be employed for systems operating with 405, 441, 525 and 625 lines.

In the 625-line system the modulation is negative, which means that the carrier amplitude is maximum during the synchronizing pulses. A signal of the polarity shown in Fig. 2 is therefore required at the cathode of the picture tube, whilst the signal at the grid of the video amplifying tube should have a polarity as shown in Fig. 3. It can therefore be seen that the polarity of the diode should be as illustrated in Fig. 4, in which the voltage across the load is also represented.

This signal would be directly suitable for the excitation of the video amplifying valve, provided the voltage at the dotted line (black level) in Fig. 4

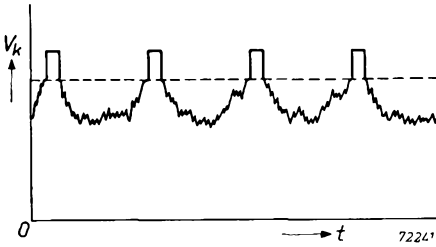

Fig. 2
Polarity of the signal required at the cathode of the picture tube.

the video valve. For this purpose the remaining section of the EB 91 can be used. Fig. 5 gives the complete circuit of the EB 91 used as vision demodulator (diode section II) and as D.C. restorer (diode section I). The potential of the whole circuit with respect to the chassis is $-V_g$, which is the fixed bias for the video amplifying valve. The bias line is normally decoupled by an electrolytic capacitor of about 100 μ F, whilst the internal resistance of the bias source is low, so that the potential of point A may be regarded as a fixed reference. It is therefore necessary to add to the signal appearing at $R_3 + L_1$ a voltage corresponding to the black level. This voltage is obtained by rectifying the I.F. signal with the diode section I. The operation of this diode needs some further explanation.

It will be clear that the voltage supplied by the restorer must be free from modulation, whilst the load on the preceding I.F. circuit should be low so as to avoid undue damping. A load circuit with a long time

is equal to the required standing bias. This is not normally the case and since, moreover, in the absence of a signal, the video amplifying tube would operate without any bias, a separate bias voltage is applied either by the inclusion of a cathode resistor or by a fixed grid voltage.

It is then necessary to apply D.C. restoration, so that the black level of the complete signal of Fig. 4 coincides with the standing bias of

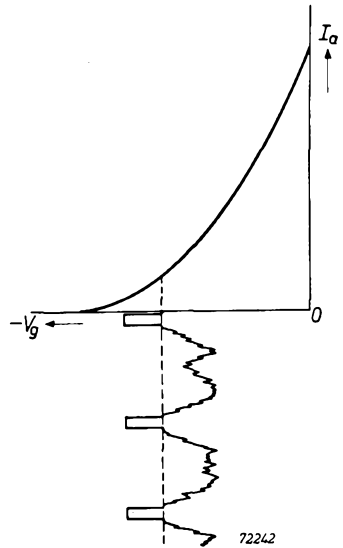

Fig. 3
Signal at the control grid of the single video stage.

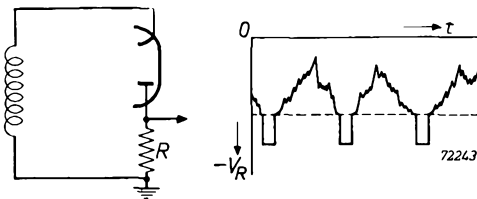

Fig. 4
Connection of the detector diode and the voltage across the load resistor.

constant and a high resistance should therefore be used. This implies that the detection efficiency of the restorer diode will be considerably greater than that of the detector diode, which has a load of only 3.9 k Ω . For average picture contrast and with one stage of video amplification, the I.F. signal required at the cathodes of the EB 91 is about

2 V_{rms} during the synchronizing pulses. This I.F. signal will give rise to a voltage across the detector load R_3 of about -1.4 V also during the synchronizing pulses, which corresponds to a black level of $0.75 \times (-1.4) = -1.05$ V. An equal voltage of opposite polarity must therefore be delivered by the restorer diode. If R_1 is short-circuited a constant direct voltage of 2.8 V, corresponding to the peaks of the synchronizing pulses, arises across R_2 . The efficiency of the restorer circuit is now reduced by means of R_1 to such an extent that the voltage across R_2 becomes 1.05 V, as required. It will be noticed that the time constants of R_2C_3 and R_1C_1 have been so chosen as to differ considerably. This has been done intentionally, so as to

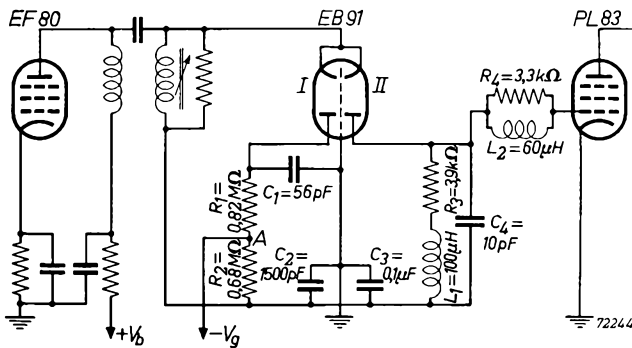

Fig. 5

Detector and D.C. restorer circuit employing the double diode EB 91.

prevent variations in the restorer voltage across R_2 during short interference pulses, such as arise from car ignition and telephone dialling. With this circuit, the voltage across R_2 does not change appreciably during a short interference pulse; the increase in rectified voltage occurring across R_1 , which together with C_1 has a low time constant. Therefore, at the end of the interference pulse the restorer circuit quickly resumes normal operation, whereas with a high time constant of the total load the increase in rectified voltage and the resultant increase in picture brightness would persist for some considerable time.

In the load of the diode section II (fig. 5) a shunt peaking coil L_1 of 100 μH is included to compensate the effect of the shunt capacitor C_4 and the wiring capacitance upon the frequency response. For the same reason a series peaking coil L_2 of 60 μH is connected in series with the input of the video amplifying valve. This coil resonates with the input and wiring capacitance of the PL 83 at a frequency of about 5 Mc/s, thus improving the response at the high end of the video frequency band whilst I.F. signals are attenuated. Damped oscillations modulating the picture brightness would, however, occur after each rapid change in signal level if this resonant circuit were not adequately damped. A damping resistor R_4 of 3.3 k Ω is therefore connected across L_2 .

DATA OF THE EB 91

Heater data

Heating: indirect by A.C. or D.C.; series or parallel supply

Heater voltage	V_f	=	6.3 V
Heater current	I_f	=	0.3 A

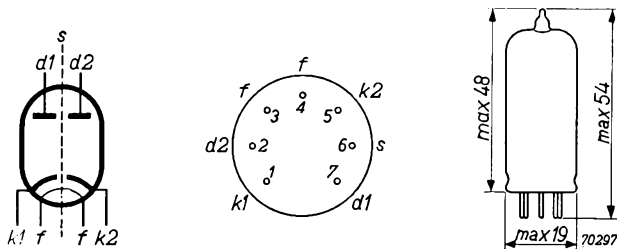

Fig. 6
Base connections and dimensions of the EB 91.

Capacitances (measured on the cold valve; with external screen)

Between anode of diode I and all others	C_{d1}	=	3.0 pF
Between anode of diode II and all others	C_{d2}	=	3.0 pF
Between the two anodes	C_{d1d2}	<	0.026 pF
Between cathode of diode I and all others	C_{k1}	=	3.5 pF
Between cathode of diode II and all others	C_{k2}	=	3.5 pF

Limiting values (each section)

Inverse anode voltage	V_{dinvp}	=	max. 420 V
Average anode current	$I_{\bar{a}}$	=	max. 9 mA
Peak anode current	I_{dp}	=	max. 54 mA
Voltage between heater and cathode	V_{fk}	=	max. 150 V
Peak voltage between heater and cathode	V_{kfp}	=	max. 330 V ¹⁾

¹⁾ Cathode positive with respect to heater.

External resistance between heater and cathode	R_{jk}	= max. 20 k Ω ¹⁾
Heater voltage during the warm- ing-up period	V_f	= max. 9,5 V

Limiting values of each section for use as rectifier

Supply voltage	V_{tr}	= max. 150 V _{rms}
Average anode current	I_d	= max. 9 mA
Reservoir capacitor	C_{filt}	= max. 8 μ F
Internal resistance of supply	R_t	= min. 300 Ω
Peak voltage between heater and cathode	$V_{k/p}$	= max. 330 V ²⁾

¹⁾ If a high undecoupled resistance between heater and cathode must be used it may be advisable, in order to avoid hum, to reduce the heater voltage to about 5 V.

²⁾ Cathode positive with respect to the heater.

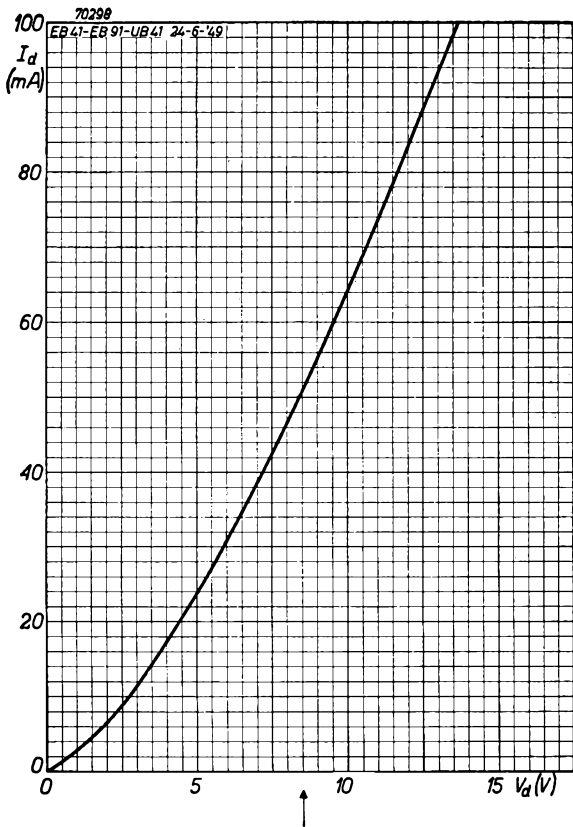

Fig. 7
Anode current plotted against anode voltage
for each diode.

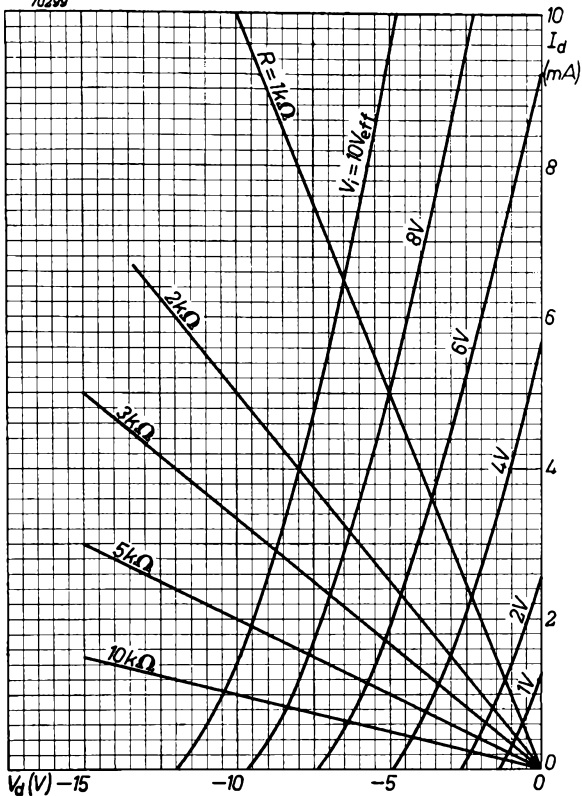

Fig. 8

Output characteristics for each diode, for input voltages between 1 and 10 V.

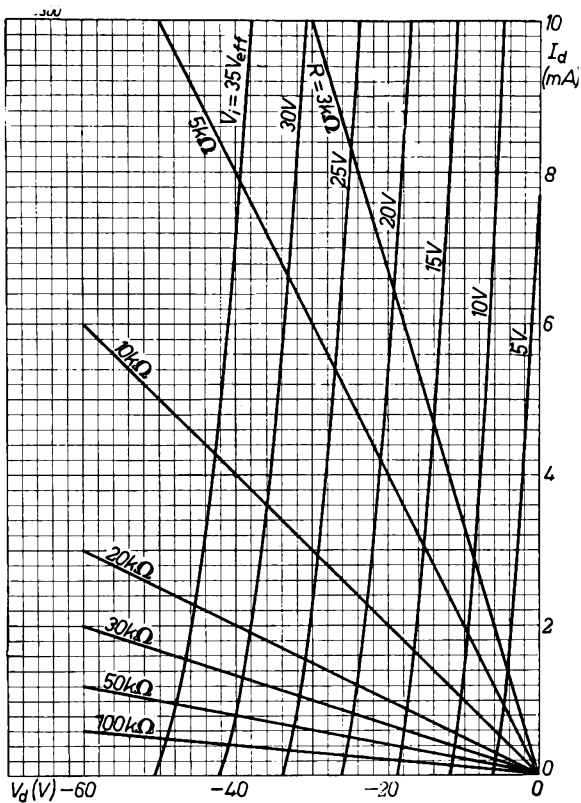

Fig. 9
Output characteristics for each diode, for input
voltages between 5 and 35 V,

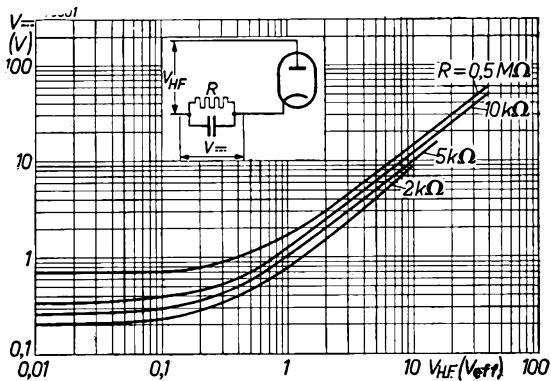
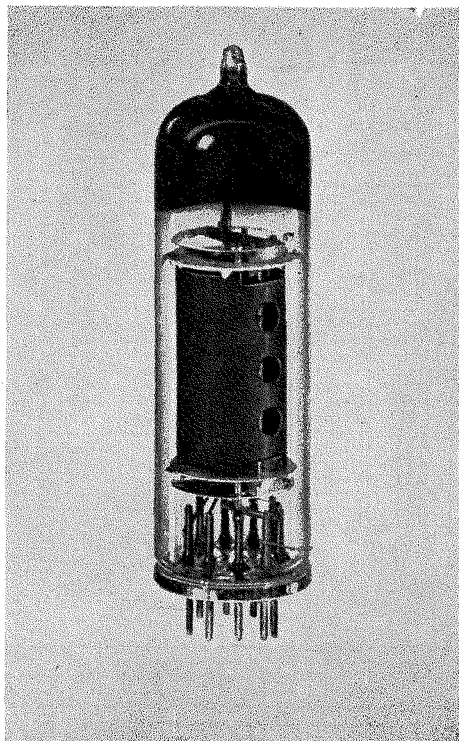

Fig. 10

Direct voltage at the load resistor plotted against the H.F. signal, with the load resistance as parameter. The curves refer to one diode section.

The video output pentode PL 83



62148

Fig. 1
The video output pentode PL 83
(about actual size).

Description

The PL 83 is a pentode on the Noval base intended for use as the video output valve in television receivers. At a screen-grid voltage of only 170 V a considerable anode current swing can be obtained, so that the anode load resistance can be kept low thus simplifying high-frequency compensation. The PL 83 can therefore be used in cases where the EF 80 would be inadequate. It should be pointed out that the EF 80 has been specially designed for use as an R.F. or I.F. amplifier. Important features of the PL 83 are its high mutual conductance and small internal capacitances. Special attention has been paid to the mechanical design so as to produce a robust and rigid assembly, which minimizes the risk of microphony.

Application

1. The PL 83 as video amplifier with cathode compensation

A circuit of a video output stage employing the PL 83 with cathode

compensation and a high-tension line voltage of 180 V is represented in Fig. 2. Compared with anode compensation by means of a shunt peaking coil, cathode compensation has the advantage that it permits of a simple and inexpensive circuit lay-out. Owing to the negative feedback, however, the gain of a cathode-compensated stage is usually lower.

In the circuit of Fig. 2 it is assumed that the total capacitance in the anode circuit of the PL 83 is 35 pF. With a cathode resistor of 470 Ω and an anode load of 5 k Ω the capacitor shunting the cathode resistor should have a value of 390 pF, thus providing equal time constants in the anode and in the cathode circuit. A 3 db drop in frequency response occurs at about 5 Mc/s when the signal is applied directly to the control grid of the PL 83. Under static conditions with $V_{g1} = -5.6$ V the anode current is 10.5 mA and the screen-grid current 1.4 mA. The gain of the stage is 7.5 and, if the black level of the input signal is at chassis potential, a peak video output

voltage of 80 V, excluding synchronizing pulses can be obtained at the anode. This signal is ample for driving any direct-viewing picture tube and also sufficient for the projection tube type MW 6-2. The video output valve also provides the signal for the synchronizing pulse separator. The complete signal is applied via a resistor of 10 kΩ to the separator, the resistor being included to prevent an increase of the total anode capacitance of the video output stage.

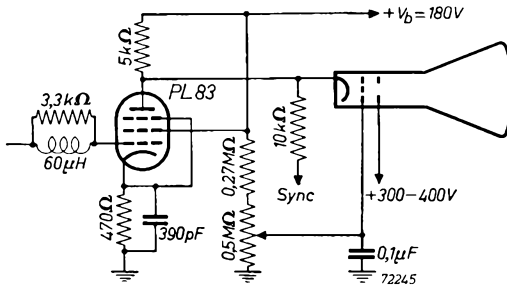

Fig. 2
The PL 83 as video amplifier with cathode compensation.

2. The PL 83 as video amplifier with anode compensation

Fig. 3 gives a circuit employing the PL 83 with anode compensation. The high-tension line voltage is 180 V and the circuit is suitable for driving any direct-viewing picture tube or a projection tube. The series peaking coils in the control-grid circuit of the PL 83 and in the cathode of the picture tube are shunted by damping resistors in order to prevent overshoot.

The anode current under static conditions is 11 mA and the screen-grid current 1.5 mA when the grid bias is -5.6 V. If the black level of the input signal is at chassis potential a peak output voltage of about 100 V can be delivered, whilst the gain is 25. This gain is substantially higher than that of a stage with cathode compensation, but, on the other hand, anode compensation is more complicated. In order to obtain a bandwidth of 5 Mc/s, combined series and shunt peaking is required in the anode circuit.

A cathode resistor is not used in the circuit of Fig. 3, so that it is necessary to apply a fixed grid bias, which can be done as indicated in Fig. 5 on page 41 (description of EB 91).

When the PL 83 is used as represented in Fig. 3 one stage of video amplification between the detector and the picture tube will normally provide sufficient video amplification. In a stage with cathode compensation, however, the required input signal is so large that a preamplifier must be used. This is due to the fact that the output signal of the last I.F. stage cannot exceed a certain value without causing distortion and this, of course, imposes a limit upon the undistorted signal available at the detector load.

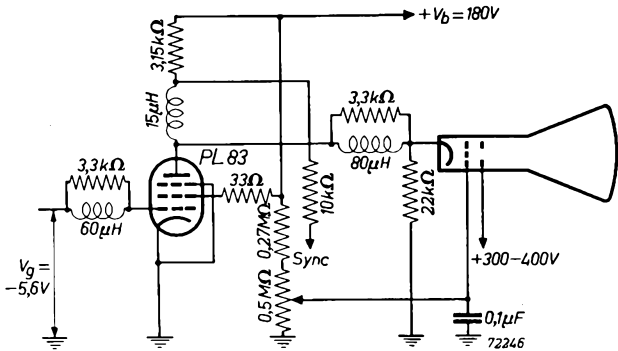

Fig. 3
 The PL 83 as video amplifier with anode compensation. The stopper resistor in the screen-grid lead should not be higher than 33 Ω.

DATA OF THE PL 83

Heater data

Heating: indirect by A.C. or D.C.; series supply
 Heater voltage V_f
 Heater current I_f

= 15 V
 = 0.3 V

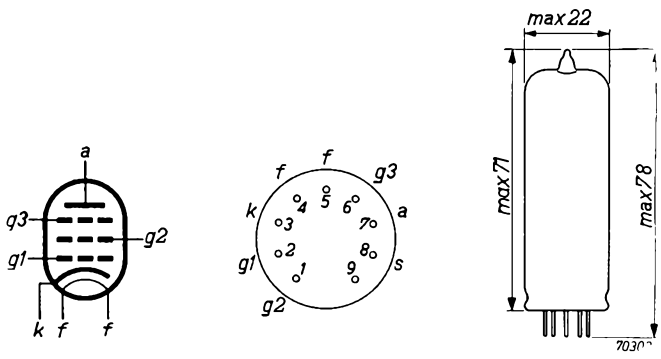

Fig. 4
 Base connections and dimensions of the PL 83.

Capacitances (measured on the cold valve)

Input capacitance	C_{g1}	=	10.4 pF
Output capacitance	C_a	=	6.6 pF
Capacitance between anode and control grid	C_{ag1}	= <	0.1 pF
Capacitance between heater and control grid	C_{g1f}	= <	0.15 pF

Typical characteristics

Anode voltage	V_a	=	170	200 V
Suppressor-grid voltage	V_{g3}	=	0	0 V
Screen-grid voltage	V_{g2}	=	170	200 V
Control-grid voltage	V_{g1}	=	-2.3	-3.5 V
Anode current	I_a	=	36	36 mA
Screen-grid current	I_{g2}	=	5	5 mA
Mutual conductance	S	=	10.5	10.5 mA/V
Internal resistance	R_i	=	0.1	0.1 MΩ
Amplification factor between screen grid and control grid	μ_{g2g1}	=	24	24

Limiting values

Anode voltage at zero anode current	V_{a0}	=	max.	550 V
Anode voltage	V_a	=	max.	250 V
Screen-grid voltage at zero screen-grid current	V_{g20}	=	max.	550 V
Screen-grid voltage	V_{g2}	=	max.	250 V
Grid current starting point (grid current + 0.3 μA)	V_{g1}	=	max.	-1.3 V
Heater voltage during warming-up period	V_f	=	max.	22.5 V
Voltage between heater and cathode	V_{fk}	=	max.	150 V
Cathode current	I_k	=	max.	70 mA
Anode dissipation	W_a	=	max.	9 W
Screen-grid dissipation	W_{g2}	=	max.	2 W
External resistance between control grid and cathode, with fixed bias	R_{g1}	=	max.	0.5 MΩ
with automatic bias	R_{g1}	=	max.	1 MΩ
External resistance between heater and cathode	R_{fk}	=	max.	20 kΩ

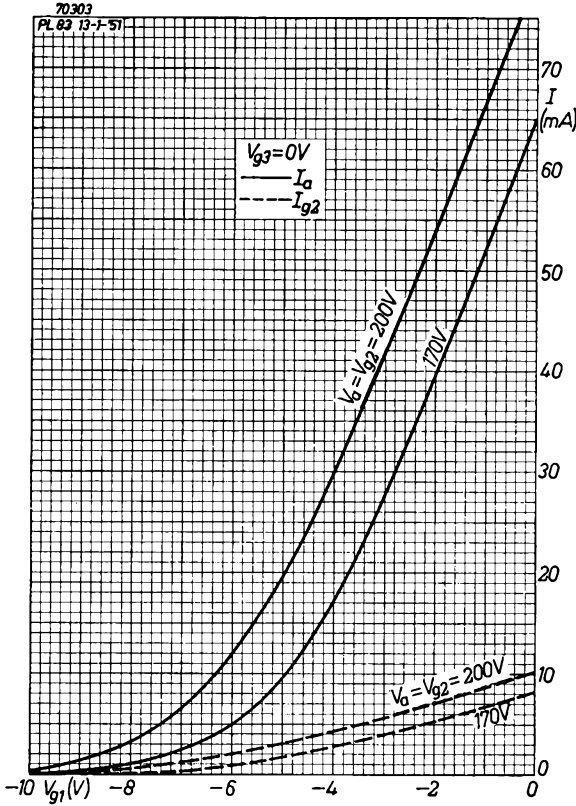
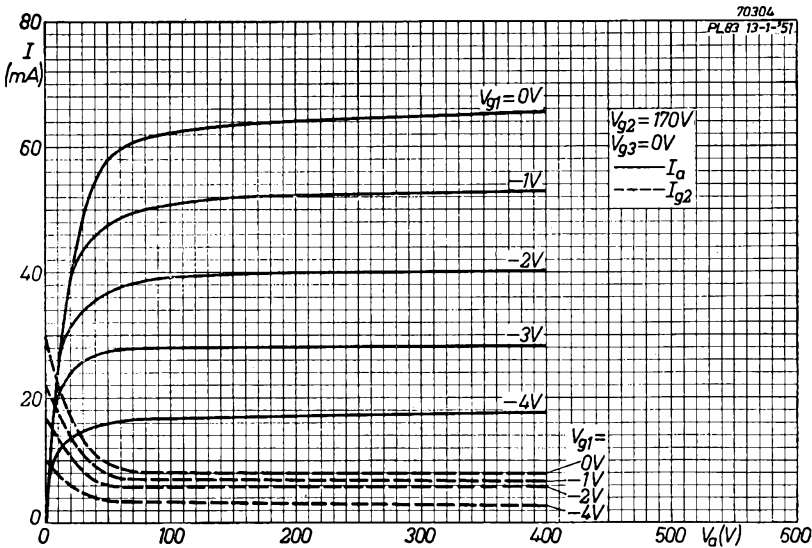

Fig. 5
 Anode current and screen-grid current plotted against control-grid voltage, with anode and screen-grid voltage as parameter.

Fig. 6
 Anode current and screen-grid current plotted against anode voltage for screen-grid voltage of 170 V, with control-grid voltage as parameter.



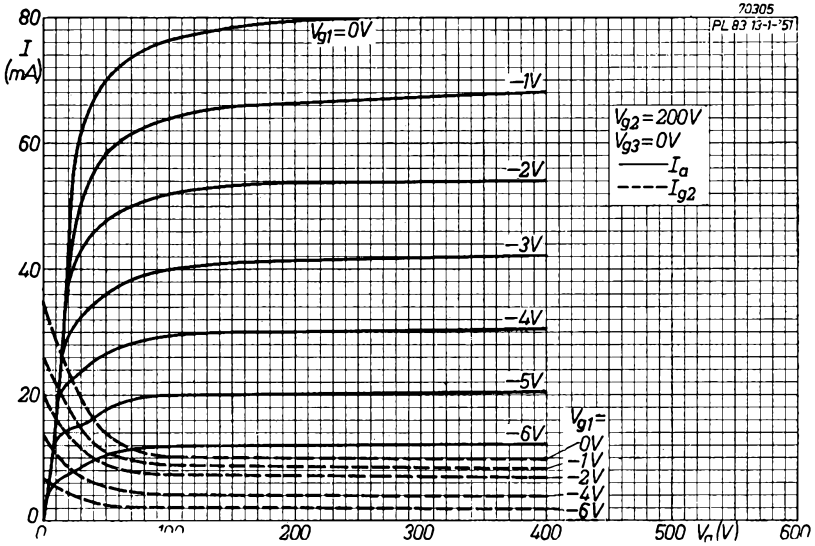

Fig. 7

Anode current and screen-grid current plotted against anode voltage for screen-grid voltage of 200 V, with control-grid voltage as parameter.

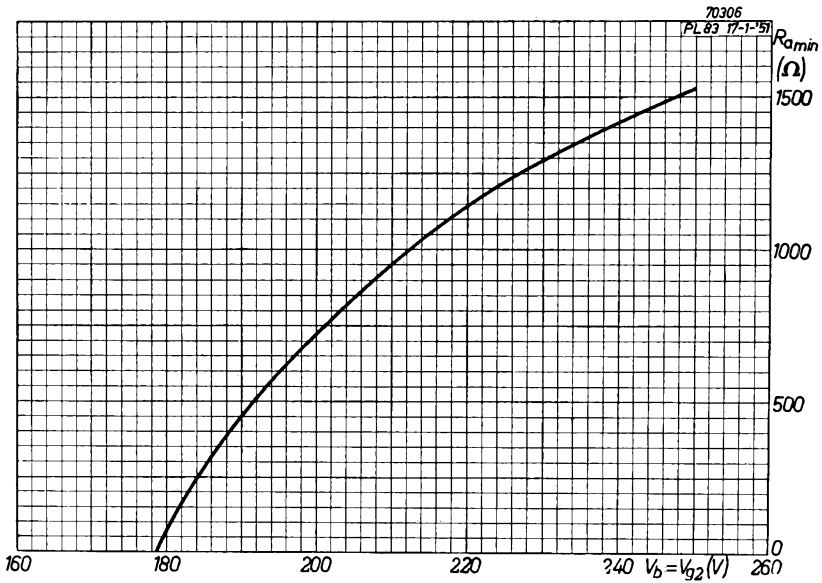

Fig. 8

Minimum permissible anode load resistance plotted against supply and screen-grid voltage.

The direct-viewing picture tube MW 36-44

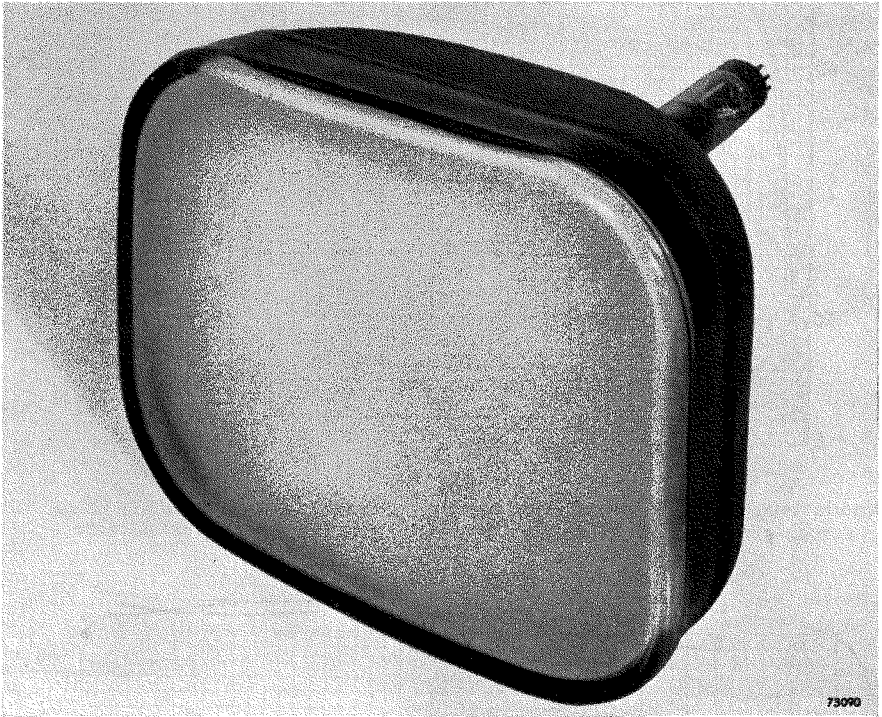

Fig. 1
The picture tube MW 36-44.

Description

The MW 36-44 is a direct-viewing picture tube the screen of which, in contrast to earlier tubes, has a rectangular shape with slightly rounded corners. The height-width ratio of the screen corresponds to the C.C.I.R. standards, in which a ratio of 3 to 4 is prescribed. The colour of the emitted light is white and the minimum useful dimensions of the screen are 21.7×28.8 cm, the corners being rounded with a radius of 5.5 cm.

The glass face of the tube has a neutral grey colour, which results in improved picture contrast, particularly under conditions of ambient illumination. In a tube with a clear glass face, ambient light is reflected also from dark parts of the picture, so that the contrast is reduced. In the grey glass face used in the MW 36-44, however, 33% of the light is lost during transmission. This is, of course, also the case for the light emitted by the fluorescent screen, but the ambient light must pass the tinted glass face twice, resulting in a

reduction of the intensity of 50%. The loss of contrast under ambient illumination is therefore much smaller with a tube having a grey glass face than with one having a faceplate made of clear glass.

The MW 36-44 is designed for magnetic focusing and deflection of the electron beam. The deflection angle corresponding to the full width of the screen is 65° . The large deflection angle has made it possible to reduce the total length of the tube, so that a cabinet having a comparatively shallow depth can be used.

A large part of the outside of the cone is covered by a conductive coating, which should be connected to the chassis of the receiver. This coating screens the tube against external electrostatic fields, whilst electromagnetic radiation by the electron beam is reduced. The capacitance between this outer coating and a conductive layer connected to the anode on the inside of the cone can be used as reservoir capacitor for the E.H.T. supply.

The most outstanding feature of this tube is that it incorporates an electron optical system of novel design, with which very uniform picture quality over the entire screen area can be obtained. For this purpose an additional electrode preceding the anode has been built in, so that the entire gun now comprises a heater-cathode assembly, a first grid for modulating the intensity of the electron beam, a second grid, a third grid and an anode.

With the potential on the third grid (g_3) the width of the electron beam can be varied. When this electrode is connected to the cathode a very small beamwidth is obtained, the width of the beam increasing with increasing positive potential on the third grid (see Fig. 2). Compared with a picture tube having an electron gun of earlier construction, i.e. without g_3 , the beamwidth of the MW 36-44 is 12% smaller when g_3 has a positive potential of 400 V and 50% smaller when this electrode is connected to the cathode. The beamwidth as shown in Fig. 2 has been measured on the screen, without focusing and deflection fields being applied.

Fig. 2 also shows the relative diameter of the focused luminous spot on the centre of the screen, plotted against the potential on the third grid. For this measurement use has been made of a point raster and it is seen that the diameter of the spot decreases with increasing potential on g_3 , i.e. with increasing beamwidth.

When in a conventional tube the picture is focused on the centre of the screen it may be observed that the definition gradually decreases towards the corners of the screen. This is caused by a variation in beam length when the beam is deflected across the screen, so that in the corners the point at which the beam has the smallest diameter no longer coincides with the screen surface and by the non uniformity of the deflecting field. A considerable improvement can be obtained in this respect by decreasing the beamwidth, but according to Fig. 2 this would lead to a loss of definition in the centre of the picture. In the MW 36-24, however, the electron gun has been so designed that, compared with previous picture tubes, the diameter of the spot in the centre of the picture is decreased, provided the same beamwidth is used. It is then possible to decrease the beamwidth by means of g_3 and to maintain ample definition in the centre of the screen. At the same time deflection defocusing is reduced, so that a picture of substantially

uniform definition is obtained over the entire screen area. This effect is most pronounced when the third grid is connected to the cathode. When, however, very high definition is required in the centre of the screen the third grid may be given a positive potential of, for example, 250 V. In the latter case, of course, deflection defocusing becomes again noticeable.

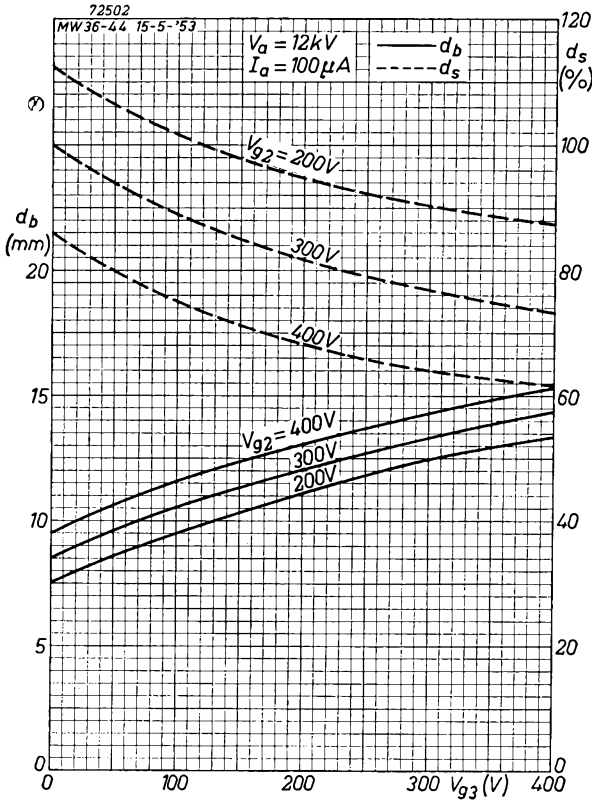

Fig. 2
Beamwidth (d_b) measured on the screen and relative spot diameter (d_s) plotted against the third-grid potential, with the second-grid potential as parameter. The beamwidth is measured without focusing and deflection fields.

It is thus seen that with the MW 36-44 it is possible to choose between uniform picture quality with ample definition over the entire screen area, and a very high definition in the centre which gradually decreases towards the corners. According to particular requirements any compromise between these two adjustments can be obtained by choosing the potential at g_3 . From the description given above it may be deduced that the third grid exerts a prefocusing action on the electron beam, so that when the beam enters the main magnetic focusing field the divergence is smaller than in the case of former electron gun constructions. This means that the magnetic field required for focusing the beam on the screen is slightly smaller. For focusing and deflection the unit AT 1002 can be used.

As already indicated, the MW 36-44 is provided with an ion-trap which prevents the occurrence of ion burn on the screen. This ion trap is of the bent-gun type and an external magnet, Type 55402, giving a field strength of 60 gauss is required. The cathode of a picture tube emits not only electrons but also a beam of negative ions. These ions have a very much greater mass than the electrons and are far less sensitive to magnetic deflection fields. The result is that in a conventional picture tube without ion trap the centre of the screen is continually subjected to bombardment by the heavy ions, and this eventually leads to discoloration of that part of the screen. In the MW 36-44 both the electron and the ion beams leave the cathode at a small angle to the tube axis. On the neck of the tube, at a position to be indicated later, is placed a small magnet. Since the electron beam is very sensitive to a magnetic field it is deflected along the axis of the tube and passes normally to the screen. The ions, however, which are far less sensitive to any magnetic field, are not deflected to any appreciable extent, and thus continue on a line at an angle to the tube axis and are finally captured by the anode. In this way the ions are prevented from reaching the screen. The following procedure should be adopted for adjusting the position of the magnet:

1. With the voltage supplies to the tube switched off and the base socket removed; slip the magnet over the tube base with the arrow pointing away from the screen, see Fig. 3. The magnet should be in line with the vacant position for pin Nr. 9 (see Fig. 5). Adjust the magnet so that it is only slightly in advance of the tube base.

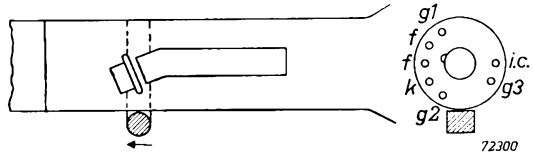

Fig. 3
Position of the ion-trap magnet on the neck of the picture tube.

2. Fit the socket to the tube. Switch on the voltage supplies and adjust the brightness control and, if necessary, the position of the magnet until the raster is just visible. The adjustment is best carried out with a stationary test pattern on the screen.
3. Move the magnet towards the screen, without rotating it around the tube axis, until the focused raster attains maximum brightness. The brightness may now be adjusted to give the correct level for the peak white portions of the image and, if necessary, the position of the magnet should be slightly readjusted to obtain maximum brilliance.
4. If the raster cannot be centered by adjusting the position of the focus field, the magnet should now be rotated slightly in order to assist in centering, provided that this does not cause any decrease in brilliance.
5. When optimum conditions are obtained, the magnet should be clamped in position by means of the thumb screw, taking care not to alter the position of the magnet.
6. If a position of adequate brilliance cannot be obtained another magnet should be tried.

Notes

- a. The ion trap magnet must always be in the position which gives maximum picture brightness.
- b. The magnet should never be adjusted to remove a shadow from the raster if by so doing the brightness of the image is decreased. In such cases the shadow should be eliminated by adjusting the position of the focusing coil and/or deflection coils.
- c. Incorrect adjustment of the magnet may result in the production of circular areas of discoloration on the screen, even though the negative ions have been efficiently trapped. This is due to bombardment of the edge of the aperture of the anode by the incorrectly centred electron beam, as a result of which the metal of the diaphragm is vaporized and deposited on the screen.
- d. Finally, the ion trap magnet should be handled with reasonable care, because if it is subjected to very strong magnetic fields or mechanical shocks its magnetism may be partially lost.

Application

The installation of a tube having large dimensions and operating with a high supply voltage calls for a few special precautions which will be briefly discussed in the following paragraphs. Other important points in connection with the use of a picture tube are the generation of sawtooth currents for the deflection, and the E.H.T. supply. Circuits for deflection and E.H.T. are, however, discussed in the descriptions of the ECL 80, the PL 82 and the PL 81.

In designing a receiver cabinet in which the MW 36-44 is to be used it should be borne in mind that the main support of the tube should be placed around the large end of the cone close to the tube face. In order to avoid local strain on the glass the support should be lined on the inside with a soft flexible material such as felt, rubber or plastic.

The neck of the tube must be supported by the deflection yoke, which should therefore have an independent support on the receiver chassis. The deflection and focusing coil assembly should never be supported by the neck of the tube, as this may lead to breakage when the receiver is subjected to shocks. The tube socket should be allowed to move freely and flexible leads should be used for the wiring.

The reference line indicated in the dimensional drawing, Fig. 5, is determined by the upper edge of the reference line gauge, the dimensions of which are given in Fig. 6. Various dimensions are given in Fig. 5 with the reference line as the datum line. In order to prevent the electron beam from being intercepted at maximum deflection by the neck of the tube, the distance between the reference line and the centre of deflection must be kept below 29 mm. Correct location of the deflection coils can therefore be ensured most conveniently by giving the inside contour of the yoke the same dimensions and shape as that of the reference line gauge.

The total length of the deflection and focusing assembly may not exceed a certain value (see note 3 in Fig. 5), as otherwise the space available for the adjustment of the ion-trap magnet would be too small.

Adequate provision should be made to hold the deflection yoke firmly against the cone of the tube, but it should be possible to rotate the yoke over a few degrees around the tube axis for registering the raster on the screen.

As with all other picture tubes for television, the MW 36-44 is highly evacuated and may, in the event of breakage, result in injury from splintered glass. The tube should therefore be handled with the utmost care and not be subjected to shocks or vibration. In this connection it is advisable to use a shatter-proof, transparent cover in the receiver cabinet in front of the screen and to provide sufficient distance between screen and cover to obtain air cushioning.

High voltages are used to operate this tube. The utmost care should therefore be exercised to avoid accidental contact with terminals and leads carrying a high potential. These should be adequately insulated. The external conductive coating must be connected to the chassis, otherwise it may attain a high potential and become a source of danger. For this reason it is not permissible to use this tube as a replacement for an uncoated tube unless provision is made to connect the coating to the chassis. Contact between the coating and chassis can conveniently be made by means of a resilient strip mounted on the chassis and resting with a slight pressure against the cone of the tube.

The driving voltage for the MW 36-44 may be applied either to the cathode or to the grid. When driving on the grid the circuit design should be such that the instantaneous potential of the grid with respect to the cathode remains between the limits of $+2$ V and -150 V. The external impedance between grid and cathode must not exceed 0.5 M Ω . Cathode drive may also be used, when an additional limiting factor is the maximum permissible voltage between heater and cathode. During the warming-up period, not exceeding 45 seconds, the maximum permissible voltage is 410 V, provided the heater- the cathode is positive with respect to the heater. During normal operation cathode voltage must not exceed 200 V, again when the cathode is positive with respect to the heater. When the cathode is negative with respect to the heater the maximum permissible voltage is 125 V. In order to avoid hum, the A.C. component of V_{fk} should be kept as low as possible and must not exceed 20 V_{rms}.

With grid drive, indirect coupling with the preceding video stage is normally employed and this necessitates the use of a D.C. restorer circuit between the grid and earth. A positive bias voltage for the cathode can then be taken from the high-tension supply line of the receiver. This bias voltage should be variable to form the *brightness* control.

In the alternative arrangement the video signal is applied to the cathode and direct coupling with the video stage can then be used provided the high-tension line voltage is not too high. In a receiver with a transformerless supply system the high-tension is usually not more than 180 V but in a receiver with mains transformer it may be 250 V. In the latter case a potentiometer

meter is required between the cathode of the picture tube and the anode of the video stage in order to prevent the maximum permissible heater-cathode voltage from being exceeded. The voltage for the bias and *brightness* control should be applied to the grid and, as in the case of grid drive, this voltage can be taken from a potentiometer across the high-tension supply. It should be realised that the type of drive used considerably influences the design of the video stage and the detector stage. In the case of grid drive the synchronizing signals must be negative-going and for cathode drive positive-going.

In a receiver circuit where the cathode is positive with respect to the chassis and where only a low high-tension line voltage is available, as in a receiver with a transformerless supply system, the second-grid voltage may be taken from a potentiometer across the boosted high tension in the line-output circuit.

The axial magnetic field for focusing the electron beam on the screen may be obtained from a permanent magnet, an electro magnetic coil or a combination of these two. The focus can be adjusted by varying the direct current through the focusing coil. If a permanent magnet is used, focusing adjustment can be either by adjusting the air gap, or by obtaining part of the focusing field from a coil, the current in which can be varied. The focusing field required is approximately proportional to the square root of the anode voltage, so that an adequate range of current variation should be provided to cover variations in the anode voltage.

In a practical arrangement the focus coil will be mechanically fixed to the deflection yoke, the position of which is determined by the reference line. Owing to inevitable tolerances in the length of the neck of the picture tube (± 4 mm) it is advisable to make provision for displacing the focusing coil axially, so as to obtain optimum focusing over the entire picture area. Interaction between the fields of the focusing coil and of the deflection coils and the ion-trap magnet should be avoided by adequate spacing of these parts. In a practical deflection and focusing coil assembly a metal end plate is often used, carrying the screws for adjusting the position of the focusing coil. If a steel plate is used for this purpose the distance between this plate and the ion-trap magnet should be sufficiently great not to distort the magnetic field of the latter. It is therefore advisable to use an end plate made of a non-magnetic material such as brass. Since a definite space is required for adjusting the ion-trap magnet the total length of the deflection and focusing coil assembly measured from the reference line should not exceed the value indicated in the dimensional drawing.

The current required for correct focusing also depends upon the beam current. As the beam current increases a higher focusing current is required to maintain correct focus. It is quite impracticable in a normal design to modulate the focusing current in sympathy with the beam current but with increasing beam current a reduction in anode voltage produces the same result. The inherent regulation of the E.H.T. source should therefore be such that the anode voltage varies with the beam current. An internal resistance of about $1\text{ M}\Omega$ will provide reasonable compensation. In practice it will be difficult to attain such a low internal resistance, so that there will

normally be some overcompensation. Due to the time constant of the filter circuit of the E.H.T. supply, this type of compensation is effective only for slow changes in picture brightness.

Means for centering the picture on the tube screen must be provided to compensate for small alignment errors and for non-linearity of the deflection. Two methods of centering are available. One is to apply adjustable direct currents to the deflection coils, but this involves a more complicated and expensive circuit, whilst with low-impedance coils a comparatively large current would be required. The alternative, and less expensive, method is to vary the angle between the axis of the focusing coil and the axis of the tube, thus altering the position of the raster. A similar method, which is more favourable with regard to spot resolution, consists in moving the focusing coil or magnet radially.

As in all other picture tubes a stationary, high-intensity spot will eventually burn the screen. Failure of the deflection circuits may therefore result in damage to the screen, unless provision is made to reduce the beam current automatically when the scanning fields are no longer present. A circuit arrangement in which the E.H.T. is obtained from the line flyback is particularly useful in this respect, since the anode voltage drops to zero when the line-output circuit ceases to function. A stationary horizontal line, which would occur upon failure of the vertical deflection, is far less serious than a stationary spot.

MW 36-44

DATA OF THE MW 36-44

Heater data

Heating: indirect by A.C. or D.C.; series or parallel supply

Heater voltage	V_f	=	6.3 V
Heater current	I_f	=	0.3 A

When the tube is used in a series heater chain, the heater voltage must not exceed 9.5 V when the set is switched on.

Capacitances (measured on the cold tube)

Grid to all other electrodes	C_{g1}	=	7 pF
Cathode to all other electrodes	C_k	=	5 pF
Between anode and external coating	C_{am}	=	1100 pF

Focusing and deflection

Focus method	magnetic
Deflection method	magnetic
Deflection angle for full screen width	65°
Ion trap	single-field ion-trap magnet, Type 55402; field strength approx. 60 gauss.

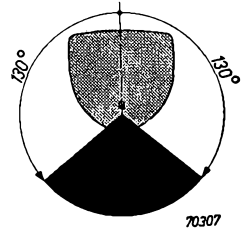

Fig. 4

Mounting of the MW 36-44. The tube must be so mounted that the centre of the screen does not fall within the shaded area of the circle. Vertical and near vertical positions of the tube with the tube face down are therefore not permissible.

Screen data

Colour of fluorescence	white
Colour temperature	7500 °K
Minimum useful screen diagonal	318 mm
Minimum useful screen width	288 mm
Minimum useful screen height	217 mm
Transmission of faceplate	66%

Net weight 4.2 kg

Typical operating conditions

Anode voltage	V_a	12	14	kV		
Second-grid voltage	V_{g2}	250	250	V		
Grid bias for visual extinction	V_{g1}	-33 to -72		V		
Third-grid voltage	V_{g3}	0	250	0	250	V
Number of ampere-turns for focusing coil		960	1015	1025	1090	

(Coil without ferro-magnetic casing. Distance between centre of the field and reference line, 78 mm).

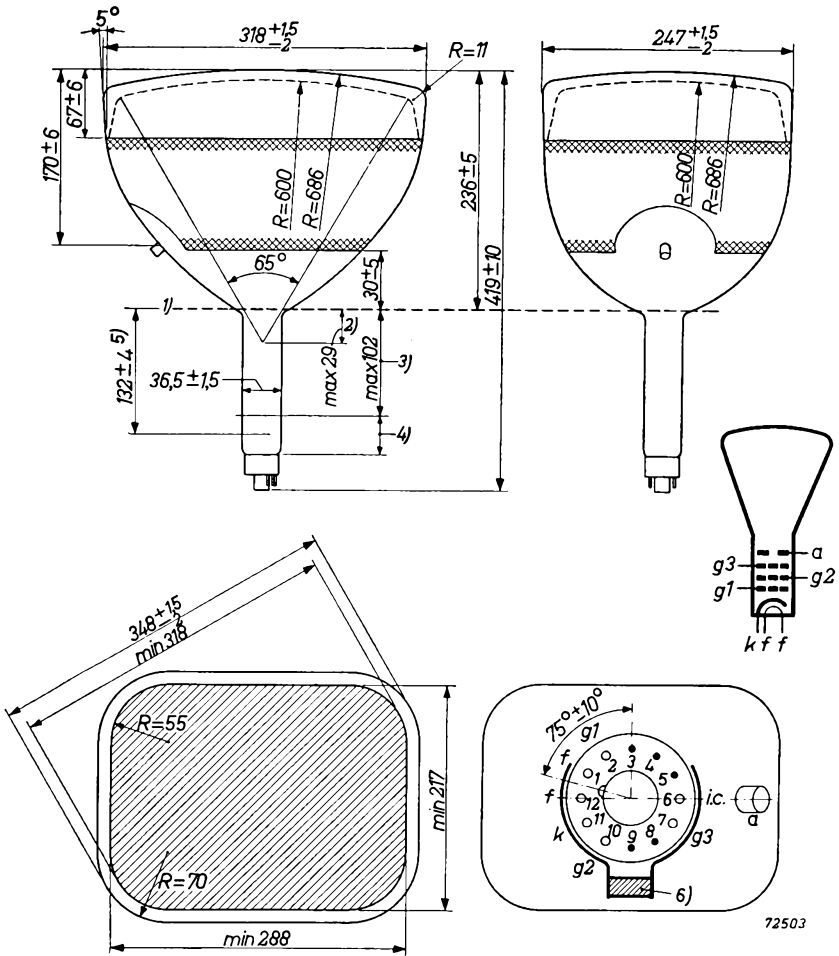

Fig. 5

Electrode connections and dimensions of the MW 36-44.

The notes in the drawing have the following meanings:

- 1) Reference line is determined by the plane of the upper edge of the reference line gauge (Fig. 6) when this is resting on the cone.
- 2) The distance from the deflection centre to the reference line should not exceed 29 mm.
- 3) Space available for the deflection and focusing assembly.
- 4) Space for the ion-trap magnet.
- 5) Distance from reference line to top centre of grid.
- 6) Ion-trap magnet.

72503

MW 36-44

Limiting values

Anode voltage	V_a	= max. 14 kV
	V_a	= min. 7 kV
Positive voltage at third grid.	V_{g3}	= max. 410 V
Negative voltage at third grid	$-V_{g3}$	= max. 100 V
Second-grid voltage	V_{g2}	= max. 410 V ¹⁾
Negative grid voltage	$-V_{g1}$	= max. 150 V
Positive grid voltage	V_{g1}	= max. 0 V
Peak positive grid voltage . . .	V_{g1p}	= max. 2 V
Screen dissipation	W_l	= max. 6 W
External impedance for mains frequency between grid and cathode	Z_{g1}	= max. 0.5 MΩ
External resistance between grid and cathode	R_{g1}	= max. 1.5 MΩ
External resistance between heater and cathode	R_{fk}	= max. 20 kΩ

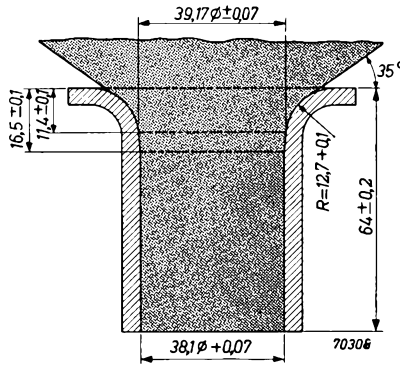

Fig. 6

Dimensions in mm of the reference line gauge. The deflection coils must not extend into the shaded area.

Heater-cathode voltage

During warming-up period not exceeding 45 seconds, cathode positive with respect to heater

$$V_{fkp} = \text{max. } 410 \text{ V}$$

¹⁾ In order to ensure good picture definition V_{g2} should not be chosen lower than 200 V.

After the warming-up period,
 cathode positive with respect
 to heater V_{fk}
 cathode negative with respect
 to heater V_{fk}

= max. 200 V²)
 = max. 125 V²)

The inherent regulation of the power supply should be such that the continuous short-circuit current does not exceed 5 mA.
 If the supply to any of the electrodes permits the instantaneous short-circuit current to exceed 1 A, or is capable of storing more than 250 μC, the effective resistance between that electrode and the output capacitor should be as follows:

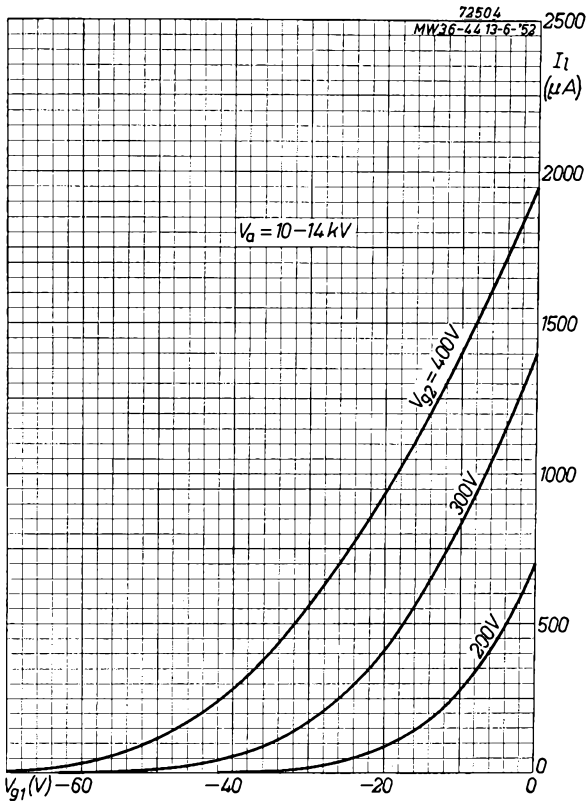

Fig. 7
 Beam current plotted against negative grid voltage with the second-grid potential as parameter.

²) In order to avoid hum, the A.C. component of V_{fk} should be kept as low as possible and must not exceed 20 V_{rms}.

MW 36-44

Grid circuit resistance . . .	R_{g1}	=	min. 150 Ω
Second grid circuit resistance .	R_{g2}	=	min. 470 Ω
Third grid circuit resistance .	R_{g3}	=	min. 470 Ω
Anode circuit resistance . . .	R_a	=	min. 16 k Ω^3

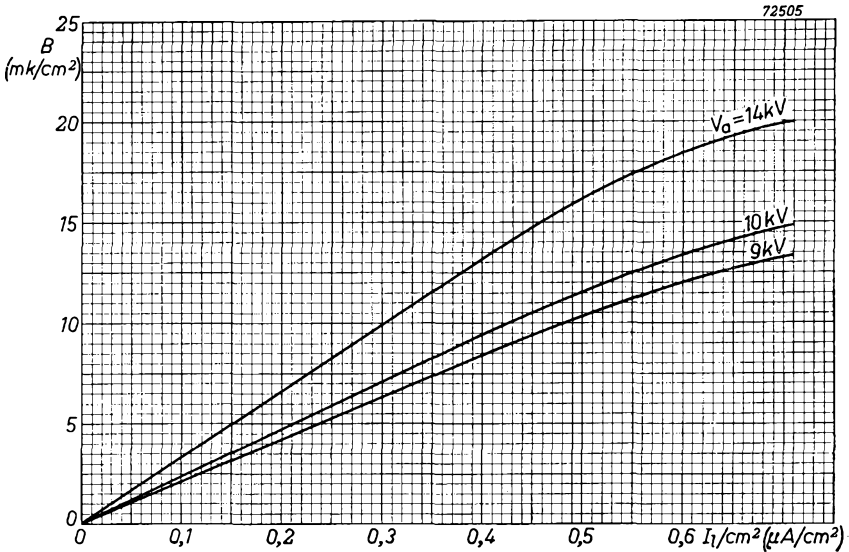

Fig. 8

Brightness plotted against beam current per square cm screen area with the anode potential as parameter.

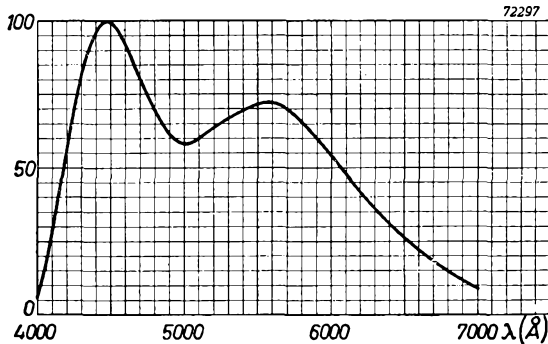

Fig. 9

Spectral energy emission characteristic of the screen.

³) If the E.H.T. is obtained from a low-frequency source, for example 50 c/s, a higher value of output capacitance than that provided by the tube will be required. An external output capacitor, of which the charge will normally be more than 250 μC , will have to be used in this case and a limiting resistor should then be included between this capacitor and the anode terminal.

The direct viewing picture MW 36-24

The picture tube MW 36-24 is very similar to the MW 36-44 described previously. The data are practically identical and it is therefore sufficient to deal here with a few important differences.

The MW 36-24 is not provided with a third grid, which has been incorporated in the MW 36-44 to obtain a narrow electron beam. The base pins 6 and 7 are, therefore, missing on the MW 36-24 base, all other connections being identical to those of the MW 36-44.

The MW 36-24 has a coloured line along the tube neck, for indicating the required position of the ion-trap magnet. The instructions for adjusting the ion-trap magnet are identical to those for the MW 36-44 with the exception of point 1), which reads for the MW 36-24:

Slip the ion-trap magnet gently over the tube base, taking care that the arrow marked on the magnet points towards the screen and is immediately over the line marked on the neck of the tube. Adjust the magnet so that it is only slightly in advance of the tube base.

MW 43-43

The direct viewing picture tube MW 43-43

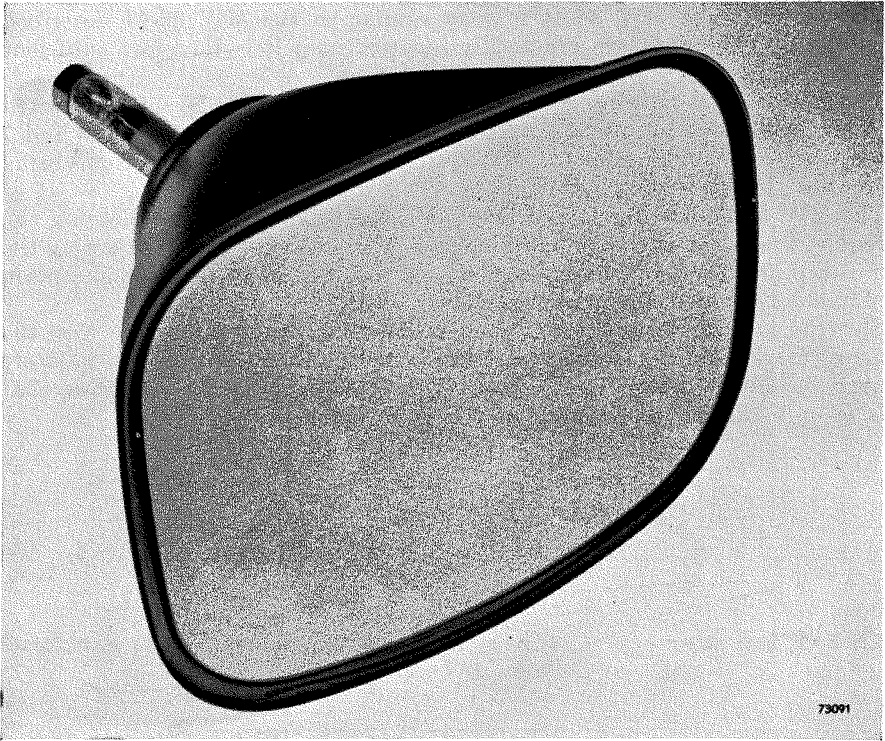

Fig. 1
The picture tube MW 43-43.

Description

Compared with the MW 36-44 the MW 43-43 shows a few important differences, which will be dealt with here. Apart from these differences the general application notes given with the MW 36-44 also apply for the MW 43-43. One of the most conspicuous features of the MW 43-43 is that it has a large rectangular screen (useful screen area 27.2×36.5 cm). The glass face is tinted, giving improved picture contrast, and in addition to the corners the sides of the screen are also slightly rounded. The MW 43-43 has a metal cone, which has the important advantage that the weight is small for a tube of these dimensions.

The use of a metal cone has some influence upon the design of the E.H.T. circuit. Since a capacitance between internal and external coating is not available with the MW 43-43, it is necessary to use a separate reservoir

capacitor, which should have a working voltage rating of approx. 18 kV to provide sufficient safety margin at the supply voltages with which the tube will normally be used. With a metal cone the risk of accidental contact is, of course, comparatively great and in this connection it is advisable to choose a reservoir capacitor smaller than 750 pF. With the receiver switched off it is always wise to earth the cone before touching it.

The metal cone must not come in contact with a magnet, by which it would become permanently magnetized. A magnetized cone results in picture distortion, particularly at the corners.

During normal operation the cone, which is connected to the anode, carries a high potential with respect to the chassis. The supporting mask must therefore be sufficiently insulated to withstand the high voltage. A special mask (Type 55404) is available for the MW 43-43.

The MW 43-43 has the same electrode system as the MW 36-44, with which a very uniform picture quality can be obtained over the entire screen area. The instructions for adjusting the ion-trap magnet are also identical.

PROVISIONAL DATA OF THE MW 43-43

Heater data

Heating: indirect by A.C. or D.C.; series or parallel supply

Heater voltage V_f = 6.3 V

Heater current I_f = 0.3 A

When the heater is included in a series chain, the heater voltage must not exceed 9.5 V during the heating-up period.

Capacitances (measured on the cold tube)

Grid No. 1 to all other electrodes C_{g1} = 7 pF

Cathode to all other electrodes. C_k = 5 pF

Focusing and deflection

Focusing method magnetic

Deflection method magnetic

Deflection angle for full screen width 66°

Deflection angle for diagonal 70°

Ion trap single-field ion-trap magnet, Type 55402; field strength approx. 60 gauss.

MW 43-43

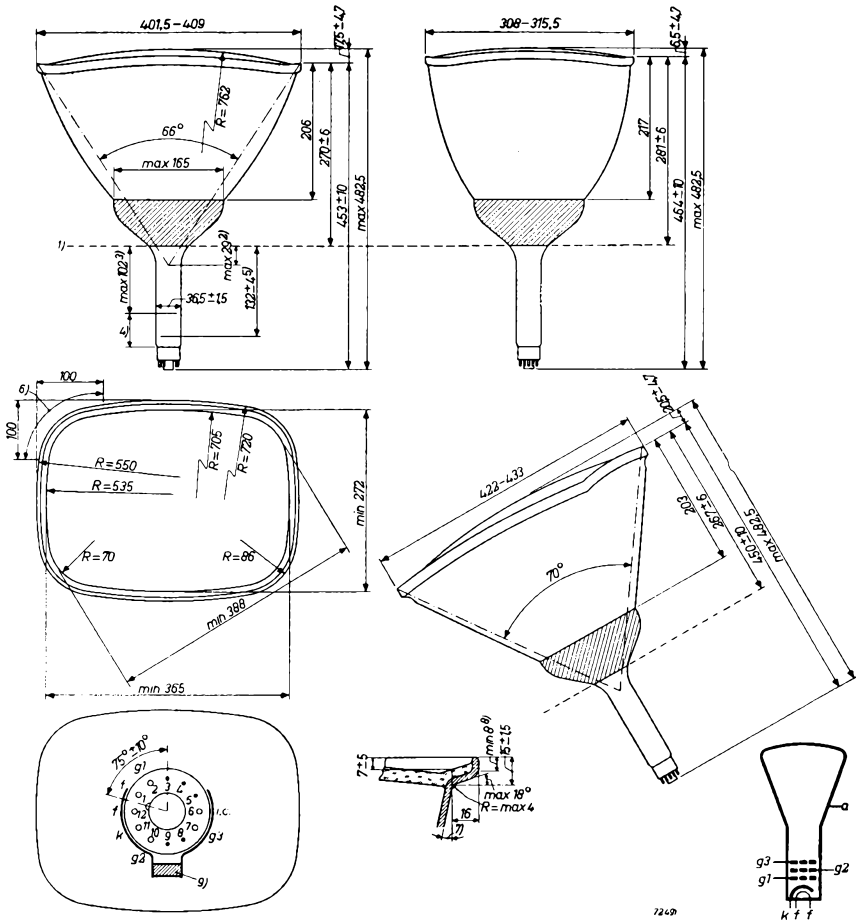

Fig. 2

Dimensional outline of the MW 43-43 (dimensions in mm).

Notes:

- 1) Reference line; determined by the plane of the upper edge of the reference line gauge (Fig. 4) when this is resting on the dome.
- 2) The distance from the reference line to the deflection centre should not exceed 29 mm.
- 3) Space for deflection and focusing unit.
- 4) Space for the ion-trap magnet.
- 5) Distance from reference line to top centre of first grid.
- 6) Support large end of cone only at corners within this space.
- 7) In this region the angular variation around the periphery of the cone is $0-25^\circ$.
- 8) Anode contact area. Contact can for example be made by means of a resilient metal strip on which the cone rests.
- 9) Ion-trap magnet.

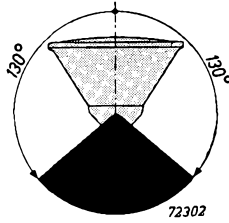

Fig. 3

Mounting position of the MW 43-43. The tube must be mounted in such a way that the centre of the face does not fall within the shaded area of the circle. Vertical and near vertical positions of the tube with the face down are therefore not permissible.

Screen data

Colour of fluorescence	white
Colour temperature	7500 °K
Minimum useful diagonal	388 mm
Minimum useful width	365 mm
Minimum useful height	272 mm
Transmission of faceplate	66 %
Net weight	4.5 kg

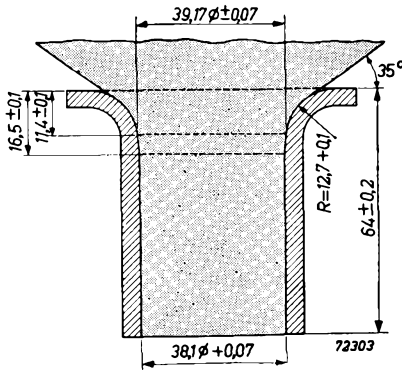

Fig. 4

Reference line gauge (dimensions in mm). The deflection coils may not extend into the shaded area.

Typical operating conditions

Anode voltage	V_a	=	14 kV
Voltage on second grid	V_{g2}	=	300 V

MW 43-43

Grid bias for visual extinction	V_{g1}	=	—40 to —86 V
Voltage on third grid	V_{g3}	=	$\overbrace{0 \quad 250}^{\text{V}}$
Number of ampere-turns for focusing		=	1015 1065 ¹⁾

Limiting values

Anode voltage	V_a	=	max. 16 kV
	V_a	=	min. 10 kV
Voltage on third grid	$+V_{g3}$	=	max. 410 V
	$-V_{g3}$	=	max. 100 V
Voltage on second grid	V_{g2}	=	max. 410 V
	V_{g2}	=	min. 200 V
Negative bias voltage on first grid	$-V_{g1}$	=	max. 150 V
Positive bias voltage on first grid	V_{g1}	=	max. 0 V
Peak positive voltage on first grid	V_{g1p}	=	max. 2 V
Screen dissipation	W_l	=	max. 6 W
External resistance between first grid and cathode	R_{g1}	=	max. 1.5 M Ω
External impedance for mains frequency between first grid and cathode	Z_{g1}	=	max. 0.5 M Ω
External resistance between heater and cathode	R_{fk}	=	max. 20 k Ω

Voltage between heater and cathode

I Cathode positive with respect to heater

- a) During heating-up period, not exceeding 45 sec
- b) After heating-up period

V_{fkp}	=	max. 410 V
V_{fk}	=	max. 200 V ²⁾

II Cathode negative with respect to heater

V_{fk}	=	max. 125 V ²⁾
----------	---	--------------------------

The inherent regulation of the power supply should be such that the continuous short-circuit current does not exceed 5 mA. If the supply to any of the electrodes permits the instantaneous short-circuit current to exceed

¹⁾ Coil without ferromagnetic casing. Distance between centre of field and reference line, 78 mm. Anode current 40 μ A.

²⁾ In order to avoid modulation of the electron beam by the mains voltage, the A.C. component of V_{fk} should be kept as low as possible and must not exceed 20 V_{rms} .

1 A, or is capable of storing more than 250 μC , the effective resistance between that electrode and the output capacitor should be as follows:

Grid No. 1 circuit resistance	R_{g1}	= min. 150 Ω
Grid No. 2 circuit resistance	R_{g2}	= min. 470 Ω
Grid No. 3 circuit resistance	R_{g3}	= min. 470 Ω
Anode-circuit resistance	R_a	= min. 16 k Ω

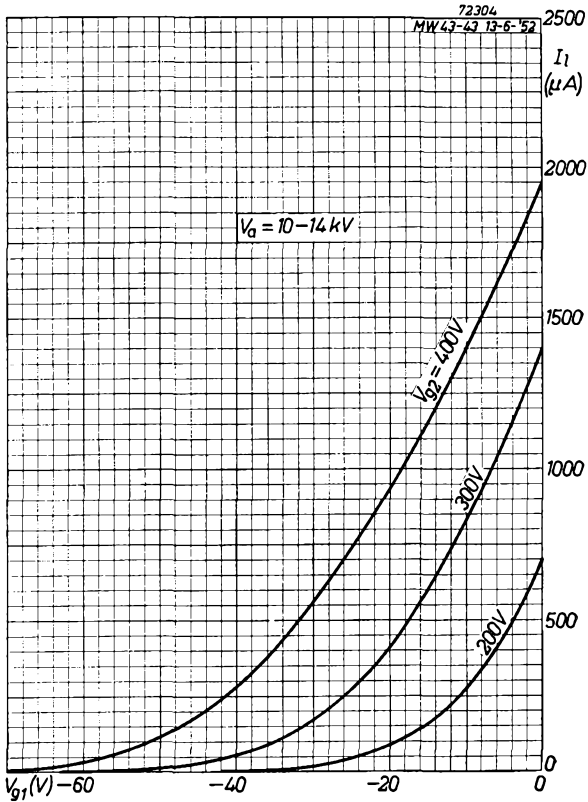

Fig. 5
Beam current plotted against the first-grid voltage with the second-grid potential as parameter.

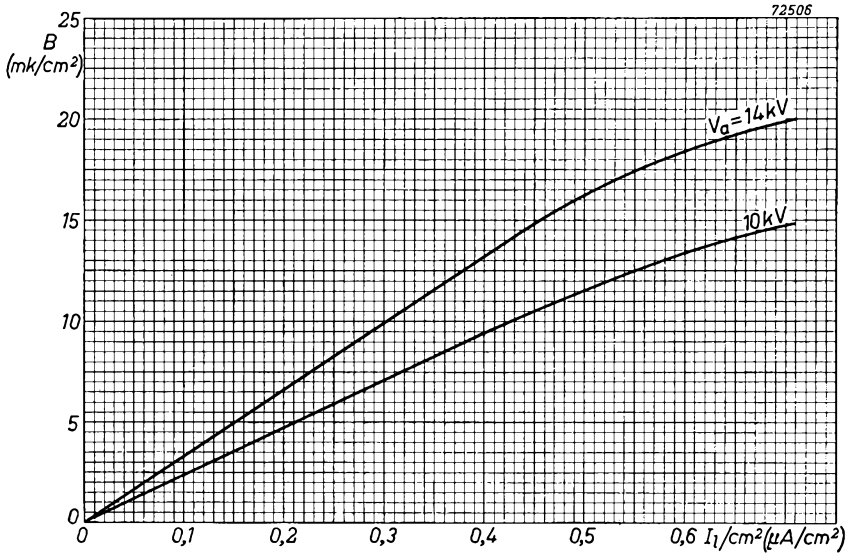

Fig. 6

Brightness plotted against the beam current per square cm screen area, for anode potentials of 10 and 14 kV.

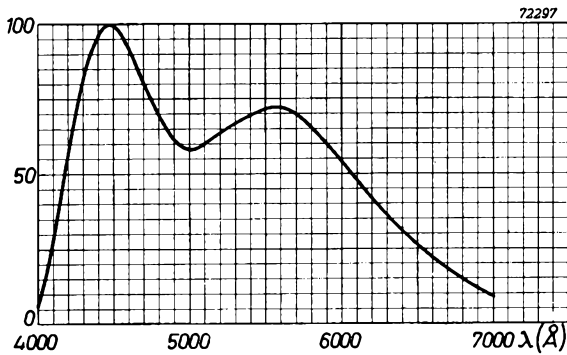

Fig. 7

Spectral energy emission characteristic of the screen.

Instructions for the installation

A special mask Type 55404 is available for supporting the MW 43-43 at the large end of the cone. The dimensions of this mask are given in fig. 8. As all other picture tubes the MW 43-43 is highly evacuated and may, upon breakage, result in injury from flying glass fragments. Care should therefore be taken not to strike or scratch the tube and to avoid undue pressure, when installing it or removing it from the receiver. In this connection the use of a shatter-proof cover in front of the tube face is recommended. It should be borne in mind that any not highly insulated material in contact with the tube face may result in local picture distortion.

The tube should only be handled by neck and metal cone, or preferably by its metal cone only. The glass section between metal cone and neck should not be touched, because fingerprints may spoil its insulating properties. This section should, for the same reason, also be kept free from excessive accumulation of dust.

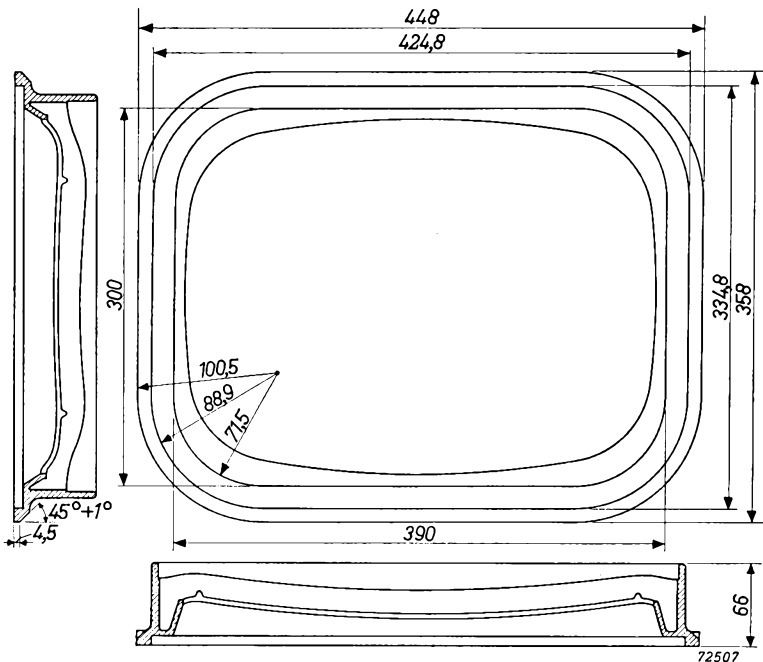

Fig. 8
Dimensions in mm of the mask Type 55404.

The output pentode PL 82

Description

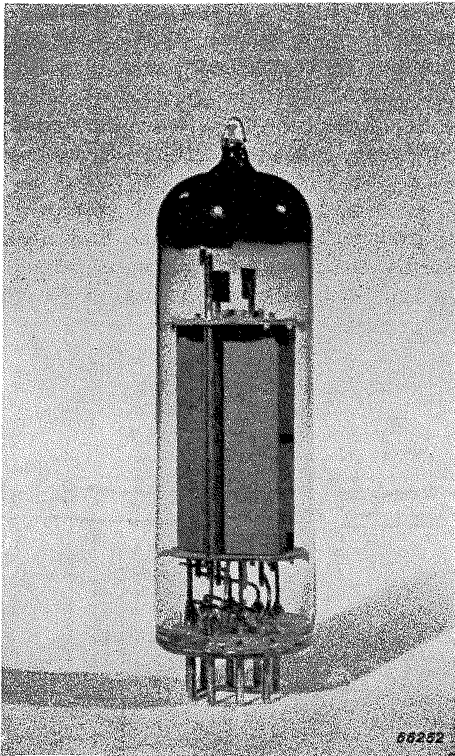

Fig. 1
The output pentode PL 82 (about actual size).

The PL 82 is an output pentode on Noval base intended for use as audio output or as frame output valve in television receivers. Special attention has been paid to the mechanical design so as to produce a robust and rigid assembly which minimizes the risk of microphony.

There are a number of cases in which the audio output of the pentode section of an ECL 80 will be considered insufficient. The PL 82, giving an output of 4 W at 10 % total distortion and at anode and screen-grid voltages of 170 V, may then be used. Although the PL 82 has no extra triode section, which could be used as A.F. voltage amplifier, this is no real disadvantage when an EQ 80 enneode is used for F.M. detection. If a sufficiently high supply voltage is available (boosted H.T. supply from line-output circuit) the latter valve gives an output voltage large enough for driving a PL 82 pentode without preamplification. A separate description of the EQ 80 is not given in this book, but is included in book IIIA of this series. In the

second chapter of this book, however, the application of this valve is discussed in the description of a circuit for intercarrier sound reception.

Also for the frame-output stage two different valve types are available. With the ECL 80 the pentode section can be used as output valve and the triode as blocking oscillator. According to the circuit in which the valve is used it may, however, occur that the pentode section is not capable of providing a sufficiently large peak anode current for obtaining the required picture height. This may be the case when a picture tube with wide-angle deflection operating at a high E.H.T. is used. The PL 82 which can provide a peak anode current three to four times as large as that of the ECL 80 may then be used.

Application

1. The PL 82 as sound output valve

As already indicated above, at a line voltage of 170 V the PL 82 is capable of giving an output of 4 W at 10 % total distortion and with a matching resistance of 3 k Ω . The driving voltage required for this output is 6 V_{rms} and the bias 10.4 V. Either fixed or automatic bias may be applied. Automatic bias has the advantage that a higher value of control-grid resistor is permitted, which may increase the gain of the preceding stage. A disadvantage connected with automatic bias, however, is that, due to the voltage drop in the cathode resistor, the voltage between anode and cathode is somewhat reduced, and this also reduces the available output.

At a line voltage of 200 V the output of the PL 82 is about the same as that at 170 V, although the operating conditions are somewhat different. These conditions are to be found in the valve data.

2. The PL 82 as frame output valve

The PL 82 can deliver a large peak anode current at comparatively low anode and screen-grid voltages. In order to avoid incursion into the knee of the I_a/V_a characteristic, the frame output stage is normally so designed that the minimum anode voltage at the end of the scan does not fall below 50 V. From the valve characteristics it may be seen that with a screen-grid voltage of 170 V and an anode voltage of 50 V the anode current of the average valve can greatly exceed 100 mA. In order to allow for inevitable spread between individual valves and for deterioration during life, the circuit should, however, be designed around a peak anode current not exceeding 90 mA at $V_a = 50$ V and $V_{g2} = 170$ V.

In the design of a frame output stage a choice must be made between an output transformer of small dimensions, which leads to a large peak anode current, and a larger output transformer, with which the peak anode current will be lower. Since there are also other important factors to be taken into account, the choice of the output transformer will be dealt with at some length.

The deflection coils used for vertical deflection have resistance and self-inductance, but the rate of change of the deflection current is so low that the voltage occurring across the self-inductance is negligible compared with that across the resistance. It may therefore be assumed that the matching transformer is loaded with a pure resistance, R_a ; see Fig. 2.

If it is now assumed that the operating conditions are such that a linear saw-tooth current having a peak-to-peak value I_a flows in the deflection coils, the saw-tooth current in the primary will be I_a/n , whilst a linear saw-tooth voltage occurs across the primary self-inductance L_p . Due to this saw-tooth voltage a current having a parabolic shape is added to the saw-tooth current in the primary. The relative magnitude of this parabolic component depends upon the ratio between the primary self-inductance and the load resistance transformed to the primary, and also upon the funda-

mental frequency of the saw-tooth current. It will be understood that a relatively low primary self-inductance, as with a transformer of small dimensions, causes a relatively large parabolic component, which considerably influences the shape of the total anode current. In the other extreme case of a very high primary self-inductance, involving a transformer of large dimensions, the parabolic component becomes very small and the total anode current has a linear shape.

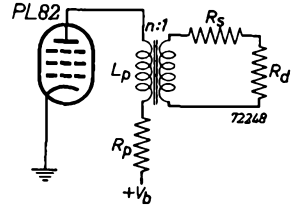

Fig. 2
Basic diagram of a frame output stage.

The shape of the total anode current required to give a linear saw-tooth current in the deflection coils is depicted in Fig. 3 for different values of T_1/T , in which $T_1 = L_p/n^2 (R_d + R_s)$ and T the duration of the frame scan. R_s is the resistance of the transformer secondary.

It appears from this figure that with $T_1/T = 0.1$ the parabolic component assumes a very high value, resulting in a considerable distortion of the total anode current and a high value of the required peak anode current.

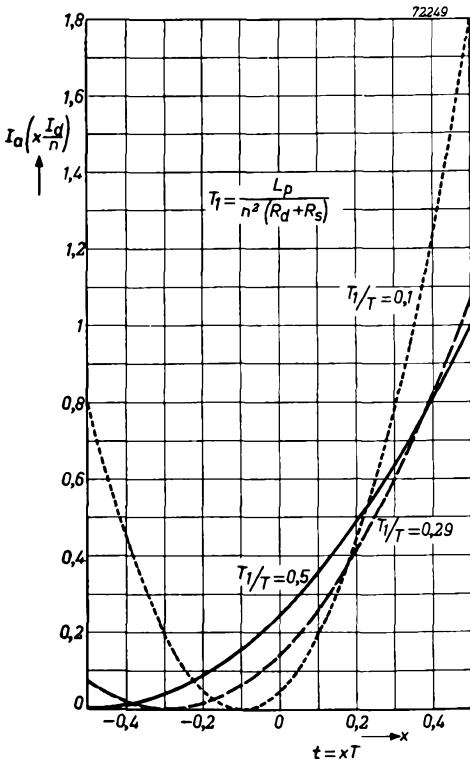

Fig. 3.
Shape of the total anode current required to give a linear deflection current, for different values of T_1/T .

Another important disadvantage is that the minimum in anode current occurs quite a considerable time after the commencement of the scan. In Fig. 3 it is assumed that the minimum value of the anode current is just zero, which is, of course, most economical as regards current consumption. At minimum anode current the valve characteristic shows a strong curvature and it is consequently difficult to distort the driving voltage in such a way that the required shape of anode current is obtained. Non-linearity of the frame scan is therefore apt to occur at about 0.4 of the total picture height, and this is very annoying. A higher value of T_1/T should therefore be employed and this involves a higher value for the primary self-inductance. With $T_1/T = 0.29$ the shape of the total anode current is much more favourable but the minimum in anode current still occurs at 0.2 of the total picture height. It can be shown that with this value of T_1/T the average anode current is a minimum.

Finally, with $T_1/T = 0.5$ the minimum in anode current coincides with the commencement of the scan, which consequently is the most favourable situation. Moreover, it is seen that the shape of the anode current closely resembles that of the I_a/V_g characteristic of the valve, so that the problem of obtaining a driving voltage of the required shape is considerably simplified. With this value of T_1/T the required peak anode current reaches the minimum. A further increase of T_1/T , i.e. a higher value for L_p , does not decrease the required peak anode current and, although the total anode current assumes a more linear shape, the required average anode current becomes higher.

The two important characteristics of the anode current, viz. the average anode current $I_{a\text{ med}}$ and the peak anode current I_{a0} , are plotted in Fig. 4 against the value of T_1/T . It may be seen that with $T_1/T = 0.29$ the average anode current is a minimum and equal to $0.29 I_d/n$. At $T_1/T = 0.5$ the peak anode current has reached the minimum, which is I_d/n . In this case the average current is only slightly higher than that with $T_1/T = 0.29$. By way of example an output transformer for use in conjunction with the PL 82 will now be calculated. The influence of the stray self-inductance will be disregarded, and the following practical figures have been chosen:

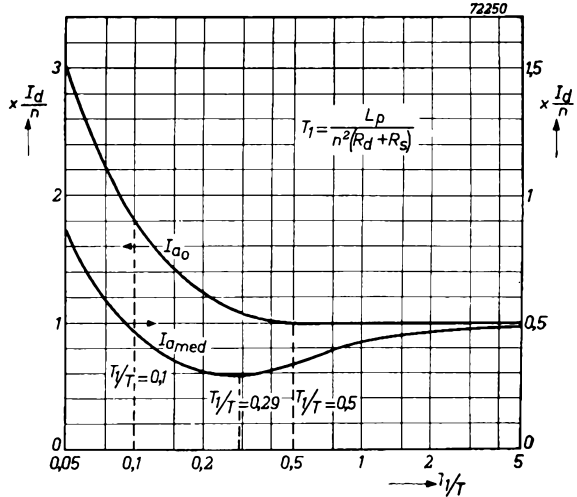

Fig. 4
Peak anode current and average anode current plotted against T_1/T .

Supply voltage	V_b	=	170 V
Resistance of the deflection coils	R_d	=	50 Ω
Self-inductance of the deflection coils	L_d	=	50 mH
Deflection current peak-to-peak	I_d	=	350 mA
Frame frequency	$1/T$	=	50 c/s

In view of the maximum permissible drop of the anode voltage below the H.T. line the turns ratio of the transformer must first be calculated. Assuming that the secondary has a resistance R_s of 15 Ω , the drop occurring at the end of the scan across the primary self-inductance is: $\frac{1}{2} I_d n(R_d + R_s) = 11.4 n$. In order to avoid incursion in the knee of the I_a/V_a characteristic, and to make allowance for some additional voltage drop caused by the primary resistance and the self-inductance of the deflection coils,

the above-mentioned drop must not be chosen too high, a suitable value in this case being 80 V. The turns ratio will therefore be $80/11.4 = 7$.

It must now be checked whether the additional drop, caused by the resistance of the primary and the self-inductance of the deflection coils, does not bring the momentary anode voltage below 50 V. In this example a drop of 40 V is still permissible. If the primary self-inductance is so chosen that $T_1/T = 0.5$ (see Figs. 3 and 4), the peak anode current occurring at the end of the scan becomes: $I_{ao} = I_d/n = 50$ mA. If it is assumed that the primary resistance will be 500 Ω , the maximum drop due to this resistance will be 25 V. Owing to the self-inductance of the deflection coils a constant voltage drop occurs during the scan across the primary. When the saw-tooth current is linear this amounts to $n.L_d.I_d/T$. Disregarding the duration of the flyback, for a system operating with 50 frames per second the duration of the scan $T = 0.02$ sec. This gives for the drop due to the self-inductance of the deflection coils, $7 \times 0.05 \times 0.350/0.02 = 6.1$ V.

The total drop below the H.T. line now is $80 + 25 + 6 = 111$ V, so that the minimum anode voltage at the end of the scan becomes 59 V, which is a sufficiently high value. In fact the anode voltage may be allowed to become as low as 50 V, but it should be realized that in determining I_{amed} and I_{ao} the minimum momentary anode current has been assumed to be zero. This condition can hardly be fulfilled in normal practice and the minimum value of the anode current will actually be 1 or 2 mA. This will result in a slightly higher drop in the resistance of the primary winding. As a final check the total voltage drop should again be calculated when the actual resistances of the primary and the secondary are known.

Finally, the required primary self-inductance must be calculated. It has been assumed that $T_1/T = 0.5$, so that with $T = 0.02$ the value of T_1 becomes $T_1 = 0.01 = L_p/n^2 (R_d + R_s)$, and $L_p = 7^2 \times (50 + 15) \times 0.01 = 32$ H.

Summarizing, the transformer data are as follows:

Primary self-inductance	32 H
Turns ratio	7 : 1
Resistance of the primary	500 Ω
Resistance of the secondary	15 Ω
Direct current in the primary (see Fig. 4)	(16.5 + 2) mA

From the valve characteristics it may be seen that when the screen-grid voltage is 170 V a bias of about 16 V is required. If this bias is obtained automatically by means of a cathode resistor the available supply voltage will be reduced by an amount equal to the cathode voltage. This might well bring the momentary anode voltage below the permissible level but, on the other hand, in most television receivers operating with a transformerless supply system from the 220 V mains the available H.T. line voltage is somewhat higher than 170 V, for example 190 V.

The driving voltage for the tube must have a shape that gives the required form of anode current. According to the shape of the available saw-tooth voltage and the figure of T_1/T , provision has to be made for obtaining the required shape of driving voltage. The means employed for this are given in the application notes of the ECL 80.

PL 82

DATA OF THE PL 82

Heater data

Heating: indirect by A.C. or D.C.; series supply

Heater voltage	V_f	=	16.5 V
Heater current	I_f	=	0.3 A

Capacitances (measured on the cold valve)

Input capacitance	C_{g1}	=	11 pF
Output capacitance.	C_a	=	8.3 pF
Capacitance between anode and control grid	C_{ag1}	=	< 1 pF
Capacitance between control grid and heater	C_{g1f}	=	< 0.15 pF

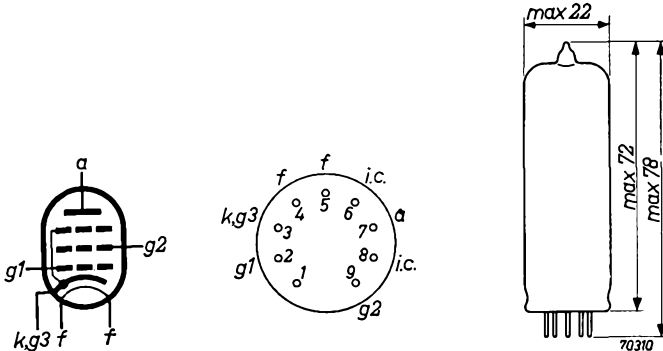

Fig. 5
Base connections and dimensions of the PL 82.

Typical characteristics

Supply voltage	V_b	=	170	200 V
Anode voltage	V_a	=	170	200 V
Screen-grid voltage.	V_{g2}	=	170	V
Screen-grid resistor.	R_{g2}	=	—	680 Ω
Control-grid voltage	V_{g1}	=	-10.4	-13.9 V
Anode current	I_a	=	53	45 mA
Screen-grid current.	I_{g2}	=	10	8.5 mA
Mutual conductance	S	=	9.0	7.6 mA/V
Internal resistance	R_i	=	20	24 kΩ
Amplification factor between screen grid and control grid	μ_{g2g1}	=	10	10

Operating conditions for sound output (one valve in Class A)

Supply voltage	V_b	=	170	200 V
Anode voltage	V_a	=	170	200 V
Screen-grid voltage.	V_{g2}	=	170	V
Screen-grid resistor.	R_{g2}	=	—	680 Ω
Control grid voltage	V_{g1}	=	—10.4	—13.9 V
Anode current	I_a	=	53	45 mA
Screen-grid current.	I_{g2}	=	10	8.5 mA
Matching resistance	R_a	=	3	4 k Ω
Power output ($d_{tot} = 10\%$)	W_o	=	4	4.2 W
Input signal ($d_{tot} = 10\%$)	V_i	=	6	7 V_{rms}
Input signal ($W_o = 50$ mW)		=	0.5	0.55 V_{rms}

Operating conditions for sound output (two valves in push-pull)

Anode voltage	V_a	=	170	200 V
Screen-grid voltage.	V_{g2}	=	170	200 V
Common cathode resistor	R_k	=	100	135 Ω
Matching resistance between anodes	$R_{aa'}$	=	$\overbrace{4} \quad \overbrace{4 \text{ k}\Omega}$	
Input signal	V_i	=	$0 \quad \overbrace{2 \times 9.3} \quad 0 \quad \overbrace{2 \times 13.5} V_{rms}$	
Anode current	I_a	=	$2 \times 46 \quad 2 \times 50 \quad 2 \times 45 \quad 2 \times 52$ mA	
Screen-grid current.	I_{g2}	=	$2 \times 8.7 \quad 2 \times 17 \quad 2 \times 8.5 \quad 2 \times 19$ mA	
Power output	W_o	=	9	12 W
Total distortion	d_{tot}	=	5	5 %

Limiting values

Anode voltage at zero anode current	V_{ao}	=	max.	550 V
Anode voltage	V_a	=	max.	250 V*
Positive peak anode voltage (10% of the duration of a cycle with a maximum of 2 m sec.)		=	max.	2.5 kV
Negative peak anode voltage		=	max.	500 V
Screen-grid voltage at zero screen-grid current	V_{g2o}	=	max.	550 V
Screen-grid voltage.	V_{g2}	=	max.	250 V
Grid current starting point (grid current + 0.3 μ A)	V_{g1}	=	max.	—1.3 V
Heater voltage during warming-up period	V_f	=	max.	24.5 V
Voltage between heater and cathode	V_{fk}	=	max.	200 V

*) At anode dissipations smaller than 4.5 W the maximum permissible anode voltage is 450 V.

PL 82

Cathode current	I_k	= max.	75 mA
Anode dissipation	W_a	= max.	9 W
Screen-grid dissipation	W_{g2}	= max.	2.5 W
External resistance between control grid and cathode with fixed bias	R_{g1}	= max.	0.4 M Ω
with automatic bias	R_{g1}	= max.	1 M Ω
External resistance between heater and cathode	R_{fk}	= max.	20 k Ω

In frame output applications, to allow for inevitable spread between individual valves and for deterioration during life the circuit should be designed around a peak anode current not exceeding 90 mA at $V_a = 50$ V and $V_{g2} = 170$ V.

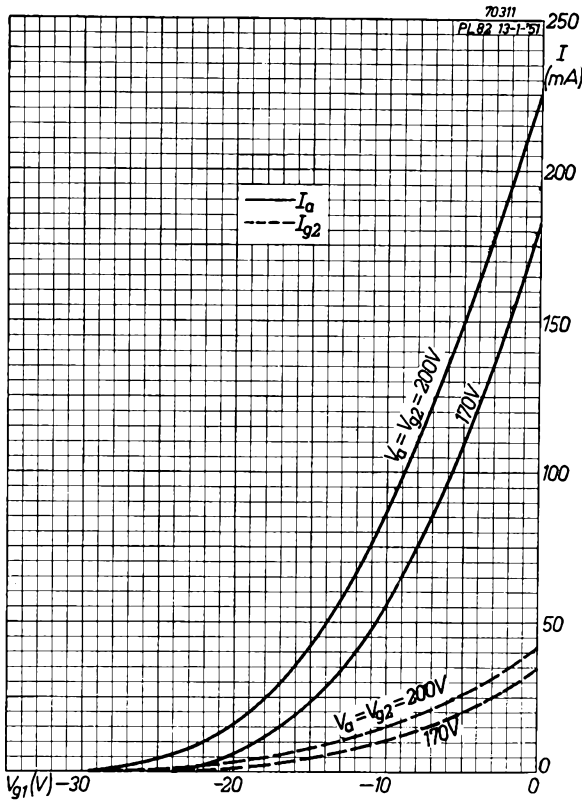

Fig. 6
Anode current and screen-grid current plotted against control-grid voltage with anode and screen-grid voltage as parameter.

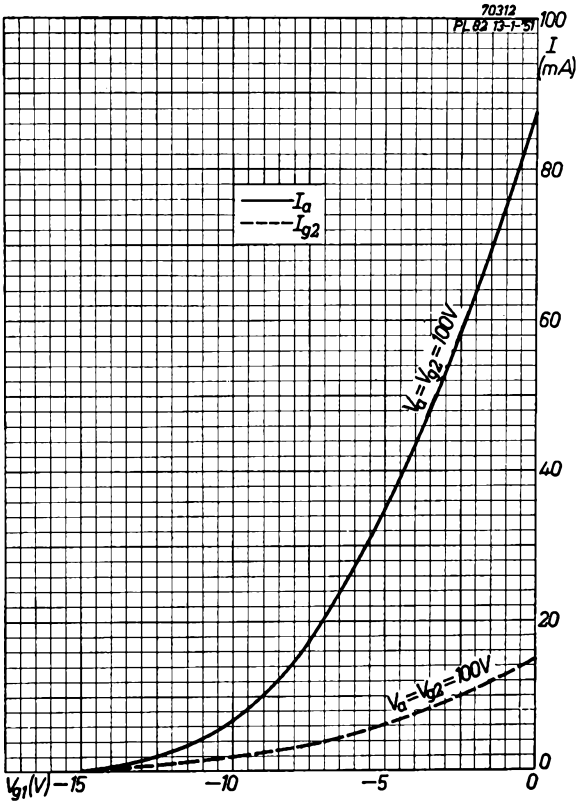

Fig. 7
Anode current and screen-grid current plotted against control-grid voltage for anode and screen-grid voltage of 100 V.

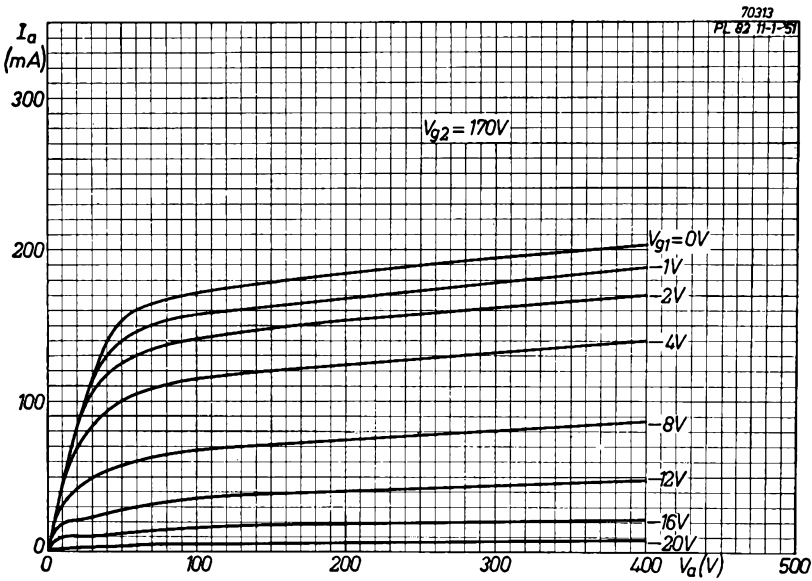

Fig. 8
Anode current plotted against anode voltage for screen-grid voltage of 170 V, with control-grid voltage as parameter.

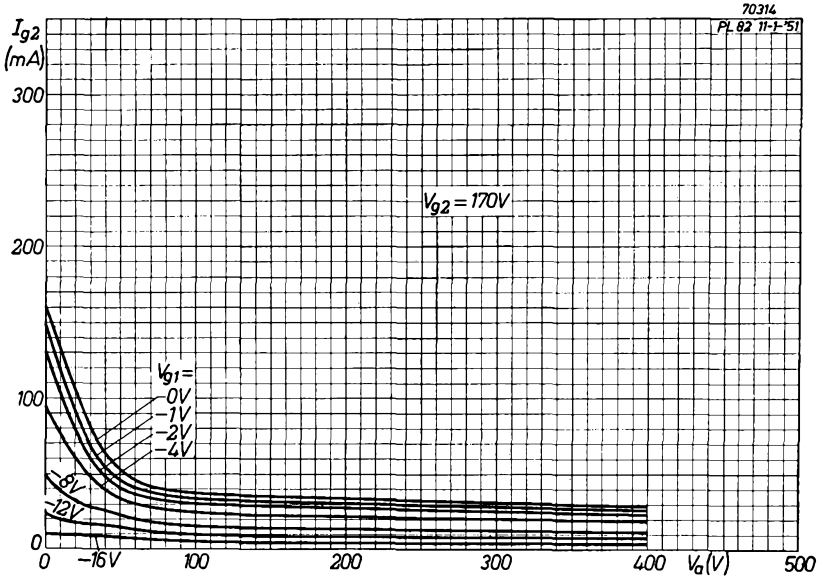

Fig. 9
Screen-grid current plotted against anode voltage for screen-grid voltage of 170 V, with control-grid voltage as parameter.

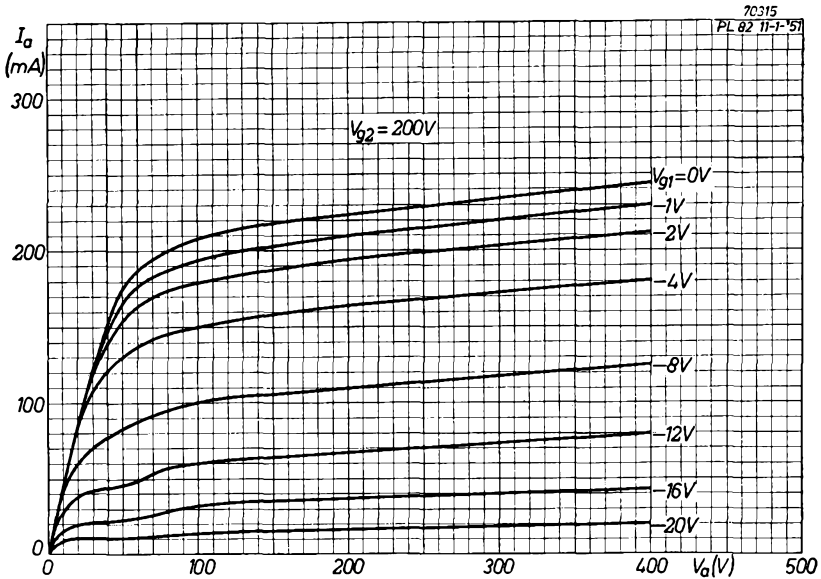

Fig. 10
Anode current plotted against anode voltage for screen-grid voltage of 200 V, with control-grid voltage as parameter.

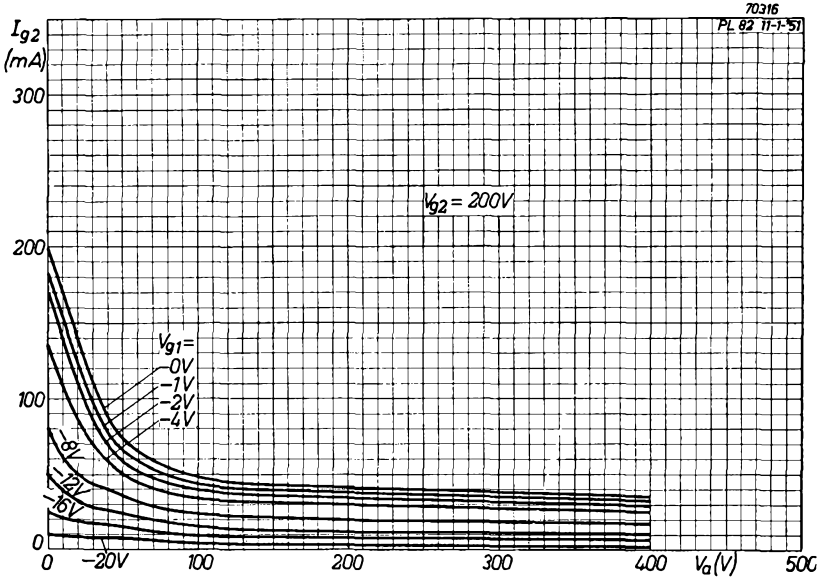

Fig. 11

Screen-grid current plotted against anode voltage for screen-grid voltage of 200 V, with control grid voltage as parameter.

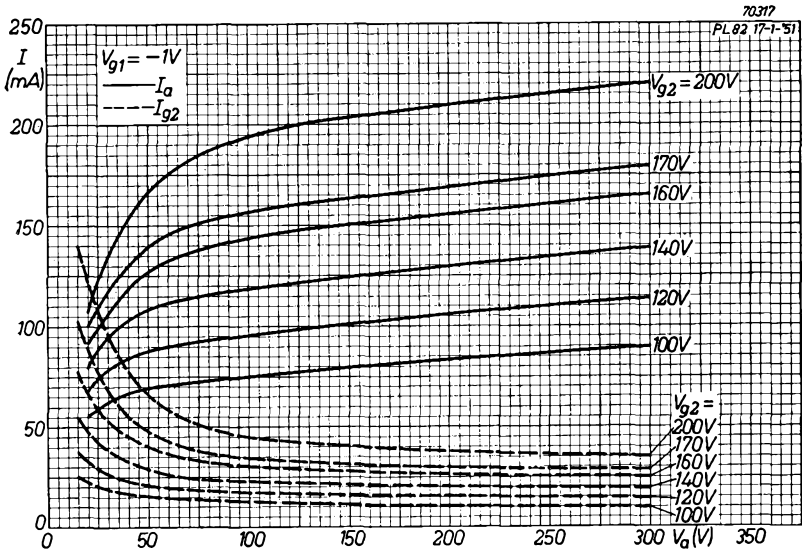

Fig. 12

Anode current and screen-grid current plotted against anode voltage for control-grid voltage of -1 V, with screen-grid voltage as parameter.

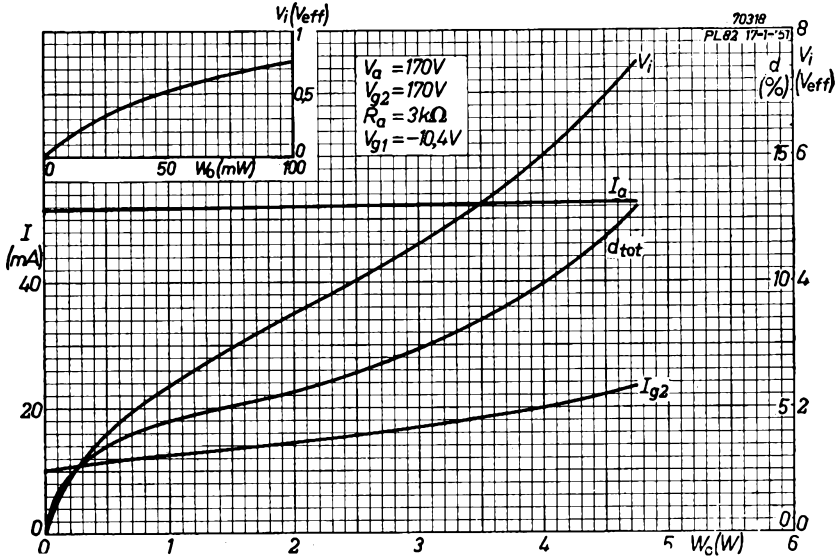

Fig. 13

Anode current, screen-grid current, input voltage and total distortion of one PL 82 valve in Class A, plotted against output power for anode and screen-grid voltage of 170 V.

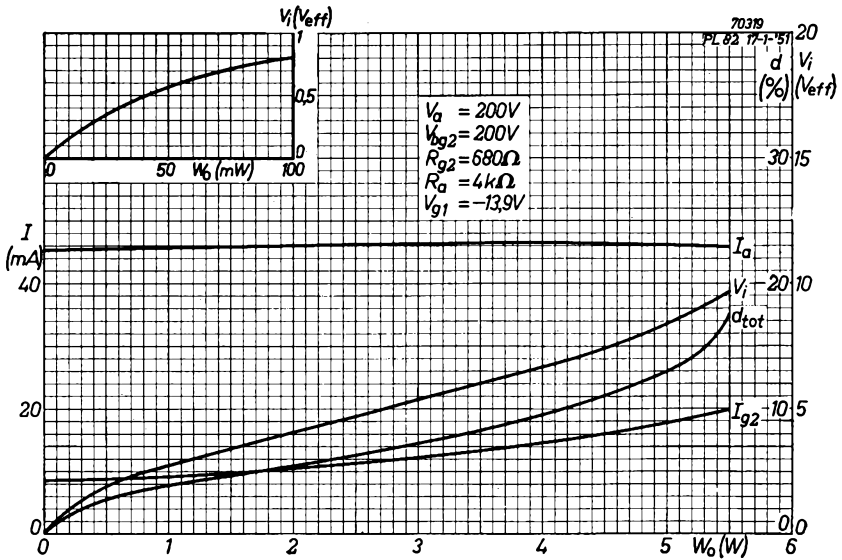

Fig. 14.

As fig. 13, but for a supply voltage of 200 V.

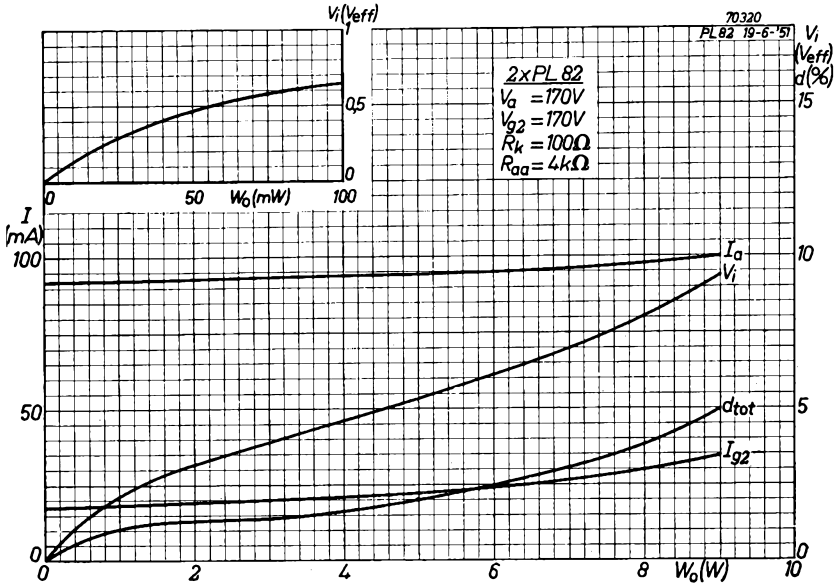

Fig. 15

Anode current, screen-grid current, input voltage and total distortion plotted against output power of two valves PL 82 in push-pull for anode and screen-grid voltage of 170 V. The currents indicated are of the two valves together.

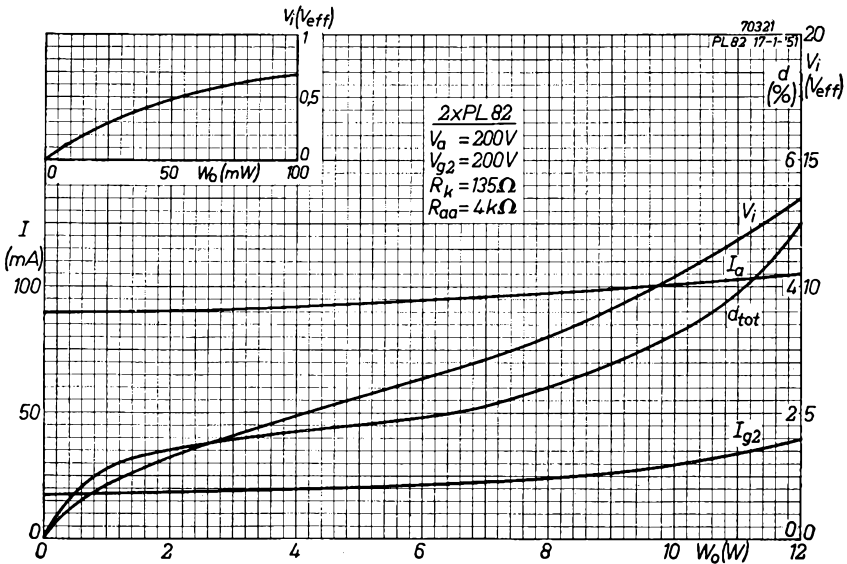

Fig. 16

As fig. 15, but for a supply voltage of 200 V.

The triode pentode ECL 80

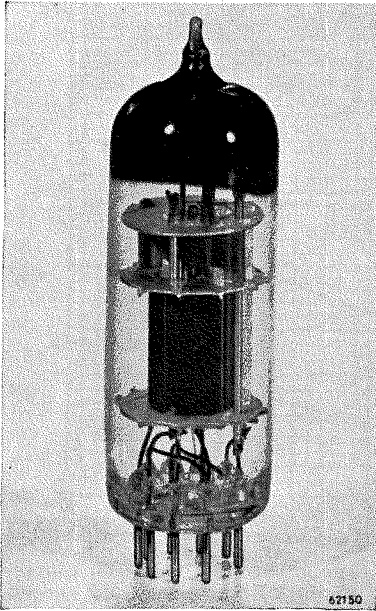

Fig. 1
The triode pentode ECL 80
(about actual size).

Description

In all stages of the picture channel and in the I.F. stages of the sound channel of a television receiver, single valves are used almost exclusively. In other stages, however, valves with two electrode systems in one envelope are frequently used. This obviously reduces the total number of valves to be employed, thus effecting economies in chassis space and also in the cost of the receiver. The most commonly used multiple valves are double diodes and double triodes, but in some applications a pentode system would offer advantages. However, each section of a double pentode of small dimensions will normally be incapable of providing sufficient power to permit it to be used in the frame output stage or as the sound output tube. These considerations have led to the design of the triode-pentode, Type ECL 80, which is not only suitable for a large number of functions but is also of small dimensions. The heater of this triode-pentode is suitable for either series

or parallel supply, A.C. or D.C., the heater voltage and current being 6.3 V and 0.3 A respectively.

Some of the wide variety of functions for which the ECL 80 may be employed are listed below:

Triode section	Pentode section
1. Frame blocking oscillator	Frame output
2. Line-blocking oscillator	Frame output
3. A.F. voltage amplifier	Sound output
4. Frame or line oscillator	Sync. separator
5. Half of frame multivibrator	Frame output
6. Half of line multivibrator	Other half of line multivibrator

Application

1. Triode as blocking oscillator (frame frequency)

Pentode as frame output valve

A circuit for vertical deflection in a picture tube MW 36-24 is given in Fig. 2. The output stage is matched to the deflection coils incorporated in the unit AT 1000/01 (data on page 123), and gives full deflection with an E.H.T. of 10 kV. In order to keep the peak anode current of the pentode sufficiently low, it is necessary to use an output transformer with a comparatively high turns ratio, which in turn involves the use of a high supply voltage. The anode is therefore fed from the boosted H.T. obtained from the line-output pentode, which is dealt with in the description of the PL 81 line-output pentode. The operation of the circuit of Fig. 2 will now be briefly discussed.

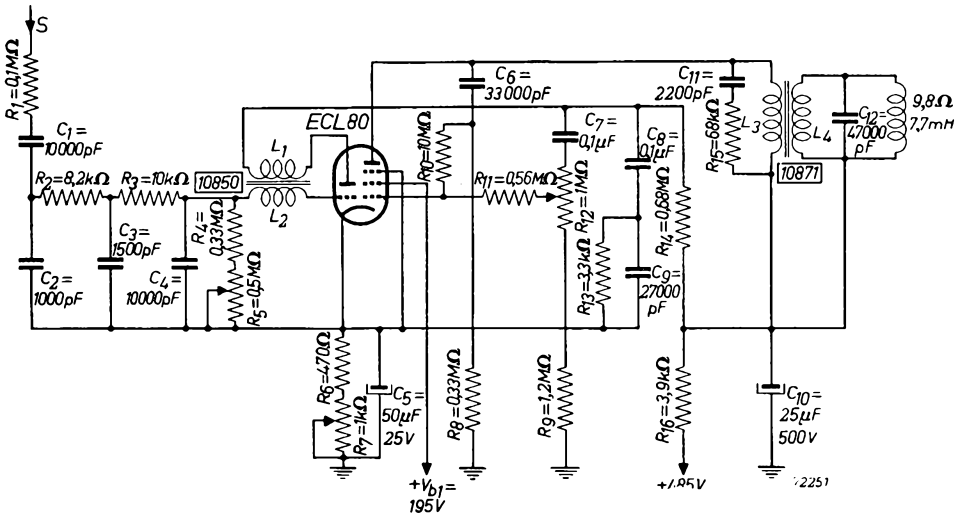

Fig. 2

Circuit for frame deflection using the ECL 80. The triode section is used as blocking oscillator and the pentode section as output valve.

The synchronizing signal is applied to the blocking oscillator via a double integration circuit, which gives a better interlace than with single integration. The charge capacitor C₄ in the triode grid circuit has been kept small so as to facilitate synchronization with the integrated synchronizing signal. A synchronizing signal of about 75 V peak-to-peak is required at the terminal S, and this can be obtained with the separator circuit given in Fig. 3. A standard blocking transformer Type 10850 with a turns ratio of 2 : 1 between L₂ and L₁ is used. The potentiometer R₅ is the vertical hold control. The saw-tooth voltage for driving the output pentode is obtained in the anode circuit of the triode section, which is supplied via R₁₆ from 485 V.

R_{13} and C_9 in series with the charge capacitor C_8 serve to give a negative peak during the fly-back, which blocks the pentode. This is necessary to prevent a delay in the flyback. The saw-tooth part of the alternating voltage at the top of C_8 has an amplitude of about 30 V peak-to-peak, whilst the negative peak is 150 V. The total amplitude across $C_8 + C_9$ is therefore about 180 V peak-to-peak.

The frequency of the blocking oscillator is almost entirely determined by the time constant of the grid circuit and the feedback. For adjusting the amplitude of the saw-tooth voltage applied to the pentode (height control) the charge resistor R_{14} could be varied. An increase of R_{14} would then reduce the saw-tooth amplitude in the anode circuit of the triode and vice versa. This method, however, has the disadvantage that, owing to the large time constant of R_{14} and C_8 , there is a time delay in the adjustment of the picture height. The arrangement represented in Fig. 2, where R_9 and R_{12} form a potentiometer, does not have this disadvantage, because the time constant in the anode circuit of the blocking oscillator is practically independent of the picture height control.

Negative feedback is applied across the output stage for two reasons. First of all the feedback circuit is so dimensioned that a form of driving voltage is obtained which gives a linear saw-tooth current in the deflection coils. Secondly, negative feedback reduces the risk of microphony, which would be manifest in vibration of the picture in the vertical direction. The capacitor C_6 and the resistor R_8 form a voltage divider and the feedback voltage is applied to the control grid of the pentode via the resistor R_{10} . The saw-tooth voltage from the blocking oscillator reaches this grid via the height control R_{12} and the resistor R_{11} . The time constant of C_6R_8 has been so chosen that an appreciable alternating voltage having a parabolic form occurs across the capacitor. Since the saw-tooth voltage at the anode of the pentode is practically linear, the voltage across R_8 is the difference between a linear saw-tooth voltage and the parabolic voltage occurring across C_6 . The voltage across R_8 is in antiphase with the voltage reaching the control grid via R_{11} and the result is that a parabolic component is added to the driving voltage. The parabolic component gives a reduction in the rate of change at the beginning of the scan and an increase towards the end.

It will be clear that the time constant of C_6R_8 can give linear deflection only when the primary self-inductance of the output transformer has a certain value (see description of PL 82). In production this self-inductance will vary, however, from transformer to transformer and it is therefore advisable to adjust R_8 experimentally or to make this resistor variable. Once adjusted to the correct value with a given output transformer R_8 need not be readjusted.

When adjusting C_6R_8 it will be noticed that it is difficult to obtain good linearity for both the upper and the lower half of the picture. The causes of this will not be discussed here. In the circuit of Fig. 2 correct linearity for the lower half of the picture is obtained with the combination of C_6 and R_8 , and after that the linearity of the upper half of the picture (beginning of the scan) is adjusted by varying the resistor R_7 in the cathode circuit. This results in a variation of the working point of the valve, so that the

influence of the curvature of the valve characteristic upon the shape of the anode current becomes greater or smaller.

A standard output transformer Type 10871 is used. The data of this transformer are as follows:

Turns ratio L_3 to L_4	37.4
Inductance of primary, approx.	80 H
Resistance of primary	4600 Ω
Resistance of secondary	2.7 Ω
Core dimensions	40 \times 60 mm
Height of stacking	20 mm

Owing to the high supply voltage and the consequently high turns ratio of this transformer, a positive voltage peak of considerable amplitude would occur across the primary during the flyback. This peak has been kept below 1200 V by the inclusion of the damping circuit $R_{15}C_{11}$. The capacitor C_{12} serves to prevent the occurrence of line pulses across the secondary during the line flyback.

The currents and voltages measured in the output circuit are as follows:

Deflection current peak-to-peak	750 mA
Average anode current of the pentode	9.5 mA
Peak anode current of the pentode	21 mA
Average screen-grid current	1.7 mA
Peak screen-grid current	6 mA
Cathode voltage	approx. 8.7 V

2. The ECL 80 as synchronizing pulse amplifier and separator

A circuit in which the ECL 80 is used as synchronizing pulse separator and amplifier is given in Fig. 3. The composite video signal, of which the synchronizing pulses must be positive going, is applied via a CR combination to the control grid of the pentode section. A resistor of 10 k Ω is included in the input lead to prevent an increase in the capacitance of the anode circuit of the preceding video amplifier. An undue increase of this capacitance would make it difficult to obtain the required video bandwidth.

The screen-grid resistance of the pentode has been given a high value, which results in a low screen-grid voltage and a control-grid base of only 2 V. Since the peaks of the synchronizing pulses give grid rectification, effective separation of the synchronizing pulses is ensured.

In normal operation, when a signal of which the synchronizing pulses have an amplitude of at least 2 V is applied to the pentode, the average anode voltage is approximately 48 V. During the synchronizing pulses this voltage drops below the knee of the I_a/V_a characteristics, so that interference pulses are limited.

The total amplitude of the synchronizing signal at the anode of the pentode is 45 V and this signal is applied to the triode grid for further amplification and limiting. The leak resistor of the triode is not connected as usual to

ECL 80

the chassis, but to the H.T. line of 180 V. This has the advantage that should the grid be driven far negative by an interference pulse the triode quickly resumes normal operation, because the negative charge at the grid capacitor is carried off in a relatively short time. The synchronizing pulses at the anode of the triode have an amplitude of 75 V peak-to-peak.

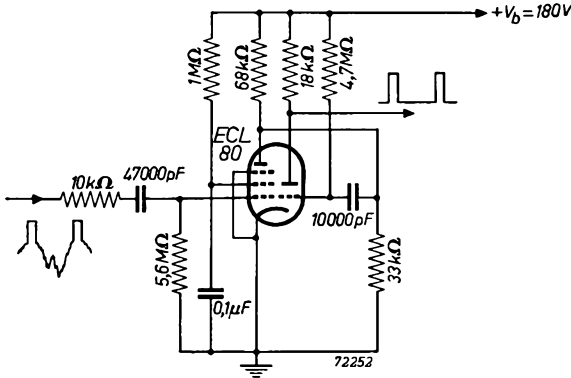

Fig. 3

Circuit for the ECL 80 as synchronizing pulse separator and amplifier.

3. Triode as A.F. voltage amplifier

Pentode as sound output valve

Extensive information referring to these uses are given in the data section. The ECL 80 permits the design of an audio amplifier of higher sensitivity than that of a normal single audio stage. Precautions should be taken, however, to avoid two possible sources of oscillation.

Oscillation at a low audio frequency may occur due to feedback through the common cathode resistor circuit when a common cathode resistor, tapped for the triode, is used. This may be avoided by using a long time constant in the cathode circuit ($C_k = 100 \mu\text{F}$) and a short one for the coupling between the triode anode and the pentode grid ($C_{g1} = 5000 \text{ pF}$; $R_{g1} = 0.68 \text{ M}\Omega$). The A.C. earth return of the circuit feeding the triode grid should be connected to the cathode, as otherwise the time constant of $C_{g1}R_{g1}$ may have to be further reduced. If fixed bias is used for both the triode and the pentode, there is, of course, no risk of oscillation at low frequencies.

Oscillation at a high audio frequencies may occur due to coupling through the capacitance between the pentode anode and the triode grid. The impedance in the triode grid circuit should therefore be kept as low as possible ($R_{gt} = 0.2 \text{ M}\Omega$). The output transformer primary should also be shunted by a high-frequency RC damping circuit to prevent a rise in the anode load impedance of the pentode at the higher frequencies. In extreme cases it

may be necessary to use a capacitor between triode anode and triode grid, or between triode grid and earth.

The tendency to oscillation at a high frequency as mentioned above may, however, most conveniently be reduced by applying negative feedback from the anode of the pentode section to the triode anode. A resistor of 0.68 MΩ will suffice for this purpose. The effect of this form of feedback on distortion and sensitivity is such that the sensitivity is reduced to about half that obtained without negative feedback whilst the distortion is considerably reduced, especially at low output; for example at 0.1 W without negative feedback $d_{tot} = 2.5\%$, and with negative feedback $d_{tot} = 0.5\%$.

DATA OF THE ECL 80

Heater data

Heating: indirect by A.C. or D.C.; series or parallel supply

Heater voltage	V_f	=	6.3 V
Heater current	I_f	=	0.3 A

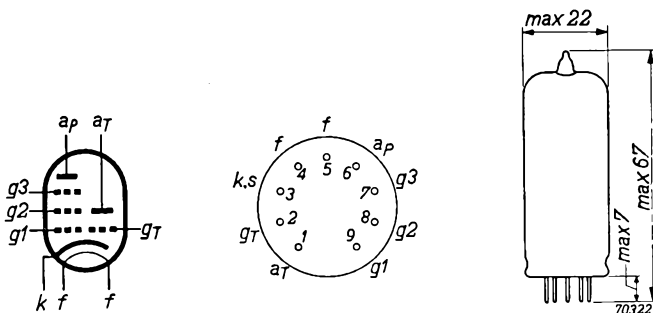

Fig. 4
Base connections and dimensions of the ECL 80.

Capacitances (measured on the cold valve)

Pentode section

Input capacitance	C_{g1}	=	4.5 pF
Output capacitance	C_a	=	5.0 pF
Capacitance between anode and control grid	C_{ag1}	=	< 0.2 pF
Capacitance between control grid and heater	C_{g1f}	=	< 0.25 pF
Capacitance between heater and cathode	C_{fk}	=	3.7 pF

ECL 80

Triode section

Input capacitance	C_g	=	2.1 pF
Output capacitance.	C_a	=	0.8 pF
Capacitance between anode and grid	C_{ag}	=	0.9 pF
Capacitance between grid and heater	C_{gf}	=	<0.05 pF
Capacitance between heater and cathode	C_{fk}	=	3.7 pF

Between sections

Capacitance between grid of triode and anode of pentode .	C_{gTaP}	=	<0.12 pF
Capacitance between anode of triode and anode of pentode .	C_{aTaP}	=	< 1.2 pF
Capacitance between grid of triode and control grid of pentode	C_{gTg1P}	=	< 0.2 pF
Capacitance between anode of triode and control grid of pentode	C_{aTg1P}	=	< 0.2 pF

Typical characteristics

Pentode section

Anode voltage	V_a	=	170	200	250 V
Suppressor-grid voltage	V_{g3}	=	0	0	0 V
Screen-grid voltage.	V_{g2}	=	170	200	240 V
Control-grid voltage	V_{g1}	=	-6.7	-8	-12.2 V
Anode current	I_a	=	15	17.5	14 mA
Screen-grid current.	I_{g2}	=	2.8	3.3	2.6 mA
Mutual conductance	S	=	3.2	3.3	2.6 mA/V
Internal resistance	R_i	=	0.15	0.15	0.2 MΩ
Amplification factor between screen grid and control grid .	μ_{g2g1}	=	14	14	14

Triode section

Anode voltage	V_a	=	100 V
Grid voltage	V_g	=	0 V
Anode current	I_a	=	8 mA
Mutual conductance	S	=	1.9 mA/V
Amplification factor	μ	=	20

Operating conditions

Pentode as sound output valve

Supply voltage	$V_b =$	170	200	250 V
Anode voltage	$V_a =$	170	200	250 V
Suppressor-grid voltage	$V_{g3} =$	0	0	0 V
Screen-grid voltage.	$V_{g2} =$	170	200	V
Screen-grid resistor.	$R_{g2} =$	—	—	4.7 k Ω
Control-grid voltage	$V_{g1} =$	-6.7	-8	-12.2 V
Anode current	$I_a =$	15	17.5	14 mA
Screen-grid current.	$I_{g2} =$	2.8	3.3	2.6 mA
Mutual conductance	$S =$	3.2	3.3	2.6 mA/V
Internal resistance	$R_i =$	0.15	0.15	0.2 M Ω
Matching resistance	$R_a =$	11	11	17.5 k Ω
Power output ($d_{tot} = 10\%$)	$=$	1	1.4	1.55 W
Input signal ($d_{tot} = 10\%$)	$=$	3.7	4.1	5.3 V _{rms}
Power output ($\eta = 50\%$)	$=$	1.27	1.75	1.75 W
Input signal ($\eta = 50\%$)	$=$	4.4	5.1	5.9 V _{rms}
Input signal ($W_o = 50$ mW)	$=$	0.7	0.7	0.75 V _{rms}

Pentode as synchronizing pulse separator

Anode voltage	$V_a =$	=	20 V
Suppressor-grid voltage	$V_{g3} =$	=	0 V
Screen-grid voltage.	$V_{g2} =$	=	12 V
Control-grid voltage	$V_{g1} =$	=	0 $\overbrace{-1.45 \text{ V}}$
Anode current	$I_a =$	=	2 0.1 mA

Triode as A.F. voltage amplifier

V_b (V)	R_a (k Ω)	$R_g^{(1)}$ (k Ω)	$-V_g$ (V)	I_a (mA)	$V_o^{(2)}$ (V _{rms})	V_o/V_i	d_{tot} (%)
170	47	150	3.5	1.8	22	9.5	8.7
170	100	330	3.5	1.0	24	10.5	7.6
170	220	680	3.5	0.5	24.5	11	6.5
200	47	150	4.2	2.2	27	9.5	9.0
200	100	330	4.2	1.2	29	10.5	8.0
200	220	680	4.2	0.6	30	11	6.5
250	47	150	5.5	2.8	36	9.5	9.2
250	100	330	5.5	1.5	39	10.5	8.3
250	220	680	5.5	0.75	40	11	7.0

¹⁾ Grid resistor of following valve.

²⁾ Output voltage at start of I_g . At lower output voltages the distortion is proportionately reduced.

ECL 80

Limiting values

Pentode section

Anode voltage at zero anode current	V_{a_0}	= max.	550 V
Anode voltage	V_a	= max.	400 V
Positive peak anode voltage (10% of the duration of a cycle with a maximum of 2 m sec.)		= max.	1200 V
Negative peak anode voltage .		= max.	500 V
Screen-grid voltage at zero screen-grid current	V_{g2_0}	= max.	550 V
Screen-grid voltage.	V_{g2}	= max.	250 V
Control-grid current starting point (grid current + 0.3 μ A)	V_{g1}	= max.	-1.3 V
Heater voltage during the warming-up period	V_f	= max.	9.5 V
Voltage between heater and cathode	V_{fk}	= max.	150 V
Cathode current	I_k	= max.	25 mA
Peak cathode current (10% of the duration of a cycle with a maximum of 2 m sec.) . .	I_{kp}	= max.	350 mA
Anode dissipation	W_a	= max.	3.5 W
Screen-grid dissipation . . .	W_{g2}	= max.	1.2 W
External resistance between control grid and cathode with fixed bias	R_{g1}	= max.	1 M Ω
with automatic bias	R_{g1}	= max.	2 M Ω
External resistance between heater and cathode	R_{fk}	= max.	20 k Ω

In frame output applications, to allow for inevitable spread between individual valves and for deterioration during life, the circuit should be designed around a peak anode current not exceeding 26 mA at $V_a = 50$, $V_{g2} = 170$ V. At $V_a = 60$ V, $V_{g2} = 200$ V the corresponding value for the peak anode current is 31 mA and at $V_a = 70$ V, $V_{g2} = 250$ V it is 42 mA.

Triode section

Anode voltage at zero anode current	V_{a_0}	= max.	550 V
Anode voltage	V_a	= max.	200 V
Grid current starting point (grid current + 0.3 μ A)	V_g	= max.	-1.3 V

Heater voltage during warming-up period	V_f	= max.	9.5 V
Voltage between heater and cathode.	V_{fk}	= max.	150 V
Cathode current	I_k	= max.	8 mA
Peak cathode current (10% of the duration of a cycle with a maximum of 2 m sec.) . .	I_{kp}	= max.	200 mA
Anode dissipation	W_a	= max.	1 W
External resistance between grid and cathode			
with fixed bias	R_g	= max.	1 M Ω
with automatic bias	R_g	= max.	3 M Ω
External resistance between heater and cathode	R_{fk}	= max.	20 k Ω

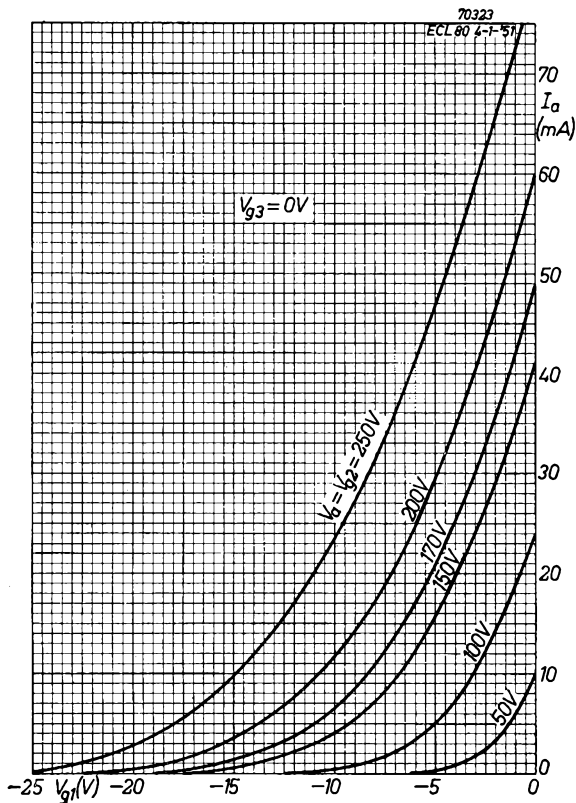

Fig. 5

Anode current of **pentode section** plotted against control-grid voltage for anode and screen-grid voltages between 50 V and 250 V.

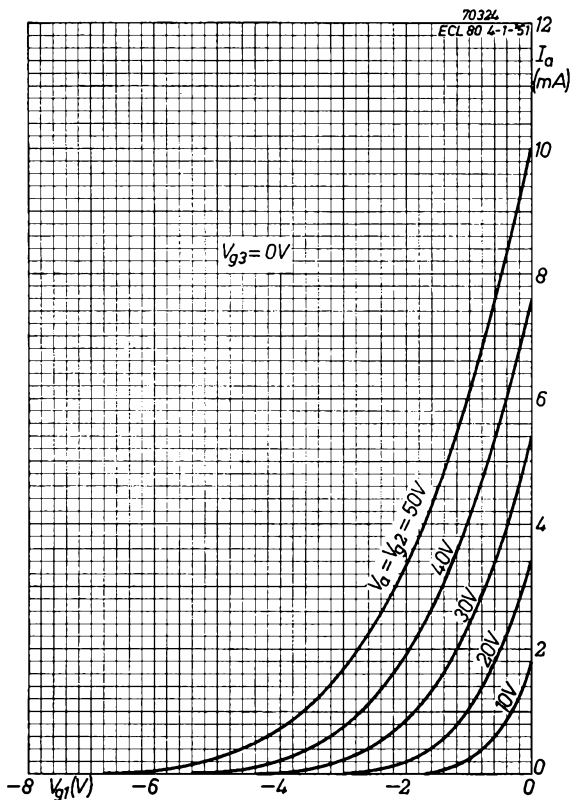

Fig. 6

Anode current of **pentode section** plotted against control-grid voltage for anode and screen-grid voltages between 10 V and 50 V.

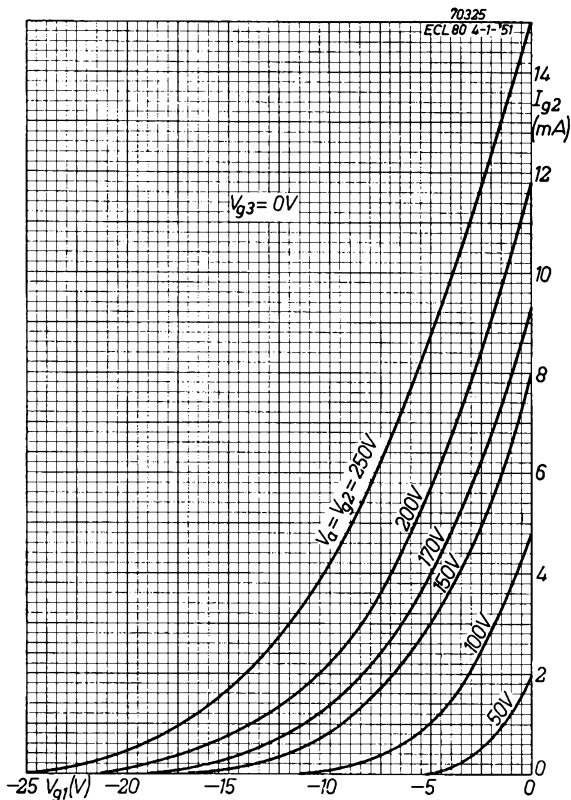

Fig. 7

Screen-grid current of **pentode section** plotted against control-grid voltage for anode and screen-grid voltages between 50 V and 250 V.

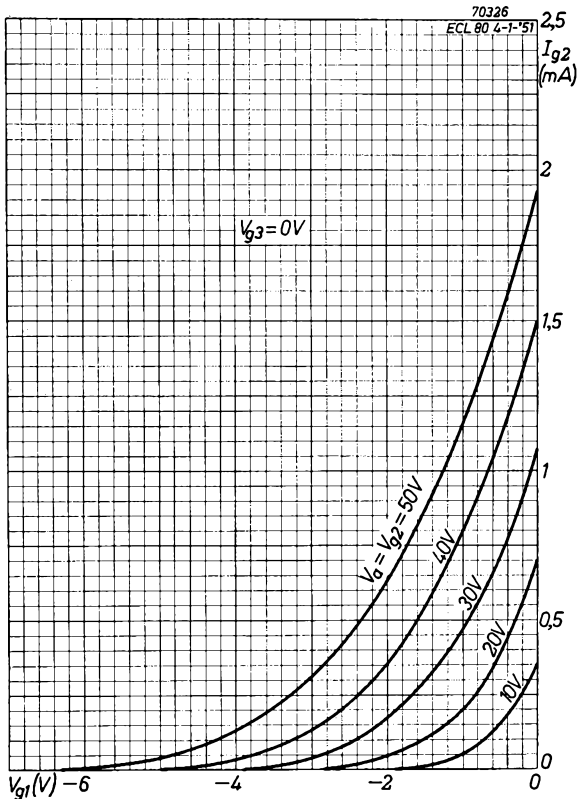

Fig. 8

Screen-grid current of **pentode section** plotted against control-grid voltage for anode and screen-grid voltages between 10 V and 50 V.

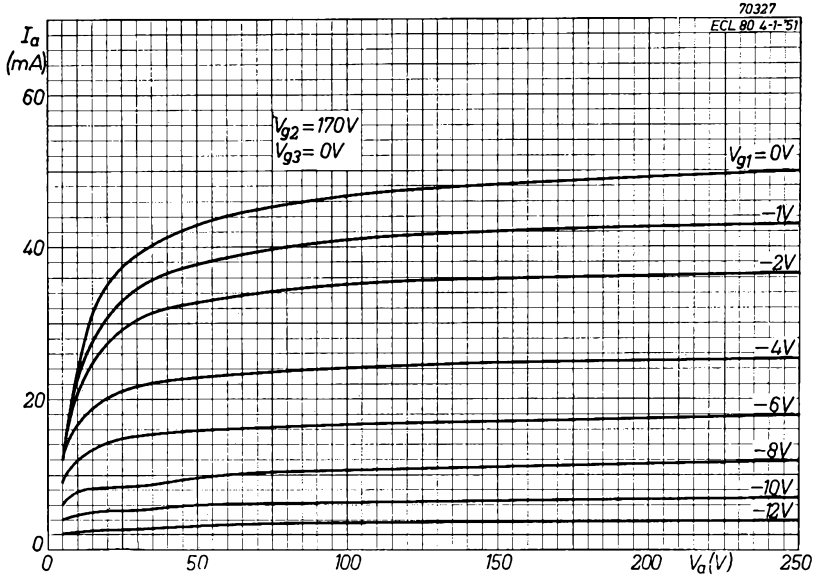

Fig. 9
Anode current of **pentode section** plotted against anode voltage for screen-grid voltage of 170 V, with control-grid voltage as parameter.

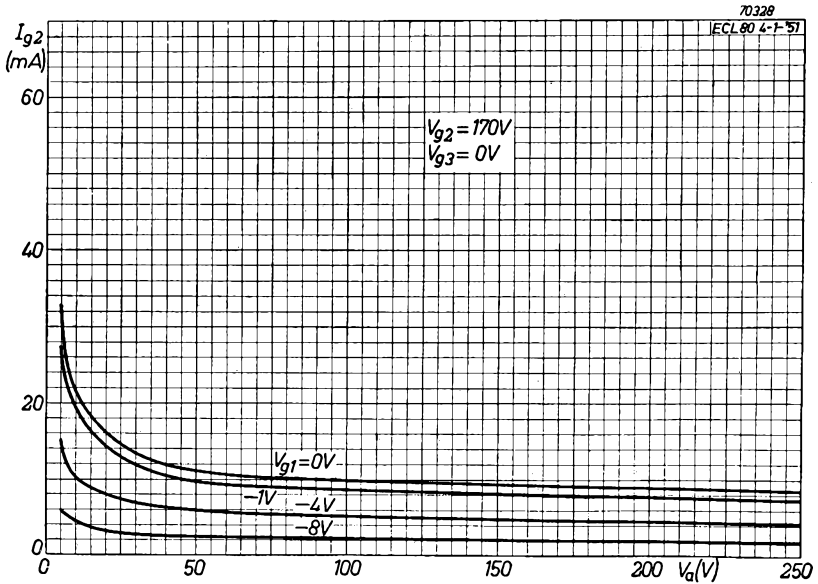

Fig. 10
Screen-grid current of **pentode section** plotted against anode voltage for screen-grid voltage of 170 V, with control-grid voltage as parameter.

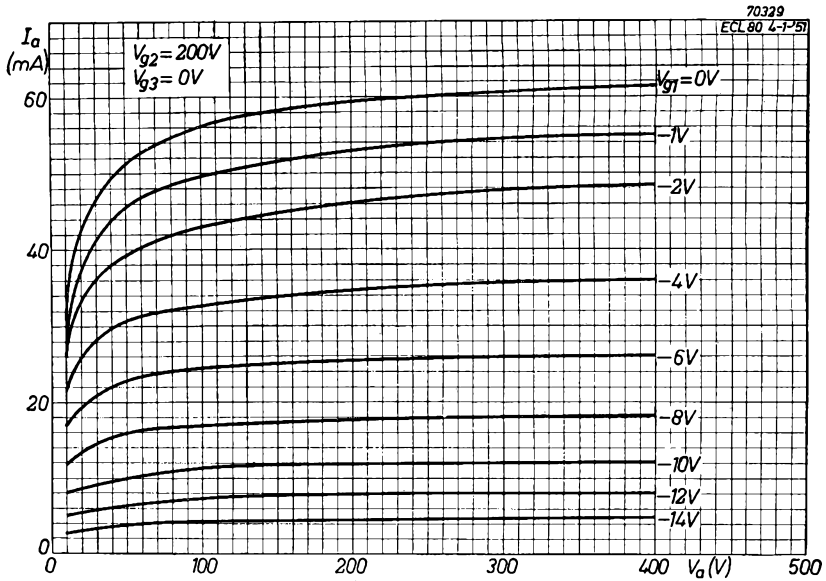

Fig. 11

Anode current of **pentode section** plotted against anode voltage for screen-grid voltage of 200 V, with control-grid voltage as parameter.

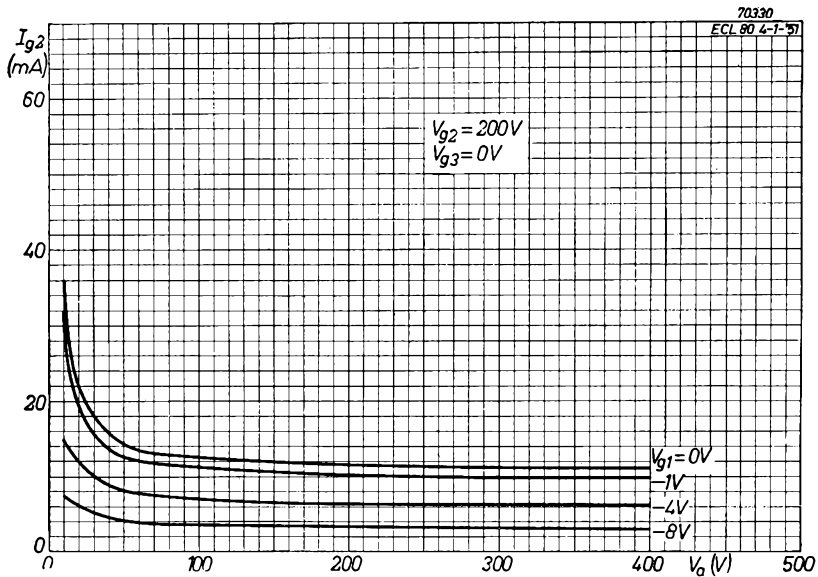

Fig. 12

Screen-grid current of **pentode section** plotted against anode voltage for screen-grid voltage of 200 V, with control-grid voltage as parameter.

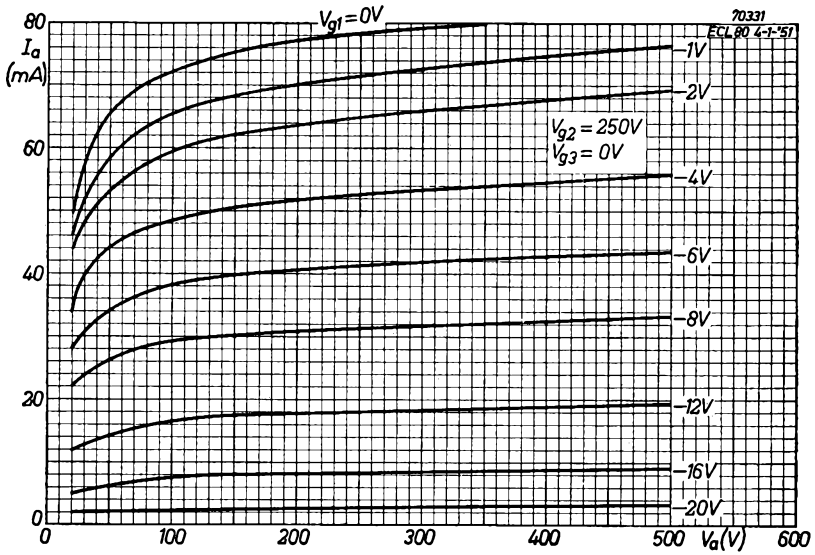

Fig. 13

Anode current of pentode section plotted against anode voltage for screen-grid voltage of 250 V, with control-grid voltage as parameter.

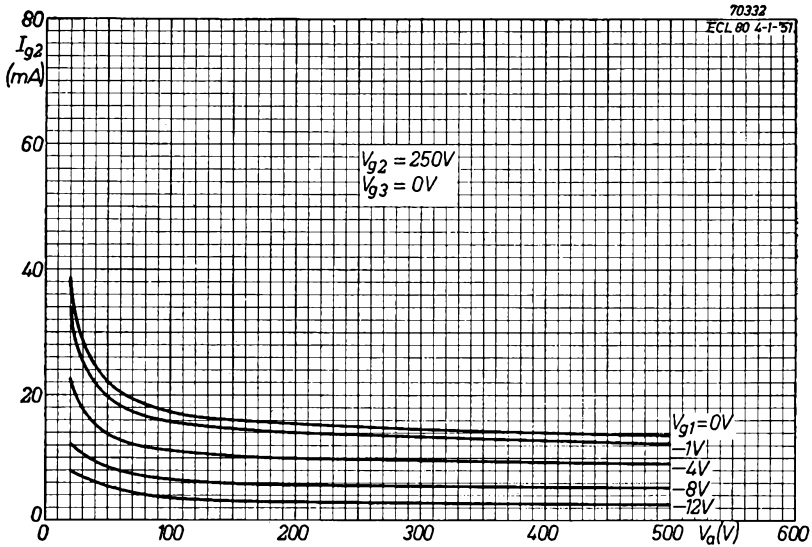

Fig. 14

Screen-grid current of pentode section plotted against anode voltage for screen-grid voltage of 250 V, with control-grid voltage as parameter.

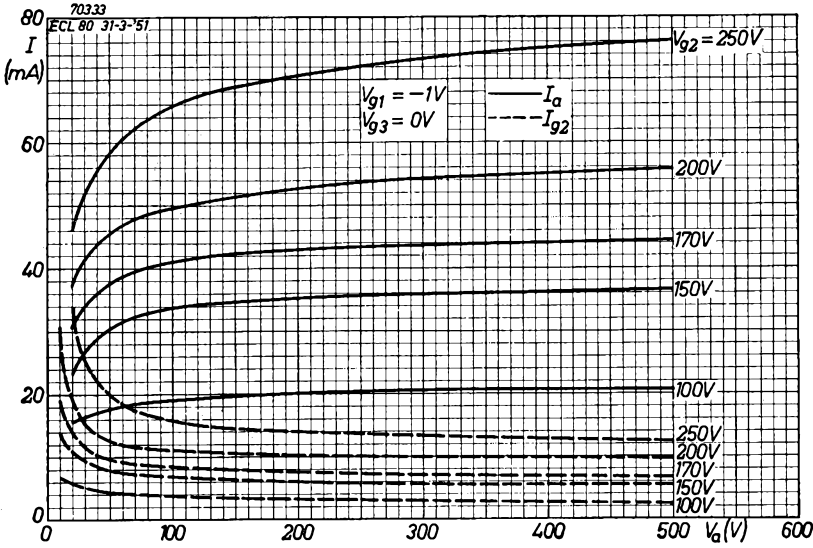

Fig. 15
Anode current and screen-grid current of **pentode section** plotted against anode voltage for control grid voltage of -1 V, with screen-grid voltage as parameter.

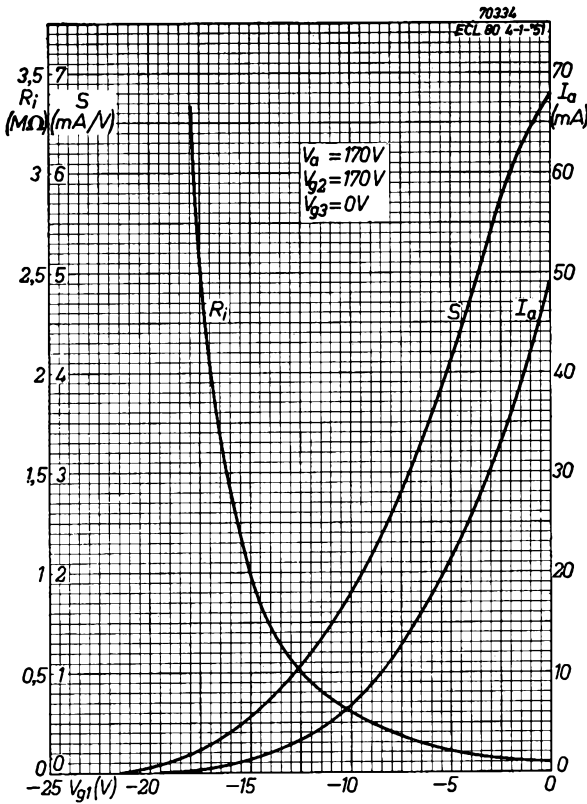

Fig. 16
Anode current, mutual conductance and internal resistance of **pentode section** plotted against control-grid voltage for anode and screen-grid voltage of 170 V.

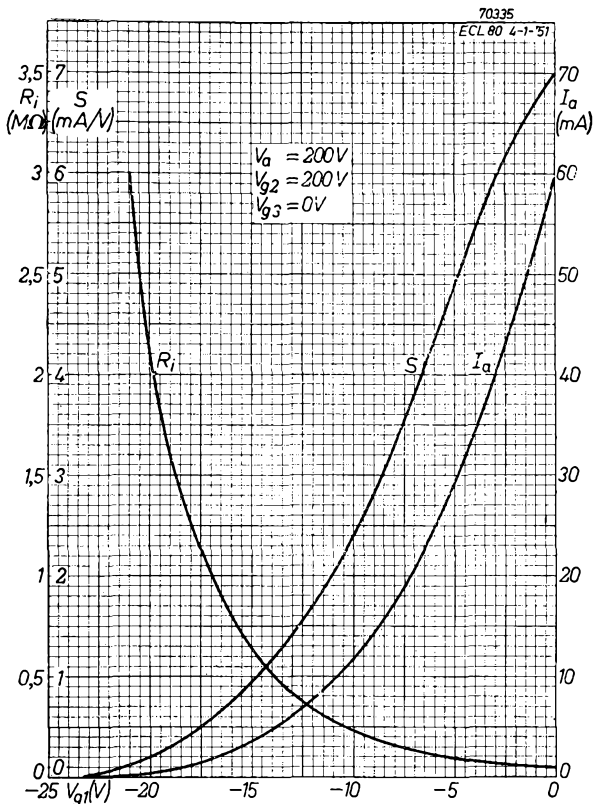

Fig. 17
 Anode current, mutual conductance and internal resistance of **pentode section** plotted against control-grid voltage for anode and screen-grid voltage of 200 V.

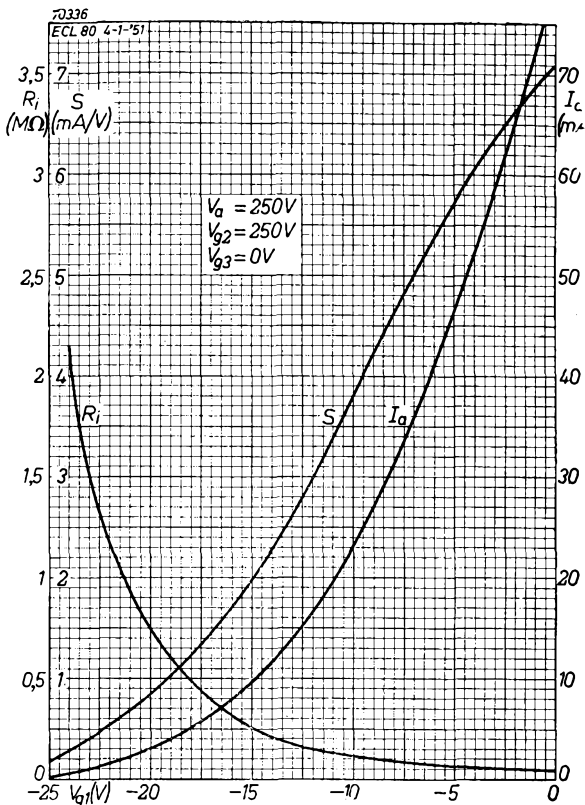

Fig. 18

Anode current, mutual conductance and internal resistance of **pentode section** plotted against control-grid voltage for anode and screen-grid voltage of 250 V.

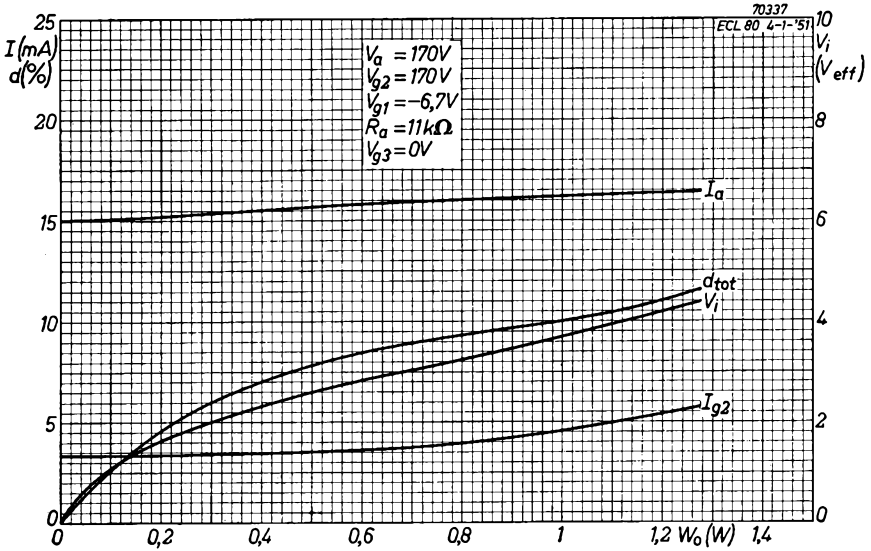

Fig. 19
Anode current, screen-grid current, input voltage and total distortion of pentode section plotted against output power for anode and screen-grid voltage of 170 V.

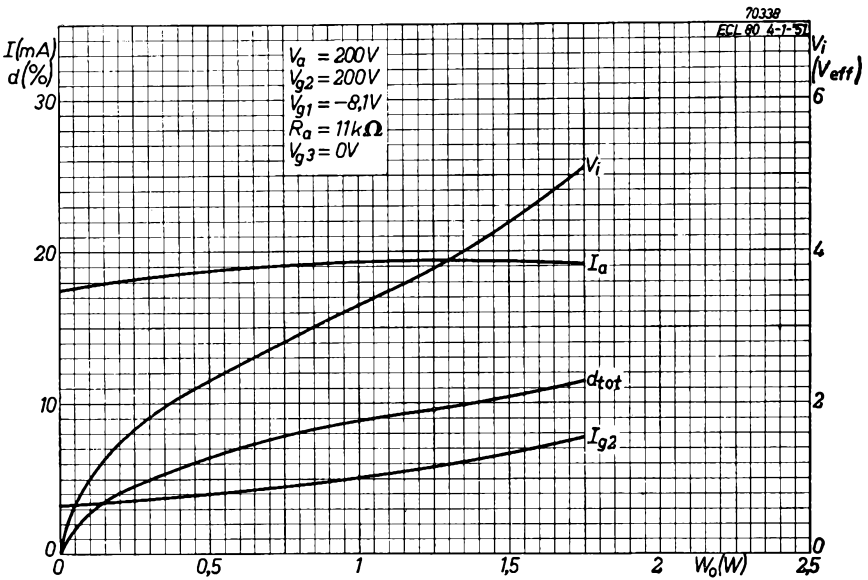

Fig. 20
Anode current, screen-grid current, input voltage and total distortion of pentode section plotted against output power for anode and screen-grid voltage of 200 V.

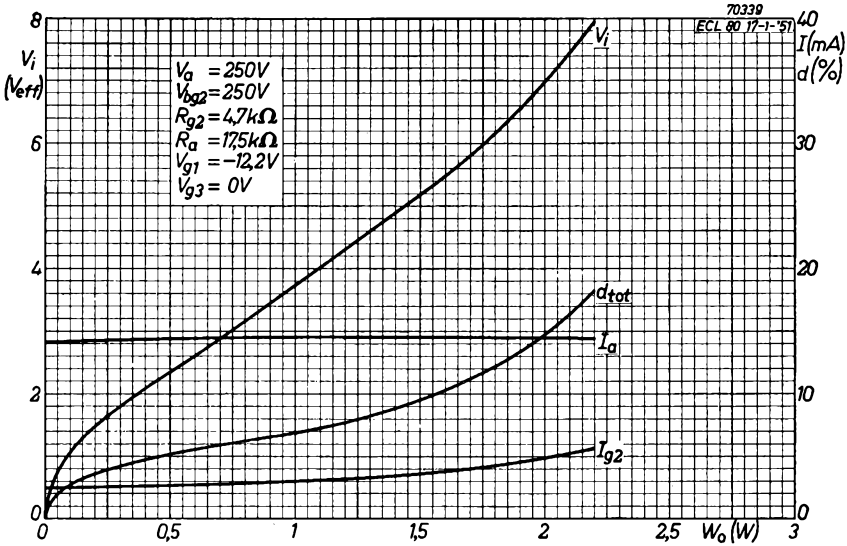

Fig. 21

Anode current, screen-grid current, input voltage and total distortion of **pentode section** plotted against output power for anode and screen-grid supply voltage of 250 V.

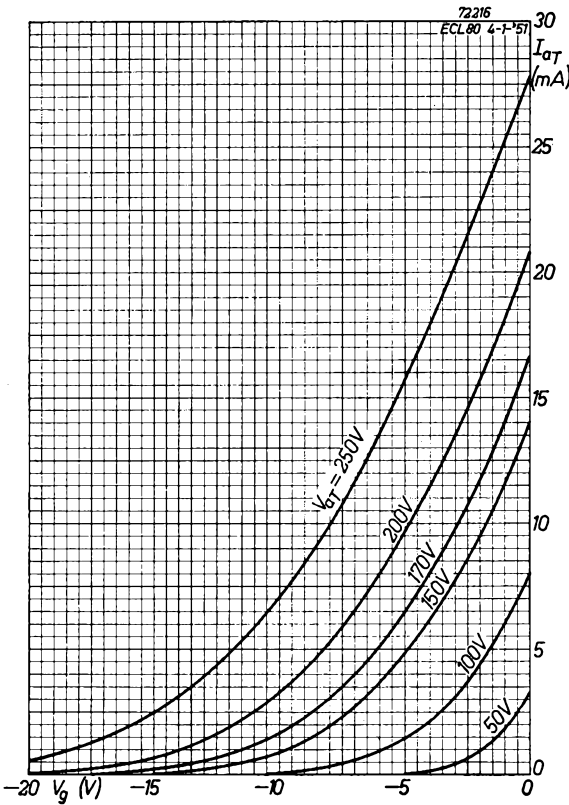

Fig. 22

Anode current of **triode section** plotted against grid voltage for anode voltages between 50 V and 250 V.

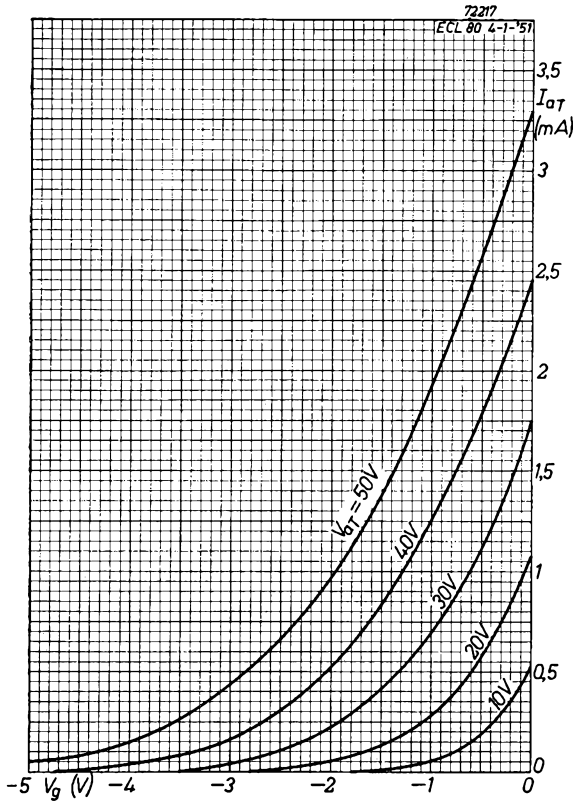
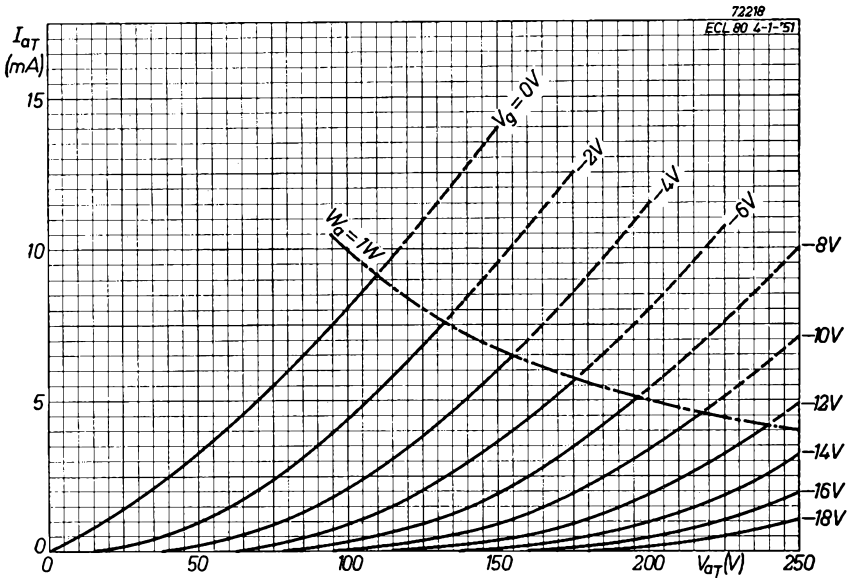

Fig. 23
Anode current of triode section plotted against grid voltage for anode voltages between 10 V and 50 V.

Fig. 24
Anode current of triode section plotted against anode voltage, with grid voltage as parameter.



The line output pentode PL 81

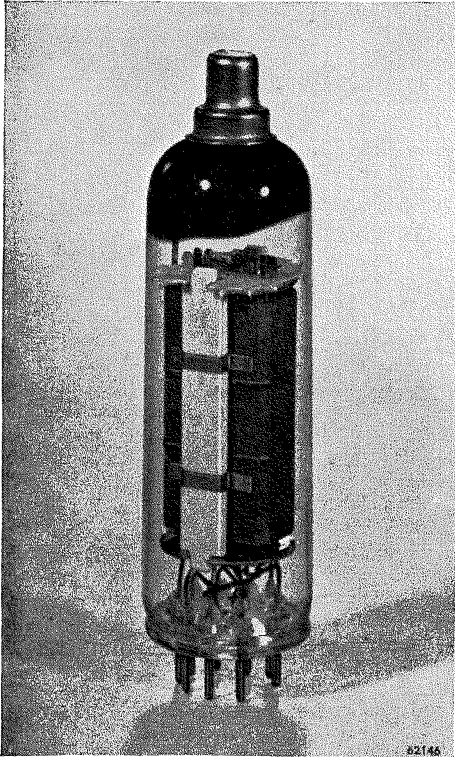

Fig. 1

The line-output pentode PL 81 (about actual size).

Description

The requirements which a line-output valve must satisfy are quite different from those for a normal output valve. In a line-output circuit a high peak anode current must be delivered at the end of the scan with a low voltage drop across the valve. The PL 81 pentode has been so designed that the knee in the I_a/V_a characteristic occurs at a very low anode voltage. With a screen-grid voltage of 170 V, an anode voltage of 70 V and a grid bias of -1 V the anode current of the average valve is 350 mA, which is a very high value for a valve of these small dimensions. In the conventional circuit the driving voltage has such a shape that during the scan the anode operates at an average potential of approximately 25 V. The screen-grid current and consequently the screen-grid dissipation are therefore comparatively high, but the valve has been so designed that it can withstand this condition, the permissible continuous screen-grid dissipation being 4.5 W.

Another important difference from a normal output circuit is that the anode of the line-output valve is subjected to a very high peak voltage during the line flyback. The anode must therefore be very well insulated from the rest of the valve, and this is ensured in the PL 81 by a top connection and special ceramic supports inside the envelope. The valve can thus be used safely with peak anode voltages of 7 kV.

Although the PL 81 has been specially designed for use in television receivers, its characteristics render it also suitable for A.F. amplifying purposes. With a supply voltage of only 170 V, two valves in push-pull can give an output of 13.5 W, whilst at 200 V an output of 20 W can be obtained. This application will not be dealt with in this book, the operating conditions being, however, tabulated in the data section.

Application

1. General introduction

The output stages for line and frame deflection both serve to drive linear sawtooth currents through the deflection coils. There are, however, considerable differences in the dimensioning of the two stages. This is due to the fact that the fundamental frequency of the sawtooth current for frame deflection is 50 c/s (or 60 c/s in the U.S.A.), whilst for line deflection a current having a fundamental frequency of 15,625 c/s (625 lines) is required. At line frequency the load formed by the deflection coils is therefore almost purely inductive. It has been shown in the description of the PL 82 pentode that, disregarding the special form of the anode current, the operation of the frame-output stage does not differ fundamentally from that of a normal A.F. output stage.

With the line-output stage, however, this is by no means the case. By way of example it may be mentioned that the line coils of one standard deflection yoke have an inductance of 5.3 mH and a resistance of 5.8 Ω . For the fundamental wave of the sawtooth current the inductive reactance is therefore 520 Ω , which is almost ten times the resistance.

The example given above indicates that the line coils are usually so designed that a comparatively low impedance is obtained. This has not only constructional advantages (few turns of fairly thick wire), but also prevents the occurrence of high peak voltages during the flyback. It is true that a transformer is used for matching to the output valve and that the high peak voltages still occur at the primary of this transformer, but it is much more easy to provide sufficient insulation at this point.

A line output circuit in its most simple form is given in Fig. 2, in which the capacitor indicated by dotted lines represents the total capacitance of the transformer, the deflection coils and the wiring. The saw-tooth voltage at the control grid and the anode current are indicated in Fig. 3. Although the anode current may be fairly linear this need not be the

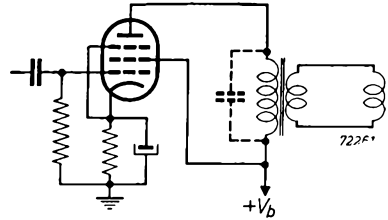

Fig. 2
Basic line-output circuit.

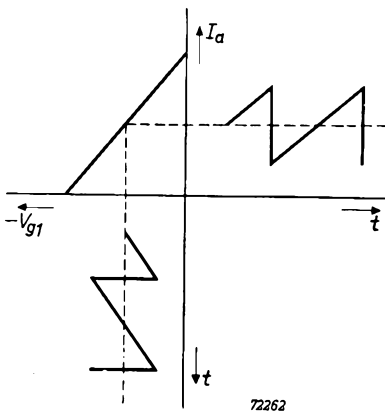

Fig. 3
Saw-tooth voltage at the control grid and anode current of the pentode of Fig. 2.

case for the current in the deflection coils; this is due to a damped oscillation starting during the flyback, the frequency of which is determined by the total inductance of the anode circuit and the associated capacitance. This may be explained as follows.

During the scan the anode voltage of the output valve is fairly low, for example 20 or 30 V. When, however, the flyback starts the anode current instead of increasing, decreases rapidly, so that, owing to the inductive load, the voltage drop across the transformer primary changes polarity and the



Fig. 4
Current in the deflection coils
in the case of little damping.

anode voltage assumes a very high value. This voltage may reach a value of 5 kV. A high anode voltage corresponds to a high internal resistance, which results in the valve contributing very little to the damping of the output circuit. The result is that the current in the deflection coils shows a negative peak (see Fig. 4), the amplitude of which depends upon the losses introduced by the transformer core, and the resistance of the windings and of the deflection coils. At the point where the deflection current again increases in the

positive direction, the anode voltage and also the internal resistance of the valve are again low, provided the valve is not cut off. The damping is now much heavier, but normally not sufficient to prevent variations in scanning speed at the beginning of the next scanning period. This is manifest in alternate dark and bright bands in the left half of the picture.

This phenomenon is, of course, inadmissible and it is therefore necessary to provide so much damping that variations in scanning speed at the beginning of the scan cannot occur. The anode circuit must then be critically damped, which may, for example, be obtained by using a transformer core with high losses and by shunting the deflection coils with a resistor. In this connection it may be remarked that in order to complete the flyback in the available time the resonant frequency of the output circuit must be at least 50 kc/s, so that in a normal transformer core large losses occur during the flyback.

In this way it is indeed possible to prevent oscillatory variations in scanning speed at the beginning of the scan, but an important disadvantage is that the magnetic energy stored in the deflection coils and the transformer at the end of the scanning period is dissipated uselessly in the transformer core and the damping resistor if any. The efficiency of the circuit is then low and the total power consumption is consequently high. In a practical circuit the power to be supplied via the H.T. line may be 50 W, whilst from the fact that the impedance of the deflection coils is almost purely inductive it may be deduced that it must be possible to maintain a sawtooth current without the expenditure of a large amount of power. To obtain this it is necessary to make use of the stored magnetic energy.

During recent years a number of circuits for energy recovery have been proposed and used, but the one most frequently used nowadays is that in-

corporating a booster diode. In a booster diode circuit the energy in the scanning system circulates between the magnetic field of the deflection coils and transformer and a capacitor, so that only the losses occurring in this exchange must be covered by the power supply. For circuits of this type it is very important that a transformer core with low losses is used, a condition which is satisfied by the special magnetic material sold under the name Ferroxcube.

One of the first circuits operating with a booster diode, and one which is still in use at the present time is represented in Fig. 5. In this circuit a transformer is used the secondary of which is extended, whilst during the

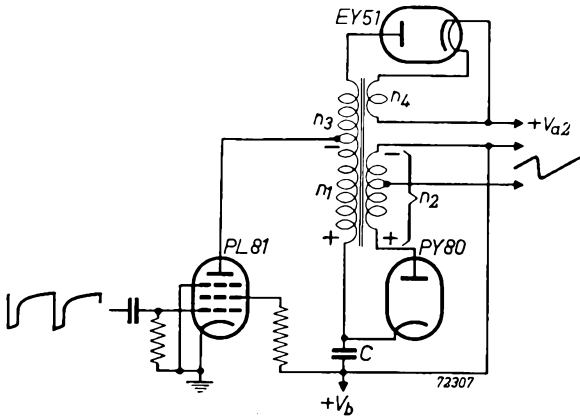

Fig. 5

Line-output circuit with booster diode in which a transformer is used with separate secondary and primary windings.

scan the polarity of the voltages across the windings n_1 and n_2 is such that the anode voltage of the pentode is negative with respect to the cathode of the booster diode PY 80, the anode of the latter valve having a voltage with respect to the chassis which is the sum of the voltage across n_2 and the supply voltage V_b . If, therefore, the diode conducts, the voltage occurring across the booster capacitor C is equal to the voltage across n_2 , the voltage drop in the PY 80 diode being small. The supply voltage available for the pentode is thus increased. This circuit is therefore specially suitable for receivers in which the available H.T. line voltage is low, for example if this voltage is obtained by direct rectification from the mains.

A further feature of the circuit is that the E.H.T. for the picture tube (10 to 15 kV) is obtained by rectifying the positive voltage peaks occurring across the transformer primary during the flyback by means of a special diode Type EY 51 the heater of which is supplied via a few additional turns (n_4) on the transformer. In order to increase the E.H.T. to the required value the primary is extended by the E.H.T. winding n_3 .

A more detailed analysis of the operation of the circuit shows that during the flyback the polarity of the voltages across the transformer is opposite to that shown in Fig. 5. The flyback is initiated by blocking the output pentode, and since during the flyback the anode of the booster diode is highly negative with respect to the cathode, the latter valve is also blocked. Owing to the large amount of magnetic energy in the transformer and the deflection coils, when blocking the output valve a damped oscillation starts, the frequency of which is determined by the total inductance and the associated capacitance. Since after half a period of oscillation the voltages across the output transformer again change polarity, current starts to flow in the booster diode at that instant, so that the capacitor C is charged. The voltage drop across the booster diode is but small, as a result of which the voltage across n_2 is kept constant, which implies a practically linear variation of the current in the deflection coils. It is true that the voltage across C may vary slightly, but this is a second order effect.

From the explanation given above it may be seen that the duration of the flyback is approximately equal to the duration of half a period of the free oscillation. It is therefore necessary, by means of suitable winding methods, to keep the resonant frequency of the transformer and the deflection coils so high that the flyback can be completed in the available blanking time. A practical lower limit for the resonant frequency is 60 kc/s. In a loss-free circuit no power is dissipated during the flyback, which implies that the magnetic energy available at the end of the flyback to charge the booster capacitor is equal to the magnetic energy at the beginning of the flyback. The interval during which the capacitor is charged then corresponds to the duration of the first half of the scan. The energy for the second half of the scan must be delivered via the output pentode, which must be unblocked to rebuild the magnetic field. The charge drawn from the booster capacitor during this interval, corresponds to the charge supplied to it during the first half of the scan. It is seen that the energy circulates between the booster capacitor and the magnetic field, so that, without any losses, i.e. also without any voltage drop across the valves, the circuit would operate without any power being supplied to it. The H.T. line voltage could then be zero, but this, of course, is not possible in practice for the following reasons. During the flyback power is dissipated in the transformer core, the resistance of windings and deflection coils and the circuit for the E.H.T. and for feeding the heater of the E.H.T. rectifier. The result is that the energy in the magnetic field at the end of the flyback is smaller than that at the beginning, so that it is not sufficient to complete the first half of the next scanning period. Since also during the scan losses occur in the valves and in the resistance of transformer windings and deflection coils, the output pentode must be unblocked well before the first half of the scan is completed. With low losses this instant can almost coincide with the centre of the scanning period. For high efficiency the use of a low-loss core material such as Ferroxcube is very important.

It has been indicated previously that when the booster diode conducts the voltage drop across it is but small, so that the voltage across the winding n_2 is kept constant, which implies an almost linear rate of scan. To ensure

good linearity during the whole scanning period the driving voltage applied to the output pentode is normally given such a shape that the booster remains conductive during the whole scan.

There is another reason for making the pentode conductive at a still earlier instant than that indicated previously and to make it coincide with the beginning of the scan. The coupling between the primary and the secondary windings of the transformer is not ideal, so that stray inductance is present. The energy stored in the stray inductance at the end of the scan gives rise to an oscillation at the start of the flyback, which, when the pentode is blocked, is not damped out when the next scanning period begins. Since the secondary winding itself has also stray inductance, so that it is not entirely short circuited by the booster diode, the oscillation can be superimposed upon the deflection current, resulting in alternately dark and bright vertical bands at the left side of the picture. If the pentode is unblocked at the beginning of the scan, the oscillation is more rapidly damped by the internal resistance of the valve.

In a practical circuit working with an H.T. line voltage of approximately 200 V, the voltage available at the cathode of the booster diode (top of booster capacitor) is usually between 400 and 600 V. Since in a few circuits in the receiver a supply voltage higher than 200 V may be desirable, these circuits can be fed from the boosted H.T. supply. Examples of this are the second grid of the picture tube, the anode of the output valve for frame deflection and the anode of the F.M. detector valve EQ 80. The current drain may then be 10 to 15 mA, the power for this being delivered during the scan via the output pentode.

The circuit of Fig. 5 possesses a few disadvantages, which have been avoided in two more recent circuits. Since a proportion of the magnetic energy at the end of the scan is lost during the flyback, these losses may be reduced by keeping the magnetic energy in the transformer small, which implies a high inductance. This results, however, in an increase of the stray inductance, which has already a comparatively high value in a transformer with separate windings. The energy stored in the stray field at the end of the scan is not available to contribute to the beginning of the next scanning period, but gives rise to unwanted oscillations. Starting with a small transformer inductance, therefore, and increasing this gives an increase of the overall efficiency, until an optimum is reached, after which the losses due to stray inductance preponderate and reduce the efficiency. In practice it may occur that the optimum efficiency cannot be attained owing to difficulties with oscillations in the stray inductances. The circuit of Fig. 5 has nevertheless been used with good success in receivers with a narrow-angle picture tube operating at an E.H.T. smaller than 10 kV. The deflection energy required for such a tube is fairly small, so that the power required from the H.T. supply can also be kept reasonably small. With the introduction of wide-angle picture tubes and the use of an E.H.T. of 10 kV or greater it became necessary, however, to reduce the stray inductance of the line transformer.

A circuit in which a transformer with a low stray inductance is used is represented in Fig. 6. An autotransformer is employed, the booster diode

and the deflection coils being connected to taps on the primary. The stray field, and consequently the losses in the stray inductance, can thus be kept low. A complication is, however, that the cathode of the booster diode is connected to a point on the transformer at which a positive voltage peak of 3 to 4 kV occurs during the flyback. The heater of this valve must be included in the normal series chain and, compared with the voltage peak on the cathode, would be almost at chassis potential, so that in a valve of conventional construction breakdown would occur between these two elec-

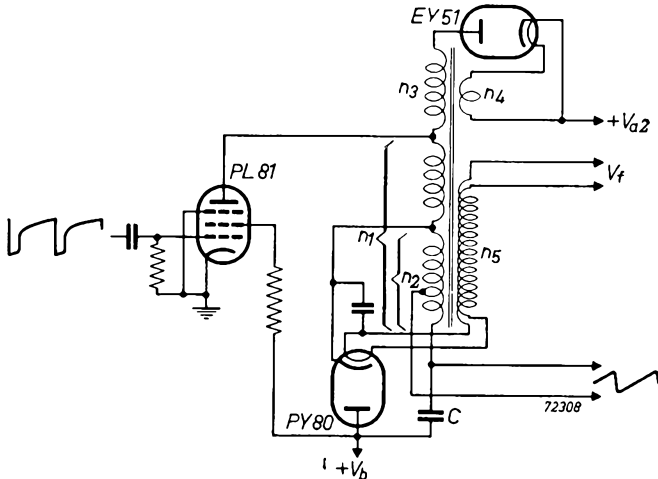

Fig. 6

Line-output circuit with booster diode in which an autotransformer is used. The heater of the PY 80 booster must be fed via a bifilar winding on the transformer.

trodes. Using the PY 80 it is then necessary to feed the heater via a special bifilar winding (see n_5 in fig. 6) across which a voltage occurs equal to that across n_2 . Moreover, by interconnecting the heater and the cathode by means of a capacitor, so that a difference in the peak voltages at the two windings is compensated, the occurrence of high peak voltages between these electrodes is prevented. The circuit of Fig. 6 is suitable for use with a wide-angle picture tube.

A disadvantage of the circuit of Fig. 6 is, however, that the heater of the booster diode must be supplied via a special winding. It must be bifilar-wound to prevent the induction of hum voltages in the other windings. The heater current of the PY 80 is 0.3 A, so that fairly thick wire must be used to prevent additional voltage drop in the heater chain, or excessive generation of heat. The winding therefore requires much space on the transformer, whilst, in addition, difficulties may be encountered with oscillations set up in it during the flyback.

These disadvantages are avoided when a booster diode Type PY 81 is used. This valve has special insulation between heater and cathode, such that it

is no longer necessary to use a bifilar winding on the line transformer for feeding the heater (see fig. 7). It can therefore be included directly in the series chain. The dimensions of the transformer can then be reduced, whilst the efficiency is increased. The new booster diode PY 81 is therefore specially suitable for use in a circuit supplying the deflection current for wide-angle picture tubes operating with a high E.H.T.

From the foregoing qualitative description of the line-output stage it is clear that the application of the output pentode PL 81 and that of the booster diodes PY 80 and PY 81 are closely interrelated. The notes on these applications are therefore combined in this section, a description being given in the following pages of a line-output stage using PL 81, PY 80 and EY 51. The use of the booster diode PY 81 is illustrated in the description of a complete receiver on page 177.

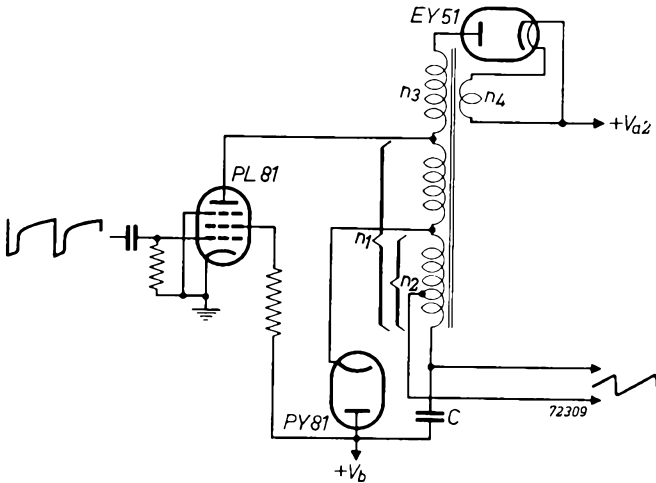

Fig. 7

Line-output circuit in which the PY 80 is replaced by a PY 81 booster diode. With the PY 81 it is no longer necessary to feed the heater via a bifilar winding.

2. A circuit for line deflection and an E.H.T. of 10 kV

A complete circuit for horizontal deflection and E.H.T. for use with a picture tube MW 36-24 is given in Fig. 8. This circuit also contains the sawtooth generator for driving the output stage and a coincidence detector for flywheel synchronization. The functions of the various valves are as follows:

- ECH 42 coincidence detector
- ECL 80 multivibrator
- PL 81 output valve
- PY 80 booster diode
- EY 51 E.H.T. rectifier

For full picture width on the screen of the MW 36-24 picture tube a saw-tooth current of 1100 mA peak-to-peak is required in the line coils of the deflection and focusing unit Type AT 1000/01. The data of this unit are given at the end of this circuit description. The deflection current should be linear and since the inductance and resistance of the deflection coils are 5.3 mH and 5.8 Ω respectively, at a line frequency of 15625 c/s (625 lines) the voltage across the line coils has an almost constant value of 105 V during the scan.

It has been indicated previously that the output valve is so driven that the booster diode conducts during the whole scan. If, therefore, the total inductance connected between the points *a* and *b* of the line transformer is increased by connecting an inductor in series with the line coils, then the voltage between these points will remain almost constant, but the amplitude of the sawtooth current decreases, because at a constant voltage the rate of change is inversely proportional to the total inductance. Use is made of this principle to control the picture width. In series with the deflection coils is connected a variable inductor Type AT 4000, the inductance of which can be adjusted between 220 and 1170 μ H.

The voltage across the winding *ab* is stepped up by the winding *bc*, so that, during the scan, between *a* and *c* a voltage of approximately 295 V occurs, point *a* being positive with respect to *c*. Since during the scan the booster diode conducts, the same voltage occurs across the booster capacitor C_{17} , so that the voltage between point *a* and the chassis is $190 + 295 = 485$ V. The voltage across the booster capacitor does not change appreciably during the flyback. From the point *a* can be fed the second grid of the picture tube, the anode of the output valve for frame deflection and the anode of the F.M. detector valve.

The value of the booster capacitor C_{17} has been so chosen that an appreciable parabolic component of voltage occurs across its terminals, which greatly contributes to the linearity of the scan. This may be explained as follows.

Since the voltage across an inductance is directly proportional to the rate of change of the current flowing through it, a constant voltage across the transformer during the scan results in a constant rate of change of the current through the deflection coils, dissipative resistances being disregarded. This, in turn, gives rise to a practically constant angular velocity of the electron beam. Since, however, the face of the MW 36-24 picture tube is almost flat, this constant angular velocity will cause the speed of the luminous spot to increase as the deflection angle becomes greater. This is counteracted by adding to the voltage across the transformer a parabolic component, so that it is at a maximum when the luminous spot passes through the centre of the screen and gradually decreases as the distance of the spot from the centre becomes greater. This is obtained by giving C_{17} a low value, the saw-tooth current flowing in it due to the charge during the first part of the scan and to the discharge during the second part producing the required parabolic component.

It should be mentioned that as a result of the rapid variation of current during the flyback the PY 80 is subjected to a very large peak inverse

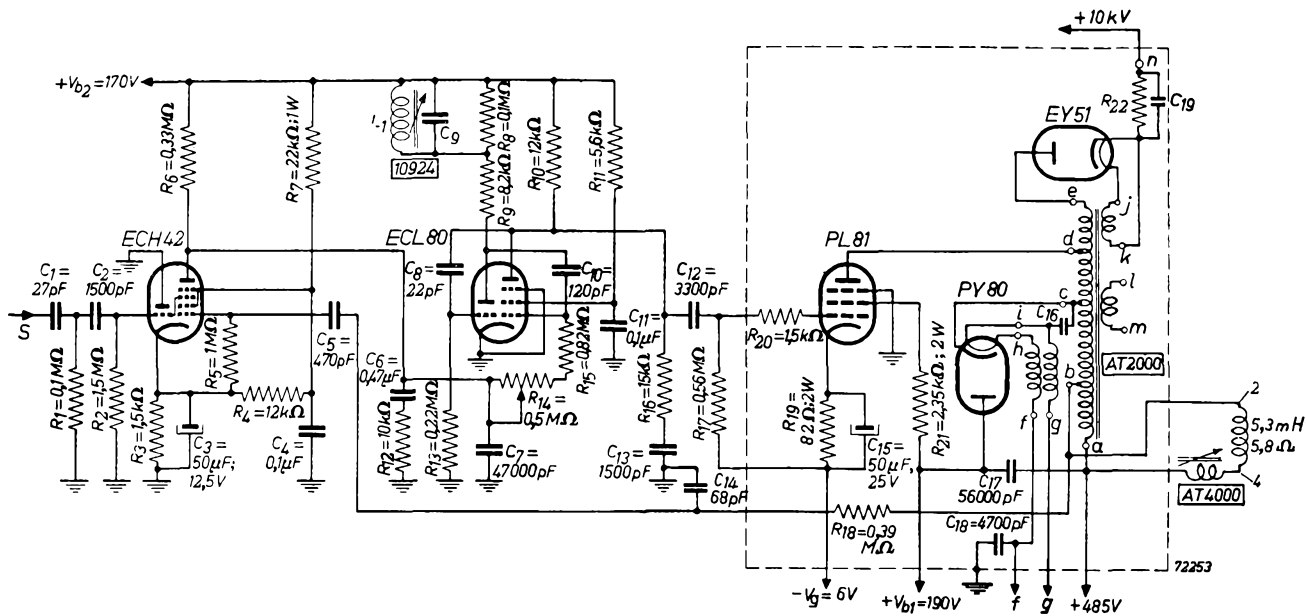

Fig. 8
Complete circuit for horizontal deflection and an E.H.T. of 10 kV.

PL 81

voltage. The valve, however, is adequately insulated to withstand this condition. It is, however, essential that suitable insulation is provided in the valve holder, the cylindrical centre shield of which should be removed, whilst it is also advisable to remove contact 8, thus further reducing the risk of flashover and minimizing the leakage through the holder. In addition, certain types of holder may have to be mounted in a plate of insulating material.

In the circuit of Fig. 8 the cathode of the booster diode is connected to a tap on the primary of the output transformer. As indicated previously when using the PY 80 it is then necessary to feed the heater via a bifilar winding, to prevent the occurrence of high peak voltages between heater and cathode. The drop of heater voltage in this winding is 5.5 V.

With the transformer Type AT 2000 the turns ratio between the whole primary ad and the section ab is 3.8 to 1, and this means that the anode voltage of the PL 81 is about $485 - 3.8 \times 114 = 48$ V during the scanning period. With this figure allowance has been made for the voltage drop across the line amplitude control. Owing to resistance in the transformer windings and in the deflection coils, the voltage drop across the primary is not entirely constant; a voltage varying between 23 and 57 V during the scan has actually been measured between anode and cathode of the PL 81. This low anode voltage might result in overloading of the screen-grid, but this is prevented by a non-bypassed resistor in the screen-grid supply lead.

Moreover, to protect the output valve in the case of accidental failure of the driving voltage a cathode resistor has been used. This resistor is connected

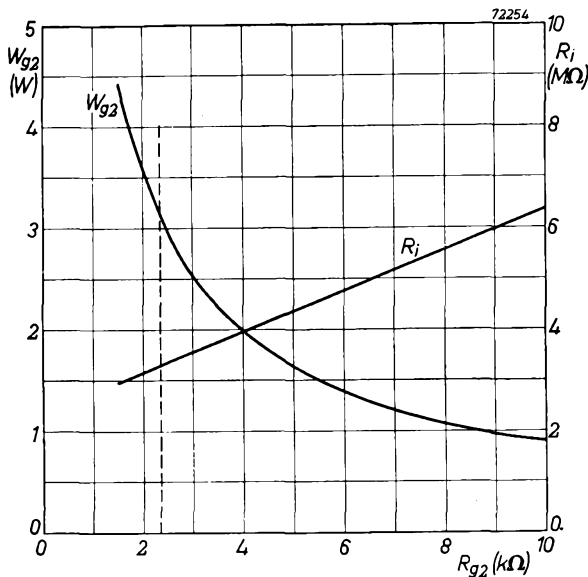

Fig. 9
Internal resistance of the E.H.T. supply and screen-grid dissipation of the PL 81 plotted against the value of the screen-grid resistor.

to a point in the receiver circuit where the potential is -6 V with respect to the chassis, thus preventing a reduction of the available supply voltage. The E.H.T. for the picture tube is obtained by rectifying the positive voltage peaks occurring at the primary of the line transformer during the flyback. For the rectification a diode Type EY 51 is used, the heater of which is supplied from the winding jk . The primary of the transformer is extended by the section de to obtain the required E.H.T.

The internal resistance of the E.H.T. supply must be sufficiently low to prevent defocusing and variations in deflection amplitude when the brightness control is adjusted. A low internal resistance is obtained by so driving the output valve that the anode voltage during the scan is lower than that corresponding to the knee of the I_a/V_a characteristic. From the figures given previously it may be seen that this is indeed the case.

The internal resistance of the E.H.T. supply also depends upon the value of the resistor in the screen-grid lead of the output valve. This dependency is plotted in Fig. 9, in which also the screen-grid dissipation is shown a function of the screen-grid resistor. The dotted vertical line corresponds to the resistance used in the circuit of Fig. 8.

The shape of the voltages and currents and also the occurrence of oscillations in the stray inductances of the transformer may give rise to interference in neighbouring radio and television receivers. This can be prevented by enclosing the whole line-output circuit in a perforated metal screening case, as indicated by the dotted rectangle in Fig. 8.

The following currents and voltages with respect to the chassis have been measured in the circuit of Fig. 8.

Mean values

Supply voltage V_{b1}	190 V
Current from supply	122 mA
Anode current PL 81	98 mA
Screen-grid current PL 81	24 mA
Current drawn from 485 V terminal	10.5 mA
Voltage across R_{19}	10 V
E.H.T. (terminal n) at 100 μ A.	10.3 kV

Peak Values

Anode current PL 81	270 mA
Screen-grid current PL 81	40 mA
Ripple at C_{17} (peak-to-peak)	19 V
Driving voltage PL 81 (peak-to-peak)	140 V

The driving voltage applied to the control grid of the PL 81 is represented in Fig. 10. This voltage is delivered by a multivibrator employing the triode

pentode ECL 80. During the flyback the output valve is blocked, whilst towards the end of the scan grid current flows, which provides a charge on the grid capacitor such that the valve operates with a comparatively high grid bias. The time constant of the grid circuit is large compared with the duration of a line period.

The saw-tooth generator is an asymmetrical multivibrator, i.e. the durations of the consecutive half periods of the output voltage are unequal, which is obtained by using different time constants in the grid circuits. The duration of the negative peak, the start of which coincides with the start of the flyback in the output stage, is slightly longer than that of flyback, the flyback time being approximately 12% of a cycle. The output valve therefore starts to draw current very soon after the flyback is completed.

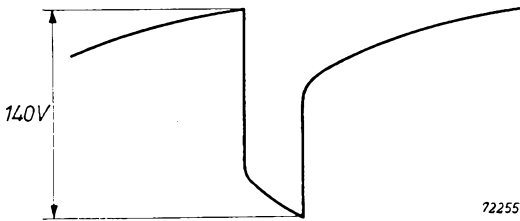

Fig. 10
Shape of the driving voltage at the control grid
of the PL 81.

In order to improve the frequency stability of the multivibrator a tuned circuit, L_1C_9 , has been included in the anode circuit of the triode section. This circuit is tuned to 15,625 c/s with the aid of an adjustable Ferroxcube core. The free-running frequency of the multivibrator can further be adjusted by R_{14} of 0.5 M Ω . L_1 and C_9 are available as one unit under the Type Number 10924. The nominal inductance of L_1 is 10 mH and the regulating range is from 6 to 14 mH. C_9 has a capacitance of 10,000 pF.

A circuit which is very insensitive to interference is used for synchronizing the multivibrator. This circuit is built around a triode hexode type ECH 42, the operation of which is discussed in the following paragraphs. First of all it should be indicated, however, that if the heater of the ECH 42 is included in a series chain with a nominal current of 0.3 A, it is necessary to shunt the ECH 42 heater by a resistor of 100 Ω , the rated heater current of this valve being 0.23 A.

A synchronizing signal of 75 V peak-to-peak is applied to the grid of the triode section of the ECH 42, which is internally connected with the third grid of the hexode. This signal is obtained from the synchronizing pulse separator given in the description of the ECL 80. Grid rectification takes place in the triode section of the ECH 42, with the result that the third grid of the hexode section is at cathode potential only during the synchronizing pulses, and is heavily negative during the intervals between the pulses.

There is, therefore, a possibility of anode current flowing in the hexode during the synchronizing pulses, provided this section is not blocked by a negative voltage on the first grid. This grid is supplied with a part of the alternating voltage occurring across the primary of the line-output transformer; see terminal *b*. The flyback pulses of the latter voltage are positively directed, so that grid rectification again takes place and the hexode section is consequently blocked during the intervals between the flyback pulses. Anode current can therefore flow in the hexode section only when both the synchronizing pulses and the line flyback pulses occur simultaneously, whilst the average value of the anode current is determined by the degree of overlapping of these pulses. This is illustrated in Fig. 11, in which the shape of the pulses is idealized.

As a result of the anode current pulses a voltage drop occurs in the anode resistor R_6 and the pulsatory character of this drop is smoothed out by C_6 and C_7 . In the dimensioning of the network $C_6 R_{12} C_7$ certain requirements must be satisfied to prevent waved vertical sides in the upper half of the picture. Further details of this are given in the article dealing with flywheel synchronization in the next chapter. The voltage at C_7 is applied via R_{14} and R_{15} to the control grid of the pentode section of the multivibrator and thus influences the frequency.

If it is assumed that the relative position of the pulses represented in Fig. 11 applies to the steady state condition, it will be clear that when the frequency of the multivibrator increases, that is when the pulses V_{g1H} move to the left relative to V_{gT} , the average anode current of the hexode section of the ECH 42 will also increase. This results in a higher voltage drop in R_6 , as a consequence of which the frequency deviation of the multivibrator is compensated. The same reasoning can be applied for the case where the frequency of the multivibrator decreases. In this case the anode current of the ECH 42 will decrease, resulting in a lower voltage drop in R_6 , which also compensates the frequency deviation. It is thus seen that the multivibrator frequency is kept constant and "in phase" with the synchronizing pulses. In the absence of a signal, or if, as a result of a burst of interference, the synchronizing signal fails for some time, it is necessary that the frequency of the multivibrator is maintained. For this reason the resistors R_3 , R_4 and R_7 have been so chosen that the anode currents with and without synchronizing signal are about equal.

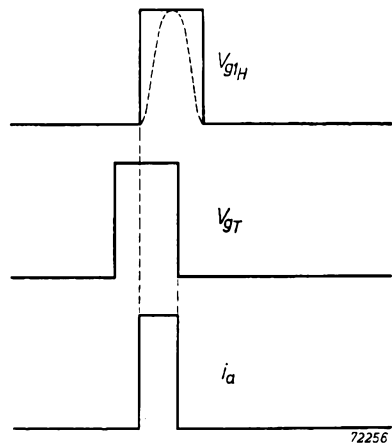

Fig. 11

The anode current of the hexode section of the ECH 42 is determined by the relative position of the pulses applied to the grid of the triode and the first grid of the hexode.

On closer examination of Fig. 11 it will be seen that the synchronizing pulse starts before the flyback pulse, so that the time available for the flyback of the line-output circuit is reduced. This is not so serious as it might seem at first sight. Actually, the shape of the flyback pulse V_{o1H} is approximately sinusoidal (see dotted line), whilst the amplitude is very large. Therefore the hexode section of the ECH 42 can draw current only during the peak of the sinusoidal pulse, so that it is quite possible to adjust R_{14} in such a way that the beginnings of the flyback pulses and the synchronizing pulse coincide. Moreover, an integrator circuit $R_{18}C_{14}$ is included between the grid of the hexode section of the ECH 42 and terminal b of the line-output transformer, this circuit providing a time delay in the arrival of the peak of the flyback pulse at the hexode grid. The value of C_{14} depends upon the wiring capacitance in the grid circuit and is best determined experimentally. Finally, in the actual circuit differentiation has been applied to the synchronizing pulse (see C_1 and R_1 in Fig. 8) as otherwise during the frame pulses the average anode current of the hexode section would change, resulting in curved sides at the top of the picture. It is therefore seen that Fig. 11 serves only to explain the principle of the synchronizing system. The multivibrator and the synchronizer should be fed from the power supply via an extra smoothing filter so as to prevent hum interference. The total current drawn by the multivibrator is 15 mA and by the synchronizer 5 mA, including the current through the bleeder for screen grid and cathode.

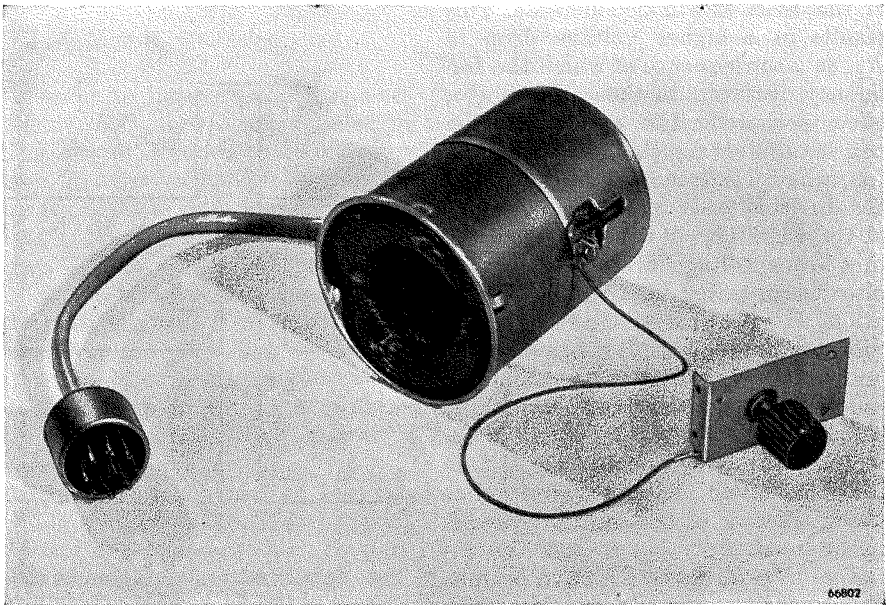

Fig. 12.
The deflection and focusing unit Type AT 1000/01.

3. Standard components for the circuit of fig. 8

a. Deflection and focusing unit Type AT 1000/01

In the circuits for horizontal and vertical deflection (see description ECL 80) previously described the output transformers are matched to the deflection and focusing unit Type AT 1000/01. This unit is intended for use in conjunction with the picture tube MW 36-24 for anode voltages between 7.5 and 11.5 kV, i.e. correct focus can be obtained within this voltage range.

A permanent magnet is built in for focusing. This magnet is provided with a shunt ring which can be moved axially by means of a lever (see drawing) which, in turn, can be operated via a bowden cable and a knob (Type AT 7003) in the receiver cabinet for adjusting the focus on the picture tube. This unit can be supplied with or without bowden cable and knob. The picture on the face of the picture tube can be registered by loosening the thumb screws at the rear of the unit and moving the focusing magnet radially. A displacement of 5 mm to either side of the central position is possible. The wiring of the line and frame coils to the receiver is simplified by providing the unit with a cable ending in an octal base. In addition to the contacts for the line and frame coils this base has a separate contact for connecting the metal screening can of the unit and the cable screen to the receiver chassis. The connections are given in Fig. 13 and in the following data.

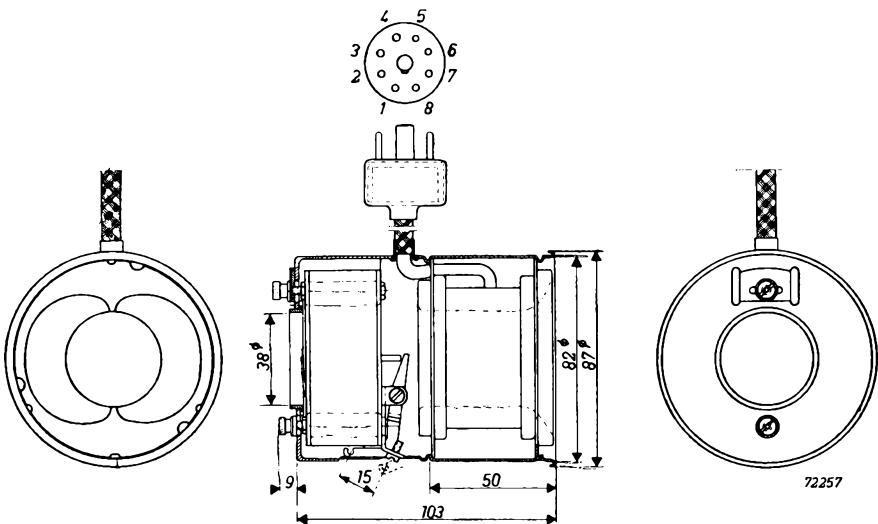

Fig. 13

Dimensions of the deflection and focusing unit Type AT 1000/01.

PL 81

Technical data

Line coils:

Inductance	5.3 mH
Resistance	5.8 Ω
Sensitivity on the MW 36-24	10.33 $\sqrt{V_a}$ mA/cm*
Connections	pins 2 and 4

Frame coils:

Resistance	9.8 Ω
Inductance	7.7 mH
Sensitivity on the MW 36-24	10.17 $\sqrt{V_a}$ mA/cm*
Connections	pins 6 and 8

Focus between 7.5 and 11.5 kV

Connection for screen pin 7

Maximum operating temperature 85° C

b. Line-output transformer Type AT 2000

In this line-output transformer components for obtaining the E.H.T. are built in. It is designed for use in conjunction with a line-output valve type PL 81 and a booster diode type PY 80. A dimensional drawing is given in Fig. 15, in which the indications at the terminals refer to the circuit of Fig. 8. In the latter circuit the winding between *l* and *m* is not used. The voltage appearing across this winding may be used for blanking the picture during the line flyback. The turns ratio between the windings *ab* and *lm* is 14 : 1.

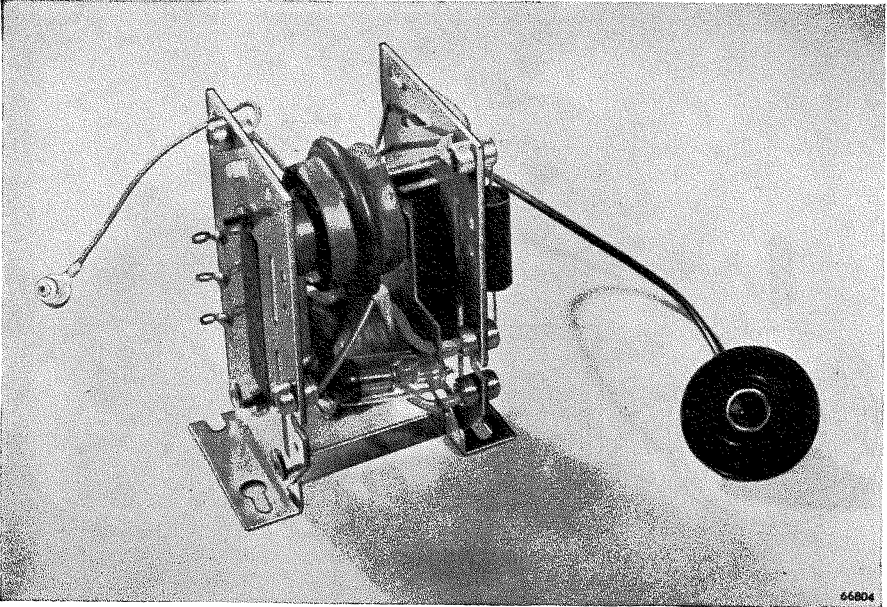

Fig. 14
The line-output transformer Type AT 2000

*) V_a in kV.

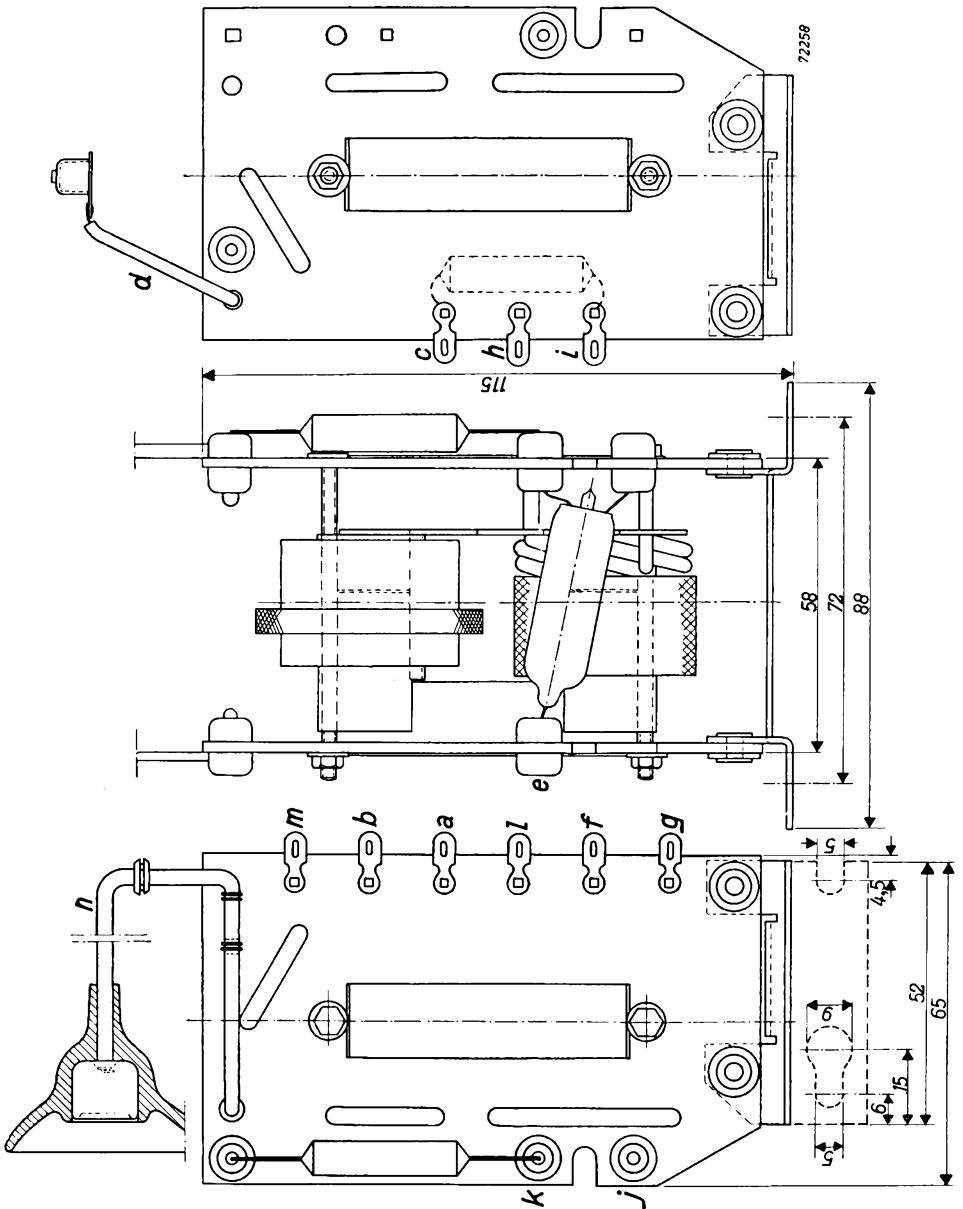

Fig. 15

Dimensions of the line-output transformer Type AT 2000. The indications at the various terminals correspond to those of the circuit diagram of Fig. 8.

Technical data

Inductance between <i>a</i> and <i>d</i> at 500 c/s and 30 mA D.C.	325 mH
Turns ratio between <i>ad</i> and <i>ab</i>	3.8 : 1
Resistances of windings	
between <i>a</i> and <i>b</i>	2.5 Ω
„ <i>b</i> and <i>c</i>	6.2 Ω
„ <i>c</i> and <i>d</i>	5.8 Ω
„ <i>d</i> and <i>e</i>	144 Ω
„ <i>f</i> and <i>h</i>	9.4 Ω
„ <i>g</i> and <i>i</i>	9.4 Ω
„ <i>j</i> and <i>k</i>	0.26 Ω
Maximum operating temperature	85° C

c. Picture width control Type AT 4000

The picture width control Type AT 4000 is a coil with variable inductance. The dimensions are given in Fig. 16. It can be used in combination with the line output transformer Type AT 2000 and the deflection and focusing unit Type AT 1000/01.

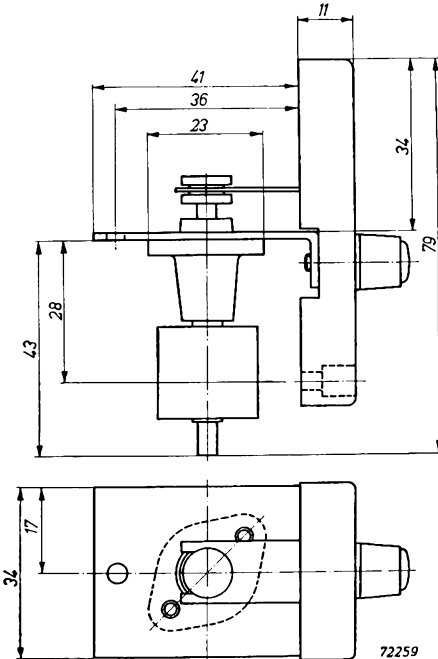

Fig. 16
Dimensions of the picture width control Type AT 4000.

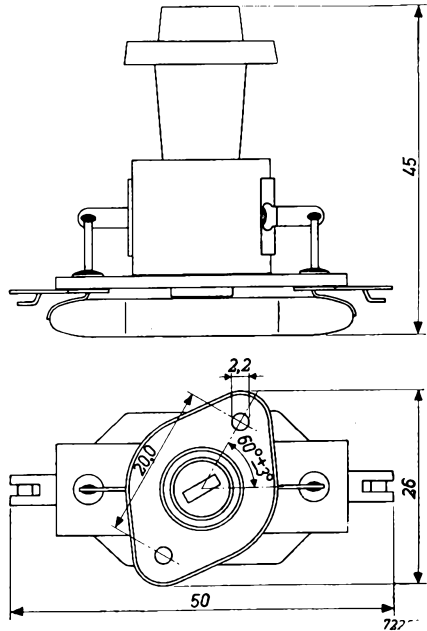

Fig. 17
Dimensions of the tuned circuit Type 10924 for stabilizing the line-multivibrator frequency.

Technical data

Minimum inductance	0.22 mH
Maximum inductance	1.17 mH
Maximum operating temperature	85° C

d. Tuned circuit for line multivibrator Type 10924

This unit comprises an inductor with a nominal inductance of 10 mH and an adjustable *Ferroxcube* core. A fixed mica tuning capacitor of 10,000 pF has been built in. The tuned circuit serves to improve the frequency stability of a multivibrator driving the line-output stage. The dimensions are given in Fig. 17.

Technical data

Minimum inductance	6 mH
Maximum inductance	14 mH
Fixed tuning capacitor	10,000 pF
Maximum operating temperature	85° C

DATA OF THE PL 81

Heater data

Heating: indirect by A.C. or D.C.; series supply

Heater voltage V_f	=	21.5 V
Heater current I_f	=	0.3 A

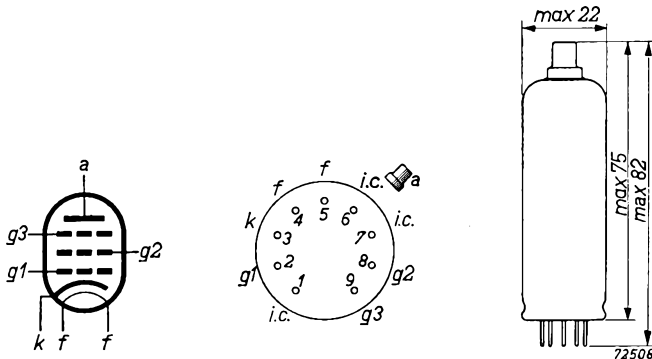

Fig. 18
Base connections and dimensions of the PL 81.

PL 81

Capacitances (measured on the cold valve)

Input capacitance	C_{g1}	=	14.7 pF
Output capacitance	C_a	=	6.0 pF
Capacitance between anode and control grid	C_{ag1}	=	< 0.8 pF
Capacitance between anode and cathode	C_{ak}	=	< 0.1 pF
Capacitance between control grid and heater	C_{g1f}	=	< 0.2 pF

Typical characteristics

Anode voltage	V_a	=	170	200 V
Suppressor-grid voltage	V_{g3}	=	0	0 V
Screen-grid voltage	V_{g2}	=	170	200 V
Control-grid voltage	V_{g1}	=	-22	-28 V
Anode current	I_a	=	45	40 mA
Screen-grid current	I_{g2}	=	3	2.8 mA
Mutual conductance	S	=	6.2	6 mA/V
Internal resistance	R_i	=	10	11 kΩ
Amplification factor between screen grid and control grid.	μ_{g2g1}	=	5.5	5.5

Operating conditions as A.F. power amplifier (two valves in push-pull B)

Anode voltage	V_a	=	170	200 V
Suppressor-grid voltage	V_{g3}	=	0	0 V
Screen-grid supply voltage	V_{bg2}	=	170	200 V
Grid bias	V_{g1}	=	-27	-31.5 V
Common screen-grid resistor.	R_{g2}	=	1	1 kΩ
Matching resistance between anodes	$R_{aa'}$	=	2.5	2.5 kΩ
Input signal	V_i	=	$\overbrace{0 \quad 19} \quad 0 \quad \overbrace{22.5} V_{rms}$	
Anode current	I_a	=	$2 \times 20 \quad 2 \times 73 \quad 2 \times 25 \quad 2 \times 87$ mA	
Screen-grid current	I_{g2}	=	$2 \times 1.5 \quad 2 \times 10 \quad 2 \times 2 \quad 2 \times 12.5$ mA	
Power output	W_o	=	0 13.5 0 20 W	
Total distortion	d_{tot}	=	— 5.5 — 5.5 %	

Limiting values

Anode voltage at zero anode current	V_{ao}	=	max.	550 V
Anode voltage	V_a	=	max.	250 V
Peak anode voltage (max. pulse duration 18% of one cycle, with a maximum of 18 μ sec.)	V_{ap}	=	max.	\pm 7 kV
Screen-grid voltage at zero screen-grid current	V_{g2o}	=	max.	550 V
Screen-grid voltage	V_{g2}	=	max.	250 V
Grid current starting point (grid current + 0.3 μ A)	V_{g1}	=	max.	-1.3 V
Heater voltage during warming-up period	V_f	=	max.	32 V
Voltage between heater and cathode	V_{fk}	=	max.	200 V
Cathode current	I_k	=	max.	180 mA
Anode dissipation	W_a	=	max.	8 W
Screen-grid dissipation.	W_{g2}	=	max.	4.5 W
Sum of anode and screen-grid dissipations	$W_a + W_{g2}$	=	max.	10 W
External resistance between control grid and cathode	R_{g1}	=	max.	0.5 M Ω
External resistance between heater and cathode	R_{fk}	=	max.	20 k Ω

To allow for spread between individual valves and for deterioration during life, the circuit for horizontal deflection should be designed around a peak anode current not exceeding 250 mA at $V_a = 70$ V and $V_{g2} = 170$ V. At these voltages with $V_{g1} = -1.0$ V, the average new valve may be expected to give a peak current of 350 mA. For $V_a = 70$ V and $V_{g2} = 200$ V the corresponding values for the peak current are 310 mA and 420 mA respectively.

If the PL 81 is used in a circuit for horizontal deflection in conjunction with a booster diode type PY 81, the maximum permissible screen-grid dissipation during the warming-up period is 6 W.

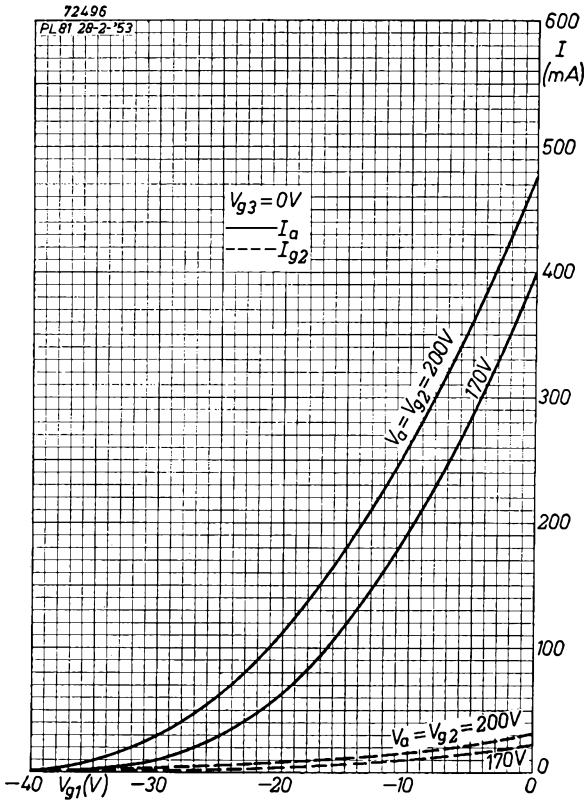
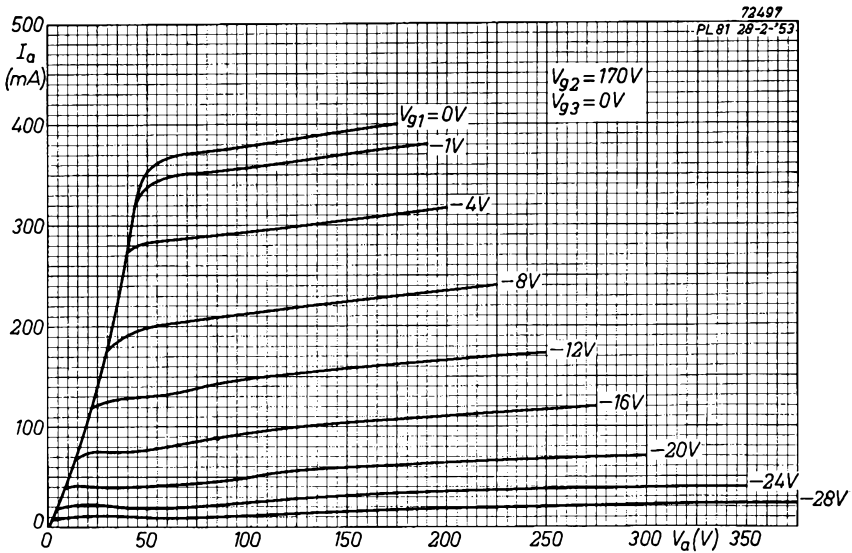

Fig. 19
Anode current and screen-grid current plotted against control-grid voltage, with anode and screen-grid voltage as parameter.

Fig. 20
Anode current plotted against anode voltage for screen-grid voltage of 170 V, with control-grid voltage as parameter.



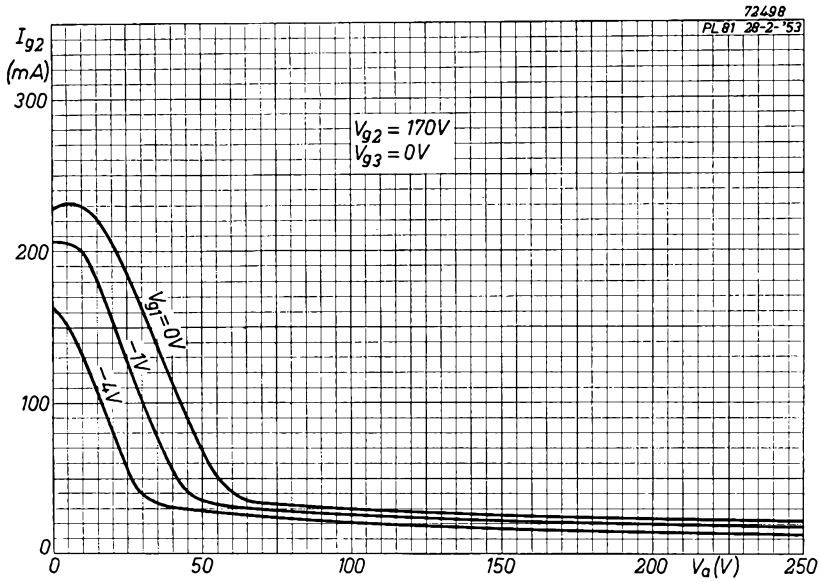

Fig. 21

Screen-grid current plotted against anode voltage for screen-grid voltage of 170 V, with control-grid voltage as parameter.

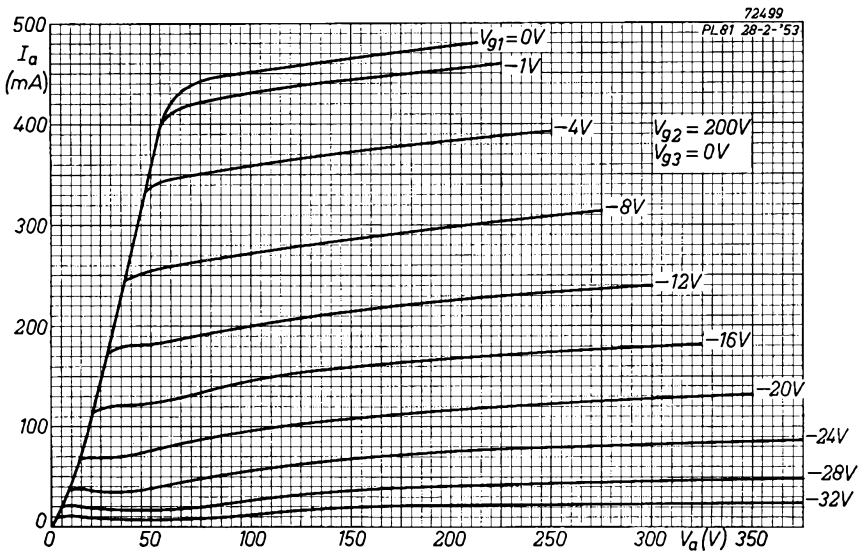

Fig. 22

Anode current plotted against anode voltage for screen-grid voltage of 200 V, with control-grid voltage as parameter.

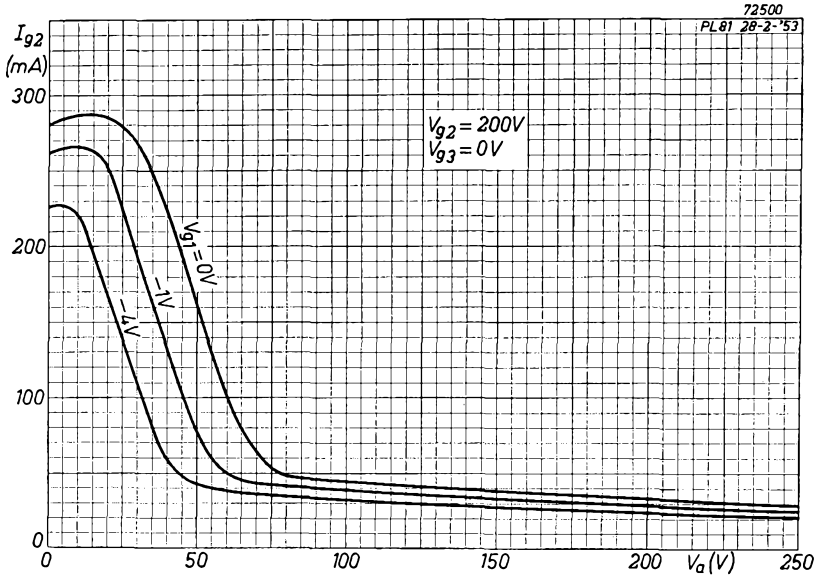

Fig. 23
Screen-grid current plotted against anode voltage for screen-grid voltage of 200 V, with control-grid voltage as parameter.

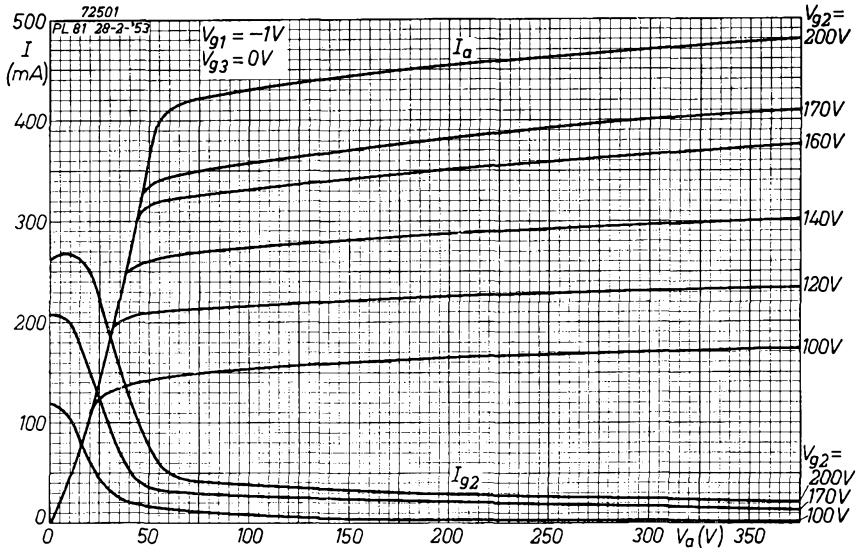

Fig. 24
Anode current and screen-grid current plotted against anode voltage for control-grid voltage of -1 V, with screen-grid voltage as parameter.

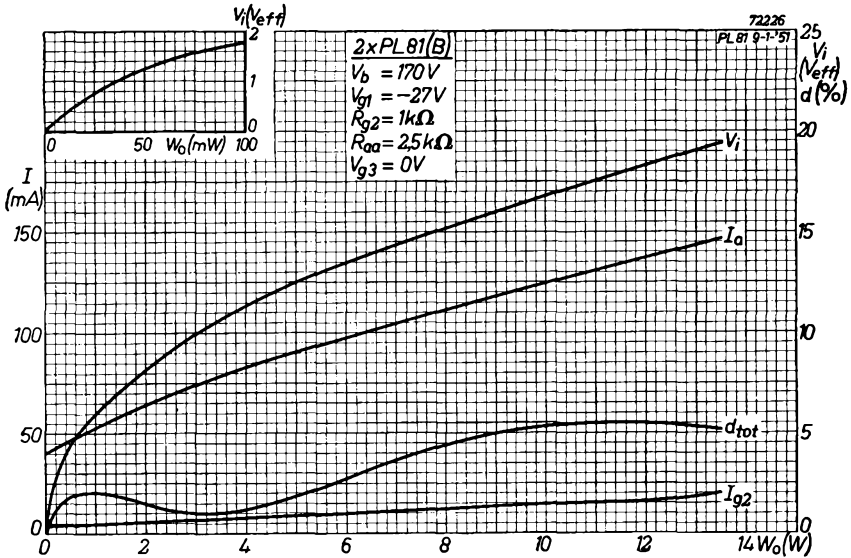

Fig. 25

Anode current, screen-grid current, input voltage and total distortion plotted against output power of two valves PL 81 in push-pull B for anode and screen-grid supply voltage of 170 V.

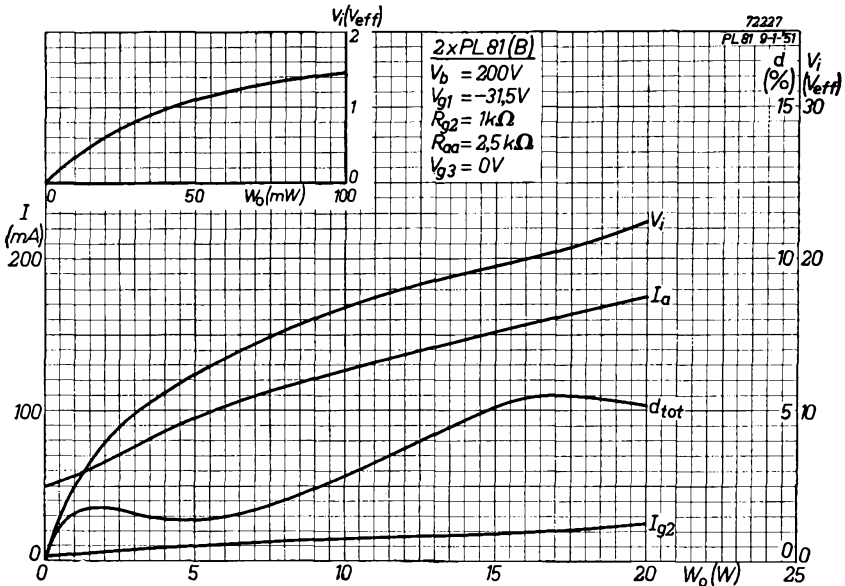
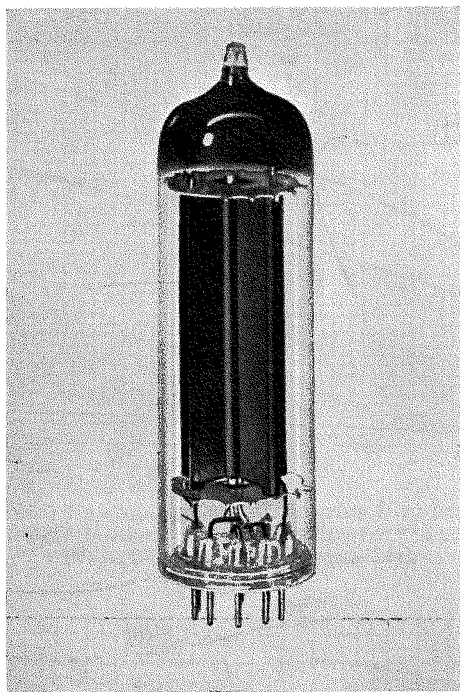

Fig. 26

Anode current, screen-grid current, input voltage and total distortion plotted against output power of two valves PL 81 in push-pull B for anode and screen-grid supply voltage of 200 V.

The booster diode PY 80



62147

Fig. 1
The booster diode PY 80 (about actual size).

The PY 80 is a special diode intended for the use as booster in the line-output stage. In a suitable circuit a considerable improvement in efficiency and linearity can be obtained by means of this diode. For examples of application the reader is referred to the description of the PL 81 output pentode.

The maximum permissible voltage between heater and cathode of the PY 80 is 650 V, so that this valve can be used as a secondary booster, without incorporating special means for keeping the heater-cathode voltage low. If the valve is used in a circuit where the cathode is connected to a tap on the primary of the output transformer, it is necessary to provide the transformer with a special bifilar winding, through which the heater is supplied and which serves to prevent the occurrence of flyback pulses between heater and cathode. With another booster diode, type PY 81, such a winding is not required.

DATA OF THE PY 80

Heater data

Heating: indirect by A.C. or D.C.; series supply

Heater voltage	V_f	=	19 V
Heater current	I_f	=	0.3 A

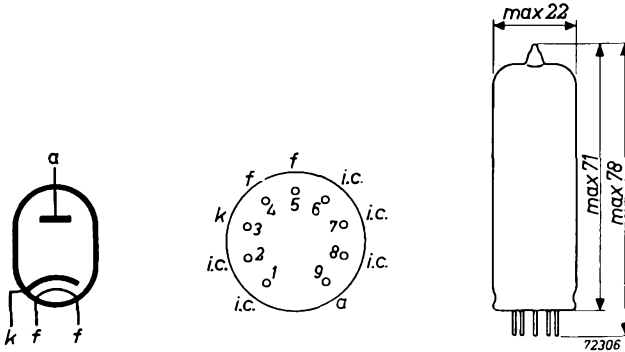

Fig. 2
Base connections and dimensions of the PY 80.

Capacitance between anode and cathode (measured on the cold valve)

C_a	=	5.5 pF
-------	---	--------

Limiting values

Peak inverse anode voltage	V_{ainvp}	= max.	4 kV ¹⁾
Peak anode current	I_{ap}	= max.	400 mA
Mean anode current	I_a	= max.	180 mA
Voltage between heater and cathode	V_{fk}	= max.	650 V ²⁾
Heater voltage during the warming-up period	V_f	= max.	28.5 V

The contacts 1-6 and 8 of the valve holder may not be used to support the wiring. When the valve holder 5908/03 is used no special precautions need be taken provided the peak inverse voltage does not exceed 3 kV. Between 3 and 4 kV however, the cylindrical centre shield and contact 8 should be removed from the holder, this then being mounted in a plate of insulating material of about 4 cm diameter.

1) Maximum pulse duration 18% of one cycle, with a maximum of 18 μ sec.
 2) Maximum 100 V_{RMS} mains voltage + maximum 500 V direct voltage. Cathode positive with respect to the heater.

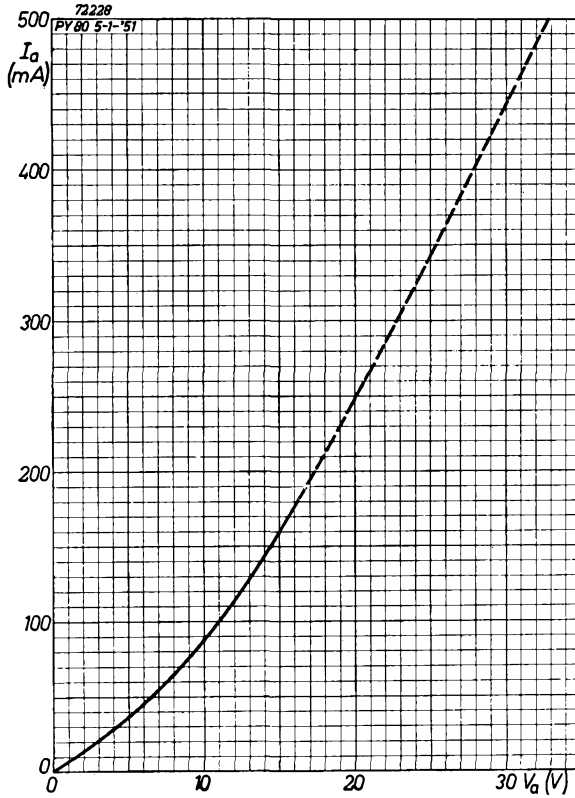

Fig. 3
Anode current of the PY 80 plotted against
the anode voltage.

The booster diode PY 81

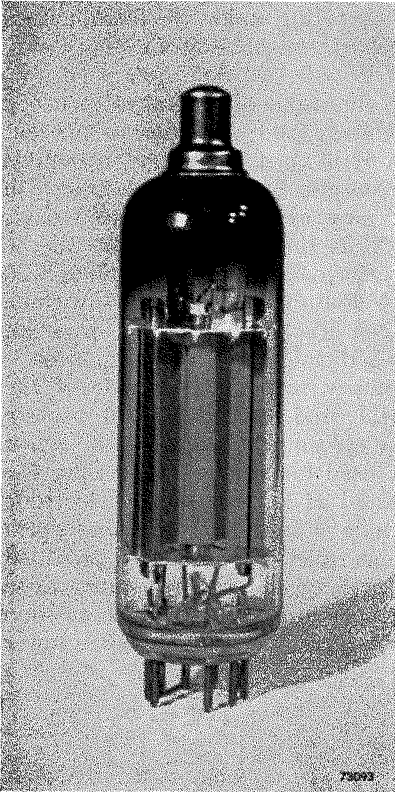

Fig. 1
The booster diode PY 81 (about
actual size).

Like the PY 80 described previously the PY 81 is intended for use in the line-output circuit for improving the efficiency and the linearity. With the latter valve, however, special insulation has been provided between heater and cathode, so that the cathode may be connected to a tap on the transformer primary, without it being necessary to feed the heater via a bifilar winding. The cathode of the PY 81 is brought out at the top of the envelope.

There are a few important details of the heater-cathode insulation of the PY 81 which should be discussed briefly here. The required insulation could have been obtained by increasing the distance between the heater and the inside of the cathode sleeve, the latter then being heated by direct radiation. If, however, in a line-output circuit the cathode becomes heavily positive during the fly-back, an appreciable electron current will flow from the heater to the cathode. This results in an extra load on the line-output circuit during the flyback and a consequent reduction of the efficiency and the E.H.T. To avoid this, in the PY 81 an insulating tube is provided between heater and cathode, which prevents the occurrence of electron current between these two electrodes.

Owing to the special insulation between the cathode and the heater of the PY 81

the heating-up time of the cathode is somewhat longer than that of the former booster diode type PY 80. With the PY 81 the heating-up time is such that, when the heater is included in the normal heater chain of a receiver, the booster diode is not capable of passing current until about 50 seconds after the other valves have started to draw current. During this interval those electrodes of valves that are supplied from the boosted H.T. cannot draw current and the entire electron current of a given valve will then flow to the preceding electrode. This might result in temporary overloading. An example is the line-output pentode, the anode of which must draw current via the booster diode, whilst the screen grid is supplied from the general H.T. line. For this reason a new rating has been added to the data

PY 81

of the PL 81. The maximum permissible continuous screen-grid dissipation of this valve is 4.5 W, but when it is used in combination with a PY 81 booster diode, a screen-grid dissipation of 6 W is permissible during the heating-up time. In a practical circuit this new rating makes the introduction of special measures against overloading during the heating-up time unnecessary.

In a normal circuit for horizontal deflection the anode of the output pentode operates during the scan at a very low voltage and, in order to prevent continuous overloading of the screen-grid, it is then necessary to include non-bypassed series resistance in the screen-grid lead. This resistor will normally have a value around 2 kΩ. It may easily be calculated that, when the screen-grid is supplied from an H.T. line voltage of 200 V, the theoretical maximum in screen-grid dissipation will be 5 W, which is well below the maximum permissible value of 6 W during the heating-up time. The resistor required for protecting the screen grid during normal operation therefore also serves to prevent overloading during the heating-up time.

In modern television receivers it is customary to feed the anode of the frame output pentode from the boosted H.T. and, when a PY 81 booster diode is used, temporary overloading of the screen grid might occur. When the pentode section of an ECL 80 tube is used for vertical deflection, the screen grid can also be fed from the boosted H.T., because this electrode draws but a small current. If a PL 82 pentode is used, with the screen grid supplied from the general H.T. line, sufficient resistance should be provided in the screen-grid lead. The inclusion of screen-grid series resistance need not lead to an undue voltage drop during normal operation, since as soon as anode voltage is available, the screen-grid current drops to a much lower value.

DATA OF THE PY 81

Heater data

Heating: indirect by A.C. or D.C.; series supply

Heater voltage	V_f	=	17 V
Heater current	I_f	=	0.3 A

Capacitances (measured on the cold valve)

between anode and cathode .	C_a	=	6.4 pF
between heater and cathode.	C_{fk}	=	3.6 pF

Limiting values

Peak anode current	I_{ap}	=	max. 450 mA
Mean anode current	I_a	=	max. 150 mA

Voltage between cathode and heater (cathode positive) . .

$$V_{fk} = \text{max. 600 V DC} + 220 V_{\text{rms}} \text{ mains voltage}$$

Peak voltages during the flyback (max. 18% of a period with a maximum of 18 μsec)

between cathode and heater (cathode positive)

$$V_{fkp} = \text{max. 4.5 kV (5.6 kV*)}$$

between anode and cathode (cathode positive)

$$V_{akp} = \text{max. 4.5 kV (5.6 kV*)}$$

between anode and heater (anode negative)

$$V_{afp} = \text{max. 3 kV (3.8 kV*)}$$

*) These values are absolute maxima.

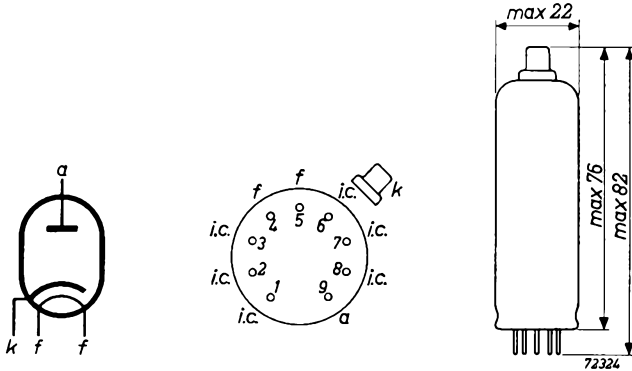

Fig. 2
Base connections and dimensions of the PY 81.

PY 81

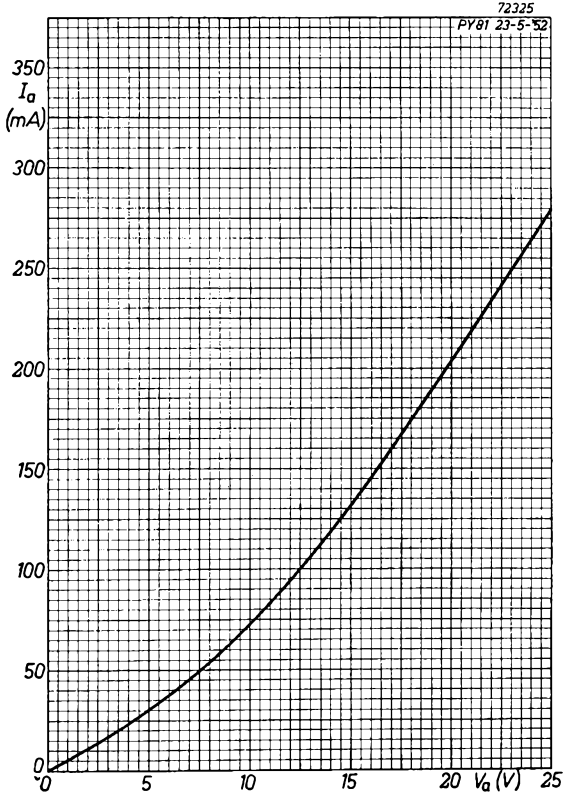

Fig. 3
Anode current of the PY 81, plotted against
anode voltage.

The mains rectifier PY 82

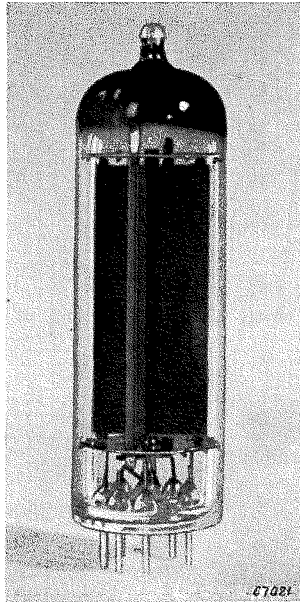

Fig. 1
The mains rectifier PY 82 (about actual size).

The PY 82 is a single-anode indirectly heated rectifying valve with a heater current of 0.3 A, intended for use in transformerless television receivers. With one valve, a rectified current of 180 mA can be obtained, so that in the normal television receiver supplied from the 220 V mains two of these valves will be used in parallel. The cathode is adequately insulated to permit the heater to be included at the high potential end of the heater chain.

DATA OF THE PY 82

Heater data

Heating: indirect by A.C. or D.C.; series supply			
Heater voltage	V_f	=	19 V
Heater current	I_f	=	0.3 A

PY 82

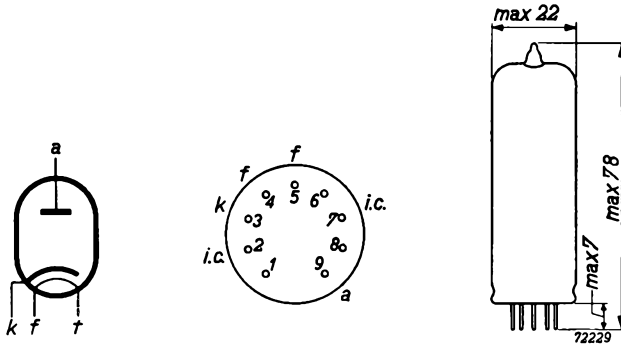

Fig. 2
Base connections and dimensions of the PY 82.

Typical operating conditions

Input voltage	V_{tr}	=	250	240	220	200	127	V_{rms}
Reservoir capacitance	C_{filt}	=	60	60	60	60	60	μF
Limiting resistor.	R_t	=	125	105	65	30	0	Ω
Output current	I_o	=	180	180	180	180	180	mA
Output voltage	V_o	=	195	195	195	195	127	V

Limiting values

Input voltage	V_{tr}	=	max.	250	V_{rms}			
Peak inverse voltage	$V_{a invp}$	=	max.	700	V			
Output current	I_o	=	max.	180	mA			
Voltage between heater and cathode	V_{fkp}	=	max.	550	V ¹⁾			
Reservoir capacitance	C_{filt}	=	max.	60	μF ²⁾			
Heater voltage during the warming-up period	V_f	=	max.	28.5	V			
Minimum permissible values for the limiting resistor	V_{tr}	=	250	240	220	200	127	V_{rms}
	R_t	=	100	80	40	30	0	Ω

¹⁾ Maximum 220 V_{rms} alternating voltage + maximum 250 V direct voltage. Cathode positive with respect to heater.

²⁾ When two valves PY 82 are connected in parallel the maximum reservoir capacitance is 100 μF . In this case each anode must have the minimum limiting resistor specified above.

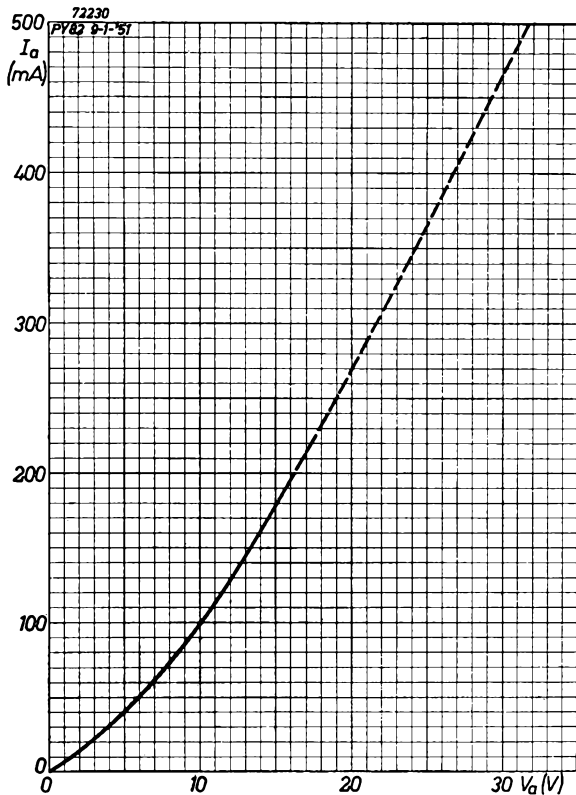

Fig. 3
Anode current of the PY 82, plotted against
the anode voltage.

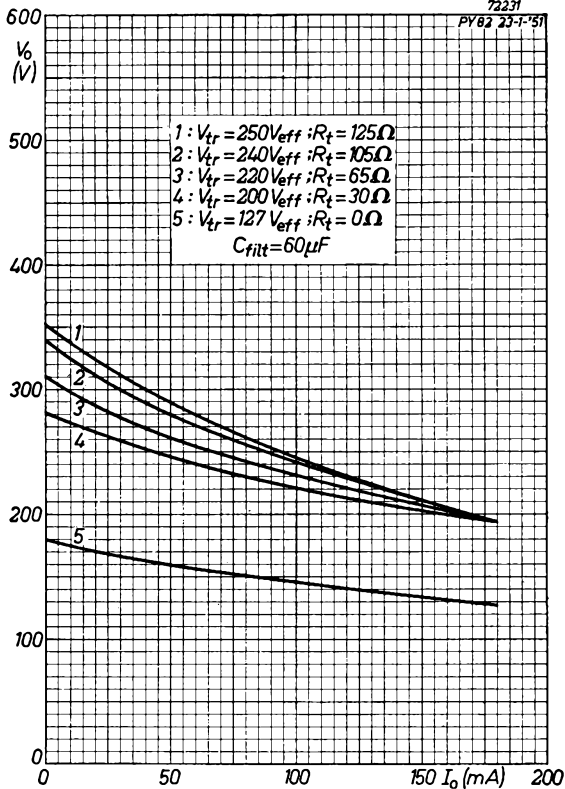

Fig. 4

Rectified output voltage of the PY 82 plotted against the output current, with the alternating input voltage and the limiting resistor as parameters.

EY 51

The E.H.T. Rectifier EY 51

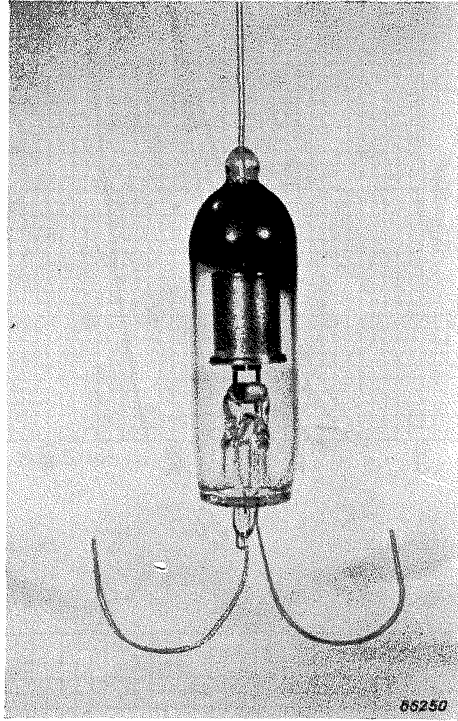

Fig. 1
The E.H.T. rectifier EY 51 (about actual size).

The EY 51 is a miniature all-glass half-wave rectifier of the wire-in type, specially designed for rectifying the E.H.T. for the picture tube in television receivers. The small dimensions and the low heater wattage render the valve particularly suitable for circuits in which the E.H.T. is obtained by rectifying the flyback pulses in the line output circuit. The heater may then be fed from a subsidiary winding on the line-output transformer, whilst the valve can be soldered directly to the transformer terminals. In practical cases three or four well-insulated turns on the transformer are sufficient for the heater supply. The EY 51 can, of course, also be used in circuits with sinusoidal input voltage, but then with reduced input voltage.

DATA OF THE EY 51

Heater data

Heating: indirect by A.C. or D.C.; parallel supply

Heater voltage	V_f	=	6.3 V
Heater current	I_f	=	90 mA

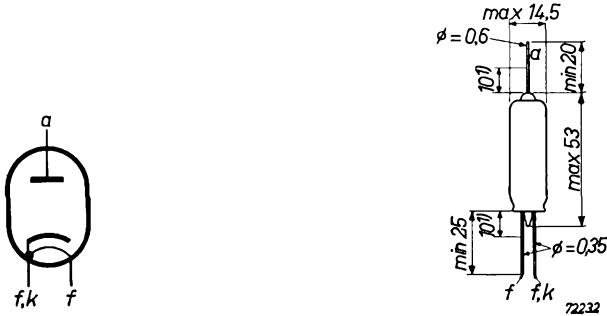

Fig. 2
Electrode connections and dimensions of the EY 51.

Capacitance between anode and cathode (measured on the cold valve)

C_a	=	0.8 pF
-------	---	--------

Limiting values

a. With sinusoidal input (mains frequency):

Input voltage	V_{tr}	=	max. 5 kV _{rms}
Rectified output current	I_o	=	max. 3 mA
Reservoir capacitance	C_{filt}	=	max. 0.1 μF
Limiting resistance	R_t	=	min. 0.1 MΩ

b. With sinusoidal input (10-500 kc/s):

Peak inverse voltage	$V_{a invp}$	=	max. 17 kV
Rectified output current	I_o	=	max. 3 mA
Reservoir capacitance	C_{filt}	=	max. 0.01 μF
Limiting resistance	R_t	=	min. 0.1 MΩ

c. With pulse input

Peak inverse voltage	$V_{a invp}$	=	max. 17 kV
Rectified output current	I_o	=	max. 0.35 mA
Peak anode current	I_{ap}	=	max. 80 mA ¹⁾
Reservoir capacitance	C_{filt}	=	max. 5000 pF

1) For maximum pulse duration ½ % of one cycle, with a maximum of 5 μsec.

EY 51

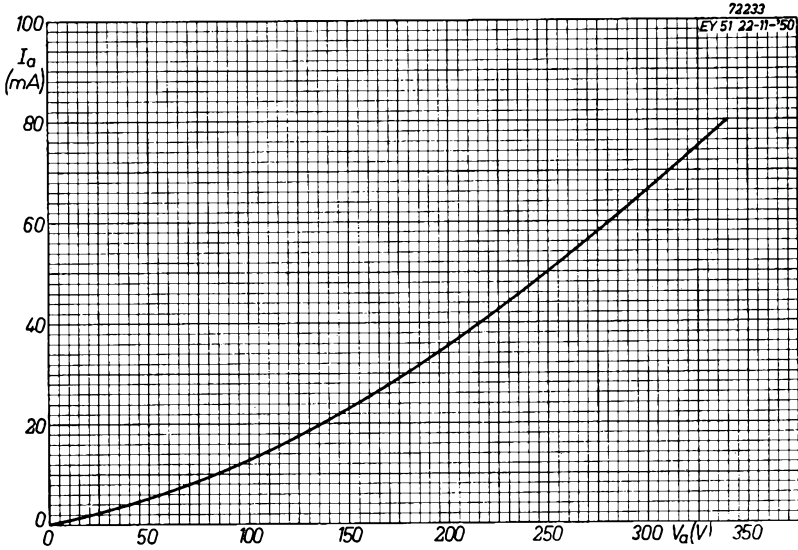

Fig. 3
Anode current of the EY 51, plotted against the anode voltage.

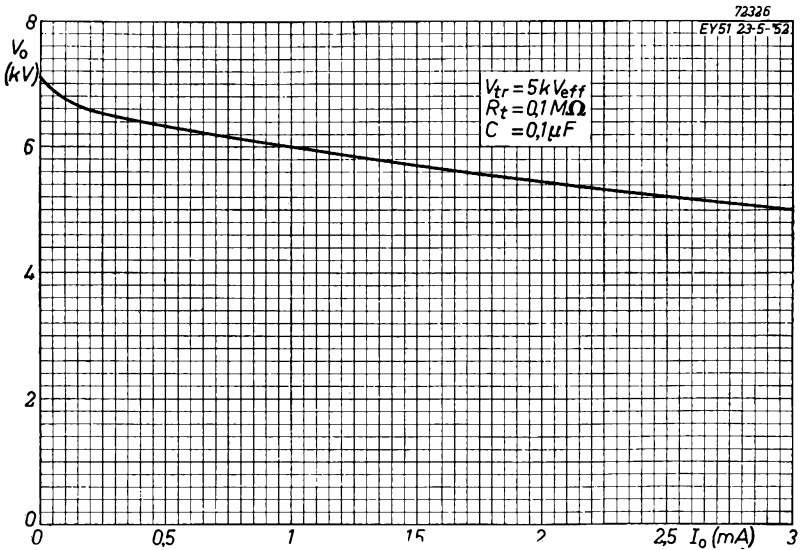

Fig. 4
Rectified output voltage of the EY 51 plotted against the output current, for a sinusoidal input voltage of $5kV_{rms}$ and a limiting resistance of $0.1 M\Omega$.

Circuit descriptions

In the preceding pages a review has been given of the complete range of television receiving valves. In this chapter a few important aspects of television receiving technique are discussed, namely, intercarrier sound and flywheel synchronization and this is followed by a description of a complete receiver. Intercarrier sound and flywheel synchronization are fairly recent innovations, and it is for this reason that they are dealt with separately.

Intercarrier sound

Introduction

In television systems using a frequency-modulated sound carrier and an amplitude-modulated picture carrier, two different methods are available for the amplification of the sound carrier, after this has passed the frequency changer stage. The conventional method is familiar, and calls for only a brief description, but the features of intercarrier sound reception require more detailed treatment.

Fig. 1 shows a block diagram in which the picture carrier and the sound carrier are applied to a common tuner unit. Such a unit normally contains an R.F. stage and a frequency changer. After frequency changing the picture and sound signals are amplified in separate I.F. amplifiers. It is also possible to use one or two common stages of I.F. amplification before the vision and sound signals are separated, but this does not make any fundamental difference.

The intermediate frequencies for sound and picture are determined by the carrier frequencies and by the frequency of the local oscillator. Since the difference in frequency between sound carrier and picture carrier is standardized (according to the C.C.I.R. system this is 5.5 Mc/s), the frequency difference between the two I.F. signals is constant, provided sufficient care is exercised at the transmitter to keep the frequency difference between the carriers constant.

The difference in frequency of the two I.F. signals is, therefore, independent

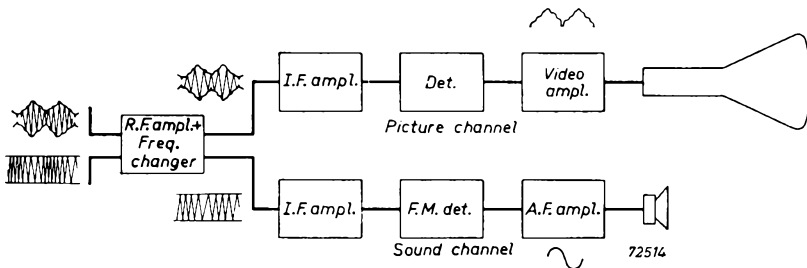

Fig. 1

Block diagram of a receiver in which the I.F. signals are amplified in separate channels.

of the local oscillator frequency, although the frequency of any one of the I.F. signals varies with it. So far as satisfactory reception of the picture is concerned in a receiver according to the block diagram of fig. 1 this does not lead to difficulties. A variation in oscillator frequency of, for example, 100 kc/s does not normally impair the picture quality. For sound reception, however, the situation is entirely different. The bandwidth of the sound section in the receiver is of the order of 150 kc/s, so that with a frequency deviation of 100 kc/s the carrier frequency is situated on one of the flanks of the response curve, resulting in distortion and high sensitivity to interfering signals.

It may be gathered from the above that particularly in the frequency band from 174 to 216 Mc/s, tuning of the receiver becomes fairly critical, and frequency drift during the heating-up period should be less than 10 to 20 kc/s. Moreover, variations in oscillator frequency due to microphony of the oscillator valve or components will result in a frequency modulation, which will be detected and reproduced by the loudspeaker. This may give

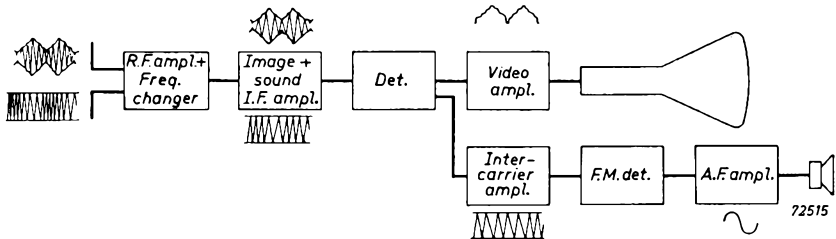

Fig. 2
Block diagram of a receiver using intercarrier sound.

rise to microphonic howl. These phenomena are most likely to occur when the oscillator frequency is high, i.e. in the band from 174 to 216 Mc/s. These difficulties can be avoided by taking advantage of the fact that the frequency difference between the two I.F. signals is independent of the frequency of the local oscillator. This has led to the development of intercarrier sound reception.

Fig. 2 shows the block diagram of a receiver with intercarrier sound. In this diagram, the picture and sound signals pass through one common chain of amplifier stages up to the video amplifier. The detector demodulates the picture signal in the normal way. The sound signal is also applied to this detector which, owing to its non-linear characteristic, acts also as a mixer, so that a signal with a frequency equal to the difference in frequency between the picture and sound signals can be taken from the load. This is the "intercarrier" signal. Since the frequency of the picture carrier is constant the intercarrier signal will contain only the original frequency modulation of the sound carrier.

The picture I.F. signal is modulated in amplitude and since this signal serves the same purpose as the oscillator signal in a conventional frequency

changer, the amplitude of the intercarrier signal will vary in sympathy with this modulation. This undesirable amplitude modulation can be kept low by taking care that the sound I.F. signal at the input of the video detector is several times smaller than the smallest instantaneous amplitude of the picture I.F. signal. The remaining amplitude modulation of the intercarrier signal can then be suppressed by an amplitude limiter combined with or preceding the sound detector. It should be noted that this limiting action is also required for limiting amplitude modulation resulting from interference.

It may be assumed that the picture and sound carriers induced in the aerial are of the same order of magnitude and it is therefore necessary to give the I.F. response curve such a shape, that the desired ratio between the amplitudes of picture and sound I.F. is obtained at the video detector. In the normal television receiver wave traps are included in the picture channel for completely suppressing the sound carrier. When intercarrier sound reception is applied, however, the attenuation should not be greater than 26 db

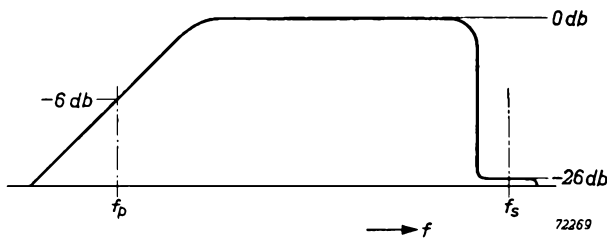

Fig. 3
Required shape of the response curve for intercarrier sound.

with respect to the centre of the pass band, as otherwise the sound I.F. signal at the detector would be too small. Moreover, the response curve should have such a shape that a flat portion occurs in the region of the sound I.F. This prevents amplitude modulation of the sound I.F. as a result of the frequency modulation. These amplitude variations would otherwise be detected and give rise to interference in the picture. To make tuning of the receiver less critical and to avoid the effects of frequency drift of the local oscillator, the width of the flat portion in the response curve (see fig. 3) should be several times greater than the total frequency sweep of the sound signal.

Although they are not essential for the reception of the picture, for undisturbed sound reception the picture transmitter must satisfy the following requirements:

- 1) The amplitude of the picture carrier must not drop below a certain critical value. If, for example, 100% modulation were applied, the picture

- carrier would be entirely absent at certain intervals and interruption of the intercarrier signal during these intervals would result. According to the C.C.I.R. standards the instantaneous minimum amplitude of the picture carrier may not be smaller than 10% of the maximum amplitude.
- 2) The picture transmitter must be so designed that the amplitude modulation of the carrier is not accompanied by frequency or phase modulation. This would result in interference in the intercarrier signal which cannot be removed.
 - 3) Since the intercarrier frequency is determined by the frequency difference of the two carriers, this difference must be kept reasonably constant at the transmitter.

Circuit description

Before the video signal across the load of the detector is applied to the picture tube it is normally amplified by one or two stages of video amplification. Attempts might be made to use the video amplifier for amplifying the intercarrier signal before this is applied to the sound detector. The intercarrier signal would then become sufficiently large for frequency detection and a tuned amplifier stage preceding the detector would not be required. This method, however, has the following disadvantages.

The mutual conductance of the video amplifying valve varies with the instantaneous value of the video voltage applied to its input and this results in amplitude modulation of the intercarrier signal. Additional amplitude limitation is then required. The video signal at the input of the video amplifier must never become so large that the anode current of the tube would be momentarily interrupted, as this would lead to interruption of the intercarrier signal.

Another disadvantage is that the intercarrier signal must be taken from the anode of the video amplifying valve via a coupling element, which reduces the amplification of high video frequencies. A loose coupling with the video amplifier could be used when one stage for amplifying the intercarrier signal is included between the anode of the video amplifier and the frequency detector, but the danger of momentary interruption of the intercarrier signal remains.

The most satisfactory solution therefore consists in sacrificing the extra gain available in the video amplifier and taking the intercarrier signal directly from the video detector load. The intercarrier signal available at this point is approximately 30 mV, so that it is necessary to use one amplifying stage preceding the sound detector. Interference resulting from intermodulation in the video amplifier is, however, avoided.

In order to keep the intercarrier signal at the video detector load reasonably constant it is necessary to apply automatic gain control in the preceding I.F. amplifier and, if necessary, in the R.F. amplifier. Contrast control must then be effected in the video amplifier.

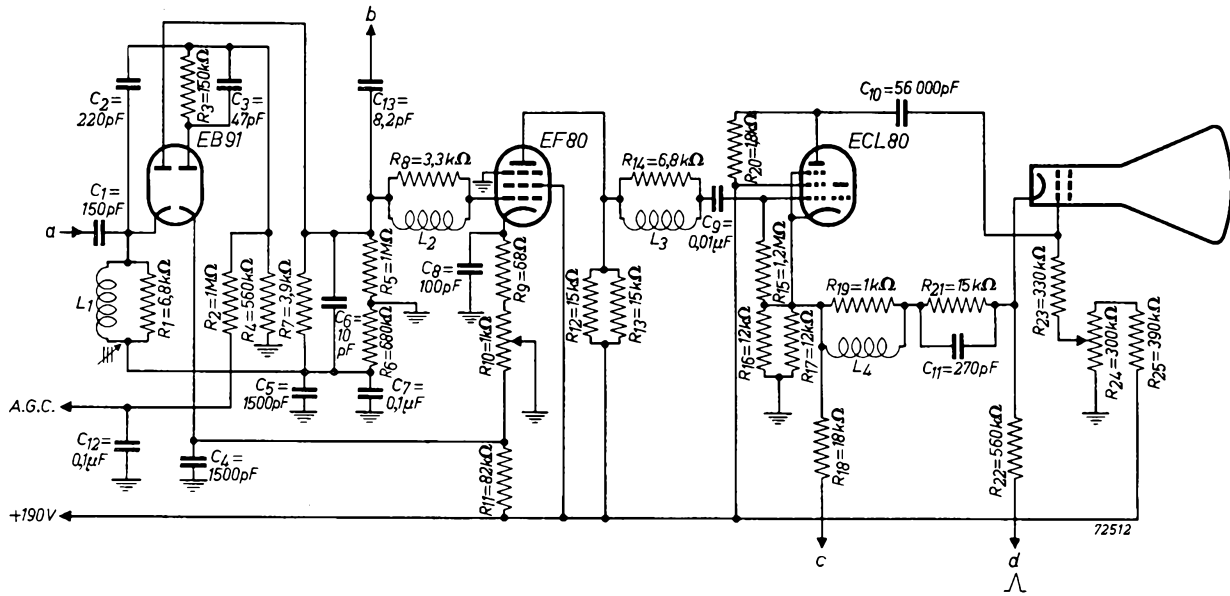

Fig. 4

Circuit diagram of the video amplifier with the preceding stages for detection and A.G.C. The left-hand section of the EB 91 double diode serves as video detector and the right-hand section as A.G.C. diode. The I.F. voltages, on which picture and sound are modulated, are applied via lead a , L_1 being the inductor of the final I.F. circuit. The intercarrier signal is taken off via lead b , whilst the complete video signal is fed to the synchronizing-pulse separator via lead c . For blanking the picture during the vertical retrace, flyback pulses are applied via lead d . The self-inductances of L_2 , L_3 and L_4 are 60, 130 and 80 μ H respectively.

Video detection and amplification

The circuit diagram of fig. 4 shows the video detector (left-hand section of EB 91), the A.G.C. circuit (right-hand section of EB 91) and the video amplifier (EF 80 plus pentode section of an ECL 80). The triode section of the ECL 80 triode pentode is not used.

The video signal is applied to the control grid of the EF 80 pentode via a series peaking coil L_2 , which serves to improve the response at high video frequencies. In order to prevent the video pentode from being periodically cut off at high values of the I.F. voltage at the detector diode, it is necessary to arrange the circuit in such a way that only part of the D.C. component across the detector load R_7 is passed on to the pentode grid. This may be explained by reference to fig. 5.

At the given screen-grid voltage the grid base of the EF 80 pentode is approximately 4 V, whilst when the potentiometer R_{10} is adjusted for maximum contrast (sliding contact in upper position) the voltage across the cathode resistor is approximately 1.5 V. The video voltage across the load may have a peak-to-peak value of 4 V. With I.F. voltages corresponding to peak white in the picture the voltage across R_7 is approximately 0.4 V, so that, when the entire D.C. component is passed on to the pentode, the maximum instantaneous negative grid voltage will be $1.5 + 0.4 + 4 = 5.9$ V (see fig. 5a). The synchronization pulses would then fall beyond the cut-off point. To avoid this a voltage divider R_5R_6 is connected across the diode load, so that only part of the D.C. component is passed on to the pentode. In the example given the peak whites now correspond to zero grid volts (see fig. 5b) and the synchronization pulses are no longer cut off.

Contrast control is effected by means of the potentiometer R_{10} . Moving the sliding contact upwards decreases the bias on the EF 80 pentode, whilst the negative feedback caused by the non-bypassed cathode resistance is reduced (C_8 only serves to improve the response at high video frequencies). At the same time the positive bias at the cathode of A.G.C. diode is increased, so that a higher I.F. voltage will occur at the detector diode. When the sliding contact is

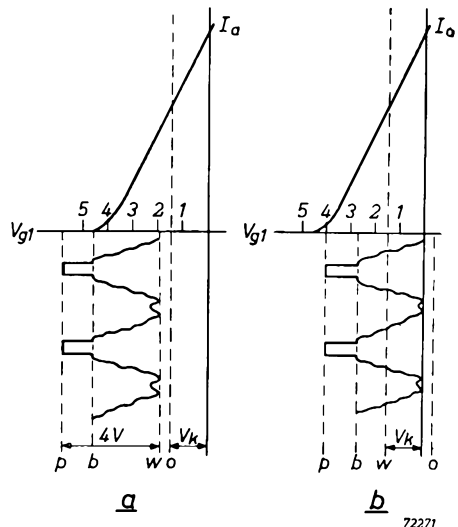

Fig. 5
Position of the video signal on the characteristic of the EF 80 pentode. The point O corresponds to a picture carrier signal of zero volts. Fig. 5a represents the case when the entire D.C. component is passed on to the pentode. In fig. 5b only part of the D.C. component is passed on.

displaced in the opposite direction the contrast is reduced. The bias on the EF 80 pentode and the negative feedback are then increased and the delay voltage on the A.G.C. diode is reduced.

Since the pentode section of the ECL 80 valve operates as cathode follower, resulting in a low effective input capacitance, the load resistance of the EF 80 pentode may be given a fairly high value without impairing the response at high video frequencies. For a bandwidth of 5 Mc/s a load of 7.5 k Ω is permissible if a series peaking coil L_3 is used and the cathode resistance of the EF 80 pentode is bridged by a small capacitor C_8 . The product of cathode resistance and capacitance of the EF 80 pentode influences the frequency response of this stage. Fig. 6 shows how the fre-

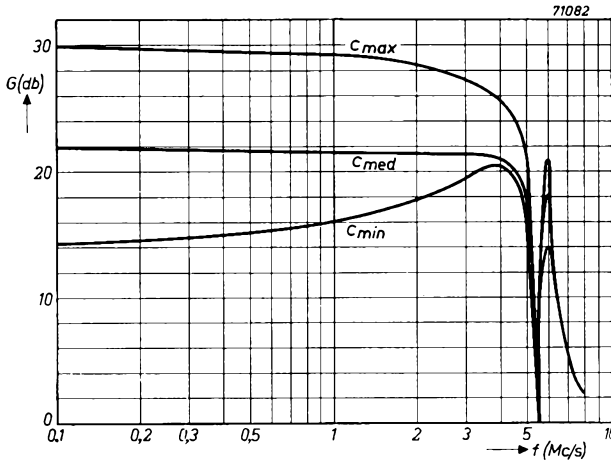

Fig. 6
The video gain plotted against frequency. The curve marked c_{max} corresponds to the condition when R_{10} is adjusted for maximum contrast, c_{med} to an average contrast control setting and c_{min} to minimum contrast.

quency response depends upon the position of the contrast control. At maximum contrast the gain of the EF 80 pentode is approximately 28. In the video signal applied to the pentode section of the ECL 80 valve the synchronization pulses are positive going. During these pulses grid current flows and the time constant of C_9R_{15} has been chosen so high that peak detection occurs. This gives D.C. restoration. Variation of the contrast would, however, result in a corresponding variation of the black level. This has been avoided by applying the video signal not only to the cathode of the picture tube, but also to the control grid, in the latter case without the D.C. component. For this purpose a small resistor R_{20} is included in the anode circuit of the ECL 80 pentode. Across this resistor appears a video voltage having an amplitude of about 20% of the total video voltage

applied to the picture tube. Theoretically this ratio should be 50%, but it should be recognized that, owing to the curvature of the characteristic of the EF 80 pentode, the amplitude ratio between the synchronization pulses and the video voltage is changed.

In order to prevent variations in the black level during the frame period the time constant of the coupling network $C_{10}R_{23}$ must be given a sufficiently high value, so that the signal applied to the control grid of the picture tube is free from variations in synchronism with the frame frequency. This is obtained by choosing the product $C_{10}R_{23}$ large compared with the duration of the frame synchronizing signal. In the circuit diagram of fig. 4 this RC -product is 19 milliseconds.

The black level is, therefore, practically independent of the position of the contrast control. Small variations, which might occur owing to variations in picture content, are not objectionable, since the picture is not likely to be entirely white or entirely black, and the variations in the content of a normal signal are very small.

When the contrast control is adjusted for maximum contrast and the I.F. signal at the detector has a high value, it may occur that the video voltage applied to the picture tube has such an amplitude that grid current flows. This results in a reduction of contrast in those parts of the picture where the brightness is high and, when the video signal is further increased, shifting of the grey parts towards the black level.

The occurrence of these phenomena is therefore an indication that the drive of the picture tube is too large and that the contrast must be reduced. To prevent the grid current of the picture tube from becoming excessive the grid leak R_{23} is given a high value (330 k Ω).

Another series peaking coil (L_4) compensates for the attenuation of the high video frequencies of the signal taken from the cathode of the ECL 80 tube. The frame flyback is blanked by applying a flyback pulse from the frame output circuit to connection d . Since the impedance at the cathode of the ECL 80 is very low, it is necessary to include series resistance (R_{21}) to provide a sufficiently high impedance for the flyback pulse. The capacitor C_{11} in parallel with R_{21} serves to prevent a drop in response at high video frequencies that would be caused by the combination of R_{21} and the input capacitance of the picture tube. The video signal is fed to the synchronizing pulse separator in the receiver via R_{18} and connection c .

There is no need to provide high-frequency compensation for the signal taken from the anode, since the anode resistance and capacitance are sufficiently low to ensure reasonably uniform gain within the entire video band. The video signal at the cathode of the ECL 80 tube is 97%, of the signal at the control grid whilst that at the anode is 25%. The gain of this stage is therefore 1.22, which gives for the overall gain from the grid of the EF 80 valve: $28 \times 1.22 = 34$. Owing to the presence of the potentiometer formed by the resistors R_{21} and R_{22} about 6% of the signal is, however, lost. When no signal is present the cathode voltage of the ECL 80 valve is 102 V, the anode voltage then being $190 - 25 = 165$ V with respect to chassis. The maximum output voltage which can be supplied by the ECL 80 valve (video signal plus synchronizing pulses) is $102 + 25 = 127$ V_{p.t.p.}. Hence the output

voltage of the EF 80 valve must be $127/1.22 = 104$ V_{p.t.p.}. With a load resistance of 7.5 kΩ this amounts to an alternating anode current of 14 mA_{p.t.p.} — a value which can easily be supplied by this valve.

In order to prevent the video signal at the control grid of the EF 80 valve from becoming too large, which would result in the synchronizing pulses being cut off, the A.G.C. must be such that the direct voltage across the load resistor of the detector does not exceed 4 V. In a television receiver equipped with one R.F. amplifying valve and four I.F. amplifying valves it is therefore advisable to apply A.G.C. to the R.F. amplifying valve and the first three I.F. amplifying valves.

The voltages and currents measured at the EF 80 and ECL 80 valves are summarized in the table below. The left-hand columns apply to an adjustment without signal and noise and with the contrast control adjusted to maximum contrast, while the right-hand columns were measured with the contrast control at an average setting and with input signal. All operating voltages quoted are voltages with respect to the chassis.

Operational data of the EF 80 and ECL 80 valves

	EF 80		ECL 80	
	without signal	with signal	without signal	with signal
Anode voltage . . .	90 V	150 V	165 V	167 V
Screen-grid voltage . .	190 V	190 V	190 V	190 V
Control-grid voltage .	-0.15 V	-1.5 V	101 V	
Cathode voltage . . .	1.5 V	1.5 V	102 V	93 V
Anode current . . .	13.5 mA	5.3 mA	14 mA	12.6 mA
Screen-grid current . .	5 mA	2.5 mA	3 mA	2.85 mA
Anode dissipation . .	1.2 W		0.88 W	
Screen-grid dissipation.	0.95 W	0.48 W	0.26 W	

The sound channel

It has been explained above that the intercarrier signal becomes modulated in amplitude owing to the amplitude modulation of the picture carrier. The magnitude of this amplitude modulation may be obtained from fig. 7, in which the intercarrier signal at the detector load is plotted against the picture carrier voltage, for different values of the sound carrier, both at the input of the detector. It will be seen that with a sound carrier voltage of 100 mV_{rms} and a picture carrier varying between 3 and 0.3 V_{rms} the intercarrier voltage varies between 30 and 15 mV_{rms}. This modulation must not occur in the output of the F.M. detector, so that amplitude limiting must be applied.

In the circuit fig. 8 limitation is obtained by using the F.M. detector valve EQ 80, in which the functions of detection and amplitude limitation are combined, and by rectifying the amplitude modulation and feeding it back

to the control grid of the preceding amplifier valve. When the phase of the feedback voltage is correct, amplitude modulation is very greatly reduced before the signal is applied to the F.M. detector. The total limitation obtained with the circuit of fig. 8 is so great that synchronization rattle is absent at all settings of the contrast control.

In addition, the circuit has been so arranged that, when the intercarrier signal at the F.M. detector is too small for interference-free detection, the EQ 80 valve is blocked, so that rattle, noise and microphony are efficiently suppressed. Due to the high total limitation factor, the adjustment of the EQ 80 valve is not critical. It is, for example, not necessary to use a cathode resistor of small tolerance, as would have been necessary if the amplitude limitation were only just sufficient

under the most favourable operating conditions. The circuit diagram of fig. 8 will now be described in more detail. The EF 80 pentode operates as a normal amplifier. The circuit L_5C_{16} is connected via a coupling capacitor C_{13} of 8.2 pF to the load resistor of the video detector, the combination being tuned to the intercarrier frequency of 5.5 Mc/s. The value of C_{13} has been so chosen that stability of the pentode amplifier is ensured and that the voltage gain between the control grid and the detector load reaches the optimum value. In trimming the input circuit of the EF 80 tube the signal generator

should not be connected directly to the load of the video detector, but via a resistor. Direct connection would result in instability of the amplifier, owing to the absence of the damping introduced by the detector load R_7 .

The voltage gain in the input circuit is 8, i.e. the intercarrier voltage across L_5C_{16} is 8 times that across R_7 . The anode of the pentode is connected to a capacitive tap, which is necessary to ensure stability. L_8 is a small R.F. choke for parallel feed to the anode. The voltage gain between the control grid of the pentode and the fifth grid of the EQ 80 tube is approx. 40. Before proceeding further with the description of the circuit of fig. 8, it will be necessary to give a brief description of the operation of the EQ 80 F.M. detector valve. A detailed description of this valve is given in Book III A of this series.

In contrast to many other F.M. detector circuits, in which the frequency modulation is first converted into an amplitude modulation before demodulation takes place, the operation of the EQ 80 is such that the anode current is a function of the phase difference between the signal voltages applied to the third and the fifth grids. Graphs in which the anode current of the valve is plotted against the voltages at g_3 and g_5 respectively, are given

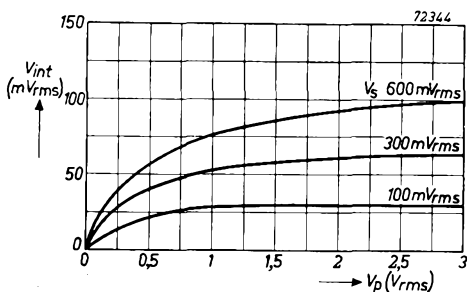

Fig. 7

The intercarrier voltage at the load of the detector diode plotted against the picture carrier voltage at the input of the detector, with the sound carrier voltage at the input of the detector as parameter.

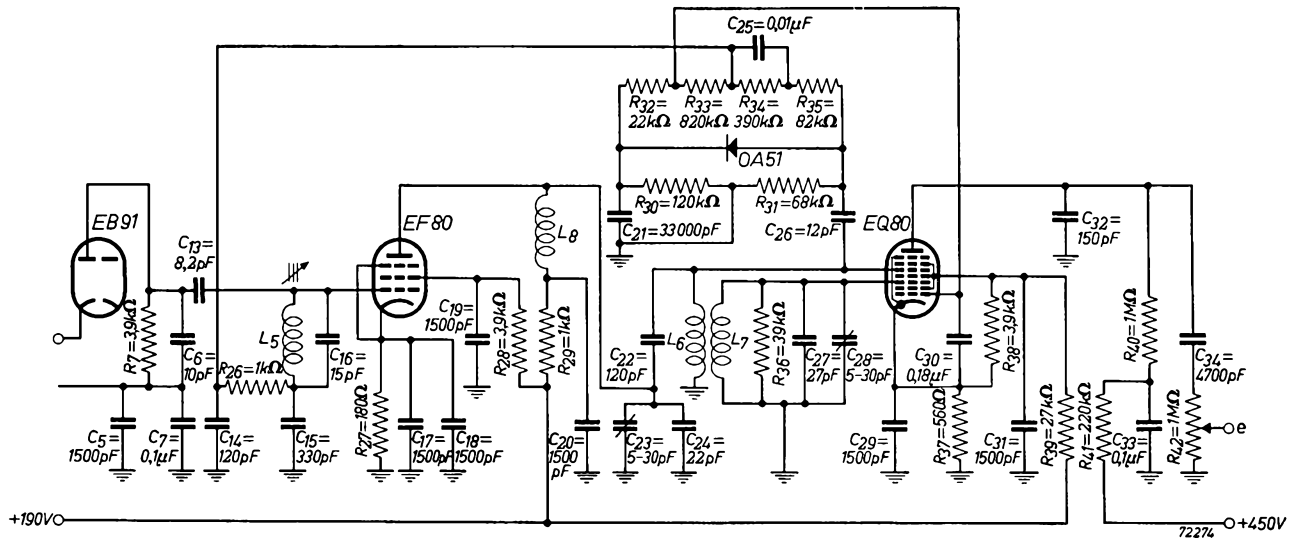

Fig. 8

Circuit diagram of the sound channel. The intercarrier signal is taken from the load of the video detector via the capacitor C_{13} (see also fig. 4). The A.F. output voltage at connection e can be applied to the A.F. output stage. L_8 is an R.F. choke of approx. 1 mH. Details of L_5 and L_6, L_7 are given in the text.

in figs. 23 and 24 on pages 172 and 173. During normal operation the negative bias on these grids is approximately 4 V, whilst the first grid is connected to the cathode. The screen grids g_2 , g_4 and g_6 are interconnected internally, and have an operating voltage of approx. 20 V with respect to the cathode. The grids g_3 and g_5 are connected to the secondary and primary respectively of an I.F. transformer, which is tuned to the signal frequency (see fig. 8). At resonance the phase difference between the two voltages is 90° , this difference increasing with increasing signal frequency and decreasing with decreasing frequency. As a result of the shape of the valve characteristics, anode current can flow only when both the grids g_3 and g_5 are positive simultaneously. The flat trend of the characteristics for positive voltages on these grids results in the anode current varying very little with the signal amplitude, provided the r.m.s. value of these voltages is greater than approximately 8 V. This gives amplitude limitation, because variations in signal amplitude have a very small influence upon the mean anode current.

The detector operation may conveniently be explained by reference to fig. 9, where the anode current is shown for different phase angles between the signal voltages at g_3 and g_5 . At a phase difference of 90° (signal frequency corresponding to resonant frequency), during each period an anode current pulse occurs as represented by the block II. With smaller phase difference the width of the pulse increases (see I), whilst with a greater phase difference the pulse width is decreased.

The anode circuit of the EQ 80 always has parasitic capacitance and by increasing this intentionally, the alternating components of the anode current are effectively bypassed, so that a direct voltage on which no pulse ripple is present occurs across the load resistance. The total capacitance in the anode circuit is, however, so small that audio-frequency variations in anode current can be followed. The A.F. voltage thus appearing across the load

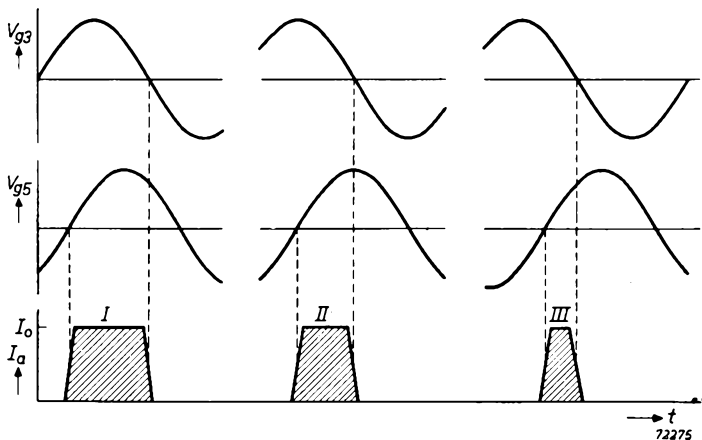

Fig. 9

Anode current of the EQ 80 for different phase angles between the signal voltages at the third and the fifth grids.

is caused by A.F. variations in the phase difference of the signals applied to g_3 and g_5 .

It is thus seen that the frequency modulation of the signal gives rise to a corresponding modulation of the phase difference of the signal voltages at g_3 and g_5 and that the latter modulation is detected by the valve. The mean anode current of the EQ 80 is an almost linear function of this phase difference. Moreover, the variation in phase difference is almost directly proportional to the frequency deviation, provided the total phase sweep is kept between certain limits, which may be ensured, according to the relative frequency sweep of the signal, by damping the secondary of the I.F. transformer (see R_{36} in fig. 8).

In most F.M. detector applications the first grid of the EQ 80 is connected to the cathode. If, however, a negative voltage of about 2 V is applied to this grid the anode current is blocked. It is by making use of this property that the F.M. detector is blocked when the signals at the third and fifth grids are too small to give interference free detection. The signal voltages required for satisfactory amplitude limitation are 8 V_{rms} at each signal grid.

The circuit of fig. 8 has been so arranged that when no signal is received the first grid is at chassis potential, the bias with respect to the cathode then being 4 V (voltage across R_{37}). With increasing signal strength the first grid goes positive with respect to the chassis, until its potential reaches that of the cathode and a further increase is prevented by the occurrence of grid current. The control voltage is obtained from the circuit operating with the germanium diode Type OA 51.

This diode rectifies the alternating voltage across the primary of the transformer L_6L_7 , the junction of the load resistors R_{30} and R_{31} being earthed. At the anode side of the diode (arrow) a negative voltage with respect to earth occurs, and at the cathode (bar) a positive voltage. The resistors R_{30} and R_{31} have been so chosen that the positive voltage is about twice the negative voltage.

In parallel with the load of the germanium diode is connected a voltage divider consisting of R_{32} to R_{35} . The junction between R_{32} and R_{33} is connected to the first grid of the EQ 80, whilst the junction of R_{33} and R_{34} is connected to the bottom of the tuned circuit L_5C_{16} via the decoupling resistor R_{26} . The relation between the various resistors in the bridge circuit around the germanium diode is such that:

$$\frac{R_{32} + R_{33}}{R_{30}} = \frac{R_{34} + R_{35}}{R_{31}},$$

which means that when the first grid of the EQ 80 does not draw current the control grid of the EF 80 pentode is at chassis potential.

In fig. 10 the various voltages occurring in the circuit containing the germanium diode type OA 51 are plotted against the intercarrier voltage at the control grid of the EF 80 pentode. For signal voltages between 0 and 200 m V_{rms} the various voltages increase linearly. With larger signal voltages the potential of the first grid of the EQ 80 becomes gradually equal to the cathode potential of this valve, so that grid current flows. The bridge circuit

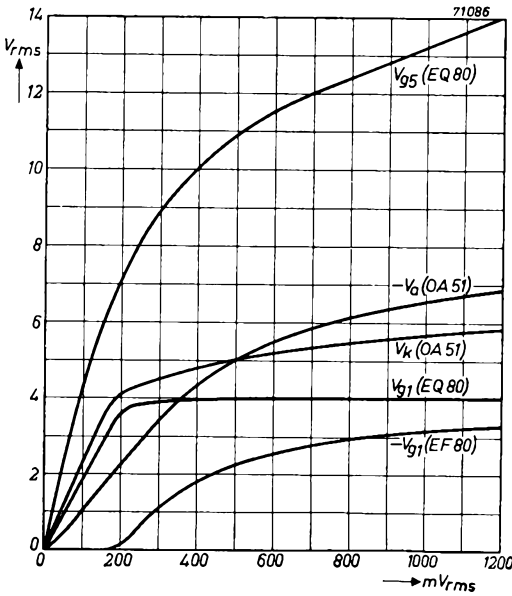

Fig. 10

Voltages at various points in the circuit of fig. 8, plotted against the intercarrier signal at the control grid of the EF 80 valve. It should be borne in mind that the voltage gain in the control-grid circuit of this valve is 8.

the grid circuit of the EF 80 pentode have only a small value, so that by shunting R_{34} with a fairly large capacitor practically the whole of the rectified alternating voltage is applied to the control grid of the EF 80. The phase of this alternating voltage is such that, owing to the curvature of the characteristic of the EF 80, the amplitude modulation of the intercarrier signal is counteracted. With small signal voltages, when the EQ 80 is inoperative, the limiting factor thus obtained is 1.5, whilst with a signal voltage of 1 V on the control grid of the EF 80 the limiting factor is 3.5. The total limiting factor, including that of the EQ 80, is therefore very large, so that efficient suppression of interference and synchronisation rattle is obtained.

For a signal voltage of 8 V_{rms} on the fifth grid of the EQ 80 a signal of 250 mV_{rms} is required at the control grid of the EF 80 (see fig. 10). The voltage gain in the grid circuit is 8, so that the intercarrier voltage at the load of the video detector must be 32 mV_{rms}. With an I.F. picture carrier voltage of 3 V_{rms} at the input of the video detector the sound carrier must then be at least 120 mV_{rms} (see fig. 7).

Fig. 11 shows the response curves of the intercarrier amplifier. These curves were determined by applying two signals to the input of the picture channel of the receiver, one signal having a fixed frequency of 23.75 Mc/s and the frequency of the other being varied between 18.0 and 18.5 Mc/s. In fig. 11

formed by the resistors R_{30} to R_{35} is then thrown out of balance and a negative voltage is applied to the control grid of the EF 80 pentode.

It is seen that with signal voltages up to 200 mV_{rms} the EF 80 operates at maximum mutual conductance, whilst the EQ 80 valve is initially blocked. When the alternating voltage at the fifth grid of the EQ 80 reaches approx. 6 V_{rms} detection occurs. At the same time A.G.C. is applied to the EF 80 pentode, which prevents the occurrence of excessive signal voltages at g_3 and g_5 of the EQ 80. This is so arranged because the limiting action of the EQ 80 is most favourable with signal voltages of approx. 8 V_{rms}. Due to the unwanted amplitude modulation of the intercarrier signal, an alternating voltage is developed at the anode of the germanium diode in addition to the direct voltage. The capacitors C_{14} and C_{15} in

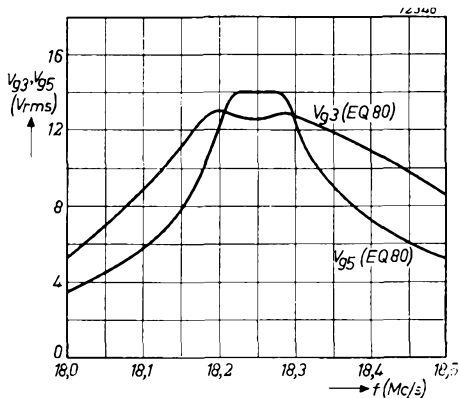

Fig. 11
Response curves of the sound channel, plotted against the sound I.F.

The dimensions of the inductors L_5 fig. 8 are given in figs. 13 and 14. The inductor L_5 is wound on a former having a diameter of 7 mm. An iron-dust core of 6 mm diameter is used for tuning. The screening can has a diameter of 19 mm and a height of 22 mm. The winding consists of 63 turns of enamelled copper of 0.12 mm diameter, wound in one layer without spacing between turns. The self-inductance is approx. 29 μ H, the quality factor Q is 36.5, giving an impedance of 38 k Ω in the control-grid circuit of the EF 80.

Fig. 14a gives the dimensions of the transformer L_6L_7 , the screening can of which is 30 mm in diameter and 60 mm high. Both windings have 34 turns of enamelled copper of 0.2 mm diameter, wound in one layer without spacing between turns. The self-inductance of each winding is 15 μ H and the total tuning capacitances 56 pF.

The mounting position on the receiver chassis is shown in fig. 14b, in which S is a screening plate having a height of approx. 5 cm.

The primary of the transformer is damped by the circuit containing the germanium diode type OA 51 (damping approx. 50 k Ω for signal voltages smaller than 8 V_{rms}), and the secondary by an additional damping resistor R_{36} of 39 k Ω . With these extra dampings the coupling KQ is 1.2, the impe-

the frequency of 18.25 Mc/s therefore corresponds to the intercarrier frequency of 5.5 Mc/s.

In fig. 12 is shown a statically measured detection curve of the EQ 80. It is seen that with a total frequency sweep of 50 kc/s the anode voltage variation is 90 V. The dynamic load of the EQ 80 is, however, half the static load, so that a total frequency sweep of 50 kc/s results in an alternating voltage of 16 V_{rms} at the anode.

For full output of a PL 82 output pentode 6 to 7 V_{rms} is required at the control grid, and it is clear that this is obtained with a total frequency sweep of approx. 20 kc/s.

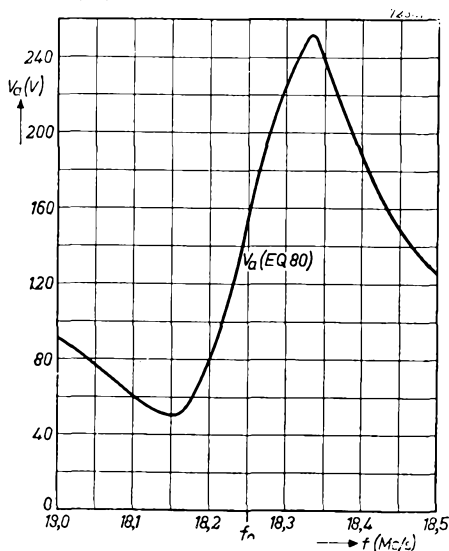

Fig. 12
Anode voltage of the EQ 80 valve plotted against the sound I.F.

dance of the primary 20 kΩ and that of the secondary 18.2 kΩ, from which it follows that the input impedance is 8.2 kΩ. The product of this input impedance and the impedance in the grid circuit of the EF 80 is too great to ensure stability. The anode is therefore connected to a tap of 0.7 on the primary, where the input impedance has a value of $0.7^2 \times 8.2 = 4$ kΩ. The following table gives the currents and voltages of the EF 80 and EQ 80 valves under no-signal conditions. The voltages are measured with respect to the chassis, the first grid of the EQ 80 being connected to the cathode. The figure given for the screen-grid current of the EQ 80 also includes the current in the bleeder resistor R_{38} .

	EF 80	EQ 80
Anode voltage . . .	180 V	85 V
Screen-grid voltage. . .	180 V	24 V
Control-grid voltage. . .	0 V	4 V
Cathode voltage . . .	2.2 V	4 V
Anode current . . .	10 mA	0.3 mA
Screen-grid current . . .	2.5 mA	6.2 mA

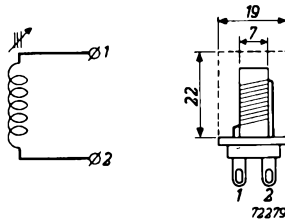

Fig. 13
Dimensions of the inductor
 L_5 .

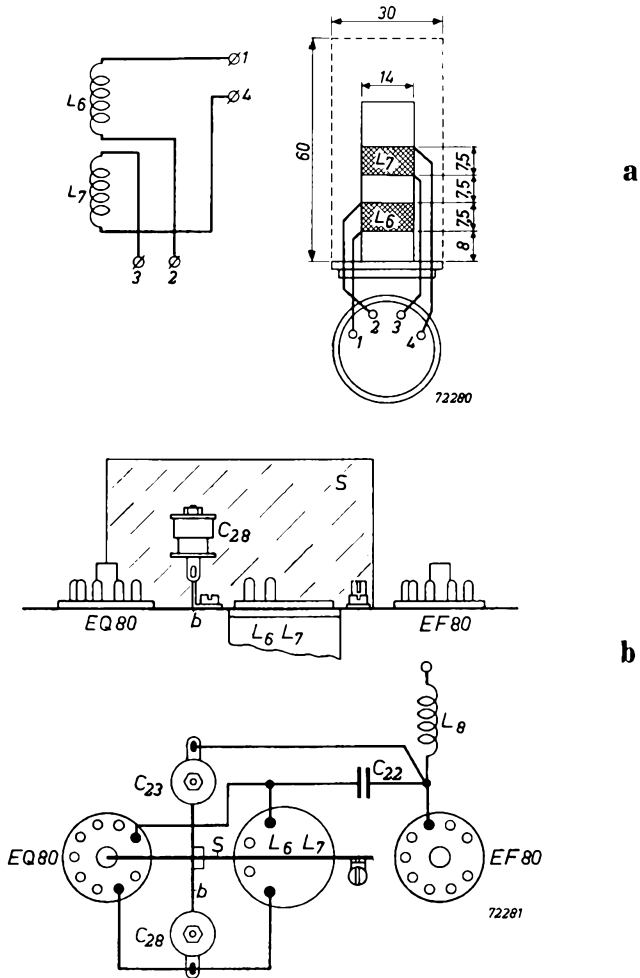

Fig. 14

- a. Dimensions in mm of the transformer L_6L_7 .
- b. Position on the receiver chassis.

Flywheel synchronization

In the description of the application of the PL 81 line-output valve on pages 109 to 125, a circuit for flywheel synchronization is described, in which the triode-hexode type ECH 42 is used as coincidence detector. The mean anode current of this valve, and therefore also the anode voltage, are determined by the amount of overlapping of the line synchronizing pulses and the flyback pulses obtained from the line-output stage. A deviation of the frequency of the multivibrator driving the output stage then results in a corresponding variation in anode voltage of the coincidence detector, which compensates the original frequency deviation. This action is due to the fact that anode of the coincidence detector provides the bias for one of the grids of the multivibrator. When, therefore, the repetition rate of the synchronization pulses is increased or decreased, a variation in anode voltage of the coincidence detector occurs, causing a corresponding variation of the multivibrator frequency. This type of automatic frequency and phase control is, of course, effective only for deviations between certain limits.

The triode-hexode operates entirely satisfactorily in such circuits. It has one disadvantage, however, in that the triode grid is internally connected to the third grid of the hexode. It is true that the triode grid functions as a peak detector for the differentiated line synchronizing pulses, but the triode is not available for other purposes, such as amplification or limitation of the synchronizing pulses. Differentiation of the synchronizing signal, before it is applied to the triode grid, is necessary to prevent variations in mean anode current of the coincidence detector during the frame synchronization pulses.

In the triode-pentode type ECL 80 two valve sections are available which, except for the common cathode, are not interconnected internally. The pentode section of this valve may very well be used as a coincidence detector, so that the triode remains for amplifying and limiting the synchronizing signal. A circuit in which the ECL 80 is used in this way is described below.

The enneode type EQ 80 has been designed primarily for use as an F.M. detector, but since this valve has three control grids it is also very suitable for flywheel synchronization circuits. The shape of the characteristics is such that a considerable degree of immunity to interference can be obtained. A circuit using this valve is also described.

Circuit with the ECL 80 triode pentode

A circuit in which an ECL 80 triode pentode is used as coincidence detector is shown in fig. 15.

The complete video signal from the output of the video amplifier is applied via lead *A*, the coupling network $C_{15}R_{22}$ and the parallel combination $C_{16}R_{23}$ to the control grid of the pentode P_1 . The time constant of $C_{15}R_{22}$ has been so chosen that peak detection occurs, so that only the synchronizing pulses fall within the grid base of the pentode. In order to obtain effective separation at low settings of the contrast control, the grid base has been kept

small by employing a low screen-grid voltage of approximately 16 V, which is obtained by means of the voltage divider $R_{24}R_{25}$. The parallel combination $C_{16}R_{23}$ serves to prevent the pentode P_1 from becoming temporarily inoperative when interference pulses of large amplitude and short duration occur. If the control grid were connected directly to the junction of C_{15} and R_{22} , the valve would be driven into grid current on the occurrence of an interference pulse of large amplitude and capacitor C_{15} would be charged negatively. At the end of the pulse, therefore, the pentode would be blocked, and since the combination $C_{15}R_{22}$ has a comparatively large time constant, the synchronizing signal at the anode would fail for an appreciable time. Owing to the presence of $C_{16}R_{23}$, of which the time constant is small compared with that of $C_{15}R_{22}$, when an interference pulse of short duration occurs equal charges are supplied to each capacitor. Since,

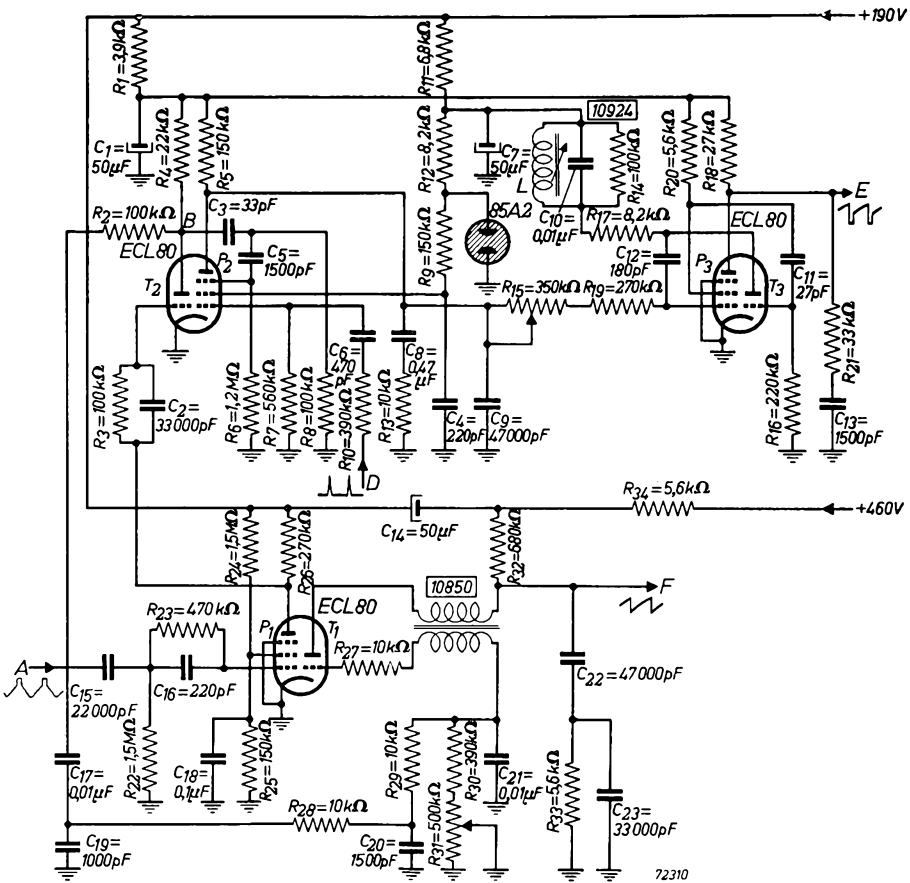

Fig. 15
Circuit for flywheel synchronization, with the pentode section of an ECL 80 triode pentode as coincidence detector.

however, C_{16} is much smaller than C_{15} the voltage across C_{16} becomes much greater than that across C_{15} , but C_{16} is rapidly discharged via R_{23} because the time constant of this combination is small. The pentode is thus blocked for a very short period only.

At the anode of the pentode a synchronizing signal the pulses of which are negative going is available, this signal being applied to the grid of the triode T_2 via the parallel combination C_2R_3 . The latter valve inverts the phase of the synchronizing signal, so that at point B the pulses are positive going. The coupling between the anode of P_1 and the grid of T_2 is rather unconventional in that a capacitor for blocking the D.C. potential of the anode is not used. This results in grid current in the triode, which is interrupted

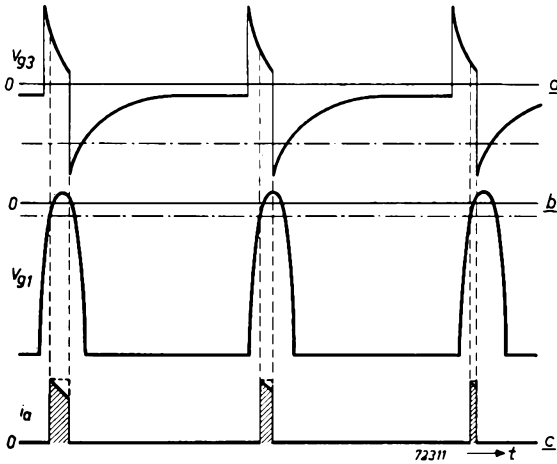

Fig. 16
 Voltages on the third and the first grids of the pentode and the resulting anode current pulses.

only during the synchronizing pulses. This current flows through the resistors R_3 and R_{26} and reduces the anode voltage of P_1 . It is desirable to operate this valve at a low anode voltage, because during the synchronizing pulses the anode voltage then drops to a value below the knee in the I_a/V_a characteristic, so that efficient limitation is obtained.

The synchronizing signal at point B is differentiated by the circuit C_3R_8 and then applied via the coupling capacitor C_5 to the third grid of the pentode P_2 which operates as a coincidence detector. The time constant of C_5R_6 is large compared with the duration of a line period so that, dependent upon the voltage on the first grid, rectification occurs, giving a wave form on the third grid as shown in fig. 16a, in which the dot-dash line represents the cut off level of the third grid.

To the first grid of the coincidence detector P_2 are applied flyback pulses obtained from the output transformer for horizontal deflection (see point D in fig. 15). This results in peak detection, so that current can flow in the pentode only during the peaks of these pulses. This is shown in fig. 16b,

in which the dot-dash line represents the cut off voltage of the first grid. Fig. 17 shows the anode current of the pentode P_2 as a function of the voltage at the third grid, with the control-grid voltage as parameter. From this figure and from fig. 16 it may be deduced that the anode current pulses will have a shape as shown in a somewhat idealized form in fig. 16c.

It will be seen that the mean anode current will have the highest value when the starting points of the synchronizing pulses and the flyback pulses almost coincide, and that with delayed flyback pulses the mean anode current decreases. The time constant in the screen-grid circuit of P_2 is comparatively small (see C_4 in fig. 15), so that the screen-grid voltage drops during the

time the control-grid voltage is above the cut off level. The anode current therefore decreases during each anode current pulse (see fig. 16c).

The part of a complete period during which anode current flows may be termed the "current angle", and it has been shown that with an increasing current angle the mean anode current increases and thus the anode voltage decreases. With a decreasing current angle the anode voltage increases. The variation in anode voltage of the coincidence detector P_2 is used to control the frequency of a multivibrator (see T_3 and P_3 in fig. 15) in such a way that deviations of the multivibrator frequency from the synchronizing pulse frequency are corrected. The multivibrator generates a saw-tooth voltage suitable for driving the line output pentode. The triode T_3 and the part of the pentode P_3 consisting of the cathode, the control grid and the screen-grid form a multivibrator

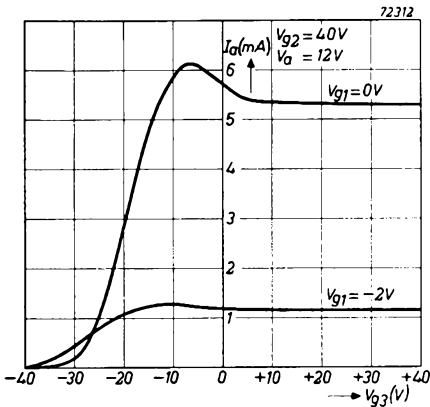

Fig. 17

Anode current of the pentode section of an ECL 80 triode pentode plotted against the voltage on the third grid. The curves were determined with a screen-grid voltage of 40 V, an anode voltage of 12 V and with the control-grid voltage as parameter. The screen-grid and anode voltages are about equal to those occurring during normal operation.

of the asymmetrical type, i.e. the negative-going half periods of the saw-tooth voltage at the anode of P_3 have a much shorter duration than the positive going half periods. This is ensured by choosing different time constants for the RC circuits $C_{11}R_{16}$ and $C_{12}R_{19}R_{15}$. During the short intervals in each period that the pentode conducts, the capacitor C_{13} is discharged and charged exponentially during the time between these intervals. The resistor R_{21} serves to provide a negative pulse during the intervals that the capacitor is discharged. The negative pulse is required to block the line output pentode during the flyback. The use of the screen grid of the pentode P_3 as an anode in the multivibrator circuit has the advantage that the influence of the line output stage upon the multivibrator is kept very small.

A tuned circuit LC_{10} is included in the anode circuit of the triode T_3 . This circuit can be tuned to the line frequency of 15625 c/s by means of a Ferro-

cube core and stabilizes the frequency of the multivibrator. The inductor and the capacitor are available as one unit under the type number 10924. In order to reduce variations in the current angle as a result of mains voltage fluctuations a voltage stabilizing tube type 85 A2 is used to stabilize the screen-grid supply of the coincidence detector. The anode of the triode T_3 is fed from a voltage divider between the H.T. supply line and the voltage stabilizer. Variations in the screen-grid voltage of the coincidence detector would result in anode current variations. In order to maintain synchronization, these variations must be compensated by a corresponding variation of the current angle. This variation in current angle is manifest as a horizontal displacement of the picture.

The bottom P_3 end of the leak resistance in the control-grid circuit of the pentode P_3 is connected to the anode of the coincidence detector, whilst a network $C_8C_9R_{13}$ is included between this anode and the chassis. This network serves to prevent the occurrence of periodic variations in the anode voltage of the coincidence detector at the beginning of the vertical scan. If such a network is not used, or if it is not correctly dimensioned, the periodic variations in anode voltage are accompanied by corresponding variations in the current angle and a damped oscillatory horizontal displacement of the picture, starting at the top. The variation in anode voltage of the coincidence detector is due to the fact that during the vertical blanking period synchronizing pulses of a different form than those occurring during the vertical scan are applied to the third grid. This results in variations in the mean anode current and voltage of the coincidence detector, in synchronism with the vertical scanning frequency. The parasitic anode current pulses will have a damped oscillatory character when the network $C_8C_9R_{13}$ is not correctly dimensioned, and give rise to waved vertical sides of the picture. When correctly dimensioned the network gives critical damping for the parasitic pulses.

Although it is possible to prevent the occurrence of oscillatory anode voltage variations of the coincidence detector, the mean anode current and voltage will assume a different value during the vertical blanking period. The magnitude of the deviation depends to a considerable extent upon the dimensions of the differentiator network C_3R_8 . When the deviation is great the current angle at the end of the vertical blanking period will differ quite considerably from that at the beginning. This is manifest in a curvature of the vertical sides at the top of the picture. Whether the vertical sides are curved towards the left or the right depends upon whether the mean anode current of the coincidence detector at the beginning of the vertical blanking period is greater or smaller than that at the end. The circuit C_3R_8 in combination with C_5R_6 has been so dimensioned experimentally that the variation in mean anode current during the vertical blanking period is as small as possible, so that the hold control R_{15} can be varied over a wide range without causing curved vertical sides in the picture. The current angle is influenced by the position of R_{15} , so that a horizontal displacement of the picture occurs when R_{15} is altered.

Fig. 18 gives the relation between the multivibrator frequency and the anode voltage of the coincidence detector. This curve corresponds to one given

setting of the horizontal hold control R_{15} , with other settings the curve is shifted in the horizontal direction.

The wave form of the synchronizing signal on the third grid of the coincidence detector and the direct voltage on this grid resulting from detection depend not only upon the dimensions of the RC circuits C_3R_8 and C_5R_6 , but also upon the current angle. When the third grid is sufficiently positive and the valve is not blocked by a negative voltage on the first grid the third grid will draw current. The preceding circuits are then loaded, which results in a reduction of the third-grid voltage during the current angle, as can be ascertained by examining the current angle by means of an oscilloscope.

The temporary reduction of third-grid voltage does not influence the anode current to any appreciable extent, because with positive third-grid voltages the anode current is fairly constant (see fig. 17).

It may be seen from fig. 16 that the total variation in current angle can never be greater than the width of a line synchronizing pulse, so that the horizontal displacement of the synchronized picture as a result of variation in current angle cannot be greater than $9/91 =$ approximately 10% of the total picture width. With a picture having a total width of 29 cm the maximum displacement is therefore 29 mm.

With the circuit of fig. 15 it has been found experimentally that synchronization could be maintained over a total horizontal displacement of the picture of 24 mm. The anode voltage of the coincidence detector is plotted in fig. 19 against the horizontal displacement. Since the mean anode voltage decreases with increasing current angle a low anode voltage corresponds to a large current angle.

It has been indicated previously that during the current angle the anode current drops. This is due to the small bypass capacitor between screen grid and earth. The relative drop in anode current will be greater when the current angle is greater, which explains the flat trend of the curve in fig. 19 with low anode voltages. In this region large variations in current angle give only small variations in mean anode current or voltage. This is no real disadvantage, because in the steep part of the curve the variation in mean anode voltage is still 8 V, which, according to fig. 18, corresponds to a frequency range of the multivibrator of 0.6 kc/s.

The screen-grid bypass capacitor C_4 has been made small intentionally to assist in preventing a large variation in mean anode current during the vertical blanking period. The vertical synchronizing signal is interrupted by inverted horizontal synchronizing pulses, the repetition frequency of which is twice that of the normal horizontal synchronizing pulses, see fig. 20, which represents the voltage at the third grid of the coincidence detector

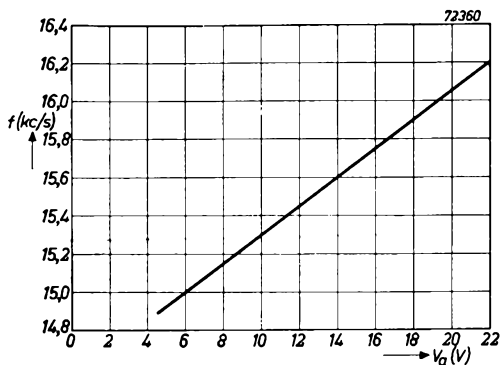

Fig. 18

Relation between the multivibrator frequency and the anode voltage of the coincidence detector.

during this time. The ends of the inverted pulses correspond to the starts of the normal horizontal synchronizing pulses shown in fig. 16, so that after the occurrence of, for example, each of the pulses *a*, *b* and *c* in fig. 20 anode current can flow for a comparatively long time, because the positive peak in third-grid voltage is not immediately followed by a negative peak. A large increase in mean anode current during this time is prevented by a drop in screen-grid voltage, which is obtained by giving C_4 a low value. A very good way of assessing the usefulness of a synchronizing circuit is to observe its performance with a mutilated synchronizing signal. In this respect the circuit represented in fig. 15 is very satisfactory. Owing to the fact that, with positive voltages on the third grid of the coincidence detector, the anode current varies but little with varying third-grid voltage, an increase of the amplitude of the synchronizing signal will produce only a small variation in mean anode current.

Insensitivity to failure of the synchronizing signal for a short time, for example as a result of interference, is obtained by choosing the circuit parameters such that in the absence of a synchronizing signal the coincidence detector is automatically adjusted at a mean anode current corresponding as closely as possible to the mean anode current during synchronization. How closely this ideal performance is approached depends upon a large number of factors, but mainly upon the bias on the third grid and the way in which this is obtained. The circuit parameters given in fig. 15 were determined experimentally for optimum performance in this respect.

In the course of this description the function of the triode T_1 in fig. 15 has not been mentioned. This triode operates as a blocking oscillator for generating the saw-tooth voltage driving the frame output pentode. The output voltage taken from the anode can drive a PL 82 output pentode.

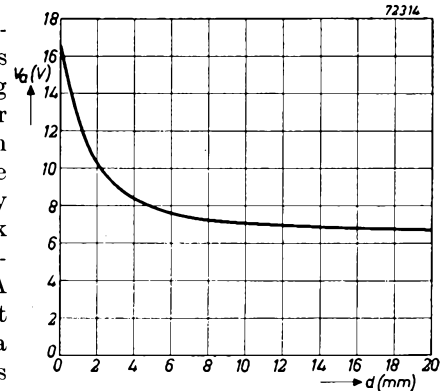

Fig. 19
Anode voltage of the coincidence detector plotted against the horizontal displacement of the picture. This displacement corresponds to a total picture width of 29 cm, as on an MW 36-24 picture tube.

A standard blocking transformer is used, which is available under type number 10850. The blocking oscillator is synchronized by means of the complete synchronizing signal at point *B*, which is applied to the grid circuit via two integrating circuits. C_{17} serves only for blocking the D.C. potential, R_{31} being the vertical hold control.

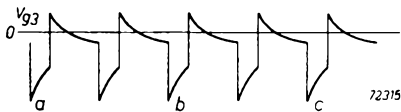

Fig. 20
Voltage at the third grid of the coincidence detector during the frame synchronizing signal.

Circuit with EQ 80 enneode

A circuit for flywheel synchronization in which an EQ 80 enneode is used as phase detector is shown in fig. 21. With this tube three control grids are available, thus offering great flexibility in circuit design.

Those characteristics of the EQ 80 which are important for explaining its operation as a phase detector, are given in figs. 22, 23 and 24. It is seen that at the supply voltages indicated, a bias of -2 V is required at the first grid for blocking the anode current. At the third and the fifth grids a bias of approx. -10 V is required, when the first grid voltage is zero. It may also be observed that the anode current increases almost linearly, when the negative bias at g_3 and g_5 is reduced, and that with positive voltages on these grids the anode current is practically constant.

The complete video signal is applied to the circuit of fig. 21 via lead A. The pentode P_1 serves as synchronizing pulse separator for synchronizing the blocking oscillator built around the triode T_1 .

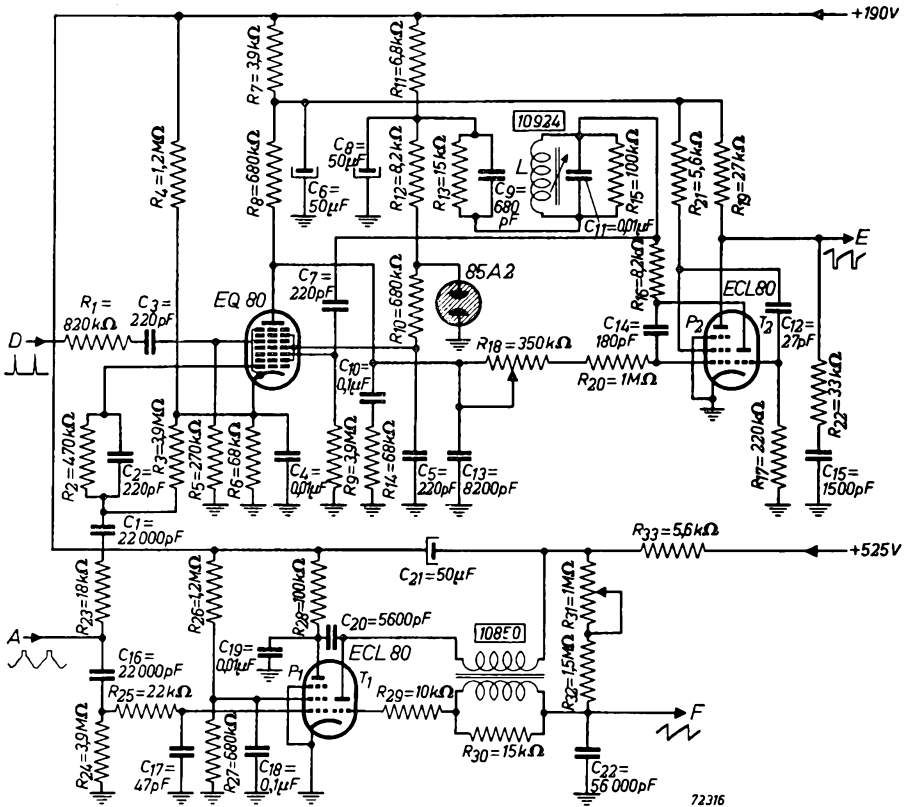

Fig. 21

Circuit for flywheel synchronization with the EQ 80 enneode as phase detector.

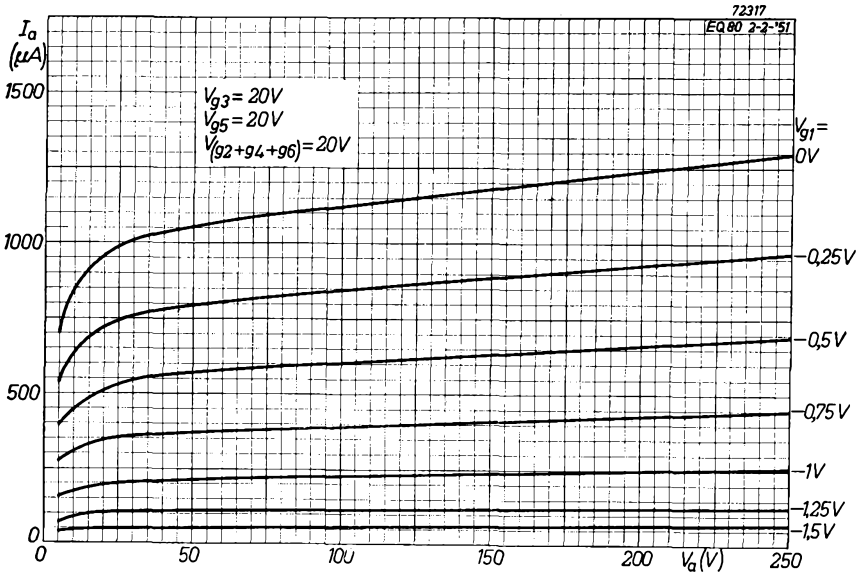

Fig. 22

Anode current of the EQ 80 enneode plotted against the anode voltage, with the voltage on the first grid as parameter.

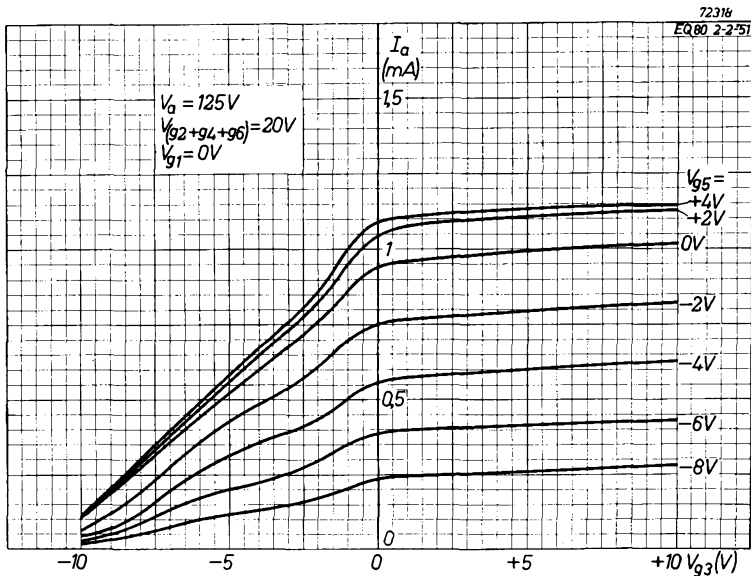

Fig. 23

Anode current of the EQ 80 enneode plotted against the voltage on the third grid, with the voltage on the fifth grid as parameter.

The RC circuit $R_{25}C_{17}$ in the input lead of the synchronizing pulse separator suppresses interference pulses of short duration and spurious H.F. signals. The separated signal is integrated by the combination R_{28} and C_{19} and applied via C_{20} to the anode of the blocking oscillator. The output voltage of the blocking oscillator is taken from the charge capacitor C_{22} in the grid circuit. The complete signal is also applied to the first grid of the EQ 80. Peak detection occurs here so that only the synchronizing pulses fall within the grid base. During the intervals between the pulses the valve is therefore blocked. In series with the first grid a parallel combination R_2C_2 is included and serves to reduce the effect of interference pulses of short duration. When the EQ 80 is not blocked by a negative voltage on the first grid anode current can flow only when the potentials of g_3 and g_5 are not highly negative.

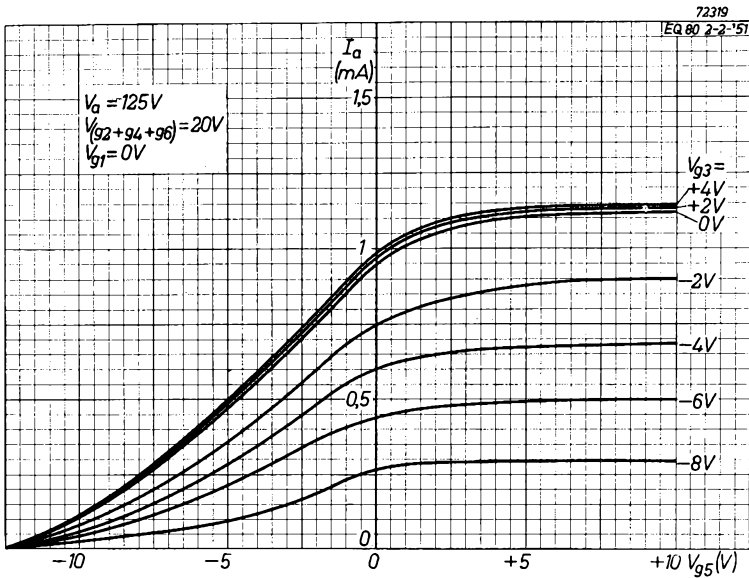

Fig. 24

Anode current of the EQ 80 enneode plotted against the voltage on the fifth grid, with the voltage on the third grid as parameter.

For the time being it will be assumed that g_5 is at cathode potential. To the third grid is applied a signal taken from the multivibrator (valve sections P_2 and T_2). This voltage is the sum of a saw-tooth voltage occurring across C_9R_{13} and the sinusoidal voltage across the tuned circuit type 10924. The amplitude of this signal and the bias of g_3 (see R_4R_6) have been so chosen that the steep part AB of the graph in fig. 25, in which the point A coincides with the start of the flyback in the line output circuit, covers a voltage range approximately equal to the third-grid base.

With normal operation a synchronizing pulse occurs for example at the instant marked τ in fig. 25. Since during this pulse the first grid is at cathode potential an anode current pulse will be produced as represented by p . A

variation in the relative phase will cause the synchronization pulse to move up or down the steep section AB . With a multivibrator frequency lower than the repetition frequency of the synchronization pulses, for example, the next synchronizing pulse will occur at the instant τ' , giving an anode current pulse p' . This results in a decrease of the mean anode current and a consequent increase of the mean anode voltage, which corrects the relative phase in the required direction. Under stationary conditions, therefore, the synchronizing pulses will occupy positions on the sections AB , $A'B'$ etc., so that equilibrium exists between the frequency and phase of the multivibrator and the corresponding mean anode voltage of the phase detector. In this way a very efficient form of automatic frequency and phase control is obtained. There are, however, two important disadvantages, which impair

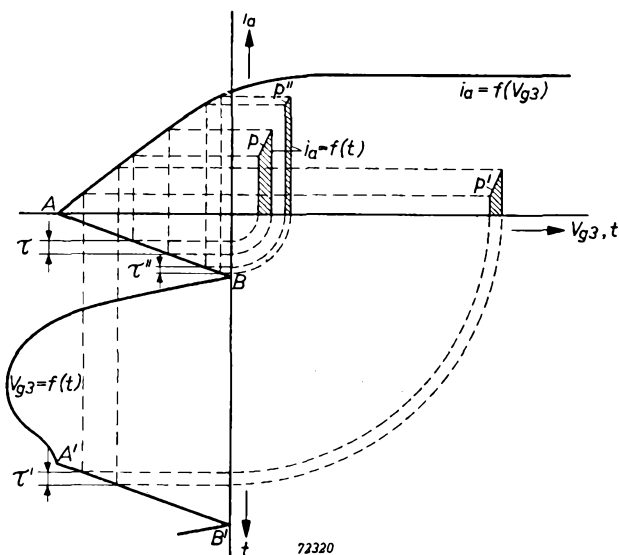

Fig. 25

Operation of the EQ 80 as phase detector. This figure represents the case when the fifth grid is connected to the cathode.

the performance of the circuit. First of all its sensitivity to interference pulses is very high. If, for example, an interference pulse occurs at the instant τ'' an anode current pulse p'' will be produced. This pulse influences the mean anode current and thus the phase and frequency of the multivibrator. It may be seen from fig. 25 that interference pulses occurring when the instantaneous third-grid voltage is only slightly negative will have a relatively large influence upon the mean anode current. Secondly, the fact that the form of the synchronizing signal changes considerably during the vertical blanking period results in a large variation of the mean anode current, so that the multivibrator frequency changes considerably during the vertical blanking period.

The sensitivity to interference and the change in multivibrator frequency during the frame blanking period can be reduced considerably by applying flyback pulses from the line output transformer to the fifth grid of the EQ 80 (see lead *D* in fig. 21). The bias on the fifth grid is the same as that of the third grid, from which it follows that anode current can only flow during the flyback pulses.

The duration of the flyback pulse is much shorter than that of the part of the alternating voltage applied to g_3 which falls within the grid base. It is thus seen that when g_5 is connected to the cathode, interference pulses have an opportunity to influence the mean anode current during a great part of the horizontal scanning period, whilst, when flyback pulses are applied to this grid the tube can draw anode current only during approximately 10% of the scan.

An important advantage is also that the starts of the flyback pulses coincide with the points *A*, *A'* etc. in fig. 25. The sections *AB*, *A'B'* etc. cover about 20% of the total scanning period, so that the valve can draw current only during the first half of each of these sections. During the time that an interference pulse could give rise to a large anode current pulse (see *p''* in fig. 25), the valve is therefore blocked, thus preventing anode current flow. A reduction in the variation of mean anode current during the frame blanking period is obtained in two ways. First, the capacitors C_4 and C_5 are so chosen that the time constants in the cathode and screen-grid circuits are small compared with the duration of the frame blanking. This gives a form of negative feedback counteracting a variation in mean anode current in synchronism with the frame synchronization. Secondly, as indicated above, flyback pulses are applied to the fifth grid. The influence of this upon the variation in mean anode current during the frame blanking can best be explained on the basis of fig. 26, in which, however, the actual scale has not been adhered to.

In fig. 26 the voltages at the first grid and at the third grid of the phase detector during the vertical blanking period are plotted against time. If the fifth grid were connected to the cathode the mean anode current of the EQ 80 would be determined by the hatched areas. By applying flyback pulses to this grid, however, the mean anode current during the frame blanking period is kept much smaller. In this case anode current can flow only during the intervals τ_1 , τ_2 etc., as indicated by the cross hatched areas.

Fig. 27 shows the relation between the frequency of the multivibrator and

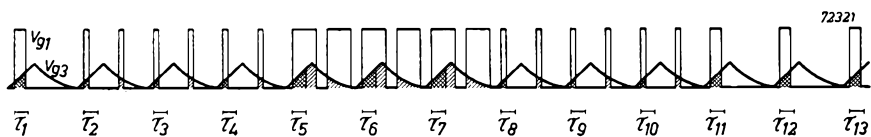

Fig. 26

Voltages on the first and the third grids of the phase detector during the frame blanking period. By applying flyback pulses to the fifth grid an anode current flows as represented by the cross hatched areas.

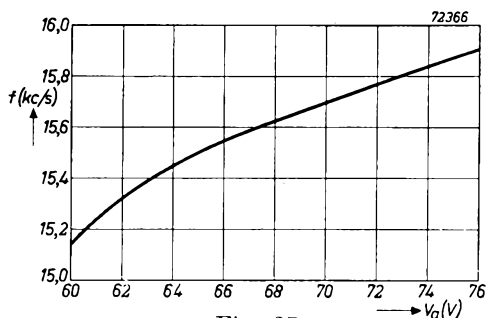

Fig. 27

The multivibrator frequency plotted against the anode voltage of the phase detector.

the anode voltage of the phase detector. This curve, of course, applies to a given setting of the horizontal hold control R_{18} .

If a potentiometer of poor quality is used for R_{18} erratic variation of the multivibrator frequency may be experienced during adjustment. This can be avoided by connecting this potentiometer between the anode of the phase detector and the filter $C_{10}R_{14}C_{13}$. The filter then has a smoothing effect upon irregular variations in resistance; the speed of the automatic control is, however, somewhat reduced. The

same alteration may, of course, be introduced in the circuit of fig. 15 in which the pentode section of an ECL 80 triode pentode is used as coincidence detector.

In fig. 28 the mean anode voltage of the phase detector is plotted against the horizontal displacement of the picture. This displacement corresponds to a total picture width of 29 cm, as is the case with a MW 36-24 picture tube. Finally it should be mentioned that the voltage stabilizer type 85 A2, used for reducing the influence of mains voltage fluctuations upon the multivibrator frequency, can be dispensed with when excessive mains voltage fluctuations are not likely to occur.

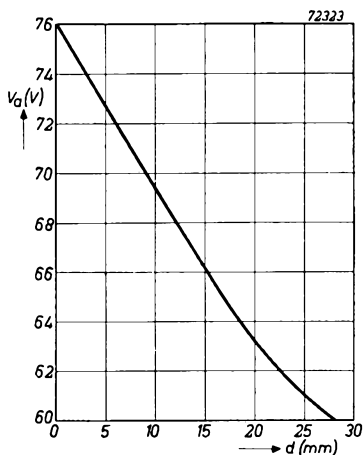

Fig. 28

Anode voltage at the phase detector plotted against the horizontal displacement of the picture. The displacement corresponds to a total picture width of 29 cm.

Description of a television receiver employing picture tube MW 43-43

Introduction

The receiver described below has been designed for the reception of image and sound according to the 625-line C.C.I.R. standard. The most important data of this system are:

Channel width	7 Mc/s
Separation between picture carrier and sound carrier (picture carrier frequency lower than sound carrier frequency)	5.5 Mc/s
Picture modulation (AM)	negative
Sound modulation (FM)	max. ± 50 kc/s
Line frequency	15 625 c/s
Frame frequency	50 c/s
Interlace	2:1

In the front end a standard channel selector, Type AT 7501, is used for the reception of ten channels in the frequency bands 40-68 Mc/s (4 channels) and 174-216 Mc/s (6 channels). The picture and sound carrier frequencies to which the receiver can be tuned are listed below.

Channel No.	Picture carrier	Sound carrier
1	41.25	46.75
2	48.25	53.75
3	55.25	60.75
4	62.25	67.75
5	175.25	180.75
6	182.25	187.75
7	189.25	194.75
8	196.25	201.75
9	203.25	208.75
10	210.25	215.75

The complement of valves and germanium diodes and the functions for which they are used is as follows: (see also fig. 29, page 215).

Picture channel

EF 80 pentode	R.F. amplifier
ECC 81 double triode	mixer and local oscillator
4 × EF 80 pentodes	I.F. amplifier
OA 60 germanium diode	video detector
OA 61 germanium diode	A.G.C. rectifier
EF 80 pentode	video amplifier
ECL 80 triode pentode	pentode as video amplifier
MW 43—43	picture tube

Sound channel

EF 80 pentode	intercarrier amplifier
OA 61 germanium diode	rectifier for A.G.C.; limiting and silencing
EQ 80 enneode	F.M. detection
PL 82 pentode	sound output

Line timebase generator

EQ 80 enneode	sync separator and phase detector
85 A2	voltage stabilizer
ECL 80 triode pentode	multivibrator
PL 81 pentode	output valve
PY 81 diode	booster diode
EY 51 diode	E.H.T. rectifier

Frame timebase generator

ECL 80 triode pentode	pentode as sync separator triode as blocking oscillator
PL 82 pentode	output valve

Power supply

2 × PY 82 diodes	mains rectifier
------------------	-----------------

It is seen that the receiver employs 21 valves (of which one is a voltage stabilizer), 3 germanium diodes and the picture tube. The 85 A2 voltage stabilizer is used to render the line synchronization less dependent upon mains voltage fluctuations. In cases where large mains voltage fluctuations are not likely to occur the 85 A2 need not be used.

1. Picture channel

a. Channel selector AT 7501

The circuit diagram of the channel selector is given in fig. 29 and a photograph and the dimensions in figs. 30 and 31 respectively.

The input of the selector is matched to a 300Ω feeder, in which two blocking

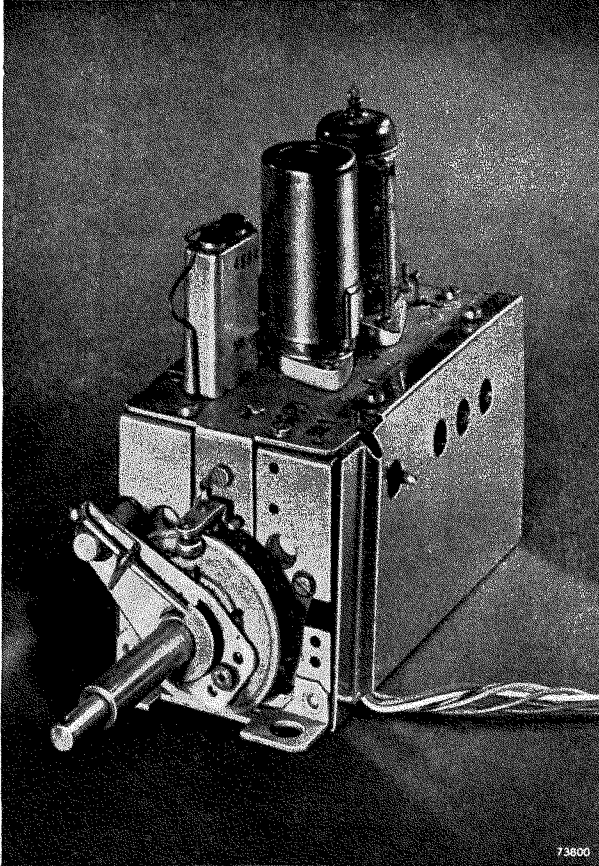

Fig. 30
Channel selector Type AT 7501.

capacitors of 1500 pF should be included to prevent direct connection of the aerial to the supply mains. For R.F. amplification an EF 80 pentode is used, the anode circuit consisting of a double-tuned transformer with inductive top coupling (see L_4). The total R.F. bandwidth is approximately 9 Mc/s on all channels. It is therefore not necessary to take the R.F. response into account in determining the staggering of the I.F. amplifier.

The two sections of an ECC 81 double triode are used as mixer and local oscillator respectively, the latter being connected as a Colpitts' oscillator. On the low frequency band injection of the oscillator voltage into the mixer circuit is effected by means of an inductive link. On the band from 174 to 216 Mc/s capacitive coupling by means of C_{36} is used. The R.F. and oscillator circuits are replaced in their entirety when switching from one channel to another. The anode circuit of the mixer triode contains the primary L_8 of an I.F. transformer, to which the secondary L_{18} can be coupled via the link L_{10} .

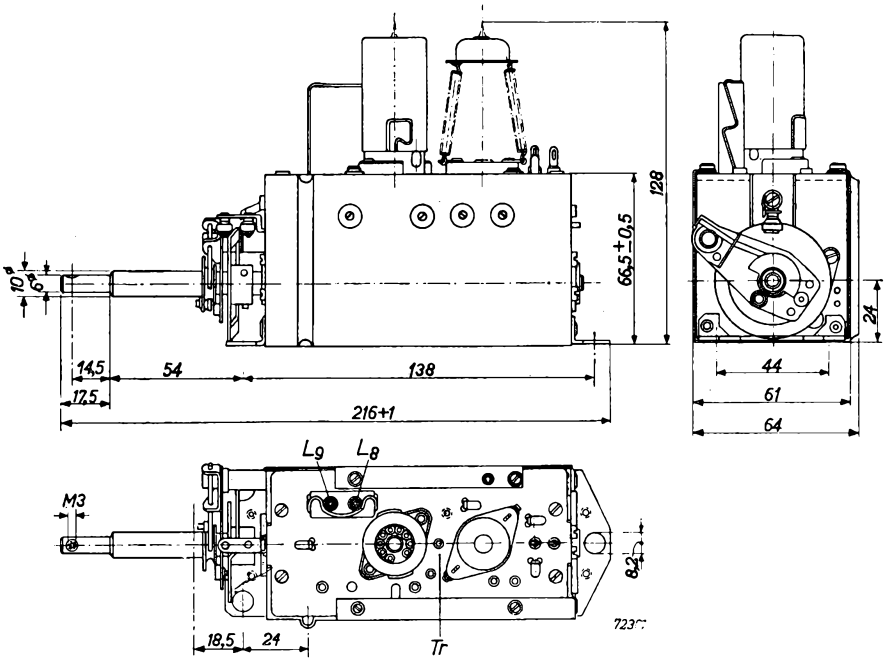

Fig. 31
Dimensions of the channel selector Type AT 7501.

This is a low-impedance coupling, so that L_{18} can be placed at the most convenient position on the receiver chassis. L_9 and C_{31} form a trap circuit. In the channel selector the picture carrier frequency is converted to 23.75 Mc/s and the sound carrier frequency to 18.25 Mc/s. For trimming the I.F. circuits included in the selector and in the subsequent I.F. amplifier an I.F. signal can be applied to the trimming point marked Tr in figs. 29 and 31. The leads from the channel selector are identified by insulation of different colours as follows:

Lead No.	Colour
1	green
2	black
3	red/black
4	blue
5	red
6	grey
7	brown
8	yellow

b. The I.F. amplifier

The I.F. amplifier is equipped with four pentodes Type EF 80, followed by a video detector employing an OA 60 germanium diode. For the automatic gain control another germanium diode Type OA 61 is used. The RC combination $R_{34}C_{71}$ prevents the occurrence of high negative voltages across the load resistor R_{35} due to short interference pulses. A variable delay in the A.G.C. is obtained via the potentiometer $R_{41}R_{42}$, of which R_{42} also serves for the adjustment of the picture contrast. This arrangement has been described in the section dealing with intercarrier sound on page 147. The A.G.C. voltage is applied to the first three I.F. valves V_3 , V_4 and V_5 , and also to the R.F. amplifier V_1 . The A.G.C. curves for R_{42} adjusted to minimum and to maximum contrast respectively are given in fig. 32.

The anode of V_5 is parallel fed via resistor R_{29} , which also provides the required damping. Parallel feed is used to prevent charging of the grid capacitor of the final I.F. tube as a result of large interference peaks. This would give rise to white spots in the picture.

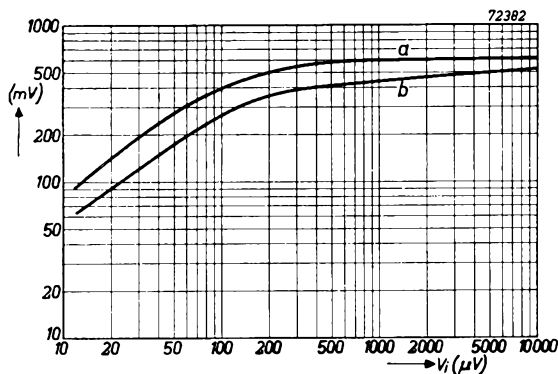

Fig. 32

A.F. voltage V_o at the video detector load plotted against the R.F. signal V_i at the aerial terminals. The curves were measured in channel 2 at the picture carrier frequency and with a 30 % modulated signal. Curve *a* refers to the contrast control adjusted for maximum contrast and curve *b* to minimum contrast.

The tuned circuits used in the I.F. amplifier are adjusted with the aid of iron-dust cores; further data of the various inductors are given in the list of components.

The stagger frequencies and dampings of the circuits are chosen to obtain a response curve with a substantially flat top. Moreover the final I.F. circuit L_{26} has a fairly large bandwidth and is tuned near to the picture carrier. This has the advantage that variation in damping of the detector circuit has little influence upon the response curve and that there is little risk of overdriving the final I.F. valve at high contrast settings.

The overall response measured on channel 2 is given in fig. 33 on a relative scale. In the table below are given the stagger frequencies and the quality factors, bandwidths and additional damping resistors of the I.F. circuits. It should be recognized that since the receiver operates with intercarrier sound, it is necessary to adjust the trap L_{21} in such a way that a flat region is obtained in the response curve on both sides of the sound carrier. This prevents amplitude modulation of the sound signal as a result of the frequency modulation. The tuning frequencies of the traps are given below.

Trap				L_9
Tuning frequency (Mc/s)				16.75
L_{19}	L_{21}	L_{23}	L_{27}	
15.75	18.4	26.5	25.25	

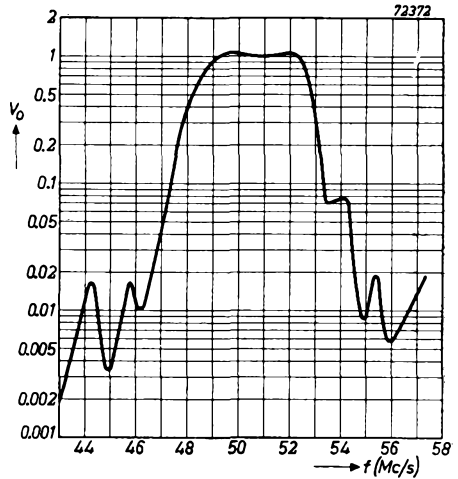

Fig. 33
Overall response of the R.F. and I.F. amplifiers measured in channel 2.

	L_8	L_{18}	L_{20}	L_{22}	L_{24}	L_{26}
Stagger frequency (Mc/s)	20.5	20.5	20.4	19.1	24.1	23
Quality factor Q in circuit	6.6	5.3	4.5	17.7	10.5	5.75
Bandwidth (Mc/s)			4.5	1.08	2.3	4.0
Extra damping resistor (k Ω)	0.1 in series	3.9	1.8	8.2	4.7	6.8
Circuit impedance (k Ω)			1.7	6.0	4.0	2.0
Stage gain at centre of band			10	9	9	9.5

c. The video amplifier

The video amplifier has been described at length in the article on inter-carrier sound. The EF 80 pentode is followed by the pentode section of an ECL 80 valve operating as cathode follower. The triode section of the ECL 80 is not used. D.C. restoration is obtained by grid rectification in the ECL 80 pentode. In order to avoid variations in the black level at different contrast settings, a small video signal is taken from the anode of the pentode and applied to the first grid of the picture tube.

The complete video signal is taken from the cathode of the ECL 80 pentode and applied via the leads *B* and *C* to the circuits for vertical and horizontal synchronization respectively.

In addition to the video signal, flyback pulses taken from the frame output transformer are applied to the cathode of the picture tube (see lead *D*). This results in blanking of the picture during the vertical retrace.

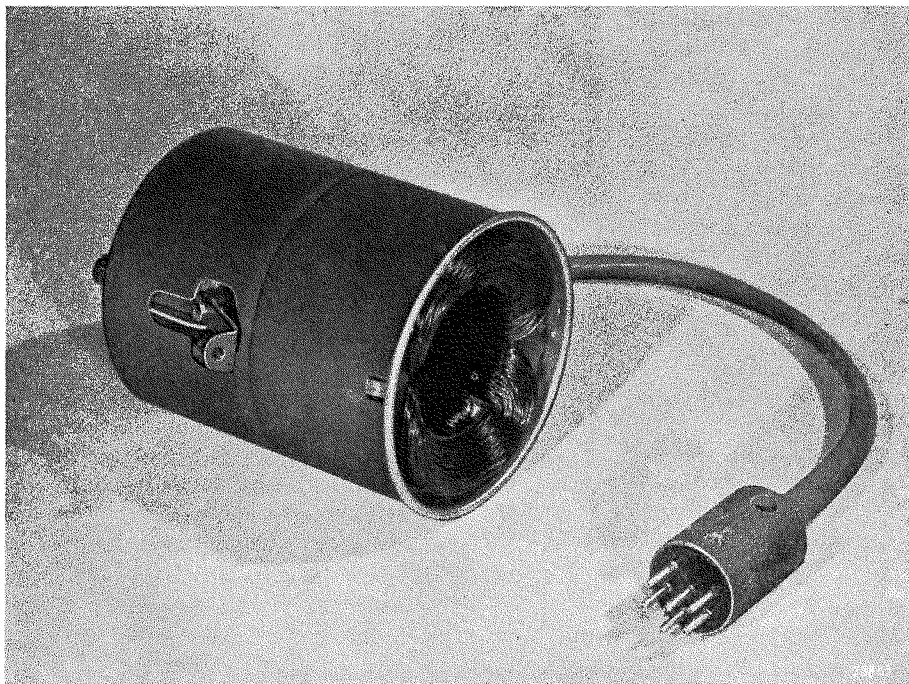

Fig. 34
Deflection and focusing unit Type AT 1001/09.

For focusing and deflection use can be made of the unit Type AT 1001/09*), which is equipped with a permanent "TICONAL" magnet for focusing and a set of deflection coils matched to the circuits for horizontal and vertical

*) Instead of AT 1001/09 the unit Type AT 1002 can as well be used.

deflection indicated in fig. 29. The data of the unit Type AT 1001/09 are given below (see also fig. 35).

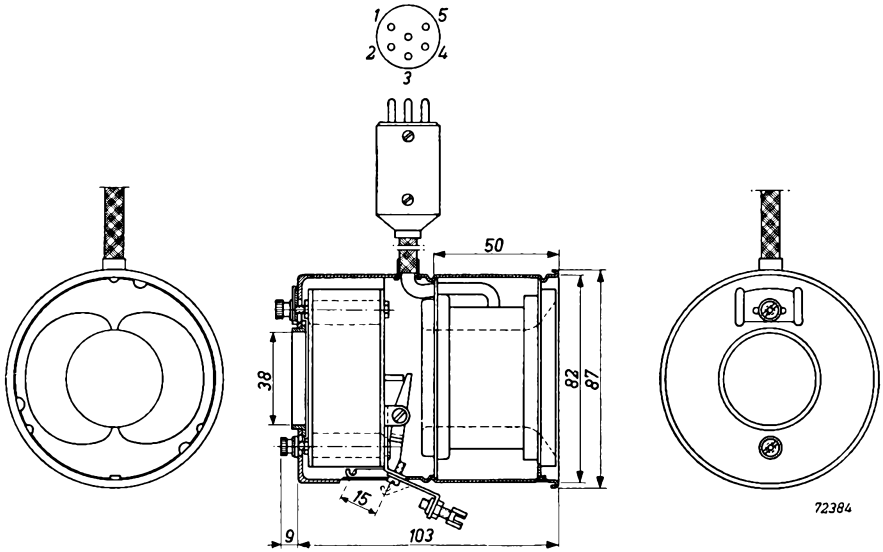

Fig. 35
Dimensions and connections of the deflection and focusing unit Type AT 1001/09.

Data of AT 1001/09

Line coils	Inductance	6 mH
	Resistance	5.6 Ω
	Sensitivity	8.9 $\sqrt{V_a}$ mA/cm*
	Connections	1—2
Frame coils	Resistance	9.6 Ω
	Inductance	8 mH
	Sensitivity	9.4 $\sqrt{V_a}$ mA/cm*
	Connections	4—5
Focus		10—16 kV
Screen	Connection	3
Max. operating temperature		85 $^{\circ}\text{C}$

For the operation of the permanent magnet focusing system included in the unit Type AT 1001/09, a separate control unit Type AT 7003 is available complete with knob, bowden cable, mounting hook, etc. With this unit the control knob can be located wherever desired on the receiver chassis, the bowden cable having a length of approx. 43 cm.

*) The data given here refer to the MW 36-24 picture tube and V_a in kV. The deflection currents required when using an MW 43-43 picture tube are given in the description of the circuits for horizontal and vertical deflection.

d. Sensitivity of picture channel

The sensitivity was measured with a 30% modulated H.F. signal applied to the aerial terminals of the receiver. The frequency of the signal corresponds to the centre of the band. In the video detector a signal of $1 V_{\text{rms}}$ then gives an A.F. voltage at the load of $0.18 V_{\text{rms}}$. At maximum contrast the video amplifier has a gain of 34. In the tuner a gain of 12 has been measured in the frequency band from 40—68 Mc/s, the total I.F. gain being 7500.

For $3 V_{\text{rms}}$ at the picture tube the signal required at the aerial terminals is therefore:

$$\frac{3}{12 \times 7500 \times 0.18 \times 34} = \text{approx. } 5.5 \mu\text{V.}$$

This corresponds to an aerial input of $22 \mu\text{V}$ at picture carrier frequency in the frequency band from 40—68 Mc/s. In the band from 174—216 Mc/s the aerial input must be $60 \mu\text{V}$, the gain of the tuner then being lower.

2. Sound channel

A complete description of the sound channel, except the output stage, has been given in the section dealing with intercarrier sound. In the circuit of fig. 29 an output pentode type PL 82 is used. The screen grid and the anode of this valve are fed via an additional *RC* filter (see V_{b4}), which prevents the penetration of audio currents into other sections of the receiver. In the receiver described, two loudspeakers are used, arranged one on either side of the picture tube, in the side walls of the cabinet. It is also possible, of course, to use one loudspeaker, which should then be mounted on the front wall of the cabinet.

The anode of the detector valve EQ 80 is fed from the boosted H.T. potential, a smoothing circuit $R_{73}C_{101}$ being included.

In the circuit of fig. 29 an OA 61 germanium diode is used for A.G.C. and silencing of the EQ 80 F.M. detector instead of an OA 51. The performances of these diodes in this circuit do not differ appreciably, so that the curves and figures given in the article on intercarrier sound still apply.

The intercarrier signal required at the video-detector load for $8 V_{\text{rms}}$ at the grids g_3 and g_5 of the EQ 80 is $32 \text{ m}V_{\text{rms}}$.

3. Line deflection and synchronization

a. Synchronization and generation of saw-tooth voltage

For synchronizing the horizontal deflection a flywheel circuit is used, operating with an EQ 80 valve as phase discriminator. This circuit has been described in the section on "Flywheel Synchronization" on page 164. The principle of operation is repeated briefly below.

The complete video signal is applied via lead *C* to the first grid of the EQ 80, which has a short grid base, so that anode current can flow only during the synchronization pulses. A saw-tooth signal taken from the multivibrator is applied to the third grid of the EQ 80, the shape of this signal being shown

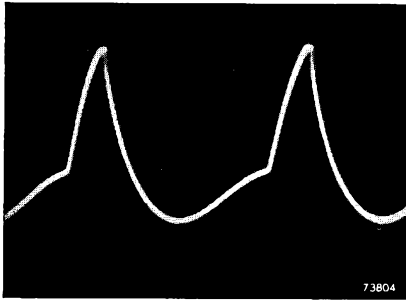

Fig. 36
Saw-tooth voltage at the third grid of the EQ 80 tube. The peak-to-peak value is 24 V.

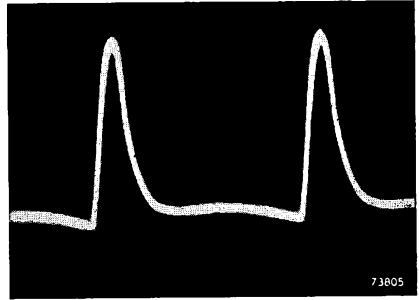

Fig. 37
Flyback pulses at the fifth grid of the EQ 80 tube. The amplitude of these pulses is 210 V.

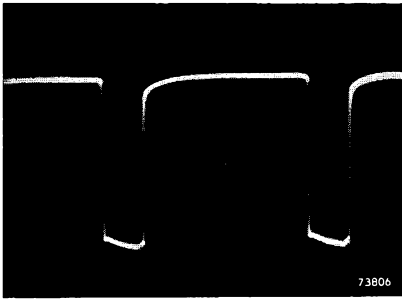

Fig. 38
Voltage at the screen grid of the pentode section of V_{15} . The peak-to-peak value is 85 V.

in the oscillogram of fig. 36. The peak-to-peak value of this signal is 24 V and, during normal operation, the line synchronizing pulses coincide with the steep positive-going flanks. Variations in the relative phase then result in corresponding variations in anode current. These current variations produce variations in voltage drop across R_{81} , which correct the phase of the multivibrator voltage. In order to make the circuit insensitive to interference during the intervals between the synchronizing pulses, flyback pulses obtained from the deflection coils are applied to the fifth grid. An oscillogram of these pulses is shown in fig. 37, the peak-to-peak value measured at the fifth grid of the EQ 80 being 210 V. Anode current can therefore flow only during the peaks of these pulses.

The stabilizing tube 85 A2 used in the circuit of fig. 29 can be omitted when excessive mains voltage fluctuations are not likely to occur. It is then necessary to make the following alterations in the circuit:

The stabilizing tube 85 A2 used in the circuit of fig. 29 can be omitted when excessive mains voltage fluctuations are not likely to occur. It is then necessary to make the following alterations in the circuit:

- a) The stabilizing tube 85 A2 is omitted.
- b) The supply line for the screen grid of the EQ 80 and the triode anode of V_{15} must be connected to V_{b3} in the power supply system.
- c) R_{84} and R_{85} are replaced by one resistor of 1.5 M Ω , 0.25 W.
- d) C_{112} must be changed to 1200 pF, tolerance 20%, working voltage 350 V.
- e) R_{86} must be changed to 0.5 M Ω , 0.25 W.

- f) R_{94} must be changed to $0.47\text{ M}\Omega$, 0.25 W .
- g) In the power supply system R_{133} can be omitted.

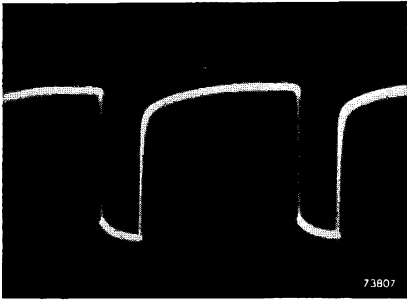

Fig. 39
Driving voltage at the control grid of the PL 81 output pentode. The peak-to-peak value is 130 V .

- h) One half of the double electrolytic capacitor C_{143} is then available for other purposes and can be used to replace C_{134} .

In the circuit diagram of fig. 29 the frequency control is placed between the anode of the phase detector and the special filter used for suppressing damped oscillations at the end of the frame blanking period. This is done to prevent erratic variations in the multivibrator frequency when operating the frequency control. Such variations would be encountered when using a potentiometer having bad contact,

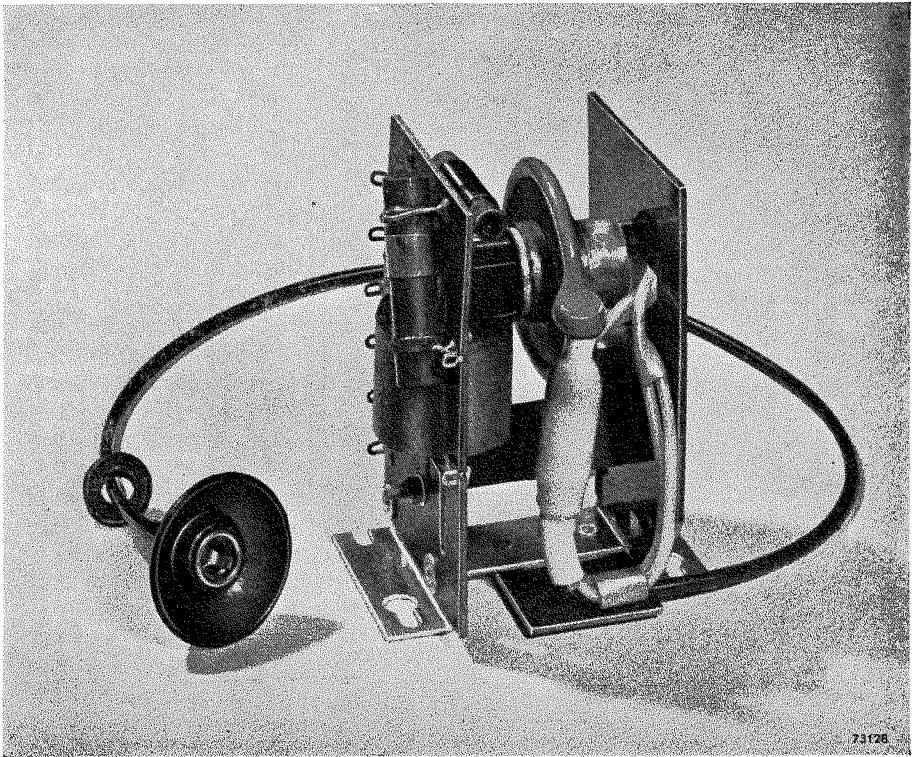

Fig. 40
Line-output transformer Type AT 2002.

connected between the filter C_{115} , C_{116} , R_{87} and the resistor R_{94} . The multivibrator for driving the output pentode PL 81 is of the asymmetrical type, stabilization of the frequency at 15 625 c/s being obtained by means of the resonant circuit Type 10924. The cathode, the control grid and the screen grid of the pentode section of V_{15} form one triode of the multivibrator. An oscillogram of the voltage at the screen grid is shown in fig. 38, the peak-to-peak value being 85 V. Fig. 39 shows the driving voltage for the PL 81 output pentode. The peak-to-peak value of this voltage is 130 V.

b. The output stage

The output stage operates in conjunction with a line-output transformer Type AT 2002 and a PY 81 booster diode. The diode for rectifying the flyback pulses (E.H.T.) is included in the line-output transformer assembly. A photograph of this transformer and a dimensional drawing are given in figs. 40 and 41 respectively.

The transformer is of somewhat unusual design in that the E.H.T. winding is not connected to the anode of the output pentode. Moreover, the primary and the E.H.T. winding are situated on different legs of the core. Owing to the looser coupling thus obtained the penetration of parasitic oscillations

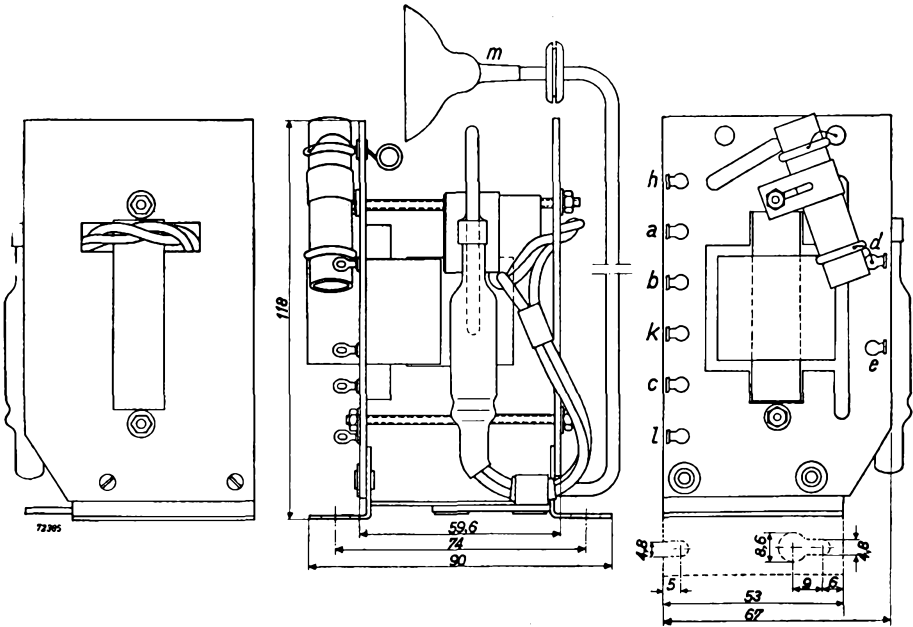

Fig. 41

Dimensions and connections of line-output transformer Type AT 2002. The indications at the terminals correspond with those in the circuit diagram of fig. 29. Type AT 2002/02 is without anode connector for the picture tube. For the MW 43-43 picture tube a connector as shown here is not required.

into the deflection coils is reduced. For the same purpose an additional winding (wound on the same leg as the E.H.T. winding) in combination with a coil with fixed inductance is connected across a part of the primary. The parallel combination of R_{102} and C_{123} in series with the E.H.T. winding serves to prevent the occurrence of excessive currents in the event of accidental short circuiting of the E.H.T. output.

The booster capacitor C_{121} has been given a comparatively small value (22 000 pF), so that the voltage across it varies parabolically during the scan. During approximately the first half of the scan, when the capacitor is charged by the energy stored in the output transformer and the deflection coils, the voltage across the capacitor increases, but decreases during the second half of the scan, when the booster capacitor is discharged. The mean voltage across the booster capacitor is 345 V and the total variation is about 115 V. This voltage variation provides a correction for the symmetrical variation in scanning speed due to the comparatively flat face of the picture tube. At both ends of the scan the voltage across the booster capacitor is at its minimum value, so that the scanning speed is then reduced. In the centre of the scan, when the voltage across C_{121} has a high value, the scanning speed is increased.

Another form of non-linearity which is asymmetrical and due to the resistance of the deflection coils and the transformer windings is corrected by means of a premagnetized inductor (see L_{40} in fig. 29). This inductor has a FERROXCUBE core which is premagnetized by a small rod-shaped "TICONAL" magnet. During the scan the inductance varies between approximately 1 and 0.2 mH, so that the reduction in the rate of change of the deflection current towards

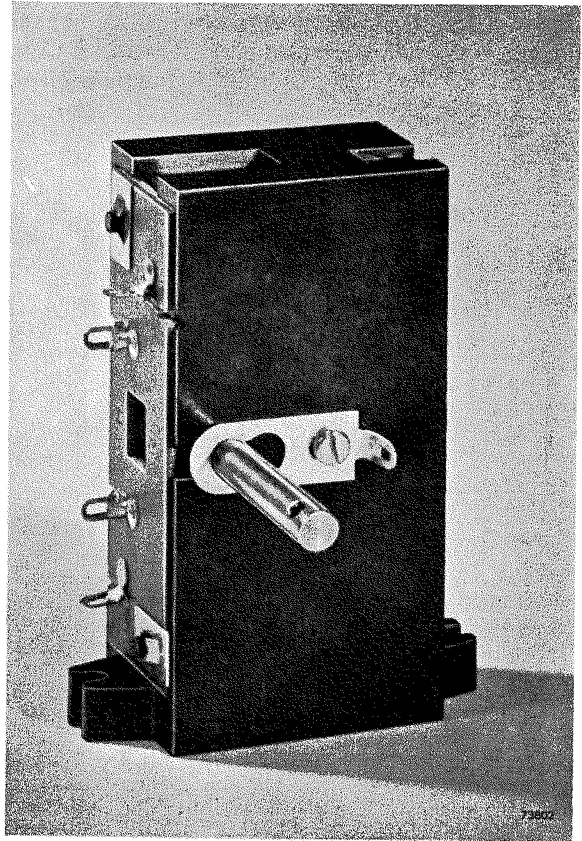

Fig. 42
Combined width control and linearity corrector
Type AT 4001.

the end of the scan is at least partly compensated. In practice the asymmetrical non-linearity can be kept below 5% in this way. To ensure that the variation in inductance is in the correct sense it is essential that the connections are made according to figs. 29 and 43. The amount of correction can be varied by adjusting the pre-magnetization of the FERROXCUBE core. This can be done by displacing the permanent magnet by means of a screw driver at the top of the unit Type AT 4001, in which the inductor L_{40} is included.

The width control consists of two variable inductors, L_{38} and L_{39} , having a common Ferroxcube core, L_{38} being in series with the line deflection coils and L_{39} in parallel. The self-inductances of these inductors can be adjusted by moving the FERROXCUBE core by means of the shaft. The variation in inductance of each section is such that the total inductance, including that of the deflection coils, remains constant. The linearity control and the width control are available as one unit under Type Number AT 4001, (see figs. 42 and 43).

The series section of the width control and the linearity control are shunted by the series connection of a resistor and a capacitor ($R_{103}C_{124}$). These components are included to damp parasitic oscillations in the deflection coils at the start of the scan.

A number of oscillograms of voltages and currents occurring in the output

circuit are given in the figs. 44 to 49. Fig. 44 shows the current in the deflection coils: the peak-to-peak value for scanning the full width of the picture tube is 1050 mA. The action of the linearity corrector is demonstrated by fig. 45. The part below the zero axis shows the variation in voltage across the inductor during the scanning period, the total variation during this period being 15 V. Fig. 46 shows the current in the booster diode PY 81. The peak-to-peak value of this current is 220 mA. The currents in the output pentode PL 81 are shown in figs. 47 and 48. The peak-to-peak

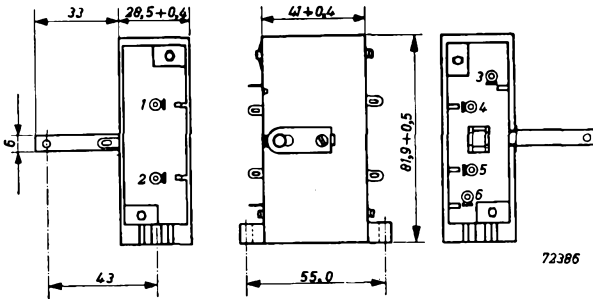

Fig. 43

Dimensions and connections (see also fig. 29) of the combined width control and linearity corrector Type AT 4001. The linearity corrector (connections 1 and 2) can be adjusted by means of a screw-driver, for which a saw-cut, visible from above, has been provided. The inductance of the linearity corrector coil is adjustable between 0.15 and 1.2 mH. The inductance of the two sections of the width control can be adjusted by means of the shaft. A soldering lug, visible at the front of the unit, can be used to earth the shaft, thus preventing the risk of corona or scintillation. The series section of the width control (connection 3 and 4) can be adjusted between 1.8 and 0.18 mH, the parallel section (connections 5 and 6) then varying simultaneously between 12 and 80 mH.

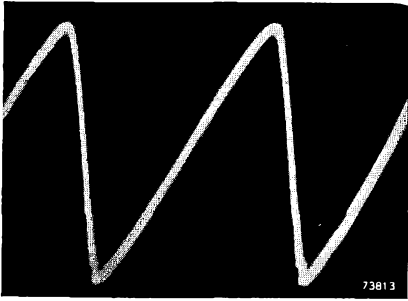

Fig. 44
Saw-tooth current in the line coils.
The peak-to-peak value is 1050 mA.

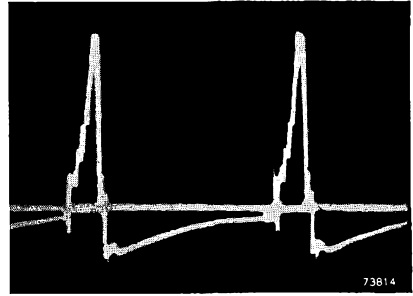

Fig. 45
Oscillogram of the voltage across
the linearity corrector. The total
variation of voltage during the scan
is 15 V (see part below the zero
axis).

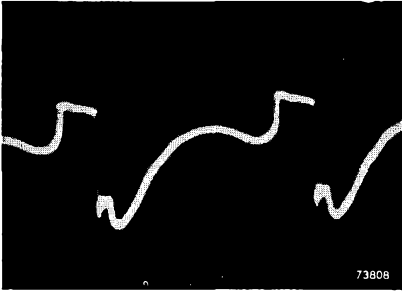

Fig. 46
Current in the booster diode PY 81.
The peak-to-peak value is 220 mA.

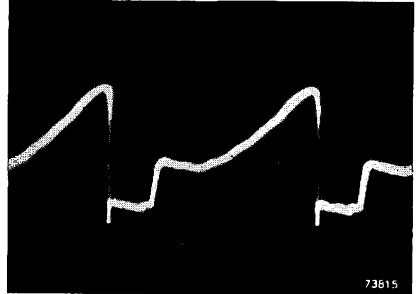

Fig. 47
Cathode current (peak-to-peak value
270 mA) of the output pentode
PL 81.

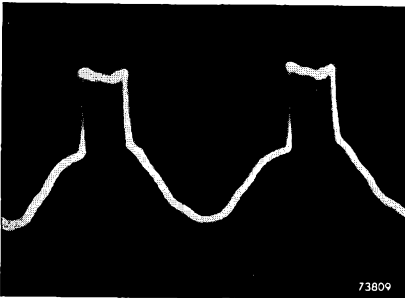

Fig. 48
Screen-grid current (peak-to-peak
value 43 mA) of the output pentode
PL 81.

value of the cathode current (see fig. 47) is 270 mA and that of the screen-grid current (see fig. 48) is 43 mA. Finally, a point raster giving an impression of the horizontal linearity obtained is given in fig. 49.

The H.T. line voltage applied to the output stage is 195 V and the mean current flowing in the booster diode 119 mA when the beam current in the picture tube is 100 μ A. Other data of the circuit, also referring to a beam current of 100 μ A in the picture tube, are given below:

Mean screen-grid voltage	145 V
Mean control-grid voltage	-30 V
Mean anode current (PL 81)	105 mA
Mean screen-grid current	26 mA
Anode dissipation (PL 81)	4.5 W
Screen-grid dissipation	approx. 3 W
Boosted H.T. supply voltage	540 V
Additional drain on boosted H.T.	14 mA
E.H.T. at 100 μ A beam current	12.5 kV
Peak voltage during flyback at anode of PL 81	4.7 kV
Peak voltage during flyback at cathode of PY 81	3.5 kV

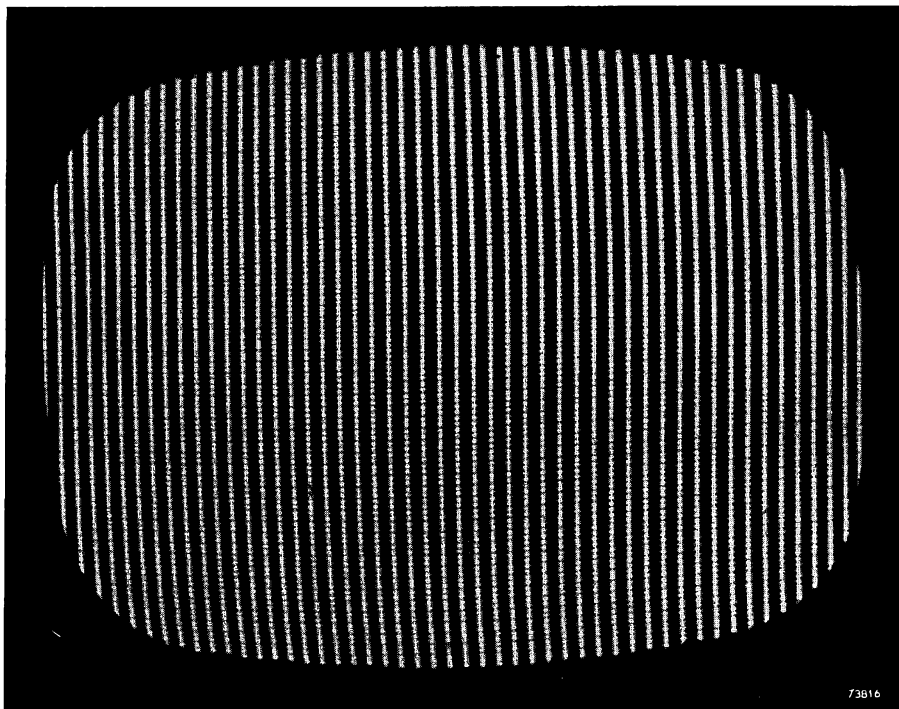

Fig. 49
Point raster on the screen of the MW 43-43 picture tube.

The various voltages and currents in the output circuit depend upon the average beam current in the picture tube. This dependency is represented in fig. 50, where the boosted H.T., the peak-to-peak value of the deflection current, the E.H.T. and the anode current of the output pentode are plotted against the beam current. It is seen from these curves that the internal resistance of the E.H.T. for slow variations in beam current is approx. 9 M Ω , which is obtained by operating the output pentode well below the knee of the I_a/V_a characteristic during the scanning period.

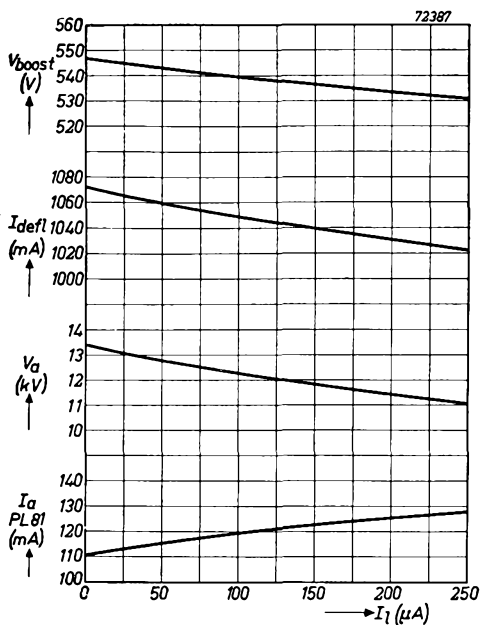

Fig. 50
The boost voltage, the peak-to-peak value of the deflection current, the E.H.T. (V_a) and the anode current of the PL 81 output pentode, plotted against beam current.

4. Frame deflection and synchronization

a. Synchronization and generation of the saw-tooth voltage

The complete video signal is applied via lead *B* to the pentode section of an ECL 80 triode pentode. This pentode serves as synchronizing pulse separator and since only the frame pulses are required for synchronizing the frame-blocking oscillator a resistor capacitor combination ($R_{105}C_{127}$) for suppressing noise and short interference peaks can be connected between the signal source and the control grid of the pentode. The anode of the pentode is shunted by a capacitor C_{129} so that integration takes place. The frame-synchronizing signal at the anode is negative going and must therefore be applied to the anode of the blocking oscillator.

The triode section of V_{19} is used as blocking oscillator in a conventional circuit with a standard blocking transformer Type 10850. The resistors R_{109} and R_{110} serve to limit the peak grid current and the amplitude of the saw-tooth voltage developed across the charge capacitor C_{131} . A number of oscillograms demonstrating the performance of the blocking oscillator are represented in figs. 51 to 56. Fig. 51 shows the anode current of the triode. The peak value of this current is 110 mA. The alternating voltage at the anode is shown in fig. 52, the peak-to-peak value being 375 V. In fig. 53 is shown the grid current, which reaches a peak value of 32 mA. Fig. 54 shows the alternating voltage at the grid. The total amplitude of this voltage is 486 V. A comparison of figs. 54 and 55 shows the limiting effect of the series grid resistor R_{109} , the alternating voltage of fig. 55 being measured at the grid side of the blocking transformer winding. In the latter case the

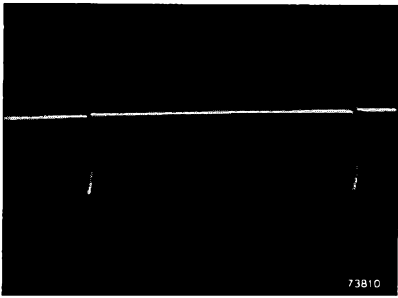

Fig. 51
Anode current pulses of the triode section of V_{19} . The pulse amplitude is 110 mA.

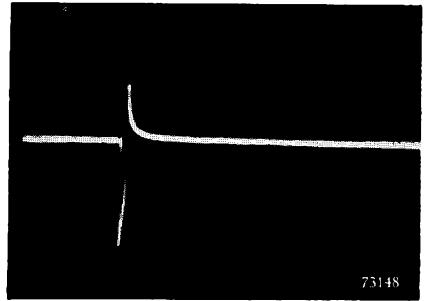

Fig. 52
Flyback voltage at the anode of the triode section of V_{19} . The peak-to-peak value is 375 V.

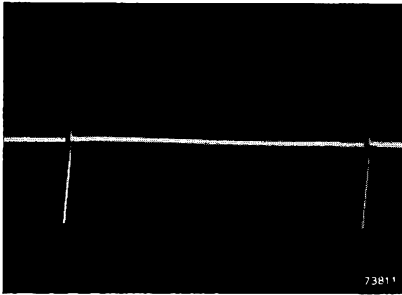

Fig. 53
Grid current pulses of the triode section of V_{19} . The pulse amplitude is 32 mA.

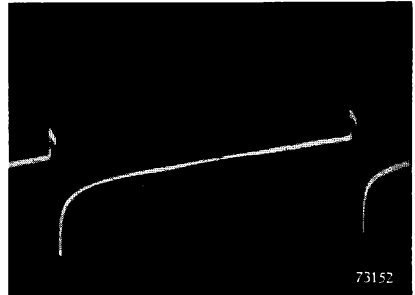

Fig. 54
Saw-tooth voltage at the grid of the triode section of V_{19} . The peak-to-peak value is 486 V. The positive peak at the start of the flyback is 100 V.



Fig. 55
Saw-tooth voltage at the grid side of the blocking transformer Type 10850. The peak-to-peak value is approx. 800 V, the positive peak at the start of the flyback is 420 V.

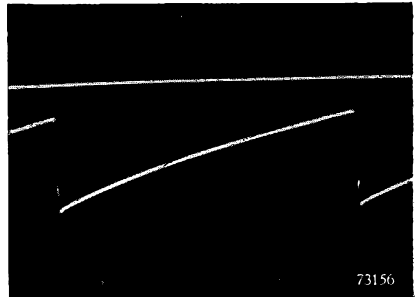

Fig. 56
Saw-tooth voltage across the charge capacitor C_{131} . The peak-to-peak value of the saw-tooth is 145 V, the negative voltage at the end of the stroke being 35 V.

positive peak is 420 V as compared with 100 V at the grid. Since the flyback starts when the grid is still 35 V negative with respect to the cathode, it may be seen from fig. 54 that during the flyback the positive grid excursion is approx. 65 V. The saw-tooth voltage across the charge capacitor is shown in fig. 56, the peak-to-peak value being 145 V. It is seen from this figure that the non-linearity is but small, which is due to the fact that the resistance through which the capacitor is charged is connected to a potential of approx. 470 V.

b. The output stage

The output stage for vertical deflection uses an entirely new method of linearisation. To explain this method it is necessary to recall briefly how linearisation is normally obtained.

During the scanning period the saw-tooth current in the deflection coils must vary linearly with time. Since the impedance of the deflection coils is almost purely resistive a linear saw-tooth voltage will then be present across the primary of the output transformer. Owing to the fact that the primary inductance of the transformer is not infinitely large, in addition to the saw-tooth current to be supplied by the valve a current having a parabolic shape must also be delivered. When the constant magnetizing current is added to these two components the total anode current can be found by simple addition. This is shown in fig. 57, where i_{defl}/n is the transformed deflection current (n is the transformer ratio), i_{Lp} the magnetizing current in the transformer primary and i_a the total anode current required. The relative magnitude of the parabolic component depends upon the saw-tooth frequency and the ratio between the transformed deflection coil resistance and the primary inductance. At a given saw-tooth frequency it is possible to keep the parabolic component small by making this ratio as small as possible, but this leads to a large, and therefore expensive, output transformer. In normal practice the parabolic component will be quite appreciable and it is then necessary to give the driving voltage applied to the grid of the output pentode such a shape that the required form of anode current is obtained. Partial correction is already obtained by the curvature of the valve characteristic, but with normal components this correction is not sufficient, so that means must be provided to distort the saw-tooth voltage from the blocking oscillator (see fig. 56) in such a way that at the beginning of the scan the rate of change is decreased whilst it must be gradually increased towards the end of the scan.

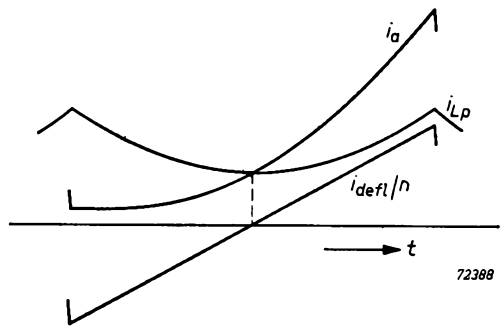

72388

Fig. 57
Transformed deflection current (i_{defl}/n), magnetizing current of the transformer i_{Lp} and the total anode current (i_a) of the output valve for vertical deflection.

The required distortion of the saw-tooth voltage can be obtained by means of an integrator circuit consisting of resistors and capacitors connected between the saw-tooth oscillator and the output pentode. Alternatively, when negative feedback is applied from the primary of the output transformer to the control grid of the pentode, differentiation of the feedback voltage can be applied to obtain the required shape of driving voltage. Both methods lead to a considerable loss of amplitude, i.e. the saw-tooth voltage to be supplied by the blocking oscillator must be much greater than that required without negative feedback and without using an integrator circuit.

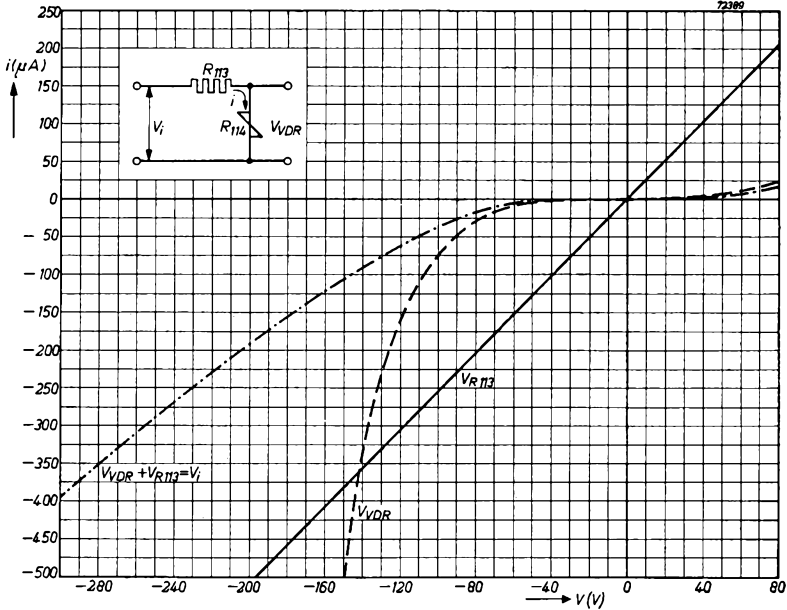

Fig. 58
Voltage-current characteristics of the VDR resistor R_{114} , the fixed resistor R_{113} and of the combination of these two.

The most important disadvantage is, however, that the low frequencies are much less attenuated than the high frequencies, so that, when the average level of the saw-tooth signal changes at a slow rate as a result of interference or adjustment of the hold control, the control-grid voltage of the output pentode changes at the same rate. This is manifest in temporary vertical expansion or contraction of the picture, and in some circuits this is of an oscillatory character. This effect is most pronounced when a large amount of correction has to be used on account of a relatively low primary inductance of the output transformer.

The unfavourable effects described above can be avoided by using a voltage dependent resistor for distorting the saw-tooth voltage. Such a resistor is, in the range considered, independent of frequency, so that the attenuation

occurring in shaping the saw-tooth voltage is the same for all frequencies. Moreover, the circuit can be simplified and remarkably good vertical linearity of the picture can be obtained.

The current-voltage characteristic of a VDR resistor is such that with increasing voltage the current increases exponentially, whilst the curve is symmetrical with respect to the origin. Fig. 58 shows the characteristic of a VDR resistor Type Number VD 1000A/680B suitable for this purpose. In fig. 58 is also shown the characteristic of the fixed resistor R_{113} , which has a value of 0.39 M Ω . The input voltage V_i as a function of the current

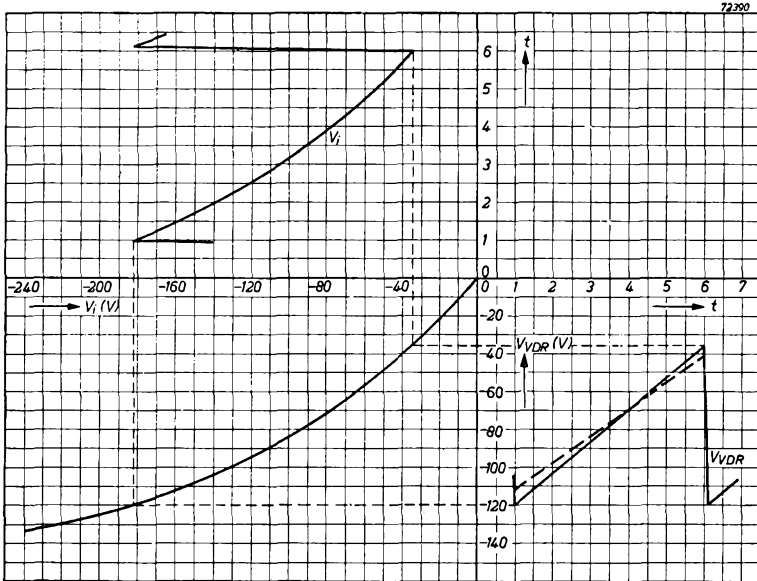

Fig. 59

Voltage across the VDR resistor as a function of the input voltage, the saw-tooth input voltage as a function of time and the resultant saw-tooth voltage across the VDR resistor as a function of time. Due to the integrating network R_{115} , C_{132} etc. (see fig. 29) the actual saw-tooth voltage across the VDR resistor follows the broken line.

can be derived from these two curves. From the curves represented in fig. 58 a new curve may be calculated giving the relation between the voltage across the VDR resistor and the input voltage (see fig. 59). By plotting also V_i as a function of time in this graph, the trend of the voltage across the VDR resistor as a function of time can be found.

In the circuit of fig. 29 an integrator network is used following the VDR resistor to provide adjustable linearity correction. Owing to the correction already obtained by the VDR resistor the correction introduced by this network is only small, so that the disadvantages introduced when an integrator circuit provides the entire correction are avoided. The presence of

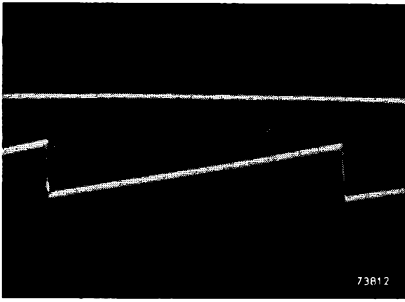

Fig. 60
Voltage across the VDR resistor R_{114} . The peak-to-peak value of the saw-tooth voltage is 70 V.

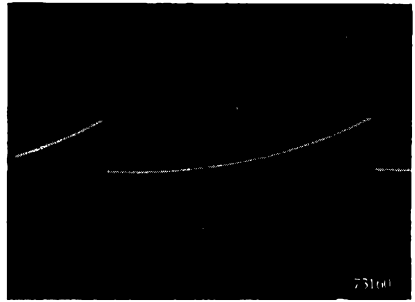

Fig. 61
Driving voltage at the control grid of the output pentode. The peak-to-peak value is 24 V.

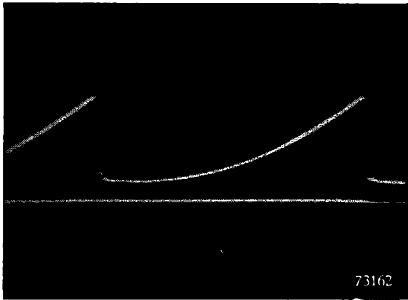

Fig. 62
Voltage across the cathode resistance of the PL 82 output pentode.

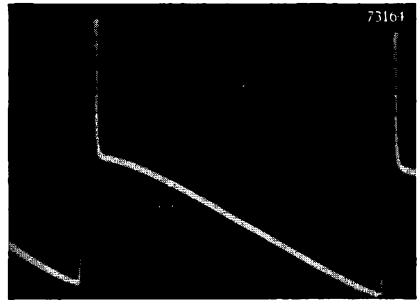

Fig. 63
Voltage across the primary of the output transformer. The anode voltage variation during the scan is 550 V and the positive peak during the flyback 600 V.

the integrator has some influence on the shape of the voltage across the VDR resistor, this being shown by the dotted curve in fig. 59.

An oscillogram of the voltage across the VDR resistor is shown in fig. 60. The peak-to-peak value of the saw-tooth voltage is 70 V. The driving voltage at the control grid of the output pentode is shown in fig. 61. Owing to the presence of the integrator circuit the shape of the saw-tooth voltage is modified and the peak-to-peak value is reduced to 24 V. Fig. 62 shows the voltage across the cathode resistor of the PL 82 output pentode. The total amplitude of this voltage depends upon the adjustment of the height control R_{120} , but the shape gives an indication of the shape of the anode current. The cathode of the output pentode is not bypassed and the negative feedback thus obtained increases the internal resistance to such an extent that a negative pulse on the control grid during the flyback is not required. Ringing at the end of the flyback is damped by the combination $C_{136}R_{122}$. The positive pulse appearing across the resistor is used for blanking the picture during the frame flyback (see lead *D*).

An oscillogram of the voltage across the primary of the output transformer is reproduced in fig. 63. The anode voltage variation during the scan is 550 V and the positive peak during the flyback 600 V. Finally, in fig. 64 is shown the current in the deflection coils. The peak-to-peak value of this current is 830 mA and this corresponds to full vertical deflection with the coils incorporated in the unit AT 1001/09.

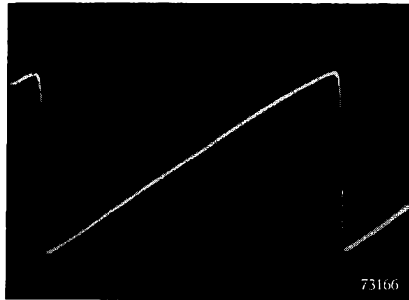

Fig. 64
Current in the deflection coils. The peak-to-peak value for full scan is 830 mA.

The mean values of the currents and the voltages with respect to the chassis are tabulated below.

	ECL 80 (V_{19})	PL 82 (V_{20})
Anode current — pentode section	0.65 mA	10.5 mA
Screen-grid current — pentode section	0.07 mA	1.3 mA
Anode voltage — pentode section	130 V	440 V
Screen-grid voltage — pentode section	38 V	60 V
Anode current — triode section	2.4 mA	
Grid current — triode section	0.3 mA	
Anode voltage — triode section	470 V	
Grid voltage — triode section	-95 V	

5. Power supply

The circuit of the power supply is conventional in all respects. For rectifying the mains voltage two PY 82 valves connected in parallel are used. It is necessary to connect a limiting resistor of 50Ω in series with each valve. The NTC resistor R_{126} in series with the heater chain is shunted by a fixed resistor R_{125} of 500Ω . This has been done to obtain sufficient delay in the heating up of the NTC resistor after switching on. Without the parallel resistor the NTC resistor would heat up very rapidly, thus causing temporary overloading of the heaters. The by-pass capacitors used in the heater chain must be connected close to the valve holders of the individual valves. The total direct current drawn from the power supply is 320 mA, when no signal is applied to the receiver. The direct voltages and ripple voltages measured in the power supply under various conditions are tabulated below.

	Contrast at minimum; no signal		Contrast at maximum; no signal		Contrast at minimum; with signal		Contrast at maximum; with signal	
	Direct volt. (V)	Ripple volt. (V _{rms})	Direct volt. (V)	Ripple volt. (V _{rms})	Direct volt. (V)	Ripple volt. (V _{rms})	Direct volt. (V)	Ripple volt. (V _{rms})
Input of filter	213	13	208	13.1	213	13	209	13
V_{b_1}	195	0.4	190	0.42	195	0.4	190	0.4
V_{b_2}	180	0.016	170	0.02	182	0.018	170	0.019
V_{b_3}	177	0.01	172	0.012	175	0.011	172	0.011
V_{b_4}	166	0.02	160	0.02	166	0.019	160	0.02
V_{b_5}	134	0.006	132	0.006	134	0.006	132	0.006

6. Voltages and currents

The currents and the voltages with respect to the chassis for the various valves in the receiver are given below. These measurements were made without signal applied to the aerial terminals and with the contrast control adjusted for maximum contrast. Under these conditions the current drawn by the R.F. pentode and the mixer in the tuner is 14 mA and that by the oscillator 7.5 mA. The MW 43—43 picture tube is used with the third grid connected to the cathode and the second grid at a potential 270 V higher than the cathode.

	Anode volt. (V)	Screen- grid volt. (V)	Control- grid volt. (V)	Cathode voltage (V)	Anode curr. (mA)	Screen- grid curr. (mA)
EF 80 pentode V_3	180	160	0	2.1	9	2.2
EF 80 pentode V_4	180	160	0	2.1	9	2.2
EF 80 pentode V_5	135	167	0	2.3	9.8	2.3
EF 80 pentode V_6	170	170	0	2.2	9.5	2.2
EF 80 pentode V_7	75	170	-0.15	1.5	12.5	3.5
ECL 80 triode- pentode V_8 pentode section	165	190		102	14	3
EF 80 pentode V_{10}	180	167	0	2.2	10	2.3
EQ 80 enneode V_{11}	180	24	4	4	0.28	6*)
PL 82 pentode V_{12}	146	160	0	11	40	9
EQ 80 enneode V_{13}	85	40	16	16		
85 A2 stabiliser V_{14}	85				4	
ECL 80 triode- pentode V_{15} pentode section	120	160	-27		2	2,3
triode section	76		-5.5		2.4	
PL 81 pentode V_{16}		140	-30		105	26
PY 81 diode V_{17}	190				119	
ECL 80 triode- pentode V_{19} pentode section	130	38			0.6	0.07
triode section	470		-95		2.4	
PL 82 pentode V_{20}	440	60		6	10.5	1.3

*) Including current in bleeder resistor. First grid connected to cathode.

7. List of parts

a. Resistors (all resistors may have $\pm 10\%$ tolerance).

<i>Ref.</i>	<i>Description</i>	<i>Resistance</i>	<i>Rating (W)</i>
R_1	Carbon, fixed	1.2 k Ω	0.25
R_2	” ”	10 k Ω	0.25
R_3	” ”	120 Ω	0.25
R_4	” ”	3.9 k Ω	0.5
R_5	” ”	1 k Ω	0.25
R_6	” ”	4.7 k Ω	0.25
R_7	” ”	0.1 M Ω	0.25
R_8	” ”	22 k Ω	0.25
R_9	” ”	4.7 k Ω	0.25
R_{10}	” ”	1 k Ω	0.25
R_{11}	” ”	100 Ω	0.25
R_{12}	” ”	3.9 k Ω	0.25
R_{13}	” ”	27 Ω	0.25
R_{14}	” ”	150 Ω	0.25
R_{15}	” ”	3.9 k Ω	0.25
R_{16}	” ”	2.2 k Ω	0.25
R_{17}	” ”	1 k Ω	0.25
R_{18}	” ”	1.8 k Ω	0.25
R_{19}	” ”	27 Ω	0.25
R_{20}	” ”	150 Ω	0.25
R_{21}	” ”	3.9 k Ω	0.25
R_{22}	” ”	1 k Ω	0.25
R_{23}	” ”	27 k Ω	0.25
R_{24}	” ”	8.2 k Ω	0.25
R_{25}	” ”	2.2 k Ω	0.25
R_{26}	” ”	150 Ω	0.25
R_{27}	” ”	27 Ω	0.25
R_{28}	” ”	1.5 k Ω	0.25
R_{29}	” ”	4.7 k Ω	1
R_{30}	” ”	1 k Ω	0.25
R_{31}	” ”	180 Ω	0.25
R_{32}	” ”	1.8 k Ω	0.5
R_{33}	” ”	6.8 k Ω	0.25
R_{34}	” ”	33 k Ω	0.25
R_{35}	” ”	0.12 M Ω	0.25
R_{36}	” ”	1 M Ω	0.25
R_{37}	” ”	3.9 k Ω	0.25
R_{38}	” ”	0.68 M Ω	0.25
R_{39}	” ”	1 M Ω	0.25
R_{40}	” ”	3.3 k Ω	0.25
R_{41}	” ”	82 k Ω	1

<i>Ref.</i>	<i>Description</i>	<i>Resistance</i>	<i>Rating (W)</i>
R_{42}	Carbon, variable	1 k Ω	0.5
R_{43}	Carbon, fixed	68 Ω	0.25
R_{44}	” ”	15 k Ω	1
R_{45}	” ”	15 k Ω	1
R_{46}	” ”	6.8 k Ω	0.25
R_{47}	” ”	1 M Ω	0.25
R_{48}	” ”	12 k Ω	1
R_{49}	” ”	12 k Ω	1
R_{50}	” ”	18 k Ω	0.25
R_{51}	” ”	1 k Ω	0.25
R_{52}	” ”	1.8 k Ω	0.5
R_{53}	” ”	0.56 M Ω	0.25
R_{54}	” ”	15 k Ω	0.25
R_{55}	” ”	0.56 M Ω	0.25
R_{56}	Carbon, variable	0.5 M Ω	0.25
R_{57}	Carbon, fixed	0.68 M Ω	0.25
R_{58}	” ”	1 k Ω	0.25
R_{59}	” ”	180 Ω	0.25
R_{60}	” ”	10 k Ω	0.25
R_{61}	” ”	1 k Ω	0.25
R_{62}	” ”	0.82 M Ω	0.25
R_{63}	” ”	0.39 M Ω	0.25
R_{64}	” ”	82 k Ω	0.25
R_{65}	” ”	22 k Ω	0.25
R_{66}	” ”	0.12 M Ω	0.25
R_{67}	” ”	68 k Ω	0.25
R_{68}	” ”	39 k Ω	0.25
R_{69}	” ”	560 Ω	0.25
R_{70}	” ”	3.9 k Ω	0.25
R_{71}	” ”	22 k Ω	1
R_{72}	” ”	1 M Ω	0.25
R_{73}	” ”	0.22 M Ω	0.25
R_{74}	Carbon, variable	1 M Ω	0.25
R_{75}	Carbon, fixed	220 Ω	1
R_{76}	” ”	100 Ω	0.25
R_{77}	” ”	3.9 M Ω	0.25
R_{78}	” ”	0.47 M Ω	0.25
R_{79}	” ”	68 k Ω	0.25
R_{80}	” ”	1.2 M Ω	0.25
R_{81}	” ”	0.68 M Ω	0.25
R_{82}	” ”	3.9 M Ω	0.25
R_{83}	” ”	0.27 M Ω	0.25
R_{84}	” ”	0.68 M Ω	0.25
R_{85}	” ”	12 k Ω	0.5
R_{86}	Carbon, variable	0.35 M Ω	0.25

<i>Ref.</i>	<i>Description</i>	<i>Resistance</i>	<i>Rating (W)</i>
R_{87}	Carbon, fixed	68 k Ω	0.25
R_{88}	" "	0.22 M Ω	0.25
R_{89}	" "	15 k Ω	0.25
R_{90}	" "	0.1 M Ω	0.25
R_{91}	" "	8.2 k Ω	0.25
R_{92}	" "	27 k Ω	0.25
R_{93}	" "	5.6 k Ω	0.25
R_{94}	" "	0.82 M Ω	0.25
R_{95}	" "	33 k Ω	0.25
R_{96}	" "	0.82 M Ω	0.5
R_{97}	" "	0.56 M Ω	0.25
R_{98}	" "	1.5 k Ω	0.25
R_{99}	" "	1.95 k Ω	2
R_{100}	" "	0.33 M Ω	0.25
R_{101}	" "	0.33 M Ω	0.25
R_{102}	" "	47 k Ω	0.5
R_{103}	" "	3.3 k Ω	1
R_{104}	" "	3.9 M Ω	0.25
R_{105}	" "	22 k Ω	0.25
R_{106}	" "	0.68 M Ω	0.25
R_{107}	" "	1.2 M Ω	0.25
R_{108}	" "	0.1 M Ω	0.25
R_{109}	" "	10 k Ω	0.5
R_{110}	" "	15 k Ω	0.5
R_{111}	Carbon, variable	0.5 M Ω	0.25
R_{112}	Carbon, fixed	1.5 M Ω	0.25
R_{113}	" "	0.39 M Ω	0.25
R_{114}	VDR resistor; Type VD 1000A/680 B		
R_{115}	Carbon, fixed	0.82 M Ω	0.25
R_{116}	" "	0.39 M Ω	0.25
R_{117}	Carbon, variable	0.2 M Ω	0.25
R_{118}	Carbon, fixed	3.9 M Ω	0.25
R_{119}	" "	270 Ω	0.25
R_{120}	Carbon, variable	1 k Ω	0.5.
R_{121}	Carbon, fixed	0.1 M Ω	0.25
R_{122}	" "	0.22 M Ω	0.5
R_{123}	" "	0.33 M Ω	0.25
R_{124}	" "	5.6 k Ω	2
R_{125}	Wire-wound	500 Ω	5
R_{126}	NTC resistor; Type 100.102		
R_{127}	Wire-wound	50 Ω	10
R_{128}	" "	50 Ω	10
R_{129}	Carbon, fixed	680 Ω	1
R_{130}	" "	3.9 k Ω	0.25

<i>Ref.</i>	<i>Description</i>	<i>Resistance</i>	<i>Rating (W)</i>
R_{131}	Carbon, fixed	1 k Ω	1
R_{132}	„ „	1 k Ω	1
R_{133}	„ „	6.8 k Ω	1
R_{134}	„ „	68 Ω	1
R_{135}	„ „	68 Ω	1

b. Capacitors

<i>Ref.</i>	<i>Description</i>	<i>Capacitance</i>	<i>Tolerance</i> (\pm %)	<i>Working</i> <i>voltage</i> (V)
C_1-C_{10}	Tuning capacitor			
$C_{11}-C_{18}$	Fine-tuning capacitor	1.5 pF		
C_{19}	Ceramic	68 pF	20	350
C_{20}	„	820 pF	20	350
C_{21}	„	68 pF	20	350
C_{22}	„	820 pF	20	350
C_{23}	„	68 pF	20	350
C_{24}	„	68 pF	20	350
C_{25}	„	27 pF	10	350
C_{26}	„	820 pF	20	350
C_{27}	„	68 pF	20	350
C_{28}	„	4.7 pF	10	350
C_{29}	„	6.8 pF	10	350
C_{30}	„	820 pF	20	350
C_{31}	„	12 pF	10	350
C_{32}	„	18 pF	10	350
C_{33}	„	68 pF	20	350
C_{34}	„	68 pF	20	350
C_{35}	„	2.2 pF	20	350
C_{36}	„	2.7 pF	20	350
C_{37}	„	68 pF	20	350
C_{38}	„	3.9 pF	10	350
C_{39}	„	820 pF	20	350
C_{40}	„	820 pF	20	350
C_{41}	„	820 pF	20	350
C_{42}	„	820 pF	20	350
C_{43}	„	1500 pF	20	350
C_{43a}	„	1500 pF	20	350
C_{44}	„	1500 pF	20	350
C_{45}	„	1500 pF	20	350
C_{46}	„	1500 pF	20	350
C_{47}	„	1500 pF	20	350
C_{48}	„	8.2 pF	20	350

<i>Ref.</i>	<i>Description</i>	<i>Capacitance</i>	<i>Tolerance</i> (\pm %)	<i>Working</i> <i>voltage</i> (V)
C_{49}	Ceramic	3.9 pF	20	350
C_{50}	"	150 pF	20	350
C_{51}	"	1500 pF	20	350
C_{52}	"	1500 pF	20	350
C_{53}	"	1500 pF	20	350
C_{54}	"	1500 pF	20	350
C_{55}	"	8.2 pF	20	350
C_{56}	"	1.5 pF	20	350
C_{57}	"	150 pF	20	350
C_{58}	"	1500 pF	20	350
C_{59}	Mica	2700 pF	20	350
C_{60}	Ceramic	1500 pF	20	350
C_{61}	"	1500 pF	20	350
C_{62}	"	1500 pF	20	350
C_{63}	"	150 pF	20	350
C_{64}	"	8.2 pF	20	350
C_{65}	"	2.7 pF	20	350
C_{66}	"	1500 pF	20	350
C_{67}	"	1500 pF	20	350
C_{68}	"	150 pF	20	350
C_{69}	"	2.3 pF	20	350
C_{70}	"	12 pF	20	350
C_{71}	"	150 pF	20	350
C_{72}	"	1500 pF	20	350
C_{73}	"	1500 pF	20	350
C_{74}	Paper	0.1 μ F	20	400
C_{75}	"	0.1 μ F	20	400
C_{76}	Ceramic	1500 pF	20	350
C_{77}	"	10 pF	20	350
C_{78}	"	8.2 pF	20	350
C_{79}	"	120 pF	20	350
C_{80}	Paper	10 000 pF	20	400
C_{81}	"	33 000 pF	20	400
C_{82}	Ceramic	270 pF	20	350
C_{83}	"	330 pF	20	350
C_{84}	"	1500 pF	20	350
C_{85}	"	1500 pF	20	350
C_{86}	"	18 pF	20	350
C_{87}	"	1500 pF	20	350
C_{88}	"	1500 pF	20	350
C_{89}	"	120 pF	20	350
C_{90}	Paper	10 000 pF	20	400
C_{91}	"	33 000 pF	20	400
C_{92}	Ceramic	12 pF	20	350

<i>Ref.</i>	<i>Description</i>	<i>Capacitance</i>	<i>Tolerance</i> (\pm %)	<i>Working</i> <i>voltage</i> (<i>V</i>)
C_{93}	Ceramic	27 pF	10	350
C_{94}	„	68 pF	10	350
C_{95}	Trimmer	3-30 pF		
C_{96}	Ceramic	27 pF	10	350
C_{97}	Trimmer	3-30 pF		
C_{98}	Ceramic	1500 pF	20	350
C_{99}	Paper	0.18 μ F	20	400
C_{100}	Ceramic	1500 pF	20	350
C_{101}	Paper	0.1 μ F	20	600
C_{102}	Ceramic	150 pF	20	600
C_{103}	Paper	4700 pF	20	600
C_{104}	Electrolytic	25 μ F		25
C_{105}	Paper	1000 pF	20	800
C_{106}	„	22 000 pF	20	400
C_{107}	Ceramic	220 pF	20	350
C_{108}	Paper	10 000 pF	20	400
C_{109}	Ceramic	220 pF	20	350
C_{110}	„	220 pF	20	700
C_{111}	„	220 pF	20	350
C_{112}	„	680 pF	20	350
C_{113}	Mica			
	(incorporated in unit Type 10924)	10 000 pF	10	400
C_{114}	Ceramic	27 pF	10	350
C_{115}	Paper	0.1 μ F	20	400
C_{116}	„	8200 pF	20	400
C_{117}	Ceramic	180 pF	20	350
C_{118}	„	1000 pF	20	350
C_{119}	Paper	3300 pF	20	400
C_{120}	„	0.1 μ F	20	400
C_{121}	„	22 000 pF	20	800
C_{122}	Ceramic (incorporated in unit Type AT 2002)	100 pF		
C_{123}	Paper	2200 pF	20	400
C_{124}	„	1200 pF	20	350
C_{125}	Ceramic	500 pF	20	16 000
C_{126}	Paper	22 000 pF	20	400
C_{127}	Ceramic	56 pF	20	350
C_{128}	Paper	0.1 μ F	20	400
C_{129}	„	10 000 pF	20	400
C_{130}	„	5600 pF	20	600
C_{131}	„	56 000 pF	10	400

<i>Ref.</i>	<i>Description</i>	<i>Capacitance</i>	<i>Tolerance</i> (\pm %)	<i>Working</i> <i>voltage</i> (<i>V</i>)
C_{132}	Paper	12 000 pF	20	400
C_{133}	„	33 000 pF	20	400
C_{134}	Electrolytic	12.5 μ F		300
C_{135}	„	50 μ F		400
C_{136}	Paper	6800 pF	20	1000
C_{137}	„	47 000 pF	20	400
C_{138}	Ceramic	560 pF	20	350
C_{139}	Paper	22 000 pF	20	800
C_{140}	Electrolytic	2 \times 50 μ F		300
C_{141}	„	2 \times 50 μ F		300
C_{142}	„	2 \times 50 μ F		300
C_{143}	„	2 \times 50 μ F		300
C_{144}	Ceramic	1500 pF	20	350
C_{145}	„	1500 pF	20	350
C_{146}	„	1500 pF	20	350
C_{147}	„	1500 pF	20	350
C_{148}	„	1500 pF	20	350
C_{149}	„	1500 pF	20	350
C_{150}	Paper	10 000 pF	20	400
C_{151}	„	10 000 pF	20	400
C_{152}	Ceramic	1500 pF	20	350
C_{153}	„	1500 pF	20	350
C_{154}	„	1500 pF	20	350

c. Inductors and transformers

<i>Ref.</i>	<i>Description</i>
L_{1-17}	Incorporated in tuner Type AT 7501.
L_{18}	Secondary of first I.F. transformer. Type number AT 4515.
L_{19}	Inductor of trap circuit. Tuning frequency 15.75 Mc/s. The mechanical details of this inductor are given in fig. 65. The diameter of the coil former is 7 mm and an iron-dust core with a diameter of 6 mm and a length of 6 mm is used for the adjustment. The diameter of the screening can is 19 mm. Other data are listed below.
	Inductance approx. 7.5 μH
	Number of turns (enamelled copper, wound without spacing) 30
	Wire diameter 0.2 mm

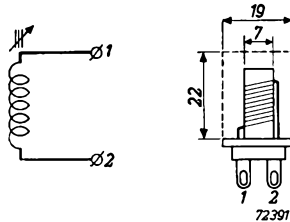

Fig. 65
Mechanical details of inductor L_{19} .

L_{20}	I.F. circuit; tuning frequency 20.4 Mc/s. The mechanical details are identical to those of L_{19} .
	Inductance approx. 3.4 μH
	Number of turns (enamelled copper, wound without spacing) 17
	Wire diameter 0.2 mm
L_{21}	Inductor of trap circuit. Tuning frequency 18.4 Mc/s. Mechanical details as for L_{19} .
	Inductance approx. 6 μH
	Number of turns (enamelled copper, wound without spacing) 25
	Wire diameter 0.2 mm
L_{22}	I.F. circuit; tuning frequency 19.1 Mc/s. Mechanical details as for L_{19} .
	Inductance approx. 4.5 μH
	Number of turns (enamelled copper, wound without spacing) 20
	Wire diameter 0.2 mm

<i>Ref.</i>	<i>Description</i>	
L_{23}	Inductor of trap circuit. Tuning frequency 26.5 Mc/s. Mechanical details as for L_{19} .	
	Inductance	approx. 3.5 μ H
	Number of turns (enamelled copper, wound without spacing)	16
L_{24}	Wire diameter	0.2 mm
	I.F. circuit; tuning frequency 24.1 Mc/s. Mechanical details as for L_{19} .	
	Inductance	approx. 2 μ H
L_{25}	Number of turns (enamelled copper, wound without spacing)	11
	Wire diameter	0.2 mm
L_{26}	R.F. choke. Inductance	1 mH
	I.F. circuit; tuning frequency 23 Mc/s. Mechanical details as for L_{19} .	
L_{27}	Inductance	approx. 3.5 μ H
	Number of turns (enamelled copper, wound without spacing)	16
	Wire diameter	0.2 mm
L_{28}	Inductor of trap circuit. Tuning frequency 25.25 Mc/s. Mechanical details as for L_{19} .	
	Inductance	approx. 3.7 μ H
	Number of turns (enamelled copper, wound without spacing)	17
L_{29}	Wire diameter	0.2 mm
	Series-peaking coil. Inductance	60 μ H
L_{30}	Series-peaking coil. Inductance	130 μ H
	Series-peaking coil. Inductance	80 μ H
L_{31-32}	Incorporated in deflection and focusing unit Type AT 1001/09.	
	First I.F. circuit of sound channel. Mechanical details as for L_{19} .	
L_{33}	Inductance	approx. 29 μ H
	Number of turns (enamelled copper, wound without spacing)	63
	Wire diameter	0.12 mm
L_{34}	R.F. choke. Inductance	1 mH
	Discriminator transformer. The mechanical details of this transformer are given in fig. 66. The primary and the secondary are identical.	
L_{35-36}	Inductance	15 μ H
	Number of turns (enamelled copper, wound without spacing)	34
	Wire diameter	0.2 mm
L_{37}	Variable inductor of tuned circuit Type 10924.	

Ref.

Description

L_{38-39}	Variable inductors for picture width control, included in unit Type AT 4001.	
L_{40}	Premagnetized inductor for linearity correction, included in unit Type AT 4001.	
L_{41}	Filter choke in power supply.	
	Inductance	3 H
	Direct current rating	370 mA

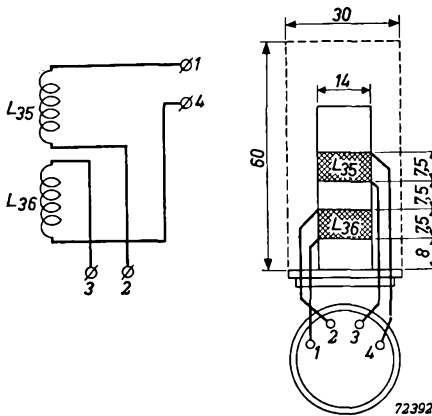

Fig. 66

Dimensions and arrangement of the coils of the discriminator transformer L_{35-36} .

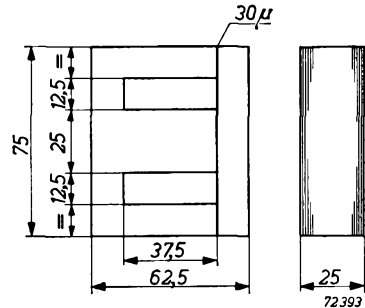

Fig. 67

Dimensions of the laminations of the output transformer for vertical deflection T_2 . The thickness of the laminations is 0.5 mm.

T_1	Loudspeaker transformer.	
	Matching resistance	3.5 k Ω
T_2	Output transformer for vertical deflection. *) The dimensions of the laminations used for this transformer are given in fig. 67. The stacking height is 25 mm and between the E and I shaped laminations a sheet of paper 30 microns thick is used to obtain the required air gap. The secondary is wound first and after that the primary. The data of the windings are given below.	
	Secondary winding	
	Number of turns	160
	Wire diameter (enamelled copper)	0.6 mm
	Number of layers	4
	Width of one layer	30 mm
	Insulation between layers	0.1 mm paper
	Resistance of winding	1.2 Ω

*) This transformer is available under Type Number AT 3501.

Description

Primary winding	
Number of turns	8000
Wire diameter (enamelled copper)	0.1 mm
Number of layers	36
Width of one layer	30 mm
Insulation between layers	30 microns paper
Resistance of winding	2800 Ω

The frame blocking transformer and the output transformer for horizontal deflection are standard types indicated in the circuit diagram.

Addendum

In the preceding components list constructional details have been given of the I.F. circuits and traps in the picture channel. It is also possible to use standard I.F. circuits and traps. The receiver circuit is not changed when this is done, but the following points should be specially mentioned.

- 1) The components L_{19} , L_{20} and C_{48} , C_{49} in the circuit diagram of fig. 29 are replaced by the unit Type AT 4505, in which these components are assembled. Tuning is done by varying the inductances by means of Ferroxcube cores.
- 2) L_{21} , L_{22} and C_{55} , C_{56} are replaced by unit Type AT 4503. The coupling capacitor of 2.7 pF between L_{21} and L_{22} in this unit must be replaced by one having a capacitance of 1.5 pF. This alteration is necessary in

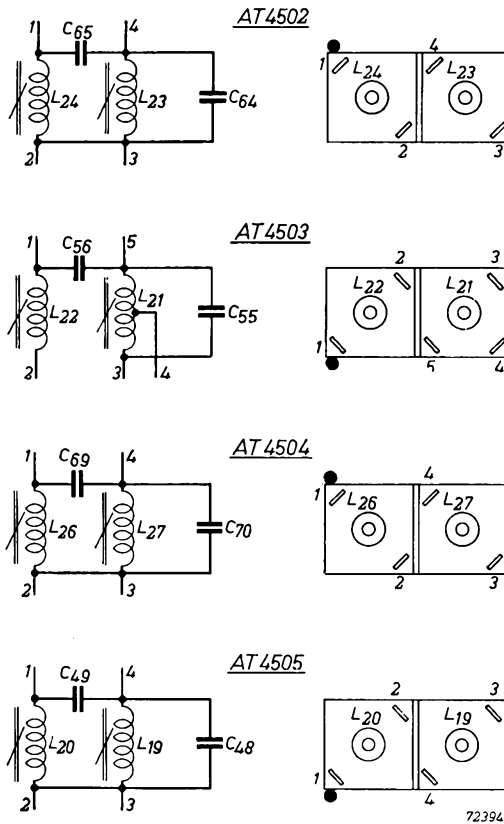

Fig. 68
Connections of the units AT 4502 to AT 4505.
The height above chassis of these units is 38
mm, the horizontal cross section being
25 × 11 mm.

order to obtain the correct amount of sound I.F. attenuation. With a capacitor of 2.7 pF the attenuation would be too great.

3) L_{23} , L_{24} and C_{64} , C_{65} are replaced by unit Type AT 4502.

4) L_{26} , L_{27} and C_{69} , C_{70} are replaced by unit Type AT 4504.

The tuning frequencies, bandwidths, extra damping resistors etc. are identical to those given on page 182. Also the figures for the stage gain are substantially the same, so that the total sensitivity of the receiver is not appreciably changed.

The connections of units AT 4502 to AT 4505 are given in fig. 68. In this figure the numbering of the inductors and the capacitors corresponds with the circuit diagram of fig. 29, the black dot printed at one of the corners of each unit indicating a colour marking.

PHILIPS' TECHNICAL LIBRARY comprises 4 series of books:

- a. Electronic Valves
- b. Light and Lighting
- c. Miscellaneous
- d. Popular series

Series a, b and c in cloth binding 6" × 9", gilt. The dimensions of the popular series, coloured "integral" binding, 5 $\frac{3}{4}$ " × 8 $\frac{1}{4}$ ".

Most of these books are published in 4 languages: English, French, German and Dutch.

a. Series on ELECTRONIC VALVES

- Book I "Fundamentals of Radio-Valve Technique", by J. Deketh
- Book II "Data and Circuits of Receiver and Amplifier Valves"
- Book III "Data and Circuits of Receiver and Amplifier Valves",
1st Suppl.
- Book IIIA "Data and Circuits of Receiver and Amplifier Valves",
2nd Suppl., by N. Markus and J. Otte
- Book IIIB "Data and Circuits of Receiver and Amplifier Valves",
3rd Suppl., by N. Markus
- Book IIIC "Data and Circuits of Television Receiver Valves", by
J. Jager
- Book IV "Application of the Electronic Valve in Radio Receivers
and Amplifiers", Volume I, by B. G. Dammers, J. Haantjes,
J. Otto and H. van Suchtelen
- Book V Ditto, Volume 2
- Book VI Ditto, Volume 3
- Book VII "Transmitting Valves", by P. J. Heyboer and P. Zijlstra
- Book VIIIA "Television Receiver Design" 1, by A. G. W. Uitjens
- Book IIIB "Television Receiver Design" 2, by P. A. Neeteson

Books IIIB, and VI are in preparation.

b. Series "LIGHT AND LIGHTING"

- 1. "Physical Aspects of Colour", by P. J. Bouma
- 2. "Gas Discharge Lamps", by J. Funke and P. J. Oranje
- 3. "Fluorescent Lighting", by Prof. C. Zwikker c.s.
- 4. "Artificial Light and Architecture", by L. C. Kalf (size 7" × 11")
- 5. "Artificial Light and Photography", by G. D. Rieck and L. H. Verbeek (size 7" × 11")
- 6. "Manual for the Illuminating Engineer on Large Size Perfect Diffusors",
by H. Zijl
- 7. "Calculation and Measurement of Light", by H. A. E. Keitz
- 8. "Light Technique", by Joh. Jansen
- 9. "Airport Lighting", by J. Stap

10. "Germicidal Lamps", by J. Hemerik
11. "Infra-red Lamps", by M. Bierman and S. J. W. Zandvoort

Books 4 and 7 are in German only. The English edition of books 7, 8, 9, 10 and 11 is in preparation.

c. Series "MISCELLANEOUS"

- a. "Television", by Fr. Kerkhof and W. Werner
- b. "Low-Frequency Amplification", by N. A. J. Voochhoeve
- c. "Metallurgy and Construction", by E. M. H. Lips
- d. "Strain Gauges", by Prof. J. J. Koch
- e. "Introduction to the study of Mechanical Vibrations", by G. W. v. Santen
- f. "Data for X-Ray Analysis" I, by W. Parrish and B. W. Irwin (size 8.2" × 11.6"), paper bound
- g. "Data for X-Ray Analysis" II, by W. Parrish, M. G. Ekstein and B. W. Irwin (size 8.2" × 11.6"), paper bound
- h. "X-Rays in Dental Practice", by G. H. Hepple
- i. "Industrial Electronics", by R. Kretzmann

"POPULAR SERIES"

The books of Philips' Technical Library are on a rather high level. Time over again we have received requests for technical books on a somewhat lower level. It was decided to comply with these requests and thus publish such books in a "popular" series. Popular does not mean here superficial, but intelligible to a larger group of readers.

1. "Remote Control by Radio", by A. H. Bruinsma
2. "Electronic Valves for L. F. Amplification", by E. Rodenhuis
3. "The Odes and Trons Family", by J. Haantjes
4. "Battery Receiving Valves", by E. Rodenhuis
5. "Germanium Diodes", by S. D. Boon
6. "Cathode-Ray Tubes for Oscilloscopes", by Harley Carter

Books 3, 4, 5 and 6 are in preparation.

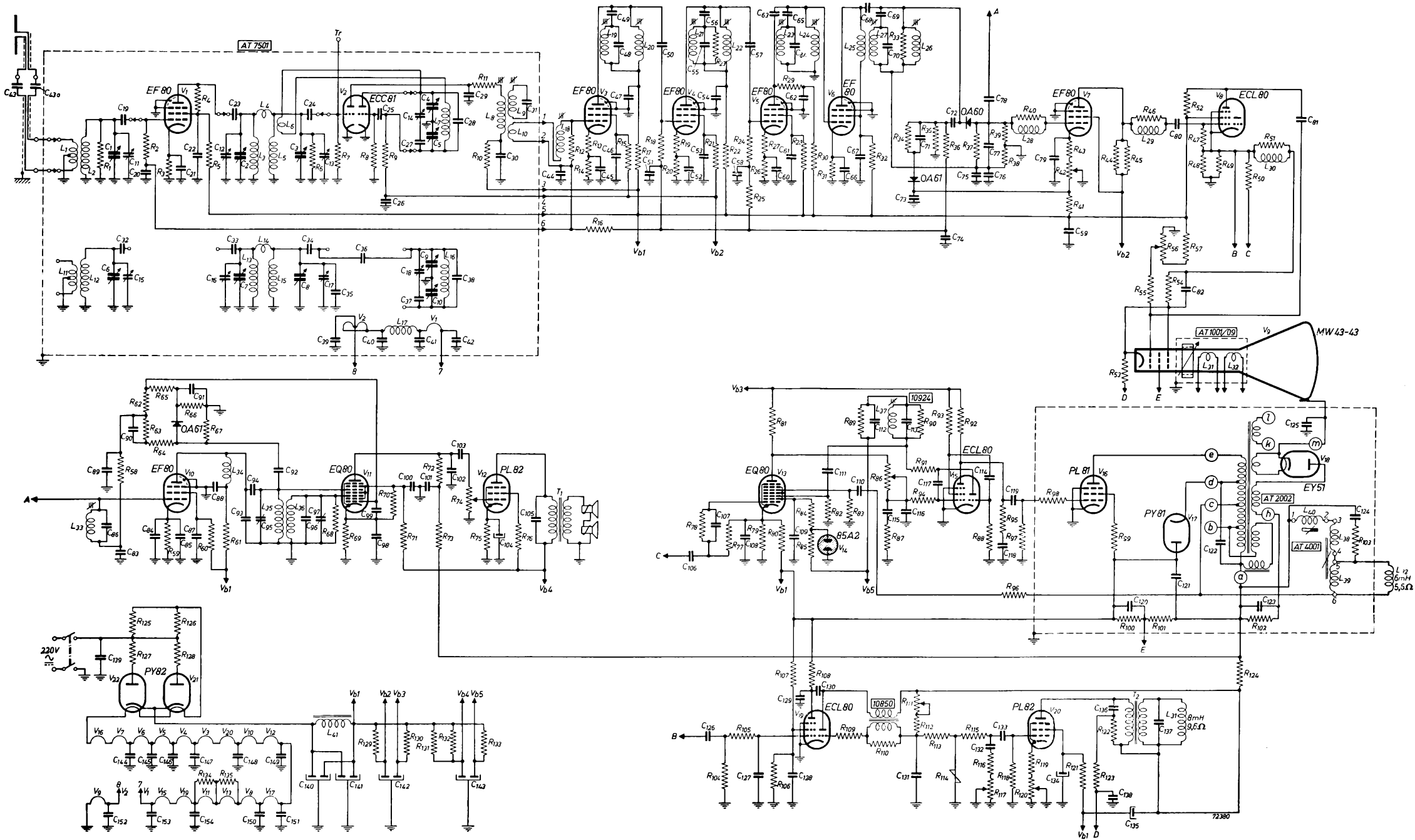

Fig. 29
 Circuit diagram of a television receiver for the 625-line system, using the picture tube MW 43-43.

