

TECHNICAL MANUAL

FM-5K

988-1761-001

994 8049 001/002/004/005

994 8049 003/006/007/008

HARRIS

T.M. No. 888-1761-012

© Copyright Harris Corporation 1986

All rights reserved

Printed: May 14, 1986

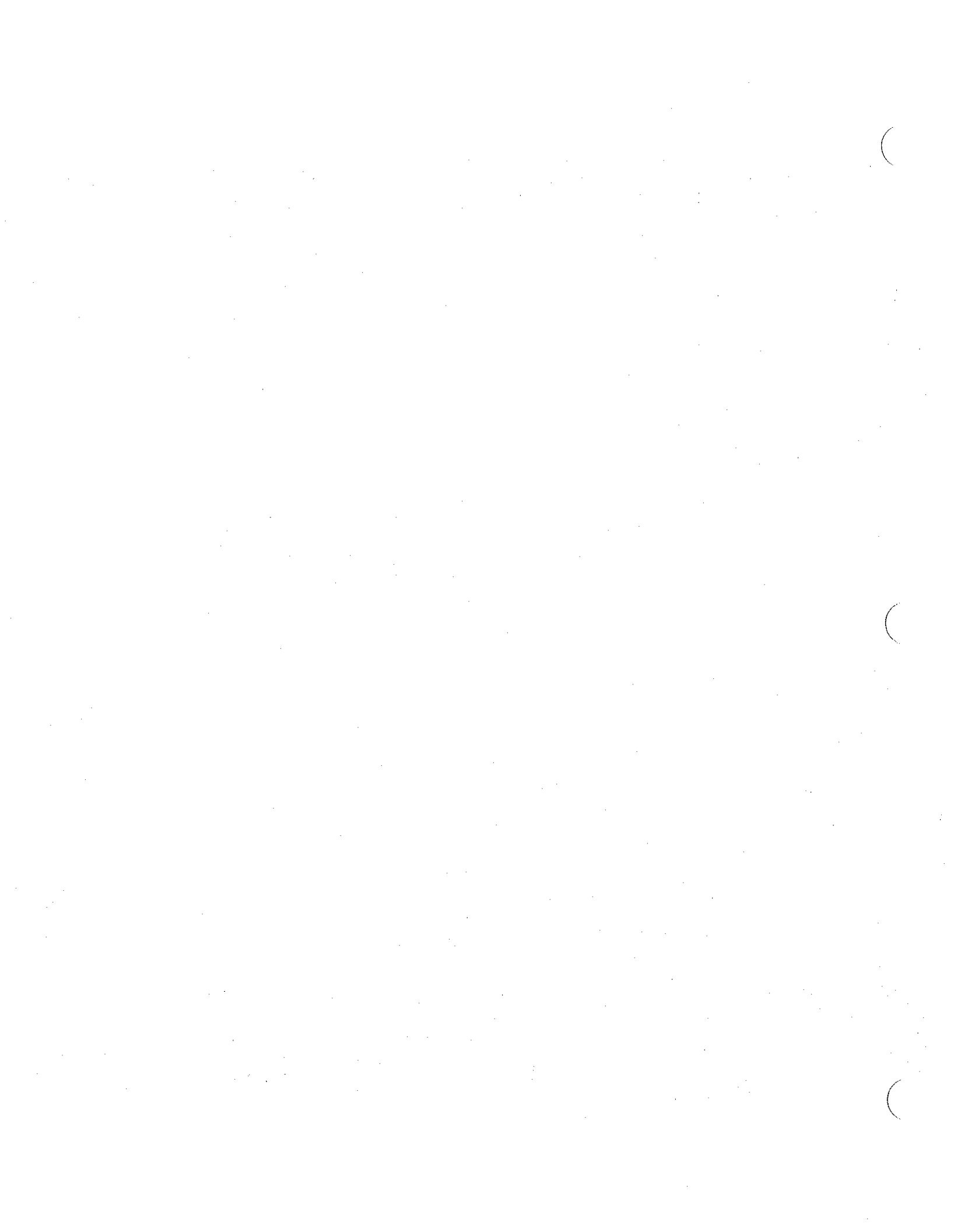

MANUAL REVISION HISTORY
FM-5K FM BROADCAST TRANSMITTER
888-1761-xxx

<u>REV. #</u>	<u>DATE</u>	<u>ECN</u>	<u>PAGES AFFECTED</u>
005	05/14/84	29037	All pages replaced. Added Manual Revision History page.
006	08/20/84	29058	Replaced the following pages: Title Page, Manual Revision History page 6-13, 7-3/7-4A, 7-3/7-4B
007	07/01/85	29382 29382A	Replaced the following pages: Title Page, Manual Revision History page 6-18, 7-3/7-4A, 7-3/7-4B
008	07/12/85	29475	Replaced the following pages: Title Page, Manual Revision History page VIII, 7-1/7-2 Added pages 7-13/7-14A, 7-13/7-14B
009	08/16/85	29500	Replaced the following pages: Title Page, Manual Revision History page, 6-3, 6-4, 6-5, 6-6, 6-7, 6-8, 6-9, 6-10, 6-11
010, 011 & 012	05-14-86	29545, 29819 & 30022	Replaced the following pages: Title Page, Manual Revision History page i, ii, 4-10 thru 4-13, 5-14, 6-1, 6-13, 7-3/7-4A, 7-3/7-4B, 7-13/7-14A & 7-13/7-14B

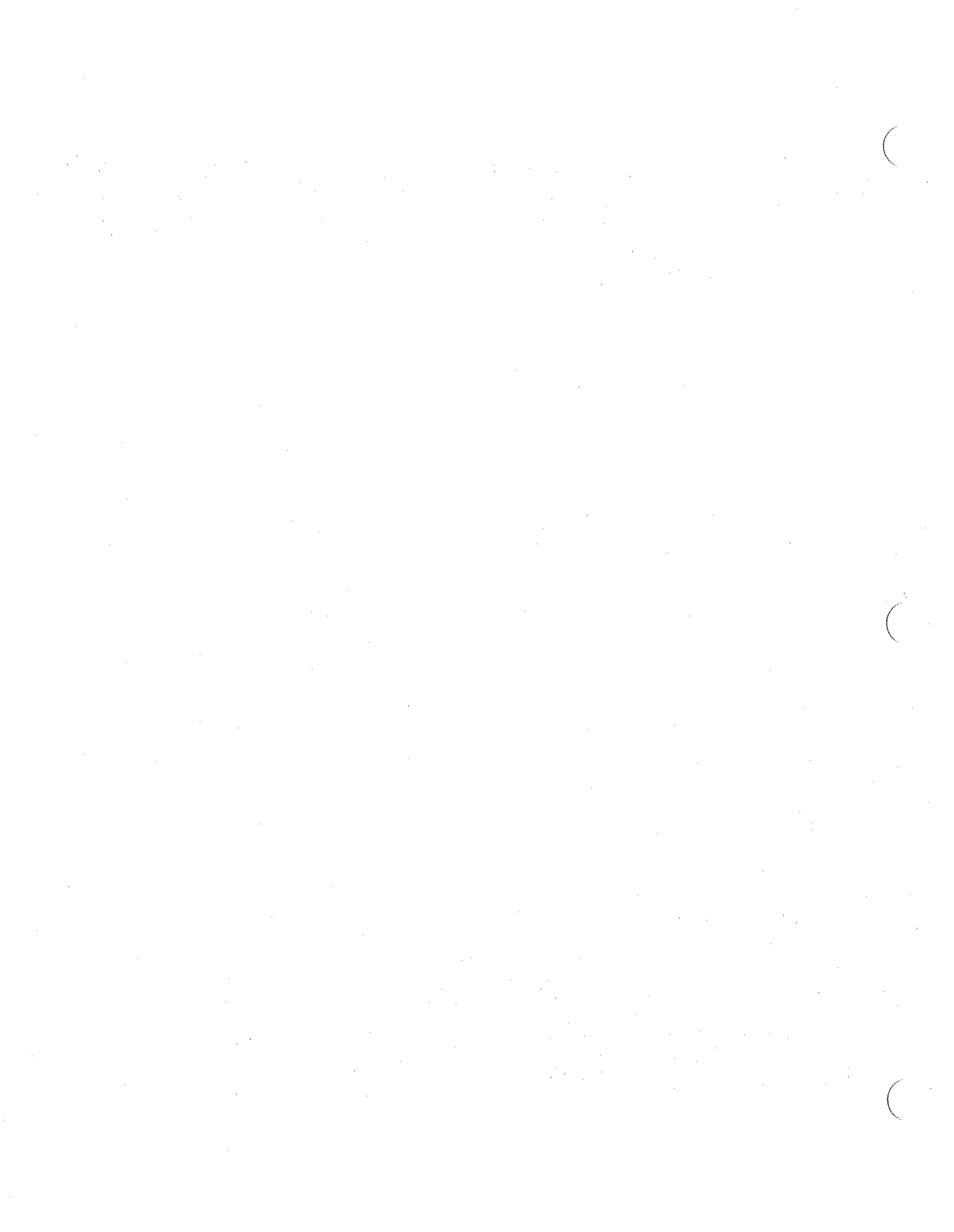

WARNING

THE CURRENTS AND VOLTAGES IN THIS EQUIPMENT ARE DANGEROUS.
PERSONNEL MUST AT ALL TIMES OBSERVE SAFETY REGULATIONS.

This manual is intended as a general guide for trained and qualified personnel who are aware of the dangers inherent in handling potentially hazardous electrical/electronic circuits. It is not intended to contain a complete statement of all safety precautions which should be observed by personnel in using this or other electronic equipment.

The installation, operation, maintenance and service of this equipment involves risks both to personnel and equipment, and must be performed only by qualified personnel exercising due care. HARRIS CORPORATION shall not be responsible for injury or damage resulting from improper procedures or from the use of improperly trained or inexperienced personnel performing such tasks.

During installation and operation of this equipment, local building codes and fire protection standards must be observed. The following National Fire Protection Association (NFPA) standards are recommended as references:

- Automatic Fire Detectors, No. 72E
- Installation, Maintenance, and Use of Portable Fire Extinguishers, No. 10
- Halogenated Fire Extinguishing Agent Systems, No. 12A

WARNING

ALWAYS DISCONNECT POWER BEFORE OPENING COVERS, DOORS, ENCLOSURES, GATES, PANELS OR SHIELDS. ALWAYS USE GROUNDING STICKS AND SHORT OUT HIGH VOLTAGE POINTS BEFORE SERVICING. NEVER MAKE INTERNAL ADJUSTMENTS, PERFORM MAINTENANCE OR SERVICE WHEN ALONE OR WHEN FATIGUED.

Do not remove, short-circuit or tamper with interlock switches on access covers, doors, enclosures, gates, panels or shields. Keep away from live circuits, know your equipment and don't take chances.

WARNING

IN CASE OF EMERGENCY ENSURE THAT POWER HAS BEEN DISCONNECTED.

WARNING

IF OIL FILLED OR ELECTROLYTIC CAPACITORS ARE UTILIZED IN YOUR EQUIPMENT, AND IF A LEAK OR BULGE IS APPARENT ON THE CAPACITOR CASE WHEN THE UNIT IS OPENED FOR SERVICE OR MAINTENANCE, ALLOW THE UNIT TO COOL DOWN BEFORE ATTEMPTING TO REMOVE THE DEFECTIVE CAPACITOR. DO NOT ATTEMPT TO SERVICE A DEFECTIVE CAPACITOR WHILE IT IS HOT DUE TO THE POSSIBILITY OF A CASE RUPTURE AND SUBSEQUENT INJURY.

TREATMENT OF ELECTRICAL SHOCK

1. IF VICTIM IS NOT RESPONSIVE FOLLOW THE A-B-C'S OF BASIC LIFE SUPPORT.

PLACE VICTIM FLAT ON HIS BACK ON A HARD SURFACE

(A) AIRWAY

IF UNCONSCIOUS.
OPEN AIRWAY

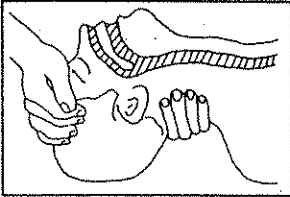

LIFT UP NECK
PUSH FOREHEAD BACK
CLEAR OUT MOUTH IF NECESSARY
OBSERVE FOR BREATHING

CHECK
CAROTID PULSE

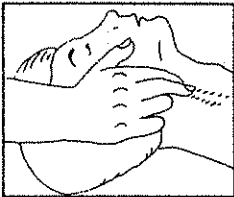

IF PULSE ABSENT.
BEGIN ARTIFICIAL
CIRCULATION

(B) BREATHING

IF NOT BREATHING.
BEGIN ARTIFICIAL BREATHING

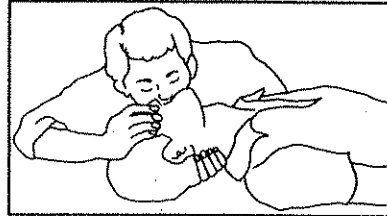

TILT HEAD
PINCH NOSTRILS
MAKE AIRTIGHT SEAL
4 QUICK FULL BREATHS
REMEMBER MOUTH TO MOUTH
RESUSCITATION MUST BE
COMMENCED AS SOON AS POSSIBLE

(C) CIRCULATION

DEPRESS STERNUM 1 1/2 TO 2 INCHES

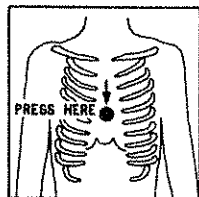

APPROX. RATE
OF COMPRESSIONS { ONE RESCUER
--80 PER MINUTE { 15 COMPRESSIONS
2 QUICK BREATHS

APPROX. RATE
OF COMPRESSIONS { TWO RESCUERS
--60 PER MINUTE { 5 COMPRESSIONS
1 BREATH

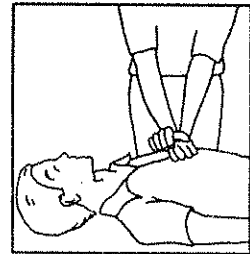

NOTE: DO NOT INTERRUPT RHYTHM OF COMPRESSIONS
WHEN SECOND PERSON IS GIVING BREATH

CALL FOR MEDICAL ASSISTANCE AS SOON AS POSSIBLE.

2. IF VICTIM IS RESPONSIVE.

- A. KEEP THEM WARM
- B. KEEP THEM AS QUIET AS POSSIBLE
- C. LOOSEN THEIR CLOTHING
- D. A RECLINING POSITION IS RECOMMENDED

FIRST-AID

Personnel engaged in the installation, operation, maintenance or servicing of this equipment are urged to become familiar with first-aid theory and practices. The following information is not intended to be complete first-aid procedures, it is brief and is only to be used as a reference. It is the duty of all personnel using the equipment to be prepared to give adequate Emergency First Aid and thereby prevent avoidable loss of life.

Treatment of Electrical Burns

1. Extensive burned and broken skin
 - a. Cover area with clean sheet or cloth. (Cleanest available cloth article.)
 - b. Do not break blisters, remove tissue, remove adhered particles of clothing, or apply any salve or ointment.
 - c. Treat victim for shock as required.
 - d. Arrange transportation to a hospital as quickly as possible.
 - e. If arms or legs are affected keep them elevated.

NOTE

If medical help will not be available within an hour and the victim is conscious and not vomiting, give him a weak solution of salt and soda: 1 level teaspoonful of salt and 1/2 level teaspoonful of baking soda to each quart of water (neither hot or cold). Allow victim to sip slowly about 4 ounces (a half of glass) over a period of 15 minutes. Discontinue fluid if vomiting occurs. (Do not give alcohol.)

2. Less severe burns - (1st & 2nd degree)
 - a. Apply cool (not ice cold) compresses using the cleanest available cloth article.
 - b. Do not break blisters, remove tissue, remove adhered particles of clothing, or apply salve or ointment.
 - c. Apply clean dry dressing if necessary.
 - d. Treat victim for shock as required.
 - e. Arrange transportation to a hospital as quickly as possible.
 - f. If arms or legs are affected keep them elevated.

REFERENCE: ILLINOIS HEART ASSOCIATION

AMERICAN RED CROSS STANDARD FIRST AID AND PERSONAL SAFETY MANUAL
(SECOND EDITION)

TABLE OF CONTENTS

<u>Paragraph</u>		<u>Page</u>
SECTION I. GENERAL DESCRIPTION		
1-1.	Introduction.....	1-1
1-3.	Related Publications.....	1-1
1-5.	Equipment Purpose.....	1-1
1-7.	Physical Description.....	1-3
1-9.	Functional Description.....	1-3
1-10.	Power Supply Circuit.....	1-3
1-12.	FM Exciter.....	1-3
1-14.	RF Circuits.....	1-4
1-17.	Metering.....	1-4
1-19.	Control Circuits.....	1-4
1-22.	Status Indicators.....	1-4
1-24.	Equipment Characteristics.....	1-7
1-25.	Electrical Characteristics.....	1-7
1-27.	Mechanical/Environmental Characteristics.....	1-7
SECTION II. INSTALLATION		
2-1.	Introduction.....	2-1
2-3.	Unpacking.....	2-1
2-5.	Returns and Exchanges.....	2-1
2-7.	Installation.....	2-1
2-9.	Cooling Air Requirements.....	2-1
2-12.	Transmitter Placement.....	2-2
2-14.	Component Installation.....	2-2
2-40.	Transmitter Wiring.....	2-10
2-42.	Exciter Wiring.....	2-10
2-46.	Ground.....	2-10
2-47.	Primary Power.....	2-11
2-50.	Monitors.....	2-11
2-51.	Antenna.....	2-11
2-54.	Connections to Remote Controls.....	2-11
2-56.	Initial Checkout.....	2-14
SECTION III. OPERATION		
3-1.	Introduction.....	3-1
3-3.	Controls and Indicators.....	3-1
3-6.	Operation.....	3-1
3-8.	Transmitter Turn On.....	3-1
3-12.	Transmitter Shutdown.....	3-2
SECTION IV. PRINCIPLES OF OPERATION		
4-1.	Introduction.....	4-1
4-3.	Functional Description.....	4-1
4-4.	Power Supplies.....	4-1
4-5.	High-Voltage Power Supply.....	4-1
4-7.	PA Bias Power Supply.....	4-2
4-9.	RF Circuits.....	4-2
4-10.	FM Exciter.....	4-2

TABLE OF CONTENTS (Continued)

<u>Paragraph</u>		<u>Page</u>
4-11.	Intermediate Power Amplifier (IPA).....	4-2
4-15.	Power Amplifier (PA).....	4-5
4-20.	Output Circuit.....	4-6
4-23.	Directional Coupler.....	4-6
4-24.	Control Circuits.....	4-6
4-26.	Power On.....	4-6
4-27.	High Voltage On.....	4-6
4-28.	Overload Circuits.....	4-9
4-29.	Recycling.....	4-9
4-30.	VSWR Overload Interlock.....	4-9
4-31.	PA Screen Control.....	4-10
4-32.	AC Restart Circuit.....	4-10
4-35.	Status Lights.....	4-10
4-38.	Remote Control Interface.....	4-11
4-40.	Metering Circuits.....	4-13
4-41.	Local Metering.....	4-13
4-42.	Remote Metering.....	4-13

SECTION V. MAINTENANCE

5-1.	Introduction.....	5-1
5-3.	Purpose.....	5-1
5-5.	Station Records.....	5-1
5-7.	Transmitter Logbook.....	5-1
5-9.	Maintenance Logbook.....	5-1
5-11.	Safety Precautions.....	5-2
5-13.	Preventative Maintenance.....	5-2
5-15.	Filter Cleaning.....	5-3
5-17.	Blower Maintenance.....	5-3
5-19.	Maintenance of Components.....	5-3
5-21.	Semiconductors.....	5-3
5-22.	Capacitors.....	5-4
5-23.	Vacuum Capacitors.....	5-4
5-26.	Fixed Resistors.....	5-4
5-27.	Variable Resistors.....	5-5
5-28.	Transformers.....	5-5
5-29.	Fuses.....	5-5
5-30.	Meters.....	5-6
5-31.	Relays.....	5-6
5-32.	Switches.....	5-6
5-33.	Indicators and Indicator Switches.....	5-7
5-34.	Tubes.....	5-7
5-35.	Corrective Maintenance.....	5-8
5-37.	Adjustments.....	5-8
5-39.	Troubleshooting.....	5-8
5-45.	Technical Assistance.....	5-14

TABLE OF CONTENTS (Continued)

<u>Paragraph</u>		<u>Page</u>
SECTION VI. PARTS LIST		
6-1.	Introduction.....	6-1
6-3.	Replaceable Parts Service.....	6-1
SECTION VII. DIAGRAMS		
7-1.	Introduction.....	7-1
APPENDIX A. MANUFACTURERS DATA		
A-1.	Introduction.....	A-2

LIST OF TABLES

<u>Table</u>	<u>Page</u>
1-1. Electrical Characteristics.....	1-8
1-2. Mechanical/Environmental Characteristics	1-9
3-1. Controls and Indicators, External.....	3-4
3-2. Internal Controls and Indicators.....	3-8
4-1. Multiphase Supply Principle Ripple Characteristics.....	4-2
4-2. Control Circuit Relays.....	4-7
4-3. Status Light Relays.....	4-12
4-4. Meter Functions.....	4-14
5-1. Miscellaneous Adjustments.....	5-9
5-2. Troubleshooting.....	5-15
5-3. Typical Operating Meter Indications.....	5-17
5-4. Typical Primary Power Requirements.....	5-17
5-5. Typical FM-5K Transmitter Operating Characteristics.....	5-18
6-1. Replaceable Parts List Index.....	6-2
6-2. FM5K 5KW FM XMTR, 60 Hz.....	6-3
6-3. FM5K 5KW FM XMTR, 50 Hz.....	6-4
6-4. FM5K 5KW FM XMTR, 220/380V, 50 Hz.....	6-5
6-5. FM-5K 5KW FM XMTR.....	6-6
6-6. XMTR FM-5K 5KW.....	6-7
6-7. XMTR FM-5K 5KW 50HZ.....	6-8
6-8. XMTR FM-5K 5KW 50HZ.....	6-9
6-9. XMTR FM-5K 5KW 50HZ.....	6-10
6-10. Xmtr FM5G 5KW FM.....	6-11
6-11. Bias & Screen Contro.....	6-12
6-12. Front Access Panel.....	6-13
6-13. VSWR Intlk Unit.....	6-14
6-14. Assembly, PC Bd Amp.....	6-15
6-15. Assembly, PC Board.....	6-16
6-16. Status Lights Assy.....	6-17
6-17. Basic Pwr Amp Encl.....	6-18
6-18. P.A. Tube Deck Assy.....	6-19
6-19. Driver Metering Assy.....	6-20
6-20. Rmte Ctrl. Interface Bd.....	6-21
6-21. FM Pwr Output Kit.....	6-22
6-22. R.F. Output Ext. Kit.....	6-23

LIST OF ILLUSTRATIONS

<u>Figure</u>	<u>Page</u>
1-1. FM-5K FM BROADCAST TRANSMITTER.....	1-2
1-2. FM-5K Transmitter Simplified Block Diagram.....	1-5
2-1. Installation Drawing FM Transmitter.....	2-5
2-2. Notch Filter and RF Balun Assembly Details.....	2-7
2-3. Critical PA Circuit Dimensions.....	2-9
2-4. Transmitter Wiring.....	2-12
2-5. IPA Filament Adjustment.....	2-16
2-6. PA Control Grid Bias Adjustment.....	2-18
3-1. External Controls and Indicators.....	3-3
3-2. Internal Controls and Indicators.....	3-7
4-1. Six-Phase Circuit.....	4-1
4-2. FM-5K Simplified Schematic.....	4-3
5-1. Simplified Filament Control.....	5-19
5-2. Simplified Plate Control.....	5-21
7-1 Schematic Diagram, FM-5K Transmitter.....	7-3
7-2. PA Efficiency Graph.....	7-5
7-3. PA Coarse Tuning Graph.....	7-7
7-4. Low-Pass Filter Details.....	7-9
7-5. Second Harmonic Filter Details.....	7-11
7-6. Schematic Diagram, 380V, 50Hz.....	7-13

SECTION I

GENERAL DESCRIPTION

1-1. INTRODUCTION

1-2. This technical manual contains information necessary to install, operate, maintain, and service the HARRIS FM-5K BROADCAST TRANSMITTER. Sections in this technical manual provide the following information:

- a. SECTION I, GENERAL DESCRIPTION, provides a description of equipment features, identifies major components, and lists operating parameters and specifications.
- b. SECTION II, INSTALLATION, provides unpacking, inspection, and installation information, preoperational checks, and power on checks to ensure correct operation.
- c. SECTION III, OPERATION, identifies controls and indicators and provides equipment and operation procedures.
- d. SECTION IV, PRINCIPALS OF OPERATION, provides a functional description and detailed diagrams with theory of operation.
- e. SECTION V, MAINTENANCE, provides preventive and corrective maintenance information and troubleshooting with instructions for equipment servicing.
- f. SECTION VI, PARTS LIST, provides information for ordering replacement components and assemblies.
- g. SECTION VII, DIAGRAMS, provides block, logic, schematic diagrams, and other drawings required for equipment maintenance.

1-3. RELATED PUBLICATIONS

1-4. The following publications provide information to associated equipment.

<u>PUBLICATION NUMBER</u>	<u>EQUIPMENT IDENTIFICATION</u>
888 1742 001	MS-15 FM EXCITER
OR	OR
988 1957 001	MX-15 FM EXCITER

1-5. EQUIPMENT PURPOSE

1-6. The HARRIS FM-5K BROADCAST TRANSMITTER is a 5000-watt FM Transmitter designed for continuous broadcast operation (refer to figure 1-1). The transmitter uses a HARRIS FM Exciter and two tubes to provide reliable and efficient operation in the 87.5 to 108 MHz commercial FM Broadcast Band. FM Exciter plug-in modules provide monaural or stereophonic operation with up

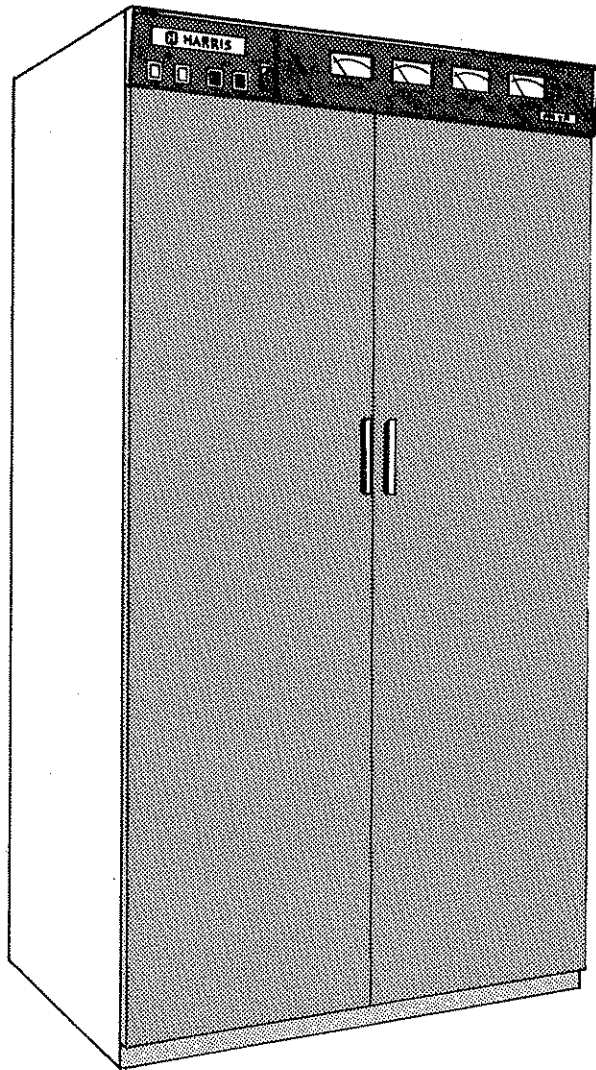

1761-5

Figure 1-1. FM-5K FM Broadcast Transmitter

to two SCA channels. Plug-in module provisions for operation of a future quadraphonic transmission system are also provided in the FM Exciter.

1-7. PHYSICAL DESCRIPTION

1-8. The entire unit, including the FM Exciter, IPA, PA, associated power supplies, metering, and control circuits are contained in one cabinet. All required metering is provided by four meters located on a panel along the top edge of the transmitter cabinet together with the four operational switches. The front doors open to expose the FM Exciter and all required operating controls necessary for normal operation in full view of all front panel indicators. Both the front and rear doors may be removed for better access if desired. The PA and IPA area is accessed through an interlocked rear cover. The control and power supply area is accessed through a hinged access panel in the front of the transmitter and also through the rear doors.

1-9. FUNCTIONAL DESCRIPTION

1-10. POWER SUPPLY CIRCUIT

1-11. Primary three-phase power at approximately 30 amperes per phase is required for the FM-5K Transmitter High-Voltage Power Supply, blower, and PA filament transformer (refer to figure 1-2). An additional single phase, 115 Vac circuit at approximately 1.5 amperes is required to power the FM Exciter, IPA filament transformer, PA bias power supply, screen voltage raise/lower motor, and the control circuits. Solid state rectifiers are used in all power supplies. The FM-5K Transmitter contains the following internal power supplies:

- a. High-Voltage Power Supply: +4300 Vdc is produced for a PA plate power supply, +2000 Vdc is produced for an IPA plate power supply, +500 to +850 is produced for a PA screen power supply, and 0 to +280 Vdc is produced for an IPA screen power supply.
- b. PA Bias Power Supply: -80 to -170 Vdc.
- c. Filament Supplies: Transformer T1 produces 7.5 Vac for the 4CX5000A PA tube filament. Transformer T2 produces 6.3 Vac for the 4CX250B IPA tube filament.

1-12. FM EXCITER

1-13. The FM Exciter produces a frequency modulated output continuously variable from three to 15 watts into a 50-ohm load for any channel assignment within the 87.5 to 108 MHz Commercial FM Broadcast Band. Servicing is simplified as the FM Exciter is modular in concept and discrete functions are complete within individual plug-in modules. The metering panel contains a true peak-reading audio meter and a multimeter which monitors important rf, audio, and control voltages. Light emitting diode (LED) status indicators monitor critical functions on each plug-in module. Operational modes include up to two SCA channels, monophonic, stereophonic, and provisions for future quadraphonic transmission.

1-14. RF CIRCUITS

1-15. Two tubes comprise the transmitter RF Chain. A 4CX250B tetrode IPA operated class B tube amplifies the FM Exciter output to a 250-watt level as required to drive the single-ended, class C operated 4CX5000A PA tube stage to output 5000 watts of rf power. Fixed bias ensure dependable PA stage operation. Grid leak bias, protected by the control circuitry and neutralization, ensures stable IPA stage operation. Forced-air cooling and an air switch arrangement ensures cool operation and long tube life.

1-16. The HARRIS developed Vari-Line system of tuning the single-ended output stage deletes the requirement for a blocking capacitor arrangement. A variable stub tunes the silver-plated tank circuit to resonance for maximum PA stage efficiency. The RF Output to the Antenna is fed through a 2nd Harmonic Stub Filter, Directional Coupler, and a Low-Pass Filter arrangement.

1-17. METERING

1-18. Two meters and an arrangement of light emitting diodes (LED) provides status indications of FM Exciter operation. Four meters monitor transmitter parameters relative to the IPA and PA stages. The MULTIMETER indicates IPA cathode current, PA filament voltage, and the relative PA RF drive level. The PLATE VOLTAGE Meter indicates PA plate circuit voltage. The PLATE CURRENT Meter indicates total PA stage dc current. An RF OUTPUT Meter provides indications of both RF Power Output and VSWR.

1-19. CONTROL CIRCUITS

1-20. The FM-5K Transmitter control circuits contain a step/start relay configuration for high-voltage application. Safety interlocks remove high voltage and interrupt the three-phase primary ac input if a transmitter access panel is opened during operation. A recycle feature monitors total IPA dc current and PA plate current. This feature turns off high voltage momentarily if a fault occurs and then automatically restores high voltage. If the fault is still present, or another overload occurs, another overload interruption cycle is accomplished. Up to three or four recycles within a preset time interval may be attempted before the transmitter shuts down and must be manually reset. The VSWR Interlock Unit will turn off the transmitter high voltage if the Transmission Line VSWR exceeds an adjustable predetermined level.

1-21. The AC Restart Circuit will return the transmitter to "on the air" automatically after a temporary or indefinite outage of either the 115 Vac single phase or the 230 Vac three-phase power source.

1-22. STATUS INDICATORS

1-23. A Status Light System is used to indicate that a malfunction has occurred in the FM-5K Transmitter. One of eight indicator lamps will illuminate if the air flow is insufficient, the front or rear door interlocks are open, an IPA or PA overload occurs, a VSWR overload occurs, the recycle lock-out due to continuous overloads has occurred, or a loss of IPA grid drive has occurred.

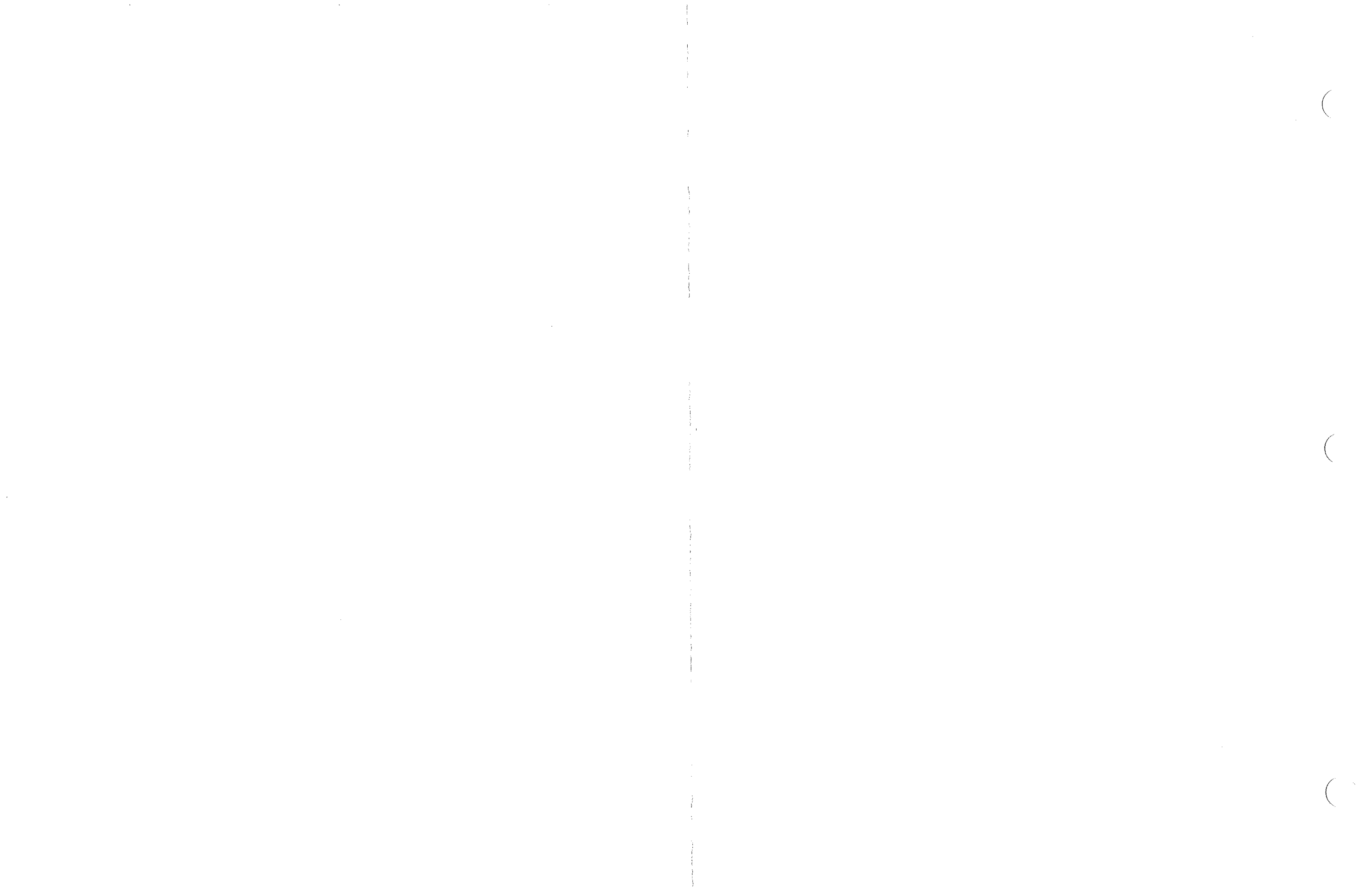

1-24. EQUIPMENT CHARACTERISTICS

1-25. ELECTRICAL CHARACTERISTICS

1-26. Table 1-1 lists electrical operating characteristics and parameters of the HARRIS FM-5K FM BROADCAST TRANSMITTER.

1-27. MECHANICAL/ENVIRONMENTAL CHARACTERISTICS

1-28. Table 1-2 lists physical and environmental characteristics of the HARRIS FM-5K FM BROADCAST TRANSMITTER.

NOTE

Specifications subject to change without notice.

Table 1-1. Electrical Characteristics

FUNCTION	CHARACTERISTIC
PRIMARY POWER REQUIREMENTS	
994-8049-001:	208/230-240 Vac $\pm 5\%$, three-phase closed delta, 50 Hz or 60 Hz (as ordered), at 30 amperes per phase (approximate).
994-8049-002:	208/230-240-250 Vac $\pm 5\%$, three-phase closed delta, 50 Hz, at 30 amperes per phase (approximate).
994-8049-004:	370-380-390 Vac $\pm 5\%$, three-phase closed delta, 50 Hz.
Exciter:	100 to 130 Vac or 200 to 260 Vac (as ordered) 50 Hz or 60 Hz, at 1.5 amperes (approximate).
POWER CONSUMPTION Typical for 5 kW output)	Three-phase circuit - 10 kW Single phase circuit - 180W
POWER FACTOR	90%
POWER LINE VARIATION (Slow)	$\pm 5\%$
RF POWER OUTPUT	1.0 to 5.1 kW (FCC Approved)
RF POWER IMPEDANCE	50 ohms
RF FREQUENCY RANGE	87.5 to 108 MHz
MAXIMUM VSWR	1.7 to 1
RF OUTPUT TERMINATION	3 1/8-inch (7.94 cm) EIA flange
RF HARMONIC SUPPRESSION	Meets all FCC requirements.
TUBES USED	1-4CX250B (IPA) 1-4CX5000A (PA)
Refer to FM Exciter specifications for additional characteristics.	

Table 1-2. Mechanical/Environmental Characteristics

FUNCTION	CHARACTERISTIC
Weight (Packed)	Export 900 pounds (405 kg) Domestic 750 pounds (338 kg)
Cubage	43.6 ft ³ (1.24 m ³)
Size	Width, 42 inches (107 cm) Depth, 33 inches (84 cm) Height, 78 inches (198 cm)
Front Door Swing	21 inches (53 cm)
Operating Temperature Range	0°C to 50°C. Usable to -20°C with slight reduction in operating parameters.
Maximum Altitude	7500 feet (2250 meters) above sea level.
Maximum Humidity	95% noncondensing
Cooling Air Requirements	400 CFM (11.33 m ³ /min) nominal 3.2 inches (8.13 cm) water gauge
Air Inlet Size	36.25 inches (92.08 cm) x 18.75 inches (47.63 cm)
Air Outlet Size	12 inches (30.48 cm) x 9 inches (22.86 cm)
Refer to FM Exciter specifications for additional characteristics.	

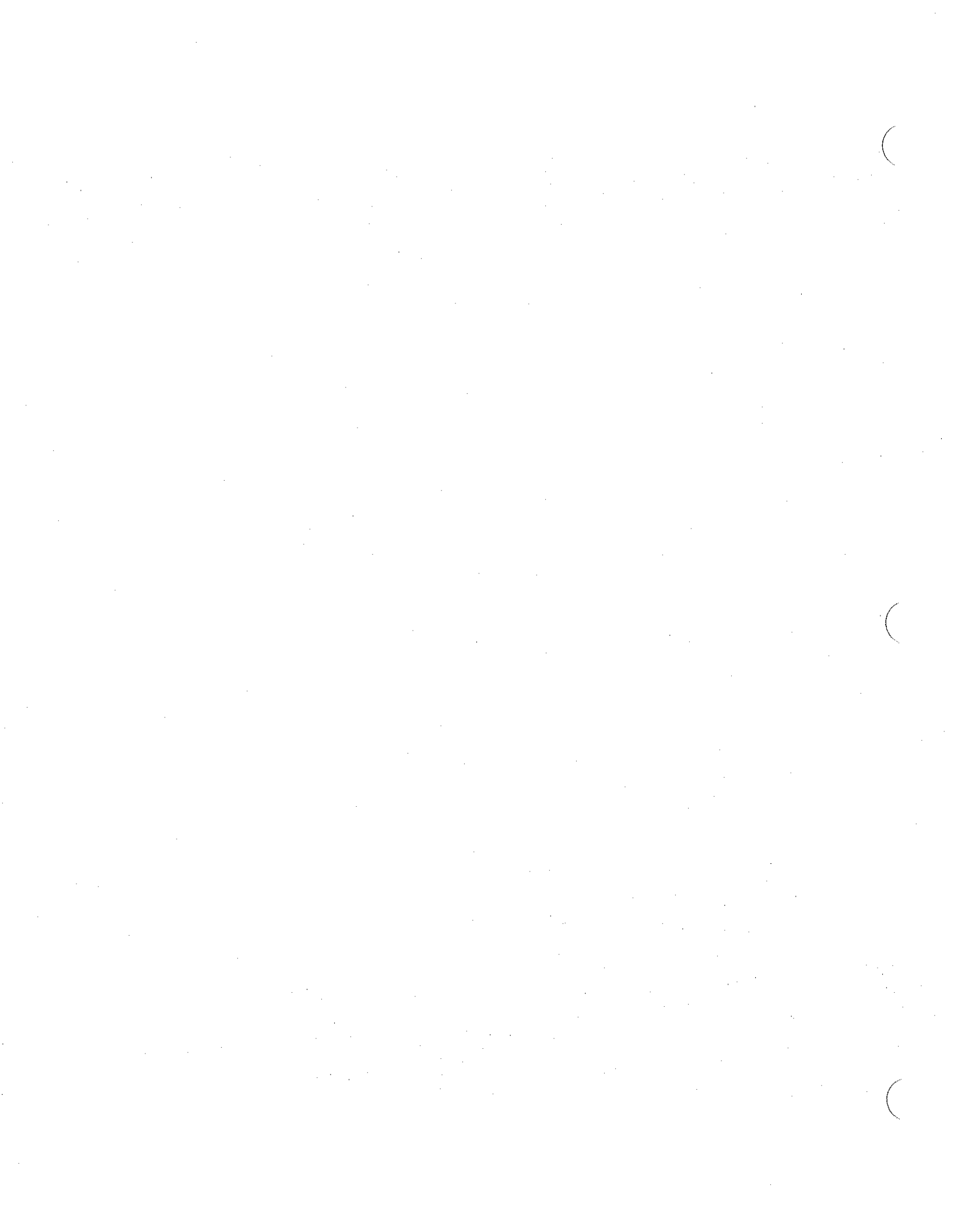

SECTION II

INSTALLATION

2-1. INTRODUCTION

2-2. This section contains information for installation of the HARRIS FM-5K BROADCAST TRANSMITTER and performing the preoperational checks. Many components are removed from the transmitter after final test for shipment. These components will be identified with appropriate instructions for reinstallation and wiring.

2-3. UNPACKING

2-4. Carefully unpack the FM-5K Transmitter and perform a visual inspection to determine that no apparent damage was incurred during shipment. Retain the shipping materials until it has been determined that the unit is not damaged. The contents of the shipment should be as indicated on the packing list. If the contents are incomplete or if the unit is damaged electrically or mechanically, notify the carrier and HARRIS CORPORATION, Broadcast Transmission Division.

2-5. RETURNS AND EXCHANGES

2-6. Damaged or undamaged equipment should not be returned unless written approval and a Return Authorization is received from HARRIS CORPORATION, Broadcast Transmission Division. Special shipping instructions and coding will be provided to assure proper handling. Complete details regarding circumstances and reasons for return are to be included in the request for return. Custom equipment or special order equipment is not returnable. In those instances where return or exchange of equipment is at the request of the customer, or convenience of the customer, a restocking fee will be charged. All returns will be sent freight prepaid and properly insured by the customer. When communicating with HARRIS CORPORATION, Broadcast Transmission Division, specify the Factory Order Number or Invoice Number.

2-7. INSTALLATION

2-8. Prior to installation, this manual should be carefully studied to obtain a thorough understanding of the principles of operation, circuitry and nomenclature. This will facilitate proper installation and initial checkout. FM-5K Transmitter installation is accomplished in four steps: (1) transmitter placement, (2) component installation, (3) transmitter wiring, and (4) initial checkout.

2-9. COOLING AIR REQUIREMENTS

2-10. If a means of exhausting hot air from the transmitter enclosure or room is used, the duct system must not introduce any back pressure on the transmitter air exhaust. Allowances must be made for a minimum air flow of 400 CFM (11.33 m³/minute) to ensure that only a limited amount of direct heat is dissipated into the transmitter interior. The duct work must have a

cross sectional area equal to the opening at the top of the transmitter. Sharp right angle bends in the duct system are not permissible. If it is necessary to turn a right angle, a radius type bend must be used. The exhaust fan in the duct system must overcome any duct losses and overcome any wind pressures if vented to the outside.

2-11. After the transmitter has operated at full output for a number of hours, the temperature rise inside the transmitter must not exceed a rise of 68°F (20°C) above the ambient temperature measured at the blower air intake. The ambient air temperature must not rise above 120°F (49-89°C) under any circumstance.

2-12. TRANSMITTER PLACEMENT

2-13. Set the transmitter in place on a level surface near power and signal cables. Either side of the FM-5K Transmitter may be placed against a wall or other equipment as complete accessibility for installation and maintenance is provided by the front and rear doors. The floor must be capable of supporting a load of 90 pounds (40.82 kg) per-square-foot (0.93 m²) (refer to figure 2-1).

2-14. COMPONENT INSTALLATION

2-15. Tubes, capacitors, connectors, cables, etc, are shipped in separate cartons. The removal of components varies due to method and requirements of shipment. All removed items will be tagged to permit reinstallation in the transmitter. Arrange these components in separate groups according to the section from which they were removed. Parts in the interior should be installed first. Both front and rear transmitter doors and access panels should be removed and left off until the installation of removed components and cabinet wiring hook-up is complete.

2-16. Items such as interconnecting wires and cables, shock-mounted devices and miscellaneous small parts may be taped or tied in for shipment. Remove all tape, string, and packing material that has been used for this purpose.

2-17. Symbol numbers and descriptions are provided on each removed component corresponding to the schematic diagram, parts list, and packing list. Symbol numbers are also stenciled near the cabinet location of each removed item. Terminals and wires are tagged with information telling how to reconnect each item. Mounting hardware will be found either in small bags attached to each removed component or inserted in the tapped holes where each component mounts. Reinstall each component in its proper location. Specific instructions follow for the following listed items (refer to figure 2-2).

QUANTITY	PART NUMBER	DESCRIPTION
1	942 3928 001	Notch Filter and RF Balun Assembly
1	374 0081 000	Tube, IPA, 4CX250B
1	813 9383 001	Exhaust Tubing and O Rings (IPA)
1	374 0016 000	Tube, PA, 4CX5000A
1	992 1600 001	Low-Pass Filter Assembly
1	994 7950 001/004	FM Exciter

2-18. Unblock the blower assembly.

2-19. Remove the two RF Coupling Loops from the exterior top portion of the balun assembly. Remove the balun inner connector. Secure the outer portion of the balun to the inside of the transmitter enclosure with four bolts.

2-20. Thread the stud, on the balun inner conductor, into the inner conductor of the Notch Filter. Tighten the connection.

2-21. Hold the Notch Filter over the balun outer conductor mounted in the transmitter and lower the center conductor into the balun. Secure the Notch Filter to the balun with the stainless steel strap clamp provided.

2-22. Remount the two RF Coupling Loops on the exterior top portion of the balun assembly.

2-23. Connect the lower end of the inner conductor of the balun to output loading capacitor C6.

2-24. Measure the vertical distance from the bottom of the adjustable portion of the balun to the PA tube deck (refer to figure 2-3). Refer to the test data sheets supplied with the transmitter for the proper measurement. This distance must be accurate within ± 0.125 inches (0.3175 cm) for proper operation. To adjust the balun, the Allen head set screws on the adjustable portion of the balun must be loosened.

2-25. Bolt the Low-Pass Filter in the transmission line between the Notch Filter and the antenna coaxial cable. The Low-Pass Filter bolts to the Notch Filter with four bolts. Six bolts secure the Low-Pass Filter to the antenna coaxial cable. Two supports are required for the filter assembly.

2-26. Note the alignment key on the 4CX250B tube base. Carefully align, insert, and push the tube into the IPA socket until properly seated.

2-27. Install the IPA anode connector around the 4CX250B tube anode and tighten securely.

2-28. Lower the air exhaust tube through the opening of the PA deck onto the top of the IPA anode connector. The tube is held in place with an O-ring above the PA deck and an O-ring below the PA deck surface.

2-29. The method of connecting the PA anode to the PA plate circuit is determined by the transmitter frequency. If one link is used, proceed to paragraph 2-30. If two links are used, proceed to paragraph 2-34.

2-30. Permanently mark the position of the PA tube connection link. Remove the link to allow installation of the PA tube.

CAUTION

AVOID BUMPING THE 4CX5000A TUBE. DUE TO THE LARGE MASS OF THE TUBE, BUMPING WILL INTRODUCE STRESSES WHICH MAY CAUSE INTERNAL DAMAGE.

2-31. Note the alignment line of the PA tube anode and the alignment line marked on the PA tube chimney. Carefully align, insert, and push the tube into the PA socket until properly seated.

2-32. Examine the underneath side of the PA tube socket to ensure the tube is properly seated and that the fingerstock makes good contact with the tube conducting rings.

2-33. Replace the PA tube connection link in the original position as marked. Loosen the PA anode connector and clamp the PA tube connection link to the PA plate. Ensure the link is inside the clamp. Proceed to step 2-39.

2-34. Permanently mark the positions of the PA tube connection links. Remove the links to allow installation of the PA tube.

CAUTION

AVOID BUMPING THE 4CX5000A TUBE. DUE TO THE LARGE MASS OF THE TUBE, BUMPING WILL INTRODUCE STRESSES WHICH MAY CAUSE INTERNAL DAMAGE.

2-35. Note the alignment line on the PA tube anode and the alignment line marked on the PA tube chimney. Carefully align, insert, and press the tube into the PA socket.

2-36. Examine the underneath side of the PA tube socket to ensure the tube is properly seated and that the fingerstock makes good contact with the tube conducting rings.

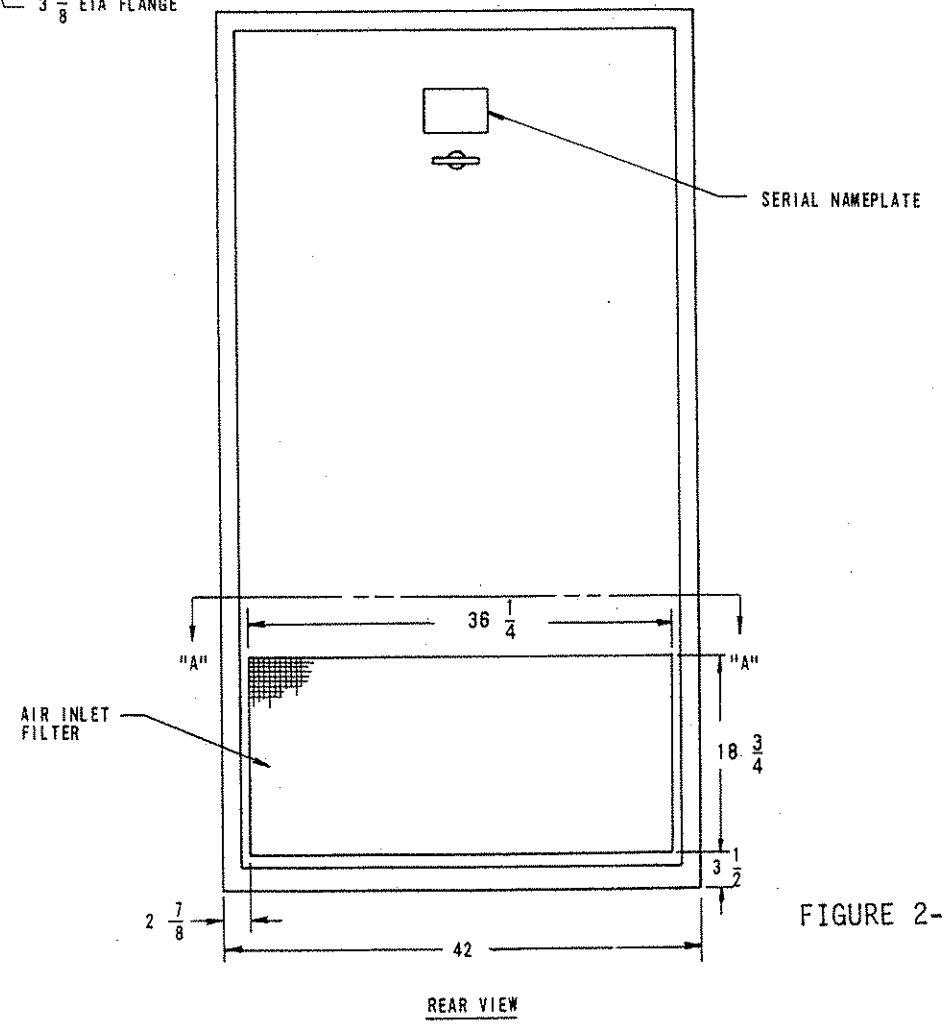
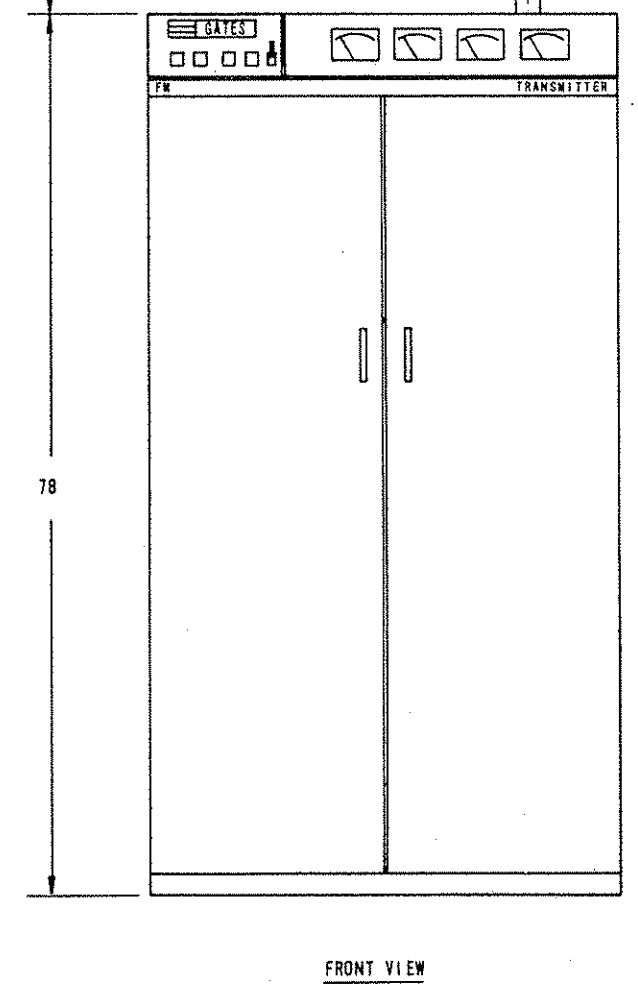
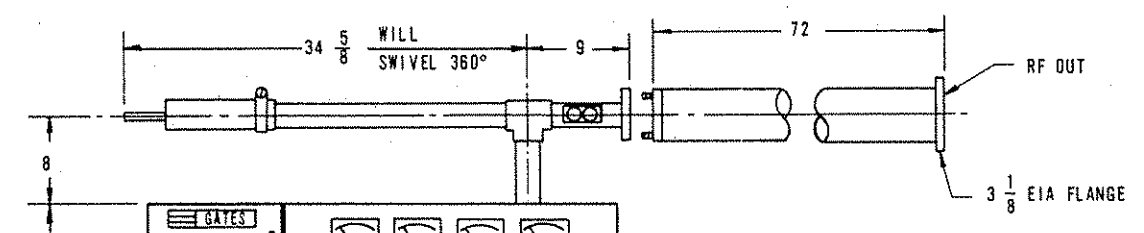
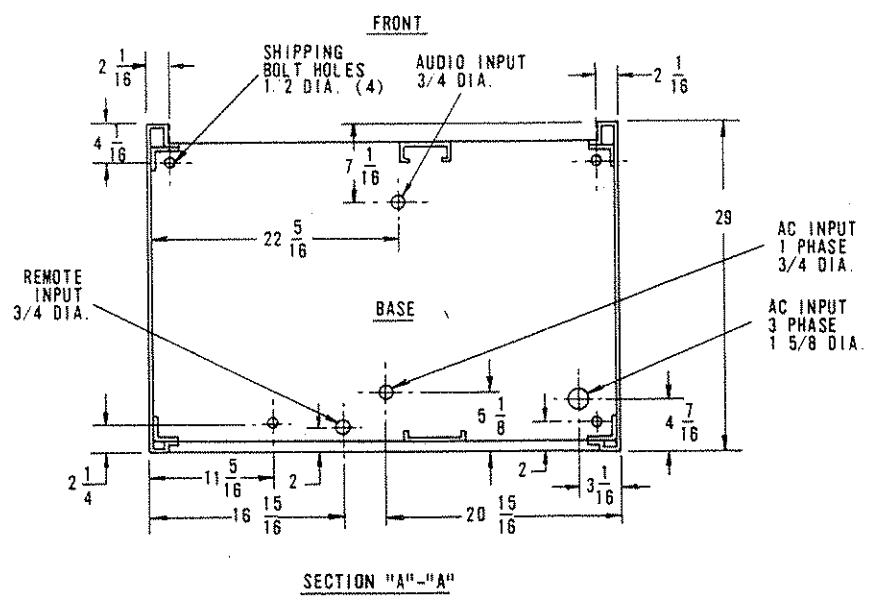
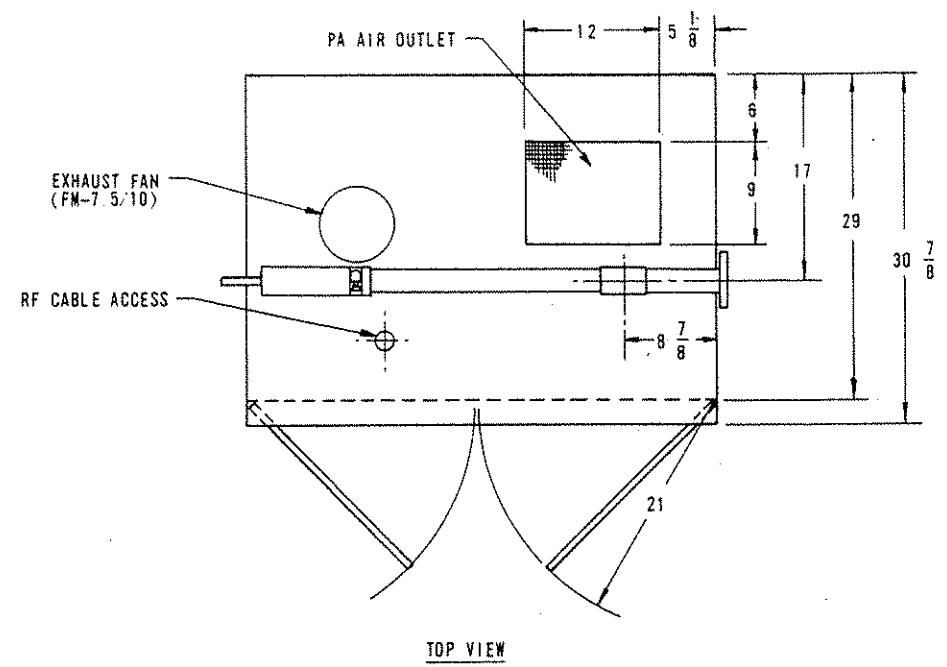
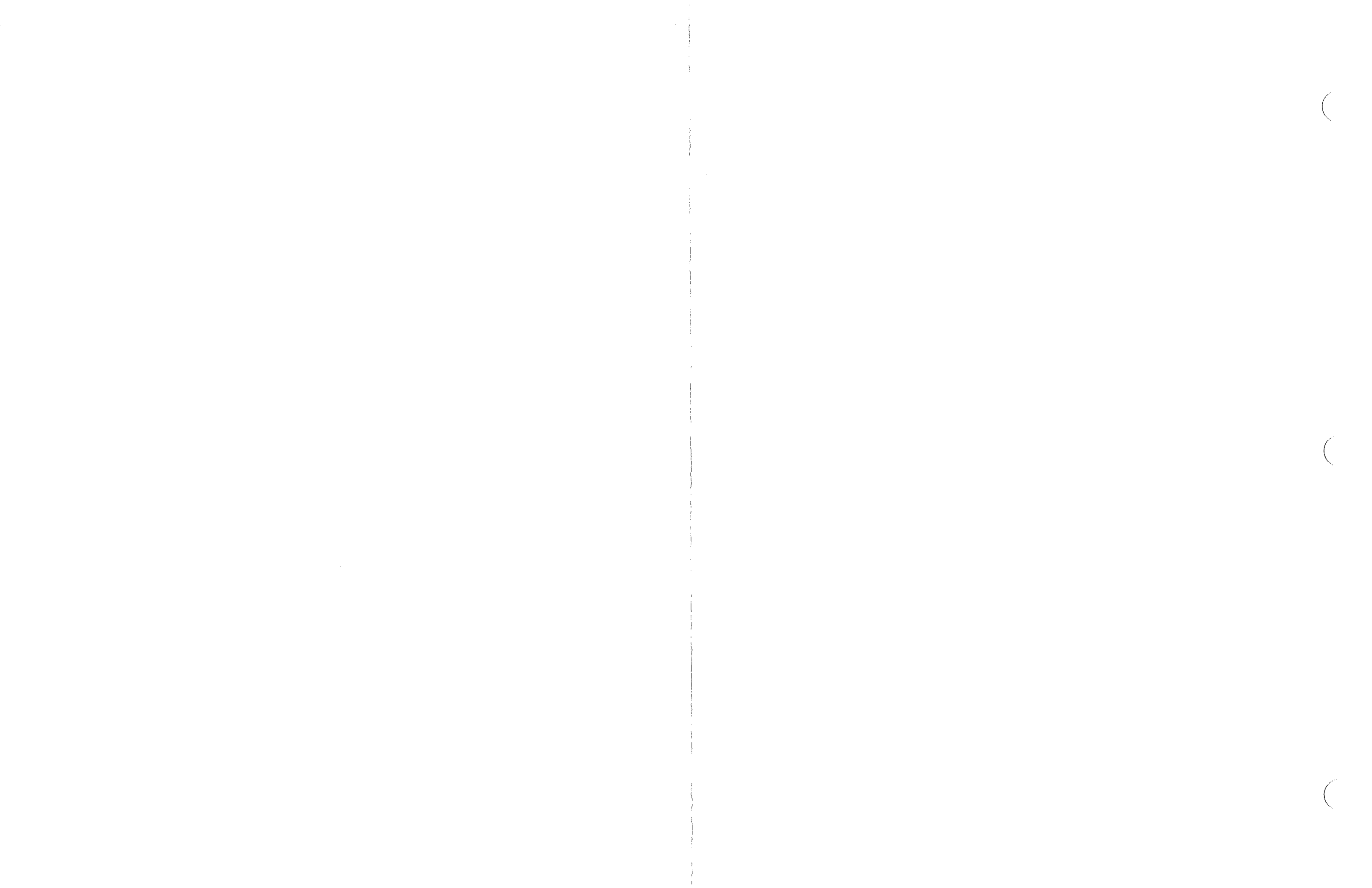
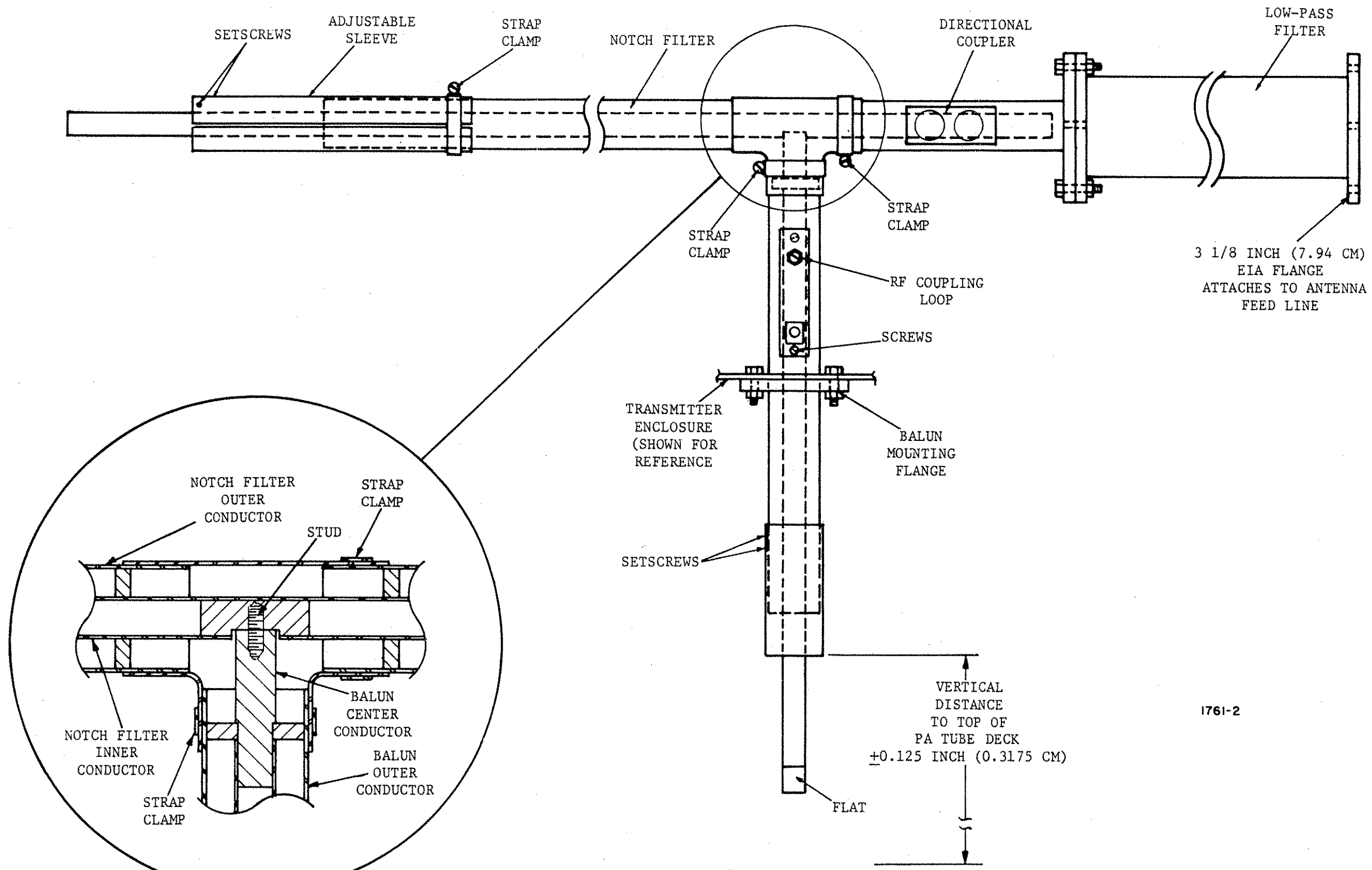

FIGURE 2-1. INSTALLATION DRAWING
FM TRANSMITTER
838 0857 001





1761-2

FIGURE 2-2. NOTCH FILTER AND RF BALUN ASSEMBLY DETAILS

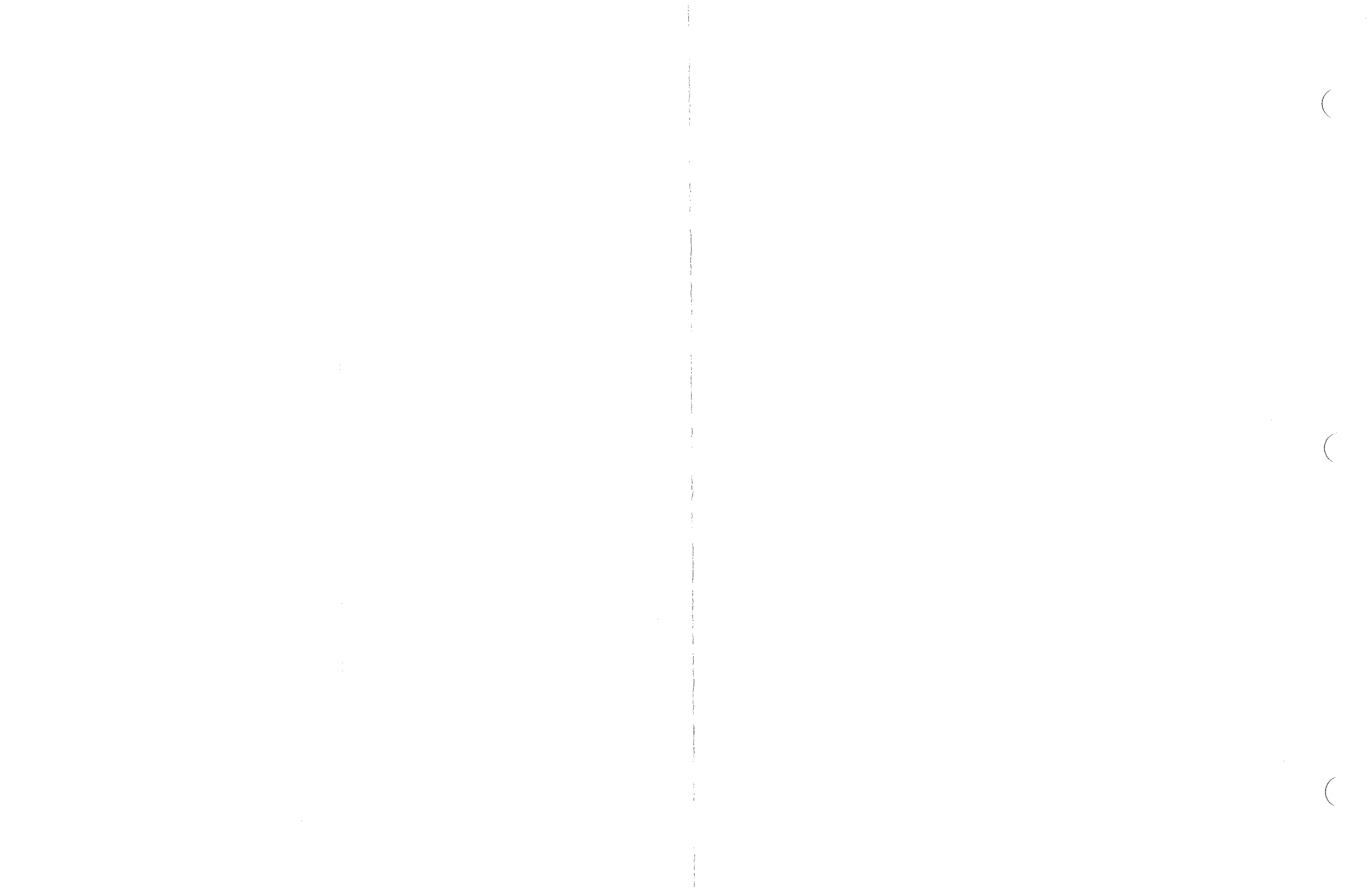

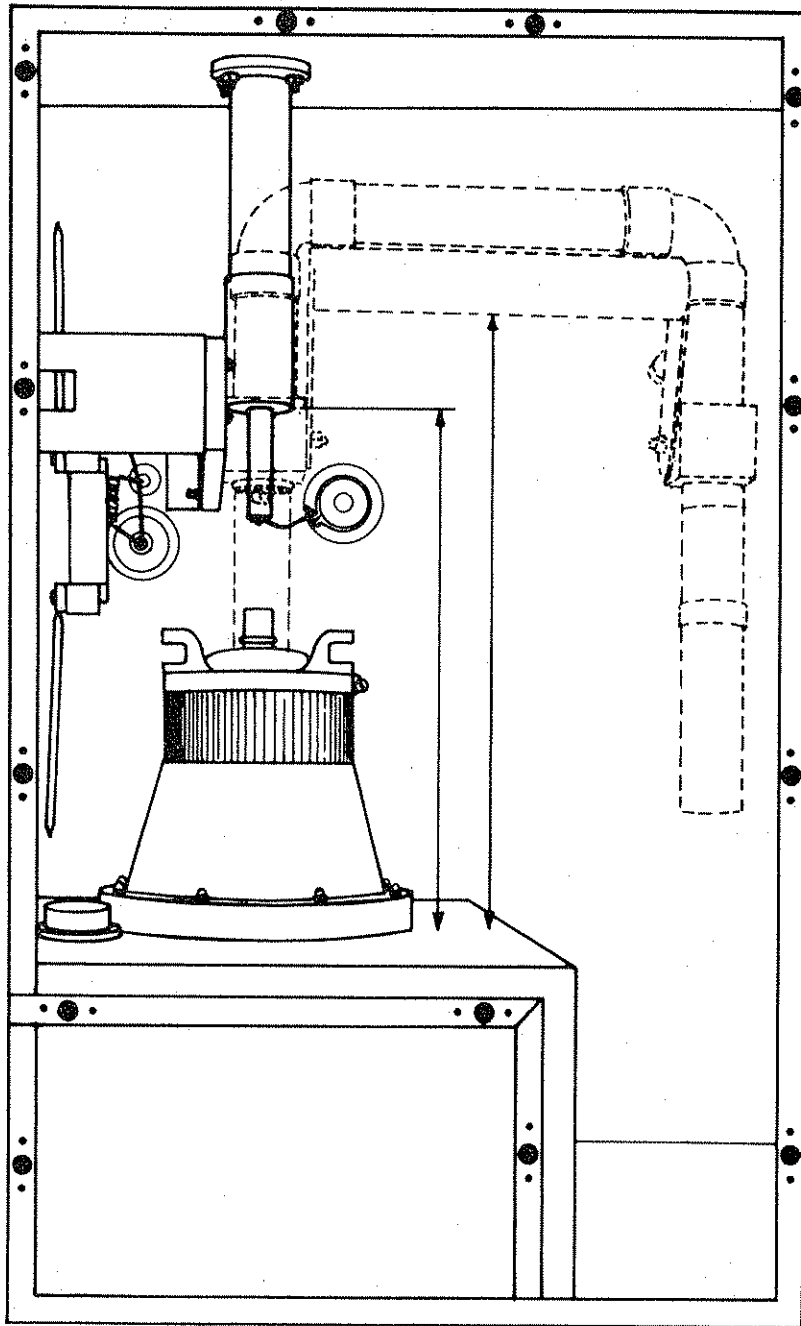

1761-9

Figure 2-3. Critical PA Circuit Dimensions

888-1761-005

2-9

WARNING: Disconnect primary power prior to servicing.

2-37. Replace the PA tube connection links in the original positions as marked. The links must be approximately 180° from each other and must not be placed over the tube handles.

2-38. Loosen the PA anode connector and clamp the PA tube connection links to the PA plate. Ensure the links are inside the clamp.

2-39. Measure the vertical distance from the bottom of the rotary portion of the PA plate circuit to the top of the PA tube deck (see figure 2-3). Refer to the test data sheets supplied with the transmitter for the proper measurement. This distance must be accurate within ± 0.0625 inches (0.15875 cm) for proper operation. Loosen the rotary section if adjustment is required.

2-40. TRANSMITTER WIRING

2-41. The following wiring connections are required. Wiring information is shown on figure 2-4.

WARNING

ENSURE PRIMARY POWER IS OFF BEFORE PROCEEDING. USE THE GROUNDING STICK AND DISCHARGE ANY RESIDUAL POTENTIAL FROM ALL COMPONENTS BEFORE TOUCHING THEM BEFORE ATTEMPTING WIRING.

2-42. EXCITER WIRING. Locate the ac power plug taped inside the transmitter near the FM Exciter. Refer to the FM Exciter publication and ensure the ac power connector is wired for the correct primary voltage configuration. Connect the ac power plug to AC POWER connector J2 on the FM Exciter rear panel.

2-43. Locate two red wires taped inside the transmitter near the FM Exciter. Connect one of the red wires to FM Exciter terminal block TB2 at terminal 35. Connect the remaining red wire to terminal 36.

2-44. Locate the coaxial cable taped inside the transmitter near the exciter. Connect the cable to RF OUTPUT 50 ohm connector J3 on the FM Exciter rear panel with the adapter furnished.

2-45. Route the audio and FM Exciter control cables up to the FM Exciter and connect the wires. Refer to the FM Exciter Technical Manual for detailed instructions.

2-46. GROUND. Chassis ground connects to earth ground at the tapped hole in the cabinet base located near the three-phase fuse block. Remove the paint from around the hole and connect the ground with number 8 THW wire or larger (a 1/4-20 X 1 inch screw and internal shake washers are required).

2-47. PRIMARY POWER. Three-phase closed-delta 208/240 Vac, 50/60 Hz at approximately 30 amperes per phase is required for the transmitter main power supply. A separate 110 to 130 Vac 50/60 Hz service at 1.5 amperes is also required.

2-48. Connect the three-phase service to fuse blocks XF3, XF4, and XF5. This service should be connected with number 8 THW wire or larger and fused at the service disconnect switch for 60 amperes per phase. Ensure the ground connection is secure.

2-49. Connect the single phase service to fuse blocks XF1 and XF2. This service should be fused at the service disconnect switch for 10 amperes.

2-50. MONITORS. Connect a signal monitor (if used) to receptacle J3 on the RF Balun Assembly (rf coupling loop) with RG 58/U coaxial cable.

2-51. ANTENNA. Connect the antenna system to the Low-Pass Filter output. The FM-5K Transmitter uses a 3-1/8-inch (7.94 cm) EIA flange with six bolts to attach the transmission line.

2-52. Route the cable from receptacle J1 on the remote power rectifier unit in the center back of the transmitter through the top of the cabinet and connect plug P2 to receptacle J2 on the RF Balun assembly (rf coupling loop).

2-53. Route the red and yellow indexed cables from the FOR PWR/VSWR CAL/VSWR switch through the top of the transmitter cabinet. Connect the red indexed cable to the TRANSMITTER jack and connect the yellow indexed cable to the LOAD jack of the Directional Coupler.

2-54. CONNECTIONS TO REMOTE CONTROLS

2-55. The FM-5K Transmitter may be operated by remote control by installing a remote control system. If the transmitter is to be remotely controlled, it is important to initiate thorough inspection and maintenance procedures at the transmitter location. Installation of equipment to monitor temperature and humidity at the remote transmitter site is also suggested. Terminations provided in the FM-5K Transmitter allow remote control of the following transmitter functions by connection to terminal boards TB6, TB10, TB201, TB202, and TS301 (refer to figure 2-4) when the REMOTE/LOCAL switch is set to REMOTE.

- a. EXCITER. Some remote functions require connections to the rear of the FM Exciter. These are described in the appropriate Exciter Technical Manual.
- b. STATUS LIGHTS. Condition of the transmitter status lights can be determined remotely from contact closures available on terminal board TB202. Refer to figures 2-4 and 7-1.
- c. FILAMENT AND PLATE VOLTAGE CONTROL. Refer to figures 2-4 and 7-1.

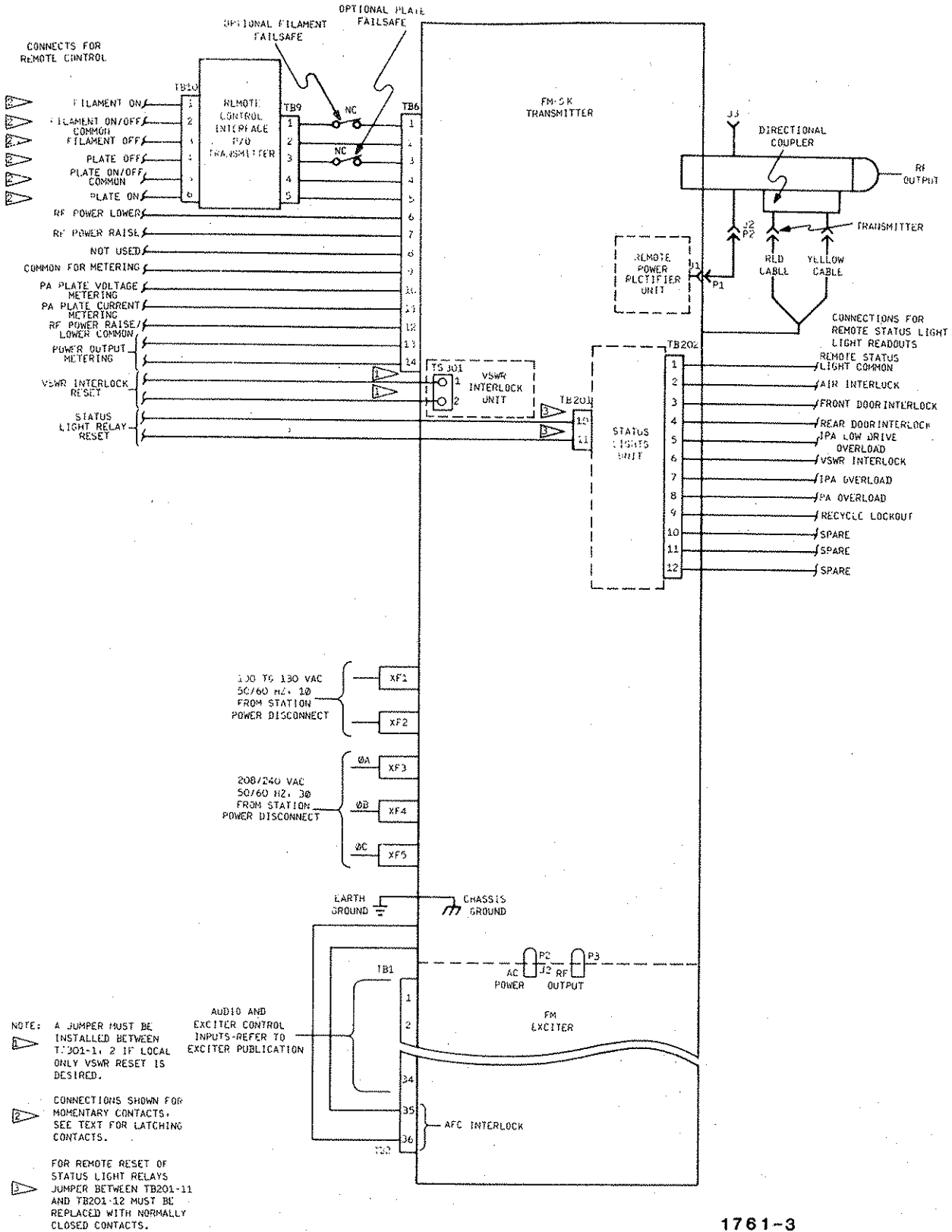

Figure 2-4. Transmitter Wiring

1. Latching Contacts. If the remote control equipment has latching or continuous contact closures, the filaments and plates are controlled at terminal board TB6. A continuous closure between terminals 1 and 2 on terminal board TB6 will maintain FILAMENT ON. PLATE OFF is obtained by opening contacts between terminals 3 and 4 on terminal board TB6. PLATE ON is obtained by either momentary or continuous closure between terminals 4 and 5 on terminal board TB6.

NOTE

It will be necessary to remove the wire between terminal 3 on terminal board TB6 and terminal 3 on terminal board TB9 when PLATE OFF is controlled by opening of contacts between terminals 3 and 4 on terminal board TB6.

2. Momentary Contacts. If the remote control equipment has momentary contact closure, the filament and plate are controlled at terminal board TB10. The filaments are turned on by a momentary closure between terminals 1 and 2 on terminal board TB10. Filaments are turned off by a momentary closure between terminals 4 and 5 on terminal board TB10. Plates are turned on by a momentary closure between terminals 5 and 6 on terminal board TB10.

NOTE

Failsafe connections may be made by installing normally closed contacts between 1 on terminal board TB6 and terminal 1 on terminal board TB9 (filament fail-safe) or between terminal 3 on terminal board TB6 and terminal 3 on terminal board TB9 (plate fail-safe).

- d. RF POWER RAISE/LOWER. The output power will rise when a contact closure is placed between terminals 7 and 12 on terminal board TB6 and will lower when a contact closure is placed between terminals 6 and 12 on terminal board TB6.
- e. PA PLATE VOLTAGE METERING. This circuit provides 10 Vdc maximum to operate a remote meter which connects to terminals 9 (-) and 10 (+) on terminal board TB6. Adjustment potentiometer R51 matches the input requirements of the monitoring device.
- f. PA PLATE CURRENT METERING. This circuit provides 10 Vdc maximum to operate a remote meter which connects to terminals 9 (-) and 10 (+) on terminal board TB6. Adjustment potentiometer R11 matches the input requirements of the monitoring device.

- g. RF POWER OUTPUT METERING. A remote indication of sampled RF Output Power is provided by the M4845 remote RF Rectifier Unit. An adjustment matches the input requirements of the monitoring device which connects to terminals 13 (+) and 14 (-) on terminal board TB6.
- h. VSWR INTERLOCK RESET. The VSWR INTERLOCK overload relay may be remotely reset by installing a normally closed set of contacts between terminal strip terminals TS301-1 and TS301-2. If local only reset is desired, a jumper must be installed between terminals TS301-1 and TS301-2.

2-56. INITIAL CHECKOUT

WARNING

DISCONNECT AND LOCK OUT STATION PRIMARY POWER BEFORE PROCEEDING. USE THE GROUNDING STICK AND DISCHARGE ANY RESIDUAL POTENTIAL FROM ALL COMPONENTS BEFORE TOUCHING THEM.

2-57. Each transmitter is thoroughly checked out during factory final test but adjustment is normally required during installation due to shipping, variations in primary power, antenna systems, or transmission line differences. A 20k ohms/volt multimeter (Simpson 260 or equivalent) is required to assist the checkout.

2-58. The complete transmitter should be inspected at this time. Check the following:

- a. Ensure that primary power is connected to the three-phase fuse block.
- b. Ensure that primary power is connected to the single-phase fuse block.
- c. Ensure that primary power is connected to the FM Exciter.
- d. Ensure that audio inputs are connected to the FM Exciter.
- e. Ensure that all connections at terminal boards and components are tight.
- f. Remove any extra hardware lying within the cabinet and tighten all nuts and bolts.
- g. Rotate the blower to be sure no obstructions are present.

- h. Manually check relay and solenoid armature operation. Ensure that they all have free unobstructed movement.
- i. All wire and cabling should be dressed properly and secured.
- j. All ducts and shielding should be in place.
- k. Ensure that the two Allen head set screws at the adjustment end of the 2nd Harmonic Trap are tight.
- l. Thoroughly clean the interior with a vacuum cleaner.

2-59. Refer to the Factory Test Data Sheets supplied with the transmitter and set the PA PLATE TUNING control, the PA OUTPUT LOADING control, and the IPA PLATE TUNING control as indicated on the sheets. The transmitter was checked into a 50-ohm resistive load. Therefore, any system with a mismatch will change the tuning and loading and the recorded control indications on Factory Test Data Sheets may not agree exactly with actual operation.

2-60. Adjust the IPA SCREEN control to the approximate center position.

2-61. Set the REMOTE/LOCAL switch to LOCAL.

2-62. Operate the MULTIMETER switch to PA FIL.

2-63. Open the transmitter rear door.

WARNING

USE THE GROUNDING STICK TO DISSIPATE
RESIDUAL POTENTIAL FROM ALL COMPONENTS
BEFORE TOUCHING THEM.

2-64. Connect a voltmeter to the FIL TEST jacks on the rear of the IPA deck (refer to figure 2-5). Adjust the range of the voltmeter to accommodate approximately 6 Vac. Run the leads of the meter to the outside of the cabinet. DO NOT BYPASS THE DOOR INTERLOCK SWITCH.

2-65. Close the transmitter rear door.

2-66. Apply station primary power to the transmitter.

2-67. Depress FIL ON pushbutton switch. The FIL ON indicator will illuminate and the blower will start.

2-68. Adjust the PA FILAMENT control to obtain a 7.5 volt MULTIMETER indication.

2-69. Adjust IPA Filament control potentiometer R18, located on the side of the IPA deck (refer to figure 2-5), to obtain a 6.0 Vac indication on the

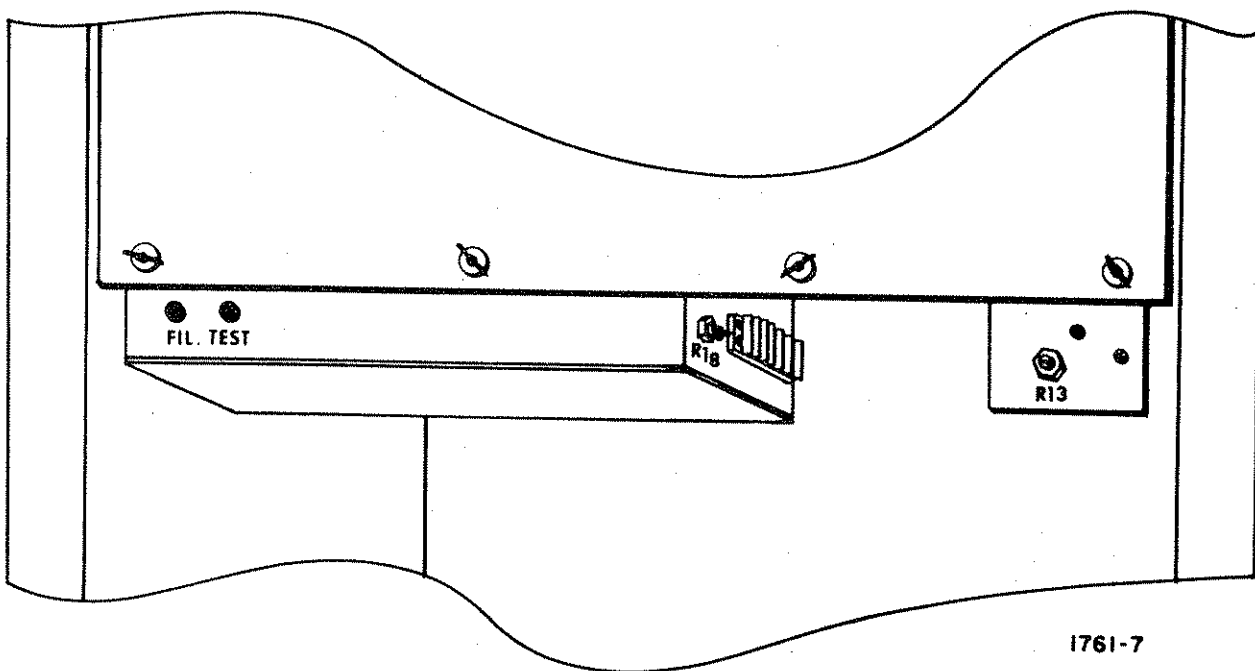

Figure 2-5. IPA Filament Adjustment

voltmeter. This adjustment will have to be accomplished in small increments due to the the rear door being interlocked which will necessitate the door being opened and closed several times. DO NOT BYPASS THE DOOR INTERLOCK SWITCH.

WARNING

DANGEROUS POTENTIALS ARE EXPOSED WITHIN THE TRANSMITTER. DO NOT TOUCH ANY COMPONENTS WITHIN THE TRANSMITTER DURING ADJUSTMENT OF R18.

2-70. Depress FIL OFF pushbutton switch.

WARNING

DISCONNECT AND LOCK OUT STATION PRIMARY POWER.

2-71. Open the transmitter rear door.

WARNING

USE GROUNDING STICK TO DISSIPATE RESIDUAL POTENTIAL FROM ALL COMPONENTS BEFORE TOUCHING THEM.

2-72. Disconnect the voltmeter from the FIL TEST jacks and close the transmitter rear door.

2-73. Open the transmitter left front access panel.

WARNING

USE GROUNDING STICK TO DISSIPATE RESIDUAL POTENTIAL FROM ALL COMPONENTS BEFORE TOUCHING THEM.

2-74. Connect a voltmeter to terminal board TB3 (refer to figure 2-6). Connect the voltmeter negative lead to terminal 3 and the positive lead to terminal 4. Adjust the range of the voltmeter to indicate approximately -150 Vdc. Run the voltmeter leads to the outside of the transmitter. DO NOT BYPASS THE PANEL INTERLOCK SWITCH.

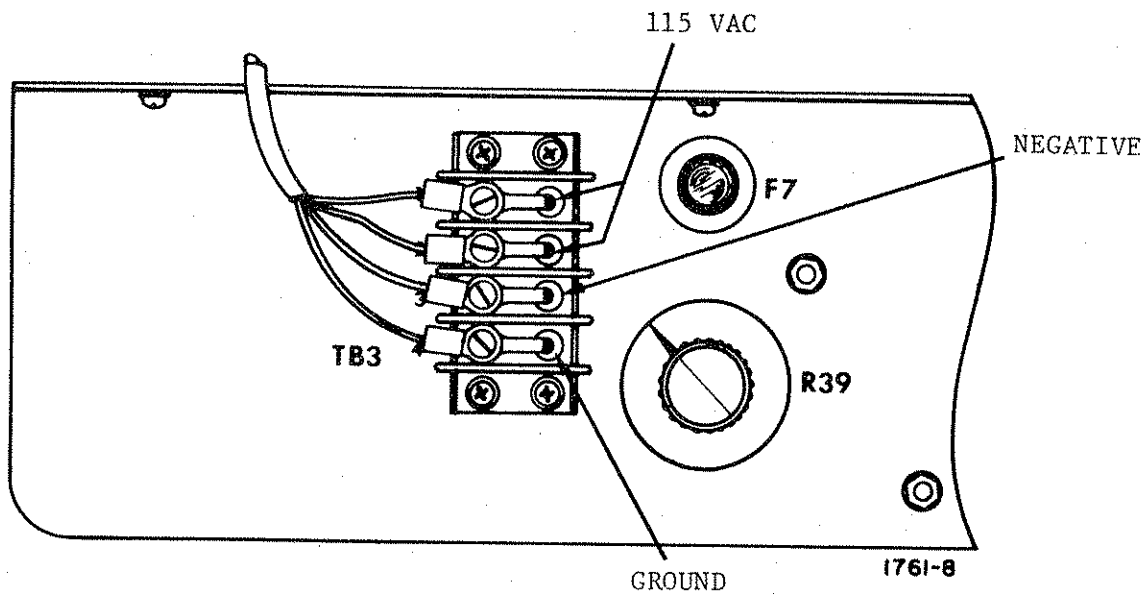

Figure 2-6. PA Control Grid Bias Adjustment

WARNING

DANGEROUS POTENTIALS ARE EXPOSED WITHIN THE TRANSMITTER. DO NOT TOUCH ANY COMPONENTS WITHIN THE TRANSMITTER DURING ADJUSTMENT OF POTENTIOMETER R39.

- 2-75. Close the transmitter left front access panel.
- 2-76. Apply primary power to the transmitter.
- 2-77. Depress FIL ON pushbutton switch.
- 2-78. Refer to the Factory Test Data Sheets supplied with the transmitter and adjust Grid Bias potentiometer R39 to obtain the PA control grid voltage listed. It may be necessary to open and close the access panel several times to accomplish this adjustment. DO NOT BYPASS THE PANEL INTERLOCK SWITCH.
- 2-79. Depress FIL OFF pushbutton switch.

WARNING

DISCONNECT AND LOCK OUT STATION PRIMARY POWER.

- 2-80. Open the transmitter left front access panel.

WARNING

USE GROUNDING STICK TO DISSIPATE RESIDUAL POTENTIAL FROM ALL COMPONENTS BEFORE TOUCHING THEM.

- 2-81. Disconnect the voltmeter from terminal board TB3.
- 2-82. Close the transmitter left front access panel.
- 2-83. Apply power to the transmitter and depress FIL ON pushbutton switch.
- 2-84. Operate the PA SCREEN RAISE/LOWER switch to LOWER and hold the switch energized until the PA Screen control is fully counterclockwise (minimum rf power).

2-85. Refer to the FM Exciter Technical Manual and complete the preliminary checkout in Section II. DO NOT set the Exciter POWER ON/OFF switch to OFF when completed.

CAUTION

EXTREME CARE MUST BE OBSERVED AT ALL TIMES TO AVOID EVEN MOMENTARY OPERATION OF THE PA UNDER CONDITIONS OF INSUFFICIENT PLATE LOADING OR EXCESSIVE RF DRIVE. THESE OPERATING CONDITIONS WILL PRODUCE EXCESSIVELY HIGH TUBE TEMPERATURES AND WILL RESULT IN DAMAGE TO THE PA TUBE.

- 2-86. Operate the MULTIMETER switch to IPA K.
- 2-87. Operate the FOR PWR/VSWR CAL/VSWR switch to FOR PWR.
- 2-88. Depress PLT ON pushbutton switch. The PLT ON indicator will illuminate.
- 2-89. Adjust the IPA SCREEN control to obtain an approximate 50 percent MULTIMETER indication (maximum IPA current is 0.250 amperes).

NOTE

During the tune up procedure, it may be necessary to readjust the IPA SCREEN control to prevent the PA from drawing excessive plate current.

- 2-90. Adjust the IPA PLATE TUNING control to obtain a dip in the MULTIMETER indication (maximum PA current is 2.6 amperes).
- 2-91. Operate the PA SCREEN RAISE/LOWER switch to RAISE and hold the switch activated until the PLATE CURRENT meter indicates approximately 1.5 amperes.
- 2-92. Adjust the PA PLATE TUNING control to obtain a dip in the PLATE CURRENT meter indication.
- 2-93. Adjust the PA OUTPUT LOADING control to peak the RF OUTPUT meter indication.
- 2-94. Operate the FOR PWR/VSWR CAL/VSWR switch to VSWR CAL.
- 2-95. Adjust the VSWR CAL control to obtain a full scale RF OUTPUT meter indication.
- 2-96. Operate the FOR PWR/VSWR CAL/VSWR switch to VSWR.

2-97. Note the RF OUTPUT meter indication. The transmitter will operate into a 1.7:1 maximum mismatch, however it is recommended the VSWR be kept to a minimum.

2-98. If the VSWR is 1.5:1 or less, the screen voltage of the IPA and the PA stage may be increased until both are at maximum or near maximum. The IPA PLATE TUNING, the PA PLATE TUNING, and the PA OUTPUT LOADING controls may be adjusted to obtain the maximum output with the most overall efficient operation. The maximum VSWR which can be tolerated is 1.7:1.

2-99. Operate the MULTIMETER switch to PA DR and record the MULTIMETER indication in divisions for future reference.

2-100. Check the VSWR INTERLOCK circuit for proper operation as follows:

- a. Depress the PLT OFF pushbutton switch.
- b. Adjust the VSWR CAL control (release the locking knob) to its CCW position.
- c. Set the VSWR INTERLOCK selector switch to TEST.
- d. Depress the PLT ON pushbutton switch and adjust for normal power output.
- e. Depress the VSWR TEST pushbutton switch and with the VSWR/VSWR CAL/FOR PWR selector switch in the VSWR CAL position adjust the VSWR CAL control until the VSWR interlock pilot light is lit.
- f. At the factory the VSWR dc amplifier is adjusted so the relay circuit is energized at a VSRW of approximately 1.5:1.
- g. Adjust the VSWR CAL control to its CCW position.
- h. Depress the VSWR INTERLOCK RESET pushbutton switch.
- i. Set the VSWR INTERLOCK selector switch to ON.
- j. Adjust the VSWR CAL control until the VSWR interlock pilot light is illuminated. At the same time the transmitter high voltage should be turned OFF. Release the VSWR TEST pushbutton switch.
- k. Depress the VSWR interlock RESET pushbutton switch.
- l. Set the VSWR INTERLOCK selector switch to OFF.
- m. Depress the PLT ON pushbutton.
- n. Adjust the VSWR CAL control for full scale reading on the power meter and then lock the control. This reference must be maintained for normal operation.

- o. Operate the VSWR/VSWR CAL/FOR selector switch in the FOR PWR position.
- 2-101. The VSWR Interlock control circuit is ready to begin operation after the VSWR INTERLOCK selector switch is set to the ON position.
- 2-102. Depress PLT OFF pushbutton switch.
- 2-103. After a three-minute delay, to allow the tubes to cool, depress FIL OFF pushbutton switch.
- 2-104. This completes the initial checkout.

SECTION III

OPERATION

3-1. INTRODUCTION

3-2. This section contains operation procedures and information pertaining to identification, location, and function of the controls and indicators on the HARRIS FM-5K BROADCAST TRANSMITTER.

3-3. CONTROLS AND INDICATORS

3-4. Figures 3-1 and 3-2 show the location of all FM-5K Transmitter controls and indicators. Tables 3-1 and 3-2 list all controls and indicators with the function of each item listed.

3-5. Controls and indicators for the FM Exciter are described in the FM Exciter Technical Manual.

3-6. OPERATION

3-7. The operation procedure is presented under the assumption that the transmitter has been thoroughly and properly aligned and is free of any discrepancies. Visually inspect the transmitter to ensure that no foreign objects are inside the cabinet, all parts and components are properly installed, all connectors are secure, and all doors and panels are closed.

3-8. TRANSMITTER TURN ON

3-9. During normal operation FIL ON pushbutton switch is depressed. If the transmitter is remotely controlled, a closed contact is established across the filament on terminals of terminal board TB6 by the remote control system to turn on transmitter power. This contact is maintained as a failsafe requirement. The FIL ON indicator will illuminate, the blower will operate, and power will be applied to the FM Exciter, IPA filament, and the transmitter control circuitry. When the blower pressure closes the air switch, power will be applied to the PA filament circuit.

CAUTION

IT IS RECOMMENDED THAT THREE MINUTES ELAPSE BETWEEN OPERATION OF THE FIL ON SWITCH AND THE PLT ON SWITCH. THIS PROCEDURE WILL TEND TO INCREASE TUBE LIFE.

3-10. After approximately three minutes of filament operation, the PLT ON pushbutton switch may be depressed. This will enable high voltage and the PLT ON indicator will illuminate. If the transmitter is remotely controlled, a momentary contact across the high-voltage ON contacts of terminal board TB6 energizes high voltage. The transmitter is now operational.

3-11. Operate the PA SCREEN RAISE/LOWER switch as required to establish the correct RF Power output level. Provisions allow remote control of this feature by connections to terminal board TB6.

3-12. TRANSMITTER SHUTDOWN

CAUTION

THE PLT OFF PUSHBUTTON SWITCH MUST BE DEPRESSED BEFORE THE FIL OFF PUSHBUTTON SWITCH TO ALLOW A PERIOD OF BLOWER OPERATION TO COOL THE IPA AND PA TUBES. THIS PROCEDURE WILL TEND TO INCREASE TUBE LIFE.

3-13. To turn the transmitter off, depress the PLT OFF pushbutton switch. The PLT ON indicator will extinguish and high voltage will be removed from the transmitter. If the transmitter is remotely controlled a momentary open contact across the high-voltage off contacts of terminal board TB6 will deenergize high voltage.

3-14. After a delay of approximately three minutes, depress the FIL OFF pushbutton switch. The FIL ON indicator will extinguish and all circuits in the transmitter will now be deenergized. If the transmitter is remotely controlled, the contact across the filament on terminals of terminal board TB6 is opened. Due to the FM Exciter design, there are no circuits such as a crystal oven which require operation when the transmitter is off.

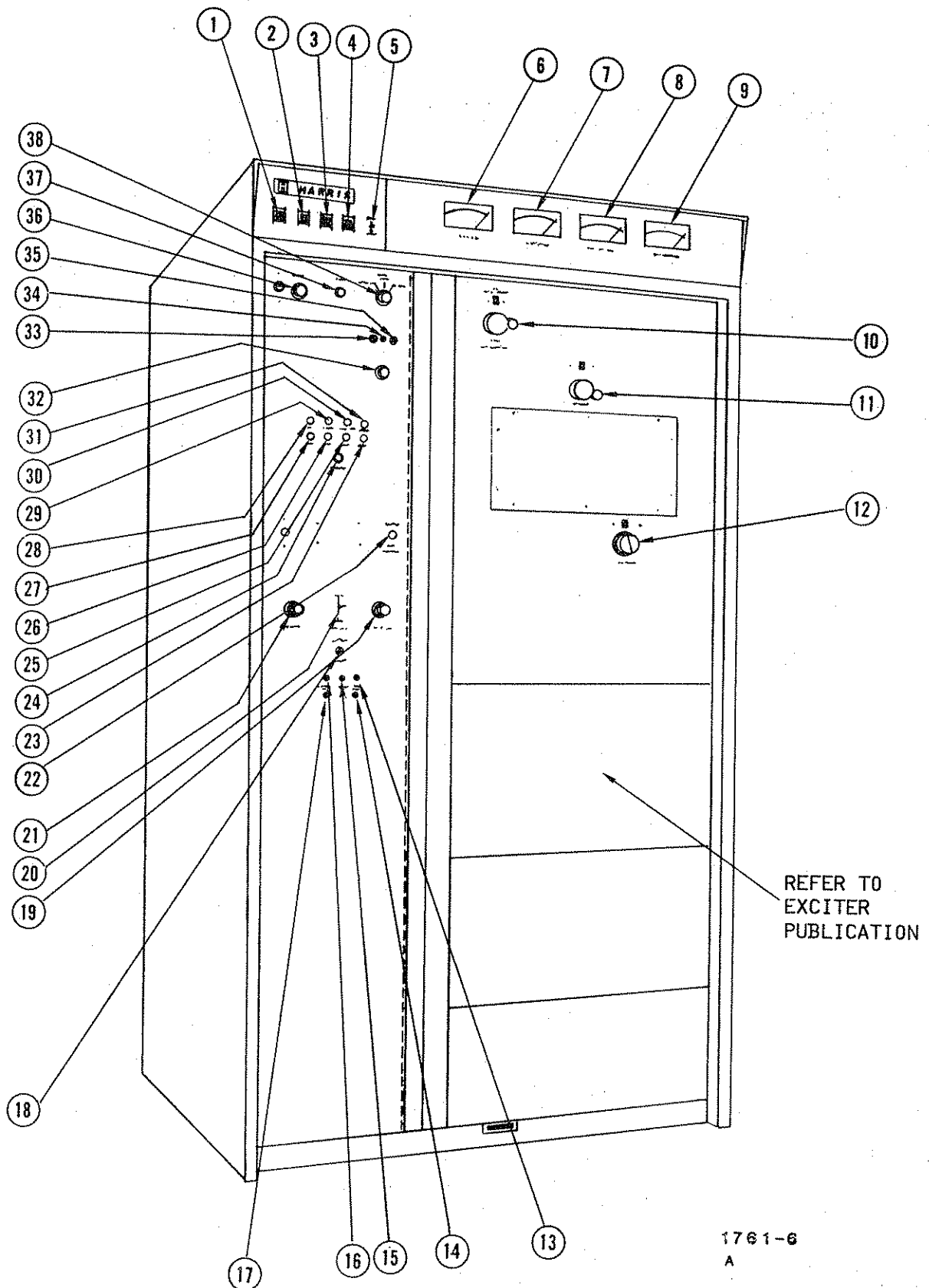

Figure 3-1. Controls and Indicators, External

888-1761-005

3-3

WARNING: Disconnect primary power prior to servicing.

Table 3-1. Controls and Indicators, External

REF.	CONTROL/INDICATOR	FUNCTION
1	FIL ON Pushbutton Switch/ Indicator S4/A1	Enables primary power and indicates voltage is applied to all circuits except the High-Voltage Power Supply.
2	FIL OFF Pushbutton Switch S3	Turns off power to entire transmitter.
3	PLT ON Pushbutton Switch/ Indicator S6/A2	Energizes the high voltage power supply primary. Indicator illuminates when high voltage is energized.
4	PLT OFF Pushbutton Switch S5	Turns off high voltage.
5	IPA K/PA FIL/PA DR MULTIMETER Switch S10	Selects desired point to monitor voltage or current with the MULTIMETER.
6	MULTIMETER Meter M1	Indicator voltage or current selected by MULTIMETER switch.
7	PLATE CURRENT Meter M2	Indicates the PA stage plate current.
8	PLATE VOLTAGE Meter M3	Indicates the PA plate potential.
9	RF OUTPUT Meter M4	Indicates VSWR or transmitter RF Output power as selected by the FORPWR/VSWR CAL/VSWR switch.
10	PA PLATE TUNING Plate Line L2	Adjusts tuning of the PA plate circuit.
11	PA OUTPUT LOADING Capacitor C6	Adjusts coupling of PA to antenna.
12	IPA PLATE TUNING Coil L6	Adjusts tuning of the IPA plate circuit and tuning of the PA grid circuit simultaneously.

Table 3-1. Controls and Indicators, External (Continued)

REF.	CONTROL/INDICATOR	FUNCTION
13	REMOTE I_p Potentiometer R11	Provides an adjustment of the remote PA plate current indicator range.
14	REMOTE E_p Potentiometer R51	Provides an adjustment of the remote PA plate voltage indicator range.
15	RECYCLE Potentiometer R25	Adjusts the sensitivity of the K5 overload circuit to allow for a variable number of power interruptions prior to automatic transmitter shutdown.
16	IPA CATHODE OVERLOAD Potentiometer R28	Presets the IPA overload relay (K6) to operate when IPA cathode current exceeds 9.250 amperes.
17	PA PLATE OVERLOAD Potentiometer R29	Presets the PA overload relay (K7) to operate when high voltage power supply current exceeds 2.6 amperes.
18	REMOTE/LOCAL Switch S7	Selects transmitter local or remote operation.
19	PA FILAMENT Potentiometer R33	Adjusts the PA filament voltage.
20	PA SCREEN RAISE/LOWER Switch S11	Controls power to PA screen grid voltage control circuit.
21	IPA SCREEN Potentiometer R26	Adjusts the IPA screen potential.
22	AC RESTART Switch S601	Provides automatic transmitter restart in the event of ac power failure when switch is in the OPERATE position.
23	LOCKOUT Indicator DS208	Illuminates when a continuous IPA or PA overload occurs.
24	RESET Pushbutton Switch S201	Extinguishes status indicators when depressed.
25	PA OVERLOAD Indicator DS207	Illuminates when PA tube draws excessive plate current.

Table 3-1. Controls and Indicators, External (Continued)

REF.	CONTROL/INDICATOR	FUNCTION
26	IPA OVERLOAD Indicator DS206	Illuminates when PA tube draws excessive current.
27	VSWR Indicator DS205	Illuminates when a transmission line VSWR overload has occurred.
28	AIR Indicator DS201	Illuminates when air flow to the tube has been interrupted.
29	FRONT DOOR Indicator DS202	Illuminates when front door interlock has been opened.
30	REAR DOOR Indicator DS203	Illuminates when rear door interlock has been opened.
31	IPA DRIVE Indicator DS204	Illuminates when IPA grid current drops below 8 ma (low rf drive).
32	VSWR INTERLOCK Switch S301	Selects between the OFF mode, TEST mode, and ON mode of the VSWR interlock unit. Allows the unit to be tested or disabled.
33	TEST Pushbutton Switch S304	When depressed allows calibration of the VSWR interlock unit.
34	VSWR Indicator DS301	Illuminates when VSWR interlock relay K302 is energized.
35	RESET Pushbutton Switch S302	When depressed resets the VSWR interlock unit.
36	VSWR CAL Potentiometer R8	Allows adjustment of the RF OUTPUT meter VSWR display.
37	PWR CAL Potentiometer R9	Allows adjustment of the RF OUTPUT meter power display.
38	FOR PWR/VSWR CAL/VSWR Switch S303	Selects between an RF OUTPUT meter display of RF Output power or VSWR. Allows calibration of the VSWR display.

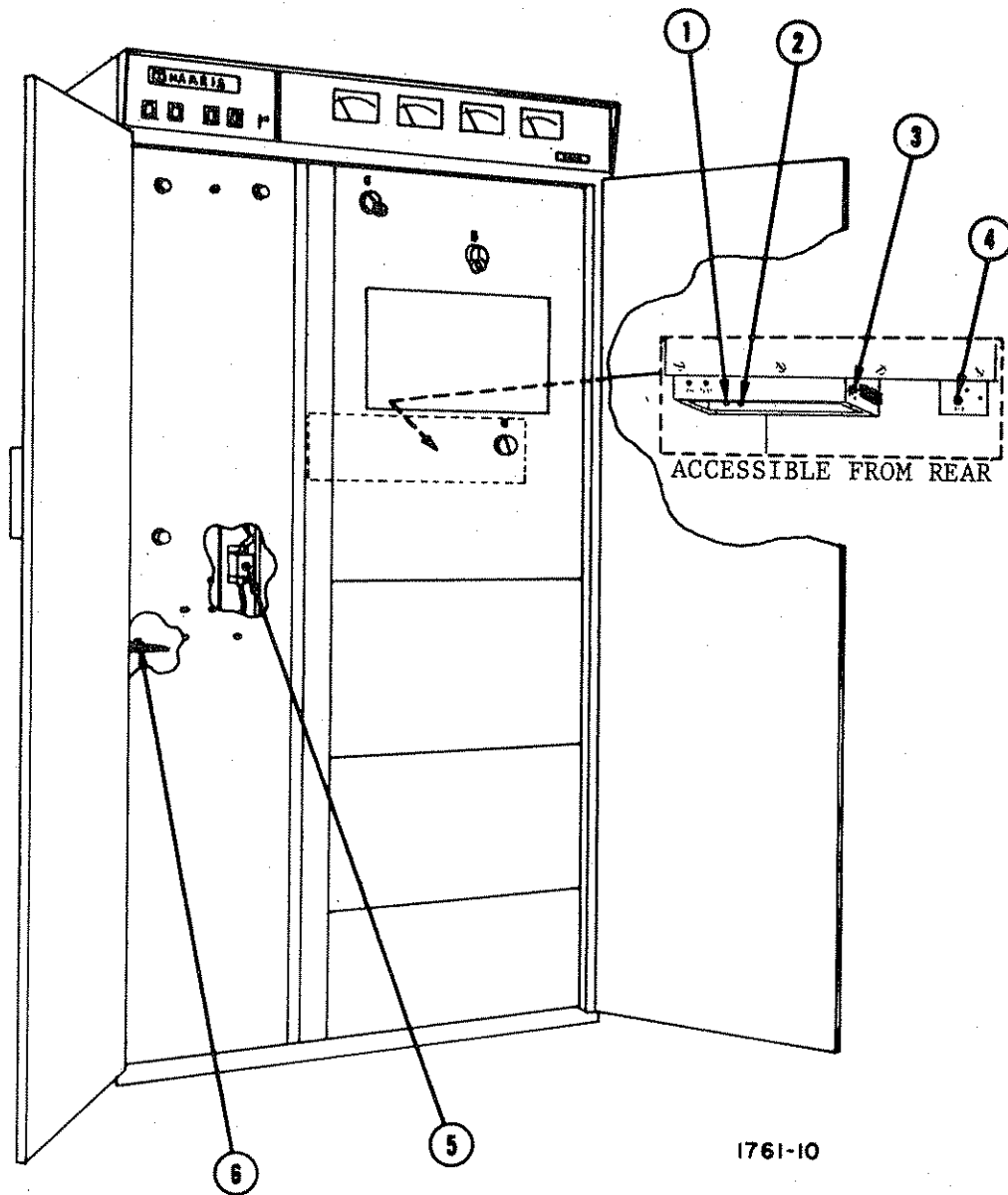

Figure 3-2. Controls and Indicators, Internal

888-1761-005

3-7

WARNING: Disconnect primary power prior to servicing.

Table 3-2. Internal Controls and Indicators

REF.	CONTROL/INDICATOR	FUNCTION
1	IPA Grid Tuning Coil L8	Adjusts IPA grid loading.
2	IPA Grid Tuning Coil L7	Adjusts IPA grid circuit tuning.
3	IPA Filament Control Potentiometer R18	Adjusts the IPA filament voltage.
4	IPA Filament Control Potentiometer R13	Calibrates the MULTIMETER PA filament voltage indication when the MULTIMETER switch is set to PA FIL.
5	Remote Power Indicator Calibrate Potentiometer R6	Provides an adjustment of the remote power indicator range.
6	PA Bias adjust Potentiometer R39	Adjusts the bias voltage applied to the PA control grid.

SECTION IV

PRINCIPLES OF OPERATION

4-1. INTRODUCTION

4-2. This section presents detailed principles of operation for the HARRIS FM-5K BROADCAST TRANSMITTER with supporting diagrams.

4-3. FUNCTIONAL DESCRIPTION

4-4. POWER SUPPLIES

4-5. **HIGH-VOLTAGE POWER SUPPLY.** The High-Voltage Power Supply primary is connected in a closed delta configuration. A half-voltage supply is provided as an IPA plate supply from the transformer center tap (refer to figure 4-1). Two adjustable voltage dividers provide a 0 to 250 Vdc IPA screen supply and a 500 to 850 Vdc PA screen supply from the IPA plate potential. The secondary of the High-Voltage Power Supply transformer is connected in a wye configuration. Due to the physical construction of the transformer, each secondary phase separation (60°) divided into one cycle of primary phase rotation (360°) will equal six secondary phases. The six-phase circuit used in the FM-5K Transformer requires little filtering as 4 percent ripple is approached without using a filter (refer to table 4-1).

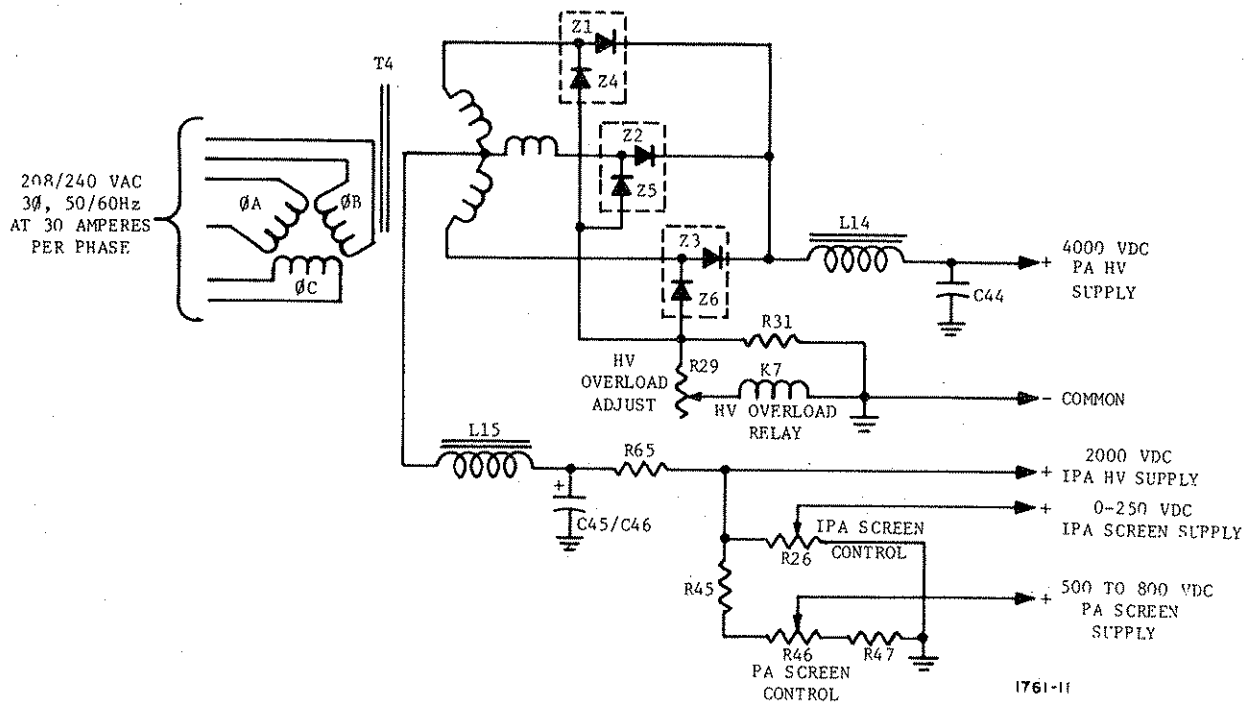

Figure 4-1. Six-Phase Circuit

Table 4-1. Multiphase Supply Principle Ripple Characteristics

SECONDARY PHASES	PRIMARY LINE POWER FACTOR	SINGLE SECTION FILTER RIPPLE VOLTAGE (Resistive or Inductive Load)	
		PEAK-TO-PEAK	RMS
3	0.83	50.0%	17.7%
6	0.96	11.4%	4.0%

4-6. A requirement of the multiphase supply is that the three-phase primary line voltage must be balanced to within the percentage of ripple voltage which is to be obtained from the power supply. The principle output ripple frequency will equal the primary line frequency times the secondary phases. Line unbalance will show up as 100 or 120 Hz ripple in the rectifier circuit and produce increased output ripple. A five percent primary line voltage unbalance will produce approximately three percent peak ripple in the secondary circuit into a resistive or inductive load at twice the power line frequency. Constant primary line unbalance can be corrected by the use of primary taps or a tapped three-phase auto transformer.

4-7. PA BIAS POWER SUPPLY. The PA Bias Power Supply produces an adjustable -90 Vdc to -170 Vdc potential for a PA fixed bias supply (refer to figure 4-2). The primary 115 Vac single phase input to the supply is energized whenever the FIL ON pushbutton switch/indicator is illuminated.

4-8. The supply comprises transformer T3, full-wave bridge rectifier Z7, and a one-stage filter circuit. Overload protection is provided by fuse F7. The Bias Adjustment Control potentiometer R39 provides an adjustment for the supply output potential. During operation, voltage drop across bleeder resistor R41 will develop additional bias whenever PA grid drive produces over 40 mA of grid current with a -160 volt fixed bias.

4-9. RF CIRCUITS

4-10. FM EXCITER. Refer to the Exciter Technical manual.

4-11. INTERMEDIATE POWER AMPLIFIER (IPA). RF from the FM Exciter is applied to the grid of tube 4CX250B through a tuned circuit several megahertz wide (refer to figure 4-2). Approximately 8 milliamperes of grid current is produced by grid leak bias to operate the stage. If less than 8 milliamperes of grid current is present, the stage is protected by relay K9 which opens to disable high voltage.

4-12. Stable operation of the IPA stage is ensured by neutralization. The degenerative feedback required for neutralization is formed by stray capacitance between the IPA anode and a small stud on a ceramic insulator adjacent to the IPA anode. This adjustment is factory sealed and should not require

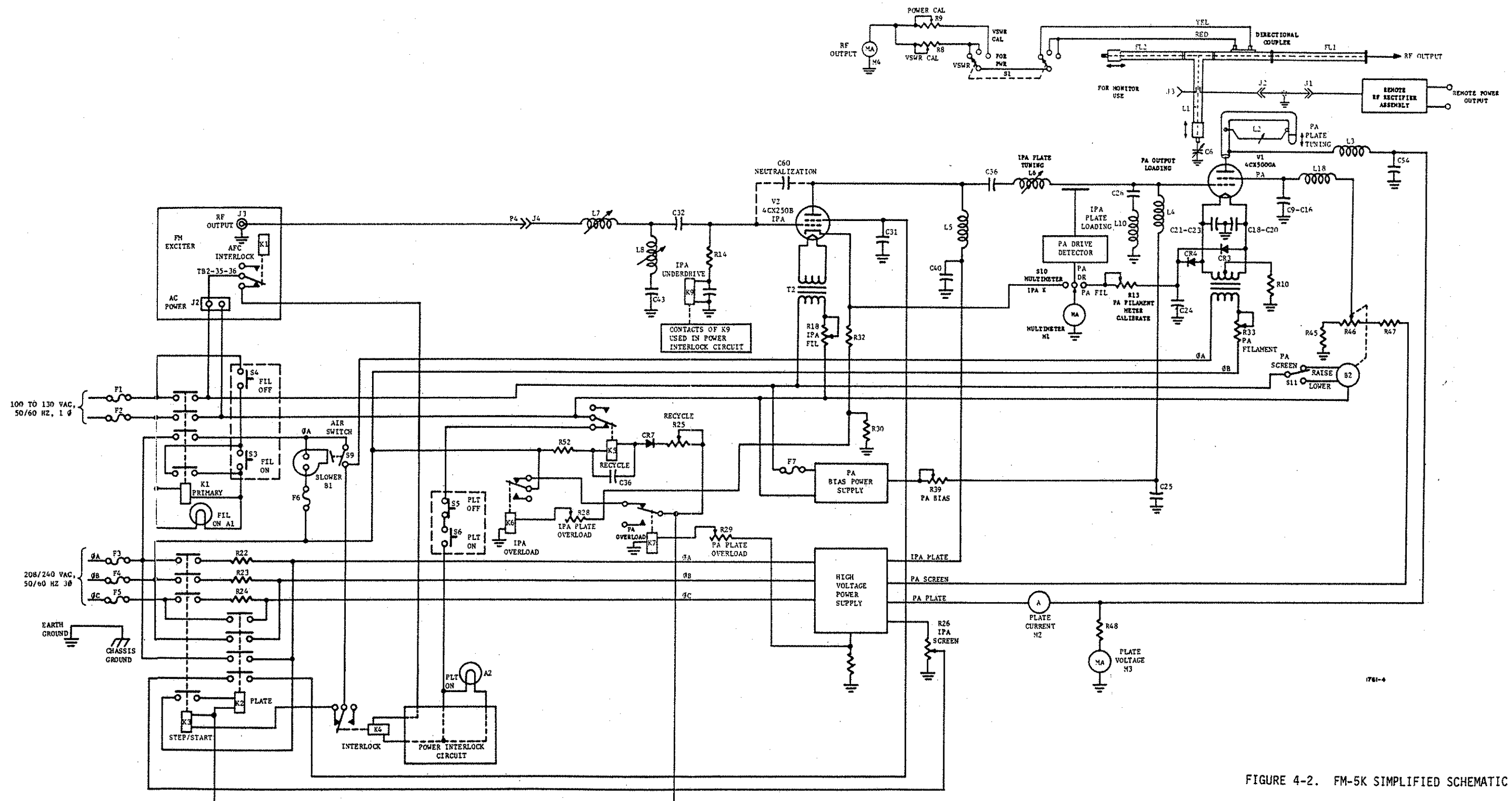

FIGURE 4-2. FM-5K SIMPLIFIED SCHEMATIC



further adjustment. The IPA screen circuit is bypassed with four ceramic button capacitors.

4-13. A tuned circuit adjusts the IPA plate and the PA grid circuits for maximum efficiency. The IPA plate capacitance, the IPA plate tuning inductance (L6), and the PA control grid capacitance form a PI network which tunes both the IPA plate and the PA grid circuits. The position and size of inductor L10 adjusts the IPA plate loading and capacitor C56 provides dc blocking.

4-14. The IPA stage is protected from overloads by relay K6 connected through IPA CATHODE OVERLOAD potentiometer R28, an adjustable resistance in the cathode circuit. In case of excessive IPA cathode current, relay K6 will momentarily open to disconnect the overload. Three or four operations of relay K6 will de-energize relay K5 which disables high voltage and power must be manually restored. A multiplier resistor in the cathode circuit provides a multimeter indication of the total dc current applied to the stage.

4-15. POWER AMPLIFIER (PA). The power amplifier grid circuit and the IPA plate circuit are tuned simultaneously by the IPA PLATE TUNING control. Approximately -160 Vdc fixed bias is produced to operate the PA stage. Voltage drop across the PA bias supply bleeder resistor produces additional bias during operation whenever PA grid drive produces over 40 milliamperes of grid current with a -160 volt fixed bias level.

4-16. The PA grid circuit is monitored by the PA drive detector which samples and rectifies a small amount of rf to provide a MULTIMETER indication of the relative activity of the PA grid circuit. PA filament voltage is full wave rectified by diodes CR3 and CR4 to provide a MULTIMETER indication of PA filament voltage. Resistor R13 acts as a filament voltmeter calibration control.

4-17. The PA screen circuit voltage is controlled by a motorized variable resistance (B2-R46). Fixed resistors in series with the screen voltage control provide a voltage range of approximately 500 Vdc to 850 Vdc. The PA filament circuit is bypassed at the tube socket and the filament transformer by a number of ceramic capacitors. The screen circuit is also extensively bypassed for rf.

4-18. High voltage is applied to the PA plate circuit through the PLATE CURRENT meter. The PLATE VOLTAGE meter is connected to the high voltage source through a five megohm multiplier resistor to provide an indication of the plate supply potential.

4-19. The PA stage is protected from overloads by relay K7 connected through PA PLATE OVERLOAD potentiometer R29 in the ground side of the High-Voltage Power Supply. In case of excessive PA plate current, relay K7 will momentarily open to disconnect the overload. Three or four operations of relay K7 will de-energize relay K5 which disables high voltage and power must be manually restored.

4-20. OUTPUT CIRCUIT. The PA plate circuit is inductively tuned by varying a length of inner conductor of a transmission line within the outer conductor. The plate line is approximately one-half wave length long, being fore-shortened by the output capacity of the PA tube. The type of coupling used deletes the requirement for a dc blocking capacitor.

4-21. The large rotary portion of the line is used for rough or approximate frequency adjustment. The variable end of the half-wave line (L2) is adjusted by the PA PLATE TUNING control as a fine frequency control. The fine adjustment covers approximately 3 Mhz at the low end of the FM band and approximately 6 Mhz at the high end of the FM band.

4-22. Output coupling is accomplished by capacity tuning (PA OUTPUT LOADING Capacitor C6) a matching stub (L1) which inductively couples RF power from the amplifier. RF is output to the antenna through a 2nd Harmonic Filter, Directional Coupler, and a Low-Pass Filter arrangement. RF coupling loops (J2 and J3) in the filter assembly provide a means to monitor the RF Output. The RF Rectifier Assembly connected to receptacle J2 provides a remote indication of transmitter RF Output Power.

4-23. Directional Coupler. The Directional Coupler provides two dc signals, each obtained by rectifying a combination of a current and a voltage sample obtained from the transmission line (refer to figure 4-2). Because of the difference in polarity of the current samples, one output is proportional to the forward traveling wave and the other sample is proportional to the reflected traveling wave. The voltages proportional to reflected and forward power are applied to the RF OUTPUT meter through the FOR PWR/VSWR CAL/VSWR switch. PWR CAL and VSWR CAL adjustments allow calibration of the forward power and VSWR meter indications. An additional indication of forward power output for remote control use is provided by the RF Rectifier unit connected to receptacle J2 on the Low-Pass Filter.

4-24. CONTROL CIRCUITS

4-25 The following text provides a description of the FM-5K Transmitter control circuits. Refer to figure 4-2 and the schematic diagram. A list of the control circuit relays and the function of each relay is provided in Table 4-2.

4-26. POWER ON. The transmitter is energized by depressing the FIL ON pushbutton switch/indicator. The FIL ON indicator will illuminate and the pushbutton switch will energize contactor K1. Contacts of contactor K1 apply single phase ac power to the FM Exciter, the interlock circuit, the IPA filament transformer, the PA bias supply, and the PA screen lower/raise motor control circuit. Additionally, phase A and B of the three phase ac input are applied through contacts of Primary Contactor K1 and operate the blower motor. Phase A is applied to contacts of the air switch. As air pressure builds up in the plenum chamber, the air pressure switch will close and apply power to the PA filament transformer.

4-27. HIGH VOLTAGE ON. High voltage may now be applied by depressing the PLT ON pushbutton switch/indicator. The PLT ON indicator will illuminate

Table 4-2. Control Circuit Relays

RELAY	NOMENCLATURE	FUNCTION
K1	PRIMARY CONTACTOR	Applies single phase ac primary voltage to the FM Exciter, IPA filament transformer, PA bias power supply transformer, PA screen raise/lower motor circuit, and the FIL ON indicator. Also applies two phases of the three-phase primary ac input to the blower motor and the air switch. Energized during normal operation after the FIL ON pushbutton switch is depressed.
K2	PLATE CONTACTOR	Applies three-phase ac primary voltage to the High-Voltage Power Supply transformer. Energized during normal operation by contacts of relay K3.
K3	STEP/START CONTACTOR	Applies voltage through the step/start resistors R22, R23, R24 to the High-Voltage Power Supply transformer. After approximately 15 milliseconds of operation Plate Contactor K2 closes and shorts across the relay contacts and resistors. Energized during normal operation by contacts of Auxiliary Relay K4.
K4	AUXILIARY RELAY	Applies holding voltage to close the STEP/START CONTACTOR K3. Energized during normal operation when the PLT ON pushbutton switch is depressed. Remains energized if all interlocks are closed and relay K5 remains de-energized. The PLT ON indicator illuminates whenever Auxiliary Relay K4 is energized.
K5	RECYCLE RELAY	Disables high voltage if three or four overloads occur within a time limit preset by RECYCLE Adjustment potentiometer R25. Energized by a preset number of operations of IPA OVERLOAD relay K6 and/or HIGH-VOLTAGE RELAY K7. One operation will de-energize Auxiliary Relay K4, STEP/START CONTACTOR K3,

Table 4-2. Control Circuit Relays (Continued)

RELAY	NOMENCLATURE	FUNCTION
		and PLATE CONTACTOR K2 to disable high voltage. De-energized during normal operation.
K6	IPA OVERLOAD RELAY	Energizes to clear an overload for the respective circuit when an overload causes a pre-determined current to flow through the respective relay coil.
K7	HIGH VOLTAGE OVERLOAD RELAY	Three or four operations of IPA OVERLOAD relay K6 and/or HIGH VOLTAGE OVERLOAD relay K7 will energize relay K5 and disable high voltage. De-energized during normal operation.
K9	GRID DRIVE RELAY	Prevents application of IPA AND PA plate and screen voltages until the IPA grid current level reaches 8 milliamperes minimum. Contacts are in series with the interlocks and one operation of GRID DRIVE relay K9 will de-energize high voltage. Energized during normal operation.
S9	AIR SWITCH	Monitors blower operation. Closes after air pressure in the plenum reaches proper pressure and applies power to the PA filament transformer. Closed during normal operation. If the air switch opens during operation, high voltage will be disabled.
K601	AC RESTART LATCHING RELAY	Controls ac restart function. When switch S601 is in OPERATE position, the contacts latch on each time high voltage is applied. Energized by relay K602 during normal operation.
K602	AC RESTART PLATE SLAVE RELAY	Controls AC RESTART LATCHING relay K601. Connected in parallel with AUXILIARY relay K4. Energizes when high voltage turns on.
K603		Removes ac restart function during re-occurring overloads.

and the pushbutton switch will energize Auxiliary relay K4. If all interlocks are closed and the FM Exciter is operating properly, contacts of relay K4 will energize Step/Start Contactor relay K3 and power will be applied to the primary of the High-Voltage Power Supply through series resistors which restrict the initial current surge to the high voltage transformer. Fifteen milliseconds later, relay Plate Contactor K2 will close, short across the step/start circuit, and apply power directly to the High-Voltage Power Supply primary. If an interlock is opened, Grid Drive relay K9 opens due to low drive from the FM Exciter, or recycle relay K5 operates the three-phase ac input to the High-Voltage Power Supply will be opened and must be restored manually.

4-28. OVERLOAD CIRCUITS. Overload relays K6 and K7 operate to remove primary voltage from the main High-Voltage Power Supply momentarily for the duration of an overload. High voltage is restored automatically. The overload relays are dc relays connected to adjustable resistors. The resistors are adjusted so that the relays will operate when the current through each resistor exceeds a preset limit. One overload relay is connected in series with the High-Voltage Power Supply secondary and a second overload relay is connected in series with the IPA cathode circuit.

4-29. Recycling. When an overload condition actuates an overload relay, a dc charge is applied to capacitor C36. If the overload occurs repeatedly, sufficient charge will build up in the capacitor to operate Recycle relay K5 and open Auxiliary relay K4 interlock circuit which de-energizes high voltage. The number of charges required to charge the capacitor sufficiently to operate Recycle relay K5 is dependent upon the adjustment of RECYCLE adjustment potentiometer R25 in series with capacitor C36. In the event of several closely spaced overloads, RECYCLE adjustment Recycle relay K5 will remove plate voltage and the transmitter must be turned back on manually. If Recycle Relay K5 does not operate, the overload circuit will reclose and re-energize the high-voltage circuit automatically.

4-30. VSWR Overload Interlock. The VSWR Interlock Unit will turn OFF the transmitter high voltage if the transmission line VSWR exceeds an adjustable predetermined level. DC amplifier integrated circuit U301, is used to amplify the VSWR signal from the transmitter Directional Coupler. As the VSWR signal increases, the voltage at jack TP301 increases until at approximately +12 Vdc relay K301 is energized. The relay contact closure completes the circuit to relay K302. As relay K302 is energized, the VSWR pilot light will be illuminated and the transmitter high voltage control interlock circuit will be opened. The transmitter high-voltage will be turned OFF. VSWR RESET pushbutton switch S302 will have to be depressed to remove the holding contact voltage of relay K302 before the transmitter high voltage can be turned ON again. VSWR TEST pushbutton switch S302 is used to connect resistor R312 in the circuit so the VSWR unit can be calibrated. Remote reset can be accomplished by connecting a normally closed set of contacts between tie points TS301-1 and TS301-2. Potentiometer R302 may be adjusted to change the VSWR signal level required to actuate the relay circuit. Adjusting the control CCW will make the circuit more sensitive.

4-31. PA SCREEN CONTROL. The PA screen circuit is controlled by a motorized potentiometer (B2-R46) arrangement. Power for the motor (115 Vac) is obtained from the single phase primary ac input. The position of PA SCREEN RAISE/LOWER switch S11 determines the direction of motor rotation. If switch S11 is operated to LOWER, motor B2 will energize and the direction of motor rotation will lower the PA screen potential to reduce the transmitter RF Output power. If switch S11 is operated to RAISE, motor B2 will rotate in the opposite direction and will raise the PA screen potential to increase the transmitter RF output power. When the transmitter is operated by remote control, care should be observed so that both raise and lower commands are not given at the same time, otherwise, fuse F1 or fuse F2 will open.

4-32. AC RESTART CIRCUIT. The AC Restart Circuit returns the transmitter to "on the air" automatically after a temporary or indefinite outage of either the 115 Vac single phase or the 230 Vac three-phase power source. AC RESTART-OFF/OPERATE switch S601, on the front panel, is used to select the operating mode.

4-33. AC Restart Latching relay K601 is used to control the restart function. When AC RESTART switch S601 is in the OPERATE position, relay coil K601-2 is energized (restart circuit operational) as the transmitter plate voltage is turned ON either locally or remotely. K603 operates at the same time as the plate control relay in the 115 VAC circuit (not the plate contactor). K603 sets the AC restart ON by energizing K601-2, the AC restart latching relay. K602's function is to turn the AC restart OFF whenever there is a PLATE OFF command. Once K602 is closed, it will hold itself in a closed position as long as AC voltage is present. If there is a PLATE OFF command, K602 will cause the AC restart latching relay, K601, to go to the OFF position. This is accomplished through contacts of K602, K603 and K605. K605 closes simultaneously with the plate contactor and delays the setting of K602 until the high voltage is on. If the 115 Vac single phase power is interrupted, the plate voltage will not be turned ON until after the FM Exciter AFC interlock is closed. The delay will vary depending on the AFC "lock-up" time. When only the 230 Vac three-phase is interrupted, the plate voltage will be turned ON immediately after the PA enclosure air pressure switch is closed.

4-34. AC Restart Latching relay coil K601-1 is energized (restart circuit not operational) as the plate voltage is turned OFF either locally or remotely. Also, the coil is energized if the transmitter recycle circuit operates or if the filaments are turned OFF locally. Unless AC RESTART switch S601 is set to the OFF position, the restart circuit will be operational each time the plate voltage is turned ON.

4-35. STATUS LIGHTS. The status lights indicate circuit faults that will remove the transmitter from operation. The following malfunctions will be indicated by the lights:

1. Loss of air flow to IPA and PA tubes.
2. Transmitter cabinet front door interlock switch open.

3. Transmitter cabinet rear door interlock switch open.
4. Loss of IPA drive (rf).
5. High VSWR on transmission line.
6. IPA overload.
7. PA overload.
8. Lockout caused by a continuous overload (recycle).

4-36. After the transmitter FILAMENT ON pushbutton switch is depressed TIME DELAY relay K210 prevents the operation of the Status Light system for 30 seconds. TIME DELAY relay K210 is then de-energized by TIME DELAY SLAVE relay K211. The AIR indication is initiated by AIR FLOW relay K209 connected across the PA filament circuit. After air switch S9 closes and the filament circuit energized, AIR FLOW relay K209 is energized. If the air switch opens under normal operation a normally closed set of contacts will energize AIR STATUS LIGHT relay K201, indicating a failure. A light will indicate if either of the transmitter cabinet rear door or front access door interlock switches are open. The loss of IPA grid drive indication is obtained by utilizing the normally closed contact of grid drive relay K9. Because the door interlocks and the grid drive contact circuits are in series, the opening of the circuit nearest the power source will disable the others from indicating. If more than one is indicating, the first failure is the one farthest from the power source.

4-37. The IPA or PA OVERLOAD indicator is controlled by a normally open set of contacts which energizes the IPA or PA Status Light relay in case there is excessive current drawn in either circuit. A lockout indication is caused by a continuous IPA or PA overload which energizes RECYCLE RELAY K5. A normally open set of contacts on RECYCLE RELAY K5 controls LOCK (RECYCLE) relay K208. Any indicating light will remain ON until the transmitter is completely shut-down or until the RESET pushbutton switch is depressed. The RESET indicator relays have the arms of one set of contacts connected together and terminated on terminal 1 on terminal board TB202. The normally open contacts are terminated on terminal board TB202. Any relay may be tested for closure from a remote location by applying a signal between terminal 1 on terminal board TB201 and any other selected terminal on terminal board TB202. To reset a relay remotely, the jumper between terminals 10 and 11 on terminal board TB201 is removed and a remote set of normally closed contacts connected to these terminals. Table 4-3 lists the Status Light relays and their functions.

4-38. REMOTE CONTROL INTERFACE. The remote control interface board is used to permit remote control of the transmitter Filament and Plate ON/OFF functions using momentary contact closure remote equipment. Refer to figures 5-1 and 5-2 in Section V under troubleshooting. When a momentary closure occurs between terminals 1 and 2 on terminal board TB102, PRIMARY CONTACTOR relay K1 will energize. The relay is held in the energized position by self-latching contacts (K1-7 and K1-5). Contacts K1-12 and K1-8 provide the

Table 4-3. Status Light Relays

RELAY	NOMENCLATURE	FUNCTION
K201	AIR STATUS LIGHT	Provides remote AIR indicator status, energized when normal air flow is interrupted and AIR FLOW relay K209 de-energizes.
K202	FRONT DOOR	Provides remote FRONT DOOR interlock indicator status, energized when front door is opened.
K203	REAR DOOR	Provides remote REAR DOOR interlock indicator status, energized when rear door is opened.
K204	IPA DRIVE	Provides remote IPA DRIVE indicator status, energized when IPA underdrive relay K9 is de-energized. Will de-energize when IPA grid current reaches approximately 8 mA.
K205	VSWR	Provides remote VSWR overload indicator status, energized when VSWR Overload Interlock relay K303 energizes.
K206	IPA OVERLOAD	Provides remote IPA OVERLOAD indicator status, energized when IPA Overload relay K6 energizes.
K207	PA OVERLOAD	Provides remote PA OVERLOAD indicator status, energized when High-Voltage Overload relay K7 energizes.
K208	LOCK (RECYCLE)	Provides remote LOCKOUT (RECYCLE) overload indicator status, energized when Recycle relay K5 is energized.
K209	AIR FLOW	Provides control of remote AIR indicator relay K201, energized when the correct amount air flow is present.
K210	TIME DELAY	Provides approximately 30-second time-delay when transmitter is first turned on, before applying voltage to status lights through slave relay K211, energized when Primary contactor K1 energized, after time delay.

Table 4-3. Status Light Relays (Continued)

RELAY	NOMENCLATURE	FUNCTION
K211	TIME DELAY SLAVE	Provides voltage to Status Lights and Remote Status relays, energized when Time-Delay relay K210 energizes.

continuous closure needed to energize the transmitter filament circuits. A momentary closure between terminals 2 and 3 on terminal board TB10 will energize PLATE CONTACTOR relay K2, which removes voltage from the coil of PRIMARY CONTACTOR relay K1. This action will cause relay K1 to de-energize and turn the transmitter filament circuits OFF.

4-39. A momentary contact between terminals 5 and 6 on terminal board TB10 will energize self latching transmitter PLATE CONTROL relay K4. When a momentary closure is placed between terminals 4 and 5 on terminal board TB10, AUXILIARY relay K3 will energize. The normally closed contacts (K3-4 and K3-12) will remove the coil voltage from PLATE CONTROL relay K4 which removes high voltage from the transmitter.

4-40. METERING CIRCUITS

4-41. LOCAL METERING. Four meters are used in the FM-5K Transmitter to provide visual indications of critical transmitter parameters and are located in full view of all normal operating controls and indicators. A description of each individual meter and the associated circuitry is provided in Table 4-4. Refer to figure 4-2 and the FM-5K Transmitter schematic diagram.

4-42. REMOTE METERING. Total PA dc current, PA plate voltage, and transmitter RF Power Output may be monitored externally using the monitoring provisions connected to terminal board TB6. An adjustable potential is provided for each parameter to match the input requirements of the monitoring device. Refer to the applicable overall schematic diagram. Use of the remote metering provisions is described in Section II, Installation.

Table 4-4. Meter Functions

METER	FUNCTION
<p>MULTIMETER Meter M1</p>	<p>Indicates voltage or current as determined by MULTIMETER switch S10. Indicates total IPA dc current, PA filament voltage, and relative PA drive. PA Filament Voltmeter Calibrate potentiometer R13 allows calibration of the PA filament voltage indication. An indication of the presence of rf in the PA enclosure is provided by the PA drive detector which is coupled to the PA grid circuit. The detector outputs a dc voltage relative to the rf drive level.</p>
<p>PLATE CURRENT Meter M2</p>	<p>Indicates PA dc plate current. Connected in series between the High-Voltage Power Supply and the PA plate circuit. The meter is insulated and isolated behind a protective plexiglass cover.</p>
<p>PLATE VOLTAGE Meter M3</p>	<p>Indicates PA dc plate voltage. Connected from the PA plate dc voltage source through five megohm multiplier resistor R48 to ground.</p>
<p>RF OUTPUT Meter M4</p>	<p>Indicates forward power or VSWR as selected by FOR PWR/VSWR CAL/VSWR switch S601. Provisions allow calibration of the forward power indication by VSWR CAL adjustment potentiometer R8 and the reflected power indication by FWR CAL adjustment potentiometer R9. This meter works in conjunction with the Directional Coupler mounted in the transmission line.</p>

SECTION V

MAINTENANCE

5-1. INTRODUCTION

5-2. This section provides preventive maintenance checks, cleaning, corrective maintenance and troubleshooting information for the HARRIS FM-5K BROADCAST TRANSMITTER.

5-3. PURPOSE

5-4. The information contained in this section is intended to provide guidance to establish a comprehensive maintenance program to promote operational readiness and eliminate downtime. Particular emphasis is placed on preventive maintenance and record keeping functions.

5-5. STATION RECORDS

5-6. The importance of keeping station performance records cannot be over-emphasized. Separate logbooks should be maintained by operation and maintenance activities. These records can provide data for predicting potential problem areas and analyzing equipment malfunctions.

5-7. TRANSMITTER LOGBOOK

5-8. As a minimum performance characteristic, the transmitter should be monitored (using front panel meters) and the results recorded in the transmitter logbook at each shift change or at least once a day.

5-9. MAINTENANCE LOGBOOK

5-10. The maintenance logbook should contain a complete description of all maintenance activities required to keep the transmitter operational. A list of maintenance information to be recorded and analyzed to provide a data base for a failure reporting system is as follows:

DISCREPANCY	Describe the nature of the malfunction. Include all observable symptoms and performance characteristics.
CORRECTIVE ACTION	Describe the repair procedure used to correct the malfunction.
DEFECTIVE PART(S)	List all parts and components replaced or repaired. Include the following details: <ol style="list-style-type: none">COMPONENT TIME IN USECOMPONENT PART NUMBERCOMPONENT SCHEMATIC NUMBERCOMPONENT ASSEMBLY NUMBERCOMPONENT REFERENCE DESIGNATOR

SYSTEM ELAPSED TIME	Total transmitter time on.
NAME OF REPAIRMAN	Person who actually made the repair.
STATION ENGINEER	Indicates chief engineer noted and approved the transmitter repair.

5-11. SAFETY PRECAUTIONS

5-12. It is very dangerous to attempt to make measurements or replace components with power on. The design of the transmitter provides safety features such that when a door is opened, an interlock switch removes transmitter ground. Use the grounding stick to touch every part in the area or circuit on which maintenance is to be performed before attempting maintenance.

5-13. PREVENTIVE MAINTENANCE

5-14. Preventive maintenance is a systematic series of operations performed periodically on equipment. As these procedures cannot be applied indiscriminately, specific instructions are necessary.

- a. Visual Inspection. Inspection is the most important preventative maintenance operation because it determines the necessity for the others. Become thoroughly acquainted with normal operating conditions in order to recognize and identify abnormal conditions readily. The remedy for most visible defects is obvious, however; care must be taken if heat damaged components are located. Overheating is usually a symptom of trouble. It is essential to determine the actual cause of overheating before the heat damaged component is replaced, otherwise the damage will be repeated. Inspect for:
 1. Overheating, indicated by discoloration, bulging of parts and peculiar odors.
 2. Leakage of grease and oil.
 3. Oxidation.
 4. Dirt, corrosion, rust, mildew and fungus growth.
- b. Feel. Check parts for overheating, especially rotating parts such as the blower motor. The need for lubrication, the lack of proper ventilation, or the existence of some defect can be detected and corrected before serious trouble occurs. Become familiar with operating temperatures in order to recognize deviations from the normal range.
- c. Tighten. Tighten loose screws, bolts, and nuts. Do not tighten indiscriminately as fittings that are tightened beyond the pressure for which they are designed may be damaged or broken.

A regular check on the tightness of the two Allen head set screws in the adjustment end of the second harmonic trap should be made as part of the transmitter preventive maintenance program. If these screws become loose, rf currents will cause heating at this point and result in burning and destruction of the short and other parts of the filter.

- d. Clean. Clean parts when inspection shows that cleaning is required.
- e. Adjust. Make adjustments when inspection shows that adjustments are necessary to maintain normal operation.
- f. Lubricate. Lubricate meshing mechanical surfaces at specified intervals with specified lubricants to prevent mechanical wear and keep the equipment operating normally. Do not over lubricate.
- g. Paint. Paint surfaces with the original type of paint (use prime coat if necessary) when inspection shows rust, worn or broken paint film.

5-15. FILTER CLEANING

5-16. An air filter is provided in the cabinet back door. Clean the filter once a week with warm water and a mild detergent with replacement done on an as-required basis. Additional filters may be ordered from HARRIS (827-5285-001) to assist in maintenance. Spraying a light coat of light weight oil on each filter after cleaning will aid in dust filtering.

5-17. BLOWER MAINTENANCE

5-18. Inspect the blower for dust accumulation monthly. Remove dust with a vacuum cleaner and brush. Check the blower for wear. The blower motor bearings are sealed and lubricated for approximately 20,000 hours of operation to provide trouble free operation. After this period, the blower motor should be removed from the transmitter and the grease in blower motor bearings should be changed. To lubricate the blower motor bearings, the top and bottom plug in each bearing must be removed and a grease fitting attached to the top of each bearing. New grease should be applied until clean grease runs out of the bottom drain plug. The grease fittings should then be removed and the plugs replaced.

5-19. MAINTENANCE OF COMPONENTS

5-20. The following paragraphs provide information for component maintenance.

5-21. SEMICONDUCTORS. Routine checking of semiconductors used in the FM-5K is not required. The best check of semiconductor performance is actual operation in the transmitter. When semiconductors are replaced, check circuitry operation which may be affected. Replacement semiconductors should

be of the original type or a recommended direct replacement. Preventive maintenance of transistors is accomplished by performing the following steps:

- a. Inspect the semiconductors and surrounding area as accumulations of dirt or dust could form leakage paths.
- b. Examine all semiconductors for loose connections or corrosion.

5-22. CAPACITORS. Preventive maintenance of capacitors is accomplished as follows:

- a. Examine all capacitor terminals for loose connections or corrosion.
- b. Ensure that component mountings are tight.
- c. Examine the body of each capacitor for swelling, discoloration, or other evidence of breakdown.
- d. Inspect oil-filled and electrolytic capacitors for leakage signs.
- e. Use standard practices to repair poor solder connections with a low-wattage soldering iron.
- f. Clean cases and bodies of all capacitors.

5-23. VACUUM CAPACITORS. In relation to most types of capacitors, the vacuum capacitor is very expensive. Care in handling and maintenance are prime requisites in order to assure maximum service life. As the vacuum capacitor is evacuated to a higher degree than most vacuum tubes, it is even more susceptible to shock and rough handling. It should never be placed in containers with other components without proper packing. During periods of maintenance, the capacitors should be provided with substantial protective coverings. The weakest portion of the capacitor is the glass-to-metal seal on each end of the unit. Particular care should be exercised to prevent seal damage during removal or installation.

5-24. Current ratings of vacuum capacitors are limited by the glass-to-metal seal temperature and the temperature of the solder used to hold the capacitor plates. Seal temperature is raised by poor connecting clip pressure, excessive ambient temperatures, corrosion of the end cap and/or connecting clip, excessive dust and dirt accumulation, or excessive currents. The solder temperature is affected by high external temperature and high currents.

5-25. Dust accumulation or sharp points existing in the high voltage circuitry close to the capacitor can cause arcs or corona which may burn holes through the glass envelope.

5-26. FIXED RESISTORS. Preventive maintenance of fixed resistors is accomplished by the following steps:

- a. When inspecting a chassis, printed circuit board, or discrete component assembly, examine resistors for dirt or signs of overheating. Discolored, cracked, or chipped components indicate a possible overload.
- b. When replacing a resistor ensure the replacement value corresponds to the component designated by the schematic diagram.
- c. Clean dirty resistors with a small brush.

5-27. VARIABLE RESISTORS. Preventive maintenance of variable resistors follows:

- a. Inspect and tighten all loose mountings, connections and control knob setscrews (do not disturb knob alignment).
- b. If necessary clean components with a dry brush or lint-free cloth.
- c. When dirt is difficult to remove clean with a cloth moistened with an approved cleaning solvent.

5-28. TRANSFORMERS. Preventative maintenance of transformers is accomplished by performing the following:

- a. Feel each transformer soon after power removal for signs of overheating.
- b. Inspect each transformer for dirt, loose mounting brackets and rivets, loose terminal connections, and insecure connecting lugs. Dust, dirt, or moisture between terminals may cause flashovers. Insulating compound or oil around the base of a transformer indicates overheating or leakage.
- c. Tighten loose mounting lugs, terminals, or rivets.
- d. Clean with a dry lint-free cloth. Use an approved cleaning solvent if required.
- e. Clean corroded contacts or connections with crocus cloth.
- f. Replace defective transformers.

5-29. FUSES. Preventative maintenance of fuses is accomplished by the following:

- a. When a fuse blows, determine the cause before installing a replacement.
- b. Inspect fuse caps and mounts for charring and corrosion.
- c. Examine fuse clips for dirt, improper tension, and loose connections.

- d. If necessary tighten fuse clips and connections to the clips. The tension of the fuse clips may be increased by carefully pressing the clip sides closer together.
- e. Dust fuses and clips with a small brush.

5-30. METERS. Preventative maintenance of the meters is accomplished as follows:

- a. Inspect meters for loose, dirty, or corroded mountings and connections.
- b. Examine leads for frayed insulation and broken strands.
- c. Check for cracked or broken plastic cases and cover glasses.
- d. Tighten loose mountings or connections. Since meter cases are made of plastic, exercise care to prevent breakage.
- e. Clean meter cases and glass cover with a dry cloth.
- f. Remove dirt from mountings and connections with a stiff brush.
- g. Remove corrosion with crocus cloth.

5-31. RELAYS. Replace hermetically sealed relays if defective. Nonhermetically sealed relays are considered normal if:

- a. The relay is mounted securely.
- b. Connecting leads are not frayed and the insulation is not damaged.
- c. Terminal connections are tight and clean.
- d. Moving parts travel freely.
- e. Spring tension is correct.
- f. Contacts are clean, adjusted properly and make good contact.
- g. The coil shows no signs of overheating.
- h. Clean any dirty or corroded terminal connection or switch section with crocus cloth.
- i. Replace defective switches.

5-32. SWITCHES. Preventative maintenance of switches is accomplished by checking the following:

- a. Inspect switches for defective mechanical action or looseness of mounting and connections.
- b. Examine cases for chips or cracks. Do not disassemble switches.
- c. Inspect accessible contact switches for dirt, corrosion, looseness of mountings and connections.
- d. Check contacts for pitting, corrosion, or wear.
- e. Operate the switches to determine if each moves freely and is positive in action. In gang and wafer switches, the rotor should make good contact with the stationary member.
- f. Tighten all loose connections and mountings.
- g. Adjust contact tension.
- h. Clean any dirty or corroded terminal connection or switch section with crocus cloth.
- i. Replace defective switches.

5-33. INDICATORS AND INDICATOR SWITCHES. Preventative maintenance of indicator lamps and indicator switches is accomplished by checking the following:

- a. Examine indicator sockets for corrosion, loose nuts and condition of rubber grommets.
- b. Examine indicator switch by pulling the plastic cover (indicator assembly) from the case.
- c. Inspect indicator assemblies for broken or cracked covers, loose envelopes, loose mounting screws, and loose or dirty connections.
- d. Tighten loose mounting screws and solder loose connections. If connections are dirty or corroded, clean with crocus cloth before soldering.
- e. Clean indicator covers, bases, and glass bulbs with a dry cloth.
- f. Clean corroded socket contacts and connections with crocus cloth. Low operating voltages require clean contacts and connections.

5-34. TUBES. Life of the tubes used in the FM-5K Transmitter is dependent upon correct filament voltage and the flow of air over the anode of each tube. Once each month the tubes should be removed and the fins cleaned of dust to assure free air flow and long tube life. Air may be blown through the fins in the reverse direction or the anode may be cleaned with soap and water.

5-35. CORRECTIVE MAINTENANCE

5-36. Corrective maintenance for the transmitter is limited by the objective of minimum down time. Maintainability and care are considerably simplified for operation and maintenance personnel as the transmitter is designed and built with highly reliable and proven elements to minimize down time. If the need to remove and replace a defective component rises, refer to Section II, Installation. Reverse the sequence of installation to remove the component and reinstall as described.

5-37. ADJUSTMENTS

5-38. Table 5-1 provides an adjustment procedure for all controls which are not described in Section II, Installation.

5-39. TROUBLESHOOTING

5-40. Most troubleshooting consists of visual checks. Because of high voltages present in the transmitter, it is not safe to work with the power energized. The meters, indicators, and fuses should be used to determine which stage is malfunctioning. The meters which indicate transmitter operating parameters are located across the front of the cabinet. All tuning controls are adjustable in view of the meters. Internal components may be accessed from both the front and rear.

5-41. In event of problems, isolate the trouble area to one of the following with the meters and indicators for each section:

- a. Antenna and Feedline
- b. Power Supply and Control Circuits
- c. IPA Section
- d. PA Section
- e. Exciter

5-42. Once the trouble is isolated to a specific area, refer to the theory section of this technical manual for circuit discussion to aid in problem resolution. Table 5-2 lists some typical trouble symptoms, probable causes, and corrective actions pertaining to the overall transmitter. The corrective action given for a trouble symptom is not necessarily the only answer to a problem. It only tends to lead the repairman into the area that may be causing the trouble. In event parts are required, refer to Section VI, Parts List.

Table 5-1. Miscellaneous Adjustments, Sheet 1 of 5

ADJUSTMENT	EQUIPMENT REQUIRED	PROCEDURE
<p>FL2 Second Harmonic Trap</p>	<p>Spectrum Analyzer (Hewlett-Packard: 141 T Display Unit 8554 RF Section 8552 ID Section 8554 L Sampling Head)</p>	<p>NOTE</p> <p>This adjustment is factory calibrated and sealed. The adjustment should not be disturbed unless the transmitter frequency is being changed.</p> <ol style="list-style-type: none"> 1. Operate the transmitter and note the second harmonic indication. 2. Turn off power. <div data-bbox="781 569 873 823" style="border: 2px solid black; padding: 5px; text-align: center; width: fit-content; margin: 10px auto;"> <p>WARNING</p> </div> <p>DO NOT ATTEMPT ADJUSTMENT WITH POWER ENERGIZED.</p> <ol style="list-style-type: none"> 3. Mark the position of the filter stub. Loosen the two setscrews and the strap clamp securing the stub. Move the stub slightly and resecure the setscrews and strap clamp. <div data-bbox="1166 596 1227 793" style="border: 2px dashed black; padding: 5px; text-align: center; width: fit-content; margin: 10px auto;"> <p>CAUTION</p> </div> <p>ENSURE THE SETSCREWS AND STRAP CLAMP ON THE FILTER ADJUSTMENT ARE SECURE.</p>

Table 5-1. Miscellaneous Adjustments, Sheet 2 of 5

ADJUSTMENT	EQUIPMENT REQUIRED	PROCEDURE
<p>L7 IPA Grid Tuning, L8 IPA Input Loading</p>	<p>Thru-Line Wattmeter (Bird Model 43 and one watt element)</p>	<p>4. Energize power and note the second harmonic indication.</p> <p>5. Repeat steps 2 through 4 until the second harmonic is nulled to minimum. Ensure all clamps are secured.</p> <p style="text-align: center;">NOTE</p> <p>L7 and L8 are factory sealed adjustments and should be adjusted only if it is required to repair the IPA grid circuitry.</p> <p>1. Connect the wattmeter in the FM Exciter RF output line and adjust the wattmeter to indicate reflected power.</p> <div style="text-align: center; border: 1px solid black; padding: 5px; width: fit-content; margin: 10px auto;"> <p>WARNING</p> </div> <p style="text-align: center;">DO NOT ATTEMPT TO READ EXCITER FORWARD POWER OUTPUT WITH THE ONE WATT ELEMENT INSTALLED IN THE WATTMETER.</p> <p>2. Operate the FM Exciter only and adjust L7 and L8 for minimum reflected power.</p>

Table 5-1. Miscellaneous Adjustments, Sheet 3 of 5

ADJUSTMENT	EQUIPMENT REQUIRED	PROCEDURE
<p>R9 PWR CAL Adjustment</p>	<p>50 ohm 5 kW non-inductive Dummy Load RF power indicator accurate to <u>+3%</u></p>	<p>NOTE R9 is a factory sealed and calibrated adjustment and should be adjusted only if it is required to repair the transmitter power indicator circuitry.</p> <ol style="list-style-type: none"> 1. Operate the transmitter into a dummy load and calibrated RF indicator. 2. Operate the FOR PWR/VSWR CAL/VSWR switch to FOR PWR. 3. Adjust R9 until the RF OUTPUT indicator matches the calibrated standard.
<p>S9 Air Pressure Switch</p>	<p>Air Pressure Gauge</p>	<p>NOTE S9 is a factory sealed adjustment and should be adjusted only if it is required to replace the air switch.</p> <ol style="list-style-type: none"> 1. Measure the air pressure in the IPA chamber. 2. Adjust the air switch to open whenever air pressure equals on inch of water or less.

Table 5-1. Miscellaneous Adjustments, Sheet 4 of 5

ADJUSTMENT	EQUIPMENT REQUIRED	PROCEDURE
<p>R13 PA Filament Voltage Multi-meter Calibrate</p>	<p>Calibrated AC volt-meter (Fluke 8000A)</p>	<div style="border: 1px solid black; padding: 5px; width: fit-content; margin-bottom: 10px;"> <p>WARNING</p> </div> <p>ENSURE ALL TRANSMITTER POWER IS OFF.</p> <ol style="list-style-type: none"> 1. Attach the voltmeter test leads to the point where filament supply enters the PA enclosure. Route the test leads out through the transmitter door. 2. Depress FIL ON. 3. Operate the MULTIMETER switch to PA FIL. 4. Adjust R13 until the MULTIMETER matches the calibrated standard.
<p>R28 IPA CATHODE OVERLOAD Adjust</p>	<p>-----</p>	<ol style="list-style-type: none"> 1. Operate the MULTIMETER switch to IPA K. 2. Adjust R25 fully clockwise. 3. Operate the transmitter at full power. 4. Note the IPA PLATE TUNING control setting and adjust the control until 0.300 amperes of current is noted on the MULTIMETER. 5. Adjust R28 until the transmitter goes off the air. 6. Readjust the IPA PLATE TUNING control to the original setting noted in step 4. 7. Adjust R25 (RECYCLE Adjustment).

ADJUSTMENTS	EQUIPMENT REQUIRED	PROCEDURE
<p>R29 PA PLATE OVERLOAD Adjust</p>	<p>-----</p>	<ol style="list-style-type: none"> 1. Adjust R25 fully clockwise. 2. Operate the transmitter at full power. 3. Note the <u>PA OUTPUT LOADING</u> control setting and adjust the control until 2.6 amperes of current is noted on the <u>PLATE CURRENT</u> meter. 4. Adjust R29 until the transmitter goes off the air. 5. Readjust the <u>PA OUTPUT LOADING</u> control to the original setting noted in step 3. 6. Adjust R25 (<u>RECYCLE Adjustment</u>).
<p>R25 RECYCLE Adjustment</p>	<p>-----</p>	<ol style="list-style-type: none"> 1. Adjust R25 fully clockwise. 2. Operate the transmitter at full power. 3. Note the <u>PA OUTPUT LOADING</u> control setting and adjust the control until the PA overload circuit cycles (2.6 amperes maximum). 4. Adjust R25 counterclockwise until two or three operations of the PA overload circuit disables the transmitter. 5. Readjust the <u>PA OUTPUT LOADING</u> control to the original setting noted in step 3.

5-43. As aids to troubleshooting, table 5-3 lists FM-5K Transmitter typical operating characteristics. The simplified diagrams in figures 5-1 and 5-2 may be used as aids in troubleshooting the filament and plate control circuits.

5-44. Prior to starting a troubleshooting procedure check all switches, power cord connections, connecting cables, and power fuses.

5-45. TECHNICAL ASSISTANCE

5-46. HARRIS Technical and Troubleshooting assistance is available from HARRIS Field Service during normal business hours (8:00 AM - 5:00 PM Central Time). Emergency service is available 24 hours a day. Telephone 217/-222-8200 to contact the Field Service Department or address correspondence to Field Service Department, HARRIS CORPORATION, Broadcast Group, P.O. Box 4290, Quincy, Illinois 62305-4290, USA. The HARRIS factory may also be contacted through a TWX facility (910-246-3212) or a TELEX service (247319).

Table 5-2. Troubleshooting

TROUBLE SYMPTOM	PROBABLE CAUSE	CORRECTIVE ACTION
No RF Carrier Output	Defective FM Exciter	Refer to the Exciter Technical Manual and check Exciter operation.
	Defective Power Supply	Check PA bias and IPA and PA high-voltage power supplies. Repair as necessary.
RF Carrier Level Will Not Adjust	Defective Motor B2	Check operation of motor B2. Replace as necessary.
	Defective Screen Voltage Control	Check R46 and replace as necessary.
	Motor Supply Voltage Absent	Check single-phase ac input wiring. Repair as necessary.
Inadequate RF Carrier Output	Weak tubes	Check tube operation and replace as necessary.
	Incorrectly tuned PA	Check PA operation and retune as necessary.
	PA RF drive	Check IPA operation and retune as necessary.
	Inadequate High Voltage	Check PA bias and IPA and PA high-voltage power supplies.
	Incorrect measurement of power output	Compare transmitter power output measurement device to standard.

Table 5-2. Troubleshooting (Continued)

TROUBLE SYMPTOM	PROBABLE CAUSE	CORRECTIVE ACTION
Transmitter Off Frequency	Defective FM Exciter	Refer to the Exciter Technical Manual and check FM Exciter operation.
Audio Distortion	Incorrect Transmitter Tuning	Check transmitter operation and retune as necessary.
	Defective FM Exciter	Refer to the Exciter Technical Manual and check FM Exciter operation.
Noisy Audio	Defective FM Exciter	Refer to the Exciter Technical Manual and check Exciter operation.
No Modulation	Defective FM Exciter	Refer to the Exciter Technical Manual and check Exciter operation.
AM Noise on RF Carrier	Defective Power Supply	Check PA bias and IPA and PA high-voltage power supplies. Repair as necessary.
	Defective FM Exciter	Refer to the Exciter Technical Manual and check Exciter operation.

Table 5-3. Typical Operating Meter Indications

METER	SWITCH POSITION	INDICATION
MULTIMETER	MULTIMETER Switch IPA K	0.183 Amperes
	PA FIL	7.5 Volts
	PA DR	70 Divisions
PLATE CURRENT	-----	2.14 Amperes
PLATE VOLTAGE	-----	4150 Volts
RF OUTPUT	Output Meter Switch	
	FOR PWR	5000 Watts
	VSWR CAL	1.0
	VSWR	1.05
ALL READINGS BASED ON OPERATION INTO A 50-OHM DUMMY LOAD AT 5 kW POWER LEVEL.		

Table 5-4. Typical Primary Power Requirements

CIRCUIT	FREQUENCY	LINE VOLTAGE	LINE CURRENT	POWER
3 ϕ	60 Hz	235-235-235 VRMS	31-31-26 A	10 kW
1 ϕ	60 Hz	117 VRMS	1.5 A	180 W

Table 5-5. Typical FM-5K Transmitter Operating Characteristics

IPA TUBE 4CX250B

<u>PARAMETER</u>		<u>MEASUREMENT</u>
Plate Voltage	-	+2000 Volts
Plate Current	-	0.185 Amperes
Power Output	-	250 Watts
Filament Voltage	-	6 Volts
Filament Current	-	2.9 Amperes

PA TUBE 4CX5000A

<u>PARAMETER</u>		<u>MEASUREMENT</u>
Plate Voltage	-	+4150 Volts
Plate Current	-	2.14 Amperes
Power Output	-	5,000 Watts
Plate Dissipation	-	3,400 Watts
Plate Efficiency	-	57 Percent
Control Grid Voltage	-	-160 Volts
Filament Voltage	-	7.5 Volts
Filament Current	-	78 Amperes

ALL READINGS BASED ON OPERATION INTO A 50-OHM DUMMY LOAD AT 5 kW POWER LEVEL.

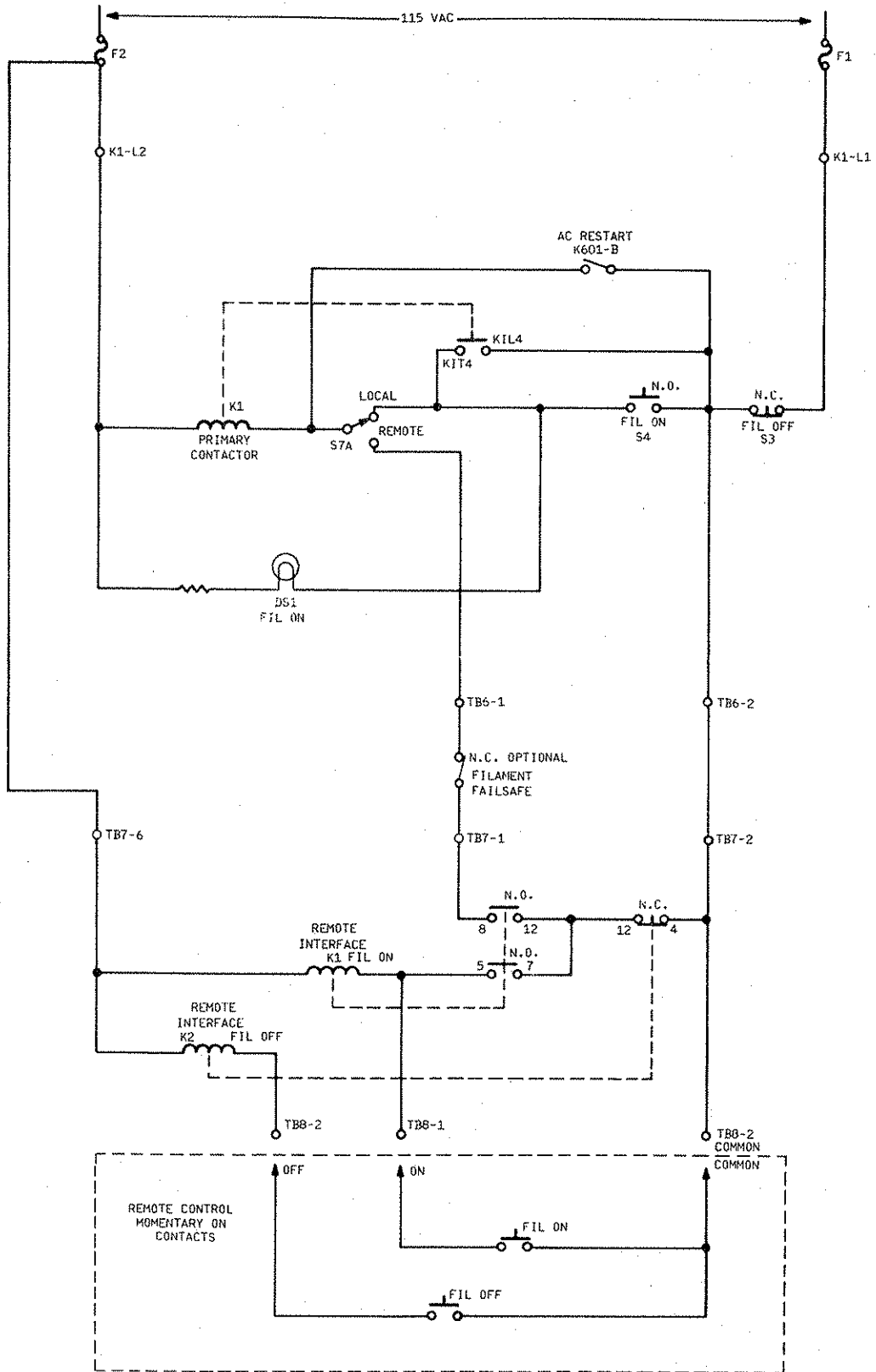
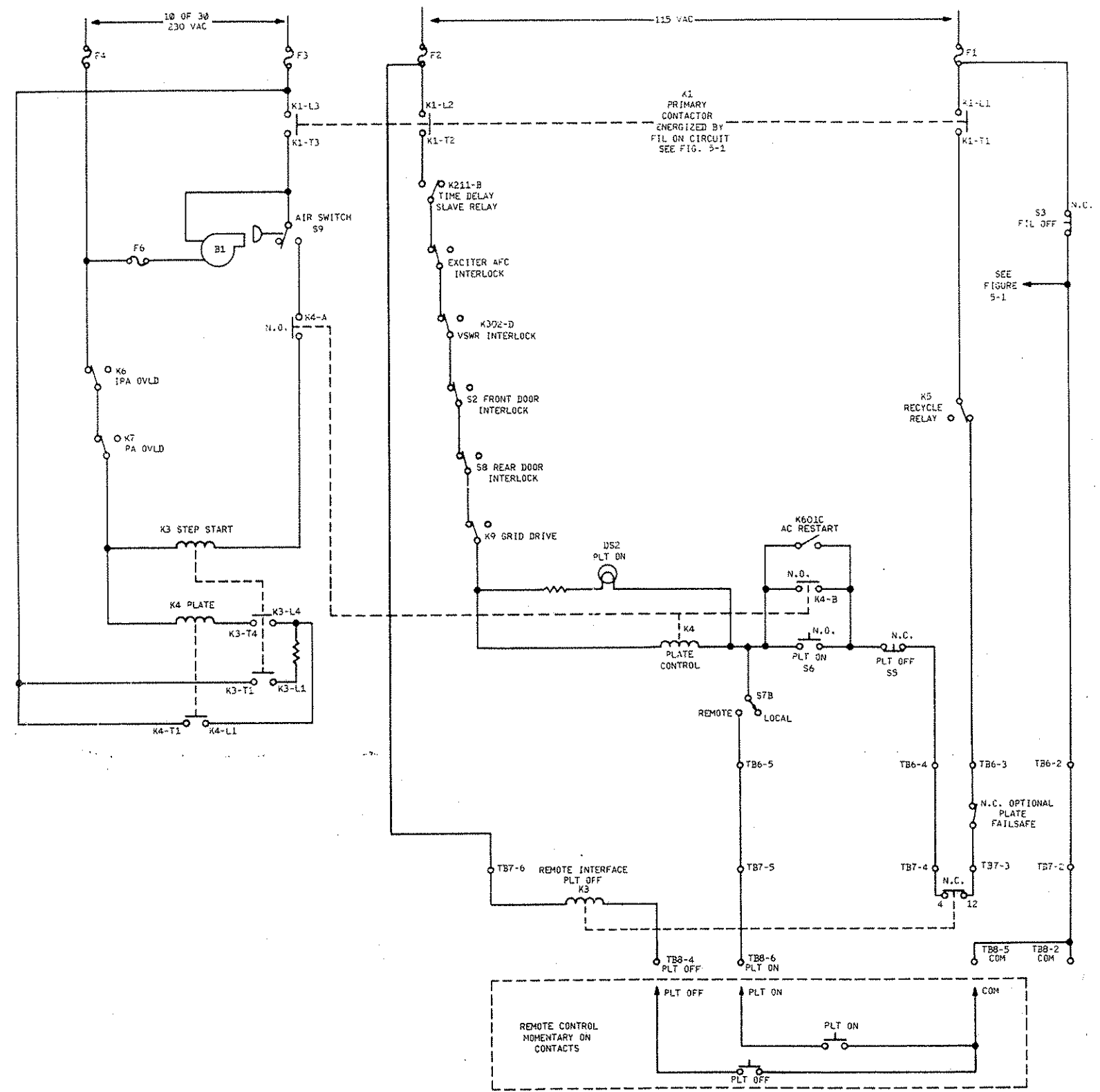

Figure 5-1. Simplified Filament Control 1761-12





1761-13

FIGURE 5-2. SIMPLIFIED PLATE CONTROL

SECTION VI

PARTS LIST

6-1. INTRODUCTION

6-2. This section provides a description, reference designator and part number for selected replaceable parts and assemblies required for proper maintenance of the HARRIS FM-5K BROADCAST TRANSMITTER. Table 6-1 lists assemblies having replaceable parts, the table number listing the parts, and the page number on which the table is located. Identity of the assembly nomenclature in table 6-1 signifies the equipment level with in the overall equipment configuration.

NOTE

Actual component values may vary slightly from component values listed on schematics and parts lists. Due to industry-wide shortages, it is sometimes necessary to use parts other than those specified. In every case, however, a substitute part is selected for conformance to overall design specifications so that equipment performance is not affected. Components that are frequency determined or peculiar to an individual transmitter are identified by a HARRIS part number and FM-5K Transmitter component number on the final test addendum sheets shipped with the equipment.

6-3. REPLACEABLE PARTS SERVICE

6-4. Replacement parts are available 24 hours a day, seven days a week from the HARRIS Service Parts Department. Telephone 217/222-8200 to contact the service parts department or address correspondence to Service Parts Department, HARRIS CORPORATION, Broadcast Group, P.O. Box 4290, Quincy, Illinois 62305-4290, USA. The HARRIS factory may also be contacted through a TWX facility (910-246-3212) or a TELEX service (247319).

Table 6-1. REPLACEABLE PARTS LIST INDEX

TABLE NO.	UNIT NOMENCLATURE	PART NO.	PAGE
6-2	FM5K 5KW FM XMTR, 60 Hz	994 8049 001	6-3
6-3	FM5K 5KW FM XMTR, 50 Hz	994 8049 002	6-4
6-4	FM5K 5KW FM XMTR, 220/380V, 50 Hz	994 8049 004	6-5
6-5	FM-5K 5KW FM XMTR	994 8049 005	6-6
6-6	XMTR FM-5K 5KW	994 8049 003	6-7
6-7	XMTR FM-5K 5KW 50HZ	994 8049 006	6-8
6-8	XMTR FM-5K 5KW 50HZ	994 8049 007	6-9
6-9	XMTR FM-5K 5KW 50HZ	994 8049 008	6-10
6-10	XMTR FM5G 5KW FM	994 6394 002	6-11
6-11	BIAS & SCREEN CONTRO	992 2728 001	6-12
6-12	FRONT ACCESS PANEL	992 2729 001	6-13
6-13	VSWR INTLK UNIT	992 5767 001	6-14
6-14	ASSEMBLY, PC BD AMP	992 3767 001	6-15
6-15	ASSEMBLY, PC BOARD	992 3768 001	6-16
6-16	STATUS LIGHTS ASSY	992 5768 001	6-17
6-17	BASIC PWR AMP ENCL	992 3608 001	6-18
6-18	P.A. TUBE DECK ASSY	992 3610 001	6-19
6-19	DRIVER METERING ASSY	992 1518 001	6-20
6-20	RMTE CTRL. INTERFACE BD.	992 5759 001	6-21
6-21	FM PWR OUTPUT KIT	994 4845 001	6-22
6-22	R.F. OUTPUT EXT. KIT	991 1170 001	6-23

Table 6-2. 5KW FMXMTR - 994 8049 001

REF. SYMBOL	HARRIS PART NO.	DESCRIPTION	QTY	UM
FL1	992 1600 001	LOW PASS FILTER	1.0	
FL2	942 3928 004	FILTER NOTCH	1.0	
2	839 0743 002	CONNECTOR, ANODE	1.0	
1	839 0743 003	CONNECTOR, ANODE	1.0	
V1	374 0016 000	TUBE 4CX5000A	1.0	
V2	374 0081 000	TUBE 4CX250B	1.0	
	994 6394 002	XMTR FM5G 5KW FM	1.0	
	994 7950 001	FM EXCITER MS15	1.0	

Table 6-3. FM5K 5KW FMXMTR - 994 8049 002

REF. SYMBOL	HARRIS PART NO.	DESCRIPTION	QTY	UM
B001	913 9392 003	MOTOR BASE, MOD.	1.0	
FL1	992 1600 001	LOW PASS FILTER	1.0	
FL2	942 3928 004	FILTER NOTCH	1.0	
T4	472 0398 000	TRANSFORMER POWER	1.0	
V1	374 0016 000	TUBE 4CX5000A	1.0	
V2	374 0081 000	TUBE 4CX250B	1.0	
	994 6394 002	XMTR FM5G 5KW FM	1.0	
	994 7950 001	FM EXCITER MS15	1.0	

Table 6-4. FM5K 5KW FMXMR - 994 8049 004

REF. SYMBOL	HARRIS PART NO.	DESCRIPTION	QTY	UM
B001	913 9392 003	MOTOR BASE, MOD.	1.0	
FL1, FL001	992 1600 001	LOW PASS FILTER	2.0	
FL2, FL002	942 3928 004	FILTER NOTCH	2.0	
R20	542 0297 000	RES 1500 OHM 100W	1.0	
R47	542 0368 000	RES 7500 OHM 200W	1.0	
T4	472 0623 000	XFMR. PLT	1.0	
T5	474 0085 000	XFMR AUTO	1.0	
V001, V1	374 0016 000	TUBE 4CX5000A	2.0	
V002, V2	374 0081 000	TUBE 4CX250B	2.0	
	994 6394 002	XMR FM5G 5KW FM	1.0	
	994 7950 001	FM EXCITER MS15	1.0	

Table 6-5. FM-5K 5KW FM XMTR - 994 8049 005

REF. SYMBOL	HARRIS PART NO.	DESCRIPTION	QTY	UM
B001	913 9392 003	MOTOR BASE, MOD.	1.0	
C70,C71,C72	510 0574 000	CAP 30UF 370VAC 60HZ	3.0	
FL1	992 1600 001	LOW PASS FILTER	1.0	
FL2	942 3928 004	FILTER NOTCH	1.0	
F1	398 0181 000	FUSE, 1 TIME CART 6A 250V	1.0	
F3,F4,F5	398 0394 000	FUSE, SLOW 35A 600V	3.0	
R20	542 0297 000	RES 1.5K OHM 100W	1.0	
R47	542 0368 000	RES 7.5K OHM 200W	1.0	
T4	472 0623 000	XFMR. PLT	1.0	
T5	472 1089 000	XFMR, STEP-DOWN	1.0	
V1	374 0016 000	TUBE, 4CX5000A	1.0	
V2	374 0081 000	TUBE, 4CX250B	1.0	
	994 6394 002	XMTR FM5G 5KW FM	1.0	
	994 7950 001	FM EXCITER MS15	1.0	
	994 8019 001	MONO OPTION	0	
	994 8020 001	STEREO GENERATOR MODULE	0	
	994 7992 001	41/67KHZ SCA GEN MODULE	0	
	994 8377 001	INTERFACE MODULE	0	
	402 0171 000	FUSEHOLDER 3P 600V 60A	1.0	

Table 6-6. XMTR FM-5K 5KW - 994 8049 003

REF. SYMBOL	HARRIS PART NO.	DESCRIPTION	QTY	UM
FL001	992 1600 001	LOW PASS FILTER	1.0	
FL002	942 3928 004	FILTER NOTCH	1.0	
V001	374 0016 000	TUBE, 4CX5000A	1.0	
V002	374 0081 000	TUBE, 4CX250B	1.0	
	994 6394 002	XMTR FM5G 5KW FM	1	
	994 7950 004	BASIC - MX-15 FM EXCITER	1	

Table 6-7. XMTR FM-5K 5KW 50HZ - 994 8049 006

REF. SYMBOL	HARRIS PART NO.	DESCRIPTION	QTY	UM
B001	432 0046 000	BLOWER 1/3 HP PW9	1.0	
FL001	992 1600 001	LOW PASS FILTER	1.0	
FL002	942 3928 004	FILTER NOTCH	1.0	
T004	472 0398 000	TRANSFORMER POWER	1.0	
V001	374 0016 000	TUBE, 4CX5000A	1.0	
V002	374 0081 000	TUBE, 4CX250B	1.0	
	994 6394 002	XMTR FM5G 5KW FM	1	
	994 7950 004	BASIC - MX-15 FM EXCITER	1	

Table 6-8. XMTR FM-5K 5KW 50HZ - 994 8049 007

REF. SYMBOL	HARRIS PART NO.	DESCRIPTION	QTY	UM
B001	432 0046 000	BLOWER 1/3 HP PW9	1.0	
FL001	992 1600 001	LOW PASS FILTER	1.0	
FL002	942 3928 004	FILTER NOTCH	1.0	
R020	542 0297 000	RES 1.5K OHM 100W	1.0	
R047	542 0368 000	RES 7.5K OHM 200W	1.0	
T004	472 0623 000	XFMR. PLT	1.0	
T005	474 0085 000	XFMR AUTO	1.0	
V001	374 0016 000	TUBE, 4CX5000A	1.0	
V002	374 0081 000	TUBE, 4CX250B	1.0	
	994 6394 002	XMTR FM5G 5KW FM	1	
	994 7950 004	BASIC - MX-15 FM EXCITER	1	

Table 6-9. XMTR FM-5K 5KW 50HZ - 994 8049 008

REF. SYMBOL	HARRIS PART NO.	DESCRIPTION	QTY	UM
B001	432 0046 000	BLOWER 1/3 HP PW9	1.0	
C070,C071,C072	510 0574 000	CAP 30UF 370VAC 60HZ	3.0	
FL001	992 1600 001	LOW PASS FILTER	1.0	
FL002	942 3928 004	FILTER NOTCH	1.0	
F001	398 0181 000	FUSE, 1 TIME CART 6A 250V	1.0	
F003,F004,F005	398 0394 000	FUSE, SLOW 35A 600V	3.0	
R020	542 0297 000	RES 1.5K OHM 100W	1.0	
R047	542 0368 000	RES 7.5K OHM 200W	1.0	
T004	472 0623 000	XFMR. PLT	1.0	
T005	472 1089 000	XFMR, STEP-DOWN	1.0	
V001	374 0016 000	TUBE, 4CX5000A	1.0	
V002	374 0081 000	TUBE, 4CX250B	1.0	
	402 0171 000	FUSEHOLDER 3P 600V 60A	1	
	994 6394 002	XMTR FM5G 5KW FM	1	
	994 7950 004	BASIC - MX-15 FM EXCITER	1	

Table 6-10. XMTR FM5G 5KW FM - 994 6394 002

REF. SYMBOL	HARRIS PART NO.	DESCRIPTION	QTY	UM
B1	913 9392 001	MODIFICATION-MOTOR B	1.0	
C6	514 0218 000	CAP 6.5-50 PF 10KV	1.0	
C37,C38	516 0082 000	CAP, DISC .01UF 1KV GMV	2.0	
C44,C45,C46	510 0612 000	CAP 8.0UF 3KV 10%	3.0	
C47	516 0082 000	CAP, DISC .01UF 1KV GMV	1.0	
C48	516 0054 000	CAP, DISC .001UF 1KV 10%	1.0	
C51,C52,C53	516 0389 000	CAP 9300 PF 10KV	3.0	
DC1	620 0350 000	CPLR 88 108MC 50 OHM	1.0	
DS1,DS2	396 0169 000	LAMP 28V 40MA 387	2.0	
F1,F2	398 0182 000	FUSE 1 TIME 10A 250V	2.0	
F3,F4,F5	398 0222 000	FUSE SLOW 60A 250V	3.0	
F6	398 0213 000	FUSE 8A 250V	1.0	
K2,K3	570 0119 000	CONTACTOR 40AMP	2.0	
L14	476 0168 000	REACTOR 2HY 3AMP	1.0	
L15	476 0296 000	REACTOR, FLTR 10HY	1.0	
M1	632 0547 002	MULTIMETER	1.0	
M2	632 0610 002	MTR 0 3ADC	1.0	
M3	632 0546 002	MTR 0 5KV DC SCALE	1.0	
M4	632 0667 000	METER, % PWR & VSWR	1.0	
R22,R23,R24	542 0164 000	RESISTOR 1 OHM 25 W	3.0	
R32	548 0167 000	RES .16 OHM 2W 1PCT	1.0	
R60,R61,R62	542 0090 000	RES 7000 OHM 10W	3.0	
R65	542 0360 000	RES 1500 OHM 200W	1.0	
R66,R67	542 0038 000	RES 2500 OHM 5W	2.0	
S2	604 0196 000	SWITCH DOOR INTERLOC	1.0	
S3,S4,S5,S6	604 0445 000	SW PB LESS LENS CAP	4.0	
S8	604 0196 000	SWITCH DOOR INTERLOC	1.0	
S10	602 0005 000	SWITCH LEVER 2P 3POS	1.0	
TB6	614 0104 000	TERM BOARD 14 TERM	1.0	
TS1,TS2	614 0129 000	TERM STRIP 1 RIGHT	2.0	
T4	472 0494 000	XFMR,PLATE	1.0	
	384 0185 000	RECTIFIER	3.0	
	402 0015 000	FUSEHOLDER 3 POLE	1.0	
	402 0087 000	FUSEHOLDER 60A 250V	1.0	
	598 0118 000	LENS CAP SW GREEN	2.0	
	598 0119 000	LENS CAP, SW, RED	2.0	
	650 0129 000	KNOB 813 6081 001	1.0	
	813 9381 001	TERM STEP START RES	6.0	
	813 9388 001	WINDOW METER	1.0	
	827 5285 014	AIR FILTER	1.0	
	910 7844 003	COAX CABLE ASSY	1.0	
	929 8345 001	CABLE ASSY	1	
	992 2728 001	BIAS & SCREEN CONTRO	1.0	
	992 2729 001	FRONT ACCESS PANEL	1.0	
	992 3607 001	PANEL ASSY	1.0	
	992 3608 001	BASIC PWR AMP ENCL	1.0	
	992 5759 001	RMTE CTRL. INTERFACE BD.	1	
	994 4845 001	FM PWR OUTPUT KIT	1.0	

Table 6-11. BIAS & SCREEN CONTRO - 992 2728 001

REF. SYMBOL	HARRIS PART NO.	DESCRIPTION	QTY	UM
B2	436 0013 000	MOTOR 1 RPM 115VAC 60HZ	1.0	
C42	524 0099 000	CAP 30 30 UF 450V	1.0	
F7	398 0017 000	FUSE 3AG FAST 1A 250	1.0	
K8	572 0066 000	RELAY TEL AK12285	1.0	
L13	476 0014 000	REACTOR 6HY 160MA	1.0	
R39	552 0324 000	RHEOSTAT 5K 25W	1.0	
R40	540 0579 000	RES 2W 47 OHM 5PCT	1.0	
R41	542 0218 000	RESISTOR 4000 OHM 50	1.0	
R45	542 0224 000	RES 10000 OHM 50W	1.0	
R46	552 0423 000	RHEOSTAT 10K OHM150W	1.0	
R47	542 0367 000	RES 5000 OHM 200W	1.0	
R48	914 3424 001	METER MULTIPLIER MM5	1.0	
R49,R50	542 0312 000	RES 100K OHM 100W	2.0	
S12,S13	604 0052 000	SW PRECISION SPNC	2.0	
TB3	614 0071 000	TERM BOARD 4 TERM	1.0	
TB4	614 0052 000	TERM BOARD 8 TERM	1.0	
T3	472 0208 000	TRANSFORMER ISOLATIO	1.0	
XC42	530 0044 000	PLT, 1-3/8" CAP, PHENOLIC	1.0	
XF7	402 0074 000	FUSEHLDR INDICATING	1.0	
Z7	384 0121 000	RECT BLOCK SILICON	1.0	
	650 0021 000	KNOB RD SKIRT .911	1.0	

Table 6-12. FRONT ACCESS PANEL - 992 2729 001

REF. SYMBOL	HARRIS PART NO.	DESCRIPTION	QTY	UM
CR2,CR6	386 0016 000	DIODE ZENER 10V	2.0	
CR7	384 0020 000	RECTIFIER IN4005	1.0	
C36,C36A	522 0133 000	CAP 16 UF 450V	2.0	
C309	516 0055 000	CAP DISC .001UF 1KV	1.0	
DS301	406 0496 000	INDICATOR, NEON RED	1.0	
K1	570 0120 000	CONTACTOR 40 AMP	1.0	
K4	574 0099 000	RELAY DPDT 110VAC	1.0	
K5	574 0455 000	RELAY, SPDT 24VDC COIL	1.0	
K6,K7	572 0125 000	RELAY TEL AK12670	2.0	
K9	572 0052 000	RELAY TEL AK12175	1.0	
K210	576 0091 000	RELAY, TIME DELAY	1.0	
K211,K302	574 0224 000	RELAY 4PDT 120VAC	2.0	
K601	574 0062 000	RELAY LATCHING 4 PDT	1.0	
K602	574 0349 000	RELAY 120VAC DPDT	1.0	
K603	574 0224 000	RELAY 4PDT 120VAC	1.0	
K605	574 0182 000	RELAY DPDT 240 VAC	1.0	
R9	550 0067 000	POT 10K OHM 2W 10%	1.0	
R10	542 0204 000	RESISTOR 5 OHM 50W	1.0	
R11	550 0061 000	POT, 1K OHM 2W	1.0	
R25	550 0067 000	POT 10K OHM 2W 10%	1.0	
R26	552 0807 000	RHEOSTAT 20K OHM 50W	1.0	
R28	550 0061 000	POT, 1K OHM 2W	1.0	
R29	550 0055 000	POT, 100 OHM 2W	1.0	
R30	542 0058 000	RES 50 OHM 10W	1.0	
R31	542 0165 000	RESISTOR 3 OHM 25W	1.0	
R33	552 0380 000	RHEOSTAT 10 OHM 100W	1.0	
R51	550 0061 000	POT, 1K OHM 2W	1.0	
R52	540 0630 000	RES 2W 6200 OHM 5PCT	1.0	
R53	540 0456 000	RES 1W 100 OHM 10%	1.0	
R63,R64	542 0309 000	RES 50K OHM 100W	2.0	
R308,R309	540 0936 000	RES .25W 10K OHM 5%	2.0	
R310	540 0910 000	RES .25W 820 OHM 5%	1.0	
R311	914 9092 003	CONTROL MODIF.	1.0	
R312	540 0952 000	RES .25W 47K OHM 5%	1.0	
S7	604 0032 000	SWITCH TOGGLE DPDT	1.0	
S11	602 0056 000	SWITCH LEVER 1455	1.0	
S301	914 9091 001	SELECTOR SWITCH (MOD	1.0	
S302	604 0391 000	SW PUSHBUTTON RED	1.0	
S303	914 9091 004	SEL. SWITCH MODIF.	1.0	
S304	604 0391 000	SW PUSHBUTTON RED	1.0	
S601	604 0032 000	SWITCH TOGGLE DPDT	1.0	
TS301	614 0149 000	TERM STRIP 5 CENTER	1.0	
XK210	404 0016 000	SOCKET, TUBE 8 PIN OCTAL	1.0	
	650 0021 000	KNOB RD SKIRT .911	4.0	
	650 0108 000	KNOB LOCK	1.0	
	650 0117 000	KNOB ROUND WHITE DOT	1.0	
	650 0129 000	KNOB 813 6081 001	1.0	
	928 8339 003	CABLE ASSY	1.0	
	992 5767 001	VSWR INTLK UNIT	1.0	
	992 5768 001	STATUS LIGHTS ASSY	1.0	

Table 6-13. VSWR INTLK UNIT - 992 5767 001

REF. SYMBOL	HARRIS PART NO.	DESCRIPTION	QTY	UM
C301,C302,C303	516 0319 000	CAP FEEDTHRU 1000PF		
C304,C305,C306			6.0	
F301	398 0040 000	FUSE SLOW 1/8A 250V	1.0	
K301	574 0100 000	RLY 41R0 2500 S SIL	1.0	
L301	494 0231 000	CHOKE, RF 10UH	1.0	
TS302	614 0130 000	TERM STRIP 2 LT 1 GD	1.0	
T301	472 0443 000	XFMR POWER A38296	1.0	
XF401	402 0024 000	FUSE HOLDER	1.0	
	992 3767 001	ASSEMBLY, PC BD AMP	1.0	
	992 3768 001	ASSEMBLY, PC BOARD	1.0	

Table 6-14. ASSEMBLY, PC BD AMP - 992 3767 001

REF. SYMBOL	HARRIS PART NO.	DESCRIPTION	QTY	UM
CR301, CR302	384 0134 000	DIODE, SILICON 1N914	2.0	
C307	516 0055 000	CAP DISC .001UF 1KV	1.0	
C308	516 0453 000	CAP .1UF 100V 20%	1.0	
R301	540 0936 000	RES .25W 10K OHM 5%	1.0	
R302	550 0418 000	POT 1 MEGOHM 3/4W 10%	1.0	
R303	540 0980 000	RES .25W 680K OHM 5%	1.0	
R304	540 0888 000	RES .25W 100 OHM 5%	1.0	
TP301	612 0502 000	JACK, TEST, BLACK	1.0	
U301	382 0108 000	IC 2151/6741	1.0	
XK301	404 0065 000	SOCKET TUBE 8 PIN PC	1.0	
	915 5091 001	PRINTED BOARD	1.0	

Table 6-15. ASSEMBLY, PC BOARD - 992 3768 001

REF. SYMBOL	HARRIS PART NO.	DESCRIPTION	QTY	UM
CR303, CR304	384 0020 000	RECTIFIER IN4005	2.0	
CR305, CR306	386 0136 000	DIODE. ZENER 1N4745A	2.0	
C310	522 0414 000	CAP 500UF 50V	1.0	
R305	540 0308 000	RES 1W 100 OHM 5%	1.0	
R306, R307	540 0332 000	RES 1W 1000 OHM 5%	2.0	
	915 5376 001	PC BOARD	1.0	

Table 6-16. STATUS LIGHTS ASSY - 992 5768 001

REF. SYMBOL	HARRIS PART NO.	DESCRIPTION	QTY	UM
A201, A202, A203	406 0358 000	PILOT LIGHT AMBER		
A204, A205, A206				
A207, A208			8.0	
K201, K202, K203	574 0154 000	RELAY 115V 50/60HZ		
K204, K205, K206				
K207, K208			8.0	
K209	574 0182 000	RELAY DPDT 240VAC	1.0	
S201	604 0151 000	SW PUSHBUTTON RED	1.0	
TB201, TB202	614 0056 000	TERM BOARD 12 TERM	2.0	
	929 8388 001	CABLE, LIGHT PNL STS	1.0	

Table 6-17. BASIC PWR AMP ENCL - 992 3608 001

REF. SYMBOL	HARRIS PART NO.	DESCRIPTION	QTY	UM
CR3,CR4	384 0020 000	RECTIFIER IN4005	2.0	
C7	516 0713 000	CAP 500PF 15KVDC 10%	1.0	
C8	516 0205 000	CAP HV 500 UUF 5000V	1.0	
C18,C23	516 0206 000	CAP HV 1000 UUF 5000	2.0	
C24	522 0071 000	CAP 50 UF 25V	1.0	
C25	516 0361 000	CAP FEEDTHRU 1000PF	1.0	
C27,C28,C29,C30	516 0250 000	CAP, BUTTON 500PF	4.0	
C32	500 0852 000	CAP 1000 PF 500V	1.0	
C40,C41	516 0205 000	CAP HV 500 UUF 5000V	2.0	
C43	516 0450 000	CAP 1000PF 500V 20%	1.0	
C49	516 0227 000	CAP FEED-THRU 500PF	1.0	
C50	516 0205 000	CAP HV 500 UUF 5000V	1.0	
C54	516 0713 000	CAP 500PF 15KVDC 10%	1.0	
C57,C58	516 0206 000	CAP HV 1000 UUF 5000	2.0	
C61,C62	516 0205 000	CAP HV 500 UUF 5000V	2.0	
J4	612 0233 000	RECEPTACLE N UG-58A/U	1.0	
L2	942 3910 001	PLATE LINE	1.0	
L3	927 4249 001	PLATE LINE COIL ASSY	1.0	
L5	494 0004 000	CHOKE R F 7 UH	1.0	
L7	914 9991 001	COIL ASS'Y, GRID TUN	1.0	
L8	914 9992 001	COIL ASS'Y, INPUT LOA	1.0	
L16,L17	914 7670 002	R.F. CHOKE ASSY (2UH	2.0	
L18,L19	494 0004 000	CHOKE R F 7 UH	2.0	
R12	540 0580 000	RES 2W 51 OHM 5PCT	1.0	
R13	550 0067 000	POT 10K OHM 2W 10%	1.0	
R14	540 0746 000	RES 2W 3300 OHM 10%	1.0	
R18	550 0054 000	POT, 50 OHM 2W	1.0	
R19	540 0833 000	RES 100 OHM 25/100W 10%	1.0	
R20,R21	540 0563 000	RES 2W 10 OHM 5PCT	2.0	
R27	540 0611 000	RES 2W 1000 OHM 5PCT	1.0	
R34,R35,R36	544 1613 000	RES 100 OHM 4W 5%	3.0	
R37	542 0209 000	RESISTOR 200 OHM 50W	1.0	
R38	540 0603 000	RES 2W 470 OHM 5PCT	1.0	
S9	604 0258 000	SW, PRESSURE	1.0	
TB5	614 0114 000	TERM BOARD 6 TERM	1.0	
T1	472 0409 000	XFMR, FIL	1.0	
T2	472 0090 000	TRANSFORMER FIL	1.0	
XV2	404 0251 000	SOCKET, TUBE 8 PIN	1.0	
	358 0185 000	RCPTCL 85 SPRING	17.0	
	927 4704 001	SPURIOUS SUPPRESSOR	2.0	
	992 3610 001	P.A. TUBE DECK ASSY	1.0	
	992 1518 001	DRIVER METERING ASSY	1.0	

Table 6-18. P.A. TUBE DECK ASSY - 992 3610 001

REF. SYMBOL	HARRIS PART NO.	DESCRIPTION	QTY	UM
C9,C10,C11,C12	516 0205 000	CAP HV 500 UUF 5000V		
C13,C14,C15,C16			8.0	
C19,C20,C21,C22	516 0206 000	CAP HV 1000 UUF 5000	4.0	
C26	516 0201 000	CAP HV 50 UUF 7500V	1.0	
C56	516 0210 000	CAP 200 PF 7500V 10%	1.0	
L4	494 0004 000	CHOKER F 7 UH	1.0	
XV1	404 0069 000	SOCKET TUBE	1.0	
	829 0846 001	L10 INDUCTOR	1.0	
	913 9382 001	CABLE ASSY FM5G M639	1.0	
	913 9382 002	CABLE ASSY FM5G M639	1.0	

Table 6-19. DRIVER METERING ASSY - 992 1518 001

REF. SYMBOL	HARRIS PART NO.	DESCRIPTION	QTY	UM
CR5	384 0134 000	DIODE, SILICON 1N914	1.0	
C33,C34	516 0054 000	CAP, DISC .001UF 1KV 10%	2.0	
C35	516 0043 000	CAP, DISC 470PF 1KV 10%	1.0	
R15	540 0068 000	RES .5W 6200 OHM 5%	1.0	
R16	540 0073 000	RES .5W 10K OHM 5%	1.0	
R17	540 0058 000	RES .5W 2400 OHM 5%	1.0	

Table 6-20. RMTE CTRL. INTERFACE BD. - 992 5759 001

REF. SYMBOL	HARRIS PART NO.	DESCRIPTION	QTY	UM
K1, K2, K3	574 0364 000	RELAY 4PDT 120VAC	3.0	
TB9, TB10	614 0727 000	TERM BOARD 8 TERM	2.0	
	839 5734 001	PC BOARD	1.0	

Table 6-21. FM PWR OUTPUT KIT - 994 4845 001

REF. SYMBOL	HARRIS PART NO.	DESCRIPTION	QTY	UM
	991 1170 001	R.F. OUTPUT EXT. KIT	1.0	

Table 6-22. R.F. OUTPUTEXT. KIT - 991 1170 001

REF. SYMBOL	HARRIS PART NO.	DESCRIPTION	QTY	UM
CR1, CR2	384 0195 000	DIODE SILICON 1N914	2.0	
C1	516 0043 000	CAP, DISC 470PF 1KV 10%	1.0	
C2, C3	516 0054 000	CAP, DISC .001UF 1KV 10%	2.0	
J1	612 0237 000	RECEPTACLE BNC UG-290A/U	1.0	
R1, R2, R3, R4	540 0594 000	RES 2W 200 OHM 5PCT	4.0	
R6	550 0067 000	POT 10K OHM 2W 10%	1.0	
R7	540 0070 000	RES .5W 7500 OHM 5%	1.0	
TB1	614 0069 000	TERM BOARD 2 TERM	1.0	

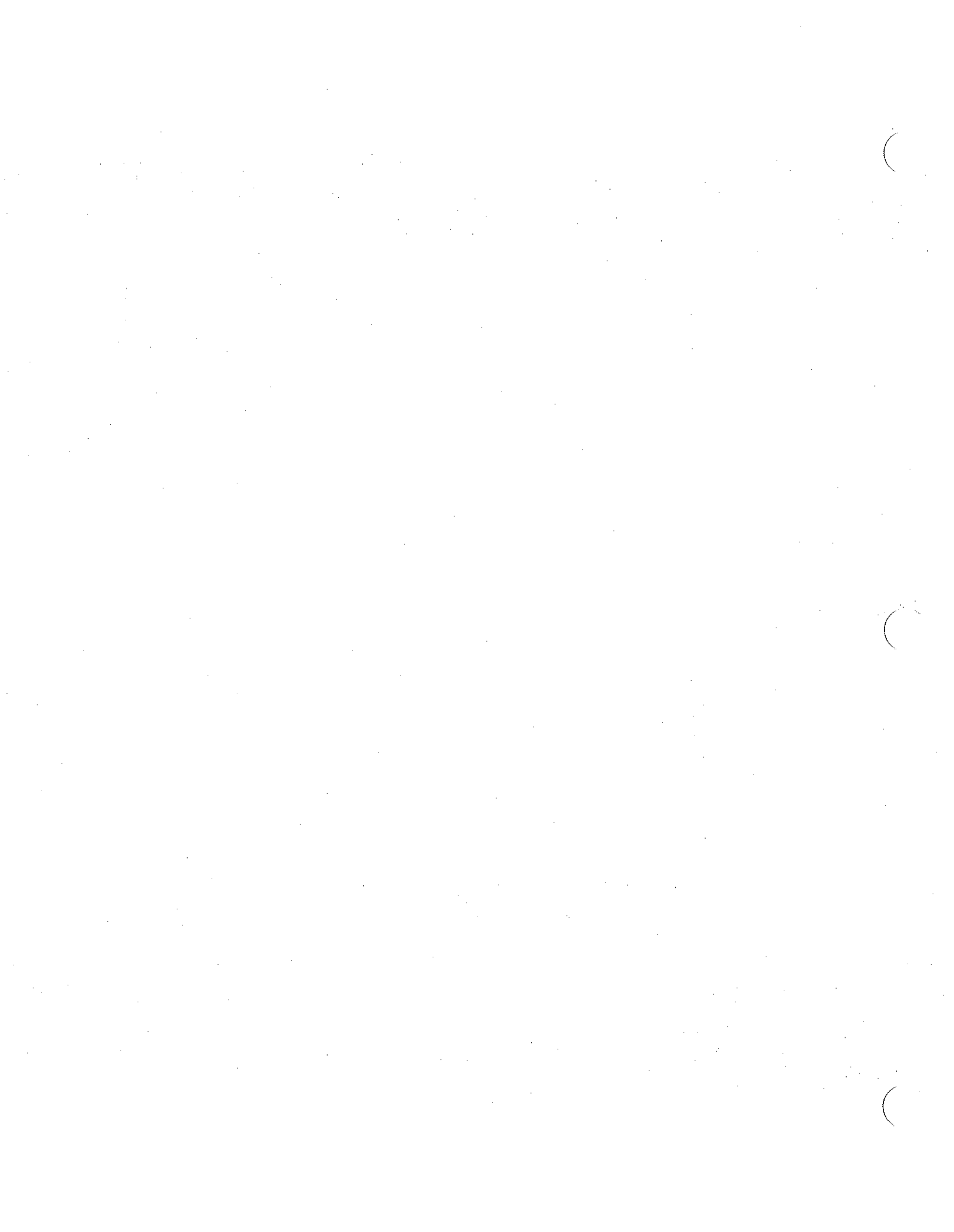

SECTION VII

DIAGRAMS

7-1. INTRODUCTION

7-2. This section provides schematic, interconnection, and wiring diagrams required for maintenance of the HARRIS FM-5K BROADCAST TRANSMITTER. The following diagrams are contained in this section:

<u>Figure</u>	<u>Title</u>	<u>Number</u>	<u>Page</u>
7-1	Schematic Diagram, FM-5K Transmitter	852 6320 002	7-3/7-4
7-2	PA Efficiency Graph	814 1335 001	7-5/7-6
7-3	PA Coarse Tuning Graph	814 1733 001	7-7/7-8
7-4	Low-Pass Filter Details	814 8556 001	7-9/7-10
7-5	Second Harmonic Filter Details	814 8554 001	7-11/7-12
7-6	Schematic Diagram, 380V, 50 Hz	852 9094 001	7-13/7-14

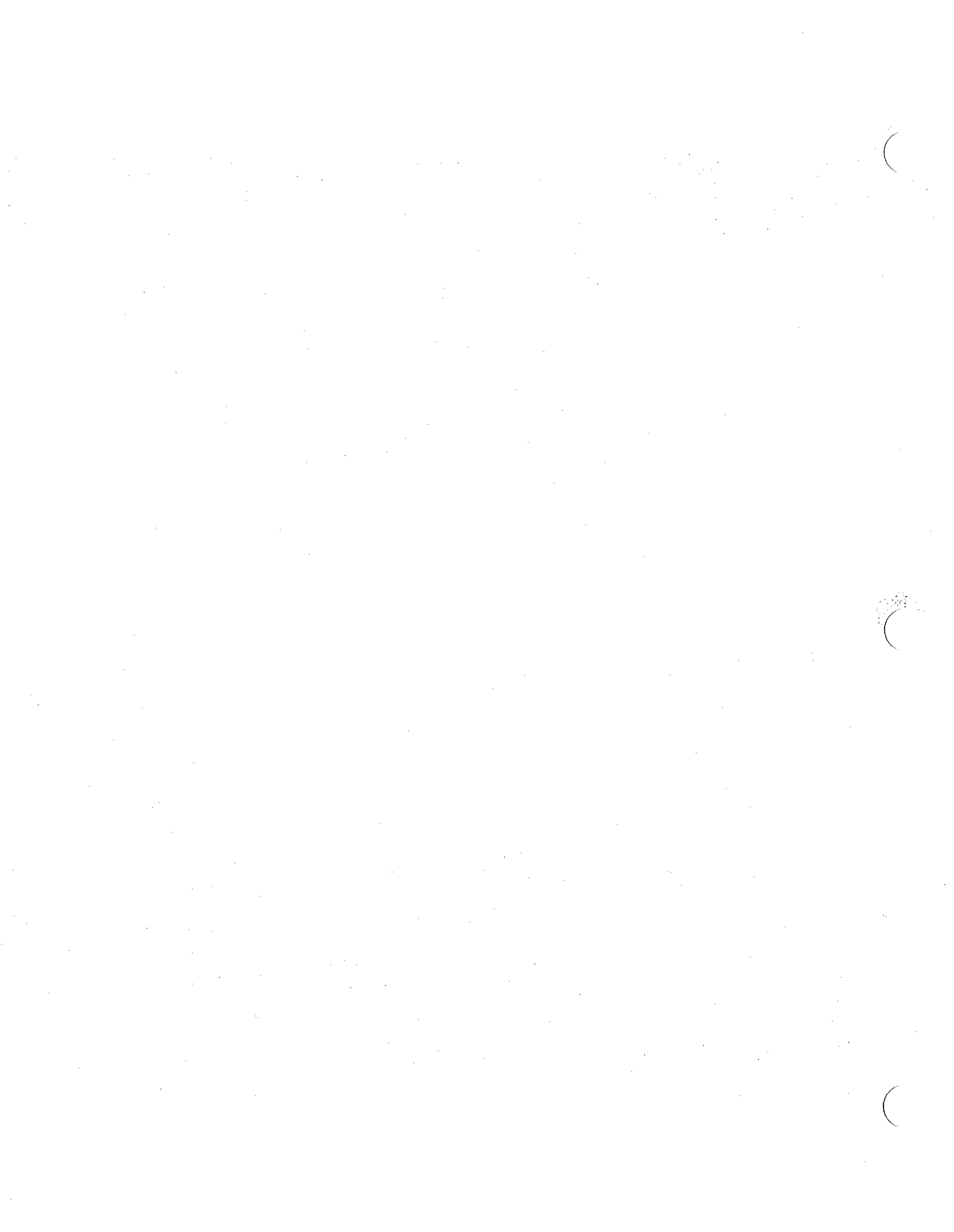

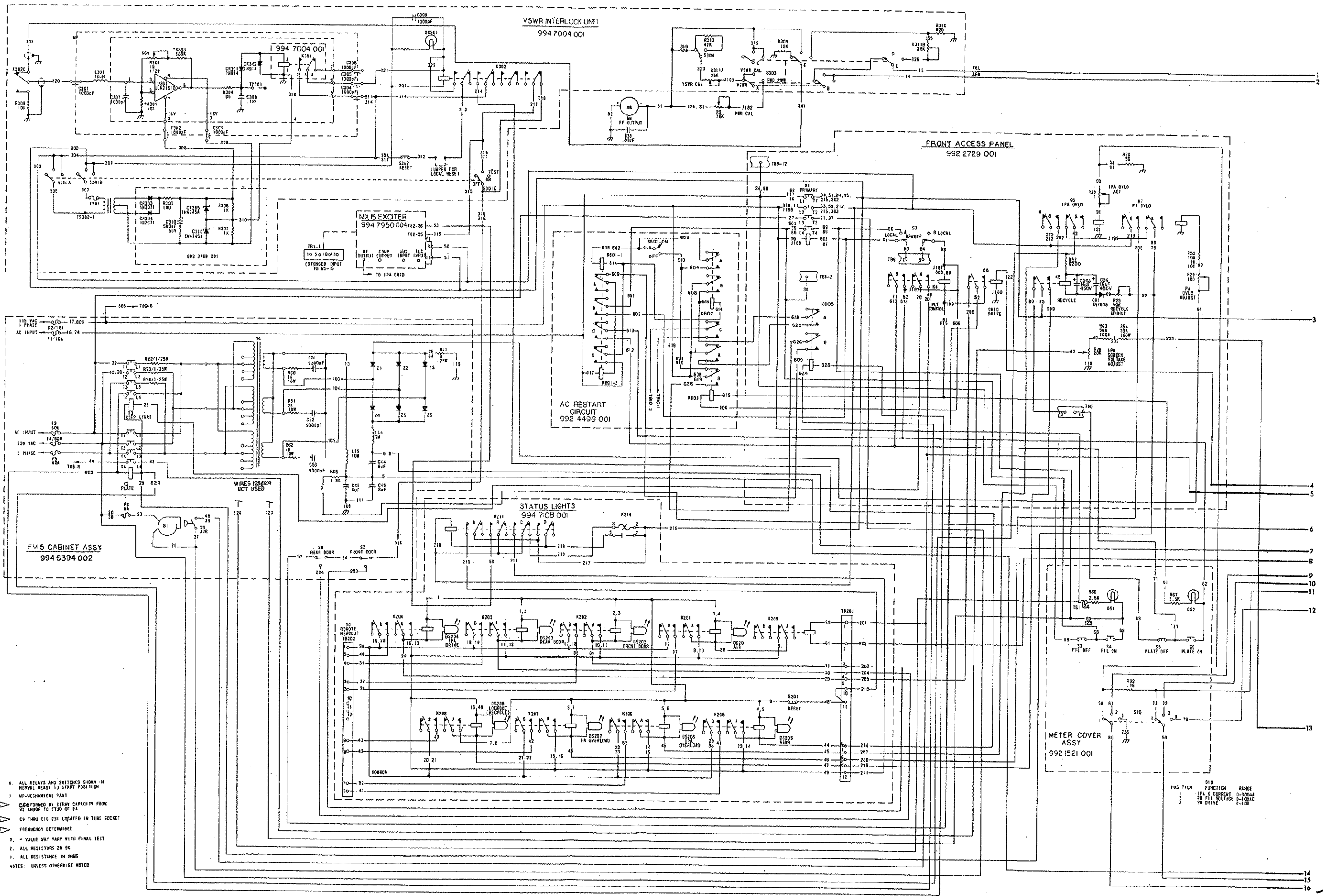

- 6. ALL RELAYS AND SWITCHES SHOWN IN NORMAL READY TO START POSITION
 - 7. MP-MECHANICAL PART
 - 8. C₀ FORMED BY STRAY CAPACITY FROM V₂ ANODE TO STUD OF E₄
 - 9. C₅ THRU C₁₆, C₃₁ LOCATED IN TUBE SOCKET
 - 10. FREQUENCY DETERMINED
 - 11. * VALUE MAY VARY WITH FINAL TEST
 - 12. ALL RESISTORS 2% 5%
 - 13. ALL RESISTORS IN OHMS
- NOTES: UNLESS OTHERWISE NOTED

POSITION	S10 FUNCTION	RANGE
1	IPA X CURRENT	0-300MA
2	PA FIL VOLTAGE	0-100VAC
3	PA DRIVE	0-100

CONTJ
PAGE

14
15
16

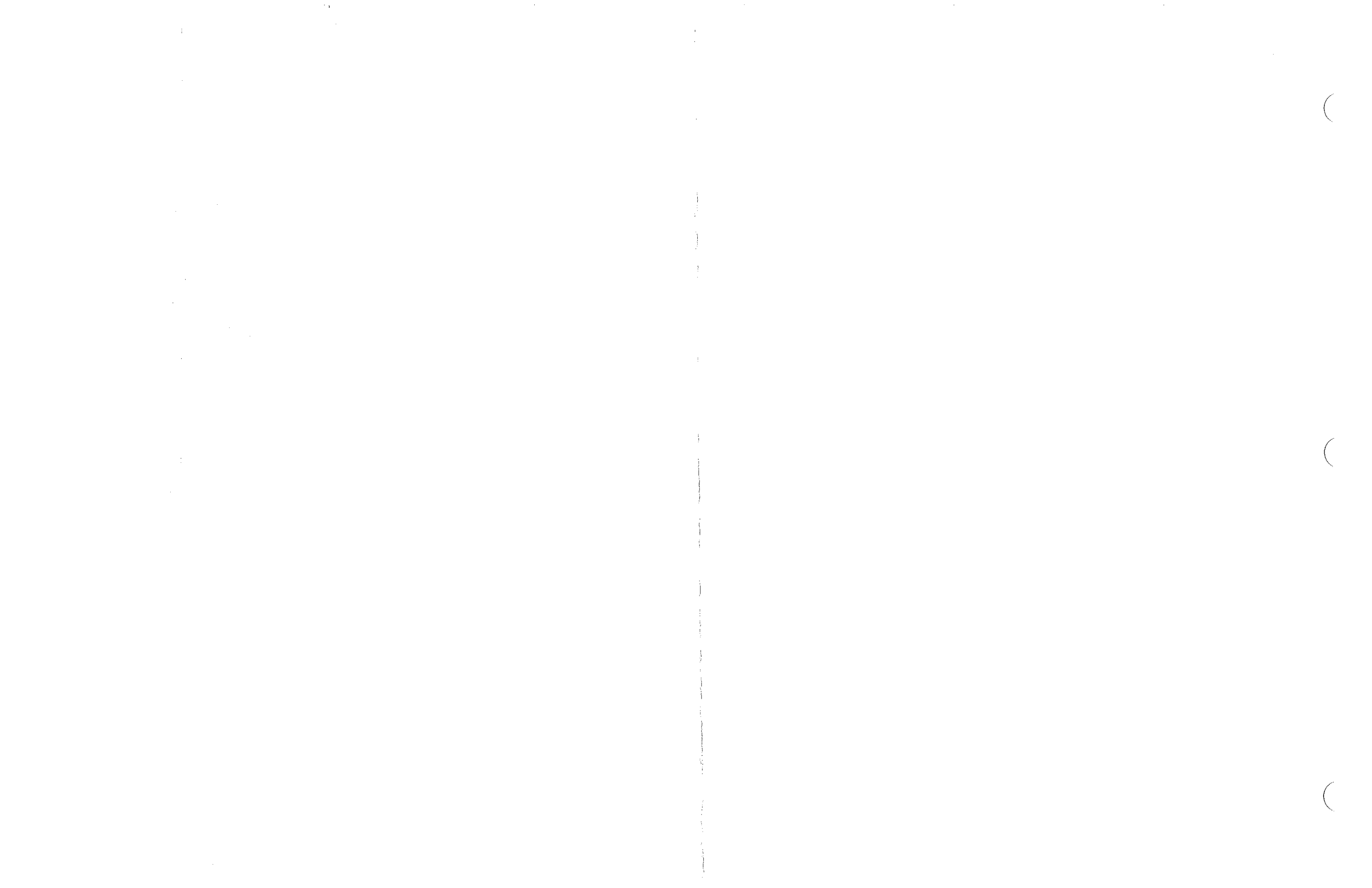

CONTINUED FROM
PAGE 7-3/7-4A

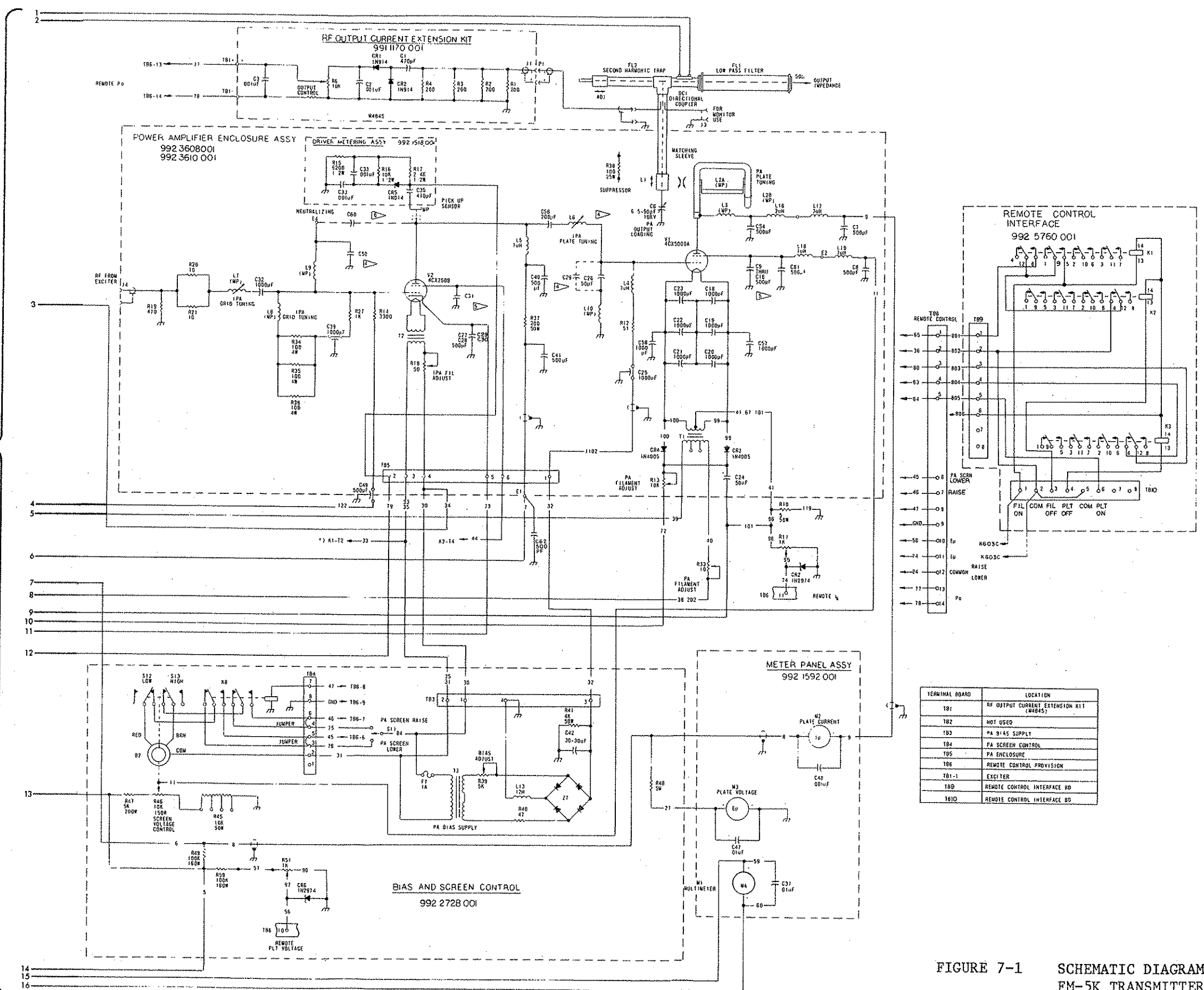

TERMINAL BOARD	LOCATION
TB1	RF OUTPUT CURRENT EXTENSION KIT (9911170)
TB2	NOT USED
TB3	PA BIAS SUPPLY
TB4	PA SCREEN CONTROL
TB5	PA ENCLOSURE
TB6	REMOTE CONTROL PROVISION
TB1-1	EXCITER
TB9	REMOTE CONTROL INTERFACE 8D
TB10	REMOTE CONTROL INTERFACE 8D

FIGURE 7-1 SCHEMATIC DIAGRAM
FM-5K TRANSMITTER
852 6320 002-K

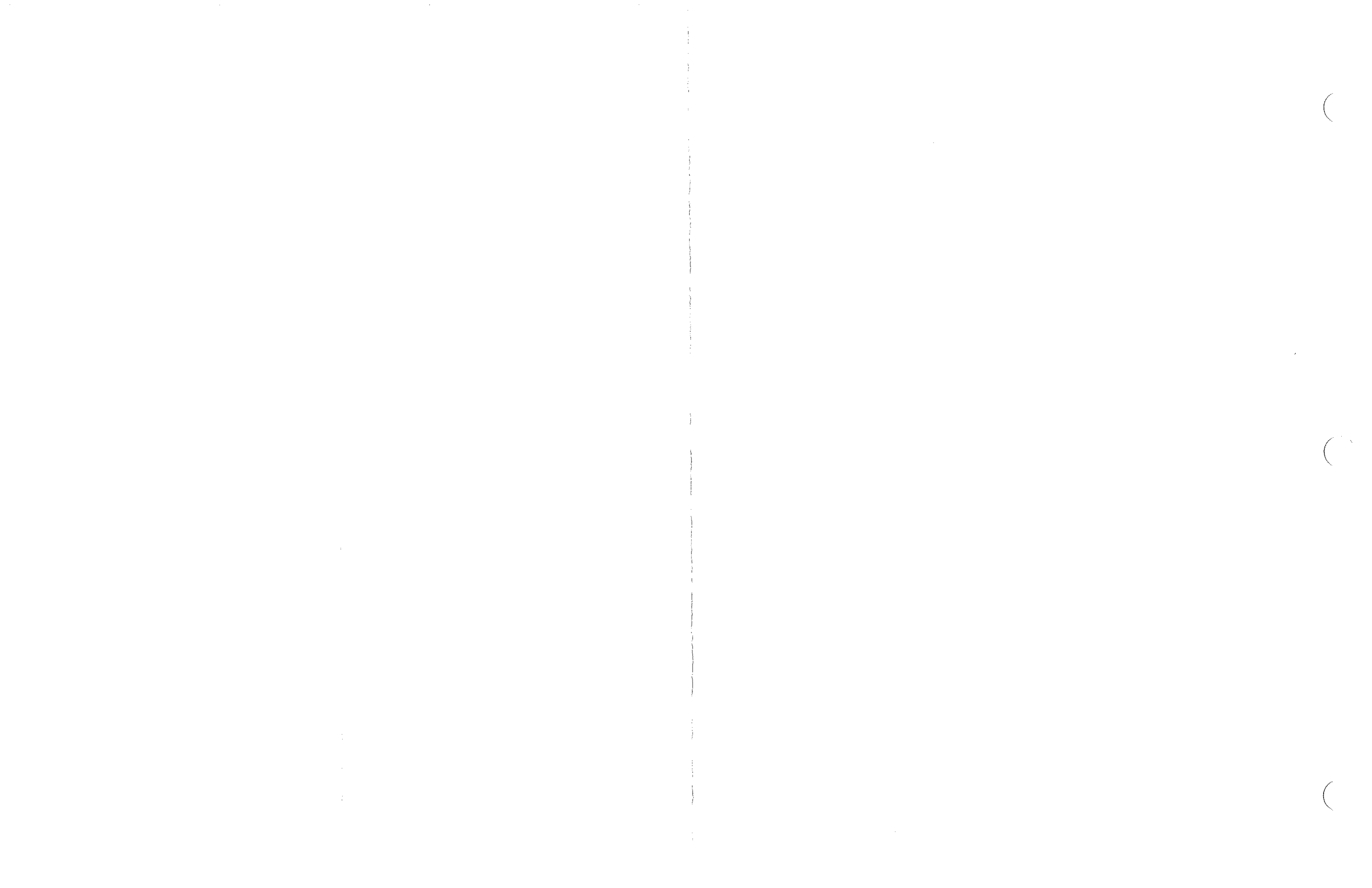

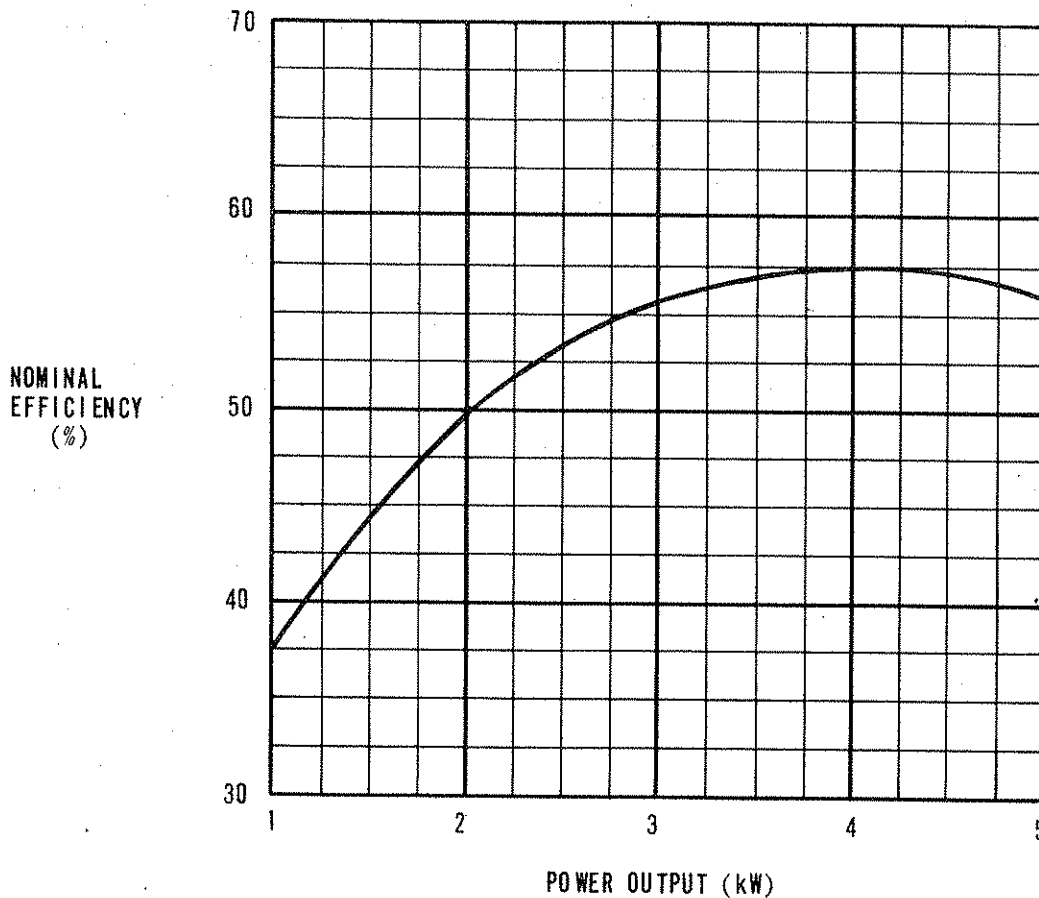

REFER TO THE TRANSMITTER FACTORY TEST DATA FOR THE EFFICIENCY FACTOR DETERMINED ON FINAL TEST

FIGURE 7-2. PA EFFICIENCY GRAPH
814 1335 001

888-1763-005
7-5/7-6

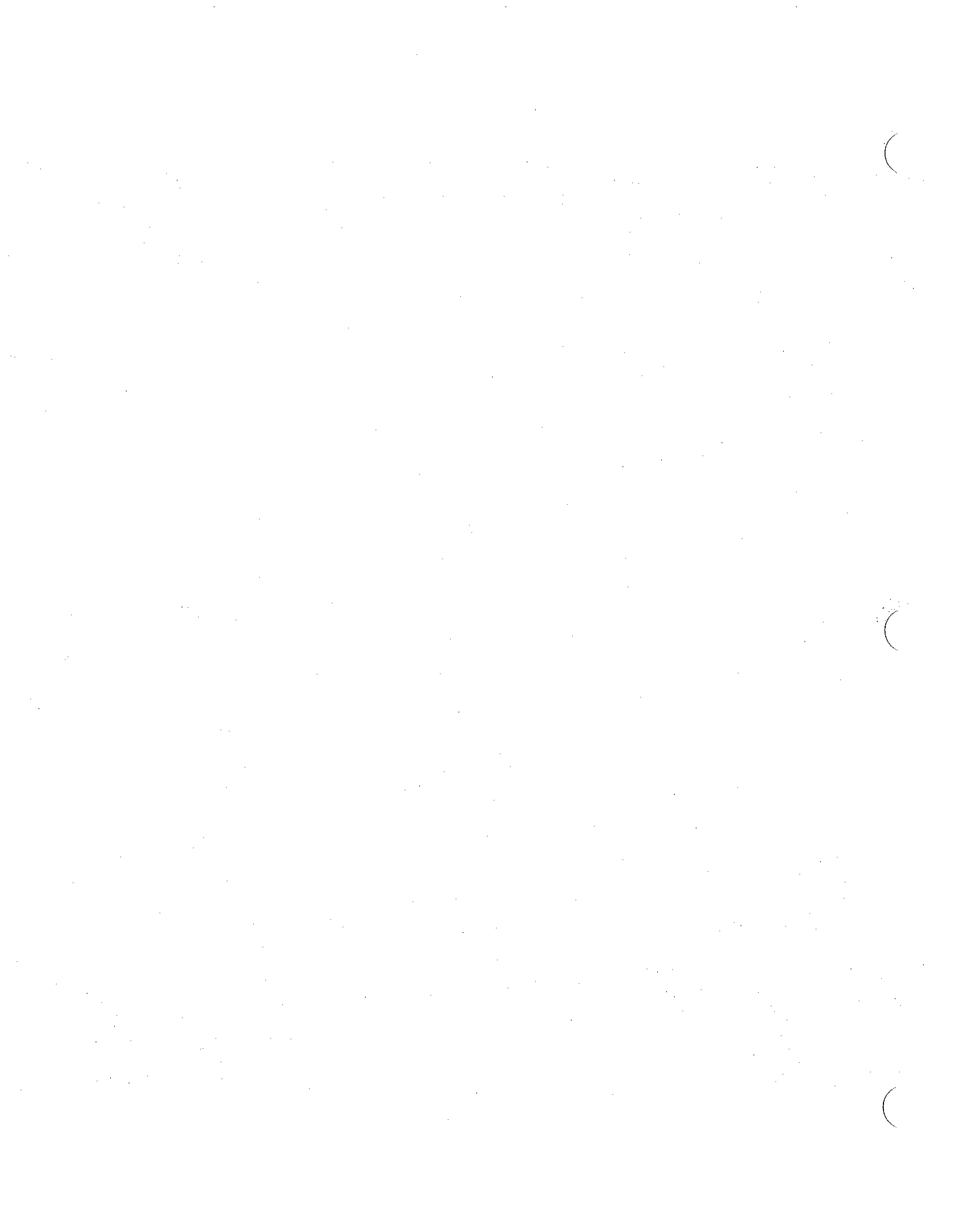

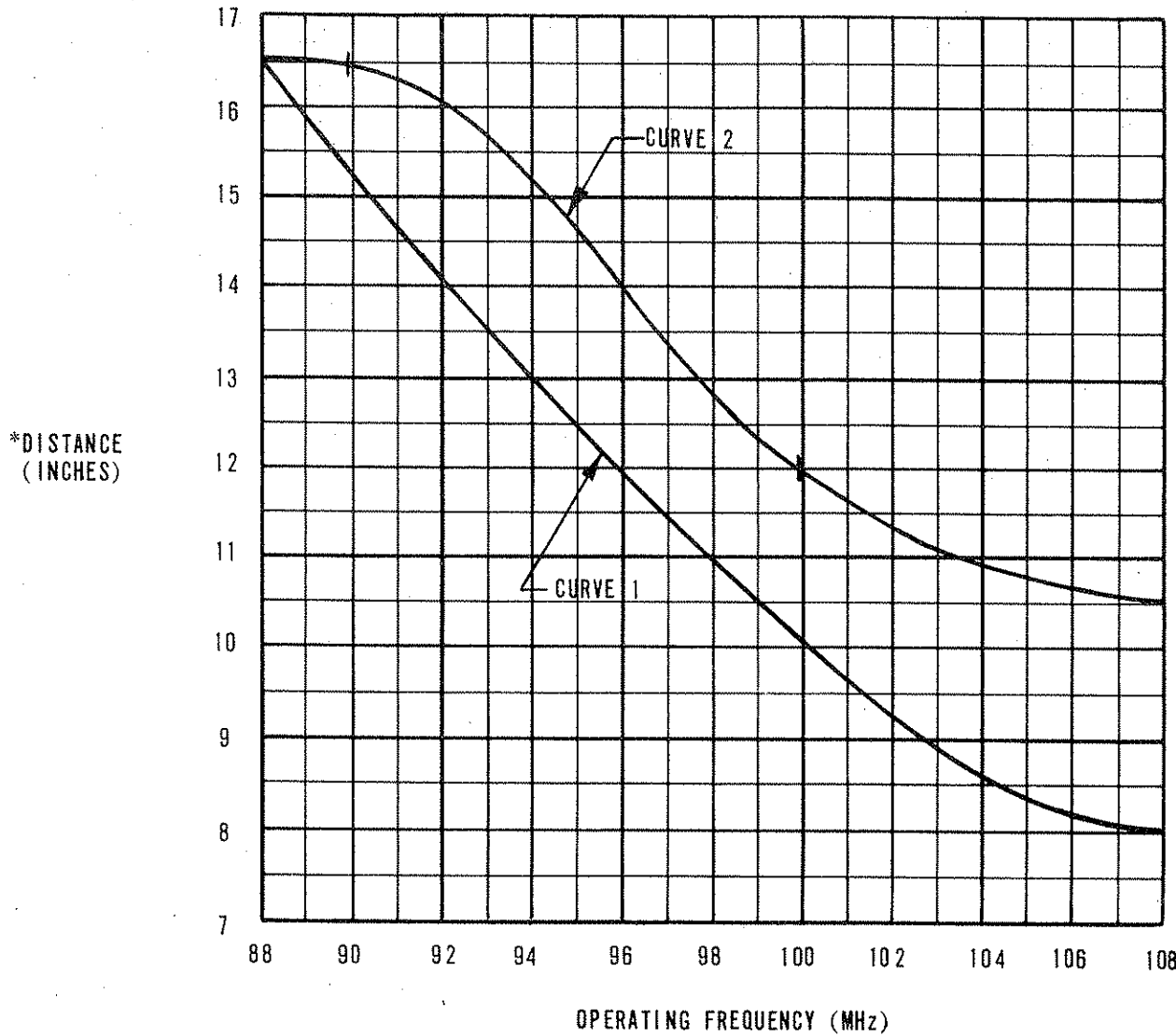

CURVE 1: COPPER ANODE CLAMP.
 CURVE 2: ALUMINUM ANODE CONNECTOR(S)
 98.1 TO 89.9 MHz: 1 2.25 INCH CONNECTOR
 90.1 TO 99.9 MHz: 1 3 INCH CONNECTOR
 100.1 TO 107.9 MHz: 2 1.75 INCH CONNECTORS

*DISTANCE FROM THE PA TUBE DECK TO THE BOTTOM OF THE ROTARY SECTION OF THE PLATE CIRCUIT. FINAL POSITION MAY VARY FROM CURVE.

FIGURE 7-3. PA COARSE TUNING GRAPH
 814 1733 001

888-1761-005
 7-7/7-8

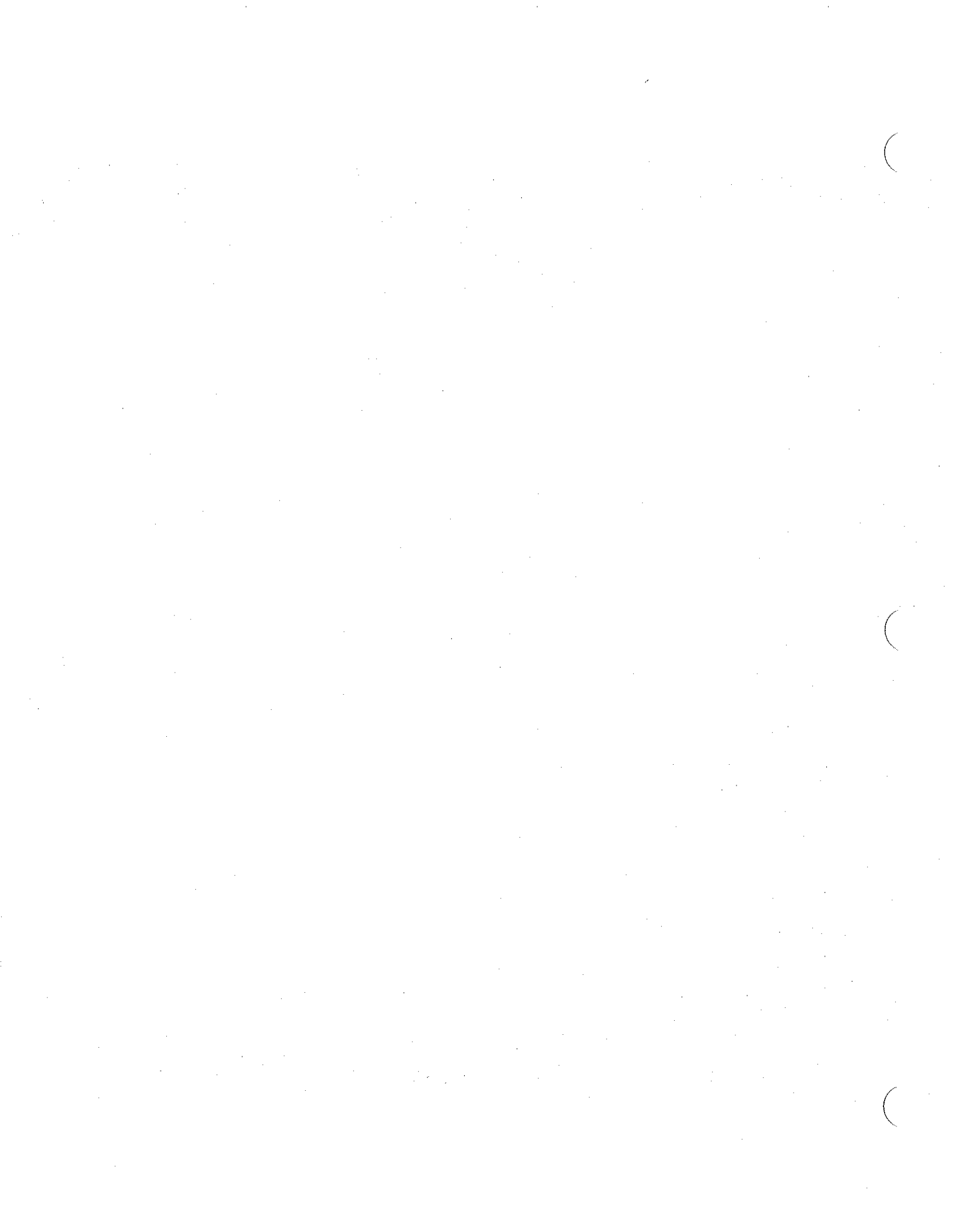

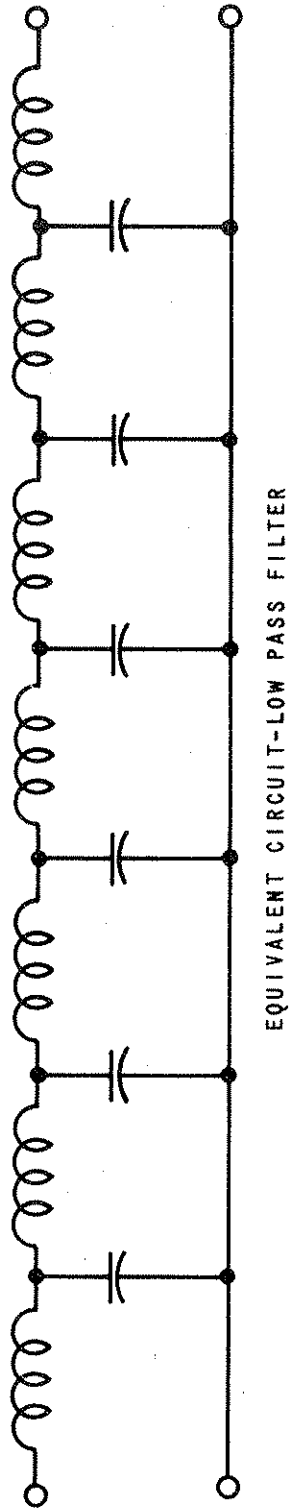
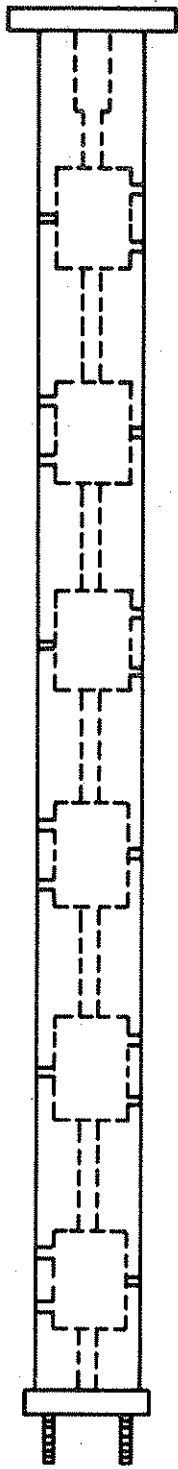

EQUIVALENT CIRCUIT-LOW PASS FILTER

3 1/8" TRANSMISSION LINE, OVERALL LENGTH 72 1/8".

LOW PASS FILTER
FM TRANSMITTERS

FIGURE 7-4. LOW-PASS FILTER DETAILS
814 8556 001

888-1761-005
7-9/7-10

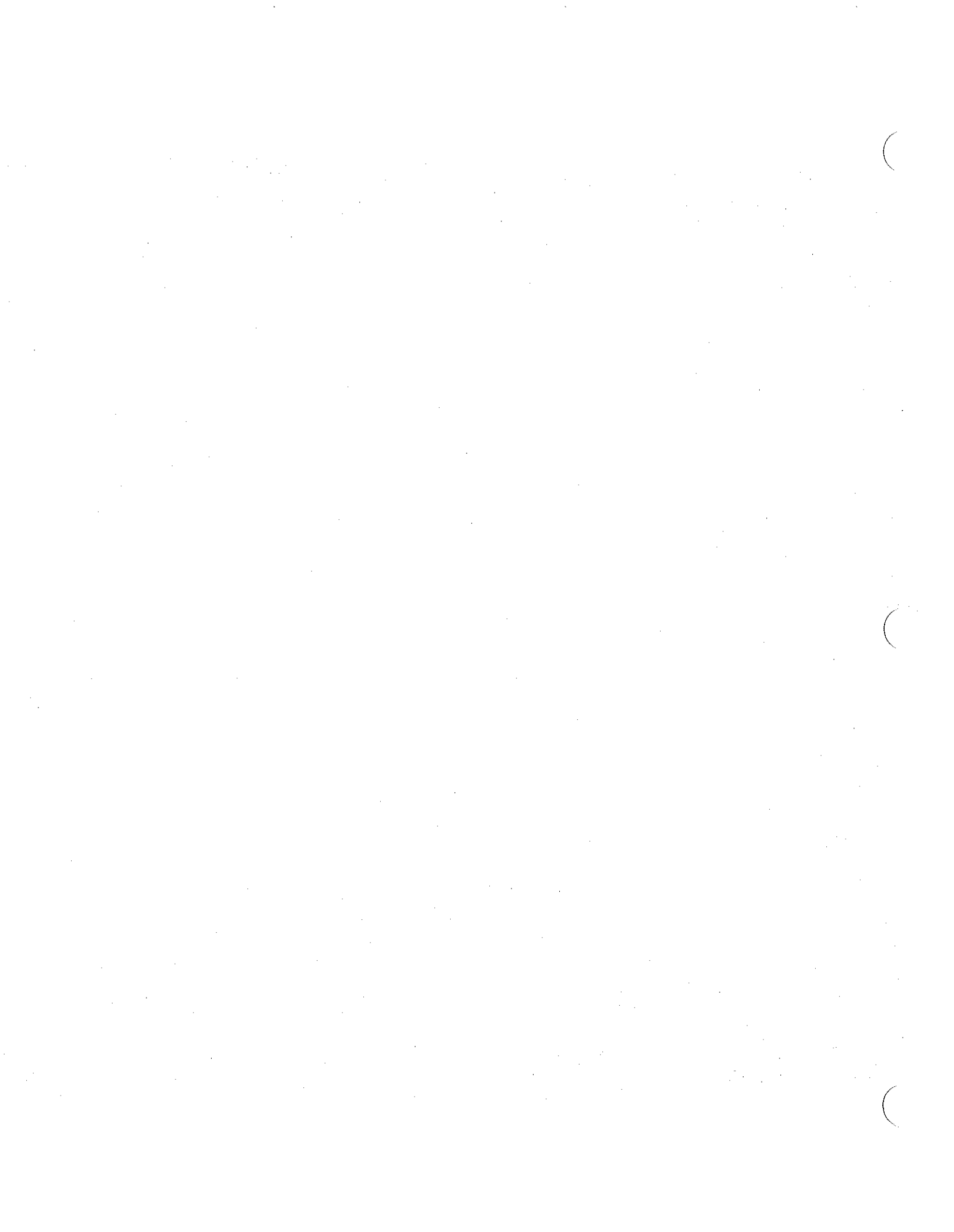

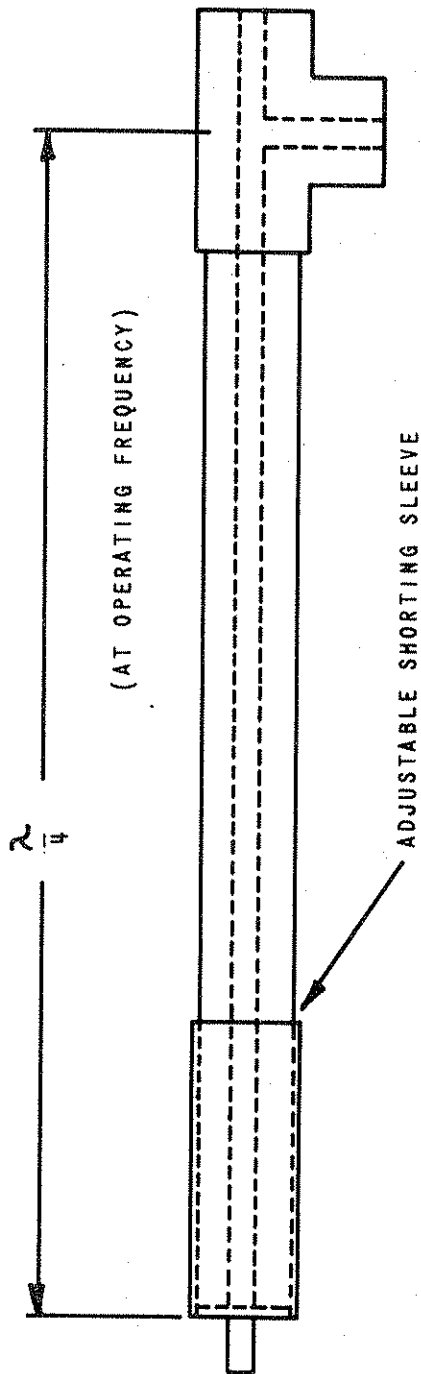

AT FREQUENCIES BELOW RESONANCE
THE "STUB" APPEARS AS AN INDUCTANCE.

AT FREQUENCIES ABOVE RESONANCE THE
"STUB" APPEARS AS A CAPACITY.

AT THE SECOND HARMONIC FREQUENCY,
THE "STUB" APPEARS AS A SERIES
RESONANT CIRCUIT OR DEAD SHORT.

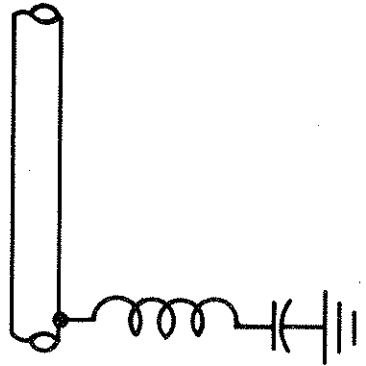

APPEARANCE OF NOTCH FILTER
AT SECOND HARMONIC

2nd HARMONIC FILTER -
FM TRANSMITTERS

FIGURE 7-5. SECOND HARMONIC FILTER DETAILS
814 8554 001

888-1761-005
7-11/7-12

WARNING: Disconnect primary power prior to servicing.

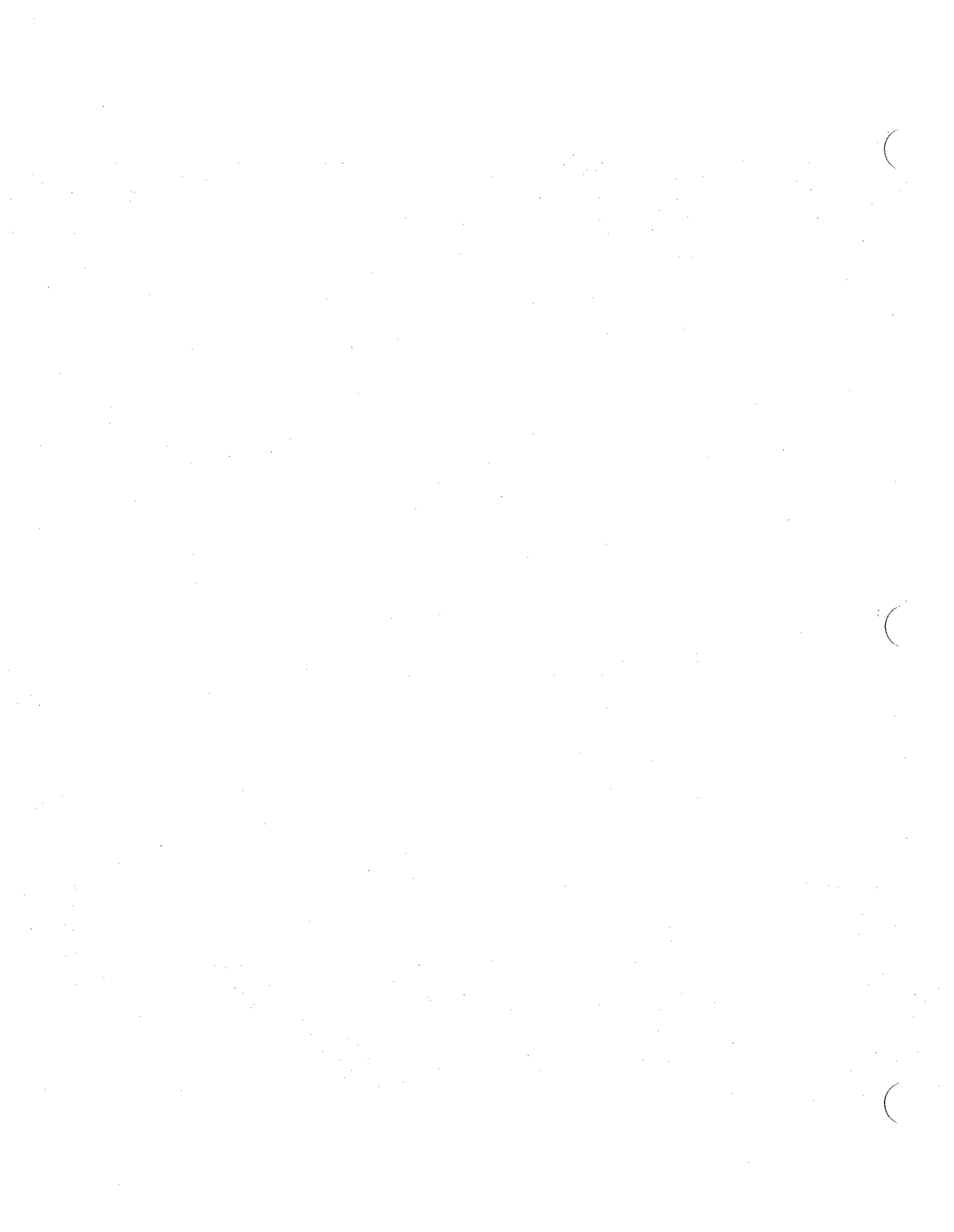

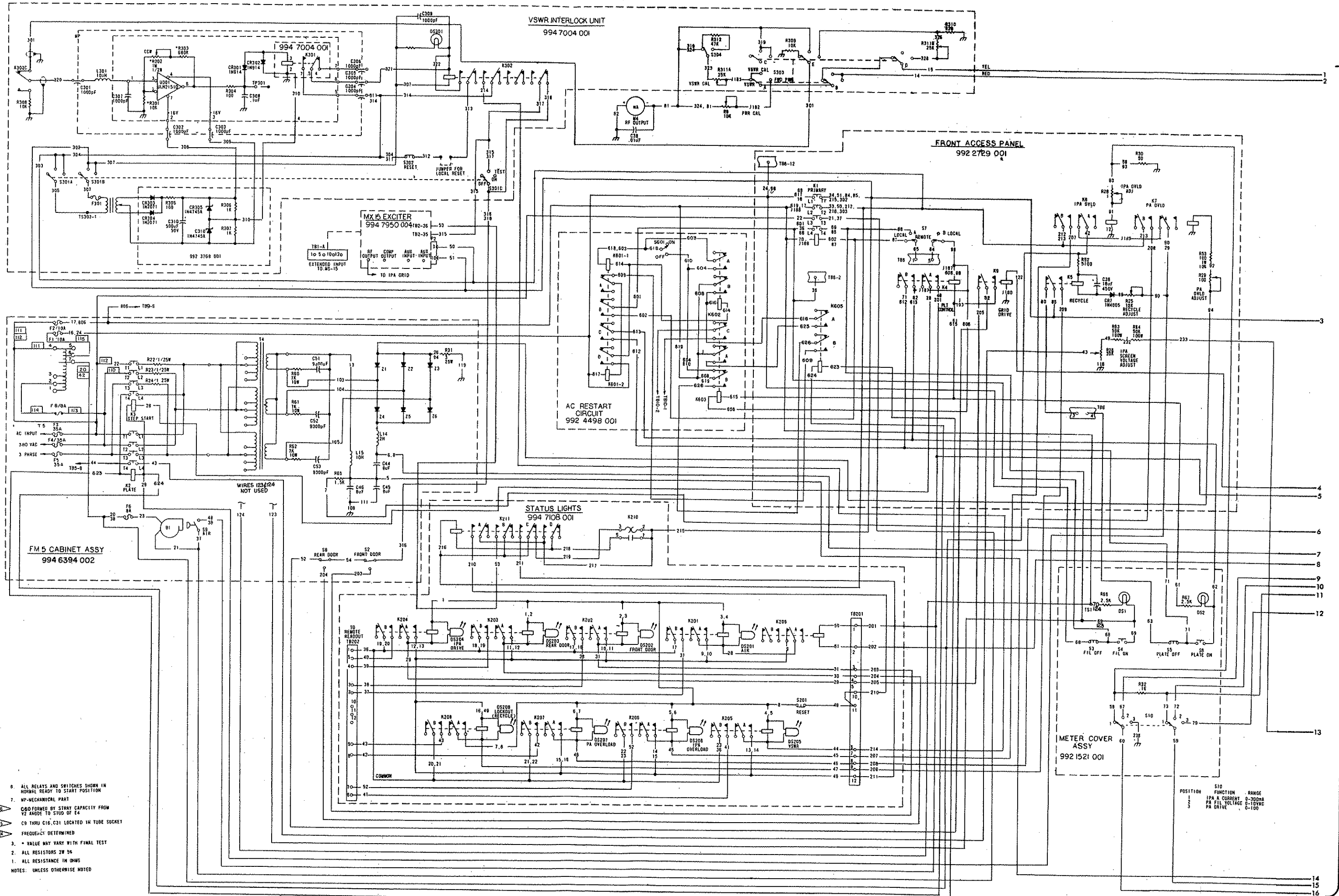

- 8. ALL RELAYS AND SWITCHES SHOWN IN NORMAL READY TO START POSITION
- 7. WP-MECHANICAL PART
- 6. CAP FORMED BY STRAY CAPACITY FROM V2 AND TO GRID OF E4
- 5. C9 THRU C16, C31 LOCATED IN TUBE SOCKET
- 4. FREQUENCY DETERMINED
- 3. * VALUE MAY VARY WITH FINAL TEST
- 2. ALL RESISTORS 2W 5%
1. ALL RESISTORS IN OHMS
- NOTES: UNLESS OTHERWISE NOTED

POSITION	S10	FUNCTION	RANGE
1		IPA X CURRENT	0-300MA
2		PA FIL VOLTAGE	0-10VAC
3		PA DRIVE	0-100

CONT.
PAGE

CONTINUED FROM
PAGE 7-13/7-14A

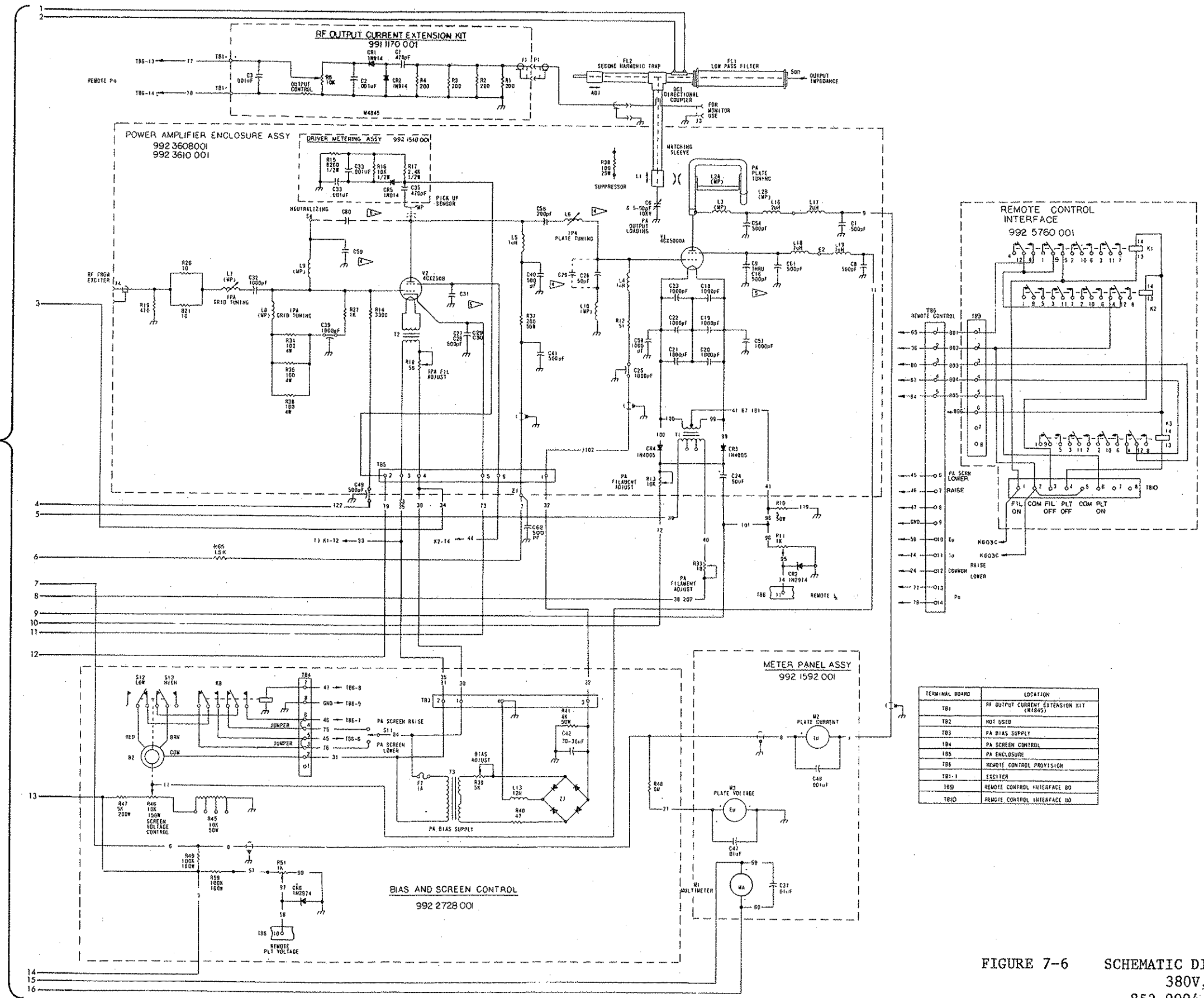

TERMINAL BOARD	LOCATION
TB1	RF OUTPUT CURRENT EXTENSION KIT (M4845)
TB2	NOT USED
TB3	PA BIAS SUPPLY
TB4	PA SCREEN CONTROL
TB5	PA ENCLOSURE
TB6	REMOTE CONTROL PROVISION
TB1-1	EXCITER
TB9	REMOTE CONTROL INTERFACE BD
TB10	REMOTE CONTROL INTERFACE BD

FIGURE 7-6 SCHEMATIC DIAGRAM
380V, 50HZ
852 9094 001-B

APPENDIX A
MANUFACTURERS DATA

APPENDIX A

MANUFACTURERS DATA

A-1. INTRODUCTION

A-2. This appendix consists of the following technical data which identifies operating characteristics and parameters for various replaceable items used in the HARRIS FM-5K BROADCAST TRANSMITTER.

A1 - Eimac Engineering Newsletter - WHM65D29 MOD. 9-20-65

A2 - Eimac Technical Data Sheet - 4CX250B Tetrode

A3 - Eimac Technical Data Sheet - 4CX5000A Tetrode

A4 - Harris Engineering Power Distribution Recommendations



LIFE VS. FILAMENT VOLTAGE

TUBE TYPES WITH THORIATED-TUNGSTEN FILAMENTS OR CATHODES.

Power tube users and equipment manufacturers are naturally interested in extending the life of these tubes. A very large factor in tube life is the temperature of the thoriated-tungsten cathode.

The equipment manufacturer and the end user of the equipment have more control over tube life through proper adjustment of filament voltage (filament power) than is generally realized. This is true because tube ratings and most equipment designs are conservative in peak cathode emission required of the tube compared with peak cathode emission available at nominal rated filament voltage.

It is good practice to determine in the field for each particular combination of equipment and operating power level, the nominal filament voltage for best life. This is best done in the field by measuring some important parameter of performance such as plate current, power output, or distortion while filament voltage on the power tube is reduced. At some point in filament voltage there will be a noticeable reduction in plate current, or power output, or an increase in distortion. Operation may safely be at a filament voltage slightly higher than that point at which performance appeared to deteriorate. A recheck should be made in 12 to 24 hours to make certain that emission is stable.

The thoriated-tungsten filament or cathode is processed in a hydrocarbon atmosphere to form a deep layer of di-tungsten carbide on the surface. Stable emission is not possible without the carbide. If the carbide layer is too deep the filament becomes too brittle to withstand shipping and handling. The end of useful life for this type of filament occurs when most of the carbon has evaporated or combined with residual gas, depleting the carbide surface layer.

Theoretically it is estimated that a 3% increase in filament voltage will result in a 20°K increase in temperature, a 20% increase in peak emission, and a 50% decrease in life due to carbon loss. This, of course, works the other way, too. For a small decrease in temperature and peak emission, life of the carbide layer and hence tube life can be increased by a substantial percentage. Peak emission as meant here is the emission obtained in the test for emission described in the Test Specification. This is normally many times the peak emission required in communication service.

Continued.....

Obviously, if small percentage variations in filament voltage are to have a large percentage effect on tube life, it is important to be able to measure and adjust filament voltage measured at the tube terminals with accuracy of about 1%.

The common rectifier type of multimeter which is used for almost every measurement in electronic gear, should not be relied on for AC filament voltage measurement. A simple iron-vane AC meter which has recently been checked against a reliable standard is the best inexpensive instrument for this measurement because it responds to the RMS, or heating value, of the voltage wave form.

As a guide for use with most communications, and broadcast equipment, to get the best life service from your EIMAC power tubes, the following table has been prepared. It is not meant to imply that lower filament voltage will not be satisfactory in some instances.

SUGGESTED NOMINAL FILAMENT VOLTAGE

FOR

EXTENDED LIFE IN BROADCAST AND COMMUNICATION SERVICE

TUBE TYPE

3X2500A3 and F3	7.2 volts
3X3000A1 and A7	7.2
3CX2500A3 and F3	7.2
3CX3000A1 and A7	7.2
3CX10,000A3, A1 and A7	7.2
3CX15,000A3	6.0
6697A	12.3
4-125A	4.8
4-400A	4.8
4-1000A	7.2
4W20,000A	(2300 watts cathode heating power)
4CX3000A	8.6 volts
4CX5000A	7.2
4CX10,000D	7.2
4CX15,000A	6.0
4CX35,000C	9.0
4CV100,000C	9.0
4E27A	4.8
5-500A	9.5
5CX1500A	4.8
5CX3000A	8.6

Credit is due the paper, High Power Transmitting Valves ---, by Walker, Aldous, Roach, Webb and Goodchild, IEE Paper No. 3200E March, 1960, also the paper Life Expectancy Tubes ---, Eitel-McCullough, October 6, 1963, by Paul Williams.



TECHNICAL DATA

4CX250B
8621
4CX250FG

**RADIAL-BEAM
POWER TETRODE**

The 7203/4CX250B and 8621/4CX250FG are ceramic/metal forced-air cooled, external-anode radial-beam tetrodes with a maximum plate dissipation rating of 250 watts and a maximum input-power rating of 500 watts. The 7203/4CX250B is designed to operate with a heater voltage of 6.0 volts, while the 8621/4CX250FG is designed for operation at a heater voltage of 26.5 volts. Otherwise, the two tube types have identical characteristics.

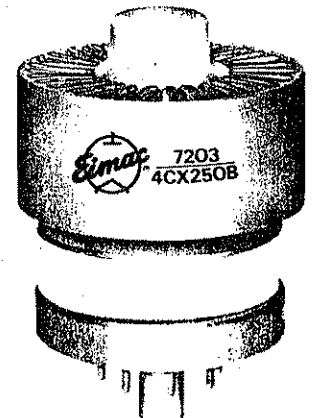

GENERAL CHARACTERISTICS¹

ELECTRICAL

Cathode: Oxide Coated, Unipotential

Heater: Voltage (4CX250B)	6.0 ± 0.3 V
Current, at 6.0 volts	2.6 A
Cathode-Heater Potential, maximum	+150 V
Heater: Voltage (4CX250FG)	26.5 ± 1.3 V
Current, at 26.5 volts	0.54 A
Cathode-Heater Potential, maximum	+150 V

Amplification Factor (Average):

Grid to Screen	5
----------------------	---

Direct Interelectrode Capacitances (Grounded cathode)²

Input	15.7 pF
Output	4.5 pF
Feedback	0.04 pF

Direct Interelectrode Capacitances (grounded grid and screen)²

Input	13 pF
Output	4.5 pF
Feedback	0.01 pF

Frequency of Maximum Rating:

CW	500 MHz
----------	---------

1. Characteristics and operating values are based upon performance tests. These figures may change without notice as the result of additional data or product refinement. EIMAC Division of Varian should be consulted before using this information for final equipment design.

2. In Shielded Fixture.

MECHANICAL

Maximum Overall Dimensions:

Length	2.46 in; 62.5 mm
Diameter	1.64 in; 41.7 mm
Net Weight	4 oz; 113 gm
Operating Position	Any



Maximum Operating Temperature:

Ceramic/Metal Seals 250°C
 Anode Core 250°C

Cooling Forced Air

Base Special 9-pin JEDEC-B8-236

Recommended Socket EIMAC SK-600 Series

Recommended Chimney EIMAC SK-600 Series

RADIO FREQUENCY LINEAR AMPLIFIER

GRID DRIVEN (SSB)

Class AB₁

MAXIMUM RATINGS

DC PLATE VOLTAGE	2000 VOLTS
DC SCREEN VOLTAGE	400 VOLTS
DC GRID VOLTAGE	-250 VOLTS
DC PLATE CURRENT	0.25 AMPERE
PLATE DISSIPATION	250 WATTS
SCREEN DISSIPATION	12 WATTS
GRID DISSIPATION	2 WATTS

TYPICAL OPERATION (Frequencies to 175 MHz)

Class AB₁, Grid Driven, Peak Envelope or Modulation Crest Conditions

Plate Voltage	1000	1500	2000	Vdc
Screen Voltage	350	350	350	Vdc
Grid Voltage 1	-55	-55	-55	Vdc
Zero-Signal Plate Current	100	100	100	mAdc
Single Tone Plate Current	250	250	250	mAdc
Two-Tone Plate Current	190	190	190	mAdc
Single-Tone Screen Current ²	10	8	5	mAdc
Two-Tone Screen Current ²	2	-1	-2	mAdc
Single-Tone Grid Current ²	0	0	0	mAdc
Peak rf Grid Voltage ²	50	50	50	v
Plate Output Power	120	215	300	W
Resonant Load Impedance	2000	3000	4000	Ω

1. Adjust to specified zero-signal dc plate current.
2. Approximate value.

RADIO FREQUENCY LINEAR AMPLIFIER

GRID DRIVEN, CARRIER CONDITIONS

Class AB₁

MAXIMUM RATINGS

DC PLATE VOLTAGE	2000 VOLTS
DC SCREEN VOLTAGE	400 VOLTS
DC GRID VOLTAGE	-250 VOLTS
DC PLATE CURRENT	0.25 AMPERE
PLATE DISSIPATION	250 WATTS
SCREEN DISSIPATION	12 WATTS
GRID DISSIPATION	2 WATTS

TYPICAL OPERATION (Frequencies to 175 MHz)

Class AB₁, Grid Driven

Plate Voltage	1000	1500	2000	Vdc
Screen Voltage	350	350	350	Vdc
Grid Voltage 1	-55	-55	-55	Vdc
Zero-Signal Plate Current	100	100	100	mAdc
Carrier Plate Current	150	150	150	mAdc
Carrier Screen Current	-3	-4	-4	mAdc
Peak rf Grid Voltage ²	25	25	25	v
Plate Output Power	30	50	65	W

1. Adjust to specified zero-signal dc plate current
2. Approximate value.

RADIO FREQUENCY POWER AMPLIFIER OR OSCILLATOR

Class C Telephony or FM Telephony (Key-Down Conditions)

MAXIMUM RATINGS

DC PLATE VOLTAGE	2000 VOLTS
DC SCREEN VOLTAGE	300 VOLTS
DC GRID VOLTAGE	-250 VOLTS
DC PLATE CURRENT	0.25 AMPERE
PLATE DISSIPATION	250 WATTS
SCREEN DISSIPATION	12 WATTS
GRID DISSIPATION	2 WATTS

TYPICAL OPERATION (Frequencies to 175 MHz) | 500 MHz²

Plate Voltage	500	1000	1500	2000	2000	Vdc
Screen Voltage	250	250	250	250	300	Vdc
Grid Voltage	-90	-90	-90	-90	-90	Vdc
Plate Current	250	250	250	250	250	mAdc
Screen Current 1	45	38	21	19	10	mAdc ²
Grid Current 1	35	31	28	26	10	mAdc ²
Peak rf Grid Voltage ¹ ..	114	114	112	112	---	v
Measured Driving Power ¹	4.0	3.5	3.2	2.9	---	W
Plate Input Power	125	250	375	500	500	W
Plate Output Power	70	190	280	390	290	W ²
Heater Voltage (4CX250B)	6.0	6.0	6.0	6.0	5.5	V
Heater Voltage (4CX250FG)	26.5	26.5	26.5	26.5	24.3	V

1. Approximate value.
2. Measured values for a typical cavity amplifier circuit.



PLATE MODULATED RADIO FREQUENCY POWER AMPLIFIER-GRID DRIVEN

Class C Telephony (Carrier Conditions)

MAXIMUM RATINGS

DC PLATE VOLTAGE	1500 VOLTS
DC SCREEN VOLTAGE	300 VOLTS
DC GRID VOLTAGE	-250 VOLTS
DC PLATE CURRENT	0.20 AMPERE
PLATE DISSIPATION ¹	165 WATTS
SCREEN DISSIPATION ²	12 WATTS
GRID DISSIPATION ²	2 WATTS

1. Corresponds to 250 watts at 100% sine-wave modulation.
2. Average, with or without modulation.

TYPICAL OPERATION (Frequencies to 175 MHz)

Plate Voltage	500	1000	1500	Vdc
Screen Voltage	250	250	250	Vdc
Grid Voltage	-100	-100	-100	Vdc
Plate Current	200	200	200	mAdc
Screen Current	31	22	20	mAdc
Grid Current	15	14	14	mAdc
Peak rf Grid Voltage	118	117	117	v
Calculated Driving Power	1.8	1.7	1.7	W
Plate Input Power	100	200	300	W
Plate Output Power	60	145	235	W

3. Approximate value.

AUDIO FREQUENCY POWER AMPLIFIER OR MODULATOR

Class AB₁ Grid Driven (Sinusoidal Wave)

MAXIMUM RATINGS (Per Tube)

DC PLATE VOLTAGE	2000 VOLTS
DC SCREEN VOLTAGE	400 VOLTS
DC GRID VOLTAGE	-250 VOLTS
DC PLATE CURRENT	0.25 AMPERE
PLATE DISSIPATION	250 WATTS
SCREEN DISSIPATION	12 WATTS
GRID DISSIPATION	2 WATTS

1. Approximate value.
2. Per Tube.

TYPICAL OPERATION (Two Tubes)

Plate Voltage	1000	1500	2000	Vdc
Screen Voltage	350	350	350	Vdc
Grid Voltage 1/3	-55	-55	-55	Vdc
Zero-Signal Plate Current	200	200	200	mAdc
Max Signal Plate Current	500	500	500	mAdc
Max Signal Screen Current 1	20	16	10	mAdc
Max Signal Grid Current 1	0	0	0	mAdc
Peak rf Grid Voltage 2	50	50	50	v
Peak Driving Power	0	0	0	W
Plate Input Power	500	750	1000	W
Plate Output Power	240	430	600	W
Load Resistance (plate to plate)	3500	6200	9500	Ω

3. Adjust to give stated zero-signal plate current.

NOTE: TYPICAL OPERATION data are obtained from direct measurement or by calculation from published characteristic curves. Adjustment of the rf grid voltage to obtain the specified plate current at the specified bias, screen and plate voltages is assumed. If this procedure is followed, there will be little variation in output power when the tube is changed, even though there may be some variation in grid and screen current. The grid and screen currents which result when the desired plate current is obtained are incidental and vary from tube to tube. These current variations cause no difficulty so long as the circuit maintains the correct voltage in the presence of the variations in current. In the case of Class C Service, if grid bias is obtained principally by means of a grid resistor, the resistor must be adjustable to obtain the required bias voltage when the correct rf grid voltage is applied.

RANGE VALUES FOR EQUIPMENT DESIGN

	Min.	Nom.	Max.
Heater: 4CX250B Current at 6.0 volts	2.3	---	2.9 A
Heater: 4CX250FG Current at 26.5 volts	0.45	---	0.62 A
Cathode Warmup Time	30	60	--- sec.
Inter-electrode Capacitances ¹ (grounded cathode connection)			
Input	14.2	---	17.2 pF
Output	4.0	---	5.0 pF †
Feedback	---	---	0.06 pF
Inter-electrode Capacitances ¹ (grounded grid and screen)			
Input	---	13.0	---
Output	4.0	---	5.0 pF †
Feedback	---	0.01	---

¹ Cou values shown are for 4CX250B; for 4CX250FG, values are 4.0 --- 5.3 pF



APPLICATION

MECHANICAL

MOUNTING - The 4CX250B and 4CX250FG may be operated in any position. An EIMAC Air-System Socket, SK-600 series, or a socket having equivalent characteristics, is required. Sockets are available with or without built-in screen capacitors and may be obtained with either grounded or ungrounded cathode terminals.

COOLING - Sufficient forced-air cooling must be provided for the anode, base seals, and body seals to maintain operating temperatures below the rated maximum values. Air requirements to maintain anode core temperatures at 200°C with an inlet air temperature of 50°C are tabulated below. These requirements apply when a socket of the EIMAC SK-600 series and an EIMAC SK-606 chimney are used with air flow in the base to anode direction.

SEA LEVEL			10,000 FEET	
Plate Dissipation (watts)	Air Flow (CFM)	Pressure Drop (in. of water)	Air Flow (CFM)	Pressure Drop (in. of water)
200	5.0	0.52	7.3	0.76
250	6.4	0.82	9.3	1.20

The blower selected in a given application must be capable of supplying the desired airflow at a back pressure equal to the pressure drop shown above plus any drop encountered in ducts and filters. The blower must be designed to deliver the air at the desired altitude.

At 500 MHz or below, base cooling air requirements are satisfied automatically when the tube is operated in an EIMAC Air-System Socket and the recommended air flow rates are used. Experience has shown that if reliable long life operation is to be obtained, the cooling air flow must be maintained during standby periods when only the heater voltage is applied to the tube. The anode cooler should be inspected periodically and cleaned when necessary to remove any dirt which might interfere with effective cooling.

VIBRATION - These tubes are capable of satisfactorily withstanding ordinary shock and vibration, such as encountered in shipment and normal handling. The tubes will function well in automobile and truck mobile installations and similar environments. However, when shock and vibration more severe than this are expected, it is suggested that the EIMAC 4CX300A or 4CX250R be employed.

ELECTRICAL

HEATER - The rated heater voltage for the 4CX250B and 4CX250FG is 6.0 volts and 26.5 volts, respectively, and the voltage should be maintained as closely as practicable. Short-time changes of $\pm 10\%$ will not damage the tube, but variations in performance must be expected. The heater voltage must be maintained within $\pm 5\%$ to minimize these variations and to obtain maximum tube life.

At frequencies above approximately 300 MHz transit-time effects begin to influence the cathode temperature. The amount of driving power diverted to heating the cathode by back-bombardment will depend upon frequency, plate current, and driving power. When the tube is driven to maximum input as a class-C amplifier, the heater voltage should be reduced according to the table below;

Frequency MHz	4CX250B	4CX250FG
300 and lower	6.00 volts	26.5 volts
301 to 400	5.75 volts	25.3 volts
401 to 500	5.50 volts	24.3 volts

CATHODE OPERATION - The oxide coated unipotential cathode must be protected against excessively high emission currents. The maximum rated dc input current is 200 mA for plate-modulated operation and 250 mA for all other types of operation except pulse.

The cathode is internally connected to the four even-numbered base pins and all four of the corresponding socket terminals should be used to make connection to the external circuits. At radio frequencies it is important to keep the cathode leads short and direct and to use conductors with large areas to minimize the inductive reactances in series with the cathode leads.

It is recommended that rated heater voltage be applied for a minimum of 30 seconds before other operating voltages are applied. Where the circuit design requires the cathode and heater to be operated at different potentials, the rated maximum heater-to-cathode voltage is 150 volts regardless of polarity.

GRID OPERATION - The maximum rated dc grid bias voltage is -250 volts and the maximum grid dissipation rating is 2.0 watts. In ordinary audio and radio-frequency amplifiers the grid dissipation usually will not approach the maximum rating. At operating frequencies above the 100 MHz region, driving-power requirements for



amplifiers increase noticeably. At 500 MHz as much as 20 watts of driving power may have to be supplied. However, most of the driving power is absorbed in circuit losses other than grid dissipation, so that grid dissipation is increased only slightly. Satisfactory 500 MHz operation of the tube in a stable amplifier is indicated by grid-current values below approximately 15 mA.

The grid voltage required by different tubes may vary between limits approximately 20% above and below the center value, and means should be provided in the equipment to accommodate such variation. It is especially important that variations between individual tubes be compensated when tubes are operated in parallel or push-pull circuits, to assure equal load sharing.

The maximum permissible grid-circuit resistance per tube is 100,000 ohms.

SCREEN OPERATION - The maximum rated power dissipation for the screen is 12 watts, and the screen input power should be kept below that level. The product of the peak screen voltage and the indicated dc screen current approximates the screen input power except when the screen current indication is near zero or negative.

In the usual tetrode amplifier, where no signal voltage appears between cathode and screen, the peak screen voltage is equal to the dc screen voltage.

When signal voltages appear between screen and cathode, as in the case of screen-modulated amplifiers or cathode-driven tetrode amplifiers, the peak screen-to-cathode voltage is the sum of the dc screen voltage and the peak ac or rf signal voltage applied to screen or cathode.

Protection for the screen should be provided by an over-current relay and by interlocking the screen supply so that plate voltage must be applied before screen voltage can be applied.

The screen current may reverse under certain conditions and produce negative current indications on the screen milliammeter. This is a normal characteristic of most tetrodes. The screen power supply should be designed with this characteristic in mind so that the correct operating voltage will be maintained on the screen under all conditions. A current path from screen to cathode must be provided by a bleeder resistor, gaseous voltage regulator tubes, or an electron

tube *shunt* regulator connected between screen and cathode and arranged to pass approximately 15 milliamperes per connected screen. An electron tube *series* regulator can be used only when an adequate bleeder resistor is provided.

Self-modulation of the screen in plate-modulated tetrode amplifiers using these tubes may not be satisfactory because of the screen-voltage screen-current characteristics. Screen modulation from a tertiary winding on the modulation transformer or by means of a small separate modulator tube will usually be more satisfactory. Screen-voltage modulation factors between 0.75 and 1.0 will result in 100% modulation for plate-modulated rf amplifiers using the 4CX250B or 4CX250FG.

PLATE OPERATION - The maximum rated plate dissipation power is 250 watts. In plate-modulated applications the carrier plate dissipation power must be limited to 165 watts to avoid exceeding the plate dissipation rating with 100% sine wave modulation. The maximum dissipation rating may be exceeded for brief periods during circuit adjustment without damage to the tube.

MULTIPLE OPERATION - Tubes operating in parallel or push-pull must share the load equally. It is good engineering practice to provide individual metering and individual adjustment of bias or screen voltage to equalize the inputs.

Where overload protection is provided, it should be capable of protecting the surviving tube(s) in the event that one tube fails.

VHF OPERATION - The 4CX250B and 4CX250FG are suitable for use in the VHF region. Such operation should be conducted with heavy plate loading, minimum bias, and the lowest driving power consistent with satisfactory performance. It is often preferable to operate at a sacrifice in efficiency to obtain increased tube life.

HIGH VOLTAGE - The 7203/4CX250B and 8621/4CX250FG operate at voltages which can be deadly, and the equipment must be designed properly and operating precautions must be followed. Equipment must be designed so that no one can come in contact with high voltages. All equipment must include safety enclosures for high-voltage circuits and terminals, with interlock switches to open the primary circuits of the power supplies and to discharge high-voltage condensers whenever access doors are opened. Interlock switches must not be bypassed or "cheated" to allow operation with access doors open. Always remember that **HIGH VOLTAGE CAN KILL**.

SPECIAL APPLICATIONS - If it is desired to operate these tubes under conditions widely different from those given here, write to Application Engineering Dept., EIMAC Division of Varian, San Carlos, Calif. 94070 for information and recommendations.



4CX250B-4CX250FG

TYPICAL CONSTANT CURRENT CHARACTERISTICS

SCREEN VOLTAGE = 250V

— PLATE CURRENT — AMPERES - - - - - SCREEN CURRENT — AMPERES - - - - - GRID CURRENT — AMPERES

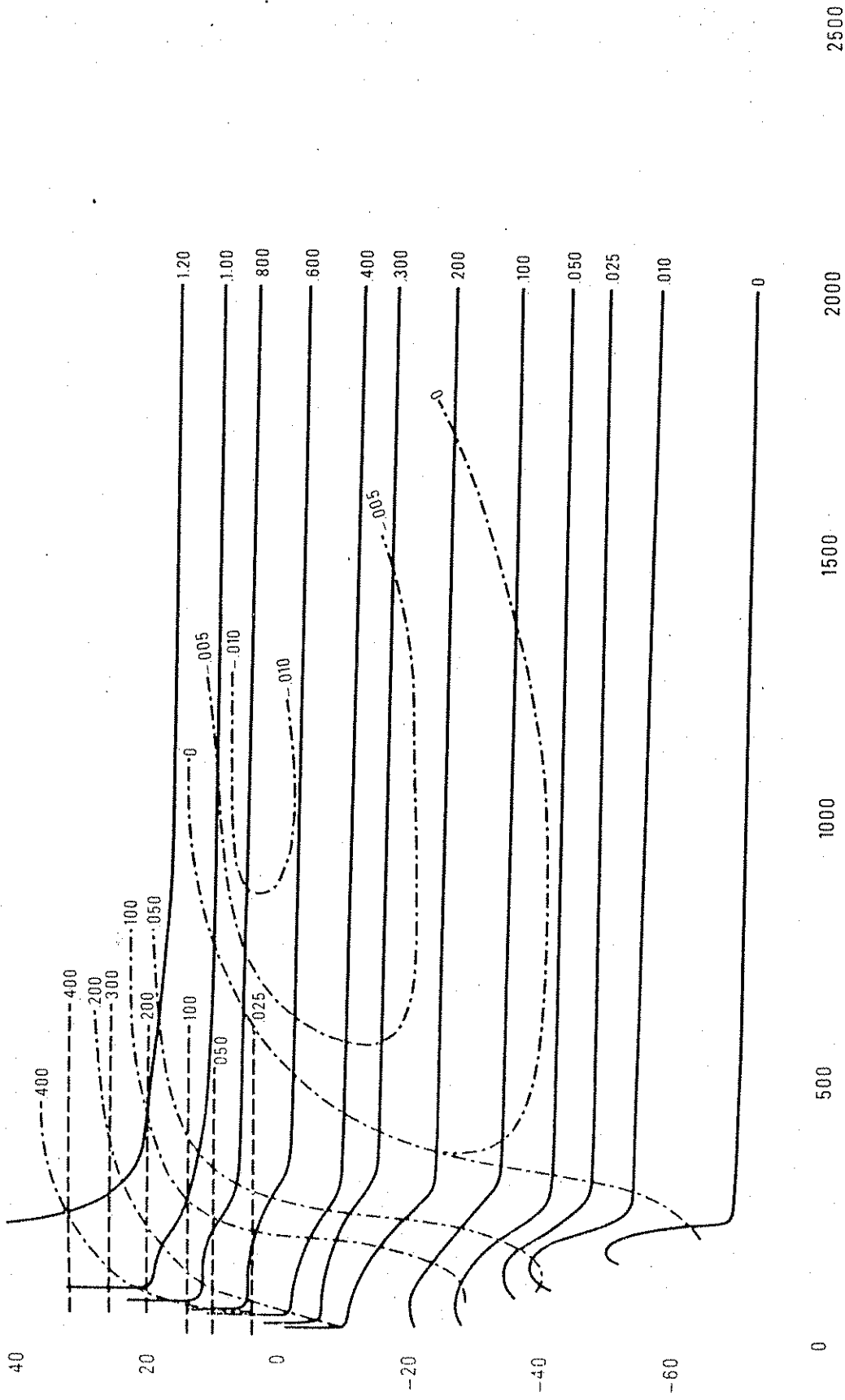

888-1761-005
GRID VOLTAGE (V)



TYPICAL CONSTANT CURRENT CHARACTERISTICS

SCREEN VOLTAGE = 350V

— PLATE CURRENT — AMPERES - - - - - SCREEN CURRENT — AMPERES - - - - - GRID CURRENT — AMPERES

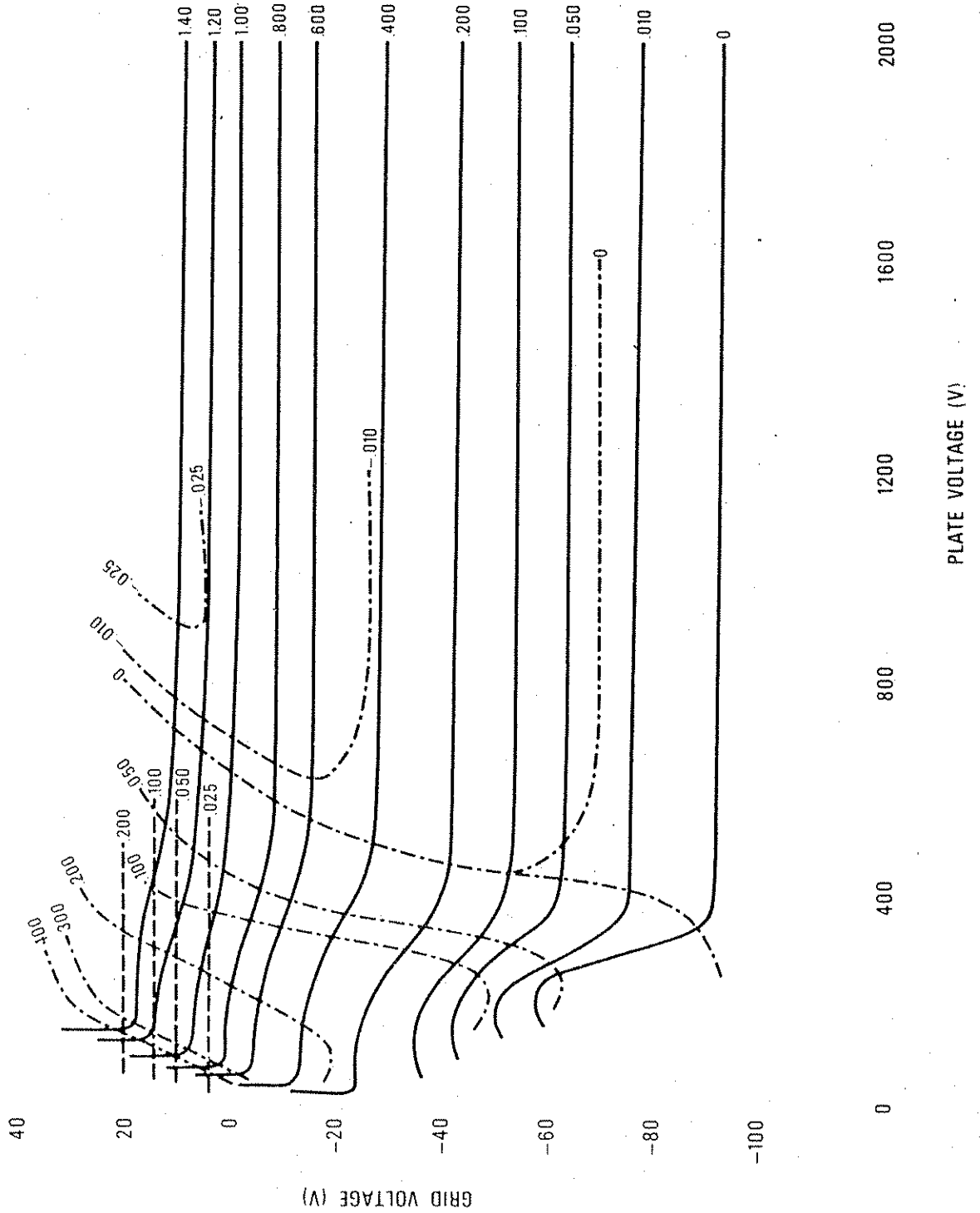



4CX250B-4CX250FG

PIN DESIGNATION

PIN NO. 1	SCREEN GRID
PIN NO. 2	CATHODE
PIN NO. 3	HEATER
PIN NO. 4	CATHODE
PIN NO. 5	I.C. DO NOT USE FOR EXTERNAL CONNECTION.
PIN NO. 6	CATHODE
PIN NO. 7	HEATER
PIN NO. 8	CATHODE
CENTER PIN-CONTROL GRID	

DIMENSIONAL DATA

DIM	INCHES		MILLIMETERS	
	MIN	MAX	MIN	MAX
A	2.342	2.464	59.03	62.59
B	1.610	1.640	40.89	41.66
C	1.810	1.910	45.97	48.51
D	0.750	0.810	19.05	20.57
E	0.710	0.790	18.03	20.07
F	--	1.406	--	35.71
G	0.187	--	4.75	--
H	BASE 88-236 (JFDEC DESIGNATION)			
J	0.559	0.573	14.20	14.55
K	0.240	--	6.10	--

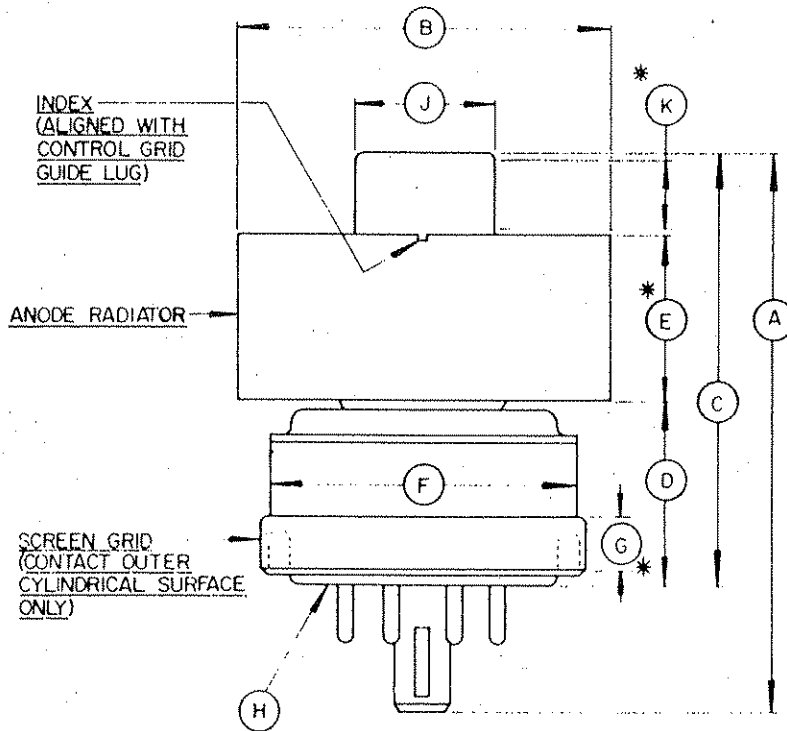

- NOTES:**
- REF DIMS. ARE FOR INFO ONLY AND ARE NOT REQD. FOR INSPECTION PURPOSES.
 - (*) CONTACT SURFACES.



EIMAC

Manufactured by
 EIMAC CORPORATION
 10000 E. 15th Avenue
 Denver, Colorado 80231, U.S.A.

8170
4CX5000A
 RADIAL-BEAM
 POWER TETRODE

The EIMAC 8170/4CX5000A is a compact high-power ceramic and metal tetrode cooled by forced air. It is useful as an oscillator, amplifier, or modulator at frequencies up to 110 megahertz and is particularly suited for use as a linear single-sideband amplified, Class-AB₁ audio amplifier, or as a screen-modulated radio-frequency amplifier.

A pair of these tubes will deliver 17.5 kilowatts of audio-frequency or radio-frequency power with zero driving power. The rated plate dissipation is five kilowatts for most classes of services and six kilowatts for Class-AB operation.

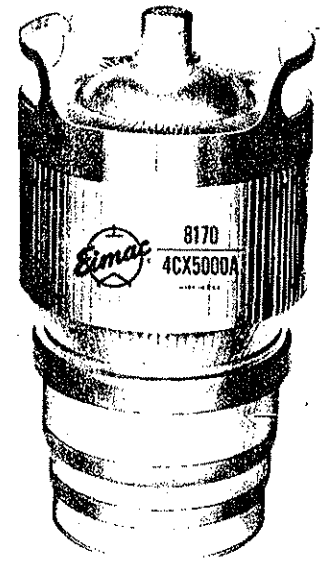

GENERAL CHARACTERISTICS

ELECTRICAL

Filament: Thoriated Tungsten	<u>Min.</u>	<u>Nom.</u>	<u>Max.</u>	
Voltage - - - - -		7.5		volts
Current - - - - -	73		78	amperes
Amplification Factor (Grid Screen) - -		4.5		
Direct Interelectrode Capacitances, Grounded Cathode:				
Input - - - - -	108		122	pF
Output - - - - -	18		23	pF
Feedback - - - - -			1.0	pF

Direct Interelectrode Capacitances, Grounded Grid and Screen:	<u>Min.</u>	<u>Max.</u>	
Input - - - - -	48	58	pF
Output - - - - -	18	23	pF
Feedback - - - - -		0.16	pF

MECHANICAL

Base - - - - -	Special concentric
Maximum Seal Temperature - - - - -	250°C
Maximum Anode-Core Temperature - - - - -	250°C
Recommended Socket - - - - -	EIMAC SK-300A
Recommended Chimney - - - - -	EIMAC SK-306
Operating Position - - - - -	Axis vertical, base up or down
Maximum Dimensions:	
Height - - - - -	9.13 inches
Diameter - - - - -	4.94 inches
Cooling - - - - -	Forced air
Net Weight - - - - -	9.5 pounds
Shipping Weight (Approximate) - - - - -	22 pounds

**RADIO-FREQUENCY POWER AMPLIFIER
 OR OSCILLATOR (Up to 30 megahertz)**

Class-C Telegraphy (Key-down conditions)

MAXIMUM RATINGS

DC PLATE VOLTAGE - - - - -	7500 VOLTS
DC SCREEN VOLTAGE - - - - -	1500 VOLTS
DC PLATE CURRENT - - - - -	3 AMPS
PLATE DISSIPATION - - - - -	5000 WATTS
SCREEN DISSIPATION - - - - -	250 WATTS
GRID DISSIPATION - - - - -	75 WATTS

TYPICAL OPERATION

(Frequencies below 30 megahertz)

DC Plate Voltage - - - - -	7500 volts
DC Screen Voltage - - - - -	500 volts
DC Grid Voltage - - - - -	-350 volts
DC Plate Current - - - - -	2.8 amps
DC Screen Current - - - - -	0.5 amp
DC Grid Current - - - - -	0.25 amp
Peak RF Grid Voltage - - - - -	590 volts
Driving Power - - - - -	150 watts
Plate Dissipation - - - - -	5000 watts
Plate Output Power - - - - -	16,000 watts

**RADIO-FREQUENCY POWER
AMPLIFIER OR OSCILLATOR**
(From 30 to 220 MHz)

Class-C Telephony or FM Telephony

MAXIMUM RATINGS

DC PLATE VOLTAGE:	
30 to 60 MHz - - - -	7000 VOLTS
60 to 110 MHz - - - -	6500 VOLTS
110 to 220 MHz - - - -	5800 VOLTS
DC SCREEN VOLTAGE - 1500 VOLTS	
DC PLATE CURRENT:	
30 to 60 MHz - - - -	2.8 AMPS
60 to 220 MHz - - - -	2.6 AMPS
PLATE DISSIPATION - 5000 WATTS	
SCREEN DISSIPATION - 250 WATTS	
GRID DISSIPATION - 75 WATTS	

TYPICAL OPERATION

	108MHz	220MHz	
DC PLATE VOLTAGE - - - - -	6500	5500	volts
DC SCREEN VOLTAGE - - - - -	750	680	volts
DC GRID VOLTAGE - - - - -	-350	-140	volts
DC PLATE CURRENT - - - - -	2.3	1.6	amperes
DC SCREEN CURRENT - - - - -	.2	.034	amperes
DC GRID CURRENT - - - - -	.05	.030	amperes
DRIVING POWER - - - - -	100	---	watts
USEFUL OUTPUT POWER - - - - -	10,000	5,500	watts

PLATE-MODULATED RADIO-FREQUENCY POWER AMPLIFIER

Class-C Telephony
(Carrier conditions except where noted)

MAXIMUM RATINGS

DC PLATE VOLTAGE - - - -	5500 VOLTS
DC SCREEN VOLTAGE - - - -	1000 VOLTS
DC PLATE CURRENT - - - -	2.5 AMPS
PLATE DISSIPATION* - - - -	3500 WATTS
SCREEN DISSIPATION - - - -	250 WATTS
GRID DISSIPATION - - - -	75 WATTS

*Corresponds to 5000 watts at 100-percent sine-wave modulation.

TYPICAL OPERATION (Frequencies below 30 megahertz)

DC Plate Voltage - - - - -	5000 volts
DC Screen Voltage - - - - -	500 volts
Peak AF Screen Voltage (For 100-percent modulation) -	450 volts
DC Grid Voltage - - - - -	-400 volts
DC Plate Current - - - - -	1.4 amperes
DC Screen Current - - - - -	0.26 ampere
DC Grid Current - - - - -	0.05 ampere
Peak RF Grid Voltage - - - - -	520 volts
Grid Driving Power - - - - -	25 watts
Plate Dissipation - - - - -	1100 watts
Plate Output Power - - - - -	5.8 kilowatts

SCREEN-MODULATED RADIO-FREQUENCY POWER AMPLIFIER

Class-C Telephony
(Carrier conditions except where noted)

MAXIMUM RATINGS (Per Tube)

DC PLATE VOLTAGE - - - -	7500 VOLTS
DC SCREEN VOLTAGE - - - -	750 VOLTS
DC PLATE CURRENT - - - -	3.0 AMPS
PLATE DISSIPATION - - - -	5000 WATTS
SCREEN DISSIPATION - - - -	250 WATTS
GRID DISSIPATION - - - -	75 WATTS

NOTE: Two tubes can be employed under conditions listed in the first column to obtain more than five kilowatts plate output power. Likewise, three tubes can be utilized at conditions listed in the second column to obtain better than ten kilowatts output power.

TYPICAL OPERATION (Frequencies below 30 megahertz per tube)

DC Plate Voltage - - - - -	7500	7500	volts
DC Screen Voltage - - - - -	350	350	volts
Peak AF Screen Voltage (For 100-percent modulation) 550	550	550	volts
DC Grid Voltage - - - - -	-300	-300	volts
DC Plate Current - - - - -	0.9	1.14	amperes
DC Screen Current* - - - - -	-0.01	-0.01	ampere
DC Grid Current - - - - -	0.015	0.03	ampere
Peak RF Grid Voltage - - - - -	350	375	volts
Grid Driving Power - - - - -	7	11	watts
RF Load Impedance - - - - -	2000	1600	ohms
Plate Dissipation - - - - -	4000	5000	watts
Useful Output Power - - - - -	2750	3550	watts

*DC Screen Current is a function of loading; values of plus or minus 20 milliamperes may be considered typical at carrier level.

AUDIO-FREQUENCY AMPLIFIER OR MODULATOR

Class-AB₁

MAXIMUM RATINGS (Per Tube)

DC PLATE VOLTAGE - - - -	7500 VOLTS
DC SCREEN VOLTAGE - - - -	1500 VOLTS
DC PLATE CURRENT - - - -	4.0 AMPS
PLATE DISSIPATION - - - -	6000 WATTS
SCREEN DISSIPATION - - - -	250 WATTS
GRID DISSIPATION - - - -	75 WATTS

TYPICAL OPERATION, two tubes

DC Plate Voltage - - - - -	4000	5000	6000	7000	volts
DC Screen Voltage - - - - -	1250	1250	1250	1250	volts
DC Grid Voltage - - - - -	-270	-280	-310	-325	volts
Max-Signal Plate Current - - - -	5.10	4.40	4.25	3.65	amperes
Zero-Signal Plate Current - - - -	1.25	1.00	0.83	0.70	amperes
Max-Signal Screen Current - - - -	0.35	0.33	0.30	0.24	ampere
Zero-Signal Screen Current - - - -	0	0	0	0	amperes
Peak AF Driving Voltage - - - - -	250	240	270	235	volts
Driving Power - - - - -	0	0	0	0	watts
Load Resistance, Plate-to-Plate -	1500	2370	2940	4100	ohms
Max-Signal Plate Dissipation* - -	4200	4200	4200	4200	watts
Max-Signal Plate Output Power - -	11,500	13,500	17,000	17,500	watts

*Per Tube

RADIO-FREQUENCY LINEAR AMPLIFIER

Class-AB₁

MAXIMUM RATINGS

DC PLATE VOLTAGE - - - -	7500 VOLTS
DC SCREEN VOLTAGE - - - -	1500 VOLTS
DC PLATE CURRENT - - - -	4.0 AMPS
PLATE DISSIPATION - - - -	6000 WATTS
SCREEN DISSIPATION - - - -	250 WATTS
GRID DISSIPATION - - - -	75 WATTS

TYPICAL OPERATION, Peak-Envelope or modulation-Crest Conditions, (Frequencies below 30 megahertz)

DC Plate Voltage - - - - -	7500	volts
DC Screen Voltage - - - - -	1250	volts
DC Grid Voltage* - - - - -	-300	volts
Max-Signal Plate Current - - - -	1.9	amperes
Zero-Signal Plate Current - - - -	0.50	ampere
Max-Signal Screen Current - - - -	0.20	ampere
Peak RF Grid Voltage - - - - -	300	volts
Driving Power - - - - -	0	watts
Plate Dissipation - - - - -	4200	watts
Plate Output Power** - - - - -	10,000	watts

*Adjust grid voltage to obtain specified Zero-Signal plate current.
**PEP output or rf output power at crest of modulation envelope.

NOTE: In most cases, "TYPICAL OPERATION" data are obtained by calculation from published characteristic curves and confirmed by direct tests. No allowance for circuit losses, either input or output, has been made. Exceptions are distinguished by a listing of "Useful" output power as opposed to "Plate" output power. Values appearing in these groups have been obtained from existing equipment(s) and the output power is that measured at the load.

APPLICATION

MECHANICAL

Mounting — The 4CX5000A must be operated with its axis vertical. The base of the tube may be down or up at the convenience of the circuit designer.

Socket—The EIMAC SK-300A Air-System Socket is designed especially for the concentric base terminals of the 4CX5000A. The use of recommended air-flow rates through this socket provides effective forced-air cooling of the tube. Air forced into the bottom of the socket passes over the tube terminals and through an Air Chimney, the SK-306, into the anode cooling fins. The SK-300 socket may be used instead of the SK-300A, but its use will result in a slightly less efficient cooling system at high dissipation levels.

Cooling — The maximum temperature rating for the external surfaces of the 4CX5000A is 250°C. Sufficient forced-air circulation must be provided to keep the temperature of the anode at the base of the cooling fins and the temperature of the ceramic-metal seals below 250°C. Sea level air-flow requirements to maintain seal temperatures at 200°C in 50°C ambient air are tabulated below (for operation below 30 megahertz).

Plate Dissipation* (Watts)	SK-300A Socket		SK-300 Socket	
	Air Flow (CFM)	Pressure Drop (Inches of water)	Air Flow (CFM)	Pressure Drop (Inches of water)
2000	75	0.4	75	0.4
3000	105	0.7	100	0.7
4000	145	1.1	135	1.2
5000	190	1.5	165	1.8
6000	230	2.0	200	2.5

*Since the power dissipated by the filament represents about 560 watts and since grid-plus-screen dissipation can, under some conditions, represent another 200 to 300 watts, allowance has been made in preparing this tabulation for an additional 1000 watts dissipation.

The blower selected in a given application must be capable of supplying the desired air flow at a back pressure equal to the pressure drop shown above plus any drop encountered in ducts and filters.

At higher altitudes, higher frequencies, or higher ambient temperatures the flow rate must be increased to obtain equivalent cooling. The flow rate and corresponding pressure differential must be determined individually in such cases, using maximum rated temperatures as the criteria for satisfactory cooling.

ELECTRICAL

Filament Operation—The rated filament voltage for the 4CX5000A is 7.5 volts. Filament voltage, as measured at the socket, should be maintained at this value to obtain maximum tube life. In no case should it be allowed to deviate by more than 5 percent from the rated value.

Electrode Dissipation Ratings—The maximum dissipation ratings for the 4CX5000A must be respected to avoid damage to the tube. An exception is the plate dissipation, which may be permitted to rise above the maximum rating during brief periods, such as may occur during tuning.

Control Grid Operation — The 4CX5000A control grid has a maximum dissipation rating of 75 watts. Precautions should be observed to avoid exceeding this rating. The grid bias and driving power should be kept near the values shown in "Typical Operation" sections of the data sheet whenever possible.

Screen-Grid Operation — The power dissipated by the screen of the 4CX5000A must not exceed 250 watts.

Screen dissipation, in cases where there is no ac applied to the screen, is the simple product of the screen voltage and the screen current. If the screen voltage is modulated, the screen dissipation will depend upon loading, driving power, and carrier screen voltage.

Screen dissipation is likely to rise to excessive values when the plate voltage, bias voltage, or plate load are removed with filament and screen voltages applied. Suitable protective means must be provided to limit the screen dissipation to 250 watts in the event of circuit failure.

Plate Dissipation—The plate-dissipation rating for the 4CX5000A is 5000 watts for most applications but for audio and SSB amplifier applications, the maximum allowable dissipation is 6000 watts.

When the 4CX5000A is operated as a plate-modulated rf power amplifier, the input power is limited by conditions not connected with the plate efficiency, which is quite high. Therefore, except during tuning there is little possibility that the 3500-watt maximum plate dissipation rating will be exceeded.

Special Applications—If it is desired to operate this tube under conditions widely different from those given here, write to Power Grid Tube Marketing, EIMAC Division of Varian, 301 Industrial Way, San Carlos, California, for information and recommendations.

DIMENSION DATA			
REF	NOM.	MIN.	MAX
A		4.812	4.938
B		.855	.895
C		.720	.760
D		1.896	1.936
E		3.133	3.173
F		3.792	3.832
G		3.980	4.020
H		.188	
J		.188	
K		.188	
L		1.764	1.826
M		4.188	4.563
N		2.875	3.250
P		8.625	9.125
R		.986	1.050
S		3.875	4.250
T		.375	

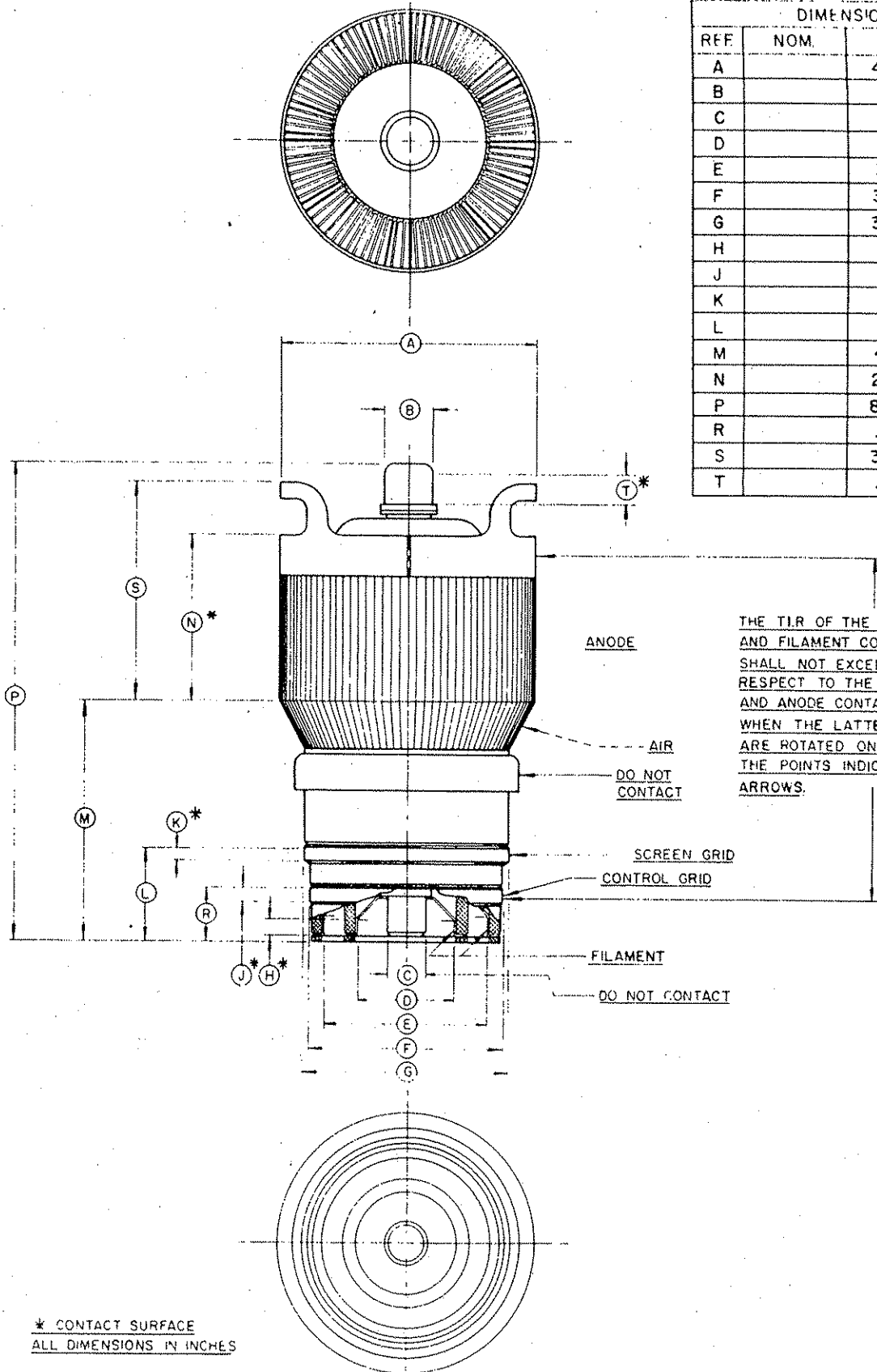

* CONTACT SURFACE
ALL DIMENSIONS IN INCHES



EIMAC 4CX5000A
TYPICAL
CONSTANT CURRENT
CHARACTERISTICS

SCREEN VOLTAGE — 500 VOLTS
— PLATE CURRENT — AMPERES
- - - SCREEN CURRENT — AMPERES
- - - GRID CURRENT — AMPERES

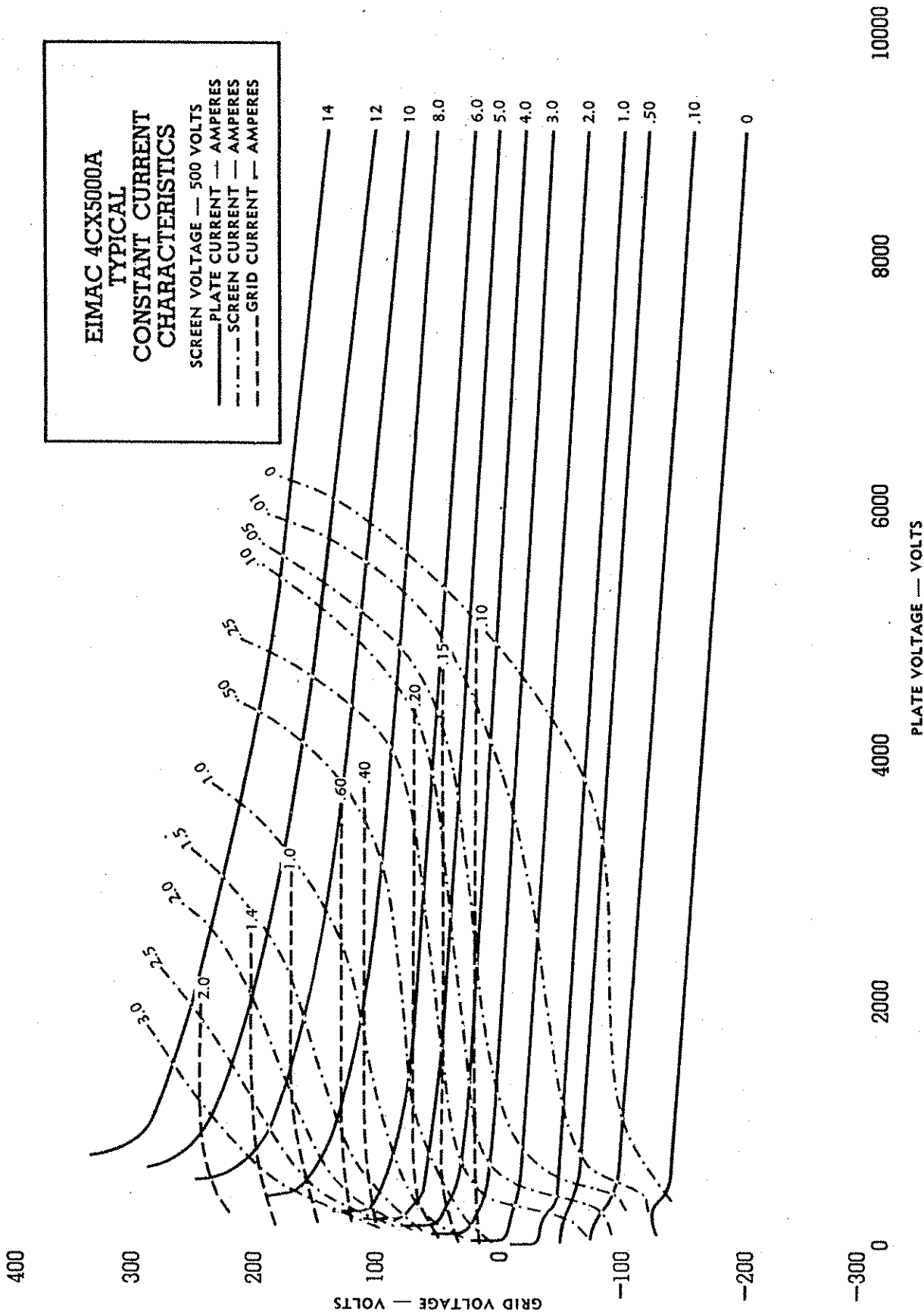



EIMAC 4CX5000A

TYPICAL

CONSTANT CURRENT CHARACTERISTICS

SCREEN VOLTAGE — 1250 VOLTS

— PLATE CURRENT — AMPERES

- · - · - SCREEN CURRENT — AMPERES

- - - - - GRID CURRENT — AMPERES

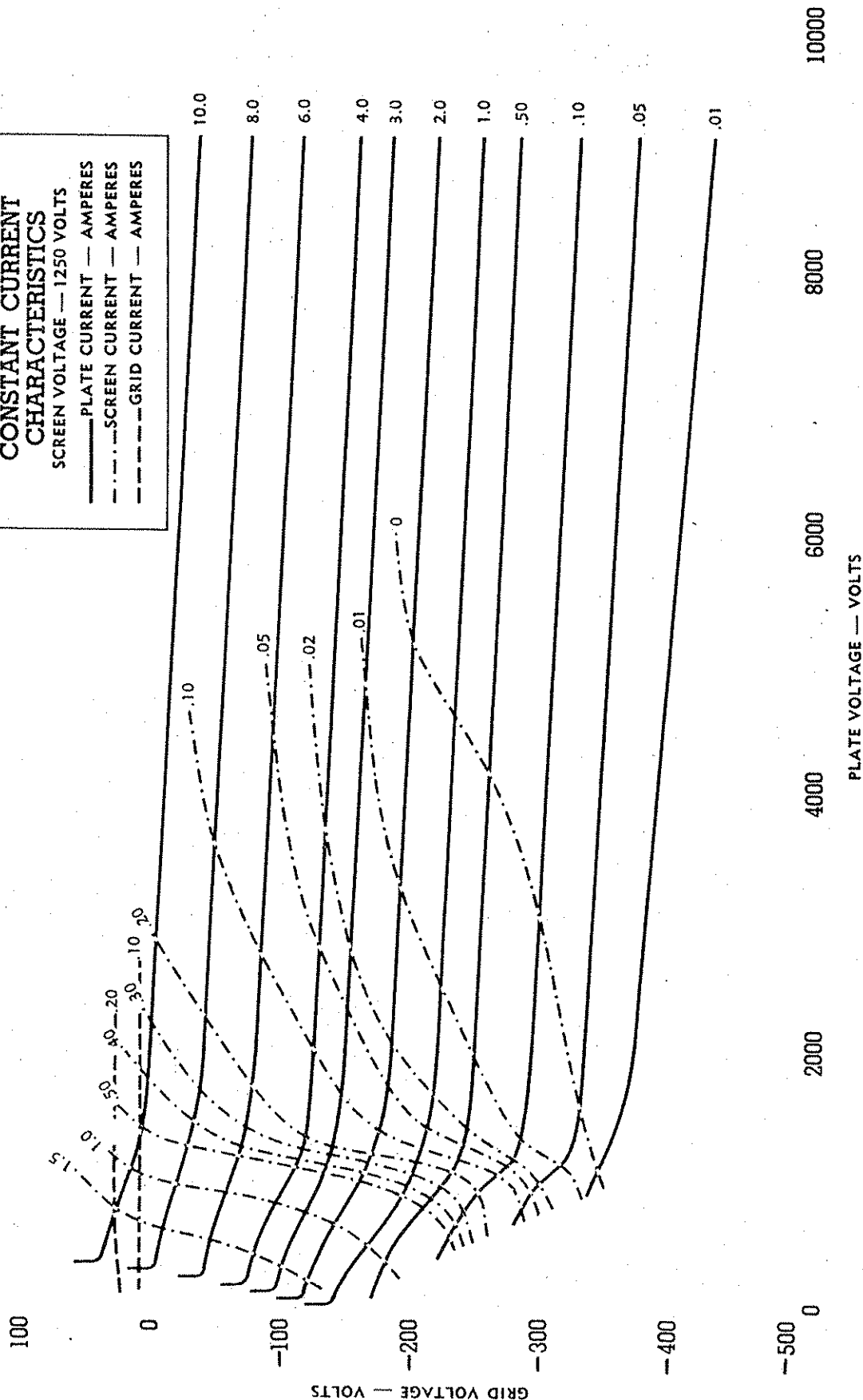

HARRIS ENGINEERING DEPARTMENT
POWER DISTRIBUTION RECOMMENDATION

Radio and Television transmitters using three-phase power must operate with the line-to-line voltages well balanced. Operation with the incoming line-to-line voltages substantially unbalanced will increase the ripple from the three-phase power supplies, primarily at twice the power line frequency, and thus increase the hum of the transmitter. Unbalanced line voltages result in unbalanced currents in the windings of the three-phase transformers, and in unbalanced currents in the windings of three-phase motors.

Three-phase motors should be run with line voltage balance within 1%; a 3-1/2 percent line voltage unbalanced will produce a temperature rise approximately 25% above normal in the winding carrying the greater of the unbalanced currents, while a 5% unbalance will produce a temperature rise approximately 50% greater than normal.

The regulation of a three-phase open delta transformer bank is much poorer than that of a closed delta bank.⁽¹⁾ The closed delta bank is symmetrical; the open delta is not; so the regulation in each of the three phases differs widely, and the effect of this may be an appreciable line voltage unbalance. The regulation of a closed delta is symmetrical on each phase.

Depending upon the impedances of the two transformers making up the open delta this appreciable line voltage unbalance may be great enough to impair satisfactory operation of the transmitter. HARRIS customers have experienced this with open delta distribution, and when the third transformer was added for closed delta service, the problem disappeared.

Transient overvoltages with open delta distribution can cause transmitter damage, particularly to the silicon rectifiers used in the main HV power supply. This is sometimes troublesome when the open delta transformers are at the end of a long overhead open wire distribution system. Several HARRIS

1. "Transformer Engineering" - Blume, Boyajian, Camilli, Lennox, Minneci, & Montsinger (John Wiley & Sons). 2nd 1967.

customers, upon following the HARRIS recommendation and adding the third transformer, have found the difficulty gone.

Although the above argument specifically calls out Closed Delta distribution, a WYE distribution also uses three transformers, and is symmetric, avoiding the difficulties arising from the non-symmetrical configuration of the Open Delta distribution.

WYE TYPE POWER DISTRIBUTION

In large segments of the world the power distribution is four-wire WYE. Single phase service is derived between the neutral of the WYE distribution and any one of the three other wires.

Three-phase main power supply transformers for small transmitters - 10 kilowatts or less - in the United States are generally operated from three-phase lines in the 210 to 250 volt range, line to line. HARRIS has adopted the practice of specifying three-phase transformers for transmitters of this class with three separate primaries, each having appropriate taps to accommodate the several nominal voltages in this range. For service in the United States these primaries are connected in Delta.

For service in those parts of the world in which the power distribution is four-wire WYE in the 360 to 415-volt range these three primaries are connected in WYE, with each primary tapped for the line to neutral voltage. The neutral point of the three primaries of the transformer within the transmitter is solidly connected to the power distribution system neutral, to provide a path for zero sequence currents, as well as any harmonic currents which might flow due to the rectification of the secondary voltages.

The line-to-line voltage is equal to the line to neutral voltage multiplied by the square root of three (1.732 approximately), nominally.

Typical system voltages: (Nominal)

LINE TO NEUTRAL (single phase)

210 volts
220 volts
230 volts
240 volts
250 volts

LINE TO LINE (three phase)

364 volts
380 volts
400 volts
415 volts
433 volts

In summary, either a closed delta or WYE distribution system is satisfactory for HARRIS transmitter.

