

M-6543

SOLID STATESMAN LIMITER

IB-888 0943 001

Gates Radio Company  
Quincy, Illinois

INDEX

PAGE

SPECIFICATIONS .....	1
INTRODUCTION .....	2
INSTALLATION .....	2
OPERATION .....	3
Input Level Control (AT1) .....	3
Recovery Time Switch (S1) .....	4
"Positive Peaks" Selector Switch (S3) .....	4
Automatic Peak Phasing .....	4
Meter Zero Control (R60) .....	5
Limiter Disable (S2) .....	5
Output Level Control (AT2) .....	5
FM Stereo Operation .....	6
MAINTENANCE .....	6
CIRCUIT DESCRIPTION .....	8
PARTS LIST .....	11-13
BLOCK DIAGRAM.....	14
SCHEMATIC DIAGRAM .....	838 2470 001

## SOLID STATESMAN LIMITER

### SPECIFICATIONS

- GAIN:** 50 dB,  $\pm 2$  dB maximum @ 1 kHz. May be reduced by the input and/or output attenuator, both built-in.
- FREQUENCY RESPONSE:**  $\pm 1.0$  dB maximum from 30 Hz to 16 kHz, with or without limiting.
- HARMONIC DISTORTION:** Less than 1.0% from 30 Hz to 16 kHz, except with fast recovery on low frequencies where there is partial recovery on each half cycle, from zero to 10 dB of limiting.
- NOISE:** 70 dB or better below the threshold of limiting, from 30 Hz to 16 kHz.
- ATTACK TIME:** Less than 10 microseconds. Typical: 3 to 5 microseconds. There is never any "thumping".
- RECOVERY OR RELEASE TIME:** Gated to program content, with three positions for individual preferences.
- AMOUNT OF LIMITING:** At least 30 dB, with a 30:1 dB compression ratio: An increase of 30 dB of input level will cause 1 dB increase in output level.
- THRESHOLD OF LIMITING:** Approximately -27 dBm input level, +23 dBm output level. Use -22 to -17 dBm input level for normal 5 to 10 dB of limiting action.
- SOURCE IMPEDANCE:** 600 ohms, balanced or unbalanced. An input level control accommodates input levels from -22 dBm to +18 dBm for 5 dB of limiting.
- LOAD IMPEDANCE:** 600 ohms, balanced or unbalanced. The output level of +23 dBm (determined by the threshold of limiting) may be reduced by a stepless 600/600 ohm control in the output circuit to -17 dBm or any level desired in between.

## INTRODUCTION

The M6543 Solid Statesman Limiter is an exceedingly smooth operating unit that performs all of the services a limiting amplifier is supposed to, without the usual problems most of its predecessors have shown. Its incredibly fast attack time and infinitely variable release time and complete freedom of "thumping" permits limiting of 15 to 20 dB on most program content before it is even noticed. Its 30:1 compression ratio allows 99.5% negative modulation with no chance of overmodulation. Asymmetrical Limiting and Automatic Peak Phasing permits maximum use of the station's AM channel. Symmetrical Limiting is obtained by a simple turn of a switch for FM and TV channels, where asymmetrical limiting offers no advantage (in fact, it could cause a violation if improperly used).

The 3 to 5 microsecond attack time is true limiting, not a peak clipper that acts for several milliseconds while the limiting section catches up. Thus, even the most critical ear can detect no fuzzy changes in the voice of some instruments that might be apparent with hard clipping. The very low distortion is typically 0.2% at 30 Hz and 0.3% at 16 kHz with 10 dB of limiting. It is less than 1.0% with up to 30 dB of limiting.

## INSTALLATION

The 5-1/4 x 19 inch panel is punched for standard rack mounting and its 12 inch maximum depth prevents problems in quite shallow cabinets. The unit is completely enclosed in a vented housing to permit internal circulation of air. It can be operated in ambient temperatures of up to +55°C and very strong RF fields. The unit has RFI protection for frequencies of 60 MHz and above in the form of ferrite beads on all incoming wires. For excessively strong RF fields below 60 MHz a kit is available to install on the rear of the unit, in which RFI gasketing is used to seal critical slots in the enclosure, with RF chokes and feed-through capacitors used for all external connections.

A three-wire AC line cord is provided to plug into the 117 volt 50/60 Hz AC outlet, with the third wire grounded to the Limiter chassis. In installations where the chassis ground should not be connected to the AC ground system, or where only a two wire outlet is provided, an adaptor is supplied. Be sure to follow the local electrical code by providing a reliable ground connection to the limiter chassis.

The unit may be connected for 235 volt operation by reconnecting the primary of T4: Remove the BLU/W and BLK/W wires from their parallel connection with the BLU and BLK wires respectively. Connect the BLU/W to the BLK/W wire. Remove one of the wires connecting to A1 (the front panel lamp) from its connection to the BLU wire, reconnect to the new BLU/W and BLK/W junction to retain 117 volts across A1. Be sure the new junction of T4 primary wires (BLU/W, BLK/W and wire to A1) is insulated from the chassis and all other conductors.

Input connections and output connections are provided on a barrier terminal block located on the rear of the unit. See the schematic diagram for details. The AC power fuse is also located on the rear panel.

#### OPERATION

Since the operation of the M6543 Solid Statesman Limiter is automatic, it is necessary to make only an initial calibration after selecting its mode of operation. Several of the controls are for factory calibration and are located away from the main control panel, inside the unit. These include the only balance control (R8), the voltage set control (R77) and the peak phasing sensitivity control (R36). The other controls and switches are located behind the front panel access door. Their functions are as follows:

INPUT LEVEL CONTROL (AT1): Adjust with normal input level for the nominal amount of limiting desired. This is generally set for 5 to 10 dB of limiting for average use.

RECOVERY TIME SWITCH (S1): Position 2 is the normal operating position, with position 1 for faster and position 3 for slower than normal operation.

"POSITIVE PEAKS" SELECTOR SWITCH (S3): Should be set to "SYMMETRICAL" for FM and TV use, where asymmetrical limiting is not desired. On AM Stations, where the transmitter has the power capability to handle higher positive peaks, they may be set to limit at "110%" in the center position. The third position causes limiting of the positive peaks at 120% modulation, yet limits negative peaks at 100% modulation if properly phased into the transmitter.

BE SURE THAT THE POSITIVE PEAKS ARE THOSE ACCENTED IN THE TRANSMITTER RATHER THAN THE NEGATIVE PEAKS. This can be changed by interchanging the output pair on the Limiting Amplifier.

This ASYMMETRICAL LIMITING causes no base line shift in the Limiter and does not artificially alter the balance of the program content. It does permit greater modulation of the natural positive peaks with the resultant increase in power if the transmitter and its power line source are capable of delivering this extra power without excessive carrier shift.

Be sure to keep the transmitter air filters and power components clean and free of dust or air restrictions. The increased modulation voltages and power can cause arcing and overheating in poorly maintained equipment.

AUTOMATIC PEAK PHASING is provided by the operation of K1 and its associated circuitry for AM operation with Asymmetrical Limiting for optimum performance. The sensitivity of this circuit is factory set by the strapping of CR11, 12, 21 or 22 and adjustment of R36. Details of this calibration are given in the Maintenance section.

Of course, it works best with Asymmetrical Limiting and this is the only condition under which it offers any advantage. With Symmetrical limiting, a little power increase is noted by changing peak polarity.

DISABLE THE AUTOMATIC PEAK PHASING for FM and TV operation, or for AM where it is not desired, by removing Q12 from its socket. It could be taped inside the Limiter enclosure to prevent its loss in the event future use is desired.

METER ZERO CONTROL (R60): This is factory set at 10 dB of limiting, to coincide with 10 dB of gain reduction as measured from a test set with a sine wave signal. Notice that the meter reads from left to right with increasing levels of limiting, instead of the rather awkward reverse indication common on most limiting amplifiers. Also, the scale is quite linear although functionally calibrated, instead of the very non-linear scales which are difficult to read on most limiters.

LIMITER DISABLE (S2): A front panel switch permits the limiter to be disabled for proof-of-performance tests, etc. by a simple increase in bias voltage on the limiter diodes - leaving the circuit otherwise unchanged. The limiter will now have a threshold of approximately +29 dBm instead of +23 dBm. The input level should be reduced to bring the output back to approximately +23 dBm, the normal operating level, while running the "proof". Allow a few seconds for recharging of the DC isolation capacitors (C14 and C17) when switching the Limiter back "ON". Readjust the input level for the desired amount of limiting and resume normal operations.

OUTPUT LEVEL CONTROL (AT2): With the normal amount of limiting (as selected with AT1), adjust AT2 for the precise amount of negative peak modulation desired. Since the fast attack time permits very high levels of modulation, and most modulation meters are too slow to show maximum instantaneous peaks, a precise scope measurement is preferred for this important calibration. It can be set with a sine wave signal if the transmitter does not have excessive carrier shift. The use of 20 dB of limiting on a 1 kHz signal to set 100% negative modulation will provide maximum utilization of the AM transmitter. Then complex wave signals will approach but never exceed full negative modulation. After this calibration of the output level, readjust the input level for the desired amount of limiting.

FM STEREO OPERATION is achieved by the use of two of the M6543 Solid Statesman Limiters. Convenient cross-coupling is provided by the use of the interconnecting cable supplied with each unit. Simply plug one of the cables (one is supplied with each unit, but only one of the two are required) between J1 of each Limiter. This jack is located on the rear panel along with the terminal block.

This cross-coupling provides uniform gain reduction of both Limiters by the action of either one - thus, keeping an optimum balance from "Left" to "Right" under all types of programming. Of course, they will act independently by simply removing the jumper cable, but this mode of operation is seldom used for stereo programming.

In cases where the "Right" channel is used alternately for stereo and SCA, the jumper may be severed and connected to a switch or relay to allow cross-coupling for stereo operation and separate action for SCA. Under this mode of operation, an output pad should also be incorporated to adjust for the different modulating level required by SCA operation.

#### MAINTENANCE

R36 is adjusted for the threshold of sensitivity of the Automatic Peak Phasing Circuit. The sensitivity is increased by turning this ten-turn trim potentiometer counter-clockwise from its factory calibration. If it is adjusted so the Limiter phasing relay (K1) changes position excessively, turn R36 clockwise to decrease sensitivity.

R8 is the balance control of the Limiter, located on the printed chassis. It is used to balance closely matched pairs of transistors Q1 and Q2 for lowest harmonic distortion. This is most effective with a 10 kHz input signal and 10 dB of limiting, adjust R8 for the lowest amount of harmonic distortion. If the reading exceeds 0.7%, select Q1 and/or Q2 for a closer match.

R77 is the voltage set control in the +39 volt power supply, used to reset the voltage should CR19 or any of the other voltage



determining components are replaced after factory calibration.

R82 is used to set the idling current in the output stages (Q7 and Q8) of the Limiter. With no signal it is to be adjusted for 0.25 volts (1/4 volt) across R84 (10 ohms). This results in a nominal idling current of 25 mA in Q7 and Q8.

R40 is a fixed resistor used to trim the voltage across C13 to +9.0 volts in the factory as a reference for the Peak Comparator. In some instances it may be deleted.

R23 will be used only to correct a slight unbalance in T2 if and when this may occur in the factory. There will be no reason for adding or changing R23 unless T2 is changed and R23 is required to reduce the 16 kHz distortion to 0.7% or less at 10 dB of limiting. When R23 is used, it will normally be around 620 ohms or higher.

R34 will be factory installed occasionally to reduce 1 kHz distortion at the threshold of limiting to correct for accumulated amplifier component unbalances. It should not be necessary to change it or add it unless many of the components associated with Q3 through Q8 are replaced. A typical value for R34 is 1.2 ohms when used.

R55 and C28 are used to give a slight corrective boost at 10 kHz to 16 kHz on the Limiter. They may be strapped out to obtain approximately 0.75 dB more roll-off at 16 kHz.

Q12 is a Field Effect Transistor which must be biased properly to operate the Automatic Peak Phasing circuit. Since this particular parameter is quite variable in most FET's, CR11, CR12, CR21 and CR22 are series connected and sometimes some of them strapped out to select the desired source to gate bias to obtain from +8.5 to +10.5 volts on the drain (on J4, also). If Q12 is replaced, the new unit must be recalibrated in the same manner. Occasionally an FET is encountered which will not calibrate as desired. Select another unit or units until an FET is found that can be properly biased. DO NOT REMOVE OR INSTALL Q12 WITH POWER APPLIED TO THE LIMITER.

## CIRCUIT DESCRIPTION

The M6543 Solid Statesman Limiter uses the diode sections of Q1 and Q2 as a variable resistance shunt following the series elements of R5 and R6 to form a high speed adjustable "U" attenuator. The control signal into the bases of Q1 and Q2 is fed through a shaper network (C3, CR1, R13) from Q14 (emitter). The control signal is obtained by rectifying a small fraction of the program appearing on the Y/WH winding of T3, through C14, C17, CR14, CR15, Q15 and Q14.

The control signal derived from CR14/CR15 is fed to a filter/storage section (C1, C2, R4) and to J1 where it can be cross connected to a second Limiter for stereo operation of the pair. The recovery time is adjustable by the selection of R1, R2 and/or R3 by S1.

Short random peaks charge up only C2 and the recovery time is quite fast. With high level program content of larger and reoccurring peaks, both C1 and C2 will charge and recovery time is proportionally slower.

The control signal also feeds the meter stage, Q13, after being shaped by C3, CR1 and R13. It is shown as a connection from points AA on the base of Q1/Q2 to AA through R61 into the base of Q13, which is biased on its emitter through R60, R58, CR13 and R59 from +39 volts. R60 is adjusted so the meter (M1) reads 10 dB of limiting as established when a 20 dB increase on the input of the Limiter results in a 10 dB increase on the output.

Symmetrical limiting is obtained by biasing both CR14 and CR15 to approximately +15 volts through R66/R67 when S3 is in the SYM position. When the program peaks exceed +15.6 volts (the 0.6 volts is the forward step of the silicon diodes, CR14/CR15) control signal is obtained to cause gain reduction by the subsequent action of Q1/Q2. Thus, the threshold of limiting is established.

Asymmetrical limiting results from a different bias voltage on CR14 than on CR15 when S3 is switched to the 110% or 120% positions. When properly phased, this higher resultant peak becomes the positive modulation peak in the transmitter. With program input having a natural unbalance in positive and negative peaks, the unit will limit negative peaks at 100% while allowing positive peaks to reach 110% or 120% before limiting occurs.

A peak comparator is used to control the action of the Automatic Peak Phasing circuit. CR6 is biased +9 volts by R40/R41/R35 so that a signal peak must exceed -9.6 volts to cause conduction. CR7 is biased approximately -9 volts by R43/R36 so that a signal peak from the same half of T3 secondary winding must exceed +9.6 volts to conduct. R39 and R42 feed the resultant comparator signals into C20 or C21 where the predominant polarity of signal will cause the gate of Q12 to go positive or negative. A phase reversal in T3 allows the negative signal peaks from the comparator to be coincident with the positive modulation peaks in the associated transmitter. Thus, if the output of the comparator is predominantly negative, Q12 is driven further into "pinch-off" and Peak Phasing remains unchanged.

When the output of the comparator is predominantly positive of a sufficient length of time to charge up C20 or C21 and increase the forward gate bias of Q12 to cause the drain voltage to drop from its normal value of around 10 volts to approximately 6 volts--the Automatic Peak Phasing circuit will reverse the phase of the input program signal by action of K1-A/K1-B into T1.

The Automatic Peak Phasing Circuit is comprised of K1, Q9, Q10 and associated components. It is a bistable or flip-flop circuit where in one condition Q9 conducts while Q10 is cut off, while in the other condition Q10 conducts and Q9 is cut off. When Q9 is conducting, K1 is energized; when Q10 conducts, K1 is de-energized. Contacts K1-C alternately select the base

circuit of Q9 and Q10 so that Q12 can drive the base of the conducting transistor (Q9 or Q10) to cut-off when the transmitter modulation peaks are predominantly negative and K1-A/K1-B can switch the input signal to make the modulation peaks predominantly positive again.

PARTS LIST  
M6543 LIMITER

Final Assembly

<u>Symbol No.</u>	<u>Gates Stock No.</u>	<u>Description</u>
A1	406 0388 000	Pilot Lamp, Red
C31 thru C34	516 0074 000	Cap., .005 uF., 1 kV
C35	516 0054 000	Cap., .001 uF., 1 kV
C36, C37	516 0084 000	Cap., .02 uF., 600 V.
F1	398 0017 000	Fuse, 1A.
J1	612 0372 000	Jack, Phono
M1	632 0627 000	Meter, 0-1 MADC
TB1	614 0027 000	Terminal Board
XF1	402 0023 000	Fuseholder

Main Chassis Assembly

AT1, 2	914 8167 001	Attenuator, 600/600 ohm
C11, 26	524 0094 000	Cap., 500 uF., 50V
C22, 23, 24	524 0134 000	Cap., 200 uF., 150V
CR13	384 0018 000	Diode, 1N2069
J3	612 0311 000	Jack, Black
J4	612 0312 000	Jack, White
Q7	380 0065 000	Transistor, 2N3766
Q8	380 0066 000	Transistor, 2N3740
Q17	380 0062 000	Transistor, 40310
R1, 2	540 0132 000	Res., 3 megohm, 1/2 W. 5%
R36, 77	552 0783 000	Pot., 10K ohm
R58	540 0037 000	Res., 330 ohm, 1/2 W.
R60	552 0809 000	Pot., 500 ohm
R64	540 0073 000	Res., 10K ohm, 1/2 W. 5%
R68	540 0034 000	Res., 240 ohm, 1/2 W. 5%
R69	540 0035 000	Res., 270 ohm, 1/2 W. 5%
R80	540 0151 000	Res., 18 megohm, 1/2 W. 5%
S1, 3	600 0431 000	Switch, 1 Pole, 3 Pos.
S2	600 0432 000	Switch, DPDT
T1	478 0118 000	Transformer, Input
T3	478 0289 000	Transformer, Output
T4	472 0580 000	Transformer, Power
XQ7, 8, 17	404 0206 000	Socket

Amplifier Printed Chassis

<u>Symbol No.</u>	<u>Gates Stock No.</u>	<u>Description</u>
C1	526 0004 000	Cap., 1 uF., 35V
C2	508 0306 000	Cap., .33 uF., 100V
C3, 7	508 0215 000	Cap., .01 uF., 100V
C4	522 0178 000	Cap., 25 uF., 6V
C5, 9	522 0164 000	Cap., 250 uF., 3V
C6, 14, 17	522 0244 000	Cap., 50 uF., 25V
C8	508 0076 000	Cap., .005 uF., 100V
C10	522 0243 000	Cap., 35 uF., 25V
C12, 15	508 0268 000	Cap., .1 uF., 100V
C13, 16	522 0192 000	Cap., 25 uF., 10V
C27	516 0386 000	Cap., .22 uF., 3V
CR1, 6, 7, CR14, 15	384 0204 000	Diode, 1N456A
J2	612 0437 000	Jack, Phono
Q1, 2	380 0018 000	Transistor, 2N1307
Q3	380 0092 000	Transistor, 2N4400
Q4, 5	380 0111 000	Transistor, 2N3417
Q6	380 0044 000	Transistor, 40319
Q13, 14, 15	380 0091 000	Transistor, 2N4250
R3	540 0132 000	Res., 3 megohm, 1/2 W. 5%
R4	540 0121 000	Res., 1 megohm, 1/2 W. 5%
R5, 6, 61	540 0069 000	Res., 6.8K ohm, 1/2 W. 5%
R7, 9	540 1130 000	Res., 620 ohm, 1/2 W. 5%
R8	550 0301 000	Pot., 500 ohm
R10	540 0101 000	Res., 150K ohm, 1/2 W. 5%
R11, 12, R14, 15	540 0008 000	Res., 20 ohm, 1/2 W. 5%
R13	540 0077 000	Res., 15K ohm, 1/2 W. 5%
R16	540 1106 000	Res., 6.2K ohm, 1/2 W. 5%
R17	540 1131 000	Res., 30K ohm, 1/2 W. 5%
R18	548 0216 000	Res., 1.37K ohm, 1/2 W. 1%
R19	540 1110 000	Res., 68 ohm, 1/2 W. 5%
R20	540 1107 000	Res., 20K ohm, 1/2 W. 5%
R21	540 1142 000	Res., 240K ohm, 1/2 W. 5%
R22	540 1143 000	Res., 24K ohm, 1/2 W. 5%
R23		Res., (Det. by Test)
R24	540 0078 000	Res., 15K ohm, 1/2 W. 5%
R25	540 0049 000	Res., 1K ohm, 1/2 W. 5%
R26	540 0025 000	Res., 100 ohm, 1/2 W. 5%
R27	540 0010 000	Res., 24 ohm, 1/2 W. 5%
R28	540 0033 000	Res., 220 ohm, 1/2 W. 5%
R29	540 0065 000	Res., 4.7K ohm, 1/2 W. 5%
R30	540 0048 000	Res., 910 ohm, 1/2 W. 5%
R31	559 0014 000	Thermistor, 500 ohm @ 25°C
R32, 33	540 0032 000	Res., 200 ohm, 1/2 W. 5%
R34		Res., (Det. by Test)
R35	540 0072 000	Res., 9.1K ohm, 1/2 W. 5%
R37, 38, R39, 42	540 0097 000	Res., 100K ohm, 1/2 W. 5%
R41	540 0084 000	Res., 30K ohm, 1/2 W. 5%
R43	540 0073 000	Res., 10K ohm, 1/2 W. 5%

Amplifier Printed Chassis Cont'd.

<u>Symbol No.</u>	<u>Gates Stock No.</u>	<u>Description</u>
R59	540 0343 000	Res., 3K ohm, 1 W. 5%
R62	540 0083 000	Res., 27K ohm, 1/2 W. 5%
R63	540 0059 000	Res., 2.7K ohm, 1/2 W. 5%
R65	540 0056 000	Res., 2K ohm, 1/2 W. 5%
R66, 67	540 0080 000	Res., 20K ohm, 1/2 W. 5%
R81	540 0071 000	Res., 8200 ohm, 1/2 W. 5%
R82	550 0300 000	Pot., 750 ohm
R83	540 0041 000	Res., 470 ohm, 1/2 W. 5%
R84	540 0001 000	Res., 10 ohm, 1/2 W. 5%
R85, 86	540 0029 000	Res., 150 ohm, 1/2 W. 5%
T2	478 0183 000	Transformer, Input
XQ1 thru XQ4	404 0066 000	Socket
XQ5, 6, 13, XQ14, 15	404 0198 000	Transipad

Relay and Power Supply Board

C18	522 0258 000	Cap., 50 uF., 50V
C19	522 0160 000	Cap., 100 uF., 3V
C20, 21	526 0004 000	Cap., 1.0 uF., 35V
C25, 29, 30	508 0253 000	Cap., .04 uF., 100V
C28	516 0386 000	Cap., .22 uF., 3V
CR8 thru 12, CR16, 17, 18	384 0018 000	Diode, 1N2069
CR19, 20	386 0034 000	Diode, Zener, 1N3031B
CR21, 22	384 0128 000	Diode, 1N270
K1	572 0134 000	Relay, 590 ohm Coil
Q9, 10, 11, 16	380 0111 000	Transistor, 2N3417
Q12	380 0067 000	Transistor, 2N3819
R44	540 0319 000	Res., 300 ohm, 1 W. 5%
R45, 48	540 0072 000	Res., 9100 ohm, 1/2 W. 5%
R46, 47, R50, 51	540 0069 000	Res., 6.8K ohm, 1/2 W. 5%
R49, 52	540 0617 000	Res., 1.8K ohm, 2 W. 5%
R54	540 0034 000	Res., 240 ohm, 1/2 W. 5%
R55	540 0018 000	Res., 51 ohm, 1/2 W. 5%
R56	540 0086 000	Res., 36K ohm, 1/2 W. 5%
R57	540 0001 000	Res., 10 ohm, 1/2 W. 5%
R70	540 0025 000	Res., 100 ohm, 2 W. 5%
R71, 72	540 0563 000	Res., 10 ohm, 2 W. 5%
R73	540 0070 000	Res., 7.5K ohm, 1/2 W. 5%
R74	540 0036 000	Res., 300 ohm, 1/2 W. 5%
R75, 78	540 0060 000	Res., 3K ohm, 1/2 W. 5%
R76	540 0083 000	Res., 27K ohm, 1/2 W. 5%
R79	540 0063 000	Res., 3.9K ohm, 1/2 W. 5%
XK1	404 0209 000	Socket, Relay
XQ9, 10, 11, 16	404 0198 000	Transipad
XQ12	404 0066 000	Socket

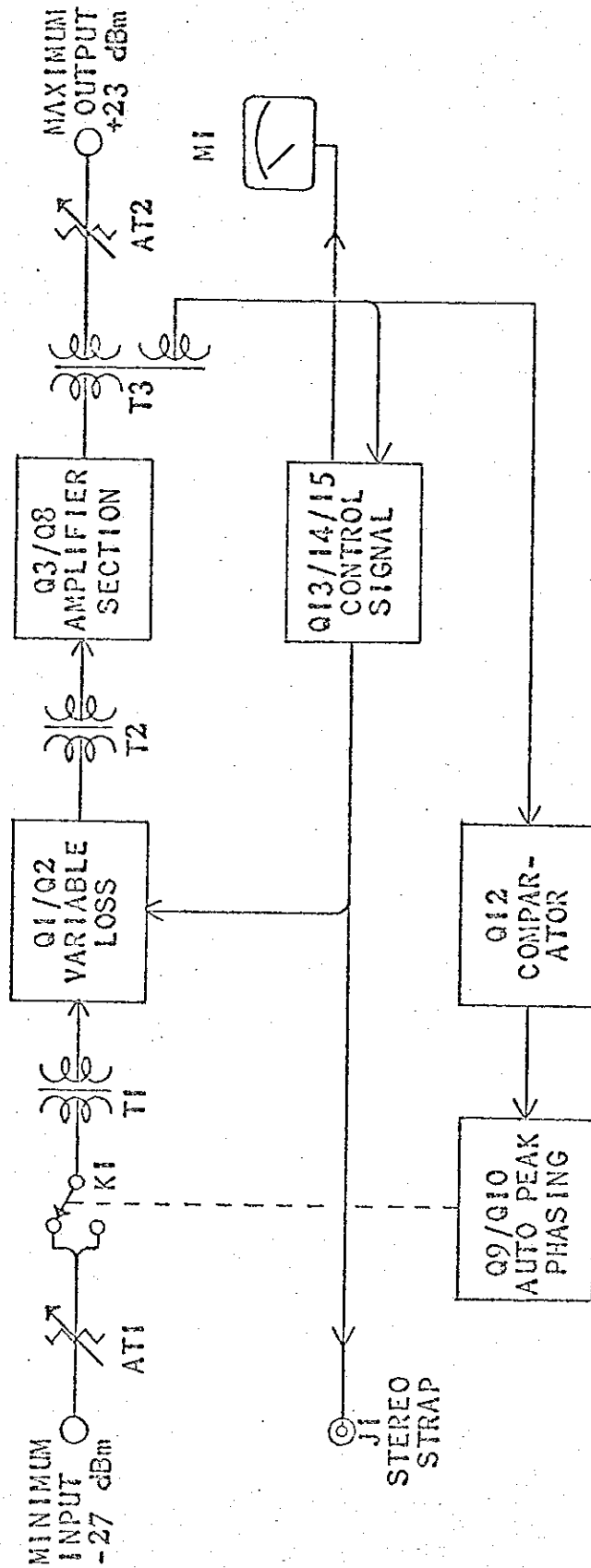

BLOCK DIAGRAM



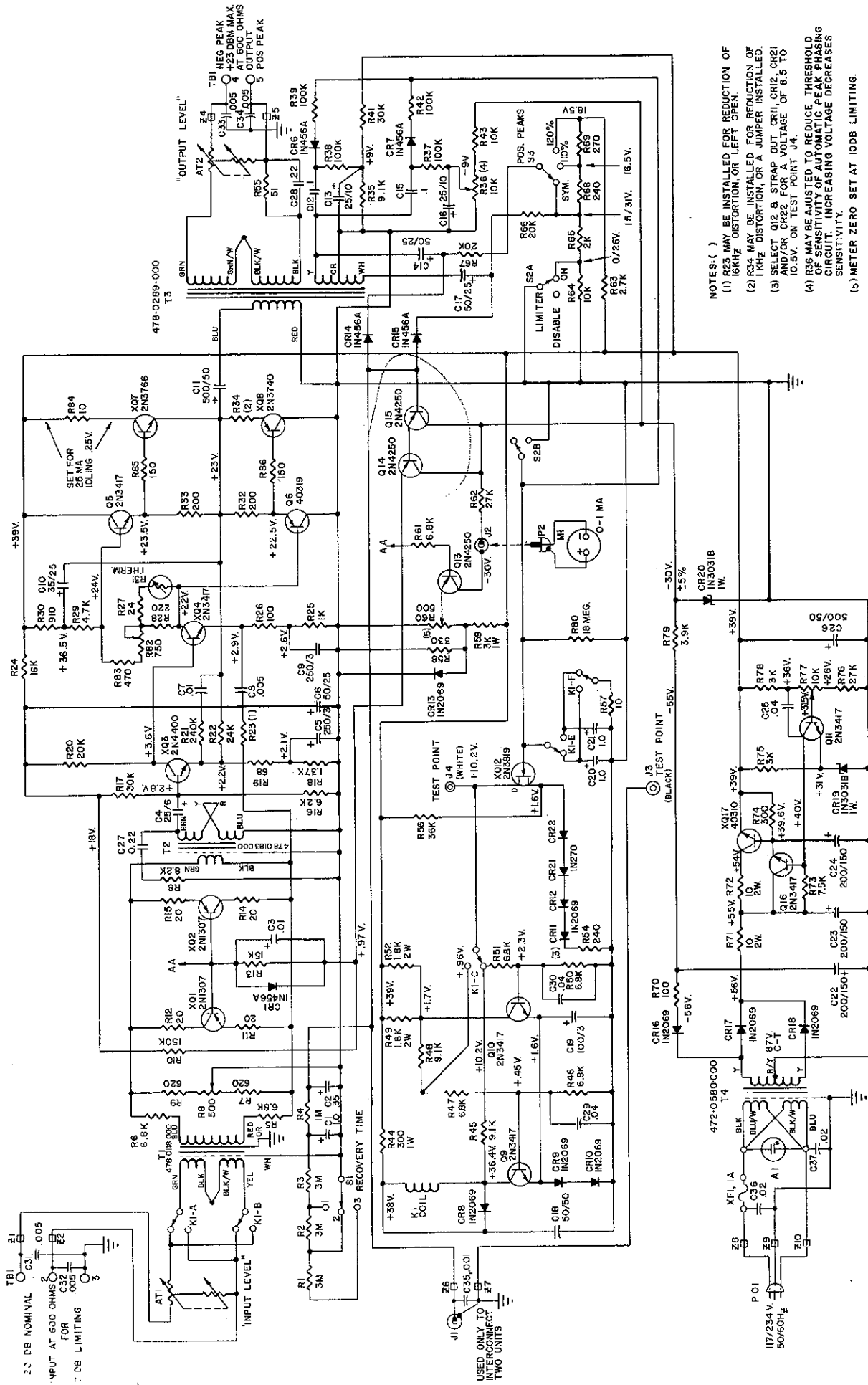

- NOTES: ( )
- (1) R23 MAY BE INSTALLED FOR REDUCTION OF 16KHZ DISTORTION, OR LEFT OPEN.
  - (2) R34 MAY BE INSTALLED FOR REDUCTION OF 1 KHZ DISTORTION, OR A JUMPER INSTALLED.
  - (3) SELECT Q12 & STRAP OUT CR11, CR12, CR21 AND/OR CR22 FOR A VOLTAGE OF 8.5 TO 10.5V. ON TEST POINT J4.
  - (4) R36 MAY BE ADJUSTED TO REDUCE THRESHOLD OF SENSITIVITY OF AUTOMATIC PEAK PHASING CIRCUIT. INCREASING VOLTAGE DECREASES SENSITIVITY.
  - (5) METER ZERO SET AT 10DB LIMITING.