

I GENERAL AND INTRODUCTORY

The Gates SA-39A Limiting Amplifier is a high quality low distortion amplifier for AM and FM to be used as a device to limit the audio output above a set amount with said limitation possible without affecting the quality of broadcast transmission. It is constructed in the new type cast aluminum service housing with drop-down front panel. When properly installed it will give a lifetime of satisfactory service. However, as limiters require more than normal understanding of their functions we urge even the very experienced engineer to thoroughly acquaint himself with these instructions and the equipment.

II DETAILED DESCRIPTION

1 - The SA-39A limiter is a three-stage all push-pull amplifier using highly shielded components for low noise and accurately designed parts for good balance and low distortion. The first stage employs a pair of 16L2 (6L7) tubes, the second stage a pair of 6SJ7 tubes and the final stage a pair of 6V6 tubes.

2 - Limiting Circuit

To obtain limiting or automatic peak control action a portion of the output voltage is rectified by a 6H6 tube as a full wave rectifier and a negative DC voltage applied to the second control grid of the 16L2 tubes. As the audio voltage increases the grid becomes more negative retarding the flow of current thus lowering the gain of the stage. A-3984 shows the curve of the limiting action obtained. It will be noted that beyond the point where limiting action starts that the curve is substantially flat and up to the overload point of the amplifier only slight increase in gain is noted. Regardless of the amount of limiting action (up to overload) the quality of the program is unimpaired. Referring to the schematic D-20773 the point of limiting is determined by the network R30-R29-R28 and R27. This has been arbitrarily set in design for convenient operation. The scale on the meter, M1, is to measure the plate current of V1 and calibrate it for a direct indication of limiting action. For convenience the scale is calibrated in "Decibels Compression". Switch S1 sets the recovery time as desired. An attenuator, R1, is inserted in the input to control the input level and set the gain to the desired degree of compression. The output, as indicated from the curve in Drawing A-3984, must be maintained at a comparatively constant level, hence an output attenuator R24, is provided to set the proper level to succeeding equipment.

3 - Power Supply

An electronically regulated power supply maintains constant voltage on the first two stages. This circuit employs a 5V4G cathode type rectifier which will relieve initial surge voltage on the input filter capacitor. As a further aid to keeping the equipment in service the capacitor is a plug-in type which may be readily kept in stock for immediate replacement. The conventional regulator circuit uses a 1-6X5, 1-6SJ7, and 1-6J6 tubes.

4 - Mechanical Construction

The amplifier is built upon a flat plate chassis. This in turn is mounted in a cast aluminum frame with a drop front door which may be mounted in a standard 19" rack or cabinet. Necessary controls and the meter are located on the front door. The tubes are available from the rear and opening the door gives access to the electrical components. By removing the controls from the front door the chassis may be removed from the frame for major repair without removing the style strips from the cabinet. A pilot light inside the frame will provide illumination when powered from an external 6.3 volt source through a plug provided.

1 - Unpacking

The SA-39A Limiting Amplifier is shipped as an integral unit completely assembled. The rectifier tube and the plug for the trouble light are removed for packing. A check of the packing list will show exact contents of container. The remaining tubes are shipped in their respective sockets. Remove any padding or tape added to safeguard delivery. Open the front door by loosening thumbscrew. Inspect the interior for additional packing materials as well as concealed damage due to rough handling by the transportation agency. Insert the rectifier tube in its socket and check the remaining tubes that the proper tubes are in the sockets as stencilled.

2 - Installation

Fourteen inches of rack or cabinet space must be provided for the amplifier. The 115 Volt A.C. terminals will be found on the left side (from the rear) of the chassis. The audio connections are on the right side. The terminals are stencilled with their function in each case. The input and output impedances are 500 ohms into and out of resistive attenuators. Reference to the schematic diagram will clarify the terminations. Care should be taken that all audio leads are run in shielded pair and kept away from 60 cycle A.C. lines as far as possible. Due to the cast aluminum frame and aluminum chassis little trouble should be encountered from stray R.F. fields. It is suggested that if possible the ungrounded side of the A.C. line be connected to terminal number 8 (stencilled on under-side of chassis) then when the fuse is removed the entire chassis will be at neutral or ground potential and danger of accidental shocks removed when it is necessary to work on the equipment.

CAUTION: If the above precaution is not taken, remember that the A.C. switch on the front door is liable to be live even with the fuse removed, and to work accordingly.

IV OPERATION

1 - Preliminary Adjustments

The instrument has been carefully checked in the laboratory under actual operating conditions and should be ready for operation as described below without further adjustment.

2 - Initial Operating Procedure

To place the SA-39A Limiting Amplifier in operation set the front panel controls as follows:

1 - Set "Input" attenuator R1 to infinity. The amplifier should operate with a constant input of approximately -20 V.U. However, it is suggested that a level of -10 to 0 V.U. be maintained at the terminals and the input attenuator adjusted to proper operating level.

2 - Set "Output" attenuator R24 to infinity.

3 - Turn on the power switch, S2. The pilot light should light up. If not check fuse on rear of chassis.

4 - With the Input attenuator at infinity or off, the DB Compression scale should show 0 DB Compression or full scale reading. To adjust the meter open the front door and a knob, R3 will be noted in the lower left hand corner of the chassis. This knob controls R3 changing the bias slightly on the 16L2 stage to adjust the plate current so that the meter reads 0 DB Compression. It may be found that after the limiter has been in operation

an hour or two that the zero setting will change; the needle dropping slightly. It is suggested that the setting be rechecked after complete warm-up and this setting be used for continuous service.

5 - Now, increase the program input until the meter just begins to swing with peaks, this is the minimum level that the limiter should be operated. For satisfactory operation "average" program level should not be allowed to compress beyond 5 DB. At this point it should be pointed out that the scale indicates a steady sine wave compression and that dynamic program material will have a different behavior with a higher degree of compression than actually indicated on the meter; however, for all practical considerations the meter gives the operator an excellent indication of the operation of the limiter.

6 - Increase the output gain control until the desired level is reached. The limiter is now ready to be placed in service.

3 - Operating Suggestions

Actual operation of the limiter will depend to a large extent upon the individual desires of the personnel involved. The principal reason for the use of a limiter is to permit the transmitter to be operated at a high modulation value with the limiter being a safety valve to prevent sudden or sustained program increases from causing overmodulation. In FM the SA-39A Limiter is indeed ideal; preventing excessive transmitter swing and resultant receiver distortion. Where it would be desired to have considerable dynamic range to the music the amount of compression should be reduced to a minimum. As compression is increased the dynamic range would be compressed to where the music would lose its pleasing expression. Under normal operation the compression should not exceed 5 DB for average program level.

The recovery time of the limiter is set by switch S1 on the rear of the chassis. A dial is calibrated for six positions. Position #1 gives a time recovery of approximately .2 sec. and each succeeding position increases by .2 sec. Position #3 or .6 sec. gives a good average recovery time, however, for certain types of program it may be desirable to increase or decrease the time constant.

The jack J7 on the front door may be used for aural monitoring by plugging in phones. A signal will be heard at this point regardless of the position of the output attenuator.

V MAINTENANCE

The Gates SA-39A Limiting Amplifier is carefully tested in the laboratory before shipping and all controls and adjustments set as indicated in the preceding test. The amplifier has been carefully designed and should give long uninterrupted service. For the assistance of the engineer in servicing the amplifier the various operating voltages are indicated on the schematic drawing. These readings were taken with a high impedance vacuum tube voltmeter. If an ordinary 20,000 ohm per volt meter is used a slight discrepancy will be noted at tube sockets although main voltages should read approximately the same.

A current jack has been placed in each cathode of the amplifier circuit. If a multi-range D.C. milliammeter is available a standard two circuit phone plug may be inserted. The readings should approach those shown on the schematic. The polarity of the jack plug is the same as used on the companion units of the GATES SA line of amplifiers; that is, the tip is positive and the sleeve is negative.

Drawings C-17330 and C-17331 show the locations of the resistors on the terminal boards and their terminations.

The layout of the SA-39A Limiting Amplifier lends itself rapid routine maintenance. With the front door lowered the attenuators are readily available for occasional cleaning.

Modern tube design assures long life; however, it is well to occasionally check the cathode currents, watching for unbalance in the tubes. In changing tubes care should be taken that the 1612 tubes are evenly matched which may be checked by plugging a current meter into jacks J1 and J2. Unbalance may cause fluttering or thumping in the limiter circuit on extreme low notes. It may also be a source of noise (hum) where extremely low level circuits are employed.

Removing the tubes for periodic checking has the further advantage of lowering contact potential between the pins and socket clips. The plug-in capacitor should also be removed and reinserted to insure good contact. Good housekeeping also indicates that all equipment should be kept clean and dust-free.

The output of the regulated power supply is indicated at 275 volts. This voltage may be adjusted by varying R43, a screwdriver slot control located on the rear of the chassis. The voltage will be found to maintain very constant over quite wide variations of current and line voltage fluctuations. In case of minor repairs to the equipment reference to the schematic and resistor board drawings should enable the engineer to make most repairs without removing the chassis from the rack. A new type of terminal has been employed on the resistor boards, allowing easy removal of components by the application of a hot soldering iron. If a major repair is indicated the unit may be removed with the following procedure:

- 1 - Disconnect leads from rear terminal boards.
- 2 - Remove knobs and lock nuts from the controls and switches on the front door. Also the leads from the meter.
- 3 - Remove the filister head screws from the rear of the chassis.
- 4 - Remove the chassis pulling the switches and controls through the frame.
- 5 - If necessary the meter may be removed separately and the connections made on the work bench.
- 6 - To replace the chassis reverse the process. Studs are provided on the rear of the frame to assist in guiding the chassis to its proper position and to relieve the load while replacing the screws.

PARTS LIST

265-PE-101

<u>SYMBOL NO.</u>	<u>DRAWING NO.</u>	<u>DESCRIPTION</u>
A1		Pilot Light Assembly, 810M-431, Red, Dial Light
A2		Lamp #40
A3		Lamp socket "made from Dial Light #611 Socket"
A4		Lamp, 1/4W Neon NE-45
A5		Fuseholder, #341001 Littlefuse
A6		Trouble Light Socket, #505 Dial Light
A7		Trouble Lamp, #40
C1		Capacitor, .1 mfd., 400V., C-D #DT-4P1
C2		Capacitor, .1 mfd., 400V., C-D #DT-4P1
C3		Capacitor, .1 mfd., 400V., C-D #DT-4P1
C4		Capacitor, .1 mfd., 400V., C-D #DT-4P1
C5		Capacitor, .1 mfd., 400V., C-D #DT-4P1
C6		Capacitor, .1 mfd., 400V., Aerovox P82
C7		Capacitor, .1 mfd., 400V., Aerovox P82
C9		Capacitor, .5 mfd., 400V., Aerovox P82
C10		Capacitor, 20-20 mfd., 450V., Plug-in C-D #QC-2245
C11		Part of C10
C12		Capacitor, .5 mfd., 400V., Aerovox P82
C13		Capacitor, .5 mfd., 400V., Aerovox P82
C14		Capacitor, .5 mfd., 400V., Aerovox P82
C16		Capacitor 16 mfd., 450 V. #BR-1645 C-D
F1		Fuse, 3 amp. 3 AG Littlefuse
J1		Jack, 2-A Utah-Carter
J2		Jack, 2-A Utah-Carter
J3		Jack, 2-A Utah-Carter
J4		Jack, 2-A Utah-Carter
J5		Jack, 2-A Utah-Carter
J6		Jack, 2-A Utah-Carter
J7		Jack, #701 Mallory
L1	AC-3122	Filter Choke, U.T.C.

6/25/51

- 5 -

SA-39A Limiting Amp.

PARTS LIST

265-PE-101

<u>SYMBOL NO.</u>	<u>DRAWING NO.</u>	<u>DESCRIPTION</u>
M1	A-5743-1	0-1 MADC Meter with Special Compression Scale
R1		Control, 500/500 ohms, Daven LA-350F
R2		Resistor, 510 ohms, 1 W., 5% A-B
R3	A-3404-5	Potentiometer, 500 ohms Wirewound 3/4" Shaft
R4		Resistor, 62K ohms 1 W. 5% A-B
R5		Resistor, 82K ohms 1 W. 10% A-B
R6		Resistor, 220 ohms 1 W. 5% A-B
R7		Resistor, 82K ohms 1 W. 10% A-B
R8		Resistor, 100K ohms 1/2 W. 10% A-B
R9		Resistor, 150K ohms 1 W. 10% A-B
R10		Resistor, 150K ohms 1 W. 10% A-B
R11		Resistor, 100K ohms 1/2 W. 10% A-B
R12		Resistor, 1800 ohms 1 W. 10% A-B
R13		Resistor, 1800 ohms 1 W. 10% A-B
R14		Resistor, 470K ohms 1 W. 10% A-B
R15		Resistor, 82K ohms 1 W. 10% A-B
R16		Resistor, 82K ohms 1 W. 10% A-B
R17		Resistor, 68K ohms 1 W. 10% A-B
R18		Resistor, 68K ohms 1 W. 10% A-B
R19		Resistor, 100K ohms 1 W. 10% A-B
R20		Resistor, 100K ohms 1 W. 10% A-B
R21		Resistor, 10K ohms 1 W. 10% A-B
R23		Resistor, 180 ohms 10 W. Lectrohm type 1 3/4E
R24		Control, 500/500 ohms Daven LA-350F
R25		Resistor, 270 K ohms 1 W. 10% A-B
R26		Resistor, 270 K ohms 1 W. 10% A-B
R27		Resistor, 100K ohms 1 W. 10% A-B
R28		Resistor, 18K ohms 1 W. 10% A-B
R29		Resistor, 470K ohms 1 W. 10% A-B
R30		Resistor, 470K ohms 1 W. 10% A-B
R31		Resistor, 2.2 megohm 1/2 W. 10% A-B
R32		Resistor, 2.2 megohm 1/2 W. 10% A-B
R33		Resistor, 2.2 megohm 1/2 W. 10% A-B
R34		Resistor, 2.2 megohm 1/2 W. 10% A-B
R35		Resistor, 2.2 megohm 1/2 W. 10% A-B
R36		Resistor, 2.2 megohm 1/2 W. 10% A-B
R37		Resistor, 5.1 megohm 1 W. 5% A-B
R38		Resistor, 33K ohms 1 W. 10% A-B
R39		Resistor, 1 megohm 1 W. 10% A-B
R40		Resistor, 4700 ohms 1 W. 10% A-B
R41		Resistor, 10K ohms 1 W. 10% A-B
R42		Resistor, 4700 ohms 2 W. 10% A-B

6/25/51

- 6 -

SA-39A Limiting Amp.

PARTS LIST

265-PE-101

<u>SYMBOL NO.</u>	<u>DRAWING NO.</u>	<u>DESCRIPTION</u>
R43	A-3404-6	Potentiometer, 10K ohms 4 W. wirewound
R44		Resistor, 33 K ohms 2 W. 10% A-B
R46		Resistor, 1500 ohms 10W Lectrohm type 1 3/4 E
R47		Resistor, "X" value to be determined by tube current
R48		Resistor, 5600 ohms 1/2 W. 10% A-B
R49		Resistor, 5600 ohms 1/2 W. 10% A-B
R50		Resistor 4700 ohm, 1 W., 10% A-B
S1	B-11139-7	Selector Switch
S2		Toggle switch, SPST, 8280K16 C-H
T1	AI-3002	Input Transformer U.T.C.
T2	AO-3045	Output Transformer
T3		Power Transformer, Triad #6676
T4	AF-3097	Filament Transformer
TB1		Terminal Board, 7-142Y Jones
TB2		Terminal Board, 3-142Y Jones
V1		Tube 1612/6L7/6L7G
V2		Tube 1612/6L7/6L7G
V3		Tube 6SJ7
V4		Tube 6SJ7
V5		Tube 6V6 GT
V6		Tube 6V6 GT
V7		Tube 6H6
V8		Tube 6X5 GT
V9		Tube 6SJ7
V10		Tube 6L6 G
V11		Tube 5V4G
X1		Socket MIP8-T Amphenol
X2		Socket MIP8-T Amphenol
X3		Socket MIP8-T Amphenol
X4		Socket MIP8-T Amphenol
X5		Socket MIP8-T Amphenol
X6		Socket MIP8-T Amphenol

6/26/51

- 7 -

SA-39A Limiting Amp.

PARTS LIST

265-PE-101

<u>SYMBOL NO.</u>	<u>DRAWING NO.</u>	<u>DESCRIPTION</u>
X7		Socket MIP8-T Amphenol
X8		Socket MIP8-T Amphenol
X9		Socket MIP8-T Amphenol
X10		Socket MIP8-T Amphenol
X11		Socket MIP8-T Amphenol
X12		Socket MIP8-T Amphenol
X13		Trouble light connector socket, 80-PC2F Amphenol

6/26/51

- 8 -

SA-39A Limiting Amp.

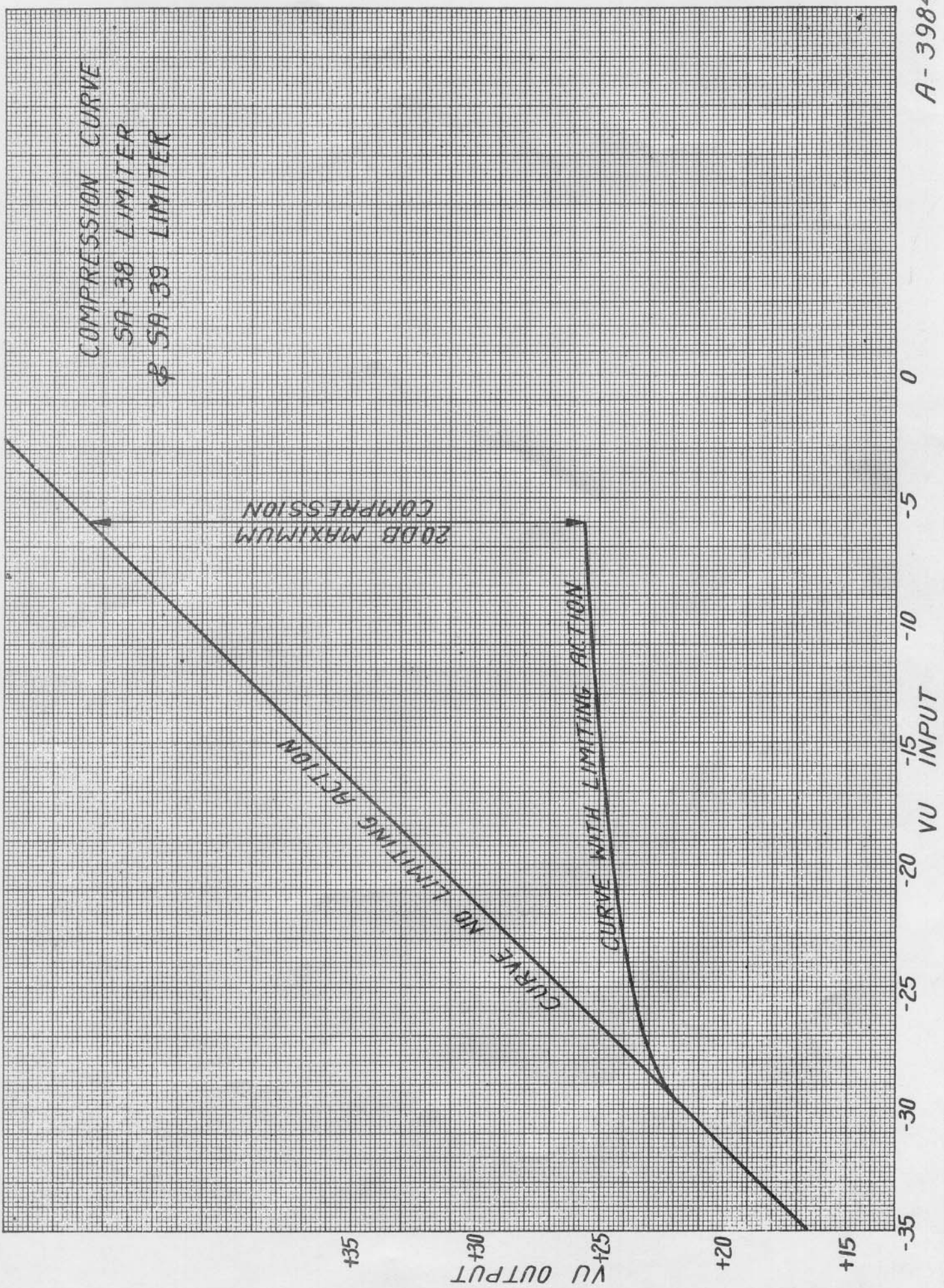

LIST OF PARTS

RESISTOR BOARD ELECTRICAL ASSEMBLY C-17330

QTY	UNIT	DESCRIPTION	QTY	UNIT	DESCRIPTION	QTY	UNIT	DESCRIPTION
1	PCB	THIS DWG	100					
1	PCB	C-15980						
1	PCB	R13						
1	PCB	R6						
1	PCB	R2						
2	PCB	R1, R13						
1	PCB	R4						
2	PCB	R11, R18						
4	PCB	R5, R7, R15						
2	PCB	R10, R12						
2	PCB	R9, R10						
1	PCB	R14						
4	PCB	C1, C3, C5						
4	PCB	C2, C4, C6						

QTY	UNIT	DESCRIPTION	QTY	UNIT	DESCRIPTION
		ASSEMBLY			
		BOARD ASSEMBLY			
		180Ω 10% ELECTROM. TYPE 1W			
		220Ω 5% ALLEN-BRADLEY 1W			
		570Ω 5% ALLEN-BRADLEY 1W			
		1800Ω 5% ALLEN-BRADLEY 1W			
		52KΩ 5% ALLEN-BRADLEY 1W			
		68KΩ 10% ALLEN-BRADLEY 1W			
		82KΩ 10% ALLEN-BRADLEY 1W			
		100KΩ 10% ALLEN-BRADLEY 1W			
		150KΩ 10% ALLEN-BRADLEY 1W			
		470KΩ 10% ALLEN-BRADLEY 1W			
		0.1 MFD. 400V. C.D. PAPER			
		.1 MFD. GOV. RTW-GPI C-D			

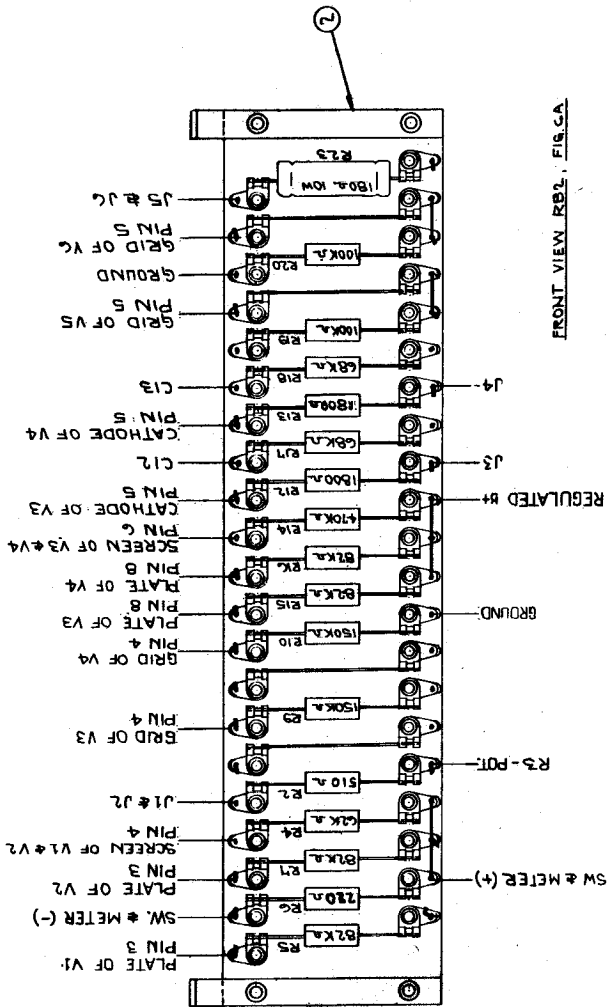

FRONT VIEW RB2, FIG. 6A

GRUPE 101 SHOWN

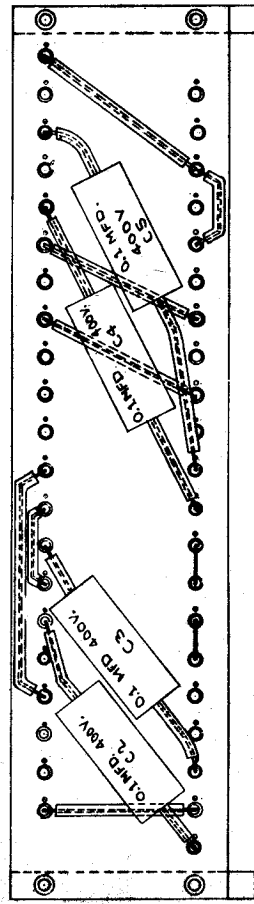

REAR VIEW RB1, FIG. 6A

SYMBOLS REFER TO:
 SCHEMATIC D-20711 FOR SA-38A
 SCHEMATIC D-20713 FOR SA-39A
 SA-38A LIMITER AMPLIFIER - MO-2996A
 SA-39A LIMITER AMPLIFIER - MO-3519A

RESISTOR BOARD ELECTRICAL ASS'Y FOR
 FIRST MADE FOR SA-38A & SA-39A LIMITER AMPLIFIER.
 DRAWN BY: R.L.V.
 CHECKED BY: M.J.G.
 FORMED BY: J.-15-51
 GATES RADIO COMPANY
 C-17330

LIST OF PARTS

NO.	QTY.	PART NO.	DESCRIPTION	MATERIAL	ASSEMBLY	
					QTY.	PART NO.
1	X	THIS DWG.	MECHANICAL ASSY.			
2	1	C-15902	5.1MEG. 5% ALLEN-BRADLEY 1W.			
3	1	R37	1MEG. 10% ALLEN-BRADLEY 1W.			
4	2	R39	100K. 10% ALLEN-BRADLEY 1W.			
5	2	R38	100K. 10% ALLEN-BRADLEY 1W.			
6	1	R27	33K. 10% ALLEN-BRADLEY 2W.			
7	1	R44	33K. 10% ALLEN-BRADLEY 2W.			
8	1	R36	100K. 10% ALLEN-BRADLEY 1W.			
9	1	R16	10K. 10% ALLEN-BRADLEY 1W.			
10	1	R41	10K. 10% ALLEN-BRADLEY 1W.			
11	1	R42	100. 10% ALLEN-BRADLEY 2W.			
12	1	R40	100. 10% ALLEN-BRADLEY 1W.			
13	2	R23	100K. 10% ALLEN-BRADLEY 1W.			
14	2	CG & C7	0.1 MFD. 400V. AEROVOK. P62			
15	2	CG & C7	0.1 MFD. 400V. AEROVOK. P62			
16	2	CG & C7	0.1 MFD. 400V. AEROVOK. P62			
17	2	CG & C7	0.1 MFD. 400V. AEROVOK. P62			

C-17331

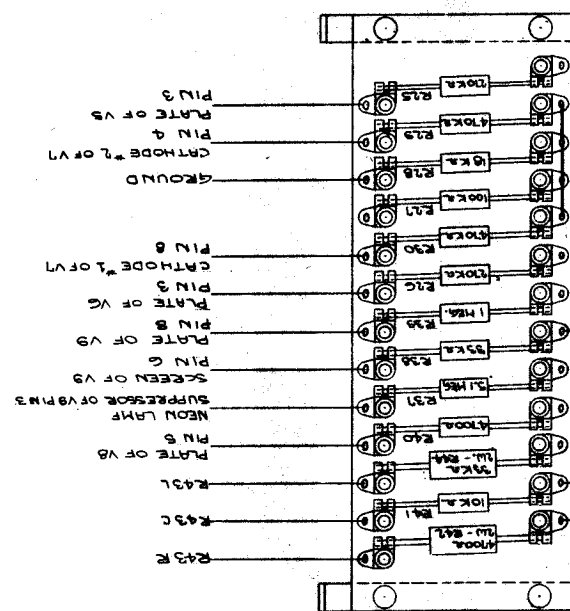

FRONT VIEW RESISTOR BOARD ASSEMBLY (FIG. 5A)

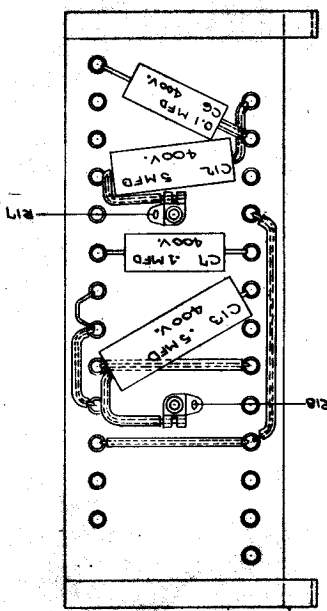

REAR VIEW RESISTOR BOARD ASSEMBLY (FIG. 5B)

SYMBOLS REFER TO:
SCHEMATIC D-20772 FOR SA-38A
SCHEMATIC D-20773 FOR SA-38A

REV.		DATE	BY
1	1		
2	1		

QTY.	3000
DATE	2-7-52
BY	J. J. S.
CHKD PER	2112
DATE	7-2-51

REV. 1	DATE 2-7-52
REV. 2	DATE 7-2-51

FIRST MADE FOR SA-38A & SA-38A LIMITED AMP.
DRAWN BY: R.E.K.
TRACED BY: J.J.S.
DATE: 2-18-51

GATES RADIO COMPANY
114008
QUANTITY
C-17331

RESISTOR BOARD ELECTRICAL ASSY.

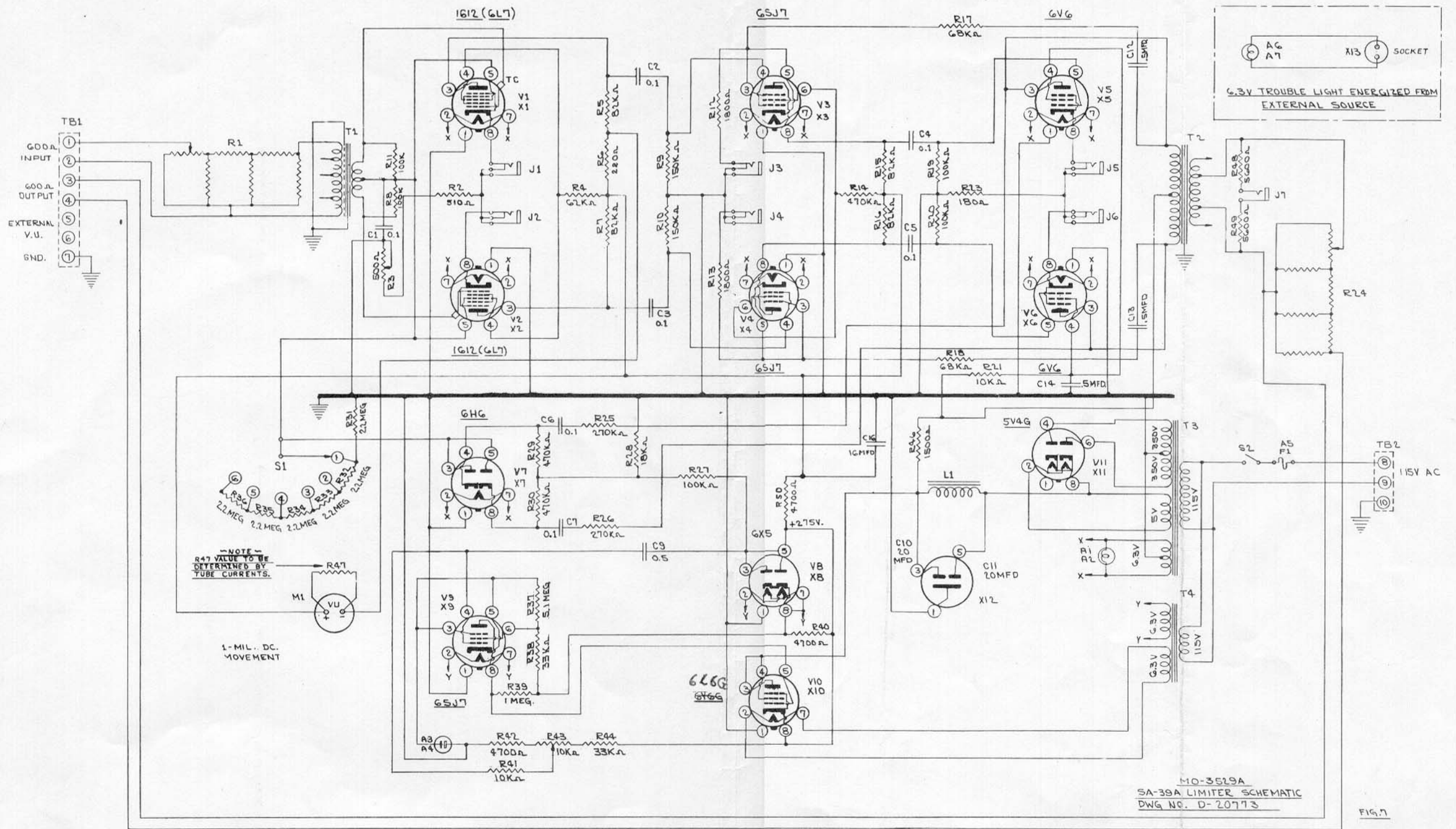

ECN 5379	5	GATES RADIO COMPANY
AWC 1-10-53	4	QUINCY, ILLINOIS
ECN 53518	3	LIMITER SCHEMATIC
AWC 5-29-52	2	SA-39A MO-3529A
CHKD BY ECN	1	DR BY RLW
DRAWN BY D.F.W. 1-29-52		DATE 2-13-51
ECN 5382		DR. BY X
AWC 12-11-51		DATE N.Y.K.
1 COPY PER SET		D-20773