

CEDTM

Engineering Conference
Spring

Fiber Optics Construction
Special Business Systems Section

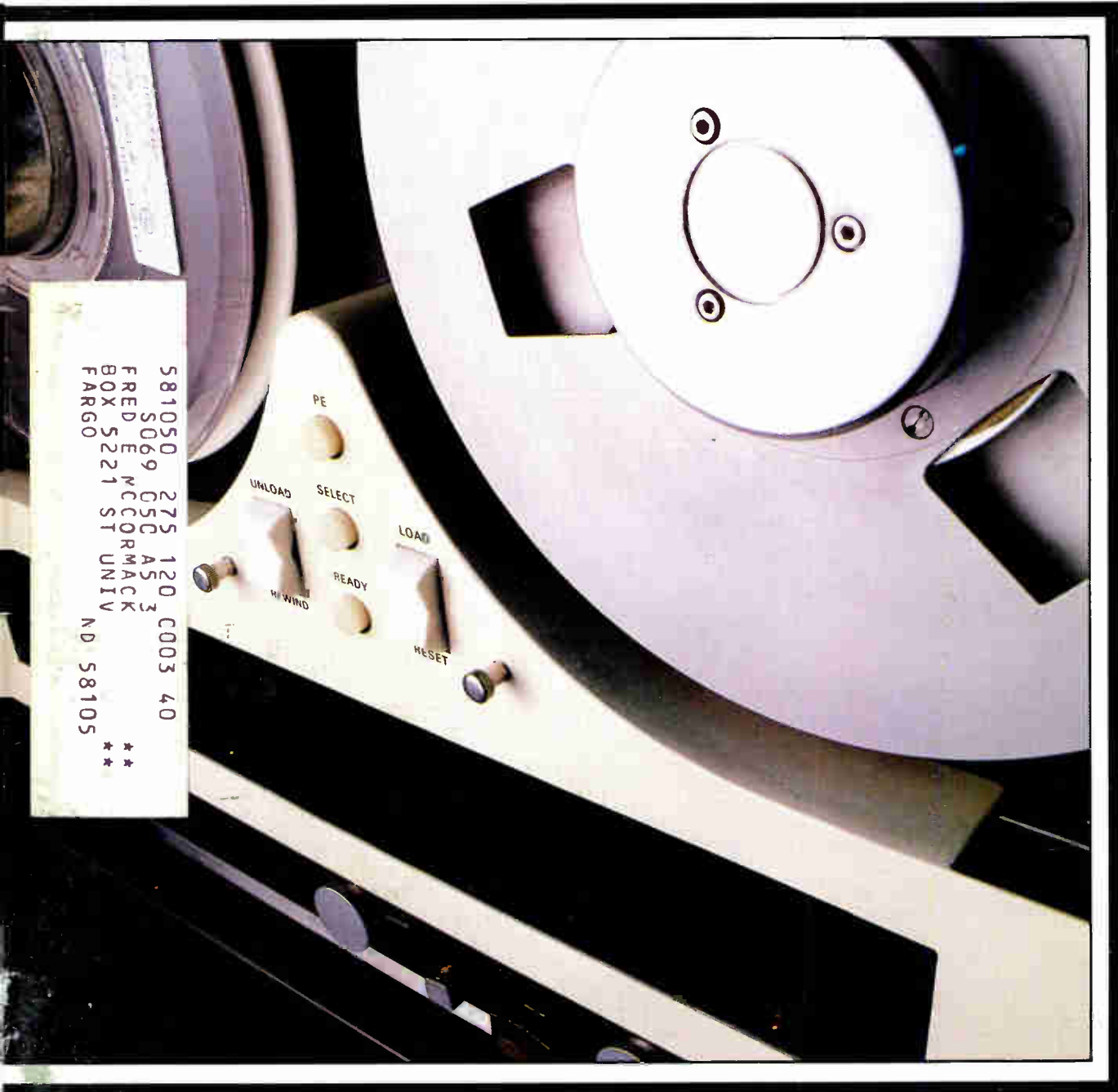

581050 275 120 C003 40
S0699 CSC AS 3
FRED E NCCOR MACK
BOX 5221 ST UNIV
FARGO ND 58105
**
**

Communications-Engineering Digest
Reporting the Technologies of Broadband Engineering

February 1980
Volume 6, No. 2

A man in a dark suit, white shirt, and striped tie stands in a server room. He is smiling and looking towards the camera. His right hand rests on a small black rectangular device on a table, while his left hand is held out in a gesture. The background is filled with racks of electronic equipment.

**“Unmatched
product quality
and a
one-year
warranty.”**

“That’s why I chose Oak.”

Product quality is *the* essential ingredient of system reliability. Charlie knows it, and so do the hundreds of other small-system operators and MSO’s who have chosen Oak. They know that the rigid quality control procedures at Oak offer them protection from downtime and lost revenue, unmatched by any other manufacturer.

Oak also shares this confidence and, instead of promises, continues to offer all customers a one-year full warranty on all converter and decoder products... still the best warranty in the industry.

In order to back its converters and decoders this well, Oak has invested heavily in research and facilities, demonstrating a continuing commitment to design and build every product it sells. That’s a high price for a manufacturer to pay, but there are no short cuts to product quality.

Cable operators like Charlie find that the price of quality is no higher than its alternatives. In fact, with Oak, his long term hardware costs are likely to be much lower.

To request the latest Oak product information packet, call our Locator Operator toll-free at 800-323-6556 (in Illinois, call 800-942-6345) and ask for the CATV information desk.

OAK
Communications | **CATV**
Inc. | **Division**

Crystal Lake, Illinois 60014 Telephone 815/459-5000 TWX: 910-634-3353

Texscan-Your Test Equipment Company

**HERE'S
PROOF!**

FROM HEADEND



TO TRUNK



TO
DISTRIBUTION



TO BENCH



SPECTRUM ANALYZER



VSM-5A

- 4-350 MHz
 - -50 dBmV Sensitivity
 - Phase Lock
 - Storage Interface
- Performs all FCC tests except system flatness

FREQUENCY COUNT



TFC-7

- All Channel Performance
- Stripper/Preselector Integral
- -5 dBmV Sensitivity
- Accuracy 1 part in 10⁶

BENCH SWEEP



SWEEP GENERATOR

VS-40Z

- 1-300 MHz
- ±0.25 Flatness
- +54 dBmV Output
- 7 Markers Available



DISPLAY SCOPE

DU-720 Large screen, 12" — AC or DC coupling P7 phosphor standard, 1 mV/div. sensitivity

TEXSCAN'S PROOF PACKAGE!

SIMULTANEOUS SWEEP



SWEEP TRANSMITTER

9550T

- +60 dBmV Output
- ±0.25 dB Flat
- Low Spurious Output
- Rack Mount in Headend

RADIATION KIT



RADIATION DIPOLE

AFS-1

Radiation dipole kit contains antenna, fiberglass mast sections, calibration chart which includes downlead loss.



BROAD BAND AMPLIFIER

VSX-92

Preamp has 29 dB gain from 40 to 890 MHz, with 7 dB noise figure and flatness of ±1 dB. Operates from internal rechargeable battery.

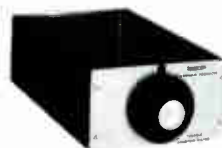

TUNABLE BANDPASS FILTER

VF Series

Eliminate preamp overload with 3 or 5 section filters. Available with 3 or 5% bandwidth. Low insertion loss.



SWEEP RECEIVER

9550R

- Battery Operated
- Portable
- Long Persistence Phosphor
- High Resolution

ACCESSORIES

- ROTARY ATTENUATORS
- DC BLOCKS
- DETECTORS
- FIXED PADS
- REFLECTION BRIDGES

Texscan

For More Proof — Write
Texscan Corp.
2446 N. Shadeland Ave.
Indianapolis, IN 46219
(317) 357-8781

For Your CATV Distribution Needs:
Theta-Com Div. Texscan Corp.
2960 Grand Ave.
Phoenix, AZ 85017
(602) 252-5021 or 800-528-4066

Overseas
Texscan
Northbridge Rd.
Berkhamstead
Hertfordshire
England, UK

Now Transient Surge Damage Is Your Fault—Not Ours



If you are not using
RMS **'POWER-KING'**™ power
supply series for a significant increase in
performance reliability, while greatly reducing
maintenance and operational cost, then don't blame us.
Models PS-30, PS-60 and PS-60/30 Regulated AC Power Supplies.

RMS CATV DIVISION
ELECTRONICS, INC.

RMS ELECTRONICS, INC.
50 ANTIN PLACE
BRONX, NY 10462
CALL COLLECT (212) 892-1000
TOLL FREE (800) 223-8312

Canadian Representatives: Desklin Sales Corp.

C-ED News at a Glance

WASHINGTON, D.C.—**The FCC has turned down a request** by the three major broadcast networks and the National Association of Broadcasters **that it reconsider its decision** last May **to expand CARS** from 12.7-12.95 GHz to 12.7-13.20 GHz and put it on a shared, co-equal and primary basis with TV auxiliary stations, and to set aside 13.15-13.20 GHz for use by TV and cable pickup for electronic news gathering within 50 kilometers of the top 100 markets. The FCC said the underlying issues presented in the petitions were similar in content to comments previously submitted and do not have sufficient merit. Further, it said the petitioners failed to substantiate any claim that irreparable injury would occur to operation of TV auxiliary stations as a consequence of the 12.95-13.20 GHz allocation to CARS.

WASHINGTON, D.C.—**The National Cable Television Association will sponsor an "Executive Seminar" this month on videotex services at the Contemporary Resort Hotel, Orlando, Florida, Feb. 3-5.** The seminar will be the first in a series of programs sponsored by NCTA designed to provide "leaders in the cable industry" with the information necessary to answer what the role of the cable television industry will be in meeting the demands of the coming information society. The seminar will present an extensive discussion of viewdata technology and an analysis of its current and potential ability to deliver vast quantities of information to the private business consumer. According to a promotional brochure for the seminar, also addressed will be the options for cable television in the provision of two-way information services, the marketplace, the technology, the competition, and the critical bottom line.

STURBRIDGE, MA—**Fiber optic cable will be used for the first time by a major network, ABC, to transmit broadcast-quality audio and video television signals at the Winter Olympics,** to be held at Lake Placid, New York, **in February.** The cable, which will transmit the opening and closing ceremonies of the Games was manufactured by Galite, Inc., a Massachusetts Corporation. The six-channel cable will run between a mobile unit at the site of the ceremonies and ABC's transmission center approximately 500 meters away.

The ABC cable consists of six fibers, each a separate channel. Four fibers will carry video signals, and each of the other two fibers will carry four multiplexed audio signals. Each fiber has a bandwidth of one gigahertz. Fiber loss was tested after installation at 5dB/Km.

"The use of fiber optic cable in broadcasting is a very exciting thing from a technical standpoint," says Joe Maltz, Manager of Central Facilities, Broadcast Engineering, for ABC. "We believe that fiber optics is the up and coming way to transmit all video and audio signals."

"First," explains Maltz, "unlike copper cable, fiber optic cable is not subject to radio frequency interference (RFI), electrical disturbances, ground loops, or hum." Another attraction, according to Maltz, is that "fiber optic cable occupies far less real estate than copper cable." His major concern is with the use of fiber optics for in-plant distribution; "the 'highways' now used to carry cable are totally congested," he notes. The much smaller size of fiber optic cable will make better use of the space available. Fully jacketed, a single channel has a diameter of about 3.5mm. A kilometer of fiber optic cable weighs 80% less than copper cable.

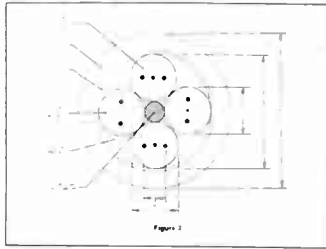

Page 28



Page 37



Page 48

FEATURES

Spring Engineering Conference Preview <i>C-ED looks at some of the presentations scheduled for the Phoenix conference</i>	25
A 12 Channel, 8.6 KM Fiber Optic Super Trunk for Teleprompter of Lompoc, California <i>Sol Yager, Former Director, CATV Engineering, Times Fiber Communications discusses the construction of the Lompoc fiber optic system</i>	28
An Optical Solution to Fiber Optic Connection <i>By Peter Duyan, Program Manager—Fiber Optics, The Deutsch Company</i>	37
Special Business Systems/Data Processing Section <i>C-ED presents a tech review of cable-related computer systems</i>	48

DEPARTMENTS

C-ED News at a Glance	5
Inside C-ED	6
Editor's Letter	7
SCTE Comments and Chapter News	9
News	14
Satellites	57
Bibliography	65
Technology	66
People	72
Ad Index	65

Cover: Photo depicting reels of magnetic tape used in data processing. Courtesy of CableData Corporation.

PRESIDENT
Robert Titsch

**EXECUTIVE VICE PRESIDENT
AND EDITOR-IN-CHIEF**
Paul FitzPatrick

WASHINGTON BUREAU CHIEF
Pat Gushman

NEW YORK BUREAU CHIEF
Barbara Ruger

CONTROLLER
Michael Borer

CORPORATE COUNSEL
Gary Witt

DIRECTOR OF MARKETING
Judy S. Lockwood



**V.P. SALES/PUBLISHER,
COMMUNICATIONS DIVISION**
Paul R. Levine

**EDITORIAL DIRECTOR,
COMMUNICATIONS DIVISION**
Michael McCready

EXECUTIVE EDITOR
Gary Witt

ASSISTANT EDITOR
Wayne Lasley

CONTRIBUTING EDITOR
Raleigh Stelle

EDITORIAL ASSISTANT
Pamela Foster

ARTISTS
Brad Hamilton, Syl Detterman,
Sharon Lasley, Carol Rush
Dale Waters

TYPESETTERS
Larry Hill, Fred Karstens, Dori Kobliscnke
Cindy Roberts,
Joyce Smith, Barbara Scott, Don Stroh

CIRCULATION DIRECTOR
Michael Gumb

ASSISTANTS
Linda Christensen, Susan Barnes

**DIRECTORY COORDINATOR/CONVENTION
MANAGER**
Yvonne Bauer Livingston

ADVERTISING MANAGER
Martin Laven

ASSISTANT TO THE PUBLISHER
Patricia Kay

ADVERTISING PRODUCTION DIRECTOR
Joyce Hemmen

TRAFFIC MANAGER
Sheila Geary

OFFICES
Titsch Publishing, Inc.
1139 Delaware Plaza
-or- P.O. Box 4305
Denver, Colorado 80204
(303) 573-1433

Washington Bureau
3800 N. Fairfax Dr.
Arlington, Virginia 22203
(703) 522-3888

New York Bureau
1270 Avenue of the Americas
Room 905
New York, New York 10020
(212) 265-4770

Editor's Letter

This year, there have been a few changes in the SCTE's reliability conference. For starters, it is no longer being called the reliability conference; it is now the Fifth Annual Spring Engineering Conference, a shift which, according to Larry Dolan, reflects the "expanding range of discussion" which will take place in Phoenix. Without minimizing the importance of reliability per se, the SCTE this year has made a conscious effort to extend the scope of this its annual membership meeting.

Dolan, SCTE's incoming president, explains that "the SCTE organization is extremely dynamic; there's a new look at every meeting. All our meetings are getting better, and more professional—and we simply wanted to reflect that growth in the conference title."

This year's conference will include discussions on teletext and viewdata services, expanding system bandwidth, and cable/computer/broadband systems. In Dolan's words, each day of the conference promises to be "seven or eight hours of solid learning." For a preview of the speeches slated for the conference, see page 25.

Another change at this year's conference is that the Institute of Electrical and Electronics Engineers will not be participating. The exact reasons for this are unclear; however, Archer Taylor of the IEEE notes that previous conferences have found the IEEE rather short-handed. "The thing is," said Taylor, "the SCTE has a full-time staff, and the IEEE doesn't. All our work is done by volunteers. And you can get more done with a paid staff than with a group of volunteers. It's as simple as that." Taylor also noted that the IEEE is currently taking steps to alleviate this problem.

Also included in this issue is a special technical section on computers and data processing equipment with application to cable systems. Beginning on page 48, the section includes some of the latest developments in cable-oriented data processing.

Paul A. FitzPatrick



Protect your picture with our new expandable antenna.

The new Hughes earth station antenna will keep the "sparklies" from interfering with your game plan. Whenever you need extra gain, for any reason, our antenna easily converts from 5 to 6 meters, delivering 43% more receiving area and more than 1½ dB additional gain.

That's just the start of advanced features to protect your picture—and your profits—now and in the future. For example, Hughes' unique expandable antenna survives winds of 125 mph, preventing problems and saving repairs.

A carousel mount and anti-friction roller bearings make it easy to set-up and, later on, to redirect the antenna to other satellites.

And options tailor it to your opera-

tion, whether you're in a strong or weak signal area.

This remarkable new antenna is part of a complete earth station, developed, built, and supported by Hughes. Complete with an advanced receiver system, it keeps you ready for anything, including

new satellites, transponder changes, and EIRP degradation.

For details, contact Hughes Microwave Communications Products, P.O. Box 2999, Torrance, CA 90509, or call 213/534-2146.

Lean on the leader to keep ahead.

HUGHES MICROWAVE™
COMMUNICATIONS
PRODUCTS
HUGHES AIRCRAFT COMPANY

Call our service number any time, day or night: 213/534-2170.





So Who Needs A Computer?

We Do . . . at GMS we already have eight IBM Systems in use in our Regional Data Centers. And we've ordered more to meet industry demands. In fact, our concept of Regional Centers has been so well received that we will open our tenth Center before January, 1980.

Our original concept was to relieve the individual CATV system of computer hardware and related investments. Several systems would be served simultaneously by a central computer and a GMS-trained staff of professional data processing experts.

The concept works. Already we have 30 client systems with nearly 500,000 subscribers; and commitments to take us over 750,000 subscribers by year-end.

We are pleased to announce the opening of our newest Regional Center in Fort Lauderdale, Florida.

Yes! We do need a computer.

You Do . . . our computer will keep you "up to the minute" with answers for your CUSTOMER BILLING INQUIRIES, DAILY OPERATIONS, DISPATCH RECORDS, and ACCOUNTS RECEIVABLE. And MORE.

And don't forget timely Financial, Management and Marketing Reports.

Yes, you do need a computer!

We Both Do . . . sure, we both need computers.

We'll support your efforts with hardware and software to keep you "up to the minute, every second." And you can concentrate on managing your cable system.

We'll include your CRT's, a printer and a data line all in one basic charge.

Incidentally, IBM maintains your on-site equipment on a 24-hour basis.

It's the perfect match . . . your cable office and our Regional Center. Call us today.



*We've Got The Alternatives
for Hardware and Maintenance*

GMS

• Customer Service • Repair Service • Cycle Billing • MSO Reporting • General Accounting • And More To Come
675 No. First St. Suite 1200
San Jose, C 95112 (408) 998-8078



Introducing the SCTE

For our February issue, Larry Dolan, president of the Society of Cable Television Engineers, has provided us with a statement of the principles behind the SCTE, as well as with a roster of the newly-elected SCTE officers for 1980.

By Larry Dolan

What is SCTE?

A professional organization of 2,500 technicians, engineers and others with an interest in the success of the cable/broadband communications industry.

What Do You Mean "Professional"?

SCTE's charter is to promote cable television engineering and its technology as an important and viable profession.

What's the Purpose?

The purpose of SCTE is to provide tools so that members become more skilled at their profession. It's done through meetings, workshops, conferences, and video and printed training materials. When you join SCTE you say, "I want to get better at my job. I want to advance. I want to learn. And, I want to share my knowledge with others."

How is SCTE Organized?

SCTE is organized as a national non-profit educational membership group. It is more specifically constructed with definite groups with definite responsibilities. The officers and directors have the responsibility of guiding SCTE and developing policy. They are to listen to member's wishes and give SCTE direction. They must have time to work on committees, review technical data, provide input on meetings, give guidance on financial matters and help organize functions for the membership.

The staff is charged with implementing the wishes of the members. The staff is responsible for maintenance of all membership records, financial management of funds through direction of the officers, site selections and preparations for all meetings and conferences, dues collection, publicity and public relations, tax forms, working with our attorney, insurance mat-

ters, lining up speakers, dealing with schools such as the University of Alabama, publishing SCTE's monthly newsletter, and everything else required to keep this group going and growing. The staff is also responsible for preparation of training tapes and written publications. Most of these projects are conceived, written, published and distributed by the SCTE staff.

What are the Members' Responsibilities?

Getting involved and being a part of SCTE. If you enroll in school you still have to go to class and study to learn something. SCTE is the same way. You get out of the organization what you put into the organization. We learn by getting together and sharing ideas. SCTE holds nearly a dozen excellent technical meetings each year. Attend some! And, it doesn't stop (or begin) there because smaller, more local meetings can also be held, and you can do it. An SCTE meeting can be two or three people on Saturday morning discussing a mutual problem over coffee. Get active with your local SCTE members. Start a chapter. Contact your regional director and let him know you're willing to help. That's what he is there for.

Here's a list of the officers and directors of SCTE. Please feel free to contact them. Remember, SCTE is not *them*. SCTE is *all of us*.

SCTE 1980-81 Officers and Board of Directors

President:
Lawrence C. Dolan
President
Mid State Communications
174 S. First Street
Beech Grove, IN 46107
317-787-9426

Eastern Vice President:
Jerry O. Bybee
North-Central Regional Engineer

CHAIRMAN
Harold R. Null
Storer Cable TV

PRESIDENT
Lawrence C. Dolan
Mid-State Communications

EASTERN VICE PRESIDENT
Jerry O. Bybee
American TV & Communications

WESTERN VICE PRESIDENT
Richard Covell
Sylvania CATV Division

SECRETARY
James Grabenstein
Potomac Valley TV Cable

TREASURER
Kenneth Gunter
U-A Columbia Cablevision

EXECUTIVE VICE PRESIDENT
Judith Baer
Washington Office
1900 L Street N.W., Suite 614
Washington, D.C. 20036
(202) 293-7841

REGIONAL DIRECTORS

REGION 1
Kenneth D. Wall
Western Communications, Inc.

REGION 2
Larry Flaherty
U-A Columbia Cablevision

REGION 3
Michael J. Gardner
Cox Cable of Oklahoma City

REGION 4
Thomas Jokerst
Quincy Cablevision

REGION 5
Ralph A. Haimowitz
Indian River Cablevision

REGION 6
Thomas Bird
Rollins Cablevision

REGION 7
Robert Tenten
Manhattan Cable TV

REGION 8
Kenneth Hancock
Philip A Lapp Ltd.

AT LARGE DIRECTORS
Michael F. Jeffers
Jerrold Electronics Corp.

Martin J. Moran
Toner Cable Equipment, Inc.

A.H. "Abe" Sonnenschein
Hughes Microwave Communications Products

American TV &
Communications Corp.
1620 S. Lawe St., Box 2759
Appleton, WI 54913
414-731-3272

Western Vice President:
Richard Covell
Manager of Technical Support
Sylvania CATV Division
10841 Pellicano Drive
El Paso, TX 79935
800-351-2345

Secretary:
James Grabenstein
Chief Engineer
Potomac Valley TV Cable
100 S. Liberty
Cumberland, MD 21502
301-722-6540

Treasurer:
Kenneth Gunter
Executive Vice Pres. & Director
UA-Columbia Cablevision, Inc.
26 West Concho
San Angelo, TX 76903
915-655-0634
Chairman &
Immediate Past President
Harold R. Null
Vice President-Engineering
Storer Cable TV
1800 Century Blvd.
Suite 1700
Atlanta, GA 30345
404-329-8420

Regional Directors

Region 1
Kenneth D. Wall
Western Communications, Inc.
Interland Executive Park
Suite 225
2855 Mitchell Drive
Walnut Creek, CA 94598
415-935-3055

Region 2
Larry Flaherty
UA-Columbia Cablevision-TX
415 North Main Street
San Antonio, TX 78205
512-222-9912

Region 3
Michael J. Gardner
Cox Cable of Oklahoma City

Box 82729
Oklahoma City, OK 73148
405-848-8261

Region 4
Thomas Jokerst
Quincy Cablevision
116 N. 5th Street
Quincy, IL 62301
217-222-5440

Region 5
Ralph A. Haimowitz
Indian River Cablevision
Box 327
Sebastian, FL 32958
305-589-2726

Region 6
Thomas Bird
Rollins Cablevision
700 Barksdale Road
Suite 10
Newark, DE 19711
302-658-7127

Region 7
Robert Tenten
Manhattan Cable TV
120 E. 23rd Street
New York, NY 10010
212-477-8700

Region 8
Kenneth Hancock
Philip A. Lapp Limited
56 Sparks Street
Suite 100
Ottawa, Ontario
Canada K1P 5A9
613-238-2452

At-Large Directors

Michael F. Jeffers
Jerrold Electronics
Box 487
Byberry Road & PA Turnpike
Hatboro, PA 19040
215-674-4800

Martin J. Moran
Toner Cable Equipment, Inc.
969 Horsham Road
Horsham, PA 19044
215-675-2053

A. H. "Abe" Sonnenschein
Hughes Microwave Comm. Products
3060 W. Lomita Blvd.

Torrance, CA 90505
213-534-2146

James Stilwell
Times Mirror Cable
Benjamin Fox Pavilion
Jenkintown, PA 19046
215-885-6350

Rudden, Queeney Join SCTE Staff

SCTE Executive Vice President Judith Baer has announced the appointment of Jane Rudden as Director of Meetings, Sites and Services and Susan Queeney as Director of Publications and Publicity.

An experienced meeting planner, Rudden came to SCTE from Smith-Bucklin & Associates, the nation's largest and oldest multiple association management firm. While with SBA, she assisted in providing management services for six trade associations.

With SCTE, Rudden has direct responsibility for all meetings and conference arrangements, including site visits and selection, food and beverage services, audio visuals, hotel guarantees and bookings. Additionally, she will handle panel development, SCTE's certificate program, and the Continuing Education Unit series sponsored by the University of Alabama.

A native of St. Louis, Rudden received her B.A. from Fontbonne College.

As Director of Publications and Publicity, Susan Queeney will coordinate production of all publications, videotapes, training materials, curricu-



Jane Rudden, SCTE's new Director of Meetings, Sites, and Services.

lum, texts, guidelines, brochures, promotional materials, published articles and periodicals. She also is responsible for dealing with the related trade press and handling all industry-related publicity efforts.



Susan Queeney, Director of Publications and Publicity for SCTE.

Prior to joining SCTE, Queeney was Director of Communications for William S. Bergman Associates, a Washington, D.C.-based association management firm. Her experience in

the cable television industry also includes two years as Public Relations Coordinator for the National Cable Television Association.

A graduate of the University of Dayton, Ohio, Queeney holds a B.A. in communication arts.

SCTE, with nearly 2,500 members is the largest membership organization in the cable television industry. SCTE's charter mandates management development and technical training through meetings, publications and audio-visual products.

SCTE Announces Creation of President's Award

SCTE President Harold Null has announced a new SCTE award as part of the organization's effort to recognize the support given to SCTE by a number of state and regional cable associations, individuals and operating companies.

The first recipient of the President's Award is the Southern Cable Tele-

vision Association. Null will make the presentation during the 1980 SCTE Honors & Awards Luncheon, February 5 in Phoenix.

According to Null, "The Southern Association has given SCTE time, space, consideration and most important, a lot of moral support over the past four years."

The SCTE President continued, "SCTE's greatest growth in membership has come from the southeastern part of the country since 1977 and the Southern was very instrumental in introducing SCTE to the University of Alabama—a relationship that now includes CEU's for SCTE meetings and more good things in the future."

"Discounts for technical program registrations, lots of information about SCTE programs in the Southern newsletter, and interest in generally promoting SCTE and its goals have all been a part of the SCTE Southern Cable Television Association relationship since the mid-seventies," concluded Null.

My doctor pronounced me cured of cancer.

My boss didn't.

My boss didn't understand that I was healthy again.

So I was let go.

A lot of people are like my boss. They think that everyone dies of cancer. I thought so, too. Until the American Cancer Society, through one of its service and rehabilitation programs, helped me return to a normal life.

The ACS also has local Units that help Americans who've never had cancer understand it better.

Today, more and more, cancer is a curable disease. Ignorance about cancer is curable, too.

 American Cancer Society

more dB's per dollar.

Our Multi-Output Distribution Amplifier offers the most gain for the least cost.

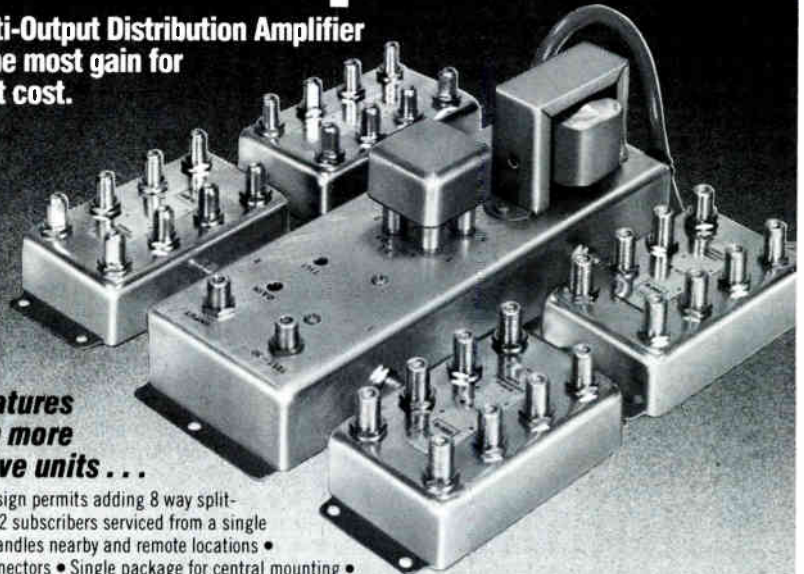

With features of much more expensive units . . .

- Modular design permits adding 8 way splitters
- Up to 32 subscribers serviced from a single amplifier
- Handles nearby and remote locations
- Threaded connectors
- Single package for central mounting
- 30dB and 40dB gain models available
- 30/60V switchable cable powered or 117 VAC powered

Write for complete data and designers guide



CERRO COMMUNICATION PRODUCTS
COAXIAL CABLE/RF DEVICES

Member of The Marmon Group

Halls Mill Road, Freehold, NJ 07728 ■ (201) 462-8700

The SCTE President's Award will be presented annually, at the direction of the current President. Individuals, companies, industry groups or non-industry interests supportive of SCTE will be considered as recipients.

Another group from the south, the Alabama Cable TV Association, also will be honored during SCTE's 1980 Honors & Awards Luncheon.

The special recognition award is being made to note the direct support of the Alabama group's officers and members toward SCTE's programs with the University of Alabama.

Sammons Communications Becomes SCTE's 100th Sustaining Member

SCTE President Harold Null has announced that Sammons Communications, Dallas, Texas, has become SCTE's 100th Sustaining Member. This marks a dramatic growth in this special category membership, up from just five Sustaining Members four years ago.

"We're delighted to have the support and participation of Sammons Communications in our endeavors. I

expect that their entry into the Sustaining Membership category will attract other interested suppliers, cable operating companies, state and regional associations and others with an eye to the future of cable television," said Null.

Sustaining Member dues are used to help SCTE provide more membership services including publications, technical training, industry seminars and conferences. Annual dues are \$100. For further information, contact Susan Queeney at the SCTE office, 202-293-7841.

SCTE will present Sammons with a special Sustaining Member award at the Spring Engineering Conference February 6 in Phoenix. Bill Strange, Sammons Vice President for Corporate Development, will be on hand to accept the award.

Spring Engineering Conference to Focus on Computers and Teletext

The future of cable television and the emerging computer and teletext technologies will be examined by the

experts at SCTE's Fifth Annual Spring Engineering Conference, February 5-6 at the Adams Hotel in Phoenix.

The conference marks the cable industry's first in-depth study of its impact on and future with computers and teletext services. Appropriately, SCTE has lined-up a nationally recognized group of computer and teletext authorities to examine the issues.

SCTE also will hold its Annual Membership Meeting at the Phoenix conference. At that time, new officers and board members will assume their responsibilities. The annual awards luncheon also will take place during the conference. Honorees include: SCTE Member of the Year and Sammons Communications, the 100th SCTE Sustaining Member. The President's Award and Special Recognition to State Association Award also will be presented.

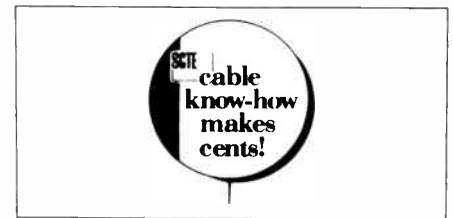

this versatile meter is dependable—and it's a workhorse!



- 4MHz to 300MHz
- Direct Reading Hum
- Light Weight
- Internal Audio
- -40 dBmV to +60 dBmV
- Internal Calibrator
- Internal Charger
- Signal to Noise

Write or call for complete information .

MSC
MID STATE
Communications Inc.

174 South First Ave.
 Beech Grove, Indiana 46107
 (317) 787-9426

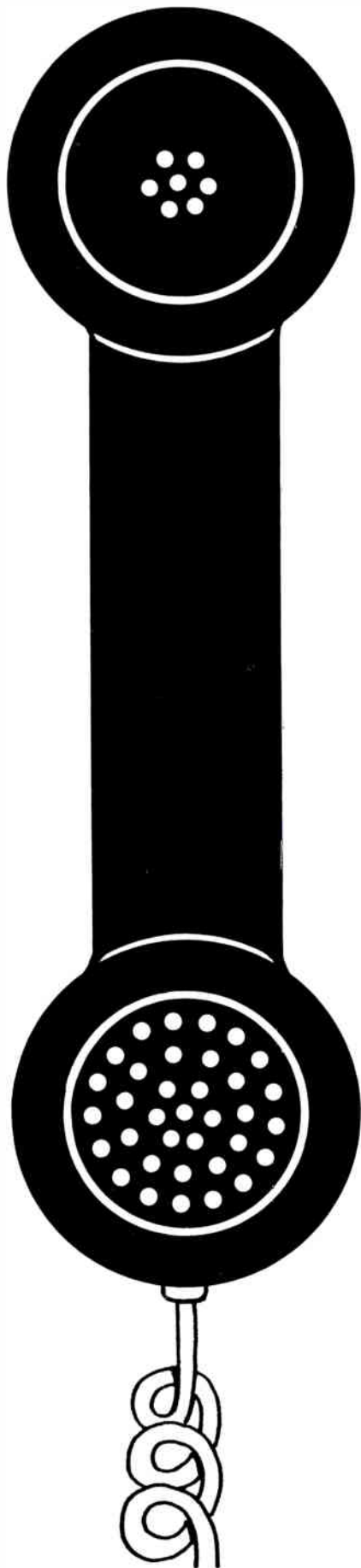

Connections in the right places.

LRC Electronics knows how important it can be to have connections in the right places. So we've established a nationwide network of sales representatives to make it easy for you to connect with us . . . wherever you are.

Our sales representatives are as close as your telephone. And they're ready to do more than just take your order. With years of experience in the CATV industry, they're ready to help you solve your problems. They'll work with you to determine the LRC connector best suited to your system's requirements.

Connect with the experts. Consult the LRC sales representative nearest you for all your connector needs.

SALES REPRESENTATIVES

Colorado, Utah, Wyoming

Steve Grossman
Brenda Crossland
Mega-Hertz
P.O. Box 2001
3501 S. Corona #3
Englewood, CO 80110
Phone: 303-761-3304

Delaware, Maryland, Ohio,

Penna., Virginia, W. Vir.
Tom Carbaugh
Jim Manari
Kirk Gadberry
Diana Riley
Jerry Conn & Assoc.
550 Cleveland Ave.
Chambersburg, PA 17201
Phone: 717-263-8258

California, Arizona, Nevada

Ben Duval
Gil Clinker
Noel Wren
B. E. Duval Co.
29619 S. Western Ave.
San Pedro, CA 90733
Phone: 213-833-0951

Alabama, Florida, Georgia, Miss., Carolinas, Tenn.

Carl Rosekrans
Steve Rosekrans
C. Harrison Assoc.
Suite E
6290 McDonough
Norcross, GA 30093
Phone: 404-449-7696

New England, New Jersey, Eastern NY State

Jim Miller
D/B CATV Supply, Inc.
90 Jerusalem
Hicksville, NY 11801
Phone: 516-822-6513

Arkansas, Louisiana, Oklahoma, Texas

Art Witaker
Al Laufflin
Terry Jones
Cable TV Services
412 Colonial Bank Bldg.
Garland, TX 75042
Phone: 214-494-3348

Illinois, Indiana, Michigan, Kentucky, Southern Wisconsin

Terry French
Wendell Whitaker
Charles Binford
C. W. Y. Electronics
405 Earl Ave. N.
Lafayette, Indiana 47904
Phone: 317-447-4617

Idaho, Montana, Oregon, Washington

Don Thomsen
Cable Market Specialists
P.O. Box 613
Kirkland, Washington 98033
Phone: 206-822-4113

Northern Wisc., Minn., N. Dakota, S. Dakota

Tom Pitts
T. R. Pitts Co.
P.O. Box 57
458 W. Sanborn
Winona, Minn. 55987
Phone: 507-452-2629

LRC ELECTRONICS, INC.

901 SOUTH AVE., HORSEHEADS, N.Y. 14845 PHONE 607-739-3844

AVAILABLE IN EUROPE THRU: Electro Service N.V., Kleine Nieuwendijk 40, B 2800 Michelen, Belgium
CANADA THRU: Electroline TV Equipment, Montreal, Quebec

Wheeler Proposes Alternative Olympics Coverage

WASHINGTON, D.C.—Two days before President Carter announced on NBC's *Meet the Press* that he has asked the U.S. Olympic Committee (USOC) to advise the International Olympic Committee (IOC) that Moscow is an unsuitable sight for the 1980 games unless the Soviet Union withdraws from Afghanistan by February 20, National Cable Television association (NCTA) President Tom Wheeler announced that the cable television industry has the ability to provide TV coverage of an alternative olympics.

At a press conference here, attended by several news and sports reporters, Wheeler stated that in order to facilitate the organization of an alternative Olympics, the cable industry is in a position to provide coverage on a non-exclusive basis through the existing cable satellite-facilities of ESPN and Turner Communications if the Olympics are moved from Moscow.

According to Robert Kane, USOC president, the committee will meet with the IOC February 10 to discuss the possibility of pulling out the Olympics, or urging that an alternative site be named. Lord Killanin, IOC president, has indicated, however, that moving the site would be legally and technically impossible. In his statement to the press, Wheeler stated that the cable industry strongly believes that the athletes who have trained for the Olympics should not be deprived of their right to compete, and the public should not be deprived of watching the competition.

Wheeler stressed, "Should the United States not participate in the Moscow games, we hope our announcement of an interest in and ability to provide TV coverage will be the first step toward participation by American athletes in alternative Olympic competition. We anticipate that our commitment will assure enjoyment of that competition by the American people."

FCC Renews Big Valley License

WASHINGTON, D.C.—The dispute between Big Valley Cablevision and

Great Western Broadcasting over signal carriage in Stockton, California, which has been continuing for more than four years, appears to be closer to a resolution. Earlier this month the Federal Communications Commission (FCC) renewed Big Valley's CARS license for WSH-22 and deferred action on signal carriage until Great Western has a chance to review market impact analyses done by the FCC Cable Bureau.

Great Western, licensee of KXTV, a CBS affiliate in Sacramento, had petitioned to deny Big Valley's CARS renewal on the basis that the signals Big Valley proposed to carry from San Francisco were available off-air and therefore, Great Western argued, there was no need to import them via microwave. Big Valley argued that the CARS would enhance signal quality, thus benefiting subscribers. In support of the signal carriage waiver request, it argued there would be no substantial impact on the local stations as they were healthy despite competition from stations in nearby markets. The other Sacramento stations contended that Big Valley was attempting to have the San Francisco stations treated as significantly viewed, although they did not meet the requirements.

The commission noted that while Big Valley had confronted issues such as the requested off-air signals viewability, the system's financial position, and the potential fractionalization of local station audiences due to additional carriage, it had not included the market-wide impact study usually required to justify a waiver of signal carriage rules. The FCC stated that to be consistent with a previous decision, it would normally deny Big Valley's request for a waiver for failing to submit a market-wide impact study. The principal reason why Big Valley's waiver request was still pending four years after its initial filing was that the standard for waiving signal carriage rules had concurrently been evolving with its pendency.

The commission added that according to a market-wide study prepared by its staff, Big Valley's addition of the three signals to its cable system, as well as to all other systems in the Sacramento-Stockton Modesto market not authorized to carry them, would

produce a total audience loss to the market stations of 0.34 percent at current penetration levels and 0.82 percent if potential penetration levels were attained. Since the basis for not dismissing Big Valley's request depended largely on the market-wide impact analysis prepared by the FCC staff, the commission suggested interested parties file further oppositions to the requested waiver within 20 days. Big Valley would then have 15 days in which to reply.

In denying Great Western's objections to Big Valley's CARS renewal, the FCC said Great Western had not shown that Big Valley had misrepresented material facts to the commission, either regarding the need for microwave to relay the San Francisco signals, or the ready availability of the same signals of the air in Stockton.

RCA Americom and Princeton Laboratories Collaborate in Video Experiment

PISCATAWAY, NJ—According to RCA, the scarcity of frequency allocations for microwave systems is about to be alleviated by a new 'two for one' transmission system. A cooperative effort by RCA Americom and David Sarnoff Research Center engineers has resulted in installation of a new video transmission system for experimental testing, conveying two new video channels within the same frequency band formerly assigned for one. The experiment is being carried out on RCA's microwave link between New York City and its major satellite transmission facility at Vernon Valley, NJ.

Gerry Kaplan, an RCA Americom systems engineer and video expert explained the existing frequency situation this way: "The ever-dwindling availability of frequency allocations, especially in urban areas, has been aggravated by the increased use of satellites for distribution of TV signals. Frequencies are reserved for use by a communication common carrier upon application to the FCC after coordination with all other carriers. They permit video transmission originating from TV studios located in metropolitan cen-

ters to be conveyed via terrestrial radio to the earth station for transmission to a satellite."

John Christopher, vice president Technical Operations for RCA Americom, said, "The performance of the new system is comparable to that achieved with the prior transmission techniques. It yields high-quality television pictures that meet the stringent requirements of the cable TV industry."

"The ability to convey two video channels in the frequency band that formerly carried a single channel will allow RCA Americom to effectively double the capacity of its video terrestrial transmission facilities without a corresponding increase in required frequency allocations," Mr. Christopher said. "The benefits of this technique are of great significance to Americom, the television industry, and the public."

Comsat To Be Reviewed

WASHINGTON, D.C.—The House Communications Subcommittee has set an ambitious schedule for itself during the first three months of the new

session of Congress, including hearings on the structure and operation of the Communications Satellite Corporation (Comsat) which announced plans to introduce satellite-to-home broadcasting in the future.

The Comsat hearings will be held in March, but no dates have been set. An independent, publicly owned company, Comsat, was established in 1962 to represent the United States in what became Intelsat, the global communications satellite system. "Congress created Comsat, and Congress should make sure that the corporation continues to reflect congressional intentions," stated Lionel Van Deerlin (D-CA), chairman of the subcommittee, noting that hearings on Comsat were last held in 1975. "The hearings should help us consider the nature and necessity of future legislation," he continued. "And they will certainly complement the inquiry already underway at the Federal Communications Commission."

Immediately after Congress was to reconvene January 21, the subcommittee was scheduled to begin markup of H.R. 6121, the telecommunications act of 1979, which has the

sponsorship of the full subcommittee. The purpose of the bill is to promote competition in the telecommunications and information industries by deregulating the manufacture and sale of services and equipment. Leadership is resisting any attempts to involve cable television in the bill.

On January 29, the subcommittee is scheduled to hold hearings on H.R. 5430, a bill requiring radio and television broadcasters to make public their financial statements. The bill was co-sponsored by Ron Mottl (D-OH), Ted Weiss (D-NY) and Robert Edgar (D-PA). This could prove more controversial than many of the key provisions of the common carrier bill.

On February 7, hearings will be held on H.R. 6103, a bill to partially repeal broadcasters' "equal time" requirements. Limited to presidential and vice presidential elections and to time not paid for by candidates, i.e., special documentaries, interviews, debates and other news programming. This bill was co-sponsored by Van Deerlin and Albert Gore, Jr. (D-TN).

Beginning in March, the subcommittee will review the entire status of Comsat. In fact, the International

SADELCO'S super PORTA-BRIDGE II 5-300 MHz BRIDGE BALANCE: 40 dB



Model PB II

Available at major CATV distributors

Sadelco, INC.

75 West Forest Ave., Englewood, N.J. 07631 (201) 569-3323

General representative for Europe:
Catec AG Luzern/Switzerland, Habsburgerstr 22
Tel. 041-41-75-50 Telex TELFI 78168
IN CANADA: Comm-Plex Electronics Ltd.

Measure return loss and VSWR
without an oscilloscope.
Also gain, loss, amplifier response,
splitters, filters and cables.

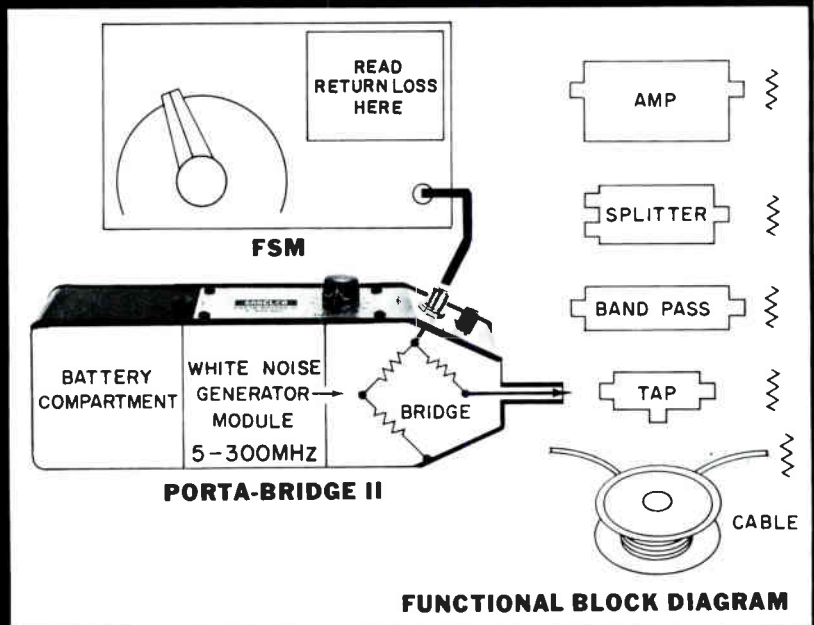

Maritime Satellite Telcocommunications Act of 1978, which named Comsat the exclusive U.S. Representative in Inmarsat, an organization which operates a global maritime satellite system, requires the FCC to submit a review of Comsat's operations and structure to Congress this May. According to Van Deerlin, in addition to examining Comsat's role in Inmarsat, the hearings will focus on two other areas including Comsat's monopoly status in international satellite communications, particularly its role as U.S. representative and systems manager for Intelsat.

Also under scrutiny will be Comsat's entry into the domestic market through Comsat General which manages the Comstar satellite system for AT&T, is a partner with IBM and Aetna Life in Satellite Business Systems, manufactures and sells satellite terminal equipment, and is developing the proposal for satellite-to-home broadcasting service.

Cable Experts Form New Consulting Group

WASHINGTON, D.C.—A group of six

leading independent consultants have joined to form National Cable Consultants. The agreement was announced by Edward Shafer, one of the principals in the firm, in Washington, D.C., where NCC will be located. Mr. Shafer said that NCC was created in recognition of the need for a multi-disciplinary professional group capable of offering the full range of cable television consulting services. The company will serve municipalities, states, financial institutions and other clients who require comprehensive CATV consulting services.

The principals of NCC include the following consultants: Frank N. Cooper (Smith, Cooper Associates, Inc.) and F. Gordon Fuqua (Fuqua Associates) will be responsible for system management and pay-TV and ancillary services; Thomas A. Muth (East Lansing Research Associates) and Neal Orr (Cable Program Services, Inc.) will direct market research and programming services; Edward Shafer (Shafer Associates, Inc.) will provide economic and financial expertise; and Walter S. Wydro (Walter Wydro Consultants) will direct engineering services for the new group. Lee G. Lovett

(Lovett Ford & Hennessey) will serve as NCC's General Counsel.

National Cable Consultants will be located at 1901 L Street, N.W., Second Floor, Washington, D.C. 20036; Tele: (202) 293-6487.

Burnup & Sims Enters T.V. Earth Station Business

FORT LAUDERDALE—Burnup & Sims Inc has announced entry into the satellite communications field with the acquisition of Gardiner Communications Corporation, Houston, Texas. Gardiner Communications is the second largest in its industry and has captured over 30% of the earth station business within the cable T.V. industry.

Nick A. Caporella, President and Chief Executive Officer of Burnup & Sims Inc., said, "Our combined expertise and visibility in the cable T.V. industry provide us with unique opportunities as we integrate our engineering, manufacturing, installation, and maintenance capabilities. This is an expanding industry," Caporella continued, "and with the Gardiner acquisition we plan to increase our total market share significantly."

*Congratulations to Larry Dolan and all of the incoming SCTE officers from your friends at C-ED.
Best of Luck*

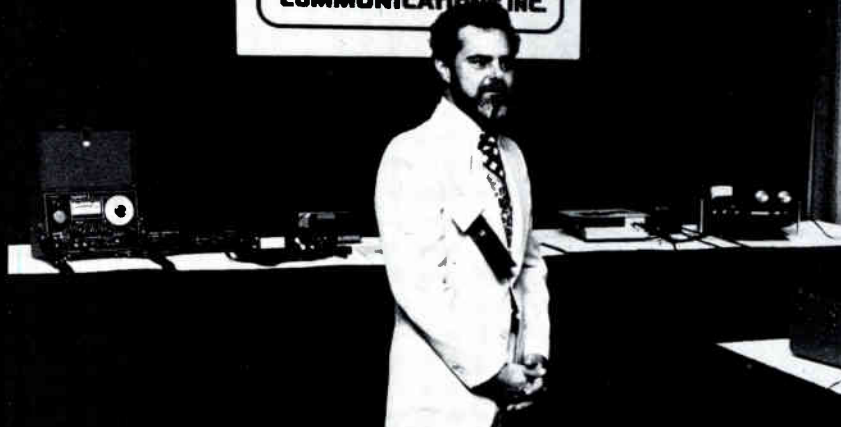

Introducing the new Gardiner time and tone programmable switcher.

1.
Basic unit will control up to four channels on time command.

3.
Basic Tone unit provides time switching for up to eight channels with remote control/override capability.

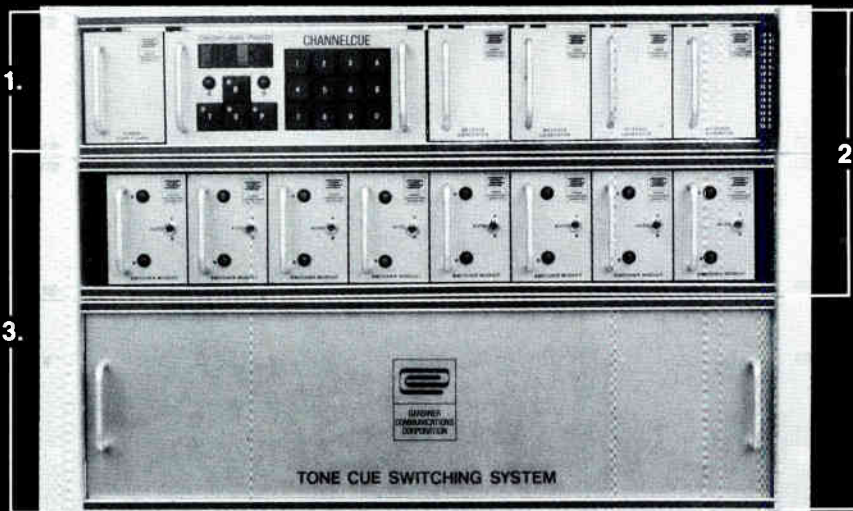

2.
Expanded Basic unit provides time switching for up to eight channels with 2,552 switch functions.

4.
Complete Time and Tone unit switches on both time and tone command. Allows integrated switching capability for up to eight channels.

You get more than your money's worth with the new Gardiner CHANNELCUE™. Because it's the most versatile programmable switcher on the market today, CHANNELCUE™ is unique because with Channelcue's video switching there's no worry about troublesome external relays. And only CHANNELCUE™ offers field-programmable tone modules. If command tones change, you simply reset the binary switches on the tone card. CHANNELCUE™ offers you four options and more too. You purchase only what you need. With option

(1) or (2), you can program for time switching to comply with non-duplication or syndicated exclusivity requirements. And also, for those video services on fixed time schedules. Where tones are required because of uncertain program length or other complexities, the tone control option (3) may serve your needs. If there are combinations of time and tone requirements, option (4) can do it all. Call our toll free number today. In the U.S.A. 1-800-231-2602. Texas only, 1-800-392-9646



FUSED DISC III



Truly, the lowest low-loss cable.

Compared with other "low-loss" cables, FUSED DISC III makes a remarkable showing:

ATTENUATION @ 300 MHz

Cable Size	dB per 100 feet	
	Nominal	Maximum
.412"	1.42	1.46
.500"	1.15	1.20
.750"	.77	.80
1.00 "	.63	.65

FUSED DISC III establishes the standard for low-loss CATV Systems. FUSED DISC III cable provides an average loss improvement of 12% over other cables.

The superior electrical performance of FUSED DISC III provides you with these economic advantages:

- Reduced Electronics
- Lower Maintenance Costs
- Lower Powering Charges

More and more systems are being built, re-built and expanded with our cable. For an information package on this high-performance cable, write: General Cable Company, CATV Division, P.O. Box 700, Woodbridge, N.J. 07095, or call toll free: 800-526-4241, if calling from New Jersey, please dial: 201-636-5500.

General Cable
Company 
a **GK Technologies** company

CATV
DIVISION

From Washington

Signal Leakage Report Made Public

By Pat Gushman, Washington Bureau Chief

We have just had the opportunity to review one of the early copies of the report by the advisory committee on cable signal leakage which was completed last November. Remember, it was about 10 years ago that the IEEE first addressed the question and suggested that the Office of Telecommunications Policy, the FCC and the Department of Commerce investigate the potential threat to air control traffic caused by signal leakage from cable systems. Then, in 1977, after a couple of "scares," the Commission issued some interim rules and established an advisory committee which included the FAA, NTIA, NCTA and some 13 cable operators. Their two years of research have now been released.

The advisory committee found that it is possible to make cable signal leakage measurements which reliably identify cable TV systems that could cause harmful interference to aeronautical radio services. Leakage performance can be measured either on the ground or in the air-space above the cable system. It determined that a well designed and properly maintained cable system radiates too little signal leakage to cause interference to aeronautical radio communications services. And, therefore, it has recommended that the Commission adopt a new set of regulations under which cable television operations on certain frequencies assigned to aeronautical radio services would be permitted or prohibited on the basis of the system's signal leakage performance.

Here is a brief synopsis of the advisory committee's recommendations:

1.) Allow existing systems to remain in operation under a modified version of existing rules, for a period of time long enough to permit cable system improvement in the normal course of rebuilding.

2.) Adopt a new set of rules based on proof that cable system leakage is below a specified threshold. A cable system meeting the criteria would be permitted to use any frequency desired (with a very minor restrictions). Either air space or ground measurements could be used to show that leakage criteria are met.

3.) Increase the permissible level of individual cable leakage sources.

4.) Retain the authority to terminate cable system operation if harmful interference occurs, regardless of whether or not leakage criteria are nominally met.

Electroline SWITCH MATCH Transformers & Dual Cable Switch

Cable operators, who want satisfied customers, are switching to Electroline switch-transformers and cable switches which are of **very high isolation**.

Protect yourself against outages caused by power failures, cable breaks, labor problems, customer-installed contraptions. Electroline equipment is tested for reliability and durability — and installation is so easy.

SWITCH MATCH ESM-2B

Input-75 ohm
& 300 ohm
Output to TV
300 ohm

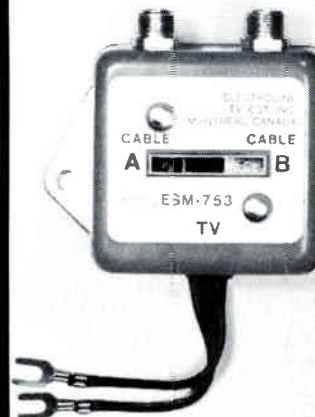
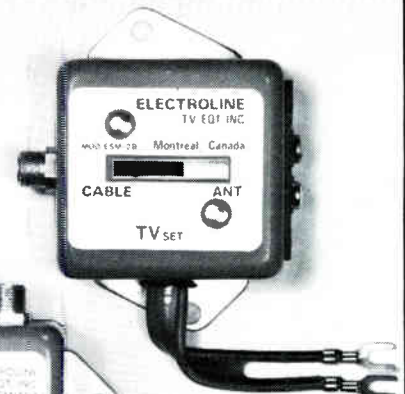

SWITCH MATCH ESM-753

Inputs, 75 ohm
Output, 300 ohm

CABLE SWITCH ESM-75

All ports — 75 ohm
Excellent match
Isolation — 80 db

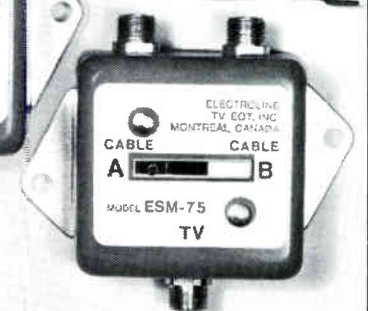

- SPECIAL AMPLIFIERS
- COUPLERS
- FILTERS
- SPLITTERS
- TAPS
- TEST ADAPTORS
- SWITCH-TRANSFORMERS

ELECTROLINE Television Equipment Inc.

8750, 8th Avenue
Ville St-Michel
Montreal, Que. H1Z 2W4
or phone collect
(514) 725-2471

Representatives across Canada
and the U.S.A.
Offering a line of
quality equipment
for the cable industry.

Complete Low-Cost MDS Reception Package From Winegard

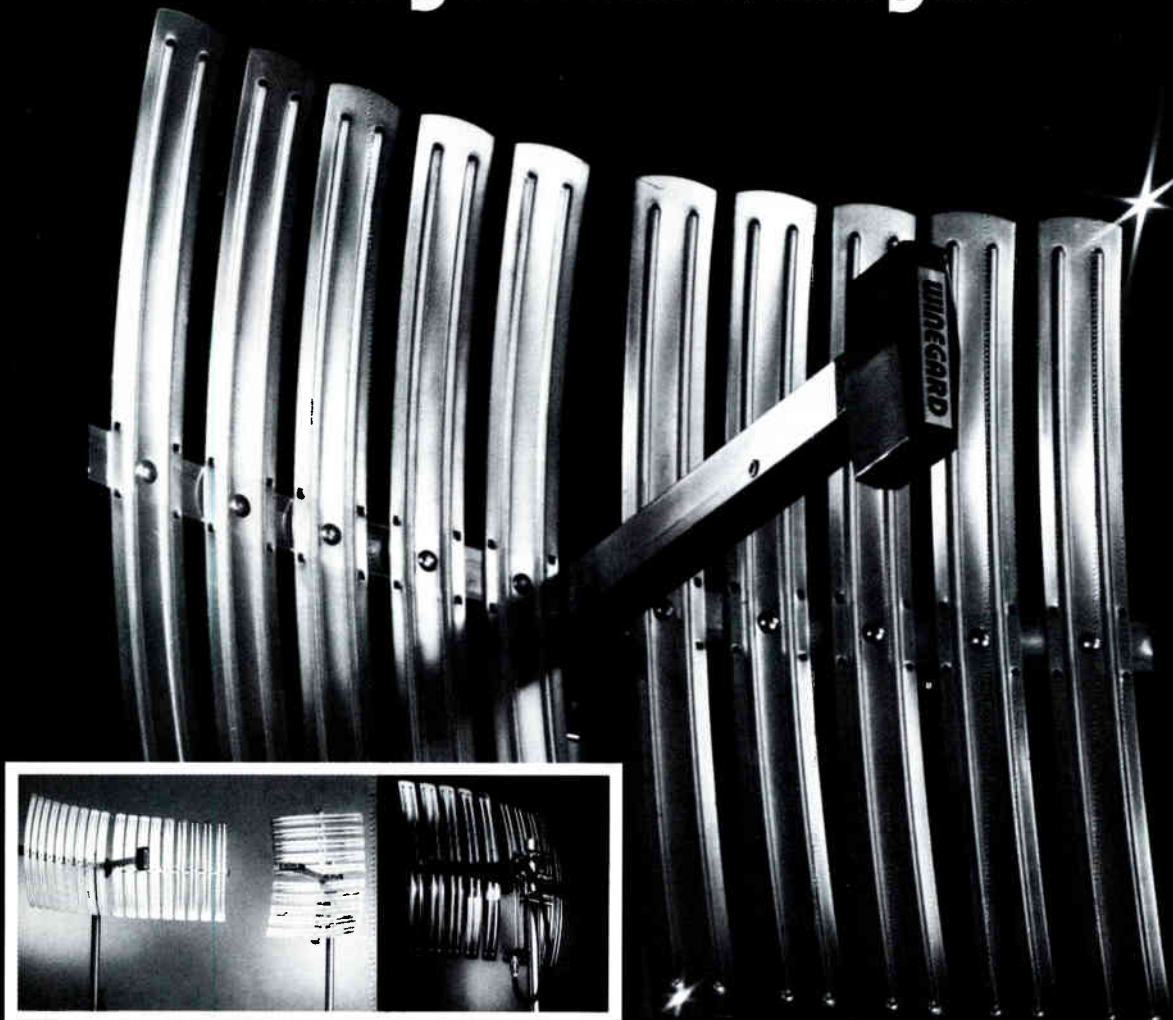

PT-1800 has 21dB gain. PT-1000 has 18dB gain. Can be mounted vertically or horizontally.

Crystal-controlled down-converter. No field adjustments.

Serving the over-the-air pay TV industry with Antennas, Down-Converters and MATV Systems

Winegard invites comparison! ■ High Performance ■ High Reliability ■ More Installs Per Day ■ Competitive Pricing ■ Superior Technology ■ Total System

Winegard Industries offers a truly cost-effective solution to outfitting MDS subscribers' homes with a complete receiving package. Our easy-to-install antennas and crystal-controlled down-converters give your customers maximum picture quality while keeping your installation costs down.

Many MDS "pay" operators have been able, by using Winegard equipment, to turn "no-go" locations into happy subscribers. Others have been able to provide satisfactory reception in fringe areas where competitive equipment simply couldn't do the job.

For specs and information on MDS systems and related equipment,

CALL OR WRITE: John von Harz, Winegard Industries, P.O. Box 832, Burlington, Iowa, 52601, (319) 752-3607

W WINEGARD
Industries Inc.

A Spring Engineering Conference Preview

By Gary Witt, Executive Editor

Tuesday and Wednesday, the 5th and 6th of February, in Phoenix, the SCTE will sponsor its fifth annual Spring Engineering Conference. On the agenda for the meeting is a series of panel discussions dealing with three broad technical areas: teletext and viewdata services; expanding system bandwidth; and cable/computer/broadband systems. Conference coordinator Bill Ellis of Evansville Cable TV notes that the philosophy behind the meeting is to maintain the high level of competence within the cable engineering profession by continually updating SCTE members on the most recent industry-wide technical developments. Ellis feels that it is only by being fully aware of current state-of-the-art technology that today's technical personnel will be able to see where the future of cable lies.

The first scheduled discussion will take place at 9:00 a.m. on the 5th. Covering the subject of teletext and viewdata services, the panel will consist of moderator James Stilwell from Times Mirror, and panelists Joseph Roizen of Telegen, Howard Prosser of Oak Industries, and William Loveless of Bonneville International. At press time, there was considerable doubt as to whether Walter Cicorra from Zenith would be able to make his scheduled appearance.

Contacted on the subject of specific points to be covered by the panel, Stilwell noted that aside from carrying out his duties as moderator, he would like to see the discussion focus at least briefly upon Public Broadcasting Service (PBS) plans for captioning programs for the deaf. The proposed

captioning service would begin early this year on PBS stations, and would be accessed via a set-top adaptor manufactured by Sanyo and marketed through Sears Roebuck. In addition, Stilwell noted that the major networks are also planning to introduce captioned programming in the near future. Stilwell pointed out that considerable interest in the current system had been generated at a recent Electronic Industries Association meeting in Portland. He hopes to provide a demonstration of the apparatus at the Phoenix conference.

"One thing that really needs to be emphasized," said Stilwell, "is that we're a long way off from the days when these converters will sell for fifty or sixty dollars. Right now the units are being sold for \$249 each—and that's a barebones price to get this program started and under way."

Challenges to Industry

But Stilwell of course sees the teletext and viewdata services industry as facing other challenges aside from this imperative to make adapters more affordable and more widely available. For example, there is the application of two-way technology and the choice of an appropriate systems approach for given situations. Videotex, for instance, involves a two-way telephone line link-up. Teletext, on the other hand, implies data transmission via coaxial cable. And a third alternative involves a combination of these two elemental approaches: utilizing telephone lines for the more limited upstream data request traffic, and then responding downstream with high speed teletext. Stilwell hopes that one result of the Phoenix conference will be to establish

a context from which to address these issues of the new technology.

In addition to this presentation by Stilwell, however, the panel will also feature Joseph Roizen from Telegen. Roizen will review the current status of the teletext industry worldwide, with particular emphasis on areas of concern to the EIA Teletext Subcommittee of the FCC. Roizen's remarks will center upon two current system developments—KMOX and KCET. Additional consideration will be given to the KSL system by Bill Loveless, another of the panelists.

Uniform Standards

Currently, one of the concerns of the EIA Subcommittee is the establishment of uniform standards for the industry. As it stands now, different systems allow for differing degrees of software flexibility. Interfacing various systems can be a problem. To remedy this, the EIA is reviewing four systems, subjecting each to field tests. These four systems are the English-made Ceefax and Oracle, the French Antiope, Canadian Telidon, and a composite American system. The committee report is presently due out in April, in time for the NAB show.

Another of the featured speakers for the conference is Howard Prosser from Oak Industries. Prosser will examine teletext specifically as it applies to cable. He will discuss various aspects of set top adaptor units, as well as vertically integral teletext, and the kinds of equipment necessary to upgrade quality based on dollar/benefit and laboratory analysis.

The morning session will then be concluded in time for the SCTE Honors and Awards Luncheon.

At 2:30 p.m. a second panel discus-

sion will convene, this time focusing on expanding system bandwidth. Dick Covell of Sylvania will serve as moderator for the session, which will include presentations by Jim Eachus of Motorola, George Luettgenau of TRW, Jack Kouzoujian of Matrix Electronics, Bert Henscheid of Theta-Com, Jack Arbuthnott of Times Wire, and Michael Jeffers of Jerrold.

Jim Eachus has said that his remarks will center on the problem of hybrid amplifier applications in the expansion of channel capacity from 35 to 50 and beyond. According to Eachus, the lack of hybrid amps with 400 MHz capacity has been solved by the development of a useable hybrid by Motorola. Eachus went on to say that his presentation at the Phoenix conference will include "substantial statements regarding availability and specifications" of the new hybrid.

Dana Wilcox of TRW had planned to participate in this panel; however, because of scheduling conflicts, he has been replaced by George Luettgenau, who is also with TRW. Luettgenau's background includes emphasis in research and development, and at one time he was employed at TRW's plant in Bordeaux, France. His presentation in Phoenix will concentrate on aspects and peculiarities of extended bandwidth hybrids, relating a few of the test experiences encountered at TRW, in addition to supplying details concerning a few of the products currently available from TRW.

Luettgenau is also working on a paper for presentation at a later meeting which will focus upon the impact of extended bandwidth on system cost, and the cost-effectiveness of given system improvements.

System Design Aspects

Bert Henscheid from Theta-Com will also be participating in the Phoenix conference, focusing attention upon certain system design aspects of extended bandwidth technology. Henscheid intends to present calculations showing the effects of 400 MHz expansion on spacing, levels, cascading, taps, and other design considerations of trunk and feeder. Based on preliminary information, Henscheid says that the higher attenuation prevalent in a 400 MHz system will necessitate a 15 to 18 percent increase in total equivalence throughout the system. In other words the maintenance of a 22 dB attenuation in a 400 MHz

system, as compared with the same loss at 300 MHz, will require an 18 percent increase in the number of amplifiers in the system.

Henscheid also intends to examine problems in circuit design, power chokes, spurious resonances, and other factors in extended bandwidth, including return loss, isolation, radiation, feed-back, and so forth.

Another featured speaker of the extended bandwidth panel will be Jack Arbuthnott from Times Wire and Cable. Arbuthnott will discuss the effect of expanded band width on suppliers, and what specifically suppliers will have to do to keep up with demand and maintain operations at optimum levels.

The first day's activities will then close with a speaker's reception.

Cable Computer Systems

At 8:30 a.m. on February 6th, the conference will re-convene with a panel discussion on cable/computer/broadband systems. Moderated by Bill Ellis of Evansville Cable TV, the panel will include presentations by S. Michael Shofner from GE Cablevision, Hernan Otano from the National Air and Space Museum, Marvin Rahm from Dow Chemical, James Crocker from Control Communications, and Sol Yager from Warner Cable.

Marvin Rahm's discussion will center upon the industrial use of data transmission by broadband coaxial cable, including application of two-way technology for process and quality control, inventory, and other internal plant communications. Dow Chemical currently has 15 cable systems installed in various plants, including one facility in Texas with over 70 miles of cable. In addition, Dow is planning 21 more systems to be completed in the near future.

Rahm pointed out that GM, Ford, US Steel, and many other major multinational corporations rely heavily on coaxial systems to maintain control procedures. Rahm went on to predict that within the next four years there will be as much industrial use of cable data transmission as entertainment use of cable.

Also focusing on cable and broadband computer systems will be panelist S. Michael Shofner from GE. However, Shofner's emphasis will fall on the use of small business computers by cable operators. In particular, Shofner will relate GE's experience with its Biloxi, Mississippi computer system

and its use of programming for descrambler inventory, plant design, construction scheduling and installation reports, among other things.

James Crocker of Control Communications is also scheduled to give a presentation for the computer technology seminar. Crocker has been involved for several years in the field of digital data and control, with special emphasis on traffic and transportation systems. His remarks will center upon the technology behind municipal and state owned traffic control and coordination systems.

According to Crocker, in the past most of these systems have been completely separate from area cable operations. For example, the Columbus, Ohio, traffic control system and the Detroit freeway control system are both municipally owned and operated using standard CATV technology. In fact, the Detroit system, says Crocker, cost nearly \$15 million for the installation of coaxial cable.

Within this context, however, there is a new development: the incorporation of traffic and freeway control systems within the operations of the local CATV system.

Franchise Considerations

Crocker says this development will be extremely important in the acquisition of new franchises in the eighties. His scheduled speech before the SCTE Phoenix conference will focus on the details of a current project in Arlington, Virginia, which includes traffic control data transmission within the local CATV operation. Crocker also pointed to a proposed application of data collection and control within the existing system of Grand Rapids, Michigan.

In addition, Crocker will look into current control system technology, including the use of various types of microprocessors in the municipally owned systems. He will also examine some of the mistakes that have been made in this field, and how technical expertise can be used to avoid them. Crocker is also expected to propose that the SCTE undertake to write specifications and guidelines for the standardization of systems, and the efficient application of current technology.

The conference will wind up with the annual SCTE membership meeting, including the installation of SCTE officers and directors for 1980. **C-ED**

For a better signal, here's how Rockwell SAWs shape up.

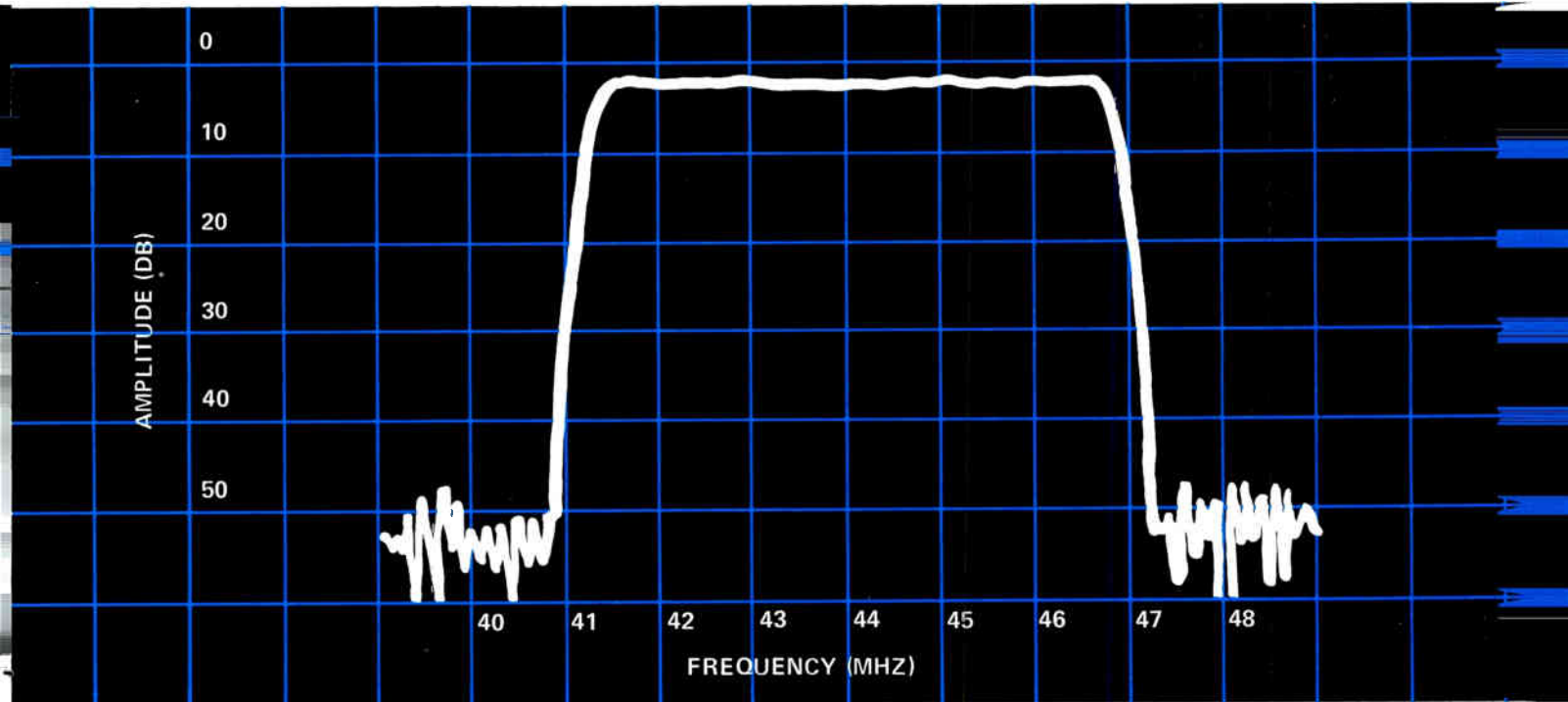

Now you can get Rockwell technology in solid state,
space saving, maintenance-free SAW filters.

**MICRO
POWER**

Rockwell International announces the latest addition to its SAWD (Surface Acoustic Wave Device) product line. The Rockwell SAW CATV Modulator Filter. It combines the solid state advantages of SAW technology with the volume production and research and development resources of Rockwell International. The result: A better signal for cable TV transmission of higher resolution video. That's Rockwell Micropower!

Rockwell's SAW bandpass filter provides the CATV Modu-

lator designer with unique benefits. Shown in the graph above, the Rockwell SAW CATV filter has excellent band pass characteristics. Its solid state construction requires no tuning or maintenance, making it ideal for remote, unattended locations. Its compact size



means it saves space and allows design flexibility. Add to that its flat group delay characteristics and reliability and you'll know why Rockwell SAWs are shaping up to be the technology leader.

Rockwell's SAWD products are the result of over 10 years of research and development together with nearly 30 years of Collins mechanical filter design and production.

For more information, contact Filter Products Marketing, Electronic Devices Division, Rockwell International, 4311 Jamboree Road, Newport Beach, CA 92660. Phone: 714/833-4544/4324.



Rockwell International

...where science gets down to business

A 12 Channel, 8.6 KM Fiber Optic Super Trunk for Teleprompter of Lompoc, California

By Sol Yager, Former Director CATV Engineering, Times Fiber Communications, Wallingford, Connecticut.

The titled installation took place between November 17 and December 7, 1978 and was announced during the meeting of the California Cable Television Association in Anaheim.

This analog, multi-channel cascaded system demonstrates the practical application of fiber optics to the needs of the CATV industry.

We will describe herein, our installation, operating and maintenance experience.

The Application

Teleprompter of Lompoc had transported distant signals, via point to point microwave, from Vandenberg Village, California to their Lompoc office; from which point their Trunk

and Distribution System originates. Necessary modifications to that microwave system led Teleprompter to expand upon their pioneering Fiber Optic experiment in New York City and construct a multi-channel Fiber Optic Supertrunk to serve Lompoc.

The Environment

Lompoc is located some 50 miles north of Santa Barbara and 7 miles inland of the Pacific. The locale is semi-arid with ambient temperatures varying from an infrequent low of 30° F to a high of 100° F. Twenty-four hour temperature excursions of 50° are not uncommon. Moderate to high winds are prevalent as are, in the winter rainy season, torrential rains and electrical storms.

Preliminary Planning

The cable route was carefully sur-

veyed and existing strand maps verified.

Our desire to install continuous kilometer lengths of Opti-link cable required examination of each length's route to determine direction of installation, special handling requirements and location of splices and repeaters.

Special plans were laid pertaining to a 900 foot underground freeway crossing. The remainder of the system would be overlashed to existing strand.

The System

An analog, frequency division multiplexed, frequency modulation transmission system was chosen for this application. The Optical sources, GaALAs injection laser diodes, are intensity modulated by the composite VHF FDM-FM signals. Figure 1 describes the system. The frequency plan was chosen: a) to eliminate effects of

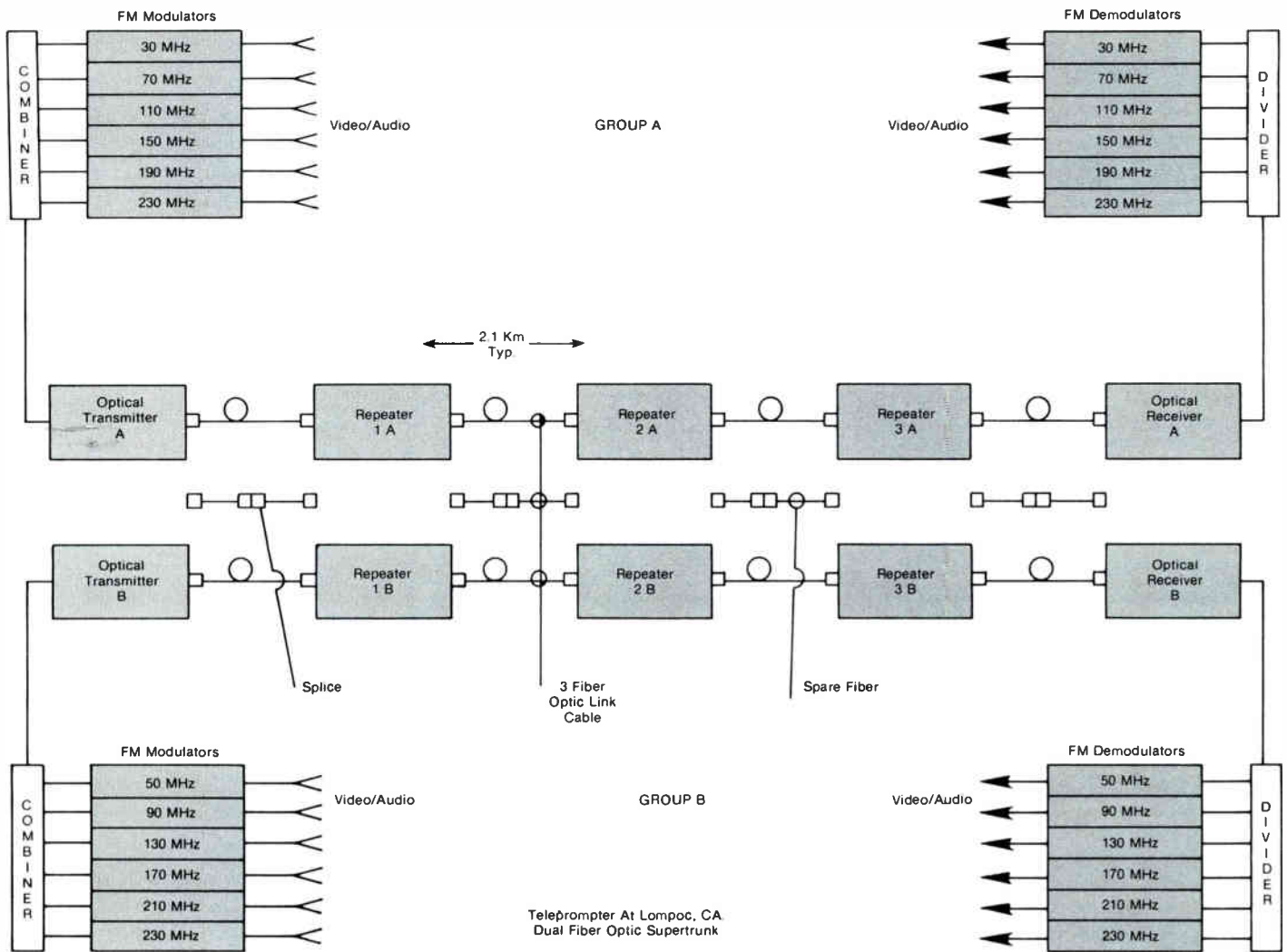

Figure 1

2nd order distortion; b) to minimize effects of 3rd order distortion; c) to allow future upgrading of the system from 6 to 12 channels per fiber; d) to permit emergency operation with 12 channels per fiber; and e) to allow frequency deviation to 3 MHz for improved signal to noise performance.

The optical loss budget was established at 17 dB between repeaters, including splicing and connecting losses. An additional 3 dB of margin is provided by receiver AGC action. Maximum repeater spacing is 7350' (2.24 Km).

The system was planned to provide EIA weighted Signal to noise ≥ 50 dB with no visible distortion. FM modulation with 3 MHz deviation was expected to yield this S/N with a carrier to noise ratio ≥ 33 dB.

The system carries 6 channels per fiber with a spare fiber provided for future expansion and/or as a service spare.

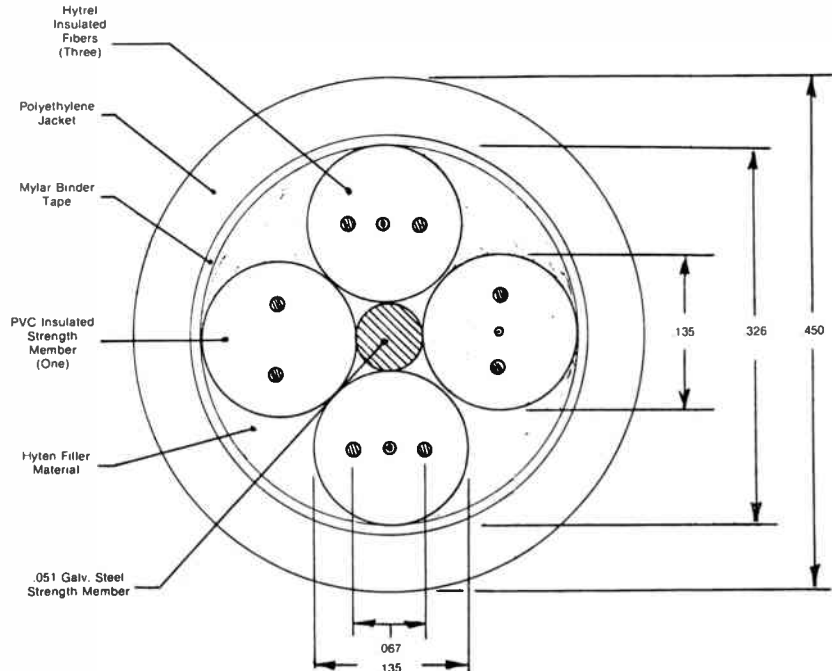

Figure 2

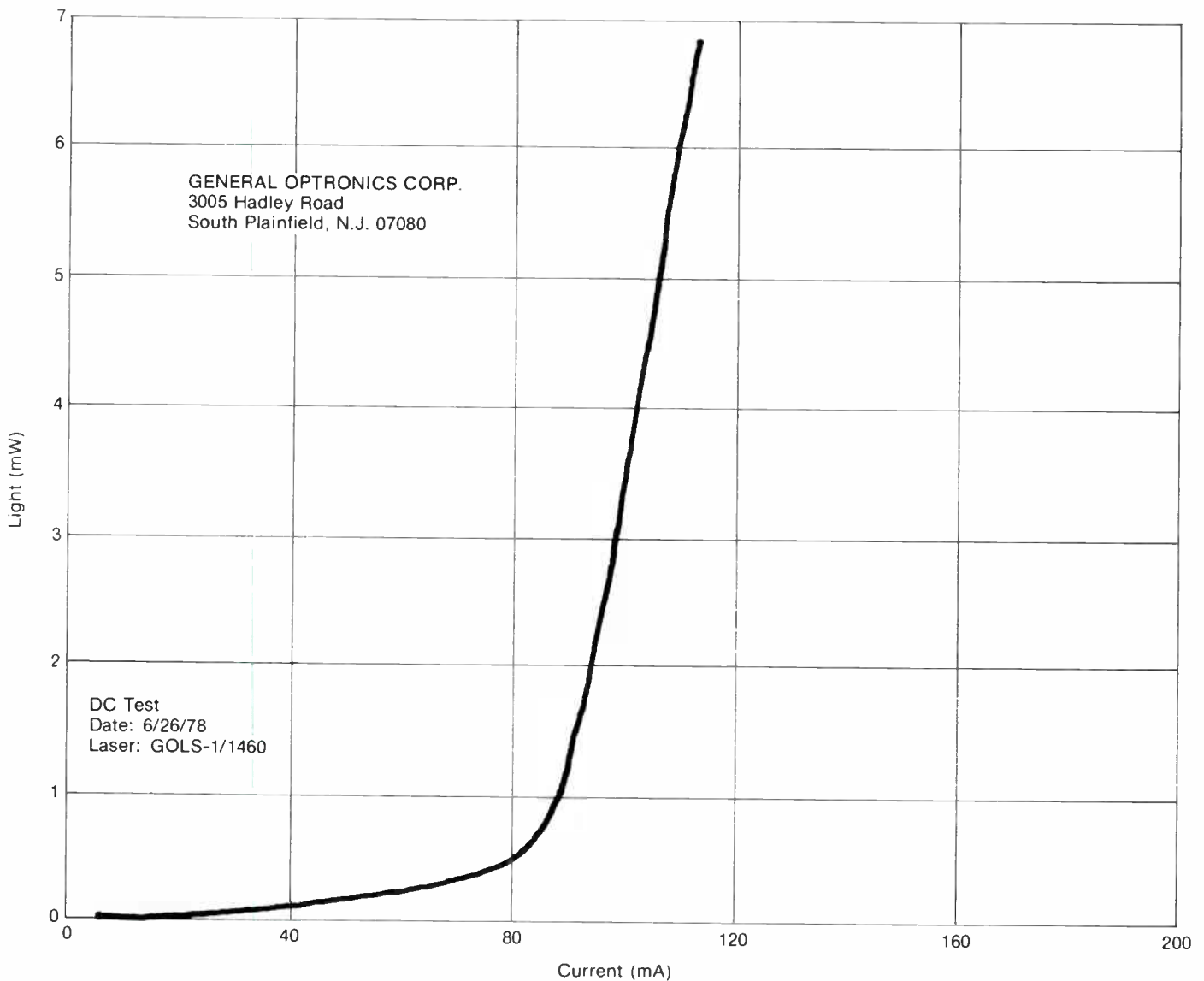

Figure 3

Component Description

I. Opti-Link Cable

Figure 2 is a cross section view of the Lompoc cable. The design of the cable affords mechanical protection to the optical fiber during manufacture and installation and allows the fibers to maintain performance in their operating environment.

Individual fibers are buffered to prevent abrasion during cabling processes. The buffered fibers are encased in a polyester cushioning jacket, along with 2 parallel steel wires which lend strength during cabling and control the expansion and contraction of the polyester with temperature changes. This element, which has good handling properties (important when splicing or connecting to electronics) is then spiralled around a central steel strength

member. Suitable fillers round out the assembly, a mylar tape is applied and a black polyethylene jacket extruded overall.

II. Optical Transmitters

These rack mounted units comprise the ILD and its associated control circuits, coupling networks and power supplies. Test Points are provided to monitor input signals, laser modulation, optical power out, laser operating bias, control loop shunt and cooler current and power supply voltages. Optical power is coupled to the output connector via a short fiber pigtail.

III. Optical Receiver

These rack mounted units utilize an

Avalanche photo detector, its control circuits and power supplies. The control loop automatically maintains the detector's sensitivity under changing ambient temperatures. Test points are provided for monitoring output VHF signals and significant voltages and currents.

IV. Optical Repeater

These units, which may be rack mounted or set into special field housings, actually comprise all the elements of the previously described Receiver and Transmitters. The VHF signal package is detected, amplified and remodulates an ILD. A common power supply, powered locally from 110 V 60 cycle, is self contained. A dust cover serves to protect internal optical and electronic components.

The more logical way to look inside an IC.

CSC Logical Analysis Test Kits: everything you need for over 90% of your digital testing.

Everything you need is at your fingertips. Circuit-powered. And easy to use. Ready to read logic activity at a glance, point-by-point or IC by IC. Or to inject digital signals for testing.

Let the LEDs of our Probes, Pulsers and Logic Monitors light the way to answers for your troubleshooting, design and educational needs. The CSC Logical Analysis Test Kit comes in two versions: our \$235.00* High-Speed Kit, LTC-2, which captures pulses as narrow as 6 nsec, rep rates to 60 MHz; and our \$205.00* Standard Kit, LTC-1, which goes to 50 nsec, 10 MHz. Both include complete manuals, accessories and a compact, custom-molded case. Either way, you've got a strong case for simplified digital testing.

Smarter tools for testing and design.

CSC's 23-oz. Logical Analysis Test Kits include Logic Probe, Digital Pulser, Logic Monitor, complete manuals and accessories, plus case.



CONTINENTAL SPECIALTIES CORPORATION



70 Fulton Terrace, New Haven, CT 06509 (203) 624-3103, TWX 710-465-1227
OTHER OFFICES: San Francisco: (415) 421-8872, TWX 910-372-7992
Europe: CSC UK LTD. Phone Saffron-Walden 0799-21682, TLX 817477
Canada: Len Finkler Ltd., Ontario

Call toll-free for details **1-800-243-6077**

*Suggested U.S. resale. Available at selected local distributors. Prices, specifications subject to change without notice.
© Copyright 1979 Continental Specialties Corporation

ABRACADABRA! Add a premium channel to your 12-channel system with the **Magnavox MX-SCCD...**



For fully-loaded 12-channel systems, the MX-SCCD Single Channel Converter Descrambler provides a low-cost convenient addition of a premium 13th channel, for both conversion and descrambling. An efficient, compact unit that operates with low power drain, the MX-SCCD prevents rolling and fluttering with exact sync-to-picture ratio restoration. Increase your channels and your revenues with the fastest-selling single channel converter-descrambler, the MX-SCCD.

**COME SEE US AT THE TEXAS
SHOW AT BOOTH 105
FEB. 20, 21, 22.**



...Or add 3 premium channels (2 secured) with the **Magnavox MX-BCCD**

Also for fully-loaded 12-channel systems, the Magnavox MX-BCCD 3-Channel Block Converter Descrambler gives the option of adding three premium channels, of which two may be secured. The MX-BCCD offers the same outstanding performance and dependability as the Magnavox MX-SCCD, in the same compact size.

The MX-SCCD and MX-BCCD. Two more reasons why Magnavox makes your system—for performance and profit.

Magnavox
CATV SYSTEMS, INC.

133 W. SENECA ST., • MANLIUS, N.Y. 13104

Phone: Toll-free, West of Mississippi: 800-448-5171
East of Mississippi: 800-448-9121
New York State: 315-682-9105

SWITZERLAND: CATEC AG (Lucerne)
Phone: 041-226619

CANADA: rf communications Ltd. (Markham)
Phone: 416-495-1030

ACTION CARD 27

V. Repeater Housing

This steel cabinet is designed to contain 1 or 2 Repeaters, and is equipped with a temperature controlled circulating fan, AC terminals, controls and transient suppressors. The louvered cabinet is designed for pole or stake mounting. It is equipped with a full width, locking door for access.

VI. Optical Connectors

All fiber connections, including splices, are made with the same type of connector. Transmitters, receivers and repeaters have output bulkhead

mounted optical receptacles.

For splicing, this receptacle is used, in line, between mating plugs.

The plugs have provision for seizing the fiber element's parallel steel wires. This makes for a secure interface permitting ease of handling when connecting and re-connecting.

Plugs are spring loaded, affording protection to the fiber end when plug is withdrawn from the receptacle.

A convenient, hand held tool makes proper plug assembly to the fiber simple and repetitive.

VII. FM Modulators and Demodulators

These units are standard products for the CATV industry. Their application to this System is only unique in the choice of frequencies and deviation.

Installation

I. Cable

The Opti-Link Cable was installed using equipment and techniques normally employed in the installation of coaxial cable.

Each reel of cable was tested before installation, using an Optical Time Domain Reflectometer. This instrument allows attenuation measurement, by comparison of Rayleigh back-scattering from the near and far end of the fiber under test, as well as displaying the location and nature of defects. The reel lengths were also verified.

After installation of each length of cable, it was retested in the same manner.

No installation induced defect was experienced in the aerial portion of the system.

During installation through the underground freeway crossing, a total of 2200 feet of Opti-link cable was actually pulled through the 900 foot, 4 inch diameter duct. The last 900 feet was pulled with a 3/4 inch and 1/2 inch co-axial cables. During this operation, 2 fibers were broken at the pulling grip and the damaged section discarded. The 1300 feet of fiber was then overlashed to aerial plant.

Lengths of cable, greater than a kilometer, were erected; posing the most unusual challenge to the contractor. In some cases, cable was pulled around two 90 degree corners using corner roller blocks.

Cable ends were brought down to repeater housings in plastic conduit with drip loops at the waterproof entrance ports.

The overall jacket was removed at the box entrance, leaving a suitable length of the fiber elements for connecting and splicing. The central steel strength member was fastened to a ground lug within the cabinet and a ground lead taken to a common driven ground at the base of the pole.

Some excess length was arranged at each pole conforming to the expansion loops in the existing coaxial cable.

II. Optical Electronics

Upon installation of the cable, the two optical paths were established

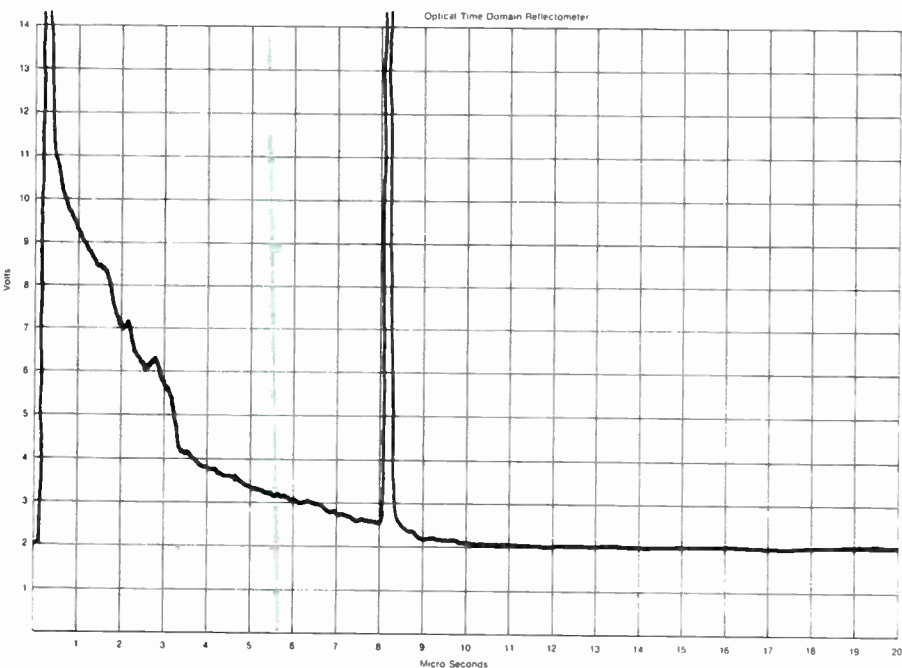
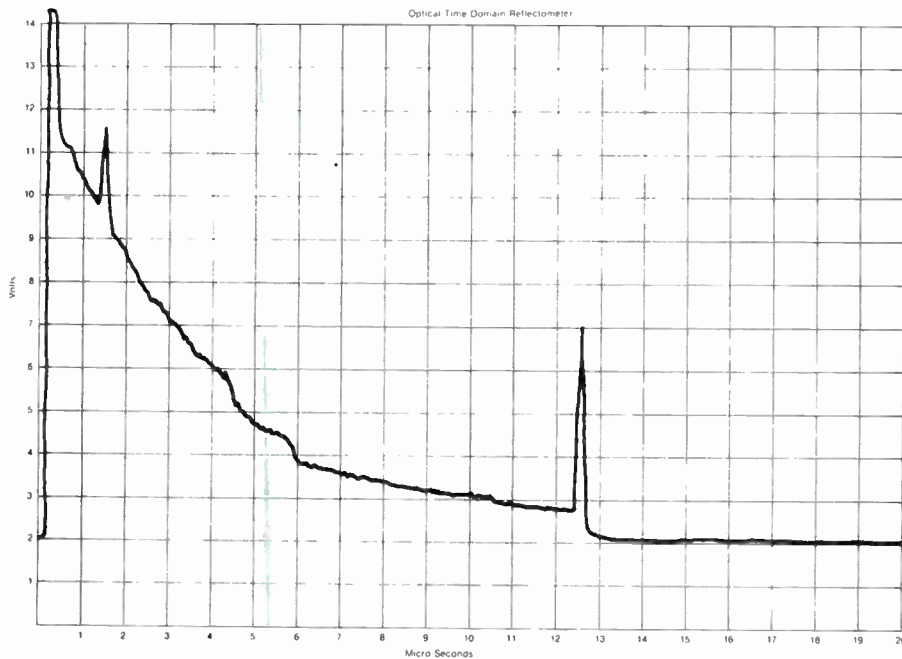

from end to end before modulation was applied.

Starting at Vandenberg Village; a fiber was connected to each laser's output receptacle, the optical power measured at the end of the first kilometer of cable using an optical power meter and the 2 fibers spliced to the next kilometer of cable.

Moving to the repeater location, the power was measured, first by a power meter reading at the fiber ends, and then confirmed after connection to the repeater by measurement of photo current in the APD.

This process was repeated from repeater to repeater and to the end receiver terminal.

Each receiver in line was adjusted to set the AGC control range for the optical power received.

Modulation was then applied and, at each repeater in line, receiver gain was adjusted to set laser modulation depth for optimum carrier to noise and distortion ratios using a Spectrum Analyzer.

Finally, System Carrier to noise, carrier to distortion and baseband signal to noise were measured at the Lompoc office.

C/N was measured as >33 dB

C/3rd order distortion was measured as >28 dB

S/N (EIA weighted) was measured as >50 dB

Subjective evaluation of each video channel, by a group of observers, confirmed the absence of visible distortion under these conditions.

Reliability

Between the energization of the electronics on November 17 and preparation of this paper, some 4000 hours of operation have been accumulated.

Two lasers have failed within 300 hours and these are attributed to infant mortality.

Two failures have occurred in the temperature control loops. The mode of failure cooled the lasers below their thresholds, causing loss of light output but not laser failure. Correction of the defect allowed the repeaters to be restored to operating condition.

Changing temperatures have not perturbed the system due to action by transmitter and receiver control circuits.

Heavy rain and some severe electrical storms have also occurred with no effect on the system.

Opti-link fiber optic cable was

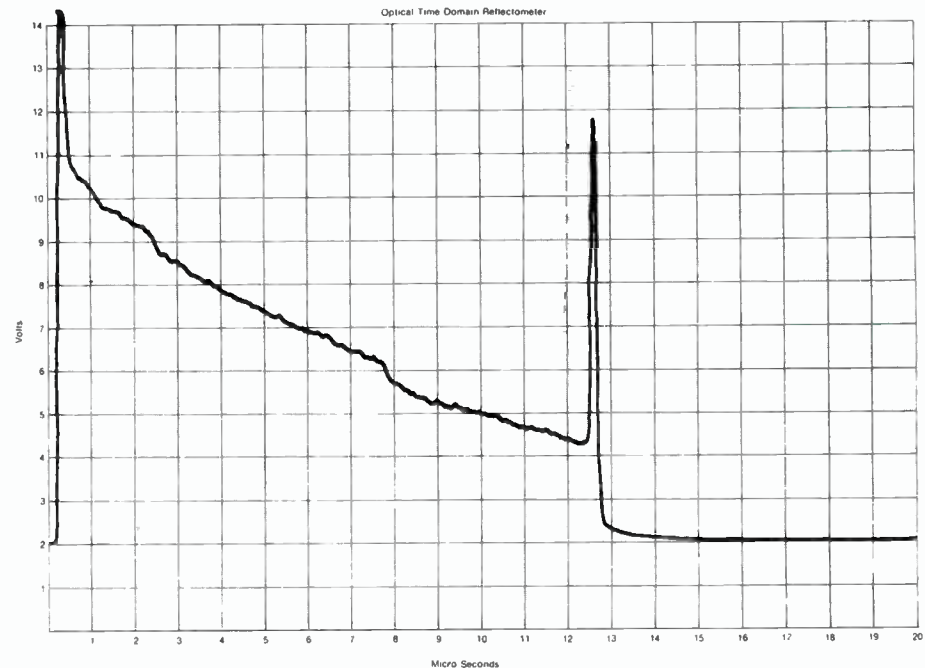
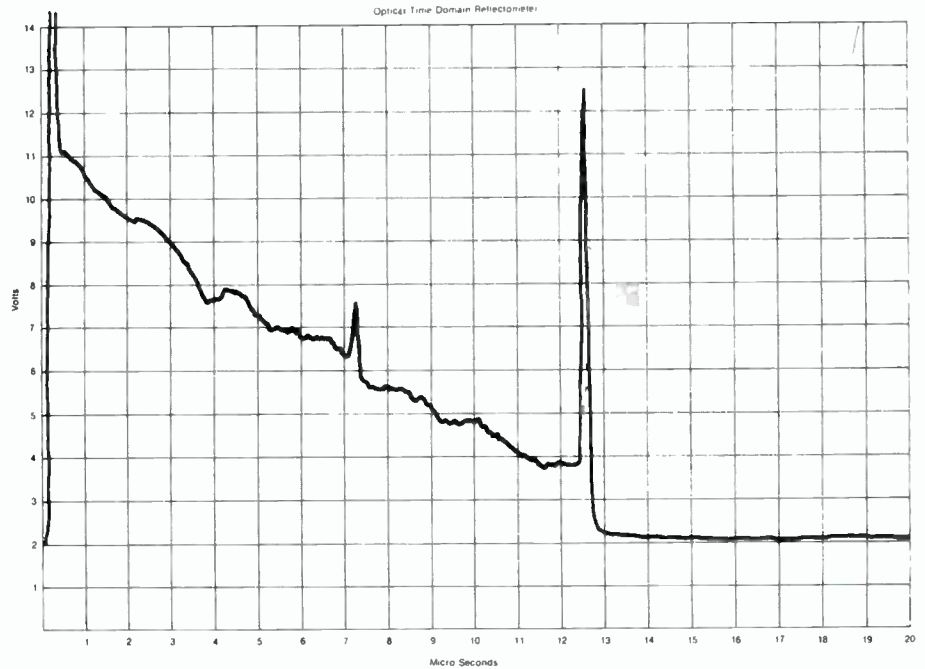

manufactured by Times Wire and Cable Division as were the laser and detector modules used in the optical equipment.

Other companies contributing to the project are: **Electro Optic Devices, Inc.** - Optical Transmitters, Receivers, and Repeaters; **General Optronics** - Injection Laser Diodes; **Tomco Communications** - FM Modulators and Demodulators; **RCA** - Avalanche Photodetectors; **Deutsch** - Optical Connectors; and **Can-Am Communications** - Installation of Opti-link cable and Repeater housings.

Editor's note: This article was written by Sol Yager in his capacity as director of CATV engineering for Times Fiber Communications. It describes the Lompoc system as it was configured in mid-1979. Since then, Times Fiber has made a number of improvements in the system, such as reducing the repeater locations from three to one. Coverage of these latest changes and improvements will be the subject of another article in the near future.

Superfit™ for a King



RMS CATV DIVISION
ELECTRONICS, INC.

RMS ELECTRONICS, INC.
50 ANTON PLACE
BRONX, N.Y. 10452
CALL COLLECT (212) 633-8888

An Optical Solution To Fiber Optic Interconnection

*By Peter Duyan, Jr., Program Manager—
Fiber Optics, The Deutsch Company,
Los Angeles, California*

Dramatic engineering developments have been a hallmark of the communications industry since its inception. In recent years a good deal of these developments have been in the field of fiber optics, and in creating new practical applications for this young technology.

While previous transmission system developments took decades to translate from theories into functioning installations, fiber optics has been developed at a comparatively blinding pace. The last five years have seen progress in fiber optic systems channel capacity and repeater separation of more than double the achievements of 30 years' work with FDM coaxial cable systems, and over three times greater than the accomplishments in PCM systems over the last 15 years. But despite its youth, fiber optic technology is already being employed in various permanent installations around the world, and important new contributions are being made to expanding its usefulness to entirely new applications.

One of these contributions is the development of a standardized field-terminable connection system for optical fibers. Fiber interconnection had been a major stumbling block to widespread use of optical fiber transmission systems due to the difficulty of achieving the necessary precision in the field—two strands of glass finer than human hair have to be joined end-to-end with microscopic angular and axial precision. Any misalignment causes significant losses, such as the one full decibel loss which results from a gap one-fifth the fiber diameter.

Creating a connection system which would perform with the necessary precision as well as stand up to environmental abuse was only part of the problem, however. To be practical for widespread application, it also has to be economical and rapidly and repeatedly installed by semi-skilled workers in the field.

An application demonstrating how well this has been accomplished has been in use since 1978 in Lompoc, California, where the Teleprompter Corporation has the world's longest cable television fiber optics installation in service. Measuring 8.4 kilometers in

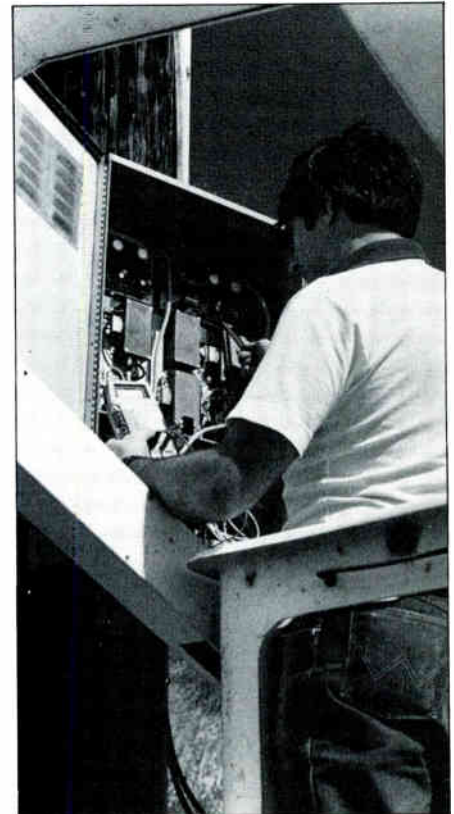

Pole-mounted optical repeater containing field terminated Deutsch fiber optic connectors.

Arvin

SAT-WEATHER™

WEATHER SATELLITE RECEIVER

**CONVERTS NOAA SATELLITE
WEATHER PICTURES INTO COLOR VIDEO.**

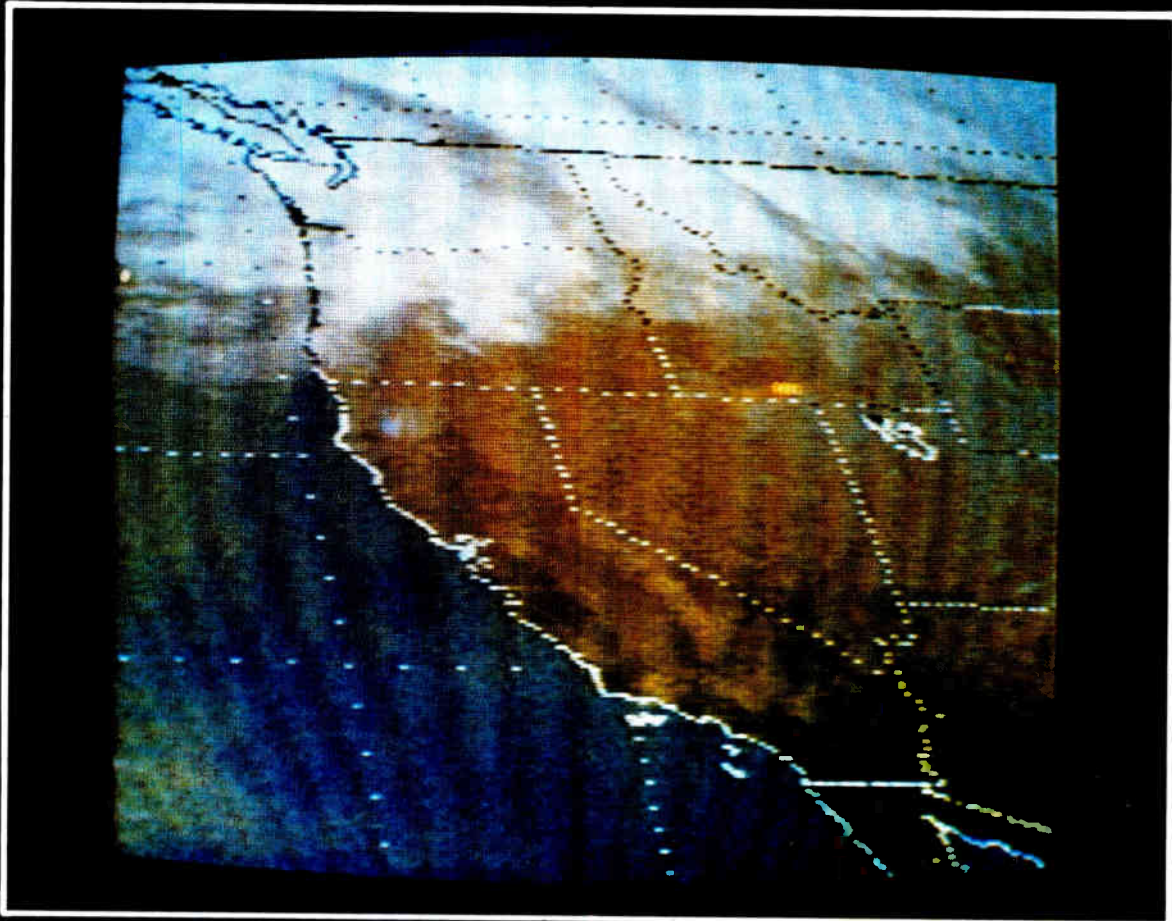

Arvin's Sat-Weather™

Provides:

- **Current Weather Pictures From NOAA Satellites**
- **Continuous Video Output**
- **Automatic Operation**
- **Realistic sea, land, and cloud colors**

**Cablevision Equipment
Company**

**Garland, TX 75042
214-272-8551**

**Comm-Plex Electronics
Montreal, Quebec CANADA
H4P1V4**

514-341-7440

**Comse Sales Corp
Lawrenceville, GA 30245
404-963-7870**

**Signal Vision, Inc.
Laguna Hills, CA 92653
714-586-3196**

**Videosystems, Inc.
Lodi, WI 53555
608-592-3272**

**Emjay Electronics
Drexel Hill, PA 19026
215-461-0353**

ARVIN/CATV®

AN ARVIN COMPANY

4490 Old Columbus Rd., N.W., Carroll, Ohio 43112 Phone 614-756-9211

How The Lompoc System Works

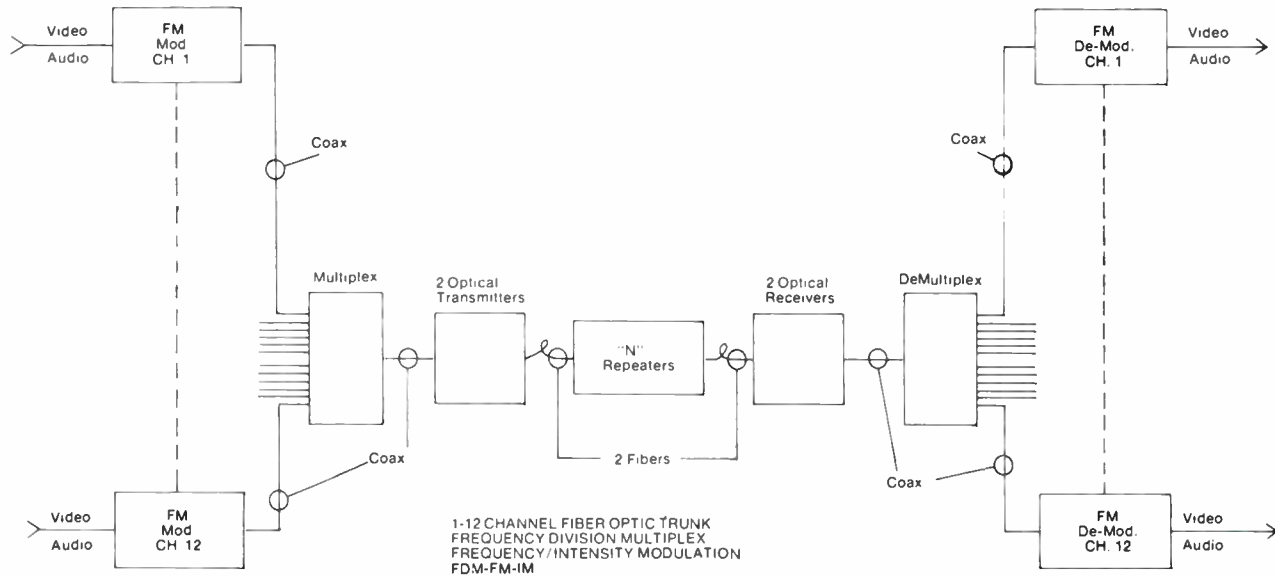

Figure 1

length, the 12-channel super trunk system replaced a microwave link connecting the firm's 12,000 subscribers with programming from the Los Angeles area.

The system was installed on a turnkey basis by Times Fiber Communications of Wallingford, Connecticut, who supplied the optical fiber and cables, the optical transmitter, receiver and repeaters along with supervising the installation. The firm had pioneered the CATV industry's first fiber optic link in 1976 for Teleprompter's New York City system.

In the Lompoc Times Fiber installation, all fiber connections—including splices—employ the Optical Waveguide System manufactured by The Deutsch Company. The system includes optical detector and emitter connectors, connector plugs and receptacle feed-throughs—and the Deutsch Termination Tool which makes in-field connector installation possible.

The Deutsch system makes interconnection of optic fibers an operation no more complicated than stripping and terminating conventional communications wire; permits convenient disconnection and reconnection; re-

quires no new operator skills level; and in system-wide applications such as Lompoc, it also makes possible the additional advantages of full component standardization.

In Lompoc, the Deutsch system is

part of an installation which employs two optical fibers to carry 12 channels, and which is the first cascade of an analog system. At present six channels are carried by each fiber, though the
(Continued on page 44.)



Electro-optical engineer verifying the end-to-end performance of the complete system.



Why gamble with pay-TV performance when you can have a sure thing?

Home Box Office has the most successful record by far for launch and after-launch growth. We're with you from the start, and we're there all along the way.

HBO provides the most effective marketing and promotion support programs for our affiliates with custom-tailored plans and materials for each system. So after we've worked with you on your launch, we'll keep you moving in the right direction.

No guesswork, no misses—we're the most experienced and successful Pay-TV company in the business and you can place your bets on that.

The results are evident in our extraordinary percentages of pay penetration of both cable and homes passed.

So call one of our General Managers now: Peter Frame (212) 841-4241, Bill Hooks (214) 387-8557, or Don Anderson (213) 557-1010.



Where Performance is Fact.



**INTRODUCING
"ROOM AT THE TOP"**





ANOTHER FIRST FROM COMM/SCOPE. NEW PATENTED PIII PLUS™ COAXIAL CABLE 30db SRL* 5-450 MEGAHERTZ.

6 Reasons why PIII Plus™ coaxial cable offers you more.

1. PIII Plus cable means 50% more bandwidth with access from 5-450 megahertz. Now that's "room at the top!"
2. Return loss (SRL)* is tested to assure that PIII Plus cable has a minimum of 30 db (SRL)* throughout 5-450 MHz.
3. Stable attenuation is assured to 450 megahertz, the same super low loss characteristics you've learned to expect from our standard PIII cable.
4. The mechanical characteristics of PIII Plus coax are identical to those
5. Even with all this increased capability and "room at the top," PIII Plus cable uses the same connectors as PIII.
6. Comm/Scope's reputation and commitment to manufacturing only the highest quality coaxial cable stands behind every reel of new PIII Plus coax.

time proven properties that have made patented PIII so successful.

PIII Plus is the ultimate cable for all your telecommunication needs. For more information on how to put a plus in your system, contact Comm/Scope Company.

*Available in copper clad aluminum center conductor. Additional size inch cable specifications are available from Comm/Scope.

"See us at the Texas Show
Booths 301 and 402"

Light years ahead in cable innovation

 **Comm/Scope Company**

ROUTE 1/BOX 199-A/CATAWBA, N.C. 28609
TELEPHONE: 704-241-3142/TELEX: 800-521



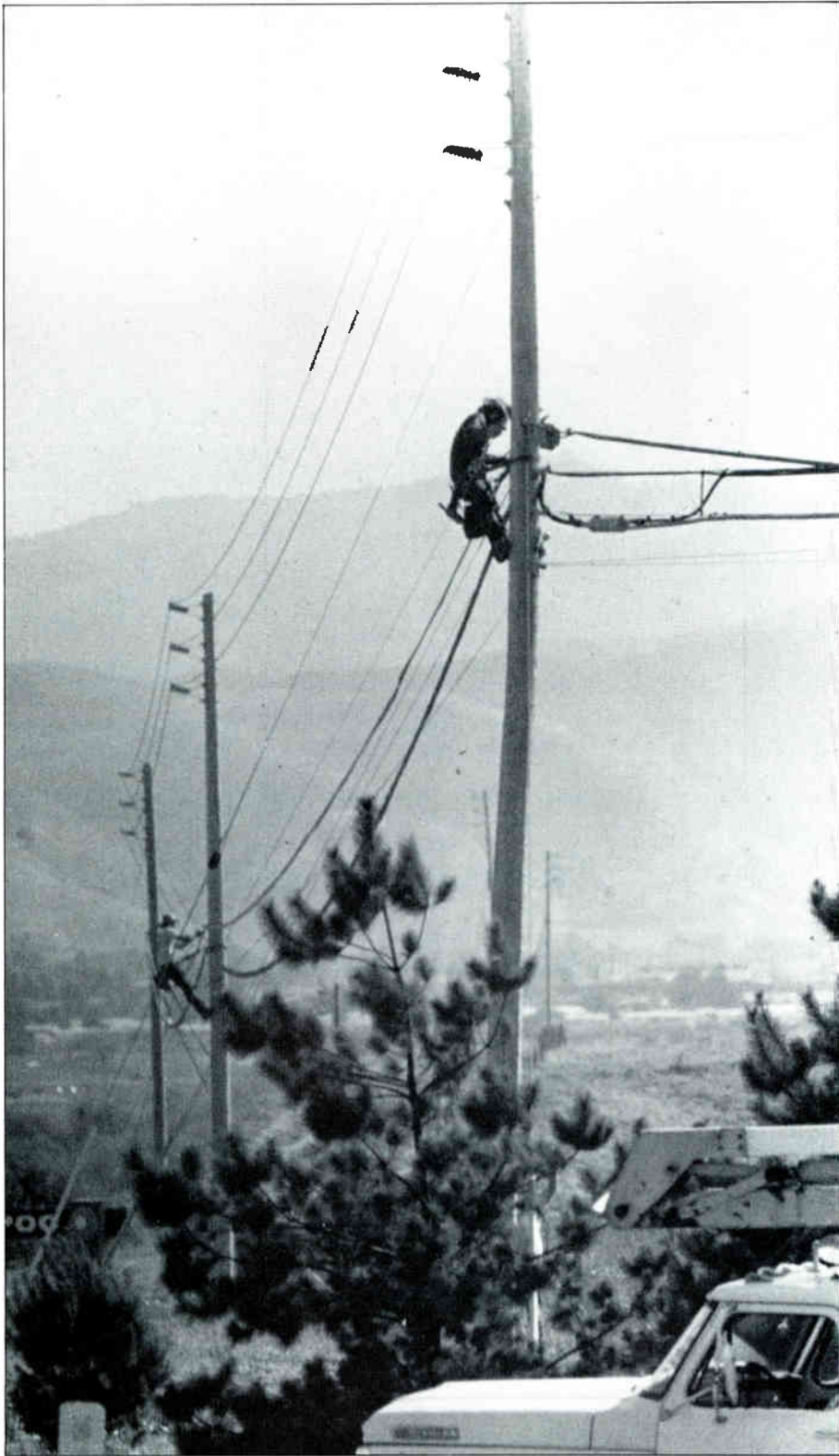

Cable construction crew hanging fiber optic cable in Lompoc.

(Continued from page 39.)
design allows for future upgrading and emergency operation of the system at 12 channels per fiber. A third fiber is included for expansion or use as a service spare.

The installation was accomplished using equipment and techniques nor-

mally employed in the installation of coaxial cable. The one-kilometer continuous cable lengths were routed almost entirely above ground by over-lashing them to existing strands, with the only exception being one 900-ft. underground freeway crossing.

The Opti-link cable used is designed

to protect the optical fiber throughout manufacture, installation and operation. To prevent abrasion during the cabling process, each fiber is buffered, then encased in a polyurethane primary jacket, wrapped with aramid strength reinforcement, and an outer jacket of polyethylene. The elements are spiralled around a central steel strength member, wrapped with mylar binding tape and encased in an extruded polyethylene jacket.

An analog, frequency division multiplexed and frequency modulation transmission system was chosen for use in the Lompoc installation. The baseband audio and video signals are first applied to FM modulators, and that output is then frequency division multiplexed and applied to an intensity modulator. The modulated light is then introduced into the fiber cables.

Losses in the successive spans, which have a nominal length of 2.2 kilometers, are made up by repeaters. Each consists of a photo detector, amplifier, and intensity modulator. A photo detector recovers the FM carriers at the system terminus and applies them to a demultiplexer. The signal is then introduced to an FM demodulator, where the baseband video and audio signals are recovered for receiver use.

All of the Lompoc system's terminal equipment is rack mounted, while the repeaters and their power supplies are housed in weatherproof enclosures for pedestal mounting. In all cases the equipment is powered by 110 VAC lines.

Times Fiber has found numerous advantages to the fiber optic system. Possibly the most notable is that only three repeaters are needed in the entire 8.4 km run, as opposed to the 12 repeaters which would be necessary in a conventional cable television system of the same length. Other improvements over older technologies include the optics' immunity to electro-magnetic interference and cross-talk between fibers, and improved security—it cannot be tapped by electro-magnetic or surface conduction. Also, the optical fiber's dielectric properties make it completely free from the effects of voltage and current transient surges.

The firm has also found an additional advantage in the smaller size and greater strength optical cable has in comparison to conventional transmission lines. Combined with its flexi-

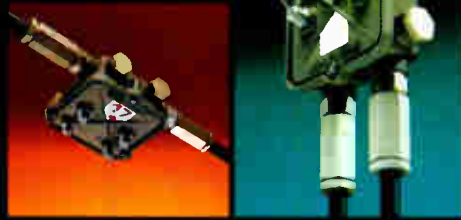

This Is Our New Tap

The heart of our new tap is a plug-in module complete with the following mechanical features:

- Weather-tight, tin plated brass "F" connectors.
- High quality, long lasting O-ring permanently held in place in a recessed groove.
- Plastic protective cover
- Captive sealing bolts

And...of course, it plugs into a unique, pressure tested, weather-tight housing with a built-in "quick-change" conversion feature for either aerial or pedestal mounting.

Look at these specs

- Extremely Low Insertion Loss
- Maximum R.F.I. Integrity
- 7 Amp Power Passing
- 20 dB or Better Return Loss at Feeder Lines and Tap Ports
- -70 dB Hum Modulation at 7 Amps
- 5 to 300 MHz Bandwidth
- 30 dB Tap to Tap Isolation

NEW!

A MORE VERSATILE...MORE ECONOMICAL TAP.

NOW 8-10 WEEK DELIVERY

THETA-COM
CATV

a division of **Texscan** corporation

Theta-Com CATV, a division of **Texscan Corporation**
2960 Grand Ave. P.O. Box 27548 Phx. Az. 85061
Phone: (602) 252-5021 Toll-free (800) 528-4066
TWX 910-951-1399

YOU'LL LIKE THE WAY WE TREAT YOU.

"See us at Booth 211 at the Texas CATV Show"

Patent Pending



A Deutsch Optical Waveguide with the connector plugs attached to the connector receptacle feed-through.

bility, it results in greatly reduced ice loading and wind reaction along with easier installation in underground ducting.

Deutsch engineers began the task of developing the first detachable optical connector for field use by defining ideal performance parameters, which included quick and easy field terminability by semi-skilled technicians; no need for grinding or polishing the fiber ends; no need for chemical processes or epoxies; the accommodation of optical waveguides of varying physical and optical properties; the assurance of fiber end integrity during coupling and disconnection; repeatable coupling loss of less than -1.0 decibel; the requirement for no special fixtures; interchangeability of connector plugs

and receptacles; the meeting of rigorous environmental standards; and availability in high volume at reasonable cost.

Although the mechanical act of quickly and precisely joining tiny glass strands was a problem of no small magnitude, the Deutsch engineers first focused on the fundamental optical aspects of radiance and acceptance. Connection efficiency, they reasoned, would be dependent not only on mechanical alignment, but would also vary with power distribution in the fiber, the typical variance in fiber index profile, mechanical aperture and fiber core diameter.

Using an optical analysis model to study various interconnection concepts, Deutsch decided a system utilizing

lenses as the best approach. The use of precisely molded, self-aligning lenses integral with the central body of a three-part connector emerged as the most practical answer to the requirement for simplicity and minimal use of tight tolerances.

The final design is one in which light is coupled by the use of compound lenses. The three-part connector consists of two male connector plugs to hold the fiber ends, and a central receptacle containing the lens. Each connector plug has a fluid-filled conical cavity in a transparent body which mates with the lens—the fiber end is inserted into the cavity and rests at its nearly-spherical apex.

The half-domes in front of each fiber, along with a medium of selected

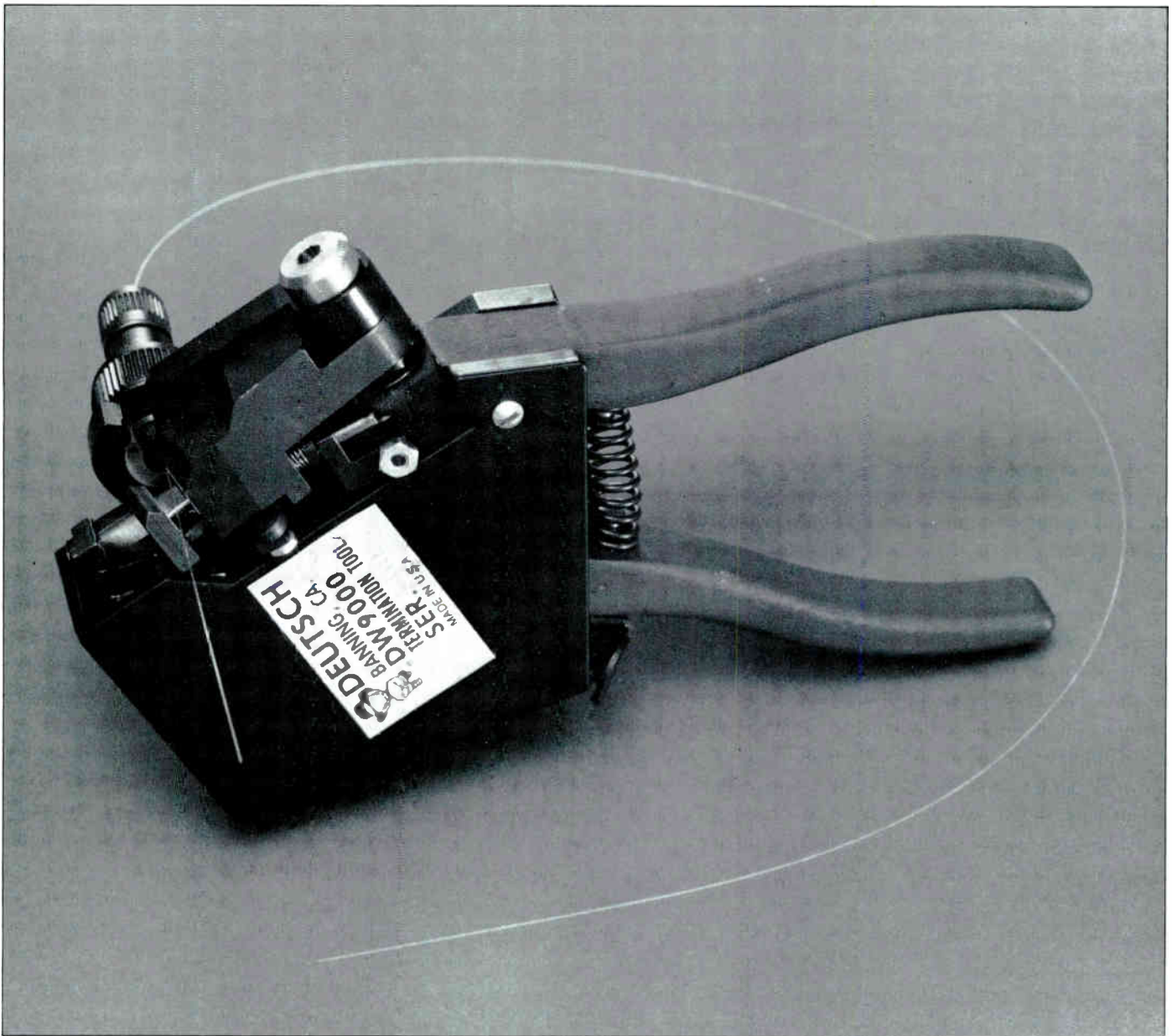

A Deutsch hand-held termination tool with a connector plug installed to make an optical quality break on the fiber.

refractive index, form a three-element compound lens of high light-coupling efficiency. The central lens is molded in one self-aligned piece within tolerances of a few micrometers, and thus the need for extremely tight tolerances in other connector parts is reduced. It is also the key to high-speed repeatable interconnection, and allows the use of the Deutsch-developed interconnection termination hand tool.

Before being inserted in the tool, the fiber is fed through the back of a connector plug. The plug has a coupling nut which holds the fiber under the proper tension for the scribe-and-break process to follow. This process, accomplished by connecting the plug to the tool and merely squeezing the

handle, produces the necessary optical-quality fiber endface. Removing the plug from the tool causes the fiber to retract inside the plug, assuring fiber end integrity. The connector plug containing the fiber is then inserted into a connector body and the coupling ring tightened, thus inserting the fiber end into the bottom of the conical lens cavity.

Excess fiber length accumulates in a chamber between the plug tip and a clamp at the rear, which provides forward pressure to retain the fiber end in the cavity—and also makes the connector insensitive to the longitudinal position of the fiber in the plug.

The result is a connector which surmounts the typical problems of end-to-end optical mating. It is field terminable,

requires no polishing or epoxy in cable applications, and has quick-disconnect capability with less than -1.0 dB coupling loss. The connector accepts fibers of a variety of diameters.

The development of systems oriented Optical Waveguide Connectors has been an important step in making the advantages of fiber optics applicable to an increasing spectrum of communications uses. Times Fiber's CATV installation in Lompoc is only one example—but one which serves well to point out many of its benefits as well as being a showcase for the technological achievements which make it possible. The future of fiber optics in CATV systems is enormous and will present opportunities never before available to the industry. **C-ED**



Data Processing/Business Systems

This month, C-ED presents a review of available computer and data processing systems with applications in the cable industry.

Cablebus Systems Corporation Announces Production of New Home Terminals

Don Tuite, Marketing Manager for Cablebus Systems has announced that the company has begun to produce addressable home terminals with bus output to allow operators to stack modules to design custom systems. Some of the units currently available include an alarm/reporting module, a cable control module (with on/off taps), a utility meter reporting module, an energy control module with four inputs and four outputs, and an installer's module, with automatic self test to determine status of the system. The network is tied in at the headend to a Digital Equipment Corporation model LSI-11 computer running on proprietary software.

Basic price for head-end installation is \$39,000. Addressable terminals at the subscribers' end run \$150 per unit, when purchased in quantities of 100.

For further information, contact

Cablebus Systems Corporation, 7869 Southwest Nimburs, Beaverton, Oregon (503) 595-6926.

CableData's Management Information System

CableData's on-line operating system is a management information system designed to eliminate paperwork, increase efficiency, and give you greater visibility into the day-to-day operations of your cable system.

The system provides on-line data displays of the information needed to support the following functions:

- Order Taking
- Scheduling
- Routing
- Dispatching
- Installer Check-in
- Rescheduling
- Management Reporting
- Dynamic Posting of Payments
- Collections
- Customer Service Inquiries
- Complete Customer History
- Complete Technical History

• Handling of Trouble Calls

The design on the on-line system is based upon techniques successfully used in the airline and other industries. Interaction with the computer is provided through a Cathode Ray Tube (CRT) designed for simplicity and ease of operation. Access to customer information or work in process information is obtained by key entry of either customer name, address, account number or phone number. The computer searches the on-line data files and displays the answer on the screen, along with the instructions concerning what actions may be taken.

The primary consideration in the development of CableData's on-line system has been relating the computer to the person who will use it in the simplest manner. Considerable effort has been directed toward limiting the amount of information that must be entered by the operator to complete various work functions. Where practical, information already in the data files is displayed without the need for the operator to request such information.

If you could see FIVE YEARS into the future you would install this equipment today.

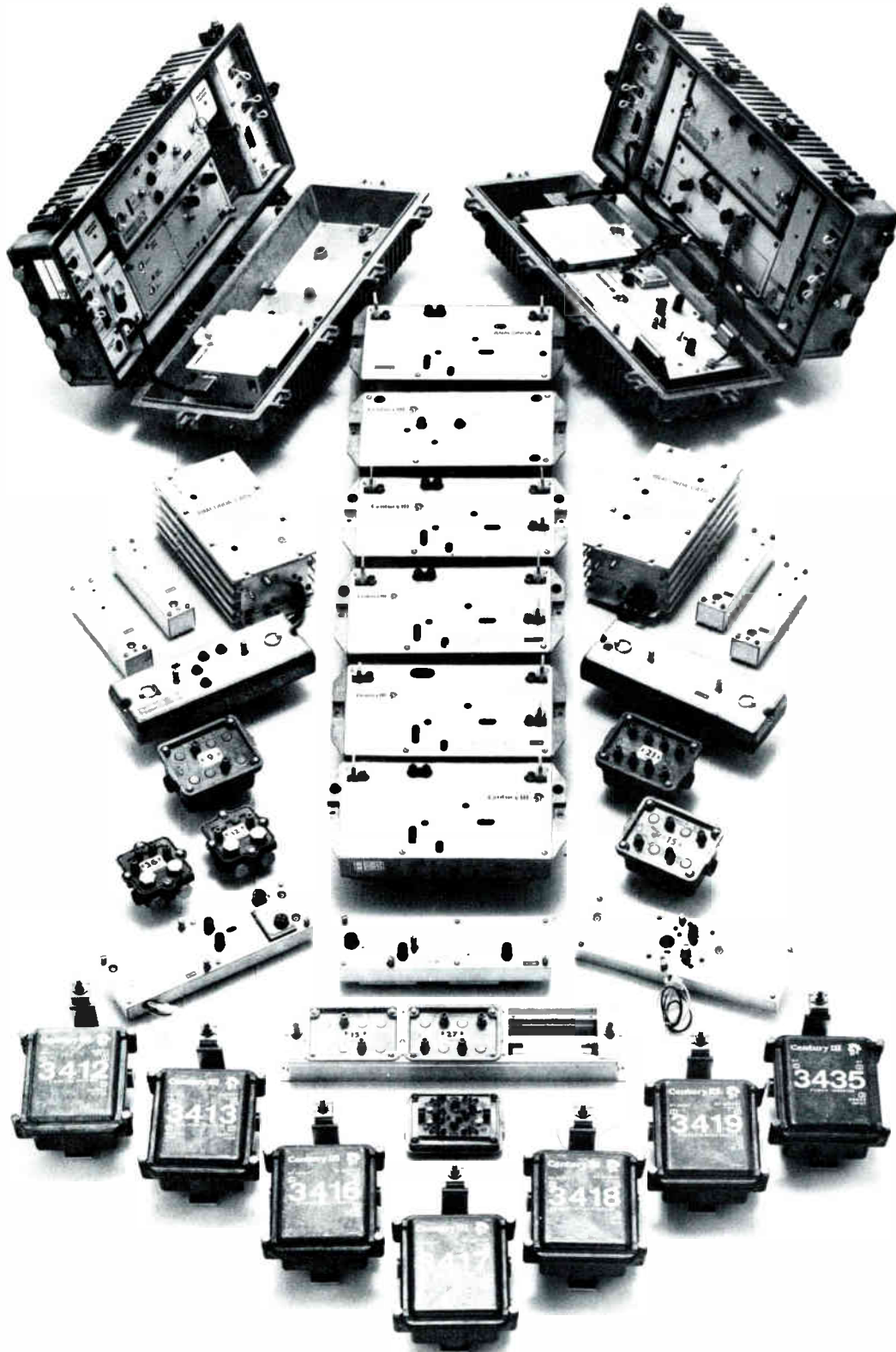

Century III
"Innovators in
Broadband
Communications"

Century III Electronics, Inc.

Head Office—Canada

1580 Rand Avenue
Vancouver, B.C.
V6P 3G2
Tel: (604) 263-0911
Telex: 04-55490

Head Office—U.S.A.

3880 E. Eagle Drive
Anaheim, California
92807
Tel: (714) 630-3714

Central Canada

#13—5200 Dixie Road
Mississauga, Ontario
L4W 1E4
Tel: (416) 625-6263
Telex: 06-961359

Eastern Canada

8439 Dalton Road
Town of Mount Royal
Montreal, Quebec
H4T 1V5
Tel: (514) 739-1976
Telex: 055-61633

Europe

Electro Service N.V.
Belgium Telex 46-34093
Richard Hirschmann Electric
Austria Telex 47-52239



The on-line computer then creates billing and data transactions for transmission to the Sacramento Data Center. There, bills are created using large-scale computers and high-speed printing and inserting equipment. This relieves the cable system computer and personnel from the heavy workload of producing and handling subscriber bills and stuffers.

For further information, contact CableData, 3200 Arden Way, Sacramento, California 95825, (916) 485-2911.

Control-Com, Inc. Omni I Service Control System

The Service Control System is an advanced computer controlled communications system with applications in energy control, entertainment, security, and records maintenance. Pay television, room energy control, message light and wake-up, fire, burglar, medical alert, and built-in system testing are some of the control functions. Transmission medium is a television antenna system and no other wires are required for operation.

The heart of the system is the front desk control unit. The unit contains a 20 character per line printer, 20 character alpha-numeric display and full keyboard with special function keys. The operator can control and monitor room functions; in addition, records of pay television functions are stored (battery backup) for billing purposes. The unit also contains provision for additional hardcopy or communication units.

Software features include a unique room monitor program which turns on

the heat (A/C) upon check-in and resets all room functions to off at check-out, and an energy management cycling program to reduce peak load requirements.

System hardware consists of a central (Front Desk) microcomputer, a central transmitter/power supply, a data receiver/decoder for each room, and a customer interface electronics package for each room. The system is capable of transmitting, under programmed control or by operator intervention, control data from the front desk to a specific room and energizing a specific control function in that room. Control functions can include switching of television service (multiple levels), wake-up alarms, message lights, and heaters or air-conditioners. The system is also capable of receiving a signal at the front desk from any room. Each customer interface package may have up to four return channels. The return channels will be polled room by room, function by function, under programmed control.

Software for the Omni 1 System Controller is designed to provide automated control of the various Omni 1 hardware features with a minimum of operator intervention. The programs are modular in nature so that software can be supplied for the hardware options installed and may be expanded easily if more options are desired later.

The main features of the software are:

- (1) Maintain date and time and display this information on the System Controller front panel display;
- (2) Maintain internal status tables for each room including occupied or vacant status;
- (3) Transmit data to the in-room units either on a keyboard command or on a predetermined time-of-day basis;
- (4) Allow operator control of the system.
- (5) Monitor security return data from each room.

On initial power application, the System Controller will initialize the internal status tables to an all zero, or unoccupied, state and will prompt the operator with this message:

ENTER MO, DAY, YR,

The operator then presses the space bar and enters the requested information. The machine responds with ENTER HR, MIN, SEC, and the operator again presses the space bar

and enters the information. The machine responds with AM or PM? The operator then enter A or P. If an error is made in the entry the operator may press the "ERROR" key and begin again. After the date and time are correctly entered the System Controller display will contain time-of-year information as in the following example:

10/1/79 11:12:33

This is the normal display and is always present unless the operator is entering commands from the keyboard.

The Omni 1 System Controller has internal batteries to supply power during power failures so this start up procedure does not have to be repeated after short term blackouts.

The Omni 1 system is designed so that a minimum of operator training is required. All commands can be entered in short, easily understood format using the special function keys provided. The operator begins the entry by pressing the key labeled "ROOM". The controller will respond with "ROOM #". The operator then enters the desired room number and presses the space bar. The machine will respond with "ROOM XXXX OCC" or "ROOM XXXX VAC". Then, depending on which options are installed, the operator may select one or more of the following single key commands:

- (1) CHECK IN
- (2) CHECK OUT
- (3) MESSAGE ON
- (4) MESSAGE OFF
- (5) BASIC TV ON
- (6) BASIC TV OFF
- (7) PAY TV ON
- (8) PAY TV OFF
- (9) WAKE UP
- (10) WAKE UP CANCEL

If a command such as BASIC TV ON is entered and BASIC TV is already on in that room, the controller will simply ignore the command. Each time a new command is entered it will be displayed in the following manner.

"ROOM XXXX MSG ON"

or

"ROOM XXXX PTV OFF"

If the WAKE UP command is entered, the operator will be prompted with "ENTER HR, MIN". He may then press the space bar and enter the requested information. The data will be stored in a table and the wake up call will be transmitted at the correct time. Wake up calls are processed at six (6) minute intervals, so if a call is entered for 7:15 AM it will actually be transmitted at some time between 7:12 AM



***With RELEASE 5, we've got
all the bases covered.***

You've been in the cable television industry long enough to know that what you put on the screen is only half of what you do to keep your customers. Your customers expect you to have a well-run, efficient office team that can solve any problem they pitch in your direction within seconds. And because they are more concerned with their problems than yours, it makes very little difference to them that your dispatcher is in one end of the building, your customer service people are in the other end, and your technicians are in the field. They expect each staff member to have every customer's information at their fingertips. This is where our new Release 5 can help you can hit a home run every time.

For the first time in cable television history, you can have instant, computerized two-way communication between the customer, your customer service people, the dispatcher, and the technicians in the field. For instance, our "FLASH" feature enables the customer service representative to inform the dispatcher, through the computer, of any problems with work already routed and in the field

— information such as reschedules, time changes, cancellations, etc.

And our "ALERT to Customer Service" feature allows the dispatcher to enter messages that will instantly be displayed at all customer service stations — information such as "Outage — South end of town. Schedule no more trouble calls for that area."

And just to be sure we're batting a thousand, Release 5 is set up so that "non pay" disconnects are automatically cancelled by a payment. If the scheduled disconnect is already routed and in the field, a "FLASH" is automatically sent to the dispatcher.

So if you find your office team isn't communicating like they should, and your customers aren't getting the answers they need, CableData could be the answer. Give us a call. We've got all the bases covered.

CableData. 3200 Arden
Way, Sacramento, CA 95825.
Telephone (916) 485-2911.

**cable
data**

and 7:15 AM, but no later than the requested time.

If the operator makes a mistake during any entry, he may cancel the entry by pressing the "ERROR" key. When the entry is correctly made, he must terminate the commands by pressing the key labeled "SEND". After the "SEND" key is pressed the printer will output the new room status in the following manner:

```
ROOM XXXX OCC
PTV ON BTV ON
WAKE UP 7:12 AM
```

If the operator wishes to check status of a room without sending any commands, he may enter the room number, press the space bar and then press "STATUS". The printer will respond as follows:

```
ROOM XXXX
PTV ON BTV ON
WAKE UP 7:12 AM
```

Whenever a room is checked out and the Pay TV or Basic TV options are installed, the printer will output the following message:

```
ROOM XXXX   CHK OUT
**PAY TV     4 Days**
**Basic TV   5 Days**
```

An option to the software package is the energy cycle program. The controller normally cycles the room climate control (heat or air-conditioning) on at check-in and off at check-out, but this option allows more energy savings by cycling the room controls at a fixed, predetermined rate (usually 90 percent on, 10 percent off).

For further information, contact Control-Com, Inc., 123 Ragland Road, Jackson, Tennessee 38301, (901) 668-1002.

GMS Presents Its Customer Service System

The GMS Customer Service System replaces traditional microfiche and paperwork with an instantaneous video display of data relevant to current and potential customers.

Information regarding customers and serviceable addresses is captured by the computer for display and use by system personnel. Tracking, controlling, and display of the information renders elaborate paperwork and filing systems obsolete.

From a single request by customer name, address, account number or phone number, customer service personnel can reference all information about the customer or address. Simul-

taneously, the computer allows entry of future action requirements such as connect or disconnect orders. The capture and scheduling of these events eliminates the duplication of effort and loss of control associated with manual and batch computer processes.

As an adjunct to total customer base, the GMS system produces timely accounts receivable and financial reports directly from the regional computer center on your in-house printer, thus avoiding lengthy mail and processing delays associated with large central billing facilities.

The GMS system was originally the response of a cable television operator to his unsatisfied need for a faster, more accurate and economical approach to front office and field procedures. The basic design and implementation of the system began in 1975 and was completed in early 1976. After two years of operation in the live environment, the GMS system was offered to the public in 1978. In the first year, the system was employed by 19 companies to serve over 50,000 customers.

Because of its real world genesis, the GMS system is oriented to the pragmatic aspects of system operations. The emphasis is on simplicity, rather than the over-engineered sophistication so often displayed by systems developed in the computer room environment.

For further information, contact GMS, 675 North First Street, Suite 1200, San Jose, California 95112, (408) 998-8078.

LDM Provides Management Consulting and Technical Services

LDM has experienced personnel in a wide variety of business areas: manufacturing, finance, retail, distribution, and many others. They propose, develop, and implement computer appli-



cations, and can analyze and study your business requirements, suggest manual or automated solutions, and implement them at your convenience and under your direction.

LDM offers the services of its systems and programming personnel to perform feasibility studies, write systems specifications, analyze methods and procedures, design computer systems and provide all accompanying documentation. Their programming staff will code and maintain new and current systems, and help in performing system conversions and updates.



LDM provides its clients with reliable computer processing on a variety of large scale and minicomputer devices. They also arrange for communications, on-line and batch processing, time sharing, facilities management, and computer hardware backup. LDM also makes available the services of their efficient Data Entry Department, which uses the latest in modern equipment.

Office supplies, pre-printed forms, paper products—LDM is capable of supplying all your business needs at competitive rates. They also have complete printing facilities on-premises, and offer full range mailing services for the convenience of their customers.

LDM has several turn-key computer software packages available for immediate implementation—from payroll to order entry to inventory, and more. If your special needs require customized systems, LDM's professionals are available to tailor packages to fit your desired results.

For further information, contact LDM, 529 South Second Avenue, Covina, California 91723, (213) 967-1506 or (714) 990-0501.

SBS Presents "The Uncompromising CATV Subscriber Business System"

The new Subscriber Business System from Station Business Systems is the result of in-depth research with

CATV system operators of all sizes—from 3000 subscribers to huge MSO's—all over North America.

The SSB system offers flexibility, low cost, and capabilities to substantially improve billing, credit controls, service scheduling, marketing, and collection procedures. The system is capable of high speed operation without turnaround time, is easy to use for training, and incorporates high reliability with minimum down time.

Because the system is in-house, there are no lines, no mailing of data for processing, and no "turnaround" time. Your information stays secure, in your offices, and you can run reports whenever you need them. In addition, those will be completely up to the minute, since data are entered directly into your computer. Input forms and errors are also dramatically reduced.

The SBS system is a complete turnkey package. SBS provides all the necessary components, including hardware, computer programs (software), training, and installation. SBS also arranges for hardware support, and will maintain a continuing relationship with you and your staff to keep the system, and the personnel involved with it, up-to-date. These services are included in the package price.

Terminal sharing, modular design, and a variety of service plans are also available from SBS.

SBS is a subsidiary of Control Data Corporation.

For further information, contact Station Business Systems, 600 West Putnam Avenue, Greenwich, Connecticut 06830, or call toll-free (800) 243-5300.

The TOCOM Central Data System

TOCOM has introduced a data processing system for specific application with two-way cable technology. TOCOM's new system is comprised of



the TOCOM III-A central data system and the TOCOM III-B security and communications system, either or both of which may be used in conjunction with the TOCOM HT-3B home terminal.

The TOCOM III-A central data system (CDS) can monitor and control as many as 3000 HT-3A or HT-3B home terminals through miles of coaxial cable plant. It can store up to 64 characters of demographic information for each home terminal, which the system operator logs into the CDS with an easy to learn English type command structure. Usually the information consists of subscriber's name, address, medical history, and other emergency related facts.

The TOCOM III-B security and communications system is a highly sophisticated computer-based, general-purpose data acquisition and control system that communicates over bi-directional coaxial cable. The system is designed to provide the basic capability for home security alarm monitoring services such as fire, medical emergency, and so forth. As many as 64,000 homes may be monitored in the fully expanded system configuration (11,000 initial capacity), with the alarm status of each home checked every few seconds. The system also incorporates design features that will easily allow expansion to provide additional functions, such as energy (load) management, meter reading, information retrieval, pay-per-view TV, opinion polling, etc.

Optional equipment allows remote terminals to be installed at a guard station, fire station, police station, or hospital.

For further information, contact TOCOM, Inc., P.O. Box 47066, Dallas, Texas 75247, (214) 438-7691.

New Business System For Cable Operators

Cable Computer Systems, a division of Toner Cable Equipment, Inc., has introduced a new computer system, specifically developed for the cable TV operator, and designed to effect each facet of your business in a fully integrated mode. By handling a document just one time, you are able to eliminate redundant postings, and update many areas of your business simultaneously.

The major modules provided by the Cable Computer System are: sub-

scriber billing, inventory order entry, and payroll.

The subscriber billing mode enables the operator to create all necessary files within the system, including master subscriber file, master bill-to files, daily activity files, month and year to date files, and a control table file. The mode allows a variety of revisions in the master file data including daily activity posting and totals, and automatic generation of receivables for interest on past-due accounts plus automatic posting of current monthly charges.



One feature of the system is the automatic aging of accounts receivables—on the basis of a) all customers, b) 15-30 day balances, c) 30-60 day balances, d) 45-90 day balances, and e) suggested disconnects. In addition, the system has print-out capability for master subscriber file activity and for sequencing subscriber files.

All programs are selected by a master screen selection display and each individual step provides all necessary prompts to allow required job functions as well as corrections for mistakes.

The inventory order entry system has been built to keep track of inventory quantities and subsidiary operations such as schedules for receipt and distribution. In conjunction with this system is an account payable for inventory items received plus work order processing for new and current subscribers.

The payroll programs when written will be table oriented, and will allow for changes in the tax rates plus the ability to handle various kinds of pay scales including salary, hourly, incentive, commission, contractual, and sub-contractual.

For further information, contact Cable Computer Systems, c/o Toner Cable Equipment, Inc., 969 Horsham Road, Horsham, PA 19044, or call toll-free (800) 523-5948. **C-ED**

See us at the
Texas Show
Booth Nos.
106 & 107



We Thrive on Rejection..

and with VITEK's Band Reject Filters so can you!

You know VITEK Filter Cable Traps offer the best security because they're passive, negative and on-the-pole . . . and have the durability of coaxial cable.

What you may not know is that in addition to single and multi-channel traps, they are also offered in 3 different Band Reject configurations . . . with 50 dB min. attenuation (-20° to +120° F).

Now you can market blocks of channels in either Mid-band or Super-band (or both) to your subscribers. Or, you can start out with a single premium channel in either mid-or super-band, and, utilizing the band reject trap and a converter, you'll have all the security you need.

If you are rejected . . . so is their Pay TV Signal.

If a block is sold . . . simply remove the trap.

And if at some future date you wish to expand to additional



premium channels and programming it's easy to do with VITEK Single or Multi-Channel Traps.

- Forget about illegal converters or varactor-tuned TV sets.
- Forget about maintenance, returns, "lock-outs", loaners and other TV security problems.

With Vitek you get maximum security . . . with maximum flexibility . . . at minimum expense.

That's an offer no one can reject.

For additional information, call or write:



A Subsidiary Of AUGAT®
4 Gladys Court, Edison, NJ 08817
(201)287-3200 TELEX-VITEK-EDIN

Direct Video Access to NOAA Weather Satellite Pictures

By J.D. Cauldwell and R.D. Richards, Arvin CATV

The United States operates weather satellites that send back to the ground both visible and infra-red pictures. These satellites are in orbit around the Earth to provide coverage of the whole world.

For the United States the best coverage is provided by GOES and WEFAX Satellites. These Geostationary Operational Environmental Satellites are in orbits precisely adjusted so that the rotation exactly coincides with the rotation of the Earth. The satellites are located in orbits of about 22,000 miles and travel at 6,800 miles per hour. This corresponds exactly to the rotation of the Earth at the point directly below the satellite.

NOAA has two operational satellites. GOES-EAST covers the Atlantic Ocean and the Eastern U.S.A. GOES-WEST covers the Eastern Pacific and the Western U.S.A.

The satellites spin on their axes at 100 revolutions per minute.

Each satellite is equipped with a visible and infra-red radiometer that scans the earth on each spin of the satellite. The radiometer scans North to South in 1821 steps and has eight visible channels and two infra-red. Definition of this camera system is a half-mile on the earth at the sub-point (the point directly below the satellite) for visible pictures, and 5 miles for infra-red.

Signal Processing

The signals from the satellite are received at the satellite command station at Wallops Island, Virginia; where the data

rate is reduced for simplification of transmission.

From Wallops Island, the data is retransmitted via the satellites; and is received by the National Environmental Satellite Service (NESS) in Washington D.C., via microwave from ground station at Suitland, Maryland.

At NESS in Washington, the data is fed into a special computer system.

Each picture received by the computer is information that contains an "Earth disc" picture. That is the circle of the earth's surface viewed from the satellite, and is 8000 miles in diameter, about one quarter of the total surface of the earth.

The computer processes the information to give pictures in facsimile format. Sectors of the earth disc are enlarged to give full frame pictures of 4000 mile, 2000 mile, and 1000 mile sectors.

The computer also processes the data to produce enhanced pictures that have better tonal separation than the original satellite image.

Distribution

Satellite pictures are re-transmitted by telephone line to Weather Service offices that are accessible from anywhere in the US, and also retransmitted as radio signals that are relayed by the same satellite, and can be received by simple ground stations.

Pictures are sent each half-hour during daylight. The program includes both visible and infra-red pictures that are required by the WSFO. At night, only infra-red pictures are available. Connection to WSFO GOES-TAP is available to communicators at no charge, and access to the retransmitted radio signals is available to any ground station.

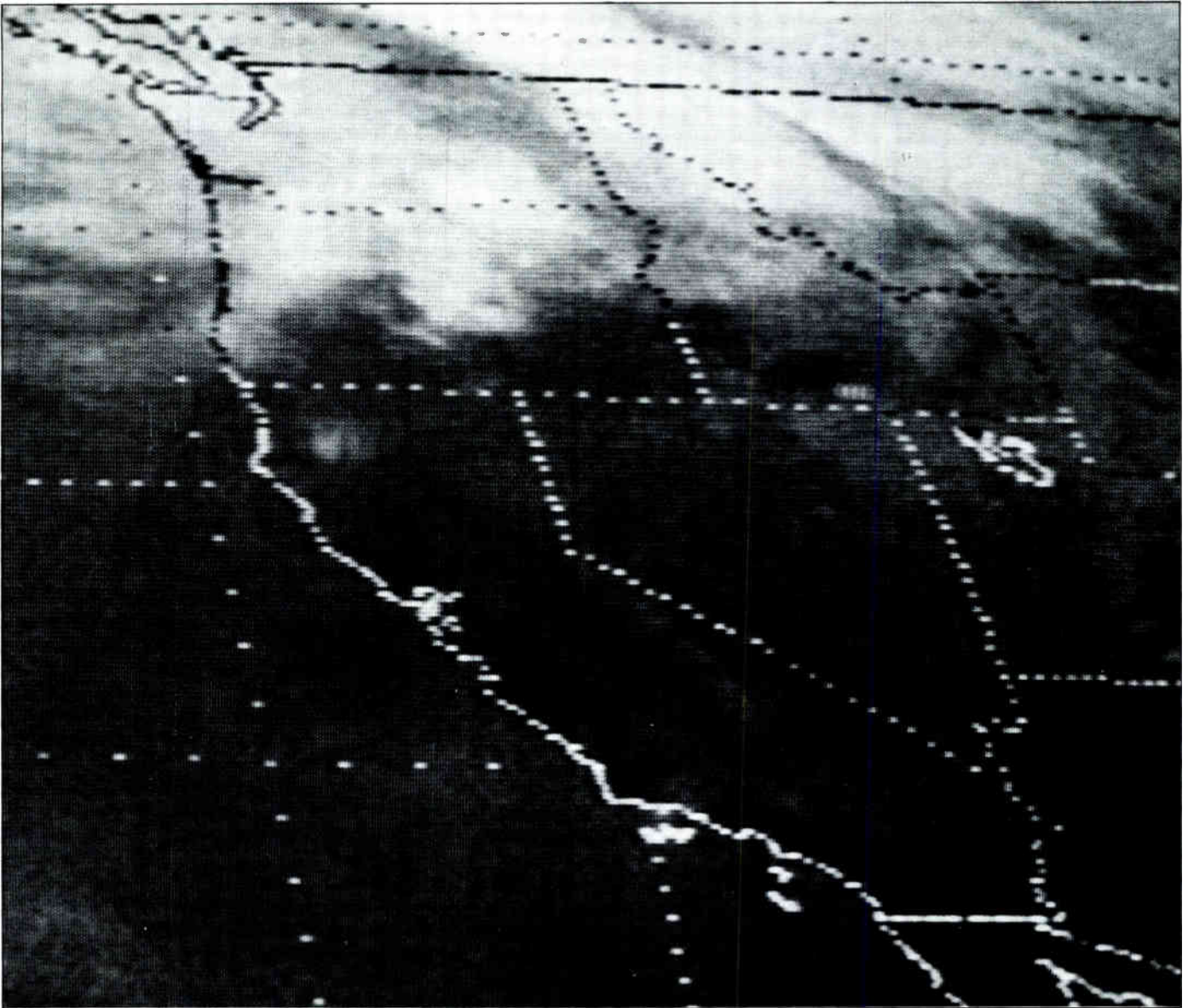

Access to GOES Satellite Pictures by Arvin's Weather-Sat Receiver

The Weather-Sat receiver is designed specifically for access to satellite weather pictures, and to produce automatically a video output. This video can be put on air without intermediate manual processing.

Weather-Sat can be connected to the GOES signal at the

nearest WSFO by telephone line, or to the WEFAX radio signals by antenna and ground converter. The Arvin Weather-Sat converts the satellite signal automatically into video, in realistic sea, land, and cloud colors. The incoming signal is entered into an electric memory in the Weather-Sat and is stored until up-dated or erased.

This process eliminates the need for studio camera work and computer assistance. **C-ED**

Cable Programming for February

Signal	Day	Start/Stop	Alert Tones	Satellite/ Transponders	Signal	Day	Start/Stop	Alert Tones	Satellite/ Transponders
C-SPAN (times approximate) Mondays 9:00 a.m. to 6:00 p.m. Tuesdays 10:30 a.m. to 6:00 p.m. Wednesdays 9:30 a.m. to 6:00 p.m. Thursdays 9:30 a.m. to 6:00 p.m. Fridays 10:30 a.m. to 5:00 p.m.					195*/# F1, #9				
Calliope		6:30 pm-7:30 pm (Mon., Tues., & Thurs.)	168*/#	F1, #9	Newstime		24 hrs.	276*/#	F1, #6
CBN		24 hrs.	No	F1, #8	Nickelodeon		10 am-11 pm (weekdays) 9 am-11 pm (weekends)	749*/#	F1, #11
ESPN Monday thru Thursday 6:00 p.m. to 4:00 a.m. Friday, 6:30 p.m., to following Monday, 4:00 a.m.					F1, #7				
Front Row		2:30 pm-2:30 am	481*/#	E,C F1, #12 P,M F1, #10	PTL		24 hrs.	No	F1, #2
HBO		1 5:00 pm- 1:47 am 2 2:00 pm- 1:30 am 3 3:00 pm-12:30 am 4 6:00 pm- 1:33 am 5 5:30 pm- 2:21 am 6 5:30 pm- 2:11 am 7 6:00 pm- 1:30 am 8 5:00 pm- 2:03 am 9 2:00 pm- 1:15 am 10 3:00 pm- 1:15 am 11 5:30 pm-12:49 am 12 6:00 pm- 1:33 am 13 5:30 pm- 2:00 am 14 5:30 pm- 2:12 am 15 5:00 pm- 1:30 am 16 3:30 pm- 1:19 am 17 2:30 pm- 2:17 am 18 6:00 pm- 2:44 am 19 6:30 pm- 1:15 am 20 6:00 pm- 2:03 am 21 6:00 pm- 1:30 am 22 6:00 pm- 2:06 am 23 2:00 pm- 2:42 am 24 3:00 pm- 2:09 am 25 6:00 pm- 1:49 am 26 6:00 pm- 1:12 am 27 5:30 pm- 1:30 am 28 5:30 pm- 2:00 am 29 5:00 pm- 1:31 am	Program 729*/# Scramble 835*/# Duplication 940*/# Take-2 E. 592*/# Take 2 W. 681*/#	F1, #24 F1, #22 F1, #23 F1, #20	Reuters		4:00 a.m. to 7:00 p.m. Monday thru Friday	No	F1, #18
					SPN		10 pm-8 pm (Mon.-Sat.) 24 hrs. (Sun.)	429*/# auto switch to commercial, on/off respectively 517# end SPN, begin HTN 517* end HTN, begin SPN	F1, #21
					Showtime		1 6:00 pm- 2:05 am 2 3:15 pm- 2:15 am 3 3:00 pm-12:59 am 4 6:30 pm-12:50 am 5 6:00 pm- 1:05 am 6 5:45 pm- 1:32 am 7 6:00 pm- 1:12 am 8 6:00 pm- 2:02 am 9 3:15 pm- 2:45 am 10 3:30 pm-12:50 am 11 6:30 pm- 1:32 am 12 6:00 pm- 1:32 am 13 6:15 pm- 1:03 am 14 6:30 pm-12:29 am 15 6:30 pm- 2:05 am 16 2:15 pm- 2:41 am 17 3:30 pm- 1:35 am 18 5:30 pm-12:32 am 19 6:30 pm- 1:21 am 20 6:15 pm- 1:56 am 21 6:00 pm-12:57 am 22 6:00 pm- 1:33 am 23 2:45 pm- 2:02 am 24 3:00 pm- 1:02 am 25 5:30 pm-12:41 am 16 6:30 pm- 2:21 am 27 5:15 pm- 1:05 am 28 6:00 pm-12:51 am 29 6:30 pm- 2:32 am		576*/#†† E, C, F1, #12; P, M, F1,
HTN		8 pm-10 (11) pm	517*/#	F1, #21	SIN		2:30 pm-1 am (weekdays) 4 pm-12 am (Sat.) 11 am-11:15 pm (Sun.)	No	Westar II, #7
KPIX (time permitting)		2-4 hrs. per day	No	F1, #1	Star Channel		9:30 am-2:20 am	311*/#E, 519*/#W.	F1, #5
KTVU		7 am-1 am (weekdays) 7 am-4 am (weekends)	No	F1, #1	Trinity (KTBN)		24 hrs.	No	F1, #14
MSG Sports Start times only; stop times are subject to length of events					438*/#† F1, #9				
		1 7:30 pm 2 8:30 pm 3 1:30 pm 4 9:00 pm 5 6 9:00 pm 7 7:50 pm 8 9 2:00 pm 10 7:30 pm 11 8:00 pm 12 8:00 pm 13 8:00 pm 14 7:50 pm 15 8:00 pm	16 1:30 pm 17 7:30 pm 18 8:00 pm 19 8:00 pm 20 7:30 pm 21 7:50 pm 22 8:00 pm 23 1:30 pm 24 4:00 pm 25 26 9:00 pm 27 7:30 pm 28 7:30 pm 29 8:00 pm		WGN		5:42 am-3 (3:30) am (Mon.-Thurs.) 24 hrs. Sat. & Sun. Ends 3 am on Sun.	No	F1, #3
					WOR		6:30 am-1:30 am		F1, #17
					WTBS		24 hrs.	No	F1, #6

E = eastern
C = central
M = mountain
P = pacific

All program times are listed for the eastern time zone, unless otherwise noted.

† Commercial substitution 601*/#; Thurs. baseball 706*/#.
†† On-line 679*/#; off-line 753*/#; access 843*/#.

Lindsay

need line extenders... **RIGHT NOW?**

Call your distributor for *IMMEDIATE DELIVERY* on the
Lindsay 900 Series Modular Line Extender

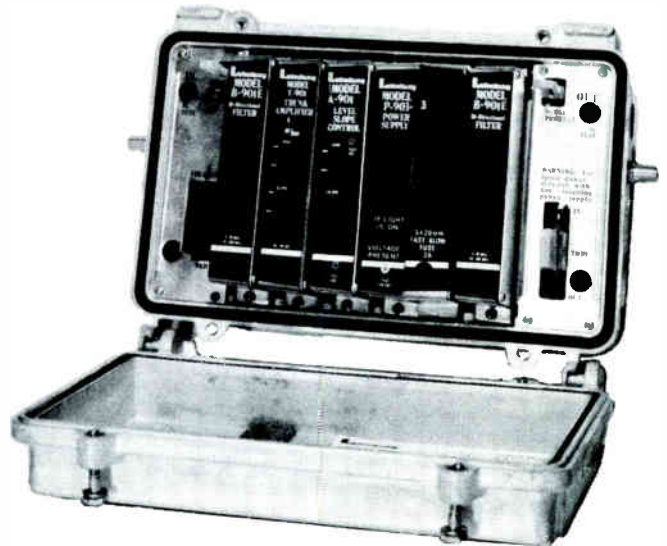
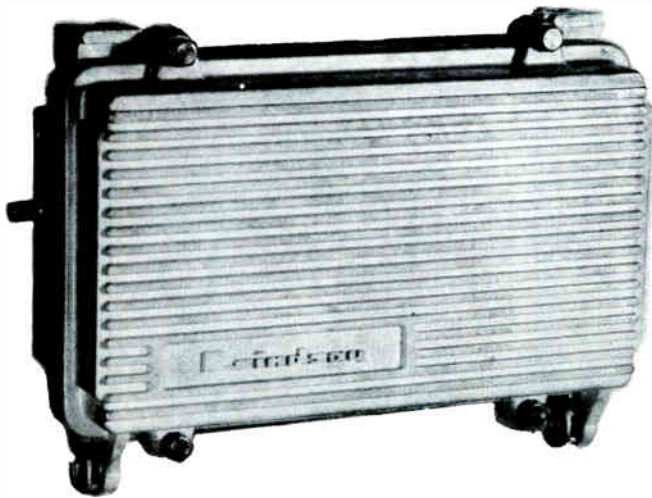

YOU BENEFIT...

- MODULAR DESIGN, CUTS SERVICE TIME
- TWO CHIP 40-300 MHz AMPLIFIERS FOR OPTIMUM PERFORMANCE AND LOW NOISE FIGURE
- 27 dB & 40 dB GAIN MODULES; EFFICIENT "SWITCHING" POWER SUPPLY MODULE
- PLUG IN MODULES TO UPGRADE TO TWO WAY OR ADD AGC
- SEPARATE RFI AND WATERPROOFING HOUSING GASKETS
- BUILT IN TEST POINTS, EXTERNAL ACCESS
- 20-60 INPUT VOLTAGE OPERATION WITHOUT CHANGING TRANSFORMER TAPS
- SURGE PROTECTION ON INPUT AND OUTPUT PORTS (PLUG IN)
- PRICE COMPETITIVE WITH SINGLE MODULE LINE EXTENDERS

IN STOCK at your local distributor...

IN EUROPE : **TECNICOBEL S.A.**

26 Rue des Deux-Eglises
1040 Bruxelles Le Belgium
Telephone : 02 / 219-3570

CALL HIM TODAY!

Lindsay Specialty Products Limited
50 Mary St. W., Lindsay
Ontario, Canada K9V4S7 Tel. 705-324-2196

DISTRIBUTED BY :

COMSE SALES CORP.
P.O. Box 645
Lawrenceville, Georgia 30264
Telephone : 404 / 963-7870

FLORIDA ADDRESS :
P.O. Box 10185
Sarasota, Florida 33582
Telephone : 813 / 371-3444

WESTEC ENGINEERING SALES CO.
7305 East Evans Road
Scottsdale, Arizona 85260
Telephone : 602 / 948-4484

TONER CABLE EQUIPMENT INC.
969 Horsham Drive
Horsham, Pennsylvania 19044
Telephone : 215 / 675-2053
Toll Free : 800 / 523-5947

WOULDN'T YOU RATHER SWITCH

. . . . than fight your customers over outages due to satellite receiver failure? The Comtech "PRIORITY PROTECTION PACKAGE" will eliminate this source of aggravation for you and your customer.



**RCV-450A
AGILE RECEIVER**

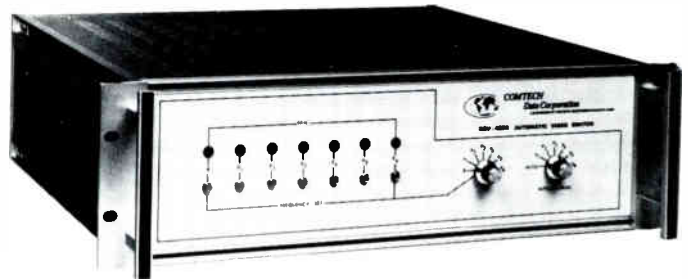

**RCV-450S
SIX CHANNEL SWITCH**

The Comtech "Priority Protection Package" will accept up to six satellite receiver outputs. The switch will detect a video failure and substitute the agile receiver for the failed equipment. The agile receiver may be used simultaneously as an on-line receiver for some non-premium channels as long as there is no premium channel failure.

CALL COMTECH TODAY



COMTECH
Data Corporation

A SUBSIDIARY OF COMTECH TELECOMMUNICATIONS CORP.

613 S. ROCKFORD DR. • TEMPE, AZ 85281 • (602) 968-2433 • TWX 910-950-0085

International Fiber Optics and Communications Magazine

The only trade magazine devoted exclusively to the application of fiber optics to communications and related industries, will be published six times a year starting in January, 1980; and will include a Fiber Optics Handbook and Buyers Guide as the seventh issue.

The technology of Fiber Optics for Communications will revolutionize the electronics field. Major developments in this field have occurred within the last five to ten years. It is no longer a laboratory curiosity, but is finding rapid acceptance in all fields. The world market for Fiber Optics Systems, Components, and Services is expected to grow to \$1 billion by 1985. Every major industry will be affected by fiber optics (communications, radio & TV, CATV, data, power, defense, process control, automotive, etc.).

To subscribe, and receive all six issues, plus the Fiber Optics Handbook and Buyers Guide, contact: Marketing Director, I.F.O.C., 167 Corey Road, Brookline, MA 02146, (617) 739-2022.

Opportunities for Engineers Outlined in New Brochure

Opportunities for experienced engineers to work in such state-of-the-art GTE technologies as fiber optics, digital integrated circuits, highest complexity MOS memory, bubble memory, codecs and many others are outlined in a brochure from GTE Automatic Electric Laboratories Incorporated.

Entitled "Career Opportunities in Telecommunications," the brochure describes the excitement and rewards that come with operating at the leading edge of the state-of-the-art in applying new technology effectively to large-scale systems.

Copies of the brochure are available from J. Douglas Allen, GTE Automatic Electric Laboratories Incorporated, 400 North Wolf Road, Northlake, Ill. 60164.

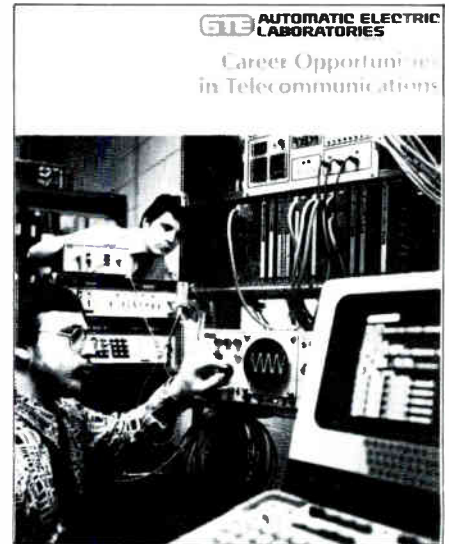

New Brochure from GTE



**People
Power**

**helps
prevent
birth
defects**

March of Dimes

THIS SPACE CONTRIBUTED BY THE PUBLISHER



**TRIPLE CROWN
ELECTRONICS INC.**

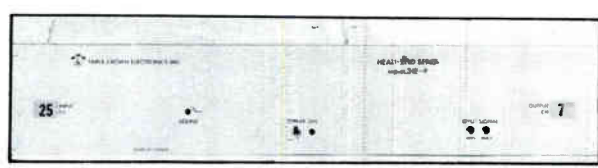

MODEL HE-P SIGNAL PROCESSOR

The HE Series of processors and modulators was designed to meet today's needs of small systems for high quality processing and adjacent channel loading at an economical price. All frequency conversions are crystal controlled and have IF accessibility. Input signal range: baseband or 5-900 MHz. Output signal range 5-300 MHz.

Come by and see us
at Booth 232 at the Texas Show

**Write or call: 42, RACINE ROAD,
REXDALE, ONTARIO, M9W 2Z3.
Tel. (416) 743-1481**

We specialize in being active!

Power Supplies/Test Equipment

New Standby Power System

Standby Electronics Corp. of Mississauga, Ontario, announces the new SPS-900 standby power system. The SPS series is specifically designed for use in the CATV, data and telecommunications industries. (The efficiency specification of the SPS-900 is 96%, from 25% to 90% of full load in the standby mode.)

In the CATV application, the SPS-900 system can utilize existing ferroresonant power supply modules. Simply remove them from the pole and install right in the SPS-900 cabinet. This makes system updating very economical. The unit is also available with the ferroresonant module.

Time elapsed meters, events counters, status monitor indicators are just some of the options on the new system. A unique "bypass" switch completely isolates inverter and ferroresonant modules to allow maintenance and troubleshooting while eliminating any system interruptions. The same is true of external drive from a generator. A 110 volt version is available for microwave sites, head-ends and TVRO installations.

For complete details, including pricing, contact Emberson, Trainor Communications Ltd.; 151 Carlingview Drive; Rexdale, Ontario; M9W 5E7; (416) 675-2020.

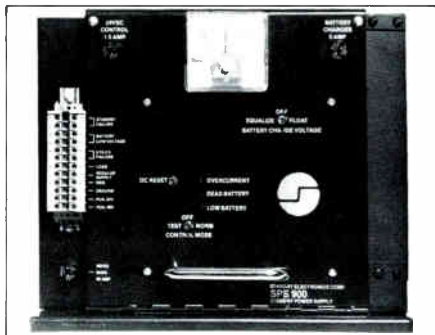

Earth Station

Up/Down Converters Product Improvement

LNR Communications, Inc., has

redesigned their Model UC6 and DC4 Earth Station Frequency Converters in order to allow simplified adjustment of the frequency on the crystal oscillators.

This new design allows the Crystal Oscillators to be easily accessible from the rear of the converter.

This improvement is of particular interest in applications such as Digital SCPC where carriers are very closely spaced in frequency.

In the previous design of these Ultra Low Phase Noise Converters, a top panel had to be removed in order to make the adjustment.

Since LNR's Frequency Converters are completely self-contained, with power supply, all adjustments can be made while the units are still in operation.

For further information, contact LNR Communications at (416) 842-1492.

New Silicon Diodes from Microwave Associates

Microwave Associates, Inc. has announced the development of its "1N" Series of high power silicon epitaxial multiplier varactor diodes. These diodes are specifically designed for efficient frequency conversion at output frequencies from 150 MHz thru 10 GHz.

This series of diodes is offered in a variety of case styles (with custom packaging available upon request) and is intended for use in frequency multipliers which are specifically designed to function as transmitters in communications, telemetry, portable TV and other similar communication



system applications.

Features include: high power capability, hermetic seals; and low thermal resistance. Complete specifications and selection guide are provided in a new brochure which is now available. For information request Bulletin 4404 or contact Mr. Joseph Corvino at Microwave Associates, Inc. (617) 272-3000.

Video

Chyron Announces New Mobile Electronic Titling And Graphics System

To meet the demand of electronic news gathering (ENG) for high quality mobile electronic graphics equipment which can be mounted in vans for on-location coverage of events, Chyron Telesystems, Melville, L.I., N.Y. has developed the new Model RGU-1. Incorporating many of the most important features of the top-of-the line Chyron IV, the RGU-1 provides TV stations with the capability for both field and studio operation.

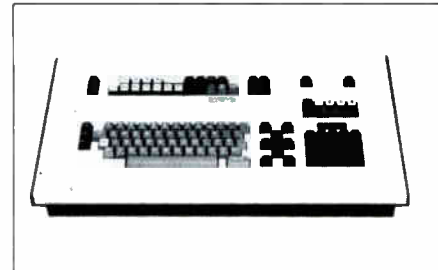

Among the most significant features of the modular RGU-1 are: 27-nanosecond resolution; flexibility; simple, uncomplicated operation; a large standard Font Library compatible and interchangeable with the Chyron IV Standard Font Library; unlimited font storage in groups of four complete fonts at a time; individual character-by-character color may be produced with optional colorizer/keyer/edger; keyboard console specifically designed for easy operation; controllable from an unlimited number of keyboards at different locations; an optional second channel which converts the RGU-1 into a high-resolution dual channel system; optional external interface units to handle RS232 and other information interchange disciplines.

Technology

Additional capabilities such as roll, crawl, slow reveal, flash, centering, insert and delete, are described in the new .RGU-1 brochure, available on request from Chyron Telesystems, 265 Bethpage-Spagnoli Road, Melville, N.Y. 11747, (516) 694-7137.

Miscellaneous

Obstruction Lighting System Controller

An improved obstruction lighting system master controller that permits unmanned and remote site monitoring has been introduced by Flash Technology Corporation of America, of Nashua, New Hampshire. The system is used to monitor and control beacon lights on broadcast towers.

The Flash Technology ElectroFlash™ Controller monitors and displays individual beacon condition, day/twilight/night system status, and system fail. Each display indicator can be provided with an optional interface to allow complete remote system monitoring.

Accommodating systems with up to 28 beacons, the Flash Technology ElectroFlash™ Controller SC-205 optionally provides monitor function and individual beacon tests. Typical applications include AM, FM, TV and microwave communications towers, and power plant chimneys and towers.

The Flash Technology ElectroFlash™ Controller SC-205 is priced at \$5,080 base; \$990 for monitor section test; \$990 for both beacon and monitor test; and \$300 base plus \$300 per card for remote monitoring. Literature is available on request. For more information contact: Flash Technology Corporation of America, Donald J. Rowe, Marketing Department, 55 Lake St., Nashua, NH 03060, (603) 883-6500.



Thanks
for your readership support!

G-ED

Communications-Engineering Digest
Reporting the Technologies of Broadband Engineering

Build a headend with a future.

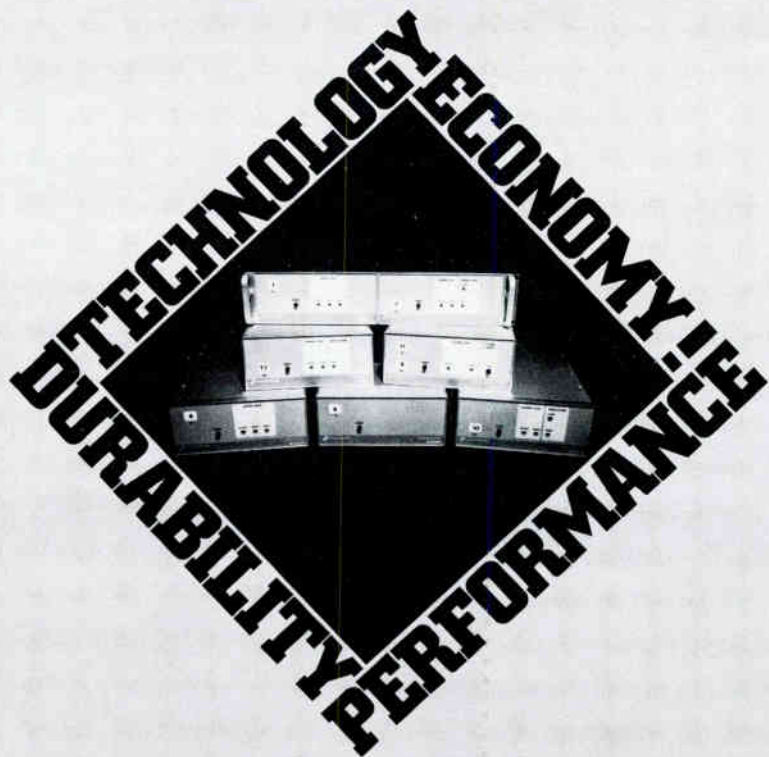

Phasecom's fundamental approach to headend electronics defines a new standard of value.

Unsurpassed technical specifications in an integral package design... optimizing long term reliability and performance.

This means that what you buy today, will still be good tomorrow...time wise, technology-wise.

Modulators, Demodulators, Heterodyne Processors. Pre-packaged Headend Systems in

standard or coherent configurations.

Phasecom Headend Electronics. It's something you can depend on. Now, and for the future.

PHASECOM CORP.
The Headend Experts

6365 Arizona Circle
Los Angeles, CA 90045
Tele: (213) 641-3501

LECTRO PRODUCTS CATV Standby Supply



SV-L-4-60-BC

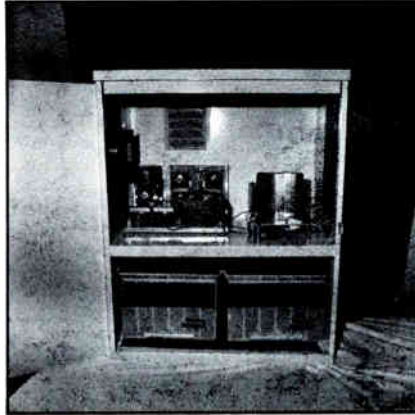

SV-S-4-60-BC

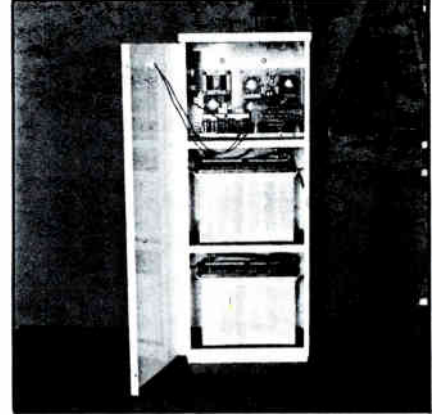

SV-L-3-60-C

FOUR YEARS OF PROVEN PERFORMANCE FEATURES:

- Plug in PC cards for easy maintenance
- Automatic overload and short circuit protection
- 24V DC input for minimum battery cost
- Under voltage protection
- Aluminum pole mount housing
- Pedestal mount optional
- Constant voltage battery charger
- Power supply status indicators
- Metered battery voltage and output current
- Surge protection to power transistors, 115V AC input and 30/60V AC output
- Temp. range -40° to +140° F
- Output Power -720 watts, 30 or 60 volts
- Low voltage shutdown -18 volts
- Utilizes any make of ferroresonant transformer

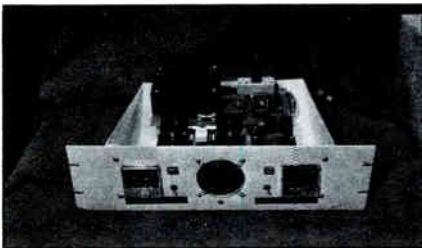

SH-0-3-11-0

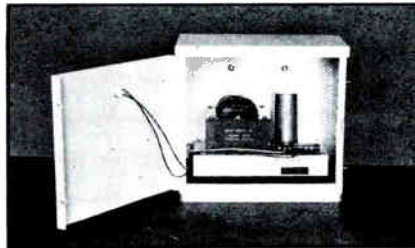

FR-F-1-60-BC

FEATURES SH-0-3-11-0

- Designed for maximum reliability at minimum cost
- Surge protection provided for power transistors as well as 115V AC input and output
- Plug in PC cards for easy maintenance
- Front panel power supply status indicators
- Metered battery voltage and output current
- Fan cooled for maximum reliability
- Automatic overload and short circuit protection
- Low voltage battery protection
- Constant voltage battery charger
- 24V DC input for minimum battery cost
- Rack mounts in 5 1/2" rack space

SPECIFICATIONS FR-F-1-60-BC

Input 95-135VAC, 60 Hz 840W
 Output 14A @ 30 or 60VAC
 Line and Load Regulation +or-4% 1/4to full load
 Efficiency90% full load
 Overload Protection
 Fold-back limited above 16AMP
 Dimensions 13W-8D-11H
 Weight 36 lbs.

LECTRO
has a definite aim,
POWER
is our middle name,
SUPPLIES,
no others are quite the same,
STANDBY,
we don't consider a game,
RELIABILITY
is our claim to fame.

COME SEE US IN TEXAS IN BOOTH #109

**COMMUNICATIONS
DISTRIBUTION CORP.**
P.O. Box 567 • Athens, Georgia 30601
(404) 353-1159

Employment Oppt.

LOOKING FOR QUALIFIED JOB APPLICANTS OR A NEW POSITION?

We are an employer-paid personnel service organization maintaining data on positions and personnel available nationwide. Call or write for our free "Top Job Candidates" bulletin. Confidential services. Licensed by the California Bureau of Employment Agencies.



Research, Brokerage,
Personnel and Marketing
Services
Established 1971

**COMMUNICATIONS MARKETING, INC.
PERSONNEL SERVICE**

2326 Tampa Ave., El Cajon, Ca 92020 (714) 461-7891

PROMOTE YOURSELF/CABLE CAREERS

- **TECHNICIAN** \$14 to \$16,500 K.
Outside maintenance, Colorado mountain location.
- **CHIEF TECHNICIAN TRAINEES** \$6 per hour plus, plus
Oklahoma and Kansas, have own system in one year.
- **CHIEF TECHNICIAN** \$17 K
Illinois location.
- **CHIEF TECHNICIAN** \$14 to \$16 K
Texas Gulf coast, 65 miles plant.
- **CHIEF TECHNICIAN** SALARY OPEN
Houston, Texas, must know head-in.
- **MANAGER TECHNICIAN** SALARY OPEN
Upper New York, 3,000 subscriber system.
- **CHIEF TECHNICIAN** \$19 K
Second class FCC, Kansas location.
- **CHIEF ENGINEER** \$20 to \$25 K.
Southwest location, over four systems
- **CONSTRUCTION SUPERINTENDENT** \$25 to \$30 K
Sunny south location.
- **SPLICERS** \$8 per hour plus, plus.
Texas location.

Call collect day, evening or weekends for information about these and other opportunities. (713) 941-3236

Jim Young & Associates • P.O. Box 225 • South Houston, TX 77587

CATV Recruiters

Fees Paid

Help Wanted

T.C.I.

Choice positions open. Are you stalemated? Would you like to join the third largest MSO and grow with the CATV industry? Tired of cold northern climate? We have openings in our Southeast Region for the following positions: Engineering Assistant, Engineering Technicians, Construction Supervisors, Construction Technicians, System Designers, Chief Technicians, Senior Technicians, Field Technicians and Bench Technicians. Excellent benefit package. Wages \$6.00 to \$10.00 an hour. Salaries from \$18,000. Send resume in confidence to Henry S. Swindle Sr., S.E. Region Engineer, Tele-Communications, Inc. P.O. Box 3665 Knoxville, Tenn. 37917

CHIEF ENGINEER

Capable of handling the operation and maintenance of sophisticated 35 channel system in Central Texas. Also should have experience in satellite and microwave equipment. Salary open. Call collect. Tom Campbell (713) 463-3543 or write 5228 Highway 6 North, Houston, TX 77084

TECHNICIANS

Immediate opening in Southeast Texas with medium sized MSO for experienced service and maintenance techs. Excellent pay and benefits. Contact:

J. A. DiBacco
Liberty TV Cable Inc.
(713) 962-8332
E.O.E.

CHIEF TECHICIANS

Immediate openings available in rapidly expanding Northeast Ohio market with state-of-the-art two way 40 channel system. The right person will be a self-starter, experienced in system maintenance from head-end to subscriber. FCC testing, TVRD, and construction experience helpful, but not necessary. Excellent salary and benefits package. We are an Equal Opportunity Employer. Please send resume or contact Douglas MacLeod, Regional Engineer, Continental Cablevision of NE Ohio, 322 Broad Street, Elyria, OH 44035 (216) 323-9923

IMMEDIATE OPENINGS

Experienced installers, technicians and Installation Foreman. MUST CLIMB. S.E. Texas. CONTACT:

J.A. DiBacco
713-962-9814
9 a.m. to 4 p.m.
LIBERTY CABLE TV
E.O.E.

Chief Technician

MSO is looking for an experienced chief technician to assume responsibility for it's technical operation in southern Florida. Applicant must have second-class FCC license and microwave, earth-station experience. Heavy system and head end maintenance experience are also required. Salary commensurate with experience. Send resume to:

JDF Communications
P.O. Box 97
Minoa, NY 13116

Help Wanted

Help wanted: CATV construction personnel needed immediately. Openings in all phases of construction. Top wages. Send resume in confidence to or call: G.M. Gest
P.O. Box 1168
Carefree, AZ 85331
602-971-0450

DIRECTOR OF ENGINEERING High Versatility Industry Position Washington, D.C.

Excellent opportunity as Director of Engineering for ARTEC's 72,000 home cable television franchise in Arlington County, Virginia across the Potomac River from Washington, D.C.

Successful candidate must have extensive working and theoretical knowledge, experience and inter-relationship understanding in the following areas:

- Two-way interactive system design
- System aerial and underground construction practices; proof of performance and formal acceptance practices
- 35 channel, interactive multi-hub system operation and maintenance
- Design, construction, operation of CARS and common carrier microwave
- Apartment pre-wire design and construction techniques
- Subscriber installations and service practices
- Satellite receiving and transmitting technology and operations
- Fiber optics technology and practices

Successful candidate will, in addition, have good interpersonal skills:

- To manage engineering department personnel and subcontractors
- To effectively communicate and operate within a results oriented, high achievement expanding corporate environment
- To assist in representing the National industry to regulatory, legislative, industry, international and local groups interested in and learning about cable television
- To assist with technical presentations of franchise applications

Excellent compensation package. Send resumes to:

John D. Evans, Vice-President and
Chief Operating Officer
Arlington Telecommunications
Corporation
2707 Wilson Boulevard
Arlington, Virginia 22201

An Equal Opportunity Employer

Take Charge Tech

For a successful LO operation near Chicago. Full studio and control room responsibilities. Respected communications parent company brings full benefits. Call:
Don Curley
815-937-2750

Business Directory

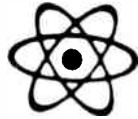

RMT ENGINEERING

CATV MATV REPAIRS

60-DAY WARRANTY
10-15 DAYS TURNAROUND

FOR PRICES WRITE TO

625 E. TAYLOR AVENUE
SUNNYVALE, CALIFORNIA 94086
(408) 733-4830

**JERRY CONN
ASSOCIATES,
INC.**

- Amps
- Cable
- Connectors
- Components
- Drop Mat'l
- Hardware
- Passives
- Traps
- Switchers
- Stand-by Power
- Sweep Gear
- Test Gear

**MANUFACTURERS'
REPRESENTATIVES**
TO THE CABLE INDUSTRY

P.O. Box 444
Chambersburg, Pa.
17201

Call (717) 263-8258 or
(717) 264-5884

TELE-ENGINEERING CORP Engineers and Contractor

FOR QUALITY CABLE COMMUNICATIONS SYSTEMS

- Strandmaps
- System Design
- Construction Supervision
- Head End Surveys and Design
- MW Surveys and Design
- TURNKEY IMPLEMENTATION

As independent turnkey contractor we will take your project from conceptual stages to completion. Through selection of quality system components, we will deliver a plant of highest reliability, performing to the most stringent system performance specifications.

2 Central St
Framingham, Mass 01701
Tel 617-877-6494

CATV EQUIPMENT REPAIRS

- Line & Distr. Amplifiers
- Field Strength Meters
- Headend & CCTV Gear
- Fast Turnaround
- Quality Workmanship
- Reasonable Rates

All repairs are
unconditionally guaranteed.
For more information call collect

**VideoTech
Service Inc.**
CATV - MATV - CCTV

4505-D W ROSECRANS AVENUE
HAWTHORNE, CALIFORNIA 90250
213-675-3266

SUBSCRIBE TO C-ED

RONALD C. COTTEN & ASSOCIATES

Professional Engineers

**General Consultation, CATV Strand Mapping
and System Engineering, Microwave, and
Satellite Communications Services Offered**

Phone: 303-770-4175

8775 E. Orchard Rd., Suite 817 Englewood, Colorado 80111

Professional Services

L.P. CATV SERVICES, INC.

- STRAND MAPPING
- POLE SURVEYS
- MAP SERVICES
 - Base Maps
 - As Builts
- SYSTEM DESIGN
- APARTMENTS
 - Layout-Design
- CONSTRUCTION
- CONSULTING
 - Construction
 - Operations
 - Technical
- PLANT AUDITS
- SYSTEM BALANCING

**CALL PAUL DECKMAN
609-693-0791**

P.O. Box 595

Manahawkin, NJ 08050

KATEK, INC.

"The Converter People"

Jerrold Authorized Servicer.
Hamlin Authorized Service.

Fast Turn-Around
Quality Work
Guaranteed Repairs

OFFICES:

Middlesex, NJ Jupiter, FL
(201) 356-8940 (305) 747-1808

Equipment for Sale

FOR SALE—Discounted for immediate sale "H" and "L" EHS galv. guy-wire. Installation avail. Call Tower Specialists Inc., (912) 285-2133.

**Look For
CABLEFILE/80**

CED Classified Rates and Information

Payable in advance. Check or money order only. (Billing charge \$1.00 additional.)

When placing an ad, indicate the exact category desired: Help Wanted, Position Wanted, Professional Services, Business Directory, etc. If this information is omitted, we will determine the appropriate category according to the copy.

Deadline is two weeks prior to cover date. Orders will be accepted by written confirmation or taken over the phone. Replies with Blind Box numbers should be addressed to (Box Number) c/o CableVision Magazine, 1139 Delaware Plaza, Denver, Colorado, 80204. Rates: \$25.00 per column inch. Minimum order one inch. For further information or to place your classified advertisement, contact Sheila Geary at 303/573-1433.

**Subscribe
To
CableVision**

AD INDEX

Arvin CATV Systems 38
 CableData 52
 Century III
 Electronics, Inc. 50
 Cerro Communication
 Products 11
 Comm/Scope
 Company 42-43
 Communications
 Distribution Corp. 68
 Comtech Data
 Corporation 60, 61
 Continental Specialties
 Corporation 31
 Eagle Comtronics, Inc. . . 79
 Eastern
 Microwave, Inc. 78
 EEG Enterprises, Inc. . . . 17
 Electroline Television
 Equipment, Inc. 23
 Gardiner Communication
 Corp. 20, 21
 General Cable Corp. 22
 Gill Management
 Services, Inc. 8
 Home Box Office 40-41
 Hughes
 Aircraft Company 7
 Lindsay Specialty
 Products 59
 LRC Electronics, Inc. 13
 Mid State
 Communications, Inc. . . 12
 Oak Communications,
 Inc. 2
 Phasecom Corp. 67
 Rockwell
 International 27
 RMS Electronics,
 Inc. 4, 19, 36, 80
 Sadelco, Inc. 15
 Texscan Corp. 3
 Theta-Com CATV 4
 Times Wire
 & Cable 62, 74-75
 Triple Crown
 Electronics 65
 TRW RF
 Semiconductors 73
 Vitek Electronics, Inc. . . . 55
 Wavetek 76-77
 Winegard Industries. 24

★ **Ernest L. Massei, III** has been named sales manager of the southwest region for **Comm/Scope Co.**

Massei will direct sales of coaxial cable in a five-state area. His territory includes Arkansas, Louisiana, Texas, Oklahoma and New Mexico. Comm/Scope Co. maintains its corporate headquarters and manufacturing facility in Catawba, N.C.

Massei is a native of Fayetteville, N.C. He is a 1977 graduate of East Carolina University, and has a bachelor's degree in economic geography. At present he lives in Dallas, Texas.

Prior to joining Comm/Scope Co., Massei was a production supervisor for Kelly-Springfield Co., Fayetteville.

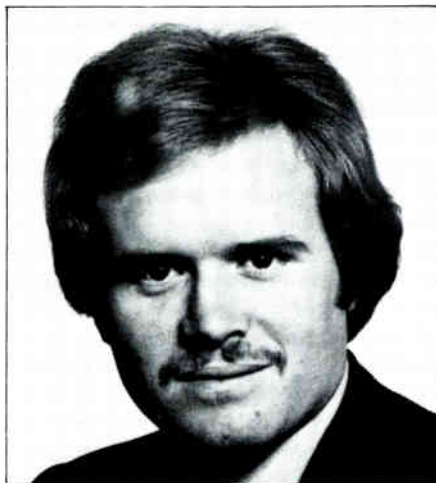

Ernest L. Massei III

★ **William Nashburn**, a veteran of 11 years in the cable television industry, is now Pacific District sales manager for **Comm/Scope Co.**

Nashburn, 33, joined Comm/Scope after working in construction management for American Television and Communication Co., San Diego, and in contract administration for RCA in Los Angeles. He has held other positions in construction and contracting for cable television as well.

Nashburn is a graduate of Central High School, Columbia, Tenn. and attended Columbia State Community College, where he earned an associate degree in liberal arts.

He and his wife, Joani, live in Sherman Oaks, Calif., and have two children, Bill and Courtney.

★ **Telex Communications, Inc.** has announced the promotion of **Gregory C. Dzubay** to Sales Manager of its

Broadcast/Professional Audio Products group. **Frank A. Olson** has also joined the group as Product Manager and **D. Stephen Lichtenauer** was named to the newly created position of OEM Sales Manager.

Dzubay has been Product Manager for the Broadcast/Professional Audio group since joining Telex in 1976. In his new capacity, Dzubay will be responsible for sales and marketing of the Telex Broadcast/Professional Audio product line on a national and international scale. He will work with distributors and rep organizations, aiding them in sales, product application, and training seminars.

Olson brings extensive electronic sales experience to Telex. He had been Store Manager at various Olson Electronics stores across the United States for the past 20 years. In his new position, he will be working with both representatives and end users in specifying particular product applications for the Telex Broadcast/Professional Audio and Turner microphone lines.

Lichtenauer, with over seven years of OEM sales and management experience at Turner and Midland Forge in Cedar Rapids, Iowa, will be introducing Telex Broadcast/Professional Audio and Turner microphone OEM products to new markets as well as serving existing OEM customers.

Telex is a manufacturer of tape recording, microphone, headphone, hearing aid and antenna products serving diverse markets in over 80 foreign countries.

★ **James E. Wilbanks** has joined WEHCO Video, Inc. as Vice President of Engineering. Mr. Wilbanks was most



James E. Wilbanks

recently Chief Engineer and Construction Manager at Tulsa Cable Television.

WEHCO Video, Inc., a Little Rock based MSO has moved its offices to suite 326, Donaghey Building, Little Rock, AR 72201.

★ **Magnavox CATV Systems, Inc.** in Manlius, New York is pleased to announce the promotion of **Rocco Lupo** to Supervisor of Quality Assurance.

Mr. Lupo will be responsible for the quality of the out-going products, equipment, maintenance, repair and calibration and new product qualifications.

Mr. Lupo is a 1974 graduate of Syracuse University where he obtained a B.S. in Electrical Engineering. Prior to his employment with Magnavox, Mr. Lupo served as a project engineer for Welch Allen.



Marguerite G. Shapalis

★ **Marguerite G. Shapalis** has joined **Valtec Corporation**, Communication Fiberoptics, as marketing services coordinator, it was announced by Richard A. Cerny, director of marketing. Shapalis will be responsible for coordinating the group's advertising, public relations and trade show activities.

According to Cerny, "We have newly created this position in an effort to better centralize and control our marketing support function, and to provide faster response to customer inquiries."

Shapalis comes to Valtec with three years experience in industrial advertising and public relations gained at The Nigberg Corporation in Framingham, MA. Here she worked as project manager and writer on many of the agency's high technology accounts.

Four Major Milestones in CATV Amplifiers.

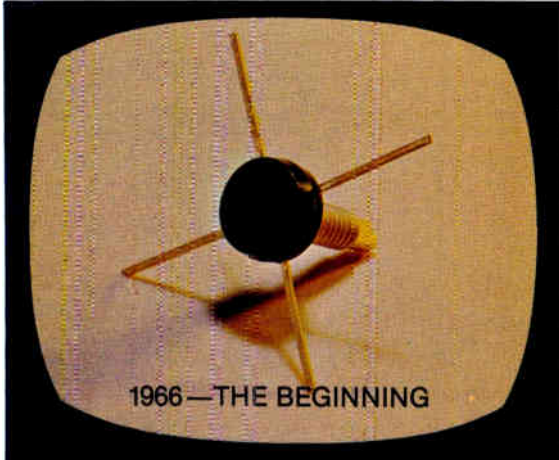

First transistors made and characterized especially for CATV amplifiers.

From TRW, of course.

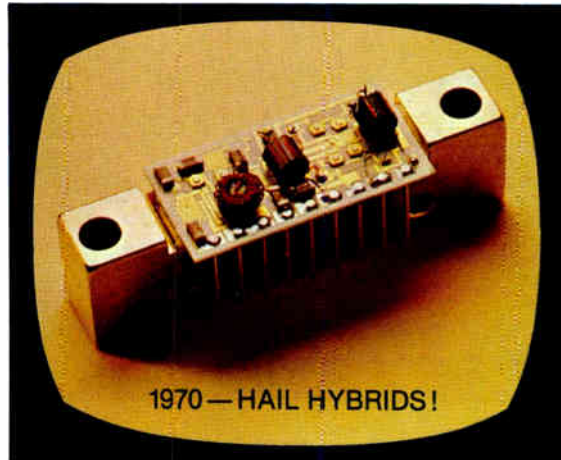

First hybrids for CATV. Elimination of interconnects provides inherent increase in reliability, ease of field repairs. Improved performance over discrete amplifiers.

TRW does it first. Again.



First hybrids with all gold systems, the optimum for ruggedness and reliability. Gold die with ballasting resistors and fine geometry has dramatically improved the performance.

And TRW is first. Again.



1980 will bring another major milestone in CATV amplifier development. Improved reliability, improved performance, improved design.

Watch and wait for the leader, TRW. Again.

An Electronic Components Division of TRW Inc.,
14520 Aviation Boulevard, Lawndale, CA 90260

TRW RF SEMICONDUCTORS

ANOTHER PRODUCT OF A COMPANY CALLED TRW





**PULL HERE
TO SAVE TIME.**



12 miles of Times cable. (5.5' x 4' x 4')

Times introduces another factor in the time/space continuum ... the TimeSaver® for CATV.

1000 feet of Times drop cable specially packaged to play out effortlessly, stopping the instant you do. There's no spool, reel, tangles or over-runs. So the TimeSaver really lives up to its name.

And since time and space are related, it should come as no surprise to anyone that the TimeSaver will save stocking space, as well as time.

You'll find the most popular of our drop cables available in this convenient package. And we've got a TimeSaver sling for you, too. The TimeSaver. It'll help you get the job done on time instead of overtime.

For more information, speak to your Man From Times. Or contact us at 358 Hall Avenue, Wallingford, CT 06492, telephone (800) 243-6904.



Times Wire & Cable
The #1 Cable Company
DIVISION OF TIMES FIBER COMMUNICATIONS, INC.



**We predict this new program
will sweep the nation.**



It's the Model 1855/65 Sweep Recovery System, an action-packed display of microprocessor ingenuity and Wavetek precision.

Here's the plot: You hand one of these to your system technician, then watch how fast it sets up, how accurately it portrays your system performance, how easily he can balance your trunk.

What will the home viewers think? They won't see a thing, thanks to the unique combination of high speed (down to 1 millisecond) and low level. However, they'll probably notice a steady improvement in your signal.

The star of the show is our microprocessor control. It takes care of most of the setup that used to take so long. Digital signal processing lets the display continuously refresh itself for a bright,



accurate picture of the most recent sweep. There's a future option planned for storing the display on magnetic cards or tape. Sweep this fall, rerun next summer.

Alpha-numeric readouts on the screen give amplitude, frequency, even deviation between peak to valley. You

haven't seen anything this easy to understand since Sesame Street. The price of the basic Model 1855/65 is \$6450. How's that for a happy ending?

To carry this (no copyright) program on your system, call collect: (317) 783-3221, CATV Dept., Wavetek, Indiana, P.O. Box 190, 66 North First Ave., Beech Grove, IN 46107.

WAVETEK®





A lot of people are losing sleep over WOR

It's hard to say goodnight to WOR.

In fact, it's hard to turn WOR off anytime with 24-hour programming like this! Over 35 award-winning movies to choose from each week... that's full length films. Just think, over 63 hours of movies. Over 3,000 films, including the classic RKO motion picture favorites. That's why from Alaska to Florida, Vermont to Hawaii, people everywhere are happily losing sleep over WOR.

Why let other stations leave your subscribers in the dark?

WOR's 24-hour programming or our special Movie Package will captivate your customers night after night. The faces of Bing Crosby, Katharine Hepburn, Fred Astaire, and Barbara Stanwyck will light up the late night TV screen from dusk 'til dawn.

Don't let another day go by, call Sam Morse or Charlie Mills now at (315) 455-5955.



EASTERN MICROWAVE, INC.

3 Northern Concourse PO Box 4872 Syracuse, NY 13221

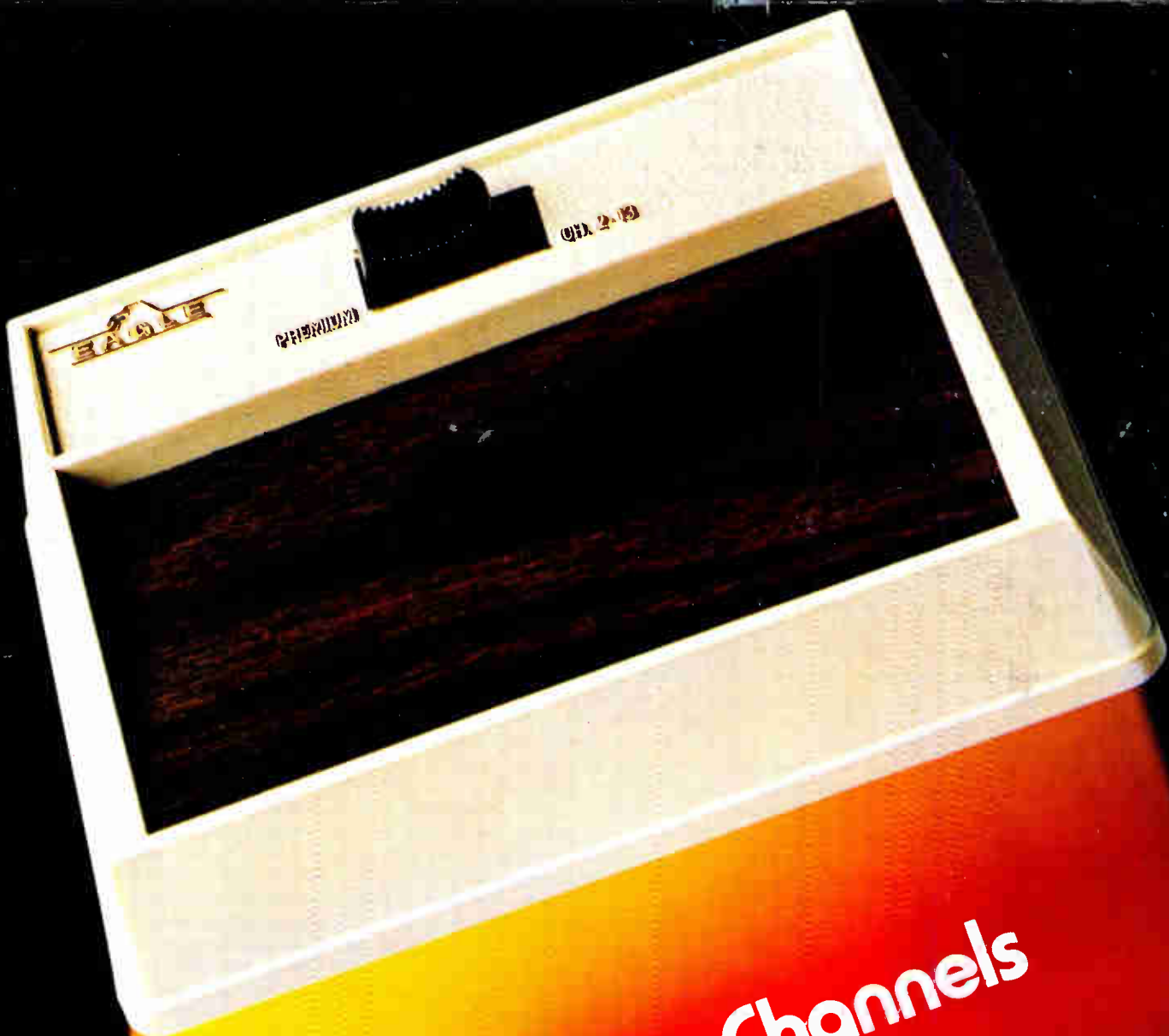

Convert Your Channels To Profits.

The Eagle Converter economically offers 3 premium channels to your subscribers.

The Eagle Converter expands your system's capacity by giving your 12-channel system three additional premium channels for unexcelled multi-tiered service. With the Eagle Converter your customers get the flexibility they want while you get the profits you want.

- Technically you'll find:
- Totally printed board
 - Separate power filter cavity
 - Rugged die-cast housing
 - Crystal controlled for stability
 - Made In U.S.A.



8741 West River Road
Baldwinsville, New York 13027
(315) 638-2586

**CALL TOLL FREE TO ORDER
800-448-3311**

Available Now For Immediate Delivery

CA-2500

A MOVE TO QUALITY



RMS
CATV DIVISION
ELECTRONICS, INC.

RMS ELECTRONICS, INC.
50 ANTIN PLACE
BRONX, NY 10463
CALL COLLECT (212) 892-1000

Canada Representative Desklin Sales Corp.

RMS Electronics, Incorporated 1978