

Lawson W. Dams

DIAL CORD *Stringing* GUIDE

DC-5

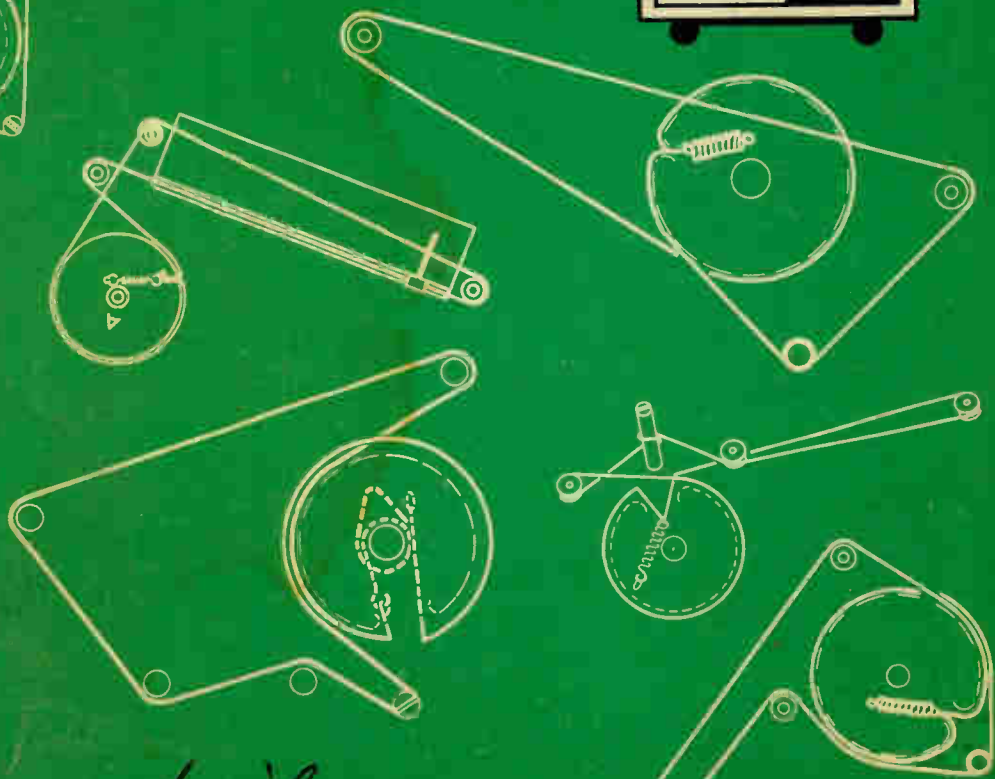
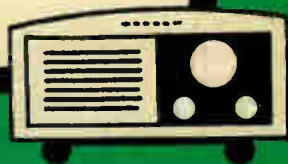

A *Lawson W. Dams* **PHOTOFACT PUBLICATION**

\$1.00

Howard W. Sams
DIAL CORD
Stringing **GUIDE**

DC-5

FIRST EDITION • FIRST PRINTING • NOVEMBER 1955

Reproduction or use, without express permission, of editorial or pictorial content, in any manner, is prohibited. No patent liability is assumed with respect to the use of the information contained herein.

Entire Contents Copyrighted 1955 by Howard W. Sams & Co., Inc.

Indianapolis, Indiana, U. S. A.

Copyright Under International Copyright Union

All Rights Reserved Under Inter-American Copyright Union (1910)

By Howard W. Sams & Co., Inc.

Compiled and Published by
HOWARD W. SAMS & CO., INC.
Indianapolis, Indiana

LITHO IN U. S. A.

DC-5

PREFACE

This manual, which covers radio and television receivers manufactured from 1953 through mid-1955, is the fifth of the "DIAL CORD STRINGING GUIDE" series. The data presented herein is intended to make easier the service technician's job of restringing a dial cord.

The index lists all receivers which were presented in the previous manuals as well as those covered in this manual. Thus, it is necessary to look in only one place to determine the diagram number which pertains to the receiver being serviced. The diagrams presented in this manual are consecutively numbered, the first one being the next consecutive number after the last number in the preceding manual in the series. This prevents any possible confusion which might result from consulting a diagram in the wrong manual.

The acceptance of the previous manuals in this series has prompted the preparation of this manual in order to make available to the service technician this practical, easy-to-use data.

Name & Model or Chassis No.	Vol. 5 Diag. No.	Previous Vols. Diag. No.
ADMIRAL		
Chassis		
UL5K1	2	553
UL7C1	1	9
3C1	3	1064
4A1	1	4
4B1	1	10
4H1, 4J1, 4K1	3	1065
4L1	3	1067
4R1	3	1067
4S1	3	1066
4T1	4	1459
4W1	4	1460
4Z1	1808	
5A3	4	1461
5B1, 5B1A	1	5
5B2	3	1066
5C3	4	1462
5D2	3	1068
5D3	1809	
5E2	4	1463
5E3	1810	
5G2	4	1464
5H1	1	8
5J2	4	1465
5K1	2	553
5L2	4	1466
5M2	4	1467
5N1	2	554
5R1	2	555
5R2	4	1468
5W1	3	1069
5X1	3	1070
5X2	4	1469
5Y2	4	1460
6A1	1	1
6A2	3	1071
6C2, A	1811	
6E2, 6E1N	1	6
6E3	4	1471
6L1	2	561
6M1	7	
6M2	4	1471
6Q1	3	1072
6R1	2	556
6S1	3	1073
6W1	3	1074
7B1	1	2
7C1	1	9
7E1	2	558
7G1	2	560
8A1	2	559
9E1	2	562
10A1	1	3
15HF1	1812	
19D2, A	1813	
19E1 (Radio Ch.)	4	1472
19E2, A		
19G1, A	1813	
19N1 (Radio Ch.)	4	1472
19P1	4	1472
20D2	1814	
21C3Z	1815	
21W1 (TV Ch.)	4	1473
21W1 (Radio Ch.)	4	1474
22A2, 22A2A (TV Ch.)	4	1473
22A2, 22A2A (Radio Ch.)	4	1474
22C2, 22E2	4	1475
22M1 (TV Ch.)	4	1473
22M1 (Radio Ch.)	4	1474
22P2	1816	
22Y1 (TV Ch.)	4	1473
22Y1 (Radio Ch.)	4	1474
Model		
H1F1 6, H1F1 7, H1F1 8		1812
K2216, K2217		1813
K2216A, K2217A		1814
K2226, K2227		1813
KU2216, KU2217		1813
L2326Z, L2327Z		1815
4H15, A, B, C, CN, S, SN, 4H16, A, B, C, CN, S, SN, 4H17, A, B, C, CN, S, SN, 4H18, C, CN, S, CN, 4H19, C, CN, S, SN		1065
4H115, 4H116, 4H117 (Sor SN)		1065

Name & Model or Chassis No.	Vol. 5 Diag. No.	Previous Vols. Diag. No.
ADMIRAL (Continued)		
4H126A; B, C, CN, S, SN	3	1065
4H137A, B, C, CN, S, SN	3	1065
4H145A, B, C, CN, S, SN		
4H146A, B, C, CN, S, SN		
4H147A, B, C, CN, S, SN	3	1065
4H155A, B, C, CN, S, SN		
4H156A, B, C, CN, S, SN		
4H157A, B, C, CN, S, SN	3	1065
4H166A, B, C, CN, S, SN		
4H167A, B, C, CN, S, SN	3	1065
4R11, 4R12	3	1067
4T11	4	1459
4W18, 4W19	4	1460
4Z11, 4Z12, 4Z14, 4Z18, 4Z19	1808	
5A32/12, 5A32/15, 5A32/16, 5A33/12, 5A33/15, 5A33/16		
5A33/17	4	1461
5D31, 5D32, 5D33	1809	
5E21, 5E22, 5E23	4	1463
5E31, 5E32, 5E33	1810	
5E38, 5E39	1810	
5G21, 5G21/15, 5G22, 5G22/15, 5G23, 5G23/15	4	1464
5J21, 5J22, 5J23	4	1465
5K11, 5K12, 5K13, 5K14, 5L21, 5L22, 5L23	2	553
5M21, 5M22	4	1466
5R10, 5R11, 5R12, 5R13, 5R14	2	555
5S21AN, 5S22AN, 5S23AN	4	1462
5W11, 5W12	3	1069
5X11, 5X12, 5X13, 5X14	3	1070
5X21, 5X22, 5X23	4	1469
5Y22	4	1470
6A21, 6A22, 6A23	3	1070
6C22, A, 6C23, A	1811	
6C71	1	3
6J21, 6J22	4	1471
6N25, 6N26, 6N27	4	1469
6P32	1	6
6Q11, 6Q12, 6Q13, 6Q14	3	1072
6R11	2	556
6RT41, A, 6RT42, A, 6RT43, A	1	5
6S11, 6S12	3	1073
6T01	1	5
6T02, 6T03	1	5
6T05	1	1
6T06, 6T07	1	4
6T11	1	5
6T12	1	4
6T44A	1	2
6W11, 6W12	3	1074
7C81, 7C82, A, 7C22UL	1	7
7C83, A, 7C83UL	1	9
7C65B, M, W, 7C63	2	558
7G11, 7G12, 7G14, 7G15, 7G16	2	559
	2	560

Name & Model or Chassis No.	Vol. 5 Diag. No.	Previous Vols. Diag. No.
ADMIRAL (Continued)		
7P32, 7P33, 7P34, 7P35		
7RT41, 7RT42, 7RT43	2	561
7T01, 7T01M-UL, 7T04, -UL	2	564
7T06	1	10
7T10	2	553
7T12	1	10
7T14, 7T15	2	553
9B14, 9B15, 9B16	2	562
24X15, S, 24X16, S, 24X17S	3	1066
30F15, A, 30F16, A, 30F17, A	3	1065
32X15, 32X16, 32X26, 32X27, 32X35, 32X36	3	1066
34R15, A, 34R16, A	3	1064
34R37, 34R45, 34R46	3	1068
36X35, A, 36X36, A, 36X37, A	3	1066
37F15, A, B, 37F18, A, B	3	1068
37F27, A, B, 37F28, A, B	3	1068
37F35, A, B, 37F55, 37F56, 37F57	3	1068
37K16, A, B, 37K16, A, B, 37K27, A, B	3	1064
37K35, A, B, 37K36, A, B	3	1064
37K55, 37K56, 37K57	3	1064
37M15, 37M16	3	1064
39X16, A, B, 39X17, A, B	3	1066
39X35, 39X36, 39X37	3	1064
47M15, 47M16, 47M17	4	1473 1474
121M10, 121M11A, 121M12A	4	1473 1474
221K45A, 221K46A, 221K47A	4	1473 1474
222DX15S, 222DX16, 222DX17, 222DX26, 222DX27, 222DX48, 222DX49	4	1475
321DX15, A, 321DX16, A, 321DX17, A, 321DX18, 321DX16L, 321DX17L	4	1472
321DX25E, 321DX26, B, 321DX27B	4	1472
321F15, 321F16, 321F18	3	1068
321F27, 321F35, 321F36, 321F46, 321F47, 321F49	3	1068
321F65, 321F66, 321F67	4	1473 1474
321K15, 321K16, 321K18, 321K27, 321K35, 321K36, 321K46, 321K47, 321K49, 321K65, 321K66, 321K67	3	1064
321M25A, 321M26A, 321M27A	4	1473 1474
322DX16	4	1475

Name & Model or Chassis No.	Vol. 5 Diag. No.	Previous Vols. Vol. No.	Diag. No.
ADMIRAL (Continued)			
321DX16A	1816	
421M15A		
421M16A		
421M35		
421M36		
421M37 4 1473	
	 1474	
520M11		
520M12		
520M15		
520M16		
520M17 4 1473	
	 1474	
521M15A		
521M16A		
521M17A 4 1473	
	 1474	
AEROMOTIVE			
181-AD 1 11	
AIRADIO			
SU-41D		
SU-52A, B, C 1 12	
3100 2 563	
AIRCASLE			
C-300 3 1075	
G-516, G-518 2 564	
G-521 2 565	
G-724 2 566	
G-725 2 567	
RE V-248 3 1076	
PX 1 13	
WEU-262 3 1077	
9 2 568	
102B 3 1078	
106B 1 11	
171, 172 3 1080	
198 3 1081	
201 3 1082	
350 3 1083	
472, 254 4 1476	
568 1 14	
572 2 569	
602-182144 3 1084	
602-PR-8, I 3 1085	
606-400WB 3 1086	
607-314, 315 3 1087	
610.C351 4 1477	
610.C.1L52B, M 4 1478	
610.F100 4 1479	
610.F151 4 1480	
610.H400 4 1481	
610.P-651.1 4 1481	
610.S500 4 1480	
610.W-100 1817		
651 1 15	
652.575E, V 1818		
652.5X5 1819		
652.8T1E, V 4 1482	
652.8TF1 1820		
738.5400, UL 1821		
782. FM-99-AC 1822		
5000, 5001 1 11	
5002 1 16	
5003, 5004		
5005, 5006 1 17	
5008, 5009 2 570	
5010, 5011, 5012 1 18	
5015.1 3 1089	
5020 1 16	
5022 3 1089	
5024 2 571	
5025 2 572	
5027 2 573	
5028, 5029 2 574	
5036 3 1090	
5044 3 1091	
6050 3 1092	
6053 3 1093	
6514, 6541		
6544 1 15	
6547 1 15	
6611, 6612, 6613		
6630, 6631, 6632		
6634, 6635 1 19	
7553 2 575	
9009I 3 1094	
10002 2 576	
10003-1 2 560	
108014, 108504 2 577	
121104 3 1095	

Name & Model or Chassis No.	Vol. 5 Diag. No.	Previous Vols. Vol. No.	Diag. No.
AIRCASLE (Continued)			
127084 2 578	
131504 2 579	
138104 2 578	
139144 2 580	
149654 3 1096	
150084 3 1097	
AIR CHIEF (See Firestone)			
AIR KING			
A-501, A-502 2 581	
A-510 2 574	
A-511, A-512 2 582	
A-600 2 583	
A-604 3 1098	
A-625 2 583	
A-650 2 584	
17K1C 4 1483	
4601 1 30	
4603 1 31	
4604, D 1 34	
4607, 4608 1 32	
4609, 4610 1 30	
4700 2 585	
4704 1 37	
4705, 4706 1 35	
4708 1 37	
AIR KNIGHT			
CA500 1 6	
N5-RD291 1 6	
AIRLINE			
GSE-1606A,		
GSE-1607A 1823		
GSL-1581A,		
GSL-1582A 1824		
WG-1572C 1825		
04BR511A,		
04BR512A 1 40	
04BR515A, B 1 43	
04WG468 1 38	
04WG568,		
04WG569, B 1 39	
04WG619, 04WG621,		
04WG621N1 1 41	
04WG672 1 42	
04WG673,		
04WG674 1 44	
04WG695 1 45	
04WG727,		
04WG728,		
04WG732 1 45	
04WG803 1 44	
04WG804 1 45	
04WG1108A 1 46	
05GSE-3030A,		
B, C 3 1099	
05GSE-3037A,		
3042A 3 1099	
05WG-1813A 3 1100	
05WG-2748 F,		
05WG-2749D 3 1101	
05WG-2752 3 1102	
05WG-3038A,		
-3045A 3 1103	
14BR474 1 48	
14BR521A,		
14BR522A 1 40	
14BR523A 1 48	
14BR613A 1 48	
14BR624A 1 48	
14BR147 1 48	
14WG468 1 47	
14WG518,		
14WG519 1 6	
14WG610B,		
14WG611B 1 49	
14WG624A,		
14WG625A,		
14WG628A 1 11	
14WG680 1 42	
14WG683A 1 51	
14WG690 1 50	
14WG737 1 52	
14WG739 1 47	
14WG740		
14WG741 1 52	
14WG756,		
14WG757 1 56	
14WG808M, MA,		
14WG808W, WA 1 56	
14WG1202B,		
14WG1203B, M, W 1 54	

Name & Model or Chassis No.	Vol. 5 Diag. No.	Previous Vols. Vol. No.	Diag. No.
AIRLINE (Continued)			
15BR-1536B,		
15BR-1537B 4 1485	
15BR-1543A, B		
15BR-1544A, B 4 1486	
15BR-1547A 4 1487	
15BR-1548A,		
15BR-1549A 4 1488	
15PR-2756B,		
15BR-2757A 4 1489	
15BR-3035A 4 1490	
15GSE-2764A 4 1491	
15WG-1545A, B,		
15WG-1546A, B 4 1492	
15WG-2745C 3 1104	
15WG-2749E, F,		
15WG-2752D, E 4 1493	
15WG-2758A 4 1494	
15WG-3050A, B 4 1495	
25PR-1542A 4 1496	
25BR-3058A, B,		
25BR-3061A,		
25BR-3067A,		
25BR-3068A,		
25BR-3069A 4 1497	
25GHM-1073A 1826		
25GSE-1555A,		
B, 25GSE		
-1556B,		
25GSE-1557B 4 1498	
25GSE-3065A 4 1499	
25GSL-1814A 4 1500	
B, 25WG-1571A,		
B, 25WG-1572A,		
25WG-1573A 4 1501	
25WG-1573B 4 1502	
25WG-2758B 4 1494	
25WG-2758C, D 4 1503	
25WG-2765E, E 4 1494	
25WG-2766A, B 4 1503	
25WG-3060A 4 1504	
25WG-3070A 4 1504	
35BR-1557A,		
35BR-1558A,		
35BR-1559A 1827		
35BR-3158A,		
35BR-3167A,		
35BR-3168A,		
35BR-3169A 1828,		
 1829		
35BR-6796A 1830		
35GHM-1073		
B, C 1826		
35GHM-1074		
A 1831		
35GSE-1555C,		
35GSE-1556C 4 1498	
35GSL-2770A 1832		
35WG-1573B 1833		
35WG-2767A 2105		
35WG-3171A,		
A, P, 35WG		
-3175A,		
35WG-3177A,		
35WG-3179A 1834		
45BR-3186A 2031		
54BR1501A,		
54BRI502A 1 40	
54BR1503A,		
B, C		
54BR1504A,		
54BR1505A, 1 58	
54BR1505A, B 1 55	
54BR1506A, B 1 55	
54KPI209A, B 1 53	
54WG1801A, B 1 6	
54WG2007A, B 1 6	
54WG2500A,		
54WG2700A 1 57	
61-6787 1835		
61-6792 1836		
61-6793 1919		
61-6794 1856		
61-6795 1857		
61-12601 1858		
62-123 1 11	
62-131, -133 1 11	
62-142 1 11	
62-144 1 11	
62-152 1 11	
62-158 1 11	
62-237 1 11	
62-239 1 11	
62-270 1 59	
62-292 1 11	

Name & Model or Chassis No.	Vol. 5 Diag. No.	Previous Vols. Vol. No.	Diag. No.
AIRLINE (Continued)			
62-294	1	11	
62-303	1	59	
62-309	1	59	
62-321	1	59	
62-347	1	59	
62-373, -374	1	11	
62-417	1	59	
62-443	1	59	
62-447	1	59	
62-449	1	59	
62-451	1	59	
62-471, 472	1	61	
62-704, -705, -706, -707, -708, -709, -710, -711, -712	1	60	
62-752, -753	1	64	
62-901	1	64	
62-919	1	60	
64BR105A, B	1	62	
64BR1205A			
64BR1206A	1	65	
64BR1208A	1	63	
64BR1503, P	1	58	
64BR1504, B	1	58	
64BR1513A, P	2	586	
64BR1514A, B	2	586	
64BR1808A	1	66	
64BR2200A	1	63	
64BR2701A	1	66	
64WG1052A	1	67	
64WG1207B	1	69	
64WG1511A, B	1	68	
64WG1512A, B	1	68	
64WG1801C	1	6	
64WG1804A, B, C	1	71	
64WG1807A, B	1	71	
64WG1809A, B	1	68	
64WG2007A, B	1	68	
64WG2009A, B	1	68	
64WG2010B	1	68	
64WG2500A	1	57	
64WG2700A, B	1	57	
74BR1513B	2	586	
74BR1514B	2	586	
74BR2001A, B	2	587	
74BR2701A	2	588	
74KR1210A	2	589	
74KR2706B	2	591	
74KR2713A	2	591	
74WG1052B	1	67	
74WG1056A	2	593	
74WG1207B	1	69	
74WG1509A			
74WG1510A	2	594	
74WG1511B			
74WG1512B	1	68	
74WG1802A			
74WG1803A	2	595	
74WG1804C	1	71	
74WG1807A, B	1	71	
74WG2002A	2	594	
74WG2004A	2	595	
74WG2007B, C	1	6	
74WG2009B			
74WG2010B	1	68	
74WG2500A	1	57	
74WG2504A, B, C	2	596	
74WG2505A	1	70	
74WG2700A, B	1	57	
74WG2704A, B, C	2	596	
74WG2709A	2	597	
84CA A3967A	3	1105	
84HA 1529A	3	1106	
84KR1520A	2	592	
84WG2015A	2	598	
84WG2506	2	601	
84WG2506B	2	599	
84WG2712A, B	2	600	
84WG2714A, F			
G. H. J.	2	601	
84WG2718A, B	2	600	
84WG2720A	2	600	
84WG2721A, B	2	601	
84WG2724A	2	600	
84WG2728A	2	600	
84WG2732A, B	2	600	
84WG2734A	2	600	
93WG510	1	72	
93WG754, 93WG755	1	74	
93WG800	1	74	
93WG1102	1	80	
93WG1103			
93WG1104	1	46	
93WG1110	1	80	
94BR-1533A	3	1107	

Name & Model or Chassis No.	Vol. 5 Diag. No.	Previous Vols. Vol. No.	Diag. No.
AIRLINE (Continued)			
94BR-2740A,			
-2741A, P	3	1108	
94GA A3654A	3	1109	
94GSE-2735A,			
-2736A	3	1110	
94WC-1509A	3	1111	
94WG-1804D	3	1112	
94WG-1811A	3	1113	
94WG-2742A,			
C, D	3	1114	
94WG-2745A	3	1115	
94WG-2746A, B,			
-2747A	3	1114	
94WG-2748A, C,			
94WG-2749A	3	1116	
94WG-3008A	3	1117	
94WG-3016A,			
B, C	3	1117	
94WG-3028A	3	1117	
ALGENE			
AR5U	2	555	
AR6U	2	555	
ALLIED RADIO (See Knight)			
ALLSTATE			
Model			
6240		1837	
9264, 6266		1838	
8284		1839	
6286-4			
6287-4		1840	
6330		1841	
Chassis			
528.6264			
528.6266		1838	
528.6284		1839	
528.6286-4			
528.6287-4		1840	
528.62400		1837	
528.63300		1841	
ALTEC LANSING			
ALC-101	3	1118	
303A	4	1505	
AMC			
20CD2B, 20C2B,			
20T2B, 21CD2A,			
21CA2		2007	
125 P	1	82	
126	1	76	
AMERICAN COMMUNICATIONS (See Liberty)			
ANDREA			
BT-VK12	3	1119	
C-VN21		1842	
CO-U15	2	602	
CO-VK15,			
CO-VK16	3	1120	
COVK-125	3	1119	
CO-VL19	4	1506	
CVK-126	3	1119	
T-16	2	603	
T-U15	2	602	
T-U16	2	603	
T-VN21	3	1119	
T-VN21		1842	
TVK-127B, M	3	1119	
2C-VN21		1842	
ANSLEY			
Model 53	2	604	
APEX			
4B5	2	574	
APPROVED ELECTRONIC INSTRUMENT CORP.			
FM Tuner	2	605	
A-710	4	1507	
ARCADIA			
37D14-600	1	78	

Name & Model or Chassis No.	Vol. 5 Diag. No.	Previous Vols. Vol. No.	Diag. No.
ARIA			
554-1-61A	1	79	
ARTHUR ANSLEY			
R-1	4	1508	
ARTONE			
524	3	1121	
ARVIN			
Model			
15-550KB-UHF. 1842			
21-550KBU,			
KMU,			
21-551TBU,			
TMU,			
21-552KBU,			
KMU,			
21-553TBU,			
TMU	1844		
140P	2	606	
1507C, 151TC	2	607	
152T, 153T	2	606	
160T, 161T	2	609	
182TFM	2	610	
240P, 241P, 244P	2	611	
250P	2	612	
280T FM, 281T FM	2	614	
350-PB, -PL,			
351-PB, -PL,			
352-PL, 353-PL	3	1122	
355T, 356T, 357T	3	1123	
358T	2	608	
450T, 451T	3	1124	
460T, 461T	3	1125	
462-CB, 462-CM	3	1126	
480T FM,			
481T FM,	3	1127	
482CFB, 482CFM	3	1128	
547, A	2	614	
551T	4	1590	
552AN, N	1	77	
553	4	1510	
554CCB, 554CCM	4	1509	
555, A	1	77	
558	1	81	
580T FM	4	1511	
581T FM		1845	
582CFB, 582CFM	4	1512	
650	4	1513	
651T		1846	
652-P, 654-P	4	1513	
655SWT	4	1511	
657-T	4	1514	
664, A	1	6	
665	1	83	
753T		1847	
758T		1848	
760T		1849	
780T FM		1845	
857T		1850	
858T, 859T		1851	
2120CM,			
2121FM,			
2122FM,			
2124CCM,			
2126CM	3	1129	
2160, 2161,			
2162, 2164	3	1130	
2410P	2	611	
4080T, 4081T	3	1131	
6173T-UHF,			
6213T-UHF,			
6213T-UHF,			
6215CB-UHF,			
6215CM-UHF	4	1515	
6640	1	6	
7210CB-UHF,			
7210CM-UHF,			
7212CFP-UHF,			
7212MEA-UHF,			
7214CM-UHF,			
7216CB-UHF,			
7218CB-UHF,			
7218CM-UHF,			
7219CM-UHF	4	1515	
7276CB-UHF,			
7279CM-UHF. 1852			
9210CE-UHF,			
9210CM-UHF. 1852			
9211TB-UHF. 1853			
9212CFP-UHF,			
9212MEA-UHF. 1852			

Vol. 5
Diag.
No.

Previous Vols.
Vol.
Diag.
No.

Name & Model
or Chassis No.

Vol. 5
Diag.
No.

Previous Vols.
Vol.
Diag.
No.

Name & Model
or Chassis No.

Vol. 5
Diag.
No.

Previous Vols.
Vol.
Diag.
No.

ARVIN (Continued)

9213TM-UHF,
9215CM-UHF. 1853
9216CB-UHF,
9218CB-UHF,
9218CM-UHF,
9219CM-UHF. 1852
9240CB-UHF,
9240CM-UHF. 1852
9245CM-UHF. 1853

Chassis

RE-202 1 77
RE-204 1 81
RE-206, -1, -2 1 6
RE-209 2 606
RE-213 3 1123
RE-228, -1 2 607
RE-229 1 83
RE-231 1 77
RE-232 2 609
RE-233 2 608
RE-237 2 610
RE-242 2 614
RE-243, RE-244 2 611
RE-248 2 612
RE-253 2 613
RE-254, -255,
-256, -259 2 611
RE-267-1, -2 3 1122
RE-273 3 1123
RE-277, RE-277-1 3 1127
RE-277-2 3 1122
RE-281 3 1124
RE-284 3 1125
RE-287-1 3 1126
RE-288-1 3 1128
RE-292 4 1513
RE-297 4 1509
RE-306 4 1509
RE-307 4 1514
RE-308 4 1510
RE-310 4 1512
RE-313 4 1511
RE-323 1846
RE-327 4 1511
RE-333 1845
RE-342 1849
RE-348 1847
RE-350 1848
RE-374 1851
RE-378 1850
TE-282 3 1131
TE-289-2, -3 3 1129
TE-290 3 1130
TE-330, TE-332 4 1515
TE-340, -1, -2 1852
TE-341, -2 4 1515
TE-395, -1 1852
TE-362 1853
TE-363, -1,
-2, -3 1852
TE-373 1853
TE-379 1844

ASTATIC

CB-1 1854
UHF 1855

ATLAS

AB-45 1 73

AUDAR

AV-7T 4 1516
PR-6 1 84
PR-6A 1 85

AUTOMATIC

Tom Boy 2 555
Tom Thumb Buddy 2 615
Tom Thumb
Camera-Radio 2 616
Tom Thumb Jr. 2 555
B-44 2 616
C51 4 1517
C54 4 1518
C-60 1 86
C-60X 2 555
C-300 3 1075
C-351 4 1519
CL-152B, M 4 1520
CM-333 1919
D-200 3 1132
D-251 4 1521

AUTOMATIC (Continued)

DM-132 1836
F-100 3 1133
F-151 4 1522
M-86 2 618
P-851 4 1523
PM-236 1856
MM-430 1857
S-551 4 1522
TR-12 1858
TV-P490 3 1134
TV-1649,
TV-1650,
TV-1651 4 1524
601, 602 (Series A) 1 73
601, 602 (Series B) 2 555
612X, 613 1 73
614X, 615X 1 86
620 1 87
640 (Series B) 1 73
660, 662, 666 2 619
720 2 620

AVIOLA

509 1 88
601 1 89
608 1 91
612 1 89
618 1 91

BELL SOUND

PA-3715-B,
PA-3725-B,
PA-3750-B 1859
2120 1860
2255 1861
3715 2 621
3715-B 1859
3725 2 621
375-B 1859
3728 2 621
3750 2 621
3750-B 1859

BELTONE

500 1 90

BELMONT

A6D110 1 94
4B17 1 93
4B112, 4B113 1 65
4BA1, 4BA2 1 48
5D16 1 48
5D110 2 622
5D128 1 96
5DA1 1 48
5P19 1 95
6D111 (Series A & B) 1 92
6D120 2 623
8A59 1 66
533 (Series P & C) 1 43
716 1 48

BENDIX

FB21CU 4 1525
FM21C, FM21CU 4 1525
FM27C 4 1525
HE21C, HB21CU 4 1525
HB27C, HM21C,
HM21CU 4 1525
KM21CU 4 1525
PAR-80 2 624
TB21CU, TB24DS,
TM17C, TM21CU,
TM24DS, DU 4 1525
0526, 0526A, B,
C, D, E, F 1 97
0626A 1 97
5512, 5513 2 625
55P2, 55P3 2 625
55X4 2 626
65P4 2 627
75B5, 75M5,
75M8, 75P6 2 629
75W5 2 628
95B3, 95M3,
95M9 2 628
110, 110W, 111,
111W, 112 2 625
114, 115 2 625
300, 300W,
301, 302 2 627
416A 2 630

BENDIX (Continued)

526MA, MB, MC 2 631
613 2 632
626A 1 97
636A, B, C 1 98
646A 1 99
656A 1 100
676B, C, D 1 101
697A 2 633
736B 1 100
753F, V, W 4 1526
847B, S 2 634
951, 951W 3 1135
1217, B 2 635
1217D 2 636
1518, 1519 2 637
1524 2 637
1524, 1525 2 637
1531 2 638
1533 2 638
6100 3 1136

Chassis

C-19 4 1526
T14-3, T14-10,
-11 4 1525

BLONDER TONGUE

BTU-2 1862

BREWSTER

9-1084, 9-1085,
9-1086 1 103

BROOKS LABORATORIES, INC.

ST10 4 1527
ST-10A 1863
ST-14A 4 1527
ST-15A 1864

BROWNING

PF-12 2 639
RJ-12 2 639
RJ-12B 4 1528
RJ-12A 2 640
RJ-14A 2 640
RJ-20A 3 1137
RJ-42 1865
RJ-43 1866
RJ-48 1867
RJ-49 (AM) 1867
RJ-49 (FM) 1868
RV-10 2 641
RV-10A 3 1138
RV-11 2 641
RV-31 4 1529
RV-32 1869

BRUNSWICK

A1020 1 102
A2020 1 102
A2600 1 107
A2700 1 102
A3720 1 102
BJ683 2 642
C-3300 2 642
D-1000, D-1100 2 643
D-6876 2 644
T-4000, T-4000 1/2 2 644
T-6000, S, SS,
SX, T-6000 1/2 2 644
T-9000 2 643
512, 513, 812, 816 4 1530
1680 1 107
1700 1 102
2600 1 107
2889 2 645
5000 2 645
5125, 6165,
8125, 8165 4 1530

BUICK

980690, 980733 1 104
980744, 980745 1 104

BUTLER BROS. (See Air Knight or Skyrover)

CAPEHART

C-14 1870
P-213 1871

Name & Model or Chassis No. Vol. 5 Diag. No. Previous Vols. Vol. Diag. No.

CAPEHART (Continued)

RP-152	1531
RP-153	1872
RP-154E, M	1873
RP-254	1872
T-54	1874
T-522	4.....1532
1T174B-1,		
BS-1, M-1,		
MS-1, S-1,		
1T174-1,		
2T214B-1,		
BS-1, D-1,		
MD-1, MS-1,		
M-1, S-1,		
2T214-1,		
4C174M-1,		
MS-1,		
5C214B-1,		
D-1, MD-1,		
M-1,		
5C214-1,		
7H214B-1,		
D-1, M-1,		
7H214-1,		
9F214BD-1,		
MD-1,		
9F214-1,		
11F244B-1,		
M-1,		
11F244-1	1875
11RP-125F	1873
12F274M-1,		
14W214-1,		
15W214BD-1,		
MD-1,		
15W214-1,		
16T244BS-1,		
ES-1, M-1,		
MS-1, S-1,		
16T244-1,		
18W214FD-1,		
19C214M-1,		
MD-1,		
21T214ES-1,		
23C214B-1,		
M-1	1875
35P7	3.....1139
325F, M, 326M,		
332B, M, 334M	3.....1140
1005B, M, W	3.....1141
1006B, M, W	3.....1141
1007A, M	4.....1533
3011B, M,		
3012B, M	3.....1140

Chassis

C-318	4.....1533
CR-85	1871
CR-129	1873
CR-147	1872
CT-27, CT-38,		
CT-45	4.....1534
CT-108, CT-110,		
CT-112, CT-116,		
CT-123, CT-124,		
CT-127, CT-129,		
CT-131, CT-134,		
CT-144, CT-146	1875
CX-37-1 Series	1875

CAVALIER

6A2	1876*
-----	-------	-------

CBS COLUMBIA

22K58	1877
2001(UHF Conv.)	4.....1535

CENTURY (20th)

100X, 101, 104	1.....73
----------------	-------	----------

CHANCELLOR

35P	2.....574
-----	-------	-----------

CHEVROLET

985538	1.....105
985696	1.....108
985697	1.....106
985792	1.....109
985793	1.....110
985794	1.....106
986146	2.....846
986516	4.....1536

CHEVROLET (Continued)

986669	1878
986771	1879
987089	1880

CHRYSLER (See Mopar)

CISCO

1A5	2.....574
9A5	1.....73

CLARION

C100, C101	1.....11
C102	1.....113
C103, C104, C105	1.....116
C105A	1.....90
C108	1.....13
11011	1.....115
11305	1.....90
11801, 11802V-M	2.....647
12110M	2.....648
12310W	2.....649
12708	2.....619
13101	2.....579
14601	2.....574

CLEARSONIC

5C66	1.....11
------	-------	----------

COLLINS AUDIO PRODUCTS

FMA-6	3.....1142
45-D	3.....1143

COLLINS RADIO

75A-1	2.....650
75A-2	4.....1537

COLONIAL

629	1.....112
671, A	1.....112

CONCORD

CD61P	1.....79
6C51B, W	1.....6
6D51B	1.....117
6D51I	1.....117
6D51W	1.....117
6D61B	1.....120
6D61P	1.....79
6D61X	1.....120
6D82W	1.....114
6E51B	1.....119
6F28W	1.....18
6T61W	2.....555
7G28C	1.....38
1-402, 1-403	2.....614
1-411	2.....574
1-501	1.....18
1-504	2.....651
1-509, 1-510	1.....6
1-516, 1-517	2.....652
1-601, 1-602,		
1-603	1.....38
1-606	2.....568
1-608	1.....119
1-609	2.....555
1-611	2.....653
1-1201	2.....654

CONTINENTAL

A-11, A-11PH	1.....118
B6	1.....122
B11	1.....118
L5	1.....122
XB6	1.....122
XLS	1.....122

CO-OP

6AWC2, 6AWC3	2.....655
6A47WCR,		
6A47WT,		
6A47WTR	2.....655

CORONADO

RA33-9858D	1881
05RA1-43-775A,		
05RA1-43-775B	3.....1144
05RA1-43-9901A	3.....1145

CORONADO (Continued)

05RA2-43-9230A	4.....1538
05RA4-43-8515A,		
05RA4-43-9876A	3.....1147
05RA37-43-8360A	3.....1148
15RA1-43-7654A	4.....1539
15RA1-43-7902A	3.....1149
15RA33-43-8365	4.....1540
15RA37-43-9230A	4.....1540
15TV1-43-8958A,		
B, 15TV1-43-		
9020A, B, 15TV1-		
43-9021A, B	4.....1541
15TV2-43-9101A,		
15TV2-43-9102A,		
(Radio Ch.)		
15TV4-43-8948A,		
15TV4-43-8949A	4.....1543
35RA2-43-5101A	4.....1544
35RA4-43-		
9856A	1883
35RA37-43-		
8355	1884
35TV2-43-		
9023A	1885
35TV2-43-		
9050A,		
35TV2-43-		
9061A	1835
43-5005	2.....656
43-631	1.....13
43-6451	1.....124
43-6485	2.....657
43-7601	1.....38
43-7601B	1.....38
43-7602	1.....38
43-7651,		
43-7652	1.....66
43-7851	2.....599
43-8160	1.....121
43-8180	1.....11
43-8213	1.....124
43-8240, 43-8241	1.....127
43-8305	1.....71
43-8312A	1.....68
43-8330	1.....123
43-8351, 43-8352	1.....126
43-8353, 43-8354	2.....658
43-8420	2.....659
43-8470	1.....71
43-8471	1.....68
43-8576	1.....71
43-8685	1.....125
43-9196	1.....128
43-9201	2.....622
45RA1-43-		
7666A	1885
45TV4-43-		
9023B	1834
45TV2-43-		
9061B,		
45TV2-43-		
9064A	1834
45TV13-43-		
9038A,		
45TV13-43-		
9081A	1886
94RA1-43-		
7656A,		
94RA1-43-		
7657A	3.....1150
94RA1-43-		
7751A	3.....1151
94RA1-43-		
8510A,		
94RA1-43-		
8511A	3.....1152
94RA1-43-		
8510B,		
94RA1-43-		
8511B	3.....1153
94RA31-43-		
94RA1A	3.....1154
94RA33-43-		
8130C,		
94RA33-43-		
8131C	3.....1155
7656A, 7657A	3.....1150
7751	3.....1151
7755A, B	3.....1144
7901A	3.....1145
7902A	3.....1149
8130C, 8131C	3.....1155
8360A	3.....1148
8510A, 8511A	3.....1152
8510B, 8511B	3.....1153
8515	3.....1146
9841A	3.....1154
9876A	3.....1147

Name & Model or Chassis No. Vol. 5 Diag. No. Previous Vols. Vol. No. Diag. No.

Name & Model or Chassis No. Vol. 5 Diag. No. Previous Vols. Vol. No. Diag. No.

Name & Model or Chassis No. Vol. 5 Diag. No. Previous Vols. Vol. No. Diag. No.

CORONET

C-2 1 130

CRAFTSMEN (Also See Radio Craftsmen)

C900 1887
C1000 1888

CROMWELL

1020 3 1156

CROSLLEY

D-25BE, CE, GN, MN, TN, WE 4 1545
DU-17CDB, CDM, CHB, CHM, CHN, (Ch. 356-1, -2) 4 1546
DU-17CDB, CDM (Ch. 1-356-3, -4) 4 1546
DU-17CHN1 4 1546
DU-17COB, COM, (Ch. 356-1, -2) 4 1546
DU-17COL, (Ch. 356-3, 4) 4 1546
DU-17PDB, PDM, PHB, PHM, PHN, PHNI 4 1547
DU-17TOB, TOL, TOL1, TOM 4 1546
DU-20CDM, CHB, COB, COM 4 1546
DU-21CDM1, CDN, CHM, COB, COL, COLB, COM 4 1546
E10BE, CT, RD, WE 4 1548
E15BE, CE, SL, TN, WE 4 1549
E30BE, GN, MN, TN 4 1550
EU-17COM, TOB, TOM 4 1546
EU-21CDB, CDM, CDN, COBa, COMa 4 1546

CROSLLEY (Continued)

11-100U, 11-101U, 11-102U, 11-103U, 11-104U, 11-105U 3 1159
11-106U, 11-107U, 11-108, 11-109U, 11-128U, 11-127U, 11-128U, 11-129U 3 1160
11-207MU, 11-208BU 4 1551
11-550MU, 11-560BU 4 1549
46FA, 46FB, 56FA, 56FB, 56FC 2 595
56FA, 56PB 1 11
56TA, 56TA-L, 56TC, 56TC-L 1 73
56TD 2 667
56TG 1 131
56TJ 1 129
56TL-L, 56TN, 56TN-L, 56TP 1 73
56TQ 2 668
56TR, 56TS 1 133
56TU 1 131
67TW 1 73
68CP, 68CR 2 670
68TA, 68TW 2 680
68CC, 68CS 2 671
68CR 2 671
68TA, 68TC 2 672
106CS 1 66
146CS, 146CP, 148CC 2 673
154927 (UH F Conv) 4 1552

Chassis
10E, 10E-1 4 1548
15-20E 4 1549
30E, 30E-1 4 1550
285 3 1157
301 3 1159
302 4 1549
311 4 1545
312 3 1160
356-1, -2, -3, -4 4 1546
357, -1 4 1546
359, 360, 361 4 1546
380, 381, 383, 384 4 1546
402-1, 403-1, 404-1, 411-1, 412-1, 416-1 1889
426, 431, -2 1890

DALBAR

100 1 134
400 1 11
1000 1 134
Barcombo Jr. 1 134
Barcombo Sr. 1 134

DAVID BOGEN

AM901 4 1553
FM400A 1891
FM801 4 1553
R300 1892
R501 2 587
R-504 4 1553
R701 1893
R750 1894
RR500 1892
UCT 1895
UCT-1 1896

DEARBORN

100 2 614

DELCO

R1175 1 135
R1176, R1177 1 136
R1178, R1179 1 139
R1181 1 136
R1206, R1207, R1208, R1209 1 138
R1212 1 137
R1214 1 140
R1216, R1217 1 141
R1220 1 142
R1227, R1228, R1229 1 143
R1230A, R1231A, R1232A 1 73
R1233 2 574

DELCO (Continued)

R1234, R1235 1 143
R1236, R1237 2 674
R1238 2 574
R1242 2 669
R1243 2 675
R1244, R1245, R1246 2 676
R1251, R1252, R1253, R1254, R1255 2 677
R1408 1 73

DETROLA

554 1 79
558, 558-1-49A 1 145
568, 568-13-221D 1 14
571, 571A, 571AL, 57AX, 571B, 571BL, 571BX, 571L, 571X 1 117
572 1 144
572-220-226A 1 114
576, 576-1-6A 1 144
579 1 120
582 1 14
610A, 611A 2 678
7156 2 679
7270 1 146

DEWALD

A500, A5001, A500W 1 148
A501, A502, A503 1 148
A504, A505 1 149
A507 2 680
A509 2 681
A514 2 682
A602, A605, A608 1 150
B-400 2 682
B-402 2 683
B-403 2 627
B-504 2 684
B-506 2 685
B-510, B-512 2 686
B-512 2 687
B-614 2 688
D-E517A 4 1554
D-508 3 1161
D-517 3 1162
D-518 3 1163
D-519 2 685
D-616 3 1164
DT-120, DT-122 3 1165
DT-181 3 1166
DT-182R, DT-163A 3 1166
DT-190D 3 1166
DT-1020, DT-1020A 3 1165
DT-1030, DT-1030A 3 1165
DT-X-160 3 1165
E-520 3 1167
E-522 4 1555
E-170 3 1166
ET-140R, ET-141R 3 1166
ET-171, ET-172 3 1166
ET-190D 3 1166
F-405 4 1556
F-523 4 1555
H-300 1897
511 3 1168

DUMONT

RA-103D, RA-104A 3 1169
RA-109-A3 3 1170
RA-109-A7 3 1170
RA-110A 3 1169
RA-112-A1, -A2, -A3, -A4, -A5, -A6 (below serial No. 126293) 4 1557
RA-112-A1, -A2, -A3, -A4, -A5, -A6 (Above serial No. 126293) 4 1558
RA-113-B1, -B2, -B3, -B4, -B5, -B6, -B7, -E8 (below serial No. 135323) 4 1557
RA-113-E1, -E2, -E3, -E4, -E5, -E6, -E7, -E8 (above serial No. 135323) 4 1558
RA-119A 4 1559

Name & Model or Chassis No.	Vol. 5 Diag. No.	Previous Vols. Diag. No.
S4C20, S4C40,		
S4T15, S4T30	4	1569
S8C55, S8C70,		
S8T65	3	1196
STC20, STC30,		
ST7C0, ST7E5	3	1196
S9C10	3	1196
S20T20	3	1196
S10B0, S10E5	3	1196
UDL2100T,		
UH21T	1913	
U1700CD,		
U1770CD	1914	
U2100C, T,		
U2150C	1913	
802	1	178
605, 606	1	185
609, 610	1	73
637	1	175
652	1	171
700	2	705
711	2	574
740	2	574
795	2	706
806	3	1197
845	3	1198
855	3	1199
1000 series	1	173
1001	1	175

FARNSWORTH		
BC86	1	176
BC103, BC105	1	177
BC601, BC601X	1	186
BK106, PK107,		
BK108	1	177
BK110, EK111,		
BK112	1	188
BK602	1	186
BK6025, EK6025X	1	186
BT20	1	73
BT22	1	176
BT52, BT53, BT54	1	73
BT55, BT56,		
BT61, BT63	1	176
BT600, ET600X	1	186
CC70	1	187
CK58, CK66	1	179
CK73, CK74, CK75	1	187
CK111	1	177
CT50, CT51, CT52,		
CT53, CT54	1	179
CT61, CT62,		
CT63, CT64	1	179
DK73, DK75	1	187
EC280	1	28
EK-081, EK-082,		
EK-083	2	707
EK-262, EK-263,		
EK-263BL,		
EK-263WL, EK-264,		
EK-264BL,		
EK-264WL, EK-265	1	28
EK-681	2	707
ET-060, ET-061,		
ET-062, ET-063,		
ET-064, ET-065,		
ET-066	1	180
GK-100, GK-102,		
GK-103, GK-104,		
GK-111, GK-112,		
GK-114, GK-115	2	707
GK-140, GK-141,		
GK-142, GK-143,		
GK-144	2	708
GT-060, GT-061,		
GT-064, GT-065	2	709

Chassis		
150	1	180
152, 153	1	28
156, 157	2	707
158, 159	1	180
162	1	28
170	2	707
193, 194	2	707
201	2	707
216	2	707

FEDERAL		
1030T	1	138
1040T, 1040TB	2	710
1540T	1	138

Name & Model or Chassis No.	Vol. 5 Diag. No.	Previous Vols. Diag. No.
C81-B	1	184
T61-B	2	711

FIRESTONE		
4-A-2	1	21
4-A-3	2	560
4-A-10	2	712
4-A-11	2	713
4-A-12	2	714
4-A-15	2	715
4-A-17	2	716
4-A-20	1	20
4-A-21	1	22
4-A-21X	1	24
4-A-22	1	22
4-A-22X	1	24
4-A-23	1	25
4-A-24	1	23
4-A-25	1	26
4-A-26	2	717
4-A-27	2	718
4-A-31	1	28
4-A-37	1	27
4-A-41	2	719
4-A-42	2	644
4-A-60	2	720
4-A-61	2	721
4-A-66	3	1200
4-A-71	2	722
4-A-78, 4-A-79	3	1201
4-A-85	3	1202
4-A-86	3	1203
4-A-86 (late)	3	1203
4-A-87	4	1570
4-A-108	4	1571
4-A-110	4	1520
4-A-113,		
4-A-114	1915	
4-A-115	1916	
4-A-127,		
4-A-128	1917	
4-A-133	1918	
4-B-1, 4-B-2	1	29
4-B-56	3	1133
4-B-57	3	1075
4-B-58	3	1132
4-B-60	4	1522
4-B-61	4	1519
4-B-62, 4-B-67	4	1522
4-B-69	1858	
4-B-71	1856	
4-B-72	1919	
4-B-74	1920	
4-C-3, 4-C-6	1	36
4-C-16, 4-C-17	3	1205
4-C-18	3	1206
4-C-21	4	1207
4-C-24	1921	
13-G-3	3	1207
13-G-4	3	1208
13-G-33	3	1209
13-G-48	4	1572
13-G-57	4	1573
13-G-128,		
13-G-129,		
13-G-130,		
13-G-132	1834	
13-G-145,		
13-G-146	1834	
S7400-4, -5, -7	1	33

FISHER		
FM-80	1922	
50R, 50RT	1923	
70RT	1924	

FLUSH WALL		
5P (Early)	2	614
5P (Late)	1925	

FORD		
7070 (51A-18805-B2)	2	723
5BF (FDH-18805-B1)	1926	
5MF (FDH-18805-B2)	1927	
5MF (FDH-18805-A2)	1926	
6MF080	1	181

Name & Model or Chassis No.	Vol. 5 Diag. No.	Previous Vols. Diag. No.
46	1	193
717, 750	1928	

FRED EISEMANN		
C4B15, C4B16	1	48
C5D14	1	40
C5D16	1	48
15C6A	1	191
15C6B	1	190
864	1	80
3128 (Late)	1	182
4132	1	182
4164	1	183
4956	1	45

GAMBLE SKOGMO (Also See Coronado)		
5A-1	2	724
5A-2	1	192
5A-3	2	725
5A-4	2	726
5AP1-Y	1	189
5D, 5D-2	1	194
5D-3, 5D-3A	2	727
5D-4, 5D-5	2	728
5RC-1	2	726
6A-2	2	724
6AU-1	1	82
6BU-1A	1	195
6DPS, 6DPS-A	1	196
10T2, 10T21,		
10T22, 10T23,		
10T24, 10T25	2	729
11FMP	2	730
12T2, 12T21,		
12T22, 12T23,		
12T24, 12T25,		
12T26A, 12T27A	2	729
15T2, 15T26,		
15T27	2	729
62B	2	661
306	2	731
900TV, 910TV,		
1000TV, 1001TV,		
1100TVP, 1110TVP,		
1200TVP, 1210TVP	2	732

GENERAL ELECTRIC		
G61	1	197
G64, G65	1	200
G66, G68, G69	1	197
G75	1	200
G78	1	197
G85	1	198
G86	1	197
G95	1	202
G99	1	198
GDE-73	1	204
GE-52	1	206
GE-73, GE-78	1	204
GE-93, GE-96	1	205
H73, H77, H78,		
H79, H87	1	203
H116, H118	1	203
H800, H500U,		
H601	1	207
H610, H610U,		
H611	1	207
H620, H620U,		
H621, H622,		
H623, H625	1	208
H630, H630U,		
H631, H632,		
H632U, H633	1	208
H634	1	203
H638, H640	1	203
H708	1	209
H736	1	209
HET4, HET4L	1	204
HE100, HE100H,		
HE100L, HE100LH	1	199
HE105, HE105L	1	199
HE740, HE740L	1	204
HJ119	1	203
HJ737	1	209
HJ905, HJ908,		
HJ908B	1	203
HJ1005	1	203
HJ1205	1	203
J62, J63	1	210
J64	1	211
J71	1	211
J105	1	211
J602, J603	1	212
J614	1	212

Name & Model or Chassis No.	Vol. 5 Diag. No.	Previous Vols. Vol. No. Diag. No.
GENERAL ELECTRIC (Continued)		
J620	1	210
J664	1	212
J709	1	209
J718, J728	1	211
J805, J808, J809,		
J818, J828	1	211
J1106, J1108	1	211
JE81	1	213
JE101, JE107	1	215
JE810	1	213
L800, L601, L610,		
L611	1	212
L631, L642, L643	1	212
L650, L651, L652	1	214
L653	1	212
L660	1	214
L663, L673, L674	1	212
LF115, LF116	1	216
LFC1118, LFC1128,		
LFC1228	1	216
X115, X125, X145	1	220
X225A, X225V	1	212
10C101, 10C102,		
10T1, 10T4, 10T5,		
10T6	3	1210
12C101, 12C102,		
12C105	3	1210
12C107, 12C107B,		
12C108, 12C108B,		
12C109, 12C109F	3	1211
12T1	3	1210
12T3, 12T3B,		
12T4, 12T4B	3	1211
14C102, 14C103	3	1211
14T2, 14T3	3	1211
16C103	3	1211
16C110, 16C111	3	1211
16C113	3	1211
16C115, 16C116,		
16C117	3	1211
16T1, 16T2, 16T3,		
16T4, 16T5	3	1211
17C101, 17C102	3	1211
17C103, 17C104,		
17C105, 17C107,		
17C108, 17C109,		
17C112, 17C114	4	1574
17T1, 17T2, 17T3,		
17T4, 17T5, 17T6,		
17T7	4	1574
17T20	1929,	
1930		
20	1	210
21C40	1931	
21C103,		
21C104	1929,	
1930		
21C130,		
21C131	1931	
21C151,		
21C152,		
21C156,		
21C157	1931	
21C240		
21C241 (Early)	1929,	
1930		
21C240,		
21C241 (Late)	1929,	
1932		
21C347,		
21C348,		
21C349,		
21C350,		
21C351	1930	
21T22,		
21T23,		
21T24,		
21T25	1929,	
1930		
21T26,		
21T27 (Early)	1929,	
1930		
21T26,		
21T27 (Late)	1929,	
1932		
21T30,		
21T31	1930	
35	1	215
40	1	216
41, 42, 43, 44, 45	2	793
50	2	218
100, 101	1	217
102, 102W	2	734
103, 105	1	217
106	1	221
107, 107W	2	734
114, 114W, 115,		
115W	2	734

Name & Model or Chassis No.	Vol. 5 Diag. No.	Previous Vols. Vol. No. Diag. No.
GENERAL ELECTRIC (Continued)		
118	2	735
119M, 119W	2	735
123, 124	3	1212
131	2	735
135, 136	3	1213
143	3	1214
145	2	736
150	2	737
160	2	738
165	3	1215
180	1	219
200, 201, 203,		
205, 205M	1	222
210, 211, 212	2	1216
218, 218 "H"	3	1217
219, 220, 221	1	227
226	3	1217
250	1	225
254	2	740
260	1	225
280	2	678
303	1	223
304	2	741
321	1	224
326, 327	1	226
354, 355	2	742
356, 357, 358	2	743
376, 377, 378	2	744
400, 401	3	1218
404, 405	3	1219
408	3	1220
409	4	1575
410	3	1219
411	3	1218
412	4	1576
412F	4	1577
414	4	1576
414F	4	1577
415	4	1576
415F	4	1577
416	4	1576
416F	4	1577
417	1	230
422, 423	4	1578
427, 428,		
429	1933	
430	4	1576
431, 432	1934	
440	1935	
442, 443,		
444	1933	
446, 447,		
448	1936	
502	2	733
535	4	1579
546, 547, 548,		
549	4	1580
551, 552	4	1581
564, 565, 566	1937	
572, 573,		
574, 575	1938	
577, 578	1939	
580, 581, 582	1940	
590	1941	
600	3	1221
601, 603, 604	3	1222
605, 606, 607, 608	4	1582
610, 611	4	1583
612, 613	1942	
614	4	1584
630, 631, 632	1943	
650	3	1223
741	4	1585
752, 753	3	1224
754	4	1586
755	3	1225
757	3	1225
800A, B, C, D	3	1226
805, 806,		
807, 809	3	1226
810	4	1587
811	3	1227
A6E		
814 (Fine Tuning)	3	1227
A		
814 (Focus Control)	3	1228
817	3	1226
821	3	1226
830, 835, 840	3	1229
GENERAL IMPLEMENT		
9A5	2	574
GENERAL TELEVISION		
1A5, 2A5, 3A5,		
5A5	1	73

Name & Model or Chassis No.	Vol. 5 Diag. No.	Previous Vols. Vol. No. Diag. No.
GENERAL TELEVISION (Continued)		
9A5	2	574
14A4 F	1	6
15A5, 17A5,		
19A5, 21A4,		
22A5C, 23A6	1	574
4B5	2	773
5B5G, 5B5Y	2	745
9B5P	2	574
24B6, 25B5	2	574
GILFILLAN		
56A, 56B, 56BC-1,		
56BC, 56C,		
56D, 56E	1	73
58A, 58W	2	555
66A, 66AM	1	73
66B	1	73
66D, 66DM	1	229
66P, 66PM	1	231
68BD	2	746
68 F	2	747
86C, 86P, 86U	2	748
108-48	2	749
GLOBE		
5BP1	1	233
6AP1	1	228
6D1	1	232
6P1	1	228
6U1	1	232
7CP1	1	237
62C	1	237
456	2	750
457	2	560
500	2	751
517	2	752
457	2	560
500	2	751
517	2	752
551	1	11
552	2	753
553	2	614
GON-SET		
10-11 (Meter Con-		
verter)	2	689
GOODRICH (Also See Mantola)		
92-523, 92-524,		
92-525, 92-526,		
92-527, 92-528	4	1588
GRANCO		
LCU	1944	
MTU	1945	
610	1946	
GRANTLINE		
500, 501	1	234
507	2	754
508-7	2	755
510-A	2	756
605, 606 (Series A)	1	92
651	1	15
5610	2	757
6547	1	15
HALLICRAFTERS		
CA-2, CA-2A, CA-4	2	758
S-38	1	235
S-38B	3	1230
S-38C (Run 2)	4	1589
S-40	1	236
S-40A	2	759
S-40B	3	1231
S-41B, S-41G,		
S-41W	1	242
S-47	2	677
S-51	2	555
S-52	2	759
S-53	2	760
S-53A, AU	4	1590
S-55, S-56	2	761
S-56, S-59	2	762
S-72	3	1232
S-72L	4	1591
S-76, S-76U	4	1592
S-77	4	1593
S-78	3	1233
S-78A	4	1594

Name & Model or Chassis No.	Vol. 5 Diag. No.	Previous Vols. Vol. No. Diag. No.
-----------------------------	------------------	-----------------------------------

HALLICRAFTERS (Continued)

S-80	4	1595
S-81, S-82	4	1596
ST-74	3	1234
ST-83	1947	
SX-42	2	763
SX-43	2	764
SX-71	3	1235
TW-500		
TW-600	1948	
TW-1000	1949	
TW-2000	1950	
5R10	3	1236
5R10A	4	1597
5R30, A, 5R31A, 5R32, A, 5R33, A,		
5R34, A	4	1598
5R50, 5R51, 5R52	4	1598
5R60, 5R61	1951	
8R40, 8R40C, 400, 406, 409, 410, 411, 412	2	677
611, 612	1952	
621, 622	1952	
680, 681	3	1237
690	3	1237
715, A, 716	3	1237
730, 731	3	1237
740, 741	3	1237
810A, 811, 815, 818, 820, 822	3	1238
860, 861	3	1238
870, 871	3	1238
880	3	1238
1005, 1006, 1015, 1016, 1017, 1018, 1019	4	1600
1035	4	1601
1621, 1622	1953	
17811-H, 17816, 17817, 17824-A, 17906, 17930, 17931, 17932, 17933, 17934	4	1602
20823C	4	1602
20990, 20990S, 20994	4	1601
21923, 21928, 21940, 21980	4	1602
Chassis		
A1100D	4	1600
Z1000D	4	1600

HARVEY-WELLS

ATR-3-6	2	765
ATR-3-12	2	765

HOFFMAN

A-200	1	239
A-202	1	240
A-300	1	82
A-309	1	240
A-401	1	82
A-501	1	241
A-700	1	238
B-400	1	244
P-1000	1	18
C-501	2	766
C-502	2	767
C-503	2	766
C-504	2	767
C-506, C-507	2	768
C-511	2	766
C-512	2	767
C-513	2	766
C-514	2	767
C1006, C1007	2	767
C1006, C1007	2	767
21B907, 21M906, 21P908	1954	

Chassis

102	1	82
103	1	239
108ST	1	241
110S	1	238
114	1	18
119	1	240
123	2	767

HOWARD

4P7	1	171
220, 221	1	171

Name & Model or Chassis No.	Vol. 5 Diag. No.	Previous Vols. Vol. No. Diag. No.
-----------------------------	------------------	-----------------------------------

HOWARD (Continued)

270, 271	1	171
300 Series	1	243
307-4, 307TP-2	1	243
430 (Series 2)	1	246
438	1	246
460	1	250
472AC, 472AF, 472C	2	769
472 F	2	770
474	2	555
482, 482A	2	761
500 Series	1	245
718 PM	1	249
765, 768, 780	1	248
806, 808	1	247
808 (Series X)	1	259
810	1	247
865, 868	1	255
901A-E, -H, -I, -M, -P, -W	1	73
906, 906C	1	253
909M	2	771
920	1	73

HUDSON

DP39	1	256
DB40	1	252
SA39	1	256
SA40	1	252

JACKSON

150, 153	3	1239
254	4	1603
255	4	1604
350	3	1240

JEFFERSON TRAVIS

MR-2B, MR-3	1	251
-------------	---	-----

JEWEL

500A, P, C, 501A, B, C, 502A, B, C, 503A, B, C, 504A, B, C, 505A, B, C	1	18
960, 960U, 961	3	1241
5020, 5020U	3	1242
5057U	3	1243

KAPPLER

102T	2	772
------	---	-----

KARADIO

M80B	1955	
1276	3	1244

KNIGHT

D-182	1	249
D-197	1	249
SX8L727	1909	
SX11L719	1911	
SX14L721	1956	
SX19L720	1957	
4D-450	2	633
4G-420	3	1245
5A-150, 5A-152, 5A-154	1	15
5A-190	1	11
5B-160	1	18
5D-175, 5B-176	1	16
5B-185	2	773
5C-290	2	573
5D-250, 5D-251	2	570
5D-455	2	572
5F-565	2	574
57705	4	1605
5K715	4	1606
6A-122	1	254
6A-127	1	261
6A-195	1	16
6B-122	1	254
6B-127	1	261
6C-225	2	578
6D-225, 6D-226	2	578
6E-745	2	745
6D-360	2	649
6C-400	3	1249
6H-580	3	1246
6K718	1958	
7E-220	2	754
7D-405	2	774

Name & Model or Chassis No.	Vol. 5 Diag. No.	Previous Vols. Vol. No. Diag. No.
-----------------------------	------------------	-----------------------------------

KNIGHT (Continued)

8B-210	1	258
8D-340	2	645
8G-200, 8G-201	3	1247
10P-249	2	775
11C-300	2	645
11D-302	2	667
12H10	4	1607
19F-492, 19F-497, 19F-498	2	776
20H511	4	1607
93-326	4	1608
94S445	1959	
94SX728	1960	
97-870	3	1248
200	1957	
449	3	1249
511D	3	1250
722	1909	

LAFAYETTE

B33	1	6
F112	1	41
E195	1	183
B9 (A)	1	191
B9 (B)	1	190
FA15W, FA15Y	1	257
J62, J62C	1	237
MC10B, MC10Y	1	11
MC11, MC12	2	777
MC13	1	11

LEARADIO

R971	2	778
RM402C	2	779
561, 562, 563	1	260
565, 565BL, 566, 567, 568	1	260
661	1	270
1281PC	2	761
6610PC, 6611PC, 6612PC	1	270
6614, 6615, 6616, 6617PC, 6619	1	260

LEWYTT

615A	1	265
711	2	560

LEXINGTON

6545	1	15
------	---	----

LIBERTY

A6K, A6P	1	264
6K	1	264
507A	1	264

LINCOLN

SL3L-N	1	185
--------	---	-----

LINCOLN (Allied Radio Corp.)

5A-110	1	26
--------	---	----

LYRIC

546T, 546TY, 546TW	1	73
--------------------	---	----

MAGIC TONE

500, 501	1	19
----------	---	----

MAGNAVOX

Chassis		
CMU-422A	1961	
CMUA-435AA		
CMUA-436AA	1961	
CMUA-455AA		
CMUA-456AA	1961	
CR-101, CR-101M	1	262
CR-108M	1	266
CR-122	1	266
CR-187, CR-188	1	263
CR-189A, CR-189B	1	267
CR-190	1	271
CR-190A, CR-190B	2	780
CR-192A, CR-192B	1	267
CR-193	1	263
CR-197C	2	781
CR-198A, CR-198B, CR-198C	1	263

Name & Model or Chassis No.	Vol. 5 Diag. No.	Previous Vols. Vol. No. Diag. No.
-----------------------------	------------------	-----------------------------------

MAGNAVOX (Continued)

CR-200A, B, C, D, E, F	2	782
CR-207A; B, C, D	2	781
CR-208A, B	2	783
CR-330A-A-1	1962	
CR-700	1963	
CR-702A, B (260M Series)	1964	

MAGUIRE

500B1, 500BW, 500D1, 500DW, 561B1, 561BW, 561D1, 561DW	1	269
571	1	269
571	2	784
561, 561A	1	269
700A, 700E	1	268

MAJESTIC

4P1	1985	
5A410, 5A430	1	272
5A445, 5A445R	2	614
5AK711, 5AK731, 5AK790	2	785
5C-2, 5C-3	4	1609
5LA5, 5LA6	3	1251
5LA7, 5LA8	3	1252
6FM714	2	786
6FM773	2	787
7C432, 7C447	1	274
7FM877, 7FM888	2	787
7JK777R	2	788
7JL866	2	788
7P420	2	789
7S433, 7S450, 7S470	2	790
7YR752	2	791
7YR753, 7YR772	2	789
8FM744, 8FM775, 8FM776, 8FM889	2	792
8JL885	2	793
8S452, 8S473	1	273
12FM475, 12FM778, 12FM779, 12FM895	2	794
20FP88, 20PP89 (Radio Ch.)	4	1610
21P82, 21P83 (Series 110, 111), 1966		
80FM2	4	1610

Chassis

5B01A, 5B05A	2	785
6B02D	2	786
6B11D	2	787
7B04A	2	791
7B09A, 7B09A.1	2	789
7C11D	2	787
7C25A	2	788
8B06D, 8B07D, 8B08D, 8C07D	2	792
12B26E, 12C22E	2	794
4501, 4504	1	272
4506	2	614
4702, 4703	2	790
4705	2	788
4706, 4707	1	274
4708R	2	788
4810	1	273
4810B	2	793
4120T	2	794

MALLORY

TV-101	4	1535
--------	---	------

MANTOLA

R459	1	118
R643	1	4
R652, R652N	1	6
R654-PM, -PV	1	275
R655W	1	275
R662, R662N	1	6
R664PM, PV, W	2	795
R7543	1	73
R75143	2	574
R75152	2	796
R75343	2	574
R76143	2	574
R76162	2	796
R76262	2	797
R78162	2	798
24B6	2	574
92-529	4	1611

MASCO

RK-5SLR	4	1612
---------	---	------

MASON

45-1A, 45-1B, 45-1P	1	73
45-3, 45-4, 45-5	1	73

MATTISON

630 DXM, 630 MDXL	1967	
-------------------	------	--

MAYFAIR

510, 510W	2	799
520, 520W	2	799
530, 530W	2	799
550, 550W	2	799

MECK

CD-500, CE-500	2	800
CR-500	2	801
EF-730, EG-731	3	1253
MM510T, MM512T, MM518C, MM516T	3	1254
PM-5C5-DW10, PM-5C5-PW10	1	6
RC-5C5-P	1	6
RC-6A7-P8	2	802
XOB, XQA, XQR, XRA, XRPT, XSA, XSP, XTA, XTR, XX900	3	1254
4C7	2	803
6A6-W4	1	187
9030	1	1988

MEDCO (See Telesonic)

MEISSNER

4E	4	1613
8BT	4	1614
8C	2	804
9AJ	3	1255
9-1065	1	6
9-1091A, 9-1091B	2	805
9-1091C	3	1256
9-1093	2	806
16A	3	1257
2961 Series	2	807

MERCURY (Pacific Mercury)

2081, 2181 (Radio Ch.)	4	1615
2217, 2218, X, 2224, 2284	4	1616
2701	1993	

Chassis

155	4	1615
200-11	4	1616

MIDLAND

M6B	1	278
-----	---	-----

MIDWEST

KD-16	1969	
P6, PB6	1	276
R12, RG12, RT12	2	808
R15, RC16	2	808
RN-1B	1	19
RT-16	2	808
S8, ST8	1	282
SI2, SG12, ST12	2	809
SI6, SG16, ST16	2	809
TM8	1	282

MINERVA

L-702	1	171
L-728	1	19
W-117	1	6
W-117-3	1	11
W-702-B	1	171
W710, W710A	1	281
W-728	1	19
410, 411	2	810
702H, 702H-1	2	810
729	2	704

MITCHELL

1254	4	1617
1278	1970	
1287	1971	

MONITOR

M510	2	811
M3070	2	812
RA50	2	813
TA56M, TW56M	1	129

MONITORADIO

AR-1, AR-3	4	1618
DR-200	1972	
M-51	4	1619
M-101	4	1618
MR-32	1973	

MONTGOMERY WARD (See Airline)

MOPAR

600, 601, 602	1	112
802	1	111
802 Revised	1	111
805	3	1258
808, 809	3	1259
812	4	1620
814	4	1621
819	4	1620
829	1974	
830	1975	

MOTOROLA

PK2M	4	1622
EK-6	1	279
CR-6	1	280
CR-76	2	815
CTM3	1976	
CT1M	4	1623
CT2M	4	1622
CT-6	1	279
CT52M6	1977	
FD-6, FD-7	1	279
GMT2M, HJ2M, HN2M	4	1624
HN4M6	1977	
HN53M6	1977	
KR2M	4	1624
NH6	1	279
OE2M	4	1624
OE6	1	279
PC2M	4	1624
PC6	1	279
PD2M	4	1624
SR0B	3	1260
SR1B	3	1282
SR2M (Early)	4	1625
SR2M (Late)	4	1624
SR52M6	1977	
VF102, VF102A, VF102C	2	814
VF103, VF103M	3	1261
VK101, VK101M	2	814
VT101	2	814
Y21F5, F (Radio Ch.)	1977	
5C1, 5C2, 5C3, 5C4, 5C5, 5C6	3	1262
5H11U, 5H12U, 5H13U	3	1263
5X11U, 5X12U, 5X13U	3	1264
5X21U, 5X22U, 5X23U	3	1265
6F11, 6F11B	3	1266
6L1, 6L2	3	1267
6X11U, 6X12U	3	1268
7F11, 7F11E	3	1269
8FM21, 8FM21B, 9FM21, 9FM21B	3	1270
9-24, 9-24A	1	285
9-44	1	288
16-C	1	284
17-F1, BH, H	3	1280
17-D	1	287
17F1, A, E, BA, 17F2W, WA, 17F3B, BA, 17F4, A, 17F5, A, E, BA	3	1281
17F11 (Radio Ch.)	4	1626
17F12, A, E, BA	4	1626
17F13, E, 17F13C, 17F13C	4	1626

Name & Model or Chassis No.	Vol. 5 Diag. No.	Previous Vols. Vol. No. Diag. No.
MOTOROLA (Continued)		
18-O, 19-B	1	289
21 F1, E	4	1627
21 F5, B		
(Radio Ch.)	1978	
25-F	1	290
26-C, 26-CT	1	291
27-D, 27-D6	1	293
28-O, 29-B, 29-B6	1	291
30-P	1	291
35-F	1	294
35-N	1	292
36-C1, 36-C2	1	295
37-D1, 37-D2	1	296
38-O	1	291
39-B1, 39E2	1	291
40-P	1	286
43-H	1	297
44-K	1	298
45-B12	1	158
45-N	1	299
47B11	2	818
51-A, 51-C	1	73
51F11	1	300
51F12	1	301
51R11	1	300
52-C	1	73
52C1, 52CIA		
52C6	4	1628
52H1U, 52H12U		
52H13U, 52H14U	4	1629
53-A, -C	1	73
53H, 53H2		
53H3, 53H4	1978	
53LC1		
53LC2		
53LC3	1980	
53X1, 53X2		
53X3, 53X4	1981	
54-A, -C	1	73
55F11	1	303
55X11	1	302
55X11A	1	304
55X12	1	302
55X12A	1	304
55X13	1	302
55X13A	1	304
56X11	2	669
57X11, 57X12	2	817
58A11, 58A12	2	669
58X11, 58X12	2	818
59H1U, 59H12U	3	1272
59X11, 59X121	3	1273
59X21U		
59X221U	3	1274
60-XW	1	301
61-A, 61-B	1	305
61-C, 61-D	1	308
61-E	1	305
61-F	1	307
61T21	1	308
61T23	1	314
61X11, 61X12		
61X13	1	301
62-A, 62-B	1	305
62C1, 62C1A		
62C2, 62C2A		
62C3, 62C3A	4	1630
62CW1	4	1631
62-E	1	305
62-F1	1	312
62L1U, 62L2U		
62L3U	4	1632
62X11U, 62X12U		
62X13U	4	1633
62X21	1982	
63-A, 63-E	1	305
63LSS	1983	
63L1, 63L2		
63L3	1984	
63X1, A		
63X2, 63X3	1985	
63X21	1986	
64X1, 64X2	1987	
65F11, 65F12	1	303
65F21	1	309
65T21, 65T21B	1	310
65X11, 65X11A		
65X12, 65X12A		
65X13, 65X13A		
65X14, 65X14A		
65X14P	1	19
67F11, 67F12		
67F12P	2	819
67F14	2	820
67F16B	2	821
67L11	2	822

Name & Model or Chassis No.	Vol. 5 Diag. No.	Previous Vols. Vol. No. Diag. No.
MOTOROLA (Continued)		
67X11, 67X12		
67X13		
67XM21	2	823
68F11, 68F12		
68F14, 68F14P	2	819
68F14M		
68T11, 68X11		
68X11A, 68X12		
68X12A	2	825
69L11	3	1275
69X11, 69X121	3	1276
71-A	1	313
72-C	1	311
72XM21, 72XM22	4	1634
75 F21	1	315
75 F31, 75 F31A		
75 F31B	2	826
76F31	2	826
77 F21, 77 F22		
77 F22M		
77 F22ZWM		
77 F22	2	823
77XM21, 77XM22		
77XM22P	2	823
78F11, 78F11M		
78FM12M		
78FM21, 78FM21M		
78FM22M	2	827
79XM21, 79XM22	3	1277
81-C	1	306
81 F21, 81 F22	1	308
81K31	1	316
82-A	1	317
83F1	1	312
83K1	1	321
85 F21, 85K21	1	309
88 FM21	2	827
93 F1	1	312
95F31, 95F31B		
95F33	1	320
99FM21R	3	1278
101 F21, 101 R21	1	319
103C2	1	318
103 F, 103 F2	1	312
103K1	1	322
107F31, 107F31P	2	828
250, 251	1	325
395, 395-12	1988	
401A, 412	4	1635
Chassis		
AS-22	1	279
HS-2	1	19
HS-8	1	158
HS-22, HS-26	1	309
HS-30, HS-31	1	303
HS-32	1	310
HS-36, HS-36A	2	826
HS-38, HS-39	1	320
HS-50	1	304
HS-52	1	309
HS-58	2	820
HS-59	2	822
HS-60	2	817
HS-63	2	819
HS-64	2	823
HS-69	2	821
HS-72	2	816
HS-87	2	828
HS-89	2	823
HS-91	1	315
HS-94	2	669
HS-97	2	823
HS-98	2	826
HS-102	2	823
HS-108	2	814
HS-119	2	824
HS-122	2	820
HS-124	2	819
HS-125	2	818
HS-127, HS-127A	2	825
HS-128, HS-132		
HS-133	2	827
HS-137	2	814
HS-144	2	825
HS-150, HS-155	2	827
HS-158	2	669
HS-168	3	1277
HS-170	3	1278
HS-175	3	1275
HS-180	3	1273
HS-181	3	1276
HS-192	3	1274
HS-210	3	1272
HS-226	3	1267
HS-228	3	1262
HS-230	3	1279

Name & Model or Chassis No.	Vol. 5 Diag. No.	Previous Vols. Vol. No. Diag. No.
MOTOROLA (Continued)		
HS-234	3	1280
HS-243	3	1264
HS-244	3	1263
HS-245	3	1268
HS-246	3	1271
HS-247	3	1270
HS-253	3	1281
HS-258	3	1262
HS-259	3	1265
HS-261	3	1281
HS-262	3	1262
HS-264	3	1266
HS-265	3	1269
HS-270, HS-271		
HS-272	3	1262
HS-299	4	1630
HS-302	4	1626
HS-303	4	1634
HS-308	4	1632
HS-309, HS-310	4	1628
HS-313	4	1629
HS-314	4	1633
HS-316	4	1627
HS-319	4	1626
HS-324	4	1631
HS-326	1982	
HS-335	1985	
HS-336	1981	
HS-337	1979	
HS-347	1980	
HS-361	1984	
HS-385	1986	
HS-415	1983	
HS-440	1987	
CB	3	1260
QTS-502, Y	1978	
R16M6	1977	
TS-3, TS-5, TS-7	2	814
TS-8	3	1261
1B	3	1282
MURPHY		
113, 122	1	258
NATIONAL		
Criterion	1989	
HRO-50	3	1283
HRO-50R1	4	1636
HRO-60	4	1637
NC-33	2	829
NC-46	1	326
NC-57	2	830
NC-98	1990	
NC-108R, NC-108T	2	831
NC-125	4	1638
NC-2-40DR		
NC-2-40DT	2	832
SW-54	4	1639
NATIONAL UNION		
571, 571A, 571B	1	117
G-613	1	324
G-619	1	189
OLDSMOBILE		
982160	1	323
982282	1	327
982375	1	323
982543, 982579	4	1640
OLYMPIC		
HF500	1991	
6-501, 6-501VU		
6-501WU	1	328
6-502, 6-602P		
6-502U	1	328
6-503	1	328
6-504, 6-504L	1	6
6-601V, 6-601W		
6-602	1	329
6-604 Series	2	833
6-606, 6-606A		
6-606U	1	272
6-617, 6-617U	1	329
7-421V, 7-421W		
7-421X	2	834
7-435V, 7-435W	2	834
7-526	2	704
7-532V, 7-532W	2	833
7-537	2	835
7-622, 7-638	2	774
7-724, 7-728	2	836

Name & Model or Chassis No.	Vol. 5 Diag. No.	Previous Vols. Vol. No. Diag. No.
7-925, 7-934,		
7-936	2	837
8-451	2	838
8-533V, 8-533W	2	839
8-618	2	840
8-925, 8-934,		
8-936	2	841
9-435V, W	4	1641
17K41, 17K42,		
17K50 (Radio Ch.)	4	1642
20K43, 20K51,		
21K61, 21K62,		
21K63B	4	1642
51-421W	4	1643
488	4	1644
505, B		
572B, M	1992	

PACKARD-BELL

5DA	1	73
5D8	2	574
5FP	1	73
100	2	574
551, 551-D	1	333
556	1	333
561, 563	1	330
566	1	333
568	1	73
571, 572	2	842
575	1	333
651	1	331
661	1	331
662	1	332
673A, 673B	2	843
682	2	844
771	2	845
861	1	332
872	2	846
880, 880A	2	843
881A, 881B	2	847
884, 892	3	1284
1052	1	334
1054B	1	337
1063	1	272
1181, 1181A	3	1285
1273	2	848
1472	2	849
2301-TV (Radio Ch.)	3	1286
2302 (Radio Ch.)	3	1286
2311, 2811A		
(Radio Ch.)	4	1645
2801-TV,		
2801A-TV (Radio Ch.)	3	1286
2803TV	3	1287

PENTRON

AFM 1994

PHILCO

A-T2294	4	1646
A-UT2272	1995	
B570, B574	1996	
B652	1997	
B714, X	1998	
B956	1998	
B1349, B1352	1999	
B1752, B1753	1999	
B1756	2000	
C667	2001	
C1348	1999	
C-4608	1	111
C-4608 Revised	1	111
CR-2	2	850
CR-4, CR-6	2	851
CR-8	2	852
CR-9	2	853
CR-12	2	852
CR-501, CR-503,		
CR-505	3	1288
RT-14	2002	
UNB-100	1	336
UNB-450, UNB-500	1	335
UT-21A	2003	
UT-21B	2004	
18BU000,		
18BU3001	1995	
18BU3002	2005	
18BU3100,		
L, HM	1995	
18BU3102, L	2005	
18BU3104	1995	
22BU4000	1995	
22BU4002,		
22BU4004	2005	

PHILCO (Continued)

22BU4008,		
22BU4009	1995	
22BU4100, L		
22BU4101	1995	
22BU4102, L		
22BU4106	2005	
22BU4108	1995	
22BU4109HM	2005	
22BU4110, L	1995	
22BU4302	2005	
22BU4303	1995	
22BU4304,		
22BU4306,		
22BU4307HM	2005	
22BU4308	1995	
22CA016,		
22CA020	2006	
22CA119,		
22CA120, L		
22CA123,		
22CA124, L		
22CA126, L		
22CA128M,		
22CA129,		
22CA132L	2006	
22CA310, L		
22CA412, L	2006	
24BU06106, L		
24BU06300	2005	
39-40, 39-45	1	339
39-55	1	342
39-118	1	342
39-70	1	338
40-110	1	341
40-130, 40-135,		
40-140, 40-145	1	340
40-150, 40-155	1	344
40-158	1	348
40-160, 40-165	1	345
40-170CS	1	340
40-180, 40-185,		
40-190	1	344
40-195, 40-200,		
40-201	1	338
40-205, 40-215,		
40-216, 40-217	1	342
40-503, 40-506,		
40-507	1	340
40-518	1	342
40-525, 40-526,		
40-527	1	340
40-710, 40-715	1	351
40-725, 40-748,		
40-755, 40-756,		
40-780	1	349
40-2710	1	351
40-2725, 40-2780	1	349
41-230, 41-235	1	350
41-250, 41-255	1	353
41-260, 41-265	1	352
41-280, 41-285,		
41-287, 41-290	1	353
41-295	1	338
41-296	1	353
41-300, 41-315X	1	338
41-316	1	342
41-608, 41-609	1	353
41-610, 41-611	1	353
41-616	1	342
41-629	1	353
41-712, 41-713	1	354
41-714	1	346
41-722, 41-745,		
41-758, 41-759	1	347
41-788	1	356
42PT-2, 42PT-4,		
42PT-7	1	343
46-421	1	363
42-122	1	358
42-123	1	361
42-124, 42-125,		
42-126	1	364
42-35	1	357
42-380	1	363
42-395	1	363
42-400	1	338
42-706	1	343
42-724	1	360
42-730	1	366
42-760, 42-761,		
42-762	1	359
42-788	1	356
42-1002	1	362
42-1003, 42-1005	1	367
42-1009, 42-1009M,		
42-1009W	1	365

PHILCO (Continued)

42-1012, 42-1013M,		
42-1013W	1	368
42-1015, 42-1016	1	338
46-131	1	370
46-131 Revised	2	854
46-132	1	371
46-142	2	854
46-200, 46-200-1,		
46-201, 46-202,		
46-203	1	173
46-250, 46-250-1,		
46-251	1	372
46-350	1	373
46-420, 46-420-1	1	377
46-421, 46-421-1	1	374
46-480	1	375
46-480	1	376
46-1201	1	379
46-1203	1	378
46-1209	1	380
46-1213	1	382
46-1226	1	380
47-204, 47-205	2	745
47-1227	2	855
47-1230	2	856
48-141, 48-145	2	857
48-150	2	858
48-200, 48-200-1,		
48-206, 48-214,		
48-225, 48-230	2	560
48-250, 48-250-1	2	859
48-300, 48-360	2	860
48-460, 48-460-1	2	861
48-481	2	859
48-482	2	862
48-472-1	2	863
48-472 Revised	2	864
48-475	2	865
48-482	2	866
48-485	2	867
48-1201	2	868
48-1253	2	869
48-1256	2	870
48-1260	2	868
48-1262	2	867
48-1263	2	871
48-1264	2	872
48-1266	2	856
48-1270	2	873
48-1274, 48-1276	2	874
48-1282	2	867
48-1284	2	875
48-1286	2	867
48-1290, 48-2500-5	2	873
48-2500, 48-2500-5	3	1289
49-101	3	1290
49-500, 49-500-1	2	745
49-503	2	560
49-504, 49-504-1	2	859
49-508	2	876
49-506	2	745
49-601, 49-602	2	877
49-605, 49-607	2	878
49-900E, 49-900-1	2	879
49-902	2	745
49-904	2	880
49-905	2	881
49-906	2	882
49-909	2	883
49-1076, 49-1077		
(Radio Ch.)	3	1291
49-1100	2	867
49-1101	2	883
49-1175 (Code 122		
& Code 124), 49-1278		
(Code 123), 49-1279,		
49-1280	3	1291
49-1401	2	884
49-1403	2	885
49-1475, 49-1480		
(Codes 121A or B,		
123A or B, 1237A		
or B)	3	1292
49-1600, 49-1601,		
49-1602, 49-1603,		
49-1604, 49-1605	2	886
49-1606, 49-1607	2	883
49-1613	3	1293
50-T701, 50-T702	4	1647
50-T1104,		
50-T1105,		
50-T1106	3	1294
50-T1400,		
50-T1401,		
50-T1402	3	1294

Name & Model or Chassis No.	Vol. 5 Diag. No.	Previous Vol. No.	Diag. No.
PHILCO (Continued)			
50-T1403,			
50-T1404,			
50-T1406 (Codes			
123, 124, 125)	3		1294
50-T1406 (Codes			
121 & 122)	3		1294
50-T1430	3		1294
50-T1432 (Code 122)	3		1294
50-T1432 (Code 124)	3		1294
50-T1476,			
50-T1477,			
50-T1478,			
50-T1479	3		1295
50-T1481,			
50-T1482,			
50-T1484	3		1295
50-520, 50-520-I	3		1296
50-522, 50-522-1,			
50-524	3		1297
50-526	3		1298
50-620	3		1299
50-621	3		1300
50-920, 50-921,			
50-922	3		1301
50-925, 50-926	3		1302
50-1420, 50-1421,			
50-1422, 50-1423	3		1303
50-1720	3		1304
50-1721, 50-1723,			
50-1724	3		1305
50-1727	3		1306
51-T1443PL, PM,			
PW (Radio Ch.)	3		1307
51-T1872,			
51-T1874, L,			
51-T1875,			
51-T1876	3		1308
51-T2175,			
51-T2178	3		1309
51-530, 51-532,			
51-534	3		1310
51-629	3		1311
51-631	3		1312
51-632	3		1311
51-930, -931, -932	4		931
51-934	3		1313
51-1330	4		1649
51-1730, (L)	4		1650
51-1731, 51-1732	3		1314
51-1733, (L),			
51-1734	4		1651
52-940, -1,			
52-941, -1,			
52-942-1	4		1652
52-640, -641	4		1653
52-643	4		1654
52-940, -941,			
+942	4		1655
52-944	4		1656
52-1340	4		1649
53-T2285,			
-T2286, T2287	4		1646
53-561, -662	4		1657
53-563	4		1658
53-569	4		1659
53-651	4		1653
53-652	1997		
53-656, -658	4		1660
53-702, -706,			
-707	4		1657
53-800, -804	4		1661
53-950, -952,			
-954	4		1662
53-956	1998		
53-958	4		1663
53-960	4		1664
53-1350, -1750	4		1665
53-1754	4		1666
Chassis			
R-181U,			
R-181	1995		
R-191U,			
R-191	2005		
R-201,			
R-201	1995		
R-207,			
D-208	2005		
TV-400	2006		
300, 301, 350	2006		

Name & Model or Chassis No.	Vol. 5 Diag. No.	Previous Vol. No.	Diag. No.
PHILHARMONIC (Continued)			
349C	2		890
920, 924	2007		
5000, 5200, 5201,			
5250, 5400, 5401,			
5450, 5600, 5601,			
5650, 5700,			
5700RT, 5701,			
5750, 5750RT,			
5800	4		1530
6810	1		196
8701, 8702, 8703	1		196
8710, 8711, 8712	1		196
9120, 9121,			
9820, 9821	2007		
PHILLIPS PETROLEUM CO.			
(See Wooleroc)			
PILOT			
AF-605	4		1667
AF-723, U	2008		
AF-821A, U	4		1668
AF-824	2009		
AF-860	2010		
FM-607	2011		
T-411-U	1		381
T-500	1		73
T-510, T-511	1		381
T-521	1		383
T-530	1		393
T-601	2		614
T-741	?		891
POLICE ALARM			
PR-8	3		1315
PR-31	3		1316
PONTIAC			
983667	1		384
983679	1		386
983680	1		394
983775	1		386
983910	1		108
983911	1		386
984170	1		108
984171	1		386
PORTO BARDIO			
PA510, PB520	2		892
PREMIER			
15LW	1		127
PURE OIL (See Puritan)			
PURITAN			
501	1		385
501X	1		124
502	1		385
502X	1		124
503, 503W	1		388
504, 504W	1		387
506, 506X, 507,			
507W	1		20
508	1		25
509	2		893
515	2		894
RCA VICTOR			
A55	3		1317
A-82	4		1669
A-106	3		1318
A-108	4		1670
BK-42, BT-42	4		427
BX5	3		1319
BX55, BX57	3		1320
B-52	1		419
E-80	1		43
HF-2, HF-4	1		390
HF-6, HF-8	1		401
K-50	1		107
K-60	1		434
K-61	1		107
K-62, K-81, K-82	1		434
K-105	1		434
M-50, M-60	1		409
M-70	1		439
M1-1210T	2012		
PX600	4		1871
Q-11, Q-12	1		397

Name & Model or Chassis No.	Vol. 5 Diag. No.	Previous Vol. No.	Diag. No.
RCA VICTOR (Continued)			
Q-14, Q-14E,			
Q-15, Q-15E	1		412
Q-16, Q-16E, Q-17	1		416
Q-18	1		398
Q-22, Q-22A	1		391
Q-23	1		416
Q-24	1		391
Q-25	1		420
Q-26	1		396
Q-27	1		420
Q-30, Q-31	1		423
Q-33	1		399
Q-44	1		428
QB-1, QB-2	1		391
QB-3	1		399
QB-5	1		397
QB-6, QB-8	1		391
QH-51C	1		428
QK-23	1		392
QU-2C, QU-2M	1		392
QU-3C, QU-3M	1		396
QU-5	1		392
QU-7, QU-8	1		407
QU-51M	1		428
QU-52C, QU-52M	1		392
QU-55	1		430
QU-56C, QU-56M	1		432
ST-1	2013		
SVT-1	2013		
T-55, T-56, T-60,			
T-62, T-63	1		107
T-64, T-65, T-80	1		433
TA-128, TA-129,			
TA-169	3		1321
TRK-5	1		395
TRK-9, TRK-12	1		410
TRK-90, TRK-120	1		410
TT-5	1		395
U-10, U-12, U-20	1		107
U-25, U-26	1		395
U-30	1		414
U-40, U-42, U-43	1		107
U-44, U-45	1		425
U-50	1		400
U-70	4		1672
U-115	1		443
U-119	1		395
U-121	1		443
U-122E	1		395
U-123 (1 band)	1		443
U-123 (2 band)	1		441
U-124, U-125	1		395
U-126	1		414
U-127E	1		443
U-128, U-129	1		414
U-130	1		390
U-132, U-134	1		401
V-101	1		440
V-102	1		413
V-140	1		446
V-170, V-175	1		413
V-200	1		447
V-201	1		139
V-205	1		447
V-209, V-210	1		142
V-215, V-219,			
V-221, V-222	1		142
V-300, V-301,			
V-302	1		447
V-405	1		447
VHR-202, VHR-207	1		447
VHR-212	1		142
VHR-307, VHR-407	1		447
X-55, X-60	1		107
X711	3		1322
1R81	4		1673
1X591, 1X592	4		1671
2BX63	4		1674
2C521, 2C522,			
2C527	4		1675
287	2014		
2S10	4		1678
2U57	4		1677
2X81, 2X82,			
2X621	4		1678
2XF91, 2XF931,			
2XF932, 2XF933,			
2XF934	4		1679
3BX671	2015		
3RF91	2016		
4C671, 4C672	2017		
4T141	3		1323
4X641	2018		
4X681	2019		
4X511	2020		
5BX41	2021		
5C581	2022		

Name & Model or Chassis No. Vol. 5 Diag. No. Previous Vols. Vol. Diag. No.

RCA VICTOR (Continued)

5C591, 5C592..	2022		
5Q5, 5Q6, 5Q8	1	398	
5Q12, 5Q12A	1	400	
5Q55, 5Q56, 5Q66	1	398	
5X560, 5X562, 5X563	2023		
6QU	1	400	
6Q1, 6Q4, 6Q4X	1	402	
6Q7, 6Q8, 6QK8	1	400	
6T84	3	1323	
7Qb, 7QbK	1	403	
7Q4, 7Q4X, 7QK4	1	405	
7T143 (Radio Ch.)	3	1327	
8Bx8, 8Bx65	2	895	
8QB, 8QBK	1	403	
8Q1	1	406	
8Q2	1	404	
8Q4	1	406	
8Q5C, 8Q5M	1	404	
8R71, 8R72, 8R74, 8R75, 8R76	2	896	
8TK29 (Radio Ch.)	3	1324	
8TK320	3	1324	
8TR29	3	1324	
8TV321, B	3	1325	
8TV323, B	3	1325	
8V90, 8V91	2	897	
8V111, 8V112	2	897	
8X53	2	898	
9Bx56	3	1326	
9M1, 9M2	1	409	
9QK, 9Q1	1	408	
9Q4	1	405	
9T89	3	1327	
9T147	3	1327	
9TW333	3	1325	
9W101, 9W102, 9W103, 9W105	3	1328	
9X561, 9X562	3	1329	
9X571, 9X572	3	1329	
9X641, 9X642	3	1330	
9X651, 9X652	3	1331	
9Y7	4	1380	
9Y510, 9Y511	3	1332	
10Q1	1	406	
10X	1	411	
11QK, 11Q, 11Q4	1	414	
11X1	1	411	
12AX, 12AX2	1	411	
12QK, 12Q, 12Q4	1	414	
12X, 12X2	1	411	
14AX, 14AX2, 14X, 14X2	1	411	
15X	1	397	
18K, 18T2, 18T3, 18T4	1	413	
16X4	1	415	
16X11, 16X13, 16X14	1	397	
17K	1	139	
17S349U, 17S350U, 17S351U, 17S360U	2024		
17T352U, 17T361U	2024		
18T	1	139	
19K	1	417	
21D346U	2025		
21D527U	2026		
21S348KU, 21S355KU, 21S357KU, 21S362KU, 21S367KU, 21S369KU	2027		
21S501U, 21S502U, 21S503NU, 21S504NU, 21S505U, 21S506NU, 21S507NU, 21S510NU, 21S511NU, 21S516NU, 21S517U, 21S518U, 21S519NU, 21S521NU, 21S522NU, 21S523NU, 21S525U, 21S526NU, 21S537NU	2026		

Name & Model or Chassis No. Vol. 5 Diag. No. Previous Vols. Vol. Diag. No.

RCA VICTOR (Continued)

21S548, N, NU, U (Radio Ch.)	2028		
21S548NU, U (TV Ch.)	2026		
21S5022U, 21S5251U, 21S5252U	2024		
21T1197DE, 21T244	4	1676	
21T244	4	1681	
24D542U, 24D543U, 24D544U	2026		
24S512U, 24S513U, 24S514U, 24S529U, 24S531U, 24S532U	2026		
25BK	1	418	
25B72	1	419	
25B73	1	418	
26BP	1	421	
26K1, 26X3, 26X4	1	397	
27K	1	422	
28T	1	139	
28X, 28X5	1	140	
29K, 29K2	1	411	
34X, 35X	1	411	
36X	1	397	
45-W-10	4	1682	
45X18	1	424	
55AU	1	429	
55F, 55FA	1	419	
55U	1	429	
56X, 56X2, 66X3	1	431	
56X5, 56X10, 56X11	1	397	
58AV, 58V, 58AV', 59V1	1	142	
64F1, 64F2, 64F3	1	138	
65AU	1	429	
65BR9	2	899	
65U	1	429	
65X1, 65X2, 66BX	1	435	
66X1, 66X2, 66X3, 66X4, 66X9	1	436	
66X11, 66X12, 66X13, 66X14, 66X15	2	900	
67AV1, 67V1, 68R1, 68R2, 68R3, 68R4	2	901	
75X11, 75X12	2	902	
77U	2	903	
77V1	2	904	
77V2	2	905	
94BK2, 94BT2	1	442	
95T5, 95T5LW	1	443	
96BK6, 96BT6	1	443	
96E	1	395	
96E2	1	395	
96K, 96K2, 96K5, 96K6	1	395	
96T, 96T1	1	443	
96T2, 96T3	1	395	
96T4, 96T5, 96T6	1	441	
96T7	1	395	
96X1, 96X2, 96X3, 96X4	1	444	
96X11, 96X12, 96X13, 96X14	1	444	
97E, 97K, 97KG, 97K2	1	395	
97T, 97T2	1	395	
97X	1	443	
97Y	1	398	
98EY	1	395	
98K	1	414	
98K2, 98T, 98T2	1	395	
98X, 98YG	1	395	
99K, 99T	1	414	
110K, 110K2, 111K, 211K	1	141	
315	1	397	
516, 517, 522, 526, 527	1	411	
610V1, 610V2	2	906	
612V1, 612V2, 612V3	1	448	
648PTK, 648PV (Radio Ch.)	3	1333	
710V2	2	906	
711V1, 711V2, 711V3	2	907	

Name & Model or Chassis No. Vol. 5 Diag. No. Previous Vols. Vol. Diag. No.

RCA VICTOR (Continued)

730T7V1, 730T7V2 (Radio Ch.)	2	906	
910KG, 911K	1	414	
Chassis			
KCS70	4	1672	
KCS78H, J	2024		
KCS84H, K	2026		
KCS88F, H	2027		
KCS88J, JX, K, KX, L, LX, M, MX, VA, VAX	2026		
KCS89A, C	2026		
KCS90A	2026		
KCS92D, DX, E, EX, F, FX, H, HX, M, MX, NU	2026		
RC-604, RC-605	1	142	
RC-606	1	437	
RC-608	1	905	
RC-608C	2	901	
RC-610, RC-610A, RC-610B	2	906	
RC-613A	2	906	
RC-615	2	904	
RC-616, RC-616A, RC-616B, C	3	897	
RC-616H	2	897	
RC-616J, K	3	1325	
RC-616N	3	1325	
RC-618, RC-618A (Model 8V90)	2	897	
RC-618, RC-618B, RC-618C (Model 9W101)	3	1328	
RC-622	3	1318	
RC-1004E	1	419	
RC-1011	1	431	
RC-1017, RC-1017A	1	429	
RC-1023B	1	397	
RC-1034	1	138	
RC-1037, RC-1037A	1	138	
RC-1038, RC-1038A	1	436	
RC-1040, RC-1040A	1	435	
RC-1040C	2	895	
RC-1048	2	899	
RC-1050, RC-1050B	2	900	
RC-1057A	2	903	
RC-1057B	4	1680	
RC-1060, RC-1060A	2	896	
RC-1064 (Model 8X53)	2	898	
RC-1064 (Model 65X1)	1	138	
RC-1068	3	1326	
RC-1070A	3	1322	
RC-1077, A, B	3	1332	
RC-1079, A, B, C	3	1329	
RC-1079K, L	4	1671	
RC-1082	3	1319	
RC-1085, A	3	1331	
RC-1085B	4	1678	
RC-1087	3	1317	
RC-1088, A	3	1320	
RC-1090	3	1323	
RC-1092	3	1327	
RC-1094	4	1669	
RC-1096	4	1670	
RC-1096A	4	1682	
RC-1102	4	1673	
RC-1110	4	1671	
RC-1111, A	4	1676	
RC-1115	4	1674	
RC-1117A	4	1677	
RC-1117B	4	1676	
RC-1117C	4	1677	
RC-1117D	2014		
RC-1120, A	4	1675	
RC-1121, A	4	1679	
RC-1125	2015		
RC-1129	2016		
RC-1134	2020		
RC-1140	2018		
RC-1141	2019		
RC-1142	2017		
RC-1148A	2022		
RC-1150	2023		
RK-121	1	448	
RK121A	3	1233	
RK-135, RK-135A, RK-135A-1, RK-165D	3	1324	
RK191	3	1321	
RK191	2028		
RS1147	2021		

Name & Model or Chassis No.	Vol. 5 Diag. No.	Previous Vols. Vol. No.	Diag. No.
RADIOLA			
61-1, 61-2, 61-3,			
61-5	1		397
61-8, 61-9	2		898
61-10	1		397
75ZU	2		908
76ZX11, 76ZX12	2		909

RADIO CRAFTSMEN (Also See Craftsmen)			
RC-1 (Tuner)	2		910
RC-10	3		1334
10	4		1683
800	4		1684

RADIONIC			
6W	1		167
Y62N, Y728	2		911

RADIO RECEPTOR			
C-1709-P	2029		

RAY ENERGY			
AD	1		449
AD4	1		453
SRB-1X	1		450

RAYTHEON			
C-1735A,			
C-1736A	4		1685
C-2108A,			
C-2110A,			
C-2111A	4		1686
C-2112A,			
C-2113A,			
C-2114A,			
C-2115A,			
C-2116A,			
C-2118A	4		1687
C-2137A,			
C-2138A	2030,		
	2031		
C-2401A,			
C-2402A	2031		
CR-41, A, CR-42,			
A, CR-43, A	4		1688
FR81A,			
FR82A	2032		
M-2131A	2030,		
	2031		
PR-51, A	2033		
RC-1618A, B,			
RC-1619A, B	3		1336
RC-1718A, B,			
RC-1719A, B	3		1336
RC-1720A	4		1689
UC-2139A,			
UC-2141A,			
UC-2142A,			
UC-2144A,			
UC-2145A	2030		
UC-2403A,			
UC-2404A,			
UC-2405A,			
UC-2406A	2030		
UHF-100	4		1690
UM-2133A,			
UM-2134A,			
UM-2135A,			
UM-2136A	2030		
10AXF43	3		1335

Chassis			
4P12, A	2033		
5A125A	2032		
21T8	2030		
21T11	2030,		
	2031		
24T2	2030		
24T3	2031		

RECORDIO			
6B10, 6B20, 6B30,			
6B32	1		451
7D42, 7D44	2		912
7E40, 7E44	2		913
9G10	3		1337
9G40M, 9G42	3		1338
9G40B	3		1339
Chassis			
7D1	2		912

Name & Model or Chassis No.	Vol. 5 Diag. No.	Previous Vols. Vol. No.	Diag. No.
REGAL			
BP48	2		914
C-527	4		1691
CR761	2		915
CR-762	4		1692
L76	1		171
P-175	4		1693
W700, W800, W801	1		171
W900, W901	1		454
17FD36, 19C36,			
19D36, 2036			
20D36, 20HD36			
(Radio Ch.)	4		1694
205	2		916
271	4		1693
575	4		1695
747	2		917
777	2		918
1049	1		452
1107	2		919
1500	2		920
1749	2		921
1877	4		1696
7251	2		922

REGENCY			
RC-600	4		1697

REMLER			
MP-5-5-3	1		173
5300B, 5300B1,			
53001	2		923
5310	2		924
5400, 5410	2		925
5500, 5505, 5510,			
5515, 5520, 5530	2		926
6000	3		1340

ROLAND			
5P4	2034		
5T2M	4		1698
5T5	2035		
5X1, 5X2,			
5X3, 5X4	2036		
6P2	2034		
6T1M	4		1699
8FT1M	4		1700
8XF6M	4		1701
8XFP4-M	2037		
10TF1	2038		
10XF1	2039		

ROYAL			
AN150	4		1702

SCOTT (E. H.)			
16A	2		927
310	4		1703
510	3		1341
515	4		1704
800-B	1		456
1000	4		1705
1510	4		1706
2000	2040		
2510	2041		
9052	2042		

SENTINEL			
1U-284GA	2		928
1U-2841, 1U-284NA,			
1U284NI, 1U-284W	1		26
1U-285, 1U-285P	1		261
1U-2931	1		459
1U-293CT	2		929
1U-293T, 1U-293W	1		459
1U-2941, 1U-294NI,			
1U-294T, 1U-294W	1		459
1U-312PG,			
1U-312PW	3		1342
1U-3131, 1U-313W	2		935
1U-314E, 1U-3141,			
1U-314W	2		928
1U-316PM,			
1U-316PT	2		937
1U-335PG, PI,			
PM, PW	3		1343
1U-338-I, 1U-338-R,			
1U-338-W	3		1345
1U-339-K	3		1345
1U-340-C	3		1345
1U-343	4		1707

Name & Model or Chassis No.	Vol. 5 Diag. No.	Previous Vols. Vol. No.	Diag. No.
SENTINEL (Continued)			
1U-344	4		1708
1U-345P	4		1709
1U-416	3		1346
1U-419, 1U-420	3		1346
1U-420B	3		1347
1U-423, 1U-423B,			
1U-423-17	3		1347
1U-424, 1U-424-17	3		1347
1U-425	3		1347
1U-428, 1U-429,			
1U-430, 1U-431			
1U-432, 1U-435	3		1347
1U-438, 1U-439,			
1U-440, 1U-441,			
1U-443, 1U-444,			
1U-446, 1U-447,			
-A, 1U-448, -A,			
1U-449, -A, 1U-450,			
-A, 1U-451, -A	4		1710
1U-520,			
1U-521,			
1U-522,			
1U-523,			
1U-525,			
1U-542,			
1U-562,			
1U-564	2043		
1U-581,			
1U-582,			
1U-584,			
1U-585	2044		
1U-921,			
1U-924,			
1U-991	2045		
L-2841, L-284NA,			
L-284NI,			
L-284NR, L-284W	2		928
283, 284, 273	1		459
284GA	2		928
284I, 284NA,			
284NI, 284W	1		26
285P	1		261
289T	1		23
292K	1		454
293 Series	1		459
293CT	1		459
293I	2		929
293T, 293W	1		459
2941, 294N, 294T	1		459
295T	2		930
296B, 296M	2		775
302-I, 302-T,			
302-W	2		932
305-I, 305-I-3,			
305-W, 305-W3	2		933
309-I, 309-N,			
309-R, 309-W	2		934
313-I, 313-W	2		935
314-E, 314-I,			
314-W	2		928
315-I, 315-W	2		929
316PM, 316PT	2		937
332	2		935
333	2		929
335PG, PI, PM,			
PW	3		1343
338-I, 338-R,			
338-W	3		1344
339-K	3		1345
340-C	3		1345
343	4		1707
344	4		1708
345P	4		1709
416, 419, 420	3		1346
420B	3		1347
423, 423B, 423-17	3		1347
424, 424-17	3		1347
425, 428, 429,			
430, 431, 432,			
435	3		1347
438, 439, 440,			
441, 443, 444,			
446, 452, 453	4		1710
SETCHELL CARLSON			
416	1		192
427	2		938
437	2		939
447	2		940
458-RD	3		1348
469	3		1349
570	3		1350
SIGNAL			
AF252	2		942
241	2		941
341-A, 341-T	2		943

Name & Model or Chassis No.	Vol. 5 Diag. No.	Previous Vol. Diag. No.
63A, 64	2046	
SILVERTONE		
R-381	1	460
R-1161	1	458
5, 6	4	1711
10, 11	4	1712
15, 16, 18	4	1713
25, 27	4	1714
41, 41A	3	1351
51, 53	3	1352
54, 56	3	1352
64, 65, 67	3	1353
69	4	1715
102A	4	1716
106, 107 (Ch.		
132, 889-2)	4	1717
112	3	1354
120	3	1354
125	3	1355
141 (Ch.		
132, 889-2)	4	1717
143, 143A	3	1356
144 (Radio Ch.)	4	1718
150-14, 163-16	4	1719
179-16, 180-16,		
194-16, 195-16	3	1357
220, 222, 223, 224	3	1356
225	3	1359
771	1	458
1017, 1018	4	1720
1040, A, 1045, A	4	1721
1052, A, 1053, A,		
1054, A, 1055, A	4	1722
1058, 1059,		
1062, 1063	4	1723
1771	1	458
1781, 1781A	1	462
2003, 2004, 2005,		
2006	4	1724
2009, 2010, 2011,		
2012, 2013	4	1725
2011	1	725
2014, 2015, 2016,		
2022	4	1722
2023, 2024, 2025,		
2026, 2027	4	1712
2028	4	1726
2051	1	723
2056, 2060, 2061	4	1727
2063, 2064	4	1723
2200, 2202, 2203	4	1728
2225	4	1729
2276, 2277	2047	
2411	1	73
2461	1	458
2511	1	73
2761	1	458
3004		2048
3025, 3026,		
3027	2049	
3040	4	1730
3040A	2050	
3045, 3046	4	1730
3052, 3053,		
3054, 3055	2051	
3058, 3059,		
3063, 3064,		
3067	2052	
3068	2053	
3106	4	1515
3109, 3110B,		
3112B	2054	
3136	2077	
3150L, 3151B,		
C, 3170D	2054	
3175	4	1515
3181, 3185	2077	
3200, 3202,		
3203	2055	
3276, 3277	2047	
3376, 3377	2056	
4016, 4017	2057	
4025, 4026	2058	
4041, B	2059	
4045A, B, C,		
4046A, B, C	2060	
4056, 4057	2061	
4068A	2062	
4111	2054	
4112B	1844	
4113, 4114,		
4115, 4116,		
4117, 4118,		
4119	2054	

Name & Model or Chassis No.	Vol. 5 Diag. No.	Previous Vol. Diag. No.
4126, 4127	2054	
4127A	2063	
4128, 4129,		
4131, 4139	2054	
4140D, 4143D,		
4145D, 4149	2054	
4150D, 4153D,		
4155D	2054	
4200	2064	
4204, 4206	2065	
4225	2066	
4608, 4609	1	461
4626, 4629	1	461
4636, 4639	1	461
4646, 4649	1	461
4666	1	465
4667	1	465
4686	1	465
4688	1	465
4728, 4748	1	461
4766	1	465
4767, 4777	1	463
4791, 4792	1	465
4798	1	463
5045, 5046	2067	
5101, A	2068	
5106, 5107, A,		
5112A, C	2068	
5113B	1844	
5115, A, B, C,		
D, 5117, A,		
C, D	2068	
5125, 5127, A, B,		
C, 5129, A, B,		
C, D, 5131, A,		
B, C, D	2068	
5227	2069	
5502	1	466
5511, 5511-A	1	460
5571, 5571-A	1	460
5581	1	458
5601-A	1	460
5621	1	458
6008, 6009	1	464
6011, 6012	1	467
6016	1	464
6016 (Ch. 132, 820)	2	944
6017, 6018,		
6019, 6022	1	464
6036, 6038	1	470
6045, 6047, 6048,		
6049	1	464
6050	1	6
6051, 6052	1	468
6068, 6069	1	464
6071	1	6
6072	1	469
6074, 6079	1	470
6092, 6093	1	466
6100	1	73
6104, 6105	1	466
6106A, 6111A	2	945
6111	1	466
6122, 6132	1	464
6136, 6138	1	470
6146, 6148	1	464
6157	1	473
6168	1	464
6190	1	474
6200-A	1	475
6220, 6220-A	1	475
6230, 6230-A	1	477
6285-A	1	478
6286, 6287	4	1731
6293	3	1360
6301	1	474
6303	1	476
6320	1	480
6321, 6322, 6323,		
6324	1	471
6325, 6335, 6336,		
6337	1	472
6346, 6346A	1	472
6359, 6360, 6361,		
6362, 6363, 6364	1	472
6368, 6379, 6380,		
6381, 6382	1	472
6407, 6408, 6409	1	472
6421, 6424	1	471
6425, 6435, 6436,		
6437, 6438, 6438-A,		
6438-B, 6439,		
6439-A, 6440,		
6441	1	471
6446	1	472
6447	1	471
6449	1	460

Name & Model or Chassis No.	Vol. 5 Diag. No.	Previous Vol. Diag. No.
6490, 6490-A	1	472
6495, 6497	1	472
6551, 6561	1	482
6621, 6661	1	482
6721, 6751, 6751-A	1	482
6761, 6761-A	1	482
6921	1	482
6950	2070	
7010	1	479
7021	1	481
7025	2	946
7034	1	479
7037	1	483
7038	1	484
7048	1	483
7049	1	466
7054	1	489
7065, 7066	1	73
7067, 7068	1	466
7069, 7070	1	483
7071	1	487
7080 (Ch. 101, 809)	1	486
7080 (Ch. 101, 809-2)	2	947
7080-A	2	947
7085	2	948
7086	2	949
7090	1	488
7100	1	485
7102	2	948
7103	2	949
7104, 7106	1	491
7111	2	950
7112	1	491
7115, 7116, 7117	1	480
7167, 7168	1	466
7210	2	951
7220	1	475
7226	2	952
7228	1	410
7230	1	395
7245	1	492
7905	1	396
7915	1	408
8005	2	953
8010	2	954
8020	2	955
8024, 8025	3	1381
8050	2	956
8051	2	957
8080	2	958
8083, 8083-A,		
8084, 8084-A	2	947
8090	2	959
8100, 8101,		
8101-A, 8101-B,		
8101-C	2	947
8103	2	960
8105, 8105A	2	947
8124, 8125, 8126,		
8127, A, B, C,		
8128, A, B, C	2	961
8132, 8133	3	1362
8200, 8201	1	475
8210	3	1363
8220, 8221, 8222	1	475
8230, 8231	2	952
9005, 9006	3	1364
9022	3	1365
9101, 9102	2	947
9105	3	1366
9115, 9116	3	1367
9122	3	1362
9133, 9134	3	1368
9270	3	1379
9280	3	1370
41122, 41292,		
41312, A	2068	
Chassis		
100, 111	3	1356
100, 174	2053	
100, 176	2062	
100, 201	4	1715
100, 425-2,		
-4, -8	2077	
101, 660-1A	1	73
101, 662-2B,		
101, 662-2D,		
101, 662-3C	1	466
101, 662-4E,		
101, 662-5F	2	945
101, 666-1B	1	478
101, 672-1A,		
101, 672-1B	1	466
101, 773	2	961

Name & Model or Chassis No.	Vol. 5 Diag. No.	Previous Vols. Vol. No.	Diag. No.
SILVERTONE (Continued)			
101. 800-1			
101. 800-1A		1	475
101. 800-3		1	475
101. 801-1A		1	475
101. 802			
101. 802-1		1	477
101. 807			
101. 807A		1	481
101. 808		1	489
101. 809		1	486
101. 809-1A			
101. 809-1B		2	947
101. 809-2			
101. 809-3C		2	947
101. 810		1	488
101. 811		1	485
101. 813		2	956
101. 814			
101. 814-1A		2	948
101. 817		1	483
101. 819A		2	952
101. 820		2	951
101. 821		2	959
101. 822			
101. 822A		2	982
101. 825			
101. 825-1A			
101. 825-1B		1	490
101. 829		2	947
101. 829-1		3	1362
101. 831			
101. 831A			
101. 831-1		2	961
101. 833		2	947
101. 835		2	952
101. 839		2	957
101. 846		3	1362
101. 852		2	958
101. 859		3	1368
101. 859-1			
101. 859-2		3	1353
101. 860		4	1723
101. 860-3	2052		
101. 861		4	1727
101. 864, 101. 866		3	1362
110. 451, 110. 452		1	468
110. 454		1	469
110. 466			
110. 466-1		2	949
110. 473		2	960
132. 011, -1,			
132. 012-1,			
132. 021		4	1722
132. 022		4	1725
132. 024, -1, -2		4	1724
132. 026-3		4	1727
132. 026-6	2061		
132. 027		4	1722
132. 045, -1		4	1515
132. 053			
132. 058	2051		
132. 066	2049		
132. 067	2065		
132. 807-2		2	946
132. 816			
132. 816A		1	467
132. 820		1	464
132. 825-4		1	6
132. 826-1		1	6
132. 839		2	953
132. 840		2	954
132. 841		2	955
132. 858		3	1364
132. 871		3	1365
132. 875		3	1366
132. 877		4	1713
132. 881		4	1711
132. 884, -1, -2		4	1713
132. 887		3	1352
132. 888		3	1352
132. 889, -2		4	1717
132. 890		3	1357
132. 896, -1		4	1712
132. 08500	1844		
135. 245		3	1351
434. 140		2	950
456. 150-14,			
-18, -61	2047		
456. 200-111,			
-112, -113,			
-114, -115,			
-121, -122,			
-123, -124,			
-125	2056		
478. 206-1		3	1361
478. 222, 478. 224		3	1367
478. 240		4	1718

Name & Model or Chassis No.	Vol. 5 Diag. No.	Previous Vols. Vol. No.	Diag. No.
SILVERTONE (Continued)			
478. 257		3	1355
478. 289		3	1354
478. 311		3	1354
478. 319, 478. 338		4	1719
528. 168		3	1370
528. 171-1		3	1359
528. 173		3	1358
528. 194		4	1721
528. 210, -1		4	1720
528. 229		4	1728
528. 230		4	1726
528. 233		4	1729
528. 253, 528. 254		4	1730
528. 259	2055		
528. 261, 528. 263,			
-1, -2, 528. 264,			
-1, -2, 528. 266,			
-1	2054		
528. 268	2063		
528. 270			
528. 286	2054		
528. 304, -1	2059		
528. 308	2058		
528. 307	2066		
528. 311	2050		
528. 312, -1	2060		
528. 6286, -1, -3			
528. 6287, -1, -3		4	1731
528. 6289-2		3	1360
528. 6329-1			
528. 61600			
528. 31700	2068		
528. 33200	2069		
528. 33800			
528. 33900	2068		
528. 34200			
528. 34600			
528. 34601			
528. 34602			
528. 34603	2068		
528. 34900	2087		
547. 245		3	1369
549. 939-3		4	1716
725. 101-1	2070		
757. 110		4	1724
757. 130	2048		
757. 140	2064		
757. 150	2057		
SIMPLON			
CA-5		2	963
WV2		1	494
SKY KNIGHT			
CB-500-P		1	6
SKYROVER			
N5-RD-250			
N5-RD-251		1	20
SONORA			
RB-207, RBU-176		1	451
RCU-208		1	495
RDU-209		1	189
RET-210		2	964
RCGMF-212,			
RCGMF-230		2	965
RKRU-215		1	498
RMR-219, RMR-220		1	496
RMR-245		1	496
RQU-222		1	501
RX-223		1	497
WBRU-239		2	966
WDU-233,			
WDU-249		2	967
WBU-282		2	968
WKRU-254A		2	969
WLRU-219A			
WLRU-220A		2	970
WLRU-254A		2	970
100		2	971
101, 102		2	972
171, 172		3	1371
306		3	1372
314, 315, 379	2071		
389, 390	2072		
401			
441, 442	2071		
458, 459	2073		
477, 478	2071		
401		2	969

Name & Model or Chassis No.	Vol. 5 Diag. No.	Previous Vols. Vol. No.	Diag. No.
SOUND, INC.			
5R2		2	973
SPARTON			
4AW17, 4AW17A		2	974
5AM26PS		1	500
5A116		2	974
5AW06		1	503
5AW16		2	974
6AM06		2	975
6AW26PA		1	502
6-66A		2	976
7AM46, 8AM46		1	499
10A376-PA,			
10AM76-PA,			
10BM77-PA,			
10BW78-PA		1	504
100, 101		2	974
121		2	977
141		2	977
141A		3	1373
141XX		3	1374
150, 151, 152, 155		3	1375
1000, 1001, 1003		2	978
1005, 1006, 1007,			
1008		2	979
1010		2	980
1015		1	504
1020, 1021, 1023		2	978
1030, 1030A,			
1031, 1031A		2	981
1051, 1052		2	982
1058, 1059, 1060,			
1061, 1064, 1072		2	977
1080		3	1376
1080A		3	1373
1081		3	1376
1081A		3	1373
1210, 1211		3	1374
4900TV (Radio Ch.)		3	1376
4916, 4917, 4918,			
(Radio Ch.)		4	1732
5082, 5083			
(Radio Ch.)		3	1374
5088, 5089, 5090			
(Radio Ch.)		3	1374
5182, 5183, 5188,			
5189 (Radio Ch.)		3	1374
22312, 22313,			
23322, 23323	2074		
24542, 25544	2075		
Chassis			
PC-5-6-26		1	502
4E10		3	1375
5A7		2	974
5-06		1	503
5-16		2	974
5-28PS		1	500
6B9		2	982
6L8		2	981
6S10		4	1732
6-06		2	975
7L7		2	980
7-46		1	499
8L9		2	977
8L10		3	1373
8W10		3	1374
8-46		1	499
8-57		2	979
9L8A		3	1376
10-77PA		1	504
12L7		2	978
29U213	2074		
29U273	2075		
417, 417A		2	974
666A		2	976
STARRETT			
Gotham		3	1377
John Hancock		3	1378
STEELMAN			
AF1100		4	1733
3AR3	2076		
6000		4	1734
STEWART-WARNER			
A51T1, A51T2,			
A51T3, A51T4		1	515
A61CR1, A61CR2,			
A61CR3, A61CR4		2	985

Vol. 5 Previous Vols. Name & Model or Chassis No. Diag. No. No. No.

STEWART-WARNER (Continued)

A61P1, A61P2, A61P3	2	986
A72T1, A72T2, A72T3, A72T4	2	987
A92CR3, A92CR3S, A92CR6, A92CR6S	2	720
B51T1, B51T2, B51T3	2	988
B61T1, B61T2	2	717
B72CR1	2	990
C51T1, C51T2	2	989
R35B1, R35B9	1	513
R38B1, R38B9	1	513
01-5H	1	509
01-6A, 01-6B, 01-6C	1	509
01-6D, 01-6DX	1	507
01-6F, 01-6F9	1	509
01-6G, 01-6GZ	1	507
01-8C7, 01-8C7-Z, 01-9A, 01-9A-Z	1	506
010-6AX, 010-6BX, 010-6CX	1	509
11-6U, 11-6U-Z	1	505
11-7A1, 11-7A9	1	508
11-8D, 11-8F, 11-8R	1	510
11-8R8, 11-8R9	1	508
11-9B, 11-9B-Z	1	506
11-10A	1	510
21C-9325F, G, 21C-9340E, K, KB, L, LB, M, MB, F, 2077	2	983
21T-9340A, B, D, R, RB, S, T, 2077	2	983
51T46, 51T56	2	983
51T126, 51T136, 51T146, 51T176	1	20
61T16, 61T26	1	20
61TR36, 61TR46	1	511
62T16	1	512
62T36	1	20
62TC18, 62TC26, 62TC36	1	512
72CR16, 72CR26	1	510
205GA, 205GZ	1	513
9000-B, 9001-C, 9001-D, 9001-E, 9001-F, 9002, 9002A, 9002B, 9002P, 9002R	2	984
9003	1	514
9004	1	510
9005-A, 9005-B, 9007-A, 9007-F, 9007-G	1	516
9014-E	1	20
9017-A, B, C	1	20
9104-A, -B, -C	3	1379
9108A, B, 9113A	3	1380
9121-A, -B, 9122-A	4	1735
9150-B, -D, -DZ	4	1736
9151-A	3	1381
9152-A, -B, -C	3	1382
9154-C, -CZ	4	1737
9181-A, -B, -C, 9182A, B, 9164-A, -B, 9185-A, -B, 9182-C, -H, -J, 2078	4	1739
9203-A (Radio Ch.)	4	1735

STRATOVOX

579-1-58A	1	120
-----------	---	-----

STROMBERG-CARLSON

SR-401	4	1741
SR-405 (Series 103)	2079	
TC-10	3	1383
TC-19	3	1384
TS-15, TS-16, TS-125	3	1385
16CM, 16TM	3	1386
16RP (TV Ch.)	3	1386
16RP (Radio Ch.)	2	997
17CM, 17TM	3	1386
17RP (TV Ch.)	3	1386
17RP (Radio Ch.)	2	997

Vol. 5 Previous Vols. Name & Model or Chassis No. Diag. No. No. No.

STROMBERG-CARLSON (Continued)

21TM, TQ, 22TM, TQ	2080	
24 Series	4	1742
116CM, 116TM	3	1386
116RP (TV Ch.)	3	1386
116RP (Radio Ch.)	2	997
117 Series	3	1387
119CDM, CM, 119MSA, D, G, I, M, R, 119RPM2 (TV Chassis)	3	1387
119MSA, D, G, I, M, R, 119RPM2 (Radio Chassis)	3	1387
621A Series, 622 Series	2081	
624 Series	2080	
625 Series (TV Ch.)	2080	
625 Series (Radio Ch.)	2082	
1100-H, 1100-HI, 1101-HB, 1101-HI, 1101-HM	1	517
1101-HPW, 1101-HW, 1101-HY	1	519
1105 (Series 10-11), 1110PTW (Series 10)	1	519
1121 (Series 10-11-12), 1121-HW, 1121-LW, 1121M1-0, 1121-M2-W, 1121-M2-Y	1	520
1121-PFM, 1121-PFW, 1121-PGM, 1121-PGW, 1121-PLM, 1121-PLW, 1121-PSM	1	520
1135-PFM, 1135-PLM, 1135-PLW	2	992
1200	2	991
1202	2	993
1204	2	994
1210M2-M, 1210M2-W, 1210M2-Y	2	995
1210-PGM, 1210-PLM, 1210-PGW	2	995
1220 Series, 1235 Series	2	996
1400	2	992
1407-PFM, 1407-PLM	2	997
1500	3	1388
1507	3	1389
1608	4	1743

STUDEBAKER

AC-2113	4	1744
AC-2301	4	1745

SUPREME

750	2	998
-----	---	-----

SUTCO

21-A (UHF Conv.)	4	1746
------------------	---	------

SWANK

DUI01	1	521
-------	---	-----

SYLVANIA

C32M	4	1535
1-075	3	1390
1-076	3	1391
A&B		
1-090	3	1391
A		
1-113, 1-114	3	1390
1-124, 1-125	3	1390
1-125-1	3	1392
1-128	3	1391
A&B		

Vol. 5 Previous Vols. Name & Model or Chassis No. Diag. No. No. No.

SYLVANIA (Continued)

1-177	3	1390
1-197	3	1390
1-197-1	3	1392
1-210	3	1390
1-245, 1-246	3	1390
1-245-1, 1-246-1	3	1392
1-247	3	1391
A		
105BU, 105MU	4	1747
105-14 "U"		
Series	2083	
120BU, 120MU	4	1747
120-14 "U"		
Series	2083	
126BU, 126LU, 128MU	4	1747
128MU, 172MU, 175BU, 175LU, 175MU	4	1747
175-18 "U"		
Series	2083	
176BU, 176MU, 177BU, 177MU	4	1747
178B, 178BU, 178M, 178MU	4	1747, 1748
300 "U"		
Series, 301 "U" Series, 306 "U", Series	2083	
325 "U"		
Series, 326 "U" Series	2083	
331 "U"		
Series, 336 "U" Series	2084	
372 "U"		
Series, 373 "U" Series, 375 "U", Series, 376 "U" Series, 377 "U"	2083	
Series	2083	
386BU, MU	2084	
410 "U"		
Series	2083	
511 "U"		
Series	2085	
514 "U"		
Series	2085	
518 "U"		
Series	2086	
529 "U"		
Series	2083	
540B, BA, 540H, HA, 540M, MA, 541B, H, M, 542BR, CH, GR, RE, YE	3	1393
543		2087
548		2086
593		2087
596BU, 596MU, 598	2088	
1110X, 1210X	3	1394
5130B, M, W, 5140B, M, W, 5150M, 5848	3	1395
5150M	3	1396
710XFA, 7110MFA, 7120MFA, 7130MFA, 7140MA, 7140WA, 7150M, 7160B	3	1396

Chassis

1-108	3	1391
A&B		
1-139	3	1390
1-168	3	1391
A		
1-186	3	1392
1-274	3	1396
1-290	3	1395
1-357	3	1396
1-381	3	1394
1-437	3	1396
1-442	3	1396
1-504-1, -2, -4	4	1747
1-508-1, -2, -3	4	1747
1-510-1, -2, -4	4	1747

Name & Model or Chassis No.	Vol. 5 Diag. No.	Previous Vols. Vol. No.	Diag. No.
SYLVANIA (Continued)			
1-512-2,			
1-513-2, -4	2084		
1-514-4, -6,			
1-518-2, -6	2083		
1-522-2	2088		
1-527-2	2085		
1-530-2,			
-4, -6	2083		
1-601-1		4	1749
1-602-2, -3	2087		
1-602-4, -5,			
-6, -7	2086		
1-603-1		4	1748

TELESONIC			
1635	1		6
1638	2		999
1642	1		167
1643	2		1000

TELEPHONE			
TV-208	3		1397
TV208TR	3		1398
TV-220	3		1398
TV-250	3		1399
TV-254, TV-255,			
TV-256	3		1399
TV-262	3		1400
TV-283	3		1399
TV-284	3		1398
TV-285	3		1399
TV-300, TV-301			
(Ch. TW)	3		1401
TV-304, TV-305			
(Ch. TX)	3		1401
TV-306, TV-307,			
TV-308	3		1398
TV-314	3		1402
TV-416	3		1403
TV-318, TV-322,			
TV-323	3		1404
TV-324, TV-325,			
TV-328	3		1405
TV-328, TV-329	3		1405
TV-330, TV-331,			
TV-332, TV-333	3		1398
TV-335, TV-336	3		1405
TV-340, TV-345,			
TV-348, TV-349,			
TV-352	3		1405
TV-358, TV-359	3		1405
100, 100A, 101	2		1001
109	1		258
111, 113	2		1001
117-A	1		258
122, 123, 125, 127,			
130, 131	2		1001
133, 134	1		258
135	1		260
138	2		1002
142, 143, 144, 145	2		1003
148	2		1004
150	2		1005
156	2		1006
157	2		1005
158	2		1008
159	2		1007
160	2		1009
161, 162	2		1005
166, 167, 168	2		1005
171	2		1005
172	2		1006
174	2		1005
176	2		1006
185	2		1010
198	2		1008
206	3		1406
228	4		1750
235	4		1751

Chassis			
Series A	2		1001
Series AA	2		1007
Series AE	2		1005
Series AH	2		1010
Series AT	2		1008
Series BL	4		1750
Series BQ	4		1751
Series C, CA, D	1		258
Series H	1		260
Series J	1		258
Series N	2		1002
Series R	2		1003
Series S	2		1004

Name & Model or Chassis No.	Vol. 5 Diag. No.	Previous Vols. Vol. No.	Diag. No.
TELEPHONE (Continued)			
Series T	2		1005
TAC	3		1398
TAH	3		1403
TAJ	3		1402
TAM	3		1404
TAO	3		1398
TAP, TAP-1,			
TAP-2	3		1405
TS	3		1399
TW, TX	3		1401
TY, TZ	3		1398
Series U	2		1006
Series Y	2		1009

TELEVOX			
RP	2		1011

TEMPLE			
E510	1		189
E511	1		11
E519	1		189
F611	1		324
F616	1		523
F617	1		524
G410	2		893
G513	2		1012
G515, G516	1		189
G518	2		584
G521	2		585
G522	2		584
G619	2		1013
G622	2		1014
G721, G722, G723	2		1015
G724	2		566
G725	2		587
G1430	2		1016
H622	2		1014

TEMPOTONE			
500E Series	1		269

TRAVLER			
12L50, 12L50A	3		1407
14B50, A, 14C50, A	3		1407
16G50A, 16R50A,			
16T50A	3		1407
20A50	4		1752
55-37			2089
55-38			2089
62R50, 63R50	4		1752
64R50, -1, -2,			
65G50, -1, -2,			
75A50, -1, -2	4		1752
219-8A, -8B	4		1753
5000, 5000-I	1		11
5002	1		73
5007, 5008, 5009,			
5010, 5011, 5012	1		18
5015, 5019	2		572
5020	1		73
5021	2		936
5022	3		1408
5027	2		571
5028, 5029	2		574
5030, 5031	2		572
5036	2		1017
5051	2		936
5059, 5061	3		1409
5068	2		1005
5091			2091
5170	4		1754
5301			2092
5310			2093
5372			2094
6040	2		1018
6050	2		1019

Chassis			
11A2	4		1753
32A1	4		1752
104, 105	1		18
109	1		73
800	2		936

TRUETONE			
D705	1		80
D934	1		466
D1015, D1016	1		40
D1034A, B, C	3		1410
D1042	1		45
D1046A, B, C, D	3		1410

Name & Model or Chassis No.	Vol. 5 Diag. No.	Previous Vols. Vol. No.	Diag. No.
TRUETONE (Continued)			
D1070	1		43
D1117	1		525
D1118	1		162
D1124	1		48
D1145	1		41
D1172, D1176	1		41
D1202	1		162
D1215	1		40
D1224	1		48
D1234A, B,			
D1240A	4		1755
D1435A,			
D1436A	2095		
D1612	2		591
D1844	1		189
D1845	1		38
D1747, D1748	2		588
D1752	2		796
D1835	2		1020
D1836, A	2		599
D1840	2		810
D1845	2		596
D1846A, B, C	2		599
D1949, D1950	2		1021
D1992 (Radio Ch.)	3		1411
D1994 (Radio Ch.)	3		1412
D2017, D2018	3		1413
D2020	3		1414
D2025A	3		1413
D2027A	3		1415
D2102A, B,			
D2103A, B	4		1756
D2127	1		182
D2133	1		526
D2145	4		1757
D2149	1		41
D2210, D2211	1		40
D2214A	4		1758
D2224	1		182
D2226	4		1759
D2237A	4		1760
D2261	1		48
D2263	4		1761
D2325-A	4		1762
D2363	4		1763
D2385			2096
D2410A,			
D2411A,			
D2412A,			
D2413A	2097		
D2410B,			
D2411B,			
D2412B,			
D2413B	2098		
D2418A,			
D2419A,			
D2420A	2099		
D2463	2100		
D2553A	2101		
D2560A	2102		
D2610, D2611	1		527
D2612, D2613	1		20
D2615	1		529
D2616	1		528
D2616B	2		1022
D2619	2		1023
D2620	1		531
D2621	1		530
D2622	1		275
D2623	1		18
D2624	1		78
D2626	2		1024
D2630	1		78
D2634	1		125
D2640	2		1025
D2642	1		275
D2644	1		13
D2645	1		68
D2661	1		527
D2663	1		4
D2665	2		1026
D2692	2		1027
D2710	2		1028
D2718	2		1029
D2745	1		38
D2748	2		1030
D2810	2		1031
D2815	2		1022
D2819	2		1032
D2919	2		1033
D2963	3		1416
D-3120A	4		1764
D-3130A, B	4		1765
D3210A	4		1766
D3265A	4		1767
D3619	1		95
D3630, N	1		73

Name & Model or Chassis No.	Vol. 5 Diag. No.	Previous Vols. Vol. No.	Diag. No.	Name & Model or Chassis No.	Vol. 5 Diag. No.	Previous Vols. Vol. No.	Diag. No.	Name & Model or Chassis No.	Vol. 5 Diag. No.	Previous Vols. Vol. No.	Diag. No.
TRUETONE (Continued)				WELLS-GARDNER (Continued)				WESTINGHOUSE (Continued)			
D3720	2		1034	A117		1	46	H-338T5U,			
D3721	2		1035	A29		1	45	H-341T5U		4	1773
D3722	2		811	1A62 Series,				H-342P5U		4	1774
D3809, D3810	2		633	1A62-4		1	183	H-345T5,		4	1773
D3840	2		1036	1A63 Series,				H-348T5		4	1773
D4320, B,				1A63-3, 1A63-4		1	183	H-349P5		4	1774
D4321, A	1881			5A25S		1	72	H-349P5		4	1774
D4425B,				6A43, 6A44		1	41	H-350T7			
D4426A	1881			6A65 Series		1	47	H-351T7		4	1775
D4620	2		656	6B10, 6B16, 6B18		1	532	H-354C7		4	1776
D4818	2		580	7A40, 7A41		1	45	H-357C10		4	1777
2D1093A	3		1417	7A66		1	526	H-359T5,			
2D1094A	3		1410	7D11 Series		1	182	H-360T5		4	1778
2D1194A				8A30, 8A31		1	45	H-361T6		4	1779
(Radio Ch.)	4		1768	8A51 Series		1	41	H-368P5,			
2D1315A	4		1769	321MS39-322,				H-369P5		4	1774
2D1316A		1829,		-372-2,				H-370T7,			
		2103		-376-2	1834			H-371T7		4	1780
2D1325A	4		1769	2321MS39-324,				H-382T5,			
2D1326A		1829,		-370, -396-1	1834			H-383T5		4	1781
		2103		WESTINGHOUSE				H-385T5,			
2D1331A, B,				H-104, A, H-105,				H-386T5,			
2D1338A	1834			A, H-107, A, H-108,				H-387T5,			
2D1344A, B	4		1770	A, H-110, H-111	1		533	H-388T5		4	1782
2D1353A	2104			H-113, H-114,				H-391T5		2106	
2D1359A	2077			H-116, H-117,				H-393T6		4	1783
2D1415A,				H-119	1		535	H-397T5			
2D1416A,				H-122	1		534	H-398T5		2107	
2D1426A	1829			H-125, H-126	1		536	H-400P4,			
2D2312A	4		1769	H-130	1		534	H-401P4,			
2D2313A		1829,		H-133	1		539	H-402P4,			
		2103		H-137, H-138	1		533	H-403P4		4	1784
2D2313C	1829			H-147	2		936	H-405P5,		2108	
2D2314A	4		1769	H-148, A	1		538	H-408P5		2108	
2D2315A		1829,		H-153, A	1		534	H-420T5,			
		2103		H-154	1		533	H-421T5		2106	
2D2321A	4		1769	H-155, H-156	1		534	H-442P4,			
2D2334A	1834			H-157	2		1040	H-423P4,			
2D2414A,				H-161	2		1041	H-424P4,		2109	
2D2415A				H-164	2		1042	H-425P4			
2D2422A, B	1829			H-165	2		1043	H-434T5			
3D6000	1829			H-166, H-167	2		1042	H-435T5			
ULTRADYNE				H-168, A, B,	2		1041	H-436T5			
L-46	1		35	H-169	2		1044	H-437T5			
UNITONE				H-171, A, C	1		534	H-438T5		2110	
88	1		171	H-178	2		1045	H-443T5			
U. S. TELEVISION (Clearsonic)				H-182	2		1046	H-444T5, A,			
5-16 Series,				H-183, A	2		1047	H-445T5, A,		2111	
5-46 Series	1		174	H-185	2		1048	H-446T5, A		2111	
5A86, 5B66, 5C68,				H-186M, H-187	2		1049	H-457T6			
5D66MPA	2		1037	H-188	2		1037	H-458T6			
8-16M	2		1038	H-190, H-191, A	2		1050	H-459T6		2112	
VAN-CAMP				H-195	2		1048	H-460T6			
576-1-8A	1		144	H-198	3		1419	H-468R6			
VIEWTONE				H-202	2		1051	H-467R6			
RC-201A,				H-203	3		1418	H-468R6		2112	
RRC-201A	1		173	H-204	2		1051	H-469R12,			
VOGUE				H-207AM	3		1418	H-470R12		2113	
553R, 554R	1		11	H-207A (DX),				H-475T5,			
WALGREEN				H-207B (DX)				H-476T5,			
568	1		14	(Radio Ch.)	3		1419	H-477T5,			
571	1		117	H-212	3		1418	H-478T5		2114	
WATTERSON				H-214, A	3		1420	H-480C12		2113	
4581, RC4581	1		73	H-217, A, B				H-482PR5		2115	
4582	1		11	(Radio Ch.)	3		1419	H-487T5,			
ARC-4591A	1		73	H-220	2		1050	H-488T5,			
4782	1		555	H-251	3		1432	H-489T5		2116	
4790	1		132	H-300T5, H-301T5	3		1421	H-600T16,			
4800	2		1039	H-302P5	3		1422	H-601K12,			
WELLS-GARDNER				H-303P4, H-304P4	3		1423	H-602K12		3	1430
A10 Series	1		61	H-307T7, H308T7	3		1419	H-603C12		3	1431
A20 Series	1		64	H-309P5, H-309P5U	3		1424	H-604T10, A		3	1432
A22 Series,				H-310T5, H-310T5U,				H-608C12		3	1431
A23 Series,				H-311T5, H-311T5U	3		1425	H-609T10		3	1432
A24 Series	1		60	H-312P4, H-312P4U,				H-611C12,			
S2	1		64	H-313P4, H-313P4U,				H-615C12		3	1433
T3 Series	1		64	H-314P4, H-314P4U,				H-630C17,			
WG-30A8				H-315P4, H-315P4U	3		1426	H-634C17		3	1434
-A-496	2105			H-316C7, H-317C7	3		1427	H-660C17			
				H-318T5, U,				H-661C17			
				H-320T5, U,				(Radio Ch.)	4		1777
				H-321T5, U,				H-667T17,			
				H-322T5, U,				H-668T17,			
				H-323T5, U,	3		1428	H-673K21,			
				H-324T7,				H-676T21,			
				H-325T7, U,				H-678K17,			
				H-326C7	3		1427	H-679K17,			
				H-327T8U	3		1429	H-681T17,			
				H-328C7, U	4		1771	H-688K24,			
				H-331P4, U				H-693T16			
				H-332P4, U	4		1772	H-690K21,			
				H-334T7U, UR,				H-692T21,			
				H-335T7U	4		1771	H-695K21,			
				H-338T5U,				H-699K17			
				H-337T5U	3		1428	(Ch. V-2217-2)	4		1785

Name & Model or Chassis No.	Vol. 5 Diag. No.	Previous Vols. Vol. No.	Diag. No.
WESTINGHOUSE (Continued)			
H-700T17,			
H-701T17,			
H-701K21,			
H-702K17,			
H-703K17,			
H-704T17,			
H-705K17,			
H-710T21,			
H-711T21 (Ch.			
V-2217-2),			
H-713K21,			
H-714K21 (Ch.			
V-2217-2),			
H-715K21 (Ch.			
V-2217-2),			
H-720K21 (Ch.			
V-2217-2),			
H-721K21 (Ch.			
V-2217-2),			
H-722K21 (Ch.			
V-2217-2),	4	1785	
H-730C21,			
H-732C21,			
H-733C21,	4	1786	
H-1251	1	536	
WR-12X7	1	537	
WR-12X8	1	411	
WR-12X9,			
WR-12X12	1	397	
WR-12X14	1	415	
WR-12X15	1	137	
WR-12X16	1	140	
WR-12X18	1	541	
WR-42X3	1	413	
WR-42X4, 42X5	1	437	
WR-42X7	1	413	
WR-42X14,			
-42X15	1	437	
WR-42X42	1	446	
WR-158	1	443	
WR-168, A	1	540	
WR-170, -172,			
-175, -176	1	107	
WR-186	1	537	
WR-258	1	443	
WR-260	1	541	
WR-264	1	395	
WR-270, WR-272	1	107	
WR-274	1	102	
WR-290	1	417	
WR-366, -368,			
-370	1	420	
WR-372, -373	1	107	
WR-374	1	102	
WR-388	1	417	
WR-473, -474	1	107	
WR-476	1	102	
WR-480, -482, -484	1	537	
Chassis			
V-2102, -1	1	533	
V-2103	1	534	
V-2103-3	3	1420	
V-2107	1	539	
V-2118	2	1041	
V-2119-1	2	1042	
V-2120	2	1043	
V-2122	2	1040	
V-2123	2	1045	
V-2124-1	2	1044	
V-2127	2	1047	
V-2128, -1	2	1046	
V-2128-2	2	1051	
V-2130-21DX,			
22DX	3	1419	
V-2131, -1	2	1048	
V-2132	2	1049	
V-2133	2	1037	
V-2134	2	1050	
V-2136	3	1419	
V-2136-1, -2	3	1427	
V-2136-4, -5R	4	1771	
V2137	3	1418	
V-2137-2	3	1419	
V-2137-5U	4	1771	
V-2148	3	1421	
V-2150-41, A	3	1430	
V-2150-61, A, B	3	1430	
V-2150-81, -82,			
-84	3	1432	
V-2150-91A,			
-94, -94C	3	1432	
V-2151-1	3	1422	
V-2152-01	3	1431	
V-2152-16	3	1433	
V-2153	3	1423	

Name & Model or Chassis No.	Vol. 5 Diag. No.	Previous Vols. Vol. No.	Diag. No.
WESTINGHOUSE (Continued)			
V-2153-1	3	1426	
V-2156	3	1424	
V-2156-1U	4	1774	
V-2156-2, 2108			
V-2157, U, -1,			
-1U	3	1428	
V-2157-2, -2U	3	1428	
V-2157-3U	3	1429	
V-2157-4U	4	1773	
V-2157-6	4	1778	
V-2157-10	4	1781	
V-2157-11, -12	4	1782	
V-2157-13			
-14	2106		
V-2161, U	3	1425	
V-2164-2	4	1784	
V-2173	3	1434	
V-2180-1	4	1775	
V-2180-2	4	1776	
V-2180-3, -5	4	1777	
V-2180-8	4	1780	
V-2180-9, -10	4	1786	
V-2180-13	2113		
V-2181-1	4	1779	
V-2182-2	4	1783	
V-2184-2	2107		
V-2188-1	2109		
V-2189-2	2110		
V-2189-4	2111		
V-2214-1,			
V-2215-1	4	1775	
V-2218-1, -2,			
-3, -4, -5,	4	1777	
V-2217-1, -2, -3,	4	1785	
-4, -5			
V-2218-1, -2,			
-11	4	1786	
V-2219-1	4	1785	
V-2229-1,			
-2, -3	2112		
V-2229-5	2115		
V-2236-1	2114		
V-2236-2	2116		
WOOLAROC			
3-1A, 3-2A	1	20	
3-3A	1	25	
3-4A	1	516	
3-5A	2	574	
3-6A, 5	2	1052	
3-9A, 3-10A	1	385	
3-11A	1	387	
3-17A, 3-18A	2	1053	
3-20A	1	564	
3-29A	1	388	
3-70A	2	1055	
3-71A	2	781	
3-81A	2	1016	
ZENITH			
G500	3	1435	
G503	3	1436	
G510, G510Y	3	1437	
G511, G511W,			
G511Y	3	1438	
G516	3	1439	
G615, G615W,			
G615Y	3	1440	
G650, G663, G665	3	1441	
G723, G724	3	1442	
G824	3	1443	
G881, G882, G883,			
G884, G885	3	1444	
G2322, G2340, R,			
G2346R, G2353E			
(Fine Tuning)	3	1445	
G2322, G2340, R,			
G2346R, G2353E			
(Vol. Cont)	4	1807	
G2420E, -EOX,			
-R, -ROX	3	1445	
G2441, R, G2442E,			
R, G2448R (Fine			
Tuning)	3	1445	
G2441, R, G2442E,			
R, G2448R (Vol.			
Cont)	4	1807	
G2454R, -ROX	3	1445	
G2951, R, OX,			
ROX, G2952, R,			
OX, ROX	3	1446	
G2957, R, G2958R			
(Fine Tuning)	3	1445	

Name & Model or Chassis No.	Vol. 5 Diag. No.	Previous Vols. Vol. No.	Diag. No.
ZENITH (Continued)			
G2957, R, G2958R			
(Vol. Cont)	4	1807	
G2957, R, G2958R			
(Radio Ch.)	3	1451	
G3059, R, G3062			
(Fine Tuning)	3	1445	
G3059, R, G3062			
(Vol. Cont)	4	1807	
G3059R, G3062			
(Radio Ch.)	3	1451	
H-401, G	4	1787	
H-500	4	1788	
H-503, Y	4	1787	
H511, H511W,			
H511Y	3	1442	
H-615	4	1789	
H-615Z1	4	1790	
H661E, H661R,			
H665, R, RZ, Z	3	1447	
H-664	4	1791	
H723	3	1448	
H723Z	3	1449	
H-723Z2	4	1792	
H724	3	1448	
H-724Z, H-724Z1	4	1792	
H725	3	1443	
H880, H880R	3	1450	
H880RZ	3	1451	
H2029R, H2030E,			
H2030R, H2041R,			
H2052R, H2053E	4	1793	
H2226E, R,			
H2227E, R,	3	1452	
H2252R, H2255E,	3	1452	
H2328E, EZ, R, RZ,			
H2329R, RZ,			
H2330E, R	3	1453	
H2341R	4	1453	
H2352R, RZ,			
H2353E, EZ	3	1453	
H2437E, R,			
H2438R, H2439R,			
H2443E, H2445R,			
H2447R, H2449E			
(TV Ch.)	3	1454	
H3074	4	1794	
H3267, R, (TV Ch.)	3	1454	
H3267R, (Radio Ch.)	3	1451	
H3273E, H3274R,			
H3284R	4	1794	
H3467R (TV Ch.)	3	1454	
H3467R (Radio Ch.)	3	1455	
H3469E (TV Ch.)	3	1454	
H3469E (Radio Ch.)	3	1455	
H3475R (TV Ch.)	3	1454	
H3475R (Radio Ch.)	3	1455	
H3477R (TV Ch.)	3	1454	
H3477R (Radio Ch.)	3	1455	
H3478E (TV Ch.)	3	1454	
H3478E (Radio Ch.)	3	1455	
H3490E	4	1794	
HFM1184E,			
HFM1190R	2117		
HFR1283E,			
HFR1286R,			
HFR1280R	2118		
J402	4	1795	
J420T	4	1796	
J514	4	1797	
J615, F, G, W, Y	4	1798	
J616	4	1797	
J644, J665E, R	4	1799	
J733, G, R, Y	4	1800	
J860, J860R	4	1801	
J1083E, EZ,			
J1086R, RZ,			
J1087, Z	4	1794	
J2026R, J2027E,			
R, J2029E, R,			
J2030E, R,			
J2031R, J2032R,			
J2040E, J2042R,			
J2043R, J2044E,			
R, J2049R,			
J2050R, J2051E,			
J2053R, J2054R,			
J2055R, J2126R,			
J2127E, R,			
J2128E, R,			
J2130E, R,			
J2140E, J2142R,			
J2143R, J2144E,			
R, J2151E,			
J2153R, J2154R,			
J2155R	4	1793	
J2888R, J2968R	4	1793,	
		1801	

Name & Model or Chassis No.	Vol. 5		Previous Vols.	
	Diag. No.	No.	Vol. No.	Diag. No.

Name & Model or Chassis No.	Vol. 5		Previous Vols.	
	Diag. No.	No.	Vol. No.	Diag. No.

Name & Model or Chassis No.	Vol. 5		Previous Vols.	
	Diag. No.	No.	Vol. No.	Diag. No.

ZENITH (Continued)

7E02, Z	2	555
7E22	2	1061
7F01	3	1443
7F02	3	1442
7F03	3	1457
7F04	3	1442
7G01, Z	3	1443
7G02	3	1442
7G04	3	1442
7H02	3	1448
7H02Z, 7H02Z1	4	1792
7H04	3	1448
7H04Z	3	1449
7H04Z2	4	1792
7J03	4	1800
7K01	4	1803
7K20	4	1805
7L05	2128	
8C01	1	551
8C20	1	552
8C21	1	542
8C40	1	542
8C40T (Z1), (Z2)	2	1057
8E20	2	1062
8G20	3	1444

ZENITH (Continued)

8H20	3	1451
8H20 Revised	3	1450
8H20Z	4	1801
8L20	2130	
8L21	2129	
8T01	2135	
9E21	2	1062
9E21 Z	3	1458
10H20Z	4	1794
10L20	2130	
11C21	1	35
11M20	2117	
12R20,		
12R21	2118	
13D22	2	1063
19K20, 19K22, -3,		
19K23, 19K24-3	4	1806
19L25, 19L26,		
19L27, 19L28,	2119	
19M20, U, Z,		
19M21, U,		
U, Z, Z	2133	
19R20, U,		
19R21, U,		
19R22, U	1934	
20H20, 20J21,		
20J22	4	1793

ZENITH (Continued)

20M20, U, Z,		
20M21, U,		
U, Z	2119	
21J20, 21J21	4	1793
21K20	4	1806
21K20-3	2119	
21L21	2119	
22H20	3	1452
22L20	2119	
23G22, 23G23 (Fine Tuning)	3	1445
23G22, 23G23 (Vol. Cont)	4	1807
23H22, Z	3	1453
24G20, -OX	3	1445
24G21, -OX	3	1445
24G22, 24G23, 24G24, 24G25 (Fine Tuning)	3	1445
24G22, 24G23, 24G24, 24G25 (Vol. Cont)	4	1807
24H20	3	1454
28K20	4	1806
29G20	3	1446

TUNING GANG FULLY CLOSED

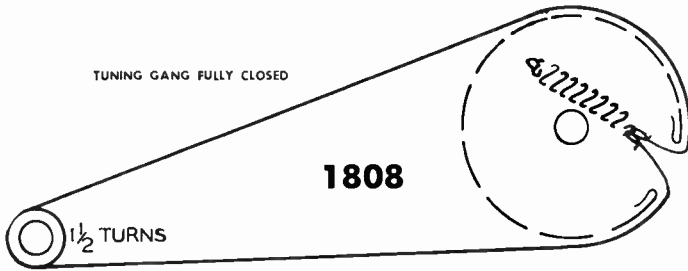

1809

TUNING GANG FULLY OPEN

2 1/2 TURNS

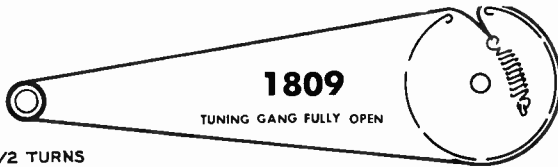

TUNING GANG FULLY CLOSED

1810

3 TURNS

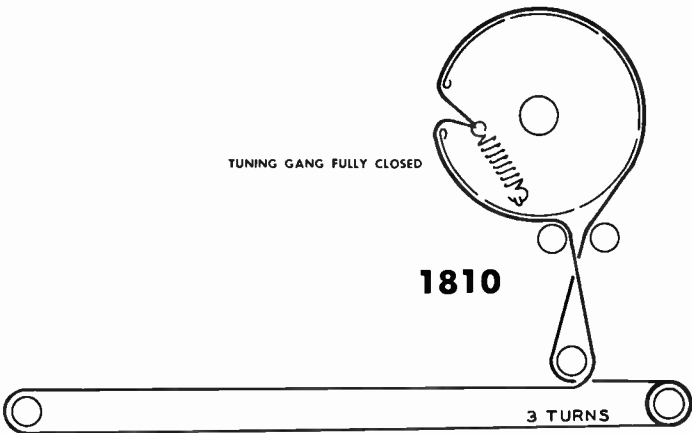

1811

2 TURNS

TUNING GANG FULLY CLOSED

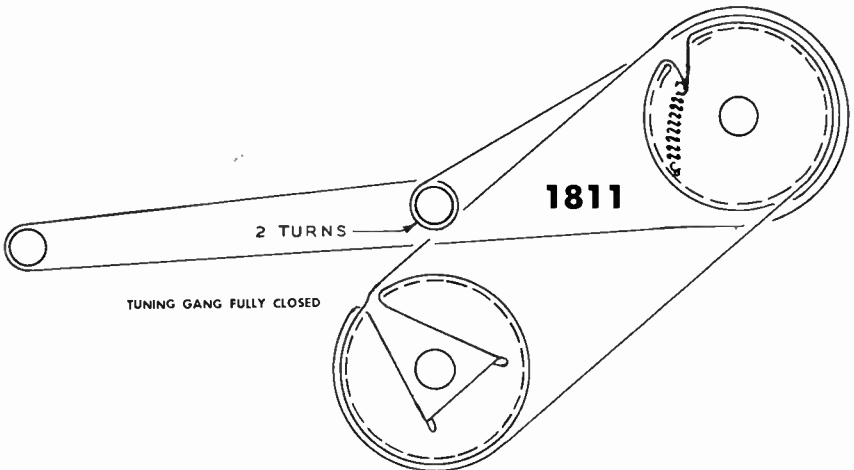

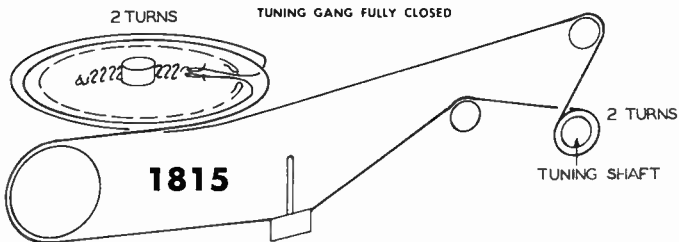
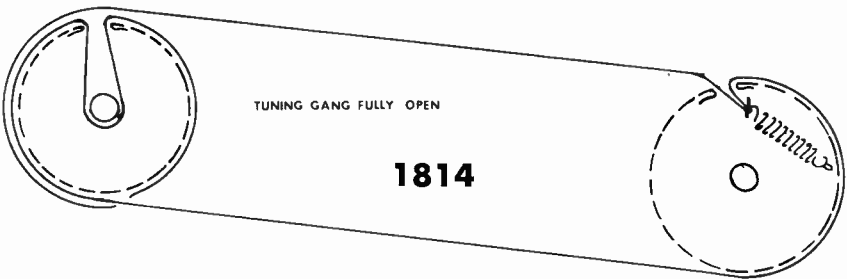
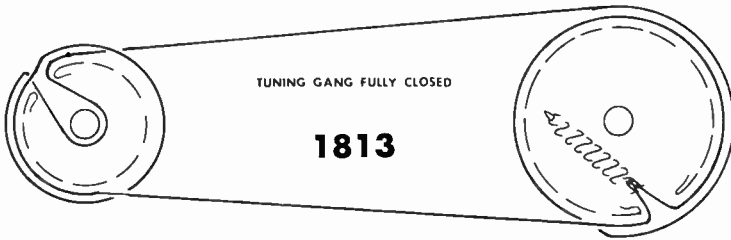
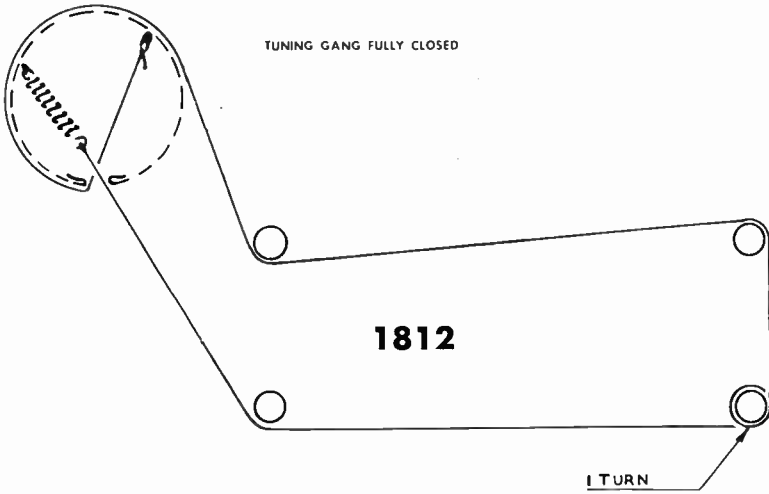

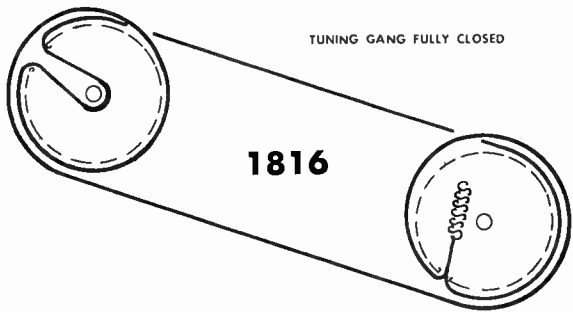

TUNING GANG FULLY CLOSED

1816

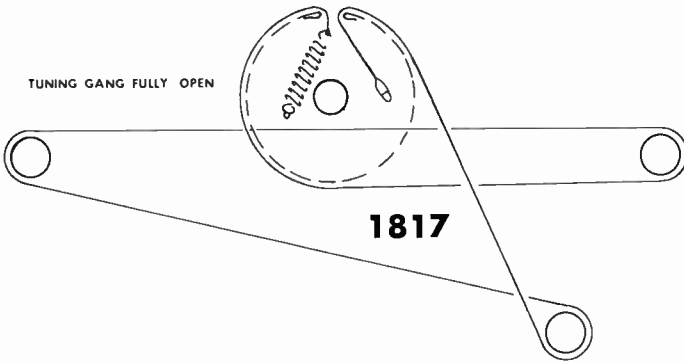

TUNING GANG FULLY OPEN

1817

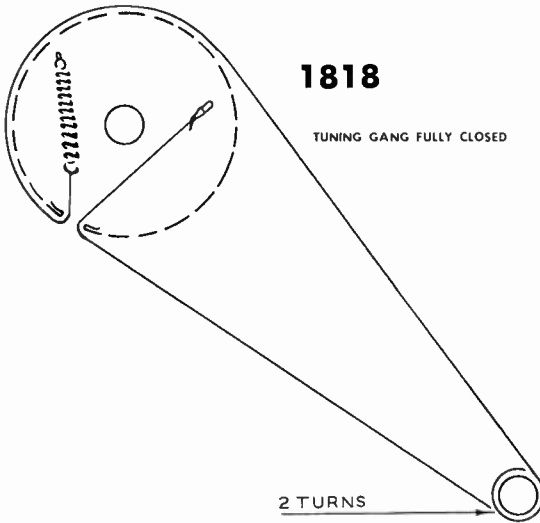

1818

TUNING GANG FULLY CLOSED

2 TURNS

TUNING GANG FULLY CLOSED



1819

1/2 TURNS
TUNING HUB

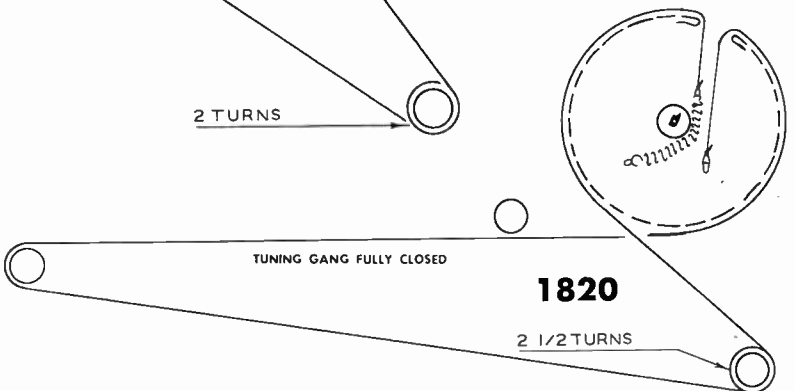

TUNING GANG FULLY CLOSED

1820

2 1/2 TURNS

TUNING GANG FULLY CLOSED

1821

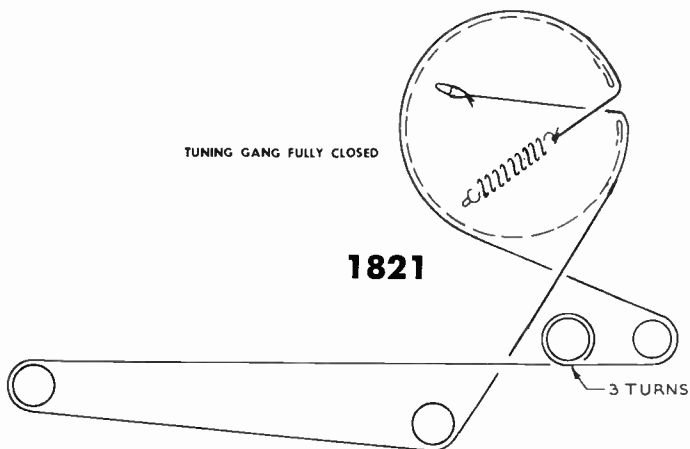

#1 - STATION TUNING
#2 - DIAL POINTER

TUNING GANG FULLY CLOSED

1822

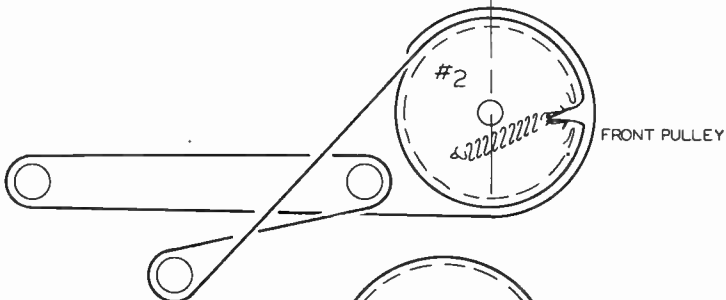
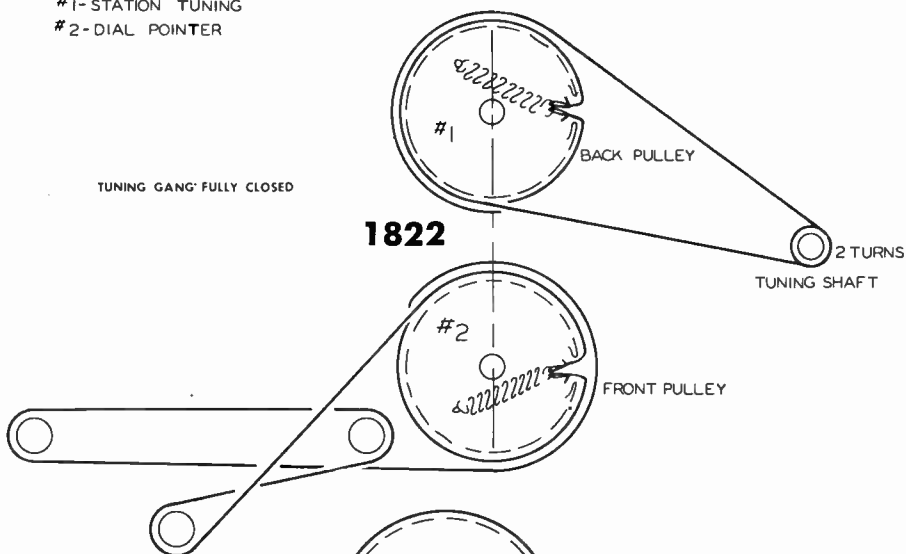

TUNING GANG FULLY CLOSED

1823

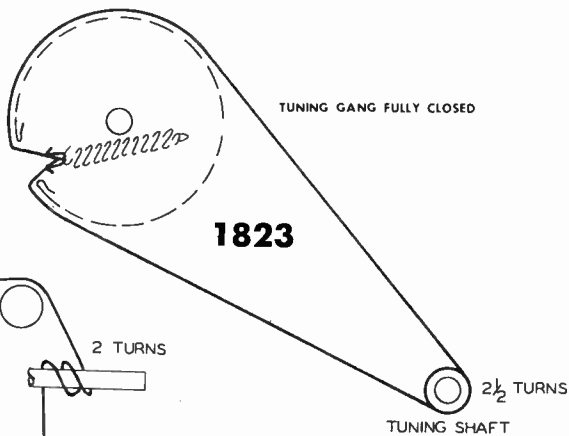

TUNING GANG FULLY CLOSED

1824

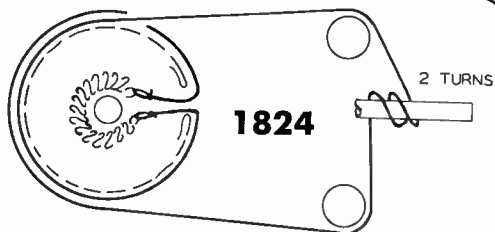

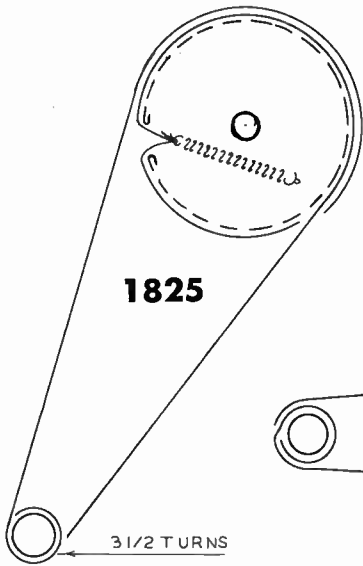

TUNING GANG FULLY CLOSED

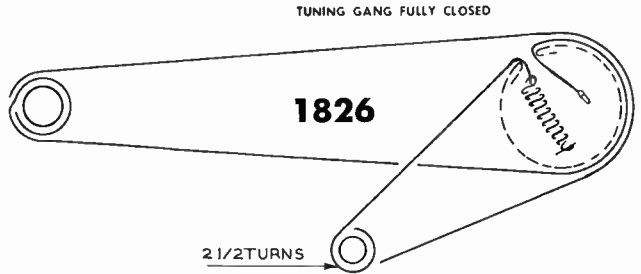

TUNING GANG FULLY CLOSED

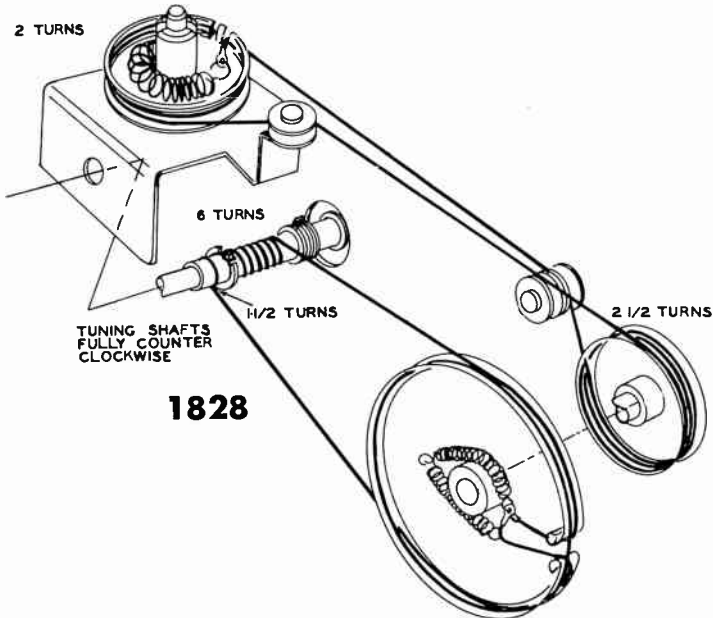

TUNING SHAFT FULLY CLOCKWISE

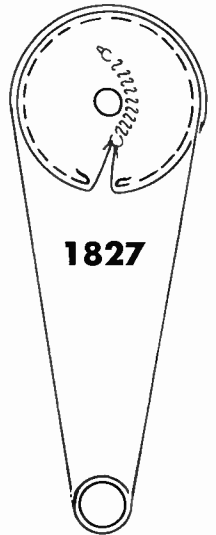

If for any reason the drive cord of either the RF or oscillator cavities need replacement, the exact cord and length are recommended. The cord used is of a special material which is not affected by temperature or moisture. Refer to the parts list for the correct replacement. The oscillator drive assembly consists of four (4) separate drive cords each locked to the oscillator drive pulley (Fig. 1) Each RF drive assembly consists of two (2) separate drive cords which are locked to the RF cavity drive pulley (Fig. 2) If the drive cord requires replacement, the picture tube should be removed along with the cavity cover. Follow the diagram and replace the cord as indicated. After replacement follow the instruction for realignment.

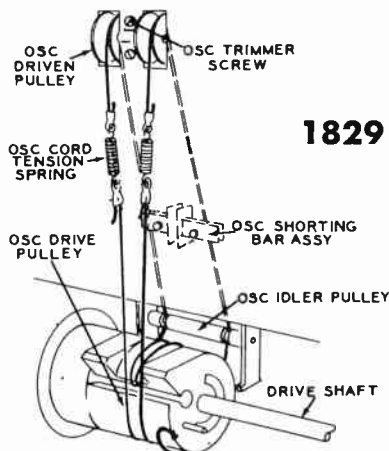

FIG. 1

1829

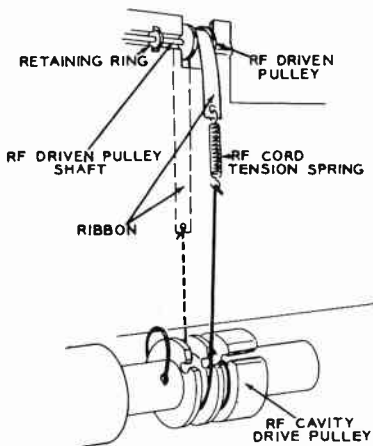
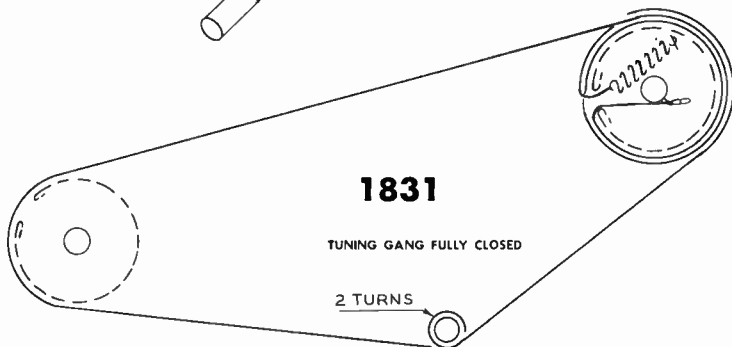
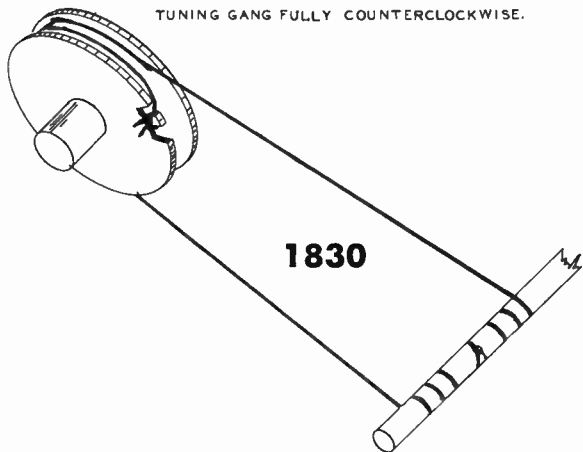
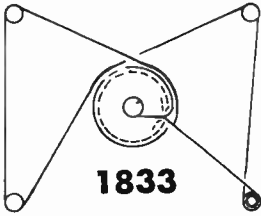
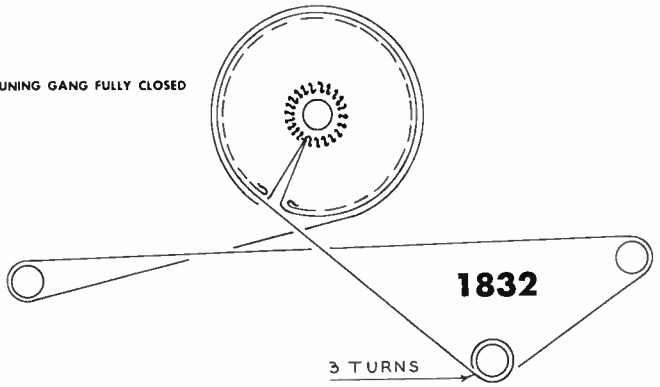

FIG. 2

TUNING GANG FULLY COUNTERCLOCKWISE.



TUNING GANG FULLY CLOSED



TUNING GANG FULLY CLOSED

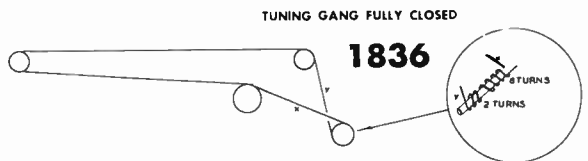
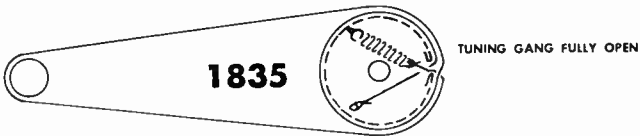
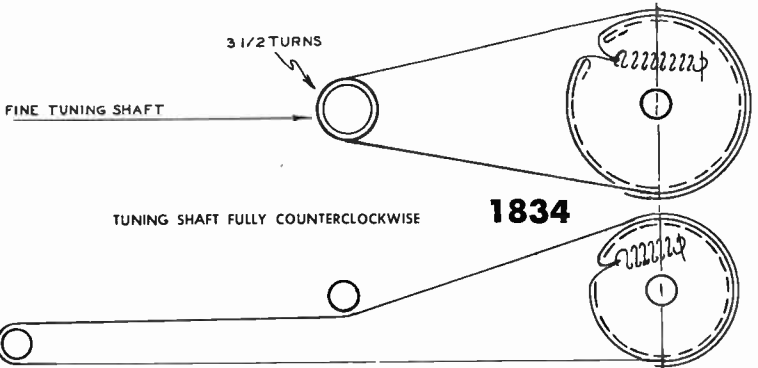

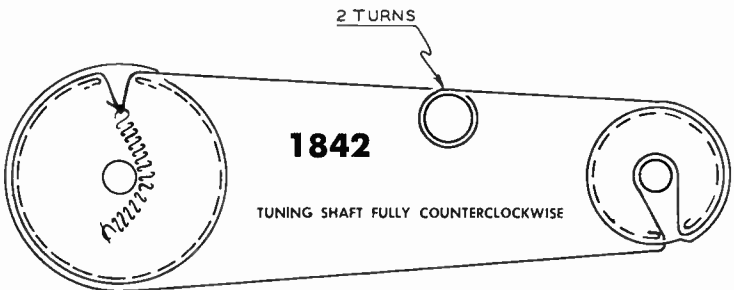
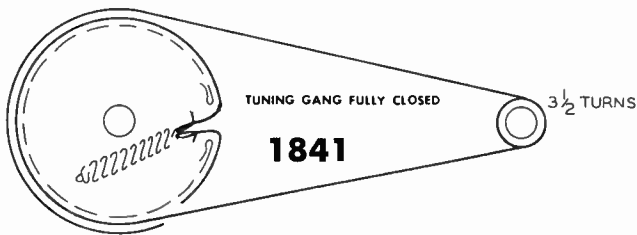
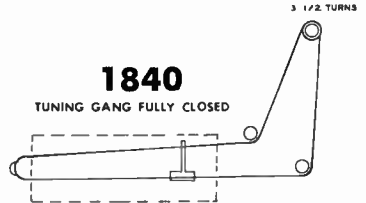
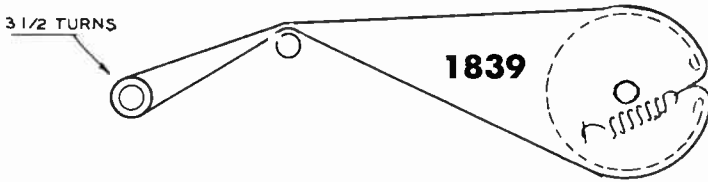
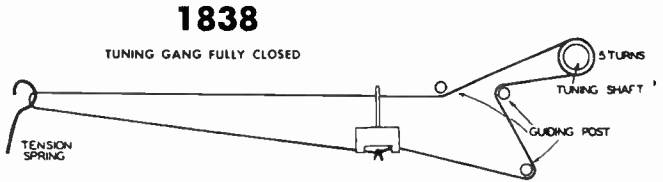
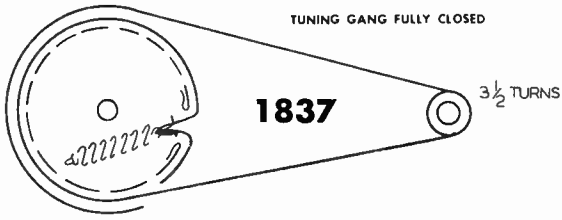

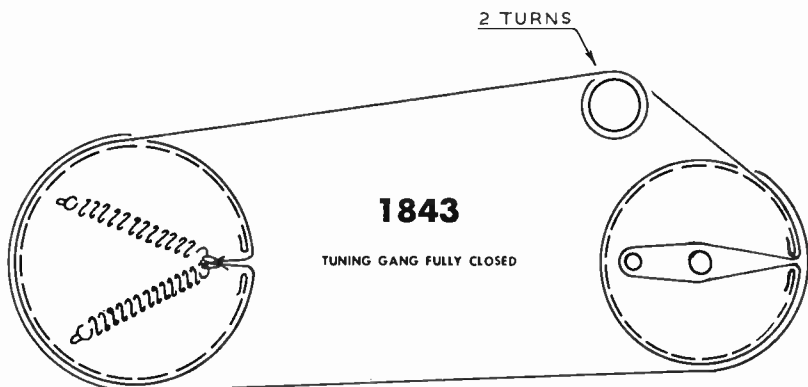

FINE TUNING IN MAX. COUNTER-CLOCKWISE POSITION.

UHF TUNING IN MAX. COUNTER-CLOCKWISE POSITION.

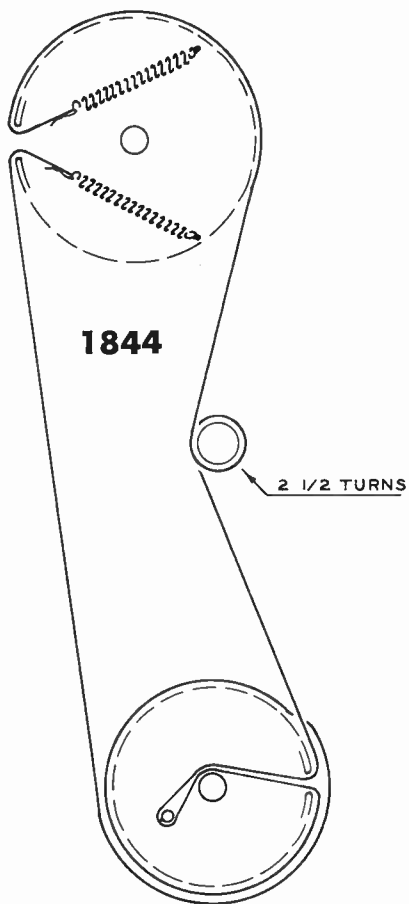

TUNING GANG FULLY CLOSED

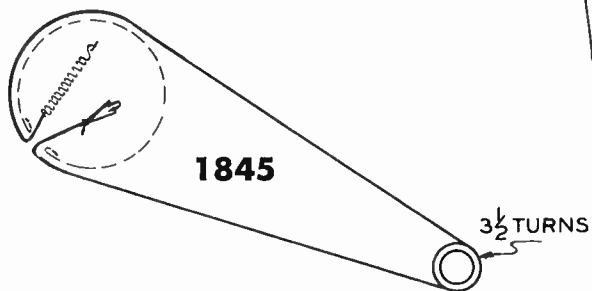

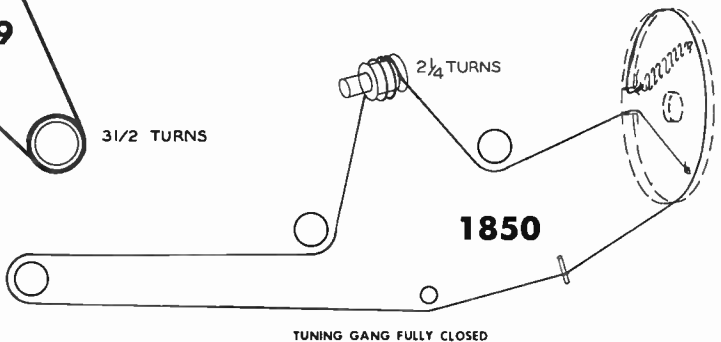
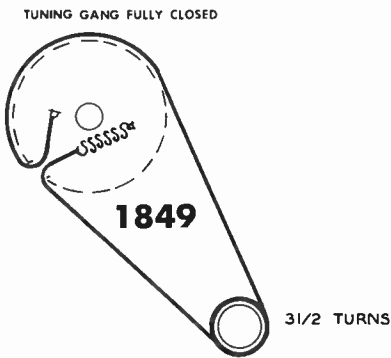
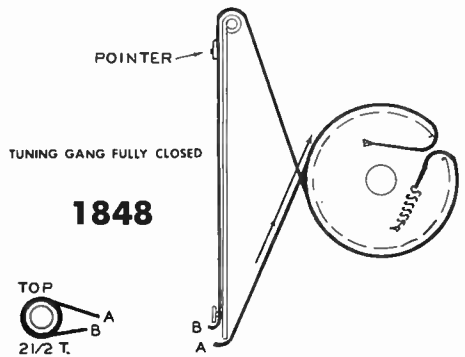
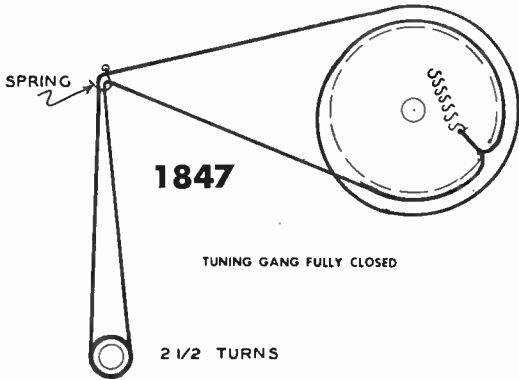
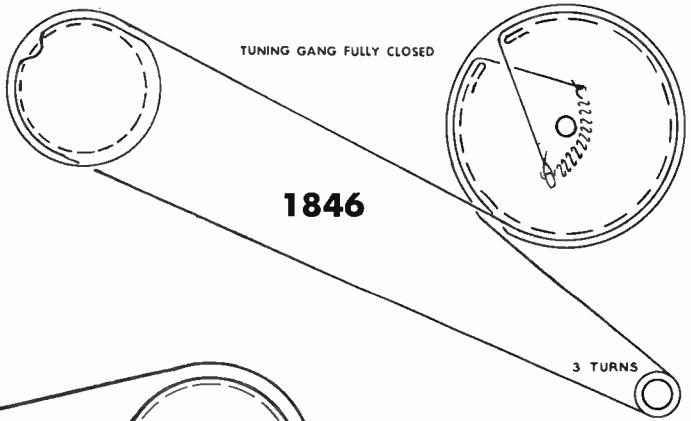

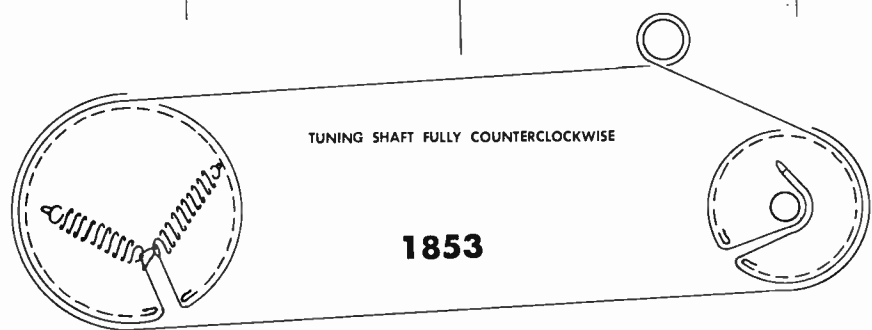
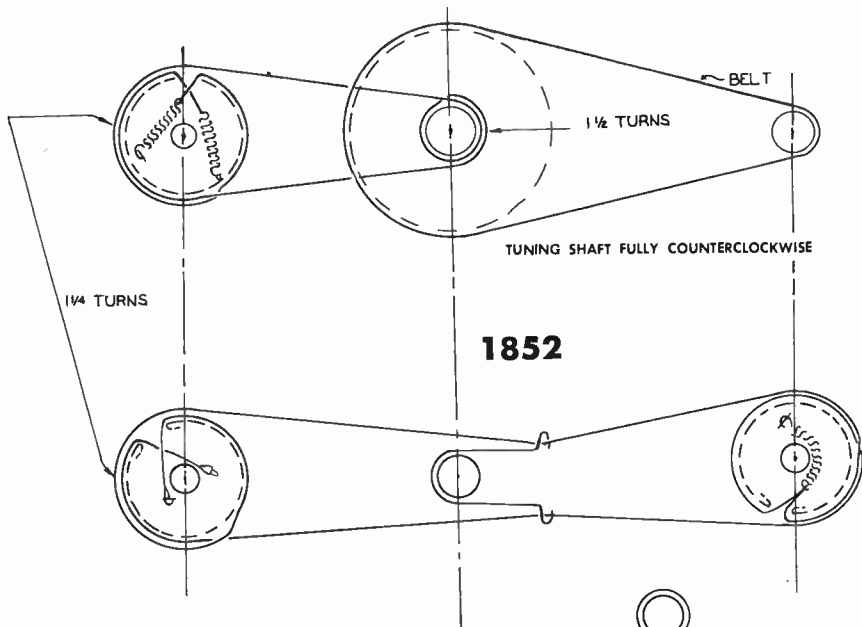
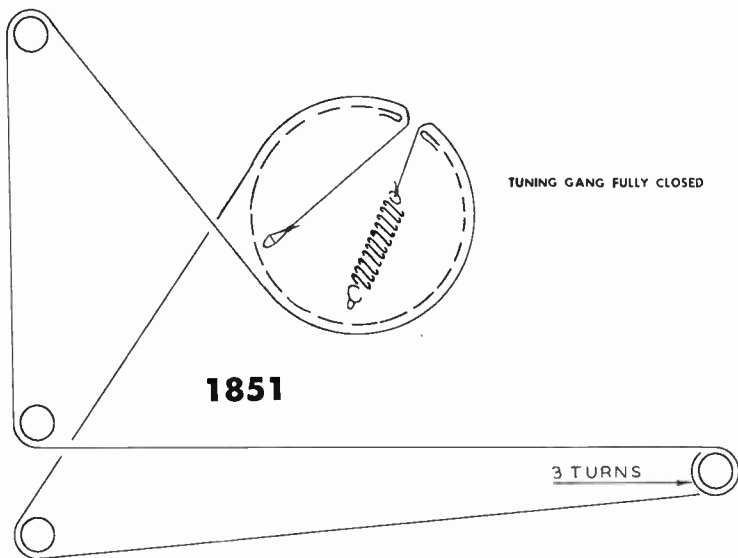

TUNER SET WITH PULLEY CUTOUTS FACING EACH OTHER

3 1/2 TURNS
TUNING SHAFT-REAR

1854

CONVERTER TUNER

REAR
2 1/2 TURNS
2 3/4 TURNS
FRONT

START

4° ± 2°
VERTICAL

REAR - 2 1/2
TURNS ON
SMALL PULLEY.

1 TURN

1855

VERTICAL ± 45°
APPROX.

THIS ANGLE MUST BE HELD TO PERMIT COVERAGE OF ENTIRE TUNING RANGE

WITH BOTTOM PULLEY IN FULL COUNTER-CLOCKWISE POSITION & OTHER PULLEYS IN POSITION SHOWN. WIND DIAL CORD AS INDICATED. ALL SPRINGS MUST BE UNDER TENSION.

REAR

FRONT

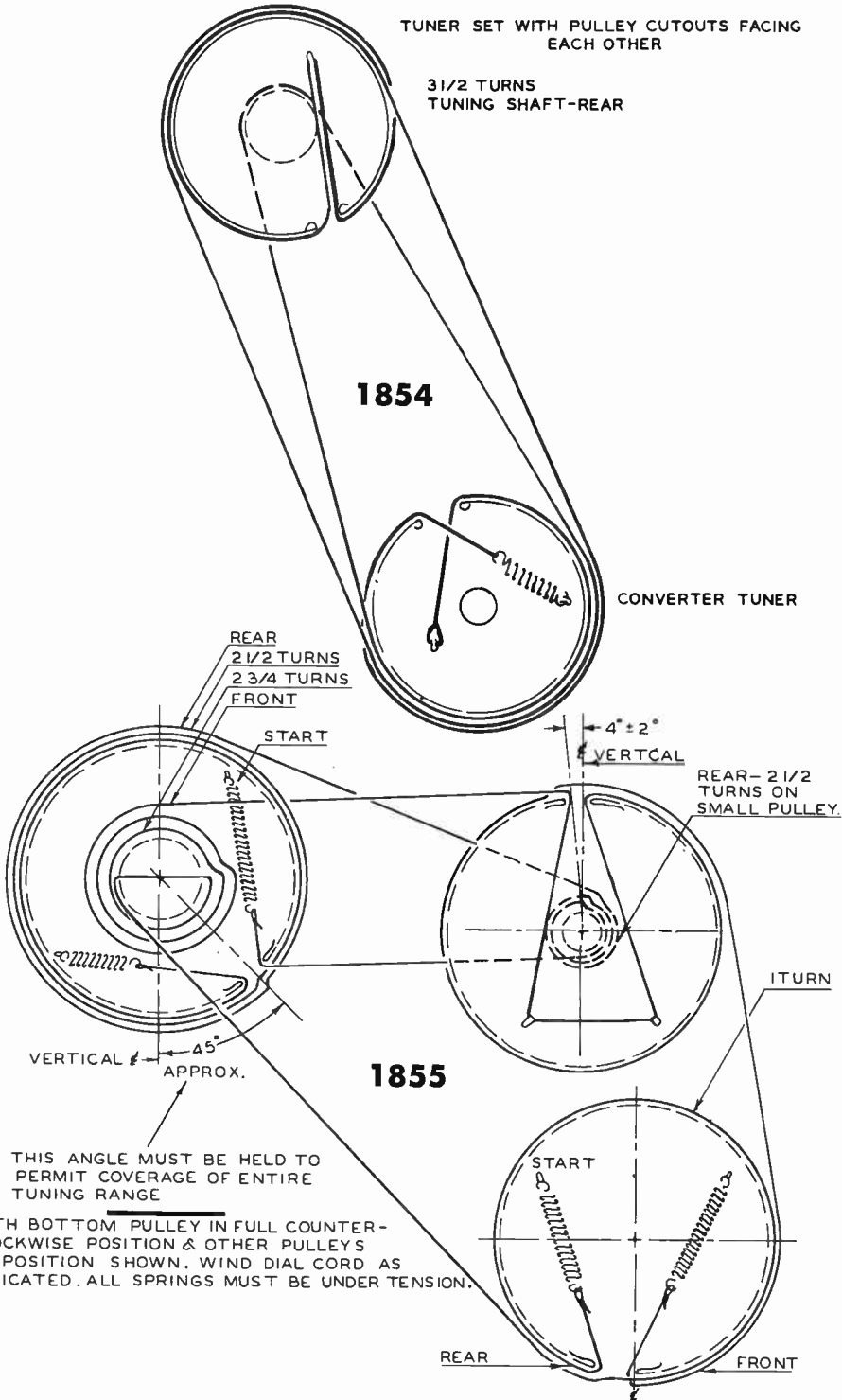

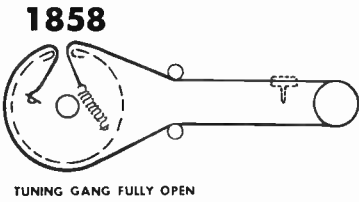
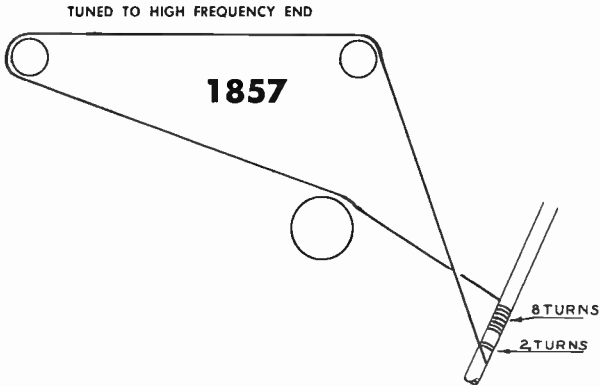
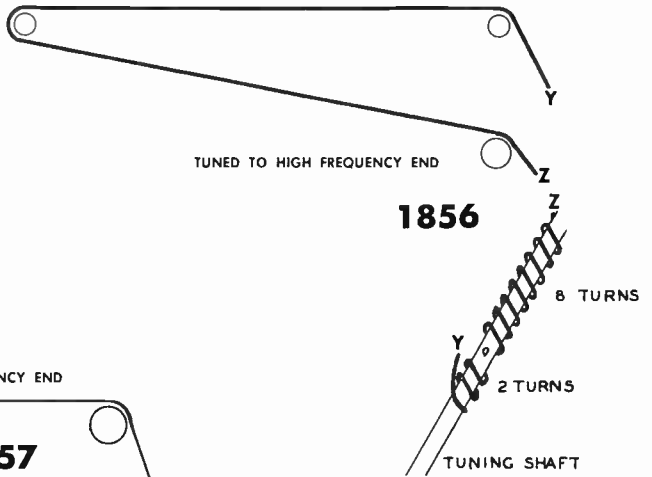

DIAL CORD STRINGING FOR ALL CONTROLS.

DIALS FULLY CLOCKWISE

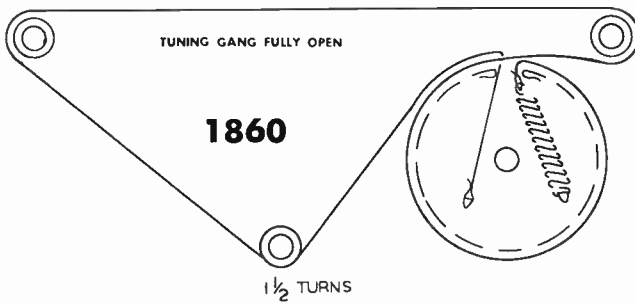
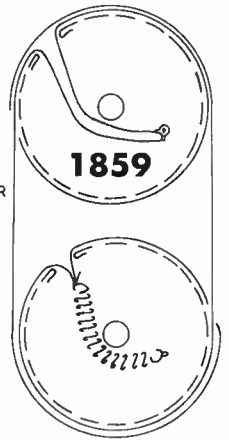

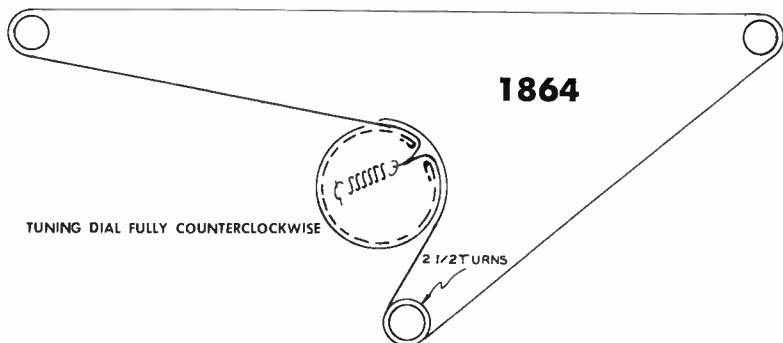
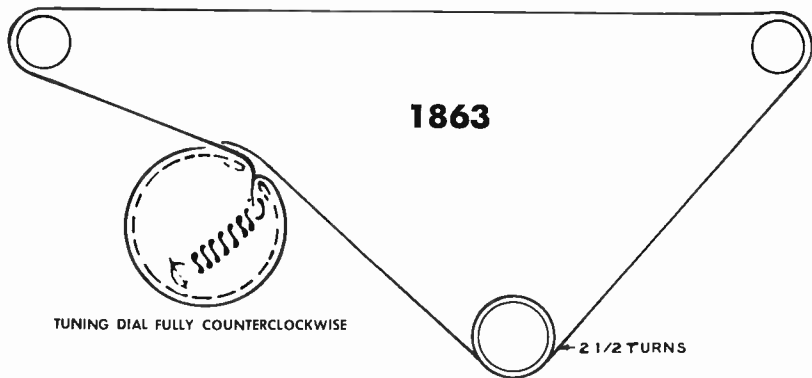
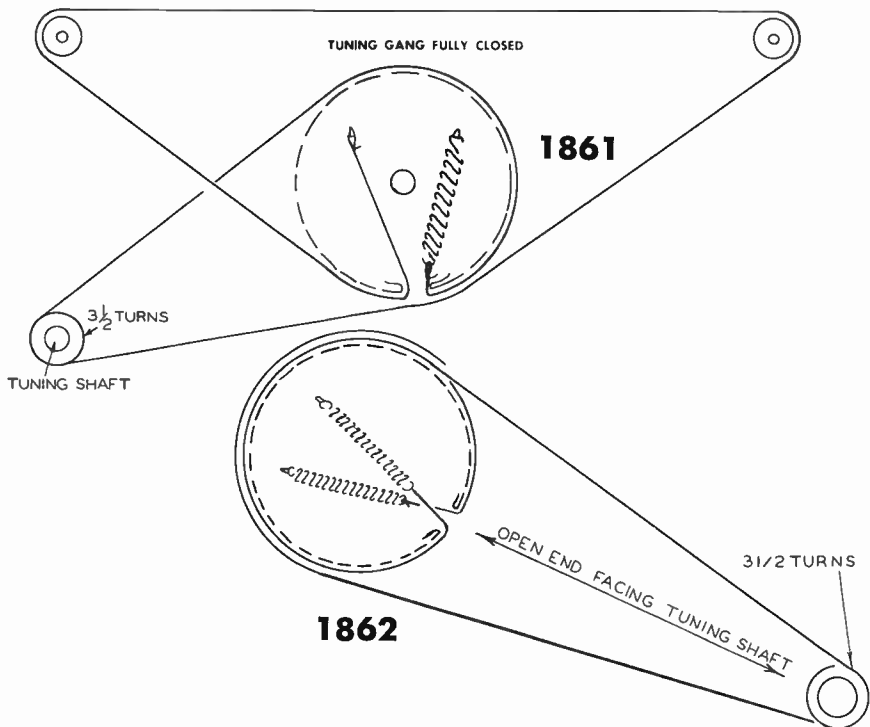

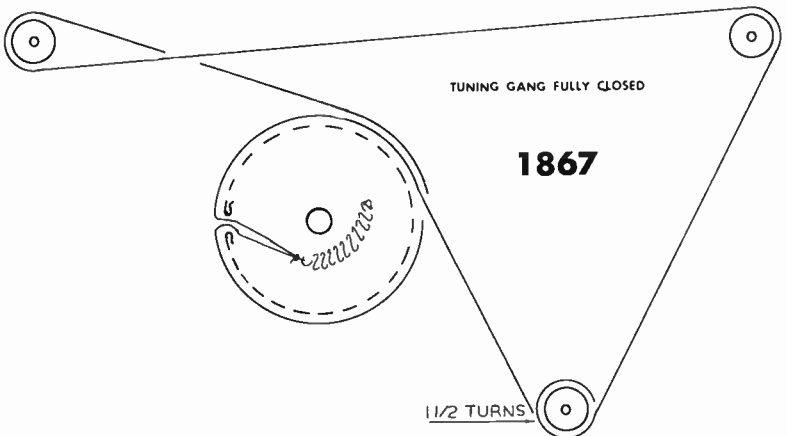
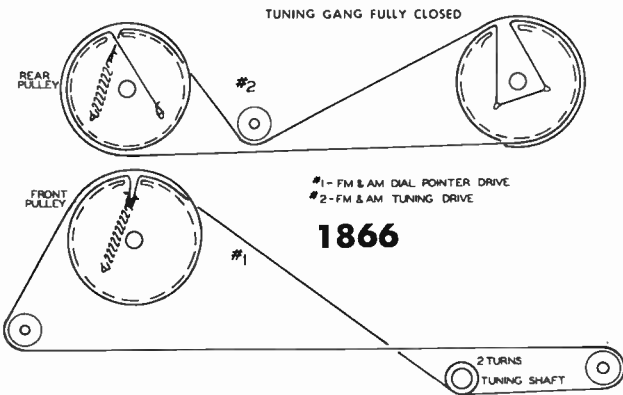
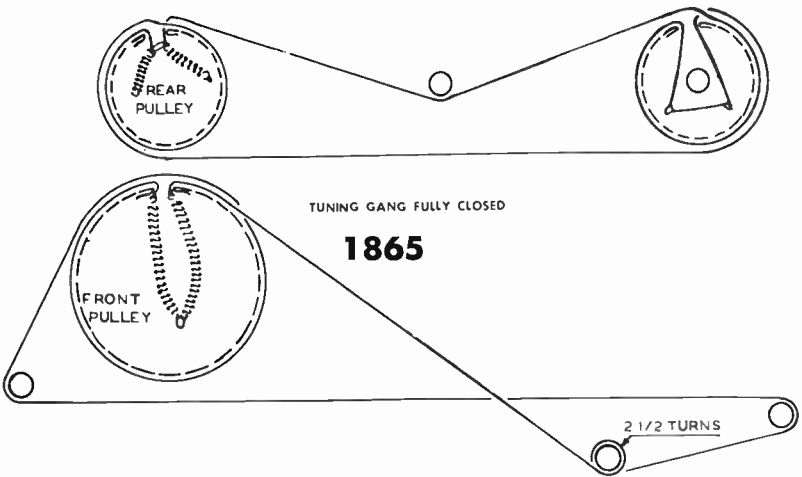

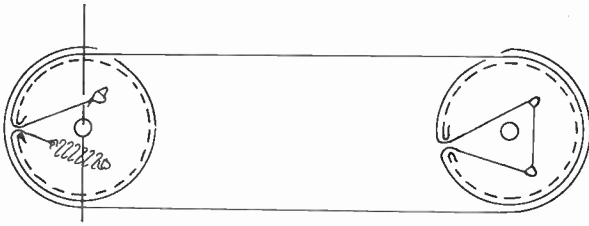

1868

TUNING GANG FULLY CLOSED

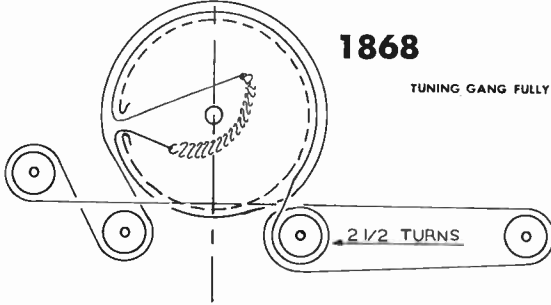

TUNING GANG FULLY CLOSED

1869

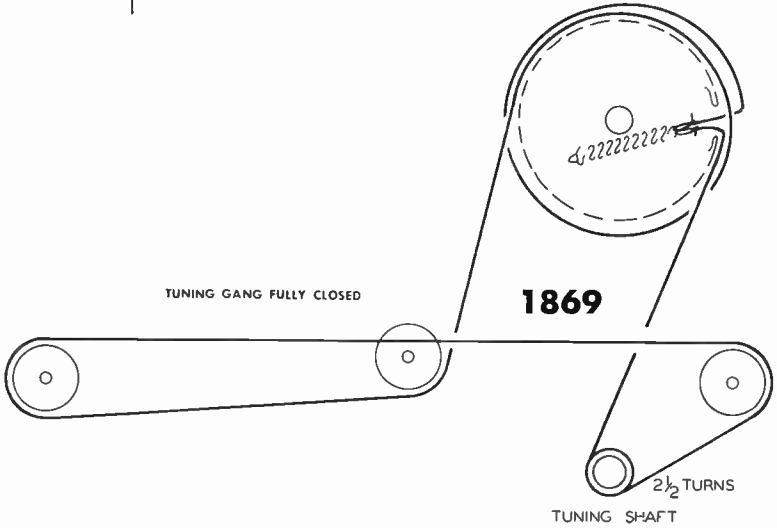

TUNING SHAFT

TUNING GANG FULLY CLOSED

2 1/2 TURNS

1870

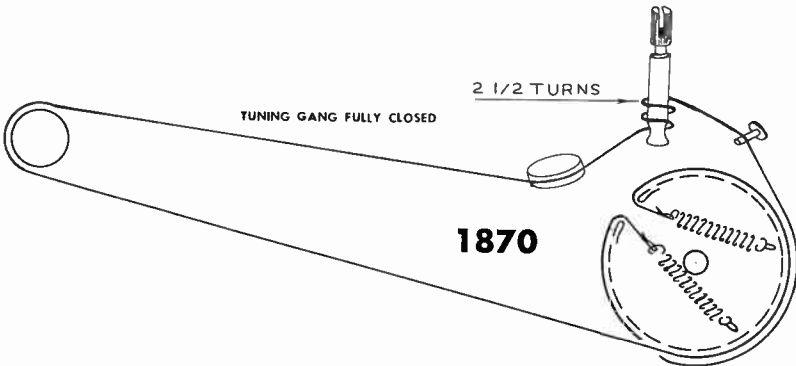

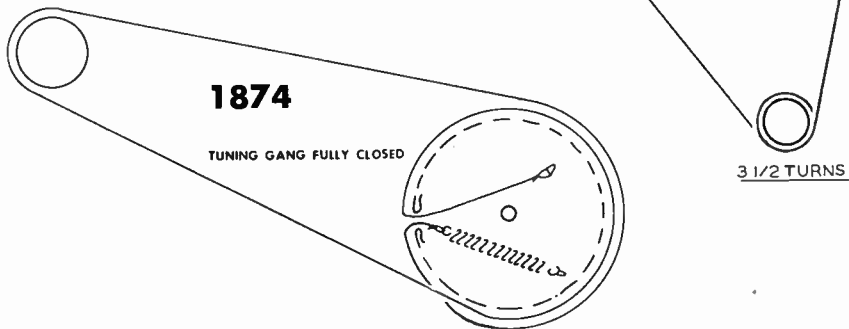
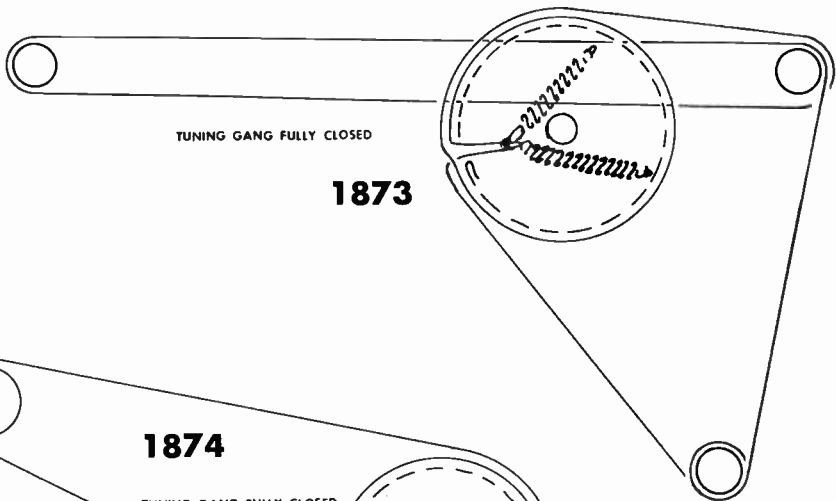
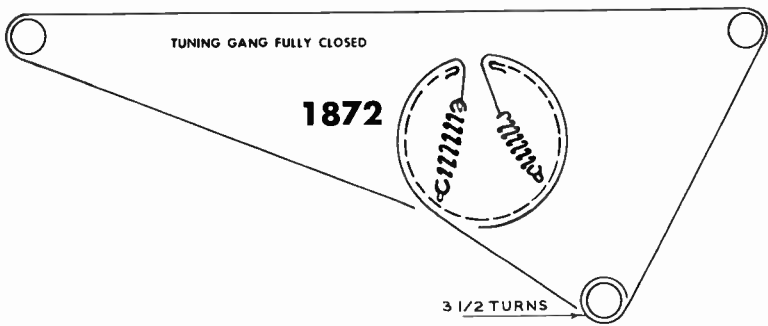
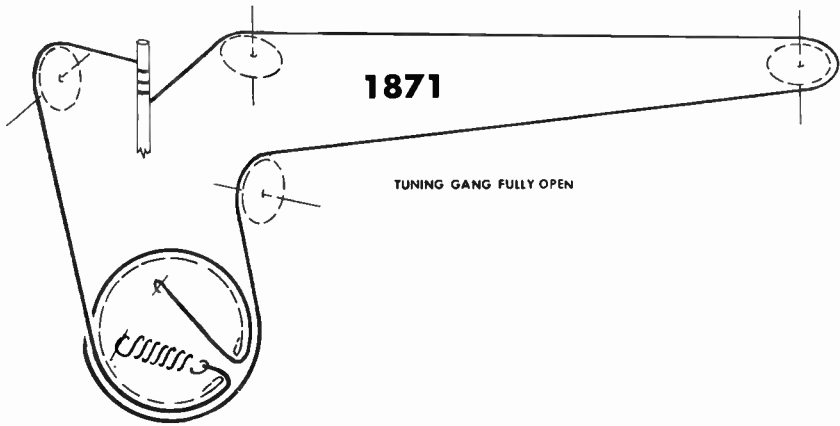

TUNING GANG FULLY CLOCKWISE

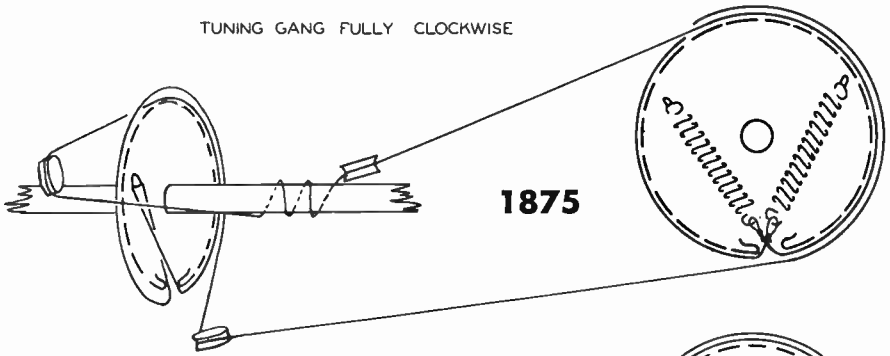

TUNING GANG FULLY CLOSED

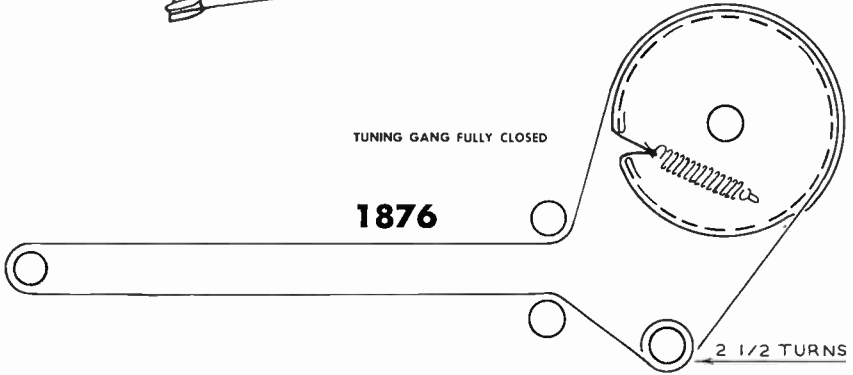

TUNING GANG FULLY CLOSED

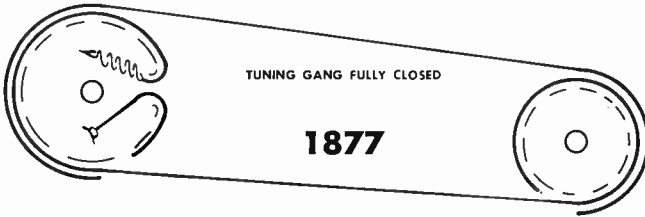

8 1/2 TURNS

TUNED TO HIGH FREQUENCY END

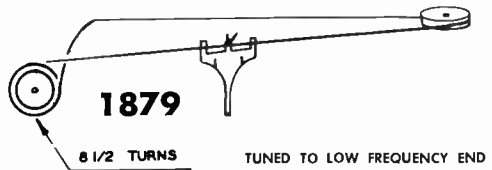
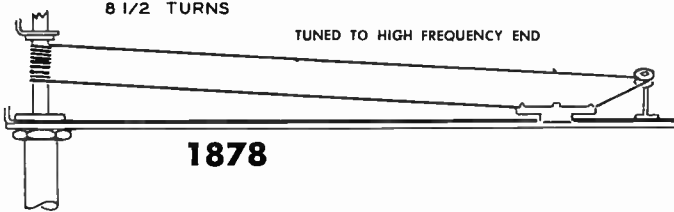

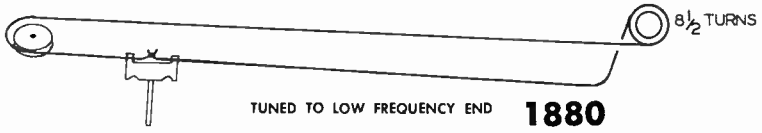

1880

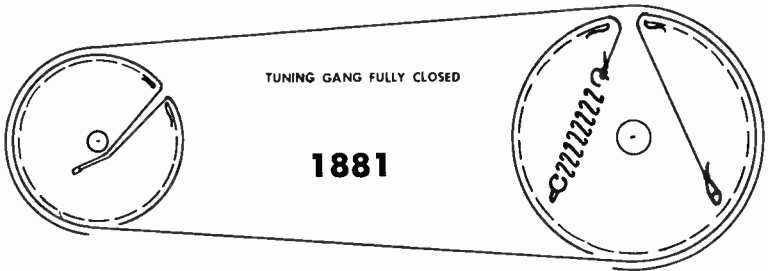

1881

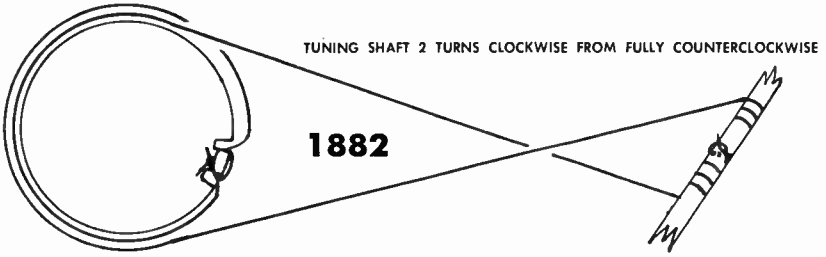

1882

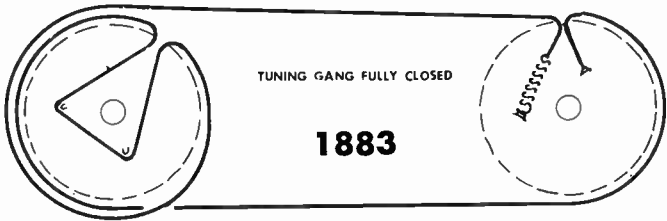

1883

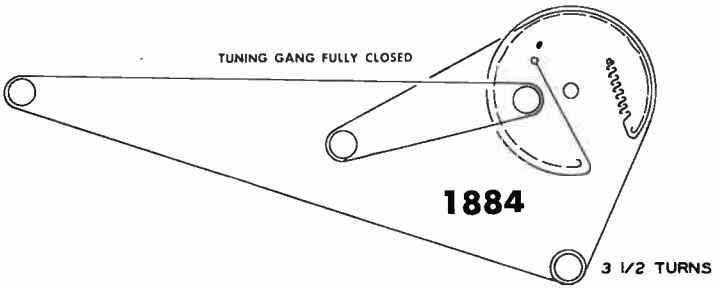

1884

TUNING GANG FULLY CLOSED

1885

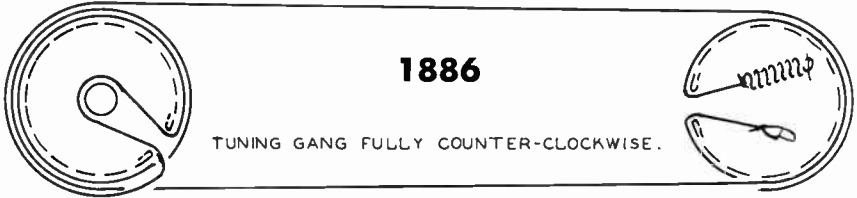
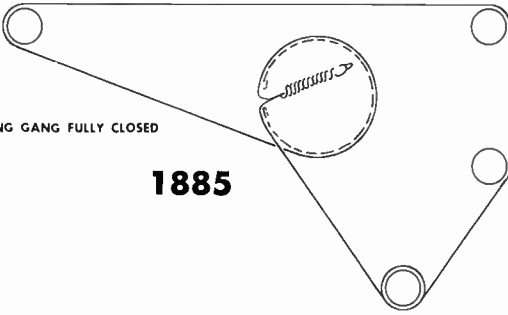

1886

TUNING GANG FULLY COUNTER-CLOCKWISE.

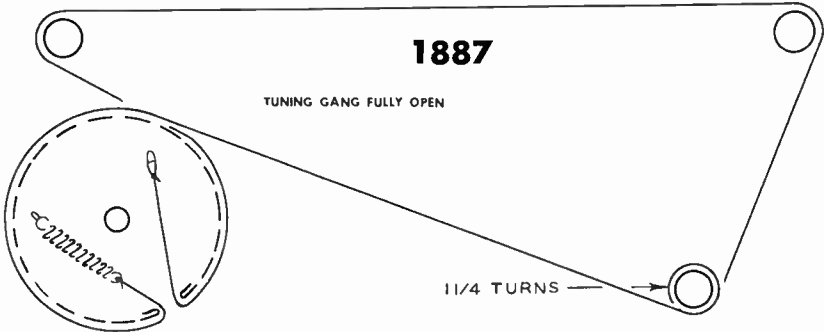

1887

TUNING GANG FULLY OPEN

1 1/4 TURNS

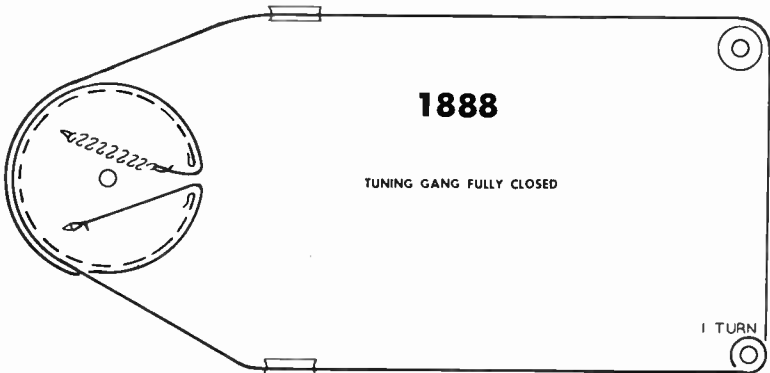

1888

TUNING GANG FULLY CLOSED

1 TURN

TUNING SHAFT

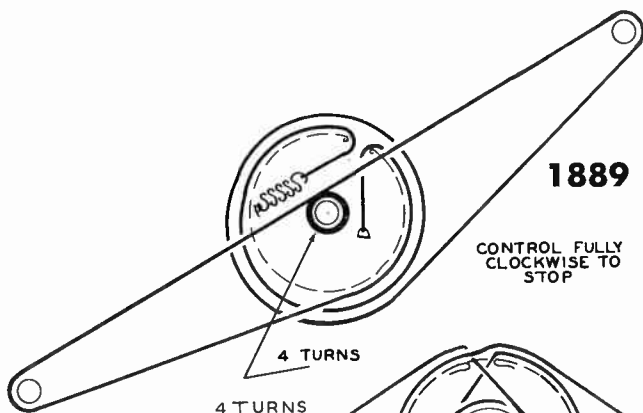

1889

CONTROL FULLY
CLOCKWISE TO
STOP

4 TURNS

4 TURNS

2 TURNS

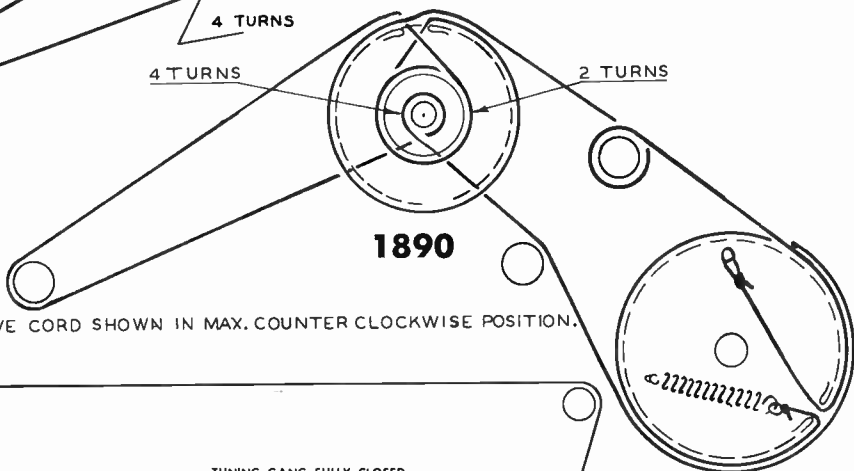

1890

DRIVE CORD SHOWN IN MAX. COUNTER CLOCKWISE POSITION.

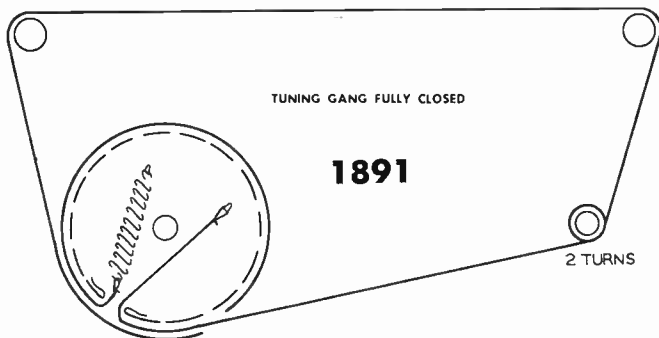

TUNING GANG FULLY CLOSED

1891

2 TURNS

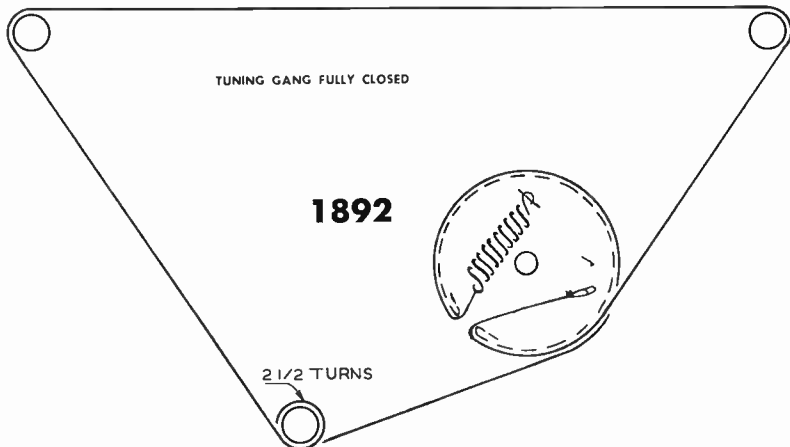

TUNING GANG FULLY CLOSED

1892

2 1/2 TURNS

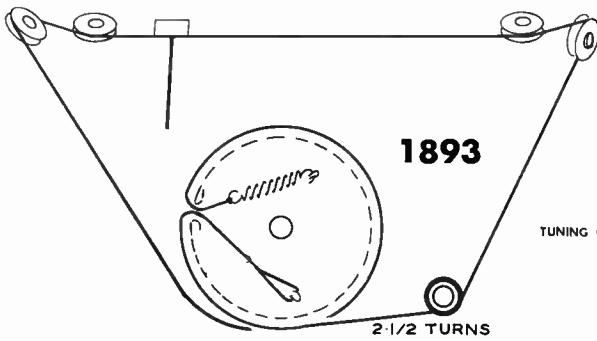

1893

TUNING GANG FULLY CLOSED

2 1/2 TURNS

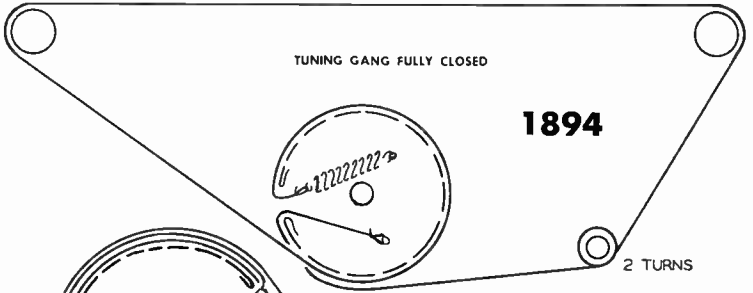

TUNING GANG FULLY CLOSED

1894

2 TURNS

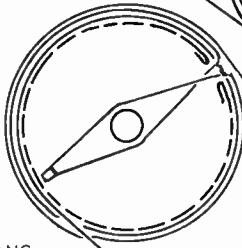

TUNING GANG FULLY COUNTER-CLOCK WISE.

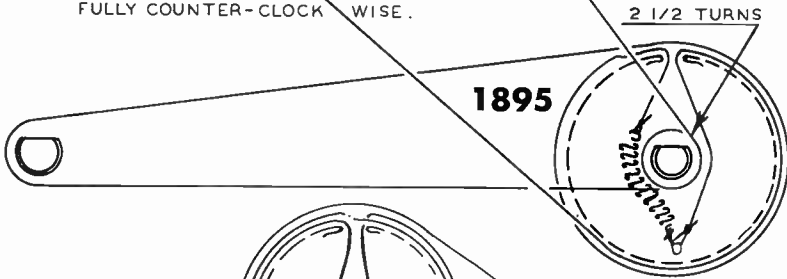

2 1/2 TURNS

1895

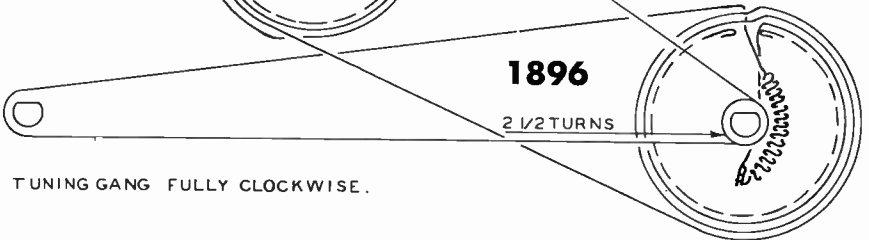
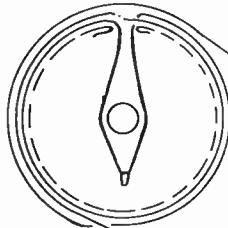

2 1/2 TURNS

1896

TUNING GANG FULLY CLOCKWISE.

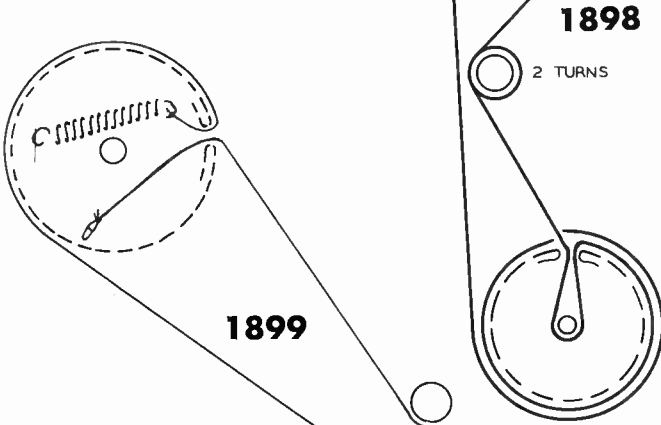
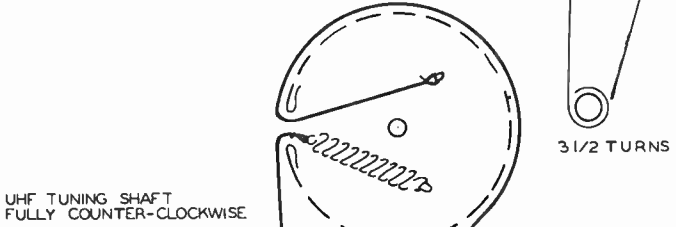
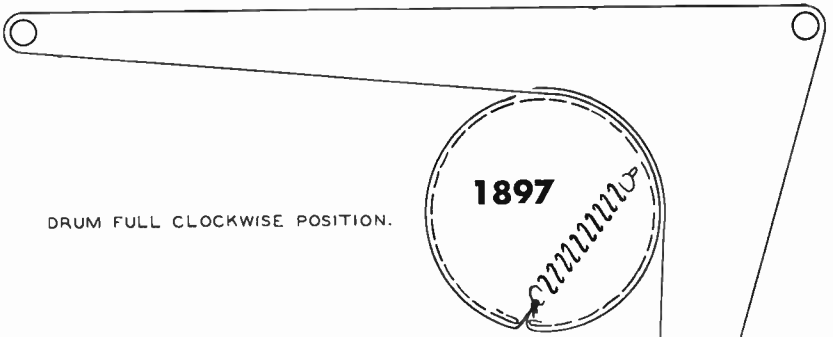

UHF PULLEY SHAFT IN FULL CLOCKWISE POSITION.



TUNING GANG FULLY CLOSED

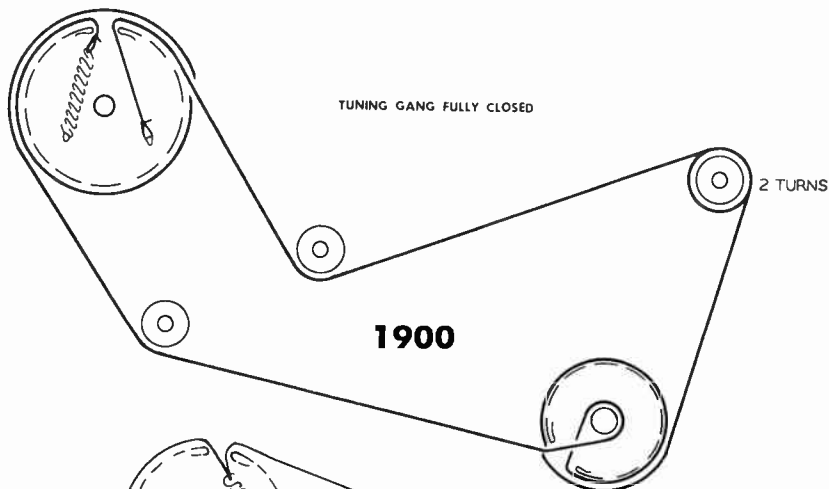

1900

TUNING GANG FULLY OPEN

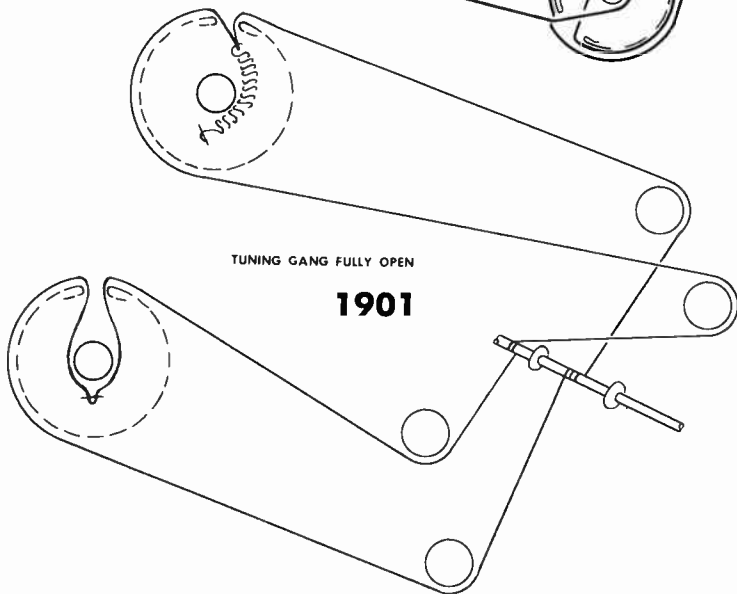

1901

TUNING GANG FULLY CLOSED

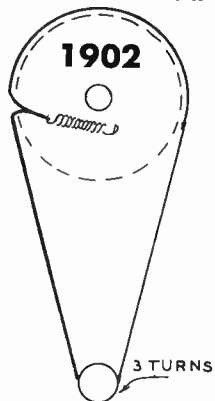

1902



STEP 1

1/2 MM SLEEVING - 1/4" LONG
INSERTED ON LANCE BEFORE
WRAPPING DIAL CORD ONE
TURN AROUND LANCE.

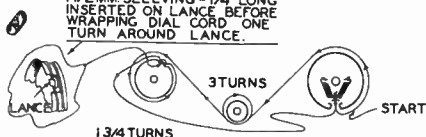

STEP 2

TUNING SHAFT FULLY COUNTERCLOCKWISE

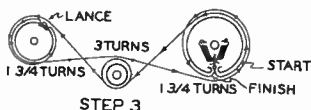

STEP 3

1903

1904

FULL COUNTER
CLOCKWISE
POSITION

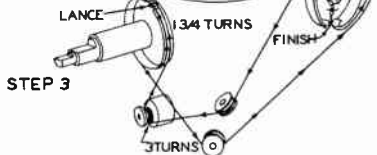
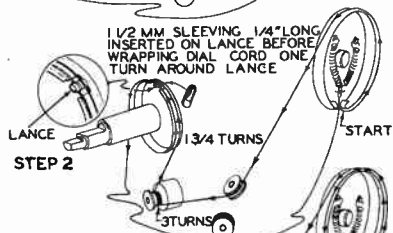
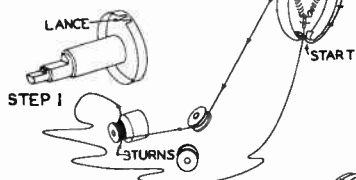

2 1/2 TURNS

TUNING GANG FULLY CLOSED

1905

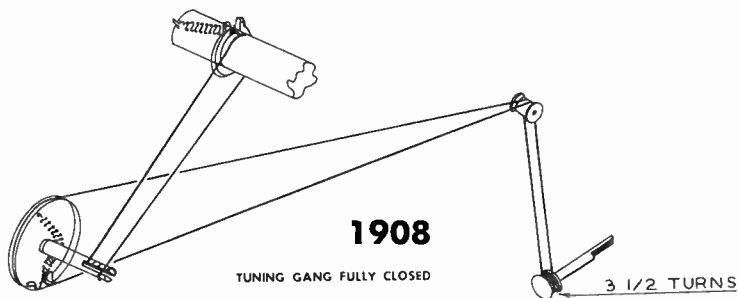
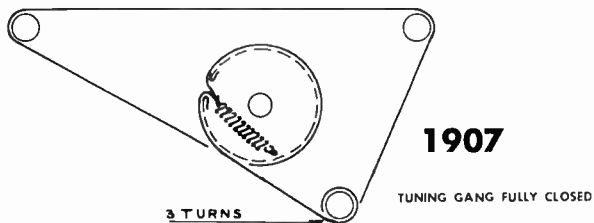
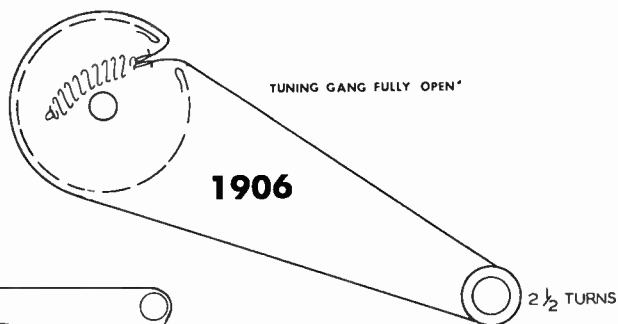
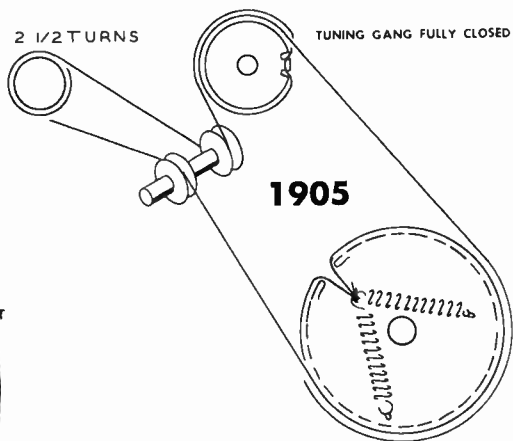

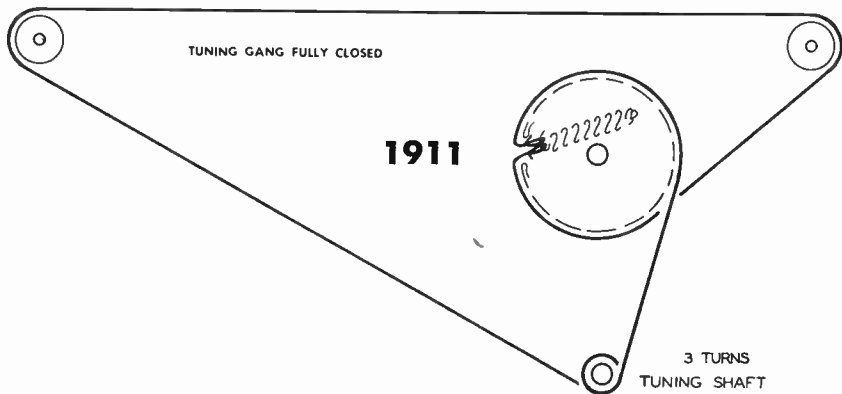
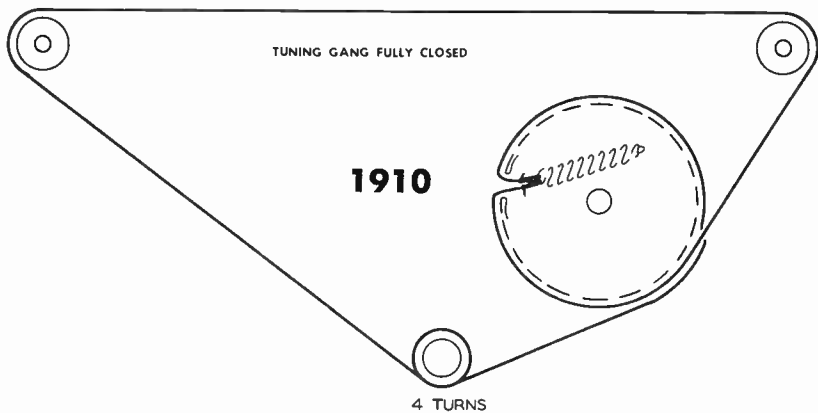
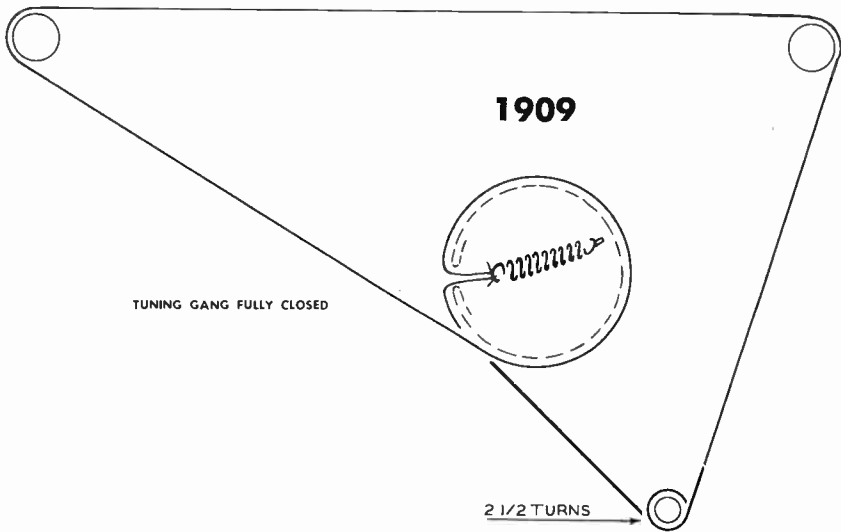

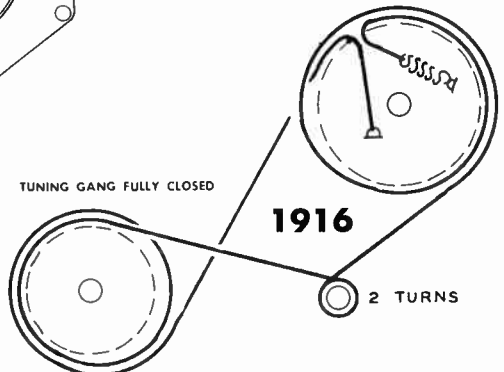
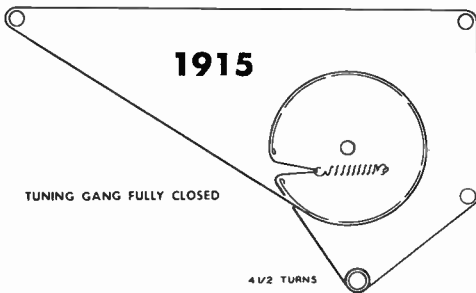
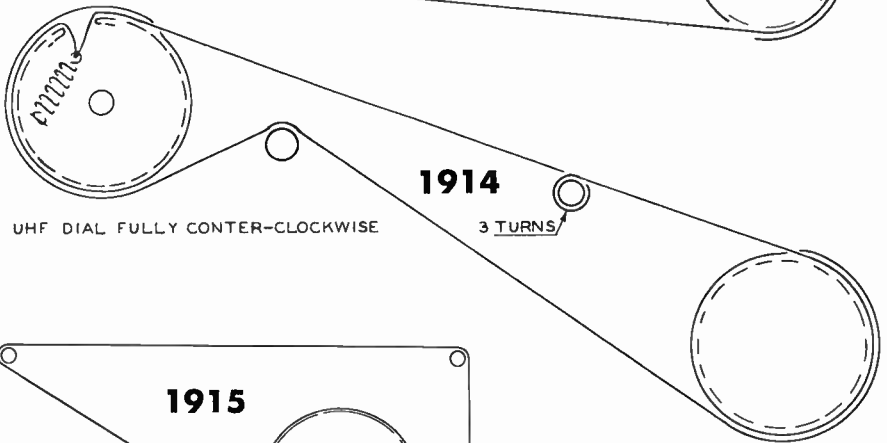
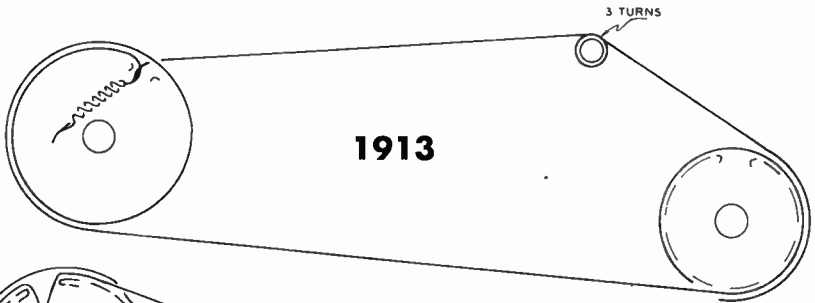
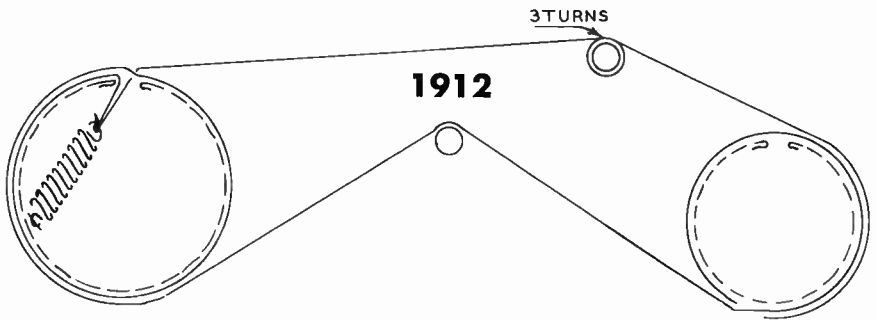

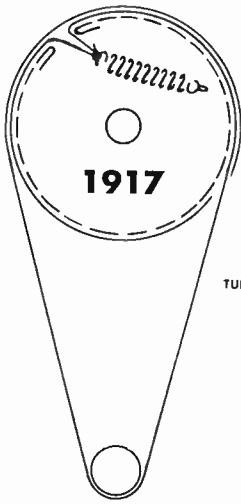

TUNING GANG FULLY OPEN

TUNING GANG FULLY CLOSED

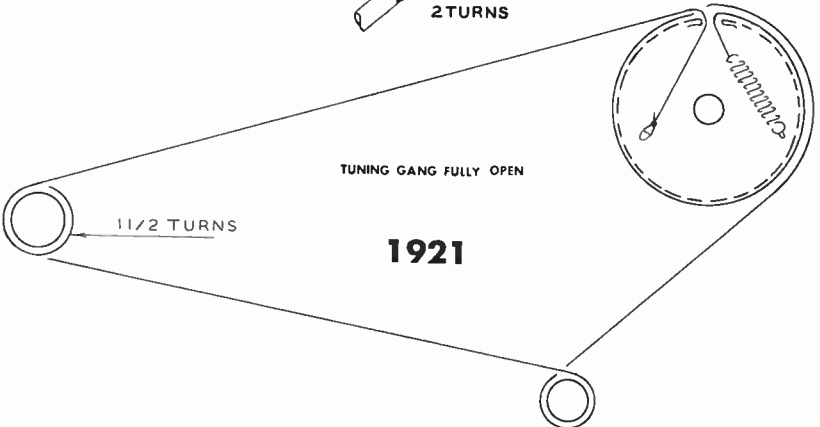
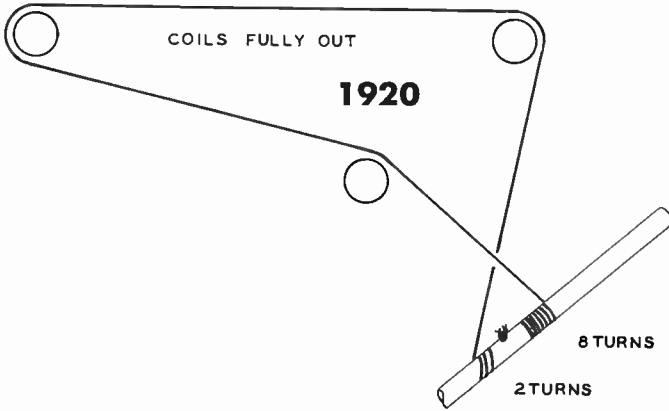
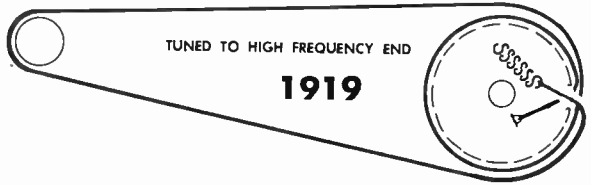
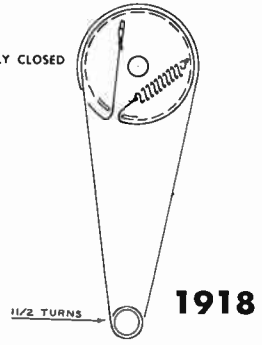

TUNING GANG FULLY CLOSED

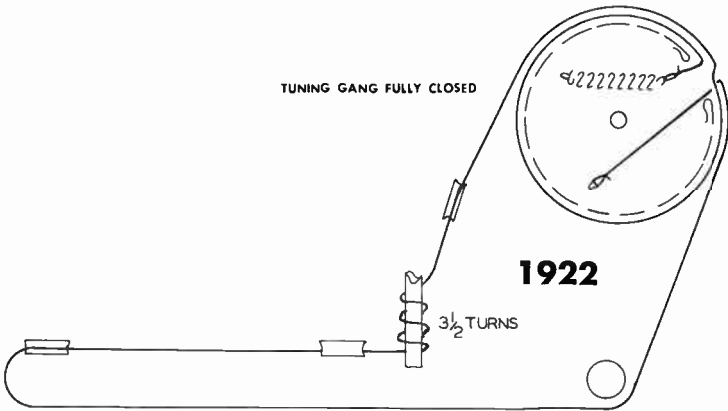

1923

TUNING GANG FULLY CLOSED

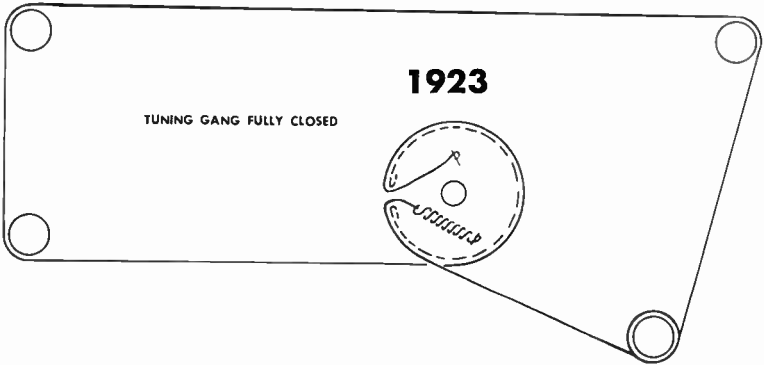

TUNING GANG FULLY COUNTER-CLOCKWISE

1924

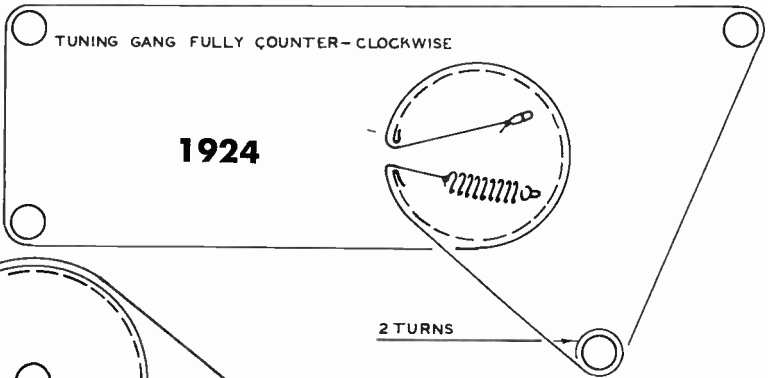

2 TURNS

1925

TUNING GANG FULLY CLOSED

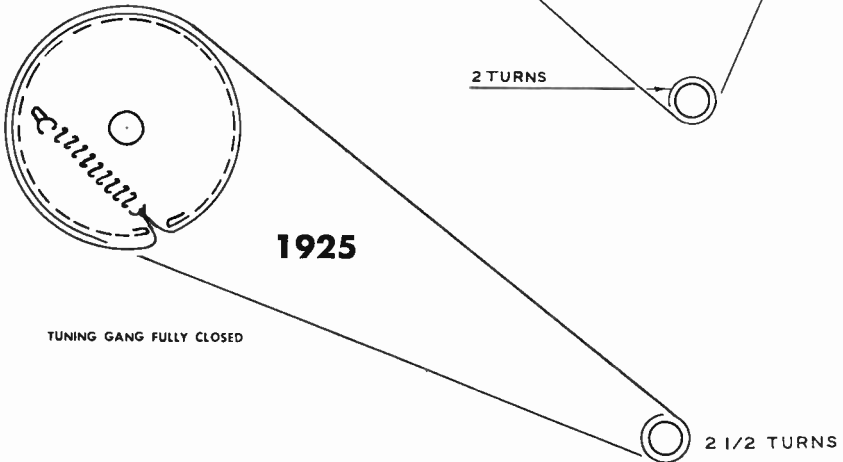

2 1/2 TURNS

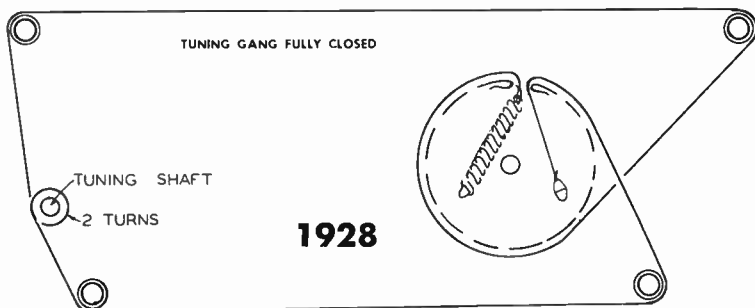
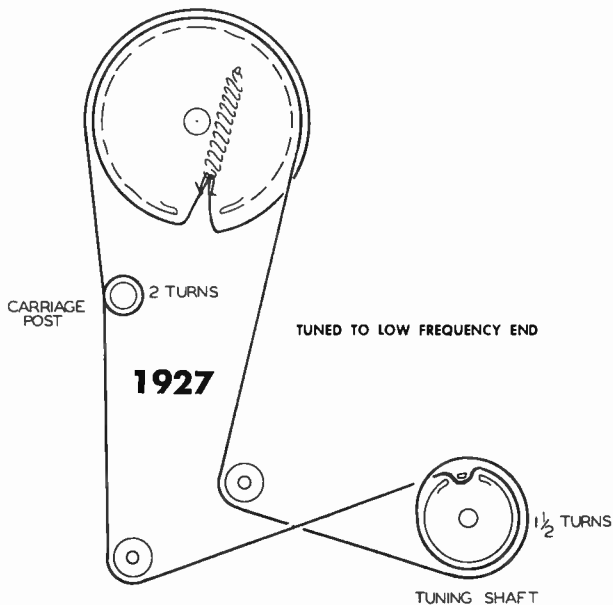
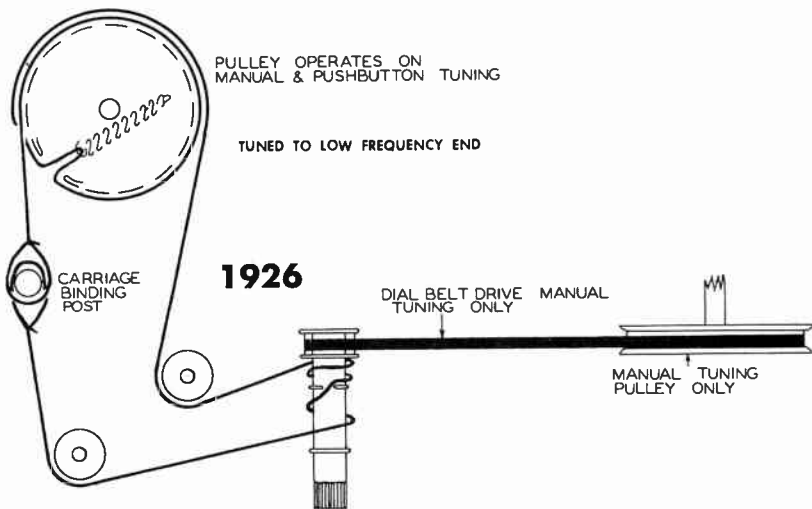

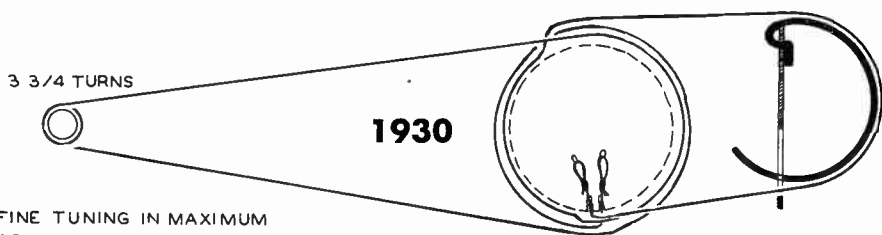
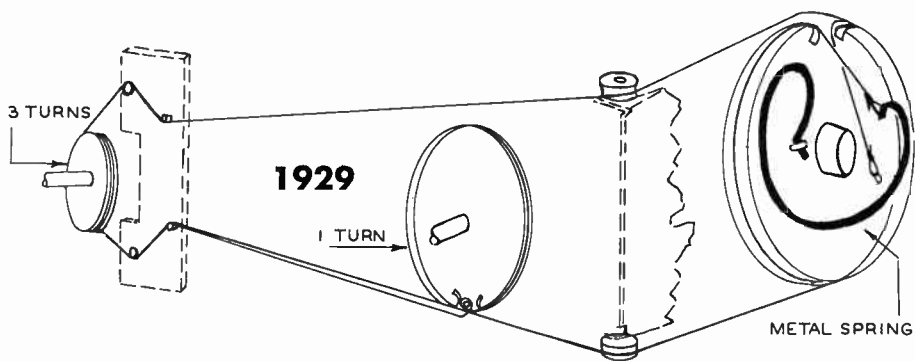

EARLY PRODUCTION

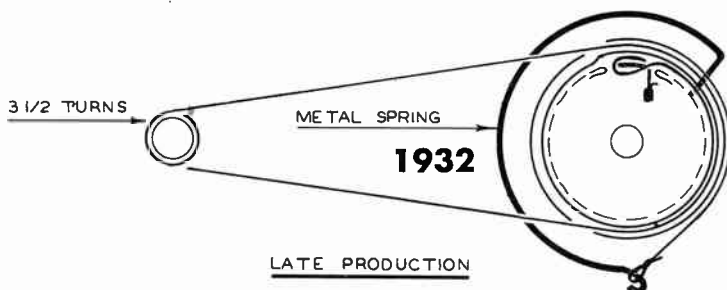
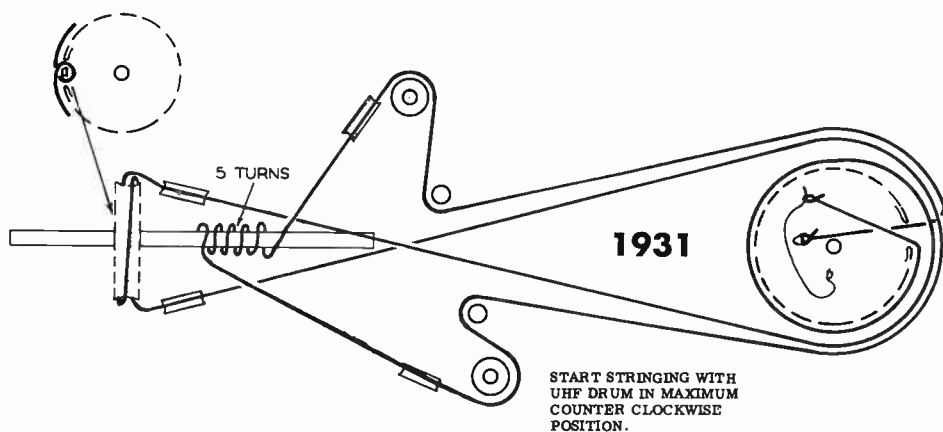

TUNING GANG FULLY OPEN

1933



TUNING GANG FULLY CLOSED

1934



1935

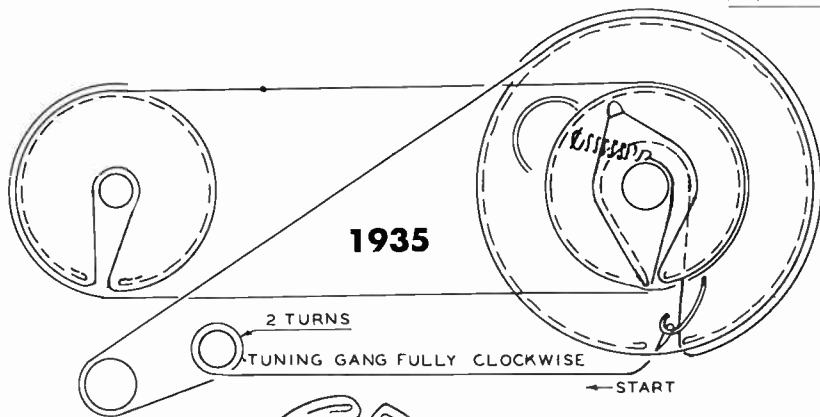

TUNING GANG FULLY OPEN

1936

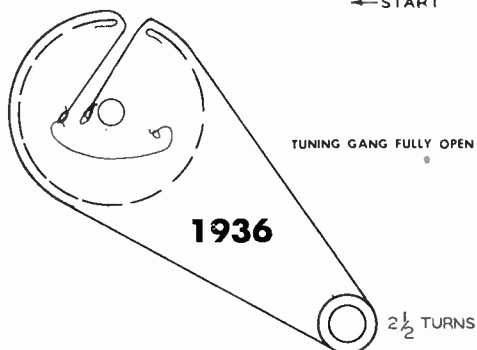

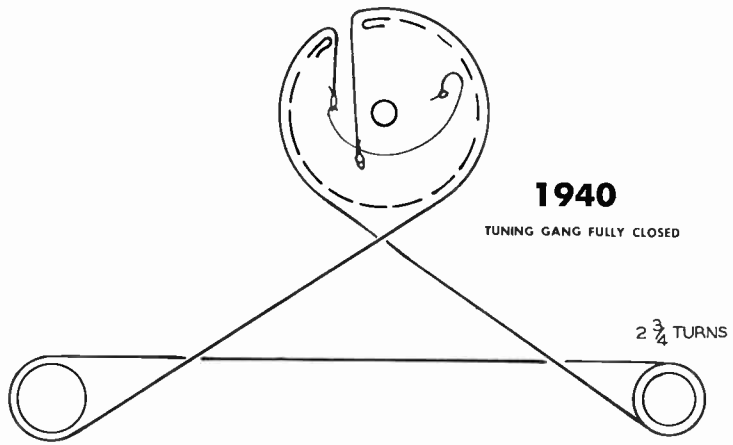
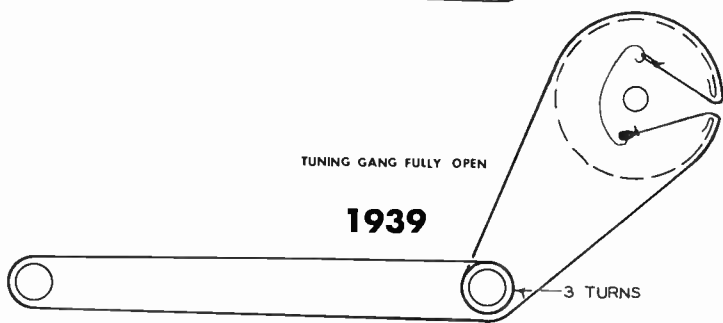
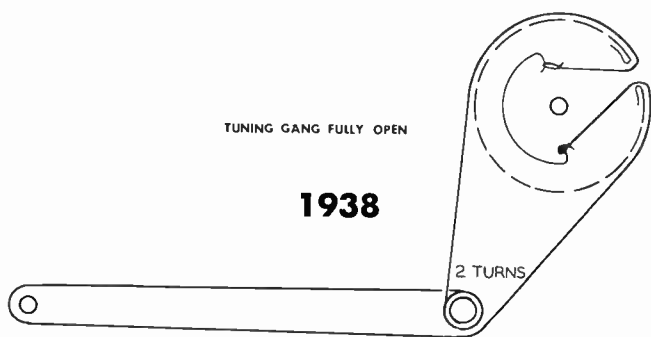
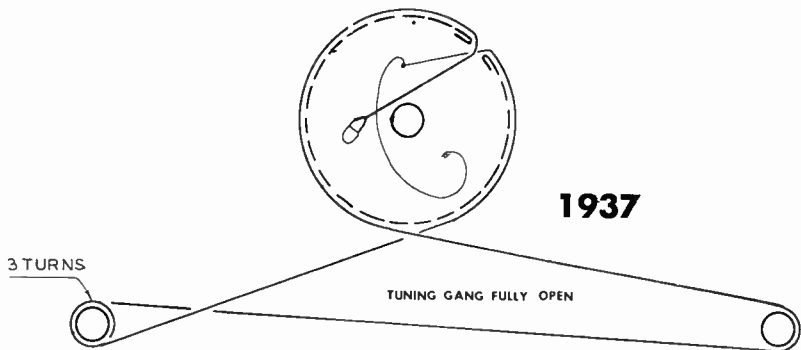

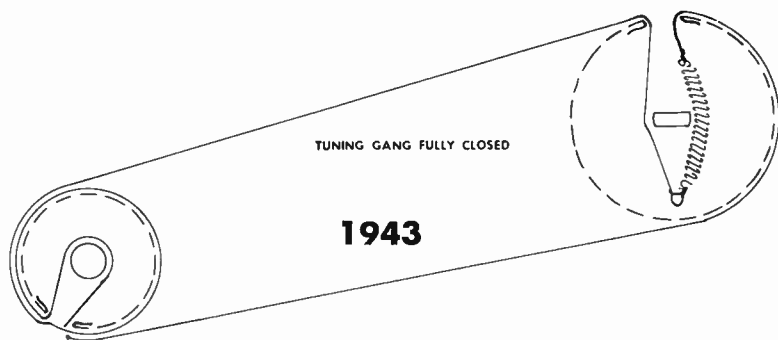
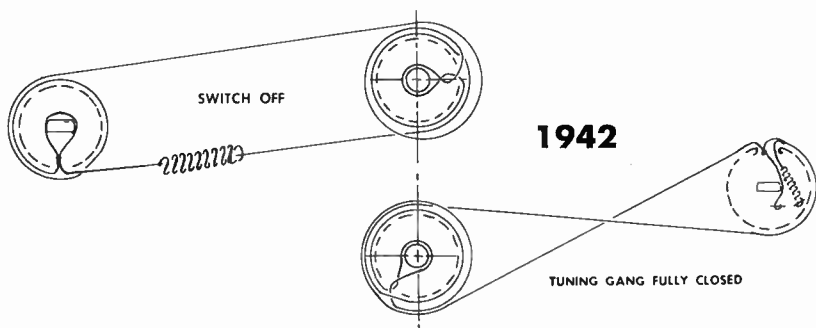
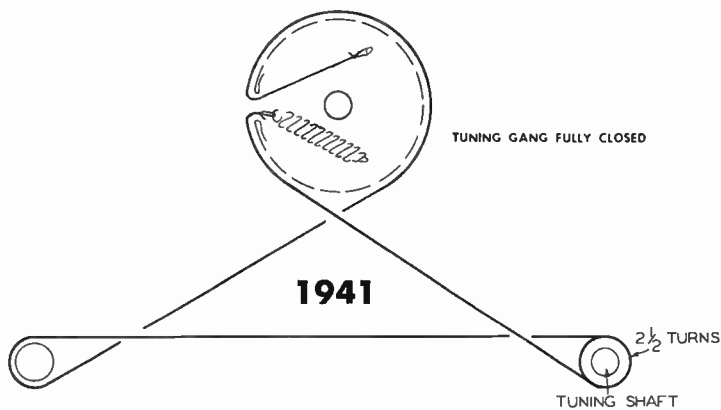

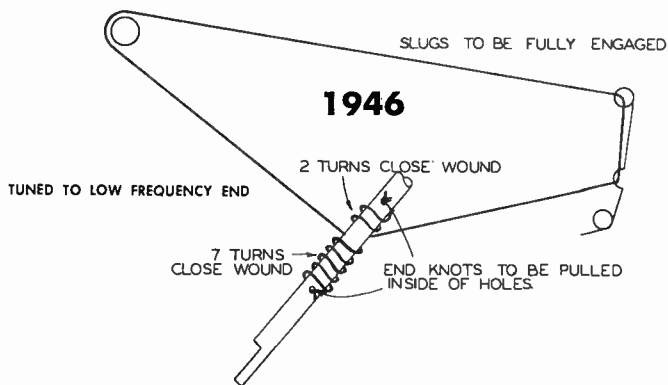
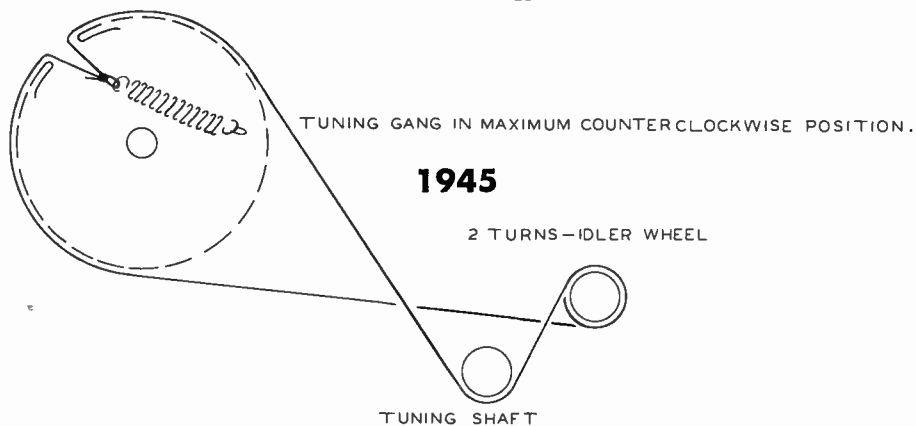
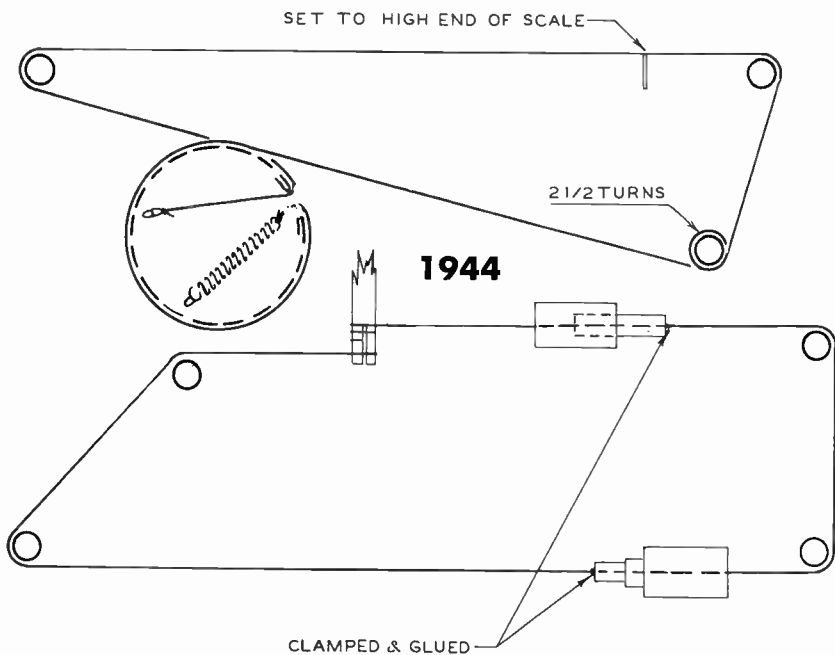

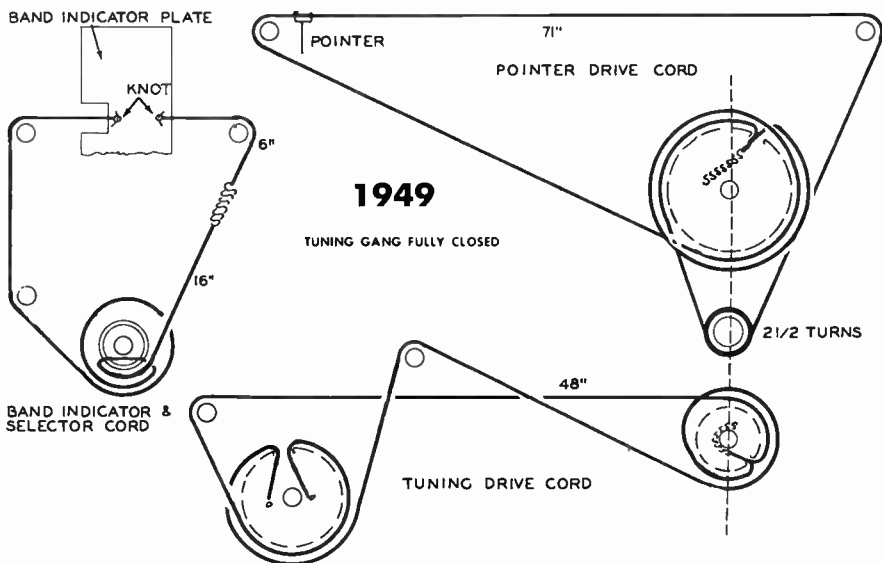
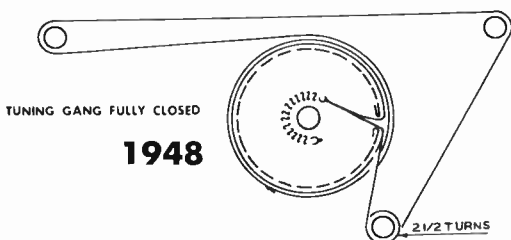
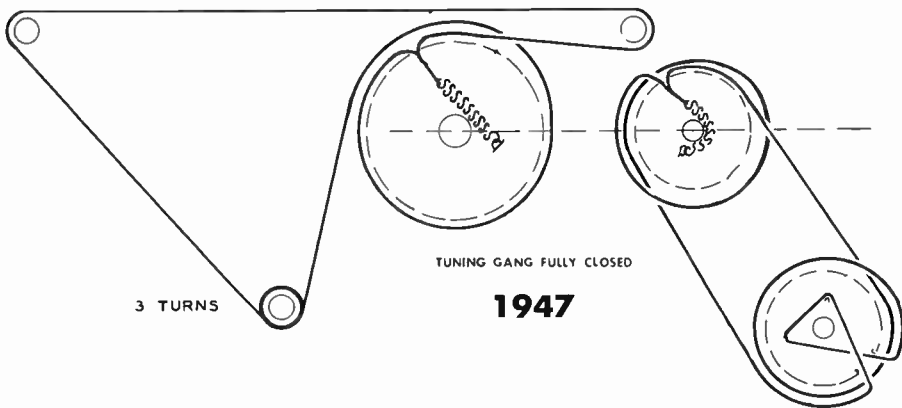

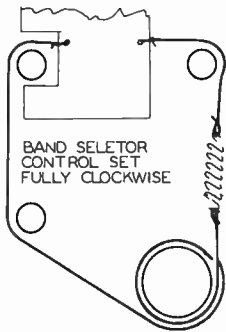

1950

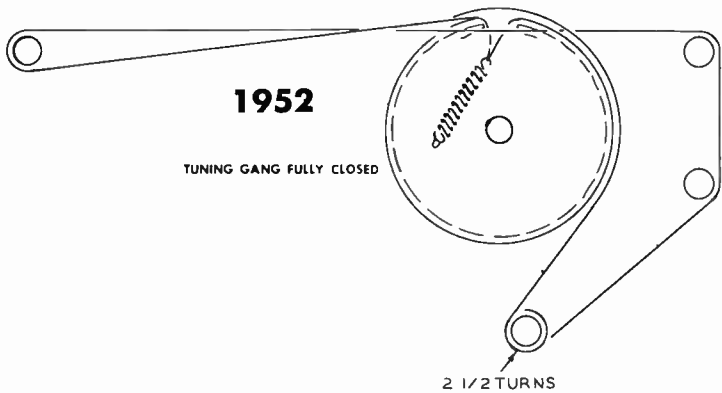
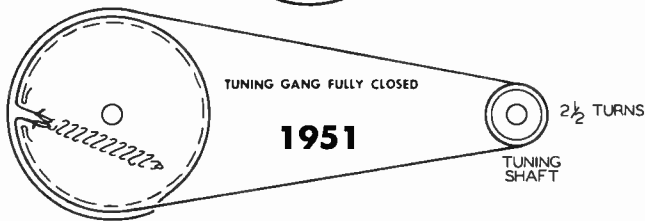
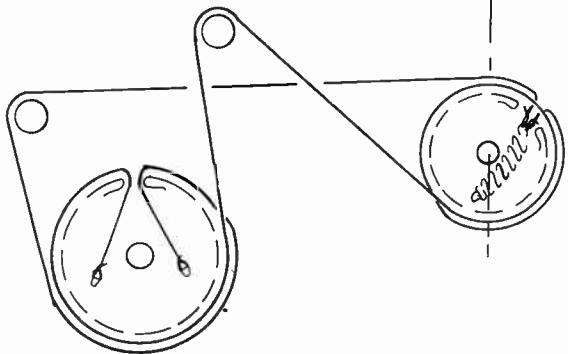
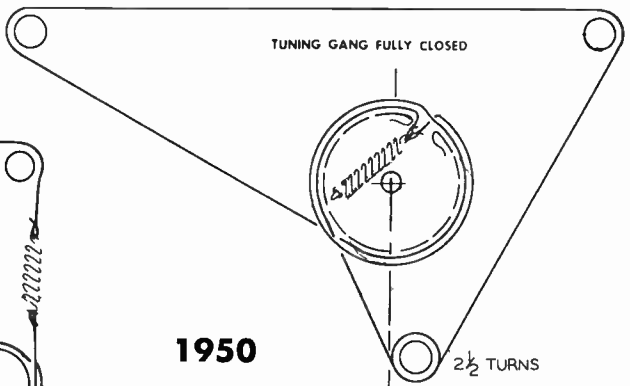

TUNING GANG FULLY CLOSED

1953

2 TURNS

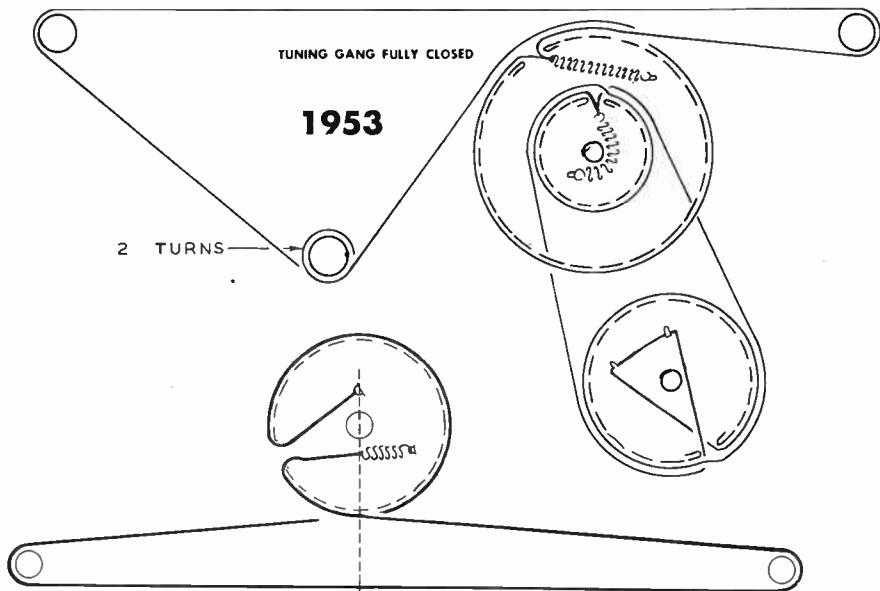

1954

TUNING GANG FULLY CLOSED



3 1/2

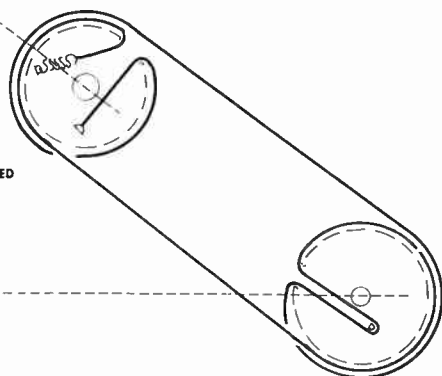

TUNING GANG FULLY CLOSED

1955

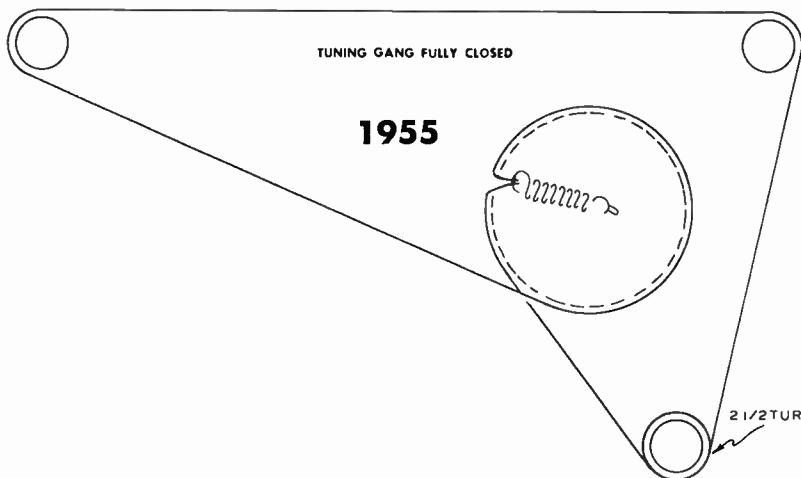

2 1/2 TURNS

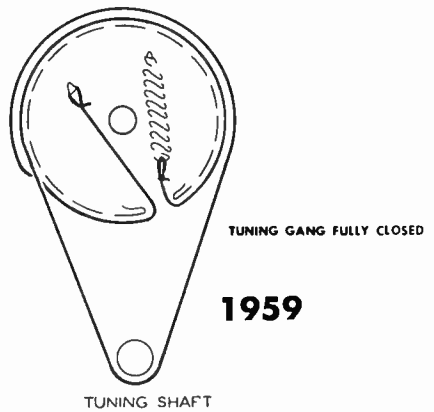
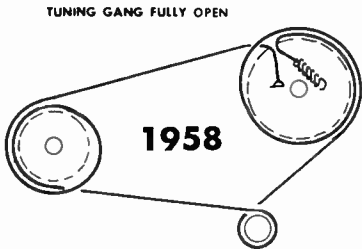
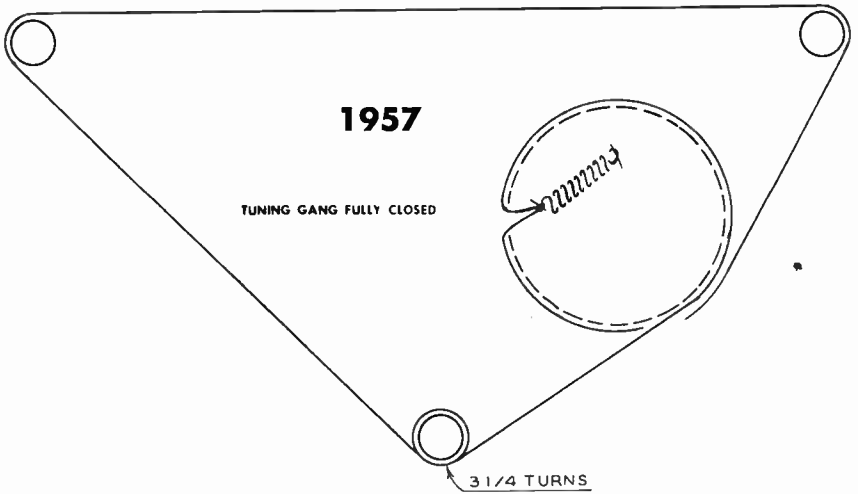
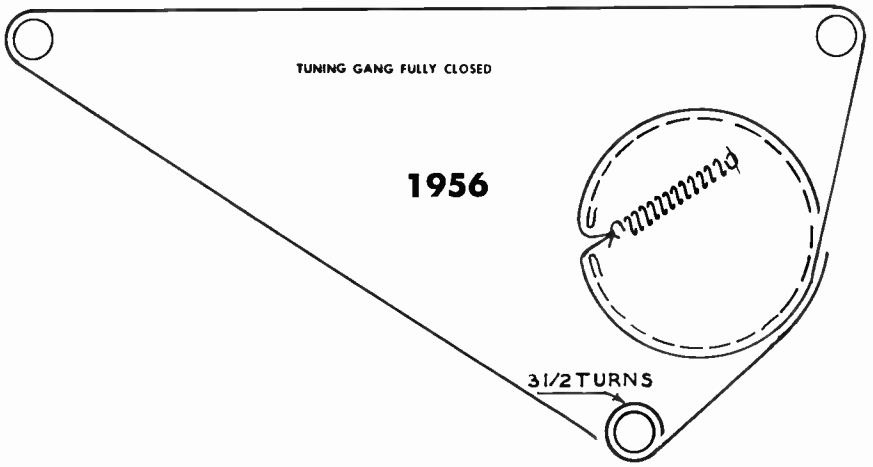

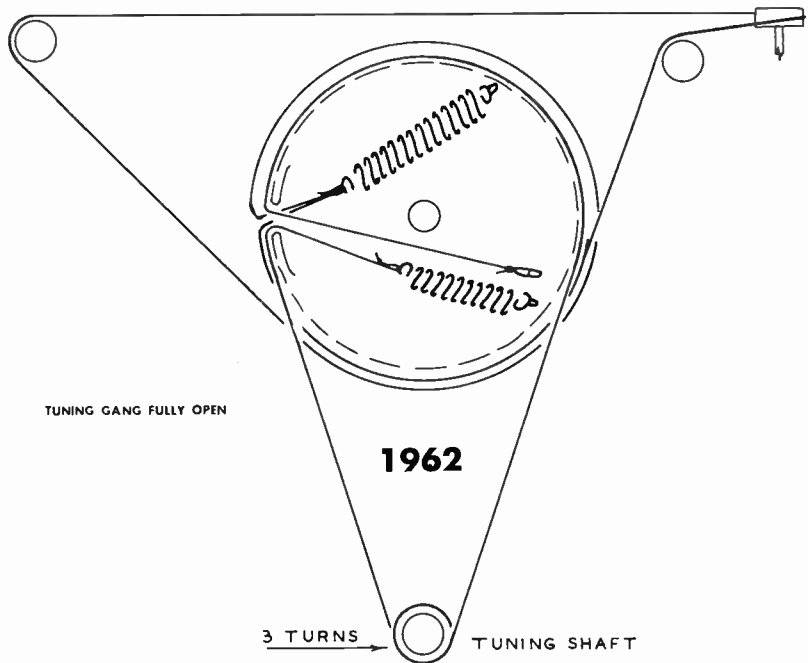
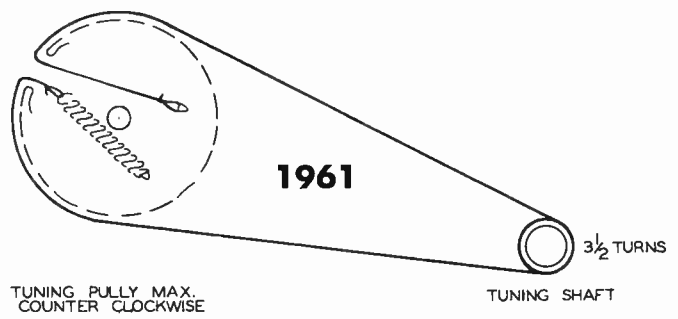
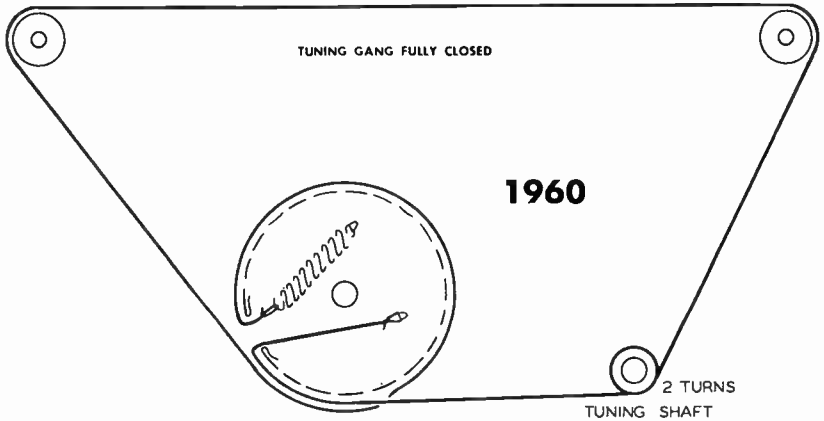

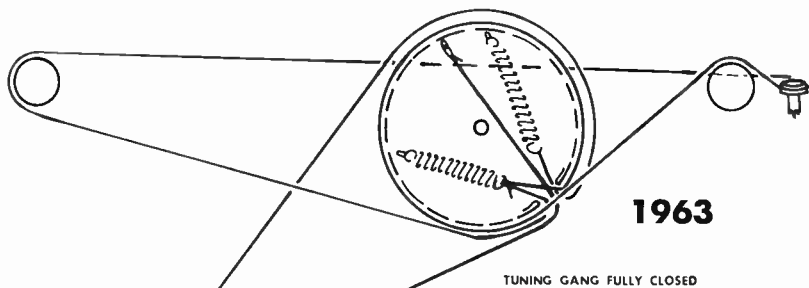

3 TURNS

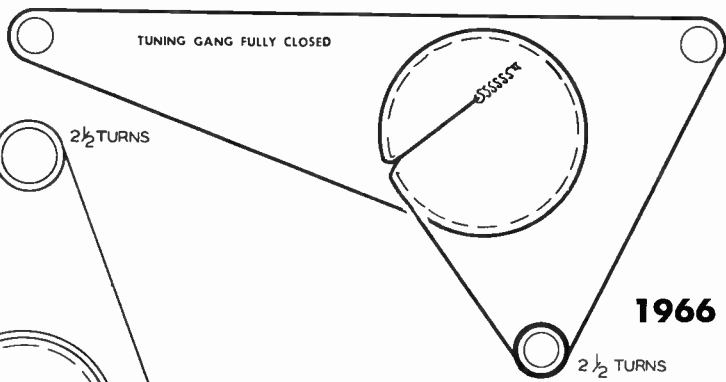
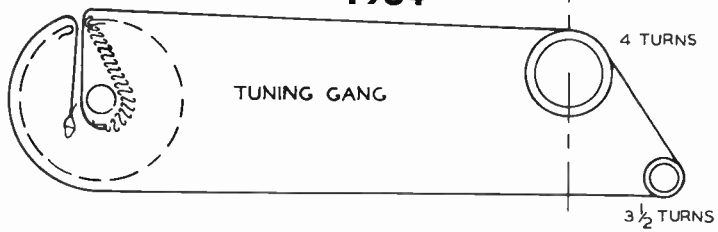
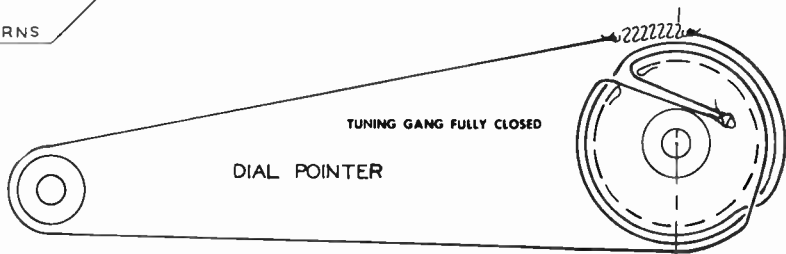

1965

2 1/2 TURNS

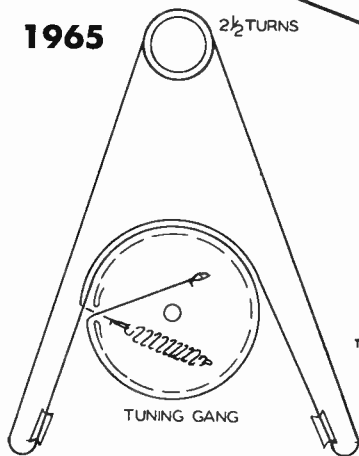

TUNING GANG FULLY CLOSED

2 1/2 TURNS

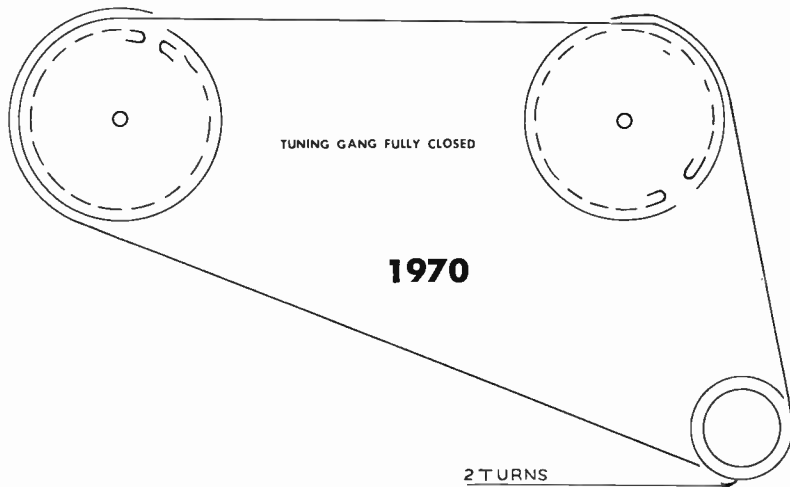
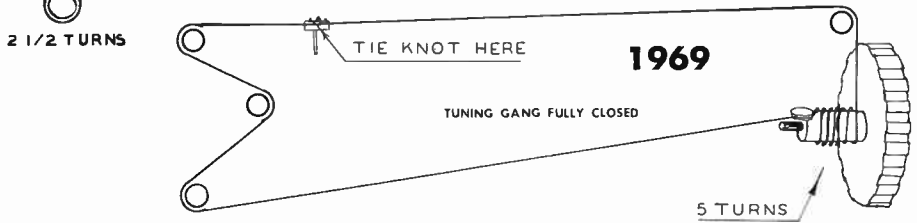
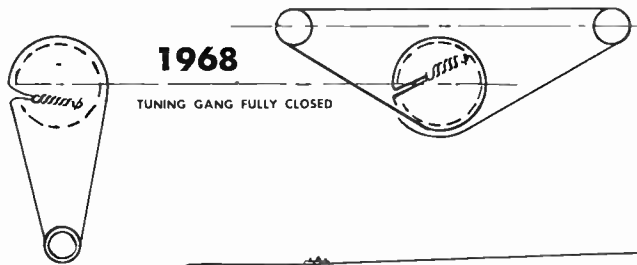
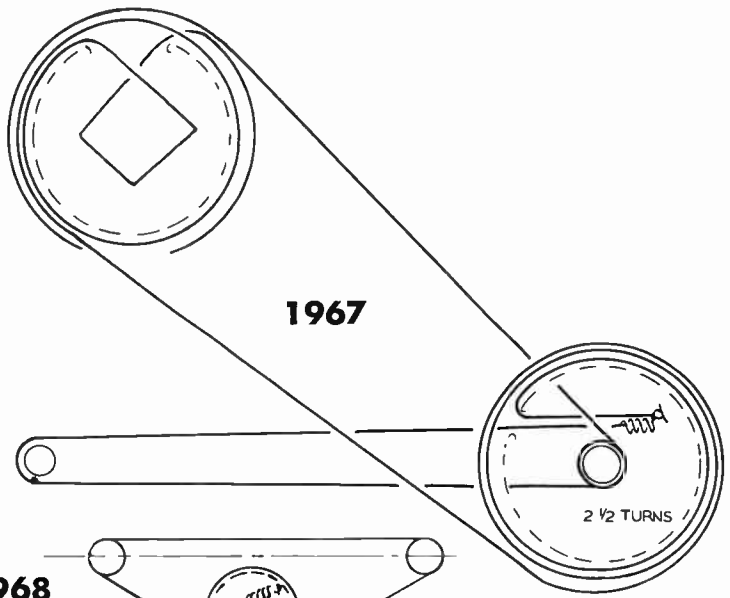

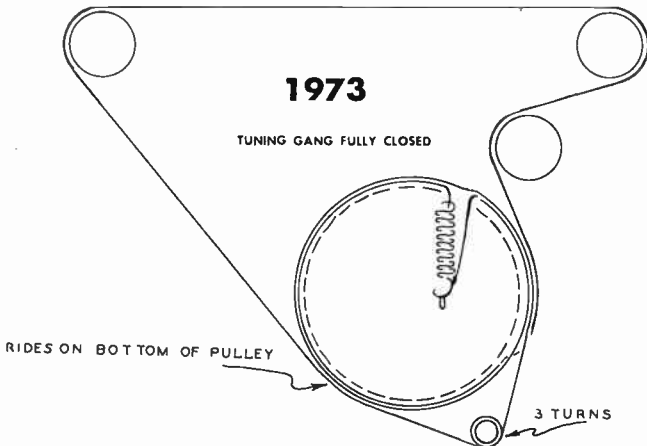
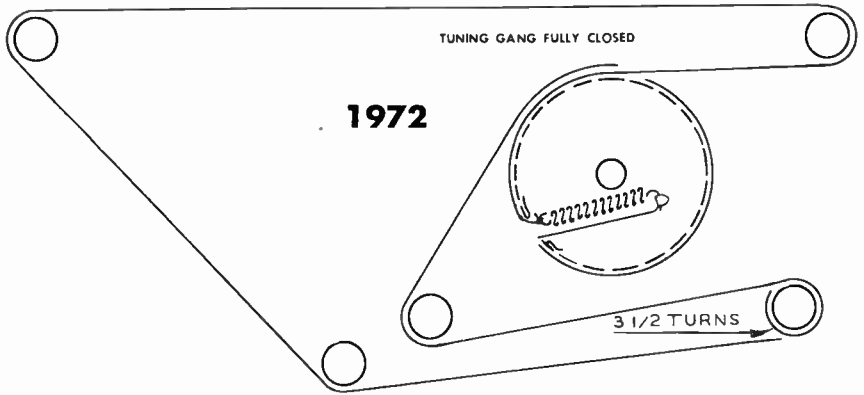
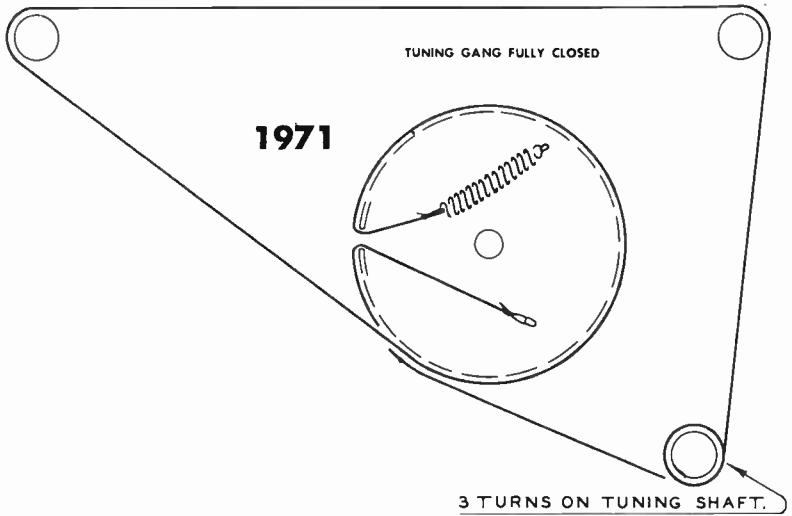

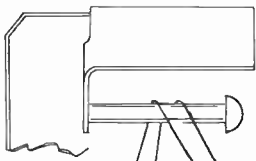

TUNED TO HIGH FREQUENCY END

1974



3 TURNS

7 TURNS

TUNING CONTROL

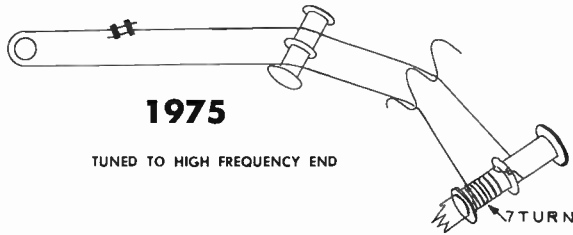

1975

TUNED TO HIGH FREQUENCY END

7 TURNS

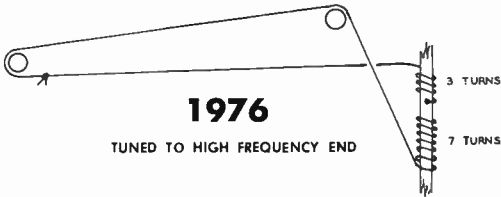

1976

TUNED TO HIGH FREQUENCY END

3 TURNS

7 TURNS

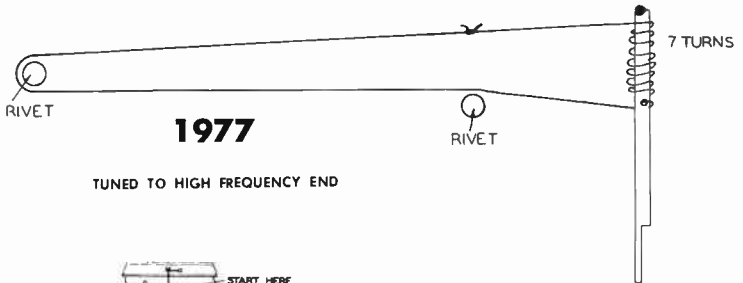

RIVET

1977

TUNED TO HIGH FREQUENCY END

RIVET

7 TURNS

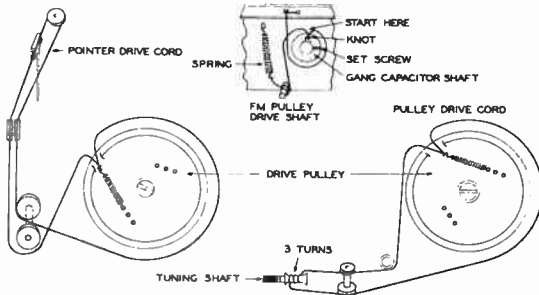

POINTER DRIVE CORD

SPRING

START HERE
KNOT
SET SCREW
GANG CAPACITOR SHAFT

FM PULLEY
DRIVE SHAFT

PULLEY DRIVE CORD

DRIVE PULLEY

TUNING GANG FULLY CLOSED

1978

3 TURNS

TUNING SHAFT

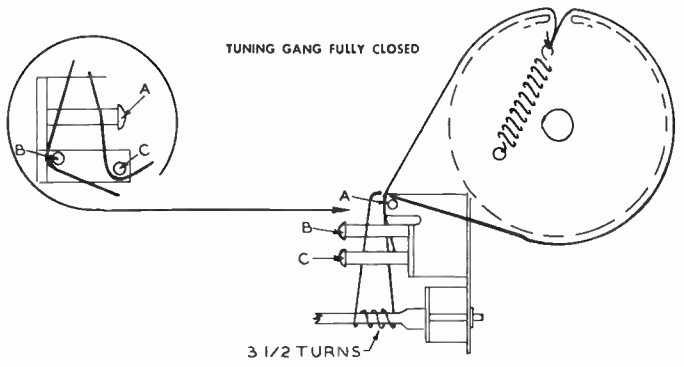

1979

TUNING GANG FULLY CLOSED

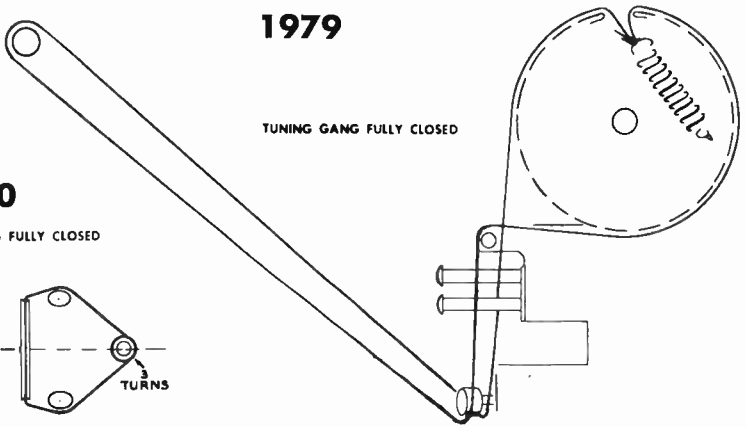

1980

TUNING GANG FULLY CLOSED

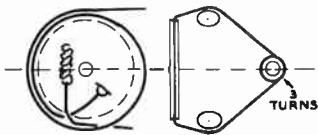

TUNING GANG FULLY CLOSED

1981

2 1/2 TURNS

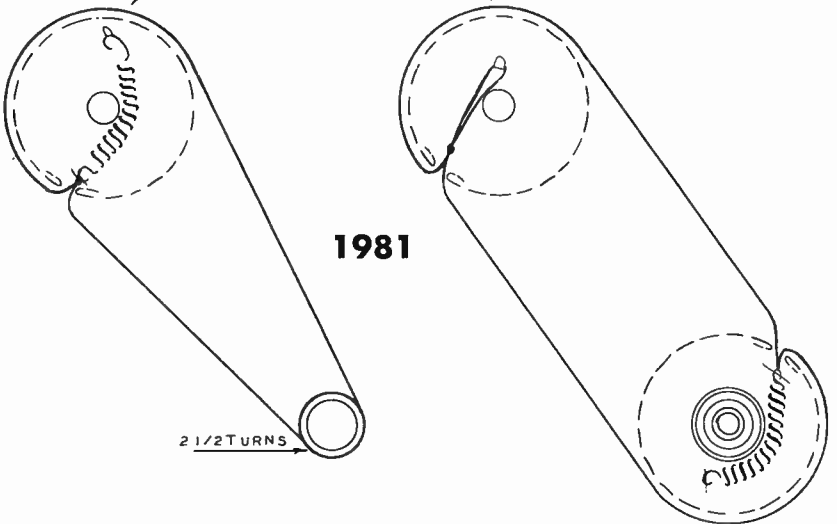

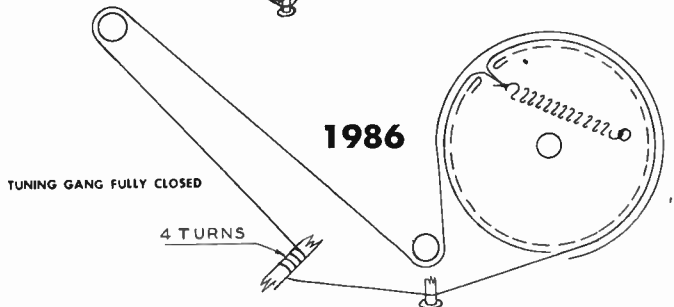
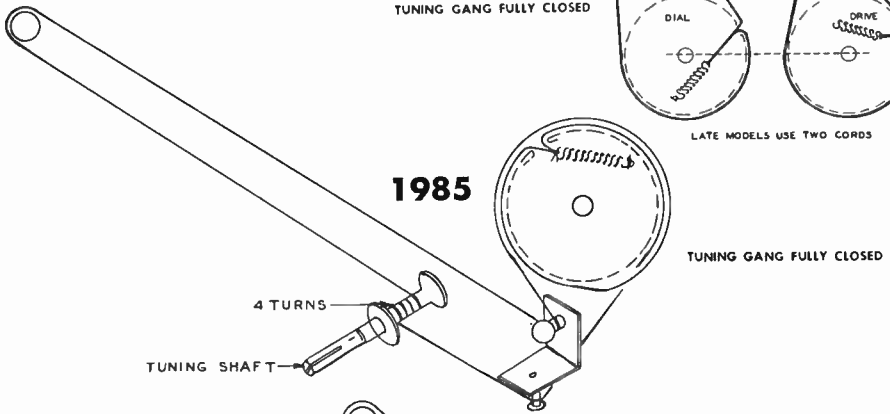
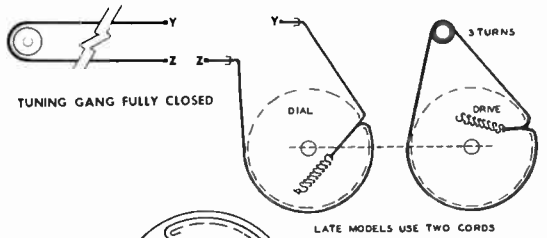
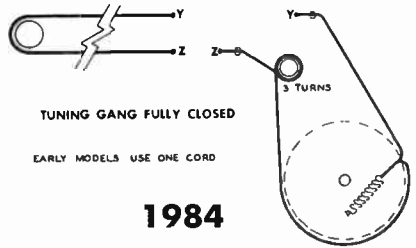
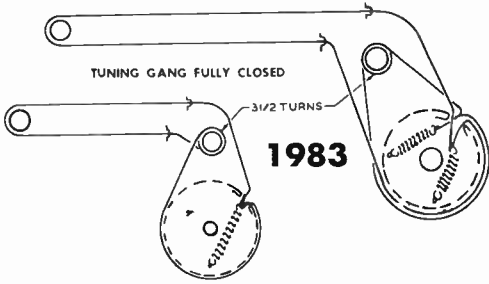
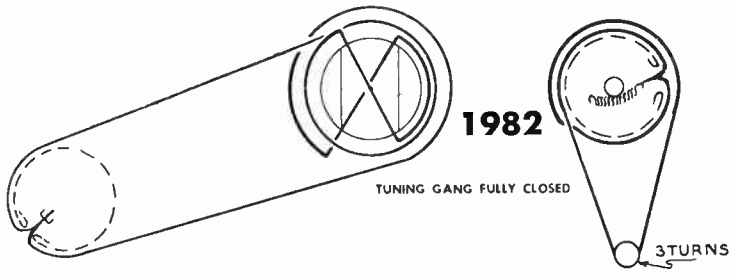

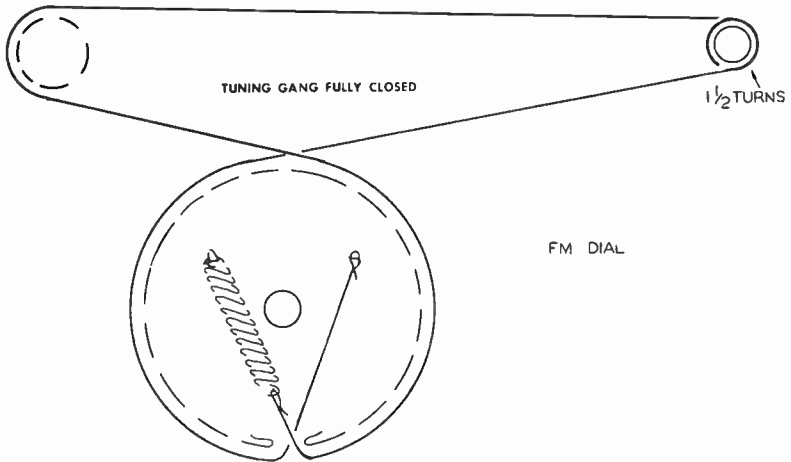
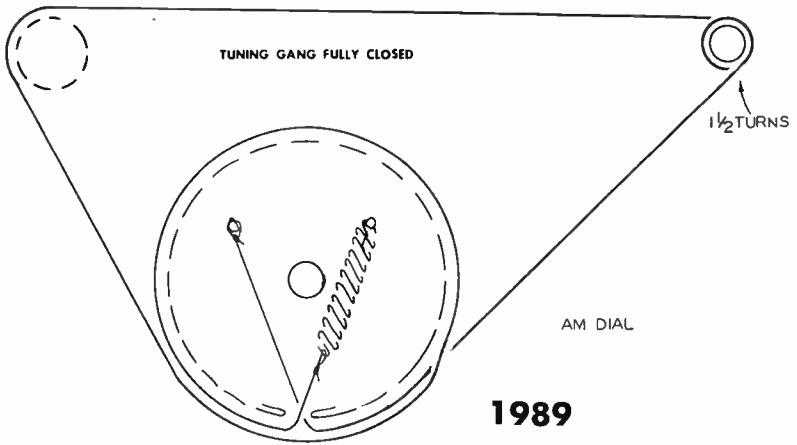
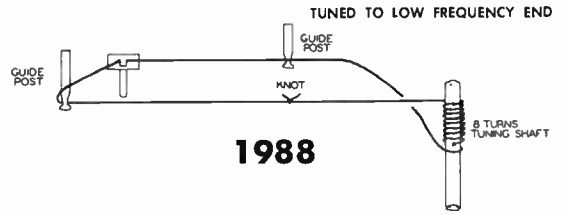
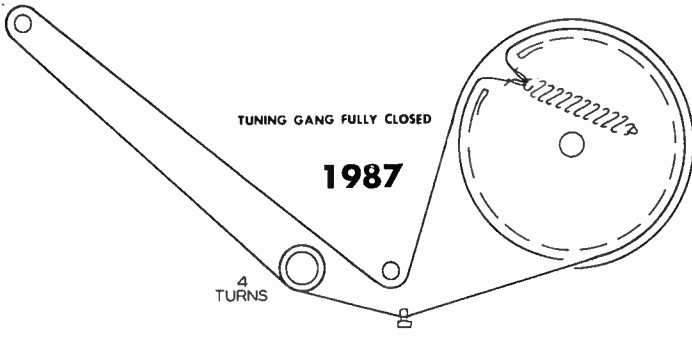

BAND SPREAD DIAL
CORD ASSEMBLY

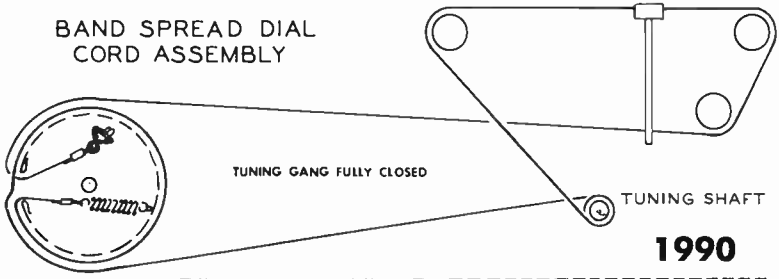

1990

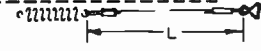

CORD LEGEND	
CORD-B. S. DIAL-L	= 573/8"
CORD-GC. DIAL-L	= 46"

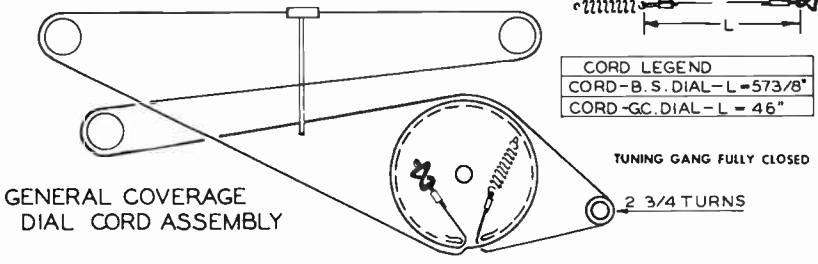

GENERAL COVERAGE
DIAL CORD ASSEMBLY

1991

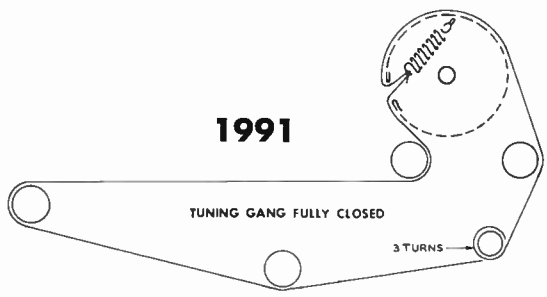

1992

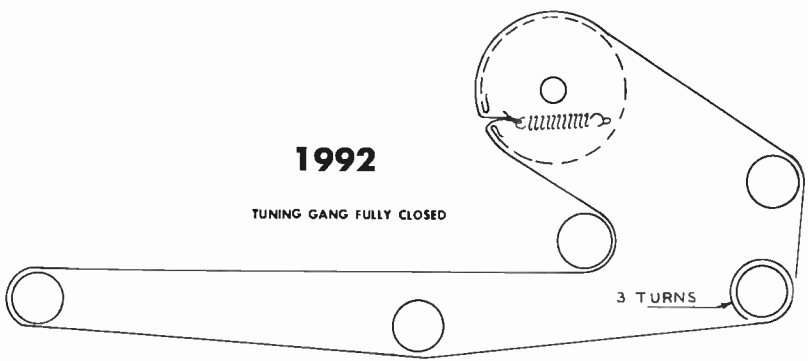

AM DRIVE CORD STRINGING

(DIAL POINTER MOVEMENT)

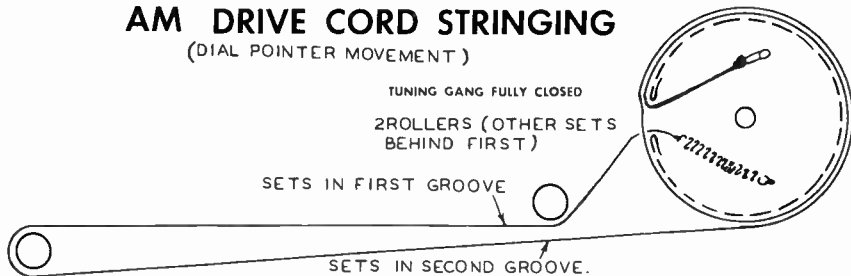

AM DRIVE CORD STRINGING

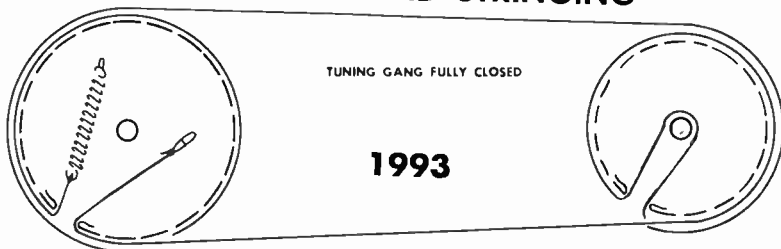

UHF DRIVE CORD STRINGING

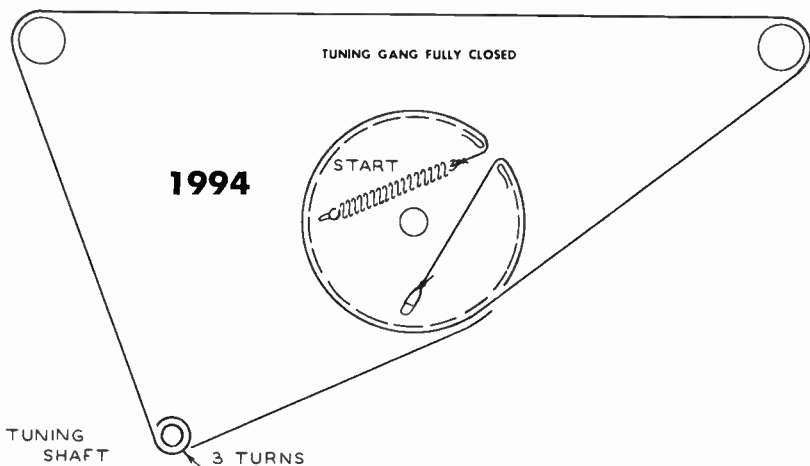
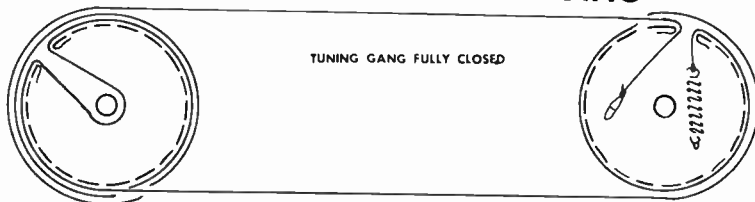

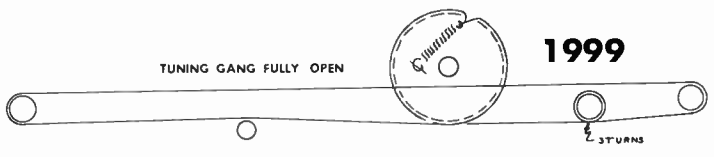
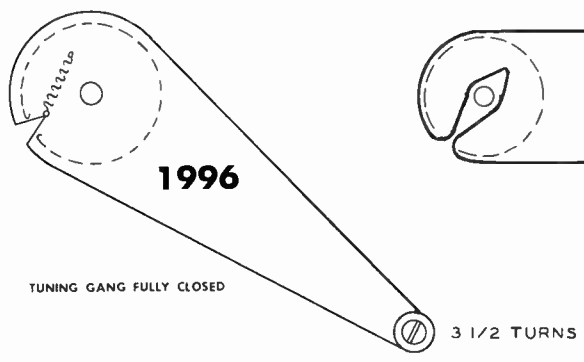
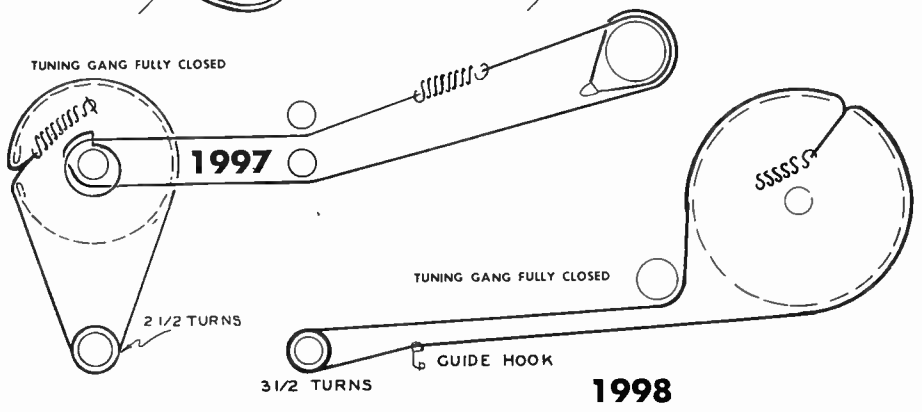
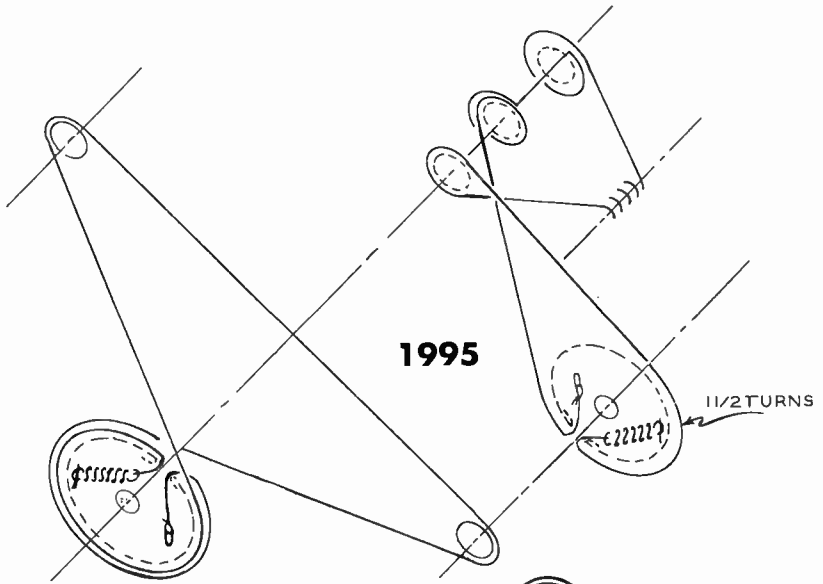

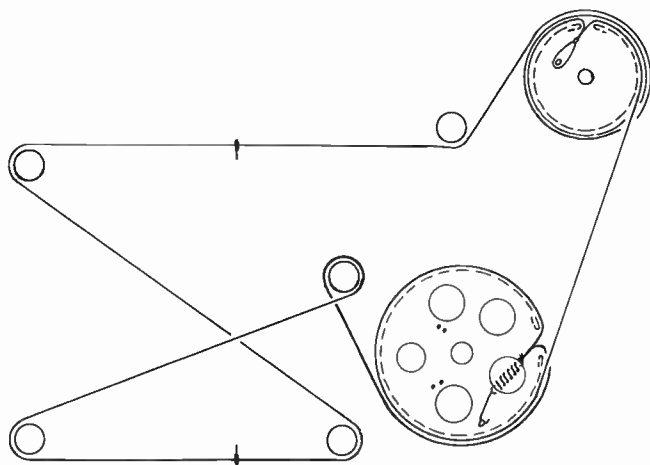

POINTER

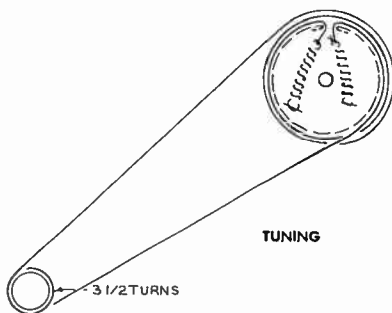

TUNING

2000

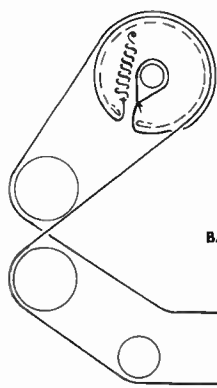

BASS

SHUTTER

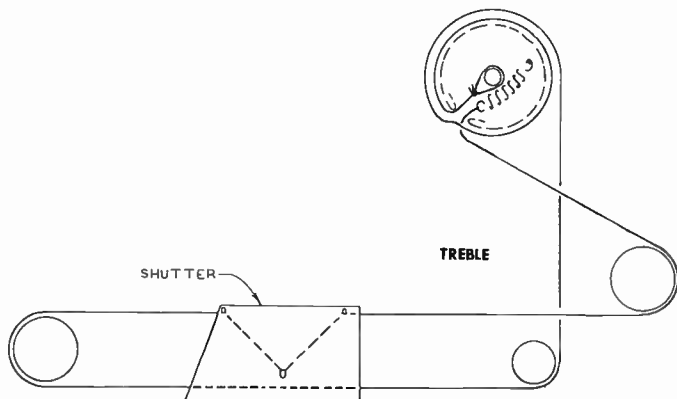

TREBLE

SHUTTER

TUNING GANG FULLY CLOSED

2001

3 TURNS

1 TURN 1 1/2 TURNS 3 1/2 TURNS

2002

TUNING GANG FULLY CLOSED

3 3/4 TURNS

2003

2004

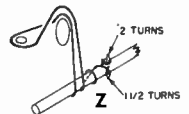
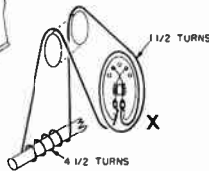
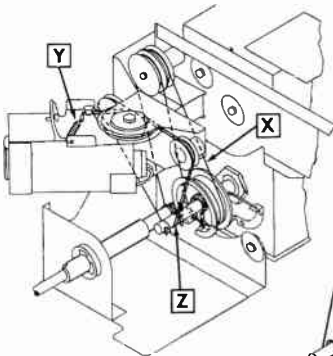
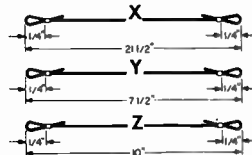



2005

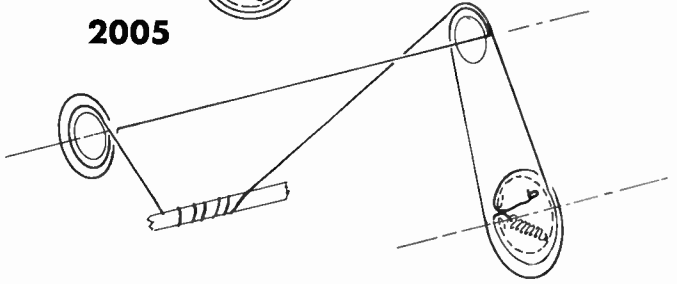

CORD "B"

1 1/2 TURNS

2006

CORD "A"

FINE TUNING MAX. CLOCKWISE

2 1/2 TURNS

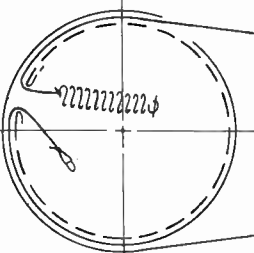
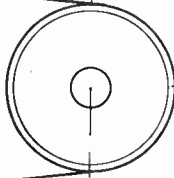
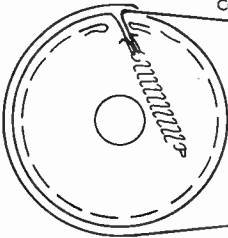

2007

3 1/2 TURNS

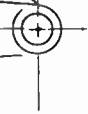
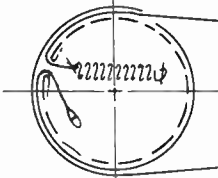

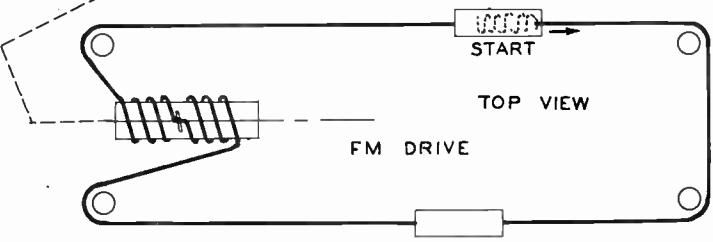
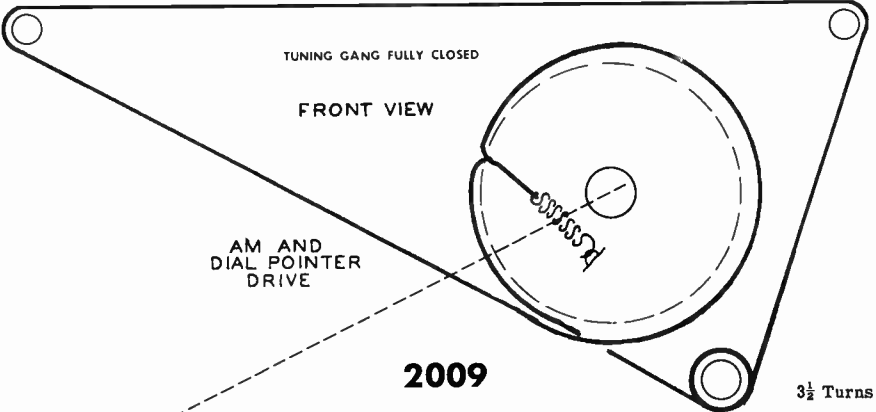
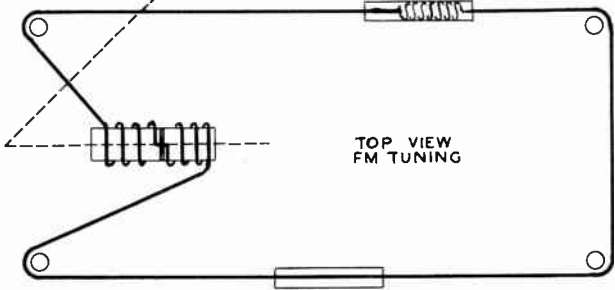
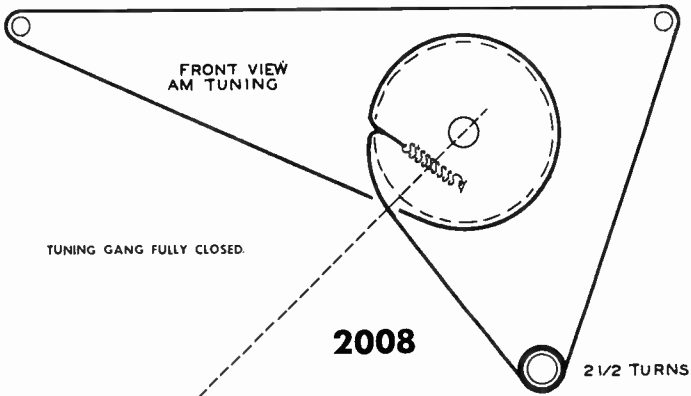

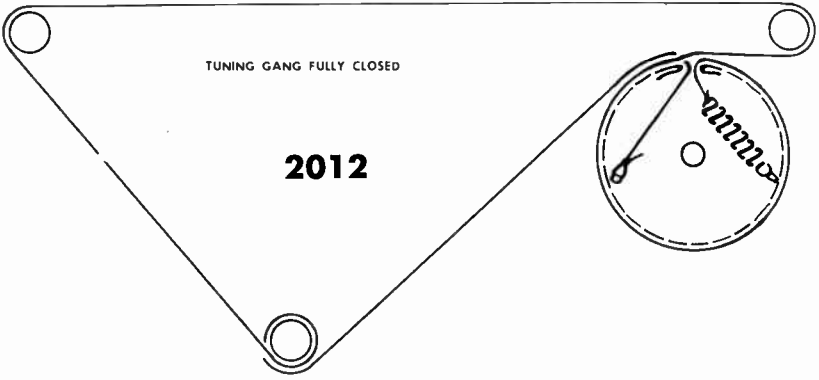
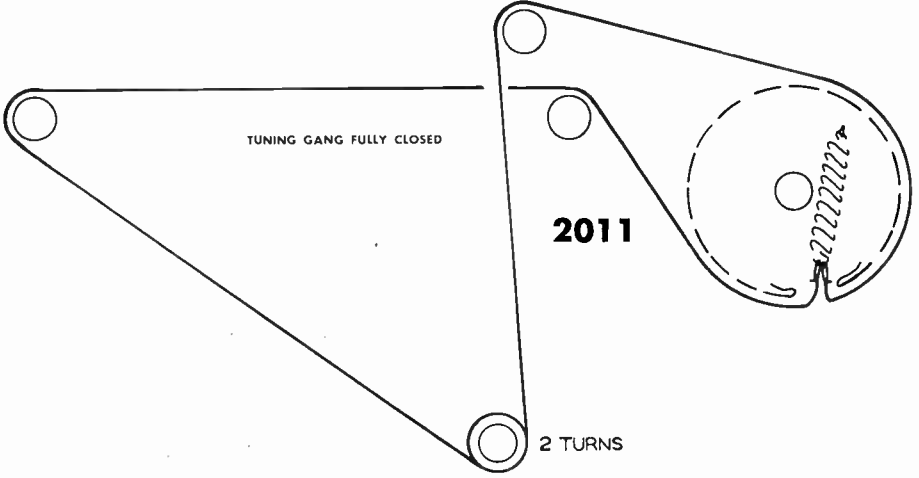
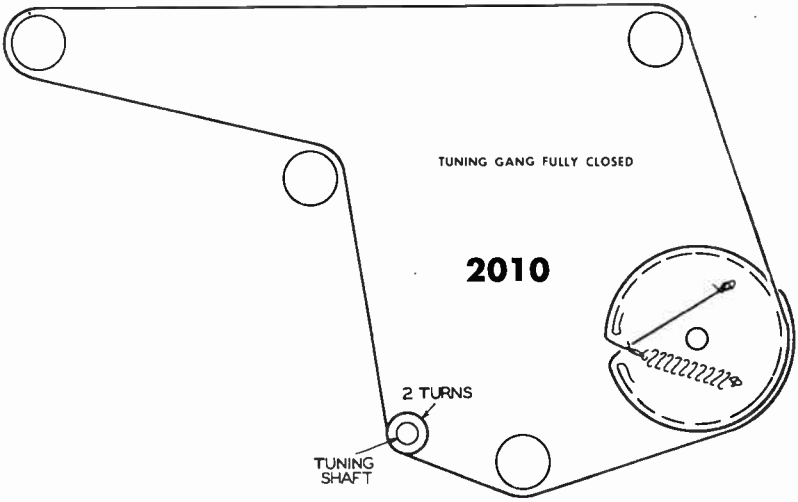

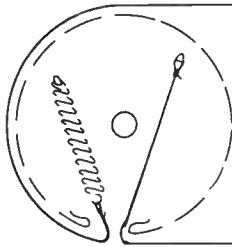

2013

TUNING GANG FULLY CLOSED

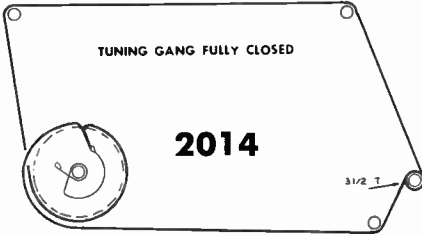

TUNING GANG FULLY CLOSED

2014

3 1/2 T

1 TURN
TUNING SHAFT

2015

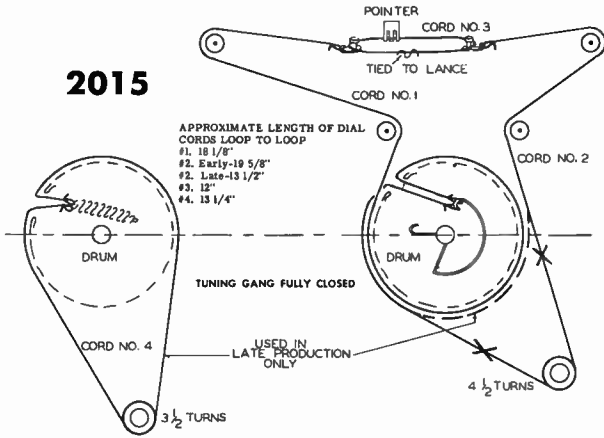

2016

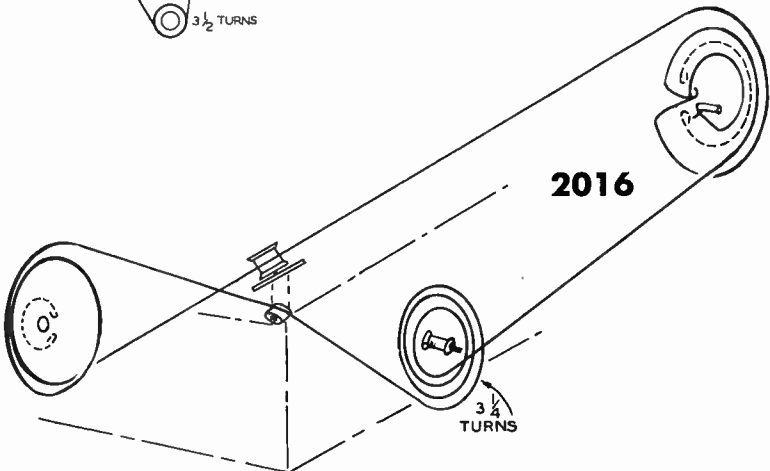

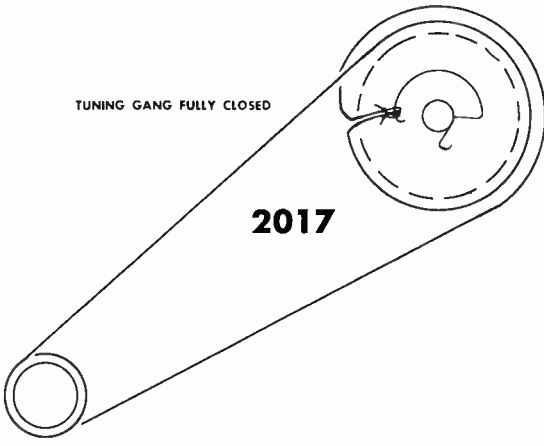

TUNING GANG FULLY CLOSED

2017

2 1/2 TURNS

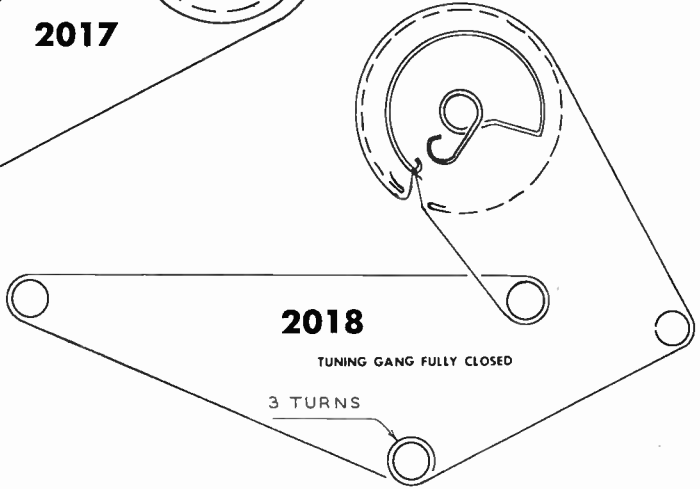

2018

TUNING GANG FULLY CLOSED

3 TURNS

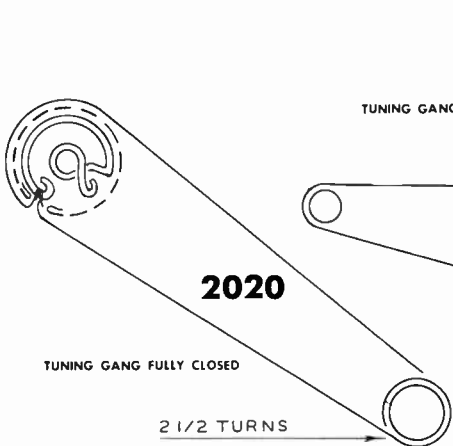

TUNING GANG FULLY CLOSED

2020

TUNING GANG FULLY CLOSED

2 1/2 TURNS

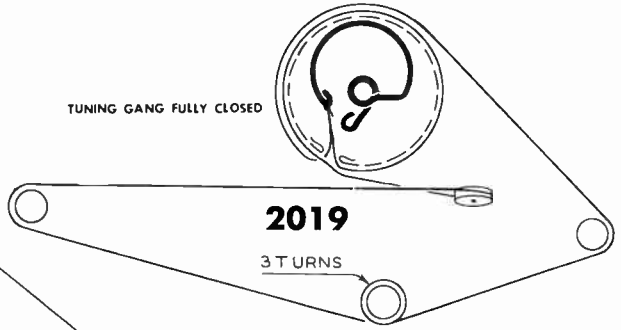

2019

3 TURNS

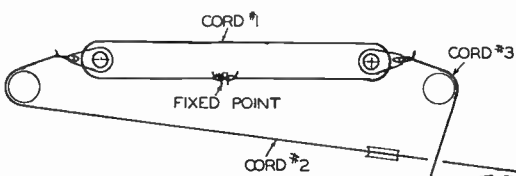

TUNING GANG FULLY CLOSED

2021

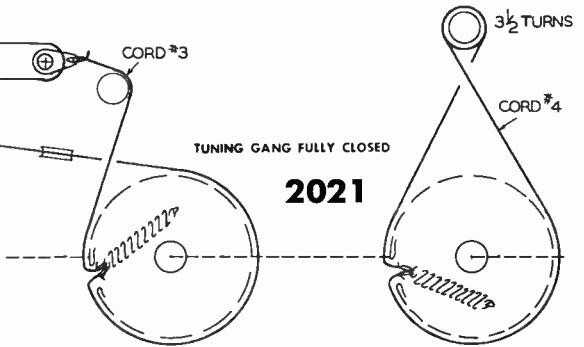

3 1/2 TURNS

CORD #4

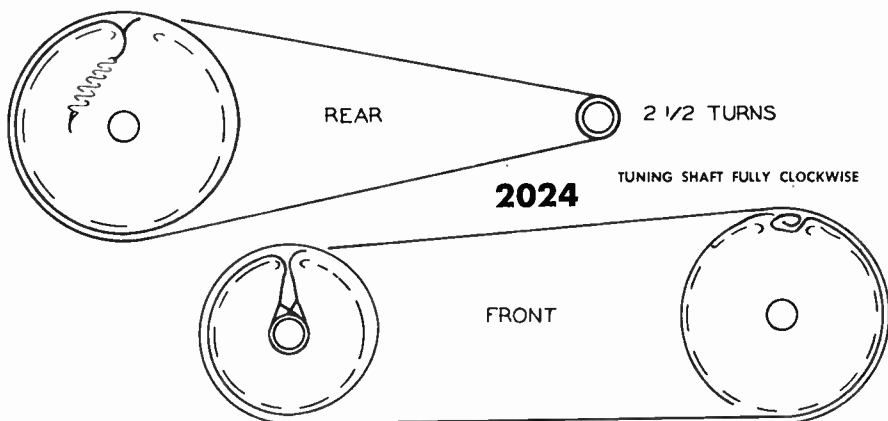
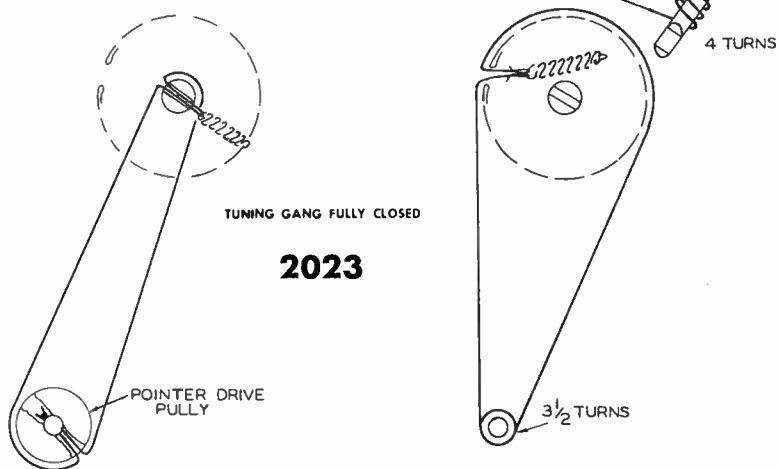
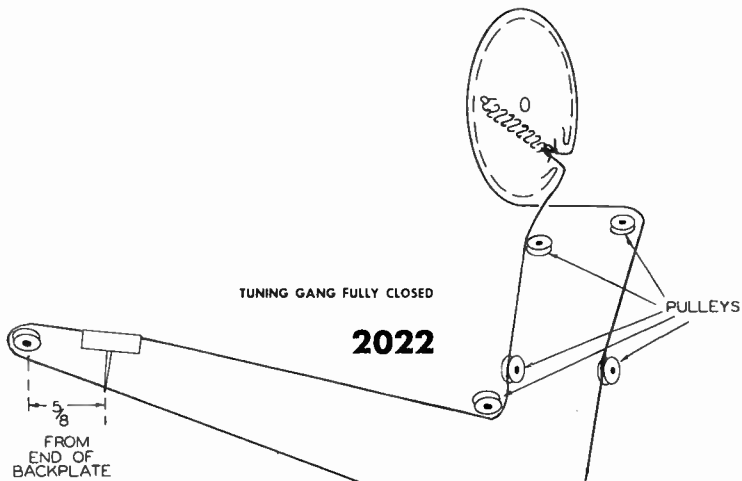

2025

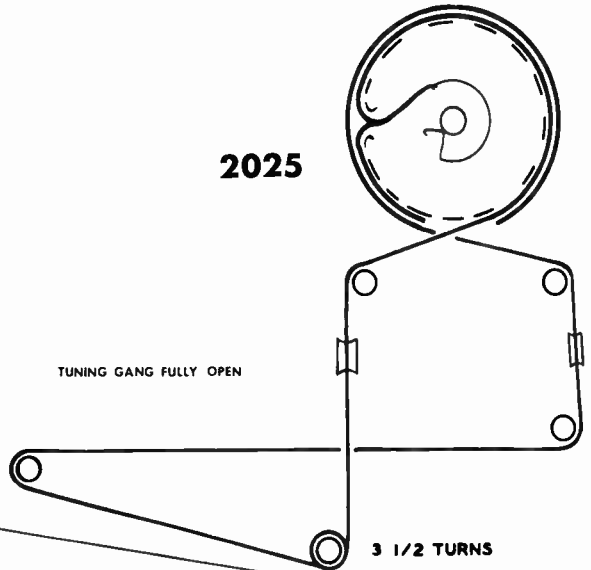

TUNING GANG FULLY OPEN

3 1/2 TURNS

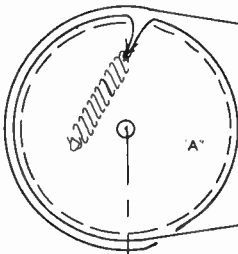

PULLY POSITION WITH STUD AT TOP
WHEN SHAFT "A" IS FULLY COUNTER-
CLOCKWISE

2026

2 1/2 TURNS

2 1/2 TURNS

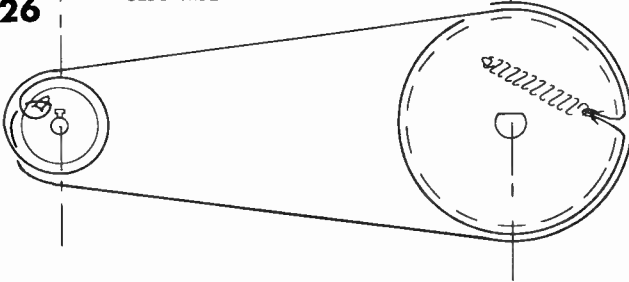

TUNING SHAFT FULLY COUNTERCLOCKWISE

2027

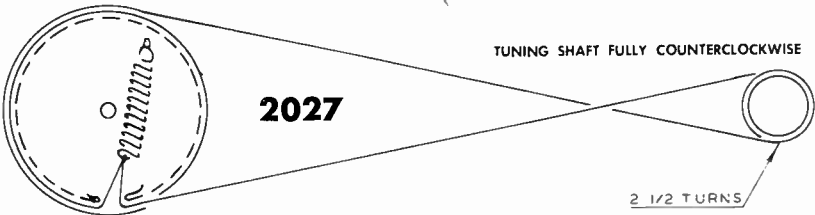

2 1/2 TURNS

2028

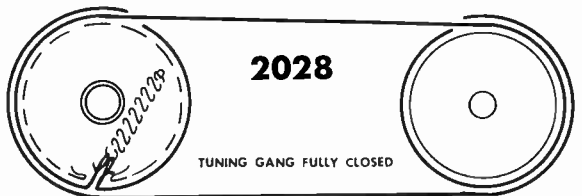

TUNING GANG FULLY CLOSED

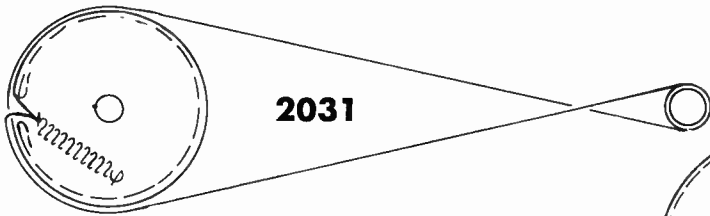
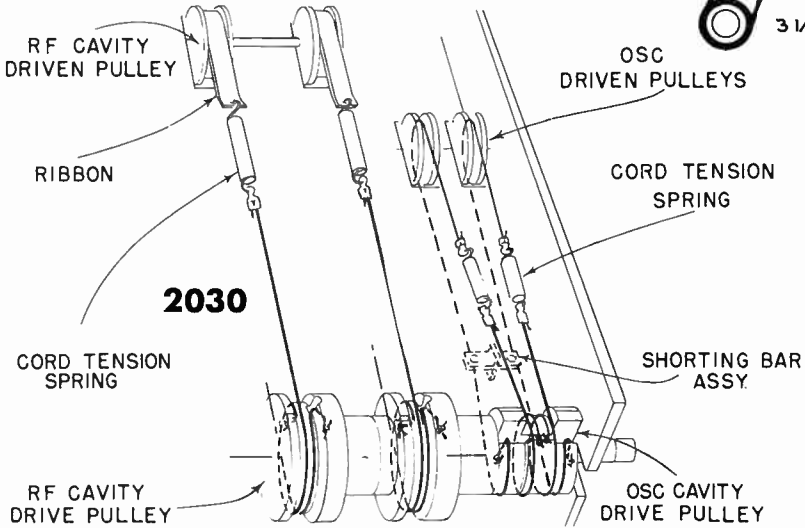
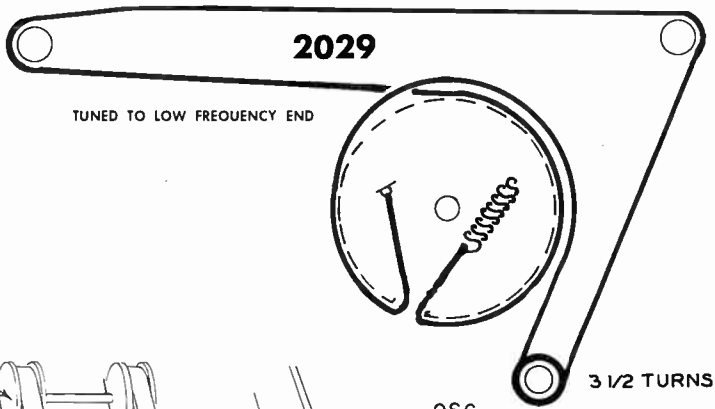

TUNING SHAFT FULLY COUNTERCLOCKWISE

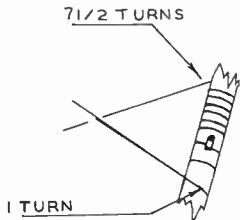

TUNING SHAFT FULLY COUNTERCLOCKWISE

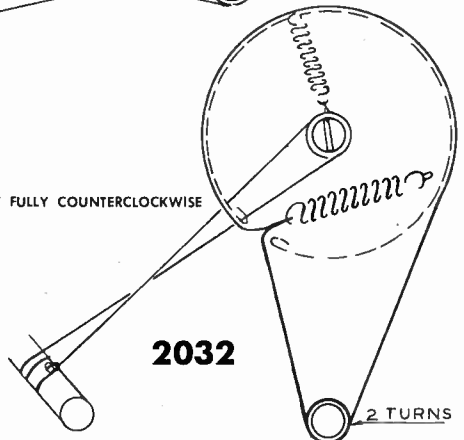

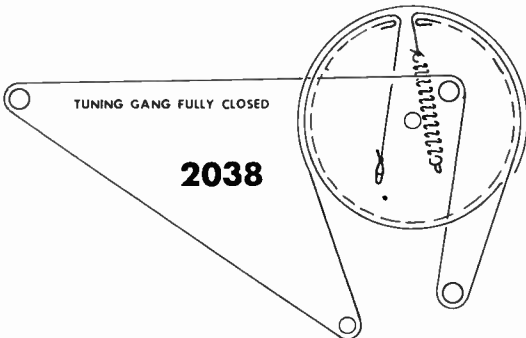
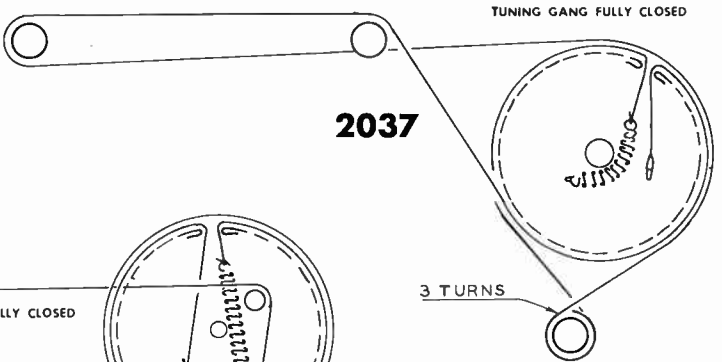
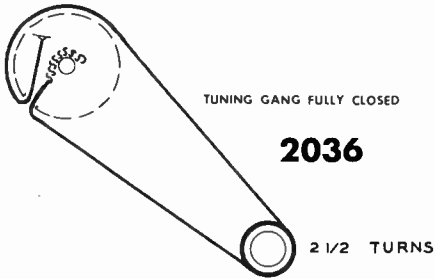
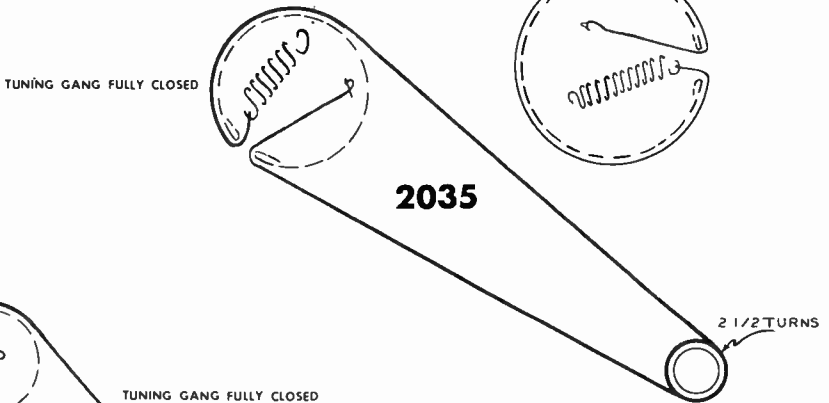
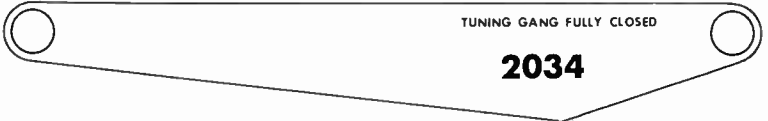
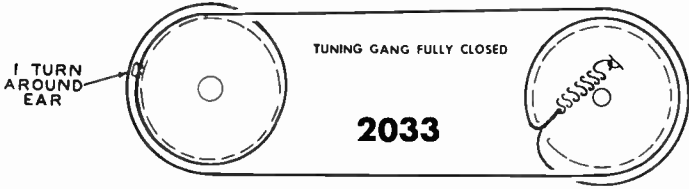

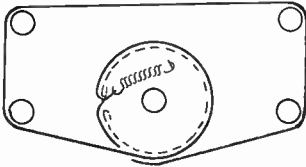
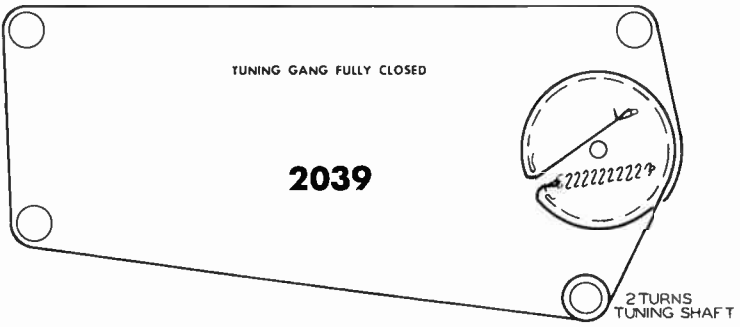

TUNING GANG FULLY CLOSED

2040

3 1/2 TURNS

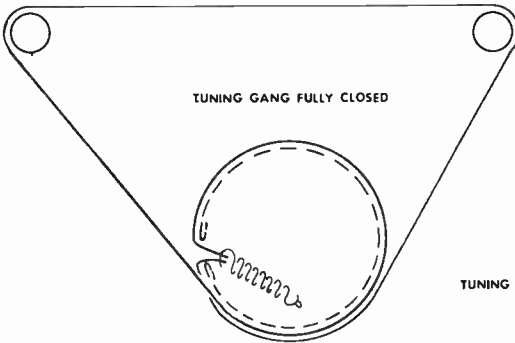

TUNING GANG FULLY CLOSED

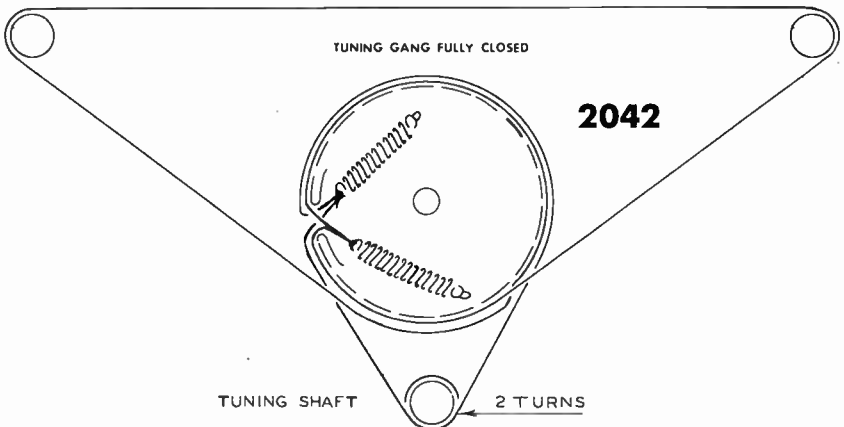
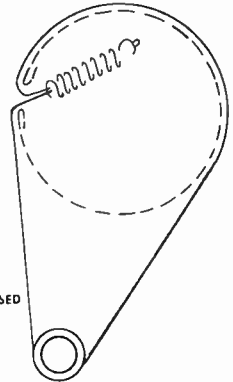

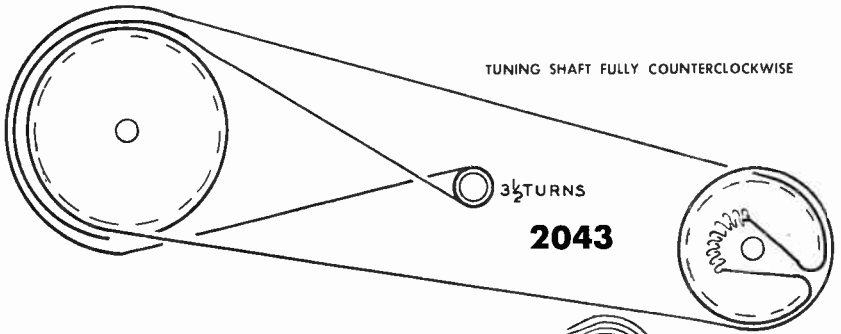

BOTH UHF PULLEYS MUST BE IN THE EXTREME CLOCKWISE POSITION.

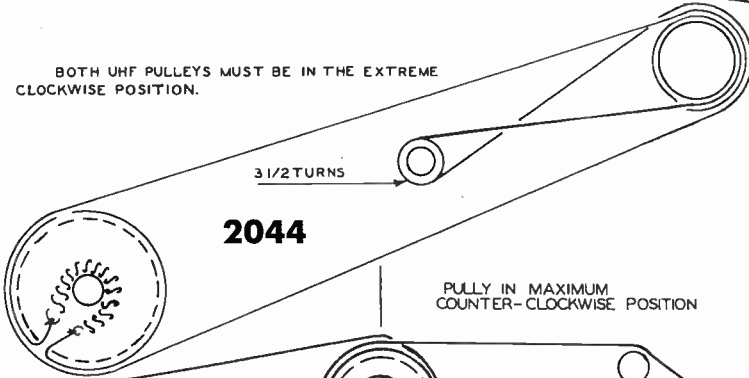

PULLEY IN MAXIMUM COUNTER-CLOCKWISE POSITION

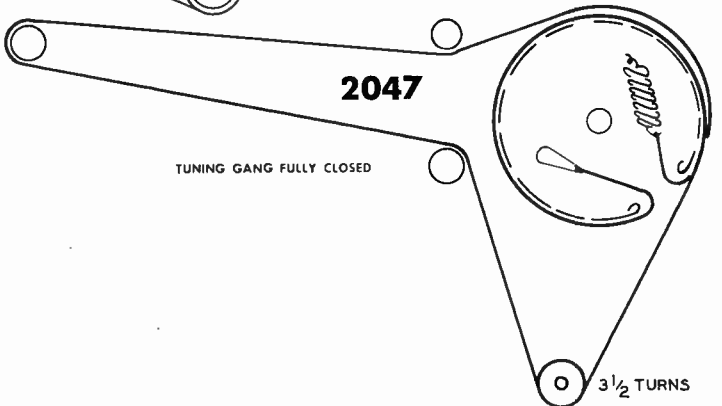
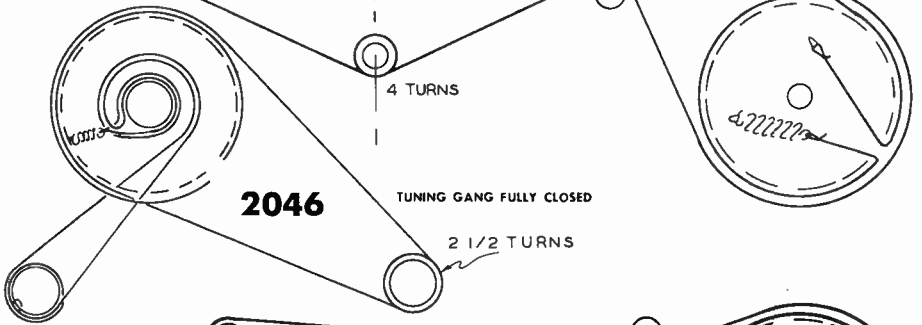
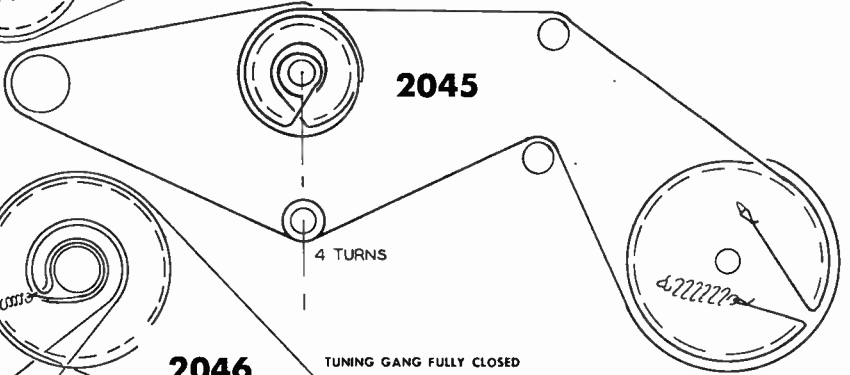

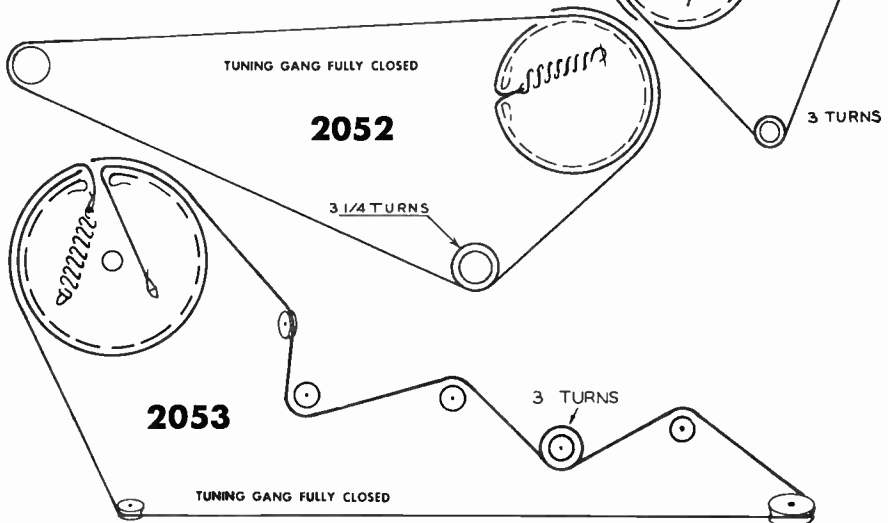
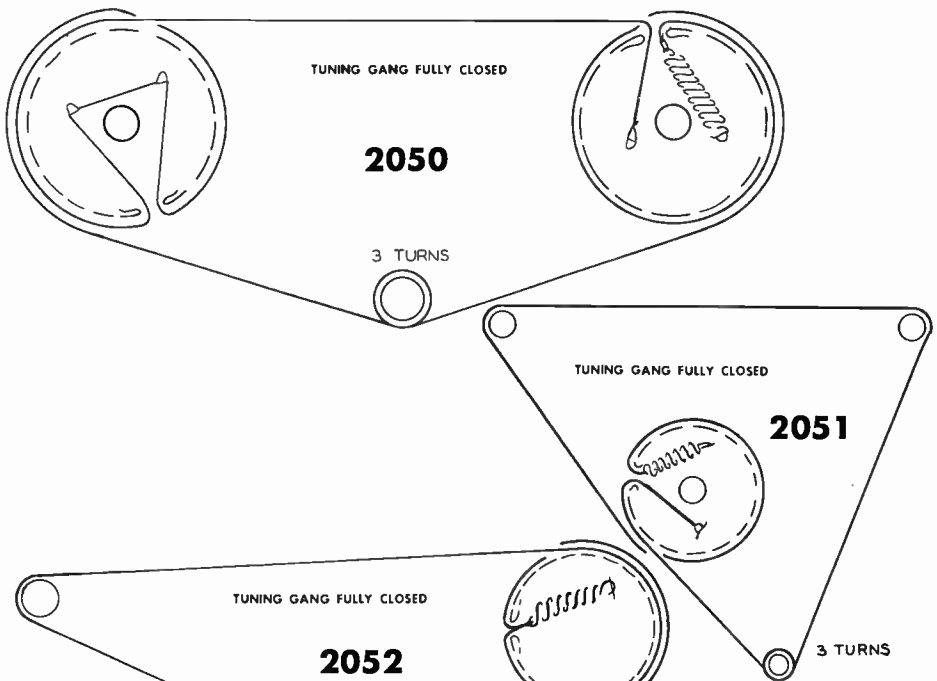
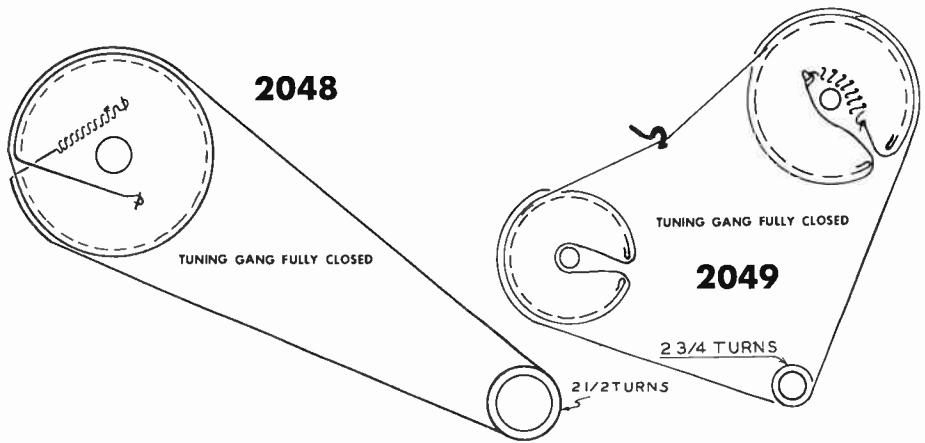

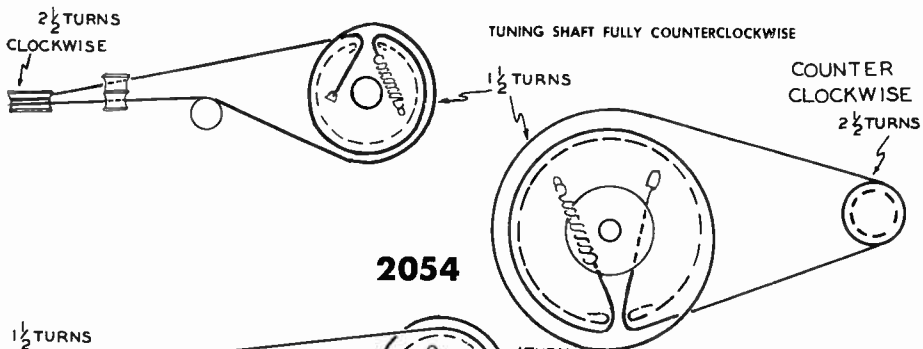

2054

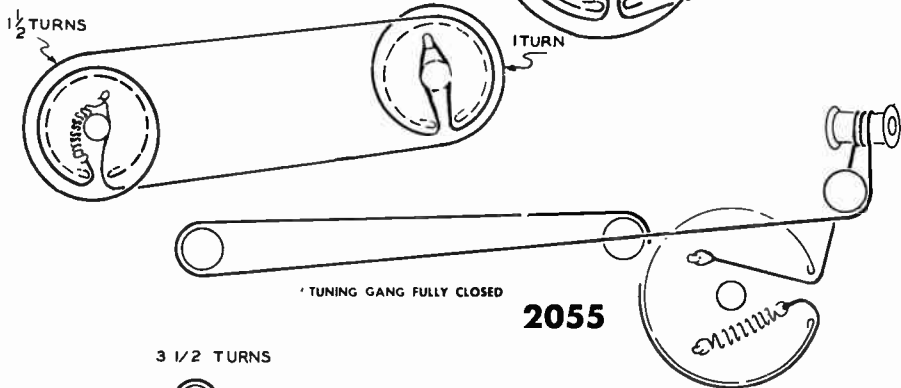

2055

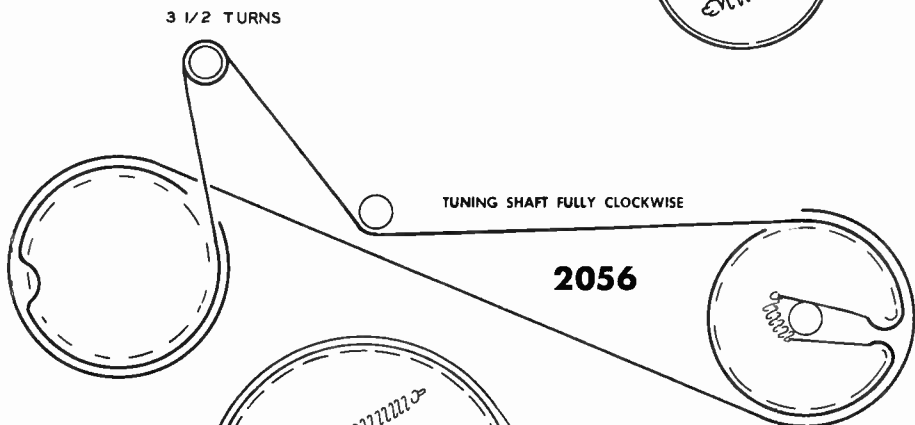

2056

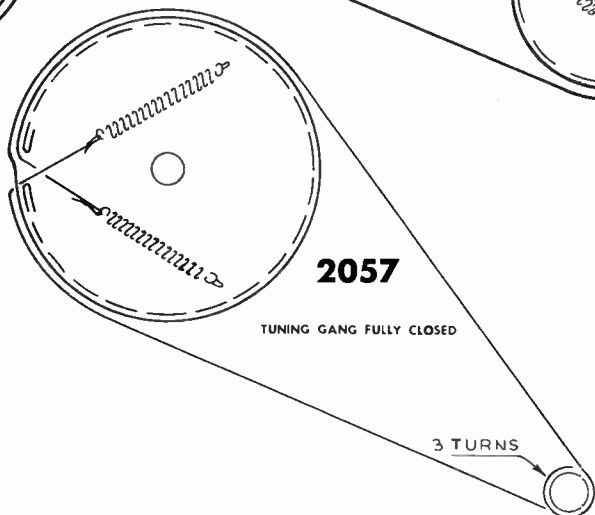

2057

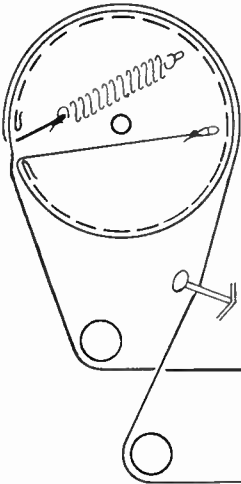

TUNING GANG FULLY CLOSED

2058

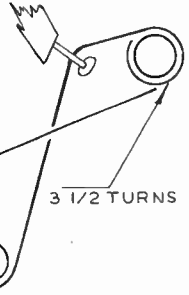

TUNING GANG FULLY CLOSED

2059

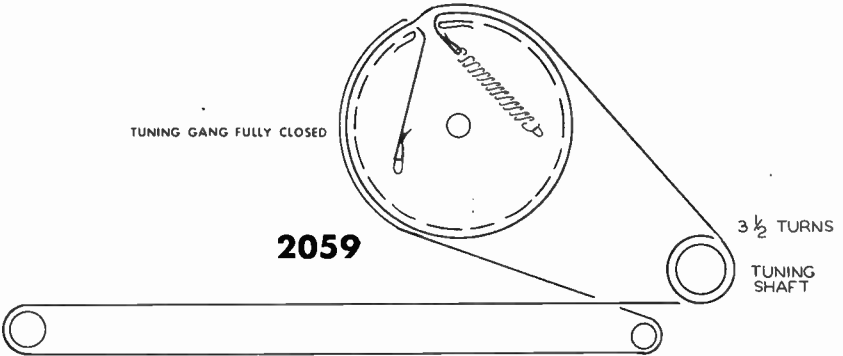

TUNING GANG FULLY CLOSED

2060

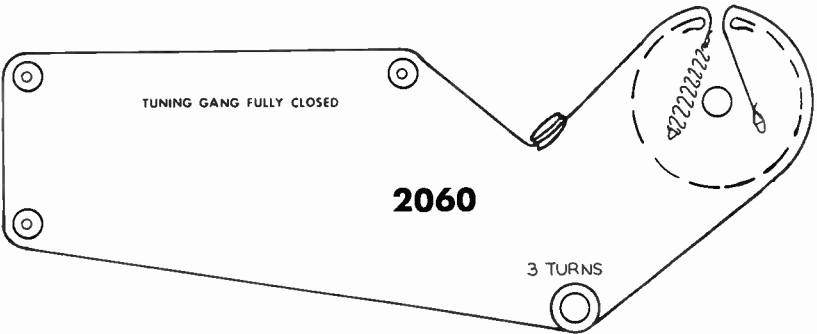

TUNING GANG FULLY CLOSED

2061

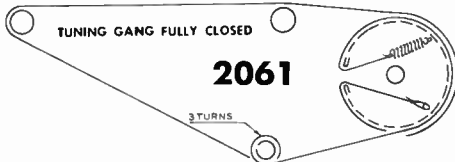

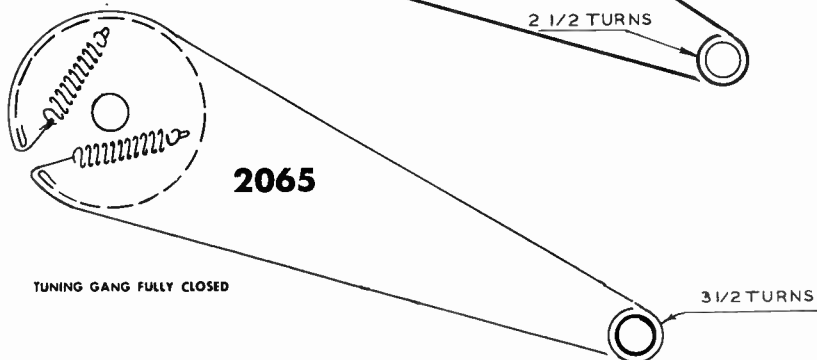
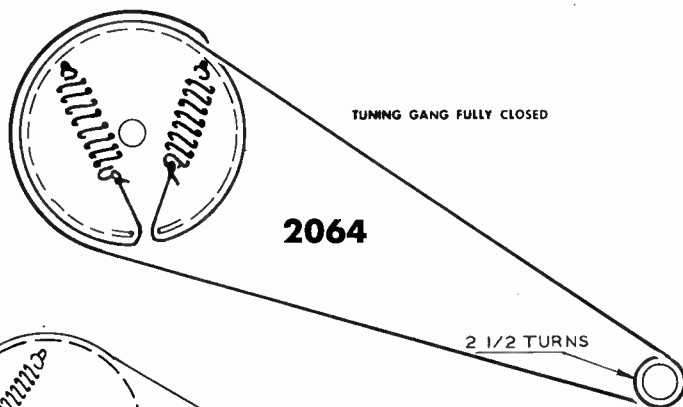
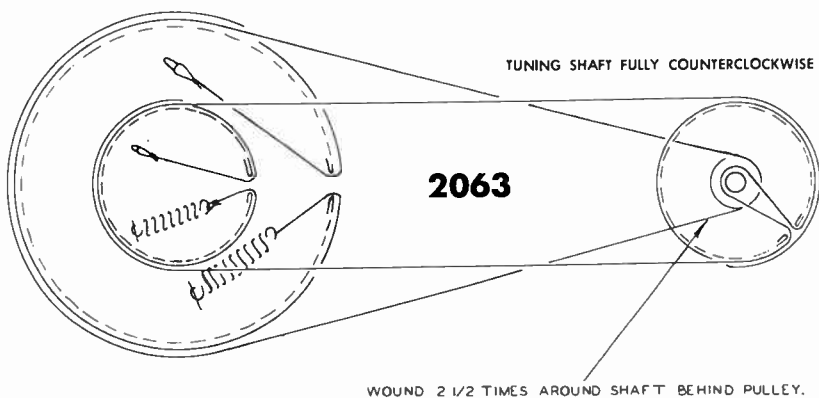
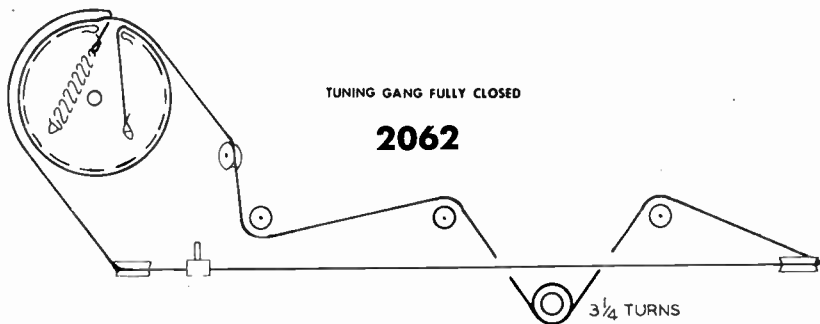

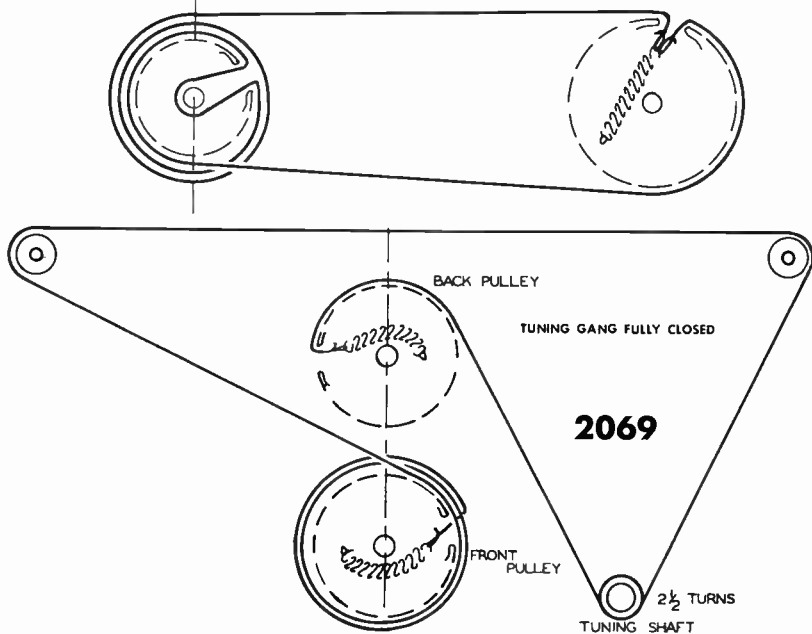
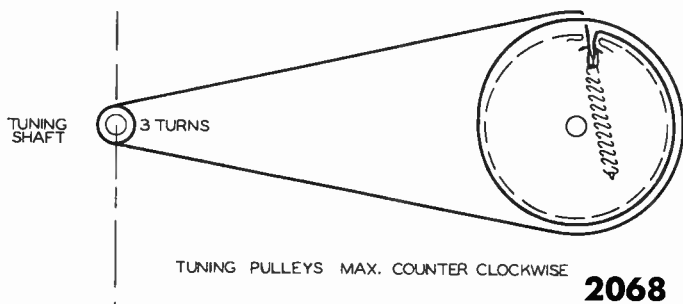
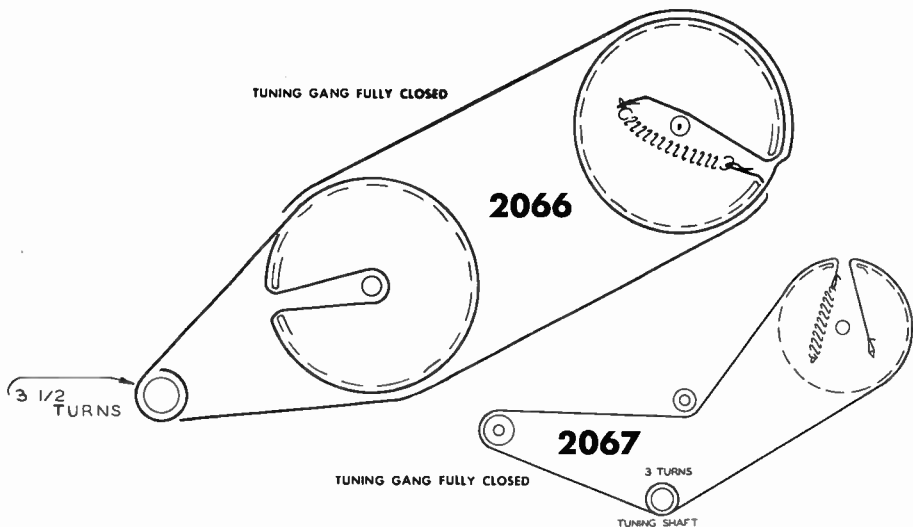

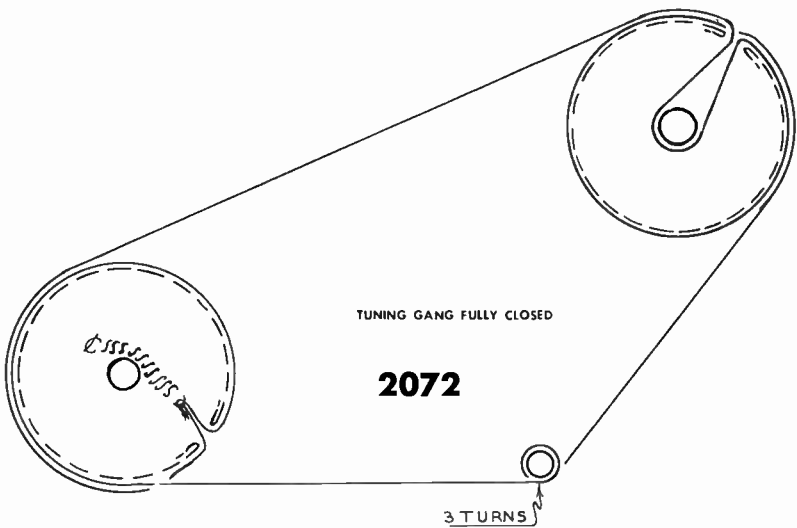
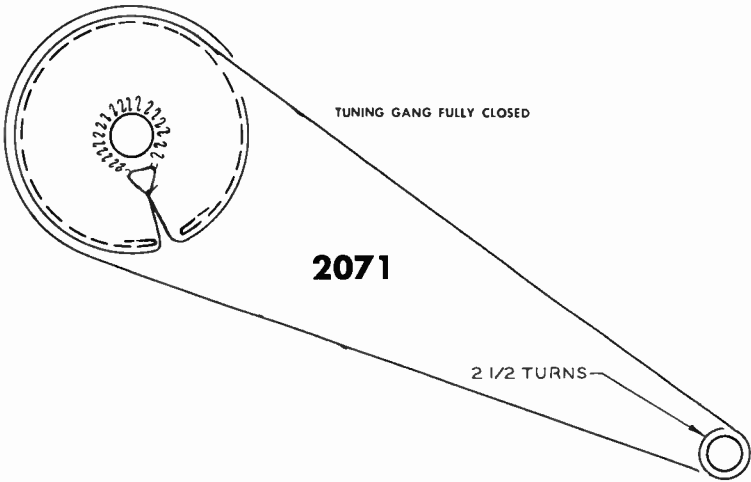
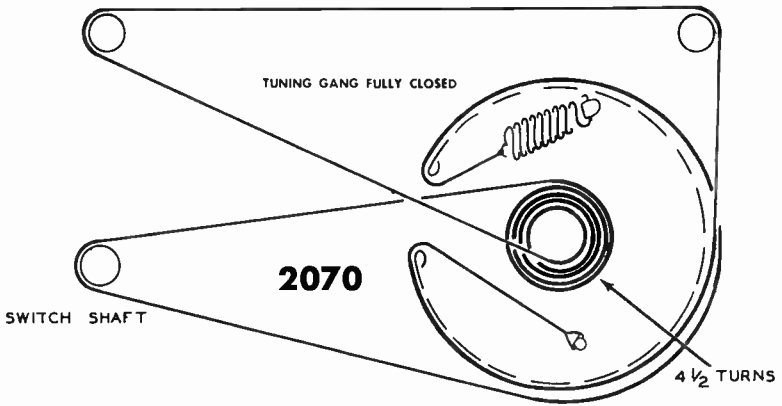

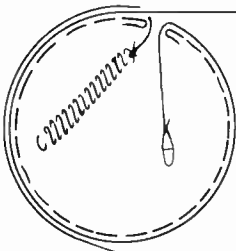

2073

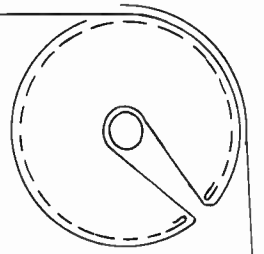

TUNING GANG FULLY CLOSED

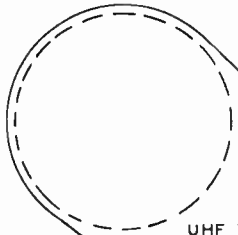

UHF TUNING
(REAR)

2 1/2 TURNS

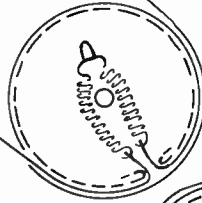

2074

UHF TUNING
(FRONT)

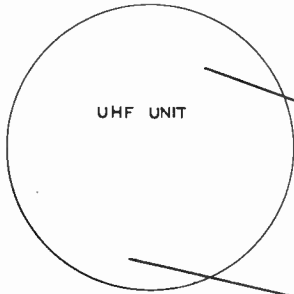

UHF UNIT



TUNING DIAL FULLY
COUNTERCLOCKWISE

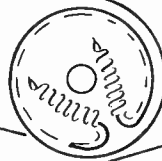

2075

TUNING CONTROL FULLY
COUNTERCLOCKWISE

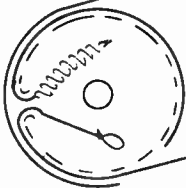
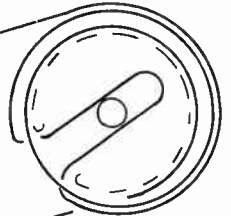

2076



TUNING GANG FULLY CLOSED



TUNING GANG FULLY CLOCKWISE.

2078

TUNING GANG FULLY CLOSED

4 TURNS

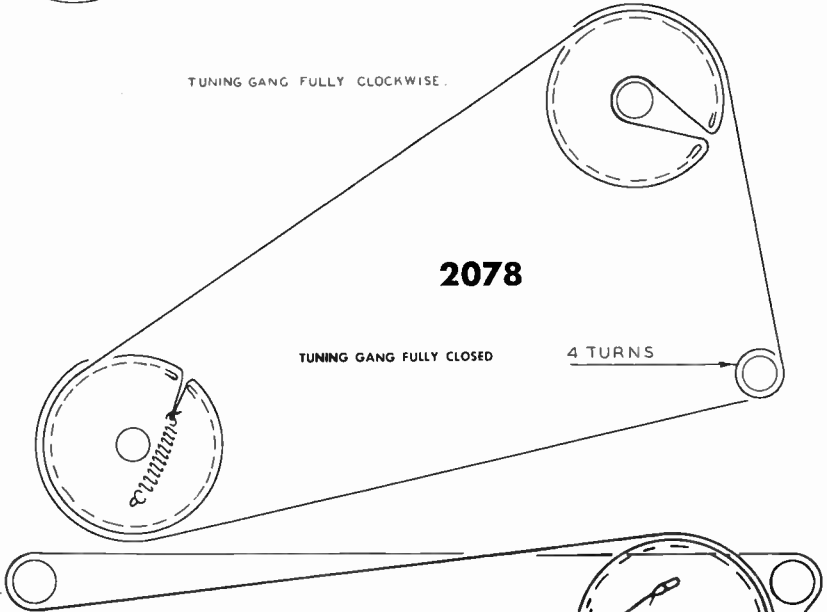

TUNING GANG FULLY CLOSED

2079

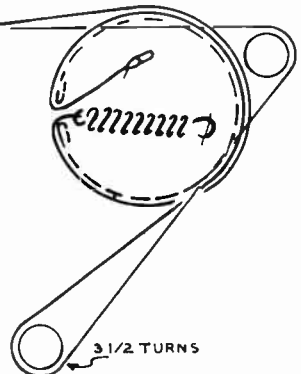

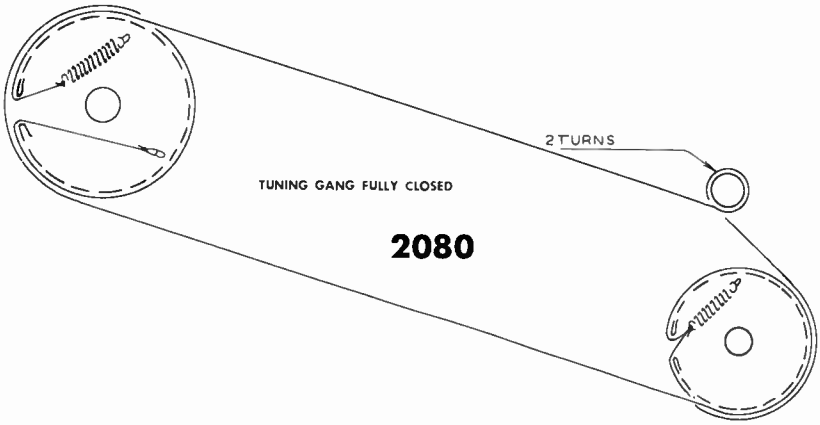

2080

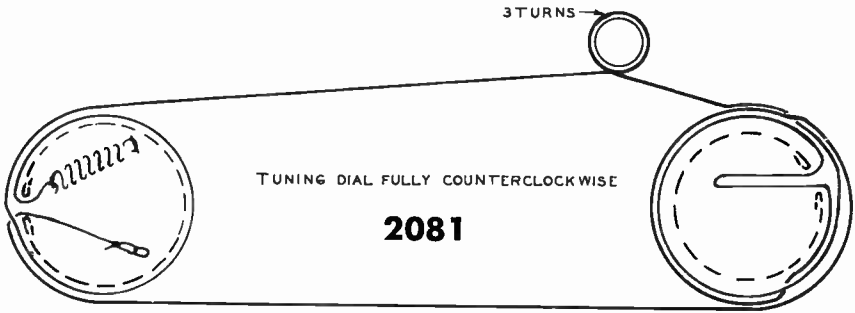

2081

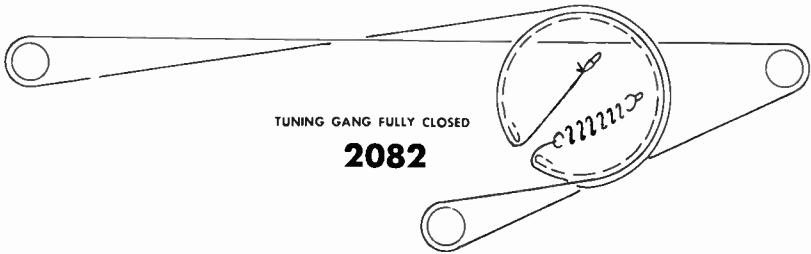

2082

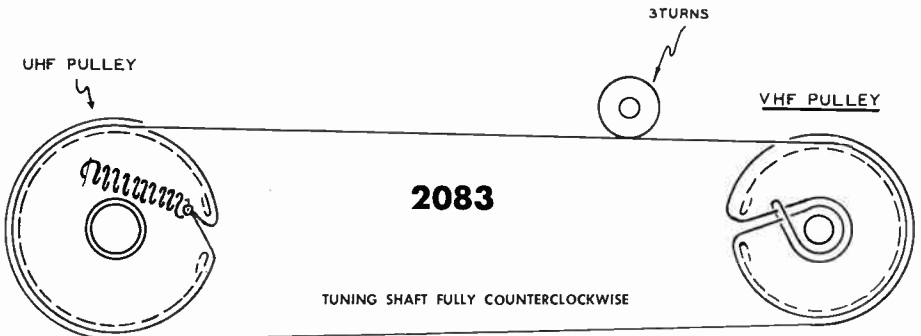

2083

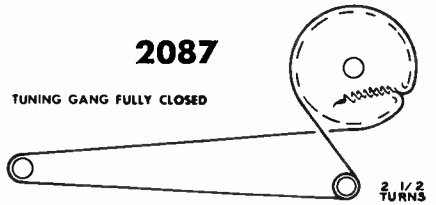
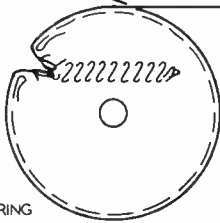
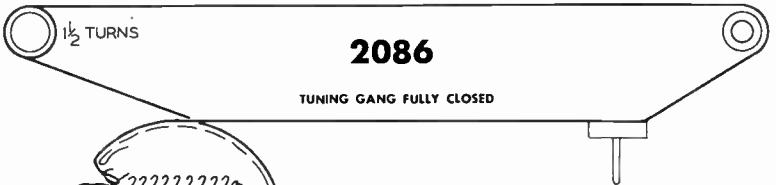
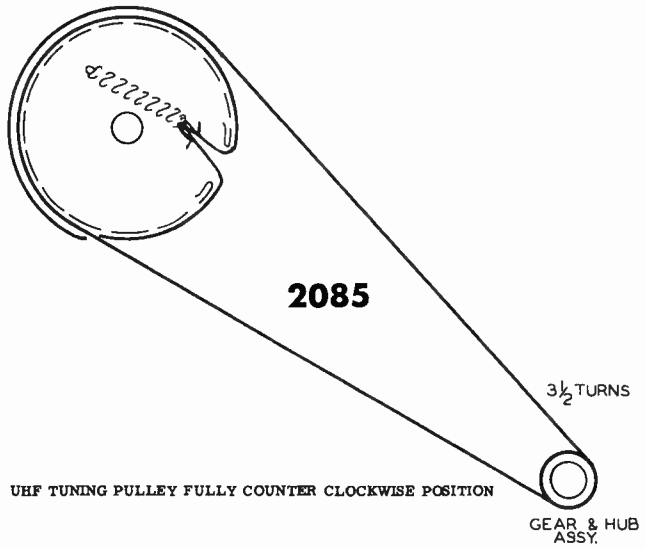
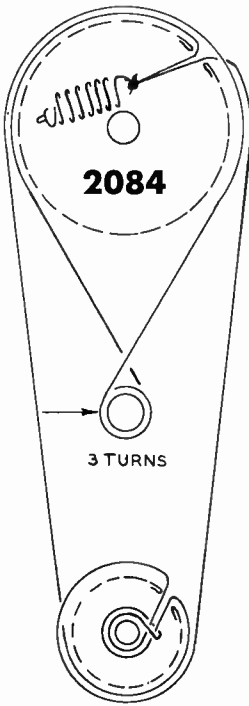

METAL TENSION SPRING

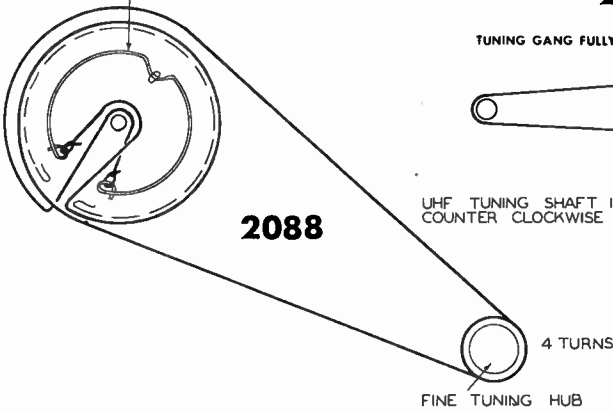

UHF TUNING SHAFT IN MAX. COUNTER CLOCKWISE POSITION

TUNING GANG FULLY CLOSED

2089

3 1/2 TURNS

TUNING SHAFT

TUNING GANG FULLY CLOSED

2090

3 TURNS
TUNING SHAFT

TUNING GANG FULLY CLOSED

2091

TUNING GANG FULLY CLOSED

2092

3 1/2 TURNS

TUNING GANG FULLY CLOSED

2093

2 TURNS

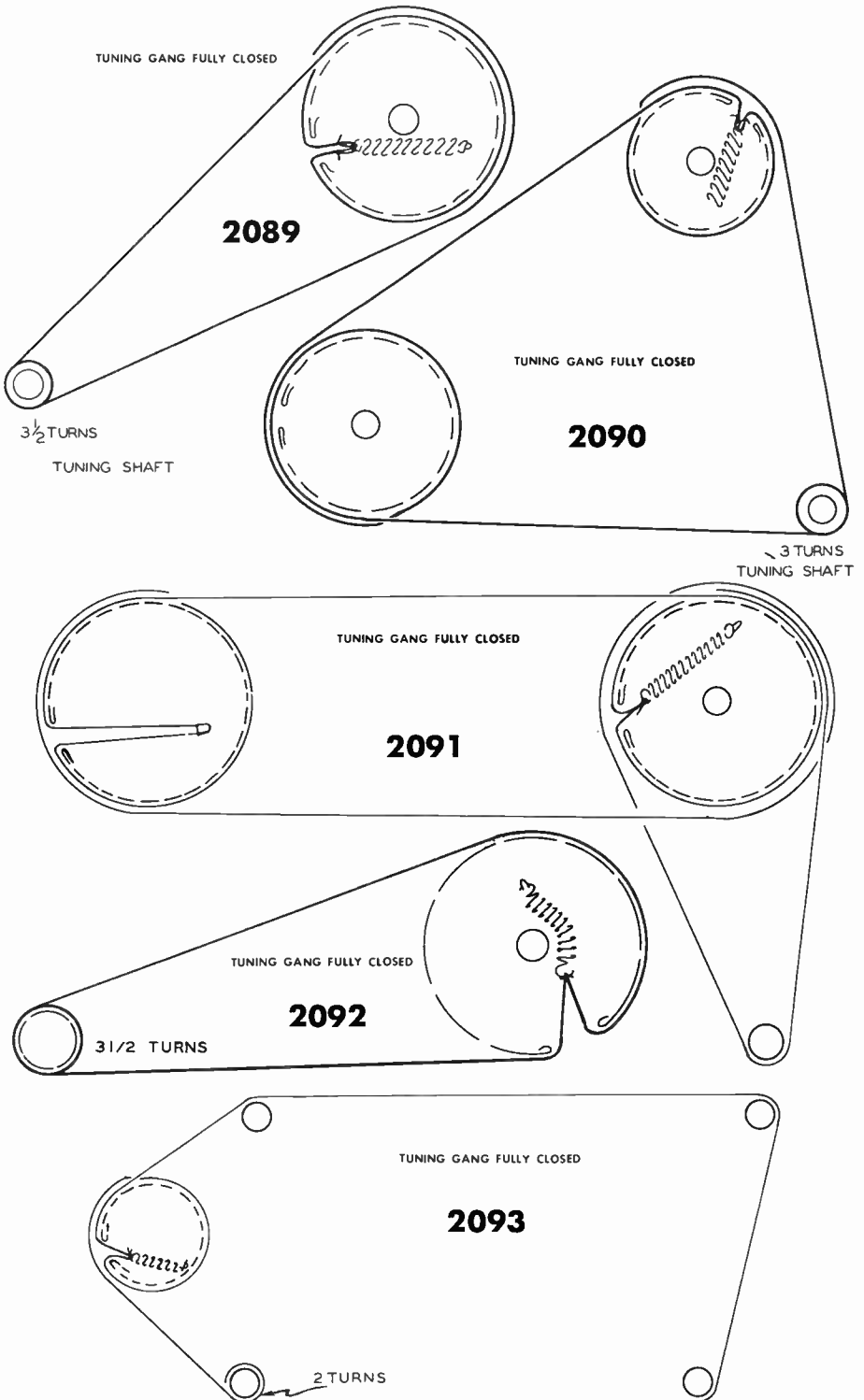

2 1/2 TURNS

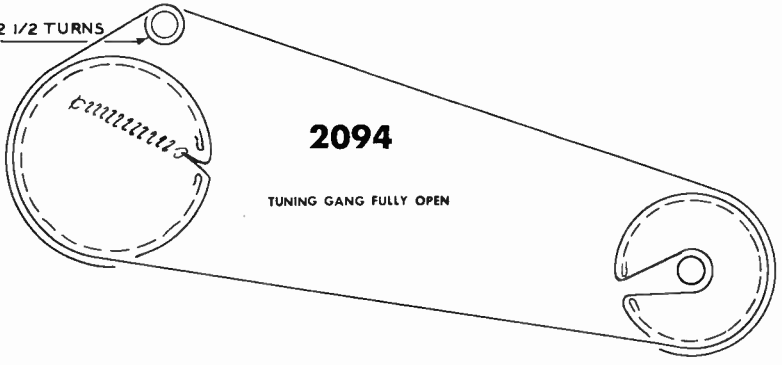

2094

TUNING GANG FULLY OPEN

TUNING GANG FULLY CLOSED

2095

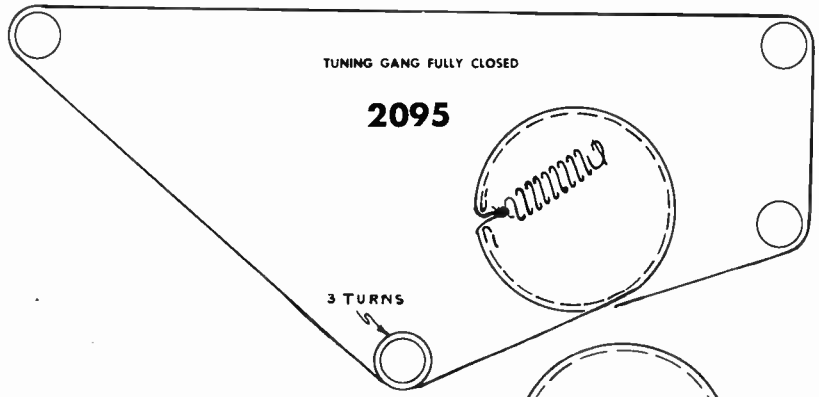

3 TURNS

TUNING GANG FULLY CLOSED

2096

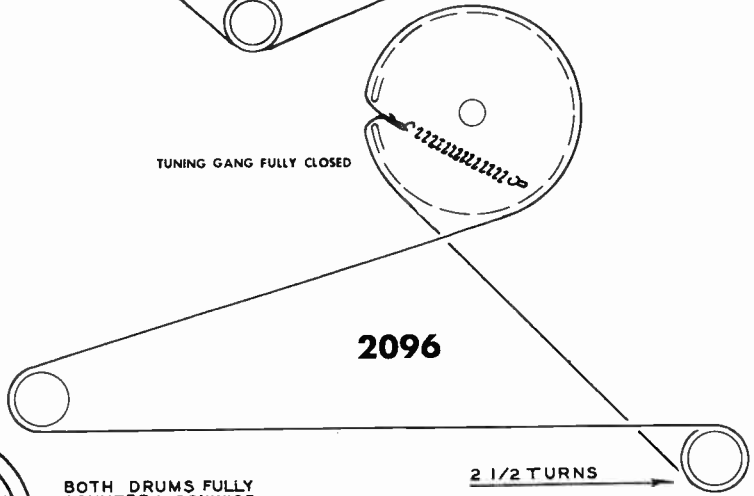

2 1/2 TURNS

2097

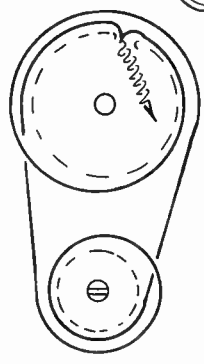

BOTH DRUMS FULLY COUNTERCLOCKWISE

TUNING GANG FULLY CLOSED

2098

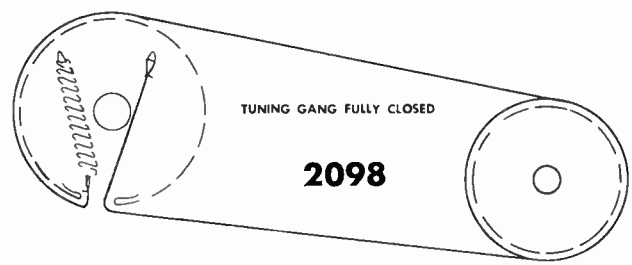

1 1/2 TURNS

TURN DRUM COMPLETELY COUNTER-CLOCKWISE

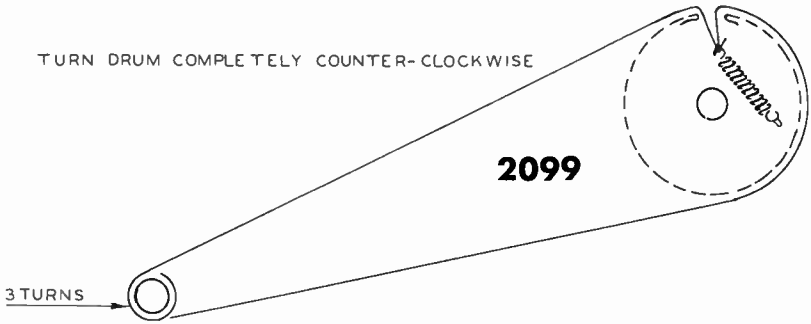

TUNING GANG FULLY CLOSED

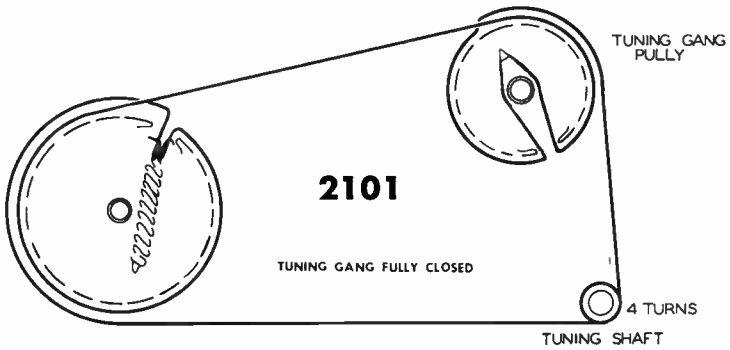
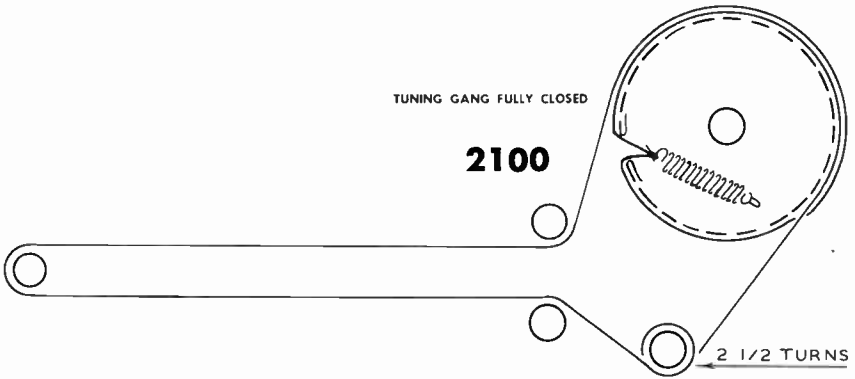

TUNING GANG FULLY CLOSED

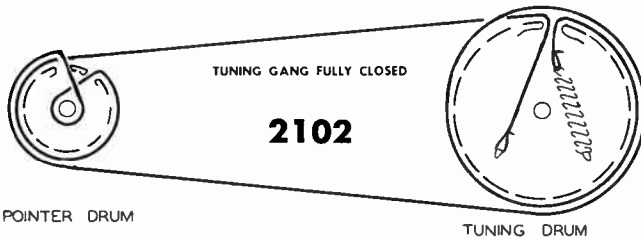

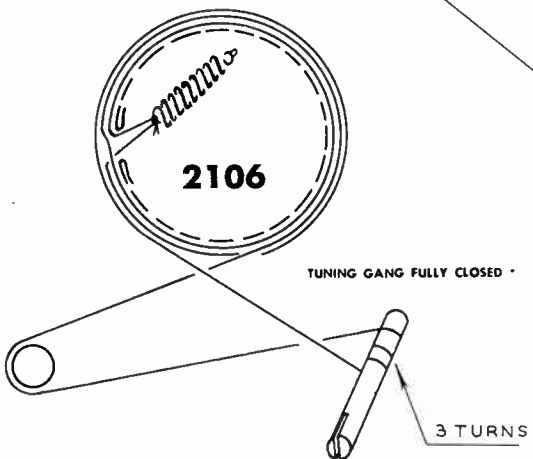
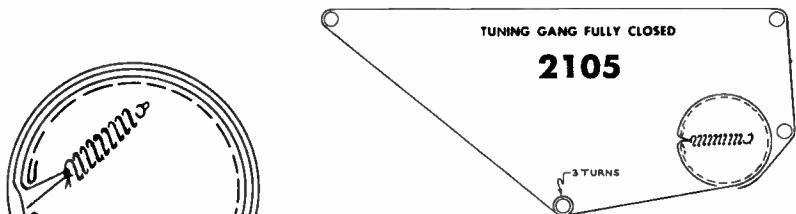
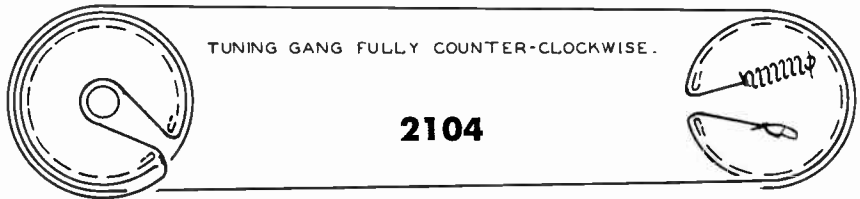
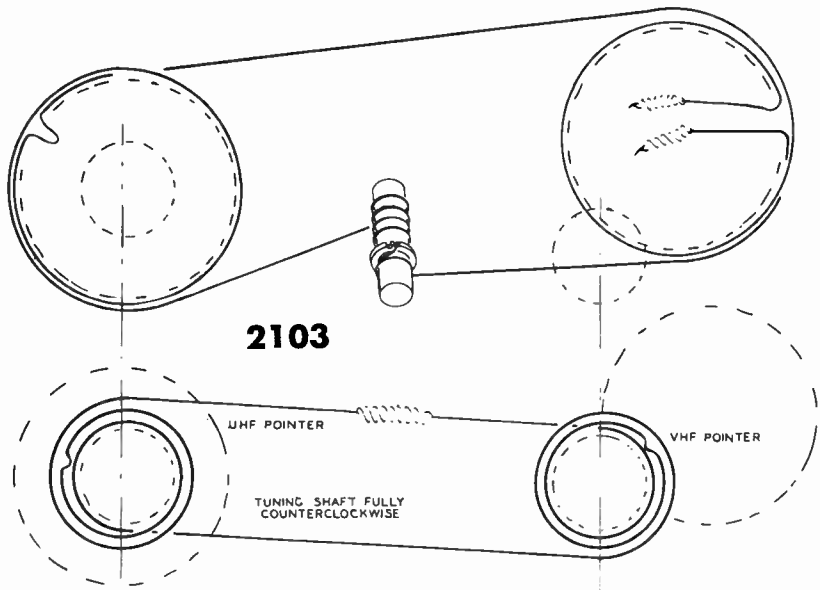

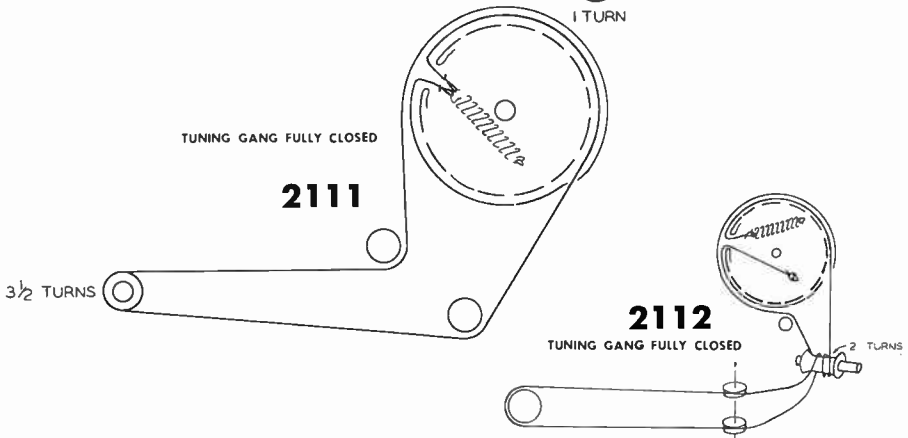
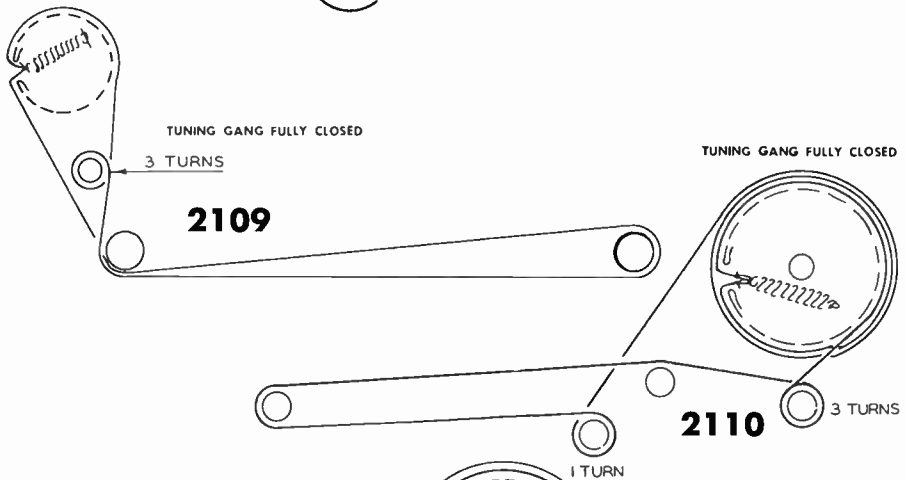
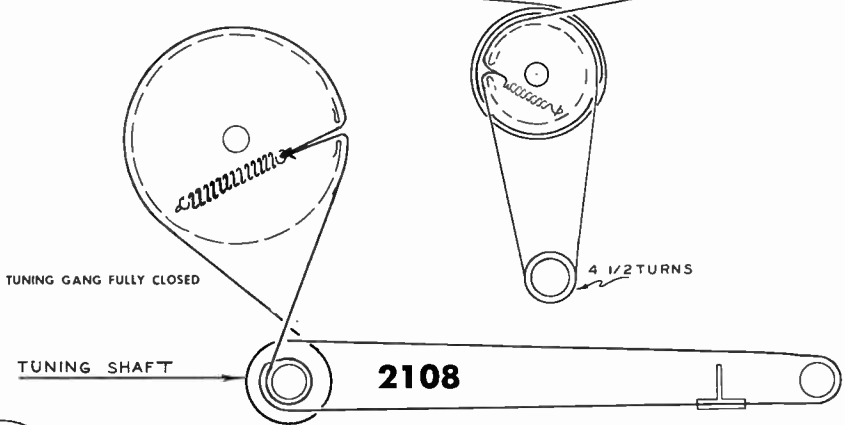
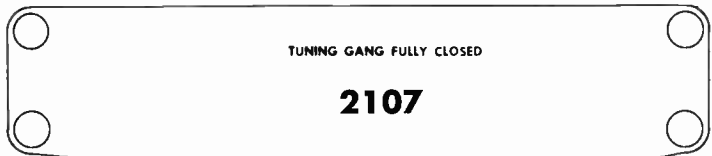

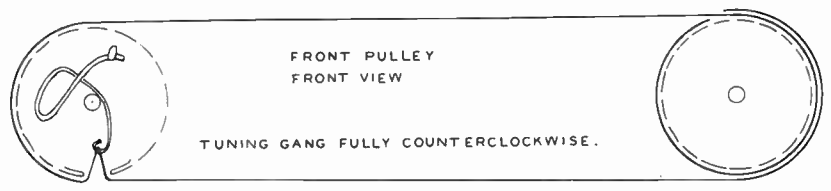
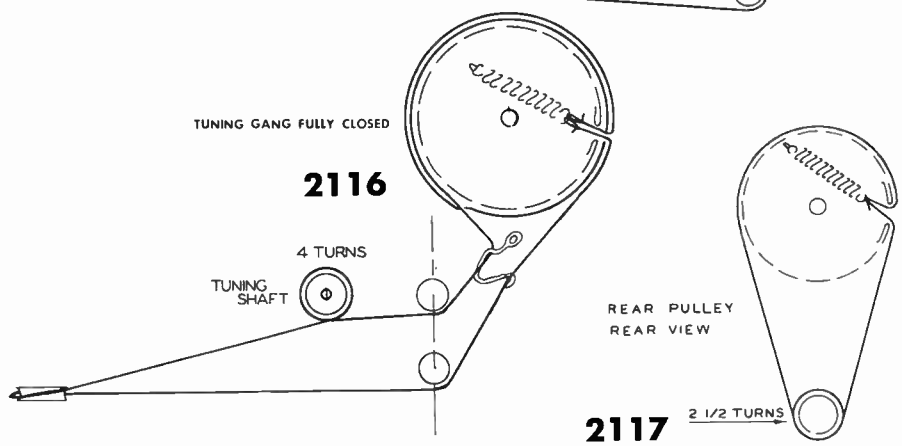
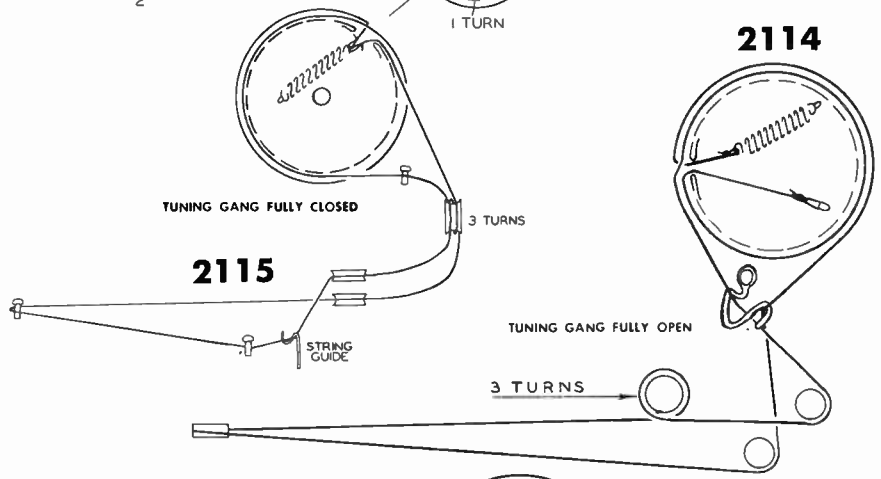
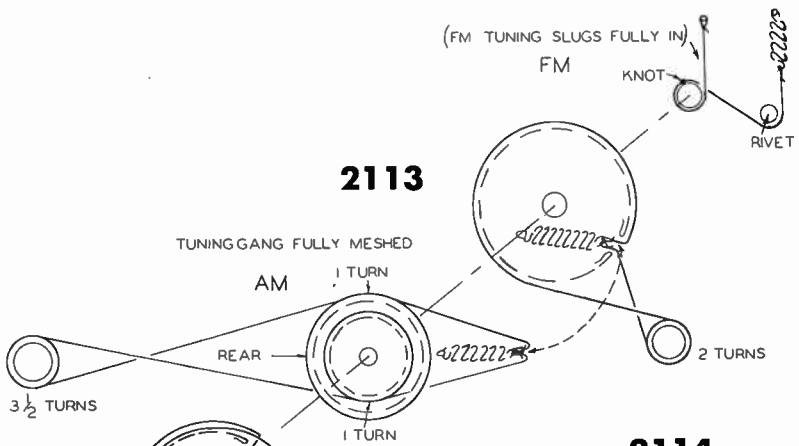

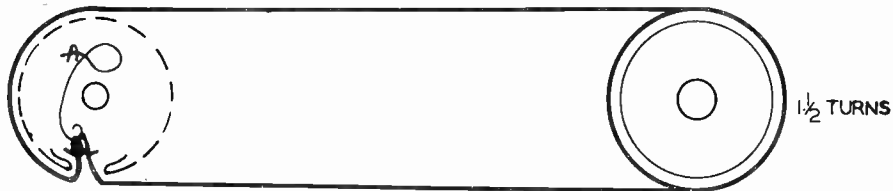

TUNING GANG FULLY CLOSED

2118

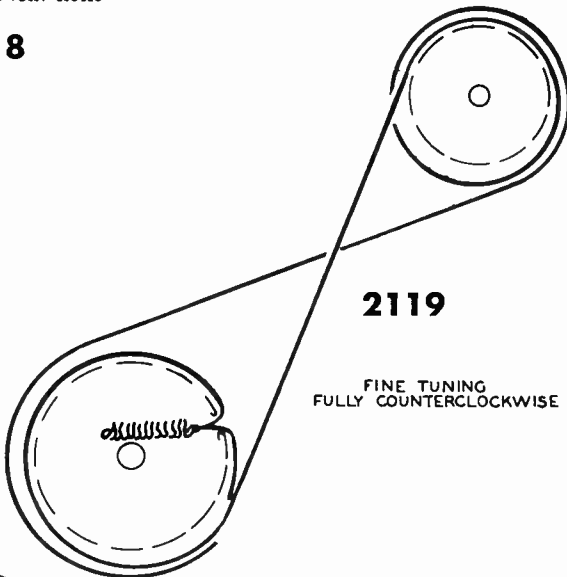
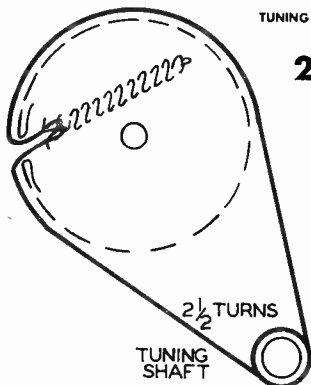

2120

TUNING GANG FULLY CLOSED

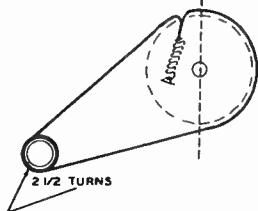
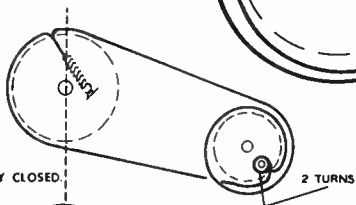

TUNING GANG FULLY CLOSED

2121

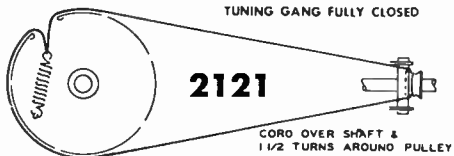

2122

TUNING GANG FULLY CLOSED

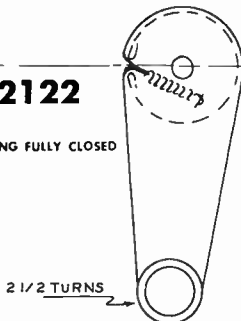

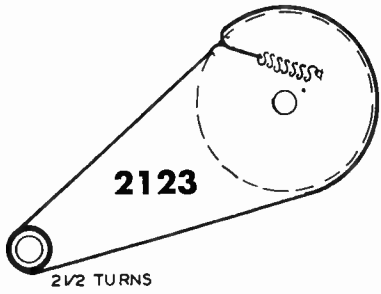

TUNING GANG FULLY CLOSED

2 1/2 TURNS

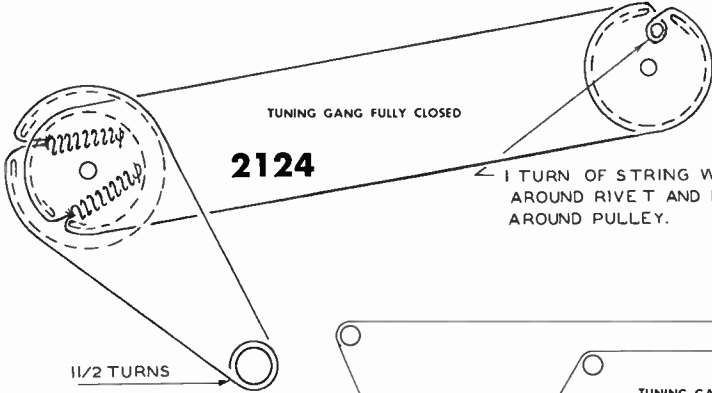

TUNING GANG FULLY CLOSED

2124

1 TURN OF STRING WRAPPED AROUND RIVET AND 1 1/2 TURNS AROUND PULLEY.

1 1/2 TURNS

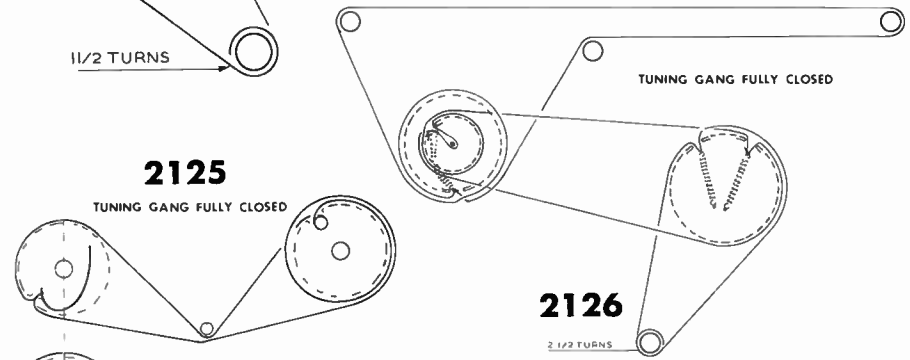

2125

TUNING GANG FULLY CLOSED

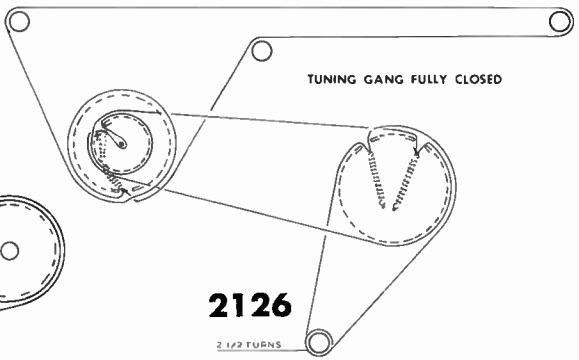

TUNING GANG FULLY CLOSED

2126

2 1/2 TURNS

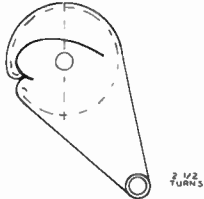

2 1/2 TURNS

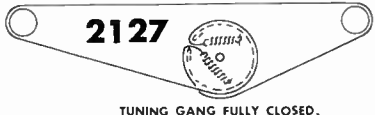

2127

TUNING GANG FULLY CLOSED.

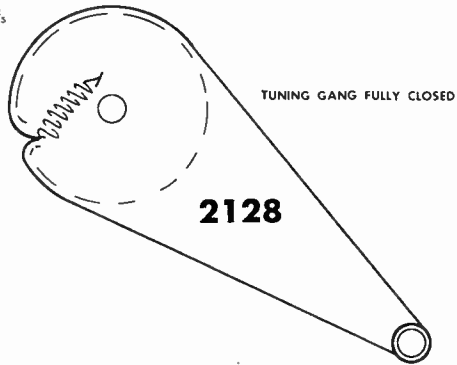

TUNING GANG FULLY CLOSED

2128

2 1/2 TURNS

TUNING SHAFT FULLY CLOCKWISE

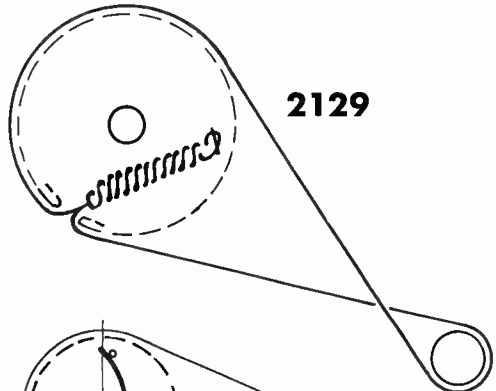

2129

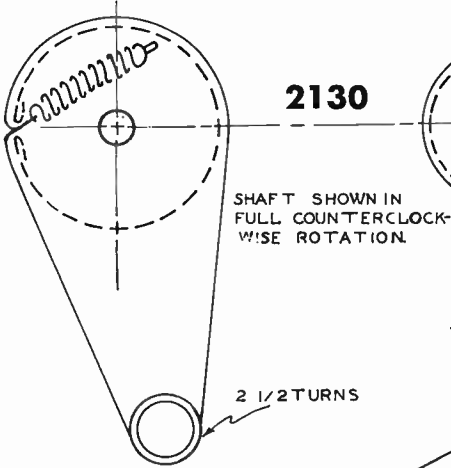

2130

SHAFT SHOWN IN FULL COUNTERCLOCKWISE ROTATION

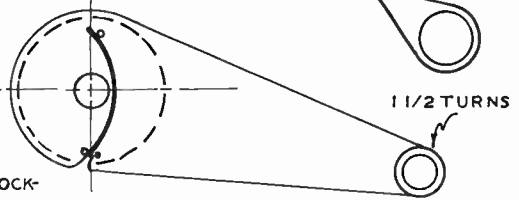

1 1/2 TURNS

TUNING GANG FULLY CLOSED

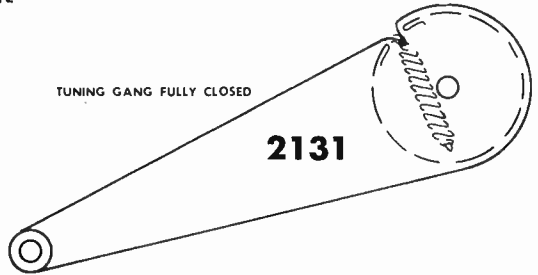

2131

2 1/2 TURNS

2 1/2 TURNS

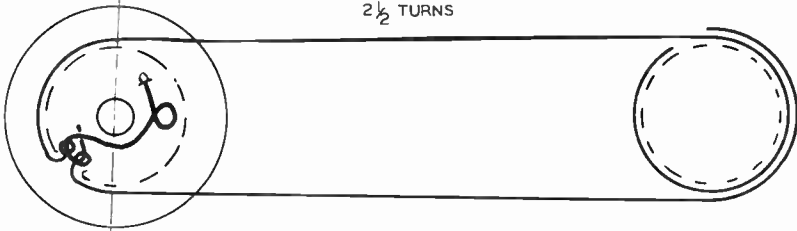

TUNING GANG FULLY CLOSED

2132

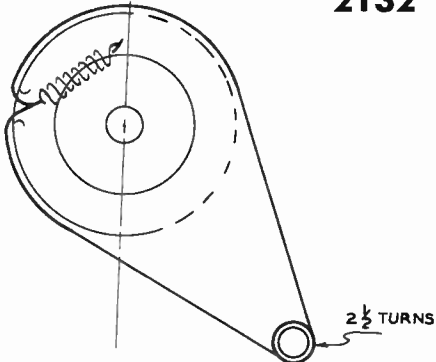

2 1/2 TURNS

SHAFT IN MAXIMUM COUNTER CLOCKWISE POSITION.

2133

FINE TUNING IN MAX COUNTER
CLOCKWISE POSITION.

2134

$\frac{1}{2}$ TURNS AROUND PULLEY
AND ONE TURN
AROUND RIVET

$\frac{1}{2}$ TURN

$\frac{1}{2}$ TURNS ON STUD

2135

TUNING GANG FULLY CLOSED

$2\frac{1}{2}$ TURNS

