

February 1989

Spotlight
on safety

IT INSTALLER TECHNICIAN

The cable magazine for installers and technicians.

Formerly CATJ, Cable Tech.



SAYT

From Raychem's EZF Connector to Regal's Passives...

Hook up a new subscriber today...

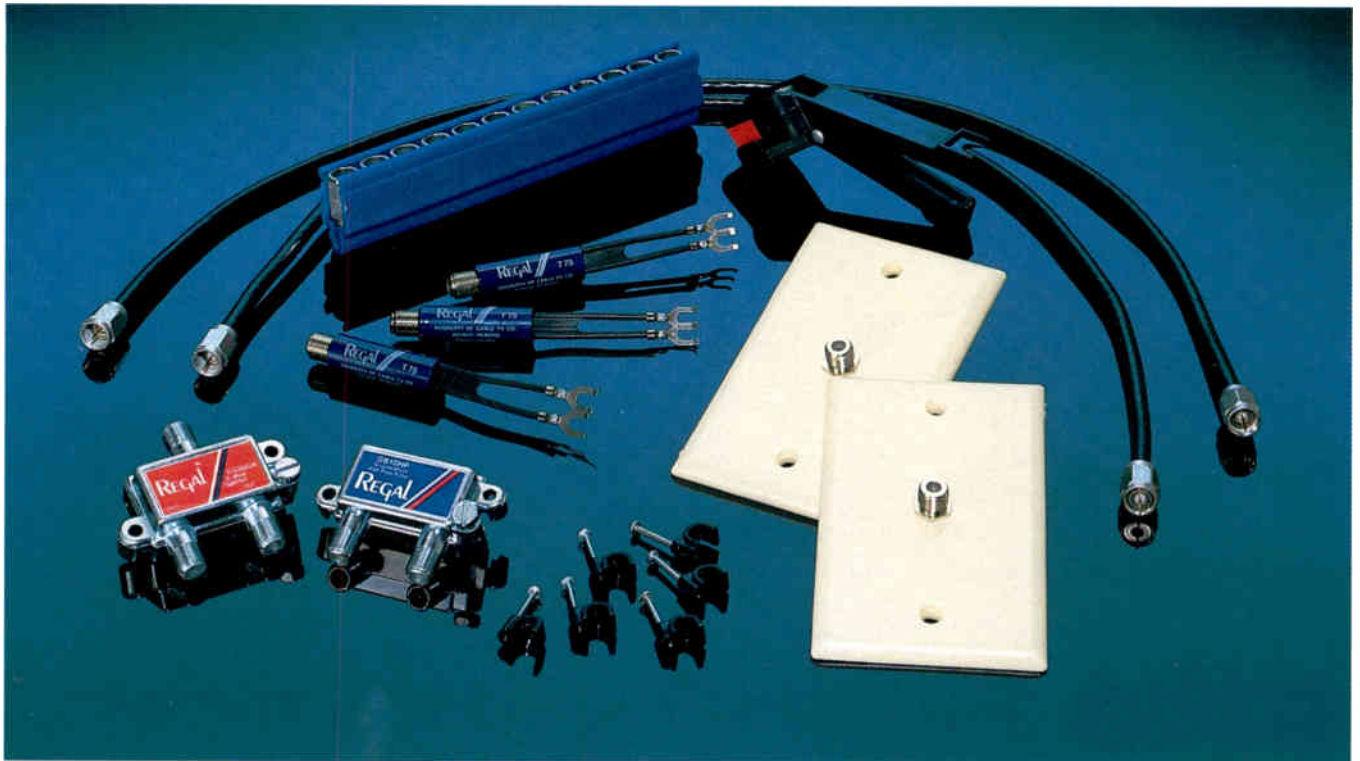

...with **ANIXTER**'s top quality products.

ANIXTER
CABLE TV

"LIGHTING THE WAY TO THE FUTURE"

Call us — We'll ship today!

WEST-ANAHEIM: (714) 779-0500, (800) 854-0443; **ANCHORAGE:** (907) 274-8525; **DENVER:** (303) 373-9200, (800) 841-1531; **SEATTLE:** (206) 251-6760, (800) 426-7665; **MIDWEST-CHICAGO:** (312) 364-7000, (800) 544-5368; **DALLAS:** (214) 446-7337, (800) 231-5006; **IRON MOUNTAIN, MI:** (906) 774-4111, (800) 624-8358; **SKOKIE, IL HDQTRS:** (312) 677-2600; **EAST-ATLANTA:** (404) 449-6533, (800) 241-5790; **EAST FARMINGDALE, NY:** (516) 293-7788, (800) 645-9510; **NEW JERSEY:** (201) 328-0980, (800) 631-9603; **TAMPA:** (813) 626-7115, (800) 237-6466; **CANADA-CALGARY:** (403) 250-9646; **MONTREAL:** (514) 636-3636; **TORONTO:** (416) 625-5110; **VANCOUVER:** (604) 321-5885.

In an emergency, weekends and holidays or after 5 P.M. call toll free 1-(800) 323-8167.
CORPORATE OFFICES, ANIXTER BROS., INC., 4711 Golf Road, Skokie, IL 60076, (312) 677-2600

© 1987 Anixter Bros., Inc.

Reader Service Number 1.

CATV HEADEND & AMP

Sale!

SERVICE



Depend on BradPTS for fast quality remanufacturing service. Complete

Complete Remanufacturing Service
25% OFF
All Standby and Pole Mounted Power Supplies

service is available for all makes – all models of Receivers, Signal Processors, Modulators and Field Strength Meters. Call today for fast "Better Than Brand New", service!

IN-STOCK INVENTORY



Line Gear Sale!

Any FSM Complete clean and calibration only
\$29.95

10%...20% up to
50% OFF
Line and Distribution Equipment in stock

BradPTS™

Call our Tampa Servicenter toll free.

1-800-759-2288

Or FAX your purchase order to:
813-621-6617
Offer Expires 2/28/89

Call toll free today!

Contents

Departments

From the Editor 6

News 8

You and the SCTE 11

What's new with the Society plus technical sessions for the Texas Show.

Installer Input 34

Alan Babcock of Warner Cable Communications provides tips for safely drilling holes during an install.

Installer's Tech Book 37

Drop clearance requirements for routing cable are covered by Jones Intercable's Pam King.

Business Directory 39

Products 40

Ad Index 42

From the NCTI 42

Byron Leech highlights new lessons available under the Graduate Update Program.

Cover

Safety and CLI should be top priorities in your system.
Art by Geri Saye.

— — — — 2.2 ℓ — — — —

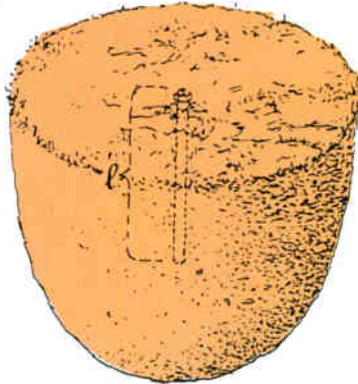

Grounding and bonding 12

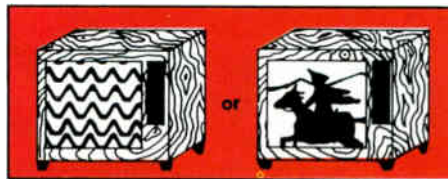

Consumer interfacing 29

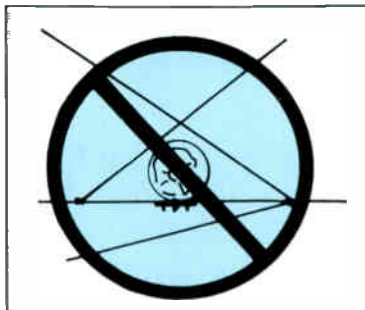

Installer's Tech Book 37

Features

Grounding, bonding of electrical systems 12

Roy Carpenter of LEC discusses the art of making a safe connection between a conductor and a semiconductor.

Electric shock: effects, precautions 20

NCTI's Ray Rendoff reveals hazards encountered when working around electricity and how to prevent them.

Complying with CLI requirements 22

The installer/technician's role in creating a leak-free system is highlighted by Robert Saunders of Sammons.

Traffic safety—the forgotten area 25

SCTE's Ralph Haimowitz provides the statistics on vehicular accidents and their causes.

Basic electronics 26

Ken Deschler of Cable Correspondence Courses discusses capacitors and capacitance.

Interfacing with consumer electronics 29

Part III of a series from the NCTA's Engineering Committee illustrates various installation setups.

IT-Installer/Technician © 1989 by Communications Technology Publications Corp. All rights reserved. Installer/Technician (ISSN 104-1253) is published monthly by Communications Technology Publications Corp., 12200 E. Briarwood Ave., Suite 250, Englewood, Colo. 80112—or—P.O. Box 3208, Englewood, Colo. 80155, (303) 792-0023. February 1989, Volume, 1, Number 10. Office of publication is 12200 E. Briarwood Ave., Suite 250, Englewood, Colo. 80112. Change of address notices should be sent promptly; provide old (or copied) mailing label as well as new address, including ZIP code; allow 6 to 8 weeks for change. Second-class postage paid at Englewood, Colo., and additional mailing offices. POSTMASTER: Please send address changes to Installer/Technician, Box 3208, Englewood, Colo. 80155.

ON THE ROAD AGAIN!

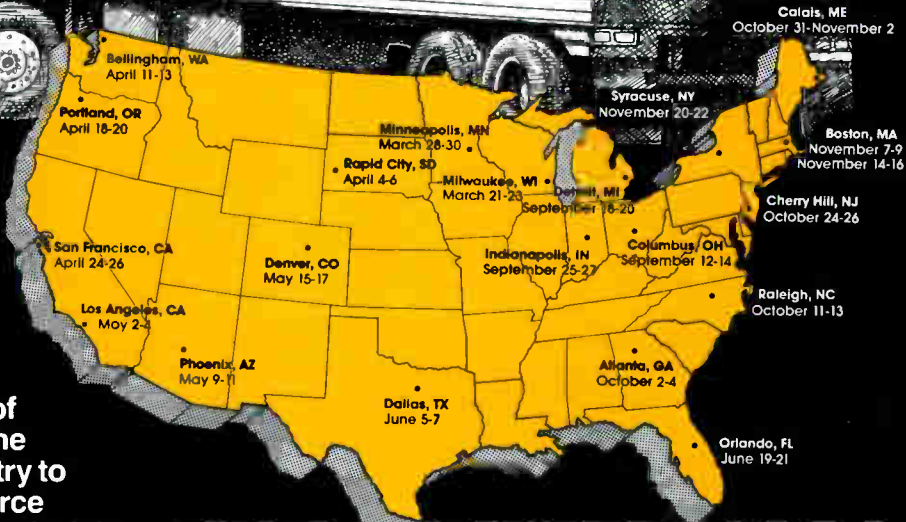

We'll be clocking 20,000 miles to 20 cities to bring the best in CATV training to you.

The Magnavox Mobile Training Center is beginning its eighth year of traveling coast-to-coast, bringing the most intensive training in the industry to a city near you. We'll help you reinforce practical skills, improve efficiency and minimize errors.

Three days of basic theory, practical applications and hands-on training.

At each stop our three day seminar covers plenty of ground. From cable fundamentals and theory to hands-on operation of field test equipment, our Mobile Training seminars provide valuable information to anyone in the CATV industry.

If you're interested in enhancing your CATV skills, choose a seminar near you. Space is limited. Fill in the coupon and mail it to us or call. Your \$300 tuition covers all training, materials and lunches.

(800) 448-5171

In New York State call 800-522-7464.

Reader Service Number 3.

Please send me your Mobile Training Seminar brochure.

Please reserve space for me at the seminar listed below. I've enclosed a check for \$300 (payable to Magnavox CATV Systems) for the three day session.

NAME _____

TITLE _____

COMPANY _____

ADDRESS _____

CITY _____ STATE _____ ZIP _____

PHONE _____

SEMINAR SITE _____ DATE _____

IT 2/89

Mail to: Mobile Training Center Seminars
Magnavox CATV Systems Co.
100 Fairgrounds Drive, Manlius, NY 13104
Or call 1-800-448-5171 (In NY call 1-800-522-7464)

MAGNAVOX
CATV SYSTEMS CO.

From the Editor

Consider the consequences

Would you skydive without a parachute, drive in the dark with no headlights on or put your hand in a running garbage disposal? Of course not. From the ridiculous to the sublime, common sense would prevail. How about climbing a pole without a hard hat, safety belt or proper gaffs? The answer for a lot of you is probably not. And if you do wear all the proper equipment, it may only be because it is demanded by your cable system.

But how many of you hop into your trucks and drive to a job site without buckling up? Do you take shortcuts when performing a job because it's easier? If you do, perhaps you feel you know what you're doing (you're an old pro after all, right?). Or maybe you just don't think of such trivialities. Well, in case you didn't know, carelessness can be deadly.

Reality rears its ugly head in the statistics. According to an article in the Jan. 8 issue of *Parade* by Earl Ubell titled "Is Your Job Killing You?" electric power line and cable installers and repairers ranked fourth (in blue collar jobs) for risk of work-related deaths. The study from which this information was taken ("Job-Related Deaths in 347 Occupations," by J. Paul Leigh, San Jose State University) found that there are 50.7 deaths per 100,000 workers—more than the death rate for firefighters! Rather alarming statistics, don't you think?

What can be done to reduce this needless tragedy? Although there are some dangerous situations you cannot foresee or avoid, the responsibility for your safety lies with you. This month, we hope to open your eyes to the potential dangers involved with your job, as well as provide some tips to prevent these hazards.

Consider the article by Ralph Haimowitz on traffic safety. Installers and technicians often spend a great deal of time on the road. By wearing a safety belt and being alert to ever-changing road conditions, you could save yourself and others from becoming one of the many traffic fatalities each year.

Working around electricity, the installer/technician is exposed to the risk of electrical shock—not a pleasant experience, to say the least. In his article, Ray Rendoff

describes the body's response to shock and provides some hints to avoid this potentially life-threatening situation.

The bottom line here is that you are ultimately responsible for your own safety, as well as the safety of others. Let's make 1989 a safer and saner year for everyone!

Flori-days ahead

As you may have read in previous issues of *IT*, the Society of Cable Television Engineers' Cable-Tec Expo is coming up June 15-18. The Orange County Convention Center in Orlando, Fla., will be the site for what promises to be an exciting and educational event. In addition to an exhibit floor filled with the latest in equipment and services for the broadband industry, there will be two days devoted to presenting technical sessions covering topics such as CLI and new technologies (see "You and the SCTE" for more on these sessions). This expo will be a great opportunity for you to increase your knowledge and become a more valuable employee. Why not point this out to your manager? There's still time to take this chance to expand your intellectual horizons (and just maybe you'll get a day or two of Florida sun to boot.)



IT INSTALLER TECHNICIAN

Paul R. Levine
President/Publisher

Toni I. Barnett
VP of Editorial

Martin L. Laven
VP of Sales and Marketing

Wayne H. Lasley
Editor in Chief

Neil Anderson
National Sales Manager

Rikki T. Lee
Managing Editor

Lu Ann Curtiss
Account Executive

Shelley Bolin
Assistant Editor

Cindy Cole
Marketing Director

Chuck Grossman
Editorial Assistant

Barbara Bellomo
Classified Ad Manager

Sharon F. Lasley
Art Director

Marie T. Beert
Marketing Administrative Asst.

Brad Hamilton
Asst. Art Director

Marla Sullivan
Production Coordinator

Mary L. Sharkey
Circulation Manager

Jim Watts
Asst. Production Coordinator

Kathleen Jackson
Circulation Clerk

Kenny Edwards
Controller

Geneva Hobza
Assistant Controller

Office: Communications Technology Publications Corp.,
12200 E. Briarwood Ave., Suite 250, Englewood, Colo.
80112, (303) 792-0023. Mailing Address: P.O. Box 3208,
Englewood, Colo. 80155.

Advisory Board

Alan Babcock
Warner Cable Communications Inc.

Wendell Bailey
National Cable Television Association

Richard Covell
Society of Cable Television Engineers

Dana Eggert
dB Associates

Joseph Girard
Cooke Cablevision Inc.

Roland Hieb
National Cable Television Institute

Ron Hranac
Jones Intercable Inc.

Patrick K. McDonough
United Cable Television Corp.

Larry R. Linhart
NaCom

Celeste Rule Nelson
Television Publications Inc.

David Pangrac
American Television and Communications Corp.

Dan Pike
Prime Cable

Rex Porter
Pyramid Industries

Jon Ridley
Jerrold Division / General Instrument Corp.

William Riker
Society of Cable Television Engineers



The right way for installers to figure out what's wrong.

The best time to discover a subscriber installation problem is at hook-up. *Before* you have to make an expensive service call.

That's why Wavetek developed MicroSAM, a new hand-held installer's meter that gives digital readouts of channel signal levels.

For instant troubleshooting.

If an installer discovers a problem, he can track it down simply by



retracing his steps. Testing every point from the TV to the tap. Until he finds it.

An LCD display gives the *exact* signal level (without dummy lights or needles to read.) *At three* frequencies, not just two. Frequencies *you* set, not the factory.

MicroSAM has programmable band ranges up to 550 MHz. At ± 1 dB accuracy, with 0.1 dB resolution.

Reader Service Number 4.

MicroSAM gets rid of the guesswork. So you get it right the first time.

Call Wavetek at 1-800-622-5515 (in Indiana call 317-788-5965) for more information and the name of the nearest MicroSAM distributor.

WAVETEK®

News

Biddle offers courses in electrical measurement

BLUE BELL, Pa.—Biddle Technical School is offering specialized courses in several areas of electrical measurements on power distribution and power apparatus here this spring. Courses range from two to five days in length, providing background on the subject matter and utilizing classroom demonstrations and hands-on field testing.

Topics covered include power factor testing of power apparatus high voltage insulation, DC testing of power apparatus insulation, partial discharge detection in insulation systems, earth resistance testing and cable fault locating in power systems. Courses begin in March and are offered through June.

For more information, registration forms and a descriptive brochure, contact Biddle Technical School, Biddle Instruments, 510 Township Line Rd., Blue Bell, Pa. 19422, (215) 646-9200.

Official jackets available from SCTE

EXTON, Pa.—An official Society of Cable Television Engineers (SCTE) jacket is now available to its members, allowing them

to display embroidered patches they have earned through Society participation. The jackets are grey nylon with the SCTE logo embroidered on the back and may be personalized for an additional fee.

Patches that may be placed on the jacket include the member patch and the 20th anniversary patch sent to national members in election packages last year and this year. Other patches are available denoting special honors, such as Senior Member and Outstanding Achievement Award, and progress in the BCT/E program. SCTE also will offer Cable-Tec Expo patches in the near future. For more details, contact SCTE, 669 Exton Commons, Exton, Pa. 19341, (215) 363-6888.

Comcast selects Jerrold for rebuild

WEST PALM BEACH, Fla.—General Instruments' Jerrold Division was selected by Comcast Cable Communications to supply fiber optic and conventional CATV electronics for its system rebuild here. The rebuild is expected to cost approximately \$25 million, with Jerrold supplying about \$10 million worth of equipment.

The fiber optic electronics will be used for an FM supertrunk connecting the new headend near Greenacres to strategically

located hubs in Jupiter, West Palm Beach and Boynton Beach. This will allow Comcast to transmit as many as 83 forward channels throughout the system and 20 on the return path between two selected hub sites.

The entire Florida rebuild, which covers 1,100 miles, is expected to be completed in four years. The system will eventually be comprised of more than 100,000 subscribers in 18 communities, including Palm Beach County. Plans call for two additional hub sites to be added at a later date.

Street named for N.Y. cable company

STATEN ISLAND, N.Y.—Mayor Edward Koch recently signed a bill officially renaming a one-block section of Goodrich Ave. as Cable Way, honoring Staten Island Cable as the first cable TV company to wire an entire borough. The bill was sponsored by Councilman Jermone O'Donovan and was unanimously passed by the council Nov. 22. Currently serving more than 42,000 Staten Island families, Staten Island Cable has already provided cable service to all local areas serviced by overhead utilities. Underground wiring is underway.



Owsley Drop Saddle

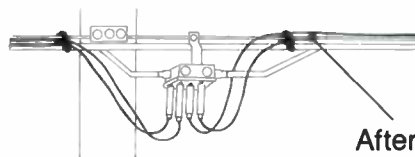
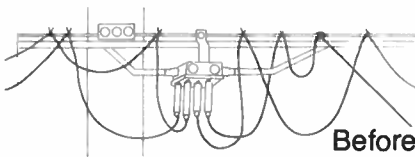

Not only neat and professional, they are practical.

The Owsley Drop Saddle keeps drops organized for efficient installation, trouble shooting, and removal.

For more information and a sample call 800-548-7243.

 **Telecrafter Products**

Products creatively designed for the cable industry

REPRINTS

Communication
Visibility
Knowledge
Information

Reprints work for you!

For more information
call Marla Sullivan at
CT Publications today!
(303) 792-0023.

Reader Service Number 5.

You and the SCTE

Razorback Chapter meeting for installers

In an effort to get cable personnel at the installer level more involved in the Society of Cable Television Engineers (SCTE), the Razorback Chapter recently held a special installer's meeting Oct. 22 at the Best Western Hotel in Little Rock, Ark. According to Razorback Chapter Secretary Jim Dickerson, the meeting was held on a Saturday morning to allow installers to attend.

The chapter drew speakers from its own membership to present the technical program for the event. The speakers were Allan Phillips of Pine Bluff Cable TV on basic electronics, Mike Allbright of Pine Bluff Cable TV on installation procedures, Robert Hagan of Resort Cable TV on troubleshooting install problems and Arnold Morriss of TCA on headends. "The meeting was a great success, with 59 people in attendance," Dickerson reported. "We will plan this type of meeting again due to the overwhelming success of this one."

BCT/E incentive from Northland Communications

The Society's Inland Empire Meeting Group recently reported on a new policy established by Northland Communications, which has 35 systems in the Northwest United States. The operator is making available a \$1,000 cash bonus to any employee in each of its systems who passes all seven categories of the Society's Broadband Communications/Engineer (BCT/E) Certification Program.

Successful BCT/E candidates employed by Northland will receive the \$1,000 bonus at the end of each year that they work for the company and maintain their BCT/E certification. This policy was established to encourage employees to become more knowledgeable in their field and to prevent these well-trained and valuable employees from leaving the company.

Chesapeake Meeting Group gains chapter status

The Chesapeake Meeting Group has been officially elevated to full chapter status. The new SCTE Chesapeake Chapter is based in Timonium, Md. and was recognized as an official chapter at its meeting held Dec. 1 at the Holiday Inn

in Columbia, Md. SCTE Executive Vice President Bill Riker was on hand to present the chapter status award to the group.

The Society currently has 29 chapters and 18 meeting groups for a total of 47 local groups. Recent months have witnessed the formation of two new meeting groups under the auspices of the Society. The new groups are the Big Sky Meeting Group, based in Harlowtown, Mont., and the Hawaiian Island Meeting Group, based in Kahului, Hawaii. The Big Sky Meeting Group held its initial gathering Dec. 8 at TCI State Headquarters in Helena, Mont. The Hawaiian Island Meeting Group met Sept. 15 for an organizational meeting at which its officers were elected. The group held its first general meeting Nov. 16.

Technical sessions for 1989 Texas Show

SCTE will sponsor the technical sessions for the Texas Cable Show, to be held Feb. 22-24 in San Antonio, Texas. The

agenda of technical sessions on Thursday, Feb. 23, is as follows: "CLI: It's Not Just for Engineers Anymore," with Ted Hartson (Post-Newsweek Cable) and John Wong (FCC); "CLI: Protecting Your Channel Capacity," with Robert V.C. Dickinson (Dovetail Systems), Les Reed (Sammons Communications) and Raleigh Stelle (Austin Cablevision); and "New Technologies: A Look at the Future," with Wendell Bailey (NCTA) and John Holobinko (American Lightwave Systems).

The SCTE Interface Recommended Practices Committee will hold a meeting in conjunction with the Texas Show Feb. 22 from 8 a.m. to 1 p.m. in room 106 of the San Antonio Convention Center. BCT/E examinations will be administered Feb. 23 following the conclusion of the technical sessions. SCTE Executive Vice President Bill Riker will be serving as proctor. The FCC "mobile testing laboratory" also will be on the exhibit floor and will be staffed by compliance engineers from the FCC field offices in Houston and Kingsville, Texas. ■

FREE CATALOG!

The 1989 BUDCO catalog is here.

Call us for your free copy. You'll find an expanded selection of identification, installation, and security products; and much more.

BUDCO is a stocking distributor for: Lemco Tools, Aervoe-Pacific, Masterlock, MultiLink, Gilbert, W. H. Brady, and Tyton Corp. Great selection. Superior quality. Quick response. Fair prices. It all comes with the 1989 BUDCO catalog.

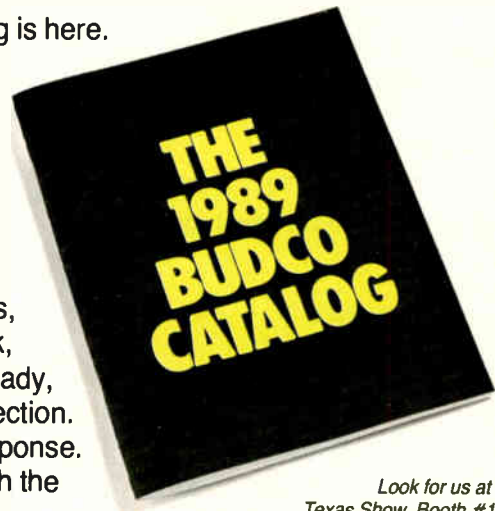

Look for us at the Texas Show. Booth #118.

1-800-331-2246*

*IN OKLAHOMA, CALL COLLECT (918) 252-3420 / FAX: (918) 252-1997

Budco P.O. Box 3065, Tulsa, OK 74101

Reader Service Number 6.

Installer/Technician February 1989 11

The art of grounding and bonding

By Roy B. Carpenter Jr.
 Chief Executive Officer
 Lightning Eliminators & Consultants Inc.

Grounding and bonding of electrical and electronic systems is considered an art rather than a science because there is no way to set parameters for all of the factors that influence the results. The results can be measured, observed or experienced but not predetermined. Further, the assessed results, measured under one set of conditions, are not necessarily indicative of what may be found later, even when the conditions appear to be the same. It is therefore necessary to understand the conditions that influence the results (at least qualitatively), know those factors you can influence and understand the parameters related to your specific grounding problem.

Grounding is the act of establishing an

"The soil within the interfacing hemisphere must be above freezing and contain enough moisture and minerals to provide a satisfactory interface..."

electrical connection with earth. The interface between your system and earth is the grounding system. Usually the lower the resistance of that interface, the better. However, this is not always required for optimum system performance. It is therefore necessary to examine the requirements

related to your specific grounding objective.

There are about four different reasons for grounding but they impose only one of two requirements on that earth interface called ground:

1) Low resistance interface: required for

Figure 2: Interaction between interfacing hemispheres

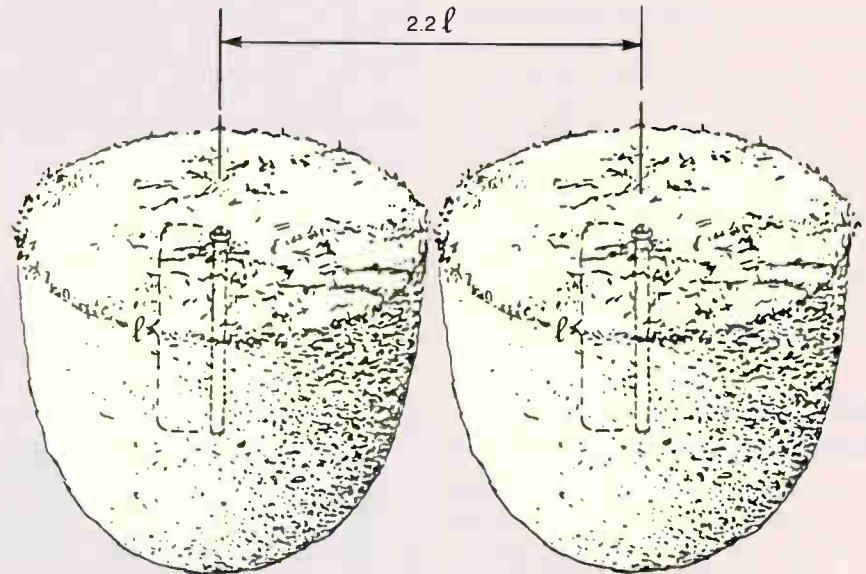

Note: For a 10-foot rod the separation distance should be 22 feet.

Figure 1: The interfacing hemisphere

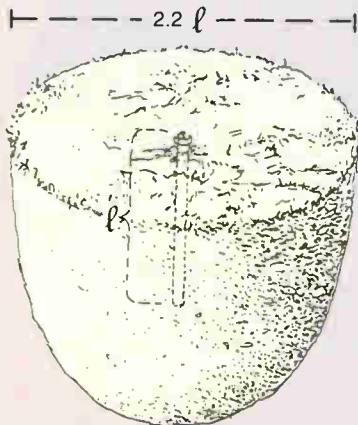
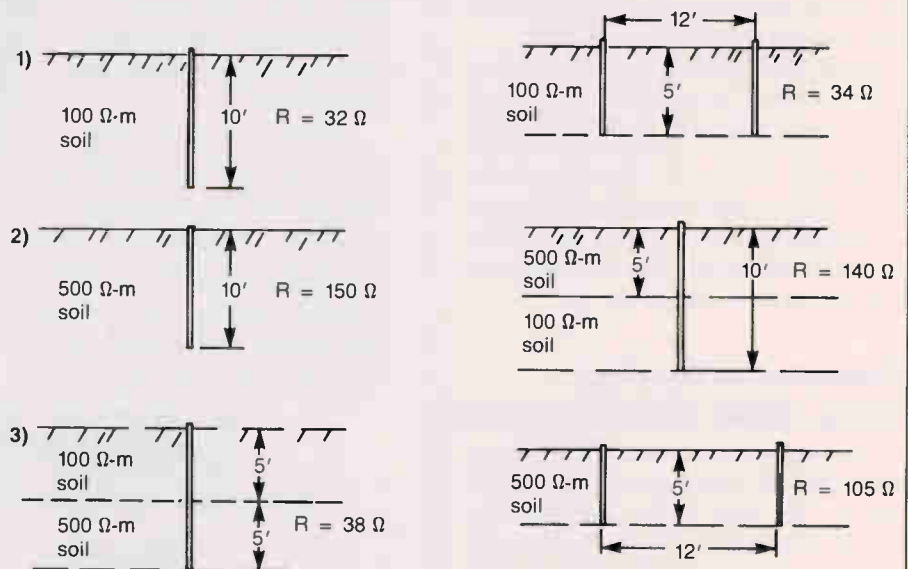
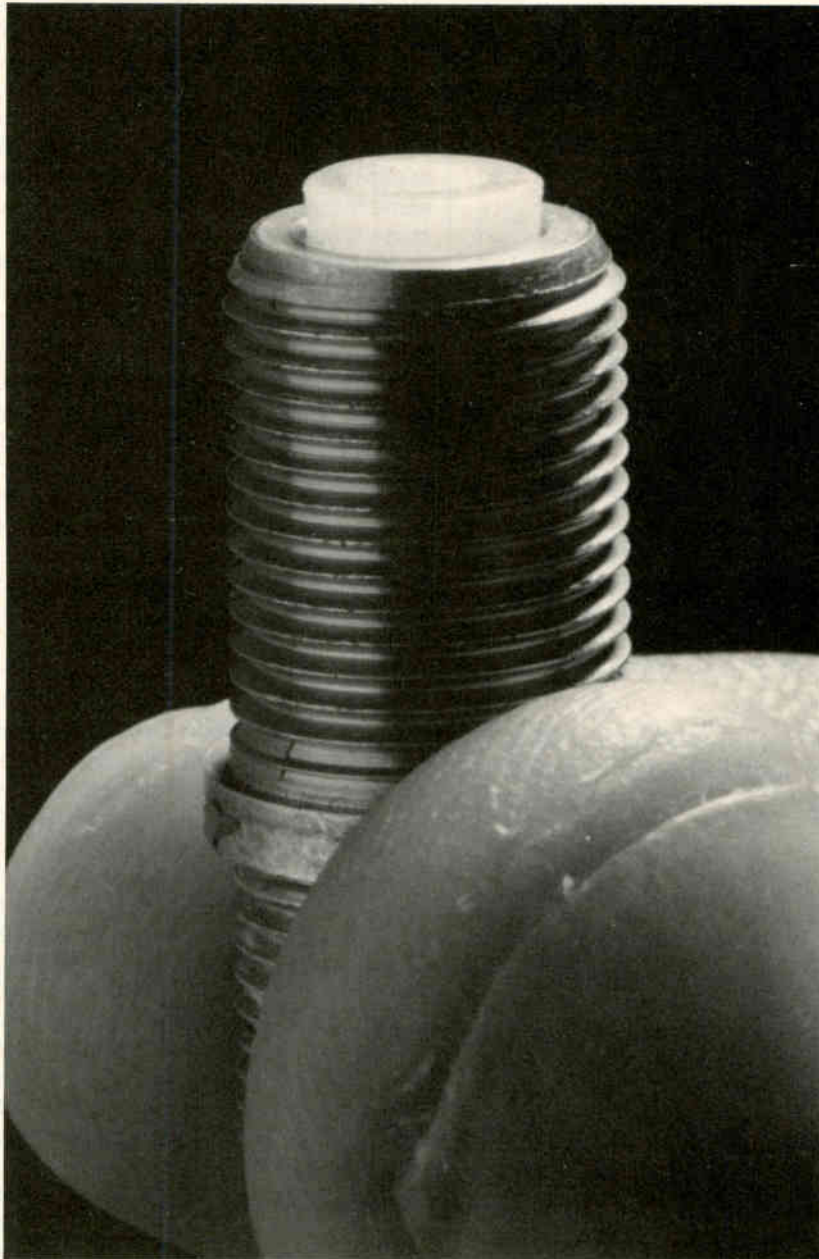

Figure 3: Impact of rod length and stratification



Antronix Brings You The Greatest Cable Invention Since Cable Itself.

The New Antronix® CAM-Port® The "Connector Activated Mechanism" (CAM)



CAM-Port® is a registered trademark of Antronix®
Antronix® 1989.
Patent Pending.

Introducing a revolution in cable port design: the Antronix® CAM-Port®.

The new CAM-Port delivers the most reliable, intermittent-free connections since the dawn of the cable era.

New CAM Action.

The new CAM mechanism will automatically grip any size center conductor with the exact contact pressure to insure a reliable, intermittent-free connection.

New Contact Design.

The key to a proper mechanical and electrical connection is the contact area. Present design, by its own nature has to have a marginal contact area. In the CAM-Port, the whole contact is the contact area.

Normally Open Contact.

This normally open contact design allows perfect plating over the entire contact area.

The Incredible Result:

Exact contact pressure. No insertion wear on the contact. Perfect contact plating. No more loose connections. No more port failures.

The new CAM-Port is rapidly setting a new industry standard.

Soon, it will be standard equipment on all Antronix cable products.

Antronix is now connecting the world of communications better than ever. And suddenly, every other cable port is obsolete.

Made your perfect connection by calling Antronix at 201-446-2626.

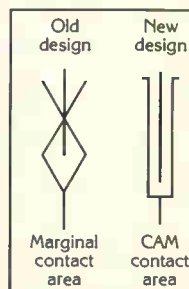

ANTRONIX

Connecting the World of Communications.

Reader Service Number 7.

all lightning protection systems (except the LEC dissipation array¹). Electrical substations also require low resistance grounds since ground faults create safety hazards and equipment damage.

- 2) Ground reference: required for any electronic system, which is merely a point of common reference called "ground." Its actual resistivity is of little significance if all of the equipment within the given facility is properly bonded to that reference point. This reference point is often called *the common point ground (CPG), ground win-*

dow or ground reference.

Achieving the low resistance interface demands an understanding of those factors that influence grounding resistance. Establishing a good ground reference demands an understanding of good bonding practices and those factors that influence both contact resistance and ground loops. This article discusses the factors related to each of these problems individually and collectively as they influence each other.

Making a good connection

As previously mentioned, grounding is

the art of making a connection with earth. Since soil is a semi-conductor, grounding also is the art of making a connection between a conductor (the rod or wire) and a semiconductor (the surrounding soil). Many factors influence the effectiveness of this connection including the type of soil, the size and orientation of the conductor, and the soil condition. The connection itself requires a significant volume of earth (soil) surrounding the conductor. It has been shown through experimentation² that each ground rod requires a hemispheric shaped volume of that soil with a diameter 2.2 times the rod length in the soil (Figure 1). Therefore, where two or more rods are used in close proximity they must be separated by 2.2 times their length (Figure 2) or the effectiveness of each additional rod is reduced proportionally. As an example, two 10-foot rods separated by one foot yields about the same resistivity to earth as only one of the same length rods.

Use of rods longer than 10 feet is usually wasteful because the return in reduced resistivity for increased rod length decreases exponentially with length in uniform soil. As an example, where a 10-foot rod yields 100 ohms, a 100-foot rod yields 50 ohms in the same soil. Two or three 10-foot rods, properly deployed, would yield the same or better results for far less cost and effort. As a general rule, many short rods are far better than one long rod. This is illustrated by Figure 3, which also shows the impact of soil stratification.

Tests have shown that where stratified soil is present, it is better to work with the upper soil levels, even if there is more conductive soil below. This holds only as long as there is enough moisture in the upper soil levels; where there is little to no moisture, there is no soil contact.

Figure 4 illustrates the number of 3/4-inch by 10-foot ground rods required to achieve a given grounding resistance as a function of soil resistance. Rod diameter exercises little influence on the ultimate resistance. From this, it should be clear that soil resistance is the determining factor. Where low resistance is required many rods are needed. For example, 800 rods are required for a 1 ohm ground resistance in 1,000 ohm-meter soil.

After the grounding conductors have been selected, the soil resistivity is the remaining factor to consider. Its condition will determine the achievable resistivity for any given rod/wire grounding matrix. It has been shown² that the soil part of the electrical interface is a hemispheric volume as in Figure 1. It also follows that

CLIDE

Control Leakage Index Data Easily

A **powerful** solution to your
system's CLI Management problems.

*Easy to use • Menu driven for ease of operation
Wide selection of printed reports • Inexpensive*

CLIDE is a software program designed and developed by a cable TV engineer to aid CATV technicians in controlling RF signal leakage in their cable TV system.



*Get the facts before you
buy. Remember, all software
is "not created equal!"*

For details call
(717) 267-3939

*Sold and supported by a company
known for their genuine customer support!*



**Telecommunication
Products Corporation**
Chambersburg, PA 17201

Reader Service Number 8.

on tap at **Toner**



XMT SERIES
2-Way, 4-Way, 8-Way
5-550 MHz Multi-Taps

- Plated Solid Brass F Connectors
- Baked Acrylic Corrosion Coating
- Stainless Steel Mesh RFI Gasket
- Neoprene Weather Gasket
- Stainless Steel Hardware
- Sealed F Ports
- Plastic Cover Over PC Board

toner
cable equipment, inc.

800-523-5947

IN PA 800-492-2512

FAX 215-675-7543

969 Horsham Road

Horsham, Pennsylvania 19044

Figure 4: Ground rod requirements as a function of soil resistivity

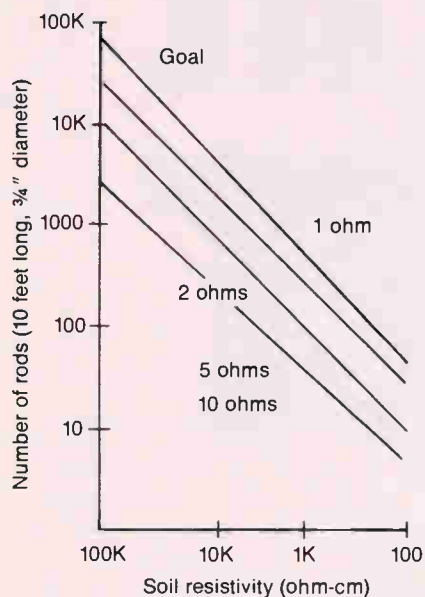

the condition of resistivity of that soil alone will determine the ultimate resistance of the grounding connection for that hemisphere/rod interface.

Since soil is the determinant, the factors that influence its resistivity must be carefully considered. There are three factors that may be controlled or influenced by man: moisture content, mineral content and temperature. Other factors such as soil type and granularity may have a significant influence but are not considered controllable.

Figure 6 illustrates the impact of temperature. Temperatures above freezing are required as frozen earth is not a conductor (work in permafrost is a real challenge). Higher temperatures exercise little influence. Figure 7 illustrates the impact of adding a mineral such as salt (NaCl); in simplistic terms, high resistance can be made low. As an example, the addition of 10 percent salt solution will reduce a 1,000 ohm-meter soil to 100 ohm-meters. However, after a year or so, the rain will wash it away and the soil will eventually return to its original resistance.

So overall, the soil within the interfacing hemisphere must be above freezing and contain enough moisture and minerals to provide a satisfactory interface with your conductor. How then do we deal with the less than ideal situations? The only solution is to condition the soil.

To condition the soil, we must influence

Figure 5: Influence of moisture on resistivity

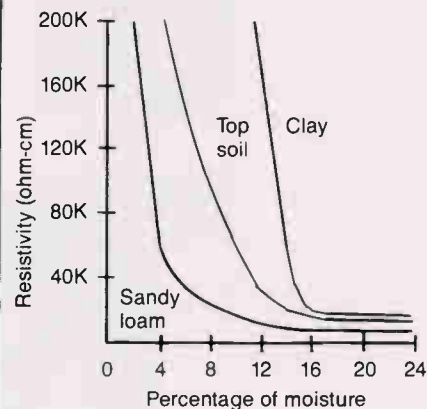

one or all of the three parameters. To deal with temperature we must go below the frost line or add heaters within the interface.

To alter the mineral content, we must provide a metallic salt that will constantly replenish that which is washed away by rainfall. As a side effect, we also will raise the frost line by lowering the freezing point of that soil (salt water freezes at lower temperatures than water). Constant replenishment of the mineral content can only

INSTANT CABLE TV

Triple Crown helps to control the start-up costs of your system by designing, racking, testing and shipping your complete Head End ready to plug in. **There are no extras required.**

... and we do this very economically. **Over 1200 system operators** have selected Triple Crown Electronics for their own pre-packaged Head End requirements.

Example: 12 Channel PRE-RACKED Head End

- 7 - Satellite Channels using Synthesized Satellite Receivers and SAW Filtered Modulators.
- 5 - Off-Air Channels using SAW Filtered Hetrodyne Processors only. (No Strip Amps)
- Design, Racking, Combining, Burn-In, VC-II Wiring Harness, Layout Drawing, Proof of Performance Spectrum Photo & Certificate. . . . **ALL THIS FOR ONLY \$10,920.00**

For your Pre-packaged Head End, call Triple Crown firstbecause we are!

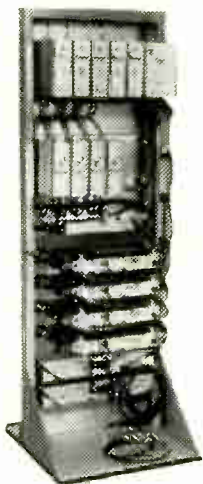

TRIPLE CROWN ELECTRONICS

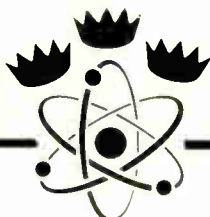

4560 Fieldgate Dr.
Mississauga, ON L4W 3W6

(416) 629-1111
1-800-387-3205

Reader Service Number 10.

From Headend to Drop

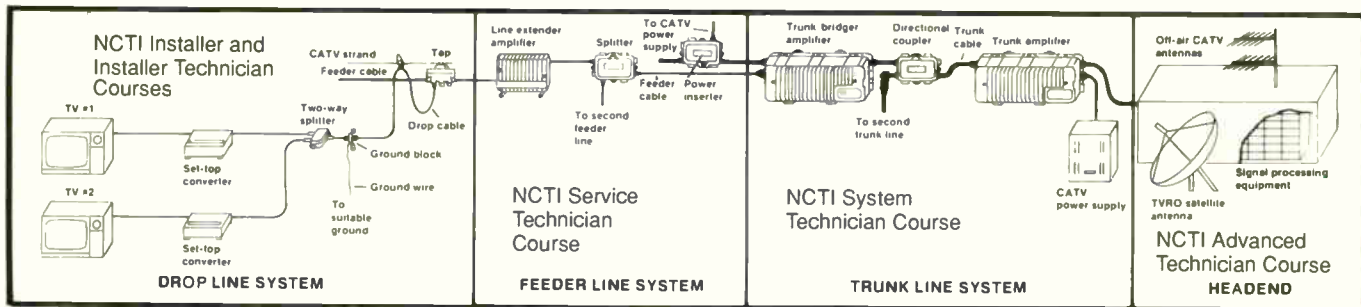

NCTI is the industry's technical training source

Where is your technical training need?

At the installer level? Continuing education for your Chief Tech? Technical insight for your Customer Service Reps? No matter what level of technical training your operation needs, NCTI has courses to offer.

For more than 20 years NCTI has been providing the technical training cable industry professionals need to ensure engineering excellence. Why has NCTI become the industry's technical training source?

Technical Excellence

NCTI lessons are authored by experts and reviewed by a Board of Technical Advisors which includes some of the industry's most experienced engineers and technicians.

Up To Date

NCTI lessons have been undergoing an intensive updating process. Material is carefully screened and changed to reflect the rapid advancement in technology and techniques.

Comprehensive

From F-connectors to satellite receivers, from modulators to set-top converters, NCTI covers the full range of cable industry technical issues.

Self Paced

NCTI's courses are designed to allow students to progress at their own pace, and to study when and where they are most comfortable. As a result, NCTI students complete a far greater proportion of courses than most like training programs.

Easy To Administer

NCTI takes the pain out of your technical training. We make it simple to enroll students and monitor their progress. Each time a student submits an exam, a grade report is promptly returned. And, each quarter management receives a Progress Report showing the status of each student in their system.

Our goal is to provide the industry's best training materials and to produce qualified technicians and engineers equipped to construct and operate first class cable television systems.

To learn how you can put NCTI training to work in your system, or how to enroll, call us at (303) 761-8554, or return the coupon. **Do it today!**

Send For Your FREE Training Kit Today!

Name _____

Title _____

Company _____

Address _____

City _____ State _____ Zip _____

Phone _____



Mail this form to:

NATIONAL CABLE TELEVISION INSTITUTE

P.O. Box 27277, Denver, CO 80277
(303) 761-8554

IT 2/89

Figure 6: Influence of temperature on resistivity

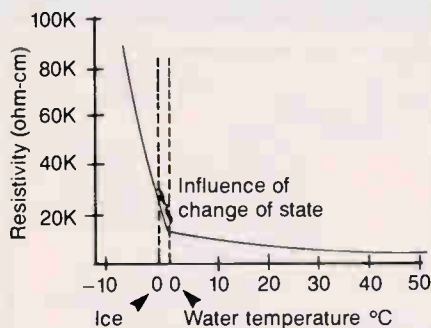
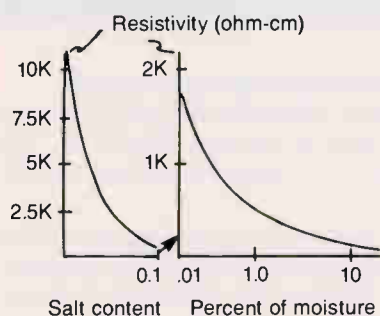

Figure 7: Influence of metallic salts on resistivity



be accomplished through use of a chemically activated grounding electrode (such as Chem-Rod³) that also may be fitted with automated moisturization attachments.

Bonding considerations

Bonding is the art of providing a good connection that has low resistance, a long life and is independent of weather or atmospheric conditions. There are two general types of connections, each with two subclasses:

- 1) Compression connections
 - a) crimp-on connectors (squeezed on with special tools)
 - b) clamp-on connectors (tightened in place with bolts)
- 2) Union of metals
 - a) thermoweld (e.g., cadweld)
 - b) brazing, soldering, welding, etc.

Listing these in order of effectiveness, they are: 2a, 2b, 1a; 1b is not recommended for any external connections as it is subject to corrosion and loosening.

Use of a CPG or ground window is the safest, surest and most effective grounding concept for any electrical or electronic system (Figure 8). Basically, it is a method of providing an independent grounding bus for each piece of equipment, which in turn is common to all systems.

Figure 8: The CPG concept

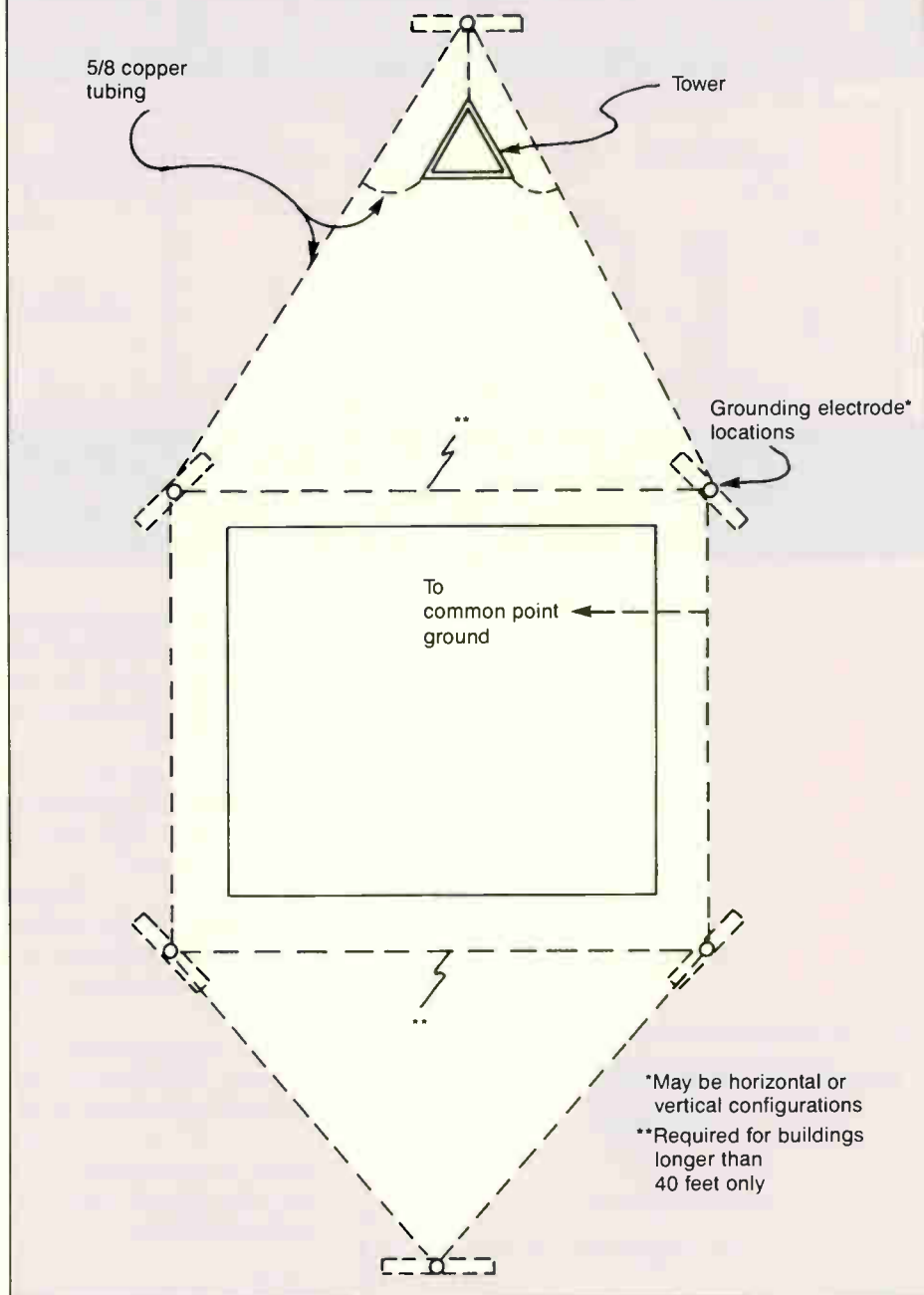

For single-story buildings, the CPG should be located at the electrical service entrance, where a ground is established for the meter box. Each piece of equipment must have a separate ground wire to the CPG that is independent of all other ground wires. Every piece of equipment, every rack and every metallic object must be bonded to that CPG, but with a separate wire. This eliminates the possibility of "ground loops"; separate paths eliminate the possibility of induction from one wire to another. Cable trays look great but they can spell trouble.

For multistory buildings with a remote ground system establish a CPG at the main breaker panel for the respective

systems and proceed as for a single-story building, but make a single autonomous connection from that CPG to the remote ground. Permit no other connections to that wire until it reaches the building CPG or ground system and use a separate conduit where possible. ■

References

- ¹Roy B. Carpenter, "Lightning Strike Protection, Criteria, Concepts, and Configurations," LEC 01-86.
- ²G.F. Tagg, *Earth Resistance*, London WC2, George Newnes Ltd.
- ³Roy B. Carpenter, "Achieving Low Resistance Grounding Interface," LEC Report, 1987.



Sustaining Members

are cable industry organizations that show their support for the Society through financial contributions and personal involvement. Proceeds from Sustaining Membership dues are used to fund the Society's Satellite Tele-Seminar Program, now in its fifth year, which uplinks technical training videotapes for cable television systems across the country to downlink, view and record free of charge.

SCTE thanks the following sustaining member companies for their continued support.

ADS/LineX Inc. *
 Alpha Technologies Inc. *
 AM Communications
 American Cablesystems
 Anixter Communications *
 Antenna Technology Corp. *
 ATC Corporate Headquarters
 AT&T *
 Atlantic Cable Show
 AVT Inc.
 Belden Wire and Cable *
 Ben Hughes Communication
 Blonder-Tongue Labs *
 BradPTS *
 Broadband Engineering/Augat *
 Budco Inc. *
 C-Cor Electronics Inc. *
 Cable Converter Service *
 Cable Link Inc. *
 Cable Resources Inc.
 Cable Security Systems *
 Cable Services Co. Inc. *
 Cable TV Supply Co.
 Cablecom Specialists *
 Cabletek Center Products *
 Calan Inc. *
 California Cable Television Association
 Caribbean Communications Corp.
 Catel Telecommunications *
 CED
 Centel Cable TV
 Channel Commercial *
 Channel Master *
 Channelmatic Inc. *
 Coaxial Communications
 Comm/Scope *
 Common Inc.
 Communications Technology
 Comsonics Inc. *
 Converter Parts Inc. *
 Corning Glass Works *
 Cox Cable Communications
 CWY Electronics Inc.
 Daniels and Associates
 Diamond Communication Products *
 Digitrace Inc.
 Di-Tech Inc.
 Drop Shop Ltd. *

DX Communications Inc. *
 Eagle Comtronics Inc. *
 Eastern Microwave Inc.
 FM Systems *
 Foresight Products Inc. *
 Galaxy Communications Systems
 General Instrument/Jerrold *
 Gilbert Engineering *
 Goldak/UDSEC *
 Hall's Safety Equipment *
 Hewlett-Packard Co. *
 Home Box Office Inc.
 Hughes Microwave Products *
 Intercept Sales *
 Interstate Cable Enterprises *
 Intrastellar Electronics
 ISS Engineering Inc. *
 ITW Linx
 Jerry Conn Associates *
 John Weeks Enterprises *
 Jones Intercable
 Kalun Communications *
 Kennedy Cable Construction *
 Layton Utility Eq. Co. *
 Lectro Products *
 Lenfest Cable Group
 Lindsay Speciality Product *
 Locite Corp. *
 LRC Electronics Inc.
 M/A COM *
 Magnavox CATV Systems *
 Mainline Equipment *
 Matrix Test Equipment
 Mega Hertz *
 Microdyne Corp.
 Midwest CATV *
 Montgomery Communications Co.
 Moore Diversified Products *
 Nacom *
 National Cable Television Institute
 NCS Industries Inc. *
 Newhall Pacific and Yumen *
 Newport Cablevision
 Northeast Filter Co. Inc. *
 Northern CATV Sales/Arcom *
 Oak Communications *
 Panasonic Industrial *

PCC Inc. *
 Pico Macom Inc. *
 Pioneer Communications *
 Power and Telephone Supply
 Power Technologies Inc. *
 Production Products Co. *
 Pyramid Industries *
 Qintar Inc. *
 Quality RF Services *
 R.L. Drake *
 Reliable Electric/Utility Products *
 Resource Recovery Systems *
 Riser-Bond Instruments *
 RMS International Inc. *
 RTK Corp. *
 Sadelco Inc.
 Scala Electronic Corp.
 Scientific-Atlanta Inc. *
 Shoreline Professional Video Systems
 Signal Sources Inc. *
 Standard Communications *
 Storer Communications
 Tamaqua Cable Products *
 Tele-Communications Inc.
 Telecrafter Products Corp. *
 Televents Inc.
 Tempo Enterprises
 Texas Cable Television Association
 Theta-Com CATV/Texscan *
 Times Fiber Communications *
 Toner Cable Equipment Co. *
 Triangle Communications Systems
 Trilogy Communications Inc. *
 Triple Crown Electronics *
 Tulsa Cable Television
 TVC Supply Co. Inc. *
 United Artists Cablesystems Corp.
 United Video Inc.
 US Cable Inc. *
 U.S. Electronics *
 Viacom Cablevision
 Viewsonics Inc. *
 Wavetek RF Products Inc. *
 Wegener Communication *
 Western Communications Inc.
 Wometco Cable Television Inc.
 Zenith Electronics Corp. *

THE CABLE-TEC EXPO '89 EXHIBIT FLOOR IS ALREADY SOLD OUT

thanks to the participation of the Sustaining Member companies noted by asterisks.

SHOULDN'T YOUR COMPANY BE AN SCTE SUSTAINING MEMBER TOO?

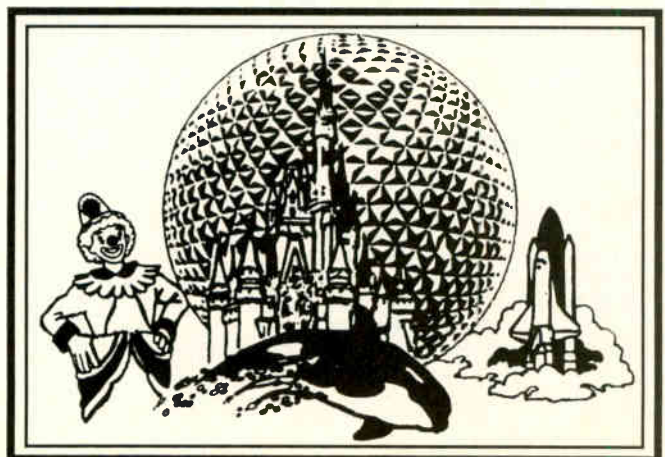

Electric shock effects, factors and precautions

By Ray Rendoff

Technical Training Director, National Cable Television Institute

For cable industry field personnel, working around electricity is a part of life. You may occasionally work near high voltage power lines (2,400, 7,200, or 12,500 VAC) or daily with lower voltages (30-115 VAC). An installer commonly works with 115 VAC at the television, VCR, house amplifier and converter and to power an electric drill. Hot chassis conditions and improper polarity at the AC wall outlet are an ever present possibility. Service, line and maintenance technicians measure and work with 30 or 60 VAC on feeder and trunk cable and at passives, amplifiers and CATV AC standby power supplies.

Familiarity and daily work routine can often create a complacent and careless attitude toward the ever present potential danger of electric shock. Electricity represents a serious potential danger, especially if you have become complacent to the risk or don't understand the factors that determine the seriousness of an electric shock.

Deaths have been recorded that were caused by electric shocks from a very low voltage (32 VAC) farm lighting system. Injuries and deaths caused by electric shocks from 115 VAC are very common since it is the voltage used in virtually every household for lighting and powering electrical appliances. Higher voltages between 200 and 1,000 V at commercial power line frequencies are particularly dangerous since under these conditions heart muscle spasm and paralysis of the respiratory center occur in combination. These are the two conditions most likely to cause death or serious injury in an electric shock accident.

Body responses to shock

It is important to understand that the body responds to certain magnitudes of current in different ways (See accompanying table). One milliampere (mA) of current passing through the body produces a tingling sensation and 3 to 10 mA causes a painful shock feeling. Ten to 20 mA can paralyze the hand and arm muscles; this is particularly dangerous, because this current flowing from one arm to the other may render the victim incapable of releasing himself from the current source and can simultaneously paralyze the muscles needed for breathing.

Electric shock effects

Amount of current	Effect on body
1 mA	Tingling sensation
3-10 mA	Painful shock
10-20 mA	Paralysis of hand and arm muscles
20-30 mA	Paralysis of chest muscles stopping respiration
50 mA to 2 amperes	Ventricular fibrillation (heart muscle spasm)

Figure 1: Current path through the heart

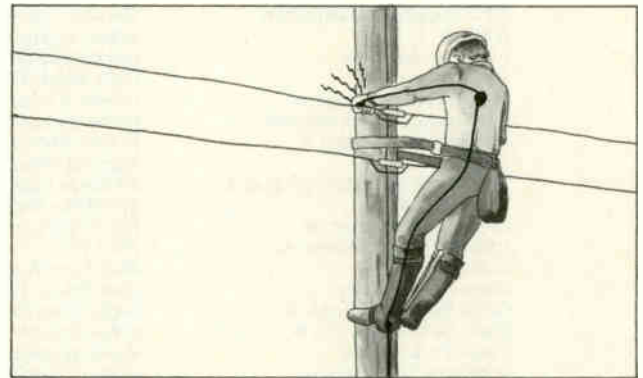

Courtesy NCTI

Twenty to 30 mA paralyzes the chest muscles and stops respiration. Without proper first aid treatment the victim will die from suffocation.

The most dangerous range of shock currents is from approximately 50 mA to 2 amperes. An electric current passing through the body at this level can reduce the rhythmic pulsation of heart muscles to a state of spasmodic contraction (heart muscle spasm or ventricular fibrillation). If this condition occurs, the heart cannot supply purified blood to the body and death may result if the shock victim is not released from the current source within about three minutes. If the person is released soon enough the heart muscles may resume their regular rhythmic contractions normally. Cardiopulmonary resuscitation may be necessary if a normal heart rhythm doesn't return. Electric shock damage to the part of the brain that regulates the action of the breathing muscles can cause death by suffocation. Suffocation also can result from current passing through the chest muscles even when the heart and breathing control centers of the brain are not damaged or paralyzed.

The four factors that determine the seriousness of an electric shock are 1) the voltage contacted by the body, 2) the electrical resistance of the body, 3) the duration of the current and 4) the exact path the current takes through the body. The amount of current that passes through the body is determined by the amount of voltage contacted and the electrical resistance of the body. The path of the current through the body is critical since the current will take the most direct route through the body between the voltage source and ground. For this reason, any current path that involves the heart or brain is particularly dangerous (Figure 1).

Dangerous situations

Two situations encountered in cable television field work that

present the potential of a serious electric shock accident are working in wet conditions and unknowingly contacting an electrically hot CATV strand and/or coaxial cable. Wet materials, even those that are normally nonconductors when dry, are conductors of electricity. For example, a wet tree limb, when touching both an aerial secondary power line and an aerial unjacketed CATV cable, can become a conductor and pass electricity from the power line to the CATV cable causing it to become electrically hot. An unsuspecting installer or technician who grasps the electrically hot cable with both hands becomes a current path. In this case, the current flows through the first hand, up the arm, through the chest muscles, down the second arm, through the hand and back onto the electrically hot cable. If the current is above 10 mA it can render the installer or technician incapable of releasing himself and could cause suffocation due to chest muscle paralysis. Wet conditions are always a reason to exercise extreme caution.

All work on a pole should be performed from a position below the live conductors or apparatus, including secondary power lines (Figure 2). Adequate clearance from all pole grounds must be maintained with all areas of the body at all times when working on or near energized CATV equipment (power-passing passives, line amplifiers, AC or standby power supplies). In addition, when two people are working on a pole at the same time, if it becomes necessary for one to change position, the other should stop work and break contact with any strand, coaxial cable, amplifier, seizure screw or power-passing passive device until the first person has reached his new position. Initial accidental contact with an AC power source is most likely when changing position.

Working around electricity can and should be safe. But safety can only be maintained by workers who understand that elec-

Figure 2: Proper working position

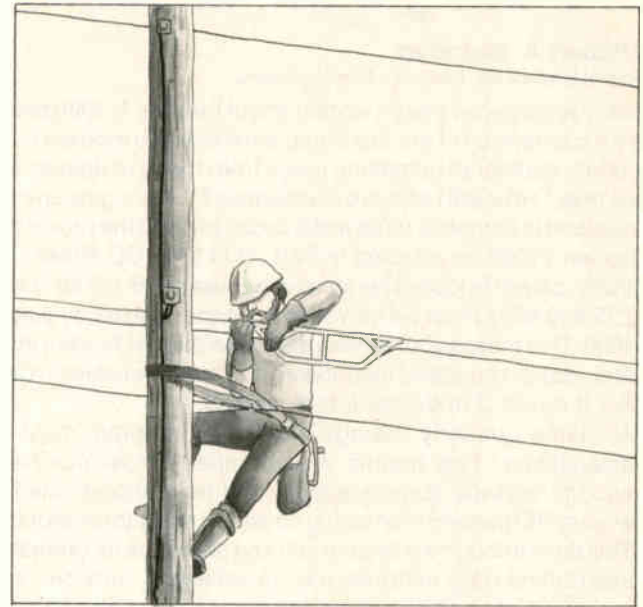

Courtesy NCTI

tricity is potentially dangerous and should always be treated with caution and respect. Remember the factors that determine the seriousness of an electric shock and to exercise precautionary measures to prevent experiencing electric shock. ■

Portions of the preceding article were extracted from NCTI's *Installer Course*.

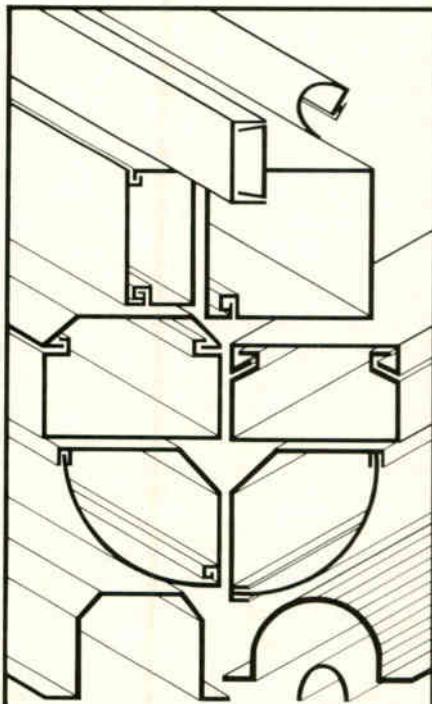

THE BEST YOU CAN BUY
- IN QUALITY AND PRICE.

**CABLETEK CENTER
PRODUCTS, INC.**

850 TAYLOR STREET
ELYRIA, OH 44035
1-800-562-9378 • ELYRIA 216-365-3889



Reader Service Number 14.

You & Cable Link
See us at the Texas show
booth# 210!



(614) 221-3131

Cable Link, Inc.

Your source for CATV equipment

Reader Service Number 15.

It's in your hands

By Robert A. Saunders

Director of Engineering, Sammons Communications

Many articles have been written about the July 1, 1990 deadline for submission of our first cumulative leakage indexes (CLI) but many additional questions result from trying to answer the basic one, "How will I achieve compliance?" Your company will be required to complete three tasks to comply with the provisions of Docket 21006 as adopted in Part 76 of the FCC Rules:

- 1) Video carrier frequencies located between 108-137 MHz and 225-400 MHz must be moved to a standard offset by July 1, 1990. This means your system engineer/chief technician must recrystal the headend modulators and/or processors on Chs. A-2 through C and Chs. L through QQ.
- 2) A routine quarterly leakage monitoring program must be established. This means your company must purchase enough leakage test equipment and train enough staff to ensure 100 percent monitoring coverage every three months. This drive through the system can and should be incorporated into routine daily activities (i.e., installations, service calls, sweeping, etc.). This is where you come in. All leaks detected that exceed 20 microvolts/meter must be repaired. A permanent record of these activities will be maintained on file for FCC inspection.
- 3) Starting July 1, 1990, an annual CLI will be reported to the FCC. This means an intentional one-time pass of your system will be made by driving the system or an airplane flyover to determine the cumulative effect of all the leaks in your system. A formula is then used to determine if that total field strength will interfere with aircraft communications and navigations traffic.

I believe a "good faith effort" toward the development and implementation of a successful routine quarterly leakage monitoring program is the single most important path to a passing CLI and perhaps a "leak free" system. System engineers and chief technicians must develop the procedures to follow that will properly document all the efforts made to keep your system tight. However, the most important players in the introduction of any leakage monitoring plan are the installers and technicians whose daily work skills and attitudes determine its success or failure.

Even the oldest systems stand a better chance of compliance through professional work habits by all its employees, especially those whose responsibility is the daily care of the coaxial plant. Complete rebuilds using the best materials available won't be an effective course of action to leakage compliance unless each construction lineman, technician and installer uses care lashing each cable, preparing and tightening each connector, sealing and torquing each housing, hanging each housedrop without twists, preparing and tightening each F fitting, etc.

Learning the necessary skills

As technicians and installers, the future of the CATV industry is in your hands. It is your responsibility to learn the necessary skills to control leakage and make the transition from dBmV to

microvolts per meter ($\mu\text{V/m}$). You should be able to calibrate your receiver regularly and be as confident with its operation as you are with a field strength meter. The following formula converts a field strength at a specific frequency to a signal in dBmV:

$$\text{dBmV} = 20\log_{10} \left(E \div \frac{.021 \times f}{1000} \right)$$

where:

E = field strength in microvolts per meter

f = frequency in megahertz

Example:

$$\begin{aligned} \text{dBmV} &= 20\log_{10} \left(20\mu\text{V/m} \div \frac{.021 \times 150 \text{ MHz}}{1000} \right) \\ &= 20\log \left(20 \div \frac{3.15}{1000} \right) \\ &= -44 \end{aligned}$$

The solution demonstrated derives the signal necessary to introduce a $20 \mu\text{V/m}$ field strength at a frequency of 150 MHz to an appropriate receiver. Similar calculations can be used to determine the necessary signals for the receive frequencies of your leakage equipment so that a test arrangement similar to the one outlined in the accompanying figure can be established at your bench for calibration purposes. A lab quality signal generator is not necessary for the purpose of calibrating leakage receivers. Field strength meters with separate calibration signal ports and various independent field strength meter calibrators are suitable signal sources usually available to any installer/technician.

A professional work quality attitude is equally important to the mastering of leakage control technical skills. "Prevention" must be the key word to a successful program. If a few employees are creating leaks as fast as the balance of the staff is repairing them, the target of a "leak free" system can never be met. Picture the proverbial dog chasing his own tail. Every employee must dedicate himself to accepting nothing less than professional work. If an F fitting has that famous bulge just below the crimp ring, don't crimp it and leave. Rework it until it is right or someone else will have to come back. Keep those crimp tools tight, tighten every fitting, repair damaged cables and use cable reel stands to avoid twists caused by pulling drop cable from the end of the spool. In short, don't leave a job until it is right!

Logs must be complete and accurate. It's inexcusable to operate an efficient leakage monitoring and repair program and still incur fines simply because a "good faith effort" was not demonstrated to the FCC. During an inspection the only proof of all your labors and intentions is the thoroughness of your records. It is the responsibility of every employee to take the time to write it down, report it to the dispatcher or follow whatever company logging procedure is established.

Finally, I feel I must define "leak free." A coaxial cable plant is never totally absent of leaks at all times. Temperature changes, corrosion, lightning, metal fatigue, over aggressive hunters, squirrels, lawn mowers, cable pirates, etc., cause RF leaks to develop on a regular basis. Your system can be labeled "leak free" when leaks that develop from natural causes as opposed to avoidable causes (poor work habits) are quickly detected and repaired. The fortunate result of all this effort is better signal quality to our customers. Our future is in your hands. ■

Test arrangement for calibration

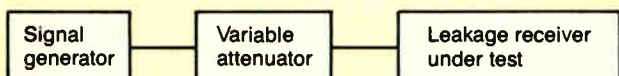

Cable Exchange

Technically certified equipment
Largest database of equipment available

The following is a partial listing
available for immediate shipment to qualified buyers.

Call: 1-(800)-422-2567 to place your order.

In Colorado, call 1-(303)-694-6789

Item Number	Description	Item Number	Description
C229760	INPUT CONV. 6150 CH-A	SDH-P	DISTRIBUTION MOD.
C229860	OUTPUT CONV. 6350 CH-02	SDHP-300	DIST. AMP 300 MHZ NH
C229865	OUTPUT CONV. 6350 CH-07	SJAS-400	TRUNK AMP 400 MHZ NH
C229868	OUTPUT CONV. 6350 CH-10	SJBM-300	BRIDGER MODULE 300 MHZ
C229870	OUTPUT CONV. 6350 CH-12	SJBM-301	BRIDGER MAN. 300 MHZ NH
C229871	OUTPUT CONV. 6350 CH-13	SJBM-400	BRIDGER MAN. 400 MHZ NH
C229872	OUTPUT CONV. 6350 CH-A	SJBM-450	BRIDGER MANUAL 450 MHZ NH
C229873	OUTPUT CONV. 6350 CH-B	SJDL-301	DIST. AMP 301 MHZ NH
C229874	OUTPUT CONV. 6350 CH-C	SJDL-400	DIST. AMP 400 MHZ NH
C229875	OUTPUT CONV. 6350 CH-D	SJDL-405	DIST. MOD.
C229876	OUTPUT CONV. 6350 CH-E	SJDL-450	DIST. AMP 450 MHZ NH
C229877	OUTPUT CONV. 6350 CH-F	SJM-400	TRUNK AMP 400 MHZ NH
C229878	OUTPUT CONV. 6350 CH-G	SJMM-300	MANUAL MODULE 300 MHZ NH
C229882	OUTPUT CONV. 6350 CH-K	SJMM-301	MANUAL MODULE 301 MEG
C229884	OUTPUT CONV. 6350 CH-M	SJMM-400	MANUAL MODULE 400 MHZ NH
C229888	OUTPUT CONV. 6350 CH-Q	SJMM-450	MANUAL MOD. P/P 450 MHZ NH
C229890	OUTPUT CONV. 6350 CH-S	SJSP-60	POWER PACK 60V
C230250	SPECTRUM INVRT. 6350	SJSW-30	POWER PACK
C274780	LO REF. LOOP THRU 6350	SJSW-60	POWER PACK 60V
C342690	AUDIO MOD. 6350	SLE-2P	LINE EXTENDER
C345153	OUTPUT CONV. 6350 CH-A+	SLE-300	LINE EXTENDER
XRPG-3	PILOT CARRIER GENERATOR	SLE-300-2W	LINE EXTENDER 300 MHZ NH
122006-02	POWER SUPPLY TRUNK AMP	SLE-300A-2W	LINE EXTENDER 300 MEG
142000-01	BRIDGER AMP T4XX	SLE-300H	HOUSING FOR SLE-300
142014-02	BRIDGER AMP	SLH-2	STARLINE L.E. HOUSING
300199-01	POWER SUPPLY T4XX	SLR-300-2W	LINE EXTENDER
E-417E	LINE EXTENDER	SMM	MANUAL MOD.
E-417H	HOUSING FOR E-417E	SMM-P	MANUAL MOD. NH
T400H	HOUSING W/PS T4XX	SMM-PT	MANUAL MODULE
T400HB	HOUSING BER T4XX	SMM-S	MANUAL MODULE
T421-002	TRUNK AMP	SMMS-300	MANUAL MOD. 300 MHZ NH
T470-002	TRUNK AMP	SPCM-30	POWER CONTROL MOD 30V
T470-003	TRUNK AMP	SPCM-60	POWER CONTROL MOD 60V
T470-030	TRUNK AMP	SPP	POWER PACK
T470-051	TRUNK AMP	SPP-30	POWER PACK
T470-052	TRUNK AMP	SPP-60	POWER PACK 60V
T500H	HOUSING W/XF T5XX	SPP-S-30	POWER PACK
T507-030	TRUNK AMP	SPP-S-60	POWER PACK 60V
JLE-300	LINE EXTENDER 300 MHZ NH	SPS-12	POWER SUPPLY 12V
JLE-300H	HOUSING FOR JLE 300	SPS-30	POWER SUPPLY 30V
JLE-7400-2W	LINE EXTENDER 400 MHZ	SPS-30B	POWER SUPPLY 30V
JLE-7450-2W	LINE EXTENDER 450 MHZ	STH-7	STARLINE TRUNK HOUSING
JLH	HOUSING FOR J SERIES L.E.	STH-7B	HOUSING BER
RCG-115N	RETURN CARRIER GENERATOR	TRA-108A	RETURN AMP
SAM	AUTO SLOPE MOD.	5-D440	DISTRIBUTION AMP 440 MHZ
SAM-PT	AUTOMATIC MODULE	5-T330	TRUNK AMP 330 MHZ
SAM-PT-300	AUTOMATIC MOD. 300 MHZ NH	5CC-440	COMPLETE CONTROL 440 MHZ
SAS-300	AUTO SLOPE AMP 300MEG	5LE-440/30	LINE EXT. 440 MHZ 30V
SAS-S	AUTO SLOPE AMP	5LE-440/60	LINE EXT. 440 MHZ 60V
SAS-S-300	AUTO SLOPE AMP 300 MHZ NH	MX-504H	HOUSING FOR MX-504
SBM-300	BRIDGER MAN. 300 MHZ NH	CEPS-3	POWER SUPPLY (CASCADE)
SBM-P	BRIDGER MODULE	234430	TRUNK I/T FORWARD NH
SBM-S	BRIDGER MODULE	CTN-1200	POWER SUPPLY
SCD	TRUNK CHASSIE	KCMG	MANUAL GAIN BRIDGER
SCD-2W	CHASSIE FOR TRUNK AMP	PCAB-1	TRUNK AGC BRIDGER
SCD-2W-300	TRUNK AMP 300 MHZ NH	PCAD-1D	BRIDGER TRUNK AGC NH
SCD-2W-300H	HOUSING FOR SCD-2W-300	PCAD-1H	HOUSING FOR PCAD-1D
SCD-2W-R115	TRUNK CHASSIE W/RFC-115	PCM-4	TRUNK AMP NH
SCD-2W-T108	TRUNK CHASSIE W/TRA-108M	PCM-4H	HOUSING FOR PCM-4
SCD-2W-T30	TRUNK CHASSIE W/TRA-30M	PCMB-2	TRUNK AMP NH
SCD-2WD	CHASSIE FOR TRUNK AMP	PCMB-2H	HOUSING FOR PCMB-2
SCD-2WE	BASEPLATE CHASSIS	PCRA	RETURN AMP
SCL	TRUNK CHASSIE		
SCL-2W	CHASSIE FOR TRUNK AMP		
SCL-2WD	TRUNK CHASSIE		



Cable Exchange

Item Number	Description	Item Number	Description
PCTB-6	TRUNK TERMINATING BRIDGER	FFT4-17D	TAP 4W 17DB
PH	HOUSING—P SERIES TRUNKS	FFT4-17F	TAP 4W 17DB
T3LE	LINE EXTENDER NH	FFT4-20	TAP 4W 20DB
T4CM	CONTINUITY MOD. NH	FFT4-20D	TAP 4W 20DB
TFAV	TRUNK AMP AGC	FFT4-20F	TAP 4W 20DB
TFM	TRUNK AMP MGC	FFT4-23	TAP 4W 23DB
TFPS	POWER SUPPLY	FFT4-23D	TAP 4W 23DB
TH	HOUSING FOR T SERIES L.E.	FFT4-23F	TAP 4W 23DB
XH	HOUSING FOR X SERIES L.E.	FFT4-23H	TAP 4W 23DB
XR2A	FORWARD AGC MOD.	FFT4-26	TAP 4W 26DB
XR2B	BRIDGER INTERMEDIATE	FFT4-26D	TAP 4W 26DB
XR2B-2	BRIDGER 2 OUTPUT	FFT4-29	TAP 4W 29DB
XR2B-4	BRIDGER 4 OUTPUT	FFT4-29D	TAP 4W 29DB
XR2DA	DIST AMP HYBRID AGC	FFT4-32D	TAP 4W 32DB
XR2DM	DIST AMP HYBRID MGC	FFT4-7T	TAP 4W 7DB
XR2F-1	INPUT MOD.	FFT4-7TD	TAP 4W 7DB
XR2F-13	INPUT MOD.	FFT8-4D	TAP 8W 4DB
XR2F-14	OUTPUT MOD.	SHS-2	HYBRID SPLITTER
XR2F-19	OUTPUT MOD.	SO-2	FEEDER MAKER
XR2F-3/110	INPUT MOD.	SO-4	FEEDER MAKER 4DB
XR2F-4	INPUT MOD.	SPJ-2	POWER COMBINER
XR2F-5	OUTPUT MOD.	SPJ-3C	DIRECTIONAL COUPLER 3DB
XR2F-7/110	OUTPUT MOD.	SPX-0.5	PAD 0.5DB
XR2F-8	OUTPUT MOD.	SPX-00	PAD 00 DB
XR2HA	LINE AMP HYBRID HRC	SPX-01	PAD 01 DB
XR2HM	LINE AMP HYBRID HRC	SPX-02	PAD 02 DB
XR2LA-PS	POWER SUPPLY	SPX-03	PAD 03 DB
XR2LAF-1	POWER INPUT MOD.	SPX-06	PAD 06 DB
XR2LAF-2	POWER INPUT MOD.	SPX-09	PAD 09 DB
XR2LAF-3	POWER OUTPUT MOD.	SPX-1.5	PAD 1.5 DB
XR2LAF-4	POWER OUTPUT MOD.	SPX-12	PAD 12 DB
XR2LARA	REVERSE AMP MOD.	SSP-12	POWER INSERTER
XR2LS-3	LINE EXT.	STC-12	DIRECTIONAL COUPLER
XR2M	FORWARD MGC MOD.	STC-12C	DIRECTIONAL COUPLER 12DB
XR2PS	POWER SUPPLY	STC-16	DIRECTIONAL COUPLER
XR2RHA110	REVERSE AGC MOD.	STC-3	DIRECTIONAL COUPLER
XR2SPH	HOUSING FOR XR2SP	STC-3B	DATA LINE
XRBI	INTERMEDIATE BRIDGER	STC-3C	DATA LINE
XRCE-3	LINE EXT.	STC-3D	DIRECTIONAL COUPLER 3DB
XRCE-6	LINE EXT.	STC-8	DIRECTIONAL COUPLER
XRDC-16	LINE EXT.	STC-8B	DIRECTIONAL COUPLER 8DB
XRDC-8	LINE EXT.	STC-8C	DIRECTIONAL COUPLER 8DB
XRLA	LINE EXT.	STC-8D	DIRECTIONAL COUPLER 8DB
XRLS-2	LINE EXT.	DCW-06DB	MINITAP 06 DB
XRLS-3	LINE EXT.	DCW-09DB	MINITAP 09 DB
XRPR	POWER SUPPLY	DCW-12DB	MINITAP 12 DB
XRRP	LINE EXT.	DCW-16DB	MINITAP 16 DB
XRSP	LINE EXT.	DCW-20DB	MINITAP 20 DB
N4-S5	TRAP CH. 5	2-14BW	TAP
BPF-B	BAND PASS FILTER CH. 8	2-17BW	TAP
BADC	B.A. DIRECTIONAL COUPLER	2-20BW	TAP
BAEQ-12-1	B.A. EQUALIZER	2-23BW	TAP
BAEQ-3-3	B.A. EQUALIZER	2-26BW	TAP
BAEQ-8-1	B.A. EQUALIZER	4-08BW	TAP
BASP	B.A. SPLITTER	4-14BW	TAP
CSA-300-3	EQUALIZER T4XX	4-26BW	TAP
DISP-3	DISTRIBUTION SPLITTER 3-3	4-32BW	TAP
EQ-450/13	EQUALIZER 450 MHZ 13DB	8-17BW	TAP
EQ-450/15	EQUALIZER 450 MHZ 15DB	8-20BW	TAP
EQ-450/8	EQUALIZER 450 MHZ 8DB	8-26BW	TAP
EQA-1A	EQUALIZER T4XX	8-29BW	TAP
EQA-220-2	EQUALIZER T4XX	8-32BW	TAP
EQA-220-4	EQUALIZER T4XX	EQ-04DB	EQUALIZER 450MHZ
EQA-220-6	EQUALIZER T4XX	EQ-08/250	EQUALIZER
EQS-0	EQUALIZER LAN 0DB	EQ-08/300	EQUALIZER
EQS-186-4	EQUALIZER LAN 4DB	EQ-08DB	EQUALIZER 450 MHZ
EQT-450/10	EQUALIZER 450 MHZ 10DB	EQ-12/300	EQUALIZER
PB-0	PAD 0DB	EQ-15DB	EQUALIZER 450MHZ
PB-1	PAD 1DB	EQ-16DB	EQUALIZER 450MHZ
PB-2	PAD 2DB	EQ-18DB	EQUALIZER 450MHZ
PB-5	PAD 5DB	PCSPL-1	SPLITTER
PB-6	PAD 6DB	PCSPL-2	SPLITTER
PPLUG	POWER PLUG T4XX	PCSPL-3	SPLITTER
DS-200	SPLITTER 2-WAY 3.5 DB	PD-0	PLUG-IN PAD 0DB
DS-300	SPLITTER 3-WAY 5.5 DB	PD-3	PLUG-IN PAD 3DB
DS-3EL	SPLITTER 3-WAY 5.5 DB	PD-6	PLUG-IN PAD 6DB
DS-400	SPLITTER 4-WAY 6.5 DB	PD-9	PLUG-IN PAD 9DB
DS-4GB	SPLITTER 4-WAY 6.5 DB	PPLUG	POWER PLUG
DS-800	SPLITTER 8-WAY 11DB	T4BDC-8	PLUG-IN PAD
FFT4-10D	TAP 4W 10DB	T4BDL-12	PLUG-IN PAD
FFT4-10F	TAP 4W 10DB	T4SPL	PLUG-IN PAD
FFT4-14	TAP 4W 14DB	VEQ-08/300	EQUALIZER
FFT4-14D	TAP 4W 14DB	VEQ-12/250	EQUALIZER
FFT4-14F	TAP 4W 14DB	VEQ-12/300	EQUALIZER
FFT4-17	TAP 4W 17DB	XR2-13	TAP 4WAY 13DB

Safety—The forgotten area

By Ralph Haimowitz
 Director of Training and Safety
 Society of Cable Television Engineers

The very last thing that anyone ever seems to think about, if at all, is safety. Consider how many times you have had a minor accident like straining your back or stubbing your toe, and how many times you have had a "close call."

For the most part we assume that we are responsible human beings acting in a sane and safe manner, but how often have you driven just a little faster than the speed limit because you were late or driven your car after just a few alcoholic beverages? And how many of you have some excuse or other, or just plain don't remember, to fasten your seat belts when you drive?

Let's take a closer look at vehicular accidents in 1987. According to the National Safety Council there were 48,700 deaths from motor vehicle accidents in 1987 resulting from a total of 43,300 accidents and 59,000 vehicles involved. In addition, there were 1,800,000 disabling injuries from motor vehicle accidents in 1987. Total cost of these accidents involving death or disabling injuries was \$64.7 billion. Add to that the 19,600,000 motor vehicle accidents that have resulted in property damages and non-disabling injury and you have an enormous rate of 20,843,300 motor vehicle accidents in 1987 involving some 33,000,000 vehicles.

From the chart you can see that two out

of three traffic deaths occurred in rural areas where most of those were drivers or passengers in motor vehicles. In the urban areas, more than one third of the victims were pedestrians. Of the 8,500 pedestrian deaths, 2,750 of them were young people under the age of 24, with more than half that number under age 14.

Alcohol was a factor in 52.1 percent of the motor vehicle deaths in 1986 (the figures for 1987 were not available yet) with those involved having a blood alcohol concentration (BAC) of 0.01 percent or higher. Forty-one percent of the 1986 fatalities had a BAC of 0.10 percent or higher.

No more excuses

Everyone has probably heard just about every excuse that can be made as to why not to wear a seat belt when driving, from "It's just not comfortable" to "What if I get into an accident and I am trapped in the car by my seat belt?" Studies by the National Highway Traffic Safety Administration have clearly indicated that safety belts are 45 percent effective in preventing fatalities, 50 percent effective in preventing moderate to critical injuries, and 10 percent effective in preventing minor injuries.

What do all these statistics prove and what does it have to do with the heading of this article? It shows that safety is an important part of our day-to-day lives and it is something that we do not think about very much. Our industry has a fairly poor safety record that can only be changed if

"Our industry has a fairly poor safety record that can only be changed if we all work at living safer."

we all work at living safer. Managers must actively insist upon having a working safety education program. Supervisors must present ongoing safety education and training, and each of us must become more aware of safety hazards, as well as reporting and correcting each and every safety hazard that we see. If your cable system has not experienced a lot of accident problems it may not be because your system operates safely, maybe you have just been lucky—so far! ■

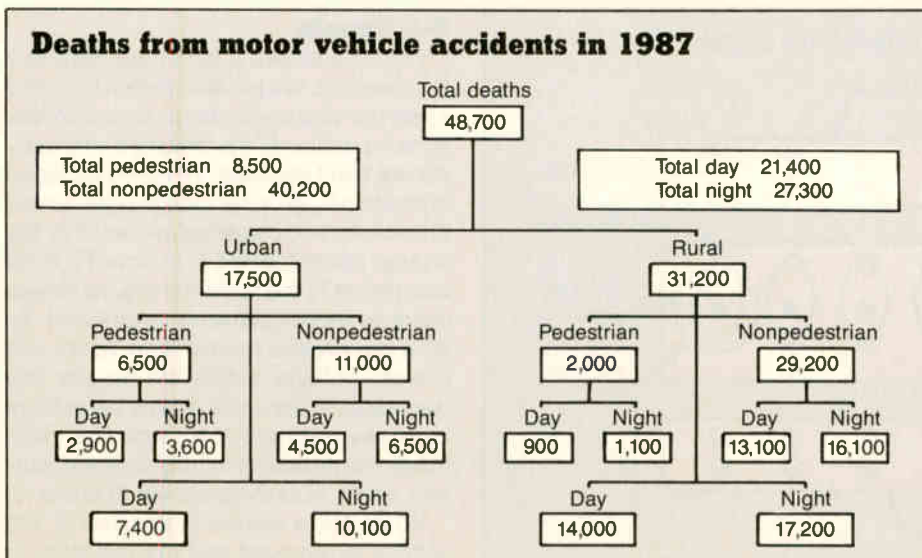

Lemco
 the
 tools
 of the
 trade

Call for your free catalogue.
(800) 233-8713
 Reader Service Number 17.

Basic electronics theory

This is Part X of a series about basic electrical and electronic principles, designed for the individual with little or no training in either electricity or electronics.

By **Kenneth T. Deschler**
Cable Correspondence Courses

This month we will cover one of the more common components used in electricity and electronics, the capacitor. It has been said that without the capacitor modern electrical systems as well as electronic circuits would never have been possible.

Capacitors

Capacitors are devices that have the ability to store an electrical charge and consist of two metal surfaces separated by an insulating material. The two metal surfaces are called *plates* and the insulating material between the plates is known as the *dielectric*. Figure 1 shows two schematic symbols used for capacitors. *Capacitance* is the ability of a capacitor to store electrical energy; its unit is the farad (F) and its letter symbol is "C".

Figure 2 shows what happens within a

capacitor when a voltage is placed across its plates. The instant switch S1 is closed a momentary current begins to flow resulting in plate A becoming positively charged and plate B becoming negatively charged. Within the dielectric, a stationary (static) field is created due to the oppositely charged plates. This field is called an *electrostatic* field. When the switch is opened the capacitor is said to be charged to the value of the battery because no means exists for the oppositely charged plates to equalize their charges.

The factors that determine the electrical size of a capacitor are plate area, distance between the plates and the numerical value assigned to the insulating material between the plates, known as the *dielectric constant*. This can be summed up in the following formula:

$$C = 0.2249 \left(\frac{K A}{D} \right)$$

Where:

- C = Capacitance in picofarads (10^{-12})
- 0.2249 = Numerical constant
- K = Dielectric constant of the insulating material
- A = Area of the plates in square inches
- D = Distance between the plates in inches

For example, find the capacitance of a capacitor with plates 1.5 square inches in area that are separated 0.1 inch apart,

"Some common power losses in capacitors include hysteresis loss within the dielectric and minute current leakage from plate to plate through the dielectric material."

having a dielectric whose constant is equal to 3.5.

Solution:

$$\begin{aligned} C &= 0.2249 \left(\frac{3.5 \times 1.5}{0.1} \right) \\ &= 0.2249 \left(\frac{5.25}{0.1} \right) \\ &= 0.2249 \times 52.5 \\ &= 13.8 \text{ pF} \end{aligned}$$

The dielectric constants of some common materials used as dielectrics in the construction of capacitors are as follows: air (1.0), paper (3.5) and mica (3.0 to 6.0). Some common power losses in capacitors include hysteresis loss within the dielectric and minute current leakage from plate to plate through the dielectric material. Ordinarily this leakage is so small as to be negligible under normal circumstances.

R-C Circuits

Figure 3 shows a circuit containing a DC source, a two position switch (S1), and a resistor and capacitor in series. When S1 is in position B, the resistor and capacitor are short circuited. When S1 is placed in position A, all of the voltage is felt across the resistor and capacitor as shown by the charge curve labeled E at time T_0 . Note also that at T_0 the current is at a maximum value as shown on the curve labeled I. As time progresses toward time T_1 , we see that the voltage across the resistor (e_R) decreases at the same rate as the voltage increases across the capacitor (e_C). When the capacitor is fully charged, current drops to zero as shown in curve I.

When S1 is placed in position B, the voltage is removed and the capacitor is

Figure 1: Schematic symbols for capacitors

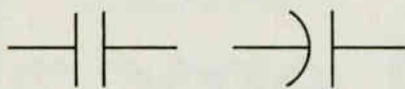
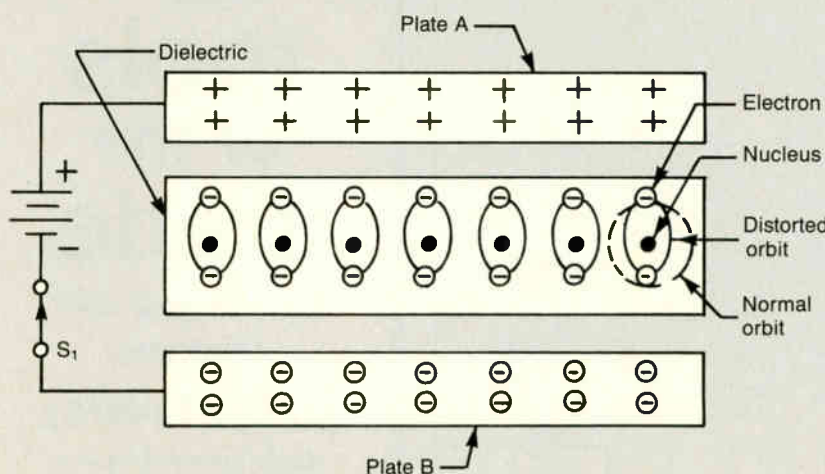

Figure 2: Effect of voltage across a capacitor's plates.



allowed to discharge through the resistor. We can see on the discharge curve that at time T_0 the total current and the voltage across both the resistor and capacitor will drop to zero at the same rate until time T_1 .

As with inductors, the amount of time to charge or discharge the capacitor 63 percent of its charge is known as a *time constant* (TC). Figure 4 shows the time constant for an R-C circuit. Figure 5 is a universal time constant charge for both L-R and R-C circuits. Using Figure 5, let us determine the amount of time it took for the capacitor in Figure 3 to attain full charge (5 TC). One time constant equals:

$$\begin{aligned}
 T_{\text{seconds}} &= R_{\text{ohms}} \times C_{\text{farads}} \\
 &= 50 \times 2 \times 10^{-6} \\
 &= 100 \times 10^{-6} \text{ or } 100 \text{ micro-seconds } (\mu\text{s})
 \end{aligned}$$

Therefore in 5 TC, it takes $500 \mu\text{s}$ for a 2 microfarad (μF) capacitor to reach full charge when connected to a 50 ohm resistance.

When capacitors are placed in parallel their effective plate area is increased. Therefore the total capacitance of capacitors in parallel is equal to the sum of the individual capacitors:

$$C_T = C_1 + C_2 + C_3, \text{ etc.}$$

When capacitors are placed in series, the effect is the same as an increase in the distance between the plates thereby causing the total capacitance to be lowered:

$$C_T = \frac{1}{1/C_1 + 1/C_2 + 1/C_3, \text{ etc.}}$$

Types of capacitors

The more common types of capacitors found in electrical and electronic equipment include the following:

1) *Variable capacitors*: One type consists of two sets of plates that are mounted on a rotor and are intermeshed to provide a range of capacitance values. Another type known as a trimmer capacitor allows the distance between its plates to be varied through the use of a screw. Both are shown in Figure 6.

2) *Fixed capacitors*: These have a fixed value that cannot be adjusted. Fixed capacitors are classified according to the way they are constructed and the type of dielectric used. Some of the more common types are:

a) paper—constructed of metal foil separated by waxed paper; typical

Figure 3: R-C circuit

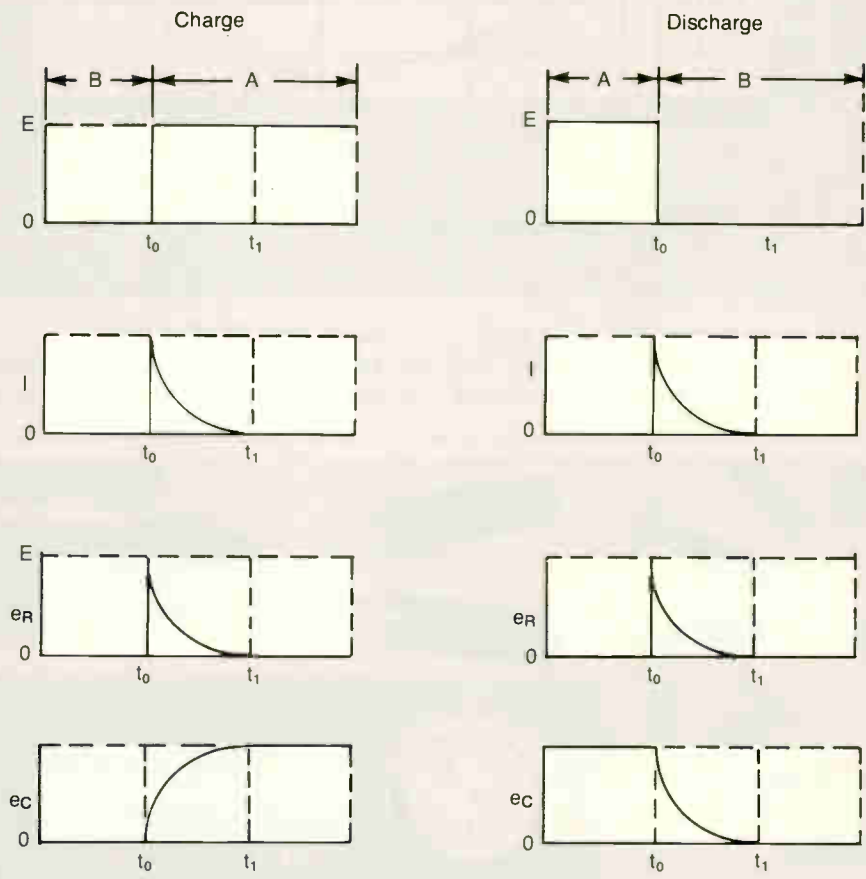
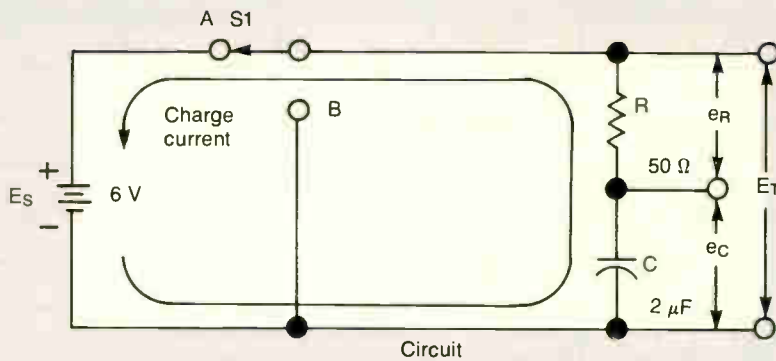

Figure 4: R-C time constant

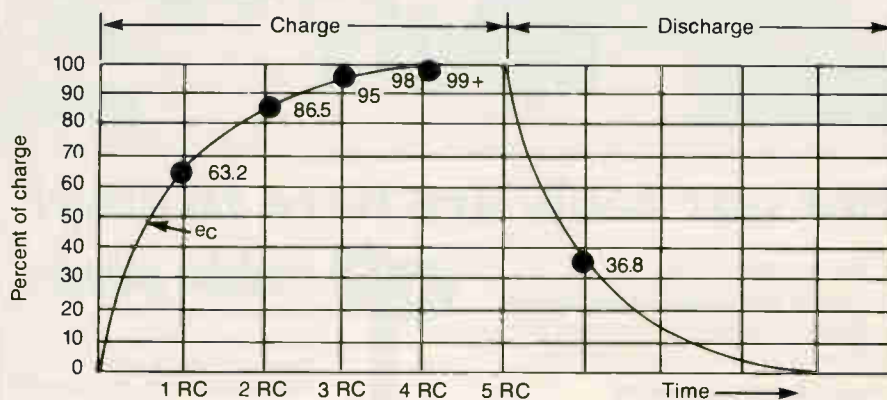

Figure 5: Universal time constant chart

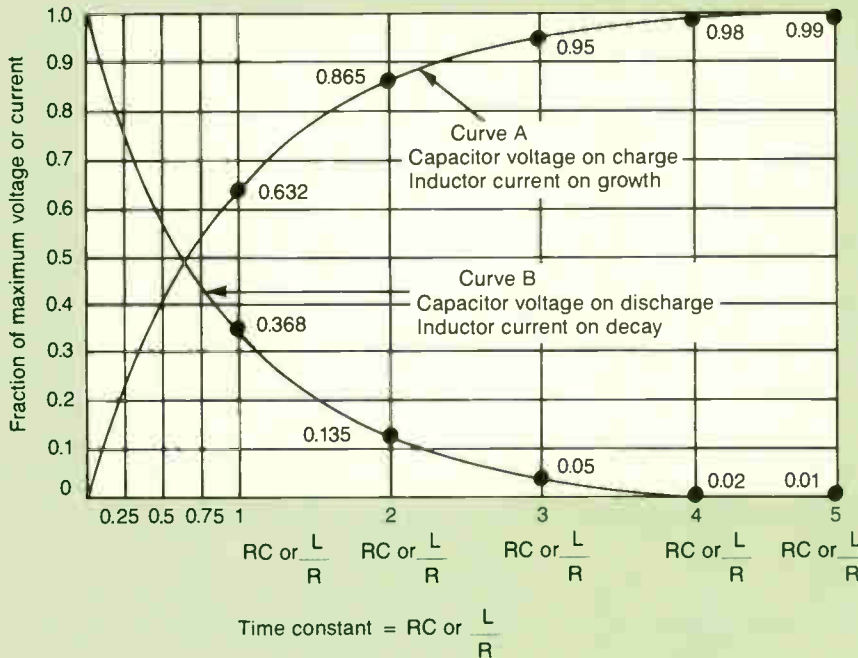
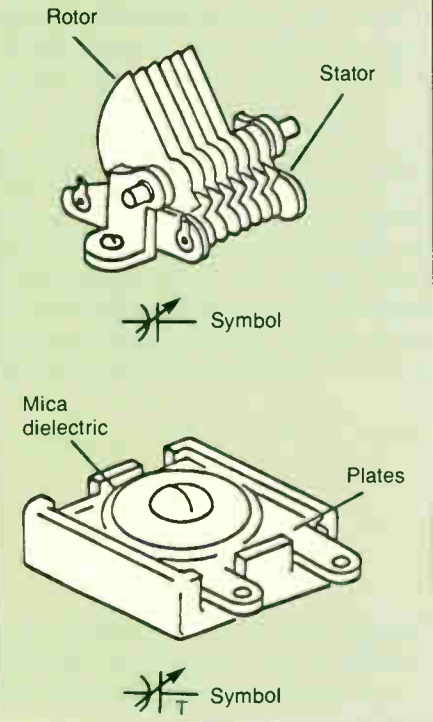

Figure 6: Variable capacitors



a) values range from 300 pF to 4 μ F.
 b) mica—constructed of metal foil separated by mica; typical values

c) range from 50 pF to 0.02 μ F.
 ceramic—constructed by depositing thin films of metal on a ceramic form;

d) typical values range from 1 pF to 0.01 μ F.
 electrolytic—constructed of metal foil separated by an electrolyte soaked strip of paper or gauze; typical values range from several microfarads up to thousands of microfarads.

Next month we will study inductive and capacitive reactance as well as impedance.

Test your knowledge

- 1) Define a capacitor.
- 2) How is a paper capacitor constructed?
- 3) What type of field exists between the plates of a charged capacitor?
- 4) How much time does a capacitor require to charge to 95 percent of full charge in a circuit containing a resistance of 100 ohms and a capacitor of 5 μ F?
- 5) What is the total capacitance created when three individual capacitors of 30 pF each are connected in series? ■

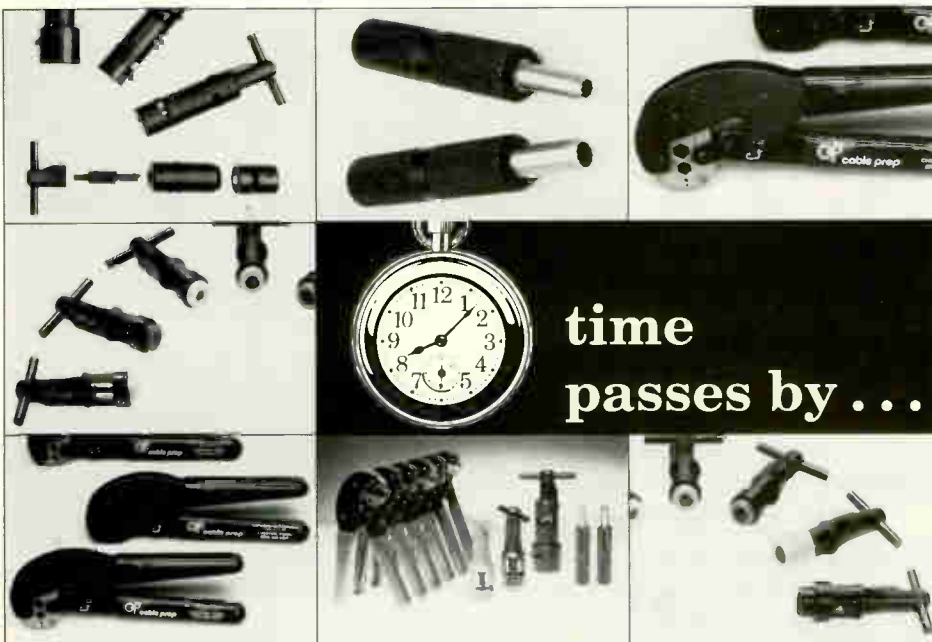

but our tools are here to stay!

- Made in the U.S.A.
- Proven in the field for durability
- Hand-crafted from precision parts
- Service-oriented manufacturer

Reader Service Number 18.

GP cable prep
 BEN HUGHES COMMUNICATION PRODUCTS CO
 207 Middlesex Avenue
 Chester, CT 06412-0373
 (203) 526-4337 FAX: (203) 526-2291

Answers

- 1) Two plates separated by a dielectric.
- 2) Two foil plates separated by waxed paper are rolled in the form of a cylinder.
- 3) Electrostatic.
- 4) 95 percent equals 3 TC, therefore 3 $\times 100 \times 5 \times 10^{-6}$ equals 1500 μ s.
- 5) 10 pF.

Recommended practices for consumer interfacing

This is the third part in a series on connecting consumer electronics products in the subscriber's home. Part II considered sources of ingress and egress.

By the NCTA Engineering Committee's Subcommittee on Consumer Interconnection

The lowest cost and easiest to implement method of over-









coming some of the feature limitations of converter/VCR interconnections is through the use of A/B switches and splitters. The advantages are that typically both are available to the operator with excellent specifications and at relatively low cost. Also, they may be arranged in a variety of ways to solve specific situations.

(Continued on page 31)

Selection Guide

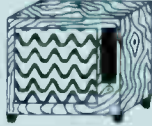
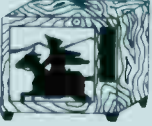
Step 1

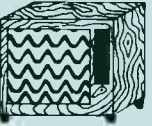
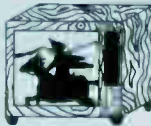
Step 2

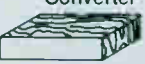
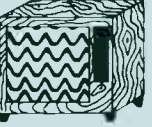
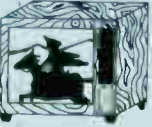
Number of required converters	Precludes use of TV remote 	Preserves use of TV remote for non-scrambled channels only 
 Converter		12, 13, 17, 25
 Converter	Can record  while viewing same  7	5, 6, 9, 16, 24
	Can record  while viewing  ④ 23, 26	
	Can record  while viewing  ①, ③, ⑧, ⑩	11, 15
 Converter  Converter	Can record  or  while viewing the same or another channel ②, ⑭	18, 19, 20, ⑮, 22, 27

Step 3

Step 4

Notes:

- * (No converter) i.e., a trap system or else presence of cable-compatible TV and VCR
- All configurations allow use of converter remotes
- Most popular illus.: 1, 2, 4, 5, 7, 12

Key



Scrambled channels

Non-scrambled channels



TV's remote control

○ does not permit timed, multievent multichannel VCR recordings

Figure 1

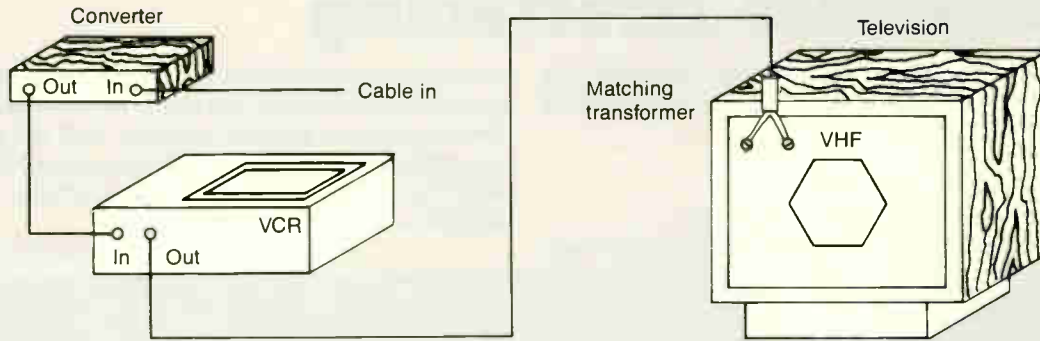

Allows:

- recording of any channel, while viewing the same channel

Precludes:

- timed, multichannel, multievent recording (i.e., ability to pro-

gram the VCR to record a movie on Ch. 5 at 6 p.m., and then a second program on Ch. 26 at 8 p.m.)

- channel selection by the TV remote control
 - channel selection by the VCR remote control
- Necessary drop level: 0 dBmV

Figure 2

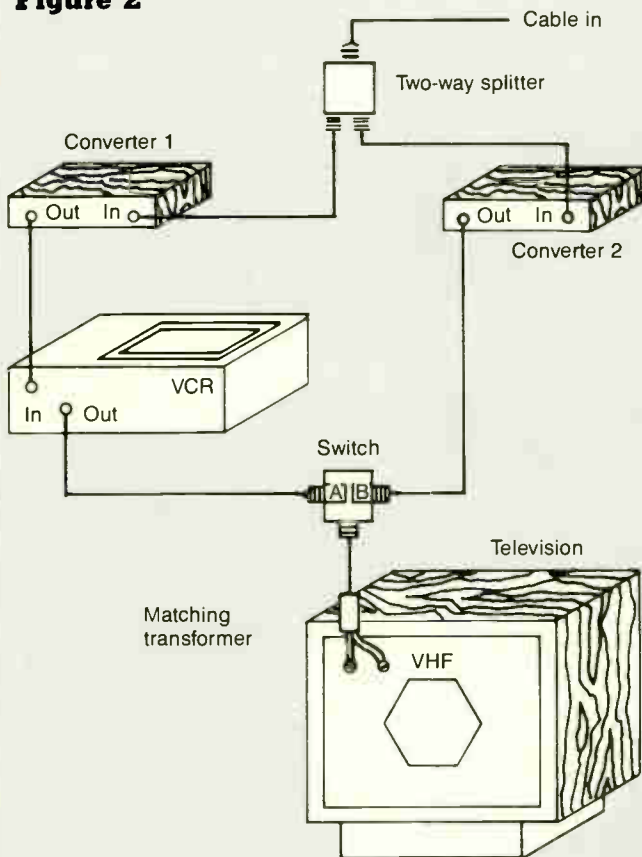

Allows:

- recording of any channel, while viewing any channel

Precludes:

- timed, multichannel, multievent recording (i.e., ability to program the VCR to record a movie on Ch. 5 at 6 p.m., and then a second program on Ch. 26 at 8 p.m.)
 - channel selection by the TV remote control
 - channel selection by the VCR remote control
- Necessary drop level: +3.5 dBmV

Figure 3

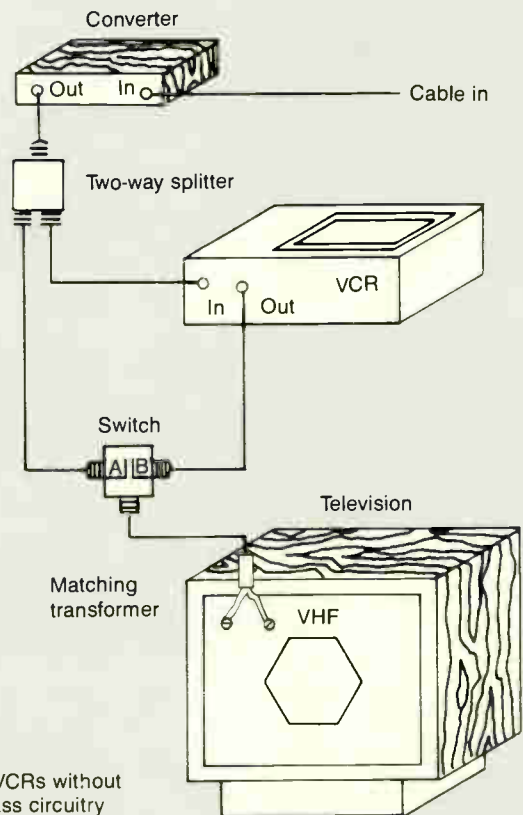

For VCRs without bypass circuitry

Allows:

- recording of any channel, while viewing the same channel

Precludes:

- timed, multichannel, multievent recording (i.e., ability to program the VCR to record a movie on Ch. 5 at 6 p.m., and then a second program on Ch. 26 at 8 p.m.)
 - channel selection by the TV remote control
 - channel selection by the VCR remote control
- Necessary drop level: 0 dBmV

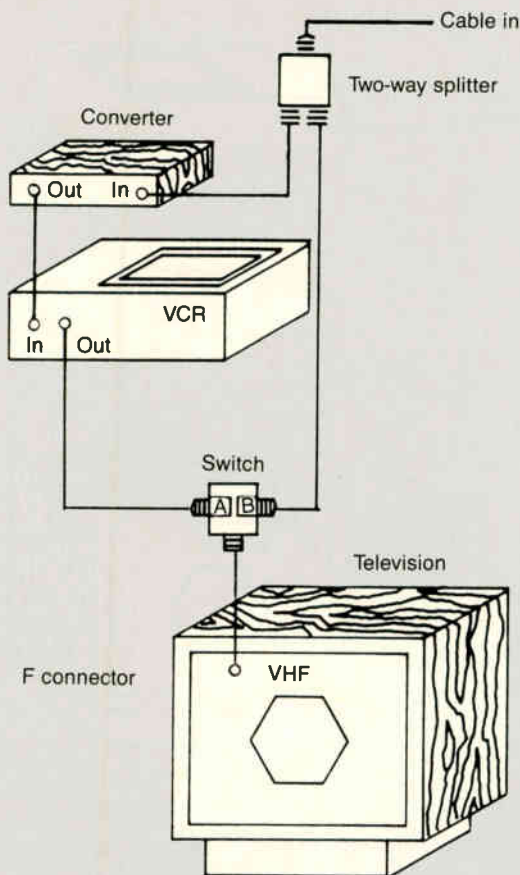
Figure 4**Allows:**

- recording of any channel, while viewing any non-scrambled channel
- *use of TV remote control for non-scrambled channels (only)

Precludes:

- timed, multichannel, multievent recording (i.e., ability to program the VCR to record a movie on Ch. 5 at 6 p.m., and then a second program on Ch. 26 at 8 p.m.)
- channel selection by the TV remote control
- recording of non-scrambled channel while viewing a non-scrambled channel

Note: scrambled channels can only be viewed through converter and VCR

Necessary drop level: +3.5 dBmV

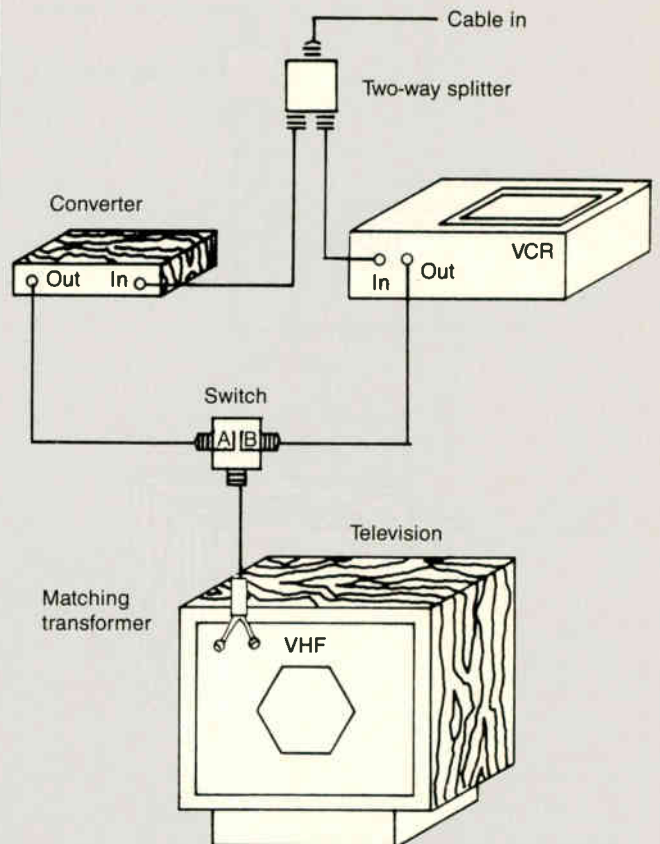
Figure 5**Allows:**

- recording of (only) non-scrambled channel, while viewing any channel
- timed, multichannel, multievent recording (i.e., ability to program the VCR to record a movie on Ch. 5 at 6 p.m., and then a second program on Ch. 26 at 8 p.m.) of non-scrambled channels only
- full use of the TV remote control—with VCR in bypass mode (+8.5 dBmV drop level required)
- full use of the VCR remote control

Precludes:

- recording of scrambled channels
- Necessary drop level: +3.5 dBmV

(Continued from page 29)

On the negative side, even relatively complex networks do not give all the desired flexibility while the array of unlabeled, identical A/B switches is both messy and confusing for the subscriber and can result in the loss of remote control capabilities. In addition, component signal losses can degrade system performance.

How to use this guide

The first few installation setups depicted in this article are the least expensive to install and the easiest for a subscriber to use. Unfortunately, the configurations that are least likely to confuse subscribers are the same ones that can limit the subscribers' ability to take advantage of features in their televisions or VCRs. Some subscribers may prefer to lose some remote control or VCR flexibility in favor of simplicity of operation; others may not.

The selection guide summarizes installation trade-offs.

You will need to keep these factors and their relative importance in mind when choosing a configuration:

- simplicity of operation
- ability to use TV or VCR remote control (all illustrations allow for use of a converter remote control)
- ability to use timed, multichannel, multievent VCR feature
- total signal attenuation (i.e., if your system levels are near 0 dBmV and the installation diagram calls for a four-way splitter, your subscriber will get snowy pictures)
- number of high-quality A/B switches (yielding 70 to 80 dB of isolation at minimum) needed
- 0 dBmV is assumed to be the minimum input level for a converter
- mid-UHF converters may not translate all super-band channels to UHF
- VCRs in bypass require high drop levels

Figure 6

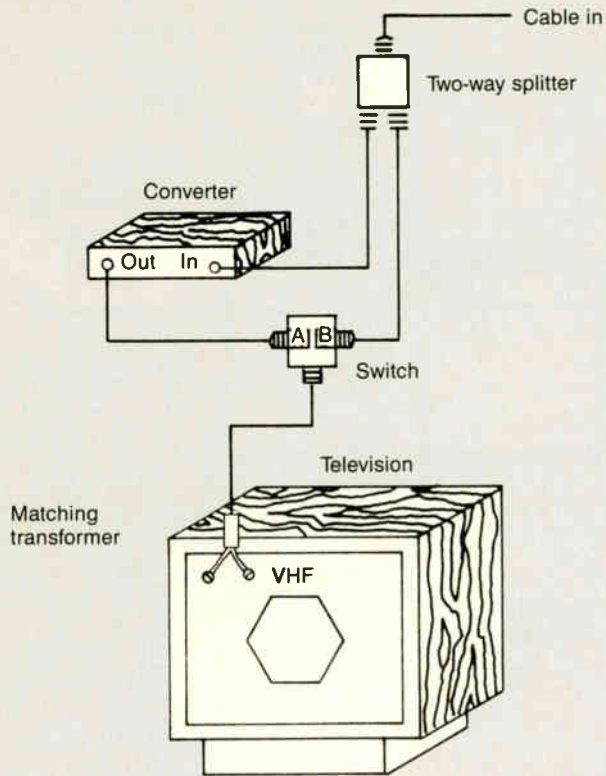

Allows:

- viewing of any channel
 - use of TV remote control (for non-scrambled channels only)
- Necessary drop level: +3.5 dBmV

Figure 7

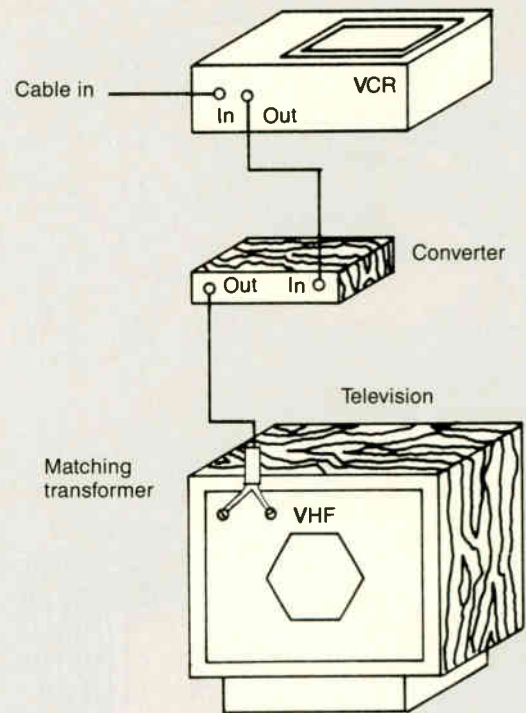

Allows:

- recording of only non-scrambled channels, while viewing any channel
- timed, multichannel, multievent recording (i.e., ability to program the VCR to record a movie on Ch. 5 at 6 p.m., and then a second program on Ch. 26 at 8 p.m.) of off-air channels only
- full use of the VCR remote control

Precludes:

- channel selection by the TV remote control
 - may preclude use of converter's remote control
- Necessary drop level: 0 dBmV

Equipment, drop level and signal leakage considerations

In the accompanying figures:

- 1) Some TV sets are shown with 300 ohm input terminals, others with direct coaxial inputs. Either input terminal type is acceptable as far as the diagrams are concerned.
- 2) If direct connection to external antenna systems is part of the installation scheme, operators *have* to keep potential signal leakage in mind and avoid it with proper A/B switch quality and isolation.
- 3) If three-way splitters are used, note that the dot in the illustration's splitter denotes the higher level output leg, assuming one leg at -3.5 dB and two legs at -7 dB. If the splitter has equal splits or is hooked up differently, the minimum acceptable drop signal level will need to be increased.
- 4) Where only one input and output cable is shown for a VCR, it is intended to designate the VHF terminals.
- 5) Presence of cable-compatible TVs and VCRs is assumed in "no-converter" hookups.
- 6) It is assumed that most converters do not have a timed channel selection scheme.
- 7) Connections can accommodate two TV sets by the addition of a two-way splitter at the drop.

The following terms are used in the figures:

- **Allows:** assumes that simultaneous TV and VCR use (to a greater or lesser degree of access to a full range of paid-for

cable programming) is the subscriber's aim

- **Any channel:** "any" means whatever channels a subscriber's home equipment (TV, VCR, converter) is capable of receiving and that a subscriber has paid for
- **Scrambled:** a signal that requires a descrambler
- **Non-scrambled:** a signal that is never scrambled; sent in the clear
- **Off-air:** channels received via an external TV antenna, not delivered via "over-the-wire" cable TV service
- **Cable channels:** any channels delivered via "over-the-wire" cable TV service that a subscriber has paid to receive
- **Recording:** videocassette recording

To use the selection guide:

Step 1) The first thing to determine (and then locate in the selection guide) is the *number of converters* needed. For example, a cable system that uses traps will not need converters in the subscribers' homes, nor will a basic tier subscriber owning a cable-compatible TV and VCR need a converter. The top left-hand square of the selection guide says "no converter" indicating that the top row of the guide will list all applicable illustration numbers.

Step 2) The second thing to determine is the desirability of keeping the TV's or VCR's *remote control* feature and to scan

JONES INTERNATIONAL PROUDLY PRESENTS NEW PRODUCTS AND PROGRAMMING SERVICES

WE HAVE SOMETHING FOR LITERALLY EVERYONE!

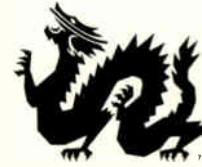

MIND EXTENSION™ UNIVERSITY!

A FREE basic cable programming service allowing subscribers to earn college credits from major universities through quality telecourses

GALACTIC RADIO!

Enhance your basic cable with our FM stereo service including six stereo music formats, three sports/news/talk superstations, plus In-Touch, a reading service for the visually impaired.

JONES BUSINESS LEARNING GROUP!

Interactive video and video tape training products for CSR's/Techs and in-house personnel.

THE JONES DICTIONARY!

The resource of cable terminology.

FOR MORE INFORMATION, CALL TOLL-FREE
1-800-525-7002

Figure 8

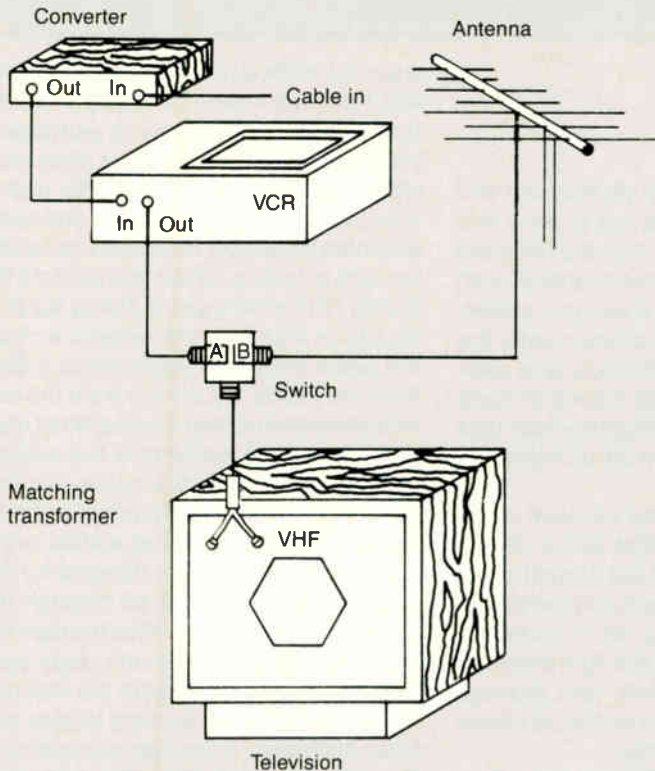

Allows:

- recording of any channel, while viewing the same cable channel or any off-air channel

Precludes:

- timed, multichannel, multievent recording (i.e., ability to program the VCR to record a movie on Ch. 5 at 6 p.m., and then a second program on Ch. 26 at 8 p.m.)
- channel selection by the TV remote control
- channel selection by the VCR remote control

Note: requires high-isolation A/B switch

Necessary drop level: 0 dBmV

the middle or right-hand columns of the selection guide according to that choice. (All illustrations allow for use of a converter remote control). For example, if one converter is used and the TV and VCR do not have a remote control you would look at the rows adjacent to the "one converter" box and find that Figures 1, 3, 7, 8 and 10 would all fit these requirements.

Step 3) You can also determine the importance of full range of service, *simultaneous TV viewing and VCR recording* and find which TV remote control column subset lists the preferred options. For example, if I wanted to be able to watch any channel while my VCR recorded either the program I was viewing or a program on another channel, I would know that the setups in Figures 18 through 22 and 27 would allow that option.

Step 4) Finally, to determine which illustrations do not allow use of a VCR's timed and sequential *multichannel recording* feature, note which illustration numbers are circled. For example, Figure 21. ■

Figures 1 through 8 are shown in this installment. Future installments will provide Figures 9 through 27.

Reprinted with permission from "Connecting Cable Systems to Subscribers' TVs and VCRs—Guidelines for the Cable Television Industry" (1987) by the NCTA.

Amplify Your Services

A classified in Installer/Technician can boost the power of your business!

When you are looking for the right individual to fill a position or a source to advertise your products or services, look to the classified section of Installer/Technician.

Call Barbara Bellomo,
classified advertising manager,
for rates, information and assistance.



P.O. Box 3208 • Englewood, Colo. 80155 • (303) 792-0023
TELEFAX (303) 792-3320

Installer Input

A drilling drill

By Alan Babcock
Manager of Technical Training
Warner Cable Communications Inc.

It seems like such an easy task to drill a hole through the floor or wall. Yet virtually all who have attempted this task have horror stories about it. In this article, I will point out some ways to make the job less dangerous to you and to the customer's property.

In most new single family home installations you will have two choices for drilling a hole to allow entry for the cable TV drop—through an outside wall or through the floor to a crawl space or basement. Many of the precautions and tips apply to both situations.

At ground level

When drilling through the floor, it is advisable to drill down through the floor into the space below. A case in point: An installer was drilling up through the floor from the customer's basement. After drilling his hole he proceeded to push about six inches of the cable up. He then went upstairs to pull it through but could not find the cable end. After several trips up and down the stairs to try to resolve the problem, he finally gave up and redrilled the hole a foot or so away from the original.

Being a conscientious employee he got a small piece of wooden dowel and some glue from his truck and filled the original hole with the dowel. The customers were very happy with their cable installation and service until some months later when they attempted to move their piano, which, of course, was glued to the floor.

By drilling down through the floor you are almost guaranteed not to have this type of problem. There are other difficulties however, that can be encountered with electrical wires and water/gas pipes, which are often routed directly under the floor. I drilled into an electrical wire once and it was embarrassing having to leave a drill bit protruding through the floor until an electrician could arrive to repair the electric service.

The best way to avoid problem situations is to make careful observations before drilling the hole. Look around to see where the wires and pipes are located and measure any that may be in question. When actually drilling, put light pressure on the drill—do not "stand" on it. (A sharp bit helps here.) As soon as the bit clears the flooring, stop drilling.

When drilling through carpeting, use a knife or carpet punch to prevent the carpet from becoming entangled with the bit. With a knife, make a small "x" in the carpet and pull the carpet back. When using a carpet punch, make the hole large enough for your drill bit to fit through. In both cases, make certain there are no strands of carpet fiber that may get caught in the bit. It only takes one small fiber tangled in an electrical drill to totally ruin many square yards of carpeting.

Up against a wall

If you need to drill through an outside wall, decide first whether to drill from the outside in or the inside out as there are good reasons for both methods. It is easiest to drill from the inside out in order

to get the outlet positioned properly in the wall. However, with certain types of siding, such as brick, shingle, stucco and others, it is best to drill from the outside. With brick siding, drilling through the mortar (rather than the brick itself) looks best and helps eliminate breakage; it takes an incredible amount of luck to hit the mortar from the inside. With other types of siding, such as stucco or shingles, the exterior surface will break away very easily when drilling from the inside. By drilling from the outside you stand a better chance of not chipping away large sections of the siding.

When drilling from the inside, position the wall plate at the same height and configuration as the electrical outlets in the house unless otherwise directed by the customer. Start the drill bit through the wall and as soon as it breaks through the first layer, stop. After the drill stops spinning move the bit around in the wall and feel for wires, pipes, framing braces and other obstacles. If you feel something in the wall, proceed only after you have determined that it will not present a problem. The hole to the outside should be at a slight downward angle from inside to out to prevent water from following the cable route into the house.

Extreme care must be used any time small children are in the area. In one instance, an installer was drilling from the inside of a home while outside, a small child was playing and became curious about the noise she heard coming from the wall. Placing her ear against the outside wall to hear better was a natural reaction many children would have. Luckily, in this case, the child was not seriously injured.

If you begin on the outside, make certain the measurements you take to position the outlet correctly are accurate and made from a good reference. Windows and doorjamb work the best for me because you can determine height as well as distance to the sides. Judging is difficult without a good reference.

When drilling a hole, taking the appropriate precautions should help reduce the number of errors and accidents. Unfortunately, accidents still happen. If you inadvertently cause damage to the customer's property call it to the attention of the customer and notify your supervisor. Both parties might be angry at you for a short while at the time, but imagine trying to explain to your boss how you damaged your back while trying to move a piano! ■

**10,000
MDU Enclosures
IN STOCK
At ALL Times**
Most Locking Systems
and Sizes
Lockinator™, Pedlock™, Intertite,
Vendor, Padlock, etc.



Viewsonics inc.
170 Eileen Way • Syosset, N.Y. 11791 • Toll Free: 800-645-7600 • In NY: (516) 921-7080

Reader Service Number 12.

Installer's Tech Book

Drop clearances

By Pam King
Jones Intercable Inc.

As an installer, there are various drop clearances you need to be concerned with as you route your cable. These include vertical and horizontal clearances (see table and Figure 1), as well as ensuring there is adequate climbing space on the pole and avoiding aerial trespass situations. Be sure to verify the following with local regulations since these may differ depending upon the circumstances.

Typical drop clearances

State highway	20 feet*	
Public street/alley	18 feet	
Easements	12 feet	
Driveways not accessible by truck	12 feet	
Track rails of railroad	27 feet	
Water (no sailboating)	15 feet	
Earth	8 feet	
Flat roof buildings	8 feet	
Neon signs	4 feet	
Peak roof buildings	3 feet	
Billboards	2 feet	
Lightning rod conductors	6 feet	
Power service wires	At the house	At the pole
Telephone service wires	12 inches	40 inches**
	4 inches	12 inches

* Generally, drops are not permitted to cross state highways and state permits are required *prior* to installation.

** Some areas and circumstances may allow 30 inches. →

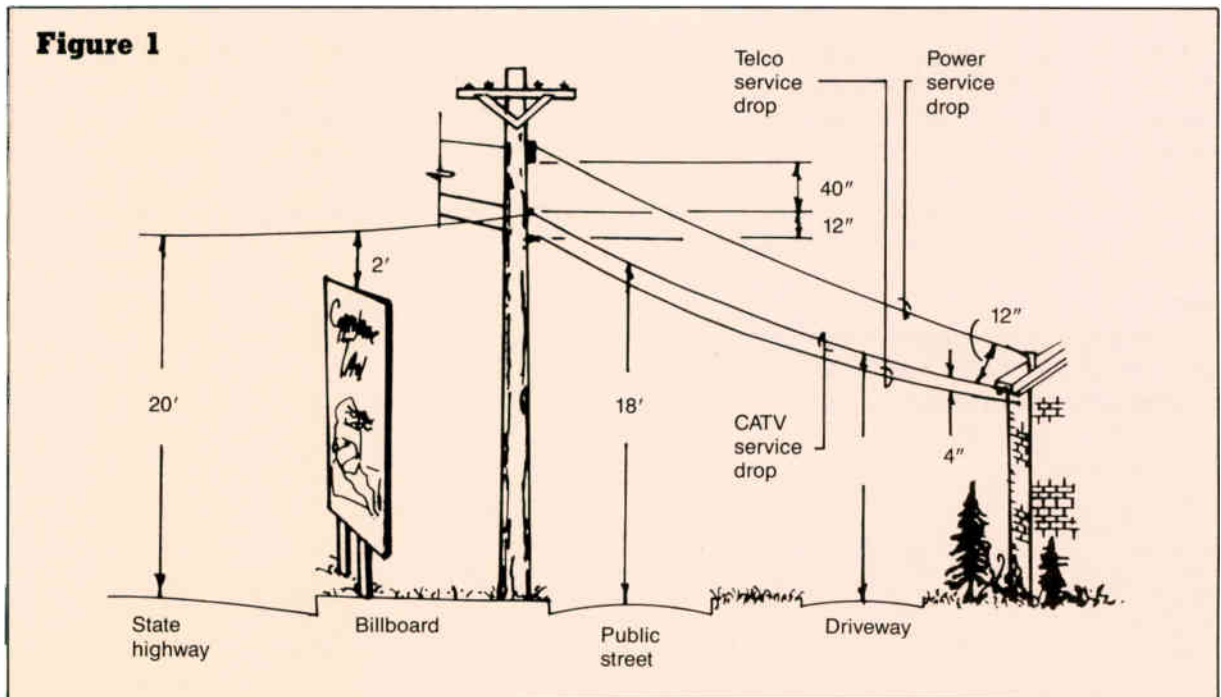

Figure 2

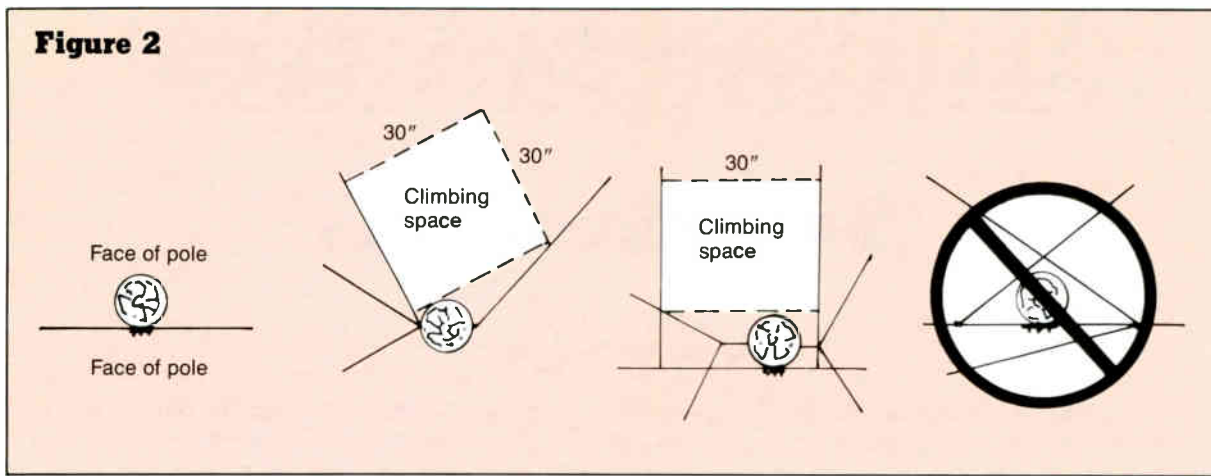
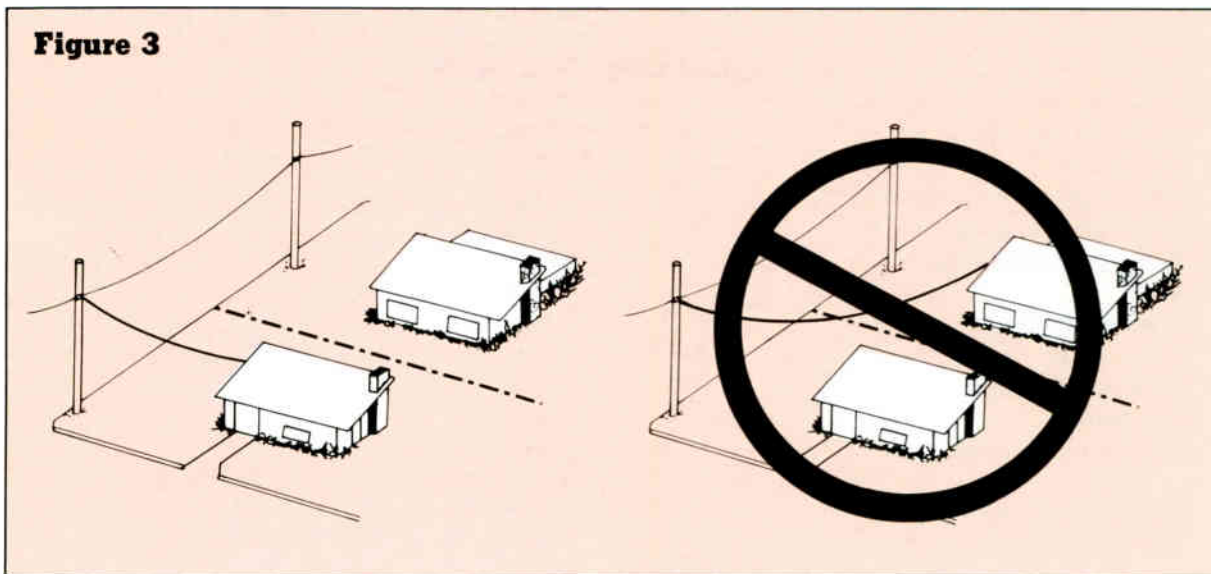

Figure 3



A 30-inch climbing space must be maintained around the pole. The aerial drop must not pass through this climbing space (Figure 2).

When routing the drop cable to the house, the cable must not cross over another person's property (Figure 3). This is called aerial trespassing and most cable systems do not permit this situation to occur. In potential aerial trespass situations, the installer should consider a mid-span drop installation. Also, the drop must be buried within the lot boundaries and easements to prevent property trespassing.

For additional information on clearances, refer to the National Electrical Safety Code, the National Electrical Code and your state and local policies.

References

- 1) National Electrical Safety Code (NESC) 1987.
- 2) National Electrical Code (NEC) 1987.
- 3) The Jones Intercable Inc. Qualified Installer Program.



Business Directory

SIGNAL LEVEL METER REPAIR

*Prompt, Professional Service
at Reasonable Prices*



JGL

ELECTRONICS, INC.

4425 BLACKSTONE DRIVE
INDIANAPOLIS, INDIANA 46237
317 783 6130

I R W I N



SUPERIOR
GENTEC (A COMPANY)

Communications



Construction, Inc.

"Committed To Service Excellence."

Customer Installations • Multiple Dwelling Units
Plant Construction and Maintenance

(714) 542-1055 • (619) 442-0713

CONTRACTOR'S LICENSE NO. 526824-A/SUPERCC 121M2



CONTRACT INSTALLERS, INC.

UHF Radio Equipped Trucks • Uniformed Installers

HOUSE INSTALLATIONS

Aerial • Underground • Pre-wire

APARTMENT INSTALLATIONS

Post wire • Pre-wire • Commercial Building

Tap Audits

Install or Remove Traps and/or Converters
Drop change over for System Rebuilds

LENNY FISCHER
(414) 582-7087

P.O. Box 1564
Appleton, Wisconsin 54913-1564



L.C.E.



Long Cable Electronics

"For the Finest in Converter Repair"

"Equipment Brokered"

Call Ned:

518-393-5415

1228 Albany Street, Schenectady, NY 12304

See us at the Western Show, Booth 740.

WAVETEK SALE

1855 B/1865 B \$ 5995

WHILE THEY LAST

Bench and Converter Sweep Systems

Display Monitors

Spectrum Analyzers

and more

EMS Instruments

800-234-7434

CATV DESIGN

ASSOCIATES, INC.

- Design
- Strand Mapping
- As-Built Mapping
- System Analysis
- AutoCad Drafting
- LinexCad Drafting
- Cad Training/Setup
- Drafting Services

3100 S. LAMAR, SUITE 101, AUSTIN, TX. 78704

STEVE WILLIAMS (512) 444-2461 **DOUG BURNS**
President Vice President

MC COMMUNICATIONS

NATIONWIDE CABLE SPECIALISTS

- Aerial/Underground Installations
- Converter Recovery
- Prewire/Postwire MDU's
- Drop Replacements
- Auditing Services
- Postwire Repairs
- Complete Operational Support
- Management Consultants



"Contractor Opportunities Nationwide"

Call Toll-Free Nationwide

1-800-348-9988



PUBLICATIONS CORP.

Barbara Allen Bellomo
Classified Ad Manager

**COMMUNICATIONS TECHNOLOGY • CABLE STRATEGIES
INSTALLER/TECHNICIAN**

12200 E. Briarwood Ave. • Suite 250 • Englewood, Colo. 80112 • (303) 792-0023
Mailing Address: P.O. Box 3208 • Englewood, Colo. 80155
TELEFAX (303) 792-3320

Products

Earth anchors

Foresight Products is offering three new Manta Ray utility pole earth anchors in addition to its original MR-1 anchor. The MR-2 is designed to hold 10,000 to 12,000 pounds in normal soils and more than 20,000 pounds in harder soils. Its narrower wings allow it to be driven into harder soils faster. It also can be used in extremely

hard soil where a 4-inch predrilled hole is necessary.

The MR-3 is rated between 6,000 and 8,000 pounds holding capacity and is said to be ideal for applications where aerial lines are strung and new guy lines and anchors must be installed. The MR-4 is rated at 3,000 to 4,000 pounds in normal soils. All Manta Rays are made of galvanized ductile iron, can be driven with the stan-

dard SG-C gad set and proof loaded with the Foresight load locker.

For additional details, contact Foresight Products, 6430 E. 49th Dr., Commerce City, Colo. 80022, (303) 286-8955; or circle #132 on the reader service card.



60/30 VAC POWER SUPPLY TESTER (LOAD TYPE)

MODEL VSPSLT-60

Specifications:

- Load Voltage: 60 or 30 VAC (Sine or Square Wave)
- Load Current: 0A, 5A, 10A, 15A (Selective)
- Dimension: 11" X 9" X 5 1/2"
- Weight 5 lbs.

Features:

- RMS Voltage and Current Reading Meters
- Selective Load
- Voltage Wave Form Reading Port with test probe supplied
- Light weight (portable)
- Over-heating protection
- Fan Cooled
- No External Power (Bench or Field Use)

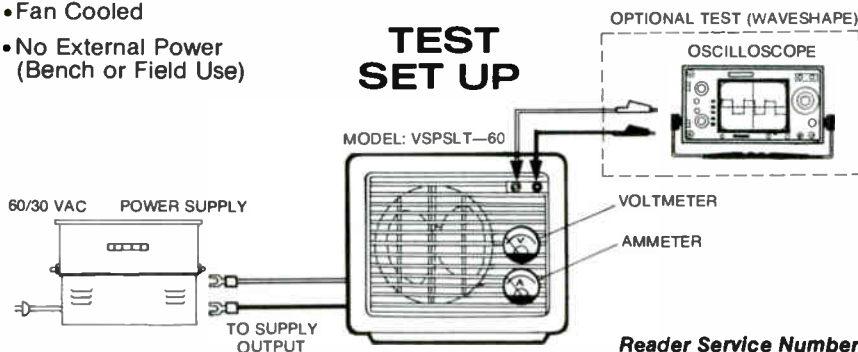
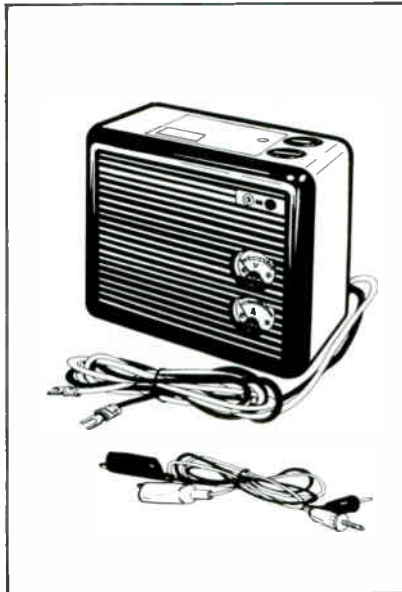

Reader Service Number 20.

Viewsonics inc
"PRODUCTS WITH INTEGRITY"

170 Eileen Way, Syosset, NY 11791
Call Toll Free: 800-645-7600
In New York City: 516-921-7080
FAX: 516-921-2084

DC-AC inverter

Atlantic Solar Products introduced the Pocket Power Inverter, a 12 VDC to 115 VAC power supply. The unit measures 1.2 x 3.5 x 4.5 inches, weighs 14 ounces and can fit into tool boxes, glove compartments and briefcases. It plugs into a vehicle's cigarette lighter to operate electronic test equipment or recharge battery powered devices.

The product features automatic shut-down in the event of overloading and excessive discharging of the battery and audible low battery voltage alarm. The input operating range is from 10 to 15 VDC with a voltage out of 115 ampere, 200 watt surge capability.

For more information, contact Atlantic Solar Products, 9351-J Philadelphia Rd., P.O. Box 70060, Baltimore, Md. 21237, (301) 686-2500; or circle #128 on the reader service card.

Cable protection

Pirelli Cable is producing the Poly Duct system, which incorporates a conduit loosely extruded over the conductor to provide a flexible pipe that is impact resistant. It also provides protection against acids and other corrosive chemicals commonly found in soil. According to the company, the system makes it possible to remove and replace the cable without excavation and impedes or eliminates water migration, if installed properly.

For further details, contact Pirelli Cable Corp., 800 Rahway Ave., Union, N.J. 07083, (201) 687-0250; or circle #135 on the reader service card.

HOW TO TELL THE GOOD GUYS FROM THE BAD GUYS.



Test with Battery In-circuit

The Performance Universal 12 Volt Battery Tester™ determines the condition of deep cycle, high capacity storage batteries used in standby, uninterruptable and back-up power supplies. The tester is able to determine the condition of an individual battery although series connected with others—even when they are actively being charged.

Test with State-of-the-Art Electronic Load

This hand-held tester shows the condition of your battery while it is subjected to an 80 ampere electronic load for ten seconds. The LED readout reveals your battery's internal impedance, determining its ability to hold a charge.

An LED indicates when leads are connected to the correct battery terminals, especially important when battery post markings are hard to read. Another LED indicates when improperly connected across two or more batteries.



PATENT PENDING

Testing Allows Preventive Maintenance

Since batteries deteriorate gradually, regular testing with this unique device enables you to log changes in voltage levels as they occur. Having this history lets you know when to do preventive maintenance—before a critical battery fails.

Two features of the battery tester facilitate these tests. Pin jacks on the tester accommodate an auxiliary voltmeter which allows precise measurements during testing. The automatic timer provides a repeatable reference for the tests.

Easy to Use

Easy to interpret—merely clip the tester to a battery and the LED indicators tell the story.

The Model 1200 Performance Universal 12 V. Battery Tester™ is a hand-held (7.47" x 4.33" x 2.24") lightweight (2.5 lbs.) unit encased in a high-impact ABS thermoplastic case with flame-retardant properties. Copper-plated steel clips are color coded for polarity. Lead length is 12". Price: \$159.00.

Performance

ANALYTICAL DEVICES

1770 Macland Road (Hwy. 360)
Dallas, Georgia 30132
Phone: (404) 443-2788

Reader Service Number 21.

©1988 by Performance Cable TV Products

Graduate Update Program

By **Byron K. Leech**

President, National Cable Television Institute

Last summer I told you a little bit about a program we've been developing that allows NCTI graduates to keep current with changes in the industry and protect the value of their investment in NCTI training. Called the Graduate Update Program, it allows you to obtain copies of newly released or updated lessons to add to your NCTI reference materials if you have graduated from an NCTI course.

We've recently released five lessons under the Graduate Update Program that cover bread and butter topics for installers, installer technicians and the technical personnel who manage them. Following is a listing and description of each as well as information on how you can obtain copies.

Signal Level Meters, Lesson Number 218-11: This lesson covers the importance, history, operation and use of one of the most important tools used to troubleshoot

the drop, the signal level meter (SLM), from the perspective of the installer technician. It presents the operating controls and components found on most SLMs, a step-by-step explanation of how to operate an SLM and actual instruction for using an SLM in post cable installation testing and troubleshooting.

Aerial Installation, Lesson Number 105-22: This lesson is exclusively devoted to the aerial installation of a drop cable from the subscriber tap to the ground block. It presents the procedures of cable stringing, span attachment, building attachment, grounding system installation, specifies typical installation codes and incorporates information on the 1987 National Electrical Code.

Converters and Decoders, Lesson Number 105-51: This lesson acquaints graduates with the various converters, decoders and converter/decoders, with their electrical specifications, how they work and how they are installed in the drop

system. It includes details on many new-to-the-market models as well as installation of impulse pay-per-view service.

Tuning TV Sets, Lesson Number 109-32: This lesson presents the tuning process of the installation procedure, including tuning do's and don'ts, preliminaries to attaching the cable, the critical matter of fine-tuning both color and black and white TV sets and tuning peculiarities. It reflects procedures relevant to current TV sets on the market and includes information on MTS stereo, SAP (second audio program) and automatic frequency control.

Signal Level Testing, Lesson Number 114-12: This lesson covers similar material as signal level meters but from the perspective of the installer. It is most appropriate for graduates of NCTI's Installer course.

Aerial Installation, Converters and Decoders, Tuning TV Sets and Signal Level Testing all represent major revisions of lessons by the same names that were available prior to mid-1988. Since the Graduate Update Program is designed to protect the training investment of NCTI students you must be an NCTI graduate to purchase lessons under the program. However, since NCTI has trained more than 27,000 industry professionals since its inception in 1968, chances are you are an NCTI graduate.

Signal Level Meters is available to graduates of the Installer Technician course or any higher level NCTI course. The other four lessons described above are available to graduates of the Installer course or any higher level NCTI course. Lessons are available for \$6.50 each and can be ordered by contacting Tom Brooksher at the NCTI, P.O. Box 27277, Denver, Colo. 80227 or by calling (303) 761-8554. If you would like a full Graduate Update Program kit with lesson descriptions, procedures and order forms drop us a note or give us a call.

We will follow these five lessons with a series of lessons on signal leakage and another series on troubleshooting the drop. We will begin taking pre-publication orders under the Graduate Update Program for many of these lessons in the next 30 days. I'll keep you posted on them in coming issues of *Installer Technician*. ■

Ad Index

Anixter	2
Ben Hughes/Cable Prep	28
BradPTS	3
Budco	11
Cable Exchange	23, 24
Cable Link	21
CableTek Center Products	21
CaLan	44
Intercept/Antronix	13
Jones International	33
Lemco Tool Corp.	25
Magnavox CATV	5
NCTI	17
Performance Cable TV	41
SCTE	19
Sencore	43
Telecommunication Products	14
Telecrafter	8
Toner	15
Triple Crown Electronics	16
Viewsonics	34, 40
Wavetek	7

**Completely Performance Test Every Single TV Channel,
In Any RF Distribution System, To FCC Specifications,
100% Automatically . . .**

Reader Service Number 22.

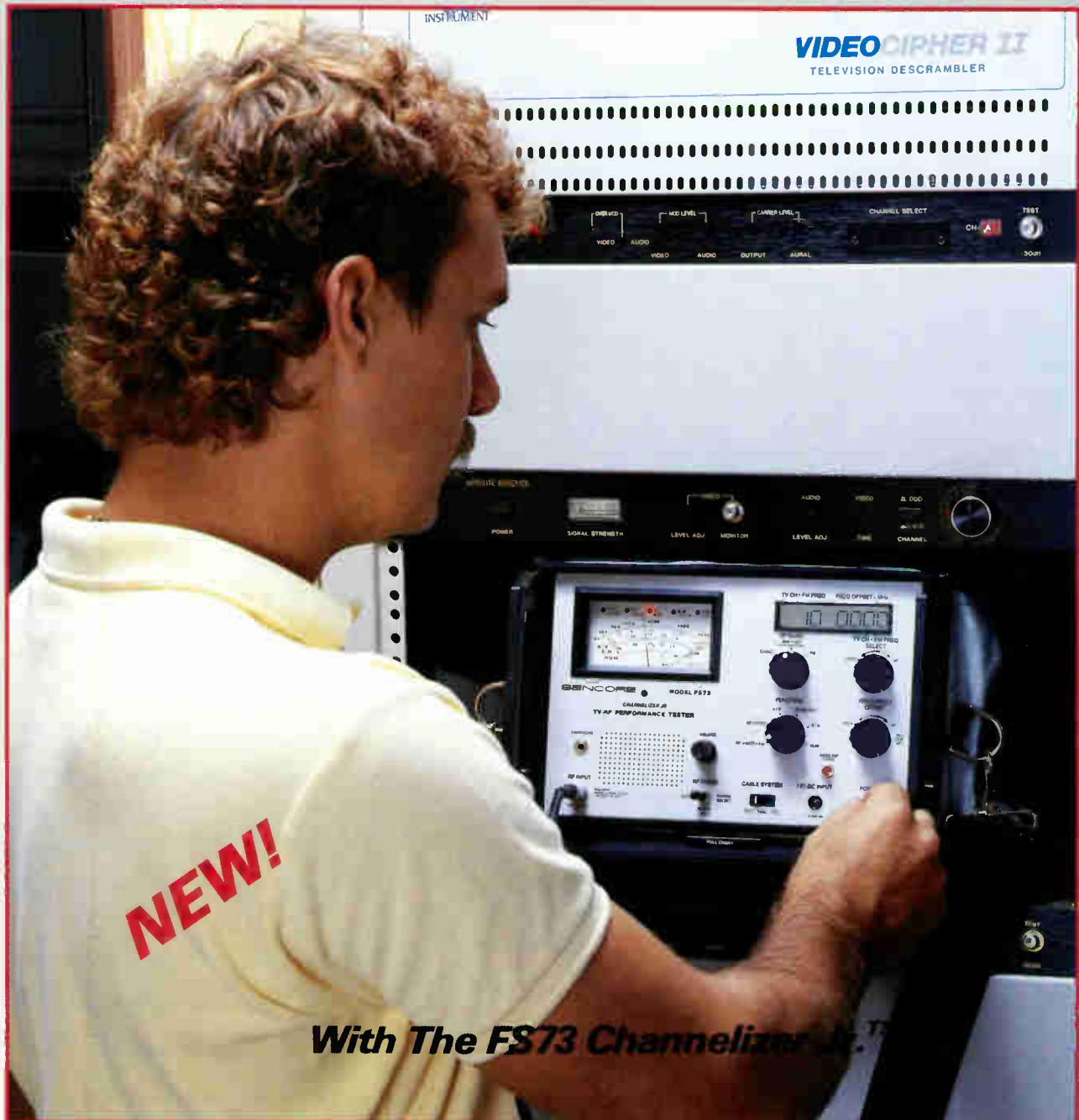

- **Get fast, accurate results when you tune direct to any channel from 5 MHz to 890 MHz, with ± 1 dB accuracy.**
- **Exclusive -46 dBmV (5 μ V) sensitivity with automatic attenuation and ranging for fast hands-off operation.**
- **Exclusive automatic Hum and Signal-to-Noise tests on any in-use channel for instant, error free readings.**
- **Exclusive microprocessor controlled fine tuning with offset frequency readout makes it easy to see how far a channel is from its assigned frequency.**
- **IEEE computer interface allows all tests to be performed under computer control for monitoring signal parameters over an extended period of time.**

Try an FS73 on your system for 10 days!

Call Or Write For A Free FS73 Brochure!

Call 1-800-843-3338

SENCORE

3200 Sencore Drive Sioux Falls, South Dakota 57107

Psssst...

Rumor has it
that the best
kept secret
for testing
Broadband
Networks is

OUT
of the
BAG!

The Calan 1776/1777 Sweep/Analyzer System

Unique in the industry, the Calan 1776/1777 is the only synchronized receiver/transmitter with a built-in spectrum analyzer that provides a true sweep response and non-interference to data or video.

In addition, it offers a portable, lightweight design and the reputation of being the **Most Reliable** sweep/analyzer system ever designed for broadband test and measurement requirements.

If you have a Broadband Network and don't have the Calan 1776/1777 Sweep/Analyzer System, you can **Pounce** on one by calling a Calan representative for a demonstration in your system.



CABLE AND LOCAL AREA NETWORKS

CALAN, Inc.
R.R. 1, Box 86T
Dingmans Ferry, PA 18328
800-544-3392 • In PA: 717-828-2356